

---

This is a reproduction of a library book that was digitized by Google as part of an ongoing effort to preserve the information in books and make it universally accessible.

Google™ books

<https://books.google.com>

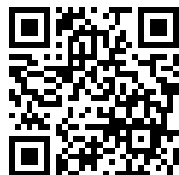



*The boy's playbook of science*

John Henry Pepper

**THE  
PENNSYLVANIA  
STATE UNIVERSITY  
LIBRARY**



**COLLEGE OF AGRICULTURE**

**Gift of  
George Rex Green**

*Index*







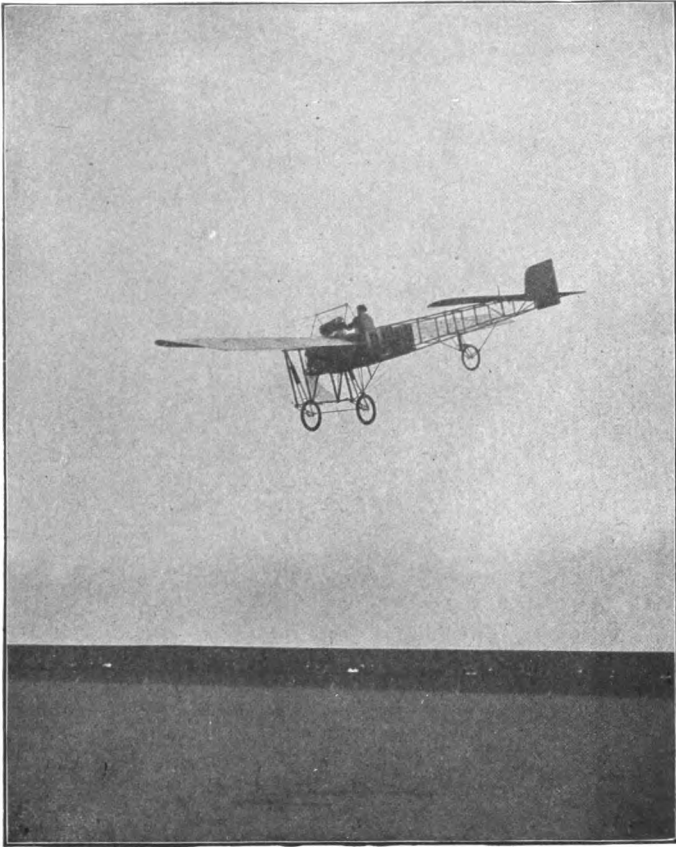

**Monoplane Flying at Brooklands.**  
(Copyright photograph, by permission of  
The Thornton-Pickard Manufacturing Co., Ltd.)

# THE BOY'S PLAYBOOK OF SCIENCE

BY

**JOHN HENRY PEPPER**

*Author of The Playbook of Metals*

ILLUSTRATED WITH FIVE HUNDRED AND NINETY-THREE ENGRAVINGS  
REVISED, REWRITTEN, AND REILLUSTRATED  
WITH MANY ADDITIONS

BY

**JOHN MASTIN, M.A., D.Sc., Ph.D.,**

F.S.A. Scot., F.L.S., F.C.S., F.R.A.S., F.R.M.S., R.B.A.

*Author of The Chemistry, Properties and Tests  
of Precious Stones, etc.*



LONDON

GEORGE ROUTLEDGE AND SONS, LTD.

NEW YORK

E. P. DUTTON & COMPANY

1912  
100

**COPYRIGHT, 1912,**  
**By E. P. DUTTON & COMPANY**



# CONTENTS

CHAPTER		PAGE
I	THE PROPERTIES OF MATTER	
	IMPENETRABILITY . . . . .	1
	OSMOSIS . . . . .	7
	CRYSTALLOIDS . . . . .	9
	COLLOIDS . . . . .	9
	DIALYSIS . . . . .	9
	INERTIA OR PASSIVENESS . . . . .	12
	GRAVITATION . . . . .	14
II	CENTRIFUGAL FORCE . . . . .	21
III	THE SCIENCE OF ASTRONOMY . . . . .	25
	COMETS . . . . .	42
	SHOOTING STARS . . . . .	46
IV	CENTRE OF GRAVITY . . . . .	48
V	SPECIFIC GRAVITY . . . . .	65
VI	ATTRACTION OF COHESION . . . . .	79
VII	ADHESIVE ATTRACTION . . . . .	86
VIII	CAPILLARY ATTRACTION . . . . .	88
IX	CRYSTALLISATION . . . . .	93
X	CHEMISTRY . . . . .	103
	CHEMICAL AFFINITY . . . . .	105
	CHEMICAL EXPERIMENTS . . . . .	111
	THE ALLOTROPIC CONDITION OF OXYGEN GAS . . . . .	129
	NITROGEN . . . . .	133
	AMMONIA . . . . .	139
	HYDROGEN . . . . .	142
	THE LIQUEFACTION OF GASES . . . . .	158
XI	AÉROSTATION, ANCIENT AND MODERN . . . . .	162
XII	THE HALOGENS . . . . .	
	CHLORINE . . . . .	185
	IODINE . . . . .	196
	BROMINE . . . . .	198
	FLUORINE . . . . .	201
XIII	THE ART OF PHOTOGRAPHY . . . . .	206
	THE CARBON PRINTING PROCESS . . . . .	212
	THE DIAZOTYPE PROCESS . . . . .	216
	THE ZINCO PROCESS . . . . .	217
	THE HALF-TONE PROCESS . . . . .	218
	THE TRI-COLOUR PROCESS . . . . .	220
	MICRO-PHOTOGRAPHY . . . . .	223
XIV	CARBON, BORON, ETC. . . . .	224
XV	FRICTIONAL ELECTRICITY . . . . .	262
XVI	VOLTAIC ELECTRICITY . . . . .	287
XVII	MAGNETISM AND ELECTRO-MAGNETISM . . . . .	309

447849

# CONTENTS

CHAPTER		PAGE
XVIII	ELECTRO-MAGNETIC MACHINES . . . . .	315
XIX	THE ELECTRIC TELEGRAPH . . . . .	321
	A. THE BATTERY . . . . .	322
	B. THE CONDUCTING WIRES . . . . .	323
	C. THE INSTRUMENTS TO BE WORKED . . . . .	328
	THE TELEPHONE, PHONOGRAPH AND MICROPHONE . . . . .	348
XX	RUHMKORFF'S, HEARDEE'S AND BENTLEY'S COIL APPARATUS	363
XXI	MAGNETO-ELECTRICITY . . . . .	376
XXII	DIA-MAGNETISM . . . . .	388
XXIII	LIGHT, OPTICS AND OPTICAL INSTRUMENTS . . . . .	396
XXIV	THE REFRACTION OF LIGHT . . . . .	446
	THE BLIND SPOT . . . . .	450
XXV	REFRACTING OPTICAL INSTRUMENTS . . . . .	452
	1. THE MAGIC LANTERN . . . . .	452
	2. THE OXY-HYDROGEN MICROSCOPE . . . . .	459
	3. THE OPAQUE LANTERN . . . . .	462
	4. LANTERN EXPERIMENTS . . . . .	464
	5. THE DECOMPOSITION OF LIGHT—ITS ANALYSIS AND SYNTHESIS . . . . .	469
	6. DURATION OF THE IMPRESSION OF LIGHT . . . . .	480
	7. THE ZOETROPE AND OTHER SIMILAR PHILOSOPHICAL TOYS . . . . .	480
	8. SIMPLE MICROSCOPES AND TELESCOPES . . . . .	485
	9. THE STEREOSCOPE . . . . .	489
XXVI	LIGHT . . . . .	497
	A. THE ABSORPTION OF LIGHT . . . . .	497
	B. THE INFLECTION OR DIFFRACTION OF LIGHT . . . . .	498
	C. THE POLARISATION OF LIGHT . . . . .	506
	POLARISATION BY REFLECTION AND BY SINGLE REFRACTION . . . . .	509
	POLARISATION BY DOUBLE REFRACTION . . . . .	511
	POLARISATION BY THE TOURMALINE . . . . .	513
	CHROMATIC EFFECTS PRODUCED BY POLARISED LIGHT . . . . .	515
XXVII	RADIO-ACTIVITY . . . . .	524
	A. THE RONTGEN, OR "X" RAYS . . . . .	524
	B. THE "N" RAYS . . . . .	527
	C. RADIO-ACTIVE ELEMENTS . . . . .	530
	D. WIRELESS TELEGRAPHY . . . . .	533
	E. WIRELESS TELEPHONY . . . . .	534
XXVIII	HEAT . . . . .	536
	SENSIBLE HEAT . . . . .	539
	CONDUCTION OF HEAT . . . . .	555
	RADIATION OF HEAT . . . . .	584
XXIX	STEAM . . . . .	594
	HEAT THE CAUSE OF VAPOUR . . . . .	601
XXX	THE EVOLUTION OF THE STEAM ENGINE . . . . .	606
XXXI	THE WATER TURBINE . . . . .	628

## REVISER'S PREFACE.

For a long time past there has been a continuous call for further copies of "The Boy's Playbook of Science," but as the previous editions were hopelessly out of date, the publishers, Messrs. George Routledge and Sons, Ltd., entrusted me with the work of revision and re-illustration, in order that the increasing demand for the volume might be supplied by an entirely new edition which should be thoroughly up to date in its matter and illustration.

Since the preceding editions were placed before the public, extraordinary advances have been made in all branches of science, especially in those of chemistry, electricity, the application of steam and of water, etc., whilst the interim has also seen the discovery of many new elements, the breaking up of hitherto-considered elements into compounds, the inauguration of new sciences, such as wireless telegraphy and telephony, and new branches of physics, as radio-activity, the "X" rays, "N" rays, etc., as well as great alterations in nomenclature; also several of the then accepted laws which governed certain chemical and physical changes—in the light of modern science, with fuller knowledge and more perfect instruments—have undergone complete revolution. So that in order to bring the work into conformity with modern views of science, it has been necessary to reconstruct, re-illustrate, and re-write the greater part of the book and to add a considerable portion of new matter, which not only extends the volume, but will, it is to be hoped, add to its general interest.

Whilst dealing with almost all important branches and departments of science, I have had before me the desire that it should be a "boy's" book, and have therefore followed on the lines of its predecessors. Though some of the experiments cannot well be performed outside a laboratory, the majority are within the compass of execution in an ordinary house-kitchen, with the assistance of the glass and crockery generally found there. Where the experiments are difficult, and usually performed by means of special and costly appli-



ances, I have, wherever practicable, explained how simple substitutes may easily be made in wood, card, paper, etc., by any ingenious youth. I have also avoided using technical terms as much as possible, treating the subject somewhat conversationally, as to my own students, so that the school-boy—and even the “boy” of maturer age—may find the volume an engrossing “playbook of science,” as well as a work of scientific reference, shorn of what might prove, to many, dry and irksome technicalities. When leisure hours are spent in pleasurable work and interesting experiments, much is unconsciously learned even during fascinating “play.” The intelligent use of recreation not only benefits the body, but places the mind, along with the individual, on a higher level, bringing future results, maybe, of incalculable good.

All living insects and animals incite us to employ our powers rightly and to the best of our ability, for if we turn to nature as our guide, we see that “bees are geometers. The cells are so constructed as, with the least quantity of material, to have the largest sized spaces and the least possible interstices. The mole is a meteorologist. The bird called the nine-killer is an arithmetician, also the crow, the wild turkey, and some other birds. The torpedo, the ray, and the electric eel are electricians. The nautilus is a navigator. He raises and lowers his sails, casts and weighs anchor, and performs nautical feats. Whole tribes of birds are musicians. The beaver is an architect, builder, and wood-cutter. He cuts down trees and erects houses and dams. The marmot is a civil engineer. He does not only build houses, but constructs aqueducts and drains to keep them dry. The ant maintains a regular standing army. Wasps are paper manufacturers. Caterpillars are silk-spinners. The squirrel is a ferryman. With a chip or a piece of bark for a boat, and his tail for a sail, he crosses a stream. Dogs, wolves, jackals, and many others, are hunters. The black bear and heron are fishermen. The ants are day-labourers. The monkey is a rope dancer. Shall it, then, be said that any boy possessing the Godlike attributes of mind and thought with free-will can only eat, drink, sleep, and play, and is therefore lower in the scale of usefulness than these poor birds, beasts, fishes, and insects? No, no! Let “Young England” enjoy his manly sports and pastimes, but let him not forget the mental

race he has to run with the educated of his own and of other nations; let him nourish the desire for the acquisition of scientific knowledge, not as a mere school lesson, but as a treasure, a useful ally which may some day help him in a greater or lesser degree to fight the battle of life."

My acknowledgments and thanks are due to the Council of the Royal Astronomical Society for permitting me the use of a number of Plates of Comets, which illustrations have appeared in the Monthly Notices of the Society.

Also to Professor E. E. Barnard, D. Sc., Assoc. R. A. S., of The Yerkes Observatory, U. S. A., for permitting me the use of his photographs of Comet c 1908 (Morehouse), which illustrated his paper given before the Royal Astronomical Society.

To J. Evershed, Esq., F. R. A. S., The Observatory Kodai-kánal, Palani Hills, South India, for permitting me the use of his photographs of Halley's Comet, 1910, which illustrated his paper given before the Royal Astronomical Society.

To Mrs. Johnson, for permitting me the use of a photograph by her late husband, R. C. Johnson, Esq., F. R. A. S., of Comet c 1908 (Morehouse), which illustrated his paper given before the Royal Astronomical Society.

To Harold E. Perrin, Esq., of the Royal Aero Club, Piccadilly, for his kind assistance in the compilation of the list of aviation disasters during 1910.

To the Editor of "Flight" for the loan of three copyright pictures of modern aeroplanes.

To Dr. W. Harwood Nutt, of Sheffield, for lending the three excellent radiographs which follow my description of the "X" Rays.

To Henry Fowler, Esq., Chief Mechanical Engineer for the Midland Railway Company, for the loan of the four drawings of Compound Engines for express service on the Midland Railway.

To Messrs. Ilford, Limited, of Ilford, London, E., for the loan of a picture of a flash of lightning.

To F. Holmes, Esq., Mere, Wiltshire, for the use of a copyright photograph of a lightning-flash.

To John Browning, Esq., F. R. A. S., etc., 146 Strand, London, W. C., for loan of picture of Induction Coil.

To Messrs. T. Cooke and Sons, Limited, Buckingham Works,

York, for the loan of photograph of a Transit Instrument and the use of a drawing of modern Observatory Telescope.

To Messrs. Adam Hilger, Limited, 75a, Camden Road, London, N. W., for the loan of three plates of Spectroscopes.

To Messrs. The India-Rubber, Gutta Percha and Telegraph Works Company, Limited, Silvertown, London, E., for the loan of a number of drawings of modern telegraph instruments and apparatus.

To Messrs. Townson and Mercer, 34 Camomile Street, London, E. C., for the loan of a number of drawings illustrating chemical and physical apparatus.

To Messrs. The General Electric Company, Limited, 71 Queen Victoria Street, London, E. C., for the loan of a number of photographs of electrical apparatus.

To Messrs. Canning and Company, of Birmingham, for the loan of an illustration of an electro-plating plant.

To Messrs. The Thornton-Pickard Manufacturing Company, Limited, Altrincham, for the loan of photographs of a modern camera and of a flying aéroplane.

To Messrs. Longmans, Green & Company, Limited, Paternoster Row, London, E. C., for three illustrations of apparatus for reducing the temperature of gases, from Watson's "Text-book of Physics."

To Messrs. Merryweather and Sons, Limited, Greenwich Road, London, S. E., for the loan of photograph of modern fire-apparatus and for permission to copy drawings of chemical fire-extinguishers.

And to Messrs. W. H. Allen, Son and Company, Limited, Queen's Engineering Works, Bedford, for particulars and illustrations relating to water turbines.

JOHN MASTIN.

Totley Brook, near Sheffield.

# THE BOY'S PLAYBOOK OF SCIENCE

## CHAPTER I

### THE PROPERTIES OF MATTER—IMPENETRABILITY

In the present state of our knowledge it seems to be universally agreed, that we cannot properly commence even popular discussions on astronomy, mechanics and chemistry, or on the Energy or Force of heat, light, electricity, and magnetism, without a definition of the general term "matter"—which is an expression applied by scientists to every species of substance capable of occupying space, and, therefore, to everything which can be seen and felt.

The sun, the moon, the earth, and other planets, rocks, earths, metals, glass, wool, oils, water, alcohol, air, steam, and hosts of things, both great and small, all solids, liquids and gases, are included under the comprehensive term *matter*. Such a numerous and varied collection of bodies must necessarily have certain qualities, peculiarities, or properties; hence we come in the first place to consider "The general powers or properties of matter." Thus, if we place a block of wood or stone in any position, we cannot take another substance and put it in the space filled by the wood or stone, until the latter be removed. Now this is one of the first and most simple of the properties of matter, and is called *impenetrability*, being the property possessed by all solid, liquid, and gaseous bodies, of filling a space to the exclusion of others until they be removed, and it admits of many interesting illustrations, both as regards the proof and modification of the property.

Thus, a block of wood fills a certain space: how is it (if impenetrable) that we can drive a nail into it? A few experiments will enable us to answer this question.

Into a glass (as depicted at Fig. 1) filled with spirits of wine, a quantity of cotton wool many times the bulk of the

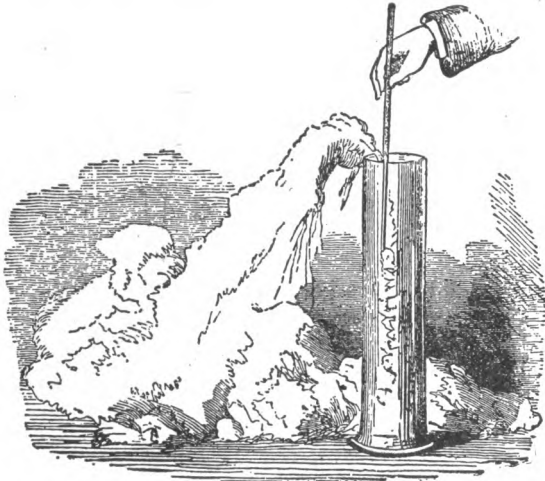

Fig. 1.

alcohol may (if the experiment is carefully performed) be pushed without causing a drop to overflow the sides of the vessel.

Here we seem to have a direct contradiction of the simple and indisputable truth, that "two things cannot occupy the same space at once." But let us proceed with our experiments:—

We have now a flask full of water, and taking some very finely-powdered sugar, it is easy to introduce an appreciable quantity of that substance without increasing the bulk of the water; the only precaution necessary, is not to allow the sugar to fall into the flask in a mass, but to drop it in grain by grain, and very slowly, allowing time for the air-bubbles (which will cling to the particles of sugar) to pass off, and for the sugar to dissolve. Matter, in the experiments adduced, appears to be penetrable, and the property of impenetrability seems only to be a creation of fancy: reason, however, enables us to say that the latter is not the case.



Fig. 2.

A nail may certainly be hammered into wood, but the particles are *thrust aside* to allow it to enter. Cotton wool may be placed in spirits of wine because it is simply greatly extended and bulky matter, which, if compressed, might only occupy the space of the kernel of a nut, and if this were dropped into a half-pint measure full of alcohol, the increase of bulk would not cause the spirit to overflow. The cotton-wool experiment is therefore no contradiction of *impenetrability*. The experiment with the sugar is the most troublesome opponent to our term, and obliges us to amend and qualify the original definition, and say, that the ultimate or smallest particles or atoms of bodies only are impenetrable; and we may believe they are not in close contact with each other, because certain bulks of sugar and water occupy more space separately than when mixed.

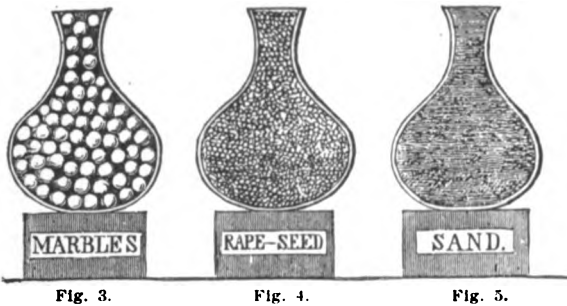

If we compare the flask of water to a flask full of marbles (Fig. 3), and the sugar to some rape-seed (as in Fig. 4), it will be evident that we may almost pour another flask full of the latter amongst the marbles, which are not in close contact with each other, but have spaces between them; and after pouring in the rape-seed, we might still find room for some fine sand (as in Fig. 5).

The particles of one body may thus enter into the spaces left between those of another without increasing its volume; and hence, as has been before stated, "The atoms only of bodies are truly impenetrable."

This spreading, as it were, of matter through matter assumes a very important function when we come to examine the constitution of the air we breathe, which is chiefly a mechanical mixture of gases: seventy-nine parts by volume

or measure of nitrogen gas, twenty-one parts of oxygen gas, and four parts of carbonic acid vapour in every ten thousand parts of air, having the following relations as to weight:—

	Specific gravity, compared with air as 1., decimally.
Nitrogen .....	0.97333
Oxygen .....	1.10569
Carbonic acid.....	1.5291

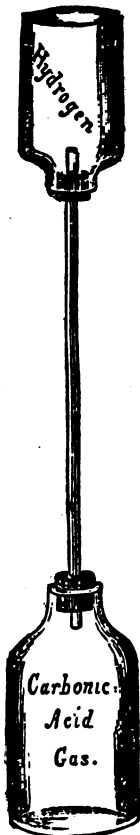

Fig. 6.

It might be expected that these gases would arrange themselves in our atmosphere in the above order, and if that were the case, we should have the carbonic-acid *gas* (a most poisonous one) at the bottom, and touching the earth, then the oxygen, and, last of all, the nitrogen; a state of things in which *organized* life could not exist. The gases do not, however, separate: indeed, they seem to act as it were like vacuums to one another, and become disseminated by simple gaseous diffusion. This fact is curiously illustrated, as shown in our cut (Fig. 6), by filling a bottle with carbonic acid, and another with hydrogen; and having previously fitted corks to the bottles, perforated so as to admit a tube, place the bottle containing the carbonic acid on the table, then take the other which is full of hydrogen, keeping the mouth downwards, and fit in the cork and tube: place this finally into the cork of the carbonic-acid bottle, which may be a little larger than the other, in order to make the arrangement stand firmer; after leaving them for an hour or so, the carbonic acid, which is twenty-two times heavier than the hydrogen, will have ascended to the latter, whilst the hydrogen will have descended to the carbonic acid. The presence of the carbonic acid in the hydrogen bottle is easily proved by pouring in a wineglassful of clear lime-water, which speedily becomes milky, owing to the production of carbonate of

lime; whilst the proof of the hydrogen being present in the carbonic acid is established by absorbing the latter with a little

cream of lime—*i. e.*, slaked lime mixed to the consistency of cream with some water—and setting fire to the hydrogen that remains, which burns quietly with a yellowish flame if unmixed with air; but if air be admitted to the bottle, the mixture of air and hydrogen inflames rapidly, and with some noise.

One of the most effective methods of showing the diffusion of gases is by taking a large round dry porous cell, such as would be employed in a voltaic battery, and having cemented a cap with a glass tube attached to its open extremity, it may then be supported by a small tripod of iron wire, and the end of the glass tube placed in a tumbler containing a small quantity of water coloured blue with sulphate of indigo. If a tolerably large jar containing hydrogen is now placed over the porous cell, bubbles of gas make their escape at the end of the tube because the hydrogen diffuses itself more rapidly into the porous cell than the air which it already contains passes out. When the jar is removed, the reverse occurs; hydrogen diffuses out of the porous cell, and the blue liquid rises in the tube. (Fig. 7.)

This diffusive force prevents the accumulation of the various noxious gases on the earth, and spreads them rapidly through the great bulk of the atmosphere surrounding the globe.

Liquids, also, are subject to the same laws of diffusion, which compel the molecules to exert themselves till a state of equality in the various liquids is reached.

#### *First Experiment*

Saturate some water with salt and colour it red, blue, or yellow. Fill a small flask or bottle to the brim with this saturated solution, and place over it a strip of greased glass.

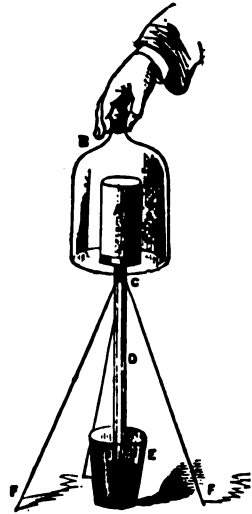

Fig. 7.

A. The porous cell. B. The jar of hydrogen. C. The brass or other form of cap and glass tube D. the end of which dips into the tumbler containing the solution of indigo E. F. F. The wire and stand supporting the porous cell and tube in tumbler.



Now immerse the whole in a jar or larger glass bottle filled with distilled water. When at the bottom of the jar, insert

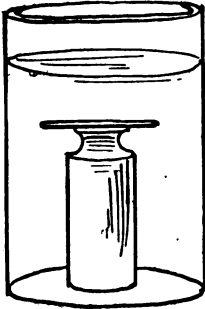

Fig. 8. Jar containing distilled water and bottle of brine.

the hand, and very gently slide off the glass cover. As the small bottle is full to the brim, no bubbles will rise, and if the plate is withdrawn carefully, little movement in either contents will take place. Heavy as is the salt-saturated water compared with the distilled water in the outer vessel, it will not remain in its previous position, but molecules will slide or roll on molecule, till in the course of from twenty-four to thirty hours, the liquid in the flask and in the jar will be exactly alike, both equally saline and equally coloured. (See Fig. 8.)

### Second Experiment

Another experiment with the same coloured salt water gives a much more rapid result. Half fill a tall beaker with distilled water; place in it a thistle funnel, as in Fig. 9.

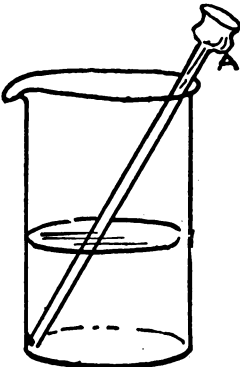

Fig. 9. Large tall beaker with thistle funnel. the force of the water falling on bowl at A.

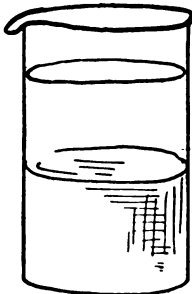

Fig. 10. The same beaker as in Fig. 9 with brine at bottom.

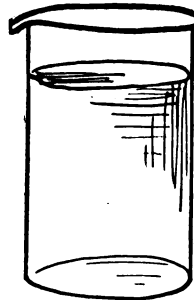

Fig. 11. Same as in Fig. 10, but complete diffusion has taken place.

Now pour down the funnel, slowly, some red-coloured salt water, allowing the water to fall on the *bowl* of the thistle,

as at A, so as to overflow with a gentle trickle down the funnel to the bottom. Then it will be seen that the heavier salt water remains at the bottom as a red mass, whilst the lighter distilled water is forced upwards and forms a layer of transparent water at the top, as in Fig. 10. Carefully withdraw the funnel, and in a few hours the whole contents will be equal in salinity and colour, as in Fig. 11.

Other forms of diffusion are known as dialysis and osmosis. These are the mixture of one fluid with another through membranes, and as they are closely associated with colloids and crystalloids, all four should be considered together.

OSMOSIS

Osmosis is the tendency shown by a fluid or gaseous body to pass through a membrane or other porous partition, and become diffused through another adjoining fluid or gaseous body, separated from it by a membrane. So that in the case of two salts or saline liquids of varying strengths, which are separated from each other by a mere membrane, they will pass more or less freely into one another and commingle, but with different rates of speed, so that eventually, one liquid will be higher than that at the other side of the membrane.

*Experiment*

Get a wide-mouthed thistle-funnel, and stretch across the thistle end a piece of bladder, to cover the opening, tying it securely on the outside. Now turn it the other way up, and pour down the stem sufficient coloured brine to fill the thistle, or about an inch-and-a-half up the stem. Immerse this in a beaker of distilled water, mouth downwards, and suitably suspended through a cork in a glass disc, or held in

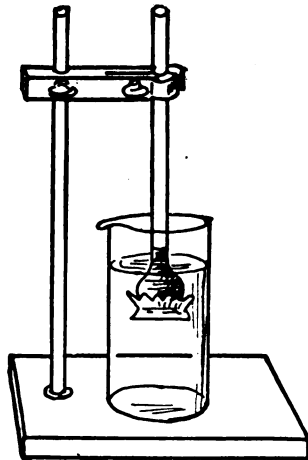

Fig. 12. Thistle funnel capped and supported in burette stand.

a burette stand, as in Fig. 12. Gum a little stamp-edging on the stem of the funnel to mark the height of the brine, and another strip on the outside of the beaker to mark the height of the distilled water, and let the whole remain undisturbed for a while. In time, the coloured salt water will have found its way through the bladder to the distilled water in the beaker, and the water in the beaker will, likewise,

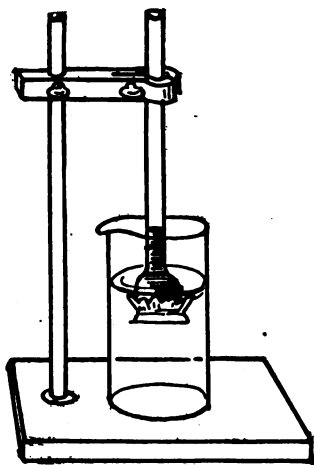

Fig. 13. The same as in Fig. 12 illustrating osmose.

have gone through the bladder to the brine, but their relations are changed; the distilled water has passed through the bladder septum much more rapidly than has the brine to the water, for though the distilled water is coloured, proving that some brine has come into it, a reference to the mark shows the beaker less full, whilst the liquid in the funnel has risen considerably up the stem, their relative positions being now more like Fig. 13.

This is an example of osmosis, and is even more remarkably seen in the experiment of Nolle—to whom science owes its first record of the observation of osmose. His experiment may be conducted with the same simple funnel and beaker used in the last experiment. Stretch across the thistle end of the funnel, a piece of bladder, as before. Now fill the whole tube with alcohol and immerse and support in the beaker of water, as before (see Fig. 12). The entry of the water will be so rapid as often to burst the bladder. By changing the places of the liquids, that is, placing the water in the funnel and the spirit in the beaker, the opposite effect is seen. Such was Nolle's original experiment.

This is a most important molecular action, for it is these forces of the molecules which enable the sap to rise to the extreme tops of plants and to the uttermost limits of the highest trees, notwithstanding the fact that the whole of the gravity of the earth is vainly endeavouring to pull it down;

the sap still creeps up and up, slowly but surely, in spite of gravity.

CRYSTALLOIDS

Certain substances in solution have power to penetrate a septum opposed to their progress, such as parchment, or bladder. These substances were named crystalloids by Prof. Graham, because he found they were of a crystalline nature. Almost all the poisons known to-day are crystalloids, as well as many other substances—such as strychnine, arsenic, oxalic acid, sugar-of-lead, metallic salts, and organic bodies like sugar, morphia, etc.

COLLOIDS

Colloids are the opposite to crystalloids. They have little or no power to permeate membranes, but they have a curious property of being exceedingly sensitive to all chemical changes and action, so that in the human system, the colloids are greatly affected by their closeness to the food, and are easy of assimilation. They have no crystalline structure, and, while permeable by crystalloids, are impermeable to each other; of these, gelatine, gum, and the like, may be considered as types of colloidal substances. This name, colloid, was given to them by the discoverer, Prof. Graham.

DIALYSIS

Dialysis is the action—discovered by Prof. Graham—of separating the crystalloids from the colloids in a liquid or fluid substance by means of a membrane, or dialyser, which is a septum of parchment or skin stretched across a ring, usually of wood or gutta-percha. There are many forms and patterns of these, but the one illustrated here (Fig. 14), will answer, and is easily made. Get a small, stout ring of gutta-percha, glass or wood (Fig. 14), and stretch across it a piece of wet parchment-paper, or bladder. Pull up the edges tightly and tie with a string. The bought dialysers have a narrow hoop which fits over the ring and grips the parchment tightly. The hoop is now like a half-drum, or a miniature tambourine.

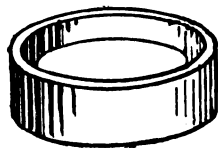

Fig. 14. Ring of glass, wood, etc., for dialyser.

(Fig. 15). Briefly, the action is to put a mixture of the crystalloid and colloid on the membrane inside the ring; the ring is then floated on distilled water in a beaker or dish. At once action commences. The crystalloid passes through the membrane to the water beneath, whilst the colloid remains in the ring.

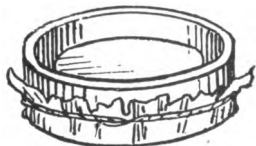

Fig. 15. The same ring as shown in Fig. 14, with bladder on one end and now a dialyser.

### *Experiment*

Mix a solution of gruel or gum, and salt, and pour into the dialyser to the depth of half-an-inch or so; then float it on water, as in Fig. 16. In the course of a few hours—according to the thickness of the gruel or gum—all the salt, which is the crystalloid, will have become dissolved in the water,

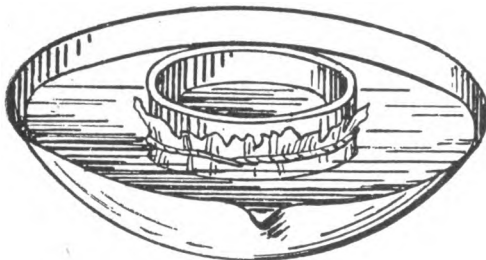

Fig. 16. The dialyser (Fig. 15) floating on water in an evaporating basin.

whilst the gum, or gruel—the colloid—will remain in the dialyser.

This is one of the most important processes known, and is especially useful to the toxicologist.

Whilst waiting for the separations to take place, we return to the subject of impenetrability in relation to gases.

Although air and other gases are invisible, they possess the property of impenetrability, as may easily be proved by various experiments. Having opened a pair of common bellows, stop up the nozzle securely, and it is then impossible to shut them; or, fill a bladder with air by blowing into it, and tie a string fast round the neck; you then find that you cannot, without breaking the bladder, press the sides together.

It is customary to say that a vessel is empty when we have poured out the water which it contained. Having provided

two glass vessels full of water place each of them in an empty pan, to receive the overflow, then lay an orange upon the surface of the water of one of them, and being provided with a cylindrical glass, open at one end, with a hole in the centre of the closed end, place your finger firmly over the orifice, and endeavour, by inverting the glass over the orange, and pressing upon the surface of the water, to make it enter the interior of the glass cylinder; the resistance of the air will now cause the water to overflow into the pan, whilst the orange will not enter the cylinder. (See Fig. 17.) The

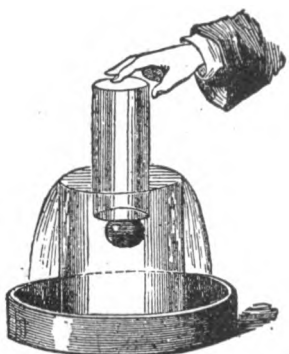

Fig. 17 represents the water overflowing, as the glass, with the orifice closed, is pressed down, proving the impenetrability of air.



Fig. 18. The orange has entered the glass vessel, and the air having passed from the orifice, no water overflows.

orange may now be transferred to the other vessel of water, or if one vessel only is used, it must be refilled, the orange remaining in it, and on removing the finger from the orifice of the cylindrical glass, and inverting it as before over the orange, the air will rush out and the orange and water will enter, whilst there will be no overflow as in the preceding experiment. (See Fig. 18.) The comparison of the two is very striking, and at once teaches the fact desired.

Whilst the vessels of water are still in use, another pretty experiment may be made with the metal potassium. First throw a small piece of the metal on the surface of the water, to show that it takes fire on contact with that fluid; then, having provided a gas-jar, fitted with a cap and stop-tap, and a little spoon screwed into the bottom of the stop-tap inside the gas-jar, place another piece of potassium in the little

spoon, and, after closing the tap, push the jar into one of the vessels of water: as before, the impenetrability of the air prevents the water flowing up to the potassium; but, on opening the tap, the air escapes, the water rushes up, and directly it touches the potassium, combustion ensues.

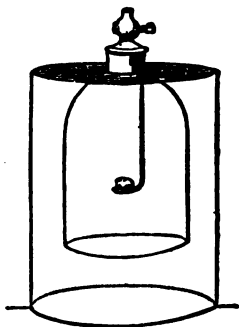

Fig. 19. Gas-jar with stop-tap closed, and potassium in ladle; air prevents the entrance of the water.



Fig. 20. Gas-jar; stop-tap open; the air passes, the water enters, and the potassium is inflamed.

Having sufficiently indicated the nature and meaning of impenetrability, we may proceed to discuss experimentally three other marked and special qualities of matter—viz., *inertia*, *gravity*, and *weight*.

#### INERTIA OR PASSIVENESS

*Inertia* is a power, which (according to Sir Isaac Newton) is implanted in all matter, of resisting any change from a state of rest. It is sometimes called *vis inertiae*, and is that property possessed by all matter, of remaining at rest till set in motion, and *vice versâ*; and it expresses, in brief terms, resistance to motion or to rest.

A pendulum clock wound up and ready to go, does not commence its movements until the inertia of the pendulum is overcome, and motion imparted to it. On the other hand, when seated in a carriage, should any obstruction cause the horse to stop suddenly, it is only perhaps by a violent effort, if at all, that we can resist the onward movement of our bodies.

To illustrate inertia, get a wooden box about two inches deep, and nail a leg at each corner. Saw out the bottom of the box, leaving on all four sides just sufficient to support the legs and also a piece of window-glass the size of the inside of the box, which will form the bottom, putting all the joints and angles to make them watertight. Cut away the lid in a similar manner, to form a frame, or nail together four pieces of narrow wood, to make the size of the lid. Stretch a piece of white calico or thin white paper across the opening, as in Fig. 21; set the box on a stone floor or out in the open, and fill with water; then place a candle or small lamp underneath. If the calico-covered lid is now placed at an angle of thirty degrees above the water and the experiment tried in the dark, except for the lamp underneath, all that occurs on the surface of the water will be rendered visible on the screen. Attention may now be directed to the quiescence, or the inertia of the water, while the opposite condition of movement and formation of the waves may be beautifully shown by touching the surface of the water with the finger, the miniature waves being depicted on the screen, and continuing their motion till set at rest by striking against the sides of the tray. (Fig. 22.) See also page 501 for a more advanced experiment of a similar nature.

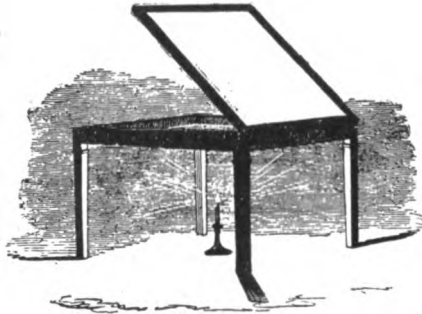

Fig. 21. Tray, with glass bottom, full of water; candle placed underneath.

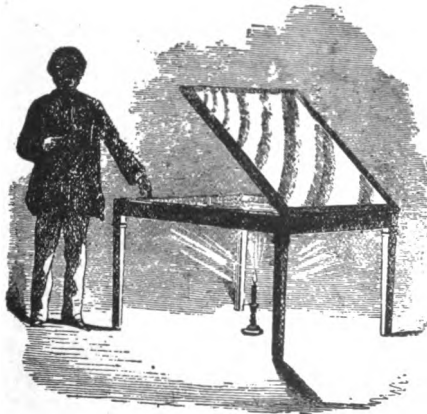

Fig. 22. Same tray, with calico screen; showing the waves as they are produced by touching the surface of the water with the finger.

If the calico-covered lid is now placed at an angle of thirty degrees above the water and the experiment tried in the dark, except for the lamp underneath, all that occurs on the surface of the water will be rendered visible on the screen. Attention may now be directed to the quiescence, or the inertia of the water, while the opposite condition of movement and formation of the waves may be beautifully shown by touching the surface of the water with the finger, the miniature waves being depicted on the screen, and continuing their motion till set at rest by striking against the sides of the tray. (Fig. 22.) See also page 501 for a more advanced experiment of a similar nature.



Inertia may be demonstrated in a simpler manner by filling a tea-cup or other convenient vessel with water, and after moving rapidly with it in any direction, if we stop suddenly, the rigidity of all parts of the cup we hold brings them simultaneously to a state of rest; but the mobility of the liquid particles allows of their continuing in motion in their original direction, and the liquid is spilled. Thus, carelessness in handing and spilling a cup of tea (though not to be recommended) serves to illustrate an important principle. The inertia of bodies in motion is further and lamentably illustrated by the accidents caused from the sudden stoppage of a railway train whilst in rapid motion, when heads and knees come in contact with frightful results.—It is more especially demonstrated by the earth, the moon, and the other planets continuing their motion for ever in the absence of any friction or resistance to oppose their onward progress. It is the friction arising from the roughness of the ground, the resistance of the air, and the force of the earth's attraction, which puts a stop to bodies set in motion about the surface of the earth.

#### GRAVITATION

*Inertia* represents a passive force, and *gravitation* an active condition of matter; this latter may truly be termed a force of attraction, because it acts between masses at sensible or insensible distances: it is illustrated by a stone, unsupported, falling to the ground; by the stone pressing with force on the earth, and requiring power to raise it from the ground: indeed, it is commonly understood that it was by accident—an apple falling from a tree—that Newton was led to reflect on the universal law of gravitation, and to pronounce upon it in the following memorable words:—

*“Every particle of matter in the universe attracts every other particle of matter with a force or power directly proportional to the quantity of matter in each, and decreasing as the squares of the distances which separate the particles increase.”*

These words may appear very obscure to some readers; but when dissected and examined properly, they clearly define the property of gravitation. For instance, “every particle attracts every other with a force proportional to the quantity of matter in each.” This statement was verified in 1774 by Maskelyne, who, having sought out and discovered a steep,

precipitous rock in the Schichallion mountains, in Scotland, suspended from it a metal weight by a cord; then going to a convenient distance with a telescope, and observing the weight, he found that it did not hang perpendicularly, like an ordinary plumb-line, but was diverted, or impelled to the sides of the rock by some kind of attraction, which, of course, could be no other than that indicated by Newton as the attraction of gravitation. (Fig. 23.)

This truly wonderful power of attraction pervades all masses; and being, as before stated, proportional to the quantity of matter, if a man could be transported to the surface of the sun, he would become about thirty times heavier: he would be attracted, or impelled, to the sun with thirty times more gravitating force than he is to the surface of the earth, and would weigh about two of our tons; whilst on some of the smaller planets, such as Ceres and Pallas, a man would probably gravitate with a force of a few pounds only, and with the same muscular power now possessed, he would quite emulate the exploits of those domestic little creatures sometimes called "the industrious fleas," and his jumping would be something marvellous.

There are not many very good lecture-table experiments that will illustrate gravitation, although attention may be directed to the fact of a piece of potassium thrown on the surface of water in a plate generally rushing to the sides, and, as if attracted, attaching itself with great force to the substance of the pottery or porcelain; or, if a model ship, or lump of wood, be allowed to float at rest in a large tank of

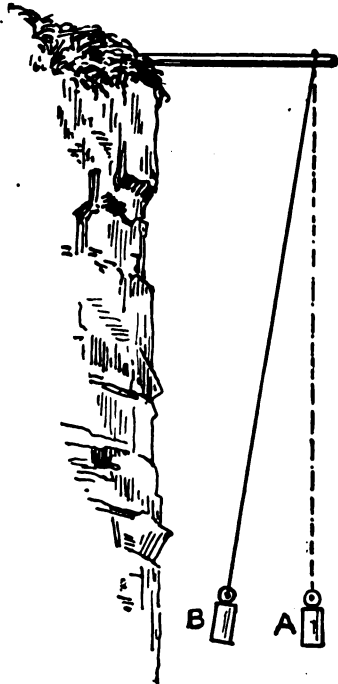

Fig. 23. The Schichallion Rocks. The dotted line and weight A represent the ordinary position of a plumb-line, whilst the line of the weight B indicates (of course, with some exaggeration) the attractive power of the mass of the rock drawing it from the perpendicular.

water, and a number of light chips of wood or bits of straw be thrown in, they generally collect and remain around the larger floating mass.

A very good idea, however, may be afforded of the universal action of gravity maintaining all things in their natural position on the earth by taking a hoop and arranging in and upon it balls, or a model ship, or other toy, and wires, as depicted in our diagram. (Fig. 24.)

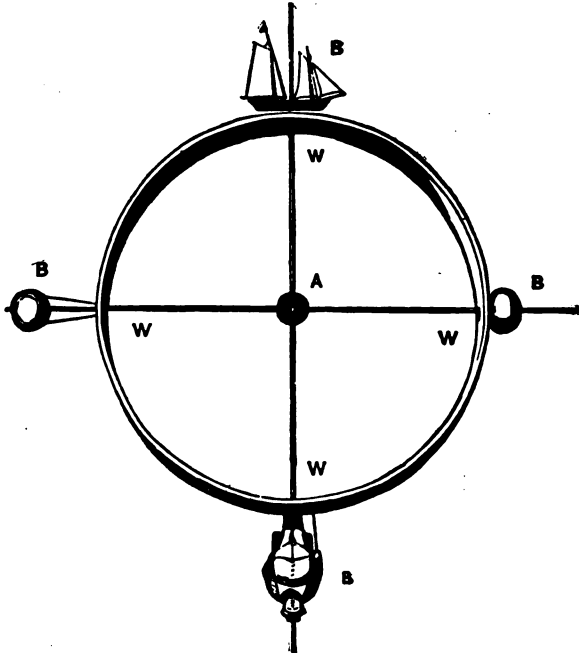

Fig. 24.

A. The centre ball, representing the earth's centre of gravity.

W W W W. Four wires fixed into centre ball, and passing through and secured in the hoop, projecting a little from the circumference.

B B B B. Two balls, a model ship and toy, working on the wires like beads, with India-rubber rings or elastic attached to them and the circumference of the hoop.

With this simple apparatus we may illustrate the upward, downward, and sideway movement of bodies from the earth, and the counteraction by the force of gravitation of any tendency of matter to fall away from the globe, being represented in the model by the elastic pulling the balls and toys back again to the circumference of the hoop.

The attraction of gravitation decreases (quoting the remainder of Newton's definition) as the squares of the distances which separate the particles increase—*i. e.*, it obeys the principle called "inverse proportion"—*viz.*, the greater the distance, the less the gravitating power; the shorter the distance, the greater the power of gravitation. Gravitation is like the distribution of light and other radiant forces, and may be thus illustrated,—

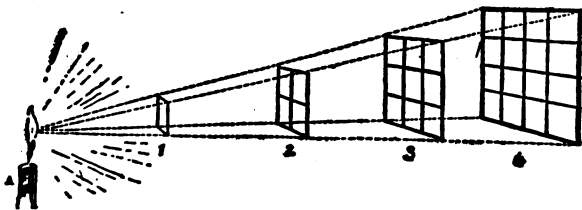

Fig. 25. Place a lighted candle, marked A, at a certain distance from No. 1, a board or piece of stiff card one inch square; at double the distance the latter will shadow another board, No. 2, four inches square; at three times, No. 3, nine inches square; at four, No. 4, sixteen inches; and so on.

To make the comparison between the propagation of light and the attraction of gravitation, we have only to imagine the candle, *a*, to represent the point where the force of gravity exists in the highest degree of intensity; suppose it to be the sun—the great centre of this power in our planetary system. A body, as at No. 1, at any given distance will be attracted (like iron-filings to a magnet) with a certain force; at twice the distance, the square of two being four, and by inverse proportion, the attraction will be four times less; at thrice the distance, nine times less; at the fourth distance, sixteen times less; and so on. With the assistance of this law, we may calculate, roughly, the depth of a well, or a precipice, or the height of a column, by ascertaining the time occupied in the fall of a stone or other heavy substance. A falling body descends about 16 feet in one second, 64 feet in two seconds, 144 feet in three seconds, 256 feet in four seconds, 400 feet in five seconds, 576 feet in six seconds; the spaces passed over being as the squares of the times.

Suppose a stone takes three seconds in falling to the surface of the water in a well, then  $3 \times 3 = 9 \times 16 = 144$  feet would be a rough estimate of the depth. The calculation will work out a little too high in consequence of the stone being retarded in its passage by the resistance of the air.

All bodies gravitate equally to the earth: for instance, in a box, like a cigar box, place a number of substances, such as wood, cork, marble, iron, lead, copper, arranged in a row; shut down the lid, turn the box upside down and directly the hand is withdrawn, the lid flies open, and if the manipulation with the disengagement of the lid is good, the whole of the substances are seen to proceed to the earth in a straight line, as shown in our drawing. (Figs. 26 to 28.)



Fig. 26.

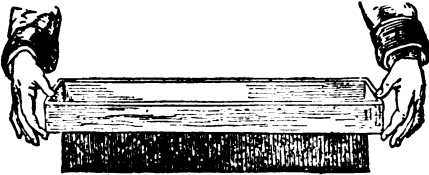

Fig. 27.



Fig. 28.

If a heavy substance, like gold, be greatly extended by hammering and beating into thin leaves, and then dropped from the hand, the resistance of the air becomes very apparent; a gold coin and a piece of gold-leaf would not reach the earth at the same time if allowed to fall from any given height. This fact is easily displayed by the assistance of a long glass cylindrical vessel placed on the air-pump, with suitable apparatus arranged with little stages to carry the different substances; upon two of them may be placed a feather and a gold coin, and on the third, another gold coin and a piece of gold-leaf.

In arranging the experiment, great care ought to be taken that the little stages are all well cleaned, and free from any oil, grease, or other matter which might cause the feathers or the gold-leaf to cling to the stages when they are disengaged by turning the stop that works in the collar of leathers. Sometimes these leathers are oiled, and in that case, when the vacuum is made, the oil, by the pressure, is squeezed out,

and, passing down, may reach the stages and spoil the experiment by causing the feathers and gold-leaf to stick to the metal, producing great disappointment, as the illustration, usually called the "*guinea and feather glass experiment*" takes some time to prepare. The air-pump being in good order, the long glass is first greased on the lower welt or edge, and then placed firmly on the air-pump plate. The top edge, or welt, may now be greased, and the gold coins, feathers, and gold-leaf arranged in the drop-apparatus; this is carefully placed on the top of the glass, and firmly squeezed down. A little vaseline or tallow is the best grease to smear the glass with for air-pump experiments; if the weather is

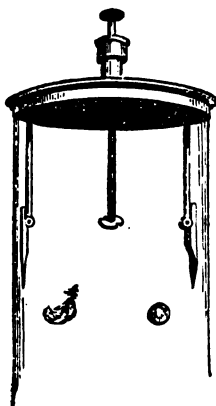

Fig. 29.

cold, the tallow may be placed for a few minutes before an ordinary fire to soften. Vaseline answers perfectly well when the surfaces of glass and brass are all carefully ground; but as air-pumps and glasses by use get scratched and rubbed, the tallow seems to fill up better all ordinary channels by which air may enter to spoil a vacuum.

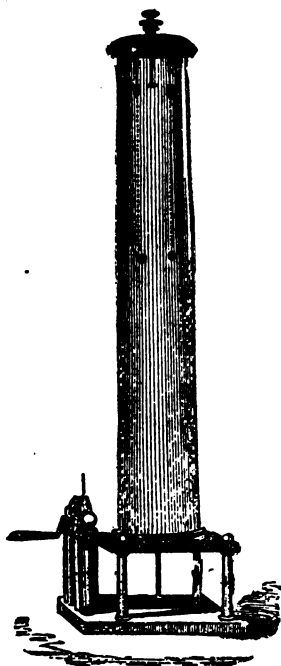

Fig. 30.

The apparatus being now arranged, the air is pumped out; and here, again, care must be taken not to shake the gold off the stages. When a proper vacuum has been obtained, which will be shown by the pump-gauge, the stop is withdrawn from one of the stages, and the gold and feather are seen to fall simultaneously to the air-pump plate. Another stage, with the gold-leaf and coin, may now be detached; both showing distinctly, that when the resistance of the air is withdrawn, all

bodies, whether called *light* or *heavy*, gravitate equally to the earth. Then, the screw at the bottom of the pump-barrels being opened, attention may be directed to the whizzing sound the air makes on entering the vacuum, and when the air is once more restored to the long glass vessel, the last stage may be allowed to fall; and now, the gold coin reaches the pump-plate first, and the feather, lingering behind, loses (as it were) the race, touching the plate after the gold coin; thus demonstrating clearly the resistance of the air to falling bodies.

Another, and perhaps less troublesome, mode of showing the same fact, is to use a long glass tube closed at each end with caps cemented on. One cap should have the largest possible aperture closed by a screw, and the other may fit a small hand-pump.



Fig. 31. A B. Glass tube containing a piece of gold and a feather, which are placed in at the large aperture A. C. Small hand-pump.

If a piece of gold and a small feather are placed in the tube, it may be shown that the former reaches the bottom of the tube first, whilst it is full of air, and when the air is withdrawn by means of the pump, and the tube again inverted, both the gold and the feather fall in the same time.

Because of this air-resistance, all attempts to measure heights or depths by observing the time occupied by a falling body in reaching the earth must be incorrect, and can only be rough approximations. An experiment tried at St. Paul's Cathedral, with a stone, which was allowed to fall from the cupola, indicated the time occupied in the descent to be four and a half seconds: now, if we square this time, and multiply by 16, a height of 324 feet is denoted; whereas the actual height is only 272 feet, and the difference of 52 feet shows how the stone was retarded in its passage through the air; for, had there been no obstacle, it would have reached the ground in  $4\frac{3}{20}$ ths seconds.

The force of gravitation is further demonstrated by the action of the sun and moon raising the waters of the ocean, and controlling the tides; and also by the earth and moon, and other planets and satellites, being prevented from flying

from their natural paths or orbits around the sun. It is also very clearly proved that there must be some kind of attractive force resident in the earth, or else all movable things, the water, the air, the living and dead matter, would fly away from the surface of the earth. See page 22 "centrifugal force." Our earth is twenty-four hours in performing one rotation on its axis, which is an imaginary line drawn from pole to pole, and represented by the *wire* round which we cause a sphere to rotate. (See Fig. 32.) All objects, therefore, on the earth are moving with the planet at an enormous velocity; this movement is called the earth's diurnal, or daily rotation. Coming down to the results following rapid revolution as seen daily in the streets, it will be noticed that mud or other fluid matter flies off, and is not retained by the circumference or periphery of a wheel in motion: when a mop is trundled, or dogs or sheep, after exposure to rain, shake themselves, the water is thrown off by what is called centrifugal force (*centrum*, a centre, *fugio*, to fly from), because the particles cannot obtain the force which is necessary to keep them travelling in a curved path and they therefore resume their normal straight line by flying off at a tangent. See Chapter II "Centrifugal Force" below.



Fig. 32.

## CHAPTER II

### CENTRIFUGAL FORCE

At one time, this force was considered to be that power which drives a revolving body from a centre, but modern science has proved this to be an erroneous conclusion.

If no force is exerted, an object endowed with energy of movement will travel in a straight line; but if that direction is altered so as to take the form of a curve, then force must be brought to bear upon it; and at the slightest relaxation of this force, the object will fly off at a tangent, or in other words, resume its original straight line.

This force—centrifugal force as it is called—increases according to the velocity, and to such an extent that in the case of an unyielding object in rapid revolution, like a grind-



stone, or the fly-wheel of an engine, the momentum may increase so greatly, that the cohesion of the particles can no longer obtain that extra supply of force which is necessary if the particles have to continue their circular movement. Consequently, fracture, or maybe disintegration follows, and the liberated pieces fly off at a tangent till their force is spent, when gravity gets them again and they fall to earth.

In the case of a plastic, or semi-plastic object, the effect is different; the speed of revolution and the increase of centrifugal force cause the object to swell out at the part which is perpendicular to the axis of revolution, and a consequent shrinkage takes place at each end of this axis. This is the reason why our earth is flattened at the poles and swollen at



Fig. 33.



Fig. 34

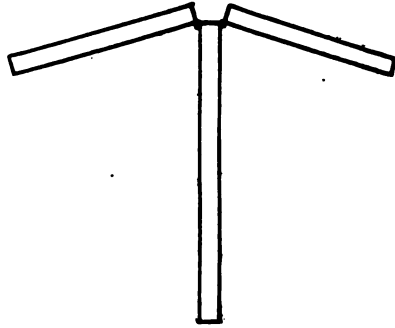

Fig. 35.

the equator, and could our axis be suddenly transferred to the equator, the shape of the globe would at once begin to alter; the present flattened poles, being on the equator, would slowly swell out, whilst what are now the equatorial parts, being at the poles, would begin to shrink. Other effects would follow, but as illustrating the point at issue, in course of time the earth would practically be the shape it is now—flattened at the poles and bulged at the equator.

Centrifugal force is also the cause of tramway and railway lines being most worn on the outer rail of a curve, for from this line has to be drawn all the supply of force which is necessary to keep the vehicle on its curved track. It may

also be illustrated by turning a closed parasol, or umbrella, rapidly round on its centre, the stick being the axis—the ribs fly out, and if there is much speed of motion, the illustration is more certain by attaching a bullet to the end of each rib, as shown in drawing, where the bullets have risen with the motion and are flying round with horizontally-stretched string. (See Fig. 33. Page 22.)

The same illustration can make clear a second example of centrifugal force. After an opened umbrella has been exposed to a heavy shower of rain, it may be twirled round rapidly, when the water will be seen to fly off in drops, each at a tangent.

The same fact may be illustrated by a square wood rod, say one inch square and three feet long, with two flaps eighteen inches in length, hanging by hinges, and parallel to the sides of the centre rod, which immediately fly out on the rotation of the long centre piece. (Figs. 34 and 35.)

A similar effect follows with the governors of an engine, which, in a state of quiescence, are in the position shown in Fig. 36, but when the engine is being run, they rise and take the position shown at Fig. 37.

When a can of water is filled to the brim and swung round and round in circular motion, the

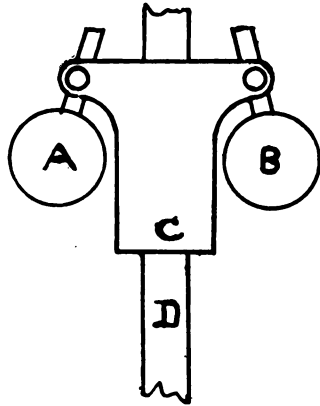

Fig. 36. Simple form of governor merely to show principle of action. When at rest, the balls A and B remain as shown, with sleeve, C, on spindle D. (See Fig. 37.)

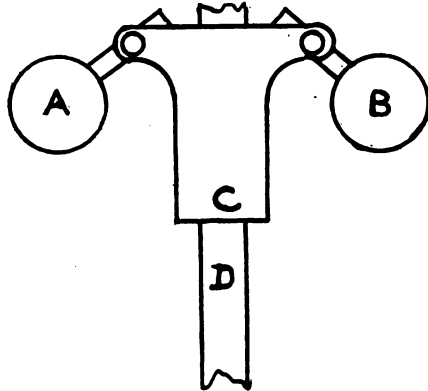

Fig. 37. In this view, owing to rapid revolution, the balls, A and B, have risen, lifting up the sleeve, C, on the spindle, D (for illustration of one type of actual governor, see Fig. 494, page 619).

centrifugal force is so greatly in-

creased by the movement, that it is in excess of the weight of the water, and this excess of force over weight is sufficient to retain the water, even when the can is upside down. (See Fig. 52. Page 34.)

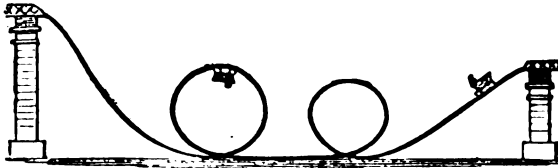

Fig. 38.

The toy called the centrifugal railway is also a good illustration of the same fact. A glass of water, or a coin, may be placed in the little carriage, and although it must be twice hanging perpendicular in a line with the earth, the carriage does not tumble away from its appointed track, but is held firmly to the interior of the circle round which it revolves.

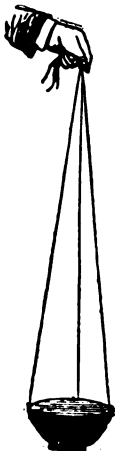

Fig. 39.

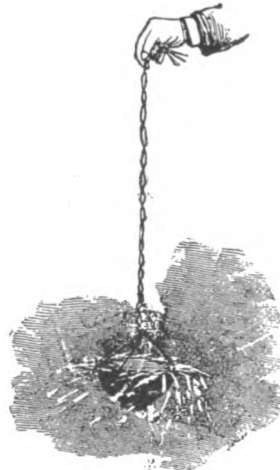

Fig. 40.

Another striking and very simple illustration is to suspend a common flanged basin by three cords as in Fig. 39. Twist the cords, fill the basin with water, and directly the hand is withdrawn, the torsion of the cord causes the basin to rotate, and the water describes a circle on the floor, flying off at a tangent from the basin, as may be noticed in the accompanying cut. (Fig. 40.)

## CHAPTER III

## THE SCIENCE OF ASTRONOMY

It is impossible, in a work of this nature, to do more than merely touch, in a very light manner, on this noble science of astronomy. The subject is so vast that even brief details of the science and the various apparatus and instruments used at the present day in connection therewith, would more than fill several volumes the size of this. We will therefore content ourselves with a brief glance into the history of astronomy to the present day and then discuss a few of the problems of some of the stars visible from this world of ours, and the chief features of the solar family, of which we form an unit.

When astronomy was first studied is mere hypothesis. It is impossible to think otherwise than that man, in his primal state, must have been oppressed by the sight of the galaxy of glorious lights and of the silvery moon, which would be canopied over his head each night, and by the passage of the sun each day from east to west. So there is little wonder that the beauty and majestic motion of the heavenly bodies filled his soul with such awe and veneration, that his very being went out to them in worship.

Instead of the stars maintaining their approximate positions with regard to us, and the earth turning round, as we know it does, his untutored mind would see the sun as a great god, beneficent and holy, bringing light and health to all things, as it slowly sailed across the sky; in the moon he saw a child of the sun, and the numberless stars as holy eyes, all watching and guarding the earth. So it is easy to understand why, from the earliest time known, all these heavenly bodies were devoutly worshipped.

The most ancient records seem to have been kept by that at one time cultured, but now sadly fallen race, the Chinese. Nearly 3,000 years B.C., they recorded the dates and recurrences of comets, which were considered evil spirits, and the reckless burning of these and many of the later records in 221 B.C., opens a deplorable gap which so far has not been filled.

The Chaldeans, too, as early as 2559 B.C.—how much earlier is not known—were well acquainted with astronomy,

particularly with the movements and main features of the planets. To so great an extent did this science enter into their studies, that they regulated their lives and actions by the heavenly bodies; each court, and even each household of the well-to-do, having its own specially appointed astrologers, who believed and argued that since the sun gave life and was absolutely necessary to life here, so also did all the stars and planets affect the lives of human beings to a vast extent, according as they were born under what was considered a lucky or unlucky star.

The early Egyptians, also, were of the same opinion, and considered the rising of the sun as typical of human birth—its rise to the zenith and the setting, as the life of man, increasing to the zenith for middle age, then slowly declining to darkness and death; its dull or glorious setting seeming to them to show how passing life was ending, either for a future of woe, or one of bliss.

That the ancients understood astronomy most profoundly is evidenced by the Great Pyramid, which fronts the cardinal points of the compass, and there is little doubt but that it was used for purposes of astronomical study, though in what manner is not intelligible to us to-day.

Then we find in the Book of Job, the date of which is about 1520 B.C., many passages referring to the beautiful Pleiades and other stars with which he was conversant.

To the Greeks is posterity indebted for raising the standard of astronomy into an actual science, Thales being its chief exponent. Thus will he ever be immortalised, for his genius in bringing what hitherto might almost be considered a "black art" to be one of the most learned of sciences. Some idea of his skill, or, more correctly, genius, may be gathered from the fact that he foretold several astronomical events, and was the first to formulate the theory of the roundness of the earth from seeing its outline on the moon, in eclipse, and from other deductions, all of which are brought forward to-day as proof, yet Thales was born in 640 B.C., and died in 548 B.C. (See also page 262.)

Thales was the first to use the Little Bear as a guide for vessels at sea; he was also the first to assert that the true stars were masses of fire, like our own sun, and to state many other facts which are known as truths to-day. He was far

in advance of his time, and after him, the study of astronomy went forward on an entirely different basis, from that moment ever becoming a more and more intellectual study.

Then came Pythagorus, about 500 B.C., who was ridiculed because he asserted that the sun ruled and governed the Solar System, of which it formed the life-giving centre. Such is now an established fact, which no one would dare to question.

Menton, at Athens, in 426-424 B.C., gave the world its first sun-dial. Then followed other men of genius who gave their small but precious mites to the science, till we come to the year 180 B.C. and onwards. Up to this time the records were fragmentary; a little here, a discovery there, and that was all; no one made systematic records of observations, so that we only find mention of the occasional flash of a startling discovery, or the equally startling event of the passage of a comet, a solar eclipse, and the like.

Hipparchus, however, commenced the first systematic record of astronomy. He catalogued over one thousand separate stars, thus instituting the first catalogue (about 140 B.C.), which catalogue has been kept up ever since, the number and identification of the stars being added to month by month as the years go by and the instruments increase in perfection, till they now number many millions, the exact position and value of every one being separately stated. Thus we find many which have been missing are again seen as new stars, but reference to these catalogues proves them to be old ones again become visible. Notwithstanding these, the number is ever increasing, and the mind becomes awed at the immensity of space.

Of the more recent exponents, such as Copernicus, Reinhold, Recorde—who gave us the first mention of astronomical matters in English; Nonius, Tycho Brahe, Kepler, Galileo, and a host of others to Newton, Halley, Herschel, and the later giants in the science—of the work of these it is unnecessary to give details, as their chief discoveries are to be found in all school-books.

Perhaps the most fascinating astronomical phenomenon is the eclipse, especially that of the sun, which may be briefly described:—

A general idea of an eclipse may be shown very simply by means of a common oil lantern, or even a dark-lantern.

This should be lit, and placed in a darkened room so that its rays may fall on an india-rubber or other ball which, together with a marble, should be previously whitened. The lantern we will call the sun, it being, of course, understood that correct comparative sizes are not attempted in this arrangement; if it were so, the globe representing the earth would have to be a mere speck, for if we made the light-giving portion of the lantern as representing the sun, to the proportion of a sphere (representing earth) the size of a cricket-ball, a very large room indeed would be required to contain it. Therefore, eliminating the question of relative proportion, attention is directed to the lantern, which, like the sun, is self-luminous, and is giving out its own rays; these fall upon the globe we have designated the earth, and illuminate one-half, whilst the other is shrouded in darkness, reminding us of the opacity of the earth, and teaching, in a familiar manner, the causes of day and night. Another globe, say a marble, supported by a string attached with glue, may be compared to the moon, and, like the earth, is now luminous, shining only by borrowed light: the moon is simply a reflector of light; like a sheet of white cardboard, or a metallic mirror. When, therefore, the small globe is passed between the lantern and the large globe, the lantern lens (the sun) is obliterated from the sight of those people on a certain portion of the larger globe (earth),—that shaded by the intervening marble (the moon), see Fig. 41: it is also seen that only the half of the small globe turned towards the lantern is illuminated, while the other half, opposite the large globe, is in shadow or darkness. And here we understand why the moon appears to be black while passing before the sun; so also by moving the small globe about in various curves, it is shown why eclipses are only visible at certain parts of the earth's surface; and as it would take (roughly speaking) fifty globes as large as the moon to make one equal in size to our earth, the shadow it casts must necessarily be small, and cannot obscure the whole hemisphere of the earth turned towards it. An eclipse of the sun is, therefore, caused by the opaque mass of moon passing between the sun and the earth. Whilst an eclipse of the moon is caused by the earth moving directly between the sun and the moon. The large shadow cast by the earth renders

a total eclipse of the moon visible to a greater number of spectators on that half of the earth turned towards the moon. All these facts can be clearly demonstrated with the arrangement already described, of which we give the following pictorial illustration:—

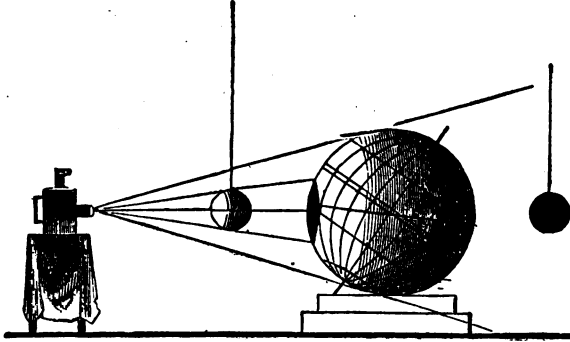

Fig. 41.

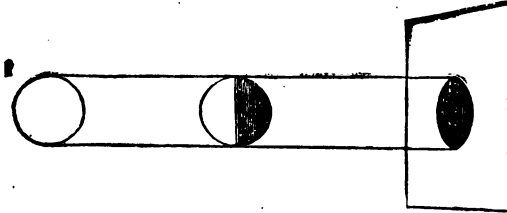

Fig. 42.

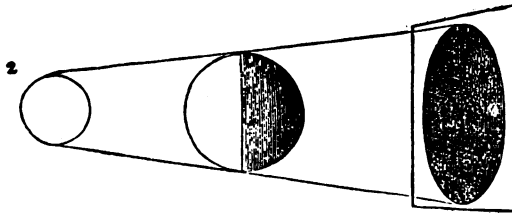

Fig. 43.

In using this apparatus, it should be explained that if the moon were as large as the sun, the shadow would be cylindrical like the figure 1, and of an unlimited length. If she were of greater magnitude, it would precisely resemble the shadow cast in the experiment already adduced with the lantern and shown at No. 2. But being so very much smaller than



the sun, the moon projects a shadow which converges to a point as shown in the third diagram. (Fig. 44.)

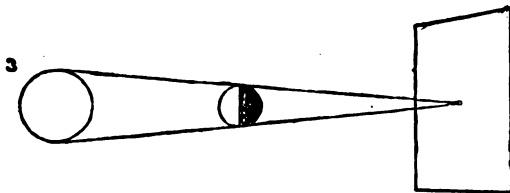

Fig. 44.

In order to comprehend the difference between an annular and a total eclipse of the sun, it is necessary to mention the apparent sizes of the sun and moon: thus, the former is a very large body—viz., eight hundred and sixty-seven thousand miles in diameter; but then, the sun is a very long way off from the earth, being ninety-three millions of miles distant; therefore, he does not appear to be very large: indeed, the sun seems to be about the same size as the moon; for, although the sun's diameter is (roughly speaking) four hundred times greater than that of the moon, he is four hundred times further away from us, consequently, the sun and moon *appear* to be the same size, and when they come in a straight line with the eye, the nearer and smaller body, the moon, covers the larger and more distant mass, the sun; hence, we have either an annular, or a total eclipse, showing how a small body may come between the eye and a larger body, and either partially or completely obscure it.

With respect to an annular eclipse, it must be remembered, that the paths of all bodies revolving round others are elliptical; *i. e.*, they take the form of an ellipse, which is a figure easily demonstrated; and is, in fact, one of the conic sections.

If a slice be taken off a cone, parallel with the base, we have a circle thus—

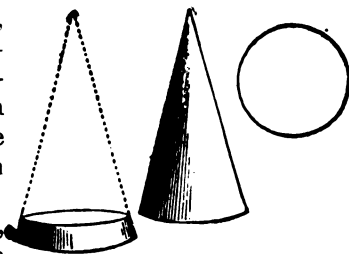

Fig. 45.

If it be cut obliquely, or slanting, we see at once the figure spoken of, and have the ellipse as shown in Fig. 46.

Now, the ellipse has two points within it, called "the foci," and these are easily indicated by drawing an ellipse on a diagram-board, in which two nails have been placed in a straight line, and a few inches apart. Having tied a string so as to make a loop, or endless cord, a circle may

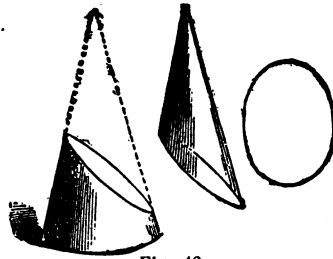

Fig. 46.

first be drawn by putting the cord round one of the nails; by holding a piece of pencil in the loop of the string, it may be extended to its full distance, and a circle described (see Fig. 47); here a figure is produced round one point, and to show the difference between a circle and an ellipse, the endless cord is now placed on the two nails, when the pencil, being carried round inside the string, no longer produces the circle, but that familiar form called the oval, or more correctly, the ellipse, as in Fig. 48. As a gardener would say, an oval has been struck; and the two points round which it has been

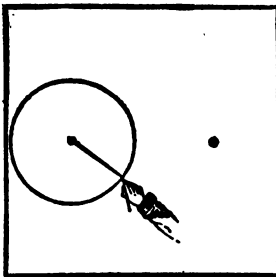

Fig. 47.

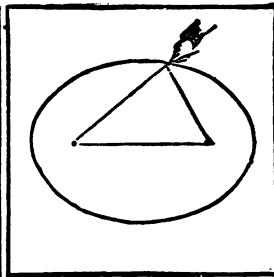

Fig. 48.

described are called the *foci*. This explanation enables us to understand the next diagram, showing the motion of the earth round the sun; the latter being placed in one of the foci of a very moderate ellipse, and the various points of the earth's orbit designated by the little round globes marked A, B, C, D, where it is evident that the earth is nearer to the sun at B than at D. In this diagram the ellipse is exaggerated, as it ought, in fact, to be very nearly a circle. (Fig. 49.)

We are about three millions of miles nearer to the sun in

the winter than we are in the summer; but from the more oblique or slanting direction of the rays of the sun during the winter season, we do not derive any increased heat from

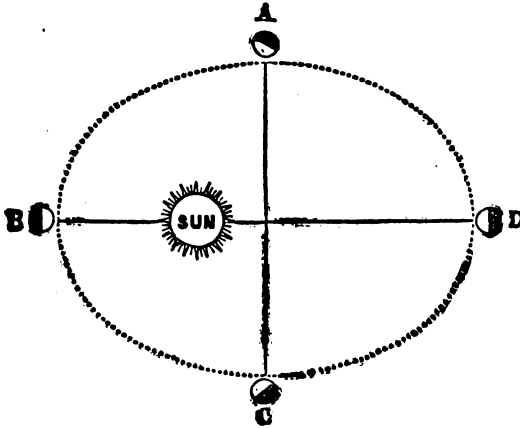

Fig. 49.

the greater proximity. The sun, therefore, apparently varies in size; but this seeming difference is so trifling that it is of no importance in the discussion: and here we may ask,

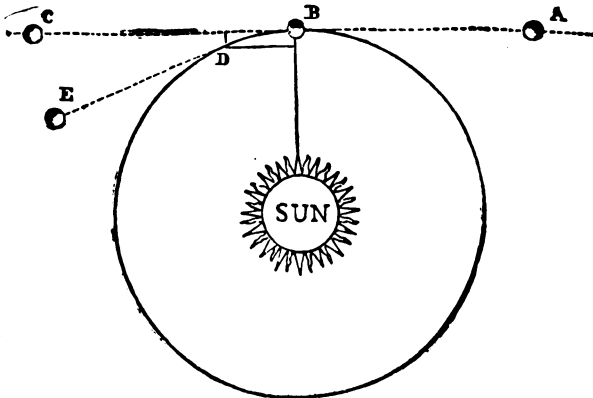

Fig. 50.

why does the earth move round the sun? Because it is impelled by *two forces*, one of which has already been fully explained, and is called the *centrifugal power*, and the other,

although termed the *centripetal* force, is only another name for the "attraction of gravitation."

To show their mutual relations, let us suppose that, at the creation of the universe, the earth, marked A, (Fig. 50) was hurled from the hand of its Maker; according to the law of inertia, it would continue in a straight line, A C, for ever, through space, provided it met with no resistance or obstruction. Let us now suppose the earth to have arrived at the point B, and to come within the sphere of the attraction of the sun S;

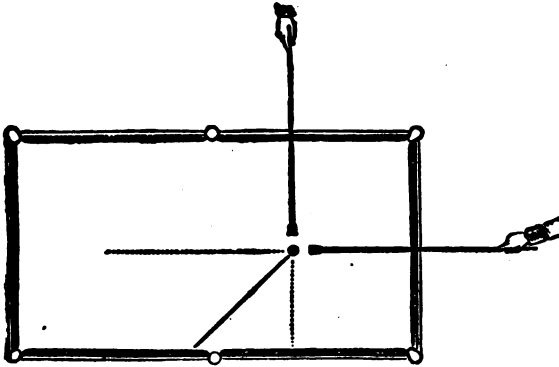

Fig. 51.

here we have at once contending forces acting at right angles to each other; either the earth must continue in its original direction, A C, or fall gradually to the sun. But mark the beauty and harmony of the arrangement: like a billiard-ball struck with equal force at two points at right angles to each other, it takes the mean between the two, or what is termed the diagonal of the parallelogram (as shown in our drawing of a billiard-table, Fig. 51), and passes in the direction of the curved line, B D; having reached D, it is again ready to fly off at a tangent to E; but the centrifugal force which compels a travelling body to keep on a curved path controls it, and, instead of travelling in a straight line, it describes an ellipse, though almost a circle, which is governed in part by centrifugal force, because in order that a moving body may retain its motion on a curve, instead of continuing its normal straight line, a force (centrifugal force) directed towards a point corresponding with the centre of the curvature of the path must be exerted. So the earth pursues its elliptical path, or orbit,

till the Almighty Author who bade it move shall please to reverse the command.

The mutual relations of the centripetal and centrifugal forces may be illustrated by suspending a tin can by two or three strings, and having filled it with water, the vessel may be swung round without spilling a single drop; of course, the movement must be commenced carefully, by making it oscillate like a pendulum.

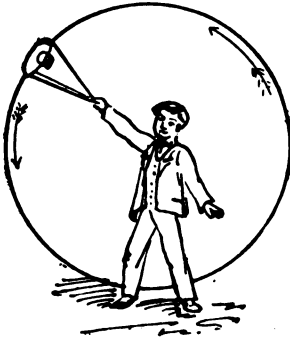

Fig. 52.

The cord which binds it to the finger may be compared to the centripetal force, whilst the centrifugal power is illustrated by the water pressing against the sides and remaining in the vessel. See page 24. Upon the like principles the moon revolves about the earth, but her orbit is more elliptical

than that of the earth around the sun; and it is evident from our diagram that the moon is much further from the earth at A than at B. As a natural consequence, the moon appears sometimes a little larger and sometimes smaller than the sun; the apparent mean diameter of the latter being

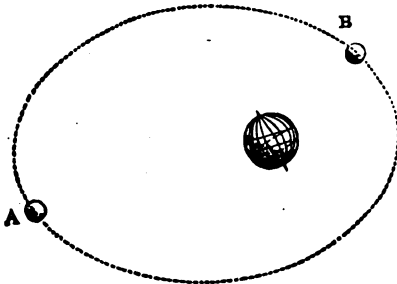

Fig. 53.

thirty-two minutes, whilst the moon's apparent diameter varies from twenty-nine and a half to thirty-three and a half minutes. Now, if the moon passes exactly between us and the sun when she is apparently largest, as at B, then a total eclipse takes place; whereas, if

she glides between the sun and ourselves when smallest—*i. e.* when furthest off from the earth as at A,—then she is not sufficiently large to cover the sun entirely, but a ring of sunlight remains visible around her, and what is called an annular eclipse of the sun occurs. This fact may be shown in an

effective manner by placing the lantern used in the previous experiment (pages 29-30, Fig. 41) before a sheet, or other white surface, and throwing a bright circle of light upon it, which may be called the sun; then, if a round disc of wood be passed between the lantern and the sheet, at a certain distance from the nozzle of the lantern, all the light is cut off, the circle of light is no longer apparent, and we have a resemblance to a total eclipse.

By taking the round disc of wood further from the lantern, and repeating the experiment, it will be found that the

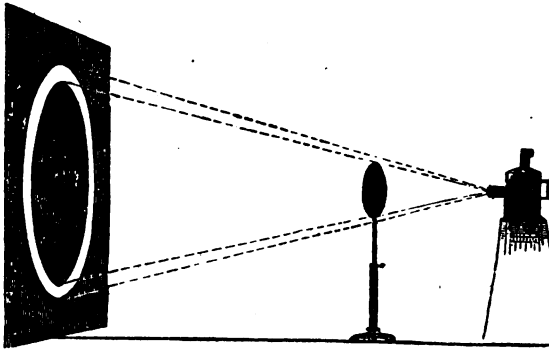

Fig. 54.

whole circle of light is not obscured, but a ring of light appears around the dark centre, corresponding with the phenomenon called the annular (ring-shaped) eclipse. (See Figs. 54, 55.)

If a bullet be placed very near to one eye whilst the other remains closed, a large target may be wholly shut out from vision; but if the bullet be adjusted at a greater distance from the eye, then the centre only will be obscured, and the outer edge or ring of the target remains visible.

When the advancing edge, or first *limb*, as it is termed, of the moon approaches very near to the second limb of the sun, the two are joined together for a time by alternations of black and white points, called Baily's beads.

This phenomenon is supposed to be caused partly by the uneven and mountainous edge of the moon, and partly by that inevitable fault of telescopes, and of the nervous system of the eye, which tends to enlarge the images of luminous

objects, producing what is called irradiation. An astronomer, speaking of an annular eclipse, says:—

“All the phenomena of an annular eclipse were clearly and beautifully visible on the Fotheringay-Castle-mound, which is a locality easily identified. Baily's beads were perfectly

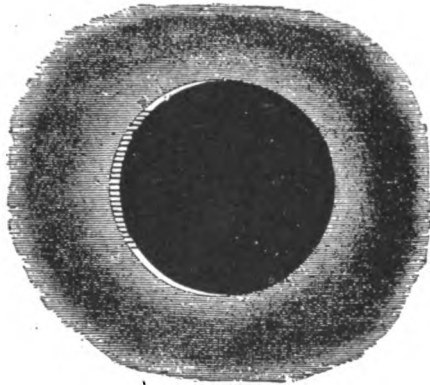

Fig. 55.

plain on the completion of the *annulus*, which occurrence took place, according to my observation, at about seventy seconds after 1 o'clock; it lasted about eighty seconds. The 'beads,' like drops of water, appeared on the upper and under sides of the moon, occupying fully three-fourths of her circumference.

“Prior to this, the upper edge of the moon seemed dark and rough, and there were no other changes of colour. At 12.43, the cusps, for a few moments, bore a very black aspect.

“There was nothing like intense darkness during the eclipse, and less gloom than during a thunderstorm. Bystanders prognosticated rain; but it was the shadow of a rapidly-declining day. At 12 o'clock, a lady living on the farm suddenly exclaimed, 'The cows are coming home to be milked!' and they came, all but one; that followed, however, within the hour. Cocks crowed, birds flew low or fluttered

about uneasily, but every object far and near was well defined to the eye.

“A singular Broadway of light stretched north and south for upwards of a quarter of an hour; from about 12.54 to 1.10 P. M.”

If the annular eclipse of the sun be a matter for wonderment, the total eclipse of the same is much more surprising; no words can describe the effects of totality, and of the sud-

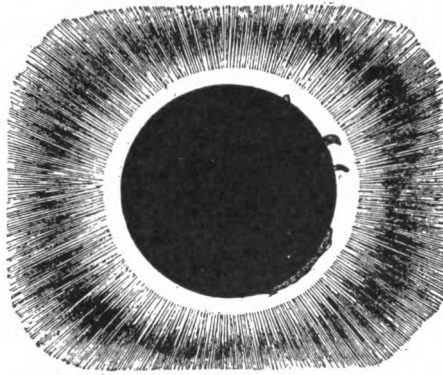

Fig. 56.

denness with which it obscures the light of heaven. The darkness comes dropping down like a mantle, and as the moment of full obscuration approaches, people's countenances become livid, owing to the peculiar light, the horizon is indistinct and sometimes invisible, and there is a general appearance of horror on all sides. These effects are not simply the inventions of active human imaginations, for they produce equal, if not greater effects, upon the brute creation. M. Arago, the noted French astronomer and physicist, quotes an instance of a half-starved dog, who was voraciously devouring some food, but dropped it the instant the darkness came on. A swarm of ants, busily engaged, stopped when the darkness commenced, and remained motionless till the light reappeared. A herd of oxen collected themselves into a circle and stood still, with their horns outward, as if to resist



a common enemy; certain plants, such as the convolvulus and silk-tree acacia, closed their leaves. A "total eclipse" of the sun has always impressed the human mind with terror and wonder in every age: it was supposed to be the forerunner of evil; and not only is the mind powerfully impressed, as darkness gradually shuts out the face of the sun, but at the moment of totality, a magnificent corona, or "glory" of light, is visible, and prominences, or flames, as they are often termed, make their appearance at different points round the circle of the dark mass. This "glory" does not flash suddenly on the eye; but commencing at the first limb of the sun, passes quickly from one limb to the other. Our illustration (Fig. 56) shows "the corona" and the "rose-coloured prominences," whose nature we shall next endeavour to explain. Airy, when astronomer royal, described the change from the last narrow crescent of light to the entire dark moon, surrounded by a ring of faint light, as most curious, striking, and magical in effect. The progress of the formation of the corona was seen distinctly. It started on the side of the moon opposite to that at which the sun disappeared, and seemed to oppress all nature; the moon and the corona in some places were seen double. The texture of the corona appeared as if fibrous, or composed of entangled threads; in other places brushes, or feathers of light proceeded from it, and one estimate calculated the light at about one-seventh part of a full moon light. The question, whether the corona is concentric with the sun and moon, was specially mooted by M. Arago, and Professor Baden Powell produced such excellent imitations of the "corona" by making opaque bodies occult, or conceal, very bright points, that it cannot be considered as material or real, although it ought to be remembered that the best theory of the zodiacal light represents it to be a nebulous mass, increasing in density towards the sun, and yet no portion of this nebulous mass was seen during the totality. But by far the most remarkable of all the appearances connected with a "total eclipse" are the rose-coloured prominences, mountains, or flames, projecting from the circumference of the moon to the inner ring of the corona; and although they had been observed by Vaserius (a Swedish astronomer) in 1733, they took the modern astronomers entirely by surprise in 1842, and they were not prepared with instruments to

ascertain the nature of these strange and almost portentous forms. In 1851, however, great preparations were made to throw further light on the subject. Airy went to make his observations, and he says that the suddenness of the darkness in 1851 appeared much more striking than in 1842, and the forms of the rose-coloured mountains were most curious. One reminded him of a boomerang (that curious weapon thrown so skilfully by the aborigines of Australia); this same figure has been spoken of by others as resembling a Turkish scimitar, strongly coloured with rose-red at the borders, but paler in the centre. Another form was a pale-white semicircle based on the moon's limbs; a third figure was a red detached cloud, or balloon, of nearly circular form, separated from the moon by nearly its own breadth; a fourth appeared like a small triangle, or conical red mountain, perhaps a little white in the interior; and Airy proceeds to say, "I employed myself in an attempt to draw roughly the figures, and it was impossible, after witnessing the increase in height of some, and the disappearance of another, and the arrival of new forms, not to feel convinced that the phenomena belonged to the sun, and *not* to the moon."

The sun and moon cannot have fewer than two eclipses nor more than seven in one year, and the total solar eclipses, compared with their frequency, are not visible in the same place except at very long intervals. Thus, from 1140 for an interval of 575 years (to 1715) no total eclipse was visible in London.

The more recent notable eclipses were,—one occurring in 1850—the year before that mentioned by Airy above—visible in the Pacific Ocean; another occurred in 1868, visible in India, to which country Janssen, a French astronomer, was sent to make observations; one occurred in 1886, visible in the Southern portion of Africa; and another in 1904, which was visible in South America.

There has been much controversy at various times with regard to the nature of those "rose-coloured prominences" seen round the sun during a time of total eclipse, but as a result of the researches of Lockyer, Huggins, and others, the spectroscope has shown them to consist of various elements, such as hydrogen, helium, carbon, etc., in a state of tenuous vapour. Briefly,—these "prominences" rise up to enormous

heights, and as they get higher, they cool, become a little darker in consequence, also lose their vapour tenuity, become heavier, and sink down towards the photosphere, where they are reheated and again projected upwards in a state of highly tenuous vapour, to be continually cooled and reheated.

They are known as prominences of "clouds," and "flames." Of these two simple classes, the "clouds" are not unlike those of our earth but with long tendrils downwards, and are of a curious and beautiful rosy tint. "Flames," on the other hand, are decidedly eruptive, especially in the neighbourhood of the sun-spots, and are not only subject to, and much influenced by, but also eject, strong electric currents, which affect our earth, and probably the whole solar system very considerably.

Other phenomena are present, one of the most striking being a variety of zodiacal light, the formation of which has also been the subject of much discussion in the past, the various arguments claiming four notorious theories. The first, that it consisted entirely of meteorites in enormous quantities of streamers. The second, that the matter was of a cometary nature, partly or entirely. The third, that a mass of matter which was wholly or partly self-luminous, surrounded the sun. On its inner edge, this mass was level with the sun's equator, and spread out laterally like an enormous lens, convex on both sides, and extending outwards to a great distance, even far beyond our own earth. The fourth theory was that the whole phenomenon was due entirely to the glare on our own atmosphere. Modern science has, however, practically disproved all these theories, though in a small degree one or more of the suggested causes may contribute to the effect; but it is now generally admitted that the real cause is the heated gases, helium and hydrogen, carbon in vapour and fine particles, and tremendous and incessant electrical discharges or bombardments. Unfortunately, such phenomena cannot be successfully investigated apart from an eclipse, though the sun is under constant daily examination through the spectroscope.

Piazzi Smyth, when astronomer-royal for Scotland, gave a graphic account of a total eclipse as seen by him on the western coast of Norway, from which we may form some no-

tion of the imposing appearance of the surrounding country when obscured during the occurrence of this rarely witnessed astronomical phenomenon.

The Professor remarks, "To understand the scene more fully, the reader must fancy himself on a small, rocky island on a mountainous coast, the weather calm, and the sky at the beginning of the eclipse seven-tenths covered with thin and bright cirro-strati clouds. As the eclipse approaches, the clouds gradually darken, the rays of the sun are no longer able to penetrate them through and through, and drench them with living light as before, but they become darker than the sky against which they are seen. The air becomes sensibly colder, the clouds still darker, and the whole atmosphere murkier.

"From moment to moment as the totality approaches, the cold and darkness advance apace; and there is something peculiarly and terribly convincing in the two different senses, so entirely coinciding in their indications of an unprecedented fact being in course of accomplishment. Suddenly, and apparently without any warning (so immensely greater were its effects than those of anything else which had occurred), the totality supervenes, and darkness *comes down*. Then came into view lurid lights and forms, as on the extinction of candles. This was the most striking point of the whole phenomenon, and made the Norse peasants about us flee with precipitation, and hide themselves for their lives.

"Darkness reigned everywhere in heaven and earth, except where along the north-eastern horizon, a narrow strip of unclouded sky presented a low burning tone of colour, and where some distant snow-covered mountains, beyond the range of the moon's shadow, reflected the faint monochromatic light of the partially eclipsed sun, and exhibited all the detail of their structure, all the light, and shade, and markings of their precipitous sides with an apparently supernatural distinctness. After a little time, the eyes seemed to get accustomed to the darkness, and the looming forms of objects close by could be discerned, all of them exhibiting a dull-green hue; seeming to have exhaled their natural colour, and to have taken this particular one, merely by force of the red colour in the north.

"Life and animation seemed, indeed, to have now departed

from everything around, and we could hardly but fear, against our reason, that if such a state of things was to last much longer, some dreadful calamity must happen to us all: while the lurid horizon, northward, appeared so like the gleams of departing light in some of the grandest paintings by Danby and Martin, that we could not but believe, in spite of the alleged extravagances of these artists, that Nature had opened up to the constant contemplation of their mind's-eye some of those magnificent revelations of power and glory which others can only get a glimpse of on occasions such as these."

It can be easily imagined, that under such peculiar and awful circumstances, the careful observation of these effects must be somewhat difficult, and the only wonder is that the astronomical observations are conducted with any certainty at all.

#### COMETS

This brief summary of the science of astronomy would not be complete without a word about comets—those strange

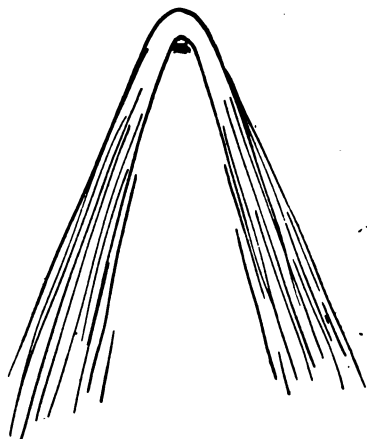

Fig. 57. Rough drawing to show the form of the head of a comet and the spreading of its tail, which becomes more and more tenuous till lost to sight. (For illustrations of actual comets see Figs. 59 to 62.)

heavenly bodies which visit us so mysteriously, and as mysteriously pass out of our vision, and about which so little is known. Even the most powerful refracting telescopes reveal scarcely anything to us beyond the fact that they are most curiously irregular in shape, and are composed of materials, substances, and gases, all in an extremely tenuous condition. The head has several parts, viz:—the nucleus, which is the brightest portion, because at this spot the materials are more dense than at any other part of equal area; around

this nucleus is the coma, or head, which may be of any size, from a thousand to a million or more miles in diameter; from

this coma the tail begins to flow in a kind of stream, its substances becoming more and more attenuated as it leaves the head, till it forms a mass of almost invisible "something" which is too tenuous for definition, and loses itself in the darkness of space.

Opinion is much divided as to the composition of this tail, but most authorities agree that it is a form of gas or vapour, or both, since the spectroscope reveals earth-known elements in a state of extreme tenuity.

To this general description there are endless modifications and changes, even in the same object, so that measurements become of no practical value whatever, which makes identification by size and shape doubtful, if not impossible. But just as the planets move in elliptical orbits round our sun, so do comets have their fixed orbits, which when known, enable them to be identified with unerring accuracy. It will be seen that if a comet is travelling in an ellipse, one of its foci being the sun, the time will come when this same comet will return on its old path, and behave not unlike a planet, as will be seen by Fig. 58.

Thus did Halley argue when he felt he had discovered the path of the comet of 1682, and knowing that the period occupied in traversing this great track would be a calculated time of seventy-five or seventy-six years, he searched backwards, to find, in 1607, a comet which followed an almost identical orbit, this also resembling a still earlier one which was traced in 1531. Surely these must be the same

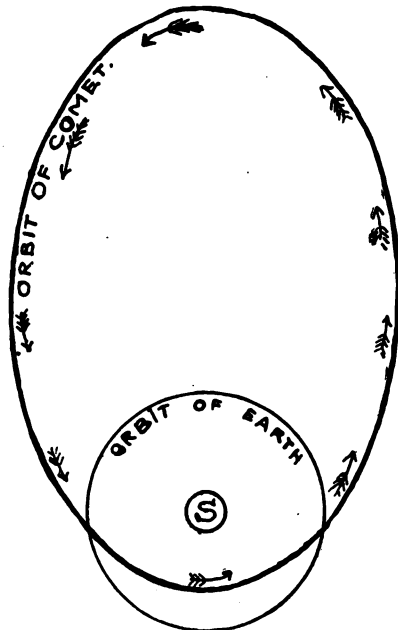

Fig. 58. Sketch showing the sun in one of the foci of the orbit of a periodic comet—which behaves like a planet—its orbit crossing that of Earth.

object, appearing and reappearing with a regularity which brooked of no mistake! Therefore, sure of his deductions, he



1910 April 22, 4h. 44m. to 5h. 17m. I. S. T.



1910 May 13, 4h. 40m. to 5h. 8m. I. S. T.

Fig. 59. HALLEY'S COMET.

From Photographs by J. Evershed, Esq., F. R. A. S., The Observatory, Kodalkānal, South India.

foretold the further appearance of this comet in the year 1757 or 1758, or, owing to several planetary disturbances about this time, probably early in 1759.

True to prediction, the comet, named Halley's comet, was seen first on Christmas day, 1758, and was closest to the sun on the 12th of the following March, 1759. Again, in 1835, it visited us, and owing to the power of our telescopes it was seen in September, 1909, drawing nearest to the sun in May, 1910. A photograph of this comet is given in Fig. 59; also of Comet-C, Morehouse, 1908, in Fig. 60; also Comet-C, Morehouse, 1908, in Fig. 61; also spectra of Halley's Comet and Venus, 1910, in Fig. 62.

Many comets, however, visit our system, race round the sun, and are never seen again. In these circumstances, the path taken is that of a parabola, which may be likened to an ellipse, the foci of which are so far apart as practically to be in infinity. Fig. 63 will make this clear.

Such a comet coming out of the infinite vastness at A, (see Fig. 63, page 48), will then enter the solar system, spin round the sun, rush out of the system, into the other and equally



1908 Nov. 15d. 6h. 6m. C. S. T.

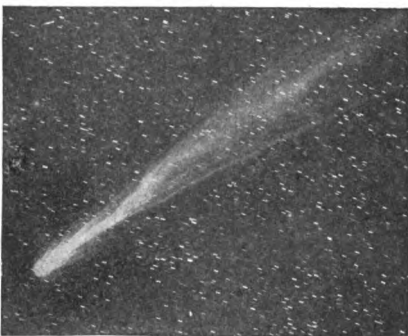

1908 Nov. 16d. 7h. 10m. C. S. T.



1908 Nov. 17d. 7h. 37m. C. S. T.

Fig. 60.

COMET c 1908 MOREHOUSE.

From Photographs by Professor E. E. Barnard,  
D. Sc., Assoc. R. A. S.,  
Taken at Yerkes Observatory, U. S. A.



infinite vastness at B, to pursue its ever-widening and more distant path, perhaps never to return, or perhaps to come round again millions of years hence.

Such is the accepted belief of the paths of comets; these theories are looked upon as certainties, because they fall in line with modern science and no difficulties are left without possible and logical explanation.



Fig. 61. COMET 1908 c MOREHOUSE.  
Nov. 15d. 6h. 3m. G. M. T. 6¾ in. Reflector.  
From Photograph by the late R. C. Johnson, Esq., F. R. A. S.

#### SHOOTING STARS

In looking through a telescope, there are often seen flashes of light, which are so small that without such an aid, they would not be visible. These are the "shooting stars," or meteoric stones, which are incessantly bombarding this earth of ours, crashing down to it with such terrific speed, that but for our providential covering of atmosphere, the world would literally be pounded to dust.

Owing to the absence of atmosphere in space, the meteors

rush onward with a frightful velocity, which is altogether unchecked, but becoming involved in the attraction of our earth, they rush to it, or pass through the outer edge of our atmosphere. This envelope of air offers a certain amount of resistance, and heats the object as it flies through the fringe, so that if sufficiently large to be seen with the naked

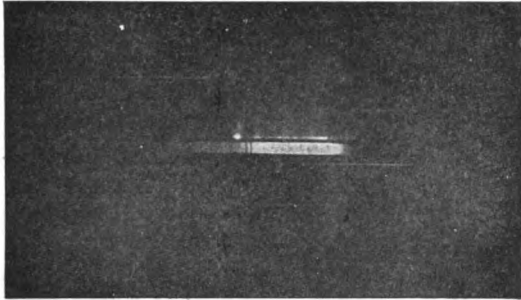

Fig. 62.

SPECTRA OF HALLEY'S COMET AND VENUS, 1910, MAY 1.

4h. 40m. to 5h. 10m. I. S. T.

From photograph by J. Evershed, Esq., F. R. A. S., The Observatory, Kodaikānal, South India.

eye, we perceive a streak of light flit across the sky,—the passage of a shooting star.

In some cases, as already mentioned, the telescope only reveals them, as flashes of light, but there are myriads of meteors attracted to Earth, to which they rush with annihilating impetuosity, strike through the rarefied atmosphere, which resistance heats them considerably; then through the denser air, and then the still denser, as they near the earth, becoming hotter and ever hotter with the enormous friction till they are white hot, then liquid, and then,—so great is the density of the lower atmosphere and the consequent increase of heat,—the meteors become vaporous: with a shower of sparks, or a streak of light, the deadly visitor has, by our kindly shield, been transformed into harmless vapour, or divided into equally harmless meteoric dust, slowly and gently settling on the earth, which, but for the terrible friction set up, it might have utterly destroyed.

This dust is always falling on land and sea, slowly sinking

in the latter, thus building up slightly the solid matter of the world.

Occasionally some large mass, thus heated, is not sufficiently small to become dust, but is merely burst. While the

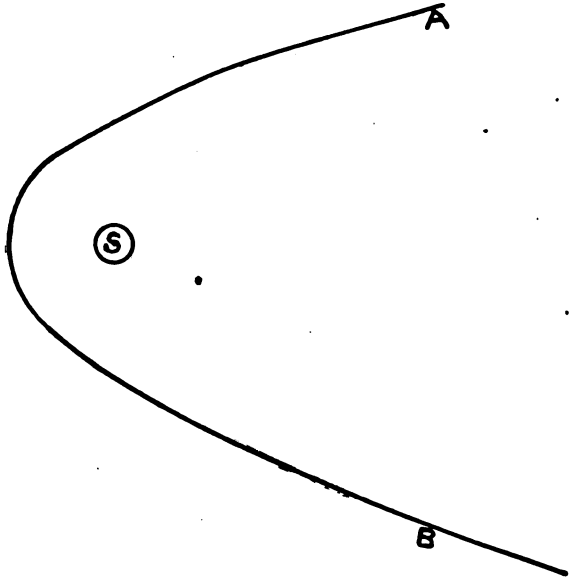

Fig. 63. The parabolic path of a comet encircling our sun, which forms one of its foci; the other foci is so far away as to be in infinity.

greater part of this may be blown to dust, one or more larger pieces fall intact as meteoric stones or as fire-balls, and it is in such as these and these only, that rare elements—absolutely pure iron, for instance—are found native.

## CHAPTER IV.

### CENTRE OF GRAVITY

*That point about which all the parts of a body do, in any situation, exactly balance each other.*

The discovery of this fact is due to Archimedes, and it is a point in every solid body (whatever the form may be) in which the *forces of gravity* may be considered as *united*. In our globe, which is a sphere, or rather an oblate spheroid,

the centre of gravity will be the centre. Thus, if a plummet be suspended on the surface of the earth, it points directly to the centre of gravity, and, consequently, two plummet-lines suspended side by side cannot, strictly speaking, be parallel to each other: see Fig. 64. Therefore it is not quite accurate to say that every body has a centre of gravity, but only an approximate centre; also every atom of matter has

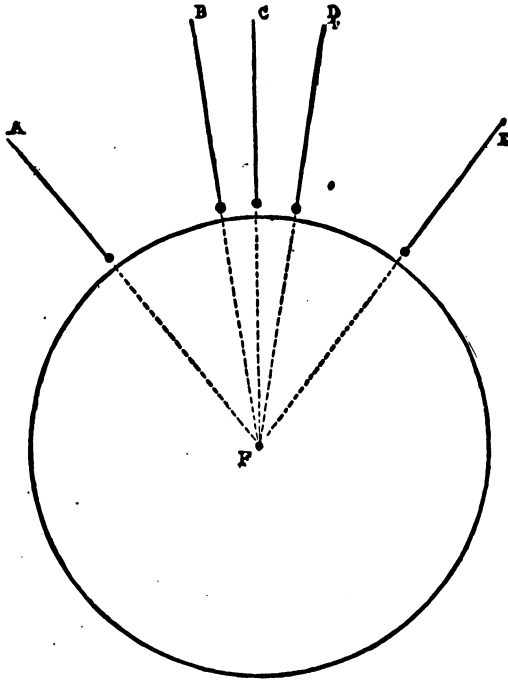

Fig. 64. F. The centre. A B C D E. Plummet-lines, all pointing to the centre, and therefore diverging from each other.

its centre of inertia, and it may be said with sufficient correctness, that in all objects of moderate size, the centre of inertia and centre of gravity are identical, or coincident.

If it were possible to bore or dig a gallery through the whole substance of the earth from pole to pole, and then to allow a stone or the fabled Mahomet's coffin to fall through it, the momentum—*i. e.*, the force of the moving body, would carry it beyond the centre of gravity. This force, however,

becoming exhausted, there would be a retrograde movement, and after many oscillations the stone or coffin would gradually come to rest, till, unsupported by anything material, it would be suspended by the force of gravitation, and now enter into and take part in the general attracting force; and being equally attracted on every side, the stone or coffin must be totally without weight. *Momentum* may be illustrated by a series of inclined planes cut in wood or cardboard, with a grooved channel at the top; if a marble is allowed to run down the first incline, the momentum will

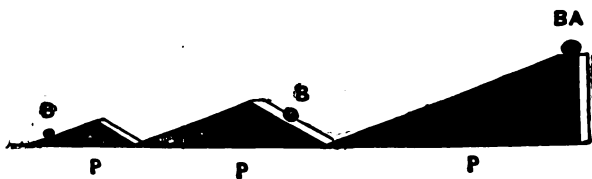

Fig. 65. P P P. Inclined planes, gradually decreasing in height, cut out of card or wood, with a groove at the top to carry an ordinary marble. B B B. Different positions of the marble, which starts from B A.

carry it up the second, from which it will again descend and pass up and down the third and last miniature mountain. An amplification of this method is used in order to lower grain, the full trucks starting from a level at a great height, down a steep incline, by their own gravity; their momentum then carries them up a hill and over the brow of it, when gravity brings them down the second slope, and so on, till finally the momentum gathered on the last descent, enables the trucks to ascend a bank, when, there being no descent, but a level, they come to rest gently on a siding, and after being emptied, they are hauled back by machinery to the higher ground. Such a railway is called a switch-back, and various modifications of it are used at many pleasure resorts, for the entertainment of such of the public as care for the experience of rapid thrilling motion.

In a sphere of uniform density, the centre of gravity is easily discovered, but not so in an irregular *mass*; and here, perhaps, an explanation of terms may not be altogether unacceptable.

*Mass*, is a term applied to solids, such as a mass of lead or stone.

*Bulk*, to liquids, such as a bulk of water or oil,

*Volume*, to gases, such as a volume of air or oxygen.

To find the centre of gravity of any mass, as, for example, an ordinary school-slate, we must first of all suspend it from any part of the frame; then allow a plumb-line to drop from the point of suspension, and mark its direction on the slate, as in Fig. 66. Again suspend the slate at various other points, always marking the line of direction of the plummet, and at the point where the lines intersect each other, there will be the centre of gravity.

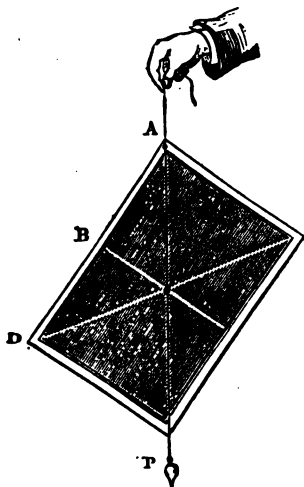

Fig. 66. A B D. The three points of suspension. C. The point of intersection, and, therefore, the centre of gravity. P. The line of plummet.

If these lines have been drawn carefully and the slate be now placed (as shown in Fig. 67) on a blunt wooden point at the spot where the lines cross each other, it will be found to balance exactly, and this place is called the *centre of gravity*, being the point with which all other particles of the body would move with par-

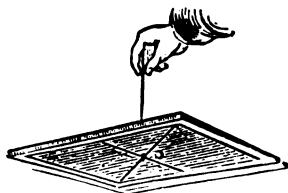

Fig. 67.

allel and equable motion during its fall. The equilibrium of bodies is therefore much affected by the position of the centre of gravity. Thus, if we cut out an elliptical figure from a board one inch in thickness, and rest it on a flat surface by one of its edges (as at No. 1, fig. 68), this point of contact is called the point of support, and the centre of gravity is immediately above it.

In this case, the body is in a state of secure equilibrium, for any motion on either side will cause the centre of gravity to ascend in these directions, and an oscillation will ensue. But if we place it upon the smaller end, as shown at No. 2 (fig. 68), the position will be one of equilibrium, but not stable or secure; although the centre of gravity is directly

above the point of support, the slightest touch will displace the oval and cause its overthrow. The famous story of Columbus and the egg suggests a capital illustration of this fact;

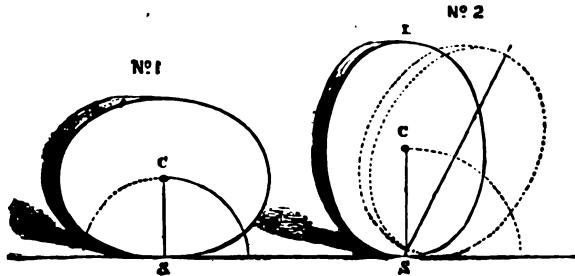

Fig.. 68. The point of support. C. The centre of gravity.

and there are two modes in which the egg may be poised on either of the ends.

The one usually attributed to the great discoverer, is that of scraping or slightly breaking away a little of the shell, so as to flatten one of the ends, thus:—

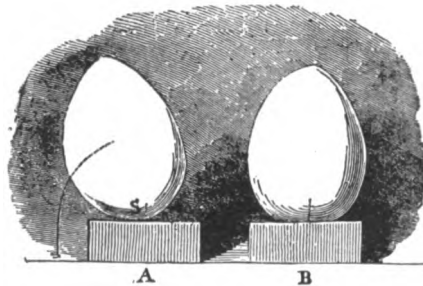

Fig. 69. A represents the egg in its natural state, and, therefore, in unstable equilibrium; B, another egg, with the surface, S, flattened, by which the centre of gravity is lowered, and if not disturbed beyond the extent of the point of support the equilibrium is stable.

The most scientific method of making the egg stand on its end and without disturbing the exterior shell is to alter the position of the yolk, which has a greater density than the white, and is situated about the centre. If the egg is now shaken so as to break the membrane enclosing the yolk, and thus allow it to sink to the bottom of the broader end, the centre of gravity is lowered; there is a greater proportion of weight concentrated in the broad end, and the egg stands erect, as depicted at Fig. 70.

It is this variable position of the centre of gravity in ivory balls (one part of which may be more dense than another) that so frequently annoys even the best billiard-players; and

on this account a ball will deviate from the line in which it is impelled, not from any fault of the player, but in consequence of the ivory ball being of unequal density, and, therefore, not having the centre corresponding with the centre of gravity. A good billiard-player should, therefore, always try the ball before he engages to play in any large event.

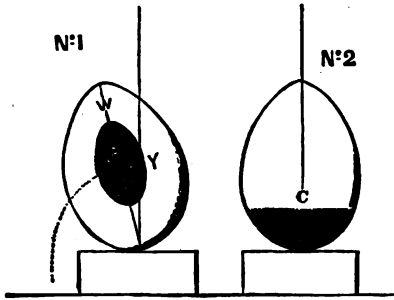

Fig. 70.—No. 1. Section of egg. C. Centre of gravity. Y. The yolk. W. The white.  
No. 2. C. Centre of gravity, much lowered. Y. The yolk at the bottom of the egg.

The manikin toy called the “tombola” reminds us of the egg-experiment, as there is usually a lump of lead inserted in the lower part of the hemisphere, and when the toy is put down it rapidly assumes the upright position because the centre of gravity is not in the lowest place to which it can descend; the latter position being only attained when the figure is upright.

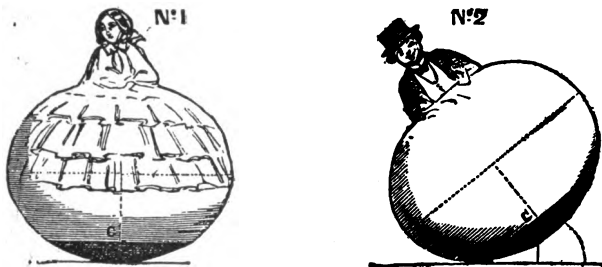

Fig. 71.—No. 1. C. Centre of gravity in the lowest place, figure upright.  
No. 2. C. Centre of gravity raised as the figure is inclined on either side, but falling again into the lowest place as the figure gradually comes to rest.

There is a popular paradox in mechanics—viz., “a body having a tendency to fall by its own weight, may be prevented from falling by adding to it a weight on the same



side on which it tends to fall," and the paradox is demonstrated by another well-known child's toy, horse and manikin, as depicted in the next cut. Fig. 72.

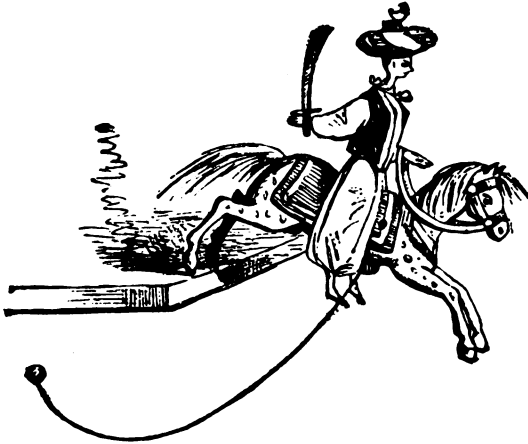

Fig. 72. The line of direction falling beyond the base; the bent wire and lead weight throwing the centre of gravity under the table and near the leaden weight, the hind legs become the point of support, and the toy is perfectly balanced.

After what has been explained regarding the improvement of the stability of the egg by lowering the situation of the centre of gravity, it may at first appear singular that a stick, loaded with a weight at its upper extremity, can be

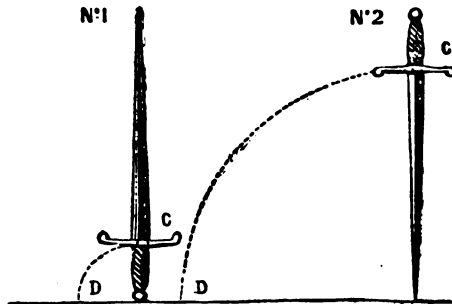

Fig. 73.—No. 1. Sword balanced on handle: the arc from C to D is very small, and if the centre, C, falls out of the line of direction it is not easily restored to the upright position.

No. 2. Sword balanced on the point: the arc from C to D much larger, and therefore the sword is more easily balanced.

balanced perpendicularly with greater ease and precision than when the weight is lower down and nearer the hand; and that a sword can be balanced best when the hilt is uppermost; but this is easily explained when it is understood that

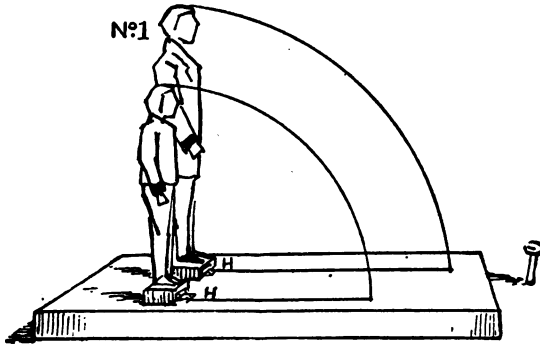

Fig. 74.—No. 1. The two pieces of wood, carved to represent a man and a boy, one being 10 and the other 5 inches long, attached to board by hinges at H H.

with the handle downwards a much smaller arc is described as it falls than when reversed, so that in the former case the balancer has not time to readjust the centre, whilst in the latter position the arc described is so large that before

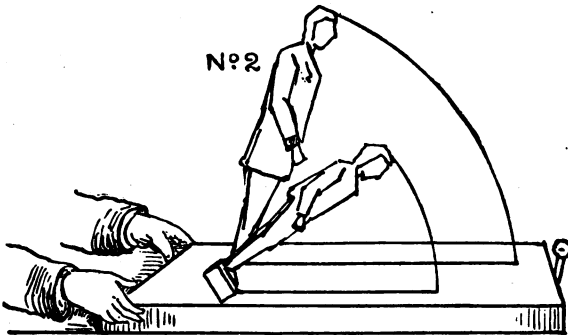

Fig. 75.—No. 2. The board pushed forward, striking against a nail, when the short piece falls first, and the long one second.

the sword falls the centre of gravity may be restored within the line of direction of the base. See Fig. 73, page 54.

For the same reason, a child tripping against a stone will fall quickly; whereas a man can recover himself; this fact can be shown by fixing two square pieces of wood of different

length, by hinges on a flat base or board, then if the board be pushed rapidly forward and struck against a lead weight or a nail put in the table or bench, the short piece is seen to fall first and the long one afterwards; the difference of time occupied in the fall of each piece of wood (which may be carved to represent the human figure) being clearly denoted by the sounds produced as they strike the board. (Figs. 74, 75.)

Boat-accidents frequently arise in consequence of ignorance on the subject of the centre of gravity, and when per-

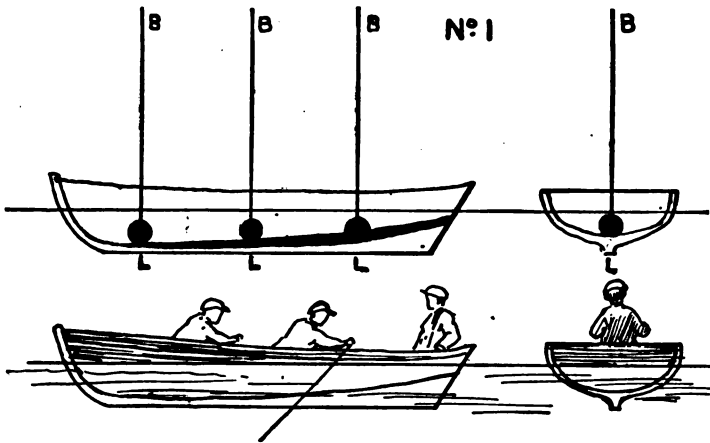

Fig. 76.—No. 1. Sections of a toy-boat floating in water. B B B. Three wires or knitting needles placed at regular distances fastened in the bottom of the boat, with cuts or slits at the top so that when the leaden bullets, L L L, which are perforated and slide upon them like beads, are raised to the top, they are retained by the cuts springing out; when the bullets are at the bottom of the lines they represent persons sitting in a boat, as shown in the lower drawings, and the centre of gravity will be within the vessel.

sons are alarmed whilst sitting in a boat, they generally rise suddenly, raise the centre of gravity, which falling, by the oscillation of the frail bark, outside the line of direction of the base, cannot be restored, and the boat is upset; if the boat were fixed by the keel, raising the centre of gravity would be of little consequence, but as the boat is perfectly free to move and roll to one side or the other, the elevation of the centre of gravity is fatal, and it operates just as the removal of the lead would do, if changed from the base to the head of the "tombola" toy. Fig. 71, page 53. A diver, but for his lead boots, would turn upside down, his helmet, in that case, being the heaviest; he would not by any possi-

bility be able to right himself, because his helmet would act exactly like the weight in the two manikins illustrated on page 53. (Fig. 71.)

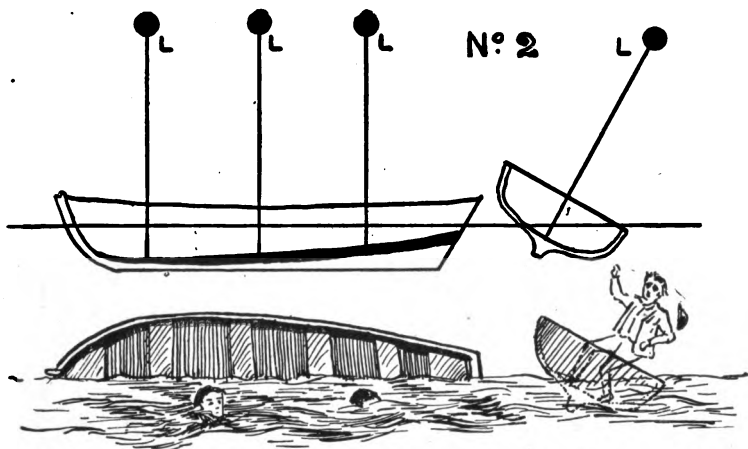

Fig. 77. No. 2. The leaden bullets raised to the top now show the result of persons suddenly rising, when the boat immediately turns over, and either sinks or floats on the surface with the keel uppermost.

A very striking experiment, exhibiting the danger of rising in a boat, may be shown by the model depicted at Nos. 1 and 2, figs 76 and 77.

We thus perceive that the stability of a body placed on a base depends upon the position of the line of direction and the height of the centre of gravity.

Security results when the line of direction falls within the base. Instability when just at the edge. Incapability of standing when falling without the base.

The leaning-tower of Pisa is one hundred and eighty-two feet in height, and is swayed sixteen and a half feet from the perpendicular, but yet has remained firm and secure, as the line of direction falls considerably within the base. If it was of a greater altitude it could no longer stand, because the centre of gravity would be so elevated that the line of direction would fall outside the base. This fact may be illustrated by taking a board several feet in length, and having cut it out to represent the architecture of the leaning-tower of Pisa, it may then be painted in distemper, and fixed at the right angle with a hinge to another board representing the

ground, whilst a plumb-line may be dropped from the centre of gravity; it may be shown that as long as the plummet falls within the base, the tower is safe; but directly the model tower is brought a little further forward by a wedge so that the plummet hangs outside, then, on removing the support, which may be a piece of string to be cut at the right moment, the model falls, and the fact is at once comprehended. (Fig. 78.)

This tower at Pisa is, unfortunately, slowly settling, its angle of inclination becoming more and more acute, one foot

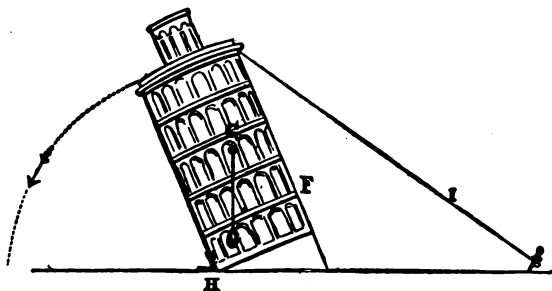

Fig. 78. F. Board cut and painted to represent the leaning tower of Pisa. G. The centre of gravity and plummet-line suspended from it. H. The hinge which attaches it to the base board. I. The string, sufficiently long to unwind and allow the plummet to hang outside the base, so that, when cut, the model falls in the direction of the arrow.

of its present lean having been increased during the last century; so that if measures are not taken to stop this increase of sway from the vertical, the line of direction of its centre of gravity must soon come outside its base, when it will fall, as did the Campanile at Venice, which collapsed a few years ago.

The two leaning towers at Bologna are likewise celebrated for their great inclination. One of them inclines three feet four inches, with a height of 274 feet; the other, which is 137 feet high, leans eight feet two inches. So also (in England) is the hanging-tower, or, more correctly, the massive wall which has formed part of a tower at Bridgenorth, Salop; it deviates from the perpendicular, but the centre of gravity and the line of direction fall within the base, and it remains secure.

One of the most curious paradoxes is displayed in the ascent of a billiard-ball from the thin to the thick ends of two billiard-cues placed at an angle, as in our drawing, Fig. 79;

here the centre of gravity is raised at starting, and the ball moves in consequence of its actually *falling* from the high to the low level.

Much of the stability of a body depends on the height through which the centre of gravity must be elevated before the body can be overthrown. The greater this height, the

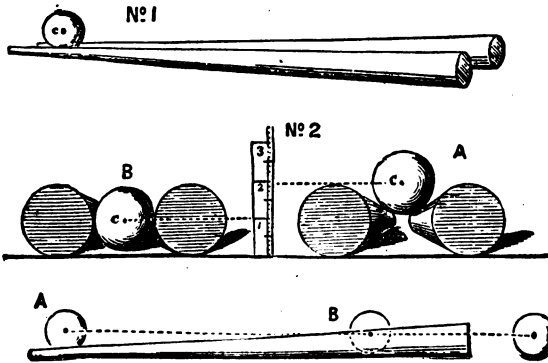

Fig. 79.—No. 1. Two billiard-cues arranged for the experiment and fixed to a board: the ball is rolling up.

No. 2. Sections showing that the centre of gravity, C, is higher at A than at B, which represents the thick end of the cues; it therefore, in effect, rolls down hill.

greater will be the immovability of the mass. One of the grandest examples of this fact is shown in the ancient Pyramids; and whilst gigantic palaces, with vast columns, and all the solid grandeur belonging to Egyptian architecture, have succumbed to time, and lie more or less prostrate upon the

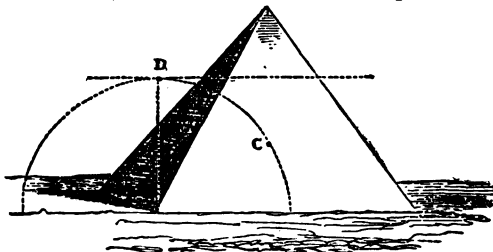

Fig. 80. C. Centre of gravity, which must be raised to D before it can be overthrown.

earth, the Pyramids, in their simple form and solidity, remain almost as they were built, and it will be noticed, in the accompanying sketch, how difficult, if not impossible, it would be to attempt to overthrow bodily one of these great monuments of ancient times.

The principles already explained are directly applicable to the construction or secure loading of vehicles; and in proportion as the centre of gravity is elevated above the point of support (that is, the wheels), so is the insecurity of the carriage increased, and the contrary takes place if the centre of gravity is lowered. Again, if a waggon be loaded with



No. 1.



No. 2.

Fig. 81.—No. 1. The centre of gravity is near the ground, and falls within the wheels.

No. 2. The centre of gravity is much elevated, and the line of direction is outside the wheels.

a very heavy substance which does not occupy much space, such as iron, lead, or copper, or bricks, it will be in much less danger of an overthrow than if it carries an equal weight of a lighter body, such as pockets of hops, or bags of wool or bales of rags.

In the one instance, the centre of gravity is near the ground, and falls well within the base, as at No. 1, Fig. 81. In the other, the centre of gravity is considerably elevated above the ground, and having met with an obstruction which has raised one side higher than the other, the line of direction has fallen outside the wheels, and the waggon is overturning as at No. 2.

The various postures of the human body may be regarded as so many experiments upon the position of the centre of gravity which we are every moment unconsciously performing.

To maintain an erect position, a man must so place his body as to cause the line of direction of his weight to fall within the base formed by his feet.

The more the toes are turned outwards, the more con-



Fig. 82.

tracted will be the base, and the body will be more liable to fall backwards or forwards; and the closer the feet are drawn together, the more likely is the body to fall on either side. Acrobats, dancing dogs, etc., unconsciously acquire the habit of accurately balancing themselves in all kinds of

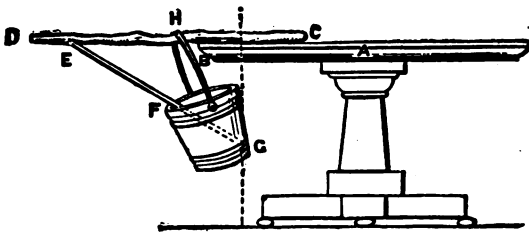

Fig. 83.

strange positions; but as these accomplishments are not to be recommended to young people, some other marvels (such as balancing a pail of water on a stick laid upon a table) may be adduced, as illustrated in Fig. 83.

Let A B represent an ordinary table, upon which place a



broomstick, *c d*, so that one-half shall rest upon the table and the other extend from it; place over the stick the handle of an empty pail (which handle may possibly require to be elongated for the experiment) so that the handle touches or falls into a notch at *H* to prevent slipping; and in order to bring the pail well under the table, another stick is placed in the notch *E*, and is arranged in the line *G F E*, one end resting at *G* and the other at *E*. Having made these preparations, the pail may now be filled with water; and although it appears to be a most marvellous result, to see the pail apparently balanced on the end of a stick which may easily tilt up, the principles already explained will enable the observer to understand that the centre of gravity of the pail falls within the line of direction shown by the dotted line; and it amounts in effect to nothing more than carrying a pail on the centre of a stick, one end of which is supported at *E*, and the other through the medium of the table, *A B*.

This illustration may be modified by using a heavy weight, rope, and stick, as shown in our sketch below.

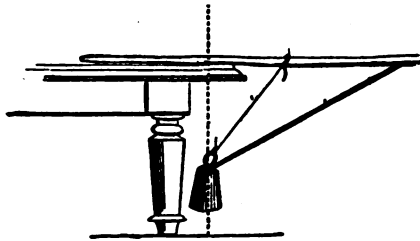

Fig. 84.

Before we dismiss this subject it is advisable to explain a term referring to a very useful truth, called the centre of percussion; a knowledge of which, gained instinctively or otherwise, enables the workman to wield his tools with increased power, and gives greater force to the cut of the swordsman, so that, with some physical strength, he may perform the feat of cutting a sheep in half, cleaving a bar of lead, or neatly dividing, *à la Saladin*, in ancient Saracen fashion, a silk handkerchief floating in the air. There is a feat, however, which does not require any very great strength, but is sufficiently startling to excite much surprise and some inquiry—viz., the one of cutting in half a broomstick sup-

ported at the ends on goblets of water without spilling the water or cracking or otherwise damaging the glass supports.

These and other feats are partly explained by reference to time: the force is so quickly applied and expended on the centre of the stick that it is not communicated to the supports; just as a bullet from a pistol may be sent through a pane of glass without shattering the whole square, but

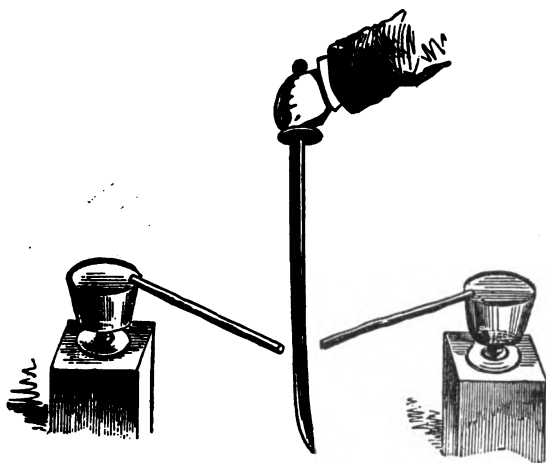

Fig. 86.

making a clean hole through it, or a candle may be sent through a plank, or a cannon-ball pass through a half opened door without causing it to move on its hinges. But the success of the several feats depends in a great measure on the attention that is paid to the delivery of the blows at the *centre of percussion* of the weapon; this is a point in a moving body where the percussion is the greatest, and about which the impetus or force of all parts is balanced on every side. It may be better understood by reference to drawing 86. Applying this principle to a model sword made of wood, cut in half in the centre of the blade, and then united with an elbow-joint, the handle being fixed to a board by a wire passed through it and the two upright pieces of wood, the fact is at once apparent, and is well shown in Nos. 1, 2, 3, Fig. 86.

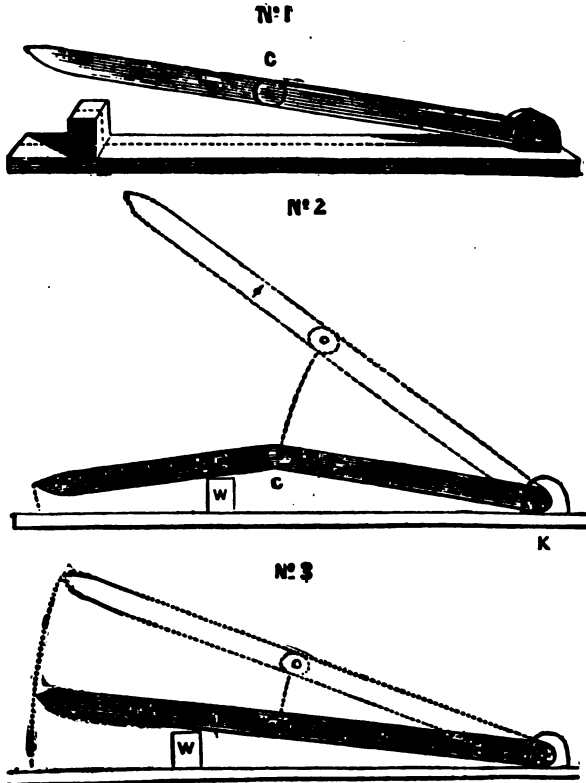

Fig. 86.—No. 1, is the wooden sword, with an elbow-joint at C. No. 2. Sword attached to board at K, and being allowed to fall from any angle shown by dotted-line, it strikes the block, W, outside the centre of percussion, P, and as there is unequal motion in the parts of the sword it bends down (or, as it were, breaks) at the elbow-joint, C.

No. 3 displays the same model; but here the blow has fallen on the block, W, precisely at the centre of percussion of the sword, P, and the elbow-joint remains perfectly firm.

When a blow is not delivered with a stick or sword at the centre of percussion, a peculiar jar, or what is familiarly spoken of as a *stinging* sensation, is apparent in the hand.

This is particularly noticed in playing cricket, when the batsman strikes a fast ball outside or inside the centre of percussion of his bat, the jar giving a painful and stinging sensation, not only to the fingers, but often up the whole arm to the shoulder. Such a blow is also a great strain on

the bat, and in some cases fractures it. On the other hand, every player will have noticed how, on occasion, with comparatively little exertion, he knocks a tremendous "skier," probably far out of bounds. Such a ball has been struck on the exact centre of percussion.

On noticing or recalling with which part of the bat he struck the ball, he will find it was about a third of the length,

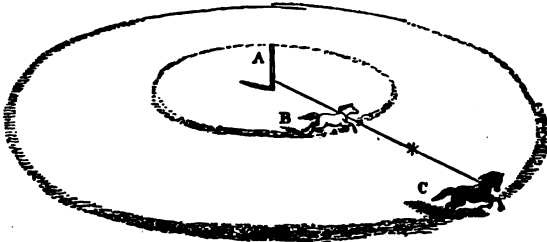

Fig. 87. A. The post to which a rope is attached. B and C are two horses running round in a circle, and it is plain that B will not move so quick as C, and that the latter will have the greater moving force; consequently, if the rope was suddenly checked by striking against an object at the centre of gravity, the horse C would proceed faster than B, and would impart to B a backward motion, and thus make a great strain on the rope at A. But if the obstacle were placed so as to be struck at a certain point nearer C, viz., at or about the little star, the tendency of each horse to move on would balance and neutralize the other, so that there would be no strain at A. The little star indicates the centre of percussion.

reckoning from the bottom, although the spot will vary slightly according to the make or model of the bat.

This is the reason why one who plays intelligently any game, such as cricket, tennis, football, golf, etc., where striking is an essential feature, plays with more effect and less exertion than one who is ignorant of the physical properties of the tools he uses and trusts only to brute strength.

The cause of disagreeable and painful results and broken appliances will be understood from this explanation, and may be further elucidated by Fig 87, in which the post, A, corresponds with the handle of the sword in Figs. 85 and 86.

## CHAPTER V

### SPECIFIC GRAVITY

It is recorded of Wollaston, the eminent chemist and philosopher, that when Sir Humphry Davy placed in his hand what was then considered to be *the* scientific wonder of the day—viz., a small bit of the metal potassium, he ex-

claimed at once, "How heavy it is," and was greatly surprised, when Sir Humphry threw the metal on water, to see it not only take fire, but actually *float* upon the surface; here, then, was a philosopher possessing the deepest learning, unable, by the sense of touch and by ordinary handling, to state correctly whether the new substance (and that a metal), was heavy or light; hence it is apparent that the property of specific gravity is one of importance, and being derived from the Latin, means *species*, a particular sort or kind, and *gravis*, heavy or weight—i. e., the particular weight of every substance compared with a fixed standard of water.

We are so constantly in the habit of referring to a standard of perfection in music and the arts of painting and sculpture, that the youngest will comprehend the office of water when told that it is the scientist's unit or starting-point for the estimation of the relative weights of solids and liquids. A good idea of the scope and meaning of the term specific gravity, is acquired by a few simple experiments, thus: if a cylindrical glass, say eighteen inches long, and two and

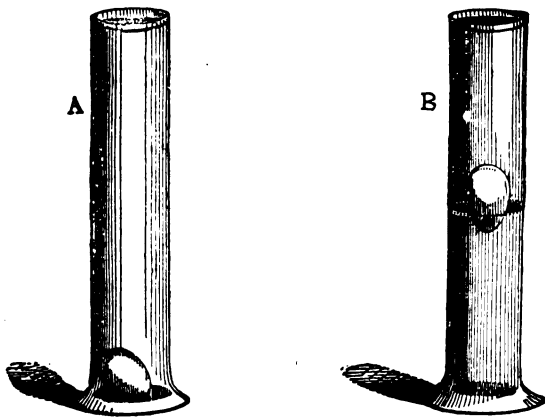

Fig. 88. A. A large cylindrical vessel containing water, in which the egg sinks till it reaches the bottom of the glass. B. A similar glass vessel containing half brine and half water, in which the egg floats in the centre—viz., just at the point where the brine and water touch.

a half wide, is filled with water, and another of the same size is also filled, one half with water, the other half with a saturated solution of common salt, or what is commonly termed brine, a good comparison of the relative weights of

equal bulks of water and brine, can be made with the help of two fresh eggs; when one of the eggs is placed in the glass containing water, it immediately sinks to the bottom, showing that it has a greater specific gravity than water; but when the other egg is placed in the second glass containing the brine, it sinks through the water till it reaches the strong solution of salt, where it is suspended, and presents a most curious appearance; seeming to float like a balloon in air, and apparently suspended upon nothing, it provokes the inquiry, "whether magnetism has anything to do with it?" The answer, of course, is in the negative, it merely floats in the centre, in obedience to the common principle, that all bodies float in others which are heavier than themselves; the brine has, therefore, a greater weight than an equal bulk of water, and is also heavier than the egg. A sequel to this experiment may be shown by demonstrating how the brine is placed in the vessel without mixing with the water above it; this is done by using a glass tube and funnel, and after pouring away half the water contained in the vessel (Fig. 89), the egg can be floated from the bottom to the centre of the glass, by pouring the brine down the funnel and tube. The saturated solution of salt remains in the lower part of the vessel and displaces the water, which floats upon its surface like oil on water, carrying the egg with it.

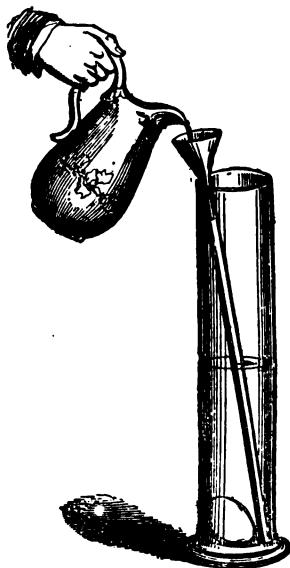

Fig. 89. A vessel half full of water, and as the brine is poured down the tube the egg gradually rises.

The water of the Dead Sea is said to contain about twenty-six per cent. of saline matter, which chiefly consists of common salt. It is perfectly clear and bright, and in consequence of the great density a person may easily float on its surface, like the egg on the brine, so that if a ship could be heavily laden whilst floating on the water of the Dead Sea, it would most likely sink if transported to the Thames. This

illustration of specific gravity is also shown by a model ship, which being first floated on the brine, will afterwards sink if conveyed to another vessel containing water. One of the tin model ships sold as a magnetic toy answers well for this experiment, but it must be weighted or adjusted so that it just floats in the brine, A; then it will sink, when placed in another vessel containing water only.

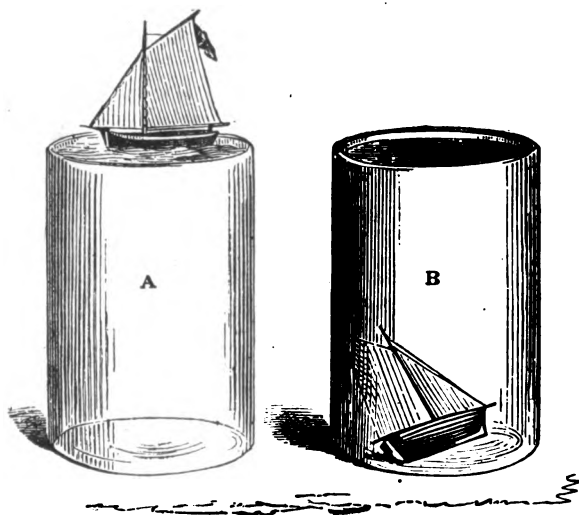

Fig. 90. A. Vessel containing brine, upon which the little model floats.  
B. Vessel containing water, in which the ship sinks.

Another illustration of the same kind is displayed with gold-fish, which swim easily in water floating on brine, but cannot dive to the bottom of the vessel, owing to the density of the saturated solution of salt. If the fish are taken out immediately after the experiment, and placed in fresh water, they will not be hurt by contact with the strong salt water.

These examples of the relative weights of equal bulks, enable the mind to grasp the more difficult problem of ascertaining the specific gravity of any solid or liquid substance; and here the strict meaning of terms should not be passed by. *Specific* weight must not be confounded with *Absolute* weight; the latter means the entire amount of ponderable matter in any body: thus, twenty-four cubic feet. of sand weigh about one ton, whilst specific weight means the *relation*

that subsists between the *absolute weight* and the *volume* or *space* which that *weight* occupies. Thus a cubic foot of water weighs sixty-two and a half pounds, or 1000 ounces avoirdupois, but changed to gold, the cubic foot weighs more than half a ton, and would be equal to about 19,300 ounces—hence the relation between the cubic foot of water and that of gold is nearly as 1 to 19.3; the latter is therefore called the specific gravity of gold, this being the average. (See page 71.)

Such a mode of taking the specific gravity of different substances—viz., by the weight of equal bulks, whether cubic feet or inches, could not be employed in consequence of the difficulty of procuring exact cubic inches or feet of the various substances which, by their peculiar properties of brittleness or hardness, would present insuperable obstacles to any attempt to fashion or shape them into exact volumes. It is therefore necessary to adopt the method first devised by Archimedes, about 260 B.C., when he discovered the admixture of another metal with the gold of King Hiero's crown. (See also page 169.)

This story, ending in the discovery of a philosophical truth may thus be given:—King Hiero gave out from the royal treasury a certain quantity of gold, which he required to be fashioned into a crown; when, however, the emblem of power was produced by the goldsmith, it was not found deficient in weight, but had that appearance which indicated to the monarch that a surreptitious addition of some other metal must have been made.

It may be assumed that King Hiero consulted his friend and philosopher Archimedes, and he might have said, "Tell me, Archimedes, without pulling my crown to pieces, if it has been debased with any other metal?" The philosopher asked time to solve the problem, and going to take his accustomed bath, discovered then specially what he had never particularly remarked before—that, as he entered the vessel of water, the liquid rose on each side of him—that he, in fact, displaced a certain quantity of liquid. Thus, supposing the bath to have been full of water, directly Archimedes stepped in, it would overflow. Let it be assumed that the water displaced was collected, and weighed 90 pounds, whilst the philosopher had weighed, say 200 pounds. Now, the



train of reasoning in his mind might be of this kind:—  
 “My body displaces 90 pounds of water; if I had an exact cast of it in lead, the same *bulk* and *weight* of liquid would overflow; but the weight of my body was, say 200 pounds, the cast in lead 1000 pounds; these two sums divided by 90 would give very different results, and they would be the specific gravities, because the rule is thus stated:—‘Divide the gross weight by the loss of weight in water, the water displaced, and the quotient gives the specific gravity.’” The rule is soon tested with the help of an ordinary pair of scales, and the experiment made more interesting by making a model crown of some metal, or an empty bottomless meat can would answer. For convenience, the pan of one scale is suspended by shorter chains than the other, and should have a hook inserted in the middle; upon this is placed the crown, or ring of tin, supported by very thin copper wire. For the sake of argument, let it be supposed that the crown weighs  $17\frac{1}{2}$  ounces avoirdupois, which are duly placed in the other scale-pan and without touching these weights, the crown is now placed in a vessel of water. It might be supposed that directly the crown enters the water, it would gain weight, in consequence of being wetted, but the contrary is the case, and by thrusting the crown into the water, it may be seen to rise with great buoyancy so long as the  $17\frac{1}{2}$  ounces are retained in the other scale-pan; and it will be found necessary to place at least two ounces in the scale-pan to which the crown is attached before the latter sinks in the water; and thus it is distinctly shown that the crown weighs only about  $15\frac{1}{2}$  ounces in the water, and has therefore *lost* instead of *gaining* weight whilst immersed in the liquid. The rule may now be worked out:

	Ounces
Weight of crown in air.....	17 $\frac{1}{2}$
Ditto in water.....	15 $\frac{1}{2}$
	2
Less in water .....	2
	2) 17 $\frac{1}{2}$
	8.75

The quotient  $8\frac{3}{4}$  demonstrates that the crown is manufac-

tured of copper, because it would have been about  $19\frac{1}{2}$  if made of pure gold.

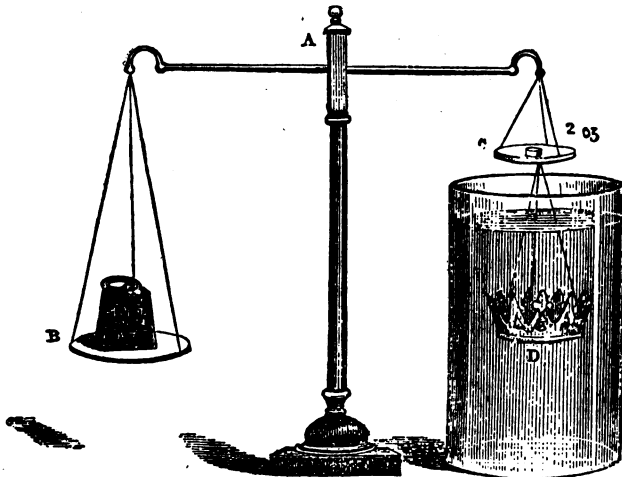

Fig. 91. A. Ordinary pair of scales. B. Scale-pan, containing  $17\frac{1}{2}$  ounces, being the weight of the crown in air. C. Pan, with hook and crown attached, which is sunk in the water contained in the vessel D; this pan contains the two ounces, which must be placed there to make the crown sink and exactly balance B.

*Table of the Specific Gravities of the Metals in common use.*

Platinum .....	21.1	to	21.7
Gold .....	19.26	to	19.56
Mercury .....	13.59	at 0°C.,	14.93 solid.
Lead .....	11.24.	After poured hot into water	11.36
Silver .....	10.423	to	10.575
Bismuth .....	9.75	to	9.90
Copper .....	8.81	to	8.96
Iron .....	7.62	to	7.84
Tin .....	7.293		
Zinc .....	6.71	to	7.22

The simple rule already explained may be applied to all metals of any size or weight, and when the mass is of an irregular shape, having various cavities on the surface, there may be some difficulty in taking the specific gravity, in consequence of the adhesion of *air-bubbles*; but this may be obviated either by brushing them away with a feather, or, what is frequently much better, by dipping the metal or

mineral first into alcohol, and then into water, before placing it in the vessel of water by which the actual specific gravity is to be taken.

The mode of taking the specific gravity of liquids is very simple, and is usually performed in the laboratory by means of a thin globular bottle which holds exactly 1000 grains of pure distilled water at 60° Fahrenheit. A little counterpoise of lead is made of the exact weight of the dry globular bottle, and the liquid under examination is poured into the bottle and up to the graduated mark in the neck; the bottle is then placed in one scale-pan, the counterpoise and the 1000-grain weight in the other; if the liquid (such as oil of vitriol) is heavier than water, then more weight will be required—viz., 845 grains—and these figures added to the 1000 would indicate at once that the specific gravity of oil of vitriol was 1.845 as compared with water, which is 1.000. When the liquid, such as alcohol, is lighter than water, the 1000-grain weight will be found too much, and grain weights must be added to the same scale-pan in which the bottle is standing, until the two are exactly balanced. If ordinary alcohol is being examined, it will be found necessary to place 180 grains with the bottle, and these figures deducted from the 1000 grains in the other scale-pan, leave 820, which, marked with a dot before the first figure (*sic* .820), indicates the specific gravity of alcohol to be less than that of water.

The difference in the gravities of various liquids is displayed in an interesting manner by an experiment, which consists in the arrangement of five distinct liquids of various densities and colours, the one resting on the other, and distinguished not only by the optical line of demarcation, but by little balls of wax, which are adjusted by leaden shot inside, so as to sink through the upper strata of liquids, and rest only upon the one that it is intended to indicate.

The manipulation for this experiment is somewhat troublesome, and is commenced by procuring some pure bright quicksilver, upon which an iron bullet (black-leaded, or painted of any colour) is placed, or a coloured glass ball.

Secondly. Put into a half pint of boiling water as much white vitriol (sulphate of zinc) as will dissolve, and when cold, pour off the clear liquid, make up a ball of coloured

wax (say red), and adjust it by placing little shot inside, until it sinks in a solution of sulphate of copper and floats on that of the white vitriol.

Thirdly. Make a solution of sulphate of copper in precisely the same manner, and adjust another wax ball to sink in water, and float on this solution.

Fourthly. Some clear distilled water must be provided.

Fifthly. A little cochineal is to be dissolved in some common spirits of wine (alcohol), and a ball of cork painted white provided.

Finally. A long cylindrical glass, at least eighteen inches high, and two and a half or three inches in diameter, must be provided to receive these five liquids, which are arranged in their proper order of specific gravity by means of a long tube and funnel.

The four balls—viz., the iron, the two wax, and the cork balls, are allowed to slide down the long glass, which is

inclined at an angle; and then, by means of the tube and funnel, pour in the tincture of cochineal, and all the balls will remain at the bottom of the glass. The water is poured down next, and now the cork ball floats up on the water, and marks the boundary line of the alcohol and water. Then the solution of blue vitriol, when a wax ball floats upon it. Thirdly, the solution of white vitriol, upon which the second wax ball takes its place; and lastly, the quicksilver is poured down the tube, and upon this heavy metallic fluid the iron or glass ball floats like a cork on water.

The tube may now be carefully removed, pausing at each liquid, so that no mixture take place between them, and the result is the arrangement of five liquids, giving the appearance of a cylindrical glass painted with bands of crimson,

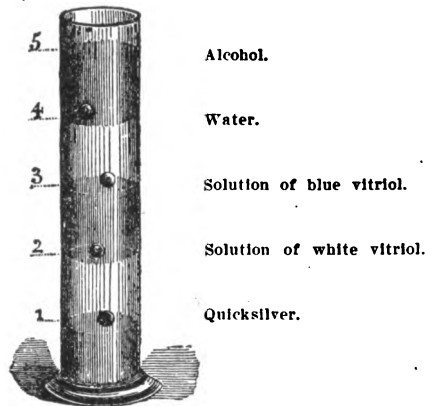

Fig. 92. Long cylindrical glass, 18x3 inches, containing the five liquids.

blue, and silver; and the liquids will not mingle with each other for many days.

A more permanent arrangement can be devised by using liquids which have no affinity, or will not mix with each other—such as mercury, water, and turpentine.

The specific weight or weights of an equal measure of air and other gases is determined on the same principle as liquids, although a different apparatus is required. A light capped glass globe, with tap, from 50 to 100 cubic inches capacity, is weighed full of air, then exhausted by an air-pump, and weighed empty, the loss being taken as the weight of its volume of air; these figures are carefully noted, because *air* instead of *water* is the standard of comparison for all gases. When the specific gravity of any other gas is to be taken, the glass globe is again exhausted, and screwed on to a gas jar provided with a proper tap, in which the gas is contained; when perfect accuracy is required, the gas must be dried by passing it over some asbestos moistened with oil of vitriol, and contained in a glass tube, and the gas jar should stand in a mercurial trough. (Fig. 93.) The taps

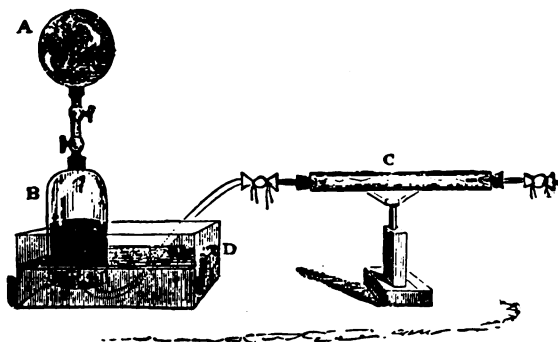

Fig. 93. A. Glass globe to contain the gas. B. Gas jar standing in the mercurial trough, D. C. Tube containing asbestos moistened with oil of vitriol.

are gradually turned, and the gas admitted to the exhausted globe from the gas jar; when full, the taps are turned off, the globe unscrewed, and again weighed, and by the common rule of proportion, as the weight of the air first found is to the weight of the gas, so is unity (1.000, the density of air) to a number which expresses the density of the gas required. If oxygen had been the gas tried, the number would

be 1.111, being the specific gravity of that gaseous element. If chlorine, 2.490. Carbonic acid, 1.523. Hydrogen being much less than air, the number would only be 69, or decimally 0.069.

A very good approximation to the correct specific gravity (particularly where a number of trials have to be made with the same gas, such as ordinary coal gas) is obtained by suspending a light paper box, with holes at one end, on one arm of a balance, and a counterpoise on the other. The box can be made carefully, and should have a capacity equal to a half or quarter cubic foot; it is suspended with the holes

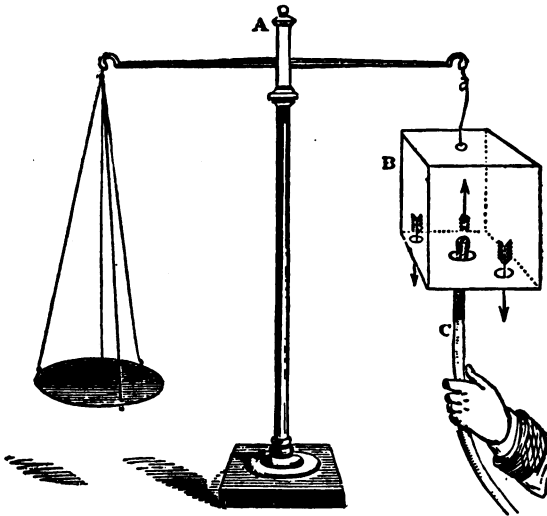

Fig. 94. A. The balance. B. The paper box, of a known capacity. C. Gas-pipe blowing in coal-gas, the arrows showing entrance of gas and exit of the air.

downward, and is filled by blowing in the coal gas until it issues from the apertures, and can be recognised by the smell. The rule in this case would be equally simple: as the known weight of the half or quarter cubic foot of common air is to the weight of the coal gas, so is 1.000 to the number required. (Fig. 94.)

As an illustration of the different specific weights of the gases, a small balloon, containing a mixture of hydrogen and air, may be so adjusted that it will just sink in a tall glass shade inverted and supported on a pad made of a piece of

oilcloth shaped round and bound with list. On passing in quickly a large quantity of carbonic acid, the little balloon will float on its surface; and if another balloon, containing only hydrogen, is held in the top part of the open shade, and a sheet of glass carefully slid over the open end, the density of the gases (although they are invisible) is perfectly indicated; and, as a climax to the experiment, a third balloon can be filled with laughing gas, and may be placed in the glass shade, taking care that the one full of pure hydrogen does not escape, owing to the lightness of the gas, which will cause it to ascend; the last balloon will sink to the bottom of the jar, because laughing gas is almost as heavy as carbonic acid, and the weight of the balloon will determine its descent. (Fig. 95.)

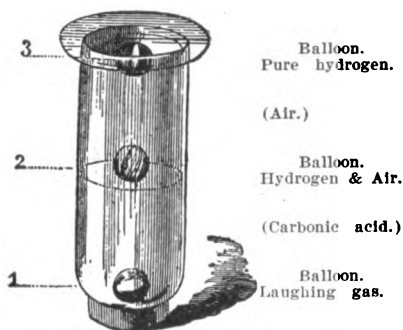

Fig. 95. Inverted large glass shade, containing half carbonic acid and half common air.

A soap-bubble will rest perfectly on a surface of carbonic acid gas, and the aërial and elastic cushion supports the bubble till it bursts. The experiment is best performed by taking a glass shade twelve inches broad and deep in proportion, and resting it on a pad; half a pound of sesqui-carbonate of soda is then placed in the vessel, and upon this is poured a mixture of half a pint of

oil of vitriol and half a pint of water, the latter being previously mixed and allowed to cool before use. An enormous quantity of carbonic acid gas is suddenly generated, and rising to the edge, overflows at the top of the glass shade. A well-formed soap-bubble detached neatly from the end of a glass-tube, oscillates gently on the surface of the heavy gas, and presents a most curious and pleasing appearance. (Fig. 96.) The soapy water is prepared by cutting a few pieces of yellow soap, and placing them in a two-ounce bottle containing distilled water with a little glycerine. (See pages 145 and 151.) The specific gravity of the gases may therefore be either greater or less than

atmospheric air, which has been already mentioned as the standard of comparison, and examined by this test the vapours of some of the compounds of carbon and hydrogen are found to possess a remarkably high gravity; in proof of which, the vapour of ether may be adduced as an example, although it does not consist only of the two elements mentioned, but contains a certain quantity of oxygen. In a cylindrical tin vessel, two feet high and one foot in diameter, place an ordinary hot-water plate, of course full of boiling water; upon this warm surface pour about half an ounce

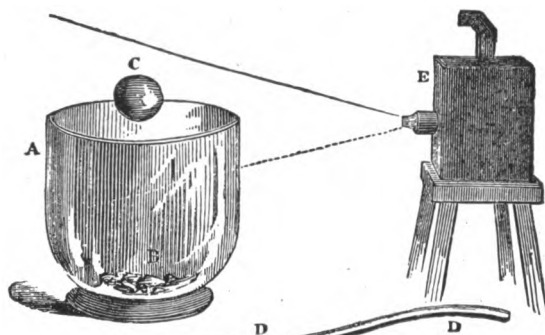

Fig. 96. A. Inverted glass shade, containing the material, B, for generating carbonic acid gas. C. The soap-bubble. D D. The glass tube for blowing the bubbles. E. Small lantern, to throw a bright beam of light from the oxy-hydrogen jet upon the thin soap-bubble, which then displays the most beautiful iridescent colours.

of the best ether; and, after waiting a few minutes until the whole is converted into vapour, take a syphon made of half-inch glass tube, and warm it by pouring through it a little hot water, taking care to allow the water to drain away from it before use. After placing the syphon in the tin vessel, a light may be applied to the extremity of the long leg outside the tin vessel, to show that no ether is passing over until the air is sucked out as with the water-syphon; after this has been done, several warm glass vessels may be filled with this heavy vapour of ether, which burns on the application of flame. Finally, the remainder of the vapour may be burnt at the end of the syphon tube; demonstrating in the most satisfactory manner that the vapour is flowing through the syphon just as spirit is often removed by the distillers from the casks into the cellars of public-houses. (Fig. 97, see also page 602.)



Before dismissing the important subject of specific gravity (or, as it is termed by the French *savants*, "density"), it may be as well to state that astronomers have been enabled, by taking the density of the earth and by astronomical observations, to calculate the gravity of the planets belonging to our solar system; and it is interesting to observe that the

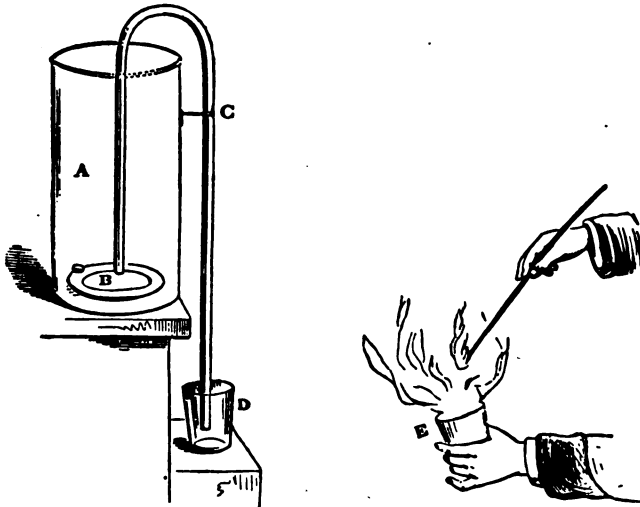

Fig. 97. A. Tin vessel containing the hot-water plate, B, upon which the ether is poured. C. The siphon. D. Glass to receive the vapour. E. Combustion of the ether vapour in another vessel.

density of the planet Venus is the only one approaching the gravity of the earth:

The Earth .....	1.00
The Sun .....	0.25
The Moon .....	0.63
Mercury .....	1.26
Venus .....	0.92
Mars .....	0.45
Jupiter .....	0.23
Saturn .....	0.11
Uranus .....	0.25
Neptune .....	0.17

## CHAPTER VI

## ATTRACTION OF COHESION

In previous chapters one kind of attraction—viz., that of gravitation, has been discussed and illustrated in a popular manner, and pursuing the examination of the invisible, active, and real forces of nature, the attraction of cohesion will next engage our attention. There is a peculiar satisfaction in pursuing such investigations, because every step is attended by reasonable proof; there is no fantasy in scientific studies; the mind is not suddenly startled with that which seems more than natural; nor is it carried away in an ecstasy of wonder and awe.

It may be asked, how is cohesion defined? and the answer may be given, by directing attention to the three physical conditions of water, which assumes the form of ice, water, or steam.

In the Polar regions, and also in the Alpine and other mountains where glaciers exist, the traveller meets ice hundreds of feet in thickness. Here the withdrawal of a certain quantity of heat from the water evidently allows a new force to come into full play. We may call it what we like; but cohesion, from the Latin *cum*, together, and *hæreo*, I stick or cleave, appears to be the best and most rational term for this power which tends to make the atoms or particles of the same kind of matter move towards each other, and to prevent them being separated or moved asunder. That it is not merely hypothetical is shown by the following experiments.

If two pieces of lead are cast, and the ends well scraped, taking care not to touch the surfaces with the fingers, they may by simple pressure be made to cohere, and in that state of attraction may be lifted from the table by the ring which is usually inserted for convenience in the upper piece of lead; they may be hung for some time from a proper support, and the lower bit of lead will not break away from the upper one; at the first thought it may be considered that they form an air-tight joint, and are held together tightly by the mere pressure of the atmosphere, as in the next example; but such is not the case, for if the two adhering pieces are suspended in a bell-jar and a high vacuum created around them, the

lower weight is still firmly attached to the upper, which, of course, would not be possible were atmospheric pressure the sole cause. And when the union is broken by physical force,

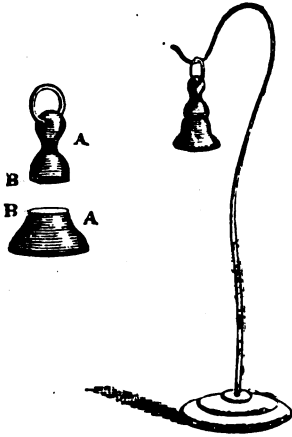

Fig. 98. A A. Two pieces of lead, scraped clean at the surfaces B B. C. Stand, supporting the two pieces of lead attached to each other by cohesion.

it is surprising to notice the limited number of points, like pin points, where the cohesion has occurred; whilst the weight of the lump of lead upheld against the force of gravitation reminds one forcibly of the attraction of a mass of soft iron by a powerful magnet. (Fig. 98.)

A fine example of the same force, but in this case due to atmospheric pressure, is shown in the pair of flat iron or steel surfaces, much used by engineers and called "surface plates." These surfaces are planed so true, that when placed upon each other, the upper will freely rotate when pushed round, in consequence of the thin film or air remaining between the surfaces, which acts like a cushion, and prevents the metallic cohesion. (Fig. A. 99.) When, however, the upper plate is

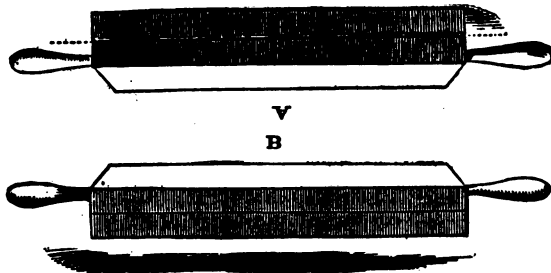

Fig. 99. A. Surface plates with film of air between them. B. Film of air excluded when cohesion occurs.

slid over the lower one gradually, so as to exclude the air, then the two may be lifted together, because cohesion has taken place. (Fig. B. 99.)

A glass vessel is a good example of cohesion. The mate-

rials of which it is composed have been soft and liquid when melted in the fire, and on the removal of the excess of heat it has become hard and solid, in consequence of the attractive force of cohesion binding the particles together; in the absence of such a power, of course the material would fall into the condition of dust, and a mere shapeless heap of silicates of potash and lead would indicate the place where the moulded and coherent glass would otherwise stand.

A lump of lead, six inches long by four broad, and half an inch thick, may be supported by dexterously taking off a thick shaving with a proper plane, and after pressing an inch or more of the strip on the planed surface of the large lump of lead, the cohesion is so powerful that the latter may be lifted from the table by the strip of metal. This is analogous to the experiment described on page 80, Fig. 98.

Bullets projected from a machine gun, even at the rate of three hundred per minute, are thrown with such violence, that, when received on a thick plate of lead backed up with sheet iron, a cold welding takes place between the two surfaces of metal in the most perfect manner, just as two soft pieces of the metal potassium may be squeezed and welded together. The surfaces of an apple torn asunder will not readily cohere, but if cut with a sharp knife, cohesion easily occurs; so with a wound produced by a jagged surface, it is difficult to make the parts heal, whereas some of the most desperate sabre-cuts have been healed, the cohesion of the surfaces of cut flesh being very rapid; hence, if the top of a finger is cut off, it may be replaced, and will grow, in consequence of the natural cohesion of the parts.

The art of plating copper with silver, which is afterwards gilt, and then drawn out into flattened wire for the manufacture of gold lace and epaulets, usually termed bullion, is another example of the wonderful cohesion of the particles of gold, of which a single grain may be extended over the finest plate wire measuring 1000 feet in length.

Other examples of cohesion are shown by icicles, stalactites and stalagmites; which last two are produced by the gradual dropping of water containing chalk (carbonate of lime) held in solution by the excess of carbonic acid gas; the solvent gradually evaporates, and leaves a series of calcareous films, which cohere in succession, producing the most fantastic

forms, as shown in various remarkable caverns, especially in the cave of Arta, in the island of Majorca, and in many of the mines and caverns of Derbyshire.

In metallic substances the cohesion of the particles assumes an important bearing in the question of relative toughness and power of resisting a strain; hence the term cohesion is modified into that of the property of "tenacity."

The tenacity of the different metals is determined by ascertaining the weight required to break wires of the same

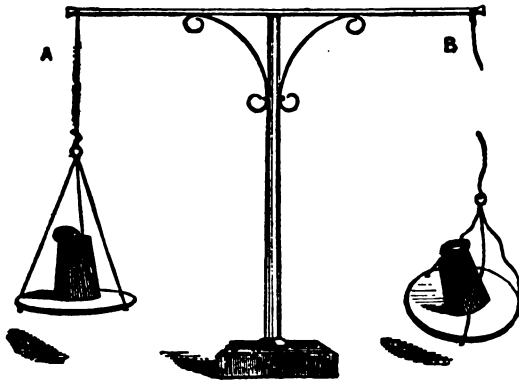

Fig. 100. B. Pan supported by leaden wire broken by a weight which the iron wire at A easily supports.

length and gauge. Iron possesses the property of tenacity in a great, and lead in a small degree. (Fig. 100.)

The strength of a continued cellular construction can be easily imagined, and may be well illustrated by a thin sheet of common tin plate. If the ends be rested on blocks of wood, so as to lap over the wood about one inch, they are easily displaced, and the mimic bridge broken down from its supports by the addition to the centre of a few ounce weights; whilst the same tin plate rolled up in the figure of a tube, and again rested on the same blocks, will now support many pounds' weight without bending or breaking down. (Fig. 101.)

Not the least of this remarkable power of cohesion is demonstrated in our own bodies every moment of our lives.

With these illustrations of cohesion we may return to the abstract consideration of this power with reference to water. in which we have noticed that the antagonist to this kind

of attraction is the force or power termed caloric or heat. The latter influence removes the frozen bands of winter and converts the ice to the next condition, water. In this state cohesion is almost concealed, although there is just a slight excess to hold even the particles of water in a state of unity, and this fact is beautifully illustrated by the formation of the brilliant diamond drops of dew on the surfaces of various leaves, as also in the force and power exercised by great

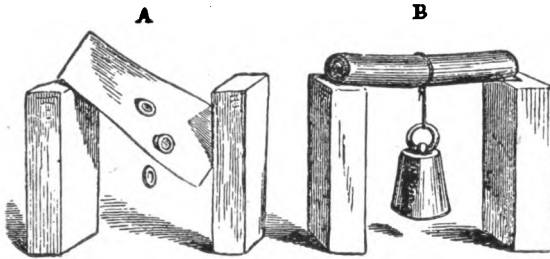

Fig. 101. A. Flat tin plate, breaking down with a few ounce weights. B. Same tin plate rolled up supports a very heavy weight.

volumes of water, which exert their mighty strength in the shape of breaker-waves, dashing against rocks and light-houses, and making them tremble to their very base by the violence of the shock; here there must be some unity of particles, or the collective strength could not be exerted; it would be like throwing a handful of sand against a window—a certain amount of noise is produced, but the glass is not fractured; whilst the same amount or weight of sand united by any glutinous material, would break its way through, and soon fracture the brittle glass. It is so usual to see the particles of water easily separated, that it becomes difficult to recognise the presence of cohesion; but this bond of union is well illustrated in the experiment of the water hammer. The little instrument is generally made of a glass tube with a bulb at one end; in this bulb the water which it contains is boiled, and as the steam issues from the other extremity, drawn out to a capillary tube, the opening is closed by fusion with the heat of a blowpipe flame. As the water cools the steam condenses, and a vacuum, so far as air is concerned, is produced; if now the tube is suddenly inverted, the whole

of the water falls *en masse*, collectively, and striking against the bottom of the tube, produces a metallic ring, just as if a piece of wood or metal were contained within the tube. If the end to which the water falls is not well cushioned by the palm of the hand, the water hammers itself through

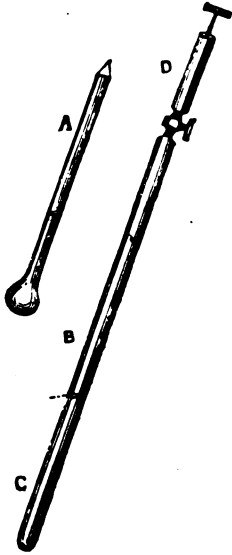

Fig. 102. A. Ordinary glass water hammer. B. Copper tube ditto, showing exhausting syringe at D, the height of the water at B, and the end to be placed in the fire, at C.

and breaks away that part of the glass tube. But this is of little moment, as such a tube with its bulb may be made in a few minutes, blown in ordinary glass tubing by any boy. For those who do not mind expense, it is, of course, better to construct the water hammer of copper tube, about three-quarters of an inch in diameter and three feet long; at one end a screw-piece is inserted, into which a tap is fitted; when the tube is filled to the height of about six inches with water, and shaken, the air divides the descending volume of water, and the ordinary splashing sound is heard; there is no unity or cohesion of the parts; if, however, the end of the copper tube is thrust into a fire and the water boiled so that steam issues from the open tap, which is then closed, and the tube removed and cooled, a smart blow is given, and distinctly heard when the copper tube is rapidly

inverted or shaken so as to cause the water to rise and fall. The experiment may be rendered still more instructive by turning the tap and admitting the air, which rushes in with a whizzing sound, and on shaking the tube the metallic ring is no longer heard, but it may be again restored by attaching a small air syringe or hand pump, and removing the air by exhaustion. (Fig. 102.)

In the fluid condition water still possesses a surplus of cohesion over the antagonistic force of heat; when, however, the latter is applied in excess, then the quasi-struggle terminates; the heat overpowers the cohesive attraction, and converts the water into the most willing slave which has ever lent

itself to the caprices of man—viz., into steam: and now the other end of the chain is reached, where heat triumphs; whilst in solids, such as ice, cohesion is the conqueror, and the intermediate link is displayed in the fluid state of water.

A good and striking experiment, displaying the change from the liquid to the vapour state, is shown by tying a piece of sheet caoutchouc over a tin vessel containing an ounce or two of water. When this boils, the india-rubber is distended, and breaks with a loud noise; or in another illustration, by pouring some ether through a funnel carefully into a flask placed in a ring stand. If flame is applied to the orifice, no vapour issues that will ignite, provided the neck of the flask has not been wetted with the ether. When, however, the heat of a spirit-lamp is applied, the ether soon boils, and now on the application of a lighted taper, a flame some feet in length is produced, which is regulated by the spirit-lamp below, and when this is removed, the length of the flame diminishes immediately, and is totally extinguished if the bottom of the flask is plunged into cold water; the withdrawal of the heat restores the power of cohesion. Another illustration of the vast power of steam is displayed in the steam hammer invented by Nasmyth. The progress of modern engineering rendered necessary the employment of some means of beating into shape the enormous masses of iron which are so largely used in constructive works. It is true that steam was applied to this purpose before Nasmyth took the matter up, but it was done in such a roundabout fashion, that very little advantage accrued thereby. Nasmyth's original steam hammer consisted of an anvil supported upon a very strong foundation of masonry. Above this anvil rose a huge arm supporting a steam cylinder—to the piston rod of which was attached a block of iron forming the head of the hammer. The steam was admitted below the piston to raise the hammer, and above it as it delivered its blow, the force of which was of course greatly augmented by the weight of the falling mass of iron.

Other hammers and presses worked by water (hydraulic) and electricity give different qualities and variation of result, though affording analogous illustration.



## CHAPTER VII

## ADHESIVE ATTRACTION

The term cohesion must not be confounded with that of adhesion, which refers to the clinging to or attraction of bodies of a dissimilar kind. Professor Daniell defined co-

hesion to be an attraction of homogeneous ( $\delta\mu\delta\varsigma$ , like, and  $\gamma\epsilon\upsilon\omicron\varsigma$  kind) or similar particles; adhesion to be an attraction subsiding between particles of a heterogeneous, ( $\epsilon\tau\epsilon\rho\omicron\varsigma$ , different, and  $\gamma\epsilon\upsilon\omicron\varsigma$ ) kind

There are numerous illustrations of adhesion, such as mending china, and the use of glue, or paste, in uniting different surfaces, and mortar or cement in building with bricks; it is also well shown at the lecture table by means of a pair of scales, one scale-pan of which being well cleaned with alkali at the bottom, may then be rested on the surface of water contained in a plate; the adhesion between the water and the metal is so perfect, that many grain weights may be placed in the other pan before the adhesion is broken; and after breakage, if the pan be again placed on the water, and a few grains removed from the other, so as to adjust the two pans, and make them nearly equal, a drop of oil of turpentine being added instantly spreads itself over the water, and breaking the adhesion between the latter and the metal, the scale-pan is immediately and again broken away, as the adhesion between the turpentine and the metal

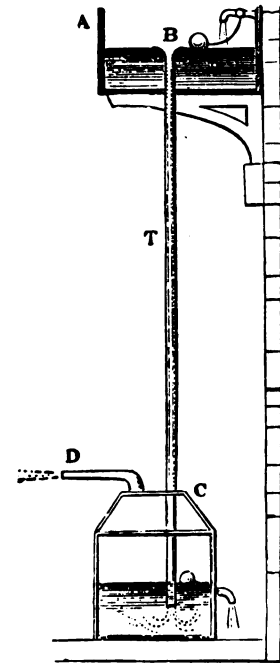

Fig. 103. Model of the apparatus for drawing down air. A, cistern of water, supplied by ball-tap, and kept at one level, so that the water just runs down the sides of the tube, and draws down the air in the centre. B C. The vessel to which the air and water are conveyed by a tube. T. There is another ball-tap to permit the waste water to run away when it reaches a certain level; the end of the pipe always dips some inches into this water, whilst the air escapes from the jet, D.

is not so great as that of water and metal. The adhesion of air and water is well displayed in an apparatus often used for

ventilating mines, in which a constant descending stream of water carries with it a quantity of air, which being disengaged, is then forced out of a proper orifice. The same kind of adhesion between air and water is displayed in the ancient and historic Spanish Catalan forge, where the blast was supplied to the iron furnace on a similar principle, but in this case advantage was taken of a natural cascade instead of an artificial fall of water through a pipe.

The adhesion of air and water becomes of some value when a river flows through a large and crowded city, because the water in its passage to and fro, must necessarily drag with it a continuous column of air, and assist in maintaining that constant agitation of the air which is desirable as a preventive to any accumulation of noxious air charged with fœtid odours arising from mud banks or from other causes. The fact of adhesion, existing between water and air, is readily shown by resting one end of a long tube, of at least one inch in diameter, on a block of wood one foot high, or on several bricks. If water is allowed to flow down the tube, so as to leave a sufficient space of air above it, the adhesion between the two ancient elements becomes apparent, directly a little smoke is produced, near the top end of the glass tube resting on the block of wood. The smoke, which has a greater tendency to rise than to fall, is dragged down the glass tube, and accompanies the water as it flows from the higher to the lower level. The same truth is also illustrated in horizontal troughs or tubes through which water is caused to flow. (Fig. 103, page 86.)

The adhesion between air and glass is so great, that it is absolutely necessary to boil the mercury in the tubes of the best barometers; and if this is not carefully attended to, the adhering air between the glass and mercury gradually ascends to, and destroys, the Torricellian vacuum at the top of the barometer tube. Even after the mercury is boiled, the air will creep up in course of years; and in order to prevent its passage between the glass and quicksilver, in some instances a platinum ring is welded on to the end of the glass tube, because mercury has the power of wetting or enfiling the metal platinum, and the two, being in close contact, as it were, close the only door by which the air could enter the barometer tube.

## CHAPTER VIII

## CAPILLARY ATTRACTION

This kind of attraction is termed capillary, in consequence of pores or tubes of a calibre or bore as fine as hair, attracting and retaining fluids.

If water is poured into a glass, the surface is not level, but cupped at the edges, where the solid glass exerts its adhesive attraction for the liquid, and draws it from the level. If the glass be reduced to a very narrow tube, having a hair-like bore, the attraction is so great that the water is retained in the tube, contrary to the force of gravitation. Two pieces of flat glass placed close together, and then opened like a book, draw up water between them, on the same principle. A mass of salt put on a plate containing a little water coloured with indigo displays this kind of attraction most perfectly, and the water is quickly drawn up, as shown by the blue colour on the salt. A little solution of the ammonio-sulphate of copper imparts a finer and more distinct blue colour to the salt. A small piece of dry mahogany or other short-grained wood one inch square, or less, placed in a saucer containing a little turpentine, is soon found to be wet with the oil at the top, which may then be set on fire, and will burn as on a wick.

Almost every kind of wood possesses capillary tubes and will float, on account of these minute vessels being filled with air; if, however, the air is withdrawn, then the wood sinks, and by boiling a small piece or slip of wood in water, and then placing it under the vacuum of an air pump in other cold water, it becomes so saturated that it will no longer float. A remarkable instance of the same kind is mentioned by Scoresby, the Arctic explorer and savant, in which a boat was pulled down by a whale to a great depth, in the ocean, and after coming to the surface it was found that the wood would neither swim nor burn, the capillary pores being entirely filled with salt water.

A piece of ebony sinks in water on account of its density, closeness, and freedom from air. A gauge made of a piece of oak, with a hole bored in it of one inch diameter, accurately receives a dry plug of willow wood which will not enter the orifice after it is wetted. Millstones are split by

inserting wedges of dry hard wood, which are afterwards wetted and swelled, and burst the stone asunder. One of the most curious instances of capillary attraction is shown in the currying of leather, a process which is intended to impart a softness and suppleness to the skin, in order that it may be rendered fit for the manufacture of boots, harness, machine bands, etc. The object of the currier is to fill the pores of the leather with oil, and as this cannot be done by merely smearing the surface, he prepares the way for the oil by wetting the leather thoroughly with water, and whilst the skin is damp, oil is rubbed on, and it is then exposed to the air; the water evaporates at ordinary temperatures, but oil does not; the consequence is that the pores of the leather give up the water, which disappears in evaporation, and the oil by capillary attraction is then drawn into the body of the leather; the oil in fact takes the place vacated by the water, and renders the material very supple, and to a considerable extent waterproof. In paper making, the pores of this material, unless filled up or sized, cause the ink to blot or spread by capillary attraction when writing on it and this same unsized paper is the blotting paper of commerce. The porosity of soils is one of the great desideratums of the skilful agriculturist, and drainage is intended to remove the excess of water which would fill the pores of the earth, to the exclusion of the more valuable dews and rains conveying nutritious matter derived from manures and the atmosphere.

A cane is an assemblage of small tubes, and if a piece of about six inches in length (cut off, of course, from the joints) be placed in a bottle of turpentine, the oil is drawn up and may be burnt at the top; it is on this principle that indestructible wicks of asbestos, and wire gauze rolled round a centre core, are used in spirit lamps. Oil, wax, and tallow, all rise by capillary attraction in the wicks to the flame, where they are boiled, converted into gas, and burnt.

The capillary attraction of skeins of cotton for water was known and appreciated by the old alchemists; and Geber, one of the most ancient of these pioneers of science, who lived about the seventh century, describes a filter by which the liquid is separated from the solid. This experiment is well displayed by putting a solution of acetate of lead into a glass, which is placed on the highest block of a series of

three, arranged as steps. Into this glass is placed the short end of a skein of lamp cotton, previously wetted with distilled water; the long end dips into another glass below, containing dilute sulphuric acid, and as the solution of lead passes into it, a solid white precipitate of sulphate of lead is formed; then another skein of wetted cotton is placed in this glass, the long end of which passes into the last glass, so

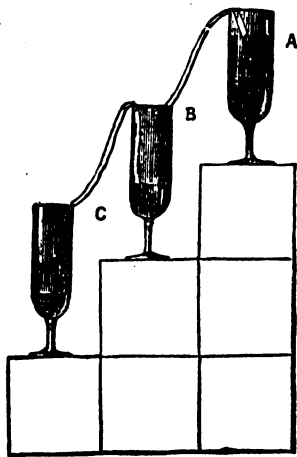

Fig. 104. Geber's filter. A. The solution of acetate of lead. B. The dilute sulphuric acid. C. The clear liquid, separated from the sulphate of lead in B.

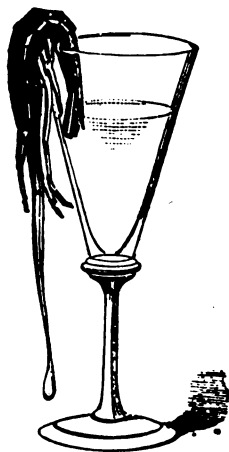

Fig. 105. Prawn syphon.

that the clear liquid is separated and the solid left behind. (Fig. 104.)

In this filter the lamp cotton acts as a syphon through the capillary pores which it forms. On the same principle, a prawn may be washed by placing the tail, after pulling off the fan part, in a tumbler of water, and allowing the head to hang over, when the water is drawn up by capillary attraction, and continues to run through the head. (Fig. 105.) The threads of which linen, cotton, and woollen cloths are made are small cords, and the shrinkage of such textile fabrics is well known and usually inquired about, when a purchase is made; here again capillary attraction is exerted, and the fabric contracts in the two directions of the warp and woof

threads; thus twenty-seven yards of common Irish linen will permanently shrink to about twenty-six yards in cold water. In these cases the water is attracted into the fibres of the textile material, and causing them to swell, must necessarily shorten their length, just as a dry rope strained between two walls for the purpose of supporting clothes, has been known to draw the hooks after being suddenly wetted and shortened by a shower of rain.

The capillarity of fabrics is also utilised commercially in many ways, especially in carrying moisture from place to place and in supplying constant degrees of this moisture to certain objects. For instance,—some seed growers sprinkle

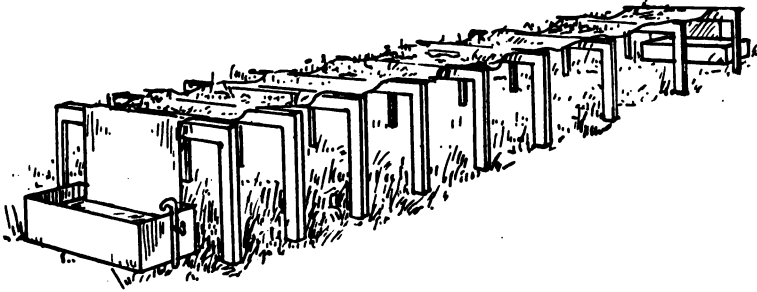

Fig. 106. Rows of posts supporting flannel on which seeds are germinating.

various seeds on long lengths of flannel supported on trestles, the ends of the fabric dipping into pails or troughs of water, thus keeping the material moist. The seeds, if healthy, germinate on the fabric and force their roots through it. Tons of seeds are annually tested in this way. (See Fig. 106.)

In order to tighten a bandage, it is only necessary to wind the dry linen round the limbs as close as possible, and then wet it with water, when the necessary shrinkage takes place.

If a piece of dry cotton cloth is tied over one end of a lamp glass, the other may be thrust into, or removed from a basin of water, which water enters and runs out easily, but when the cotton is wetted, the fibres contract and prevent air from entering, so that the glass retains water just as if it were an ordinary gas jar closed with a glass stopper.

A Spanish proverb, expressing contempt, says, "go to the well with a sieve," but even this seeming impossibility is sur-

mounted by using a cylinder of wire gauze, which may be filled with water, and by means of the capillary attraction between the meshes of the wire gauze and the water, the whole is retained, and may be carefully lifted from a basin of water; the experiment only succeeds when the air is completely driven out of the interstices of the gauze, and the little cylinder completely filled with water; this may be done by repeatedly sinking and drawing out the cylinder, or still more effectually, by first wetting it with alcohol and then dipping the cylinder in water.

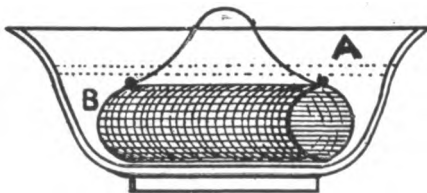

Fig. 107. A. Basin of water. B. Cylinder of wire gauze closed at both ends with gauze. When full of water it may be lifted from the basin by the handle.

A balloon, made of cotton cloth, cannot be inflated by means of a pair of bellows, but if the balloon is wetted with water, then it may be swelled out with air just as if it had been made of some air-tight material; hence the principle of varnishing silk or filling the pores with boiled oil, when it is required in the manufacture of balloons.

Biscuit ware, porous tubes for voltaic batteries, water coolers, etc., are all examples of the same principle.

Whilst speaking most favourably of the benevolent labours of many people who have erected drinking fountains in the dusty atmosphere and crowded streets of cities, it must not be forgotten that pious Mohammedans have, in bygone times, already set us the example in this respect; and in the palmy days of many of the Moorish cities, the thirsty citizen could always be refreshed by a draught of cool water from the porous bottle provided and endowed by charitable Mussulmans, and placed in the public streets. (See Fig. 108.)



Fig. 108. Moorish niche and porous earthenware bottle containing water.

CHAPTER IX  
CRYSTALLISATION

It has been already stated that the force of cohesion binds similar particles of substances together, whether they be *amorphous* or shapeless, or *crystalline* of a regular symmetrical and mathematical figure. The term crystal was originally applied by the ancients to silica in the form of what is usually termed rock crystal, or Brazilian pebble; and they supposed it to be water which had been solidified by a remarkable intensity of

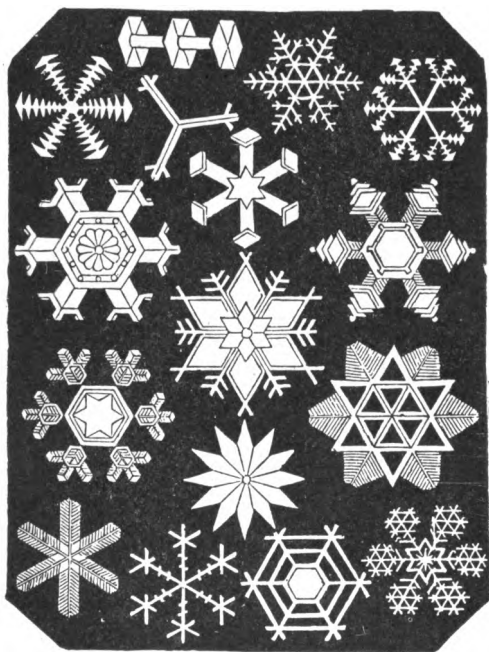

Fig. 109. Crystals of snow.

cold, and could not be thawed by any ordinary or summer heat. Indeed, this idea of the ancients has been embodied (to a certain extent) in the shape of artificial ice made by crystallising large quantities of sulphate of soda, which ice is made as flat as possible, for use in real-ice skating rinks at all seasons of the year. A crystal is now defined to be an inorganic body, which, by the operation of affinity, has assumed the



form of a regular solid terminated by a certain number of planes or smooth surfaces.

Thousands of minerals are discovered in the crystallised state—such as cubes of iron pyrites (sulphide of iron) and of fluor spar (fluoride of calcium), whilst numerous saline bodies called salts are sold only in the form of crystals. Of these salts we have excellent examples in Epsom salts (sulphate of magnesia), nitre (nitrate of potash), alum (sulphate of alumina), and potash; the term salt being applied specially to all substances composed of an acid and a base, as also to other combinations of elements which may or may not take a crystalline form. Thus, nitre is composed of nitric acid and potash; the first, even when much diluted, rapidly changes paper, dipped in tincture of litmus and stained blue, to a red colour, whilst potash shows its alkaline nature, by changing paper, stained yellow with tincture of turmeric, to a reddish-brown. The latter paper is restored to its original yellow by dipping it into the dilute nitric acid, whilst the litmus paper regains its delicate blue colour by being passed into the alkaline solution. An acid and an alkali combine and form a neutral salt, such as nitre, which has no action whatever on litmus or turmeric; whilst the element iodine, which is not an acid, unites with the metallic element potassium, forming a salt that crystallises in cubes called iodide of potassium. In aqueous or water solutions it has little or no action on turmeric paper, and when mixed with acids does not effervesce. Again, cane sugar, which is composed of charcoal, oxygen, and hydrogen, crystallises in hard transparent four-sided and irregular six-sided prisms, but is not called a salt. Silica or sand is found crystallised most perfectly in nature in six-sided pyramids, but is not a salt; it is an acid termed silicic-acid. Sand has no acid taste, because it is insoluble in water, but when melted in a crucible with an alkali, such as potash, it forms a salt called silicate of potash. Magnesia, from being insoluble, or nearly so, in water, is all but tasteless, and has barely any alkaline reaction, yet it is a very strong alkaline base; 20.7 parts of it neutralise as much sulphuric acid as 47 of potash. A salt is not always a crystallisable substance, and *vice versa*. The progress of our chemical knowledge has therefore demanded a wider extension and application of the term *salt*, and it is not now confined merely to a combination of an

acid and an alkali, but is conferred even on compounds consisting only of sulphur and a metal, which are termed *sulphur salts*.

So also to combinations of chlorine, iodine, bromine, and fluorine, with metallic bodies, the term *haloid salts* has been applied by Berzelius, from the Greek (*ἅλας*, sea salt, and *εἶδος* form), because they are analogous in constitution to sea salt; and the mention of sea salt again reminds us of the wide signification of the term salt, originally confined to this substance, but which may be extended into four great orders:

ORDER I. *The oxy-salts*.—This order includes no salt the acid or base of which is not an oxidised body (ex., nitrate of potash).

ORDER II. *The hydro-salts*.—This order includes no salt the acid or base of which does not contain hydrogen (ex., chloride of ammonium).

ORDER III. *The sulphur salts*.—This order includes no salt the electro-positive or negative ingredient of which is not a sulphur compound such as a sulphide (ex. hydrosulphide of potassium).

ORDER IV. *The haloid salts*.—This order includes no salt the electro-positive or negative ingredient of which is not haloidal. (Exs., iodide of potassium and sea salt.) To fix the idea of salt still better in the mind, it should be remembered that alabaster, of which works of art are constructed, or marble, or lime-stone, or chalk, are all salts, because they consist of an acid and a base.

In order to cause a substance to crystallise it is first necessary to endow the particles with freedom of motion. There are many methods of doing this chemically or by the application of heat, but we cannot by any mechanical process of concentration, compression, or division, persuade a substance to crystallise, unless perhaps we except that remarkable change in wrought or fibrous iron into crystalline or brittle iron, by constant vibration, as in the axles of a carriage, or by attaching a piece of fibrous iron to a tilt hammer.

If we powder some alum crystals they will not again assume their crystalline form; if brought in contact there is no freedom of motion. It is like placing some globules of mercury on a plate; these have no power to create motion; their inertia keeps them separated by certain distances,

and they do not coalesce; but incline the plate, give them motion, and bring them in contact, they soon unite and form one globule. The particles of alum are not in close contact, and they have no freedom of motion unless they are dissolved in water, when they become invisible; the water by its chemical power destroys the mechanical aggregation of the solid alum far beyond any operation of levigation. The solid alum has become liquid, like water; the particles are now free to move without let or hindrance from friction. A solution (from the Latin *solvo*, to loosen) is obtained. The alum must indeed be reduced to minute particles, as they are

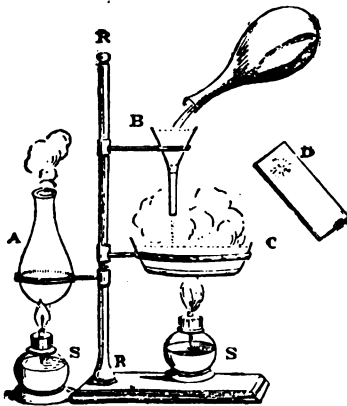

Fig. 110. R R. Ring-stand. S S. Spirit-lamps. A. Flask containing boiling solution of alum.—Solution. B. Funnel, with a bit of lamp-cotton stuffed in the bottom.—Filtration. C. Evaporating dish.—Evaporation. D. Drop on glass.—Crystallisation.

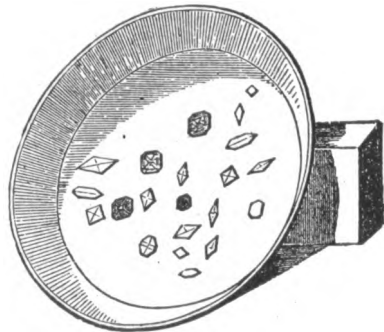

Fig. 111.

alike invisible to the eye whether assisted by the microscope or not. No repose will cause the alum to separate; the solvent power of the water opposes gravitation; every part of the solution is equally impregnated with alum, and the particles are diffused at equal distances through the water; the heavy alum is actually drawn up against gravity by the water.

How, then, is the alum to be brought back again to the solid state? The answer is simple enough. By evaporating away the excess of water, either by the application of heat or by long exposure to the atmosphere in a very shallow ves-

sel, the minute atoms of the alum are brought closer together, and crystallisation takes place. The assumption of the solid state is indicated by the formation of a thin film (called a *pellicle*) of crystals, and is further and still more satisfactorily proved by taking out a drop of the solution and placing it on a bit of glass, which rapidly becomes filled with crystals if the evaporation has been carried sufficiently far. (Fig. 110.)

After evaporating away sufficient water, the dish is placed on one side and allowed to cool, when crystals of the utmost regularity of form are produced, and, denoted by a geometrical term, are called octohedral or eight-sided crystals, when in the utmost state of perfection. (Fig. 111.)

The science of crystallography is too elaborate to be discussed at length here; the terms connected with crystals will therefore only be explained, and experiments given in illustration of the formation of various crystals.

When the apices—*i. e.*, the tips or points of crystals—are cut off, they are said to be truncated; and the same change occurs on the edges of numerous crystals.

If some of the salt called chloride of calcium in the dry and amorphous state is exposed to the air, it soon absorbs water, or what is termed *deliquesces*: the same thing occurs with the crystals of carbonate of potash, and if an ounce is weighed out in an evaporating dish, and then exposed for about half an hour to the air, a very perceptible increase in weight is observed by the assistance of the scales and grain weights. *Deliquescence* is a term from the Latin *deliqueo*, to melt, and is in fact a gradual melting, caused by the absorption of water from the atmosphere. The reverse of this is illustrated with various crystals, such as Glauber's salt (sulphate of soda), or common washing soda (carbonate of soda); if a fine clear crystal is taken out of the solution, called the mother liquor, in which it has been crystallised, wiped dry, and placed under a glass shade, this salt may remain for a long period without change, but if it receive one scratch from a pin, the door is opened apparently for the escape of the water which it contains, chemically united with the salt, and called water of crystallisation; the white crystal gradually swells out, the little *quasi* sore from the pin-scratch spreads over the whole, which becomes opaque, and crumbling down falls into a shapeless mass of white dust; this

change is called *efflorescence*, from *effloresco*, to blow as a flower—caused by the abstraction from them of chemically-combined water by the atmosphere. With reference to the preservation of crystals, these should be oiled and wiped, and placed under a glass shade, if of a deliquescent nature; or if efflorescent, they are perfectly preserved by placing them under a glass shade with a little water in a cup to keep the air charged with moisture and prevent any drying up of the crystal.

Deliquescent crystals may be preserved by placing them, when dry, in naphtha, or any liquor in which they are perfectly insoluble. Some salts, like Glauber's salt, contain so much water of crystallisation that when subjected to heat they melt and dissolve in it, and this liquefaction of the solid crystal is called "watery fusion." Other salts, such as bay salt, chlorate of potash, etc., when heated, fly to pieces, with a sharp crackling noise, which is due sometimes, to the unequal expansion of the crystalline surface, or the sudden conversion of the water (retained in the crystal by capillary attraction) into steam; thus nitre behaves in this manner, and frequently retains water in capillary fissures, although it is an anhydrous salt, or salt perfectly free from combined water. The crackling sound is called *decrepitation*, and is well illustrated by throwing a little bay salt on a clear fire; but this property is destroyed by powdering the crystals.

Many substances when melted and slowly cooled concrete into the most perfect crystals; in these cases heat alone, the antagonist to cohesion, is the solvent power. Thus, bismuth may be melted in a crucible, and when cooling, and just as the pellicle (from *pellis*, a skin or crust) is forming on the surface, two small holes should be instantly made by a rod of iron and the liquid metal poured out from the inside, one of the holes being for the entrance of air, the other for the exit of the metal; on carefully breaking the crucible, the bismuth will be found to be crystallised in the most lovely cubes. Sulphur, again, may be crystallised in prismatic crystals by pursuing a similar plan; and the great blocks of spermaceti exhibited by chemists in their windows, are crystallised in the interior and prepared on the same principle.

There are other modes of conferring the crystalline state upon substances—viz., by elevating them into a state of va-

pour by the process called sublimation (from *sublimis*, high or exalted), or the lifting up and condensation of the vapour in the upper part of a vessel; a process perfectly distinct from that of *distillation*, which means to separate drop by drop. Both of these processes are very ancient, and were invented by the Arabian alchemists long antecedent to the seventh century. Examples of sublimation are shown by heating iodine, and especially benzoic acid; with the latter, a good imitation of snow is produced, by receiving the vapour on some sprigs of holly or other evergreen, or imitation (paper) snow-drops and crocuses, placed under a glass vessel. The benzoic acid should first be sublimed over the sprigs or artificial flowers in a gas jar, which may be removed when the whole is cold, and a clear glass shade substituted for it. (Fig. 112.)

All electro deposits on metals are more or less crystalline; and copper or silver may be deposited in a crystalline form by placing a scraped stick of phosphorus in a solution of sulphate of copper or of nitrate of silver. The phosphorus takes away the oxygen from the metal, or deoxidises the solution, and the copper or silver reappears in the metallic form. The surface of the phosphorus must not be scraped in the air, but under water, when the operation is perfectly safe.

A singular and almost instantaneous crystallisation can be produced by saturating boiling water with Glauber's salt, of which one ounce and a half of water will usually dissolve about two ounces; having done this, pour the solution, whilst boiling hot, into clean oil flasks, or vials of any kind, previously warmed in the oven, and immediately

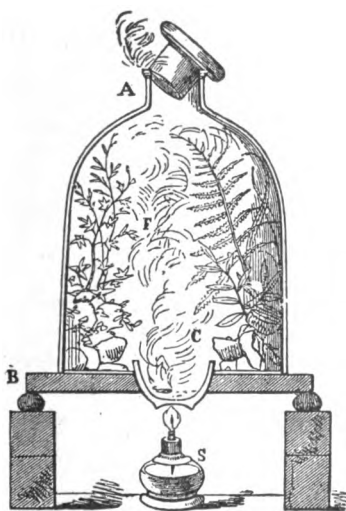

Fig. 112. A. Gas-jar, with stopper open at first, to be shut when the lamp is withdrawn. B. Wooden stand, with hole to carry the cup C, containing the benzoic acid, heated below by the spirit-lamp, S. F. Flowers or sprigs arranged on pieces of rock or mineral.

kind, previously warmed in

cork them, or tie strips of wetted bladder over the orifices of the flasks or vials, or pour into the neck a small quantity of olive oil, or close the neck with a cork through which a thermometer tube has been passed. When cool, no crystallisation occurs until atmospheric air is admitted; and it was formerly believed that the pressure of the air effected this object, until someone thought of the oil, and now the theory is modified, and crystallisation is supposed to occur in consequence of the water dissolving some air which causes the deposit of a minute crystal, and this being the turning point, the whole becomes solid. However the fact may be explained, it is certain that when the liquid refuses to crystallise on the admission of air, the solidification occurs directly a minute crystal of sulphate of soda, or Glauber's salt, is dropped into the vessel

When the crystallisation is accomplished, the whole mass is usually so completely solidified, that on inverting the vessel, not a drop of liquid falls out.

It may be observed that the same mass of salt will answer the same purpose any number of times. All that is necessary to be done, is to place the vial or flask in a saucupan of warm water, which gradually raise to the boiling point till the salt is completely liquefied, when the vessel must be corked and secured from the air as before. When the solidification is produced much heat is generated, which is rendered apparent by means of a thermometer, or by the insertion of a copper wire into the pasty mass of crystal in the flask, and then touching with it an extremely thin shaving or cutting of phosphorus, dried and placed on cotton wool, when the phosphorus will be set on fire by the added heat, slight as this may seem to be to all appearances. Solidification in all cases produces heat. Liquefaction produces cold.

The freezing apparatus illustrated below is a very old-fashioned variety, but extremely effective, and has the advantage of being such as any boy can make from tin or other tubes and tin scraps, utilising an old coffeepot or saucupan for the outer vessel, or better still an old wood bucket or box. In this apparatus certain measured quantities of crystallised salammoniac, nitre, and nitrate of ammonia, are placed in the outer vessel B. B., and about half a pint of

drinking water in the inner tin tube A; the mixture in the outer vessel may then have added to it some cold water, taking care not to fill it so high that any runs into the inner vessel. Close the lid and cover all up with a blanket or thick cloth for a few minutes, after which the inner cylinder will be filled with solid ice. This will adhere to the tin which should now be placed in warm water so as to thaw it gently out, just sufficiently to melt that portion of the ice which adheres to the metallic surface. The core or plug of ice may now be slipped out readily and placed in any convenient vessel ready to receive it, after the cap on the bottom of A is removed. (Fig. 113.) (See also p. 601.)

For an ingenious method of obtaining large and perfect crystals of almost any size, experimentalists are indebted to Le Blanc. His method consists in first procuring small and perfect crystals,—say, octohedra of alum—then placing them

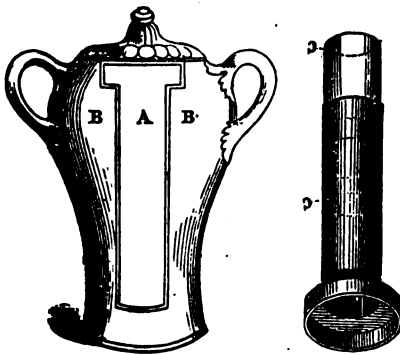

Fig. 113. A. The inner cylinder which contains the water. B B. The outer one containing the mixture. C C. The ice slipping away from the inner cylinder after the cap on the bottom of A is removed. (See also p. 601.)

in a broad flat-bottomed pan, he poured over the crystals a quantity of saturated solution of alum obtained by evaporating a solution of alum until a drop taken out crystallised on cooling. The positions of the crystals must be altered at least once a day with a glass rod, so that all the faces may be alternately exposed to the action of the solution, for the side

on which the crystal rests, or is in contact with the vessel never receives any increment. The crystals will thus gradually grow or increase in size, and when they have done so for some time, the best and most symmetrical may be removed and placed separately in vessels containing some of the same saturated solution of alum, and being constantly turned they may be obtained of almost any size desired.



Unless the crystals are removed to fresh solutions, a reaction takes place in consequence of the exhaustion of the alum from the water, and the crystal is attacked and dissolved. This action is first perceptible on the edges and angles of the crystal; they become blunted and gradually lose their shape altogether. By this method crystals may be made to grow in length or breadth—the former when they are placed upon their sides, the latter if they be made to stand upon their bases.

The sketch below affords an excellent illustration of some of Nature's remarkable concretions in the peculiar columnar structure of basalt.

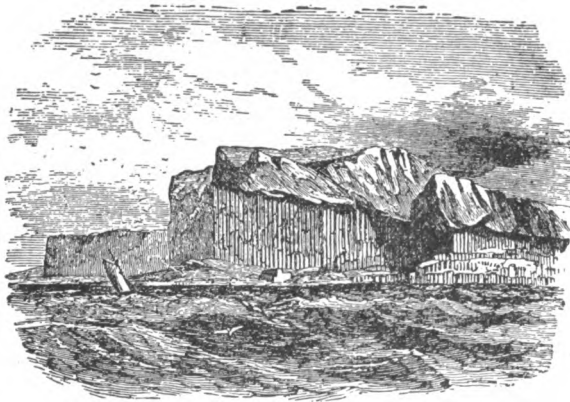
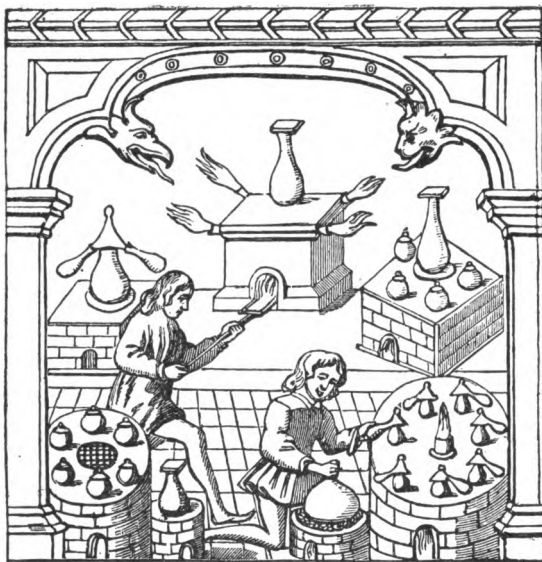

Fig. 114



Alchemists at work.  
(From an old print.)

## CHAPTER X

### CHEMISTRY

There is hardly any kind of knowledge which has been so slowly acquired as that of chemistry, and perhaps no other science has offered such fascinating rewards to the labour of its votaries as the *philosopher's stone*, which was to produce an unfailing supply of gold; or the *elixir of life*, that was to give the discoverer of the art of making gold the time, the prolonged life, in which he might spend and enjoy his precious metal.

A few thousand years ago Egypt was the great depository of all learning, art, and science, and it was to this ancient country that the most celebrated sages of antiquity travelled.

Hermes, or Mercurius Trismegistus, the favourite minister of the Egyptian king Osiris, has been celebrated as the inventor of the art of alchemy, and the first treatise upon it has been attributed to Zosymus, of Chemnis or Panopolis. The Moors who conquered Spain were remarkable for their learn-

ing, and for the taste and skill with which they designed and carried out a new style of architecture, with its beautiful Arabesque ornamentation. They were likewise great followers of the art of alchemy when they ceased to be conquerors and became more reconciled to the arts of peace. Strange that such a people, thirsting as they did in after years for all kinds of knowledge, should have destroyed, in the persons of their ancestors, the most numerous collection of books that the world had ever seen: the magnificent library of Alexandria, collected by the Ptolemies with great diligence and at an enormous expense, was burned by the orders of Caliph Omar; whilst it is stated that the alchemical works had been previously destroyed by Diocletian in the fourth century, lest the Egyptians should acquire by such means sufficient wealth to withstand the Roman power, for gold was then, as it is now, "the sinews of war."

Eastern historians relate the trouble and expense incurred by the succeeding Caliphs, who, resigning the Saracenic barbarism of their ancestors, were glad to collect from all parts the books which were to furnish forth a princely library at Baghdad. How the learned scholar sighs when he reads of seven hundred thousand books being consigned to the ignominious office of heating forty thousand baths in the capital of Egypt, and of the magnificent Alexandrian Library, a mental fuel for the lamp of learning in all ages, consumed in bath furnaces, and affording six months' fuel for that purpose. The Arabians, however, made amends for these barbarous deeds in succeeding centuries, and when all Europe was laid waste under the iron rule of the Goths, they became the protectors of philosophy and the promoters of its pursuits; and thus we come to the seventh century, in which lived Geber, an Arabian prince, stated to be the earliest of the true alchemists whose name has reached posterity.

Without attempting to fill up the alchemical history of the intervening centuries, we leap forward six hundred years, and now find ourselves in imagination in England, with the learned friar, Roger Bacon, a native of Somersetshire, who lived about the middle of the thirteenth century; and although the continued study of alchemy had not yet produced the "stone," it bore fruit in other discoveries, and Roger Bacon is said, with great appearance of truth, to have discov-

ered gunpowder, or at any rate, was the first in England to do so, for he says in one of his works:—"From saltpetre and *other* ingredients we are able to form a fire which will burn to any distance"; and again alluding to its effects, "a small portion of matter, about the size of the thumb, *properly disposed*, will make a tremendous sound and coruscation, by which cities and armies might be destroyed." (See page 180.) The exaggerated style seems to have been a favourite one with all philosophers, from the time of Roger Bacon to that of Muschenbroeck of the University of Leyden, who accidentally discovered the Leyden jar in the year 1746, and receiving the first shock, from a vial containing a little water into which vial a cork and nail had been fitted, states that he felt himself struck in his arms, shoulders, and breast, so that he lost his breath, and was *two days* before he recovered from the effects of the blow and the terror; adding, that he "would not take a *second* shock for the kingdom of France." Disregarding the numerous alchemical events occurring from the time of Roger Bacon we again advance four hundred years—viz., to the year 1662, when, on the 15th of July, King Charles II. granted a royal charter to the Philosophical Society of Oxford, which had removed to London, under the name of the Royal Society of London for Promoting Natural Knowledge, and in the year 1665 was published the first number of the *Philosophical Transactions*; this work contains the successive discoveries of Mayow, Hales, Black, Leslie, Cavendish, Lavoisier, Priestley, Davy, Faraday; and since the year 1762 has been regularly published. With this preface we now proceed to discuss some of the varied phenomena of chemical attraction, or what is more correctly termed

#### CHEMICAL AFFINITY.

The above title refers to an endless series of changes brought about by chemical combinations, all of which can be reduced to certain fixed laws, and admit of a simple classification and arrangement. A mechanical aggregation, or mixture, however well arranged, can be always distinguished from a chemical one. Thus, a grain of gunpowder consists of *nitre*, which can be washed away with boiling water, of *sulphur*, which can be sublimed and made to pass

away as vapour, of *charcoal*, which remains behind after the previous processes are complete; this mixture has been perfected by a careful proportion of the respective ingredients, it has been wetted, and ground, and pressed, granulated, and finally dried; all these mechanical processes have been so well carried out that each grain, if analysed, would be similar to any other grain; and yet it is, after all, only a mechanical aggregation, because the sulphur, the charcoal, and the nitre are unchanged. A grain of gunpowder moistened, crushed, and examined by a high microscopic power, would indicate the yellow particles of sulphur, the black parts of charcoal, whilst the water filtered from the grain of powder and dried, would show the nitre by the form of the crystal. On the other hand, if some nitre is fused at a dull red heat in a little crucible, and two or three grains of sulphur are added, they are rapidly oxidised, and combine with the potash, forming sulphate of potash; and after this change a few grains of charcoal may be added in a similar manner, when they burn brightly, and are oxidised and converted into carbonic acid, which also unites in like manner with the potash, forming carbonate of potash; so that when the fused nitre is cooled and a few particles examined by the microscope, the charcoal and sulphur are no longer distinguishable, they have undergone a chemical combination with portions of the nitre, and have produced two new salts, perfectly different in taste, gravity, and appearance from the original substances employed to produce them. Hence chemical combination is defined to be "*that property which is possessed by one or more substances, of uniting together and producing a third or other body perfectly different in its nature from either of the two or more generating the new compound.*"

To return to our first experiment with the gunpowder: take sulphur, place some in an iron ladle, heat it over a gas flame till it catches fire, then ascend a ladder, or pair of steps, and pour the sulphur gently, from the greatest height you can reach, into a pail of warm water: if this experiment is performed in a darkened room a magnificent and continuous stream of fire is obtained, of a blue colour, without a single break in its whole length, provided the ladle is gradually inclined and emptied. (See First Experiment, page 246.) The substance that drops into the warm water is no

longer yellow and hard, but is red, soft, and plastic; it is still sulphur, though it has taken a new form, because that element is dimorphous ( $\delta\iota\varsigma$  twice, and  $\mu\omicron\rho\rho\phi\eta$  a form), and, Proteus-like, can assume two forms. Some, however, consider this polymorphous since it has a number of modifications of crystalline structure. Take another ladle, and melt some nitre in it at a dull red heat, then add a small quantity of sulphur, which will burn as before; and now, after waiting a few minutes, repeat the same experiment by pouring the liquid from the steps through the air into water; observe it no longer flames, and the substance received into the water is not red and soft and plastic, but is white, or nearly so, and rapidly dissolves away in the water. The sulphur has united with the oxygen of the nitre and formed sulphuric acid, which combines with the potash and forms sulphate of potash; here, then, oxygen, sulphur, and potassium, have united and formed a salt in which the separate properties of the three bodies have completely disappeared; to prove this, it is only necessary to dissolve the sulphate of potash in water, and after filtering the solution, or allowing it to settle till it becomes quite clear and bright, some solution of baryta may now be added, when a white precipitate is thrown down, consisting of sulphate of baryta, which is insoluble in nitric or other strong acids. The behaviour of a solution of sulphate of potash with a nitrate of baryta may now be contrasted with that of the elements it contains; on the addition of sulphur to a solution of nitrate of baryta no change whatever takes place, because the sulphur is perfectly insoluble. If a stream of oxygen gas is passed from a cylinder and jet through the same test, no effect is produced; the nitrate of baryta has already acquired its full proportion of oxygen, and no further addition has any power to change its nature; finally, if a bit of the metal potassium is placed in the solution of nitrate of baryta it does not sink, being lighter than water, and it takes fire; but this is not in any way connected with the presence of the test, as the same thing will happen if another bit of the metal is placed in water—it is the oxygen of the latter which unites rapidly with the potassium, and causes it to become so hot that the hydrogen, escaping around the little red-hot globules, takes fire; moreover, the fact of the combustion of the potas-

sium under such circumstances is another striking proof of the opposite qualities of the three elements—sulphur, oxygen, and potassium—as compared with the three chemically combined and forming sulphate of potash. The same kind of experiment may be repeated with charcoal; if some powdered charcoal is made red-hot, and then puffed into the air with a blowing machine, numbers of sparks are produced, and the charcoal burns away and forms carbonic acid gas, a little ash being left behind; but if some more nitre be heated in a ladle, and charcoal added, a brilliant deflagration (*deflagro*, to burn) occurs, and the charcoal, instead of passing away in the air as carbonic acid, is now retained in the same shape, but firmly and chemically united with the potash of the nitre, forming carbonate of potash, or pearl-ash, which is not black and insoluble in water and acids like charcoal, but is white, and not only soluble in water, but is most rapidly attacked by acids with effervescence, and the carbon escapes in the form of carbonic acid gas. Thus we have traced out the distinction between mechanical mixture and chemical combination, taking for an example the difference between gunpowder as a whole (in which the ingredients are so nicely balanced that it is almost a chemical combination), and its constituents, sulphur, charcoal, and nitre, when they are chemically combined; or, in briefer language, we have noticed the difference between the mechanical mixture, and some of the chemical combinations, of three important elements. Our very slight and partial examination of three simple bodies does not, however, afford us any deep insight into the principles of chemistry; we have, as it were, only mastered the signification of a few words in a language; we might know that *chien* was the French for dog, or *cheval* horse, or *homme* man; but that knowledge would not be the acquisition of the French language, because we must first know the alphabet, and then the combination of these letters into words; we must also acquire a knowledge of the proper arrangement of these words into correct sentences, before claiming to be French scholars: so it is with chemistry—any number of isolated experiments with various chemical substances would be comparatively useless, and therefore the “alphabet of chemistry,” or “table of simple elements,” must first be acquired. The elementary bodies are under-

stood to be solids, fluids, and gases, which have hitherto defied the most elaborate means employed to reduce them into more than one kind of matter. Even pure light is separable into three parts—red, yellow, blue to indigo, which as they blend form four other colours—orange, green, violet—seven in all; which, in the spectrum, appear in the following order: red, orange, yellow, green, blue, indigo, violet; (see pages 221, 497, for primaries of “light” and “pigments”); but the elements we shall now enumerate are not of a compound, but, so far as we know, of an absolutely simple or single nature; they represent the boundaries, not the finality, of the knowledge that may be acquired respecting them.

The elements are now eighty-two in number, of which many are tolerably plentiful, and therefore common; whilst the remainder are comparatively rare, and for that reason of a lesser utility: whenever Nature employs an element on a grand scale it may certainly be called common, though all of them work for the common good and fulfil most important offices.

A few words will suffice to explain the meaning of the terms which head the names, letters, and numbers of the Table of Elements. These names have very interesting derivations, which it is not the object of this work to go into; the symbols are abbreviations, ciphers of the simplest kind, to save time and trouble in the frequent repetition of long words, just as the signs + plus, and — minus, are used in algebraic formulæ. For instance—the constant recurrence of water in chemical combinations must be named, and would involve the most tedious repetition; water consists of oxygen and hydrogen, and by taking the first letter of each word we have an instructive symbol, which not only gives us an abbreviated term for water, but also imparts at once a knowledge of its composition by the use of the letters,  $H_2O$ .

Again, to take a more complex example, such as would occur in the study of organic chemistry—a sentence such as *anhydrous oxide of acetyl* is written at once by  $C_4H_6O_3$ , the figures referring to the number of equivalents of each element—viz., 4 equivalents of C, the symbol of carbon, 6 of H (hydrogen), and 3 of O (oxygen).

The long word Naphthylamine, a substance contained in coal tar, is disposed of at once with the symbols and figures  $C_{10}H_9N$ .



## CLASSIFICATION OF THE ALPHABET OF CHEMISTRY

Compiled from "International Atomic Weights, 1912."

Name.	Symbol.	Combining proportion or atomic weight.	Name.	Symbol.	Combining proportion or atomic weight.
<b>O=16.</b>			<b>O=16.</b>		
1 Aluminium	Al	27.1	42 Molybdenum	Mo	96.0
2 Antimony	Sb	120.2	43 Neodymium	Nd	144.3
3 Argon	A	39.88	44 Neon	Ne	20.2
4 Arsenic	As	74.96	45 Nickel	Ni	58.68
5 Barium	Ba	137.37	46 Niton (radium emanation)	Nt	222.4
6 Bismuth	Bi	208.0	47 Nitrogen	N	14.01
7 Boron	B	11.0	48 Osmium	Os	190.9
8 Bromine	Br	79.92	49 Oxygen	O	16.00
9 Cadmium	Cd	112.40	50 Palladium	Pd	106.7
10 Cæsium	Cs	132.81	51 Phosphorus	P	31.04
11 Calcium	Ca	40.07	52 Platinum	Pt	195.2
12 Carbon	C	12.00	53 Potassium	K	39.10
13 Cerium	Ce	140.25	54 Praseodymium	Pr	140.6
14 Chlorine	Cl	35.46	55 Radium	Ra	226.4
15 Chromium	Cr	52.0	56 Rhodium	Rh	102.9
16 Cobalt	Co	58.97	57 Rubidium	Rb	85.45
17 Columbium	Cb	93.5	58 Ruthenium	Ru	101.7
18 Copper	Cu	63.57	59 Samarium	Sa	150.4
19 Dysprosium	Dy	162.5	60 Scandium	Sc	44.1
20 Erbium	Er	167.7	61 Selenium	Se	79.2
21 Europium	Eu	152.0	62 Silicon	Si	28.3
22 Fluorine	F	19.0	63 Silver	Ag	107.88
23 Gadolinium	Gd	157.3	64 Sodium	Na	23.00
24 Gallium	Ga	69.9	65 Strontium	Sr	87.63
25 Germanium	Ge	72.5	66 Sulphur	S	32.07
26 Glucinum	Gl	9.1	67 Tantalum	Ta	181.5
27 Gold	Au	197.2	68 Tellurium	Te	127.5
28 Helium	He	3.99	69 Terbium	Tb	159.2
29 Hydrogen	H	1.008	70 Thallium	Tl	204.0
30 Indium	In	114.8	71 Thorium	Th	232.0
31 Iodine	I	126.92	72 Thulium	Tm	168.5
32 Iridium	Ir	193.1	73 Tin	Sn	119.0
33 Iron	Fe	55.84	74 Titanium	Ti	48.1
34 Krypton	Kr	82.92	75 Tungsten	W	184.0
35 Lanthanum	La	139.0	76 Uranium	U	238.5
36 Lead	Pb	207.10	77 Vanadium	V	51.0
37 Lithium	Li	6.94	78 Xenon	Xe	130.2
38 Lutecium	Lu	174.0	79 Ytterbium (Neoytterbium)	Yb	172.0
39 Magnesium	Mg	24.32	80 Yttrium	Yt	89.0
40 Manganese	Mn	54.93	81 Zinc	Zn	65.37
41 Mercury	Hg	200.6	82 Zirconium	Zr	90.6

The figures in the third column are, however, the most interesting to the precise and mathematically exact chemist. They represent the united labours of the most painstaking and learned chemists, and are the exact quantities in which the various elements unite. To quote one example: if 16 parts by weight of oxygen—viz., the combining proportions of that element—are united with 2 parts by weight of hydrogen, also its combining number, the result will be 18 parts by weight of water; but if 16 parts of oxygen and 3 parts of hydrogen were used, two only of the latter could unite with the former, and the result would be the formation again of 18 parts of water, with an overplus of 1 equivalent of hydrogen.

It is useless to multiply examples, and it is sufficient to know that with this table of numbers the figures of analysis are obtained. Supposing a substance contained 54 parts of water, and the oxygen in this had to be determined, the rule of proportion would give it at once,  $18:54::16:48$ . 18 parts of water are to 54 parts as 16 of oxygen (the quantity contained in 18 parts of water) are to the answer required—viz., 48 of oxygen. The names, symbols, and combining proportions being understood, we may now proceed with the performance of many interesting

#### CHEMICAL EXPERIMENTS

The three gases, O, H and N, will first engage our attention, beginning with the element oxygen—Symbol O, combining proportion 16. There is nothing can give a better idea of the enormous quantity of oxygen present in the animal, vegetable, and mineral kingdoms, than the statement that it represents *one-third* of the weight of the whole crust of the globe. Silica, or flint, contains about half its weight of oxygen; lime contains forty per cent.; alumina about thirty-three per cent. In these substances the element oxygen remains inactive and powerless, chained by the strong fetters of chemical affinity to the silicium of the flint, the calcium of the lime, and the aluminum of the alumina. If these substances are heated by themselves they will not yield up the large quantity of oxygen they contain.

Nature, however, is prodigal in her creation, and hence we have but to pursue our search diligently to find a substance

or mineral containing an abundance of oxygen, part of which it will relinquish by what used to be called by the "old alchemists" the *torture* of heat. Such a mineral is the black oxide of manganese, or more correctly the dioxide of manganese,  $MnO_2$ , which consists of one combining proportion of the metal manganese—viz., 54.93, and two of oxygen—viz.,  $16 \times 2 = 32$ . If three proportions of the dioxide of manganese are heated to redness in an iron retort, they yield one proportion of oxygen, and all that has just been explained by so many words is comprehended in the symbols and figures below:—

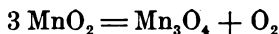

Thus the  $3MnO_2$  represents the three proportions of the dioxide of manganese before heat is applied, whilst the sign =, the sign of equation (equal to), is intended to show that the elements or compounds placed *before* it produce those which *follow* it; hence the sequel  $Mn_3O_4 + O_2$  shows that another compound of the metal and oxygen is produced, whilst the  $+ O_2$  indicates the liberated oxygen gas.

This oxygen gas is a marvellous body; it is altogether inodorous and without taste; it has a wonderful capacity for entering into combination with anything and everything, almost, and there are few things in nature in which it does not appear in a greater or lesser degree.

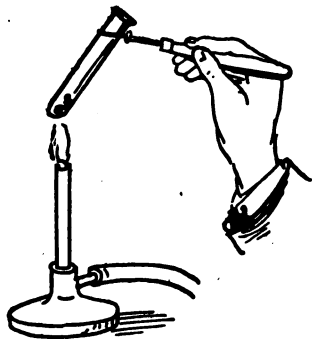

Fig. 115. Burner with test tube for the generation of a small quantity of oxygen gas.

Oxygen is non-inflammable, though it is an excellent supporter of combustion, as will be seen during the course of the experiments with this gas. So penetrating and abundant is it that it attacks almost all substances, oxidising them with more or less rapidity, which can

only be prevented, in many cases, by the total exclusion of air.

On a very small scale, the gas may be prepared by heating a little chlorate of potash in a test-tube, when the small pieces of chlorate begin to crackle; see Fig. 115.

*First Experiment*

Those who can afford it may purchase a small cast-iron retort from the chemical appliance dealers for a few shillings, which will include about three feet of iron piping to screw in. The bottle is charged with dioxide of manganese and

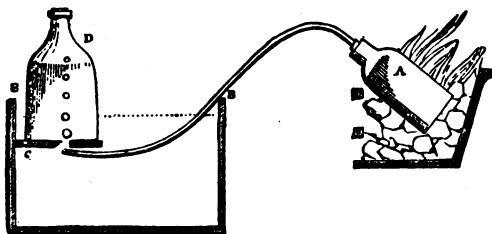

Fig. 116. A. The iron bottle, containing the black oxide of manganese, with pipe passing to the pneumatic trough, B B, in which is fixed a shelf, C, perforated with a hole, under which the end of the pipe is adjusted, and the gas passes into the gas-jar, D.

placed on a fire or on a gas-ring, the tubing being bent to fit nicely into a bottle through the shelf in a pneumatic trough, which may also be bought for a few shillings, or made in an evening out of an old biscuit tin, with the glass removed, a shelf with a hole in it soldered on the lid, then

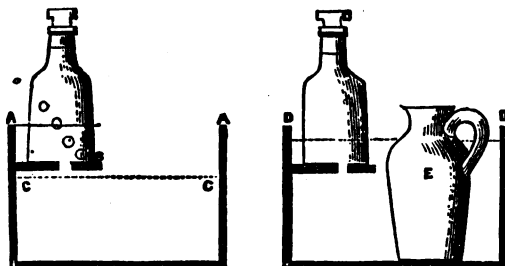

Fig. 117. A A. Pneumatic trough, with gas-jar raised to shelf; bubbles of air are rushing in at B, as the level of the water is below the shelf—viz., at C C. D D. Same trough and gas-jar with water kept over the shelf by the introduction of the stone pitcher, E, full of water.

the lid soldered down and the box made watertight. See Figs. 116 and 117. The iron retort employed to hold the mineral should be made of cast iron in preference to wrought iron, as the latter is very soon worn out by contact with oxygen at a red heat.

The oxygen is conveyed to the pneumatic trough. The gas jar must be filled with water by withdrawing the stopper and pressing it down into the trough, and when the neck is below the level of the water, the stopper is again inserted, and the jar with the water therein contained lifted steadily on to the shelf, the entry of atmospheric air being prevented by keeping the lower part of the gas jar, called the welt, under the water. Sometimes the pneumatic trough contains so small a quantity of water that on raising the gas jar to the shelf the liquid does not cover the bottom, and the air rushes up in large bubbles. In these circumstances it is better to provide a jug full of water, so that while the jar is being raised to the shelf the jug may be thrust into the trough (on the same principle as the crow adopted with the pitcher in the fable), and thus by its bulk (as the stones in the pitcher) raise the water to the proper level. When the gas jar is about half filled with gas the jug may be withdrawn. This arrangement saves the trouble of constantly adding and baling out water from the pneumatic trough. (Fig. 117.)

There are other solid oxygenised bodies in which the affinities are less powerful, hence a lower degree of heat suffices to liberate the oxygen gas, and one of the most useful in this respect is the salt termed chlorate of potash. If the substance is heated by itself, the temperature required to expel the oxygen is almost as high as that demanded for the black oxide of manganese; but, strange to say, if the two substances are reduced to powder, and mixed in equal quantities by weight, then a very moderate increase of heat is sufficient to cause the chlorate of potash to give up its oxygen, whilst the oxide of manganese undergoes no change whatever. It seems to fulfil only a mechanical office—possibly that of separating each particle of chlorate of potash from the other, so that the heat attacks the substance in detail, just as a solid square of infantry might on occasion possibly repel an attack, whilst the same body dispersed over a large space might be of little use; so with the chlorate of potash, which undergoes rapid decomposition when mixed with and divided amongst the particles of the oxide of manganese; less so with the red oxide of iron, and still less with sand or brick-dust. (Fig 118.)

A caution must here be given to boys to be sure to purchase their chemicals from some reliable dealer, and not necessarily to patronise the shop where they get most for their money. Generally speaking, this is a wise thing to do, but with regard to chemicals, exceptional quantity usually means adulteration, and adulteration in chemicals is dangerous. For instance, dioxide of manganese is very common, and cheap even when pure, yet it is often adulterated with

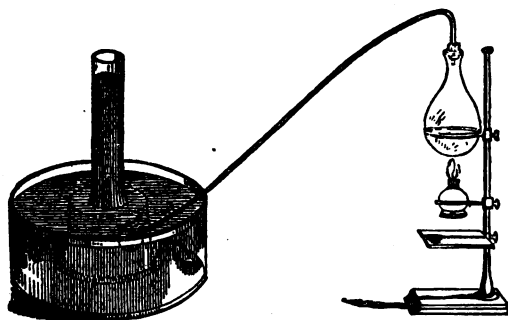
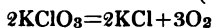

Fig. 118. Preparation of oxygen from { chlorate of potash,  
oxide of manganese.



fine coal dust. For many purposes for which this oxide is used, the presence of a little coal dust is of no moment, but if the manganese is heated with such a substance as chlorate of potash, evolving oxygen, or with hydrochloric acid, evolving chlorine gas, and the coal dust takes fire, it may explode, break the retort, whilst probably causing serious personal damage. As before remarked, the gentle heat causes the chlorate of potash to give up its oxygen, whilst the manganese suffers no loss, notwithstanding the great influence it has had on the potash.

This curious fact is usually explained by reference to what is called catalytic action, or *decomposition by contact* (*κατα*, downwards, and *λυω*, I unloosen), *being a power possessed by a body of resolving another into a new compound without undergoing any change itself*. To make this term still clearer, we may notice another example in linen rags, which may be exposed for any length of time to the action of water without fear of conversion into sugar; if, however, oil of vitriol is first added to the linen rags, and they are sub-

sequently digested at a proper temperature with water, then the rags are converted into sugar (the author has seen a specimen made of an "old shirt"); but, curious to relate, the oil of vitriol is unchanged in the process, and if the process be commenced with a pound of acid, the same quantity is discoverable at the end of the chemical decomposition of the linen rags, and their conversion into sugar.

#### SECOND EXPERIMENT

If a mixture of equal parts of oxide of manganese and chlorate of potash is placed in a clean Florence flask, with a cork and glass tube attached, great quantities of oxygen are quickly liberated on the application of the heat of a spirit lamp. Such a retort would cost about fourpence, and if the flask is broken in the operation it can be easily replaced by another, value one penny, as the same cork and tube will generally suit a number of these cheap glass vessels. Corks may always be softened by using either a proper cork squeezer,

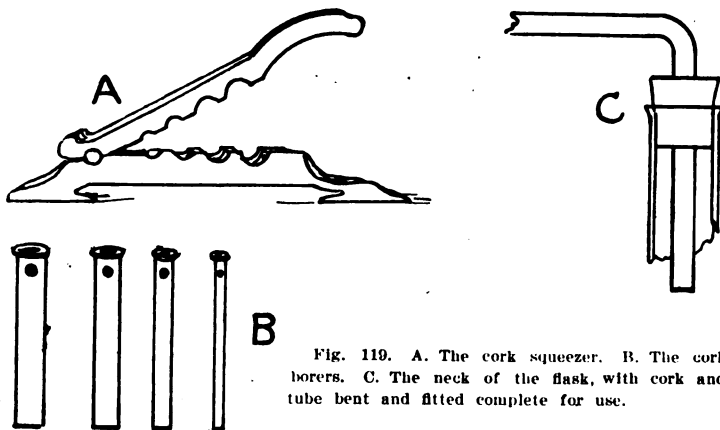

Fig. 119. A. The cork squeezer. B. The cork borers. C. The neck of the flask, with cork and tube bent and fitted complete for use.

or by placing them under a piece of board or a flat surface, and rolling and pressing them till quite elastic.

Whilst fitting the cork into the neck of a flask, it is perhaps safer to hold the thin and fragile vessel in a cloth, so that if the flask breaks the chemical experiment may not be arrested for many days by the severe cutting and wounding of the fingers. After the cork is fitted, it is to be removed from the flask and bored with a cork borer. This useful tool is

sold in complete sets to suit all sizes of glass tubes, and the glass being inserted, the flask and tube will be ready for use, provided the tube is bent to the proper curve. (Fig. 119, page 116.)

In order to bend glass tubing easily, without constriction of the bore, it should not be heated by bunsen burner, but in

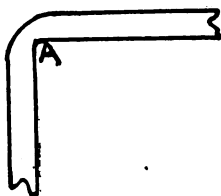

Fig. 120. Showing constriction at A in a badly bent pipe caused by heating in bunsen flame. (See figures 121 and 122.)

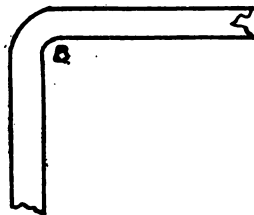

Fig. 121. This shows the equal calibre of the bend, B.

the luminous gas flame. The bunsen flame heats it too rapidly and the resultant bend is almost always as at A in Fig. 120, but if held over the ordinary gas flame so that the carbon deposits on a few inches of surface, as soon as the tube begins to feel limp, it may be withdrawn and bent to any desired angle with the bore perfectly uniform as at B,

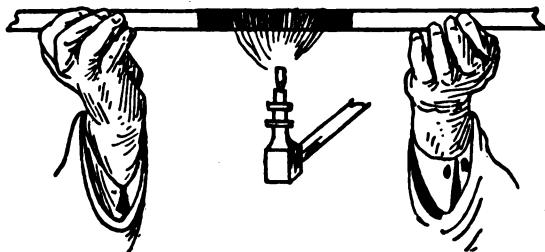

Fig. 122. Showing the position of the knuckles for very acute bends of tubing which should be continuously turned or rolled in the flame till it gives way slightly, when it may be bent as desired.

Fig. 121; the blackened coating may be wiped off when the tubing is cold. Fig. 122, will show the proper manner in which the tubing should be held in the fingers and the correct placing of the thumbs.

Having filled a gas jar with oxygen it may be removed from the pneumatic trough by sliding it into a plate under



the surface of the water, and to prevent the stopper being thrust out accidentally from the jar by the upward pressure of the gas, whilst a little compressed, during the act of passing it into the plate, it is advisable to hold the stopper of the jar firmly but gently, so that it cannot slip out of its place. A number of jars of oxygen may be prepared and arranged in plates, all of which of course must contain a little water, and enough to cover the welt of the jar.

This gas was originally discovered by Priestley, in August 1774, and was first obtained by heating red precipitate—*i. e.*, the red oxide of mercury,

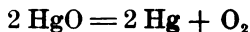

We leave these symbols and figures to be deciphered with the aid of the table of elements, etc., and return to the experiments.

There are certain thin wax tapers like waxed cord, called bougies, which can be bent to any shape, and are very convenient for experiments with the gases. If one of these tapers is bent as in Fig. 123, then lighted and allowed to burn for some minutes, a long snuff is gradually formed, which remains in a state of ignition when the flame of the taper is blown out. On plunging this into a jar of oxygen, it instantly re-lights with a sort of report, and burns with greatly increased brilliancy, as described by Dr. Priestley in his first experiment with this gas. (See copy of a newspaper report below.)



Fig. 123.

The same effect is observed on inserting a glowing match in a test tube full of oxygen; the match will at once burst into flame, burning brightly and fiercely.

“The 1st of August, 1774, is a red-letter day in the annals of chemical philosophy, for it was then that Dr. Priestley discovered dephlogisticated\* air. Some, sporting in the sunshine of rhetoric, have called this the birthday of pneumatic chemistry; but it was even a more marked and memorable period; it was then (to pursue the metaphor) that this branch of science, having eked out a sickly and infirm in-

\* From Phlogiston, a word signifying the principle of inflammability.

fancy in the ill-managed nursery of the early chemists, began to display symptoms of an improving constitution, and to exhibit the most hopeful and unexpected marks of future importance. The first experiment, which led to a very satisfactory result, was concluded as follows:— A glass jar was filled with quicksilver, and inserted in a basin of the same; some red precipitate of quicksilver was then introduced, and floated upon the quicksilver in the jar; heat was applied to it in this situation with a burning-lens, and to use Priestley's own words, *I presently found that air was expelled from it very readily. Having got about three or four times as much as the bulk of my materials, I admitted water into it, and found that it was not imbibed by it.*

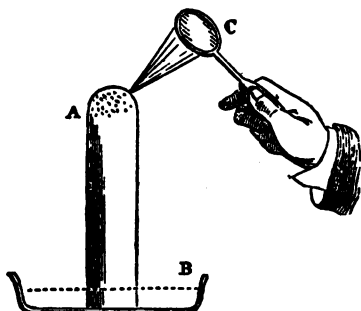

Fig. 124. A. Glass vessel full of mercury, containing the red precipitate at the top, and standing in the dish B, also containing mercury. C. The burning-glass concentrating the sun's rays on the red precipitate, being Priestley's original experiment.

*But what surprised me more than I can well express was, that a candle burned in this air with a remarkably vigorous flame, very much like that enlarged flame with which a candle burns in nitrous air exposed to iron or lime of sulphur (i. e., laughing gas); but as I had got nothing like this remarkable appearance from any kind of air besides this peculiar modification of nitrous air, and I knew no nitrous acid was used in the preparation of mercurius calcinatus, I was utterly at a loss how to account for it." (Fig. 124.)*

#### Third Experiment

Obtain some slow-burning substance, such as smouldering rag; insert it in a jar of oxygen, or pour a little of the oxygen over it, when it will at once burst into flame and be consumed rapidly.

#### Fourth Experiment

The term oxygen is derived from the Greek ( $\delta\acute{\sigma}\acute{\upsilon}\varsigma$ , acid, and  $\gamma\acute{\nu}\omega$ , I give rise to), and was originally given to this

element by Lavoisier, who also claimed its discovery; and if this honour is denied him, surely he has deserved equal scientific glory in his masterly experiments, through which he discovered that the mixture of forty-two parts by measure of azote, with eight parts by measure of oxygen, produced a compound resembling our atmosphere. The name given to oxygen was founded on a series of experiments, one of which will now be mentioned.

Place some sulphur in a little copper ladle attached to a wire, and called a deflagrating spoon, passed through a round piece of zinc or brass plate and cork, so that the latter acts as an adjusting arrangement to fix the wire at any point required. The combustion

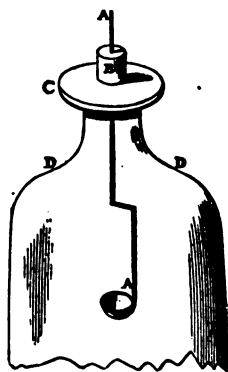

Fig. 125. A. The deflagrating spoon. B. The cork. C. The zinc, or brass, or tin plate. D D. The gas-jar.

of the sulphur, previously feeble, now assumes a remarkable intensity, and a peculiar coloured light is generated, whilst the sulphur unites with the oxygen, and forms sulphurous acid gas. It produces, in fact, the same gas which is formed by burning a sulphur match. This compound is valuable as a disinfectant, and is a very important bleaching agent. It is an acid gas, as Lavoisier found, and this property may be detected by pouring a little tincture of

litmus into the bottom of the plate in which the gas jar stands. The blue colour of the litmus is rapidly changed to red, and it might be thought that no further argument could possibly be required to prove that oxygen was *the* acidifying agent, the more particularly as the result is the same in the next illustration.

#### *Fifth Experiment*

Cut a small piece from a stick of phosphorus under water; take care to dry it properly with a cloth, or blotting paper, and after placing it in a deflagrating spoon, remove the stopper from the gas-jar, as there is no fear of the oxygen rushing away, because it is somewhat heavier than atmospheric air; then, after placing the spoon with the phosphorus in

the neck of the jar, apply a heated wire and pass the spoon at once into the middle of the oxygen; in a few seconds a most brilliant light is obtained, and the jar is filled with a white smoke; as this subsides, being phosphoric acid, and perfectly soluble in water, the same litmus test may be applied, when the liquid is in like manner changed to red. The acid obtained is one of the most important constituents of bone.

#### *Sixth Experiment*

Secure a test tube firmly near to the flange at the top with a holder (see Fig. 115, page 112). Drop in a few pellets of chlorate of potassium and warm these gently till they melt. Then insert a wood spill and violent combustion follows, often with explosive force, especially if the wood has been charred slightly. (This is a similar experiment to that on page 112, Fig. 115.)

#### *Seventh Experiment*

The same result follows the combination of saltpetre and sulphur. Melt a little saltpetre in a clean tube, as in the last experiment, with chlorate of potash, and drop in a pellet of sulphur, taking care not to inhale the fumes.

#### *Eighth Experiment*

A bit of bark-charcoal bound round with wire is set on fire either by holding it in the flame of a spirit-lamp, or by attaching a small piece of waxed cotton to the lower part, and igniting this; the charcoal may then be inserted in a bottle of oxygen, when the most brilliant scintillations occur. After the combustion has ceased and the whole is cool, a little tincture of litmus may also be poured in and shaken about, when it likewise turns red, proving for the third time the generation of an acid body, called carbonic acid—an acid, like the others already mentioned, of great value, and one which Nature employs on a stupendous scale as a means of providing plants, etc., with solid charcoal. Carbonic acid, a virulent poison to animal life, is, when properly diluted, and as contained in atmospheric air, one of the chief alimentary bodies required by growing and healthy plants.

*Ninth Experiment*

Into a deflagrating spoon place a bit of potassium, set this on fire by holding it in the spoon in the flame of a spirit-lamp, and then rapidly plunge the burning metal into a bottle of oxygen. A brilliant ignition occurs in the deflagrating spoon for a few seconds, and there is little or no smoke in the jar. The product this time is a solid, called potash, and if this be dissolved in water and filtered, it is found to be clear and bright, and now on the addition of a little tincture of litmus to one half of the solution, it is wholly unaffected, and remains blue; but if with the other half a small quantity of tincture of turmeric is mixed, it immediately changes from a bright yellow solution to a reddish-brown, because turmeric is one of the tests for an alkali; and thus is ascertained by the help of this and other tests that the result of the combustion is not an *acid*, but an *alkali*. The experiment is made still more satisfactory by burning another bit of potassium in oxygen and dissolving the product in water, and if any portion of the reddened liquid derived from the sulphurous, phosphoric, and carbonic acids taken from the previous experiments, be added to separate portions of the alkaline solution, they are all restored to their original blue colour, because an acid is neutralised by an alkali; the experiment is made quite conclusive by the restoration of the reddened turmeric to a bright yellow on the addition of a solution of either of the three acids already named. Moreover, an acid need not contain a fraction of oxygen, as there is a numerous class of *hydracids*, in which the acidifying principle is hydrogen instead of oxygen, such as the hydrochloric, hydriodic, hydro-bromic, and hydro-fluoric, acids.

*Tenth Experiment*

A piece of watch-spring is softened at one end, by holding it in the flame of a spirit-lamp, and allowing it to cool. A bit of waxed cotton is then bound round the softened end, and after being set on fire, is plunged into a gas jar containing oxygen; the cotton first burns away, and then the heat communicates to the steel, which gradually takes fire, and being once well ignited, continues to burn with amazing rapidity, forming drops of liquid dross,—which fall to the bot-

tom of the plate—also a reddish smoke, which condenses on the sides of the jar; neither the dross which has dropped into the plate, nor the reddish matter condensed on the jar, will affect either tincture of litmus or turmeric; they are neither acid nor alkaline, but *neutral* compounds of iron, called the sesquioxide of iron or Ferric Oxide ( $\text{Fe}_2\text{O}_3$ ), and the magnetic oxide or Ferroso-ferric Oxide, ( $\text{Fe}_3\text{O}_4$ ).

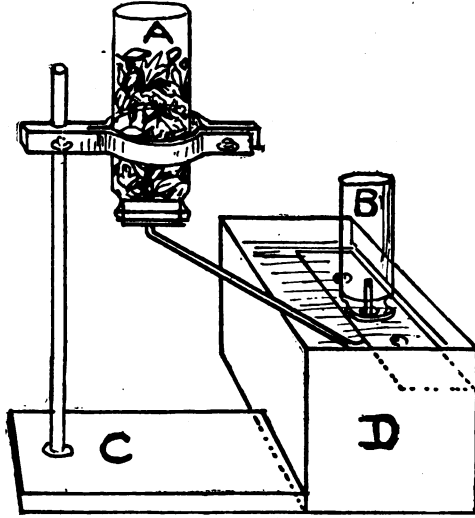

Fig. 126. A. Bottle containing water-wet leaves freshly gathered and supported on cylinder-holder, C. B. A bottle standing on shelf in pneumatic trough, D, and connected by tube to A, which, on exposure to sunlight, gives off oxygen which is collected in B.

#### *Eleventh Experiment*

In order to show the purifying effect of vegetation on the atmosphere, fill a bottle with *freshly-gathered* leaves moistened with water. Cork this, and insert a delivery-tube to reach into the pneumatic trough, as seen in Fig. 126. Expose the whole to daylight, sunshine for preference. In a short time, after the water is driven off, a gas will follow; collect some of this and plunge in it a glowing taper or match; it will be found to be oxygen.

#### *Twelfth Experiment*

Some oxygen gas contained in a cylinder or silk gasbag

provided with a proper jet may be projected upon some liquid phosphorus contained in a cup at the bottom of a bowlful of boiling water, when a most brilliant combustion occurs, proving that so long as the principle is complied with—viz., that of furnishing oxygen to a combustible substance—it will burn under water, provided it is insoluble, and possesses the remarkable affinity for oxygen which belongs to phos-

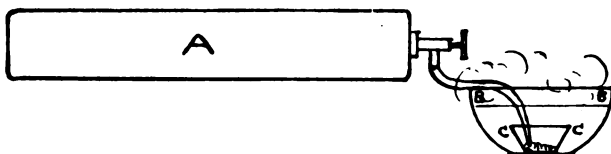

Fig. 127. A. Cylinder containing oxygen, provided with a valve and jet leading to B. B. Glass containing boiling water. C. The cup of melted phosphorus under the water. The gas escapes from the cylinder into the small glass C and supports combustion.

phorus. The experiment should be performed with boiling water, to keep the phosphorus in the liquid state; and it is quite as well to hold a square foot of wire gauze over the glass whilst the experiment is being performed. (Fig. 127.)

#### *Thirteenth Experiment*

Oxygen is available from many substances when they are mixed with combustibles; hence the brilliant effects produced by burning a mixture of nitre, meal powder, sulphur, and iron or steel filings; the metal burns with great brilliancy, and is projected in beautiful sparks, which are long and needle-shaped with steel, and in the form of miniature rosettes with iron filings; it is the oxygen from the nitre that causes the combustion of the metal, the other ingredients only accelerate the heat and rate of ignition of the brilliant iron, which is usually termed a gerb.

#### *Fourteenth Experiment.*

A mixture of nitrate of potash, powdered charcoal, sulphur, and nitrate of strontium, driven into a strong paper case about two inches long, and well closed at the end with varnish, being quite waterproof, may be set on fire, and will continue to burn under water until the whole is consumed; the only precaution necessary being to burn the composition

from the case with the mouth downward, and if the experiment is tried in a deep glass jar it has a very pleasing effect. (Fig. 128.)

The red-fire composition is made by mixing nitrate of strontia 40 parts by weight, flowers of sulphur 13 parts, chlorate of potash 5 parts, sulphide of antimony 4 parts, all by weight. These ingredients must first be well powdered *separately*, then mixed carefully on a sheet of paper with a paper-knife. They are liable to explode if rubbed *together* in a mortar, on account of the presence of sulphur and chlorate of potash, and the composition, if kept for any time, is liable to take fire spontaneously, so that no more should be weighed than is wanted for immediate experiment.

#### *Fifteenth Experiment*

Some zinc is melted in an iron ladle, and made quite red hot; if a little dry nitre is thrown upon the surface, and gently stirred into the metal, it takes fire with the production of an intense white light, whilst large quantities of white flakes ascend, and again descend when cold, being the oxide of zinc, and called by the alchemists the "Philosopher's Wool" ( $ZnO$ ). In this experiment the oxygen from the nitre effects the oxidation of the metal zinc.

#### *Sixteenth Experiment*

A mixture of four pounds of nitre with two of sulphur and one and a half of lampblack produces a most beautiful and curious fire, continually projected into the air as sparks having the shape of the rowel of a spur, and one that may be burnt with perfect safety in a room, as the sparks consume away so rapidly, in consequence of the finely divided condition of the charcoal, that they may be received on a handkerchief or the hand without burning them. The dif-

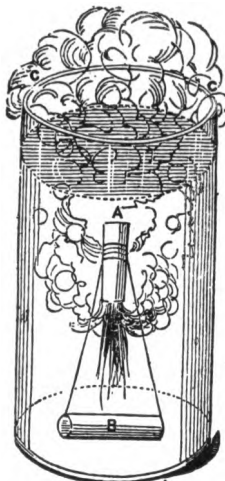

Fig. 128. A. Case of red fire burning downwards, and attached by a copper wire to a bit of leaden pipe B, to sink it. C C. Jar containing water.



ficulty consists in effecting the complete mixture of the charcoal. The other two ingredients must first be thoroughly powdered separately, and again triturated when mixed, and finally the charcoal must be rubbed in carefully, till the whole is of a uniform tint of grey and very nearly black, and as the mixture proceeds portions must be rammed into a paper case, and set on fire; if the stars or pinks come out in clusters, and spread well without other and duller sparks, it is a sign that the whole is well mixed; but if the sparks are accompanied with dross, and are projected out sluggishly, and take some time to burn, the mixture and rubbing in the mortar must be continued; and even that must not be carried too far, or the sparks will be too small. N. B.—If the lampblack is heated red hot in a close vessel, it will answer better when cold and powdered.

#### *Seventeenth Experiment*

Into a tall gas jar with a wide neck project some red-hot lampblack through a tin funnel, when a most brilliant flame-like fire is obtained, showing that finely divided charcoal with pure oxygen would be sufficient to afford light; but as the atmosphere consists of oxygen diluted with nitrogen, compounds of charcoal with hydrogen are the proper bodies to burn to produce artificial light.

#### *Eighteenth Experiment*

An interesting experiment for those who live in the country, is to take a small bottle of oxygen, and a deflagrating spoon attached to a greased plate, some dark night, and search for a glow-worm. Put it in the spoon, and immerse in the bottle of oxygen; immediately the worm will glow with magnificent brilliancy. Let the immersion be but for a moment, or it will cause the creature suffering, and will soon kill it; it should only be placed rapidly in and out, and should then be put in the grass again, when, beyond a feeling of surprise, perhaps, it will be no worse.

#### *Nineteenth Experiment. The Bude Light*

This light is obtained by passing a steady current of oxygen gas (escaping at a very low pressure) through and up the centre pipe of an argand oil lamp, which must be supplied

with a highly carbonised oil and a very thick wick, as the oxygen has a tendency to burn away the cotton unless the oil is well supplied, and allowed to overflow the wick, as it does in the lamps of some lighthouses. Sperm oil or some highly refined paraffin, such as is used in lighthouses is the best. See Fig. 129.

This name was given to the light by its inventor, Sir G. Gurney, of Bude Castle, Bude, Cornwall. The invention was patented in 1839-41, and is a modification of the Argand burner. In the Bude, two, three, four, or more (according to the desired power of the light) Argand burners are arranged so that each inner burner shall be a little higher than the outer, so as to present a solid block of light, into the interior of which oxygen is forced, resulting in a light of wonderful power, intensity and solidity. No doubt this old Bude light has influenced greatly the discovery of the incandescent-mantle burners now in universal demand.

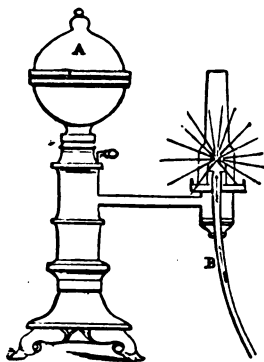

Fig. 129. A. Reservoir of oil.  
B. The flexible pipe conveying oxygen to centre of the argand lamp.

*Twentieth Experiment. A Red Light*

Clear out the oil thoroughly from the Bude light apparatus; or, what is better, have two lamps, one for oil, the other for spirit; fill the apparatus with a solution of nitrate of strontia and chloride of calcium in spirits of wine, and let it burn from the cotton in the same way as the oil, and supply it with oxygen gas.

*Twenty-first Experiment. A Green Light*

Dissolve boracic acid and nitrate of baryta in spirits of wine, and supply the Bude lamp with this solution.

*Twenty-second Experiment. A Yellow Light*

Dissolve common salt in spirits of wine, and burn it as already described in the Bude light apparatus.

*Twenty-third Experiment. The Oxy-calcium Light*

This very convenient light is used largely for lantern work in theatres, etc., though it is giving place to the more convenient electric arc; it is obtained in a simple manner, either by using a jet of oxygen as a blowpipe to project the flame of a spirit lamp on to a ball of lime; or common coal-gas is employed instead of the spirit lamp, being likewise urged against a ball of lime. By this plan one bag or cylinder

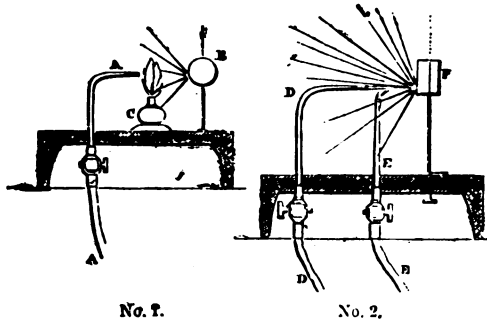

Fig. 130.—No. 1. A. Oxygen jet. B. The ball of lime, suspended by a wire. C. Spirit lamp.  
No. 2. D. Oxygen jet. E. Gas (jet connected with the gas-pipe in the rear by flexible pipe) projected on to ball of lime, F.

containing oxygen suffices for the production of a brilliant light, not equal, however, to the oxy-hydrogen light, which will be explained in the article on hydrogen. (Fig. 130.)

*Twenty-fourth Experiment*

To show the weight of oxygen gas, and that it is heavier than air, the stoppers from two bottles containing it may be removed, one bottle may be left open for some time and then tested by a lighted taper, when it will still indicate the presence of the gas, whilst the other may be suddenly inverted over a little cup in which some ether, mixed with a few drops of turpentine, may be burning—the flame burns with much greater brilliancy at the moment when the oxygen comes in contact with it.

*Twenty-fifth Experiment*

The effect of oxygen upon the system when inhaled is an increase in the work of the respiratory organs; and after

inhaling a gallon or so of this gas, the pulse is raised forty or fifty beats per second: the gas is easily inhaled from an iron bottle called a cylinder, direct, or more steadily and thus preferably through an intermediate rubber bag, by means of an amber mouthpiece or a rubber face cap; it must of course be quite pure, and if made from the mixture of chlorate of potash and oxide of manganese, should be purified by being passed through lime and water, or cream of lime.

*Twenty-sixth Experiment*

There are certain colouring matters that are weakened or destroyed by the action of light and other causes, which deprive them of oxygen gas or deoxidise them. A weak tincture of litmus, if long kept, often becomes colourless, but if this colourless fluid is shaken in a bottle with oxygen gas it is gradually restored; and if either litmus, turmeric, indigo, orchil, or madder, paper, or certain ribbons dyed with the same colouring matters, have become faded, they may be partially restored by damping and placing them in a bottle of oxygen gas. The effect of the oxygen is to reverse the deoxidising process, and to impart oxygen to the colouring matters. By a peculiar process indigo may be obtained quite white, and again restored to its usual blue colour, either by exposure to the air or by passing a stream of oxygen through it.

*Twenty-seventh Experiment*

Many of the rarest metals such as magnesium, lithium, etc., are now obtainable in the form of round, oval, flat and square wire. A wire of the metal magnesium burns magnificently in oxygen gas, and forms the alkaline earth magnesia. The metal lithium, to which such a very low combining proportion belongs—viz., 6.94—can also be procured in the state of wire, and burns in oxygen gas with an intense white light into the alkaline lithia, which dissolved in alcohol with a little acetic acid, and burnt, affords a red flame, making a curious contrast between the effects of colour produced by the metallic and oxidised state of lithium.

THE ALLOTROPIC CONDITION OF OXYGEN GAS.

The term allotropy, (from *ἄλλοτροπος*, of a different nature) was first used by the renowned chemist Berzelius. Dimor-

phism, or diversity in crystalline form, is therefore a special case of allotropy, and is illustrated with the iodide of mercury ( $\text{HgI}_2$ , Mercuric Iodide), which is made either by rubbing together equal combining proportions of mercury and iodine (both of which are to be found in the Table of Elements, page 110, or by carefully precipitating a solution of corrosive sublimate (bichloride of mercury, commonly called mercuric chloride,  $\text{HgCl}_2$ ) with one of iodide of potassium, just enough and no more of the latter being added to precipitate the metal, or else the iodide of mercury is redissolved by the excess of the precipitant. It is first of a dirty yellow, and then gradually changes to a scarlet when stirred; if this be collected on a filter, and washed and drained, it is a beautiful scarlet, and when some of this substance is rubbed across a sheet of paper, a bright scarlet is apparent, which may be rapidly changed to a lemon-yellow by heating the paper over the flame of a spirit lamp; and the iodide of mercury is again brought back to a scarlet colour by rubbing down the yellow crystals with the fingers. This experiment may be repeated over and over again with the like results. If some of the scarlet iodide of mercury is sublimed from one bit of glass to another, it forms crystals, derived from the right rhombic prism; when these are scratched with a pin they change again to the scarlet state, the latter when crystallised being in the form of the square-based octohedron.

Other cases of dimorphism may be mentioned—viz., with sulphur, carbonate of lime, and lead, and many others, whilst allotropy is curiously illustrated in the various conditions of charcoal, which, in the more numerous examples, is black and opaque, and in another instance transparent like water. Lampblack is soft, but the diamond is the hardest natural substance. The allotropic state of sulphur has been already alluded to; phosphorus, again, exists in three modifications: 1st, Common phosphorus, which shines in the dark and emits a white smoke. 2nd, White phosphorus. 3rd, Red or amorphous phosphorus, which does not shine or emit white smoke when exposed to the air, and is so altered in its properties that it may be safely carried in the pocket.

Enough evidence has therefore been offered to show that the allotropic property is not confined to one element or com-

pound, but is discoverable in many bodies, and in none more so than in the allotropic state of the element oxygen called

OZONE. ( $O_3$ .)

The Greek language has again been selected by the discoverer, Schönbein, of Basle, for the title or name of this curious modification of oxygen, and it is so termed from  $\delta\zeta\epsilon\iota\nu$ , to smell. The name at once suggests a marked difference between ozone and oxygen, because the latter is perfectly free from odour, whilst the former has that peculiar smell which is called electric, and is distinguishable whenever an electrical machine is at work, or if a Leyden jar is charged by the powerful Rhumkoff, or Hearder coil; it is also apparent when water is de-

composed by a current of electricity and resolved into its elements, oxygen and hydrogen. When highly concentrated it smells like chlorine. Ozone is prepared by taking a clean empty bottle, and pouring therein a very little distilled water, into which a piece of clean scraped phosphorus is introduced, so as to expose about one-half of its diameter to the air in the bottle,

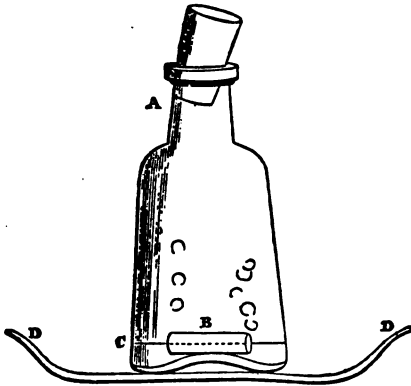

Fig. 131. A. A quart bottle, with the stopper loosely placed therein. B. The stick of clean phosphorus. C. The water level just to half the thickness of the phosphorus. D D. A soup-plate.

whilst the other is in contact with the water. (Fig. 131.)

For the sake of precaution, the bottle may stand in a basin or soup plate, so that if the phosphorus should take fire, it may be instantly extinguished by pouring cold water into the bottle, and should this crack and break, the phosphorus is received into the plate.

When the ozone is formed the phosphorus can be withdrawn, and the phosphorous-acid smoke washed out by shaking the bottle; it is distinguishable by its smell, and also by its action on test paper, prepared by painting with starch containing iodide of potassium on some soft porous paper;

when this is placed in the bottle containing ozone, it changes the test to blue, or rather to a purplish blue.

Another method of forming ozone is to pass a *silent* discharge of electricity through oxygen gas, without sparks; a considerable quantity of the oxygen gas then becomes converted into its allotropic form of ozone. If any sparks occur, either in the passage of the current through air or oxygen, then the quantity of ozone obtained is greatly diminished.

Ozone is a most energetic body, and a powerful bleaching agent; if a point is attached to the prime conductor of an electrical machine, and the electrified air is received into a bottle, it will be found to smell, and has the power of bleaching a *very* dilute solution of indigo. It attacks organic substances violently, destroying india rubber tubing, even while

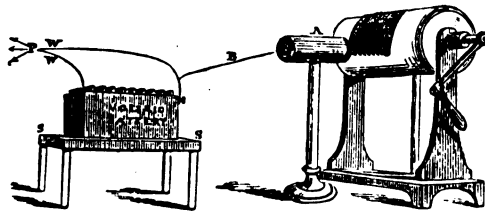

Fig. 132. V. A small voltaic battery standing on the stool with glass legs, S S, and capable of heating a thin length of platinum wire about two inches long, bent to form a point between the conducting wires, W W.—N.B. The voltaic current can be cut off at pleasure, so as to cool the wire when necessary. A is the prime conductor of an ordinary cylinder electrical machine. B is the wire conveying the frictional electricity to the conducting wires of the voltaic battery, where the point P being the sharpest point in the arrangement, delivers the electrified and ozonized air.

passing through it. It also instantly attacks potassium iodide, separating the two, and acts strongly on silver, mercury and other metals, over which, as ordinary oxygen, it had no power.

Ozone can not only be produced by certain methods, but may be destroyed by a red heat. If a point is prepared with a loop of platinum wire, and this latter, after being connected with a voltaic battery, made red hot, and the whole placed on an insulating stool, and connected with the prime conductor of an electrical machine, it is found that the electrified air no longer smells, the ozone is destroyed; on the other hand, if the voltaic battery is disconnected, and the electrified air again allowed to pass from the cold platinum wire, the smell is

again apparent, the air will bleach, and if caused to impinge at once upon the iodide of starch test, changes it in the manner already described. (Fig. 132.)

Ozone is insoluble in water, and oxidizes silver and lead leaf, finely powdered arsenic and antimony; it is a poison when inhaled in a concentrated state, whilst diluted, and generated by natural processes, it is a beneficent and beautiful provision against those numerous smells originating from the decay of animal and vegetable matter, which might produce disease or death: ozone is therefore a powerful disinfectant. A simple test for it is made by boiling together ten parts by weight of starch, one of iodide of potassium, and two hundred of water; it may either be painted on soft porous paper, and used at once, or blotting paper may be saturated with the test and dried, and when required for use it must be damped, either before or after testing for ozone, as it remains colourless when *dry*, but becomes blue after being moistened with water.

Paper prepared with sulphate of manganese is an excellent test for ozone, and changes brown rapidly by the oxidation of the proto-salt of manganese, and its conversion into the binoxide of the metal.

Ozone is also prepared by pouring a little sulphuric ether into a quart bottle, and then, after heating a glass rod in the flame of the spirit lamp, it may be plunged into the bottle, and after remaining there a few minutes ozone may be detected by the ordinary tests.

### Nitrogen

Νίτρον, nitre; γεννάω, I form; α, privative; ζωή, life. Symbol, N; combining proportion, 14.01. Also termed by Priestley, *phlogisticated* air.

In the year 1772, Dr. Rutherford, Professor of Botany in the University of Edinburgh, published a thesis in Latin on fixed air, in which he says:—“*By the respiration of animals healthy air is not merely rendered mephitic (i.e., charged with carbonic acid gas), but also suffers another change. For after the mephitic portion is absorbed by a caustic alkaline lixivium, the remaining portion is not rendered salubrious; and although it occasions no precipitate in lime-water,*



*it nevertheless extinguishes flame and destroys life.*" Such is the doctor's account of the discovery of nitrogen, which may be separated from the oxygen of the atmosphere in a very simple manner. The atmosphere is the great storehouse of nitrogen, and four-fifths of its prodigious volume consist of this element.

*Composition of Atmospheric Air in 100 Parts*

	Bulk in round figures.	Weight.	Actual bulk obtained by experiment (see below.)
Oxygen .....	20	22.3	20.962
Nitrogen .....	80	77.7	79.038
	<hr/> 100	<hr/> 100.	<hr/> 100.000

The above is, of course, taking the air, broadly speaking, as consisting of these two elements only. There are, however, other elements and compounds present, which vary considerably, according to the locality and position. Especially is this evidenced in the air in and near large and smoky cities and in the neighbourhood of houses, as compared with the purer air of the open country and that, over the sea; but the following may be taken as an average composition of air in 1000 parts by volume:

	Decimally.
1 Nitrogen .....	769.65005
2 Oxygen .....	206.59501
3 Aqueous Vapour .....	14.02850
4 Argon .....	9.36050
5 Carbon dioxide .....	.33650
6 Neon .....	.01050
7 Ammonia .....	.00801
8 Hydrogen .....	.00395
9 Helium .....	.00350
10 Ozone .....	.00150
11 Krypton .....	.00150
12 Nitric Acid .....	.00043
13 Xenon .....	.00005
	<hr/> 1000.00000

The usual mode of procuring nitrogen gas is to abstract or

remove the oxygen from a given portion of atmospheric air, and the only point to be attended to, is to select some substance which will continue to burn as long as there is any oxygen left. Thus, if a lighted taper is placed in a bottle of air, it will only burn for a certain period, and is gradually and at last extinguished; not that the whole of the oxygen is removed or changed, because after the taper has gone out, some burning sulphur may be placed in the vessel, and will continue to burn for a limited period; and even after these two combustibles have, as it were, taken their fill of the oxygen, there is yet a little left, which is snapped up by burning phosphorus, whose voracious appetite for oxygen is only appeased by taking the whole. It is for this reason that phosphorus is employed for the purpose of removing the oxygen, and also because the product (phosphoric acid) is perfectly soluble in water; thus the oxygen is first combined, and then washed out of a given volume of air, leaving the nitrogen behind.

#### *First Experiment*

To prepare nitrogen gas, it is only necessary to place a little dry phosphorus in a Berlin porcelain cup on a wine glass, and to stand them in a soup plate containing water. The phosphorus is set on fire with a hot wire, and a gas jar or cylindrical jar is then carefully placed over it, so that the welt of the jar stands in the water in the soup plate. At first, expansion takes place in consequence of the heat, but this effect is soon reversed, as the oxygen is converted into a solid by union with the phosphorus, forming a white smoke, which gradually disappears. (Fig. 133.)

Supposing two grains of phosphorus had been placed in a platinum tube, and just enough atmospheric air passed

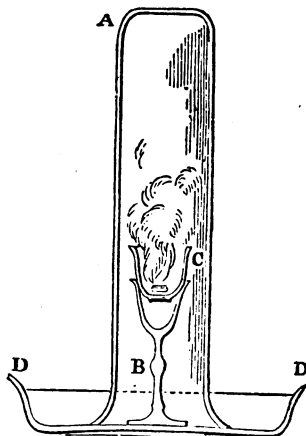

Fig. 133. A. Cylindrical glass vessel, open at one end, and inverted over B, the wine-glass, supporting C, the cup containing the burning phosphorus, and the whole standing in a soup-plate, D D, containing water.

over it to convert the whole into phosphoric acid, the weight of the phosphorus would be increased to  $4\frac{1}{2}$  grains by the addition of  $2\frac{1}{2}$  grains of oxygen; now one cubic inch of oxygen weighs 0.3419, or about  $\frac{1}{3}$ rd of a grain, hence 7.3 cubic inches of oxygen disappear, which weigh as nearly as possible  $2\frac{1}{2}$  grains, so that as 36.5 cubic inches of air contain 7.3 cubic inches of oxygen, that quantity of air must have passed over the 2 grains of phosphorus to convert it into  $4\frac{1}{2}$  grains of phosphoric acid.

For very delicate purposes, nitrogen is best prepared by passing air over finely-divided metallic copper heated to redness; this metal absorbs the whole of the oxygen and leaves the nitrogen. The finely-divided copper is procured by passing hydrogen gas over pure black oxide of copper.

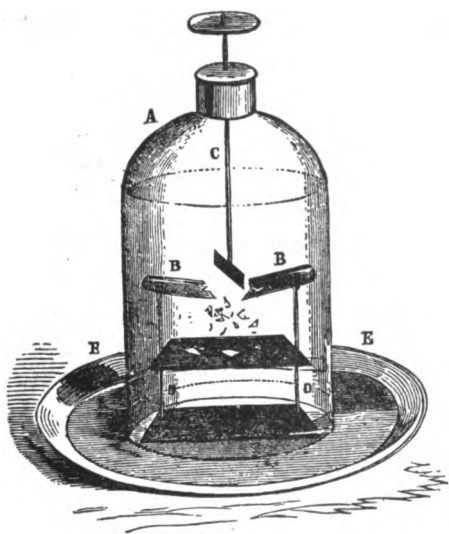

Fig. 134. A. Glass jar, with collar of leather, through which the stamper, C, works. B. B. The tube containing the finely-divided lead, part of which falls out, and is ignited, and retained by the little tray just below, being part of the iron stand, D D, with crutches supporting the ends of the glass tube, and the whole stands in the dish of water, E E.

### Second Experiment

A very instructive experiment is performed by heating a good mass of tartrate of lead in a glass tube which is hermetically sealed, and being placed on an iron support, is then covered by a capped air jar with a sliding rod and stamper, the whole

being arranged in a plate containing water. When the stamper is pushed down upon the glass the latter is broken (Fig. 134), and the air gradually penetrates to the finely divided lead, when ignition occurs, and the oxygen is absorbed, as demonstrated by the rise of the water in the jar. On the same principle, if a bottle is filled about one-

third full with a liquid amalgam of lead and mercury, then stoppered and shaken for two hours or more, the finely divided lead absorbs the oxygen and leaves pure nitrogen. Or if a mixture of equal weights of sulphur and iron filings, is made into a paste with water in a thin iron cup, then warmed and placed under a gas jar full of air standing on the shelf of the pneumatic trough, or in a dish full of water, the water gradually rises in the jar in about forty-eight hours, in consequence of the absorption of the oxygen gas.

*Third Experiment*

Nitrogen is devoid of colour, taste, smell, of alkaline or acid qualities; and, as we shall have occasion to notice presently, it forms an *acid* when chemically united with oxygen, and an alkali in union with hydrogen. A lighted taper plunged into this gas is immediately extinguished, while its specific gravity, which is lighter than that of oxygen or air, is demonstrated by the rule of proportion.

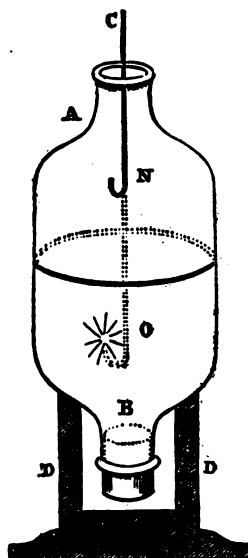

Fig. 135. A. Gas Jar containing nitrogen. N, standing on B, another Jar full of oxygen. O. The taper, C, is extinguished at N, and relighted at O. D D. Stand supporting the jars.

Weight of 100 cubic inches of air at 60° Fahr., bar. 29·92 in.	Unity.	Weight of 100 cubic inches of nitrogen at 60° Fahr., bar. 29·92 in.	Specific gravity of nitrogen.
30.829	: 1	:: 29.952	:: .971

Its levity may be shown by a simple experiment. Select two gas jars of the same size, and after filling one with oxygen gas and the other with nitrogen gas, slide glass plates over the bottoms of the jars, and proceed to invert the one containing oxygen, placing the neck in a stand formed of a box open at the top; then place the jar containing nitrogen over the mouth of the first, withdrawing the glass plates carefully; if the table is steady the top gas jar will stand securely on the lower one. Then (having previously lighted a

taper so as to have a long snuff) remove the stopper from the nitrogen jar and insert the lighted taper, which is immediately extinguished, and as quickly relighted by pushing it down to the lower jar containing the oxygen. (Fig. 135, Page 137.) This experiment may be repeated several times, and is a good illustration of the relative specific gravities of the two gases, and of the importance of the law of universal diffusion already explained at p. 4, by which these gases *mix*, not *combine* together, and the atmosphere remains in one average uniform state of composition in spite of the changes going on at the surface of the earth. See page 134.

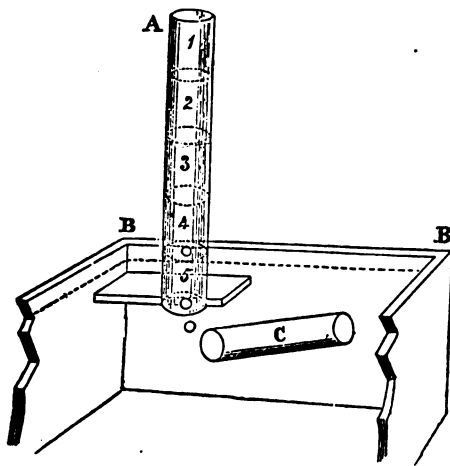

Fig. 136. A. Gas jar divided into five equal parts. B B. Section of pneumatic trough, to show the decantation of gas from one vessel to another. The gas is being passed from C to A, through the water.

#### Fourth Experiment

It was the ill-fated Lavoisier who discovered, by experimenting with quicksilver and air, the compound nature of the atmosphere; and it was the same chemist who gave the name of azote to nitrogen; it should, however, be borne in mind that it does not necessarily follow because a gas extinguishes flame that it is a *poison*. Nitrogen extinguishes flame, but we inhale enormous quantities of air without any ill effects from the nitrogen or azote that it contains; on the other

hand, many gases that extinguish flame are *specific poisons*, such as carbonic acid, carbonic oxide, cyanogen, etc.

Lavoisier's experiment may be repeated by passing into a measured jar, graduated into five equal volumes, four measures of nitrogen and one measure of oxygen; a glass plate should then be slid over the mouth of the vessel, and it may be turned up and down gently for some little time to mix the two gases. When the mixture is tested with a lighted taper, it is found neither to increase nor diminish the illuminating power and the taper burns as it would do in atmospheric air, for we have practically mixed some. (Fig. 136.)

#### *Fifth Experiment*

A well known combination of nitrogen with oxygen is found in the nitrous oxide, commonly known as "laughing gas"—formula  $N_2O$ . It is made simply by heating ammonium nitrate; this should be done in a flask or test tube fitted with a cork and delivery tube. The ammonium nitrate decomposes and gives off this gas, which, when purified, is used largely by dentists and for certain anæsthetic purposes.

#### AMMONIA

Nitrogen, with hydrogen, form ammonia, the symbol for which is  $NH_3$ , which shows that there are three volumes of hydrogen gas combined with one volume of nitrogen gas. Ammonia may be made by the silent electric discharge in a mixture of nitrogen and hydrogen, but as very few boys would be able to have the use of the necessary appliances, a simpler method is to mix some chloride of lime with about double its quantity of quick lime in a perfectly dry flask, which should be well corked and have a glass delivery tube. On gently heating this mixture over a bunsen burner, the gas is given off very readily. If required to be stored as gas, it may be collected in dry bottles inverted, for as it is lighter than air, it will drive out the air in the bottle just as will hydrogen. But if it is wanted in the wet state, it may be bubbled in water, which will absorb an enormous quantity,—one cubic centimetre (c. c.) of water at  $0^\circ C$ . will absorb nearly 1150 c. c of ammonia gas at the same temperature. It may be collected by upward displacement in a trough of mercury, but by far the simpler way is to make

or buy the ammonia liquor described above. A little of this poured into a test tube fitted with a cork and a piece of glass tubing, will give off its gas readily at atmospheric temperature, and with great rapidity if warmed. Some idea may be formed of the great solubility of ammonia in water by a simple and interesting experiment.

#### *First Experiment*

Fill a flask with ammonia gas by the displacement of air. When full, close the flask with a cork or rubber stopper, carrying a glass tube of such a length as will project to a couple of inches or so above the bottom of the flask, and a few inches above the stopper outside. Close the end of the tube quickly with a cork or the finger, to prevent escape of gas, and support it on a triangle or retort stand over a bowl of water in such a position that the tube will not quite touch the bottom of the bowl, which should be deep, and carry

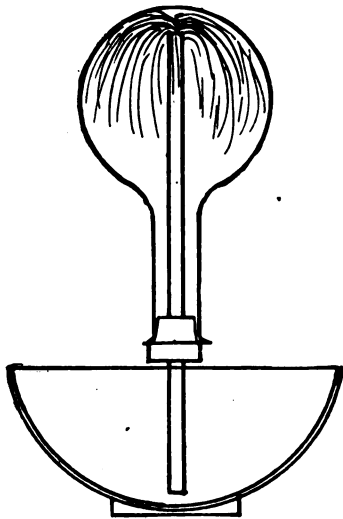

Fig. 137. Experiment for showing great solubility of ammonia in water.

more water than would fill the flask. The finger or cork may then be gently withdrawn, when the water will slowly rise up the tube as it dissolves the gas in it, but when at the top and it begins to overflow into the inverted flask, the action takes place rapidly, and with such energy that the water rushes up the tube and hurls itself across the space to the bottom of the flask, which spreads it out in all directions, forming a beautiful fountain. (See Fig. 137.)

This goes on till the vacuum caused by the dissolved gas is complete and the flask is full. If the water is coloured, by litmus, for instance, the experiment is a very pretty one. Be careful not to inhale the fumes, as ammonia vapour cannot be breathed and is a non-supporter of combustion.

*Second Experiment*

Fill a test tube with ammonia gas, and insert a lighted taper. The light goes out, and the gas also does not burn. This may seem curious, considering the greater part of it is hydrogen, but if we add oxygen, or heat the air, then it will burn.

*Third Experiment*

Fit a test tube with a cork through which is passed a short length of glass tubing, the outer end being drawn to a point. Into the test tube pour a little strong liquor ammonia and cork it tightly. Gas will now be given off through the tubing; apply a light to the orifice, when it will be seen that the gas does not burn. Now warm the orifice with a bunsen burner, and the escaping gas will burn, but it will be noticed that the light goes out immediately the heat is removed. See Fig. 138.

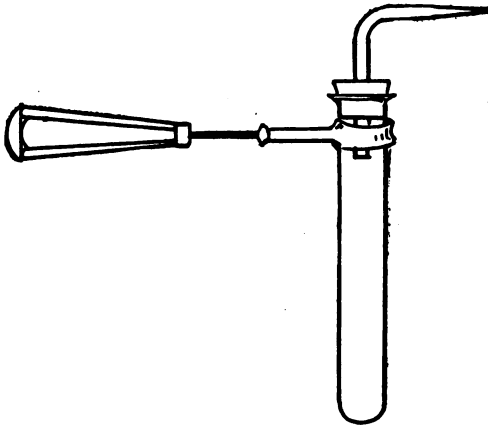

Fig. 138. Experiment for showing the conditions under which ammonia gas will burn.

*Fourth Experiment*

Direct the jet of escaping ammonia of the last experiment into a test tube containing oxygen, and apply a light. It will now be seen that in oxygen the ammonia gas will burn on the application of a flame. It would be as well, however, to wrap the oxygen tube in a cloth, lest it should burst and



the tiny pieces of flying glass injure the face and eyes, for certain proportions of oxygen and ammonia are explosive.

#### *Fifth Experiment*

Those who have not an explosion-pipette or tube might get a soda-water bottle, and put in it four parts of dry ammonia gas and three parts of oxygen. Cork it tightly, wrap round the bottle several thicknesses of cloth or dusters, leaving only the cork exposed. Hold the bottle firmly in the hand and apply a light. A very effective and noisy explosion should result. The cloth is, of course, merely to protect the hands in case the bottle bursts.

#### *Sixth Experiment*

Pour a little ammonia into a test tube, add to it a few drops of hydrochloric acid. Dense white fumes of ammonium chloride are given off.

### HYDROGEN

Hydrogen (*ἕδωρ*, water; *γεννάω*, I give rise to), so termed by Lavoisier—formerly called by other chemists inflammable air, and phlogiston. Symbol, H; combining property, 1.008. The lightest known form of matter.

Every 100 parts by weight of water contain 11 parts of hydrogen gas; and as the quantity of water on the surface of the earth represents at least two-thirds of the whole area, the source of this gas, like that of oxygen or nitrogen, is inexhaustible. Van Helmont, Mayow, and Hales had shown that certain inflammable and peculiar gases could be obtained, but it was reserved for the rigidly scientific mind of Cavendish to determine the nature of the elements contained in, and giving a speciality to, the inflammable gases of the older chemists. By acting with dilute acids upon iron, zinc, and tin, Cavendish liberated an inflammable elastic gas; he discovered nearly all the properties we shall notice in the succeeding experiments, especially demonstrating the composition of water in his paper read before the Royal Society in the year 1784.

#### *First Experiment*

Hydrogen is prepared in a very simple manner, by placing some zinc cuttings in a bottle, to which is attached a cork

and bent glass tube, and pouring upon the metal some dilute sulphuric or hydrochloric acid. Effervescence and ebullition take place, and the gas escapes in large quantities, water being decomposed; the oxygen passes to the zinc, forming oxide of zinc, which uniting with the sulphuric acid forms sulphate of zinc; this may be obtained after the escape of the hydrogen by evaporation and crystallisation. (Fig. 139.)

Equation of sulphuric acid on zinc:

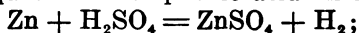

or

Equation of hydrochloric acid on zinc:

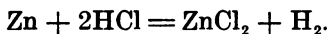

In nearly all the processes for the generation of hydrogen gas, a metal is usually employed, and this fact has suggested the notion that hydrogen may not be in its elementary state as a gas, but may possibly be a metal, although it is the lightest known form of matter; and it will be observed in all the succeeding experiments that a metallic substance will be employed to take away the oxygen and displace the hydrogen.

Whenever hydrogen is prepared it should be allowed to escape from the generating vessel for a few minutes before any flame is applied, in order that the atmospheric air may be expelled. The most serious accidents have occurred from carelessness in this respect, as a mixture of hydrogen and air is explosive, and the more dangerous when it takes fire in any close glass bottle.

### *Second Experiment*

If a piece of potassium is confined in a little coarse wire gauze cage, attached to a rod, and thrust under a small jar full of water, placed on the shelf of the pneumatic trough, hydrogen gas is produced with great rapidity, and is received into the gas jar. The bit of potassium being surrounded with water, is kept cool, whilst the hydrogen escaping under

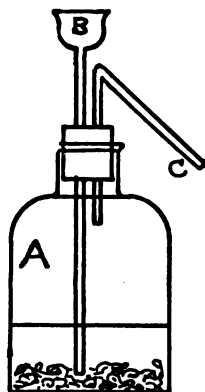

Fig. 139. A. Bottle containing zinc cuttings and water and fitted with a cap and two tubes, the one marked B, a thistle funnel, conveys the sulphuric acid to the zinc and water, whilst the gas escapes through the pipe C.

the water is not of course burnt away, as it is whenever the metal is thrown on the *surface* of water.

### *Third Experiment*

Across a small iron table-furnace is placed about eighteen inches of 1-inch iron gas-pipe containing iron borings, the whole being red-hot; attached to one end is a pipe conveying steam from a boiler, or flask, or retort, whilst another pipe is fitted to the opposite end, and passes to the pneumatic trough. Directly the steam passes over the red hot iron borings it is deprived of oxygen, which remains with the iron, forming the rust or oxide of iron, whilst the hydrogen, called in this case *water gas*, escapes with great rapidity.

Water-gas was first discovered by Lavoisier in 1793, since when there have been many attempts to revive it and bring it into common service, but though it is used at the present time in many parts of England and America, chiefly, and gives out a quick and ready heat, coal-gas is about twice as powerful in its heat-giving properties. Thirty per cent. of the possible heat of the coal is retained in the resultant coke and twenty per cent. in the coal-gas. A comparison given below of the two forms of heating shows the difference in favour of coal-gas. The figures are compiled from actual tests:

Heating power of coal-gas is 150,000 calories per each thousand feet, as against water-gas 74,950 calories per each thousand feet.

To be effective as an illuminant, water-gas requires to be strongly carburetted as by exposure with the vapours of naphtha, petroleum and the like, to a high temperature, after which it makes a good illuminant, though even then much inferior to well-refined coal-gas.

When steam is passed over red-hot coke or charcoal, hydrogen is also produced with carbonic oxide gas, and this in fact is the ordinary process of making *water gas*, which being purified is afterwards saturated with some volatile hydrocarbon and burnt. At first sight, such a mode of making gas would be thought extremely profitable, and in spite of the numerous failures the *discovery* (so called) of *water gas* is reproduced as a sort of chronic wonder; but experience and practice have clearly demonstrated that *water gas* is a fallacy,

and as long as we can get coal it is not worth while going through the round-about processes of first burning coal to produce steam; secondly, of burning coal or coke to heat other coke or charcoal, over which the steam is passed to

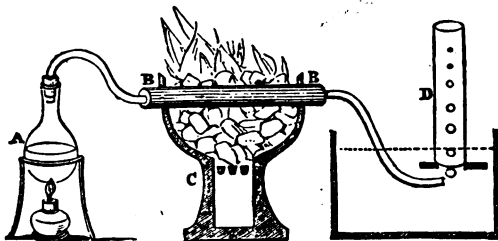

Fig. 140. A. Flask containing water, and producing steam, which passes to the iron tube, B B. containing the iron borings heated red hot in the charcoal stove C. The hydrogen passes to the jar D, standing on the shelf of the pneumatic trough.

be converted into gas, which has then to be purified and saturated with a cheap hydrocarbon obtained from coal or mineral naphtha; whilst ordinary coal gas is obtained at once by heating coal in iron retorts. (Fig. 140.)

Thus, by the metals zinc, tin, potassium, red-hot iron (and several others might be added), the oxygen of water is removed and hydrogen gas liberated.

#### *Fourth Experiment*

Hydrogen gas may be passed by means of a piece of glass tubing into a mixture of soap, glycerine, and warm water, or a solution of oleate of soda; the resulting bubbles being filled with the gas, which is much lighter than air, will rise quickly to the ceiling, where they will float about and remain till they burst, or till the gaseous diffusion referred to in Chapter I causes the hydrogen to mix with the air, thus losing its lifting property. See also page 76 and seventeenth experiment, page 151.

#### *Fifth Experiment*

If bottles of hydrogen gas are prepared by all the processes described, they will present the same properties when tested under similar circumstances. A lighted taper applied to the mouths of the bottles of hydrogen, which should be inverted, causes the gas to take fire with a slight noise, in consequence of the mixture of air and hydrogen that invariably takes

place when the stopper is removed; on thrusting the lighted taper into the bulk of the gas it is extinguished, showing that hydrogen possesses the opposite quality to oxygen—

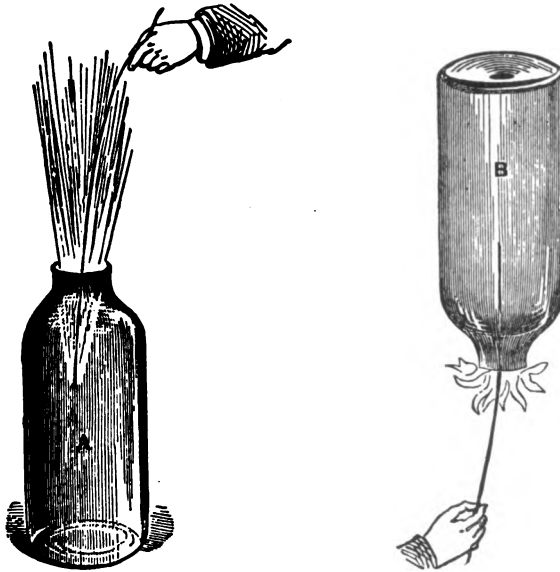

Fig. 141. A. Bottle opened upright, and hydrogen exploding. B. Bottle opened inverted, and hydrogen burning quietly at the mouth.

viz., that it takes fire, but does not support combustion. By keeping the bottles containing the hydrogen upright, when the stopper is removed the gas escapes with great rapidity, and atmospheric air takes its place, so much so that by the time a lighted taper is applied, instead of the gas burning quietly, it frequently astonishes the operator with a loud pop. This sudden attack on the nerves may be prevented by always experimenting with inverted bottles. (Fig. 141.)

#### *Sixth Experiment*

If a little spongy platinum is fastened to a rod of wire, it will not only light hydrogen gas, but coal gas, if it is placed over the burner with the gas turned on. This is the active principle in the automatic gas-lighters which are sold in the form of sticks, tubes, and the like, the ends being placed over the burner as the gas issues from it. Effective as is this

spongy platinum for such a purpose, it is scarcely safe to have exposed, but ought to be kept in a well-stoppered bottle, since if there should be an escape of gas, the platinum, if exposed, would soon be reached, the escaping gas ignited, and an instant explosion follow. The explanation of this curious phenomenon will be found on page 155.

### Seventh Experiment

Fit a bottle with a cork containing a glass tube drawn out to a point and bent at right angles. Fill the bottle with hydrogen gas, insert the cork, and when the air is expelled and the gas escapes through the fine hole of the tube, apply a light and the hydrogen will burn quietly with its characteristic flame. (See caution in Experiment 8.)

If a cold beaker is inverted over the burning hydrogen, fine drops of moisture will be seen to gather inside. This is caused by the chemical union of the hydrogen gas with the oxygen contained in the small portion of atmospheric air inside the beaker, the combination forming water, which is made up of two parts of hydrogen and one of oxygen, the symbol for water being  $H_2O$ , as we have seen.

### Eighth Experiment

Get a bottle with two necks, such as a Woulfe's bottle, Fig. 142 "B." Take the same taper-ended tube from the last experiment, and place it in a cork to fit "B" 1.

2. Bend another tube at each end, at right angles, on one end placing a cork to fit "B" 1, on the other end a cork to fit "A" 1. Fill bottle or flask "A" with hydrogen gas, pour a little benzene into bottle "B" and connect up quickly. Escape will take place through the fine hole at "B" 3. A little air which has remained in the tube and the bottle "B" will come off first, but in a few moments this will be expelled and a light may be applied. It is always safest

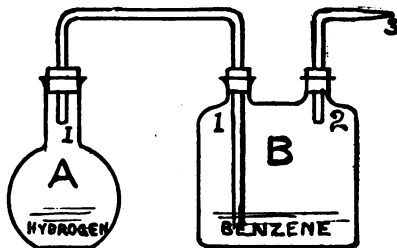

Fig. 142. Experiment for showing the burning of hydrogen with a luminous flame. (Read exper. 8 before lighting the gas.)

to hold a test tube over the escaping gas and light the hydrogen collected in that first; if air is present, there will be a sharp "pop," and a fresh trial must be made till the gas burns quietly; not till then should the gas issuing from the bottle direct be lighted, or an explosion may result. To return to the experiment: when the air has passed away, apply a light to "B" 3, and this time, instead of the non-luminous flame of hydrogen of Experiment 7, there will now be a flame giving excellent illumination, but not so much heat as in the last experiment with hydrogen only.

#### *Ninth Experiment*

Hydrogen is 14.39 times lighter than air, and for that reason may be passed into bottles and jars without the assistance of the pneumatic trough. One of the proofs of its levity is that of filling paper bags or balloons with this gas; and it is quite a common thing to see at fêtes balloons ingeniously constructed to represent animals, so that a regular aerial hunt is exhibited, with this drawback only, that occasionally the animals prefer to ascend with their legs upwards, a circumstance which provokes mirth. The lightness of hydrogen may be shown in two ways—first, by filling a small goldbeater's-skin or silk balloon with *pure* hydrogen (prepared by passing the gas made from zinc and dilute pure sulphuric acid through a strong solution of potash, and afterwards through one of nitrate of silver), and allowing the balloon to ascend; then afterwards, having of course secured the balloon by a thin twine or strong thread, it may be pulled down and the gas inhaled, when a most curious effect is produced on the voice, which is suddenly changed from a manly bass to a ludicrous nasal squeaking sound. The only precautions necessary are to make the gas quite pure, and to avoid flame whilst inhaling the gas. Of course, if it were possible to change by some extraordinary power the condition of the atmosphere in a concert-room or theatre, all the bass voices would become extremely nasal, whilst the sopranos would emulate railway whistles and screech fearfully; and supposing the specific gravity of the air was continually and materially changing, our voices would never be the same, but alter day by day, according to the state of the air, so that the "familiar voice" would be an impossibility.

A bell rung in a gas jar containing air emits a very different sound from that which is produced in one full of hydrogen—a simple experiment is easily performed by passing a jar containing hydrogen over a self-acting bell, such as is used for telegraphic purposes, or that of an ordinary common alarm clock. (Fig. 143.)

#### *Tenth Experiment*

Some of the small pipes from an organ may be made to emit the most curious sounds by passing heavy and light gases through them; in these experiments cylinders containing the gases should be employed, which may drive air, oxygen, carbonic acid, or hydrogen, through the organ pipes at precisely the same pressure.

#### *Eleventh Experiment*

Get a piece of combustion tubing about three-quarters of an inch inside diameter and about eighteen inches long. Turn up the bent taper-delivery tube from the hydrogen apparatus, so that both tube and flame are vertical; take the length of combustion tube and place it over the hydrogen jet so that the flame will be two or three inches inside it. Hold the combustion tube vertical and it will emit a musical note. By varying the width and length of these pieces of combustion tubing, it is possible to get a complete gamut of notes, and several philosophical organs have been constructed to play by jets of burning hydrogen.

#### *Twelfth Experiment*

One of those toys called "The Squeaking Toy" affords another and ridiculous example of the effect of hydrogen on sound when it is used in a jar containing this gas. (Fig. 144.)

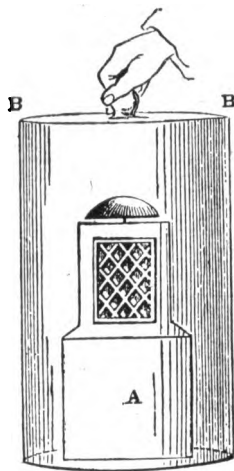

Fig. 143. A. Stand and bell. B B. Tin or glass cylinder full of hydrogen, which may be raised or depressed at pleasure, by lifting it with the knob at the top, when the curious changes in the sound of the bell are audible.



*Thirteenth Experiment*

Any musical instrument played in a large receptacle containing hydrogen gas demonstrates still more clearly what would be the effect of an orchestra shut up in a room containing a mixture of a considerable portion of hydrogen with air, as the former, like nitrogen, is not a poison, and only kills in the absence of oxygen gas.



Fig. 144. The squeaking toy, used in a jar of hydrogen.

*Fourteenth Experiment*

Some very amusing experiments with balloons have been devised by firework manufacturers, to carry signals of various kinds, and thus the motive or ascending power may be utilised to a certain extent. These are dealt with in the following chapter on Aërostation, which see (P. 162).

*Fifteenth Experiment*

Soap bubbles blown with hydrogen gas ascend with great rapidity, and break against the ceiling; if interrupted in their course with a lighted taper they burn with a slight yellow colour and dull report.

*Sixteenth Experiment*

By constructing a glass or metallic mould in two halves, of the shape of a tolerably large flask, a balloon of collodion may be made by pouring the collodion *inside* the vessel, taking care that every part is properly covered; the mould may be warmed by the external application of hot water, so as to drive off the ether of the collodion, and when quite dry the mould is opened and the balloon taken out. Such balloons may be made and inflated with hydrogen by attaching to them a strip of paper, dipped in a solution of wax and phosphorus, and sulphide of carbon; as the carbondisulphide evaporates, the phosphorus takes fire and spreads to the balloon, which burns with a slight report. The mould must be very perfectly made, and should be bright in-

side; if the balloons are filled with oxygen and hydrogen, allowing a sufficient excess of the latter to give an ascending power, they explode with a loud noise directly the fire reaches the mixed gases. Glass moulds will answer equally well and are considerably cheaper than metal; both, however, can be obtained from the scientific apparatus dealer.

#### *Seventeenth Experiment*

In a soup-plate place some strong soap and water; then blow out a number of bubbles with a mixture of oxygen and hydrogen; a loud report occurs on the application of flame, and if the room is small the window should be placed open, as the concussion of the air is likely to break the glass.

The best solution for bubble blowing is made by dissolving a quarter of an ounce of Castile, brown-windsor, or other non-transparent soap (or better still, oleate of soda, pure), in not more than ten ounces (half a pint) of water; then filter through clean, unused blotting paper, and add five ounces of glycerine. Stir the mixture well, and it will be found to give a permanent and most tenacious film. See page 76, and fourth experiment, page 145.

#### *Eighteenth Experiment*

Any noise repeated at least thirty-two times in a second produces a musical sound, and by causing a number of small explosions of hydrogen gas inside glass tubes of various sizes, the most peculiar sounds are obtained. The hydrogen flame should be extremely small, and the glass tubes held over it may be of all lengths and diameters; a trial only will determine whether they are fit for the purpose or not.

#### *Nineteenth Experiment*

Flowers, figures, or other designs, may be drawn upon silk with a solution of nitrate of silver, and the whole being moistened with water, is exposed to the action of hydrogen gas, which removes the oxygen from the silver, and reduces it to the metallic state.

In like manner designs drawn with a solution of chloride of gold are produced in the metallic state by exposure to the action of hydrogen gas the design appearing as if drawn in silver or gold, as the case may be. Chloride of tin, usually

termed muriate of tin, may also be reduced in a similar manner, care being taken in these experiments that the fabric upon which the letters, figures, or designs are painted with the metallic solution be kept quite damp whilst exposed to the hydrogen gas.

### *Twentieth Experiment*

A mixture of two volumes of hydrogen with one volume of oxygen explodes with great violence, and produces two volumes of steam, which condense against the sides of the

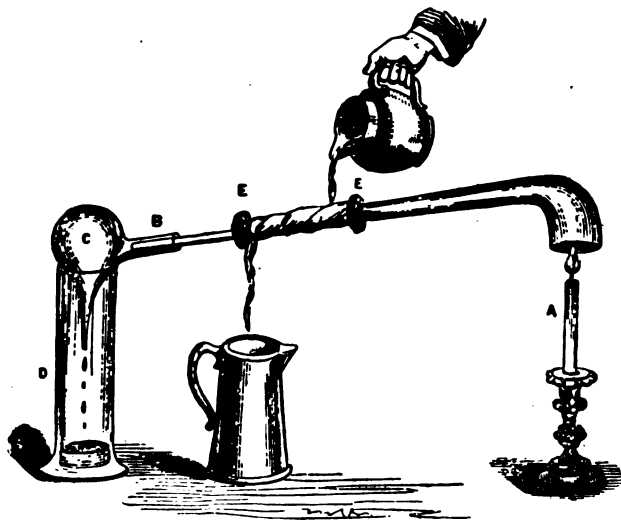

Fig. 145. A. Burning candle, or oil or gas lamp. Copper head and long pipe fitting into B C, the receiver from which the condensed water drops into D. E E. Two corks fitted, between which is folded a wet rag, cold water being poured or dripped on it to cause rapid condensation in the tube round which the rag is folded.

strong glass vessel, in which the experiment may be made, in the form of water. As the apparatus called the Cavendish bottle, by which this experiment only may be safely performed, is somewhat expensive, and requires the use of an air-pump, gas jars with taps, and an electrical machine and Leyden jar, other and more simple means may be adopted to show the combination of oxygen and hydrogen, and formation of water.

If a little alcohol is placed in a cup and set on fire, whilst an empty cold gas jar is held over the flame, an abundant

deposition of moisture takes place from the combustion of the hydrogen of the spirits of wine. Alcohol contains six combining properties of hydrogen, with four of charcoal and two of oxygen. If a lighted candle, or an oil, camphine, or gas flame, is placed under a proper condenser, large quantities of water are obtained by the combustion of these substances. (Fig. 145.)

#### *Twenty-first Experiment*

During the combustion of a mixture of two volumes of hydrogen with one of oxygen, an enormous amount of heat is produced, which is usefully applied in the arrangement of the oxy-hydrogen blowpipe. The flame of the mixed gases produces little or no light, but when directed on various metals contained in a small hole made in a fire brick, a most intense light is obtained from the combustion of the metals, which is variously coloured, according to the nature of the substances employed. With cast-iron the most vivid scintillations are obtained, particularly if after having fused and boiled the cast-iron with the jet of the two gases, one of them, viz., the hydrogen, is turned off, and the oxygen only directed upon the fused ball of iron, then the carbon of the iron burns with great rapidity, the little globule is enveloped in a shower of sparks, and the whole affords an excellent notion of the principle of Bessemer's method of converting cast-iron at once into pure malleable iron, or, by stopping short of the full combustion of carbon, into cast-steel.

The apparatus for conducting these experiments are of various kinds, and different jets have been from time to time recommended on account of their alleged safety. It may be asserted that all arrangements proposed for burning any quantity of the *mixed* gases are extremely dangerous: if an explosion takes place it is almost as destructive as gunpowder, and should no particular damage be done to the room, there is still the risk of the sudden vibration of the air producing permanent deafness. If it is desired to burn the *mixed* gases, perhaps the safest apparatus are those so arranged that backfiring is impossible. Names of makers cannot be given, but the appliances are obtainable from the scientific dealers.

In the oxy-hydrogen blowpipe usually employed, the gases

are kept quite separate, either in cylinders, gasometers or gas bags, and are conveyed by distinct pipes to a jet of very simple construction, originally devised by Daniell, where

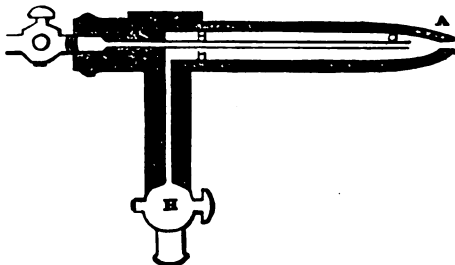

Fig. 146. Daniell's jet. O O. The tap and pipe conveying oxygen, and fitting inside the larger tube H H. to which is attached a tap. H. connected with the hydrogen receiver. A. The orifice near which the gases mix, and where they are burnt, the gases being stored in cylinders of drawn steel or the hydrogen orifice connected by tubing to the coal gas supply.

they mix in very small volumes, and are burnt at once at the mouth of the jet. (Fig. 146.)

The oxy-hydrogen jet is further varied in construction by receiving the gases from separate reservoirs, and allowing

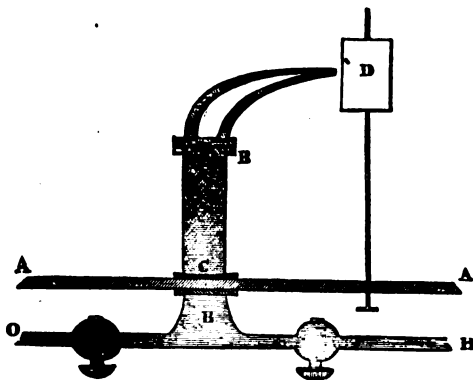

Fig. 147. A A. Board to which B B is fixed. O. Oxygen pipe. H. Hydrogen pipe. C C. Space filled with wire gauze. D. Lime cylinder.

them to mix in the upper part of the jet, which is provided with a safety tube filled with circular pieces of wire gauze. (Fig. 147.) With this arrangement a most intense light is

produced, called the Drummond or lime light, and coal gas is usually substituted for hydrogen, except when very high temperatures are necessary.

*Twenty-second Experiment*

There are many circumstances that will cause the union of oxygen and hydrogen, which, if confined by themselves in a glass vessel, may be preserved for any length of time without change; but if some powdered glass, or any other finely-divided substance with sharp points, is introduced into the mixed gases at a temperature not exceeding 660° Fahrenheit, then the gases silently unite and form water.

This curious mode of effecting their combination is shown in a still more interesting manner by perfectly clean platinum foil, which if introduced into the mixed gases gradually begins to glow, and becoming red-hot causes them to explode. Or still better, by the method first devised by Dobereiner, in 1824, by which finely prepared spongy platinum—*i. e.*, platinum in a porous state, and exposing a large metallic surface—is almost instantaneously heated red-hot by contact with the mixed gases. When this fact became known, it was further applied to the construction of an instantaneous light, in which hydrogen was made to play upon a little ball of spongy platinum, and was immediately kindled. These Dobereiner lamps were possessed by a few of the curious, and would no doubt be extensively used if the discovery of phosphorus had not supplied a cheaper and more convenient fire-giving agent. When the spongy platinum is mixed with some fine pipeclay, and made into little pills, these may (after being slightly warmed) be introduced into a mixture of the two gases, and will silently effect their union.

A similar effect is seen if a little ether is poured into a small and narrow test tube, and a rod of thin platinum wire twisted in the form of a spiral is inserted. (For a description of the automatic gas-lighter see Experiment 6, page 146.)

The theory of the combination is somewhat obscure, but it may be taken that the cause lies in the fact that its mere presence will start the instant oxidation of many substances, accompanied by the generation of considerable heat. Also that it brings about the combination of hydrogen with the oxygen—the oxygen in the air and the hydrogen in the coal-

gas—which will burn so long as the two gases are simultaneously present. See also Experiment 6, page 146.

When Davy invented the safety-lamp, he was aware that, in certain explosive conditions of the air in coal mines, the flame of the lamp was extinguished, and in order that the miner should not be left in the dreary darkness and intricacies of the galleries without some means of seeing the way

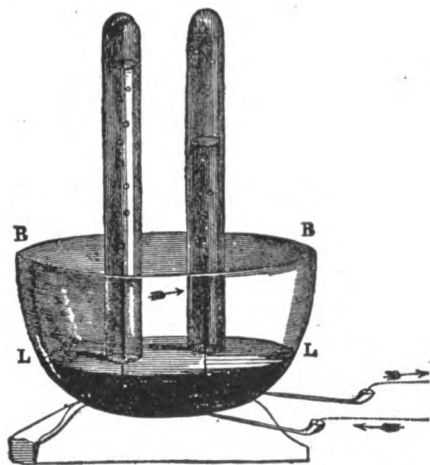

Fig. 148. P P. Two platinum plates connected with wires to the cups. The wires are passed through holes in the bowl, B B, and are fixed perfectly steady by pouring in cement composed of resin and tallow to the line L L. Two glass tubes filled with water acidulated with sulphuric acid, and placed over the platinum plates in bowl, which also contains dilute sulphuric acid to improve the conducting power of the water. The wires of the battery are placed in the cups, and the arrows show the direction of the current of electricity.

out, he devised an ingenious arrangement (see page 565) with thin platinum wire, which was coiled round the flame of the lamp, and fixed properly, so that it could not be moved from its place by any accidental shaking. When the flame of the safety-lamp, having the platinum wire attached, was accidentally extinguished by the explosive atmosphere in which it was burning, the platinum commenced glowing with an intense heat, and continued to emit light as long as it remained in the dangerous part of the mine.

Davy warned those who might use the platinum to take care that no portion of the thin wire passed *outside* the wire gauze, for the obvious reason that, if ignited *outside* the wire gauze protector, it would inflame the fire-damp.

### *Twenty-third Experiment*

Water is decomposed by passing a current of voltaic electricity through it by means of two platinum plates, which may be connected with a ten-cell Grove's battery. The gases are collected in separate tubes, and the experiment offers one of the most instructive illustrations of the composition of water. (Fig. 148.)

There is a current of electricity passing from and between two platinum plates decomposing water, offering the converse of the Dobereiner experiment, and highly suggestive of the probability of the theory already advanced, in explanation of the singular combination of oxygen and hydrogen in the presence of clean platinum foil, and more especially when we consider the operation of Grove's gas battery, in which a current of electricity is produced by pieces of platinum foil covered with finely-divided platinum, called platinum black; each piece is contained in a separate glass tube filled alternately with oxygen and hydrogen, and by connecting a great number of these tubes a current of electricity is obtained, whilst the oxygen and hydrogen are slowly absorbed and disappear, having combined and formed water, although placed in separate glass tubes. (Fig. 149.)

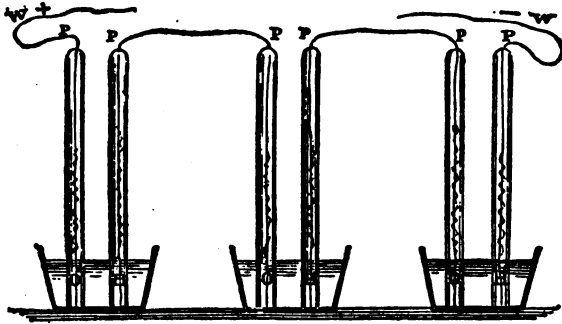

Fig. 149. Grove's gas battery consists of tubes containing oxygen and hydrogen alternately, and having a thin piece of platinum foil, P, inserted by the blowpipe in each glass tube. The foil hangs down the full length of the interior of the glass. Each pair of tubes is contained in a little glass tumbler containing some dilute sulphuric acid, and the hydrogen tube, H, of one pair, is connected with the oxygen tube, O, of the next. W W. The terminal wires of the series.

The analysis of water is shown very perfectly on the screen by fitting up some very small tubes and platinum wires in the same manner as shown in fig. 148. The vessel in which the tubes and wires are contained with the dilute sulphuric acid must be small, and arranged so as to pass nicely into the space usually filled by the picture in an ordinary magic lantern, or, still better, in one lighted by the oxy-hydrogen or lime light. If the dilute acid is coloured with a little solution of indigo, the gradual displacement of the fluid by the production of the two gases is very perfectly developed on



the screen when the small voltaic battery is attached to the apparatus.

With respect to the application of the light produced from a jet of the mixed gases thrown upon a ball or stick of lime, it is necessary to mention this process of brilliant lighting, though it is almost entirely superseded by the electric arc, oil vapour, and the like. It is seldom used now, although

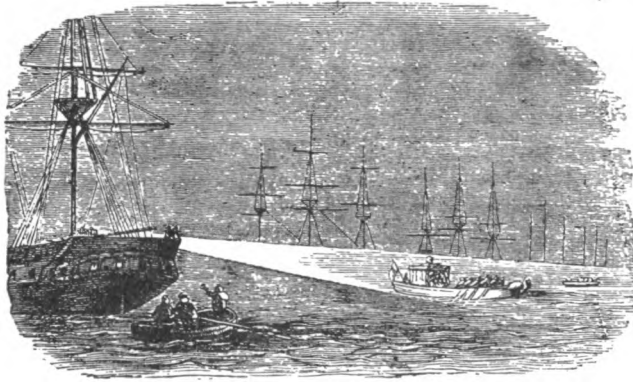

Fig. 150. Napoleon at Cherbourg.

there are certain points in its favour, but it is of extreme interest, in that, up to a comparatively recent date, dissolving views, lantern-projections, etc., were entirely dependent on it. The mixed gases condensed in the old-fashioned oil-gas receivers, and projected on a ball of lime was the light that illuminated the British men of war when Napoleon III. left H. M. yacht at night in the docks at Cherbourg. (See Figs. 149 and 150.)

Fig. 151 is an adaptation of similar gases, projected on a cylinder of lime, and used formerly by divers for submarine lighting. As this is now superseded by the electrical incandescent light, with flexible, insulated wire, it needs but passing mention.

#### THE LIQUEFACTION OF GASES

At one time, the three elements with which the preceding experiments have been made, viz:—hydrogen, oxygen, and nitrogen,—were termed “permanent gases,” because all attempts to reduce them to a liquid or solid state had pre-

viously been attended with failure, but at the present day the term "permanent gas" is altogether meaningless. Every known gas may be reduced to the liquid or even solid state when it is possible to bring down the temperature sufficiently low to make the necessary change in its condition. It is, however, interesting to note the particulars of the first successful attempt to bring the gases to a liquid state, for after many years of fruitless and laborious experimenting the scientific world became excited, when, at the close of the year 1877 Cailletet, of Paris, and Pictet, of Geneva, each working independently of the other, demonstrated that these three gases were no exception to the general law of molecular cohesion.

The first of these gases which in the hands of Pictet was made to give up its vaporous condition was oxygen, and the *Journal de Genève* of Dec. 23, 1877, thus refers to the experiments:—

"One of the most interesting physical experiments of our time has just been made at Geneva with rare success in the laboratory of the Society for the Manufacture of Physical Instruments. M. Raoul Pictet has succeeded in obtaining by means of ingeniously combined apparatus, the liquefaction of oxygen gas. The following is the process by which this curious result was obtained:—

"By a double circulation of sulphurous acid and carbonic acid, the latter gas is liquefied at a temperature of  $65^{\circ}$  of cold, under a pressure of from four to six atmospheres. The liquefied carbonic acid is conducted into a tube four metres long; two combined pumps produce a barometric vacuum over the acid, which is solidified in consequence of the difference of pressure. Into the interior of this first tube containing solidified carbonic acid is passed a tube of slightly less diameter, in which circulates a current of oxygen produced in a generator containing chlorate of potash, and the form of

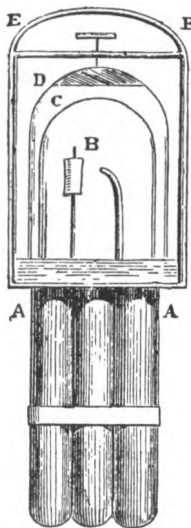

Fig. 151. A A. Tube reservoir to hold the mixed gases. B. The jet and lime ball. D. The first glass shade, held down by a cap and screw. C. The second glass shade. E E. The handle by which it is lowered into the water.

which is that of a large shell thick enough to prevent all danger of explosion. The pressure may thus be carried to 800 atmospheres.

“Yesterday morning (December 22) all the apparatus being arranged as described, and under a pressure which did not exceed 300 atmospheres, a liquid jet of oxygen issued from

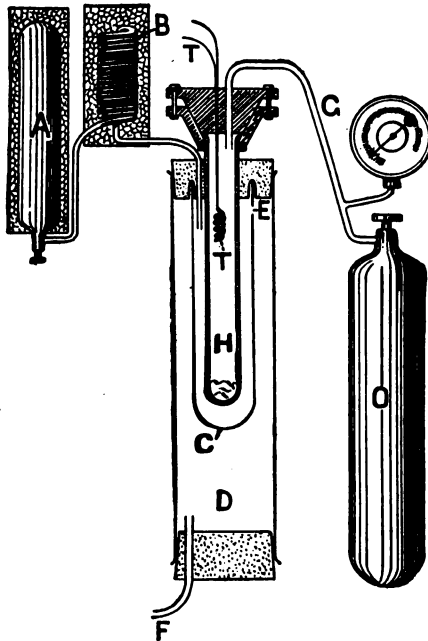

Fig. 152. Apparatus employed by Wroblewski for reducing temperature for the liquefaction of gases. (From Watson's Text Book of Physics, by permission of Longmans, Green and Co.)

the extremity of the tube, at the moment when this compressed and refrigerated gas passed from that high pressure to the pressure of the atmosphere.”

Strangely enough only twenty days before the interesting experiment above detailed Cailletet had in Paris accomplished the same thing, only he had not then published the fact. There now remained only two of the then-called “permanent gases”—nitrogen and hydrogen. The gases were subjected to more and still more pressure, in the hope that this would eventually give the desired result. This hope was realised on

the last day of the year at Paris, by Cailletet. At a pressure of 200 atmospheres nitrogen appeared in the liquid form. Hydrogen was next experimented with, and was reduced to the form of a cloud. Although both the constituents of the atmosphere—oxygen and nitrogen—had been made to succumb, as a matter of scientific interest the apparatus was charged with air, and presently a stream of liquid air was seen issuing from it.

There are various methods and apparatus for obtaining gas in liquid form, but the essential feature necessary to achieve this result is the reduction of temperature. So that all the apparatus and arrangements which are effective, resolve themselves simply into a variety of processes by which extremely low temperatures may be obtained. (See Figs. 152, 153, and 154.)

#### ACETYLENE GAS

This beautiful illuminant was originally obtained, in 1835 (exploited 1836), from metallic potassium. It was in the form of a by-product which evolved the gas on the application of water, but since the early nineties it has been made from calcium carbide.

Originally, the gas was a laboratory curiosity, but the discovery of newer and easier methods has not only reduced the cost, but simplified its manufacture.

A mixture of carbon, coke, or coal with lime, is fused in an electric furnace; this produces a substance commercially known as carbide of calcium. When water is added to this carbide, an offensively pungent, highly inflammable gas is given off. The hydrogen in the water attacks and unites with the carbon, forming acetylene gas,  $C_2H_2$ , whilst the oxygen in the water joins the lime (calcium) to form slaked lime, which is found in the water as a muddy refuse. This

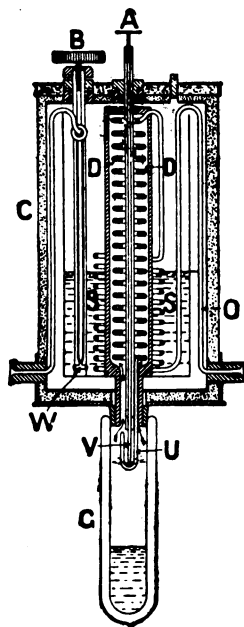

Fig. 153. Apparatus for reducing temperature for the liquefaction of gases. (From Watson's Text Book of Physics, by permission of Longmans, Green and Co.)

gas is used largely for bicycle, motor, and hand lamps; for photography, for which it forms an ideal light; for house-lighting, signaling, and a host of other purposes.

Great care must, however, be exercised in storing this car-

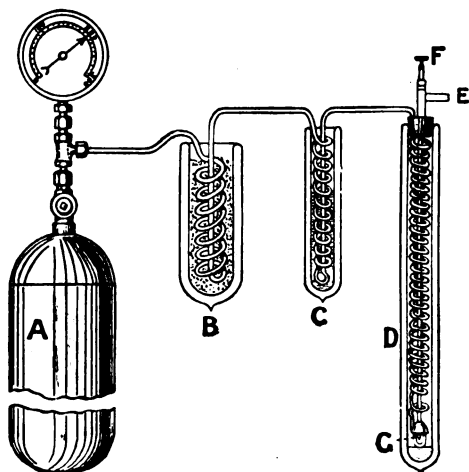

Fig. 154. Apparatus for reducing temperatures for the liquefaction of gases. (From Watson's Text Book of Physics, by permission of Longmans, Green and Co.)

bide of calcium, otherwise disastrous results may follow, as the gas is highly explosive in a certain mixture of atmospheric air.

## CHAPTER XI

### AEROSTATION—ANCIENT AND MODERN

The subject of expansion of air and gases in balloons by heat is dealt with briefly on pages 551 and 552, in the chapter on heat, to which it applies, so that the following account will be but a condensed history of the noble science and art of aviation.

Attention may first be directed to the manufacture of a good, serviceable, and cheap balloon, made of paper, cut with mathematical precision: the gores or divisions being made equal, and when pasted together, strengthened by the insertion of a string at the juncture; so that the skeleton of the balloon is

made of string, the whole terminating in the neck, which is further stiffened with calico, and completed when required by a good coating of boiled oil. These balloons are about nine feet high and five feet in diameter in the widest part, exactly like a pear, and tapering to the neck. They retain the hydrogen gas remarkably well for many hours, and do not leak, in consequence of the paper of which they are made being well selected and all holes stopped; also from the circumstance of the pressure being so well distributed over the interior by the almost mathematical precision with which they are cut, and the careful preparation of the paper with proper varnish. One of their greatest recommendations is cheapness; for whilst a gold-beater's skin balloon of the same size would cost about £5, these can be furnished at 2s each, and at much less in large quantities.

A balloon required to carry one or more persons must be constructed of the best materials, and cannot be too carefully made; it is therefore a somewhat costly affair, and as much as £200, £500, and even £1000 or more is often expended in the construction of these aërial chariots.

The chief points requiring attention are:—first, the quality of the silk; secondly, the precision and scrupulous nicety required in cutting out and joining the gores; thirdly, the application of a good varnish to fill up the pores of the silk, which must be insoluble in water, and sufficiently elastic not to crack.

The *gores* or parts with which the balloon is constructed require as before stated, great attention; it being a common saying amongst aëronauts, "*that a cobweb, if properly shaped, will hold the gas,*" the object being to diffuse the pressure equally over the whole bag or balloon.

Some makers use a closely-woven cloth, light and strong, containing in its substance a coating of rubber, but this is not very serviceable if subjected to much use, as hydrogen acts upon rubber in time. Others use the cloth after steeping it in various mixtures, and varnish it inside and out after it is made up. Needless to say, each maker has his own special material and method of manufacture, and given a good maker, the product is reliable.

Immense journeys have occasionally been safely accomplished by means of balloons in times past, and one of the

most noteworthy excursions was that undertaken in the year 1836 by the English aëronaut Green. The distance traversed upon this memorable occasion was no less than 1200 miles, namely, from London to Germany. The entire journey occupied less than twenty hours, and it is worthy of note that sufficient gas remained in the balloon to have doubled or even trebled the distance traversed had the aëronauts wished to continue their journey. Balloons of extremely large dimensions have more than once been constructed, but have mostly proved to be wholly unmanageable. One of the largest was made about fifty years ago at New York, when the bold project of crossing the Atlantic by its aid was seriously entertained. It was perhaps a fortunate circumstance for the would-be passengers, that the machine, owing to faulty manufacture, split into ribbons during its inflation. This foreshadowed the modern attempts to cross the Atlantic by aëroplane which will be fresh in the minds of all.

Such another monster balloon was the "Géant" constructed for Nadar in 1863. The car of this balloon, which was subsequently exhibited at the Crystal Palace, Sydenham, was a little two-storied house, containing every domestic convenience. The immense machine started from Paris on Sunday, Oct. 18th, 1863, and, after sailing over Belgium and Holland, descended in Hanover in such a disastrous manner that it is a matter for wonder that any of its thirteen passengers escaped with his life.

The voyagers, however, in ignorance of what awaited them seem to have left their mother earth in the highest spirits. After having satiated their eyes with the lovely panorama spread out below them, there was a general demand for dinner. Every one ate with unusual appetite, and numberless champagne bottles were speedily emptied. But as darkness fell upon them the travellers found themselves enveloped in a dense fog, a fog so damp that they were all very soon wet through to the skin. There was no moon that night, and as artificial lights were disallowed, the gloom of the passengers can be better imagined than described. "The water," writes one of these unfortunates, "which had collected on the balloon during its ascent, now began to take effect and caused it to descend with such rapidity into the dark abyss that the ballast, which was immediately thrown overboard, was over-

taken in its descent, and fell on our heads again." The balloon eventually came to the ground with an awful shock, and the passengers narrowly escaped with their lives.

The *Géant* made one more voyage which had a still more disastrous termination. On this occasion nine passengers occupied the car. They descended during a high wind, and the balloon, dragging away the grappling irons which were thrown out to catch the ground, was bumped along the earth at a terrific speed, carrying away telegraph wires and posts, and indeed everything which offered an obstacle to its fearful career. It was eventually brought to a stop by becoming entangled in a wood at Hanover, and many broken limbs and other serious injuries were received by the passengers as mementoes of their foolhardy enterprise.

The most perfect, as well as the largest balloon ever constructed up to that time, was that which rose during the 1878 Exhibition at Paris. It was designed and owned by Giffard, who is perhaps better known by the steam injector of which he was the inventor. This balloon measured more than 100 feet in diameter; a size which can be better estimated when it is stated that 100 girls were employed for one month in sewing its seams together. It was what is called a "captive balloon," that is to say, it was held by a stout rope which was wound on a steam drum. This rope allowed an ascent of 600 metres; a height sufficient to give an all-round view of the surrounding country for sixty miles. A special fabric was used in the construction of this balloon. It consisted of alternate layers of india-rubber, cloth, and canvas. It was filled with pure hydrogen, which is much lighter than the carburetted hydrogen supplied by the gas companies, and gives greater ascending power. The balloon was capable of lifting a weight of twenty-two tons, and fifty passengers could find accommodation in its car. The then Prince and Princess of Wales were among the passengers during their visit to the Exhibition.

This balloon, by its daily ascents, earned so much money for its owner, that it was decided it should again go up the following year. But one day, during an unusually high wind, it was rent from top to bottom. Thus perished the most perfect aerial machine that had ever been made; its destruction representing a loss of £20,000.



Balloons have many times been used for scientific purposes both in England and abroad. An ascent in France was so fruitful in its results, that the Academy of Sciences immediately voted a large sum to cover the expense of another ascent. Accordingly the same balloon ascended with three well-known scientists, namely, M. Tissandier, Captain Sivel, both experienced aëronauts, and M. Croce-Spinelli. By some mischance the balloon was allowed to attain a height where respiration was almost impossible, and in the sequel M. Tissandier returned to the earth with his two companions lying dead at the bottom of the car.

In this country many famous scientific ascents were made by Glaisher, accompanied by the celebrated balloonist Coxwell. In one of these ascents both of these gentlemen nearly lost their lives. They both lost the use of their hands for a time, indeed, Glaisher became quite insensible. His companion had just enough strength left to grasp the valve cord with his teeth, so as to let out some of the gas, when the descent of course began, and they were eventually saved. On this occasion a height of no less than seven miles was attained. We may therefore note this as the extreme limit to which a man may venture above the earth without sacrificing his life, and we may be quite sure that under no circumstances could he remain there except for an extremely brief period.

In modern times the balloon has been recognised as an important aid to warfare. As early as the year 1794, the French armies were provided with two companies of aëronauts. Placed in the car of a balloon these men signalled to their comrades below as to the position and movements of the enemy's troops. France, where the first of these modern balloons was made (by the brothers Montgolfier), has perhaps paid more attention to this special application of it than any other country, and her endeavours to make balloons useful in this way never met with more marked success than in the siege of Paris. At this eventful period a regular balloon post was organised, and by its aid thousands of letters found their way to anxious friends outside the confines of the city. Two of these balloons were carried out to sea and lost, some fell into the enemy's hand, but the majority escaped to friendly territory.

Our own war authorities have long been alive to the im-

portance of using balloons for military purposes, and many select committees have from time to time been appointed to report upon the subject. A series of experiments were carried out at Woolwich in the seventies, and some of the results recorded are most striking and interesting. The generation of hydrogen in the field was accomplished by passing steam over red-hot iron by means of a portable stove. As a result of these trials at Woolwich, two balloons were placed in commission.

Many attempts have been made from time to time to reach the North Pole wholly or partly by balloon; one of these earlier projects being that of Commander Cheyne, who had served on three Arctic explorations, and detailed elaborate plans which were at that time deemed feasible, but, like many previous enterprises, ended in failure. The most important of recent times was that of Andrée, a Swedish engineer, who left Dane's Island, Spitsbergen, in 1897 with a 60 ft. diameter balloon, his fate being still unknown.

No one who has witnessed the ascent of a number of these great balloons collected together can ever forget the sight. The giant envelopes, expanded to the full with gas, sway to and fro on the breeze, dragging angrily at their ropes in mighty unrest, as if their mass would dash the frail cars to atoms the instant freedom was obtained. The occupants-to-be, meanwhile, walking below, seem in comparison but animated dolls, whom the great ball or other-shaped mass overhead was trying, with frantic energy and fretfulness, to crush.

At length the aëronauts board their cars, an electric flash or other signal is given, the ropes are cast off, and the immense masses of wobbling impotence, their impatience satisfied, are now docile, and, gently as the movement of a swan, slowly and majestically glide away, becoming fainter and fainter till lost in the blue of the sky and the distance, and the fact is realised that science is gradually conquering the air as certainly as she has conquered many of the difficulties of the companion element, water.

It is true ships can be guided and are not as a rule at the complete mercy of the elements, except by accident, whereas the simple uncontrollable balloon is under the direct influence of every wind that blows.

For centuries past, science has recognised that if a balloon is to be of any permanent value as a means of locomotion, it must be capable of being steered, which gives rise to a problem which has filled and is still occupying the mind of every one interested in aërostation.

Many scientists, in their endeavours to solve this problem, have lost their lives, martyrs to the cause of aërial advancement, their sacrifice showing to successors wherein they failed. Intelligent survivors are not slow to profit by such sad experience, so that not only do intrepid enthusiasts enroll themselves on the list of men who have died for science, but every such death brings nearer the conquest of the air. It is also safe to say that each one of these fatalities, in the subsequent remedying of the causes, saves countless lives.

Theory is not everything. Only by means of actual flight has it been found that the enormous surface exposed to the pressure and force of the winds by a balloon of any size, is a matter which science must negotiate; not entirely at present, perhaps, but without enthusiasm we may say the time is sufficiently near to cast its shadow of success before it on the present, or maybe, the next succeeding generation. Therefore, the scientific war of friendly emulation goes on; with steadily increasing keenness as the climax seems to be perceived, far away perhaps, like looking through the wrong end of a telescope, but there all the same, and, like such a view, not so distant as it appears.

Thus in the many varieties of shape and construction, scientific workers have, amongst others, the following important problems always in mind,—the bulk of their vessels, be they planes or balloons; the desired motion as against the force of the wind which may be moving at any speed from a quarter of a mile to eighty or more miles per hour; and the machinery carried.

In the first place, it will readily be understood that the fabrics of the gas-filled balloon would give way in any attempt to tear, work, or pull itself against such a force as a swiftly-moving wind, and in the last case the engine or other power has not yet been invented that will enable it to do all this safely and effectively, without grave danger to the occupant of the vessel, who usually fully realises that he goes with his life at stake at every ascent, no matter how short.

Science should therefore be deeply grateful to the men who are ready and willing to risk so much in order to add a little knowledge to that left by their predecessors, for it is only by such "littles" that success can eventually come.

During the last few years the strides made in this direction have been phenomenal; so much so, indeed, that one might almost be tempted to think that the science and art of aerial flight must be new, and that every success recorded has really and truly opened up new ground; yet the science is one of the oldest known, for the art of ballooning and of aerial navigation may truly be said to have arisen in about the year 260 B.C., when Archimedes made his simple but wonderful discovery of the scientific estimation of specific gravity. (See page 69.) It is not to be inferred that differences in specific gravity were not known before then, because even from the earliest times, the primeval races of man would see that twigs, trees and the like floated on water, so that the building of boats followed in proper sequence from the hewn-out logs, in simple evolution. It was thus self-evident that grass, wood, and many other substances were lighter, as most stones are heavier, than water. Archimedes, however, brought the matter to its scientific application,—that a fluid will support just so much only of the weight of a body immersed in it, as equals the weight of that portion of the fluid which is displaced by the immersed body.

To this discovery science owes the present ironclad, which floats gently on the water when the same iron, in separate pieces, would immediately sink.

To this same discovery, also, we owe the possibility of aerial flight, for if we are able to work out correctly weight and force, as compared with displacement, with added contingencies of wind-force, we can then construct balloons, airships, aeroplanes, and the like, and be sure of attaining more or less of navigable success. Therefore, applying this same law of Archimedes, we find that when a block of wood is immersed in water, (or any other substance placed in air, water, or other fluid) the force supporting it is exactly equal to the weight of the fluid displaced.

If the object is heavier than the liquid, it then goes on displacing more and more, sinking deeper and deeper, till grav-

ity pulls it to the bottom, and we say it sinks. But if the body is lighter than the liquid and is therefore unable entirely to resist the buoying-up force of such liquid, this force will be equal to the difference between the weight of the object and that of the fluid which is displaced by it.

To give an illustration of this. Suppose we take an aëroplane, airship, or balloon, which covers as much space as displaces 20,000 lbs. of atmospheric air, itself weighing, complete with men and fittings, 15,000 lbs.; there would thus be a difference of 5000 lbs. between the two, or in other words, the aëroplane would be 5000 lbs. lighter than the air displaced. This aëroplane, therefore, without any motor or outside assistance whatever, would thus be impelled upwards by a force equal to 5000 lbs., and this force would slowly diminish as the aëroplane rose, and as the air became more rarefied, until a stratum of air was reached which, being more rarefied, weighed only 15,000 lbs., or roughly, the same weight as the aëroplane complete; that is, the volume of displaced air which weighed 20,000 lbs. on the ground, higher up would weigh 15,000 lbs., for the purpose of comparison eliminating the slightly reduced weight of the aëroplane, owing to the altitude attained, Faraday calculating that a body lost about a 350,000th of its weight at a height of 30 feet from the ground—its source of gravity.

Both now weighing the same, the aëroplane would float in that particular stratum of air, just as a well-built ship floats on the sea, unable of itself to sink or rise unless the conditions are altered, and then only so much as a difference could be made between the two, such as by altering a vane which would present an edge to cut through the air and vary the amount displaced, or to present a vane-surface to the wind and gather force from that.

Simply put, this is the whole crux of the science of aërostation, water-navigation or of that of any other object which floats upon a liquid, the ultimate success or failure depending entirely on the correct or imperfect adherence to the law discovered by Archimedes long ago.

It must not be forgotten that though air is transparent, and we seem apparently surrounded by empty space, yet air, or atmosphere, is even more a liquid than water, since its particles are so extremely mobile that they will penetrate

where water cannot be made to pass, except under great pressure. So mobile is air that no instrument yet known has been successful in creating a perfect vacuum; air, more or less attenuated, is always present, and even the highest vacuum ever created cannot be maintained for any long period; atmospheric air will creep in, no matter what is done to exclude it.

Air must therefore be looked upon as a tangible substance, not perceptible to the grasp, or to the touch of closing or moving fingers, as is water, but when it is in bulk and beaten or opposed by the great mass of an *aéroplane*, it becomes a compact thing, an actual substance like springy, quivering jelly. So that air, given proper conditions, will support great objects, may be cleaved by them as is water by the nose of a boat, and becomes an actual buoyant substance which, if used rightly, is perfectly safe, but if wrongly, allows free passage for the rapid precipitation of any object to the earth below, with all the speed with which gravity can pull.

All of us must have noticed how, when air is in violent motion, as with a strong wind, it becomes a perfectly solid yet flexible substance, filling and bagging out our garments and making them heavy as if they were packed with small shot or sand, the force often causing physical fatigue, and in extreme cases, exhaustion or disaster.

The earliest form of *aërial* flight appears to have been made by means of broad wings, which gave a great surface with little displacement, and no doubt originated the story in Greek mythology of *Dædalus*, who, after making the *Crossian* labyrinth in which to imprison the *Minotaur*, was himself imprisoned by King *Minos*, but having made some wings for himself and his son *Icarus*, they flew across the *Ægean* Sea. *Icarus*, however, flew too near the sun, which melted the wax by which his wings were attached to his body, and he fell, to be drowned in the sea.

Several attempts at flight by wings strapped to the shoulders and legs seem to have been made between the years 800 and 1100 A.D. The next authentic record is, that at the crowning of *Fo Kien* in 1306 A.D. at *Pekin*, as related by *Basson*, in 1694, a large balloon was sent up in honour of the event. This is supposed to have been made of extremely fine silk and sent up by heated air, and was no doubt the proto-

type of the hot-air balloons made by the brothers Montgolfier, in 1772 and 1782.

The discovery of hydrogen gas by Cavendish in 1766 was destined to revolutionise matters, for the following year, when the gas had been proved to be nearly fifteen times lighter than atmospheric air, it occurred to Professor Black (Edinburgh), that if this air could be confined in a very light bag, in rising it would take up a weight with it. He made the experiment, proved the soundness of his reasoning, and thus inaugurated the first gas-filled balloon.

Notwithstanding the great cost, then as now, of hydrogen gas, the science of ballooning became increasingly popular. Based on the old law of Archimedes, all shapes of balloons were produced, the makers finding, in the severe school of experience, that all failures were due to the want of some impossible compliance with the great law of displacement and weight, or to some careless or faulty construction.

For many years this state of things continued, lives being lost here and there, to the benefit of those following, so that there has been evolved and is still being evolved, greater perfection in construction. Valves which originally stuck and often caused bursts and disaster, are now brought under better action by springs; balloons that were unmanageable, were brought more under control by the guide-line, and improvement slowly followed improvement to the highly efficient and dirigible balloons of to-day.

This guide-line is a long rope which hangs down from the balloon, often trailing on the ground, thus forming a drag on the balloon's progress, at the same time steadying its motion. It will be understood that as the weight of this rope has to be carried, it acts as a kind of anchor, preventing a too high rising. When too much of it lies on the ground there is less drag on the balloon, which becomes lighter in consequence and rises, till pulled down again by the weight of the rope. This rope, therefore, acts both as an elevator and depressor, tending to keep the balloon at one normal height, and that without wasting gas or ballast, the loss of either being vital. If gas is let out for a fall, it is irretrievably lost, and on the other hand, every grain of ballast thrown over the side for a rise is equally irrecoverable when weight is wanted. Either of these if done to excess is like killing

one's camel for water, and then dying in the desert for want of the camel.

All makes of balloons, aéroplanes and the like, may be placed in two simple classes—those lighter than the air displaced, and those heavier.

In the former class, we have gas balloons of all kinds. These are seldom filled with pure hydrogen, owing to its cost and the difficulty of obtaining it in large quantities when and where wanted, so coal gas is mostly used instead. This is a carburetted hydrogen, with carbon in addition to the hydrogen and is far more convenient to use, besides being considerably cheaper, though it is only about two and a half times lighter than atmospheric air, whilst pure hydrogen is 14.3875 times lighter. All in this class are true lifters, rising into the air much as a cork rises in water, and are at the mercy of every wind that blows. Beyond a little steadying and a somewhat imperfect form of guidance, they can only really be directed by rising or falling from one stratum of air-current into another which chances to have a wind travelling in the direction in which the aëronauts wish to proceed. In the dirigible balloons, the addition is made of propellers and vanes which may be driven by a motor, reliance being placed chiefly on the support and stability of the buoyant balloon overhead, which balloon the machinery and vanes keep under control. With this combination, aëronauts are enabled to pass through, and contrary to, moderately strong winds.

In these as well as in some types of ordinary balloons, there is often a miniature balloon enclosed, and in some instances encased, in the envelope. This internal bag is filled with air, driven into it by a fan worked from the motor in the framework below, and when the gas expands—as from a sudden ray of sunshine, or the increased heat due to long subjection to the sun's rays,—instead of the envelope bursting as it might possibly do, the gas presses on the outside of the air-bag, and in squeezing it, drives out the air; so that the collapsed inner bag gives the necessary space for the expansion of the gas. When the temperature has lowered, the force of gas-expansion is lessened, producing a consequent reduction of pressure on the air-bag, which then admits the air, so again swelling out, giving the necessary pressure to the



gas. Thus, not only is the loss of gas prevented, but the contour and position of the envelope is compelled to remain always constant in the various changes of atmospheric pressure and temperature through which the balloon passes; changes so rapid and severe that the air-bag is often in a constant state of quick inflation and deflation, the while, thanks to this simple but clever contrivance, the precious gas is saved and the envelope remains unchanged.

In the second class,—those heavier than air—are placed the aëroplanes proper, consisting of mono-, bi-, tri-, and multi-planes.

These owe their movement partly to the planes and partly to a motor which is carried with the machines and is driven by means of electricity, oil, spirit, etc., being mostly internal-combustion engines.

These motors and engines do not greatly differ from those used on motor cars, and get up a great speed. Compared with the balloons, etc., in the first class—the lifters—these are true “fliers,” their vanes or planes acting or vibrating on the air in similar manner to the wings of a bird.

To explain this. If a piece of thin card is cut away in the centre of one edge, in a line gradually tapering to the right and left points and the edge is slightly bent, after the manner of propeller blades, this, when held to the wind, will be found to be pulled strongly *into* it, and unless held very firmly, will be sucked or dragged out of the hand altogether. If this card is cut moderately large, to a size giving perceptible displacement, according to the law of Archimedes, then it will be dragged out of the grasp, projected upward on the air-plane at a long angle and blown away. A little net with stones may be placed on it, or suspended from it, and it is surprising how many pebbles the strip of card will carry. It is well to tie a piece of fine, strong silk to it, with which to haul it back, this also helping to steady it.

An ordinary kite is really a simple form of monoplane without motor, yet it will carry a great number of “chickens,” as its tail is called, which steady and help to control its flight much in the same manner as the silk controls the strip of card. The “pull” of such a kite is enormous, yet in expert hands it is more under a boy's control when it is high in the

air than if he had it beside him on the ground, for he can make it "dip" over, under, or into another kite near, or pass across the other's path with such force as to cut his neighbour's string, and that when the kite is so far away as to be but a tiny object.

Just as one must run with a kite and coax it up into its right air-plane by gauging the correct angle for its rising, so must a large *aéroplane* be started by motor or some other means till the air gets a distinct "pull" on it. Then it rises, the aviator controlling the planes so that he travels at a safe angle. When up, at his desired altitude, his motors drive him forward, the wind helping or "braking," as it may chance, the while he steers, raises or depresses, arches or expands his vanes, as he "feels" the need of each movement. So that by intelligent skill, he controls, not only his flight, but the direction of it and also of his safe descent.

All the time he must bear in mind the balance of his apparatus; so that in the constantly shifting centre of gravity he always keeps himself and his machine safe; manipulating his vanes and planes so that the wind, no matter the direction of it, is made of service to him; working by "feel" rather than by rule, for sudden changes of wind, or changes in the pressure of it, or a vane allowed too severe an angle will, in all probability, if not calmly and instantly controlled, mean the death of the aviator and the destruction of his machine.

If the vanes, by their area or movement displace more air than the apparatus weighs, the *aéroplane* will rise with a force equal to the difference—as already explained; when

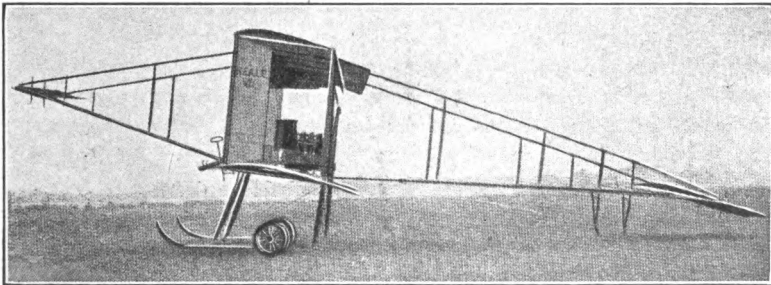

Fig. 155. Side view of the Neale Biplane. (Copyright photo reproduced by permission of "Flight.")

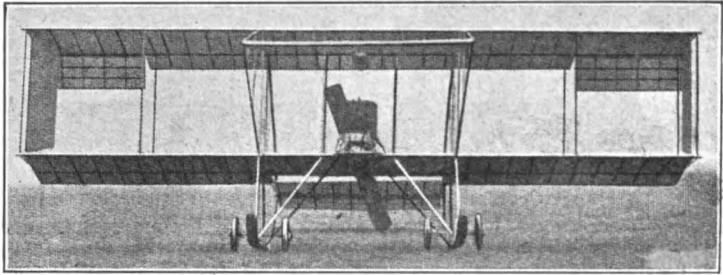

Fig. 156. Front view of the Neale Biplane. (Copyright photo reproduced by permission of "Flight.")



Fig. 157. Davies at Brooklands flying on a Hanriot Monoplane. (Copyright photo reproduced by permission of "Flight.")

once up, the aviator's skill and manipulative control will not only ensure his safety, but place the air itself almost as much under subjection to his purpose as is water to the captain of a ship. (For illustrations of modern monoplane and biplane see Figs. 155, 156, 157.)

A chronological list of some of the most celebrated aëronauts, accidents, etc., up to 1874, is appended:

- 1675. Bernair attempted to fly—*killed*.
- 1678. Besnier attempted to fly.
- 1772. L'Abbé Desforges announced an aërial chariot.
- 1783. Montgolfier constructed the first air balloon.
- 1783. Roberts *frères*, first gas balloon, destroyed by the peasantry of Geneva, who imagined it to be an evil spirit or the moon.
- 1784. Madame Thiblé, the first lady who was ever up in the clouds; she ascended 13,500 feet.
- 1784. Duke de Chartres, afterwards *Egalité* Orleans, travelled 135 miles in five hours in a balloon.
- 1784. Testu de Brissy, equestrian ascent.
- 1784. D'Achille, Desgranges, and Chalfour—Montgolfier balloon.
- 1784. Bacqueville attempted a flight with wings.
- 1784. Lunardi—gas balloon.
- 1784. Rambdaud—Montgolfier balloon, which was burnt.
- 1784. Andreani—Montgolfier balloon.
- 1785. General Money—gas balloon, fell into the water, and not rescued for six hours.
- 1785. Thompson, in crossing the Irish Channel, was run into with the bowsprit of a ship whilst going at the rate of twenty miles per hour.
- 1785. Brioschi—gas balloon ascended too high and burst the balloon; the hurt he received ultimately caused his *death*.
- 1785. A Venetian nobleman and his wife—gas balloon—*killed*.
- 1785. Pilâtre de Roziers and M. Romain—gas balloon took fire—both *killed*.
- 1806. Mosment—gas balloon—*killed*.
- 1806. Olivari—Montgolfier balloon—*killed*.
- 1808. Degher attempted a flight with wings.
- 1812. Bittorf—Montgolfier balloon—*killed*.

1819. Blanchard, Madame—gas balloon—*killed*.  
 1819. Gay Lussac—gas balloon, ascended 23,040 feet above the level of the sea. Barometer 12.95 inches; thermometer 14.9 Fah.  
 1819. Gay Lussac and Biot—gas balloon for the benefit of science. Both returned safely to the earth.  
 1824. Sadler—gas balloon—*killed*.  
 1824. Sheldon—gas balloon.  
 1824. Harris—gas balloon—*killed*.  
 1836. Cocking—parachute from gas balloon—*killed*.  
 1847. Godard—Montgolfier balloon fell into and extricated from the Seine.  
 1850. Poitevin, a successful French *aéronaut*.  
 1850. Gale, Lieut.—gas balloon—*killed*.  
 1850. Bixio and Barral—gas balloon.  
 1850. Graham, Mr. and Mrs.—gas balloon.—Serious accident ascending near the Great Exhibition in Hyde Park.  
 1850. Green, a most successful *aéronaut*.  
 1862. Coxwell—narrow escape.  
 1862. Glaisher—narrow escape.  
 1871. De Groof—flying machine from Chelsea—*killed*.  
 1874. Sivel—*killed*.  
 1874. Croce Spinelli—*killed*.  
 1874. Tissandier—escaped.

Of the 47 persons enumerated, 17 were killed, and nearly all the *aéronauts* met with accidents which might have proved fatal.

From 1874 the art of *aërial* navigation appears to have advanced little, to be revived with increasing energy and enthusiasm towards the close of the 19th century, each year, unfortunately, showing a decided increase in the death-roll, but owing to the great length of the list, mention need only be made of the chief accidents of the last few years, in which aviators of great reputation have perished:

1896. Herr Lilienthal, Germany.  
 1899. Percy S. Pilcher, an English engineer.  
 1908. Sept. 11th, Lieut. Selfridge, passenger on a Wright biplane, at Washington, U. S. A.  
 1909. Sept. 7th, Lefebvre, on a Wright, at Juvisy, France.  
 1909. Sept. 7th, E. Rossi, at Rome.

1909. Sept. 22nd, Capt. Ferber, on a Voisin biplane at Boulogne.
1909. Dec. 6th, Señor Fernandez, on a Fernandez biplane. at Nice.
1910. Jan. 4th, Mons. Delagrance, on a Blériot monoplane, at Bordeaux.
1910. April 2nd, Mons. Le Blon, on a Blériot, at San Sebastian.
1910. May 13th, Mons. Hauvette-Michelin, on an Antoinette monoplane, at Lyons.
1910. June 17th, Sperger, at San Francisco.
1910. June 18th, Herr Thaddeus Robl, on a Farman biplane, at Stettin.
1910. July 3rd, Charles Wachter, on an Antoinette monoplane, at Rheims.
1910. July 11th, Daniel Kinet, on a Farman, at Ghent.
1910. July 12th, Hon. C. S. Rolls, on a Wright, at Bour-nemouth.
1910. July 14th, Herr Oskar Erbsloch and four companions, near Cologne. This was in a balloon, not an aëro-plane.
1910. Aug. 3rd, Nicolas Kinet (brother of Daniel Kinet), on a Farman, at Brussels.
1910. Aug. 20th, Lieut. Vivaldi Pasqua, on a Farman, at Centocelle, Italy.
1910. Aug. 25th, Mons. Poillot, at Chartres, on Savary bi-plane.
1910. Aug. 25th, Mons. Fontenelle, at Maubeuge.
1910. Aug. 25th, four men of dirigible balloon "Repub-lique," between Trevol and Villeneuve.
1910. Aug. 27th, Clement Van Maasdyck, on an Antoinette, at Arnheim.
1910. Sept. 27th, Chavez, on a Blériot monoplane, at Do-modossola after successfully flying over the Alps.
1910. Sept. 28th, Herr Plochmann, at Habsheim.
1910. Oct. 4th, Haas, at Trèves, on a Wright biplane.
1910. Oct. 7th, Capt. Maziewitch, at St. Petersburg.
1910. Oct. 23rd, Capt. Madiot, at Douai.
1910. Oct. 25th, Lieut. Mente, at Magdeburg.
1910. Oct. 26th, G. Blanchard, at Issy-les-Moulineus.
1910. Oct. 27th, Lieut. Saglietti, at Rome.

1910. Nov. 17th, Ralph Johnstone, at Denver, Col., U. S. A.  
1910. Dec. 3rd, Cammarota, at Centocelle, Italy; passenger, Castellani, also killed.  
1910. Dec. 22nd, Cecil S. Grace, lost in the North Sea.  
1910. Dec. 31st, Arch. Hoxsey, at Los Angeles, on Wright bi-plane.  
1910. Dec. 31st, J. B. Moisant, at Harahan, La., U. S. A., on Blériot monoplane.  
1910. Dec. 31st, Laffont, at Mourmelon, on Antoinette monoplane; passenger, Mario Pola, also killed.  
1910. Dec. 31st, Lieut. De Caumont, at Bue, on Nieuport monoplane.

#### AERIAL SIGNALS

Over a hundred years ago (1803) the first ascent for purely scientific purposes was made, and these scientific ascents have been continued from time to time ever since.

Earlier still, war balloons were used, and it is more than possible that the increased perfection of aërostats will revolutionise the whole scheme and science of warfare, for to cope with the dropping from above of bombs filled with ball, or deadly or corrosive gases, any of the modern schemes are absolutely ineffectual.

It is interesting to note some of the signals which have been sent from balloons, and also how balloons themselves have been used as signals.

In some of the early Chinese records mention is made of kites, air-balloons and balloons made of fine paper, which have been lit with coloured fire by the manipulators on the ground below. These no doubt have been mere pyrotechnic displays, started by some special jerk on the string.

Taking a long jump from this period, we come to the time of the crowning of Fo Kien, in 1306, at Pekin, where, in addition to the large balloon already mentioned, there is recorded, by some historians, the ascent of a luminous balloon in the form of a dragon, "with fiery eyes and tongue, with scorching breath of flame which it devoured, and became destroyed thereby, falling to the ground in a mass of fire and flying sparks." This could only refer to a pyrotechnic balloon, for though Roger Bacon first introduced gunpowder into England, (see page 105) the origin of it is very remote. In-

dia and China are responsible for great quantities, if not the bulk, of the imported saltpetre, and its explosive nature when mixed with charcoal was known to the Chinese many centuries before the Christian era. Certainly the first mention of the full mixture as gunpowder is in the 7th century, where, at the defence of Constantinople when it was held against the Saracens, "Greek-fire" was used freely; the Saracens also used it against the Crusaders, sending it through the air as liquid fire, in rockets. Later still, in the 12th century, it was used, presumably for the first time in artillery, in the wars in Spain; thus we come to early in the 13th century, when Friar Bacon gave it to England.

Coming rapidly to about the middle of the 19th century, we find the Darby aërial signals, which were of various kinds, and intended to appeal to the senses by night as well as by day; and first, by *audible sounds*. Such means had long been recognised, from the ancient float and bell of the "Inchcape Rock," to the painful minute-gun at sea, or the shrill railway whistle and detonating signals employed to prevent the horrors of a collision between two trains. The signal sounds were produced by the explosion of

shells capable of yielding a report equal to that of a six-pounder cannon, and they were constructed in a very simple manner. A ball, composed of wood or copper, and made up by screwing together the two hemispheres, was attached to a shaft or tail of cane or lance-wood, properly feathered like an arrow; at the side opposite to that of the arrow—viz., at its antipodes—

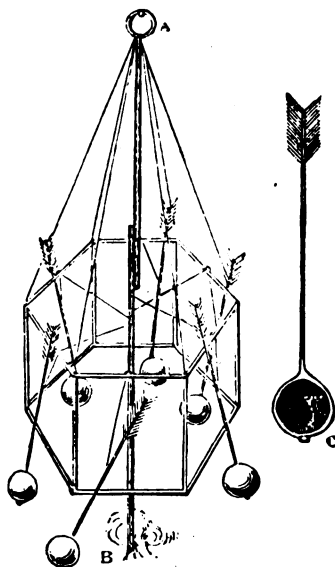

Fig. 158. A. Ring attached to balloon, carrying an hexagonal framework with six shells. B. Hollow fuse, which burns slowly up to the strings, and detaches each shell in succession. C. Section of shell. The shaded portion represents the gunpowder.



was placed a slight protuberance containing a minute bulb of glass filled with oil of vitriol, and surrounded with a mixture of chlorate of potash and sugar, the whole being protected with gutta-percha, and communicating by a touch-hole with the interior, which was of course filled with gunpowder. These shells were attached to a circular framework by strong whipcord, which passed to a central fuse, and became detached one after the other as the slow fuse (made hollow on the principle of the argand lamp) burned steadily away. Directly a shell fell to the ground, the little bulb containing the oil of vitriol broke, and the acid, coming in contact with the chlorate of potash and sugar, caused the mixture to take fire, when the gunpowder exploded. (Fig. 158, Page 181.)

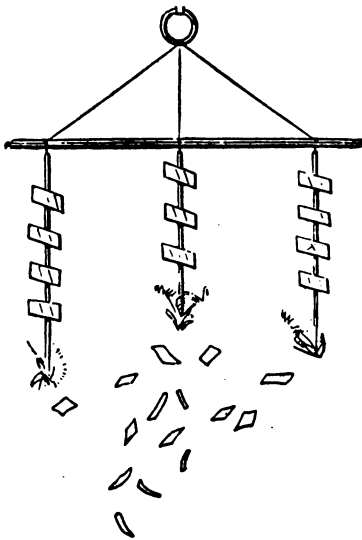

Fig. 159. The bill distributor, consisting of three hollow fuses, with bills attached in packets.

The advertising bill distributor consisted of a long piece of wood, to which were attached a number of hollow fuses, with packets of bills, protected from being burned or singed by a thin tin plate; 10,000 or 20,000 bills were thus delivered and the wind assisted in scattering them, whilst the balloon travelled over a distance of many miles. It must be recollected that in each case the shells and the bills were detached by the string burning away as the fire crept up from the fuse. (Fig. 159.)

Similar arrangements for distributing bills over a wide area were made use of by means of the Montgolfier fire balloon, which usually caught fire on the last packet being set at liberty, but by that time it had answered its purpose. Such a method of advertising is seldom if ever seen at the present day, yet for the cost of a two shilling balloon, bills were

spread over an area which the expenditure of pounds would not cover by any other method, and many people would not scruple to catch and retain a bill from a balloon, who would not accept it on any account if tendered by hand. However, this medium of advertising appears to have had its day.

Another most ingenious arrangement, termed the "Land and Water Signal," may thus be described:—A small hollow

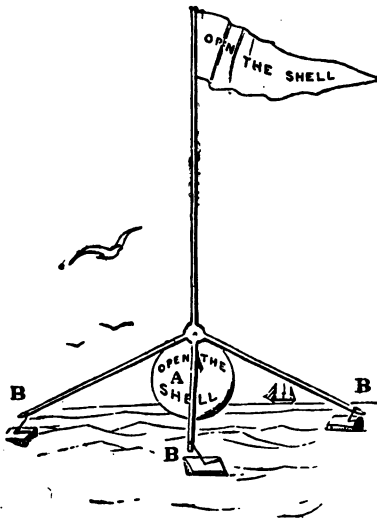

Fig. 160. The land and water signal, which remains upright on land, or floats on the surface of water. A. The water-tight gutta-percha shell, containing the message or information. B B B. Sticks of cane to keep the flag in an upright position: at the end are attached cork bungs.

ball of gutta-percha, or other convenient material, five or six inches in diameter, and filled with printed bills, or the information, whatever it may be, that is required to be sent, is attached to a cap to which are fitted a red flag, having the words "Open the shell," and four cross sticks, canes, or whalebones with bits of cork at equal distances. The whole is connected by a string to the fuse as before described. These signals are adapted for land and water: in either case they fall upright. In consequence of the sticks projecting out they float

well in the water, and can be seen by a telescope at a distance of three miles. (Fig. 160.)

Other aerial signals might be mentioned, but two further examples will be sufficient to illustrate their general utility. Some years ago, an ingenious invention was used in the form of a saucer containing plain or coloured fire, lighted by means of a time fuse. The saucer was attached to cords extending upwards to a parachute. This could be sent up by various means, when it opened, and the contents of the saucer, when fired, made a floating light, which the extending white or grey inner cover of the parachute reflected downwards over an

enemy, or on men operating or working below. The contrivance could be captive, or set free, as desired. (See Fig. 161.)

Another invention for a similar purpose, but for use at sea, is made in several forms and modifications, so that it is only necessary to explain here the broad principle which is common to all.

Calcium carbide, as we shall see, gives off a highly inflammable vapour in contact with water, and as is also seen, potassium ignites spontaneously in atmospheric air on contact with water. A simple apparatus is made which may be fired from a ship towards the region where an enemy is supposed to be lurking. On coming in contact with the water, the missile floats, being so made and weighted that it is always the right way up.

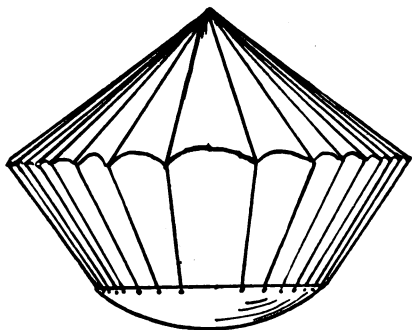

Fig. 161. Floating light.

A little below, or on, the water-line, carbide of calcium is placed, with suitable openings for ingress of water, and close by this, where it can soon get wet, is fixed a small quantity of metallic potassium. The instant the missile touches the water, the carbide becomes saturated, and acetylene gas is generated in great volume; the water also ignites the gas, so that immediately there is a great light of extraordinary intensity and power. This illuminates the sea, revealing every object on it within a radius of a mile or more, and that at a distance perhaps far beyond the power of the reconnoitering ships' searchlights to penetrate. These ships, themselves in darkness, are enabled to examine the distant vessels, so long as the carbide lasts. Should the little apparatus be struck by a shot it would still float, being made of wood and cork, and the gas would continue to burn fiercely till consumed.

Other aerial signals will readily recall themselves to the memory of the boy of average reading, using the word aerial as covering all those signals for offence or defence which are dispatched on the air, excluding arms, such as shot and shell.

## CHAPTER XII

## THE HALOGENS

## CHLORINE, IODINE, BROMINE, FLUORINE

*The four Halogens, or Producers of Substances like Sea Salt.*

Of these four elements chlorine is a gas, iodine a solid, bromine a liquid, and fluorine a gas, at ordinary temperature and pressure, and notwithstanding their differences they are much alike in their actions. Consequently, though they are considered separately, they have a great deal in common, and at the outset it is well to caution the student to be extremely careful to perform the experiments with these elements either in a good fume-cupboard, or in a room where there is a strong air-current, as their action is corrosive and highly dangerous if breathed into the system, but more will be said on this matter when dealing with their individual characteristics.

## CHLORINE

Chlorine (*Χλωρός*, green). Symbol, Cl. Its molecular weight is 70.90; its atomic or combining proportion, 35.46. Compared with air as 1, its specific gravity is 2.49. Scheele termed it dephlogisticated muriatic acid; Lavoisier, oxymuriatic acid; Davy, chlorine.

The consideration of the nature of this important element introduces to our notice one of the most original chemists of the eighteenth century—viz., the illustrious Scheele, who was born at Stralsund, in 1742, and in spite of every obstacle, fighting his “battle of life” with sickness and sorrow, he succeeded in making some of the most valuable discoveries in science, and amongst them that of chlorine gas. It was in the examination of a mineral solid—viz., of manganese—that Scheele made the acquaintance of a new gaseous element; and in a highly original dissertation on manganese, in 1774, he describes the mode of procuring what he termed *dephlogisticated muriatic acid*—a title which was strictly in accordance with the then established theory of phlogiston; and if the latter is considered synonymous with hydrogen, quite in accordance with our present views of the nature of this element. Scheele discovered the leading characteristics of chlorine, and especially its power of bleaching, which is alone sufficient to place this gas in a high commercial position, when it is con-

sidered that all our linen was formerly sent to Holland, where they had acquired great dexterity in the ancient mode of bleaching—viz., by exposure of the fabric to the atmospheric air or to the action of the damps or dews, assisted greatly by the agency of light. Some idea may be formed of the present value of chlorine, when it is stated that the linen goods were retained by the Dutch bleachers for nine months; and if the spring and summer happened to be favourable, the operation was well conducted; on the other hand, if cold and wet, the goods might be more or less injured by continual exposure to unfavourable atmospheric changes. At the present time, as much bleaching can be done in a few days as might formerly have been conducted in the same number of months; and the whole of the process of chlorine bleaching is carried on independent of external atmospheric caprices, whilst the money paid for the process no longer passes to Holland, but remains in the hands of our own bleachers and manufacturers.

*First Experiment.*

As Scheele first indicated, chlorine is obtained by the action of the black oxide of manganese on hydrochloric acid; and

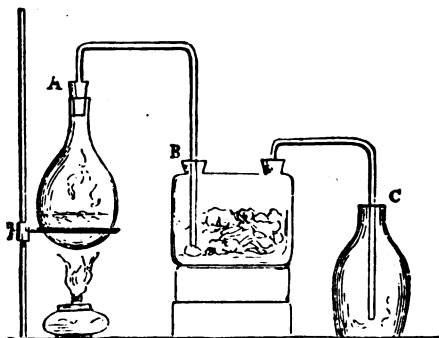

Fig. 162. A. Flask containing the fuming hydrochloric acid, which is gently boiled by the heat of the spirit lamp. B. Tube passing to the Woulfe's bottle containing pumice-stone or asbestos moistened with sulphuric acid. C. Second tube passing into a dry empty bottle, which receives the hydrochloric acid gas.

the most elementary and instructive experiment showing its preparation can be made in the following manner:—

Place in a clear flask, to which a cork and bent tube have been first fitted, some strong fuming hydrochloric acid. Arrange the flask on a ring-stand, then pass the bent tube either

to a Woulfe's bottle containing some pumice stone moistened with oil of vitriol, or to a glass tube containing either pumice or asbestos wetted with the same acid. Another glass tube, bent at right angles, passes away from the Woulfe's bottle into a receiving bottle. (Fig. 162.) On the application of heat, the hydrochloric gas is driven off from its solution in water, and any aqueous vapour carried up is retained by the asbestos or pumice stone wetted with oil of vitriol; the application of the latter is called *drying the gas*—i. e., depriving it of all moisture; sometimes the salt called chloride of cal-

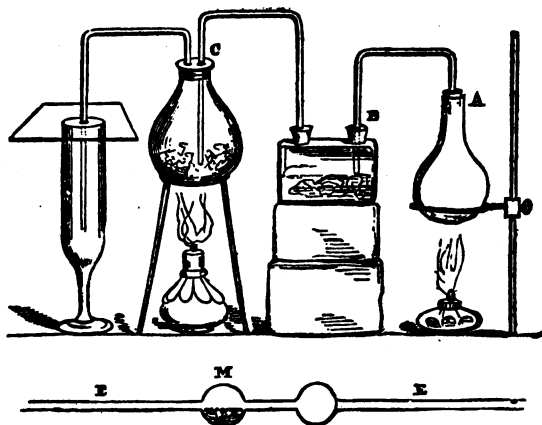

Fig. 163. A. The flask containing the fuming hydrochloric acid, heated by spirit lamp. B. Tube passing to Woulfe's bottle, containing the pumice-stone or asbestos wetted with oil of vitriol. C. Second tube, which passes into a wide-mouthed small flask containing black oxide of manganese, partly in powder and partly in lump; and the third tube conveys the chlorine to any convenient vessel. The double bulb tube, E E, may be substituted for the flask, the oxide of manganese being contained in the bulb M.—N.B. Any tube may be joined on to another by a bit of india-rubber tubing.

cium is used for the same purpose, and it must be understood by the amateur chemist that gases are not dried like towels, by exposure to heat, or by putting them in bladders before the fire, as we once heard was actually recommended, but by causing the gas charged with invisible steam to pass over some substance having a great affinity for water. The dry hydrochloric gas falls into the bottle, and displaces the air, being about one-fourth heavier than the latter, and gradually overflowing from the mouth of the vessel, produces a white smoke, which is found by litmus paper to be acid, but

has no power to bleach, and is not green; it is, in fact, a combination of one combining proportion of chlorine with one of hydrogen, and to detach the latter, and set the chlorine free, it is necessary to convey the hydrochloric gas to some body which has an affinity for hydrogen. Such a substance is provided in the use of the black oxide of manganese, which is placed either in a small flask or in a tube provided with two bulbs, and when heated with the lamp it separates the hydrogen from the hydrochloric gas, and forms water, which partly condenses in the second bulb. And now the gas that escapes is no longer acid and fuming with a white smoke on contact with the air, but is green, has a strong odour, bleaches, and is so powerful in its action on all living tissues, that it must be carefully avoided and not inhaled; if a small quantity is accidentally inhaled, it produces a violent fit of coughing, which lasts a considerable time, and is only abated by inhaling the diluted vapour of ammonia, or ether, or alcohol, and swallowing milk and other softening drinks. (Fig. 163. Page 187.)

#### *Second Experiment*

The mode of preparing chlorine, as already given, though very instructive, is troublesome to perform; a more simple process may therefore be described:—

Pour a little strong hydrochloric acid upon some powdered black oxide of manganese, contained in a bottle or flask, taking care that the whole of the black powder is wetted with the acid, so that none of it clings to the bottom of the flask in the dry state, to cause the glass to crack on the application of heat. The flask should have a delivery tube in the cork, and when gently heated, the gas will come off strongly. It may be collected by downward displacement, though some people collect it in the pneumatic trough, using strong salt water, or ordinary soft water made hot; the first portion that escapes, although it contains atmospheric air, should be carefully collected in order to prevent any accident from inhaling the gas; it will do very well to illustrate the bleaching power of the gas, therefore need not be wasted. The above process may be described in symbols, all of which are easily deciphered by reference to the table of elements, page 110.



*Third Experiment*

The gas is largely soluble in water, which afterwards, especially when saturated, has the same properties as the gas. If a little is poured into a stoppered bottle and placed in sunlight, the strong yellow colour departs along with the characteristic smell of the gas. The cause of this curious change is interesting; under the influence of sunlight it forms hydrochloric acid by absorbing the hydrogen in the water, which is thus decomposed and the oxygen in it liberated.

*Fourth Experiment*

Another and still more expeditious mode of preparing a little chlorine, is by placing a small glass beaker, containing half an ounce of chlorinated lime, usually termed chloride of lime, or bleaching powder, carefully at the bottom of a deep and large glass; then, by means of a tube and funnel, conveying to the chloride of lime some dilute oil of vitriol, composed of half acid and half water; effervescence immediately occurs from the escape of chlorine gas, and as it is produced it falls over the sides of the small beaker into the large one, when it may be distinguished by its green colour.

If a little gas be dipped out with a very small glass arranged as a bucket, and poured into a cylindrical glass containing some dilute solution of indigo, and shaken therewith, the colour disappears almost instantaneously; and if a piece of Dutch metal is thrown into the beaker it will take fire if enough chlorine has been generated, or some very finely-powdered antimony will demonstrate the same result. Thus,

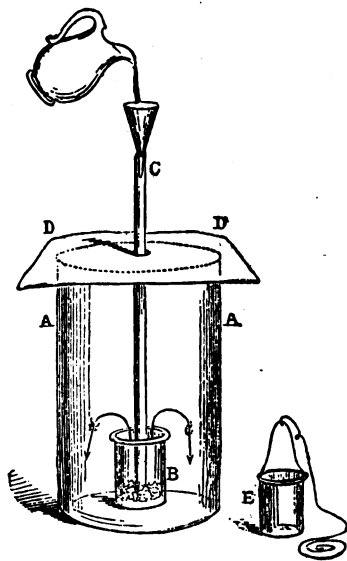

Fig. 164. A A. The large glass beaker. B. The small one, containing the chloride of lime. C. The tube and funnel down which the dilute sulphuric acid is poured. D D. Sheet of paper over top of large glass, with hole in centre to admit the tube. E. The little beaker used as a bucket.



with a few glass beakers, some chloride of lime, sulphuric acid, a solution of indigo, and a little Dutch metal, the chief properties of chlorine may be displayed. (Fig. 164.) Compare with 8th experiment page 191.

#### *Fifth Experiment*

If a combustion tube is filled with a mixture of hydrogen and chlorine, and a spark sent on the wire, there will be heard the "click" of an explosion. These mixed gases will also explode on exposure to sunlight, or to magnesium light. See Fig. 165.



Fig. 165. Exper. showing explosion of hydrogen and chlorine.

#### *Sixth Experiment*

Carefully melt some metallic sodium and place in a deflagrating spoon, and no change takes place, as at A Fig. 166.

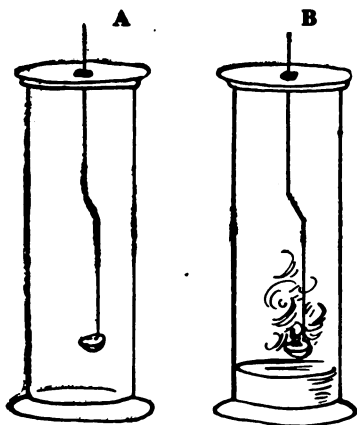

Fig. 166. A and B. Bottles containing chlorine. Sodium is spontaneously ignited in bottle, B, but not in A.

Now let the gas be moist, that is, with a little water at the bottom, as at B. The sodium is seen to ignite on immersion, burning clearly and producing chloride of sodium (common salt).

To inhale chlorine would be fatal, and sodium would be set on fire if placed on the tongue, which it would most probably burn out, together with the whole of the inside of the mouth, making a horrible wound, yet strange to say, when chemically combined these two dreadful poisons form the harmless, necessary salt, as in this and the next experiment.

#### *Seventh Experiment*

Another good experiment with sodium is to place in a little

spoon a small pellet of the metal sodium, and after heating it in the flame of a spirit lamp, introduce the metal into a bottle of chlorine, when a most intense and brilliant combustion occurs, throwing out a vivid yellow light, and the heat is frequently so great that the bottle is cracked. After the combustion, and when the bottle is cool, it is usually lined with a white powder, which will be found to taste exactly the same as salt, and, in fact, is that substance, produced by the combination of chlorine, a virulent poison, with the metal sodium, which takes fire on contact with a small quantity of water; hence the use of salt for the preparation of chlorine gas when it is required on the large scale.

	Parts.
Common salt .....	4
Black oxide of manganese .....	1
Sulphuric acid .....	2
Water .....	2

#### *Eighth Experiment*

Get a one-inch test tube, a boiling tube, and put in it a thin leaf of copper. Fit a delivery tube with a tap to the

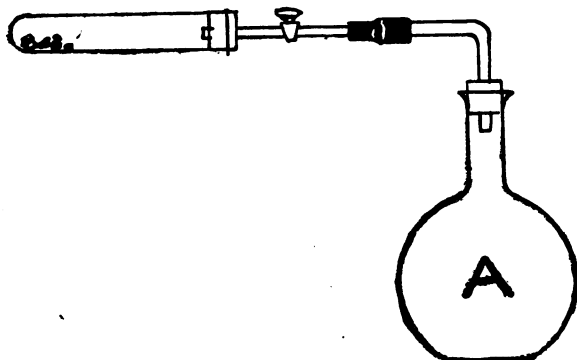

Fig. 167. The combustion of a leaf of metallic copper by chlorine coming from flask A.

cork, extract the air from the tube by means of a pump, then shut off the tap and connect to a bottle of chlorine, as in Fig. 167. Turn on the tap, when the gas from A will rush into the tube to replace the vacuum, and will set fire to the cop-

per leaf, giving off fumes of copper chloride. Compare fourth experiment, page 189.

#### *Ninth Experiment*

Some Dutch metal, or powdered antimony, or a bit of phosphorus, immediately takes fire when introduced into a bottle containing chlorine gas, forming a series of compounds termed chlorides; demonstrating by the evolution of heat and light, the energetic character of chlorine; also that oxygen is not the only supporter of combustion; chlorine gas has even, in some cases, greater chemical power, because some time elapses before phosphorus will ignite in oxygen gas, whilst it takes fire directly when placed in a bottle of chlorine.

#### *Tenth Experiment*

The weight and bleaching power of chlorine are well shown by placing a solution of indigo in a tall cylindrical glass, leaving a space at the top of about five inches in depth. By inverting a bottle of chlorine over the mouth of the cylindrical glass, it pours out like water, being about two and a half times heavier than atmospheric air, and then, after placing a ground glass plate over the top of the glass, the chlorine is recognized by its colour, whilst the bleaching power is demonstrated immediately the gas is shaken with the indigo solution.

#### *Eleventh Experiment*

As a good contrast to the last experiment, another cylindrical jar of the same size may be provided, containing a solution of iodide of potassium with some starch, obtained by boiling a teaspoonful of arrowroot with some water; any chlorine left in the bottle (tenth experiment) may be inverted into the top of this glass and shaken, when it turns a beautiful purple blue in consequence of the liberation of iodine by the chlorine, whose greater affinity for the base produces this result. The colour is caused by the union of the iodine and the starch, which form together a purple compound, and thus the apparent anomaly of destroying and producing colour with the same agent is explained. (See also page 197 and fourth experiment page 198.)

#### *Twelfth Experiment*

Dry chlorine does not bleach, and this fact is easily proved

by taking a perfectly dry bottle, and putting into it two or three ounces of fused chloride of calcium broken in small lumps, then if a bottle full of chlorine is inverted over the one containing the chloride of calcium, taking the precaution to arrange a few folds of blotting paper with a hole in the centre on the top of the latter, to catch any water that may run out of the chlorine bottle at the moment it is inverted, the gas will be dried by contact with the chloride of calcium, and if a piece of paper, with the word chlorine written on it with indigo, and previously made hot and dry, is placed in the chlorine, no change occurs, but directly the paper is removed, dipped in water, and placed in a bottle of damp chlorine, the colour immediately disappears. (Fig. 168.)

This experiment shows that chlorine is only the means to the end, and that it decomposes water, setting free oxygen, which is supposed to exert a high bleaching power in its nascent state, a condition which many gases are imagined to assume just before they take the gaseous state, a sort of intermediate link between the solid or fluid and the gaseous condition of matter. The nascent state may possibly be that of ozone, to which we have already alluded as a powerful bleaching agent.

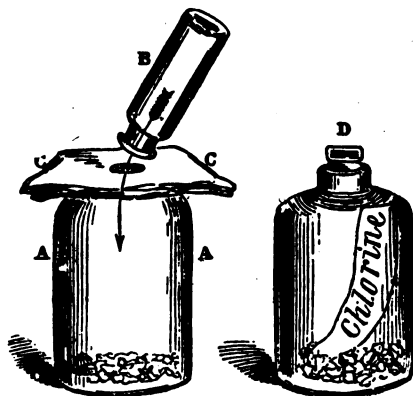

Fig. 168. A A. Dry bottle, containing chloride of calcium. B. Bottle of chlorine. The arrow indicates the gas. C C. The blotting paper, to catch any water from the bottle, B. D. The bottle closed, and containing the paper.

### Thirteenth Experiment

A piece of paper dipped in oil of turpentine emits a dense black smoke, and frequently a flash of fire is perceptible directly it is plunged into a bottle containing chlorine gas; here the gas combines only with the hydrogen of the turpentine, and the carbon is deposited as soot.

*Fourteenth Experiment*

If a lighted taper is plunged into a bottle of chlorine it continues to burn, emitting an enormous quantity of smoke, for the reason already explained, and demonstrating the perfection of the atmosphere in which we live and breathe, showing that had oxygen gas possessed the same properties as chlorine, the combustion of compounds of hydrogen and carbon would have been impossible,

in consequence of the enormous quantity of soot which would have been produced, so that some other element that would freely enter into combination with it must have been provided to produce both artificial light and heat. Chlorine is a gas which cannot be inhaled, and ozone presents the same features, as a mouse confined for a short time with an excess of ozone soon dies; but ozone is the allotropic condition of oxygen; the element in the ordinary state is harmless, and is the one which enters so largely into the composition of the air we breathe.



Fig. 169. Remarkable deposition of carbon during the combustion of one volume of olefiant gas with two of chlorine.

*Fifteenth Experiment*

When one volume of olefiant gas (prepared by boiling one measure of alcohol and three of sulphuric acid) is mixed with two volumes of chlorine, and the two gases agitated together in a long glass vessel for a few seconds with a glass plate over the top, which top should have a welt ground perfectly flat, they unite on the application of flame, with the production of a great cloud of black smoke, arising from the deposited carbon, whilst a sort of roaring noise is heard during the time that the flame passes from the top to the foot of the glass. (Fig. 169.)

*Sixteenth Experiment*

Formerly Bandanna handkerchiefs were in the highest estimation, and no gentleman's toilet was thought complete without one. The pattern was of the simplest kind, consisting only of white spots on a red or other coloured ground. At that time these spots were produced in a very ingenious manner by pressing together many layers of silk with leaden plates perforated with holes; a solution of chlorine was then poured upon the upper plate, and pressure being applied it penetrated the whole mass in the direction of the holes, bleaching out the colour in its passage. This result may be imitated on the small scale by placing a piece of calico dyed with Turkey red between two thick pieces of board, each of which is perforated with a hole two inches in diameter, and corresponding accurately when one is placed upon the other. The pieces of board may be squeezed together in any convenient way, either by weights, strong vulcanized india-rubber bands, or screws, or by a piece of hoop iron, and when a strong solution of chlorine gas or of chloride of lime is poured into the hole and percolates through the cloth, the colour is removed, or the part is bleached almost instantaneously by first wetting the calico with a little weak acid, and then pouring on the solution of chloride of lime. On removing and washing the folded red calico it is found to be bleached in all the places exposed to the solution, and is now covered with white spots. (Fig. 170.)

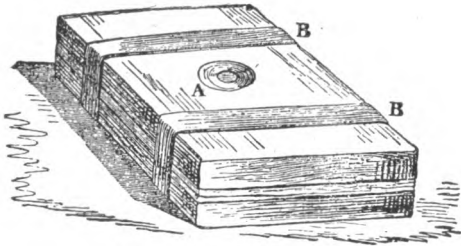

Fig. 170. A. Circular hole in the upper piece of wood, a similar one being perforated in the lower one. B B. The strong india-rubber bands. The bleaching solution is poured into A.

In addition to those properties already made evident by the foregoing experiments, it should also be repeated that chlorine is a powerful irritant and caustic, dissolving the

membranes of the throat, lungs and eyes, and if inhaled pure is almost certain death.

#### IODINE

Iodine (ἰώδης, violet coloured). Symbol, I; combining proportion 126.92; specific gravity, 4.948. Specific gravity of iodine vapour, 8.72 = air as 1.

In the previous section, devoted to the element chlorine, little or nothing has been said of that inexhaustible storehouse of chlorine, iodine, and bromine—the boundless ocean. Some one has remarked that, as it is possible the air may contain a little of everything capable of assuming the gaseous form, so the ocean may hold in a state of solution a modicum of every soluble substance, in proof of which we read of some very important experiments resulting in the separation of the metal silver from sea water, not certainly in any profitable quantity, as yet, but quite enough to prove its presence in the ocean.

No elaborate research is necessary to ascertain the presence of chlorine, when it is remembered that all the oceans on the globe contain three millions fifty-one thousand three hundred and forty-two cubic geographical miles of salt, or about five times more than the mass of the Alps.

Now, salt contains about 60 per cent. of chlorine gas, and therefore the bleachers can never stand still for want of it; but iodine is not so plentiful, and was discovered in 1812 by Courtois, of Paris, in *kelp*, a substance from which he prepared carbonate of soda, or washing soda; but as this is now more cheaply prepared from common salt, the kelp is at present required only for the iodine salts it contains, as also for the chloride of potassium. Kelp is obtained by burning dried sea-weeds in a shallow pit; the ashes accumulate and melt together, and this fused mass broken into lumps forms kelp. The ocean bed has its fertile and barren plains and mountains, and amongst the so-called “oceanic meadows” are to be mentioned the two immense groups and bands of seaweed called the Sargasso Sea, which occupy altogether a space exceeding six or seven times the area of Germany.

The iodine is contained in the largest proportion in the deep sea plants, such as the long elastic stems of the *fucus palmatus*, etc. The kelp is lixiviated with water, and after

separating all the crystallisable salts, there remains behind a dense oily-looking fluid, called "iodine ley," to which sulphuric acid is added, and after standing a day or two the acid "ley" is placed in a large leaden retort, and heated gently with black oxide of manganese. The chlorine being produced very slowly liberates the iodine, as already demonstrated in experiment eleven, p. 192, and it is collected in glass receivers.

Although quantities of iodine are made in this way, the greater part of that used is made from Chilian saltpetre.

Iodine, when quite pure and well crystallised, has a most beautiful metallic lustre, and presents a bluish-black colour, affording an odour which reminds one at once of the "sea smell."

#### *First Experiment*

A few grains of iodine placed in a flask may be sublimed at a very gentle heat, and afford a magnificent violet vapour, which can be poured out of the flask into a warm bottle. Or, if the bottle is cold, the iodine condenses in minute and brilliant crystals. (Fig. 171.)

#### *Second Experiment*

Upon a thin slice of phosphorus place a few small particles of iodine; the heat produced by the combination of the two elements soon causes the phosphorus to take fire.

#### *Third Experiment*

Heat a brick, and then throw upon it a few grains of iodine; by holding a sheet of white paper behind, the splendid violet colour of the vapour is seen to great advantage. It was by the discovery of iodine in the ashes of sponge—which had long been used as a remedy for goitre, a remarkable glandular swelling—that this element began to be used for medical purposes, and the important salt called iodide of potassium is now used in large quantities, not only in medicine, but also in photography.

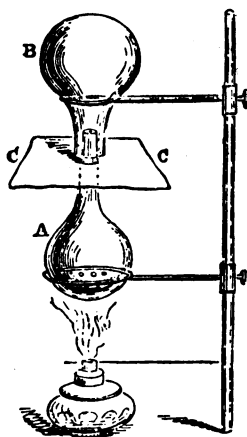

Fig. 171. A. Flask containing iodine heated by spirit lamp. B. Cold flask above to receive the vapour. C. Sheet of cardboard to cut off the heat from the spirit lamp.



*Fourth Experiment*

Perhaps the most interesting of the many interesting properties of iodine is its power of imparting a beautiful blue colour to dilute starch-paste, this being one of the analytical tests for iodine. On heating the solution, the blue colour first fades, then disappears, but returns as the solution cools. This is an extremely delicate test, and shows even the slightest trace of iodine. (See also eleventh experiment, page 192, and compare with third experiment, page 200.

## BROMINE

Bromine (Βρωμος, a bad odour). Symbol, Br. Combining proportion, 79.92. Specific gravity, 3.188.

The connexion between chlorine, iodine, and bromine has been pointed out already; and as we have to notice the colour of the element bromine, the chromatic union of the triad may be alluded to. These elements present very nearly all the colours of the spectrum:

Bromine ..... red to orange.  
 Chlorine ..... yellow to green.  
 Iodine ..... blue, indigo, violet.

These three elements also furnish examples of the three conditions of matter; iodine being a solid, bromine a fluid, chlorine a gas; the relation of their combining proportions is also curious: as might be expected, the fluid bromine takes an intermediate position, and (according to the axiom that half the sum of the extremes is equal to the mean) by dividing the combining proportions of iodine and chlorine, and adding them together, we have, as nearly as possible, the combining proportion of bromine.

Chlorine .....	$35.46 \div 2 = 17.73$
Iodine .....	$126.92 \div 2 = 63.46$
	81.19

The combining proportion of bromine is 79.92, but 81.19 is so near, that it may reasonably be conjectured future experiments will reduce the number of the three elements, and may prove that they are only modifications of a single one. This is the only kind of alchemy which is tolerated in

the present century, and any philosopher who will reduce the number of elements, and prove that some of them are only modifications of others, will achieve renown.

Bromine was discovered by Balard, in 1826, and, like chlorine and iodine, is a constituent of sea water. The chief source of bromine is Stassfurt carnallite. The process by which it is obtained from mineral waters and salt springs offers a good example of chemical affinity; the water of the mineral spring is evaporated, all crystallisable salts removed, and a current of chlorine gas passed through the remaining solution, which changes to a yellow colour, in consequence of the liberation of the bromine by the combinations of chlorine with the bases previously united with the former; the liquid is then shaken with ether, which dissolves out the bromine. In the next place, the ethereal solution is agitated with a strong solution of potassa, and is thus obliged to part with the bromine which is converted into bromate of potassa; this is ultimately changed by fusion to bromide of potassium; and by distillation with black oxide of manganese and sulphuric acid, the bromine is finally obtained. Six processes are therefore necessary before the small quantity of bromine contained in the mineral-spring-water is separated.

Bromine is made mostly from sea-salt and saline deposits, and is a dark red, heavy liquid, giving off red fumes or vapour. Its effect on the human body is corrosive and suffocating, attacking the throat and lungs in a similar manner to chlorine; it is particularly destructive to the eyes, causing excruciating pain and irritation. Particular care must be taken not to drop any bromine on the skin, which it will corrode, making a sore which is a very long time in healing; on some skins it is impossible to heal the wound and a permanent sore is made.

#### *First Experiment*

Dissolve a little bromide of potassium in water and add to it a small quantity of chlorine water. The chlorine sets free the potassium, which becomes chloride of potassium, and the bromine being liberated, colours the water.

#### *Second Experiment*

Bromine combines instantly and violently with potassium,

yet metallic sodium does not combine readily, notwithstanding its close resemblance to potassium in many of its properties; but if a little water is added to unite the two (bromine and clean sodium), then reaction takes place readily. A couple of drops of bromine may be placed in a test tube in which a small pellet of sodium, about the size of an ordinary pin's head, may be dropped. It will be seen that no reaction takes place till a spot of water is placed on them.

*Third Experiment.*

Mix a little starch paste and add to it a spot of bromine, when the whole will be coloured a beautiful yellowish orange. (Compare with fourth experiment, page 198.)

*Fourth Experiment*

Bromine is a very heavy fluid, which should be preserved by keeping it in a bottle covered with water; when required, a few drops may be removed by means of a small tube, and dropped into a warm bottle, which is quickly filled with the orange-red vapour. If some phosphorus is placed in a deflagrating spoon, and exposed to the action of bromine vapour, it takes fire spontaneously.

*Fifth Experiment*

Powdered antimony sprinkled into the vapour of bromine immediately takes fire.

*Sixth Experiment*

A burning taper immersed in a bottle containing the vapour of bromine is gradually extinguished.

*Seventh Experiment*

Liquid bromine exposed to a freezing mixture of ice and salt, or reduced to a temperature of about eight degrees below zero, solidifies into a yellowish-brown, brittle, crystalline mass.

*Eighth Experiment*

A solution of indigo shaken with a small quantity of the vapour of bromine is quickly bleached. Many substances, when brought in contact with liquid bromine, combine with explosive violence; therefore experiments with liquid bromine

are not recommended, as all the most instructive and conclusive results can be obtained by the use of the vapour of bromine, which is easily procured by allowing a few drops to fall into a warm, dry bottle.

Bromine, as already mentioned, is used in the art of photography.

#### FLUORINE

Symbol, F. Combining proportion, 19.

This singular element seems almost to embody the ancient idea of the alchemists, being a sort of *alkahest*, or universal solvent; or in plainer language, its affinities for other bodies are so powerful, that it attacks every substance (not even excepting gold), at the moment of its liberation, and combines therewith, so that its isolation has not often been effected.

Fortunately, fluorine is not found in nature in a pure state. It exists largely, however, in combination with lime as calcium fluoride, better known as fluor spar. Little is known about this strange element, because its energy is so active that it is almost impossible to obtain it pure. Several processes will evolve it, but strange to say, the instant it is produced, and while it is being produced, as already stated, it acts on the vessel containing it, and at once becomes contaminated, either by the substance of which the vessel is composed or by that of its inner coating. So that instead of dealing with fluorine as an element, we are better able to note its properties as existing in combination with some other element. So we turn to it in its association with hydrogen in hydrofluoric acid, the symbol for which is HF.

As a gas, fluorine is greenish yellow, somewhat resembling chlorine; when brought into combination with hydrogen in the dark, it explodes, often very violently. It is the most active element known, for the instant it is liberated, it permeates the room and even the building in which it is being produced. This property is transmitted to hydrofluoric acid, which is dangerous in the extreme, except with the exercise of the greatest care.

In 1869, Professor Nickles, who was then trying to isolate the gas, accidentally inhaled a little of the vapour, with fatal result.

It is most corrosive in its action; a single drop of the acid,

full strength, would penetrate the flesh like a bullet, making a wound of a terrible nature, most difficult to heal and afterwards leaving an ugly scar, its effect being something like that of bromine but much more severe.

In its full strength, as a *pure*, anhydrous acid, fluorine has an instant *solvent* action on gutta-percha, but has *no* action on glass. This acid, however, is such an extremely dangerous substance to keep, that it is usually sold in a weakened condition by the addition to it of distilled water. Very curiously, when water is present, its properties are completely reversed; it then acts on glass most energetically and eats it away, which property makes the acid of great use commercially for etching glass and other substances containing silica. The acid in such a condition is sold in gutta-percha bottles, on which it has no action when dilute.

For etching purposes, it should be highly diluted, preferably by the chemist at the time of purchase; otherwise, if too strong, its remarkable activity is so great that the instant the stopper is removed from the container, the vapour will spread itself all over the room or house, and act on the glassware, such as the mirrors and the glazing of pictures, which will be bitten or "frosted" and thus rendered useless till repolished.

With all these cautions in mind, and with the exercise of reasonable care, no danger need be feared, so that the interest of the youthful scientist having been aroused, maybe, he will probably be anxious to try the following experiments.

#### *First Experiment*

Take out the glass from the face of a watch, warm it gently, and rub over it some beeswax, or an ordinary composition candle or melt the wax and dip the glass in, so that it is completely covered with a thin coating. Particular care must be taken that this coating is thin as possible, the object being merely to protect the surface of the glass, and the merest film is sufficient. If too thick, the writing is apt to be blurred. Then with a pin, or a steel pen, the points of which are too hard to separate readily, write your name and address on what is the outside of the watch glass, using just enough pressure to expose the glass underneath but no more. Scrape or pick off with a pin or needle-point any specks of wax

which may have fallen on the written part, because if the glass is not clearly exposed the acid cannot get at it, and no biting will result; be sure also that the writing is on the side of the glass that will be outside when in position, or it will show reversed.

Then get a little more wax, and after making it plastic in the fingers, build a rim round the edge of the glass to form a well or trough for the acid. (See Fig. 172.)

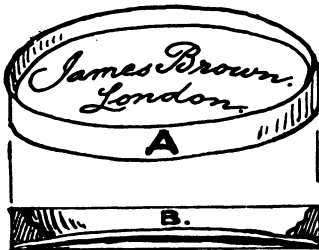

Fig. 172. A. Watch glass with built-up edge for acid. B shows what it would be like if cut across the middle, i.e., in section.

Get ready a common tumbler, and placing the waxed glass on a waxed board out in the open air, or in an outhouse, fill the trough with dilute acid and instantly invert the tumbler over it, pressing the edge well down on the waxed board so as to make an airtight joint. An old basin would answer the same purpose.

In a short time the glass will be bitten. After being well washed in water, the wax is warmed off, or removed with a little turpentine, when the glass may be cleaned and replaced, having the name and address of the owner engraved on it, more or less deeply, according to the length of time it has been exposed to the acid.

The best effect is obtained when the surface only is bitten, for then the letters appear strongly "frosted." This may take anything from fifteen seconds to two minutes according to the strength of the acid; if left longer it produces an actual cut into the glass, which might possibly go right through and spoil it.

### *Second Experiment*

Glass is now sold "flashed" various colours; that is, clear glass is made with an extremely thin film or "flash" of colour on one or both sides. So that what may appear to be red or yellow glass throughout, is only so coloured in a thin film, with clear glass in the body of it.

Buy a strip of red-flashed glass, about six inches by three, which will cost a penny or twopence. Coat it thinly with

wax as in experiment 1, and scratch out on the flashed side a name and address as before. Wax the inside of a cigar-box, insert the glass, placing it at the bottom, writing side upwards, and pour on a little of the acid. Shut down the lid,

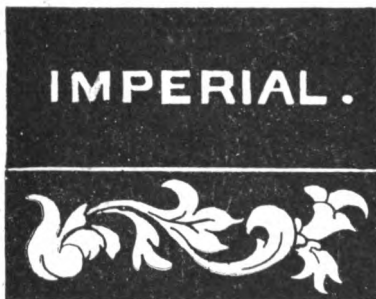

Fig. 173. Letters and a floral design have been etched away, showing clear glass on a dark (red) ground.

which may be lifted occasionally to examine the glass. Rock the box gently, as if developing a photographic plate, and in a short time the red flashing will be eaten away, which will be ascertained by seeing clear glass through all the letters. When the red has disappeared, take out the plate and wash as before, and the strip of glass when cleaned and polished will have clear letters on a red ground as in sketch. (Fig. 173.)

#### *Third Experiment*

Get another strip of similar glass, but in this case, cut the letters out of paper, wax them and stick them tightly to the flashed side of the glass,

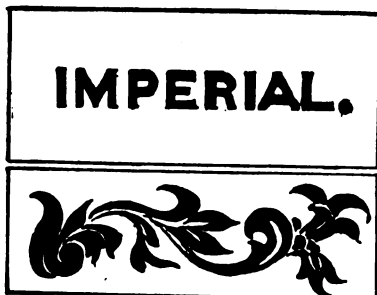

Fig. 174. Shows exactly the same lettering and design as seen in Fig. 173, but in this case the ground is etched away, leaving the "flashing" for the letters and design, which appear dark (red) on a clear-glass ground.

to which they will easily adhere, if warmed slightly. Trim off any wax which may chance to squeeze out from the letters, the edges of which must be clean and sharp on the glass. Now proceed as in the second experiment, but in this case, the flashed side must be left free from wax, except where the letters come. This time there will be red letters on a clear glass ground. (Fig. 174.)

#### *Fourth Experiment*

Get a strip of glass flashed red at one side and yellow at the

other, the two showing as orange-coloured glass. Proceed on the red side as in the second experiment. The result will be that where the red has been taken away, as in the name, the yellow on the other side will show through and where the red remains there will be no change, so that by transmitted light, yellow letters will show up strongly on an orange ground.

With this double-flash the following varieties can be made:

#### RED AND YELLOW FLASH

By etching the Red side as in Exper. 2 there will be Yellow letters on an Orange ground.

By etching the Red side as in Exper. 3 there will be Orange letters on a Yellow ground.

By etching the Yellow side as in Exper. 2 there will be Red letters on an Orange ground.

By etching the Yellow side as in Exper. 3 there will be Orange letters on a Red ground.

#### BLUE AND RED FLASH

By etching the Blue side as in Exper. 2 there will be Red letters on a Purple ground.

By etching the Blue side as in Exper. 3 there will be Purple letters on a Red ground.

By etching the Red side as in Exper. 2 there will be Blue letters on a Purple ground.

By etching the Red side as in Exper. 3 there will be Purple letters on a Blue ground.

#### RED AND GREEN FLASH

By etching the Green side as in Exper. 2 there will be Red letters on an Olive ground.

By etching the Green side as in Exper. 3 there will be Olive letters on a Red ground.

By etching the Red side as in Exper. 2 there will be Green letters on an Olive ground.

By etching the Red side as in Exper. 3 there will be Olive letters on a Green ground.

In all these cases, where both sides are etched away, the central portion of clear glass will, of course, be left.

Other colours may be selected, and most pleasing effects obtained, especially if three-coloured glass is used, such as yellow glass with a flashing of blue at one side and of red at the other.

Flashed glass is much in demand for ornamental signs, tramcar and other forms of advertising, figured lamps, window-glasses, etc. Any boy with a little taste for drawing



may obtain some beautiful effects in this manner, for both glass and the dilute etching acid are very cheap and, as already stated, require but reasonable care in their manipulation.

## CHAPTER XIII

### THE ART OF PHOTOGRAPHY

In the year 1556, a philosopher named Fabricius, in his "Book of the Metals," recorded the fact that if an image from a lens were allowed to fall upon a surface of "*luna cornea*," or horn silver, that image printed itself in black and white. This horn silver is the old term for chloride of silver, the precipitate which occurs when a solution of common salt (chloride of sodium) is mingled with a solution of nitrate of silver. The preparation of this compound is very easy, and we can readily prove for ourselves that when it is exposed to sunlight it speedily changes from light to dark.

From this relatively unimportant chemical change has sprung the beautiful art of photography, an industry which finds workers in every part of the habitable globe, and which gives employment to thousands of busy brains and hands. The invention of the "art science," as its votaries in justice dignify it, cannot very well be credited to any one man, for many workers contributed to it. And it must be noted that many of these experimenters almost unconsciously added their mite to the general result. For in their restless search after the secrets of the natural world, they recorded facts which have proved of immense service to the photographer, but which had not been sought after with that object. For many of the properties of certain chemicals were discovered and passed over as unimportant by the old alchemists, who may be said to have considered everything unimportant which did not point towards their only goal—the transmutation of the baser metals into those of greater value. The action of light upon silver chloride is, however, the most important contribution to photography that was made until quite recent years.

Another discovery, or invention, which must also be noted as one of the chief links in the chain which was gradually being forged, and which only wanted some clever artificer to join together and call photography, was that of the camera

obscura. This invention is credited to an Italian philosopher of the 16th century. He observed that if a lens were fitted into a hole in the shutter of a darkened room, a picture of all that was passing outside was formed upon the opposite wall of the room, or upon a white screen placed for its reception.

In walking beneath the shade of trees on a sunny summer's day, who has not noticed the little rays of light which find their way through the interstices of the leaves overhead, and strike upon the roadway in circular patches? We are so accustomed to see these little spots of light that we do not stop to inquire why they should be round, when the chinks in the foliage through which they find their way are necessarily of varied and irregular form. The answer to the problem will no doubt strike many with surprise. Each of those little circular patches is no less than an image of the round sun itself. The darkened grove of trees forms a rudimentary camera obscura, and the spaces between the leaves where they allow the sun's rays to penetrate, are equal to so many lens apertures. To imitate the phenomenon in a small way, we can pierce a piece of cardboard with a knitting needle, and hold it against a candle flame, when the inverted image of the flame can be projected upon another card held near. A more convenient form of camera obscura can be made out of a cigar box, by inserting a lens at one end, and a piece of ground glass at the other end, taking due care that the lens is adapted to the length of the box.

The camera obscura was at one time a very favourite and common piece of apparatus. A room built for the purpose was often attached to country houses. It was also to a certain extent used by artists as a help to correct drawing. It was one of these artists—Daguerre, a Parisian scene-painter—who was destined to be one of the first to point out how the camera could be made to yield a photograph. Day by day, he saw the lovely pictures cast in all their natural colours on the screen by the sun; and as he saw them he wondered whether some means could not be found of preserving them indefinitely. He was soon deep in experiments; but he failed over and over again. At last, a mere accident directed him on the right track. He inadvertently left a silver plate which had been treated with iodine, and exposed in the

camera, near a bottle of mercury. To his surprise and joy, he found traces of a picture on the plate; and a few more experiments quickly told him how such pictures could be produced at will.

The Daguerreotype process, the outcome of these experiments, may be briefly described as follows:—A plate of silvered copper after being carefully cleaned was placed in a box with some crystals of iodine. By this means, its surface became coated with a yellow covering of iodide of silver. It was then exposed in the camera, where the light decomposed the iodide. But there was no visible change until the plate was developed by exposure to the vapour of mercury. The mercurial fumes condensed upon those parts where the light had acted, and avoided those still covered by the unaltered iodide of silver. The plate was finally *fixed* by a solution of hyposulphite of sodium, as photographic plates are fixed to-day. (The discovery of this salt as a fixing agent—a most important one, by the way—is due to a countryman of our own, Sir John Herschell, who was born at Slough, near Windsor).

While Daguerre was busy with his experiments, another Frenchman, by name Niépce, was striving hard to obtain the same end by other means. He was experimenting with a substance called bitumen of Judæa; this when exposed to light becomes insoluble in liquids such as naphtha, in which, under other circumstances, it easily dissolves. It is not necessary to describe his operations, suffice it to say that he and Daguerre became acquainted, and finally they entered into partnership. He died just at the time that Daguerre had triumphed over all difficulties, and produced a photographic picture.

In the meantime Fox Talbot, an Englishman, was working at the problem of obtaining sun pictures by means of silver chloride on paper. He treated ordinary writing paper with a solution of common salt, afterwards washing it over with silver nitrate. By this means he obtained a sensitive surface which speedily blackened under light; and by placing fern leaves, pieces of lace, and the like above such a surface, he obtained beautiful images of such things—white on a black ground. By taking one of these prints, and placing a sensitive sheet of paper below it, he obtained other

copies, as many as he wished—black on a white ground. The first he called a *negative*, and the second a *positive*; and these terms are employed in photography to the present day.

Three years later, namely in 1847, a nephew of Niépce succeeded in producing a negative picture upon a glass plate which had been previously coated with a film of albumen, or white of egg. From such a picture positives could of course be produced by Fox Talbot's process. A better film for holding the tender image was, however, soon discovered, and the credit of the introduction is due to Archer, who first pointed out the advantages of collodion for that purpose.

Collodion is made by dissolving gun-cotton in a mixture of alcohol and ether. It is further prepared for the use of photographers by adding to it certain iodides and bromides. In this state it is quite insensitive to light, for the necessary silver compound is not formed until the glass plate bearing it has been bathed in a solution of silver nitrate. Archer's process, with hardly any variation, is practised largely at the present time, and we cannot do better than describe it in detail. Any intending beginner may commence with this process, for upon it are founded all other processes. It is not difficult, and is sure in its results.

First a word as to apparatus. Let the beginner at the outset fix a definite plan of action. If it be within his means he can have a studio constructed, and do his best to rival the productions of the professional photographer. But as it is more likely that he will be content with an occasional portrait of some friend, taken in the garden and finished in a cellar for a dark room, he need not go to much expense. The best plan is to visit some reliable dealer, and ask his advice as to the outfit required, taking care to state the sum available for the purpose. The cheapest and simplest form of camera which a boy can make himself is that shown at Fig. 175. It consists of two boxes sliding one within the other so that the picture can be focussed upon the ground glass screen, which is seen in the cut lifted half out of its groove. In the more expensive cameras the body is of bellows form and made of leather. The focus is gained by a rack mo-

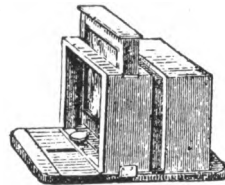

Fig. 175.

tion and a screw, this screw being turned by its milled head at the side of the camera as shown in Fig. 176. Many of the modern lenses are fixed in rigid settings, and this form of camera is for them indispensable. A convenient form of tent for landscape work, or where the operator has no dark room, is that shown at Fig. 177.

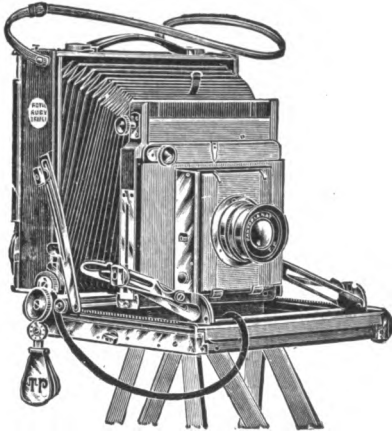

Fig. 176. Tourist's camera ready for use.

curtain at the back of the operator folds round him so as to exclude all light, except that which finds its way through the red or yellow window with which the tent is furnished. The use of the best chemicals will save the photographer from a host of troubles. These can be purchased in small quantities, and a little will be found to go a very long way.

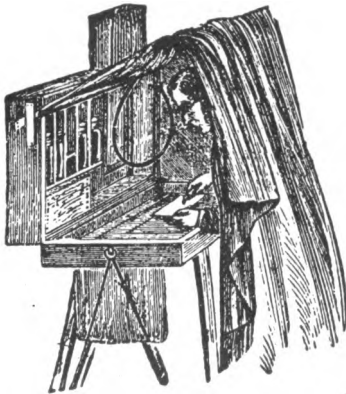

Fig. 177.

It folds up into small compass, is of light weight, and is furnished with all the necessaries for the work, which also a boy can make by means of some old boxes and some closely woven dark cloth, the boxes being covered outside with strong brown paper or else painted. The use of the best chemicals will save the photographer from a host of troubles. These can be purchased in small quantities, and a little will be found to go a very long way.

Then we come to the benefits accruing from the great strides in the advancement of chemistry, which enables workers to discard the "messy" and cumbersome wet processes, by the introduction of dry plates. At the first these would keep good and active for a few hours only after being prepared, then this time was extended to weeks; further im-

provements extended it to months, and so we arrive at the excellent modern dry plates which, when stored under proper conditions, will be active and perfect as new many years after preparation. In addition to dry plates, modern science provides stiff and flexible films, which may be loaded into the camera and even developed in daylight, making the use of a dark room almost unnecessary. The makers of photographic plates and highly efficient cameras are too numerous to mention, each specialising in certain advantages. So that beyond a brief résumé of the progress of photography this work cannot go, and the reader is advised to peruse the many excellent books specially devoted to the subject which are published by Messrs. George Routledge & Sons, the publishers of the present volume. In their list will also be found books dealing with the art of taking and producing "living pictures" both in monotone and colour; an art which brings the science of photography to such a high pitch of perfection, that events of the day may be reproduced within a few hours, as distinctly and as truly as if actually taking place on the screen.

Briefly, in photographing these living pictures,—a long, narrow, sensitised film is drawn from one spool to another, in doing which the film passes before a shuttered lens. An arrangement of gearing causes the shutter to fly back and take an instantaneous photograph on that portion of the film which is immediately behind the shutter. The operator controls the speed, and as the film passes the lens, the shutter opens and closes in rapid succession, giving a long series of instantaneous photographs, each one of which is slightly different. When prints from these, on a positive film, are drawn through a lantern and at the same rate of movement as that at which they were taken, the effect on the screen is that of a moving picture, true to life in every detail. Such in brief is the process of taking and projecting a cinematograph.

It will now suffice concisely to recount the various photographic processes in use at the present day for commercial purposes, leaving the reader to study the books on this subject, as already advised for ordinary photography, whether the aim be pleasure only or profit.

The first to mention is the carbon process, which is abso-

lutely permanent, for the so-called carbon pictures are free from the charge of want of permanency, for they are produced in pigments as lasting as the paper upon which they are laid, in many cases more so. The operator can, too, choose the colour in which the finished picture shall appear. A brief outline of this interesting process will not be out of place. It will be observed that it merely applies to the *printing* of the positive image from a negative taken in the camera in the usual manner. It may therefore be more properly called the pigmented gelatine, the Autotype, or

#### THE CARBON PRINTING PROCESS

A certain family of chemical salts possess the property of rendering gelatine insoluble after exposure to light. Taking the bichromate of potash as a type of these salts, we will follow the various manipulations involved in producing a carbon print. These may be varied to suit special needs or individual requirements, but they may be followed in the main for most purposes. Carbon tissue, consisting of paper covered with a mixture of gelatine and pigment, can be bought so cheaply, that it is unnecessary to attempt to prepare it, especially as the amateur would most probably fail in such an attempt. It is sold of various tints for different purposes, the most popular being purple, brown, black, or red, as required. After having cut the tissue to a convenient size, it must be immersed in the following solution in yellow light:—

Bichromate of potash .....	3 drs.
Water .....	12 oz.
Liquor ammonia .....	20 drops.

The solution should be placed in a dish, and the sheet of tissue should remain in it, face upwards, until it becomes flat and limp, say for 30 seconds. It is better to do this in the dark room, although a very dim or subdued light does not appear to affect the solution to any great extent, but the dark room is more satisfactory in practice. It must then be hung up on a lath, by means of a pin put through one corner, until it is perfectly dry; an operation which in a warm atmosphere will occupy four or five hours. This constitutes the sensitising operation. When perfectly dry, it is placed in a printing

frame beneath a negative, just as if it were a piece of ordinary sensitised silver paper. We cannot, however, tell how the operation of printing is proceeding, as we can in the latter case, for the colour of the tissue is uniformly dark. But we can judge of the action of the light upon it by exposing at the same time a piece of silver paper, removing the printing frame from the light when that is sufficiently darkened. A useful little instrument called an actinometer has been devised and may be purchased of any photographic dealer for sixpence and upwards. By its aid the operator can very well judge how long any particular negative will require to be exposed, in order to yield a satisfactory print. The next operation is to fix the prints on a temporary support during development. For this purpose ordinary glass may be used. It should be coated with a mixture of bees' wax and ether in the following proportions:—

Bees' wax .....	1 gr.
Methylated ether .....	1 oz.

A small quantity of the mixture should be applied to the glass, and wiped off vigorously with a piece of coarse flannel. But enough will remain on the glass to serve the purpose for which it is required, and which will be presently seen. The waxed glass is now coated with thin *plain* collodion, allowed to set, and is then placed in a dish of cold water.

The printed tissue is now removed from the frame and placed in another dish of water. When it becomes limp it should be applied to the glass plate, under water, the tissue side being pressed against the collodionised glass, to which it will readily adhere. The tissue and its support are now taken out of the water, and placed under a piece of mackintosh cloth, tissue side uppermost. The cloth is firmly rubbed with a squeegee, (an india-rubber instrument which on a large scale is often used for removing mud from the street pavements) after which the glass and adhering tissue are laid aside for ten minutes or so.

The development of the picture may then be proceeded with. Here, the only liquid required is hot water, that is to say, water of such a heat that the hand can be placed in it without inconvenience. Soon after the plate is removed to such a bath, the pigmented gelatine which has not been affected by



light, and which is therefore soluble, will begin to ooze out between the paper and the glass. By gently laving the paper with the hand, it will gradually soften, and the unaltered gelatine will come away, a dark, slimy mass, leaving the insoluble gelatine on the glass to constitute the picture. It must now be transferred to a bath of alum and water, and will then be ready for further treatment, *i.e.*, its transference to paper.

For this purpose a transfer paper is sold. After soaking in tepid water, it is applied to the print, and left to dry. Now comes apparent the use of the beeswax on the glass; without it, the transfer paper would resolutely refuse to leave the support, but by its aid, the print will either leave the glass of itself without interference, or will yield to the gentlest persuasion. The gelatine image is thus transferred to the paper, its final support, and the work is done.

The above is just a brief outline of carbon printing, without which this chapter upon photography might have been considered incomplete. Those who wish to practise this charming mode of printing, should consult the manuals published by Messrs. Dawbarn & Ward Ld.

The more common method is to save a double transfer by taking a print from the reverse of a negative.

Another simple printing process has comparatively recently been introduced, in which the picture flashes out directly it is placed in the developing bath. In this process salts of the rarer metals such as platinum, iridium, palladium, &c., are employed. These metals, when in a state of fine sub-division, are black or almost black, and the salts (held in the paper, which is exposed beneath a negative in the usual printing frame) are reduced to the metallic state by the immersion of the print in a hot solution of oxalate of iron and oxalate of potash. The picture is faintly visible when the print is removed from the frame, and, as already remarked, it flashes out directly the developer is applied. The tone of the pictures produced by this process is perhaps rather too cold to suit the taste of most people, but they have the merit of permanence.

A similar process much used abroad is based on the principle that a sticky preparation of gum, glycerine, sugar, and such-like substances, to which a little bichromate of potash is

added, becomes less sticky in proportion to the quantity, quality, and duration of light which is allowed to fall on it. The properties of bichromate of potash and other salts under the action of light have already been discussed in dealing with the carbon process.

This sticky emulsion process, which goes under various names, such as the powder, plumbago, or paste process, is remarkably simple and efficacious. As already stated, light destroys the stickiness of the preparation, so that by smearing or coating a glass plate with this solution and exposing it in a special printing-frame under a negative, the surface will be more or less reduced in stickiness, according as the light has, or has not, acted on the tacky film; the clear parts in the negative allowing free access of light, will represent a corresponding freedom from tackiness on the plate below, whilst under the black opaque parts of the negative, the emulsion will retain its original tackiness. Between the two extremes, the film will show all the gradations and shapes of the negative above, it being in reality a print of it, not in colour or chiaroscuro, but in an infinite variety of grades of stickiness.

The next process is to dust over it some highly impalpable powder which is not soluble in water;—for black, using an extremely fine plumbago, which has been well and impalpably ground, and sifted through the finest lawn or silk. This extremely fine powder will, of course, adhere in the greatest quantity to the most sticky parts, and least to the light-altered parts. The film, completely covered with the powder, is then subjected to a steady and continuous blast of air for a few moments, which removes all the superfluous powder. This powder is collected in a hood and hopper, a drum, box, or similar appliance, to be used again. The film is no longer tacky, but is coated with the plumbago in various degrees from a strong deposit in places to none, presenting a permanent film showing all shades from black, through the gamut of delicate tones to none at all.

The film as it now stands is then coated with collodion, to which the powder adheres. There is thus at this stage, at the top, a film of collodion; below this, and adhering to it, is the varying film of black-lead; below this is a sticky emulsion; next to that, is the glass, as in sketch. (Fig. 178.)

The whole is then immersed in warm water which dissolves

the gum-film, C, and leaves a beautifully soft and permanent black-lead film-print, B, on a collodion backing, A, which merely requires mounting on paper or card. When carefully

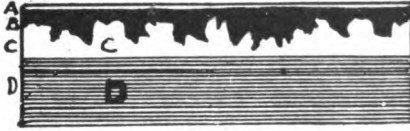

Fig. 178. Section of finished plate greatly magnified. A shows the film of collodion. B, the blacklead, which is placed here as quite distinct, but actually the collodion mixes with the powdered blacklead; C is the sticky gum-film; D, the glass.

done, this is equal to the finest "carbon," or "platinotype" print, with not a quarter of the cost and trouble. Any coloured powder may be used, provided it is not soluble in water, and that it is brought to a state of

extremely fine impalpability

Many of the finest Continental photographs and also reproductions of pictures for art and advertising purposes are executed by this process.

#### THE DIAZOTYPE PROCESS \*

This process is much used in the printing of calicos and other fabrics by means of light, and is an important branch of industry.

A fabric containing diazotised primuline (which is a fabric dyed with "primuline"—a bright yellow—and diazotised by being soaked or washed in a mixture of sodium nitrate and acetic acid), is exposed under some drawn or printed design to the action of light, preferably daylight. Where the light can pass, and in accordance with the intensity of its passage through or round the design, the parts become decomposed, whilst the covered parts which obstruct the light remain unaltered. The fabric is then dyed with any of the many available permanent dyes. Whilst the fabric itself may be dyed one or a number of colours, the dyes do not act on the design, which shows all the gradations in tone appearing in the copy or design, the print being really a positive. Owing to the remarkable cheapness and simplicity of the process, it is used very largely indeed for printing all manner of substances, such as silk, paper, velvet, wool, cotton, linen, etc.

\* A description of this process appears in the report of the British Association meeting in 1890, at Leeds, by the inventor of "primuline," Mr. A. G. Green.

## ZINCO-PROCESS

This is a highly popular and rapid process for the production of illustrations. It is absolutely necessary that the original drawings shall be made in black lines on white paper. A negative is taken which is very heavily developed, so that in the result, the lines appear perfectly transparent on an opaque ground. The negative is made the size of the desired reproduction, or usually one-third less than the size of the drawing, although the photograph may, of course, be larger or smaller. A plate of zinc is prepared with a solution of gelatine and bichromate of potash; it is then exposed to light under the negative. The light, entering the transparent lines, renders the corresponding parts below insoluble, whilst under the opaque parts of the negative the gelatine is unaffected. On washing the zinc plate the soluble gelatine is dissolved in the water, whilst the exposed parts still retain their coating.

Bitumen is also used largely for this purpose in place of the bichromated gelatine, the soluble parts being treated with a suitable solvent, both methods yielding the same result. The zinc plate, protected where the lines appear, is immersed in a bath of etching-acid, and kept in motion by oscillation. Experience and care only can decide how far the biting must be carried, so there is necessity for taking out the plate and "varnishing" it at intervals, lest it should be eaten away *under* the lines instead of at right angles to them. (See Figs. 179A and 179B.)

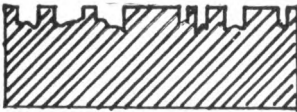

Fig. 179A. Section of a well-bitten plate enlarged. (Compare with the same design at Fig. 179B.)

Fig. 179B. A badly bitten plate.

Naturally, the liquid acid would not only bite downwards, but laterally in all directions,—so that the experienced worker so protects his plate in its various stages, by coating the sides of the lines with a varnish through which the acid cannot pass, that all the eating away is confined to the *bottom*

of each depression, however short or narrow it may be. This method is continued till all the upper surface of the plate, except the projecting lines, is bitten so deeply that it is well below the original surface covered by the gelatine, and out of all danger of being inked by the roller in the printing machine as it passes over the lines.

When the etching is complete, the plate is washed, the superfluous portions are cut away by means of suitable tools, and the plate is mounted on a hard-wood block of such a thickness that the two together are type high. They may thus be used in the printing machine along with ordinary type. Such is the process used to illustrate the text in this volume, with the exception of a few wood cuts and half-tone blocks, which will be readily distinguishable after reading the explanation of the half-tone process.

It will at once be understood that in order to obtain a good line-block, the drawing from which it is made must have clear lines of equal blackness. The "shading" is produced by varying their breadth or thickness, and where a great amount of shade is required, in order to avoid the coarse and untrue effect that would follow the use of very broad lines, it is usual to let moderately firm strokes cross each other at an angle, like lattice-work, called "hatching." There must on no account be any attempt made to shade by "wash," because washes, no matter their difference in tone, would come out as solid surfaces, being inked as such in the machine, and printed as masses of opaque and meaningless blackness.

Where it is necessary to show masses, washes of various tints, and delicate varieties of tone, which cannot very well be suggested in "line," the most common method of reproduction is by a process known as "half-tone."

#### THE HALF-TONE PROCESS

By this process practically anything can be reproduced with more or less exactness, though it is used almost exclusively for such work as contains gradation of tone, rather than line, as already explained.

When taking the photograph, a screen is interposed between the lens and the plate. This screen is a piece of glass etched in a series of diagonal lines, as in Fig. 180A.

Some workers make half the exposure with the screen in the position of Fig. 180A, the corners A, B, being at the top, whilst the lines run downward from right to left; then shielding the lens, they turn the screen half round, bringing the corners, A and B, at the side, as in Fig. 180B. So that the lines then run from left to right, downward, and the screen remains in this altered position for the second half of the exposure. Other workers, in order to avoid the changing of the

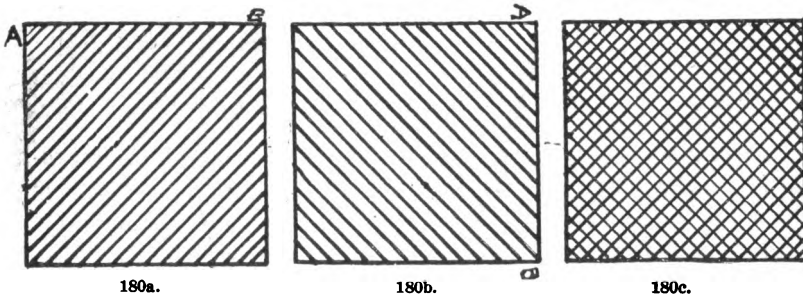

Fig. 180a. Screen with A and B at the top.  
 Fig. 180b. Screen with A and B at the side.  
 Fig. 180c. Double screen.

screen, and to obtain more perfect results, use two of these glasses or screens cemented together, so placed that their lines run at opposites, as in Fig. 180C.

Others again use a screen of very fine gauze in which the spaces are tiny round holes.

The result shows a multitude of fine dots, or diamonds, which allow the various gradations of tone and colour to be shown on the block in their true value, otherwise they would be solid.

For poster-work and all forms of large illustrations where effect at a distance is desired, these lines measure 20 to 50 to the inch, according to the size and character of the illustration; for newspaper-work and general rapid printing of this nature, there will be from 80 to 90 lines in every inch; for general art work, the number of lines contained in each inch of surface, will be from 100 to 150; whilst for high-class printing, on specially prepared, or "art" paper, there will be as many as 200 lines to the inch. These fine-grain blocks, are,

however, extremely difficult to print, owing to the ink being liable to clog and print "solid"; for which reason such blocks can never be printed rapidly.

There are many methods of obtaining the "grain-photo," as it is called, but they do not differ substantially from that described under "zinc-process," the block being etched with acid and finished with various kinds of tools, necessitating the employment of experienced workmen before the block is ready for the printer. A few minutes spent in the examination of a print from such a block, assisted by a magnifying glass, will show clearly the result of the "screen," or "grain-work," as it is technically termed.

#### HALF-TONE TRI-COLOUR PROCESS

One of the most important photographic methods of reproduction for press-printing purposes, is what is known as the tri- or three-colour process. This is the outcome of the suggestions of Maxwell and Vogel, and consists in photographing the coloured object three times, each time through a differently coloured screen, all the photographs being otherwise identical in size, position, etc. Half-tone blocks are then made from these photographs, by one of the many processes available, after which each block is printed in turn in the same colour as the screen used when taking its negative. Each block is very carefully superimposed, so that the light, split up in the first instance by the coloured light-filters or screens, is recombined by the coloured inks on the several blocks; the superimposed prints from which thus produce a mechanical replica of the natural-coloured objects.

All who have had anything to do with photography, will have felt the difficulty of getting true colour-values. Owing to the composition of light, the chemicals used in sensitising the plate are more easily affected by some of the colours of the spectrum than by others; thus blue takes lighter than it is, whilst red and green come out darker. Filters and also chromatic plates regulate this difficulty to a certain extent, but it will readily be understood that perfect reproduction of natural colours cannot be obtained when the whole of the components of white light are allowed to act on the sensitive plate at once. Since the three primary colours of pigment are red, yellow, and blue, and red, green and violet the sup-

posed primaries of *light* (see below), and all other colours found in nature are composed of various proportions of two, or all, of these primaries, it follows that if a screen is used that will admit red rays only, it will produce a negative that contains the red, and every other portion of the object photographed in which red appears even to the minutest trace, and nothing else. So that where the object is grey, there will be the merest film shown; where more red comes, as in the violets and browns, the detail will be more evident, and so on to the pure red, should there be any. Likewise with the other two primaries, each picking out its own colour in its multitudinous combinations, for no other rays can pass.

It is still an open question as to the identification of the three primary colours. The primaries of *pigments* are red, blue and yellow; those of *light* were formerly considered the same, but Helmholtz doubts this and suggests instead, red, green, and violet, supporting this view by showing that yellow and blue *light*-rays form white *light*, whereas the same coloured *pigments* give green *colour*. Other phenomena leave him unconvinced, and the matter is still an open question, as stated. (See also pages 109 and 497.)

Separately, the three negatives obtained through the three screens are unintelligible except to the practised eye, for it will be understood that each one represents only a one-third part of the complete spectrum of white light, therefore it requires the other two-thirds adding to it before the spectrum is complete. It will also be understood that if the spectrum of white light is split up into three, and exactly those three portions can be put together again, it is possible to get back the same colours and combinations of colours which were originally present in the white light by which the photographs were taken. Briefly put, this is the principle of the three-colour process:—it splits the light up into its elements of colour, and each block represents one of these elements; so that when they are superimposed in colour, there is an excellent copy of the object reproduced, in its natural colours.

In good hands, this is an ideal form of reproduction, giving almost perfect results. Some of our finest pictures, in the National and other galleries, have been copied in this way, with striking success.

Another method of photographing in colour, is to take three



negatives through the three coloured light-filters, or screens, one through each, as just described for the three-colour work. To prove the argument brought forward there, and at the same time obtain an accurately-coloured photograph by a different method, make a positive from each of these three negatives, and colour each positive over its whole surface by hand, the same colour exactly as the screen through which it was taken. The transparent lantern-slide colours with which this should be done may be purchased from any photographic dealer very cheaply. There will then be three positives, each of the identical colour of their respective screens, and each should be of such a perfect match as to appear as if covered with the screen instead of being painted.

When thoroughly dry, superimpose them carefully and place a thin sheet of clear glass over the one which will have the film exposed. Bind all four glasses together at the edges with a thin strip of gummed needle-paper, as in the making of a lantern-slide, and if they have been well placed together, the block of plates, when held to the light, will show the identical natural colours of the object photographed. So perfect will it be, that the finest tones and shades are faultless, and it may be placed in a window, or even projected on a screen by means of a lantern, with marvellous effect.

Of course, blocks cannot be made from these positives, as each set must be printed in the printing-frame and coloured separately, but the result being a perfect copy of the original, it is well worth the trouble. It is one of the most interesting forms of colour-photography, in that a boy can execute the whole process in an evening or so.

The photograph should be taken in daylight preferably, though not necessarily, as incandescent and acetylene gas give excellent results, but the colours are neither so soft nor so beautiful as those of daylight.

There are other methods of photographing direct in colour, the colour being given to the film by various chemicals, the negative, meanwhile, being turned into a positive. This makes a fresh negative necessary for every positive, and the process is too elaborate in detail to be described here. The subject is fully dealt with in the various excellent books to which reference has already been made.

## MICRO-PHOTOGRAPHY

In this, the usual lens of the camera is replaced by the attachment of a microscope, so that an object on the stage of the microscope, itself invisible except under powerful lenses, is thrown on the photographic plate, which can be readily examined in detail with the naked eye, or, by taking a transparency (a positive), be projected through a lantern on a screen, where the same detail may be examined by a large audience. It follows that if an object, so small as to be invisible without the aid of a microscope, can be enlarged to be perfectly distinct, on a quarter or half-plate, by reversing the instruments, as one might look through the wrong end of a telescope, the opposite effect is seen. So that instead of bringing the infinitesimally small to the large and visible, the large and visible may easily be rendered infinitesimal.

Much instructive scientific amusement may be obtained in this way. A picture, engraving, a long poem, or other printed matter, or illustration, may, by reversing the apparatus, be so reduced in size as to occupy less space than a pin's point, and even be altogether invisible except under the highest powers of the microscope, which reveal them with perfect clearness. Some dozens of pages of printed matter may thus be reduced to lie well in the centre of a small pin's head, and this method, though not carried to such an extreme, is often used for the transmission of messages by means of birds. The communications are usually reduced without the employment of a microscope, being merely photographed so small as to be within the limits of the capacity of an ordinary lantern to project them on a screen to a readable size.

Having obtained the negative, a print is taken from it and enclosed in a fine quill, which is tied to a carrier-pigeon, or some such bird. History records many instances where birds have been so used, especially in war time, to establish communication between distant points. During the siege of Paris, for instance, newspapers and all kinds of information were photographed, and despatched in this way.

“X-ray” photography—(see page 527).

## CHAPTER XIV

## CARBON, BORON, SILICON, SELENIUM, SULPHUR, PHOSPHORUS

These various non-metallic elements were formerly styled "Metalloids," meaning substances allied to, but not possessing, all the properties belonging to a metallic substance; therefore perhaps the expression, non-metallic solids, is the best that can be adopted. They may be subdivided into two classes of three each, which have properties more or less allied to each other—viz.,

Carbon, Boron, Silicon; and  
Selenium, Sulphur, Phosphorus.

## CARBON.

Symbol, C; Combining proportion, 12.0.

This element has almost the property of ubiquity, and is to be found not only in all animal and vegetable substances, in common air, sea, and fresh water, but also in various stones and minerals, especially in chalk and limestone.

There is, perhaps, no element which offers a greater variety of experiments and elementary facts than carbon, whether it be considered either in its simple or combined state.

A piece of carbon, in the shape of the great Cullinan Diamond, is one of the finest examples of crystallised carbon the world has ever seen. The diamond is the hardest and most beautiful form of charcoal; how it was made in the great laboratory of nature, or how its particles came together, seems to be a mystery which up to the present time has not been conclusively solved, at all events no artificial process has yet produced the diamond. (See Boron page 240.)

Sir D. Brewster, speaking of the Koh-i-Nur, or "mountain of light," remarks that on placing it under a microscope, he observed several minute cavities surrounded with sectors of polarised light, which could only have been produced by the expansive action of a *compressed gas or fluid*, that had existed in the cavities when the diamond was in the *soft* state.

Now it is known that bamboo, which is of a highly silicious nature, has the property of depositing in its joints a peculiar form of silica, called tabasheer. Silicon is one of the triad with carbon—*i.e.*, it is allied to carbon on account of certain analogies; may it not then be supposed that, in times gone by,

ages past, when the atmosphere was known to be highly charged with carbonic acid gas, there might possibly have existed some peculiar tree which had not only the power of decomposing carbonic acid (possessed by all plants at the present period), but was enabled, like the bamboo, to deposit, not silica, which is the oxide of silicium, but carbon, the purest form of charcoal—viz., the diamond? Speculation in these matters is ever more rife than stern proof, and it may be stated that all attempts to manufacture this precious gem (like those of the alchemists with gold and silver) have most signally failed, except from the fusion, at a very high temperature, of boron and aluminium, and then only in diamonds of microscopic size of no commercial use whatever. (See Boron, page 240.)

#### *First Experiment*

Box and various woods, dried bones, and different organic matters, placed in a nearly closed iron or other vessel, and heated red hot,—so that all volatile matter may escape,—leave behind a solid black substance called charcoal. If that kind obtained from bones, and termed bone black or ivory black, is roughly powdered, and placed in a flask with some solution of indigo or some vinegar, or syrup obtained by dissolving common moist sugar in water, and boiled for a short period, the colour is removed, and on filtering the liquid it is found to be as clear and colourless as water, provided sufficient ivory black has been employed.

#### *Second Experiment*

Charcoal is a disinfectant, and is used for respirators by workmen in certain trades, to absorb gas and noxious fumes; it has even been recommended medically, in the form of charcoal biscuits and lozenges. If a few drops of a strong solution of ammonium hydrosulphide (which has the odour of putrid eggs) is mixed with half a pint of water, it will of course smell strongly, and likewise precipitate Goulard water, or turn a solution of acetate of lead black; but on shaking the water with a few ounces of charcoal, it no longer smells of sulphuretted hydrogen, and if filtered and poured into a solution of lead does not now turn it black. This chemical action of charcoal, independent of its seeming mechanical attraction

for colouring matter, would appear to show that the pores of charcoal contain oxygen, which in that peculiar condensed state destroys colouring matter, and oxidises other bodies.

### Third Experiment

A very satisfactory experiment, proving that the diamond and plumbago or black lead are identical with charcoal, although differing in outward form and purity, can be made at a little cost, by purchasing a fragment of refuse diamond, called "bort," of some working jeweller or from a chemist's store. A small piece costs a few shillings. The fragment should be carefully supported by winding some *thin* platinum wire round it, as, if the wire is too thick, it cools down the heat of the bit of diamond and prevents it kindling in the oxygen gas. A difficulty may arise in preparing the fragment, in consequence of the wire continually slipping off. The "bort" should therefore be grasped by the thumb and finger, and the wire wound round; then it must be carefully turned and again wound across with the platinum wire, as shown in the sketch. (Fig. 181.)



Fig. 181. A. The platinum wire.  
B. The fragment of "bort" or refuse diamond, considerably enlarged.

A piece of black lead (so called) may now be taken from a lead pencil and also supported by platinum wire; likewise a bit of common bark charcoal or hard coke. Three bottles of oxygen should now be prepared from chlorate of potash and oxide of manganese, an extra bottle being provided for the diamond in case there should be any failure in its ignition. The bark charcoal can be first ignited by holding a corner in the spirit lamp for a few seconds; when plunged into oxygen it immediately kindles and burns with rapidity, and if the cork is well fitted, the product of combustion—viz., carbonic acid gas—is retained for future examination. The small piece of black lead is next heated red hot in the flame of the spirit lamp, and being attached by its platinum support to a stiff copper wire thrust through a cork, which fits the bottle of oxygen, is placed whilst red hot in the gas, and continues to glow until consumed. The fragment of diamond is by no

means, however, so easily ignited, the flame of the spirit lamp must be urged upon it with the blowpipe; when quite red hot, an assistant may remove the stopper from the bottle of oxygen, and the person heating the diamond should plunge it instantly into the gas; if this is dexterously managed, the fragment of bort glows like a little star, and the combustion frequently continues till the piece diminishes so much that it falls out of its platinum support.

Sometimes the diamond cools down without igniting, the same process must therefore be repeated, and a few extra bottles of oxygen will prevent disappointment, as every failure destroys the purity of the gas by admixture with atmospheric air when the stopper is removed. (Fig. 182.)



Fig. 182. A. Bottle containing bark charcoal. B. Ditto the plumbago or black lead. C. Ditto the diamond.

The combustion having ceased in the three bottles, the corks are removed, and the glass stoppers again fitted for the purpose of testing the *products*, which offer no apparent indication of any change, as oxygen and carbonic acid gas are both invisible. In each bottle a new combination has been produced; the charcoal, the black lead, and the diamond, have united with the oxygen, in the proportion of six parts of carbon to sixteen parts of oxygen, to form twenty-two parts of carbonic acid gas, which may be easily detected by pouring into each bottle a small quantity of a solution of slaked lime in water, called lime water. This test is easily made by shaking up common slaked lime with rain or distilled water for about an hour, and then passing it through a calico or paper filter. The test, though perfectly clear when poured in, becomes immediately clouded with a white precipitate, usually termed a *milkiness*, maybe in allusion to milk, which is face-

tiously supposed to contain a notable proportion of chalk and water, for in this case the precipitate is chalk, the carbonic acid from the diamond and the charcoal having united with the lime held in solution by the water and formed carbonate of lime, or chalk, a substance similar in composition to marble, limestone, Iceland or double refracting spar, these three being nearly similar in composition, differing only, like carbon and the diamond, in external appearance.

The milkiness, however, must not be held as conclusive of the presence of carbonic acid gas until a little vinegar or other acid, such as hydrochloric or nitric, has been finally added; if it now disappears with effervescence (like the admixture of tartaric acid, water, and carbonate of soda), the little bubbles of carbonic acid gas again escaping slowly upwards, leaving the liquid in the three bottles quite clear, then the experimentalist may sum up his labours with these effects, which prove in the most decisive manner that common charcoal, black lead, and the diamond, are formed of one and the same element—viz., carbon.

#### *Fourth Experiment*

Having effected the synthesis (or combining together) of the diamond and oxygen, it is no longer possible to recover it in its brilliant and beautiful form. If the product of combustion is retained in a flask made of thin, hard glass, and two or three pellets of the metal potassium are placed in directly after the diamond has ceased to burn, and the flame of a spirit lamp applied till the potassium ignites, then the metal, by its great affinity for oxygen, takes away and separates it again from that which was formerly the diamond; but instead of the jewel being deposited, there is nothing but *black*, shapeless, and minute particles of carbon obtained, if the potash produced is dissolved in water, and the charcoal separated by a filter.

#### *Fifth Experiment*

Chalk is made by uniting carbonic acid gas with lime; it may therefore be employed as a source of the gas, by placing a few lumps of chalk, or marble, or limestone, in a bottle such as was used in the generation of hydrogen gas; on the addition of some water and hydrochloric acid, effervescence takes place from the escape of carbonic acid gas, and the cork and pipe

being adapted, it may be conveyed by its own gravity into glasses, jugs, or any other vessels, and a pneumatic trough will not be required. Carbonic acid gas has a specific gravity of 1.524, and is therefore rather more than half as heavy again as atmospheric air.

#### *Sixth Experiment*

A further proof of the presence of carbonic acid in chalk, marble, and similar substances, may be seen by heating a small chipping of marble in a crucible to a fairly high temperature. Carbonic acid will escape, and quick lime remain in the crucible.

#### *Seventh Experiment*

In order to satisfy the mind of the operator that the gas obtained from chalk is similar to the *product of combustion from the diamond*, some lime-water may be placed in a glass, and the gas from the bottle allowed to bubble through it; instantly the same milkeness is apparent, which again vanishes on the addition of acid. And this experiment is rendered still more striking if a lighted taper be placed in the glass just after the addition of the acid, when it will be immediately extinguished.

#### *Eighth Experiment*

A similar effect is obtained by pouring a little lime water into a bottle filled with carbonic acid. The white sediment which forms is calcium carbonate.

#### *Ninth Experiment*

Ammonium carbonate may be obtained in like manner. Cover the mouth of a bottle of carbonic acid with a glass plate, place it on a table the right way up, and bring down on to it a similar and inverted bottle filled with ammonia gas. Now carefully invert them so that the light ammonia is at the bottom, and the heavy carbonic acid at the top. Gently withdraw the plate, so that the two bottle mouths will come together. The gases will then change places, during which fine particles of ammonia will be produced in the form of a cloud.

#### *Tenth Experiment*

If a tall cardboard box, supported by threads or chains, is



hung on one end of a scale-beam, and counterbalanced by a scale pan and a few shot, it is immediately depressed on pouring into the box a quantity of carbonic acid gas, which may have been previously collected in a large tin vessel. After showing the weight of the gas, the box is detached from the scale-beam, and the contents poured upon a series of lighted candles, which are all extinguished in succession. (Fig. 183.)

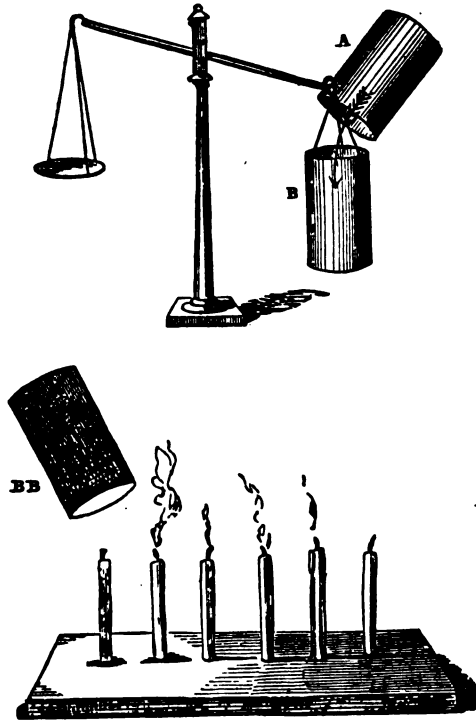

Fig. 183. A. Carbonic acid gas poured out of the tin box into B, the card-box. B B. Detached box, and candles extinguished by the carbonic acid gas poured from it.

### *Eleventh Experiment*

Re-light one of the candles and hold over the burning wick a cold carving knife. Instantly the previous supply of oxygen is reduced, and the candle burns less brightly. The cold blade lowers the temperature of the flame, and the particles of carbon which normally are being slowly consumed, their

combustion showing as the light-giving portion of the flame, are immediately cooled by the close presence of the cold steel, and failing to reach the required temperature for combustion, deposit themselves on the underside and edges of the steel, as soot.

#### *Twelfth Experiment*

Around the wick of the candle there is always a considerable quantity of combustible gas, arising from the heated wax or fat which, close as it is to the flame, never ignites, but escapes into the atmosphere. If a length of glass tubing is gently warmed, which assists in the passage of the gas, and one end of it is placed in the middle of the dark part of the flame, not too far in, the gas will rise up the narrow tube and escape at the other end. Apply a light and it will burn. If those who are sufficiently expert to analyse the gas will collect a little and experiment with it, they will find it contains a considerable quantity of gas from the wax or composition of which the candle is composed.

#### *Thirteenth Experiment*

The property of carbonic acid gas of extinguishing flame, as compared with the contrary property of oxygen, is shown by first passing into a large and tall gas jar one-half of its volume of oxygen gas; a large cork perforated with holes may be introduced, so as to float upon the surface of the water in the gas jar, and is usefully employed to break the violence with which the carbonic acid enters, as it is passed in to fill up the remaining half volume of the jar, which now contains oxygen at the top, and carbonic acid gas at the bottom. On testing the contents with a lighted taper, it burns fiercely in the oxygen, but is immediately extinguished in the carbonic acid gas, being alternately lighted and put out as it is raised or depressed in the jar.

#### *Fourteenth Experiment*

On page 4, Fig. 6, will be found an experiment whereby simple gaseous diffusion is illustrated by the heavy gas, carbonic acid, rising up a long tube and diffusing itself amongst the extremely light gas, hydrogen. A similar experiment may here be performed, using atmospheric air instead of hydrogen. Just as hydrogen and carbonic acid were found in

both bottles, so now do atmospheric air and carbonic acid mingle, which may be proved by disconnecting the bottles, pouring a little lime-water into each, corking tightly and shaking. The milky precipitate of carbonate of lime already mentioned, will form in each bottle.

#### *Fifteenth Experiment*

A little treacle, water, and a minute portion of size, may be placed with some yeast in a quart bottle, to which a cork with glass pipe is attached; directly the fermentation begins, quantities of carbonic acid gas may be collected, and tested either with lime-water or the lighted taper.

#### *Sixteenth Experiment*

Some clear lime-water placed in a convenient glass is quickly rendered milky on passing through it the air from the lungs by means of a glass tube; thus proving that respiration and (as shown by the fifteenth experiment) fermentation, as well as the combustion of charcoal, produce carbonic acid gas.

#### *Seventeenth Experiment*

Having performed the foregoing experiments, showing the manufacture and certain of the properties of carbon dioxide, called also carbonic anhydride, or carbonic acid, it may perhaps be interesting to reverse the process and split up some of the carbonic acid which has been made, to bring it into its component or elementary parts, the symbol,  $\text{CO}_2$ , showing that it contains two volumes of oxygen to one of carbon. If, therefore, the gas can be passed over something which has a great affinity for oxygen, it may be possible by such means to withdraw the oxygen from the gas. And if this is done, seeing that carbonic acid contains two elements only, the carbon which will be left must be thrown out of the gaseous state, and become a solid, for carbon as an element is a solid, even at high temperatures, excepting, of course, such temperatures as exist on the sun, in which carbon is in a state of highly tenuous vapour.

There are several substances which will absorb oxygen, but perhaps the best for the purpose is potassium. Generate some carbonic acid gas, as already explained, using a Woulfe's bottle with thistle funnel and delivery-tube sinking nearly to

the bottom of a second bottle. From this second bottle should be attached another short tube connected to a short length of combustion tubing, the free end of which is drawn to a point. In this last tube is placed a small pellet of metallic potassium, which must be well dried between blotting-paper before its insertion. A previous experiment has shown its behaviour on contact with water, so that it is necessary that all gas passing over it shall be thoroughly dried,—that is, it shall contain no water—to ensure which, a little pure sulphuric acid is placed in the small bottle to above the outlet of the delivery tube from the Woulfe's bottle. Fig. 184 will make this arrangement clear.

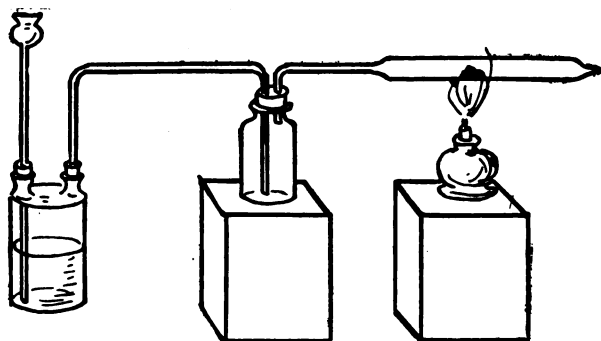

Fig. 184. Apparatus for absorption of oxygen.

The gas, as formed, will bubble through the sulphuric acid, which will dry it, and in this condition it will safely pass out of the bottle and through the combustion tube over the potassium, the small orifice at the end ensuring the tube being filled with gas. As soon as the gas is passing steadily, heat the tube immediately under the potassium, which will then extract the oxygen, leaving the carbon in the tube as a solid.

#### *Eighteenth Experiment.*

Carbonic acid gas is not only generated by the above processes, but is liberated naturally in enormous quantities from volcanoes, and from certain soils: hence the peculiar nature of the air in the Grotto del Cane. Dogs thrust into this cave drop down immediately, and are immediately revived by the tender mercies of the guides, who throw them into the adjoin-

ing lake. This natural phenomenon is well imitated by taking a box, open at the top, and nailing on to it a frame of cardboard, which may be painted to represent rocks, taking

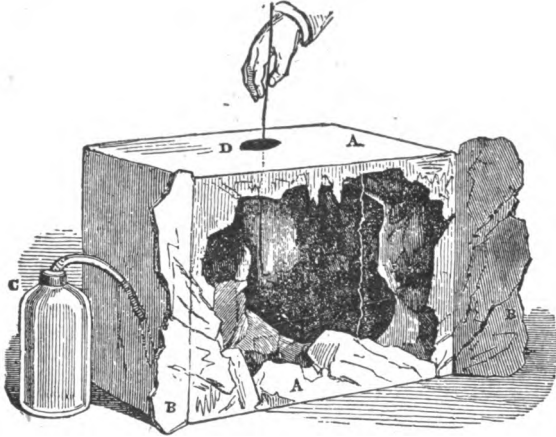

Fig. 185. A A. The box model of the Grotto del Cane. B B. Cardboard fixed in front of box, and painted to imitate rocks. C. Carbonic acid gas bottle, with bent tube passing through hole in the side of the box. A taper introduced at D burns in the upper, and is extinguished in the lower, part of the model.

care that a portion (about three inches deep) at the lower part is well pasted to the box at the edges, so that the gas may be retained; a hole is perforated at the top to admit a lighted taper, and another at the side for the pipe from the carbonic acid bottle; when the bottom is filled with gas, a taper is applied, which is found to burn in the upper part, but is immediately extinguished when it reaches the lower division, where the three inches of pasteboard prevent the gas pouring out: thus showing in a simple manner why a guide may enter the cave with impunity, whilst the dog is rendered insensible because immersed in the gas. (Fig. 185.)

#### *Nineteenth Experiment*

Many fatal accidents have occurred in consequence of the air in deep pits, graves, &c., becoming unfit for respiration by the accumulation of carbonic acid gas, which may arise either from cavities in the soil, where animal matter has undergone decomposition, or it may happen from the depth and narrowness of the hole or well preventing a proper draught or

current of air, so that it becomes foul by the breathing of the man who is digging the pit. Air which contains one or two per cent. of carbonic acid will support the respiration of man, or maintain the flame of a candle; but it produces the most serious results if inhaled for any length of time; a lighted candle let down into a well (suspected to contain foul air) before the descent of the person who is to work in it, may burn, but does not indicate the presence of the small percentage of the poison, carbonic acid. Frequently no trouble is taken to test the air with a lighted candle; a man is lowered by his companions, who see him suddenly become insensible, another is then lowered quickly to rescue him, and he shares the same fate; and indeed cases have occurred where even a third and a fourth have blindly and ignorantly rushed to their death in the humane attempt to rescue their fellow creatures. What is to be done in these cases? Are the living to remain idle whilst the unfortunate man is suffocating rapidly at the bottom of the pit? No; provided they do not venture themselves into the pit, they may try every known expedient to alter the condition of the foul air, so as to enable them to descend to the rescue. One should be despatched to any neighbouring house or cottage for a pan of burning coals; if any

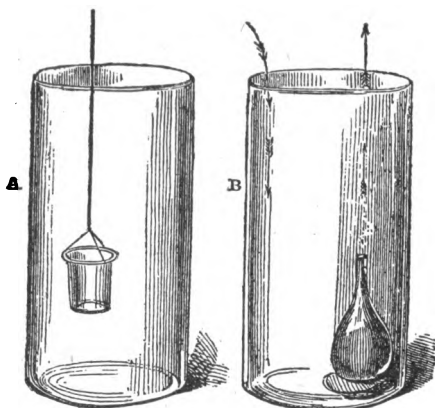

Fig. 186. A. Deep jar containing carbonic acid gas, which is being removed by the little glass bucket. B. Jar containing corked flask of boiling water on a pad; the heated gas rises and the cold air descends to take its place.

slaked lime is to be had, it may be rapidly mixed with water and poured down the side of the pit; a bundle of shavings set on fire and let down, keeping it to one side, so as to establish a current; or even the empty buckets constantly let down empty and pulled up full of the noxious air, may appear a somewhat absurd step to take, but in the circumstances any plan that will change the air sufficiently to enable another

person to descend must be adopted; in proof of which the following experiments may be adduced:

Fill a deep glass jar with carbonic acid, and ascertain its presence with a lighted taper; if a glass beaker to which a string is attached is let down into the vessel and drawn up, and then inverted over a lighted taper, the utility of this simple plan is at once rendered apparent; the beaker represents the empty bucket, and can be let down and pulled up full of carbonic acid until a sensible change in the condition of the atmosphere is produced. The best plan, however, is to set the air in motion by heat obtained from burning matter, or even from a kettle of boiling water, lowered by a cord, which fact is well shown by putting a small flask full of boiling water, and corked, at the bottom of the deep glass jar containing the carbonic acid gas, which rises like other gases when sufficiently heated, and passing away, mixes with the surrounding air. (Fig. 186. Page 235.)

#### *Twentieth Experiment*

Carbonic acid gas dissolved in water under considerable pressure, forms the beverage called soda-water; the gas is not only useful in this respect, but has been applied most successfully as a means of attacking fire and preventing the spread of combustion, especially in closed apartments, as in the rooms of buildings and on ships, but in the open air these methods obviously are not so reliable, owing to the want of restriction of space in which the gas may be confined.

Many forms of fire-extinguishers are obtainable, most of them generating carbonic acid gas as the active means of subduing the flames, by depriving the fire of oxygen, although other substances will answer the same purpose, as will be seen by the following.

A very popular form is that of a cylinder in which is placed potassium ferrocyanide, well dried and mixed with potassium chlorate and sugar. In this is fixed a bottle containing sulphuric acid, so placed that it may be broken by a blow, or spilled when the cylinder is turned upside down. The vitriol (sulphuric acid) then mixes with the powder, and a combustion-preventing gas is generated with great rapidity, rushing out of a flexible or solid tube with fierce energy, to be directed at will to the heart of the fire.

Another popular extinguisher is made from oxide of iron, sulphur, coal, and salt-petre, in certain proportions; this sprinkled or thrown rapidly on the flames stops combustion.

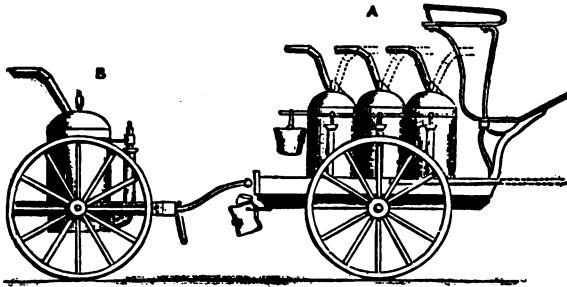

THE "PHILLIPS" FIRE-EXTINGUISHER.

Fig. 187a. A carriage with six fire annihilators, No. 5 size, fitted with moveable pipes. The body of the carriage forms a tank for forty gallons of water.

Carbonic acid gas is an enemy to all kinds of combustion, and water, being capable of absorbing a considerable quantity of this gas, is often saturated with it and placed in bottles,

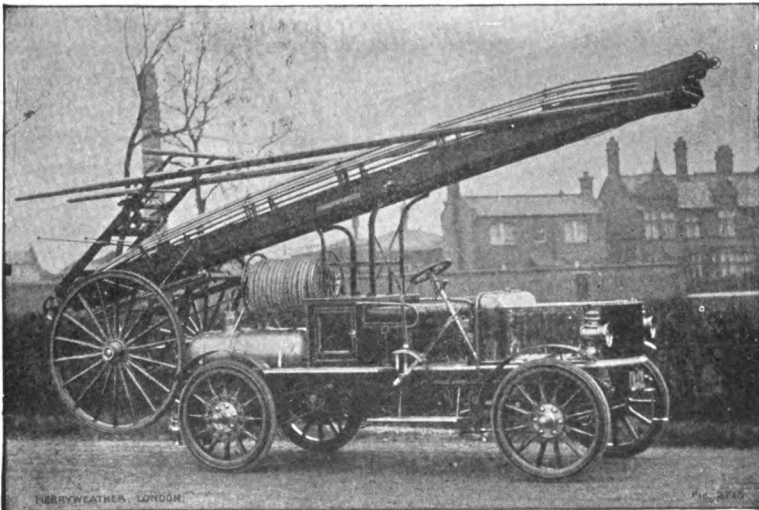

Fig. 187b. Petrol-Motor Fire Combination. This shows one of the most modern fire-destroying appliances and is a combination of petrol-motor, hose tender, fire-escape, water tower, and has two powerful and capacious chemical cylinder extinguishers in duplicate. The comparison of this with its prototype, Fig. 187a, is interesting.



to be hung on walls within easy reach. On the outbreak of fire, these are flung where it is hottest, when not only does the water act beneficially, but the gas in it is set free. On the heat evaporating the water, the whole of its gas is given up, to the extinction of the surrounding flames and heat.

Another method which is popular is to have a saturated solution of carbonate of soda in a cylinder or tank. Enclosed in this is a vessel containing sulphuric acid, some means being provided by which this inner bottle



Fig. 187c. Chemical outfit for home use in case of fire.

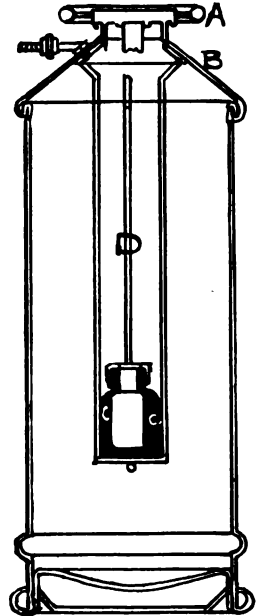

Fig. 187d. Section of a "Kemik" portable chemical fire-extinguisher. A is screw cover; B is the water level; C, the lead bottle which, when apparatus is turned upside down, slides down the cage, D, and has its capsule perforated or cut off by the prickers seen under the cover A. The jet of gas-charged water is then directed to seat of fire.

can be broken or pierced from the outside, such as by a hammer or pricker terminating in an outer knob, which, when struck, breaks the bottle, if glass, or pierces the top, if lead. The contents then mix with the soda solution (an acid and an alkali) when a pressure of gas can be regulated in such manner, equal to from 80 to 150 lbs. or more to the square

inch, according to the proportions of chemicals present. By means of a tap and pipe, this gas-charged water is projected on the fire with great force. Further combustion is not possible, because the carbonic acid gas deprives the surrounding air of oxygen for the moment, and without oxygen, as we have seen, most substances will not burn.

These appliances, however, require to be ready beforehand, but a good and effective extinguisher may be made at a moment's notice by mixing common carbonate of soda with vinegar or acetic acid and flinging it on the flames. The accompanying drawing (Fig. 187a, Page 237) shows the original "Phillips'" fire-extinguisher, the model from which the present popular forms of cylinder extinguishers are taken. Though comprising many modifications, the modern forms do not differ substantially from this old design, which contains the alkaline powder and the acid, as in the first appliance described. The modern adaptations (Fig. 187c and d) are seen in conspicuous places in almost every public building, many of them projecting water with the gas as in the fourth appliance described, instead of gas only as in the first, whilst others contain powder of a similar nature to the second, which may be taken as a type of the "powder" fire-extinguisher appliances. Fig. 187b, page 237, shows the most modern engine for fighting fire in comparison with its (now) crude prototype.

#### BORON

Symbol, B; combining proportion, 11.0.

Discovered by Davy, in 1807, in borax or sodium pyroborate ( $\text{Na}_2\text{B}_4\text{O}_7$ ); is used very extensively in the manufacture of glass, and is a valuable flux in various crucible operations, etc. Anhydrous borax absorbs ten molecules of water if it is exposed to air containing moisture and becomes the prismatic or common borax possessing the formula,  $\text{Na}_2\text{B}_4\text{O}_7 \cdot 10\text{H}_2\text{O}$ . Borax is made either from tincal, a substance that occurs naturally in some parts of India, China, and Persia, or by the addition of carbonate of soda to boracic acid, a substance obtained from the volcanic districts of Tuscany, whence it is imported to this country, and used in the manufacture of borax.

The element boron may be obtained by placing some pure boracic acid and some small bits of potassium in a tube to-

gether, and applying the flame of a spirit-lamp; a glow of heat takes place, and when the tube is cold the potash may be washed away, and the boron remains as a dark brownish powder somewhat resembling carbon. Deville and Wöhler made some important discoveries with respect to this element, and disproved the statement that it is uncrystallisable. Their researches prove it to be producible under three forms and of various colours, such as honey-yellow and garnet-red, the crystals in some cases being like diamonds of the purest water—*i.e.*, limpid and transparent. A combination of aluminium and boron possesses the most remarkable properties. It is harder than the diamond, and in the state of powder will cut and drill rubies, and even the diamond itself, with more facility than diamond powder. Deville and Wöhler believed that the diamond is dimorphous, and capable (in conditions yet to be described) of assuming the same forms as boron. Microscopic diamonds have been made from boron and alumina. See note before first experiment, page 225. At a high temperature, boron, like titanium, absorbs *nitrogen* only from the atmosphere, and rejects the oxygen.

#### *First Experiment*

Boil a little water in a test tube, and place in it sufficient borax to give a saturated boiling solution. Before cooling, when the borax would crystallise out, add a drop of sulphuric acid. Let the whole cool, when it will be found to have become crystalline, smooth and scaly, being now boracic acid, sometimes called boric acid.

#### *Second Experiment*

Pour a few drops of alcohol on a piece of glass, or, better still, in an evaporating basin or watch glass. Have ready some of the same alcohol, in which has been dissolved boracic acid, and pour a little of this into a corresponding vessel. Place the two side by side, light both, and notice the great difference in the colour of the two flames; that from the spirit saturated with boracic acid being a beautiful green.

Borax is used very largely for a great number of purposes, some of which are for imparting a glaze to linen and other fabrics, both in the dressing and admixed with starch; as a mild antiseptic and cleaner; as a flux in enamels and in pot-

tery colours generally; as a glaze for china, earthenware, etc.; also for brazing and other forms of welding and joining one metal to another. Borax is also used very extensively in metallurgical analyses, under certain conditions isolating metals by their distinctive colours. A few of these may be tried.

#### *Third Experiment*

Get a piece, three or four inches long, of thin, solid glass rod; heat one end till soft, when a short length of platinum wire may be attached to it by pushing about a quarter of an inch into the soft end of the glass rod, which will thus form a handle to the platinum wire. Now heat the free end of the wire in the bunsen flame and gently wipe it clean. When cold, make a tiny loop at the end of the wire and dip it in some borax, so that it picks up a little on the loop. Put it into the flame, when the borax will bubble and boil, become crystalline or opaque in appearance, but as the heat is increased, it will run into a bead or globule of perfectly clear glass. This is known as the borax bead, and on sprinkling upon it a very little—a few specks—of the substance under examination, then heating the bead in the inner and outer flame of the bunsen burner, it will be coloured characteristically according to the powdered metal sprinkled upon it. Many coloured substances may be identified in this way.

#### *Fourth Experiment*

On the borax bead sprinkle a few grains of an iron salt. In the outer flame it will show red; if pushed to the inner flame, it will show green or olive.

#### *Fifth Experiment*

Break off the bead that is left over from the last experiment, and make another as in experiment three, and sprinkle on it a few grains of a chromium salt. Insert the bead in the outer or oxidising flame and it will be seen to be green; push it a little further, into the inner or reducing flame and now it will be green as before, the two flames not greatly altering the colour, as in the last experiment.

#### *Sixth Experiment*

Take this used bead from the wire and make another, on

which sprinkle a little copper salt. In the outer, or oxidising flame, this will be green; in the reducing, or inner flame, it will be red. If too much of the substances have been used on the bead in any of these experiments, the colour will be lost, the result being a black or dirty bead. It is much more satisfactory to make a fresh bead for each trial, instead of using the same bead for the inner and outer flame. (See page 472.)

#### SILICON

Symbol, Si; combining proportion, 28.3.

Davy was the first to obtain this element, in 1807. Silicon in the pure state is a dark brown powder; if ignited at a very high temperature it assumes a chocolate colour, which is supposed to be the allotropic condition, because it no longer burns when heated moderately in oxygen or air, and is not attacked by hydrofluoric acid. The most interesting combination of silicon is the dioxide called silica ( $\text{SiO}_2$ ). Silicon is next to oxygen so far as regards its plentifulness, and is found in the state of silica in nearly every mineral, but especially in rock crystal, quartz, flint, sand, jasper, agate, and tripoli. It is largely used in the manufacture of glass, and a most useful "soluble glass" is obtained by melting together in a crucible fifteen parts of sand, ten parts of carbonate of potash, and one part of charcoal.

Cold water merely washes away the excess of alkali, and after this is done the powdered soluble glass may be boiled with water in the proportion of one of the former with five of the latter, when it gradually dissolves; the solution may be evaporated to a thick pasty fluid, which looks like jelly when cool, and on exposure to the air in thin films changes to a transparent, colourless, brittle, but not hard glass. Wood, cotton, and linen fabrics are rendered less combustible when coated with this glass, which excludes the oxygen of the air, and it has been employed to fill up the porous and capillary openings in stone exposed to the atmosphere, being very efficacious as a preservative of the stone in some cases.

#### *First Experiment*

Pour a little of the silicate of soda into a test tube or basin, and add to it, slowly, pure hydrochloric acid. This will form a precipitate which is white and gummy. Then fold a filter

paper and place it in a funnel over another test tube; pour the mixture into the filter. The gummy portion will not pass; after it has drained a little, wash with hot water from a wash bottle, allow the precipitate to dry, when it will be found to be pure silica, which has been extracted from its compound, the experiment being analogous to experiment 17, page 232, in which carbon is extracted as a solid.

### *Second Experiment*

Those boys who wish to make and colour their own glass will find the following formula good:—get a small fire-clay crucible and in it put 100 grammes of sand, 68 grammes of red lead, 32 grammes of carbonate of potash,  $\frac{1}{2}$  gramme of black oxide of manganese.

When these are heated strongly they will fuse together and form clear glass, which may readily be coloured by metallic oxides. If the above quantities are divided, or if several crucibles are heated together, in each crucible a small portion of a different oxide may be placed which will show how easily glass may be coloured throughout its entire substance. We have seen how readily the borax bead, which is a form of glass, may be coloured, and the two are somewhat similar. The glass may be poured from the crucible on an oven plate slightly greased, or better still, on this small scale, on the greased and polished surface of a laundry hand-iron. The cold metallic surface will cool the glass almost instantly and make beautiful coloured buttons. It will be some little time before they are sufficiently cooled to be handled.

A compound of tin and gold, commercially known as “Purple of Cassius,” gives beautiful shades of crimson. Oxide of gold is expensive, but is extremely powerful and produces red tints to blood red of a quality and delicacy unobtainable by other means. Two specks of this oxide are sufficient to colour the whole of the above quantity of glass a rich pink, or rose colour. Another strong rich red may be obtained by using a small quantity of the black oxide of copper, commonly called protoxide of copper, and strange to say this oxide will give a great variety of tints the extreme opposite of each other, according to the amount of oxide used and the temperature to which it is fired, the colours ranging from powerful reds to faint pinks, and almost all shades of green from the

most brilliant to black. Many blues also are made with this oxide, though the more common colouring agent for blue is the oxide of cobalt. Oxide of antimony produces beautiful yellows, whilst the oxide of uranium (sesquioxide) gives that curious opalescent yellow which seems to be "shot" with green; one speck of gold with this gives glass which appears to have "fire" in it, showing red and pink flecks or bright green streaks in the opalescent material, this being one of the most admired features in certain forms of Venetian glass-ware. Oxide of chromium gives beautiful greens of all shades.

There is a variety of quartz of a vitreous nature called "aventurine," which is mostly translucent, and is found in a great variety of colours, amongst which are all shades of brown, yellow, green, red, grey, and occasionally blue. One of the chief characteristics of this substance is the presence in the body of the vitreous quartz of a number of minute flecks of mica, or copper in the metallic state, or of both these minerals. These flecks, which are sometimes of many colours present together, give the quartz the appearance of being filled with little spangles, which gleam brilliantly and iridescently, giving an exceptionally beautiful effect. It is much used in jewellery for the setting in rings, seals, etc., and ranks amongst the lower precious stones. If a little of this quartz is mixed with the fused glass, it will, even in a minute portion, cause the glass to assume the appearance of "aventurine" quartz, glittering with gold, red, green, and other brilliant flecks, as the specks of mica and copper have disseminated themselves throughout its substance. This was used largely by the old Venetian glass makers; it is used at the present day, but the modern "aventurine" glass makers do not obtain the exquisite blending of their predecessors.

#### SULPHUR

Symbol, S; combining proportion, 32.07.

Sulphur, like charcoal, is of common occurrence in nature, and is chiefly supplied from the volcanic districts of Tuscany and Sicily: there is an abundance of this element in the United Kingdom, but then it is locked up in combination with iron, copper, and lead, under the name of iron pyrites,

copper pyrites, galena; and whilst Sicily and Tuscany supply thousands of tons weight in the uncombined state, it is not, of course, worth while to go through expensive operations at home for the separation of sulphur from the ores. During a dispute between Sicily and England, several patents were secured for new and economical processes by which sulphur was obtained from various minerals; and had this country been excluded from a supply of native sulphur, no doubt some of these patents would have been in active operation.

It is almost possible to estimate the commercial prosperity of a country by the sulphur it consumes, not, happily, by war-like operations, but in the manufacture of oil of vitriol or sulphuric acid, which is the starting point of a great number of useful arts and manufactures.

#### *First Experiment*

Some very curious results may be obtained by heating sulphur at certain temperatures; in the ordinary state it is a pale yellow solid, and when subjected to a temperature of  $238.1^{\circ}$  Fahr. ( $114.5^{\circ}$  C.) it melts to a brownish-yellow, transparent, thin fluid; according to all preconceived notions of the properties of substances which liquefy by an increase of heat, it might be imagined that every additional degree of heat would only render the melted sulphur still more liquid, but strange to say, when it reaches a temperature of about  $320^{\circ}$  Fahr. it changes red, and becomes thick like treacle; as the heat rises to  $446^{\circ}$  Fahr. ( $230^{\circ}$  Cent.) it becomes so tenacious that the ladle in which it is contained may be inverted, and the sulphur will hardly flow out: at about  $500^{\circ}$  Fahr. ( $260^{\circ}$  Cent.) it again becomes liquid, but not so fluid as at the lower temperature. If allowed to cool from  $500^{\circ}$  Fahr. ( $260^{\circ}$  Cent.) the above results are simply inverted; the sulphur becomes thick, again liquid, and finally crystallises in long, thin, rhombic prisms, which are seen most perfectly by first allowing a crust of sulphur to form on the liquid portion, and then having made two holes in this crust, the sulphur is poured out, when the remainder is found in the interior of the crucible crystallised in the form already mentioned. Sulphur takes fire in the air when exposed to a heat of  $685.4^{\circ}$  Fahr. ( $363^{\circ}$  Cent. Roscoe), and burns with a pale blue flame; as already stated, it may be



poured from a considerable height on a still dark night, and produces a continuous column of blue fire, just like an unbroken current of electricity. (See page 106.) If the melted and burning sulphur is received into a vessel containing boiling water, it is no longer yellow, but assumes a curious *allo-tropic* state, in which it is a reddish-brown, transparent, shapeless mass, that may be easily kneaded and used for the purpose of taking casts of seals, which become yellow in a few days, and are found then to be hard and crystallised.

#### *Second Experiment*

Bend a piece of wide tubing, pass each end through a cork and fit each cork to a test tube. Take one tube away and place the other so that it stands in a bowl of water. In the other test tube drop a few pellets of sulphur and heat over a burner till dark red fumes come off. Now insert the cork with delivery tube so that the vapours must pass out through the delivery tube into the test tube which is standing in water, causing it to act as a condenser. This vapour will condense in the large tube in the form of a soft yellow powder, called flowers of sulphur.

This sulphur vapour has many curious properties, not the least of which is its capacity for causing many metals with which it is brought in contact to ignite spontaneously.

#### *Third Experiment*

Put a little sulphur in a test tube, and the same quantity by weight of iron filings. Heat the two together till red hot; allow to cool, when it will be found that the two have combined. Such is the behaviour when sulphur and iron are heated together. We will now watch their actions when the iron is in the vapour only.

#### *Fourth Experiment*

Heat some sulphur in a test tube till the vapour comes off. Now insert a piece of clean iron wire so that it comes in contact with the vapour, but is not consumed. If, however, it but gets a start it will burn readily, so if we take an extremely small paring of metallic potassium dried with blotting paper and impale it on the iron wire, we shall find that on inserting the wire the potassium will immediately be set

afame, and set fire to the iron, which will continue to burn in the sulphur vapour.

#### *Fifth Experiment*

Another mode of starting the iron burning is to use copper, which melts in sulphur vapour with generation of great heat.

Get a piece of copper wire and twist it round a second piece of thin iron wire, both bright and clean. Wrap the two round a lead pencil for about an inch, then withdraw the pencil, leaving a coil of wire in the form of a spiral. Insert this in the vapour, when the copper will at once glow, become red hot, then set fire to the iron wire.

#### *Sixth Experiment*

Roll up loosely into a small tube a narrow strip of tin foil, and drop it into a tube of hot sulphur. Immediately it comes in contact with the sulphur vapour it catches fire.

#### *Seventh Experiment*

Sulphur vapour, in one sense, may be regarded as a supporter of combustion: if a clean flask is filled with copper turnings, and a little roughly-powdered sulphur sprinkled in, and heat applied, the copper glows with an intense heat, and burning in the vapour of the sulphur, produces a sulphide of copper; from this compound the sulphur may be again obtained by boiling the powdered sulphide with weak nitric acid, which oxidises and dissolves the copper, leaving behind the greater part of the sulphur, which may be collected, melted, and burnt, and will be found to display all the properties belonging to that element. This experiment is a very good example of simple analysis; and if the copper is weighed and the combined sulphur also, a good notion may be formed of the principles of combining proportions.

#### *Eighth Experiment*

A little sulphur burnt under a gas jar, or in any convenient box (a hat-box, for instance), produces sulphur dioxide—sulphurous anhydride—( $\text{SO}_2$ ), which will bleach a wetted red rose or dahlia, and many other flowers. This gas is employed most extensively in bleaching straw, and sundry woollen goods, such as blankets and flannel, and likewise silk, and

is perhaps one of the best fumigating disinfectants that can be employed; when fever has been raging in dwellings, all metallic substances should be removed, the doors and windows closed, the bedding, &c., well exposed, and then a quantity of sulphur may be burnt in an old frying-pan placed on a brick, taking care to avoid setting the place on fire; after a few hours the doors and windows may be opened, and the disinfectant (if all conditions are favourable, which seldom happens), will be found to have done its work cheaply and surely. Though many people still believe in this form of disinfecting, it has so many objections,—it is not without danger, it is more often than not ineffectual outside a laboratory, since the germs of disease cannot elsewhere be isolated and treated,—that the consensus of modern opinion is in favour of the “spray.”

#### *Ninth Experiment*

The presence of sulphur in various organic substances, such as hair, the white of egg, and fibrine, is easily detected by heating them in a solution of potash, and adding acetate of lead as long as the precipitate formed is redissolved; finally the solution must be heated to the boiling point, when it instantly becomes black by the separation of sulphide of lead.

#### *Tenth Experiment*

Sulphuric acid,  $H_2SO_4$ , or oil of vitriol, is made in such enormous quantities that it is never worth while to attempt its preparation on a small scale. In consequence of its great affinity for water, many energetic changes are produced by its action. Oil of vitriol poured on some loaf sugar placed in a breakfast-cup with the addition of a dessert-spoonful of boiling water, rapidly boils and deposits an enormous quantity of black charcoal. If a word be written on a piece of white calico with dilute sulphuric acid, and then rapidly and thoroughly washed out, no visible change occurs; but if the calico is exposed to heat, so that the excess of water is driven off, the remaining and now concentrated oil of vitriol attacks the calico, and the word is indelibly printed in black by the decomposition of the fabric of cotton. A very remarkable process was introduced many years ago by which paper is converted into a sort of tough parchment-like material, by the action of oil of vitriol and water of a certain fixed

strength; and any departure from the exact proportions destroys the toughness of the paper. After the paper has been acted upon by the acid, it becomes extremely tenacious, and will support a considerable weight without breaking. Smee used this paper in the construction of a hygrometer, and claimed "that it may save many a traveller from catching a severe rheumatism in a damp bed."

### *Eleventh Experiment*

When the vapour of sulphur is passed over red-hot charcoal and the product carefully condensed, a peculiar liquid is obtained, called disulphide of carbon ( $\text{CS}_2$ ), which possesses a peculiar odour, is extremely transparent and brilliant-looking, and enjoys a high refractive power. This liquid is used as a solvent for phosphorus and other substances, and is extremely volatile and combustible, and burns silently with a pale blue flame. The combustion of its vapour; mixed with

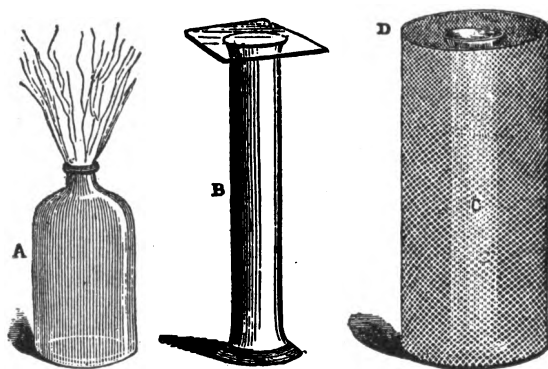

Fig. 188. A. Air and disulphide of carbon. B. Nitric oxide and ditto. C. Oxygen and ditto. D. Stout cylinder of double wire gauze, open top and bottom.

certain gases, offers a good example of the fact that slow burning may be a peaceful experiment, whilst very rapid combustion often resolves itself into an explosion. Thus, if a few drops of disulphide of carbon are dropped into a narrow-mouthed dry quart bottle containing common air, and flame applied, the combustion takes place with rapidity, a rushing or roaring sound being audible, in consequence of the diffused vapour being supplied with more oxygen, and burning more rapidly than it would do if simply consumed from

a stick or glass rod wetted with the fluid. A still greater rapidity of combustion is ensured by dropping some disulphide of carbon into a long stout cylindrical jar, about fifteen inches long and three inches in diameter, containing nitric oxide gas (NO); when flame is applied the mixture burns with a bright flash and some noise, and if burnt in a narrow mouthed bottle would most likely blow it to atoms.

The greatest rapidity of combustion, and of course the loudest noise, is obtained by shaking some disulphide of carbon in a similar stout and strong cylindrical jar filled with oxygen gas, but in this case the jar must be protected with a double cylinder of stout wire gauze; it does not always break, but if it is blown to fragments each particle becomes a lancet-shaped piece of glass, which is capable of producing the most dangerous wounds. (Fig. 188, Page 249.)

#### *Twelfth Experiment*

Another example of rapid combination with detonation is seen in the rubbing of sulphur with potassium chlorate. This is a somewhat dangerous experiment except with care. To be safe, a tiny piece only of potassium chlorate should be used, one no larger than a grain of linseed with a piece of sulphur the same size. Rub these together with a pestle in a mortar, when they will explode violently.

#### *Thirteenth Experiment*

The following is a very showy experiment. Heat a poker, or preferably a thicker bar of iron in a hot fire, to a pale orange colour, the hotter the better. Get a long stick of sulphur, and immediately on withdrawing the iron bar from the fire, rub on the hot end of it the point or extremity of the stick of sulphur. This will melt, dropping on the floor in a stream of brilliant sparks like a splash of fiery spray. Needless to say, this experiment should be performed in an outbuilding with a stone floor.

#### SELENIUM

Selenium (*σεληνή* the Moon\*); symbol, Se; combining proportion, 79.2.

This metallic element is allied to sulphur, and is a species

\* Called selenium, signifying the moon, on account of its strong analogy to tellurium (*tellus*, the earth).

of chemical curiosity, being found in minute quantities in various minerals; it may be melted and cast into any form. Medallions of the discoverer (Berzelius) of selenium in little cases, were imported from Germany, for the cabinets of the curious and were at one time very popular.

Selenium does not appear to exist alone, but in association with sulphur, silver, mercury and other elements, as selenides, and also with sulphides. It is a curious substance, existing in several allotropic forms. As a metal it has the strange property of doubling its electric conductivity on being exposed to daylight. If selenium is heated in hydrogen, it forms a substance known as selenuretted hydrogen, the formula of which is  $H_2Se$ . It is analogous to sulphuretted hydrogen in many ways, but is rather more pungent in its odour; it is highly dangerous to breathe, producing paralysis in various forms. If this substance is experimented with at all, a good fume cupboard should be used and the utmost care exercised.

#### PHOSPHORUS

Phosphorus ( $\phi\acute{\omega}\varsigma$ , light;  $\phi\acute{\epsilon}\rho\epsilon\upsilon\nu$ , to bear; symbol, P; combining proportion, 31.04.)

Salverte, in his work on the Occult Sciences of the Ancients, quotes a remarkable story respecting the probable discovery of the nature of phosphorus in 1761:—"A Prince San Severo, at Naples, cultivated chemistry with some success; he had, for example, the secret of penetrating marble with colour, so that each slab sawed from the block presented a repetition of the figure imprinted on its external surface. In 1761, he exposed some human skulls to the action of different reagents, and then to the heat of a glass furnace, but paying so little attention to his manner of proceeding, that he acknowledged he did not expect to arrive a second time at the same result. From the product he obtained a vapour, or rather a gas was evolved, which kindling at the approach of a light, burned for several months without the matter appearing to die or diminish in weight. San Severo thought he had found the impossible secret of the inextinguishable lamp, but he would not divulge his process, for fear that the vault in which were interred the princes of his family should lose the unique privilege with which he expected to enrich it, of being illu-

minated with a *perpetual lamp*." Had he acted like a philosopher of the present day, San Severo would have attached his name to the important discovery of the existence of *phosphorus* in the *bones*, and made public the process by which it might be obtained.

This element, formerly sold at four or five shillings the ounce, has now fallen so much in price, from the greater demand and larger production, that it may be bought for about two shillings the pound, and is imported in tin cases in large quantities from Germany. It was discovered in 1669 by Brandt, a merchant of Hamburg, and may be prepared on a small scale by distilling at a red heat phosphoric acid previously fused with one-fourth of its weight of powdered charcoal.

#### *First Experiment*

Phosphorus, when pure, is without taste or colour, but generally of a very pale buff-colour, and semi-transparent; it is extremely combustible, and is usually preserved under the surface of water; when perfectly dry, a thin slice will take fire at 60° Fah., and burns with great brilliancy. It melts at 111.74° F. (44.3° Cen.) and ignites spontaneously at 113° F. (45° Cen.), a little over its melting point. Considering the heat produced during the combustion of phosphorus, it might be thought that it would infallibly set fire to any ordinary combustible, such as paper or wood, but this is not the case when phosphorus is employed by itself, as may be proved by the following experiment.

Cut five very small pieces of phosphorus, and place them like the five of diamonds on a sheet of cartridge-paper laid upon the table, set the bits of phosphorus on fire, when they will be rapidly burnt away leaving only five black spots, but not firing the paper, as would be the case if some red-hot coals or charcoal were placed in the same position. The cause is very simple. Phosphorus in burning produces phosphoric acid, which is an anti-combustible, and coats the surface of the paper round the spot where the combustion occurs, and acting as a kind of glaze or glass, excludes the oxygen of the air, and prevents the fire spreading.

If some powdered sulphur is sprinkled round the spot where the bit of phosphorus is to be burnt, the case is very

different; the heat melts and sets fire to the sulphur, which being uncoated with the phosphoric acid, communicates to the paper; and it is on this principle that lucifer-matches used to be made as instantaneous lights. The tip of the wood of which they were composed was first dipped in sulphur, then the phosphorus composition made of gum, chlorate of potash, vermilion, and phosphorus, was placed over it; if the latter were used alone without the sulphur, not one match in a hundred would take fire properly.

#### *Second Experiment*

Dry phosphorus will melt and ignite spontaneously on coming in contact with carbon. If a little phosphorus, about the size of a pea, is cut from a stick of it, under water, and placed on blotting paper, any moisture remaining will be absorbed. It may then be rolled on the blotting paper to a dry part, and covered with soot; it will instantly take fire. Needless to say, as phosphorus is easily ignited by the mere contact of anything dry and warm, it should always be cut under water, and lifted by forceps, as the warmth of the hand might set it on fire, and produce a severe and painful wound. The next experiment will show how easily combustion is induced.

#### *Third Experiment*

Another small piece of phosphorus may be placed on a dish and touched, or almost touched, with a warmed knife-blade, or a piece of wire. It will immediately burst into flame and burn fiercely. Many curious and pretty experiments may be performed by dissolved phosphorus, which, when wet, comes off in luminous fumes.

#### *Fourth Experiment*

Melt a little phosphorus in a small quantity of ether in a stoppered bottle. Place a couple of drops on some porous substance, such as a lump of sugar, and drop the sugar into a teacupful or so of boiling water. If the light is now turned out so that the room is dark, there will appear to come from the sugar flames which rise to the surface, and the steam is rendered so luminous as to seem like clouds of fire.

#### *Fifth Experiment*

In the bunsen flame draw a glass rod to a point and make



smooth. Using this as a pen and the phosphorised ether as ink, write your name or make a drawing of some object on a piece of slate, wood, or other substance, and at once take it into a dark room, when the signature or design will give off flaming smoke.

A few spots dotted here and there on the garden path at night glow strongly, with luminous smoke, for some little time, giving a curious and weird effect. Many similar experiments with this substance will be self-suggestive to most boys.

#### *Sixth Experiment*

Common phosphorus is also perfectly and rapidly dissolved by disulphide of carbon. The solution must be carefully preserved, as it is a liquid combustible, which takes fire spontaneously after the disulphide of carbon evaporates; so that wherever it is dropped, a flame, arising from the spontaneous combustion of the finely-divided phosphorus, is sure to be produced. This liquid was recommended many years ago to the Government for the purpose of setting sails of ships or other combustible matter on fire. The solution of phosphorus alone did not answer the purpose, as already explained in the first experiment; but when wax was dissolved with the phosphorus, it then became a most dangerous fluid, which it was recommended should be used in shells, and discharged from a mortar or howitzer in the ordinary manner. Playfair was the first to make this proposed application of the solution, and it has since been used in liquid-fire shells.

#### *Seventh Experiment*

Phosphorus is to a certain extent soluble in olive oil. Place a piece of phosphorus about the size of a pin's head in a tablespoonful or so of olive oil. The small quantity dissolved, together with the oil, will render it harmless when applied to the skin. If the hand is smeared with this oil it will become luminous in the dark, as will the face, ears and neck, appearing in the dark to be white, ghastly, and to be slowly burning away. Carefully avoid touching the eyes, nostrils, mouth, and the orifice of the ears; this is not only safer but also gives the head the appearance of a flaming, animated skull.

This mixture was much used by the wizards of the dark ages, and is utilised largely to-day by spiritualists to produce many of the mysterious effects and manifestations which so impress the credulous at séances.

### *Eighth Experiment*

One of the most curious facts in connection with phosphorus, is its assumption of the allotropic state in what is termed *amorphous* (shapeless) or red phosphorus. This substance, when handled for the first time, might be mistaken for a lump of badly-made Venetian red. There is no risk of its taking fire like the common phosphorus, and it does not (according to Schrötter, of Berlin, who discovered this peculiar condition, and to later experience) exhale those fumes which are so prejudicial to certain lucifer-match makers.

The difference between common and red phosphorus is well shown—first, by placing a few small pieces of both kinds in separate bottles or vials containing disulphide of carbon; the common phosphorus, as already explained, quickly dissolves in the liquid, and if poured on a sheet of paper, and hung up, is soon on fire; whilst the red variety is wholly unaffected, and if the disulphide of carbon is poured off on to paper, it merely evaporates, and no combustion occurs.

The similarity in composition, though not in outward form, is further shown by filling two jars with oxygen gas, and having provided two deflagrating spoons, some common phosphorus is placed in one, and red phosphorus in the other; a wire, gently heated by dipping it into some boiling water, is now applied to the former, which immediately takes fire, and may be plunged into the jar of oxygen gas, when it burns with the usual brilliancy. The red phosphorus, however, must be brought to a much higher temperature (500° Fah.) before it will even shine in the dark and then with a still further increase of heat it takes fire, and on being placed in the other jar of oxygen burns up much more slowly than the yellow phosphorus, but at last exhibits that brilliant flash of light which is so characteristic of the combustion of phosphorus in oxygen.

Loud exploding and dangerous lucifers were formerly made by dipping bundles of matches, previously coated with sulphur at the tips, into a thick solution of gum, at a temperature of 104° Fahr., coloured with smalt or red lead, in which

was dissolved a certain proportion of chlorate of potash, and also containing finely divided particles of phosphorus obtained by the constant stirring and rubbing of the materials in a mortar. When dry the matches exploded if rubbed against a gritty surface, and there was always a risk of a fragment flying off and entering the eye. To obviate this danger, silent or noiseless lucifer matches were invented, and the composition used is as follows:—Gum arabic, 16 parts by weight; phosphorus, 9 parts; nitre, 14 parts; powdered black oxide of manganese, 16 parts. The above ingredients are worked up in a mortar with water, at 104° Fahr., and the matches previously tipped with sulphur are dipped therein and afterwards dried.

The amorphous or red phosphorus is largely employed, though not exclusively so, in the manufacture of safety matches. Up to comparatively recent times the match-making industry was an extremely unhealthy one, owing to the employment of ordinary phosphorus, the fumes from which, when regularly inhaled, cause a serious and unsightly disease, similar to gangrene, of the lower jaw, called caries or necrosis, which completely destroys the whole jaw, whilst the bones in other parts of the body, especially those of the arms, become almost as brittle as glass, and are fractured with the slightest blow. This was the fate which "dippers" and all employed in the dipping rooms had to face until quite recently, but the advance of more scientific methods and the use of the red or amorphous, instead of the ordinary phosphorus, has practically stamped out this loathsome disease.

In the manufacture of safety matches, some of the best firms employ no substance whatever which gives off poisonous fumes, or is poisonous to the touch, so that one of the most terrible trades known has been transformed to a harmless, if a hard, occupation, and thousands of lives have been saved thereby. Ordinary phosphorus is still largely used in the common matches, but most English makers prefer the amorphous or red phosphorus, with which there is no danger.

The safety matches have their active ingredients divided, one part being on the box and one part on the match-head, so that no ignition by friction is possible, unless the two divided ingredients are brought together by the match head being rubbed on the prepared portion of the box; whereas in ordinary matches, each one is self-contained, and may be

ignited by friction on any rough surface, such as sand or glass-paper, a file, or similar substance, or even cloth.

Five distinct processes must be followed in the main, though each has several other minor ones, such as the first process including the selection of the wood, sawing and planing it into blocks ready for splitting.

The first process, then, is preparing and cutting the wood slips or "splints," as they are called; the second is the dipping of these splints in heated paraffin; the third is the preparation of the dipping composition; the fourth is the dipping of the matches into this "igniting composition"; and the last is the boxing of the perfect matches.

Phosphorus is usually sold in sticks about half an inch in diameter, nine to the pound. When fresh it is almost like wax but this waxy transparency soon deepens, either in the dark or light, to an opaque white. The action of light deep-

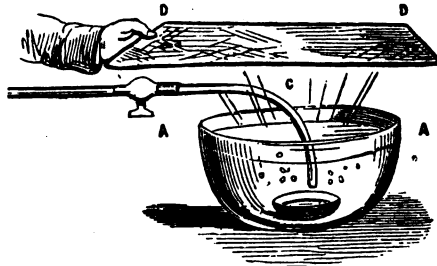

Fig. 189. A A. Bowl of boiling water containing a metallic cup with melted phosphorus. C. Jet of oxygen gas. D D. Sheet of wire gauze.

ens this still further in time, till it becomes of a dirty grey blackness, and sometimes almost black. At ordinary temperatures it may be cut with a knife like curd soap, which it much resembles in appearance. It oxidises so rapidly that on exposure to dry atmospheric air it first melts, then spontaneously ignites, especially when in fine particles, for which reason it must always be preserved under water.

#### *Ninth Experiment*

The combustion of phosphorus under water is easily demonstrated by placing some ordinary stick phosphorus in a metallic cup, and then plunging it rapidly under the surface of boiling water. If a jet of oxygen gas is now directed upon

the liquid phosphorus, it burns with great brilliancy. When the oxygen escapes too rapidly from the jet, it causes some small particles to be thrown out of the water, so that it is advisable to defend the face with a sheet of wire gauze held a few inches above the glass whilst the experiment is being conducted. (Fig. 189, Page 257.)

#### *Tenth Experiment*

Get a wide boiling-test tube and drop in it a small pellet of phosphorus. Pour in the tube a little chlorine gas. The phosphorus will at once take fire.

#### *Eleventh Experiment*

Phosphorus burns and emits beautiful flashes of light in the presence of the gas called peroxide of chlorine ( $\text{ClO}_2$ ) which must be very carefully generated under the surface

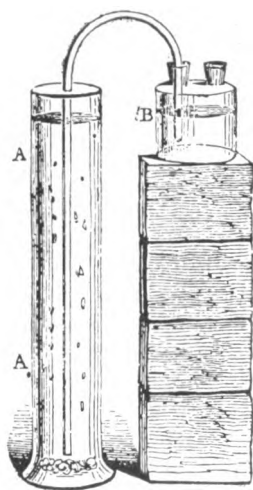

Fig. 190. A A. Tall glass nearly full of water; at the bottom are the chlorate of potash and phosphorus. B. Woulfe's bottle and syphon, conveying the oil of vitriol to bottom of A A.

of water by first placing some cut phosphorus and chlorate of potash at the bottom of a long and stout cylindrical glass nearly full of water; sulphuric acid is then conveyed to the chlorate of potash by means of a syphon, the end of which must be drawn out to a small opening, or else the oil of vitriol will descend too rapidly, and the glass will be cracked by the heat. Immediately the peroxide of chlorine comes in contact with the phosphorus it explodes, and passes again to its original elements, oxygen and chlorine. These bubbles envelope minute particles of phosphorus, which rapidly ascend, like water-spiders, to the surface, and burn as they pass upwards, producing a continual series of sparks of fire, which have an extremely pretty effect. (Fig. 190.)

The syphon is of course first filled with water, and as that is displaced, the oil of vitriol fills the vacuum in substitution of the water.

*Twelfth Experiment*

If a little phosphorus is placed in a small copper boiler, and the steam allowed to escape from a jet, it is observed to be luminous, in consequence of a minute portion of phosphorus being carried up mechanically with the steam. The same fact is shown by boiling water in a flask containing some phosphorus.

*Thirteenth Experiment*

Phosphorus explodes violently when rubbed with a little chlorate of potash, and in order to perform this experiment safely, it should be made in a strong iron mortar, the pestle of which must be surrounded with a large circle of cardboard and wire gauze; so that when it is brought down upon the phosphorus and chlorate of potash, any particles that may fly out are detained by the shield. Without this precaution the experiment is one of the most dangerous that can be made. (Fig. 191.)

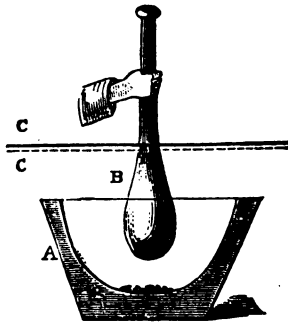

Fig. 191. A. The iron mortar containing the phosphorus and chlorate of potash. B. the pestle, with the shield, C C, composed of a circle of wire gauze, covered with one of cardboard.

*Fourteenth Experiment*

Hydrogen phosphide (phosphoretted hydrogen) owes its property of spontaneous combustion to the presence of the vapour of a liquid, phosphide of hydrogen,  $P_2H_4$ , which may be prepared by placing some phosphide of calcium in a flask with water heated to a temperature of  $140^\circ$  Fah., and conveying the gas into a U-shaped tube surrounded with a mixture of ice and salt.

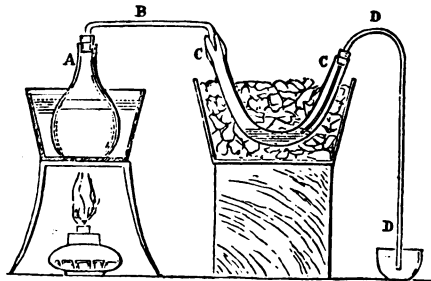

Fig. 192. A. The flask containing the phosphide of calcium and water, and placed in a water-bath heated to  $140^\circ$  Fah. B. Bent tube conveying the gas to C. C. The U-shaped tube, to which it is attached by india-rubber tubing. C C. The U-shaped tube, surrounded with a freezing mixture. D D. Bent tube, passing into a cup of water to prevent contact with air.

The liquid obtained is colourless, and must be preserved from contact with air, as it takes fire spontaneously directly it is exposed to the atmosphere. (Fig. 192.)

#### *Fifteenth Experiment*

Phosphide of calcium is quickly prepared by placing some small pieces of lime in a crucible and making them red-hot; if lumps of dry phosphorus are thrown into the crucible, and the cover placed on quickly, the phosphorus unites with the calcium, forming a brown substance which produces gaseous phosphide of hydrogen ( $\text{PH}_3$ ) when placed in water, and the gas takes fire spontaneously when it comes in contact with the air, owing to the presence of a small quantity of the liquid hydride ( $\text{P}_2\text{H}_4$ ) formed during the reaction.

#### *Sixteenth Experiment*

Phosphorus placed in a retort with a tolerably strong solution of potash, and a small quantity of ether, affords a large

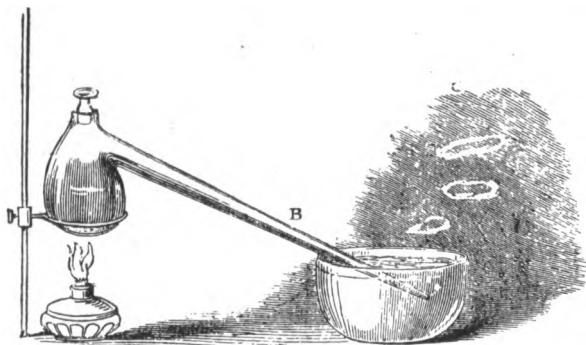

Fig. 193. A retort containing the phosphorus, water, potash, and ether. B. Neck dipping into a basin of water. C. The gas burning, and producing beautiful rings of smoke.

quantity of phosphide of hydrogen (commonly called phosphoretted hydrogen) when boiled. The neck of the retort must dip into a basin of water, and the object of the ether is to prevent the combustion of the first bubbles of gas *inside* the retort, which by their explosion would probably break the glass. If the neck of the retort is kept under water in which potash is dissolved, the gas may be generated for many days at pleasure, although it is not a desirable experiment to

renew too often, on account of the disagreeable odour produced. (Fig. 193.)

*Seventeenth Experiment*

When a jar of oxygen is held over the neck of the retort generating the phosphoretted hydrogen, a bright flash of light and explosion are observed; and if the experiment is performed in a darkened room, it is just like a sudden flash of lightning. A bottle of chlorine held over the neck of the retort, and dipping of course in the water of the basin, produces a green flame every time the bubble of gas passes into it. That curious appearance of light, sometimes seen in marshy districts, called will-o'-the-wisp, is commonly supposed to be due to the escape, from decomposing matter, of bubbles of hydrogen, nitrogen, &c., through which the spontaneously inflammable phosphide of hydrogen is diffused. This is, however, mere hypothesis, for there is no scientific explanation of this remarkable phenomenon, called also "ignis fatuus," and "Jack-o'-lantern," nor has it as yet been possible to study it even in a slight degree, because of its evanescence. This "will-o'-the-wisp," must not be confused with the light carburetted hydrogen ( $\text{CH}_4$ ), commonly known as "marsh-gas" above ground and "fire-damp" below. This latter is the gas which is found in mines, and is such a terrible foe to the miner.

Ages ago, during the formation of coal, quantities of marsh-gas would be generated, and being underground, it would not be able to work its way out, light as it is. For ages it may have been there imprisoned; during that time becoming more compressed by the formation of further gas, until there comes a time when the miner, totally unconscious of the deadly fire-damp, digs out a piece of coal and creates an outlet for it. Being exceedingly light and probably highly compressed, it soon disseminates itself throughout the air of the mine, and even if not encountering an actual flame to ignite it, it mixes with the air of the mine till the explosive proportions combine and disaster follows. The explosive proportions are—one volume of marsh-gas with ten volumes of atmospheric air, or with two volumes of oxygen.



## CHAPTER XV

## FRICTIONAL ELECTRICITY

Of all the agents with which man is acquainted, not one can afford a greater source of wonderment to the untutored, of meditation to the learned, than the effects of that marvellous force pervading all matter, called electricity. We look at matter endowed with life, and matter wanting this divine gift, with some degree of interest, depending on our various tastes and occupations; we know at a glance a bird, a beast, or a fish; we observe with pleasure and admiration the wonderful changes of nature, knowing that a few seeds thrown into the broken clods and well-tilled earth may become either the waving, golden corn-field, or in time may grow from the tender little shrub to the stately forest-tree; we know all these things because they belong to the visible world, and are continually passing before our eyes: but in looking at the visible, we must not forget and ignore the invisible. It may with truth be stated that the greatest powers of nature are all concealed, and if any truth would lead us from nature to nature's God, it is the fact that no visible, solid, tangible agent can work with so much force and power as invisible electricity.

Historical evidences abound, proving that in ages past, long before the Christian era, electricity was known and used to an extent far surpassing the knowledge of the profoundest electricians of the present day, and then lost. Period followed period before the human mind was again prepared to appreciate this great power of nature; other forces had claimed attention, and the difference in the presence or absence of two of the "imponderable" agents, heat and light, as derived from the sun, in the effects of the change of the seasons and other common facts, had led philosophers to speculate early upon their nature; but electricity, from its peculiar properties, long escaped observation, and it was not until about six hundred years before Christ that Thales, the Greek philosopher, discovered that gum amber would attract certain bodies when rubbed with woollen cloth. (See also page 26.)

The Greek for amber is "electron," from which our word "electricity" is derived. With this discovery of Thales' the knowledge of the science seems to have remained quiescent for over 2,000 years, till we come to the year 1600, when Dr.

Gilbert, who was Queen Elizabeth's physician, observed that resin, glass, and other materials became electrified by rubbing. Then, in 1730, or thereabouts, Stephen Grey, a pensioner of the Charterhouse, discovered what he termed "electrics" and "non-electrics," and also the use of insulating materials, such as silk, resin, glass, hair, etc.; it is obvious that, until the latter fact was discovered, the science would remain in abeyance, because of the absence of some mode of preserving the electrical excitement without any non-conductors of this force.

The year 1800 was remarkable for Volta's discoveries and Franklin's identification of the electricity of the machine with the stupendous effects of the thunderstorm,—obtained from his memorable experiment with a kite in a storm in June, 1792. (See page 286.) Then Davy threw fresh light upon the already numerous electric effects discovered, and in 1821 Faraday commenced his studies in this branch of philosophy, his views being held to-day by most scientists. From the commencement of the 19th century, discoveries have succeeded each other in regular order and with the most amazing results, and now electricity is constantly employed commercially all over the world.

Formerly electricity was considered to be an imponderable, elastic, tenuous "fluid," on the theory of Franklin, but modern science shows a preference for the theory of Faraday, that electricity is a form of "force," or "energy," as evidenced in lightning, and as elucidated in Faraday's inimitable researches during the years 1831 to 1851, the details of which will be found in the "Philosophical Transactions" of the Royal Society for these dates. This latter theory (Faraday's) offers an easy explanation of phenomena and suggests a natural language intelligible to all.

There are at least five simple well-ascertained sources of electricity, and three which are considered to be somewhat uncertain. The five sources are friction, chemical action, heat, magnetism, peculiar animal organisms. The three uncertain sources are contact, evaporation, and the solar rays.

Curious phenomena are brought about in the simplest manner by electrical means. If woollen fabric is rubbed on a piece of common sealing-wax, resin, or vulcanite, any one of these becomes so electrified that it will pick up small ob-

jects such as slips of paper, postage stamps, etc., but the best results are obtained when silk and the like are rubbed on glass, fur on vulcanite or simple resin, wool on sealing-wax, (which is composed largely of resin); thus, each of these—glass, vulcanite or resin, and sealing-wax—is specially electrified, for there are certain objects capable of electrification, but curious to relate, not only is the object with which we rub electrified, but also that on which the rubbing is performed.

This is particularly evidenced in the fur of a cat, for it is well known that if this is rubbed gently but firmly up the length of the animal's body in a darkened room, 'crackling sparks of electricity will soon fly from the fur. Sprinkle some small pieces of stamp-edging or paper on the fur and they will be found to adhere; the fur will also pick up pieces from the floor like a magnet. The hands with which the rubbing is performed will be electrified, too, attracting the paper as strongly as the fur. For several minutes this power will continue, the hands, meanwhile, being covered with pieces of paper magnetised there till the power gradually becomes too feeble, first to attract, then to retain, the pieces of paper.

During the process of rubbing, a further curious effect will be noticed. Instead of the hand slipping easily over the fur as at first, the latter becomes adhesive, as if filled with resin, till it requires the expenditure of considerable strength to draw the hand along the fur, each movement being a wrench or jerk of an inch or so, accompanied by a miniature flash of light and crackle.

This shows a further property of electrification—"that two objects electrified by rubbing are *oppositely* electrified, and therefore *attract* each other. This needs a little explanation, because as both woollen cloth and sealing-wax, hands and fur, glass and silk or resin, are all electrified by mutual rubbing, two of each kind, such as two pieces of wax, two of fur, two of silk, two of glass or resin, would *repel* one another, yet they at once attract each other if joined to different substances, as the hands to the fur, the wool or paper to the sealing-wax, the silk to the glass, or the resin or vulcanite to the fur, and so on.

A further well-known simple experiment in physics illustrates this action splendidly. A common pith-ball is at-

tached to a fine thread of silk, the opposite end of which is gripped in a cleft stick, so placed that the ball may swing free, the thread being vertical. As soon as it is perfectly still and a piece of glass, resin, or vulcanite is brought near, the ball will be attracted and will swing towards any one of these. If now, it is allowed to come into actual contact with, say, the resin, at once it will be repelled and attracted to the glass. If this is reversed and the ball allowed to bump against the glass, in actual contact, then also will its action be reversed; the glass, which before attracted it, now repels it, whilst the resin which previously repelled it, now attracts; thus can the ball be made attractive or repellent, as desired.

Further, just as two electrified hairs, two pieces of glass, two of paper, two of vulcanite, two of resin, etc., will repel each other, so will two of these electrified balls roll or swing away from each other; it is impossible to keep them side by side without force.

So that these curious phenomena, common to all electrified objects, show a second law, which is that "when bodies are similarly electrified, they repel one another, and when differently or oppositely electrified, they attract one another." This explains why two pieces of glass or two other objects of the same nature will not electrically adhere. Though perhaps treated with different substances, the result is the same; they receive the identical kind of electrification which is not present with substances of a different nature, such as silk with glass, and so on; these therefore attract.

A few simple experiments, such as can be performed at home, will explain the foregoing.

#### *First Experiment*

A stick of sealing-wax or a bit of glass tube, perfectly dry, rubbed against a warm piece of flannel, has absorbed upon its surface a new power, which will attract bits of paper, straw, or other light materials; and after these substances are endowed with the same force, a repellent action takes place, and they fly off. One of the most convenient arrangements for making experiments with the attractive and repellent powers of electricity is to fix with shellac varnish round discs of gilt paper, of the size of a half-crown, at each end of a long straw that is supported about the centre with a silk thread,

which may hang from the ceiling or any other convenient support. (Fig. 194.)

The varnish is easily prepared by placing four or eight ounces of shellac in a bottle, and pouring enough pyroxylic spirit (commonly termed wood naphtha) upon the lac to cover it. After a short time, and by agitation, solution takes place.

In a variety of ways friction is proved to be a source of electricity, and forms a distinct branch of the science, under the name of *frictional* electricity.

### *Second Experiment*

The nature of chemical action has been already explained, and is alluded to here as a source of electricity of which the proof is very simple. A piece of copper and a similar-sized plate of zinc have attached to them copper wires; these plates are placed opposite to, but do not touch each other, in a vessel containing water acidulated with a small quantity of sulphuric acid. When the wires are brought in contact, a current of electricity circulates through the arrangement, but has no power to attract bits of paper, straw, &c. In order to ascertain whether the current of electricity passes or not, a piece of covered cop-

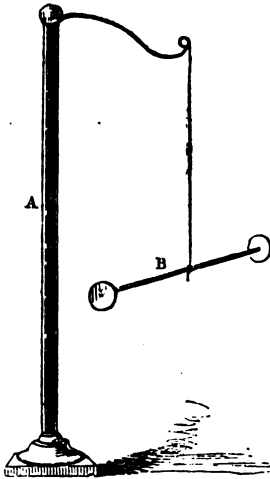

Fig. 194. A. The glass pillar support. B. Straw with discs, hanging by a silk thread.

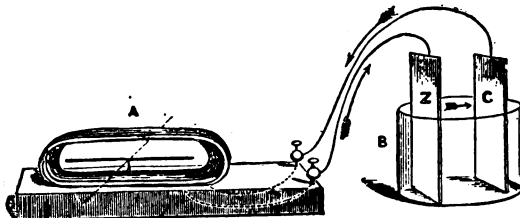

Fig. 195. A. The galvanometer needle. B. Vessel containing weak acid and the zinc and copper plates. The arrows show the path of the electric current.

per wire is bent several times round a magnetic needle, so that it has freedom of motion inside the core or hollow

formed by twisting the copper wire. This arrangement, properly constructed, is called the galvanometer needle, and is invaluable as a means of ascertaining the passage of electricity derived from chemical action. (Fig. 195.)

When the wires leading from the metal plates are connected with the extremities of the coil in the galvanometer, the needle is deflected or pushed aside to the right hand or to the left, according to the direction of the current.

### *Third Experiment*

The third source of electricity is heat, and the effect of this agent is well shown by twisting together a piece of platinum and of silver wire, so as to form one length. If the silver end is attached to either screw of the galvanometer, and the

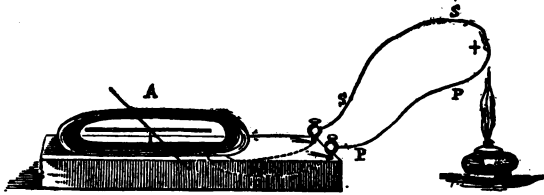

Fig. 196. A. The galvanometer needle, with wires attached. S, S. Silver wire joined to P, P, the platinum wire. The heat of the spirit-lamp is applied at the point of juncture, +.

platinum end to the second screw, no movement of the magnetic needle takes place until the heat of a spirit-lamp is applied for a moment to the point of juncture between the silver and platinum wires, when the magnetic needle is immediately deflected. (Fig. 196.)

### *Fourth Experiment*

The fourth source of electricity—viz., magnetism—requires a somewhat more complicated arrangement to illustrate; and a most delicate galvanometer needle must be provided, to which is attached the extremities of a long spiral coil of copper wire covered with cotton or silk. Every time a bar magnet is introduced inside the coil, so that the conducting wire cuts the magnetic curves, a deflection of the galvanometer needle takes place, and the same effect is produced on the withdrawal of the magnet, the needle being deflected in the opposite direction.

The magnetic spark can be obtained by employing a magnet of sufficient power; and the arrangement for this purpose is very simple. A cylinder of soft iron is provided, and round its centre are wound a few feet of covered thin copper wire, one end of which is terminated with a copper disc well amalgamated, and the other end, after being properly cleaned and coated with mercury, is brought into contact with the disc. Directly this cylinder is laid across the poles of the magnet, and as quickly removed, the point and disc, from the elasticity of the former, separate for the moment, the contact is broken between the point and disc, and a brilliant but tiny spark is apparent. (Fig. 197.)

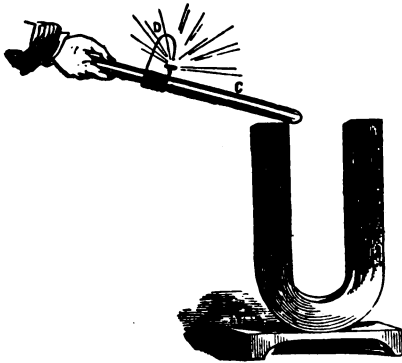

Fig. 197. A B. Horse-shoe magnet. C. Cylinder of soft iron. D. Coil of copper wire and contact breaker.

#### *Fifth Experiment*

The fifth mode of producing electricity requires the assistance of living objects capable of generating and discharging electricity, such as electric fishes, of which the best known are the electric eel, the African cat fish, and the electric ray, of which the chief is the torpedo. The ancient chemists and philosophers were well ac-

quainted with the electric eel and ray, which they employed in the healing art, and it has been truly said that these fishes were "the earliest electrical machines used by man." Experiments with these curious creatures prove that the electric current is induced through the agency of the nervous system. The important fact that this form of electricity is due to nervous energy was first recorded thus:—"A cylinder of wood is firmly fixed against the edge of a table; two vessels filled with salt and water are placed on the table, in such a position that a person grasping the cylinder may, at the same time; insert the fore-finger of each hand in the water. Each vessel contains a metallic plate, and communicates, by two wires, with an extremely sensitive

galvanometer. In the instrument employed the wire is about  $3\frac{1}{4}$  miles in length. The apparatus being thus arranged, the experimenter grasps the cylinder of wood firmly with both hands, at the same time dipping the fore-finger of each hand in the saline water. The needle of the galvanometer remains undisturbed; the electric currents passing by the nerves of each arm, and being of the same force, neutralise each other. Now, if the experimenter grasp with energy the cylinder of wood with the right hand, the left hand remaining relaxed and free, immediately the needle will move from west to south, and describe an angle of  $30^\circ$ ,  $40^\circ$ , and even  $50^\circ$ ; on relaxing the grasp, the needle will return to its original position. The experiment may be reversed by employing the left arm, and leaving the right arm free: the needle will, in this case, be deflected from west to north. The reversing of the action of the needle proves the influence of the nervous force. The conditions, it may be added, essential to the success of the experiment are: 1st, great muscular and nervous energy; 2nd, the contraction of only one arm at a time; 3rd, dryness and cleanliness of skin; and 4th, freedom from any kind of wound on the immersed part."

#### *Sixth Experiment*

In dealing with metals, these require insulating, for unless this is done, they are almost all incapable of electrical excitation. Insulating substances are those capable of electrification, as we have seen in the earlier experiments, such as silk, woollen goods, fibre, glass, resin, wax, vulcanite, paraffin, or pith, and the easier is the substance selected capable of being electrified by friction or contact, as already described, so much is it the better an insulator.

Those substances which do not insulate are called conductors, and most metals and other than absolutely pure water come under this class, being more or less good conductors of electricity. To make this clear:—

In many trades small brass balls are used—for tea-pot knobs, feet of cruet stands, etc.—which may be purchased by the dozen for a few pence. If one of such balls is placed on a pad of felt or silk, and another is held with iron tongs, the one insulated by the silk may be electrified at the mere touch of an already electrified body; whilst that held by the tongs



cannot possibly be electrified till the conducting tongs, which take the current away, are removed; then the ball may be electrified as readily as that on the silk, if it is placed on glass, fibre, or some other insulating substance. Compare with 10th Experiment, page 272.

Electricity may also be made to jump across an insulating body, giving a spark and shock through a second unelectrified body to a third body, at the same time giving to this also a spark and shock.

### *Seventh Experiment*

Electrify one of these small brass balls very strongly and surround it with wool, fibre, wax, or other insulating material; place one to half a dozen of the same balls round it, but

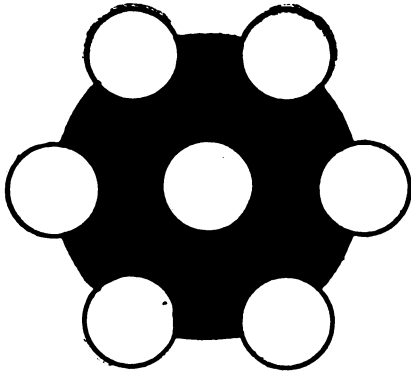

Fig. 198. Arrangement of balls for showing electrification by induction.

none of these must be electrified. The electrified ball is thus made the centre of a strongly insulated and insulating surface, through and over which no passage of electricity can take place.

Then, by putting a finger near any one of the outside balls, before touching it a spark will fly from the centre ball, the finger feeling a slight shock at the same

time. This is electrifying by induction, and the portion of space occupied by the non-conducting material which contains the electrified body, represented by the centre ball, is called the "electric field"; whilst these non-conducting substances comprising the electric field in which and through which the forces become energetically active, are called "dielectrics"; so that the finger, on being brought near an outer ball, causes that ball, though unelectrified, to act as a bridge, or stepping-stone for the current to pass from the centre to itself. (See Fig. 198.) This will be made clear in the following experiments:

*Eighth Experiment*

In making electrical experiments of the simplest kind, it may here be repeated, for it soon becomes apparent, that certain substances, such as glass, sealing-wax, etc., retain the condition of electrical excitement; whilst other bodies, and especially the metals, seem wholly incapable of electrical excitation: hence the classification of bodies into conductors and non-conductors of electricity. This arrangement is not strictly correct, because no substance can be regarded as absolutely a conductor, or *vice versâ*. It is better to consider these terms as meaning the two extremes of a long chain of intermediate links, which pass by insensible gradations the one into the other. In the manufacture of electrical apparatus, glass is of course largely employed, and this substance with brass and wood, constitute the usual materials. One of the most instructive pieces of apparatus is the electro-scope, which can be made with a gas jar, a cork, a piece of glass tube, brass wire and ball, or a flat disc of brass, with some Dutch metal, or still better, gold leaf. The latter is first cut into strips by retaining the leaf between a sheet of well-glazed paper and cutting through the paper and the copper or gold leaf, otherwise it would be impossible to cut the metal, on account of its excessive thinness, except with a gilder's knife and cushion. The cork is next fitted to the gas jar, and perforated with a hole to admit the glass tube, which must be thoroughly dry, and is best coated both inside and out with the shellac varnish described on page 266. Some dry silk is wound round the brass wire, so that it remains fixed and upright in the glass tube, the end outside the jar having a ball, or still better, a flat disc of brass attached, the other extremity being split so as to act like a pair of forceps, to retain a piece of card to which the gold leaves are attached. By removing the cork, tube, and brass wire bodily from the neck of the gas jar, and then in a perfectly still atmosphere carefully placing the card, slightly wetted with gum at the extremity, on two of the cut

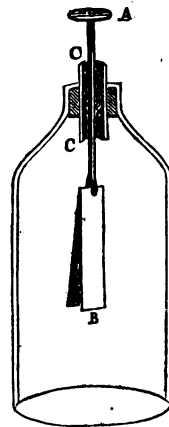

Fig. 199. A. The brass wire, with flat disc outside, and forceps holding gold leaf B inside the jar. C C. The glass tube.

gold leaves, they may be stuck on, and the whole is again arranged inside the dry gas jar, and forms the important instrument called the electroscope. (Fig. 199.) With the help of this arrangement, a number of highly instructive experiments are performed.

#### *Ninth Experiment*

First, the difference between conductors and non-conductors is admirably shown by rubbing a bit of sealing-wax against a piece of woollen cloth or flannel; on bringing the wax to the brass disc of the electroscope the gold leaves no longer hang quietly side by side, but stand out and repel each other, in obedience to the law "*that bodies similarly electrified repel each other.*" If the brass cap is touched whilst the leaves are in this electrical state, they fall again to their original position, showing that sealing-wax, after being excited, retains its electrical condition, as also do the gold leaves, because they are supported on glass, or what is termed *insulated*—i.e., cut off from conducting communication with surrounding objects. When, however, the sealing-wax is passed through a damp hand, or the brass disc of the electroscope touched, the electricity is conveyed away to the earth, because the human body is a conductor of electricity.

#### *Tenth Experiment*

When a brass wire is rubbed and brought to the electroscope, the leaves do not move, in consequence of the electricity passing away to the earth through the body as fast as it is generated: it is just like pouring water into a leaky cistern; but if the brass wire is tied to a long stick of sealing-wax, and this latter held in the hand whilst the wire is rubbed with a bit of flannel, then the gold leaves of the electroscope are affected, on account of the insulation of the metal, as every substance which can be rubbed (even fluids, as water) produces electricity. Compare with 6th Experiment, page 270.

#### *Eleventh Experiment*

An insulating stool is merely a piece of strong square board, supported on glass legs, which should be well varnished. If a person stands on this stool and touches the disc of the electroscope, no movement of the leaves takes place until his coat

is briskly struck with a piece of dry silk or skin, when the usual repulsion occurs.

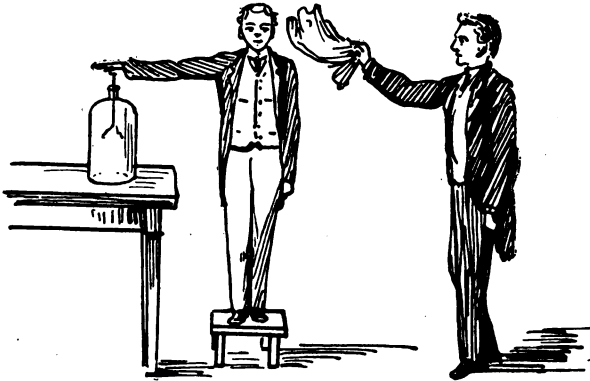

Fig. 200. Person standing on the insulating stool and touching the disc of the electroscope whilst being struck with a dry handkerchief.

#### *Twelfth Experiment*

If a little powdered chalk is placed inside a pair of bellows, and then forcibly ejected on to the disc of the electroscope, the friction of the particles of chalk against the inside of the nozzle of the bellows and against the disc of the instrument soon liberates sufficient electricity to cause the gold leaves to stand out and repel each other.

#### *Thirteenth Experiment*

Whilst the leaves of the electroscope are repelled from each other by the application of a bit of rubbed sealing-wax, they may be again caused to approach each other on bringing near a dry glass tube previously rubbed with a silk-handkerchief; because the electricity obtained from sealing-wax is different from that procured from glass: the former is called *resinous* or *negative* electricity, the latter *positive* or *vitreous* electricity. Either, separately, is *repulsive* of its own particles, but *attractive* of those of the other. No electrical excitation can occur without the separation of these two curious states of electricity, and electrical quiescence takes place when the two electricities are brought together; hence the fall of the gold leaves repelled by rubbed wax when the excited glass is brought towards the disc of the electroscope. This experi-

ment may be reversed by repelling the leaves first with the excited glass, and then bringing near the rubbed wax, when the same effect takes place.

*Fourteenth Experiment*

To show the important elementary truth, that in all cases of electrical excitation the two kinds of electricity are generated, take a dry roll of flannel, and holding it as lightly as possible, rub it against a bit of wax. If the flannel is brought to the electroscope, the leaves repel each other, and they immediately fall when the wax is now approached, because the flannel is in the positive or vitreous state of electricity, whilst the sealing-wax is in the negative or resinous condition.

*Fifteenth Experiment*

Any kind of friction generates electricity. A little roll brimstone placed in a dry mortar and powdered, and then thrown on to the electroscope, quickly causes the repulsion of the leaves.

*Sixteenth Experiment*

A sheet of dry brown paper laid on a flat surface, and vigorously rubbed with a piece of india-rubber, produces so much electricity that sparks and flashes of light are apparent in a dark room when the paper is lifted from the table; it also affects the leaves of the electroscope very powerfully, so much so that care must be taken to apply it very carefully to the disc, or the violence of the repulsion may cause the fracture of the gold leaves, and then a great deal of time is wasted before they can be put on again.

*Seventeenth Experiment*

A dry wig or bunch of horse-hair when combed becomes electrical, and likewise affects the leaves of the electroscope.

*Eighteenth Experiment*

Two dry silk ribbons, the one white and the other black, passed rapidly together through the fingers, exhibit sparks and flashes of light when drawn asunder, and also cause the gold leaves to repel each other.

*Nineteenth Experiment*

Much instructive amusement is afforded by testing the gold

leaves when separated from each other during either of the former experiments with an excited piece of sealing-wax. If the electricity produced is negative, they repel each other further when the excited wax is approached; if positive, they fall when the excited wax is brought near them.

*Twentieth Experiment*

When fresh, dry ground coffee is received on to the disc of the electroscope, as it falls from the mill, powerful electrical excitation is displayed, and this is sometimes so apparent, that the particles cling around the lower part of the mill or to the sides of the cup or basin held to catch it.

*Twenty-first Experiment*

After playing a tune on a violin, hold the bow (well rosined) to the electroscope, when the usual divergence of the leaves will be apparent.

*Twenty-second Experiment*

Cut some chips from a piece of wood with a knife attached to a glass handle, and as they fall on to the electroscope the leaves are repelled.

*Twenty-third Experiment*

Warm a piece of bombazine by the fire and then draw out some of the threads (which are of two kinds—viz., silk and wool), and place them on the electroscope, when divergence of the leaves immediately takes place.

*Twenty-fourth Experiment*

Put upon the same leg a worsted stocking and over that a silk one, if the latter is now quickly rubbed all over with a dry hand and near the fire, and then suddenly slipped off, the sides repel each other, and the silk stocking retains very much the same shape as if the leg still remained in it, but of course collapses as the electricity passes away.

*Twenty-fifth Experiment*

Electrical machines consist only in the better arrangement of larger pieces of glass and a more convenient mechanical contrivance for rubbing them, and are of two kinds—viz., the cylinder and plate machines; it is usual to give directions for

the manufacture of an electrical machine from a common bottle, and doubtless such rude instruments have been made,

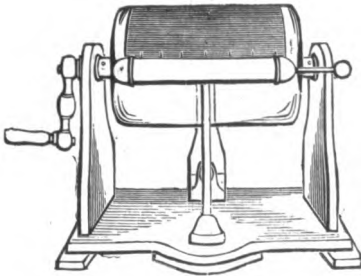

Fig. 201. A cylinder electrical machine.

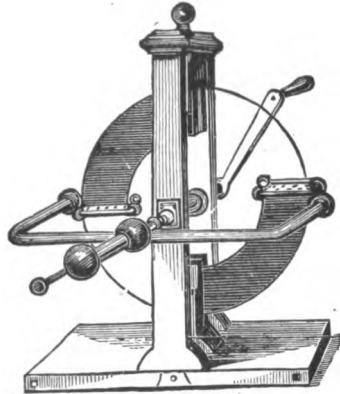

Fig. 202. The ordinary plate electrical machine.

but as most stores now supply excellent small machines at a very low cost, it is hardly worth while to incur even a small expense for an instrument that must at the best be a very imperfect one and frequently out of order. (Fig. 201.)

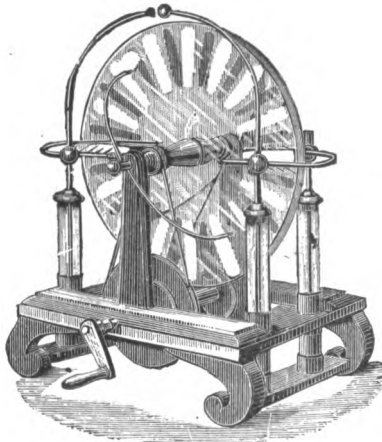

Fig. 203. Electrical machine.

Plate machines are somewhat more expensive than cylinder ones, but at the same time are more quickly prepared for experiments, and it is well to state that the secret of obtaining the greatest amount of electricity from a cylinder machine, is to keep the inside of the glass absolutely clean, dry, and free from dust. Sometimes the glass of which electrical machines are made is wholly unfit for electrical purposes, in consequence of

the decomposition of the surface from the imperfect manufacture and the liberation of the alkali. (Figs. 202-204.)

*Twenty-sixth Experiment*

Cylinder and plate machines are furnished with proper rubbers, and before using the instrument it is usual to remove them, and after carefully cleaning the glass with a dry silk handkerchief before a fire, the rubbers are scraped with a paper-knife to remove the old amalgam, and fresh applied by first melting the end of a tallow candle slightly, and after

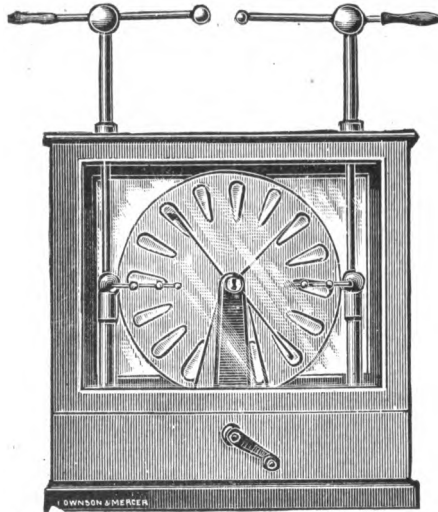

Fig. 204. Powerful Wimhurst's electrical machine.

passing this over the rubber, the finely powdered amalgam is now dusted on to it. Electrical amalgam is prepared by fusing one part of zinc with one of tin, and then agitating the liquid mass with two parts of hot mercury placed in a wooden box; when cold it should be carefully powdered and kept in a well-stoppered bottle for use. When the amalgam has been applied, the rubbers are again screwed in their places, and the machine when turned (if the atmosphere is tolerably dry) will emit an abundance of bright sparks.

*Twenty-seventh Experiment*

Attraction and repulsion are shown on a larger scale, with the assistance of electrical machines, by placing a fishing rod (the last joint of which is made of glass) in an erect position,



and attaching to the extremity a long tassel of paper from which a thin wire passes to the prime conductor of the electrical machine; on turning the instrument, the strips of paper all stand out and repel each other. (Fig. 205.)

*Twenty-eighth Experiment*

Suspend from the prime conductor by a chain a circular brass plate and under this place another supported by a brass adjusting stand. If pith figures of people (which may be purchased for a few pence) are placed on the lower plate, they rise directly the machine is turned, although sometimes,

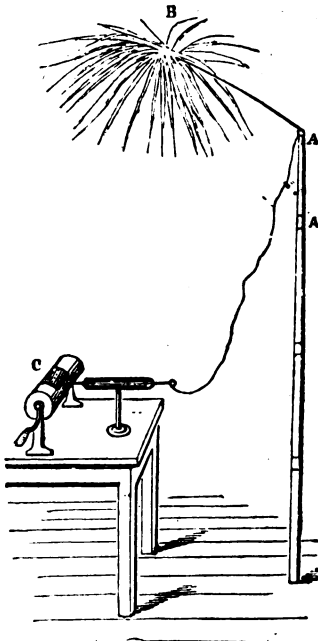

Fig. 205. A A. The glass joint of the fishing-rod, from which the wire carrying the paper tassel, B, projects. C. The electrical machine.

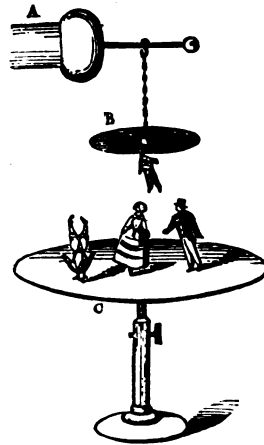

Fig. 206. A. Prime conductor. B. Upper brass-plate. C. Lower ditto. The figures are seen between B and C.

in consequence of irregularity in the adjustment of the centre of gravity, they perversely dance on their heads instead of in the usual position; out of half a dozen figures, one only perhaps will be found to dance well, by alternately jumping to the upper plate and falling to the lower one to discharge the excess of electricity; and indeed the experiment will be found to succeed better with one or two only on the plate instead of

a number, as they cling together and impede each other's movements. (Fig. 206.)

*Twenty-ninth Experiment*

A person provided with a wig of well-combed hair presents a most ridiculous appearance when standing on the insulating stool and connected by a wire with the prime conductor of the electrical machine, every hair, when not matted together,

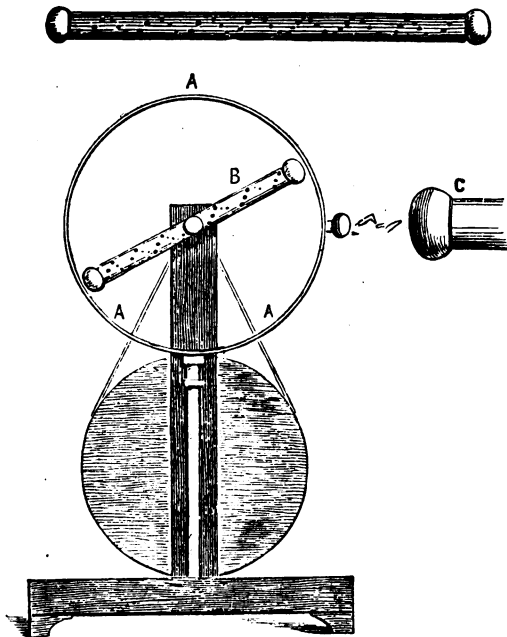

Fig. 207. A A A. A ring of brass wire supported on a glass pillar inside which the spiral tube, B, revolves, and produces beautiful and ever-changing circles of light, when connected with the conductor, C, of the electrical machine.

standing out in the most absurd manner, when the machine is put in motion; or the experiment may be performed by the use of a figure (manikin) which costs a few pence and is sold by the philosophical toy dealers.

*Thirtieth Experiment*

Whilst standing on the stool, sparks may be obtained from a person's body; also if some tow is tied over a brass ball, and moistened with a little ether, then presented to the tip of his

finger, a spark flies off which quickly sets fire to the inflammable liquid.

#### *Thirty-first Experiment*

If small discs of tinfoil, cut out with a proper stamp, are pasted in continuous lines over plate glass, or spirally round glass tubes, a very interesting effect is produced when they receive the sparks from the electrical machine, and the passage of the electricity from one disc to the other produces a vivid spiral or other line of light. When the tube is mounted in a proper apparatus, so as to revolve whilst the sparks pass down the spiral tube, the effect of the continuous electric sparks is much heightened. (Fig. 207.)

#### *Thirty-second Experiment*

A great variety of experiments may be performed, depending on the proper arrangement of discs of tinfoil on various tubes of coloured glass; some are in the form of windmills, the sails being made luminous by the passage of the electricity. The names of illustrious persons, beautiful crescents, stars, and even profile portraits, have been produced in continuous streams of electric sparks.

#### *Thirty-third Experiment*

When an electrified body is brought towards another which is not electrical, the latter is thrown into the opposite state of electricity as long as the excited body remains in its neighbourhood; this condition of electrical disturbance, set up without any contact or supply of electricity, is called *induction*, and involves a vast number of interesting facts, which are thoroughly discussed in the many excellent works on electricity, but can only be briefly alluded to here.

If a number of lengths of brass wire, supplied with balls at the extremities, are supported on glass legs and arranged in a line, with a little pith ball attached to a thread hanging from each end of the length of brass wire, the effect of induction is well shown. When an electrically excited glass rod is brought towards one end of the series, the rising of the pith balls to each other betrays the change which has occurred in the electrical state of the brass wires by the mere neighbourhood of the excited glass tube. The glass tube is electrified positively, and attracts the negative electricity from the brass

wire towards the end nearest to it; the other extremity of the brass wire is found to be in the positive state; this re-acting on the next, and so on throughout the lengths, completes the electrical disturbance in the whole series. (Fig. 208.)

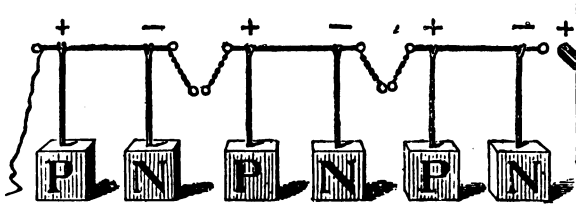

Fig. 208. The lengths of brass wire supported on glass rod pillars indented by blowpipe, so as to retain the brass wire with the pith balls hanging from each series, the letters P and N mean Positive and Negative, and the signs for these terms are placed above. The letters P and N are painted on the blocks which support the glass rods.

*Thirty-fourth Experiment*

If an insulated brass rod (such as the brass wires described in the last experiment) is touched by the finger whilst under induction, it remains permanently electrified on the removal of the disturbing electrified body; and it is on this principle that the useful electrical machine called the Electrophorus is constructed. This *constant* electrical machine—for it will remain in action during weeks and months if kept sufficiently dry—was invented by Volta in the year 1774, and has been greatly improved since; so that with a little additional apparatus the whole of the fundamental principles of electricity can be demonstrated. It consists of a flat brass or tin circular dish about two feet in diameter and half an inch deep, which is filled with a composition of equal parts of black resin, shellac, and Venice turpentine; the resin and the Venice turpentine being first melted together, and the shellac added afterwards, care of course being taken that the materials do not boil over and catch fire, in which case the pot must be removed from the heat, and a piece of wet baize or other woollen material thrown over it. A far better but somewhat longer method is to use a water-bath. Another tin or brass circular plate of twelve inches diameter, and supported in the centre with a varnished glass handle nine inches long, is also provided, and the resinous plate being first excited by several smart blows with a warm roll of flannel, the plate held by the

glass handle is now laid upon the centre of the resinous one, and if removed directly afterwards, does not afford the electric spark; but if, whilst standing upon the excited resinous

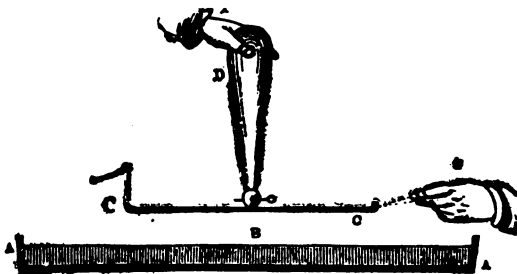

Fig. 209. A A. Large circular tin or brass disc with turned-up edge half an inch deep, and containing the resinous mixture B, which is rubbed with the warm flannel. C C. The upper plate supported by the glass handle D, a pith ball attached to a wire shows the electrical excitation, and the spark is supposed to be passing to the hand E.

plate, it is touched, and then removed by the glass handle, a powerful electric spark is obtained; and this may be repeated over and over again with the like results, provided the plate with the glass handle is touched with the finger just before lifting it from the resinous plate. (Fig. 209.) The electricity excited on the resinous plate is not lost, and by induction sets up the opposite condition in the plate with the glass handle. The resinous plate, being excited with negative electricity, disturbs the electrical quiescence of the upper plate, and positive electricity is found on the surface touching the resinous plate, and negative electricity on the upper one, so that when this is removed without being touched, the two electricities come together again, and no spark is obtained; but if, as already described, the upper plate is touched whilst under induction, then positive electricity appears to pass from the finger to the negative electricity on the upper side of the plate, when the two temporarily neutralise each other, and then, when the plate is removed, the excess of electricity derived from the earth through the finger becomes apparent. Induction requires no sensible thickness in the conductors, and can be just as well produced on a leaf of gold as on the thickest plate of metal; and it should be remembered that non-conductors do not retain their state of electrical excitation when the disturbing cause is removed, whereas conductors

possess this power, and this fact brings us to the consideration of the Leyden jar.

#### *Thirty-fifth Experiment*

If one side of a dry glass plate is held before and touches a brass ball proceeding from the prime conductor of an electrical machine whilst in action, the other side is soon found to be electrical; this does not arise from the conduction of the electricity through the particles of the glass, but is produced by induction, the side nearest the ball being in the positive state, and the other side negative: as glass is a non-conductor of electricity, the effect is much increased by coating each side with tinfoil, leaving a margin of about two inches of uncovered glass round the covered portion, then, if one side of such a plate is held to the prime conductor of the electrical machine, and the other connected with the ground, a powerful charge is accumulated; and if the opposite sides are brought in contact with a bent brass wire, a loud snapping noise is heard, and the two electricities resident on either side of the glass come together with the production of a brilliant spark, or if the hands are substituted for the bent brass wire, that most disagreeable result is obtained—an electric shock; hence these glass plates are sometimes fitted up as pictures, and when charged and handed to the unsuspecting recipient, he receives the electric discharge to the great discomfort of his nervous system.

Mica is sometimes substituted for glass, and long ago there was constructed a powerful combination of coated plates of this mineral. It consisted of seventeen plates of thin mica, each five inches by four, coated on both sides with tinfoil within half an inch of the edge. They were arranged in a box with a glass plate between each mica plate, all the upper sides were connected by strips of tinfoil to one side of the box, and all the under surfaces in the same manner with the opposite extremity of the box. They were charged like an ordinary Leyden battery.

#### *Thirty-Sixth Experiment*

If the glass plate coated with tinfoil is charged, and then placed upright on a stand, it may be slowly discharged by placing a bent wire on the edge with the extremities stuck in

pith balls. The wire balances itself, and continues to oscillate with noise until the electricities of the two surfaces neutralise each other. (Fig. 210.)

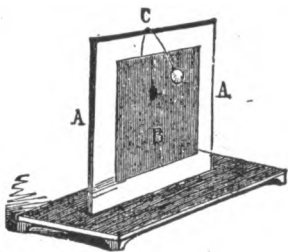

Fig. 210. A. A. Glass plate or stand coated with tinfoil on each side. B. C. Wire with pith balls oscillating during the discharge of the glass plate.

The Leyden jar is charged by holding the ball to the prime conductor of the electrical machine until a sort of whizzing noise is heard, caused by the excess of electricity passing round the uncovered part of the jar and not

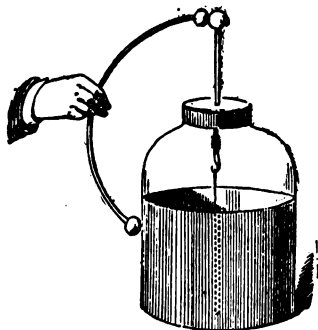

Fig. 211. The Leyden jar and brass wire discharger.

### *Thirty-Seventh Experiment*

It is easy to imagine the glass plate of the last experiment rolled up into the more convenient form of the Leyden jar, which consists of a glass vessel lined both inside and out with tinfoil, leaving some two or three inches of glass round the mouth uncovered and varnished with shellac; a piece of dry wood is fitted into the mouth of the jar, through which a brass wire and chain are passed, and the end outside is fitted with a ball. The Leyden jar is charged by holding the ball to the prime conductor of the electrical machine until a sort of whizzing noise is heard, caused by the excess of electricity passing round the uncovered part of the jar and not through it, as the smallest crack in the glass of the Leyden jar would render it useless. The noise, the bright spark, or the shock are obtained by grasping the outside with one hand and touching the ball with a brass wire held in the other. (Fig. 211.)

### *Thirty-eighth Experiment*

The jar is silently discharged if the balls are removed from the discharger and points used instead; also, the whole of the electricity produced by an electrical machine in full action may be readily drawn off by a pointed conductor, such as a needle, placed at the end of a brass wire. Electricity passes much more rapidly through points than rounded surfaces, hence the reason why all parts of electrical apparatus are free from sharp points and asperities.

*Thirty-ninth Experiment*

Extremely thin wires may be burnt by passing the charge of a large Leyden jar through them. The show jars, called specie jars, usually decorated and placed in the windows of chemists' shops, make excellent Leyden jars, when not thick; with two of the largest, all the interesting effects produced by

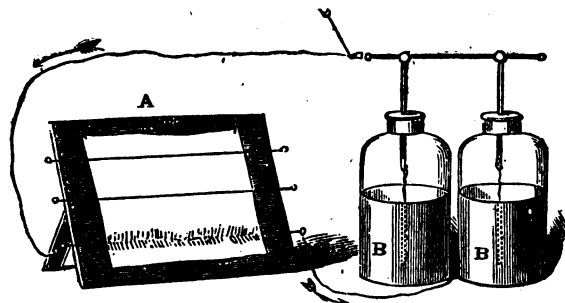

Fig. 212. A. Board with a sheet of white paper and three pairs of brass wires and balls fixed in the wire, three on each side. The thin wires are stretched between the balls, and the lower one is in course of deflagration. B B. Charged large Leyden battery of two jars; the arrows indicate the path of the electricity.

accumulated electricity may be displayed. To pass the discharge through wires, nothing more is required than to strain them across a dry board, between two brass wires and balls, and if a sheet of white paper is placed under them, most curious markings are produced by the fine particles of the deflagrated metal blown into the surface of the paper. An arrangement of two or more Leyden jars is usually called a Leyden Battery, just as a single cannon is spoken of as a gun, whilst two or more constitute a battery. (Fig. 212.)

*Fortieth Experiment*

Little models of houses, masts of ships, trees, and towers are sold by the instrument makers very cheaply; by placing a long balanced wire on the top of the pointed wire of a large Leyden jar, having one end furnished with wool to represent a cloud, a most excellent imitation of the effects of a charged thundercloud is produced. The mechanical effect of a flash of lightning has been analysed, and it has been stated, in one instance, that the power developed through fifty feet was equal to a 12,220 horse-power engine, and that the explosive



power was equal to a pressure of three hundred millions of tons. (Fig. 213.)

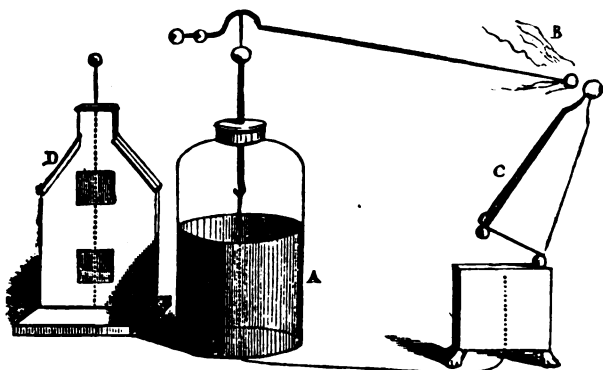

Fig. 213. A. Charged Leyden jar with balanced wire and wool at B, representing a thundercloud. C. The obelisk overturned with the discharge. D. Another model of the gable end of a house; the square pieces of wood fly out when the continuity of the conductor is broken.

Franklin established the identity between the mimic effects of the electrical machines (such as have been described), and the awe-inspiring thunder and lightning of nature. See page



Fig. 214. Photograph of a flash of lightning. Taken on an Ilford Ordinary plate at 9.40 p. m. (Copyright photograph by F. Holmes, Esq., Mere, Wilts.)

263. A copper rod, half an inch thick, pointed and gilt at the extremity, and carried to the highest point of a building, will protect a circle with a radius of twice its length. The bottom of the rod must be passed into the earth till it touches a damp stratum. These form the lightning conductors usually fixed on tall, isolated and valuable structures.

## CHAPTER XVI

### VOLTAIC ELECTRICITY

In describing the various means by which electricity may be obtained, it was stated that chemical action was a most important source of this remarkable agent; at the same time it must be understood that it is not every kind of chemical action which is adapted for the purpose; there are certain principles to be rigidly adhered to—first, in the generation of the force; and secondly, in carrying it by wires so as to be applicable either for telegraphic purposes, or for many highly valuable processes such as electrotyping, electro-silvering, plating, gilding, etc.

A lighted candle, or an intense combustion of coal, coke, or charcoal, no doubt involves the production of electricity, but there are no means at present known by which it may be collected and conducted; when that problem is solved, the cheapest voltaic battery will have been constructed, in which the element decomposed is charcoal, and not a metal, such as iron or zinc. The first and most simple experiment that can be adduced in proof of electrical excitation by chemical means, is to take a bit of clean zinc and a clean half-crown (each should be well boiled to avoid infection), and placing one on the tongue and the other below it, as long as they remain separate no effect is observed, but directly they are made to touch each other, whilst in that position, a peculiar thrill is rendered evident by the nerves of the tongue, in this case answering the same purpose as the electroscope already described, and in a short time a peculiar metallic taste is perceptible.

It has been stated over and over again that it was to a somewhat similar circumstance we owe the discovery of voltaic electricity, and the story of the skinned frogs agitated and

convulsed by an accidental communication with two different metals, or, as some say, with the electricity from an ordinary machine, has been repeated in nearly every work on the science. Silliman, however, asserts that the galvanic story is doubtful, and is a fabrication of Alibert, an Italian writer of no repute, and that greater merit is due to Galvani than that of being merely the accidental discoverer of this kind of electricity, because he had been engaged for *eleven* years in electro-physiological experiments, using frogs' legs as electroscopes. It was whilst experimenting on animal irritability, Galvani noticed the important fact that when the nerve of a dead frog, recently killed, was touched with a steel needle, and the muscle with a silver one, no convulsions of the limb were produced until the two different metals were brought in contact, and he explained the cause of these singular after-death contortions by supposing that the nerves and muscles of all animals were in opposite states of electricity, and that these nervous contractions were caused by the annihilation, for the time, of this condition, by the interposition of a good conductor between them.

This theory of Galvani had several opponents, one of whom, Volta, succeeded in pointing out its fallacy; he maintained that the electrical excitement was due entirely to the metals, and that the muscular contractions were caused by the electricity thus developed passing along the nerves and muscles of the dead animal.

To Volta we are indebted for the first voltaic battery, and he may truly be said to have laid the foundation of this valuable branch of science.

#### *First Experiment*

If a plate of clean bright zinc is placed in a vessel containing some dilute sulphuric acid, energetic action occurs from the oxidation of the metal and its union as an oxide with the acid and the escape of a multitude of bubbles of hydrogen gas. After the action has proceeded some time, the zinc may be removed, and if a little quicksilver is now rubbed over the surface with a woollen rag tied on the end of a stick, it unites with the metal, and the surface of the zinc assumes a brilliant silvery appearance, and is said to be amalgamated. In that condition it is no longer acted upon by dilute sul-

phuric acid, and for the sake of economy this is the only form in which zinc should be employed in the construction of voltaic batteries or single circles.

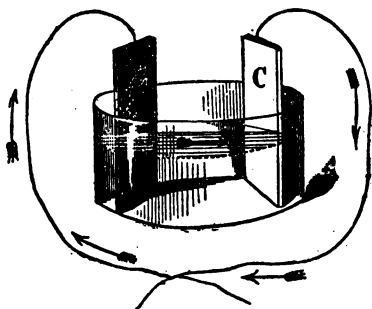

Fig. 215. A single voltaic circle, consisting of a zinc and copper plate (marked Z and C) in dilute acid, called the electrolyte. The arrows show the direction of the current.

If a clean plate of copper, with a wire attached, is now placed in the dilute acid opposite to and not touching the amalgamated zinc plate, which may also be furnished with a conducting wire, no bubbles of hydrogen escape until the wires from the two metals are brought in contact; then, singular to relate, the hydrogen escapes from the copper plate,

whilst the oxygen is rapidly absorbed by the zinc, and a current of electricity will now be found to pass from the zinc through the fluid to the copper, and back again through the wire to the starting-point; if the wires are disconnected, the chemical action ceases, and no more electricity is produced. (Fig. 215.)

The passage of the current of electricity is not discoverable by the electroscope, because it is adapted only to indicate electricity of high tension or intensity, such as that produced from the electrical machine, which will pass rapidly through a certain thickness of air, and cause pith balls to stand out and repel each other; such effects are not producible by a single voltaic circle, or even an ordinary voltaic battery, although one comprising some hundreds of alternations would produce an effect on a delicate electrometer; hence voltaic electricity is said to be of low intensity, and this property makes it much more useful because it has no desire to leave a metallic path prepared for it, and does not seize the first opportunity, like the electricity from the electrical machine, to run away to the earth through the best and shortest conductor offered for it. If electricity had only been producible by friction, we should never have heard of electrotyping and the other useful applications of electrical force of low intensity.

*Second Experiment*

To ascertain the passage of a current of voltaic electricity, the instrument called the galvanometer needle is provided, which consists of a coil of copper wire surrounding a magnetic needle, so as to leave the latter freedom of motion from right

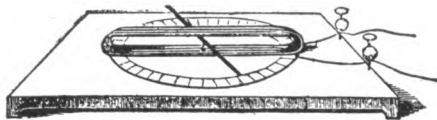

Fig. 216. A galvanometer needle, consisting of a coil of covered copper wire, the ends of which terminate at the binding screws. The magnetic needle is suspended on a point in the centre, and the coil is surrounded with a graduated circle.

to left, or *vice versâ*. When this coil is made part of the voltaic circle it becomes magnetic, and reacting on the magnetised needle, deflects it to one side or the other, according to the direction of the current. (Fig. 216.)

*Third Experiment*

If a number of simple voltaic circles, such as the one described in the first experiment, are connected together, they form a voltaic battery, in which of course the quantity of electricity is greatly increased. Batteries of all kinds, from the original Volta's pile, consisting of round zinc and copper plates soldered together with interposed cloth moistened with dilute sulphuric acid, or his *couronne des tasses*, consisting of zinc and silver wires soldered together in pairs, and placed in glass cups containing dilute acid, to the improved batteries of Cruikshank, Wilkinson, Babington, Wollaston, and the still more perfect arrangements of Daniell, Lelanché, Bunsen, Grove, and others have been from time to time recommended for their own peculiar features.

Amongst these several inventions, none will be found more useful than the *constant* battery of Daniell for electrotyping, silvering, gilding, and other purposes, and Grove's or Bunsen's battery for all the more brilliant results, such as the deflagration of the metals or the production of the electric light. The construction of the Daniell and Bunsen batteries will therefore be described as types of the most suitable batteries for the two forms of work. It is well to state here that if

the E. M. F. (Electro Motive Force) is high, the metal is deposited on the object so quickly and with such force as to be in a granular condition, so that where this effect is desired, a battery with high E. M. F. becomes a necessity. On the other hand, where the deposit must be gentle and the result smooth and delicate, a battery with low E. M. F. must be used, or else the solution in the more powerful battery must be considerably weakened. Therefore, the class of work to be done must invariably determine the manner of the doing, and the character of the battery to be employed. The Daniell cell will be most suited to the finer and more delicate work, such as copper, silver, and gold plating, and high-class electrotyping, because its E. M. F. is low, and it has a very constant volume of current. Even this is too strong for some work, such as jewellery, when a battery of the Smee kind is used, its E. M. F. being lower than the Daniell and its deposit finer.

For coating objects with nickel, brass, and copper, the most suitable battery would be such an one as the Bunsen, the E. M. F. of which is high; the current, therefore, is able to overcome high resistance, which causes the metal to come off the anode strongly and rapidly, thus to be deposited heavily on the cathode (which is the object being plated) in a granular and coarse condition of surface, as already pointed out.

With this brief explanation, the two types of battery may now be described:—

#### THE DANIELL BATTERY.

This is a very old type of battery, which has gone through many forms and modifications since its inception, without its essential features being disturbed. There are many varieties of this type, but the most useful for the purpose is that shown in Fig. 217.

Inside a non-porous glass jar, J, is placed a piece of sheet copper in the form of a nearly closed cylinder, C; inside this

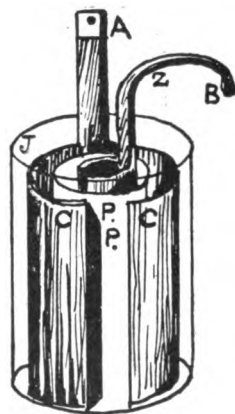

Fig. 217. Daniell "Quantity" Cell. (For other forms see Figs. 218a and b.)

is a porous pot, PP, made of biscuit-surfaced, or unglazed earthenware, and inside this is the zinc rod, Z. The porous pot, PP, contains a quantity of dilute sulphuric acid, in which the zinc rod, Z, stands. This zinc rod should first be amalgamated, or covered with quicksilver, to preserve the zinc and prevent loss of current.

This pot with its contents is then placed in the non-porous glass jar, J. Around it is slid the cylindrical copper plate,

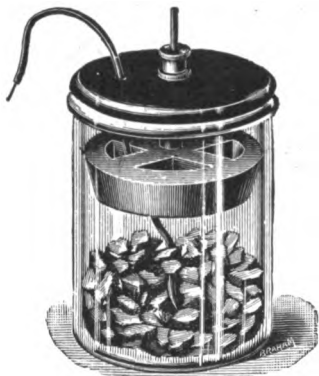

Fig. 218a. Daniell "Gravity" cell.

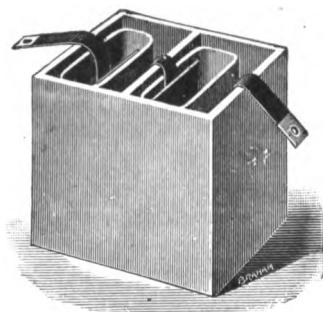

Fig. 218b. Double Daniell cell.

care being taken to see that this is not in contact with the inner pot, P. The glass jar is then partially filled with copper sulphate in saturated solution, in which the copper stands. So that, briefly,—the inner pot contains the zinc and acid, and is surrounded on the outside with the saturated solution of sulphate of copper in which stands the metallic copper, the whole in the glass jar, J. The terminals A, and B, are then ready for connection. Two other forms of Daniell batteries are shown at Fig. 218 (A and B).

#### THE BUNSEN BATTERY

This battery also is used in various modified forms of the original, that illustrated (Fig. 219), being a very useful variety for the purpose.

The outer jar, J, is of glass or stoneware and contains a cylinder of zinc, Z, amalgamated with mercury. Inside this zinc cylinder is a porous pot, PP, of unglazed earthenware, containing a long square block of carbon, C. In the jar J, is

placed dilute sulphuric acid, in which the amalgamated zinc stands, the acid acting on both sides of it. Away from contact with this zinc, yet in the acid, stands the porous pot, PP, containing the carbon, and in this pot is placed nitric acid, of full "commercial" strength.

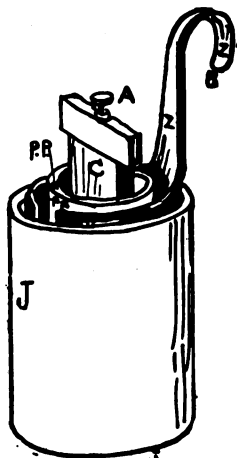

Fig. 219. Bunsen battery.

As before remarked, the E. M. F. of this battery is high, and capable of overcoming high resistance, so that if it is used to silver or gild smooth articles, such as spoons, forks and small ornaments, they must be slung in the solution by very fine wires, so as to create a high resistance. Otherwise, as such a battery—when the current is strong and the circuit short—deposits nearly seventy grains of gold and one hundred and twenty grains of silver per hour, the resulting plated surface would be so coarse and rough as to be altogether useless should any form of burnish be desired.

The Grove's battery is illustrated here, but as this cannot very well be made so cheaply as the two others mentioned, no detailed description is necessary. (See Fig. 220.)

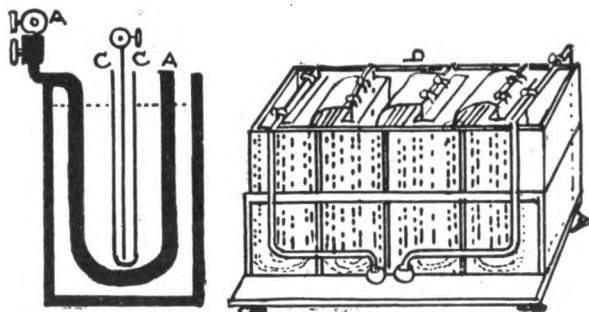

Fig. 220. A A. Amalgamated zinc plate in flat earthenware trough. Attached to a binding screw is the platinum plate in porous cell, C C. D. A series of single cells forming a Grove's battery.

Commercially, metallic deposit by electric current is usually done by means of a dynamo, but as the chief object of this book is to deal with what can be done and made by a boy at



home, the use of such a machine extends somewhat beyond our scope.

Both the batteries described can be bought for very little, or be made in the course of an evening or so by any intelligent boy with such means as lie at his hand. In each case, a common wide-necked pickle-bottle or jar, or a glazed jam pot will answer admirably for the non-porous pot. The porous pot may be made of several thicknesses of strong, tough brown paper, formed round a ruler and pasted together; or better still, of an unglazed jar, which may be bought at any glass or crockery warehouse for a penny. The sheet copper or zinc may be so purchased and bent; the terminals should be soldered on the top edge, out of contact with the liquid, or be formed of thick wire tied through a hole at the top of the sheet driven in with a nail. The carbon and zinc rods can be purchased for a few pence, the zinc being easily amalgamated by first scraping it chemically clean, then dipping it in weak acid and rubbing mercury well over its surface with a wad of cloth or fustian, as already described.

The complete batteries can be made at small cost, and with them any ingenious boy may silver or gild small objects, or take metallic impressions and electros of coins, seals, cameos, etc., as will be explained later.

By making several batteries and coupling them together, negative to positive, so as to leave a positive terminal at one end and a negative terminal at the other, enormous power can be obtained. John Frederick Daniell, the inventor of the battery bearing his name, whilst he was professor at King's College, London, prepared there an enormous battery consisting of seventy of his cells. A continuous arc of flame was produced between two charcoal points, when distant from each other three quarters of an inch, and the light and heat were so intense that the professor's face became scorched and inflamed, as if it had been exposed to a summer heat. The rays collected by a lens quickly fired paper held in the focus.

By the light from this same battery many photographs were taken, and the heating power was so great as to fuse with the utmost readiness a bar of platinum one-eighth of an inch square: and all the more infusible metals, such as rhodium, iridium, titanium, etc., were melted like wax when

placed in small cavities in hard graphite and exposed to the current of electricity emanating from the battery.

These cells were of a different type to the Daniell cell just described. The battery used by Professor Daniell himself consisted of a cylindrical vessel made of copper, in which was suspended a porous earthenware tube, containing an amalgamated rod of zinc—instead of this earthenware porous pot he often used one made of membrane (bladder), brown paper, or canvas.

To charge this battery, a strong solution of sulphate of copper with some sulphuric acid was poured into the copper vessel, which was provided with a sort of colander at the top to hold the crystals of sulphate of copper, and into the porous tube containing the zinc rod was poured dilute sulphuric acid. (See Fig. 221.)

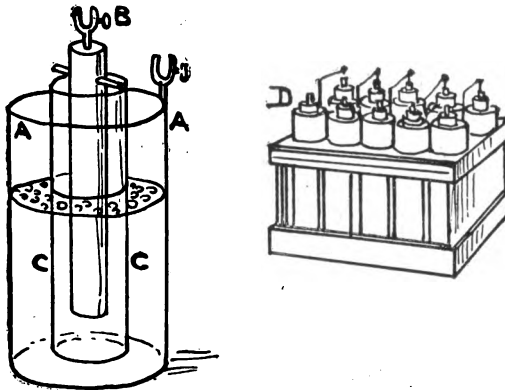

Fig. 221. A A. Copper cylindrical vessel with colander to hold the crystals of sulphate of copper. B. The amalgamated zinc rod inside the porous cell C. C. D. A series of single cells forming a Daniell's battery.

#### *Fourth Experiment*

It is by chemical action that this form of electricity is produced, and as action and reaction are always equal, but contrary, we are not surprised to find that the electricity from the voltaic battery will in its turn decompose chemically many compound bodies, of which water is one of the most interesting examples. It was in the year 1800, and immediately after Volta's announcement to Sir Joseph Banks of his discovery of the pile, that Nicholson and Carlisle con-

structed the first pile in England, consisting of thirty-six half-crowns, with as many discs of zinc and pasteboard soaked in salt water. Whilst experimenting with the pile, they observed that bubbles of gas escaped from the platinum wires immersed in water and connected with the extremities of the Volta's pile, and covering the wires with a glass tube full of water, on the 2nd of May, 1800, they completed the

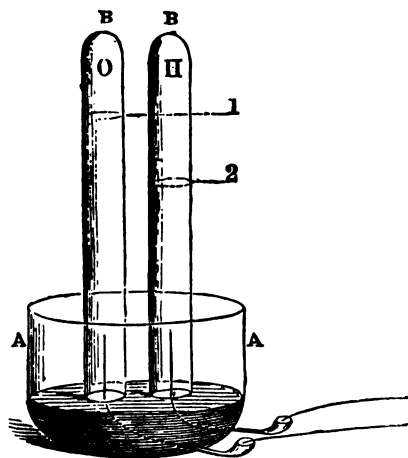

Fig. 222. A A. A glass bowl with two holes drilled in through which pass the wires, imbedded in cement up to the platinum plates. B B. Glass tubes, closed at one end and open at the other, which are placed over the platinum plates to receive the liberated oxygen and hydrogen. The scale at the side shows the respective volumes of two of H to one of O.

passing to small metallic cups full of mercury, are cemented inside a glass vessel, which is then filled with dilute sulphuric acid. Just above the platinum plates and over them, stand two glass tubes also containing the same fluid in contact with the battery. Two measures of hydrogen are found in one tube, and one of oxygen in the other. (Fig. 222.)

To measure the quantity power of the voltaic battery, an important instrument invented by Faraday is used. It consists of separate platinum plates cemented in a wooden stand, over which a capped air-jar with a bent pipe is also cemented. This apparatus contains dilute sulphuric acid of the same strength as that used in the battery under exami-

splendid discovery of the fact that the Volta's current had the power to decompose water and other chemical compounds. In 1801, Davy had succeeded to a vacant post in the Royal Institution, and on Oct. 6th, 1807, made his discovery of potassium with the aid of the voltaic battery, and from that and other experiments inferred that the whole crust of the globe was composed of the oxides of metals.

To exhibit the decomposition of water, two platinum plates with proper connecting wires,

nation, and by taking the time, the quantity of the mixed oxygen and hydrogen gases producible by a battery per minute is accurately determined, the gases of course being collected in a graduated jar. (Fig. 223.)

#### *Fifth Experiment*

By grouping the simple circles forming a voltaic battery in various numerical relations, the *quantity* and *intensity* effects are modified.

Thus, if a series of thirty pairs of Bunsen's battery are all connected together in consecutive order, the smallest *quantity* and the largest *intensity* effect is produced.

If changed to two groups of fifteen each, the quantity is doubled—that is to say, it will produce double the quantity of the mixed gases from the voltameter with half the intensity.

If arranged in three groups of ten each, it is trebled with a proportional loss of intensity, until the grouping reaches six series of five each, when a maximum supply of the mixed gases is obtained from the voltameter.

In arranging the groups, all the zinc ends of each series are connected, and all the platinum ends are likewise joined by proper wires.

#### *Sixth Experiment*

Get a plate-glass trough,—which may be bought for a few pence or made by cementing some pieces of glass together with shellac varnish and tying with string—and place in it a few grains of iodide of potassium dissolved in water with some starch; the iodide is quickly decomposed into its elements by placing in the liquid two platinum plates and connecting them with the wires of the voltaic battery. If the glass trough is divided in the centre with a bit of cardboard, the purple colour of the iodine and starch is shown very

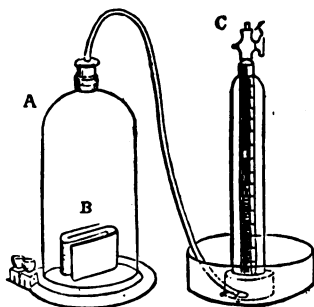

Fig. 223. A. Gas jar with cap and bent tube passing to the graduated tube C; the jar is cemented in the same stand which carries the connecting cups, wires, and platinum plates, which are bent round each other to improve the action of the voltameter.

clearly on one side, but not on the other, as iodine is liberated at one pole and the alkali at the other. (Fig. 224.)

### Seventh Experiment

Some solution of common salt coloured with sulphate of indigo and placed in the trough is decomposed into chlorine, which bleaches one side of the indigo solution, and the alkali liberated on the other does not affect it.

### Eighth Experiment

Some nitrate of potash dissolved in water and coloured with litmus placed in the glass trough, changes red on one side of the cardboard by the liberation of acid, and is not affected on the other.

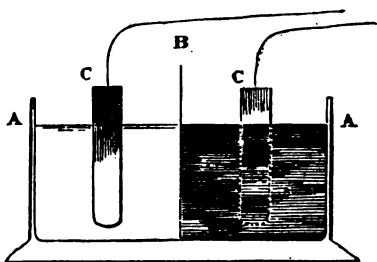

Fig. 224. A A. A glass trough containing the salt dissolved in water, and divided temporarily with a bit of cardboard, B. C C are the two platinum plates connected with the battery, and the shaded side is supposed to represent the liberation of the iodine.

In these experiments the oxygen, iodine, chlorine, and nitric acid are liberated at the electro-positive pole, and are hence termed electro-negative bodies, whilst hydrogen and the alkalis are set free at the electro-negative pole, and are therefore called electro-positive bodies. Faraday modified these terms, and called the two classes "anions" and "cathions," and the two poles "anodes" and "cathodes."

Anode, from ἀνά, up, and ὁδός, a way: the way the sun rises. Anions, from ἀνά, up, εἶμι, to go: that which goes up; a substance which passes to the anode during the passage of electricity.

Cathode, from κατά, down, and ὁδός, a way: the way the sun sets. Cathion, from κατά, down, and εἶμι, to go: that which goes down; a substance which passes to the cathode during the passage of electricity from the anode to the cathode.

### Ninth Experiment

In the process of the electrotype is presented a valuable application of the chemical power of the voltaic circle or battery, and it may be conducted either as a single cell opera-

tion or by distinct batteries. In the former case the most simple arrangement will suffice; the only articles necessary are—a large mug or tumbler; some brown paper and a ruler; a bit of amalgamated zinc, four inches long and half an inch wide; a short length of copper wire; some black lead, blue vitriol, and oil of vitriol, and an excellent home-made apparatus can be manufactured. (See Fig. 225.)

The mould from which the electrotype is to be taken may be made of common sealing wax, plaster of Paris, white wax, gutta percha, or fusible alloy. Supposing the first to be selected—a common seal; the face of this is first thoroughly black-leaded,\* then one end of the copper wire is bent round the top of the amalgamated zinc, and the other is gently warmed and melted into the side of the seal, leaving a small portion uncovered by the wax, which is then well black-leaded. A few ounces of blue vitriol are dissolved in boiling water, and when cold the solution is poured into the tumbler; the porous cell, to contain the mixture of eight parts water to one of sulphuric acid, is made by rolling the brown paper three or four times round the ruler, closing the end, and fixing the side with a little sealing wax. This porous cell of brown paper is now filled with the dilute acid, and placed in the tumbler containing the solution of blue vitriol, the amalgamated zinc being arranged in the paper cell, and the attached seal in the copper solution; in about twelve hours a good deposit of copper is produced on the black-leaded portion and a perfect cast in metal of the seal obtained. (Fig. 225.)

In brief, the process of electro-metallic deposit is made clear by the following sketch and description:—The vat is

\* The application of plumbago, or black lead, for electrotype purposes, was first made by Murray.

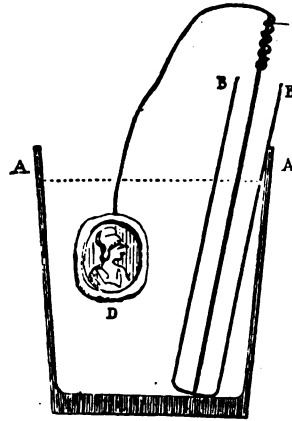

Fig. 225. A A. The tumbler containing the solution of sulphate of copper. B B. The brown paper cell containing the dilute sulphuric acid, inside which is the amalgamated zinc with wire attached to the seal D.

usually made of lead lined with wood, see Fig. 226A, but in the sketch B it is shown as of glass, so that the contents may be clearly seen. The object to be plated is made chemically



Fig. 226a. Solution vat, made of wood, showing a casing, or lining, of lead between the two surfaces, as described above.

Compare this with Fig. 226b (below), which is shown transparent, in order that the working and the correct position of the anode may be seen, together with the objects being plated, which objects form the cathode

clean, then washed with nitrate of mercury, which gives a coating enabling the silver to adhere more closely. It is then immersed in the plating vat, which contains a solution of

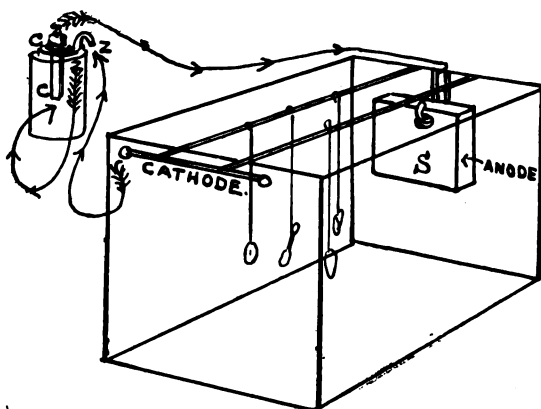

Fig. 226b. Vat and battery shown as of glass to explain working of current.

cyanide of potassium, cyanide of silver, and water. A plate, bar, or sheet of silver forms the positive electrode, and this is immersed in the solution which, for the purpose, is made incapable of dissolving any more silver till the current enables

it to do so. On the top of the vat are rods in metallic contact, holding the negative portion, or electrode, and from these are suspended, by means of wires called "slinging wires," the object to be plated, which becomes immersed in the liquid, the electric connection being then made. The positive element, or the zinc, Z, Fig. 226B, of the battery, generates the current and gives it to the carbon, C, which is the negative element, because it receives the current which the positive, Z, generated; and because the negative element, C, transmits its current along the wire connected to it, to some distant source outside, it becomes the positive pole, the positive element being the negative pole. So that on the generation of current, the negative element, C, receives it and

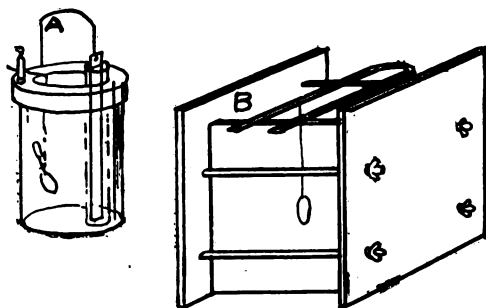

Fig. 227. A. Single cell apparatus with proper vessel, porous tube, and binding screws. B. A large trough divided by a diaphragm of biscuit-ware or very thin porous wood.

becomes the positive pole by transmitting the current to the anode, or positive electrode, which is represented by the bar or sheet of silver, S.

Through the water, or electrolyte, the current is transmitted to the object to be plated, which forms the cathode, or negative electrode. Thence it travels on to the positive element, Z, in the battery, and so the circuit is complete.

In passing through the liquid, the silver is deposited at the cathode (the object being plated), and an equivalent amount of silver is taken from the anode (the bar of silver), to replace it, so that the electrolyte (the liquid in the vat), remains the same strength and is not impoverished.

The formula for the electrolyte is—10 parts of cyanide of potassium; 1 part of cyanide of silver; 100 parts of water.



Chemists provide every kind of convenient vessel for the purpose, and in the picture (Page 301) it will be noticed that the single cell apparatus, though not so economical as the simple tumbler arrangement already described, is perhaps more convenient for electrotyping. (Fig. 227.)

*Tenth Experiment*

A single cell apparatus is only adapted to produce small electrotypes, but when larger ones are required, a separate battery of three or four Daniell's or Smee's cells is required;

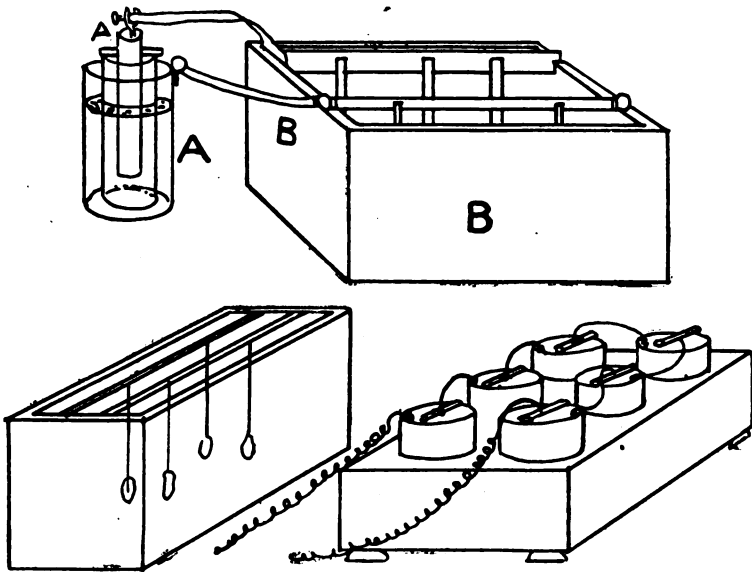

Fig. 228. A. A single cell, Daniell's, attached to B, the trough containing the mould and the plate of copper. Below is a Smee's battery ready to be attached to a larger trough for the purpose of electrotyping a great number of moulds at the same time.

and it is usual to place the mould to be copied in a separate wooden trough, attaching it to the cathode wire, whilst a copper plate is connected with the anode, so that as the solution of sulphate of copper undergoes decomposition by the passage of the electricity, it is kept almost in a normal state, in consequence of the oxygen of the water and the acid passing to the copper plate, which they attack and dissolve as fast as the oxide of copper and hydrogen are liberated at the

cathode, where the latter deoxidizes the oxide of copper, and by a secondary action deposits metallic copper; the object being to dissolve fresh metal as the copper is deposited on the mould. (Fig. 228.)

### *Eleventh Experiment*

To silver electrotypes or other brass and copper articles, the first attention must be paid to the cleanness of them; and when an electrotype is just removed from the copper solution, and washed in clean water, it is at once ready to receive the coating of silver; otherwise, if it has been handled, or is slightly greasy, it should be first boiled in a solution of common washing soda, and then the oxide removed by passing it rapidly in and out of some "dipping acid," which is prepared by mixing together equal parts of oil of vitriol and nitric acid; when removed from the dipping acid, it must be well washed in water, and may remain immersed in it until the silvering solution is ready. A silver solution

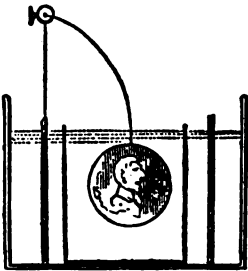

Fig. 229. The gallipot containing the solution of sal ammoniac, with the circular amalgamated zinc with wire and binding screw to which the medal is attached, and contained in the porous vessel holding the silvering solution and medal.

may be prepared by dissolving a sixpence in some nitric acid contained in a flask; it is then poured into a solution of common salt, which precipitates the chloride of silver, and leaves the copper in solution—the latter is poured off when the chloride has subsided, which, after being well washed in some boiling water, is dissolved in a solution of cyanide of potassium. If a clean electrotype is plunged into this solution, it is immediately covered with a very thin coating of silver, which of course would soon wear off, and in order to increase the thickness of the silver deposit, a single cell arrangement may be constructed of a large gallipot containing a wide porous cell and a circle of amalgamated zinc around it; the arrangement is set in action by pouring a solution of salt (or, still better, sal ammoniac) into and around the porous vessel, and the silvering solution into the latter; a connecting wire passes from the zinc, and the article being attached to it, is now plunged into the porous cell, when a

current of electricity slowly passes and deposits the silver on the copper article. (Fig. 229.)

#### *Twelfth Experiment*

Separate batteries and large troughs containing a solution of cyanide of silver in cyanide of potassium are used on a large scale in electroplating establishments, where the finest specimens of the art are to be obtained; a plate of silver being attached to the anode to supply the loss of silver in these troughs.

#### *Thirteenth Experiment*

The art of gilding by the agency of electricity is quite as simple as the processes already described, although greater care is necessary to avoid any loss of the precious metal. A small bit of gold is dissolved in a mixture of three parts muriatic acid and one of nitric acid, which forms the chloride of gold. This is then digested with an excess of calcined magnesia, and the gold is precipitated as an oxide of the metal; the latter is collected and washed, then boiled in strong nitric acid to remove the magnesia clinging to it, and being again thoroughly washed with water, is dissolved in a solution of cyanide of potassium, forming a solution of cyanide of gold and potassium, which may be placed in the porous cell of the single cell arrangement already described in the eleventh experiment.

#### *Fourteenth Experiment*

The safest and surest mode of making a gilding solution is to dissolve some cyanide of potassium in water in a gallipot, and having placed a porous vessel therein containing the same solution, put a plate of copper into the porous cell, and some thin foil of pure gold into the gallipot; connect the gold with the anode of a single cell of Daniell, and the copper in the porous cell with the cathode, and in a few hours sufficient gold will be dissolved for the purpose of gilding.

It is usually recommended to warm the gilding solution till it reaches a temperature of about 150° Fahr., and a very moderate battery power is employed in electro gilding. Indeed the same arrangement, shown in the eleventh experiment, Fig. 229, will also answer for the gilding solution. After being gilt, the articles may be rubbed with a little tripoli, or burnished by the handle of a key.

*Fifteenth Experiment*

Passing on to the more brilliant results obtainable from a powerful voltaic battery (of at least thirty pairs of Grove),

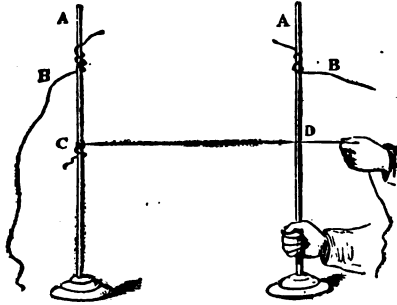

Fig. 230. A A. Two ring stands with the battery wires B B (which should be a convenient length) attached. C. Platinum wire, fixed end. D. The other end held in one hand and shortened as the stand is moved by the other hand.

the beautiful incandescence of platinum wire may first be noticed. If a wire of this metal is stretched between the brass standards of two ring stands, the length must be proportioned to the power of the battery; the adjustment can be made very conveniently by twisting the platinum

stand may be brought nearer and nearer to the first, until the desired intensity of light from the incandescent wire

is obtained. (Fig. 230.) If the wire is contained in a glass tube the cooling effect of currents of air is prevented, and a much greater length of wire can be made hot.

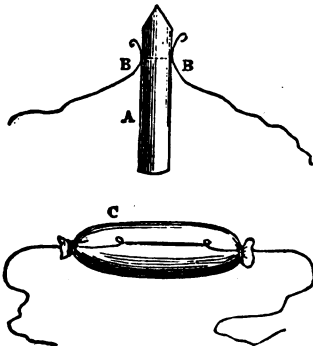

Fig. 231. A. A Gerb firework with two holes punctured, through which the bit of iron wire passes, and is wound round the battery wires tied to the outside of the case. C. A gut bladder containing the thin wire and powder for a miniature submarine explosion.

*Sixteenth Experiment*

With the same arrangement, a chain composed of alternate links of silver and platinum wire presents a very pretty effect, every alternate link of platinum being incandescent, whilst the silver, from its excellent conducting power, remains comparatively cool.

*Seventeenth Experiment*

Fireworks or gunpowder, arranged in proper cases, are fired at a great distance from the voltaic battery by heating

a thin iron or platinum wire contained within them, by the passage of the electricity; and submarine and other explosions of gunpowder by the same agency have become a common engineering operation. (Fig. 231. Page 305.)

### *Eighteenth Experiment*

The burning of various metals by the battery is displayed with great effect by the De la Rue discharger, as also the incandescence of the charcoal points producing electric light. The illuminating power derived from a forty-cell Grove's battery of the ordinary size is about equal to the light of 500 candles.

Fizeau and Foucault made a careful comparison of the light obtained from 92 carbon couples as arranged in a Bun-

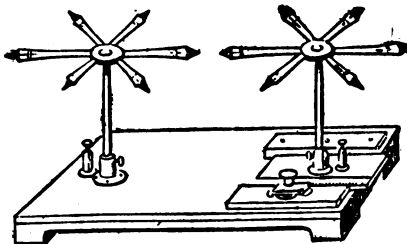

Fig. 232. De la Rue discharger, containing a series of six pairs of different substances, such as charcoal, iron, lead, zinc, copper, antimony, in six pairs of crayon holders, and turning on a centre, so as to be charged at pleasure.

sen's battery, and of the oxy-hydrogen, or Drummond light, as compared with that of the sun, with the result that "On a clear August day, with the sun two hours high, the electric light (assuming the sun as unity) bore to it the ratio of one to two and a half—*i.e.*, the sun was two and a half times

more powerful while the Drummond light was only  $\frac{1}{46}$ th that of the sun." Bunsen found the light from 48 carbons equal to 572 candles. In Bunsen's battery carbon is substituted for the platinum in Grove's arrangement; and simultaneously with Bunsen, Cooper (in England) applied charcoal for the same purpose.

### ELECTRIC ALARMS

An interesting and useful pastime within the power and skill of any boy is to fit up his home with burglar-alarms, and also to waken himself by means of an electric alarm clock. Taking the burglar-alarms first:—

Contacts may be purchased for a few pence each at any electrical store, there being plenty of variety of types from

which to make a selection. The accompanying sketch shows two good designs. (See Figs. 233A and 233B.)

These require letting into the hinged side of the door-frame so that the plate is flush with the surface of the wood. The ball will then project, but when the door is closed, this ball is pushed in and forces the spring away from contact with the plate. One wire is joined to contact A, and goes to the bell, the other is joined to contact B, and runs to the battery.



Fig. 233a. Alarm rubbing contact for door.



Fig. 233b. Ebonite barrel for window contact.

The contacts for the windows should be so placed that the slightest alteration of position in either sash releases the ball, just as does the opening of a door, when the two metallic surfaces snap together, causing the bell to ring so long as the door or window is open. Of course, casement windows are treated as doors.

In order to save wire, all the battery wires in one room, or from all doors or windows on a landing, may be joined together, and all the "A" wires may be joined also, one wire only going to bell and one to battery. From the remaining terminal of the bell, there should run a single wire to the remaining terminal of the battery.

It is usual to have a distinctive colour, commonly red, for the battery wires, the other colour being for the bell. This prevents any possibility of joining the wrong wires, which would create a short circuit; it also gives easier location.

If all these wires are hidden beneath the wall-paper or carpet, and taken through the door and window-frames at the back of the holes in which the fittings are placed, so that the wires come out at the junction of the plaster with the wood-work in the angle of the wall or door or window-frame, there will not then be the slightest evidence of the installation, either inside the room or out of it. The wires from the downstairs rooms and windows are coupled together and taken upstairs as two wires, those from the upper rooms being likewise coupled, and joined to the two from below; all "A's"

to "A," and "B's" to "B," so as to run forward to the bedroom in which the alarm and battery are fixed, as two wires. One of these may be carried round the walls to a spot within easy reach at the bed-side, where it may be broken by a switch, then go forward to the bell or battery, as the case may be. This switch is left open in the daytime, but after the house is shut up for the night, on retiring the switch is closed, and until it is opened again the next morning, the slightest movement of door or window throughout the house, will set the alarm bell ringing vigorously. The accompanying sketch will make this clear. (Fig. 234.)

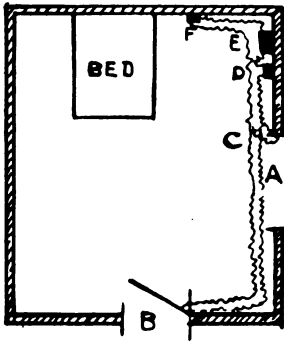

Fig. 234. Plan of bedroom. Wires enter at door, B, pick up window connections A which are joined at C. One wire goes direct to bell, D; the other passes forward to switch, E, at bed side; thence back to battery, F, the remaining terminal of which is connected with the vacant terminal of bell, D.

#### ELECTRIC ALARM CLOCK.

Terminals for attachment to any ordinary cheap American alarm-clock may be purchased at an electrician's store for about four pence, or one of these clocks may be obtained with the electric arrangement fitted complete.

If the clock is kept below stairs, so that its ticking shall not disturb the quiet of the bedroom, a wire must be run from each terminal of the clock, one to the bell, the other to the battery, both of which should be in the bedroom for convenience. As in the burglar-alarm, one wire, in its passage to the bell or battery, according to which wire is selected, should be broken by a switch, preferably near the door, or as far removed from the bed as possible.

Before retiring, the pointer on the alarm-dial of the clock is placed at the desired time, the clock being left downstairs. On entering the bedroom the clock-switch is closed and quiet rest may be confidently taken, for to the second fixed upon, the wire in the clock will fall and make contact. At once the bell will ring loudly, awakening the sleeper, and continuing to ring for from thirty to forty-five minutes, or until the switch is moved, which necessitates the sleeper's getting out of bed and walking across the room, which is usually sufficient to

rouse thoroughly even the drowsiest individual. The following diagram will make the method of installation clear. (Fig. 235.)

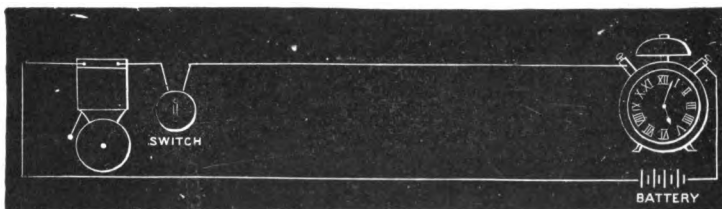

Fig. 235. Diagram showing installation of clock alarm.

## CHAPTER XVII

### MAGNETISM AND ELECTRO-MAGNETISM

If a small helix, or coil of covered wire, is arranged with an unmagnetised steel needle within it, so that the discharge of a large Leyden jar may take place through the coil, the needle will be found strongly magnetic after the discharge of the electricity. (Fig. 236.) Many years before this was known, it had been noticed that when a ship was struck by lightning, the compasses were generally reversed; and in a

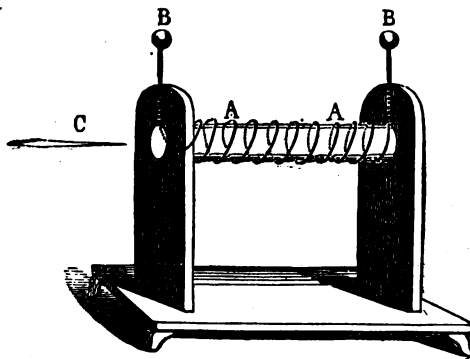

Fig. 236. A A. A glass tube supported on two uprights of wood, with coil of copper wire passing round it, terminating in the balls B B. C. Needle to place inside glass tube.

special case, where a house was struck, the electricity entered a box of knives, fusing some, tearing the handles off others, but leaving them strongly magnetic. Electricians tried to



repeat the effect by sending the discharge of powerful Leyden batteries through bars of steel, without any important result; and it was not until Oersted, in the year 1819, made his important discovery that the copper wire conveying the electricity possessed peculiar magnetic power, that the principle began to be understood, and then the electricians succeeded in imitating the effects of lightning on steel, as already described in the beginning of this chapter. (Fig. 236, Page 309.)

#### *First Experiment*

When the electricity has passed away from the Leyden jar through the coil of copper wire, it no longer possesses any power to affect a piece of steel or iron, but if the wires of the voltaic battery are now connected with the coil of copper wire, which should be covered with cotton or silk, and many yards in length, then a bar of steel or soft iron is not only rendered magnetic, but remains permanently so, as long as the current of electricity continues to pass along the coil of wire, so that if some nails or iron filings are brought to the bar of iron, one end of which projects from the coil, they cling to it with considerable force, and a great number of nails may be hung on in this manner, but they immediately fall off when the contact with the battery is broken. (Fig. 237.)

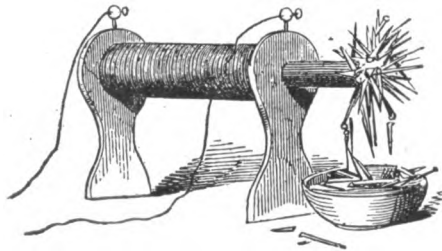

Fig. 237.

Electricity thus becomes a source of magnetism, and the discoverer, Oersted, found that only needles or bars of steel or iron were thus affected, and not those of brass, shellac, sulphur, and other substances; he termed the conducting wire "a conjunctive wire." and described the effect of the electric current or "electric conflict," as he called it, as resembling a helix (from *ἐλίσσω*, to turn round; a screw or spiral),

and that it is not confined to the conducting wire, but radiates an influence at some distance. This latter statement is exactly in accordance with our present notions, hence the coil conveying the current is said to *induce* magnetism in the iron or steel, just as the phenomena of induction are produced with frictional electricity. The effect of Oersted's discovery, says Silliman, was truly *electric*; the scientific world was ripe for it, and it was instantly seized upon by Arago, Ampère, Davy, Faraday, and a crowd of philosophers in all countries. The activity with which this new field of research has been cultivated, has never relaxed even to this hour, while

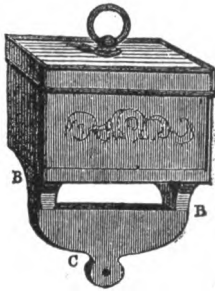

Fig. 238. A loadstone mounted in brass or silver, with the iron cheeks B B attached. C. The bit of soft iron called the armature.

it has borne fruit in a multitude of theoretical and practical truths, and above all, in the wireless telegraph, the electro-magnetic telegraph, and especially in connexion with the cables which have been aptly called "*the great international nerve of sensation.*"

Magnetism is not only the result of a current of electricity through any good conductor, but there are certain oxides of iron, called magnetic iron ores, which have the property of attracting iron filings, and are mostly found in primitive rocks, being abundant at Roslagen, in Sweden, and called the loadstone, from always pointing, when freely suspended, to the Polar, North, or Load Star. If a tolerably large specimen of this mineral is examined, there will be found usually two points where the iron filings are attracted in greater quantities than in other parts of the same specimen. These attractive points are called poles, and the loadstone being properly mounted with soft iron bars, termed cheeks, bound round it (in old-fashioned loadstones) with silver plate and duly ornamented with engraving, has its magnetic power greatly increased, and is then said to be endowed with magnetic polarity; to prevent the loss of power, a soft piece of iron, called the armature, is placed across and attracted to the poles of the loadstone just as is the strip of iron which

is usually left attracted to both poles of an ordinary horse-shoe magnet. (Fig. 238.)

### Second Experiment

If a needle of tempered steel (fitted with a little brass cup in the centre to work upon a point) is rubbed with the load-stone in one direction only, it is rendered permanently magnetic, and will now be found to take a certain fixed position, pointing always in a direction due north and south. The end which points towards the north is called the north pole, the other extremity the south pole, and it is usual to mark the north pole with an indentation, a cut with a file, or a scratch, to distinguish it at all times.

### Third Experiment

If another bar of steel is magnetised, and the north pole duly marked, then brought towards the same pole of the suspended magnet, instant repulsion takes place; the magnet, of

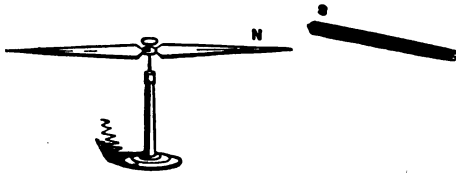

Fig. 239. A magnetic needle, the north pole N being attracted to the south pole of the bar magnet S, and repelled from the north end.

course, grasped in the hand is not free to move, but the small magnet immediately shows the same fact noticed with electricity, viz., *that similar magnetisms repel*. Two north poles repel each other, but when the bar of steel is reversed, the opposite effect occurs, and the suspended magnet is attracted, showing that *dissimilar magnetisms attract*, and a north will attract a south pole, or, to quote an old proverb—"extremes meet." (Fig. 239.)

### Fourth Experiment

By contact, the magnetic power is transferred from the magnet to a piece of unmagnetised steel, and the highest magnetising effect is that produced by a simple method. A horseshoe magnet has its poles brought in contact with the intended poles of another bar of steel, likewise bent in the

form of a horseshoe, and by drawing the feeder over the unmagnetised horse-shoe in the direction of the arrow in the cut, and, when it reaches the curve, bringing it back again

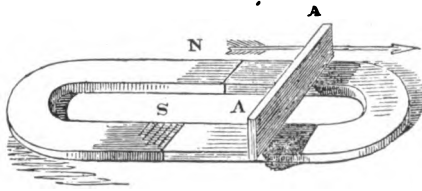

Fig. 240. The horse-shoe magnet, and another one unmagnetised, placed end to end; the one shaded and lettered N and S is the magnet. A A. The piece of soft iron moved in the direction of the arrow.

to the same place, say at least twelve times, then, after turning the whole over without separating the poles, and repeating the same operation on the other side likewise twelve times, the steel is then powerfully magnetised. A horse-shoe magnet of

one pound weight may be thus charged so as to sustain twenty-six and a half pounds; by the old method of magnetising it would only have sustained about twenty-two pounds. (Fig. 240.)

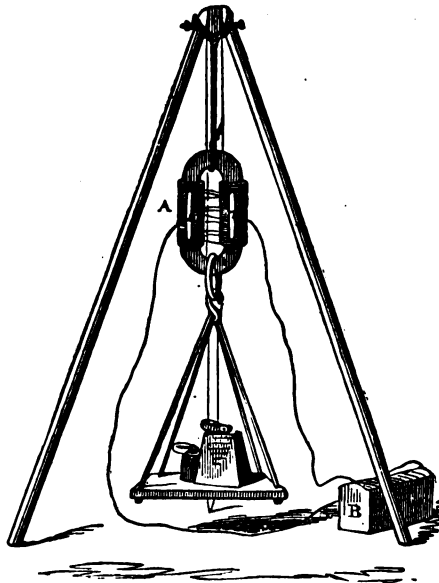

Fig. 241. A. Powerful electro-magnet supporting a great weight. B. The battery.

*Fifth Experiment*

If the horse-shoe magnet is placed on a sheet of paper, and some iron filings are dusted between the poles, a very beautiful series of curves are formed, called the magnetic curves, which indicate the constant passage of the magnetic power from pole to pole.

*Sixth Experiment*

The magnetic force exerted by a horse-shoe-shaped piece of soft iron, surrounded with many strands of covered copper wire in short lengths, is extremely powerful (Fig. 241), and



Fig. 242. Magician and his loadstone-rock.—Vide *Fairy Tale*.  
(From an old print.)

enormous weights have been supported by an electro-magnet when connected with a voltaic battery. Supposing a man were dressed in complete armour, he might be held by an electro-magnet, without the power of disengaging himself, thus realising the fairy story of the bold knight who was caught by a rock of loadstone, and, in full armour, detained by an unfriendly magician. (See Fig. 242.)

*Seventh Experiment*

When a piece of soft iron is held sufficiently near one of the poles of a powerful magnet, it becomes by *induction* endowed with magnetic poles, and will support another bit of soft iron, such as a nail, brought in contact with it. When the magnet is removed, the inductive action ceases, and the soft iron loses its magnetic power. This experiment affords another example of the connexion between the phenomena of electricity and magnetism. It is in consequence of the inductive action of the magnetism of the earth that all masses of iron, especially when they are perpendicular, are found to be endowed with magnetic polarity; hence the reaction of the iron in ships upon the compasses, which have to be corrected and adjusted before a voyage, or serious errors in steering the vessel would occur, and there is no doubt that many shipwrecks are due to this cause. Few metals beside iron, steel, nickel, cobalt, can receive or retain magnetism after contact with a magnet.

The remarkable effect of magnetism upon all matter, so ably investigated by Faraday and others, will be explained in another part of this book, in the section on Dia-Magnetism.

## CHAPTER XVIII

## ELECTRO-MAGNETIC MACHINES

The experiments already described in illustration of some of the phenomena of electro-magnetism are of such a simple nature that they may be comprehended without difficulty;

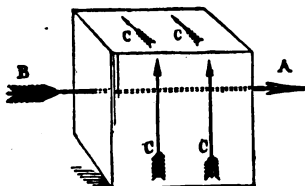

Fig. 243. Portion of a square copper conductor, in which A B represents the direction of the electricity, and the small arrows, C C C C, the magnetic current or whirl at right angles to the electrical current, and exercising a tangential action. (See note, Fig. 244.)

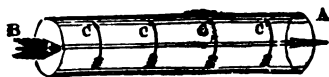

Fig. 244. A round conducting wire, in which the electrical current is flowing in the direction of the large dart A B, and the small arrows indicate the direction of the magnetic force. For easier comprehension, the piece of wire (and the copper cube in Fig. 243) is shown as of glass, so that the arrow may be seen through-out its length.

but it is not such an easy matter to appreciate the curious fact of an invisible power producing motion. It has already been explained that a copper or other metallic wire conveying a current of electricity becomes for the time endowed with a magnetic power, and if held above, or below, or close to, a suspended magnetised steel needle, affects it in a very marked degree, causing it to move to the right or left, according to

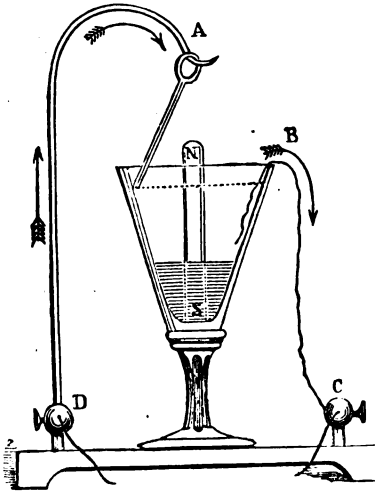

Fig. 245. N. A small bar magnet cemented into a wineglass, the north pole being at N. A is a moveable wire looped over the hook, which is the positive (+) pole of the battery; the free extremity rotates round the pole of the magnet when the current of electricity passes. The dotted line represents the level of the mercury which the glass contains. The electricity passes in at A, and out at the wire B, as shown by the arrows. C is connected with the negative, and D with the positive, pole of the battery.

the *direction* of the electric current; in order to form some notion of the condition of a metallic wire whilst the electricity is passing through it, the diagrams, Figs. 243, 244. Page 315 may be referred to.

Roget says that the magnetic force which emanates from the electrical conducting wire is entirely different in its mode of operation from all other forces in nature with which we are acquainted. It does not act in a direction parallel to that of the current which is passing along the wire, nor in any plane passing through that direction. It is evidently exerted in a plane perpendicular to the wire, but still it has no tendency to move

the poles of the magnet in a right or radial line, either directly towards, or directly from, the wire, as in every other case of attractive or repulsive agency. The peculiarity of its action is that it produces motion in a circular direction *all round* the wire—that is, in a direction at right angles to the radius, or in the direction of the tangent to a circle described round the wire in a plane perpendicular to it; hence the electro-magnetic force exerts a tangential action, or that which

Wollaston called a vertiginous or whirling motion. (See page 388 Dia-magnetism.)

Faraday concluded that there is no real attraction or repulsion between the wire and either pole of a magnet, the action which imitates these effects being of a compound nature; and he also inferred that the wire ought to revolve round a magnetic pole of a bar magnet, and a magnetic pole round a wire, if proper means could be devised for giving effect to these tendencies, and for isolating the operations of a single pole. For the first idea of electro-magnetic rotation the world is indebted to Wollaston; but Faraday, with his usual ingenuity, was the first who carried out the theory practically. The rotation of a wire (conveying a current of voltaic electricity) round one of the poles of a magnet is well displayed with the simple contrivance devised by him. (Fig. 245.)

By a careful observation of the complex action of an electrified wire upon a magnetic needle, Faraday was enabled to analyse the phenomena, and he found, as Daniell relates,—

“That if the electrified wire is placed in a perpendicular position, and made to approach towards one pole of the needle, the pole will not be simply attracted or repelled, but will make an effort to pass off on one side in a direction dependent upon the attractive or repulsive power of the pole: but if the wire be continually made to approach the centre of motion by either the one or the other side of the needle, the tendency to move in the former direction will first diminish, then become null, and ultimately the motion will be reversed, and the needle will principally endeavour to pass in the opposite direction. The opposite extremity of the needle will present similar phenomena in the opposite direction; hence Dr. Faraday drew the conclusion that the direction of the forces was *tangential* to the circumference of the wire, that the pole of the needle is drawn by one force, not in the direction of a radius to its centre, but in that of a line touching its circumference, and that it is repelled by the other force in the opposite direction. In this manner the northern force acted all round the wire in one direction, and the southern in the opposite one. Each pole of the needle, in short, appeared to have a tendency to revolve round the wire in a direction opposite to the other, and, consequently, the wire round the poles. Each pole has the power of acting upon the wire by itself, and not as connected with the opposite pole, and *the apparent attractions and repulsions* are merely *exhibitions* of the *revolving motions* in different parts of their circles.”

The same fact illustrated at Fig. 239, is also demonstrated in a still more striking manner by means of wire bent into a rectangular form, and so arranged that whilst the current



of electricity passes, it is free to move in a circle; and when the poles of a magnet are brought towards the electrified wire, it may be attracted or repelled at pleasure, and in fact becomes a magnetic indicator, and places itself (if carefully suspended) at right angles to the magnetic meridian. (Fig. 246.)

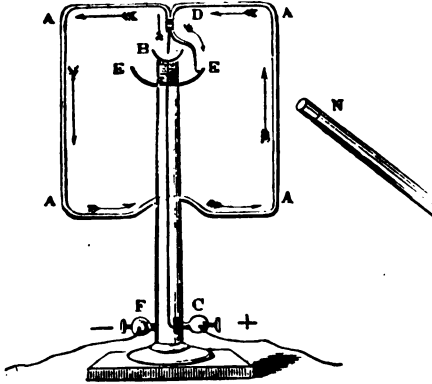

Fig. 246. A A A A. The rectangular wire covered with silk and varnished, one end of which being pointed, rests on the little cup B, connected with a covered wire passing down the centre of the brass support to the binding screw C let into ivory. D. The other extremity of the rectangular wire; this being covered and varnished, is not in metallic contact with the end B, but is likewise pointed, and dips into the mercury contained in the large cup E E. The upper and lower cups do not touch, and are separated by ivory, marked by the shaded portion, and the cup E E is in metallic communication with the brass pillar, and is connected with the negative pole of the battery at F, whilst C is connected with the positive pole of the battery, and the electricity circulates round the wire in the direction of the arrows. When a bar magnet, N, is brought towards the wire, the latter is immediately set in motion; by alternately presenting the opposite poles of the magnet, the rectangular wire rotates freely round the cup B.

These curious movements of a magnetised needle, and rotations of wires and magnets, brought about by the agency of an active current of electricity, induced Brewster to advance his admirable theory, which supposes the affection of the mariner's compass needle, and all other suspended pieces of steel, to be due to the agency of electrical currents continually circulating around the globe; the following experiment illustrates Brewster's theory. A wooden globe, sixteen inches in diameter, is made hollow, for the purpose of reducing its weight, and while still in the lathe, grooves one-

eighth of an inch deep and broad are cut to represent an equator, and parallels of latitude at every four and a half degrees each way from the equator to the poles. A groove of double depth is also cut like a meridian from pole to pole, but only half round. The grooves are cut to receive the copper wire covered with silk, and the laying on is commenced by taking the middle of a length of ninety feet of wire one-sixteenth of an inch in diameter, which is applied to the equatorial groove

so as to meet in the transverse meridian; it is then made to pass round this parallel, returned again along the meridian to the next parallel, then passed round this again, and so on, till the wire is thus led in continuation from pole to pole. The length of wire still remaining at each pole is returned from each pole along the meridian groove to the equator, and at this point, each wire being fastened down with small staples, the wires from the remaining five feet are bound together near their common extremity, when they open to form separate connexions for the poles of a voltaic battery. When the battery is connected, and magnetic needles placed in different positions, they behave precisely as they would do on the surface of the earth, the induction set up by the electrified wire being a perfect imitation of that which exists on the globe.

The opposite effect to that already described—the rotation of one pole of a magnet round the electrified wire,—was also arranged by Faraday in the following manner. (Fig. 247.)

In the examination of the magnetic phenomena obtained from wires transmitting a current of electricity, it should be borne in mind that any conducting medium which forms part of a closed circuit—*i.e.*, any conductor, such as charcoal, saline fluids, acidulated water, which forms a link in the endless chain required for the path of the electricity,—will cause a magnetic needle placed near it to deviate from its natural position.

These positions of the electrified wire and the magnetic

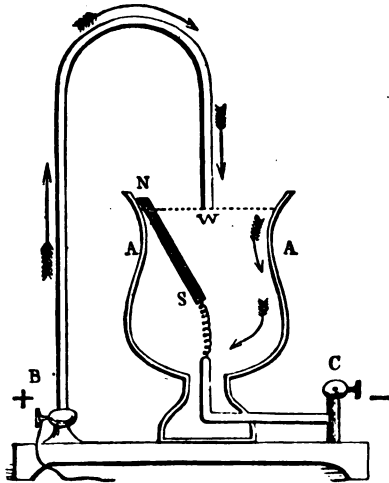

Fig. 247. N S. A little magnet floating in mercury contained in the glass A A; the north pole is allowed to float above the surface of the quicksilver, and the south pole is attached to the wire passing through the bottom of the glass vessel. The electricity passes in at B, and taking the course indicated by the arrows travels through the glass of quicksilver to the other pole of the battery at C. Direct contact is made with the battery, the little magnet rotates round the electrified wire, W. The dotted line shows the level of the mercury in glass.

needle are of course almost unlimited, and in order to assist the memory with respect to the fixed laws that govern these relative movements, Ampère suggested a most useful mechanical aid; he says:—"Let the observer regard himself as the conductor, and suppose a positive electric current to pass from his head towards his feet, in a direction parallel to a magnet; then its north pole in front of him will move to his right side, and its south pole to his left.

"The plane in which the magnet moves is always parallel to the plane in which the observer supposes himself to be placed. If the plane of his chest is horizontal, the plane of the magnet's motion will be horizontal, but if he lie on either side of the horizontally-suspended magnet, his face being towards it, the plane of his chest will be vertical, and the magnet will tend to move in a vertical plane."

This very lucid comparison will be seen to apply perfectly to the direction of the rotations in Figs. 245 and 247.

The apparatus (Fig. 248) consists of two flat bar magnets doubly bent in the middle, and having agate cups fixed at the under part of the bend (by which they are supported) upon

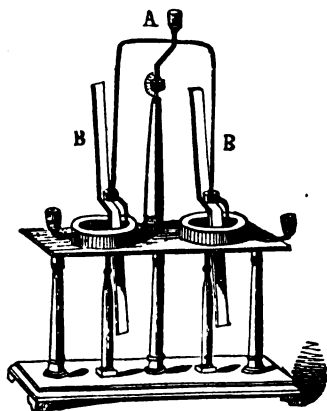

Fig. 248. A. Wire conveying the current of electricity. B B. The magnets balanced on points rotating round the wires.

pointed wires, the latter being fixed upright on the wooden base of the apparatus, and the magnets turn round them as upon an axis. Two circular boxwood cisterns, to contain quicksilver, are supported upon the stage or shelf above the base. A bent pointed wire is directed into the cup of each magnet, the ends of which dip into the mercury contained in the boxwood circular troughs on the stage. By using a battery to each magnet, and taking care that the currents of electricity flow precisely alike, they will then rotate in opposite directions.

## CHAPTER XIX

## THE ELECTRIC TELEGRAPH

We of to-day who are accustomed to the hurry and bustle of modern life and look upon communication with distant people by means of the telegraph and telephone, wireless and otherwise, as a necessity of existence, can scarcely realise what would happen if these two inventions alone were suddenly thrown out of action and we reverted to the restricted methods of but a century ago. The business of the time was conducted perhaps better than that of to-day, but every phase of modern business, directly or indirectly, would be rendered altogether impossible under the old conditions and even under those of the present time, without the aid of the electric telegraph and the sister invention, the telephone. So important have these become, that to give details of the phases through which each has passed would create too wide a subject for consideration here, therefore, a very brief account of the principles only can be attempted.

The first practically useful telegraphic line, not only in Great Britain but in the whole world, was due to a Russian, Baron Schilling; his electro-magnetic instrument, without its inventor's connection with it being known, was brought to London, and thus instituted the science. The first line to be constructed in England ran from Paddington to West Drayton along the Great Western Railroad, and was fixed in 1838-9; soon after this had started, Steinheil, in 1838, made a most important discovery—that if a conducting wire is well connected with earth at a terminus, and a similar connection is made with earth at the second terminus, no matter the distance, the earth itself will act as a conducting wire and connect the termini, thus saving a wire and increasing the power also. This will, however, be explained on page 327. And to Wheatstone is due the ingenious construction of the vertical-needle telegraph. Cooke's name, also, will always be associated with the practical establishment of the first telegraph lines in England, whilst in British India, in 1838-9, O'Shaughnessy constructed the first long line of telegraph, twenty-one miles in length and embracing 7,000 feet of river surface; that in the United States of America, from Washington to Baltimore, being arranged and worked by Morse.

The construction of the electric telegraph may be considered under three heads:

- A. The Battery, *the motive power.*
- B. The Wires, *the carriers of the force.*
- C. The Instruments to be worked—*the bell and the needle telegraph.*

#### A—THE BATTERY.

The construction and rationale of the batteries generally in use have been explained in another part of this work; those used for telegraphic purposes consist of one or more couples, of which zinc is one, the second being copper, silver, platinum, or carbon. Each couple is termed an *element*, and a series of such couples a *battery*.

With the general construction of the different kinds of batteries and their special adaptability to various purposes, the reader will now be familiar, these having been discussed in the sections devoted to electricity, electro-plating, etc.

Many of these batteries are called into service for the transmission of messages by telegraphy on wires, according to the work required of them, and amongst these we find various modifications of the Leclanché, Daniell, bichromate and secondary batteries, which last are the most common. These "accumulators" or "storage," or "secondary" batteries, as they are variously called; do not generate *their own* current, as the word "generate" is understood, but require to be charged from a dynamo. Where a number of circuits having similar resistance terminate at one centre, they are usually connected up in fours, or sixes, to one battery, to save both cost and space.

Steinheil's discovery of "earth" connections (mentioned on pages 321 and 327), has proved a most important one, and it is usual to connect this return, or "earth" wire to the water-pipe which takes it deep into the earth, where the general dampness does the rest. The current, however, in its passage, is brought into opposition or juxtaposition with the ever-existing earth-currents which, from causes not yet ascertained, differ and vary considerably in their motive energy or potentiality. It is this variableness and susceptibility to electrical influences and magnetic attraction, which cause the upsetting of telegraphic instruments during times of electric and magnetic storms, such as are present coincident with

the appearance of sun-spots, volcanic eruptions, and all manner of earth-crust disturbances.

These, traversing the path of the earth-return so affect it as to divert or stop it, and possibly to render it altogether unreliable, so that telegraph instruments at such times become almost if not absolutely useless. So serious are these disturbances on occasion, that cables are often parted or destroyed, and inter-communication is also rendered impossible, except in cases where a return-wire, instead of the earth-return, is fixed. No satisfactory scientific explanation of this is at present forthcoming, though there are many theories.

As in the ordinary battery, the current cannot be effective unless it makes a true unbroken circuit,—from the battery, through the instrument, the various connections, the wire, the instruments at the other end, and its return through the earth back to the battery. If, during this circuit, it should meet a point where there is little or no resistance, such as where a staple, driven in too hard; cuts through the insulation of the wire and bridges the two wires, the current, meeting no resistance, is deflected, and becomes what is known as a “short,” or, more correctly, is “short circuited.”

The continual energy of the battery, whatever may be its construction, depends on the circulation of the electricity, the object being to pass the force from the positive end of the series through the wires, back again to the negative extremity of the voltaic series.

The wire (the carrier of the force) must be continuous throughout, unless, of course, water or earth forms a part of the endless conducting chain.

#### B—THE CONDUCTING WIRES.

These roads for the electricity may be of any convenient metal, and the one preferred and used is iron, which is well calculated from its great tenacity (being the most tenacious metal known) and cheapness, to be used in conveying the electricity, although it is not such a good conductor as copper, and offers about six times more resistance to the flow of the current than the latter metal. The wire does not appear to be made of iron, because it is galvanized or passed through melted zinc, which coats the surface and defends it from destructive rust, at the same time its valuable property of ten-

acity or power of resisting a strain is not destroyed. About one ton of wire is required for every five miles, and to support this weight, stout posts of fir or larch, from ten to twenty-five feet high, are erected. At every quarter mile, on many lines, are straining-posts with ratchet wheel winders, for tightening the wires. On some of the lines the wires are attached to the posts by side brackets carrying insulators, which were formerly composed of brown salt-glazed stoneware of the hour-glass shape, as shown in the drawing. (Fig. 249.)

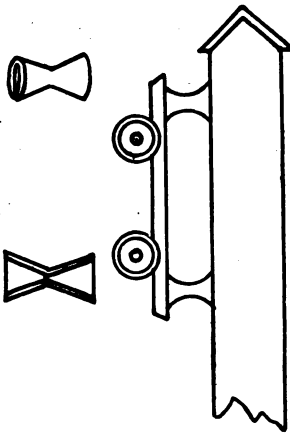

Fig. 249. Walker's insulator. (Old pattern.)

There were some objections to the hour-glass insulators which proved very unsatisfactory and were improved by the employment of a very strong stone-ware hook open at the side, so that the wire could be placed on the hook without threading, and the hook replaced in case of breaking, without cutting the tele-

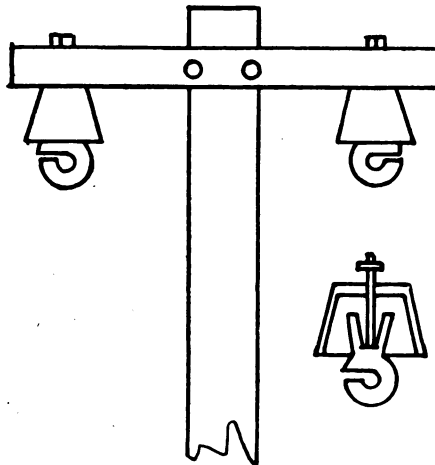

Fig. 250. Clark's insulator. (Old pattern.)

graph wire, which was securely fastened to each insulator by turns of thinner wire. An inverted cap of zinc served to keep the insulator dry. (Fig. 250.)

The later patterns in use at the present time are made as in Fig. 251, A and B, the porcelain itself forming a kind of bonnet which prevents any moisture creeping up, or the rebounding of splashing rain causing leakage of current, or short-circuit. Even at the best, a porcelain or indeed any other form of outside insulator is by no means ideal. Should the insulator be protected from rain, change of atmosphere causes moisture to form, which saps the current, as also will actual rain, dew, and varying temperature. The moisture hangs on the glazed surface of the ware, or on the glass, and a considerable quantity of current from the naked wire is held there. This is especially the case when the insulator is hooded, for then evaporation takes place so slowly that there is often a bath of moist vapour around the inside, which causes waste, and a little lost at every tie of the wire round each insulator means a very serious loss indeed in miles of wire. Such a loss is inevitable under present conditions of outside wiring, for the perfect insulator has yet to be invented. The only safeguard against loss is well and closely-insulated wire placed underground.

There are usually about forty to sixty poles to the mile, as they are, on an average, from thirty to fifty yards apart, the distance varying according to whether it is a main or a branch line. Overhead wires are, however, subject to many disadvantages, especially in time of storm, and in winter, when the weight of snow and the keen frost break the wires, deranging the complete service, so that the modern method is to lay them underground wherever possible, as already mentioned. In and near towns almost all wires are so placed, being arranged in cast iron pipes. Each of such wires is made of hard copper, well insulated with gutta-

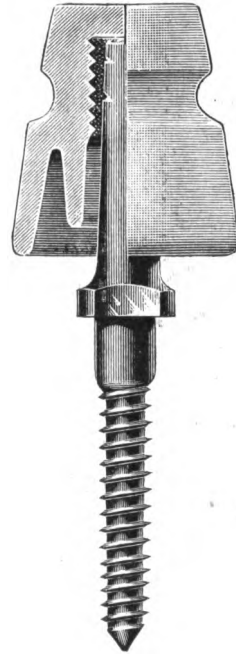

Fig. 251a. Modern insulator of white porcelain for horizontal support.



percha, whilst at intervals in the service there are provided inspection chambers, called "flush-boxes," where the tests are made and faults located and repaired.

In India the conductor is often a rod rather than a wire.

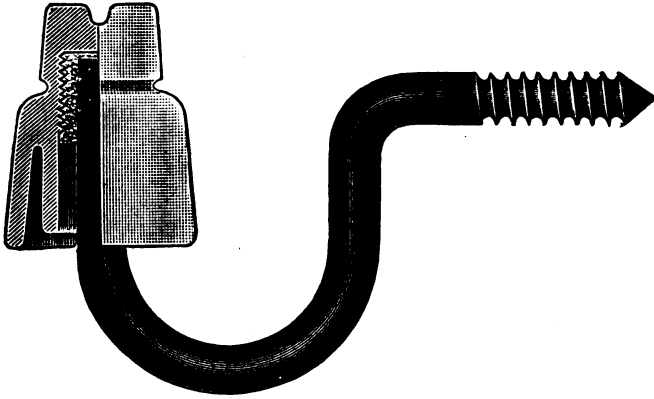

Fig. 251b. White porcelain insulator for wall or the side of other vertical support.

and weighs about half a ton per mile; it is erected in the most substantial manner, and many miles of the rod are supported on granite columns, other portions on posts of the iron-wood of Arracan, or of teak.

The number of wires required by the electric telegraph often puzzles the railway traveller, and people ask why so many wires are used on some lines and so few on others? The answer is very simple: they are for convenience. Two wires only are required for the double needle telegraph, and one for the single needle instrument. But as so many instruments are required at the terminal stations, an increased number of wires, like rails for locomotives, must be provided.

If the earth was not a conductor of electricity, and employed in the telegraphic circuit, four wires would be required for the double needle telegraph, and two for the single instrument. To understand this, let us suppose a battery circuit extending from Paddington to the instrument at Slough, and the wire returning from Slough to Paddington, it is evident that one wire would take the electricity to Slough, and the other return it to London, as in the diagram, (Fig. 252.)

If the whole of the return wire is cut away except a few feet at each end, which are connected by plates of copper with the damp earth, the current not only passes as before, but actually has increased in intensity, and will cause a much more energetic movement of the needle in the telegraph in-



Fig. 252. A. The battery. B. The instrument. The arrows show the passage of the electricity to the single needle telegraph instrument by one wire, and the return current by the other.

strument. (Fig. 253.) These plates are called Earth Plates; and Steinheil was the first who proved that the earth might perform the function of a wire; see pages 321 and 322.

It must be obvious that a message may be received at any station without a battery, but in order to be able to return an answer, every station must have its own battery.

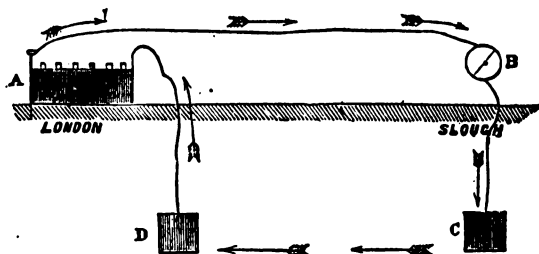

Fig. 253. A. The battery. B. The instrument. C. Earth plate at Slough. D. Earth plate at London. The arrows show the direction of electric current.

Ingeniously-constructed lightning-conductors are attached to the posts which carry the wires, so that in case of a storm, the natural electricity is conveyed to the earth, whilst the voltaic electricity artificially produced pursues its own course without deviation. Protectors are also required for the instruments at the stations, and the plan devised may thus be described:—

A portion of the wire circuit—say for six or eight inches—is enveloped in blotting-paper or silk, and a mass of metallic filings, in connexion with the earth, is made to surround it. This arrangement is placed on each side of the telegraph in-

strument at a station. When a flash of lightning happens to be intercepted by the wires of the telegraph, the myriads of infinitesimally fine points of metal in the filings surrounding the wire at the station, on having connexion with the earth, at once draw off nearly the whole charge of lightning, and carry it safely to the earth.

C—THE INSTRUMENTS TO BE WORKED—THE BELL.

In every system of telegraphy, bells are used at each end of the line, to call the attention of the clerks in charge. They are also largely used for railway signalling. There are three kinds of electric bells:—Firstly, those connected with a train of clockwork, which is set in motion by the removal of a trigger attached to the armature of an electro magnet; secondly, those where the hammer of the bell is itself attached to the armature, and which give a single stroke each time the circuit is completed by the depression of a key at the distant station; and lastly, the trembler, in which the action of the hammer makes and breaks contact several times in a second, for as long as the current is caused to pass.

This last form is the most common of all, and is largely

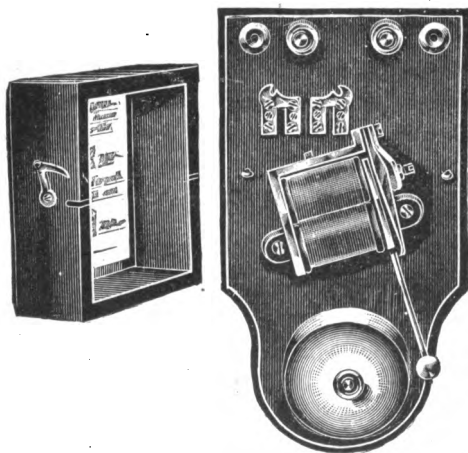

Fig. 254. Electric bell.

used for domestic purposes, especially in hotels, clubs, and other large buildings, where it entirely supersedes the wires and cranks which so constantly required the attentions of the bell-hanger. The annexed cut will enable the reader to under-

stand the way in which it works; the case with which it is usually covered to protect it from the dust is shown off at side. In order to avoid the confusion which would arise from the ringing of different bells in a house, without some way of ascertaining from which apartment the call arises, it is usual to employ an instrument called an indicator. This consists of a wood case, somewhat like a picture-frame, enclosing so many numbered square spaces, each space denoting a certain room and connected with an electro-magnet having an armature with a cardboard or paper disc attached to it. Upon ringing the bell the disc oscillates or drops across the space denoting the room where the button was pressed. By this plan one bell will serve for a number of rooms.



Fig. 255. Leclanché cell. Carporous pattern.

The ordinary electric bell push is too common to require description, it being hardly necessary to say that the act of pressing it completes the electrical circuit, and so the electro-magnet of the bell is called into action. A great many forms of burglar alarms are constructed on the same principle, contact being made by the opening of a window, or of a door, or by the pressure of a footstep on a particular board of the flooring. (See page 307.)

These bells are almost invariably worked by a Leclanché battery, a single cell of which is here shown. The outer cell is of glass which contains a perforated porous pot and an outer carbon cylinder. The carporous pot contains the depolarising peroxide of manganese mixture.

#### COOKE AND WHEATSTONE'S DOUBLE NEEDLE TELEGRAPH.

The principle of this instrument, as already explained, is involved in the elementary experiment of Oersted,—the deflection of a magnetic needle from the inside of a coil of wire conveying a current of electricity, and as it is difficult to give a good description and drawing of the interior of the instru-

ment that can really be understood, it may be sufficient to state that the handles give the operator the power of reversing the current of electricity, so that the needles are deflected with the utmost certainty to one side or the other, either separately or simultaneously. (Fig. 256.)

Originally, this instrument had five needles, then two, as in Fig. 256, but latterly one only. See Fig. 257, which is a

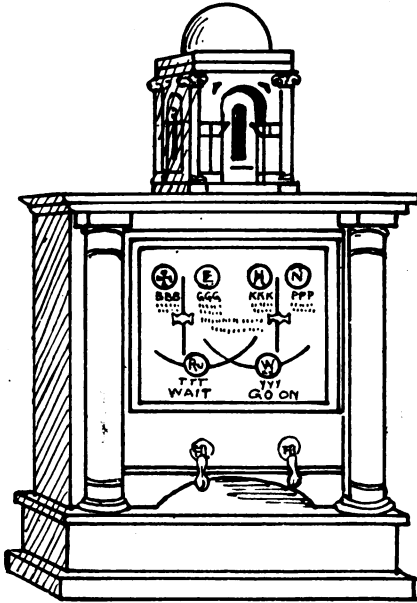

Fig. 256. Cooke and Wheatstone's double-needle telegraph instrument.

single needle instrument, fitted with a pedal key commutator instead of the drop handles as in Fig. 256; also Fig. 258, which is a Wheatstone A. B. C. instrument. These are the instruments most in use on railways and the like and are the easiest of all instruments to learn, requiring in the operator nothing more than reasonable attention and a knowledge of the Morse alphabet.

In certain parts of India there is still employed an old form of telegraphic instrument which is of such remarkable simplicity as to

merit detailed description:—

It consists of a coil of fine wire on a card or ivory frame, a magnetic needle with a light index of paper pasted across it; two stops of thin sheet lead to limit the vibrations of the index; a supporting board eight inches square, and a square of glass in a frame of wood, or a common glass tumbler placed over it as a shade, to prevent the index being moved by currents of air. It is stated that the office boys, with the assistance of a native Indian carpenter, make up these telegraphs at a price not exceeding two shillings each.

In England of course they would be more expensive; but

the simplicity and perfection of the arrangement are so much to be commended that we give the details for the benefit of those boys who might wish to establish a telegraph on a small scale for amusement, as the whole of this can be made by any boy for the outlay of about five shillings at most.

#### THE FRAME

This is a piece of dry wood eight inches square and one inch thick, with a hollow groove cut in its centre two inches

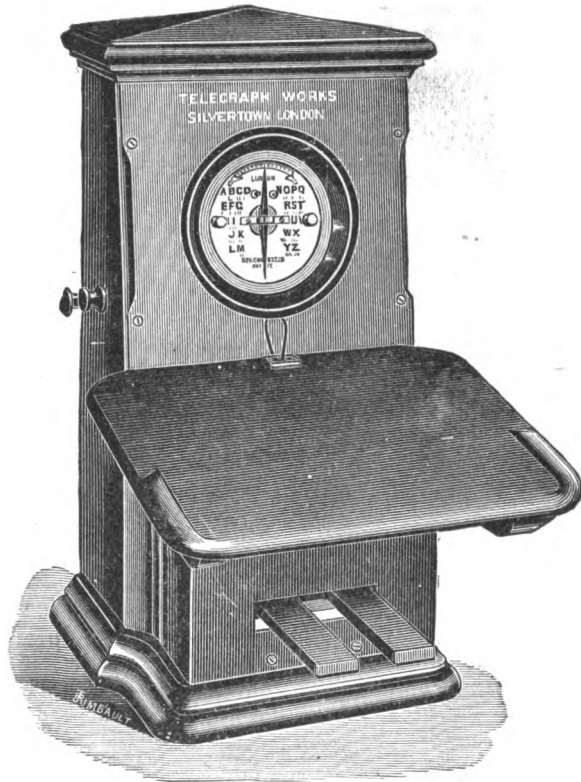

Fig. 257. Single needle instrument fitted with a pedal key commutator instead of the drop handle.

and a half long, half an inch wide, and a quarter of an inch deep; a ledge of the same wood one inch wide and half an inch deep surrounds the frame, leaving the inner surface

seven inches square; this is stained black to make the motions of the index more conspicuous.

#### THE COIL

This consists of fifty feet of the finest silk-covered copper wire wound on a frame of card two inches long, half an inch



Fig. 258. Wheatstone's A. B. C. Instruments, one set consisting of indicator, communicator and bell.

broad, three-eighths deep in the open part.

An edge or flange of card, three-eighths of an inch wide, is attached at each side to keep the wire in its place. The frame may be of thin wood, and the winding of the wire commences at the lower left corner, and it is coiled from left to right, as the hands of a watch would move in the same plane. (Fig. 259.)

Two inches of each end of the coil wire are now stripped of their silk covering by being rubbed with sand-paper. The



Fig. 259. The coil.

coil is mounted in the frame by inserting its lower edge or flange in the groove, so that the lower part or floor of the inside of the coil is almost level with that of the frame, as shown in Fig. 260, and it is now ready to receive the magnetised needle.

## THE NEEDLE

This is one inch long, one-twelfth of an inch wide, of the thinnest steel, and fitted with a little brass cap turned to a true cone to receive the point on which it is balanced. These can be purchased complete for one penny and are so cheap as not to be worth the trouble of making and fitting unless the boy is anxious himself to make his instrument throughout. The needles are of hard tempered steel, and are magnetised

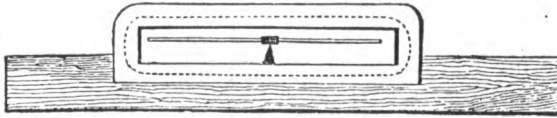

Fig. 260. The coil fitted into frame.

by a single contact with the poles of an electro-magnet or other ordinary powerful magnet.

The magnet is now to be balanced on a steel point one-eighth of an inch high; these are nipped off with cutting pliers from common sewing needles, and soldered into a slip of thin copper three inches long, half an inch wide. (Fig. 261.)

As the north end of the needle will be found to dip, it is advisable to counteract this by touching the south end with a little shellac varnish, which dries rapidly, and soon restores the needle to a perfect equilibrium.

The needle is completed for use by fixing to it an index of



Fig. 261. A. The needle. B. The point on the slip of copper.

paper (cut from glazed letter paper) two inches long, tapering from one-eighth of an inch to a point, and fastened at right angles on to the needle with lac varnish, so as to be truly balanced, and pointing the sharp end to the east, when the needle placed on the point settles due north and south, its north pole being opposite the observer's right hand, the observer facing west. (Fig. 262.)

The coil frame is placed north and south, and the needle is now introduced by sliding the end of the slip of copper into the opening in the frame.

To limit the vibrations of the paper index a *stop* is placed at each side. The stops are made of a strip of thin sheet-lead



or copper, a quarter of an inch broad, one inch and a half long, and turned up at a right angle, so that one inch rests on the board and half an inch is vertical.

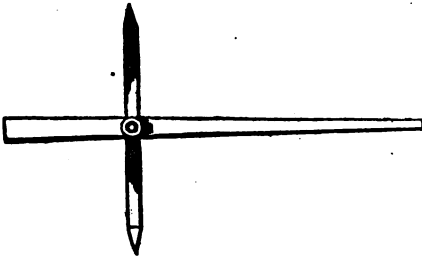

Fig. 262. The needle with the paper index.

For ordinary practice these stops are placed each at half an inch from the index.

The telegraph is placed in a box, which may have a piece of looking-glass in the lid, so that the readings can be taken with the needle in the vertical instead

of the horizontal position, if required. (Fig. 263.)

The ends of the fine wire of the telegraph coil are joined on to the wires from the reversing instrument, and this is connected with a voltaic series of one or more elements, so that

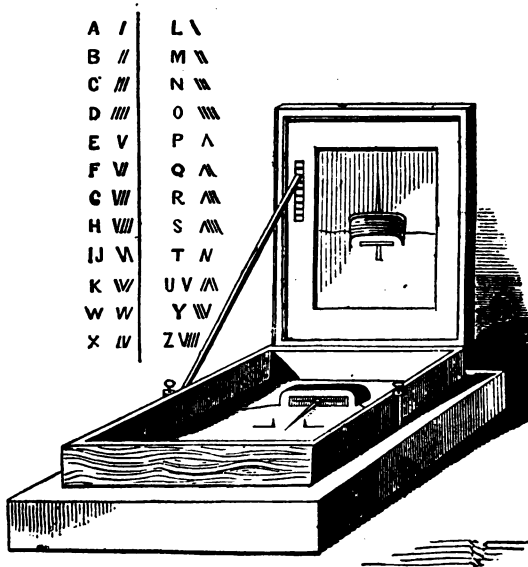

Fig. 263. Box containing the telegraph, with the looking-glass in the lid. A small steel magnet is placed on or near the frame, if required, the south pole of this magnet being opposite to the north pole of the needle in the telegraph coil. The bar is four inches long, half an inch broad, three-sixteenths of an inch thick, and it is only used to counteract any local deviation which may arise in using the instrument with miles of wire. It would not be required under ordinary circumstances. The alphabet used is shown to the left.

by the employment of the reverser the needle is caused to move to the right or left at pleasure. The white paper index on the black ground can be followed with the greatest certainty, and with this instrument a telegraph clerk may read at the rate of twenty words per minute with a double needle wire, being equal to forty words per minute.

## THE REVERSER

consists of a block of wood, two inches and a half square, in which four hollows, half an inch deep, are cut, and these hollows are joined diagonally by copper wires let into the substance of the wood, and most carefully insulated from each other by melted cement, but exposing a clean metallic surface in each cell, which is filled with mercury. (Fig. 264.)

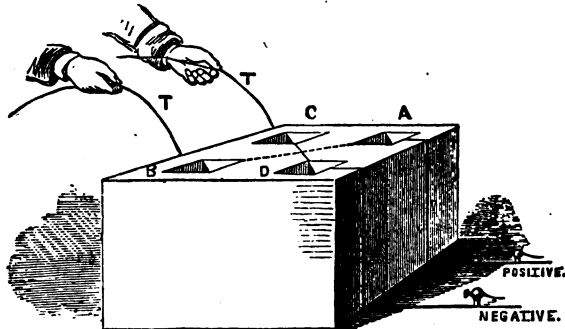

Fig. 264. Block of wood with four holes; the positive terminal is connected with the holes A and B, the negative with C and D; the hollows are filled with mercury. T T are the wires of the telegraph box, and it is obvious that by dipping them alternately into C B and A D the current is reversed, and the needle deflected right or left at pleasure.

In practice a more elaborate reverser is employed, but to demonstrate the principle the simple block above described is quite sufficient.

With the telegraph placed at the top of a house, or in a distant cottage, and a single cell of Grov e's battery, or at most two (Fig. 220, page 293), for any short distances, with the reverser, messages may be passed with great rapidity from the bottom of the house to the top, or from a mansion to its lodge, it being understood that a battery, reverser, and telegraph, are required at both places where messages are received and *answered*; but if no answers are required, the battery and reverser are placed at one end of the wire in the house, and

the telegraph at the other extremity in the cottage, and earth plates may be arranged to return the current, or another wire used for that purpose.

The alphabet for the needle telegraph, so long in use in England, differs from that of the Morse system. The signs for the two alphabets are shown side by side in the

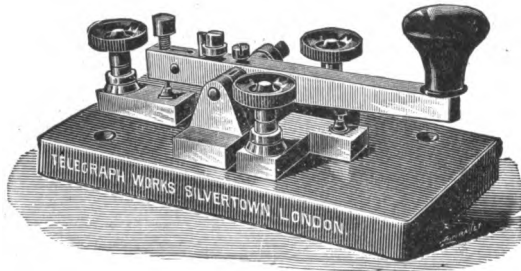

Fig. 265. Single current Morse key. G. P. O. pattern.

table on page 337. In the needle alphabet, it will be seen that the characters are of course made up of the right and left movements of the needle, and their nature will be readily understood. In the Morse, the alphabet is made up of dots and dashes, the dot answering to a left-hand de-

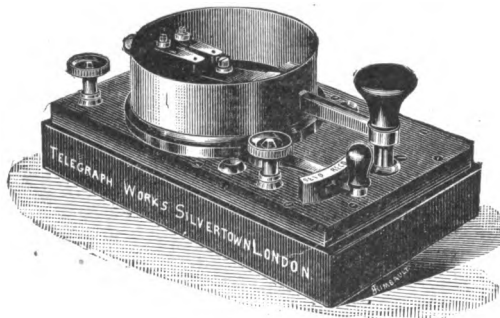

Fig. 266. Double current Morse key and switch. G. P. O. pattern. With five terminals.

flection in the needle instrument, and the dash corresponding with a right-hand deflection. A person therefore who has learnt to work the needle instrument can very soon acquire a

proficiency in the Morse system. The alphabet is as follows, the short lines representing dots and the long ones dashes:—

MIRROR AND NEEDLE	MORSE	MIRROR AND NEEDLE	MORSE
∨/	A --	∨//	UE -----
∨/∨/	Æ -----	∨∨/	V -----
/∨∨	B -----	∨//	W -----
/∨/	C -----	/∨/	X -----
/∨	D -----	/∨//	Y -----
∨	E -	//∨	Z -----
∨/∨	F -----	///	Ch -----
//∨	G -----	∨∨∨∨	. -----
∨∨∨	H -----	∨//∨	? -----
∨∨	I --	//∨//	! -----
∨//	J -----	∨//∨/	' -----
/∨/	K -----	/∨//∨/	( -----
∨/∨	L -----	∨/∨/∨/	" -----
//	M --	∨////	1 -----
/∨	N --	∨////	2 -----
///	O -----	∨∨//	3 -----
///∨	OE -----	∨∨//	4 -----
∨//∨	P -----	∨∨∨	5 -----
//∨/	Q -----	/∨∨∨	6 -----
∨/∨	R -----	//∨∨	7 -----
∨∨	S --	///∨	8 -----
/	T --	///∨/	9 -----
∨/	U -----	////	0 -----

Dashes and dots similar to these are printed in ink by the action of the current. The transmitting instrument consists of a key (Fig. 265), which being pressed for a long or short duration of time, makes at the receiving end of the circuit a dash or a dot, as explained on page 339.

Another means of recording the Morse signals was by Bain's chemical telegraph, in which the electro-magnet was not used. The travelling slip of paper was soaked in a certain chemical

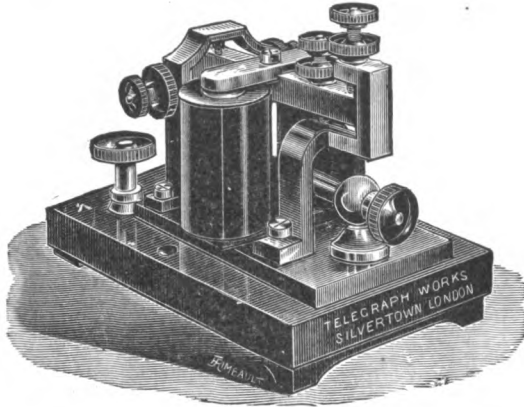

Fig. 267. Morse sounder. G. P. O. pattern. For working on a local circuit. Resistance 20 ohms, shunted with 500 ohms.

solution, which decomposed directly the electric current passed through it. A steel pointer rested against the paper, and every time the circuit was completed, it left a mark, short or long as the transmitter wished.

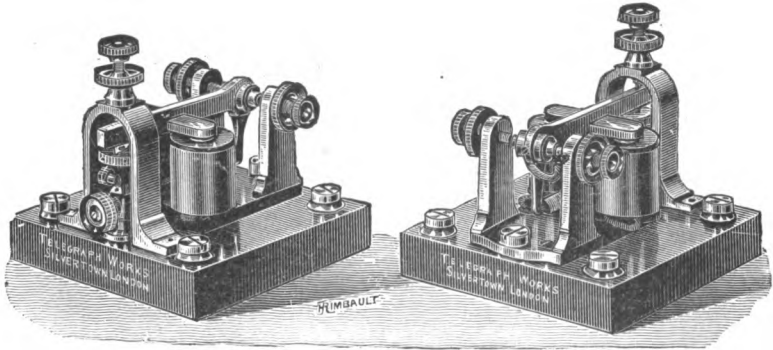

Fig. 268. Relaying sounder (uprighter), G. P. O. pattern. For Quadruplex working, wound to 20 ohms with shunt coil of 500 ohms.

Latterly, however, the usual method of recording telegraphic messages by the Morse or "dot-and-dash" system, is

by means of an instrument called an "inker," which is virtually a sounder and inker combined. (Fig. 269.) It carries an electro-magnet and armature, a long lever, and disc, which is in constant movement in a reservoir of ink. Over this disc a strip of paper is slowly pushed forward by clockwork, and when the magnet attracts the armature, the ink-covered disc impinges on the moving paper and marks a dot or a dash, according to the length of time the operator keeps the lever depressed; thus a sharp tap makes the mark of a dot, or tiny dash, whilst a longer depression keeps the paper on the disc,

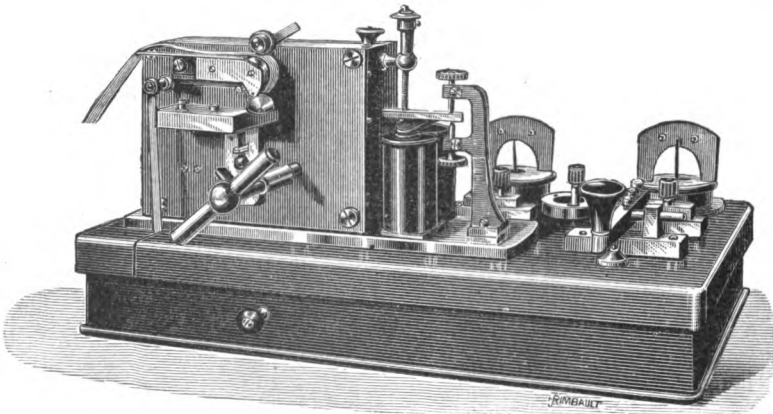

Fig. 269. Morse instrument for terminal stations, consisting of the inking apparatus, coils, and clockwork, with one galvanoscope, Morse key, and terminal plates. Resistance 600 ohms.

as both move, so that an elongated dot or a line is the result. The Morse alphabet, therefore, consisting of dots and dashes, as shown on page 337, is recorded as desired.

#### THE SOUNDER SYSTEM

The Sounder system is by far more advantageous for commercial purposes than the single or double needle. By its use, the recording instrument may be dispensed with altogether, the operator depending entirely on his hearing faculties for understanding the signals sent. When a dot is expressed, there is heard a sharp click and the interval between that and the next click gives a dash, or space, or close of sentence, as the case may be.

Between two dots, the down and upstrokes of the armature lever are quick, so the interval, when there is silence, is very short; but if this interval is three times the length—that is, long enough to make three dots—then a dash is represented by the next click after the interval. Therefore, these variously-timed intervals express spaces, closings of sentences,

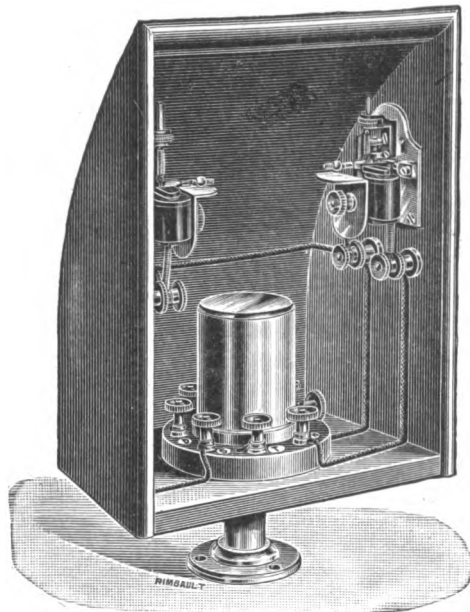

Fig. 270. Plate sounder with screen and relay. G. P. O. pattern. Consisting of a pair of plate sounders, having steel and brass plates, mounted in screen, with a neutral standard relay.

etc., their duration, to an experienced operator, being so plain that he can read off the message as easily and as fast as the operator at the distant instrument can transmit it.

In order to save current, these instruments are almost invariably fitted with some form of relay. (See Figs. 270 and 271.)

Those used in the General Post Office are mostly polarised, thus allowing the current to go in one direction only, though many users prefer the non-polarised instruments, which allow of being actuated by current flowing in either direction.

Of these relays there are scores of varieties and patterns, each claiming special features; but in all of them the main object is to save current, give more efficient working, prolong the life, both of instrument and battery, and, incidentally, of the operator.

It is obvious that, in a busy centre, if only one message could be sent at a time, on one wire, that wire might be occupied in despatching messages, say from Birmingham to London, for a whole day, without there being even a remote possibility

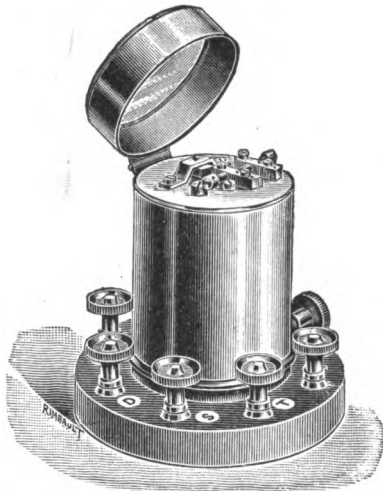

Fig. 271. Polarised relay. G. P. O. pattern. Differentially wound for duplex and quadruplex working. Resistance of each coil 100 ohms, making 200 ohms in all.

of any message coming from London to Birmingham. This might occur every day, with every wire, even if the wires and the instruments at each end were considerably increased; because it would seem plain, on the face of it, that if an operator at Birmingham is using a wire to send a message to London, and another operator in London is receiving the message sent, that line will be monopolised, and any attempt of the London man to use that wire and send his own message on it, must of course,

break into and spoil the Birmingham message. But necessity, which is ever the mother of invention, has introduced a wonderful system, known as the "Duplex" system, and one even more wonderful still, in the "Quadruplex" system.

The method by which these work is far too complicated to be explained here in detail, but it is based on the simple and self-evident fact that if a current is equally divided between two lines, each offering precisely the same resistance, then each line must have exactly the same amount and strength of current.

To continue the illustration:—This is brought about by the Birmingham, (B), instrument being in constant circuit with



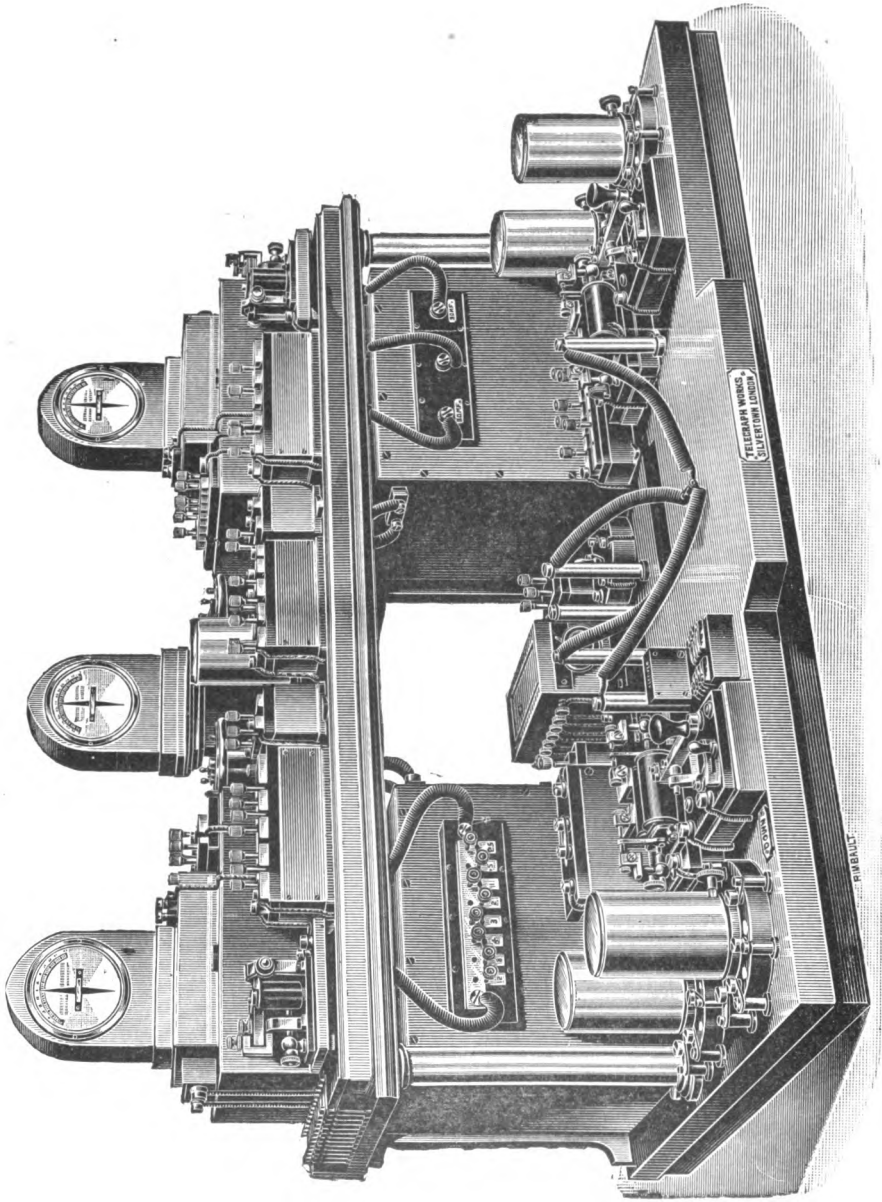

Fig. 272. Fast repeater. G. P. O. pattern.

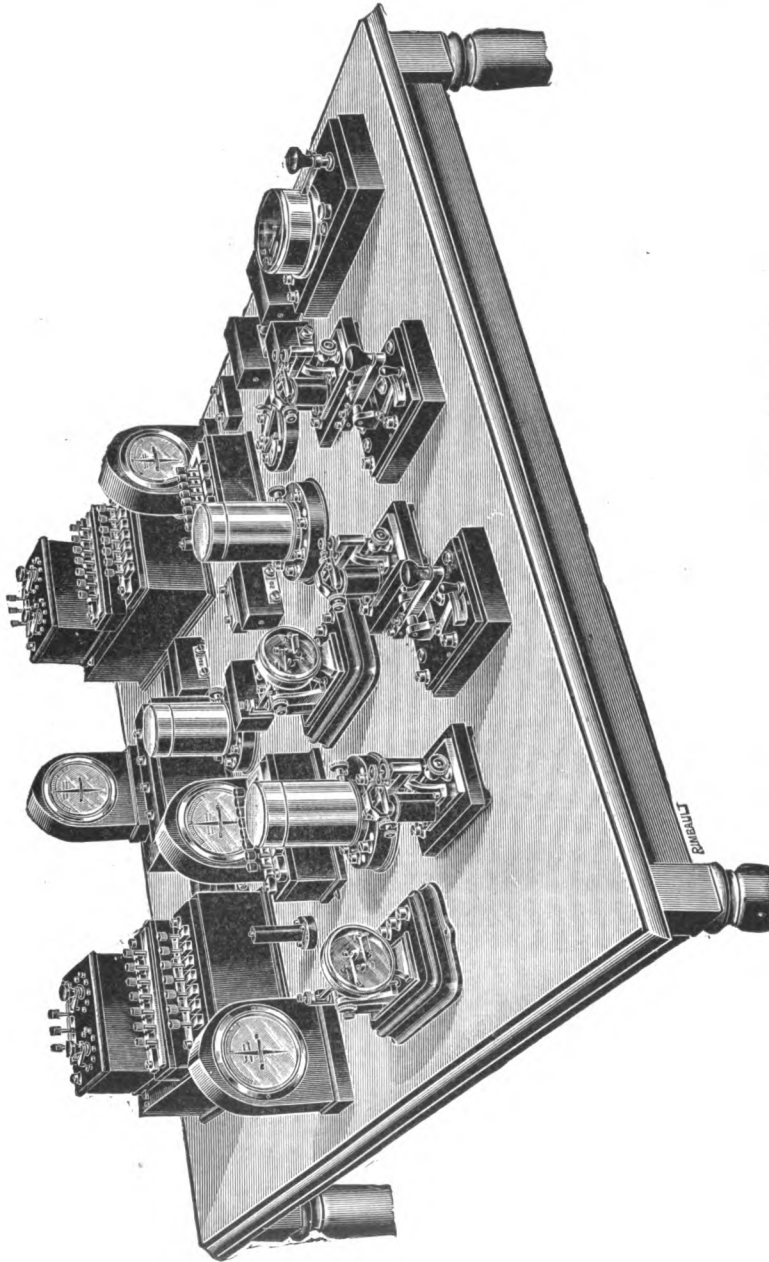

Fig. 273. Quadruplex repeater set—"A" slide relayed.

that in London, (L), by means of a line wire on the one hand, whilst on the return, or "earth" side, there is some kind of electro-magnet and resistance-coil—forming a compensating current—in connection with each instrument. When B, or L, only, uses his instrument, it acts exactly as an ordinary instrument, for the magnets are not excited, because the force of one neutralises that of the other, seeing that both are equal. But when B sends his message and L also sends one at the same time, then the current is interrupted, and the magnets come into play, when B's receiving instrument becomes excited by L's message, and L's instrument by B's message, and on these occasions only. By this means, L sends a message to B, and B to L, at one and the same time, and on the one wire.

If two sending-keys are provided, with other additions, such as arrangements for increasing the power of the batteries, then two different messages may be sent on the same wire from each end, making four messages in all, at the same time. This is what is termed the "Quadruplex" system. (See Figs. 272 and 273.)

In such manner are the numerous messages despatched, at all hours of the day or night, so efficiently that we hand in our telegrams at some central office without a thought of the hundreds of other people who are doing the same thing, each one in all good faith that the message will be received at some distant centre in perhaps a few minutes of its despatch. When, half-an-hour later, we receive a reply, maybe from the other end of the country, we look upon its receipt as a mere matter of course, never thinking of the hundreds of telegrams which have passed to and fro in the interim on the selfsame wire.

Another system of importance is the

#### MULTIPLEX SYSTEM

by which many centres may be brought in contact with each other, in turn, and from one to six messages despatched at the same time.

Another instrument which must not pass unnoticed is Hughes' printing telegraph, in which the message sent is actually printed in ordinary type as it arrives at its destination. In this system two type wheels—having the letters of

the alphabet on their edges—revolve, one at each station, with equal velocity. The required letters are brought above a slip of travelling paper by the revolution of the type wheel, and are impressed thereon in printers' ink.

Many plans have been from time to time suggested for transmitting handwriting. The first of these was Bakewell and Casselli's copying telegraph. It depends, as in Bain's telegraph, upon the decomposition of certain chemical salts by the passage of the electric current. These phenomena were first pointed out by Sir Humphry Davy, but were not acted upon for the use of the telegraph until 1850, when Bakewell produced his copying telegraph. The message is written on tinfoil in resinous ink, such as sealing-wax dissolved in spirit. This foil is then attached to a cylinder, so arranged that a pointer traverses every part of its surface as it revolves, the action being similar to the travelling tool of a screw-cutting lathe. Another cylinder with a similar pointer forms the recording instrument, but in this case the foil is replaced by chemical paper. By clockwork the two cylinders are caused to revolve at exactly the same pace. An electric current passes through the pointers to the cylinders which they touch. Supposing that no interruptions occur, the two pointers will make spiral lines on each cylinder, one being indicated by a slight depression upon the tinfoil, the other by a coloured continuous line caused by the decomposition of the salt employed. (A solution of prussiate of potash and ammonia gives a blue mark—the well-known prussian blue—but a mixture of iodide of potash and starch will give a brown mark, owing to the liberation of iodine.) The resinous ink, however, on the sending cylinder, forms a barrier through which the electricity cannot venture; whenever, therefore, the pointer passes over a piece of the writing, the current is stopped, so the recording pointer on the chemical paper ceases to act. The result is a white writing upon a background made up of a multitude of fine lines, like the engraved sky of a good wood block.

This instrument has been modified and now prints in letter form, instead of in strips, and is used for some kinds of Continental work and in some private firms, but it requires an operator of some skill.

A somewhat similar plan was tried at the General Post

Office. This invention contained many features which represented improvements upon Bakewell's system. By its aid drawings could be executed, and it was supposed that it might prove useful in war time in the transmission of plans of fortifications, maps, and the like. It has not come into general use, however, and may be regarded at present almost as a scientific curiosity, though there may be a fine future before it.

On a wholly different principle is the writing telegraph, which is adapted for extended use. It was tried for some months on the South-Western line, working from London to Woking, on a distance of more than twenty-six miles of line, and gave every satisfaction. An ordinary pencil served as the transmitting instrument, and the receiving instrument

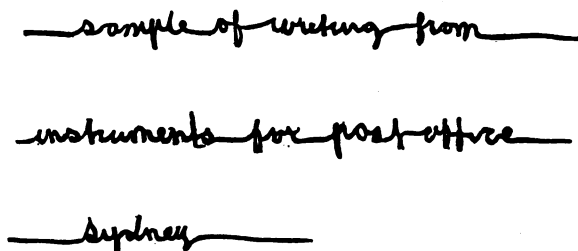

Fig. 274.

was bound to follow and transcribe its every movement. A slip of the writing, transferred to a block and engraved, is reproduced here. (See Fig. 274.) A description of the instrument is appended:—

“The object attained by this instrument is that it enables the operator to write at a distant station many miles away, just as though he were present there himself, without requiring the use of any special signals, codes, or signs (to spell each letter as is now the practice), and without the assistance of any person to translate the signals as received.

“The instrument acts upon the simple principle of communicating at all times, to the writing pen at the receiving end of the line, the exact position of the pencil of the operator at the sending station through two line wires, or so to speak, giving the latitude and longitude of the pencil continually; the position of the pencil vertically being communicated by one wire, and the position horizontally being communicated by the other wire.

“The pencil of the operator has two light ‘contact rods’ jointed to it, and one of these slides over the edges of a series of ‘contact plates,’ having various resistances interposed between them and the line wire, while the other rod slides over a second set of such plates connected to the other line wire. At the receiving end of the line, each of these wires actuates its own needle.

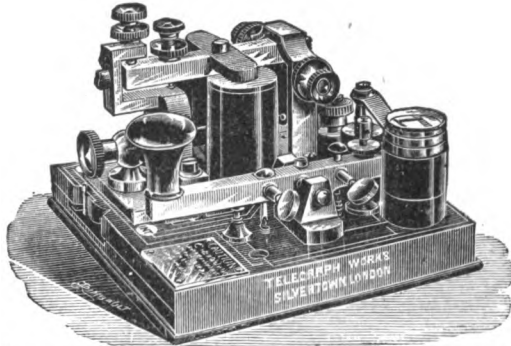

Fig. 275. Military Morse field sounder. Government pattern. Consists of a Pony sounder with repeating contacts, fitted with terminals, galvanoscope, switches, and special double spring Morse key. Resistance 330 ohms.

“The two needles (which are placed at right angles to each other, and are provided with light springs), actuate one writing pen, this pen moving up or down, and backwards or forwards, in exact obedience to the motions of the pencil in the hand of the operator at the distant station.



Fig. 276. One of the early ideas of telegraphic communication. (From an old print.)

“Both the paper written upon in pencil by the operator at the sending station and that written upon in ink by him at the receiving station move along as the writing proceeds, and the messages have only to be cut off from time to time, wound round a piece of card, and sent out to their destination, or put into an envelope and despatched.”

Fig. 275 illustrates Military Morse Sounder for field use to establish communication between two points.

#### THE TELEPHONE, PHONOGRAPH AND MICROPHONE

The announcement that it was actually possible to transmit the sounds of the human voice through a telegraphic wire was perhaps the most startling information which any one ignorant of the march of physical science could have conceived. The first intimation that such a feat had been accomplished came from Sir William Thomson (the late Lord Kelvin), in his opening address to the British Association at Glasgow in the year 1876, who recorded how he had so heard the well-known speech from “Hamlet.” Since that time many forms of telephones have appeared and have met with different degrees of success.

Long before it became possible to convey speech by means of the telephone, more than one inventor had produced instruments by which it was possible to transmit musical sounds by means of a telegraphic wire. To go back to the very beginning of these experiments, we must note some curious phenomena which were first discovered by Page in the year 1837. He found that the operation of magnetising and demagnetising an iron bar, by sending an electric current through the helix of wire surrounding it, was accompanied by an audible sound, a kind of click. By making and breaking the current several times in a second these clicks were made to follow one another so rapidly that they constituted a musical note, the greater the number of such sounds in a given time, the higher the pitch of the note produced. To understand this the reader should refer to some work on acoustics, where he will find described an instrument called Savart's wheel, the cogs of which beat against a piece of card. The greater the velocity at which the wheel is turned, the greater

the number of beats against the card in a given time, and the higher in pitch the resulting note. This proves that a musical note is simply a succession of single sounds which follow one another periodically. To constitute a note they must occur at least sixteen times in every second, or the ear will not acknowledge them but as a series of distinct taps.

In the year 1860, Philip Reiss, of Germany, took advantage of Page's discovery and constructed a transmitter by which he was enabled to control the number of electrical contacts by the action of a vibrating diaphragm. This instrument consisted of a box into the side of which was fitted a mouthpiece not unlike the mouthpiece of any ordinary speaking-tube. At the top of the box was an orifice filled in with a parchment diaphragm. In the centre of the diaphragm was a small piece of metal, over which, but not actually touching it, was a metallic point. Upon singing a note into the mouthpiece of the box, the parchment above was thrown into vibration, and every such vibration caused the piece of metal to touch the point hanging above it. So that according to the number of vibrations in any given note, a similar number of contacts were made, and as both pieces of metal were joined up with a battery and a line wire, these contacts were electrical and effected the magnetisation of an iron bar, which formed the receiving instrument at the distant station.

Some years later another form of telephone was devised, in which advantage was taken of the action of the common tuning-fork to make and break the current. Varley produced an instrument of this nature, which was probably the first form of telephone ever publicly exhibited in this country. Gray, of Chicago, was the next inventor who came upon the scene. In 1874 he produced an instrument of somewhat the same character as the one just described, but far more perfect in its action. In this telephone metal reeds were employed of the same form as those used in harmoniums. These reeds were governed by pianoforte keys, and were so arranged that electro-magnets at the distant station actuated similar reeds, and so the original sounds were reproduced.

All these instruments were capable only of producing musical notes, not speech, and they are distinguished from the more recent inventions as "tone telephones," the latter being called "articulating telephones."



Up to the year 1876 no instrument had been devised for transmitting speech, except a little toy called the thread telephone, which is sold at intervals and from time to time appears forgotten when it is again revived. It is however something more than a mere toy, cheap as it is, for it teaches us how wonderfully sounds and even articulate speech can be converted into motion, and again produced at a distance as speech. This form of telephone is shown at Fig. 277. It consists of two little boxes made of wood, card, or metal, open at one end, and closed at the other with a diaphragm of parchment. To the centres of the diaphragms are knotted the two ends of a piece of twine. With this simple contrivance people a hundred yards apart can keep up a conversation without difficulty. The action of the instrument is as follows:—the speaker into one box throws the diaphragm into vibration by the vibration of his voice, these vibrations constitute so many pulls upon the cord leading to the other diaphragm, and so the latter is made



Fig. 277.

to describe similar movements, and the sounds become audible to the listener there. It is evident then that if we can find some means of throwing a diaphragm into motion at a distance, so as to correspond with the movements of a diaphragm agitated by the voice, we can reproduce the original sounds given. Twine will of course only answer the purpose for a few yards, and although experiment has shown that this distance can be greatly increased by the use of fine copper wire, still such distance is limited to a few hundred yards. It was reserved for Professor Bell to solve the problem by the use of magnetism.

Bell's first form of articulating telephone made its appearance in 1876, but the instrument then shown has since been considerably modified. Want of space precludes the mention of many interesting details as to the manner in which Bell, step by step, surmounted every difficulty until the end which he had in view was attained. The outward form of this instrument has been compared to the handle of a skipping rope, which it much resembles both in appearance and size, its total length being only about six inches. The principal part of the instrument is the bar-magnet, which passes through its

centre, the north pole of which is surrounded by a coil of silk-covered copper wire. This end of the magnet all but touches the iron diaphragm, its other end being fitted with a screw by which its exact position can be regulated to a nicety. The ends of the coil are carried down to the back of the case, where they are connected with two binding-screws, to which the line wires can be readily adjusted. On short circuits it is as well to use two wires, but where the distance is considerable, advantage should be taken of the earth-current as explained on page 327. In this latter case the instrument will be joined up in the manner shown at Fig. 278, the letters C and Z indicating the copper and zinc elements of the battery for ringing the call-bell.

So far as the telephone itself is concerned, it requires no battery whatever, its action being dependent upon the magnet contained within it. The sonorous vibrations set up in the air by the voice are projected upon the diaphragm, which also vibrates in sympathy. These vibrations, by constantly varying the distance between the centre of the iron disc and the magnet behind it, cause variations in the current of electricity which is induced in the coil of wire, and such variations are telegraphed to the distant telephone, where the correspond-

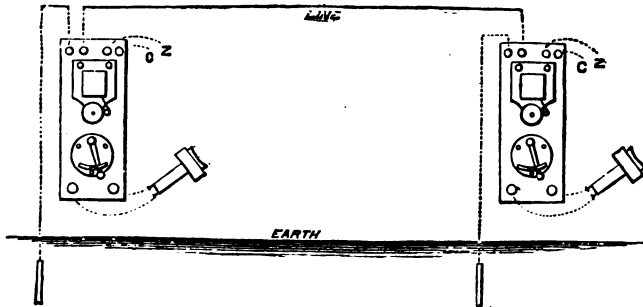

Fig. 278. Diagram showing manner of joining up a telephone circuit.

ing diaphragm is brought into similar movements, and gives out the sounds conveyed. In the next chapter it will be seen how a current can be induced in a coil of wire by the approach of a magnet; and when we know by experiment that this is the case, it is not difficult to understand how this current must be varied in its condition by the movement of a piece of iron placed near the end of the magnet. Such move-

ments are brought about by the vibrating diaphragm in Bell's telephone.

A pair of these telephones may very easily be constructed by boys who can use their fingers with neatness and intelligence.

A very convenient form of bell for use with this telephone is shown at Fig. 279, which has the advantage of dispensing

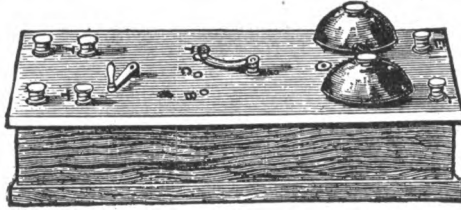

Fig. 279. Telephone bell and shunt.

with a battery. The box contains a small magneto-electric machine, which is set in motion by the handle on the left-hand side. The other handle is a *shunt* by which the bell or the telephone can be thrown into circuit as required. Without some such contrivance as this, it would be necessary to have a separate line wire to work the bell. The sounds reproduced by this form of telephone are very perfect, but unfortunately extremely weak, so that it is necessary for the transmitter to speak very distinctly, and for the hearer to hold the instrument close to his ear.

A modification by which Bell's telephone has been vastly improved was introduced by Gower. The bar-magnet was discarded, and replaced by one formed like the letter D. The two poles were thus brought close together, and each furnished with a coil. The sounds were greatly augmented by this arrangement, and the articulation improved.

It is quite impossible to notice here the various forms of telephones which have been devised since Bell pointed out how articulation could be reproduced at a distant point; their name is legion.

We now arrive at the name of one who is of world wide renown, Thomas Alva Edison, who was born at Milan, Erie County, Ohio, in 1847. He began his career as a newspaper boy on the Grand Trunk Railroad; but even at this early period his active mind was constantly turned towards scien-

tific pursuits, for we learn that he fitted up a disused car as a chemical laboratory, and advanced so far in his experiments as nearly to set the train on fire. He shortly afterwards became employed as a telegraph operator, and in this capacity he had opportunities of gaining a thorough practical knowledge of the principles of electric communication. In a few years the instruments which he invented replaced those in use at the office with which he became connected; and at the present time he is engaged in working out various wonderful instruments in his large experimental laboratory and factory at Menlo Park, near New York. He is the proprietor of some hundreds of different patents, but the instrument which first made his name famous beyond his own country was the speaking phonograph.

The first published description of this marvellous, yet simple piece of mechanism, appeared in a London paper in January, 1878, the account being copied from the *Scientific American* of Dec. 22nd, 1877.

“Mr. Thomas A. Edison recently came into this office, placed a little machine on our desk, turned a crank, and the machine enquired as to our health, asked how we liked the phonograph, informed us that *it* was well, and bid us a cordial good night. These remarks were not only perfectly audible to ourselves, but to a dozen or more persons gathered around, and they were produced by the aid of no other mechanism than the simple little contrivance explained and illustrated below.

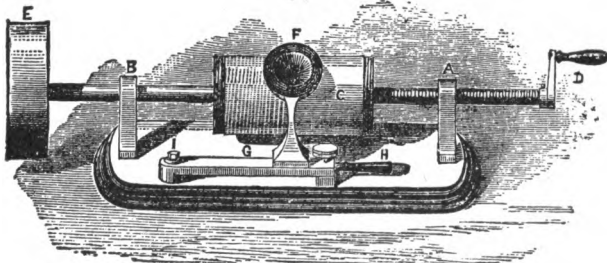

Fig. 280. Edison's early phonograph.

“There is, first, a mouthpiece F, across the inner orifice of which is a metal diaphragm, and to the centre of this diaphragm is attached a point, also of metal. Behind this

mouthpiece is a brass cylinder, C, supported on a shaft which is screw-threaded, and turns in a nut for a bearing, so that when the cylinder is caused to revolve by the crank D, it also has a horizontal travel behind the mouthpiece. It will be clear that the point on the metal diaphragm must, therefore, describe a spiral trace over the surface of the cylinder C. On the latter is cut a spiral groove of like pitch to that on the shaft, and around the cylinder is attached a strip of tinfoil. When sounds are uttered in the mouthpiece, the diaphragm is caused to vibrate, and the point thereon is caused to make contacts with the tinfoil at the portion where the latter crosses the spiral groove. Hence, the foil, not being there backed by the solid metal of the cylinder, becomes indented, and these indentations are necessarily an exact record of the sounds which produced them.

“A and B are the bearings in which the shaft turns, G is the base-board of the instrument. H is a lever for adjusting the position of the mouthpiece, I being the nut on which it works. The heavy flywheel E is to equalise the motion of the cylinder.”

So far the phonograph was simply a recorder of sounds, which record was inscribed on a piece of tinfoil, as a series of indentations dug into it by the point of the vibrating metallic diaphragm. Other instruments had long ago been invented which produced such records, notably the phonautograph of M. Léon Scott, a full description of which is given in Ganot's Physics. But now came the marvellous part of Edison's invention, the reproduction from the tinfoil record of the sounds which produced it.

In the first form of phonograph constructed, the reading or talking mechanism consisted of a duplicate diaphragm held in a tube at the other side of the cylinder, but in the perfected instrument one diaphragm was made to act both as recorder and talker. The cylinder was pushed back to its first position, and the crank again turned so that it travelled once more over the same ground. The little point on the diaphragm again found its way into the indentations in the tinfoil, and as it thus stepped in and out of its own footprints the diaphragm vibrated and gave out the sounds originally spoken. The details of construction of this instrument are shown in the section. (Fig. 281.)

It is not surprising that a machine capable of such wonderful doings should have attracted the notice of every person who could read or think; and its first appearance in this country created quite an excitement. As usual in cases of the kind, "the most absurd notions as to the capabilities of the little machine were speedily promulgated, and even thoughtful people were induced to raise wondrous dreams as to its possibilities in the future." To quote once more from the article before alluded to:—"We have already pointed out the startling possibility of the voices of the dead being reheard through this device, and there is no doubt but that its capabilities are fully equal to other results quite as astonishing. When it becomes possible, as it doubtless will, to magnify the sound, the voices of such singers as Parepa and Titiens will not die with them, but will remain as long as the metal in which they may be embodied will last. The witness in court will find his own testimony repeated by machine, confronting him on cross-examination, the testator will repeat his last will and testament into the machine, so that it will be reproduced in a way that will leave no question as to his devising capacity or sanity. It is already possible, by ingenious optical contrivances, to throw stereoscopic photographs of people on screens in full view of an audience. Add the talking phonograph to counterfeit their voices, and it would be difficult to carry the illusion of real presence much further."

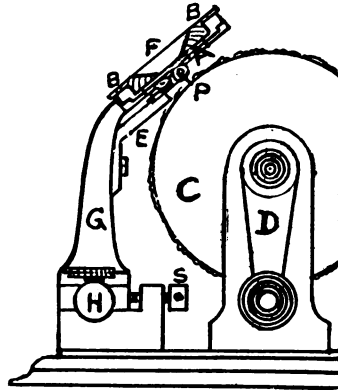

Fig. 281. Section of Edison's early phonograph with tin foil-covered cylinder. F, the mouthpiece secured in the frame. B, B, A, diaphragm. P, metallic point or stylus to indent tinfoil on the cylinder. C, E, spring support to hold the stylus rigidly in position. The two round cushions seen above the stylus are pieces of india-rubber tubing to deaden the sound, which otherwise would be too metallic in character. S, adjustment screw.

This instrument has been modified in various ways and is applied to the telephone, so that should the person called up be absent, the message is written by the caller on paper on the sensitive table of the instrument, and its fac-simile will be written on the corresponding paper on the distant instrument, in full view for the absent owner's return. (See also page 346.)

Excellent as is this adaptation of the invention, it is difficult to see how it can become popular, unless *all* the telephone instruments on an exchange were fitted with it. At present it is only applicable where both ends of the wire are fitted with a similar instrument.

It seems but natural that Edison should have early turned his attention to telephonic phenomena. His first experiments in this direction were guided by the previous attempts of Reiss, but he soon struck out into a fresh track, and produced an instrument which was known as Edison's carbon transmitter. Its main feature was a button of carbon made of compressed lamp-black. In common with other imperfect conductors of electricity, carbon possesses the property of varying its resistance with variations of pressure. And in this telephone such variations were caused by the action of sonorous vibrations upon a diaphragm placed above the carbon button. A later form of this instrument was that of an ebonite ring, about the size and shape of those old turnip watches which our forefathers used to carry in their fops. In practice it is placed in circuit with a battery and a receiving instrument at the further end of the line wire. Edison has produced some other instruments in which the same principle is employed, some of which are so exquisitely sensitive, that the heat of the hand held ten yards distant will cause the deflection of a galvanometer needle placed in circuit with them.

But the latest forms of telephones produced are those known as the "loud-speaking telephones."

The action of this class of instrument is entirely different to every telephone which preceded it, and is three-fold—namely, electrical, chemical, and mechanical. To understand the principle upon which its action is based, brief reference must be made to a little experiment which any one in the possession of a battery cell may easily try for himself.

A slip of blotting paper moistened with a weak solution of caustic potash is laid upon a metallic plate. This plate is connected with the positive pole of the battery. The negative pole is connected with a slip of brass, tipped with a facing of platinum. A key like that used in the Morse sounder is included in the circuit so that contact may be made or unmade whenever desired. Upon dragging this metallic slip upon

the surface of the paper, and exercising some little pressure upon it, there is necessarily a certain amount of friction which would under any circumstances manifest itself between two surfaces rubbed together. But directly the key is depressed so that the current is allowed to pass, this friction seems to vanish, and the metal glides over the paper as it would traverse a piece of ice.

There are two ways in which this strange phenomenon can be explained, or rather, perhaps, two theories have been advanced to account for it. Possibly they may both be wrong, but in the absence of anything more plausible we may for the present give them consideration. The first is, that the potash employed may under the action of the electric current give off minute bubbles of gas, and that these bubbles form so many cushions of vapour upon which the metal slips. The other theory suggests that the salt may in infinitesimal quantities be reduced to the metallic state, and that the friction is thus greatly reduced.

Whatever be the true explanation of this curious phenomenon, Edison turned it to excellent account in his loud-speaking telephone, the interior arrangements of which may be understood by a reference to the diagram (Fig. 282). A is a cylinder of chalk which is moulded upon a metallic roller or reel, and rotated upon a handle which projects outside the instrument. This chalk is impregnated with caustic potash, or some other chemical preparation which acts under the electric current in the manner described in the experiment just noted. This chalk cylinder, in fact, takes the place of the blotting paper there mentioned. Pressing upon the cylinder, by means of the india-rubber pad, C, is a little metallic arm, B, faced with platinum, the further end of this arm being fastened to the centre of a 4-inch diaphragm of mica, D. It will be evident that when the cylinder is turned on its axis the friction generated between the arm, B, and the surface of the chalk, will cause such a pull upon the mica diaphragm, that it will assume a slightly

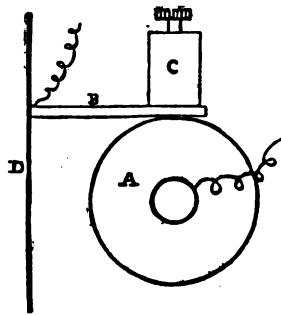

Fig. 282. Diagram to explain the action of the loud-speaking telephone.



concave form, but directly the electric current is caused to pass between A and B the friction is reduced by that curious slippery effect already alluded to, and the diaphragm springs back to its normal position. This arrangement is so sensitive to minute variations of friction, that the alterations of the strength of the current caused by a voice speaking to a carbon transmitter are immediately translated into corresponding variations of friction, the mica diaphragm vibrates to every such variation, and the sounds are reproduced. It must be noted, too, that the sounds are increased rather than diminished in their intensity by their transmission through the system. In the first instruments produced it was found necessary constantly to moisten the surface of the chalk, but in the later form which has been adopted this inconvenience is altogether obviated.

Such, as a whole, is the principle of the telephone, of which principle there are many modifications, in adjustment and minor details, which do not affect the instrument in its broad design. In the most modern types, the transmitter and receiver are combined in one appliance; in others, the Bell, Gower, or other receiver is used, the transmitter being separate.

With regard to the transmitters, these are, in reality, but modifications of the microphone, especially that of Hughes, therefore an explanation of the microphone will be an explanation of the telephone transmitter.

#### THE MICROPHONE

The microphone may be described as an instrument which changes sonorous vibrations, without the intervention of a diaphragm (as in the telephone), into forms of electrical action. It also so magnifies the original sounds, that it acts for the ear much in the same way that the microscope serves the eye, hence its name. At the time when it was first invented, the most exaggerated accounts of its capabilities were published in different newspapers, one especially remarked that the breathing of a fly was heard through the instrument "as an elephant trumpeting through his proboscis in an Indian jungle." Setting aside this very fanciful notion, it is a fact that the breathing of a common house-fly can be heard loudly by means of the microphone at a distance of many miles, and

this no doubt gave rise to the elephantine remark just quoted.

The microphone is an outcome of the telephone; indeed, without the latter instrument the former would have been impossible. Nor would the extraordinary sensitiveness of Bell's magnetic telephone have been appreciated if the microphone had not told us of what it was capable.

It will be remembered that the magnetic telephone is quite independent of battery power, but it occurred to Hughes to put it in circuit with a weak battery current in order to note how it would behave. We have already seen in previous experiments, and especially in those of Faraday, how intimately connected is electrical action with magnetism, and we shall not therefore be much surprised to find that when the magnetic telephone is attached to a battery current the one reacts upon the other. Hughes included in the circuit with the telephone a fine wire to which he attached weights until it broke. On listening through the telephone he noticed that just before the break occurred a peculiar rushing sound was manifest. He next tried the experiment of loosely binding the broken ends of the wire together so that the current still passed. He now found to his surprise that by this simple means he had hit upon a sensitive detection of minute sounds, for every noise in the neighbourhood of the joined wires was given out as a louder sound by the connected telephone. Upon modifying the arrangement by placing two nails in the circuit, as shown in Fig. 283, the same results were obtained.

The most sensitive known substance to microphonic vibrations is straight-grained willow charcoal, brought to a white heat and then immersed in mercury. So sensitive is this to impressions that the footfall of a fly can be distinctly heard ten miles distant, the instrument acting for sound as does the microscope in enlarging objects, and when suitably connected with wires, these sounds may be carried to great distances.

Hughes, following his experiment with the nails (Fig. 283), then tried a small pencil of carbon, fitted loosely into holes in two carbon blocks, as shown in section at Fig. 284, which form gave wonderful results. Astonishing as it may seem, it

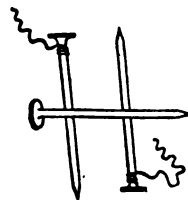

Fig. 283. The nail microphone, which is the simplest form of microphone.

is a fact that if an arrangement such as this be placed in a room where ordinary conversation is being carried on, the words spoken can be distinctly heard in a distant building by means of a telephone and a battery placed in circuit. This



Fig. 284.  
Section of  
microphone.

little contrivance need not be more than an inch long, and it is most conveniently used by being attached to a vulcanite plate, with binding screws fastened on the carbon blocks for the attachment of wires. (See Fig. 285.) It is also well to mount the arrangement on a small box, which acts as a kind of sound-board for it. Thus mounted it appears as shown in Fig. 286.

Another form of microphone from which good results have been obtained, and which perhaps is more sensitive than those already described, consists of a small pencil of

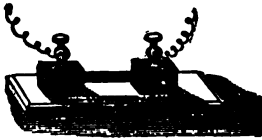

Fig. 285. Microphone on ebonite plate.

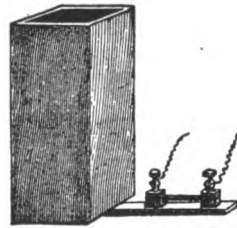

Fig. 286. Microphone mounted on sound-box.

carbon so balanced on a brass pivot that its end very lightly touches a fixed block of the same material. With this form of instrument the fly experiment can be tried. First catch your fly, and imprison him in a match box, which has an opening

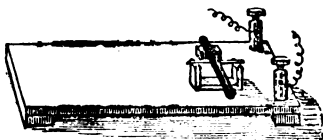

Fig. 287. Horizontal bar microphone.

cut in it for the insertion of a muslin window. Place this box on the wooden board of the microphone (Fig. 287) (which is purposely prolonged for the reception of anything of the kind), and on listening through

the telephone, the little insect is heard tramping about its prison in the vain hope of finding an exit. If a fly cannot be found, which is often the case in winter-time, any other small creature will answer the purpose. A watch placed on the

stand will also serve as a convenient test for the powers of the microphone, or a piece of paper written upon with a quill pen will give very loud results. The touch of a feather upon the carbon rod is magnified into quite a loud noise, although the sound made without the microphone would not be evident to the most sensitive ear. These few experiments will show of what this marvellous little instrument is capable. The original microphone and its belongings were of the most homely character. Indeed, they seemed to be made up of match-boxes, pen-holders, sealing-wax, and string; the battery consisted of three small pickle bottles, and were also of home manufacture. Thus a wonderful instrument was constructed and worked out by its inventor with materials the value of which was only a few pence.

It must be clearly understood that loud noises, even such as a person singing or talking, cannot be heard if too close to the true microphone, for such sounds produce a rattle of discordant vibrations, altogether unintelligible. The reproduction of these vibrations comes within the scope of the less sensitive telephone, a faint whisper being almost beyond the capabilities of the more delicate instrument.

To use a microphone for the purpose of reproducing ordinary speech, would be equivalent to attempting to use a high-power microscope to study a distant star. Both instruments are made expressly for the minute; in the one case for faint sounds otherwise inaudible to the human ear; in the other case, for the examination of objects so small as to be beyond the power of unaided human sight to detect, even at close range.

As no doubt some readers may be induced to try and construct a microphone, and may find the battery the only difficulty, a brief description is given of the one made by Hughes, one cell of which is depicted at Fig. 288. A gallipot is chosen for the cell, in lieu of a pickle bottle, because it is easier to fill, although a common pickle bottle will answer equally well. At the bottom of the jar is placed a coil of copper wire (C), the end of which projects at the top. The straight part of this wire, where it passes up the jar, must be covered with sealing-wax or gutta-percha, in order to insulate



Fig. 288. Microphone battery cell.

that part of it from the other contents of the battery. Upon the coil must be poured enough water to cover it about half an inch, and in this water must be placed two ounces of sulphate of copper (bluestone), broken into lumps the size of a pea. Above the crystals the jar must be all but filled with wet sawdust, or clay, and upon this is placed a round zinc disc (Z) with a little band projecting from it. Three cells constructed like this are quite sufficient to work a microphone efficiently.

The way in which the various parts are joined together will be understood from the diagram (Fig. 289). The battery cells must be joined so that the zinc terminal of one is attached to the copper of the next. In the diagram, B, B, B, are the battery cells, so joined, M, the microphone, and T, the telephone. Those who prefer to buy the instrument ready made, can obtain any of the forms here described of a good scientific apparatus dealer.

The microphone has been turned to account in more ways than one. By a special arrangement of it, doctors are able to hear all over a room the sound of a patient's pulse, and find it an infallible means of judging of the condition of the heart. In another instrument, the hearing capabilities of different people are accurately gauged. An aurist can test the progress of his patient

from time to time, and ascertain whether the remedies he employs are having the desired effect. There are many other uses to which the microphone can be put, and there is no doubt but that its powers will receive in time to come many new applications. Indeed, so great are the strides of science that it is no uncommon thing for sensitive people, who shrink from medical examination, to use a microphone in the privacy of their own homes, as directed by their physician, who is in telephonic communication, and who, though miles away in his surgery, is enabled to conduct a most searching examination by this means almost as perfectly as if face to face with his patient.

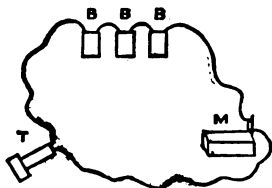

Fig. 289. The microphone in circuit with a battery and telephone.

## CHAPTER XX

## RUHMKORFF'S, HEARDER'S, AND BENTLEY'S COIL APPARATUS

In the course of the previous remarks on frictional and voltaic electricity, it has already been mentioned that whilst the *intensity effects*—such as the capability of the spark to pass through a certain thickness of air or the production of the peculiar physiological effect of the shock—belong especially to the phenomena of frictional electricity, they are not apparent with the *quantity effects*, such as may be produced by an ordinary voltaic battery, unless the latter consists of an immense number of elements, such as the famous water battery which consisted of two thousand five hundred pairs of copper and zinc cylinders, well insulated on glass stands, and protected from dust and light. If, however, the feeble intensity current of voltaic electricity, from four or five elements, is permitted to pass into a coil of a peculiar construction, fitted with a condenser, then the most remarkable effects are producible, which have created quite a new and distinct series of phenomena, and further established in the most satisfactory manner the connexion between the electricities derived from *friction* and *chemical action*.

The construction of these various coils does not differ very materially, so that a description of one may be taken as applying broadly to the coils of Ruhmkorff, Hearder and Bentley.

The following is Bentley's description of his own coil and is given in detail:

"I commence the formation of my coil by using as an axis an iron tube ten inches long and half an inch diameter; around this is placed a considerable number of insulated iron wires the same length as the tube, and sufficiently numerous to form a bundle one inch and three quarters diameter. This core is wrapped carefully in eight or nine layers of waxed silk, the necessity of which will be obvious presently.

"My primary helix, which is formed of thirty yards of No. 14 cotton-covered copper wire, is wound carefully on this core, and consists of two layers, each layer being carefully insulated one from the other by waxed silk, for I find that if a wet string or fine platinum wire be connected with the two ends of the primary wires of an induction coil in action,

there is scarcely an indication of an induced current to be obtained from the secondary wire. That this is not owing to any decrease of magnetic power is proved by testing the iron core before and after the experiment, but is simply owing to the central magnet or coil exerting the whole of its inductive powers upon the nearest closed circuit; it therefore follows that if the two layers of primary wire are connected by the cotton covering becoming moist, the whole of the induced current will take this path instead of traversing the secondary wire.

“Before describing my secondary wire I must again call attention to the important fact that the magnetism of the iron exerts its inductive power upon the nearest conducting medium; and I have constructed an instrument to demonstrate this fact. It consists simply of an ordinary coil, giving the third of an inch spark, but having the four inner layers of secondary wire brought out separately. Now, I find that when I keep the ends of this wire separate I obtain nearly the third of an inch spark, but when I connect them metallically I can obtain no intensity spark whatever from the seventeen coils which surround them.

“It follows from this that before winding the secondary wire the striking distance of a single layer must be ascertained, and I find that with my coil I can get a spark one-tenth of an inch long from one coil of wire, and sufficiently intense to penetrate with facility six layers of waxed silk.

“Waxed silk is therefore unsuited for the insulation of large coils, and I find, after numerous experiments, that there is no substance so fitted for the purpose as gutta-percha tissue, and I use five layers of this substance to each layer of wire.\*

“The secondary helix then consists of three thousand yards of No. 35 silk-covered copper wire, and is insulated in the manner described above; but as I do not use cheeks to my coil it assumes the form of a cylinder having rounded ends.

“For the protection of this instrument I place it in a mahogany box of the proper size, and it is supported and retained in its position by an iron rod, which is thrust through the hollow axis of the core and the two ends of the box, leav-

\* Vulcanite or paper impregnated with paraffin is now commonly used for this purpose.

ing half an inch of the iron projecting to work the contact breaker, which is fixed to one end of the box, while the two ends of the secondary wire are brought out of the other through gutta-percha tubes.

“The condenser is contained in a separate box, and is formed of one hundred and twenty sheets of tinfoil between double that number of sheets of varnished paper,\* the alternate sides of the foil being brought out and connected to appropriate binding screws.

“This condenser forms a convenient stand for the coil, and can be used for many interesting experiments.”

The shock which the condenser gives to the system depends in a great measure on the size of the coatings. The primary wire alone does not produce any physiological results, or at least very feeble ones. Hearder's coil is wound on a bobbin six inches in length, and four inches and a half thick, and includes three thousand yards of covered wire. The iron core consists of a bundle of small wires capped with solid ends, and the sparks obtained from it were five-eighths of an inch in air when the primary coil was excited by four pairs of Grove's

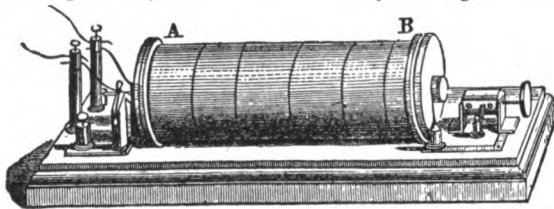

Fig. 290. Ruhmkorff's apparatus. A B. The coil, containing more than a mile of insulated wire. The stand it rests upon, and with which it is in communication, contains the condenser.

series; and when connected with the Leyden jar, the most vigorous and brilliant results were produced. The condenser is made of cartridge paper, coated in the proper manner with tinfoil. The secondary coil is quite independent of the primary one, which is laid on in different lengths, so that the coil can be adjusted to any battery power, whether for quantity or intensity.

For the successful exhibition of the capabilities of the machine, it is required to perform the experiments in a darkened room. (Fig. 290.)

\* Vulcanite or paper impregnated with paraffin is now commonly used for this purpose.



In using this apparatus, eight pairs of Grove's battery will be quite sufficient to produce the effects, and the greatest care must be taken to avoid the shock, which is most severe and painful, and might do a great deal of harm to a weakly, sensitive, and nervous person. To avoid any accidents of this kind, the convenient arrangement at one end shown in Fig. 291 must be carefully attended to, and when manipulating any part of the apparatus, if the battery is attached, the contact should

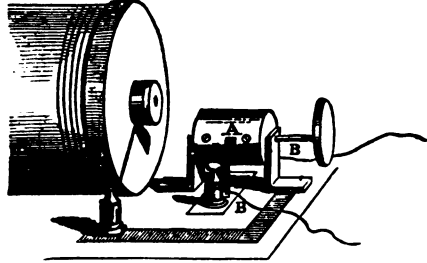

Fig. 291. One end of Ruhmkorff's coil. B B. Connexion to receive the battery wires. A is the cylinder, one half of which is ivory and the other metal. In this position no shock can be received, because the electricity is cut off by the ivory from the coil.

of the apparatus, if the battery is attached, the contact should

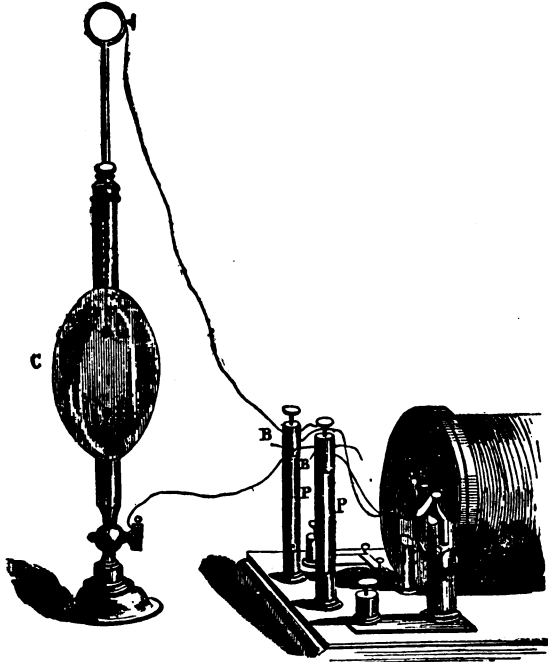

Fig. 292. End of coil where the experiments are performed. B B. Connecting screws and wires passing to the exhausted globe, C. The screws are supported on insulating glass pillars, P P.

first be broken by bringing the ivory (the non-conducting) part of the cylinder A (Fig. 291) in communication with the conductors, BB, where the wires from the battery are attached.

*First Experiment*

It is at the other extremity of the coil that the experiments are performed; for instance, if an exhausted globe is connected with the pillars BB (Fig. 292), and the connexion made with the battery, a beautiful faint blue light is apparent on one of the knobs and wires, and by reversing the current the light appears on the other knob and wire. This effect is supposed to resemble some of those magnificent streaks and undulations of coloured light called the Aurora Borealis; if the globe is removed from the foot, and screwed on to the air-pump plate, and a little alcohol, ether, naphtha, or turpen-

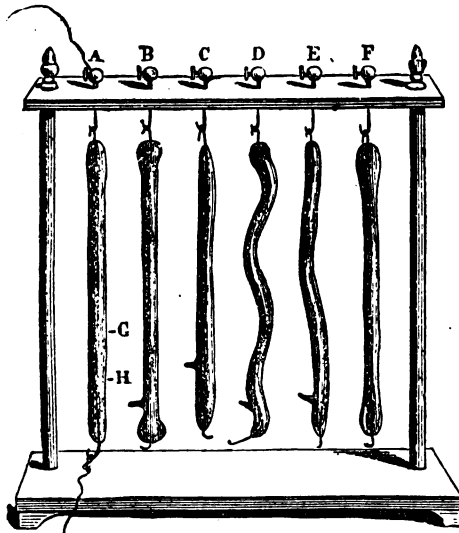

Fig. 293. A, B, C, D, E, F. Various tubes of different kinds of glass, and containing gases and vapours. Each tube has a platinum wire inserted at both ends, with which the contact is made with the coil. The tube A, contains mercury, which has been boiled in it, and the air expelled. By moving the conducting wire to G or H, the light which otherwise passes through the whole of the tubes stops at these points.

tine placed on wool or tow is held to the air-pump screw, where the air usually rushes in, and the tap turned, so that the vacuum is destroyed, a quantity of the vapour will necessarily fill the globe; if this is once more exhausted, it presents

a different appearance, being full of coloured light (varying according to the spirit employed) but stratified and of a circular form. (Fig. 292.)

### Second Experiment

The appearance of these bands of light is modified by the nature of the glass tubes employed, and the subject has been carefully investigated for the purpose of showing the connexion between these miniature effects of bands of light in tubes containing various gases, and the phenomena of the Aurora Borealis. The kind of tubes employed may be understood from the last figure; by approaching a powerful magnet to the outside of any of the glass tubes whilst the bands of light are being produced, the most remarkable modifications of them are obtained. One of these mounted tubes when connected with the coil and battery furnishes one of the most lovely "electric fire-wheels" that can possibly be described. (Fig. 293. Page 367.) Grove placed a piece of carefully-dried phosphorus in a little metallic cup, and covered it with a jar having a cap and wire. On removing the air from the receiver, and passing the current of electricity through it from the Ruhmkorff coil, he obtained a light completely stratified, and blended transversely with straight but vibrating dark bands.

### Third Experiment

When two very thin iron wires are arranged in the upright pillars (Fig. 292), and held sufficiently close to each other,

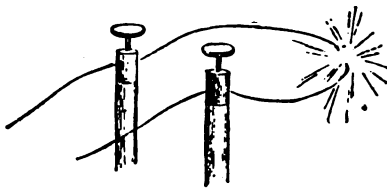

Fig. 294. Melting of the iron wire.

as in Fig. 294, light passes from one to the other. The wire from which the light passes remains *cold*, the other becomes so *hot* that it melts into a little globule of liquid iron, and if paper is held between the wires it rapidly takes fire. (Fig. 294.)

### Fourth Experiment

Remove the break. Attach two wires to  $\times \times$  (Fig. 295). Hold them so as to complete and interrupt the galvanic circle at pleasure. Two other wires are attached at PP,

their ends being about three-quarters of an inch asunder. When the current is closed or broken at AA, a spark passes between BB. (Fig. 295.)

*Fifth Experiment*

A Leyden jar may be charged and discharged with singular rapidity when connected with the coil, and the snapping noise is so rapid that it produces a continuous sharp sound. (Fig. 296.) If a piece of paper is held between the ball of the Leyden jar and the wire, it is instantly perforated, but not set on fire.

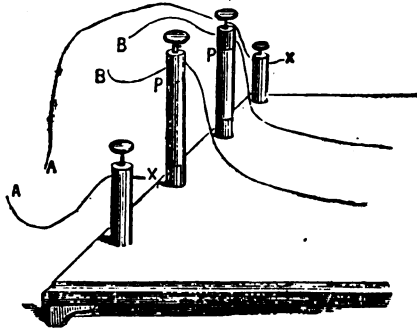

Fig. 295. The making and breaking of the circuit.

*Sixth Experiment*

When the Leyden jar is coated with spangles of tinfoil, a spark appears at each break, and the whole jar is lit up with hundreds of brilliant sparks each time it is charged and dis-

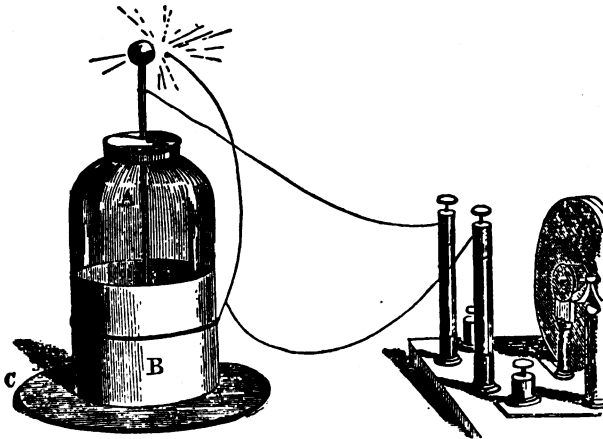

Fig. 296. A B. Leyden jar coated with tinfoil, and standing on any non-conductor, such as gutta percha or the resinous or glass plate, C.

charged, and as this occurs with amazing rapidity, the light is almost continuous. (No. 1. Fig. 297.) The larger the

Leyden jar, the shorter the spark, and *vice versâ*. By the employment of a nicely-made screw and inch-scale, the distance between the discharging points connected with a Leyden jar can be accurately determined; and supposing a Leyden jar has one square foot of charging surface, it will give a spark of one inch in length, but if a smaller jar is used,

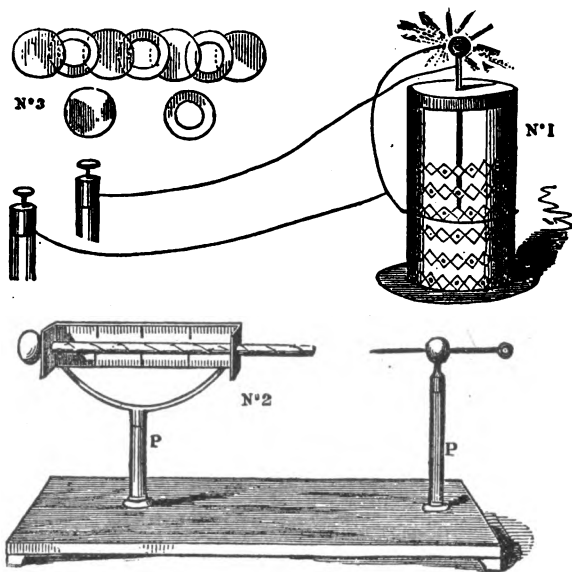

Fig. 297.—No. 1. Spangled Leyden jar. No. 2. Hearder's apparatus for measuring the length of spark for Leyden jar and coil. P P. Glass pillars. No. 3. Two best forms of spangles to paste on a Leyden jar. These spangles, in many designs, are sold cheaply by dealers in apparatus.

with only half a square foot of charging surface, the spark would be about one inch and a quarter in length. (Fig. 297.)

#### Seventh Experiment

The direction and rapidity of the current appear to influence greatly the heating and fire-giving power of the coil, and the following experiment furnishes a curious illustration of this fact.

When the current passes in the direction of the arrows (Fig. 298), the platinum wire remains perfectly cool whilst the gunpowder is fired; and the contrary takes place if the current is reversed—viz., the gunpowder does not blow up.

but the platinum wire is heated. In the second experiment, a Leyden jar is included in the circuit. (Fig. 298.)

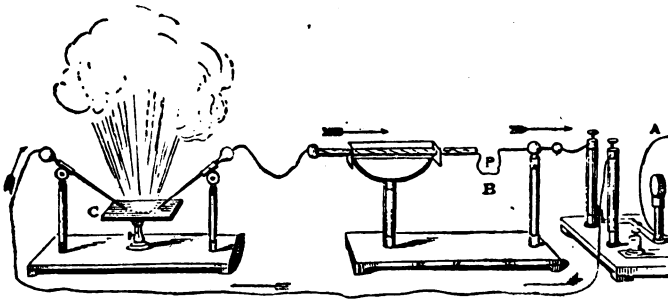

Fig. 298. A. The coil. B. Hearder's discharger, with thin platinum wire, P, hanging between the points. C. Another discharger, and powder going off between the points from the little table. The pillars of the dischargers are glass. The arrows show the direction of the current of electricity.

### *Eighth Experiment*

Amongst so many beautiful experiments, it is somewhat difficult to say which is the most pleasing, but for softness and exquisite colouring, with the continuous vibrating motion of the flowing current of electricity, nothing can surpass "the cascade experiment." This experiment is usually termed "Gassiot's Cascade," and thus may be described,—"Two-thirds of a glass beaker, four inches deep by two inches, are coated with tinfoil, leaving one inch and a half of the upper part uncoated. On the plate of an air-pump is placed a glass plate, and over it the beaker, covering the whole with an open-mouthed glass receiver, on which is placed a brass plate having a thick wire passing through a collar of leather; the portion of the wire within the receiver is covered with a glass tube; one end of the secondary coil is attached to this wire, and the other to the plate of the pump. As the vacuum improves the effect is very surprising; at first a faint clear blue light appears to proceed from the lower part of the beaker to the plate; this gradually becomes brighter, until by slow degrees it rises, increasing in brilliancy until it arrives at that part which is opposite, or on a line with the inner coating, the whole being intensely illuminated; a discharge then commences, as if the electric fluid were itself a material body running over. This result is obtained by coating the inside of a

glass goblet with tinfoil, and placing it under a jar fitted with a collar of leather and ball, and arranged in the usual manner on the air-pump. Directly a vacuum is obtained, the ball is moved down to the inside of the goblet, and the wires from the coil being attached, a continuous series of streams of electric light seem to overflow the goblet all round the edge, and

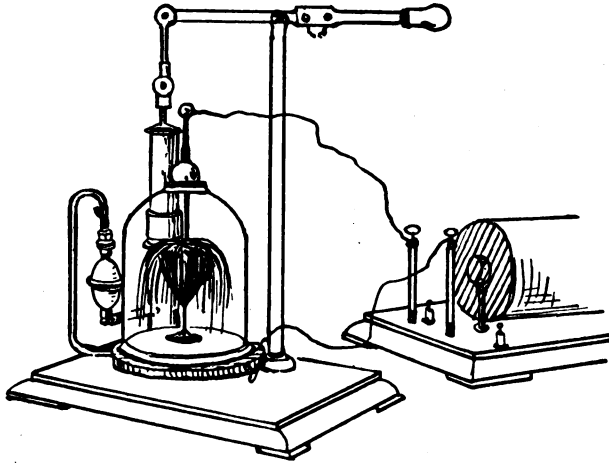

Fig. 299. Gassiott's Cascade.

it stands then the very embodiment of the brimming cup of fire." (Fig. 299.)

#### *Ninth Experiment*

If a piece of wood five inches long and half an inch square is placed on the table of the discharger, and one wire brought

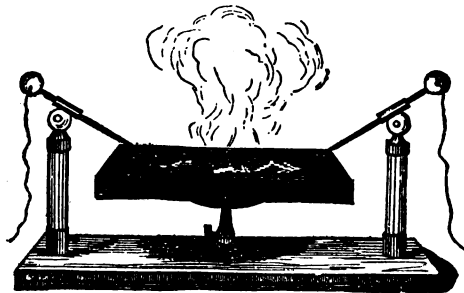

Fig. 300. Burning the piece of wood moistened with the strongest nitric acid.

on to the top edge and the other approached to within three inches of it, and touching the wood, the space between them being moistened with the strongest nitric acid, a curious effect is visible from the creeping along of the fire, which gradually carbonizes and burns the wood. (Fig. 300.)

#### *Tenth Experiment*

A glass plate wetted with gum, and then sprinkled with various filings of iron, zinc, lead, copper, etc., produces a striking effect of deflagration as one of the conducting wires is moved over its surface, the other of course being in contact with the plate. The gum quickly dries by putting the plate in a moderately-heated oven.

#### *Eleventh Experiment*

When the continuous discharges from the Leyden jar are made to pass through the centre of a large lump of crystal

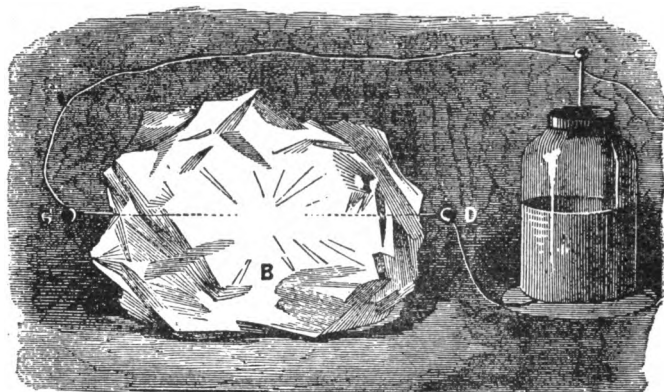

Fig. 301. A. The Leyden jar. B. Large lump of alum, with a hole bored through it in a line with C D. The discharging wires are brought within three-eighths of an inch of each other, and the whole crystal is lighted up with the brilliant electric sparks.

of alum, blue vitriol, or ferroproussiate of potash, etc., the whole of the crystal is beautifully lighted up during the passage of the electricity from one wire of the discharger to the other. (Fig. 301.)

#### *Twelfth Experiment*

When a piece of paper slightly damped is placed between the wires of the discharger, the spark is increased to a much



greater length, on account of the conducting power of the water contained in the pores of the paper.

### *Thirteenth Experiment*

Electro-magnetic coil machines have been employed for a very considerable time in alleviating pain by the administration of shocks. These may be so regulated as to be hardly perceptible, or may be so powerful as to become absolutely intolerable.

These coils are now made self-acting, and consist of two coils of covered and insulated wire wound round a bundle of soft-iron wires, with the necessary connecting screws for the voltaic battery. The contact with the battery is made and broken with great rapidity by a simple form of break, consisting of a tinned disc of iron held by a spring over the axis of the bundle of iron wires; the continual noise of the break, which is alternately attracted down to the bundle and brought back by the spring, when the coil is in contact with the battery, demonstrates (without the pain of taking the shock) when the instrument is in full working order.

Most of the experiments detailed, as well as a large num-

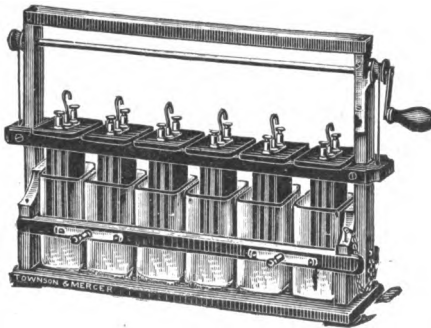

Fig. 302. Bichromate battery, with arrangement for lifting elements out of position.



Fig. 303. Bichromate Cell.

ber of others, may be performed on a small scale with the miniature coils now sold by most dealers. A capital battery for use with a small coil is the Bichromate, and the bottle form (Fig. 303) is the most convenient. It consists of an outer glass jar, containing two carbon plates, between which is a plate of zinc. To charge this battery two ounces of bichromate of potash must be dissolved in one pint of hot water.

When cold, sulphuric acid is added in the proportion of one part of acid to every 12 of solution. The bottle is filled with this mixture up to the shoulder, the neck being left empty for the reception of the zinc plate when the battery is not in use. The great convenience of this battery lies in the facility with which it can be put in action, or left idle as required. Moreover, it gives off no fumes, like those of Grove or Bunsen.

Vacuum tubes are now constructed in all kinds of ingenious devices, some of which are shown in Fig. 304. Many of the

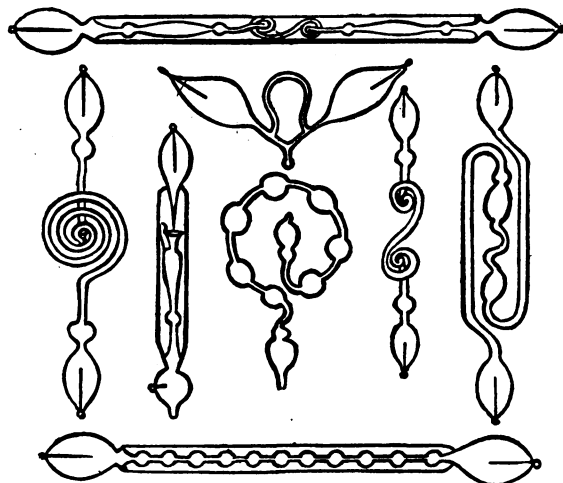

Fig. 304. Vacuum Tubes.

tubes are made of different kinds of glass, and some are charged with coloured solutions, which greatly increase the effects produced.

Of late years the construction of the Induction coil has been carried to very great perfection, and several modifications have been adopted by which the results have been much increased. In large coils the wires are generally wound in sections, separated by vulcanite discs. In the annexed cut, the edges of these discs are well seen.

An extremely powerful coil is illustrated in Fig. 305. It has two primary coils, either of which can be used according to the nature of the subject under investigation. One is made of much thicker wire than the other, and gives short, thick sparks, suitable for spectroscopic work. The other is

used for more general purposes, and will give a spark 42 inches in length. It weighs 67 lbs. The secondary coil through which these effects are *induced* contains wire of a total length of two hundred and eighty miles, a length which

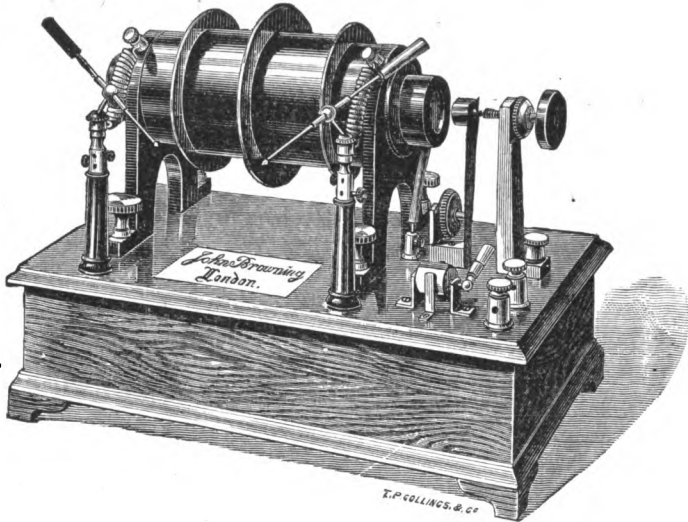

Fig. 305. Induction Coll.

would very nearly cover the distance between London and Carlisle, and it need hardly be said that a shock from a coil of this size would mean instant death; with this large coil Crookes carried out some remarkable experiments connected with molecular physics.

## CHAPTER XXI

### MAGNETO-ELECTRICITY

The correlation of the physical forces, heat, light, electricity, magnetism, and motion, is one of the most interesting subjects for study that can be suggested to the lover of science. The examination of the precise meaning of the term correlation, indicates a necessary mutual or reciprocal dependence of one force on the other. Thus, electricity will produce heat, and *vice versâ*; motion, such as friction, produces electricity, and the latter, by its attraction and repulsion, establishes

itself as a source of motion. Electricity produces light, also magnetism, and contrariwise light is said to possess the power of magnetising steel, whilst magnetism again produces light, and electricity. Such are the intimate connexions that exist between these agents, and we may trace cause and effect and its reversal amongst the several forces, until the mind is lost in the examination of the bewildering mazes, and is content

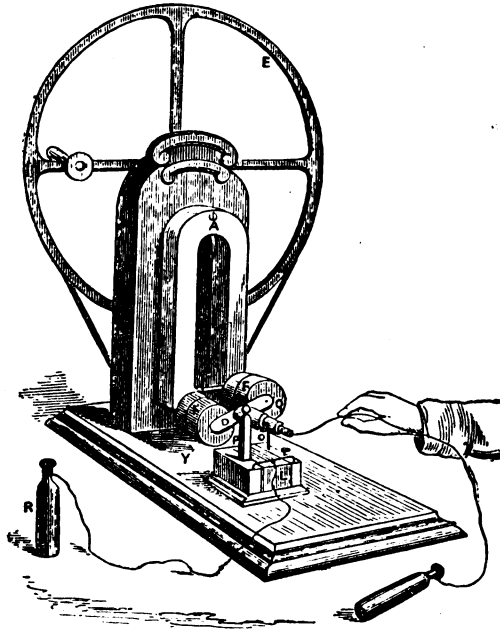

Fig. 306. Clarke's magneto-electrical machine. (See page 378.)

to return to the beaten track and work out experimentally the practical truths. We have already had occasion to notice the fact that a current of electricity causes the evolution of magnetism in its passage through various conducting media, and the truth has been specially illustrated by the various experiments in the chapter devoted to electro-magnetism. In commencing this portion of electrical science, we have no new terms to coin for the title of the discourse, as we merely reverse the other when we examine the nature and peculiarities of magneto-electricity.

## MAGNETO-ELECTRICITY

The source of the power must necessarily be a bar or horse-shoe-shaped piece of steel permanently endowed with magnetism. If the former is thrust into a cylinder of wood or pasteboard, around which coils of covered copper wire have been carefully wound, so that the extremities communicate with a galvanometer, an immediate deflection of the needle occurs, which, however, quickly returns to its first position, but is again deflected in the opposite direction on the withdrawal of the steel magnet from the coil of copper wire. (Fig. 307.)

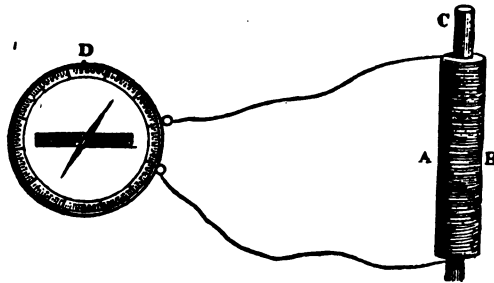

Fig. 307. A B. Coil of copper wire. C. Permanent bar magnet placed inside the coil, when the galvanometer needle, D, is deflected.

The rapid entrance and exit of the steel magnet in the helix of copper wire would be insufficient to produce any quantity of electricity, and the ingenuity of man has been taxed to arrange a method by which a magnet may be suddenly formed and destroyed inside a coil of insulated copper wire. The difficulty, however, has been surmounted by several ingenious contrivances, based on the principles first discovered by Faraday; and the one especially to be noticed is the revolution of a coil of copper wire enclosing a piece of soft iron, called the *armature*, before the poles of a powerful magnet. The first machine was invented by Pixii, of Paris, and in 1833, Saxton improved upon this machine; three years afterwards, Clarke described a very ingenious modification of the electro-magnetic machine, which is depicted at Fig. 306. In this picture, the letter A is the permanent fixed horseshoe magnets, which are very appropriately termed the *battery* magnets, because they take the position that would otherwise be occupied by a voltaic battery, and they are indeed the prime source of the electrical power that is evoked. D is the intensity *armature*

which screws into a brass mandril seated between the poles of the magnets A, motion being communicated to it by the multiplying wheel, E. This armature or *inductor* has two coils of fine insulated copper wire of 1500 yards in length, coiled on its cylinders, the commencement of each coil being soldered to the bar D, from which projects a brass stem, also soldered into D, carrying a break-piece, which is made fast in any position by a small binding-screw in a hollow brass cylinder to which the other terminations of the coils, FF, are soldered, these being insulated by a piece of hard wood attached to the brass stem. O is an iron wire spring pressing against one end of the hollow brass cylinder; P is a square brass pillar; a metal spring rubs gently on the break piece; a copper wire connects the brass pieces with the wood L between them, and out of which P and O pass; RR are two handles of brass with metallic wires, the end of one being inserted into either of the brass pieces connected with P and O, the other, which is inserted into the brass stem that carries the break, delivers a most severe shock directly the wheel is set in motion.

Many other magneto-electric machines followed that of Clarke. In most of these the number of magnets was multiplied, and the effects displayed correspondingly increased, with the disadvantages of making the machines both cumbrous and costly. Among these may be mentioned the "Alliance" machine, which is used to-day in some lighthouses; also Holmes' machine, which fulfils a similar duty in others. In this last machine an electro-magnet was used in conjunction with a so-called "permanent" magnet.

A great advance in the construction of magneto-machines was made in the year 1866, when Siemens and Wheatstone simultaneously, but independently, pointed out that permanent magnets need not be employed at all, because iron always possesses some traces of magnetism which, by proper appliances, can be utilised in the production of the electric current. From this date, therefore (with the exception of those used for medical purposes and for the lecture table), the machines produced have been furnished with electro-magnets only. Three or four new contrivances were framed on this discovery, but they have been altogether eclipsed by more modern machines.

The period covered by the years 1877-1880 will long be remembered on account of the universal interest suddenly manifested in the question of electric illumination, and it is certain that more specifications bearing upon this subject were filed during 1877 and 1878 than during all the previous time that the Patent Office had been established. This excitement was due in the first case to an extremely simple kind of lamp or regulator, the invention of a Russian engineer, and called

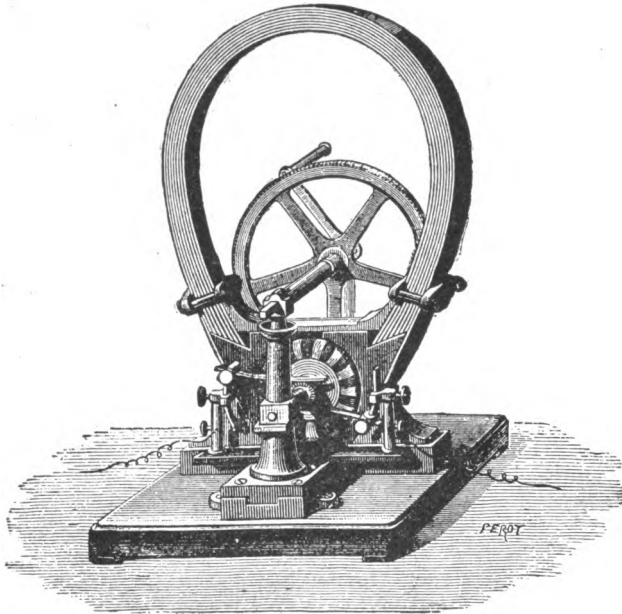

Fig. 308. Old Experimental Gramme machine.

after him "The Jablochkoff Candle," which effectively replaced the very costly and complex electric regulators previously used. This contrivance will be fully described later on. The agitation was also no doubt due to the very perfect magneto-electro machines which had by this time been invented, and by which the most brilliant effects could be obtained.

One of the most remarkable and perhaps the most commonly used machines was that of Gramme, which is still in extensive use. Fig. 308 represents one of these, made specially for lecture-room demonstration. It is capable of all the

effects which are obtainable from a Grove or Bunsen battery of several cells. Only those who know the labour and unpleasantness involved in putting a battery together, and the effect of inhaling the fumes of the acid employed, can really appreciate one of these machines, which merely requires a little "elbow grease" to put it into action.

The principal feature of the Gramme machine is the ring which forms its armature. This ring is bound round with separate coils of insulated copper wire, its core being formed of a bundle of iron wires. The ends of the several coils are brought on to the axis upon which the ring rotates, where they are separated from one another by strips of some non-conducting substance. The electric currents which are generated in these coils, as the ring revolves between the poles of the magnet, are collected by metallic brushes, which rub against the axis of the ring, where the ends of the coils are prolonged. In this manner a continuous stream of electricity is carried to the terminal wires, which can be used for the production of light, heat, or indeed for any purpose for which a battery-current is employed. It will be noticed that in this small machine for manual power a *permanent* magnet is used. This magnet is of somewhat peculiar construction, for instead of being made of one solid steel horseshoe, it is constructed of several layers of that material, each having been separately magnetised. By this means the power of the magnet is very much increased.

Fig. 309 shows another form of Gramme machine in which electro-magnets only are used, the *ring* being retained, and placed between them. This form of machine is for steam power, the engine being connected by belting with the wheel on the left-hand side of the drawing.

Another machine which is also much used is the Siemens machine, but it is so constructed that it can only give one light. This would also be the case with the Gramme machine, if another contrivance, called the distributor, were not employed with it. The Gramme lighting system is, in short, a double one, the machine (Fig. 309) providing the current, which is distributed for use by a second machine.

The Lontin machine has also been in use both in France and this country, and is not unlike the Gramme distributor.

The only other machine necessary to mention is that of Brush.



The Gramme machine referred to on page 381 is interesting in being the forerunner of the modern dynamo. It will be seen that the "gramme" does not differ substantially from the modern brush machines, and on it depended the supply of electric light in times past. Some of these old types, as illustrated, are still in regular use, though many of their com-

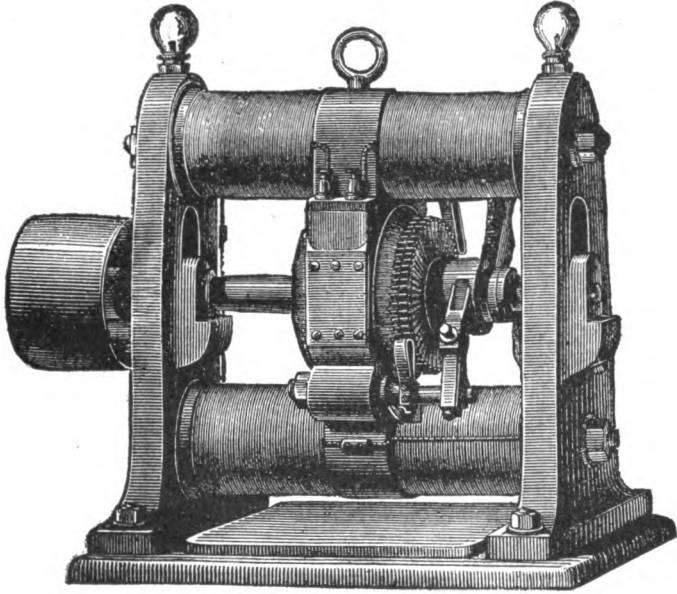

Fig. 300. Gramme Machine.

mercial disadvantages have caused them to give way before the present day highly efficient dynamos and motors.

From time to time fears have been entertained that we are using up our coal supplies so quickly, that a day must sooner or later arrive when Britain will no longer have fuel for her steam engines. It is almost unnecessary to state that if such a time should come, England's power must speedily diminish. Many persons have therefore considered the question of utilising such motive powers as are not dependent upon heat for their production. The natural force of the wind, of falling water, and even the ebb and flow of the tide, have been turned to account for the benefit of man. And although dwellers in towns have not often the opportunity

of seeing windmills and waterwheels, we know that such things are still in use in a few places. It is customary to place a windmill in some exposed situation, where the wind will catch its sails, and a waterwheel must be relegated to some stream where there is water to keep it in motion. In other words, the power obtainable by such means is localised. Because of this and other objections, windmills have become practically obsolete for their original purpose, and waterwheels are fast following suit, but both these sources of power, if properly utilised, can be made to turn one of the magnetic machines described, and the electricity so produced can be carried along wires of great length, these wires connected with another machine, and immediately the transmitted energy is turned into motion, and all this at a minimum of expense. As an instance of this:—An ingenious villager living in a remote country district where even gas is not obtainable, purchased as scrap a cast-out “Gramme” machine, similar to that illustrated in Fig. 309, page 382. After repairing this, he worked it by means of a contrivance erected in his garden and driven by the wind. This machine provides his house and shop with a plentiful supply of electric light. So great is the quantity at command, that though he uses it wastefully, the machine would give him an almost unlimited supply.

An old waterwheel, with under or over service of water, even from a small brook, would provide an equally efficient, practically costless, supply; in fact, the newest turbine is but the antiquated waterwheel modernised. See page 628. Indeed, no better example of the utilisation of natural forces can be found than in the modern water turbine—for which see chapter 31, page 628—by which the power of naturally flowing water, from the tiniest rill to the mighty Falls of Niagara may be made to drive machinery which imprisons and binds their forces in such manner that these forces are given up again in work done, not only on the spot, but conveyed by means of suitable conductors to great distances, where light and mechanical power thus transmitted may be employed in cities, towns and villages as effectively as if generated in the immediate vicinity.

Returning once more to the subject of electric lighting, we must now leave the magneto-electric machines, and look

to the manner in which the current produced is turned into brilliant illumination.

Davy first made the discovery that if the two terminal wires of a powerful battery were furnished with charcoal points, and were then brought together, a brilliant arc of light

was immediately created between them. The heat developed in the operation was so great that the most refractory substances, such as platinum, magnesia, lime, etc., were easily melted in the brilliant flame. If, however, the points were separated beyond a certain distance, proportional to the strength of the battery, the light disappeared, and could not be renewed until they were once more caused to touch. Various kinds of regulators or lamps have been devised to meet these conditions. In most of these the two charcoal points (now replaced by pencils of prepared gas carbon) were placed vertically and were caused to move towards one another as they were gradually consumed.

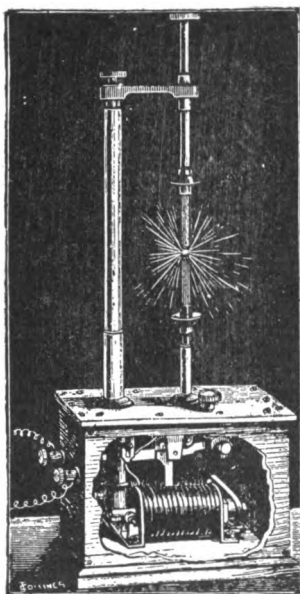

Fig. 310. Browning's lamp.

In some, if not most, of these regulators, clockwork was used to accomplish this end. Serrin's lamp, one of the best known, although reliable, was very expensive; Siemens' regulator was another in common use, but, like Serrin's, it had a train of wheel-work, which caused it to be rather complicated and therefore expensive. This form of regulator is, however, still used for the illumination of large spaces, where the question of expense is of course not a matter for consideration. In Fig. 310 is shown Browning's lamp, which was very much used for experimental work, and in conjunction with a lantern for the exhibition of spectrum analysis on a screen. Figs. 311 and 312 show a much simpler form of regulator by the same maker, with and without a reflector attached. This regulator will give a small but

brilliant light with ten cells of Grove's battery. The distance of the points is regulated by a screw, the upper carbon being clutched in its place by the electro-magnet on the back post of the lamp. When the space between the carbons becomes, by their consumption, too great, the magnet loses its power, and the upper carbon drops by its own weight, to be immediately clutched once more by the magnet which governs it.

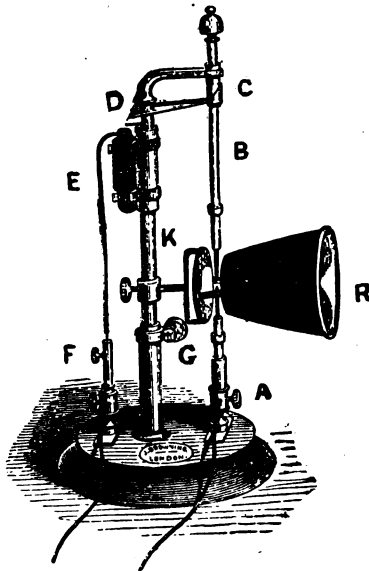

Fig. 311.

Browning's electric regulators.

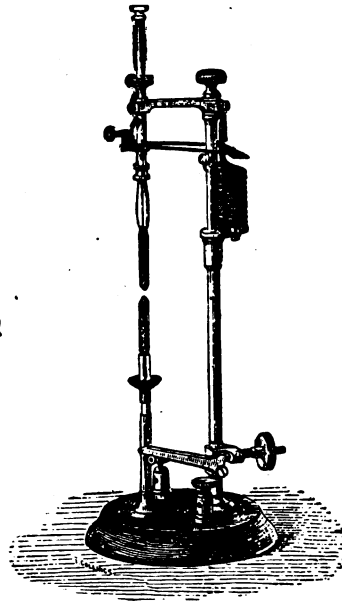

Fig. 312.

In all these lamps provision is made for one carbon being consumed at double the rate of the other, a phenomenon inseparable from a battery, and all machines which give, like a battery, a continuous current. Many of the modern machines, however, are made to give what is called an alternating current—that is to say, the terminals are alternately positive and negative several times in every second. The principal reason why this alteration has in many machines been adopted, is the invention of the Jablochköff candle, which, as will be presently seen, cannot be used with a continuous cur-

rent. Fig. 313 shows this form of electric illuminator. The carbons are not placed one above the other, as in most other forms of regulator, but are placed side by side, with a thin slip of plaster of Paris, or other non-conducting medium between them. Now it stands to reason that if a continuous current were used with this contrivance, one half of the "candle" would burn down twice as quickly as the other half, and they would soon be so widely separated at their points that the light would go out. But by alternating the current, so that each carbon is sometimes positive and sometimes negative, they are both subject to the same rate of combustion, and burn down together like a veritable candle.



Fig. 313. Jablochkoff candle.

Another "candle" was patented later which resembled the Jablochkoff arrangement in every respect, except that it had no insulating material between the carbons; in other words, they were merely separated by space. They were so inclined that their points touched, but directly the arc was established, they sprang apart by the action of a magnet, and the light was maintained between them.

A very perfect form of regulator was one with four carbons, two above and two below, the four points meeting where the light was given out. In another regulator, plates of carbon were used in lieu of rods, but the result was far from satisfactory.

Still another distinct method of employing electricity as a light producer was that of including in the circuit some substance which by its resistance was caused to become incandescent. We have seen by experiments already detailed, (Exp. 15, page 305; exp. 16, page 305 and exp. 7, page 370), that platinum wire placed between the terminals of a battery will glow with fervent heat, carbon also will exhibit the same characteristic, but as neither the one nor the other can stand such treatment with impunity, they speedily perish. This difficulty has been obviated to some extent by enclosing the incandescent substance in a vacuum, for it must be remembered that the light from electricity is in no way dependent upon oxygen for its support. Thus King's patent,

dated 1845, makes use of platinum, in thin leaves which were held in metallic forceps in a glass bulb exhausted of air. The year later, another patent was filed, of a precisely similar character. In 1872, Konn invented a lamp in which a strip of graphite was rendered incandescent, in a glass vessel charged with nitrogen. Then followed a form of regulator of no novel kind. It consisted of a wire composed of an alloy of platinum and iridium, stretched between a fixed arm and a lever. When by the incandescence of this wire the metal expanded, the lever dropped and touched a metallic button, thereby diverting the current and preventing the wire reaching its fusing point. In this manner light was given out without the wire being at once destroyed, but it is obvious that no metallic alloy whatever could withstand such treatment for any lengthened time without destruction, because a platinum wire, rendered incandescent by an electric current, presents before long a shrunken appearance and is full of deep cracks, and if the current be continued for many hours, these effects so increase that the wire falls to pieces. The metal may be made more compact by the following treatment:—Several platinum spirals are brought to the melting point by means of an electric current, and the average light of each is then found, by the photometer, to be equal to four candles (standard). Next, one spiral is placed in the receiver of an air pump, and the air exhausted, a weak current being then sent through the wire to warm it slightly and so assist the gradual escape of the air from the metal. The temperature is carefully and gently increased (by increase of the current) at intervals of ten minutes, afterwards at intervals of fifteen minutes. Before each increase the wire is allowed to cool, and a welding process occurs in it at the points previously containing air. In one hour and forty minutes the spiral will have reached such a temperature before melting that it is giving a light of twenty-five standard candles, whereas otherwise it would certainly have melted before giving a light of five candles. Under this treatment the

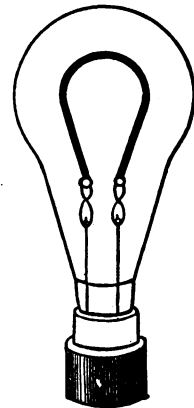

Fig. 314.  
Edison's electric lamp.  
(Earliest form.)

wire seems to become white as silver, polished, and smaller in diameter. This is the method which was employed by Edison. By the use of such material eight separate jets could be produced, each equal to a light of sixteen candles, by the expenditure of one-horse power applied to a dynamo-electric machine.

Electric lighting has progressed from the state of being a curiosity to one of indispensable commercial necessity and safety. The number of highly-efficient lamps, with all manner of filaments, is legion—all so well known that it is obvious no distinctions can be made. In this, as well as in the use of electricity for motive power and domestic service, each year brings its own great improvements. So that this wonderful, yet readily controllable power becomes more and more useful, privately and commercially.

## CHAPTER XXII

### DIA-MAGNETISM

At the end of the chapter devoted to the subject of light (see pages 522-3) will be found an experiment (Fig. 437) devised and carried out by Faraday, in which it is shown that if a bar of peculiar glass (called after the inventor, *Faraday's heavy glass*, or silicated borate of lead) is subjected to the inductive action of a very powerful electro-magnet, it has the power of changing the direction of a ray of polarised light transmitted through it. This effect is not confined to the poles of an electro-magnet, but is also perceptible (though in a diminished degree) with ordinary magnets.

The result of this important experiment was communicated to the Royal Society by Faraday on the 27th November, 1845, "when '*the line of magnetic force*' is made to pass through certain transparent bodies parallel to a ray of polarised light traversing the same body, the ray of polarised light experiences a rotation." Now, "*the line of magnetic force*" means that continual flow of magnetic current which passes from pole to pole, and is indicated by iron filings sprinkled on paper placed above the poles of a magnet, and usually termed *magnetic curves*, or the curved lines of magnetic force. (Fig. 315.)

The heavy glass already alluded to, upon which the magnet exerts a certain influence, is called, THE DIA-MAGNETIC,

and by this term is meant a body through which the lines of magnetic force are passing without affecting it like iron or steel. At page 315 is a figure representing (at Figs. 243 and

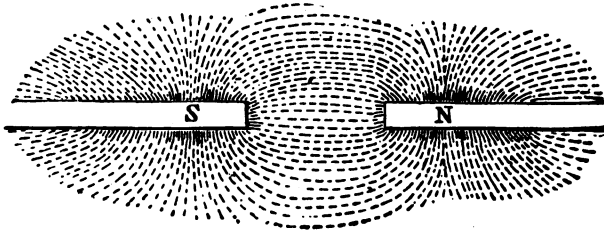

Fig. 315. The curved lines of magnetic force.

244) the direction of the electricity and that of the magnetic current or whirl at right angles to it. If, then, Fig. 244 be considered as a piece of glass, the arrow AB will show "the line of magnetic force," the point B being the north pole, and the shaft A the south pole of the magnet, and the arrows traced round will represent direction. This simple drawing expresses the whole of the law of the action of the magnet on the glass, and if kept in view, will give every position and consequence of direction resulting from it.

The phenomenon of the affection of the beam of polarised light is immediately connected with the magnetic force, and this is supposed to be proved by the *brightness* of the polarised ray being developed *gradually*, as the iron coiled with wire requires about two seconds to acquire its greatest power after being connected with the battery.

In another experiment of Faraday's, where a beam of polarised light was sent through a long glass tube containing water, and introduced as a core *inside* a powerful electromagnetic coil, the image of a candle viewed with a proper eye-piece, appeared or disappeared as the battery connexion was made or broken with the coil; but this result is not considered by many philosophers to be conclusive of the action of magnetism on light, but rather as an alteration of the *refracting* power of the medium through which the light passes. These experiments were the precursors of the other effects of magnetism upon different kinds of matter which Faraday discovered, and he commenced his examination with a small bar of heavy



glass suspended by a filament of silk between the poles of an electro-magnet, and when the twisting or effects of torsion had ceased, the battery was connected. Directly the current passed, Faraday detected a movement of the glass, and on repeating the experiment, he discovered that the movement was not accidental, but always took place in a certain fixed direction—a direction at right angles to a line drawn across and touching the two poles of a horseshoe-shaped magnet—*i.e.*, supposing the feeder or bit of soft iron usually placed in contact with the poles of the horseshoe-magnet to represent the *axial* line, any line drawn across it at right angles would be called the *equatorial line*, whilst the general space included between the poles of the magnet is called the *magnetic field*. The movement of the heavy glass was therefore *equatorial*, and it pointed east and west instead of north and south, like iron and steel.

By the use of the apparatus (Fig. 316) Faraday proved

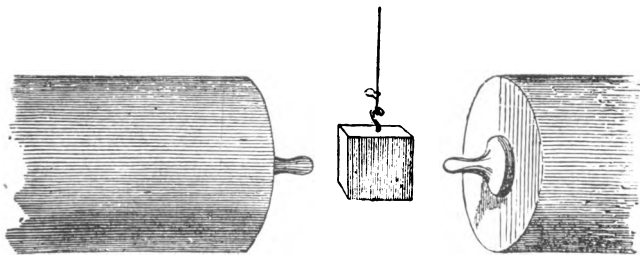

Fig. 316. A cube of copper suspended between the poles of a powerful electro-magnet.

that every substance, whether solid, fluid, or gaseous, was subject to magnetic influences, assuming either the axial or equatorial position. The apparatus consists of a prolongation of the poles of a powerful electro-magnet, between which a cube of copper, weighing from a quarter to half a pound, suspended by a thread, may be set spinning or rotating. If the electro-magnet is connected with the battery, the cube stops immediately, and whilst still in the same position or in the *magnetic field*, with the magnet in full action, it is impossible to set it spinning or twisting round again. (Fig. 316.)

A large number of other substances, solid, liquid, and gaseous, were submitted to the action of the magnet, the liquids

and gases being hermetically sealed in glass tubes, and some of the results are detailed in the following list:

*Bodies that point axially, or are paramagnetic, like a suspended needle*

Iron.	<i>Red-lead.</i>
Nickel.	Sulphate of zinc.
Cobalt.	Shellac.
Manganese.	Silkworm-gut.
Chromium.	Asbestos.
Cerium.	Vermilion.
Titanium.	Tourmaline.
Palladium.	Charcoal.
Platinum.	All salts of iron, when the
Osmium.	latter is basic.
Paper.	Oxide of titanium.
Sealing-wax.	Oxide of chromium.
Fluor spar.	Chromic acid.
<i>Peroxide of lead.</i>	Salts of manganese.
Plumbago.	Salts of chromium.
China ink.	Oxygen, which stands alone
Berlin Porcelain.	as a paramagnetic gas.

*Bodies that point equatorially, or are diamagnetic, like Faraday's heavy glass*

Olefiant gas.	Tartaric acid.
Coal gas.	Citric acid.
Bismuth.	Water.
Antimony.	Alcohol.
Zinc.	Ether.
Tin.	Sugar.
Cadmium.	Starch.
Sodium.	Gum-arabic.
Mercury.	Wood.
<i>Lead.</i>	Ivory.
Silver.	Dried matter.
Copper.	Dried mutton.
Gold.	Fresh beef.
Arsenic.	Dried beef.
Uranium.	Apple.
Rhodium.	Bread.

Iridium.	Leather.
Tungsten.	Fresh blood.
Rock crystal.	Dried blood.
The mineral acids.	Caoutchouc.
Alum.	Jet.
Glass.	Turpentine.
<i>Litharge.</i>	Olive oil.
Common salt.	Hydrogen.
Nitre.	Carbonic acid.
Phosphorus.	Carbonic oxide.
Sulphur.	Nitrous oxide (moderately).
Resin.	Nitric oxide (very slightly).
Spermaceti.	
Iceland spar.	

Nitrogen is neither paramagnetic nor diamagnetic, and is equivalent to a vacuum. Magnetically considered, it is like space itself, which may be considered as zero.

The term *magnetic* Faraday proposed should be a general one, like that of *electricity*, and include *all* the phenomena and effects produced by the power, and he proposed that bodies magnetic in the sense of iron should be called *paramagnetic*, so that the division would stand thus:

Magnetic ..... { Paramagnetic,  
Diamagnetic;

and it is this division which has been observed in the preceding tables.

All space above and within the limits of our atmosphere may be regarded as traversed by lines of force, and amongst others are the lines of magnetic force which affect bodies, as shown in the table of paramagnetic and diamagnetic bodies, which have the same relation to each other as positive and negative, or north and south, in electricity and magnetism.

The lines of magnetic force are assumed to traverse void space without change; but when they come in contact with matter of any kind they are either concentrated upon it or scattered, according to the nature of the matter.

The power which urges bodies to the axial or equatorial lines is not a central force, but a force differing in character in the axial or radial directions. If a liquid paramagnetic

body were introduced into the field of force, it would dilate axially, and form a prolate spheroid like a lemon, while a liquid diamagnetic body would dilate equatorially, and form an oblate spheroid like an orange. Plücker has demonstrated that if magnetic solutions are placed in watch glasses across the poles of the electro-magnet, they are heaped up in a very curious manner. The poles of the electro-magnet are pieces of soft iron, which may be drawn away or approached at pleasure, and according as the poles are nearer or further asunder, the magnetic liquids, such as solution of iron, are heaped up in one or two directions, as shown at B and C in Fig. 317.

“The diamagnetic power, doubtless,” says Faraday, “has

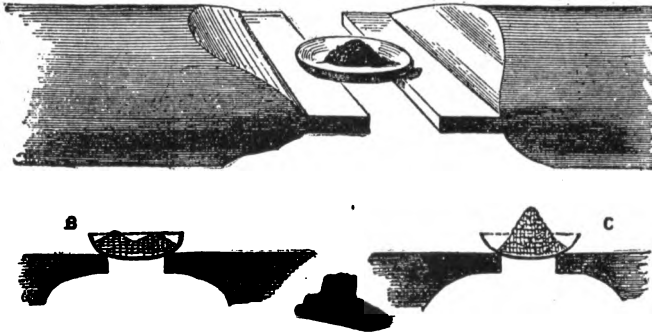

Fig. 317. Glass dish, commonly called a watchglass, holding magnetic solution of iron, and placed in the magnetic field.

its appointed office, and one which relates to the whole mass of the globe. For though the amount of the power appears to be feeble, yet, when it is considered that the crust of the earth is composed of substances of which by far the greater portion belongs to the diamagnetic class, it must not be too hastily assumed that their effect is entirely overruled by the action of the magnetic matters, whilst the great mass of waters and the atmosphere must exert their diamagnetic action uncontrolled.”

Plücker also announced—what at the time he believed to be true—the highly interesting and important fact that the optic axis of Iceland or calcareous spar is repelled by the magnet and placed equatorially—a fact which Plücker thought true of many other crystals when the magnetic axis is parallel to

the longer crystallographic axis. A piece of kyanite, which is a mineral composed of sand, clay, often lime, iron, water, and is used in India, being cut and polished as a gem, and sold frequently as an inferior kind of sapphire, will, it is said, even under the influence of the earth's magnetism, arrange itself like a magnetic needle.

Plücker believed that he had discovered an existing relation between the forms of the ultimate particles of matter and the magnetic forces, and he imagined that the results he obtained would lead gradually to the determination of crystalline form by the magnet. The experiments of Tyndall and Knoblauch led, however, to a very opposite series of conclusions, and by ingeniously powdering the crystals with water, and making them into a paste, which was afterwards dried and suspended as a model in the magnetic field—also by taking a slice of apple about as thick as a penny-piece, with some bits of iron wire through it, in a direction perpendicular to its flat surface—they were found to set equatorially not by repulsion but by the attraction of the iron wires; or instead, by using wires of bismuth, the apple now settled axially, not by attraction but by the repulsion of the bismuth. Ipecacuanha lozenges, Carlisle biscuits also, suspended in the magnetic field, exhibited a most striking directive action. The materials in these two cases are *diamagnetic*; but owing to the pressure exerted in their formation their largest horizontal dimensions set from pole to pole, the line of compression being equatorial; and it is a universal law "*that in diamagnetic bodies the line along which the density of the mass has been induced by compression sets equatorial, and in magnetic bodies axial.*" Hence they assumed, from these and many other conclusive experiments, that crystallised bodies, such as Iceland spar, take their position in the magnetic field without reference to the existence of an "optic axis."

Faraday's experiments were conducted through the medium of a specially fine magnet which could sustain a weight of 430 pounds and was purchased by the council of the Royal Institution for the use of Faraday: by means of this magnet he was enabled to discover dia-magnetism.

It was first observed by Father Bancalari, of Genoa, that when the flame of a candle is placed between the poles of a magnet it is strongly repelled. The flames of combustible

gases from various sources are differently affected, both by the nature of the combustible and by the nearness of the poles. Faraday repeated Bancalari's experiments, and by a certain arrangement of the poles of this magnet he obtained a powerful effect in the *magnetic field*, and having the axial line of the magnetic force horizontal, he found that when the flame of a wax taper was held near the axial line (but on one side or the other), and about one-third of the flame rising above the level of the upper surface of the poles, as soon as the magnetic force was exerted the flame receded from the axial line, moving equatorially until it took an inclined position, as if a gentle wind was causing its deflection from the upright position.

When the flame was placed so as to rise truly across the magnetic axis, the effect of the magnetism was very curious, and is shown at A, Fig. 318.

On raising the flame a little more the effect of the magnetic force was to intensify the results already mentioned, and the flame actually became a *fish-tailed shape*, as at C, Fig. 318. When the flame was raised until about two-thirds of it were above the level of the axial line, and the poles approached very close, the flame no longer rose between the

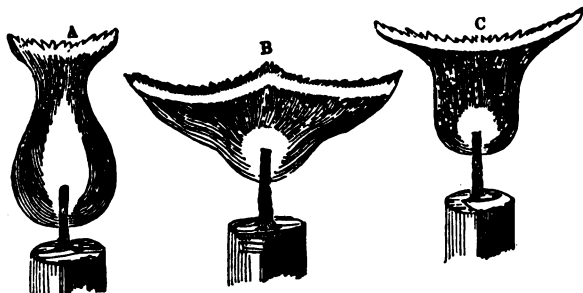

Fig. 318. Effect of magnetism on candle-flame between the poles of the magnet.

poles, but spread out right and left on each side of the axial line, producing a double flame with two long tongues, as at B, Fig. 318.

It was these experiments that led to the important discovery of the paramagnetic property of oxygen, and proved in a decided manner that gaseous bodies when heated became more highly diamagnetic. Oxygen, which (tried in the air) is

powerfully magnetic, becomes diamagnetic when heated. A coil of platinum wire heated by a voltaic current, and placed beneath the poles of Faraday's apparatus, occasions a strong upward current of air; but directly the magnetic action commences the ascending current divides, and a descending current flows down *between* the upward currents.

The discovery of the highly paramagnetic character of oxygen gas, and of the neutral character of nitrogen, the two chief constituents of air, is justly esteemed a fact of great importance in studying the phenomena of terrestrial magnetism. We thus see that one-fifth of the air by volume consists of an element of eminent magnetic capacity, after the manner of iron, and liable to great physical changes of density, temperature, etc., and entirely independent of the solid earth. In this medium hang the magnetic needles used as tests, and as this magnetic medium is daily heated and cooled by the sun's rays, its power of transmitting the lines of magnetic force is then affected, influencing undoubtedly the diurnal changes of the magnetic needle.

Coming from the highest walks of philosophy to lower and common things, one cannot help being reminded of the old-fashioned method of drawing up a sluggish fire by placing a poker in an inclined position from the hearth to the bars of the grate, when it is understood to become a weak magnet, influencing and drawing towards the fire a greater supply of magnetic oxygen gas.

## CHAPTER XXIII

### LIGHT, OPTICS, AND OPTICAL INSTRUMENTS

"To gild refined gold, to paint the lily,  
To throw a perfume on the violet,  
To smooth the ice, or add another hue  
Unto the rainbow, or with taper light  
To seek the beauteous eye of heaven to garnish,  
Is wasteful and ridiculous excess."

Perfection admits of no addition, and it is just this feeling that might check the most eloquent speaker or brilliant writer who attempted to offer in appropriate language, the praises due to that first great creation of the Almighty, when the Spirit of God moved upon the face of the waters and said, "Let there be light." If any poet might be permitted to

laud and glorify this transcendent gift, it should be the inspired Milton; who having enjoyed the blessing of light, and witnessed the varied and beautiful phenomena that accom-

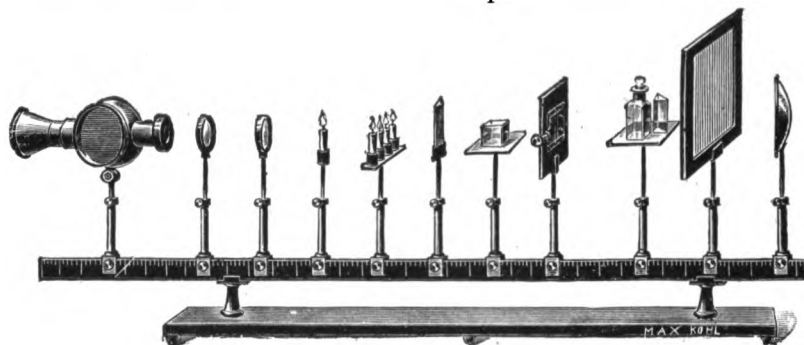

Fig. 319. Optical bench.

pany it, could, when afflicted by blindness, speak rapturously of its creation, in those sublime strains beginning with—

“‘Let there be light,’ said God, and forthwith light  
 Ethereal, first of things, quintessence pure,  
 Sprung from the deep: and from her native east  
 To journey through the airy gloom began,  
 Sphered in a radiant cloud, for yet the sun  
 Was not; she in a cloudy tabernacle  
 Sojourn’d the while. God saw the light was good,  
 And light from darkness by the hemisphere  
 Divided: light the day, and darkness night,  
 He named.”

There cannot be a more glorious theme for the poet, than the vast utility of light, or a more sublime spectacle, than the varied and beautiful phenomena that accompany it. Ever since the divine command went forth has the sun continued to shine, to remain, “till time shall be no more,” the great source of light to the world, to be the means of disclosing to the eye of man all the beautiful and varied hues of the organic and inorganic world. By the help of light we enjoy the prismatic colours of the rainbow, the lovely and ever changing and ever varied tints of the forest trees, the flowers, the birds, and the insects; the different forms of the clouds, the lovely blue sky, the refreshing green fields.

Light works insensibly, at all seasons, in promoting marvellous chemical changes, and is extensively engaged and used



for man's industrial purposes, just as heat, electricity, and magnetism, (all imponderable and invisible forces,) are employed usefully in other ways.

The sources from whence light is derived are six in number. The first is the sun, overwhelming us with his size, and destroying life sometimes with his intense heat and light, when the piercing rays are not obstructed by the friendly clouds and vapours which temper and mitigate their intensity.

It may perhaps be well to consider those curious substances called phosphorescent, especially those which retain for a shorter or longer time the light received from the sun or other source of light, and shine like glow-worms in the dark. The light given out in this manner is unaccompanied by heat, and many artificial compounds are now prepared which exhibit the phenomenon to an astonishing extent, such as luminous paint.

In the year 1602 a poor cobbler of Bologna, who was smitten with the gold fever which then prevailed in the form of a continual search after the fabulous philosopher's stone, picked up a curious mineral. His attention was attracted by its unusual weight, and he immediately jumped to the conclusion that its heaviness must be due to the presence of gold. In a word, he believed his prize to be the veritable philosopher's stone. Taking it home, he placed it in a crucible with some charcoal and eagerly watched for the appearance of the precious metal. No gold became apparent, but the stone underwent a strange modification. It had become phosphorescent, and had acquired the property of shining in the dark after insolation—*i.e.* after being exposed to sunlight.

This stone was sulphate of barium, which by treatment with charcoal was converted to barium sulphide, a well-known substance now prepared in a more direct manner. In 1663 an English chemist found that the diamond and other crystals exhibited to a certain extent the same properties. A few years later another experimenter found that a luminous substance could be prepared from nitrate of lime. But in 1761 a still more phosphorescent body was compounded by Canton, and this is still known as Canton's Phosphorus. The formula for it is as follows:—

Sifted, calcined oyster shells.....	3 parts.
Sulphur .....	1 part.

This mixture is submitted to a strong heat in a crucible, and the resulting mass is sulphide of calcium, or, as already stated, Canton's phosphorus. It can also be prepared by calcining plaster of Paris (sulphate of lime) with charcoal. It is a white powder, with that strong and extremely unpleasant odour characteristic of rotten eggs. It should be preserved in a well stoppered bottle, when it will retain its luminous property—that is after occasional exposure to light—for many years. Indeed, there is still preserved a tube of the powder, prepared one hundred and fifty years ago by Canton himself, which still shines most brilliantly after insolation. The composition of luminous paint is a modification of Canton's phosphorus so blended with oil and varnish that it can be applied as easily as ordinary pigment.

Light also emanates freely from terrestrial matter by mechanical action, either by friction, or in some cases by mere percussion. Thus the axles of railway carriages soon become red hot by friction if the grease boxes are empty; indeed hot axles are very frequent in railway travelling, and when this happens, a strong smell of burning grease is apparent, and flames come out of the axle box. The knifegrinder offers a familiar example of the production of light by the attrition of iron or steel against his dry grindstone.

The same result on a grander scale is produced by the apparatus shown on page 400; the combustion of steel ensues under the action,—the friction of a soft iron disc revolving with great velocity against a file or other convenient piece of hardened steel. (Fig. 320.) The stand has a disc of soft iron fixed upon an axis, which revolves on two anti-friction wheels of brass. The disc, by means of a belt worked over a wheel immediately below it, is made to perform 5000 revolutions per minute. If the hardest file is pressed against the edge of the revolving disc, the velocity of the latter produces sufficient heat by the great friction to melt that portion of the file which is brought in contact with it, whilst some particles of the file are torn away with violence, and being projected into the air, burn with that beautiful effect so peculiar to steel. If the experiment is performed in a darkened room, the periphery of the revolving disc will be observed to attain a luminous red heat.

The rubbing of a piece of wood (hardened by fire, and cut

to a point) against another and softer kind, has been used from time immemorial by savage nations to evoke heat and light; the wood is revolved in the fashion of a drill with unerring dexterity by the hands of the savage, and being sur-

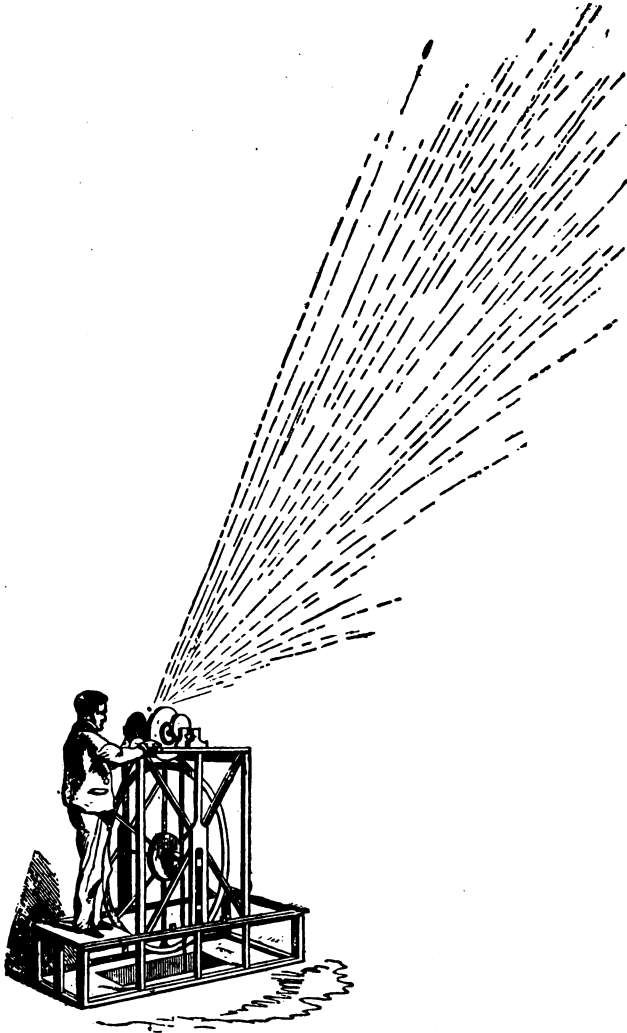

Fig. 320. Instrument for the combustion of steel.

rounded with light chips and gently aided by the breath, the latent fire is, by great and incessant labour, at last procured.

In these days of brilliant and ready forms of lighting, it may be interesting to keep in mind the slow and often tedious method of our ancestors who had only their flint and steel with which to procure light, an outfit being shown in Fig. 321.

Bridging this interval to modern times, it was a happy



Fig. 321. C. The steel. B. The flint. E. The tinder. D. The matches of the old-fashioned tinder-box, A.

thought which first devised a method of mixing together phosphorus and chlorate of potash and so adjusted these dangerous materials that they are as safe as the old tinder-box, and have now become one of our domestic necessities.

Ignition, or the increase of heat in a solid body, is another source of light, and is well illustrated in the production of illuminating power from the combustion of tallow, oil, wax, or gas. The term *ignition* (derived from the Latin *ignis*, fire), is quite distinct from, and has a totally different meaning to, *combustion*. If a glass jar is filled with carbonic acid gas, and a little tray placed in it containing some gun cotton, it will be found impossible to fire the latter with a lighted taper, *i.e.*, by combustion (*combuo*, to burn), because the gas extin-

guishes flame which is dependent on a supply of oxygen; whereas if a copper or other metallic wire is made red hot or ignited, the carbonic acid has no effect upon the heat, and the red hot wire being passed through the gas, the gun cotton is immediately fired.

Flame consists of three parts—viz., of an outer film, which comes directly in contact with the air, and has little or no luminosity; also of a second film, where carbon is deposited, and, first by *ignition*, and finally by *combustion*, produces the light; and thirdly, of an interior space containing unburnt gas, which is, as it were, waiting its turn to reach the external air to be consumed in the ordinary manner. (Fig. 322.)

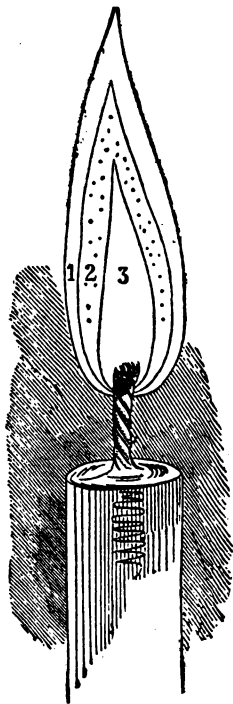

Fig. 322. A candle flame. 1. Outer flame. 2. Inner flame, which is badly supplied with oxygen, and where the carbon is deposited and ignited. 3. The interior, containing unburnt gas.

Chemical action and electricity have been so frequently mentioned in this work as a source of heat and light, that it will be unnecessary to do more than mention them here; whilst phosphorescence (the sixth source of light) in dead and living matter, a spontaneous production of light, is well known and exemplified in the glow-worm, the fire-fly, the luminosity of the water of the ocean, or the decomposing remains of certain fish, and even of human bodies. Phosphorescence is still more curiously exemplified by holding a sheet of white paper, a calcined oyster-shell, or even the hand, in the sun's rays, and then retiring quickly to a darkened room, when they appear to be luminous, and visible even

after the light has ceased to fall upon them, apart from the retentive power of the retina.

For the purpose of examining the temporary phosphorescence of various bodies, Becquerel invented a most ingenious instrument, called the "phosphorescope." It consists of a cylinder of wood one inch in diameter and seven inches long,

placed in the angle of a black box with the electric lamp inside, so that three-fourths of the cylinder are visible outside, and the remaining fourth exposed to the interior electric light.

By means of proper wheels the cylinder, covered with any substance (such as Becquerel's phosphori), is made to revolve 300 times in a second, and by using this or a lesser velocity, the various phosphori are first exposed to a powerful light and then brought in view of the spectator outside the box.

It is understood that light is produced by an emanation of rays from a luminous body. If a stone is thrown from the hand, an arrow shot from a bow, or a ball from a cannon, we perfectly understand how either of them may be propelled a certain distance, and why they may travel through space; but when we hear that light travels from the sun, which is ninety-three millions of miles away from the earth, in about seven minutes and a half, it is interesting to know what is the kind of force that propels the light through that vast distance, and also what is supposed to be the nature of the light itself.

There are two theories by which the nature of light, and its propagation through space, are explained; they are named after the celebrated men who proposed them, as also from the theoretical mechanism of their respective modes of propulsion: thus we have the Newtonian or *corpuscular* theory of light, and the Huyghenian or *undulatory* theory; the first named after Sir Isaac Newton, and the second after Huyghens, another learned mathematician. Many years before Newton made his grand discovery of the composition of light in the year 1672, mathematicians were in favour of the *undulatory* theory, which numbered amongst its supporters not only Huyghens, but Descartes, Hook, Malebranche, and other learned men. Mankind has always been glad to follow renowned leaders, it is so much easier, and is in most cases perhaps the better course, to resign individual opinion when more learned men than ourselves not only adopt but *insist* upon the truth of their theories; and this was the case with the corpuscular theory, which had been written upon systematically and supported by Empedocles, a philosopher of Agrigentum in Sicily, who lived some 444 years before the Christian era, and is said to have been most learned and eloquent; he maintained that light consisted of particles pro-

jected from luminous bodies, and that vision was performed both by the effect of these particles on the eye, and by means of a visual influence emitted by the eye itself. In course of time, and at least 2000 years after this theory was advanced, philosophers had gradually rejected the corpuscular theory, until Newton, about the middle of the seventeenth century, advanced as a champion to the rescue, and stamping the hypothesis with his approval, at once led away the whole army of philosophers in its favour, so that till about the beginning of the nineteenth century the whole of the phenomena of light were explained upon this hypothesis.

The corpuscular theory, reduced to the briefest definition, supposes light to be really a material agent, and requires the student to believe that this agent consists of particles so inconceivably minute that they could not be weighed, and of course do not gravitate; the corpuscles are supposed to be given out bodily (like sparks of burning steel from a gerb firework) from the sun, the fixed stars, and all luminous bodies; to travel with enormous velocity, and therefore to possess the property of *inertia*; and to excite the sensation of vision by striking bodily upon the expanded nerve, the retina, the quasi-mind of the eye. Young remarks, "that according to this projectile theory the force employed in the free emission of light must be about a million million times as great as the force of gravity at the earth's surface, and it must either act with equal intensity on all the particles of light, or must impel some of them through a greater space than others, if its action be more powerful, since the velocity is the same in all cases—for example, if the projectile force is weaker with respect to red light than with respect to violet light, it must continue its action on the red rays to a greater distance than on the violet rays. There is no instance in nature besides of a simple projectile moving with a velocity uniform in all cases, whatever may be its cause; and it is extremely difficult to imagine that such an immense force of repulsion can reside in all substances capable of becoming luminous, so that the light of decaying wood, or two pebbles rubbed together, may be projected precisely with the same velocity as the light emitted by iron burning in oxygen gas, or by the reservoir of liquid fire on the surface of the sun."

One of the weaknesses of this theory—and there are many

—lies in the fact that as light travels at the rate of about twelve million miles a minute, these corpuscles given off from all the objects around would strike the eye with that velocity, which would be annihilating, even if the corpuscles were exceedingly minute. Thus our first sensation of light would produce blindness if not total destruction, for what human being could withstand the constant bombardment of even inconceivably fine particles possessing a travelling energy of twelve million miles a minute.

One of the most striking circumstances respecting the propagation of light, is the *uniformity* of its velocity in the same medium. These and other difficulties in the application of the corpuscular theory aroused the attention of Young, and in the year 1801 he again revived and supported the neglected undulatory or wave theory with such great ability that the attention of many learned mathematicians was directed to the subject, and now it may be said that the corpuscular theory is rejected, whilst the undulatory theory is once more, and deservedly, used to explain the theory of light, and its propagation through space. By this hypothesis it is assumed that the whole universe, including the most minute pores of all matter, whether solid, fluid, or gaseous, is filled with a highly elastic rare medium of a most attenuated nature, called *ether*, possessing the property of *inertia* but not of gravitation. This *ether* is not light, but light is produced in it by the excitation on the part of luminous bodies of a vibratory motion, similar to the undulation of water that produces waves, or the vibration of air affording sound. Water set in motion produces waves. Air set in motion produces waves of sound. Ether, likewise set in motion, produces light. The nature of a vibratory medium is indeed better understood by reference to that which we know possesses the ordinary properties of matter—viz., the air; and by tracing out the analogy between the propagation of sound and light, the difficulties of the undulatory theory very quickly vanish. To illustrate vibration it is only necessary to procure a bowl, and having supported a little ebony ball attached to a silk thread by a bent wire directly over it, so that the ball may touch either the outside or the inside of the glass, attention must be directed to the quiescence of the ball when a violin bow is lightly moved over the edge of the glass bowl without producing



sound, and to the contrary effect obtained by so moving and pressing the bow that a sharp sound is emitted, when immediately the little ball is thrown off from the edge, the repulsive action being continued as long as the sound is produced by the vibration of the glass. (Fig. 323.)

Here the vibrations are first set up in the glass, and being

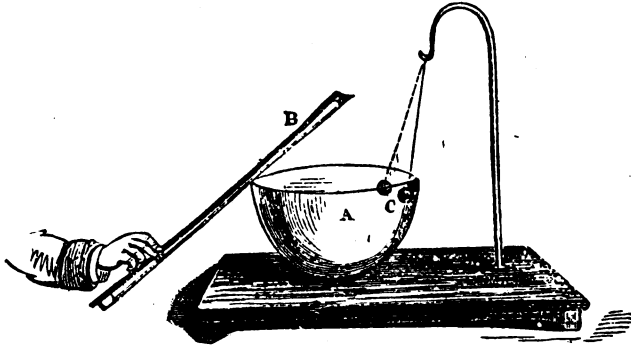

Fig. 323. A. The glass bowl. B. The violin bow. C. The ebony ball. The dotted ball shows how it is repelled during the vibration of the glass.

communicated to the surrounding air, a sound is produced; if the same experiment could be performed in a vacuum, the glass might be vibrated, but not being surrounded with air, no sound would be produced. This fact is proved by first ringing a bell with proper mechanism fixed under the receiver placed on the air-pump plate; the sound of the bell is audible until the pump is put in motion and the receiver gradually exhausted, when the ringing noise becomes fainter and fainter, until it is perfectly inaudible. This experiment is made more instructive by gradually admitting the air again into the exhausted vessel, at the same time ringing the bell, when the sound becomes gradually louder, until it attains its full power. The sun and other luminous bodies may be compared to the bowl, and are supposed to be endowed naturally with a vibratory motion (a sort of perpetual ague), only instead of the air being set in motion, the *ether* is supposed to be thrown into waves, which travel through space, and convey the impression of light from the luminous object. Another familiar example of an undulatory medium is shown by throwing a stone into a pool of water; the former immediately forces down and displaces a certain number of the

particles of the latter, consequently the surrounding molecules of water are heaped up above their level; by the force of gravitation they again descend and throw up another wave, this in subsiding raises another, until the force of the original and loftier wave dies away at the edge of the pool into the faintest ripples. It must however be understood that it is not the particles of water first set in motion that travel and spread out in concentric circles; but the force is propagated by the rising and falling of each separate particle of water as it is disturbed by the momentum of the descending wave before it. When standing at a pier-head, or on a rock against which the sea dashes, it is usual to hear the observer cry out, if the weather is stormy and the waves very high, "Oh! here comes a great wave!" as if the water travelled bodily from the spot where it was first noticed, whereas it is simply the force that travels, and is exerted finally on the water nearest the rock. It is in fact a progressive action, just as the wind sweeps over a wide field of corn, and bends down the ears one after the other, giving them for the time the appearance of waves. If the motion were of "substance" as in the Newtonian theory then the corn itself must travel from one end of the field to the other, but as the roots are fast in the ground we see that the motion is waves of "force" which pass over and over the surface, which force is generated by the wind, and we call it "waving" corn not "moving" corn. The principle of successive action is well shown by placing a number of billiard balls in a row, and touching each other; if the first is struck the motion is communicated through the rest, which remain immovable, whilst the last only flies out of its place. The force travels through all the balls, which simply act as carriers, their motion is limited, and the last only changes its position. Progressive movement is also well displayed by arranging six or eight magnetised needles on points in a row, with all their north poles in one direction. (Fig. 324. Page 408.)

On approaching the north pole of a bar magnet to the same pole of one end of the series of needles, it is very curious to see them turn in the opposite direction progressively, one after the other; as the repulsive power of the bar magnet gradually operates upon the similar poles in the magnetic needles. The undulations of the waves of water are also perfectly shown by using the apparatus consisting of the trough with the

glass bottom and screen above it, as described at page 13. The transmission of vibrations from one place to another was also admirably displayed in Wheatstone's Telephonic Concert, where the musical instruments were placed in the basement, and the vibration only conducted by wooden rods to the sounding-boards above, so that the music was laid on like gas or water, silent, except where tapped by the sounding-boards. These vibrations or undulations in air, water, and the ether have therefore been called waves of water, waves of sound, and waves of light, just as, were three clocks made of

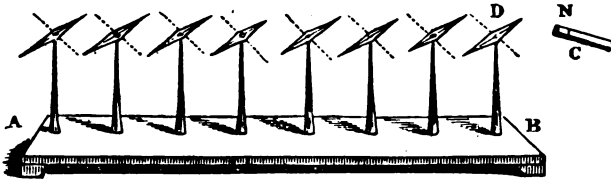

Fig. 324. A B. Series of needles arranged as described. C. The bar magnet, with the north pole N towards the needles. The dotted lines show the direction gradually assumed by all the needles, commencing at D.

three different metals, the mechanism would remain the same, though the material, or in this case the medium, be different in each.

Any increase in the number of vibrations of the air produces acute, whilst a decrease attends the grave sounds, and when the waves succeed each other not less than sixteen times in a second, the lowest sound is produced. Light and colour are supposed to be due to a similar cause, and in order to produce the red ray, no less than 492.41 millions of millions of vibrations must occur in a second of time; the orange, 503.3; yellow, 517.6; green, 570; blue, 635; indigo, 658; violet, 685; and white light, which is made up of these colours, numbers 512 millions of millions of undulations in a second.

Although light travels with such amazing rapidity, there is of course a certain time occupied in its passage through space—there is no such thing as the strictly instantaneous in nature. A certain period of time, however small, must elapse in the performance of any act whatever, and it has been proved by a careful observation of the time at which the eclipses of the satellites of Jupiter are perceived, that light travels at the rate of 186,623 miles per second, and by the aberration of the fixed stars, 186,617; the mean of these two

sets of observations would probably afford the correct rate. Such a velocity is, however, somewhat difficult to appreciate, and therefore, to assist our comprehension of their great magnitude, Herschel has given some very interesting comparative calculations.

“A cannon-ball moving uniformly at its greatest velocity would require seventeen years to reach the sun. Light performs the same distance in about seven minutes and a half.

“The swiftest bird, at its utmost speed, would require nearly three weeks to make the tour of the earth, supposing it could proceed without stopping to take food or rest. Light performs the same distance in less time than is required for a single stroke of its wing.”

Dismissing for the present the theory of undulations, it will be necessary to examine the phenomena of light, regarding it as radiant matter, without reference to contending theories.

Light issues from the sun, passes through millions of miles to the earth, and as it falls upon different substances, a variety of effects are apparent. There is a certain class of bodies which obstruct the passage of the rays of light, and where light is not, a shadow is cast, and the substance producing the shadow is said to be opaque. Wood, stone, the metals, charcoal, are all examples of opacity; whilst glass, talc, and horn allow a certain number of the rays to travel through their particles, and are therefore called transparent. Nature, however, never indulges in sudden extremes, and as no body is so opaque as not (when reduced in thickness) to allow a certain amount of light to pass through its substance, so, on the other hand, however transparent a body may be, a greater or lesser number of the rays are always stopped, hence opacity and transparency are regarded as two extremes of a long chain; being connected together by numerous intermediate links, they pass by insensible gradations the one into the other.

If a gold leaf, which is about the one two-hundredth part of an inch in thickness, is fixed on a glass plate and held before a light, a green colour is apparent, the gold appearing like a green, semi-transparent substance. When plates of glass are laid one above the other, and the flame of a candle observed through them, the light decreases enormously as the number of glass-plates are increased. Even in the air a con-

siderable portion of light is intercepted. It has been estimated that of the horizontal sunbeams passing through about two hundred miles of air, one two-thousandth part only reaches us, and that no sensible light can penetrate more than seven hundred feet deep into the sea; consequently, even the depths in which the Atlantic cables are laid must be in absolute darkness, save for the phosphorescence which is more or less present at all depths, even the abyssmal.

Light is thrown out on all sides from a luminous body, as the spokes of a cart-wheel radiate from the hub, and in the absence of any obstruction, the rays are distributed equally on all sides, diverging like the radii drawn from the centre of a circle. As a natural consequence arising from the divergence of each ray from the other, the intensity of light decreases as the distance from the luminous source increases, and *vice versâ*. Perhaps the best mechanical notion of this law is afforded by an ordinary fan; the point from which the sticks radiate, and where they all meet, may be termed the light; the sticks are the rays proceeding from it. (Fig. 325.)

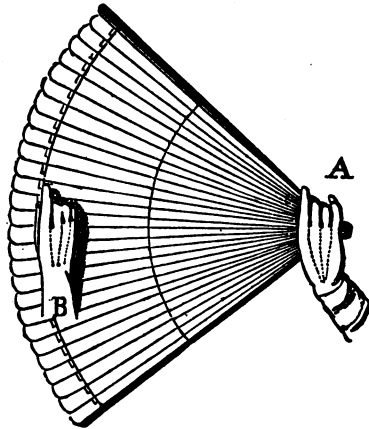

Fig. 325.

The fan is held in one hand, and the first finger of the other can be made to touch all the sticks if placed sufficiently near to A; supposing the sticks are called rays of light, the intensity must be great at that point, because all the rays fall upon it; but if the hand is removed towards the outer edge, to B, the finger now only touches some three or four sticks; and pursuing the analogy, a very few rays fall upon that point—

hence the light has decreased in intensity, or to speak correctly, "Light decreases inversely as the squares of the distance." This law has already been illustrated at page 17; as an experiment, the rays from a lantern may be permitted to pass out of a square hole (say two inches square), and should be thrown on to a transparent screen divided into squares by dark lines, so that the light at a certain distance illuminates one of them; then it will be found that at twice the distance, four may be illuminated, at three times nine, and so on. (Fig. 326; see also Fig. 25, p. 17.)

Upon this law is based the use of photometers, or instruments for measuring light, and supposing it was required to estimate roughly the illuminating power of any lamp, as com-

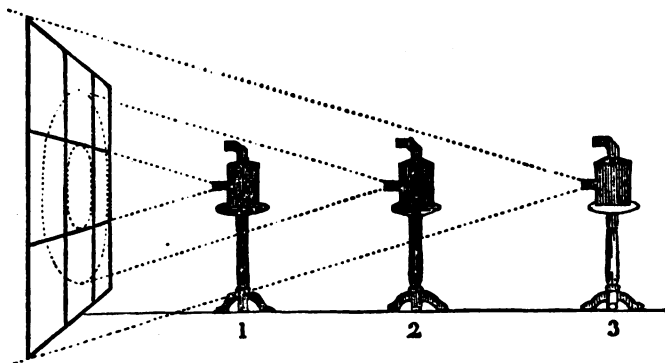

Fig. 326. Lantern at the three distances from the transparent screen, which is divided into nine equal squares.

pared with the light of a wax candle six to the pound, the experiment should be conducted in a dark room, from which every other light but that from the lamp and candle under examination must be excluded.

The lamp, with the chimney only, is now placed say twelve feet from the wall, and a stick or rod is placed upright about two inches from the latter, so that a shadow is cast on the wall; if the candle is now lighted and allowed to burn up properly, two shadows of the stick will be apparent, the one from the lamp being black and distinct, the other from the candle extremely faint, until it is approached nearer the wall—say to within three feet—when the two shadows may be now equal in blackness. (Fig. 327.) After this is apparent to one or more persons, the distances of the lamp and candle

from the wall are carefully measured, and being squared, the greater divided by the lesser number, the quotient gives the illuminating power. For example:

The lamp was 12 feet from the wall  $12 \times 12 = 144$ .

The candle was 3 feet from the wall  $3 \times 3 = 9$ .

9) 144

16

Therefore the illuminating power of the lamp is equal to 16 wax candles six to the pound.

This also shows that the greater the distance between the

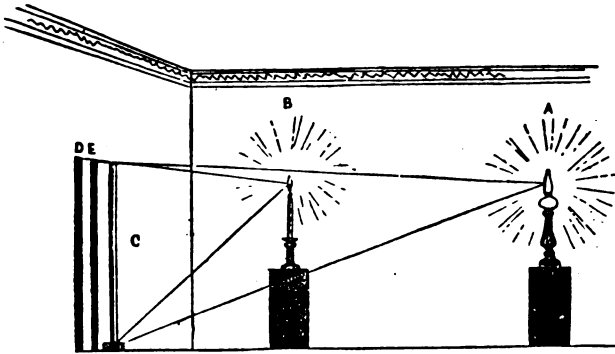

Fig. 327. A. The lamp. B. The candle. C. The rod throwing the two shadows, marked D and E, on the white wall or a sheet of paper.

point of illumination and the object illuminated, the greater must be the power of the light to illuminate that object with equal intensity. Thus we see that the light falling on the rod, C, from the candle, B, requires the intensity of a lamp, at A, to give the same value of light on C, or a light sixteen times the power of that at B.

There are other and more exact means of working out the same fact, but for a rough approximation to the truth, the plan already described will answer very fairly.

A curious effect can be produced, on the principle that every light casts its own shadow, called the "dance of death," or the "dance of the witches;" the subjects are drawn, and the outlines cut out of a sheet of cardboard. If a wet sheet is stretched or hung on one side of a pair of folding doors partly open, between which the cardboard is tacked up, and the space left at the top and bottom closed with a dark cloth,

directly the room before the sheet is darkened and a lighted candle held behind the figure cut out in the cardboard, one shadow or image is thrown upon the sheet, and these shadows may be increased according to the number of candles used; if they are held by two or three persons, and moved up and down, or sideways, the shadows follow the direction of the candles, and present the appearance of a dance.

Another comic effect of shadow is that called "jumping up to the ceiling," and when carried out on a large scale it has an amusing effect. (Fig. 328.)

This very telling result is produced by placing an oxy-



Fig. 328. The laughable effect of shadows thrown on a screen.

hydrogen light some distance behind a large sheet, and of course if any one passes between the two a shadow of the individual is cast upon the sheet, then by walking towards the light the figure increases in size, and by jumping over it the



shadow appears to go up to the ceiling, and to come down when the jump is made in the opposite direction over the light and towards the sheet. The *rationale* of this experiment is very simple, and is another proof of the distribution of light from a luminous source being in every direction. By jumping over the light the radii projected from the candle over the sheet are crossed, and the shadow rises or falls as the figure passes upwards or downward. (Fig. 329.)

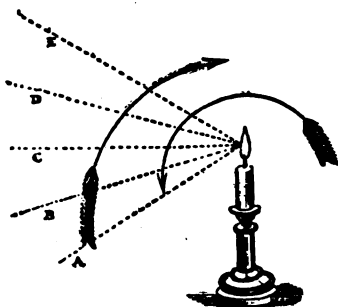

Fig. 329. The rays of light marked A B C D E proceeding from a lighted candle or oxy-hydrogen light. The arrow pointing to the right shows how these rays are crossed in jumping up to the ceiling; and the second arrow, pointing to the left, shows the reverse.

A beam of light is defined to be a collection of rays, and it is a convenient definition, because it prevents confusion to speak only of one ray in attempting to explain how light is disposed of under peculiar circumstances.

The smallest portion of light which it is supposed can be separated is therefore called a ray, and it will pass through any medium of the same density in a perfectly straight line; but if it passes out of that medium into another

of a different density, or into any other solid, fluid, or gaseous matter, it may be disposed of in four different ways, being either reflected, refracted, polarised, or absorbed.

The reflection of light is the first property that will be considered; it will be found that every substance in nature possesses in a greater or lesser degree the power of throwing off the rays of light which fall upon them. Thus if we go into a room perfectly darkened, containing every kind of work produced by nature or art, such as flowers, birds, boxes of insects, rich carpets, hangings, pictures, statuary, jewellery, &c., they cannot excite any pleasure because they are invisible. but directly a light is introduced, then the rays fall upon all the surrounding objects, and being reflected from their surfaces enter the eye, and there produce the phenomena of vision.

This connexion between luminous and non-luminous bodies becomes very apparent when we consider that the sun would

appear only as an intense light in a dark background, if the earth was not surrounded with the various strata of air, in which are placed clouds and vapours that collectively reflect and scatter the light, so as to cause it to be endurable to vision. It is when the sky is very clear during July or August that the heat becomes so intense; directly clouds begin to form and float about, the heat is then moderated.

Many years ago, a visitor to some silver mines in Sweden observed that on a clear day it was as dark as pitch underground in the shaft of the pit at sixty or seventy fathoms deep; whereas, on a cloudy or rainy day he could easily see to read at 106 fathoms deep. Inquiring of the miners, he was informed that this is always the case, and reflecting upon it he imagined very properly that it arose from this circumstance—that when the atmosphere is full of clouds, light is reflected from them into the pit in all directions, so that thereby a considerable proportion of the rays are reflected perpendicularly upon the earth; whereas when the atmosphere is clear there are no opaque bodies to reflect the light in this manner, at least, in a sufficient quantity, and rays from the sun itself can never fall perpendicularly in Sweden. The use of reflecting surfaces has now become quite common in all crowded cities, and especially in London, where even the rays of light are too few to be lost, and flat or corrugated mirrors are placed at various angles, either to throw the light from the outside on the white-washed ceiling within, and thus obtain a better diffused light through the apartment, or it is reflected bodily to some back or rather dark room, where perhaps for half a century artificial light has been required at an early hour in the afternoon. The brilliant cut in diamonds is such an arrangement of the posterior facets, or cut faces of the jewel, that all light reaching them shall be thrown back and reflected, and thus impart an extraordinary brilliancy to the gem.

The intense glare of snow in the Alpine regions has long been noticed, and the reflected light is so powerful, that scientists were even disposed to believe that snow possessed a natural or inherent luminosity, and gave out its own light. Boyle, however, disproved this notion by placing a quantity of snow in a room from which all foreign light was excluded, and neither he nor his companion could observe that any light

was emitted, although, on the principle of momentary phosphorescence, it is quite possible to conceive that if the snow was suddenly brought into a darkened room after exposure to the rays of the sun it would give out for a few seconds a perceptible light. In trying such an experiment, one person should expose the snow to the sun, and bring it into a perfectly darkened room to a second person, whose eyes would be ready to receive the faintest impression of light, and if any phosphorescence existed, it must be apparent, otherwise no reliance can be placed upon the experiment.

The property of reflection is also illustrated on a grand scale in the illumination of our satellite, the moon, by light reflected from the sun. Aristotle was well aware that it is the reflection of light from the atmosphere which prevents total darkness after the sun sets, and in places where the sun's rays do not actually fall during the daytime. He was also of opinion that rainbows, halos, and mock suns, were all occasioned by the reflection of the sunbeams in different circumstances, by which an imperfect image of the sun was produced, the colour only being exhibited, but not the proper figure.

The image, Aristotle says, is not single, as in a mirror, for each drop of rain is too small to reflect a visible image, but the conjunction of all the images is visible. He ascribed all these effects to the *reflection* of light, and it will be noticed when we come to the consideration of the refraction of light, that of course his views must be seriously modified. (See page 471.)

The reflection of light is affected rather by the condition of the surface than the whole body of a substance, as a piece of coal may be covered with gold or silver leaf and caused to shine, whilst the brightest mirror is dimmed by the thinnest film of moisture.

From whatever surface light is reflected, it always takes place in obedience to two fixed laws.

First. *The incident and reflected rays always lie in the same plane.*

Second. *The angle of incidence is equal to the angle of reflection.*

With a single jointed rule, both of these laws are easily illustrated. The rule may be held in the hand, and one end

marked with a piece of white paper may be called the incident ray, *i.e.*, the ray that falls upon the surface; the other is the reflected ray, the one cast off or thrown back. A perpendicular is raised by holding a stick upright at the joint. (Fig. 330.)

One of the most simple and pleasing delusions produced by the reflection of light, is that afforded by cutting through the outline of a vase, or statuette, or flower, drawn on card-

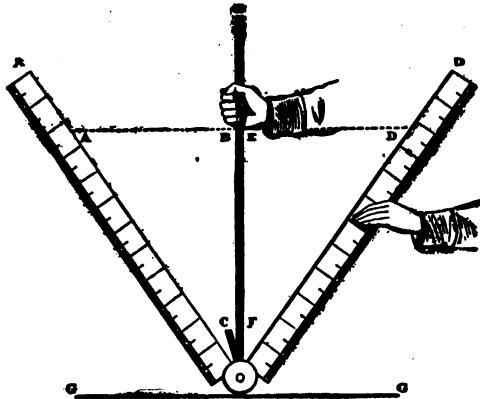

Fig. 330. A D. A long rule; the end A may be termed the incident ray, and the end D the reflected ray. S. The stick held perpendicularly. The angle A B C is equal to the angle D E F, and the whole may be moved in any direction or plane, either horizontal or perpendicular. G G. The reflecting surface.

board, and if certain points are left attached, so that the design may not fall out, all the effect of solidity is given by bending back the edges of the cardboard, so that the light from a candle placed behind it, may be reflected from the back edge of one cardboard on to the design, which is bent back. The light reflected from one surface on to the other, imparts a peculiarly soft and marble-like appearance, and when the design is well drawn and cut, and placed in a good position, the illusion is perfect, and it appears like a solid form instead of a mere design cut out of cardboard. (Fig. 331, Page 418.)

The leaf at the side of this picture is intended to give an idea of the mode of cutting out the designs, and in this case the leaf would be cut and bent back, and a small attachment slip of cardboard left to prevent it falling out.

The cardboard design is always bent toward the light, which is placed behind it. As a good illustration of the im-

portance of reflected light and its connexion with luminous bodies, a beam of light from a lantern may be allowed to pass above the surface of a table, when it will be noticed that the

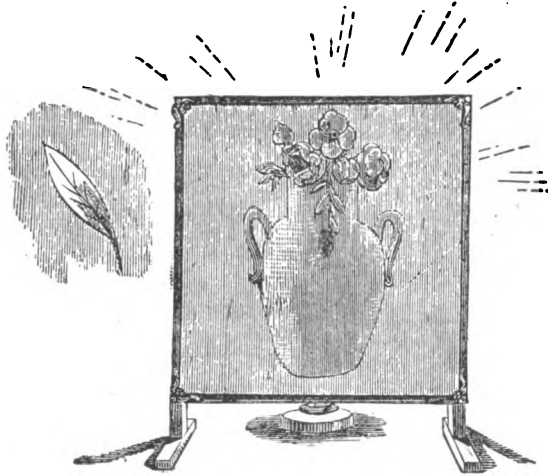

Fig. 331. Cardboard design in frame, cut and bent back. The lighted candle is behind.

latter is lighted up only when the beam is reflected downward by a sheet of white paper.

By reference to the two laws of reflection already explained, it is easy to trace out on paper, with the help of compasses and rule, the effect of plane, concave, and convex surfaces on parallel, diverging, or converging rays of light, and it may perhaps assist the memory if it is remembered that a plane surface means one that is flat on both sides, such as in the usual looking-glass: a convex surface is represented by the outside of a watch-glass; a concave surface, by the inside; parallel rays are like the straight lines of a railroad; diverging and converging rays are like the sticks of a fan spread out, as the sticks separate or diverge; the sticks of the fan come together, or converge at the handle.

The reflection of rays from a plane surface may be better understood by reference to the annexed diagram. (Fig. 332.)

By the proper arrangement of plane mirrors, a number of curious delusions may be produced, one of which is sometimes to be met with in the streets, and is called "the art of looking through a four-inch board." The spectator is first

requested to look into a tube, through which he sees whatever may be passing the instrument at the time; the operator then

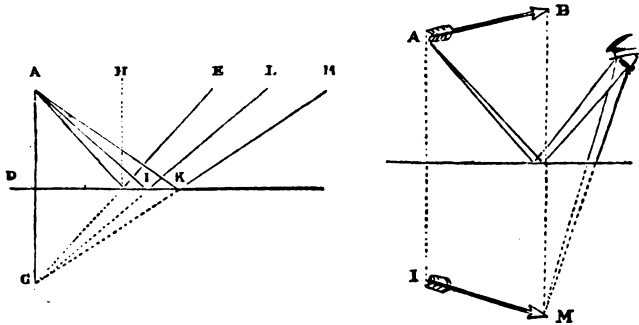

Fig. 332. A I. A. K. Two diverging rays incident on the plane surface, D. A D is perpendicular, and is reflected back in the same direction. A I is divergent, and is thrown off at I L. The incident and reflected rays forming equal angles, as proved by the perpendicular, H. Any image reflected in a plane mirror appears as far behind it as the object is before it, and the dotted lines meeting at G show the apparent position of the reflected image behind the glass, as seen at G. The same fact is also shown in the second diagram, where the reflected picture, I M, appears at the same distance behind the surface of the mirror as the object, A B, is before it.

places a board across the middle of the tube, which is cut away for that purpose, and to the astonishment of the juveniles the view is not impaired; the spectator still fancies he is looking through a straight tube; this however is not the case, as the deception is entirely carried out by reflection, and is explained in the next cut. (Fig. 333.)

Many inventions have been brought forward from time to

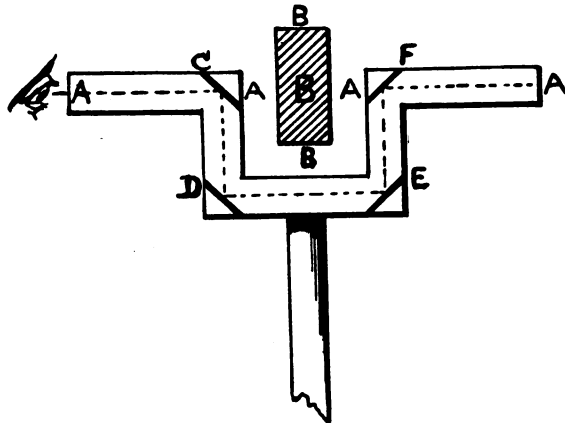

Fig. 333. A A A A. The apertures through which the spectator first looks. B. The piece of wood, four inches thick. C, D, E, F, are four pieces of looking-glass, so placed that rays of light entering at one end of the tube are reflected round to the other where the eye of the observer is placed.

time to protect gunners from the enemy when firing at close range, one of which contrivances is illustrated at Fig. 334. As shown, it is a simple arrangement of two mirrors, and easily comprehended from the sketch.

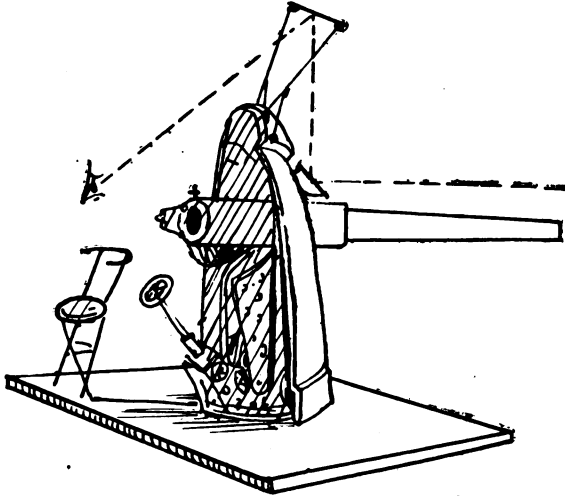

Fig. 334. A picture of enemy's battery is supposed to be on the mirror, A, whence it is reflected to B, and from that to the artilleryman at C.

By placing two mirrors at an angle of  $45^\circ$ , the reflected image of a person gazing into one is thrown into the other, and of course the effect is somewhat startling when some grotesque figure is introduced opposite one mirror, whilst some person who is unacquainted with the delusion is looking into

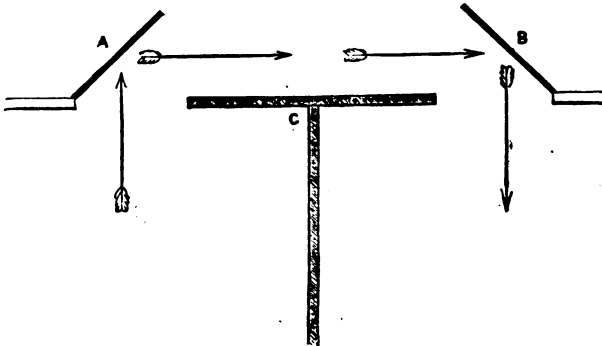

Fig. 335. A. A mirror at an angle of  $45^\circ$ . The arrows show the direction of the reflected image. B. The second mirror, also at an angle of  $45^\circ$ ; the face of the person looking in at A is reflected at B. C is the partition between the rooms.

the other. Two adjoining rooms might have their looking-glasses arranged in that manner, provided there is a passage running behind them. (Fig. 335.)

One of the most startling effects that can be displayed to persons unfamiliar with the common laws of the reflection of light, is called the "magic mirror," and is described by Sir Walter Scott in his graphic story of that name. The apparatus for the purpose must be well planned and fixed in a proper room and if carefully conducted, may surprise even those who understand it. A long and somewhat narrow room should be hung with black cloth, and at one end may be placed a large mirror, so arranged that it will turn on hinges like a door. A large wardrobe door will answer the purpose. The magician's circle may be placed at the other end of the chamber in which the spectators must be rigidly confined, and there is very little doubt that the arrangement about to be described was formerly used by clever astrologers who pretended to look into the future, and to hold communication with supernatural powers. The credulity of the persons who consulted these "wise men," is not surprising when we consider the inacquaintance of the public generally with many common physical laws, and of the wonders that may be worked without the assistance of the "evil one;" moreover, the initiated took great care to conceal the machinery of their mysteries, never imparting the illusive tricks even to their most faithful dependants except under solemn oaths of secrecy, because in many cases they derived considerable profit by their pretended conjurations and juggling tricks, therefore were interested in keeping the outer world in ignorance. The wizards were always careful to impress those who came to consult them with the awful nature of the incantations they were about to perform, and with such a powerful auxiliary as fear, and a well-darkened room, they diverted the thoughts of the more curious, and prevented them watching the proceedings too closely. Theatrical effects were not disdained, such as suppressed and dismal groans, sham thunder, the wizard usually heightening his own inspiring personal appearance by wearing a long beard and flowing robe trimmed with hieroglyphics, and with the assistance of a ponderous volume full of cabalistic signs, a few skulls and cross bones, an hour-glass, a pair of drawn swords, a black cat, a charcoal fire, and sundry drugs to throw into it, a very tolerable collection of



imps, familiars, and demons might be expected to attend without the modern practice of spirit-rapping. As before stated, the delusion must be carefully conducted, and a confederate is necessary in order to use the phantasmagoria, or magic lantern. The slides, of course, must be ready painted to suit the fortune to be unfolded—an easy road to riches for the gentlemen, a tale of love, ending in matrimony, for the ladies.

The spectators being placed in the magic circle, are directed to look into the mirror; they may even be ordered singly to fetch a skull off the mantel-shelf beside the mirror, and whilst doing so to look full into the mirror, and then return to the circle. Absolute silence is enjoined, and soft music is now

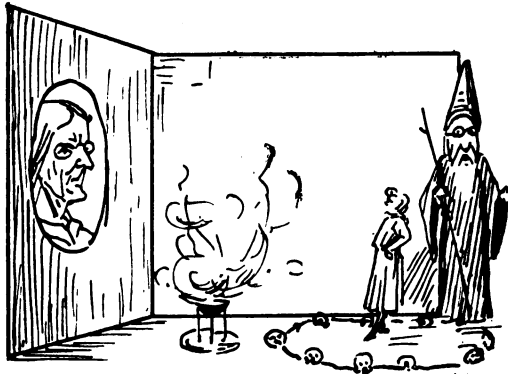

Fig. 336A. Man dressed as magician with mask, cap and wand. Girl sees herself as an old woman. (See Fig. 336B, Page 423.)

heard; the darkened room is lit up for the moment by a little yellow or green flame from chemicals thrown on to the charcoal fire, and now looking into the mirror, it no longer reflects surrounding objects, but there is apparent a picture, at first small and faint, then gradually becoming large and clearer. The picture is made visible by the confederate gently drawing the mirror from its position parallel with the frame to an angle of 45 degrees, and then throwing on from the side a picture from a magic-lantern. The picture is small and indistinct whilst the confederate holds it near the mirror and out of focus, but as he moves backwards and focuses the lenses, the picture gradually increases in size, and the reflecting angles having been well planned beforehand, only those in the circle will be able to see the picture, and great fun may

be elicited from the magic mirror by pretending to tell the future fate; indeed, there is no end to the innocent fun that may be extracted from the magic mirror, and the whole plan of the delusion may be better understood by reference to the next picture. (Fig. 336B.)

It has been remarked that "man is credulous from his cradle to his tomb; but the disposition springs from an honourable principle, the consequences of which precipitate him into many errors and misfortunes. . . . The novelty of objects, and the difficulty of referring them to known objects, will not shock the credulity of unsophisticated men. They are some additional sensations which he receives without discussion, and their singularity is perhaps a charm which causes him to receive them with greater pleasure. *Man almost always* loves and seeks the marvellous. Is this taste natural? Does it spring from the education which during many ages the human race has received from its first instructors? A vast and novel question! . . . It is sufficient to observe that as the lover of the wonderful

always prefers the most surprising to the most natural account, this last has been too frequently neglected, and is irrevocably lost. Occasionally, however, simple truth has escaped from the power of oblivion. Credulous man may be deceived once, or more frequently; but his credulity is not a sufficient instrument to govern his whole existence. The wonderful excites only a transient admiration. In 1798, the French savants remarked with surprise how little the spectacle of balloons affected the indolent Egyptian. . . . But man is led by his passions, and particularly by *hope* and *fear*."

When parallel rays fall upon a convex mirror, they are

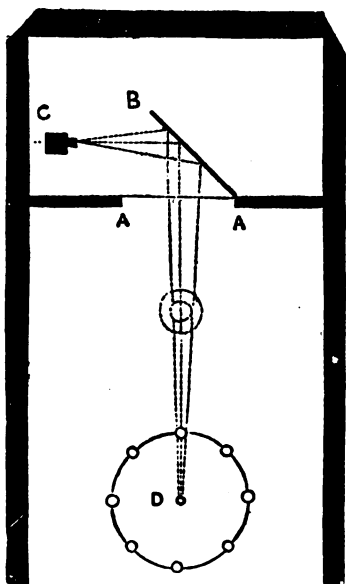

FIG. 336B. Plan of room. A A. The frame of the looking-glass. A B. Mirror put back to an angle of 45 degrees. C. The confederate who manages the lantern and shuts the glass to the frame after each fortune is told. D. The magic circle, to which the rays are reflected.

scattered and dispersed in all directions, and the image of an object reflected in a convex mirror appears to be very small, being reduced in size because the reflected picture  $I M$  is nearer the surface of the mirror than the object  $A B$ . No. 1. (Fig. 337.)

Convex mirrors are not employed in any optical deception on a large scale, although some ingenious delusions are producible from cylindrical and conical mirrors, and are thus described by Brewster:

“Among the ingenious and beautiful deceptions of the

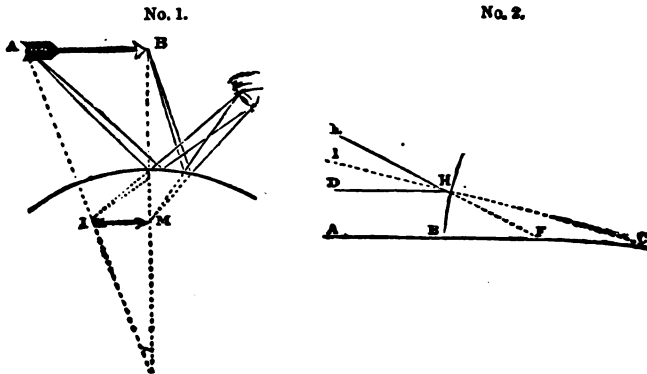

Fig. 337.  $A B, D H$ . (No. 2) represent two parallel rays incident on the convex surface  $B H$ , the one ( $A B$ ) perpendicularly, the other ( $D H$ ) obliquely.  $C$  is the centre of convexity.  $H E$  is the reflected ray of the oblique incident one,  $D H$ ; whilst  $C H I$  is the perpendicular.

seventeenth century, we must enumerate that of the re-formation of distorted pictures by reflection from cylindrical and conical mirrors. In these representations, the original image from which a perfect picture is produced, is often so completely distorted, that the eye cannot trace in it the resemblance to any regular figure, and the greatest degree of wonder is of course excited, whether the original image is concealed or exposed to view. These distorted pictures may be drawn by strict geometrical rules, and I have shown a simple method of executing them. (Fig. 338.) Let  $M$  be an accurate cylinder made of tin-plate or of thick pasteboard. Out of the further side of it cut a small aperture,  $a b c d$ , and out of the nearer side cut a larger one,  $A B C D$  (white letters), the size of the picture to be distorted; having perforated the outline of the picture with

small holes, place it in the opening A B C D (white letters), so that its surface may be cylindrical; let a candle or a bright luminous object—the smaller the better—be placed at S, as far behind the picture A B C D (white letters) as the eye is afterwards to be placed before it, and the light passing through the small holes will represent on a horizontal plane a distorted image of the picture at A B C D, which, when sketched in outline with a pencil, shaded, and coloured, will be ready for use. If we now substitute a polished cylindrical mirror of the same size in place of M, then the distorted picture, when laid horizontally at A B C D, will be restored to

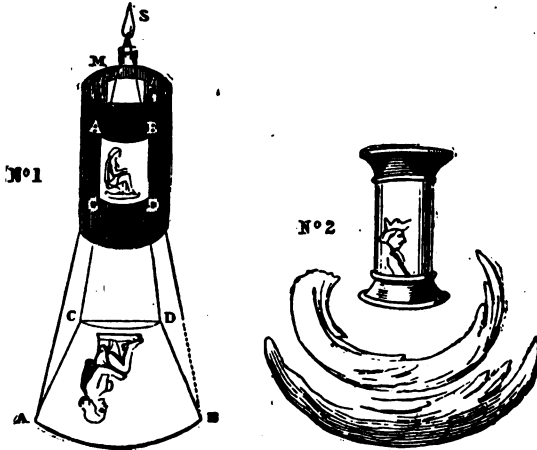

Fig. 338.

its original state when seen by reflection at A B C D (white letters) in the polished mirror.” The effect of a cylindrical mirror on a distorted picture is shown at No. 2, being copied from an old one seen by Brewster.

By looking at a reflection of the face in a dish-cover or the common surface of a bright silver spoon or of a silver mug, the face truly becomes ugly as the image is seen reflected from its surface, and assumes the most absurd form as the mouth is opened or shut, and the face advanced or removed from the silver vessel. (Fig. 339.)

In the writings of the ancients there are to be found certain indications of the results of illusions produced by simple optical arrangements, and the sudden and momentary apparition (from the gloom of perfect darkness) of splendid

palaces, delightful gardens, etc., with which—the concurrent voice of antiquity assures us—the eyes of the beholders were frequently dazzled, in mysteries such as the evocation and actual appearance of departed spirits, the occasional images of their *umbræ*, and of the gods themselves. From a passage in “Pausanias,” (Bœotic xxx.), when, speaking of Orpheus, he says there was anciently at Aornos, a place where the dead were evoked, *νεκρομαντεῖον*, we learn that in those remote ages there were places set apart for the evocation of the dead. Homer relates, in the eleventh book of the “Odyssey,” the admission of Ulysses alone into a place of this kind, when his



Fig. 339. Distorted image produced by an irregular convex surface.

interview with his departed friend was interrupted by some fearful voice, and the hero, apprehending the wrath of Proserpine, withdrew; the priests who managed these deceptive exhibitions no doubt adopted this method of getting rid of their visitors, who might become too inquisitive, and discover the secret of the mysteries.

Of all the reflecting surfaces mentioned, none produce more interesting deceptions than the concave mirror, and there is very little doubt that silver mirrors of this form were known to the ancients, and employed in some of their sacred mysteries. Salvarte industriously collected many interesting proofs of their use, and quotes the following passage of “Damascius,” in which the results obtainable from a concave mirror are clearly apparent. (Fig. 340.)

He says:—“In a manifestation which ought not to be revealed . . . there appeared on the wall of the temple a mass of light which at first seemed very remote; it transformed itself in coming nearer into a face evidently divine and supernatural, of a severe aspect, but mixed with gentleness, and extremely beautiful. According to the institution of a mysterious religion, the Alexandrians honoured it as Osiris and Adonis.”

Parallel rays thrown upon a concave surface are brought to a focus or converge, and when an object is seen by reflection from a concave surface, the representation of it is various, both with regard to its magnitude and situation, according as the distance of the object from the reflecting surface is greater or less. (Fig. 341. Page 428.) When the object is placed between the *focus* of parallel rays and the centre, the

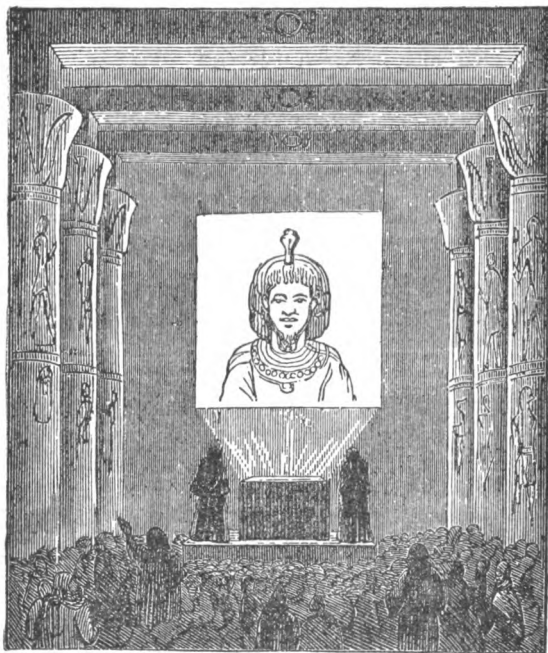
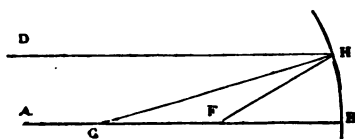

Fig. 340. The picture of a human face, possibly reflected from a concave mirror concealed below the floor of the temple; the opening being hidden by a raised mass of stone, and the worshippers confined to a certain part of the temple, and not allowed to approach it.

image falls on the *opposite* side of the centre, and is larger than the object, and in an inverted position. The rays which proceed from any remote terrestrial object are nearly parallel at the concave mirror—not strictly so, but come diverging to it in separate pencils, or, as it were, bundles of rays, from each point of the side of the object next the mirror; therefore they will not be converged to a point at the distance of half the radius of the mirror's concavity from its reflecting surface, but

in separate points at a little greater distance from the concave mirror. The nearer the object is to the mirror, the further these points will be from it, and an inverted image of the object will be formed in them, which will seem to hang pendant in the air, and will be seen by an eye placed beyond it (with regard to the mirror), in all respects like the object, and as distinct as the object itself. (No. 2. Fig. 341, also Fig. 342.)

It appears, from a circumstance in the life of Socrates, that the effects of burning-glasses were known to the ancients; and it is probable that the Romans employed the concave speculum for the purpose of lighting the "sacred fire." This is very likely to be true, considering that the priests who conducted the heathen worship of Osiris and Adonis were acquainted with the use of concave metallic specula (see description at page 385.) The effects that



No. 1.

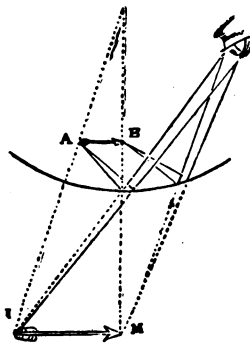

No. 2.

Fig 341.—No. 1. A, B, D, H, represent two parallel rays incident on the concave surface B B, whose centre of concavity is C. B F and H F are the reflected rays meeting each other in F, and A B being perpendicular to the concave surface, is reflected in a straight line. No. 2. A B, The object. I M, The image.

can be produced with the aid of concave mirrors are very impressive, because they are not merely confined to the reflection of inanimate objects, but life and motion can be well displayed by them; thus, if a man place himself directly before a concave mirror, but further from it than its centre of concavity, he will see an inverted image of himself in the air between him and the mirror of a less size than himself; and if he hold out his hand towards the mirror the hand of the image will come out towards his hand and coincide with it, being of an equal bulk when his hand is in the centre of concavity, and he will imagine he may shake hands with his image.

Whilst experimenting with a concave mirror, by holding out the hand in the manner described, a bystander will see

nothing of the image, because none of the reflected rays that form it enter his eyes. This circumstance is well illustrated by placing a concave mirror opposite the fire, and allowing the image of the flames projected from it to fall upon a well-polished mahogany table. If the door of the room opens towards the mirror, and a spectator unacquainted with the properties of concave mirrors should enter the apartment, the person would be greatly startled to see flames apparently playing over the surface of the table, whilst another spectator might enter from another door and see nothing but a long beam of light, rendered visible by the floating particles of dust. To give proper effect to this experiment the concave mirror should be large, and no other light must illuminate the room except that from the fire.

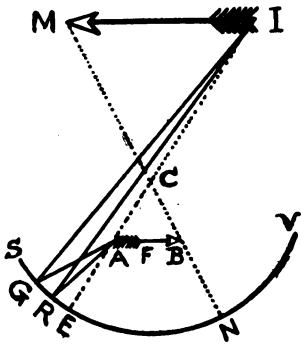

Fig. 342. A B represents the object, S V the reflecting surface, F its focus of parallel rays, and C its centre. Through A and B, the extremities of the object, draw the lines C E and C N, which are perpendicular to the surface, and let A R, A G, be a pencil of rays flowing from A. These rays proceeding from a point beyond the focus of parallel rays, will, after reflection, converge towards some point on the opposite side of the centre, which will fall upon the perpendicular, E C, produced, but at a greater distance from C than the radiant A from which they diverged. For the same reason, rays flowing from B will converge to a point in the perpendicular N C produced, which shall be further from C than the radiant B, from whence it is evident that the image I M is larger than the object A B, that it falls on the contrary side of the centre, and that their positions are inverted with respect to each other.

On the same polished table the appearance of a planet with a revolving satellite may be well shown by darkening the fire with a screen, and placing a lighted candle before it, which will be reflected by the concave mirror, and appear on the table as a brilliant star of light, and the satellite may be represented by the flames of a small wax taper moved around the large burning candle. The following is an arrangement for the purpose of exhibiting the properties of the concave mirror. A lantern enclosing a very brilliant light, such as the electric or lime light, is required for the illumination of the objects which are to be projected on to the screen. Any bright light enclosed in a box, with a plain convex lens to project the beam of light when required, will answer the purpose. (Fig. 343. Page 430.)



By removing the diaphragm required to project the picture of the charcoal points on to the screen, a very intense beam of light is obtained, which may be focussed or concentrated on any opaque object by another double convex lens, conveniently mounted with a telescope stand, so that it may be raised or lowered at pleasure. This lens is independent of the lantern, and may be used or not as desired.

The object is now placed on a shelf fixed to the screen, with a square aperture just above it. The object of the screen is to cut off all extraneous rays of light reflected from the mir-

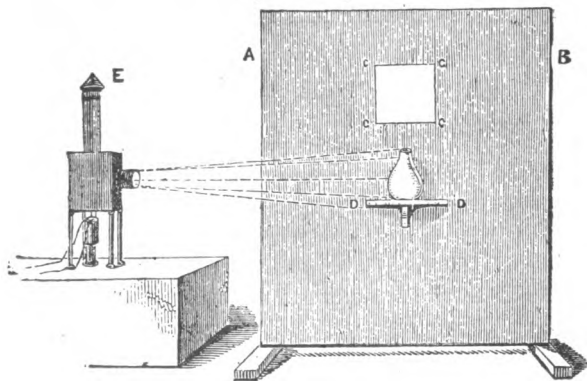

Fig. 343. A B. Portable screen of light framework, covered with black calico. C C C C. Square aperture just above the shelf. D D, upon which the object—viz., a bottle half full of water—is placed. E. Lantern to illuminate the object at D D.

ror, or to increase the sharpness of the outline of the picture of the object. The screen and object being arranged, and the light thrown on from the lantern, the next step is to adjust the concave mirror, and by moving it towards the object, or backwards, as the case requires, a good image, solid and quasi-stereoscopic, is projected on the screen. (Fig. 344.)

The act of filling the bottle with water, or better still with mercury, is one of the most singular effects that can be shown; and if all the apparatus is enclosed in a box, so that the picture on the screen only is apparent, the illusion of a bottle being filled in an inverted position is quite magical, and invariably provokes the inquiry, how can it be done?

The study of numismatics, the science of coins and medals, is generally considered to be limited to the taste of very few persons, and any description of a collection of coins at a lec-

ture would be voted a great bore, unless the members of the audience happened to be antiquaries; great light, however, may be thrown on history by a study of these interesting remains of bygone times, and a lecture on this subject, illustrated with pictures of coins thrown on to the disc by a concave mirror in the manner described, may be made very pleasing and instructive. These effects can be more easily produced by the use of the opaque lantern, described on page 463.

Coins, or plaster casts of coins *gilt*, flowers, birds, white mice, the human face and hands, may all, when fully illuminated, be reflected by the concave mirror on to the disc.

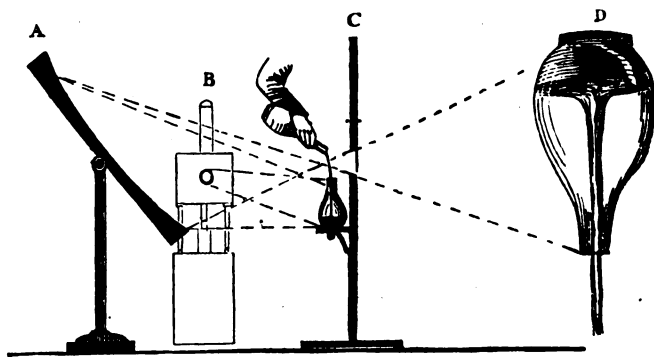

Fig. 344. A. The concave mirror. B. The lantern. C. The portable screen, shelf, and object. D. The inverted image of the bottle filling with water, with the neck downwards, and when thrown on the disc at D producing a most curious illusion.

The pictures from the concave mirror may be also projected on thick smoke procured from smouldering damped brown paper, or from a mixture of pitch and a little chlorate of potash laid on paper, and allowed to burn slowly by wetting it with water. As will be understood this is not a drawing-room experiment.

An image reflected from smoke would be visible to a number of spectators, just as the light from the fire of a locomotive is frequently visible at night, being reflected on the escaping column of steam.

It was probably with the help of some kind of smoke and the concave speculum that the deception practised on the worshippers at the temple of Hercules at Tyre was carried out, as it is mentioned by Pliny that a consecrated stone existed there "from which the gods easily rose." At the temple

of Esculapius at Tarsus, and that of Enguinum in Sicily, the same kind of optical delusions were exhibited as a portion of the religious ceremonies, from which no doubt the priests obtained a very handsome revenue, much more than could be obtained in modern times by the mere exhibition of such wonders.

The smoke from brown paper is very useful in showing the various directions of the rays of light when reflected from plane, convex, and concave surfaces. The equal angles of the incident and reflected rays may be perfectly shown by using the next arrangement of apparatus. (Fig. 345.)

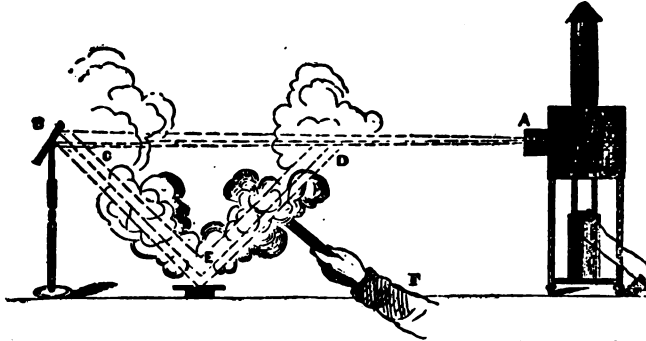

Fig. 345. A. Rays of light slightly divergent issuing from the lantern, and received on a little concave mirror, which brings the rays almost parallel, and reflects them to E, a piece of looking-glass, from which they are again reflected. C is the incident, and D the reflected rays. F. Arm holding roll of burning brown paper which provides the smoke.

A very dense white smoke is obtained by boiling in separate flasks, the necks of which are brought close together, solutions of ammonia and hydrochloric acid,—forming chloride of ammonia.

The opposite properties of convex and concave mirrors—the former scattering and the latter collecting the rays of light which fall upon them—are also effectively demonstrated by the help of the same illuminating source and proper mirrors, the smoke tracing out perfectly the direction of the rays of light. (Fig. 346.)

The smoke develops the cone of rays reflected from a concave mirror very clearly, and by producing plenty of smoke, and turning the mirror about—the position of the focus (*focus*, a fire-place), is indicated by a brilliant spot of light, and the reason the images of objects reflected by the concave mirror

are reversed, may be better understood by observing how the rays cross each other at that point. (Fig. 347.)

One of the most perfect applications of the reflection of

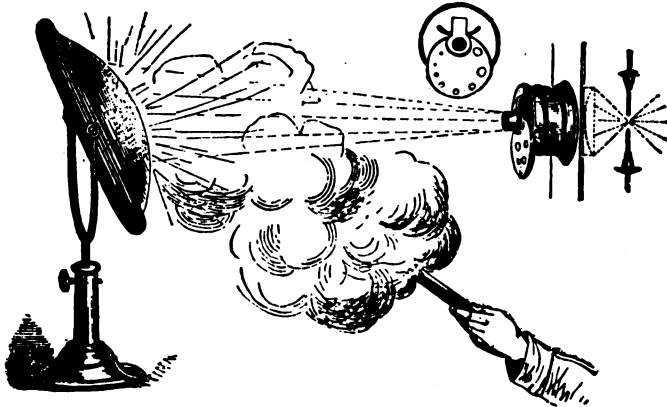

Fig. 346. The smoke shows the rays of light falling on a convex mirror, and rendered still more divergent.

light is seen in Fig. 348, which shows an observatory telescope with equatorial mounting. Such an instrument is amongst the greatest achievements in the sciences of mechan-

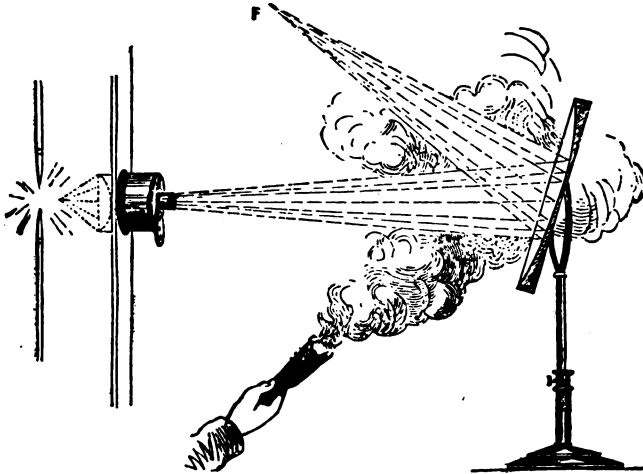
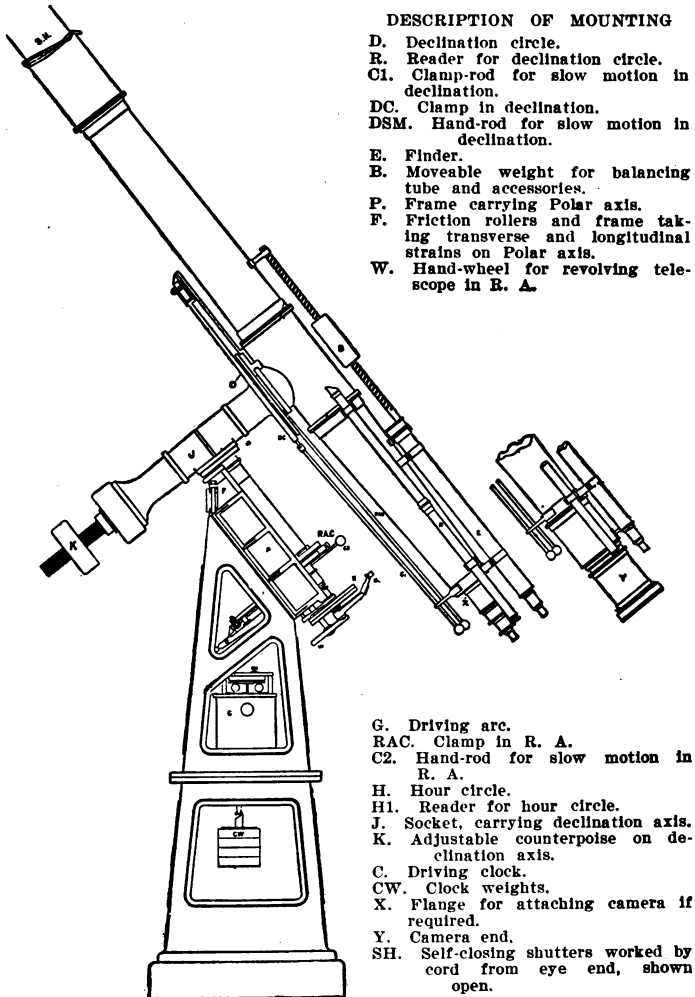

Fig. 347. The smoke shows rays of light falling on the concave mirror. In this experiment attention should be directed to the bright point, F, the focus where the convergent rays meet.

ics and optics; notwithstanding its complications, it gives wonderful power of vision and variety of movement, all under easy control.

The description of the fittings or mountings of a telescope in Fig. 348 is self-explanatory, so that it but remains to detail the action of a telescope itself. As the details of nearly



#### DESCRIPTION OF MOUNTING

- D. Declination circle.
  - R. Reader for declination circle.
  - Cl. Clamp-rod for slow motion in declination.
  - DC. Clamp in declination.
  - DSM. Hand-rod for slow motion in declination.
  - E. Finder.
  - B. Moveable weight for balancing tube and accessories.
  - F. Frame carrying Polar axis.
  - F. Friction rollers and frame taking transverse and longitudinal strains on Polar axis.
  - W. Hand-wheel for revolving telescope in R. A.
- 
- G. Driving arc.
  - RAC. Clamp in R. A.
  - C2. Hand-rod for slow motion in R. A.
  - H. Hour circle.
  - H1. Reader for hour circle.
  - J. Socket, carrying declination axis.
  - K. Adjustable counterpoise on declination axis.
  - C. Driving clock.
  - CW. Clock weights.
  - X. Flange for attaching camera if required.
  - Y. Camera end.
  - SH. Self-closing shutters worked by cord from eye end, shown open.

Fig. 348. Astronomical telescope with equatorial mounting.

all elaborate optical instruments are somewhat tedious, one diagram may be given with the explanation of the Gregorian reflecting instrument. (Fig. 349.)

At the bottom of the great tube T T T T, (Fig. 349), is placed the large concave mirror D F, whose principal focus is at *m*; and in its middle is a round hole P, opposite to which is placed the small mirror L, concave towards the greater one, and so fixed to a strong wire M, that it may be moved farther from the great mirror or nearer to it, by means of a long screw on the outside of the tube, keeping its axis still in the same line P m n with that of the great one. Now since in viewing a very remote object we can scarcely see a point of it but what is at least as broad as the great mirror, we may consider the rays of each pencil, which flow from every point of

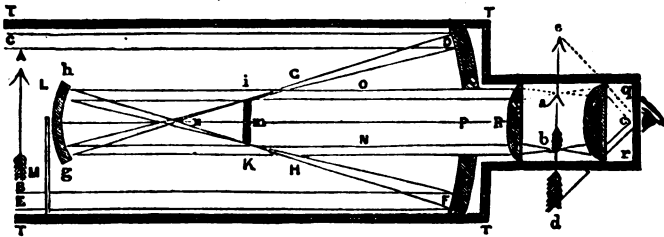

Fig. 349. The Gregorian reflecting telescope.

the object, to be parallel to each other, and to cover the whole reflecting surface D-F. But to avoid confusion in the figure, we shall only draw two rays of a pencil flowing from each extremity of the object into the great tube, and trace their progress through all their reflections and refractions to the eye, at the end of the small tube, which is joined to the great one.

Let us then suppose the object A B to be at such a distance, that the rays E flow from its lower extremity B, and the rays C from its upper extremity A. Then the rays C falling parallel upon the great mirror at D, will be thence reflected by converging in the direction D G, and by crossing at *i* in the principal focus of the mirror, they will form the upper extremity *i* of the inverted image *i K*, similar to the lower extremity B of the object A B; and passing on the concave mirror L (whose focus is at *n*) they will fall upon it at *g* and be thence reflected, converging in the direction N, because *g m* is longer than *g n*; and passing through the hole P

in the large mirror, they would meet somewhere about  $r$ , and form the lower extremity  $d$  of the erect image  $a d$ , similar to the lower extremity  $B$  of the object  $A B$ . But by passing through the plano-convex glass  $R$  in their way they form that extremity of the image at  $b$ . In like manner the rays  $E$  which come from the top of the object  $A B$  and fall parallel upon the great mirror at  $F$ , are thence reflected converging to its focus, where they form the lower extremity  $K$  of the inverted image  $i K$ , similar to the upper extremity  $A$ , of the object  $A B$ ; and passing on to the smaller mirror  $L$  and falling upon it at  $h$ , they are thence reflected in the converging state  $h o$ ; and going on through the hole  $P$  of the great mirror, they would meet somewhere about  $q$ , and form there the upper extremity  $a$  of the erect image  $a d$ , similar to the upper extremity  $A$  of the object  $A B$ ; but by passing through the convex glass  $R$  in their way, they meet and cross sooner, as at  $a$ , where that point of the erect image is formed. The like being understood of all those rays which flow from the intermediate points of the object between  $a$  and  $b$ , and enter the tube  $T T$ , all the intermediate points of the image between  $a$  and  $b$  will be formed; and the rays passing on from the image through the eye-glass, and through a small hole in the end of the lesser tube, they enter the eye which sees the image  $a b$  (by means of the eye-glass), under the large angle  $c e d$ , and magnified in length, under that angle, from  $c$  to  $d$ .

To find the magnifying power of this telescope, multiply the focal distance of the great mirror by the distance of the small mirror, from the image next the eye, and multiply the focal distance of the small mirror by the focal distance of the eye-glass; then divide the product of the latter, and the quotient will express the magnifying power. (Fig. 349.)

A modern astronomical instrument for transit observations is shown at Fig. 350.

We now come to that much disputed and often quoted experiment of Archimedes, who is stated to have employed metallic concave specula or some other reflecting surface by which he was enabled to set fire to the Roman fleet anchored in the harbour of Syracuse, and at that time besieging their city, in which he was shut up with the other inhabitants. The story handed down to posterity was not disputed till about the seventeenth century, when Descartes boldly attacked the truth

of it on philosophical grounds. Nearly a hundred years after this time the neglected Archimedes fiction was again examined by the celebrated naturalist Buffon, and the account of his experiments is so logical and conclusive, that we give a portion of it verbatim.

“For some years prior to 1747, the French naturalist Buffon had been engaged in the prosecution of those researches

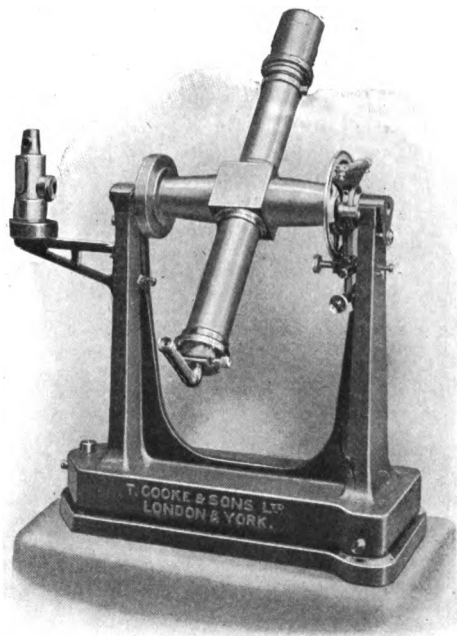

Fig. 350. Transit Instrument.

upon heat which he afterwards published in the first volume of the Supplement to his ‘Natural History.’ Without any previous knowledge, as it would seem, of the mathematical treatise of Anthemius (*περι παραδοξων μηχανηματων*) in which a similar invention of the sixth century is described,\* Buffon was led, in spite of the reasonings of Descartes, to conclude that a speculum or series of specula might be constructed sufficient to obtain results little, if at all, inferior to those attributed to the invention of Archimedes.

\* See Gibbon’s “Decline and Fall,” chap. xl., section v., note g.



“This, after encountering many difficulties, which he had foreseen with great acuteness, and obviated with equal ingenuity, he at length succeeded in effecting. In the spring of 1747, he laid before the French Academy a memoir which, in his collected works, extends over upwards of eighty pages. In this paper, he describes himself as in possession of an apparatus by means of which he could set fire to planks at the distance of 200, and even 210 feet, and melt metals and metallic minerals at distances varying from twenty-five to forty feet. This apparatus he describes as composed of 168 plain glasses, silvered on the back, each six inches broad by eight inches long. These, he says, were ranged in a large wooden frame, at intervals not exceeding the third of an inch; so that, by means of an adjustment behind, each should be moveable in all directions independently of the rest—the spaces between the glasses being further of use in allowing the operator to see from behind the point on which it behoved the various disks to be converged.

“These results ascertained, Buffon’s next inquiry was how far they corresponded with those ascribed to the mirrors of Archimedes—the most particular account of which is given by the historians Zonaras and Tzetzes, both of the twelfth century.\* ‘Archimedes,’ says the first of these writers, ‘having received the rays of the sun on a mirror, by the thickness and polish of which they were reflected and united, kindled a flame in the air, and darted it with full violence on the ships which were anchored within a certain distance, and which were accordingly reduced to ashes.’ The same Zonaras relates that Proclus, a celebrated mathematician of the sixth century, at the siege of Constantinople set on fire the Thracian fleet by means of brass mirrors. Tzetzes is yet more particular. He tells us, that when the Roman galleys were within a bow-shot of the city-walls, Archimedes caused a kind of hexagonal speculum, with other smaller ones of twenty-four facets each, to be placed at a proper distance; that he moved these by means of hinges and plates of metal; that the hexagon was bisected by ‘the meridian of summer and winter;’ that it was placed opposite the sun; and that a great fire was thus kindled, which consumed the Roman fleet.

“From these accounts, we may conclude that the mirrors

\* Quoted by Fabricius in his “*Biblioth. Græc.*,” vol. ii., pp. 551, 552.

of Archimedes and Buffon were not very different either in their construction or effects. No question, therefore, could remain of the latter having revived one of the most beautiful inventions of former times, were there not one circumstance which still renders the antiquity of it doubtful: the writers contemporary with Archimedes, or nearest his time, make no mention of these mirrors. Livy, who is so fond of the marvellous, and Polybius, whose accuracy so great an invention could scarcely have escaped, are altogether silent on the subject. Plutarch, who has collected so many particulars relative to Archimedes, speaks no more of it than the former two; and Galen, who lived in the second century, is the first writer by whom we find it mentioned. It is, however, difficult to conceive how the notion of such mirrors having ever existed could have occurred, if they never had been actually employed. The idea is greatly above the reach of those minds which are usually occupied in inventing falsehoods; and if the mirrors of Archimedes are a fiction, it must be granted that they are the fiction of a philosopher."

Supposing that Archimedes really did project the concentrated rays of the sun on the Roman vessels, one cannot help pitying the ignorance of the Admiral Marcellus. Had this officer been acquainted with the laws of the reflection of light, he might have laughed to scorn the power of Archimedes, and by receiving the unfriendly rays on one of the bright brazen convex shields of his soldiers, Marcellus could have scattered the concentrated rays, and prevented the burning of his vessels.

In these days of learning it therefore appears strange to find any one advocating the possible use of specula or reflecting mirrors for the purposes of offence or defence, but it was long ago proposed to produce great effects by mounting each mirror in a distinct frame, carrying a telescope so that one person could direct the rays to the object intended to be set on fire, and calculated, presuming on the ignorance of the attacked, that with 590 glasses of about twenty inches in diameter, a fleet could be reduced to ashes at the distance of a quarter of a league and with glasses of double that size at the distance of half a mile. What effect a shell or shot would produce upon this ancient weapon is not stated; this may be safely left for readers to determine for themselves. The ex-

periment of Archimedes has long been a favourite one with boys.

#### THE KALEIDOSCOPE

If this chapter on light and optics had gone minutely into the mathematical and purely scientific portion of the subject, we should have had frequent occasion to mention the name of Brewster, who was peculiarly identified with this interesting branch of physics. Brewster and Wheatstone have been associated with the invention of the stereoscope, an instrument that will be noticed in another part of this book, but here we shall describe one of the most original optical instruments ever devised, and although it is now regarded as a mere toy, its merits are very great. The title of the instrument is borrowed from the Greek *καλός* beautiful, *εἶδος* a form or appearance, *σκοπέω*, to see. When first obtainable the public certainly endorsed the choice of name when they purchased 200,000 of these instruments in London and Paris during the space of three months. It is said that the sensation it excited in London, throughout all ranks of the community, was astonishing, and people were everywhere seen, even at the corners of the streets, looking through the kaleidoscope. The essential parts of this instrument are two mirrors of unsilvered black parallel glass,—that is, parallel in its thickness,—or plate glass painted black on one side, from six to ten inches in length, and from one inch to an inch and a half in breadth at the object end, made narrower at the other end, to which the eye is applied. The mirrors are united at their lower edges by a strip of black calico fixed with common glue, and are left open at the upper edges, and retained at the correct angle by a bit of cork properly blackened. The angles are  $36^\circ$ ,  $30^\circ$ ,  $25^\circ\frac{5}{7}$ ,  $22^\circ\frac{1}{2}$ ,  $20^\circ$ ,  $18^\circ$ , which divide the circumference into 10, 12, 14, 16, 18, 20 parts, thus  $36 \times 10 = 360$ , or  $18 \times 20 = 360$ , and the strictest attention must be paid to this part of the adjustment, or the figures produced will not be symmetrical. After the mirrors are adjusted to the proper angle, the space between the two upper edges should be covered across with black velvet and the mirrors placed in a tin, cardboard, or brass tube, so that the broad ends shall barely project beyond the tube, while the narrow ends are placed so that the angle formed by the junction of the mirrors shall be

a little below the middle of that end of the tube. A cover with a circular aperture in the centre is then to be fitted to the narrow end of the mirrors, which should in general be furnished with a convex lens whose focal length is an inch or two greater than the length of the mirrors. A case for holding the objects, and for communicating to them a revolving motion, is fitted to the object end of the tube. The objects best suited for producing pleasing effects are small fragments

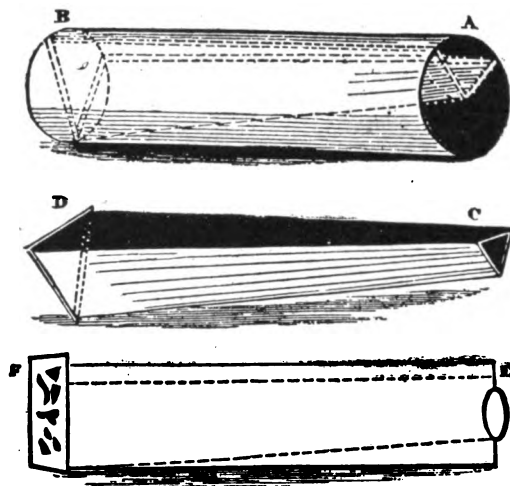

Fig. 351. A B. The tube containing the two mirrors, shown by dotted lines. A is the small end where the eye is placed. B. The object end. C D. Another view of the mirrors arranged to place in the tube; the shaded portion represents the black velvet. E. Double convex lens. F. Box to contain objects, and usually fitted with ground glass outside.

of coloured glass, wires of glass, both spun and twisted, and of different colours and shades of colours, and of various shapes, in curves, angles, circles; also, beads, bugles, fine needles, small pieces of lace, and fragments of fine sea-weed are very effective. Photographs should be taken of the most beautiful of these accidental designs, which only occur once and if not copied are lost. When so fixed, they are available for the production of every form of silk, cotton and mixed fabrics; these instruments are also largely used in designing carpet, lace, tile, oilcloth and linoleum patterns, etc.

#### FLASHING SIGNALS

The mirror with which boys have from time immemorial

annoyed any unfortunate person within convenient distance, has been put to good account in warfare, to cast a beam of sunlight in a particular direction. In the first experiments, a shaving glass was used, but this gave place to an instrument called the *heliograph*, its function being to transmit signals by means of flashes.

In warfare, it frequently happens that one section of an army becomes separated from another, without any means of communication. Such a thing has occurred many times in the South African and other wars when detachments were isolated in cities or in extemporised forts, surrounded on all sides by the enemy, with no means of egress without being cut to pieces in the attempt.

Long before the relieving column reached their goal, they were enabled to carry on constant communication with those in the fortress, and accomplished this by means of flashing signals sent by the heliograph.. Imagine a round mirror with a little of the quicksilver scratched away from its back in the centre, and you will have a very good idea of this instrument. It is swung in a frame, not unlike an ordinary toilet glass, and the whole arrangement is supported on a tripod stand to bring it up to the level of the operator's eye. A few feet in front of the mirror is planted a stick having a stop upon it which can be adjusted to any height. This stop answers to the *sight* upon a gun barrel, and is used to take aim with the mirror upon any desired spot. So that if the operator requires his flashes to be seen at a distant place, he will first of all arrange his apparatus so that the stop will just come between his line of sight through the mirror and the place to which he wishes to aim the flashes. When this is once arranged, the mirror can be so adjusted that it will always fall to the desired angle, except when a lever at the back is depressed to interrupt and separate the flashes. In the diagram Fig. 352, these arrangements are shown, and can be readily understood.

A system such as this, only worked by means of flags, has long been in use on shipboard, and each ship is furnished with a code by which the crew can transmit, and understand, signals transmitted to them by other ships. Different coloured flags, placed in different relative positions to one another, signify different numbers, and these numbers in the code will mean different sentences. Thus an Admiral's ship may run

up a few coloured flags to the masthead. The other ships of the squadron immediately refer to their code, and find the number to which that particular combination of flags is attached is, say 243. Then against these figures they see the order "weigh anchor" and they act accordingly. This is merely an imaginary case in order to demonstrate the application of the system.

The heliograph comprehends a system of the same kind,

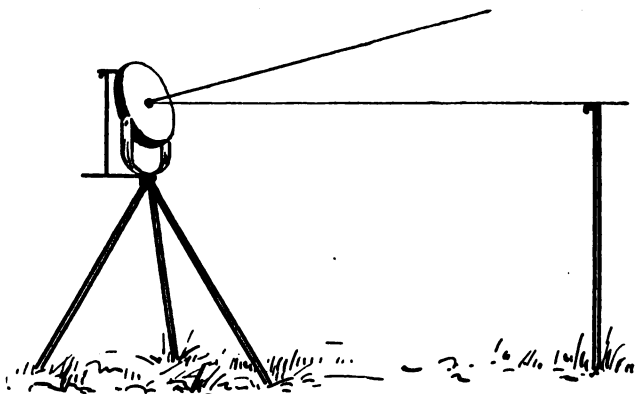

Fig. 352. Simple form of Heliograph.

only instead of flags, we have here to deal with flashes, and these flashes are converted into intelligible language. First we have an alphabet, which like the Morse telegraph alphabet already detailed on page 337 is a system of longs and shorts, or dots and dashes. Only in this case we have an alphabet of numbers, instead of letters. Thus:—

1	is expressed by a short flash	—
2	“ “ two short flashes	— —
3	“ “ three short flashes	— — —
4	“ “ four short flashes	— — — —
5	“ “ five short flashes	— — — — —
6	“ “ one long flash	————
7	“ “ a short and a long	— —————
8	“ “ the reverse of 7	———— —
9	“ “ two shorts and a long	— — —————
10	“ “ the reverse of 9	———— — —

An answering signal meaning that the receiver of the mes-

sage understands what is sent is expressed by alternate long and short flashes, thus:—

— — — — —  
 The code is made up of hundreds of different sentences, of a nature most likely to be required in warfare. And these sentences are numbered consecutively. We may suppose that on opening the code book we find the following at the top of one of the pages—

1671. Send on cavalry at once.

1672. Our ammunition is failing.

1673. The enemy is preparing to attack.

The first sentence here quoted would be expressed in flashes thus:—

$\overline{1}$        $\overline{6}$        $\overline{7}$        $\overline{1}$

On receiving such a signal, the officer in charge of the heliograph would refer to the code, and immediately report to his commanding officer the message conveyed.

Advance parties in time of war and when scouting flash back to their lines the exact position of the real or supposed enemy, and, by having duplicate paper marked in numbered squares, actual drawings of the country and positions to be taken may be made by heliograph, by the officer or operator flashing the numbered squares, the distant operator or his assistant drawing a line from square to square, as indicated by the flashes, putting down remarks as given, according to secret code.

It may be urged that without sunshine the heliograph is useless. This has been provided for in an arrangement to give flashes of light from a small electric battery or in the construction of a huge timber frame filled in with louvre boards like a venetian blind. The movement of these boards is governed by a lever, on depression of which they take up a horizontal or vertical position. When horizontal, their edges only are in view of the distant observer, so that he can hardly see them at all; but when, by the action of the lever, they are placed edge to edge, they form a dense square mass which is easily seen. By depressing the lever for long or short periods, the long and short flashes are mimicked, and so correspondence is carried on in the absence of sunshine.

Londoners well know what a fog means, and it is evident that no system such as this could be worked in one of those

thick November days such as we often have. This difficulty is also met. Powerful fog horns, such as are used on our coasts, and on ship-board in thick weather, are here called into play. The lungs, or some other bellows, pump into the fog-horn sufficient wind to yield a short or long sound, and once more the dot and dash system is rendered available. Without any great digression a story may be given here about Edison, which is a good instance of the ready tact with which he adapts to his wants anything that may be at hand.

The telegraph wire across one of the broad American rivers, for some reason or other, suddenly refused to work. It was essential that directions how to act should be immediately conveyed across, but no boat or other means of crossing was at hand. On a railway line near, however, stood a locomotive engine, so Edison jumped on the foot-plate, and in another moment the whistle was shrieking dots and dashes to those on the further side. Not long after an answering whistle was heard, and arrangements were quickly made to repair the disaster.

At night, the flash system is of course easily carried on by means of lamps. One of these constructed for the purpose is especially worthy of notice. It consists essentially of a spirit lamp enclosed in a lantern. Now a spirit lamp gives but a feeble blue flame, which cannot be seen from any distance; but it possesses plenty of heat, and this heat is utilised for the flash system, by igniting a pyrotechnic mixture which is blown into the flame when required. This mixture includes powdered magnesium, and gives a most brilliant light. It is contained in a small receptacle in the body of the lantern, and is urged into the flame by means of an india-rubber tube which passes outside the lamp to an india-rubber bulb. A long or a short squeeze will here once more illustrate the alphabet of dots and dashes.

The flashes from the heliograph can easily be seen and understood for at least twenty miles. At night if the electric light be employed as transmitter, this distance can readily be quadrupled, provided that the light is placed sufficiently high to clear the convexity of the earth between the sender and receiver.



## CHAPTER XXIV

## THE REFRACTION OF LIGHT

This term appears to be often confused with that of reflection, and signifies the bending or breaking back of a ray of light (*re*, back, and *frango*, to break); and it will be remembered that when light falls on the surface of a solid (either liquid or gaseous) body, it may be reflected (*re*, back, and *flecto*, to bend), refracted, polarised, or absorbed. In the previous chapter the property of the reflection of light has been fully investigated, and in this refraction only will be considered. It is a property which has been, and will continue to be, of the greatest practical utility in its application to the

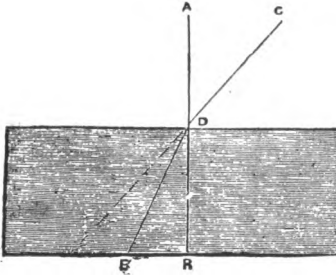

Fig. 353.

construction of all magnifying glasses, whether belonging to the telescope, microscope, magic lantern, or dissolving views; or the minor refracting instruments—such as spectacles, opera-glasses, etc.; and it should be remembered that their magnifying power depends solely on the property of refraction.

If substances such as glass had not been endowed with this property, it would be difficult to understand how the great discoveries in the science of astronomy could have been made, or what information we could have gained respecting those interesting truths so constantly revealed by the aid of the microscope. Numerous instances might be quoted of the value of this latter instrument in the detection of adulteration, and the examination of organic structures.

The simplest case of refraction occurs in tracing the course of a ray of light through the air, and into the medium water; in this case it passes from a rare to a dense medium, and the fact itself is well illustrated by the diagram (Fig. 353), in which the shaded portion represents water, and the paper upon which it is drawn represents the air. The line AR is a perpendicular ray of light, which passes straight from the air into and through the water, without being changed in its direction. The line CD is another ray inclined from the per-

pendicular, and entering the water at an angle, does not pass in the straight line indicated by the dotted line, but is refracted or bent towards the perpendicular at D E.

This fact reduced to the brevity of scientific laws is thus expressed:—When a ray of light falls perpendicularly on a refracting surface, *it does not experience any refraction or change of direction.* When light passes out of a rare into a dense medium, as from air into water, *the angle of incidence is greater than the angle of refraction.* And when light passes from a dense into a rare medium, as out of water into air, *the reverse takes place, and the angle of incidence is smaller than the angle of refraction.*

In order to illustrate these laws, a zinc-worker or tinman

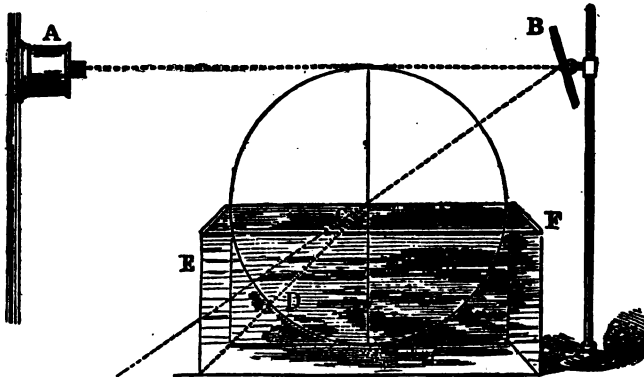

Fig. 354. A. Lantern. B. The mirror. B. C. The incident ray. C D. The refracted ray. E F. Tank, containing water up to the horizontal line of the circle.

may construct a little tank, with glass windows in the front and sides, the latter being as deep as the half-circle described on the back metal plate of the tank, which of course rises higher, in order to show the full circle; this should be japanned white, and a perpendicular and horizontal black line described upon it—the whole, with the exception of the circle, being japanned black. If a lantern is arranged with the little mirror, as described in fig. 345, page 432, the ray of light may be thrown perpendicularly, or at an angle, through the water, and the actual breaking back of the ray of light is rendered distinctly apparent. (Fig. 354.)

The refraction of light is also well displayed by a lantern apparatus, with the plano-convex lens, and an arrow cut in

cardboard as an object, with another double convex lens to focus it. When a good sharp outline of the arrow is obtained on the disc, a portion of the rays of light producing it may then be truly broken out or refracted by laying across the arrow a square bar of plate glass. (Fig. 355.)

There are many simple ways in which the refraction of light is displayed, such as the apparent breaking of an oar

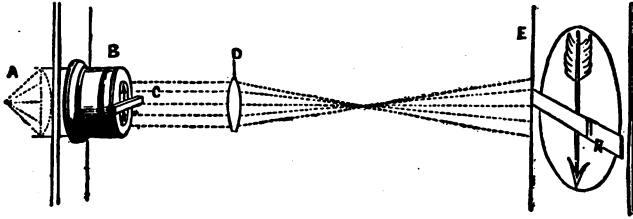

Fig. 355. A. Rays of light from the lantern. B. The cap, with figure of arrow cut out. C. The bar of plate glass. D. The double convex glass to focus E, the image on the disc, and portion refracted at R.

where it enters the water, or the remarkable manner in which the bottom is lifted up when we look, at any angle, through the clear water of a deep river or lake; the latter circumstance has unhappily led to most serious accidents, in consequence of children being induced by the apparent shallowness of the water to get in and bathe. Fish, again, unless seen perpendicularly from a boat, always appear nearer than their true position, and the Indians, when they spear fish, always take

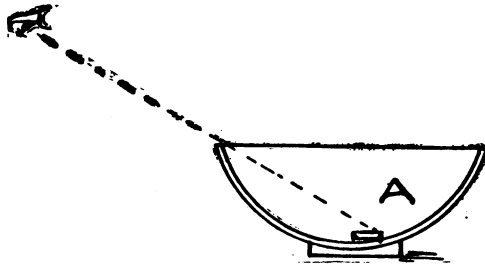

Fig. 356a. The eye catches sight of the extreme edge of the coin.

care to strike as near the vertical as possible; experienced shots know they must aim a little lower and nearer than the apparent position of a fish in order to hit it.

Another example may be illustrated by a simple experiment. (See Fig. 356.)

Place a penny in an empty bowl and so fix the bowl that the eye just catches sight of the extreme edge of the penny beyond the rim of the bowl, as at A, fig. 356. Then, without moving the eye or changing the position of coin or bowl, get someone to pour into the bowl a stream of water, so gently that the liquid rises slowly without splashing.

Immediately, the refractive power of the water, acting like a lens, appears to make the penny rise, for instead of the extreme edge only being visible, the whole coin comes into view, as at B. But for the certainty that the relative positions have not altered, and a knowledge of the reason why the penny seems to float, one would be tempted to think that the coin had actually risen in the water.

Having learnt that light is bent from its course, it might

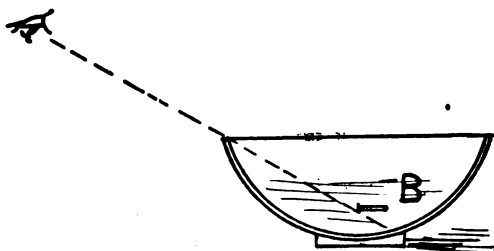

Fig. 356b. The coin appears to rise in the water.

be supposed that all objects looked at through plate glass should appear distorted; but it must be remembered that the sides of the glass being nearly parallel, an equal amount of refraction occurs in every direction—so that, unless the window is glazed with uneven wavy glass, the object, for all practical purposes, does not apparently change its position, being neither moved to the right, to the left, nor upward nor downward. In order to bend the rays of light in the required direction, the glass must be cut into certain figures called prisms, plane glasses, spheres, and lenses, some of which are shown in the annexed cut. (Fig. 357. Page 450.)

It would be tedious to trace out, by a regular series of diagrams, the passage of light through the variety of combinations of lenses; and as the plane, convex, and concave surfaces have been examined with respect to their effect on the reflection of light, they may be referred to again with regard

to their influence in refracting light, in which it will be found that convex and concave lenses have just the opposite properties of mirrors; thus, a convex lens receiving parallel rays will cause them to converge to a focus. (Fig. 358.) The case of *short-sighted* persons arises from too great a convexity

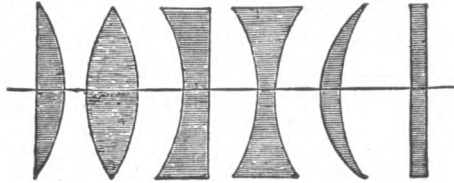

Fig. 357.

of the eye, which makes a very near focus; and that of old people is a flattening of the eye, by which the focus is thrown to a greater distance. The remedy for the latter is a convex spectacle glass, whilst a concave lens is required for the former, to scatter the rays and prevent their coming to a point too soon.

The action of a concave refracting surface is again the opposite to a concave reflecting surface—the former disperses

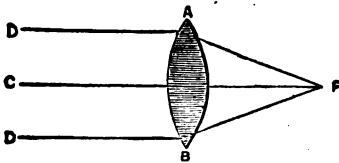

Fig. 358. A B. A double convex lens. C is a ray of light, which falls perpendicularly on A B, and therefore passes on straight to F, the focus. D D. Rays falling at an angle on A B, refracted to focus, F.

the rays of light, whilst the latter collects them. A concave lens, as might be expected, produces exactly the contrary effect on light to that of a concave mirror. (Fig. 359.)

These facts are well shown with the aid of the lantern and a strong light. (Fig. 360.) The rays of light are refracted in a visible manner when received on a concave or convex lens, provided a little smoke from paper is employed, as in the mirror experiments on pages 432 and 433.

#### THE BLIND SPOT

The blind spot in the eye is situated in that part where the optic nerve enters the retina, and is not sensitive to light. It is somewhat nearer the nose than the optic axis, and its position may easily be located. Make a black dot on a piece of cardboard, or a sheet of white paper, or better still, attach

a spot of sealing-wax, or a gummed seal. About seven or eight inches distant, make a mark like a cross,  $\times$ , or attach another seal, so as to be plainly distinct from the first, such as one marked in red and the other in black, or one being a dot, the other a cross. Hold this card with the dot at the right, some little distance from the eye. Close the left eye, and if the attention is fixed on the  $\times$ , which will be at the left of the paper, by drawing the paper nearer, or further away from the eye, it eventually reaches a position where the *right-hand* mark is invisible. Now turn the card round, close the right eye, look at the *right-hand* mark, and the *left* one will now disappear when the card is a certain distance from the eye.

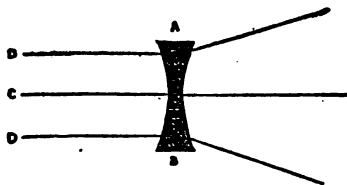

Fig. 359. A B. A double concave lens. C is a ray of light which falls perpendicularly on A B, and passes through without any alteration of its course. D D'. Rays falling at an angle on A B, are refracted and diverged.

The cause of this is that the light-rays set in vibration by the one mark, enter the lens of the eye and come to a focus on the retina at the side, so that in moving the paper backwards or forwards, this point where the rays are focussed must eventually fall on the blind spot, and invisibility results.

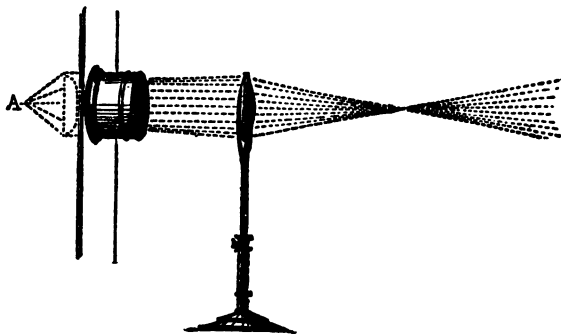

Fig. 360. A. A strong light. B. The lens.

When the proper distance has been found, it will be noticed that by drawing the card a little nearer or taking it further away, this spot is passed, and in each case, the disc comes into view again, for at this blind spot there are none of the little "rods and cones" which are necessary to sight; which rods

and cones, closely packed and extending over the retina, form a layer or membrane, often called the membrane of Jacob, and this layer of rods and cones receives all impressions of outside light.

Bearing these elementary truths in mind, it will not be difficult to follow out a complete set of illustrations explanatory of the construction and use of various popular optical contrivances.

## CHAPTER XXV

### REFRACTING OPTICAL INSTRUMENTS

#### I. *The Magic Lantern*

The most popular of all optical instruments is undoubtedly the magic lantern. Unlike the microscope, telescope, and other contrivances which can only be used by one person at a time, the lantern can be made the medium of amusement or instruction for large audiences. And since the introduction of photographic pictures to replace the coarsely painted slides formerly in use, it has become a valuable educational help.

The common toy lantern (Fig. 361) consists of a tin box crowned with a bent chimney, so that the hot air can be carried off without any escape of light. Within this box is a lamp and a reflector. The lenses are placed opposite the reflector, and consist of a condenser—to illuminate the glass picture or slide—and the objective, which magnifies the picture upon the sheet or screen placed for its reception. This form of lantern is but a toy, and the effects produced by it are only fit for the amusement of very little folk. Still its description, so far as the relative positions of the glasses and lamps are concerned, would apply generally to the arrangements of the most perfect instruments made, which owe their perfection not to any change in the bald principle or process—which is really exactly the same as in the commonest lanterns—but to the increased excellence in the *qualities* of light, lantern, condensers, and lenses or objectives.

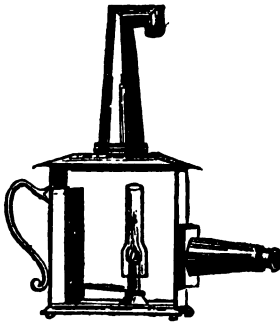

Fig. 361. The magic lantern.  
Simple form.

The magic lantern was much improved by the introduction of the Argand lamp, in which ordinary coal-gas was burnt. Later, paraffin oil, incandescent, oxy-hydrogen, and acetylene gas, and electric light have been applied to magic lantern lamps, and these have caused quite a revolution in both lamps and lanterns. The first lantern constructed to burn oil was named the "Sciopticon" (or caster of shadows), which for a long time held the first place amongst instruments of this class. As will be seen by the following cuts, (Figs. 362 and 363), its outward form differs materially from what we are accustomed to look for in a magic lantern. It could be used with the oil lamp, electric light, or with the oxy-hydrogen burner, each lantern being so arranged that these forms of light could be adopted. The oil lamp consisted of a double flame of from two, three, four, or more wicks placed edgeways, and the light given was so great that a disc eighteen-feet diameter could be illuminated with great brilliancy. This would be suffi-

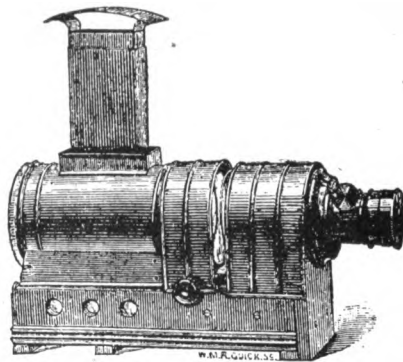

Fig. 362. The Old Sciopticon.

ciently large for any ordinary room. The general arrangement of the instrument can be readily understood from the sectional cut shown at Fig. 363.

In the more recent form of sciopticon, the lamp and flame chamber were removable, and took the form shown in Figs. 364 and 365. A great improvement was also effected in the focussing arrangement, abandoning the old-fashioned plan of fixing the slide in the same place, and focussing with the lens, for the scientific optical principle of first adjusting the front lens so that the whole of the cone of light coming from the condensers passes through it on to the screen, and then focussing with the slide. The advantage is twofold—first, the slide being in its correct optical position almost perfect sharpness is obtained all over the disc; secondly, the slide being brought forward into the cone, it is better lighted. By adjusting



the distance from the screen so that the slide when in focus is in that part of the cone which has the same diameter as the mount of the slide, it is evident that the whole of the light will pass through the picture.

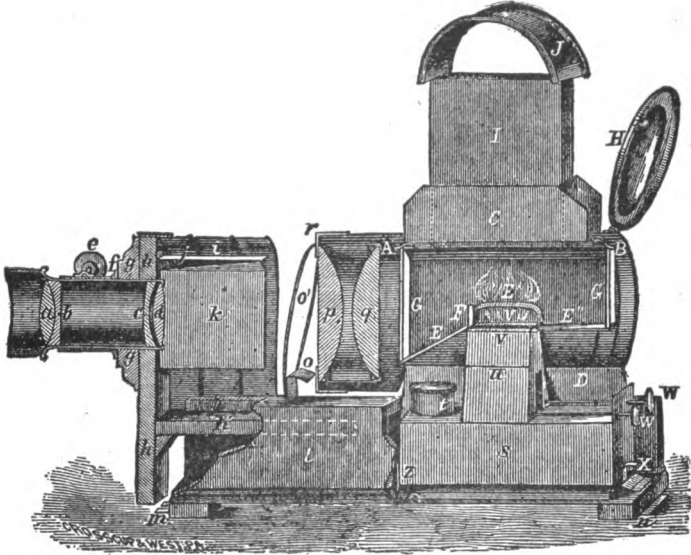

Fig. 363. P. Q. Condensing lens. S. Body of lamp containing the paraffin oil. T. Nozzle to screw off to replenish oil supply. W W. Buttons to adjust height of wicks. G G. Front and back of flame chamber. E' E'' E''' E'''. Bottom of flame chamber. H. Reflector—forming back of instrument. B. Chimney. J. Chimney cap, to prevent escape of light. O. Stage for slides, with arched wire spring to keep them firmly in position. For showing photographic slides a carrier is used, the glass pictures running in a groove and following one another as required.

The next form of lantern which became popular is the bi-unial (Fig. 366). This is one of the most convenient forms for exhibitions of dissolving views. That illustrated consists of a mahogany body lined with sheet iron, with openings at the back through which the ends of the lime jets are seen protruding. In the front are two stages made of brass, for the reception of the slides, and these stages may be so adjusted by screws that the two luminous discs upon the screen are made concentric. In front of these stages are the object glasses, the 4-inch condensers fitting into cells placed behind them.



Fig. 364. Sclopticon lamp uncovered.

The effect of one view dissolving into another was at first a mystery, for the inventor kept the manner of its production a secret. But this secret, like many others, long ago became public property. The original plan was to cause a toothed screen gradually to cover the opening of one lens, while a similar screen uncovered the orifice of the other. This plan has given place to another which has the advantage of saving fifty per cent. of the gas used, for the dissolving is now effected by turning down one jet, while the other is gradually turned up. The manipulation of four taps to attain this end would be rather a formidable task for one operator, so the plan of a dissolving tap governing the whole gas system is now universally adopted. This tap for a bi-unial lantern is shown at Fig. 367, Page 456.

When the handle of the dissolver is placed upright as shown, both lanterns are furnished with light, but shifted to the right or left, only one lens is illuminated. The small upright pipes which cross the others on each side of the centre of the instrument, are by-passes for the gas, so that neither light is ever actually turned out.

Many exhibitors use a triple lantern. The capabilities of this instrument are indeed enormous. The two lower lenses are used for ordinary dissolving views, whilst that above is reserved for what are known as "effects." Thus, suppose a summer landscape in the lowest

lantern is dissolved into a winter picture placed in the next above; the topmost stage can then be employed in the production of falling snow. This last effect is managed by rolling up a ribbon of opaque material pierced with needle pricks, the upward motion being inverted by the lens into a down-

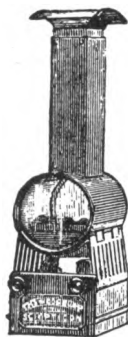

Fig. 365. Sciopticon lamp complete.

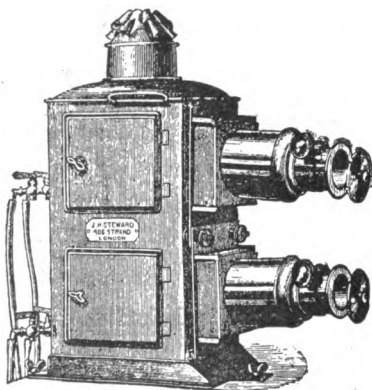

Fig. 366. Bi-unial lantern.

ward movement upon the screen. Effects of lightning, moving smoke, explosions and the like, can all be easily portrayed by this efficient apparatus. (See Fig. 368.)

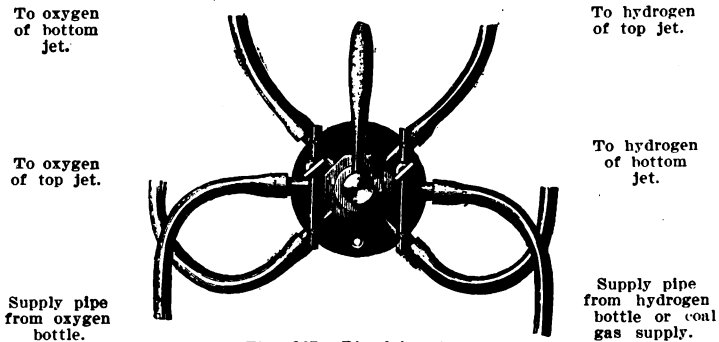

Fig. 367. Dissolving tap.

The best form of oxyhydrogen, or limelight for the magic lantern is undoubtedly that known as the "mixed jet" in which the two gases are combined just before they are projected upon the cylinder of lime.

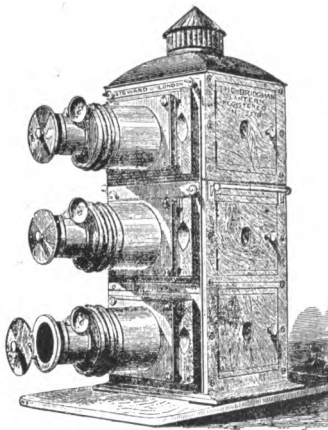

Fig. 368.

The two gases must in this instance be under equal pressure, but in inexperienced hands, the mixed jet has an element of danger in its use which it is as well to avoid. If the pressure from one cylinder becomes by any accident reduced, the other gas is forced into it, and a most dangerous explosion may ensue. The difficulty is altogether obviated by using the blow-through jet, shown at Fig. 369, many forms and modifications of which are obtainable. If ordinary care

be used, this form of jet is absolutely safe, for the two gases do not make acquaintance until they meet at the lime cylinder. This cylinder is placed upon the upright wire which passes through a hole in its centre. A milled screw at the back communicates by a spiral spring, with a little metallic

disc upon which the lime rests. A half turn of this screw will expose a fresh part of the cylinder to the flame when necessary. Ordinary house gas (carburetted hydrogen) is used with this burner, and it is supplied direct to the lantern by means of an india-rubber tube from the nearest gas bracket or chandelier. The oxygen alone is under pressure, and this may be supplied from a bag between weighted pressure-boards,

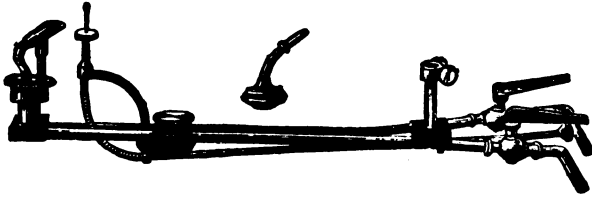

Fig. 369.

from a charged iron bottle, or it can be generated as it is wanted in the way to be presently described. Sometimes the hydrogen also is supplied from steel bottles, but as coal gas answers well, its cheapness and convenience make it in greater demand than pure hydrogen for optical lantern work.

Perhaps the most convenient way to obtain oxygen ready made (it is hardly worth while to make it at home, but if this be preferred the operation is described in a former page) is to buy it compressed in a steel bottle (see Fig. 370).

For a long time nitrous oxide, for the use of dentists, has been supplied in this manner. An india-rubber tube is connected with the nozzle of the bottle, which

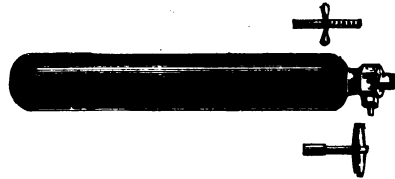

Fig. 370. Cylinder of compressed gas with union and key.

is usually fitted with tap and pressure-gauge, the other end of the tube being forced over the oxygen supply pipe of the lantern. A key is then inserted in an orifice in the side of the nozzle, a half turn of which will cause the gas to flow out steadily. Care must be taken to leave the jet tap open, and to regulate the supply from the bottle itself, or the connecting tube may burst from the gas confined within it. As the pressure is gradually reduced by consumption of gas, it will be necessary to turn the key a little more, once or twice during an exhibition. This mode of using oxygen gas is most con-

venient as well as economical, for it is supplied at a very cheap rate.

The method of generating the gas as required is cheaply and conveniently done on the spot as follows:—The retort used (Fig. 371) is of ingenious construction. In the orifice on the right hand side is placed a Bunsen burner; which heats a plate of iron above. Upon this plate is placed a moulded cake of oxygen mixture (four parts of chlorate of potash to one of manganese). As the gas is generated, it is passed off by the pipe above to a gas-holder. Should this outlet pipe by any means become stopped up, the lid of the retort, hung upon spiral springs seen at the side, rises by the pressure of the gas, and thus all risk of explosion is obviated.

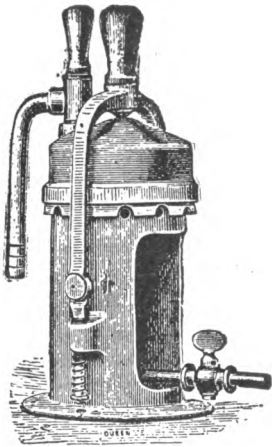

Fig. 371.

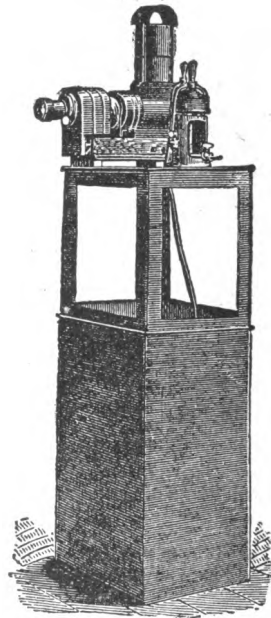

Fig. 372.

The next illustration (Fig. 372) represents a lantern fitted to the top of a gas-holder, supplied with oxygen in the way just described, which process has the advantage of being invisible to the audience.

A form of lamp for using incandescent lime without oxy-

gen, except that supplied by atmospheric air, was many years ago introduced (see Fig. 373). In this lamp common house gas is used and fulfils a double office. At the top is a large Bunsen burner heating a coil of pipe, which finds its outlet in the larger pipe projecting above a disc of lime. The other end of the coiled pipe is attached to a foot bellows. The air from this source therefore gets intensely heated before projecting a blow-pipe flame upon the lime. The light given, while not so bright as the oxyhydrogen flame, is beautifully white. The magnesium lamp has also been suggested for lantern work, but, although it gives a magnificent light, there are one or two great objections to its use. It is not only expensive, but the fumes given off require an outlet pipe to the open air, or they become disseminated over the room to fall in fine powder. It is occasionally used by photographers where a bright flash-light is now and then required.

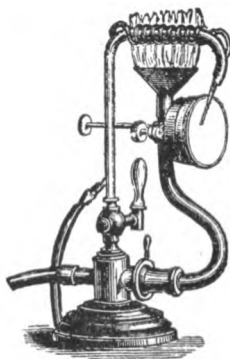

Fig. 373.

## II. *The Oxy-Hydrogen Microscope*

The oxyhydrogen microscope is one of the most instructive, as well as entertaining instruments which has been added to the capabilities of the optical lantern. It introduces us to a world of wonders and fairy forms that altogether surpass the greatest efforts of the imagination. Indeed the old saying that "truth is stranger than fiction" receives here a startling confirmation. The instrument is to be obtained in a most convenient form (see Fig. 374, Page 460.) It can readily be screwed on to the lantern in place of the usual lens, and it has an opening above through which microscopic slides, or a live tank, can be admitted for projection upon the screen.

The pleasure in using this instrument is much enhanced by the consideration that the objects it shows can be collected and prepared by the operator himself, an occupation which will afford him many a pleasant ramble over hill and dale. There is no difficulty in finding subjects for examination, the difficulty lying rather in deciding which to select from such a museum of curiosities as everything in Nature affords. The

animal, vegetable, and mineral kingdoms are all open to such investigations, and the more we come to examine them in detail by means of the microscope, the more shall we wonder at the inexhaustive beauty of their minute component parts.

Should the inquirer into Nature's secrets wish to begin upon living things, he has merely to visit the nearest pond, and fish for specimens. A bottle with a piece of string attached to its neck is all the fishing tackle he requires. This bottle held upside down is carefully lowered towards the unsuspecting insect whose capture is desired. It is then turned a little on one side, the water flows in, and with it the prisoner. In this way rotifers and many other interesting creatures may readily be secured, the specimens as they are captured being put into a reserve bottle.

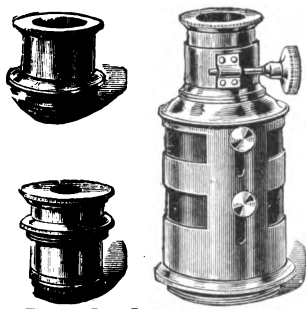

Fig. 374. Lantern projection microscope.

The mud from the bottom of any pool will also furnish abundant material for the microscope. A small portion of this mud should be placed in a test tube and covered with nitric acid, using extreme care—for the acid is fearfully corrosive and gives off deleterious fumes—and be boiled over a spirit lamp for some

minutes and allowed to settle. The liquid is carefully poured off, and a second dose of nitric acid applied and treated as before. The residue is then carefully washed, and some of it examined under a microscope, when it will be found to contain innumerable flinty skeletons of former inhabitants of the pond. The best of these can be mounted in Canada balsam and used as ordinary slides. Wings of flies, butterflies, and moths, wing-cases of beetles, scales of fishes, and hosts of other things will also furnish beautiful subjects for examination.

In the vegetable kingdom, the leaves and petals of flowers, ferns, and mosses, furnish inexhaustible subjects for study. Sections of different kinds of wood, cut with or across the grain, are also most interesting objects.

The limits of this work will only allow a brief reference to the capabilities of the microscope, but those who would wish to learn more about the matter, and to gain a knowledge re-

garding the preparation of objects, cannot do better than consult some little manual on the subject.

Another little instrument, one of the most ingenious and diverting adjuncts to the lantern which has ever been devised, is dependent for its effect upon the duration of impressions of light upon the retina. It consists of a slide upon which is depicted a figure in six or eight different positions. This slide is held in a metal frame, and by the motion of a handle the various figures painted upon it are brought opposite an opening which corresponds with the lens orifice of the lantern.

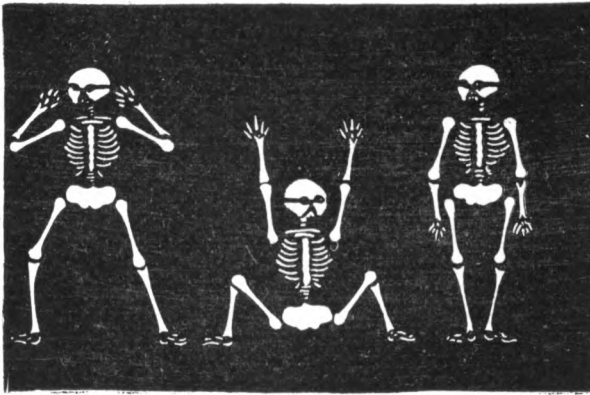

Fig. 375.

By a clever contrivance, a little shutter falls in front of this opening between the exhibition of every successive figure, and when the instrument is properly worked the various figures appear upon the screen in such quick succession that they present the appearance of a single being endowed with endless motion. One of the best designs for this is a skeleton, not painted upon glass, but cut out stencil fashion from a sheet of thin brass. By this means the whole of the light from the lantern is carried through the perforations to the disc, and a wonderfully brilliant image is the result. The annexed illustrations (Figs. 375, 376) have been copied direct from the stencil figures so that they represent the exact size of those actually used. It need hardly be said that they do not pretend to be anatomically correct, but are merely conventional representations of a skeleton. However, they answer their purpose admirably.



There is also another quaint conceit for the lantern which must not be passed unnoticed, called "The Rinker." As its name implies it consists of a skating figure, which is so contrived that it throws its arms and legs about, and tumbles down in the most amusing manner. This figure is cut out of thin metal, having at its upper part grooves into which a piece of glass is inserted. Upon this slip of glass is painted the face and shirt front. The cut (Fig. 377) will explain the manner in which the various parts are joined together, the levers shown at the left-hand side giving the figure apparent life. The arrangement is backed by a glass slide upon which

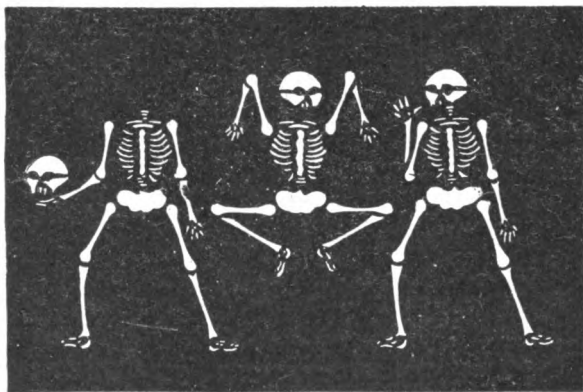

Fig. 376.

is painted a wintry landscape, and the effect when seen upon the disc is very comical. These are cheap, home-made methods of obtaining cinematograph pictures and the toys no doubt had their influence in bringing forward the science of cinematography.

### III. *The Opaque Lantern*

A great many attempts have been made, with more or less success, to cast the image of opaque objects upon the screen. The first instrument devised for this purpose was a lantern in which the light from the condenser was concentrated upon the object, the objective being placed at such an angle as to magnify the image upon the screen. It is usual with this form of lantern to use a large jet, for the amount of light lost in transmission is considerable. The moving works of

a watch appear on the screen in brobdingnagian proportions. A squeezed lemon also forms a favourite subject for exhibition. As the cells burst under the pressure applied to them, the pips and juice are forced out, and fly *upwards*, for of course in this instrument everything is reversed.

A modification of this lantern in which the inversion of the image is corrected has also been used with success. This apparatus is large enough to admit the human face and the same, magnified to colossal size, is thrown upon the screen. The effect of this immense countenance is startling.

An adaptation of the opaque lantern to fit on an ordinary lantern, or better still to a pair of lanterns, has been introduced. With this all the effects named in connection with the opaque

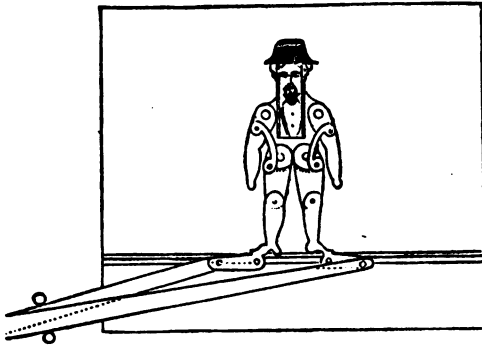

Fig. 377. The Rinker.

lantern can be obtained; collections of coins or medals are peculiarly well adapted for exhibition, for their bright surfaces and points of relief catch the rays of light with a strong effect upon the screen. (See also page 431.)

This lantern has also proved useful in the detection of fraud for on occasion it has become necessary to show the differences between a genuine signature and an imitation or forgery of the same. In the ordinary optical lantern the object to be thrown on the screen is photographed or painted on a slide of glass, and the light passes through the slide to the screen; in the reflecting (or opaque) lantern the light is thrown against the face of the object itself, and as the reflected rays from the object appear on the screen, a stronger light is required for the opaque lantern than for the ordinary instrument.

The peculiar arrangement of the lights and screen enables the examiner to discover the surface of the paper through the ink, so that patching or shading or painting of letters becomes evident the instant it is brought under the focus of the lantern. An arrangement of screens, by which the light is cut off alternately from either side of the instrument, discovers any tampering with the surface of the paper, either by scratching or washing by chemicals. The instrument is of sufficient capacity to view at once two bank notes placed side by side, and the pictures are of such fineness that the image is produced without colour from chromatic aberration, or distortion from spherical aberration.

Another method is to photograph the document by means of a perfectly focussed lens with small stop, then to make a transparency and throw that on the screen, when the disturbed and undisturbed fibres of the paper are perfectly distinct.

#### IV. *Lantern Experiments*

There are some experiments both in chemistry and physics which can perhaps be better seen by means of the lantern than in any other way. Indeed, the number of these that can be performed in miniature but shown largely magnified upon the screen is very great. Thus, suppose we take magnetism to begin with. Select a piece of thin glass, the size to fit the slide holder, and cover it with a solution of common gum. When perfectly dry, place it above the poles of an ordinary sixpenny horseshoe magnet, so that the ends of the magnet are just under its centre. Now from a fine muslin bag scatter upon the glass iron filings. Tap the glass gently with the finger, and the particles of iron will assume definite positions, showing most beautifully the magnetic curves. (See page 389.) On breathing upon the glass, the gum will be so softened as to cause the filings to retain their position when placed vertically in the lantern, and the curves in all their beauty will appear greatly magnified upon the screen.

By another arrangement we can show the electro-magnet upon the screen. The slide for this is shown in Fig. 378. It consists of a wooden frame to which is fastened a piece of soft iron, bent so that its ends nearly approach one another. Several thicknesses of covered copper wire are wound round each end, their extremities being carried outside the frame for

ready attachment to a small bichromate battery cell. At the top is a hole through both frame and iron, through which the various metals, etc., under examination can be introduced between the magnetic poles. Having focussed the image of the magnet sharply upon the screen, scatter filings through the hole, when much the same result will be obtained as in

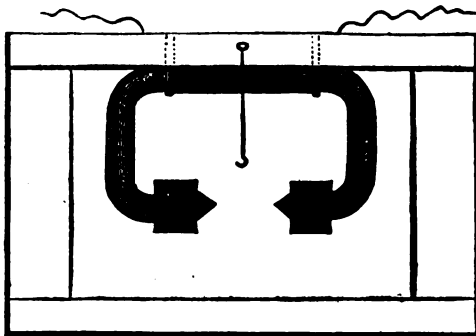

Fig. 378. Lantern slide to show effects of magnetism.

the previous experiment. Or fasten small discs of different metals to filaments of silk, and watch the effect of the magnet upon them. Thus iron will assume a different position to a disc of copper, or bismuth, the former being a magnetic substance, and the two latter diamagnetic.

The decomposition of water by the electric current is also an effective experiment for the lantern. For this as well as for several chemical experiments which will be presently described, a water-tight glass cell is necessary. A

very ingenious cell has been devised (see Fig. 379), which consists of a wood frame, inserted into the round opening of which are two glass plates, separated by a piece of red india-rubber tubing. The pressure of the glass surfaces against the flexible rubber makes the cell perfectly water-tight, and the ease with which the glasses can be removed, cleaned, and replaced in a few seconds, makes this a most useful piece of apparatus. For showing the decomposition of water this tank will re-

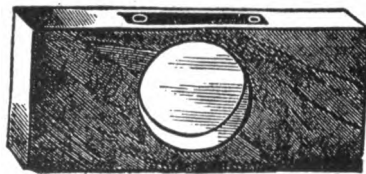

Fig. 379. Chemical-tank.

quire an adjunct which can easily be constructed. Take a piece of mahogany or other short or close grained hard wood which will just fit between the glasses, and which is the same width as the tank. Bore two holes in its centre about one inch apart. These holes are for the reception of copper wires, to the ends of which pieces of platinum foil must be soldered. The wood should be soaked in melted paraffin, so that it may resist the action of the acidulated water with which the tank is afterwards filled. The wires, also coated with paraffin, are carried outside the lantern to a battery, two Grove's or Bunsen's being sufficient. When connection is made, bubbles of oxygen will appear at one pole, and hydrogen at the other. The apparatus may be made still more complete by crowning

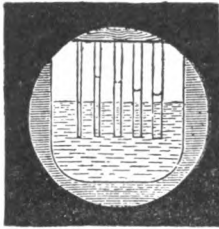

Fig. 380.

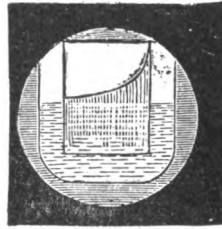

Fig. 381.

the electrodes with small test tubes in which the gases will collect, that devoted to the hydrogen filling with gas at double the rate of the oxygen tube, thus proving the truth of the chemical symbol for water,  $H_2O$ .

The formation of hydrogen alone, can be shown by dropping a few pieces of granulated zinc to the bottom of the tank when filled with acidulated water (*i.e.*, water soured by sulphuric acid). Or should we wish to obtain carbonic acid, we may readily do so by replacing the sulphuric by a dilute solution of hydrochloric acid, and dropping in pieces of lime instead of zinc.

Capillary attraction is well illustrated by the slides shown at Figs. 380 and 381. In Fig. 380 a series of glass tubes of different internal diameter are suspended above the water, when the liquid—which should be coloured or darkened with ink—will attain different levels in the different tubes. In Fig. 381, two slanting glass-plates are adjusted, and the water rises between them in a regular curve.

For many of the chemical experiments pipettes furnished with a slide or an india-rubber ball, will be found useful if not indispensable. (See Fig. 382.)

1. Fill the tank with a solution of sulphate of iron, then add to it by means of the pipette a solution of prussiate of potash for the formation of prussian blue.

2. To a weak solution of sulphate of copper, add a few drops of strong ammonia—beautiful blue clouds will become apparent on the screen.

3. Sulphate of iron on the addition of gallic acid will give dense clouds of ink.

4. Into an infusion of red cabbage drop some alum: it will change the colour to purple. A solution of potash will turn it green, and muriatic acid crimson. By dropping the three



Fig. 382. Pipette for chemical experiments.

solutions into different parts of the tank, the three colours will appear at the same time.

5. A solution of salt dropped into one of nitrate of silver will show the formation of insoluble chloride.

This last experiment might well form the first of a series illustrating the art of photography. Thus a plate may be coated with collodion emulsion, dried and exposed under a negative to a gaslight for a few seconds, and developed in the glass cell. To do this the cell must have a piece of ruby glass inserted between it and the light. It is now filled with the alkaline developer (see section on Photography) when the details of the picture will be gradually formed on the plate placed within it. The process is completed by filling the tank with a solution of hyposulphite of soda, to clear and fix the image. In this last operation the ruby glass can be omitted, for the plate is no longer sensitive to light after development. The photograph so taken may afterwards be mounted and used as an ordinary slide. In mounting a slide, a piece of thin glass must be placed in front of the film, with a paper mask between them. This mask is usually cut out of black paper, and may be round, cushion-shaped, or square in outline. The best and quickest way to cut any number is to use

a brass or card pattern, to place the black paper beneath it, and then to cut the paper with the ingenious little tool shown at Fig. 383, which is supplied by dealers for that purpose. The slide is completed by being bound round with a strip of needle paper, which holds the two glasses together, and protects the picture from that enemy of the lanternist—dust.

The formation of ice flowers can be beautifully seen by inserting a thin slab of ice into the slide aperture, when the effect is observable as the ice slowly melts under the heat from the condensers.

By filling the tank with methylated alcohol and adding a few drops of dyes of different colours, some very fine effects can be obtained.

Slips of glass brushed over with solutions of different salts in gum water, will speedily crystallise; the varying forms of different crystals can be well studied by this means. Sal-ammoniac yields very fine results when treated in this way.

An experiment showing excellent effects in the lantern is to mix a concentrated solution of chloride of cobalt; add to this a small quantity of gelatine and coat a piece of glass with the mixture. When quite dry, place it before an ordinary transparency, inserting the two in the lantern. The picture at first will be tinted with a rosy hue, but as the cobalt becomes warmed by the heat from the condensers, this rosy colour will slowly become a bright blue. On removal from the lantern to a damp place, the cobalt-coloured slide will resume its rosy colour and may be used repeatedly with the same effects.

A variation of this is to use gum with the concentrated cobalt, and this time paint a view on the slide with the solution, when the picture will turn from pink to blue, as did the emulsion only.

Another variation is to have the solution of cobalt very weak when the picture is painted with the gum, so that in the strong light of the lantern no picture is visible at first, but as the plate warms, a blue picture gradually develops itself on the screen.

Similar effects are obtainable by the use of other chemicals, but cobalt will give the most satisfactory results.

This section may well conclude with a few words respecting



Fig. 383.

the colouring of magic lantern slides. Most amateur efforts in this line of art are attended with utter failure, the reason being that too much is attempted. It is quite certain that he who cannot produce a satisfactory result upon paper, need not hope for success in working upon the smooth surface of a glass plate. The resulting picture has moreover to be reproduced upon the screen so much magnified that every defect is exaggerated. A speck of dust or a hair from the paint-brush is quite enough to spoil a sky, and unless the greatest care is exercised such accidents are frequent. Although few are able to originate a picture, there are many who can tint a photograph satisfactorily. The word tint is used advisedly, for a photograph loses its beauty by any approach to full col-

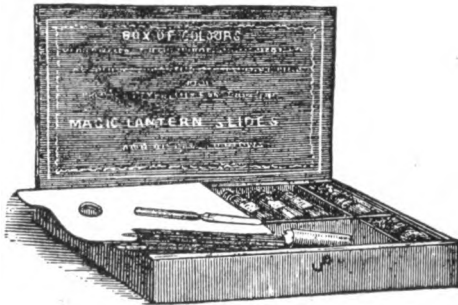

Fig. 384.

ouring. Water colours may be used, but they are somewhat difficult of manipulation. The colours made for the purpose and obtainable from all photographic dealers answer all requirements, and full instructions are issued with each box.

#### V. *The Decomposition of Light—its Analysis and Synthesis*

Physically light is not of a single nature, it is composite, and made up of seven colours. The instrument required to refract a ray of light sufficiently to break it into its elementary colours is called the prism, and is a solid having two plane surfaces, called its refracting surfaces, with a base equally inclined to them. (Fig. 385, Page 470.)

In 1672 Sir Isaac Newton made his celebrated analysis of light, by receiving a sunbeam (as it passed through a hole in a shutter) on the refracting surface of a prism, and throw-



ing the image or spectrum on to a screen, where he observed the seven colours, red, orange, yellow, green, blue, indigo, and violet, and thus proved "that there are different species of light, and that each species is disposed both to suffer a different degree of refrangibility in passing out of one medium into another, and to excite in us the idea of a different colour from the rest; and that bodies appear of that colour which arises from the composition of those colours the several species they reflect are disposed to excite."

Newton's name would have been immortalised by this discovery alone, even if he had not possessed that exceptional ability which raised him above all other mathematicians and physicists of his time. It is interesting to know that the ancient author Claudian (A. D. 420) inquires "whether colour really belongs to the substances themselves, or whether by the reflection of light they cheat the eye—*enquires sive color proprius rerum lucisne repulsa eludant aciem.*"

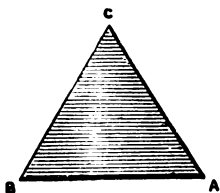

Fig. 385. The prism. The base, A B, is equally inclined to the refracting surfaces, C A, C B.

Newton determined that the spectrum could be divided into 360 equal parts, of which red occupied 45, orange 27, yellow 48, green 60, blue 60, indigo 40, violet 80. He also discovered that if the highly refracted rays, the seven colours or spectrum, were received into a concave mirror or a double-convex lens, that they again united and formed white light. In order to demonstrate the properties of the prism in various positions, the next diagram may be adduced. (Fig. 386.)

The rainbow is the most beautiful natural optical phenomenon with which we are acquainted; it is only seen in rainy weather when the sun illuminates the falling rain, and the spectator has the sun at his back. There are frequently two bows seen, the interior and exterior bow, or the primary and secondary, and even within the primary rainbow, and in contact with it, and outside the secondary one, there have been seen other bows beyond the number stated.

The primary or inner rainbow consists of seven different coloured bows, and is usually the brightest, being formed by the rays of light falling on the upper parts of the drops of rain. The exterior bow is formed by the rays of light falling

on the lower parts of the drops of rain; and in both cases the rays of light undergo refraction and reflection, hence the opinion of Aristotle, that the rainbow is caused only by the reflection of light, is not correct. (See page 416.)

The first refraction occurs when the rays of light enter, and the second when they emerge from the spheroids of water in the first bow; the refracted rays undergo only one reflection, whereas in the second the brilliancy of the colours is impaired by two reflections.

The spectrum from the electric light is one of the most gor-

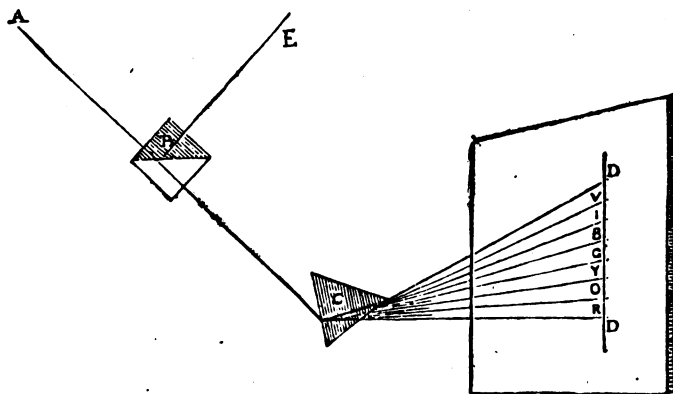

Fig. 386. A. The ray of light passing through two prisms B placed base to base. In this position the light passes through to the second prism, C, without alteration. At C the decomposition of light occurs, and the spectrum is shown at D D. The top prism at B used singly would reflect the ray to E without decomposing it into the coloured rays.

geous exhibitions of colour that can be conceived; and the instruments required for the purpose are illustrated in Fig. 387, Page 472.

On the left of the woodcut is seen a lantern furnished inside with an electric lamp. The light from this lantern passes through a narrow *slit*, thence through a lens and prism, after which it appears upon the screen placed for its reception as a band or ribbon of brilliant colours. In this way is repeated the experiment which Newton first performed nearly two hundred and fifty years ago. (Compare with spectro-scope, page 473.)

It is important to observe that whereas he used a mere hole in his window-shutter for the purpose, a narrow slit is now employed. Wollaston was the first to use this slit for ob-

erving the appearance of the spectrum, and by doing so he arrived at unexpected results. He found, by this substitution of a narrow aperture for a round one, that the coloured ribbon of light no longer showed itself as a continuous unbroken band, but that it was intersected by innumerable dark lines, for which he could not account. Many other scientists tried to make out what these signified, but they did not succeed in doing so. Fraunhofer, an optician of Munich, was the first to point out that these mysterious lines of darkness occupied a certain fixed position in the spectrum. He succeeded in mapping them to the number of several hundred, and they are in consequence known as "Fraunhofer's lines."

By means of improved apparatus, Bunsen and Kirchoff

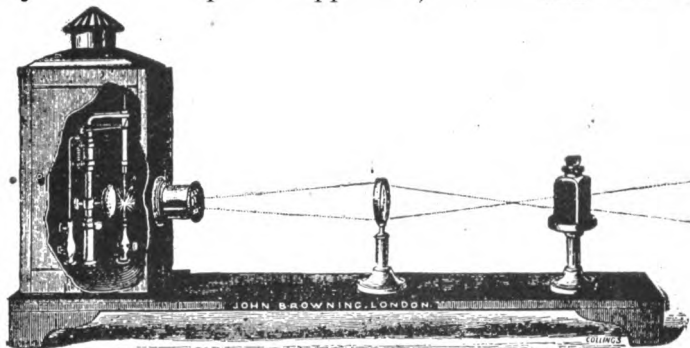

Fig. 387. Apparatus for showing spectrum on screen.

in 1860 investigated these lines of Fraunhofer, and by their researches laid the foundation of a new science which is comprehended in the term spectrum analysis.

Herschel some years before had experimented with different metals under the blowpipe, and had pointed out that each metal gave a characteristic tinge of colour to the flame. He further suggested that it might be possible by a modification of the means employed to found a new method of analysis. He little knew how well his words would be verified. (See page 242.)

Bunsen and his co-worker made the strange discovery by means of special apparatus that burning metals gave a spectrum having bright lines—so many lines for each metal. They further found that these bright lines had their counter-

parts as dark lines in the solar spectrum as mapped out by Fraunhofer. It was evident then that some sort of mysterious connection existed between the metals ignited in the laboratory and the dark lines which for so long a time had puzzled Wollaston and other scientists. What could this connection mean?

The question was not answered until *the vapours* of some burning metals were observed through the prism, when it was seen that what before were bright lines, were now dark. And so the law came to be established that "*vapours of metals at a lower temperature absorb exactly those rays which they emit at a higher.*" To simplify this we may suppose that

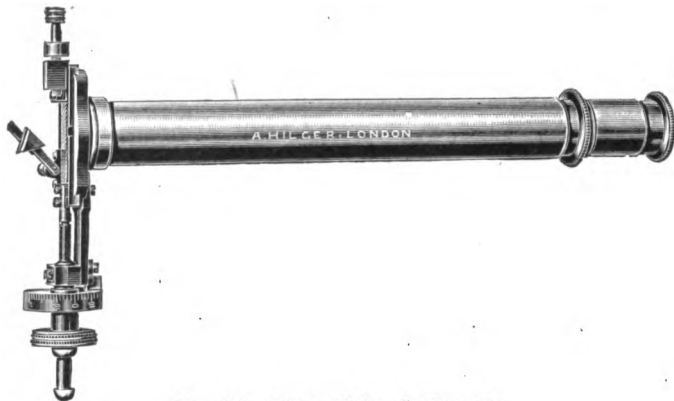

Fig. 388. Direct Vision Spectroscope.

we throw a piece of some metal into a furnace and immediately view its spectrum, when we shall see the bright lines peculiar to that metal. But on looking at the spectrum of its vapour with the sunlight as a background, we shall see dark lines only. These will occupy precisely the same position as the bright lines we before observed. Here then the scientist has a new power placed in his hands, and one so marvellously sensitive, that the presence of a minute particle of a substance, far too small to be seen by the eye, can be readily detected.

Sir Isaac's primitive arrangement has now long ago given place to the wonderful instrument called the spectroscope, which in a simple form is shown at Fig. 388. Here the darkened room is represented by a little tube, and the hole in the

window-shutters by the tiny slit at the end of it. This form of spectroscope contains what is known as a compound direct-vision prism. This is placed in a sliding drawer, at the end of which is a lens to magnify the image of the slit upon the retina of the eye. The opening of the slit is adjustable by a micrometer screw motion, a very necessary provision in the case of delicate examinations. This little contrivance will show practically all Fraunhofer's lines—the bright lines peculiar to different metals and gases—as well as absorption bands in coloured gases or liquids, and wave-length determinations.

In using this instrument it should be held like a telescope, and directed to any source of light, a bright gasflame for instance, when a continuous spectrum, like a piece cut out of a rainbow, will be plainly seen. But supposing that we wish to observe the bright lines of the metals, a different mode of proceeding must be observed. (It may be mentioned here that it is a matter of great convenience to have the tube clipped into some kind of stand, so that the hands are at liberty to carry out necessary manipulations.) A spirit lamp, or Bunsen flame, must be placed opposite the slit, and as near to it as is possible without injury to the instrument. A piece of platinum wire must now be procured and bent into a loop at one end. Into this loop can be fused a small bead of the substance or metallic salt to be examined. The wire is now supported above the lamp, so that the bead at its end is just within the front edge of the flame, opposite the slit of the spectroscope. If these directions be complied with, the lines due to the substance under examination will be plainly seen on looking through the eye-piece. Where very minute portions only of a substance are available, it is usual to dissolve it, and apply a drop of the solution to the platinum loop.

The exceeding delicacy of this mode of analysis is almost beyond belief. In experiments carried on at the Royal Mint, having for their object the examination of different mixtures of metal for coining purposes, the difference of one ten-thousandth part in an alloy is made evident. Blood in a most dilute form can be readily recognised, and the spectroscope as well as the microscope has proved a useful detective in certain criminal investigations. The sodium lines can be ob-

served in the instrument when a solution containing not more than  $\frac{1}{3,000,000}$  of a grain of sodium is employed.

A higher class of spectroscope is shown at Fig. 389, constructed specially for examining solar protuberances, and contains three compound prisms.

The apparatus for showing spectra on a screen so that the phenomena can be observed by a number of persons simultaneously, is identical with that shown at Fig. 387, Page 472.

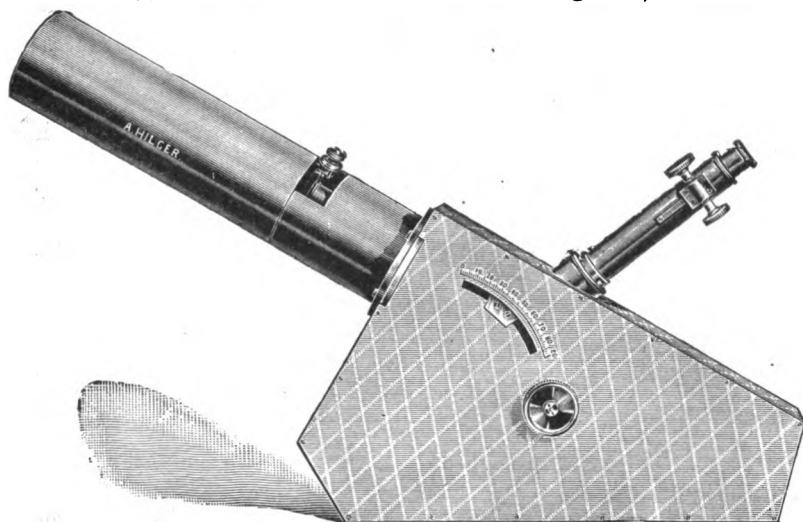

Fig. 389. The Evershed Protuberance Spectroscope with three compound prisms.

It consists of an electric lantern furnished with a slit, in lieu of condensers, a convex lens mounted upon a stand, and a bottle prism filled with disulphide of carbon. The substance under examination is placed in a hollow cup formed in the lower carbon of the lamp, and is thus exposed to the intense heat of the voltaic arc. The results thus obtained cannot approach in delicacy the observations which can be made by the forms of spectroscopes previously described, impurities in the carbon points as well as the bright lines due to incandescent carbon, interfering more or less with the general result. With care, however, these difficulties can be partly obviated, and the effects produced, if not perfect, are very beautiful and wonderful.

In using this apparatus it is customary to place the different substances under examination in separate crucibles, which so revolve upon a stand that each can successively be brought under the upper carbon of the lamp. By this means the audience is not kept waiting between each display. By burning a small piece of sodium in an iron spoon, inside the lantern, so as to fill it with vapour, and placing another piece of the same metal in the voltaic arc, the reversal of the bright yellow line due to sodium can be well observed. Salts of silver, zinc, copper, or little pieces of the metals themselves, will also afford brilliant spectra by means of this apparatus. Liquids placed in a small wedge-shaped cell in front of the slit, may also be compelled to give up their secrets. In such manner can be examined solutions of blood, chlorophyll (the green colouring matter of plants), cochineal, and many other substances too numerous to mention.

The discovery of many elementary bodies is due to spectrum analysis. Thus in 1860 Bunsen found, when operating upon the residue of a mineral water, certain lines in the spectroscopy which did not coincide with any previously noticed; these were due to the two metals *caesium* and *rubidium*. Crookes not long afterwards noticed a bright green line in the spectrum given by some specimens of pyrites. Thus was discovered *thallium*, which takes its name from the characteristic colour which led to its detection. This rare metal is soft and greyish in colour. Its spectrum shows a definite green line, hence its name—from the Greek *Thallos*, a young green shoot. Another metal which owes its discovery to the prism was *iridium*, which like the other three already mentioned is named after the colour of its most characteristic lines, which are iridescent, especially when dissolving in hydrochloric acid—hence its name, from the Greek *Iris*, a rainbow.

A curious, but very useful, application of the spectroscopy is found in the Bessemer process for converting iron into steel. In this process air is driven through the molten iron, from apertures at the bottom of the vessel in which it is melted. At the moment of conversion, the brilliant flame from the molten mass undergoes a change which is very difficult to detect by the unaided eye. But when viewed through the spectroscopy, the moment at which this change occurs and when therefore it is all-important that the process should

be stopped, the flame gives unerring indications for the guidance of the workmen. The spectrum given consists of numerous bright lines, the most brilliant of which are green. At the moment when the process becomes complete these green lines suddenly vanish. Thus can an inexperienced workman be made competent by this wonderful instrument to detect a change which otherwise would cost him years of practice.

The most wonderful application of the spectroscope is however evidenced in the means which it affords of analysing the constituents of the heavenly bodies. Kirchhoff by means of the prism demonstrated the existence in the sun of barium, copper, zinc, magnesium, chromium, calcium, and iron. With improved apparatus modern astronomers have increased

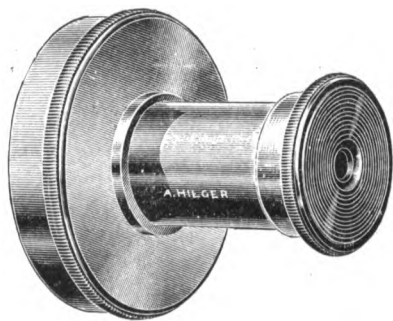

Fig. 390a.

Zöllner Star Spectroscope.

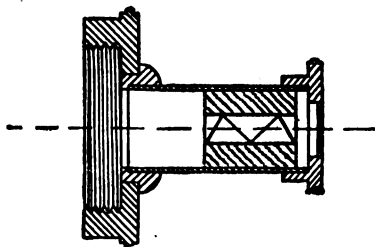

Fig. 390b.

considerably their knowledge of the number of elements existing there, whilst there seems little doubt as to the presence of many others, Dr. Henry Draper, of New York, being the first to detect the lines due to oxygen. The solar spectroscope is used with an astronomical telescope, and takes the place of the usual eyepiece.

Still more interesting are the discoveries which have been rendered possible by the spectroscope as to the constituents of the stars. It indeed seems almost incredible that by means of a little instrument, the actual size of which is but a few inches long, we can tell of what the distant stars are made. But by comparing the spectra which they give with the lines given by terrestrial substances, astronomers are able to affirm that their constituents include certain bodies which are well



known to us on this earth. Among the substances so detected are hydrogen, magnesium, sodium, calcium, bismuth, antimony, mercury, etc. Like the elements found in the sun, those in many of the stars which are themselves suns, may be held to exist in a state of vapour, at a temperature so high as to be unobtainable by any earth-means and even inconceivable to earth-minds. The spectroscope gives evidence of atmosphere surrounding the superior planets, and tells us that the moon is without atmosphere, or at any rate one such as we can appreciate or define. It has indeed opened out quite a new field of research, and one which will no doubt in the future yield even a richer harvest to science than it has done in the past.

At the close of the year 1878 a letter appeared in one of the daily papers giving news of a startling discovery, for it stated that Mr. Lockyer (later, Sir Norman,) had realised the alchemist's dream and had actually effected the transmutation of several metals. That the so-called elements were therefore not elementary and that the whole system of chemistry must be remodelled.

This letter evoked a reply from Lockyer, in which he contradicted the report in its most important particulars, but the researches to which it referred soon after formed the subject of a communication which he himself brought before the Royal Society.

In this paper he hazarded the assertion that many of the so-called elements were in reality compound bodies. Under certain circumstances he found lines in the spectra of different metals for which he could account in no other way, except that they might be due to impurities contained in the substances under examination. But as he had taken care to eliminate all chances of such adulteration he was not content to refer the appearances which he saw to that cause. The line of argument followed is far too complex for further consideration in these pages, but the subject of spectrum analysis could hardly be considered complete without some reference to the work in which Lockyer is and for long has been, engaged. There has for sometime past been an opinion among chemists that many of the present elements might some day be proved to be compound, and the spectroscope may possibly be the instrument which will solve the problem.

For instance, it must be remembered that it is not so very long ago that men believed in the existence of four elements only, namely:—earth, air, water, and fire. From these four supposed elements everything in the universe was made. We now know that the three first are compounds, and that the last is merely a chemical operation. One discovery has led to another until the elements number eighty-two and it is safe to say that as time goes on this number will be altered considerably. The general favourable reception of any new doctrine is always a difficult matter to obtain, and the history of discovery shows how learned men have been laughed at for notions which, in the end, have been universally accepted. We must therefore look upon our list of elements as the best that can be tabulated as far as present knowledge goes, and we may look to the spectroscope as one of the scientific instruments which will tell us more hereafter.

Another use to which this wonderful instrument is being applied with most successful results, is in medicine. The lines in the spectrum afforded by blood are quite different to those of other substances. And the quantity necessary to show the effect is so excessively minute that the least trace can be detected. A morsel of dried blood weighing less than the seventy-thousandth of a grain, is sufficient to give evidence of its presence to the spectroscopist. In this way the presence of blood in any of the secretions of the body where it has no business to be can be easily made out, and the lurking disease detected. Not only this, but blood of different animals can readily be classified, such as the blood of mammalians and perhaps more wonderful still, even when blood is dried, dirty and old—such as stains on garments—it may be analysed and proved conclusively to be, or not to be, the blood of the person or animal from whom it is supposed to have come. The detection of minute quantities of different metallic salts, together with their rapid diffusion through the body after administration, has also been studied by the same agency, leading to valuable physiological results. It need not be imagined that spectrum analysis is, on account of the expense of the apparatus, out of reach of ordinary folk, for of the scientific dealer may be obtained a good instrument with all necessary appliances, for about a guinea.

VI. *Duration of the Impression of Light*

If a circular disc is painted with the prismatic colours taken in the same proportion with respect to each other in which they are exhibited in the spectrum made by the prism, and the wheel is turned swiftly, then the individual colours disappear, and nearly white light is apparent. The effect is due to the same principle that creates the appearance of a complete circle of fire when a burning squib is moved quickly round before it is thrown away to burst, and as it is evident that the burning squib cannot be in every part of the circle at the same moment, there must be some inherent faculty of the human eye which enables it to retain for a definite period the impression of images that may fall upon it; and this principle has been so far pressed, as it were, beyond its limits, that it is gravely asserted the image of a man's murderer might be discovered on the retina of the eye-ball if that could be examined sufficiently quick after death, but all attempts to do this have ended in failure. If there is any truth in it, the apparatus would have to be ready beforehand, in which case it is obvious that the intending murderer could be "caught" before committing the crime. The fixture of the picture is said to be due to a sort of natural photographic process; but such fanciful statements often lead the mind into dreamland only, and so we return to the fact of the duration of the impression of light on the eye as evidenced by several ingenious optical instruments, especially by the scientific inventions of Faraday and others.

By careful experiment it has been found that the light of a live coal, moving at the distance of 165 feet, maintained its impression on the retina during the seventh part of a second. Hence the cause of the recomposition of white light when the colours on the disc are quickly rotated. Each colour at any point succeeds the other before the impression of the last is gone from the eye, and provided the colours move round within the seventh part of a second, they are all impressed together on the eye, and meeting on the retina, produce the effect of white light.

VII. *The Zoetrope and other similar Philosophical Toys.*

The first instrument described consists of a turning wheel upon which figures appear to jump, walk, or dance. The

disc or wheel is of cardboard, upon which are painted (towards the periphery) figures in eight, ten, or twelve postures. Thus, if it is desired to represent clowns turning round in a circle, twelve different positions of the figure in the act of turning are painted on the disc, and above each of the figures on the wheel a slit is cut about one inch long, and a quarter of an inch wide in a direction corresponding with the radii of the circle. This simple form of the instrument is used by placing the figured side towards a looking-glass and then causing it to revolve at a certain speed, which is ascertained by experiment; and as the spectator looks through the slits into the looking-glass, the clowns appear to turn round. (Fig. 391.)

In the "Journal of the Royal Institution" Faraday described some very interesting experiments and optical illusions produced by the revolution of wheels in different directions and velocities. The wheels are made of cardboard, and by cutting out two cog wheels of an equal size, and placing one above the other on a pin, the usual hazy tint when the cogs are acting is apparent when they are whirled round; but if the two cog wheels are made to



Fig. 391. The spectator is supposed to be looking towards a mirror through the slits. It is supported by a handle through the centre, round which it is twirled by the hand.

move in opposite directions, there will be the extraordinary appearance of a fixed spectral wheel. If the cogs are cut in a slanting direction on both wheels, the spectral wheel will exhibit slanting cogs; but if one wheel is turned so that the cogs shall point in opposite directions, then the spectral wheel will have straight cogs. A number of such wheels set in motion in a darkened room, and illuminated suddenly with the light from the electric spark or a lantern, appear to stand perfectly still, although moving with a great velocity. A somewhat elaborate and expensive instrument has been constructed for the purpose of showing these effects on a screen with the optical lantern; a very limited picture, however, is shown. (Fig. 392.) Cheap cinematographic arrangements which are obtainable of most dealers for a few shillings have done much to put these toys, useful as they are,

somewhat out of date. These and simpler modifications are, however, still used for demonstration purposes.

Another very simple toy was given the appropriate name, thaumatrope, compounded of the Greek words, *θαύμα*, wonder, *τρέπω*, to turn. The duration of the impressions of light on the eye is very apparent whilst using this toy, which is usually made of a circular piece of cardboard, having on one side a painting of a man's head, and on the other a hat; or

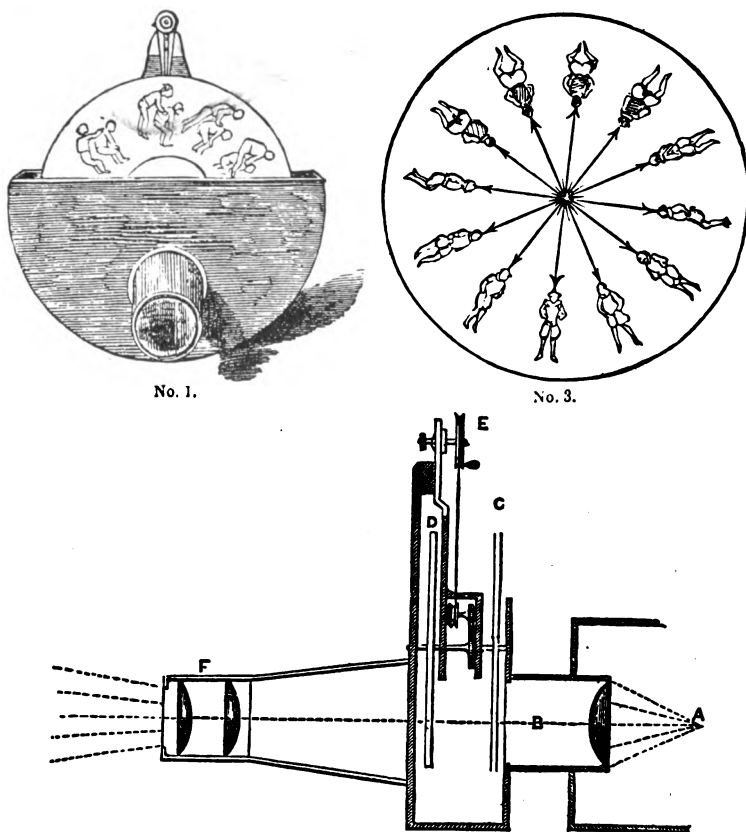

Fig. 392.—No. 1. Apparatus in elevation with the condensers. No. 2. Section of the apparatus. A. The light. B. Condenser, or plano-convex lens. C. Round glass disc with design painted on it. D. Wooden disc with four double-convex lenses placed at equal distances from each other, so as to coincide with C, whilst rotating. Both the latter and D rotate, and the picture is focussed on the disc by the lenses F. No. 3. Glass plate, with device painted thereon.

a picture of a lighted candle on one face of the cardboard, and an extinguisher on the other; or a gate, and a horseman leaping it. Each pair of designs appear to be one when twisted round by strings tied to the opposite edges of the cardboard circles. The *rationale* of this experiment being, that the picture of one design—such as the head and face—is retained by the eye until the hat appears, and being mutually impressed upon the nerve of vision at very nearly the same instant of time they appear as one picture.

Here is seen another optical arrangement, Fig. 393, which

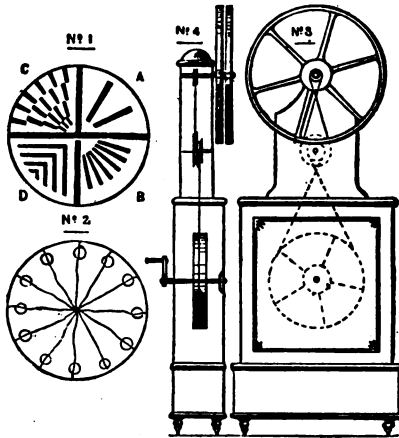

Fig. 393. Nos. 1 and 2 are the discs. No. 3. Elevation. No. 4. Side view showing the multiplying wheels and the perforated and painted discs moving in opposite directions.

was primarily designed for showing the illusions of the zoeotrope and kindred devices to a numerous audience; but remarkable for its presentations of very beautiful spectra, composed of the multiplication, combination, and involution of simple figures disposed around a disc. The arrangement consists of a movement for giving considerable velocity to two concentric wheels, working nearly in contact, and moving in contrary directions. But the only part of the apparatus that requires special explanation and illustration is the device disc and the disc of apertures, the first of which is placed on the hinder wheel, and the second on the front wheel. Figures of the two discs are given, premising, however, that each

is capable of an almost infinite variety of characters. No. 1 (Fig. 393) presents in its four quadrants the perforations for four distinct discs of apertures; and No. 2 is a device disc, consisting of twelve equidistant black balls. Under *a* the balls will be presented as twenty-four ovals; under *b*, as forty-eight involved figures, beautifully variegated; under *c*, as elaborate lacework; and under *d*, as a rich variegation of form and colour. Every fresh disc of devices and disc of apertures of course opens up a new field of effect. Thus, if we take a disc bearing twelve repeats of a ball in the interior of a ring, each repeat being so painted that its position is advanced in the ring until it reaches in the twelfth ring the point whence it started, and place this on the back disc of the machine, having previously removed the first one, no effect is observed when the wheel is rotated beyond the spreading out of the design and general appearance of hazy black circles. When, however, the disc, with twelve slits or apertures, is now placed on the front wheel, and the two rotated in opposite directions, then the whole figure starts as it were into existence, and each ball apparently moves round the interior of its circle.

A further optical arrangement for showing spectral illusions is superior to the last, inasmuch as it offers to the public lecturer an effective means of presenting these deceptions to a large audience. It differs from the last mentioned (Fig. 393) in several important points. It dispenses with the discs of apertures, and leaves the device disc with its face fully exposed to the spectators. The effects are produced by a powerful light, thrown through the tube of a lantern, and broken by a wheel working across it. The apparatus consists of two distinct parts; the one a movement for the device discs, and the other for the light. A wheel four feet in diameter is connected with a train of movement capable of giving it five or six hundred revolutions per minute. On this wheel the device disc is placed in full view of the spectators, and set in motion. From an opposite gallery the light is thrown, and broken by a wheel of such diameter and number of apertures as will admit the velocity of the machine to be at least *six* times the velocity of the device disc; whilst the apertures are of such width as to restrict the duration of the light-flash to about one-two-thousandth of a second. The

wheel working across the light has a train of movement for raising the velocity to two thousand revolutions per second. The management of the apparatus is very simple. The device-wheel is brought to a steady, rapid rotation, and the operator on the light then works his wheel with gradually increasing velocity, until he overtakes the figures of the device, where, by mere delicacy of touch, he is able to hold them stationary or give them motion, at pleasure. This is a most remarkable instrument and is capable of some startling and realistic effects, but cinematography has supplanted it.

The Kaleidoscopic Colour-top is designed to show that when white or coloured light is transmitted to the eye through small openings cut into patterns or devices, and when such openings are made to pass before the eye in rapid successive jerks, both form and colour are retained upon the nerve of the visual organ sufficiently long to produce a compound pattern, all the parts of which appear simultaneously, although presented in succession. The instrument forms, therefore, a pleasing illustration of the law that the eye requires an almost inappreciably short space of time to receive an impression, and that such impression is not directly effaced, but remains for an assignable though very limited period. The results are obtained by rotating two discs on a wheel, the lower disc containing colours, and the upper one the openings; this latter disc is made to vibrate as well as to rotate, thus allowing the eye to receive the coloured light reflected from below, which light assumes, at the same time, the forms of the patterns through which it has been transmitted. The instrument serves also to illustrate most of the important phenomena of colour.

#### VIII. *Simple Microscopes and Telescopes*

Lenses are now sold at a cheap rate, and form useful, simple, portable microscopes. Eloquent vendors of cheap microscopes are to be found in the streets, who make their instrument of a pill-box perforated with a pin-hole, in which a globule of glass fixed with Canada balsam is placed, the spherical form of the drop affording the magnifying power: or a thin platinum wire may be bent into a small circular loop, and into this may be placed a splinter of flint-glass; if the flame of a spirit-lamp is urged upon the loop of platinum



wire and glass by the blowpipe until it melts, a small double-convex lens may be obtained, which will answer very well as a magnifying-glass. Practice makes perfect, and after two or three trials, a good single lens may be obtained, which can be mounted between two small pieces of lead, brass, or cardboard, properly fixed together, with holes through them just large enough to retain the edge of the tiny lens. Such lenses may be purchased for a few pence.

A globule of water carefully dropped on the pin-hole of a blackened card, also makes an admirable lens, this being one of the earliest methods of magnification; or the same pin-hole in a blackened card, but minus the water, will cause a delicate object which is otherwise invisible to unaided sight to be distinct, if placed a little distance from the eye, with the card intervening. The brilliant sun may also be well examined by bringing this card close to the eye and looking through the pin-hole.

It will, however, be readily understood that in the globule, or spheroid of water, only that portion within the range of the centre or axis of the sphere can be placed in true focus, the object examined becoming more and more indistinct as the immediate neighbourhood of the axis is passed, till at the extreme edges, all is hopelessly blurred. To a great extent, this could be obviated or corrected by the placing of a stop inside the lens, having a fine hole in the centre, which would concentrate and alter the focus of the light-rays. This is not always possible, and altogether impracticable for so small and rough a lens as a drop of water, or fused borax, or glass globule on a piece of card.

An excellent effective pocket lens may be made in an evening from a clear-glass marble; the writer, when a boy, made one which he carried in his pocket for years. Though but a rough toy, it was capable of giving a magnification of about twenty diameters, transmitting plenty of light, and taking up little room. With this lens also, since it is spheroidal, almost any part of its surface may be used, provided the light passes through the centre of the stop, which the black portion (to be described) forms. The diagrams will be clear, with but brief explanations.

Select a transparent glass marble, clear rather than of green glass, with as few bubbles in it as possible; one or two

are of no moment. Stick it firmly between two pieces of wood, (Fig. 394). Fix this securely in a small lathe, made

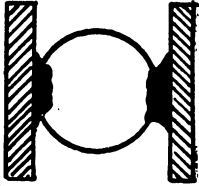

Fig. 394. Marble attached to pieces of wood.

by temporarily erecting some pieces of wood on an ordinary sewing machine table, from which the machine has been removed, the treadle below supplying the power. Mark the centre, or equator, as we will call it, Fig. 395, then gently turning the lathe by means of the treadle, dip a hard steel tool—such as a hard file, ground to an angle—(Fig. 396) in turpentine, and carefully scratch the marble, fixing on it clearly this equatorial line. Proceed to deepen this cut by grinding at each side of it, to form the letter, V, Fig. 397. By cutting gently, with the machine running steadily and by the plentiful use of turpentine in the groove, it will be possible before very long, to cut almost to the centre, as at Fig. 398. Now cease cutting, and instead polish the V-shaped opening by a wedge-shaped piece of wood covered with felt and held tight to the revolving marble. Then use fine crocus and turpentine with rapid revolution and the cut will soon be polished. Wipe it dry and fill the incision with pitch, making the edge smooth. Break off the pitch setting and roll the

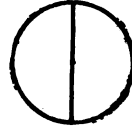

Fig. 395. Marble with equatorial line on it.



Fig. 396. File ground for cutting-edge.

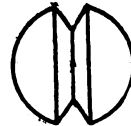

Fig. 397. Early formation of groove.



Fig. 398. Finished groove.

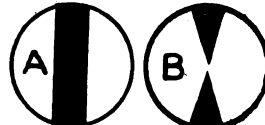

Fig. 399. A. Exterior view of finished lens. B. Section of finished lens.

marble in the hand, moistened with crocus and turpentine, finishing off with movement on the ball of the thumb, which makes an excellent polisher; give a final brightening with chamois leather.

Such a lens forms a simple and effective home-made microscope, its finished appearance being seen in Fig. 399 A and B.

A prism can be made of two small pieces of window-glass stuck together with a lump of soft beeswax, and if a few drops of water are placed in the angle, they are retained by capillary attraction. The prism is used by holding it against a large pin-hole or small slit in a bit of card, and looking through them towards the sky, when the beautiful colours of the spectrum will be apparent if the card and prism are brought close to the eye.

The most simple form of the refracting telescope is made with a lens of any focal length exceeding six inches, placed at one end of a tin or cardboard tube, which must be six inches longer than the focal length of the lens; the tube may be in two parts, sliding one within the other, and when the eye is placed at the end, an inverted image of the object looked at, is apparent. By using two double-convex lenses, a more perfect simple astronomical telescope is obtained. The object-glass, *i.e.*, the lens next the object looked at, must be placed at the end of a tin or pasteboard tube larger than its focus, and the second lens, called the eye-glass, because next the eye, is in a smaller tube, termed the eye tube; if the focal length of the object-glass is three feet, the eye-glass must have a one-inch focus, and of course the eye-tube and glass must slide freely in the tube containing the object-glass. An object-glass of forty feet focus will admit of an eye-glass of only a four-inch focus, and will, therefore, magnify one hundred and twenty times. A tube of forty feet in length would of course be very troublesome to manage, therefore it is usual to adopt the plan originally devised by Huyghens, *viz.*, that of placing the object-glass in a short tube on the top of a high pole with a ball-and-socket joint, whilst the eye-glass is brought into the same line as the object-glass, and focused with a tube and rack-work properly supported. In an ordinary terrestrial telescope there are at least four lenses, in order that the objects seen by its assistance shall not be in-

verted; and whenever objects are examined by a common telescope, they are found to be fringed, or surrounded with prismatic colours. This disagreeable effect is corrected by the use of *achromatic* lenses, in which two kinds of glass are united; the light decomposed by one glass uniting with the colours produced by the other, form white light; thus a double convex lens of crown glass, C C, may be united with a plano-convex lens of flint glass, F F, which must have a focus about double the length of that of the crown-glass lens. The concave lens corrects the colour or chromatic aberration of the other, and leaves about one-half of the refracting power of the convex lens as the effective magnifying power of the compound lens. The French opticians cement the lenses very neatly together, and use them in ordinary telescope and opera glasses. (Fig. 400.)

### IX. *The Stereoscope*

This instrument has now attained a popularity quite equal to, if it does not surpass, that formerly enjoyed by the kaleidoscope, and without entering upon the much-vexed question of priority of discovery, it is sufficient again to mention the names of Brewster and Wheatstone as identified with the discovery and use of this most pleasing optical instrument.

The principle of the stereoscope (meaning, *solid I see*) is copied from nature: *i.e.*, when both eyes are employed in the examination of an object, two separate pictures, embracing dissimilar forms, are impressed upon the retina, and produce the effect of solidity; if the pictures formed at the back of the eyes could be examined by another person with a stereoscope, they would come together, and also produce the effect of solidity.

Stereoscopic pictures are obtained by exposing sensitised films in the camera to the picture of an object taken in two positions, or two cameras are employed to obtain the same result. If the latter mode is adopted, the stereoscopic pictures must not be taken from positions too widely separated from each other; or else, when the two pictures are placed in the stereoscope, they will stand out with a relief that is

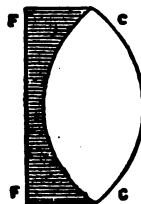

Fig. 400. A compound achromatic lens, composed of C C, the double-convex lens of crown-glass, and F F, the plano-concave lens of flint-glass.

quite unnatural, and the object will appear like a very reduced solid model, instead of having the natural appearance presented by pictures which have been taken at positions not too distant from each other.

Brewster says, "In order to obtain photographic pictures mathematically exact, we must construct a binocular camera which will take the pictures simultaneously, and of the same size; that is, by a camera with two lenses of the same aperture and focal length, placed at the same distance as the two eyes. As it is impossible to grind and polish two lenses, whether single or achromatic, of exactly the same focal lengths, even if we had the very same glass for each, I propose to bisect the lenses, and construct the instrument with semi-lenses, which will give us pictures of precisely the same size and definition. These lenses should be placed with their diameters of bisection parallel to one another, and at a distance of  $2\frac{1}{2}$  inches, *which is the average distance of the eyes in man*; and when fixed in a box of sufficient size, will form a binocular camera, which will give us at the same instant, with the same lights and shadows, and of the same size, such dissimilar pictures of statues, buildings, landscapes, and living objects, as will reproduce them in relief in the stereoscope." Thus with a single camera provided with semi-lenses, or two lenses of the same focal length, stereoscopic pictures can be obtained.

To bring the images of the two pictures together, and produce the effect of solidity, either of two instruments may be employed. The reflecting stereoscope is the invention of Wheatstone, the refracting or lenticular stereoscope that of Brewster.

The former is constructed by placing two upright boards on a wooden stand at a moderate distance from each other; the stereoscopic pictures are attached to these boards, which may be made to move up or down, and if the pictures are held in grooves, they may be pulled right or left at pleasure, and thus four movements are secured—viz., upward, downward, right, or left. Between the two stereoscopic pictures are placed two looking-glasses, so adjusted that their backs form an angle of ninety degrees with each other. (Fig. 401.)

The pictures are illuminated at night by a lamp or gas

flame placed at the back of the mirrors, which, when fixed together, have the same shape as a prism; indeed, Wheatstone substituted a prism for the mirrors, and thus paved the way for the invention of the lenticular stereoscope.

The stereoscopic effect is obtained by bringing the eyes close to the inclined mirrors, so that the two reflected images coincide at the intersection of the optic axes, the coincidence of the images is further secured by moving either picture a little to the right or left, and if the upright boards move bodily in grooves to or from the centre mirror, the greatest nicety of adjustment is procured.

The lenticular stereoscope consists of a box of pyramidal

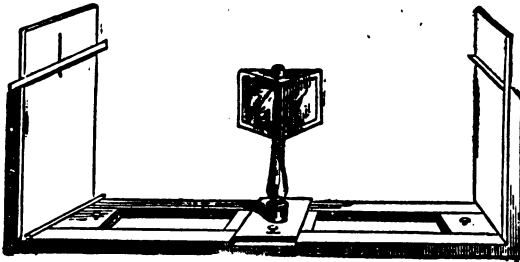

Fig. 401. Wheatstone's reflecting stereoscope.

shape, open at the base, and provided with grooves in which are placed the stereoscopic pictures; if the latter are taken on glass the base of the box is held directly against the light, but if they are paper pictures, then a side light is reflected upon them by means of a lid covered in the inside with tinfoil, which is raised or lowered at pleasure from the top part of the box. Two semi-lenses are now fitted into the narrow part of the box, and are placed at such a distance from each other that the centres of the semi-lenses correspond with the pupil of the eyes, and this distance has already been stated to amount to  $2\frac{1}{2}$  inches. (Fig. 402, Page 492.)

The principle of the lenticular stereoscope is perhaps better seen by reference to the next diagram, in which the centres of the semi-lenses (*i. e.*, a lens cut in half) are placed at  $2\frac{1}{2}$  inches apart, with their *thin* edges towards each other, and marked, A B, Fig. 403. The centres of the two stereoscopic pictures C D correspond with the centres of the

lenses, and the rays of light *diverging* from C D fall upon the semi-lenses, and being refracted nearly *parallel* are, by the prismatic form of the semi-lenses, deflected from their course, and leave the surfaces of the lenses in the same direction as if they actually emanated from E;

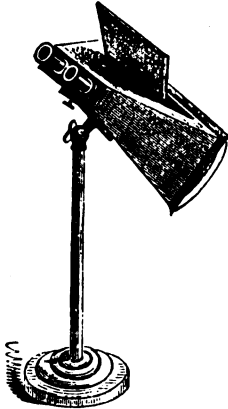

Fig. 402. Brewster's lenticular stereoscope.

and as all images of bodies appear to come in a straight line from the point whence they are seen, the two pictures are superimposed on each other, and together produce the appearance of solidity, so that a stereoscopic result is obtained when the *spectral images* of the two stereoscopic pictures are made to overlap each other. By taking one of the lenses in each hand, and looking at the two pictures, the overlapping of the *spectral images* becomes very apparent, so that the combined *spectral images*, and not the *pictures* themselves, are seen when we look into a stereoscope. (Fig. 403.)

Brewster says, "In order that the two images may coalesce without any effort or strain on the part of the eye, it is necessary that the distance of the similar parts of the two drawings be equal to twice the separation produced by the prism. For this purpose measure the distance at which

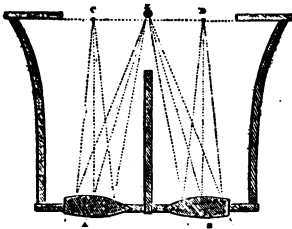

Fig. 403.

the semi-lenses give the most distinct view of the stereoscopic pictures, and having ascertained by using one eye the amount of the refraction produced at that distance, or the quantity by which the image of one of the pictures is displaced, place the stereoscopic pictures at a distance equal to twice that quantity—that is, place the pictures so that the average distance of similar parts in each is equal to twice that quantity. If this is not correctly done, the eye of the observer will correct the error by making the images coalesce, without being sensible that it is making any such effort. When the dissimilar stereoscopic pictures are thus united,

the solid will appear standing as it were in relief between the two plane representations.”

A more modern and convenient form of stereoscope is illustrated by Fig. 404. This instrument is of the same principle as that shown in Fig. 403. A, is the shield which fits against the forehead; B. B. are the lenses; C, is the horizontal bar on which the photo-print is placed, held in position by the guide-wires, E. This slides parallel to the lenses on the extension-bar, D, and is focused by a slide-catch on the underside at F. A swivel-joint, G, allows the handle, H, to be folded when not in use. When examining the print held in the wires, E, the light must fall on the face

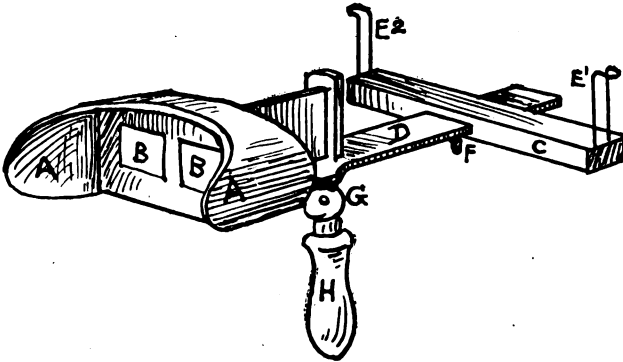

Fig. 404. Stereoscope. Common portable model.

of the picture. There are many other forms of stereoscopes, but the principle is the same in all of them.

A still simpler form, on an entirely different principle, is the "Monoscope." This is an appliance introduced specially for the stereoscopic examination of picture postcards and any photograph which has been taken with a single lens instead of by the usual stereoscopic twin-lenses.

It consists of a concave mirror, Fig. 405, in the focus of which is an arrangement to hold a picture-postcard or other photograph in an upright position. In use, the picture faces the mirror and should be so held that the light falls on it; the spectator, looking over the back of the card, sees reflected in the mirror a reversed image of the picture on the face of the card, in excellent stereoscopic effect. The same effect is seen in hand-drawn postcards and in draw-



ings, though owing to certain faults or imperfections in perspective or in the drawing, the result is not always true; but in those views which are actual photographs, or printed



Fig. 405. Concave lens for monoscope.

from blocks of photographs, or are on a photographic base, their stereoscopic effect is perfect. Sketch 406, will show the mounting and arrangement. D, is the concave mirror, the section of which is shown at Fig. 405. B, is a board the focal length of the mirror, carrying a slip at A, which keeps the card upright, and a hinge at C, which enables it to fall back over the mirror, D, when not in use, answering the dual purpose of folding flat and protecting the glass at the same time.

The Stereomonoscope is an instrument by means of which a single picture is made to simulate the appearance of solidity, and by this arrangement a number of persons may observe the effect at the same time. The apparatus required is very simple, consisting of a large double convex lens, and a screen of ground glass. The object A, Fig. 407, is highly illuminated, and placed in the focus of a double convex lens B, when an image of the object is projected, and will be found suspended in the air in the conjugate focus of the lens at C, and from this point

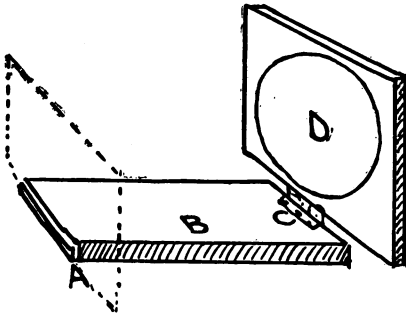

Fig. 406. Rough sketch to give general form of monoscope.

the rays of light will diverge as from a real object, which will be seen by separate spectators at D D and E E; if the screen of ground glass is placed at G G, the image will appear with all the effects of length, breadth, and depth, which belong to solid bodies. (Fig. 407.)

An image formed on ground glass in this manner can be seen only in the direction of the incident rays, and the stereoscopic effect is not apparent when the image is re-

ceived on a calico or transparent screen, on account of the rays being scattered in all directions.

The following arrangement is an important modification of the last named, and consists of a screen of ground glass (A B, Fig. 408), and two convex lenses (C D, and E F) arranged in such a manner that they will project images of

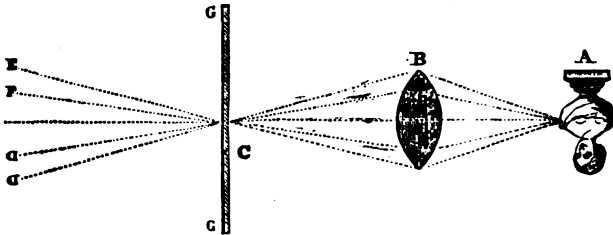

Fig. 407. The stereomonscope.

the stereoscopic pictures, G H, at the same point on the screen, A B.

It might be thought that a confusion of images would result from projecting two pictures on one point, P—viz., the focus of the two lenses; but as each photograph can be seen only in the direction of its own rays, it follows that if the eyes are so placed that each eye receives the impression of one stereoscopic picture, the two images must coalesce, and a stereoscopic effect will be the result, as is apparent at K K

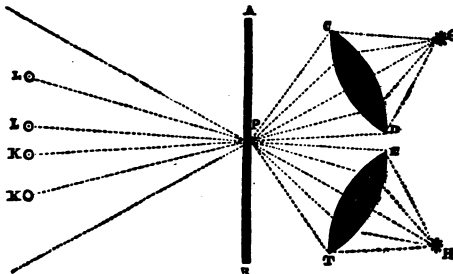

Fig. 408. The stereoscope.

and L L; so that several persons may look at the stereoscope at one time. (Fig. 408.)

A curious optical instrument, as its name, Pseudoscope, implies, produces a false image by the refracting power of prisms, and is the invention of Wheatstone. When used with both eyes, as with the stereoscope, it inverts the relief

of a solid body, and makes it appear exactly as if it were an intaglio, or sunk beneath the line surrounding it. For instance, a terrestrial globe when looked at through the pseudoscope appears to be concave, instead of convex. A vase with raised ornaments upon it looks as if it had been turned (to reverse the usual expression) outside in, and the whole of its convexity is turned to concavity; and of course a face seen under these circumstances looks very curious, all the features sinking in instead of being in relief (Fig. 409.) The cause is perhaps somewhat difficult to understand; but by taking other and more simple examples of the same effect, the principle may be gradually comprehended.

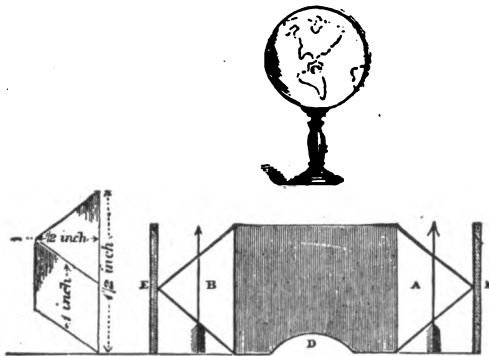

Fig. 409. Horizontal section of the pseudoscope, showing at A B two prisms placed against a block of wood about two inches long and one inch and a half wide, and cut out in the centre to admit the nose at D. The eyes are supposed to be looking at the globe, C, in the direction of the arrows. E E, Brass plates blackened, which shut out the side light, and assist in keeping the prisms in position.

Brewster remarked that "one of the most curious phenomena is that *false* perception in vision by which we conceive depressions to be elevations, and elevations depressions—or by which intaglios are converted into cameos, and cameos into intaglios. This curious fact seems to have been observed at one of the early meetings of the Royal Society of London, when one of the members, in looking at a guinea through a compound microscope of new construction, was surprised to see the head upon the coin depressed, while the other members could only see it embossed, as it really was. . . . The best method of observing this deception is to view the engraved seal of a watch with the eye-piece of an achromatic telescope, or with a compound microscope, or any combination of lenses which inverts the objects that are

viewed through it; a single convex lens will answer the purpose, provided we hold the eye six or eight inches behind the image of the seal formed in its conjugate focus."

After bringing forward various interesting experiments in further explanation of the cause, Brewster states it to be his belief that the illusion is the result of an operation of our own minds, whereby we judge of the forms of bodies by the knowledge we have acquired of light and shadow. Hence, the illusion depends on the accuracy and extent of our knowledge on this subject; and while some persons are under its influence, others are entirely insensible to it.

The pseudo-effects of vision are not confined to the results already explained, but are to be observed especially whilst riding in a conveyance when the eyes may be so fixed as to give the impression of movement to the trees and houses, whilst the conveyance appears to stand still. In railway carriages, also, after riding for some time and then coming to a stand, if another train is set slowly in motion beside the one at rest, it frequently happens that the latter appears to be moving instead of the former.

## CHAPTER XXVI

### LIGHT

#### A—THE ABSORPTION OF LIGHT

The analysis of light has been explained in a previous chapter, and it has been shown how the spectrum is produced. Colour, however, may be obtained by other means, and the property possessed by bodies, of absorbing certain coloured rays in preference to others, offers another mode of decomposing light.

Until recent times red, yellow, and blue have been regarded as the three primary colours. But the investigations of Helmholtz have shown that this choice has been based upon a consideration of painters' pigments, and not of coloured light. He, therefore, found reason to name red, green, and violet as primaries, but this selection he gives with doubts as to its correctness and leaves the matter an open question. See pages 109, 221. For further information upon this matter the reader must refer to the works of Helmholtz; or to Tyndall's lectures upon light. The subject is rather too abstruse to warrant its introduction here.

Connected with this property is the remarkable effect produced by coloured light on ordinary colours, and the sickly hue cast upon the ghost in a melodrama, or the fiery complexion imparted to the hair of Der Freischutz, or the jaundiced appearance presented by every member of a juvenile assembly when illuminated with a yellow light from the time-honoured salt and burning spirit of "snap dragon," are too well known to require a lengthened description here.

If a number of colours are painted on cardboard, or groups of plants, flowers, flags, and shawls, are illuminated by a mono-chromatic light, and especially the light procured from a large *tow* torch well supplied with salt and spirit, the effect is certainly very remarkable; at the same time it shows how completely substances owe their colour to the light by which they are illuminated. Whilst the flowers, &c., are lighted up with a yellow light, a magical change is brought about by throwing on them suddenly the rays from the oxy-hydrogen light, when the colours are again restored; or if the latter apparatus is not obtainable, the combustion of phosphorus in a jar of oxygen will answer the same purpose. The light coming from the combustion of gas affords an excess of the yellow or red rays of light, which causes the differences between colours as seen by candlelight and daylight.

#### B—THE INFLECTION OR DIFFRACTION OF LIGHT

In this part of the subject it is absolutely necessary to return to the theory of undulations with which the present subject was commenced. (See pages 405-407.) The inflection of light offers a third method by which rays of light may be decomposed and colour produced. The phenomena are extremely beautiful, although the explanation of them is almost too intricate for a popular work of this kind.

The cases where colour is produced by inflection are more numerous than might at first be supposed; thus, if we look at a gaslight or the setting sun through a wire gauze blind, protecting the eye by looking through a little tank of dilute ink, or a piece of smoke-coloured glass, a most beautiful coloured cross is apparent. An extremely thin film of a transparent matter, such as a little naphtha or varnish dropped on the surface of warm water, or soap bubbles, or a very thin film of glass obtained by blowing out a bulb

of red-hot glass till it bursts, or an exquisitely thin plate of talc or mica, all present the phenomena of colour, although they are individually transparent, and in ordinary thicknesses quite colourless.

Newton brought his powerful intellect to bear on these facts, and as a preliminary step invented an instrument for measuring the exact thickness of those transparent substances that afforded colour, and the apparatus displaying Newton's rings is still a favourite optical experiment. It consists of a plano-convex lens, A, (Fig. 410) a slice, as it were, from a globe of glass twenty-eight feet in diameter, or the radius of whose convex surface is fourteen feet. This plano-convex lens is placed on another double convex lens, B, whose convex surfaces have a radius of fifty feet each, consequently the lenses are very shallow, and the space

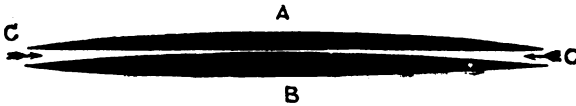

Fig. 410. The two lenses, with the plate or film of air between them, producing seven coloured rings when the lenses are brought sufficiently close to each other by screws.

(C C) included between them being filled with air, can of course be accurately measured. (Fig. 410). It is usual to secure the lenses in brass mounts which are brought together with screws, when the most beautifully coloured rings are apparent, and are produced by the extreme thinness of the film or plate of air enclosed between the two lenses. The relative thicknesses of the plates of air at which each coloured light is reflected are as follows:—

Red	.....133	10 millionths of an inch.
Orange	.....120	“ “
Yellow	.....113½	“ “
Green	.....105½	“ “
Blue	..... 98	“ “
Indigo	..... 92½	“ “
Violet	..... 83½	“ “

By dividing an inch into ten millions of parts, and by taking 133 of such parts, the thickness of the film of air required to reflect the red ray is obtained, and in like manner the other colours require the minute thicknesses of air recorded in the

table above. When the thickness of the film of air is about  $\frac{12}{178,000}$ ths of an inch, the colours cease to become visible, owing to the union of all the separate colours forming white light, but if the "Newton rings" are produced in mono-chromatic light, then a greater number of rings are apparent, but of one colour only, and alternating with black rings, *i.e.*, a dark and a yellow succeeding each other; this fact is of great importance as an illustration of the undulatory theory, and demonstrates the important truth, that *two rays of light may interfere with each other in such a manner as to produce darkness.*

To this is attributed the reason of the twinkling of the stars. When two waves of light in unequal vibration are projected, they will first coincide, when the light will be doubled; but as their vibrations will then be unequal and in opposition for a while, there will be darkness till they again coincide. This alternate light and darkness—coincidence and opposition—occurring in rapid succession, gives us the twinkling seen in the stars, which is, also, to a certain extent, augmented by the varying humidity and density of our atmosphere.

Brewster remarks that, "From his experiments on the colours of thin and of thick plates, Newton inferred that they were produced by a singular property of the particles of light, in virtue of which they possess, at different points of their paths, *fits* or dispositions to be reflected from or transmitted by transparent bodies. Sir Isaac does not pretend to explain the origin of these *fits*, or the cause which produces them, but terms them *fits of transmission* and *fits of reflexion.*"

Newton for a long time objected to the theory of undulations because experiments seemed to show that light could not travel through bent tubes, which it ought to do if propagated by undulations like sound; and it was reserved for Young to prove that light could and would turn a corner, in his experiments illustrating the inflection or bending-in of the rays of light.

Young placed before a hole in a shutter a piece of thick paper perforated with a fine needle, and receiving through it the diverging beams on a paper screen, found that when a slip of cardboard one-thirtieth of an inch in breadth was held in such a beam of light, that the shadow of the card was not merely a dark band, but divided into light and dark par-

allel bands, and instead of the centre of the shadow being the darkest part, it was actually white. Young ascertained that if he intercepted the light passing *on one side* of the slip of card with any opaque body, and allowed the light to pass freely on the other side of the slip of cardboard, then all the bands and the white band in the centre disappeared; hence he concluded that the bands or fringes within the shadow were produced *by the interference of the rays bent into the shadow*

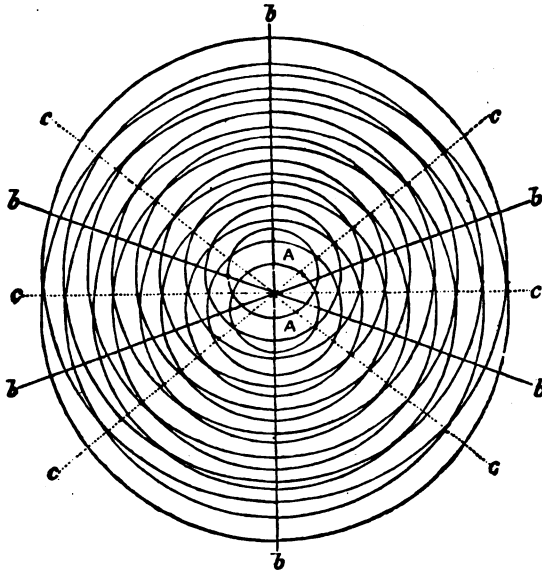

Fig. 411.

*by one side of the card, with the rays bent into the shadow by the other side.* (Fig. 411.)

In order to show how two waves may interfere so as to exalt or destroy each other, two sets of waves may be propagated on the surface of a still tank or bath of water, from the two points A A (Fig. 411), the black lines or circles representing the tops of the waves. It will be seen that along the lines B B the waves interfere just half way between each other, so that in all these directions there will be a smooth surface, provided each set of waves is produced by precisely the same degree of disturbing force, so as to be perfectly equal and alike in every respect, and the first wave of one set to be



exactly half a wave in advance of the first wave of the other, while at the curve in the direction of all the line C C, the waves coincide, and produce elevations or undulations of *double* extent; in the intermediate spaces, intermediate effects will of course be produced. This experiment may be conducted and proved by the apparatus mentioned on page 13, Figures 21 and 22.

Wheatstone invented some very simple and beautiful acoustic apparatus for the purpose of proving that the same laws of interference exist also in sound, which, as already stated, consists in the vibrations or undulation of the particles of air.

The nature and effects of interference are also admirably illustrated by the following models. (Fig. 412.)

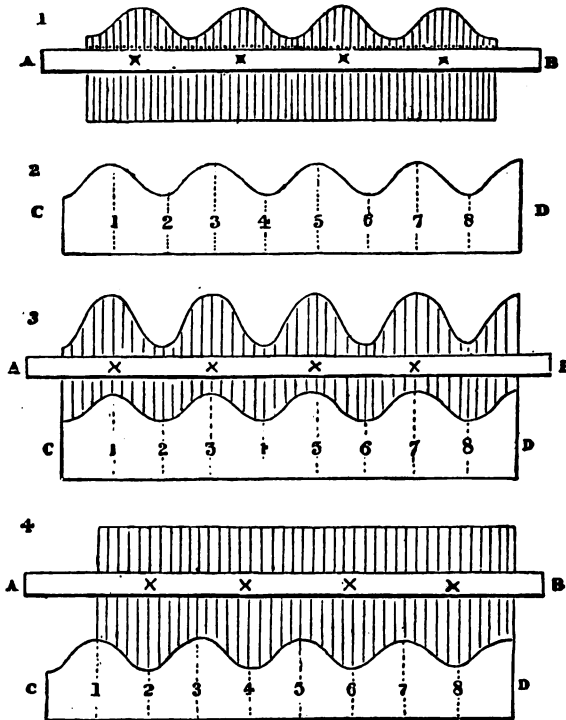

Fig. 412.—No. 1. A model of waves with moveable rods.—No. 2. A model of fixed waves.—No. 3. Intensity of waves doubled by the superposition and coincidence of two equal systems.—No. 4. Waves neutralized by the superposition and interference of two equal systems, the raised part of one wave accurately fitting into and making smooth the hollow of the other, illustrating the fact that two waves of light or sound may destroy each other.

Returning again to the coloured rings, we find that Newton discovered that at whatever thickness of the film of air the coloured ring first appeared, there would be found at twice that thickness the dark ring, at three times the coloured, at four times the dark, and so on, *the coloured rings* regularly occurring at the *odd numbers*, and the *dark ones* at the *even numbers*. This discovery is well illustrated by the models (Fig. 412). It may be noticed at No. 3 that the highest and lowest parts of the waves interfere, but coincide and produce a wave of double intensity; the little crosses of the upper model are in a straight line with the numbers 1, 3, 5, 7, and are supposed to represent the coloured rings,

whilst in No. 4 the upper series of waves is half an undulation in advance of the lower; and if the eye is again directed from the little crosses downward, the figures 2, 4, 6, 8, even numbers, are apparent, and represent the dark rings, when the waves of light destroy each other. The phenomena of thin plates, such as colours from soap bubbles, and the films of varnish, are well explained by the

law of interference. The light reflected from the second surface of the film of air (which must, of course, however thin, have two surfaces, viz., an upper and a lower) interferes with the light reflected from the first, and as they come from different points of space, one set of waves is in advance of the other, No. 4, Fig. 412; they reach the eye with different lengths of paths, and by their *interference* form alternately the luminous and dark fringes, bands, or circles. A good diffraction apparatus offers itself specially as an interesting drawing-room optical instrument. The purpose of this apparatus is to illustrate in great variety, and in the most convenient and compact form, the phenomena of the diffraction or interference of light.

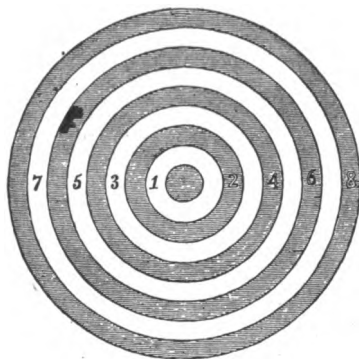

Fig. 413. Appearance of Newton's rings when produced in yellow light, 1, 3, 5, 7, being the yellow rings, and 2, 4, 6, 8, the dark rings. Light by the odd numbers; darkness by the even numbers. The central spot, where the two surfaces are in contact, is dark.

This is attained by the assistance of photography. Transparent apertures in an opaque collodion film are produced on glass, and a point of light is viewed through the apertures. The forms of the apertures are exceedingly various,—triangles, squares, circles, ellipses, parabolas, hyperbolas, and combinations of them, besides many figures of fanciful forms, are included in the set. When an image of the sun is viewed through these apertures, figures of extraordinary beauty, both of form and colour, are produced; and of each of these, many variations may be obtained by placing the eye-glass of the telescope at different distances from the object-glass. Many of the figures produced, especially when the telescope is out of focus, might suggest useful hints to those concerned in design-

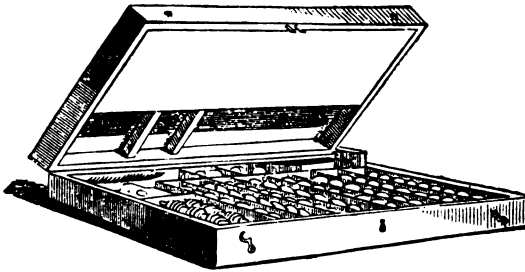

Fig. 414. Diffraction apparatus.

ing patterns. Although the phenomena are chiefly of interest to the student of science, in consequence of their bearing on theories of light, yet their beauty and variety render them amusing to all. A few words on the mode of using the apparatus may be of service. (Fig. 414.)

Choose a very bright day, for then only can the apparatus be used. Place the mirror in the sun, and let the light be reflected on the back of the blackened screen. The lens which is inserted into this screen will then form a brilliant image of the sun. Then at a distance of not less than twelve feet, clamp the telescope to a table in such a position as to view the image thus formed. Put the eccentric cap on the end of the telescope, clean the glass objects carefully, and attach them to the cap so that they may be turned each in order before the telescope. In this manner, all those which consist of a series of figures may be viewed. Then detach the eccentric cap, and replace it by the other. Into it place any of the single ob-

jects. In viewing some of the figures, brightness is advantageous—in others, delicacy; in the former case, let the lens of long focus be inserted in the screen—in the latter case, that of shorter focus. In every case, let the phenomena be observed not only when the telescope is in focus, but also when the eye-glass is pushed in to various distances.

Warren de la Rue took advantage of the colours produced by thin films of varnish, and actually *fixed* the lovely iridescent colour produced in that manner on highly polished paper, which is termed “iridescent paper,” or the “marbled” paper, such as is seen in some special books—not the ordinary marbled paper which is made by mere colours floated on water and “combed” till they blend without actually mixing; the print is then taken by laying paper on the surface, or a brush or drum picks up the marble colour and prints it rapidly on the paper moving below or round it. A tank of warm water at 80° Fahr., about six inches deep, and two feet six inches square, is provided, and a highly glazed sheet of white or black paper being first wetted on a perforated metallic plate, is then sunk with the plate below its surface, care being taken to avoid air bubbles. A peculiar varnish is then allowed to trickle slowly down a sort of tongue of metal placed in the middle of one of the sides of the tank, and directly the varnish touches the surface of the water it begins to spread out in exquisitely thin films, and by watching the operation close to a window and skimming away all the imperfect films, a perfect one is at last obtained, and at that moment the paper lying on the metal plate is raised from the bottom of the tank, and the delicate film of varnish secured. When dry, the iridescent colours are apparent, and the paper is employed for many ornamental purposes. A simple method of producing Newton’s rings was devised by Reade, and is called “Reade’s iriscope.” A plate of glass of any shape (perhaps circular is the best) is painted on one side with some quickly drying black paint or varnish and after the other side has been cleaned, it is then rubbed over with a piece of wet soap, and this is rubbed off with a clean soft duster. A tube of about half an inch in diameter, and twelve inches long, is provided and is held about one inch above the centre of the soaped side of the glass plate, and directly the breath is directed down the tube on the glass, an immense number of

minute particles of moisture are deposited on it, and these by inflection decompose the light, and all the colours of the rainbow are produced. (Fig. 415.)

The iridescent colours seen upon the surface of *mother-of-pearl*, which are attributable to fine parallel lines formed by



Fig. 415. Read's Iriscope.

its texture, are reproducible, according to Brewster's experiments, by taking impressions of them in soft wax. The gorgeous colours of certain shells and fish, the feathers of birds, "Barton's steel buttons," are not due to any inherent *pigment* or colouring matter that could be extracted from them, but are owing either to the peculiar fibrous, or parallel-lined, or laminated (plate-like) surfaces upon which the light falls, and being reflected in paths of different lengths, interference occurs, and coloured light is produced.

### C—THE POLARISATION OF LIGHT

This branch of the phenomena of light includes some of the most remarkable and gorgeous chromatic effects; at the same time, regarded philosophically, it is certainly a most difficult subject to place in a purely elementary manner, and unless the previous chapter on the diffraction of light is carefully examined, the *rationale* of the illustrations of polarised light will hardly be appreciated. We have first to ask, "What is polarised light?" The answer requires us again to carry our thoughts back to the consideration of the undulatory theory of light, already illustrated and partly explained at pages 406, 501.

After perusing this portion of the subject, it might be considered that waves of light were constituted of one motion only, and that an undulation might be either vertical or horizontal, according to circumstances. (Fig. 416.)

This simple condition of the waves of light could not, however, be reconciled theoretically with the actual facts, and it is necessary in regarding a ray of light, to consider it as a

combination of two vibrating motions, one of which, for the sake of simplicity, may be considered as vertical and the other horizontal; this idea of the nature of an undulation of light originated with Young, who while considering the results of Brewster's researches on the laws of double refraction, first proposed the theory of transversal (cross-wise) vibration. Young illustrated his theory with a stretched cord, which if agitated or violently shaken perpendicularly, produces a wave that runs along the cord to the other end, and may be often seen illustrated on the banks of a canal overhung with high

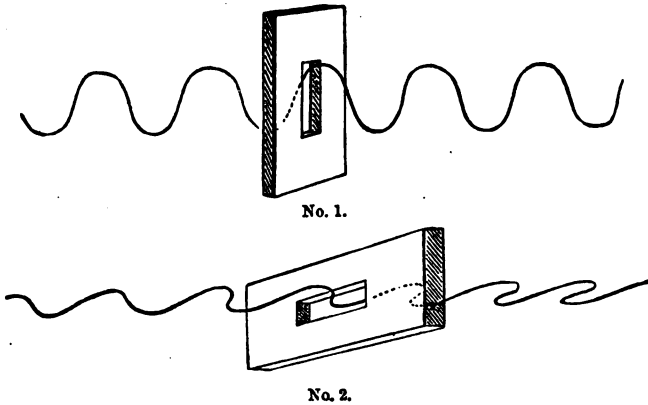

Fig. 416.—No. 1. A wire bent to represent a vertical vibration, which if kept in the latter position, will only pass through a vertical aperture.—No. 2. A wire bent to represent a horizontal wave which will only pass through a horizontal aperture.

bushes; the bargemen who drive the horses pulling the vessel by a rope, would be continually stopped by the stunted thick bushes, but directly they approach them, they violently agitate the rope vertically, which is thrown into waves that pass along it and clear the bushes. (Fig. 417, Page 508.)

If a similar movement is made with the stretched rope from right to left, another wave will be produced, which will run along the cord in a horizontal position, and if the latter is compared with the vertical undulation, it will be evident that each set of waves will be in planes at right angles to and independent of each other. This is supposed to be the mechanism of a wave of common light, so that if a section is taken of such an undulation, it will be represented by a circle A B C D (Fig. 418, Page 508), with two diameters A B, and C D;

or a better idea of the mechanical motion of a wave of common light is acquired from the inspection of another of the cardboard models. (Fig. 419.)

The existence of an *alternating motion* of some kind at minute intervals along a ray is, said Professor Baden Powell, "as real as the motion of translation by which light is prop-



Fig. 417. Bargeman throwing his tow-rope into waves to get it over the thick bushes.

agated through space. *Both* must essentially be *combined* in any correct conception we form of light. That this alternating motion must have reference to certain directions *transverse* to that of the ray is equally established as a consequence

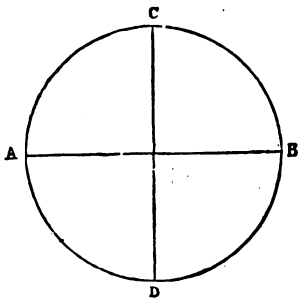

Fig. 418. A section of a wave of common light made up of the transversal vibration, A B and C D.

of the phenomena; and these *two* principles must form the basis of any explanation which can be attempted." A beam of common light is therefore to be regarded as a rapid succession of systems of waves in which the vibrations take place in different planes.

If the two systems of waves are separated the one from the other, viz., the horizontal from the perpendicular,\* they each form separately a ray of polarised light, and *common light* is merely *polarised light*, having *two planes* of

\* Or more correctly, "vertical," in the instance illustrated, since a perpendicular line is one at right angles to a given line, and thus may not necessarily be vertical and will not be so, except when the given line is horizontal.

polarisation at *right angles* to each other. To follow up the mechanical notion of the nature of polarised light, it is necessary to refer again to the card wave model below, (Fig. 419), and by separating the two cards one from the other it may be demonstrated how a wave of common light reduced to its skeleton or primary form is reducible into two waves of polarised light, or how the two cards placed together again in a trans-



Fig. 419. Model of a wave of common light.

versal position form a ray of common light. (Fig. 420.)

The query with respect to the nature of polarised light being answered, it is necessary, in the next place, to consider how the separation of these transversal vibrations may be effected, and in fact to ask what optical arrangements are necessary to procure a beam of polarised light? Light may be polarised in four different ways,—by reflection, single re-

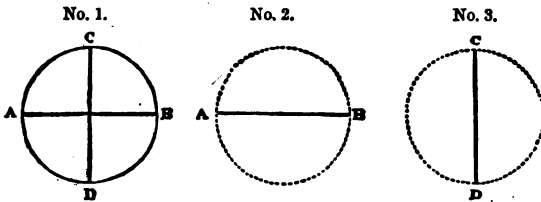

Fig. 420.—No. 1. Common light, made up of the two waves of polarised light, Nos. 2 and 3.

fraction, double refraction, and by the tourmaline—viz., by absorption.

POLARISATION BY REFLECTION AND BY SINGLE REFRACTION.

In the year 1810, the French scientist Malus, while looking through a prism of Iceland spar, at the light of the setting sun, reflected from the windows of the Luxemburg palace in Paris, discovered that a beam of light reflected from a plate of glass at an angle of 56 degrees, presented precisely the same properties as one of the rays formed by a rhomb of Iceland spar, and that it was in fact polarised. *One* of the



transversal waves of polarised light of the common light, being reflected or thrown off from the surface of the glass, whilst the other and second transversal vibration passed *through* the plate of glass, and was likewise polarised in another plane, but by *single refraction*, so that the experiment illustrates two of the modes of polarising light—viz., by reflection, and by single refraction. This important elementary truth is beautifully illustrated by the polariscope, by which a beam of

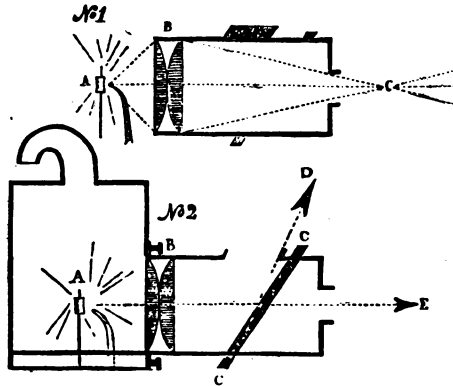

Fig. 421. Early form of polariscope for use with oxyhydrogen light.—No. 1. A is the lime light. B. The condenser lenses. C. The beam of common light. Here the glass plates are removed.—No. 2. A. Lime light. B. The condenser lenses. C C. The bundle of plates of glass at an angle of  $56^{\circ} 45'$ . D is the ray of light polarised by reflection from the glass plates, C C. and E is the beam of polarised light by single refraction, having passed through the bundle of plates of glass, C C.

common light traverses a long square tin box without change; but directly a bundle of plates of glass composed of ten plates of thin flattened crown glass, or sixteen of the thin parallel glass plates used for microscopes, are slid into the box at an angle of  $56^{\circ} 45'$ , then the beam of common light is split into two beams of polarised light, which pursue their respective paths, one passing by single refraction through the glass, the other being reflected, and rendered apparent by opening an aperture over the glass plates, and then again, by using a little smoke from brown paper, the course of the rays becomes more apparent.

The same truth is well illustrated by the cardboard model wave and a wooden plane with horizontal and vertical slits, placed at an angle of  $56^{\circ} 45'$ , as at Fig. 422.

## POLARISATION BY DOUBLE REFRACTION

The name of *Double-refracting* or *Iceland Spar* is given to a very clear, limpid, and perfectly transparent mineral, composed of carbonate of lime, and first found on the eastern coast of Iceland. Its crystallographic features are described in any work on mineralogy and crystallography, and it is sufficient for our object to state that it crystallises in rhombs, and modifications of the rhomboidal system. It must not be confounded with rock or mountain crystal, which, under the name of quartz, crystallises in six-sided prisms with six-sided pyramidal tops; quartz being composed of silica, or silicic acid, and calcareous spar of carbonate of lime. Very large specimens of the latter mineral are rare and valuable; a piece nine inches high, seven and three-quarters inches broad, and five and a half inches thick and worth at least £100 has been photographed, and its stereograph illustrates in a very striking manner the double refracting properties of the spar.

If a printed slip of paper is placed behind a rhomb of Iceland spar, two images of the former are apparent, and the stereograph already alluded to shows this fact very perfectly, at the same time illustrating the value of the stereoscope. Out of the stereoscope, words appear doubled, but seem to lie in the same plane; directly the picture is placed in the instrument, however, it is clearly seen that one image is evidently in a very different plane from the other. The double-refracting power of this mineral is illustrated by holding a small rhomb of Iceland spar, placed in a proper brass tube before the orifice as at Fig. 423, from which the rays of common light are passing; if an opaque screen such as of thin brass or card perforated with a small hole is introduced behind the rhomb, then, instead of one circle of light being apparent on the screen, two are produced, and both the rays issuing in this

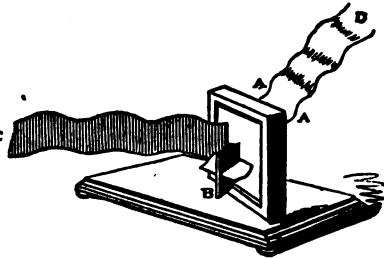

Fig. 422. A A. Model in wood of a bundle of plates of glass at an angle of  $56^{\circ} 45'$  B. Beam of common light, with transversal vibration. C. Light polarised by reflection. D. Light polarised by refraction.

manner are polarised, one being termed the ordinary and the other the extraordinary ray. (Fig. 423.)

The polarising property of the rhomb is perhaps better shown by the next diagram, where A B represents the obtuse angles of the Iceland spar, and a line drawn from A to B,

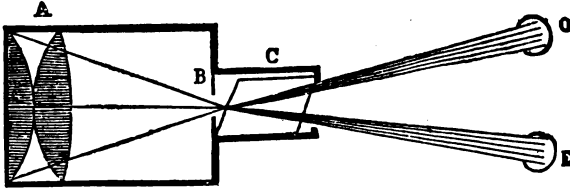

Fig. 423. A. The condensers. B. The hole in the brass screen or stop. C. The rhomb of Iceland spar. O. The ordinary, and E the extraordinary ray, both of which are polarised light.

would be the axis of the crystal. The incidental ray of common light is shown at C, and the oppositely polarised transmitted rays called the ordinary ray O, and extraordinary ray E, emerge from the opposite face of the rhomboid. If a black line is ruled on a sheet of paper as at K K, and examined

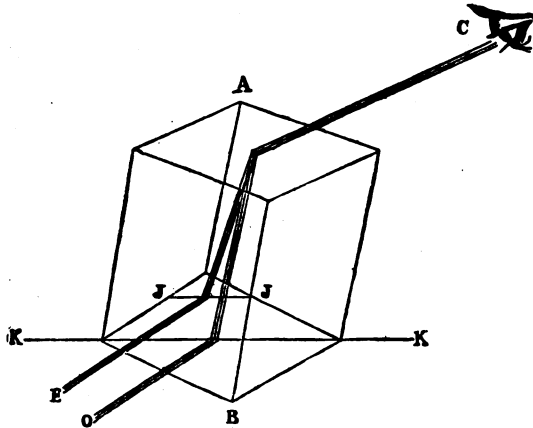

Fig. 424. Rhomb of Iceland spar.

by the eye at C, it appears double as at K K and J J. (Fig. 424.)

The cardboard model is again useful in demonstrating the polarisation of light by double refraction, and if a model of a rhomb of Iceland spar is made of glass plates, one face of

which has an aperture like a cross, and the other a horizontal and perpendicular slit, as at Nos. 1 and 2 (Fig. 425), the production of the ordinary and extraordinary rays is demonstrated in a familiar manner, and is easily comprehended.

In Newton's "Optics" we find the following description of Iceland spar:—"This crystal is a pellucid fissile stone, clear as water or crystal of the rock (quartz) and without colour. . . . Being rubbed on cloth it attracts pieces of straw and other light things like amber or glass, and with aquafortis it makes an ebullition. . . . If a piece of this crystalline stone be laid upon a book, every letter of the book seen

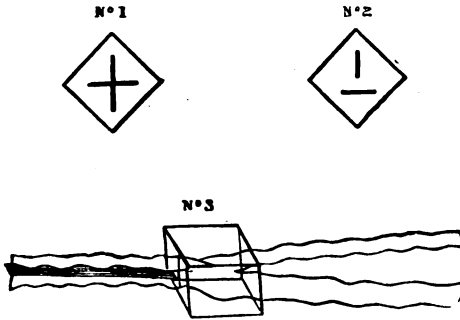

Fig. 425.—No. 1. One face of the model rhomb to admit the transversal vibration, represented by the cardboard model.—No. 2. The opposite face of the rhomb, from which issue the polarised, ordinary, and extraordinary rays.—No. 3. Side view of the model.

through it will appear double by means of a double refraction."

POLARISATION BY THE TOURMALINE

This mineral was first discovered during the sixteenth century, in the island of Ceylon, afterwards in Brazil, and since that period at various localities in the four quarters of the globe. In the Grevillian collection purchased by government for the British Museum, there is a fine specimen of red tourmaline valued at £500. The green tourmaline is named Brazilian emerald, and the Berlin blue tourmaline is called Brazilian sapphire; the mineral chiefly consists of sand (silica) and alumina, with a small quantity of lime, or potash, or soda, boracic acid, and sometimes oxide of iron or manganese. When light is passed through a slice of this mineral it is immediately polarised, one of the transversal vibrations being

absorbed, stopped, or otherwise disposed of, the other only emerging from the tourmaline, consequently it is one of the most convenient polarisers, although the polarised light partakes of the accidental colour of the mineral. Green, blue,

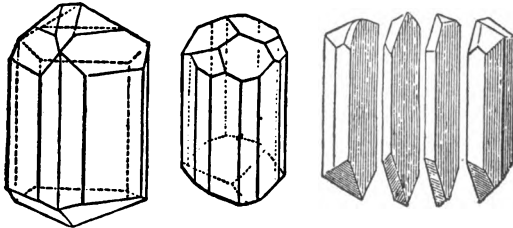

Fig. 426. Crystal of tourmaline slit (parallel to the axis) into four plates, which when ground and polished, may be used for the polarisation of light.

and yellow tourmalines are bad polarisers, but the brown and pink varieties are very good, and it is a most curious fact that white tourmaline does not polarise. (Fig. 426.)

The mineral crystallises in long prisms, whose primitive

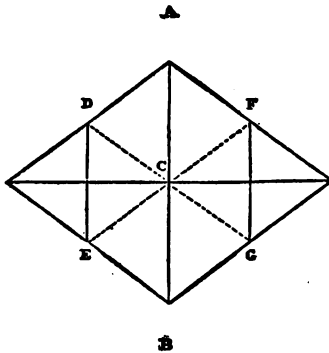

Fig. 427 represents a crystal, the axis of which is the direction A B. The dotted lines show the division of the large crystal into four other and smaller ones, each of which has its axis, A C, C B, D E, F G; and every line within the large crystal parallel to A B is an axis, consequently the term is employed usually in the plural number axes.

form is the obtuse rhomboid, having the axis parallel to the axis of the prism. The term axis with reference to the earth, as shown at page 21, is an imaginary *single line* around which the mass rotates, but in a crystal it means a *single direction*, because a crystal is made up of a number of similar crystals, each of which must have its axis, thus the whitest Carrara marble reduced to fine powder, moistened with water and placed under a microscope, is found to consist chiefly of minute rhomboids, similar to calcareous spar. The smallest crystal

of this mineral is divisible again and without limit into other rhombs, each of which possesses an axis. (Fig. 427.)

If a plate of tourmaline is held before the eye whilst looking at the sun (like the gay youth in Hogarth's picture who

is being arrested whilst absorbed with the wonders of a tourmaline, which was, in the great painter's time, a popular curiosity,) it may be turned round in all directions without the slightest difference in the appearance of the light, which will be coloured by the accidental tint of the crystal, but if a second slice of tourmaline is placed behind the other, there will be found certain directions in which the light passes through both the slices, whilst in other positions the light is completely cut off.

When the axes of both plates coincide, the light polarised by one tourmaline will pass through the other, but if the axes do not coincide and are at right angles to each other, then the polarised light is entirely stopped, and the *rationalité* of this will be appreciated at once if a tourmaline is regarded (mechanically) as if it were like a grating with perpendicular bars through which the polarised light will pass. Any number of such gratings with the bars parallel would not stop the polarised light, but if the second grating is turned round ninety degrees, the bars will be at right angles to those of the first grating, and the perpendicular wave of polarised light cannot pass. (Fig. 428.)

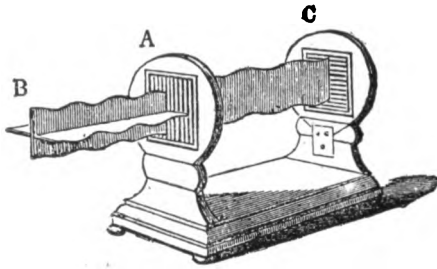

Fig. 428. A. Model of the first slice of tourmaline into which the transversal vibrations, B, are passing: the horizontal wave is absorbed, and the perpendicular polarised one proceeds to the second slice of tourmaline, C, where the bars (the axes), being at right angles to those of A, it is stopped, and cannot pass through until the bars of C are parallel with A.

CHROMATIC EFFECTS PRODUCED BY POLARISED LIGHT

Having discussed the various modes of obtaining polarised light, the next step is to arrange an apparatus by which certain double refracting crystals, and other bodies, shall divide a ray of polarised light, then by subsequent treatment with another polarising surface, the divided rays are caused to *interfere* with each other, and afford the phenomena of colour. Bodies that refract light singly, such as gases, vapours or liquids, annealed glass, jelly, gums, resins, crystallised bodies of the tessular system, such as the cube and octohedron,

do not afford any of the results which will be explained presently, except by the influence of pressure, as in unannealed glass, or a bent cold glass bar. By compression or dilatation, they are changed to double refractors of light. The bodies that possess the property of double refraction (though not to the visible extent of Iceland spar), are all other bodies such as crystallised chemicals, salts, crystallised minerals, animal and vegetable substances possessing uniform structure, such as horn and quill; all these substances divide the ray of polarised light into two parts, and by placing a thin film of a crystal of selenite (which is one of the best minerals that can be used for the purpose) in the path of the beam of polarised light, coming either from the glass plates, as in No. 2, (Fig. 421), page 510, or from a slice of tourmaline, and then receiving it through the ordinary focusing lenses or object-glasses of the oxy-hydrogen microscope, no colour is yet apparent in the image of the selenite on the screen, until another tourmaline, or a bundle of glass plates, is placed at an angle of  $56^{\circ} 45'$ , and at right angles to the plane of reflection of the first set of plates; then the most gorgeous colours suddenly appear over all parts of the film of selenite as depicted on the screen, like other objects shown by the oxy-hydrogen microscope. (Fig. 429.)

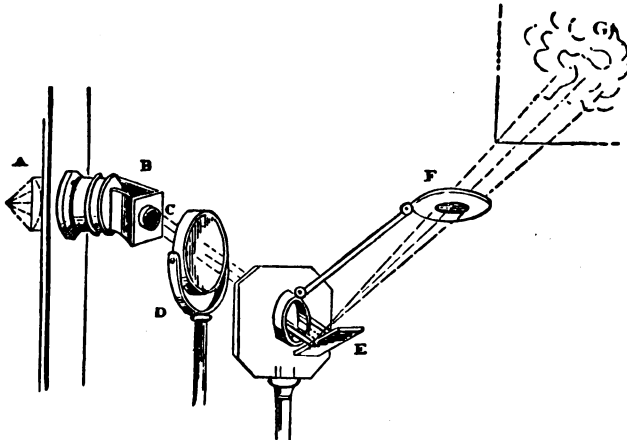

Fig. 429. Polarising apparatus. A. The light and the condenser lens. B. The plates of glass at the proper angle. C. The selenite object. D. The focusing lens. E. The second bundle of plates of glass called the analyser. F. A stop for extraneous rays of light. G. The image of the film of selenite most beautifully coloured.

The oxy-hydrogen polariscope described on page 510 is an old but convenient form, because either the reflected or refracted polarised rays can be rendered available; it consists of the apparatus shown at Fig. 421, page 510, and to this is added a low microscope power, and stage to hold the selenite or other objects, with another bundle of sixteen plates of thin microscopic glass or mica, called the analyser. A slice of tourmaline, or a Nicol's prism may be employed, instead of the second bundle of reflecting plates. When the ray of polarised light reflected from the first set of glass plates enters the doubly refracting film of selenite, which is about the fortieth or fiftieth

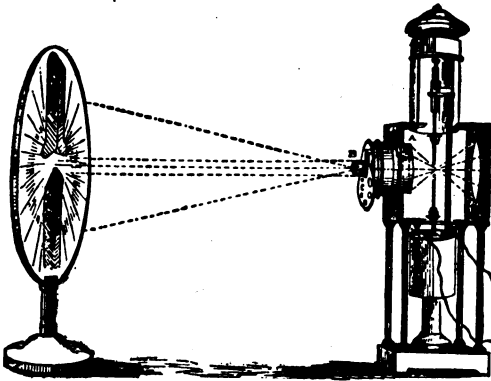

Fig. 430. The electric light and lantern, showing the projection of the carbon poles on the disc. This experiment is performed with the help of the plano-convex lens A, and the rays pass through a very narrow aperture at B.

part of an inch in thickness, it is split into the ordinary and extraordinary rays, and is said to be *dipolarised*, and forms two planes of polarised light, vibrating at right angles to each other. When the latter are received on another bundle of plates of glass called the analyser, at an angle of  $56^{\circ} 45'$ , but at right angles to the first set of glass plates, they interfere, because in the passage of the two rays from the selenite they have traversed it in different directions, with different velocities; one of these sets of waves will therefore, on emerging from the opposite face of the selenite be retarded, and lie behind the other; but being polarised in different planes, they cannot *interfere* until their planes of polarisation are made to coincide, which is effected by means of the second bundle of glass plates called the analyser; when this is brought into



a position at right angles to the first set of reflecting glass plates, half the ordinary wave interferes with half the extraordinary wave; and being transmitted through the analyser, produces, say red and orange, whilst the remaining halves also interfere, and being reflected, afford the complementary colours green and blue. (Fig. 430.) The term *complementary* is intended to define any two colours containing red, yellow, and blue, because the three combined together produce white light; (see pages 221 and 497): for example, the complementary colour to red would be green, because the latter contains yellow and blue; the complementary colour to orange would be blue, because the former contains

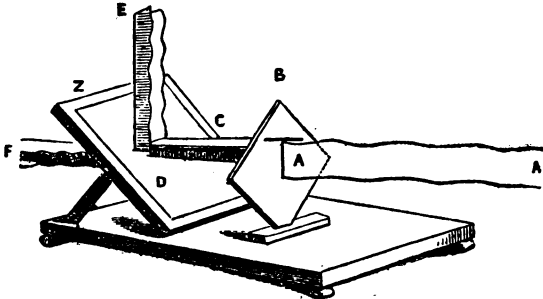

Fig. 431. A A. Card model of a beam of polarised light coming from the first bundle of plates of glass, shown at Fig. 421, p. 510. B. Model of the film of selenite, which divides or dipolarises the ray A A into C and D, which, interfering by means of the second bundle of plates of glass called the analyser Z, produce reflected chromatic effects by interference at E, and refracted effects at F.

red and yellow. Any two colours, therefore, which together contain red, yellow, and blue are said to be *complementary*. By rotating the analyser the reflected and refracted rays change colours, and if the former is red and the latter green, by moving the analyser round  $90^\circ$ , the reflected rays change to green and the refracted to red; at  $180^\circ$  the colours again change places; at  $270^\circ$  the reflected ray will be again green, and the refracted red; to be once more brought back at  $360^\circ$  to the original position, viz., reflected rays red, refracted green. The thickness of the films of selenite determines the particular colour produced.

If the selenite is of uniform thickness, one colour only is obtained, and by ingeniously connecting pieces of various thicknesses (in the same forms as stained glass for cathedral windows), beautiful designs are made. The colours of these

selenite objects are seen by placing them in front of a piece of black glass, fixed at the polarising angle, and then examining the design with a slice of tourmaline, or still better with a single-image Nicol prism, when the most brilliant colours are obtained, and varied at every change of the angle of the analyser.

Selenite, or gypsum, is the native crystallised sulphate of lime, which contains water of crystallisation ( $\text{CaSO}_4 \cdot 2\text{H}_2\text{O}$ ). It frequently occurs imbedded in London clay, and is called *quarry glass* by the labourers who find it near Oxford, in the Isle of Sheppey, and elsewhere.

At a very early period, before the discovery of glass in Europe, selenite was used for windows; and we are told that in the time of Seneca, it was imported into Rome from Spain,

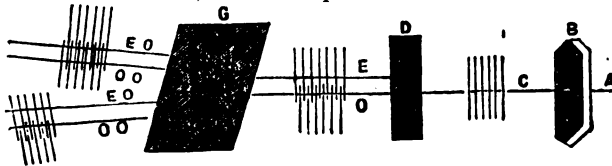

DIAGRAM OF DR. PEREIRA.

Fig. 432. A. A ray of common or unpolarised light, incident on B. B. The polariser (a plate of tourmaline). C. A ray of plane polarised light, incident on D. D. The doubly-refracting film of selenite. E. The extraordinary ray. O. The ordinary ray, produced by the double refraction of the ray C. G. The analyser (or doubly-refracting or Nicol's prism). E O. The ordinary ray. E E. The extraordinary ray, produced by the double refraction of the extraordinary ray. E. O O. The ordinary ray. O E. The extraordinary ray, produced by the double refraction of the ordinary ray. O.

Cyprus, Cappadocia, and even from Africa. It continued to be used for this purpose until the Middle Ages, for Albinus informs us, that in his time, the windows of the dome of Merseburg were of this mineral. The first greenhouses, those invented by Tiberius, were covered with selenite. According to Pliny, beehives were encased in selenite, in order that the bees might be seen at work.

The phenomena already described is here placed in the form of a most instructive diagram. (Fig. 432.)

The chromatic effects described are not confined to selenite objects only, but are obtained from glass, provided the particles are in a state of unequal tension, as in masses of unannealed glass of various forms. (Fig. 433, Page 520.) Consequently, polarised light becomes a most valuable means for ascertaining the condition of particles otherwise invisible and inappreciable. One of the most beautiful experiments can be

made with a bar of plate-glass, which refracts light singly until pressure is applied to the centre, in order to bend it into an arch or curve, when the appearance presented in Fig. 434 is apparent.

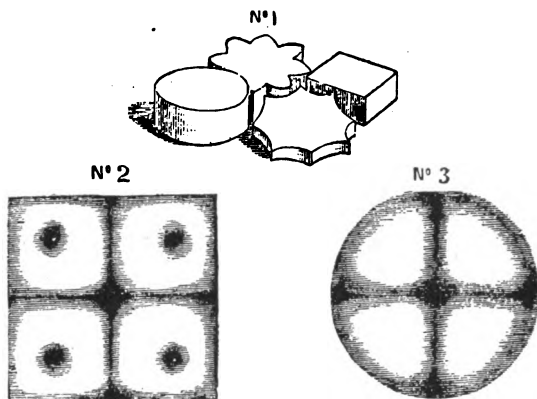

Fig. 433.—No. 1. Unannealed glass for the polariscope. Nos. 2 and 3. Appearance of the black cross and coloured circles in a square and circular piece of unannealed glass in the polariscope.

A quill placed in the polarising apparatus is also discovered to be in a state of unequal tension by the appearance of coloured fringes within it, which change colour at every movement of the analyser.

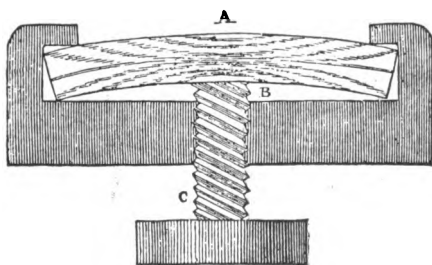

Fig. 434. A B. Bar of glass under the pressure of the screw C, and appearance of bands or fringes of coloured light, which entirely disappear on the removal of the screw. An effect, of course, only visible by polarised light.

Another series of beautiful appearances present themselves when a ray of white polarised light is made to pass perpendicularly through a slice of any crystallised substance with a single axis; if the analyser consists of a slice of tourmaline, a number of concentric coloured rings are rendered visible with a black cross in the centre, which is replaced with a white one on moving the tourmaline through each quadrant of the circle.

Crystals of Iceland spar present this phenomenon in great

beauty; and if the crystal (such as nitre) has two axes of double-refraction, a double-system of coloured rings is apparent, with the most curious changes and combinations of the black and white crosses with them. (Fig. 435.)

The optical arrangement (Fig. 436) is recommended for showing the rings with great perfection, as also the number of rings that increase in some crystals (the topaz, for example), with the divergence of the rays of polarised light passing through them.

An oxy-hydrogen polariscope and microscope, is well adapted, from its simplicity and perfection, to exhibit all the varied and beautiful effects of polarised light; the body of the apparatus is shown at page 455, where the modifications of the oxy-hydrogen light are described and figured; the polarising apparatus would be placed, of course, in front of the light issuing from the lantern.

Finally, the question of utility may be considered in answer to the query,—What is the use of polarised light?

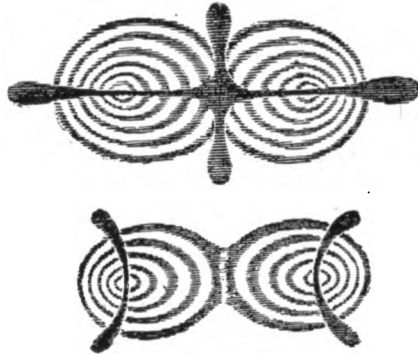

Fig. 435. Crystal of nitre with two axes, as seen in polarised light.

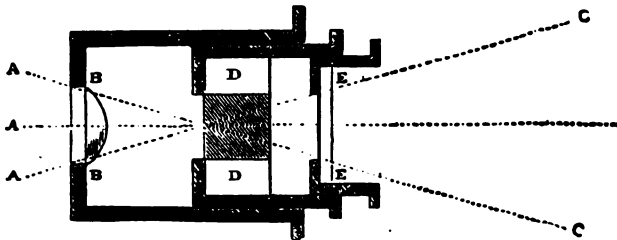

Fig. 436. A A A. Polarised light. B. B. A lens of short focus, transmitting a cone of light with an angle of divergence for its rays, C C, of  $45^\circ$ . D D. The crystal of topaz, Iceland spar, or nitre. E E. The slice of blue tourmaline for analysing.

The value to scientific men of a knowledge of the nature of this modification of common light cannot be overrated. It has given the scientist a new kind of test, by which he discovers the structure of things that would otherwise be perfectly unknown; it has given the astronomer increased data

for the exercise of his reasoning powers; whilst to the microscopist the beauty of objects displayed by polarised light has long been a theme of admiration and delight, and has served as a guide for the identification of certain varieties of any given substance, such as starch.

A tube provided with a polariser of tourmaline, or a single-image Nicol prism, is invaluable to the look-out in cases where vessels are navigating either inland or sea water, where the presence of uncharted hidden rocks is suspected, because the polariser rejects all the glare of light arising from unequal reflection at the surface of water, and enables the observer to gaze into the depths of the sea and to examine the rocks, which can only be perfectly visible by the refracted light coming from their surfaces through the water.

Wheatstone invented an ingenious polarising clock for showing the hour of the day by the polarising power of the atmosphere. Birt, Powell, and Leeson have each invented instruments for examining the circular polarisation of fluids, by which a more intimate knowledge of the relative values of saccharine solutions and the like may be obtained, besides unfolding other truths important to investigators in this branch of science.

And last, but not least, it was with the assistance of polarised light that Faraday established the relation that exists between light and magnetism, and through the latter, with the force of electricity. The next figure indicates the necessary apparatus required to repeat this highly important physical truth—viz., the deviation of the plane of polarisation of light by the influence of the magnetic force from a powerful electro-magnet. (Fig. 437.) See also Chap. XXII, page 388.

By another equally beautiful experiment Grobe demonstrated the production of all other kinds of force from light, using the following arrangement for the purpose:

A prepared photographic plate is enclosed in a box full of water having a glass front with a shutter over it; between this glass and the plate is a gridiron of silver wire; the plate is connected with one extremity of a galvanometer coil, and the gridiron of wire with one extremity of a Breguet's helix; the other extremities of the galvanometer and helix are connected by a wire, and the needles brought to zero. As soon as a beam

of either daylight or the oxy-hydrogen light is, by raising the shutter, permitted to impinge upon the plate, the needles are deflected. Thus, light being the initiatory force, we get

*Chemical action on the plate,*  
*Electricity circulating through the wires,*  
*Magnetism in the coil,*  
*Heat in the helix,*  
*Motion in the needle.*

Such, then, are some of the remarkable phenomena explained in this and the preceding chapters on light. Here we have noticed specially how completely we owe the appreciation of these phenomena to the sense of sight operating

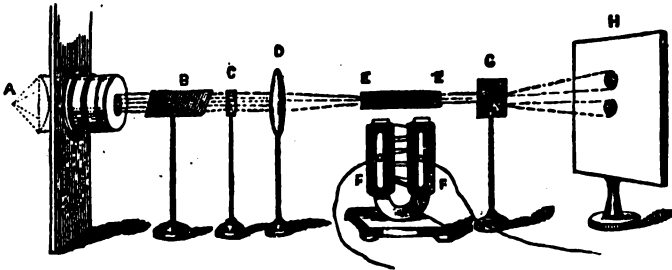

Fig. 437. A. The light and condenser lens. B. Single-image Nicol prism. C. Rock crystal of two rotations. D. A double-convex lens. E. Faraday's heavy glass. F. F. The powerful electro-magnet connected with battery. G. Double-refracting prisms. H. Image, or screen where the deviation of the plane of polarisation by the magnetic force is shown.

through the eye, the organ of vision. Well may those who have lost this divine gift speak of their darkness as of a lost world of beauty to be irradiated only by better and more enduring light, and most feelingly does the orator speak on this point when he says:—

“Conceive to yourselves, for a moment, what is the ordinary entertainment and conversation that passes around any one of your family tables; how many things we talk of as matters of course, as to the understanding and as to the bare conception of which sight is absolutely necessary. Consider, again, what an affliction the loss of sight must be, and that when we talk of the golden sun, the bright stars, the beautiful flowers, the blush of spring, the glow of summer, and the ripening fruit of autumn, we are talking of things of which we do not convey to the minds of those poor creatures who are born blind, anything like an adequate conception. There was

once a great man, as we all know, in this country, a poet—and nearly the greatest poet that England has ever had to boast of—who was blind; and there is a passage in his works which is so true and touching that it exactly describes that which I have endeavoured, in feeble language, to paint. Milton says:—

‘Thus with the year  
Seasons return; but not to me returns  
Day, or the sweet approach of even, or morn,  
Or sight of vernal bloom, or summer’s rose,  
Or flocks, or herds, or human face divine;  
But cloud instead, and ever-during dark  
Surrounds me; from the cheerful ways of men  
Cut off, and for the book of knowledge fair  
Presented with a universal blank  
Of Nature’s works, to me expunged and rased,  
And wisdom at one entrance quite shut out.  
So much the rather, thou, celestial light,  
Shine inward, and the mind through all her powers  
Irradiate; there plant eyes; all mist from thence  
Purge and disperse, that I may see and tell  
Of things invisible to mortal sight.’”

## CHAPTER XXVII

### RADIO-ACTIVITY

#### A—THE RÖNTGEN OR “X” RAYS

This is so wide and complicated a subject that it is impossible to give here more than a brief outline of this curious form of electric energy, and of the causes which led to its discovery by Röntgen. For a more detailed account the reader is referred to the many excellent works on the subject which are to be obtained.

Professor Röntgen, who specialised in the physical properties of heat in steam and gases, in 1895 obtained a peculiar variety of radiation by means of electric discharge in tubes which had been depleted of air, and are technically called vacuum-tubes.

Long before this it had been noticed that after a flask or bottle had been sucked free from air by means of a water or other air-pump, on there being sent into or through the empty bottle, or flask, an electric flash from some source of frictional electricity, the interior of the bottle (bulb) became phosphorescent. Beyond being noticed as a curious circum-

stance, this was allowed for a long time to remain undeveloped and even uninvestigated.

Then the induction-coil was brought into association with it, both as a tube containing a high vacuum of air and as one of depleted gas. That is to say, since a perfect vacuum is not possible, there would still be left in the tube a little highly attenuated air, or gas, or mixture of gases, or gas with air, as the case might be—all these gave definite and often curious results. (See page 367, experiment for reproducing the Aurora Borealis in vacuum tubes by means of the Ruhmkorff, or other coil.)

Then Mr. (later Sir) William Crookes took up the matter, and having the foregoing details before him, together with more effective appliances, he made a remarkable advance. With the obtaining of a tremendously high vacuum, the previous mere phosphorescence seen in the tube now shrank to a single ray of light, extending from point to point, and called a "streamer."

Near the cathode was a non-luminous space, and from this space there emanated certain powerful heat-rays of great energy. These are the rays, which, because of their unknown quantity, Röntgen named, "X," and they have remarkable power. If certain substances are placed so that the rays impinge upon them, or are obstructed by their presence, phosphorescence is caused and great heat generated. Even the glass tube is covered with a blue or green phosphorescence, and if a screen—coated with such fluorescing crystals as those of platino-cyanide of barium, potassium and sodium, etc.—is interposed, it is rendered luminous; the rays, also, are capable of affecting a photographic plate, and the glass of a vacuum tube will soon become so hot as to soften, if the current is continued too long without a break. Many theories have been brought forward with regard to the composition and nature of these strange rays, which are also termed the "cathode" rays, because they proceed from the cathode, or negative point.

Crookes considered them to be a stream of "radiant matter," and his view was shared by Sir George Stokes, Lord Kelvin, and others. These consider that the cathode is discharging a fusillade or bombardment of molecules, which travel separately and individually till they meet with some



obstruction, when they immediately generate great heat and become luminous or phosphorescent.

Thus we find that the dark gap near the cathode, already mentioned, filled with invisible rays, contains the molecules or particles in separate motion, but the instant these strike the walls of the vacuum tube, the impact causes heat, and the luminosity of phosphorescence, or, in other words,—“Crookes's Radiant Matter.”

Lénard, a pupil of Hertz, appeared to prove the incorrectness of this “radiant matter” theory. Hertz made the suggestion to him in the first place, and Lénard, following it up, discovered that these cathode rays penetrated a strip of aluminium when that was inserted so as to form part of the wall or side of the tube, and these rays were called the “Lénard” rays. The cathode rays may be deflected by a magnet, to which they are highly sensitive, and the Lénard rays possess similar characteristics; so the question arose as to whether these new rays were not really a part or modification of the cathode rays.

The fact of the Lénard rays being visible in air and their course clearly defined, seemed to point to an entirely new set of rays, since the cathode rays can only be produced in a very high vacuum, therefore they could not exist in atmospheric air. Many scientists came to the conclusion that they were waves of that particular component of the ether of space, called, “luminiferous ether” rather than a bombardment of molecules or particles on the walls of the tube, aluminium, or other obstructing substance.

Professor Thomson suggested that the bombardment of the rays on the slip of aluminium on the inside of the tube, might be the cause of starting similar rays on the outside of the slip, visible at atmospheric pressure and in atmospheric air. This view seemed to be confirmed by the fact that up to this time there was no conclusive scientific proof that the rays had really and truly *penetrated* the strip of metal, since the X-rays proper will not traverse metals.

Thomson made many experiments in order to measure the exact speed of the cathode rays, and showed that these could scarcely be ether vibrations, since their speed is only one-thousandth part of that of light.

Although Lénard affected a photographic plate whilst it was enclosed in a metallic case, by means of these rays, it was re-

served for Röntgen, entirely by accident, to make the astounding discovery that the bones of the living body could be photographed by the cathode or "X" rays. Every reader will be familiar with the photographs of substances enclosed in bags and boxes. The object to be photographed is placed over or before a photographic plate securely enclosed in a daylight-proof bag; over or before the object, as the case may be, is fixed a vacuum tube, and on a short exposure the plate may be developed, when the radio-graph, if of a human limb, will show the exact position of the bones inside the flesh.

It is impossible to estimate the benefit this discovery has



Fig. 438. Radiograph of hand showing position of embedded broken needle head.  
Taken by Dr. W. Harwood Nutt.

proved to science, and especially to the surgeon, for by its means, displacement of limbs and bones, the presence of foreign substances, and a host of other mishaps may readily be located. See Figs. 438, 439, and 440.

Notwithstanding the many uses to which this new science has been subjected, it still remains the "X" or "unknown quantity," and the too-frequent association with it, by the operator or the person "rayed," produces most disastrous and appalling results.

#### B—THE "N" RAYS

From the "X" rays we pass to the "N" rays. From the time of the discovery of the X rays until recently, they had eluded all efforts to polarise them. Therefore their action and speed could not be examined with any hope of conclusive results, for it was possible to bring about several. According to the method employed, so could results be obtained, which, to a certain extent, accounts for the diversity of views

held by eminent scientists, as to the composition and physical behaviour of the X rays.

Scientists are, however, working most strenuously on this difficult subject, and are discovering more certainly that

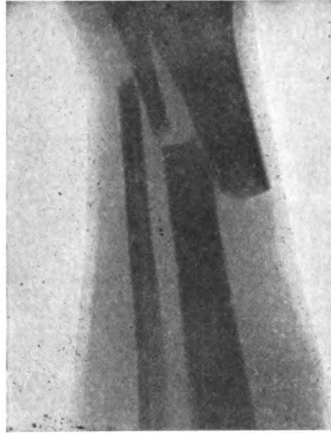

**Fig. 439.** Radiograph of leg, showing fracture of both bones—tibia and fibula.  
Taken by Dr. W. Harwood Nutt.

Röntgen truly named them, because they are not by any means the simple bundle of rays they might appear to be, on the surface. They are full of complexities, analogies, and



**Fig. 440.** Radiograph of leg, showing exact position of bullet embedded in fibula.  
Taken by Dr. W. Harwood Nutt.

anomalies; certain of them conform to certain laws and rules, whilst in the very same rays there are parts, or intermediate rays which offer distinctive and opposite features. Some of these are being slowly elucidated and show most interesting characteristics.

Not the least of these discoveries is due to Professor Blondlot who, in 1903, communicated a series of unique papers to the French Academy of Sciences. He had, for some time past, been studying the X rays with regard to their velocity of propagation, and came to the conclusion that this velocity did not apply to the X rays proper, but to another kind of rays which he called the "N" rays, proving that they were, really, light-rays, (see the Lénard rays in the X-ray section) and that they travelled at the same speed as light and as the Hertzian waves.

The first of this series of papers by Blondlot deals with the manner in which he succeeded in polarising the X rays; how, from a belief in the presence of the N rays of rays of a character altogether different, he went on step by step, accepting nothing for granted that could not be proved, when, in course of time, he found these N rays (or polarised X rays), behaved in the polariscope exactly as polarised light-rays.

The manner in which he arrived at this, simple as it is in result, is outside the scope of this volume. Suffice it to say, he discovered an entirely new series of rays, which were not the Röntgen rays, exactly, since they could be polarised, refracted, and reflected, all of which are beyond the capabilities of the true Röntgen rays. In contradistinction to these also, the N rays are diffused, are incapable of affecting a photographic plate, and cannot by any possibility be made to produce fluorescence. These N rays may also be polarised elliptically and rotatorily, and from their very emission are plane-polarised. Further, Blondlot goes on to show that even in the dark and with much increased power the rays are altogether invisible, and without the slightest trace of fluorescence.

He proved that these rays really had penetrated the aluminium disc, to which reference has been made in the X-ray section, and though in the early stages of the experiments he believed that he had really polarised the actual Röntgen rays,

he soon came to the conclusion that he had isolated an entirely new species.

A later paper, communicated in May, 1903, explains how he discovered that in the N rays themselves there existed still other rays, giving off radiations which penetrated metals, wood, and every substance which he had used except rock-salt, and he obtained photographs of them without any photographic apparatus, prints being taken by means of the rays only.

It is curious to note that the rays themselves, as already stated, do not influence the photographic plate, the active agent being the electric spark, which is under the influence of the N rays.

It appears from his June (1903) paper, that Blondlot experimented at considerable length and with success, in discovering similar rays emitted by the sun, which were capable of traversing metals, and he found that these N rays, though not themselves fluorescent, when brought in contact with substances which are already phosphorescent, greatly increase the existing fluorescence. Thus he goes on to show that the interposition of such a body as a hand before the brightness, dulls it, which light recovers on the intersecting object being taken away, out of the path of the invisible N rays.

These rays may be stored up by and in various substances, and act in no small degree on the eye in rendering objects luminous; when stored in steel, leather and other materials, these then emit the rays indefinitely, without appreciable loss.

Professor Blondlot suggests that the best method of examining these rays and their effects on a screen or other luminous substance, is to look quietly and calmly some few inches past the screen or object rather than at it, so as to get more an impression than actual sight, or no effect will be observed.

#### C—RADIO-ACTIVE ELEMENTS

It may truly be said that the science of radio-activity had its origin in the magnificent discovery of the X rays, in 1895, and the following year came another remarkable discovery, by accident, like that of Röntgen.

Professor Becquerel was experimenting with the Röntgen rays on a photographic plate, using some uranium salt, he

having forgotten or omitted to expose the salt to daylight so that fluorescence might be induced.

What was his surprise to find the plate affected and spoiled. Realising that he was on the eve of a discovery he tried again, this time selecting some new salt which he *knew* had not been exposed to daylight. Again was a fresh photographic plate fogged. What had caused this? Was it something in the element itself, or was it entirely fluorescence? He soon proved that the element uranium, as an element, possessed a form of radiation which could traverse opaque, light-proof substances, and affect a sensitised photographic plate when securely fastened in a light-proof case. The compounds of uranium having similar properties in accordance with the quantity of the element contained in them, the element, or metallic uranium was stronger than anything with which it had entered into combination.

Then came the news which startled the scientific world—that there had been discovered an entirely new feature or property in matter, that of radio-activity.

One event followed another in rapid succession. Madame Curie commenced her experiments, working on pitchblende, a quantity of which was placed at her disposal; she discovered that according to the power of a body to ionise air or gas, so is its radio-activity. The most radio-active substances then known were thorium and uranium, the latter by far the more powerful, and whilst she was working at some pitchblende, she discovered something which she could not at all understand, so it was subjected to the severest analysis.

Extracting all the uranium from the pitchblende, she obtained an enormous amount of radio-activity from what was left. Both Mme. Curie and her husband could only attribute this to the presence of a new body. Almost everyone knows that the small substance they obtained was too minute to analyse, but after the expenditure of a considerable amount of money, time and material, sufficient was produced to enable them to proceed with the analysis.

This essence, as it were, of the vast quantity of the pitchblende used, was found to have a radio-activity of incalculable power, which tiny but marvellous substance obtained was called "radium,"—the most powerful element known in radio-activity.

Later, Mme. Curie obtained another but less powerful substance, "polonium," which, however, had already been isolated. Later still, Debierne, from the same source, obtained "actinium"; but neither of these is an element.

It may be interesting to note a few of the many remarkable characteristics of the salts of radium. Apart from the rays, (which it should be stated are invisible in all the radio-active substances, their effects being the only evidence of their presence) a tube containing radium salts will glow slightly in the dark; the purer the salt the less luminous is it; probably this is owing to the fact that the rays strike inwards, as well as all round outwards, and thus cause the salt to become slightly luminous.

Ordinary pure oxygen becomes converted to its allotropic form as ozone ( $O_3$ ), on the mere approach of radium salts; the glass tube in which the salts are confined and perhaps concealed, changes colour, becoming gradually darker until black, but the reason for this change has not as yet been conclusively explained; some authorities attribute it to chemical change, whilst others consider the change to be merely physical. If a diamond, ruby, and similar stones are placed in the dark, without the slightest gleam of light to render them visible, they shine most brilliantly as a tube of radium is brought even near them.

If a tube of it is placed in foul water, certain bacilli, especially the typhoid, become active, and liquid solutions of the salt decompose water, setting free the oxygen and hydrogen.

Radium salts will affect a photographic plate, even when it is wrapped up and enclosed in the centre of a nest of boxes, metallic or wood, imprinting on the plate images of coins, etc., which have been placed on the outer box, and this when shut up in a cupboard for a few hours, along with a tube of radium.

Extreme care has to be exercised in the use and handling of radium compounds. They should be enclosed in lead capsules; the late Professor Curie's injury by exposing his arm to the rays will be remembered by all. The mere carrying of a tube in the pocket, unprotected by lead, may produce a serious wound, which is long in healing, often never healing at all. Radium should be kept in a specially constructed

safe which is lined entirely with lead. The precious substance is used largely in the medical profession in the treatment of cancer and other malignant diseases, but its therapeutic value or otherwise, and the many arguments in favour of its use and disuse for these purposes go far beyond the object of this book.

#### D—WIRELESS TELEGRAPHY

Before explaining briefly the principle of wireless telegraphy, it would be well to note the behaviour of substances under the influences of the electric current. As we have seen in the section on electricity, surrounding each pole of a magnet or electrified body, there is a certain amount of space called the electric field, and anything brought within the influence of this field which is capable of electrification becomes electrified by induction. The electric waves travel to the added body, or, to use a technical term, to the body brought within the electric field. The surrounding ether which is agitated is a complex substance occupying space, and certain atoms in it have a great affinity for electrification, which is communicated to the ether surrounding each atom and carried from point to point along the ether. All this has been known for many years, and it follows that if these points could be drawn further and further apart, the current transmitted on the ether would cause it to act as a kind of wire stretched tightly between the two points. Many attempts were made to solve this problem, but none were practical. Marconi was the first to show a workable system by which these vibrations or waves of electricity could be transmitted on the ether itself in a practical, commercial manner. Briefly, he connected a series of balls to an induction coil; the current thus obtained so electrified them that a certain impulse was given to the waves of ether, which vibrated in sympathy, and these vibrations were transmitted to the distant station, where they were received by a corresponding sympathetic instrument. The Morse code was used, the signals being imprinted on a strip of moving paper, according to the Morse alphabet, (page 337.)

These waves vibrate in all directions, therefore the higher the transmitting and receiving wires were fixed above the ground, so much the greater was the distance affected. At the first, a



distance of fourteen miles was considered the limit to which messages could be sent, but experience and experiment have not only enabled Marconi to control the vibrations with comparatively short masts, but have so extended the distance under effective control as almost to "put a girdle round about the earth in forty minutes" by no means beyond the ready command of the operator.

#### E—WIRELESS TELEPHONY

To Marconi's discovery do we owe the possibility of telephoning without wires. As will be seen in the chapter on telephones, the first form required two wires; then came the discovery of the use of one wire only, with another short one at each end connected to earth. Then, owing to certain geographical difficulties, crude attempts were made to do without even the single wire, by connecting a wire, metallicly, to a plate sunk in the sea, earth, or river, and the distant wire similarly treated. Telephonic communication was thus established between the two points, but this was very erratic and more often useless than otherwise. Then, twenty years later, an improvement was made; Gavey, in 1894, established perfect communication across Loch Ness. For his transmitter he used a microphone, the reproducer at the other end being that of an ordinary telephone receiver, and he had two long wires soldered or riveted to make a metallic connection to a plate buried in the earth, the earth and the water acting as the conductor, thus making the connection between the two points as satisfactorily as if an actual cable united them.

Then came the communication between the Cemlin coast-guard station and the Skerry lighthouse which in this case was made by the wire being metallicly attached to a plate flung in the sea at both ends, so that in this instance, there was sea connection only.

From these and many other similar experiments it was found that the length of earth-wire at each extremity would have to be not less than five per cent. of the total distance between the instruments, though six per cent. proved a better and more effective working distance. Thus, with a desired communication between two points twenty thousand yards apart, using microphones as transmitters, and telephone receivers for reproducing the message, nothing was perma-

nently effective unless the earth-wire at each end was five per cent. of that distance, or one thousand yards long; six per cent., or twelve-hundred yards answering better.

Some of these wireless telephone services are still in use, being, after many years' service as satisfactory as are any fitted with the regulation wire.

So far, however, these so-called wireless services had earth, or water, connections, or both, and no attempt had been made to use the ether of space. But when Marconi produced his wonderful ether-wave telegraph, its possibilities of reproducing the sound of the human voice seemed but a step further.

Everyone knows that sound is the result of air-vibrations, since sound is only possible in air, and that when a tuning-fork or other object is caused to vibrate, these vibrations are carried on the air-waves, strike the drum of the ear (the tympanum), and cause it to vibrate in sympathy, in exactly the same number of vibrations as are set up by the tuning-fork or other object struck.

It seemed, therefore, but a natural inference to suppose that if there could be launched on the ether, electric vibrations which the presence of air made effective in reproducing the signs and sounds of a code, such as the Morse telegraphic code, the same ether should be equally capable of reproducing actual sound-vibrations which might be launched upon it.

Scientists soon put such theories to the test of practical experiment, and discovered that the Marconi system in its general principles, was as equally applicable to telephony as to telegraphy. No great distances have as yet been covered, owing to the difficulties of current,—which are, however, but mechanical difficulties—though by the use of microphones, and in the later instruments, by a combination of telephone and microphone in one, it has been proved possible to telephone over a thousand miles, and that with perfect articulation.

This science may at present be considered as being in its infancy; no doubt as better methods of applying electricity and probably more perfect earth-connections are discovered, the range of its powers will become almost unlimited, as is that of the sister science, telegraphy.

Even in the comparatively short time that has elapsed since its inception, the limit has been extended from twenty-feet to over one thousand miles, as already stated, and any day may suddenly see this distance vastly increased, most probably far beyond the power of the wireless telegraph, because of the greater sensitiveness and simplicity of the wireless telephone instruments and for several other reasons, which make its range unlimited, theoretically. This increased perfection is partly owing to the more perfect microphones and to the use of highly effective parabolic reflectors, which project the sound in any desired direction and with great power, acting on the distant instrument in perfect sympathy with it.

## CHAPTER XXVIII

### HEAT

Throughout the greater number of the preceding chapters it will be evident that the active properties of matter may be summed up under one general head, and may be considered as varieties of attraction—such as the attraction of gravitation, cohesive attraction, adhesive attraction, attraction of composition (or chemical attraction), electrical attraction, magnetic attraction.

The absolute or autocratic does not, however, prevail in the works of nature; she seems ever anxious, whilst imparting great and peculiar powers to certain agents, to create other forces which may control and balance them. Thus, for instance, the great force of cohesive attraction is an ever-present power discernible, as has been shown, in solids and liquids; but if this agent were allowed to run riot in its full strength and intensity, it would tyrannically hold in subjection all liquid matter, and every drop of water which is at present kept in the liquid state, would succumb to its iron rule, and retain the solid state of ice. Hence, therefore, the wise creation of an antagonistic force—heat; which is not provided in any niggardly manner, but is liberally bestowed upon the globe from that all-sufficient and enormous source, the sun. And it is by the softening and liquefying influence of his rays that the greater proportion of the water on the surface of the globe is maintained in the fluid condition, and is enabled to

resist the power of cohesion, that would otherwise turn it all, as it were, to stone.

Cohesion, electricity, and magnetism fully embody the notion of powers of attraction, or *a drawing together*; whilst heat stands almost alone in nature as the type of repulsion, or *a driving back*.

Mechanically, repulsion is demonstrated by the rebound of a ball from the ground; the parts which touch the earth are for the moment compressed, and it is the subsequent repulsion between the particles in those localities of compression which causes them to expand again and throw off the ball, as they resume their original quiescent condition.

The development of heat is produced from various causes, which may be regarded as at least four in number. Thus, it was shown by Davy, that even when two lumps of ice are rubbed together, sufficient heat is obtained to melt the two surfaces which are in contact with each other. Friction is therefore an important source of heat, and one of the most interesting of demonstrating machines consists of an apparatus by which many gallons of water are kept in the boiling state by means of the heat obtained from the friction of two copper discs against each other. The machine has often attracted a good deal of attention on its own merits, especially when it supplied boiling water for the preparation of chocolate, which the public was duly informed was boiled by the heat *rubbed out* of the otherwise cold discs of copper.

Count Rumford endeavoured to ascertain how much heat was actually generated by friction. When a blunt steel bore, three inches and a half in diameter, was driven against the bottom of a brass cannon seven inches and a half in diameter, with a pressure which was equal to the weight of ten thousand pounds, and made to revolve thirty-two times in a minute, in forty-one minutes 837 grains of dust were produced, and the heat generated was sufficient to raise 113 pounds of the metal 70° Fahrenheit—a heat capable of melting six pounds and a half of ice, or of raising five pounds of water from the freezing to the boiling point. When the experiment was repeated under water, two gallons and a half of water, at 60° Fah., were made to boil in two hours and a half.

Chemical affinity has been so often alluded to in these pages, that it may be sufficient to mention only one good instance

of its almost magical power in evoking heat. When a bit of the metal sodium is placed on the tip of a knife, and thrust into some warm quicksilver, or if a pellet of sodium and a few globules of mercury are placed on a hot plate just taken from the oven, and then gently squeezed together, a vivid production of heat and light is apparent. When the mixture of the two metals is cold, it will be found that the quicksilver has lost its fluidity, and a solid amalgam of sodium and mercury is obtained, which gradually, by exposure to the air, returns to the liquid state, the mercury being set free, whilst the sodium is oxidised, and forms soda. Just as an ordinary alloy of copper and gold used by jewellers would lose its colour and brilliancy by the oxidation of the copper; and when the rusty, dirty film is removed by rubbing and polishing, the surface is again brilliant, and remains so until another film of the exposed copper is attacked; in like manner the sodium is attacked and changed by the oxygen of the air, whilst the mercury being comparatively unaffected retains its brilliancy, and at the same time regains its fluidity. The evolution of heat in the above case indicates that a chemical union has taken place between the two metals.

Examples of the production of heat by electricity and magnetism have been abundantly seen in the chapters on these subjects; and one of the best illustrations of this fact was shown on the occasion of the opening of the telegraphic communication between France and England by means of the submarine cable, when cannon were fired alternately at both ends of the conducting cable by means of electricity, and the event thus inaugurated in both countries.

That heat is a product of living animal organisation is shown, as it were, visibly by the marvellous phenomena that proceed in our own bodies. People do not very often trouble themselves to ask where the heat comes from, or even to think that this invisible power must be maintained, that slow combustion must continually go on in the body and we cannot afford to waste our heat. If the body is deprived of heat faster than it can be generated, death must inevitably occur.

Heat is of two kinds, and may be either apparent to our senses, and therefore called *sensible* heat; or it may be entirely concealed, although present in solids, liquids, and gases, and is then termed *insensible* or *latent* heat.

## SENSIBLE HEAT

The first effect of this force is a demonstration of its repulsive agency, and the dilatation or expansion of the three forms of matter whilst under the influence of heat, admits of very simple illustrations. The expansion of a solid substance, as, for instance, a metal, on the application of heat, is apparent by fitting a solid brass cylinder or thick brass wire into a proper metal gauge, which is accurately filed so as to admit the former when perfectly cold. If the brass rod is then heated, either by plunging it into boiling water or by the application of the flame of a spirit lamp, its particles are separated from each other; they now occupy a larger space, and expansion is the result, and this is clearly proved by the application of the gauge, which is no longer capable of receiving it. (Fig. 441.) When, however, the latter is cooled, the opposite result occurs, the particles of brass return to their old position, and *contraction* takes place; hence "bodies expand by heat and contract by cold;" and it is proper to state here that the term "*cold*" is of a negative character, and simply means the absence of heat.

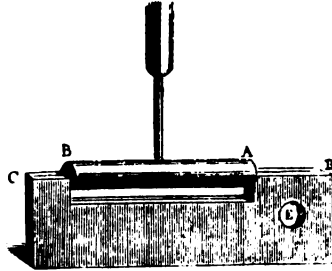

Fig. 441. A B. Cylinder of brass. C D. Iron gauge, admitting A B. longitudinally, and also in the hole E when cold, but excluding A B when the latter is heated and expanded.

Solid bodies do not expand equally on the application of the same amount of heat; thus, a bar of glass one inch square and one thousand inches long would only expand one inch whilst heated from the freezing to the boiling point of water. A bar of iron one inch square and eight hundred inches long would expand one inch in length, through the same degrees of heat; and a bar of lead one inch square and three hundred and fifty inches long would also dilate one inch in length. Hence,

Lead expands in volume.....	$\frac{1}{350}$
Iron .....	$\frac{1}{800}$
Glass .....	$\frac{1}{1,000}$

The unequal expansion of the metals is well illustrated by

an experiment devised by Tyndall, and is arranged as follows:—A long bar of brass and another of iron are supported on the edges of two pieces of wood placed at an angle, and resting against the sides of a wood framework. The metallic bars only touch one end of the frame, and are in metallic communication with a piece of brass inserted there, and forming part of a conducting chain connected with a voltaic battery; when heat is applied to both bars they expand unequally; the brass bar dilates first, and filling up the minute space left between the two ends of the frame, touches another brass plate and instantly completes the voltaic circuit, when a coil of plati-

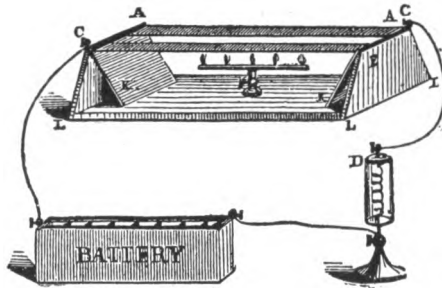

Fig. 442. A A. The brass bar which has expanded by the heat from the gas jet B, and making the contact between the brass plates in connexion with the binding screws C C, the voltaic circuit is completed, and a coil of platinum wire in the glass tube D, is immediately ignited. The iron bar at E E has not expanded sufficiently, which is shown afterwards by removing the angular wooden supports K K, when the iron falls off, and the brass remains on the two ledges of the wood framework L L L.

num wire becomes ignited, showing the fact of expansion; and secondly, the difference in the power of dilatation possessed by each is clearly shown by removing the two angular supports of wood, when the iron falls away, whilst the brass remains and still completes the voltaic circuit. (Fig. 442.)

The force exerted by the expansion of solids is enormous, and reminds us again of the amazing power of all the imponderable agents; and it is truly wonderful to notice how the entry of a certain amount of heat into and between the particles of metals, or other solids, endues them with a mechanical force which is almost irresistible, and is capable of working much harm. Kussné made an experiment with an iron sphere, which he heated from a temperature of 32° Fahr.

to 212° Fahr., and he found that the expansion of the ball exerted a force equal to 4000 atmospheres—*i. e.*,  $4000 \times 15$ —on every square inch of surface, or a pressure equal to thirty millions of pounds; the entry of only 180° of heat into the iron sphere produced this remarkable result, just as Faraday calculated that a single drop of water contains a sufficient quantity of electricity to produce a result equal to the most powerful flash of lightning, provided the electricity of quantity in the drop of water is converted into electricity of high tension or intensity.

The practical applications of this well-known property of solids with respect to heat are very numerous; thus, the iron bullet-moulds are always made a little larger than the requisite size, in order to allow for the expansion of the hot liquid lead, and the contraction of the cold metal. The tires of wheels and the hoops of casks are usually placed on whilst hot, in order that the subsequent contraction may bind the spokes and fellies, or the staves, closely together. If an allowance was not made for the expansion and contraction of the iron rails on the permanent ways of railroads, the regularity of the level would be constantly destroyed, and the position of the rails, chairs, and sleepers would be most seriously deranged; indeed it is calculated that the railway bars between London and Manchester are five hundred feet longer in the summer than in the winter.

The walls of the Cathedral of Armagh were brought back to a nearly perpendicular position, by the insertion (through the opposite walls) of great bars of iron, which being alternately heated, expanded, and screwed up tight, then cooled and contracted, gradually corrected the bulging out of the walls or main supports of the building. The principle of these practical experiments which may be seen any day as having been applied to all kinds of buildings, is well illustrated by means of an iron framework with a bar of iron placed through both its uprights, and screwed tight when hot; on cooling, contraction occurs, which is shown by a simple index. (Fig. 443, Page 542.)

It has often been remarked that there is no rule without an exception, and this applies in a particular instance to the law that “bodies expand by heat and contract by cold”—



viz., in the case of such alloys as Rose's fusible metal, which consists of

Two parts by weight of bismuth,  
 One part by weight of lead,  
 One part by weight of tin.

To make the alloy properly, the lead is first melted in an iron ladle, and to this are added first the tin, and secondly the bismuth; the whole is then well stirred with a wooden rod, and cast into the shape of a bar.

When placed in the pyrometer and heated, the bar expands

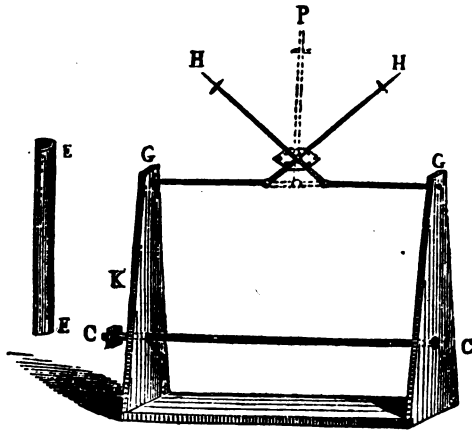

Fig. 443. The iron frame, with C C, wrought-iron bar heated by putting on the semicircular piece of iron E E, which is first made red-hot, and as the heat is communicated to the wrought-iron rod C C. It is screwed up tight by the nut K. G G. The index attached to the iron frame screwed up when hot; the arms come together at P, and separate further to H H as the contraction takes place by cooling the bar C. C.

progressively till it reaches a temperature of  $111^{\circ}$  Fahr.; it then begins to *contract*, and is rapidly *shortened*, until it arrives at  $156^{\circ}$  Fahr., when it attains a maximum density, and occupies no more space than it would do at the freezing-point of water. The bar, after passing  $156^{\circ}$ , again expands, and finally melts at about  $201^{\circ}$ , which is  $11^{\circ}$  below the boiling-point of water. Fusible metal is sometimes made into teaspoons, which soften and melt down when stirred in a cup of hot tea or basin of soup, to the great surprise and bewilderment of the victim of the practical joke.

Unequal expansion is familiarly demonstrated with a bit of

toasted bread, which curls up in consequence of the surface exposed to the fire contracting more rapidly than the other; and the same fact is illustrated with compound flat and thin bars of iron and brass, which are fixed and riveted together: when heated, the compound bar curves, because the iron does not expand so rapidly as the brass, and of course forms the interior of the curve, whilst the brass is on the exterior.

The experiment with the compound bar is made more conclusive and interesting by arranging it with a voltaic battery and platinum lamp. One of the wires from the battery is connected with the extremity of the compound bar, and as long as it remains cold, no curve or arch is produced, but when heat is applied, the bar curves upwards, and touching the other wire of the battery, the circuit is completed, and the platinum lamp is immediately ignited. (Fig. 444.)

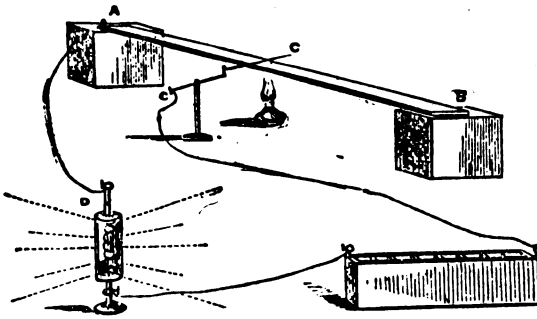

Fig. 444. A B. Compound bar resting on two blocks of wood. The end A is connected with one of the wires from the battery. The circuit is completed and the platinum lamp D ignited directly the bar curves upwards by the heat of the spirit lamp, and touches the wire C C connected with the opposite pole of the battery.

The expansion and contraction of liquids by heat and cold is also another elementary truth which admits of ample illustration, and indeed introduces us to that most useful instrument called the thermometer.

If a flask is fitted with a cork through which a long glass tube, open at both ends, is passed, and then carefully filled with water coloured with a little solution of indigo, so that when the cork and tube are placed in the neck, all the air is excluded, a rough thermometer is thus constructed, which, if placed in boiling water, quickly indicates the increased

temperature by the rising or expansion of the coloured water inside the flask. (Fig. 445.)

The thermometer embraces precisely the same principle as that already described in Fig. 445, with this difference only, that the tube is of a much finer bore, and the liquid employed, whether alcohol or mercury, is boiled and hermetically sealed in the tube, so that the air is entirely excluded. To make a thermometer, a tube with capillary bore is selected of the

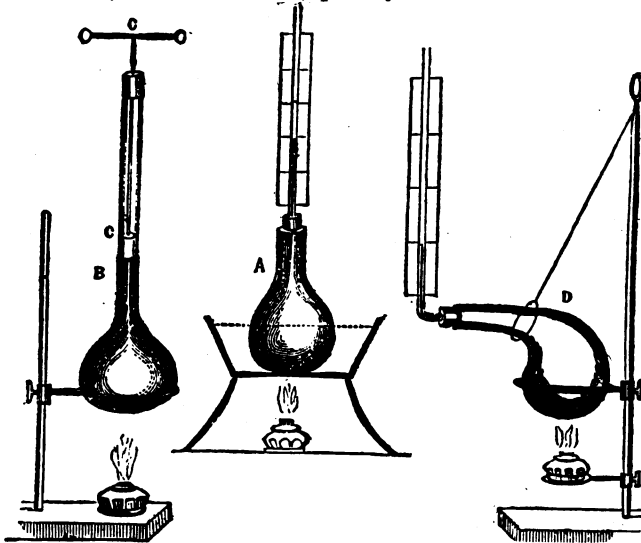

Fig. 445. Expansion of liquids shown at A by the coloured water rising in the tube from the flask, which is quite full of liquid, and heated by boiling water. B. The expansion of the water heated by the spirit-lamp is shown by the rising of the piston and rod C C. D represents a retort filled up like A to show the expansion of a liquid by heat.

proper length; it is then dipped into a glass containing mercury, so that the tube is filled to the length of half an inch with that metal. The half-inch is carefully measured on a scale, and the place the mercury fills in the tube marked with a scratching diamond or a file; the mercury is then shaken half an inch higher, and again marked, and this proceeding is continued until the whole tube is divided into half inches. The object of doing this is to correct any inequalities in the diameter of the bore of the glass tube, because if wider at one part than another, the spaces filled with the mercury are not equal; as the bore is usually conical, the careful measure-

ment of the tube with the half inch of mercury in the first place gives the operator at once a view of the interior of his tube, and enables him to graduate it correctly afterwards. (Fig. 446.)

The next step is to heat one extremity by the lamp and blowpipe, and whilst hot, to blow out a ball upon it; if this operation were performed with the mouth, moisture from the breath would deposit inside the fine bore of the glass tube, and injure the perfection of the thermometer afterwards. In

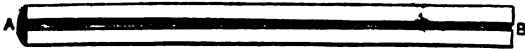

Fig. 446. A B. Magnified view of the bore of one of the thermometer tubes which are made by rapidly drawing out a hollow mass of hot glass whilst soft and ductile, consequently the bore must be conical, and larger at one end than the other. It will, however, be found more satisfactory to buy the tubing made and sold specially for the purpose, in which the bore is practically uniform and may be taken as such for all but really accurate thermometers.

order to prevent any deposit of water, the bulb is blown out, whilst red hot, with the air from a small india-rubber or silk bag fitted on to the other extremity of the tube. The operator now marks off the intended length of his thermometer, and above that point the tube is again softened with the flame and blowpipe, and a second bulb blown out. (Fig. 447.)

The open end of the tube is now placed under the surface of some pure, clean, dry quicksilver, and heat being applied to the upper bulb, the air expands and escapes through the mercury, and, as the tube cools a vacuum is produced, into

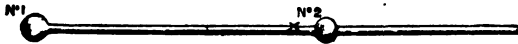

Fig. 447.—No. 1. First bulb. The intended length of the thermometer is shown at the little cross.—No. 2 is the second bulb placed above the cross.

which the mercury passes. By this simple method, the mercury is easily forced into the tube, as otherwise it would be impossible to *pour* the quicksilver into the capillary bore of the intended thermometer. (Fig. 448, Page 546.)

The tube is now taken from the glass containing the mercury, and simply inverted; but in consequence of the very narrow diameter of the bore the air will not pass out of the first bulb until heat is applied, when the air expands, and the mercury, first stationary in the second bulb, will now displace the air, and fall into the first bulb when the tube is again cool.

The ball, No. 1 (Fig. 447, above), is now full of mercury,

and there is also some left in No. 2; in the next place, the tube is supported by a wire, and held over a charcoal fire, when it is heated throughout its entire length, and the mercury on being boiled expels the *whole of the air*, so that there is nothing inside the bulbs and capillary bore but mercury and its vapour. (No. 1, Fig. 449.) The open end of the intended thermometer is now temporarily closed with sealing-wax, and the whole allowed again to cool with the sealed end uppermost, so that the ball No. 2, Fig 449, and the tube above it, are quite filled with quicksilver.

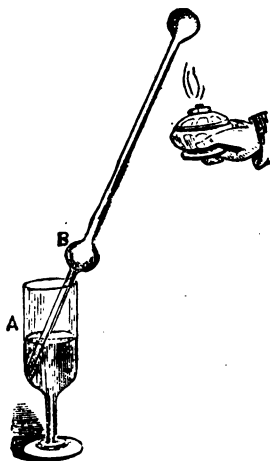

Fig. 448. Heating and expanding the air in the top bulb, so that when cool the mercury in the glass A, may rise into the tube and fill the bulb B.

After cooling, the tube is placed at an angle with the sealed end uppermost, and, guided by experience, the operator heats the lower bulb so as to expand enough mercury into the upper one to leave space for the future expansion and contraction of the mercury in the tube, which has now to be hermetically sealed. This is done by dexterously heating the tube at the cross whilst the mercury in the first bulb is still expanded; and by drawing it out rapidly with the help of the heat obtained from the lamp and blowpipe, the second bulb is separated from the first at the little cross (B, No. 3, Fig. 449), and the thermometer tube, properly filled with quicksilver, is hermetically closed. (No. 4, Fig. 449.)

In order to procure a fixed starting-point, the thermometer tube is placed in ice, with a scale attached; the temperature of ice never varies, it is always at 32 degrees. When, therefore, the mercury has sunk to the lowest point it can do by exposure to this degree of cold, the place is marked off in the scale, and represents that position in the graduated scale where the freezing point of water is indicated.

The tube is now placed in a vessel of boiling water, care being taken that the whole tube is subject to the heat of the water and the steam issuing from it, and when the mercury has risen to the highest position attainable by the heat of

boiling water, another graduation is made which indicates 212 degrees—viz., the boiling point of water. This graduation should be made when the barometer stands at 30 inches, because the boiling point of water varies according to the weight of the superincumbent air pressing upon it.

Between the graduation of the freezing and the boiling point of water the space is divided into 180 parts, which added to 32 make up the boiling point of water to 212 degrees, being the graduation of Fahrenheit, who was an in-

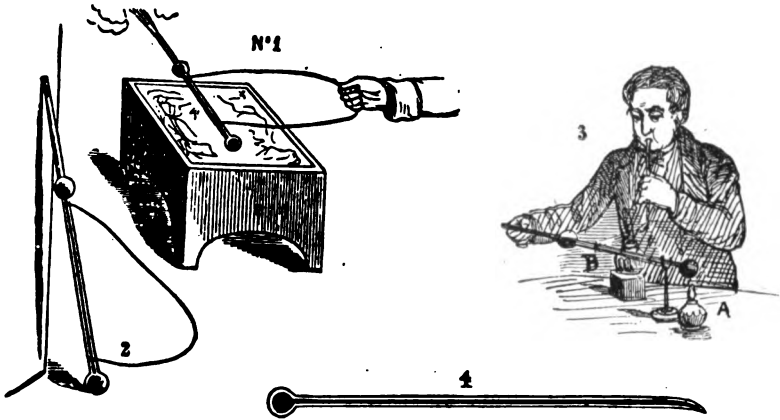

Fig. 440.—No. 1. Boiling quicksilver in the tube with two bulbs.—No. 2. Tube cooled, with the sealed end uppermost.—No. 3. Mercury in first bulb expanded by lamp A, and at the proper moment hermetically sealed by the flame urged by the blowpipe at B. The upper bulb and tube to the cross being drawn away and separated.—No. 4. Thermometer tube containing the requisite quantity of mercury, hermetically sealed, and now ready for graduation.

strument-maker of Hamburg. Why he divided the space between the freezing and boiling point of water into 180 parts nobody appears to know, unless he took a half circle of 180 degrees as the best division of space. If the thermometer contains air the mercury divides itself frequently into two or three slender threads, each separated from the other in the capillary bore, and thus the instrument is rendered useless until the threads again coalesce. If the thermometer has been well made, and is quite free from air, it may be tied to a string and swung violently round, when the centrifugal force drives the slender threads of mercury to their common source—viz., the

bulb containing the quicksilver, and the whole is again united. The string must be attached, of course, to the top of the thermometer scale. Other methods of making thermometers may be obtained from most works on chemistry and all works on physics, but the method given is simple and such as any boy may follow with success.

It is often desirable to be able to read other thermometers which are graduated in a different manner to that of Fahrenheit. In France the Centigrade scale is preferred, and in many parts of Germany Reaumur's graduation. The difference of the graduation is seen at a glance.

In the Centigrade the freezing point is 0, the boiling point 100°.

In the Reaumur the freezing point is 0, the boiling point 80°.

In the Fahrenheit the freezing point is 32°, the boiling point 212°.

The number of degrees, therefore, between boiling and freezing is 100 in the Centigrade, 80 in Reaumur, and (212—32, that is) 180 in Fahrenheit.

If, then, the letters C, R, F, be taken to denote the *number* of degrees from the freezing point at which the mercury stands in the Centigrade, Reaumur, and Fahrenheit thermometers, we have the following proportions:—

- (1)  $100 : 80 :: C : R$ , whence  $C = \frac{4}{5}$  of R, or  $R = \frac{5}{4}$  of C.
- (2)  $180 : 100 :: F : C$ , whence  $F = \frac{9}{5}$  of C, or  $C = \frac{5}{9}$  of F.
- (3)  $180 : 80 :: F : R$ , whence  $F = \frac{9}{4}$  of R, or  $R = \frac{4}{9}$  of F.

The following examples will show how to apply these formulæ:—

(1).—Suppose the Reaumur stands at 28°, at what height does the Centigrade stand? We have  $C = \frac{4}{5}$  of R (in this case),  $\frac{4}{5}$  of 28 = 35; that is, the Centigrade stands at 35°.

(2).—Suppose Fahrenheit to stand at 41°, what will Reaumur stand at?  $R = \frac{4}{9}$  of (41-32) (that is, the number above freezing in Fahr.) =  $\frac{4}{9}$  of 9 = 4. Reaumur stands at 4.

(3).—Suppose Fahrenheit stands at 23°, what will the Centigrade stand at?  $C = \frac{5}{9}$  of  $F = \frac{5}{9}$  of (32-23) =  $\frac{5}{9}$  of 9 = 5 below freezing (or—5).

(4).—If Fahrenheit stands at 4 below 0, what will Reau-

mur indicate?  $R = \frac{1}{9}$  of  $F = \frac{1}{9}$  of  $(32+4) = \frac{1}{9}$  of  $36 = 16$  below 0 (or  $-16$ ).

Or perhaps a simpler method is as follows:

$$F. \text{ to } C. = F^{\circ} - 32 \times 5 \div 9.$$

$$C. \text{ to } F. = C^{\circ} \times 9 \div 5 + 32.$$

$$F. \text{ to } R. = \text{From } F^{\circ} - 32 + 4 \div 9.$$

$$R. \text{ to } F. = R^{\circ} \times 9 \div 4 + 32.$$

$$C. \text{ to } R. = \text{From equiv. in } F^{\circ} - C^{\circ} \text{ also } -32.$$

$$R. \text{ to } C. = \text{From equiv. in } F^{\circ} - R^{\circ} \text{ also } -32.$$

The only liquid which has the exceptional property of expanding by cold is water, and it will be seen presently that this curious anomaly is of the greatest importance in the economy of nature.

If a box containing a mixture of ice and salt is placed round the top of a long cylindrical glass containing water at a temperature of  $60^{\circ}$  Fahr. the intense cold of the freezing mixture, which is zero—that is to say,  $32^{\circ}$  below the freezing point of water—very soon reduces the temperature of the water contained in the glass, and as it becomes colder it contracts, is rendered heavier, and sinks to the bottom of the vessel, its place being taken by other and warmer water. This circulation commencing downwards, proceeds till the water has attained a temperature of about  $40^{\circ}$  Fahr., when the maximum of density is obtained and the circulation stops, because after sinking below  $40^{\circ}$  the cold water becomes *lighter*, and continues to be so until it freezes, and of course, being of a less specific gravity than the warmer water, it floats (like oil on water) upon its surface; so that a small thermometer placed at the bottom of the jar indicates only  $40^{\circ}$  Fahr., whilst the solid ice enveloping the other or second thermometer placed at the

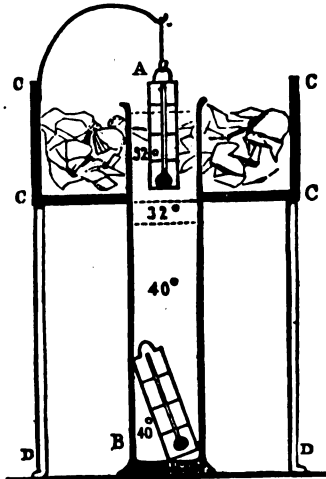

Fig. 450. A B. Long cylindrical glass containing water and two thermometers; the one at the bottom shows a temperature of  $40^{\circ}$ ; the other at the top  $32^{\circ}$ , or even lower. C C C C. Section of box containing the ice and salt, and standing on four legs, two of which are shown at D D.



top may be as low as  $29^{\circ}$ , or even lower, according to the quantity of ice and salt used in the box surrounding the top of the glass. (Fig. 450.)

The importance of this curious anomaly cannot be over-rated. If water did not possess this rare property, all the seas, rivers, canals, lakes, etc., would *gradually* become impassable from the presence of enormous blocks of ice formed during the winter. The whole bulk of water contained in them would have to sink below  $32^{\circ}$  before it could solidify, provided water increased in density or continued to contract by cold. Having once solidified, the warmth of the rays from a summer's sun would certainly melt a great deal of the ice, but not the whole, and winter would come again before the solid masses had disappeared. The ocean could not be navigated in safety even near our own shores, in consequence of the vast icebergs that would be formed, and float about and jostle each other even in the British Channel.

The expansion of gases by heat and contraction by cold take place in obedience to a law to which there is no exception, only in degree. It was discovered in 1801 by Gay Lussac, of Paris, and also about the same period by Dalton, the English scientist who established the atomic theory. Since these experiments and calculations Rudberg, Magnus, and Regnault made other researches, and their successive experiments give the following results:—

	Volumes of Air.	Volumes.
Dalton, Gay Lussac	1000 heated from $32^{\circ}$ to $212^{\circ}$ became	1375
Rudberg	1000 heated from $32^{\circ}$ to $212^{\circ}$ became	1365
Magnus, Regnault	1000 heated from $32^{\circ}$ to $212^{\circ}$ became	1366.5

As a natural result, air at  $32^{\circ}$  Fahr. expands  $\frac{1}{491}$  part of its volume for every degree of heat on the scale of Fahrenheit; and a volume of air which measures 491 cubic inches at  $32^{\circ}$  will measure 492 at  $33^{\circ}$ , 493 at  $34^{\circ}$ , and so on. The exception is only in degree, and Magnus and Regnault discovered by their searching experiments that the gases easily liquefied were more expansible by heat than air and those gases (such as oxygen, hydrogen, and nitrogen) which at that time had not been liquefied.

The expansion of air is easily shown by placing the open end of a tube with a large bulb blown at the other extremity, under the surface of a little coloured water; on the application of heat the air expands and escapes, and its place is taken,

when the tube cools, by the coloured liquid. Such an arrangement represents the first thermometer constructed by Sanctorio about A. D. 1600, which might certainly answer for rough purposes, but as the ascent and descent of the fluid depend on the bulk of air contained in the bulb, and as this is affected by every change of the height of the barometer, no satisfactory indication of an increase or decrease of temperature could be obtained with it, although the instrument itself is interesting from an historical point of view, and in a modified form as an air thermometer was employed by Sir John Leslie, under the

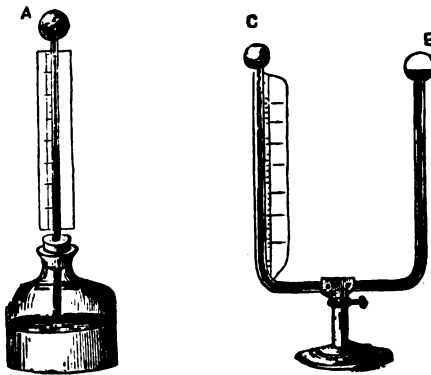

Fig. 451. A. Sanctorio's original air thermometer: the expansion and contraction of the air in the bulb indicate the rise or fall of the temperature. The cork is merely a support, and is not fitted into the bottle air-tight. B C. The differential thermometer. When both bulbs are subjected to a uniform temperature, no movement of the fluid shown at D occurs; but if the bulb B is put into any place warmer than the position of the bulb C, then the air expands in B, and drives the coloured liquid, which consists of carmine dissolved in oil of vitriol, up the scale attached to the stem of the bulb C.

name of the "differential thermometer," in his experiments with heat. (Fig. 451.)

Balloons are discussed in the section on aërostation, commencing on page 162, but a brief digest may here be made purely in the relation they bear to the subject of the present chapter on the expansion of air and gases by heat.

Fire balloons are a good example of the expansion of gases, and advantage was taken by Montgolfier of the levity of the air thus increased in bulk in the construction of his famous balloon which, with a cage containing various animals, ascended, in the presence of the King and royal family of

France, at Versailles in 1783; and in spite of huge rents in two places, it rose to a height of 1440 feet, and after remaining in the air for eight minutes, fell to the ground at the distance of 10,200 feet from the place whence it started, without injury to the animals. When it is considered that a volume of air heated from  $32^{\circ}$  to  $491^{\circ}$  is doubled, and tripled when heated to  $982^{\circ}$ , it will at once be understood how great must be the ascending power of such balloons, provided the air within them is kept sufficiently hot.

An aëronaut, Pilate de Rozier, offered himself as the first aërial navigator, and having joined Montgolfier, they made three successful ascents and descents with a large oval-shaped balloon, forty-eight feet in diameter, and seventy-four feet high. On the fourth occasion he ascended to a height of 262 feet, but in the descent a gust of wind having blown the machine over some large trees of an adjoining garden, the situation was extremely dangerous, and if he had not possessed great presence of mind, and at once given the balloon a greater ascending power, by rapidly supplying his stove with some straw and chipped wood, he might on this occasion have met with that untimely end which subsequently, in another rash aëronautic adventure, befell this brave Frenchman.

On descending again, he once more, and without the slightest fear, raised himself to a considerable height by feeding his fire with chopped straw. Some time after he ascended, in company with Giroud de Vilette, to the height of 330 feet, hovering over Paris at least nine minutes, in sight of all the inhabitants, the machine keeping all the while perfectly steady.

The danger in using this method of inflating the balloon arises from the possibility of generating gas, which escaping unburnt into the body of the balloon, may accumulate and blow up, or burn afterwards.

Fire balloons, as usually made, are very dangerous toys, and may sometimes prove rather costly to the person who may send them off, in consequence of their being perhaps blown by the wind on a hay or corn rick, or other combustible substances. The safest mode of using fire balloons is to fill them with hot air from a lighted gas stove; the balloons may then be used in large rooms, or out in the air, without fear of doing any harm to neighbouring property, as of course the stove

and the fire remain behind, and will fill any number of air balloons. (Fig. 452.)

In these times of discussion of hot-air engines it is interesting to look back to the records of civil engineering, and in the "Transactions of the Institution of Civil Engineers," to read James Stirling's account of his improved air engine, in which the great expansion of air mentioned at page 551 was successfully applied. The engine was constructed about the year 1843, and the principle, discovered thirty years before by R. Stirling, will be comprehended by reference to the cut. (Fig. 453.)

"Two strong air-tight vessels are connected with the opposite ends of a cylinder, in which a piston works in the usual manner. About four-fifths of the interior space in these vessels is occupied by two similar air-tight vessels or plungers, which are suspended to the opposite extremi-

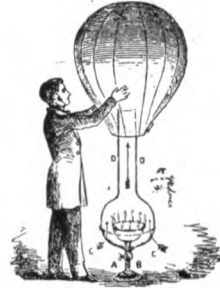

Fig. 452. A B. Wessel's gas stove, with ring of gas jets lighted inside; the air rushes in the direction of the arrows, C C, and escaping at the top of the chimney, D D, soon fills the air or fire balloon, which is usually made of paper.

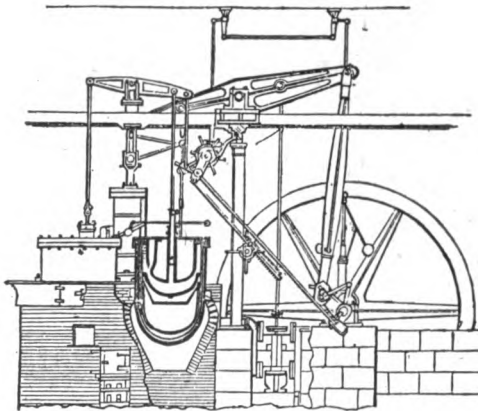

Fig. 453. Stirling's air engine.

ties of a beam, and capable of being alternately moved up and down to the extent of the remaining fifth. By the motion of these interior vessels, which are filled with non-conducting

substances, the air to be operated upon is moved from one end of the exterior vessel to the other, and as one end is kept at a high temperature, and the other as cold as possible, when the air is brought to the hot end it becomes heated, and has its pressure increased; and when it is brought to the cold end, its heat and pressure are diminished. Now, as the interior vessels necessarily move in opposite directions, it follows that the pressure of the enclosed air in the one vessel is increased, while that of the other is diminished. A difference of pressure is thus produced upon the opposite sides of the piston, which is thereby made to move from the one end of the cylinder to the other, and by continually reversing the motion of the suspended bodies or plungers, the greater pressure is successively thrown upon a different side, and a reciprocating motion of the piston is kept up. The piston is connected with a fly-wheel in any of the usual modes; and the plungers, by whose motion the air is heated and cooled, are moved in the same manner, and nearly at the same relative time, with the valves of a steam engine.

The pressure is greatly increased and made more economical by using somewhat highly-compressed air, which is at first introduced, and is afterwards maintained, by the continued action of an air-pump. The pump is also employed in filling a separate magazine with compressed air, from which the engine can be at once charged to the working pressure. Stirling's chief improvement consists *in saving all or nearly all the heat of the expanded air after it has done its work*, by passing it from the hot to the cold end of the air vessel through a multitude of narrow passages, whose temperature is at the beginning of the tubes nearly as great as that of the hot air, but gradually declines till it becomes nearly as low as the coldest part of the air vessel. The heat is therefore retained by these passages, so that when the mechanism is reversed, the cold air returns again through these hot pipes, and is thus made nearly hot enough by the time it reaches the heating vessel to do its work. Thus, instead of being obliged to supply at every stroke of the engine as much heat as would be sufficient to raise the air from its lowest to its highest temperature, it is necessary to furnish only as much as will heat it the same number of degrees by which the hottest part of the air vessel exceeds the hottest part of the intermediate

passages. This portion of the engine may be called the *economical process*, and represents the foundation of all the success to which it has attained in producing power with a small expenditure of fuel. No boiler being required, of course the danger of explosions is much lessened." The higher the pressure under which the engine was worked the greater was the effect produced. (Fig. 453.)

### *Conduction of Heat*

This property of heat with reference to matter, and the consideration of the curious manner in which it creeps, as it were, through solid substances, suggests the question, What is heat? Is it to be regarded as something real and material? or must it be considered only as a property or state of matter? These questions are not to be solved easily, and they demand a considerable amount of experiment and reasoning even to appreciate their meaning.

If a red-hot ball is placed in the focus of a concave metallic

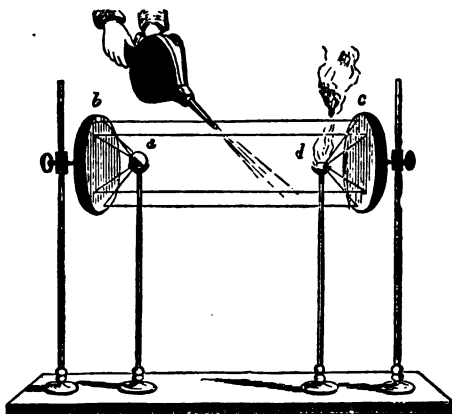

Fig. 454. Heat reflected by mirror, but not blown away by air from bellows.

speculum, it gives out certain emanations that are quite invisible, but which are reflected from the surface of the mirror in the same manner as visible rays of light, and may be collected in the focus of another and second concave speculum, when they can be concentrated on to a bit of phosphorus, and will cause the combustion of that substance. If the air from a pair of bellows is blown forcibly across the rays of heat as

they are being concentrated upon the phosphorus, the rays are not moved from their course, they are no more blown away than is a sunbeam darting through an aperture in a cloud on a stormy, windy day. The heat wave has, therefore, nothing to do with the air, and is wholly independent of that medium in its passage from one mirror to the other, but behaves in its capacity for absorption and reflection as if it were a beam of light. Such an experiment as that described would at once suggest the idea that heat is a matter *sui generis*, a component part of all bodies, and given off from incandescent matter, the sun, etc., and that it may be propagated through space much in the same manner as light, (Fig. 454, Page 555), as already explained in another portion of this book. Hence it has been supposed that heat is propagated through the air, water, and solid substances by waves or undulations from the heat-giving agent, and that these waves of heat force their way into, or along, or through them, according to circumstances.

Certain bodies are almost transparent to heat rays, such as air, whilst others take an intermedial position, and only stop a certain quantity of the heat rays, such as rock crystals, mirror glass, and alum. A third class of bodies absorbs the heat plentifully, such as charcoal, black cloth, etc.; and a fourth, when polished and placed at the proper angle, reflects or throws off the heat, as in the case of polished mirrors. The transparency or opacity of substances (so far as light is concerned) does not affect the transmission of heat. Light of every colour and from all sources is equally transmitted by all transparent bodies in the liquid or solid form, but this is not the case with heat.

Under certain conditions the rays of heat emitted by the sun and other luminous bodies have properties quite different to the rays of light with which they are accompanied, and it was for a long time considered that heat was a form of *matter*, an actual substance composed of fine "particles" of the heat-giving object, which projected themselves with great velocity from the source of heat, and, along with electricity, light and magnetism, it was classed as "imponderable," to distinguish these "substances" from those possessing weight; for it was found that an object's weight is not in the minutest degree increased by any amount of heat applied to the object, which may be solid, liquid, or gaseous.

It may and will be increased in bulk, but will weigh exactly the same after being heated as it did before any additional heat was given to it—hence its classification amongst its companion imponderable “substances” (hitherto so called). Further, considering the materiality of heat; as “matter,” no human means at present known would have been able to change its “quantity,” and the many experiments in this volume show conclusively that under no circumstances at present existing, have any means been discovered whereby the “quantity” of a substance can be changed.

We may explode a gas, burn a candle, dissolve a solid, etc., but the utmost we have done has been in each case to alter its “condition,” without disturbing its “quantity.” The total of products from the exploded gas and the means used to bring about the change of state, equal exactly the weight of gas, etc., before the explosion: the weight of the candle after a portion has been burnt, added to the products of combustion, give us exactly the original weight of the candle and the portion of air by which it was surrounded; and the total of the solution of the solid with its air or perhaps some gas generated by the combination, is exactly the weight of the solid and the substance used to dissolve it; yet in all these cases we have produced heat—and as we cannot get something from nothing and as all “material” or “substance” has been accounted for, there is no further “substance” left for the heat: from whence, therefore, could the heat come? These facts alone, as well as many other conclusive proofs which will naturally suggest themselves, dispose definitely of the “materiality” of heat.

Seeing, then, that this material or corpuscular theory of heat was so completely surrounded with contradictions and impossibilities, it became necessary to adopt another theory which would be reasonably tenable against assault, for in scientific arguments no law, or exception to a law, can be considered tenable that will not bear the test of proof, and show at least a reasonable possibility of correctness. Therefore, seeing that the companion (previously called) “imponderables”—light, electricity, etc.—were proved not to be corpuscular, or actual substances, but a form of “force,” or “energy,” attention was turned to heat from the same standpoint, and now, viewing heat as a form of “energy,” all previous



difficulties vanished, and hitherto considered vagaries and anomalies were found to dovetail and work together in one beautiful harmony. So that just as light and sound, as we have seen, are undulatory, and owe their evidence to vibrations on ether, so does heat owe its presence and continuance to vibrations set up and maintained in ether; therefore, to-day, we speak of heat as a form of *energy*, having its source and dependence on the energy of the motion of the particles of a body, which motion may be given by many means and is radiated in waves and undulations as is light, and this theory has been partly explained at pages 406, 498, 507, etc.

As the following experiments will prove, heat may be transmitted, reflected, refracted and absorbed, exactly as may light, (see page 593); therefore, it is well at the outset, to bear in mind the analogy which exists between the two, for on this theory—considering heat as “energy”—the experiments are based.

As vibrations of the ethereal light-waves affect the eye, so are there other nerves in our bodies sensitive to the waves of heat, and still others sensitive to sound-waves. It requires eight vibrations of the air to occur in a second in order to produce an audible sound; whilst if the vibrations amount to twenty-five thousand in a second, they cannot be appreciated by most human ears, although it has been ascertained that hearing organs of certain animals and insects are so susceptible to rapid vibrations, that they are able to distinguish the differences between vibrations of high velocity, which are far too rapid to be defined as sound by any human ear, and the late Sir Francis Galton, F. R. S., in his book “Enquiries into the Human Faculty,” describes a number of interesting experiments he made on cats, dogs, and other creatures with regard to their capacity for hearing shrill notes.

So may heat be carried by vibrations or undulations, and the mere fact that some people who have not a normal eye and are commonly called “colour-blind,” (which is erroneous, seeing that this defect only applies to certain colours, which vary with different people) are affected by all waves of heat and sound, and that others who have a normal eye with regard to colour, are not at all sensitive to heat, or to the influence of sound, and *vice versâ*, shows that all these different undulations,—some affording heat, some light, some sound—

may be generated and propagated or radiated through space, as from the sun, or through other shorter distances, as from burning lamps or fires, without in any way interfering with or impeding each other's progress.

This undulatory theory of *energy*, offers the best idea of transmission of heat which is carried, conducted, or propagated through solids with variable rapidity, either by the vibration of the constituent molecules of the body itself, or by the undulation of a rare subtle fluid which pervades them. If a copper and iron wire of the same length and diameter are bound together and heated at the point of union, the waves of heat travel faster through the copper than the iron, and the former is said to be the best conductor of heat; the fact

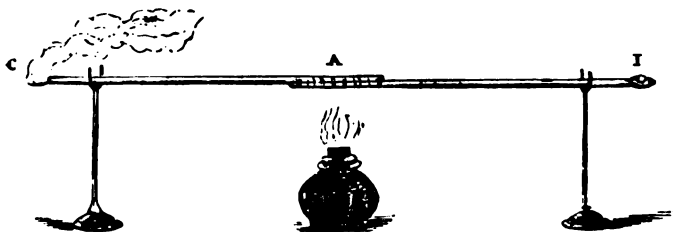

Fig. 455. C. Copper wire bound at A to I, an iron wire. After the heat of the lamp has been applied for about five minutes the heat travels to C first, and ignites the bit of phosphorus placed there. After some time has elapsed the phosphorus at I also ignites.

itself is demonstrated by placing a bit of phosphorus at the end of each metallic wire, when it will be found by experiment that the combustible substance melts first and takes fire on the copper, and that a considerable interval of time elapses before the phosphorus ignites on the iron. (Fig. 455.)

The same fact is exhibited in a striking manner by inserting a series of rods of equal lengths and thicknesses in the side of a rectangular box, allowing them to pass across the interior to the opposite side. The rods are composed of wood, porcelain, glass, lead, iron, zinc, copper, and silver, and have attached to each of their extremities, by wax or tallow, a clay marble. When the water placed in the box is made to boil, the heat passes along the different rods, and melting the wax or tallow, allows the marble to drop off. Consequently the first marble would drop from the silver rod, the next from the copper, the third from the iron, the fourth

from the zinc, the fifth from the lead, whilst the porcelain, glass, and wooden rods would hardly conduct (in several hours) sufficient heat to melt the wax or tallow, and discharge the marbles.

### *Conduction of Metals*

Gold .....	1000
Silver .....	973
Copper .....	898.2
Iron .....	374.3
Zinc .....	363
Lead .....	179.6

The experiment is made more striking if the marbles are allowed to fall on a lever connected with the detent of a clock alarm, which rings every time a marble falls from one of the rods. (Fig. 456.)

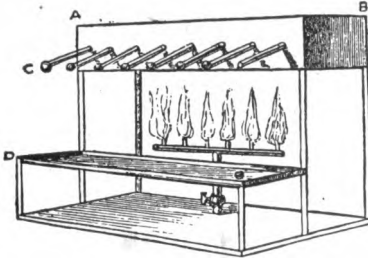

Fig. 456. A B. Trough containing boiling water, heated by gas jets below. C. The eight rods and marbles attached, one of which has fallen. D. The tray to receive the marbles.

During a cold, frosty day, if the hand is placed in contact with various substances, some appear to be colder than others, although all may be precisely the same temperature; this circumstance is due to their conducting

power: a piece of slate seems colder than a bit of chalk, because the former is a much better conductor than the latter, and carries away the heat from the body with greater rapidity, diffusing it through its own substance.

The gradual passage of heat along a bar of iron as compared with one of copper, is well illustrated by supporting the ends of the two bars on the top of the chimney of an argand lamp, or other source of direct heat, whilst the other extremities are held in a horizontal position by little blocks of wood. If marbles are attached by wax to the under side, they fall off as the heat travels along the metallic bars, and more rapidly from the copper than the iron, because the former is a better conductor of heat than the latter. (Fig. 457.)

From the experiments of Mayer, of Erlangen ("Ann. de

Ch.," xxx.), it would appear that the conducting powers of different woods are to a certain extent to be regarded as in the inverse proportion to their specific gravities—*i.e.*, the greater

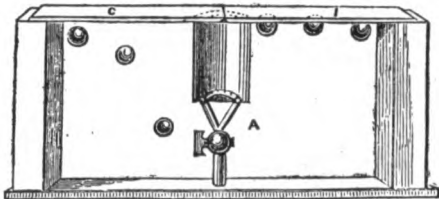

Fig. 457. A. Section of an argand gas lamp, with a copper chimney supporting the ends of the bars of copper and iron marked C and I. The balls have fallen from C, the copper bar.

the density of the wood the less conducting power, and the contrary.

If a cylindrical bar or thick tube of brass, six inches long, and about two inches in diameter, is attached to a wooden cylinder of the same size, the conducting powers of the two substances are well displayed by first straining a sheet of white paper over the brass, and then holding it in the flame of a spirit lamp. The heat being conducted rapidly away by the metal will not scorch the paper, until the whole arrives at a uniform temperature; whereas the paper is rapidly burnt when strained over the wooden cylinder, because the heat of the flame of the lamp is concentrated upon one point, and is not diffused through the mass of the wood. (Fig. 458.)



Fig. 458. Cylinder, half brass and half wood. The paper strained over the wood is taking fire. The other extremity, shaded, is the brass portion.

In the course of the experiments of Davy, which led him gradually to the discovery of the construction of the safety lamp, he connected together, by a copper tube of small bore, two vessels, each containing an explosive mixture composed of fire damp and air. When the mixture was fired in one vessel

he found that the flame did not appear to be able to travel, as it were, across the bridge—the copper tube—and communicate with the other magazine, because it was deprived of its heat whilst passing through the tube, and was no longer flame, but simply gaseous matter at too low a temperature to effect the inflammation of the mixture in the second box.

A mass of cold metal may be suddenly applied to a small flame, such as that of a night light, and depriving it rapidly of heat, it is almost immediately extinguished (Fig. 459), not by the mere exclusion of the oxygen of the air, but on account of the withdrawal of the heat necessary for the maintenance of the combustion.

Davy first thought of making his safety lamp with small

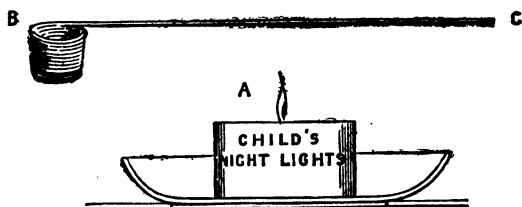

Fig. 459. A. Small flame from nightlight. B C. Large mass of cold copper wire open at both ends to place over flame, and by conduction of the heat to extinguish it.

tubes, which would supply fresh air, and carry off the burnt or foul air, at the same time they were to be so narrow that no flame could pass out of his lamp to communicate with an outer explosive atmosphere; and in speaking of his lamp with tubes he says:—‘I soon discovered that a *few apertures*, even of very small diameter, were not safe unless their *sides* were very *deep*; that a single tube of one-twenty-eighth of an inch in diameter, and two inches long, suffered the explosion to pass through it; and that a *great number* of small tubes, or of apertures, stopped explosion, even when the depth of their sides was only equal to their diameters. And at last I arrived at the conclusion that a *metallic tissue*, however thin and fine, of which the apertures filled more space than the cooling surface, so as to be permeable to air and light, offered a *perfect barrier to explosion*, from the force being divided *between*, and the heat communicated to an *immense number of surfaces*. I made several attempts to construct safety lamps which should give light in all explosive mixtures of fire

damp, and after complicated combinations, I at length arrived at one evidently the most simple, that of *surrounding the light entirely by wire gauze, and making the same tissue feed the flame with air and emit light.*"

If a number of square metallic tubes of a fine bore are placed upright side by side, and a section cut off horizontally, it would represent the wire gauze which possesses such marvellous powers of sifting away the heat from a flame, so that it is destroyed in its attempted passage through the metallic meshes; and of this fact a number of proofs may be adduced.

A gas jet delivering coal gas may be placed under a sheet of wire gauze, which the gas permeates and may be set on fire at the upper side, but the flame is cut off from the mouth of the jet by the cooling action of the interposed medium. The same experiment reversed, by holding the gauze over the gas burning from the jet, shows still more decidedly that flame will not pass through the metallic tissue. (Fig. 460.)

Davy again says: "Though all the specimens of fire damp which I had examined consisted of carburetted hydrogen mixed with different small proportions of carbonic acid and common air, yet some phenomena I observed in the combustion of a *blower* induced me to believe that small quantities of olefiant gas may be sometimes evolved in coal mines with the carburetted hydrogen. I therefore resolved to make all lamps safe to the test of the *gas produced by the distillation of coal*, which, when it has not been exposed to water, always contains olefiant gas. I placed my lighted lamps in a large glass receiver through which there was a current of atmospherical air, and by means of a gasometer filled with coal gas, I made the current of air which passed into the lamp more or less explosive, and caused it to change rapidly or slowly at pleasure, so as to produce all possible varieties of inflammable and explosive mixtures, and I found that iron gauze wire composed of wires from one-fortieth to one-sixtieth of an inch in diameter, and containing twenty-eight wires or

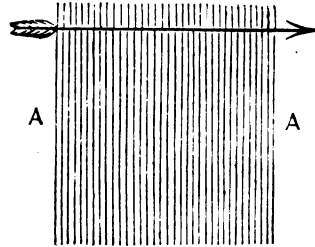

Fig. 460. A A. A number of square tubes placed upright. The arrow shows the direction of the section to obtain a figure like wire gauze.

seven hundred and eighty-four apertures to the inch, *was safe under all circumstances in atmospheres of this kind*; and I consequently adopted this material in guarding lamps for the coal-mines, when in January, 1816, they were immediately adopted, and have long been in general use."

The remarkable conducting power of wire gauze is further shown by placing some lumps of camphor on a piece of this material, and when the heat of a spirit-lamp is applied on the under side of the gauze, the camphor volatilises, and as the vapour is remarkably heavy, it falls through the meshes of the gauze, and takes fire; but the most curious and further illustration of the conducting power of the meshes is shown in the fact that the fire does not communicate through the thin film of gauze to the lumps of camphor placed upon it.

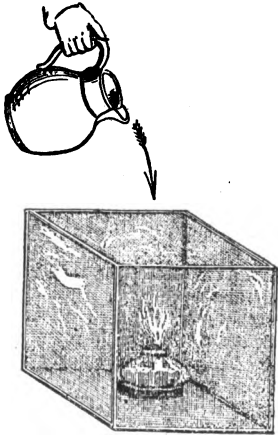

Fig. 461. A box made of wire gauze, with a hole in the bottom to admit a spirit lamp lighted. A hot jugful of the vapour of ether may be poured on to the flame, but it only burns inside the box, and does not communicate with that in the jug.

The camphor may be ignited by applying flame to the upper side of the gauze, showing that, although this substance is so exceedingly combustible, it will not take fire even if placed at no greater distance from flame than the thickness of the wire gauze, provided the latter material is interposed between it and the flame.

A square box made of wire gauze, with a hole at the bottom to admit a candle or spirit-lamp, may have a considerable jet of coal gas forced upon it from the outside, or a large jug of ether vapour poured upon it; and although the box may be full of flame, arising from the combustion of the gas or ether, the fire does not come out of the wire box or communicate with the jet or the ether vapour as it is poured from the jug. (Fig. 461.)

Davy's safety lamp consists of a common oil-lamp, *f*, with a wire through the cistern for the purpose of raising or depressing the cotton wick without unscrewing the wire gauze; *b* is the screw fitting that attached to the cylinder of wire

gauze, which is made double at the top. The entire lamp is shown at A, whilst the platinum coil which Davy recommended should be wound round the wick is shown at *h*. The small cage of platinum consists of wire of one-seventieth to one-eightieth of an inch in thickness, fastened to the wire for raising or depressing the cotton wick, and should the lamp be extinguished in an explosive mixture, the little coil of platinum begins to glow, and will afford sufficient light to guide the miner to a safe part of the mine. With respect to this platinum coil (see page 156) Davy gave a careful charge:—"The greatest care must be taken that no filament or wire of platinum protrudes on the exterior of the lamp, for this would fire externally an explosive mixture."

Since the invention of the Davy lamp, a great number of modifications have been brought forward. It was perhaps unfortunate that the lamp was called the *safety* lamp, because it is not so under every circumstance that may arise, unless it happens to be in the

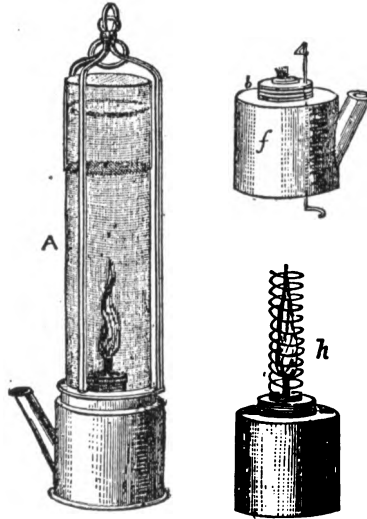

Fig. 462. Sir Humphrey Davy's safety lamp. Original model.

hands of persons who have taken the trouble to study it and understand how to correct the faults. The lamp might have escaped the incessant attacks that have been made upon its just merits, if the name had simply been that of its inventor—"a Davy lamp." No one could carp at that, whilst "safety" was held to mean *perfect immunity* from every possible and probable danger that might arise in the coal-pits. The lamps are now usually placed under the charge of one man, who trims them and ascertains that the wire gauze is in perfect order; this is usually locked upon the lamp, and as it is a penal offence, and punishable by a heavy fine and imprisonment, to remove the wire gauze



from safety lamps in dangerous parts of the mine, of course the miners have been brought to a sense of the obligations they owe themselves and their brother-miners, and the rash, ignorant, and foolhardy offences of breaking open safety lamps for more illumination, or to light pipes, and to use the oil for greasing boots, are becoming much less frequent than formerly. An ingenious "detector lamp" (Fig 463) consists of the old-fashioned Davy, but inside the rim of the wire gauze is placed a small extinguisher and spring, which does not move so long as the gauze is screwed *on* to the lamp, but directly the gauze is unscrewed, the reversed movement releases the detent, and the extinguisher falls upon the light. To prove

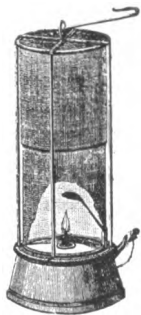

Fig. 463. Symons' self-extinguishing Davy lamp.

the remarkable perfection of the wire gauze principle, some turpentine may be poured upon a lighted safety lamp, when a great smoke is produced by the evaporation of the spirit, but no flame passes through to the outside, although the turpentine burns inside the lamp. If some coarse gunpowder is laid upon two thicknesses of fine wire gauze, it may be heated from below with the flame of the spirit lamp, and the sulphur will gradually volatilise without setting fire to the mass of powder. To show the security of the Davy lamp, it may be lighted and hung in a large box with glass sides, open at the top, and a jet of coal gas supplied at the bottom; as this rises and diffuses in the air, the

mixture becomes explosive, and the fact is at once evident by the alteration in the appearance of the flame of the lamp, which enlarges, flickers, and frequently goes out, in consequence of the suddenness with which the explosion of the mixture takes place inside the lamp, producing a concussion that extinguishes the flame. In this case the utility of the platinum coil is very apparent, and it continues to glow with a red heat until the explosive character of the air in the box is changed.

If a large basin is first warmed by some boiling water, which is then poured away, and a drachm of ether thrown in, a highly-combustible atmosphere is obtained, and when a lighted Davy lamp is placed into the basin so prepared, the flame inside the lamp immediately enlarges and flickers, but is not

extinguished, and does not communicate to the combustible vapour outside. The contrast between the safety lamp and an unprotected flame is very striking; if a lighted taper is thrown into the basin, the ether catches fire, and burns with a very large flame. The solid conductors of heat, which are said to enjoy this property in the highest degree, are the metals, marble, stone, slate, and other dense and compact solid substances; whilst the opposite quality of being non-conductors, or nearly so, is possessed by fur, wood, silk, cotton, wool, eider and swansdown, paper, sand, charcoal, and every substance which is of a light or porous nature. The practical application of this knowledge is very apparent in the affairs of every-day life. Thus if it is winter time, we encase the body in non-conductors, such as flannel and wool. When we sit down to the breakfast table we may notice the contrivances for preventing the handle of the top of the urn, or that of the teapot, from becoming too hot for the fingers, by the interposition of ivory or wood. If asked to place water in the teapot from the kettle, we instinctively seek for the well-known kettle-holder made of asbestos cloth, and therefore a bad conductor. As we cut our meat or fish at the same meal, we may shiver with cold, but our fingers are not quite frozen by contact with the knives, because we hold them by the non-conducting handles; and we are reminded that some metals are good conductors of heat, by the pleasant warmth of the silver teaspoons, as we stir our tea or coffee. Even the polish of the table is protected from the heat of the dishes by non-conducting mats, and plates are handed about with a carefully-wrapped non-conducting linen napkin, and should we prefer a bit of fresh-made toast, the fork is provided with a non-conducting handle.

The *central heat* of our globe is a reality that cannot be disputed, and after digging beyond a depth of twenty feet the thermometer gradually rises at the rate of one degree of Fahrenheit's scale for every fifteen yards. The bad conducting power of the crust of the earth must, therefore, be apparent, as it is easy, knowing the diameter of our globe, to calculate that the increase of heat downwards amounts to  $116^{\circ}$  for each mile, consequently at a depth of thirty and a half miles below the surface, there will be a temperature most likely equal to  $3500^{\circ}$ , or a heat that might easily melt cast-iron, and would

help to account for the earthquakes and eruptions of volcanoes, which still remind us by their terrible warnings, that we live only on the bad conducting upper crust of a globe, the inside of which is still, perhaps, in a liquid and molten state, or, as some scientists assert, a great hollow formed by the expanding gases swelling out the crust and, in places, breaking it, which they explain is the cause of earthquakes and of the continuous earth-pulsations. These are, however, mere hypotheses. It has been demonstrated, to prove the non-conducting power of this shell of earth-crust,—supposing the globe was wholly composed of cast-iron,—that the central heat would require myriads of years to be transmitted to the surface from a depth of 150 miles; and by inverting the process of reasoning, we may come to the conclusion that the internal heat must be excessive, because it is confined and shut out from those influences that would carry off and weaken the intensity.

There are no two words, says Tyndall, with which we are more familiar than *matter* and *force*. The system of the universe embraces two things, an object *acted upon*, and an agent *by which* it is acted upon; the object we call matter and the agent we call force. Matter, in certain respects, may be regarded as the *vehicle* of force; thus, the luminiferous ether is the vehicle or medium by which the pulsations of the sun are transmitted to our organs of vision. Or, to take a plainer case, if we set a number of billiard balls in a row, and impart a shock to one end of the series in the direction of its length, we know what will take place; the *last ball* will fly away, the *intervening* balls having served for the transmission of the shock from one end of the series to the other. Or we might refer to the conduction of heat. If, for example, it be required to transmit heat from the fire to a point at some distance from the fire, this may be effected by means of a conducting body—by a poker; for instance; thrusting one end of a poker into the fire, it becomes heated, the heat makes its way through the mass, and finally manifests itself at the other end. Let us endeavour to get a distinct idea of what we here call heat and first picture it to ourselves as an agent apart from the mass of the conductor, making its way among the particles of the latter, jumping from atom to atom, and thus converting them into a kind of *stepping stones* to assist its progress. It is a probable conclusion, even had we not a single experiment

to support it, that the mode of transmission must, in some measure, depend upon the manner in which those little molecular stepping stones are arranged. Heat, as we have seen, instead of being an agent apart from ordinary matter, consists *in a motion* of the material particles; the conclusion is equally probable that the transmission of the motion must be influenced by the manner in which the particles are arranged. It has been proved that heat is transmitted through wood with a velocity almost twice as great along the fibre as across it. This result has been expanded, and it is found that this substance possesses three axes of calorific conduction; the first and greatest axis being parallel to the fibre; the second axis perpendicular to the fibre and to the ligneous layers; while the third axis, which marks the direction in which the greatest resistance is offered to the passage of the heat, is perpendicular to the fibre and parallel to the layers.

If many solids are bad conductors of heat, they are at all events greatly surpassed by fluids, and especially by water. The conduction of heat by that fluid is almost imperceptible, so much so, that it has even been questioned whether liquids do really conduct heat downwards at all. It has, however, been found that liquid mercury will conduct heat downwards, therefore by analogy it may be assumed that other liquids must possess a conducting power, although it may be exceedingly limited.

In order to prove that water is an exceeding bad conductor of heat, a tube with a large glass bulb blown at one end is partly filled with tincture of litmus, until it will just sink below the surface of water placed in a tall cylindrical or open jar. If a copper basin, containing burning ether, is now floated on the top of the water, so as to leave about a quarter of an inch between the top of the air thermometer—viz., the bulb containing the coloured liquid—and the bottom of the copper pan, it will be noticed that whilst the water surrounding the latter almost boils, not the slightest effect arising from the conduction of heat can be perceived in a downward direction. After the ether has burnt out of the copper vessel, it may be removed, and the boiling water stirred down and around the air thermometer, when the air within it expands, drives out the colouring liquid, and the bulb becoming specifically lighter, rises to the top of the containing glass. (Fig. 464, Page 570.)

Again, if the tube of an air thermometer is placed through a cork in the neck of a gas jar, inverted and standing on a ring stand, and the jar is then filled with water, and boiled at the top with a red-hot iron heater, the heat does not pass downwards and affect the thermometer. By introducing a syphon the water surrounding the thermometer at the bottom of the jar may be drawn off, until the hot water is within a fraction of an inch of the air thermometer, and still no heat is conducted, and the liquid in the latter remains stationary. (Fig. 465.)

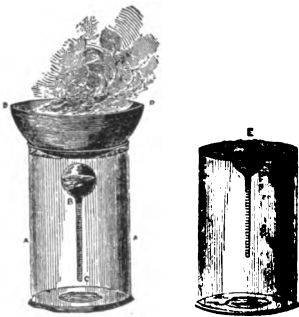

Fig. 464. A. A cylindrical glass full of water. B. The glass air thermometer containing the coloured liquid just standing upright, the mouth of the tube at C being open. D. D is the copper basin containing the burning ether. E shows how the glass bulb and tube rise after the upper basin is removed, and the hot water comes in contact with and expands the air, making the thermometer light, and causing it to rise.

heavier, water, which in like manner moves upwards, and is again succeeded by a fresh portion. Now, the first and succeeding strata of water all carry off so much heat, and thus by the convective or carrying power of the water the heat is diffused finally in the most perfect manner through the whole bulk of fluid; and indeed, the movement itself of the particles of water may easily be watched by putting a little paper pulp at the bottom of the inverted glass shade containing the water. A boiling-test-tube will answer the purpose of the experiment. (Fig. 466, Page 572.)

This bad conducting power is not merely confined to water, but is likewise apparent with oil and other fluids, and if some water is frozen at the bottom of a long test-tube by means of a freezing mixture, oil may then be poured upon it, and some

alcohol above the oil. If the flame of a spirit-lamp is now applied to the alcohol at the top of the tube it may be entirely boiled away, and no heat will travel down the oil and communicate with the ice, and even after the alcohol has been evaporated away the tube can be filled up with water; this may also be boiled, and whilst demonstrating the bad conducting power of the oil, the curious anomaly is observed of a vessel or tube containing ice at the bottom and boiling water at the top, and further showing the wisdom of the Supreme Creator in preventing the freezing of the water of lakes, rivers and seas, by the exceptional law of the expansion of water by cold. It is evident from what has been stated that liquids acquire and lose their heat by means of those currents and movements of the particles of water which have already been partly explained. Whatever interferes with this movement must prevent the passage of heat; consequently thick viscous liquids are always difficult to boil, and in consequence of their motion being impeded they rise to too high a temperature and are burnt. This fact is remarkably apparent in the manufacture of white lump sugar; as the syrup is evaporated it becomes very thick, and if boiled over a fire might frequently be burnt, but it is boiled by the heat of steam, and under a vacuum produced by an air pump, thus the sugar-boiler is enabled to avert all danger of burning.

It is, then, by a continuous motion, involving circulation of the particles, that heat travels through water; and the fact already described is still further elucidated by a simple but telling experiment. A glass tube, about three feet in length and half an inch in diameter, is bent as at A (Fig. 467, Page 573), then being filled with water, is suspended by a string attached to any convenient support inside a copper dish containing water, so that the straight end is at the top of the water, and the curved end at the bottom. Just before it is

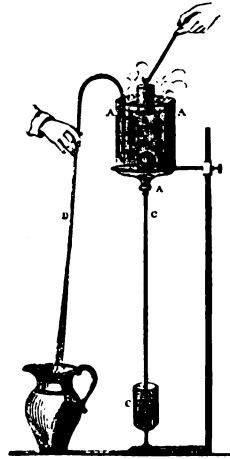

Fig. 465. A A A. Inverted gas jar supported by the ring stand. B. The red-hot iron heater. C C. The air thermometer, with the coloured liquid stationary at C. D. The syphon for drawing off the cold water, and bringing the hot down close to the bulb of C C.

used some ink or other colouring matter is poured into the copper pan of water; it should not be added till the moment the experiment is to begin, as any rise of temperature in the room promotes circulation, and interferes with the colourlessness of the water in the tube, which is compared with the inky fluid in the basin. Directly heat is applied the hot water rises to the top of the copper vessel, thence gradually up the tube; this movement is rendered visible by the hot coloured liquid matter creeping slowly up the tube, and displacing the colourless water, which falls gradually into the copper pan. (Fig. 467, Page 573.)

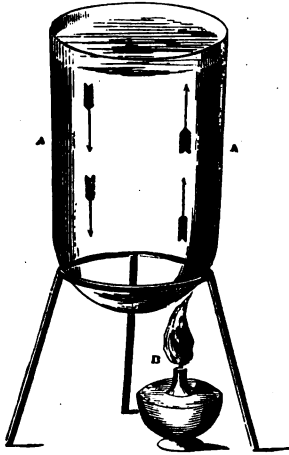

Fig. 466. A A. Inverted glass shade containing water and some paper pulp. B. Burning spirit lamp placed under one side of the glass; the pulp shows the rising of the heated water and the sinking of the cold, in the direction indicated by the arrows.

The principle of the circulation of the particles of water being once understood, it is easy to comprehend how it is applied to the heating of buildings. A coil of pipe is enclosed in a proper furnace, the bottom end communicating with a pipe coming from a second tube or set of coils placed above it in another apartment, whilst the top of the latter coil communicates with the top pipe of the first coil. When the fire is lighted, the circulation through the first coil of pipe commences, is communicated to the second, and from that back again to the first, so that the "hot water system" involves an endless chain of pipes of water, provided

with proper safety valves to allow for the escape of any expanded air or steam. Serious accidents have occurred in consequences of persons neglecting to look after the perfection of this safety valve.

Perkins, in 1824, made his name remarkable for experiments with the circulation of water through tubes, and his account of the invention and improvement of the "Steam Gun," in which the improvement consists chiefly in the circulation of water through coils of pipe, is so important that we give it verbatim, with a drawing of the steam gun.

“The expansive power of steam has often been proposed as a substitute for gunpowder, for discharging balls and other projectiles; the great danger, however, which was formerly thought to be inseparably connected with the generation and use of steam, at so extraordinary a pressure as appeared necessary to produce an effect approximating to that of gunpowder, prevented scientific men from testing the power of this new agent by experiment. It was also apparent that the apparatus which was ordinarily used for generating steam for steam-engines was wholly inadequate to sustain the necessary pressure, and that one of a totally different character must be contrived before steam could be sufficiently confined to come into competition with its powerful rival.

“In the year 1824, Mr. Jacob Perkins succeeded in constructing a generator of such form and strength, as allowed him to carry on his experiments with highly elastic steam without danger, although subjected to a pressure of 100 atmospheres. The principle of its safety consisted in subdividing the vessel containing the water and steam into chambers or compartments, so small, that the bursting of one of them was perfectly harmless in its effects, and only served as an outlet, or safety valve, to relieve the rest.

“Although Mr. Perkins’ generator was originally intended for working steam engines (it having long been evident to him that highly elastic steam used expansively would be attended with considerable economy), the idea occurred to him, in the course of his experiments, that he had already solved the problem of safely generating steam of sufficient power for the purposes of *steam gunnery*; and that the steam which daily worked his engine possessed an elastic force quite adequate to the projection of musket balls. He therefore caused

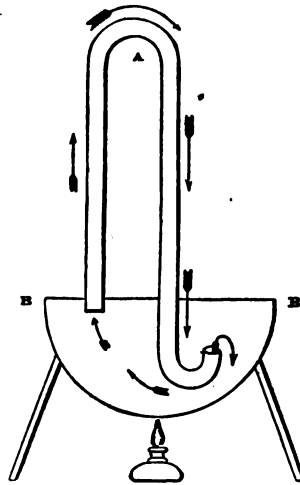

Fig. 467. A. The bent glass tube full of water. B B. The copper pan containing coloured water. The arrows show the circulation of the water.



a gun to be immediately constructed, and connected by a pipe to the generator, the first trial of which fully realised his most sanguine anticipations. Its performance, indeed, was so extraordinary and unexpected, that it gave rise to a paradox, which was difficult of explanation—viz., that *steam, at a pressure of only forty atmospheres, produced an effect equal to gunpowder*; whereas it was known that the combustion of gunpowder was attended with a pressure of from 500 to 1000 atmospheres.

“Mr. Perkins gives the following explanation of this apparent discrepancy, by referring to the small effect produced by fulminating powder, compared to gunpowder, although many times more powerful; he supposes that the action of fulminating powder, however intense, does not continue sufficiently long to impart to the ball its full power. The explosion of gunpowder, although not so powerful at the *instant of ignition*, is nevertheless, in the aggregate, productive of greater effect than that of fulminating powder, because the *subsequent expansion continues* in action upon the ball (but with decreasing effect), until it has left the barrel. The action of steam differs from either of these agents, inasmuch as it *continues in full force until the ball has left the barrel*; and to this is assigned the cause of its superiority.

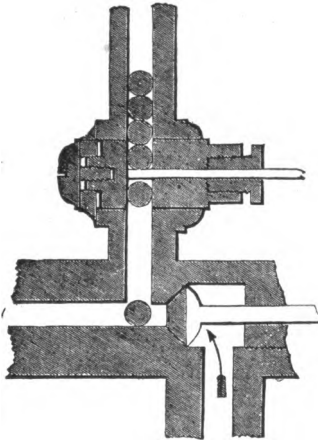

Fig. 468. Old steam gun. The charging tube and gun-barrel of steam gun.

“In the year 1826, Mr. Perkins had so perfected the mechanism of the gun and generator that, at an exhibition and trial of its power, in the presence of the Duke of Wellington and other distinguished officers of the Ordnance Department, balls of an ounce weight were propelled, at the distance of thirty-five yards, through an iron plate one-fourth of an inch in thickness; also, through eleven hard planks, one inch in thickness, placed at distances of an inch from each other. Continuous showers of balls were also projected with such rapid-

ity, that when the barrel of the gun was slowly swept round in a horizontal direction, a plank, twelve feet in length, was so completely perforated, that the line of holes nearly resembled a groove cut from one of its ends to the other.

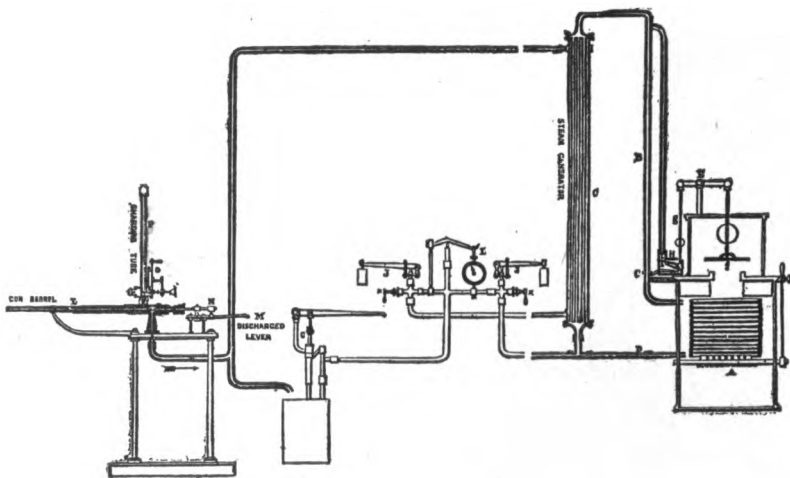

Fig. 469. Perkins's steam gun.

"A is an iron furnace, containing a continuous coil of iron tubing, 80 feet in length, 1 inch of external and  $\frac{3}{4}$ th inch of internal diameter, within which the fire is made; the upper end of this tube, B, called the flow-pipe, is extended any required distance to the top of the generator.

"The furnace is provided with a very ingenious heat governor or regulator, by which the intensity of the fire is always proportionate to the temperature which it may be requisite to maintain in the tubes.

"H is an iron box, containing a series of levers, b b b; c, a nut screwed upon the flow-pipe, and in contact with the short arm of the lowest of the levers, E. A lever, from one end of which is suspended the damper f, and from the other end the rod g, which rests upon the long arm of the highest of the levers, b b b. When the apparatus has arrived at the required temperature, the nut c is screwed down until it bears upon the lever. Any farther increase of temperature will expand or lengthen the flow-pipe, and depress the short arm of the lever, which is in contact with the nut. The combined and multiplied action of the levers will then elevate the rod g, and the damper f will descend to check the draught. When the fire slackens, and the apparatus cools, the action of the levers will be reversed, and the damper will open. The space through which the damper moves, compared with the nut c, is as 200 to 1.

"C is the generator, composed of a strong iron tube, 3 inches diameter and 6 feet in length, within which are eight smaller tubes, having their ends welded to the ends of the larger tube. These small tubes communicate at the top with the flow-pipe B, and at the bottom with the return-pipe D, which is continued to the bottom of the furnace-coil of tubing. The circulation in the tubes is occasioned by the difference in the specific gravities of the water composing the ascending and descending currents; the portion contained in the flow-pipe and fire coil becoming expanded by the heat, ascends by its superior levity; while that contained in the small tubes of the generator, having given off its heat, acquires increased density, and descends through the return-pipe D to the bottom of the furnace-coil, to take the place of the ascending current. When the hot-water current has arrived at a temperature of 212° and upwards, cold water is injected into the generator, and becomes converted into steam by its contact with the small tubes; the rapidity of evaporation and the pressure of the steam depending, of course, upon the temperature of the hot-water current, which at 500° will cause a pressure within the tubes of 50 atmospheres, or 750 lbs. upon the square inch. The whole apparatus is proved

to be capable of sustaining a pressure of 200 atmospheres, or 3000 lbs. upon the square inch.

"G. A force pump for injecting water into the generator.

"I. The indicator for exhibiting the pressure of the steam in the generator, and of the water in the boiler; it may be connected with either by means of the valves attached to the levers.

"J. Valve to regulate the pressure of water.

"J 1. Valve to regulate the pressure of steam.

"K. The steam pipe.

"L. The gun.

"M. The discharging lever acting upon the valve N.

"O. The discharging cock, by a simple adjustment in which balls are transferred from the charging tube P to the gun barrel, singly or in a continuous shower."

Clever and effective as this steam gun undoubtedly was it did not meet with the approval of our War Authorities, and is now a thing of the past.

The well-known revolver was, perhaps, the first arm which called the attention of modern artillerists to guns of this class. Even the revolver is not new, for in the armoury of the Tower of London is still shown a rough description of revolver invented some hundreds of years back. It consists of eight barrels or chambers forged in one piece, not unlike the first form of Colt's revolver, and the machine guns now in use in different nations are, broadly speaking, revolvers on an enlarged scale.

The first gun of this kind which made any sensation was the mitrailleuse which was tested by the English Government against an American weapon known, after its inventor, as the Gatling gun, with the result that the latter weapon was adopted in our Service, both on land and sea. Compared with the steam-gun already described, the Gatling is far more destructive in its effects, and as it is mounted as an ordinary piece of artillery, it can be readily moved from place to place. The original gun consisted of a number of parallel barrels which revolved and were placed upon a main shaft. A feed-case, containing cartridges, was attached, and, by a clever mechanical contrivance, these cartridges dropped into their places to be fired by turning a handle at the back of the weapon. The gun could be made to discharge nearly 500 balls per minute, and its range was something over one mile and a quarter. But the entire aspect and conditions of warfare have been completely altered since those days.

The conduction of heat through gases is very slow when heat is applied to the upper part of any stratum of air. Heat appears to be diffused through the air, as in water, by the circulation and rising of the heated and lighter strata, and the

sinking of the colder currents which take their places; hence the danger of sitting in a room under an open skylight. A current of cold air may descend upon the head of the individual, whilst the warmer air escapes. The movement of heated volumes of air is subject to definite laws, which apply themselves in every case, but are rather difficult to grasp when the subject of ventilation is concerned. No specific mode of ventilation can be found to suit all rooms and buildings; they are like the patients of a physician who cannot be cured by one medicine only, but must have a treatment adapted properly to each case. If the fires, candles, gas, or oil-lamps, doors, windows, and chimneys, were always under the control of the scientific ventilator, his task would be very simple, but it is well understood that a ventilating system which answers well if certain doors communicating with passages are closed, fails directly they are accidentally opened. The watchful care of the ventilator must begin with the lowest door, and in his calculations he must study the effect of every other door or window that may be opened, so that if a scientific man undertakes to ventilate a house, he must have a well-drawn plan hung up in the hall, and it must be clearly understood by the inmates that any interference with that plan will prejudice the whole.

There are a few common principles which will guide in ventilation, and these are, first, the rise of hot and the fall of cold air; second, that if an aperture is provided at the top of a room for the escape of hot air, an equally large aperture must be left for the entry of cold air; third, the aperture for the escape of hot air must be adapted in size to the number of persons likely to enter the room, and the number of gas or other lights burning in it. During the daytime, moderate apertures for the exit and entrance of air may suffice, but these must be largely increased at night, when the room is filled with people and lighted up. Expanding and contracting openings are therefore desirable, and they should be regulated by rules stated on the plan of the ventilating system (already alluded to as being hung up in the hall) of the house which has submitted itself to a "perfect" system of ventilation.

To show the rising of heated air, a long glass tube, about three-quarters of an inch in diameter, may be provided and held over the flame of a spirit lamp at an angle of sixty de-

grees. As the tube warms, the heated air rushes past the flame with great rapidity, and pulls it out or elongates it so much, that the sharp point of the spirit-flame will frequently be seen at the end of a tube ten feet six inches in length. The flame is, as it were, the sign-post that indicates the path or direction of the air. (Fig. 470.)

Upon the like principle, heated air may be dragged down

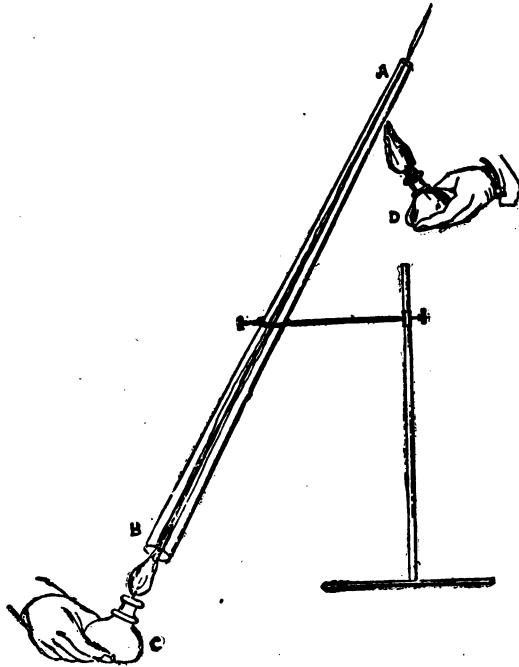
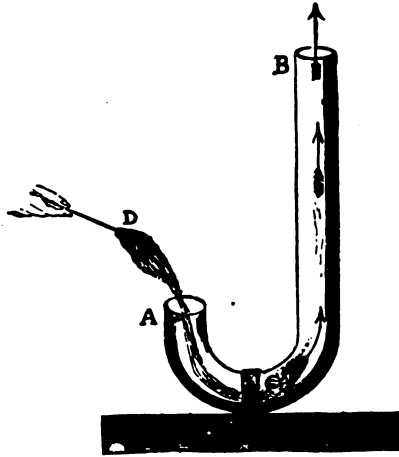

Fig. 470. A B. The glass tube. C. The spirit lamp, with a very large wick; if a little ether is mixed with the spirit in the lamp it increases the length of the flame. D. The effect of the ascension of air, increased by warming the top of the tube with the lamp D.

the short arm of a syphon, provided the other arm is sufficiently long to impart a strong directive tendency to the upward current, and this mode of setting air in motion has been frequently proposed in numerous schemes for ventilation. In order to prove the fact that an inverted syphon will act in this manner, an iron pipe of three inches diameter and six feet long may be bent round during the construction into the form of a syphon, so that the short length is about one foot

long, and the long length the remaining four feet, allowing one foot for the bend. If the interior of the long arm is first warmed by burning in it a little spirits of wine from a piece of cotton or tow wetted with the spirit (which can easily be done by dropping such a wetted piece into the bend of tube, so that it is just under the opening of the long part), the air is soon set in motion up the long pipe, and as it must be supplied with fresh volumes of air to take the place of that which rises, and as the only entrance for the fresh air can be *down* the short arm of the syphon, the circulation soon commences, and it proceeds as long as the upper arm is kept sufficiently warm. If a flame is held over the mouth of the short arm, it is immediately dragged downward, whilst, if held at the mouth of the long pipe, the motion of the air is seen by the assistance of the flame to be in the contrary direction. (Fig. 471.)



Before Faraday was appointed as adviser to the Trinity Board in connexion with lighthouses, all the lamps were burnt

in the lanterns with the smallest and most imperfect arrangement for carrying off the heated air and products of combustion; as a natural consequence, and particularly on cold nights, the windows of the lantern of the lighthouse were covered with ice derived from the condensation of the water produced by the combustion of the hydrogen of the oil, whilst the carbon generated such quantities of carbonic acid that the light-keepers were unable to stay in the lantern, and if obliged to remain there in pursuance of their duties they were almost overpowered with the excess of carbonic acid, and stated that it produced headache and sickness, and a tendency

Fig. 471. A B. Inverted sheet iron syphon. At C is seen the piece of tow moistened with alcohol, which, being set on fire, warms the tube B. D. A lighted torch of coloured spirit, the flame of which is dragged down the tube at A by the descending current, and is impelled upwards by the ascending current B.

to insensibility. Faraday immediately established a system of ventilation; and by attaching a copper tube to the top of each lamp-chimney, and centring them all in one large funnel passing to the top of the lighthouse, the whole of the water which previously condensed on the glass windows and impeded the light, besides injuring the brass and copper fittings, was carried off, as was also the poisonous carbonic acid gas; thus, as Faraday expressed himself, a "complete system of sewage was applied to the lamps of the lighthouses."

If any one of the numerous stories of ships saved by the Eddystone Lighthouse could demonstrate more than another the value of this beacon in mid ocean, it must be the graphic account in the *Times* of the gallant conduct of the British Admiral with his fleet whilst breasting the historic storm of October, 1859, and endeavouring to reach Plymouth Sound.

"It was on Saturday, the 22nd October, that the *Hero*, the *Trafalgar*, the *Algiers*, and the *Aboukir*, accompanied by the *Mersey*, the *Emerald*, and the *Melpomene*, put to sea from Queenstown. Up to the afternoon of Monday the squadron met with no remarkable adventure, but about that time, just after the crews had been exercised at gunnery practice, heavy storms of hail and sleet began to set in. Still there was no immediate indication of the tempest at hand, and at sunset topsails were double-reefed and courses reefed for the night, with no particular character about the wind, except that of extreme variability. As the morning broke on Tuesday—the day of the storm—the Land's-end was sighted, and the rain and the wind continued to increase. About nine A. M. the advent of the gale was no longer doubtful; topgallantyards were sent on deck and topgallantmasts struck, and the signal was given from the flagship, 'Form two columns; form line of battle; Admiral will endeavour to go to Plymouth.' To Plymouth accordingly, the course of the fleet was shaped, but so terrifically had the wind increased that it became very questionable whether the sternmost ships of the line could possibly succeed in entering the Sound. Upon this the Admiral determined to wear the fleet together, stand off, and face the storm, a manœuvre which, under circumstances of great difficulty, was most gallantly executed. The ships were close upon the Eddystone Lighthouse, round which they 'darted like dolphins' under the

tremendous pressure of the gale, the *Trafalgar* stopping in the midst of the storm to pick up a man who had fallen overboard. The whole squadron now stood off the land, the *Mersey* and *Melpomene* furling their sails, and the former vessel steaming along 'like an ocean giant.' Still the gale increased till about three P. M., when there occurred that remarkable phenomenon by which these rotatory tempests are characterised. The fleet had got into the very centre of the storm, the 'eye' of the tornado, and, though the sea towered up and broke in tremendous billows all around, the wind suddenly ceased and the sun shone. When, however, the signal had been given and obeyed for setting sail again, the ships soon encountered the gale once more—not, as before, from the S.E., but the N.W.—and in greater force than ever. It was now a perfect hurricane; and for three hours the whole fury of the tempest was poured upon the squadron. When it began, at length, to abate a little, the four line-of-battle ships and one of the frigates were still in company, and all doing well. The *Mersey* and the *Emerald* had steamed into Plymouth, but the five remaining vessels kept in open order throughout that terrible night, wore in succession by night signal at about one A. M., made the land at daylight, formed line of battle, came grandly up Channel under sail at the rate of eleven knots an hour, steamed into Portland, and 'took up their anchorage without the loss of a sail, a spar, or a ropeyarn.' "

The ingenious invention alluded to was succeeded by another and equally simple but scientific arrangement, which Faraday presented to his brother, and it was duly patented. (Fig. 472, Page 582.) It consisted of an arrangement for ventilating gas burners, and it must be obvious that such a necessity exists, because every cubic foot of coal gas when burnt produces a little more than a cubic foot of carbonic acid. A pound weight of ordinary coal gas contains about  $\frac{7}{16}$ ths of its weight of hydrogen, which when burnt produces two pounds and  $\frac{7}{16}$ ths of a pound of water. A pound of ordinary coal gas also contains about  $\frac{7}{16}$ ths of its weight of charcoal, which produces when burnt rather more than two and a half pounds of carbonic acid gas—2.56. In order to burn this quantity of gas nineteen cubic feet and  $\frac{3}{8}$ ths of a foot of atmospheric air, containing 4.26 cubic feet of oxygen, are required.



It is not therefore surprising, as common coal gas is sometimes purified carelessly, and contains a minute trace of sulphuretted hydrogen, with some disulphide of carbon vapour, that it should produce the most prejudicial effects in hot and badly ventilated rooms. The dangerous product of the combustion of ordinary coal gas is sulphurous acid—viz., the same gas as that generated when a sulphur match is burnt: and if it will attack the bindings of books, and damage furniture, goods in shops, curtains, etc., in consequence of the large quantity of water with which it is accompanied, how much more is it not likely to injure the delicate organism of the breathing apparatus of the lungs? Faraday's lamp is therefore in many respects a great boon, but, like a great many other clever things, it must be "adapted"—in this case to the currents of air and draught from the room,

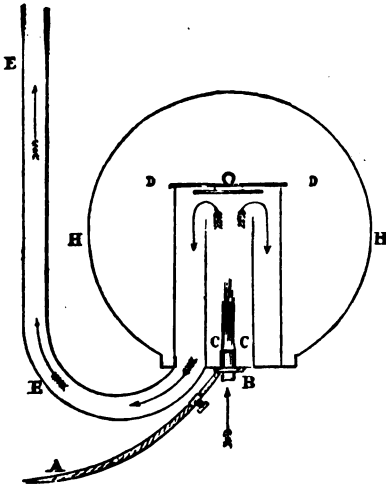

Fig. 472. A B. Gas pipe and argand burner; the air enters, as usual, up the centre of the argand. C C. The first glass chimney open at the top, with a disc of double talc, and fitting over C C, and leaving a space between the two glasses, down which the air passes into the ventilating tube, E E. H H. The ground-glass globe closed at the top, and surrounding the whole.

which is an extremely difficult matter to arrange; and means must be taken to prevent the draught becoming too powerful in Faraday's device, or else the illuminating power is destroyed by the thorough combustion of the carbon of the coal gas, and the heat generated is so intense that the glasses soon crack, and of course become useless. The lamp will answer very well if (as has been already stated) the draught in the ventilating pipe is not too great. The many difficulties attending the use of this lamp prevented its becoming popular.

The system already explained is likewise carried out on a much larger scale in the ventilation of coal pits, where a shaft is usually sunk into the ground for the admission of

air, which, after circulating through the intricate windings and mazes of the coal pit workings, escapes at last from another shaft, at the bottom of which is placed a powerful furnace, and this is kept burning night and day, so that the movement of the air is maintained in one direction—viz., from the outer air down the shaft called the *downcast*, thence to the galleries, where the men are working, to the second

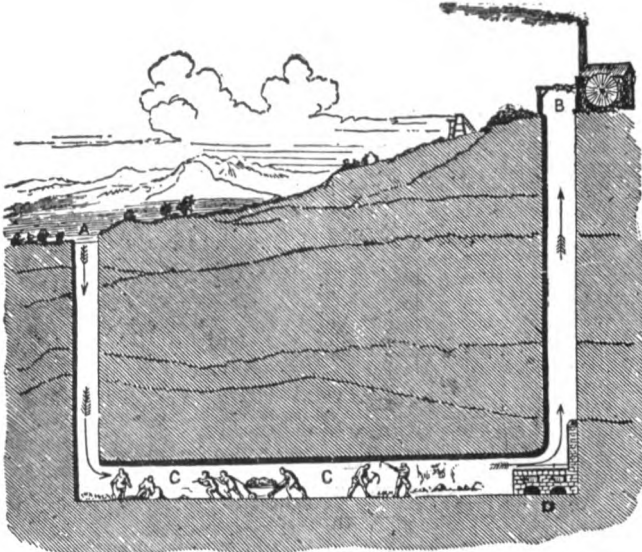

Fig. 473. Section showing the two air-shafts. A. The downcast. B. The upcast. C C. One of the working galleries in connexion with the upcast and downcast. D. The furnace at the bottom of the upcast. In this sketch one gallery only has been shown, to prevent confusion and merely to show the principle.

shaft, near which the furnace is placed, and up this latter the air travels; the shaft, pit, or funnel being very appropriately termed the *upcast*.

Should the furnace at the bottom of the upcast be neglected, the ventilation may be just balanced, or set slightly towards the downcast; in these circumstances the carbonic acid from the fire will begin to circulate in the galleries, and poison those who are not sufficiently aware of its presence to take the proper means to escape. Such accidents, amongst the host of others that occur in a coal pit, have often been recorded; and the firemen, whose duty it might be to attend

to the proper burning of the furnace, have had to pay the penalty of death for their own carelessness in falling asleep and neglecting to maintain the ventilation of the mine in one direction. (Fig. 473.) Many mines are still ventilated in this manner, but most, if not all the modern workings and shafts are ventilated by means of powerful fans driven from the engines, or in some other equally effective and reliable manner.

These details are amply sufficient to demonstrate the manner in which heat is diffused through air, whilst the rarefaction of the air by heat suggests the cause of those frightful storms of wind that rush from other and colder parts of the surface of the globe, to supply the void produced by the cooling and contraction of the enormous volumes of gaseous matter.

#### THE RADIATION OF HEAT

When rays of heat are emitted from incandescent matter, they are not necessarily visible; they are generally invisible, unaccompanied with a manifestation of light, and pass with great velocity through a void or vacuum, as also through air and certain other bodies. From what has been mentioned respecting the manner in which air, by continually moving, and by convection, carries off heat, it might be thought that no proof existed that invisible rays of heat are really thrown off from such an object, for example, as a ball filled with boiling water. But this question is set at rest by the fact that such a ball will cool rapidly when suspended by a string inside the receiver of an air pump from which the atmospheric air has been exhausted, so that no conduction of the particles of air could possibly remove the heat.

As early as 1786, examination was made of the relative conducting powers of air and a Torricellian vacuum—the vacuum being used because, as the experimenter stated, it was impossible to obtain a perfect vacuum, on account of the moist vapour which exhaled from the wet leather and the oil used in the machine, for at that time carefully *ground* brass plates were not used in air-pumps, but plates only, with a circular piece of wet leather upon them. In a paper read before the Royal Society, it is stated “It appears that the Torricellian vacuum, which affords so ready a passage to the electric fluid,

so far from being a good conductor of heat, is a much worse one than common air, which of itself is reckoned among the worst; for when the bulb of the thermometer was surrounded with air, and the instrument was plunged into boiling water, the mercury rose from  $18^{\circ}$  to  $27^{\circ}$  in forty-five seconds; but in the former experiment, when it was surrounded by a Torricellian vacuum, it required to remain in the boiling water one minute thirty seconds to acquire that degree of heat. In the vacuum it required five minutes to rise to  $48^{\circ}$   $\frac{1}{10}$ ths. but in air it rose to that height in two minutes forty seconds; and the proportion of the times in the other observation was nearly the same.

“It appears, from other experiments, that the conducting power of air to that of the Torricellian vacuum, under the circumstances described, is as 1000 to 702 nearly, for the quantities of heat communicated being equal, the intensity of the communication is as the times inversely. By others it appears that the conducting power of air is to that of the Torricellian vacuum as 1000 to 603.”

The velocity with which heat moves through a vacuum is very great, and experiment proves that no perceptible interval takes place between the time at which caloric quits a heated body and its reception by a thermometer at a distance of sixty-nine feet. It appears also, from experiments, to be thrown off or radiated in every direction, not to be diverted by any strong current of air passing it transversely. (See Fig. 454, page 555.)

Davy ignited the charcoal points connected with a battery in a vacuum, taking care to place the charcoal points at the top of the jar, and a concave mirror, with a delicate thermometer in its focus, at the bottom of the vessel placed upon the air-pump plate. The effect of radiation was ascertained first when the receiver was full of air,

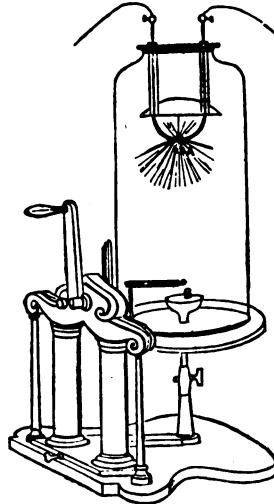

Fig. 474. The air-pump and receiver, containing at A the electric light in the focus of a concave mirror, and at B a delicate thermometer, also in the focus of a concave mirror.

and next when it was exhausted to  $\frac{1}{130}$ th, i.e., 119 parts pumped out, leaving only one part of air in the receiver. In the latter case, the effect of radiation was found to be three times greater than in an atmosphere of the common density. The greater rise of the thermometer *in vacuo* than in air is to be ascribed to the conducting power of air; for this conducting power, by reducing the temperature of the heated body, has a constant tendency to diminish the activity of radiation, which is always proportional to the excess of the temperature of the heated body above that of the surrounding medium. (Fig. 474.)

Count Rumford's experiments with a Torricellian vacuum gives the proportion of five *in vacuo* to three in air for the quantities of heat lost by radiation, and by conduction or

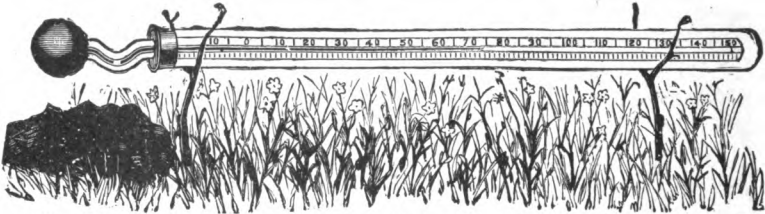

Fig. 475. Terrestrial radiation thermometer. The bulb of this instrument is transparent, the divisions being engraved on its glass stem. In use it is placed with its bulb fully exposed to the sky, resting on grass, with its stem supported by little forks of wood, and protected from the wind.

diffusion. It is not, perhaps, departing very far from the truth, if it be stated that one half of the heat lost by a heated body escapes by radiation, and that the rest is carried off by the convective power of currents of air.

If the process of radiation was not constantly proceeding, it can easily be imagined that the temperature of our globe would become so elevated by the regular accession of heat from the sun's rays, that the vegetation would be parched up and destroyed, and consequently all animals and the human race must become extinct. The best time to notice the radiation of heat from the earth is at night and after a hot summer's day. If the sky is clear, it will be noticed (with the help of a thermometer,) that the ground is several degrees colder than the air a few feet above it. (Fig. 475.) It is this reduced temperature that causes the deposition of dew, and produces the earth-cloud which so nearly resembles a sheet of water as to have been occasionally mistaken for an inundation, the

occurrence of the previous night; this cloud, which is the lowest form of these draperies of the sky, is the stratus, or evening mist; (see p. 603) but when permanent, and increased to a depth so as to rise above our heads, it is then called the morning fog. By placing a thermometer, standing at the ordinary temperature of the air, cased with a good radiating material, such as filaments of cotton, in the focus of a concave mirror, by turning this arrangement towards a clear sky in the evening, it will be noticed that the temperature falls several degrees. Good radiators of heat are black and scratched surfaces, filaments of cotton, grass, twigs, boughs, and certain leaves, especially those with a rough surface.

Bad radiators of heat are bright and polished metallic surfaces, white woollen cloth or flannel, hard and dense substances, such as a gravel path and stone, or those leaves which have a polished surface, such as the common laurel. It is the frozen dew and mist which produce the beautiful effect of hoar-frost and icicles on the trees and bushes, the primary cause being the radiation of heat from the various objects on the surface of the earth, as well as from the latter itself. When the wind is high, dew does not deposit, as it is necessary that the air should be calm, in order to receive the cooling impression of the cold earth, and to deposit the moisture, which it holds in solution as invisible steam. When the wind blows, it mixes all parts of the air together, and prevents that difference of temperature which causes the deposit of dew. Hence the evening mist will be more generally observed in the bosom of a valley surrounded by hills and screened from the winds that may blow from any quarter. The continual presence of moisture in the air is well shown by the condensation of water on the outside of a glass of cold spring water, or especially on the outside of a jug containing iced water. The invisible steam is always ready to bathe with dew the tender plants, which would otherwise perish and be burnt up during a hot summer, if they did not radiate heat at night, and thus condense water upon themselves. The presence of watery vapour in the air becomes therefore a matter of great importance, hence the construction of hygrometers or measurers of the moisture in the air.

Regnault's condenser hygrometer consists of a tube made of silver, very thin, and perfectly polished; the tube is larger

at one end than the other, the large part being 1.8 in depth by 8.10 in diameter. This is fitted tightly to a brass stand, with a telescopic arrangement for adjusting when making an observation. The tube has a small lateral tubulure, to which is attached an India-rubber tube with ivory mouth-piece; this tubulure enters at right angles near the top, and traverses it to the bottom of the largest part. A delicate thermometer is inserted in through a cork or India-rubber washer at the open end of the tube, the bulb of which descends to the centre of its largest part. A thermometer is attached for taking the temperature of the air; also a bottle for containing ether.

To use the condenser hygrometer, a sufficient quantity of sulphuric ether is poured into the silver tube to cover the thermometer bulb. On allowing air to pass bubble by bubble through the ether, by breathing in the tube, an uniform temperature will be obtained; if the ether continues to be agitated by breathing briskly through the tube, a rapid reduction of temperature will be the result. At the moment the ether is cooled down to the dew-point temperature, the external surface of that portion of the silver tube containing the ether will become covered with a coating of moisture, and the degree shown by the thermometer at that instant will be the temperature of the dew-point.

The most simple form of the hygrometer was formerly a very favourite indicator of the state of the weather, and usually consisted of the figure of a monk with his hood, which is attached to a bit of catgut; this covering of paper painted to represent the hood, falls over the head on the approach of damp weather, and inclines well back during the period that the air is dry or contains less moisture. (Fig. 476.)

A decision on the possible changes of the weather requires considerable experience, and it has been said that one of the most celebrated marshals of France asserted that he owed his invariable success in military combinations and attacks to his attention to the signs of the weather, as indicated by the state of the air during the phases of the moon.

The dry and wet bulb hygrometer, as represented in the next engraving, Fig. 477, Page 590, consists of two parallel thermometers, as nearly identical as possible, mounted on a wooden braeket, one marked *dry*, the other *wet*. The bulb of the wet thermometer is covered with thin muslin, round the neck of

which is twisted a conducting thread of lamp-wick, or common darning-cotton; this passes into a vessel of water, placed at such a distance as to allow a length of conducting thread of about three inches; the cup or glass is placed on one side, and a little beneath, so that the water within may not affect the reading of the *dry bulb thermometer*. In observing, the eye should be placed on a level with the top of the mercury in the tube, and the observer should refrain from breathing whilst taking an observation. The temperature of the air and of evaporation is given by the readings of the *two thermometers*, from which can be calculated the dew-point, tables being furnished for that purpose with the instrument. (Fig. 477, Page 590.)

The colour of the sky at particular times affords excellent guidance to doubting members of picnic or other out-of-door parties. Not only does a rosy sunset presage fine weather, and a ruddy sunrise bad weather, but there are other tints which speak with equal clearness and accuracy. A bright yellow sky in the evening indicates wind; a pale yellow, wet; a "neutral" grey colour constitutes a favourable sign in the evening, an unfavourable one in the morning. The clouds, again, are full of meaning in themselves. If their forms are soft, undefined, and feathery, the weather will be fine; if their edges are hard, sharp, and defined, it will not be good. Generally speaking, any deep, unusual hues betoken wind or rain, while the more quiet and delicate tints bespeak fine weather.

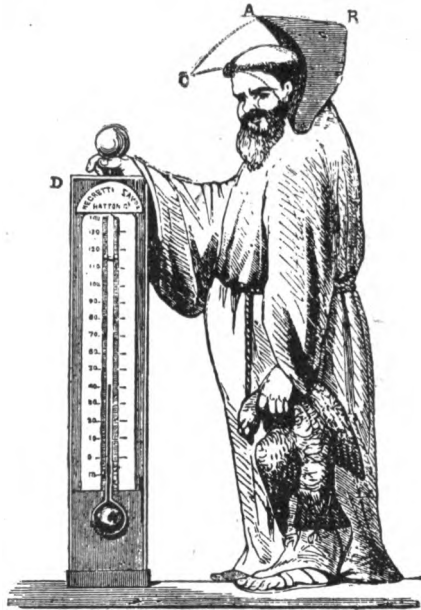

Fig. 476. The monk hygroscope, in which the hood, A B, covers the head to dotted line C in wet weather, and takes various intermediate positions, being quite back and on the shoulders in dry states of the air. A thermometer, D, is usually attached.



The principle of radiation of heat is employed by the Indian natives in the neighbourhood of Calcutta for the purpose of obtaining small quantities of ice. In that climate, the thermometer during the coldest nights does not indicate a lower temperature than about  $40^{\circ}$  Fahr.

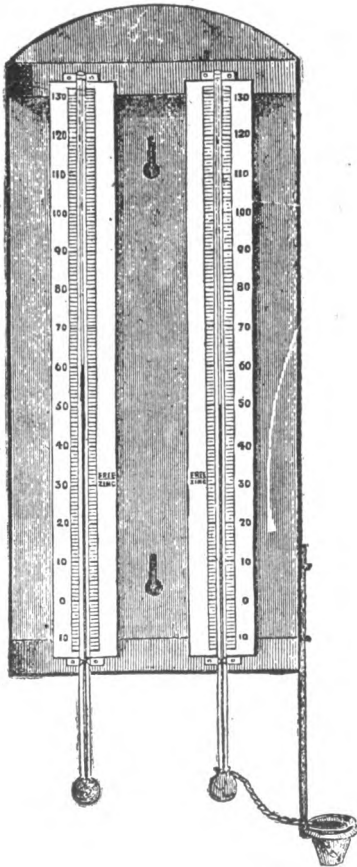

Fig. 477. The dry and wet bulb hygrometer.

However, the sky is perfectly cloudless, and as heat radiates with great rapidity from the surface of the ground, the Indian natives ingeniously place very shallow earthenware pans on straw, which is a bad conductor of heat, thus insulating the pans from communication with the parched earth. In a few hours the water in the pans is covered with a thin sheet of ice, and there can be no doubt of its production by an absolute loss of heat by radiation, because the plan does not succeed on a windy night, and succeeds best even when the pans are sunk in trenches dug in the earth. A windy night prevents that difference of temperature between one portion of the surface of the earth and another, which is so essential to a steady and uniform loss of heat, as it must be evident that the continual mixture of warmer portions

of air with that which is colder would tend to prevent the desired lowness of temperature being attained.

The manner in which heat is observed to be radiated has suggested another theory to the fertile brains of scientific observers, and it has been supposed that the conduction of heat

may be nothing more than a radiation from one particle of matter to another, as through a bar of copper, in which the particles, though packed closely together, are not supposed to be in actual contact, so that it is possible to conceive each separate atom of copper receiving and radiating its heat to the neighbouring particle, and so on throughout the length and breadth of the metal. By this theory the radiation of heat through a vacuum is brought into close connexion with that of the radiation of heat through the air and other solid and liquid bodies.

Some of the most interesting phenomena of heat prove that the rapidity with which a body cools, depends (like the reflection of light) more on the condition of the surface than on the nature of the material of which the surface is composed. With a globular and bright tin vessel it was observed that water of a certain heat contained in it, required 156 minutes to cool; but when the latter vessel was covered with a thin coating of lamp-black and size, the water fell to the same degree as that noticed in the first experiment in the space of eighty-one minutes.

By very careful observations made with a differential air thermometer the power of radiating heat in various substances has been determined as follows:—

Lamp-black .....	100
Writing paper .....	98
Sealing wax .....	95
Crown glass .....	90
Plumbago .....	75
Tarnished lead .....	45
Clean lead .....	19
Iron, polished .....	15
Tin plate, gold, silver, copper.....	12

As in the reflection of light, it was noticed that a piece of charcoal covered with gold leaf, partook of the nature of the precious metal so far as its power of throwing off or scattering the rays of light was concerned, so a piece of glass covered with gold-leaf appears to possess the same power of radiating heat as that of any brilliant metal.

Radiant heat, like light, can be propagated through a great variety of substances, but is stopped by the larger number;

and it can be reflected, refracted, polarised, absorbed, or it may undergo a secondary radiation.

The intensity of radiant heat follows the same laws as that of light, and decreases as the square of the distance from its source. The same law that governs the reflection of light, also prevails with that of heat; and it may be found by experiment that the angle of incidence is equal to the angle of reflection, so that the heat is disposed of in the same manner as light when it falls upon bright polished planes, convex and concave surfaces; hence the use of bright tin meat screens and Dutch ovens, and of all those simple pieces of culinary furniture which are employed in the kitchen for the purpose of arresting the cold currents of air that set towards burning matter, as also to reflect the heat upon whatever viands may be cooking before the fire. A bright silver teapot retains its heat better than a dirty one, and the fact is determined readily by pouring boiling water into two teapots, the one being made of bright tin and the other of black japanned tin. A thermometer inserted into each vessel will soon show that the latter radiates, and therefore loses its heat quicker than the former; the relative radiating powers of bright and blackened tin being as 15 to 100. Pipes for the conveyance of hot water or steam should be kept bright, if possible, although this trouble is avoided usually by packing them in bad conductors of heat, whilst the polish of the cylinder of a steam-engine is of great importance as a means of economising heat.

When the finger is approached within an inch or so of a red-hot ball, the heat radiated from the latter is so intense that it cannot be held there for more than a few seconds. If, however, the finger is coated with gold leaf it may be kept near the iron ball for some considerable time, because the radiant heat is reflected from the surface of the gold. If the word heat is written upon a sheet of paper and the letters afterwards gilt, the whole of the white surface is rapidly toasted and scorched when held before a fire, whilst the surface of the paper under the gold leaf remains perfectly white, which can be ascertained by turning the paper round and observing the other side. A sheet of paper gilt inside and turned round as a cone, being left open at both ends, may be employed as a reflecting surface; and if a bit of phosphorus, placed on paper, is held, say at two feet from a red-hot ball

of about two inches diameter, the radial heat from the latter has not sufficient intensity at that distance to set it on fire quickly; if, however, the cone of gilt paper is used between the two, and the phosphorus brought into the focus of the rays of radial heat, it very quickly takes fire. (Fig. 478.)

Experiments show that the radiation of heat from a body is not affected by colour, so that in winter all coloured clothes are alike in that respect, and radiate heat without any appreciable difference. The power of *absorbing* heat, however, is greatly dependent on colour; and as a general rule, good radi-

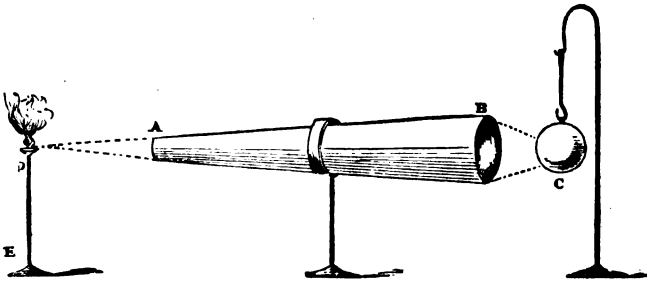

Fig. 478. A B. The cone of paper, gilt inside. C. The red-hot ball. D. Stand with wood supporting a slice of phosphorus, which is brought into the focus of the rays of heat reflected through the cone.

ators of heat (such as black cloth, or indeed any surface covered with lamp-black), are also excellent absorbents of heat. Hooke and Franklin placed pieces of cloth of similar texture and size on snow, allowing the sun's rays to fall equally upon them. The dark specimens always absorbed more heat than the light ones, and the snow beneath them melted to a greater extent than under the others; it was perceived that the effect was nearly in proportion to the depth of the shade, as in the following order:—After black, the maximum absorbent quality was possessed by, first, blue; second, green; third, purple; fourth, red; fifth, yellow. The minimum absorbent power was observed to belong to white.

When radiant heat is allowed to pass through glass, the latter substance is not found to be transparent to heat rays as it is to those of light, but a considerable proportion of heat is arrested and stopped; consequently glass fire-screens are to be preferred because they obstruct the heat but do not exclude the cheerful light and blaze of the fireside.

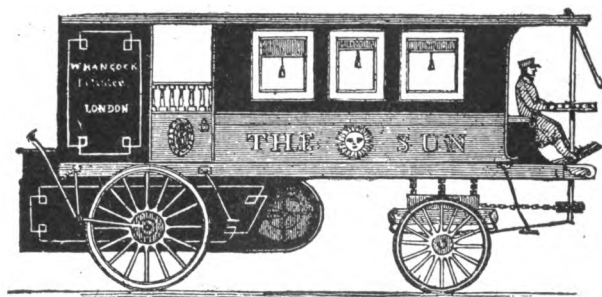

Fig. 479. Hancock's steam omnibus, which ran on the common roads.

## CHAPTER XXIX

### STEAM

The subject of steam and the steam engine is not one that could be thoroughly treated in the narrow space available, but enough may be said to impart common principles, whilst the minute details are better examined and learnt in the works of those authors who devote themselves specially to the important commercial question of steam.

The first truth to be comprehended is, that all matter contains within its substance the power of creating heat—or as it may be expressed more plainly, solids, fluids, and gases contain what is termed *latent* or insensible heat, in contradistinction to the heat which is apparent when we touch a vessel containing warm water or when we approach a cheerful fire; this form of heat is termed "*sensible* heat," and has formed the subject of the preceding chapters. The subject of latent heat is, however, most difficult and complex.

If a cold horse-shoe nail is applied to a thin dry slice of phosphorus laid on a sheet of paper, no combustion of the phosphorus ensues, because the temperature of the iron is not sufficiently high to affect that combustible substance; but if the horse-shoe nail is vigorously hammered on an anvil, the particles of metal are brought closer together, and if now it is applied to the phosphorus, so much heat has been generated, thrust or squeezed out by the hammering or *condensation* of the iron, that it is by this time sufficiently warm to set fire to the phosphorus.

The reverse or antithesis to this experiment—viz., the pro-

duction of cold—is shown in the sudden expansion of a mass of metal by first melting together

207 parts by weight of lead.

118 parts by weight of tin.

284 parts by weight of bismuth.

When these metals are in the liquid state and perfectly mixed, they are poured from a sufficient height into a pail of cold water, for the purpose of *granulating* or dividing them into small fragments.

If the granulated compound metal is now mixed with 1617 parts by weight of quicksilver, it becomes suddenly liquefied and expanded: liquefaction is the reverse of solidification, hence cold is produced from the natural heat of the compound metals being rendered latent by the change from the solid to the liquid state; so that a small quantity of water placed in a glass tube, and surrounded with the metals whilst liquefying in the mercury, becomes rapidly converted into ice, the fall of the temperature, as shown by a thermometer, being from 60° Fahr. to 14°, which is 18° below the freezing point of water. In the former case, by hammering the iron the *latent heat* is made *sensible*; whilst in the latter case, by the liquefaction of the compound metal in mercury, the *sensible* heat is rendered *latent*. The heat rendered latent by melting different substances is not a constant quantity, but varies with every special body employed.

In coining at the Mint, the cold blank pieces of gold, silver, or copper become hot directly they have sustained the violent and sudden pressure of the coining press, and they must be heated again, or annealed, to restore the equilibrium of the heat disturbed by the violent blow, or else they remain hard and unfit to sustain the finishing process of milling.

The condensation of water when it assumes a smaller bulk by union with sulphuric acid, is easily proved by measuring a pint of water and a pint of acid, and mixing them together, when a very great increase of temperature may be perceived. By placing into the mixture a cold copper wire that previously could not ignite phosphorus, it becomes very hot, and when removed and wiped it will cause phosphorus to fire directly it touches that substance. When the mixture of sulphuric acid and water is measured after it has cooled, it has no longer a bulk of two pints, but is found to have lost bulk equal to one

or more ounces by measure. The heat evolved by a mixture of four parts of strong sulphuric acid and one part water is shown by the thermometer to be  $300^{\circ}$  Fahr., and this mode of obtaining heat has been used by aëronauts for the purpose of obtaining artificial warmth without the danger of setting fire to the gas in the balloon.

When alcohol and water are mixed, a change of density occurs, and heat is produced; if equal measures of alcohol of a specific gravity of .825, and water, each at  $50^{\circ}$  Fahr., are mixed, a temperature of  $70^{\circ}$  Fahr. is obtained; if the mixture is made in a glass vessel, as shown in the annexed cut, Fig. 480, the combination is very apparent. To perform the experiment properly, water is poured into the lower tube and bulb, and alcohol into the top one; when this is done, the stopper is inserted, and the whole thoroughly shaken and mixed together; the warmth which is thus obtained is perceptible to the touch, whilst the contraction is shown after the mixture is cold, as it no longer fills the two bulbs of the instrument. (Fig. 480).



Fig. 480. Glass bulbs and tube to show the contraction in bulk of a mixture of alcohol and water.

The latent heat of gases is easily shown by suddenly condensing air in a small syringe or pump, of which the piston contains a minute fragment of amadou, which is a species of fungus, *Polyporus igniarius*; this, after having been beaten with a mallet, and dipped in a solution of saltpetre, forms the spunk or German tinder of commerce; it is also used as a styptic, and made into razor strops. This amadou takes fire, and before the invention of vesta and other matches, tobacco-smokers were in the habit of obtaining a light for their pipes and cigars in this manner—by the latent heat obtained from the contraction or compression of air. Then, again, an instructive though opposite parallel is afforded by suddenly expanding or rarefying air in a glass receiver provided with a delicate thermometer. By pumping out some of the air, a considerable diminution of the temperature occurs, equal to several degrees of the thermometer. Every child knows that steam direct from the kettle will scald, but if it issues from a high-pressure boiler, say at fifteen pounds on the

square inch (atmospheric pressure), the hand may be held with impunity in the escaping steam, as it merely feels gently warm, and not scalding. This is due partly to the loss of heat rendered latent by the expansion of the high-pressure steam directly it passes into the air, and partly to the currents of air that are dragged into an escaping jet of steam. At high pressure, however, the steam would of course, scald terribly and go through the flesh like a bullet. This tendency of the air to rush into a jet of steam was discovered by Faraday, and explains those curious experiments with a jet of steam by which balls, empty flasks, and globular vessels are sustained and supported either vertically or horizontally.

If steam at a pressure of about sixty pounds per inch is allowed to escape from a proper jet, and a large lighted circular torch composed of tow dipped in turpentine held over it, the course of the external air is shown by the direction of the flames, which are forcibly pulled and blown into the jet of steam with a roaring noise, indicating the rapidity of the blast of air moving to the steam jet. (Fig. 481.)

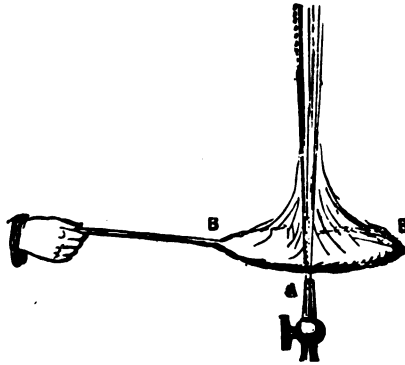

Fig. 481. A. Jet discharging high-pressure steam. B B. Lighted torch held round the escaping steam; the flames from the former all rush into the latter.

Egg-shells, empty flasks, india-rubber or light copper and brass balls, are suspended in the most singular manner inside an escaping jet of high-pressure steam; and, before the explanation of Faraday, reams of paper were used in the discussion of the possible theory to account for this effect; and what made the explanation still more difficult was the fact that the jet of steam might be inclined at any angle between the horizontal and vertical and still hold the ball, egg-shell, or other spherical figure firmly in its vapoury grasp. (Fig. 482, Page 598.)

A curious circumstance once occurred at the offices of the Westinghouse Brake Company at Westminster. Here there



was a full-sized model of the railway brake, kept charged with air at the pressure of 85 lbs. on the square inch. At one side of the apparatus was a tube furnished with a jet, which had a ball and socket joint, so that it could be turned to different angles. A tap was fixed to this jet, so that the air could be turned on or off. It seems that one day the engineer in charge took a child's india-rubber ball in his hand, in order to see how far the escaping blast would project it. To his surprise the ball remained suspended in mid-air. More than this, he found that it would also remain suspended although the nozzle through which the air was rushing was inclined almost to the horizontal, as in the case of the egg-shells figured below. This led to further experiments, and balls of all kinds of india-

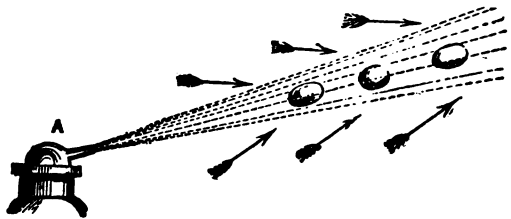

Fig. 482. A. Ball and socket jet at an angle, discharging steam. The egg-shells are supported by the enormous current of air moving into the jet in the direction of the arrows.

rubber and solid wood up to five inches in diameter were used with a like result. The hollow india-rubber balls revolved so quickly that their forms became flattened, the shape in fact of this revolving earth—an oblate spheroid. But perhaps the most remarkable effect was produced when the engineer actually picked up with the air jet a heavy wooden ball from an adjoining shelf. The nozzle was next fitted with a jet pierced with four holes, one in the centre, and the other three occupying the corners of a triangle round it. Four glass marbles were then placed one by one above these holes, and they were presently dancing in mid-air, supported apparently on nothing.

In consequence of the great rush of air towards a jet of escaping high-pressure steam, Gurney patented the application of this principle in his ventilating steam jet, which he had already successfully employed; in one case especially, where a coal mine had been on fire for several years, and the whole working of the coal-measures in the pit was jeopardised by the

spreading of the combustion to new workings; the fire was first extinguished by carbonic acid gas, pulled, as it were, into the coal-mine by a jet of steam blowing into the *downcast*, but placed in connexion with a furnace of burning coke; the circulation of the carbonic acid, called *choke-damp*, through the pit workings, was further assisted by a jet of high-pressure steam blowing upwards, and placed over the mouth of the *upcast* shaft.

The experiment succeeded perfectly at the South Sauchie Colliery, near Alloa, about seven miles from Stirling, where a fire had raged for about thirty years over an area of twenty-six acres in the waste seam of coal nine feet thick.

For the general purpose of ventilating the coalmine, Gurney's plan was tried at the Ebbw Vale Colliery, and very economically, the waste steam alone being used. Experiments were also satisfactorily made with it for blowing a cupola for smelting iron, and with dry steam—*i.e.*, steam of a very high pressure—escaping through a warm tube, the results were perfectly successful.

With this digression from the subject of latent heat derived from the compression of air, we return to the subject with another case in point, furnished by the Fountain of Hero, as it is called, at Schemnitz, in Hungary, described by Brande and evidently suggested by the fountain of Hero of Alexandria (about 150 B. C.) in which a jet of water is maintained and supported by a column of compressed air and is one of the early historic examples of pneumatics. (See also page 607.)

“A part of the machinery for working these mines is a perpendicular column of water 260 feet high which presses upon a quantity of air enclosed in a covered reservoir; the air is consequently condensed to an enormous degree by this height of water, which is equal to between eight and nine atmospheres; and when a pipe communicating with this reservoir of condensed air is suddenly opened, it rushes out with extreme velocity, instantly expands, and in so doing it absorbs so much heat as to precipitate the moisture it contains in a shower of snow, which may readily be gathered on a hat held in the blast. The force of this is so great that the workman who holds the hat is obliged to lean his back against the wall to retain it (*sic*) in its position.”

The best examples of latent heat are furnished by ice, water, and steam. When various solids are heated, they frequently pass through certain intermediate conditions of softness, terminating in perfect liquidity; but ice and many other bodies change at once to the liquid state on the application of a sufficient quantity of heat. The process of melting ice is very slow, because every portion must absorb or render latent a certain quantity of heat before it can take the liquid state—hence the difficulty of melting blocks of ice when they are surrounded with non-conducting materials.

To many it may seem curious that on melting a body, *no matter what heat is applied*, the temperature remains fixed till the whole is melted. For example:—If we take one pound of ice at  $0^{\circ}$  C. and mix it with one pound of water at  $79^{\circ}$  C. it is soon found that notwithstanding the heat we apply, the temperature remains fixed at  $0^{\circ}$  C. till every particle of the ice is melted. 79 degrees have therefore disappeared, or become latent, hence  $79^{\circ}$  C. is termed the heat of fusion of water, because 79 units of heat, or thermal units, as they are called, are used up, or made latent, in melting the ice, or in increasing the temperature of one unit of water from  $0^{\circ}$  to 1 Centigrade degree, so that  $79^{\circ}$  C. becomes the latent heat of water.

If, however, we take one pound of *water* at  $0^{\circ}$  C. (melted ice), and add this to one pound of water at  $79^{\circ}$  C., as before, we get two pounds of water at the mean temperature of  $39.5^{\circ}$  C., because half the extremes are always equal to the mean. So that in this case, the colder has been warmed by the mean of the extra heat of the hotter, which has consequently lost the heat given to the colder. Put simply, one pound at  $79^{\circ}$  and one at  $0^{\circ}$  give a difference of  $79^{\circ}$ ; half of this is given up by the one to the other, which is therefore raised in temperature to the extent of what has been given to it, and instead of having two pounds of water at  $0^{\circ}$  C., as in the case of *ice*, we have two pounds of water at  $39.5^{\circ}$  C.

It is this large quantity of latent heat required and retained by ice and snow which prevents their sudden liquefaction and the disastrous circumstances that would arise from the floods that must otherwise always be produced.

From similar experiments this important truth has been deduced,—“that in all cases of liquefaction a quantity of heat *not indicated by, or sensible to, the thermometer, is ab-*

*sorbed* or disappears, and that this heat is *withdrawn* from the *surrounding bodies*, leaving them *comparatively cold*." At p. 101 it is shown how the sudden solution or liquefaction of certain salts produces cold, and hence numerous freezing mixtures have been devised. In olden times, when officials in authority did what they pleased, without being troubled with disagreeable returns, and colonels clothed their men, and were merchant tailors on the grand scale, gun cartridges were not confined to practice on the enemy, but they did duty frequently in the absence of ice as refrigerators of the officers' wine, in consequence of the gunpowder containing nitre or saltpetre; as a mere solution of this salt finely powdered will lower the temperature of water from 50° Fah. to 35°; whilst a mixture of four ounces of carbonate of soda and four ounces of nitrate of ammonia dissolved in four ounces of water at 60°, will in three hours freeze ten ounces of water in a metallic vessel immersed in the mixture during the liquefaction or solution of the salts.

Fahrenheit imagined he had attained the lowest possible temperature by mixing ice and salt together, and it is by this means that confectioners usually freeze their ices, or ice puddings; the materials are first incorporated, and being placed in metallic vessels or moulds, and surrounded with ice and salt placed in alternate layers, and then well stirred with a stick, they soon solidify. The temperature obtained is Fahrenheit's *zero*—viz., thirty-two degrees *below* the freezing point of water.

#### HEAT THE CAUSE OF VAPOUR

Every liquid, when of the same degree of chemical purity, and under equal circumstances of atmospheric pressure, has one peculiar point of temperature at which it invariably boils. Thus, ether boils at 96° Fahr., and if some of this highly inflammable liquid is placed carefully in a flask, by pouring it in with a funnel, and flame applied within one inch of the orifice, no vapour escapes that will take fire; but if the flame of a spirit-lamp is applied, the ether soon boils, and if the lighted taper is again brought near the mouth of the flask, the vapour takes fire, and produces a flame of about two feet in length. This fire only continues as long as the flame of the spirit lamp is retained at the bottom of the flask, and on

removing it the vessel rapidly cools. The length of the flame is reduced, and is gradually extinguished for the want of that essence of its vitality, as it were—viz., heat. (Fig. 483. See also page 77.) If a thermometer is introduced into the flask, however rapid may be the ebullition or boiling of the ether, it is found to be invariably at  $96^{\circ}$ . The heat carried off by evaporation is displayed by placing a little water in a watch glass, surrounded by charcoal saturated with sulphuric acid, in the vacuum of an air-pump. The rapid evaporation

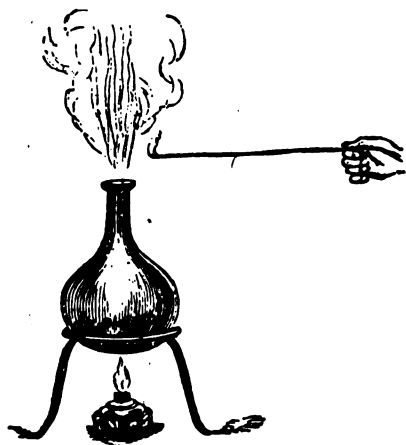

Fig. 483. Heat the cause of vapour.

and condensation of the water by its affinity for the sulphuric acid quickly produces ice.

The illustration of the determination of the fixed and invariable boiling point belonging to every liquid is further carried out by introducing some water into a second flask standing above a lighted spirit-lamp, with a small thermometer, graduated to de-

grees above the boiling point of water; when the water boils, it will be found to remain steadily at a temperature of  $212^{\circ}$ . And however rapidly the water may be boiled, provided there is ample room for the steam to escape, the heat indicated by the thermometer is like the law of the Medes and Persians, which altereth not, and it remains standing at the number  $212^{\circ}$ . The only exception (if it may be so termed) to this law is brought about by the shape and nature of the containing vessel; under a mean pressure the boiling point of water in a metallic vessel is generally  $212^{\circ}$ ; in a glass vessel it may rise as high as  $214^{\circ}$  or  $216^{\circ}$ , but if some metallic filings are dropped in, the escape of steam is increased, and the temperature may then drop immediately to  $212^{\circ}$ .

When a thermometer is inserted in a flask containing water in a state of ebullition or boiling, so that the bulb does not

touch the fluid, but is wholly surrounded with steam, it will be found that the temperature of the latter is exactly the same as that of the former; and if the liquid boils at 96°, the vapour will be 96°, if at 212°, the steam is 212°. Steam has therefore exactly the same temperature as the boiling water that produces it. (Fig. 484.)

Whilst performing the last experiment, it may be noticed that the steam inside the neck of the flask is invisible, and that it only becomes apparent in that kind of intermediate condition between the vaporous and liquid state called *vesicular vapour*—a state corresponding with the “earth fog” and called the *stratus*. (See p. 587.) When a flask containing boiling water is placed under the receiver of an air pump (as soon after the ebullition has ceased as may be possible), and the air pumped out, it will be noticed that the water again begins boiling as the vacuum is obtained, showing that the boiling point of the same fluid varies under different degrees of atmospheric pressure, and according to the height of the barometer.

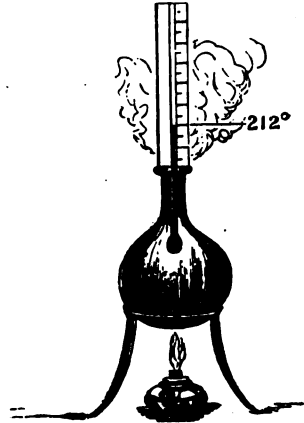

Fig. 484. Thermometer in the steam escaping from boiling water.

Height of barometer.	Boiling point of water.	Height of barometer.	Boiling point of water.
26 .....	204.91°	29 .....	210.19°
26.5.....	205.79	29.5.....	211.07
27 .....	206.67	30 .....	212
27.5.....	207.55	30.5.....	212.88
28 .....	208.43	31 .....	213.76
28.5.....	209.31		

Alcohol and ether confined under an exhausted receiver boil violently at the ordinary temperature of the atmosphere, and in general liquids boil with 124° less of heat than are required under a mean pressure of the air; water, therefore, in a vacuum must boil at 88° and alcohol at 45°.

On ascending considerable heights, as to the tops of moun-

tains, the boiling point of water gradually falls in the scale of the thermometer; thus, on the summit of Mont Blanc water was found by Saussure to boil at  $187^{\circ}$  Fahr. Wollaston's instrument for measuring the heights of mountains by the variations of the boiling point of water has long been known and used for this purpose.

If a flask is half filled with water, which is then boiled over a gas or spirit flame, the same fact already mentioned and illustrated in the preceding table may be rendered apparent

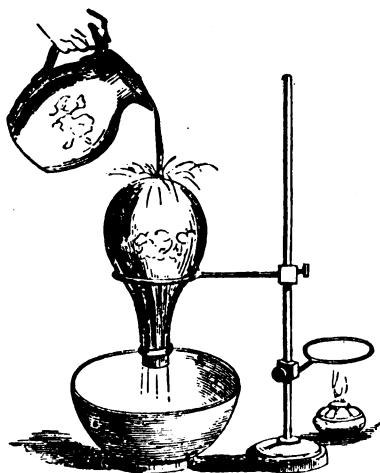

Fig. 485. The paradoxical experiment of water boiling by the application of cold water.

when the flask is corked and removed from the heat. If it is now inverted, and cold water poured over it, an ebullition immediately commences, because the cold water condenses the steam in the space above the hot water in the flask, and producing a vacuum, the water boils as readily as it would do under an exhausted receiver on an air-pump plate. (Fig. 485.)

Water may be heated considerably higher than  $212^{\circ}$ , if it is enclosed in a strong boiler, and shut off from communication with the air; by this means steam of great pressure is obtained.

Marcet invented a very instructive form of a miniature boiler, supplied with a thermometer and barometric pressure gauge, which can be purchased at any of the instrument makers, and is figured and described in nearly every work on chemistry.

The reason water boiled in an open vessel does not rise to a higher temperature than  $212^{\circ}$  is because all the excess of heat is carried off by the steam, and is said to be rendered latent in the vapour. The fixation of caloric in water by its conversion into steam may be shown by the following experiment. Let a pound of water at  $212^{\circ}$  and eight pounds of iron filings at  $300^{\circ}$  be suddenly mixed together. A large

quantity of steam is instantly generated, but the temperature of the water and escaping steam are still only 212°; hence the steam must therefore contain, latent, all the degrees of heat between 212° and 300°, or eight times 88. When the water is heated in the hydro-electric machine or other boiler, to 322.7°, it very quickly drops to 212° when the steam is allowed to blow off; yet if the latter is collected, it represents but a very small quantity of water which constituted the steam, and it has carried off and rendered latent the excess of heat in the boiler—viz., the difference between 212° and 322.7°, or 110.7°.

If steam can carry off heat, of course it may be compelled, as it were, to surrender it again; and this important elementary truth is shown by adapting a tube, bent at right angles, and a cork, to a flask containing a few ounces of water, and when it boils, the steam issuing from the end of the pipe may now be directed into and below the surface of some water contained in a beaker; in a very short time the water in the latter will be raised to the boiling point by the condensation of the steam

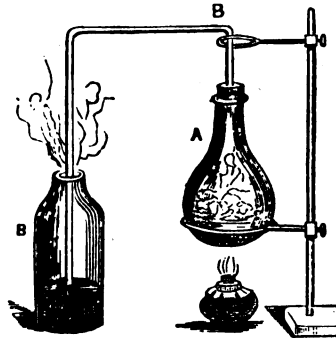

Fig. 486. A. Flask for generating steam. B. Glass pipe bent at right angles to convey the steam into the fluid containing some cold water.

and the latent heat arising from it. (Fig. 486.) The amount of latent heat is enormous, when it is remembered that water by conversion into steam has its bulk prodigiously enlarged—viz., 1698 times, so that a cubic inch of water converted into steam of a temperature of 212°, with the barometer at thirty inches, occupies a space of one cubic foot, and its latent heat amounts, according to Hall, to 950°; Southerton, 945°; Ure, 967°. When we come to the consideration of the steam-engine, it will be noticed that the question of the latent heat of steam is one of the greatest importance.

Temperature of Steam.	Elasticity in inches of Mercury.	Latent Heat.
229°	40°	942°
270	80	942
295	120	950



The same weight of steam contains, whatever may be its density, the same quantity of caloric, its latent heat being increased in proportion as its sensible heat is diminished; and the reverse. In consequence of the enormous amount of latent heat contained in steam, it is advantageously employed for the purpose of imparting warmth either for heating rooms or drying goods in certain manufacturing processes. The wet rag-pulp pressed and shaken into form on a wire-gauze frame or *deckle*, passes gradually to cylinders containing steam, and is thoroughly dried before the guillotine knife descends at the end of the paper machine, and cuts it into lengths. In calico stiffening and glazing, also in calico printing, steam-heated cylinders are of great value, because they impart heat without the chance of setting the goods on fire. The elementary principles already described with reference to heat, will prepare the reader for the application of the expansion of water into steam, as the most valuable  *motive power* ever employed to assist the labour of man.

## CHAPTER XXX

### THE EVOLUTION OF THE STEAM ENGINE

"So shalt thou instant reach the realm assign'd  
In wondrous ships, *self-mov'd*, instinct with mind.

Though clouds and darkness veil the encumbered sky,  
Fearless, through darkness and through clouds they fly,  
Tho' tempests rage,—tho' rolls the swelling main,  
The seas may roll, the tempests swell in vain;  
E'en the stern god that o'er the waves presides,  
Safe as they pass, and safe repress the tides,  
With fury burns; while careless they convey,  
Promiscuous, ev'ry guest to ev'ry bay."

Homer's description, as above, of the Phœnician fleet of King Alcinous, in the eighth book of the "Odyssey," is certainly an ancient record of an *idea*, but nothing more. In a work written by Hero of Alexandria, about a hundred or a hundred and fifty years B. C., and entitled "Spiritalia seu Pneumatica," a number of contrivances are mentioned for raising liquids and producing motion by means of air and steam, so that the first steam-engine is usually ascribed to Hero; and the annexed cut displays the apparatus. (Fig. 487. See also page 599.)

It is a remarkable circumstance that Newton applied the same principle in a little ball, mounted on wheels, containing boiling water, and provided with a small orifice; in his description he says: "And if the ball be opened, the vapours will rush out violently one way, and the wheels and the ball at the same time will be carried the contrary way." From the time of Hero, there does not appear to be any record or mention made of steam apparatus till the year 1002, when, in a work called "Malmesbury's History," a mention is made of an organ in which the sounds were produced by the escape of air (query, steam) by means of heated water. It is strange that, in these days of steam application, the Calliope, or steam organ, was not long since an important feature at the country fairs; and it only shows how the same ideas are reproduced as novelties in the ever-recurring cycles of years.

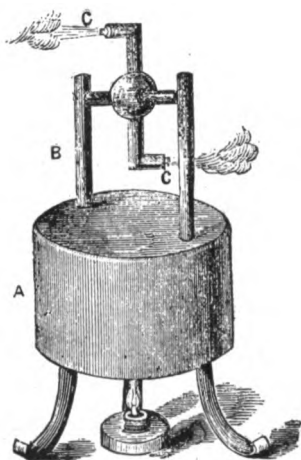

Fig. 487. Hero's steam-engine. A. The boiler in which steam is produced, and then passes through the hollow support B, from which there is no outlet but through the two apertures, C C. The reaction of the air on the issuing steam produces a rotatory motion in the jets, C C, attached to a centre but hollow axle.

On the revival of classical learning throughout Gothic Europe, the work of Hero began to attract attention, and it was translated and printed in black letter; most likely first from the Arabic character, as in the year 1543 the first fruits appeared in Spain, where Blasco de Garay, a sea captain, propelled a ship of 200 tons burden, at the rate of three miles per hour, before certain commissioners appointed by the Emperor Charles the Fifth. Alas for inquisitorial Spain! had she looked deeper into the matter, and performed her *autos-de-fé* on the boilers of steam-engines instead of the bodies of poor human beings, what lasting glories would have been her reward. The invention made its *début* in Spain, the commissioners reported, the inventor was rewarded, but the mighty giant invoked was put to sleep again for at least 150 years. The steam giant was disturbed with dreams; one Mathias, in

1563, gave him a nightmare; Solomon de Caus, in 1624, nearly woke him up; Giovanni Bianca, in 1629, did more; and the Marquis of Worcester, in the middle of the seventeenth century, as the evil genius of Spain, carried off the giant bodily to be the slave of England; at least, he experimented; and wrote such wondrous tales of the new motive power, that in 1653 we read of steam being fairly tethered to its work, and set to draw water out of the Thames at Vauxhall. Cosmo de

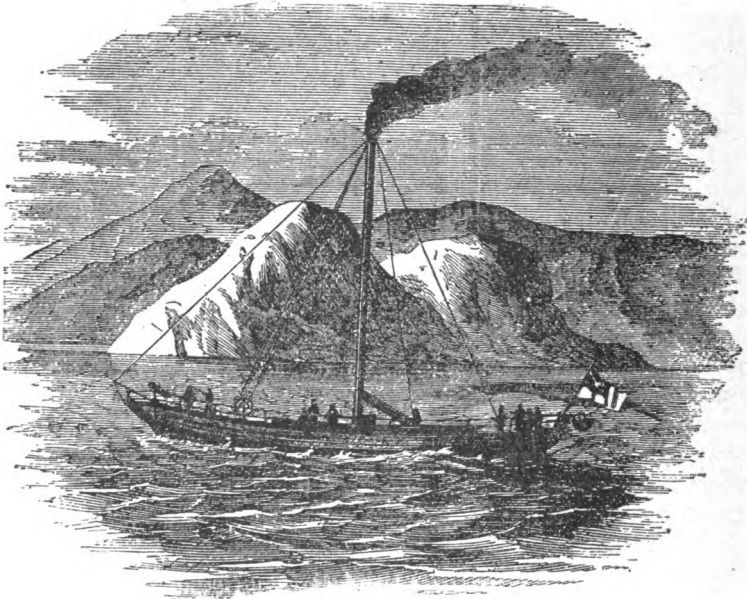

Fig. 488. The first steam-boat, the "Comet," built by Henry Bell, in 1811, who brought steam navigation into practice in Europe.  
(From an old print.)

Medici, a foreigner who inspected the apparatus in 1653, says, "It raises water more than forty geometrical feet by the power of one man only, and in a very short space of time will draw up full vessels of water through a tube or channel not more than a span in width, on which account it is considered to be of greater service to the public than the other machine near Somerest House, which last one was driven by *two horses*."

What would these worthies think could they peep into the present, and find that almost every trade and manufacture depends upon the power of steam to put in motion machines

which seem possessed of actual intelligence, so perfect is their work. And that, by the same agency, huge ships cross the seas in every latitude.

The first really useful steam-engine was made by a Captain Savery, who appears to have been the first inventor who thoroughly understood and applied the *vacuum* principle. (Fig. 489.)

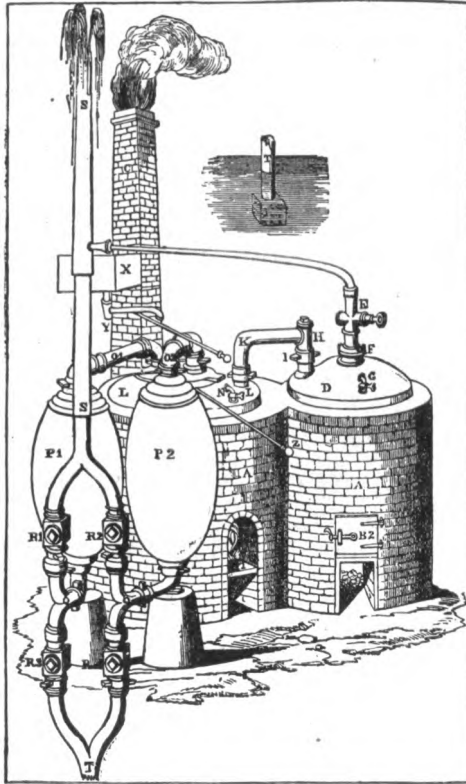

Fig. 489. Savery's engine.

"A A. The furnaces which contain the boiler. B 1 and B 2. The two fireplaces. C. The funnel or chimney, which is common to both furnaces. In these two furnaces are placed two vessels of copper, which I (Savery) call boilers—the one large as at L, the other small as D. D. The small boiler contained in the furnace, which is heated by the fire at B 2. E. The pipe and cock to admit cold water into the small boiler to fill it. F. The screw that covers and confines the cock E to the top of the small boiler. G. A small gauge cock at the top of a pipe, going within eight inches of the bottom of the small boiler. H. A large pipe which goes the same depth into the small boiler. I. A clack or valve at the top of the pipe H (opening upwards). K. A pipe going from the box above the said clack or valve in the great boiler, and passing about one inch into it. L L. The great boiler contained in

the other furnace, which is heated by fire at B 1. M. The screw with the regulator, which is moved by the handle Z, and opens or shuts the apertures at which the steam passes out of the great boiler at the steam-pipes O O. N. A small gauge cock at the top of a pipe, which goes half way down into the great boiler. O 1. O 2. Steam pipes, one end of each screwed to the regulator; the other ends to the receivers. P P. to convey the steam from the great boiler into those receivers. P 1. P 2. Copper vessels called receivers, which are to receive the water which is to be raised. Q. Screw joints by which the branches of the water-pipes are connected with the lower parts of the receivers. R 1. 2. 3. and 4. Valves or clacks of brass in the water-pipes, two above the branches Q and two below them; they allow the water to pass upwards through the pipes, but prevent its descent; there are screw-plugs to take out on occasions to get at the valves R. S. the forcing-pump which conveys the water upwards to its place of delivery, when it is forced out from the receivers by the impelled steam. T. The sucking-pipe, which conveys the water up from the bottom of the pit to fill the receivers by suction. V. A square frame of wood, or a box, with holes round its bottom in the water, to enclose the lower end of the sucking-pipe to keep away dirt and obstructions. X is a cistern with a bung cock coming from the force-pipe, so as it shall always be kept filled with cold water. Y Y. A cock and pipe coming from the bottom of the said cistern, with a spout to let the cold run down on the outside of either of the receivers. P. P. Z. The handle of the regulator to move it by, either open or shut, so as to let the steam out of the great boiler into either of the receivers."

This is Savery's own description (1702), of his water-engine, which differs from that suggested by the Marquis of Worcester, in the fact that he made the *pressure of the air* carry the water up the first stage. Savery's patent was "for raising water and occasioning motion to all sorts of mill-work by the impellent force of fire"; and the patent was granted in the reign of King William the Third.

Thus Savery overcame, as he remarks, the "oddest and almost insuperable difficulties," and introduced a steam apparatus or engine, a good many of which were constructed, and employed for raising water. The mechanical skill required to construct the boiler, the very *heart* (as it were) of the iron engine, had not been acquired in his time, hence the weakness of the boilers, and the danger of working them. As the pressure required was very considerable to overcome the resistance of a lofty column of water, these engines were gradually relinquished for those of another clever mechanician—Thomas Newcomen, an ironmonger of Dartmouth, who, about the year 1705, constructed and introduced the *cylinder*, from which the transition was gradually made to the mode of condensing by a jet of cold water, the use of self-acting valves, and the construction of self-acting engines by Smeaton, Hornblower, and Watt.

Newcomen was assisted in his work by one Cawley, a glazier; and their persevering labours were crowned with a successful result of the most memorable importance in the history of the steam-engine.

In the engine by Savery, the operation of the steam was

twofold—by the direct pressure from its elasticity, and by the indirect consequence of its condensation, which affords a vacuum. This last may be said to be the only principle used by Newcomen, who employed a boiler for the generation of steam, and conveyed it by a pipe to the bottom of a hollow cylinder, open at the top, but provided with a solid piston, that moved up and down in it, and was rendered tight by a stuffing of hemp, like the piston of a boy's common squirt. It can readily be understood, that if the jet of the latter was connected with a boiler, and steam blown into it, that the piston of the squirt would rise to the top of the barrel in which it works, being thrust up by the pressure or force of the steam; but unless the steam was cut off, and cold water applied to the interior of the barrel, the piston could not descend again. As soon, therefore, as Newcomen had thrust up the piston by the action of steam, he introduced a jet of cold water, supplied from an elevated cistern beneath the piston, when the steam was condensed into water, and a vacuum or void space obtained. The piston being free to move either up or down, was now forced down by the pressure of the air, which is a constant force equal to fifteen pounds on the square inch; and thus the piston in Newcomen's engine was raised by *heat*—viz., by steam, and thrust down by *cold*—i.e., by the condensation of the steam producing a vacuum. The void obtained in this manner was very considerable, because one cubic *foot* of steam at 212° condenses into one cubic *inch* of water. The production of a vacuum with the aid of steam is quickly effected by boiling some water in a clean can, and when the steam is issuing freely from the mouth it is then corked, and cold water thrown over the exterior. Directly the temperature is lowered, the steam inside the tin vessel is condensed suddenly into water, and a void space being instantly obtained, the whole pressure of a column of air of a breadth equal to the area of the vessel, and of a height of over forty miles, is brought quickly down like a sledge-hammer upon the sides of the tin vessel, and as they are not sufficiently strong to offer a proper resistance, they are crushed in like an egg-shell by the weight which falls upon them. This makes a very interesting experiment.

The barometer, or measurer of the weight of the air, consists of a glass tube about thirty-three inches in length, her-

metically sealed at one end, and containing mercury that has been carefully boiled within it, and being perfectly filled, the tube is inserted in a cistern of clean mercury, when it gravitates to a height equal to the pressure of the air, leaving a space at the top called the Torricellian vacuum. As the atmospheric air decreases in density by admixture with invisible steam or vapour, any given volume becomes specifically lighter; hence the column of mercury falls to a height of about twenty-eight inches; whilst if the aqueous vapour diminishes, the weight of the air becomes greater, and the barometer may rise to a height of about thirty-one inches.

Having thus secured a "reciprocating motion," Newcomen applied it to the working of a force-pump by the intervention of a great beam or lever suspended on gudgeons (an iron pin on which a wheel or shaft turns) at the middle, and suspended like the beam of a pair of scales; in fact, he invented that method of supporting the beam which is in use to the present day. Supposing we compare Newcomen's beam to a scale beam, he attached to the extremities (instead of scale pans) a water pump and his steam cylinder—the latter being at one end, and the former at the other. The beam played at "see-saw"; by the primary action of the steam on the bottom of the piston in the *cylinder* it was pushed up at the end, and of course suffered an equal fall at the other, to which the pump piston was attached; when the motion was reversed by the condensation of the steam, down went the piston again by the pressure of the air, whilst that of the water pump was again raised, and being provided with proper valves, the water was pumped slowly out of the mine, although the steam power used was very moderate, and only just sufficient to counterpoise the weight of the atmosphere. Newcomen made the end attached to the water pump purposely heavier than the steam piston of the other end of the beam, and by this means the work of the steam, by its elasticity, was very moderate, whilst the actual lift of the water from the mine was performed by the pressure of the air, equal (as already stated) to fifteen pounds on every square inch of the surface of the steam piston. This engine is called the atmospheric engine, and in the next figure we have a picture taken from a photograph of the actual model of the Newcomen engine in the Hunterian Museum of the University of Glasgow; the dimensions being—length, 27

in.; breadth, 12 in.; height, 50½ in.; from which, “in 1765, *James Watt, in seeking to repair this model, belonging to the Natural Philosophy Class in the University of Glasgow, made the discovery of a separate condenser, which has identified his name with that of the steam-engine.*”(Fig. 490.)

In Newcomen’s engine, the opening and shutting of the taps required the vigilant care of a man or boy, and it is stated on good authority that a boy who preferred (like nearly all other boys) *play* to work, contrived, by means of strings, a brick, and one or two catches on the working beam, to make the engine self-acting.

This poor boy’s ingenious contrivance paved the way for the improved methods of opening and shutting the valves, which were brought to a great state of perfection by Beighton, of Newcastle, about 1718. Between that time and the year 1763, we find mention made of Smeaton in connexion with the steam-engine, but the name of the great James Watt at this time began to be appreciated, and by a series of wonderfully simple mechanisms he at last perfected the machine whose origin could be traced back not only to the time of Blasco de Garay, in 1543, but even to the days of the ancient mechanics, such as Hero, who lived about 150 B. C.

In 1763, Watt was a maker of mathematical instruments in Glasgow, and his attention was drawn to the subject of the steam-engine by his undertaking, as mentioned above, to repair a working model of Newcomen’s steam-engine, which was used by Professor Anderson, who subsequently founded

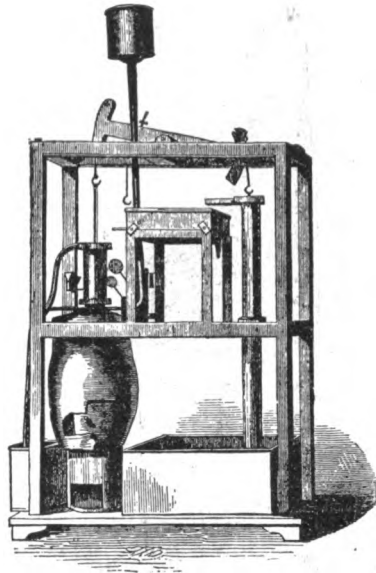

Fig. 490. Model of the Newcomen engine. In which the furnace and boiler, the steam cylinder, beam, water-pump, and elevated cistern of water, are apparent.



the Andersonian Institution. The repairs required for this model induced Watt to make another, and by watching its operation, he discovered that a vast quantity of heat, and therefore fuel, was wasted in the constant and successive heating and cooling of the steam cylinder. About two years after, when Watt was twenty-nine years of age, he had made so many experiments, that he was enabled to put into a mechanical shape his original ideas, which are embodied in his patent of 1769, as follows:—

“My method of lessening the consumption of steam, and consequently fuel, in fire-engines, consists of the following *principles*:

“First: That vessel in which the powers of steam are to be employed to work the engine, which is called the cylinder in common fire-engines, and which I call the steam-vessel, must, during the whole time the engine is at work, *be kept as hot as the steam that enters it*—first, by enclosing it in a case of wood or any other materials that transmit heat slowly; secondly, by surrounding it with steam or other heated bodies; and thirdly, by suffering neither water nor any other substance colder than steam to enter or touch it during that time.

“Secondly: In engines that are to be worked wholly or partially by condensation of steam, the steam is to be condensed in vessels *distinct* from the steam-vessels or cylinders, although occasionally communicating with them; *these vessels* I call *condensers*; and whilst the engines are working, these condensers ought at least to be kept as cold as the air in the neighbourhood of the engine, by application of water or other cold bodies.

“Thirdly: Whatever air or other elastic vapour is not condensed by the cold of the condenser, and may impede the working of the engine, is to be drawn out of the steam-vessels or condensers by means of pumps wrought by the engines themselves, or otherwise.

“Fourthly: I intend in many cases to employ the expansive force of steam to press on the pistons, or whatever may be used instead of them, in the same manner as the pressure of the atmosphere is now employed in common fire-engines. In cases where cold water cannot be had in plenty, the engines may be wrought by this force of steam only, by

discharging the steam into the open air after it has done its office.

“Lastly: Instead of using water to render the piston or other parts of the engines air- and steam-tight, I employ oils, wax, resinous bodies, fat of animals, quicksilver, and other metals in their fluid state.

“And the said James Watt, by a memorandum added to the said specification, declared that he did not intend that anything in the fourth article should be understood to extend to any engine when the water to be raised enters the steam-vessel itself, or any vessel having an open communication with it.”

“About the time he obtained his patent, Watt commenced the construction of his first real engine, the cylinder of which was eighteen inches in diameter, and after many impediments in the details of the work he succeeded in bringing it to considerable perfection. The bad boring of the cylinder, and the difficulty of obtaining a substance that would keep the piston tight without enormous friction, and at the same time resist the action of steam, gave him the most trouble, and the employment of a piston rod moving through a stuffing-box was a new feature in steam-engines at that time, and required great nicety of workmanship to make it effectual. While Watt was contending with these difficulties, Roebuck's finances became disarranged, and in 1773 he disposed of his interest in the patent to Mr. Boulton, of Soho. As, however, a considerable part of the term of fourteen years, for which the patent was granted, had already passed away, and as several years more would probably elapse before the improved engines could be brought into operation, it was judged expedient to apply to Parliament for a prolongation of the term, and an Act was passed in 1775 granting an extension of twenty-five years from that date, in consideration of the great merit of the invention.”—(Bourne's “Treatise on the Steam-engine.”)

In Fig. 491 (p. 616) we give an illustration of a low-pressure condensing engine and boiler of eight-horse power, constructed on the principle of Boulton and Watt, as the latter had fortunately united his skill, learning, originality, and experience with Boulton, of Soho, Birmingham, whose metal manufactory was already celebrated.

During the explanation of this eight horse-power engine, the opportunity may be taken to discuss occasionally the special improvements effected by Watt. The steam-pipe A conveys the steam generated in the boiler B to the slide-valve C, which is kept close to the surface, against which it works by the pressure of the steam.

Here we notice some of the valuable improvements of Watt in the admission of steam *above* as well as *below* the piston, by which he increased the power of his engine, and no longer confined it to the force of the atmospheric pressure. It is also necessary to remark the beautifully simple mechanism of the slide-valve, by which steam is admitted alternately

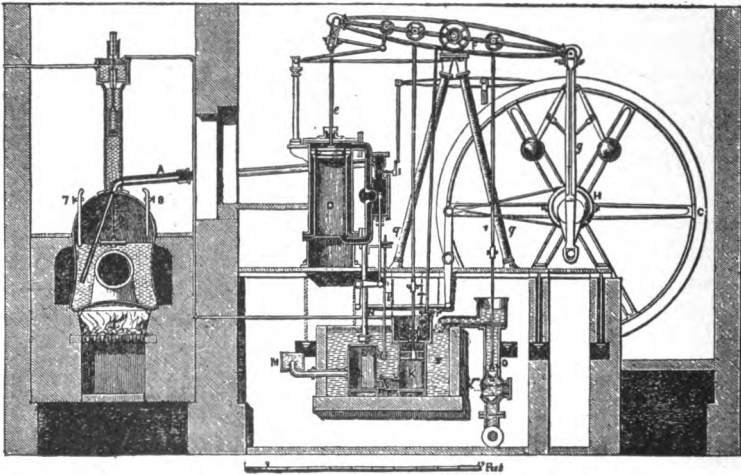

Fig. 491. An eight-horse power condensing steam-engine, after the principle of Boulton and Watt, and explained in pages 613 to 616.

above and below the piston. Want of space prevents our tracing out the gradual improvements effected by Watt, and therefore we take his invention as it stood in the year 1780.

From the above description, it will be seen that all the improvements which have led to the perfection of the steam engine in use at the present day are but modifications of this early form of Watt, and foreshadowed in his original specifications.

It occurred to Watt that the *condensation* of the steam from the *cylinder* after it had done its work, might be made more perfect if a *perpetual vacuum* was maintained beneath the

piston, while an alternate steam-pressure and vacuum were produced above it. (Fig. 492.)

Instead of obtaining a specific advantage the contrary occurred, and Watt was obliged in this case to return to the ponderous Newcomen counterweight to balance the difference in the vacuum above and below the piston, consequently this form of cylinder and valves was abandoned. The reader will perceive in the above drawing that the superior arrangement of Watt's cylinder to that of Newcomen arises from the steam operating above and below the piston, and that the piston-rod works air-tight in a *stuffing box* at the top of the cylinder. A most important improvement in the employment of steam as a motive power has been discovered in the mode of using it "expansively," by which the steam, at a pressure say of sixty pounds on the square inch, is admitted below the piston, and then cut off and allowed to expand and drive up the latter without the expenditure of any more fuel, and leaving, after lifting the piston to a height say of three feet, an average or mean power of thirty pounds on the square inch.

Returning to the eight-horse condensing engine, D is the steam cylinder surrounded by a case to prevent the steam cooling and to maintain in the cylinder the same, or nearly the same, temperature as that of the steam in the boiler, according to the condition of Art. I. of Watt's Patent, quoted at p. 614 of this book. The same outer case is apparent around the cylinder in Fig. 492.

In Fig. 493, E, the piston, which, by stuffing with

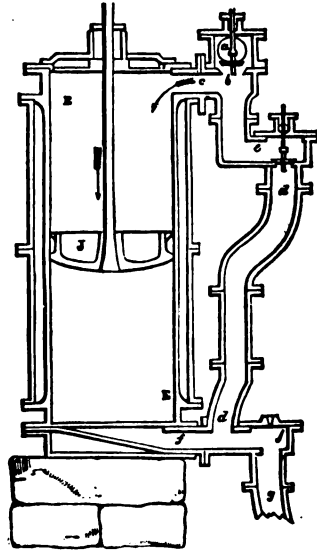

Fig. 492. "E E is the cylinder. J. The piston. a. The steam-pipe. b. The regulating or throttle valve. c. The eduction and equilibrium single valve, performing the functions of both. c. The upper, and f the under, port-holes, by which passages only the steam can enter and pass away. d, j. g. The eduction-pipe by which the steam passes from above the piston during every returning stroke to the condenser, a perpetual exhaustion being maintained beneath it."—From Bourne on the Steam-engine.

hemph or other proper material, fits the interior of the cylinder in the most accurate manner, and prevents the escape of steam by its sides; *e* is the piston rod attached to the parallel motion. This clockwork-like piece of mechanism has often been quoted as one of the masterpieces of Watt, and in its greatest perfection is called the *complete* parallel motion, and may be found in all the best land beam steam-engines. The object of the parallel motion is to cause the piston and

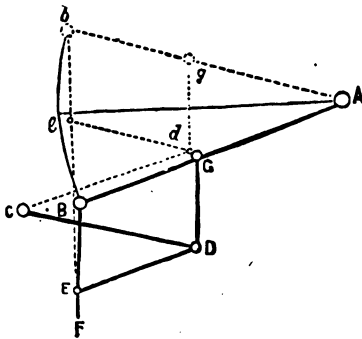

Fig. 493. A B is half the beam, A being the main centre. B E. The main links connecting the piston-rod F with the end of the beam. G D. The air-pump links, from the centre of which the air-pump rod is suspended. C, D and E D produce the parallelism, because C, D is movable only round the fixed centre C, whilst E D is not only movable round the centre D, but the centre itself in the arc described by C D, and by this action E D corrects the distorting influence of its own radius. The dotted lines and letters above enable the observer to see the effect of the movement of the beam on the parallel motion.

pump-rods to move always in straight lines, never deviating to either side. (Fig. 493.)

In the eight horse-power engine shown in (Fig. 491, page 616), *e* is also attached to the piston E, which moves the beam *f*, and the other end of this beam, by the connecting rod *g*, gives motion to the heavy fly wheel G, by means of the crank *h*,

H is an eccentric circle on the axle of the fly wheel G; it gives motion to the slide valve, which admits the steam alternately above and below the piston. The slide valve and its seat are contained within an oblong box or case, large enough to

permit the easy motion of the valve within it, and usually forming an enlargement in the course of a pipe.

The valve rod by means of which the valve is opened and shut, passes out through a stuffing box; or, instead of such a rod, a valve of moderate size often has a nut fixed to it, within which works a screw on the end of an axle which passes out through a bush, and has shoulders within and without to prevent it from moving longitudinally, and a square on the outer end on which the key fits that is used in turning it. I is the throttle valve inside the steam pipe and lever connected with a governor for regulating the admission of steam into the cylinder.

Here, again, we pause in the description of this eight horse-power engine to illustrate more particularly this admirable contrivance of Watt, which remains to the present day without any substantial alteration even in the best steam-engines. (Fig. 494.)

In the eight-horse engine already partly explained, *k* is the cylinder of an air-pump to remove any air, and the water which condenses the steam, from the condenser *L*. There is also the pipe which conducts the steam from the cylinder to the condenser *L*. *O* is the pump that supplies cold water to

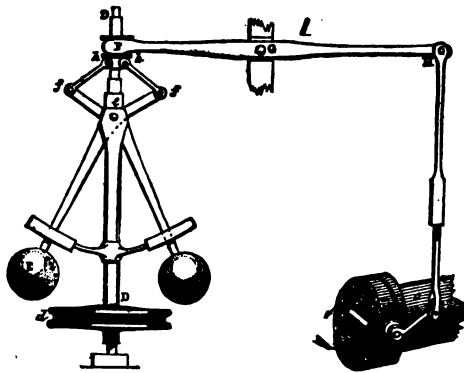

Fig. 494. *A*. The seat of the throttle valve. *Z*. The valve itself turning on a spindle, which passes through its centre. *a* is the steam pipe. *w*. The throttle valve lever on which the rod *H*, proceeding from the governor, acts. *D D*. The spindle of the governor revolving by a belt acting on the pulley *d*. *E E*. The balls hung on the ends of the arms, which cross each other at *e* like a pair of scissors. When *D D* is set in motion, the balls fly out (see centrifugal force), and in doing so draw down the collar into which the lever *F* works by means of the links *f h*. When *F* is depressed, of course *H* rises, and the valve *Z* is partly closed, and the supply of steam reduced.

the cistern *S*, in which the condenser and air-pump stand. *P*. is a rod connected with the injection valve for admitting a jet of water into the condenser from the cistern, which water is continually flowing during the working of the engine. *Q Q*, cast-iron columns, four of which support the principal parts of the engine.

We now come to the boiler of the steam-engine, which is of course of almost equal importance with the engine itself; and the one illustrated is a good type of one of the favourite boilers used by Boulton and Watt, called the "Wagon boiler." The boiler is made of wrought-iron plates riveted together, and properly strengthened where necessary; the steam-pipe

A conveys the steam to the engine. It may be remarked here that the cylindrical boiler—consisting of two cylinders, one within the other, of which the former contains the fire, whilst the furnace-draught circulates outside, the space between the two cylinders being filled with water—is the form of boiler which is most highly approved of, and is still employed in many places.

As the water evaporates in the form of steam, the boiler must be continually supplied with fresh water, which comes (as will be noticed by inspecting the illustration) from the *hot well* S, by means of the *hot-water pump* r, attached to the beam F. The water is pumped to the top of a column rising above but connected with the boiler. There is a cylindrical float inside the column of water, connected with the boiler, and suspended over a pulley by a chain passing to the damper of the furnace. The damper and float balance each other, and when the water in the boiler rises to too high a temperature, it causes the float to rise in the column of water, which, lowering the damper or shutter that stops the draught of the chimney of the furnace T, diminishes the intensity of the heat, and reduces the formation of steam. On the other hand, as the temperature diminishes, the float descends and the damper rises, permitting more air to rush to the burning fuel in the fire, thus generating a greater quantity of steam.

There is likewise a stone float inside the boiler, for regulating the supply of water by the feed pipe, or column of water, which latter must always be sufficiently lofty to press with greater force than the steam produced in the boiler, or else the power of the steam might, under certain circumstances, eject or blow out the water from the top of the column. The stone is suspended by a brass wire which works through a stuffing box, and is connected with a lever, to which is attached a heavy counterpoise, so adjusted that when the stone is immersed to a certain depth in water (according to the principle of a solid body losing weight in a fluid, explained in the chapter on specific gravity, page 65), it shall be exactly balanced, but when the water sinks in the boiler, so that the stone is no longer immersed, it becomes heavier, and sinking down opens a conical plug, ground so as to fit water-tight into a hole in the bottom of the column of water or feed pipe, and directly the plug opens, water rushes into the boiler,

being cut off again as the stone rises when immersed or surrounded with the proper height of water. Unless reference is made to the chapter on specific gravity, the otherwise seeming anomaly of a *stone float* will not be understood.

A large hole, called the man-hole, covered with an iron plate and securely fastened with screws, is provided for the purpose of allowing the engineer to enter the boiler, when cold, for the purpose of clearing out the incrustation and dirt arising from the water. To prevent the incrustation of lime and other earthy matters, it is sometimes usual, on the principle that prevention is better than cure, to put a block of "logwood" inside the boiler, as it is found that the colouring matter curiously prevents the earthy matter, so well known as the "fur" in iron kettles, forming on the sides of the boiler. Sal ammoniac and other salts also have the same property, but these are not much used, as in some cases the remedy is worse than the fault, the mechanical labour of chipping out the boiler and stopping its work for a day or so, being preferred.

There is also a safety valve and lever with weights opening outwards, allowing the steam to escape when it reaches a dangerous excess, and in order to look as it were at the state of the pressure inside the iron boiler, a proper steam gauge is provided, also two valves, one for water and one for steam, to enable the engine man or engine-tenter to ascertain if the water is up to, and does not exceed, the proper height, because when turned, supposing that all is going on properly, the one should eject water, and the other steam.

It is truly wonderful, considering the number of safeguards and warnings provided, that accidents ever happen to boilers, but the statistics of deaths and annual destruction of property show that science is powerless, if not actually dangerous, when handled by ignorant and careless persons. The great fly-wheel, which is usually such an awe-inspiring exhibition of strength in an engine of any great power, is employed for the purpose of storing up force, so that if any parts of the engine work indifferently (they all work with resistance), it shall equalise the wants of the whole, and by its inertia it will continue to move until its motion is stopped by a resistance equal to its momentum.

In starting an engine, the engine-tenter, as he is commonly



called, may sometimes be observed labouring to move the "fly-wheel," and when once he succeeds in getting it to move, the resistance of the other parts of the machinery is soon overcome.

The *high-pressure* steam-engine appears to have been first brought into general use by Trevethic and Vivian, although the primary notion of such a modification of the Newcomen or water-engines did not originate with them. As the name implies, the steam is brought to a much higher temperature and pressure than is required in the condensing engines of Boulton and Watt. It consisted, in the first place, of a cylinder open at the top, and provided with a piston. To save heat the cylinder was fixed *inside* the boiler, and was provided with a two-way valve worked by a crank, for the purpose of supplying and cutting off the steam. The downward stroke was produced by the atmosphere, and the steam having done its work, was simply blown away and wasted in the air.

The engine was provided with a fly-wheel, to which the piston-rod was at once attached, producing a continuous rotatory movement without the assistance of the heavier parallel motion, or hot and cold water pumps.

This form of engine was soon adopted for pumping work—such as that of draining fens; and in 1804 Trevethic used it for propelling the first carriage on the Merthyr Tydvil rail or tram-way, and it was then speedily adopted in all the coal districts where the levels were moderate. Stephenson the elder, succeeded by Robert Stephenson, followed with inventions and improvements of the locomotive steam-engine; and we are told in a contemporary copy of "Once a Week" that,

"One of those best qualified to speak to the latter's contributions to the development of the locomotive engine, states that from about five years from his return from America, Robert Stephenson's attention was chiefly directed to its improvement. 'None but those who accompanied him during the period in his incessant experiments can form an idea of the amazing metamorphosis which the machine underwent in it. The most elementary principles of the application of heat, of the mode of calculating the strength of cylindrical and other boilers, of the strength of riveting and of staying flat portions of the boilers, were then far from being understood,

and each step in the improvement of the engine had to be confirmed by the most careful experiments before the brilliant results of the Rocket and Planet engines (the latter being the type of the existing modern locomotive) could be arrived at.'

“Stephenson’s time was not, however, so fully taken up during the above interval as to preclude attention to his other civil engineering business, and he executed within it the Leicester and Swannington, Whitby and Pickering, Canterbury and Whitstable, and Newton and Warrington Railways; while he also erected an extensive manufactory for locomotives at Newton, in Lancashire, in partnership with the Messrs. Tayleur. About the middle of the above period, also, the first surveys and estimates for the London and Birmingham Railway were framed, leading eventually to the obtaining of the Act. Then followed the execution of that line, and here Robert Stephenson had an opportunity of showing his great talent for the management of works on a large scale. This was the first railway of any magnitude executed under the contract system; perfect sets of plans and specifications (which have since served as a type for nearly all the subsequent lines) were prepared—no small matter for a series of works extending over 112 miles, involving tunnels and other works of a then unprecedented magnitude.

“Many other railways in England and abroad were executed by him in rapid succession; the Midland, Blackwall, Northern and Eastern, Norfolk, Chester and Holyhead, together with numerous branch lines, were executed in this country by him; and among railways abroad may be enumerated as works either executed by him or recommended in his capacity of a consulting engineer, the system of lines in Belgium, Italy, Norway, and Egypt, and in France, Holland, Denmark, India, Canada, and New Zealand.

“Robert Stephenson first saw the light in the village of Willington, at a cottage which his father occupied after his marriage with Miss Fanny Henderson—a marriage contracted on the strength of his first appointment as “breaksman” to the engine employed for lifting the ballast brought by the return collier ships to Newcastle. Here Robert was born on the 17th of November, 1803. As the cottage looked out upon a tramway, the eyes of the child were naturally familiarised

from infancy with sights and scenes most nearly connected with his future profession."

In locomotive steam-engine boilers, the principal object is to generate steam with the greatest rapidity; hence the boiler consists of two parts—viz., a square box containing the fire, and around which a thin stratum of water circulates, whilst the draught for the fire rushes through a number of copper tubes placed in the second or cylindrical part of the boiler. By the use of these tubes an immenses *surface* of water is ex-

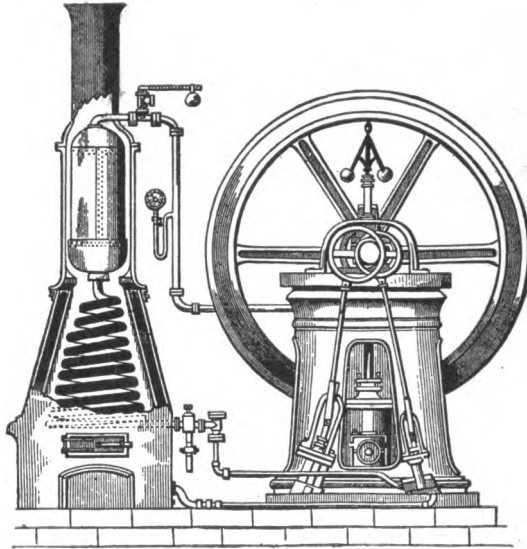

Fig. 495. Scott's patent generator, or new versus old steam.

posed to the action of the fire, and the steam is not only generated with amazing rapidity, but is also maintained at a very high pressure.

Superheated steam is also employed economically for driving certain engines. The principle consists in first generating steam, then passing it through coils of strong wrought-iron pipe, by which it acquires additional heat, and we have therefore combined in steam the ordinary principles of evaporation of water with the heated-air principle of Stirling, described at p. 553. See drawing of Scott's patent generator and superheated steam engine. (Fig. 495.)

The apparatus was used as follows:—A fire was made in the furnace, and so soon as a pyrometer connected with that indicated about 800 degrees, a little water was pumped into the coils by hand, which was immediately converted into steam. The donkey engine was then started, which maintained the necessary feed of *air* and water. The generator produced a copious supply of elastic mixed gaseous vapour, at a pressure of 250 pounds on the square inch; this engine worked satisfactorily, and started in the incredibly short time of from three to five minutes, so that for engines expecting to be started suddenly, no fuel need be burnt till the moment required. This form of engine on a small scale is used to-day in some fire engines, for pumping water, though the modern engines are driven by petrol and are of the internal combustion type.

The illustrations given of the modern locomotive show the enormous strides and developments in this class of steam engine. For beauty and symmetry of line and efficiency of working, none are finer than those of the Midland Railway Company which are made especially for express passenger traffic. These engines may therefore be taken as a type of the most modern engines running. Those illustrated are built to work the express services between London and Manchester and Carlisle; they run at a booked speed of about sixty miles an hour, and pull a load of from 350 to 450 tons. Both are Compound engines; Fig. 496, shows an elevation of one of these with tender, as running. This is 57 feet 7½ inches long over all—that is, over the buffer-faces at each end—and has a wheel-base of 48 feet, 3¼ inches. It works at a pressure of 220 lbs. to the square inch, and its heating surface is 1473 square feet, 153 square feet of which being accounted for by the fire-box, and 1320 square feet by the tubes. It has one high-pressure cylinder 19 inches with 26 inch stroke, and two low-pressure cylinders 21 inches dia. with 26 inch stroke. It is 13 feet, 3 inches high from rails to the top of smoke-stack; the weight of the tender alone, when working, is 45 tons, 18 cwts., 2 qrs.; that of engine alone, when working, is 59 tons, 18 cwts., making the total weight of engine and tender 105 tons, 16 cwts, 2 qrs. It carries 3,500 gallons of water, and 7 tons of coal.

Fig. 497 shows the front view of a similar engine, as seen

— COMPOUND EXPRESS LOCOMOTIVE — MIDLAND RAILWAY. —

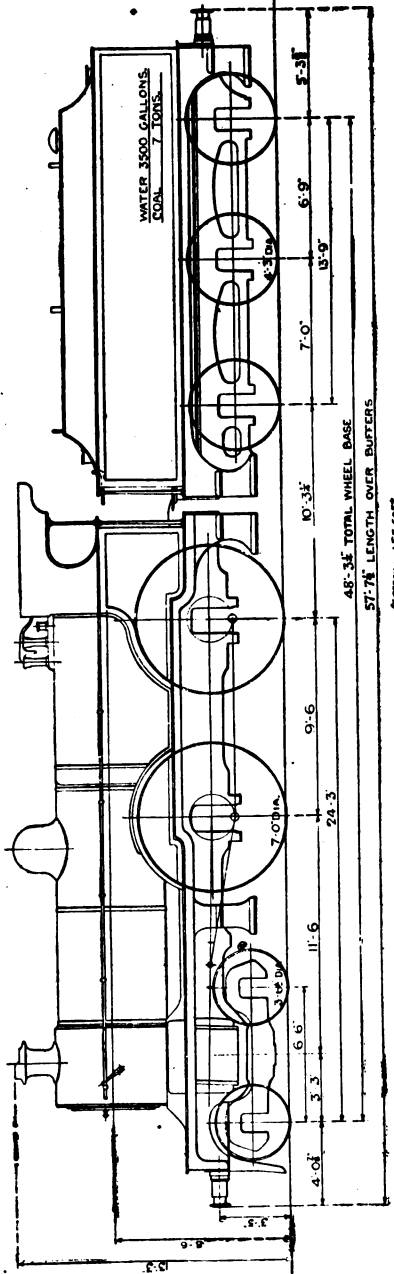

Fig. 496. Elevation of Compound Engine and Tender for Midland Railway express service.

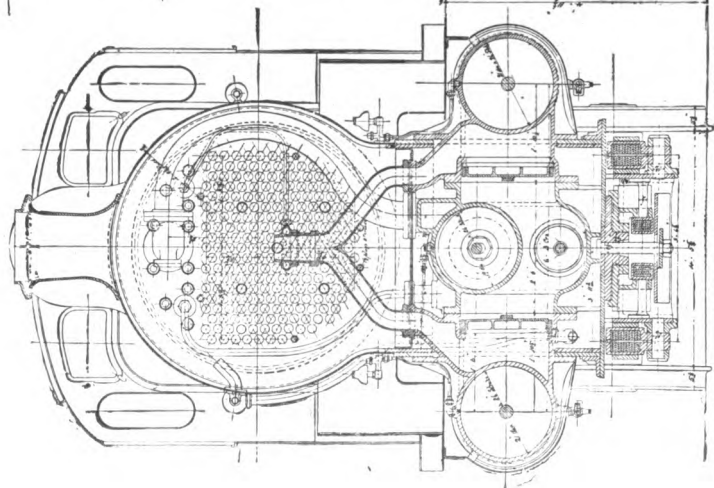

Fig. 498. Cross-section through smoke-box of the same engine as shown in Fig. 497.

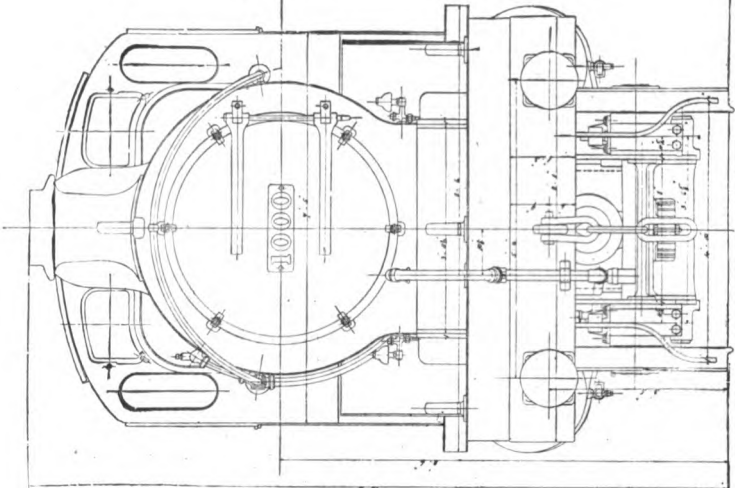

Fig. 497. Front end view of Midland Railway express engine.

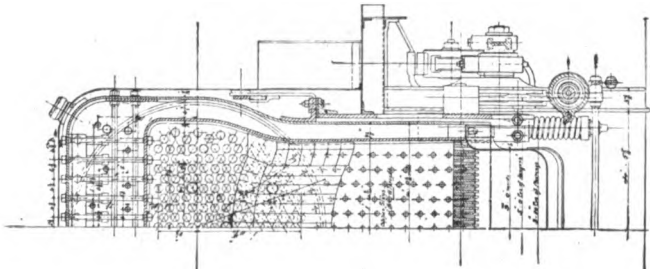

Fig. 499. Cross-section through fire-box of same engine as shown in Fig. 497.

when facing it on the line. This is also 13 feet, 3 inches high from the tread of the rails to the top of the smoke-stack.

Fig. 498 shows a cross section through the smoke-box and cylinders of this same engine, which, like Fig. 496, is a compound. Here are seen the tubes, which give an enormous heating surface.

Fig. 499 shows a cross section through the other end of the engine, that is, through the fire-box. Only one half the engine is shown here, the other side being practically the same.

## CHAPTER XXXI

### THE WATER TURBINE

One of the most important sources of power of modern time is the turbine, which has come into such universal application that it bids fair to become one of the most popular and convenient methods of giving and distributing power of almost unlimited extent to almost any distance, for in places where electricity, gas, oil, and other sources of energy are altogether unobtainable, there nearly always exist natural forces in streams, which may be utilised to drive a turbine, which in turn gives up its energy in work done. No other form of power is so elastic as is that of the turbine, for the machines are as readily adaptable to the gentle flow of a rivulet, as to the mighty force of a raging torrent, the machines combining the maximum of work with the minimum of cost, initially and in maintenance, it being one of the cheapest, easiest, yet the most powerful form of supplying energy, and few places there are in the world where running water is not procurable, either on the actual spot desired, or in such close proximity that its conduction presents no difficulties.

It is therefore to the water turbine that our attention may be directed, for though the steam turbine is equally effective, the water turbine is, on the whole, more deservedly popular.

Messrs. W. H. Allen, Son and Company, Bedford, make some of the finest turbines in the world, and in response to my application, they very generously placed the following information and illustrations at my disposal.

This volume may therefore well close with this interesting

description of the comparatively new adaptation of a very old form of motive power. (See also page 383 and Hero's Engine, page 607.)

The increasing number of opportunities which now present themselves for the introduction of Water Turbines, owing to the opening up of so many districts where suitable supplies of water for driving Water Turbines are available, has led scientific engineers to give great attention to the further development of this class of machinery.

As it very rarely happens that water power schemes are alike in any two cases, owing to the wide divergencies in the

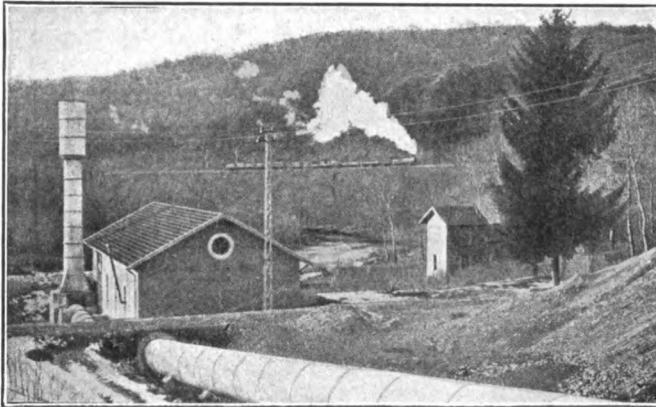

Fig. 500. View of power station equipped with water turbines.

quantities of water and the heads available, the dissimilarity of the sites where the machinery is to be installed, and the varying special conditions as to the size of the units and the most suitable speeds, the designer and manufacturer must have recourse to a number of types and designs of machinery, so as to obtain the best and most efficient results in every case.

Owing to the variety of designs of Water Turbines, it is not possible to mention machinery suitable for all Water Power Schemes, and in view of this difficulty the following description is merely intended to convey in a comprehensive form an idea of the various classes of Water Turbines which can be constructed.

The "Allen" and the "Allen-Piccard, Pictet" turbines are



known all over the world, therefore these special machines are selected as being the best type of turbines which are adaptable or specially designed for all districts and classes of work.

#### GENERAL

Water Turbines, as constructed at the present day, may be said to be divided naturally into two classes. The first of these is known as the "Reaction" or Pressure Turbine, in which only a portion of the total available pressure energy is transformed into velocity energy in the guide-blades, the remainder of the pressure energy being applied as such to the wheel itself. The second class is known as the Impulse Turbine in which the whole of the pressure energy is transformed into velocity energy before it reaches the wheel.

Of the first class, the "Francis" type of Turbine is almost exclusively used at the present time. In this machine the incoming water is led to a ring of guide blades, which direct the water into the vanes of the revolving turbine wheel over the whole of the circumference.

This type of Turbine is suitable for utilising moderate and large quantities of water from the lowest up to very considerable heads. The governing of the Francis Turbine is effected by altering either the quantity of water and the direction of flow, or the quantity of water admitted to the wheel only, and this may be done in the following ways.

(1).—The alteration of the quantity, as well as the direction of the flow of water, is brought about by a number of movable guide-blades, which alter the area as well as the shape of the passages which direct the water on to the wheel. As these guide-blades can be designed so as to give the water the correct flow over a very large range of output, this type of regulator works very efficiently from the maximum load of the Turbine down to even below half load.

(2).—The regulation of the quantity only is applied to Turbines which have to work with comparatively large quantities of water and on low heads. As in these cases the guide-blades have to be made very wide in order to pass the large quantity of water required the design as described under (1) would not permit of sufficiently sound construction, and the guide-blades are therefore cast together with the casing.

The regulation of the quantity of water is effected by means of cylindrical shutters or sluices which are generally constructed to move in the space between the guide-ring and the wheel. As on such Turbines the width of the guide-ring and the wheel can be sub-divided into two or more narrow rings, this method of regulation also yields very good efficiencies over a large range of output.

Of the second class of Turbine the most widely used is the machine known as the "Pelton Impulse" type or "Pelton Wheel." In this Turbine the water is led to one or more nozzles, and the jets of water issuing at high velocity from these nozzles are directed on to buckets arranged round the periphery of the wheel.

These buckets must be of such a design that the water may impart to the wheel the best part of its kinetic energy and may leave it at a negligible speed and in such a direction that it in no way impedes the motion of the wheel.

This type of Turbine is suitable for water power schemes with moderate up to the very highest heads, and particularly where the quantity of water available is too small to permit of the installation of a Francis Turbine, or where the revolutions per minute, owing to the high head, would come out too high if the latter type of Turbine were adopted.

Another type, on the Impulse principle, is the "Girard" Turbine, which differs from the Pelton Turbine in so far as it has its nozzles arranged inside the ring of blades. This class of Turbine, however, is not so widely used as the two former ones, since it is only under special working conditions that it possesses any advantages over them.

The Modern Water Turbine is a highly efficient machine, and, when working under suitable conditions, may be relied upon to give, as B.H.P. (Brake Horse Power), at its spindle, up to 85% of the Water Horse-Power or energy contained in the water supply. As the running costs of water power plants are generally very low, such plants compare very favourably with any other form of power plant in most cases although their first cost is higher.

Illustrations and descriptions of typical Turbines of various types are given.

As the conditions may require, the Turbine may be furnished either with an automatic governor, or with regulation

by hand only. If an automatic governor is fitted it is usually belt-driven from a pulley on the main shaft of the turbine.

The Governor, which is of a very sensitive design, by means of special gearing actuates the regulating blades or shutters in the interior of the turbine, which control the admission of the water to the wheel as the case may be. When moving the regulating blades in the flowing water a considerable amount of resistance is encountered, and it is not possible to design an ordinary governor powerful enough to overcome this resistance and at the same time to keep its size within reasonable limits. An auxiliary governor is therefore fitted, working under the control of the governor proper, the former

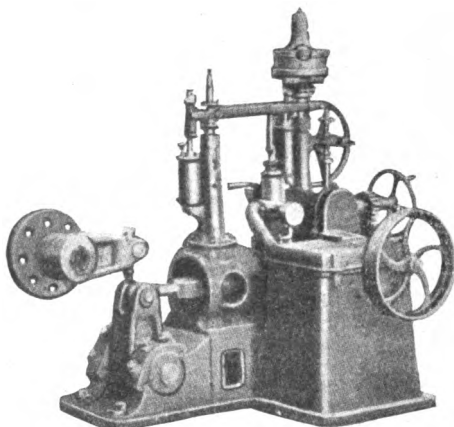

Fig. 501. Governor and governor gear.

being arranged to operate the regulating blades or nozzles, and the latter putting this auxiliary governor in or out of action as the regulation requires. The latest type of governor proper (Fig. 501) is of a design in which the governor weights are suspended entirely by springs, thus eliminating all friction, inseparable from other designs of governors; it is not only a very cheap, but also a most sensitive governor, and is not subject to any wear. The auxiliary governors are either of the hydraulic or mechanical type.

#### MECHANICAL AUXILIARY GOVERNOR

The chief advantages of this type of governor, which is of the special "Allen-Piccard, Pictet" design are that all

the working details are visible and the fact that the auxiliary governor itself does not come in contact with the water driving the turbine. It is a cheaper form of governor than the hydraulic type, the only disadvantage being that there are a greater number of working details which are subject to wear. This governor is still supplied for turbines of small power, as experience has proved that for such turbines this type of governor is entirely satisfactory, and forms a very cheap and compact arrangement. For larger turbines, however, where the power required to operate the regulating blades is very considerable, this type of governor has been abandoned, and in its place the hydraulic form of auxiliary governor is used. (Fig. 502.)

The Hydraulic Auxiliary Governor (Fig. 502) has proved to be an excellent means of governing turbines of all sizes and constructions, and even the largest powers encountered in regulating gears can be most effectively governed by this very sensitive apparatus. The chief detail of this auxiliary governor is a differential piston, and as the regulation may require it, pressure oil, supplied by a special oil pump, is admitted to one side or the other of this piston by means of a regulating valve, which is actuated by the governor proper. The rod of this piston being connected with the gear controlling the blades of the turbine, the motion of the piston will govern the movement of the blades admitting the water to the turbine wheel. The apparatus must therefore include an oil pump and this latter is generally driven by belt from the main turbine shaft.

For turbines working on a very high head, it may be possible to actuate this auxiliary governor by the pressure water available on the inlet side of the turbine and thus dispense with the oil and oil pump. This, however, is only advisable

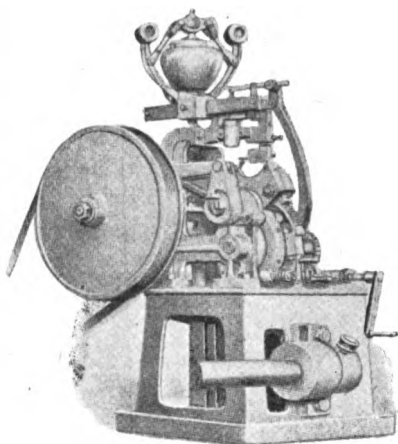

Fig. 502. Hydraulic auxiliary governor.

if the water is perfectly clean and free from grit or other foreign matter, as this would seriously affect the various parts of the governor. If the water is only slightly charged with foreign matter, an effective filter may overcome this objection. When oil is used for this auxiliary governor hardly any wear can be detected in any part of the gear.

The Turbine illustrated in Fig. 503 is of the "Francis" enclosed type, the whole of the guide rings, wheel and regulating blades being enclosed in the outer casing. The casing is built of sheet steel plates, as is also the inlet pipe; the

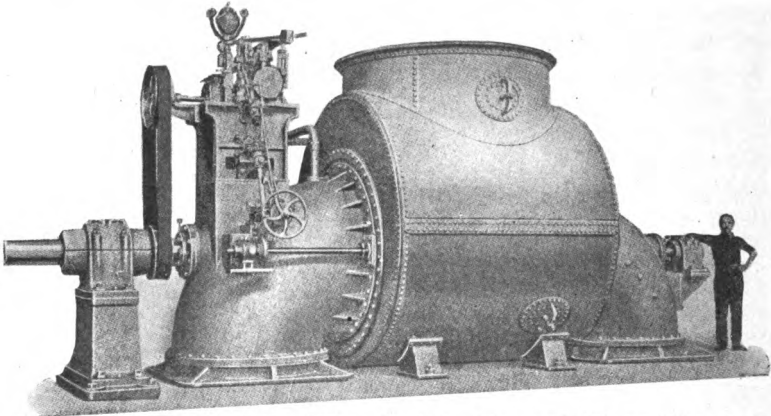

Fig. 503. 1750 B.H.P. water turbine. Head 75 feet, speed 250 revolutions per minute. (See also Fig. 511.)

two outlet branches, wheel and guide rings being of cast-iron.

The turbine shaft is carried through the outlet branches, in glands, and is supported in two ring-lubricated bearings arranged entirely outside the casing and separate from the glands. One of these bearings is constructed as a thrust bearing, as, although the turbine has a double outlet and the wheel is, therefore, hydraulically balanced, there may still be some unbalanced axial forces which have to be taken up by bearings suitably designed.

The Governor is of the mechanical type, driven by belting from the main shaft. As will be seen from the illustration, the auxiliary governor actuates two spindles which extend into the interior of the casing, the bevel wheels by means of which these spindles are controlled being clearly shewn. The regu-

lating mechanism of this turbine is of the type described as the "cylindrical shutter" type, which closes the rings of guide-blades as required; this shutter is moved to and fro by the screwed spindles mentioned above, and thus varies the area available for the flow of the water.

The illustration below shows a Station equipped with these Turbines, each of the three sets consisting of an alternator and exciter driven from a turbine by means of a flexible coupling. (Fig 504.)

Fig. 505 illustrates a Turbine of the "Francis" enclosed

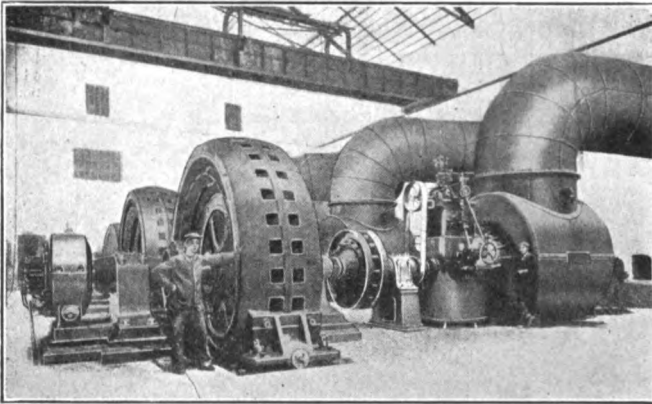

Fig. 504.

type, of a construction which differs in many respects from the types Figs. 503 and 504. The turbine casing is constructed entirely of cast-iron, and is designed as a double volute, which offers a good flow to the water, and at the same time requires a minimum of space. There are one inlet branch and two outlet branches, the latter being separate from the casing, and also constructed of cast-iron. The turbine wheel is of the symmetrical type, and is made of cast-iron. The mild steel shaft passes through the two outlet branches in glands, and is carried in two ring-lubricated bearings, of which one is again designed as a thrust block. The regulation of this turbine is effected by means of movable guide-blades. These guide-blades are generally keyed on pins in such a way as to permit of their rocking in bearings contained

in the two covers of the turbine casing. On the outer end of each of these pins a crank is mounted, all these cranks being connected up to a ring which is operated from the auxiliary governor. In most cases this mechanism is entirely inside the casing, and is rigidly connected up by means of the cranks with the guide-blade pins; a rigid connection also exists between this regulating ring and the rod of the differential piston of the auxiliary governor. This construction may be quite suitable for turbines of small power, but in the case of large units it will readily be understood that in the event of any form of foreign body finding its way into the turbine

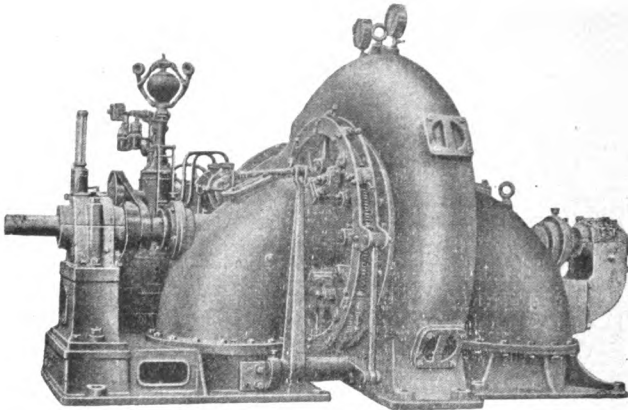

Fig. 505. 375 B. H. P. turbine, head 61 feet, speed 430 revolutions per minute.

casing, and becoming wedged between two of the moving blades, or between the blades and the casing whilst they are in the act of closing, it would either stop the governor from moving the blades any further, or the guide-blade or some other part of the governor gear must give way. Either of these alternatives is a very serious matter and may either cause the turbine to run away, or destroy parts of the mechanism. To overcome these difficulties the "Allen-Piccard, Pictet" "Francis" Water Turbine embodies a novel design in which a spring is inserted between the crank of the guide-blade and the regulating ring; if, therefore, any blade is prevented from closing freely, its spring will simply become compressed, and whilst all the other blades are regulating properly, only that single blade will remain inactive. This con-

struction has the further advantage that the whole of the regulating gear, with the exception of the blades, is outside the turbine casing, and, therefore, any trouble in connection with the guide-blades can be very easily located, and generally adjusted without dismantling the turbine. This design has proved to be extremely satisfactory, and does away altogether with the danger attached to other makes of this most modern type of "Francis" turbine with movable guide-blades.

The Auxiliary Governor of the above turbine is of the hydraulic type, and, as will be seen from the illustration, (Fig. 505), it lends itself in this case to a most compact ar-

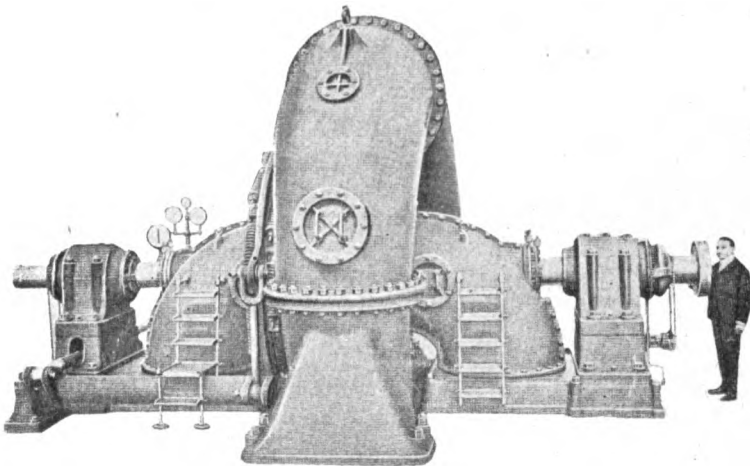

Fig. 506. 6,200 B.H.P. turbine, 165 feet head, speed 300 revolutions per minute.

angement, being mounted on a baseplate, together with one of the pedestals and outlet branches, and it does not trespass beyond the space required by the turbine inlet branch in the one direction and the bearing in the other.

Figs. 506 and 507 will convey some idea of the wide range of duties which the "Francis" type of Turbine can perform.

Fig. 506.—The casing of this Turbine is constructed of cast-iron, the Turbine being of the "Francis" Enclosed Type with double outlet and movable guide-blades provided with the outside spring device already described. Large inspection



doors and manholes are provided in the casing for easy access to all vital parts.

The bearings are in this instance lubricated by oil under pressure, the Turbine being fitted with special oil pumps for this purpose as may be seen in the illustration, and the bearings are mounted on baseplates bolted to the bottom half of the casing.

The governor, which is not included in the illustration, is

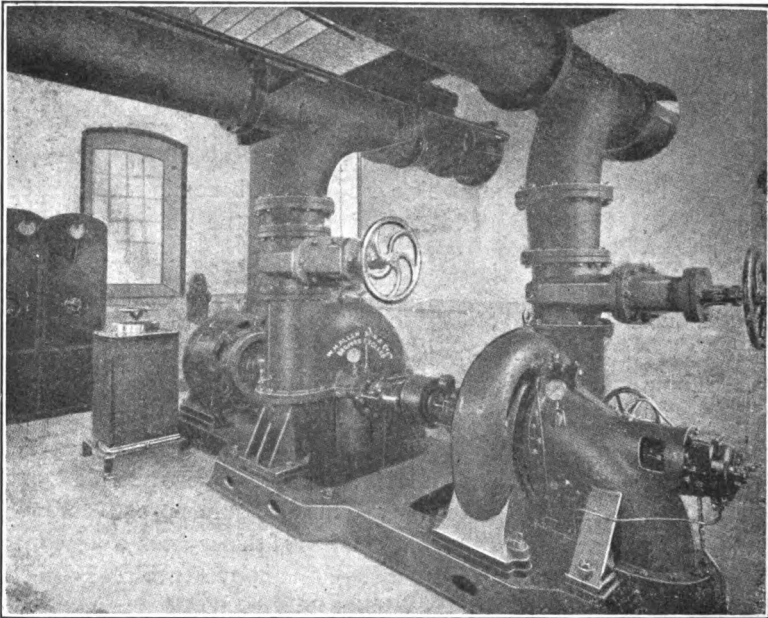

Fig. 507. 46 B.H.P. turbine, 70 feet head, speed 735 revolutions per minute.

again of the Hydraulic Type, and the powerful levers and connecting rods will give some idea of the forces which are encountered in such sizes of Turbines. When a Turbine is working on a fairly high head, and absorbing a large quantity of water, it is necessary to attach a special relief valve, which is also under the influence of the governor, and is intended to prevent water-hammer, as, should the pressure increase above certain limits owing to a sudden change of load, this valve opens and relieves the pipe-line from this extra pressure.

Fig. 507.—This Turbine is also of the "Francis" Enclosed type, with single outlet and movable guide blades. In this case, however, hand regulation only is provided, the movable

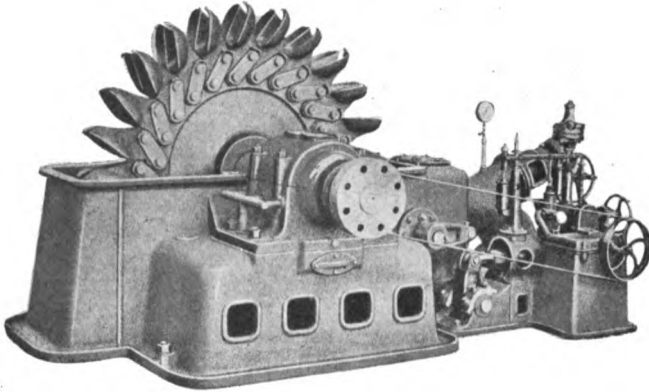

Fig. 508. 5,500 B.H.P. turbine, 2,400 feet head, 500 revolutions per minute.

guide blades being actuated by means of a handwheel and spindle with connecting rods and levers. This Turbine is of the high-speed type, the speed having been determined by the speed of the machinery to which it is connected. It is of par-

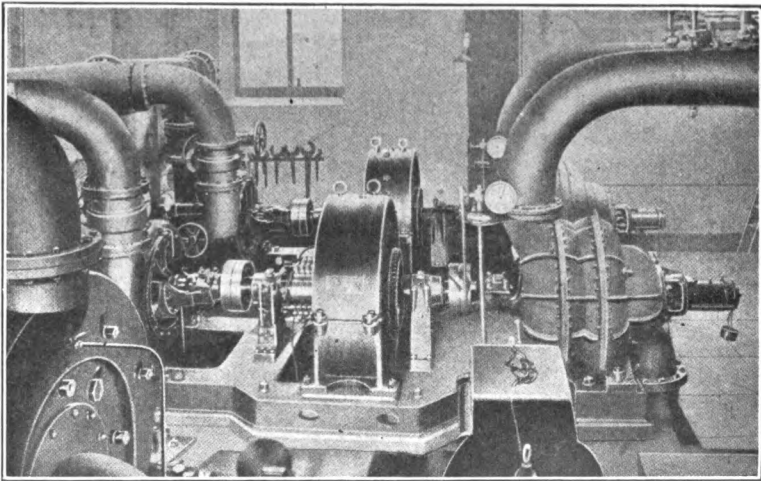

Fig. 509. Two 60 B.H.P. turbines, 101 feet head, 650 revolutions per minute.

ticular interest as it forms part of a set which works in connection with a Condensing Plant. The latter being situated some distance above its water supply, the water is pumped up

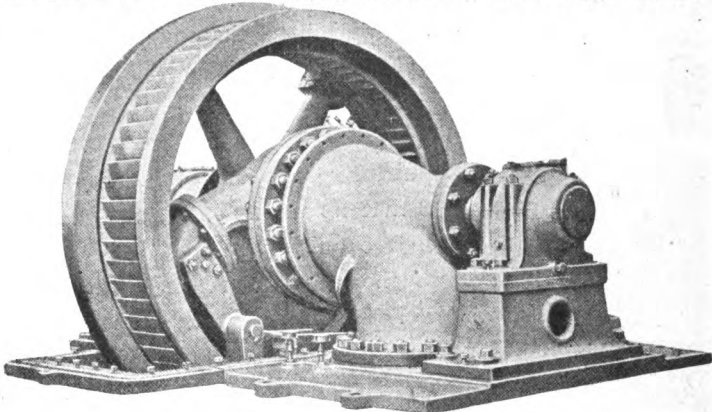

Fig. 510. 1400 B.H.P., 500 revolutions per minute, 900 feet head.

by the centrifugal pump shown coupled up to the turbine and motor, and the energy of the returning water is made use of to drive the pump by means of the turbine. The electric motor shown provides the necessary "make up" power.

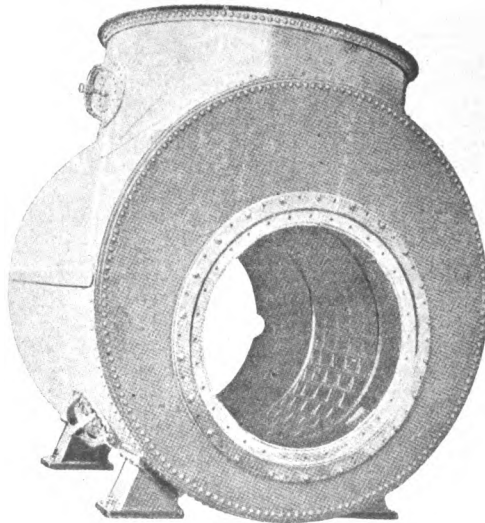

Fig. 511.

The Turbine seen in Fig. 508 is an "Impulse" Turbine, of the "Pelton" type. The illustration shows very clearly the general design and the massive construction which is required for a Turbine of such a large output and of which the speed when working under the worst conditions might rise as high as 900 revolutions per minute. The disc, which is constructed of steel, carries at its circumference the buckets, which are separate steel castings. The steel spindle is carried in two very ample bearings which have combined lubrication by means of oil rings and also by circulating oil. The

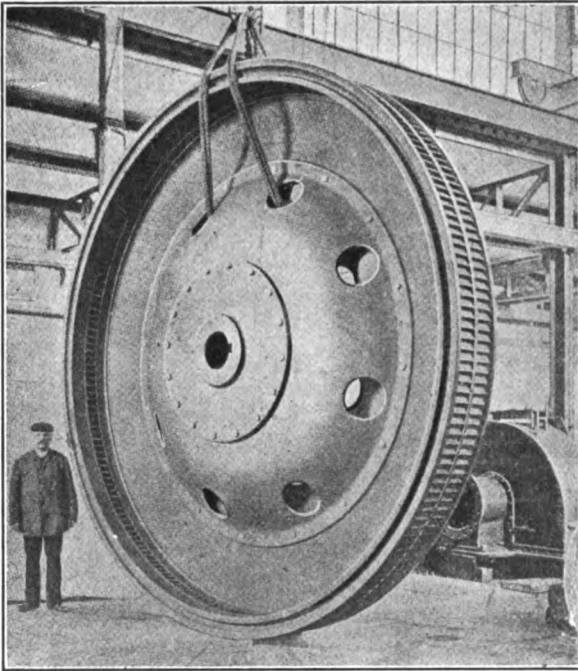

Fig. 512. Wheel for 2,200 B. H. P. turbine, 1,170 feet head, speed 180 revolutions per minute.

base-plate which also forms the bottom half of the casing is a very substantial casting, forming supports for the bearings, as well as the connections to the nozzles and the regulating gear. The regulating gear of this turbine, which works on a head as high as 2,400 feet, and to which the water is led

by a pipe-line of considerable length requires very careful consideration and design. A new patent has been applied to this purpose and this embodies many great advantages over

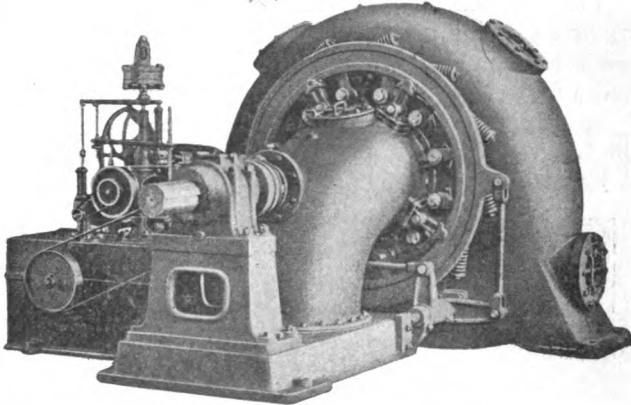

Fig. 513. 800 B.H.P., "Francis" type turbine. 95 feet head. 375 revolutions per minute.

other designs. This new device consists of a combined governor, namely, a regulator "A" which, in the case of a heavy load being thrown off the turbine, simply directs the jet

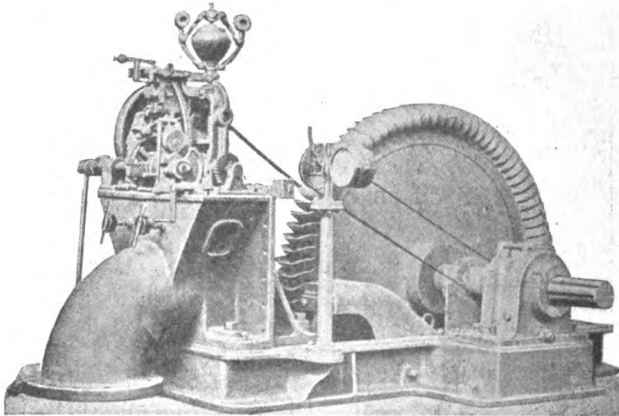

Fig. 514. "Pelton" type turbine. 500 B.H.P., 500 revolutions per minute, 1,100 feet head.

completely off the wheel, and a further regulator "B" designed so as then *slowly* to close down the nozzle and reduce the quantity of water discharged. Regulator "A" in

the meantime will re-direct the jet on to the wheel. This method has the great advantage that no undue increase of pressure in the pipe line is created through the nozzle having to be shut down too quickly in cases of the load being thrown off too suddenly, as the regulator "A" simply withdraws the water from the wheel, *i.e.*, directs the water off the wheel without closing the nozzle, and the slow closing of that nozzle can then be effected. No relief valves are thus re-

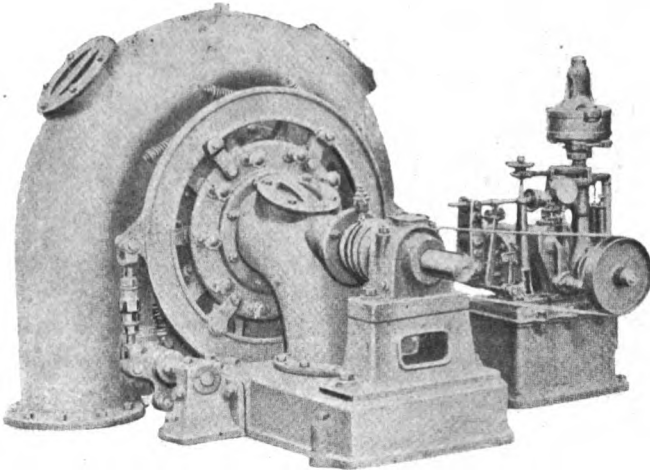

Fig. 515. "Francis" type turbine. 180 B.H.P., 850 revolutions per minute, 200 feet head.

quired, and the dangers of water hammer or pipe line bursts are entirely removed.

The governor proper of this turbine is of the very latest design, with spring suspended governor weights, and the auxiliary governor is of the hydraulic type; although on this plant the driving water would have had quite sufficient pressure to work the auxiliary governor, an oil pump is embodied in the design in order to avoid troubles which might arise due to dirty water.

Fig. 509 represents an arrangement of plant similar to that described at Fig. 507; the Turbines in this case are also the "Francis" enclosed type with single outlet and movable guide-blades. Hand regulation is provided for these Turbines, the movable guide-blades being actuated by means of a hand-wheel and spindle with connecting rods and levers.

A feature of this installation is that the whole of the parts of the Turbines and Pumps in contact with the water are of bronze. This is often necessary owing to the acidity of water and the amount of silt in suspension.

These Turbines form part of two sets of Circulating Pumping machinery which work in connection with Condensing Plants, the conditions being similar to those of turbines. Figs. 506 and 507.

Fig. 510.—This Turbine is of the “Girard” Impulse type, and, under working conditions which are not quite suitable for either the “Francis” type or the “Pelton” Impulse type, has certain advantages over the two systems mentioned.

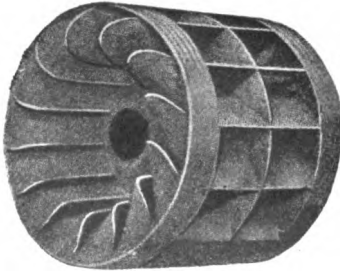

Fig. 516. Double outlet wheel.

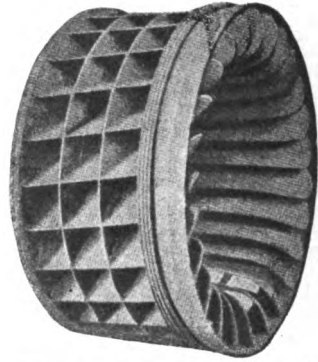

Fig. 517. One wheel of double “Francis” turbine, 4,500 B.H.P., 120 revolutions per minute, 40 feet head.

This Turbine, although lending itself to very cheap construction, is only used on special occasions, and wherever possible a “Francis” or “Pelton” type of Turbine is adopted in preference to one of this special construction, as the two former types generally give a better efficiency. As to the regulating qualities of this Turbine, it can be designed very easily to give excellent regulation, as considerable fly-wheel effect can be embodied in the construction of the wheel.

The illustration, Fig. 511, shows the outer casing or water chamber of the double outlet “Francis” Type Turbine described at Fig. 503, with the wheel, shaft and outlet branches removed. This shows very clearly the rings of guide blades, whose function it is to direct the incoming water into the

blades of the revolving wheel. The adjustable shutters work inside these guide-rings and, under the control of the governor, regulate the input of water as the load on the Turbine varies.

This construction of the casing, viz:—built up of steel plates, is mostly resorted to when a very large quantity of water, at a moderate head, has to be dealt with. The turbine in many instances thus becomes considerably cheaper than would be the case if a cast-iron casing were adopted. Where the fall of the water, however, is small, the iron casing is dispensed with altogether and the turbine wheels, with the

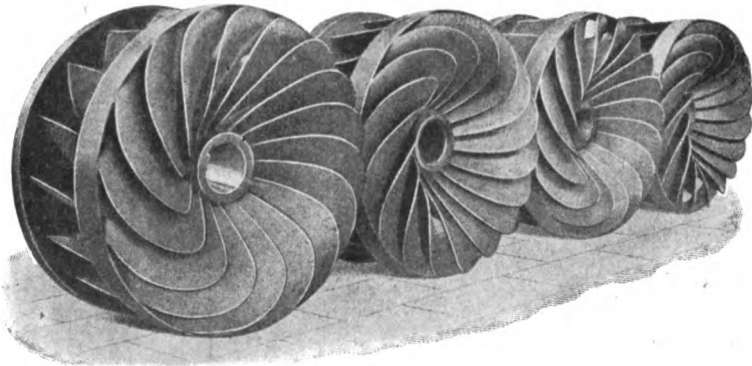

Fig. 518. Wheels of a quadruple "Francis" type turbine, 1,200 B.H.P., 120 revolutions per minute, 18-28 feet head.

guide-blades and outlet pipes are placed in an open water chamber built up in brickwork or concrete, thus replacing pipes and turbine casings. The turbine then can, according to the local conditions, be of the horizontal or vertical type. In the former case the shaft is carried through the water chamber wall, and in the latter case it is carried vertically through the chambers, is connected above the water level either to the gear wheel or the dynamo armature, and properly supported on an ample thrust block.

Fig. 512 shows a wheel for a Turbine of the "Girard" Impulse type. Where the desired speed is very low, a wheel of very considerable diameter has to be constructed. This wheel has a diameter of 14 feet, and weighs  $8\frac{1}{2}$  tons.





## INDEX



## INDEX

- Absorption of Light, 497, 498
- Accidents when Boating, Cause of, 56, 57
- Acetylene Gas, 161
- Actinium, 532
- Adhesive Attraction, 86
- Aërial Signals:—Bill Distributors, 182, 183
  - Chinese Coloured Fire (Pyrotechnic), 180
  - Chinese Dragon (Pyrotechnic), 180
  - Chinese Kites, and Paper and Silk Balloons, 180
  - Darby Explosive Shells, 181
  - Floating Lights, on Air (Parachute), 183, 184
  - Floating Lights, on Water (Acetylene), 184
  - Inchcape Rock Bell, 181
  - Land and Water Signals, 183
- Aërostation: A.—Aëroplanes, or Machines Heavier than Air, 174
  - A Card Flier, 174
  - Essential Points for Aviators, 175, 177
  - List of Noted Ascents and Accidents from 1675 to 1910, 177-180
  - Mono-plane Flying, Frontispiece
  - The Kite a Mono-plane, 174, 175
  - The Kite Controllable, 175
  - Views of Bi-plane, 175, 176
  - Views of Mono-plane, 176
- B.—Balloons, or Machines Lighter than Air, 162
  - A Balloon Fête, 167
  - Air, a Liquid, 170, 171
  - Balloon, Great Captive, 165
    - Guide Ropes, 172
  - Ballooning and Archimedes, 169, 172
    - A Question of Specific Gravity, 170
  - Balloon Journey by Green, 164
    - Military, 166, 167, 180
    - The Géant, 164
    - To Cross the Atlantic, 164
    - Valves, 172
  - Balloons at Siege of Paris, 166
    - For Scientific Ascents, 166, 167, 180
    - Montgolfer, 166
    - Must be Dirigible to be of Real Value, 168, 173
    - Various Requirements in, 168, 169
  - Earliest Flights, 171
  - Influence of Cavendish and Black on Ballooning, 172

- Aërostation. *Continued.***  
 The Internal Balloon and its Uses, 173  
 The Manufacture of a Balloon, 163  
 Uncontrollable Balloons at Mercy of Wind, 167, 173  
 Expansion of Air and Gases in Balloons, 551, 553  
 Martyrs to Aërostation, 168, 169
- Affinity in Chemistry, 105**
- Air, Composition of Atmospheric, 134**  
**Air-resistance on Falling Bodies, 20**  
**Air, See Experiments—Impenetrability**  
**Air, Vitiated by Burning Gas, 581**
- Alchemy, 103, 104, 198, 206**
- Alcohol and Wool, Demonstrating Impenetrability, 1, 2**
- Alliance Magneto Machine, 379**
- Allotropic Condition of Oxygen, see Ozone**
- Allotropy, 129**
- Alternating Current, see Electric Lighting**
- Alum Crystals, 95, 96, 97**
- Amalgamation of Electrical Machine Fittings, 277**
- Amalgamation of Plates for Batteries, 288**
- Ammonia (see also Experiments), 139-142**
- Analysis and Synthesis of Light (see also Light), 109, 469, 497**  
 By the Spectroscope, 474  
 Of Gunpowder, 105, 106  
 Of Metals by Colour, 242, 472
- Anion, 298**
- Annular and Total Eclipses of the Sun, Causes of, with Demonstrations, 34**  
 and Total Eclipses of the Sun, Difference Between, 30  
 Eclipse, Description of, 36
- Anode, 298**
- Anomalies of Heat in Ice and Water, 600, 601**
- Apparatus, Fitting up, 116, 117**  
 for Freezing, 101  
 for Photography, 209, 210
- Arabians and Chemistry, 104**
- Archer and Photography, 209**
- Archimedes and Buffon, 437, 438**  
 and Gibbons, 437  
 Roman Fleet, 436  
 Specific Gravity, 69
- Aristotle and Light, 416**
- Astronomical Telescope, 434**  
 Descriptions of Equatorial Mounting, 434  
 The Gregorian, 435
- Astronomy, 25**  
 and Copernicus, 27  
 Galileo, 27  
 Halley, 27  
 Herschel, 27

**Astronomy. *Continued.***

- Hipparchus, 27
- and Job, 26
- Kepler, 27
- Menton, 27
- Newton, 27
- Nonius, 27
- Pythagoras, 27
- Recorde, 27
- Reinhold, 27
- Thales, 26
- the Chaldaeans, 25
  - Chinese, 25
  - Egyptians, 26
  - Great Pyramid, 26
  - Greeks, 26
  - Spectroscope, 475, 477
- Tycho Brahe, 27
- Antiquity of, 25
- Baily's Beads, 35, 36
- Comets, 42
- Shooting Stars, 46
- Atmospheric Air, Composition of, 134
- Attraction, Adhesive, with Demonstrations, 86
  - Capillary, with Demonstrations and Experiments, 88
  - of Cohesion, with Demonstrations and Experiments, 79
  - Glass for Water, 88
  - Salt for Water, 88
- Automatic Gas-lighters, 146, 147, 155, 156
- Aventurine, 244
- Aviation, see *Aërostation*
  
- Bacon, Roger, and Gunpowder, 104, 105, 180, 181
- Baily's Beads, 35, 36
- Balancing (see also Experiments), 53-62
- Balloons and Hydrogen, 148, 150, 151, 551-553
  - Expansion of Air and Gases in, 551-553
  - see *Aërostation*
- Balls, Billiard, and Paradox in, 58, 59, 568
- Bancalari and Electricity, 394, 395
- Barium Sulphate, Discovery of, 398
- Batteries, see Electricity
- Beads, Borax, 241
- Becquerel and Radio-activity, 530
- Bell and the Telephone, see Telephone
- Bellows, see Experiments—Impenetrability
- Bending Glass Tubing, 117
- Pentley's Coil (see also Experiments under Induction Coils), 363
- Berzelius, Discoverer of Selenium, 251
- Billiard Balls and Paradox in, 58, 59, 568

- Bleaching by Chlorine instead of by Daylight, 185, 186  
 Blindspot in eye, 450-452  
 Blondlot and the "N" Rays, 527  
 Blotting-paper, 89  
 Blowpipe-analysis of Metals, 242, 472  
 Boating Accidents, Cause of, 56, 57  
 Bodies, Stability in Living 61  
 Boiling Points, 603-605  
 Borax Beads, 241  
 Boron (see also Experiments), 239  
     the Manufacture of, 239, 240  
 Bort (waste diamond), see Experiments  
 Bougies, 118  
 Boulton and Watt and the Steam Engine, 619  
 Brewster and Light, see Kaleidoscope  
 Brine and Water (diffusion of liquids), 5, 6  
 Bromine (see also Experiments), 198  
     the Manufacture of, 199  
 Browning's Lamp, 384  
 Bubbles, 76, 77  
 Bude Light (see also Experiments), 126  
     Coloured, 127  
 Buffon and Archimedes, 437, 438  
 Bulk, 50  
 Bunsen and Light, 472
- Camera Obscura, 206, 207  
 Canton's Phosphorus, 398, 399  
 Capillary Attraction (see also Experiments), 88  
 Carbon (see also Experiments), 224  
     disulphide, 250, 254  
 Carbonic Acid and Hydrogen, 4  
     Tests for, 4, 227, 229  
     used by Plants, 121  
 Carbon Process (photography), 211-214  
 Caries, 256  
 Catalytic Action, 115  
 Cathion, 298  
 Cathode, 298  
 Causes of Annular and Total Eclipses, with Demonstrations, 34  
 Causing Wood to Sink, 88  
 Caution with Regard to Purchase of Chemicals, 115  
 Centigrade Readings Converted to R. and F., 548, 549  
 Centre of Gravity, 48  
     How to Find, 51  
     Percussion, with Demonstrations, 62-65  
 Centrifugal Force (see also Experiments), 21  
     and Gravity Contending, 33  
     Gravity Contrasted, 34  
     Demonstrations of, 22, 23, 24, 32

- Centrifugal Force. *Continued.***  
     Railway, 24  
**Chaldaeans and Astronomy, 25**  
**Change of State, Experiment to Show, 85**  
**Charcoal, Sulphur and Potash, Experiment with, 106-8**  
**Chemical Affinity, 105**  
     Combination, as Opposed to a Mechanical Mixture, 105-8  
     Experiments, see Experiments  
**Chemistry, 103**  
**Chinese and Astronomy, 25**  
**Chlorine (see also Experiments), 185**  
     Bleaching by, instead of by Light, 185, 186  
**Chromatic Effects by Polarised Light, 515, 519-521**  
**Cinematography, 211**  
**Clarke's Magneto Machine, 377-379**  
**"Clouds" in Sun, Nature of the, 40**  
**Cohesion, with Demonstrations, 79**  
**Coils, Bentley's, 363**  
     Header's, 131, 363  
     Induction, 131, 363  
     Ruhmkorff's, 131 363  
**Colloids, 9**  
**Colour and Light Compared, 409**  
**Coloured Liquids, Demonstrations in Specific Gravity of, 72-74**  
     etc., under Influence of Oxygen, 129  
**Colour in Blowpipe, Metals Classified by their, 242, 472**  
**Colouring Lantern Slides, 221, 222, 469**  
**Colour-photography, 211, 220, 221, 222**  
**Colour-Top, 485**  
**Comet C Morehouse, 45, 46**  
     Halley's, 44  
     with Venus, Spectra of, 47  
**Comets, 42**  
**Comparison of Light with Gravity, 17**  
**Composition of Atmospheric Air, 134**  
**Condenser Hygrometer, 587, 588**  
**Conduction of Heat in Metals, Table of, 560**  
**Contending Forces, Centrifugal and Gravity, 33**  
**Contrasted Forces, Centrifugal and Gravity, 34**  
**Conversions of Thermometer Readings, C. R. F., 548, 549**  
**Copernicus and Astronomy, 27**  
**"Corona" of Sun, 38**  
**Corpuscular Theory of Light, see Light**  
**Crookes, Sir William, and Induction Coil, 376**  
     and the Röntgen or "X" Rays, 525  
     "Crookes' Radiant Matter," 525, 526  
**Crown of King Hiero, 69-71**  
**Crystallisation and Experiments to Demonstrate, 93**  
**Crystalloids, 9**  
**Crystals of Snow, 93**



- Curie Mons. and Mme., and Radium, 531  
 Current, Alternating, see Electric Lighting
- Daguerre (see also Photography), 207  
 Davy and Electricity, 263, 296, 384  
   and Heat, 537  
   the Telegraph, 345  
   Safety Lamp, 156, 563-567
- Debiere and Actinium, 532
- Decoration of Metals by Hydrogen, 151, 152
- Decrepitation, 98
- Deliquescence, 97
- Demonstration of Adhesive Attraction, 86  
   of Attraction of Cohesion, 79  
     Capillary Attraction, 88  
     Causes of Annular and Total Eclipses, 34  
     Centre of Gravity, 51-62  
       Percussion, 62-65
- Centrifugal Force and Gravity Contending, 33  
   Force and Gravity Contrasted, 34
- Light—Field of Corn, 407  
   —Luminous Bodies and Vibrations, 406  
   —Theories, see Experiments and Light  
   —Waves, 407
- Path of Electric Current, 300, 301  
   of Magnetic Current, 315, 320  
   Specific Gravity, 65-78
- Density of Planets of our Solar System, 78
- Description of Annular and Total Eclipses of the Sun, 36
- Dialysis (see also Experiments), 9, 10
- Dia-magnetic Bodies, see Magnetism and Experiments
- Dia-magnetism, see Magnetism and Experiments
- Diamond (see also Experiments), 225
- Dia-zotype (see also Photography), 216
- Differential Thermometer, 551
- Diffraction Apparatus, 504
- Diffusion of Gases (see also Experiments), 4, 5, 231  
   of Liquids (see also Experiments), 5
- Dimorphism, 107, 129, 130
- Discoveries by the Spectroscope, 476-479
- Disinfecting with Sulphur versus Spray, 248
- Distillation, 99
- Disulphide of Carbon, 250, 254
- Diurnal, Earth's Motion, 21
- Dobereiner Self-lighting Lamp, 155
- Drummond Light, 155
- Drying of Gases, 187
- “Earth” connections, see Telegraph, Electric
- Earth-fog (Evening Mist), 587, 603

- Earth Nearer Sun in Winter, 31  
 Earth's Diurnal Motion, 21  
     Motion Round Sun, 32  
     Shape, Illustrating Centrifugal Force, 22  
 Eclipses of Moon, 29  
     of Sun, Dates of, 39  
         (see also Experiments), 27, 34  
         Visible in London, 39  
 Edison and the Filament Lamp, see Electric Lighting  
     and the Phonograph, see Phonograph  
     Telephone, see Telephone  
 Effect of Oxygen on the System, 128, 129  
 Efflorescence, 98  
 Eggs, Floating, 66, 67  
 Egg to Stand on End, How to Make an, 52  
 Egypt and Astronomy, 26  
     and Chemistry, 103  
 Electric Alarms, 306, 307  
     Clocks, 308, 309  
     Illumination, 380  
     Lighting, 383  
         Browning's Lamp, 384  
         Browning's Regulators, 385  
         Davy's Improvements, 384  
         Four-carbon Regulators, 386  
         Jablochkoff's Candle, 380, 386  
         King's Platinum Lamp, 386, 387  
         Serrin's Regulator, 384  
         Siemens' Regulator, 384  
         The Alternating Current, 385  
         The Edison Filament Lamp, 387, 388  
         The Metallic Filament Lamp, 387, 388  
     Telegraph, see Telegraph  
 Electricity, Faraday on the Storage of Electricity in drop of Water, 541  
     Frictional (see also Experiments), 262  
         Electrical Machines, 275  
         Insulating Stool, 272  
         Its History, 262, 263  
         Sources of, 263  
         The Electrophorus, 281  
             How to Make, 281, 282  
         Varnish for Experiments in, 266  
     See also Magneto-Electricity  
 Voltaic (see also Experiments), 287  
     and Davy, 296  
         Galvani, 288  
         Volta, 263, 288, 295, 296  
     Anion, 298  
     Anode, 298  
     Apparatus for Electro-plating, 298-302

**Electricity, Voltaic. Continued.**

- Batteries, 290
  - .Bunsen, 292-294
  - Daniell, 291, 292, 294
  - Daniell, Power of the, 295
  - Description of E. M. F., 291
  - Grove, 293
  - Leclanché, 290, 329
- Cathion, 298
- Cathode, 298
- Electrolyte, 301
- Electro-metallic Deposits, 298-301
- Faraday's Measure of Quantity Power, 296, 297
- Path of Current in Electro-plating, 301
- Principles of Batteries, 289
- The Amalgamating of Electrical Machines, 277
- The Amalgamating of Plates for Batteries, 288
- The Galvanometer, 290
- Electro-magnetic Machines, 315
- Electro-magnetism and Magnetism (see also Experiments), 309
  - The Loadstone, 311, 314
- Elements, Nature of the, 108, 109
  - Radio-active, 530
  - Table of, 110
- Elixir of Life, 103
- Engine, Hero's, 599, 607
  - Steam (see also Steam Engine, Evolution of), 606
  - Stirling's, 553
- Equilibrium, 51
- Evaporation, 96
- Evening Mist (or Earth Fog), 587, 603
- Expansion of Gases and Air in Balloons, 551-553
- Experiments Illustrating or Demonstrating—
  - Ammonia, see also Experiments with Nitrogen, Carbon, etc. and Hydrochloric Acid, 142
    - Oxygen Explosions, 142
    - Oxygen Inflammable, 141
  - Conditions under which Inflammable, 141
  - Fountain, 140
    - Coloured, 140
    - to make, 139-140
- Balancing, 53-62
- Boron—Borax Beads, 241, 242
  - Colour of Boric Acid Flame, 240
  - Production of Boric Acid, 240
- Bromine—Action on a Flame, 200
  - Action on Antimony, 200
    - on Starch Paste, 200
    - on Phosphorus, 200
    - under Influence of Cold, 200

- Experiments. *Continued.***  
 and Potassium, 200  
 Bleaching Properties of, 200  
 Explosive Properties of, 200  
 with Metallic Sodium, 200
- Capillary Attraction, see also Lantern Experiments**  
 Attraction with Cane, 89  
 Cotton, 89, 90, 91  
 Earthenware, 92  
 Flannel, 91  
 Gauze, 92  
 Glass, 88  
 Leather, 89  
 Paper, 89  
 Prawn, 90  
 Salt, 88  
 Soils, 89  
 Sulphate of Copper, 88  
 Wood, 88, 89
- Carbon, see also Experiments with Oxygen, Hydrogen, etc.**  
 as Bort, Blacklead and Charcoal, 226-228  
 as Disinfectant, Deodoriser, etc., 225  
 Candle-flame, 230, 231  
 Fire-extinguishing Apparatus, 236-239  
 from Bones, etc., 225  
 in Ferment, 232  
 Manufacture of Carbonate of Ammonia, 229  
 of Quick Lime, 229  
 Naturally-generated Carbonic Acid, 233, 234, 235  
 Production of Carbonic Acid Gas, 226-234  
 to Demonstrate Fire-extinguishing Properties of Carbonic Acid  
 Gas, 230, 231, 236  
 to Demonstrate Weight of Carbonic Acid Gas, 230  
 with Chalk, 228, 229
- Centrifugal Force,—**  
 Can of Water, 23, 24  
 Centrifugal Railway, 24  
 Governors of Engines, 23  
 Sticks, 22, 23  
 Umbrella, 22
- Change of State, 85**
- Chlorine, see also Experiments with Oxygen, Hydrogen, etc.**  
 Action in the Decoration of Linen, 195  
 of Hydrogen and Carbon Compounds on, 194  
 of Olefiant Gas on, 194  
 on Copper, 191  
 on Phosphorus, 192, 258
- Colour-producing Properties, 192**
- Curious Action on Sodium, 190, 191**
- Dangers of, 190**

Experiments. *Continued.*

- Chlorine, Decolouring, or Bleaching, Chlorine Water, 189
  - or Bleaching Properties of Chlorine Gas, 189, 192
  - Different Actions on Wet and Dry Chlorine, 193
  - Explodes with Hydrogen, 190
  - Ignition of Dutch Metal, or Antimony, 189, 192
  - Peroxide with Phosphorus, 258
  - Preparation of, 186, 188, 189
- Dialysis, 7, 10
- Dia-magnetism, see also Lantern Experiments in Light, below
  - Apparatus for Testing the Dia- and Para-magnetism in bodies, 390, 393
  - Effect of Magnetism on Candle Flame, 395
  - Faraday's Heavy Glass and Light, 388, 522, 523
  - Light and Water in Tube (Faraday), 389
  - Lines of Magnetic Force, 388, 389
  - Para-Magnetism, 390, 393
- Diffusion of Gases—Hydrogen and Carbonic Acid, 4
  - of Gases—Hydrogen in Porous Cell, 5
  - Liquids—Brine and Water, 5, 6
    - Dialysis, 7, 10
    - Osmosis, 7, 8
      - Nollet's Experiment, 8
      - see also Lantern Experiments
- Eclipses of the Sun, 27
- Electric Alarms, 306, 307, 329
  - Alarms, Clocks, 308, 309
  - Bells, 329
    - Indicators, 329
- Induction Coils—Batteries for use with Coils, 374
  - Coils—Effect of Wet Paper on Spark, 373, 374
    - Electric Fire Wheels, 368
    - Gassiot's Electric Cascade, 371, 372
    - Imitation of Aurora Borealis, 367
    - Internal Illumination of Crystals, 373
    - Perforating Paper without Firing, 369
    - Sparks from, 368, 369
      - to Fire Gunpowder, 370, 371
      - to Melt Iron, 368
    - Travelling Fire, 372, 373
    - Used by Sir William Crookes, 376
    - Vacuum Tubes, 367, 368, 375
      - with Leyden Jar, 369, 370
      - with Metal Filings, 373
      - with Spangles, 368, 370
      - with Vacuum from Air, Gases, etc., 367-368, 375
- Electric Writing, 356, 357
- Electricity Frictional,—Conductors and Non-conductors, 269-272
  - Frictional,—Electrifying by Induction, 269, 270, 271
    - from Animal Organisms, 263, 268, 269

- Experiments, Electricity. Frictional. *Continued*  
 from Chemical Action, 263, 266  
 from Friction, 263-266, 274  
 from Heat, 263, 267  
 from Magnetism, 263, 267  
 in Stockings, 275  
 Pictures, etc., giving Shocks, 283  
 see also Voltaic, below  
 Sources of, 263, 264  
 The Leyden Jar—Effects with Balls and Points, 284  
   Electric Pictures, 285  
   Lightning and its Effects, 285-287  
 With Electric Machine, 275  
   Electric Machine and Discs and Glass, 280  
     Manikins, 278  
     Paper Leaves, 278  
     Person (see † below), 279  
     Wig (see \* below), 279  
     Windmills, etc., 280  
   by Induction, 280, 281  
   Discharging Plates, 284  
   the Electrophorus, 281, 282  
   the Electroscope, 271  
   and Bombazine, 275  
   and Brass Wire, 272  
   and Brown Paper, 274  
   and Chips of Wood, 275  
   and Coffee, 275  
   and Flannel, 274  
   and Glass, 274  
   and Hair (see \* above), 274  
   and Person (see † above), 273  
   and Powdered Chalk, 273  
   and Powdered Substances, 274  
   and Sealing Wax, 272-275  
   and Violin Bow, 275  
   Galvanometer Needle, 266, 267  
   Suspended Straw, 265, 266  
   Wax and Flannel, 265  
   Woollen and Other Goods, 263-265  
 Voltaic, Chemical Action of Current in Plating with Metals, 300, 301  
   Current via the Tongue, 287  
   Decomposition of Water, 295, 296  
   Electro-deposit of Copper, 299, 302, 303  
     of Gold, 304  
     of Silver, 303, 304  
   Electrotyping, 298, 299  
   for Burning Metals, 306  
   for Exploding Submarines—Toys and Otherwise, 306  
   Incandescence of Platinum, 305

- Experiments, Electricity, Voltaic. *Continued.*  
 Incandescence of Platinum and Silver, 305  
 Iodide and Starch, 297  
 Path of Current in Electro-plating, 300, 301  
 Salt and Indigo, 298  
 Saltpetre and Litmus, 298  
 see also Frictional Electricity above  
 Skinned Frogs, 287, 288  
 Quantity and Intensity Effects, 297  
 Fluorine—Etching Glass, 202-206  
 Gravity and Air-resistance on Falling Bodies, 20  
 and Astronomy, 33  
 and Billiard Balls, 33  
 Centrifugal Force, 21-34  
 Eclipses of the Sun and Moon, 27, 29, 34  
 Equality of Gravity in all Objects—Balls, 18  
 of Gravity in all Objects—Gold Coin, Gold Leaf and Feather, 18-20  
 Forces of Gravity and Centrifugal Contending, 33  
 of Gravity and Centrifugal Contrasted, 34  
 of Gravity—Light and Squares, 17  
 Hoop and Toys, 16  
 Potassium Floating on Water, 15  
 Wood Floating on Water, 15  
 Heat—Conduction of Heat, Burning Paper, 561, 562  
 Burning Phosphorus, 559  
 Cold Extinguishing Flame, 562  
 Falling Marbles, 559-561  
 Heat not Blown Away, 555  
 Motion of Heat in Water, 572  
 Ventilation, 578, 579  
 Water a Bad Conductor, 569-572  
 Heat and Light from Sodium and Quicksilver, 538  
 from Ice by Friction, 537  
 from Metals by Friction, 537  
 Radiation of Heat from Hot Ball, 592  
 from Tube, 593  
 Heat and Cold from Alcohol and Water, 596  
 Heat in Vacuum, 585  
 Ice from Liquid Metal, 595  
 Ice from Radiation, 590  
 Sensible Heat, Difference of Temperature in the Same Vessel,  
 549, 550  
 Expansion of Metals, 539, 542, 543  
 Home-made Rough Pyrometer, 543, 544  
 Thermometer, To Make a, 544-548  
 To Show Expansion of Air, 550  
 Tyndall's Experiment, 540  
 Hydrogen, see also Experiments with Oxygen, Carbon, etc.  
 Affected by Platinum and Spongy Platinum, 146, 147, 155, 156  
 and Carbon Compounds, 194

**Experiments, Hydrogen. *Continued.***

- Chlorine, 190, 194
- Oxygen Blow-pipe, 153, 154
- Oxygen Bubbles, 151
- Oxygen Light, 154-158
- Bubbles, 145
- Burns with Luminous Flame, 147
- Burns with Non-luminous Flame, 147
- for Metallic Decorations, 151, 152
- from Decomposition of Water, 156, 157
- in Balloons (see also Chap. XI on Aërostation, Page 162), 148, 150, 151, 551-553
- its Effects on Sound, 148, 149, 150, 151
  - Preparation from Hydrochloric Acid and Zinc, 143
  - from Metallic Iron, 144, 145
  - from Metallic Potassium, 143, 145
  - from Metallic Zinc, Tin, etc., 145
  - from Sulphuric Acid and Zinc, 143
- Lighting Bottles of, 145, 146
- Produces Moisture, 147, 152, 153
- The Hydrogen Organ, 149
- The Squeaking Toy in, 149
- Impenetrability—Marbles, Seed and Sand, 3
  - Water and Sugar, 2
  - Wood and Nail, 1
  - Wool and Alcohol, 1, 2
- Impenetrability of Air—Bellows, 10
  - of Air—Bladder, 10
  - of Air—Water and Orange, 11
- Induction Coils—see Experiments with Electric Induction Coils
- Inertia—Cup of Tea, 14
  - Tray of Water, 13
- Iodine—Iodide and Starch, 297
  - Iodine Tests for, 198
  - Vapour of, 198
  - with Phosphorus, 197
- Light, see also Light and Demonstrations of Light
  - Absorption of Light, 497, 498
  - of Light Iridescent Colour Disc, 506
  - Bar Magnets, 407
  - Billiard Balls, 407
  - Fan to Show Light-rays, 410
  - Faraday's Heavy Glass, 388, 522, 523
  - Gold Leaf, 409
  - Lantern Experiments:—
    - Capillary Attraction, 466
    - Decomposition of Water, 465
    - Diffusion of Liquids, 467, 468
    - Illusions by Philosophical Toys, 481, 482, 484
    - Iron-filings on Magnet, 464, 465



- Experiments. Lantern Experiments. *Continued.*  
 Pictures to Change Colour in Lantern, 468  
 Polarisation of Light in Lantern, 510  
 Polarisation of Light, The Oxy-hydrogen Polaroscope, 516  
 Taking and Developing Photographs in the Lantern, 467  
 The Dancing Skeleton, 461-462  
 Light and Heat from Sodium and Quicksilver, 538  
 Magnetised Needles, 407  
 Measuring Light, 411-412  
 Polarisation of Light—Double Refraction, 511  
 of Light—Experiment in Lantern, 510  
 of Light—Experiment in Lantern—The Oxy-hydrogen Polaroscope, 516  
 of Light—Wave Models, 502  
 Reflection of Light—Concave Mirrors, 427-431  
 Light—Concave Mirrors, Pictures on Smoke, 431-433  
 Convex Mirrors, 424  
 Cylindrical and Conical Mirrors, 424-426  
 Figures in Cardboard, 418  
 Magic Mirror, 421-423  
 Plane Mirrors, 418-423  
 Rule and Rod, 417  
 Seeing through Bent Tubes, 419  
 Refraction of Light—In Various Media, 447  
 of Light with Coin in Bowl, 448, 449  
 with Strip of Glass, 448  
 Shadow Pictures, 413, 414  
 The Blind Spot in Eye, 450-452  
 To make a Kaleidoscope, 440, 441  
 Undulatory Theory—Ball and Bowl, 405, 406  
 Theory—Waves of Water, 407, 408  
 Magnetism and Electro-Magnetism, 309  
 and Electro-Magnetism, Effects of Lighting, 309, 310  
 Electro-Magnetism, How to make Telegraph Instruments, see  
 Telegraph  
 Magnetising Steel, 312, 315  
 Magnets and Electro-Magnets, 313, 314  
 Magnets and Iron-filings, 314  
 See also Dia-magnetism, Electricity, etc., and Lantern Experiments  
 The Loadstone, 311, 314  
 The Magnetic Needle, 312  
 The Magnetic Needle, Action of, 312  
 To Show Path of Magnetic Current, 315, 320  
 with Nails, 310  
 Mechanical Mixture, e. g., Gunpowder, 105-108  
 Nitrogen, see also Experiments with Oxygen, etc.  
 and Hydrogen (Ammonia), 139  
 Its Properties, 137, 138, 139  
 Nitrous-oxide (Laughing Gas), 139

**Experiments, Nitrogen. *Continued.***

- Preparation from Atmospheric Air, 135
  - from Copper, 136
    - Lead Amalgam, 136, 137
    - Tartrate of Lead, 136
  - with Phosphorus, 135, 136
- Oxygen, see also Experiments with Hydrogen, Carbon, etc.
  - and Ammonia, 141, 142
    - Bougies, 118
    - Bude Light, 126, 127
    - Burning Nitre, Charcoal, Sulphur and Nitrate Strontium, 124, 125
    - Calcium Light, 128, 154-158
    - Glowing Matches, Tapers or Charcoal, 118, 121
    - Glow-worm, 126
    - Hot Lampblack, 126
    - Metallic Potassium, 122
    - Nitre, Sulphur and Lampblack, 125
    - Smouldering Rag, 119
    - Phosphoretted Hydrogen, 251
    - Phosphorus, 120, 124, 258
    - Steel and Cotton, 122
    - Sulphur, 120
    - Zinc and Nitre, 125
  - As an Acid, Changing Blue Litmus to Red, 120, 121
  - From Burning Nitre, Meal, Sulphur and Iron, 124
    - Chlorate of Potash and Dioxide of Manganese, 114, 116
    - Chlorate of Potash only, 112, 121
    - Dioxide of Manganese only, 112, 113
    - Freshly-gathered Leaves, 123
  - On Colouring Matter. Action of, 129
    - Peroxide of Chlorine and Phosphorus, 258
  - Preparation of Ozone, 131-133
    - with Ether and Turpentine, 128
- Oxy-hydrogen Blowpipe, 153-154
  - Light, 154-158
    - see also Lantern Experiments in Light
- Ozone, Its Preparation, 131, 132, 133
  - Properties Demonstrated, 132, 133
- Phosphorus, see also Experiments in Chlorine, etc.
  - Amorphous, or Red Phosphorus, 255, 256
    - and Iron, 594
  - Combustion of, under Water, 257, 258
  - Dangers of, 253, 256
  - Difference between Common and Red, 255
  - In Matches, 255-257
  - Luminous Steam, 259
  - When Dissolved, 253
    - Dissolved in Disulphide of Carbon, 254
    - in Ether, 253, 254

- Experiments, Phosphorus. *Continued.*  
 in Olive Oil, 254, 255  
 with Calcium, 260  
   Chlorate of Potash, 259  
   Chlorine, 258, 261  
   Peroxide, 258  
   Hydrogen, 259, 260  
   Oxygen and Phosphoretted Hydrogen, 261.  
   Paper, 252  
   and Sulphur, 252, 253  
 Potash, 260  
 Soot, 253  
 Warm Substances, 253  
 Silicon—Making and Colouring Glass, 243, 244  
 To Obtain Pure Silica, 242, 243  
 Specific Gravity, 77  
 Steam, Air following Air-jet, 598  
   Balls, etc., remaining in Air-jet, 598  
   Boiling Water by the Use of Cold Water, 604  
   Boiling Water by the Use of Steam, 605  
   Burning Ether, 601, 602  
   Smoke following Steam-jet, 597  
   The Thermometer in Steam, 602, 603  
 Sulphur (see also Experiments with Oxygen, etc.), 106-108, 244  
   Allotropic Condition, 246  
   And Hot Charcoal, 249  
   Dioxide, 247  
   Disulphide of Carbon, 250, 254  
   Hot, Poured into Water, 245, 246  
   Inorganic Substances, 248  
   Properties of, 247, 248  
   Sulphuric Acid (Vitriol), 248  
   with Copper, 247  
     Hot Iron, 250  
     Iron-filings, 246  
     Iron Wire and Copper, 247  
       and Metallic Potassium, 246, 247  
     Nitre and Charcoal, 105-108  
       (Saltpetre) and Chlorate of Potash, 121  
     Phosphorus, 252, 253  
     Potassium Chlorate, 250  
     Tinfoil, 247  
   Water Firing Potassium, 11, 12  
 Exploding Matches, 255  
 Eye—Blind Spot in, 450-452  
 Fabricius and Archimedes, 438  
   Photography, 206  
 Fahrenheit Readings Converted to C. and R., 548, 549  
 Falling Bodies, Gravity of, 17

- Faraday and Electricity, 263, 296, 297, 378, 394, 395, 541  
and Heat, 541
- Faraday's Heavy Glass, 388, 522, 523
- Figures, Balancing, 55
- Filter of Geber, 89, 90
- Filtration, 96
- Fire-damp, 261
- Fire-extinguishing Apparatus, 236-239
- Fitting up Apparatus, 116, 117
- "Flames" in Sun, Nature of, 40
- Flannel and Seed-testing, 91
- Flashing Signals (Heliographs, etc.), 441-445
- Fleet Destroyed by Archimedes, 436
- Floating Eggs, 66, 67  
Ship, 68
- Fluorine (see also Experiments), 201  
Dangers of, 201, 202  
Manufacture of, 201
- Fog, Earth (or Evening Mist), 587, 603  
Morning, 587
- Force, Centrifugal (see also Experiments), 21  
and Gravity Contending, 33  
Gravity Contrasted, 34  
Nature of, 22, 23, 24, 32  
of Gravity (see also Experiments), 17, 33
- Fountain or Engine of Hero, 599, 607
- Franklin and Electricity, 263
- Fraunhofer's Lines (see also Light), 472
- Freezing Apparatus, 101
- Frictional Electricity (see also Experiments Electricity), 262  
Electricity, Production or Sources of, 263, 264
- Fusible Metal, Rose's, 542
- Fusion, Watery, 98
- Galileo and Astronomy, 27
- Galvani and Electricity, 288
- Garay, Blasco de, and the Steam Engine, 607
- Gas, Acetylene, 161, 162
- Gas—Bad Effects of Burning Gas, 581  
Cylinders (see also Light), 457, 458
- Gas-Generators (see also Light), 458  
Jets (see also Light), 456, 457  
Lamp Ventilators, 581  
Lighters, Automatic, 146, 147, 155, 156  
Water (Water-gas), 144, 145
- Gases, Diffusion of (see also Experiments), 4, 231  
The Drying of, 187  
Liquefaction of, 158  
To Demonstrate the Specific Gravity of, 76
- Gavey and Wireless Telephony, 534

- Geber's Filter, 89, 90  
 Gerb, 124, 125  
 Gibbons on Archimedes, 437  
 Gilbert, Dr., and Electricity, 263  
 Glass and Attraction, 88  
   and Cohesion, 81  
   Faraday's Heavy, 388, 522-523  
   Tubing to Bend, 117  
 Glauber's Salt, 97, 99  
 "Glory" of Sun seen in Eclipse, 38  
 Glow-worm in Oxygen, 126  
 Gower and the Telephone, see Telephone  
 Graham, Discoverer of Crystalloids and Colloids, 9  
 Gramme Machine, 380-383  
 Gravitation on Sun and Planets, 15  
 Gravity (see also Experiments), 14  
   and Air-resistance on Falling Bodies, 20  
     Centrifugal Force Contending, 33  
     Centrifugal Force Contrasted, 34  
     Inertia Contrasted, 14  
     Light Compared, 17  
   Centre of, 48  
     How to Find, 51  
   Demonstrations of, 15  
   Law of, 14  
   of all Objects Equal, 18-20  
     Falling Bodies, 17  
   Specific, How to Take, 69, 71, 72, 74, 75  
     with Demonstrations, 65, 76  
   versus Osmosis, 8  
 Gray and the Telephone, 349  
 Great Pyramid and Astronomy, 26  
 "Greek Fire," 181  
 Greeks and Astronomy, 26  
 Gregorian Telescope, 435  
 Grey, Stephen, and Electricity, 263  
 Gun, Perkins' Steam, 572  
 Gunpowder and Roger Bacon, 104, 105, 180, 181  
 Gurney Sir G. and the Bude Light, 127
- Half-tone Process (Photography), 218-220  
   Tri-Colour Process (Photography), 220-222  
 Halley and Astronomy, 27  
 Halley's Comet, 43  
   with Venus, Spectra of, 47  
 Halogens (see also Experiments), 185  
 Haloid Salts, 95  
 Hammer Nasmyth's, 85  
   Water, 83

- Header's Coil (see also Experiments—Electrical and Induction Coils),  
 131, 363
- Heat (see also Experiments), 536  
 and Davy, 537  
   Rumford, 537  
 Conduction of (see also Experiments), 555  
   Heat not Blown Away, 555  
   Heat not Matter, but "Force," 557  
   Heat, Various Theories of, 556-9  
   Non-conductors, 567  
   The Davy Safety Lamp, 563-567  
   Ventilation, 577-584
- Latent (Steam), 594
- Radiation of (see also Experiments), 584  
   Hygrometers, 587-590  
   Ice from Radiation, 590  
   Radiation Thermometer, 586  
   Torricellian Vacuum, 584, 585, 586
- Sensible (see also Experiments), 539  
   Applied to the Restoration of Buildings, 541  
   Balloons, Expansion of Gases and Air in, 551-553  
   Curious Properties of Rose's Fusible Metal, 542  
   Differential Thermometer, 551  
   Expansion of Gases and Air, 550-551  
   Expansion of Metals, 539, 541  
   Faraday on Storage of Energy, 541  
   Kussné on Expansion by Heat, 540, 541  
   Stirling's Engine, 553
- Heat, the Cause of Vapour, 601
- Heavy Glass, Faraday's, 388, 522, 523
- Heliograph, 441-445
- Helmholtz and Light, 497
- Hero's Fountain (or Steam Engine), 599, 607
- Herschel and Astronomy, 27  
   and Photography, 208  
   the Analysis of Metals, 472
- Hiero, King, and Archimedes, 69, 70
- Hipparchus and Astronomy, 27
- Holmes' Magneto Machine, 379
- Hoop and Toys, 16
- Horse and Manikin, 54
- How to find Centre of Gravity, 51  
   Specific Gravity, 70-72  
   make a Kaleidoscope, 440, 441  
   make a Microphone, see Microphone  
     an Egg Stand on End, 52  
     a Simple Microscope, 486-488  
     a Simple Prism, 488  
     a Simple Telegraph Instrument, see Telegraph  
     a Simple Thermometer, 544-548

- How to find Centre of Gravity. *Continued.*  
 use the Spectroscope, 476
- Hughes and the Microphone, see Microphone
- Huyghenian Theory of Light; see Light
- Hydracids, 122
- Hydrogen (see also Aërostation and Experiments), 142  
 and Carbonic Acid, 4  
 in Porous Cell, 5
- Hydrosalts, 95
- Hygrometers, 587, 588, 589, 590
- Ice and Water, Anomalies in the Heat of, 600, 601
- Iceland Spar (see also Light, Polarisation of), 511, 512
- Ignis Fatuus, 261
- Imitation of Sun's Corona, Prof. Powell's, 38  
 Water Spiders, 258
- Impenetrability (see also Experiments), 1
- Indestructible Wicks, 89
- Induction Coils (see also Experiments), 131, 132, 363  
 Battery Required, 366  
 How made and used, 363-366
- Inertia (see also Experiments), 12  
 or Passiveness, with Demonstrations, 12-14
- Iridiotype Process (Photography), 214
- Insulating Stool, 272
- Intensity Effects, 297
- Iodine (see also Experiments), 196
- Iridescent Colour Top, 506
- Jack-o'-Lantern, 261
- Jar, Leyden 105
- Job and Astronomy, 26
- Kaleidoscope, 440  
 How to make, 440, 441
- Kaleidoscopic Colour Top, 485
- Kelvin, Lord, and the Telephone, 348
- Kepler and Astronomy, 27
- Kinematography (see Cinematography), 211
- King Hiero, see Hiero
- King's Platinum Lamp, see Electric Lighting
- Kirchhoff and Light, 472
- Knoblauch and Magnetism, 394
- Kussné's Experiment in Heat, 540, 541
- Lamp, The Davy Safety, 156, 563-567  
 Dobereiner, 155
- Lampwicks of Wood, 88
- Lantern-slides to Colour, 221-222, 469  
 The Magic, Bi-unial, etc., see Light  
 The Opaque, see Light

- Latent Heat, 594  
 Lavoisier, as Claimant for Discovery of Oxygen, 120  
   Discoverer of Water-gas, 144  
 Law of Gravity, 14  
 Lead and Cohesion, 79-81  
 Leaning Towers, 57, 58  
 Lénard and "X" Rays, 526  
 Leyden Jar, 105, 131, 284-287  
 Light—Absorption of, 497  
   Helmholtz and Light, 497  
   Analysis and Synthesis of  
   (*Refracting Optical Instruments*) } 109, 469, 497  
     and Bunsen, 472  
     and Kirchhoff, 472  
     Classification of Metals by Colour, 472  
     Frauenhofer's Lines, 472  
     Herschel's Prediction of Colour Analysis, 472  
     Newton's Analysis of Light, 469, 470  
     The Prism, 470  
     The Rainbow, 470, 471  
     The Spectroscope, 473  
   and Gravity Compared, 17  
   Course of Light-rays through Lenses, 450, 451  
   Diffraction, see Inflection or Diffraction of Light, below  
   Duration of Impressions of—  
   (*Refracting Optical Instruments,*) 480  
     Monoscope, 493, 494  
     Philosophical Toys, 480  
     Pseudo-Effects of Vision, 497  
     Pseudoscope, 496, 497  
     Simple Microscopes and Telescopes, 485  
     Stereomonoscope (or Stereomoscope), 494, 495  
     Stereoscope, 489-493  
   Inflection or Diffraction of, 498  
     Diffraction Apparatus, 505  
     Iridescent Colour Disc, 506  
     Newton's Rings, 499  
 Optics and Optical Instruments (see also Experiments), 396  
   Light and Aristotle, 416  
   and Colour, Compared, 409  
   and Sound Compared, 406  
   Canton's Phosphorus, 398, 399  
   Combustion with Light from Steel, 399, 400  
   Compared with Water, 407  
   Compared with Waving Corn, 407  
   Corpuscular or Newtonian Theory, 403-405  
   Discovery of Sulphate of Barium, 398  
   Emanation of, 403  
   Ignition, 401  
   In Deep Water, 409, 410



Light. *Continued.*

- Old Tinder and Steel, 401
- Phosphorescence, 398
- Phosphorus and Chlorate of Potash, 401
- Rays, 416, 417, 419
- Reflection, 414, 420
- Sources of, 399-403
- The Candle-flame, 402
- The Optical Bench, 397
- The Phosphroscope, 402, 403
- Travelling through Space, 406
- Undulatory or Huyghenian Theory, 403-405
- Philosophical Toys, to Demonstrate, 480
- Polarisation of (see also Experiments with Lantern), 506, 510
  - by Double Refraction, 511
    - Reflection and Single Refraction, 509
  - Rhomb of Iceland Spar, 511, 512
  - Tourmaline, 514
- Chromatic Effects, 515, 519-521
  - Its Scientific Value, 521-524
- Polarised, and Faraday's Heavy Glass, 388
- Refracting Optical Instruments
  - (see also *Analysis and Synthesis of Light and Duration of the Impression of Light*), 452
  - Gas Cylinders and Retorts, 457, 458
  - Gas Generators, 458
  - Gas Jets, 456, 457
  - The Bi-unial Lantern, 455
    - Magic Lantern, 452
    - Opaque Lantern, 462, 463
    - Oxy-calcium Light, 128, 154-158
    - Oxy-hydrogen Light, 154-158
    - Oxy-hydrogen Microscope, 460
    - Sciopticon, 453-455
    - Triple Lantern, 456
- Refraction (see also Experiments), 446
- The Blind Spot, 450-452
  - Bude Light, 126, 127
  - Coloured, 127
  - Drummond Light, 155
  - Zodiacal Light, Nature of, 40
- Lighting by Electricity, see Electric Lighting
- Limelight, see Oxy-calcium Light and Experiments
- Lines of Magnetic Force, see Magnetism—Dia-magnetism
- Liquefaction of Gases, 158
- Liquids, Coloured and Otherwise, to Demonstrate Specific Gravity, 72-74, 77
  - Diffusion of (see also Experiments), 5
- Living (Animated) Pictures—Cinematography, 211
- Loaded Vehicles, Stability of, 60

- Locomotives, Modern (see also Steam Engine), 626, 627  
 Lucifer Matches (see also Matches), 253, 255  
 Luna Cornea, 206
- Magic Lantern, see Light  
 Magnesium Lamp, 445, 459  
 Magnetism and Electro-magnetism (see also Electricity and Experiments—Electrical), 309  
     Electro-magnetism, Electric Alarms, 306, 307  
     Electric Alarms, Clocks, 308, 309  
 Dia-magnetism (see also Experiments), 388  
     Apparatus, 390, 393  
     Atmospheric Magnetism, 396  
     Baucalari's Experiments, 394, 395  
     Faraday's Experiments, 394  
     Faraday's Heavy Glass, 388, 389  
     Faraday's Heavy Glass and Polarised Light, 388, 389  
     Knoblauch's Experiments, 394  
     Lines of Magnetic Force, 389, 392  
     List of Axial or Para-magnetic Substances, 391  
     List of Equatorial or Dia-magnetic Substances, 391, 392  
     Plücker and Magnetism, 393, 394  
     Tyndall's Experiments, 394  
 Magneto-electricity (see also Experiments), 376  
     Alliance Machine, 379  
     and Faraday, 378  
     Pixii, 378  
     Saxton, 378  
     Clarke's Magneto-electrical Machine, 377-379  
     Electric Illumination, 380  
     The Jablochhoff Candle, 380  
     Holmes' Machine, 379  
     Magnet and Galvanometer, 378  
     The Gramme Machine, 380-383  
     Jablochhoff Candle, 380  
     "Permanent" Magnet, 379  
 Manganese Dioxide, see Experiments  
 Manikins, 53, 54  
 Marconi and Wireless Telegraphy, 533  
 Marsh Gas, 261  
 Mass, 50  
 Matches, Safety, 256, 257  
     Loud-exploding, 255  
     Lucifer, 253, 255, 256  
 Mechanical Mixture, as Opposed to Chemical Combination, 105-108  
     of Gases, 4  
 Menton and Astronomy, 27  
 Metal, Rose's Fusible, 542  
 Metals, Table of Conduction of Heat in, 560  
 Microphone (see also Telephone, etc.), 358

Microphone. *Continued.*

Home-made Instruments, 359-362

Hughes' Instrument, 359

Invention, 359

Microphotography, 223

Microscopes and Telescopes, 485

To make a Simple, 486-488

Mist, Evening (or Earth Fog), 587, 603

Modern Locomotives (see also Steam Engine), 626, 627

Momentum, 50

Monoscope, 493, 494

Moon, Experiment to Demonstrate Eclipse of, 29

Moors, Chemistry and the, 103, 104

Morehouse (Comet C 1908), 45, 46

Morning Fog, 587

Motion of the Earth round the Sun, 32

Muschenbroeck of Leyden, 105

Nasmyth's Hammer, 85

Nature, Example of Osmosis in, 8

of an Element, 108, 109

Photographs, 207

"N" Rays (Radio-activity), 527

Necrosis, 256

Newcomen and the Steam Engine, 610

Engine of, 613

Newton and Astronomy, 27

and Gravitation, 14

the Steam Engine, 607

Newton's Rings (see also Light), 499

Newtonian Theory of Light, see Light

Niépce and Photography, 208

Nitre, see Potash, Nitrate of

Nitrogen (see also Experiments), 133

Nollet's Experiment in Osmosis, 8

Nonius and Astronomy, 27

Opaque Lantern, 462, 463

Optics and Optical Instruments, see Light

Osmosis, 7, 8

in Nature, Example of, 8

Nollet's Experiment, 8

versus Gravity, 8

Oxy-calcium Light (see also Experiments), 128, 154-158

Oxygen (see also Experiments), 111-131

and its Effects on the Human System, 128, 129

Discovered by Priestley, 118, 119

Discovery Claimed by Lavoisier, 120

Oxy-hydrogen Blow-pipe, 153, 154

Oxy Salts, 95

- Ozone, Properties of (see also Experiments), 132, 133  
 The Allotropic Condition of Oxygen, 131-133
- Page, and the Telephone, 348, 349
- Palladiotype Process (Photography), 214
- Para-magnetic Bodies, see Magnetism—Dia-magnetism
- Passiveness, or Inertia, see Inertia and Experiments
- Pendulum Demonstrating Inertia, 12
- Percussion, Centre of, with Demonstrations, 62-65
- Periodic Comets, 43
- Perkins' Steam Gun, 572
- "Permanent" Magnet, see Magneto-electricity
- Philosopher's Stone, 103  
 Wool, 125
- Philosophical Toys—Iridescent Colour Disc, 506  
 Kaleidoscopic Colour Top, 485  
 Perforated Discs, 483, 484  
 The Thaumatrope, 482  
 Zoetrope, 480
- Transactions, 105, 142, 263
- Phonograph (see also Telephone, etc.), 352-356
- Phosphorescence, see Light
- Phosphorus (see also Experiments), 251  
 Amorphous, or Red, 255  
 Appearance of, 257  
 Canton's, 398, 399  
 Dangers of, 253, 256  
 Production of, 251, 252  
 Properties of (see also Experiments), 251, 252
- Photography, 206  
 Animated Pictures, 211  
 Apparatus, 209, 210  
 Archer and the Collodion Emulsion, 209  
 by "N" Rays, see "N" Rays  
 by "X" Rays, see "X" Rays  
 Carbon Process, 211-214  
 Cinematography, 211  
 Daguerrotypes, 208  
 Diazotype Process, 216  
 Fox-Talbot Process, 208, 209  
 Half-tone Process, 218, 220  
 Half-tone Tri-colour Process, 220-222  
 Living (Animated) Pictures, Cinematography, 211  
 Microphotography, 223  
 Niépce, Partner of Daguerre, 208  
 Platinotype, Iridiotype and Palladiotype Processes, 214  
 Sir John Herschel, Discoverer of Fixing Salt, 208  
 Sticky-emulsion Process, 214-216  
 The Dry Plate, 210, 211  
 Zinc Process, 217, 218

- Pixii and Magneto Machines, 378  
 Planets and Sun, Gravitation on, 15  
     of our Solar System, Density of, 78  
 Platinotype Process (Photography), 214  
 Platinum, Spongy, 146, 147, 155, 156  
     Wire, How to Hold, 241  
 Plücker and Magnetism, 393, 394  
 Plumb-line Demonstrating Gravitation, 15  
 Polarisation of Light. see Light  
 Polarised Light and Faraday's Glass, 388  
 Polonium, 532  
 Polymorphism, 107  
 Porous Cell, Hydrogen in (Diffusion of Gases), 5  
     Pots, 92  
 Potash, Chlorate of and Nitrate of (see also Experiments), 121  
     Nitrate of (see also Experiments), 106-108  
 Potassium Burns on Contact with Water, 11-12  
     Iodide, 130, 297, 298  
     on Water, Demonstrating Gravity (see also Experiments), 15  
 Prawn Syphon, or Filter, 90  
 Priestley, Discoverer of Oxygen Gas, 118, 119  
 Prominences (Rose Coloured) in Sun, 38  
     Nature of, 39  
 Properties of Matter, 1  
     Ozone (see also Experiments), 132-133  
 Pseudo-effects of Vision, 497  
 Pseudoscope, 496, 497  
 Purchase of Chemicals, Caution with Regard to, 115  
 Pyramid and Astronomy, 26  
     Stability of the, 59  
 Pythagoras and Astronomy, 27  
  
 Quantity Effects, 297  
  
 Radiation Thermometers, 586  
 Radiators, Good and Bad, 587, 591-593  
 Radio-active Elements, etc., 530  
     Actinium (not an Element), 532  
     Discovery of Radium (an Element), 531  
     Polonium (not an Element), 532  
 Radio-activity, 524  
     The Discovery of, 531  
     "N" Rays, 527  
     "X" Rays, 524  
 Radium, 531  
     Properties of, 532-533  
 Rags Converted into Sugar, 115-116  
 Readings of Thermometers and Conversions C. R. F., 548, 549  
 Reaumur's Thermal Readings Converted to C. and F., 548, 549  
 Recorde and Astronomy, 27

- Red Fire, 125  
 Refraction of Light, see Light  
 Regnault's Condensing Hygrometer, 587, 588  
 Reinhold and Astronomy, 27  
 Reiss, Philip, and the Telephone, 349  
 Resistance of Air on Falling Bodies, 20  
 Ruhmkorff Coil (see also Experiments, Electrical, and Induction Coils),  
 131, 363  
 Rings, Newton's (see Light), 499  
 Roman Fleet Destroyed by Archimedes, 436  
 Röntgen, or "X" Rays, 524  
 Rose's Fusible Metal, 542  
 Royal Society of London, Transactions of the, 105, 142, 263  
 Rumford and Heat, 537, 586  
  
 Safety Lamp, The Davy, 156, 503-567  
     Matches, 256  
 Salt and Attraction, 88  
     Glauber's, 97, 99  
 Saltpetre, see Potassium Nitrate  
 Salts, 95  
 Sanctorio's Differential Thermometer, 551  
 Savart's Wheel, 348  
 Savery's Steam Engine, 609, 610  
 Saxton and Magnetism, 378  
 Schönbein, Discoverer of Ozone, 131  
 Sciopticon, see Light  
 Scott's Generator for Steam Engine, 624  
 Seed-testing with Flannel, 91  
 Selenite, 519  
 Selenium, 250  
 Self-Lighting Lamp, the Dobereiner, 155  
 Serrin's Regulator (see also Electric Lighting), 384  
 Shellac Varnish for Electrical Experiments, 266  
 Ships Destroyed by Archimedes, 436  
 Shooting Stars, 46  
 Siemens and Magnetism, see Magneto-electricity  
 Siemens' Regulator, see Electric Lighting  
 Sieve to Retain Water, 91, 92  
 Signals Aërial, see Aërial Signals  
     Flashing, 441-445  
 Silica, 111  
 Silicon (see also Experiments), 242  
     Properties of, 242  
 Snow Crystals, 93  
 Society of London, Royal, Transactions, 105, 142, 263  
 Solution, 96  
 Sound and Hydrogen, 148-151  
     Light Compared, 406  
 Specific Gravity (see also Experiments), 65

- Specific Gravity. *Continued.*  
 How to Take, 69, 71, 72, 74, 75
- Spectra of Halley's Comet with Venus, 47
- Spectroscope, The, 473  
 and Astronomy, 475, 477  
 How to Use, 476  
 In Analysis, 474  
 Discovery. 476-479
- Spray, The, as a Disinfecting Appliance, 248
- Stability of Living Bodies, 61  
 Loaded Vehicles, 60  
 Pyramid, 59
- Stars, Shooting, 46
- Steam (see also Experiments), 594  
 Engine, Blasco de Garay and the, 607  
 Boulton and Watt and the, 619  
 In England, 608  
 Marquis of Worcester and the, 608, 610  
 Modern Locomotives, 626, 627  
 Newcomen and the, 610  
 Savery's, 609, 610  
 Scott's Generator, 624  
 Stirling's Engine, 553  
 Stephenson and the, 622  
 The Evolution of the, 606  
 Newcomen Engine, 613  
 Watt, and the, 613  
 Fountain (or Engine) of Hero, 599, 607  
 In Colliery Practice, 598, 599  
 Latent Heat of, at Various Temperatures, 605  
 Perkins' Steam Gun, 572
- Steinheil and the Electric Telegraph, see Telegraph
- Stephenson and the Steam Engine (see also above), 622
- Stereomonoscope (or Stereomoscope), 494, 495
- Stereoscope (see also Monoscope), 489-493
- Sticky-emulsion Process (Photography), 214-216
- Stirling's Engine, 553
- Stool Insulating, 272
- Strontium Nitrate, 124, 125
- Sublimation, 99
- Sugar from Rags, 115, 116
- Sulphate of Barium, Discovery of, 398
- Sulphur (see also Experiments), 106-108, 121, 244-248  
 As a Disinfectant (see also Spray), 248  
 Production of, 244  
 Properties of (see also Experiments); 245  
 Salts, 95
- Sulphuric Acid (see also Sugar from Rags), 115-116
- Sun (see also Experiments), 27  
 and Planets, Gravitation on the, 15  
 "Corona," 38

Sun. *Continued.*

- Powell's Imitation of, 38
- Description of Annular Eclipse of the, 36
  - Total Eclipse of the, 37
- Difference Between Total and Annular Eclipses of the, 30
- Eclipses of the, 39
  - "Glory," 38
  - Nature of the "Clouds," 40
  - Nature of the Flames, 40
    - the Rose-coloured Prominences, 39
    - Zodiacal Light, 40
  - Nearer to Earth in Winter, 31
  - Rosecoloured Prominences, 38
- Surface-plates and Cohesion, 80
- Switchback, 50
- Sword-balancing, 54
  - tricks, 62-63
- Synthesis of Light (see Light, Analysis and Synthesis of), 469
- Syphon or Filter of Geber, 89, 90
  - Prawn, 90

## Table of Conduction of Heat in Metals, 560

- Elements, 110
- Talbot, Fox, and Photography, 208
- Tea, Cup of, Demonstrating Inertia, 14
- Telegraph, Electric, 321
  - Alphabet for Home-made Instrument, 334
    - Mirror and Needle, 337, 533
    - Morse, 337, 533
  - Bain's Chemical Telegraph, 338, 345
  - Bakewell and Casselli's Copying Telegraph, 345
  - Bakewell's Copying Telegraph, 345, 346
  - Davy and the Telegraph, 345
  - Dots and Dashes, see Alphabet above
  - Double-needle Telegraph, Cooke and Wheatstone's, 329, 330
  - Duplex System, 341, 344
  - Earth-return Connections, 322, 323, 327, 351
  - Fast Repeater, G. P. O. Pattern, 342
  - How to make a Simple Instrument, 330-336
  - Hughes' Printing Telegraph, 344, 345
  - Lightning Protectors, 327, 328
  - Military Morse Field Sounder, 347, 348
  - Morse Inker, G. P. O. Pattern, 339
    - Key (Double Current), and Switch, G. P. O. Pattern, 336
    - (Single Current), G. P. O. Pattern, 336
  - Sounder, G. P. O. Pattern, 338
  - Multiplex System, 344
  - Plate Sounder, G. P. O. Pattern, 340
  - Quadruplex Repeater, G. P. O. Pattern, 343
    - System, 341, 344



- Telegraph. *Continued.*  
 Relaying Sounder, G. P. O. Pattern, 338  
 Relays, 340, 341  
 Short-circuits, 323  
 Simple Instrument to make, 330-336  
 Single-Needle Instrument, G. P. O. Pattern, 331  
 Sounder System, 339  
 Steinheil's Discovery of Earth Connections, 322  
 The Battery, 322  
   Bell, 328, 329  
   Battery, 329  
   Conducting Wires, 323  
   Writing Telegraph, 346  
 Wheatstone's A. B. C. Instruments, G. P. O. Pattern, 332  
 Wireless (see also Wireless Telegraphy), 533  
 Telephone, Phonograph and Microphone, 348  
 "Articulating," The, 349  
 Bell's Discoveries, 350  
 Earth-Currents (see also Earth-Currents in Telegraph), 351  
 Edison's Discoveries, 356  
 Electric Writing, 356, 357  
 Gower's Discoveries, 352  
 Gray's Discoveries, 349  
 Home-made Telephones, 350, 352  
 Lord Kelvin's Announcement of the, 348  
 Loud-speaking Telephone, 356-358  
 Page's Discoveries, 348, 349  
 Reiss' Discoveries, 349  
 Tone Telephones, 349  
 Toy Telephones, 350  
 Varley's Discoveries, 349  
 Telephony, Wireless (see also Wireless Telephony), 534  
 Telescope, Astronomical, 434-435  
 Telescopes and Microscopes, Simple, 485  
   To make, 486-489  
 Temperatures of Boiling Points, 603-605  
   Steam and Latent Heat, 605  
 Tenacity, 82  
 Test for Carbonic Acid Gas (see also Experiments, Carbon), 4, 227, 229  
 Testing Seeds on Flannel, 91  
 Thales and Astronomy, 26  
   Electricity, 262  
 Thaumatrope (see also Philosophical Toys), 482  
 Theories of Light, see Light  
 Thermometer, Conversion of Readings of C. R. and F., 548, 549  
   Differential, 551  
   How to make, 544-548  
   Radiation, 586  
 Thomson and the "X" Rays, 526  
 Three-Colour Process (see also Photography), 220-222

- Tombola Manikin, 53  
 Top Kaleidoscopic, 485  
 Torricellian Vacuum, 584-586  
 Total and Annular Eclipses of the Sun, Causes of and Demonstrations (see also Sun), 34  
     Difference Between (see also Sun), 30  
 Total Eclipse of Sun, Description of a, 37  
 Tourmaline (see also Light, Polarisation of), 514  
 Towers, Leaning, 57, 58  
 Toys and Hoop, Demonstrating Gravity (see also Philosophical Toys), 16  
 Transactions of the Royal Society, 105, 142, 263  
 Transit Instruments, 437  
 Travelling Bodies, Illustrating Inertia, 12  
 Tricks with Swords, 62, 63  
 Tri-colour Process (see also Photography), 220-222  
 Tubing, Glass, To Bend, 117  
 Turbine, Water, 383, 628  
 Tycho Brahe and Astronomy, 27  
 Tyndall and Heat, 540  
     Magnetism, 394  
  
 Umbrella to Demonstrate Centrifugal Force, 22-23  
 Undulatory Theory of Light, see Light  
 Uranium, 530  
  
 Vacuum, Torricellian, 584-586  
 Value of Polarised Light, 521-524  
 Vapour Produced by Heat, 601  
 Varley and the Telephone, 349  
 Varnish for Electrical Instruments, 266  
 Venus and Halley's Comet, Spectra of, 47  
 Ventilation, 577, 579, 580  
     of Lamps, 581, 582  
     of Pits, 583, 584  
 Vitiation of Atmospheric Air by Burning Gas, 581  
 Vitriol, see Sulphuric Acid  
 Volta and Electricity, 263, 288  
 Voltaic Electricity (see also Experiments, Electrical), 287  
 Volume, 51  
  
 Water and Brine, Demonstrating Diffusion, 5, 6  
     and Orange, Demonstrating Impenetrability, 11  
     Potassium, Demonstrating Gravity, 15  
     Sugar, Demonstrating Impenetrability, 2  
     Wood, Demonstrating Gravity, 15  
 Anomalies of Heat in Ice and Water, 600, 601  
 Balancing of, 61  
 Coolers, 92  
 Fires Potassium, 15

Water and Brine. *Continued.*

—Gas, 144, 145

—Hammer, 83

Retained in Sieve, 91, 92

Spiders, Imitation of, 258

To Demonstrate Centrifugal Force, 24

To Demonstrate Inertia, 13

Turbine, 383, 628

Wheel, 383

Watery Fusion, 98

Watt and the Steam Engine, 613

Weight, Balancing of, 62

Wheatstone and Light, see Kaleidoscope

Magnetism, see Magneto-electricity

Wheatstone's Telegraph, see Telegraph

Will-o'-the-Wisp, 261

Wireless Telegraphy, 533

Alphabet, 337, 533

Marconi, 533

Telephony, 534

and Gavey, 534

History of, 534-535

Principle and Uses of, 534-536

Wood and Nail, Demonstrating Impenetrability, 1

Floating on Water, Demonstrating Gravity, 15

Wool and Alcohol, Demonstrating Impenetrability, 1, 2

Philosopher's, 125

Worcester, Marquis of, and the Steam Engine, 608, 610

Worm-glow, and Oxygen, 126

"X," or Röntgen Rays, 524

"X" Ray Photography, 527

Young and Light (see Light), 404, 405

Zinc, Oxide of, 125

Zinco-Process (see also Photography), 217-218

Zodiacal Light, Nature of, 40

Zoetrope and other Philosophical Toys, 480





**E500**  
**Pepper**

**P395b**  
**1912**

AUTHOR

**Boy's playbook of science**

TITLE

DATE DUE	BORROWER'S NAME
11 3 1912	447849

**E500**

**P395b**  
**1912**

**447849**

PENN STATE UNIVERSITY LIBRARIES



A000057493237