



BIG  
BOOK  
OF  
BOYS'  
HOBBIES



A. NEELY HALL





**BIG BOOK  
OF BOYS'  
HOBBIES**

# HANDICRAFT BOOKS

BY

A. NEELY HALL

---

*8vo. Cloth. Illustrated with hundreds of full-page  
and working drawings by the author  
and Norman P. Hall*

---

THE BOY CRAFTSMAN  
HANDICRAFT FOR HANDY BOYS  
THE HANDY BOY  
HOME-MADE TOYS FOR GIRLS AND BOYS  
HANDICRAFT FOR HANDY GIRLS  
CARPENTRY AND MECHANICS FOR BOYS  
HOME-MADE GAMES AND GAME EQUIPMENT  
OUTDOOR BOY CRAFTSMEN  
BIG BOOK OF BOYS' HOBBIES

---

LOTHROP, LEE & SHEPARD CO., BOSTON





FIG. 87.—MODEL AIRPLANE BUILDERS, SOUTH PARKS PLAYGROUNDS, CHICAGO, WITH THEIR HANDICRAFT DIRECTOR,  
B. C. FRIEDMAN. (See page 59.)  
—FRONTISPIECE.

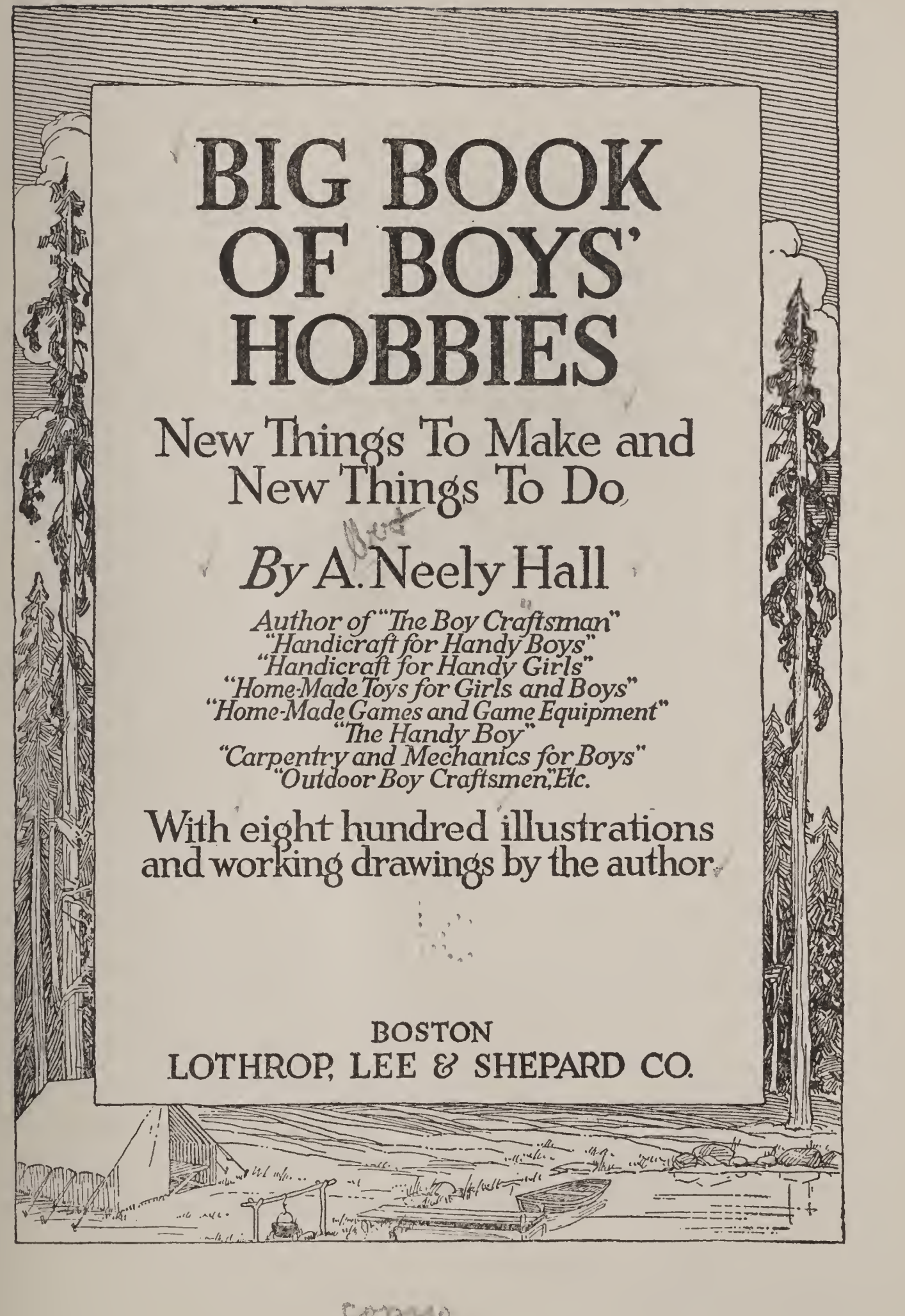

# BIG BOOK OF BOYS' HOBBIES

New Things To Make and  
New Things To Do

*Best*  
By A. Neely Hall

*Author of "The Boy Craftsman"  
"Handicraft for Handy Boys"  
"Handicraft for Handy Girls"  
"Home-Made Toys for Girls and Boys"  
"Home-Made Games and Game Equipment"  
"The Handy Boy"  
"Carpentry and Mechanics for Boys"  
"Outdoor Boy Craftsmen," Etc.*

With eight hundred illustrations  
and working drawings by the author

BOSTON  
LOTHROP, LEE & SHEPARD CO.

copy 2

TT160

H15

Copy 2

COPYRIGHT, 1929  
BY LOTHROP, LEE & SHEPARD CO.

*All Rights Reserved*

BIG BOOK OF BOYS' HOBBIES

PRINTED IN U. S. A.

©ClA 17319  
DEC 11 1929

P



## From Hobbies, Big Ideas Grow.

### PREFACE

AT a recent convention, one hundred delegates from leading American industries and colleges went on record as agreeing that creative ability, intellectual honesty, observation, and enthusiasm should be placed on a par with book learning. "Genius is the order of the day," said Dr. Delton T. Howard, professor of psychology at Northwestern University. "The advance of science depends upon original thinking. It used to be that the mind with the greatest storehouse capacity, or the fastest calculating ability, was considered the most distinguished. But knowledge has become so vast and so technical that the encyclopedia and the library have taken the place of the 'know-it-all' mind, and the adding machine and similar machines have removed the need for the calculating expert. A good scholastic record is important, but the devising of an improved method of keeping a football score, or a new way of carrying out ashes without getting dust on the family washing, is just as important."

Dr. Howard's theory stresses the value of hobbies, for a boy's individual effort along the lines in which he is most interested will develop his creative ability to a greater extent than any other agency.

We do not have to look farther than Thomas A. Edison for an example of genius brought to light and developed by hobbies. He has told of the home laboratory that he equipped at the age of ten, of his ceaseless experiments in

chemistry and electricity in his early teens, of his home-made telegraph outfits, of the newspaper that he printed and published while employed as newsboy on a railroad, and how he spent every penny that he could earn and save, in the development of his ideas. Recalling these experiences of his youth, he has said, "I did not know at the start what I wanted to do. I might have remained in that state of mind for years, as many boys foolishly do, if I had not cultivated the determination to find out as quickly as possible what I was fitted for." And speaking of a boy's chance for success, he has said, "I would advise every youth not to put off too long before he makes an effort to discover what he is fit to do. Begin at as early an age as possible, and dig, dig, until the discovery is made." Boys have another champion of their hobbies in Henry Ford, who has said, "A boy's job is to prepare himself with training, knowledge and experience. If I were bringing up a boy to-day, I would see to it that he had a shop in which he could work with tools."

**Big Book of Boys' Hobbies** has been prepared to provide a large variety of ideas of interest to boys. Following the trend of the times, a generous section of the book has been devoted to the latest types of model airplanes—indoor and outdoor models, "flying sticks," flying models that look like real ships, and scale models. The subject of model airplanes has had a large following since the first flight by the Wright brothers, but every boy has taken up the hobby since the transatlantic flight of Colonel Lindbergh, it would seem, from the demand for plans and material-kits. As an

instance of the demand from one source, the author has personally superintended the cutting of balsa sticks for more than ten thousand models supplied to his readers.

There are plans in this book, also, for galleons, yachts, and other non-sailing models, interest in which is second only to that in model airplanes, and whatever the boy's other preferences may be he will probably find them among the fifty-one chapters.

This material has been selected from the author's articles published in his departments in *Modern Mechanics*, *The American Boy*, *Child Life*, *Youth's World*, *The Pioneer*, *The Target*, *Boyland*, *The Haversack*, *Boy's Comrade*, *Boy Life*, *The Boy's Friend*, *Penn-Weekly*, and *Hi-Way*, from his articles published in *Popular Science Monthly*, *Boy's World*, *Open Road for Boys*, *The Ladies' Home Journal*, and *Woman's Home Companion*, and from his articles syndicated to newspapers and weeklies.

Since he has lived with this sort of work for many years, the author has had the satisfaction of watching the development of genius in his readers that has resulted in successful careers, and he is confident that the contents of **Big Book of Boys' Hobbies** will bring about helpful reactions. No boy will have time to make and do all the things described, but since the material has been organized into a program of winter, spring, summer, and autumn hobbies, he will find enough to keep him busy from one end of the year to the other.

A. NEELY HALL.

October 21, 1929.





## PART I

### WINTER HOBBIES

#### CHAPTER I

	PAGE
A HOBBY CLUB . . . . .	1

Organizing a Club — Choosing Club Members — The Club's Purpose — An Organization Meeting — The Officers — The Club Workshop — The Clubroom — The Club Library — Affiliate With an Organization — Exhibitions, Contests and Races — Suggested Form for a Hobby Club Constitution.

#### CHAPTER II

A MODEL-MAKING WORKSHOP . . . . .	8
-----------------------------------	---

Location of the Workshop — An Outside Shop — A Shop in a Garage — A Porch Shop — A Basement Shop — A Home-made Work-bench — The Bench-vise — A Bench Stop — A Packing-box Work-bench — The Cupboards — The Vise — Other Shop Equipment — Name Your Shop.

#### CHAPTER III

FURNISHING YOUR ROOM OR A CLUBROOM . . . . .	19
--	----

The Furnishings — A Room in an Attic — Finishing an Attic Room — Wallboard — Storage Closets — A Window-seat — A Cabinet — A Shelf for Models — Cabinet Shelves

— Cabinet Doors — Box Files — A Folding Screen — Double-acting Brass Hinges — An Interesting Room and its Owner — Picture-frames — Other Suggestions.

#### CHAPTER IV

A TREASURE-CHEST WITH A SECRET LOCK . . . . . 31

A Box for the Chest — The Cover — The Hinges — The Secret Lock — Chest Handles — Painting — Finishing Touches.

#### CHAPTER V

SCRAPBOOKS . . . . . 37

An Aeronautics Scrapbook — A Sports Scrapbook — A Scrapbook of Scouting — Notebook Covers — Home-made Covers — Binder's Board — Stock for Scrapbook Leaves — Assembly — Mounting Pictures and Articles — Classifying — Indexing — A Letter-file Scrapbook.

#### CHAPTER VI

MODEL AIRPLANE TOOLS, MATERIALS, AND TOURNAMENTS . . . . . 44

The Tools Required — Adhesives — Cement — Acetone — Banana Oil — Airplane Dope — Framework Materials — Balsa — Bamboo — Covering Materials — Japanese Tissue-paper — Chinese Silk or Linen — Metal Fittings — Music-wire — Shaping the Wire — A Fishhook Bearing — A Needle — A Brad — Thrust-washers — A Wheel from a Glass-cutter — Landing-gear — Landing-gear Axles — Struts — Shaping Bamboo — A Razor-blade Knife — Motors — Rubber-strand Motors — Care of Motors — Material Kits — Model Airplane Tournaments — Rules and Regulations for Tournaments.

#### CHAPTER VII

AN INDOOR DURATION MODEL AIRPLANE . . . . . 59

B. C. Friedman, Expert Designer and Builder — A Successful "Flying-stick" Model — Materials — A Material Kit — The Wing — The Wing Tips — Ribs — Spars — To Assemble the Wing Frame — The Dihedral — To Paper the Wing — The Motor Base — The Stabilizer — The Rudder — Metal Fittings — The Propeller-bearing — The Rear Motor-hook —

The S-hook — The Propeller-shaft — Thrust-washers — Wing-clips — The Propeller — The Blank — The Carving — Mounting the Propeller — Thrust-washers — The Motor — Tuning the Model — Launching the Model.

## CHAPTER VIII

## A TWIN PUSHER MODEL AIRPLANE . . . . . 72

A Practice Plane Built for Speed — Materials — A Material-kit — The Frame — The Longerons — The Braces — Metal Fittings — The Yoke — The Propeller-bearings — Four Cans — The Wing — The Dihedral — The Elevator — Two Dihedrals — Finishing — The Propellers — The Propeller-blanks — The Right-hand Propeller — The Left-hand Propeller — The Propeller-shafts — The Thrust-washers — The S-hooks — The Motors — A Propeller-winder — A Home-made Winder — Using the Winder — To Launch the Model.

## CHAPTER IX

## A PROFILE-FUSELAGE MODEL AIRPLANE . . . . . 84

A Model That Looks Like a Real Ship — Materials — A Material-kit — The Motor Base — The Fuselage — The Wing — The Ribs — Assembling the Wing — Covering the Wing — The Tail — The Stabilizer and Elevator — The Fin and Rudder — Metal Fittings — The Propeller-bearing — A Needle Bearing — The Rear Motor Hook — The S-hook — The Propeller-shaft — Washers — Wire Hangers — Wing-clips — The Landing-gear — The Struts — The Wheels — The Wheel Axles — The Propeller — The Blank — Mounting the Propeller — The Motor — Tuning the Model — Finishing the Cabin.

## CHAPTER X

## A LOW-WING PROFILE-FUSELAGE MODEL AIRPLANE . . . . . 95

A Model With the Low Wing of the Junkers Bremen Ship — Materials — A Material-kit — The Motor Base — The Fuselage — The Wing — The Spars — The Ribs — Assembling and Covering the Wing — The Tail — The Stabilizer and Elevator — Covering — Mounting — The Fin and Rudder — Mounting and Covering — Metal Fittings — The Propeller-bearing — The Rear Motor-hook — Two Intermediate Hangers — The S-hook — The Propeller-shaft — Thrust-washers — Wing-clips — The Landing-gear — The Struts —

	PAGE
The Axles — The Shock-absorbers — The Wheels — The Tail-skid — The Propeller — The Blank — Mounting the Propeller — The Motor — Tuning the Model — Finishing the Cabin.	
CHAPTER XI	
SCALE MODEL AIRPLANES . . . . .	106
Difference Between Flying Models and Scale Models — A True Scale Model — Contest Scale Models — Sources of Data for Scale Models — Scale Drawings — The "Spirit of St. Louis" Scale Model — The Fuselage — The Wing — The Stabilizer — Elevators, Fin and Rudder — The Landing-gear — The Whirlwind Motor — The Propeller — Finishing the Model — The Curtiss Army Hawk Scale Model — The Fuselage — The Tail Group — The Wings — The Landing-gear — The Covering — Finishing the Hawk — Other Fitments — The Ford Tri-motor Cabin Monoplane — The Fuselage — The Wing — Use of Scale Models.	
CHAPTER XII	
A GALLEON SHIP MODEL . . . . .	124
The Hobby of Building Ship-models — The Materials — The Hull — The Keel Center-piece — The Bow — The Stern-piece — Three Bulkheads — The Main Deck — The Sides of the Hull — The Superstructure — The Decks — The Bulwarks — Doors and Windows, Panelling — The Stern Balcony Railing — Lanterns — Cannon — Painting — Rigging the Galleon — The Masts — The Bowsprit — The Yards — The Sails — The Rigging — A Base for Your Ship Model.	
CHAPTER XIII	
INSTALLING A RADIO . . . . .	134
The Aerial — The Aerial Supports — An Iron-pipe Mast — A Concrete Base — Assembling the Mast — Erecting the Mast — Slack in the Aerial Wire — Insulation of the Aerial — The Lead-in Wire — A Lightning Arrester — The Ground Wire — A Direct Ground.	
CHAPTER XIV	
A WINTER FEEDER FOR BIRDS . . . . .	141
The Hanging Feeder — The Parts — The Center Compartment — The Wire Containers — Paint — Stocking the Feeder.	



## CHAPTER XV

## WINTER SPORTS EQUIPMENT . . . . . 144

Book References for Sports Equipment — An Ice Skatemobile — The Chassis — Attaching the Skate-runners — The Body — The Handle-bars — The Paint Job — A Barrel-stave Sled — The Seat — The Runners — A Foot-bar — A Rocker Coaster — A Pair of Rockers — Four Cross-bars — The Seatboards — Barrel-stave Skis — A Small Skate-sail — The Frame-sticks — To Assemble the Frame — The Covering Material — Decorating the Sail — Sailing — An Ice-hockey Stick — Making the Sharp Bend — Another Way to Shape a Stick — Length of the Stick — The Shaft End — The Blade End — Finishing a Hockey Stick — Hollow-grinding Your Skates — A File Grinder — The File — The Holder — Assembling — A Vise Support — Skates to Grind — A Snow Totem-pole — A Tree-trunk Foundation — To Start a Totem-pole — Modelling Tools — Reinforcing Projections — Eyes and Ears — Adding Color — A Snowball Shield — An Arm-and-hand Loop — Decorating the Shield.

## PART II

*SPRING HOBBIES*

## CHAPTER XVI

## A MODEL YACHT . . . . . 163

Model-yacht Building Popular — Model-yacht Organizations — Building Model-yachts with Dad — Your First Model-yacht — Larger Models — Blueprints — Material Kits — Fittings — A Twenty-four-inch Model — Materials — The Hull — To Lay Out the Hull — Templets — Carving the Hull — Hollow the Inside — Make the Deck — The Keel — The Rudder — The Rudder-post — A Port — The Tiller — The Spars — The Mast Loops — The Rigging-loops — A Mast-step — The Sails — The Rigging — Automatic Steering — Finishing — A Yacht Club — Model-yacht Regattas — Racing Rules.

## CHAPTER XVII

## A MODEL MOTOR-BOAT . . . . . 177

Time Required to Build Model Motor-boat — Cost of Plant — Boy Craftsman Prize Model Motor-boat — Materials

— The Hull — Templets — To Shape the Outside — Hollowing Process — The Cabin — The Power Plant — Toy Electric Motor — The Propeller — The Shaft — A Port — The Motor Hook-up — The Rudder — The Tiller — A Quadrant Plate — A Propeller-and-rudder Guard — Finishing — Make a Stand.

### CHAPTER XVIII

A GREAT RIG IN KITES . . . . . 188

The Conyne Model — A Cross Between a Box-kite and a Hexagonal Kite — Materials Required — Kite-sticks — The Covering Material — A Thirty-three-inch Model — The Assembly — Frame the Triangular Cells — Fasten the Horizontal Stick — The Framing-string — Cover the Side Wings — The Bridle — The Belly-band — The Flying-line — A Kite-line Reel.

### CHAPTER XIX

AN AIR-MOTOR . . . . . 193

Similarity in Motion of Windmill and Airplane — Windmill Easy to Build and Easy to Keep in Repair — Size Varies in Proportion to Height of Mounting — First Shape the Hub — The Hub-bearings — The Motor-shaft — The Shaft-bearings — Cut Four Fan-blades — Cut the Tail — Finish the Parts — Mount the Windmill — Harness the Air-motor.

### CHAPTER XX

AN AIRPLANE WEATHER-VANE . . . . . 198

Model Will Withstand Storms — Symbolizes Your Interest in Aviation — Building this Model is Simple — The Fuselage — The Wing — The Elevator and Rudder — Braces — The Propeller — Cylinders — The Landing-chassis — The Tail-skid — Finishing — The Swivel Base — An Electric Outlet Box-cover Base — An Iron Pipe Support — A Concrete Base — Points of Compass Omitted from Support.

### CHAPTER XXI

A MUSEUM . . . . . 206

Collecting is an Interesting Hobby — Collections Vary in Value — Anton Watkin's Home Museum — Your Own Room as a Museum — Bill Jones' Museum — A Boy Scout Troop Museum — A Stamp Collection — Duplicate Stamps for Ex-

changes — A Coin Collection — Mount Your Coins — To Prepare the Coin-mat — A Passe Partout Frame — A Knot Board — Material for Knot Board — A Rock and Mineral Collection — A Shell Collection — A Collection of Leaves — An Insect Collection — A Photograph Collection — A Photograph Album — A Folding Screen — A Card-index of Exhibits — A Specimen-cabinet — Shelves — To Trim the Cabinet — Cabinet Drawers — Finish the Cabinet.

CHAPTER XXII

A CRACKER-BOX AQUARIUM . . . . . 217

Few Responsibilities Connected with Keeping Goldfish — A Well-balanced Aquarium — Do Not Change Water — When a Fish Becomes Sick — Feed Sparingly — Difficulty in Building Wood-and-glass Aquarium — The Tin Cracker-box Aquarium — Materials — Make Your Aquarium Cement — Prepare the Box This Way — Paint the Tin — Set the Glass — A Castle for the Aquarium — Make a Form — Mix Sand and Cement — Build the Castle Walls — Stocking the Aquarium.

CHAPTER XXIII

A BIRD SANCTUARY . . . . . 224

Fitting Up a Bird Sanctuary Is One of the Best Hobbies — A Reader's Letter — A Wren Hut — To Prepare the Coconut — Make the Roof — To Assemble — A Bluebird House — Lay Out the Front — Lay Out the Back Board — The Sideboards — The Roof-boards — The Floor — The Doorway — The Hanger — Paint the Bluebird House — Shingle the Roof — A Wren or Bluebird House — Build Houses to Sell — Dimensions of Parts — The Side-pieces — The End-pieces — The Floor-board — Eave Strips — The Roof-boards — Hanger-blocks — For Spring Cleaning — A Nesting-material Depot — Cut the Center Stick Support — The Tin Funnel Roof — The Nesting-material Cage — To Assemble — Finishing.

CHAPTER XXIV

BIRD-BATHS AND A FISH-POOL . . . . . 233

A Bird-bath Attracts Birds to Your Grounds — Affords Rare Opportunity for Study and Photographs — A Tree-stump Bath — To Mount the Cover — A Rustic Bath — A

Fish-pond or Water-garden — A Concrete Pool — The Size of the Pool — Mark Out the Pool — Excavate to a Depth of Four Inches — Make the Rim Level — Tamp Down the Earth — A Home-made Tamper — A Cinder Sub-base — Material for Concrete — A Mixing-box — To Mix a Batch of Concrete — Shovel the Concrete into the Excavation — Reinforcing — Add Two Inches of Concrete — Finish the Edge of the Pool — The Bird-bath — Planting — A Drain.

## CHAPTER XXV

## KENNELS . . . . . 240

A Kennel Supplies Spring and Summer Quarters for Your Dog — A Well-built House — The Size — The Material — Build the House in Sections — To Make the End-wall Section — The Side Sections — Build the Floor — The Roof — Ventilation — Cover the Roof — Paint the Kennel — A Barrel Kennel — A Wooden Oil-barrel — The Crib — Preparing the Barrel — Painting — A Concrete Bowl for Drinking-water — Mix the Concrete — Pour the Concrete — Remove the Form.

## CHAPTER XXVI

## A BACK-YARD ZOO . . . . . 246

Park Zoo Is a Model for Your Back-yard Zoo — Placard the Cages of Your Pets with Their Latin Names — A Good Way to Acquire a Zoo — Care for Your Neighbors' Pets When the Owners Are Away — This Is a Pleasant Way to Earn Vacation-money — Kennels May Be Adapted to Other Pets Than Dogs — Poultry-houses May Be Used for Pigeons — An Emergency Hutch — It Is Made of a Box — An Exhibition-cage — A Rabbit-hutch — Three Compartments in a Box — Cut Floor-boards — Cut Two Doorways — The Rabbit Runways — The Stairway — Make the Doors — Cover the Sides of the Runways — A Pair of Trestles — Paint the Inside and Outside of the Hutch — A Convertible Coop or Hutch — The Construction — Build Up the Sides — A Ventilator — Cut the Roof-boards — A Chicken Coop — The Hinged Front — Cut the Small Doorway — Hinge the Front — Fasten the Floor — A Stairway — Make the Screen Doors — An Enclosed Runway — Paint the Assembled Framework — Cover the Top, Sides and Front Door Frame with Poultry Netting.

CHAPTER XXVII

A POULTRY-HOUSE . . . . . 257

Large Piece of Ground Unnecessary for Small Poultry-plant — Balanced Rations a Product of More Scientific Methods — Trap-nests Make Possible a Check on Egg-production — Scratch-shed Affords Protection in Inclement Weather — Combination Poultry-house and Scratch-shed — The Building-Material — The Scratch-shed or Basement Framework — Cut the Floor-joists — Lay the Floor-boards — The Poultry-house Framework — The Rear Frame — The Front Frame — To Erect the House Framework — The Rafters — Build the Side-wall Frames — The Doorway — Sheathe the Walls — The Roof — Trimming — Glaze the Windows — The Ventilator — Cross-ventilation — Make a Batten Door — Enclose the Scratch-shed — An Entrance Platform — Build the Steps — The Runway — Poultry Fixtures — The Roosts — The Droppings-board — The Nest-boxes — The Drop-leaf — Containers for Scratch-feed and Mash — Painting — White-washing.

PART III

SUMMER HOBBIES

CHAPTER XXVIII

A SHARPIE OUTBOARD MOTOR-BOAT . . . . . 269

Extensive Use of the Outboard Motor — Own Your Boat — The Flat-bottomed Sharpie — The Materials — The Material Bill — The Construction — Stem-piece — Center Mold — Stern-piece — The Assembly — The Side-boards — The Bottom-boards — The Keel — The Upper Side-boards — The Seats — A Deck-piece — Trim the Gunwales — Oar-lockets — Paint the Boat — Letter a Name — Overhauling the Boat — To Waterproof It.

CHAPTER XXIX

A CANVAS CANOE . . . . . 277

Model Designed by Robert McKechnie — An Inexpensive Craft — It Is Easy to Build and Easy to Transport — The Frame-work — The End-pieces — The Ribbands and Gun-

wales — The Molds — Assembling — The Covering — Painting — The Cockpit — A Double Paddle — A Life-preserver Vest.

## CHAPTER XXX

## WOODS AND WATER IDEAS . . . . . 282

A Pup-tent for an Overnight Hike May Be Carried on Your Back — A Large Tent Will Pack in a Trek Cart — Poles Must Be Jointed to Pack into a Compact Bundle — Jointing the Poles — To Pack the Poles — A Campfire Crane — Pot-hooks — An Orange-crate for Camping — An Automobile Cabinet — Cover the Cabinet — A Trek-cart Cabinet — A Fishing-line Drying-reel — A Home-made Reel — The Base — The Reel — The Axle — A Crank — Finish — A Canoe or Sharpie Headlight — The Lamp Support — The Base Board — Paint — To Assemble the Headlight — Paddle and Oar Repairs — Broken Handles — Reinforce the Connection — The Twine Splice — A Wire Splice — A Square Break — A Broken Oar-handle — A Split Handle — A Split Paddle or Oar-blade — Tip Your Paddle-blade — Protect the Upper End of the Break.

## CHAPTER XXXI

## BACK-YARD SHACKS . . . . . 294

Material for the Job — Crating-material Is Good Enough — Where You Can Get It — Boards from Packing-cases Can Be Used — A Small Shack — The Framework — The Sheathing — Lay the Roof-boards — No Floor Is Needed — The Door — The Windows — Box Furniture — A Window-seat — A Boy-scout Patrol-shack — The Essentials of a Patrol-Shack — The Framework — The Sheathing — The Window Openings — A Batten Door — The Roof — Build a Ladder — Insulation — Bunks — Painting.

## CHAPTER XXXII

## A CAVE WITH SECRET ENTRANCE . . . . . 303

This Cave Differs from Most Caves — Built for Safety — The Cave Is Dry, Light, and Well Ventilated — Attraction of the Cave Is the Secret Entrance — The Building-material — The Size of the Cave — The Underground Portion — The Above-ground Portion — The Walls — A Ventilator-shaft —

To Set Up the Walls — The Secret Entrance — Make the Walls Watertight — Outside Grading — Sow Grass-seed to Hide the Entrance.

CHAPTER XXXIII

A PLAY PERISCOPE . . . . . 309

What a Periscope Is — Ways of Having Fun with the Periscope — Imagine Your Cave a Submarine — Other Possibilities — How the Periscope Is Made — Material Required — The Construction Is Simple — Fit the Mirrors in Position — A Strap Handle — Paint the Inside.

CHAPTER XXXIV

THE WABASH LIMITED PUSHMOBILE . . . . . 315

A Step between Miniature Models and the Real Thing — The Railroad Working-capital — The Materials — The Tools — The Locomotive — The Axles — The Boiler Framework — The Boiler-jacket — The Cab — The Driving-rods — The Cylinders — The Steering-device — The Steam-dome and Sand-box — The Stack — The Headlight — The Bell — A Running-board — Steam and Water Pipes — A Pilot — Valves — The Tender — The Pullman — The Paint Job.

CHAPTER XXXV

A DUMP-TRUCK PUSHMOBILE . . . . . 321

A New Idea in Pushmobiles — It Is Easy to Build — The Chassis — The Steering-gear — The Braking-device — The Truck-cab — The Hood — The Truck-box — The Dumping-hoist.

CHAPTER XXXVI

AN AIRPLANE PUSHMOBILE . . . . . 327

An Airplane Model Big Enough to Ride In — The Fuselage — The Cabin Window — The Hatchway — The Fin — The Rudder — The Motor Cylinders — The Wing — The Stabilizer — The Landing-gear — The Covering — The Cabin — Paint the Ship.

## CHAPTER XXXVII

## BACK-YARD RAILROADING . . . . . 333

Perfection of Toy Railroad-equipment To-day — Building Model Railroad Systems a Recent Development — A Village Model — A Rocky Mountain Model — Start with a Simple Model — A Model Lake — A Wash-tub Lake — A Concrete Basin — A Mountain Creek — A Railroad Bridge — A Concrete Bridge — A Form — The Arched Openings — The Concrete — A Different Design of Concrete Bridge — A Box Girder Type of Bridge — Piers — The Roadbed — The Girders — The Ties — Paint — A Steel Bridge — A Trussed Bridge — The Girders — The Truss-members — The Tie-Rods — The Roadbed — A Railroad Tunnel — Build a Box — Build a Mountain — Finish the Entrances — A Railroad Depot — A Telegraph Line — The Poles — The Telegraph Wires — A Radio Transmitting-station — An Airport — Material for Scenery — Toy Animals and Live Stock — Toy Automobiles, Airplanes and Wagons — Additional Suggestions.

## PART IV

*AUTUMN HOBBIES*

## CHAPTER XXXVIII

## A TOY ELECTRIC BEACON . . . . . 351

Lad Uses a Toy Motor to Regulate Interval between Flashes — The Flashing Beacon — A Play Harbor — A Model Airport Beacon — The Material Needed — The Tower Framework — Two Form Blocks — The Covering — The Bridge and Railing — The Tower Base — The Electric Wiring — The Lamp Receptacle — The Lantern — A Small Bulb — The Flasher — The Outside Plastering — Finish the Tower.

## CHAPTER XXXIX

## A TOY-ELECTRIC SHOOTING-GALLERY . . . . . 357

This Model Illustrates Adaptation of Toy Motor to a Home-made Toy — How It Works — The Base of the Shooting-gallery — The Power-plant — Making a Wooden Pulley — Mounting the Wheel — Belt the Pulley to the Motor-pulley



— Mount the Motor — The Target-disk — The Rabbit Targets — Draw the Rabbit Outline — Mount the Targets — Cut Score Numbers — The Bean-blower Shooter — Finishing — Rules for Shooting and Scoring.

PAGE

## CHAPTER XL

A MODEL STATION FOR AN ELECTRIC RAILROAD . . . . . 364

You May Have a Station, But One Is Hardly Enough — A Station Makes a Good Christmas Gift — It Requires a Box — Cut the Doors and Windows — Two Gable-ends — Two Roof-boards — Mount the Depot Upon Its Platform — Cut a Chimney — Tile the Roof — Trim the Door and Window Openings — Paint the Station — Build a Freight-house — Build a Power-house.

## CHAPTER XLI

A BEAN-BLOW-GUN . . . . . 369

Model Designed to Shoot Beans at a Target — Its Barrel Is Built Upon a Tin Bean-blower — It Has a Rubber-tubing Extension Through Which to Blow — You Drop the Beans into a Magazine — The Stock — The Barrel — Cut the Rubber-tubing Extension — Encase the Bean-blower — The Sliding Sleeve — The Assembly — The Rear Sight — For the Front Sight — Make a Trigger — Finishing — How the Gun Works.

## CHAPTER XLII

THE FEEDING-HENS TOY . . . . . 374

This Pendulum Toy Is a Foreign Invention — How to Operate It — The Five Hens — The Bodies — The Legs — The Head and Neck and the Tail — The Feeding-platform — The Handle — The Pendulum — The Assembly — Finish the Toy.

## CHAPTER XLIII

AN AIR-SPINNER . . . . . 379

The Air-spinner Rises in Accordance with the Adjustment of its Tips — For Materials — The Spinning Device — The Spinner — To Launch the Air-spinner.

## CHAPTER XLIV

## A DANCING PUPPET . . . . . 382

You Vibrate the Platform to Make the Puppets Dance — The Puppet — Assemble the Parts — The Neck — The Head — Finish the Puppet — The Dancing-platform — To Manipulate the Puppet.

## CHAPTER XLV

## A PUPPET THEATRE . . . . . 386

This Could Be a Moving-picture Theater If You Own a Projector — A Reel of Pictures Will Hold Your Audience Between Acts — It is Great Fun to Make and Operate the Puppets — The Doorway Theater — The Stage — The Proscenium — Paint the Proscenium — The Stage-curtain — To Raise and Lower the Curtain — A Proscenium-drop — Stage-settings — Scenery and Properties — A Back-drop — Trees and Shrubbery — A Tower — A Cottage and Garden-wall — Puppets — Rag-dolls with Altered Joints — Changes of Costume — Use Paper Dolls — The Thread Controls — Operating the Puppets — The Stage-lighting — Puppet Plays.

## CHAPTER XLVI

## GAME EQUIPMENT . . . . . 396

Some Boys Make Games Their Hobby — Home-made Equipment — Table Tennis — The Court — Marking Out the Court — A Wallboard Court — Make the Tennis-net — The Tennis-net Posts — Make Tennis-rackets — Table-tennis Balls — Rules for Table-tennis — A Ring-toss Target — Make the Target — The Target Face — Make the Easel — Paint the Target — The Target Pins — For Tossing-rings — Rules for Tossing and Scoring — The Tossing-line — To Count the Score — A Checker-solitaire Board — The Board — To Lay Out the Playing-surface — The Peg-holes — Finish — Checker-men — Solitaire-pegs — Bags — Playing-rules.

## CHAPTER XLVII

## A QUIZ CLOCK . . . . . 407

This Model Is a Question-and-answer Device — It Is Fun to Prepare the Quiz-and-answer Cards — How the Quiz-clock Works — A Worn-out Clock Will Do — To Prepare the

Clock — The Knob-heads — To Mount the Knob-heads —  
Finish the Knob-heads — Finish the Clock-case — The An-  
swer-dial Cards — The Question Cards.

## CHAPTER XLVIII

## A GYMNASIUM WITH HOME-MADE APPARATUS . . . . . 413

Sell the Idea of a Gymnasium to Your Hobby Club —  
Where to Locate It — A Barn Loft — A Garage — A Base-  
ment — An Unfinished Attic — A Trapeze — The Trapeze-  
bar — The Suspension-ropes — An Eye-splice — The Way to  
Suspend the Trapeze — Height Adjustment — Flying Rings  
— The Pair of Rings — The Rope Hangers — A Horizontal-  
bar — The Uprights — The Bar-brackets — A Hickory Bar —  
An Iron Pipe Bar — To Set Up the Bar — Stay the Uprights  
— Parallel Bars — The Base — The Bars — The Supports —  
To Assemble the Apparatus — Finish the Woodwork — Mats  
— A Striking-bag Platform — The Platform — Suspend the  
Platform — The Hangers — Hinge the Platform — Other  
Apparatus.

## CHAPTER XLIX

## BOOK-NOOKS AND WHATNOTS . . . . . 429

Start Your Own Library — Book-nooks for Your Own  
Books, for the Family's Books, and for Gifts — An Extension  
Book-rack — The Parts — Laying Out the Parts — Assem-  
bling — A Wall-rack — The Material — A Pattern for the  
End-pieces — Saw the Curves — Shelf-grooves — The Shelves  
— Assembling — Finishing — Another Wall-rack — The Ma-  
terial — The Pattern for the Ends — The Shelves — Assem-  
bling — Finishing — A Corner Whatnot — The Turned  
Spindles — The Shelves — Finishing — Assembling — A Mod-  
ernistic Book-tower — Material — The Back-boards — Cut  
Five Shelves — Cut the Corner Post — Assembling — Finish-  
ing — A Pier-cabinet — The Material — The Side-boards —  
The Top — The Shelf-boards — The Face-board — Wallboard  
for the Back — Assembling the Parts — Finishing the  
Cabinet.

## CHAPTER L

A WASTE-BASKET AND A FOOTSTOOL . . . . .	449
--	-----

Useful Medium-sized Furniture — The Waste-basket — Material — Assembling — Enamelling the Basket — The Footstool — A Pattern for the Sides — Saw Out the Sides — To Assemble the Frame — Upholstering — Finishing — The Top-covering Fabric.

## CHAPTER LI

EARNING, SAVING AND SPENDING . . . . .	454
--	-----

A Boy's Rightful Use of Money — Henry Ford's Advice to Boys — Your Objective — Center Your Earning, Saving and Spending Program in Your Hobbies — Thomas A. Edison and His Boyhood Hobbies — Your Opportunities for Success — Hobby Equipment That You Can Earn — Many Ways in Which You can Earn Money — Making Things to Sell — Printing — Painting — Repairing — Photography — Gardening — Pets — Shows — Selling — Services.

INDEX . . . . .	461
-----------------	-----

# LIST OF HALF-TONE ILLUSTRATIONS

(In addition to more than 700 text illustrations)

## PART I

FIG. 87.	Model Airplane Builders, South Parks Playgrounds, Chicago . . . . .	} <i>Front- ispiece</i>
		FACING PAGE
FIG. 1.	Club Workshop the Best Place in Town . . . . .	} 8
FIG. 2.	Porch Shop for Building Radio Sets, etc. . . . .	
FIG. 18.	Attic Room as a Boy's Room . . . . .	} 20
FIG. 19.	An Interesting Room and Its Owner . . . . .	
FIG. 112.	Indoor Duration Model Airplane . . . . .	} 70
FIG. 113.	Twin Pusher Model Airplane . . . . .	
FIG. 114.	Launching a Forty-Inch Twin Pusher . . . . .	
FIG. 182.	Profile Fuselage Model Airplane, the P. F. 29 . . . . .	} 94
FIG. 183.	A Low-Wing Profile Fuselage Model Airplane, the P. F. 30 . . . . .	
FIG. 220.	Colonel Lindbergh's Ryan Monoplane, "Spirit of St. Louis" . . . . .	} 108
FIG. 221.	Side View of the Curtiss Army Hawk Biplane . . . . .	
FIG. 222.	Front View of the Ford Tri-Motor Cabin Monoplane . . . . .	
FIG. 223.	Side View of the Ford Tri-Motor Cabin Monoplane . . . . .	} 122
FIG. 237.	Model of Curtiss Hawk Built by Norman F. Zapf . . . . .	
FIG. 238.	Plan of Curtiss Hawk Model . . . . .	
FIG. 239.	Side Elevation of Curtiss Hawk Model . . . . .	
FIG. 240.	Model of Curtiss Hawk Built by Harold Franklin . . . . .	
FIG. 241.	Model of Curtiss Hawk Built by Garfield D. Day . . . . .	} 124
FIG. 242.	Model of Ford Tri-Motor Built by Cedric E. Galloway . . . . .	
FIG. 243.	Galleon Built by Melville Schmuldt . . . . .	} 164
FIG. 244.	Galleon Built by Leonard Feinberg . . . . .	
FIG. 319.	Model Yacht Regatta . . . . .	} 164
FIG. 320.	Yachts Built by Members of the "Ogden Park Club" . . . . .	
FIG. 321.	Randolph Cannon and His Model Yacht . . . . .	

	FACING PAGE
FIG. 341. Model Motor-Boat Built by Warren E. Leigh . . . . .	} 178
FIG. 342. Crossing a Park Lagoon . . . . .	
FIG. 375. Air-Motor. FIG. 376. Airplane Weathervane . . . . .	} 194
FIG. 420. Bill Jones' Museum . . . . .	} 206
FIG. 421. Coin Collection. FIG. 422. Knot Board . . . . .	
FIG. 423. Leaf Collection. FIG. 424. Jars for Insects . . . . .	
FIG. 425. Cracker-Box Aquarium . . . . .	
FIG. 434. Wren Hut. FIG. 435. Bluebird House . . . . .	} 224
FIG. 436. Wren or Bluebird House . . . . .	
FIG. 437. Tree-Stump Bird Bath . . . . .	
FIG. 438. A Bird Bath and a Fish Pond . . . . .	
FIG. 462. Well-Built Kennel. FIG. 463. Barrel Kennel . . . . .	} 240
FIG. 464. Emergency Hutch . . . . .	
FIG. 465. Coop or Hutch and Runway . . . . .	
FIG. 504. Speeding with an Outboard Motor . . . . .	} 269
FIG. 505. Flat-Bottomed Sharpie . . . . .	
FIG. 506. Canvas Canoe and Its Builder . . . . .	
FIG. 546. Small Shack. FIG. 547. Boy Scouts' Patrol Shack . . . . .	} 294
FIG. 570. Wabash Limited Pushmobile . . . . .	} 316
FIG. 571. Dump-Truck Pushmobile . . . . .	
FIG. 572. Airplane Pushmobile . . . . .	
FIG. 597. Village Model. FIG. 598. Rocky Mountain Model . . . . .	} 334
FIG. 623. Sign-Flasher Operates Toy Electric Beacon . . . . .	} 352
FIG. 624. Framework of Beacon . . . . .	
FIG. 626. Electric Toy Shooting-Gallery . . . . .	
FIG. 626. Toy Motor Makes Target Rabbits Run . . . . .	
FIG. 652. The Bean-Blow-Gun. FIG. 653. The Feeding-Hens Toy	} 370
FIG. 654. The Air-Spinner. FIG. 655. The Vibrating Platform	
FIG. 714. The Ring-Toss Target . . . . .	} 400
FIG. 715. The Board for Checkers and Solitaire . . . . .	
FIG. 716. The Quiz Clock . . . . .	
FIG. 717. "Question" and "Answer" Knobs . . . . .	
FIG. 776. Wall Book-Rack. FIG. 778. Corner Whatnot . . . . .	} 432
FIG. 777. Another Wall-Rack . . . . .	
FIG. 796. Modernistic Book-Tower . . . . .	} 440
FIG. 797. Pier Cabinet and Waste-Basket . . . . .	
FIG. 798. Footstool. (See Chapter L.) . . . . .	
FIG. 826. Cabinet of Tools. FIG. 827. Electric Bench Lathe . . . . .	} 456
FIG. 828. Electric Scroll Saw. FIG. 829. Printing Press . . . . .	
FIG. 830. A Hobby Library . . . . .	

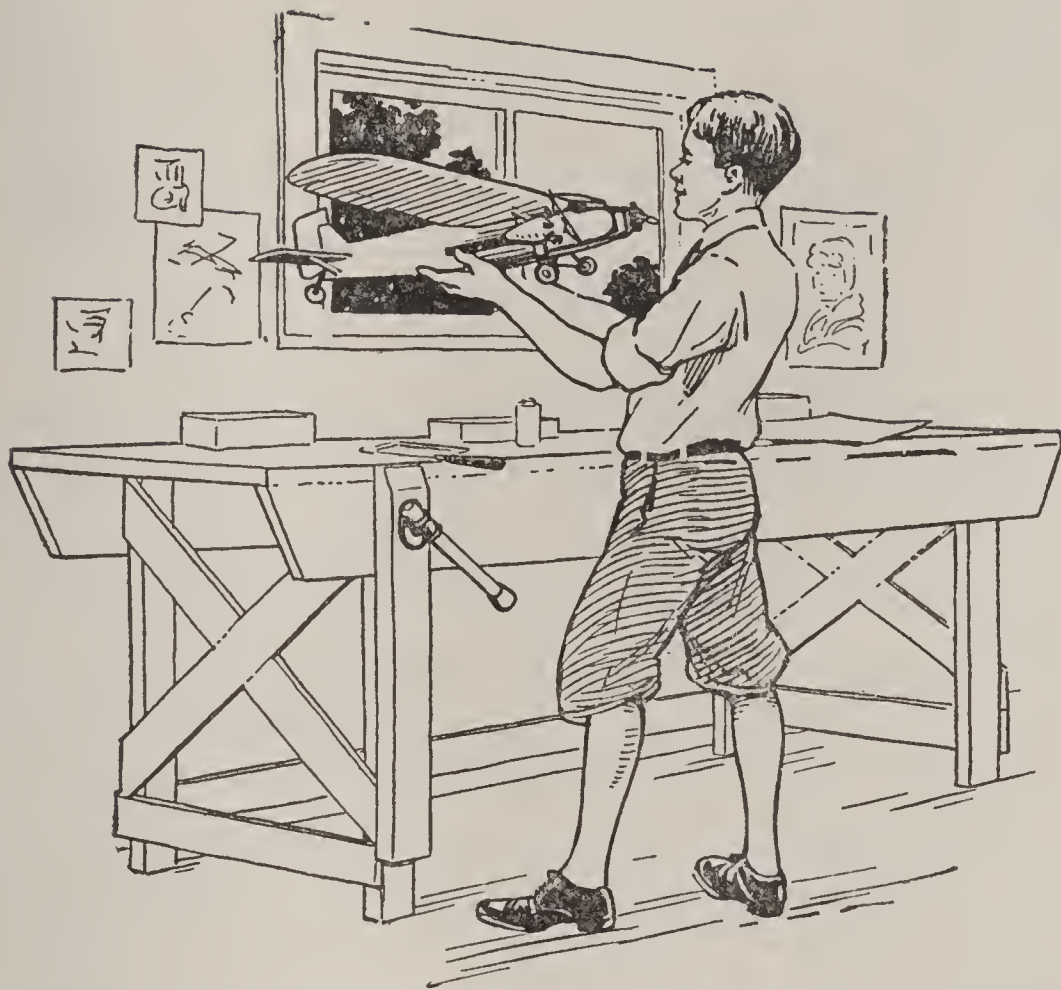

## PART I

# Winter Hobbies





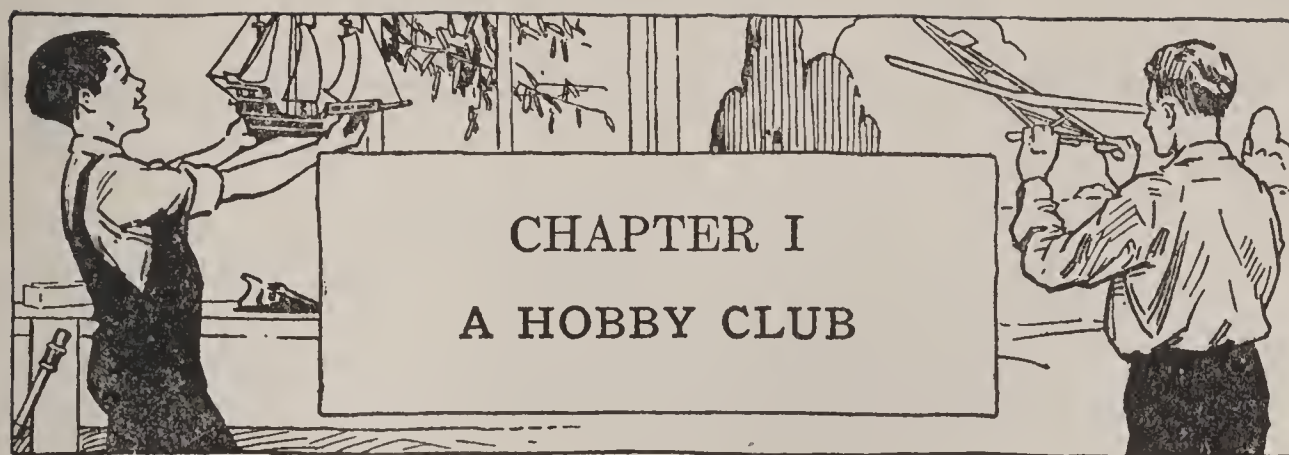

THIS is the day of organizations built around genius. An individual discovers a new process, invents a new device, or improves an old process or device; but an organization develops and promotes it along the intensive lines demanded by modern business. The process or invention may be a one-man idea, but the one-man organization is almost a thing of the past.

You boys develop ideas in your home shops, but you, too, sense the value of coöperation. When Dad helps with a project, perhaps he finds you not organized for the job. He adds a tool or two to your outfit. His interest in the work increases. Appreciating labor-saving devices, possibly he invests in one or more of the new types of motor-driven machines designed for home shops.

Your chum has interests similar to yours. He owns tools and books that you do not, and you own some that he does not. You know boys with equipment that neither of you has. What is more natural than to get the gang together and organize a hobby club? Each of you benefits by augmented equipment. Each profits by increased purchasing power. Each gains enthusiasm and new ideas from

contact with other workers. These are advantages of organization.

### CHOOSING CLUB MEMBERS

Your club may be an organization within an organization, or may be independent. It may be a patrol of your Boy Scout troop, a group from your school class, the park playgrounds, or your neighborhood. Most important, the boys must be congenial and earnest.

### THE CLUB'S PURPOSE

should be the pursuit of a chosen hobby. Let your other hobbies be subservient to the selected subject.

When you have selected a group of boys for your club, call

### AN ORGANIZATION MEETING

elect officers, appoint a committee to draw up a constitution, and another to select a club workshop and a club room.

### THE OFFICERS

If each member of the club can be made an officer or committee-man, so much the better, as it will give each a share of responsibilities for the success of the club. There will be a president, chief pilot, commander, commodore, chief engineer, editor-in-chief, or whatever you wish to call the elected head. There will be a vice-president, or whatever title you choose to designate the second in authority, a secretary or scribe, a treasurer, and an adviser.

The secretary may also be foreman of the shop and librarian, or other members may be appointed to these offices. The club adviser should be an adult qualified to give helpful counsel in matters relating to the club hobby. Dad, or the father of one of the other members, a teacher, your scoutmaster, or a man active in community work will be best fitted to serve.

### THE CLUB WORKSHOP

You will be wise to select for the club workshop the best-equipped shop that is available, unless there is reason for establishing a separate shop, possibly combined with a club room. Each member should keep his private tool collection in a portable chest or cabinet, having a lock, that there may be no charge of loss or breakage against the club, and there should be an understanding that any loss or breakage of borrowed tools must be made good by the borrower. Suggestions for building a work-bench are given in Chapter II, other suggestions for shop equipment are given in my books, "The Boy Craftsman," "Handicraft for Handy Boys," "The Handy Boy," and "Carpentry and Mechanics for Boys"; and plans for a backyard shop are given in "The Handy Boy."

### THE CLUB ROOM

may be a part of the shop, or separate. Perhaps you can have the use of a room at school for special meetings and demonstrations. The advantage of a permanent room is that you can build in cabinets and shelves for books,

models, and trophies, and you can decorate the walls with photographs, drawings, blue-prints, medals, and ribbons. Suggestions for a club room are given in Chapter III, and additional suggestions in "Handicraft for Handy Boys." Building a back-yard shack is described in Chapter XXXI, a back-yard cave in Chapter XXXII, a log cabin in "The Boy Craftsman," and plans for a tree hut in "The Handy Boy" and "Outdoor Boy Craftsmen."

#### THE CLUB LIBRARY

should be made as complete as possible. Chapter XLIX tells how to build bookcases, shelves, and racks for books. Let each member lend his handicraft books and other books related to the club's chosen hobby; also, his scientific magazines and boys' magazines. Vote to appropriate a portion of the club's yearly budget for the purchase of new books and for magazine subscriptions.

#### AFFILIATE WITH AN ORGANIZATION

that sponsors the club's hobby, if you can locate one. It will make helpful contacts. If the hobby be model airplanes, join the "Airplane Model League of America"; if it be model boats, join the "Model Yacht Racing Association of America"; if it be publishing an amateur paper, join the "National Amateur Press Association"; if it be building bird-houses, join the "American Bird-House League." And in order that you may keep in contact with new developments in hobbies, join "The Boy Craftsman League." For information concerning any of the above

organizations, send stamp to me, addressing your letter: "A. Neely Hall, Elmhurst, Illinois."

### EXHIBITIONS, CONTESTS, AND RACES

For the promotion of hobby shows, model airplane contests, model yacht races, bird-house contests and other competitions, interest the local chapter of the American Legion, Rotary, Kiwanis or Lions Club, the Chamber of Commerce, or other organization. A practical demonstration of models usually is sufficient to convince a program committee of the worthiness of an activity.

The following is offered as a suggestion for the club constitution. It may not meet every requirement, but it will assist the committee in drafting the articles.

### SUGGESTED FORM FOR A HOBBY CLUB CONSTITUTION

#### Article 1. Name

This club shall be known as . . . . ., and shall be affiliated with . . . . .

#### Article 2. Object

The club's hobby shall be . . . . .

#### Article 3. Membership

The membership of this club shall be limited to . . . . . New members shall be admitted only upon having passed the following requirements: . . . . ., and having received a majority vote of members present at a regular business meeting.

#### Article 4. Officers

The officers of this club shall consist of a president, vice-president, secretary, treasurer, shop foreman (custodian or business manager), librarian, and adviser. They shall be elected for a period of .....

#### Article 5. Duties of Officers

Section 1. The president shall preside at all regular meetings.

Section 2. The vice-president shall preside in the absence of the president.

Section 3. The secretary shall keep the minutes of the meetings, and handle the club's correspondence.

Section 4. The treasurer shall have charge of the club's finances, receive all dues and money payable to the club, and pay out such sums as he is duly authorized to pay by signed order of the finance committee. He shall keep a correct record of money received, spent, and on hand, and render a report at each business meeting.

Section 5. The shop foreman shall be responsible for club shop equipment and material, and shall be a member of the equipment committee.

Section 6. The librarian shall be responsible for the club's books and periodicals, and shall be a member of the equipment committee.

#### Article 6. Committees

There shall be a finance committee, an equipment committee, a program committee, and such other committees as the president may appoint.

Article 7. Meetings

The regular meetings of the club shall be held on . . . . .  
. . . . ., at: . . . . .

Article 8. Dues

The membership dues shall be . . . . . Special assessments for equipment and other purposes may be made only upon unanimous vote of members.

Article 9. Order of Meetings

1. Call to order
2. Roll Call
3. Reading of minutes
4. Treasurer's report
5. Committee reports
6. Unfinished business
7. New business
8. Adjournment.

Article 10. Amendments

Any article of this constitution may be amended at a regular business meeting by a two-thirds vote of members present.

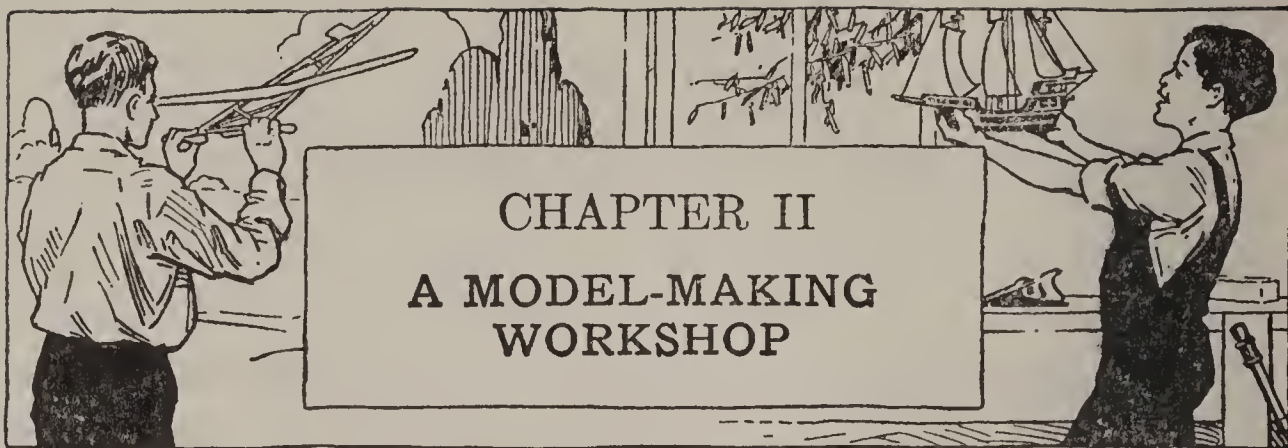

IN imagination I see you fellows at benches in a wide variety of shops, from a makeshift in Mother's kitchen to your own building in the back yard. Extremes, those, and there is probably a difference in the character of work that reflects the conditions under which it is done. Some of you must work under adverse conditions, but each year brings changes, so keep a look about you for an opportunity for betterment. The club shop suggested in Chapter I is a solution to the problem.

#### LOCATION OF THE WORKSHOP

An **Outside Shop** may be the ideal location, if it can be built large enough, with provision for heating in winter. Chapter XXXI tells how to build a shack that would serve the purpose, and Chapter I of "The Handy Boy" tells how to build several types of back-yard shops.

The photograph of Fig. 1 shows a group of boys of the class of Frank W. Neil, instructor in Home Mechanics at the John Adams Junior-High School, Los Angeles, at work on radio sets in

**A Shop in a Garage.** If a garage is large enough, is well





FIG. 2.—HERE IS A DANDY PORCH SHOP FOR BUILDING RADIO SETS AND MODEL AIRPLANES.

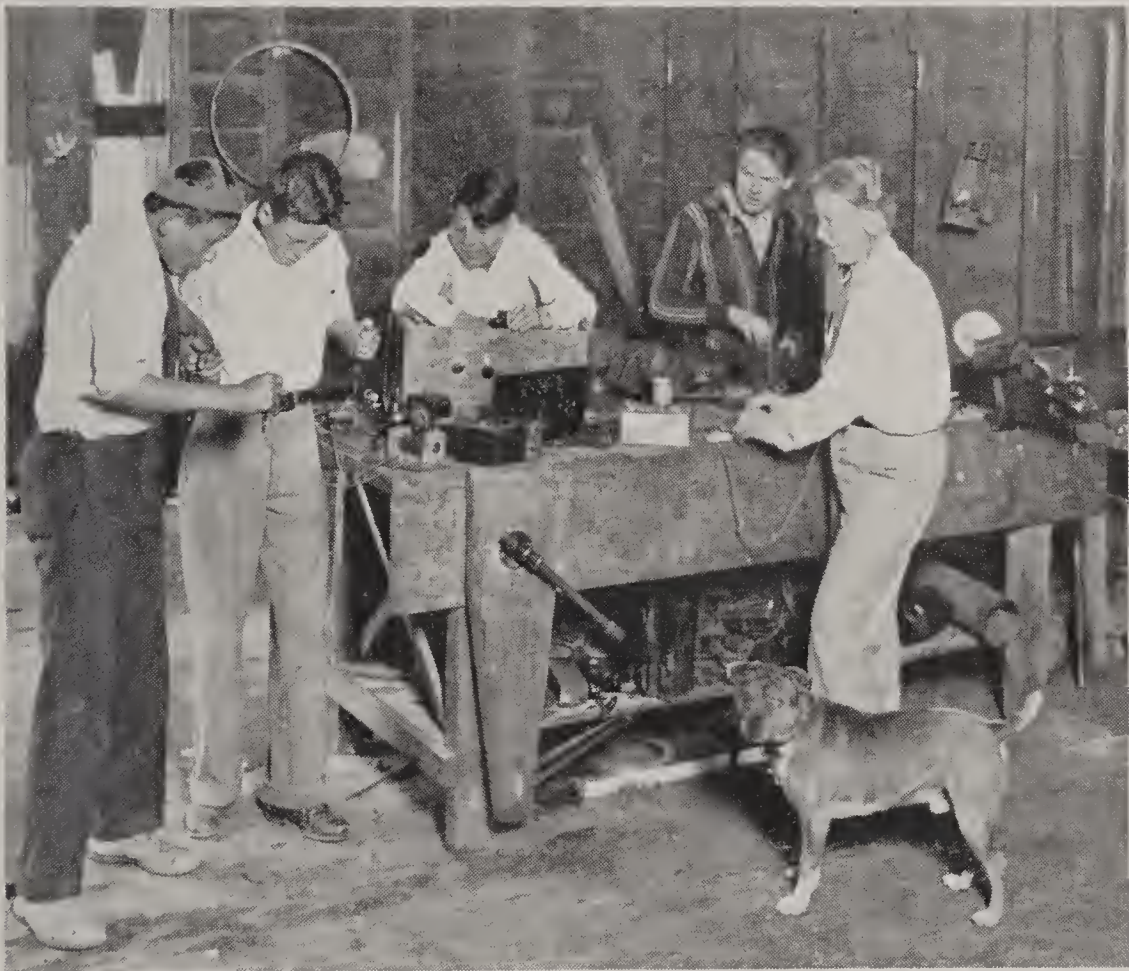

FIG. 1.—THE GANG FINDS THE CLUB WORKSHOP THE BEST PLACE IN TOWN.



lighted, and can be heated, it makes a first-class place to work in. If Dad is building a new garage, possibly he will build a two-car or three-car structure, so that one-half or one-third may be utilized for a shop.

The photograph of Fig. 2 shows two of Mr. Neil's boys in a

**Porch Shop.** It would be hard to find a better spot for building airplane models and radio sets, for experimental work, or, indeed, woodworking, provided the porch is glazed and can be heated. Here the shop is high and dry, and has all the light one could want.

The cost of enclosing a porch is not much. Possibly you can interest Dad in having it done. A local sash-and-door mill or a carpenter will give an estimate on the work.

All places considered, probably none is better than

**A Basement Shop,** provided the basement is dry and well lighted. Here there is usually room for expansion, as new equipment is added, and who among us isn't keen about equipment—a cabinet of new tools, a circular-saw, a lathe, and some of the other motor-driven time-saving machines for home shops that are so enticingly displayed in store windows and in advertisements.

### A HOME-MADE WORK-BENCH

Next to tools, a solid work-bench is the model maker's most important equipment. The bench need not be purchased. Indeed, it is better to put the savings on the purchase price into tools and materials. You can build a very good bench, like that shown in Fig. 3, for less than five dol-

lars. It has a wrought-iron bench screw that you can buy for seventy-five cents. A cabinet-maker's vise with steel jaws and device for rapid opening and closing, costs five dollars and up. You can add one later when you can better afford it.

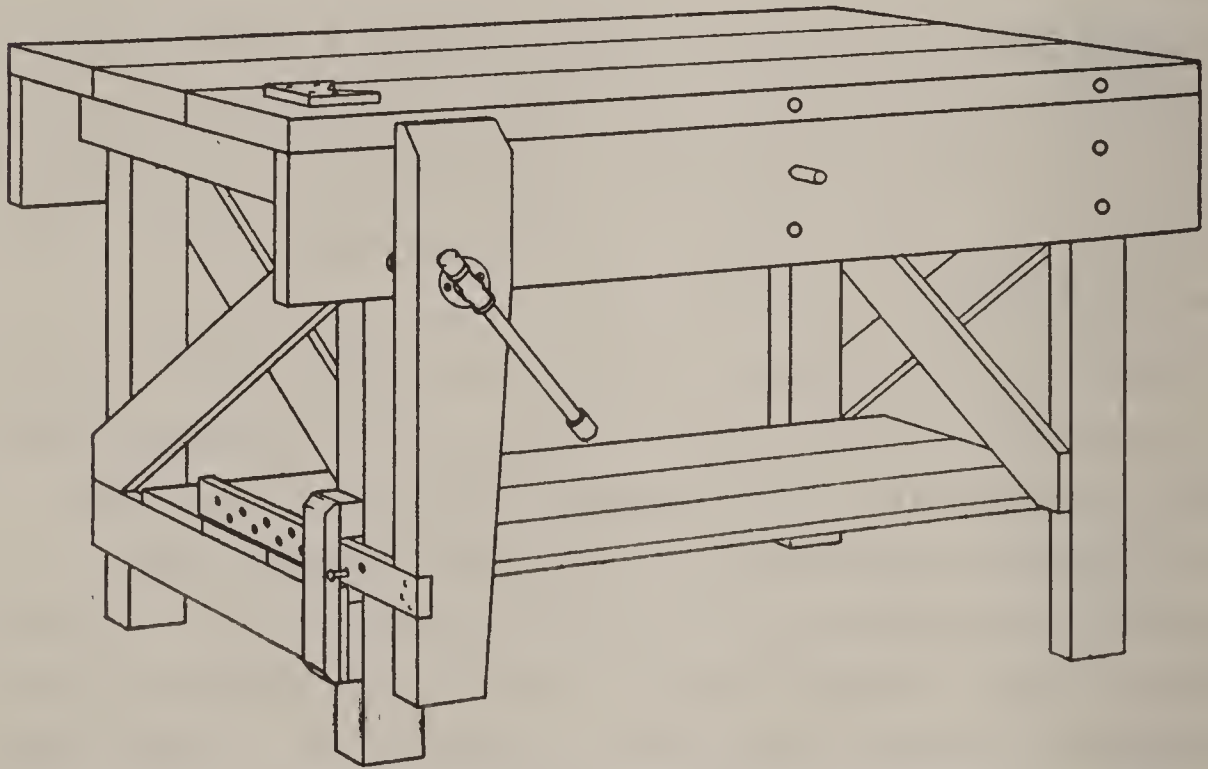

FIG. 3.—You Can Build a Bench Like This for Less Than Five Dollars.

**The Material** required and the way to cut it and assemble it is shown in Figs. 4 to 12. Buy a piece of 2-by-4 14 feet long for the legs and top plates, a 1-by-4 16 feet long for the rails and braces, a 1-by-8 10 feet long for the front and back aprons, a 2-by-8 16 feet long for the top planking, a 1-by-6 16 feet long for the bottom shelf, and a piece of 2-by-6 29 inches long for a vise jaw. This material may be of pine. Maple makes a harder working surface for a top and is used on factory-built benches, but pine costs

less and is easier to get. I have a pine-top bench that has had many years' service and is good for many more.

Fig. 6 shows a cross-section of the bench. First, cut the pieces for

**The End Frames.** Fig. 4 shows a frame and dimensions of its parts. Spike, bolt, or screw the pieces together. Carriage-bolts or lag screws  $\frac{1}{4}$ -inch in diameter make a neater job than spikes.

Before attaching the diagonal braces, make sure that corners are square. By placing one frame flat upon the floor and building the other upon it, it is easy to get the pair alike.

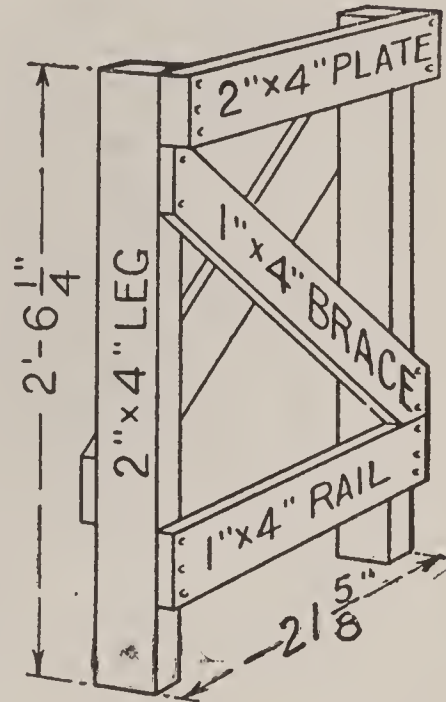

FIG. 4.—An End Frame.

With the frames assembled, stand them up and connect them with

**The Aprons** (Fig. 5). Cut these 5 feet long and fasten them with their top edges even with the leg tops, and their ends projecting 6 inches.

**The Top Planking** goes on next. Cut the 2-by-8 plank, which will measure  $1\frac{3}{4}$  inches thick by  $7\frac{1}{2}$  or  $7\frac{3}{4}$  inches wide, into three pieces 5 feet long. Spike or bolt the pieces to the plates of the end frames, with their ends and edges even with the bench aprons. With the top in place, cut

**The Bottom Shelf** boards and nail them to the bottom rails of the end frames.

**The Bench Vise** is easily assembled. Fig. 7 is a detail

of the 2-by-6 jaw. Taper the lower end, as shown. Fig. 8 shows a detail of the bench screw, the screw A, the nut

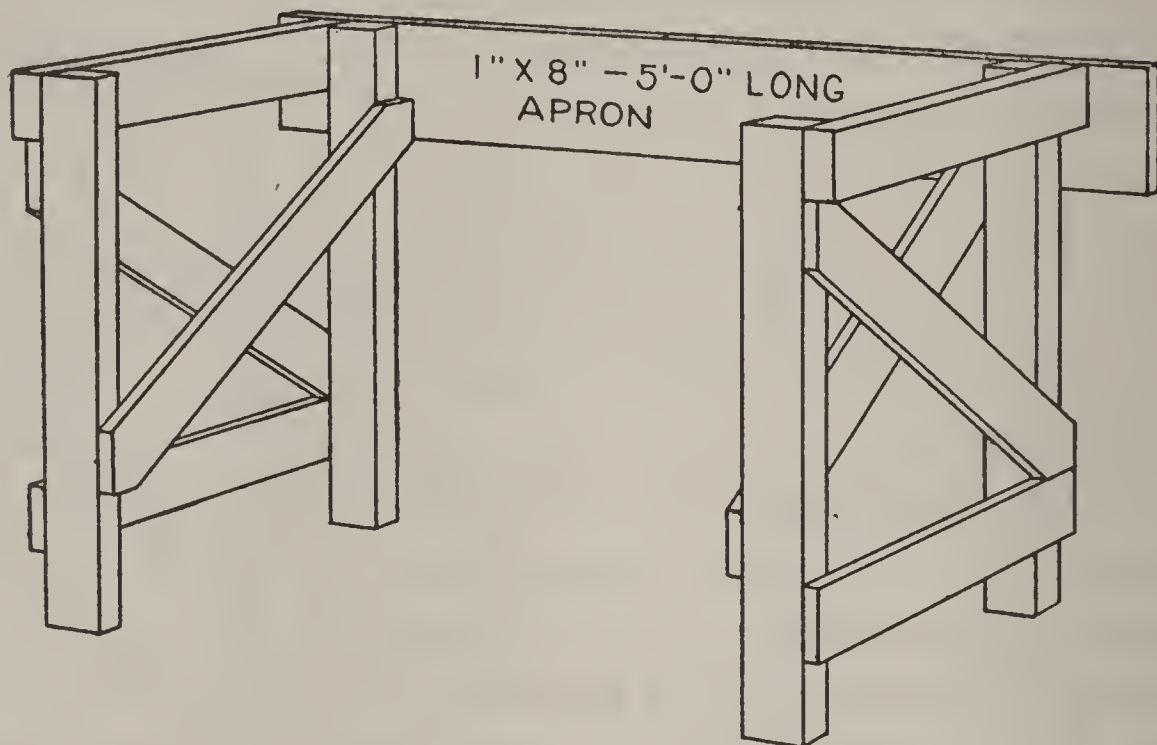

FIG. 5.—Join the End Frames Like This.

B, and the handle C. The nut may be set into a 2-by-4 block (D, Fig. 9), and the block spiked to the back of the bench leg (Fig. 6), or set directly into the leg. Some bench screws, made for 4-inch legs, are not threaded close enough to the handle to permit setting the nut into a 2-by-4 leg. They require the block D to make possible the closing of the vise.

To bore the hole for the bench screw, nail the jaw temporarily to the face of the bench, in its correct position, locate the hole, and bore through the jaw, apron, and leg. If you have an expansive bit, set it to bore a hole of the right size. If you haven't, bore a ring of small holes and cut out the wood between with a keyhole saw or chisel.

Care must be taken to hold the bit on a level, in order not to slant the hole.

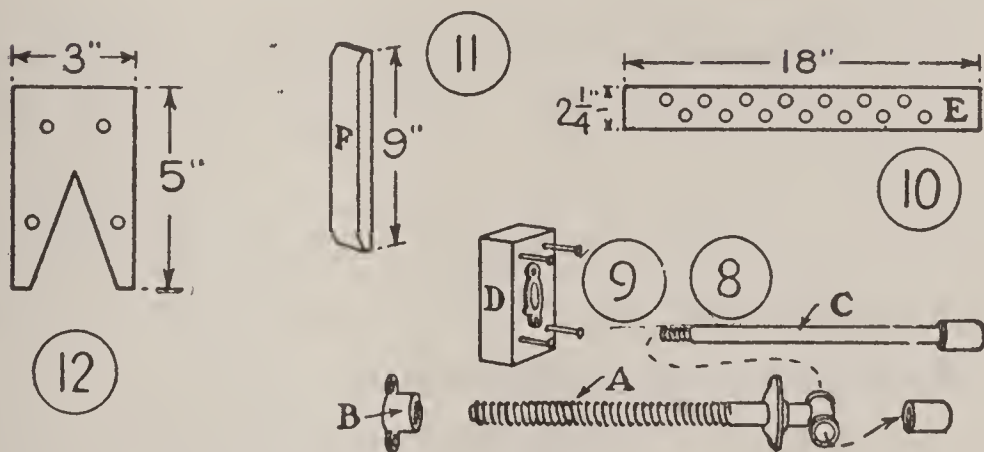
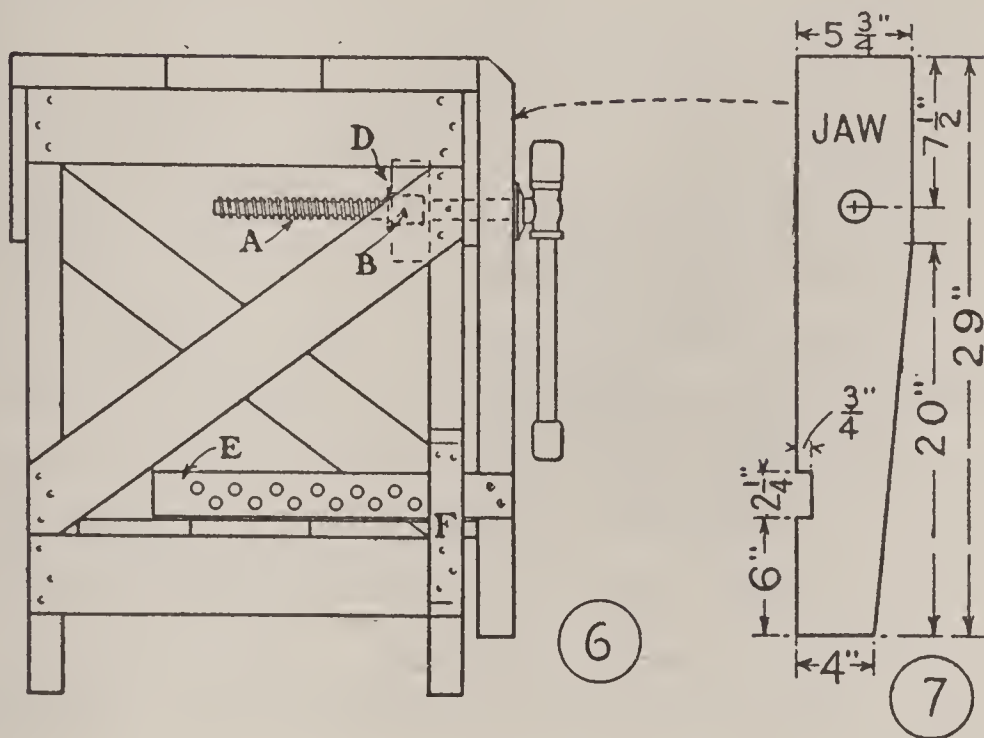

FIG. 6.—Cross-Section of Bench.

FIG. 7.—Vise Jaw.

FIG. 8.—Bench Screw.

FIG. 9.—Block for Nut.

FIGS. 10 and 11.—Sliding Strip and Pocket Block.

FIG. 12.—Bench Stop.

If you set the nut into the back of the leg, chisel away the hole to admit it. Screw the screw collar to the face of the jaw.

The lower end of the jaw must have the *sliding strip* E (Fig. 6) fastened to its edge, to guide it and keep it from pushing in beyond the upper end. The strip has a series of  $\frac{1}{4}$ -inch holes bored through it, 1 inch from center to center (Fig. 10), and a  $\frac{1}{4}$ -inch bolt is slipped into the right hole to keep the jaw from pushing in beyond that point. This device is necessary to make the jaw grip work squarely. The notch in the jaw (Fig. 7) receives the end of the sliding strip. Nail or screw the strip in place.

The sliding strip slides in a pocket built upon the side of the leg. To make the pocket, fasten a block of wood above and another below the sliding strip, and a third block (F, Fig. 11) across the pair.

The right end of long boards placed in the vise must be supported on

**An Adjustable Peg**, and rows of holes must be bored in the edge of the bench top and front apron, as shown in Fig. 3, to stick the peg into.

**A Bench Stop** at the left end of the bench top is needed to push work against. Iron stops made to set in a mortise cut in the bench top can be purchased at a hardware store. But the home-made wooden stop, with notched end, shown in Fig. 12, serves very well. Screw it to the top, with the notch to the right, as shown in Fig. 3.

### A PACKING-BOX WORK-BENCH

Fig. 13 shows a bench built upon a pair of packing-boxes. The boxes save the building of end frames, and they can be converted into cabinets, handy for tools and material.



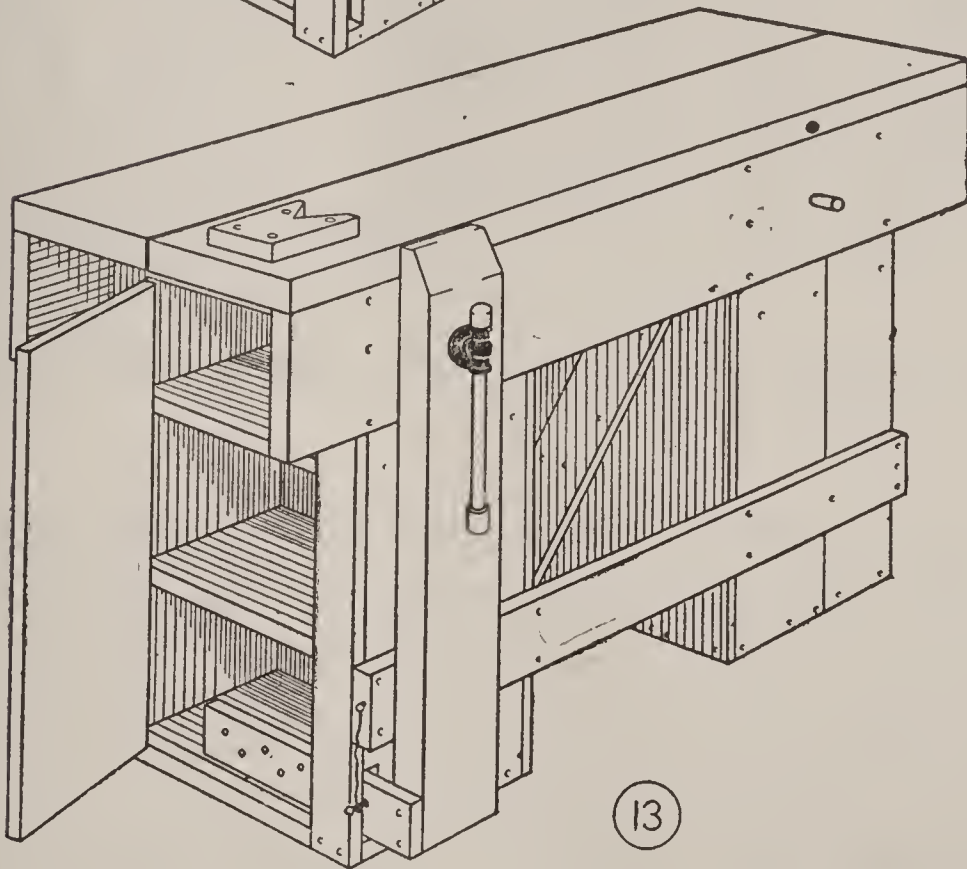
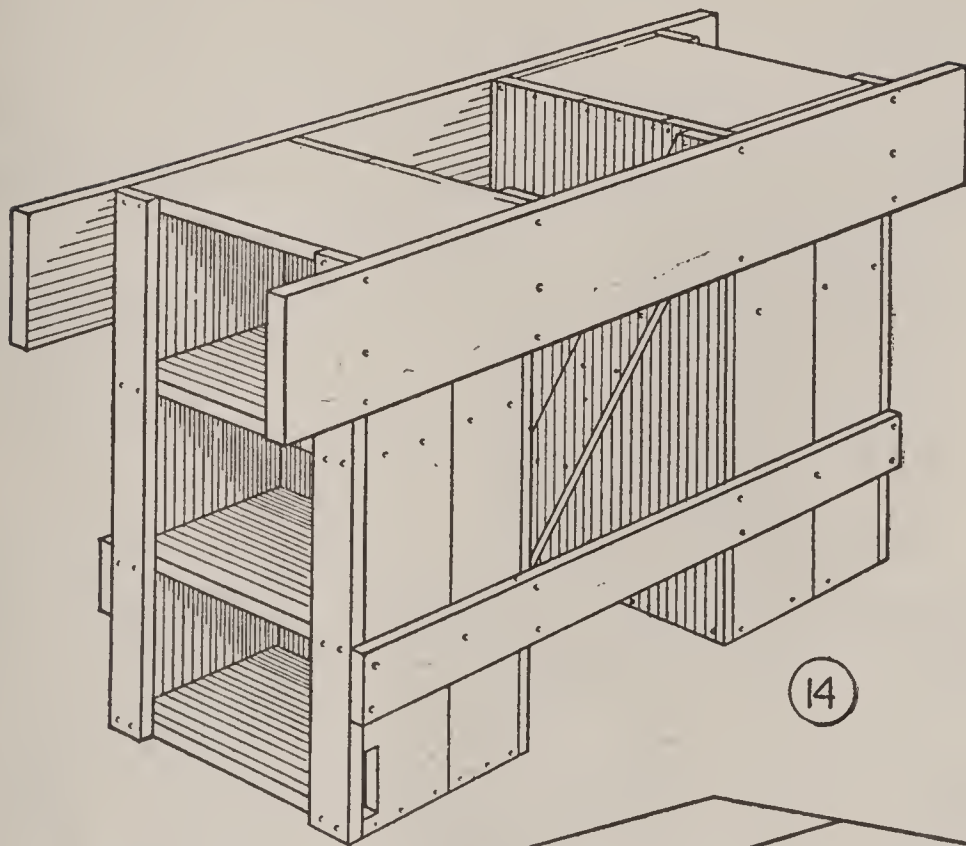
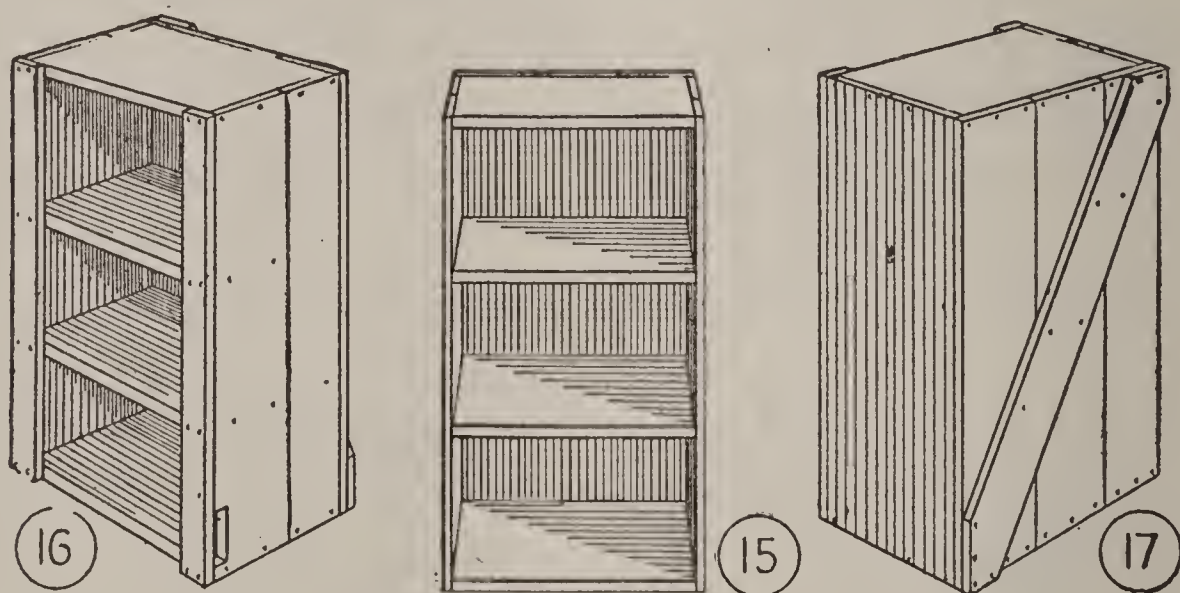

FIG. 13.—Bench Built upon a Pair of Packing-Boxes.

FIG. 14.—Connect the Boxes Like This.

The Packing-Boxes should measure about 10 inches deep, 14 inches wide, and 27 inches long. The best place to get them is a paint store, hardware store, or dry-goods store. Select boxes that are alike, and strongly made. If nails have loosened, drive in additional nails.

The Cupboards require shelves. Fasten these between the box sides (Fig. 15). Then cut strips 2 inches wide from the box cover boards, and trim the fronts of the cup-



FIGS. 15 and 16.—The End Cupboard Shelves Brace the Boxes.  
FIG. 17.—Brace on Box Bottom.

boards with them, as shown (Fig. 16). Enclose the space between the strips with a door hinged to one strip, as shown in Fig. 13, or with a burlap curtain hung upon a rod.

Nail a diagonal strip across each box bottom (Fig. 17), to give the box greater rigidity.

The Bench Top requires two pieces of 2-by-8 plank, the aprons two pieces of a 1-by-8 board, and the bottom rails two pieces of a 1-by-4 board. For a short bench, the top

and aprons may be 4 feet long, the rails 10 inches shorter. First, connect the boxes with the aprons and rails as shown in Fig. 14, then add the top planking.

The Vise will be assembled in the same manner as the vise of the larger bench (Figs. 6 to 11). Let the bottom sliding stick slide through a slot cut in the side of the left-hand box (Fig. 14).

### OTHER SHOP EQUIPMENT

You will need a tool cabinet or tool chest in which to lock up tools after use. You will need racks in which to stick tools while you are at work. You must have containers for nails, screws, bolts, hinges, and other hardware, and racks for material. You will need horses across which to place boards for marking and sawing, and a bench-hook, miter-box, sandpaper-block, and other devices. You will find plans and instructions for making them in Chapter I of "The Boy Craftsman," in Chapter II of "Handicraft for Handy Boys," and in Chapter II of "The Handy Boy."

### NAME YOUR SHOP

If your shop is a club shop, let it bear the name of the club. If you are specializing in airplane models, ship models, bird-houses, or toys, let the name of the shop designate it. Select a catchy name that you can print or have printed upon letter-heads and envelopes.

Here are the names of a few home and club shops that may include one to your liking: "Model Aircraft Shop," "The Juvenile Manufacturing Company," "Boy Toy

Model-Makers," "Feathered-Friends Home-Builders,"  
"Big Boy Boat-Builders," "Home-made in America Air-  
craft," "Pioneer Plane Plant," "The Boy Tinker Com-  
pany," "Model Mechanics," "Reliable Radio Repair  
Shop."

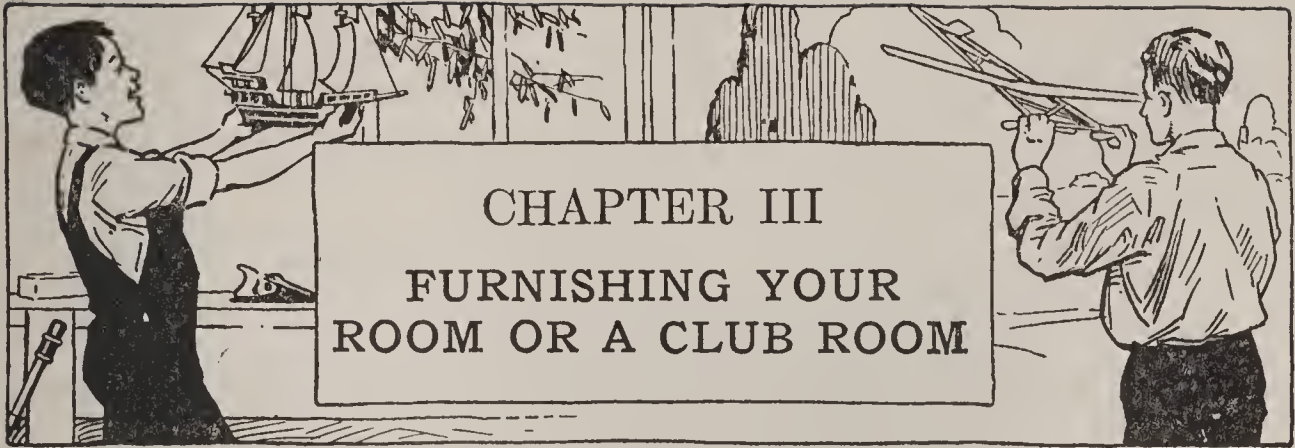

It is a big job to furnish a boy's room, and no one can do it better than the owner, if indeed, as well. Cost enters little into it. It is rather a matter of arrangement, a problem of providing storage space for a thousand and one things, to the end that the room may not have a junk-shop setting. Naturally, a fellow's interests grow with him, and, as these increase, so does the problem of caring for equipment.

### THE FURNISHINGS

Simplicity should be the keynote in furnishing the room. A bed, dresser or highboy, desk or table, and a chair are the essential pieces of furniture. A grass rug or rag rug is the proper floor covering. Window hangings may have to conform to Mother's scheme for the house, but maybe she will listen to your plea to omit frills. Heavy net curtains, with straps and harness rings to drape them back, are quite the thing, and are inexpensive.

A small room is a handicap at the outset, but by careful planning and building racks, cabinets, under-the-bed boxes, and similar catch-alls, a surprising number of effects can be

accommodated. It is really not so much a matter of space available as how well the space is organized that determines whether or not the scheme is a success.

### A ROOM IN AN ATTIC

An unfinished attic has great possibilities for bedroom, club room, radio room, indoor airport, laboratory, den, museum, one or all. Perhaps an additional window or two will be necessary; perhaps a dormer to provide sufficient headroom. Such alterations are not expensive, and, considered from the standpoint of converting storage space into living space, are a good investment. You can do the work with the aid of Dad, your chum, or several of your club members. A friendly carpenter will lay out the work, advise what is needed in millwork, lumber, and other materials, and, if necessary, lend a hand with the heavy work, charging only for his time.

Finishing an Attic Room does not necessitate plastering. The modern procedure is to set up a framework of 2-by-4 studding, for walls, and to cut off portions made low by the roof, then to cover this framework with plaster board or fiber board. Most dealers in lumber carry several types of wallboards.

Wallboard is made in widths of 32 inches and 40 inches, to provide for a spacing of studding 16 inches and 24 inches from center to center. The lengths are 6, 7, 8, and 9 feet, so the wall of average height can be put up in single lengths. Cutting can be done with a saw, where necessary, because the materials cut as easily as wood, and rough



FIG. 19.—AN INTERESTING ROOM AND ITS OWNER.



FIG. 18.—AN ATTIC HAS GREAT POSSIBILITIES FOR A BOY'S ROOM.





edges may be made smooth with sandpaper or a file. Nails with large heads are needed for fastening wallboard. Joints can be filled with plaster compounds sold for the purpose, but the usual practice is to conceal them with lattice strips or other strips, in order to produce a paneled effect. Some wallboards do not require decoration, but all take paint, calcimine, and other finishes, except wallpaper. Wallpaper has a tendency to warp fiber boards. Panel strips and baseboards are finished like the rest of the woodwork.

### STORAGE CLOSETS

The photograph of Fig. 18 shows an attic room with walls finished with plaster board. The side walls were set at a point where the ceiling height is 4 feet, and the space behind the walls was converted into closets, with doors set at convenient intervals. Shelves and boxes make every foot of the closets available for storage. This is just what you need for your seasonable equipment, or what your club needs for lockers.

### A WINDOW-SEAT

Fig. 18 shows a long window-seat, with an end cabinet and space beneath for box files. Figs. 20 to 29 show the construction of the seat and the cabinet. As the sizes will be determined by the space they are to occupy, dimensions are not given. Perhaps you will want to build only the seat, perhaps you will have room only for the cabinet.

**The Seat Height** may be regulated by the window-sill.

It ought to be chair high, or 2 inches lower, if cushioned. Fig. 21 shows how to support the seat boards, matched

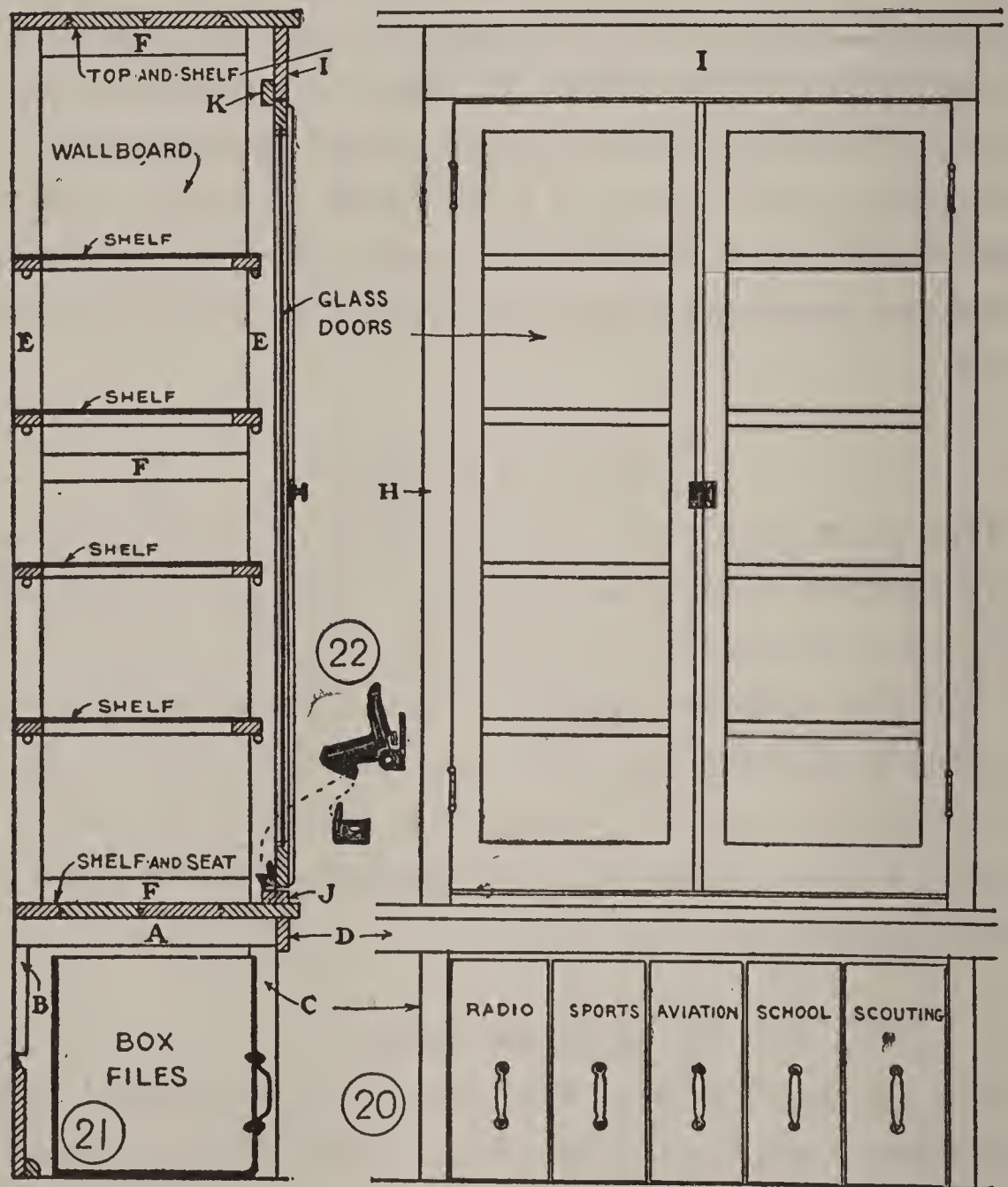

FIG. 20.—Front Elevation of Cabinet and Files.

FIG. 21.—Cross-Section.

FIG. 22.—Cupboard Door Catch.

or matched-and-beaded boards, upon cleats (A) supported on short uprights (B) fastened to the wall above the base,

and on 2-by-2 legs (C). After nailing the seat boards, finish the front with a narrow strip, or apron (D).

### A CABINET

The built-in cabinet at the end of the seat (Fig. 18) has glass doors, and is the right sort for the display of airplane models, small mechanical models, whittling projects, and curios that should be kept away from dust. Its wide, deep shelves may be adjusted to the heights required, or removed to provide hanging space. Fig. 20 shows a front view, and Fig. 21 a cross-section.

**The Cabinet Sides** are of wallboard. A framework for each must be built of 1-by-2 strips (E and F, Fig. 23). When you have nailed the frame strips together, tack wallboard to them, and trim off the edges even with the strips. Finish the edges of the wallboard with lattice strips (G, Fig. 24).

The cabinet in the photograph has a top extended to form

**A Shelf for Models.** The shelf is made of matched boards, like the seat. Cross battens on the upper side hold the boards together and prevent warping.

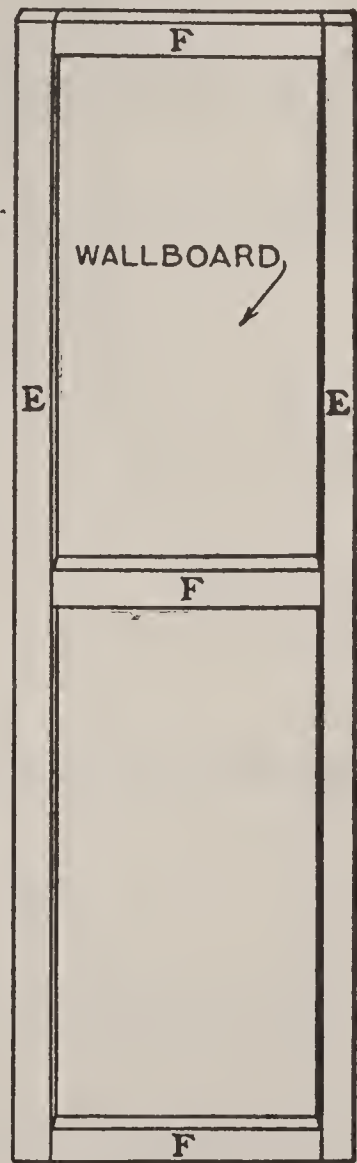
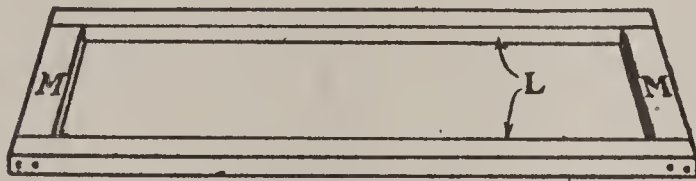

FIG. 23.—Wallboard Side of Cabinet.

Set the Side Frames in place and nail to the seat and the top shelf. Then fasten the 1-by-2 jamb strips H and the 1-by-6 facia board I to the front, and cut the sill strip J (Fig. 21) to fit between the jamb strips. Strip K across the top of the opening (Fig. 21) is a stop for the doors to swing against. A similar, narrower strip is required across the bottom of the opening.

Shelves can be made of boards, if the depth of the cabinet is 12 inches or less. Wider shelves for a cabinet for curios,



(25)

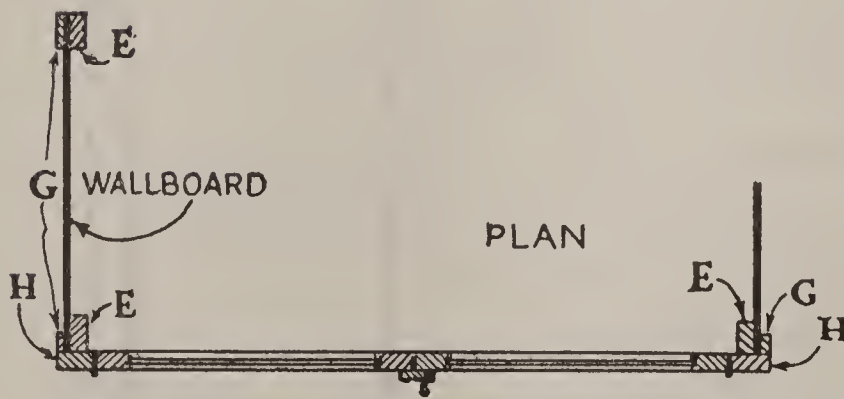

(24)

FIG. 24.—Plan of Doors and Corners.  
FIG. 25.—Shelf Frame.

models, and the like, can be built of 1-by-2 strips and wallboard. Fig. 25 suggests how to make a shelf frame, Fig. 21 shows a cross-section of four frames with the wallboard tacked in place. Metal shelf supports can then be purchased at the hardware store, or you can drive wooden pegs

into holes bored in uprights E of the side frames.

**Cabinet Doors.** The cabinet may be left open or be provided with a curtain hung upon a rod, if you cannot get

glass for doors. Doors make the cabinet nearly dustproof. You can order a pair at a local mill, or build them yourself. If you are not experienced in woodworking, you are not familiar with making the rabbets necessary to receive the glass. Here is a simple way to make a rabbeted frame. Using tongued-and-grooved stock (Fig. 26), rip off the

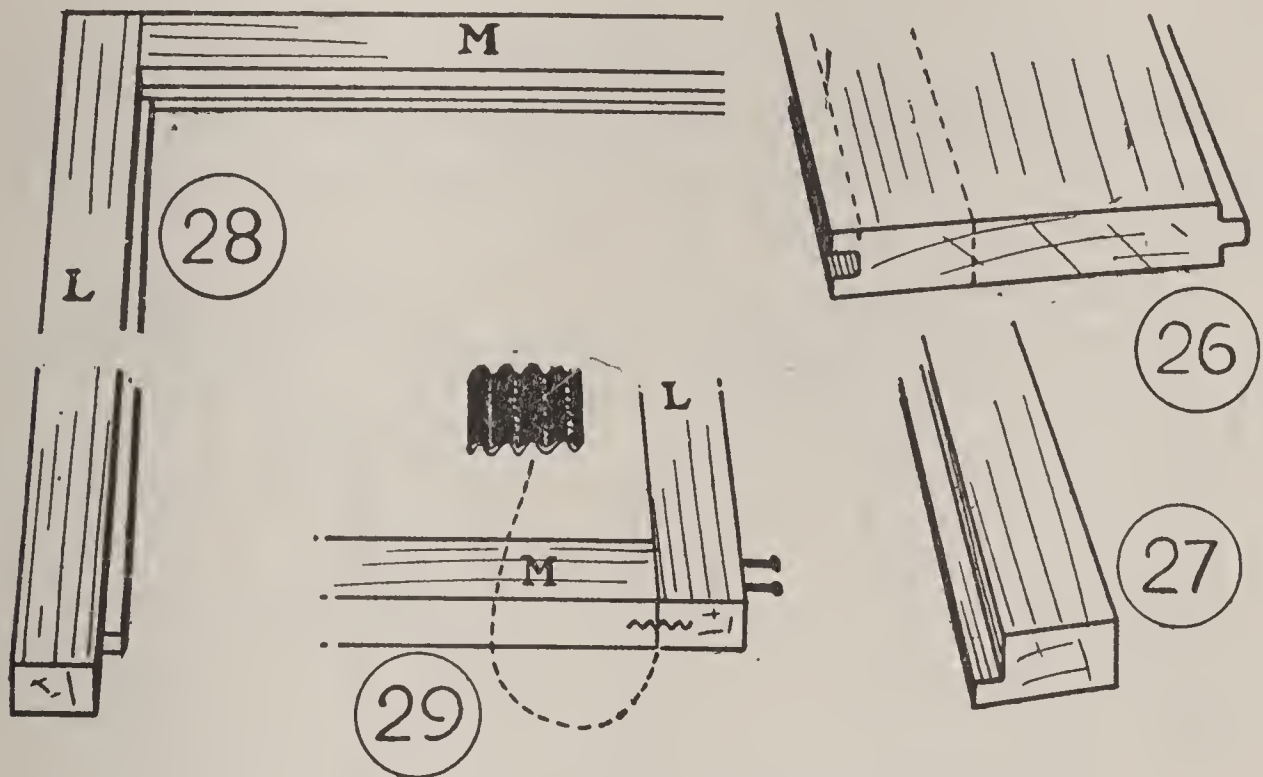

FIGS. 26-29.—Details of Cabinet Doors.

width of strip required from the grooved edge (see dotted line), then split off one side of the groove (Fig. 27). Join the strip ends as shown in Fig. 28, and reinforce the connections with wood-joint fasteners (Fig. 29).

Glass comes in widths and lengths of even inches, so it will save cutting to make doors that will accommodate glass of stock size. But make them large enough so there will be  $\frac{1}{8}$  inch clearance around the glass. Fasten the glass with

glazier's points, weather stripping, screen molding, or other narrow molding.

Hinge the doors with 3-inch brass hinges, a pair to a door. Provide a cupboard catch to hold the left-hand door shut (Fig. 22), and a cupboard latch to latch the right-hand door.

### BOX FILES

Fig. 20 shows five box files below the cabinet and Fig. 30 is a detail. You cannot have too many for the filing of

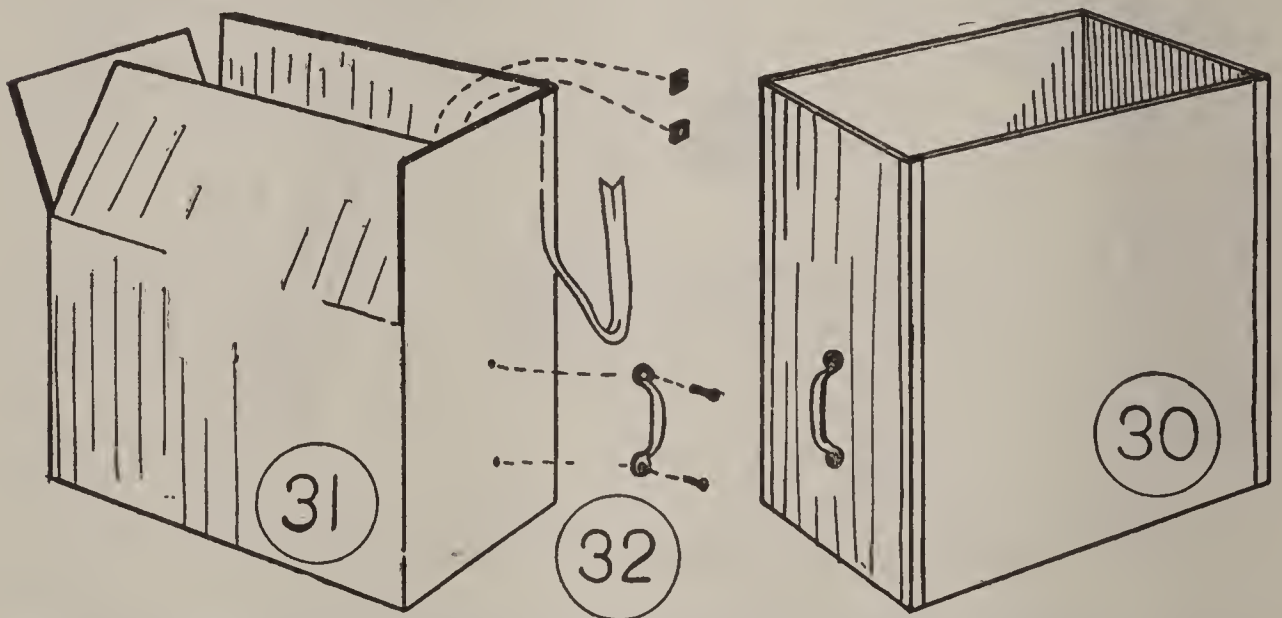

FIGS. 30-32.—File Made of Corrugated Board Carton.

catalogs, and for pictures and articles that you intend to paste later in your scrapbooks. The boxes may be made of corrugated-board cartons obtained from the grocery. Fig. 31 suggests how to increase the height of a carton by raising its folded top flaps, and binding them at the corners with gummed tape, or strips of linen coated with glue. At-

tach a drawer-pull (Fig. 32) to the front of each box with a stove-bolt.

### A FOLDING SCREEN

A screen will serve several purposes. It will obviate the necessity for drawing the shade, it will shield the bed from window drafts, and it will make a good clothes-horse. But of greater appeal is its decorative utility. Its panels will afford good pinning surfaces for dozens of snapshots, souvenir postcards, and posters.

Figs. 33 to 40 show details for making the three-section folding screen shown in the photograph (Fig. 18).

**The Frames** are built of 1-by-2 strips, the covering is of wallboard. The frames are hinged with double-acting hinges so they will fold one upon another as shown in Figs. 33 and 34.

The wallboard panels may be set in grooves cut in the frame strips (Figs. 35, 36, and 37), or tacked to the side of the frames with round-headed brass tacks (Fig. 38). The former is the neater method, the latter is the easier.

Figs. 35, 36, and 39 show dimensions of the frame strips. Be careful in marking and cutting them to get like pieces of equal length. If you groove the strips for the panels, you will need a  $\frac{1}{4}$ -inch chisel. Draw the side lines of the grooves  $\frac{1}{4}$  inch apart, then with the chisel held crosswise to the groove, cut away the wood a little at a time, working from one end of the groove to the other. Make the depth of the grooves  $\frac{1}{4}$  inch.

Nail the frame strips together with finishing-nails 3

inches long, and set the heads to provide for puttying. Fasten three strips as shown in Fig. 37, then cut the wall-board panel, slide it into the grooves, and fasten the fourth

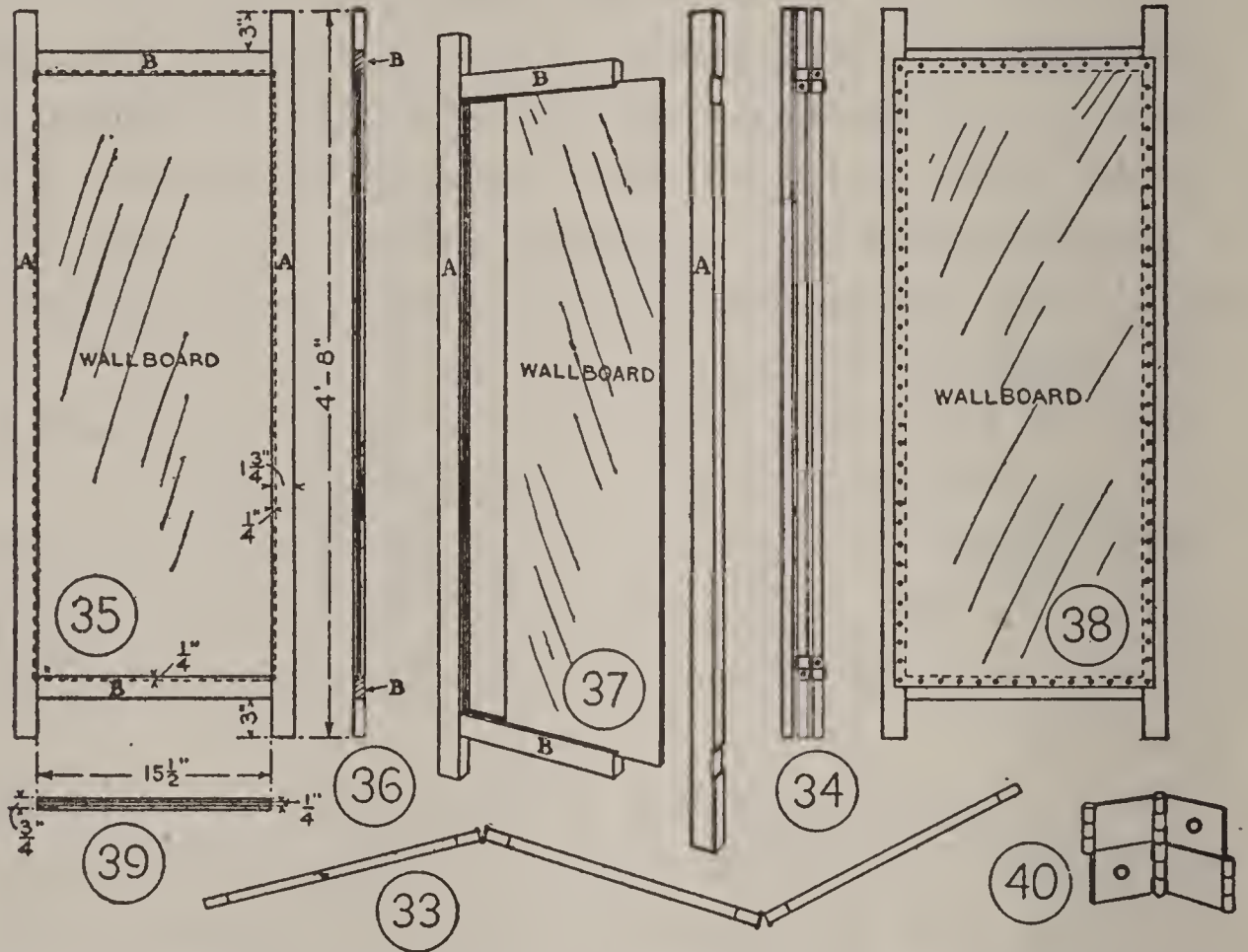

FIGS. 33-40.—This is the Way to Make the Three-Fold Screen Shown in the Photograph of FIG. 18.

strip. Glue applied to the panel edges will add stiffness to the frames.

Double-Acting Brass Hinges of the type shown in Fig. 40 can be purchased at the larger hardware stores. They are no harder to apply than ordinary hinges. Cut away the frame strips to receive the outer flap (Fig. 37).

When you have hinged the frames, sandpaper all the surfaces. Then apply several coats of enamel paint or lacquer.



## AN INTERESTING ROOM AND ITS OWNER

Fig. 19 shows Anton Watkins in a corner of the room he calls his editorial room. It reveals Anton's varied interests. Each corner is as fascinating as the one pictured. Anton has been one of my most industrious readers for seven years. He manufactured bird-houses and toys for several years under the firm name of "The Juvenile Manufacturing Company," two years he edited, printed, and published "The Handy Craftsman," and one summer he took charge of a carpenter's shop during the illness of the boss. He has built many types of ship models, and all sorts of furniture, from a footstool to a kitchen cabinet. He has won many prizes, medals, and diplomas for his work, has found time for scouting, and accomplished the feat of hiking with a 35-pound pack from his home in Easton, Pennsylvania, to Boston, Massachusetts, preparatory to entering college.

You can win prizes, medals, and diplomas for your work, too. Send a stamped, addressed envelope to me for a copy of "Handicraft News." It is full of suggestions. As soon as you have won your first diploma, frame it and hang it on the wall of your room. It will be a source of inspiration and will spur you on to greater effort and other rewards.

## PICTURE FRAMES

Anton Watkins made many of the picture frames shown in the photograph of his room. Plain frames are not difficult to make. Small pictures may be mounted behind glass without frames. Get pieces of glass of correct size at a

paint store, cut cardboard backing of the same size, place the diploma or picture between the glass and the cardboard, and bind together the three with passe-partout paper or ordinary gummed tape.

#### OTHER SUGGESTIONS

You will find other suggestions for your room in Chapter XLIX, in Chapter IV of "The Boy Craftsman," in Chapters VI, VIII, IX, and X of "Handicraft for Handy Boys," in Chapter V of "The Handy Boy," and in Chapters VIII and IX of "Carpentry and Mechanics for Boys."

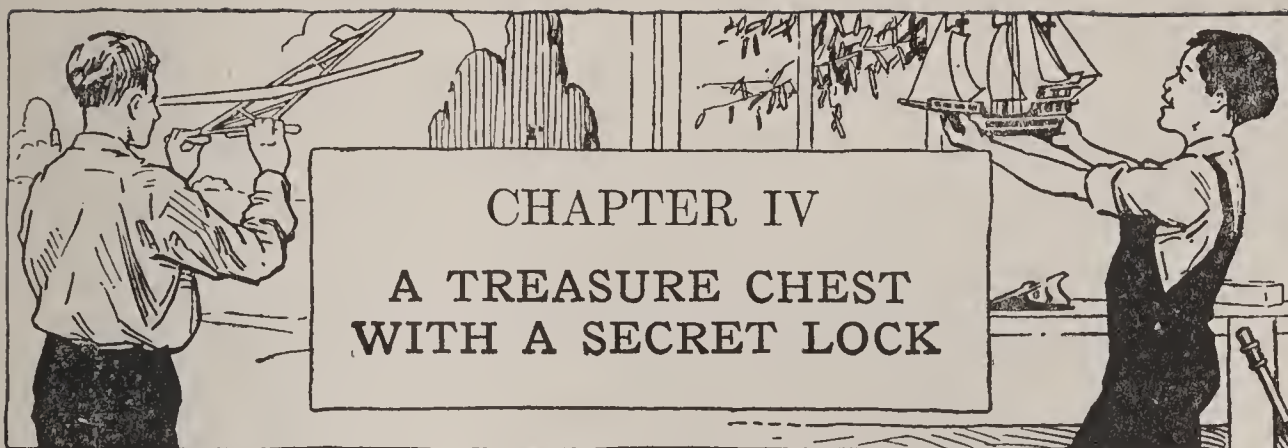

HERE is a chest like one I owned when I was a boy, and I am sure that you will want to copy it for your room. You will have more use for it than I had for mine, probably, because boys nowadays have more treasures for safe keeping. Fig. 41 shows a picture of the chest. The secret lock

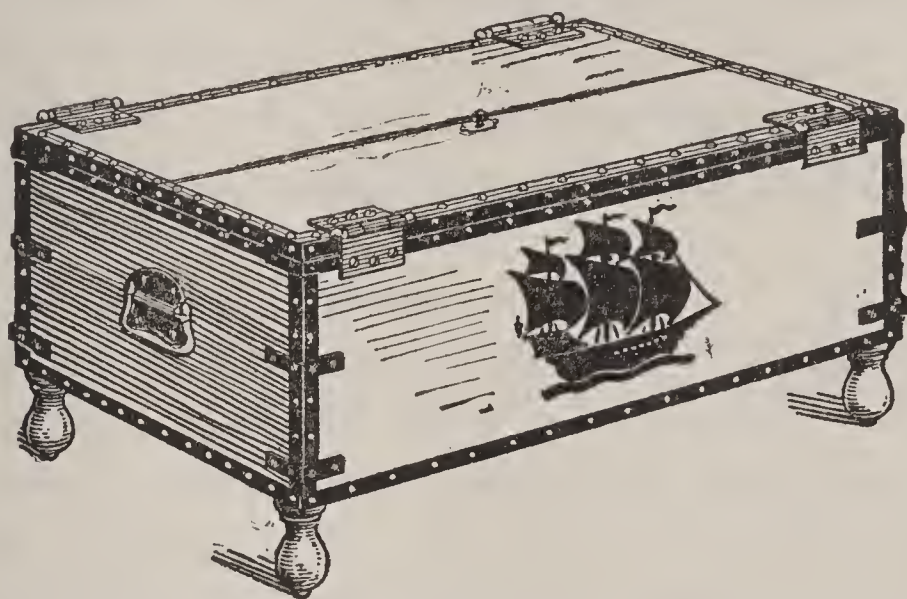

FIG. 41.—The Top of the Chest Seems to Open at the Center.  
But it Doesn't.

is dandy. Right away you think that the top opens at the center. It looks as though it did. But that is where your friends will be fooled. Read on, and the mystery will be unfolded.

### A BOX FOR THE CHEST

First of all, find a nice box. Perhaps you can get one at the grocery, but there is a better chance of finding a big box at a paint store. It may cost as much as twenty-five cents, or it may not cost anything. The chest shown in the illustrations measures 24 inches long, 12 inches wide, and 9 inches deep. But if your box is longer or shorter, wider or narrower, deeper or shallower, it will not matter. Get the cover boards, if possible, or other boards that will fit or can be cut to fit.

**Reinforce the Box.** The boards of used boxes are often loose. Examine your box and drive in additional nails where necessary. But drive the nails straight so they will not come through the box sides. If a nail breaks through, pull it out with the claw of your hammer, and drive in another nail in another place.

### THE COVER

Fig. 42 shows the box ready for its cover. Fig. 43 shows the cover. The cover will be in two or three pieces, probably, and the boards must be fastened together on the under side with strips of wood called *battens*. The best way for you to attach battens is with nails short enough so they will not go entirely through them and the boards. Then drive longer nails through the boards and battens, and *clinch* them on the under side of the battens, that is, bend over the nail points and hammer them into the surface of the battens. A good way to clinch nails is to rest the battens upon the blade of a hatchet, then drive the

nails through to the blade. The steel surface will bend over the nail ends. The cover must be made to fit even with the box sides and ends, as shown in Figs. 41 and 44.

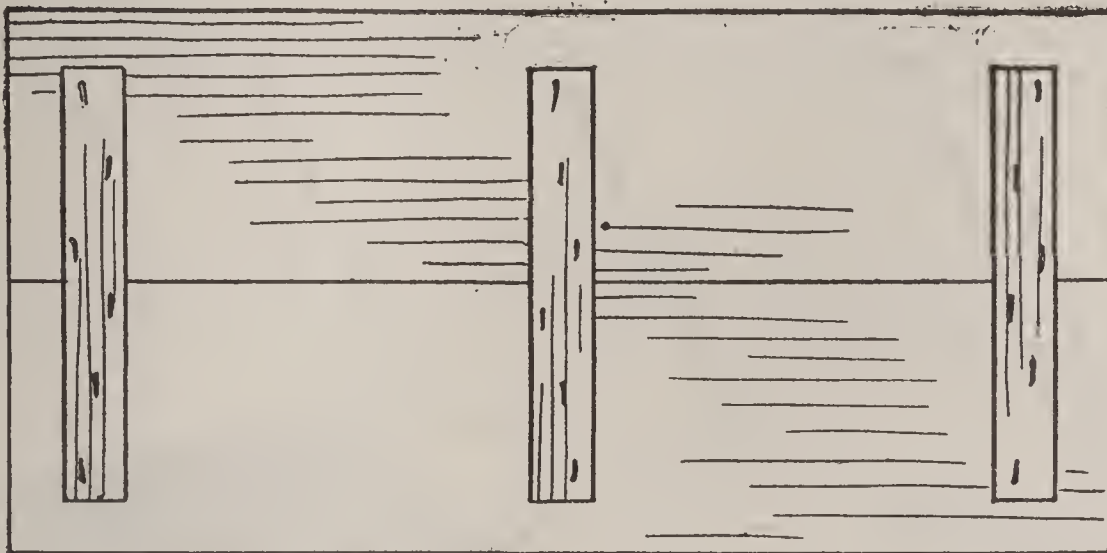

43

42



FIG. 42.—Box for Chest.

FIG. 43.—Cover.

### THE HINGES

Buy two pairs of japanned loose-pin hinges 3 inches square at the hardware store, for attaching the cover. Fig.

45 shows a loose-pin hinge. The pin is easily pulled out by means of the knob on the end, and when the pin is out, the hinge separates as shown in Fig. 44. Place a pair of the

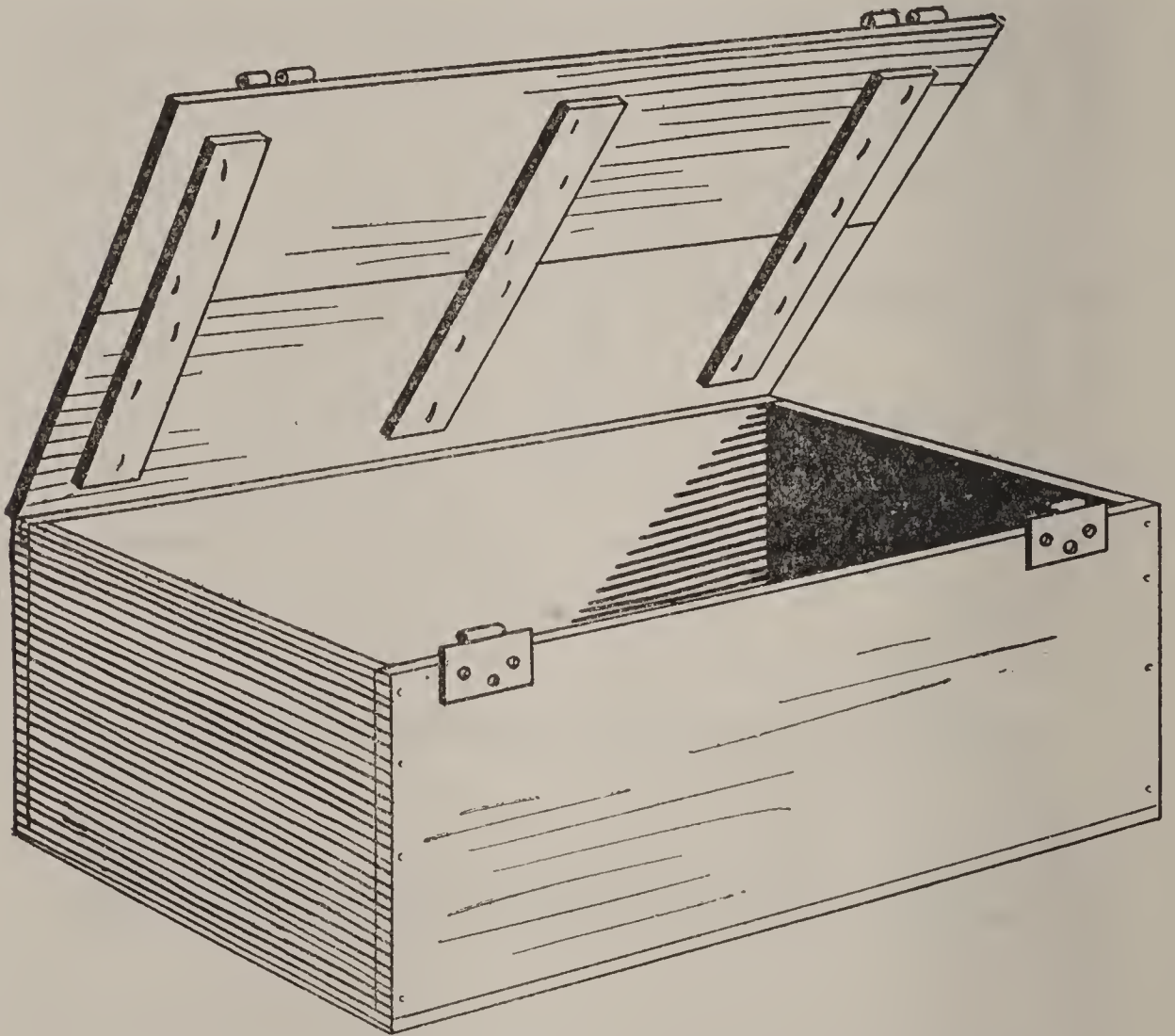

FIG. 44.—How the Cover is Hinged to Opposite Edges.

hinges on each of the long edges of the cover, several inches from the ends, and fasten them to the cover and to the box sides with round-headed screws.

### THE SECRET LOCK

Now your chest cover is fastened on tight. But you can open it on either side. All that you have to do is pull out

the loose pins on one side, and presto! the cover is unlocked. If the pins stick, file or sandpaper them, then apply several drops of machine-oil.

Of course, you want it to be thought that the cover opens at the center. The illusion is strengthened by boring a keyhole, covering it with a keyhole plate, and fitting a key in the hole.

### CHEST HANDLES

Buy a pair of chest handles, like that in Fig. 46, and screw them to the chest ends. Buy four wooden base knobs

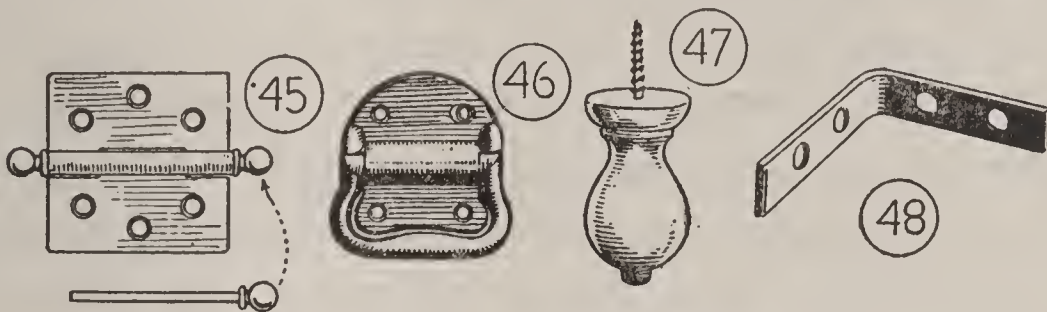

FIG. 45.—Loose-Pin Hinge.

FIG. 46.—Chest Handle.

FIG. 47.—Base Knob Foot.

FIG. 48.—Corner Brace.

like that in Fig. 47, and screw them to the chest bottom, one at each corner, for feet. Drive two finishing-nails through the rim of each knob to reinforce the screw.

### PAINTING

You will want to paint the outside of the chest and the feet with two coats of enamel or paint. I would suggest red or yellow, but blue or green will do. Then, when the surfaces are dry, you will be ready to add the finishing touches.

## FINISHING TOUCHES

The chest should look very strong. Buy a dozen iron corner-braces (Fig. 48), at the hardware store, and screw three of them to each corner, using round-headed screws. Paint the braces black. Then bind all the box edges with strips of tin or cardboard, painted black, fastening the strips with round-headed tacks, or paint narrow black bands in imitation of metal, and stud them with round-headed tacks placed about  $1\frac{1}{2}$  inches apart.

Don't neglect to add a picture of a ship model or of a skull and crossbones on the two sides of the chest. You will find it easy to copy one in crayon, then fill in between the outlines with black paint, to make it a silhouette.

On the top of the chest you might tack a card on which is printed or written something like this: "Open before Christmas—if you Can," as a challenge to friends to solve the mystery of the secret lock.





IF you haven't formed the habit of clipping newspaper and magazine articles that you like well enough to preserve, cultivate it. It's a hobby that will profit you in many ways. It isn't sufficient to slip clippings into a drawer, or into a box, where they may be torn, and probably lost track of. There is little satisfaction in keeping such a collection. File them in a scrapbook where they will be safe from injury and will be at your fingers' tips when wanted.

### AN AERONAUTICS SCRAPBOOK

is the latest thing, and every air-minded boy is making one for articles on aviation and pictures, another for articles on model airplanes and model plans.

Of books on aeronautics there are many, but developments are coming through at a rapid pace, and you can keep your scrapbook up to date with pictures and articles clipped from daily newspapers, aeronautical journals, boys' magazines, and manufacturers' circulars.

Don't collect aeronautics clippings exclusively. Make

### A SPORTS SCRAPBOOK

of clippings on games and sports events in which you have participated as player, entrant, or spectator, articles on sports, and pictures of champions, local, national, and international. Such a collection will be appreciated in later years when you old boys get together and begin reminiscing. It will revive fading memories and settle disputes as to who did what, and when, and where.

If you are a Boy Scout, don't fail to start

### A SCRAPBOOK OF SCOUTING

Each day brings its quota of articles and records of Scout deeds, in the press, each week and each month brings its quota of helpful articles, in boys' magazines. Much of this material is too good to throw away. Select, clip, and mount in a scrapbook, and before long you will have an invaluable supplementary handbook.

Your Troop should have its scrapbook, as a matter of record. Keeping one is another job for the scribe, an assistant, or a Scout selected because of a keen nose for news.

### NOTEBOOK COVERS

of foolscap size are suitable for a small scrapbook. I have before me a scrapbook of this form, the work of James Coe, an ardent aviation fan. James' book consists of eighty pages with pictures of one hundred and twenty-five types of American planes, fourteen types of foreign planes, twenty-five types of motors, instruments, and maps. This is but one of several volumes, and the loose-leaf arrange-

ment makes possible the transferring of sheets from one set of covers to another, to keep the material classified. It is well to provide for expansion, for there is no foretelling how a collection will develop.

A second form of scrapbook is one with

### HOME-MADE COVERS

Figs. 49 to 51 show three of these. They will cost less than ready-made covers. They are of bookbinder's board, and, as they measure 11 by 14 inches, they will accommo-

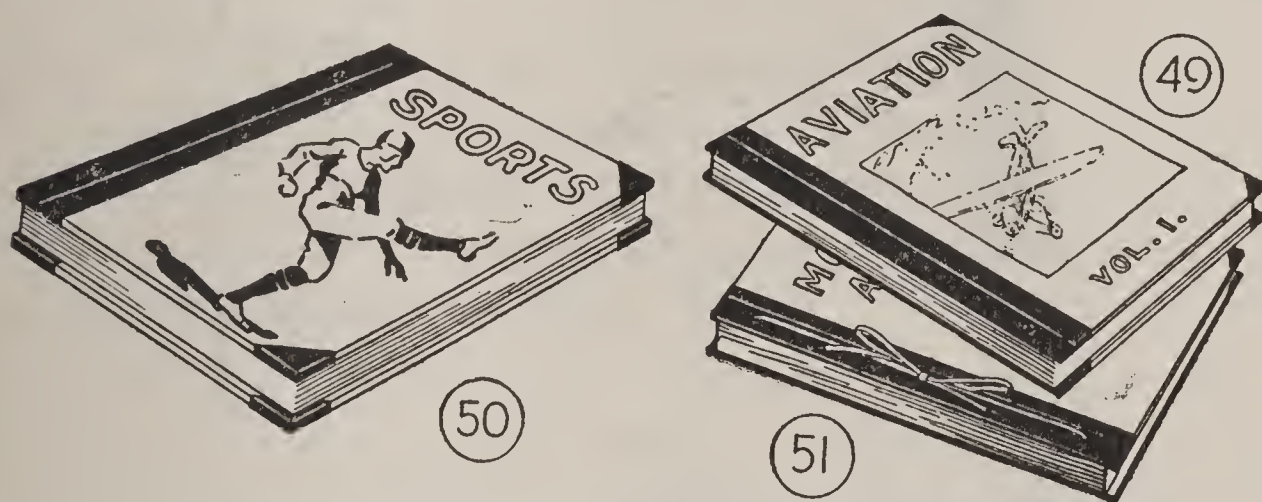

FIGS. 49-51.—Home-Made Scrapbooks.

date as large pictures as you are likely to collect. For pictures from the smaller magazines, a better size will be 10 by 12.

Binder's Board can be obtained at a book-bindery, or a printer can get it for you through a paper house. Plywood of three-ply,  $\frac{3}{16}$ , or  $\frac{1}{8}$  inch thick will make a good substitute. For large covers, wallboard may be used, but it is rather thick for the purpose.

The back cover may be in one piece (Fig. 52), but the

front cover must have a hinge strip on the binding edge, so that it will open freely. Cut the covers of equal size, then trim a strip 1 inch wide from the front cover (Fig. 53).

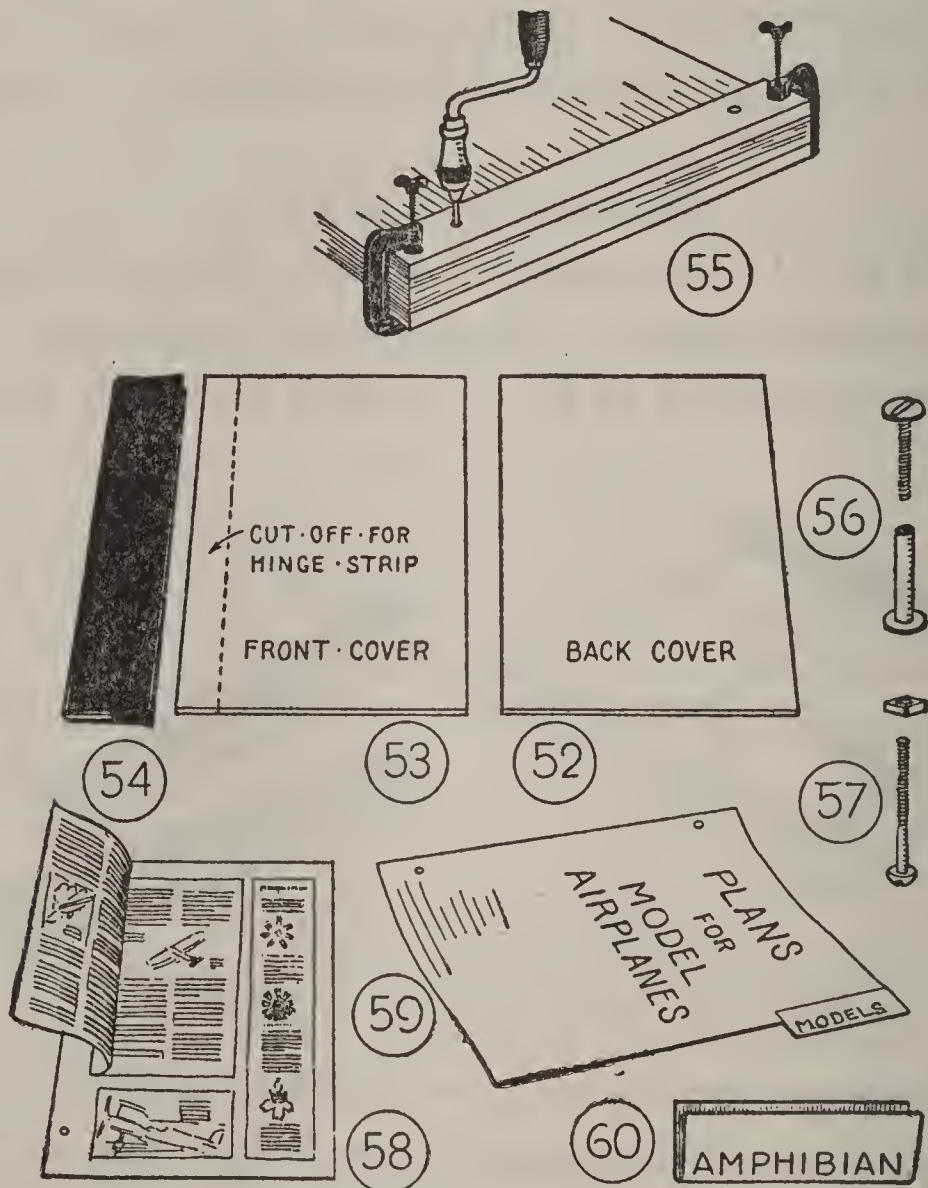

FIGS. 52 and 53.—Back and Front Covers.  
 FIG. 54.—Hinge Strip for Front Cover.  
 FIG. 55.—How to Drill Leaves for Binding.  
 FIG. 56.—Screw Post.  
 FIG. 57.—Stove Bolt Post.  
 FIGS. 58-60.—How to Mount Clippings and  
 How to Index Pages.

Hinge the 1-inch strip to the cover with a piece of black

cambric of the right width to fold over both sides of the strip, and make a lap of 1 inch over the cover. Glue the cambric to the strip and cover. Lap a similar strip over the edge of the back cover so the pair will look alike, and glue triangular tips of cambric over the right-hand corners of both covers.

Decorate binder-board covers with a colored picture, and run a title across the top, as suggested in Figs. 49 and 50. Finish plywood covers with apple green or Chinese red lacquer, and letter a title in black.

#### STOCK FOR SCRAPBOOK LEAVES

The scrapbook leaves should be of a good grade of manila paper. A printer will order the stock and cut it for you. The sheets should be  $\frac{1}{4}$  inch narrower and  $\frac{1}{2}$  inch shorter than the covers.

#### ASSEMBLY

The covers and leaves must be punched. Lacking a punch, drill holes with a  $\frac{3}{16}$ -inch drill. Fig. 55 shows

**How to Drill the Leaves.** Clamp them tightly between two strips of wood. A pair of curtain stretcher clamps can be used. Lay out the positions for the holes upon the upper wooden strip. Then drill through the strip and through the pile of paper until you reach the lower strip. That the holes may come over one another, be careful to hold the bit brace so the drill will bore the holes vertically.

Fig. 56 shows a screw post carried by stationery houses and hardware stores. If no local dealer has them, substi-

tute stove bolts (Fig. 57). An advantage of the screw post is that it provides for expansion. But you can get whatever length of stove bolts you need, and substitute longer bolts as the scrapbook increases in thickness. Instead of using posts, you can lace together the covers and paper with a shoe lace, as the covers in Fig. 51 are assembled. For a shoe-lace binder, bore three holes instead of two, and run the shoe lace through the three.

### MOUNTING PICTURES AND ARTICLES

Use library paste or flour paste for mounting articles and pictures on the scrapbook leaves. Apply the paste at the corners of the clippings with an additional touch at the center of long edges.

If an article is printed upon both sides of a clipping, apply paste to the margin and mount as shown in Fig. 58.

### CLASSIFYING

You will probably have your own ideas about arranging clippings, but here is a suggested layout for an aeronautics scrapbook. Start with a blank page. On the second left-hand page mount a suitable picture for a frontispiece. Make the third page the title page. Hand-letter this, "Aeronautics" or "Aviation," "Vol. I" (or whatever the number may be), and "Articles and Pictures collected by \_\_\_\_\_."

Let the first part of the book include articles on the history of aviation, followed by articles on aerodynamics, the

science of aviation. Collect as much of this matter as you can, and fix the facts in the mind as well as in the book.

Run pictures of different types of ships, next, then pictures of motors and accessories, and, after these, airports and equipment.

Fig. 59 suggests how to

Index the Pages with tabs of manila paper, folded in half (Fig. 60), coated with paste, and lapped over the edges.

### A LETTER-FILE SCRAPBOOK

Fig. 61 shows a scrapbook made of a letter file. The file has advantages over the book. It will hold a large number

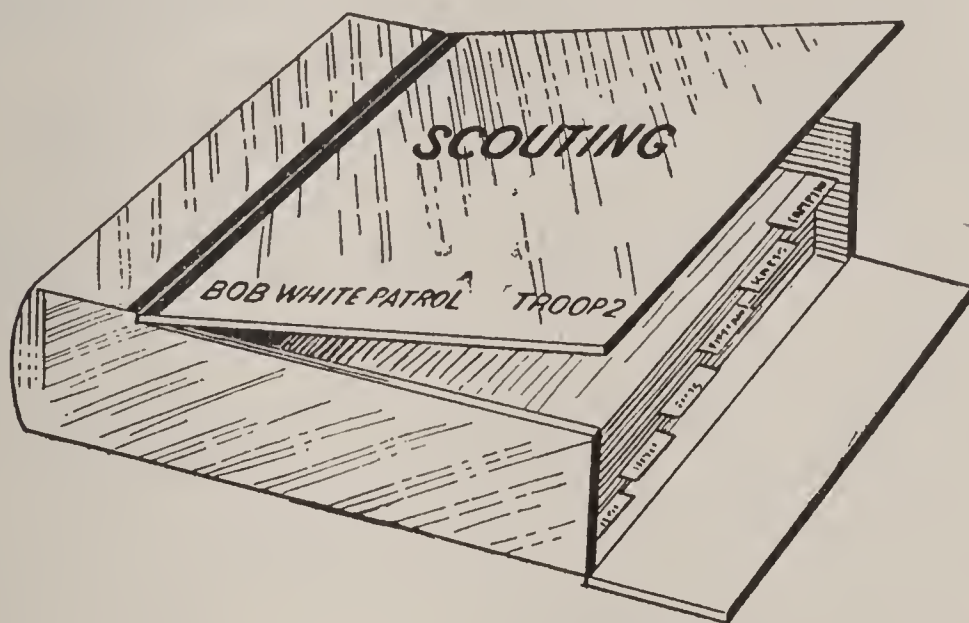
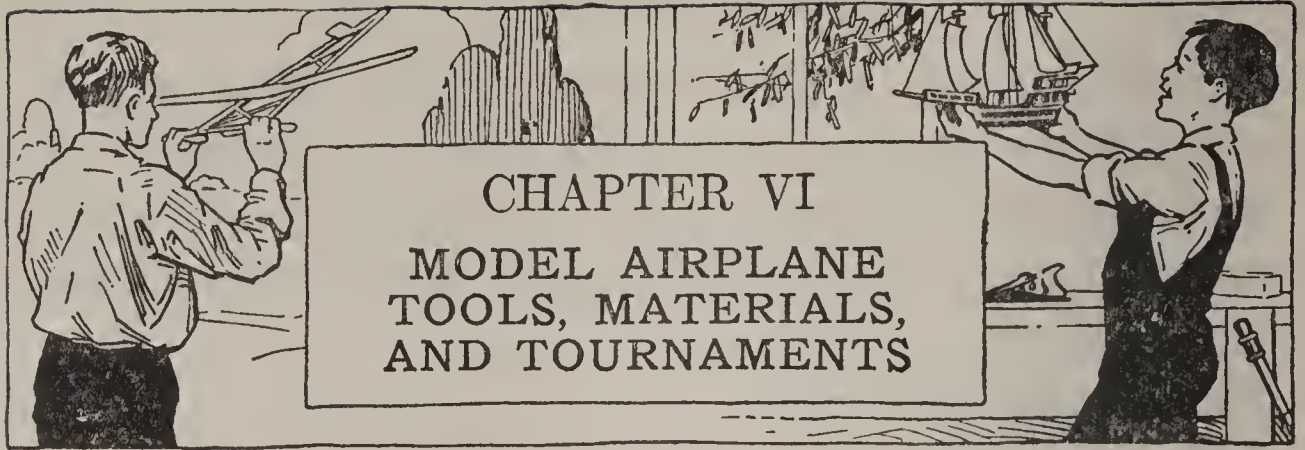

FIG. 61.—Letter-File Scrapbook.

of leaves. The leaves may be slipped in and out without fastening. There are index leaves to simplify classifying. And the closed ends of the box keep out dust.



CHAPTER VI  
MODEL AIRPLANE  
TOOLS, MATERIALS,  
AND TOURNAMENTS

BUILDING model airplanes is possible for every boy because few tools are required, and inexpensive ones at that. Indeed, they are ordinary tools such as one might expect to find in every household. Figs. 62 to 76 show sketches of an outfit that will serve excellently. A rule for measurements, a knife, coping-saw, razor blade, plane, sandpaper, and scissors, for cutting, round-nosed cutting pliers for cutting and bending wire, a drill, a hammer, a candle for heating bamboo to make it pliable for bending, one or more spring clothespins for clamping together small parts until cement has set, and a water-color brush for applying banana oil. A toothpick or other small stick is better than a brush for applying cement. The above tools will shape the raw materials into finished planes. If you purchase materials in kit form, and metal fittings ready-bent, the tool outfit may be reduced two-thirds.

#### ADHESIVES

Cement is preferable to glue for joining wooden and metal parts, and the two products in general use are Ambroid cement and Du Pont cement. The advantages



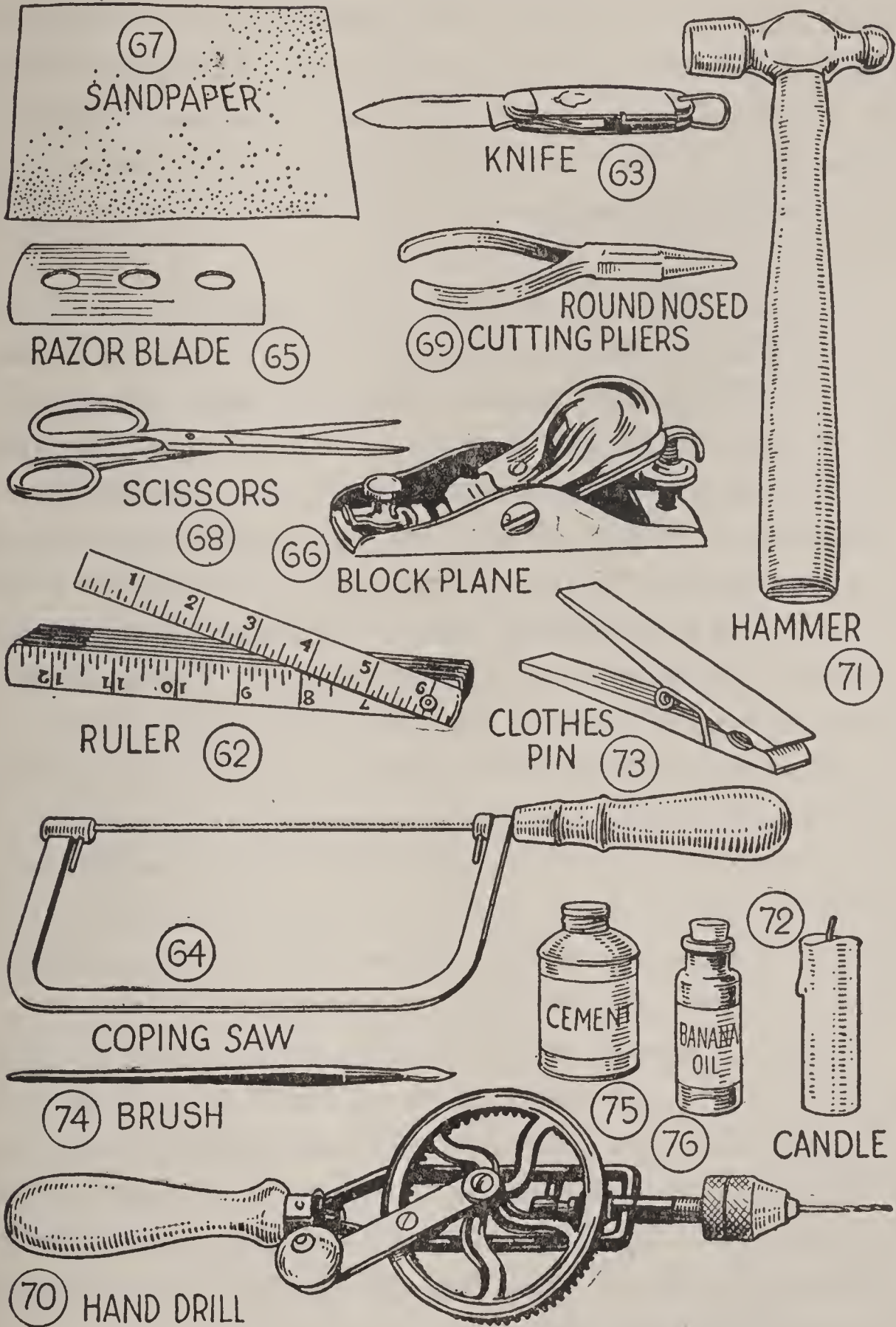

Figs. 62-76.—Model Airplane Tools and Adhesives.

cement holds over glue are that it dries quickly, holds more firmly, is flexible, lighter in weight, and waterproof. You can purchase it at sporting-goods stores and hardware stores, in a 2-ounce can, which amount lasts the average model-builder six months or more, if the can is kept tightly closed.

**Acetone.** When cement or airplane dopes become thick, through exposure to the air, they can be thinned by adding acetone. This is also a good solvent for removing cement from your fingers. A few drops on a rag will do the trick. Acetone can be purchased by the ounce at a drugstore.

**Banana Oil** is the adhesive for sticking the paper covering of wings and tails and for making these surfaces tight, airtight, and waterproof; also, for finishing wooden surfaces, for appearance and to add strength. It can be purchased at a paint store in whatever quantity is desired.

Apply banana oil with the brush specified in the tool outfit. Smooth wooden surfaces with No. 00 sandpaper, before finishing with banana oil. First, rub with the sanded side of the sandpaper, then with the reverse side. Apply four coats of banana oil, and rub down after each application with the reverse side of a piece of sandpaper.

**Airplane Dope** is the term given liquids used to make surfaces tight, airproof, waterproof, and strong. Banana oil is the form commonly used by model-builders. It may be thickened by dissolving in it pieces of celluloid. Commercial nitrate dopes are used on fabric-covered wings, for adhesive and finish. These can be purchased from dealers in model airplane supplies.

## FRAMEWORK MATERIALS

Balsa wood has no equal for models built to fly, because of its weight, which is less than one-half that of cork, and its strength, which is about one-half that of spruce. This wood, imported from South America, was difficult for model-makers to get until the demand for it became so great that a fairly wide distribution developed. A coping-saw will cut propeller blanks and motor sticks, and a safety-razor blade will rip sawed sticks into slender strips for spars and ribs, but not with the precision of a circular saw. For this reason, material kits outlined on another page have become popular. Balsa strips can be warped while held over the spout of a steaming tea-kettle, or by bending, while wet, over a lighted electric-light bulb.

Bamboo is used for wing tips, ribs, fin, rudder, landing-gear, and tail-skid, because of its strength and the ease of bending it into curved shapes. But bamboo sticks are heavier than balsa sticks of equal size. The trend is toward substituting square wing tips and fins of balsa, and balsa ribs. An old bamboo fishing-pole, Japanese umbrella, porch shade, or rug pole will furnish a supply of strips. Ask for a rug pole at a furniture store.

## COVERING MATERIALS

Japanese Tissue Paper is the most commonly used covering material for wing, stabilizer, elevator, fin, and rudder of "flying-stick" models. It can be purchased from a model-supply house. Run a hot iron over it before using it, to smooth out wrinkles. Use banana oil for adhesive.

Chinese Silk or Linen is preferred to tissue paper for covering non-flying models. Use cement or airplane dope for adhesive, and finish the covered surfaces with commercial airplane dope, lacquer, or shellac.

### METAL FITTINGS

Propeller shafts, thrust washers, bearings, hangers, yokes, S-hooks, wing clips, and cans may be purchased ready-shaped, but an expert builder prefers to bend his own, and you should learn to do so.

Music Wire, sizes 8, 10, 12, and 14, is used for fittings. You can buy it in quarter-pound rolls at a hardware store, or the dealer will get it for you. The round-nosed cutting pliers shown in Fig. 69 are the kind to use for

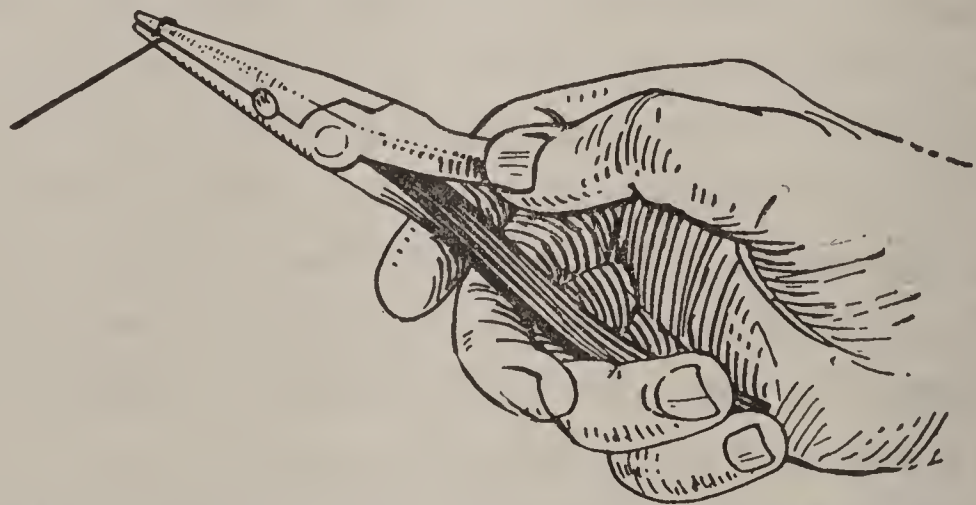

FIG. 77.—Use Round-Nosed Pliers for Shaping Metal Fittings.

**Shaping the Wire.** Start the eye for a bearing as shown in Fig. 77. The eye will be much smaller than the nose of the pliers, and must be worked down to the required size. It is important to shape propeller-bearing eyes perfectly round, and just large enough so the propeller shaft will

have free play. Music wire is springy, which makes it somewhat difficult to shape. Model-builders have tried substitutes for wire fittings, not always with success. One idea is

**A Fishhook Bearing.** A hook must be found with a very small eye. It must be annealed by holding in a flame until red hot, then cooling slowly. After you have shaped it, re-temper it, by heating it, then plunging it into water. If you do not do it right, the bearing will be either too soft or too brittle.

**A Needle** with a small, nearly-round eye, annealed, shaped, and then re-tempered is another idea for a bearing (Fig. 159), and a third idea is

**A Brad** with its head hammered flat, and drilled to receive the propeller shaft.

### THRUST WASHERS

Washers for thrust bearings are usually cut out of sheet brass, and center holes are punched with a phonograph needle. A round punch such as harness makers use is just the thing for punching out washers, and for the larger models

**A Wheel from a Glass Cutter** makes an excellent thrust washer. This has been called the "Kopecki" disk bearing, after the lad who first adapted it.

### LANDING-GEAR

Wheels for flying models are best made of disks of balsa. Paper cone hubs can be cemented to either side to make a

good axle bearing (Figs. 147 and 173), or  $\frac{1}{16}$ -inch tubing can be cut into  $\frac{3}{16}$ -inch lengths and cemented in the hub centers (Figs. 184 and 212). The tubing makes excellent hub bearings.

You can pick up toy vehicles with wheels of correct size for scale models.

**Landing-Gear Axles** may be made of music wire, bent to form shock absorbers (Fig. 210), and

**Struts** may be made of bamboo or wire (Fig. 209).

### SHAPING BAMBOO

Use only the outer or glossy portion of bamboo for wing tips, fin, and landing-gear of models. This is the stronger portion of the bamboo. The inner portion is pithy (Fig. 78). Cut a section of bamboo between joints and split it as shown in Fig. 78, or support it up and down in a vise and split it with a chisel. Then split off the pithy portion, as shown in Fig. 79.

Bamboo must be bent while heated. Slender pieces can be bent over a lighted electric lamp. But sharp bends must be made with the aid of a lighted candle. Fig. 80 suggests how to hold a strip beside a candle flame, about a quarter inch away, with the glossy side out. Move the strip back and forth in a circular path to distribute the heat, at the same time gradually bending the strip to the shape wanted. Then scrape the inner surface of the bent strip with the back of a knife blade, to remove burnt or blackened bamboo, and reduce the thickness to  $\frac{1}{32}$  inch.

Bend a pair of wing tips in one strip, then split the strip

(Fig. 81) with your knife or a safety-razor blade, to make two pieces (Fig. 82).

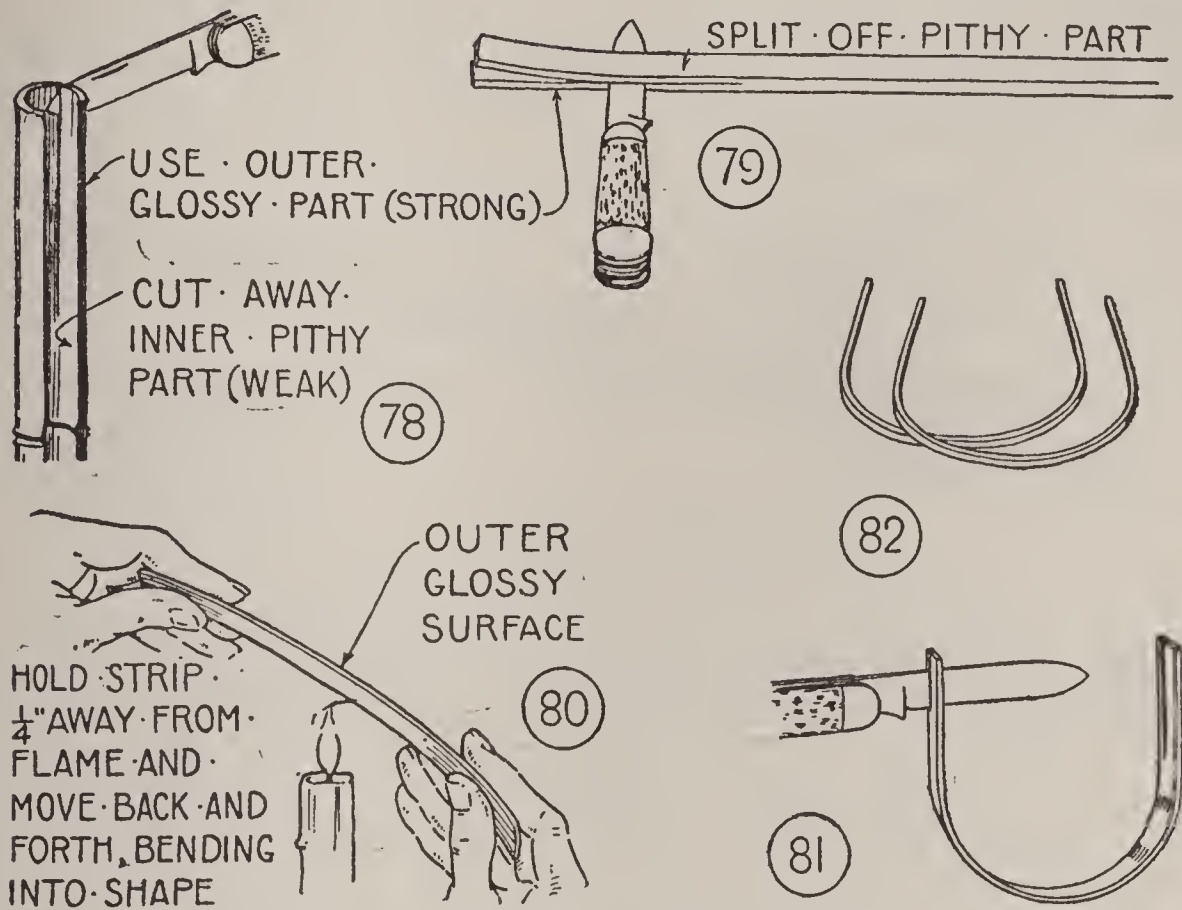

FIGS. 78 and 79.—Split Bamboo in This Way.

FIG. 80.—Bend Bamboo Wing Tips Beside Flame of Lighted Candle.

FIGS. 81 and 82.—Bend Pair of Wing Tips in One Piece, Then Split in Two.

### A RAZOR-BLADE KNIFE

Nothing better has been found for ripping thin strips of balsa and bamboo, and for trimming the edges of wing and tail coverings than a safety-razor blade. It is best to mount the blade in a handle (Fig. 83). Cut a stick about 6 inches long,  $\frac{1}{2}$  inch wide, and  $\frac{3}{16}$  inch thick, slot the end to a depth of  $1\frac{1}{4}$  inches, and bore two  $\frac{1}{8}$ -inch holes

through the end in the right positions to coincide with two of the blade holes when the blade is slipped into the slot (Fig. 84). Fasten the blade in the slot with two  $\frac{1}{8}$ -inch stove bolts,  $\frac{3}{8}$  inch long (Fig. 85). File off the bolt ends flush with the nuts.

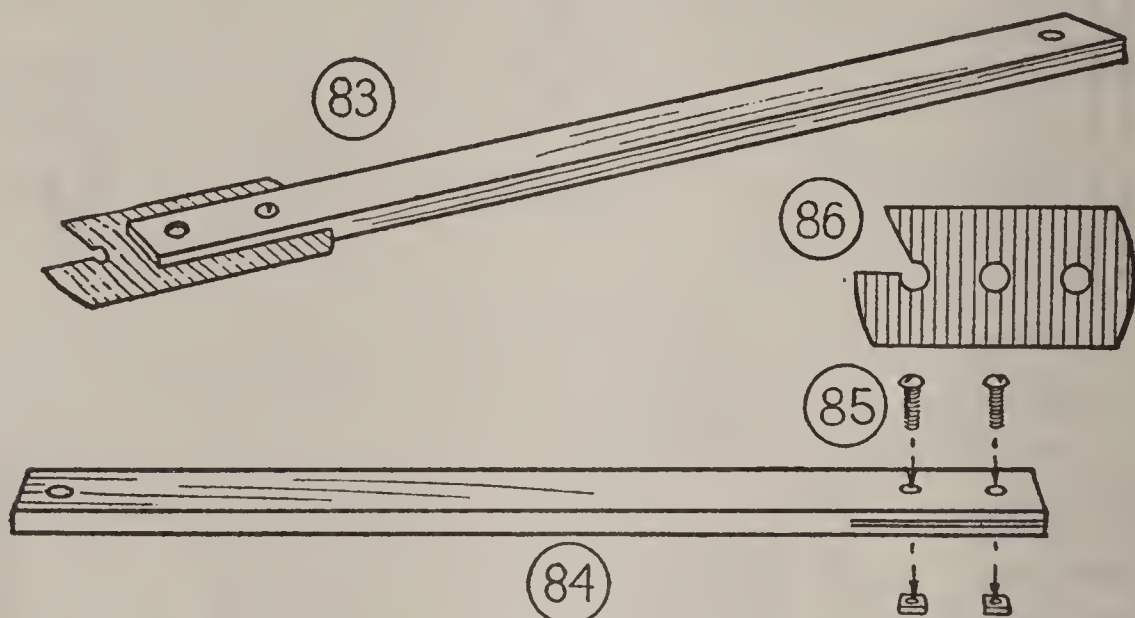

Figs. 83-86.—A Razor-Blade Knife.

A razor blade is better adapted for close trimming when one corner is broken away, as shown in Fig. 86.

## MOTORS

Clockwork, spring, and compressed-air motors are used as power plants for model airplanes, but taking weight into consideration, none is so efficient for the "duration" type of model as the

**Rubber-Strand Motor.** The size of rubber commonly used is  $\frac{1}{32}$  inch thick and  $\frac{1}{8}$  inch wide. It can be purchased by the lineal foot wherever model supplies are sold.

**Care of Motors.** You will get more out of your rubber



strands by giving them good care. Remove them from the model after flights, and put them away in a tight box or can, away from light and air, which are destructive agents. A dusting of talcum powder helps to preserve the rubber and to keep the strands from sticking.

Do not keep a motor wound for any length of time, previous to launching, as it decreases the elasticity of the rubber. Separate the strands after each flight and allow them to rest, in order that they may recover their normal length.

### MATERIAL KITS

Because certain model-making materials have been difficult to get, and because balsa wood is not easily ripped into thin strips without a circular saw, the material kit came into being, and it has proved a boon to model-builders. Some kits include the necessary balsa for a model, cut to required sizes, or to required thicknesses. Other kits contain every part needed to build a model. You will find advertisements of kit services in boys' magazines and aeronautics journals. Following the trend, kits have been prepared for the several models in Chapters VII to X. Information concerning these may be obtained by enclosing a stamp in a letter to me, addressed: "A. Neely Hall, Division of Model Airplane Kits, Elmhurst, Illinois."

### MODEL AIRPLANE TOURNAMENTS

When a group of you boys have taken up the building of models, it will be natural for you to want to hold a con-

test to determine whose models will fly longest and farthest. Interest the local chapter of the American Legion, Rotary, Kiwanis, or Lions Club, the Chamber of Commerce, or other organization, in promoting a contest. Model airplane contests are always popular, and once your community has held one, it will probably make them an annual affair.

Besides winning local honors, you may have an opportunity to represent the community at one of the national contests. At present there are two of these: the annual tournament sponsored by *The American Boy* and the Airplane Model League of America, and the tournament sponsored by the Playground and Recreation Association of America. Information concerning the former tournament will be found in the columns of *The American Boy*. Information concerning the latter tournament may be had by writing to the address given below.

The rules of the national tournaments have been drawn up by officials of many years' experience. Therefore, they are to be recommended also for local contests. Through the courtesy of the Playground and Recreation Association of America, the following is quoted from the

### RULES AND REGULATIONS FOR THE NATIONAL PLAYGROUND MINIATURE AIRCRAFT TOURNAMENT

EACH community from which competitors may desire to enter the National Tournament must have a committee to administer the local competitions and to certify to the local records. This committee should include the superintendent or director of the playgrounds of the city, or, where the playgrounds are admin-

istered under more than a single auspices, the superintendent or director of each system; the president or one of the vice presidents of the Chamber of Commerce or similar organization; editors of local newspapers; a member of the Board of Education, or superintendent of schools; the president or vice president of the local aeronautic society or similar official of a local flying field or airport. Others locally desirable may, of course, be added.

The National Committee will furnish official blanks to local committees upon which records, qualifications of contestants, and other facts are to be reported. The facts called for must be authoritatively certified by the committee responsible for the local tournament before contestants are qualified to compete in the national tournament. Information as to methods of registering competitors, trial flights, previous inspection of planes, methods of running off and judging the events, may be secured from the Playground and Recreation Association of America, 315 Fourth Avenue, New York City.

Boys and girls up to, but not including twenty-one years of age, are eligible to compete in the tournament. There are two classes:

1. Junior—those who have not yet attained the sixteenth birthday.
2. Senior—those who are past the sixteenth birthday and who have not yet attained the twenty-first birthday.

### EVENTS

There will be 7 events, 3 indoor and 4 outdoor, for each class (Junior and Senior). (Number of events varies from year to year.)

Committees arranging local tournaments are urged to include all events listed in the national tournament. Of course, other events may be added locally, but local champions will have a much better chance for success in the national tournament, if they have had practice in their local tournaments in events scheduled for the national tournament.

## INDOOR EVENTS

The following indoor events are for rubber powered airplanes, motive power carried in plane itself, tractor or pusher, competing for duration of flight. The distance from the inner face of the propeller to the opposite hook connection to be from 15 to 20 inches. Greatest overall dimension to be not greater than 30 inches.

1. Hand launched. Launchings to be not over 6 feet above floor—*Junior Class*.
2. Same as event number 1—*Senior Class*.
3. Fuselage models, rising off ground—*Junior Class*.  
All models must have landing chassis with two or more wheels in front, with either a wheel or tail skid at the rear. In launching, the model must be released with the front and rear landing-gears in contact with the floor without any pushing. See definition of *Fuselage Models* (page 58).
4. Same as event number 3—*Senior Class*.
5. Rising off water—*Junior Class*.  
All models must have hydro floats, which must support the model on the water at the take-off, with the propellers in motion.
6. Same as event number 5—*Senior Class*.

## OUTDOOR EVENTS

The following outdoor events are for rubber powered airplanes, motive power carried in plane itself, tractor or pusher, competing for duration of flight.

In planes entered in events 1, 2, 3, 4, 5, and 6, the distance from the inner face of the propeller to the opposite hook connection to be not under 20 nor over 36 inches. Greatest overall dimension to be not greater than 48 inches.

1. Hand launched; all launchings to be not over 6 feet above ground—*Junior Class*.

2. Same as event number 1—*Senior Class*.
3. Fuselage models, rising off ground—*Junior Class*.  
See definition of *Fuselage Models* (page 58).
4. Same as event number 3—*Senior Class*.
5. Rising off water—*Junior Class*.
6. Same as event number 5—*Senior Class*.
7. Any motive power other than rubber; type of launching optional; not to exceed 90 inches overall in length or span. Each model in this event must be equipped with one or more propellers, wings, and fuselage sticks and braces. This requirement is added to eliminate entries that are obviously not aircraft.—*Junior Class*.
8. Same as event number 7—*Senior Class*.

#### CONTEST RULES

Each contestant may have three flights in each event. Each launching will count as a flight regardless of time of flight or distance attained. Any flights accidentally interfered with by officials or judges will be given another trial, if the contestant desires. The same or different planes may be used. The best flight only scores except in case of tie, then second best flight will determine the winner and the other contestant second.

All planes must be made and operated by the contestant. If in the opinion of the judges special conditions warrant, a substitute may be allowed to operate a plane. In addition to raw material, contestants are allowed to purchase in finished form, only, bearings, propeller shaft, small metal fittings, and wheels. Special attention is called to the requirement that floats and propellers must be made by contestants. Any plans or patterns may be used, provided the models come within the contest requirements.

In outdoor events numbers 7 and 8, for *planes with power other than rubber*, contestants are allowed to purchase rockets, spring motors, compressed air motors, tank outfits, and other

motor devices, but in all other respects the planes must comply with the above regulations of being built by the contestants.

*Fuselage Models.* These planes must have the rubber within the fuselage. The fuselage covering must extend at least  $4/5$  of the length of the rubber motor measured from the inner face of the propeller to the opposite hook connection. They must be generally similar in appearance to real planes, but need not be built to scale nor be an exact reproduction of a specific plane. The body may be any shape. Double covered or hollow wings are required. They must have landing chassis, with two or more wheels in front, with either a wheel or tail skid at the rear.

#### METHOD OF SCORING IN THE NATIONAL FINALS

For the event championship, winners will be the 3 contestants in each class (Junior and Senior) making the 3 best records.

For the all-round championship, each contestant will score points in each event in which he competes as follows: First place, 5 points; second place, 4 points; third place, 3 points; fourth place, 2 points; fifth place, 1 point. The contestant having the largest total number of points for all events in his class will be declared the all-round national champion.

It is suggested, too, that the local interest in these events will be greatly enhanced if events other than those to be decided in the finals at ————— be added to the local program. In the nature of the case, the National Committee cannot, because of the impossibility of personal inspection, make decision as to originality of design, beauty of construction, "acrobatics," i. e., the stunt possibilities of the aircraft.

It is suggested to local committees that interest and participation can be greatly increased in the communities if the newspapers, especially, and also the local civic clubs and any clubs interested in aviation, be asked to help and coöperate in the local tournaments.

It is the hope of the National Committee that this contest will greatly stimulate originality and invention in the construction of aircraft.

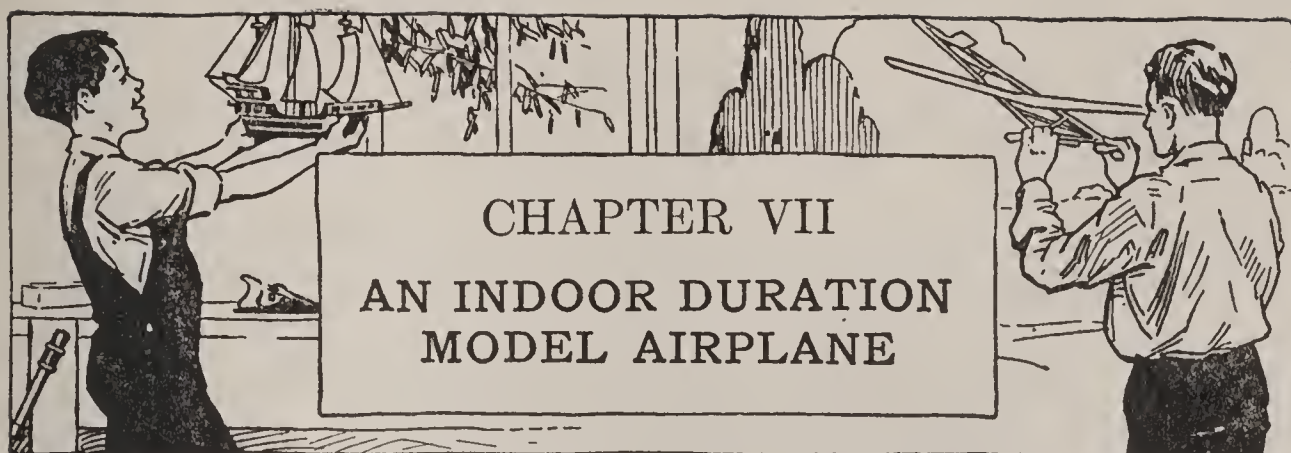

## CHAPTER VII

### AN INDOOR DURATION MODEL AIRPLANE

THIS model has been selected by Director B. C. Friedman, of the handicraft department of the South Parks Playgrounds, Chicago, as the best indoor model airplane for beginners to make. Mr. Friedman has followed the development of model airplanes for many years, knows the subject as few men do, and has developed champions among boys of his playground groups. He and several of his expert model-builders are shown in the frontispiece photograph (Fig. 87). By following the illustrations and instructions in this and succeeding chapters, prepared from Mr. Friedman's sketches and notes, you, too, can become an expert builder.

A successful "flying-stick" model depends upon correct design, the use of materials that are light and strong, and accurate workmanship. Having the design (Figs. 88 and 112), and the detail diagrams (Figs. 89 to 111), and having procured the correct materials from a dealer in model supplies, it remains for you to demonstrate your ability as a craftsman. Accuracy will come with practice.

## MATERIALS

The ID model requires the following:

- 1 piece balsa  $\frac{1}{8}$ " by  $\frac{5}{16}$ " by 15" for motor base
- 2 pieces balsa  $\frac{1}{32}$ " by  $\frac{3}{16}$ " (or  $\frac{1}{16}$ " by  $\frac{3}{32}$ ") by 20" for wing spars
- 1 piece balsa  $\frac{5}{8}$ " by  $\frac{7}{8}$ " by 9" for propeller blank
- Bamboo for wing tips, stabilizer, and fin
- Japanese tissue paper for wing and tail covering
- No. 8 and No. 10 music wire for metal fittings
- Thrust washers
- No. 50 cotton thread for stabilizer outline
- 30 inches of flat rubber, size  $\frac{1}{32}$ " by  $\frac{1}{8}$ ", for motor
- Cement, and banana oil

Before purchasing materials, read the suggestions given in Chapter VI, also note the reference to

**A Material Kit** containing parts for this model.

## THE WING

Begin the ID model by building the wing frame, shown in detail in Figs. 89 to 92. First,

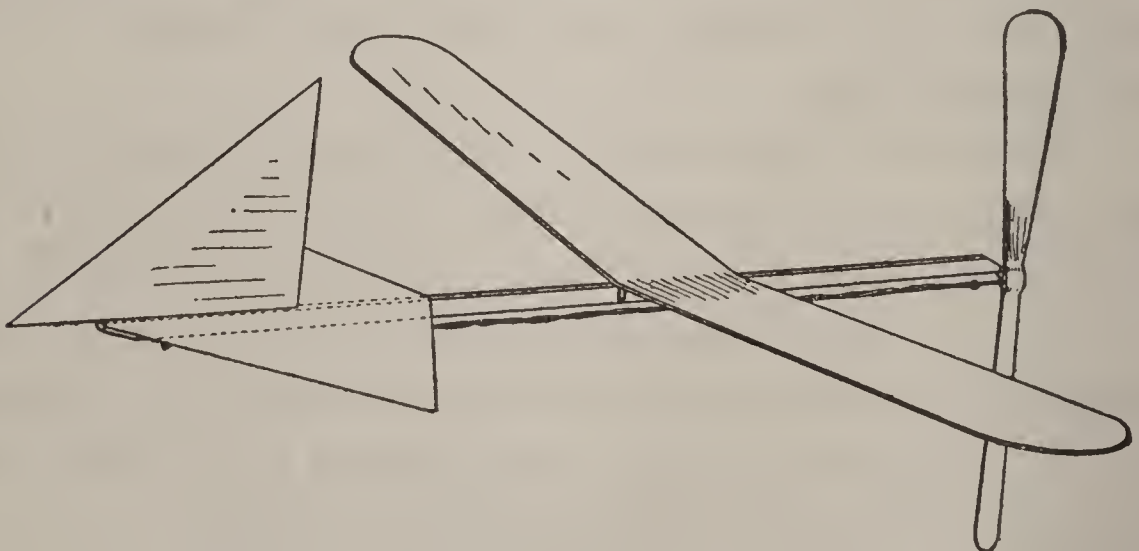
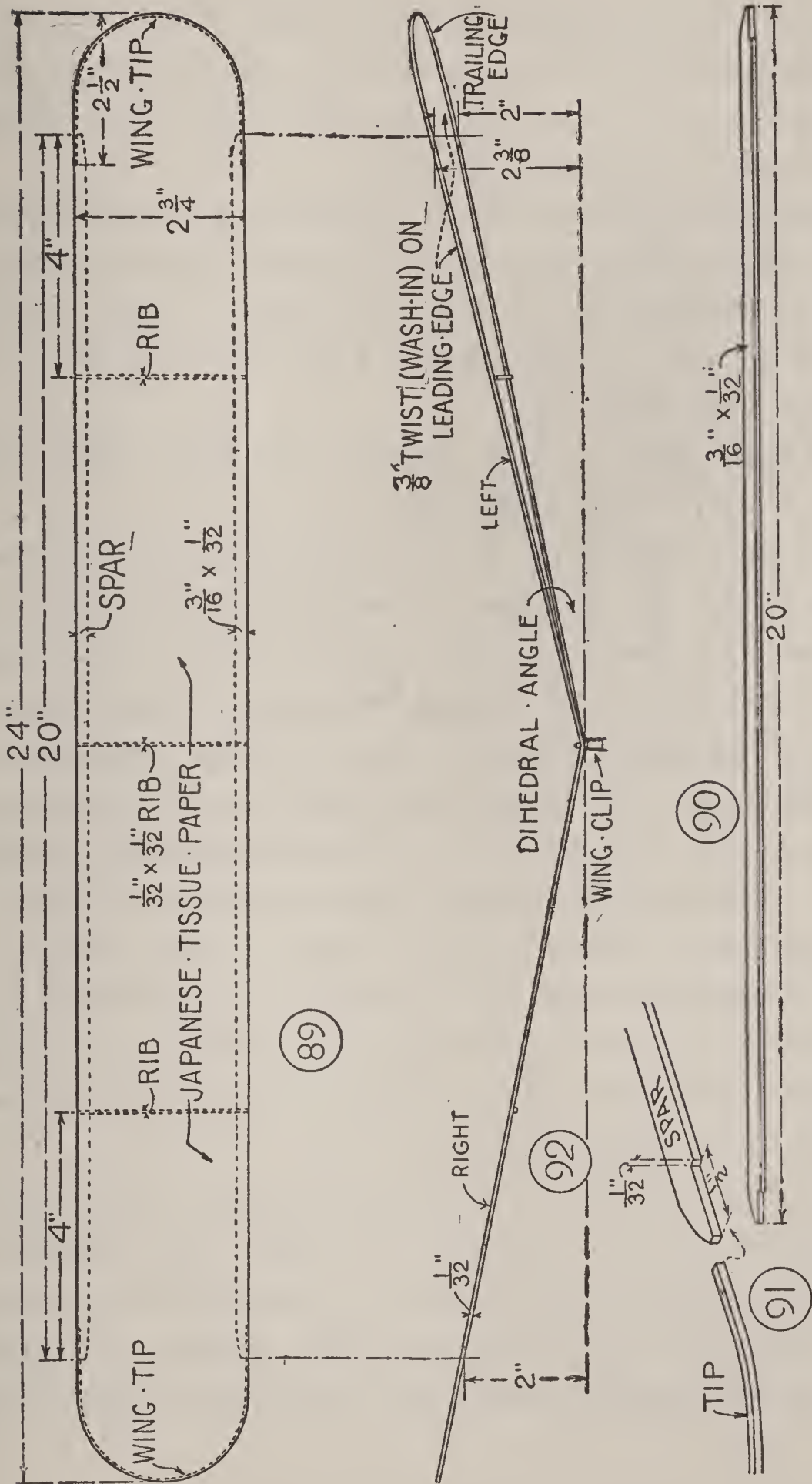

FIG. 88.—This Indoor Duration Model is a Good Type of Model for Beginners.





NOTE: At date of going to press, preference is being shown wing spars  $\frac{1}{16}$ " by  $\frac{3}{32}$ ".

FIG. 89.—Wing.  
 FIG. 90.—Wing Spar.  
 FIG. 91.—Wing Tip and Spar Assembly.  
 FIG. 92.—Wing Dihedral.

Shape the **Wing Tips** out of bamboo. Cut a strip of bamboo at least 7 inches long. Split it and bend it, as described in Chapter VI and illustrated in Figs. 78 to 82, to the form and size shown in Fig. 89.

For **Spars**, plane two 20-inch balsa sticks to a uniform thickness of  $\frac{1}{16}$  inch and width of  $\frac{3}{16}$  inch, then sandpaper them to a thickness of  $\frac{1}{32}$  inch (Fig. 90). Cut a notch  $\frac{1}{32}$  inch deep and  $\frac{1}{2}$  inch long in each end (Fig. 91), to receive the wing-tip ends.

Split **Three Ribs** out of bamboo,  $\frac{1}{32}$  inch thick,  $\frac{1}{32}$  wide and 3 inches long (Fig. 89).

To **Assemble the Wing Frame**, cement the ends of the wing tips in the spar notches. Then check up on the distance across the frame, to make sure that it is exactly  $2\frac{3}{4}$  inches, and cement a rib across the frame 4 inches from each end of the spars. Omit the center rib for the present.

**The Dihedral.** The wing must slope from its center up, as shown in Figs. 88 and 92, to give the model lateral stability. A horizontal surface has more lift to it than a sloping surface. Consequently, when a wing with a dihedral is tilted one way or the other by a current of air or other cause, the low side becomes the more nearly horizontal side, it lifts more than the high side, and the model is brought back to an even keel.

To give the wing-frame its dihedral angle, invert it so that the two ribs will be on the under side. Then place a block under the right half to raise the ends of the spars 2 inches (Fig. 92), and press down the centers with the blade of a table knife until they touch the working sur-

face. The left half of the frame must have a twist, or *wash-in*, to offset the *torque*, or unbalancing effect of the revolving right-hand propeller. Use two blocks to warp it. Place one block under the trailing-edge spar to raise the end 2 inches, and place the other block under the leading-edge spar to raise the end  $2\frac{3}{8}$  inches. Again press down the spar centers until they touch the working surface. Steam the spar centers over the spout of a tea-kettle, before bending the frame, so the wood will not break. The wash-in is sometimes obtained by twisting the front-wing clip, but it is better to make it as described.

When the frame has been shaped, put a drop of cement on the spar centers, slip the center rib into place, and hold until the cement has set. The cement will help hold the frame's dihedral, and will strengthen the spars at the point of bending. It is well to add a drop of cement to the opposite side of the bend for the same purpose. Trim off the projecting ends of the ribs flush with the frame edges. Use your razor-blade knife for trimming them.

**To Paper the Wing.** Press a sheet of tissue paper with a hot iron to remove all wrinkles, then cut a piece  $\frac{1}{4}$  inch larger all around than the frame. Fold it lengthwise at the center, unfold it, paint the center-wing rib with a thick coat of banana oil, place the tissue paper with the crease directly over the center rib, and press down the paper until it sticks. Next, paint the upper side of one-half of the frame with banana oil, stretch the tissue paper taut, and, working from the center toward the tip, press down the tissue paper. Stretch the paper to make a smooth surface.

Paint the other half of the frame in the same way, and stick on the other half of the tissue paper.

Invert the covered wing, paper side down, and with a safety-razor blade trim the paper to within  $\frac{1}{16}$  inch of the bamboo wing tips. Paint the projecting edges of paper with banana oil, fold them over the wing tips, and press down until stuck fast. Trim off the paper close to the spars, smooth with No. 00 sandpaper, and coat the edges with banana oil.

An all-balsa frame for the wing is much lighter than one with bamboo tips and ribs, and many model-builders prefer it. The wing tips must be square instead of curved.

#### THE MOTOR BASE

Fig. 93 shows the motor base. Cut a balsa stick  $\frac{1}{8}$  inch thick,  $\frac{5}{16}$  inch wide, and 15 inches long (Fig. 94). Trim off the ends as indicated. Make a  $\frac{1}{32}$ -inch square notch in the top edge, 3 inches from the rear end, to receive the stabilizer spar. Make a thread-cut 2 inches in front of the notch and another in the end of the motor base, for the stabilizer thread outline.

#### THE STABILIZER

This portion of the tail, or *empennage*, is easy to make. Cut a bamboo spar of the dimensions given in Fig. 95, and cement it at its center in the notch cut for it in the motor base. With a safety-razor blade make a thread-cut in each end of the spar, and through the cuts run a piece of No. 50 cotton thread for the stabilizer outline.

Paper the stabilizer with Japanese tissue paper, just as you covered the wing, and trim off the paper about  $\frac{1}{16}$  inch

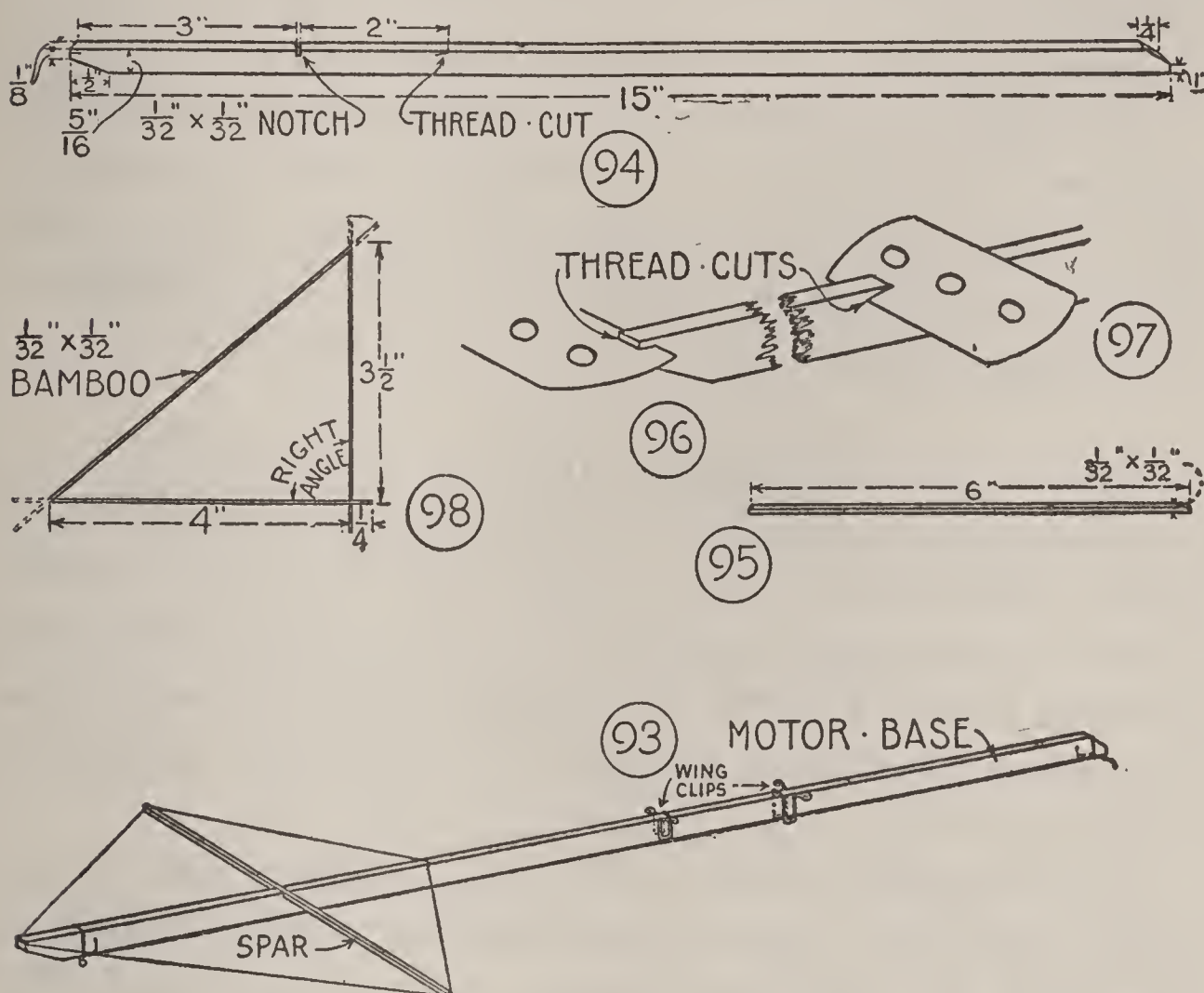

FIG. 93.—Motor Base, Metal Fittings and Stabilizer Framework.

FIG. 94.—Motor Base Diagram.

FIG. 95.—Stabilizer Spar.

FIGS. 96 and 97.—Thread-Cuts for Stabilizer Outline.

FIG. 98.—Rudder Framework.

outside of the thread outline. Some builders omit the thread outline to save weight.

### THE RUDDER

The rudder frame is made of bamboo strips of the sizes shown in Fig. 98. Cut the strips long enough to project

$\frac{1}{4}$  inch. Cement their ends together, and, when the cement has set, trim off the ends at the acute angles, as indicated by dotted lines.

Cover the frame with Japanese tissue paper.

To mount the rudder, make a pinhole in the motor base, forward of the stabilizer spar, and stick the lower projection of the vertical frame stick into the hole. The rudder can be set at any angle, and it will retain its position if the frame stick fits snugly in the motor base.

### METAL FITTINGS

We are now ready for the wire fittings. You can buy these from model supply houses, but it is best to learn how to shape them yourself. Use a pair of round-nosed cutting pliers (Figs. 69 and 77, Chapter VI), and follow the dimensions given in Figs. 99 to 106, in bending the wire into shape.

**The Propeller Bearing** (Fig. 99) requires a piece of No. 10 music wire. Form the eye not larger than  $\frac{1}{32}$  inch in diameter, and absolutely round. Let the leg extend (Fig. 100) to stick into the motor base, as shown in Fig. 99. Cement the bearing to the motor base, and add two turns of thread for reinforcement.

**The Rear Motor Hook** (Fig. 101) is made of No. 10 wire. Make a  $\frac{1}{16}$ -inch eye (Fig. 102). Stick the leg into the motor base, cement it in place, and reinforce with two turns of thread. The propeller bearing and rear motor hook are best fitted to the motor base before the stabilizer is built.

The S-Hook connects the motor with the rear hook. Make it of No. 8 music wire, of the form shown in Fig. 103.

The Propeller Shaft is made of No. 10 wire. Shape the loop like that shown in Fig. 104. Leave the other end straight until the propeller is ready for mounting.

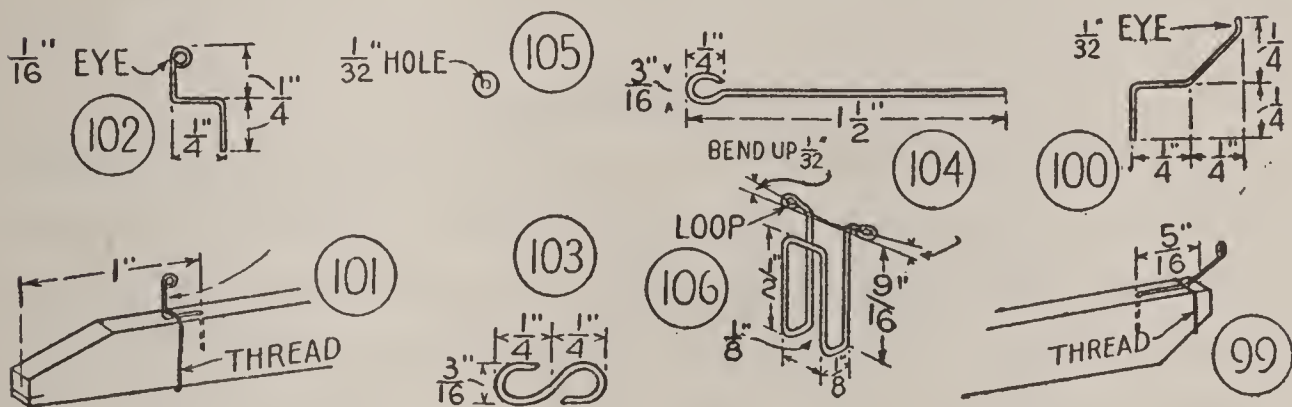

FIGS. 99 and 100.—Propeller Bearing.  
 FIGS. 101 and 102.—Rear Motor Hook.  
 FIG. 103.—S-Hook.  
 FIG. 104.—Propeller Shaft.  
 FIG. 105.—Thrust Washer.  
 FIG. 106.—Front Wing Clip.

**Thrust Washers** can be punched out of thin brass. Two or three may be used on the model. Fig. 105 shows the size of hole. Punch it with a phonograph needle.

**Wing Clips.** A pair of clips are needed for mounting the wing upon the motor base. Bend them out of No. 8 wire. Fig. 106 gives dimensions for the front clip. The rear clip will be the same, except that the 3/16-inch dimension will be 3/8 inch. The opening between the loops, marked "about 1/8 inch," should be such that the clip will make a slip-fit over the motor base (Fig. 93).

Cement the clips to the bottom center of the wing spars,

the longer clip at the front, or leading edge, the shorter one at the rear or trailing edge.

The wing clips make it possible to shift the wing forward or backward. When an even flight has been obtained, a fine variation in elevation may be obtained by slipping the front clip up for more elevation, or down for less.

### THE PROPELLER

If you have a knack for whittling, you should be able to carve a first-class propeller without difficulty. If not, you may spoil your first block. It is well to begin on a practice block. Any straight-grained soft wood will do, but balsa is best for the finished job, not only because of its lightness, but also because the wood is firm and easy to carve without splitting. Balsa requires a very sharp knife. Keep a whetstone at hand and use it frequently.

The Blank should be of the dimensions given in Fig. 107. After squaring up the block, draw diagonal lines from the corners, upon opposite faces. If the block is true, the intersection of the lines will be the true center, and a pin driven through from one center will come out at the opposite center. It is easy to push a pin through a balsa block, and a pinhole is large enough for the propeller shaft.

Draw a pair of lines parallel to the side edges,  $\frac{1}{4}$  inch apart, to establish the width of the hub. Saw or whittle the sides of the block along the diagonal lines and the hub side lines (Fig. 108), and all will be in readiness for carving, except that a diagonal line must be drawn across each end, one opposite to the other, to indicate the plane



of each blade. The lines are shown in Fig. 108, correctly drawn (one dotted) for a right-hand propeller.

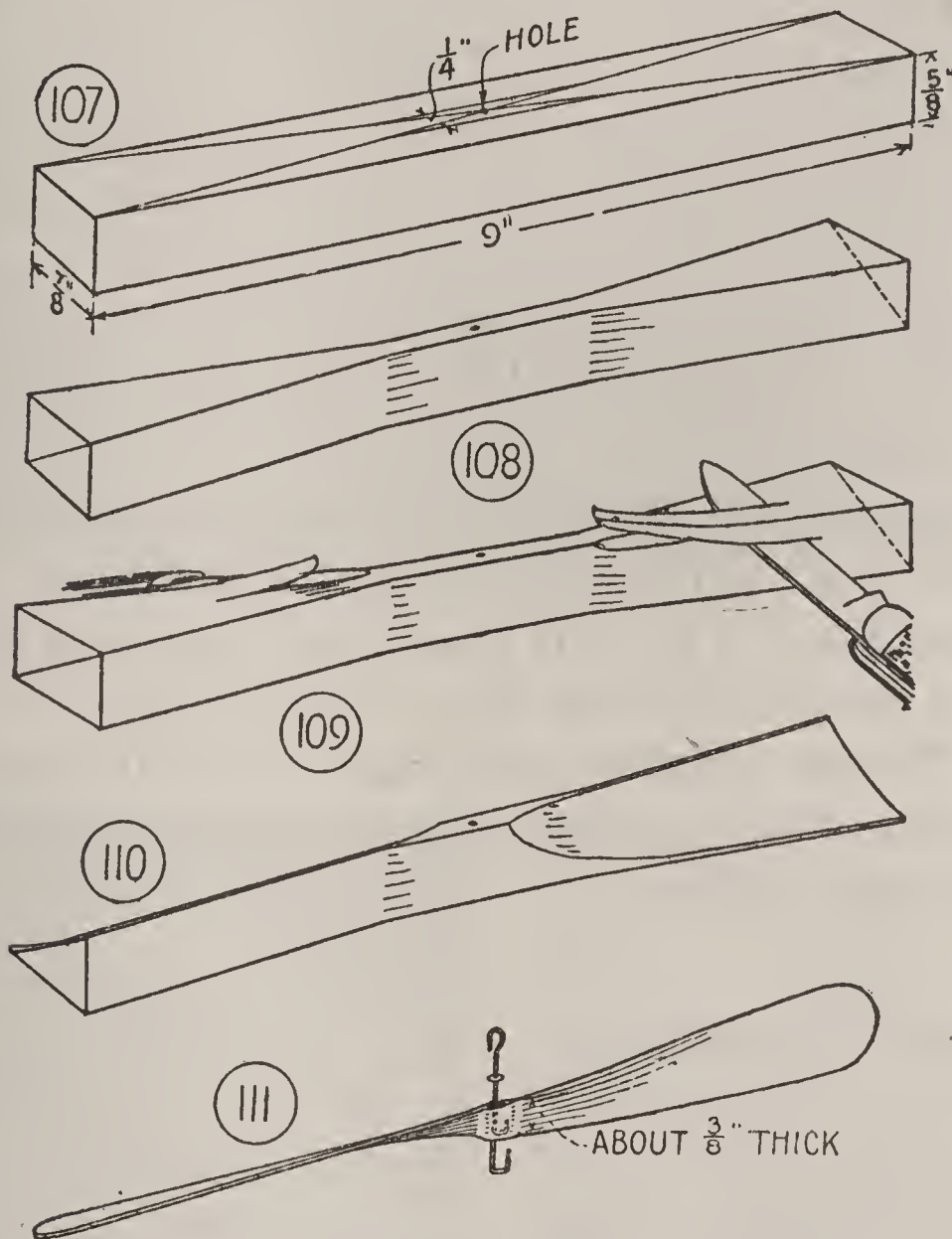

FIGS. 107-111.—Steps in Carving the Propeller.

Start the Carving as indicated in Fig. 109. Pare off opposite edges of one face until the surfaces have been reduced to a point  $\frac{1}{16}$  inch above the end diagonal lines (Fig. 110). Smooth the surfaces, then make them slightly spoon-shaped, or *cambered*, by rubbing with sandpaper.

Turn the block over, and carve in the same way you carved the opposite face, to a point  $\frac{1}{16}$  inch above the end diagonal lines, and sandpaper the surfaces convex-shaped, corresponding to the camber of the opposite surfaces.

Now go over all surfaces and reduce their thickness until the blades are not more than  $\frac{1}{16}$  inch thick. Hold the blades in front of a strong light to determine the points where the thickness is not uniform. Round the blade tips slightly. Reduce the width of the hub to  $\frac{1}{8}$  inch and the thickness to  $\frac{3}{8}$  inch (Fig. 111).

**To Mount the Propeller** on its shaft, stick the straight end of the shaft (Fig. 104) through the hub hole, make a square bend in it (Fig. 111), coat the bend with cement, and draw the bend into the hub to hold it fast.

**Two Thrust Washers** are shown upon the propeller shaft. One of these should be cemented to the propeller hub, the other left free.

### THE MOTOR

A strand of flat rubber,  $\frac{1}{32}$  inch by  $\frac{1}{8}$  inch, 30 inches long is required for this model. To assemble the motor, tie the ends of the loop of rubber, slip the loop over the propeller hook and the S-hook, with the knot at the S-hook, and engage the S-hook with the rear motor hook.

### TUNING THE MODEL

Try out the model as a glider, before using the motor. Slip the wing into position about 5 inches from the forward end of the motor base, as a starter. The position varies with the weight of parts, different with different model-

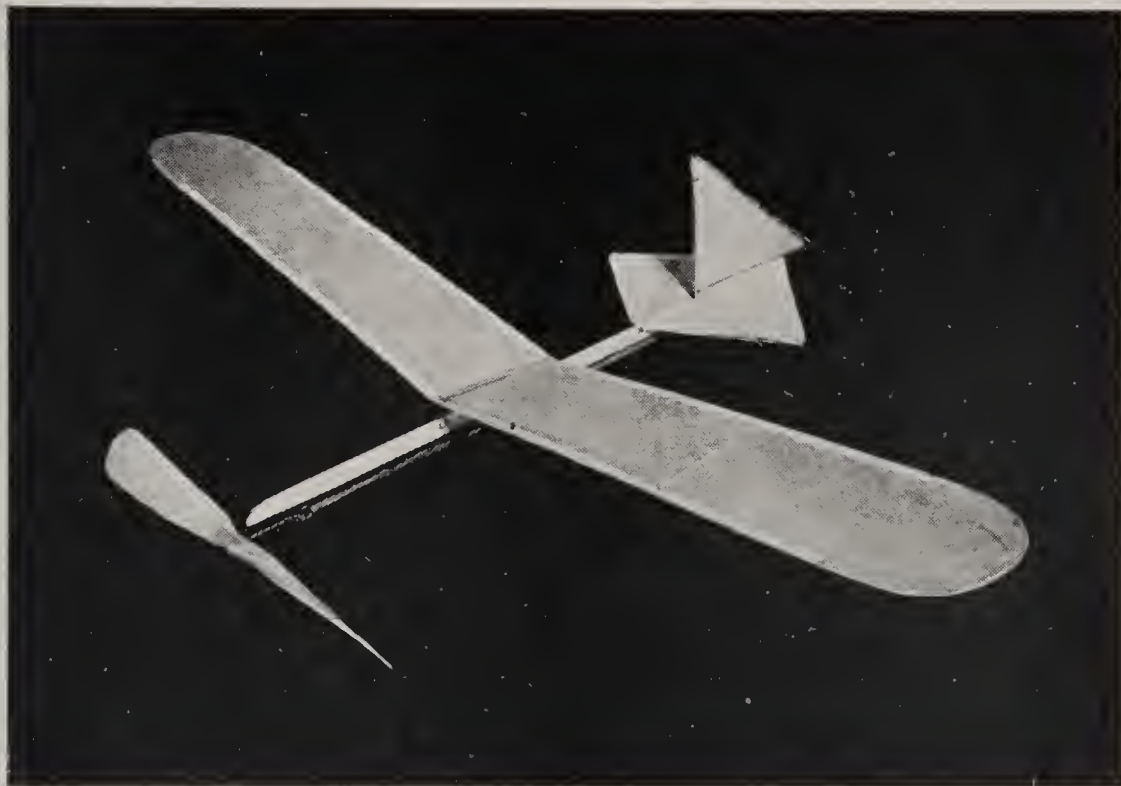

FIG. 112.—THE INDOOR DURATION (ID )MODEL AIRPLANE.



FIG. 113.—THE TWIN PUSHER (TP) MODEL AIRPLANE, BUILT FOR SPEED.

FIG. 114.—LAUNCHING A FORTY-INCH TWIN PUSHER.



builders. The correct setting will be determined in this way. If the model dives at a steep angle, when released, it is under-elevated. Move the wing forward and launch the model again. If the model climbs too steeply, stalls, and slips back, it is over-elevated. Move the wing back. By this means of adjustment, or *tuning*, you will soon find the point at which the ship glides on an even keel. By raising or lowering the front wing clip, a fine variation in elevation or angle of wing setting can be obtained.

### LAUNCHING THE MODEL

Now for the flight. Turn the propeller clockwise with your finger several hundred turns, watching the knots as they form, to see that they do not bunch. When the motor is wound, hold the propeller with the fingers of the left hand, and the motor base with the right hand, the propeller in front, of course, and launch it with a slight push. Do not throw it forward. The success of a flight depends as much upon the skill with which the model is tuned and launched, as upon the building. An expert can get twice the flight out of a model that a beginner can get, so, if you are new at the game, ask an old-timer to show you the knack of tuning and launching your ID ship.

Fig. 112 is a photograph of an ID model built by Henry and Richard Hanscom from the plans given in this chapter. The same lads built the TP model in the photograph of Fig. 113, and the two PF models in the photographs of Figs. 182 and 183, from plans in the following chapters.

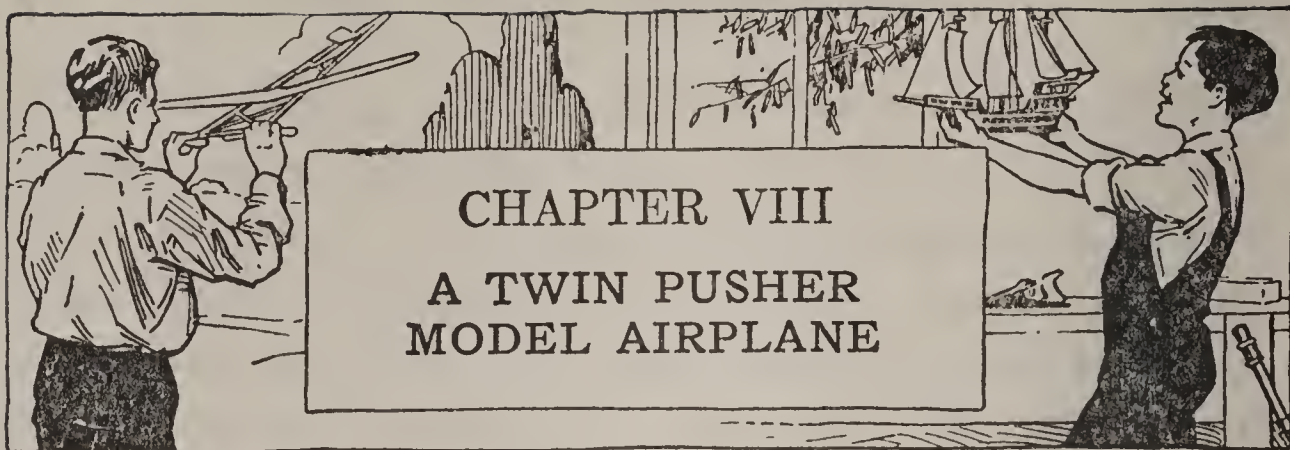

HERE is a twin pusher practice plane built for speed. It holds no records, but has given a good account of itself. It was designed by B. C. Friedman, director of model making at the South Parks Playgrounds, Chicago, whose boys have built hundreds like it. The average weight of the 24-inch model will be about 2 ounces. This weight can be reduced by refinements, when one has acquired skill in building. The wing and elevator are heavier than the built-up frames of contest planes, but they are simpler to build and will not crack up as easily.

#### MATERIALS

The TP model requires the following:

- 2 pieces balsa  $\frac{3}{16}$ " by  $\frac{3}{8}$ " by 24" for frame longerons
- 1 piece balsa  $\frac{1}{8}$ " by 3" by 18" for wing
- 1 piece balsa  $\frac{1}{8}$ " by 2" by 6" for elevator
- 2 pieces balsa  $\frac{5}{8}$ " by 1" by  $7\frac{1}{2}$ " for propeller blanks
- Bamboo for frame braces
- No. 14 music wire for metal fittings
- Thrust washers
- No. 50 cotton thread
- 3 2-inch rubber bands for mounting wing and elevator

50 feet flat rubber, size  $\frac{1}{32}$ " by  $\frac{1}{8}$ ", for motors  
Cement, and banana oil

A Material Kit containing parts for this model is available. See Chapter VI.

### THE FRAME

First, build the frame, known as an "A" frame. Plane up The Longerons, or side sticks, to the sizes shown in Figs. 116 and 117. Round off the edges with a file and

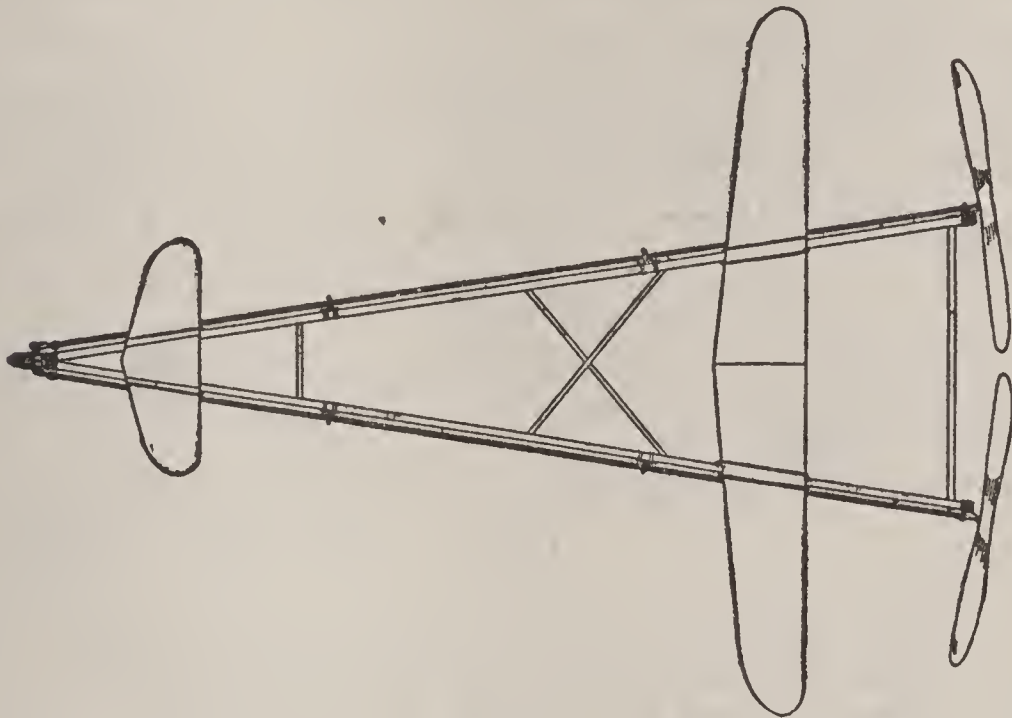

FIG. 115.—This Twin Pusher is an All-Balsa Model.

sandpaper, to give them the oval cross-section shown in Fig. 117, and bevel the front ends. The bevel must be right, so the sticks will come to a point when the opposite ends are spread 7 inches apart.

Mark off the positions for the brace ends, on the longe-

rons, where indicated in Fig. 116, and make slots at these points with the point of your knife blade (Fig. 118).

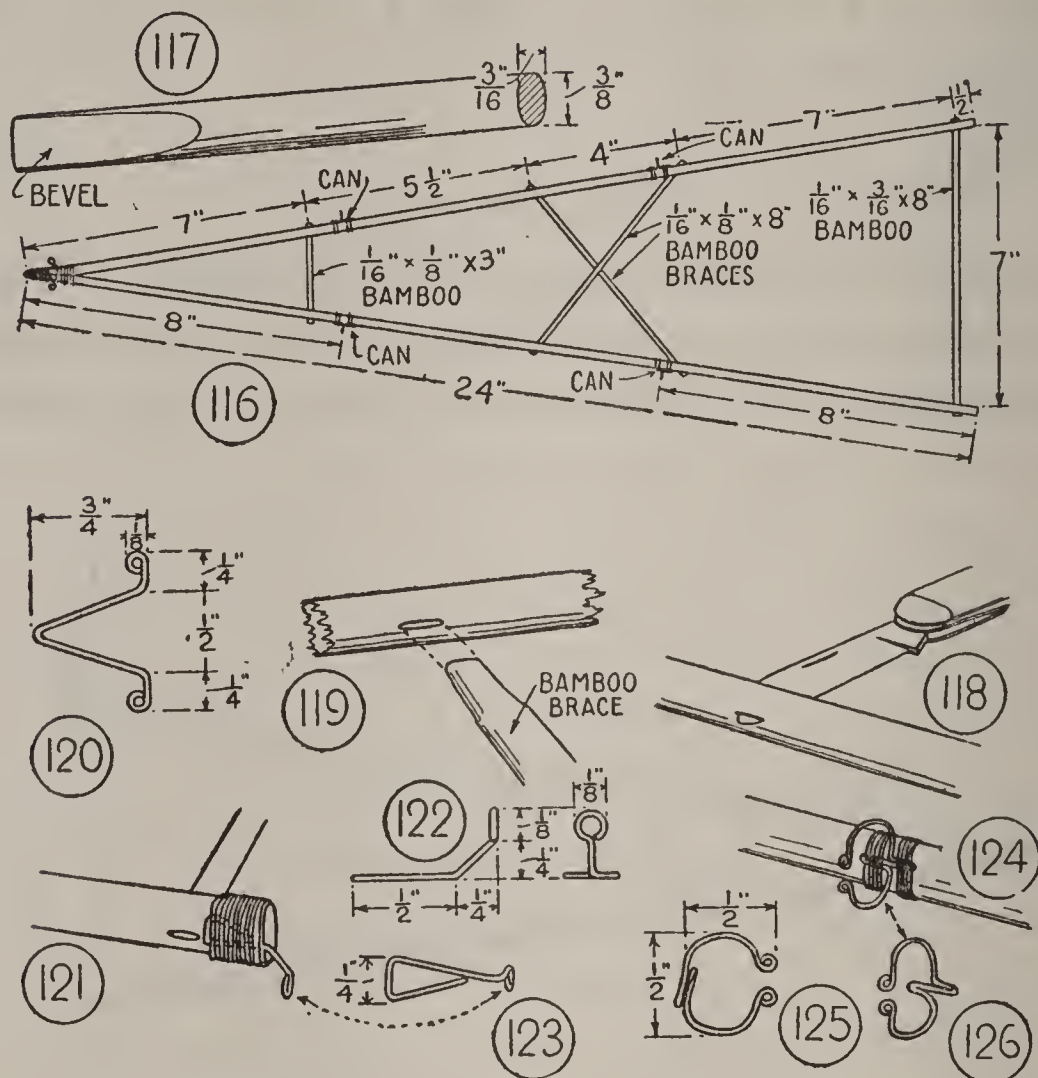

FIG. 116.—“A” Frame of the Twin Pusher Model.

FIG. 117.—Detail of Longerons.

FIGS. 118 and 119.—Insert Braces Like This.

FIG. 120.—Motor Yoke.

FIGS. 121-123.—Propeller Bearing.

FIGS. 124-126.—Cans.

**Braces.** Cut four bamboo braces of the sizes marked, and sharpen their ends chisel-shaped on the under side and edges (Fig. 119), so they will fit snugly in the frame stick slots. Make up the frame with the braces, and check up



all measurements. Then take it down, coat the brace ends, longeron ends, and the slots, with cement, and re-assemble. The brace ends will project beyond the frame. Trim them flush with the sides of the longerons.

The frame is now ready for its

### METAL FITTINGS

These are to be bent out of No. 14 music wire, with the aid of a pair of round-nosed cutting pliers. Make

**The Yoke** of the shape and size shown in Fig. 120, and

**The Propeller Bearings** of the shape and size shown in Figs. 122 and 123. It is important to make the eye of the bearings round, and just large enough to admit a propeller shaft of No. 14 wire. Some model-builders have saved themselves the trouble of shaping wire hangers by using fishhooks. See "Metal Fittings," Chapter VI.

Cement the yoke and bearings to the frame, as shown in Figs. 116 and 121, bind with wrappings of No. 50 cotton thread, and brush the thread with a thin coating of cement or shellac.

**Four Cans** are required for the support of the motor rubber. Make them of the shape and size shown in Figs. 125 and 126, and cement them to the sides of the longerons in the positions indicated in Fig. 116. Then bind with a wrapping of thread, and coat the thread with cement or shellac.

### THE WING

Fig. 127 shows the size of the piece of balsa for the wing, and Fig. 128 shows a pattern of one-half of it. To enlarge

the pattern, draw a similar series of squares upon a piece of cardboard, ruling four horizontal lines and ten vertical lines with a spacing of 1 inch, then divide the squares at

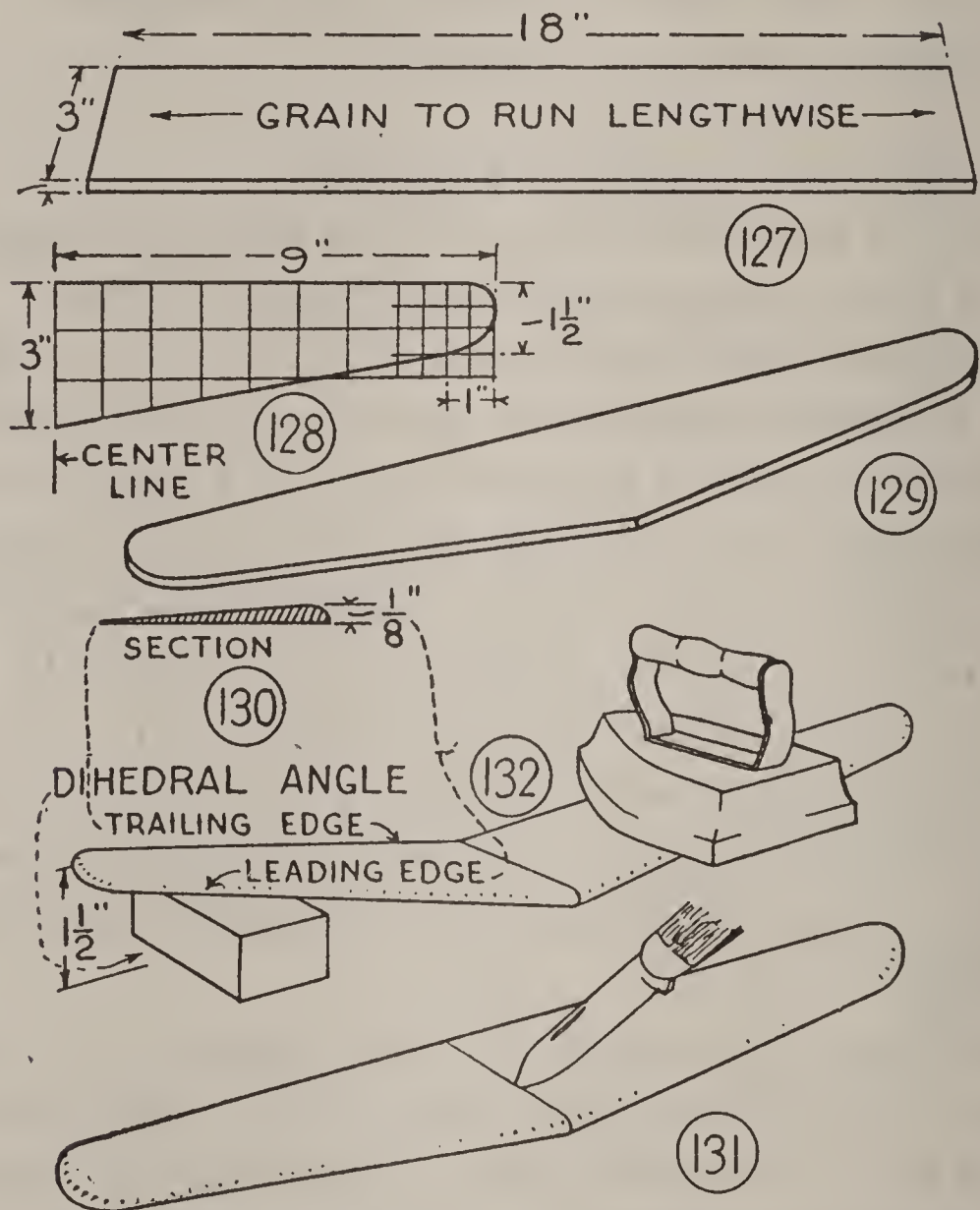

FIGS. 127-130.—Cut the Wing Like This.  
FIGS. 131 and 132.—And Give It a Dihedral Angle.

the tip into  $\frac{1}{2}$ -inch squares. On this pattern, reproduce the wing pattern exactly as it is shown in Fig. 128. By using a half pattern for the wing, it is easier to mark out the halves alike.

Cut out the balsa wing (Fig. 129), then taper it from a thickness of  $\frac{1}{8}$  inch at its *leading edge* to a feather edge at the *trailing edge* (Fig. 130). The tapering can be done entirely with sandpaper, but a plane or file will cut more quickly. Also taper off the wing tips, and round off the leading edge.

**The Dihedral.** The wing must have a dihedral angle (Fig. 132). To get this, score a line across the center of the wing with a knife (Fig. 131), then place a brick or other weight upon one half, and bend up the other half until its top is exactly  $1\frac{1}{2}$  inches above your working surface. Fill the scored groove with cement, and block up the tip until the cement has set. To reinforce the joint, run cement over the under side of the wing below the line of scoring.

### THE ELEVATOR

Fig. 133 shows the size of the piece of balsa for the elevator. Lay out a half-pattern by the diagram in Fig. 134, transfer it upon the piece of balsa, cut out the piece (Fig. 135) and taper its upper surface from  $\frac{1}{8}$  inch thick at the leading edge to a feather edge at the trailing edge (Figs. 136 and 137), and round off its tips and leading edge. The elevator has

**Two Dihedrals**, as shown in Fig. 139. Score two lines across the piece, where located in Fig. 138, fill the scored grooves with cement, bend up the tips until the distance between them and your working surface is  $\frac{3}{4}$  inch, and support them on blocks until the cement has set.

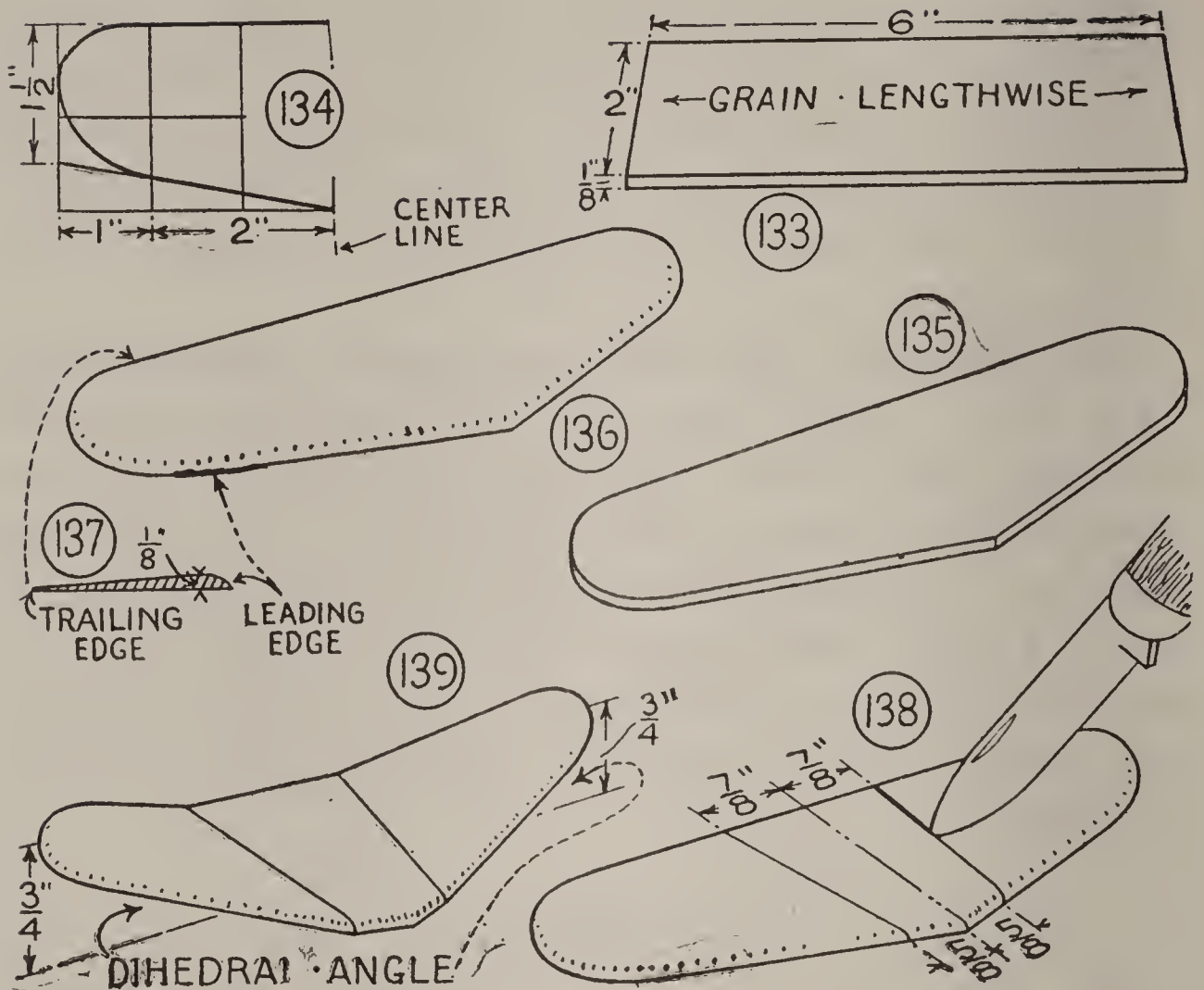

FIGS. 133-137.—Cut the Elevator Like This.  
 FIGS. 138 and 139.—And Give It Two Dihedral Angles.

### FINISHING

Smooth up the surfaces of the frame, wing, and elevator with No. 00 sandpaper, coat with banana oil, and rub down after the application with the reverse side of a piece of sandpaper. Four coats of banana oil, rubbed down after each application, will make a fine finish, and add strength to the balsa. It will increase the weight of the model somewhat, but weight is not as important a factor in a speed model as in one built for duration.

### MOUNTING THE WING AND ELEVATOR

The wing and elevator are held to the frame with rubber bands looped under the frame sticks and over the tips. Two rubber bands are needed for the wing, and one for the elevator. The correct positions for the wings and elevator must be determined by trial. The positions shown in Figs. 113 and 115 are only approximate.

### THE PROPELLERS

For the method of carving propellers, read the instructions given in Chapter VII. Fig. 140 shows the size of

**The Propeller Blanks.** Fig. 141 shows the shape of a block before carving, and Fig. 142 shows the completed propeller. This is

**The Right-Hand Propeller.** Use the same procedure in carving

**The Left-Hand Propeller,** but make the blades opposites. The right-hand propeller turns clockwise, the left-hand propeller turns counter clockwise.

Fig. 143 shows one of

**The Propeller Shafts.** Shape them out of No. 14 wire. Fig. 142 shows a propeller partly mounted upon its shaft. Coat the square bend on end with cement, then draw the bend into the hub to make it hold fast.

Use **Two Thrust Washers** on each propeller shaft. Cement one of them to the propeller hub. The little bearings from glass cutters make excellent bearings. Some cutters have a battery of five or six wheels. Maybe you can pick up a worn-out cutter.

One more pair of fittings are required. They are The S-Hooks, shown in Fig. 144. The strands of the

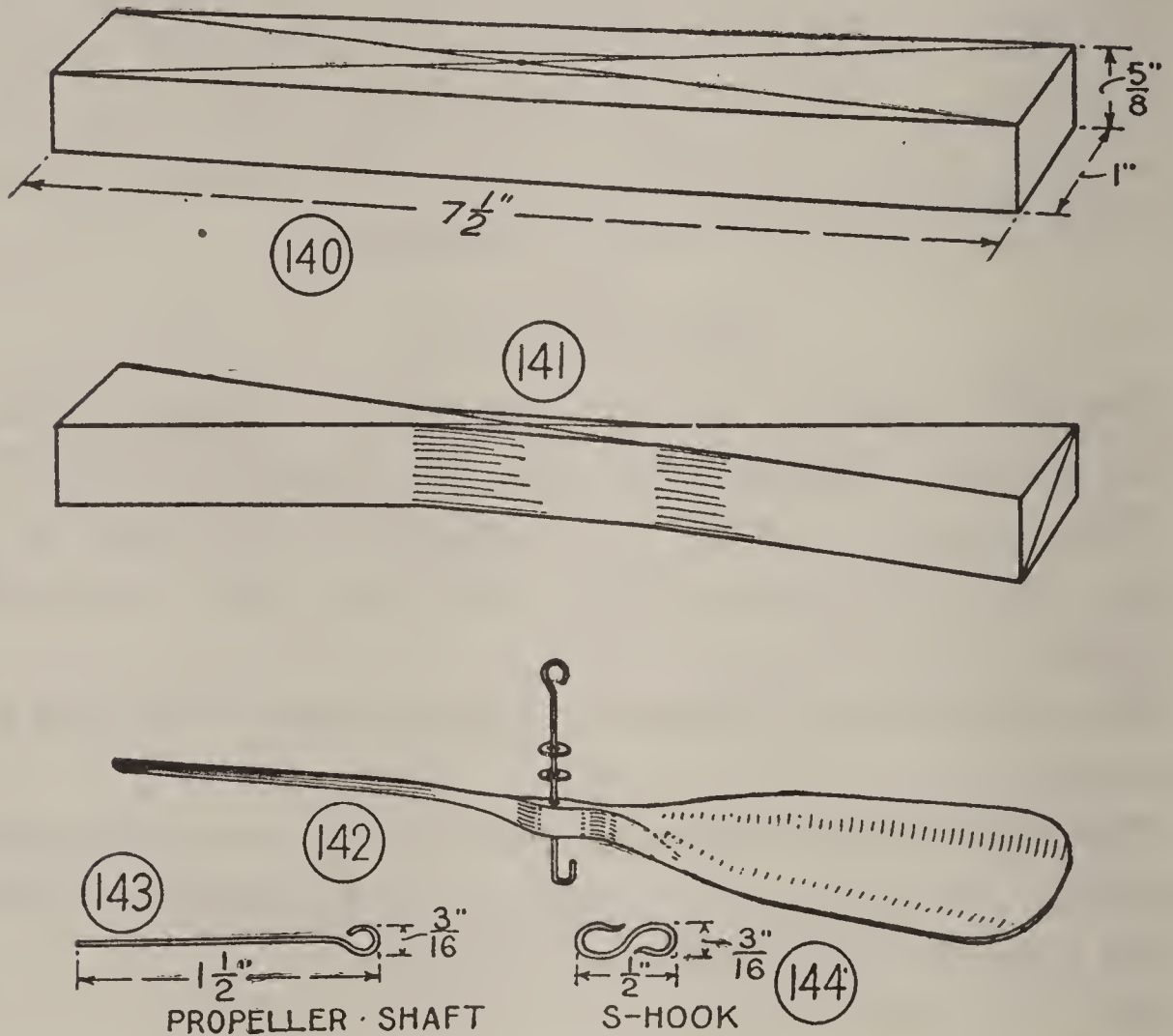

FIGS. 140-142.—Propeller Blank, Before and After Carving.

FIG. 143.—Propeller Shaft.

FIG. 144.—Motor S-Hook.

rubber motors are slipped over them, and they in turn engage the eyes of the yoke.

### THE MOTORS

The TP model has two motors, each of twelve strands of  $\frac{1}{32}$ -inch by  $\frac{1}{8}$ -inch rubber. About 50 feet of rubber are

required for the two. You may reduce the number of strands to eight for each motor, to save on the cost of rubber, but this will cut down the speed of the model.

In installing the motors, run the strands back and forth from propeller hook to S-hook, allowing a slack of from  $1\frac{1}{2}$  to 2 inches, and join the ends with a square knot at the propeller hook.

### A PROPELLER WINDER

While model airplane building was in its infancy, a model-builder decided that putting 500 turns into each motor was too much work, so he devised an egg-beater

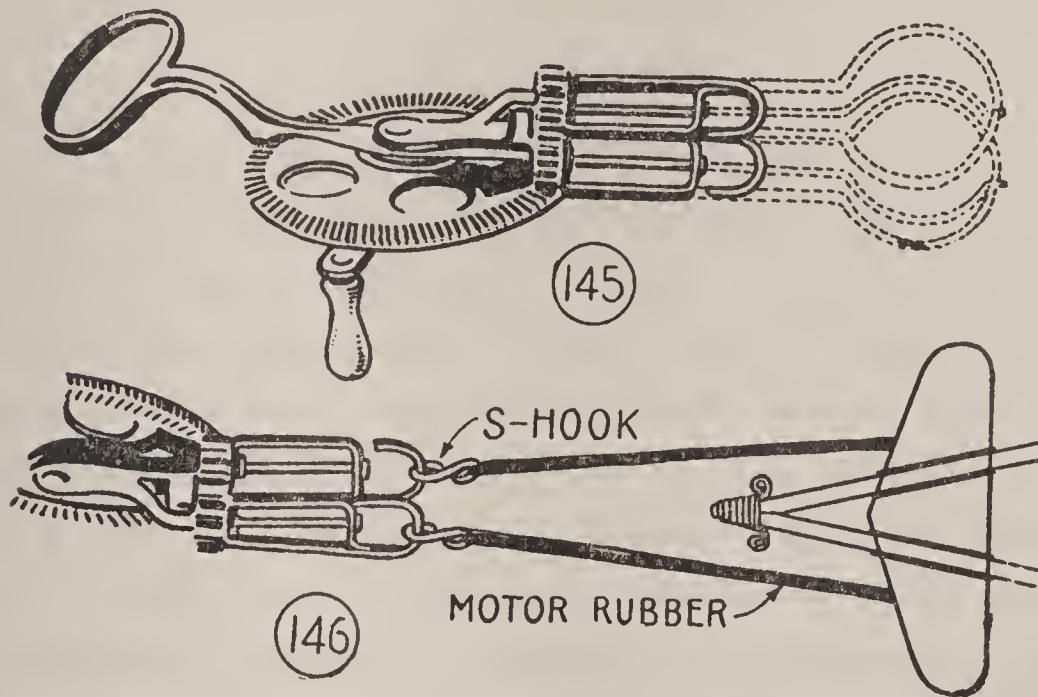

FIG. 145.—Motor Winder Made of an Egg-Beater.  
 FIG. 146.—How Winder is Used on Twin Pusher.

winder that proved a great time-saver and a means of getting more turns in the motors. The name of the in-

ventor is not known, but his ingenious winder is in general use, both in manufactured and home-made form.

A Home-Made Winder is easy to construct. Probably you can find a discarded egg-beater of the cast-iron type shown in Fig. 145 (dotted lines indicate beater before altered). Almost every household has one. If not, buy one of the newer type for a dime or two. To make the beater into a winder, cut off the loops with a pair of tinsnips, and bend the remaining ends into hooks, as shown. Punch holes through the loop shanks at the points of crossing the center pivot wire ends, stick the pivot wires through the holes, and rivet their ends. It is not much of a trick to do this, but if you haven't the tools, call on a garage mechanic.

#### USING THE WINDER

Remove the S-hooks from the yoke, and slip them over the winder hooks. Have an assistant support the model, with a propeller in each hand so they may not turn. Take a position in line with the point of the model, and back step a distance of 3 or 4 feet to stretch the rubber strands. By stretching the rubber, it is possible to put a greater number of turns into the motors. Five hundred turns are enough for a starter, but when you have acquired the knack of winding, you will use more.

#### TO LAUNCH THE MODEL

take the position of the lad in the photograph of Fig. 114, grasping a propeller in each hand. Lift the plane's nose



into the air, and give the model a slight push to start it off at a speed a trifle less than that to be produced by the propellers.

Before driving your plane by its motors, know that it is properly tuned, by testing it out as a glider. If it dives at a steep angle, move the wing forward. If it climbs, stalls, and slips back, move the wing back.

After you have built the 24-inch twin pusher, try a 40-inch model such as the lad in Fig. 114 is launching.

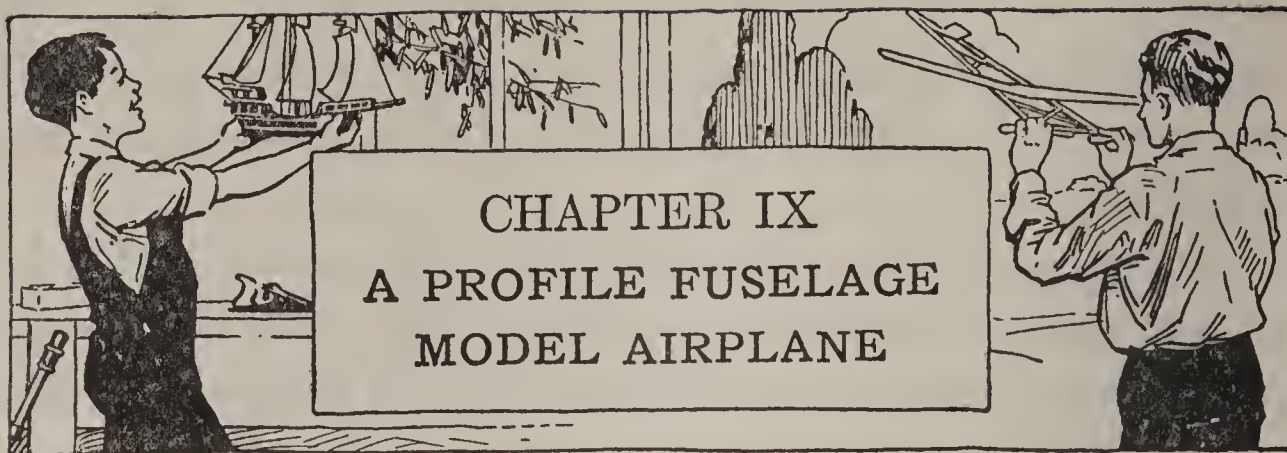

ADD this dandy ship to your airport. It was designed by B. C. Friedman, director of model making of the South Parks Playgrounds, Chicago, which is recommendation enough. The profile fuselage idea is an invention of Mr. Friedman's. The model looks like a real ship, it flies like one, it weighs less than one-sixth ounce, it costs little to build, and the assembly is much simpler than that of models with fabricated fuselage. If you are not delighted with this model, you will be the first of my readers who have built it with the PF-29 material kits.

#### MATERIALS

The PF-29 model requires the following:

- 1 piece balsa  $\frac{1}{8}$ " by  $\frac{1}{8}$ " by  $10\frac{1}{4}$ " for motor base
- 1 piece balsa  $\frac{1}{16}$ " by  $11\frac{1}{2}$ " by  $10\frac{1}{4}$ " for fuselage
- 2 pieces balsa  $\frac{1}{16}$ " by  $11\frac{1}{2}$ " by  $12\frac{1}{4}$ " for spars, ribs, and wheels
- 1 piece balsa  $\frac{3}{8}$ " by  $\frac{3}{8}$ " by  $5\frac{1}{2}$ " for propeller blank
- 1 piece bamboo  $\frac{1}{32}$ " by  $\frac{1}{16}$ " for landing-gear
- Japanese tissue paper for fuselage, wing, and tail covering
- No. 8 music wire for metal fittings
- Thrust washers
- 20 inches of flat rubber, size  $\frac{1}{32}$ " by  $\frac{3}{32}$ ", for motor
- Cement, and banana oil

Read the suggestions for purchasing materials in Chapter VI, and note the reference to **A Material Kit** for this model.

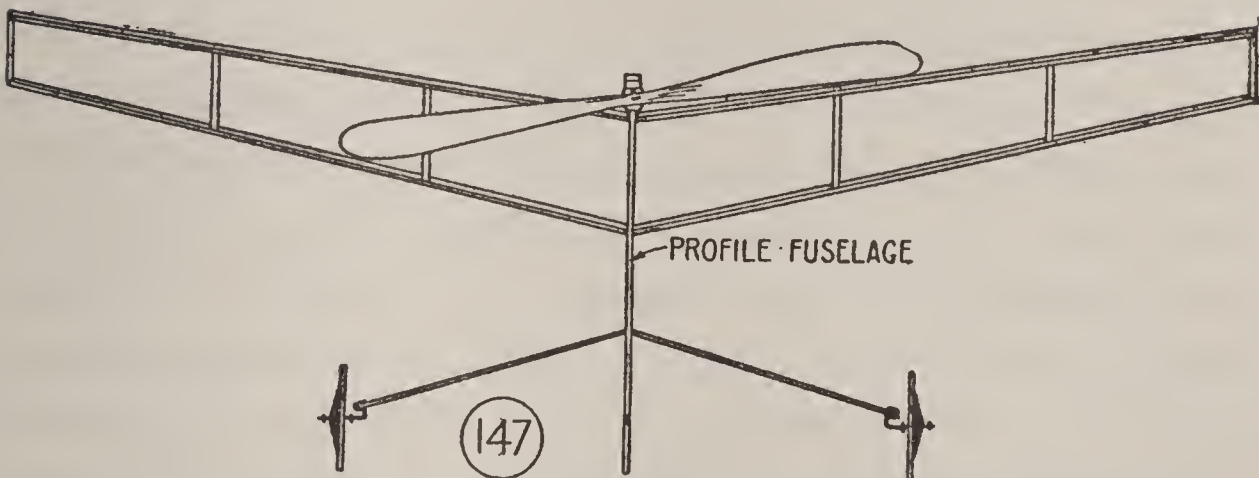
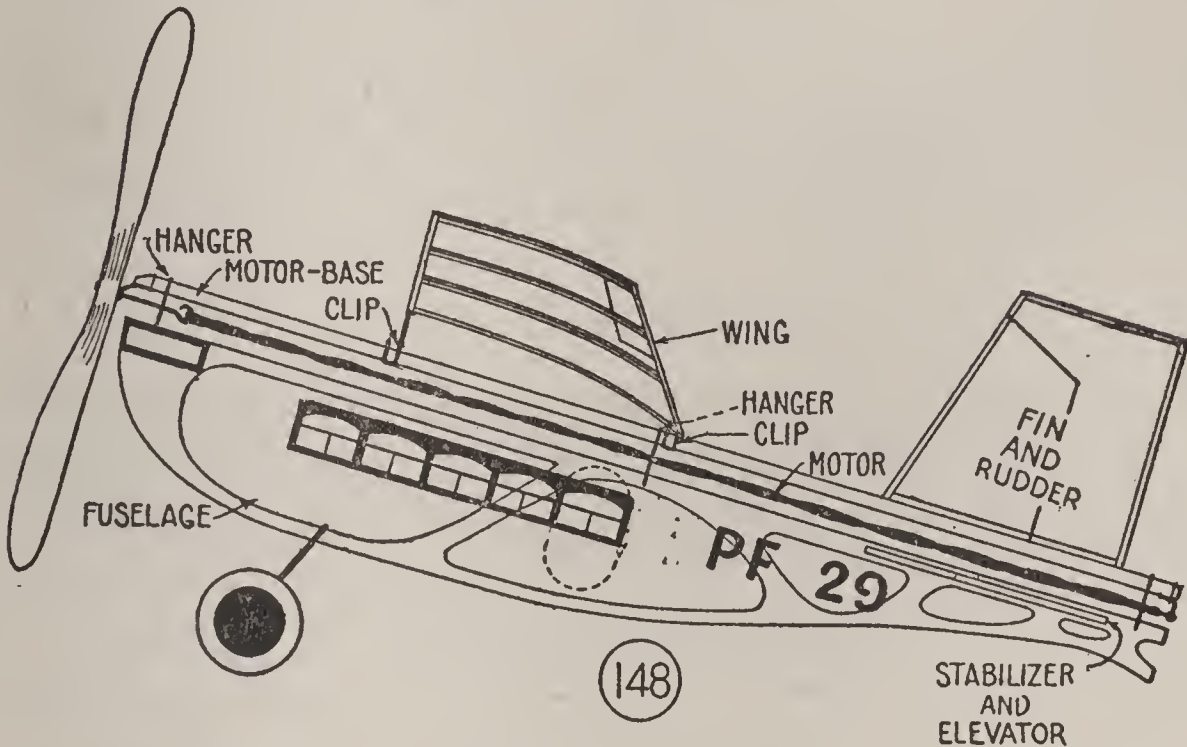

FIG. 147.—Front View of the PF-29 Profile Fuselage Model Airplane.

FIG. 148.—Side View of the PF-29 Model.

With the material in hand, examine closely the front elevation (Fig. 147), the side elevation (Fig. 148), the photograph of the completed model (Fig. 182), and read

carefully the instructions for shaping parts and assembling them.

### THE MOTOR BASE

is the first part of the PF-29 model to shape. It is a balsa stick of the dimensions given in Fig. 149. It must be absolutely straight. Smooth its edges with No. 00 sandpaper.

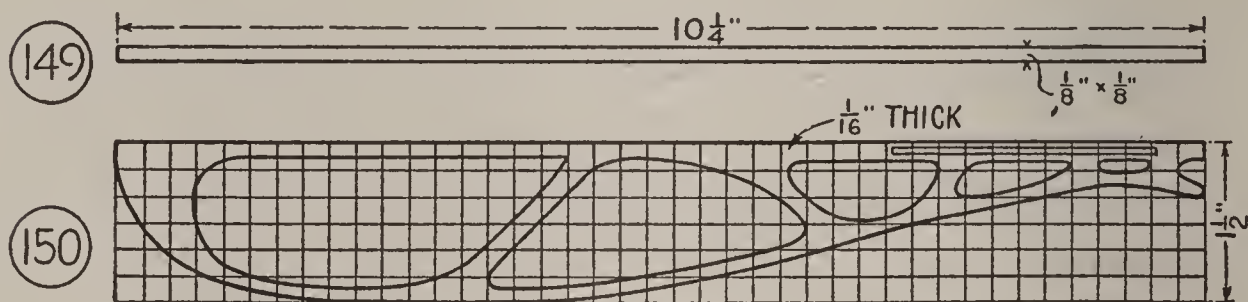

FIG. 149.—Motor Base.

FIG. 150.—Profile Fuselage.

### THE FUSELAGE

is hung from the motor base. A pattern is shown in Fig. 150, ruled off into squares to help you enlarge it. Each square represents  $\frac{1}{4}$  inch, so rule off horizontal and vertical lines, with a spacing of  $\frac{1}{4}$  inch, upon a sheet of paper, and then reproduce the small pattern, line for line. Openings are cut in the piece to save weight. Here you need not follow the pattern, except to leave enough margin around the edges and between openings for rigidity. The long, narrow slot in the tail is for the stabilizer. Instead of the slot, you can notch the upper edge of the fuselage to the right depth for the stabilizer to fit in. It is somewhat easier to do this.

When you have laid out the fuselage pattern, transfer

it to a piece of balsa, and then cut the balsa with your razor-blade knife (Fig. 83, Chapter VI). Place the wood flat upon a board, and cut as you would score cardboard.

After sandpapering the surfaces of the fuselage, cover both sides with Japanese tissue paper. Apply banana oil to the wood, spread the paper smoothly over the surface, and press down with a cloth.

### THE WING

is the next part to prepare. Follow the layout in Fig. 151. The sides of the spars and ribs are marked.

The spars must slope from the center to the tips, to give the wing a dihedral angle. The amount of the dihedral is indicated in Fig. 152. The method of bending wing spars is described on page 62. A *wash-in* is not indicated in Fig. 152, but it is well to give the leading edge of the left tip a wash-in of from  $\frac{1}{8}$  to  $\frac{1}{4}$  inch. How to shape the wash-in is described on page 63.

**The Ribs** may be straight, but they make a more efficient wing if cambered. Fig. 153 shows the right amount of camber. You can rip out the ribs with the camber on them, as shown in Fig. 154, or bend them over the spout of a steaming tea-kettle. The rib with the camber cut on it is not as strong as the bent rib, because the grain runs across it.

**In Assembling the Wing**, be careful to make square corners between the spars and ribs. Cement the parts as instructed in Chapter VII, and

**Cover the Wing** as described in the same chapter.

## THE TAIL

The Stabilizer and Elevator are shown in Fig. 155. Cut the spars and ribs of the sizes shown, and cement them together. Then cover the frame upon the upper side with

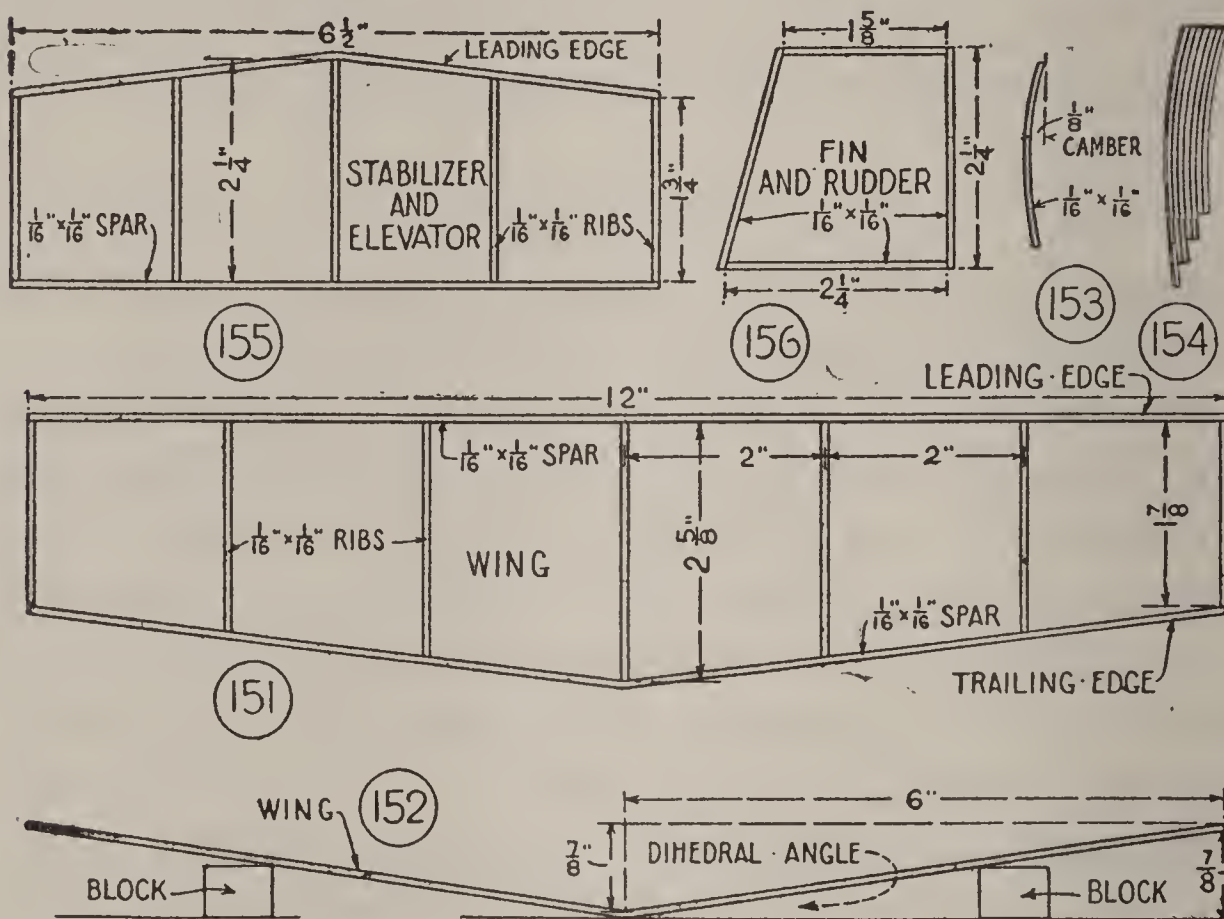

FIG. 151.—Plan of Wing.

FIG. 152.—Block up Spars This Way to Give Wing Correct Dihedral Angle.

FIGS. 153 and 154.—Rib Details.

FIG. 155.—Plan of Stabilizer and Elevator.

FIG. 156.—Plan of Fin and Rudder.

Japanese tissue paper. Slip the covered frame into the slot, or notched edge of the fuselage, and fasten with cement.

The Fin and Rudder are shown in detail in Fig. 156. Assemble the frame, and cover it on both sides with Japa-

nese tissue paper. Cement its bottom spar to the upper side of the motor base.

METAL FITTINGS

The fittings are to be of No. 8 music wire. Suggestions for shaping the wire are given in Chapter VI.

The Propeller Bearing is shown in Figs. 157 and 158. The upper end is hooked to stick into the motor base. The

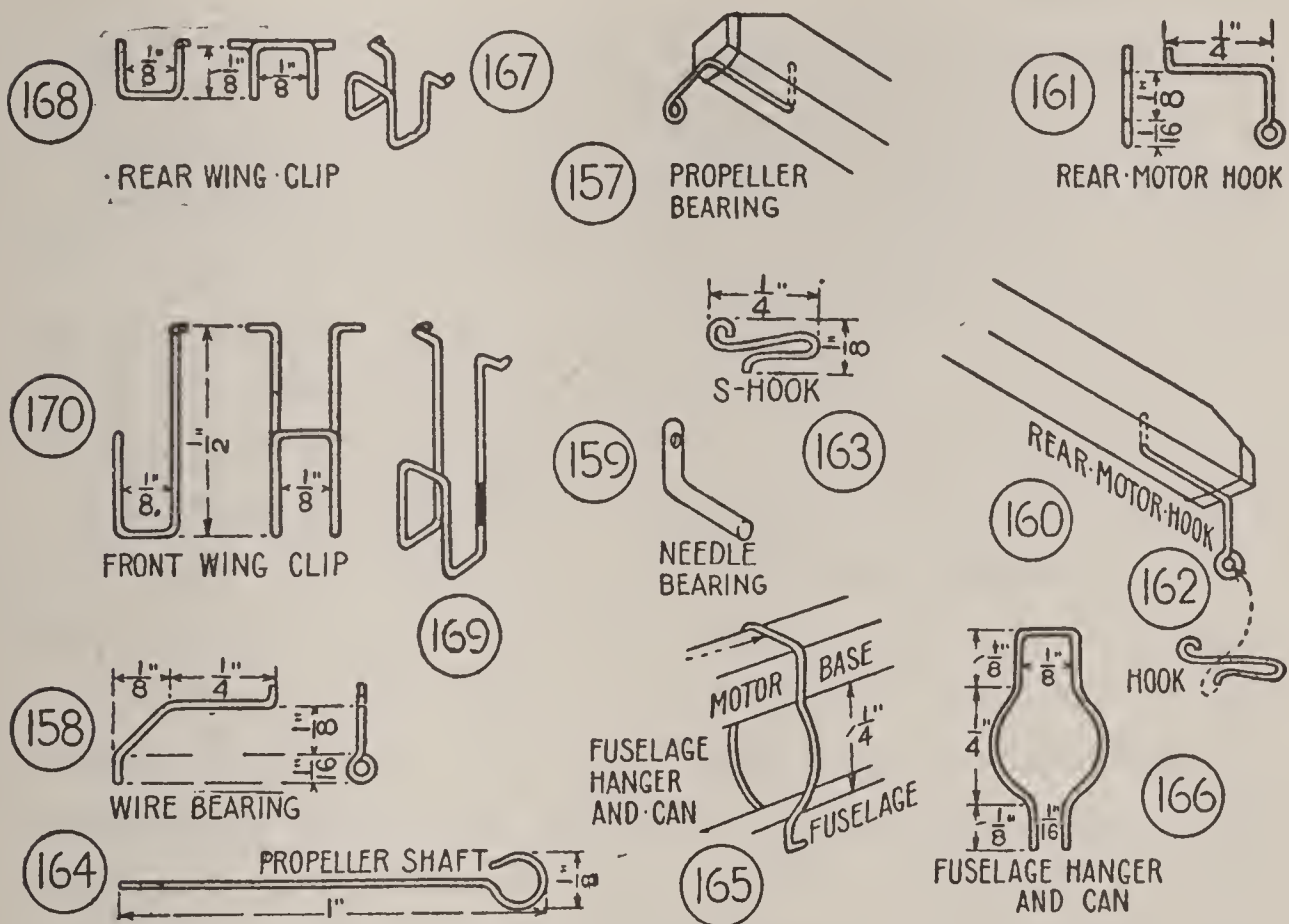

Figs. 157-170.—Metal Fittings for the PF-29 Model.

lower end has an eye just large enough to receive the propeller shaft. This eye should be as nearly round as it is possible to make it.

Instead of the wire hanger, you may use

**A Needle Bearing** (Fig. 159). Get a needle with an eye that is nearly round. Heat it in a gas burner until it is red-hot. Hold its ends with two pairs of pliers, and make a right-angle bend. Reheat it, and plunge it into water to re-temper it. Clip off the end of the needle, and cement the bearing to the motor base.

Fig. 157 suggests a wrapping of cotton thread around the bearing and motor base for reinforcement. Coat the thread with cement.

**The Rear Motor Hook** is shown in Fig. 160. Shape it as shown in Fig. 161, with an eye on one end just large enough to take the S-hook, and a hook on the other end to insert in the motor base. Cement it to the base and add a turn of thread for reinforcement.

**The S-Hook** must be shaped long and slim, as shown in Fig. 162, because it fits between the motor base and fuselage. Follow the dimensions in Fig. 163 in shaping it.

**The Propeller Shaft** is shown in Fig. 164. Shape the hook end as shown. Leave the other end straight until ready to mount the propeller.

**Washers** for thrust bearings should be cut out of very thin brass and punched with the point of a phonograph needle (Fig. 181). Three washers will do very well for this model, one to cement to the propeller hub, the others to be free, but two are sufficient.

**Wire Hangers** are used to suspend the fuselage from the motor base (Fig. 165). Three are required. Fig. 166 shows how to shape them so they will serve also as motor cans. Cement the hangers to the motor base and to the



fuselage, leaving a space of  $\frac{1}{4}$  inch for the motor rubber (Fig. 165).

**Wing Clips.** The front wing clip (Figs. 167 and 168) raises the leading edge about  $\frac{3}{8}$  inch, to give the correct *angle of wing setting*, or *angle of incidence*. The rear wing clip (Figs. 169 and 170) holds the wing's trailing edge to the motor base. Bend these clips to make a slip-fit over the motor base. Cement them to the center of the wing spars.

### THE LANDING-GEAR

The **Struts** of the landing-gear are made of a strip of bamboo (Fig. 171). Bend the strip over a lighted electric lamp bulb, or the flame of a candle. Stick it through the fuselage and fasten with cement.

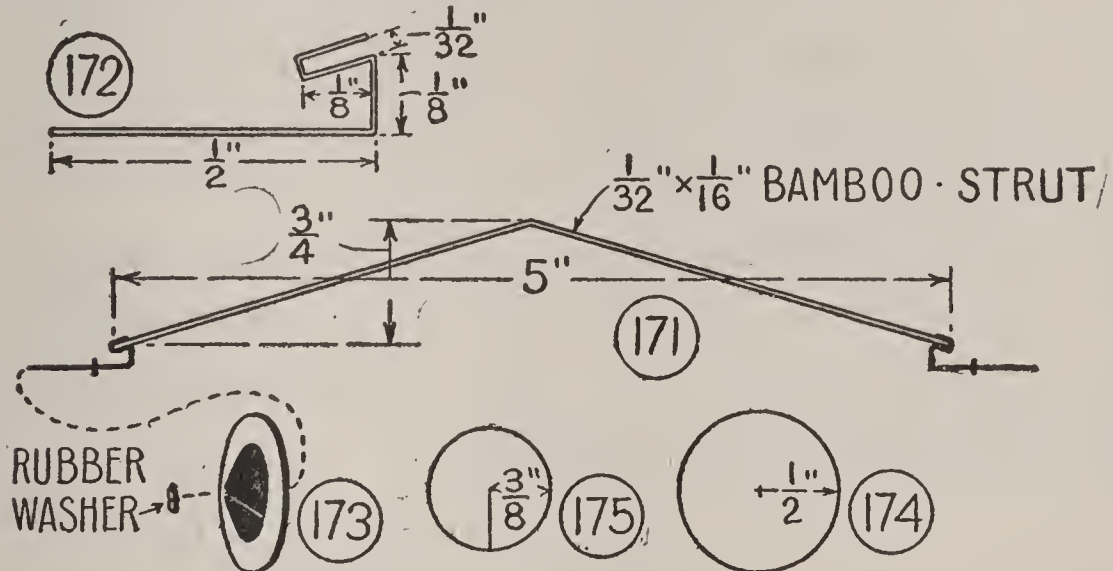

FIG. 171.—Landing-Gear Strut.

FIG. 172.—Wire Axle and Shock-Absorber.

FIGS. 173-175.—Wheel Details.

The **Wheels** are of balsa, with paper hubs (Fig. 173). You can cut them easily with a pair of drawing dividers, or

a pair of scissors. Fig. 174 shows the size. Cut the paper hubs of the diameter shown in Fig. 175, slit one edge, fold them into cones, and cement them to the wheels, with centers in line with the wheel center.

The **Wheel Axles** are of music wire, which gives the resiliency of shock-absorbers. Figs. 171 and 172 show how to shape and attach them to the strut ends. Slip bits of motor rubber over the axles, one each side of each wheel, to hold the wheels in place.

### THE PROPELLER

This model has a small propeller. Fig. 176 shows

The **Blank**, laid out for cutting, and Figs. 177 to 180 show the steps in carving it. Proceed as instructed in Chapter VII. In finishing, reduce the blades to  $\frac{1}{32}$ -inch thickness, and trim down the hub to a width of  $\frac{1}{16}$  inch and a depth of  $\frac{1}{4}$  inch. Reduce the hub's thickness on the inner or trailing surface.

In **Mounting** the propeller, stick the shaft through the hub, bend it over, coat the bend with cement, and pull the tip down into the hub. Then slip a thrust washer over the shaft and cement it to the hub.

### THE MOTOR

The **PF-29** model requires 20 inches of  $\frac{1}{32}$ -inch by  $\frac{3}{32}$ -inch motor rubber. Make a firm knot in the loop ends, and place the knot at the S-hook, and slip the S-hook through the eye of the rear motor hook.

TUNING THE MODEL

Tune the model as instructed for the ID model (Chapter VII).

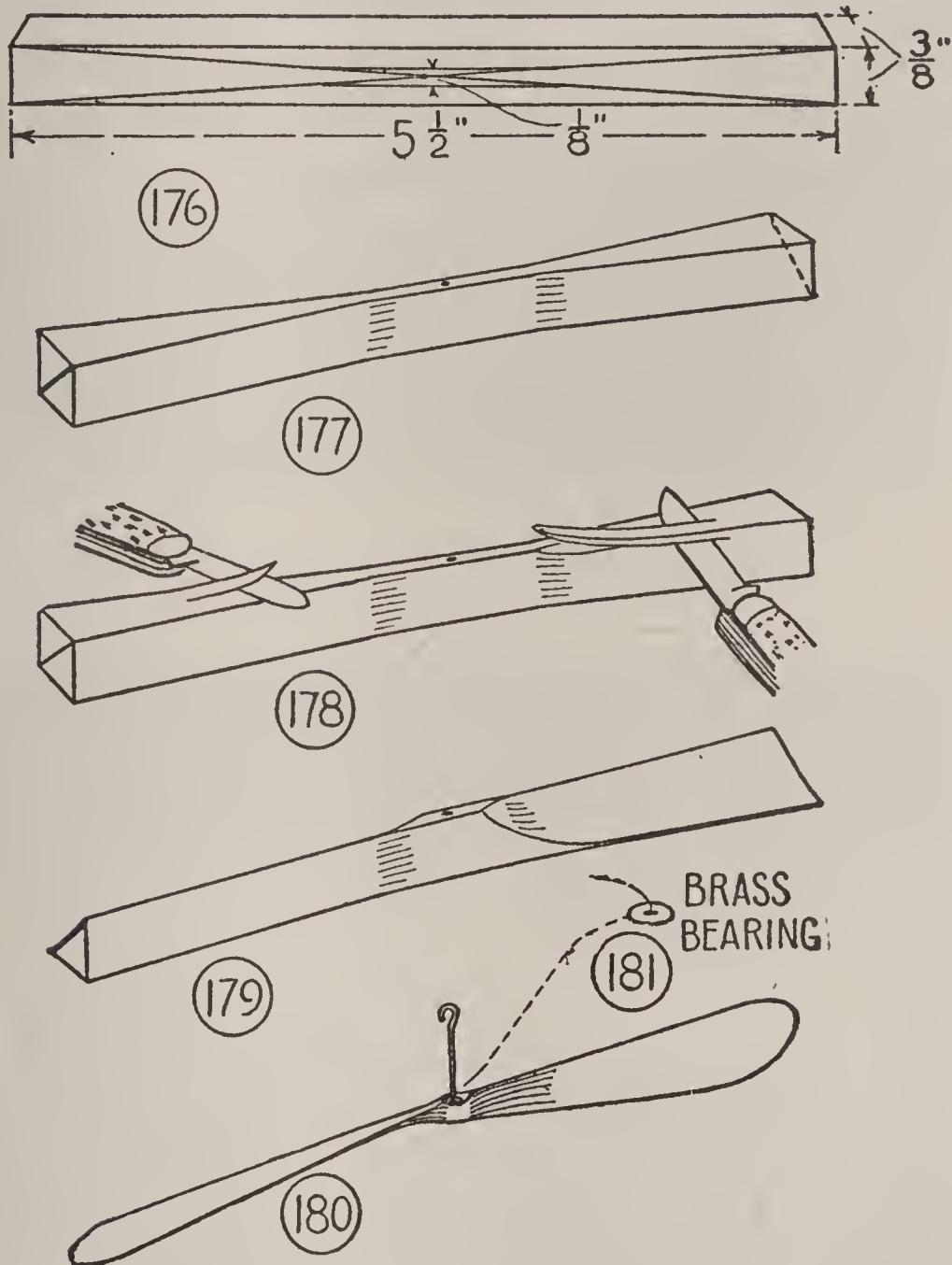

Figs. 176-181.—Steps in Carving the Propeller.

FINISHING THE CABIN

Fig. 148 of the diagrams and the photograph of Fig. 182 suggest the placement of cabin windows, and lettering.

These finishing touches may be put on with water-color or ink. Some of my readers have cut openings in the tissue paper covering of the fuselage and set in pieces of glassene paper for glass. The Japanese tissue paper furnished in the PF-29 material kit is ready printed with windows.

Indicate ailerons on the wing, also the division of stabilizer and elevator, and fin and rudder.

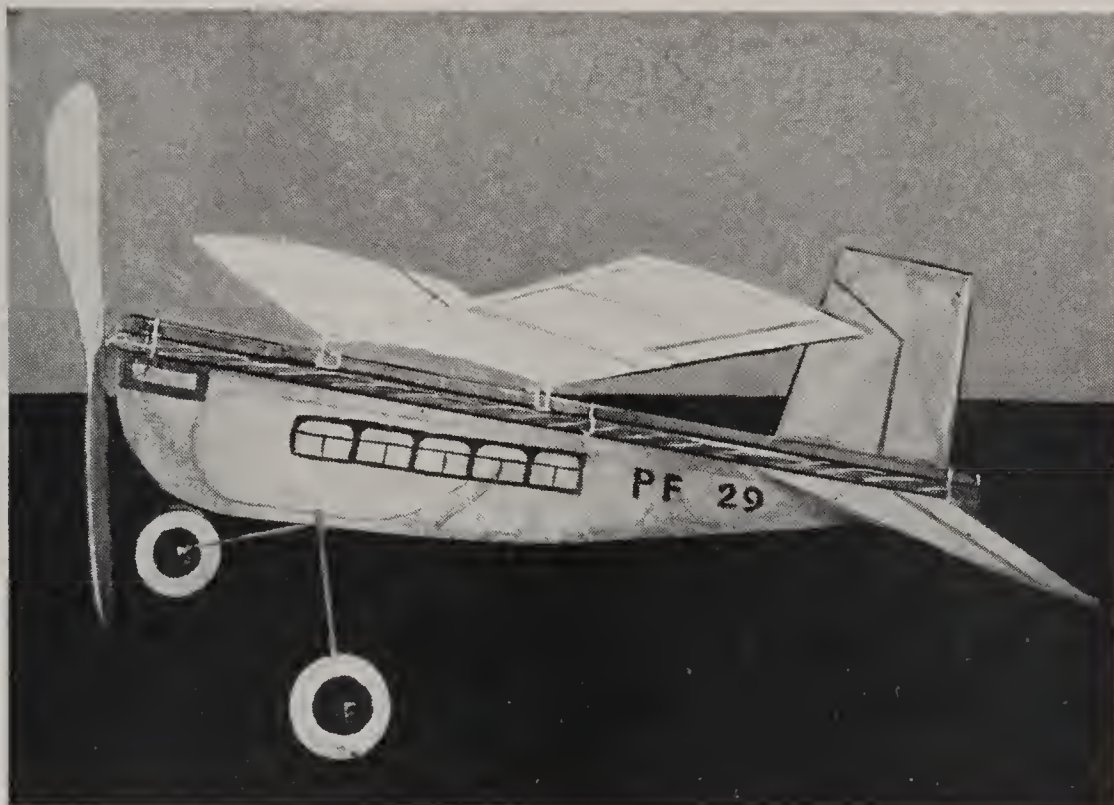
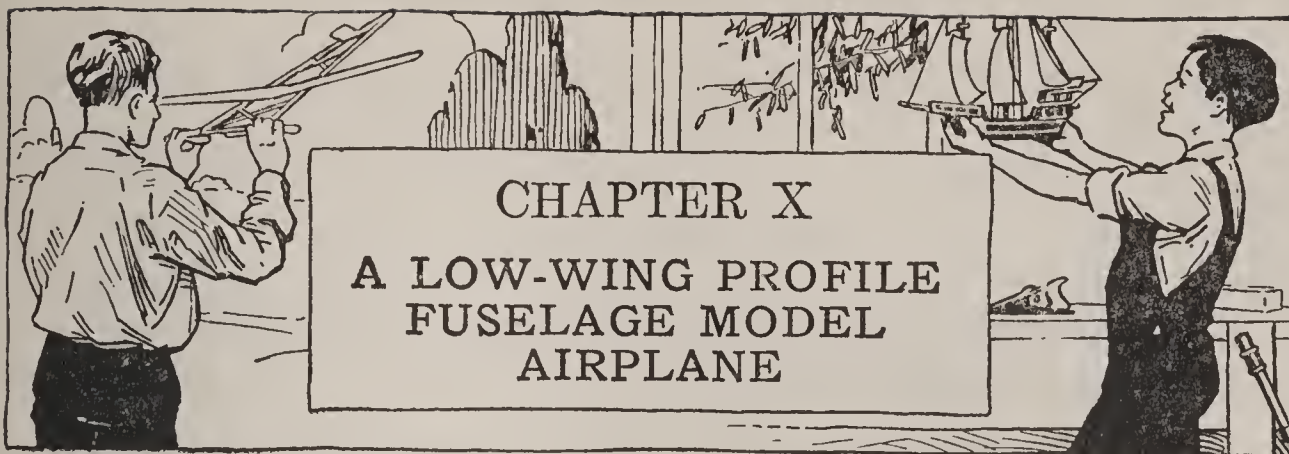

FIG. 182.—A PROFILE FUSELAGE MODEL AIRPLANE, THE P F 29. IT LOOKS LIKE A REAL SHIP, FLIES LIKE ONE, AND WEIGHS LESS THAN ONE-SIXTH OUNCE.



FIG. 183.—ANOTHER PROFILE FUSELAGE MODEL AIRPLANE, THE P F 30. THIS LARGER BABY, WITH LOW WING, BARELY TIPS THE SCALES AT ONE-QUARTER OUNCE.





AFTER your PF-29 has demonstrated its good points, nothing will stop you from building the PF-30, another design by B. C. Friedman, inventor of the profile fuselage type of model. As you will see by the photograph of Fig. 183, this model has the low wing of the Junkers *Bremen*, first airplane to make a trans-Atlantic flight from East to West. It weighs a trifle more than the PF-29, but, at that, barely tips the beam at one-quarter ounce. The profile fuselage provides a remarkably fine rudder and makes for inherent stability. Indeed, the model has been looped forward and backward, rolled, side slipped, and been put into a tailspin, always with the result that it righted itself and made a three-point landing. It is a rise-off-the-floor model, with a flight duration dependent upon one's skill in building, tuning, and launching.

### MATERIALS

The PF-30 model requires the following:

- 1 piece balsa  $\frac{1}{8}$ " by  $\frac{3}{16}$ " by 15" for motor base
- 1 piece balsa  $\frac{1}{16}$ " by 2" by 15" for fuselage
- 2 pieces balsa  $\frac{1}{16}$ " by 2" by  $18\frac{1}{4}$ " for spars, ribs, and wheels

1 piece balsa  $\frac{5}{8}$ " by  $\frac{7}{8}$ " by 7" for propeller blank  
 1 piece bamboo 6" long for landing-gear  
 Japanese tissue paper for fuselage, wing, and tail covering  
 No. 8 music wire for metal fittings  
 Thrust washers  
 28 inches of flat rubber, size  $\frac{1}{32}$ " by  $\frac{3}{32}$ ", for motor  
 Cement, and banana oil

Read the suggestions for purchasing materials, in Chapter VI, and note the reference to  
 A Material Kit for this model.

Fig. 184 shows the front elevation, and Fig. 185 the side elevation, of the PF-30 model.

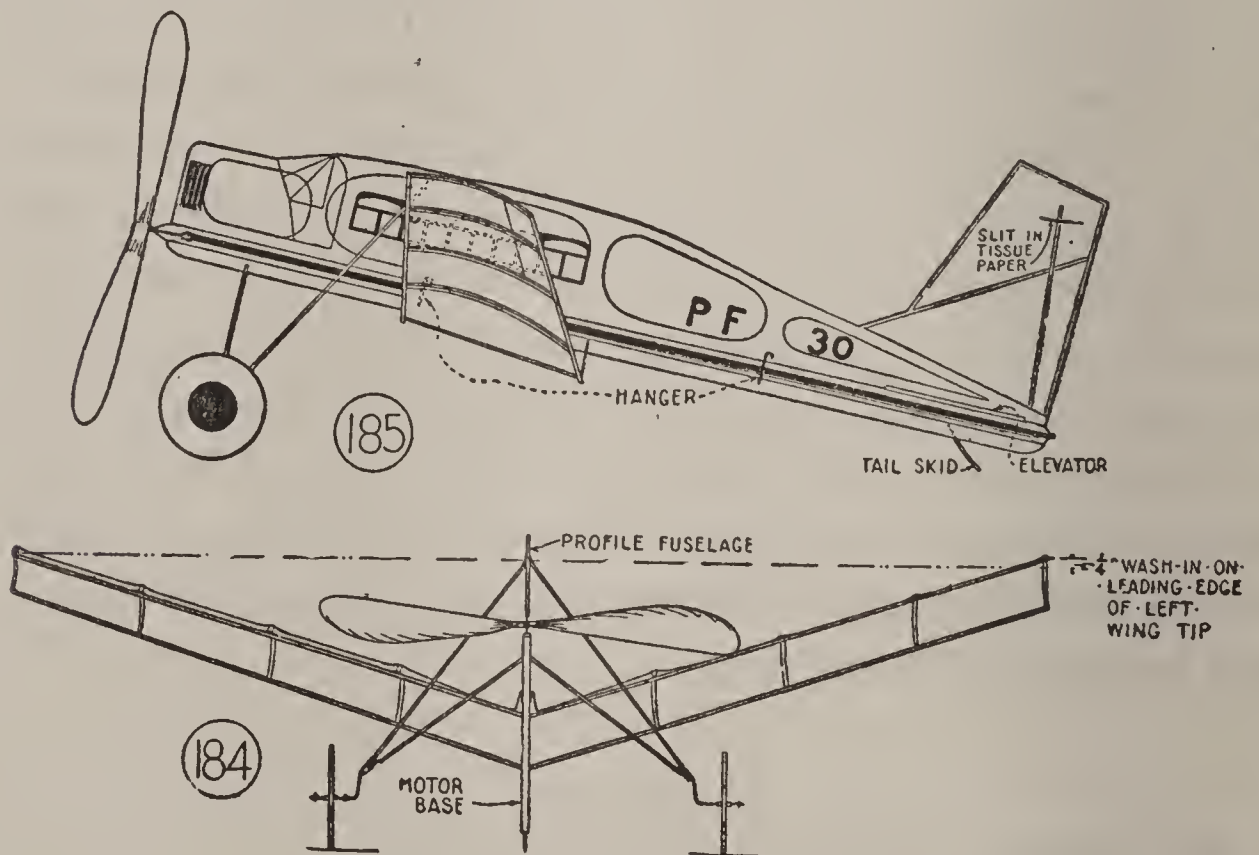

FIG. 184.—Front View of the PF-30 Model.  
 FIG. 185.—Side View of the PF-30 Model.

### THE MOTOR BASE

is shown in Fig. 186. It must be absolutely straight, and



its surfaces must be finished smooth with No. 00 sandpaper. Round the ends as shown.

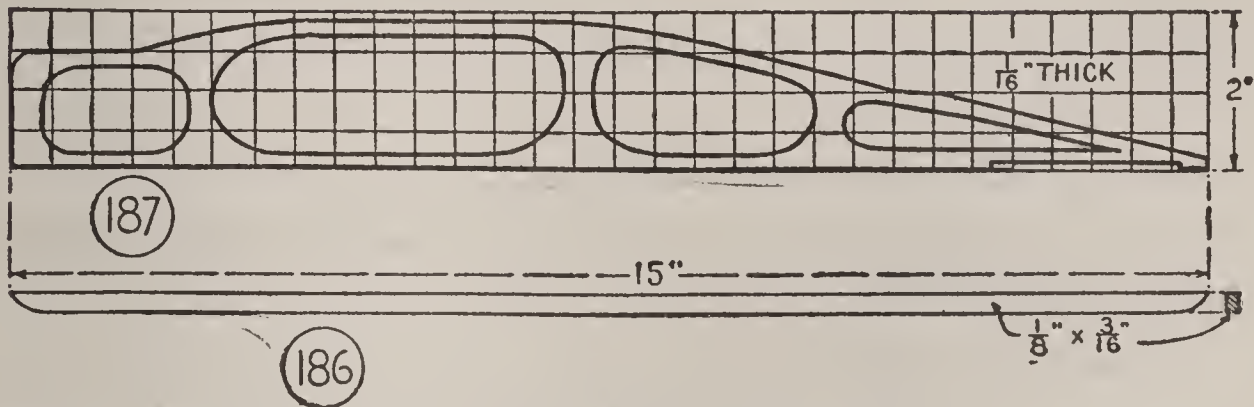

FIG. 186.—Motor Base.  
FIG. 187.—Profile Fuselage.

### THE FUSELAGE

is mounted above the motor base. A pattern is given in Fig. 187. Make a full-size pattern, enlarging the small one with the aid of the squares. Draw five horizontal lines  $\frac{1}{2}$  inch apart, and cross them with thirty-one vertical lines  $\frac{1}{2}$  inch apart, which will produce a series of squares similar to those of the pattern, but drawn full-size. Then lay out upon the large squares the outline of the fuselage just as it is shown upon the small squares. Openings are indicated to save weight. It is not necessary to locate them exactly as shown, but enough margin must be left around the edges and between openings for rigidity. The slot shown in the lower edge of the tail is for the stabilizer.

Having laid out the fuselage upon heavy paper or cardboard, cut it out, and mark out around it upon a piece of balsa. Cut the balsa with your razor-blade knife (Fig. 83, Chapter VI). Place the wood flat upon a board, and cut as you would score cardboard.

Sandpaper the sides and edges of the fuselage, then cover both sides with Japanese tissue paper. Apply banana oil to the wood, spread the paper smoothly over the surface, and press it down with a cloth.

### THE WING

is shown in plan in Fig. 188, and its trailing edge is shown in Fig. 189. Cut

The Spars of the sizes marked, then steam them preparatory to bending. The amount of the dihedral angle is

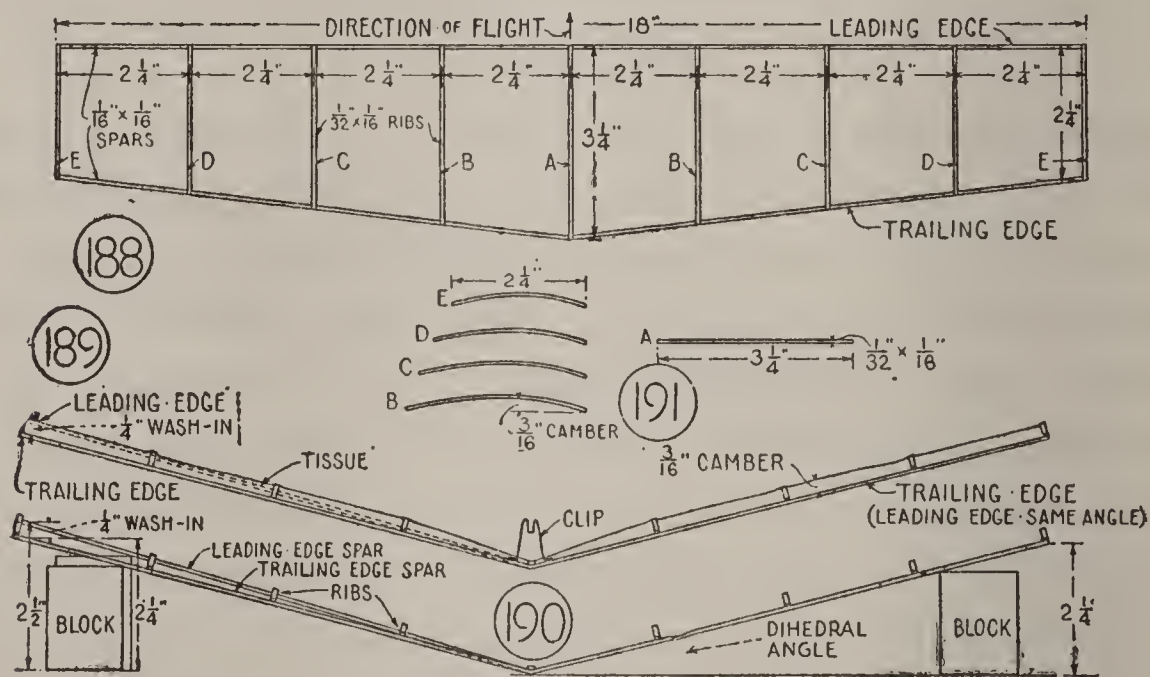

FIG. 188.—Plan of Wing.

FIG. 189.—Trailing Edge of Wing.

FIG. 190.—Block up Spars This Way to Give Wing Correct Dihedral Angle.

FIG. 191.—Rib Details.

indicated in Fig. 190, also the *wash-in* on the left half of the leading-edge spar. The trailing-edge spar must be bent two ways, as you will note. The bending of the spars is

described in Chapter VII. When they have been bent, make the bends permanent with a drop of cement applied to both sides.

**The Ribs** are nine in number, of the thickness and width marked in Fig. 188. The center rib is  $3\frac{1}{4}$  inches long, the end ribs are  $2\frac{1}{4}$  inches long, and the intermediate ribs are of lengths determined by the slant of the trailing-edge spars (Figs. 188 and 191). The center rib is straight, the other ribs have a camber of  $\frac{3}{16}$  inch. Steam over the spout of a tea-kettle, to make them pliable for bending.

**Assemble and Cover the Wing** as described for the ID model in Chapter VII.

### THE TAIL

**The Stabilizer and Elevator** are shown in detail in Figs. 192 and 193. Cut the spars and ribs of the sizes marked. In assembling, set the ribs between the spars, instead of lapping them. The right tip of the trailing edge of the elevator must have a slight warp, as indicated in Fig. 193. This warp can be produced after the frame has been assembled, by steaming the trailing-edge spar, and exerting a slight upward pressure with your fingers.

**Cover** the frame upon the upper surface. Then slip a stick of the size of a rib between the paper and the diagonal rib on the right tip, as shown. By adjusting this batten forward or backward, the warp of the tip may be increased or decreased.

**Mounting.** Center the stabilizer and elevator in the fuselage recess, and cement it.

The Fin and Rudder are shown in Figs. 194 to 196. Frame this piece as you did the stabilizer and elevator. The rudder must be warped  $\frac{1}{2}$  inch to the left, as shown in the top and front views (Figs. 195 and 196), to offset the torque of the propeller, and an adjustable batten must be

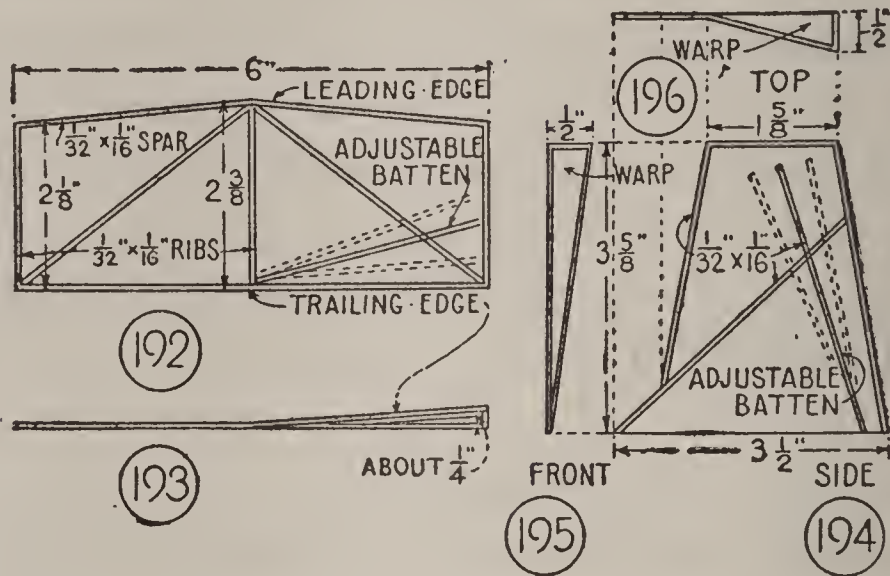

FIGS. 192 and 193.—Plan and Trailing Edge of Stabilizer and Elevator.

FIGS. 194–196.—Side, Front, and Top of Fin and Rudder.

inserted between the tissue paper covering and the diagonal rib, as in Fig. 194, by which to increase or decrease the warp. Because the fin and rudder are covered on both sides, a slit must be made in the tissue paper, as shown in Fig. 185, through which to slip a pin for the purpose of adjusting the batten.

To Mount the fin and rudder, notch the upper edge of the fuselage, and cement the frame sticks into the notches.

The Covering of the fuselage, fin, and rudder can be put on at one time, using one piece for each side.

METAL FITTINGS

The fittings require No. 8 music wire, a pair of round-nosed pliers, patience, and accuracy. If you lack patience or accuracy, practice in shaping the metal parts will help you to acquire it.

The Propeller Bearing (Figs. 197 and 198) is also a hanger for the motor base. Shape the propeller eye round,

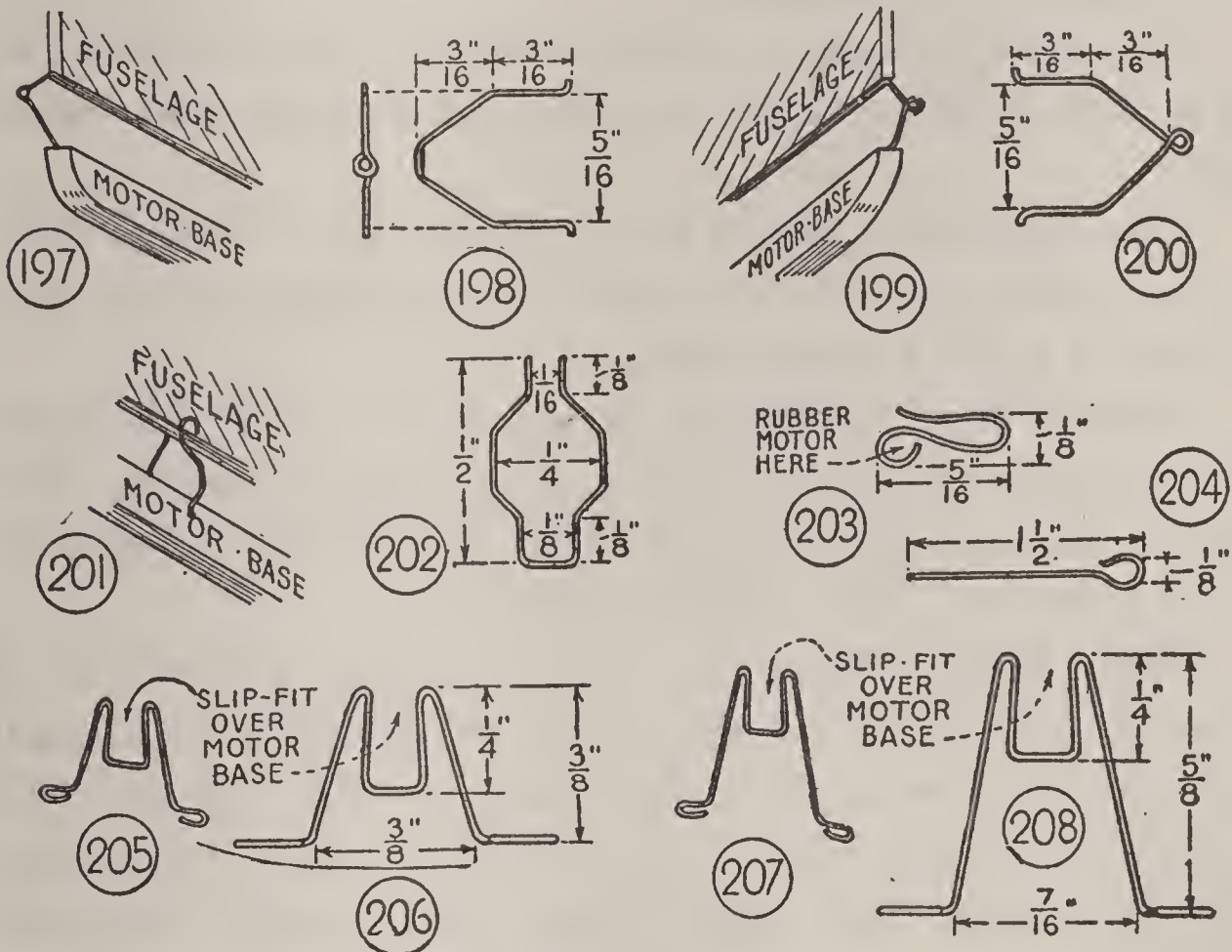

Figs. 197-208.—Metal Fittings for the PF-30 Model.

and just large enough for a No. 8-wire propeller shaft. Coat the end tips with cement, and push them into the edges of the fuselage and motor base; also cement the straight sides in place.

The **Rear Motor Hook** is similar to the propeller bearing (Figs. 199 and 200), except in the twist of the eye for the motor S-hook.

**Two Intermediate Hangers** are required. They are shown in Figs. 201 and 202. Notice that they are bent to form cans for the motor rubber. In mounting, run the lower loop through the motor base, and cement the tips to the sides of the fuselage.

The **S-Hook** must be shaped long and slim, as shown in Fig. 203, because it fits between the fuselage and motor base.

The **Propeller Shaft** is shown in Fig. 204. Shape a hook on one end, and leave the other end straight until the propeller is ready for mounting.

**Thrust Washers** should be cut out of very thin brass and punched with the point of a phonograph needle. You can use three, one to cement to the propeller hub, the other two to be free. But two are sufficient.

**Wing Clips.** There are two wing clips, shaped out of No. 8 music wire. A sketch and a dimensioned diagram of each are shown. The front wing clip (Figs. 205 and 206) holds the leading edge of the wing close to the motor base. The rear wing clip (Figs. 207 and 208) supports the trailing edge at a point about  $\frac{1}{4}$  inch below the motor base, producing the correct *angle of wing setting*. Bend the upper loop of these clips so they knee-in, with just enough space between the knees to make a slip-fit over the motor base. Cement the foot loops of the clips to the wing spars, as shown in Fig. 189.

THE LANDING-GEAR

Figs. 184 and 185 show front and side views of the landing-gear. Cut

The Struts of bamboo of the sizes given in Fig. 209. Point the upper ends to stick into the fuselage and motor base. Cement them in place. Bring the lower ends together and cement them.

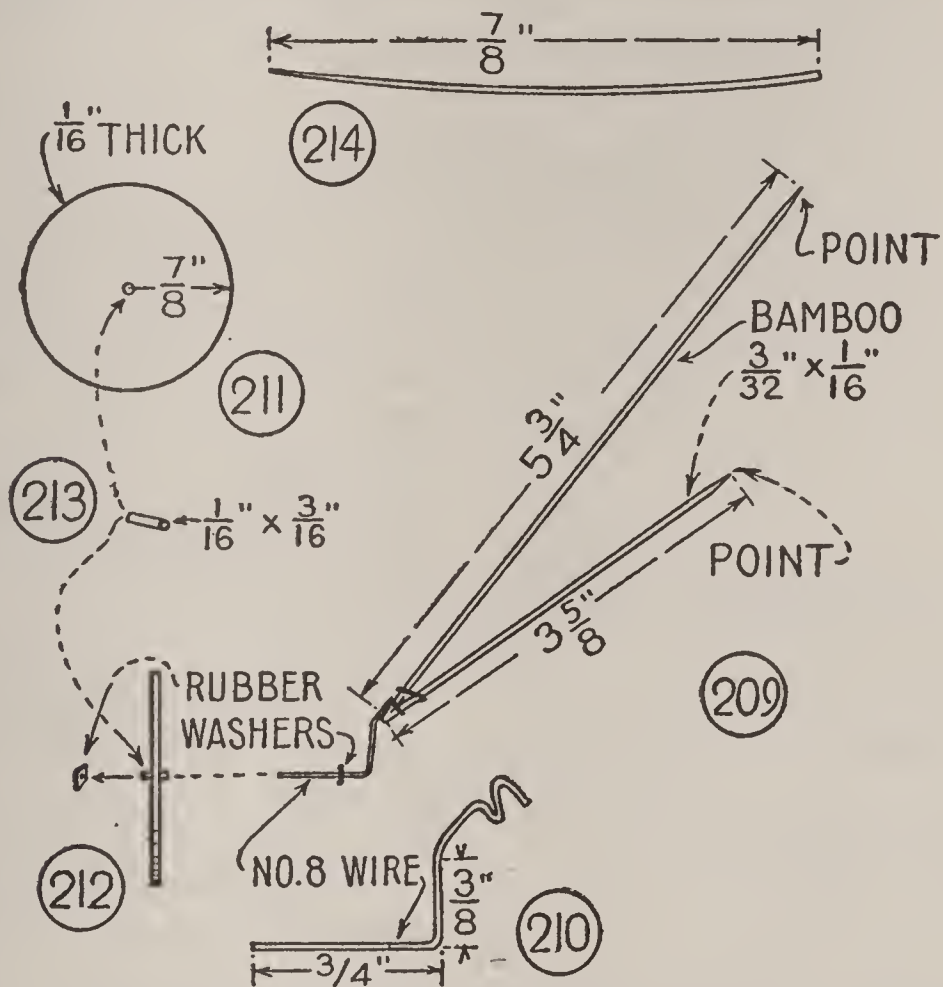

FIG. 209.—Landing-Gear Strut.  
 FIG. 210.—Wire Axle and Shock-Absorber.  
 FIGS. 211-213.—Wheel Details.  
 FIG. 214.—Tail Skid.

The Wheel Axles are of wire (Fig. 210). They also form

**The Shock-Absorbers.** Coil the upper ends about the struts, and fasten in place with a drop of cement.

**The Wheels** are of balsa (Fig. 211), with hubs of  $\frac{1}{16}$ -inch brass tubing (Figs. 212 and 213). Coat the hubs with cement, and center them in holes made through the wheel centers. Slip bits of motor rubber over the axles to hold the wheels in place.

**The Tail Skid** is of bamboo (Figs. 185 and 214). Cement it in a hole in the motor stick.

### THE PROPELLER

This ship has a 7-inch propeller. Fig. 215 shows

The Blank laid out for cutting, and Figs. 216 to 219 show the steps in carving it. Propeller carving is fully de-

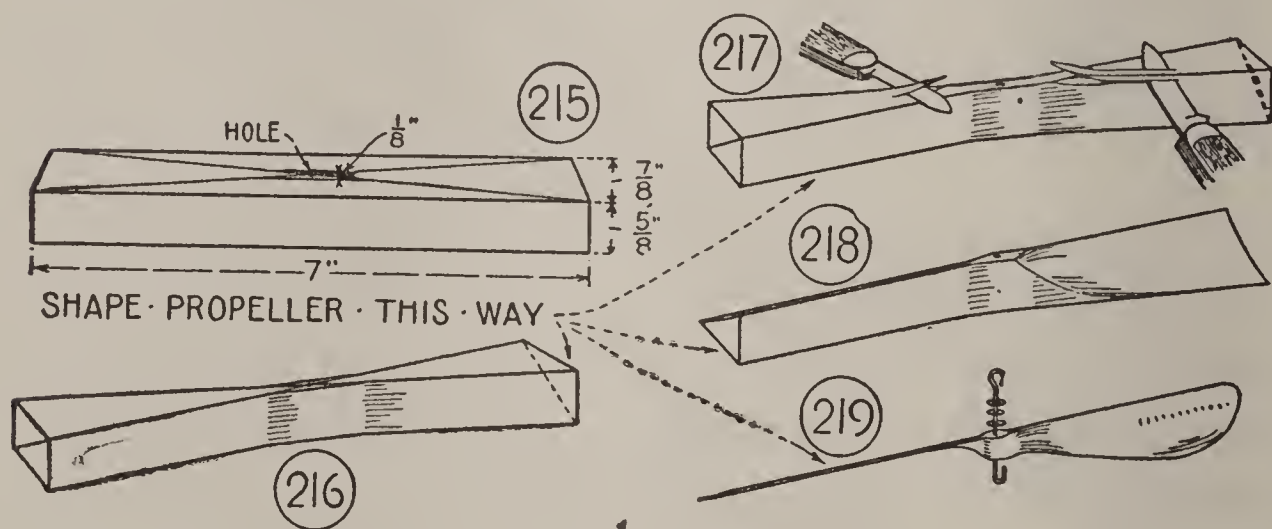

FIGS. 215-219.—Steps in Carving the Propeller.

scribed in Chapter VII. In finishing, reduce the blades to about  $\frac{1}{32}$  inch, by rubbing with sandpaper, and reduce the width of the hub to  $\frac{1}{16}$  inch, and its thickness to about  $\frac{3}{8}$  inch. Cut away the hub on the leading face, rather



than on the trailing face, so the blades will clear the fuselage.

Mount the propeller as shown in Fig. 219. Slip the shaft through the hub, bend over the straight end, daub it with cement, and pull this hooked end into the hub, embedding it in the balsa.

### THE MOTOR

The PF-30 model requires 28 inches of  $\frac{1}{32}$ -inch by  $\frac{3}{32}$ -inch motor rubber. Make a firm knot and place the knot at the S-hook, as indicated in Fig. 203, and the S-hook in the rear motor hook.

### TUNING THE MODEL

Follow the instructions in Chapter VII for tuning.

### FINISHING THE CABIN

The placement of windows, radiator, and lettering is suggested in Figs. 183 and 185. You may add these finishing touches with water-color or ink. In the PF-30 material kit, the windows and other fitments are ready printed upon Japanese tissue paper.

Don't neglect to indicate ailerons on the wing, and the division of stabilizer and elevator, and fin and rudder.

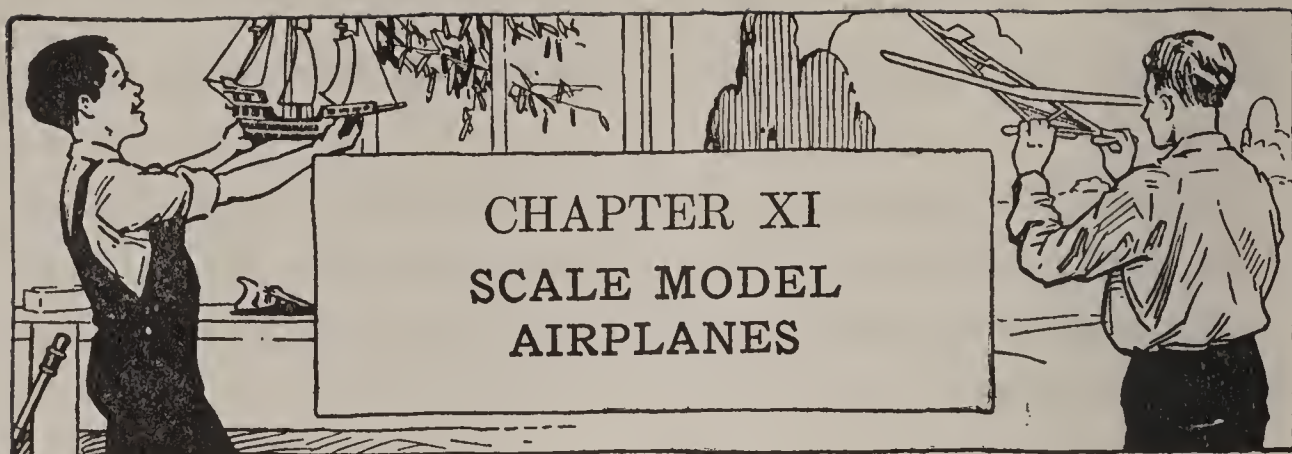

BUILDERS of efficient flying models may not be so successful in fashioning their first scale model. The jobs are distinctly different. In the one, the object is to produce a model capable of record flights. Weight is of first consideration. In the other, the object is to produce a model that follows closely the design of a real ship. Weight is of little or no consideration.

Your flying model of the fuselage type may have the general lines of an airplane, but you are handicapped by small choice of materials, and by proportions dictated by conditions not met with by builders of large planes. The first noticeable difference between the average flying model and the true scale model is that the propeller of the flying model is out of proportion. It must be larger. Next, a difference in wing placement is discovered. To offset the lack of weight at the cowling, due to the absence of a motor it is necessary to set the wing farther back on the fuselage. These matters are of little importance to one satisfied with a model that flies, but they will disqualify your model for the class of exhibition scale models.

When building a flying model, you will follow an estab-

lished design, and use approved materials and methods of construction, unless you have reached the stage in your model-making career where you are beset with the desire to create a new type. But when you undertake

**A True Scale Model** you will have considerable pioneering to do. For, having selected the ship you wish to build, you must find plans for it, or work out your own plans from such pictures and such data as you can lay hands on. You must select materials best adapted to the various parts of the model, and, last but not least, you must devise methods of shaping and assembling them. Such work as this draws upon a fellow's imagination, and usually brings out a lot of unsuspected ingenuity.

When you have acquired the skill to build models that fly, you will have learned a great deal about aerodynamics, and when you have dug up the information necessary to build true scale models there will be little about the construction of ships and their parts with which you are not acquainted.

### CONTEST SCALE MODELS

A well-built scale model will win for you prizes and honors, in local and national tournaments. At present there is a scale model event in the annual contests at Detroit, conducted by *The American Boy* and the "Airplane Model League of America," there are occasional contests conducted by scientific magazines, and there is an annual contest conducted by "The Boy Craftsman League" and a group of boys' weeklies.

The photographs facing page 122 are of some of the prize-winning scale models entered in a recent "Boy Craftsman Model-Making Contest." They are well-proportioned models, complete in detail. On following pages are notes on their construction.

#### SOURCES OF DATA FOR SCALE MODELS

It is comparatively easy to gather data for an airplane model. Pictures are plentiful in magazines and newspaper supplements, especially pictures of ships that are in the public eye, ships that are establishing new records. Illustrated literature on planes is gladly supplied by manufacturers' publicity departments. And there are opportunities at airports to make observations, and to get first-hand information from pilots—veritable flying encyclopedias on airplane types, who abound in patience with air-minded boys.

Scale Drawings of the ship to be built should be obtained if possible. Model supply houses list them. The "Airplane Model League of America," collaborating with *The American Boy*, has issued full-size plans, elevations, and airfoil sections for a group of 24-inch models, and through the courtesy of secretary Merrill Hamburg of the League, and managing editor George F. Pierrot of *The American Boy*, it has been made possible to present you with quarter-size reproductions of three sets of these drawings in this chapter. The drawings are supplemented with photographs of the real ships supplied by the *Mahoney-Ryan Aircraft Corporation, Curtiss Aeroplane and Motor*



FIG. 220.—COLONEL LINDBERGH'S RYAN MONOPLANE, "SPIRIT OF ST. LOUIS."



FIG. 221.—SIDE VIEW OF THE CURTISS ARMY HAWK BIPLANE.



FIG. 222.—FRONT VIEW OF THE FORD TRI-MOTOR CABIN MONOPLANE.

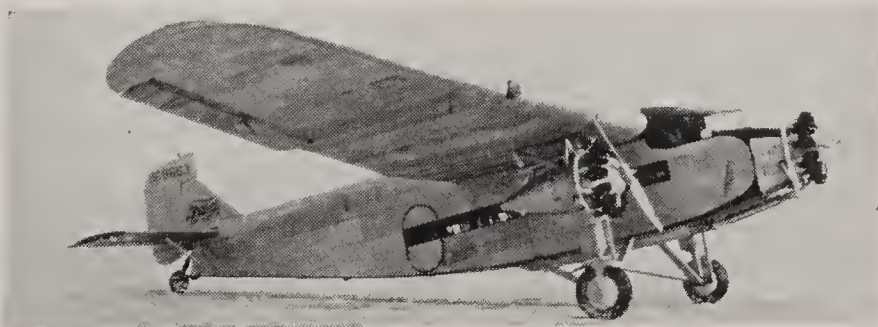

FIG. 223.—SIDE VIEW OF THE FORD TRI-MOTOR CABIN MONOPLANE.



*Company*, and *Ford Motor Company*. Together with the accompanying suggestions for building, they should enable you to turn out three excellent models.

First, is presented the Ryan monoplane

### THE SPIRIT OF ST. LOUIS

To-day's favorite types of planes will be replaced by other favorites for model-making, as improved types are developed, but the "Spirit of St. Louis," first to cross the Atlantic, shall always merit a place in every boy's collection, as the "Santa Maria" of the air, just as its intrepid pilot, Colonel Lindbergh, shall always rank high in every boy's list of heroes.

The "Spirit of St. Louis" is of

**The Best Type for Beginners**, because of its simple lines. Study the photograph (Fig. 220), the plan (Fig. 224), and the elevations (Figs. 225 and 226), and you will note the lack of complicated parts. The plans are for a model with a 24-inch wing span, and they are shown reduced to one-quarter size.

**The Fuselage** can be carved out of a solid block of wood, just as the airplane weathervane in the photograph of Fig. 375 was carved, but with greater attention to details. The windows may be painted upon the sides of the fuselage, but it is a simple job to notch the upper edge of the block, then set in pieces of clear photograph film or mica for glass.

If you prefer to build up the fuselage, read the suggestions given for the Curtiss Hawk model.

**The Wing** may also be shaped out of a solid piece of

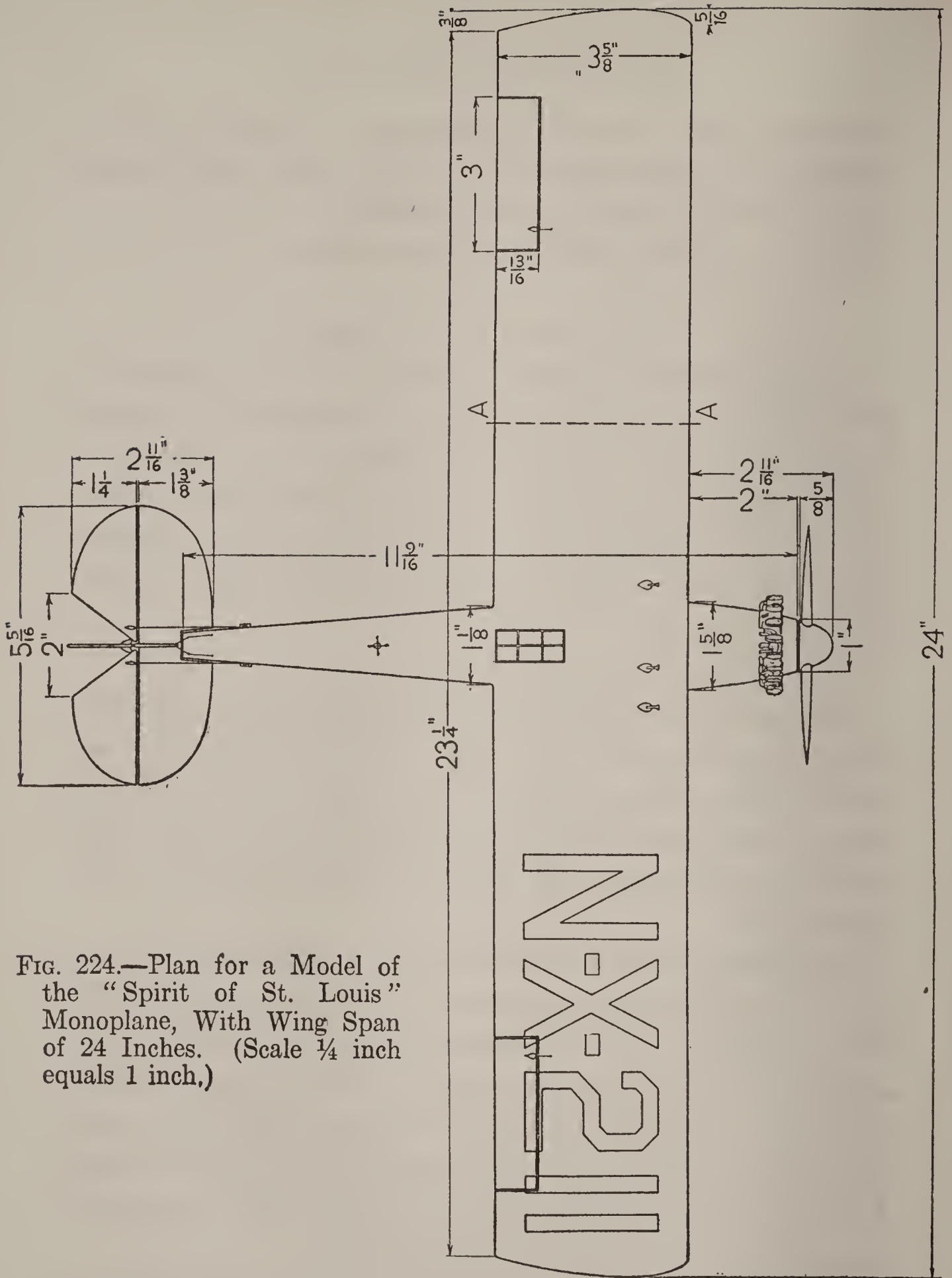

FIG. 224.—Plan for a Model of the "Spirit of St. Louis" Monoplane, With Wing Span of 24 Inches. (Scale  $\frac{1}{4}$  inch equals 1 inch.)



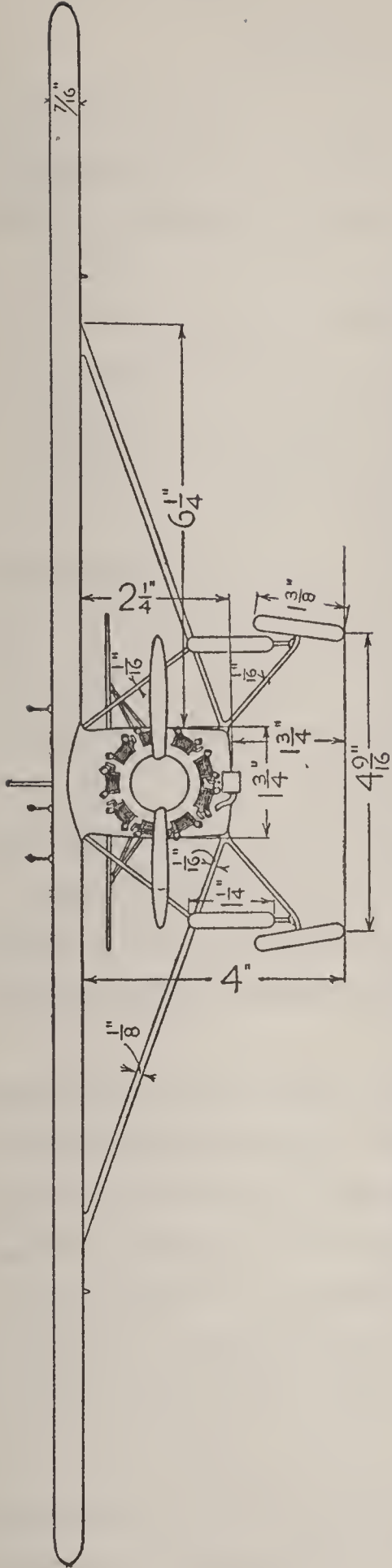

FIG. 225.—Front Elevation for a Model of the “Spirit of St. Louis.”  
(Scale  $\frac{1}{4}$  inch equals 1 inch.)

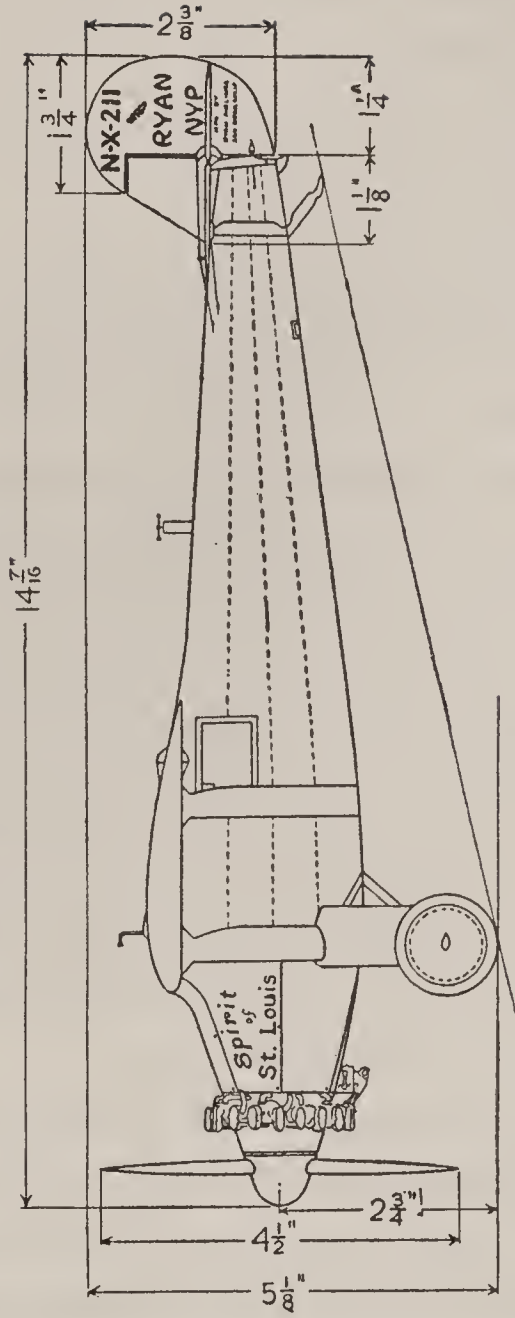

FIG. 226.—Side Elevation for a Model of the “Spirit of St. Louis.”  
(Scale  $\frac{1}{4}$  inch equals 1 inch.)

wood. The shaping will be easy, because, as you will see, there is but one wing section (Fig. 227). In shaping the solid fuselage and the solid wing, prepare templets just as

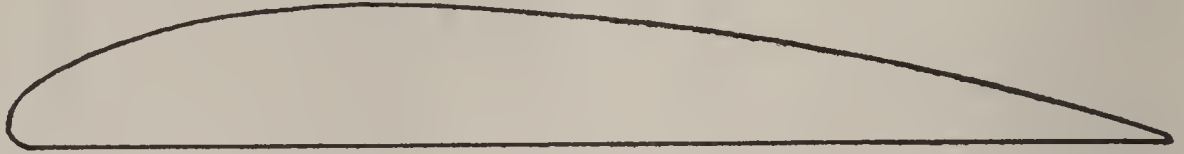

FIG. 227.—Full-Size Wing Section for a Model of the “Spirit of St. Louis.” (See Plan in Fig. 224.)

you would for shaping the hull of a yacht. Suggestions for making and using templets are given in Chapter XVI. The solid wing can be made to look like a built up wing by following the plan of Harold Franklin described among the suggestions for building a Curtiss Hawk.

Cut away the wing to admit the ailerons, then hinge the cut away pieces in place with tiny hinges or wire loops.

**The Stabilizer, Elevators, Fin and Rudder** can be made of thin wood or sheet metal, and the hinged parts can be attached with wire loops.

**The Landing-Gear** wheels, struts, and shock-absorbers are shown in detail in the diagrams. The wheels may be taken from a toy wagon, the struts may be made of wood or metal, the shock-absorbers carved out of wooden blocks.

**The Whirlwind Motor** has nine cylinders. These can be built up of pieces of dowel sticks and matches, pairs of brads with fine wire wound upon them, or carved out of blocks of wood.

**The Propeller** can be carved out of any block of straight-grained wood that cuts easily, just as you carve propellers

for flying models. The spinner cap may be built up of plastic wood, or may be the top of a talcum-powder can of the right shape and size.

Finish the Model with two or three coats of radiator aluminum paint. The mottled cowl and spinner cap, a distinguishing feature of the "Spirit of St. Louis," may be imitated by stippling the surfaces with *plastic wood* before painting. When the paint has dried, add such fittings as the control horns and wires, earth-inductor compass, and air-speed indicator. With black paint add the lettering shown in Fig. 226, upon the sides of the cowl and rudder, and the symbol shown in Fig. 224 on the top of the right half, and on the bottom of the left half of the wing. The symbol "N-X-211" identifies the ship in this way. "N" stands for "U. S. Registered." "X" signifies "Experimental Ship." "211" is the registration number of the Department of Commerce. The letters "NYP" are abbreviations for "New York to Paris."

### THE CURTISS ARMY HAWK

This swift pursuit ship of the army, with a speed of 160 miles an hour, is one of the most popular ships among model-makers. The work is more difficult than that on a monoplane type of model, and for that reason it is more creditable to complete a good model of it.

The photograph (Fig. 221) gives an idea of what the ship looks like when down, the plan (Fig. 228), and the elevations (Figs. 229 and 230), give the necessary dimensions for a 24-inch model, reduced to one-quarter size. If

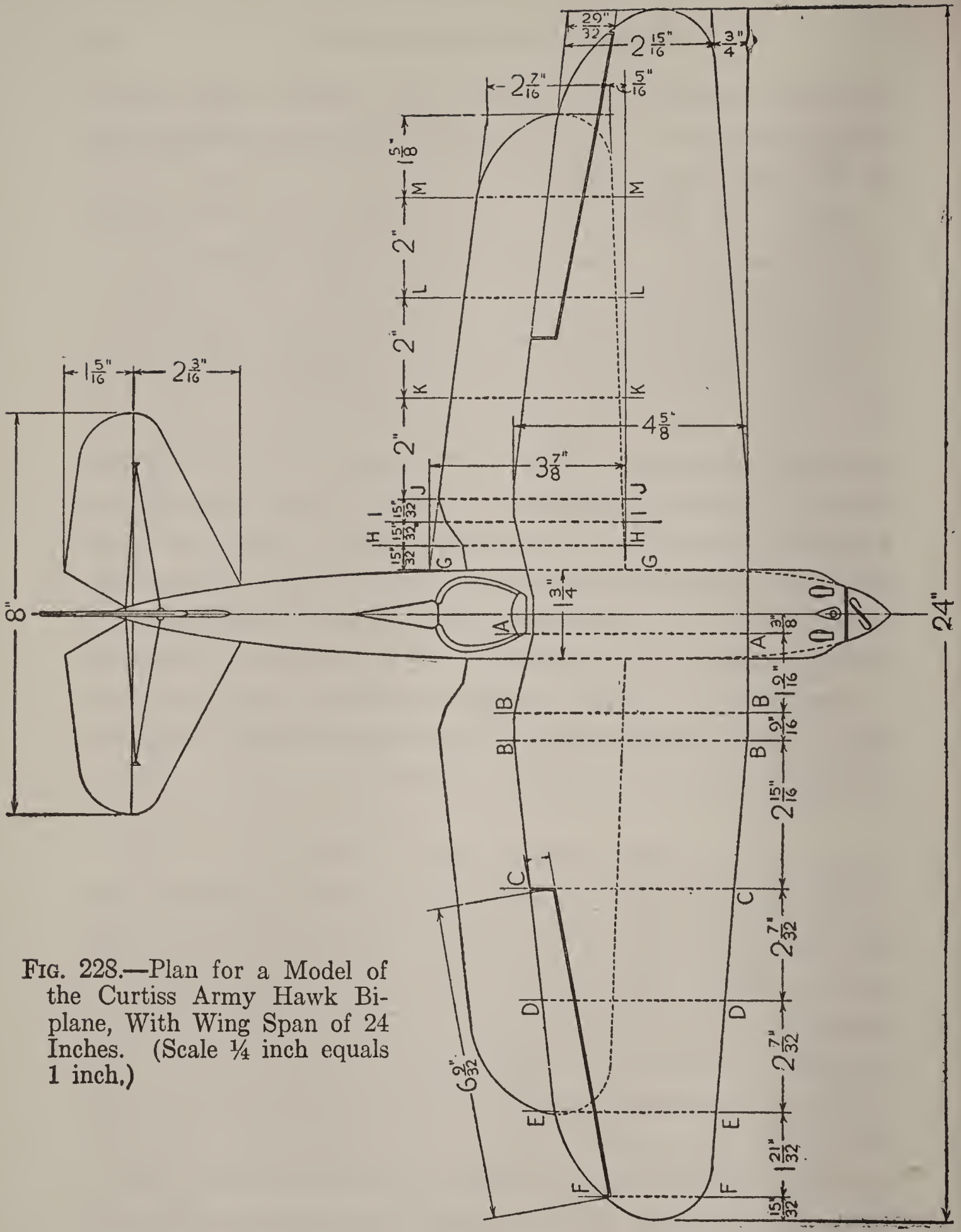

FIG. 228.—Plan for a Model of the Curtiss Army Hawk Bi-plane, With Wing Span of 24 Inches. (Scale  $\frac{1}{4}$  inch equals 1 inch.)

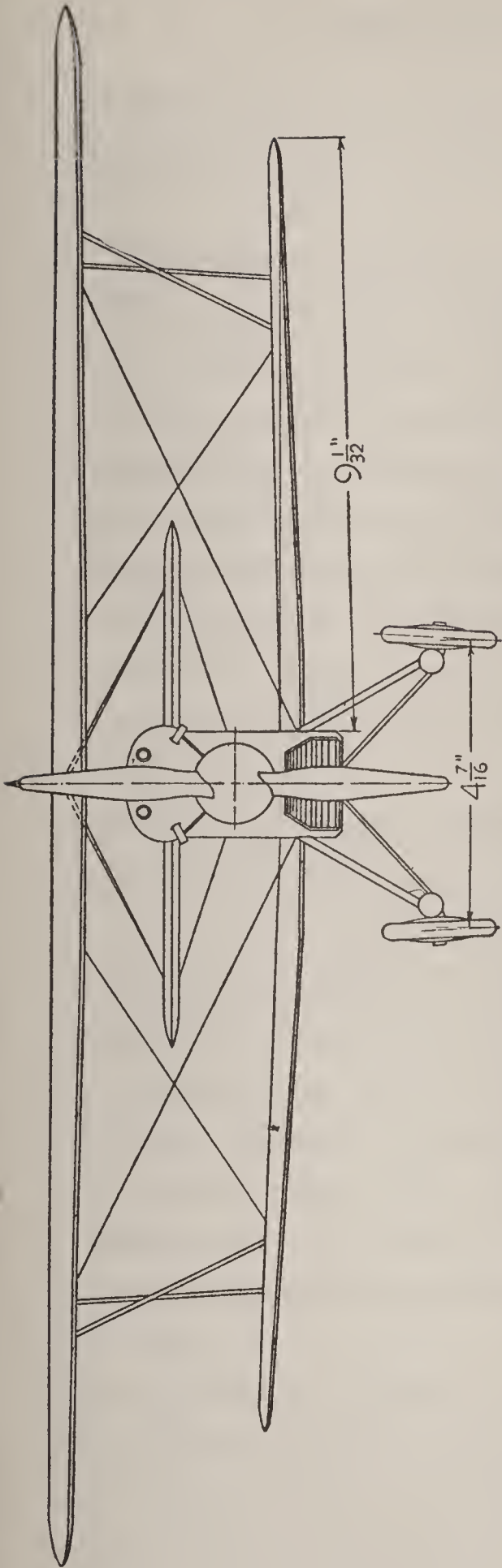

FIG. 229.—Front Elevation for a Model of the Curtiss Army Hawk.  
(Scale  $\frac{1}{4}$  inch equals 1 inch.)

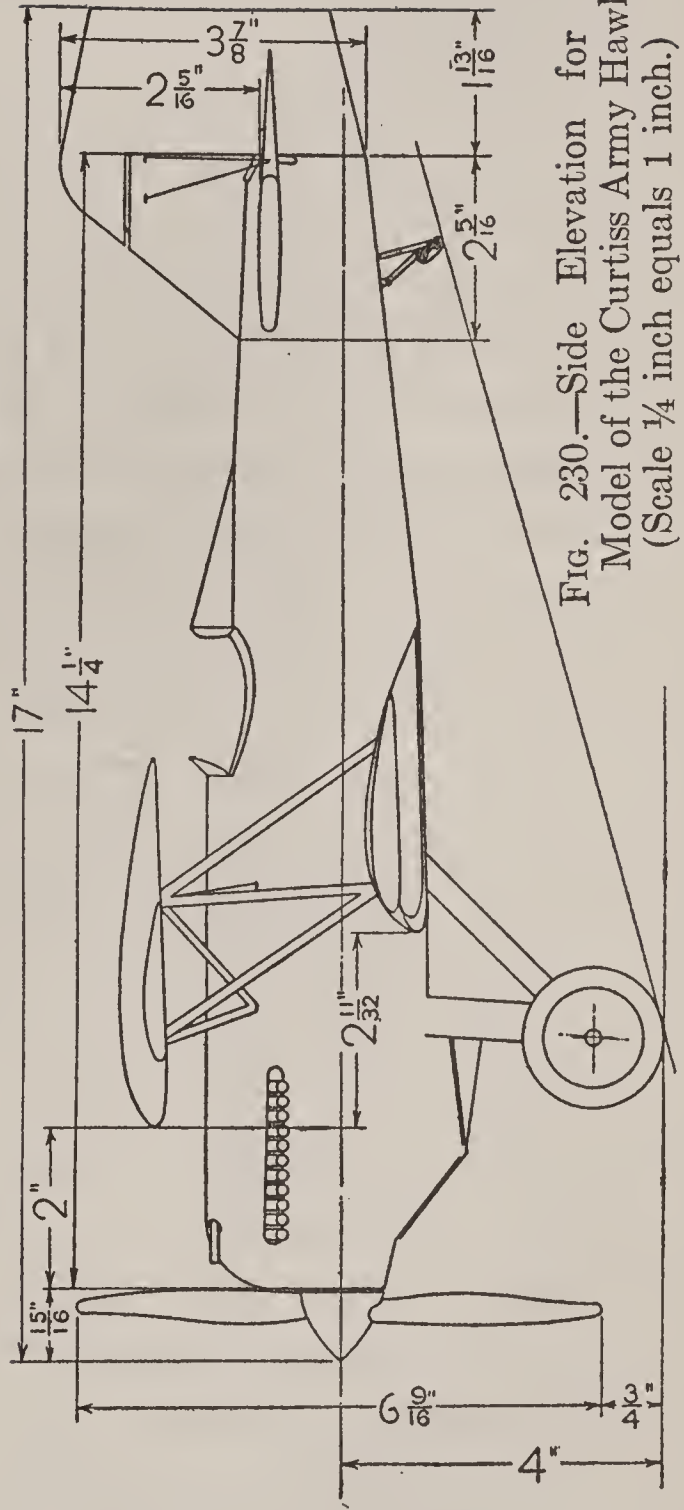

FIG. 230.—Side Elevation for a Model of the Curtiss Army Hawk.  
(Scale  $\frac{1}{4}$  inch equals 1 inch.)

you want a larger or a smaller model, you will have no difficulty in changing the dimensions to keep the correct proportions.

The Fuselage can be carved out of a solid block of wood, or built up with longerons, braced and covered. The photograph of Fig. 237 shows an excellent model with fuselage of brass tubing with soldered joints, built by Norman F. Zapf. A top view photograph of the fuselage is shown in Fig. 238, a side elevation in Fig. 239. The framework contains the same number of pieces as are built into the real ship. Instead of tubing, you can use No. 8 iron wire, which is about  $\frac{1}{8}$  inch in diameter. Build up the cockpit cowling, coaming, and head rest as shown in the photograph of Fig. 239.

The Tail Group also can be solid or built up. In the photographs of Figs. 238 and 239 you will notice that the frameworks are of tubing, like the fuselage.

The Wings are of two sizes, as you will see by Figs. 228 and 230, and they vary in thickness and chord. Note the angles of the wing setting, and that the upper wing is placed in advance of the lower wing. Sections for the upper wing are given in Fig. 231, and sections for the lower wing are given in Fig. 232. As they are shown full-size for a 24-inch model, you can make tracings of them for working templates.

The wings of the model in the photograph of Fig. 237 are built up with wooden ribs and spars. The photograph of Fig. 238 shows the lower wing in place. The wings have the same number of ribs as the wings of the real ship.

But you can shape wings out of boards, as those of Harold Franklin's model, shown in Fig. 240, were shaped. Harold made his wings look built up by gluing lengths of thread to the upper surface, with the correct spacing for ribs, then covering with China silk.

The Landing-Gear can be built with metal or wooden struts, and toy wheels.

The Covering of fuselage and wings is one of the most important parts of the construction. Careless application will offset all of the fine workmanship that may have gone into the framework. Take enough time to do a first-class job of covering, and you will not regret it. Muslin or linen can be used, with a commercial airplane dope for adhesive.

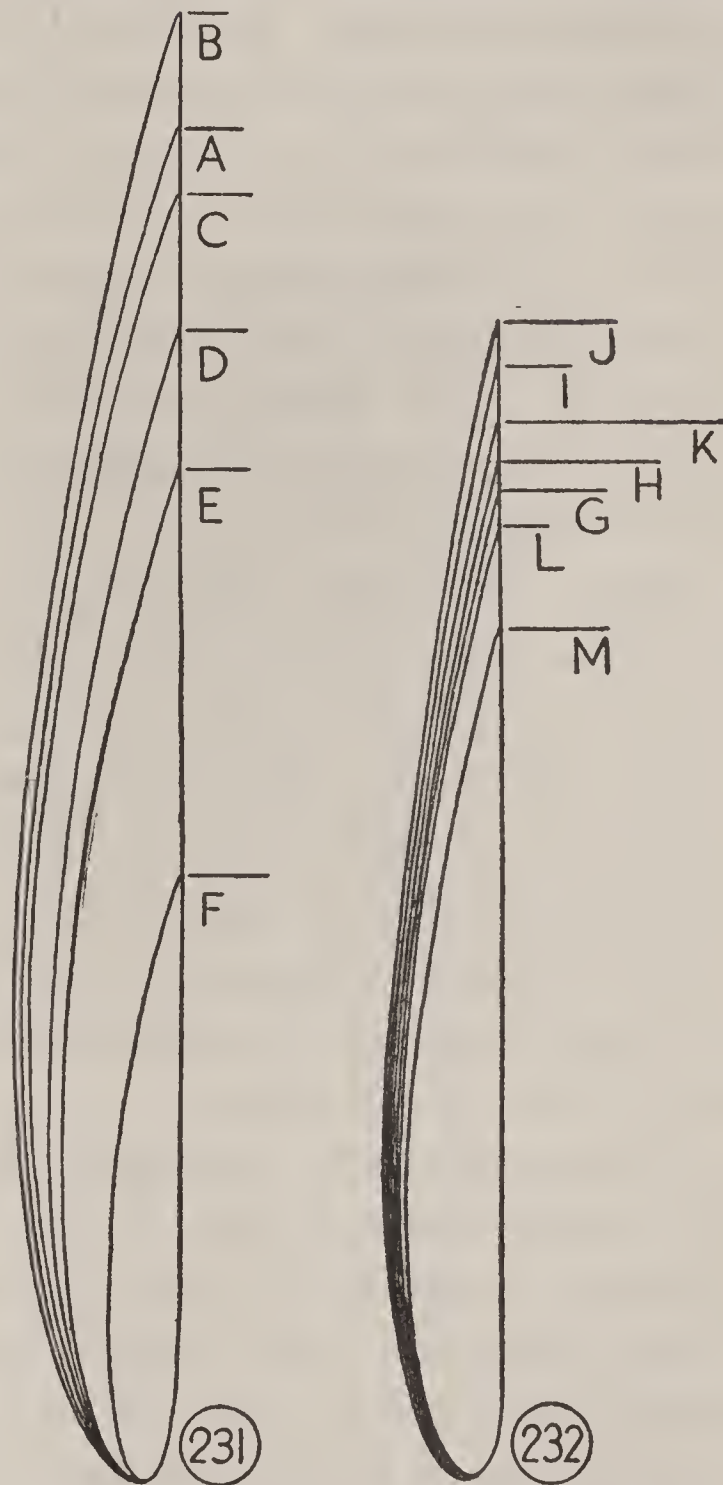

FIGS. 231 and 232.—Full-Size Wing Sections for a Model of the Curtiss Army Hawk. (See Plan in FIG. 228.)

Finishing the Hawk will give you a chance to demonstrate your ability with a brush. With it you can make or ruin the model. Brushing lacquer will be found satisfactory for small surfaces such as those of the Curtiss Hawk model, and it has quick drying in its favor. Use an army khaki color for all surfaces except those of the rudder. The rudder should have a vertical stripe of blue, seven horizontal stripes of red, and six horizontal stripes of white. The insignia for the under side of the lower wing tips is a white star inscribed upon a disk of blue, with a red disk within it.

**Other Fitments.** Suggestions for the construction of only the main portions of the ship have been given in the above paragraphs. Here are some miscellaneous suggestions. Make the gun barrels and exhaust pipes of metal tubing or lemonade straws. Use brass tubing, dowel sticks, lolly-pop sticks, or meat skewers for struts. Make the radiator front of corrugated cardboard. Line the cockpit, and upholster the seat and head rest with pieces cut from an old pair of kid gloves.

Norman F. Zapf introduced these features to complete his model shown in Figs. 237 to 239. A dummy twelve-cylinder motor, run by an auto-horn motor. A hack-saw blade fastened to the fuselage, vibrated by a lug on the shaft to produce the noise of motor exhaust. A gas tank. An instrument board with dummy instruments, pilot seat with safety belt, and fire extinguisher. A joy-stick that operates the ailerons and elevators, and pedals that operate the rudder.



Part of the fun in building a scale model is in devising equipment. It is surprising what can be found in a junk pile and in ten-cent stores that is readily adapted to models.

The photograph in Fig. 241 shows a Curtiss Hawk model built by Garfield D. Hay.

### THE FORD TRI-MOTOR CABIN MONOPLANE

As one of the first successful American passenger airplanes, the Ford Tri-Motor is popular with model-makers. Front and side views of the ship are shown in the photographs of Figs. 222 and 223. A quarter-size plan of a 24-inch model is shown in Fig. 233, and a front and a side elevation are shown in Figs. 234 and 235. The real ship is built of duralumin. It has five compartments, the control cabin, observation compartment, main cabin, washroom, and luggage compartment. In addition to the small windows in the front and sides of the control cabin, there are four windows and a door on the right side of the main cabin and five windows on the left side, and a circular window on each side of the washroom.

**The Fuselage** of this ship may be built up or hollowed out of a solid block. The scale model shown in the photograph of Fig. 242 was built by Cedric E. Galloway. It is a well-proportioned model. Cedric carved the fuselage out of a block of basswood, sawed it in half, and hollowed out the halves to form the five compartments. Then he cut the windows, and fitted pieces of film in the openings. He carved the pilot chairs, passenger chairs, and two bunks out of wooden blocks, and glued them in position. Then

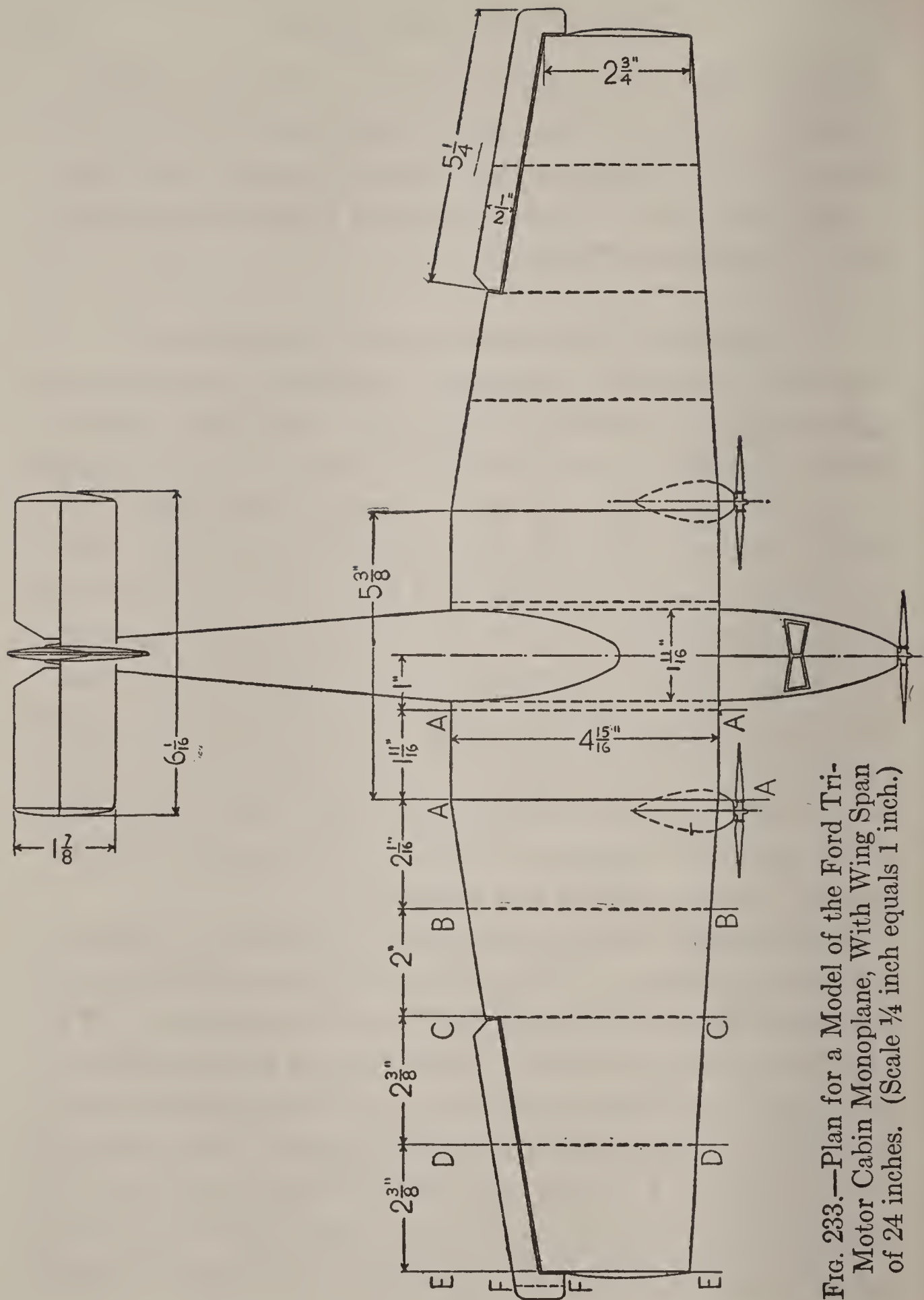

FIG. 233.—Plan for a Model of the Ford Tri-Motor Cabin Monoplane, With Wing Span of 24 inches. (Scale  $\frac{1}{4}$  inch equals 1 inch.)

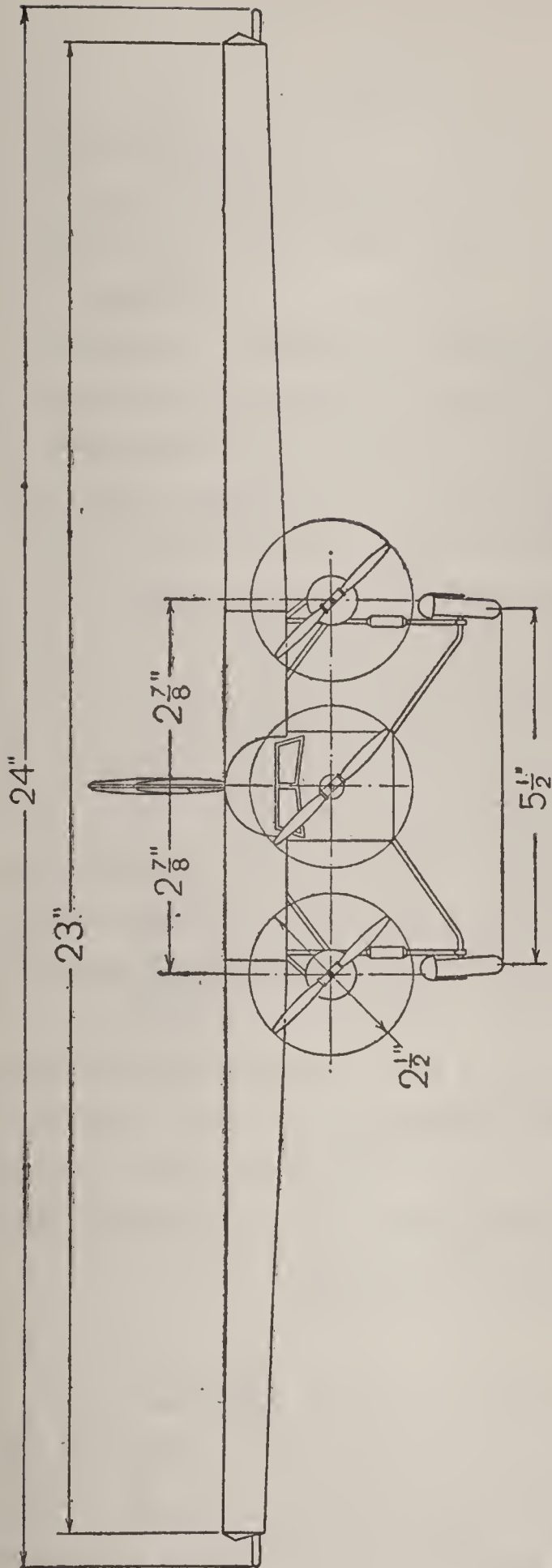

FIG. 234.—Front Elevation for a Model of the Ford Tri-Motor. (Scale  $\frac{1}{4}$  inch equals 1 inch.)

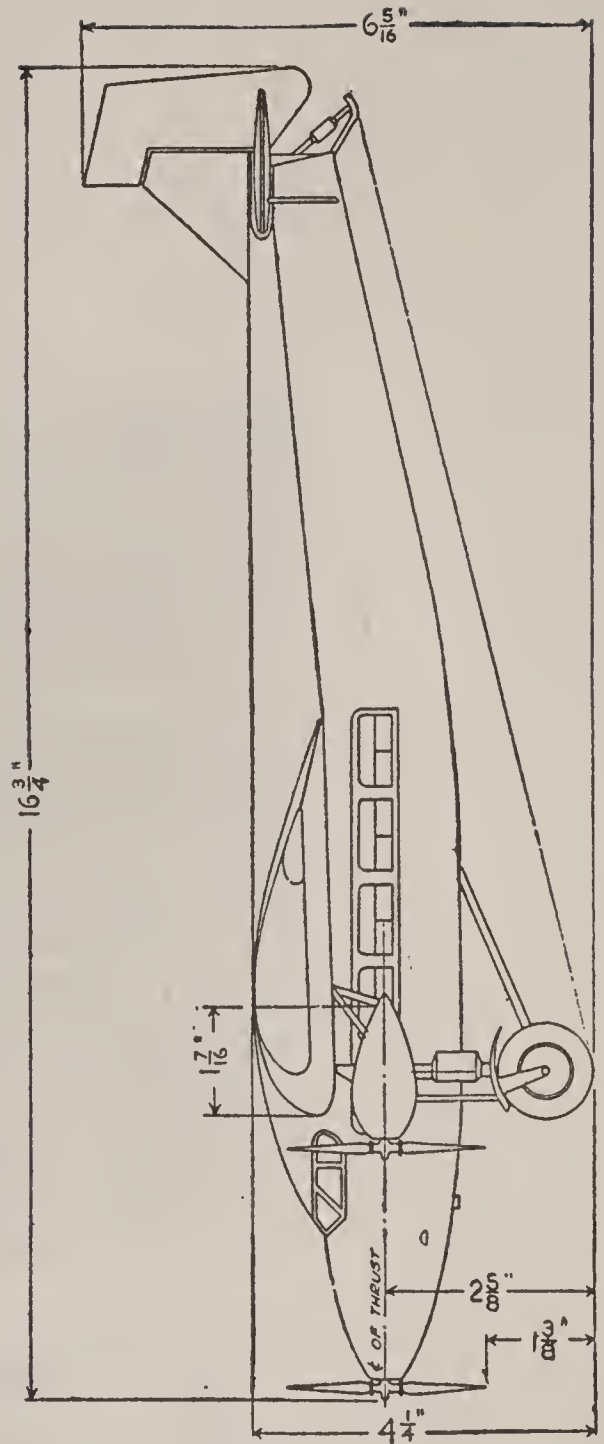

FIG. 235.—Side Elevation for a Model of the Ford Tri-Motor. (Scale  $\frac{1}{4}$  inch equals 1 inch.)



FIG. 236.—Full-Size Wing Sections for a Model of the Ford Tri-Motor. (See Plan in Fig. 233.)

he painted the compartments with aluminum paint, and the chairs yellow, and glued the fuselage halves together.

You can cover the sides of the fuselage with corrugated strawboard in imitation of the corrugated duralumin inclosure of the real ship, but you must make a neat job of it. Glue or cement the strawboard to the fuselage, with the corrugations running horizontally, then give the surfaces a coat of shellac and two coats of aluminum paint. You will be surprised how closely the painted strawboard will resemble corrugated duralumin.

The Wing may be solid or built up. Fig. 236 shows the wing sections drawn full-size, ready to trace for the making of templets.

As the plan and elevations have been reproduced one-quarter size, you can easily determine dimensions not given by using a ruler and multiplying the measurements by four.

#### USE OF SCALE MODELS

There is as much to be admired in your well-proportioned, carefully built airplane model, as in a galleon or other

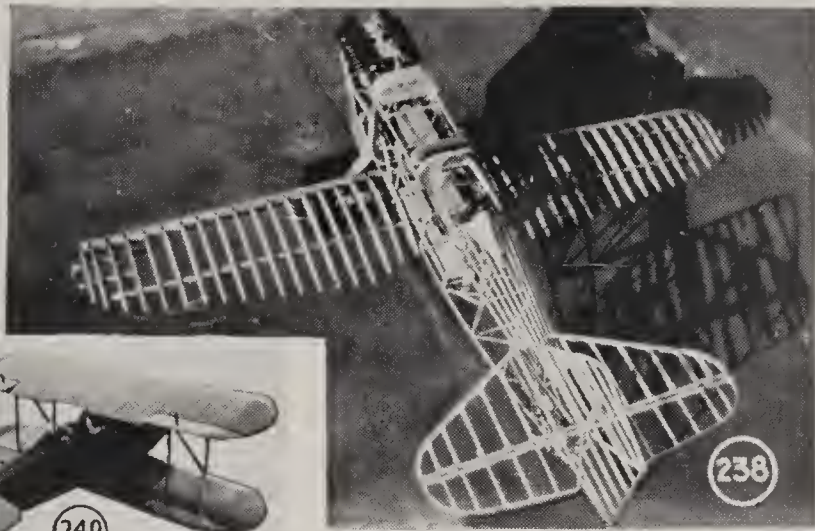
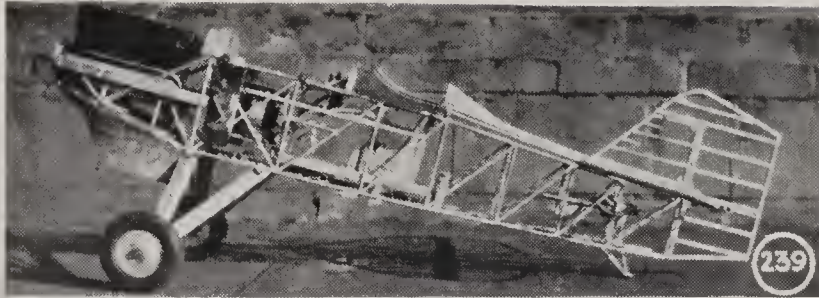
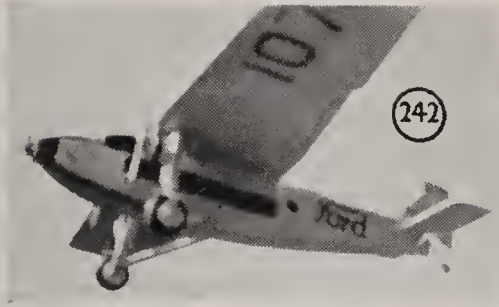
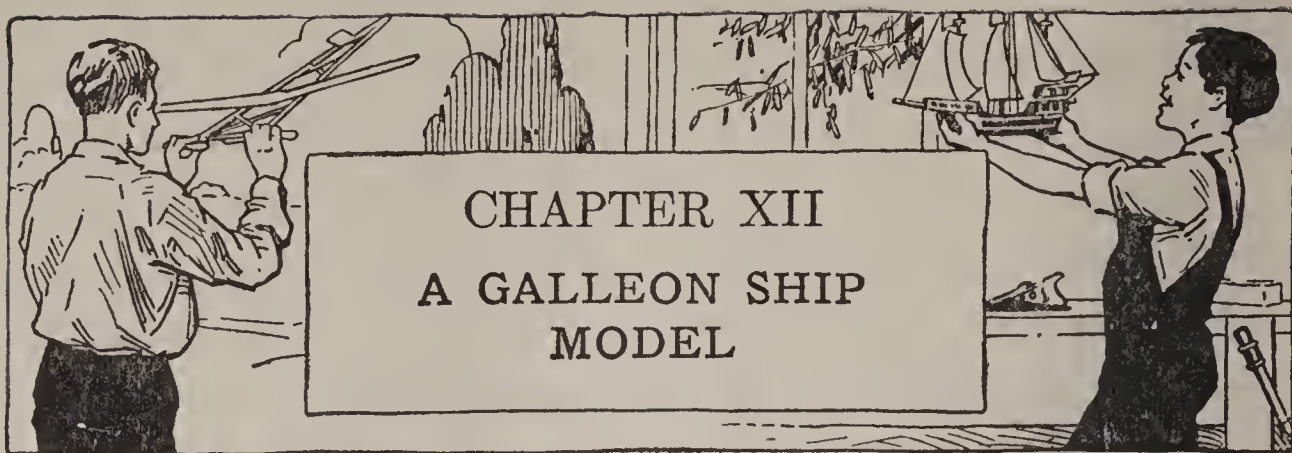

FIG. 242.—MODEL OF FORD TRI-MOTOR BUILT BY CEDRIC E. GALLOWAY.  
FIG. 241.—ANOTHER MODEL OF CURTISS HAWK, BUILT BY GARFIELD D. HAY.  
FIG. 240.—MODEL OF CURTISS HAWK BUILT BY HAROLD FRANKLIN.  
FIG. 239.—SIDE ELEVATION OF CURTISS HAWK MODEL.  
FIG. 238.—PLAN OF CURTISS HAWK MODEL.  
FIG. 237.—MODEL OF CURTISS HAWK BUILT BY NORMAN F. ZAPF.



type of ship model. And if it has won a ribbon at an exhibition, so much more to your credit. Ask Mother to give it a place upon the mantel shelf, or to permit you to suspend it from a screw-eye screwed into the ceiling. If you have a room in the attic, where you can put up hangers without limit, there will be a fine opportunity to make an interesting display of scale models. The photographs of Figs. 241 and 242 show a Curtiss Hawk and a Ford Tri-Motor suspended out of doors! Boy! Don't they look real with the sky as a background!



IT used to be every boy's ambition to excel in drawing pictures of ships. Now, the interest has turned to building and rigging ship models, and the work has proved so fascinating that, with the completion of one model, a fellow is usually spurred on to build other types. Melville Schmuldt, builder of the Spanish galleon shown in the photograph of Fig. 243, has several models to his credit. So has Leonard Fienberg, builder of the fine model shown in the photograph of Fig. 244.

### THE MATERIALS

required for making ship models can be picked up at home, for the most part, therefore, the cost involved in this hobby amounts to little or nothing. And a small tool outfit such as that needed for building model airplanes (Figs. 62-76) is sufficient. Melville Schmuldt's galleon is of wood construction, with picture-molding trimming, spool, cork, and button-mold lanterns, dowel-stick masts with half-spool crow's nests, wrapping-paper sails, and fishing-line rigging. This is the way he built it.





FIG. 243.—GALLEON BUILT BY MELVILLE SCHMULDT.

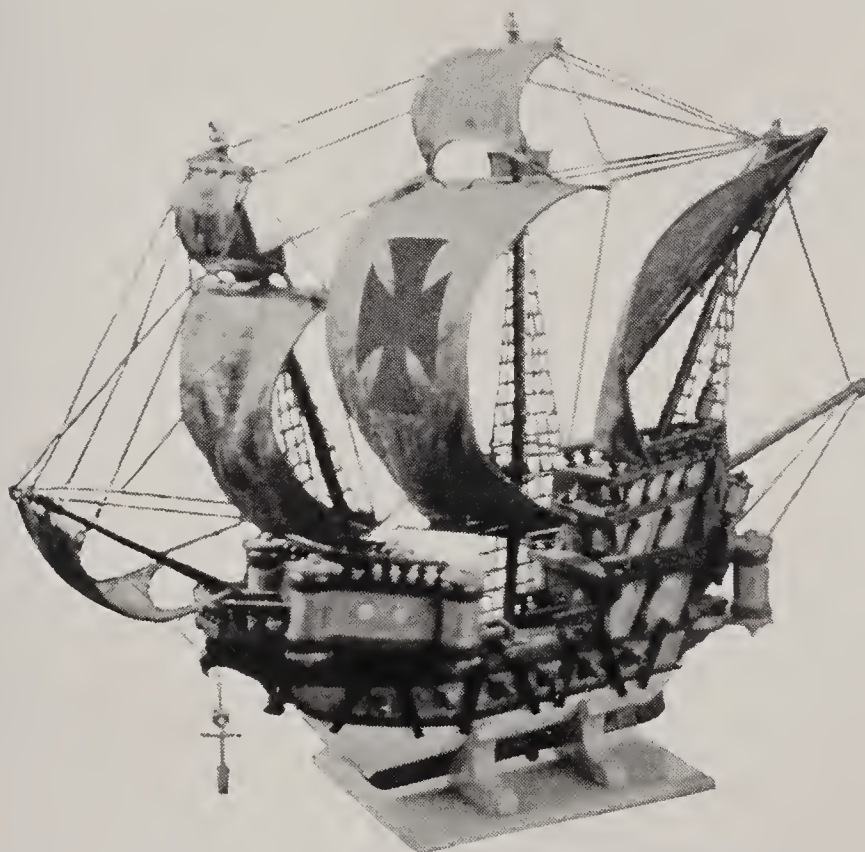

FIG. 244.—GALLEON BUILT BY LEONARD FIENBERG.



THE HULL

Fig. 245 shows a pattern for  
The Keel Center-Piece. It was laid out by the given

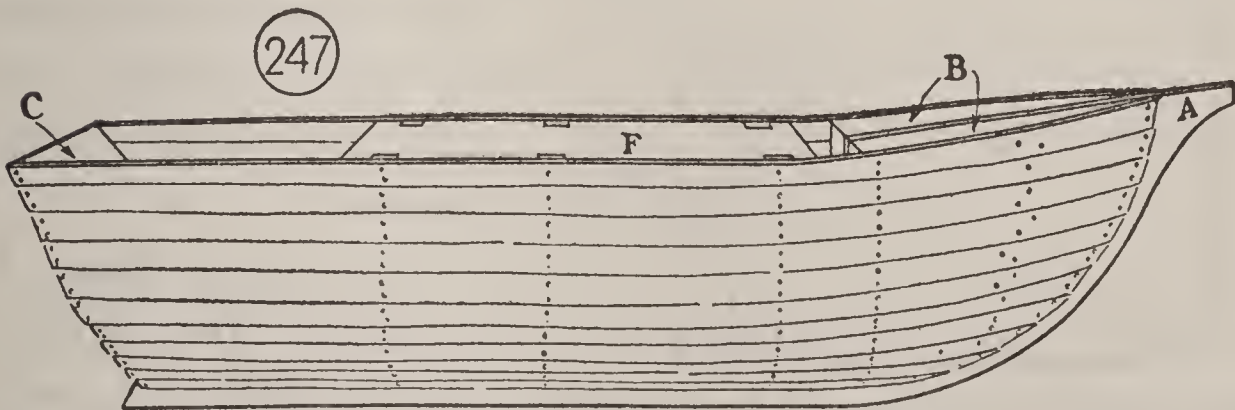
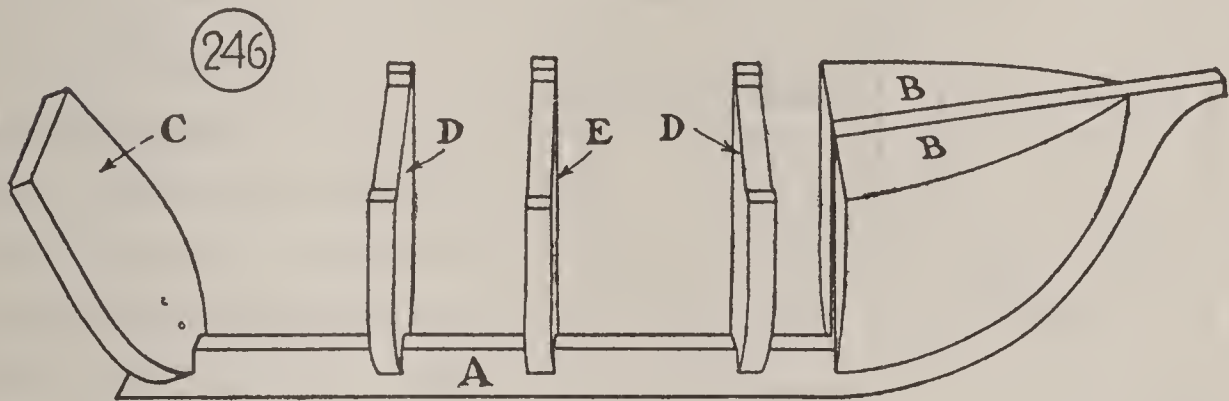
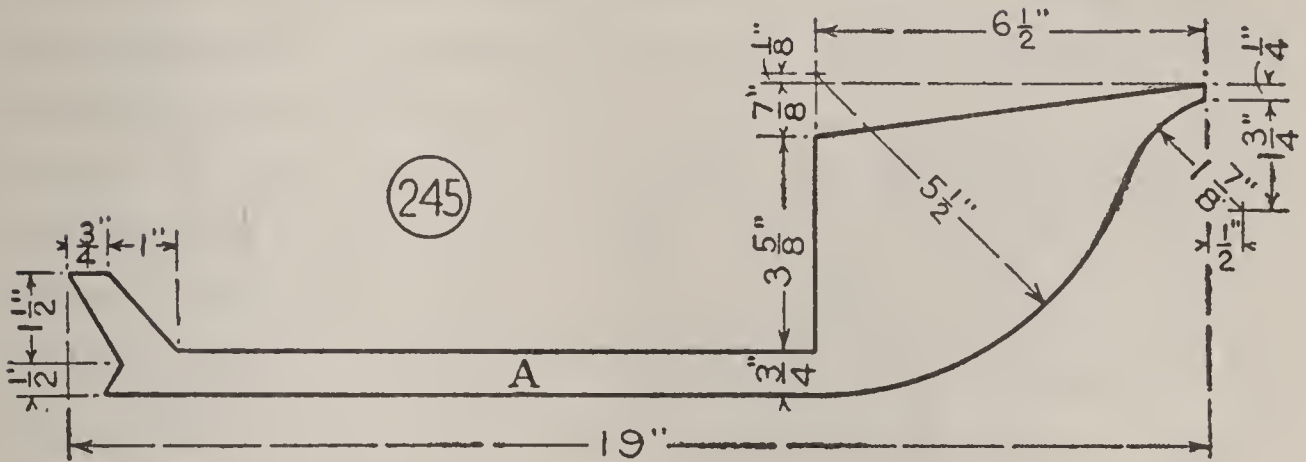

FIG. 245.—Keel Center-Piece.  
FIG. 246.—Bow Blocks, Molds and Stern Piece, Assembled.  
FIG. 247.—Hull Sheathed, With Deck in Place, Ready for Building the Superstructure.

dimensions on a piece of board  $\frac{1}{2}$  inch thick, then sawed out to the outlines, and the curved bow finished with a file and sandpaper.

**The Bow.** A pair of curved blocks completed the shaping of the bow of the hull (B, Fig. 246). The pair were

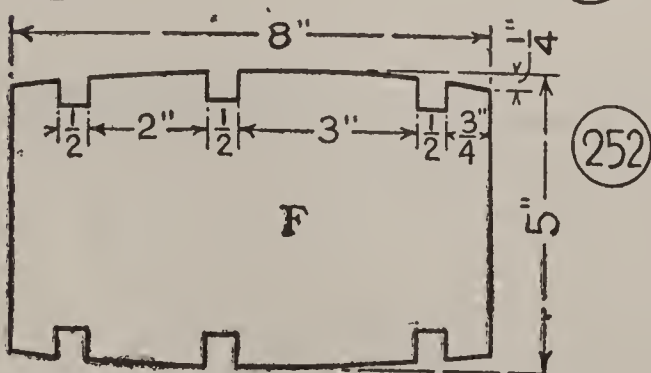
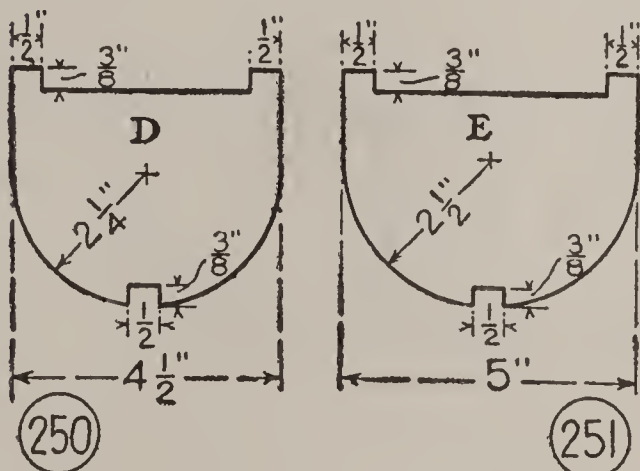
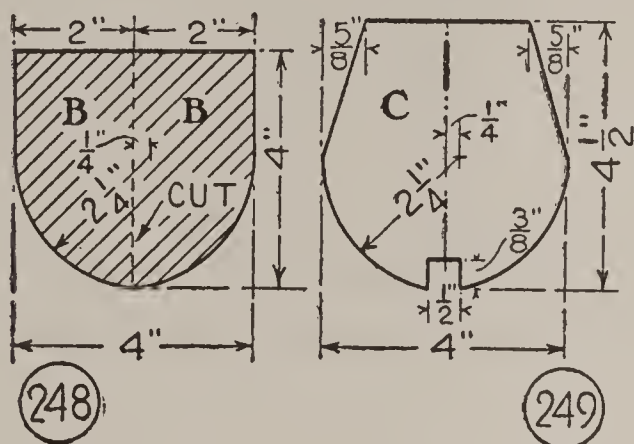

FIG. 248.—Cross-Section of Bow Blocks.  
 FIG. 249.—Stern-Piece Pattern.  
 FIGS. 250 and 251.—Bulkhead Patterns.  
 FIG. 252.—Deck-Piece Pattern.

cut out of a block 4 inches wide, 4 inches high, and 5 inches long. Fig. 248 shows a cross-section. The outline was drawn upon opposite ends of the block. The block was planed to this form, then the bow profile was marked off upon the sides, the block cut to the line, and tapered off to an edge about  $\frac{1}{8}$  inch thick. The block was then ripped in half, and the halves nailed to the sides of the keel center-piece A.

**The Stern Piece** is shown in the pattern of Fig. 249. It was notched on the bottom to fit over the keel

center-piece, and nailed to the projection at the stern (Figs. 245 and 246).

Three Bulkheads were set up between the bow and stern to fasten the sides of the hull to (D, D and E, Fig. 246). Patterns for these pieces are shown in Figs. 250 and 251. Their spacing was determined by

**The Main Deck (F, Fig. 252).** This was notched to fit over the ends of the bulkheads.

**The Sides of the Hull** were sheathed with strips of  $\frac{1}{8}$ -inch ply veneer cut  $\frac{3}{8}$  inch wide. If you cannot get ply wood for the purpose, rip laths, lattice strips, or box boards into pieces of the right width, then rip each in half in its thickness. To make the sawed strips pliable for bending, soak them in water for a few minutes.

Sheathing the hull required careful workmanship, for the edges of the strips had to be butted against one another, without overlapping, and without leaving wide joints, and the bow ends had to be fitted neatly against the keel center-piece (Fig. 247). The strips were fastened with brads and glue. Then the surfaces were gone over with a file and sandpaper, and projecting edges reduced, to make the sides round and even.

### THE SUPERSTRUCTURE

Decks G and H are shown in Fig. 253 overlapping the ends of main deck F. When these had been fitted in place,

**The Bulwarks I, J, and K** were cut and fastened to the hull. Complete dimensions are not given, but you will have no trouble figuring out what they should be by study-

ing the diagrams and the photograph of Fig. 243. A little variance in detail will not matter, because this model and most of those that you see in stores and on home mantels,

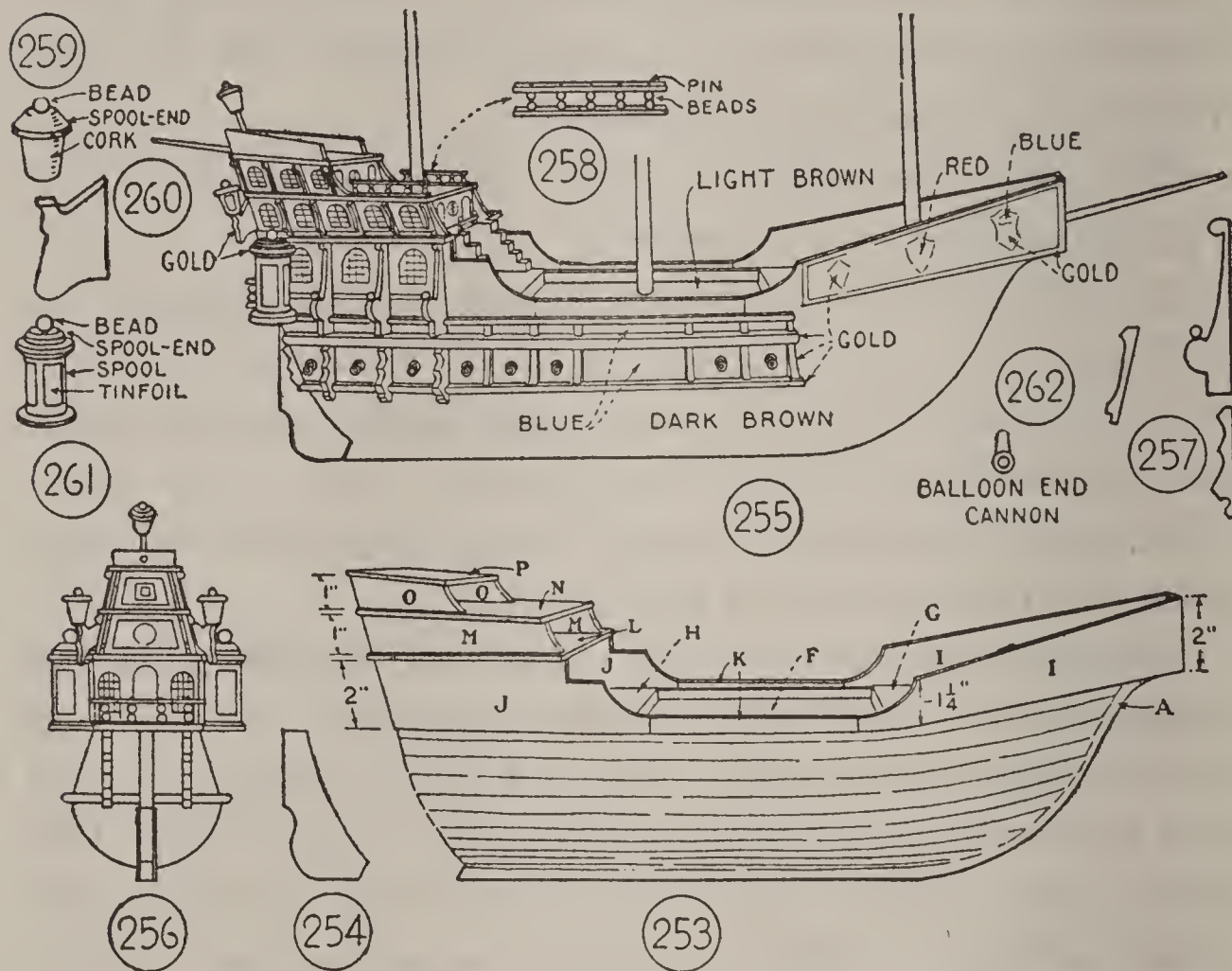

FIG. 253.—Details of Decks and Bulwarks.

FIG. 254.—Rudder Block.

FIG. 255.—Finishing Details of Superstructure.

FIG. 256.—Stern Elevation.

FIG. 257.—Panel Brackets.

FIG. 258.—Railing.

FIGS. 259-261.—Lanterns.

FIG. 262.—Cannon.

unfortunately, are not correctly proportioned. They are built as ornamental models, not as exact copies of any ships that ever sailed the seas. A different project this,

from building a scale model of an airplane, yacht, or automobile, with which almost everybody is well enough acquainted to discover irregularities.

**Decks L, N, and P.** When deck L had been laid, bulwarks M were cut and set in place, with tops sloping toward one another, as shown in Fig. 256, and a stern piece was set in between them. Then deck N was added, and bulwarks O fastened upon it, sloping as shown in Fig. 256. Deck P came next, then its bulwarks, and then the cabin bulkhead.

**Doors and Windows** were drawn upon paper, cut out and glued to the wood.

**Panelling** upon the sides and stern of the ship was formed by horizontal moldings, for which picture molding answered the purpose admirably. Screen molding and weather strips might also be used to advantage. Between the moldings are brackets. They were cut out of thin wood. Fig. 257 shows the shapes to cut them. Make a cardboard pattern or templet, of each, mark out the number that you will need upon a board, and saw out with a coping-saw. The turned ball on the large brackets may be a glass or wooden bead.

**The Stern Balcony Railing** (Fig. 256), and the railings upon the upper deck, were made of narrow strips of wood, with beads fastened between them with pins (Fig. 258).

**Lanterns.** The upper lanterns were made of a tapered cork, a spool end and a bead, assembled as shown in Fig. 259. Fig. 260 shows a lantern bracket. The large stern lanterns were made of a spool 2 inches long, a spool end

and a bead (Fig. 261). Glass in the lantern sides was imitated by cutting recesses and setting in pieces of red and green tinfoil.

Cannon were made of the wooden end-piece that comes on toy balloons (Fig. 262), and were glued in holes bored in the model. But you can whittle cannon out of small sticks, and drill holes in their ends.

### PAINTING

The colors used in painting the model are indicated in Fig. 255. The idea, of course, is to have contrasting colors. Oil paint, enamel, or lacquer may be used. The advantage of lacquer is that it dries rapidly. You can brush it on small surfaces without danger of showing laps. Radiator bronze was used for gold trimmings.

### RIGGING THE GALLEON

The Masts are shown in detail in Figs. 263 to 265. They were made of  $\frac{3}{8}$ -inch dowel sticks, tapered to  $\frac{1}{4}$  inch in diameter at the tops, the tapering being done with a file. Spool ends formed the *crow's nests*. The diagrams show the masts' lengths above decks. Allow enough additional length so they will extend through the decks to the keel.

The Bowsprit is shown in Fig. 266.

The Yards, or horizontal pieces to which the sails are attached, were cut 1 inch longer than the width of the sails.

The Sails were made of brown wrapping-paper. Figs. 267 to 273 give their dimensions. Each sail had to belly



out as indicated in Fig. 273. To make them hold this shape, the paper was coated with shellac, then wire was run through hems formed in the edges to stiffen them. Before shellacking, a cross and other decorations were painted on the sails.

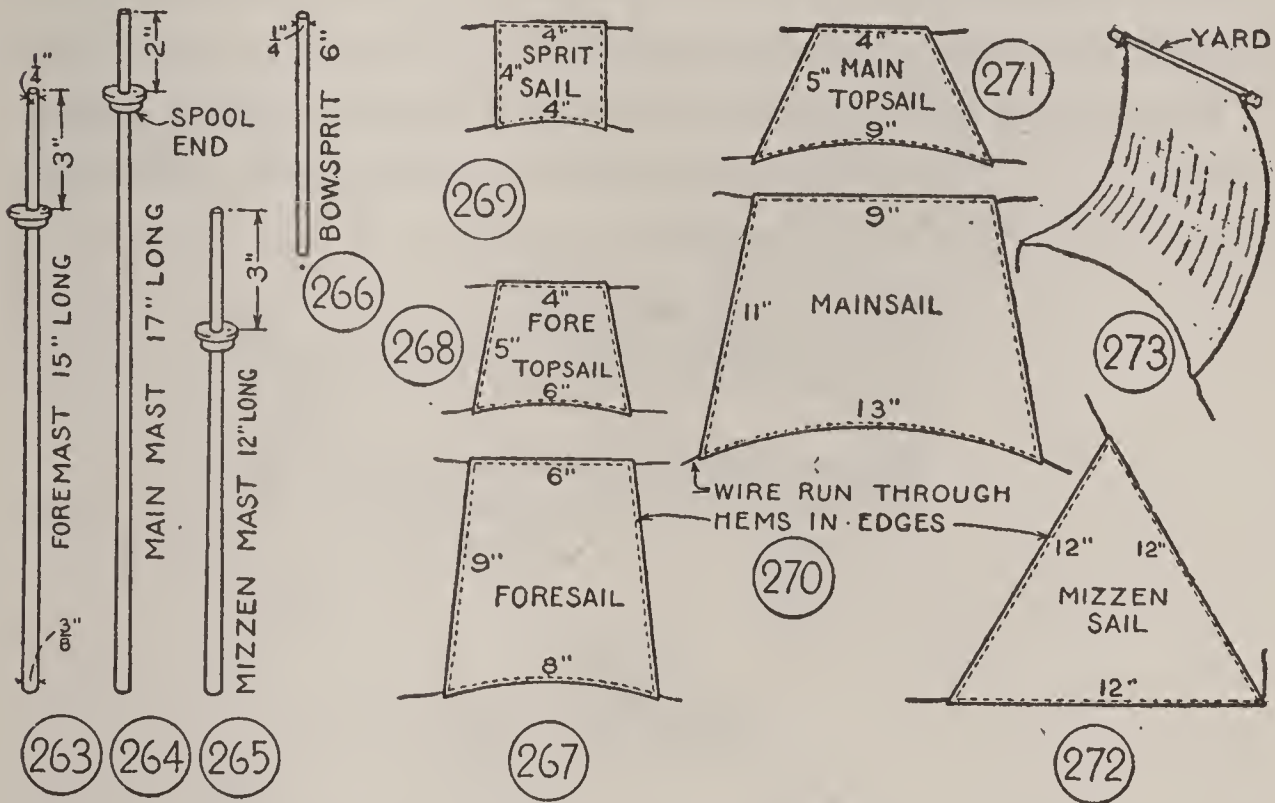

FIGS. 263-266.—Spar Details.  
 FIGS. 267-273.—Sail Details.

The Rigging was made of fishing line, fine and coarse. Glass beads were used for *dead eyes*, small tacks for fastening the rigging. The *stays*, *shrouds*, *ratlines*, *halyards*, and *sheets* are too many to show clearly upon the diagrams. You will see some of them in the photographs of Figs. 243 and 244, but for a complete diagram with parts designated by name, I suggest that you look up "ship" in a dictionary.

For plans for other ship models, look up at the public library "Ship Model Making," Volumes 1, 2, and 3, by Captain E. Armitage McCann.

### A BASE FOR YOUR SHIP MODEL

A well-made ship model deserves a base that will be in keeping with it. Use mahogany or walnut, if you can get it, and finish with a coat of shellac and several coats of varnish. Or use pine, basswood, or other wood with close grain, and finish with lacquer in color.

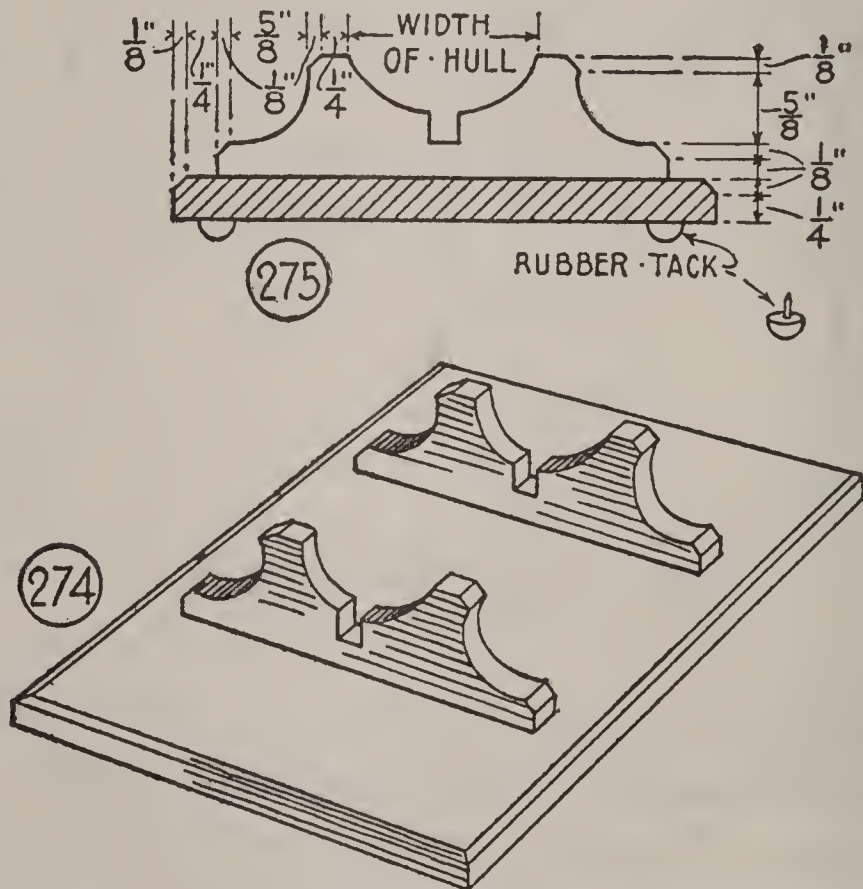

FIGS. 274 and 275.—Base for Ship Model.

The base that supports Leonard Fienberg's galleon model, shown in the photograph of Fig. 244, is easy to make. Fig. 274 shows a line drawing of it, and Fig. 275

shows a cross-section with dimensions of the cradle blocks. The width of the blocks was determined by the size of the ship's hull. The thickness was  $\frac{3}{8}$  inch. The blocks were cut with a coping-saw, then sandpapered smooth.

The bottom board measures  $4\frac{1}{2}$  inches wide and 7 inches long. It was cut out of a board  $\frac{3}{8}$  inch thick, and its upper edges were bevelled with a plane. The cradle blocks were located at equal distances from the edges of the base block, and fastened with glue and brads. Then the wood was finished, and four rubber-tipped tacks were driven into the under side, at the corners, to protect surfaces on which the model would stand.

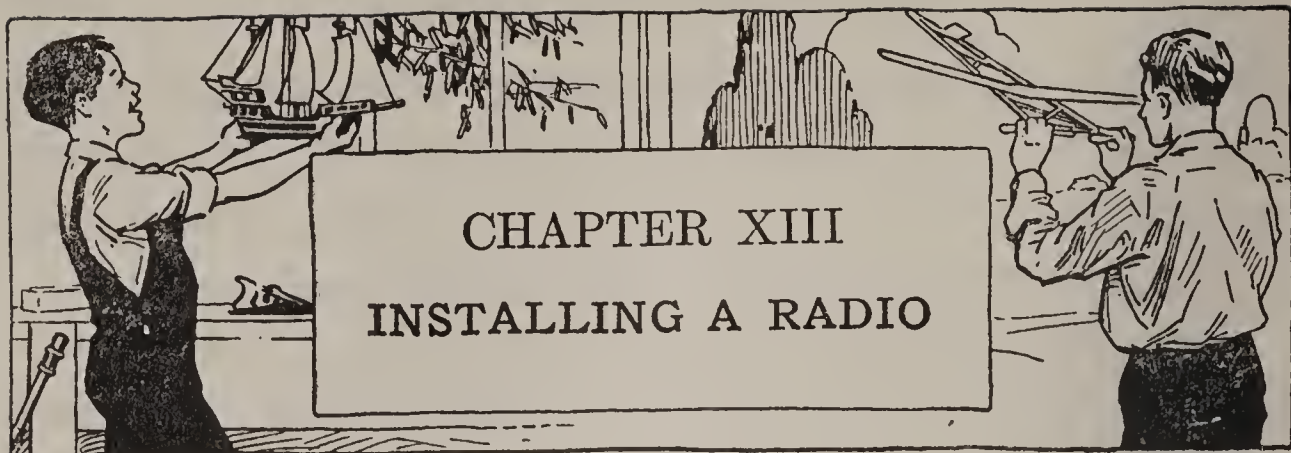

INSTALLING a radio is simple enough, granted the assembly has passed inspection. But some people cannot do the most ordinary mechanical job, others will not, and it is lucky for you that they cannot or will not, because it affords you an occasional opportunity to earn money in an interesting field of work. After you have qualified for the job by installing a set at home, let your ambition be known.

### THE AERIAL

will be the first part of the job. After tests of every conceivable form of aerial, the single wire of a length between 50 and 75 feet is accepted as being as efficient as any, and, while there are differences of opinion on minor details, it is generally agreed that the essential requirement is an unbroken path of metal from the far end of the aerial down through the lead-in wire, the set, and the ground wire, to moist earth. Therefore, one length of wire (seven-strand copper aerial wire) from the extreme end of the aerial to the set, properly supported on insulators, is a

better rig than separate aerial and lead-in, unless a perfect soldered connection can be made.

The Aerial Supports may be determined by local conditions. It may be necessary to extend the aerial over a roof-top, in which case a chimney becomes the natural support for one end, and possibly a chimney on an adjoining building the support for the second end. But where it can be done, it is better to run the aerial wire over cleared ground than over a roof-top or other obstruction. The receiver building may be one support, and a second building, a tree, or an iron pipe mast may be the other support. The farther support should be high enough to make its end of the wire of the same height as or higher than the near end (Fig. 276).

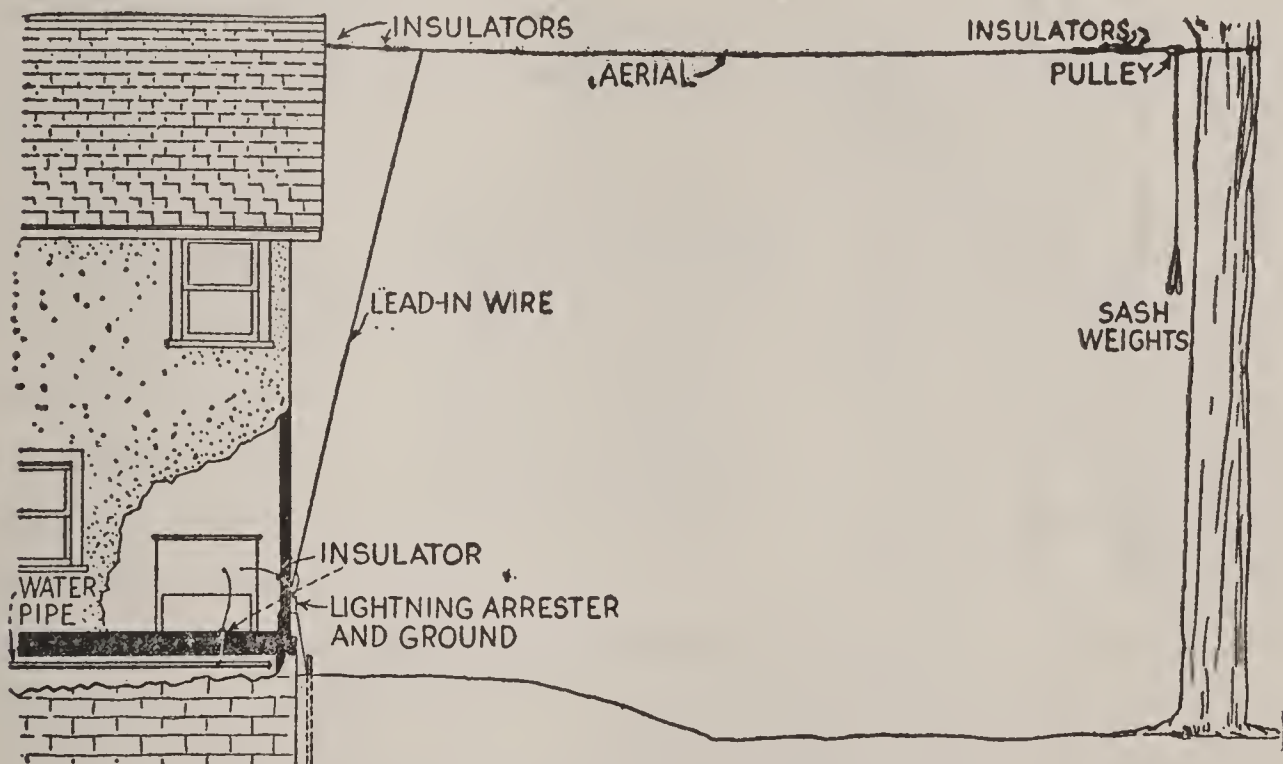

FIG. 276.—Aerial and Ground Hook-Up.

An Iron-Pipe Mast is not expensive, and not difficult to

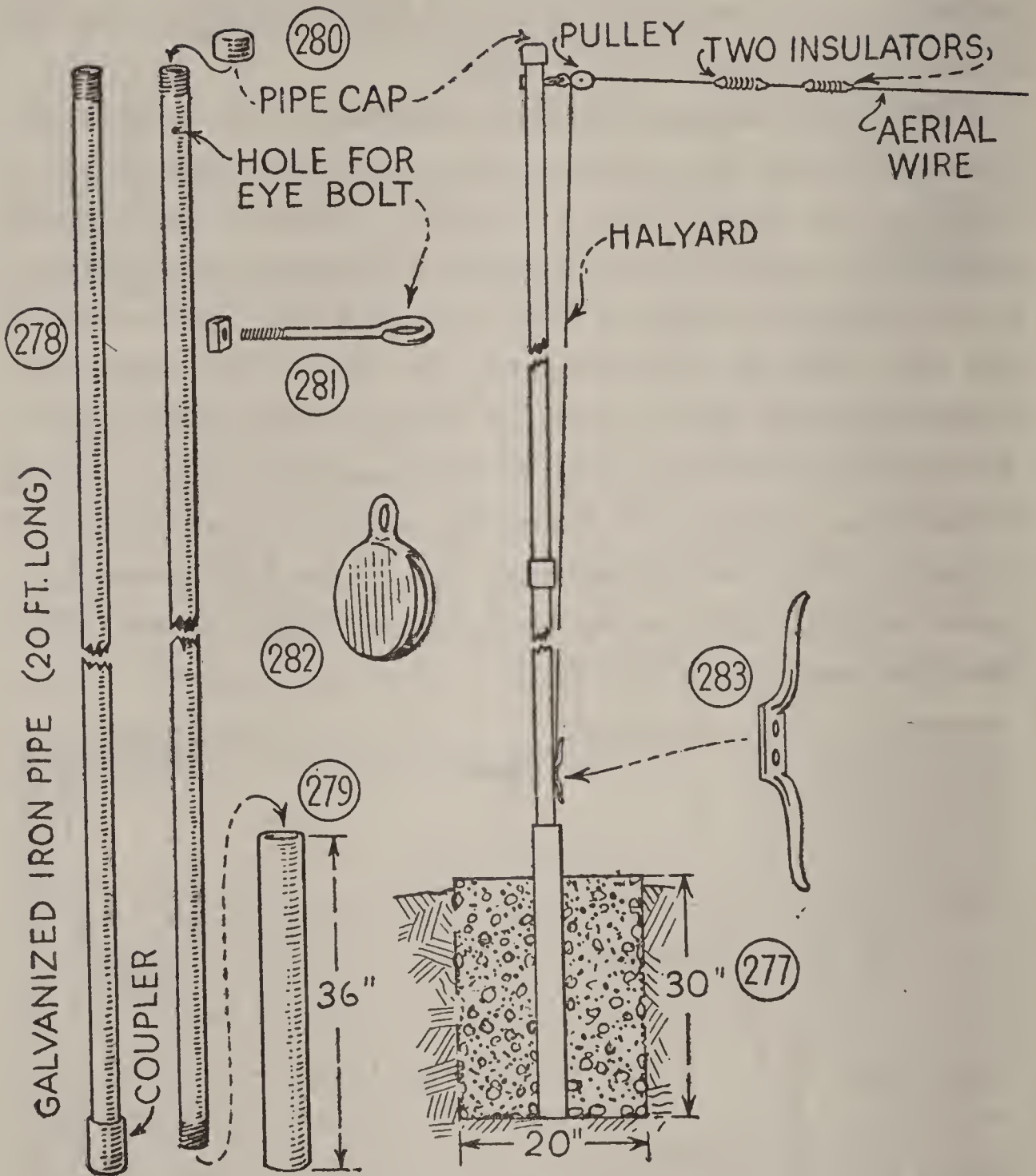

FIG. 277.—Pipe Mast for Aerial.  
 FIGS. 278 and 279.—Pipe for Mast.  
 FIG. 280.—Pipe Cap for Mast Top.  
 FIG. 281.—Eye-Bolt.  
 FIG. 282.—Pulley for Rope Halyard.  
 FIG. 283.—Halyard Cleat.

erect (Fig. 277). You can buy galvanized iron pipe in standard lengths of 20 feet, threaded on both ends, with a coupler on one end (Fig. 278), at a hardware store. Two lengths of 1-inch or 1¼-inch pipe will usually be sufficient, allowing 24 or 30 inches for ground anchorage. In addition to the mast pipe, get a 36-inch length of pipe (Fig. 279) of large-enough diameter to slip over the end for the base, a pipe cap (Fig. 280) for the top, an eye-bolt (Fig. 281), for the attachment of a clothes-line pulley (Fig. 282), a rope halyard, and an iron cleat (Fig. 283).

**A Concrete Base** must be cast for the support of the mast. It should be about 20 inches in diameter or 18 inches square, and 30 inches deep, of a mixture of gravel, or crushed stone, and sand and cement, in the proportions of 4 parts stone, 3 parts sand, and 1 part cement.

After excavating for the base, stand the 36-inch length of pipe in the center of the hole, plumb it so that it is exactly vertical, and brace its top with temporary braces. Then mix the concrete, shovel it into the excavation, and tamp it into a compact mass. Bring the top of the concrete an inch or so above the ground level.

**Assembling the Mast.** Couple the lengths of pipe, and screw the pipe cap to the top. Drill holes for the top eye-bolt, and for bolts for attaching the cleat, and fasten these fittings to the pipe. Unless the pipe and fittings are galvanized, give them a coat of red lead and a coat of black paint, or two coats of asphalt paint.

Erecting the Mast will require the help of two persons. Each should have a clothes pole or other pole, with end

crotches made of crossed sticks. With the aid of the poles it will be a simple matter to raise the pipe and drop it into the base pipe. Don't forget to run the rope halyard through the top pulley, before setting up the mast.

**Slack in the Aerial Wire** great enough to permit the wire to sway, may cause "fading" of signals. Fig. 276 suggests how to take up the slack by weighting one end of the wire with sash-weights.

**Perfect Insulation of the Aerial** requires the use of two glass or porcelain insulators (Fig. 284) on each end, placed about 12 inches apart.

Fig. 276 shows how to bring

**The Lead-In Wire** from the aerial into the building. Make it fast to a porcelain spool or cleat, then run it through a porcelain tube (Fig. 285) set in a hole bored through the wall, or through a window frame. The neatest arrangement is to set a plug receptacle in the wall, and connect the lead-in wire to it.

**A Lightning-Arrester** must be hooked up with the lead-in wire and with an outside ground at the point where the lead-in wire enters the building, to comply with the rules of fire underwriters. Solder the ground wire to the top of an iron rod or piece of pipe driven several feet into the ground (Fig. 276). This does not make a ground connection, of course, unless a bolt of lightning jumps the gap in the arrester.

**The Ground Wire** from the radio set must make contact with moist earth. If the house is piped for water, the ground wire may be connected to a water-pipe, by means



of a plumber's pipe strap, or a ground clamp made for the purpose (Fig. 286).

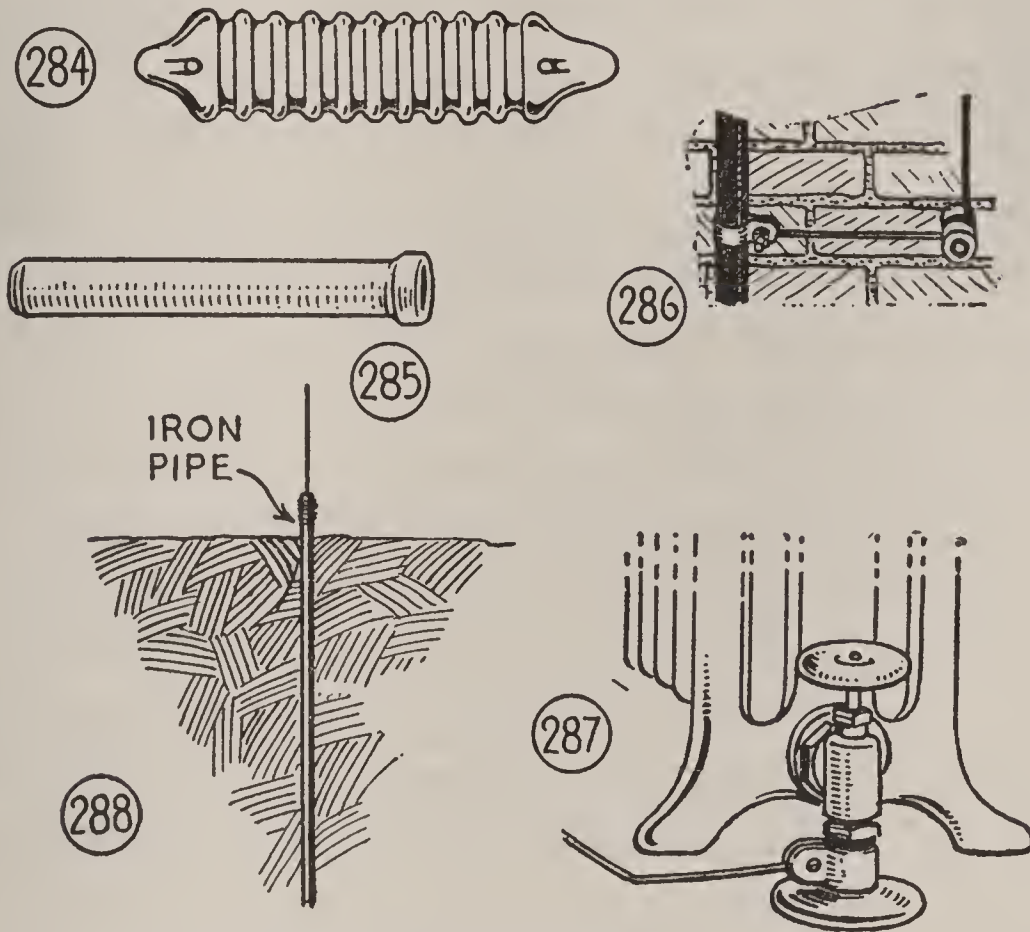
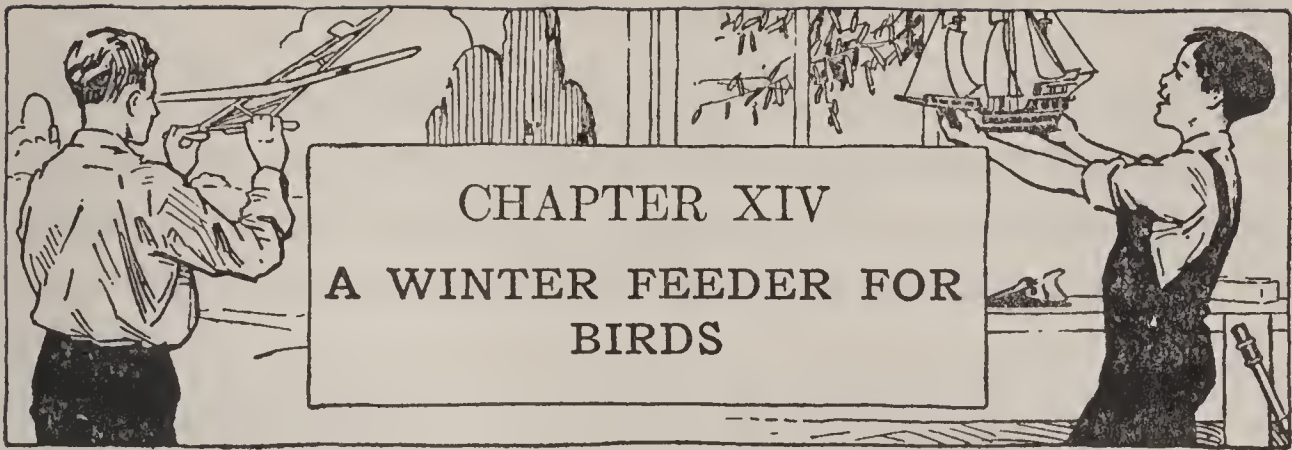

FIG. 284.—Aerial Insulator.  
 FIG. 285.—Porcelain Tube.  
 FIG. 286.—Ground Clamp on Water Pipe.  
 FIG. 287.—Ground Clamp on Radiator.  
 FIG. 288.—Direct Ground to Moist Earth.

Where a hook-up with a water pipe cannot be made conveniently, the ground clamp is attached to a radiator pipe (Fig. 287).

A **Direct Ground** to moist earth is preferred by some radio fans, and is necessary where water-pipes are not available. It necessitates another hole through the wall or window frame for the ground wire. The ground may be an iron rod or pipe 6 feet in length driven into the

ground, with the ground wire soldered to the top (Fig. 288), or it may be several copper or zinc plates joined, with the ground lead soldered to them, buried in moist earth. Where the soil is not likely to remain sufficiently moist at the depth of the plates, provision may be made for keeping it moist by setting a pipe into the ground, alongside the ground wire, and pouring water into this pipe.



WINTER-TARRYING birds and early spring arrivals can forage for themselves, with moderate weather conditions and bare ground on which to seek seeds and berries, but when deep snows cover the available food supply, large numbers perish. Late winter and early spring blizzards play havoc, since by then the advance guard of many species have put in an appearance.

There are various forms of racks and hoppers that can be made easily and quickly, among which is

#### THE HANGING FEEDER

shown in Fig. 289. Figs. 290 and 291 are cross-sections of the winter feeder, one taken lengthwise, the other cross-wise.

The Parts are lettered, and dimensions are given. Your material may dictate other dimensions, but the size is not important. The model illustrated was made of box boards  $\frac{1}{2}$  inch thick.

Ends A are of equal size, so are roof board C and base D. Back B fits between the ends. First, nail the ends to

the back, then center the three pieces upon the base board so the end projections will be equal, and the front and back projections will be equal. Nail the board in place, then center and nail the roof board in the same way.

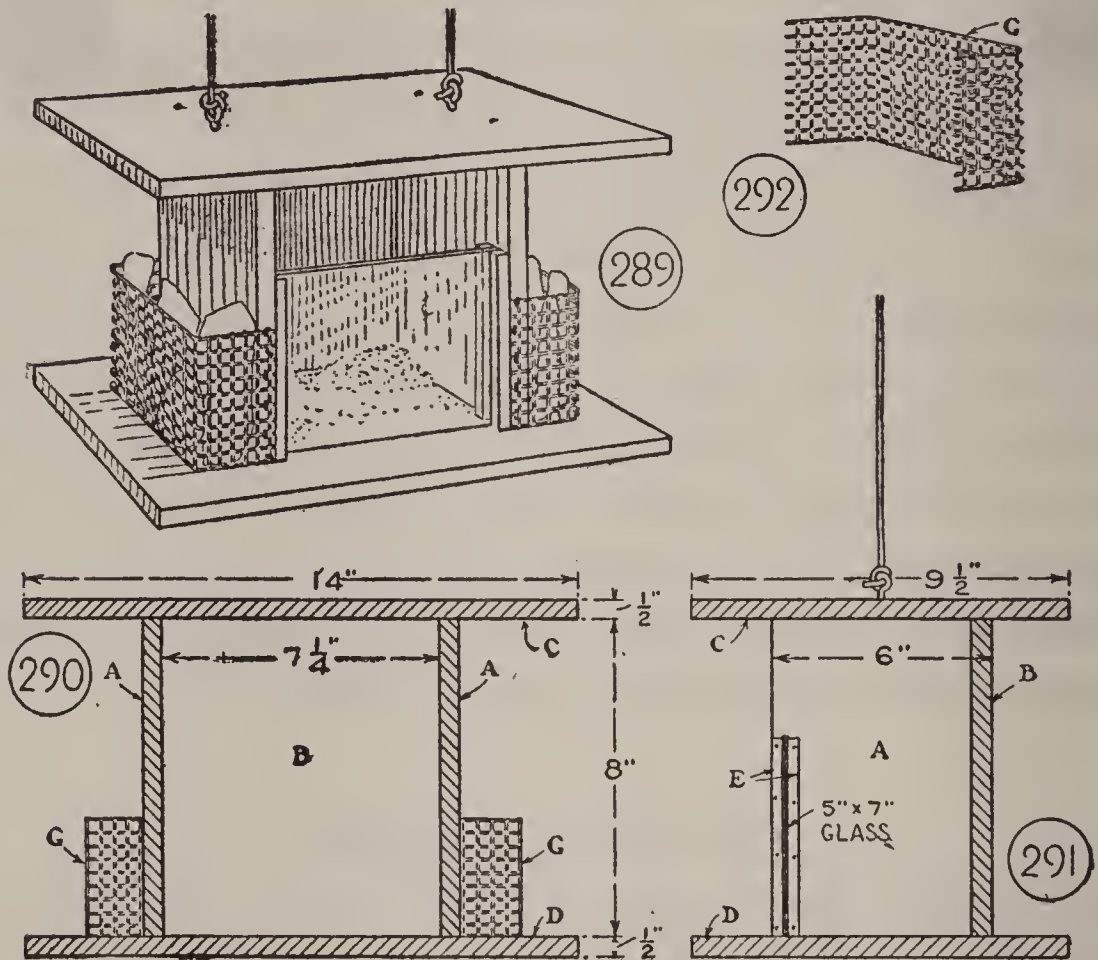

FIG. 289.—Hanging Feeder with Center Compartment and End Containers.

FIGS. 290 and 291.—Cross-Sections of Feeder.

FIG. 292.—Wire Cloth Front for End Feeder.

The Center Compartment has a two-thirds glass front that shelters bird feeders and confines scattered feed without hiding it from view. The glass (Fig. 291) is 5 by 7 inches. An old 5-by-7 negative can be obtained from a photographer, or you can get a piece of glass at a paint

store. The glass is held by two pairs of wooden strips (E, Fig. 291) fastened to the shelter ends with brads.

The Wire Containers at either end of the feeder are for suet and meat scraps. They are made of pieces of galvanized wire cloth with mesh  $\frac{3}{8}$ -inch or  $\frac{1}{2}$ -inch square. Bend the strips, as shown in Fig. 292, to lap over the edges of end pieces A, and fasten them with staples.

Paint the feeder with two coats of paint, inside and out, then screw a pair of screw-eyes into the roof board, and attach a wire hanger to each.

#### STOCKING THE FEEDER

Once you have set out the winter feeder, do not fail in your responsibility to keep it stocked with food, the wire baskets with suet and meat scraps, the inner shelter with hemp, millet and sunflower seed, poultry feed, and bread crumbs.

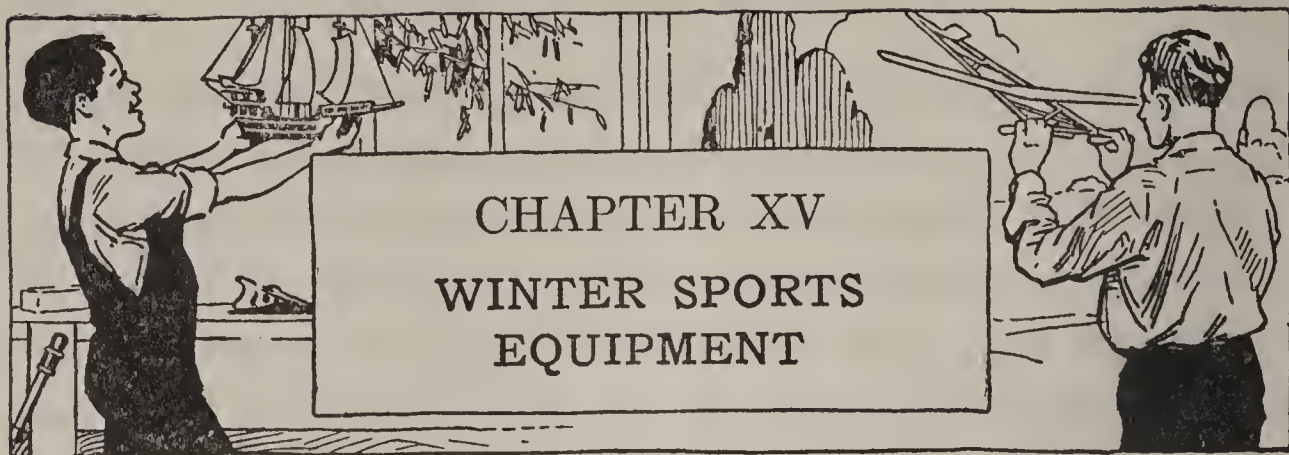

IN my books "The Boy Craftsman," "Handicraft for Handy Boys," "The Handy Boy," "Carpentry and Mechanics for Boys" and "Outdoor Boy Craftsman," you will find plans for ice boats, skate sails, skis, toboggan slides, coasters, single runners, bob-sleds, ice fishing shacks, snow huts and snow forts. In this chapter you have a group of miscellaneous sports equipment selected from my articles contributed to *The American Boy*, *Modern Mechanics*, *The Country Gentleman*, *The Ladies' Home Journal*, and *Woman's Home Companion*, and to newspapers and weeklies through my "Boy Craftsman Syndicate Service." In these books and this chapter you should locate any piece of sports equipment that you want to make, no matter what your winter outdoors hobbies may be.

### AN ICE SKATEMOBILE

Fig. 293 shows a rig for the skating pond or ice-coated sidewalk that you can make in an hour's time. Your skates, a piece of 2-by-4, several wooden blocks, a box,

your bicycle handle-bars, and a pair of plumber's pipe straps are all that are required to build it. You will not

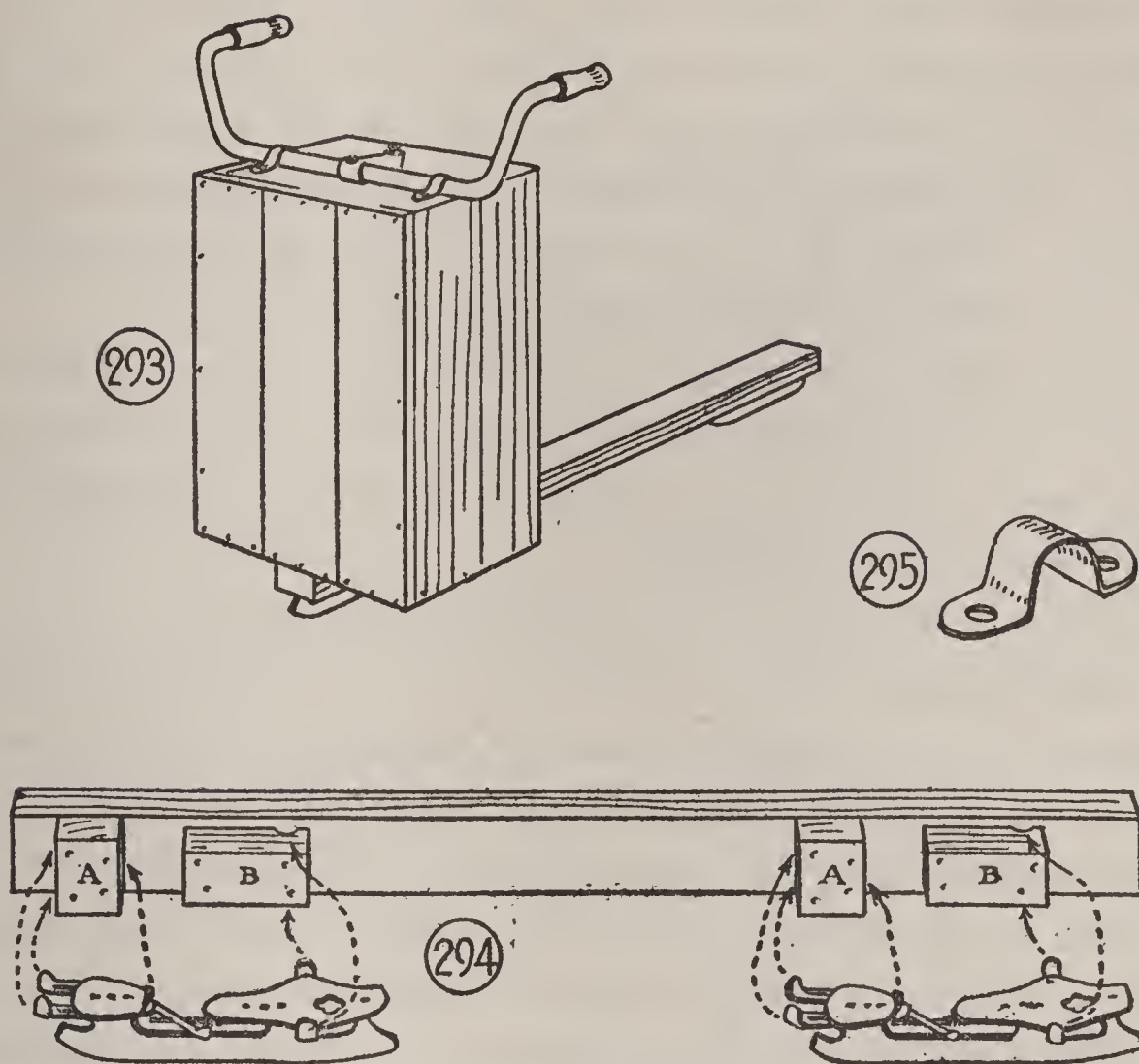

FIG. 293.—Ice Skatemobile.

FIG. 294.—Attach Skates to Chassis in This Way.

FIG. 295.—Pipe Strap for Attaching Handle-Bars.

damage your skates in using them for runner shoes, neither will you injure your bicycle handle-bars. And both skates and handle-bars are so attached that they can be removed in a twinkling when wanted. You can substitute a stick for the handle-bars, if you want to, but it will not make so neat a job.

**The Chassis** 2-by-4 should be about 3 feet long. Fig. 294 shows how to.

**Attach Your Skates** to the under side. Blocks A and B must be nailed or screwed to the 2-by-4, block A for the heel of the skate to grip, block B for the toe clamps to grip. The sizes of the blocks will be determined by your skates. Notch the upper edge of block B, on each side, so that the toe clamps will grip firmly.

**The Body** box should be about 2 feet long. Place it endwise on the front of the chassis, with the open side to the rear. The lower part may be boarded up halfway for tool-box or parcel-carrier.

Bore a hole in the box to receive the stem of

**The Handle-Bars.** If you haven't a bit large enough, make several small holes and cut them into one hole with a chisel, or enlarge a small hole with a rat-tail file. The bar ends must be fastened down, and the simplest way is to use a pair of pipe straps (Fig. 295). Attach the straps with screws so that they may be easily removed.

**The Paint Job.** Few home-made vehicles are painted. There's no reason why they should not be, because there is generally left-over paint in every household. Remove the handle-bars before applying it. If you buy paint, get a can of automobile enamel.

### A BARREL-STAVE SLED

The box and barrel-stave sled shown in Fig. 296 is one of the simplest sleds that you can make.



**The Seat** is a soap box or other small box with the cover boards nailed on.

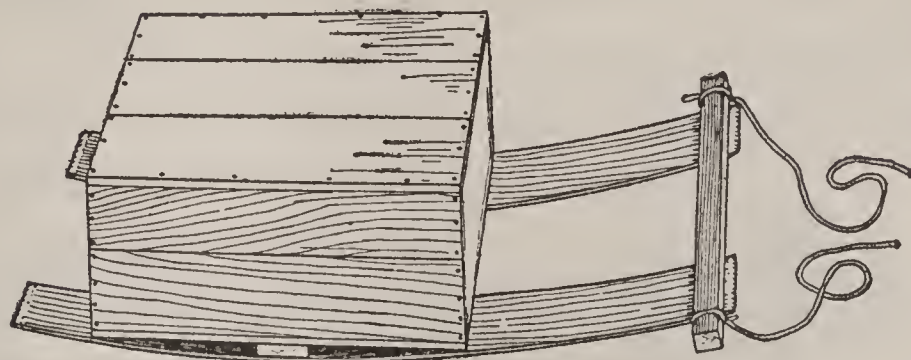

FIG. 296.—Barrel-Stave Sled.

**The Runners** are a pair of barrel staves. To attach the runners, turn the box upside down as shown in Fig. 297, nail a cross strip to the center of the bottom, and fasten the staves with nails at the points shown. Allow the staves to project 3 or 4 inches at the stern of the box.

When the runners have been put on, fasten a strip to their bows for

**A Foot Bar.** Make the bar long enough for its ends to project as shown in Fig. 296, and notch it so that the steering rope may be tied securely.



FIG. 297.—Nail Stave Runners to Box.

### A ROCKER COASTER

Cutting the runners usually is the biggest part of making a sled, but it is obviated in the rocker coaster, shown in Fig. 298, by the use of

A Pair of Rockers from a broken chair, or one which has fallen into disuse. The chances are that you will find a chair stowed away in the attic, or in the woodshed.



FIG. 298.—Rocker Coaster.

Four Cross Bars connect the rocker runners (Fig. 299). Because the rockers will probably be of hard wood, it is best to drill holes in them for screws for attaching the cross bars.

The Seat Boards must be warped to the curve of the rockers (Fig. 298) unless the center pair of cross bars are enough thicker than the end bars, to bring the tops of the four in a straight line.

### BARREL-STAVE SKIS

If one of your crowd can scare up a barrel, that barrel will furnish staves for a dozen skis. You will see by the diagram of Fig. 300 that a piece of board is fastened several inches forward of the center of the stave, and that a

house slipper is nailed to this board. If you lack a slipper, cut down an old shoe or overshoe.

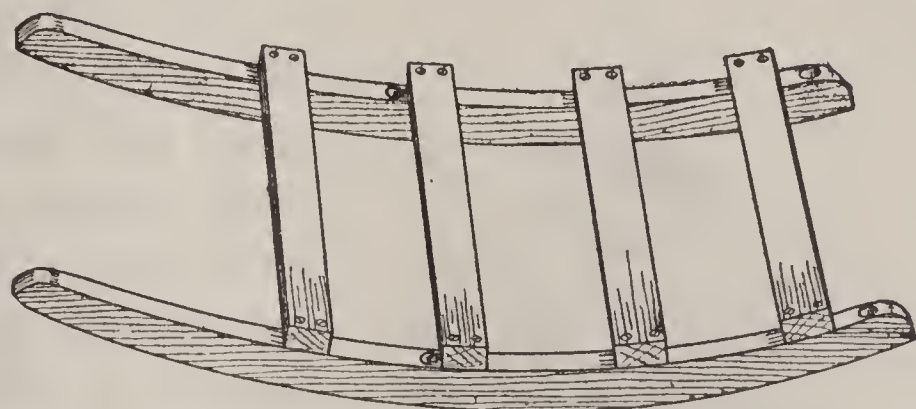

FIG. 299.—Chair Rockers Connected by Cross Bars.

For a more efficient ski, smooth the sole with sandpaper, then rub in linseed oil, and polish with floor wax.

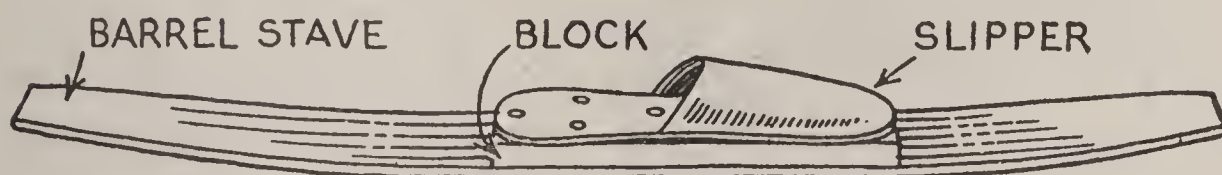

FIG. 300.—Barrel-Stave Ski.

#### A SMALL SKATE-SAIL

like that in Fig. 301 will not enable you to attain a speed of fifty miles an hour, but for that reason it is better-adapted to ponds and short stretches of ice. Indeed, this type of sail was designed by boys of the Shedd Park Playgrounds, Chicago, for the annual playground ice tournament held on a park lagoon that would not permit the use of a larger sail. This is also the rig to speed you over pavements coated with ice, on streets having little traffic.

A detail of the completed skate-sail is shown in the diagram of Fig. 302.

The Frame Sticks should be  $\frac{7}{8}$  inch square by the lengths given in Fig. 303. If there is a woodworking mill



FIG. 301.—Small Skate-Sail.

in your vicinity, you will probably find in its waste pile the sort of sticks needed for the frame, and a few pennies ought to clinch the bargain, if any charge at all is made. If a mill is not at hand, seek a local carpenter. He may have the strips you want in his pile of rippings. If these sources fail, lay off the strips upon a board and

rip them with your saw. Plane the sticks smooth, and take off the sharp edges with sandpaper, then cut them to the given lengths.

**To Assemble the Frame,** nail the 36-inch stick to the end of the 60-inch stick, then place the diagonal brace in the position indicated, trim off its ends to fit against the horizontal and vertical sticks, and nail in place. Fit the short cross brace between the diagonal and vertical sticks, as indicated.

Reinforce the frame connections by lashing fishing line or other stout cord tightly around the sticks, then coating the lashings with shellac to make them hold fast.

The Covering Material may be light-weight canvas, or muslin, or any closely woven cloth that Mother can spare.

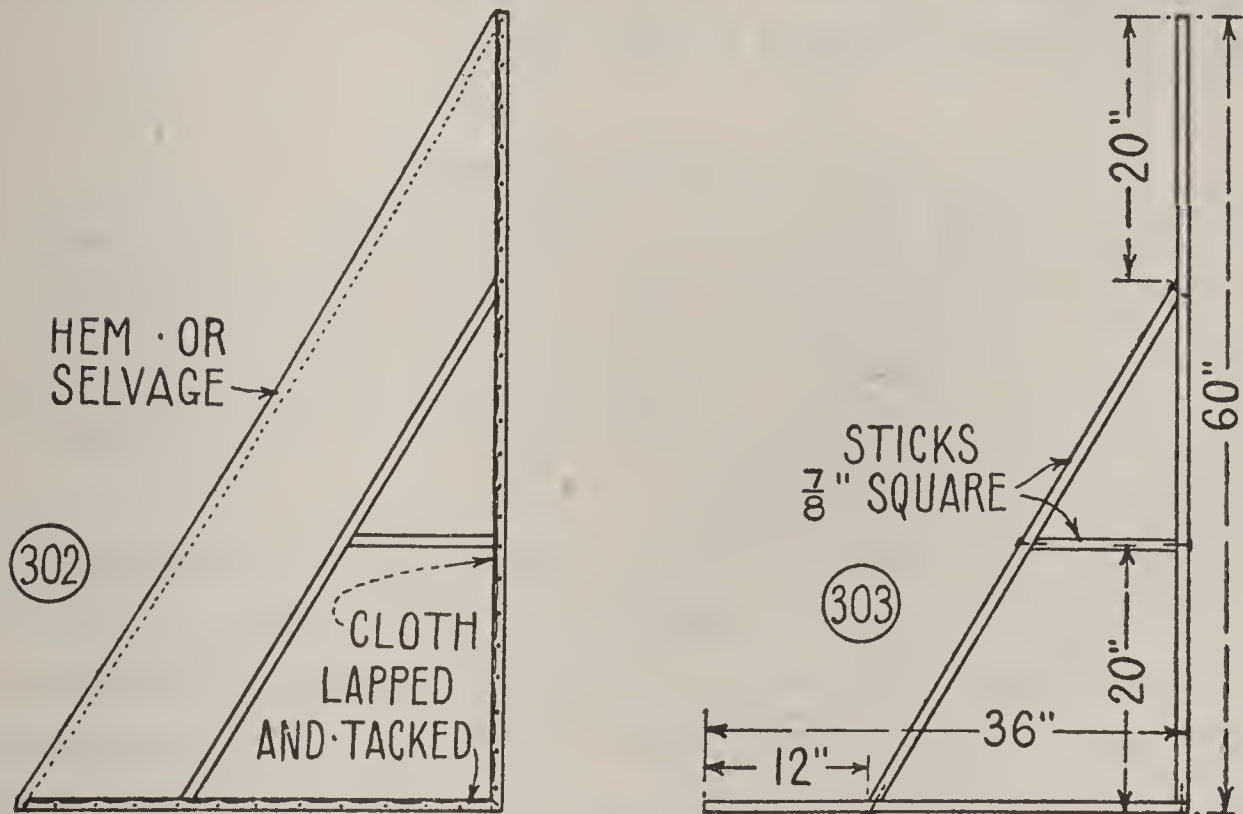

FIG. 302.—Completed Skate-Sail.

FIG. 303.—Frame Detail.

The method of lapping it over the frame and tacking it along the edges, is indicated in Fig. 302. This diagram also shows how the long edge of the cloth is turned over and stitched to form a hem.

**Decorate Your Sail.** It will give it individuality. Newspaper comic supplements and magazines contain suitable pictures to cut out and paste on sails; but, if you are clever with brush and pencil, you will probably want to work out a design of your own.

**When Sailing** with the skate-sail, adjust the angle at which you hold the sail to suit each change in the direc-

tion of sailing. Large sails are held between the body and the wind, and you preserve your balance by throwing your weight against the sail. You may hold the small sail, however, in front, as shown in Fig. 301.

### AN ICE HOCKEY STICK

is bent, not cut out, as you might imagine. The reason for bending it is that its grain must be continuous from the end of the handle to the toe of the blade. If it were not, the blade would split off where it joins the handle, perhaps at the first stroke.

Making the Sharp Bend is not easy with the equipment of the average home workshop, but you can have the job done at a local mill, where they have facilities for bending wood and making it stay bent. The rest of the shaping and finishing will be no trick at all.

Another Way to Shape a Stick is used by boys in Canada, and it was described to me by a former captain of a Canadian hockey team. A tree-branch is selected (preferably of elm) that has the correct bend to it, one like that shown in Fig. 304. This is first roughly hewn to shape with an axe, then finished to the form indicated by dotted lines with spoke-shave or draw-knife, plane and file, and sandpaper.

The dimensioned diagram of Fig. 305 shows an approved model of American hockey stick. The

Length of the Stick and the angle of the blade, however, vary with different players. Coach C. S. Smythe of the Toronto University team suggests that the way to deter-

mine your individual requirements is to stand on your skates in playing position, leaning forward, with the right

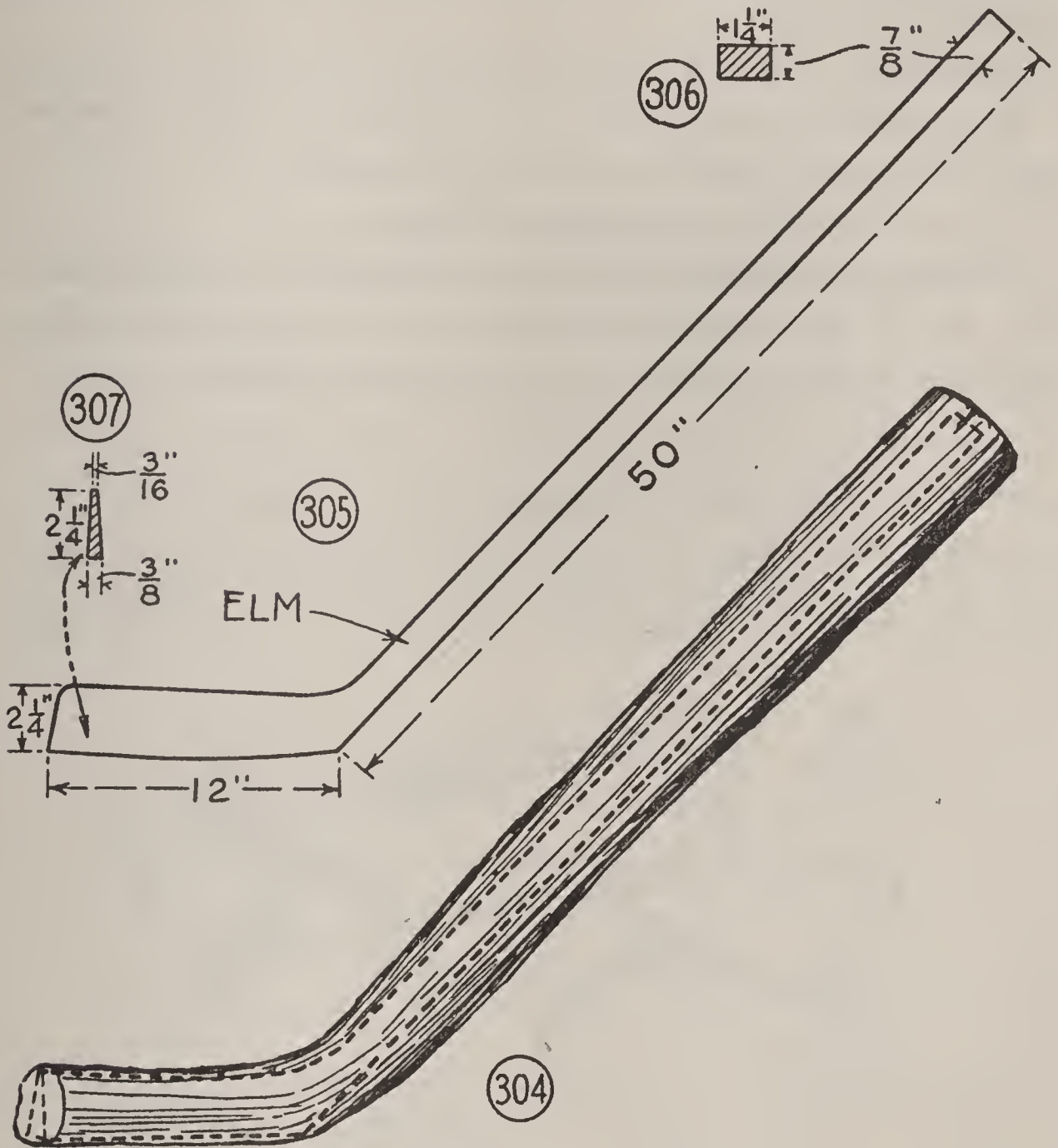

FIG. 304.—Select a Tree-Branch With a Bend Like This for Hockey Stick, and Hew to Dotted Line.

FIGS. 305-307.—Correct Dimensions for Standard Hockey Stick.

hand grasping the stick well down the shaft and the left hand at the end, and place the blade the same distance in

front of you that it is ordinarily when you are taking the puck down the rink. In that position, the blade should lie flat on the ice.

The Shaft End is shown in cross-section in Fig. 306, and

The Blade End in Fig. 307. Give the stick a gradual taper from the shaft end to the blade end.

You can spend any amount of time

Finishing a Hockey Stick, and, of course, the more time you put on the work the better the job should be. Give the stick a coat of shellac, after sandpapering it.

### HOLLOW GRINDING YOUR SKATES

It is not necessary to take your skates to a tool-grinder to have them hollow ground. If you own an emery stone

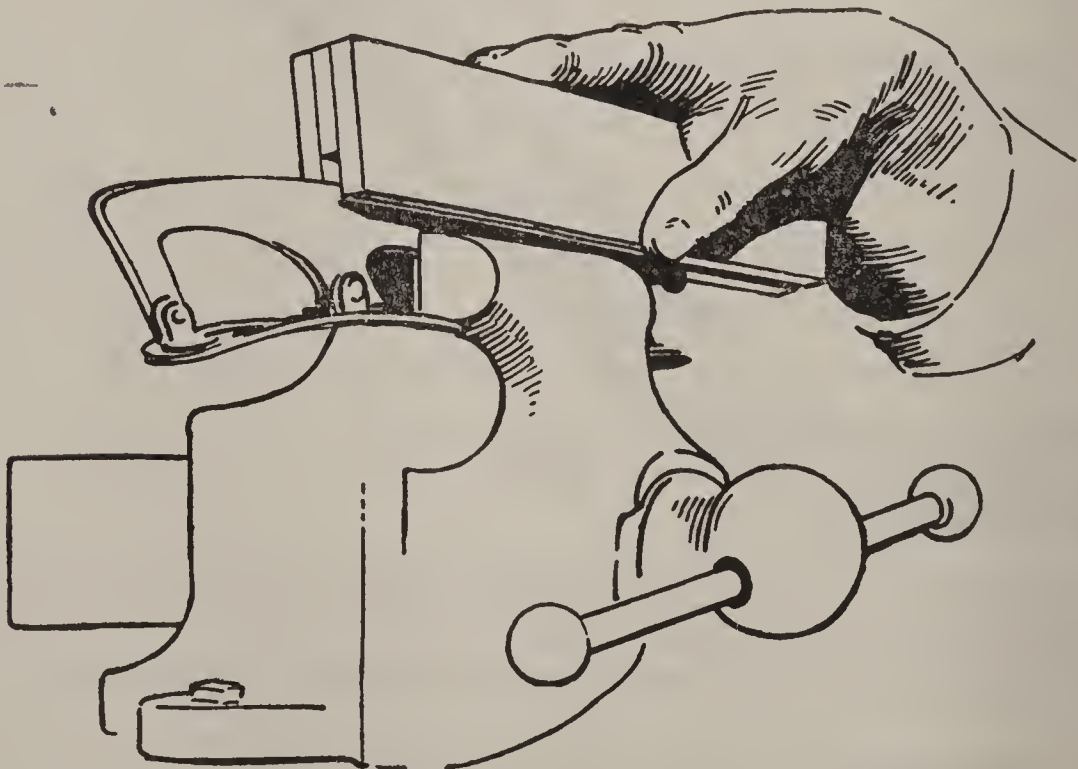

FIG. 308.—Hollow-Grinding a Skate with Home-Made Grinder.



narrow enough, it will be easy to rig up a gauging device to guide the skate so the stone will grind the hollow along the center of the runner. This is the method used by the professional grinder. But it is not necessary to invest in a grindstone, if you haven't one. Instead

Make a **File Grinder** like that shown in use in Fig. 308. Figs. 309 to 314 show details of it.

The **File for the Job** is the round rat-tail file shown in Fig. 309. One 6 or 8 inches long is right.

The **Holder**, shown in Fig. 310, is made of three strips of wood, a center strip a trifle thicker than the width of the skate runner, by the length of the file and  $1\frac{1}{8}$  inches wide, and two outer strips  $\frac{1}{4}$  or  $\frac{3}{8}$  inch thick by  $1\frac{3}{4}$  inches wide. A lattice strip or a lath will cut up to advantage.

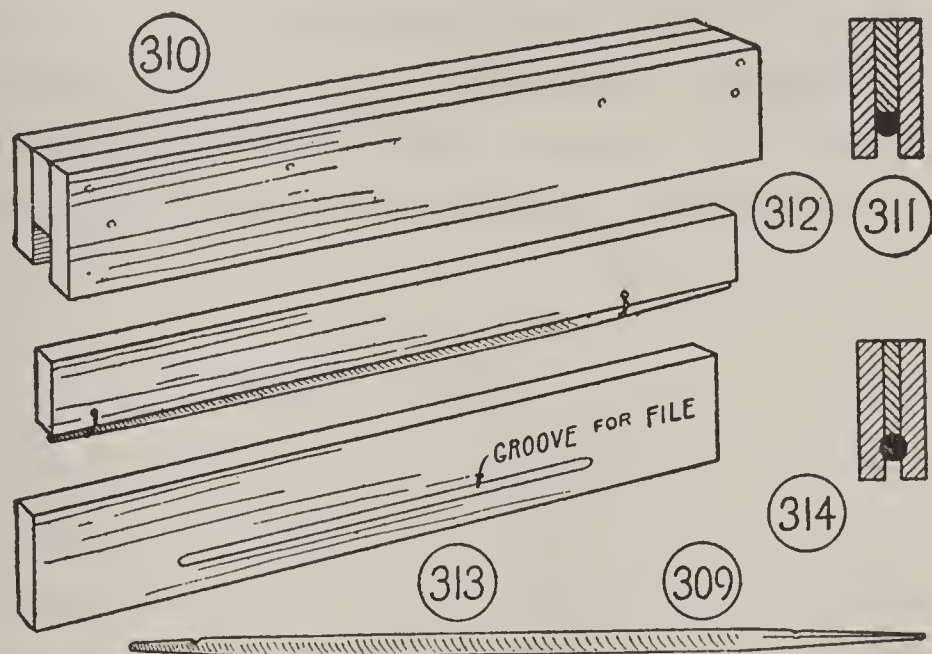

FIG. 309.—Use Rat-tail File for Skate Grinder.

FIG. 310.—Holder for File.

FIG. 311.—Cross-Section of Grinder.

FIG. 312.—Fasten File to Center Strip.

FIGS. 313 and 314.—File May be Let Into Side Strips, Like This.

**To Assemble**, fasten the file to the center strip, to come between the outer strips, as shown in the cross-section of Fig. 311. You can fasten it by wiring it as shown in Fig. 312, or by driving brads through the outer strips close to the under side of the file. The wire or brads must be below the cutting surface, so cut a notch near each end of the file with a hack-saw (Fig. 309).

When you have mounted the file, fasten the three strips together with brads or screws. If your skates have runners narrower than the file, make a groove in the outer strips (Fig. 313) so the file can be let into them as shown in Fig. 314.

Use a **Vise** to support the skates for grinding, or if you haven't a vise, screw the skates to a plank, and hold the plank by kneeling on it, or by clamping it to a table top with a pair of curtain-stretcher clamps.

**Skates to Grind.** When the other fellows see you with your hollow-ground skates, and hear that you have a grinder, you should have all the hollow-grinding jobs that you want to attend to.

### A SNOW TOTEM POLE

Of course, you fellows have seen pictures of the totem poles of Indians, symbols of families and tribes. But probably none of you unless you are a Boy Scout or Lone Scout, and have used a totem pole as a whittling problem, has attempted to make a totem pole model. A well-designed, brightly colored pole is a novelty worth having on one's home grounds, since it is different from the

usual line of garden accessories; but it is no small job to cut one.

A snow totem pole, on the other hand, like that shown in Fig. 315, can be made successfully by any one who has modeled in snow, or has made the attempt.

A **Tree-Trunk Foundation** is required. A tree in the front yard, visible from the road is best, if you want passers-by to see the totem pole. The size is not important. If it is not large enough to model on, increase its diameter by piling snow around it. The snow must be moist to pack well.

**To Start a Totem Pole**, plaster the tree trunk with snow from the ground as high as you wish to have the pole. Then roll snowballs of assorted sizes, from 12 to 18 inches, and cement them into the snow foundation, with enough snow below them to support the weight.

With the several balls in place, decide on what figures they are to be shaped into and start the modeling.

**Your Modeling Tools** will be a garden trowel, a stick, and a knife. With these you can cut away the snowballs, hollow or flatten them, and build up where necessary.



FIG. 315.—Snow Totem Pole.

**Reinforce Projections** with sticks or branches.

**Make Eyes and Ears** of chunks of coal, tin cans, orange skins, harness rings, or other odds and ends. Press them into the snow.

When you have completed the carving, you can obtain quite startling effects by

**Adding Color.** You might not think such a thing possible, but it can be done successfully with calcimines. Of course, colors will cause snow to melt to a certain extent, so do not apply them until you have sprayed the snow with water and allowed it to freeze solid.

#### A SNOWBALL SHIELD

Every red-blooded boy enjoys a snow fight, with one side entrenched in a fort, the other side the attacking party. But when you are one of the attackers, it is more fun to advance under the protection of a shield like that in Fig. 316.

**To Make the Shield,** fasten together two thin, light-weight boards of the length and width shown in Fig. 317, with a batten placed near the ends. Then draw the curves for the side edges, using the given radius, and saw along the curved lines. In nailing on the battens, be careful to place the nails so that none will come in the path of the saw.

**An Arm and Hand Loop** are required upon the back of the shield (Fig. 316). Make these of short blocks of wood, with nails driven into the ends, and loops of twisted strands of wire fastened to the nails (Fig. 318). Make the

arm loop amply large so that your overcoat sleeve will slip through it easily. Wrap the hand loop with cloth or friction tape so that it will make a good hand grip. Nail

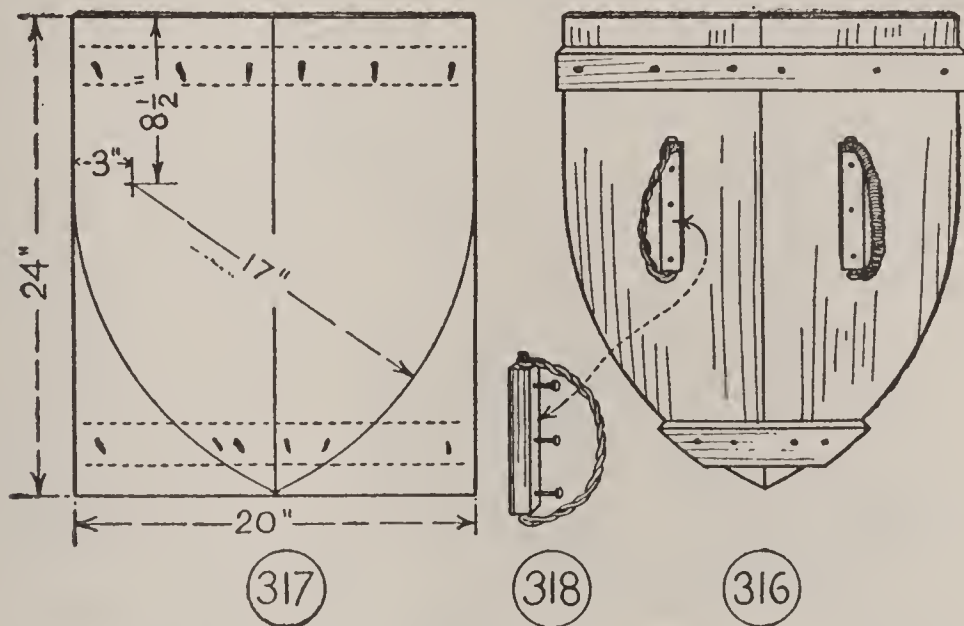

FIG. 316.—Snowball Shield.

FIG. 317.—Pattern for Shield.

FIG. 318.—Arm and Hand Loop Detail.

the loop blocks to the back of the shield in the positions shown.

Decorate the face of the shield with fantastic symbols done in bright colors.



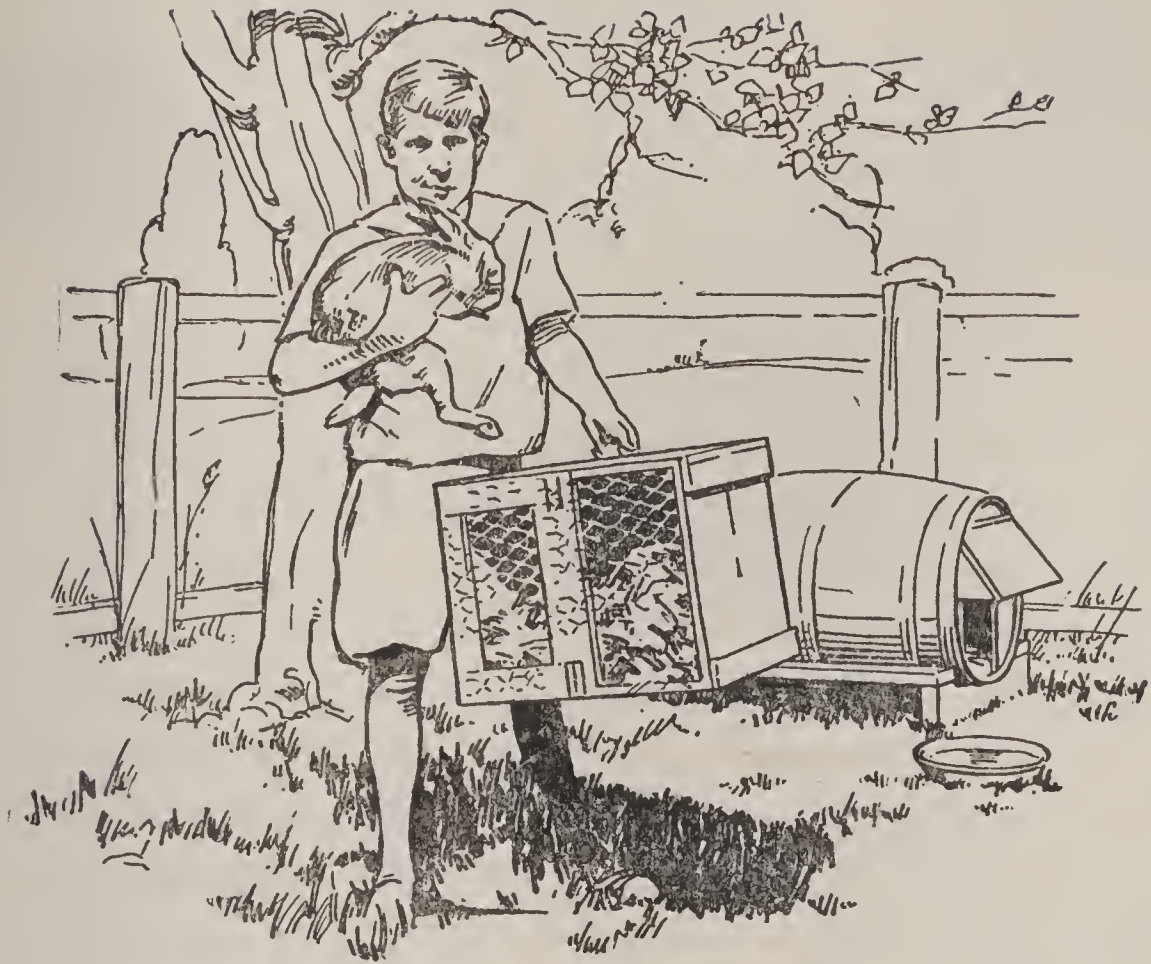

## PART II

# Spring Hobbies





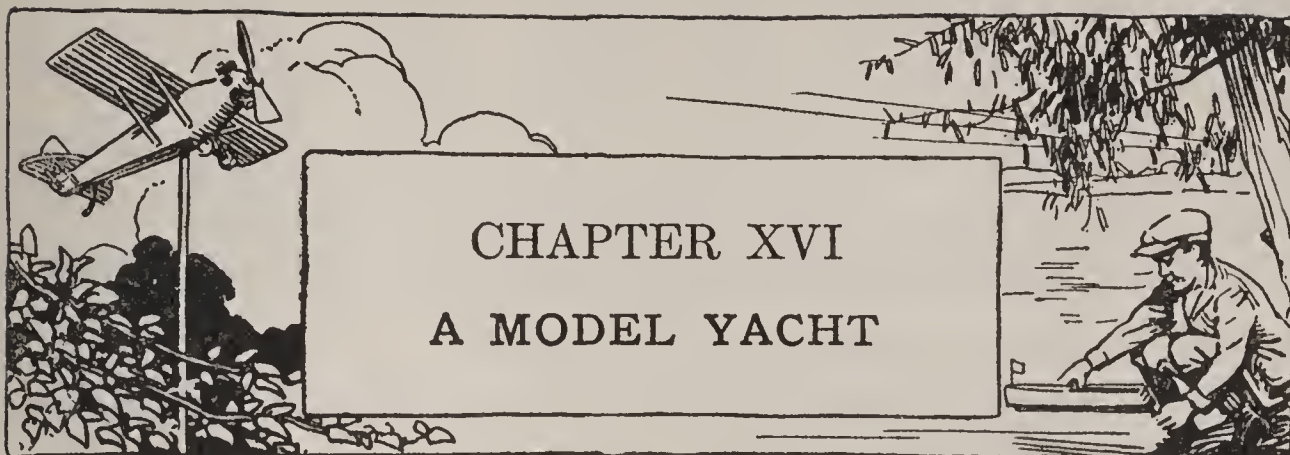

## CHAPTER XVI

### A MODEL YACHT

YEARS ago the building and sailing of model yachts was looked upon as a small boy's pastime. Now it has become the hobby of old and young alike. In parks of every large city and small town you will see evidence of growing interest in these miniature craft. Indeed, model boat regattas have become as much a part of the calendar of playgrounds, schools, Boy Scout troops, Young Men's Christian Associations, and other organizations, as kite contests, model airplane tournaments, and athletic events. The younger boy regattas include every type of simple craft from a catboat with watermelon hull to a motor boat propelled by a rubber-band motor. The older boy regattas bring out more efficient craft, with stream-lined hulls and trim rigging, and clockwork or electric motors. And the "old boy" regattas, in which participants hail from every trade and profession, reveal the ultimate in design and construction, exact scale models of the finest craft afloat, with full rigging and miniature power plants capable of remarkable performance.

The photograph of Fig. 319 (facing page 164), shows a

fleet of boys' yachts, and the photograph of Fig. 320 shows a group of models built by the older members of the Ogden Park Model Yacht Club, Chicago, one of the most active and most skilful organizations affiliated with "The Model Yacht Racing Association of America."

Dad would be quite as much interested in building a yacht as men in the model yacht clubs are. A manufacturer of toy boats has advertised "Buy your boy a boat for yourself," recognizing the fact that a father gets as much of a thrill out of it as his boy does. But half of the sport is in building the yacht, and if you can persuade Dad that this is true and obtain his coöperation, you will both have the greatest amount of fun imaginable.

### YOUR FIRST MODEL YACHT

For your first fully rigged model yacht, I suggest that you follow the plans in Figs. 321 to 340 of this chapter. A simple yacht like this requires inexpensive materials, and few tools to shape them. When you have completed it, you can turn your attention to

### LARGER MODELS

replicas of the finest craft that sail, and when you have become expert in the work, you can produce models that would cost hundreds of dollars to buy.

Blueprints of large yachts are made available by publishers of yachting magazines, and houses that specialize in model boat accessories supply

Material Kits and models in knocked-down form, also

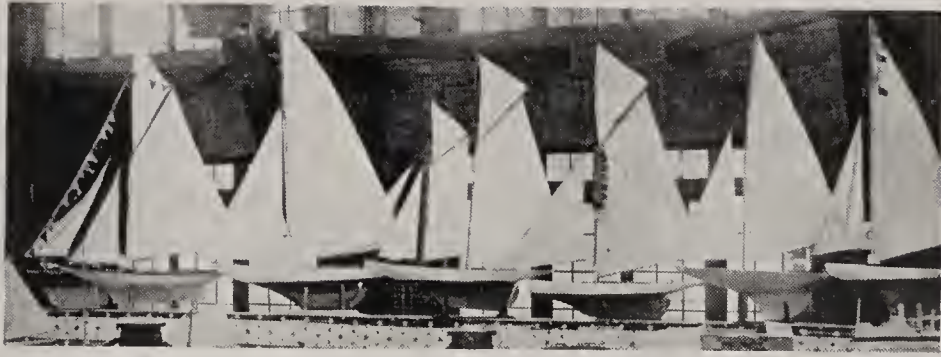

FIG. 320.—YACHTS BUILT BY MEMBERS OF THE "OGDEN PARK MODEL YACHT CLUB," CHICAGO.



FIG. 321.—RANDOLPH CANNON AND HIS MODEL YACHT.

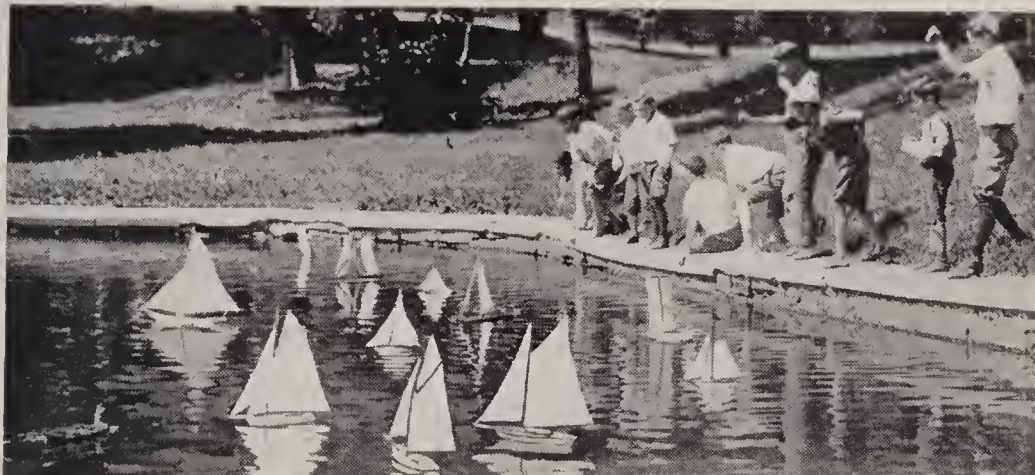

FIG. 319.—A MODEL YACHT REGATTA IS EXCITING.



Fittings such as dead-eyes, chocks, cleats, turn-buckles, and mast rings, nicely formed and made to scale.

### A TWENTY-FOUR INCH MODEL

The photograph of Fig. 321 shows a 24-inch model with its builder Randolph Cannon. Working details of the model will be found in Figs. 322 to 340. You may make changes in this model, introduce your own ideas, just as Randolph used his ideas. You will learn much by experimenting. Yet you will profit by studying a successful model like this one, and for a first model you will do well to copy it as closely as you can.

Fig. 322 is a side elevation of the completed model, Fig. 323 is a deck plan and Fig. 324 is a keel plan.

### MATERIALS

The following materials are required: one block of clear soft pine 1½ inches by 6 inches by 24 inches, or two blocks ¾ inch by 6 inches by 24 inches, for hull, a piece of mahogany or pine for deck, a small piece of No. 22 gauge sheet brass or iron for rudder, ⅛-inch brass rod 5 inches long for rudder post, ⅜-inch brass tubing 2 inches long for rudder post port, ¼-inch and ⅜-inch dowel sticks for spars, wire for spar rings and loops, muslin for sails, fancy-work rings for sail mast rings, fishing line for rigging, and small screw-eyes and screw-hooks for eyes and cleats.

### THE HULL

may be carved from a single block of wood, but unless you

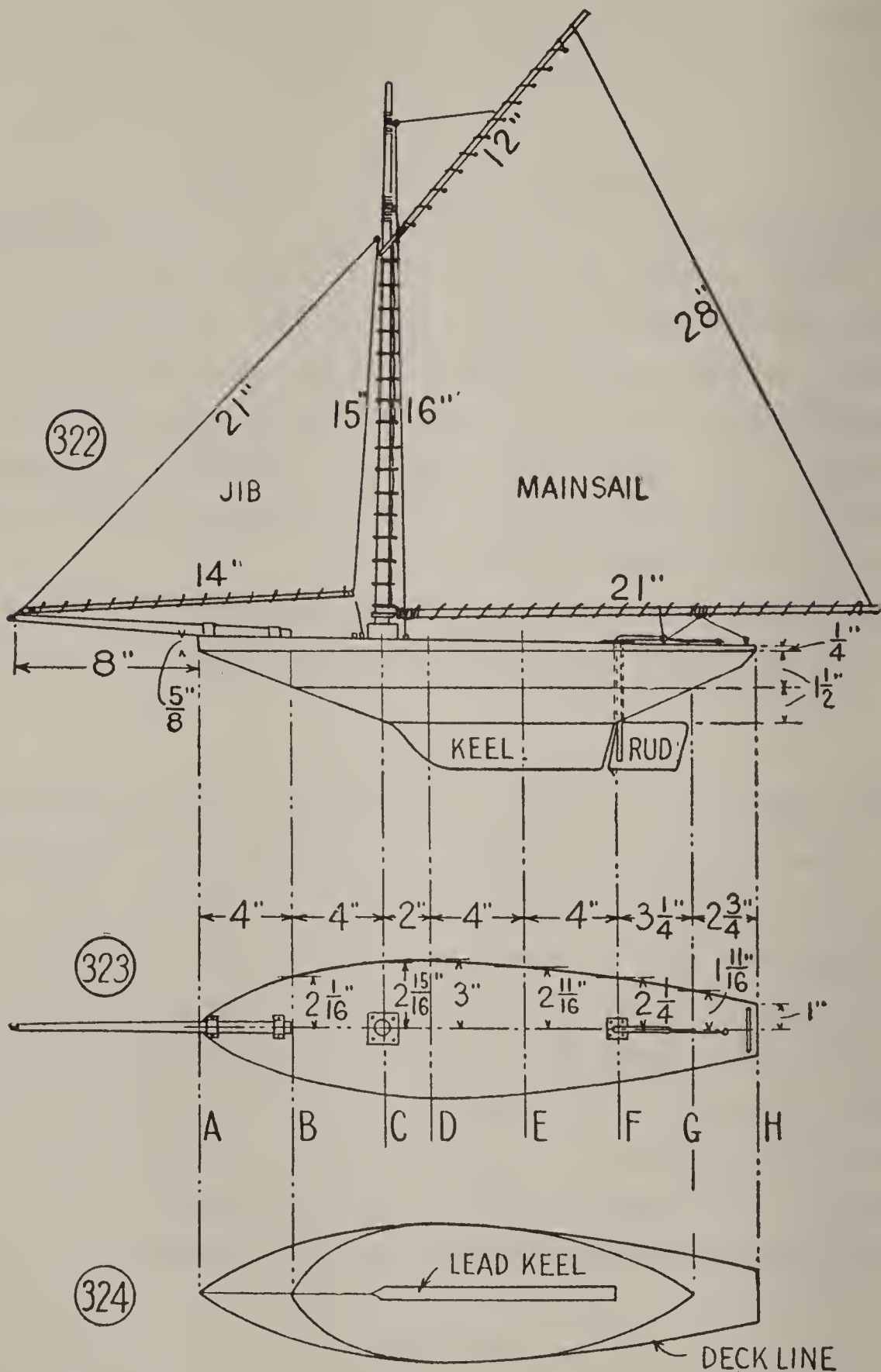

FIG. 322.—Side Elevation of 24-Inch Model Yacht.  
 FIG. 323.—Deck Plan.  
 FIG. 324.—Keel Plan.

can get a block that is free from knots and other defects, it is better to cement two pieces together as shown in Fig. 325. Use a waterproof glue, or cement of the kind recommended for model airplanes.

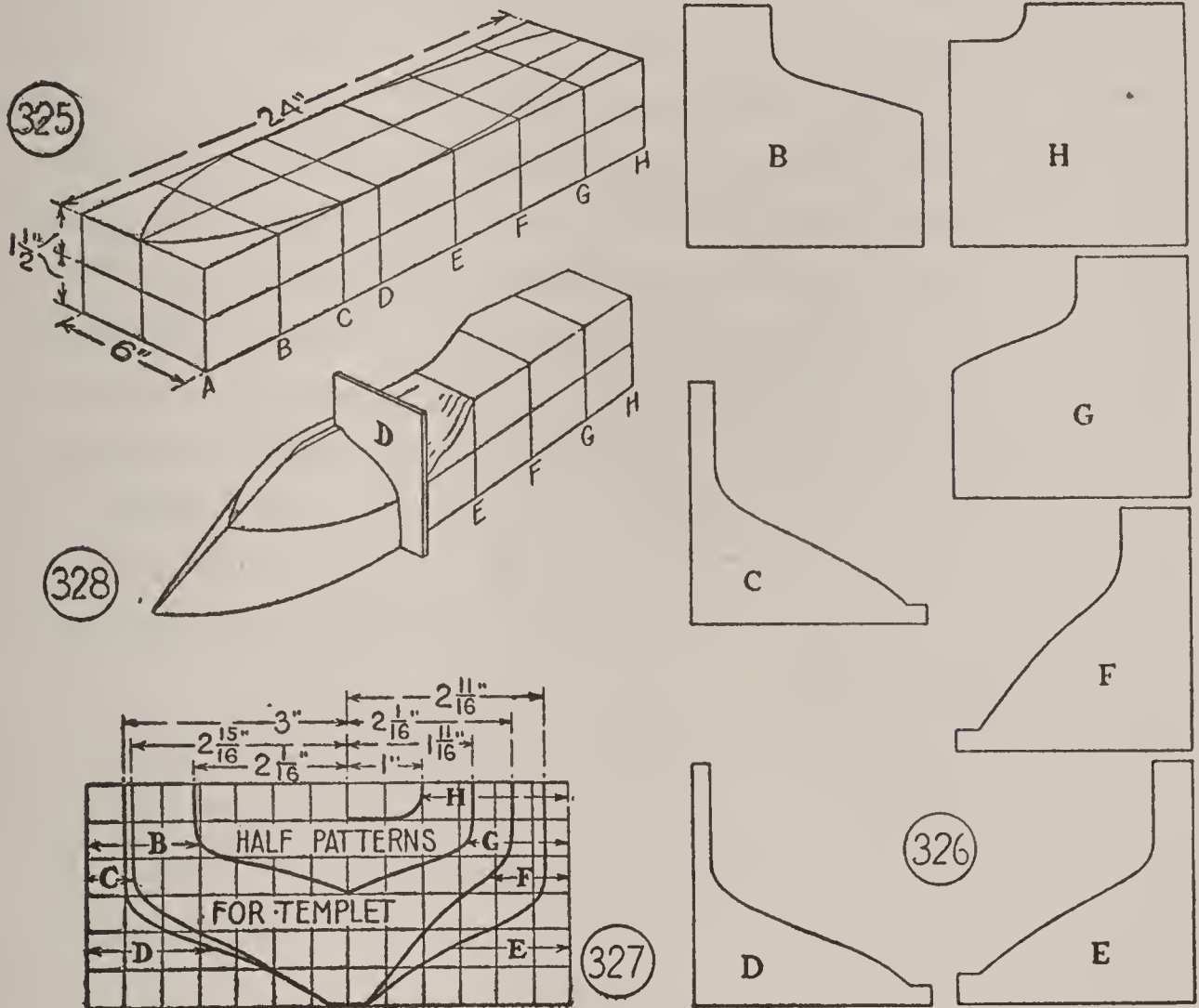

FIG. 325.—Hull Block Laid Out for Carving.  
 FIGS. 326 and 327.—Templets.  
 FIG. 328.—Applying Templet to Gauge Carving.

To Lay Out the Hull, first scribe a center line along each face and end. Then space off the templet section lines, following the dimensions given in Fig. 323, and square these lines across both faces and edges of the block as in

Fig. 325. Measure off the hull widths given in Fig. 323, along the section line of each face, and through the points draw the curved side lines. Cut the block just outside of the lines.

Templets are needed for the final shaping of the hull, by which to gauge the cutting. There should be a templet to show the true profile at each of the section lines. Fig. 326 shows the seven templets, and Fig. 327 shows patterns, squared off to aid you in reproducing the curves. Make a similar set of squares upon a sheet of paper, with each square measuring  $\frac{1}{2}$  inch across. Then upon these full-size squares lay off the curved and straight lines of the templets, just as they are shown upon the printed patterns. Having the full-size patterns, make tracings of them, and then transfer them upon heavy cardboard or sheet metal, and cut them out, leaving generous margins around the profiles.

Carving the Hull requires a draw-knife or coping-saw for the rough cutting, a wood-rasp, plane, and sandpaper for the final shaping and smoothing of the surfaces. Fig. 328 shows the application of a templet to determine the correct profile at section line D. Support the hull block as suggested for the hull of the model motor boat in Chapter XVII, while carving it. Read, also, the suggestions in Chapter XVII for shaping the motor boat hull.

When the outside of the hull satisfies you,

**Hollow the Inside.** A gouge is best for this work. Cut deep, except along the center, where the keel is to be screwed on, and at the point of the rudder post port.



MAKE THE DECK

of a piece of board  $\frac{5}{8}$  inch thick, tapering it from that thickness at the bow to a thickness of  $\frac{1}{4}$  inch at the stern (Fig. 322). Fasten down the deck with glue and small brass screws or escutcheon nails.

THE KEEL

is of lead, cast in a mold hollowed out of two blocks of wood, as shown in Figs. 329 and 330, with port and vents provided. Smooth the casting with a file, drill three screw-holes, and screw the keel to the hull, as shown in Fig. 331.

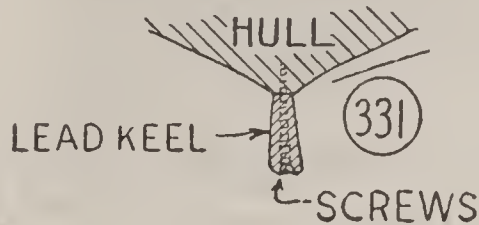

**THE RUDDER** is cut out of sheet metal. Lay it out of the dimensions given in Fig. 332.

**The Rudder Post** is a piece of  $\frac{1}{8}$ -inch brass rod or galvanized

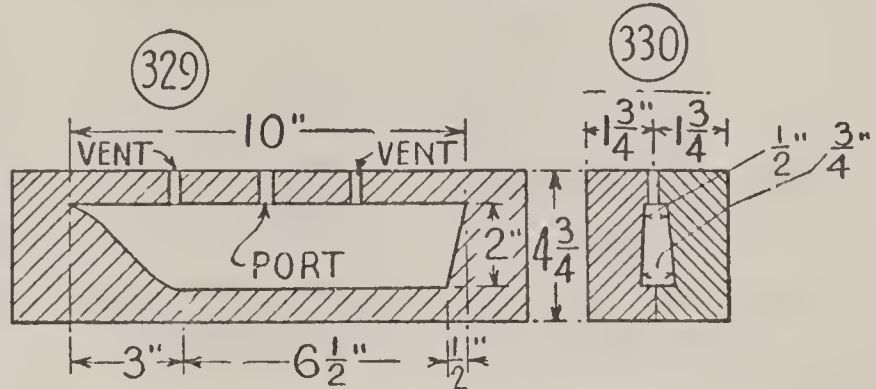

FIGS. 329 and 330.—Cast Lead Keel in a Mold Like This.

FIG. 331.—Screw Keel to Hull.

wire. Slot its end, slip the rudder into the slot and fasten with solder. The post can be run through a small hole bored through the hull, but

A Port of  $\frac{3}{16}$ -inch brass tubing (Fig. 332), packed with grease to keep out water, is a better job. Finish off the

deck end of the tubing with a brass plate (Fig. 333). Solder this plate to the tubing, then screw it to the deck.

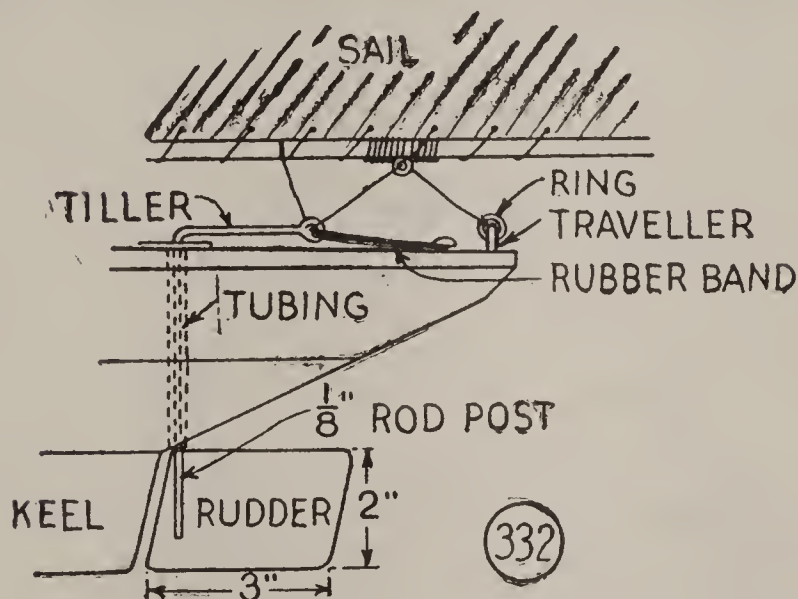
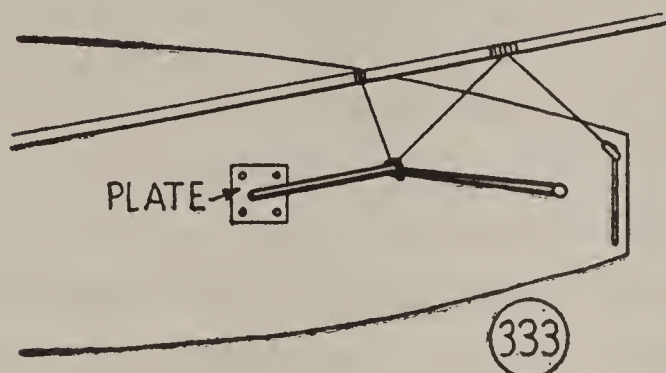

FIGS. 332 and 333.—Details of Rudder, Tiller, and Automatic Steering Device.

Make a right-angle bend in the end of the rudder post, to form

**The Tiller**, and bend an eye in the end of the tiller (Fig. 332).

Figs. 334 to 338 show details of

#### THE SPARS

Make these of dowel sticks of the diameters and lengths indicated, and taper the mast and boom spars from a diameter of

$\frac{3}{8}$  inch at one end to a diameter of  $\frac{1}{4}$  inch at the other. Make

**The Mast Loops** for boom and gaff of metal bands (Fig. 339), lash them in place with linen thread, and coat the lashings with shellac to make them hold fast. Make

**The Rigging Loops** of wire (Fig. 340), and lash them in place at the points indicated. Cut a small block of wood for

A Mast Step, drill a hole in it to receive the mast end, and fasten the block to the deck.

### THE SAILS

Use a good grade of muslin or Indian head for sails. You had better ask Mother or Sister to be sailmaker, as the work is somewhat out of your line. The sizes of the mainsail and jib are indicated in Fig. 322. Lay out a pair of paper patterns, by which to cut the cloth, and place them upon the cloth so that the selvedge runs along one edge of the sail. The other edges must be hemmed.

Sew fancy-work rings to the luff of the mainsail, to slip over the mast. Sew short lengths of thread to the head and foot for lashing the sail to the gaff and boom. Sew short lengths of thread to the corners of the jib sail in the same manner.

### THE RIGGING

may be made complete in detail, or simplified. Most model-builders use a modified form, with small screw-eyes for *blocks* and screw-hooks for *cleats*.

Fishing line makes good *stays*, *halyards*, and *sheets*. You will see by the photograph of Fig. 321, and Fig. 322 and Figs. 334 to 338 of the diagrams, where to attach them.

The scheme for

### AUTOMATIC STEERING

is shown in Fig. 332. Run the mainsail sheet from the boom to and through the tiller eye, then back to the boom,

through a loop or ring on the boom, and over to a traveler set in the stern. With this rig, when the boom swings,

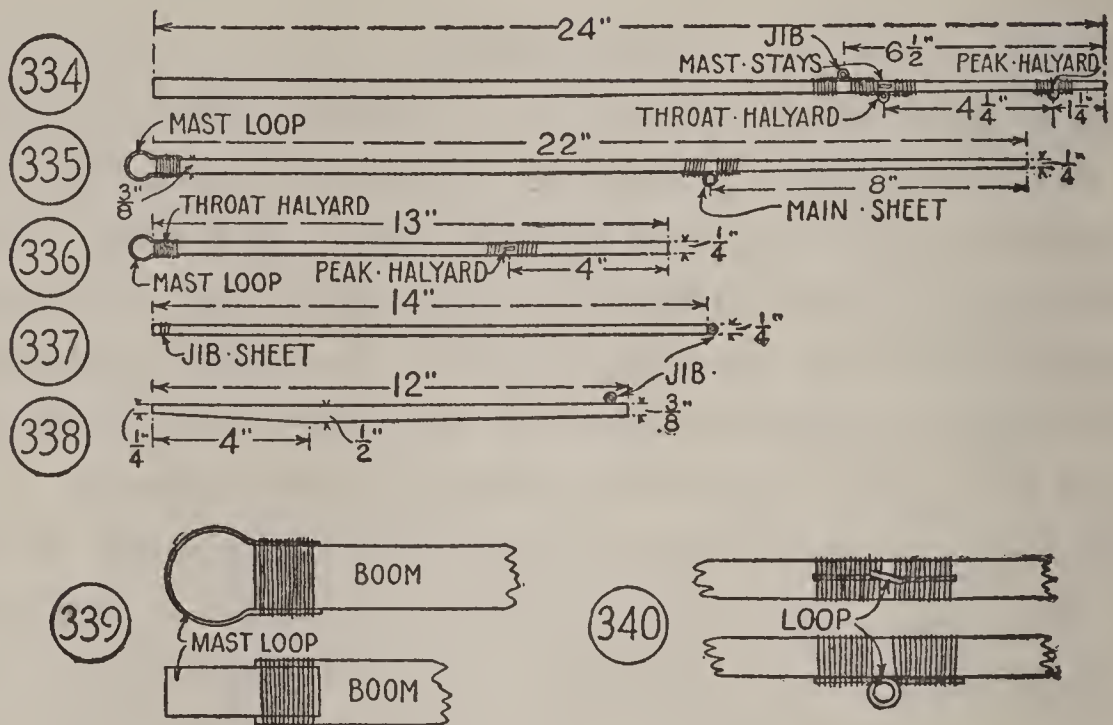

FIG. 334.—Mast. FIG. 335.—Boom. FIG. 336.—Gaff.  
 FIG. 337.—Jib Boom. FIG. 338.—Bowsprit.  
 FIG. 339.—Mast Loops for Boom and Gaff Ends.  
 FIG. 340.—Spar Loops for Sheet and Halyard.

the tiller also swings, as indicated in Fig. 333, and holds the yacht to its course. Run a rubber band from the tiller eye to a tack in the deck, to bring the tiller back to the horizontal.

### FINISHING

This job should be done before you rig the yacht. Varnish the deck and spars with two coats of spar varnish. Paint the hull white from the deck to the water line, and gray, black, or any other color that you want, from the water line to the keel.

## A YACHT CLUB

When enough of you fellows have taken up model yacht building, interest some local organization in helping you to form a model yacht club. Then the next step will be to promote

## MODEL YACHT REGATTAS

The committee in charge of the regattas should adopt the following rules, taken from the "Racing Rules for Pond Sailing," laid down by the "International Yacht Racing Association":

## DEFINITIONS:

Skipper—The person sailing the yacht, including his assistant.

Competitor—A yacht forming part of a pair.

Pair—Two or more yachts drawn to sail together in a heat.

Board—A course in one direction of the lake.

Heat—Two or more boards in which the same pairs sail.

Shore—The sides of the lake other than the starting line and the goal.

Obstruction—Anything (excluding weed) that may stop a yacht other than its competitor or the shore, including other yachts sailing in the same board.

Foul—When a yacht colliding with a competitor or obstruction is hung up, turned off her course, or has any of her gear disarranged so as to affect her chance of winning a board.

Officer of the Day—The officer appointed to take charge of the racing and act as referee.

Completion of a Board—A yacht shall be deemed to have completed a board as soon as any part of her hull or gear has passed the winning line.

When races are held on enclosed waters where yachts can be handled from the shore, the following rules shall apply:

**READINESS FOR PUNCTUAL START.** All competing yachts are to be out of the water and at the starting place at least ten minutes prior to the advertised time for the start.

**METHOD OF SAILING ON ENCLOSED WATERS.** When yachts are handled from the shore all events are to be sailed on the tournament system.

**SCORING.** In sailing races the scores shall be counted in points: For a win to windward, 3 points are to be awarded; for a win to leeward, 2 points; for a win in reaching winds, 2 points.

In the event of a dead heat the board is to be resailed.

Should the leading yachts tie with equal points at the end of a race, the yacht having the greater number of windward boards to her credit shall be declared the winner; but if there still be a tie the yachts in question are to sail one windward board to decide (in reaching winds a board in the direction in which the race was started).

**STATIONS AND STARTING.** Stations (weather and leeward berths) shall be drawn for before starting, and competitors must *both* start on the same tack (with sails full and drawing) and from the positions (or starting marks) duly determined by the starter. The starting marks shall be not less than three yards apart.

**PROPULSION.** Skippers shall be allowed to push off their yachts at the start only by hand or by pole, but at no other time during a board may yachts be propelled otherwise than by the action of the wind, unless the yacht gets aground, when she may be pushed off. Poles to be of uniform length, but not longer than is customary or necessary on the particular water.

**ENTERING THE WATER.** A skipper shall not enter the water to turn, retrim or start a yacht, except at waters where it is customary to use waders or water boots; but in no case shall a pole be used in conjunction with waders or water boots.

**HANDLING YACHTS.** Whenever a yacht comes to shore she must either: (a) be tacked, or (b) be retrimmed.

For (a) in *windward boards* yachts shall be turned fairly about by the skipper taking a firm stand and (1) turning the yacht off by placing the stick or pole against the lee bow, and (2) he may also steady her round the pole against the lee side of the counter

as she sails out. In any case her head-sail must fairly and definitely fill on the offshore tack before she leaves her skipper's control. Failure to do this shall entail disqualification for the board. No other part of the yacht, sails, or gear may be touched, unless to readjust her trim or to avoid an obstruction. When, and if, a retrim has been effected, the model shall be put off by hand only. A yacht put off on the "guy" and failing to "break tack" and returning to the shore from which she was put off, must be retrimmed.

**NOTE.**—Failure to break tack occurs when a yacht has been correctly turned (with head-sails filled on the new tack) and she returns to the same shore on the same tack, *i. e.*, not having broken tack by the action of the guy.

(A "retrim" is a readjustment of a yacht's sails, gear or rudder that will allow her to proceed fairly on her course toward the finishing line.)

For (b) in *leeward boards* (or *reaching*) the yacht shall be stopped, retrimmed, and restarted by hand every time she comes ashore.

The skippers must remain stationary whilst retrimming or turning the yacht, and the yacht must be *stopped* whilst altering trim.

Whenever a yacht is put about, or restarted after retrim, her way must not be accelerated.

The "guy" properly applied constitutes a retrim, but a jibe does not.

**AVOIDING COLLISION.** Tacking, guying, starting a yacht after a retrim, or after coming to shore foul, may not be done so as to involve the immediate risk of collision.

**COLLISIONS AND FOULS.** (a) If a competing pair foul within six yards (or a similar distance previously settled by the Officer of the Day) of the starting line, they shall be restarted from their original positions. Should the foul recur the starter may order them to start further apart, or to change positions.

(b) If a competing pair foul outside the distance mentioned above, the board shall be resailed on the order of the Officer of the Day, except as provided in Rules 12 and 13 (c) (d).

(c) If one of a pair fouls an obstruction the board shall be

resailed, unless the Officer of the Day is of the opinion that she had no chance of winning the board.

(d) Should two or more yachts come to shore foul (covering each other) that which is to windward has the right to be first restarted; but if either requires adjustment, then that which is first ready may be first restarted, in which case such yacht must restart from a position astern of the other. Neither may be advanced to effect a retrim.



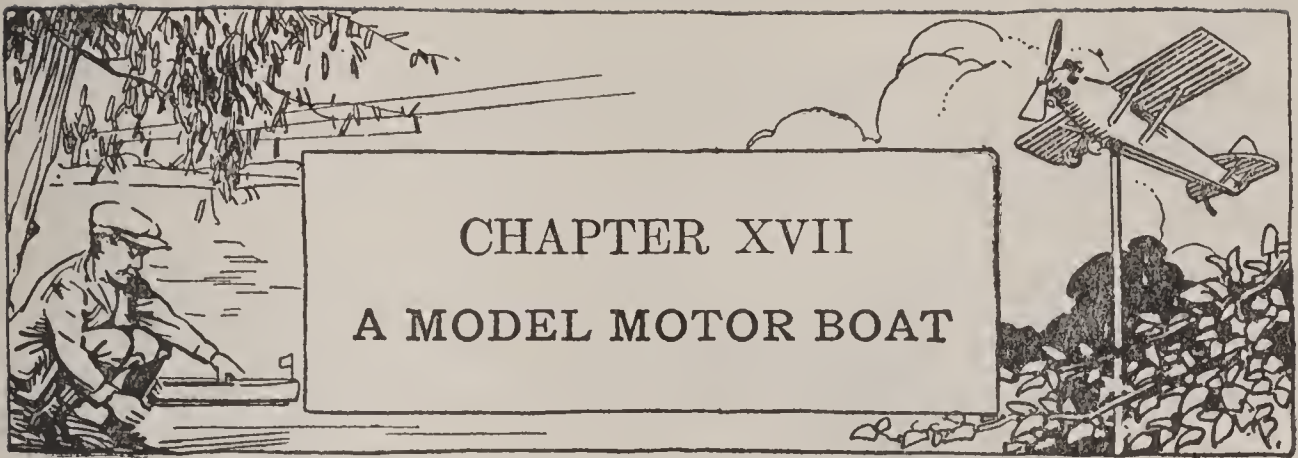

THERE is about the same amount of work to building a model motor boat as to a yacht, the installation of the power plant requiring a little more time, perhaps, than rigging a yacht. There is the added cost of the plant, it is true, a toy electric motor and battery, or other form of motor, sheet brass, brass rod and tubing, but if you own one of the electric motors that come with toy construction sets, this cost will be reduced by half.

The photographs of Figs. 341 and 342 show a nicely proportioned model built by my reader, Warren E. Leigh. This model won the first-prize cabinet of tools, in a recent "Boy Craftsman Model-Making Prize Contest," and it has won a cup and other prizes. The diagrams and instructions in this chapter will enable you to duplicate the model or help you to shape your own ideas into a practical design.

### MATERIALS

The following materials are required: one block of clear, soft pine 4 inches thick, 6 inches wide and 26 inches long, or two blocks, 2 inches by 6 inches by 26 inches, for hull,

small pieces of mahogany, walnut or cigar-box wood  $\frac{1}{8}$  inch or  $\frac{3}{16}$  inch thick, for decks and cabin,  $\frac{1}{8}$ -inch brass rod 36 inches long, for propeller shaft, rudder post and guard,  $\frac{1}{4}$ -inch brass tubing 15 inches long for shaft and post sleeve, No. 22 gauge sheet brass 4 inches square for propeller, tiller and tiller plate, brass screws, brads, electric motor, two flashlight batteries, bell wire, glue or model airplane cement, white lead, wood stain and spar varnish, or automobile enamel or lacquer.

### THE HULL

First, prepare the block of wood for the hull. If you get it in one piece, square it up to the dimensions given on the plan of hull (Fig. 343) and the side elevation (Fig. 344). If you must use two pieces, fasten them together

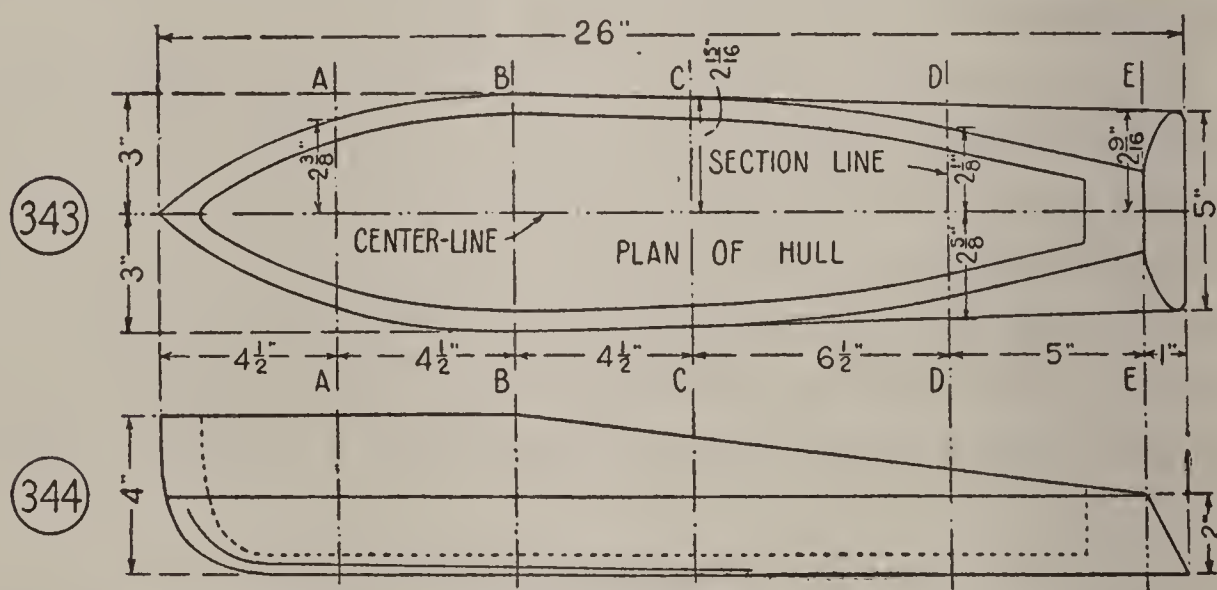

FIG. 343.—Plan of Hull.

FIG. 344.—Side Elevation of Hull.

as shown in Fig. 345, with waterproof glue or cement. The contact surfaces of glued blocks must be dressed



FIG. 341.—MODEL MOTOR-BOAT BUILT BY WARREN E. LEIGH.



FIG. 342.—CROSSING A PARK LAGOON.



absolutely true, and the blocks must be clamped together until the glue sets.

**To Lay Out the Hull,** first draw a center line along the two faces and across the ends (Fig. 345). Then mark off the measurements given on the plan (Fig. 343) for section lines A, B, C, D and E, and square lines through these

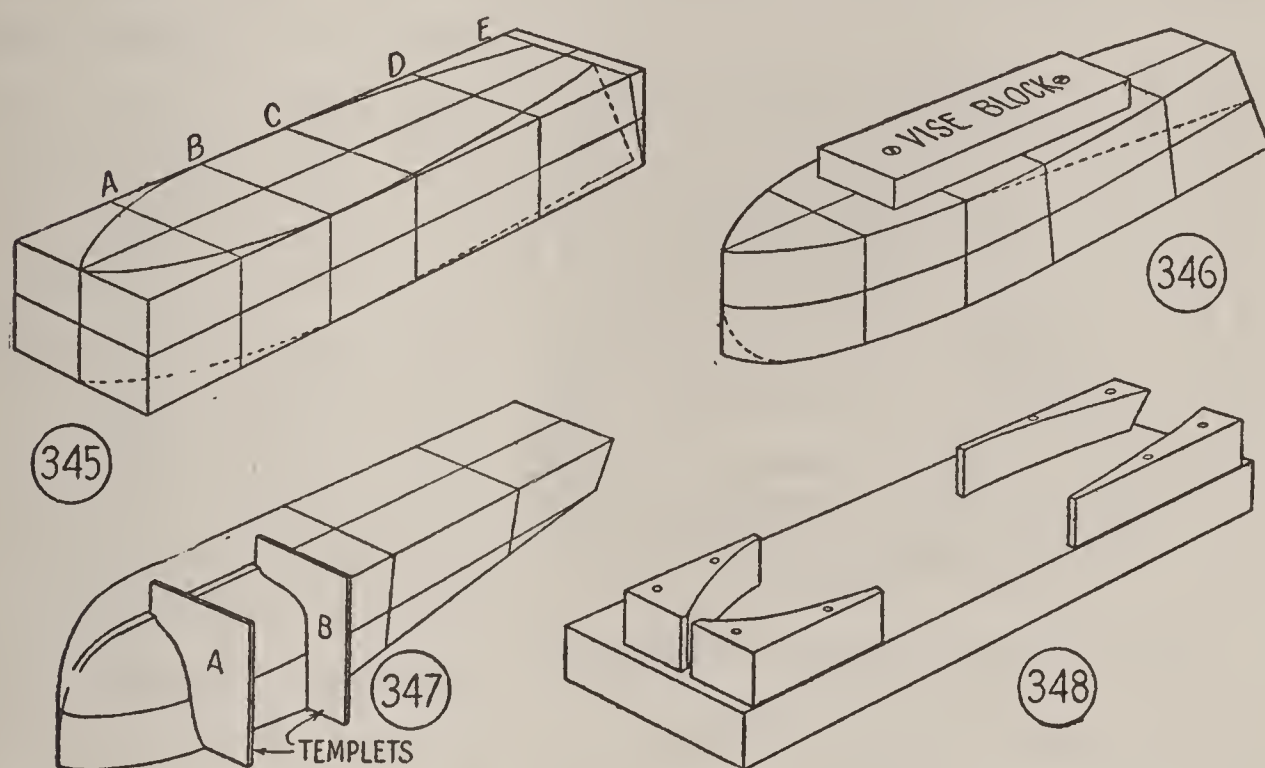

FIG. 345.—Hull Block Laid Out for Carving.

FIG. 346.—Vise Block for Supporting Hull While Shaping Outside.

FIG. 347.—Applying Templets to Gauge the Carving.

FIG. 348.—Cradle for Supporting Hull While Hollowing It.

points across the faces and edges of the block. Lay off the widths of the hull along the section lines and draw the side lines, using a bent piece of cardboard or metal to aid you in drawing the curves. The side lines on opposite faces are not alike. With the lines correctly drawn, saw out the block, or cut to the lines with a spoke-shave or a draw-

knife, and smooth the surfaces with a plane or wood-rasp, and sandpaper. Fig. 346 shows the block at this stage of the cutting.

Templets, or guides for shaping the hull, must be made next. Make five of these of the exact profiles of the hull at the section lines A, B, C, D and E. They are shown drawn to scale on the squared off pattern of Fig. 349, and

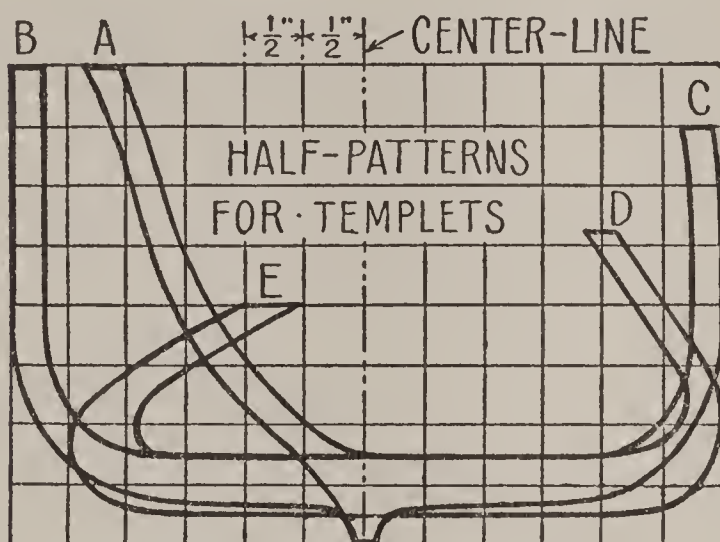

FIG. 349.—Half-Patterns of Templets.

they are shown cut out ready to use in Fig. 350. Make a set of squares similar to those of the pattern, drawing the horizontal and vertical lines  $\frac{1}{2}$  inch apart. Then reproduce the profile lines upon the full-size squares, exactly as

shown upon the printed pattern.

**To Shape the Outside of the hull,** screw or nail a block of wood to the deck face (Fig. 346), by which to clamp the hull in your vise. You can use a draw-knife, plane, wood-rasp, and gouge to advantage in the shaping. It is best to begin at the center of the hull, at section C, and work toward bow and stern. Cut carefully, and use the templets continuously. When you are satisfied that you have made a satisfactory job of shaping, finish the surfaces with sandpaper.

Next, remove the vise block (Fig. 346), and cut the sheer

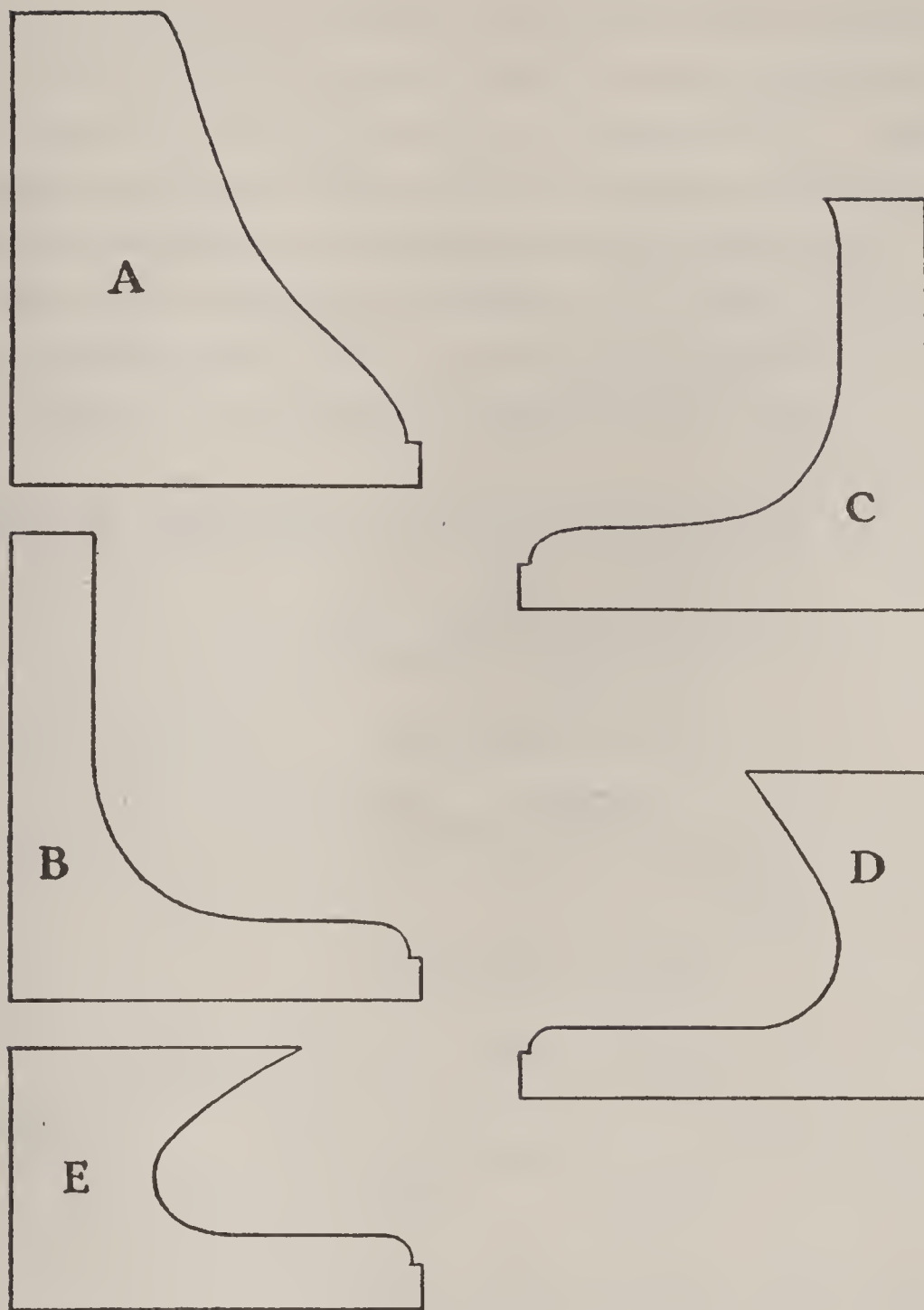

FIG. 350.—Templets Ready for Use.

of the deck surface from section B to the stern (Fig. 344). Prepare a support like that in Fig. 348 to hold the hull for the

**Hollowing process.** Pieces of felt between the blocks

and the hull will protect the surfaces. Start the hollowing by boring a row of holes along a line  $\frac{1}{2}$  inch inside the edges. Then scoop out the wood with a gouge. Cut away the wood until you have a shell of  $\frac{1}{4}$  inch thickness, or less. Cut away equal amounts of wood on each side of the center line, to preserve a balance. Fig. 349 suggests the finished thickness at the five section lines. When you have pared the surfaces as smooth as possible, finish with sandpaper.

With the hull of the motor boat completed, it is ready for

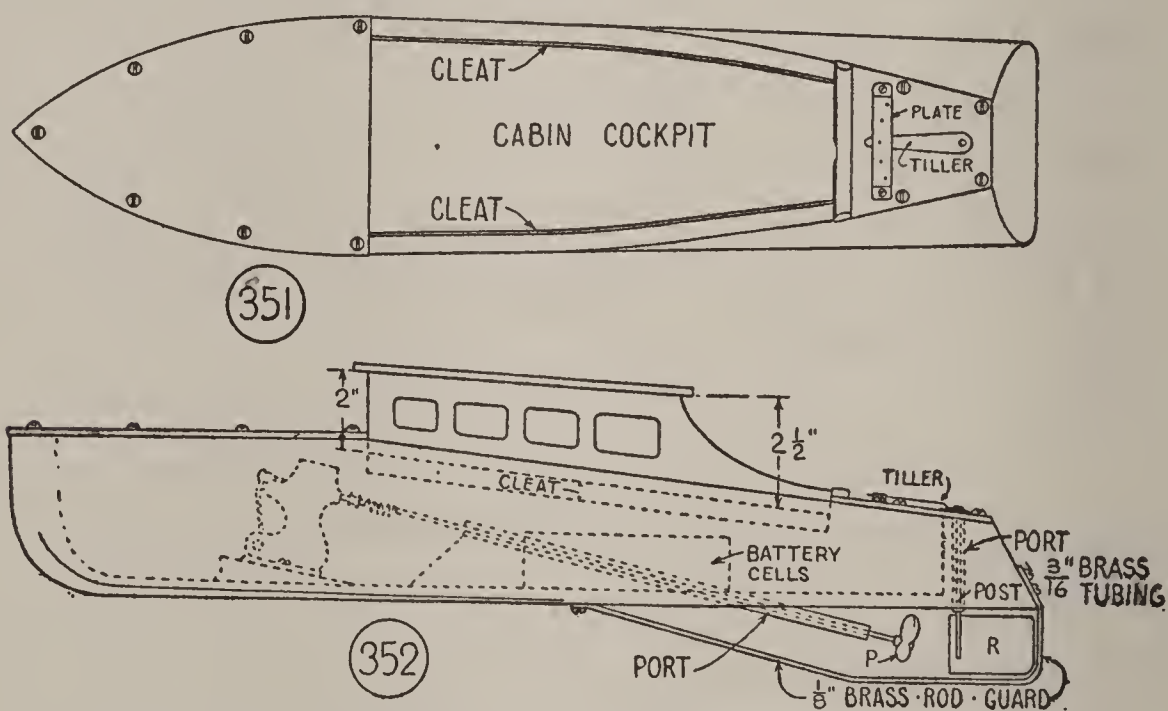

FIG. 351.—Deck Plan (Cabin Removed).

FIG. 352.—Side Elevation of Completed Motor Boat.

### THE DECKS

Warren E. Leigh, builder of the fine model shown in the photograph of Fig. 341, made decks of mahogany  $\frac{1}{4}$  inch thick. Other wood will do, and the thickness may be  $\frac{3}{16}$  inch or less. Cigar-box wood is fine for the purpose. The



decks of this model are flat, but they may be crowned, or curved, by using wood  $\frac{3}{8}$  inch thick and planing it down to a thickness of  $\frac{3}{16}$  inch along the gunwales. Cut the decks to project about  $\frac{1}{16}$  inch, and drill their edges for brass screws for attaching to the hull. If you want to, you may score the pieces lengthwise with rule and knife, in imitation of flooring joints.

### THE CABIN

Figs. 353 and 354 give the dimensions for the cabin walls and roof. Cut the window openings with a coping-saw. Assemble the parts with brads. The cabin should

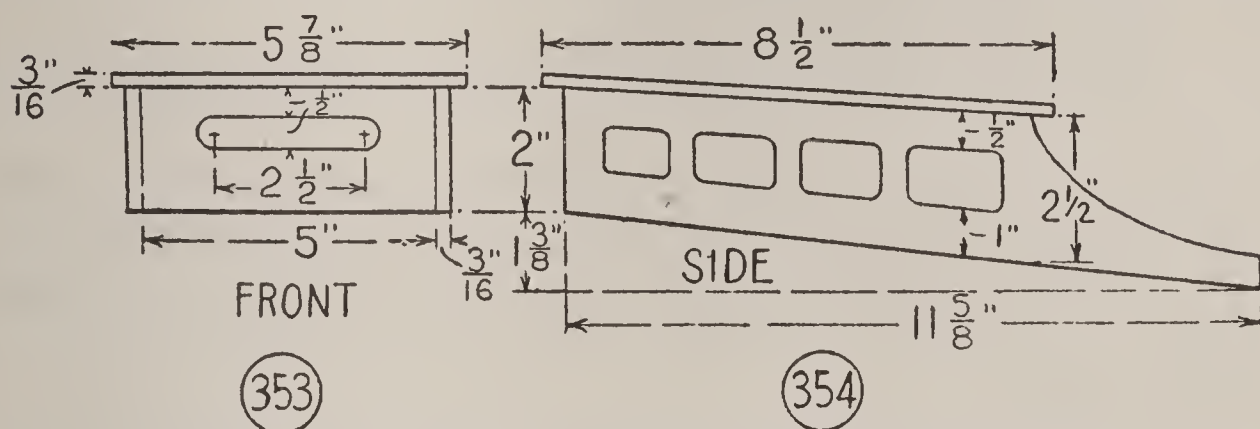

Figs. 353 and 354.—Details of Cabin Walls and Roof.

be removable to gain access to the motor. Nail a cleat to each side of the cockpit for it to rest on (Figs. 351 and 352). The window openings may be enclosed with glass or celluloid.

### THE POWER PLANT

Model motor boats may be operated by electric motors, clockwork motors or miniature marine engines. You can buy motors from a dealer in model supplies, but

A Toy Electric Motor of the type shown in Fig. 355, or a motor from a toy construction set will be satisfactory. Remove the motor from its base, and mount it upon a wedge-shaped block like that in Fig. 356, to give it the right pitch to line it up with the propeller shaft.

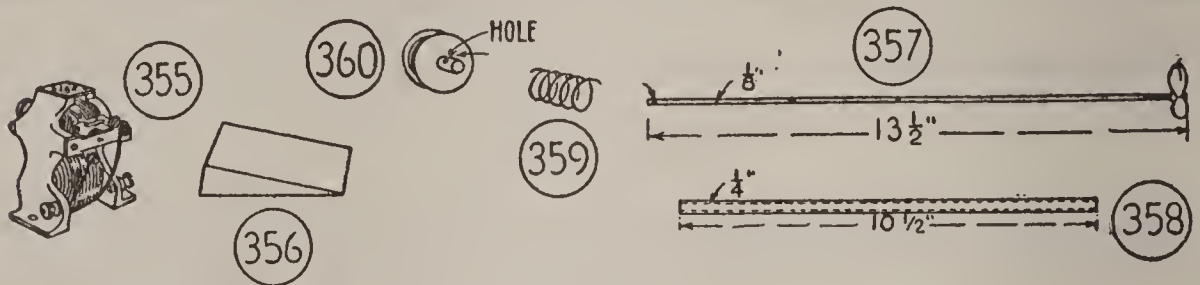

FIG. 355.—Toy Electric Motor.

FIG. 356.—Base for Motor.

FIG. 357.—Propeller and Shaft.

FIG. 358.—Port for Propeller Shaft.

FIGS. 359 and 360.—Propeller and Motor Shaft Hook-Up.

The Propeller should be of No. 22 gauge brass. Fig. 361 shows the layout. Cut it with a pair of tinsnips. Drill a  $\frac{1}{8}$ -inch hole through its center to admit the end of the shaft.

The Shaft should be of  $\frac{1}{8}$ -inch brass rod, of the length shown in Fig. 357. Solder the propeller to one end, and drill a small hole through the other end for connection to the shaft of the motor. The propeller shaft turns in

A Port of  $\frac{1}{4}$ -inch brass tubing (Fig. 358). Solder up the tube ends, then drill a  $\frac{1}{8}$ -inch hole through the center of each end to admit the shaft. Bore a slanted hole through the hull to admit the port, and caulk the hole around the tubing with thick white lead. Pack the port with grease to keep out water. Support the forward end of the port on a wooden block.

**The Motor Hook Up.** Instead of connecting the propeller shaft direct to the motor shaft, drill a small hole through the motor shaft like the one you have drilled through the end of the propeller shaft, and connect the two holes with a coil of five or six turns of piano wire, formed by winding the wire around a pencil or dowel stick (Figs. 359 and 360). The coil will prevent binding, if the shafts are slightly out of alignment. Anchor a flashlight dry cell each side of the propeller shaft, and connect the pair in series to the motor. These cells will run down with continuous use, so it is best to give them a chance to recover after a few minutes' running of the motor. The cells will last longer, if four of them are wired in series parallel.

### THE RUDDER

Cut the Rudder out of No. 22 gauge brass, of the size shown in Fig. 362, and cut

The Rudder Post out of  $\frac{1}{8}$ -inch brass rod, of the length shown in Fig. 363. Slot the end of the post as shown, slip the rudder into the slot and fasten it with solder. Make

The Port for the tiller post of  $\frac{3}{16}$ -inch brass tubing (Fig. 352). Drive it into a hole in the hull just large enough to make a snug fit. Pack the port with grease to keep out water and to make the rudder turn easily.

### THE TILLER

Cut the Tiller of No. 22 gauge brass. Fig. 364 is a pattern. Drill a  $\frac{1}{8}$ -inch hole through the large end, slip the rudder post through the hole, and fasten it with solder.

A Quadrant Plate over the small end of the tiller (Fig. 351) will make it possible to fix the rudder at any angle wanted. Make this of a strip of brass of the size shown

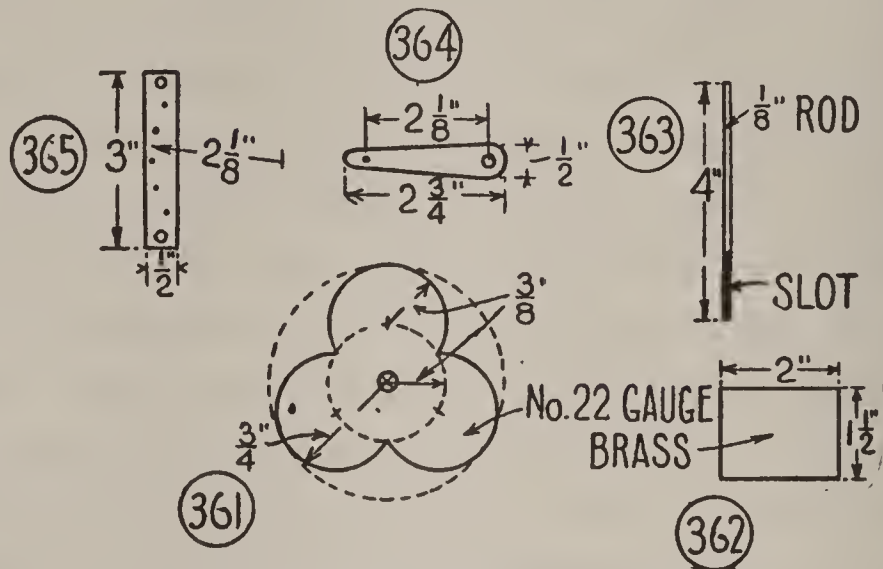

FIG. 361.—Pattern for Propeller.

FIG. 362.—Rudder.

FIG. 363.—Rudder Post.

FIG. 364.—Tiller.

FIG. 365.—Quadrant Plate.

in Fig. 365, and drill a quadrant of small holes through it, using the given radius. Drill a hole of the same size through the small end of the tiller, and screw the quadrant plate to the deck in the right position for the hole in the tiller to coincide with the holes in the quadrant plate. The tiller can be fixed where set by driving a brad through the holes into the deck.

#### A PROPELLER AND RUDDER GUARD

will protect these parts from injury when the motor boat runs aground. Bend it out of brass rod of the shape shown in Fig. 352, flatten the ends, drill for screws, and screw it to the hull.

## FINISHING

When the model is ready for finishing, rub down all surfaces with No. 00 sandpaper, and wipe clean with a cloth. Varnish the decks and cabin with spar varnish, if made of mahogany, or stain them with mahogany stain, then varnish them, if of pine. Finish the hull with automobile enamel or lacquer.

## MAKE A STAND

for your model motor boat, so that you can support it as shown in the photograph of Fig. 341. Fig. 366 shows

half patterns for the bow and stern cradles of a stand. Use your templates to lay out the correct inside hull lines. Cut the cradles out of pine, mount them upon base blocks large enough to project  $\frac{3}{8}$  inch all around, and

join them with two  $\frac{3}{8}$ -inch dowel sticks 12 inches long. Cover the cradle tops and base-block bottoms with felt.

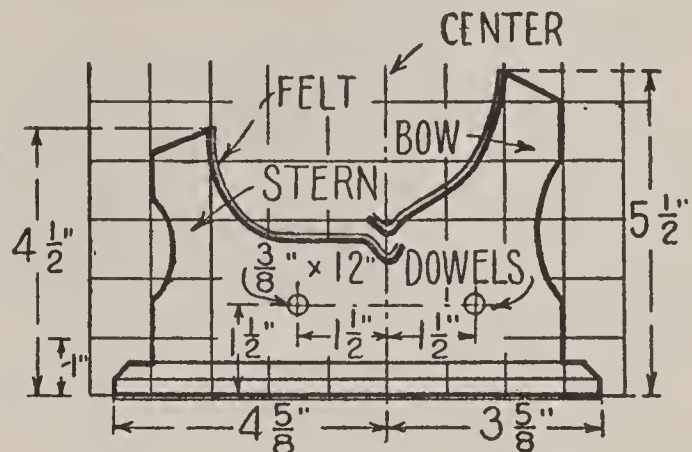
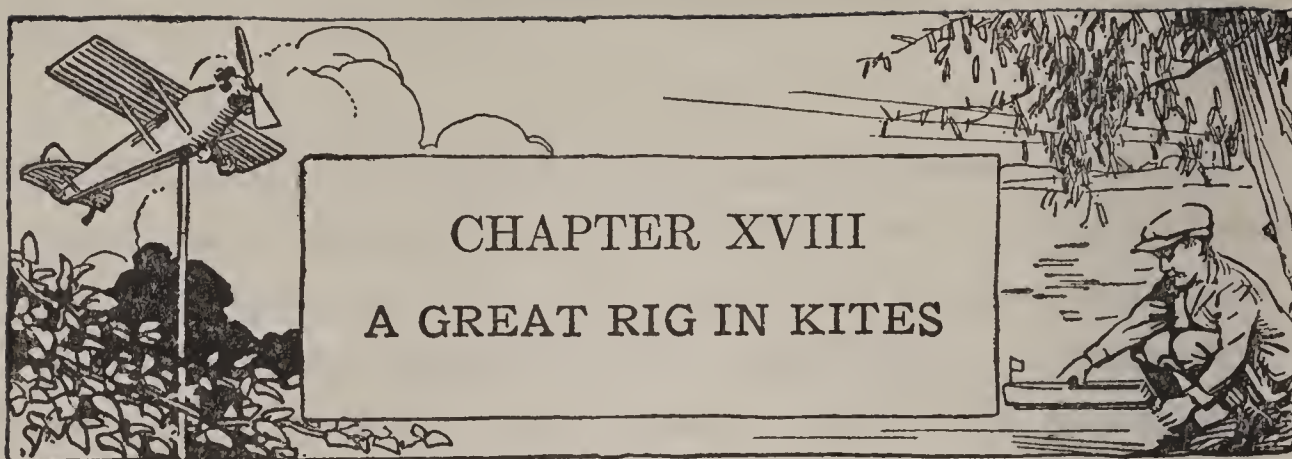

FIG. 366.—Half-Pattern for Bow and Stern Cradles of Stand.



ADD this cloud chaser to your airport. She is as fine a rig as I know of. Does she pull? Does she? She will lift a flag or any small object that you want to send aloft. And once you put her into high, there is no trouble in keeping her there.

She is somewhat of a cross between a box kite and the old timer's hexagonal rig. She is called the Conyne (Co-9) after Silas J. Conyne, her inventor, and she is the type of kite used commercially for floating advertising banners in the breeze.

There is no great mystery about building the Conyne model. Straight sticks, paper or cloth for covering, paste, string, and a little headwork are all that are required.

### KITE STICKS

A boy's principal worry used to be about procuring good sticks, but there should be no difficulty now. If there is a sash-and-door mill in your vicinity, there will probably be a large assortment of sticks in the waste pile, from which you can take what you need for the asking. If ready-cut

sticks are not available, rip what you need from a board with your rip-saw, or better yet, with a circular saw. If you own one of those new "motorized workshops," or if you can gain permission to run the school saw, you will be in luck.

Spruce or soft pine is the wood to use, unless you can find lighter wood that will have the necessary strength. Balsa, the wood airplanes have made famous, has won favor among kite mechanics, and bamboo is well liked. The advantage of bamboo is in its strength. A kite with a bamboo frame will fly in a wind that would snap pine sticks.

Cut a bundle of sticks, if you rip them, so there will be enough for several models, and for replacements.

#### THE COVERING MATERIAL

A tough wrapping-paper is all right for covering the frame, but cloth is more durable. Cambric is good and inexpensive. Maybe you can get pieces of different colors, and combine them.

#### A THIRTY-THREE-INCH MODEL

The 33-inch model of the Conyne, shown in Fig. 367, is a good average size of kite. If you want a larger model, notice by the framework diagram of Fig. 368 that the four sticks are of equal length, and that the spacings are one-third of the length. If you use pine or spruce sticks, cut them of the width and thickness given in Figs. 369 to 372, increasing this measurement a trifle for longer sticks.

## THE ASSEMBLY

Frame the Triangular Cells with three of the sticks, as shown in Fig. 373. Cut the two end-bands of covering

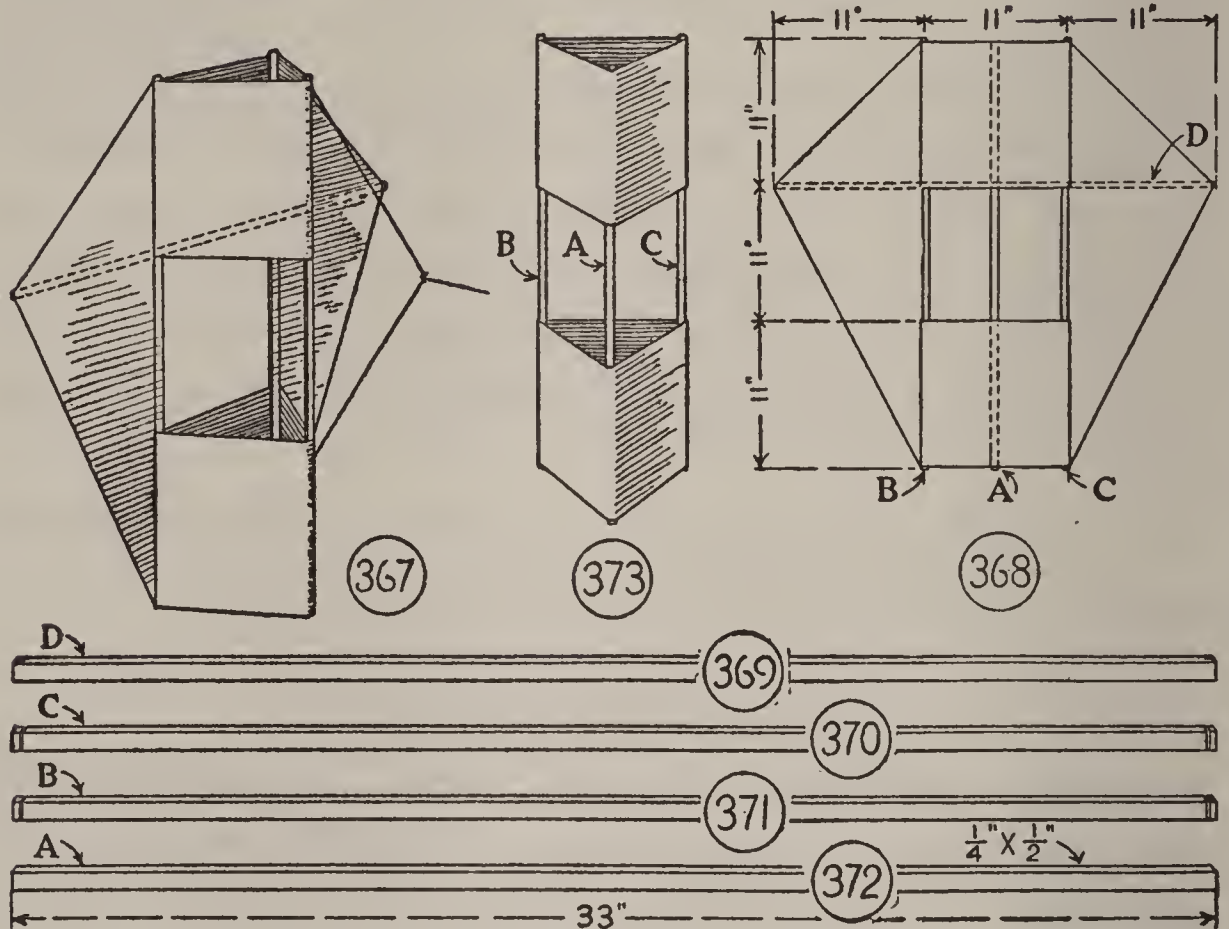

FIG. 367.—A 33-Inch Model Conyne Kite.

FIG. 368.—Diagram of Covered Frame.

FIGS. 369-372.—Stick Dimensions.

FIG. 373.—Assembly of Triangular Cells.

material 11 inches wide and 35 inches long. If cloth is used, cut it with the selvedge along one edge, and allow  $\frac{1}{2}$  inch along the other edge for turning in and gluing. Forming the bands is particular work. The sticks must be spaced equidistantly, 11 inches from center to center, and the paper or cloth must be stretched evenly so the



surfaces will be smooth. Fasten the cloth with small tacks, or with glue or cement.

Fasten the Horizontal Stick across two of the vertical sticks, at the inner edge of the upper cell, with ends projecting equally, and lash the sticks together where they cross.

Then you will be ready for

**The Framing String.** A light-weight fishing line is good for this, but strong wrapping-twine will do. Cut a V-notch in each end of the three sticks, make half-hitches in the line, and slip the hitches over the stick ends. Pull the line taut, but not so that it bends the sticks.

With the framing string in place,

**Cover the Side Wings** of the hexagonal plane, cutting two triangular pieces large enough to make a  $\frac{1}{2}$ -inch lap over the string. Paste or glue the edges.

### THE BRIDLE

The points at which to attach

**The Belly Band** are shown in Fig. 367. Make the loop long enough to come a trifle beyond the end of the horizontal stick when it is pulled to one side. Attach the flying line with a non-slipping knot, at the point indicated.

### THE FLYING LINE

You will want a reliable twine for flying your Conyne. Mason's twine is excellent for the purpose. It costs more than ordinary wrapping-twine, but it is good kite insurance.

## A KITE-LINE REEL

Fig. 374 shows a reel of large capacity. It will hold several balls of twine. You can make it larger or smaller, if you want to.

Saw notches in the ends of a piece of  $\frac{3}{4}$ -inch board cut

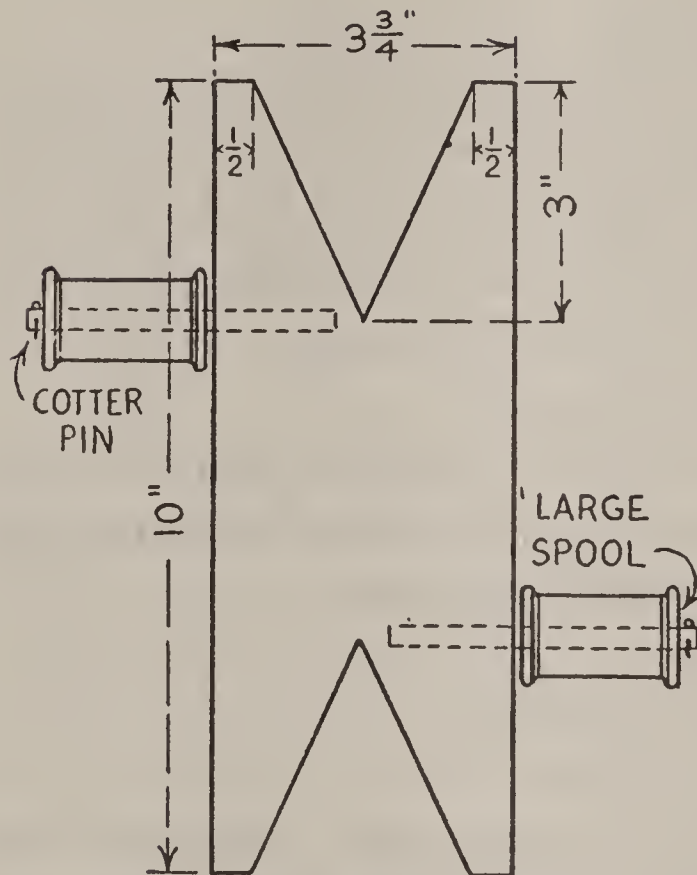
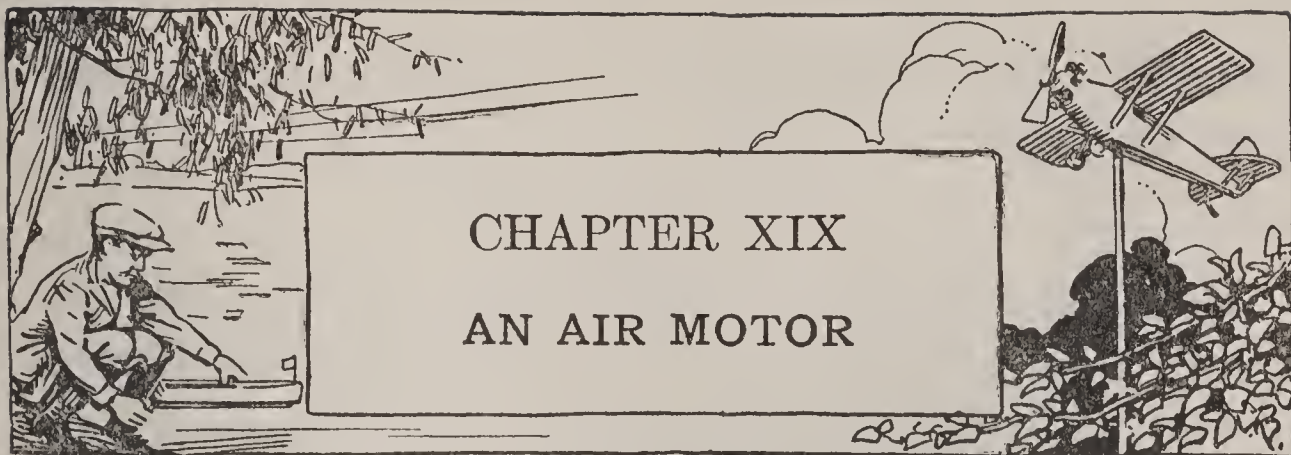

FIG. 374.—Kite-Line Reel of Large Capacity.

from a box end, and bore holes for the pair of dowel-stick handles. The large thread spools or ribbon spools, shown mounted upon the handles may be omitted to simplify the making, in which case cut the dowel sticks long enough to grip handily. Coat the stick ends with glue, drive them into the holes bored for them, and drive in a brad to reinforce the glue. If you use spool hand grips,

drill holes through the stick ends, and run cotter-pins through the holes to keep the spools from coming off.



## CHAPTER XIX

### AN AIR MOTOR

It is fascinating to watch a windmill in motion, and to note the similarity in action of the wind upon its tail and upon the tail of an airplane, keeping the nose of each headed into the wind.

The toy windmill shown in the photograph of Fig. 375 is as fine a mechanical job as you would want. You can make it quickly and when you have assembled it and mounted it upon a post, it will whizz continuously while a breath of air is stirring, and it will require no attention except an occasional greasing.

Rig up several of these stationary airplanes in your back yard, and exercise your air rights, pending the day when you will take off in your own plane, possibly from your yard airport.

The photograph shows the air motor mounted upon a clothes-post. If you want it visible from the air, as well as from the ground, mount it atop of a chimney, or on the house or garage roof.

Dimensions of parts of the motor are given in Fig. 377 and Figs. 381 to 383. Increase them by one-half, if you

mount the model high, so that it will not look too small from the ground.

### FIRST SHAPE THE HUB

This requires two blocks of the size shown in Fig. 377, halved at their centers so they will interlock as indicated in Fig. 378. Halving consists of cutting from one face of each block a piece of the width and one-half of the depth

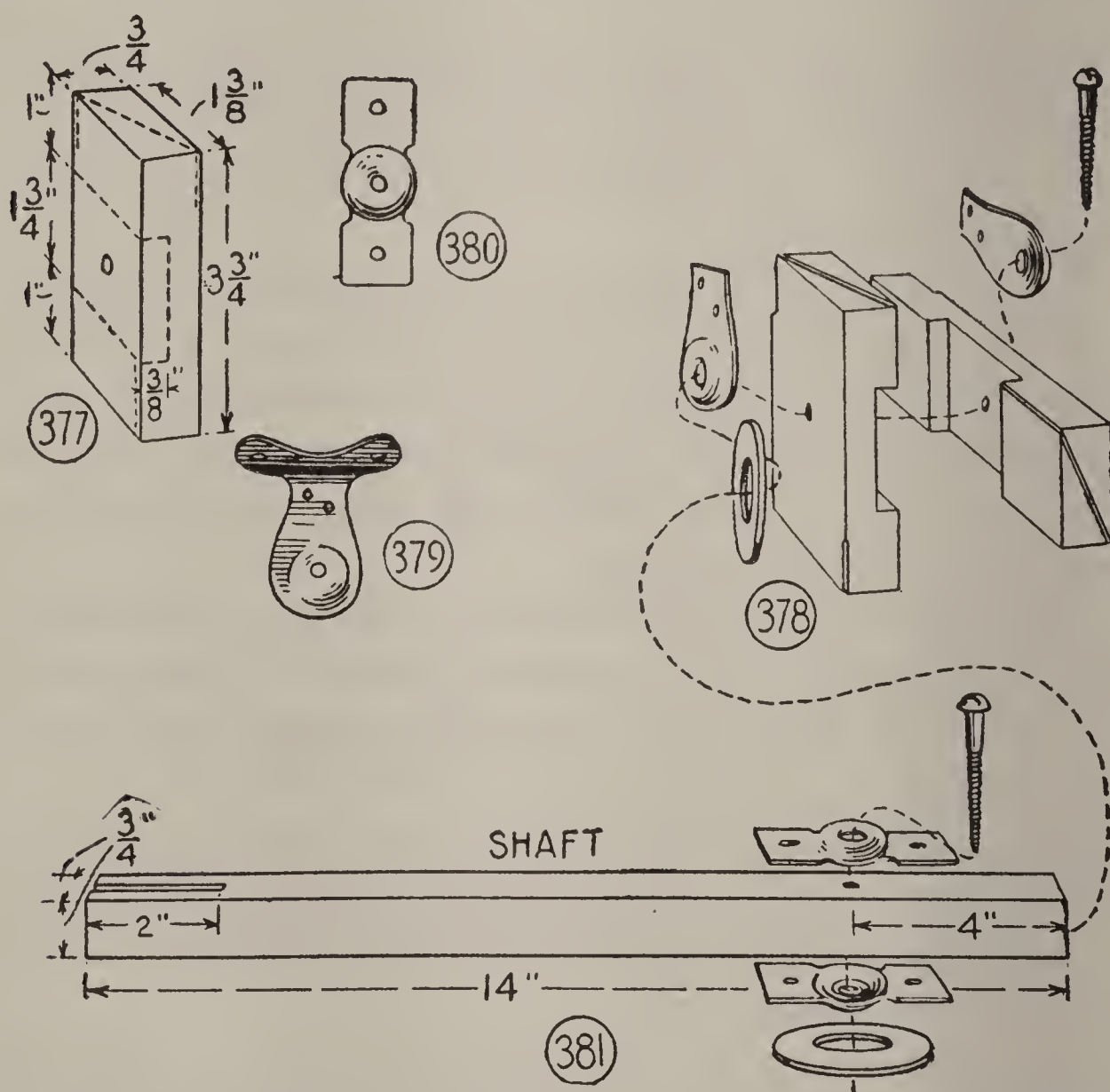

FIGS. 377 and 378.—Hub Details of Air Motor Shown in Fig. 375.  
 FIGS. 379 and 380.—Shade Bracket Hub Bearings.  
 FIG. 381.—Shaft and Shaft Bearings.

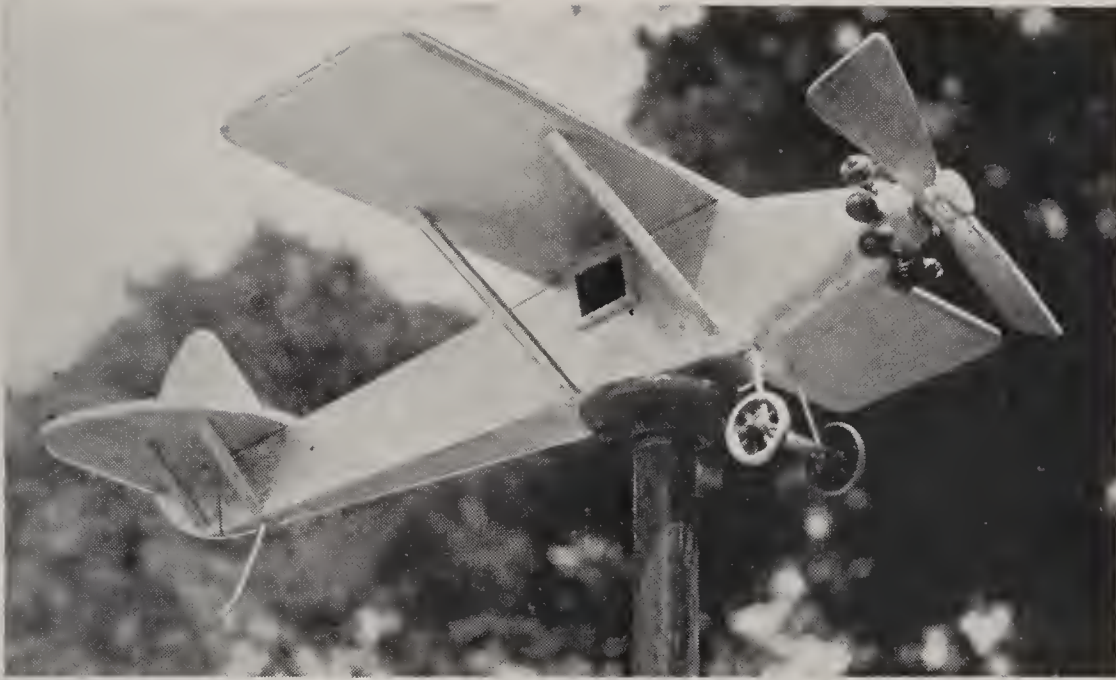

FIG. 376.—AN AIRPLANE WEATHER-VANE.

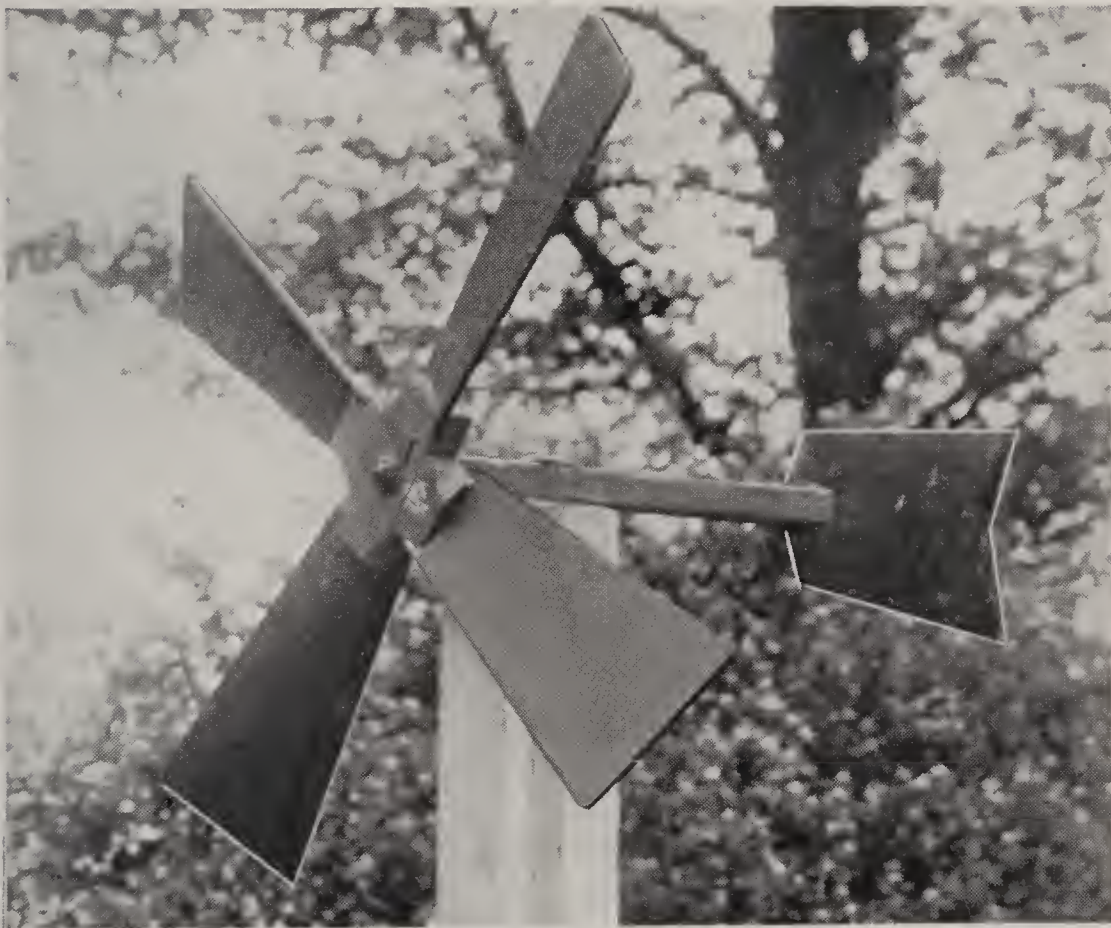

FIG. 375—AN AIR-MOTOR.



of the other block, so that the pair will interlock with a snug fit. Dotted lines in Fig. 377 indicate the halving. Cut inside of the end lines with a saw, then split out the wood between the cuts with a chisel, and finish smooth with a file and sandpaper. The block ends must be slotted to a depth of 1 inch to receive the blades, and as the blades will be  $\frac{3}{16}$  inch thick, the slots must be of that width. Cut with a coping-saw or other small saw.

Join the halved blocks with nails or screws, then locate the hub center on each face and bore a  $\frac{3}{16}$ -inch hole at that point.

### THE HUB BEARINGS

should be of metal to reduce wear to a minimum and to make the fan turn freely.

**Shade Bracket Bearings** were used on the model and they have proved excellent. The outside type of bracket (Fig. 379) can be used if you will hack off or file off the foot as indicated. The inside bracket (Fig. 380) needs no alteration. Place a bracket on each side of the hub, with its hole over the hub holes, and fasten with screws.

Use a stick of the dimensions given in Fig. 381 for

### THE MOTOR SHAFT

Slot one end of the shaft to a depth of 2 inches to receive the tail, bore a  $\frac{1}{8}$ -inch hole in the opposite end, in which to drive the hub pivot, and bore a  $\frac{3}{16}$ -inch hole 4 inches from that end for the shaft pivot.

## THE SHAFT BEARINGS

may be a pair of shade brackets. Fasten them to the top and bottom of the shaft directly over the pivot hole, as indicated in Fig. 381.

## CUT FOUR FAN BLADES

of the dimensions given in Fig. 382. Draw a center line as shown, from which to lay off the end dimensions. Cut

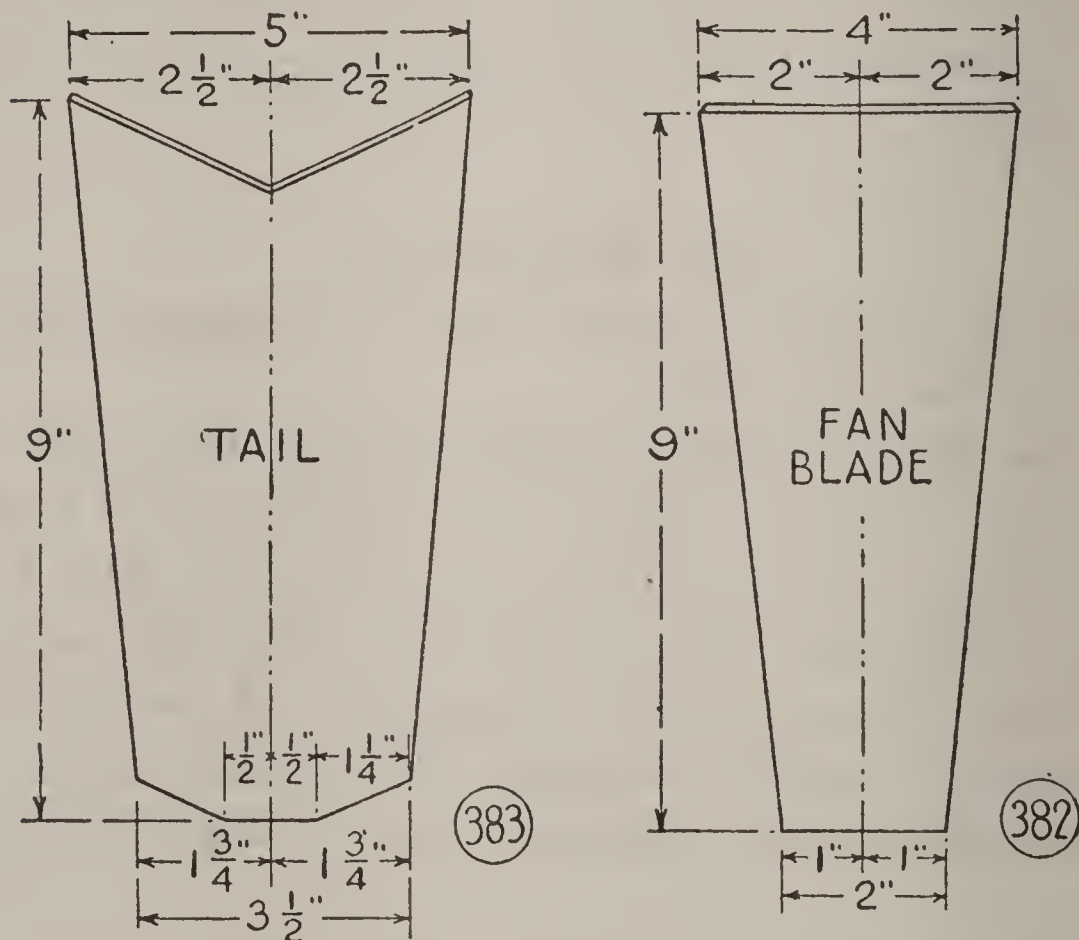

FIG. 382.—Pattern for Fan Blades.

FIG. 383.—Pattern for Tail.

the blades out of box boards. If the boards are thicker than  $\frac{3}{16}$  inch, shave off the ends to fit the hub slots. Fasten the blades in the slots with finishing nails.



### CUT THE TAIL

of the dimensions given in Fig. 383, and notch the wide end as shown. Fasten the tail in the slotted end of the shaft with finishing nails.

### FINISH THE PARTS

before assembling. Use lacquer or automobile enamel. Red fan blades and tail, and green hub and shaft, are suggested as a good color combination.

### MOUNT THE WINDMILL

hub and shaft with screw pivots  $2\frac{1}{2}$  inches long. Place an iron washer between the hub bearing and the motor shaft and another between the shaft and the post that you mount it on.

Pack the bearings with grease and you will have a silent running motor.

With a little ingenuity you can

### HARNESS THE AIR MOTOR

by means of spool pulleys and string belts, to operate jumping jacks and other small toys.

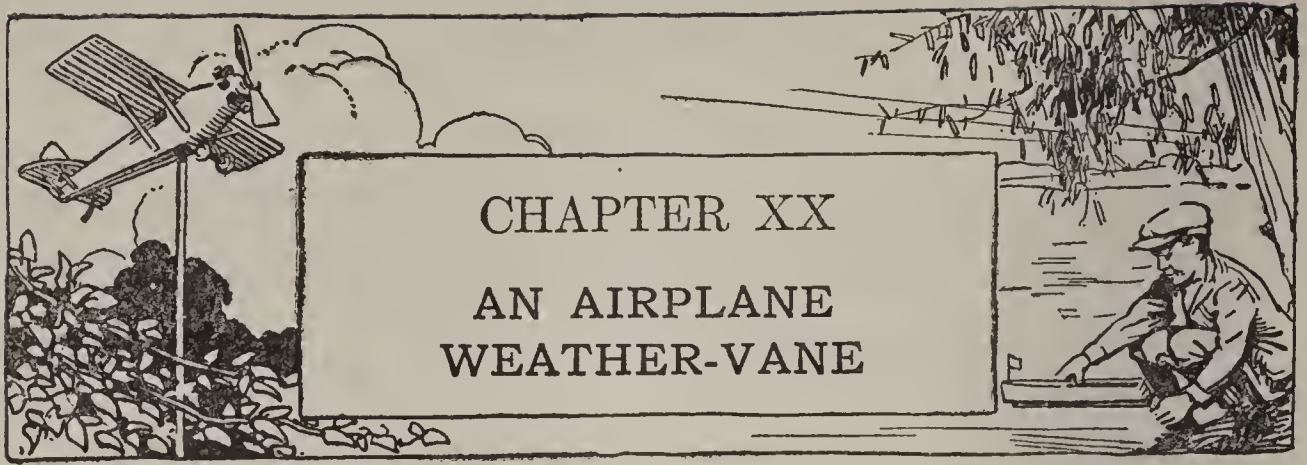

Boy! This is some weather-vane. It looks just like a real airplane, with cabin, wing, elevator, rudder, landing chassis, cylinders, and propeller, done in aluminum. Indeed, when the model is aloft on an iron pipe mast, as in the photograph of Fig. 376, silhouetted against the sky, now turning this way, now that, with propeller whirling merrily, one might mistake it at first glance for a ship in flight.

An advantage that the weather-vane airplane has over other model airplanes is this: there is nothing fragile about it. It will weather any storm short of a tornado. Of course, it has not the appeal of a successful flying model, but I suggest that you build and set it up as a symbol of your interest in aviation. Let it designate your back yard as a model airplane airport, or the garage as a model airplane hangar.

As compared with building a flying model, the work on the airplane weather-vane is elementary. Fig. 384 shows a side elevation of the model and its pipe support. Figs. 389 to 396 are patterns for its parts. Figs. 385 to 388 and Figs. 397 to 405 are assembly details.

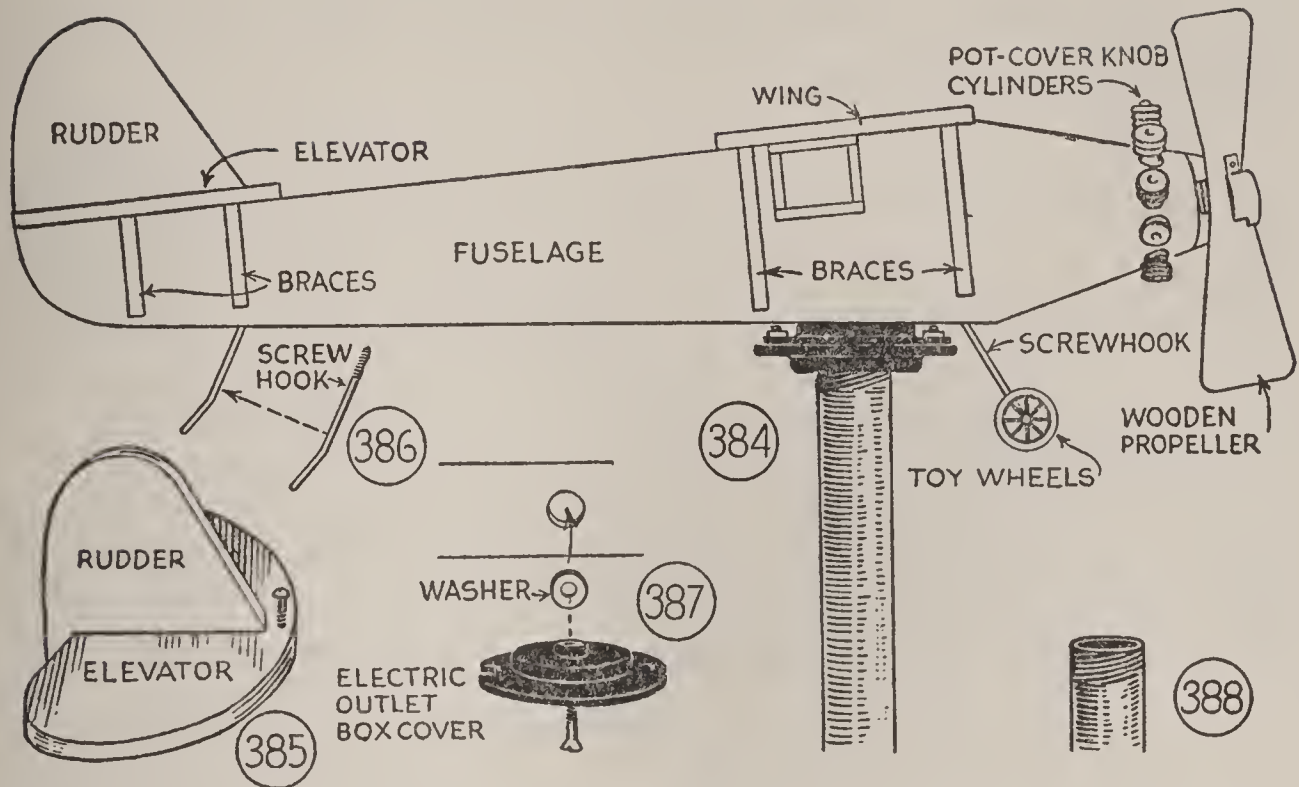

FIG. 384.—Side Elevation of Airplane Weather-Vane Shown in Fig. 376. (For convenience, we call the Stabilizer-and-Elevator "Elevator," and the Rudder-and-Fin "Rudder.")

FIG. 385.—Rudder Mounted Upon Elevator.

FIG. 386.—Skid.

FIGS. 387 and 388.—Details of Swivel Base and Iron Pipe Support.

### THE FUSELAGE

is a piece of 2-by-4. Lay it out by the diagrams of Figs. 389 and 390, with tapered nose, and the under side tapered from nose to tail. A notch in the top of the piece forms the cabin windows. After sawing out the fuselage, smooth up the curved tail and the rounded nose with a wood-rasp and sandpaper. Trim the windows with narrow strips of wood, as shown in Fig. 384.

### THE WING

Cut the wing out of a straight box board  $\frac{3}{8}$  inch thick.

Fig. 391 shows its dimensions. Screw it to the fuselage close to the nose taper.

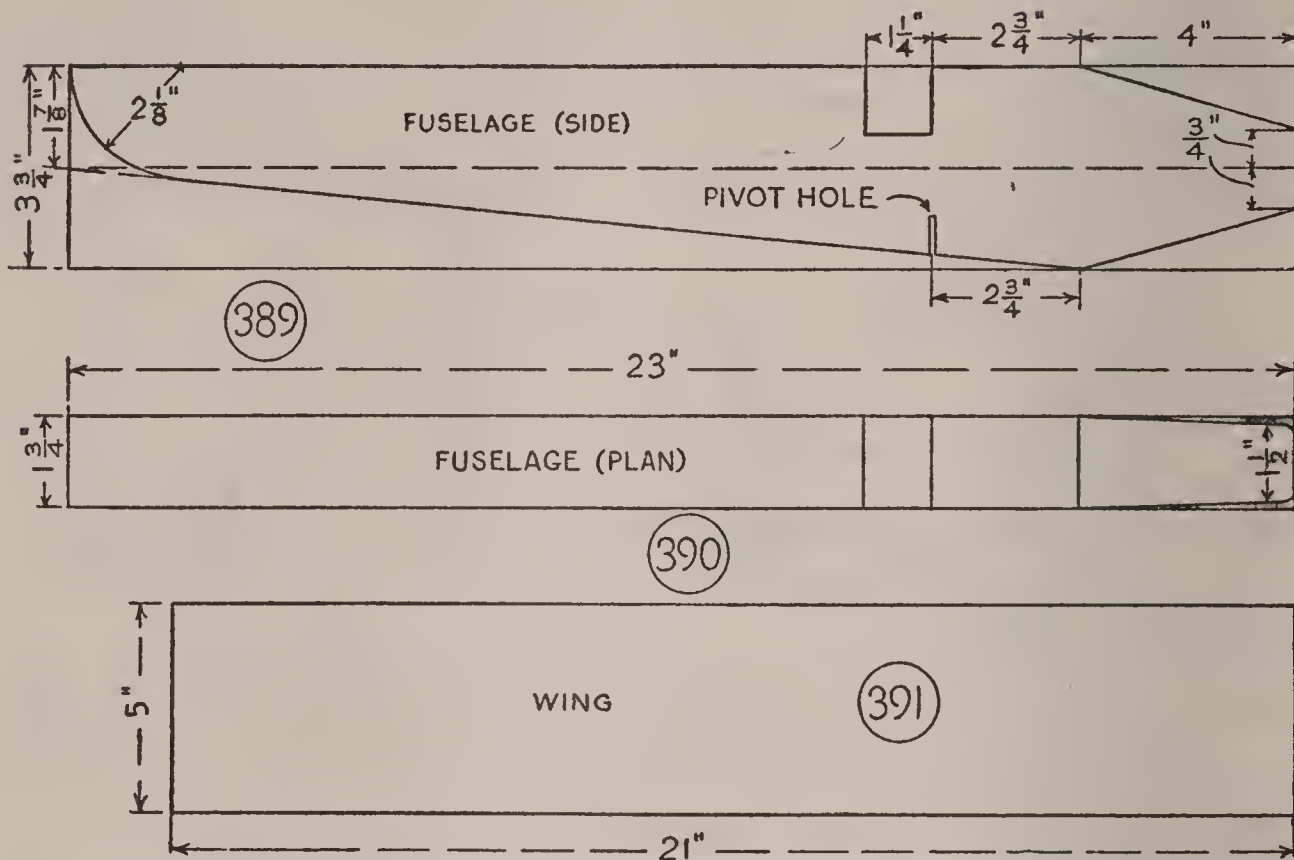

FIG. 389.—Side Elevation of Fuselage.

FIG. 390.—Plan of Fuselage.

FIG. 391.—Plan of Wing.

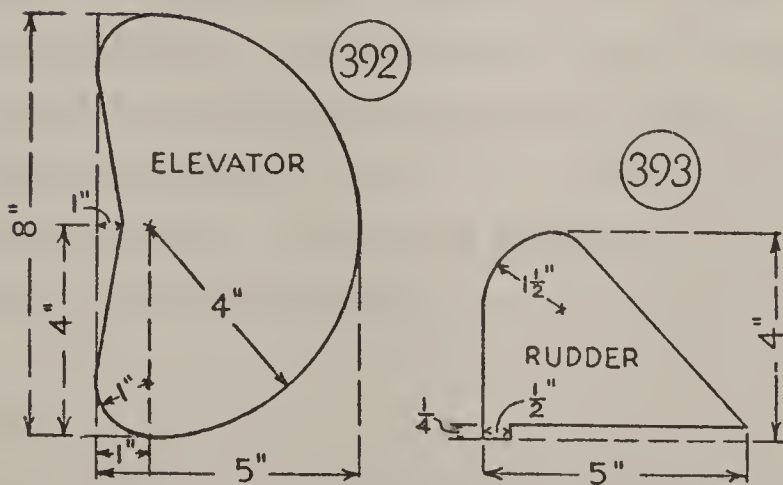

FIG. 392.—Elevator Diagram.

FIG. 393.—Rudder Diagram.

### THE ELEVATOR AND RUDDER

would really be the stabilizer - and - elevator, and the rudder-and-fin, but we shall call them elevator and rudder for convenience. Cut them out of

box boards, following the dimensions in Figs. 392 and 393. Mount the rudder along the center of the elevator, as shown in Fig. 385, then screw and nail the elevator to the fuselage so that the rudder will line up with and become part of the curved end.

### BRACES

The wing and elevator braces are strips of galvanized iron. Drill the strip ends, and bend them, as shown in Fig. 405. Then screw the lower ends to the fuselage, and rivet the upper ends to the wing and elevator. Drill holes for the brace screws and rivets.

### THE PROPELLER

is carved after the manner of model airplane propellers, but the blades are thicker. Start with a block of the dimensions given in Fig. 394. Lay it out as you would a model propeller, and carve it as shown in Figs. 395 and 396.

Use a  $\frac{1}{8}$ -inch round-headed screw  $1\frac{1}{2}$  inches long, and three iron washers, for mounting the propeller. Drill a hole in the nose of the fuselage, and drive the screw home with one washer between the screw head and hub, and two washers between the hub and nose. Drive the screw straight so that the propeller will run true.

Trim the hub with the cap from a talcum powder can (Fig. 399). This will look something like

**The Spinner Cap** on "The Spirit of St. Louis." Snip the edge of the tin cap (Fig. 400), and bend out two ears, as shown, upon opposite sides. Fit the cap over the hub,

and fasten the ears to the propeller blades with small brads or rivets (Fig. 399).

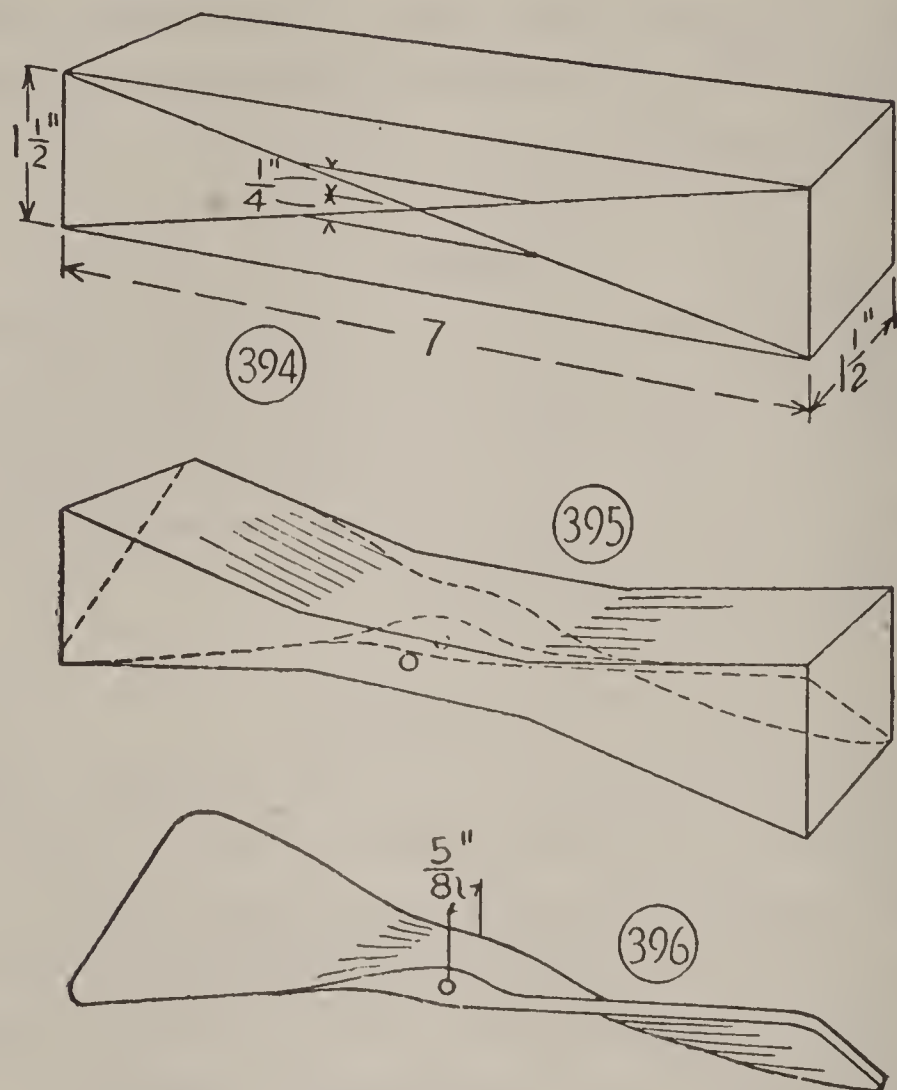

FIGS. 394-396.—Propeller Details.

### CYLINDERS

Form these around the engine cowling with pot-cover knobs (Fig. 401). Colonel Lindbergh's Wright whirlwind motor had nine cylinders. Nine small knobs will fit around the nose without crowding (Fig. 397). Bevel the bottoms of the knobs to make them fit squarely upon the tapered nose (Fig. 384). Substitute 1-inch screws for the knob bolts.

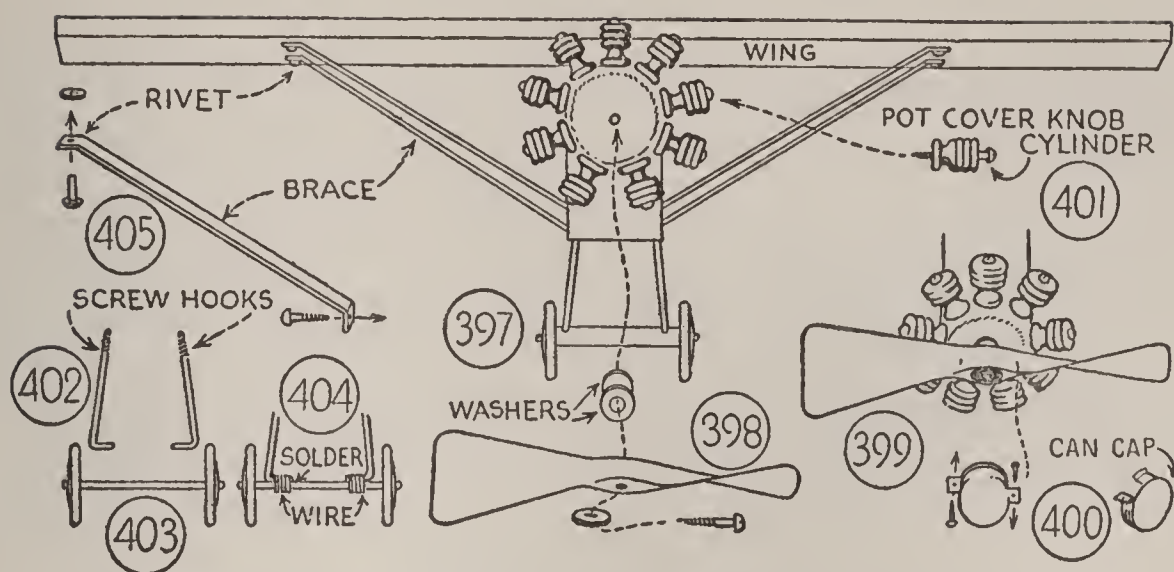

FIG. 397.—Front Elevation of Airplane Weather-Vane.

FIG. 398.—Propeller Mounting.

FIGS. 399 and 400.—Details of Spinner Cap.

FIG. 401.—Pot-Cover Knob Cylinder.

FIGS. 402-404.—Details of Chassis.

FIG. 405.—Wing Brace.

### THE LANDING CHASSIS

is shown in the photograph of Fig. 376 and Fig. 397 of the diagrams. Use screw-hooks  $3\frac{1}{2}$  inches long for the wheel struts (Fig. 402), and a pair of toy wagon wheels and their axle (Fig. 403). Screw the screw-hooks into the fuselage at the points indicated in Figs. 384 and 397, slanted as shown. Then wire the wheel axle to the hook ends (Fig. 404), and make a neat housing of solder, as shown in Fig. 397.

### THE TAIL SKID

is another screw-hook, with the end bent nearly straight (Fig. 386). Screw it into the fuselage at the point shown.

## FINISHING

Sandpaper surfaces that need smoothing. Then give the entire model a coat of shellac as a filler, and when this has dried, apply two coats of radiator aluminum paint. If you want to, letter "Spirit of St. Louis" upon the fuselage, the symbol "NX211" upon the wing, and "NYP" upon the tail. The scale drawings in Chapter XI show where to place them.

## THE SWIVEL BASE

must turn easily. An excellent base can be made of

An Electric Outlet Box Cover like that in Fig. 387. Buy one for a dime at a hardware store. This iron cover has a center hole of the right size for a screw pivot. Pivot it on the fuselage at the point indicated in Fig. 389. If it has a projecting rim around its center hole, as indicated in Fig. 387, bore a hole in the edge of the fuselage large enough for this rim to set into, then slip an iron washer into the hole for a bearing. Use a screw  $1\frac{1}{4}$  inches long for the pivot, one with a head large enough so its bevel will seat itself on the edge of the iron cover hole. Make a nice adjustment here, and the iron cover will spin upon the washer with little or no friction.

## AN IRON PIPE SUPPORT

is neater than a wooden post because it can be of smaller diameter. Pipe 1 inch or  $1\frac{1}{4}$  inches in diameter (inside measurement) is large enough. You can get a 20-foot length of it, or shorter length. Buy an iron floor flange to



fit the upper end (Fig. 384). Two of the screw holes in the floor flange should match up with holes in the electric outlet box cover. Bolt the box cover to the floor flange with a pair of stove bolts.

Set about 30 inches of the lower end of the pipe support into the ground. That will hold it in an upright position, but

**A Concrete Base** like that shown in Fig. 277 for a radio aerial mast will make a more secure footing.

#### THE POINTS OF THE COMPASS

were not mounted upon the airplane weather-vane support shown in the photograph of Fig. 376. It was thought that they would detract from the airplane weather-vane. But you can readily devise a set of arms and letters, and bolt them to the iron pipe, if you feel that it will make your model more complete.

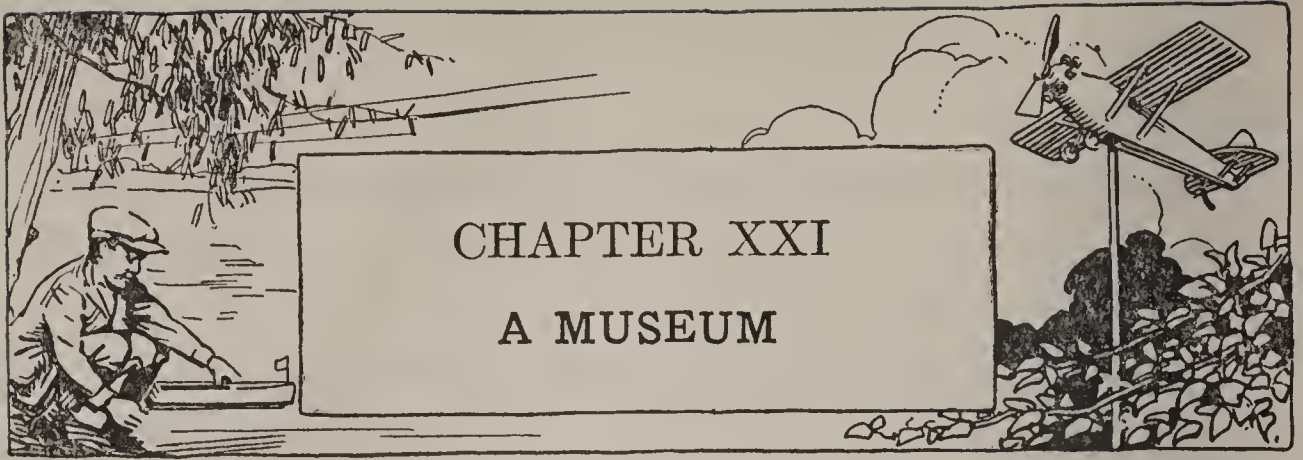

COLLECTING is one of the most interesting of hobbies, and it may be made instructive by study. Some collections have no commercial value, others have great value. It is largely a matter of whether the items collected are plentiful or scarce. Often age enters into it. A collection handed down from one generation to another is of more value from a collector's standpoint than one newly made. Then there is the individual valuation. What some boys enjoy collecting, you wouldn't care for, and vice versa.

If you have studied the photograph of Anton Watkin's den, in Fig. 19, Chapter III, you have noted that the room qualifies very well as a home museum. You can fix up

#### YOUR OWN ROOM AS A MUSEUM

by adopting Anton's method of displaying specimens upon the walls and building racks and shelves for collections that cannot be framed or otherwise prepared for hanging. And if you finish off an attic room, as suggested in Chapter III, you will have greater opportunity to install exhibits there than in any other place in the house.

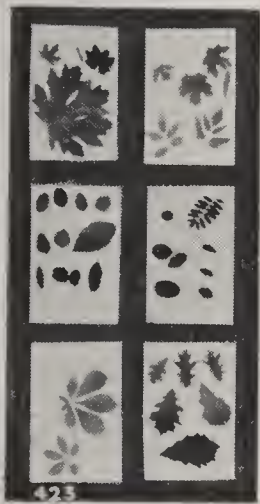
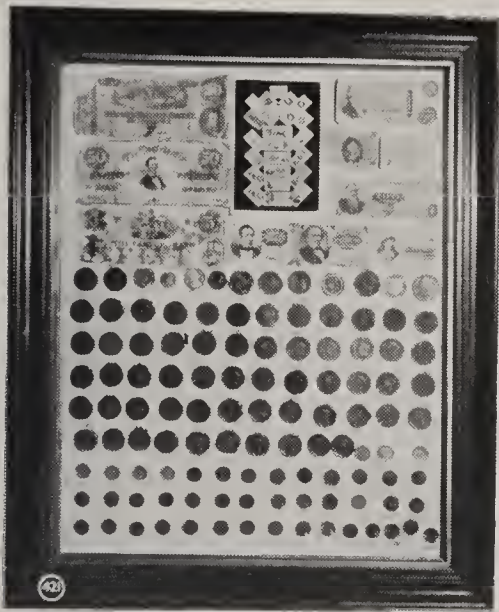

FIG. 421.—COIN COLLECTION. FIG. 422.—KNOT BOARD.  
FIG. 420.—VIEW OF BILL JONES' MUSEUM.  
FIG. 423.—LEAF COLLECTION. FIG. 424.—JARS FOR INSECTS.  
FIG. 425.—CRACKER-BOX AQUARIUM.



## BILL JONES' MUSEUM

is one of the most interesting of quarters to my way of thinking. It was adjudged a prize in a recent "Home Museum" contest conducted by "The Boy Craftsman League." A section of the room is shown in the photograph of Fig. 420. Here is a brief description of Bill's museum and exhibits, and if it makes you envious, I hope that it also gives you the museum "bug."

Bill found an excellent setting for his exhibits in the second story of a garage, which is well lighted with windows at either end. On the two side walls, he put up shelves, racks, hooks and pegs, then grouped the exhibits according to their classifications.

The most striking group in the museum is one of relics from the fields of the World War—helmets, a trench periscope, machine-gun armor, a shell, cartridges, chevrons, badges and medals.

Next to these is a collection of guns, swords, bayonets, and knives, a veritable arsenal.

Not many lads possess relics such as these, and Bill may seem to have an unfair advantage in outfitting his museum with exhibits collected by others. But the quantity and variety of articles that he had to provide for, made his a difficult task, indeed, which he carried out very well, judging from his photographs and detailed descriptions of arranging and cataloging.

Note, also, these exhibits. A collection of insects mounted, named and classified, another of minerals, one of Indian arrow-heads, one of coins, one of woods, one of

souvenirs from different parts of the United States and Mexico, skins of small animals, several mounted small animals, a mounted black bird, and jars of preserved snakes, frogs, and turtles.

In addition, Bill has a collection of bird pictures, another of school pennants and trophies, one of letters from foreign lands, foreign newspapers and comics.

### A BOY SCOUT TROOP MUSEUM

with good leadership and full coöperation of the boys, has greater possibilities of development than the individual collection. Start a museum in your patrol, and let it be the nucleus for the troop museum. It is surprising what a variety of material can be brought together by a group of fellows organized for the job and enthusiastic about the work.

### A STAMP COLLECTION

makes a good start for a museum. Of course, you have one. There are few boys who haven't. A standard album is best for a collection. But you can mount a selection of rare stamps upon cardboard, put the cardboard in a picture frame and hang the frame upon a wall.

Duplicate Stamps for exchanges should be classified so they can be found readily. A good way to keep them is in envelopes, one envelope for each country, province or state. Letter the names on the face, then arrange the envelopes alphabetically, and make a wooden or cardboard file to keep them in.

## A COIN COLLECTION

may be made as interesting as a stamp collection. One supplements the other, and the collector of stamps generally collects coins. Almost every family has a few rare coins. Let your wants be known among relatives and friends, and you will be rewarded with a nucleus for a collection.

An interesting collection of pennies may be made at a little cost. A century's issues may be collected in a generation. Start a century collection now, with as early nineteen-hundred pennies as you can get. Examine all change that passes through your hands. If you sell newspapers, you will have an excellent opportunity to find the coins that you need. Make a list of the dates. Ask your friends to watch for them. Tell your needs to a store cashier or bank teller. The pennies of a period of twenty years can be collected in a surprisingly short time.

The photograph in Fig. 421 shows a coin collection of mine that hangs in my studio, where it is a curiosity to every boy visitor. Begun by an uncle, who was killed on the battlefield while yet a boy; the collection was completed by my father. An interesting feature of this collection is that it contains a penny for each year from 1800 to 1900, except two, of which the issue was small.

## MOUNT YOUR COINS

upon cardboard, then frame the cardboard. You do not need a large frame. No doubt there is one in your store-room that will serve. A frame of the proportions shown

in Fig. 406 will hold a half-century penny collection. You can glue the coins to the cardboard backing, but a better

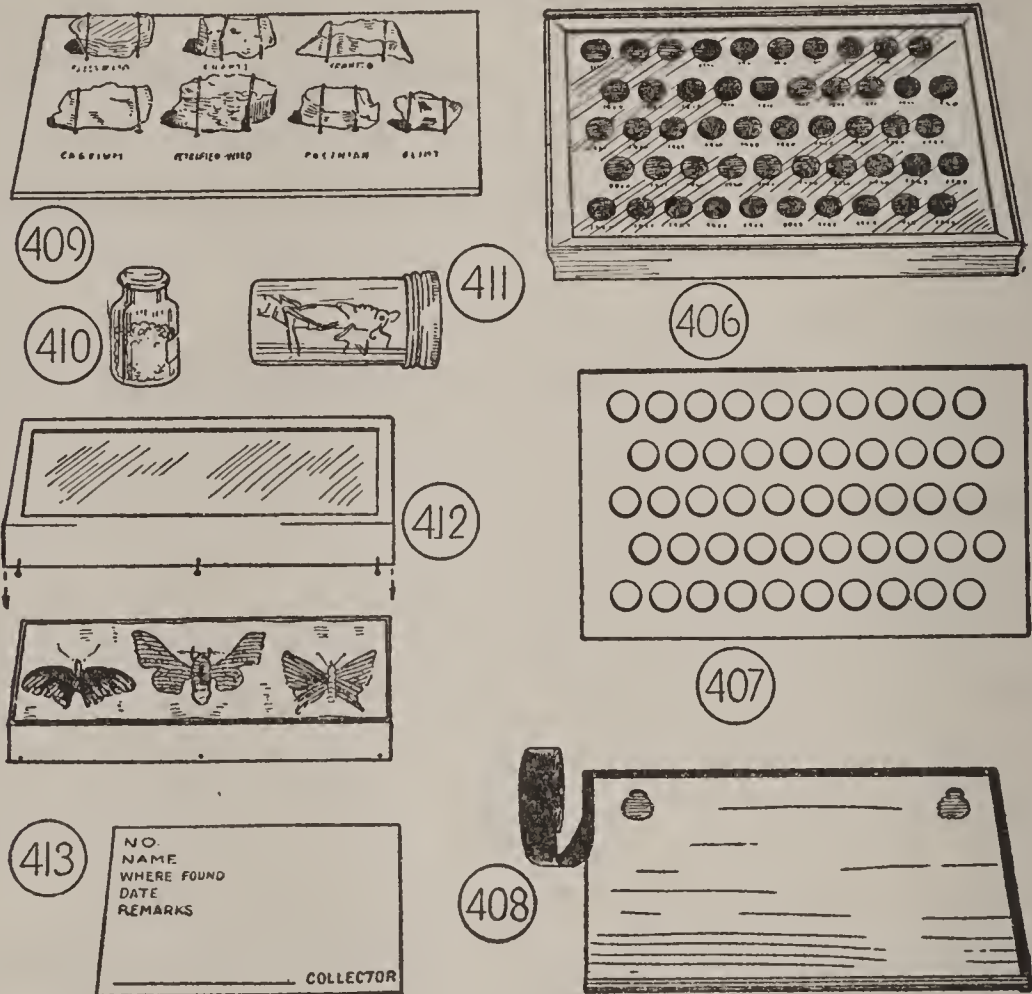

FIG. 406.—Half-Century Penny Coin Collection.

FIG. 407.—Mat for Coin Frame.

FIG. 408.—Passe-Partout Frame.

FIG. 409.—Arrange Stone Specimens on Tray Like This.

FIG. 410.—Bottle for Small Stones and Minerals.

FIG. 411.—Screw-Cap Jar for Katydid and Other Large Insects.

FIG. 412.—Box Case for Moths and Butterflies.

FIG. 413.—Index Card for File.

plan is to prepare a mat with openings in it of the correct size for the coins to fit in, like the mat shown in Fig. 407. If the mat is thick and you insert a piece of wallboard or other stiff backing that will keep the mat pressed close to the glass, there will be no chance for the coins to slip



out of place, and you will not have to affix them. But as a matter of precaution it is better to add a touch of glue or cement to the back of each coin. Ambroid or similar cement is a better adhesive for metal than glue.

**To Prepare the Coin Mat** rule horizontal lines, one for each row. Then with a coin for a marker, pencil out the openings, and cut them with a sharp jack knife.

If you cannot find a picture frame for your collection, make

**A Passe Partout Frame.** Get a piece of glass to fit the coin mat, at a paint store. Place the mat and backing on the glass, and bind together the edges of the glass, coin mat and backing with passe partout paper or other gummed tape (Fig. 408). Attach brass rings to the backing for hangers.

### A KNOT BOARD

Every Boy Scout's museum should have a knot board. Just as your aim is to collect as many different stamps, or different coins, as possible, it should be your ambition to make as complete a collection of knots as you can. The photograph of Fig. 422 shows a well planned knot board, the work of Troop 2, Elmhurst, Illinois, under the guidance of Scoutmaster Harry T. Richards. Your scout handbook shows some fifty knots and hitches, and the Columbian Rope Company, Auburn, New York, has published an illustrated folder of knot charts, with many additional forms.

**Make the Knot Board** of a piece of heavy wallboard, or

a sheet of lighter-weight board tacked to battens, or a piece of plywood. You can finish the wallboard or plywood with stain and varnish, or enamel. Fasten the knots and hitches to the board with loops of heavy linen thread or with staples. A piece of heavy rope, or braided rope makes a good finish for the edge of the board. Typewrite, print or hand letter the names of the knots and hitches upon slips of heavy paper or light-weight cardboard, and fasten these below the specimens. Attach a pair of hangers to the back of the knot board.

#### A ROCK AND MINERAL COLLECTION

is easy to get together. With diligent searching, you will discover many specimens in your vicinity. You will pick them up on hikes and motor trips. And friends who know of your hobby will bring you specimens on their return from travels.

Place your dark specimens on light backgrounds, and light specimens on dark backgrounds, to show them up to the best advantage. Use wallboard, plywood, or boards cleated to prevent warping, for trays. Stain or enamel the surfaces, or cover them with cloth. Fasten the specimens with bands of linen thread, or bands of tape, as shown in Fig. 409. Affix an identification label beside each.

Put tiny stones and crystals in bottles (Fig. 410).

#### A SHELL COLLECTION

may be a part of your stone and mineral collection, but keep specimens on separate trays.

### A COLLECTION OF LEAVES

helps you in learning to know them. You will find suggestions for making a herbarium for pressing specimens in Chapter XIII of "Outdoor Boy Craftsmen." The photograph of Fig. 423 shows a few specimens from the collection of Wilson White, mounted on cards.

### AN INSECT COLLECTION

is always interesting and instructive. Chapter XIII of "Outdoor Boy Craftsmen" tells how to make a hand net, trap, killing jar, observatory, spreading board and specimen cabinet.

**Glass Jars** with screw tops, and small bottles, like those shown in Fig. 411 and the photograph of Fig. 424, are best for preserving grasshoppers, katydids and the larger forms of insect life.

**Box Cases** with glass tops, like that in Fig. 412, are best for moths, butterflies and other delicately organized specimens. Cut down the sides of a candy box and its cover to a depth of 1 inch, cut a panel from the top of the cover, leaving a  $\frac{1}{4}$ -inch margin of cardboard around the edges, and get a piece of glass to fit snugly in the cover. Glue the glass to the cover, fill the box with cotton batting, on which to place specimens, and stick pins through the cover and box sides, as indicated, to lock the assembled case.

### A PHOTOGRAPH COLLECTION

will probably appeal to you, because of its wide range of possibilities. Use your camera instead of a gun to "shoot"

animal and bird specimens. Some big-game hunters hunt with a camera in preference to a gun, and carry a gun only as a means of defense. Try camera hunting this summer. Shoot bird nests, before and after the eggs have been hatched. Set up a screen through which to photograph birds and animals in their natural surroundings.

A **Photograph Album** is best for preserving a set of prints, but you will also want to frame your best pictures.

A **Folding Screen** like that shown in the photograph of Fig. 18 has good surfaces for the display of prints. Such a screen may be used in your museum to separate exhibits.

#### A CARD INDEX OF EXHIBITS

will be interesting, after you have your museum well organized. If you own a printing press or rubber-type outfit, set up a form like that shown in Fig. 413. Print it upon 3-by-5 index cards and make or buy a filing cabinet to hold them.

Collections that cannot be framed or otherwise prepared for hanging, are best displayed in

#### A SPECIMEN CABINET

A good cabinet for the museum can be built of packing boxes. Fig. 414 shows a cabinet made of two boxes 19 inches wide, 22 inches long and 9 inches deep. Get the boxes at a paint store.

After reinforcing the box boards with additional nailing, fasten one box upon the other as in Fig. 415. Cut

**Shelves** to fit, and fasten two at the right distance apart

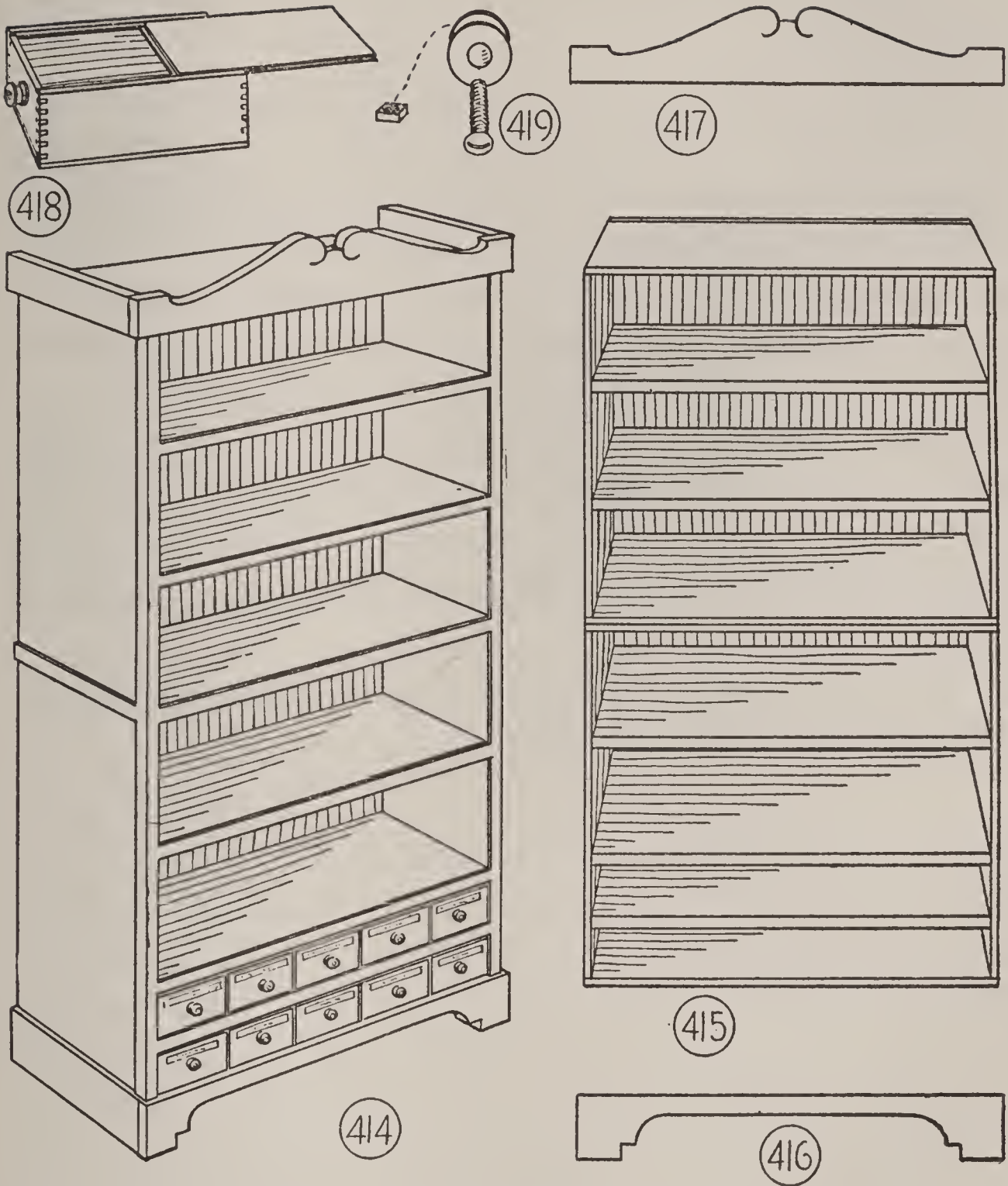

FIG. 414.—Specimen Cabinet.  
FIGS. 415-417.—Details of Cabinet.  
FIG. 418.—Box Drawer.  
FIG. 419.—Spool Drawer-Knob.

to accommodate small box drawers, the others with equal spacing.

**To Trim the Cabinet,** cut a board of the shape of Fig. 416, nail it across the front of the lower box, and nail two pieces of the same width across the box ends. Cut a board of the shape of Fig. 417, nail it across the front of the upper box, and nail two pieces to match it, across the ends. Trim the box edges and shelf edges with pieces ripped from lattice strips or laths.

**Cabinet Drawers.** Boxes that codfish is sold in (Fig. 418) make excellent cabinet drawers. Use silk-twist spools for knobs, and attach them to the box ends with stove bolts (Fig. 419), or buy small pot-cover knobs at a hardware store.

**Finish the Cabinet** with two coats of enamel, of whatever color or colors you want.

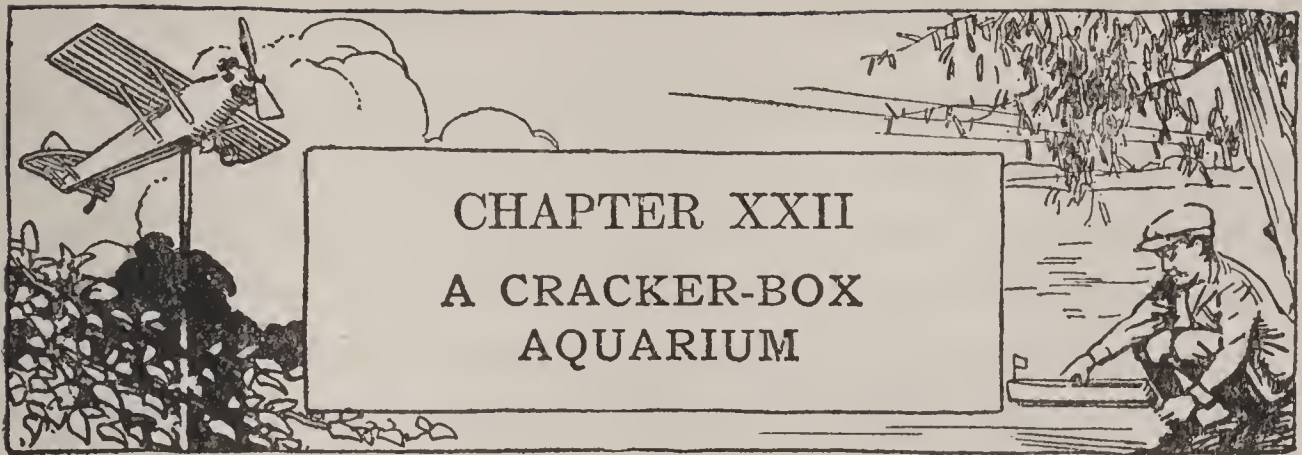

## CHAPTER XXII

### A CRACKER-BOX AQUARIUM

IF goldfish required a daily airing, three square meals, changes of bedding and a Saturday night bath, parking a kennel, herd, flock or school of goldfish somewhere about the house, would probably become one of our leading indoor sports. The goldfish corner of newspapers would be as popular as the kennel news, and the fine points which determine prize winning stock—head development, eyes, ears, tails, colors, poise, personality, and what not, would become the leading topic of conversation at home and at social gatherings.

But goldfish require no grooming, and little else. Indeed, they are more apt to die from over attention than from neglect. That takes the fun out of the thing for some people, triflers, who tire of their toy when there is nothing more to do with it. There is a lot more fun to keeping goldfish pets, however, than you may imagine. Go in for the finer varieties, tropical fish, life-bearing fish. Dealers in pets will show you interesting specimens, or tell you where to send for them. You can breed them, too, and you will find this fascinating work and remunerative, since

tropical species retail at fifty cents apiece and up. I know a fellow who makes a hobby of raising goldfish. He has gone into the game to such an extent that, besides having tanks in almost every room in the house, he has preëmpted the bathtub for a stock tank. Some families might object to sharing the tub with their goldfish. A hobby can be carried too far.

### A WELL-BALANCED AQUARIUM

stocked with fish, a snail or two, and water plants, will nearly take care of itself. The plants will keep the water pure and supply food. The snails will serve as scavengers.

**Do Not Change Water.** Add fresh water to replace that which evaporates. If the tank requires cleaning, remove the fish and the water. But pour back the same water after cleaning the tank.

**When a Fish Becomes Sick,** swims unsteadily, flounders, do not call in a specialist. He can do no more than you can. There is only one cure-all, first-aid remedy. Fill a basin with water, add a tablespoonful of salt, and transfer the sick fish with a dip-net. If it doesn't revive within a short time, its case is hopeless.

**Feed Sparingly.** A small amount of prepared natural fish food a day is sufficient. Comply with the food carton's directions. Fish sickness is largely due to overfeeding.

### DIFFICULTY IN BUILDING WOOD-AND-GLASS AQUARIUM

When I was a lad, I read an article on how to build an aquarium of wood and glass. It appeared wonderfully



fine in the illustrations, and I always intended to build one, but I never got at it. The difficulty with a wooden base and framework is in making joints that will stay tight, because wood has a tendency to shrink, split, and twist. A wooden frame will soon go to pieces unless built of thick stock. An all-metal frame is better.

### THE TIN CRACKER-BOX AQUARIUM

shown in the photograph of Fig. 425 is an exceptionally good home-made model. I devised it after experimenting with strips of angle iron and deciding that to join these at the corners would be too difficult a job for the average boy. The cracker-box aquarium requires the following

#### MATERIALS

Buy a tin cracker box at your grocery. If, by chance, the grocer hasn't one, substitute a bread box. In addition to the box, buy a dozen  $\frac{1}{8}$ -inch stove-bolts  $\frac{3}{8}$  inch long, and two pieces of glass of a width and length determined by the inside measurements of the box. Glass has been used in only two sides of this aquarium. This is sufficient for illumination, and makes a stronger job.

**Make Your Aquarium Cement** of a dime's worth of litharge, a nickel's worth of powdered rosin and a nickel's worth of plaster-of-Paris, some fine sand, and a little boiled linseed oil. To make the cement, mix dry 3 parts of litharge, 3 parts of plaster-of-Paris, 3 parts of sand and 1 part of rosin. Then add enough linseed oil to make a stiff putty.

## PREPARE THE BOX THIS WAY

Fig. 426 shows the cracker box, with openings cut in two opposite sides, and one piece of glass set in place. The other piece of glass, and its corner angles, are shown in Figs. 429 to 431. The plan diagram (Fig. 427) shows how the corner angles overlap the edges of the glass, and how they are bolted to the box.

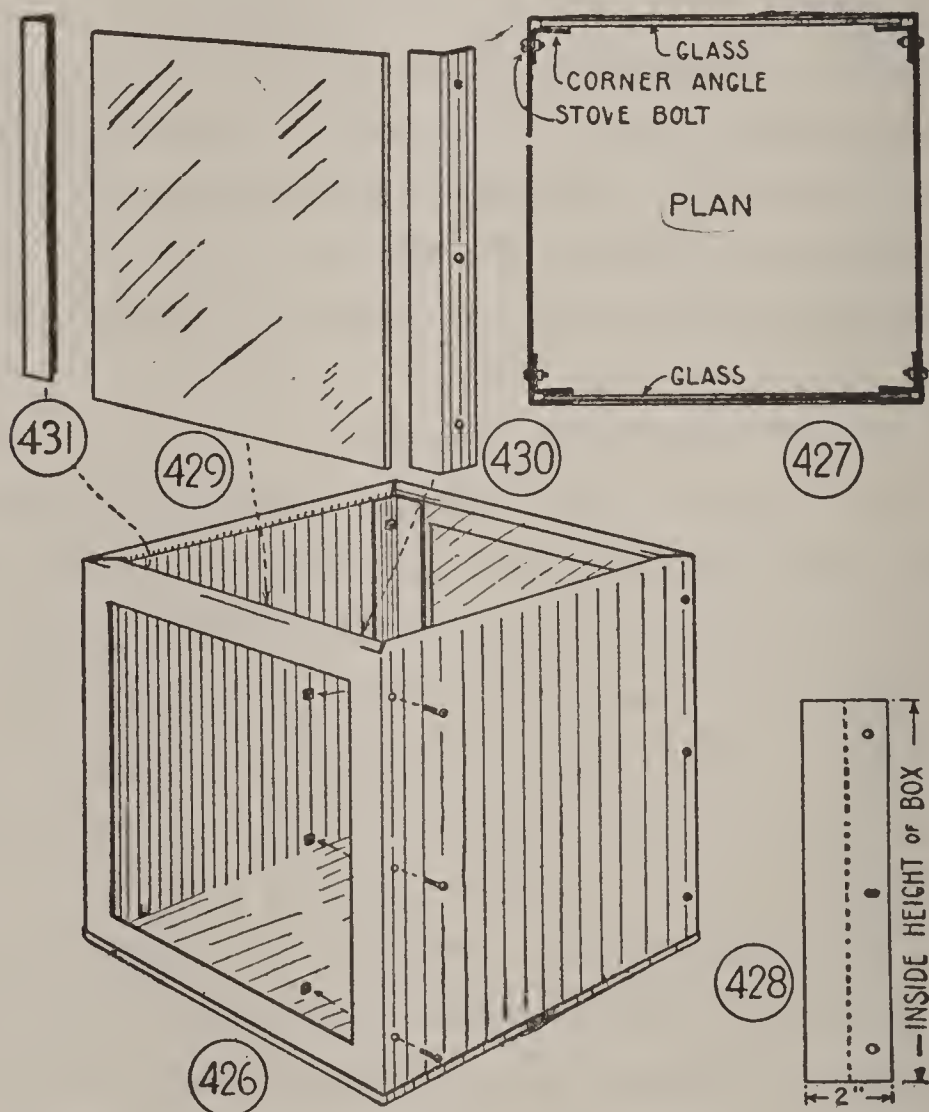

FIG. 426.—Cracker-Box Aquarium, Shown Completed in Photograph of FIG. 425.

FIG. 427.—Plan of Cracker-Box Aquarium.

FIG. 428.—Pattern for Corner Angle Strip.

FIG. 429.—Glass for Side of Aquarium.

FIGS. 430 and 431.—Corner Angle Strips.

Make the margins of tin around the openings  $1\frac{1}{8}$  inches wide. Cut the openings with tinsnips or a cold chisel, and finish the edges smooth with a file.

Use the tin removed from the openings for material for the four corner angle strips. Fig. 428 shows a pattern for these strips and Figs. 430 and 431 show two of them ready to attach. Drill three bolt holes through one-half of each strip, or punch them with a nail and smooth off the rough edges with a file. Bend the strips along the center, as indicated by dotted lines. Punch corresponding holes through the box sides.

Before assembling the aquarium,

**Paint the Tin.** But use nothing for the inside but asphaltum paint. I used white enamel on my model, and experienced no injurious effects on the fish. But Mr. Hans Jensen, authority on goldfish, and builder of the tanks in the Lincoln Park Aquarium and Shedd Aquarium, Chicago, says that he has experimented with every kind of paint and found all injurious except asphaltum paint. Paint the outside white, or any color that you want. Use lacquer or enamel.

**Set the Glass** when the paint has hardened. Smear the aquarium cement over the tin, around the opening, and embed the glass in it. Then smear the corner angle strips with cement, set them in place against the glass, and fasten them with stove bolts. Before screwing the nuts tight, run in additional cement back of the strips. Allow the cemented aquarium to stand at least two days. Then fill it with water to test it for leaks. If there are any leaks,

empty the tank, calk the leaky places, and allow the cement to harden before refilling with water.

### A CASTLE FOR THE AQUARIUM

You can buy all sorts of castles for aquariums, but a home-made model of cement, like the one I made for my aquarium, shown in Fig. 432, is just as good. But do not place it in the aquarium after casting until the cement

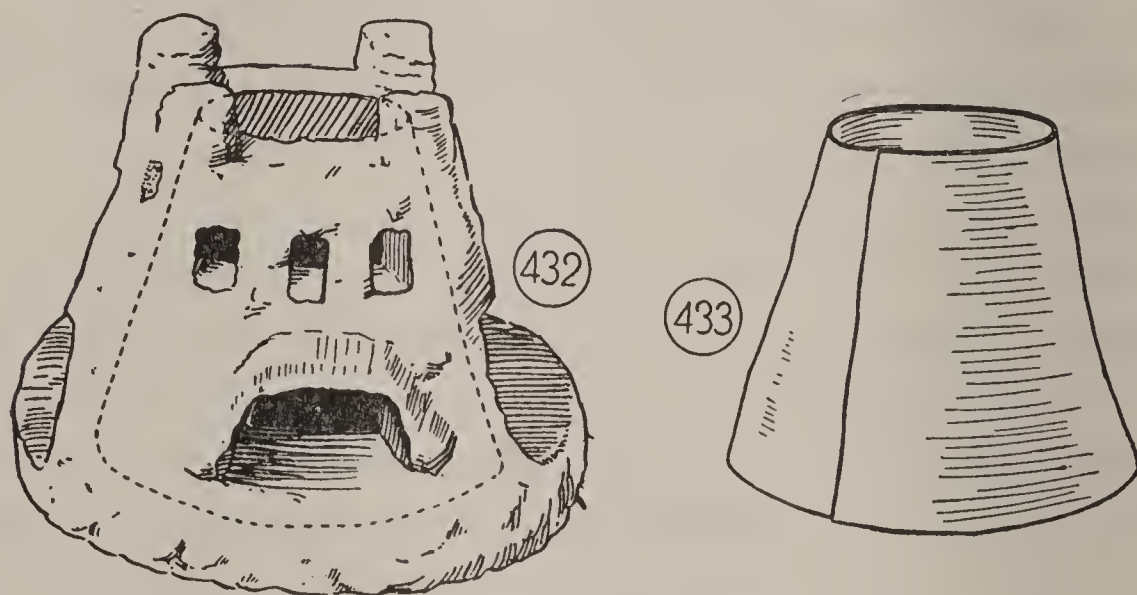

FIG. 432.—Cement Castle.

FIG. 433.—Cardboard Form.

has had a chance to season, because green cement is injurious to fish. Let the castle stand in a tub or pail of water, with frequent changes of water, for several weeks to season it.

**Make a Form** for the castle by twisting cardboard into the frustum of a cone, as shown in Fig. 433, with a base diameter of  $3\frac{1}{2}$  inches, a top diameter of 2 inches, and a height of 4 inches.

**Mix Sand and Cement** in the proportions of 1 part

cement to 2 parts sand, and add enough water to make a stiff mixture.

Build the **Castle Walls** around the cardboard form, with corner towers, as shown in Fig. 432. Allow the cement to set, but before it has become very hard take an old knife and a sharpened stick, and scoop out the arched doorways and the windows, and smooth off the surfaces.

### STOCKING THE AQUARIUM

When you are ready to stock the aquarium, cover the bottom with sand to a depth of 1 inch, place the castle in the center, arrange the water plants around it, with roots in the sand, and fill the tank about two-thirds full with water.

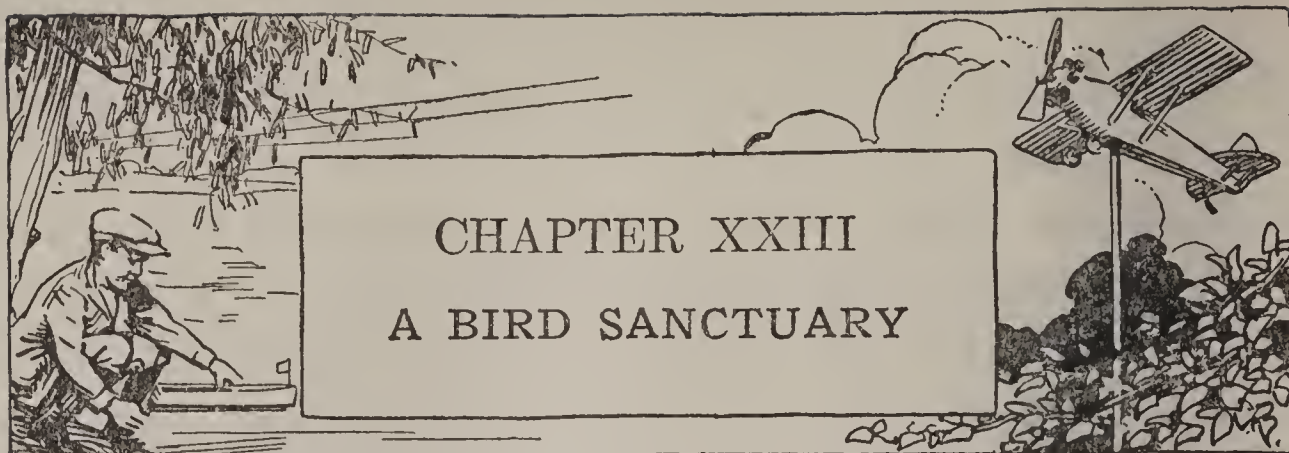

## CHAPTER XXIII

### A BIRD SANCTUARY

You have read about the establishment of bird sanctuaries in forest preserves, parks and cemeteries and on large estates. The movement is spreading. But it need not be limited to large areas. You can have a bird sanctuary in your yard, or at your summer home. Fitting up and maintaining a sanctuary is one of the best of hobbies. You will put up many bird-houses, baths, feeding-racks, and nesting-material racks. You will plant shrubs bearing fruits attractive to birds. You will provide protection from cats and other bird enemies. And when the birds have taken possession of your home-made shelters and you see them flying to and from them, if you do not experience the thrill that comes with the first successful flight of a home-made airplane, I should say that you are not more than fifty per cent airminded.

Every bird lover grows enthusiastic when speaking of his bird garden. Among my reader mail comes a letter from Norman E. Klenck, from which I quote the following:

“Last fall and winter I built models of all the bird houses described in your handicraft books, for my bird

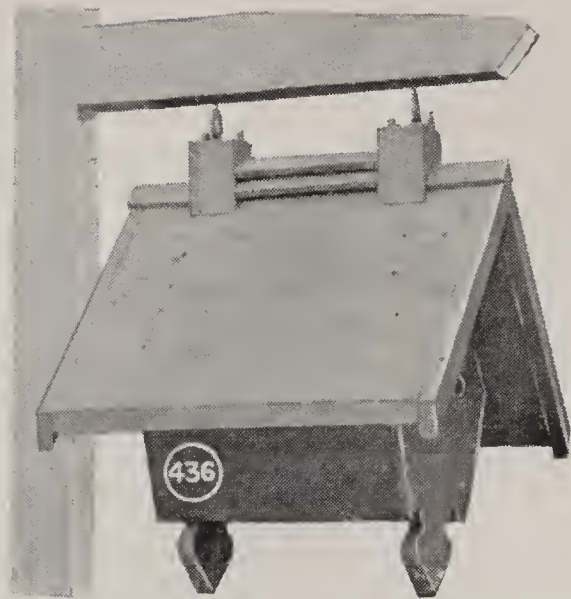

FIG. 434.—WREN HUT. FIG. 435.—BLUEBIRD HOUSE.  
FIG. 436.—WREN OR BLUEBIRD HOUSE.  
FIG. 437.—TREE-STUMP BIRD BATH.  
FIG. 438.—A BIRD BATH AND A FISH POND.





sanctuary, and have found the designs very successful. Most of the houses are already occupied, and so are eight of my ten robin shelters. Among the birds now nesting are three pairs of bluebirds, two pairs of wrens, two pairs of flickers, one pair of red-headed woodpeckers, one pair of nuthatches, and three pairs of martins."

Plans for three simple houses and a nesting material depot are shown in this chapter, a winter feeder is shown in Chapter XIV, and two bird baths are shown in Chapter XXIV. There is not room in this book for more suggestions than these, but you will find additional plans in "Handicraft for Handy Boys," "Carpentry and Mechanics for Boys" and "Outdoor Boy Craftsmen." If you do not own these books, you will find them in your public library.

### A WREN HUT

All that you need for the wren house shown in the photograph of Fig. 434 is a cocoanut shell, a piece of box board, three wood screws, or small nails, and a screw-eye.

**To Prepare the Cocoanut,** drill a  $\frac{7}{8}$ -inch hole in the side of the shell for the doorway, and drain off the milk. Then cut away the top of the shell with a saw, remove the meat, and scrape the shell clean.

**Make the Roof** octagonal in shape, as shown in the diagram of Fig. 439, inscribing the octagon in an 8-inch circle. Or make the roof 7 inches square, if you want to. After cutting the board, sandpaper the edges, then paint it green or brown, and screw a screw-eye into its center for a wire hanger.

To Assemble, drill three or four holes through the top of the shell, slanting them so nails or screws can be driven

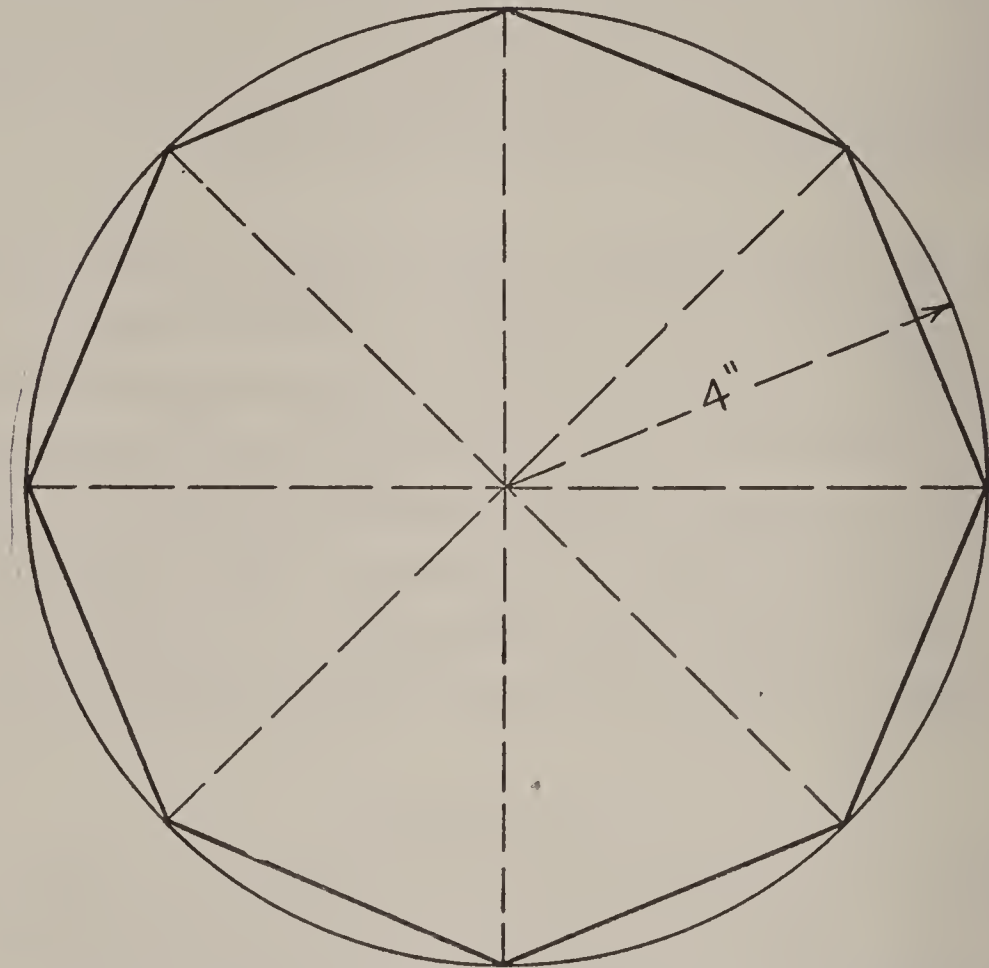

FIG. 439.—Lay Out Octagonal Roof Like This for Wren Hut Shown in FIG. 434.

through into the roof board. If you use screws, it will be easier to remove the shell to clean out the old nest.

### A BLUEBIRD HOUSE

The photograph of Fig. 435 shows an attractive bluebird house that is simpler to build than it looks. As you will see by the cross-section of Fig. 440, only the front of the house has curves. The sides are straight. Fig. 441 shows a cross-section through the front and back.

Lay Out the Front by the pattern in Fig. 442. Draw horizontal and vertical lines with a spacing of  $\frac{1}{2}$  inch, to

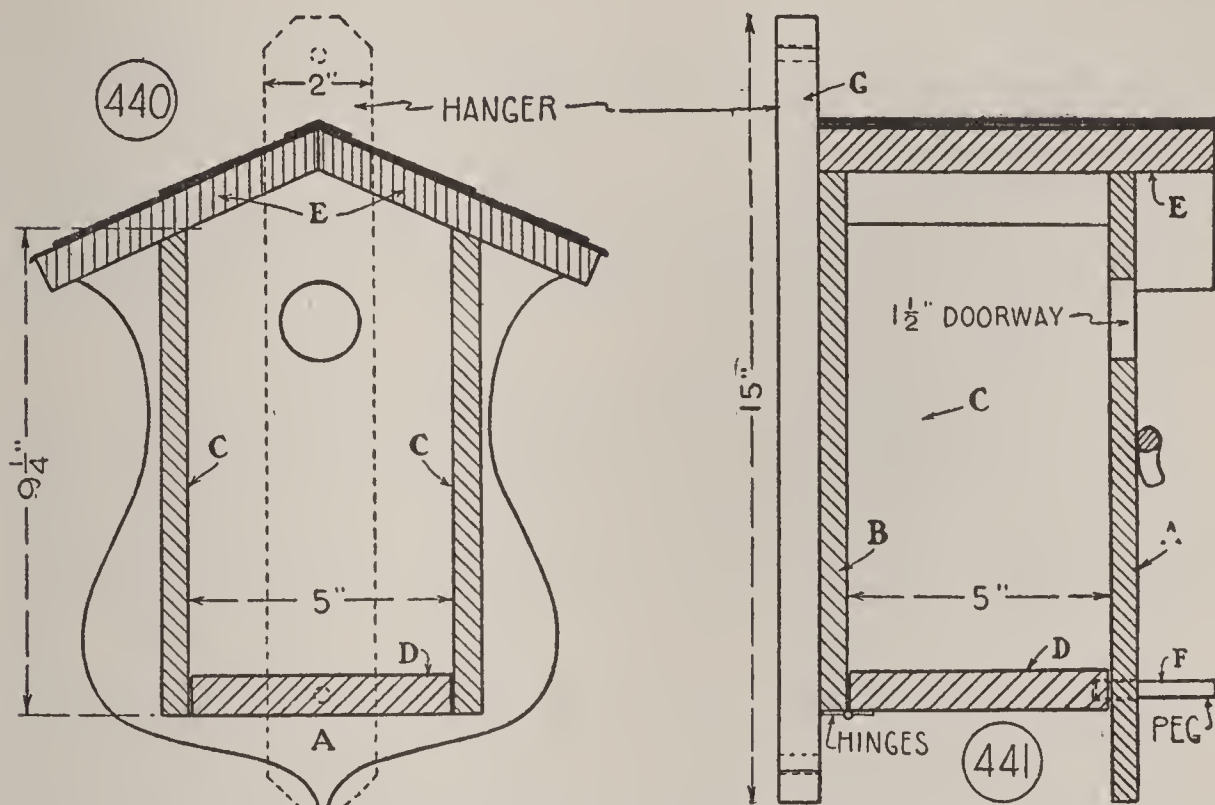

FIGS. 440 and 441.—Sections Through Bluebird House Shown in FIG. 435.

form a set of squares similar to those on the pattern, and upon these squares draw the outline of one-half of the pattern. Then draw a center line upon a piece of 10-inch board,  $\frac{1}{2}$  or  $\frac{3}{4}$  inch thick, and reproduce the half pattern on each side of the line. Cut out the piece with a coping-saw.

Lay Out the Back Board by the pattern of Fig. 443;

The Side Boards by the dimensions given in cross-sections Figs. 440 and 441. Slant the tops of the side boards to conform to the slant of the front and back pieces.

The Roof Boards must be large enough to project  $1\frac{1}{2}$

inches at the front, and  $\frac{1}{2}$  inch over the ends of the front piece. Bevel their inner edges to make a neat joint at the ridge.

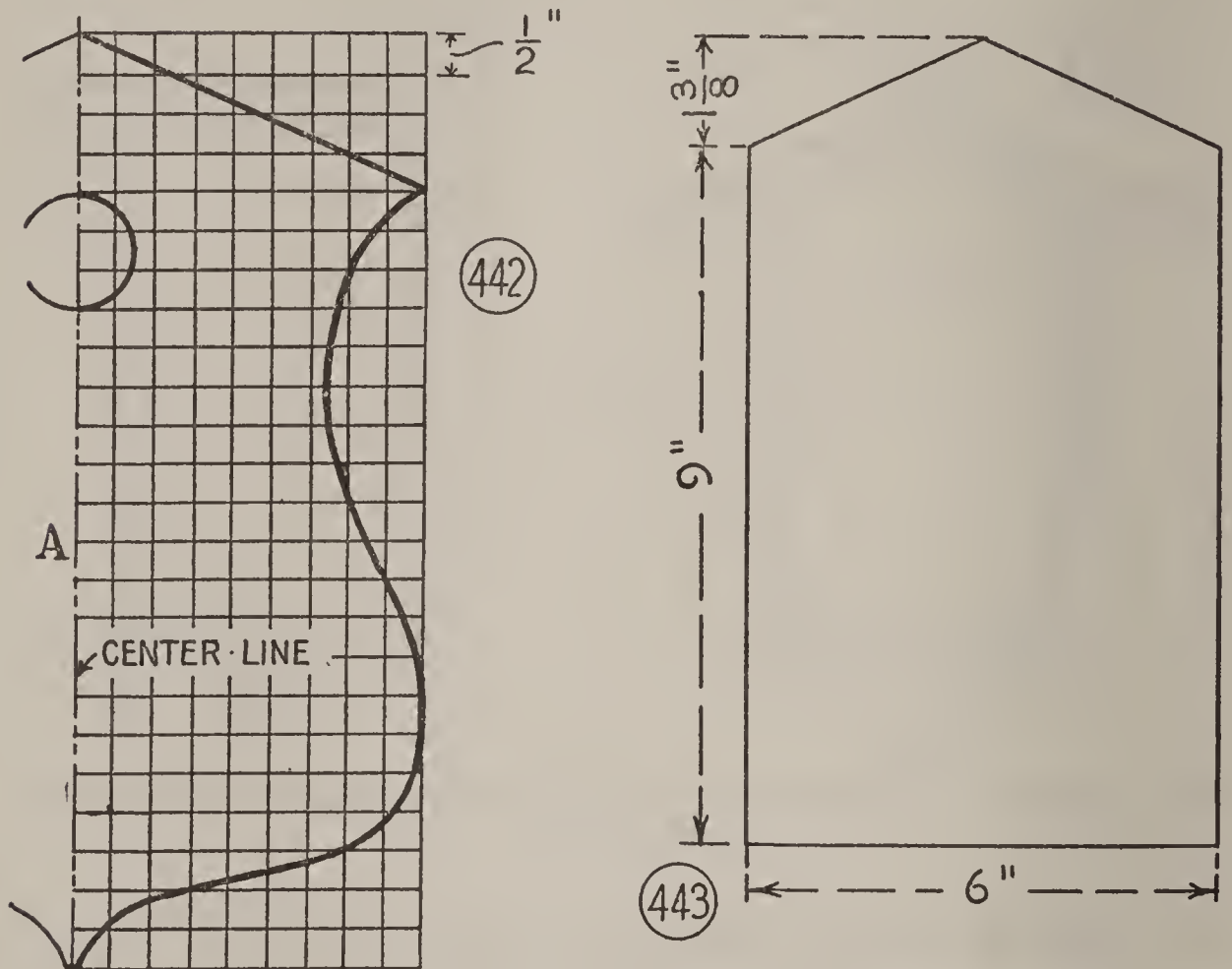

FIG. 442.—Pattern for Front.

FIG. 443.—Pattern for Back.

The Floor (D) fits between the walls, and is hinged to the bottom edge of the back wall, to open. Bore a  $\frac{1}{4}$ -inch hole through the front of the house, and another in the edge of the floor board, for a peg (F). This peg, pushed into the holes, locks the floor in place and serves as a perch.

The Doorway for a bluebird should be  $1\frac{1}{2}$  inches in diameter, and located about 6 inches above the floor.

Nail a short piece of tree branch below the opening for a perch.

**The Hanger** for this house is a strip 2 inches wide and 15 inches long (G, Fig. 441). Drill a hole through it near each end, for screws. Nail the strip to the back of the house.

**Paint** the bluebird house with brown paint, then

**Shingle the Roof** with strips of slate-coated shingles.

### A WREN OR BLUEBIRD HOUSE

The design shown in the photograph of Fig. 436 may be adapted either to wrens or bluebirds, by making a  $\frac{7}{8}$ -inch doorway for wrens or a  $1\frac{1}{2}$ -inch doorway for bluebirds. If you

**Build Houses to Sell**, in addition to those you build for your bird sanctuary, adopt a design such as this, and build a quantity alike, then bore doorways when you have obtained your orders and know how many wren and how many bluebird houses you need. By this plan, you will first build a house for a model, complete in every detail. Then you will mark out all the end pieces, sides, floors and roof boards for the entire lot, cut them and assemble them. This method is a time saver, and will enable you to lay out parts with the least possible waste of material.

**Dimensions of Parts** are given in the cross-section (Fig. 444), and the longitudinal section (Fig. 445).

**The Side Pieces B** must have their upper edges beveled to correspond to the pitch of the roof. Their height will be determined by the side edges of

**End Pieces A.** Lay out one end piece and use it for a pattern for marking the second piece.

**The Floor Board C** must be beveled on two edges to fit the sloping sides.

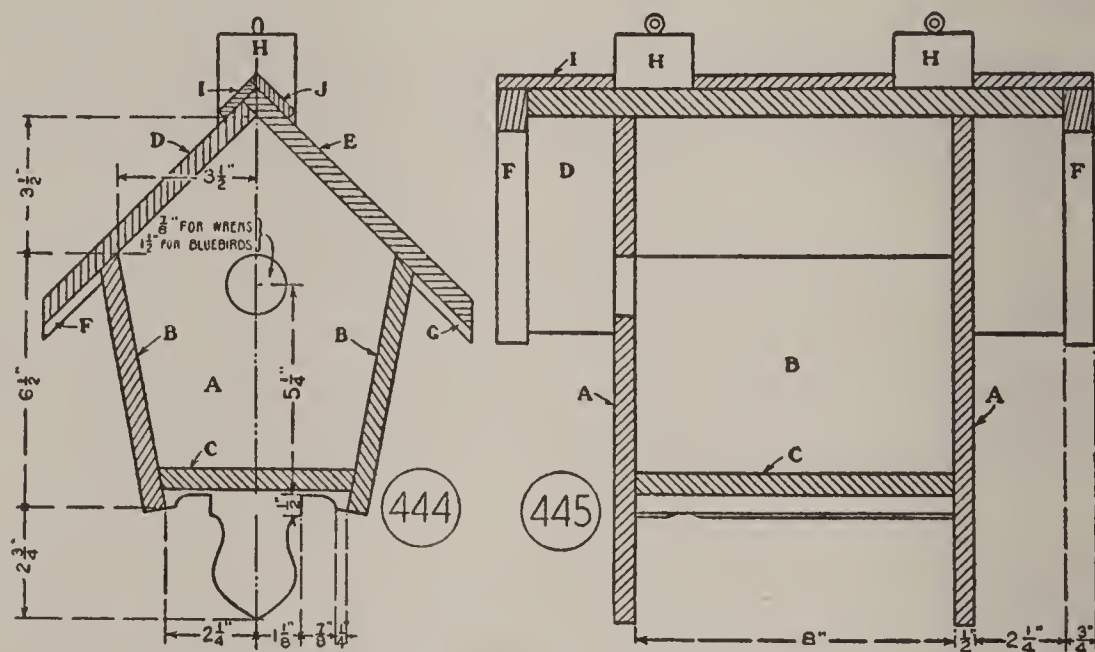

FIGS. 444 and 445.—Sections Through Wren or Bluebird House Shown in FIG. 436.

**Eave Strips F and G** trim up the ends of the roof boards, and batten together

**The Roof Boards.** Notice that roof board D is enough narrower than board E to allow for the overlapping of the latter (Fig. 444). Notch two 2-by-2 inch blocks to fit over the ridge for

**Hanger Blocks H**, and screw a screw-eye into the top of each. Fit the ridge strips I and J in place as shown.

**For Spring Cleaning**, fasten the floor board with screws so that it may be removed easily.

## A NESTING MATERIAL DEPOT

Stock this little self-help supply depot with bits of string and thread, wisps of dried grass, and combings; hang it from a tree branch in plain view of your window, and you will see dozens of feathered shoppers flying to it, then away with nesting material. Indeed, a little luxury like this often results in more nests in the vicinity.

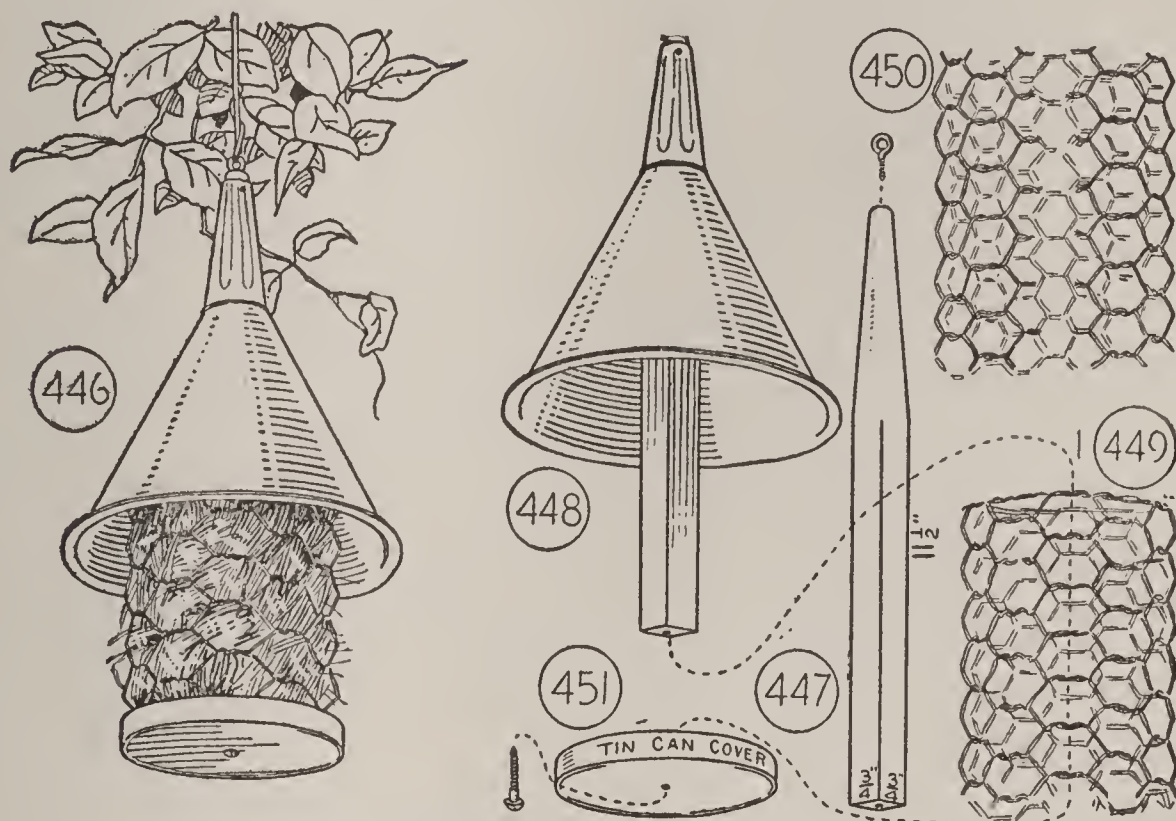

FIG. 446.—Nesting-Material Depot.

FIG. 447.—Center Stick Support.

FIG. 448.—Tin Funnel Roof.

FIGS. 449 and 450.—Nesting-Material Cage.

FIG. 451.—Can-Cover Bottom for Depot.

The depot is made of a tin funnel, a stick, a tin can cover and a piece of poultry netting. The tin funnel forms the roof. That used on the model illustrated measures  $6\frac{1}{2}$  inches across the rim, which is plenty large enough.

**Cut the Center Stick Support**  $11\frac{1}{2}$  inches long (Fig. 447), whittle off the top end to fit the spout of

**The Tin Funnel Roof.** Fasten the funnel to the stick end with a small nail driven through the side of the spout (Fig. 448). Screw a screw-eye into the top of the stick to attach a hanger to.

**The Nesting Material Cage** is enclosed with 1-inch poultry netting. Buy a foot of the narrowest width that your hardware dealer carries. To form the cylinder (Fig. 449), bring the ends of the netting together (Fig. 450), and twist them around each other. The diameter of the cylinder will be determined by the size of the cover used for the base. That of the model is 4 inches.

**To Assemble** the material depot, fit the wire cylinder inside the rim of the can cover, then slip a screw through a hole punched through the center of the cover (Fig. 451) and drive it into the end of the stick support.

**Finishing.** Of course, you must paint the depot to preserve it, and for appearance's sake. Apply two coats of green or white paint.



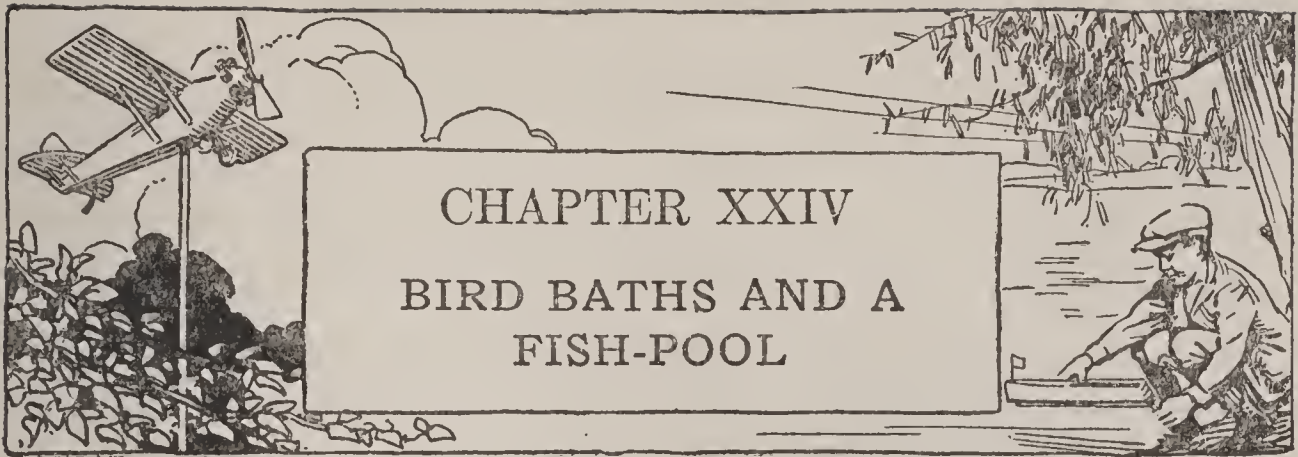

WITH room and board, the tenants of your bird sanctuary may be satisfied to bathe in a neighbor's pool, but it is barely possible that they may decide to take up their abode where there are complete accommodations. Take no chances. Install a bath. You can build one quickly, and you will be repaid for your efforts by the great numbers of birds that will patronize it. Not only the house-nesting birds will use it, but also those that nest in trees, in shrubs and on the ground. You will see species that you are not acquainted with, the more timid in the early dawn, the bolder throughout the day, with numbers increasing and bathing more prolonged, as the weather grows warmer. If you will conceal yourself near by, what a chance for bird study! And with camera in hand, what a chance to make a photographic record!

#### A TREE-STUMP BATH

Almost any shallow container will do for a bird bath. The photograph of Fig. 437 shows a bath made by fastening the cover of a garbage can upon a tree stump. A cover

can be found easily, for the cover generally remains after the can has rusted through.

To Mount the Cover on a stump or post driven into the ground, first cut its handle in two, at its center, with a hacksaw or file. Then bend up the cut halves, and drill or punch a hole near each end, as shown in Fig. 452, for nails or screws, to nail or screw the halves to opposite sides of the tree stump or post support.

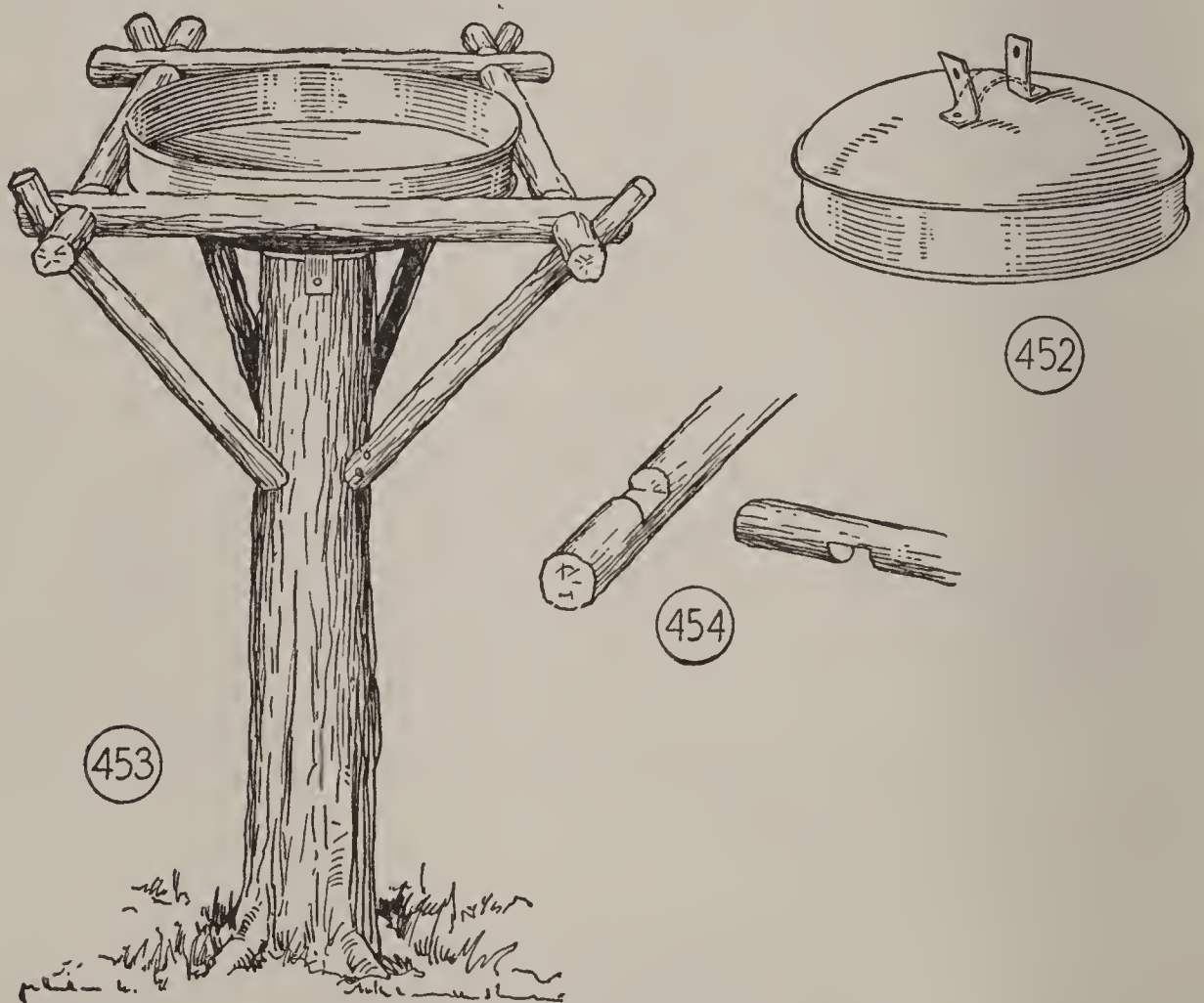

FIG. 452.—Garbage-Can Cover for Bird Bath Shown in FIG. 437.

FIG. 453.—Rustic Bird Bath.

FIG. 454.—Halve Branches Like This for Framework.

Before you attach the cover, give it two coats of green or white paint to protect the metal from rust.

### A RUSTIC BATH

can be begun in the same way, by mounting a can cover upon a tree stump, then enclosing it with a framework of branches crossed and nailed. But it makes a better job to halve the ends of the branches as in Fig. 453, so that the tops will be on the same level. This requires notching as shown in Fig. 454. Drill holes through the branch ends for the nails used in assembling the framework. It will prevent splitting.

### A FISH-POND OR WATER-GARDEN

Your interest in this pool will be in building it and stocking it with fish. Mother's interest will be in its possibilities as a water-garden. The double purpose makes it well worth the small cost and labor to build it; it also establishes a needed balance. Fish feed upon mosquito larvæ, preventing a mosquito menace. Plant life keeps the water fresh and provides fish with oxygen and food.

The photograph of Fig. 438 shows

**A Concrete Pool** that requires no wooden forms for casting. Omitting forms greatly simplifies the work, especially in building a circular or irregular pool. Indeed, little preparation is necessary before casting this pool.

**The Size of the Pool** will depend on its location, and its plantings. The pool in the photograph has an inside diameter of 10 feet, and a maximum depth of 18 inches. It is deep enough for water lilies and most water-garden plants.

**Mark Out the Pool** upon the spot it is to occupy, by

describing a circle with a piece of rope looped over a center stake, and a sharpened stick or marker slipped through a second loop formed at a distance equal to the desired

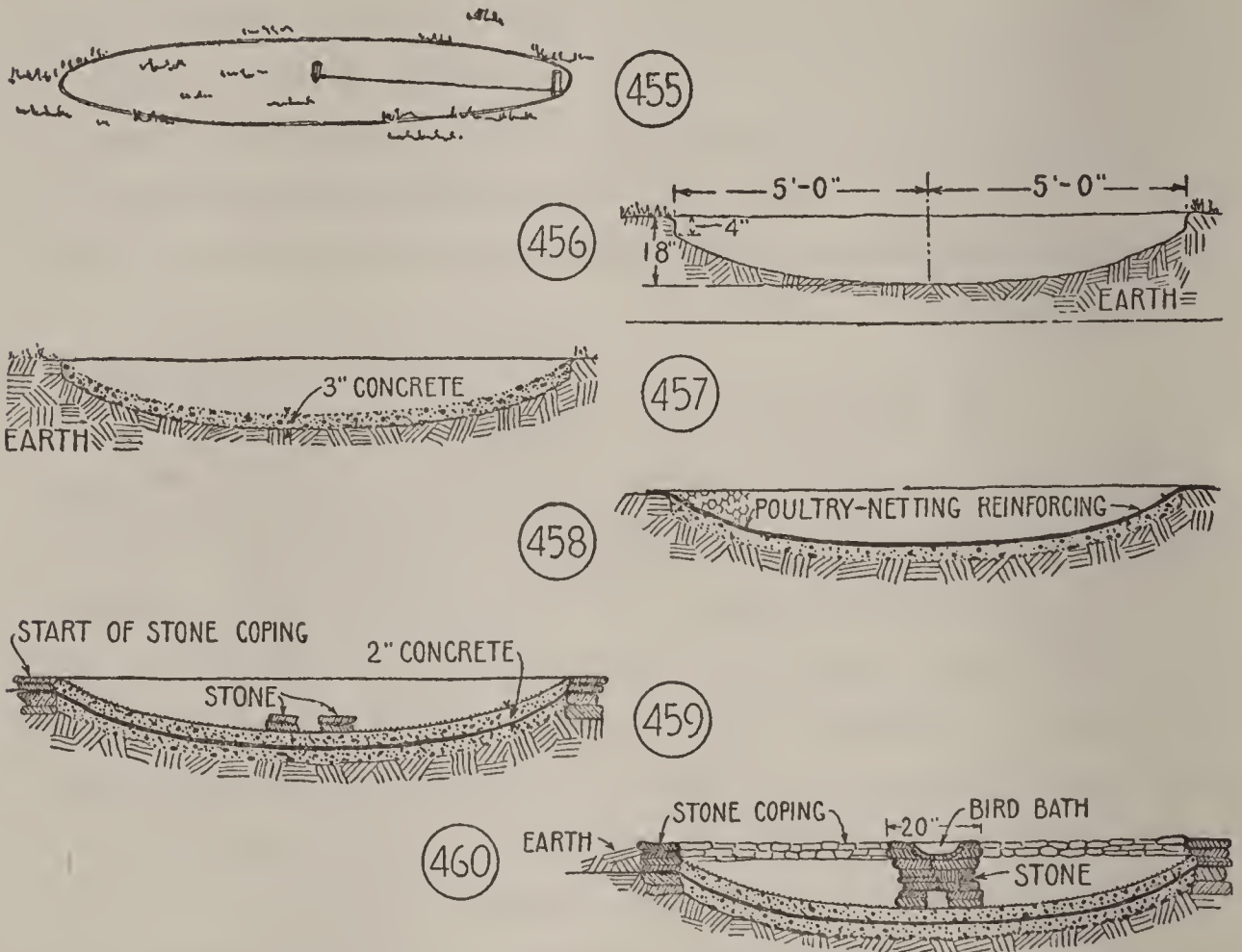

- FIG. 455.—Mark Out Circular Pool, Shown in FIG. 438, This Way.  
 FIG. 456.—Cross-Section of Excavation.  
 FIG. 457.—Cross-Section Showing Three Inches of Concrete on Pool Bottom.  
 FIG. 458.—Cross-Section Showing Poultry Wire Reinforcing.  
 FIG. 459.—Cross-Section Showing Two Inches of Concrete on Wire Reinforcing.  
 FIG. 460.—Cross-Section of Completed Pool.

radius for the circle (Fig. 455). After scratching the circle upon the ground

Excavate to a Depth of Four Inches around the edge

(Fig. 456), and from this point slope the excavation gradually to its maximum depth of 18 inches. Drive the center stake deeper as you dig, to retain the marking of the center.

Make the Rim Level, for any irregularity will be noticeable when the water level has been established. Test the rim with a spirit level placed upon the center of a straight-edged board or plank long enough to span the excavation, or, with a basin of water placed similarly. Build up the edge where it proves to be low, and cut it down where it is high.

**Tamp Down the Earth** along the edge and over the sloping bottom of the excavation, to make it compact, using

**A Home-Made Tamper** like that shown in Fig. 461. The base of the tamper is a piece of plank, the handle is a piece of 2-by-4 spiked to the base.

**A Cinder Sub Base.** If the ground is well drained, you can place concrete directly upon the tamped earth. If not, spread several inches of clean cinders or gravel over the surface and tamp them down. The excavation must be made deep enough to provide for the cinder sub base.

**Material for Concrete.** The following material is needed for a pool of the size shown: 4 bags of Portland cement, 9 cubic feet of coarse sand and 18 cubic feet of crushed stone or gravel. This will make a mixture of the proportions of 1 part cement, 2 parts sand and 4 parts stone. You should have



FIG. 461.—  
Make Tamper Like This  
for Tamping  
Concrete.

**A Mixing Box** about 30 inches wide and 5 feet long. A pail is convenient for measuring materials.

**To Mix a Batch of Concrete**, first mix the sand and stone, dry, hoeing them to one end of the box and back again; then add the cement, mix it through the sand and stone, and add enough water in a hollow formed in the pile to make a quaky, jelly-like mixture.

**Shovel the Concrete Into the Excavation**, spread it evenly over the surface to a depth of 3 inches, and tamp it down to form a compact mass (Fig. 457).

**Reinforcing.** With 3 inches of concrete in place, use galvanized wire poultry netting for reinforcing. Spread this over the concrete, with edges lapped, and 6 inches or so of it projecting over the rim (Fig. 458).

**Add Two Inches of Concrete** on top of the reinforcing, tamp it down, and trowel its surface to make it even and smooth.

**Finish the Edge of the Pool** with a coping of stone, field stone, quarry stone, or pieces of broken concrete slabs. It is generally easy to find broken sidewalk slabs, when nothing else is available. Dig around the edge of the pool to the depth of the concrete, fill in with broken stone, and tamp this down. Then lay up a wall about 6 inches high (Figs. 459 and 460), levelling up the pieces with cement mortar and chips of stone.

Frost may disturb the coping wall somewhat, though in four years' time it has not affected the wall of my pool. It will be simpler to readjust pieces that may be thrown out of alignment than to build a foundation below frost

line. Bank up earth around the wall so surface water will drain away, not run under the pool.

After the concrete pool has set for twenty-four hours, build

### THE BIRD BATH

in its center of field stone or other stone, of the form shown in the photograph of Fig. 438 and Fig. 460. Start piling the stones in the manner shown in Fig. 459, with an opening in the base for a passageway for fish. Embed the stones in cement, and form a shallow basin in the top, as shown in Fig. 460. Give the inside of the bird basin a thick top dressing of cement to make it watertight.

### PLANTING

The circular pool is deep enough for water lilies and most water-garden plants. Set out the plants in wooden boxes filled with good garden soil. An advantage in using boxes is that you can remove them when you drain the pool in the fall without disturbing their roots.

### A DRAIN

can be built into this pool, but it is not necessary, because you can easily and quickly bail out the water after removing the fish and plant boxes in the fall. If you prefer to have a drain, ask your local plumber how to install it.

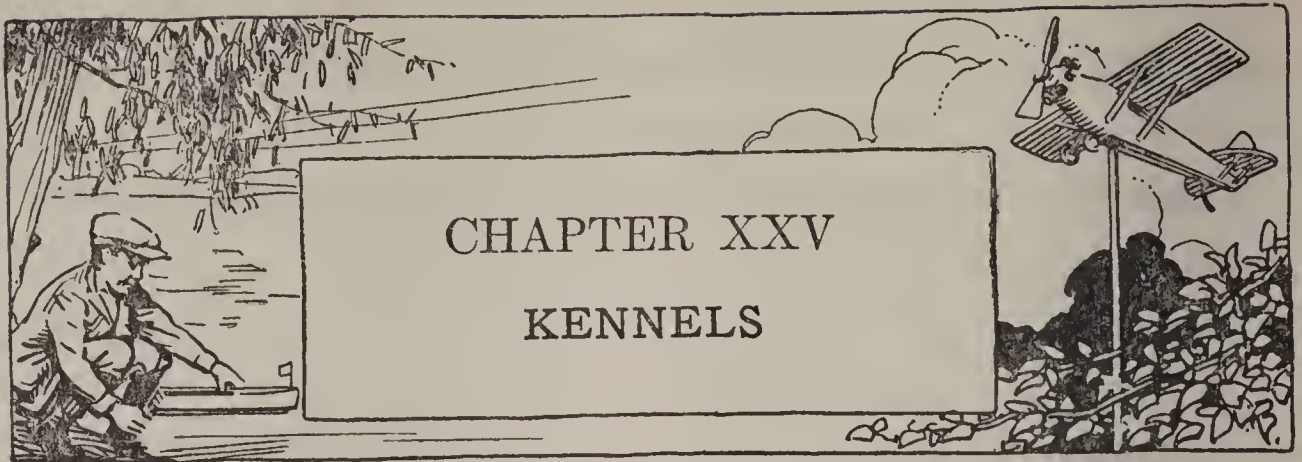

It is time to transfer Sport to his spring and summer quarters in the back yard, and unless you have already provided him with a good kennel, you will do well to build one like that shown in the photograph of Fig. 462. This is a house that has been in use many years, and it is good for many more.

#### A WELL-BUILT HOUSE

**The Size** will be determined by the breed of your dog. The house in the photograph was built for a collie. You can easily increase the dimensions for a larger dog.

**The Material** may be boards from packing-boxes, provided they are sound and not warped. But if you must buy boards, get matched boards, or shiplap, as they will make tighter walls.

**Build the House in Sections**, and you can assemble it more quickly. Fig. 466 shows a cross-section of the completed kennel. Fig. 467 shows how the ends are built, Fig. 468 shows the sides, Fig. 469 the floor, and Fig. 470 the hinged roof section.





FIG. 463.—BARREL KENNEL.



FIG. 462.—A WELL-BUILT KENNEL. FIG. 464.—AN EMERGENCY HUTCH.

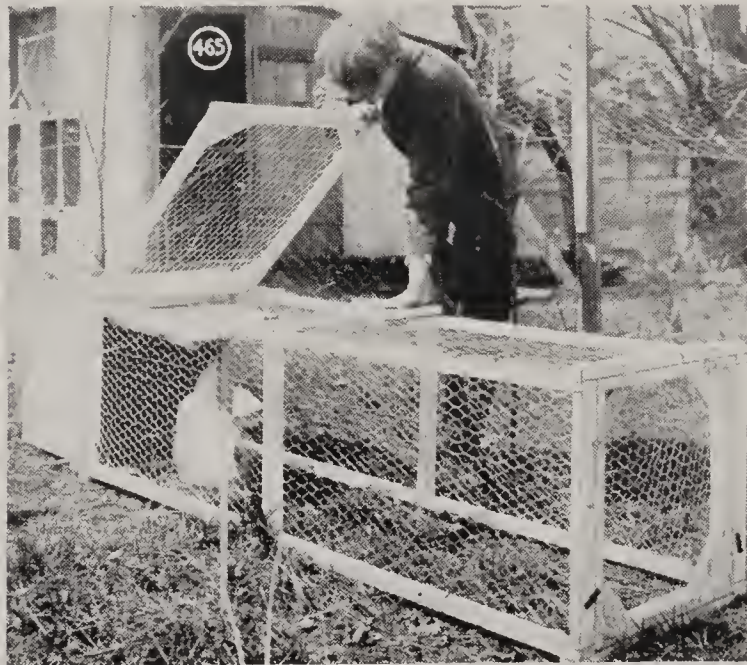

FIG. 465.—COOP OR HUTCH, AND RUNWAY.



To Make an End-Wall Section, batten together enough boards to make the width wanted, with temporary end

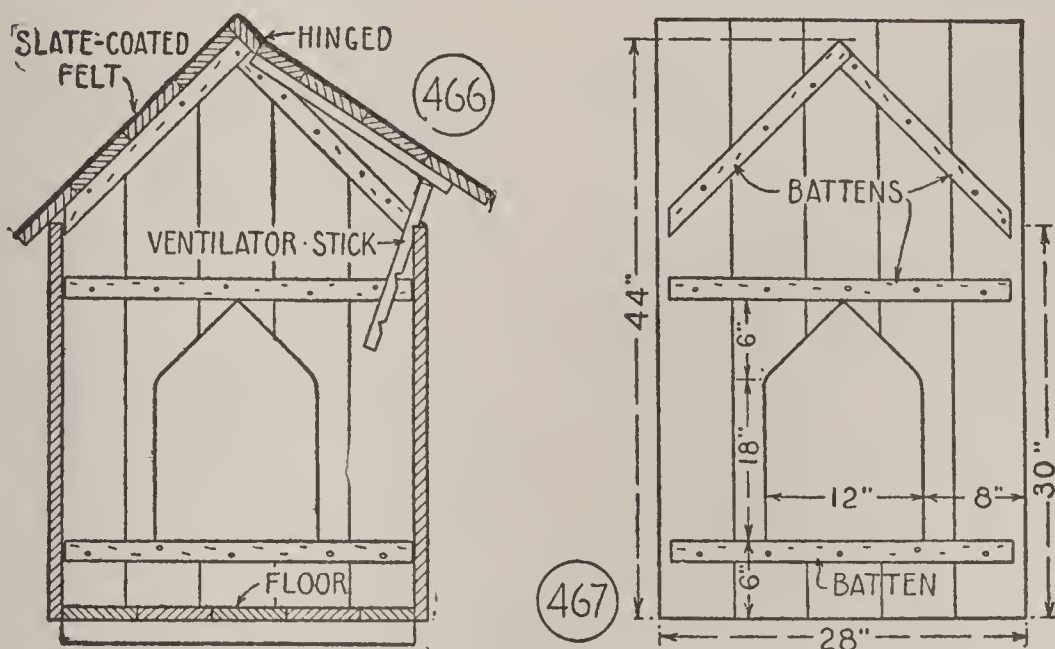

FIG. 466.—Cross-Section of Kennel Shown in FIG. 462.  
FIG. 467.—End Wall.

battens. Then locate the doorway upon the front section, fasten battens across the boards above and below the opening (Fig. 467), lay out the pitch of the roof, and batten together the boards along these lines. With one end completed, use it as a pattern for the second end.

In the same way, make

**The Side Sections** by the pattern of Fig. 468. Attach the battens with screws, or with nails long enough to drive through and clinch.

**Build the Floor** as shown in Fig. 469, using three strips of 2-by-2 for sills. As the wall sections are to be nailed to the edges of the floor boards (Fig. 466), let their dimensions determine the size of the floor section.

**The Roof.** Cut the boards for one half of the roof, long

enough to project 2 inches over each end, and nail them to the house ends. Then fasten a narrow board along the



469



471

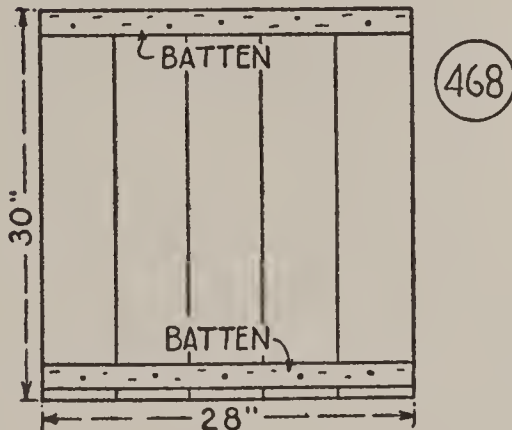

468

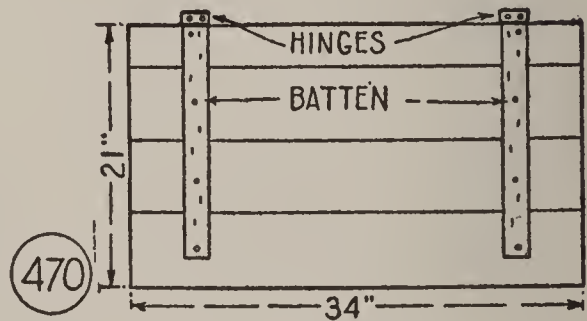

470

FIG. 468.—Side Wall.

FIG. 469.—Floor.

FIG. 470.—Hinged Section of Roof.

FIG. 471.—Ventilator Prop.

peak for a hinge strip, batten together the boards of the second half of the roof, as shown in Fig. 470, and hinge this section to the hinge strip.

Ventilation of the house is obtained by raising the roof, and this is the way to sun the house and to gain access to it for cleaning. Prepare a notched stick like that in Fig. 471, for a prop, and hinge it to the roof to catch on the wall when the roof is raised.

You may also bore four vent-holes in each gable end, as in the photograph of Fig. 462.

**Cover the Roof** with roofing felt or shingles, to make it tight.

Paint the Kennel inside and out. One coat inside is sufficient, but give the outside two coats.

### A BARREL KENNEL

If you want a neat-appearing kennel that you can build quickly, try the barrel kennel shown in the photograph of Fig. 463. The fence enclosing the kennel yard looks as though it might have been borrowed from somebody's portable baseball backstop. Nevertheless, it is a first-rate scheme, joined at the corners with hinge hasps, because it can be moved from one spot to another.

A Wooden Oil Barrel is the right kind for a kennel. Scrape it clean, inside and out.

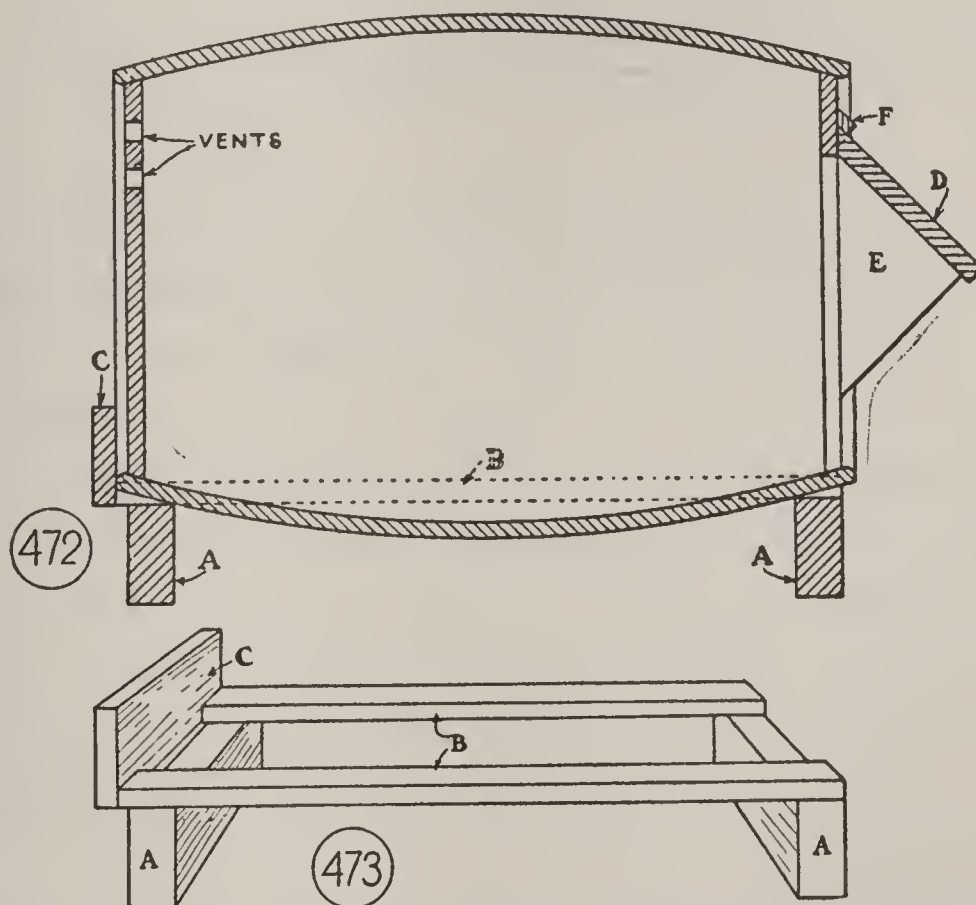

FIG. 472.—Cross-Section of Barrel Kennel Shown in Fig. 463.  
FIG. 473.—Detail of Cradle.

Fig. 472 shows a cross-section of the barrel kennel, and of **The Crib**. The crib holds the barrel off the ground, to prevent rolling and to forestall pup nightmares. A detail is shown in Fig. 473. The 2-by-4 sills A are cut long enough to catch the ends of board plates B.

There is little work to

**Preparing the Barrel.** The doorway may be circular or square, framed with pieces cut from the barrel head. Fasten a canopy over the opening, using a board (D) supported upon a pair of brackets (E), with a strip across the top (F) to make a tight joint. Bore several holes through the barrel bottom for vents, and the kennel will be ready for

**Painting.** Give the outside two coats of paint. You might use white paint, with green for trimmings.

#### A CONCRETE BOWL FOR DRINKING WATER

will not upset, it will keep water cool and it will last indefinitely. The bowl in Fig. 474 is easy to cast.

**The Form** for casting it requires a kettle for the inside, and a cheese-box for the outside (Fig. 475). Get a kettle about 10 inches in diameter. A worn-out utensil will do. Get the cheese-box from the grocery. It will measure about 13 inches high and 15 inches in diameter. Remove the box bottom, and cut down the sides to a depth of 7 inches, or so they will be about 2 inches deeper than the kettle (Fig. 476).

Spread newspaper or wrapping-paper upon a cement floor or walk; then place the cheese-box upon it, and the

kettle, inverted, in the center of the box. The form will then be ready for the cast.

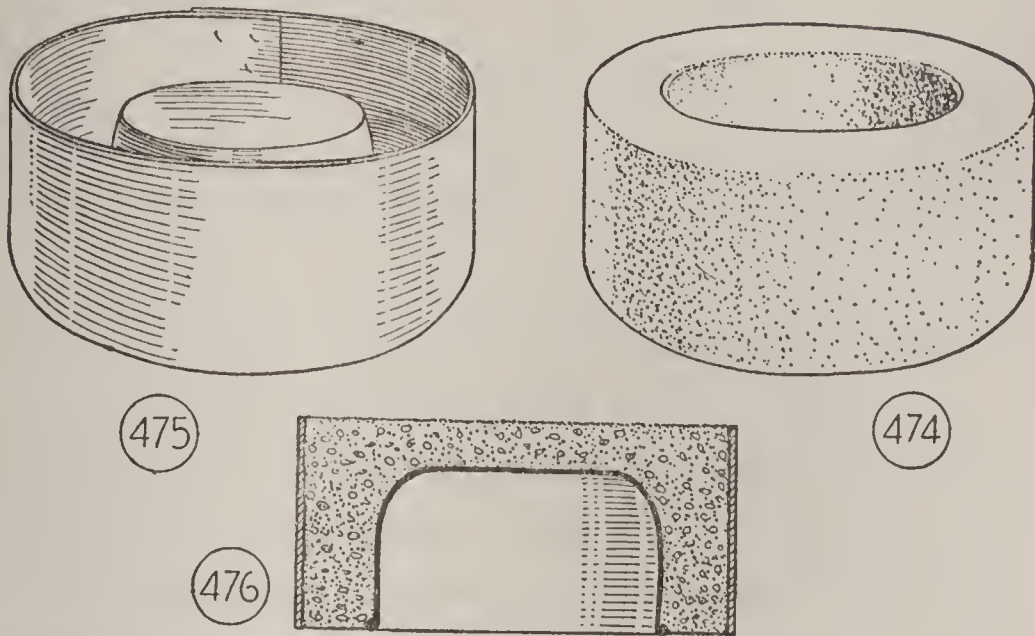

FIG. 474.—Concrete Bowl for Drinking Water.

FIG. 475.—Cheese-Box and Kettle Form.

FIG. 476.—Cross-Section of Cast Bowl.

Mix the Concrete in the proportions of 1 part cement, 2 parts sand, and 3 parts fine crushed stone or gravel. Mix the material dry, then add enough water to make a jelly-like mixture.

Pour the Concrete into the form, and tamp it down around the kettle and box with a stick. To cast smooth surfaces, it is necessary to force the *grout* or thin part of the mixture into all interstices. You can get these results by working a trowel or knife around the inside of the cheese-box form, and allowing the grout to flow down.

Remove the Form after the concrete has had twenty-four hours to set. The edge of the kettle may have become wedged, but you can cut it away without difficulty.

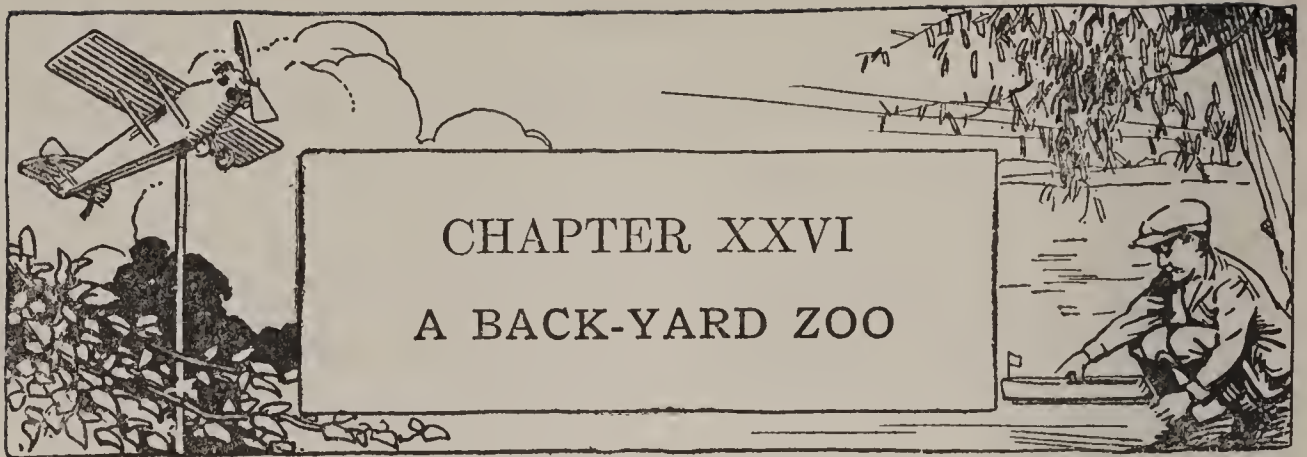

IF one of your hobbies is keeping pets, why not establish a zoo in your yard? You have visited a park zoo. You know how the houses, cages, pens, runs and pools are arranged, and you probably have an idea of how to place yours along the fence of your yard, or around the hen coop. You will want to placard the cages, of course, as they do at the park zoo. For instance, you will name your dog *canis familiaris*, your rabbits, *lepi cuniculi*, your white mice, *muscili albi*, your pigeons, *columbidæ*, your goldfish, *carasii aurati*, and so on. Look up the Latin names in an encyclopedia.

You may not own many pets, but here is

#### A GOOD WAY TO ACQUIRE A ZOO

or to augment your zoo, during the summer months, when you have the most time to give it attention. In your neighborhood there are dogs, cats, parrots and other birds, goldfish, possibly a monkey or a pony, that never get away on vacations, and whose masters and mistresses are sometimes kept from vacations because of them. Perhaps



you do not know it, and perhaps your neighbors do not, but there are kennels and catteries and bird stores, where, at considerable expense, you can board pets by the day or by the week. The care given them is no more than you could give, and if you have the confidence of your neighbors, it is more than likely that you would have no difficulty in taking on a few boarders. This would be great fun and affords another interesting way of earning vacation money.

Leaving these thoughts for you to develop, let us look into plans for home-made shelters.

In the preceding chapter are two kinds of kennels, each of which might be adapted to other pets than dogs. In this chapter are several plans for hutches, pens and yards, and in the following chapter is a small poultry house and runway that might also be used for pigeons and other pets. For additional suggestions, go to your public library and look up my books "Handicraft for Handy Boys" and "Outdoor Boy Craftsmen."

#### AN EMERGENCY HUTCH

The photograph of Fig. 464 shows an easily built single compartment hutch that will serve several purposes, among which I may mention a carrying box, hospital ward, exhibition cage and temporary quarters. Note that

It is Made of a Box with the cover removed, and that two-thirds of the opening is covered with small-mesh poultry netting, the other third with a hinged frame also covered with netting.

Hinges and a hook for the door, and a handle for the top, are required. A drawer pull or a parcel handle fastened to a pair of screw-eyes, will do for a handle. For

An Exhibition Cage it will be better to put the doorway in the end or the back of the box, and cover the entire front with netting, because by this arrangement there will be a less obstructed view of the exhibit.

### A RABBIT HUTCH

The hutch shown in Fig. 477 has

Three Compartments in a Box (Fig. 478). The box

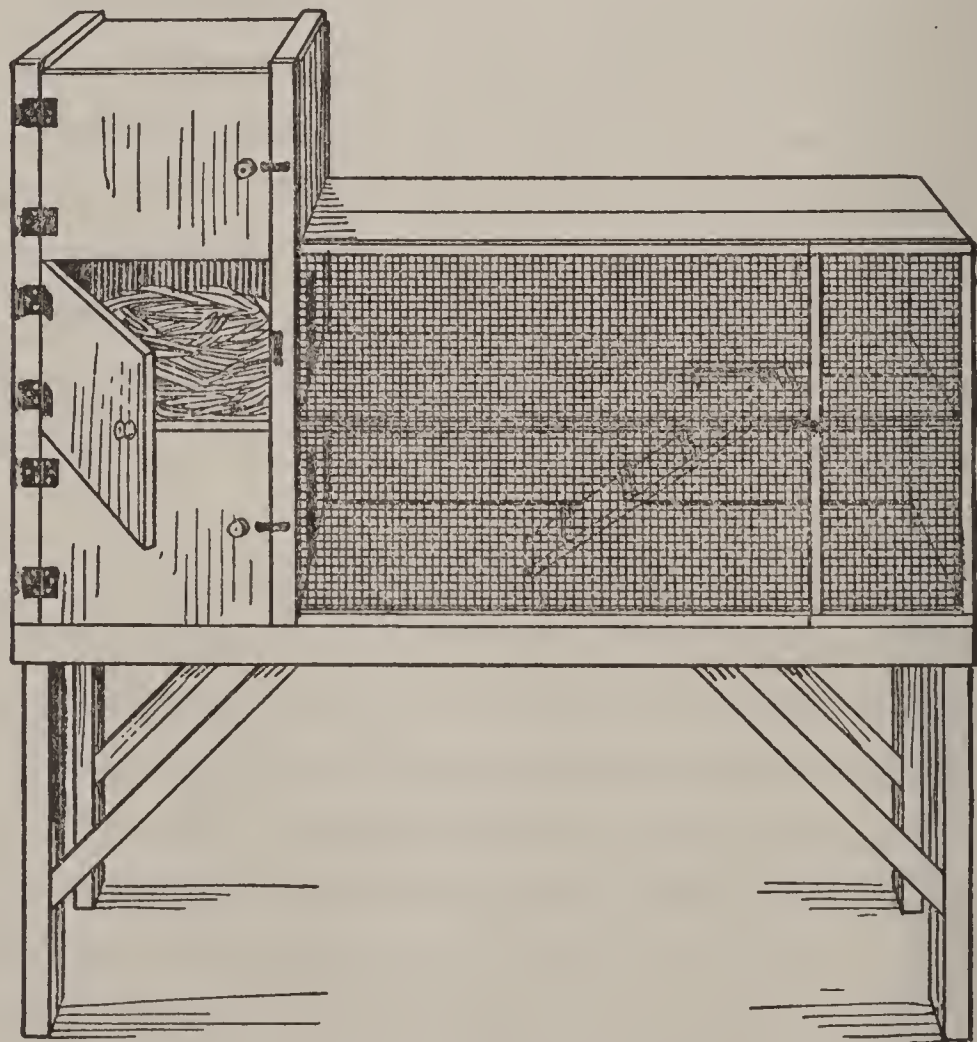

FIG. 477.—Rabbit Hutch.

stands on end. The space between floors should be not less than 9 inches. The box should be about 30 inches long. If your box is shorter, make two compartments instead of three.

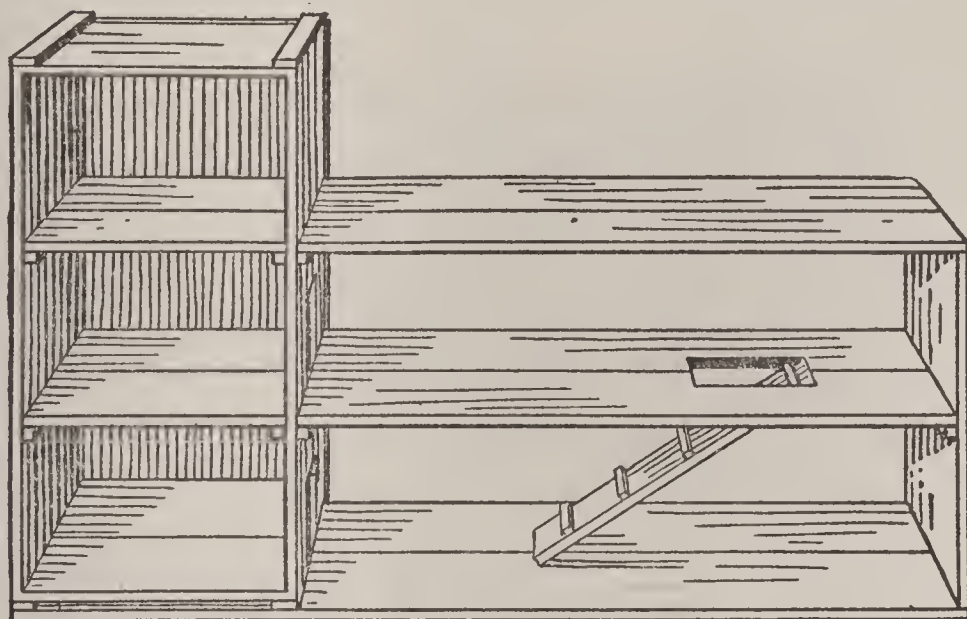

FIG. 478.—Detail of End Box Compartments and Runways.

**Cut Floor Boards** to fit in the box, and support them upon cleats nailed to the sides of the box (Fig. 478).

**Cut Two Doorways**, 3-by-7 inches in size, in the side of the box, to connect the lower two compartments with the runways.

The **Rabbit Runways** may be built of box boards or other boards. The runway floor boards should extend under and be nailed to the bottom of the compartment box, as shown. Place the second floor, and the roof of the runways on a level with the compartment floors. Support the board ends upon cleats.

The **Stairway** opening in the second floor should be cut

before the boards are fastened in place. Make the stairway of a board with cleats nailed across it.

**Make the Doors** to the compartments of boards. Nail wooden strips to the edges of the box to hinge the doors to, and to attach iron button fasteners to. Use spools for door knobs.

**Cover the Sides of the Runways** with poultry netting or wire cloth. There must be a doorway at one end, through which to gain access to the runways. If you use poultry netting, make a door frame of narrow strips and cover it with the netting. If you use wire cloth, a strip of it will be stiff enough without a frame, for a door, and it can be hinged with loops of wire. Such a door is shown in Fig. 477.

**A Pair of Trestles** similar to those shown in Fig. 477 make the best support for the hutch. The legs and braces may be made of 2-by-2s, the connecting pieces of 4 inch boards.

**Paint** the inside and outside of the hutch.

#### A CONVERTIBLE COOP OR HUTCH

is shown in the photograph of Fig. 465. It may be adapted to chicks, rabbits or guinea pigs. The first part of

**The Construction** will be the same for coop or hutch. Procure a box 18 inches square, or larger, for the base (Fig. 479). This will save work because the corner posts A and B can be fitted in the box corners, as shown, and the box sides can be extended to the height of the posts. The size of the box used will determine the dimensions

of the various parts of the coop, but I suggest that you make posts A and B of 1-by-2s, posts A 15 inches long and posts B 20 inches long. Cut plates C to fit across the post tops.

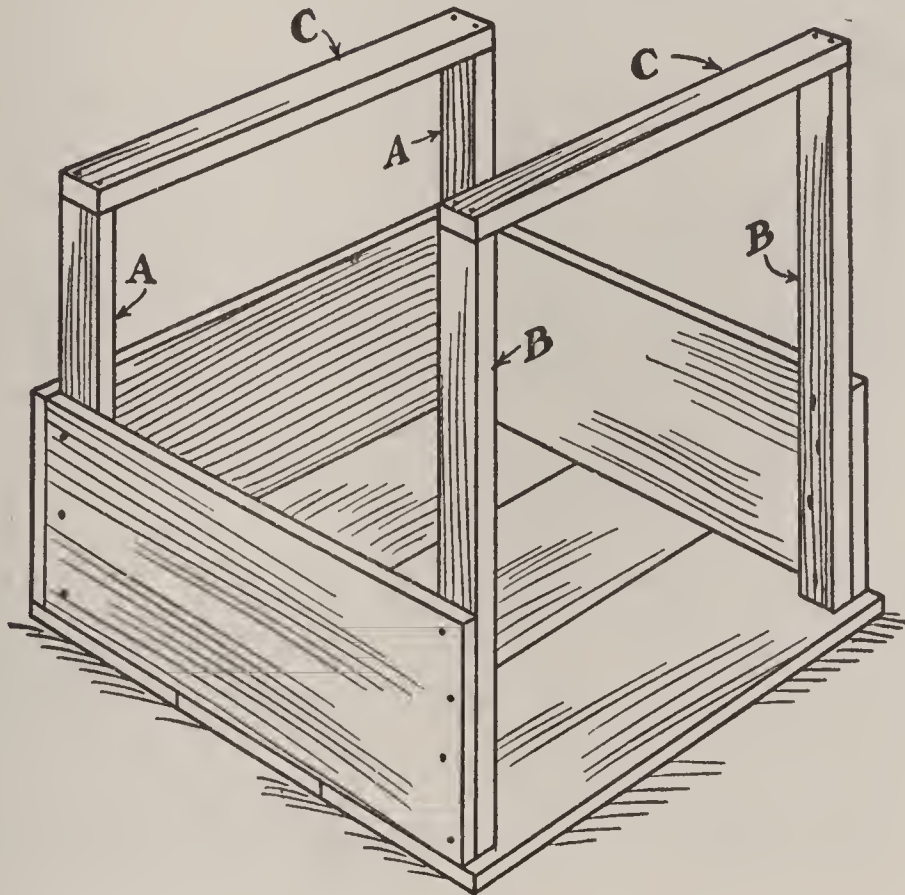

FIG. 479.—Framework of Coop Shown in Photograph of FIG. 465.

Build Up the Sides as shown. Cut the top board on each side 2 inches longer than the boards below it, so that it will project beyond the rear wall, as shown in Fig. 480. Build up the rear wall to the height of the under edge of the projecting side boards. Then fasten a board between the projecting ends of the side boards. This will form

A Ventilator, as you will see by Fig. 480. The board outside of the opening will keep out rain. A piece of

screen wire or wire netting fastened across the vent opening will keep out rodents, and a narrow strip hinged as shown in Fig. 482 will form a shutter.

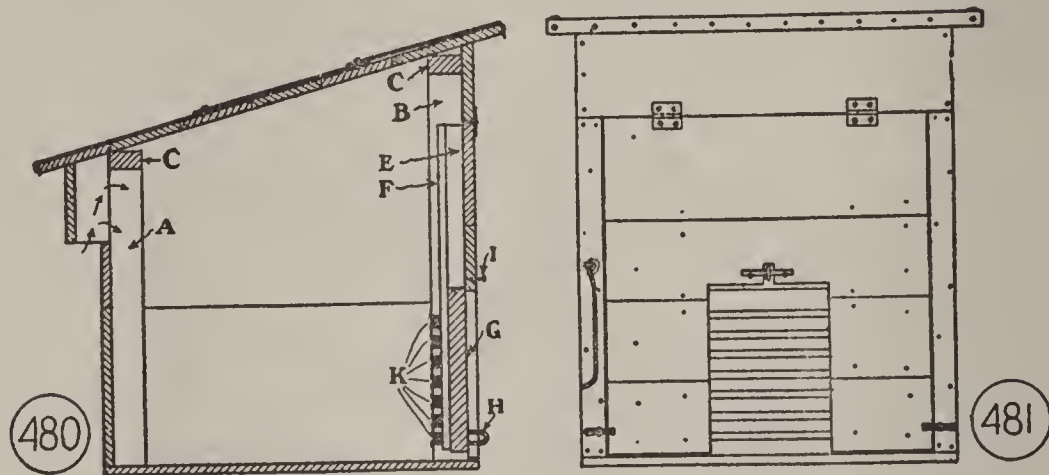

FIG. 480.—Cross-Section of Chick Coop.  
FIG. 481.—Front of Chick Coop.

Cut the Roof Boards long enough to project  $1\frac{1}{2}$  inches over the sides of the coop, and lay them so there will be a  $1\frac{1}{2}$  inch projection over the front and rear walls. Tack roofing felt to the roof boards.

From this point on the construction will be different. For

#### A CHICKEN COOP

enclose the front as shown in Fig. 481. Fasten a board 4 inches wide against the roof boards, and then cut a pair of narrow strips to fit between this board and the floor, to finish off the sides of the opening (Fig. 481). Details of

The Hinged Front are shown in Figs. 480 to 484. Cut the boards for it about  $\frac{3}{8}$  inch shorter than the width of the opening. Batten them together with the strips D and E (Fig. 483), with strips D 1 inch from the board ends,

and strips E  $3\frac{1}{2}$  inches each side of the center. The purpose of strips E (Fig. 483) is to hold together the boards that are to be sawed through in cutting the small door-

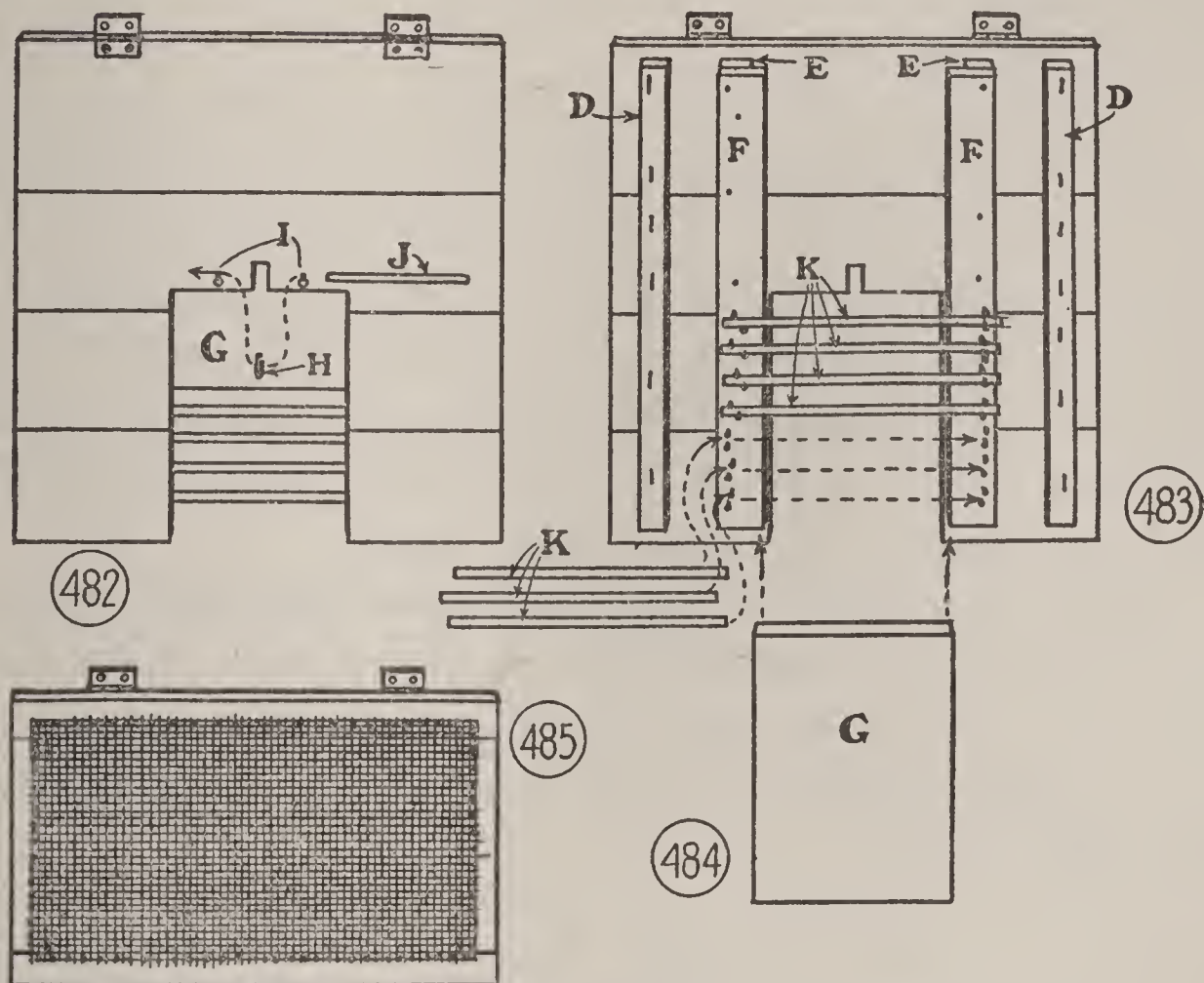

FIGS. 482-484.—Details of Hinged Front for Chick Coop.  
 FIG. 485.—Hinged Screen Door for Rabbit Hutch.

way; also, to form the sides of the pocket in which the small door (G, Fig. 484) is to slide. Nail strips F (Fig. 483) to strips E to form backs to the pocket. Project them  $\frac{1}{2}$  inch over the inner edges of strips E.

Cut the Small Doorway about 8 inches high. Cut door G (Fig. 484) to fit loosely in the pocket. Drive a staple into the front of the door near the lower edge (H, Fig.

482), cut a notch in the head of the doorway for this staple to slide into, and drive a small nail (I) each side of the notch. Slip the stick J through the staple, with its ends resting upon nails I, to support the door when it has been raised (Fig. 481).

Movable bars (K, Fig. 483) slipped between the heads of large tacks driven into strips F, will keep mother hen and chicks inside of the coop when the small door is raised. When the lower bars are removed as shown in Fig. 483, the chicks can enter or leave the coop at will, but the hen is confined. Use  $\frac{1}{4}$ -inch dowel sticks or sticks whittled to this diameter, for bars, and space the tacks so that the bars will be about 1 inch apart.

Hinge the Front to the board below the roof. Screw an iron button at each side near the bottom, for locks, and provide a wire hook like that shown in Fig. 481, for a prop when the front is opened, as in the photograph of Fig. 465.

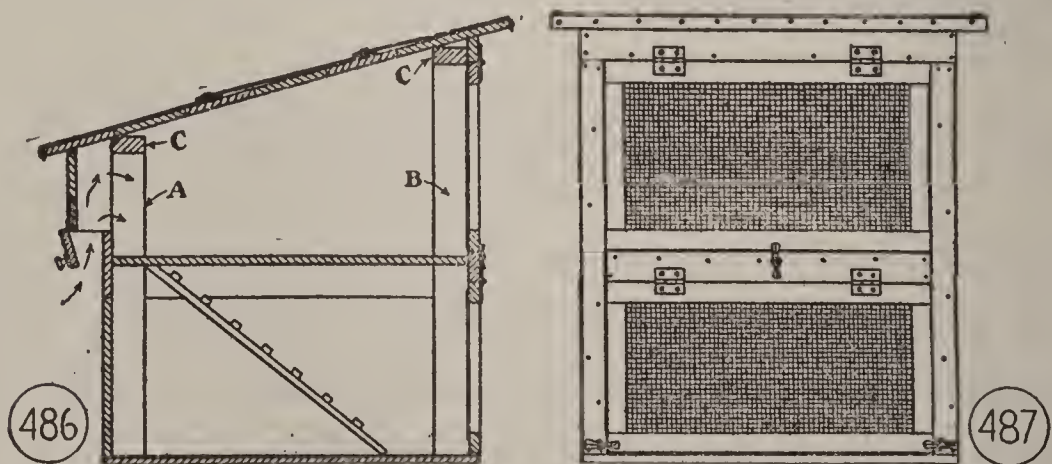

FIG. 486.—Cross-Section of Rabbit Hutch.  
FIG. 487.—Front of Rabbit Hutch,



A RABBIT OR GUINEA PIG HUTCH

requires a second floor (Fig. 486) and two screen doors (Fig. 487).

Fasten the Floor boards half-way between the bottom and top. Cut

A Stairway opening and build stairs of a board 4 inches wide with cleats nailed across it.

Make the Screen Doors as shown in Fig. 485, with 1-by-2 strips covered with heavy wire cloth having about  $\frac{3}{8}$ -inch mesh. Hinge them as shown in Fig. 487, and provide iron buttons for locking them.

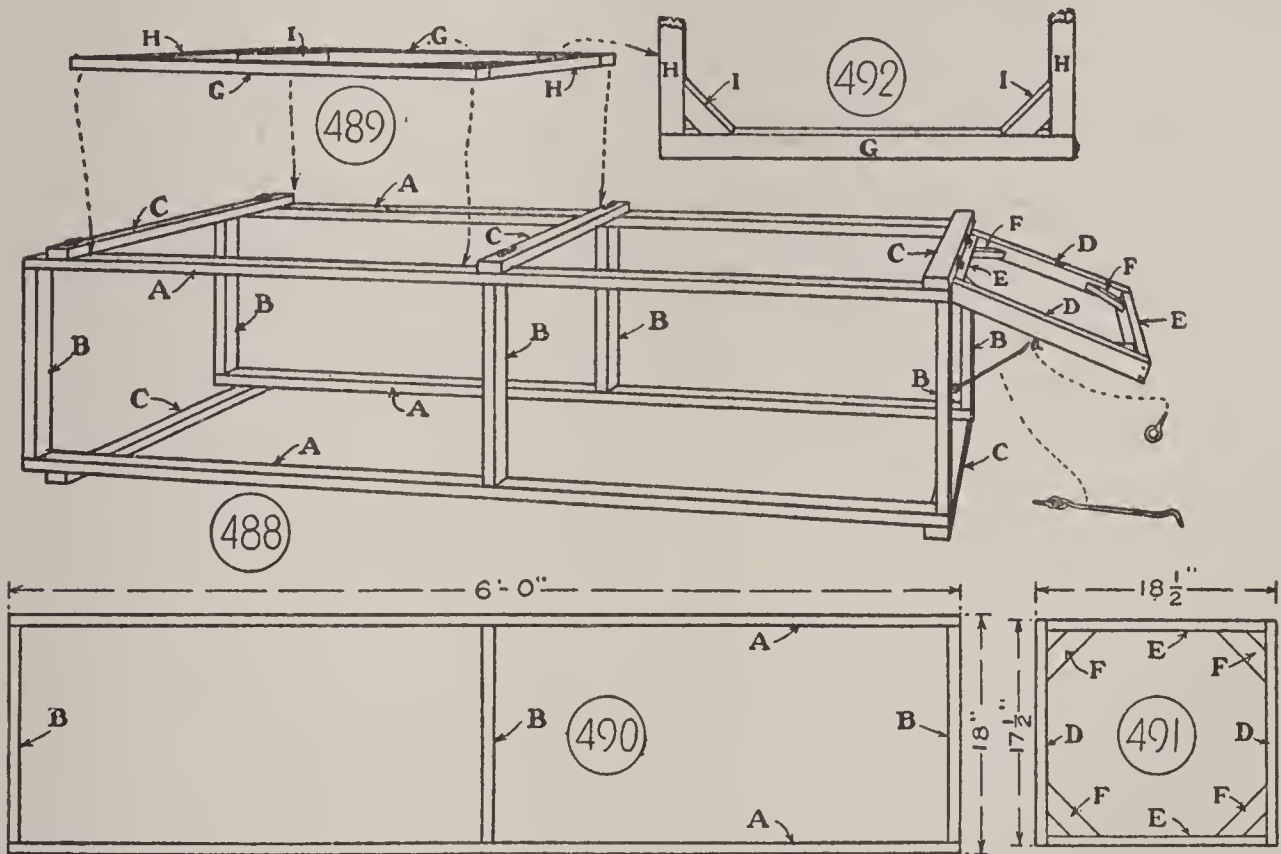
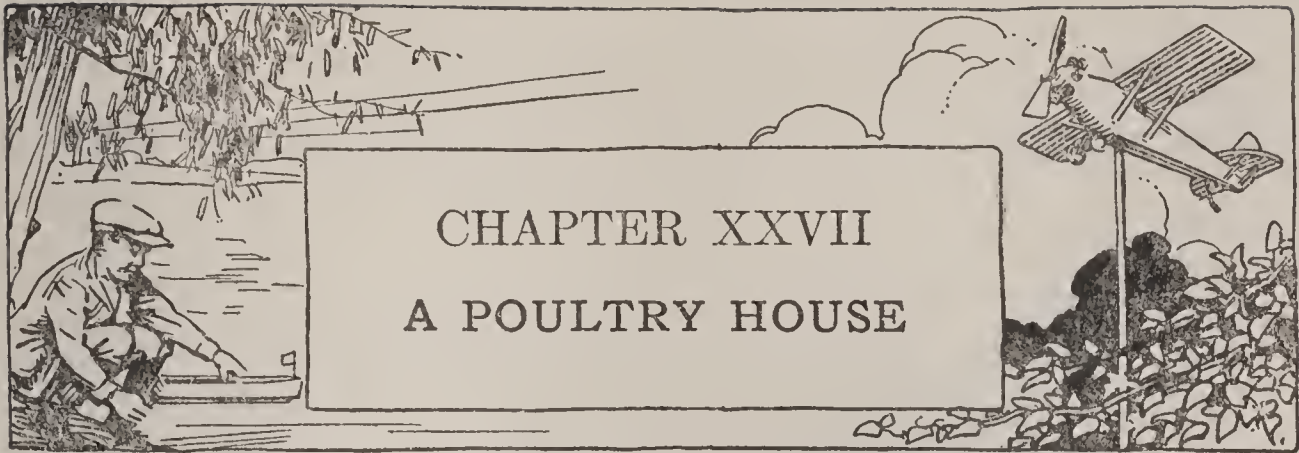

FIG. 488.—Completed Framework of Runway Shown in FIG. 465.  
 FIG. 489.—Top Frame.  
 FIG. 490.—Side Frame.  
 FIG. 491.—Hinged End Frame.  
 FIG. 492.—Top Opening Frame.

## AN ENCLOSED RUNWAY

The photograph of Fig. 465 shows a run for your coop or hutch, 6 feet long and 18 inches wide. It has a framework of 1-by-2 strips covered with poultry netting having a 1-inch mesh. Fig. 488 shows the completed framework, and Fig. 489 shows the frame for the top opening. First, make a pair of frames like that shown in Fig. 490, for the sides, then join them with the cross plates C. Build the end door frame as shown in Fig. 491, and hinge it at its top. Build the top opening frame as shown in the detail of Fig. 492. Give the assembled framework two coats of paint.

Cover the top, sides and front door frame with poultry netting, and the job is done.



## CHAPTER XXVII

### A POULTRY HOUSE

It is not necessary to have a large piece of ground for a small poultry plant. Indeed, some poultrymen advocate the confinement of the flock to a scratch shed instead of a yard, covered to afford protection from inclement weather, and open to the air. Quite contrary, this, to the old time notion of farmers that hens must have the range of stock. The modern practice makes possible more scientific feeding, since nothing is given but balanced rations—grain scattered in the litter, and mash and green food, shell and charcoal in hoppers. Then, too, a check on egg production is possible with confined hens, by the use of trap nests, and of course this is essential to profitable poultry keeping, that the layers may be known and non layers culled from the flock.

A COMBINATION POULTRY HOUSE AND SCRATCH SHED like that shown in Fig. 493 is especially well adapted to the city or suburban lot, for a small flock of hens. With the double-decking arrangement, the scratch shed requires little or no additional space. Then too, the high and con-

sequently dry floor with a hatchway door that can be closed at night makes the coop as nearly rat-proof as can

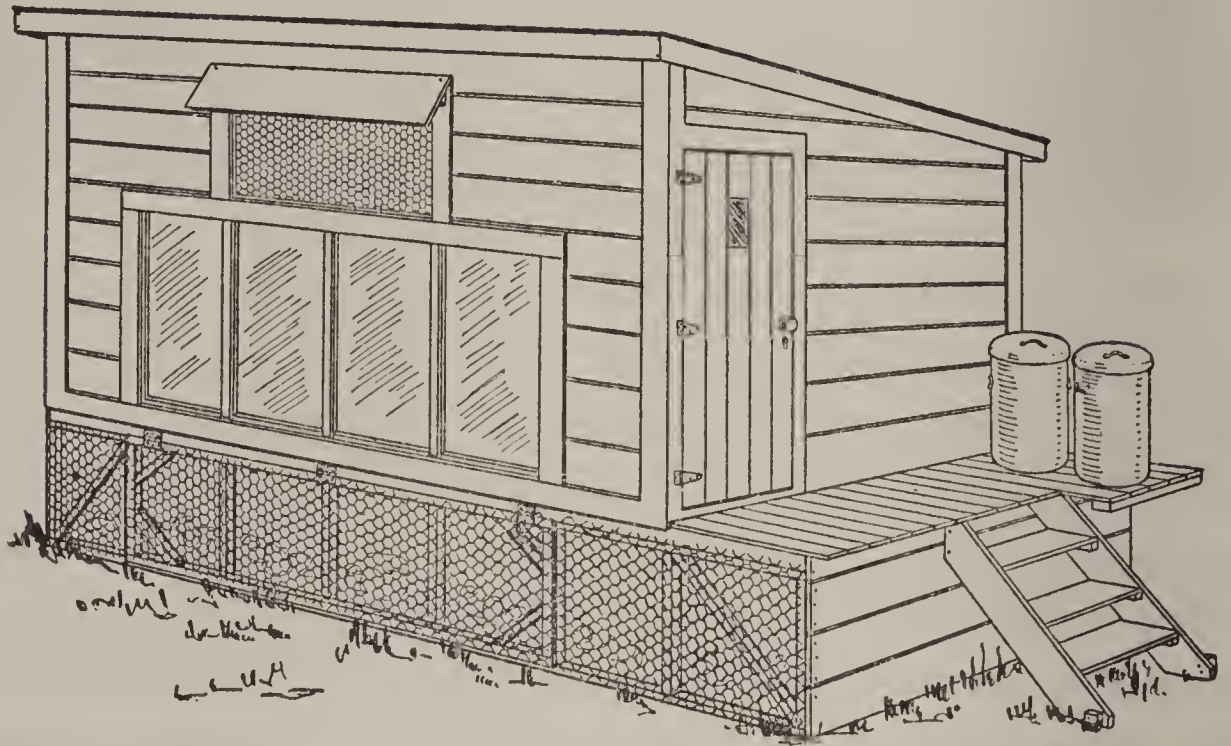

FIG. 493.—Completed Poultry House and Scratch Shed.

be. A house of this design will suit the conditions of almost any back yard. It may be screened by a grape arbor, or hidden behind the garage, or, as is often done, combined with the latter structure.

The cross-section diagram of Fig. 494 shows the arrangement of the scratch shed and house, shows how the front of the shed opens to permit changing the straw litter, how the shed and house are connected by a runway, how the house is lighted by glass, and ventilated by a screened opening, and how the roosts, droppings-board, and nest-boxes are placed in tiers along the rear wall.

## THE BUILDING MATERIAL

The Kind of Lumber to use will depend on what is available in your locality. Ask your local carpenter or

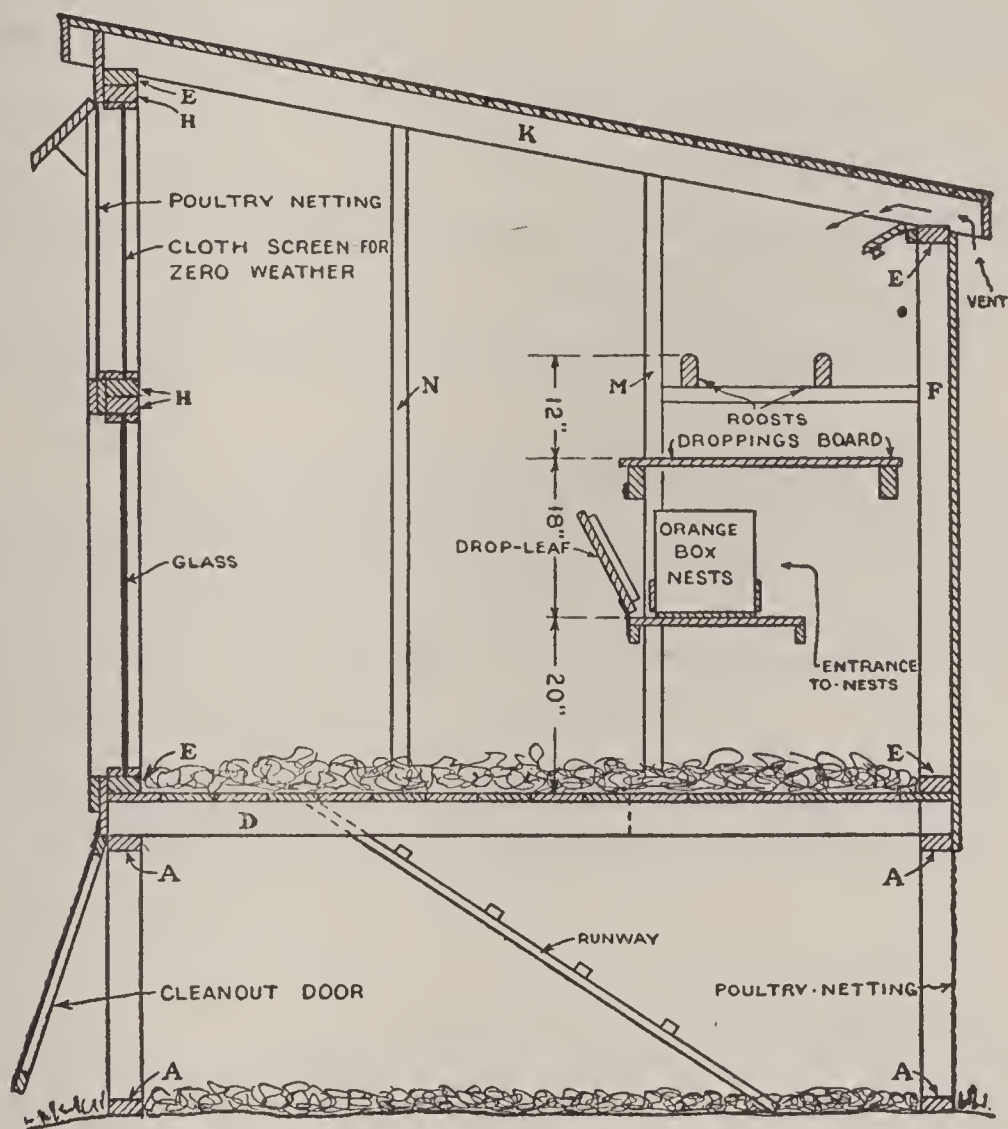

FIG. 494.—Cross-Section of Poultry House and Scratch Shed.

lumber dealer. Second-hand lumber for the framework will make as substantial a structure as new stuff will, and will save considerable money. New lumber is preferable for the outside, unless you stucco the house.

Quantities and Dimensions will be determined by the

size of structure you want. If you follow the plan here described, you can easily determine quantities needed. Use 2-by-4s for the framework studding, floor joists and rafters, 6-inch, 8-inch or 10-inch siding for sheathing the framework, 1-by-6-inch boards for floor and roof, and 1-by-4-inch boards for trim.

THE SCRATCH SHED OR BASEMENT FRAMEWORK is the first portion to build.

The Framework is shown in Fig. 495. It requires two

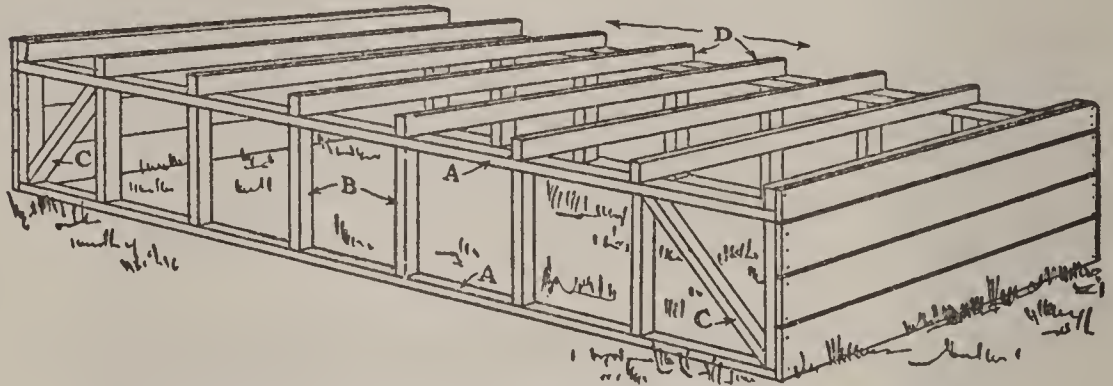

FIG. 495.—Completed Scratch-Shed Framework.

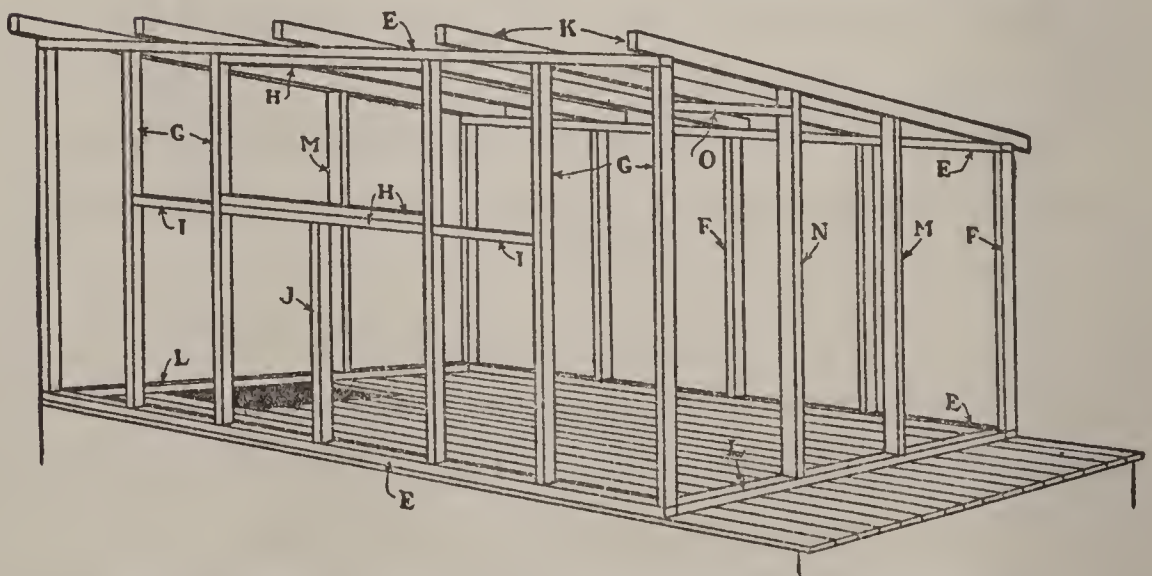

FIG. 496.—Completed Poultry-House Framework.

frames similar to that in Fig. 497, with top and bottom plates A 14 feet long, and studs B 2 feet 8 inches long, spiked between with a spacing of 24 inches. Diagonals C are set between the end studs for bracing.

When the pair of frames have been built, place them 8 feet apart (outside to outside measurement), and join their ends with pieces of siding, as shown in Fig. 495.

Cut the Floor Joists D and spike them to top plates A of the framework, 24 inches on centers. Then

Lay the Floor Boards and all will be ready for

### THE POULTRY-HOUSE FRAMEWORK

A detail of this is shown in Fig. 496. It is built in sec-

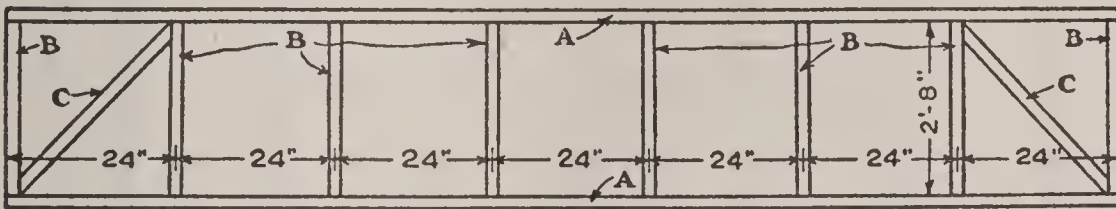

FIG. 497.—Make Two Frames Like This for Scratch Shed.

tions in the manner of the scratch-shed framework. Fig. 498 shows

The Rear Frame with the lengths of top and bottom plates E, and the lengths and spacing of studs F. Fig. 499 shows

The Front Frame with the lengths of the top and bottom plates E, and lengths and spacing of studs G and J, and plates H and I.

The floor of the house will be a good surface on which to build the wall frames. Assembling the frames will be

simple work, but be careful to cut like pieces of equal length, and to spike them together with square corners.

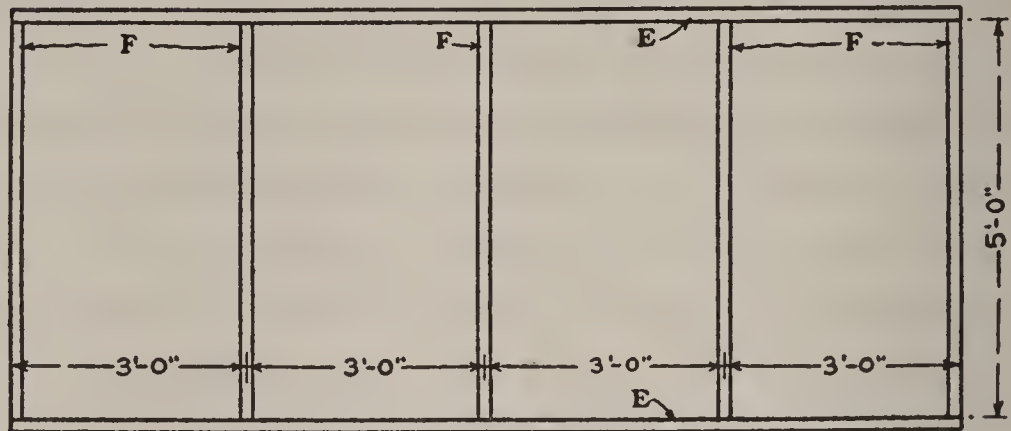

FIG. 498.—Rear-Wall Frame.

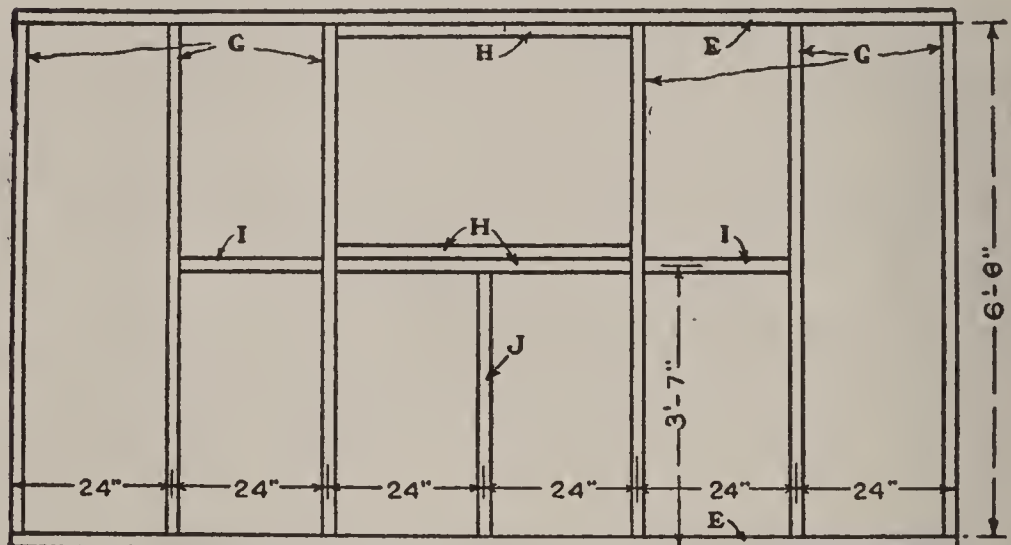

FIG. 499.—Front-Wall Frame.

**To Erect the House Framework,** stand the frames in position on the floor, and spike the lower plates to the floor. Support the tops temporarily with diagonals nailed across the ends.

**The Roof Rafters (K, Fig. 496)** must be notched slightly to fit on top plates E. Cut them of the right length to project 4 inches over the plates, and make their ends parallel to the sides of the framework. Space the rafters



the same as the wall studding, and spike them to top plates E.

**Build the Side-Wall Frames** between the front and rear frames. Fit floor plates L between plates E, and cut studs M and N to fit between the plates and rafters, and spike in place. Complete

**The Doorway** framing by fitting head plate O between corner stud G and side stud N.

When the framework has been completed,

**Sheathe the Walls** with siding, then cut the window openings.

**The Roof** boards should project 4 inches over the walls. When you have cut and laid these, cover them with one of the slated roofing materials sold in rolls at the hardware store. You can buy it by the yard of the right width so two strips with edges overlapped will cover the surface. Roofing nails and cement for joints come with the material.

**Trimming.** Trim the edges of the roof with 1-by-4 verge boards, nailing these to the roof boards and rafter ends, as shown in Figs. 493 and 494. Trim the outside walls with 1-by-4 boards, running them around the openings and up the corners, as shown in Fig. 493.

Fasten a board cap across the head of the front wall ventilator, pitched as shown, and supported on triangular brackets nailed to the side trim pieces.

**Glaze the Windows** with glass  $\frac{1}{2}$  inch narrower and shorter than the opening measurements. You may prefer to divide the openings with a horizontal bar, to make smaller lights of glass. The cost of replacing an occasional

broken light will be less. Fasten the lights in the openings with narrow wooden strips nailed around the inside of the studding and plates, inside and outside of the glass.

The Ventilator opening will be enclosed with poultry netting. Provide a screen built up of 1-by-2 inch strips and covered with muslin, to slip into the opening inside of the wire screen, for zero weather protection.

Cross Ventilation will be obtained by means of rear vents shown in Fig. 494. These will admit air between the roof rafters, as indicated by arrows. Cut pieces of board to fit between the rafters, and hinge them as shown, for winter shutters.

Make a Batten Door of several tongued-and-grooved boards fastened with battens screwed across them near the top and bottom, and hinge it with a pair of T-hinges to the door casing. A small light of glass is shown set in the door (Fig. 493). This makes a handy peek-hole. Provide for it when building the door by sawing a piece from the center board. Set glass in the opening, or lap it over the inside, and hold it in place with stop strips. Provide a door-lock and handles.

Enclose the Scratch Shed on the front and rear with poultry netting. The front should have a clean-out door, built up of 1-by-2 inch strips braced at the corners, and covered with netting. Hinge it at its top, as shown in Figs. 493 and 494, and provide hooks to fasten it shut, and another set to fasten it open.

An Entrance Platform at the top of the steps will be handy. That is why the scratch shed was built longer than

the house. Let the floor boards extend far enough over the side of the platform to support feed containers.

Build the Steps as shown in Fig. 493, with 8-inch boards for stringers and 8-inch board treads set in between them on cleats.

The Runway from scratch shed to house is shown in Fig. 494. Fig. 496 shows where to place it. After cutting the hatchway, build the runway of a board with cleats nailed across it. Then batten together several boards to form a hatch for protection at night.

Fig. 494 and Figs. 500 to 503 show a good arrangement of

### POULTRY FIXTURES

The Roosts, a pair of 2-by-4s, with tops rounded with

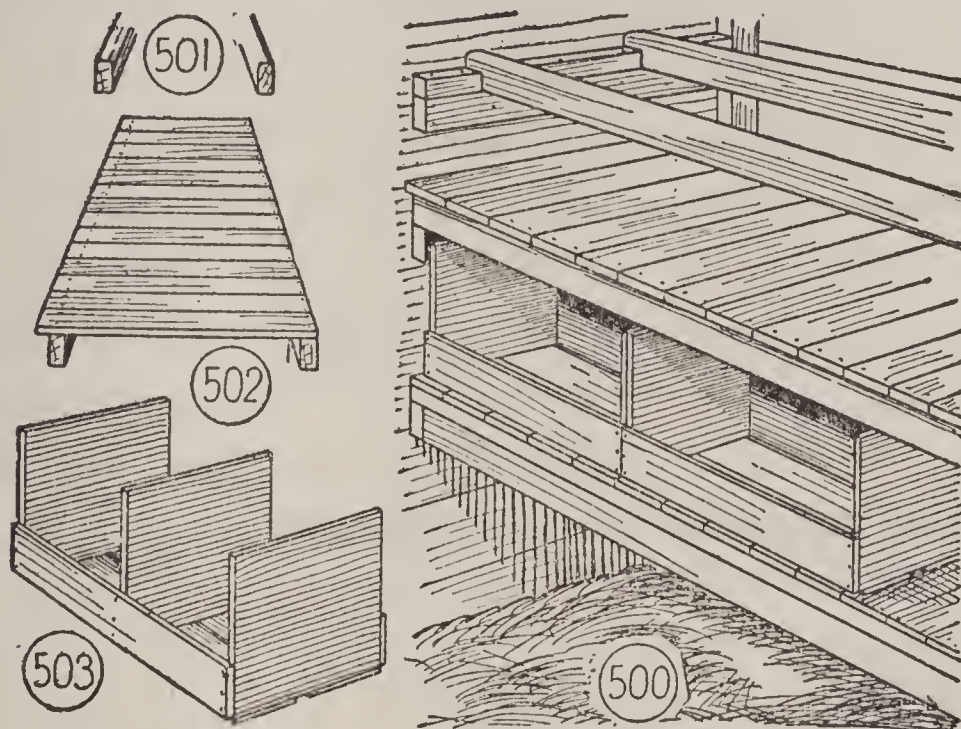

FIG. 500.—Arrangement of Poultry Fixtures.

FIG. 501.—Detail of Roosts.

FIG. 502.—Droppings-Board.

FIG. 503.—Nest-Box.

draw-knife or plane (Fig. 501) are supported between the ends of the house parallel with the rear wall, and 4 feet 6 inches above the floor, on 2-by-4s blocked up to form pockets (Fig. 500). Eight inches below them place

**The Droppings-Board.** Build this as shown in Fig. 502, and beneath it on a shelf place

**The Nest-Boxes.** Orange boxes, with the upper two boards of the sides removed (Fig. 503), make excellent nest-boxes.

**The Drop Leaf** shown in Fig. 494 is a good arrangement for darkening the nest-boxes. Hinge it as shown, so that it may be opened for the gathering of the eggs.

**Containers for Scratch-Feed and Mash.** A pair of garbage cans will serve excellently for these.

### PAINTING

When your carpentry is done, give the outside of the poultry house a priming coat of good outdoor paint. When this has dried, putty all nail-holes, and apply a second coat. You may paint the trim the same color as the body of the house, or a contrasting color. Paint the inside of the house, and all fixtures, with one of the disinfectant whitewashes prepared for the purpose.



## PART III

# Summer Hobbies





FIG. 504.—SPEEDING WITH AN OUTBOARD MOTOR, A SURF BOARD IN TOW.



FIG. 505.—THE FLAT-BOTTOMED SHARPIE IS WELL ADAPTED TO THE OUTBOARD MOTOR.



FIG. 506.—A CANVAS CANOE AND ITS BUILDER,  
ROBERT MCKECHNIE, JR.





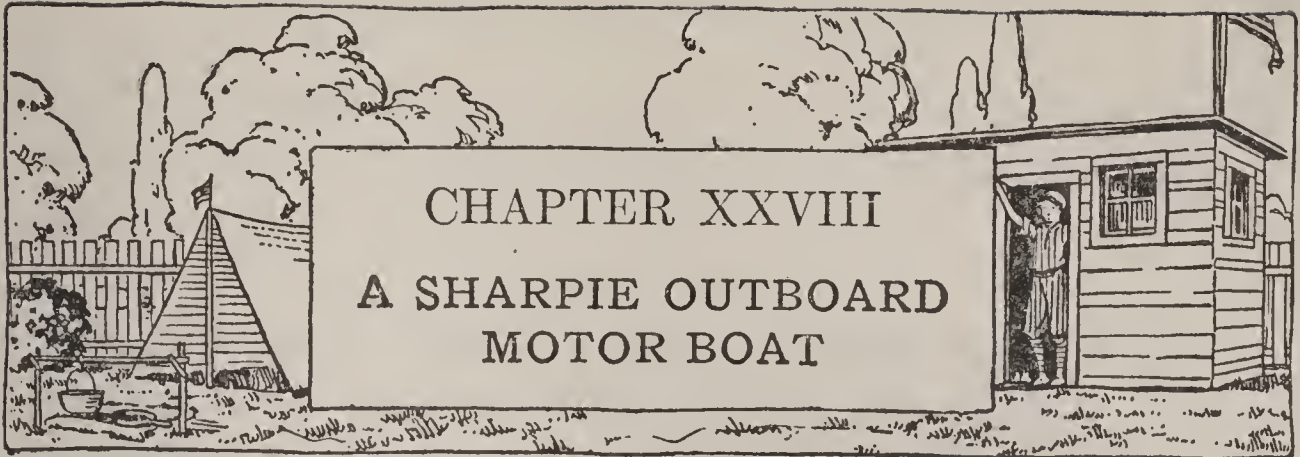

PORTABILITY, small cost and simplicity of operation have combined to build up the extensive use of the outboard motor. It fits compactly in a case, it can be carried with the ease of a suitcase. You can put it in the car, drive out to a lake, adjust it to a rented boat or your own and be off to the fishing grounds in one, two, three. And you can have great fun with it at the bathing beach, speeding over the water with a surf boat in tow, as the lad in the photograph of Fig. 504 is doing.

Usually you can find a boat available at a lake, but sometimes you are out of luck, and if there is one lake or stream which you frequent, I advise you to own your boat. You can padlock it after you are done with it, as the native locks his.

#### THE FLAT-BOTTOMED SHARPIE

is a popular type of outboard motor boat that you can build yourself because the construction is simple. It is not a fast boat, but it is dependable, and you will find more of its kind among home-made boats than any other.

The photograph of Fig. 505 shows the sharpie that I used

last summer, and the accompanying diagrams show the measurements and details for building her.

### THE MATERIALS

for boat building are available in almost every locality. Pine is probably more generally employed than any other wood, but cypress and cedar are well suited to it because of their rot-resisting qualities, and spruce and fir are good. Lacking a choice, select any easily worked wood that is seasoned, and free from knots and other defects.

In the plan (Fig. 507), the stem piece details (A, Figs. 511 and 512), the center mold detail (B, Fig. 513) and the

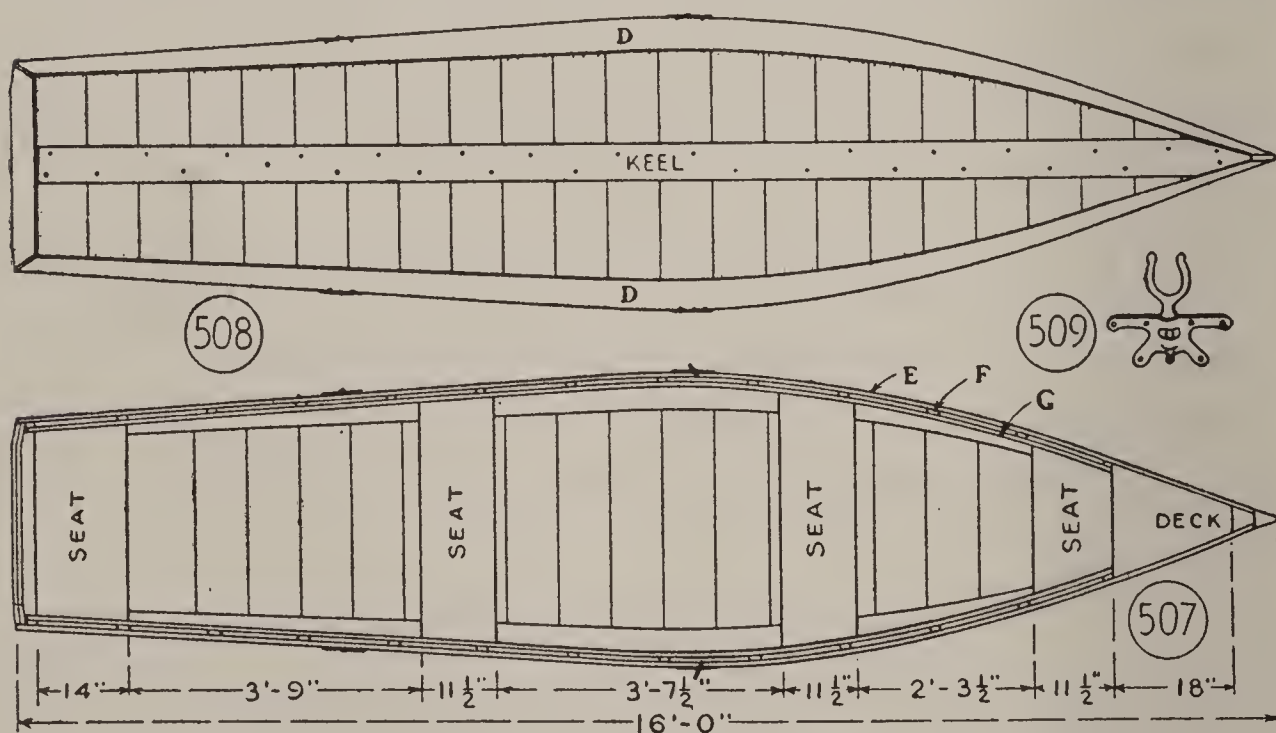

FIG. 507.—Plan of Sharpie Flat-Bottomed Boat.

FIG. 508.—Plan of Keel.

FIG. 509.—Side-Plate Oar Lock.

stern piece detail (C, Fig. 514), you will find all of the measurements for figuring out

**The Material Bill.** The sides of the boat are 16 inches wide. You may get boards of this width in your locality, but 12-inch boards (11½ inches actually) are usually as wide as are carried in stock at lumber yards, and if you cannot get wider you must use two pieces for each side. A 12-inch board and a 6-inch board (D and E, Fig. 510) will do nicely. The length should be 16 feet. A piece of 4-by-8

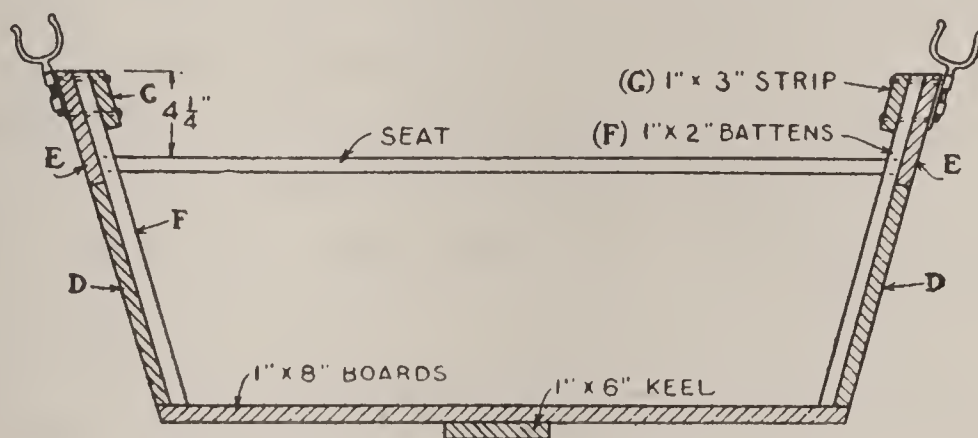

FIG. 510.—Cross-Section of Sharpie.

is required for the stem piece, 10-inch or 12-inch boards are needed for the center mold and stern piece, 1-by-6-inch, or 1-by-8-inch boards for the bottom and the keel, 12-inch boards for seats, 1-by-2s for side battens, and 1-by-3-inch strips for trimming the gunwales. Buy galvanized or cement-coated nails for nailing, and brass screws for parts to be screwed.

### THE CONSTRUCTION

**Stem Piece A** is the first part to shape. Figs. 511 and 512 show its dimensions. Lay it out carefully, and rip it with a rip-saw. You will have no difficulty in shaping this rabbeted block, but, if you prefer, you can have it cut at a

local mill. You might prepare this piece at home where you probably have a bench with a vise. Indeed, you might make the mold and stern piece there, also. They are small enough to carry in the car from home to the lake.

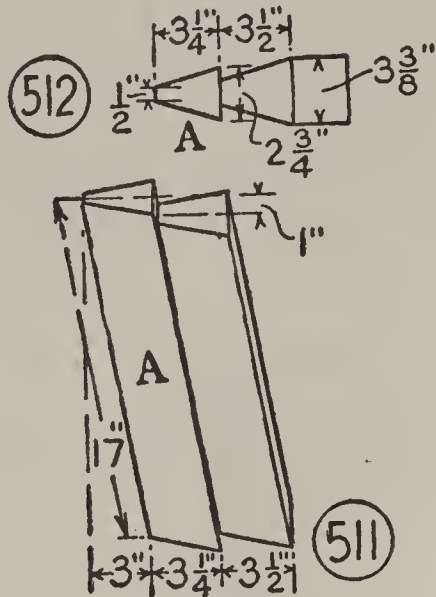

FIG. 511.—Stem Piece.  
FIG. 512.—Plan of Stem Piece.

The purpose of the beveled rabbets in the stem piece is to provide recesses to let in the side boards flush with the surface of the nose of the piece. Make the depth of the exact thickness of the boards. Trim carefully until you obtain a good fit. Notice that the stem piece ends are trimmed off to allow for a rake or pitch, of 3

inches (Fig. 511); also, that the rabbeted portion is cut away at its top to a depth of 1 inch.

Center Mold B, shown in Fig. 515, is a temporary form, set half-way between the stem and stern to bend the side boards around. Prepare it by the pattern of Fig. 513.

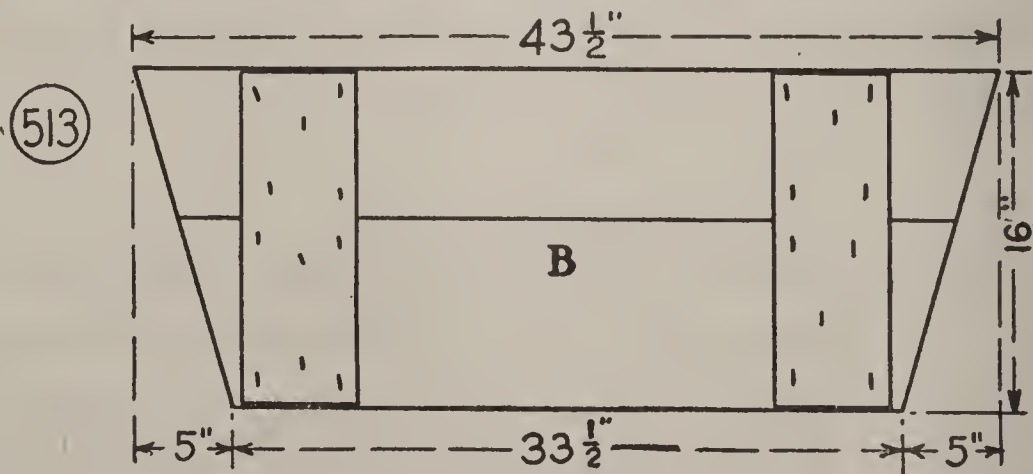

FIG. 513.—Center Mold.

Stern Piece C is of double thickness, to make a solid support for the motor. Use two boards for each thickness, one wider than the other, and place the boards so that the joint between one pair will be overlapped by a board of the other pair, as indicated by dotted line in Fig. 514. Cut off the upper corners as shown.

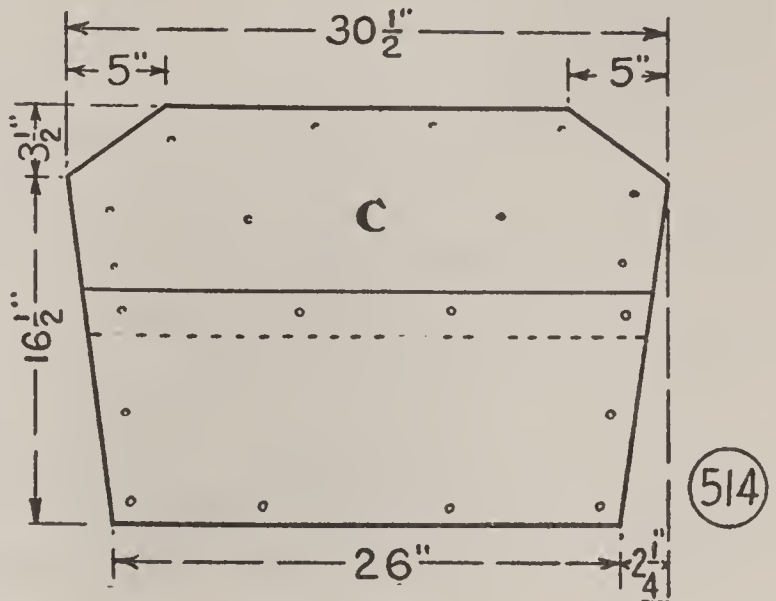

FIG. 514.—Stern Piece.

The Assembly of the stem piece, center mold, stern piece, and lower side boards is shown in Fig. 515. Trim off the bow ends of

The Side Boards to fit in the stem piece rabbets. Daub the rabbets with thick lead paint, and nail securely. Locate the half-way point on each side, set the center mold in position, and nail the boards to its edges. Leave the nail heads exposed for withdrawal later.

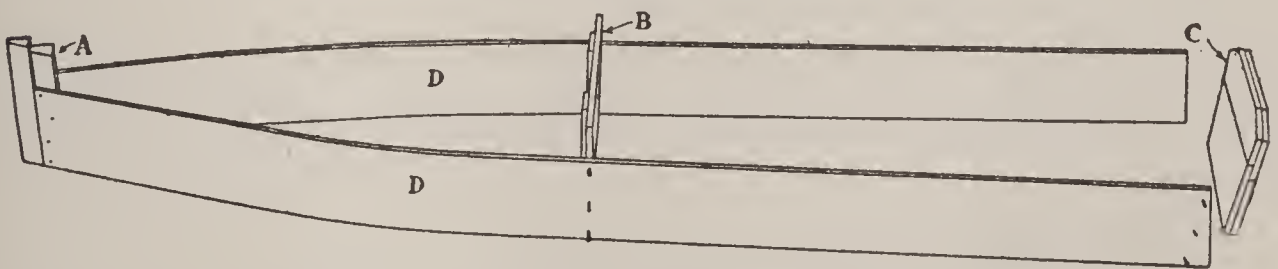

FIG. 515.—Assembly of Stem Piece, Center Mold, Stern Piece, and Lower Board of Sides.

When you bend the boards around the mold, and twist

them to draw them in to meet the stern piece ends, it will be well to have assistance. A pair of cabinet maker's clamps will help, but a doubled piece of wire looped over nails driven into the board ends can be twisted with a nail or bolt until the boards are drawn to the right point. The stern piece has a rake of 3 inches. Stand it so that it pitches this amount, nail the boards to its edges, and then trim off their ends flush with the piece.

The next step is to nail on

**The Bottom Boards.** These should have square, not tongued-and-grooved edges. Select pieces that are straight, 6 inches or 8 inches wide. The narrower boards will require more pieces, but there will be less shrinkage per board, and the joints should be tighter. The bottom boards will vary in length. Before nailing, coat the edges of the side boards, also the edges of the bottom boards, with lead paint. Start nailing at the stern and work forward. Drive each board tight against the one preceding it, and slant the nails to help close the joints. When you have nailed the bottom boards, trim off their edges flush with the boat sides, and finish smooth with wood-rasp and sandpaper.

Complete the bottom with

**The Keel.** Make this of a 1-by-6-inch board. Screw it to the bottom boards along the exact center (Figs. 508 and 510).

Next, right the boat, and attach

**The Upper Side Boards (E, Fig. 510).** These must conform to the curves of the lower boards. Bind them together with 1-by-2 battens (F, Figs. 507 and 510). Screw thirteen

battens to each side of the boat, with equal spacing. Trim the lower ends to fit against the boat bottom (Fig. 510). Trim off the tops even with the edge of upper boards E.

The Seats are next in order. Cut them to fit between the boat sides, and rest them on cleats nailed to the side battens. The seat spacing is shown in Fig. 507. When you have fastened the seats in place, remove the temporary center mold.

A Deck Piece cut to fit between the sides back of the stem piece will complete the bow.

Trim the Gunwales with 1-by-3-inch strips (G, Figs. 507 and 510). Run them from stem to stern, and screw them to battens F.

### OAR LOCKETS

The best type of oar lockets for the sharpie are of the side-plate pattern shown in Fig. 509. Any dealer in oars and other water craft supplies will have them. Fasten the plates to the outside of the boat, with their attachment bolts run through the gunwales (Fig. 510).

### PAINT THE BOAT

inside and outside before launching her. To make a first-class paint job, sandpaper surfaces where necessary. Also, calk all cracks with lead paint. Three coats of good paint are none too many for the outside. You might make the inside of a lighter color than the outside, and the gunwale strips of a contrasting color.

Letter a Name upon the bow. Sketch the letters upon

paper, true them up, then transfer them to the bow with carbon paper, and fill in between the outlines with paint. Or, buy aluminum letters at the hardware store, or through one of the mail order houses, and nail them to the bow.

### OVERHAULING THE BOAT

With the best of care, a boat's seams will open and require calking. Thick lead paint is sufficient for narrow seams. Oakum is best for wide seams. A good way to make a tight boat for all time is

**To Waterproof It.** The approved process is to coat outside surfaces with marine glue, then apply a good grade of unbleached cotton cloth. Marine glue can be obtained from any ship chandler or dealer in water craft, and complete directions for waterproofing accompany the glue.



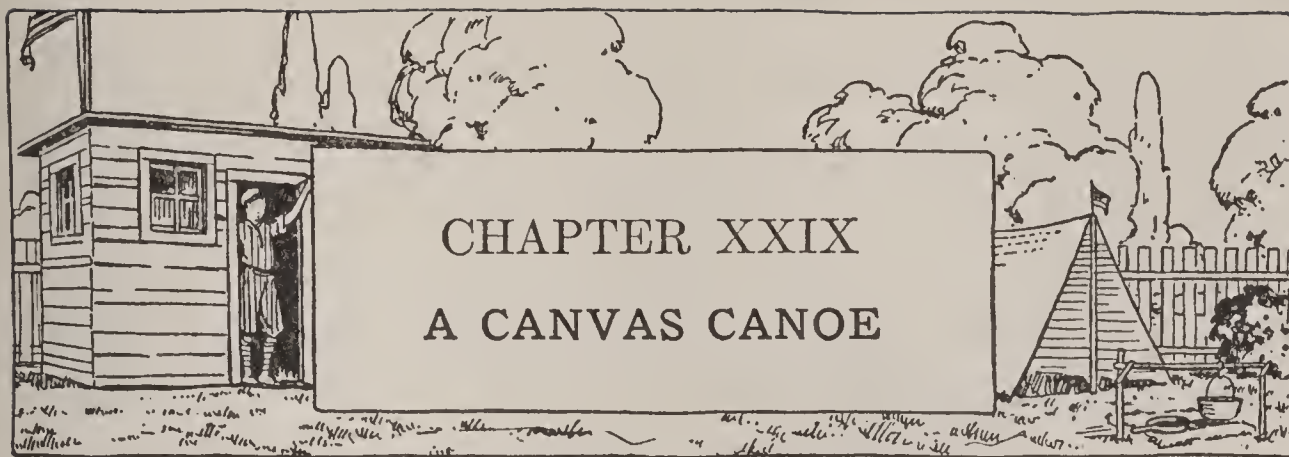

## CHAPTER XXIX A CANVAS CANOE

IN the frontispiece to Part III you will see a photograph (Fig. 506) of the dandy light-weight canoe described in this chapter. The canoe was designed by Robert McKechnie, Jr., who is shown in the photograph paddling it. It is an inexpensive little craft to build, and the work is simple. You would find it of handy size to transport on a car, or to carry on your Boy Scout trek cart when you are bound for camp or a week-end hike.

In the diagrams, the completed job is shown in Fig. 516,

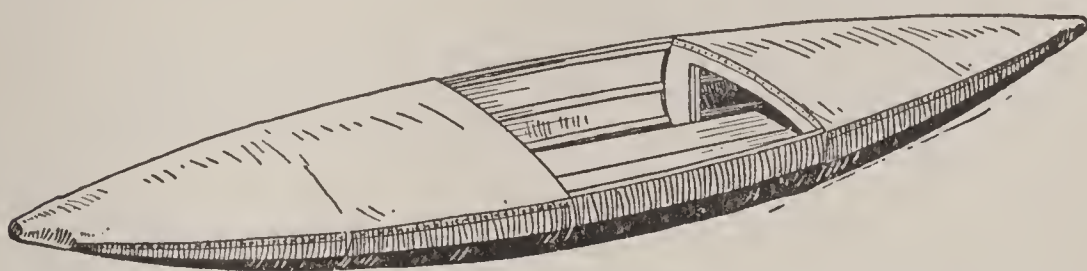

FIG. 516.—Completed Canvas Canoe, Shown in Photograph of FIG. 506.

the assembled framework without covering in Fig. 517, and a plan of the framework in Fig. 518.

### THE FRAMEWORK

The End Pieces were made of No. 20 galvanized iron,

bent into a cone, to measure 6 inches long, 6 inches in diameter across the wide opening, and  $1\frac{1}{2}$  inches across the small end, then riveted (Fig. 519). It was not much of a trick to make them, but you can get the work done at a tinshop at small cost. The conical pieces support the ends of the ribbands and gunwales (Fig. 517). Each had eight

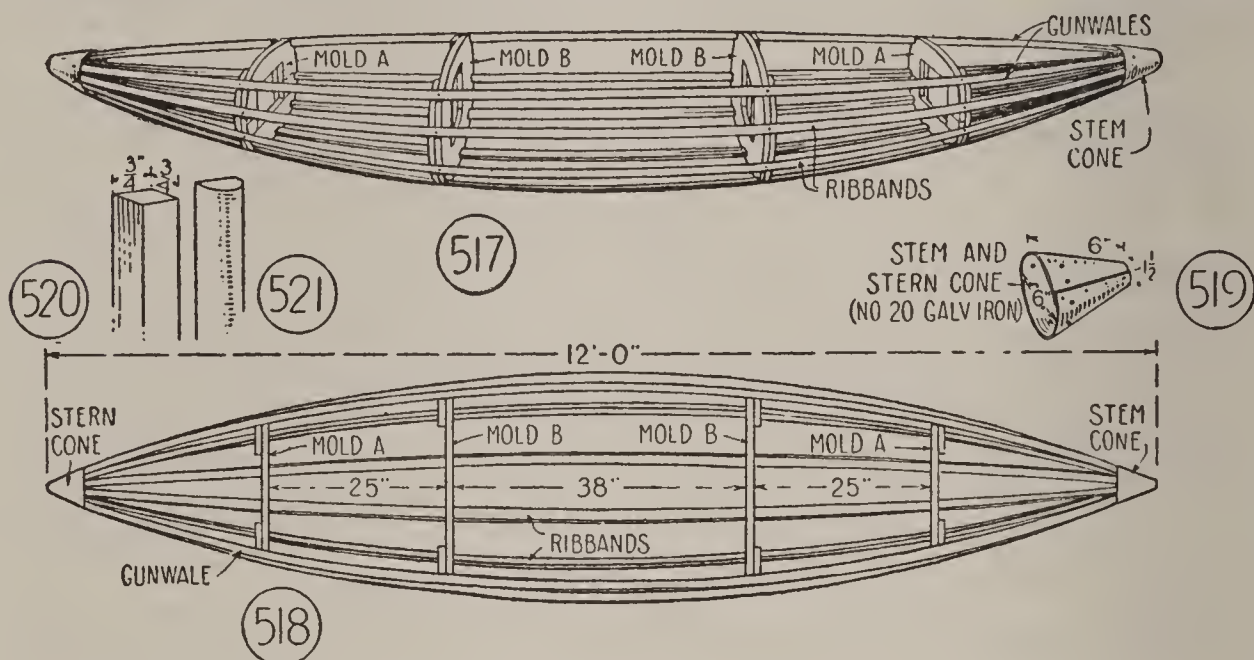

FIG. 517.—Completed Framework.

FIG. 518.—Plan of Framework.

FIG. 519.—Stem and Stern Cone.

FIGS. 520 and 521.—Details of Ribband and Gunwale Strips.

$\frac{3}{16}$ -inch holes drilled through it, with equal spacing, for bolts for attaching the strips.

The Ribbands and Gunwales were made of ash strips  $\frac{3}{4}$  inch square (Fig. 520). If you cannot get ash in your vicinity, use spruce or pine. The outer edges of the strips were rounded off as shown in Fig. 521.

The Molds that support the ribbands and gunwales, between ends, are shown in detail in Figs. 522 and 523. These shape the sides of the canoe. Robert cut his molds out of

boards 15 inches wide, but stock wider than 12 inches may not be easy to obtain in your vicinity, in which case build your molds of two pieces each, fastened with battens, as shown in Figs. 522 and 523. The larger or center pair of molds were skeletonized, as shown, to provide leg room fore

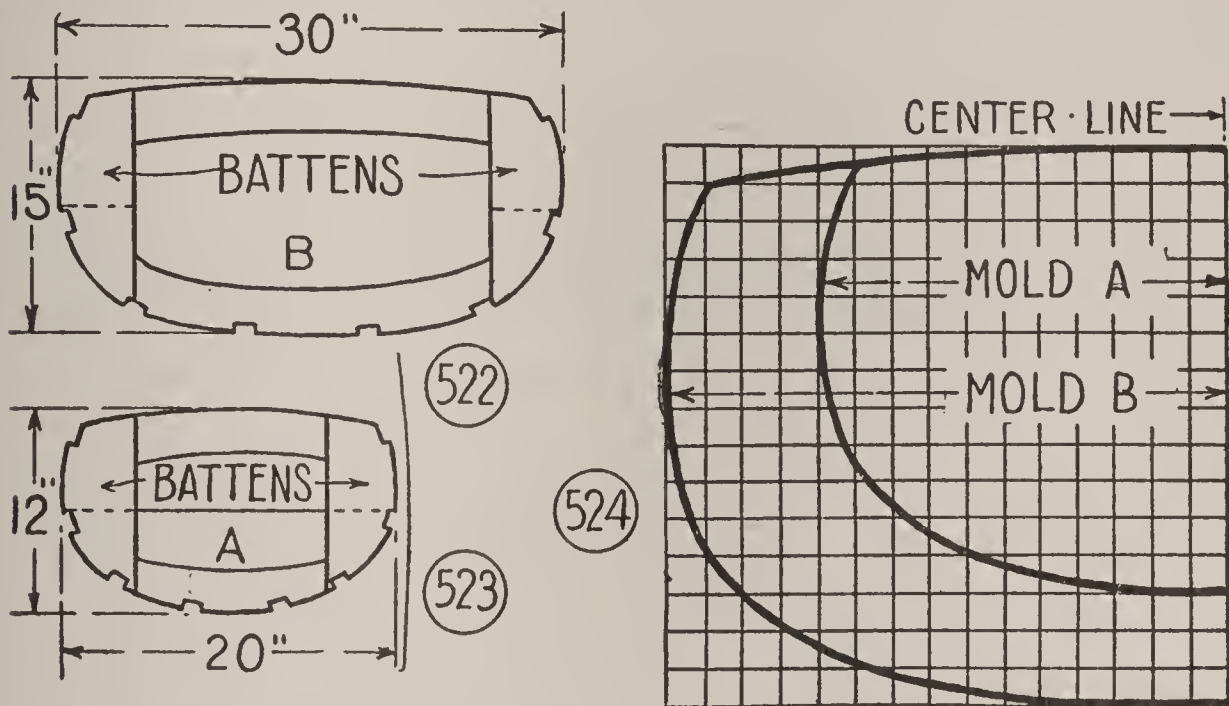

FIGS. 522 and 523.—Details of Molds A and B.  
FIG. 524.—Half-Patterns of Molds.

and aft of the cockpit. The smaller forms were cut away to save weight.

Half-patterns for the mold outlines are shown in Fig. 524, ruled off into 1-inch squares. To enlarge the patterns, lay off a similar set of 1-inch squares upon heavy paper or cardboard, then reproduce the outlines upon them as shown upon the diagram squares, and cut out the pieces.

Batten together the mold boards with galvanized or cement-coated nails, then place the patterns upon the molds, mark out the outlines, and saw out the pieces. Lay off the

ribband spacing around the edges of the molds, and cut notches at these points to drive the ribbands into.

Assembling the parts was easy. The ends of the ribbands were tapered to fit in the end cones, then bolted to the cones with  $\frac{3}{16}$ -inch round-headed bolts, with heads out. Connection with the molds was made with brass screws  $1\frac{1}{2}$  inches long.

### THE COVERING

With the framework completed, Robert covered it with 8-ounce cotton duck. First, he spread a piece 60 inches wide and 14 feet long over the bottom from end to end, and side to side, stretched it tightly and fastened it to the gunwales with copper tacks. Then he cut two pieces 30 inches wide by 5 feet long, spread them over the decks from the cockpit to the ends, and tacked them in place.

Take plenty of time to this work, since the more smoothly the covering is put on, the neater the job will be, and the less skin resistance there will be.

### PAINTING

came next. Two coats of good quality of house paint were used. These filled the pores of the cloth, and made a water-tight job. You might find a third coat necessary. Much will depend upon the quality of paint used. Certainly at the end of the season another coat will be needed.

### THE COCKPIT

required a floor. Robert made his by attaching two boards

$\frac{1}{2}$  inch thick, 8 inches wide and 5 feet long across the lower part of the center molds. Then he varnished them.

#### A DOUBLE PADDLE

was shaped from a piece of white pine 8 feet long. Possibly you will prefer to buy yours. It will cost little.

#### A LIFE-PRESERVER VEST

should not be overlooked, for the best of canoes will sometimes upset. You know how to swim, no doubt, but do not despise a safety rig that is part of the equipment of every speedboat pilot.

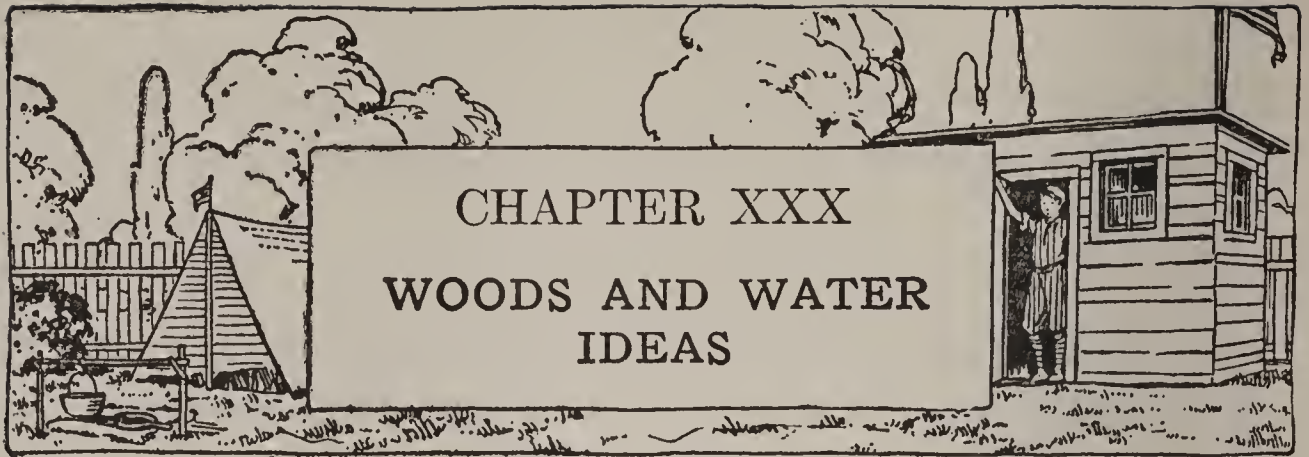

WHETHER your camping consists of overnight hikes, motor camping or sleeping in the back yard, the following suggestions will be helpful in organizing equipment.

An overnight hike usually necessitates "going light" with pack upon one's back, including a pup tent or shelter tent. Tent poles and stakes are procured on the camp site. With a trek cart, however, additional equipment is possible. Perhaps a tent large enough to accommodate all of the fellows is available. The tent will pack in a trek cart, but what of its poles? Poles are always a nuisance unless jointed so they may be made into a compact bundle.

#### A TENT-POLE PACK

like that shown in Fig. 525 is handy not only for transportation by trek cart, but also by automobile.

Jointing the Poles is a simple job. Two pairs of 4-inch strap hinges for the ridge-pole and a pair for each upright pole are needed; also, sixteen stove bolts with which to fasten the hinges to the poles. The bolt length will depend upon the thickness of the poles. Fig. 526 shows how to saw the ridge-pole into three lengths, and Fig. 527 shows how to saw each upright into two lengths. Make the cuts on the

diagonal. Attach the hinges with bolts. Bore bolt holes that will make a snug fit.

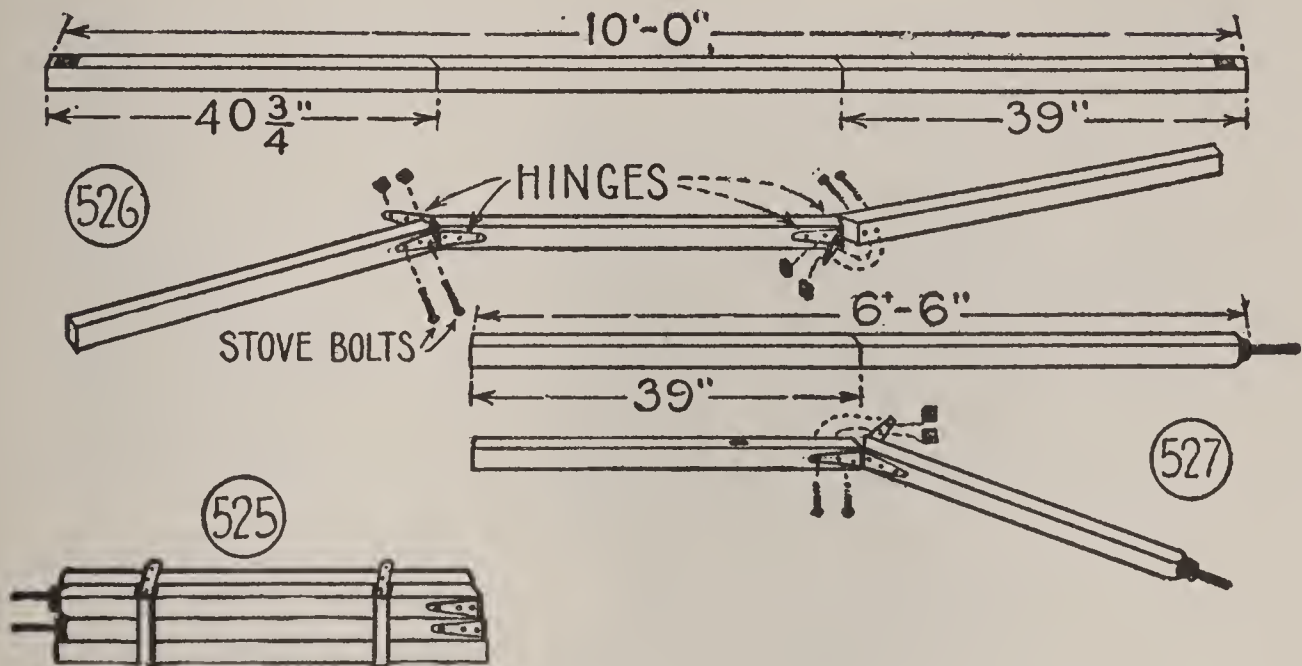

FIG. 525.—Tent-Pole Pack.

FIGS. 526 and 527.—Joint Ridge-Pole and Uprights Like This.

To Pack the Poles, remove two bolt nuts at each connection (Figs. 526 and 527), fold the released hinge flaps away from the poles, and replace the nuts on the bolts. Use skate straps to fasten the pack.

### A CAMPFIRE CRANE

like that in Fig. 528 is easy to assemble. It is made of pipe and pipe-fittings. An old piece of gas pipe 4 feet long will do for the upright. One end must be threaded on which to screw a tee pipe-fitting. Two nipples 10 or 12 inches long, of the diameter of the pipe, complete the device. To make the crane more compact for carrying, cut the upright pipe in half and join the halves with a coupler fitting. Then you can take it down in three pieces.

Make Pothooks of heavy wire bent into the shapes shown in Fig. 529.

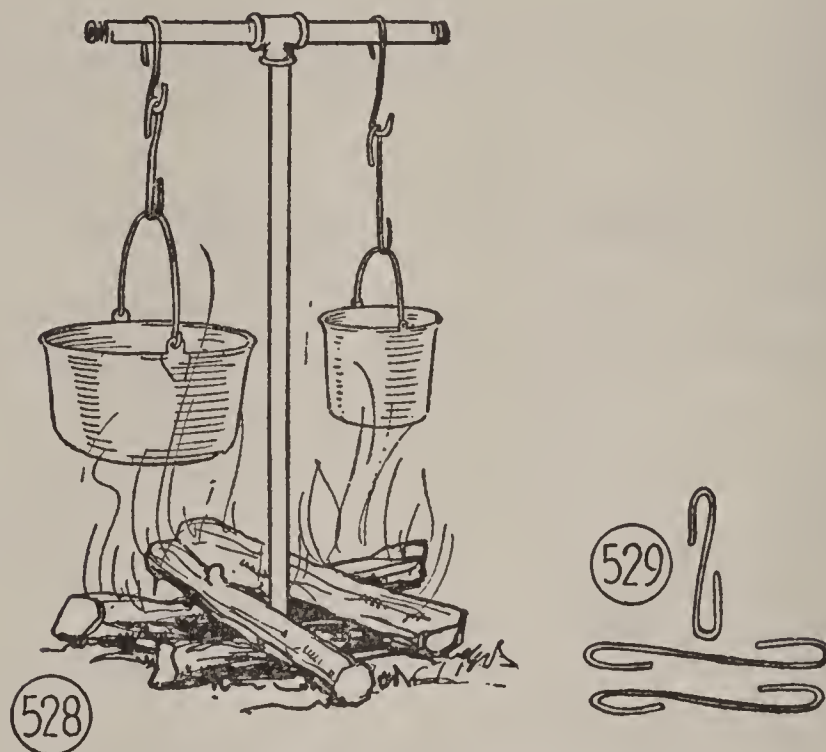

FIG. 528.—Campfire Crane.  
FIG. 529.—Pothooks.

#### AN ORANGE CRATE FOR CAMPING

has possibilities not generally recognized. It offers a light-weight receptacle for transporting food and utensils. It serves well as a kitchen cabinet, magazine rack and book rack, small table or washstand, in camp. Fig. 530 suggests how to fasten the crate upon a tree trunk at the right height for a wash basin, and how to hang a mirror above it. Give this utility box two coats of paint or lacquer before you leave home.

#### AN AUTOMOBILE CABINET

like that in Fig. 531 is excellent for motor camping food



supplies and cooking utensils. It may be carried upon the running-board or rear bumper. Fig. 532 is a cross-section

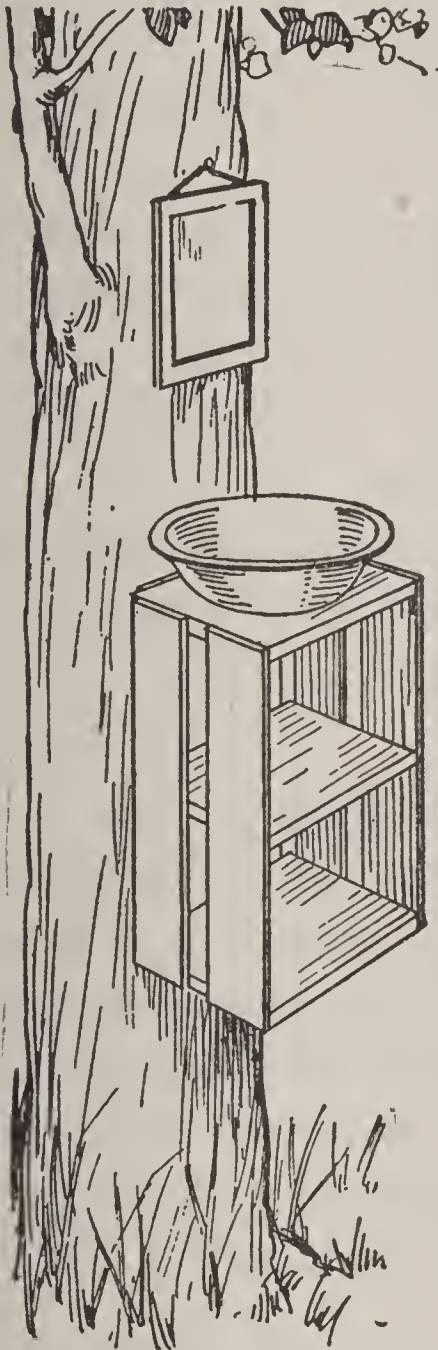

FIG. 530.—Orange-Crate Wash-Stand.

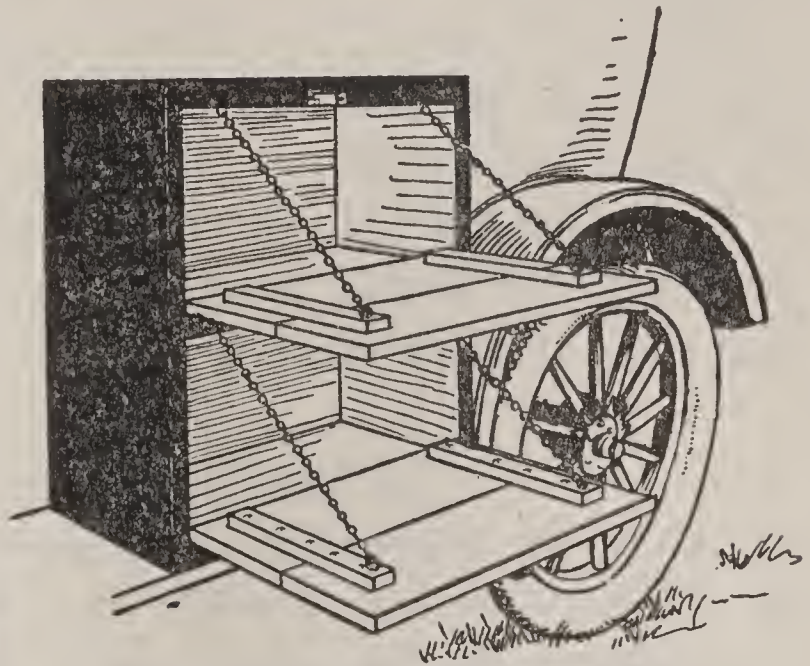

FIG. 531.—Automobile Cabinet.

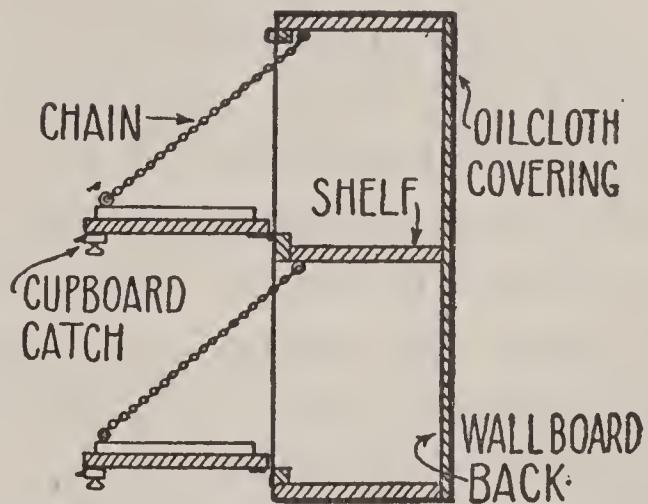

FIG. 532.—Cross-Section of Cabinet.

of a cabinet. Dimensions are not given, because they will vary under different conditions.

Make the cabinet back of wallboard and save weight.

Hinge the drop-leaves of the two compartments with 2-inch hinges. Fasten chain to them for supports, and attach cupboard catches.

When you open the cabinet along the road, the upper hinged leaf will form a work table of convenient height, the lower leaf will be a handy shelf.

**Cover the Cabinet** on the outside with black oilcloth, and paint the inside, including the drop-leaves, with several coats of white enamel.

#### A TREK CART CABINET

similar to the automobile cabinet can be built into the end of the cart. It will simplify the problem of keeping the commissary supplies separate from equipment.

#### A FISHING LINE DRYING REEL

As a mechanic is judged by his tools, so is a fisherman judged by his tackle. If you don't want your line to break at the critical moment, and let a big fellow get away, buy a well-known tested brand, and see that it is kept in the best possible condition. Never leave it wound upon your reel to dry. As soon as you can conveniently do so, transfer it to something that will permit air to circulate around every inch of its length.

The best device is a drying reel, and Figs. 533 and 534 show

**A Home-Made Reel** that is easily constructed. The base of this reel (A) is clamped to a table or shelf edge, the fishing rod handle is slipped into a hole bored in the

end of the base block, which brings the reel into line with the drying reel. In this position the fishing line can be reeled off on to the drying reel, then reeled back when dry.

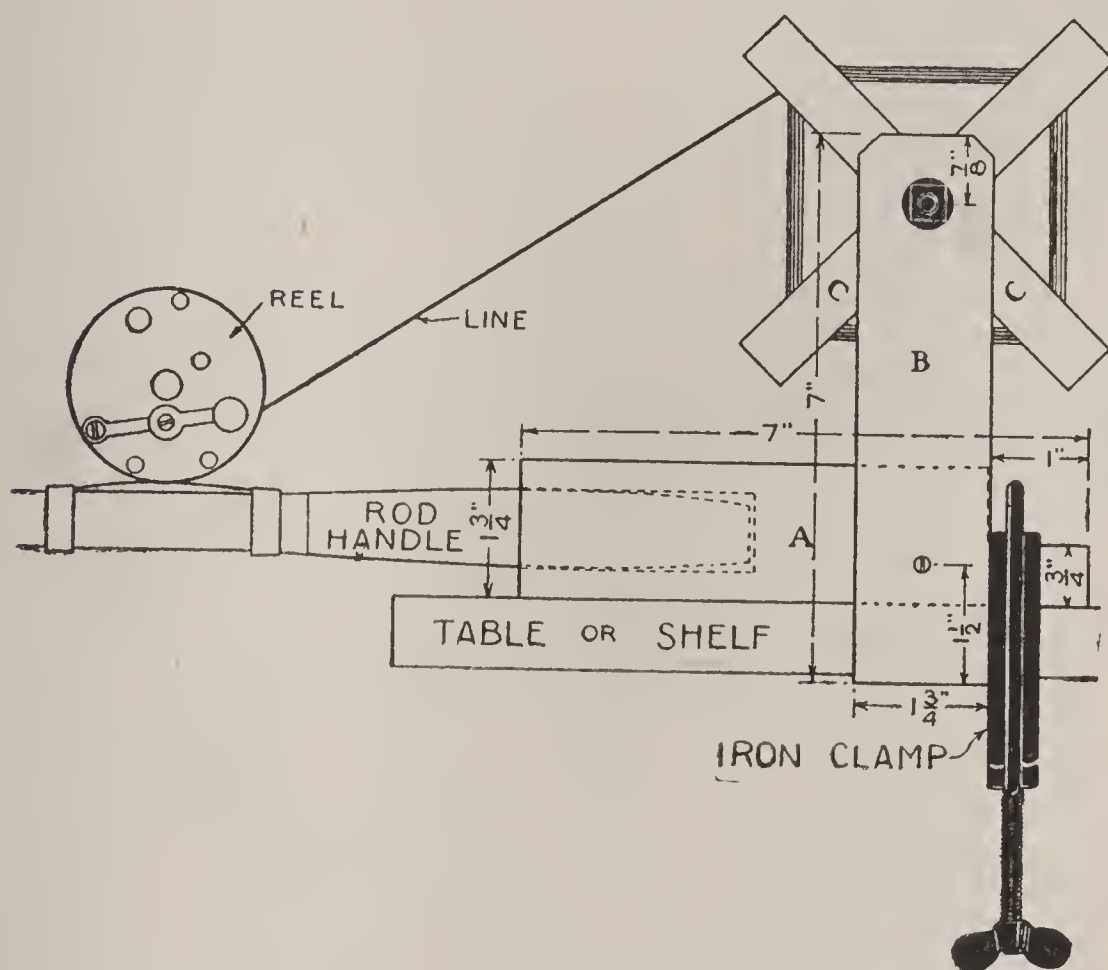

FIG. 533.—Transfer Fishing Line from Rod Reel to Home-Made Drying Reel.

After use, the drying reel can be removed and made into a compact package, with arms C unbolted and knocked down, and upright B folded to lie along base block A.

**The Base.** Cut the base block A from a piece of 2-by-2, and upright B from a piece of 1-by-2, of the lengths marked in Fig. 533.

Bore the socket hole in block A just large enough for the rod handle to fit snugly in. Cut down the other end of the

block so that the jaw of a curtain-stretcher clamp will be large enough to grip it and the table or shelf the reel may

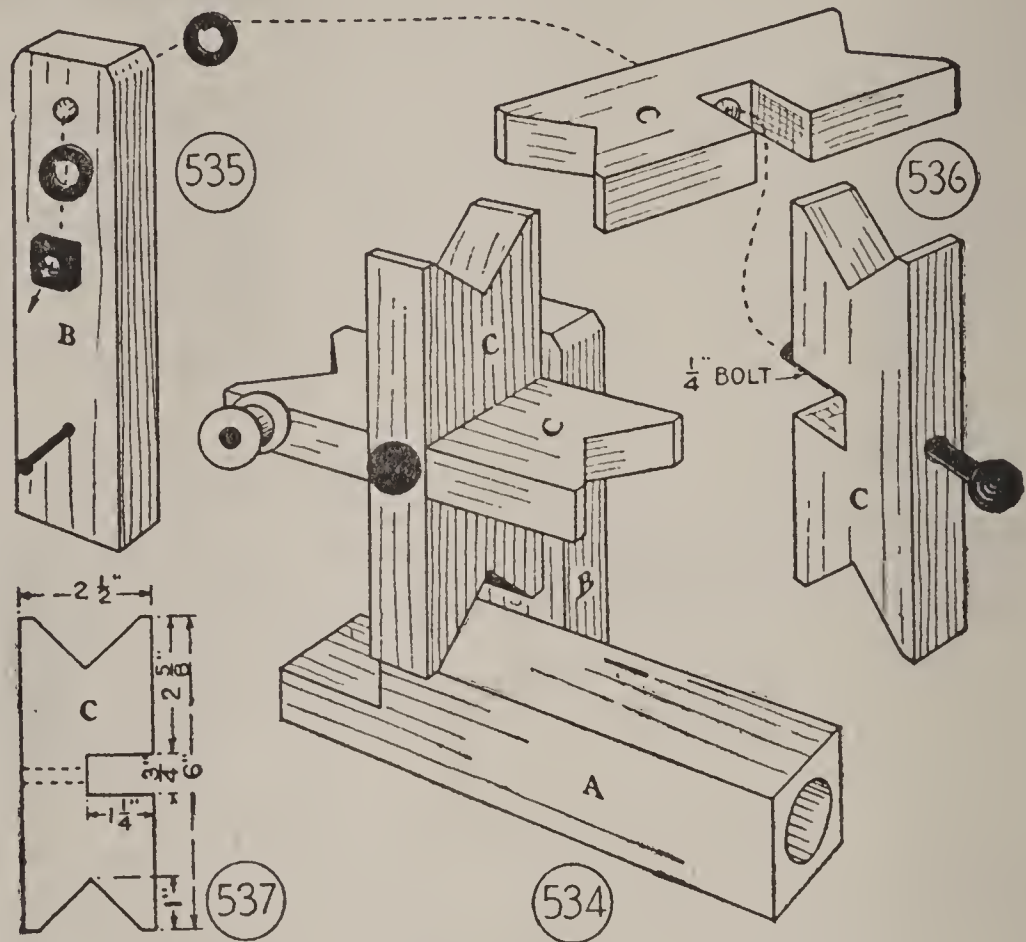

FIG. 534.—Completed Line Drying Reel.  
FIGS. 535-537.—Details of Reel.

be clamped to (Figs. 533 and 534). Bore a  $\frac{1}{4}$ -inch hole near the top of upright B for the reel axle to slip through (Fig. 535), a  $\frac{1}{8}$ -inch hole below it where indicated, for a screw to attach the block to the base block.

The Reel is made of two blocks halved at their centers as shown in Fig. 536, so that one block will interlock the other. A diagram of the blocks is shown in Fig. 537. Bore a  $\frac{5}{16}$ -inch hole through the center of each for the axle to run through.

The Axle is a  $\frac{1}{4}$ -inch carriage bolt 4 inches long.

Mount the reel upon the axle as shown in Figs. 534 to 536, and make

A Crank of a thread spool. Attach the spool with a screw.

Finish the reel and base with a coat of shellac or varnish stain.

### A CANOE OR SHARPIE HEADLIGHT

like that in the sketch of Fig. 538 is a simple rig. All that it requires is an automobile spotlight, battery, switch, board

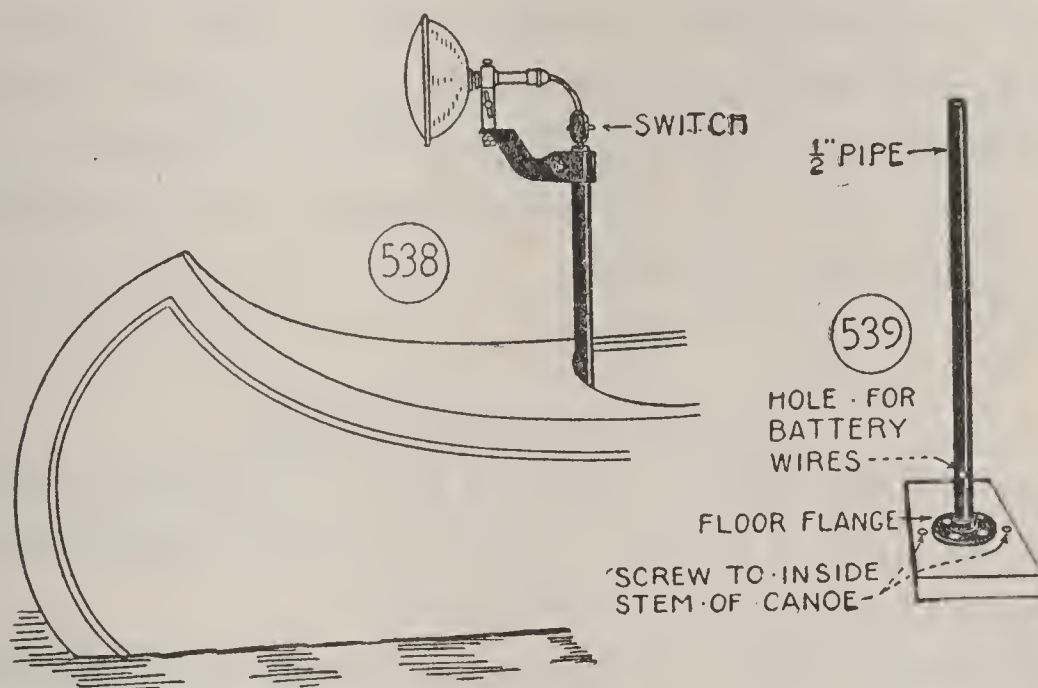

FIG. 538.—Canoe Headlight.

FIG. 539.—Support for Automobile Spotlight.

base, two screws, a piece of gas pipe or water pipe threaded upon one end, and a floor flange.

You can set up and take down this headlight so quickly, that you can use it interchangeably in your canoe, sharpie and other craft.

The Lamp Support is a piece of  $\frac{1}{2}$ -inch pipe 24 inches long (Fig. 539). A local plumber will sell you a piece, thread one end, and furnish a floor flange to screw it into. Drill a hole through the lower end of the pipe to admit the battery terminals.

Cut the Base Board to fit the bottom of the canoe or other boat, and drill it for the screws for attaching it to the boat bottom.

Paint the support and base with two coats of automobile enamel, or radiator aluminum paint.

To Assemble the Headlight, clamp the spotlight to the top of the pipe support, and fish the terminal wires through the hole near the base and up through the pipe. The switch shown at the top of the pipe is of the kind used on household appliances. It will be unnecessary if your spotlight is equipped with a switch.

### PADDLE AND OAR REPAIRS

As summer wears on, paddles and oars require attention. Taken in time, a broken handle or blade may be restored to a condition almost as good as new.

Broken Handles are harder to mend than split blades, especially when the break is straight across. A diagonal break can be spliced as shown in the diagram of the broken paddle (Fig. 540). First, coat the surfaces of the break with a waterproof glue or cement. Then bring them together, clamp them, and allow to stand until the glue has set. Next, drill a hole through the center of the length of the splice, and drive a screw into the hole.

Reinforce the Connection with a wrapping of heavy twine, fishing line or wire. Figs. 541 and 542 show The Twine Splice. Probably you know how to make it,

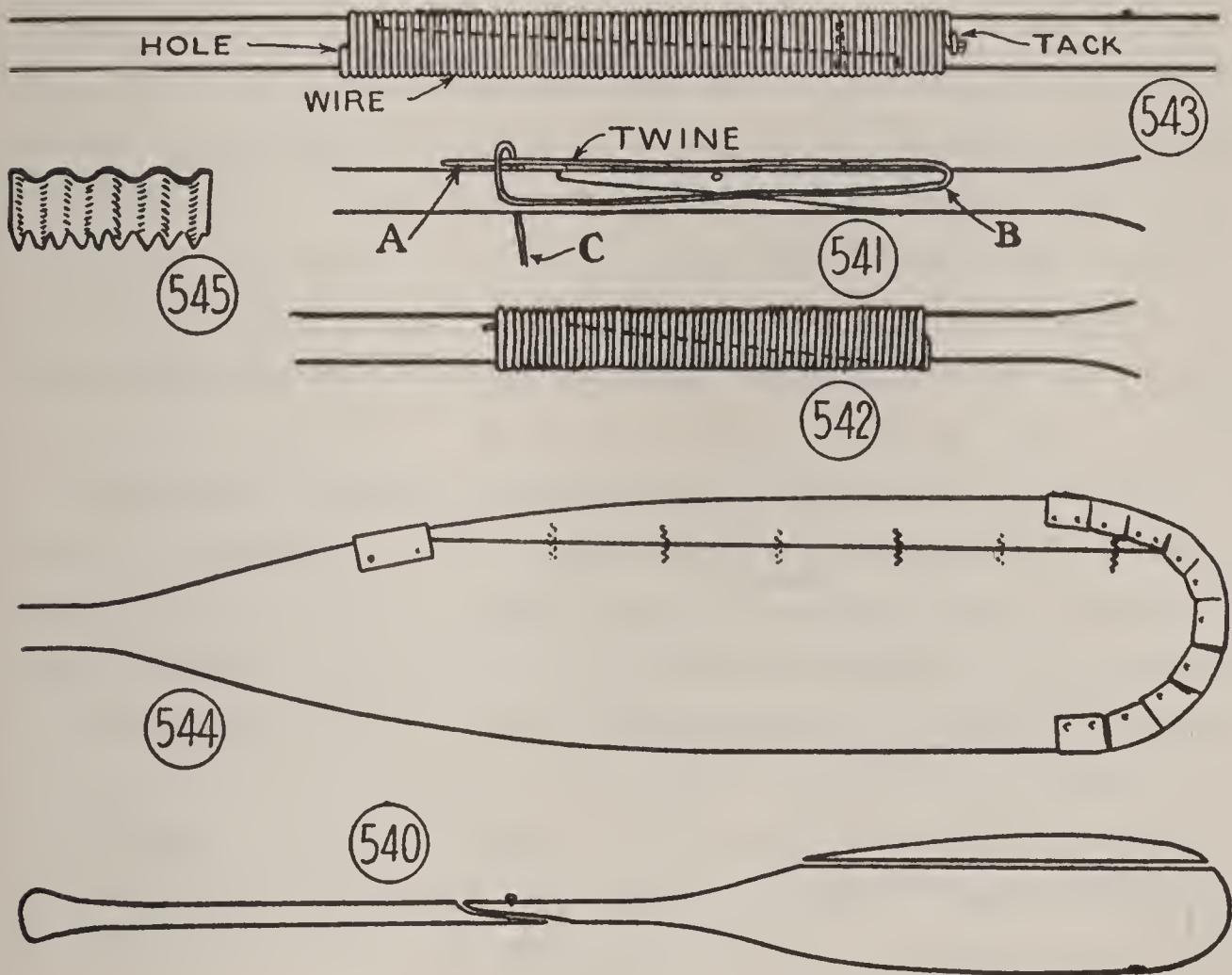

FIG. 540.—Paddle With Broken Handle and Blade, Before Mending.

FIGS. 541 and 542.—Twine Splice of Handle.

FIG. 543.—Wire Splice of Handle.

FIG. 544.—Blade, After Mending.

FIG. 545.—Wood Joint Fastener.

since it is described in the Boy Scout handbook. Lay twine along the handle as shown in Fig. 541, with one end at A and a loop formed at B. Then wind the remainder of the twine (C) tightly around the handle from end A as far

as loop B, slip it through the loop, and pull end A so as to draw the loop under the turns to hold it fast, as shown in Fig. 542. Finish the splice with a coat of shellac.

**A Wire Splice** is stronger. Bale wire will answer the purpose. Drive one end of the wire into a hole drilled in the handle (Fig. 543). Then wind the wire tightly around the handle, pushing the turns close together, and at a point beyond the end of the splice cut off the wire and fasten it with a double-pointed tack.

**A Square Break** may be spliced in the same way. First, bevel the broken ends so they can be overlapped. This will shorten the handle 4 inches or more.

**A Broken Oar Handle** requires a longer splice than a paddle handle, because it is subjected to greater leverage. This may make the oar too short for practical purposes. But possibly you will find another broken handle and can get enough length out of the two handles to make one of standard length.

Glue or cement the oar handle splice, then drive a bolt or screw through it, being careful not to split the wood, and bind with wire as shown in Fig. 543.

**A Split Handle** should be given immediate attention. Fill the crack with glue or cement, and bind with twine or wire.

**A Split Paddle or Oar Blade** can be mended with wood joint fasteners (Figs. 544 and 545), otherwise known as *saw-edge divergent corrugated fasteners*. These fasteners are available at most hardware stores, in several sizes. Buy a length that is a trifle shorter than the thickness of the blade



at the line of break. If you cannot get a short enough length, cut off longer ones with a hack-saw.

First, coat the edges of the broken parts of the blade with glue or cement, and clamp them together. Then drive the fasteners into the blade, crosswise of the grain, as shown in Fig. 544. Space the fasteners about 4 inches apart, on one face of the blade. Then turn over the blade and drive in another set of fasteners to come half-way between the first set, as indicated by full and dotted lines. Rest the under side of the blade upon a hard flat surface while you drive home the fasteners.

Fig. 544 suggests how to

**Tip Your Paddle Blade** with a strip of sheet copper, if it isn't so protected. This reinforcement is necessary for a split blade. Snip the edges of the copper strip, fold the strip in half lengthwise, hammer it over the end of the blade, and fasten with copper tacks. Drive the tacks through and clinch them. Fig. 544 suggests how to protect the upper end of the break with a folded strip of copper.

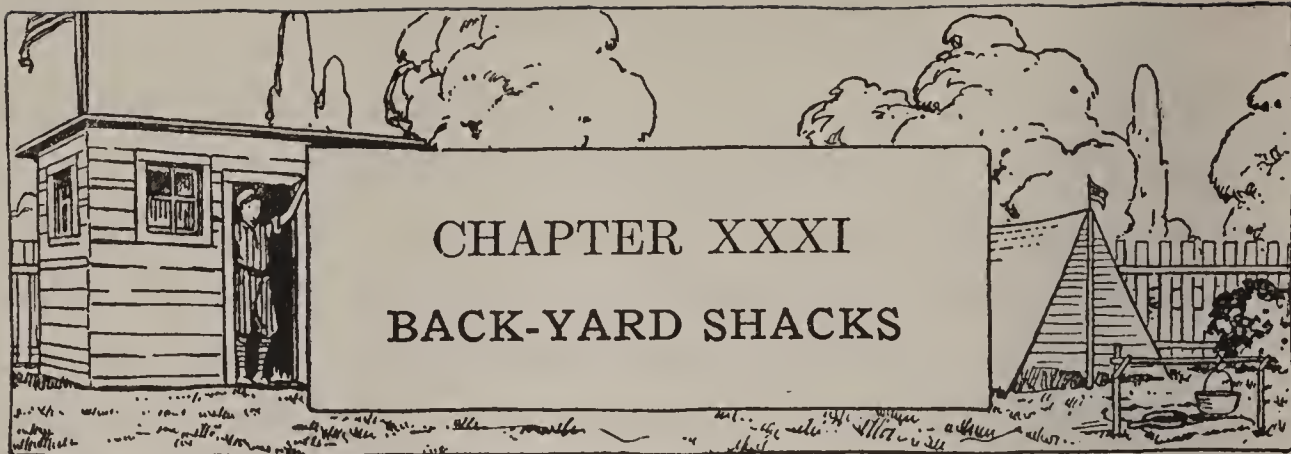

## CHAPTER XXXI BACK-YARD SHACKS

THE main problem in building a back-yard workshop, museum, club house, Boy Scout patrol hut, shanty or shack is usually getting together enough

**Material for the Job.** Crating material is good enough, and there are several sources from which you can draw it. First, are the sites of new and remodeled buildings. Get acquainted with a builder's foreman. Quantities of this material are used in crating bath tubs and other plumbing fixtures, and heating equipment. Visit a plumbing and heating shop and ask for what they have on hand. Go to a paint store and ask for the crates that window glass and mirrors are shipped in. And don't overlook the furniture store and the hardware store. Boards from large packing cases can be used also.

Crating material will do for the shack framework, but 2-by-2s and 2-by-4s are better. Buy them if you can.

In the photograph of Fig. 546 is

### A SMALL SHACK

built by Richard Franklin, shown perched upon the roof, and Bud Cramer, standing in the doorway. These lads dis-



FIG. 546.—A SMALL SHACK.



FIG. 547.—A BOY SCOUTS' PATROL SHACK.



covered a large pile of crating material on the site of a building that was nearing completion. The building con-

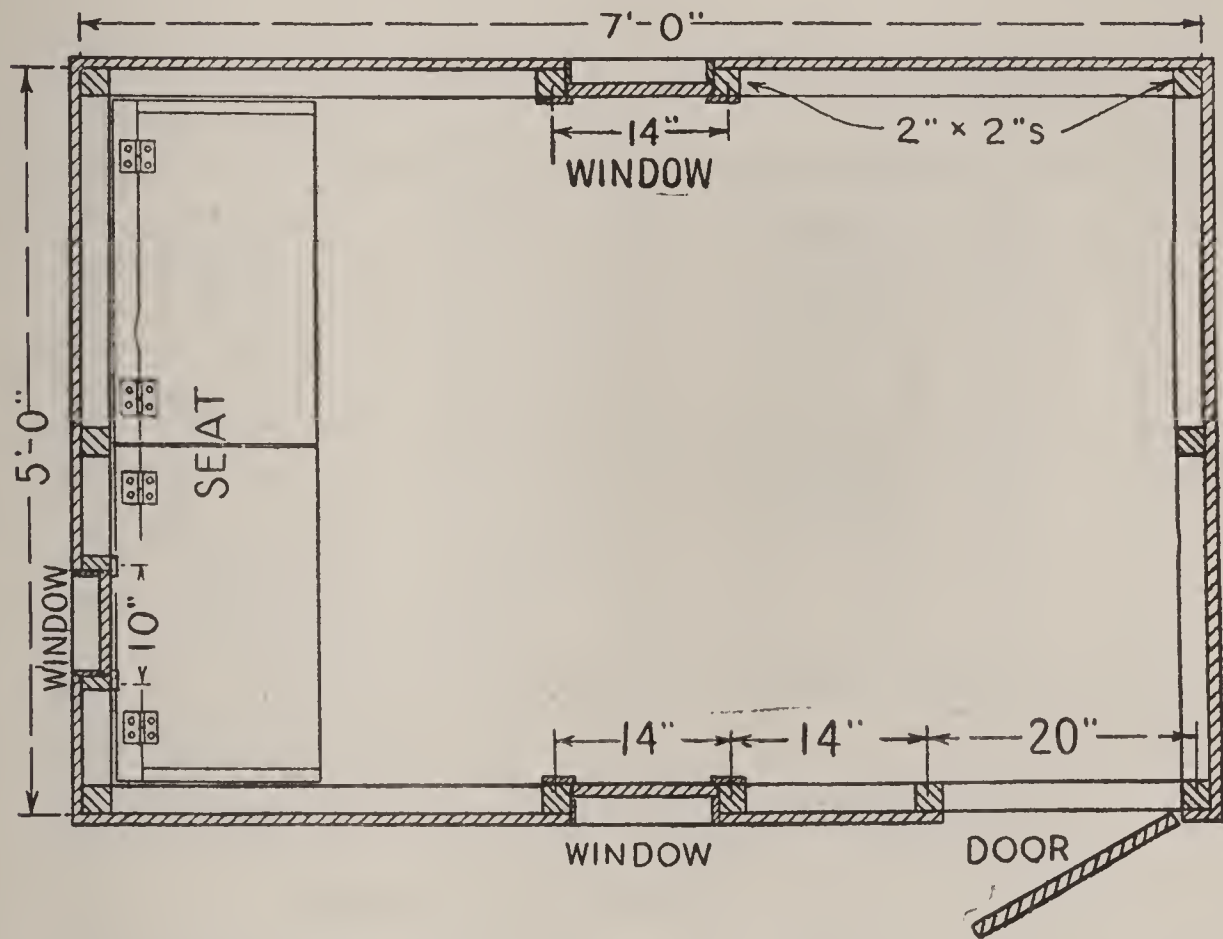

FIG. 548.—Plan of Shack Shown in Photograph of FIG. 546.

tractor was about to set fire to the pile, but they gained possession upon promise to get it out of the way quickly. Then, in return for running errands, they obtained enough parts of rolls of building paper for roofing, and for lining the walls inside, and all of the nails they needed.

Fig. 548 is a plan of the shack. You may object that it is too small. But maybe it is as large as you can get material for. Let this determine the size. It will be no trick to enlarge the plan.

The Framework is shown in perspective in Fig. 549.

First lay the sill plates. Level them with bricks or stones. Then set the corner posts and brace them with temporary

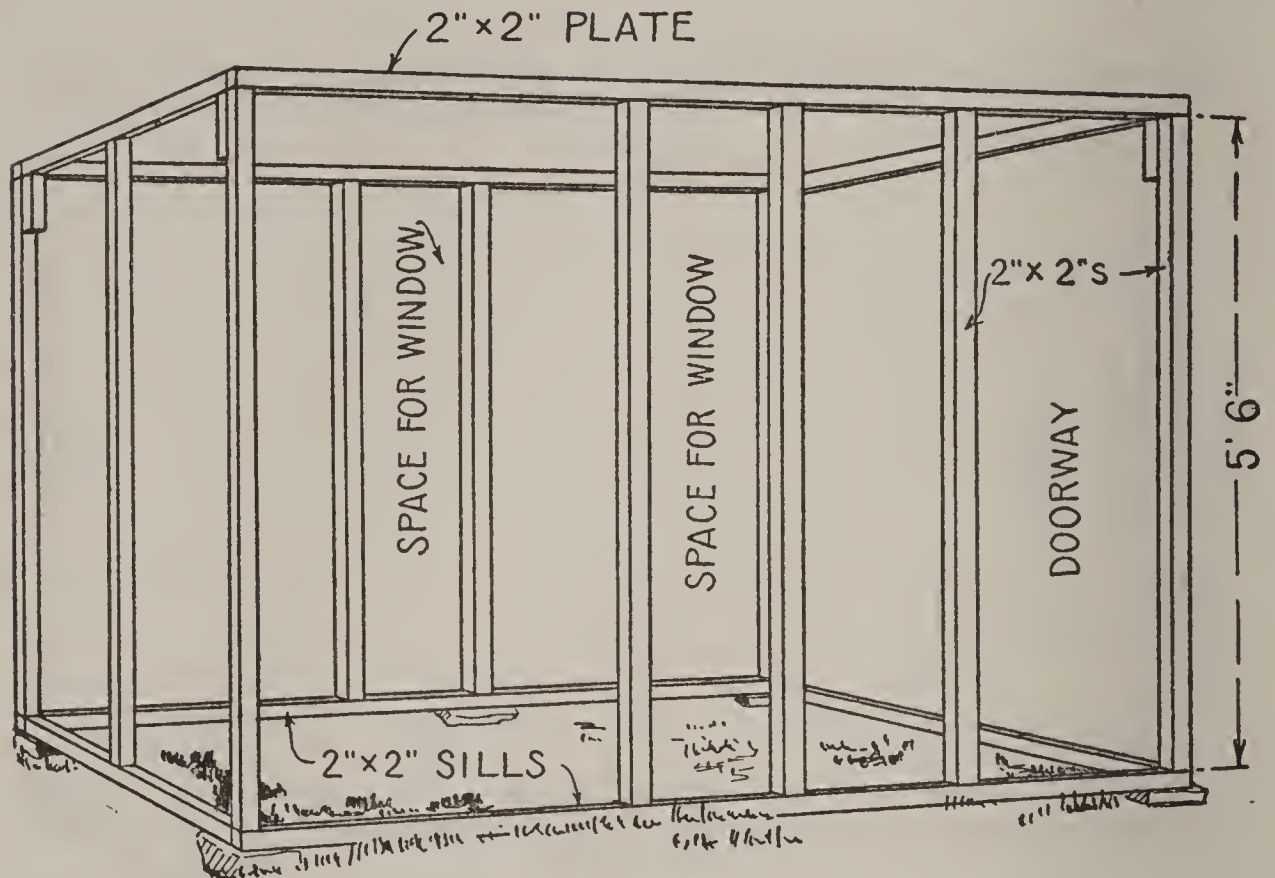

FIG. 549.—Framework Perspective.

diagonal braces. The front posts of this hut are only 5 feet 6 inches long, the rear posts 6 inches shorter. Maybe you will want to cut them longer to provide more head room. Space the studs, or intermediate posts, to suit door and window openings. Nail the top plates to the posts and studs, spiking 2-by-2 blocks to the corner posts, as shown in Fig. 549, for additional support.

With the framework completed, it will be a simple job to put on

**The Sheathing.** Cut the boards of the right lengths so their ends will strike studs. Fit them around the window

and door openings. The windows of this shack are small. It would be better to increase their size, to admit more light and air.

Lay the Roof boards from front to rear. If your material isn't long enough to reach from plate to plate, set in an intermediate plate to support the ends of short pieces. If you cannot get heavy building paper or tar paper to make a tight roof, perhaps you can find some tent canvas, old awning goods or sheet metal.

No Floor is Necessary in this shack, if you bank the walls with earth on the outside to keep out surface water.

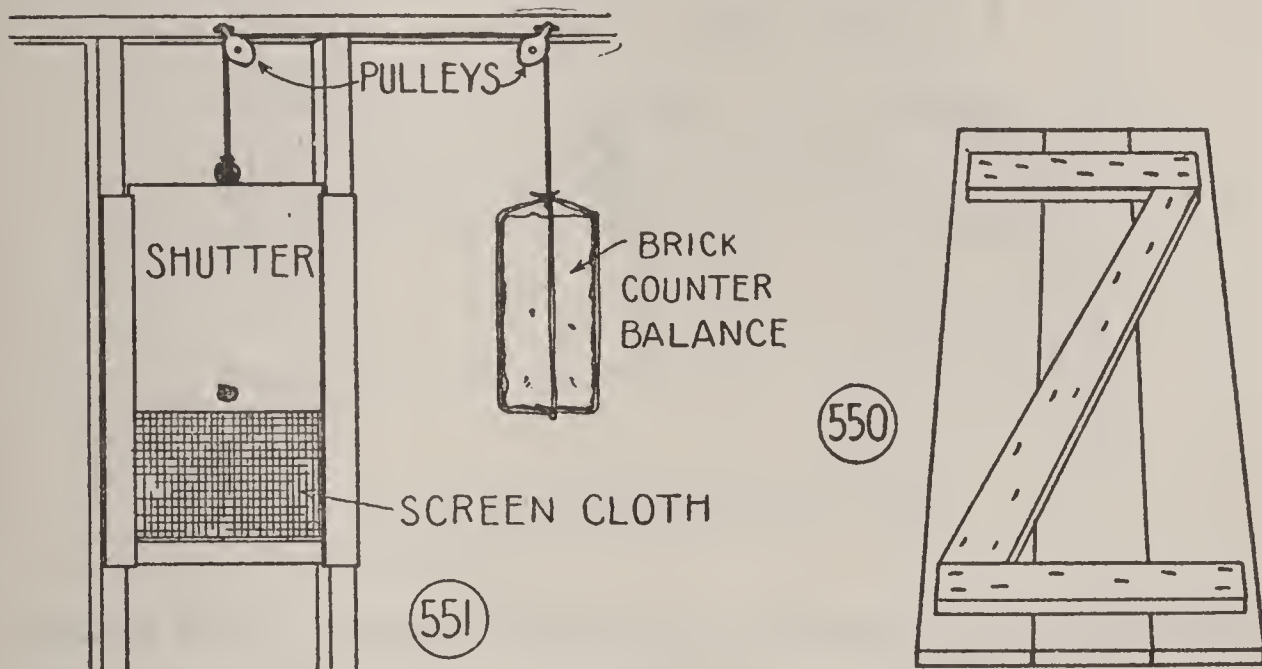

FIG. 550.—Batten Door.

FIG. 551.—Window Shutter With Counter-Balance.

The Door is shown in Fig. 550. It is what is called a batten door with the boards fastened together with two horizontal strips, or battens, and braced with a diagonal strip. Use nails long enough to drive through the boards and battens, and clinch upon the inner face of the battens.

The Windows may have wooden shutters instead of sash. Fig. 551 suggests how to make grooves for the shutters to slide in, and how to rig up a counter-balance with rope, pulleys and a brick or other weight.

### BOX FURNITURE

is the right kind for the shack. Fig. 552 shows how to build A Window Seat across one end wall. By using boxes and hinging the cover boards as shown, there will be storage

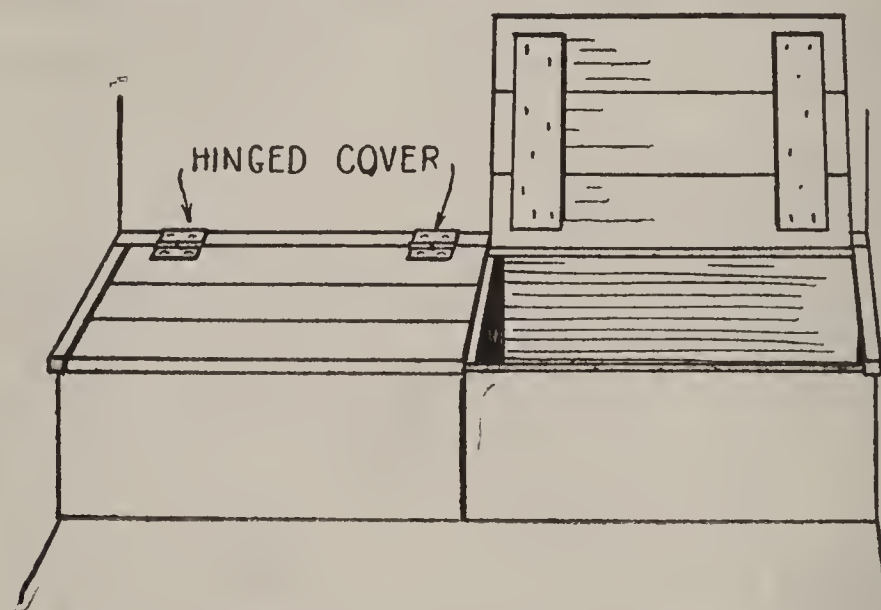

FIG. 552.—Box Window-Seat.

space for books, magazines and other treasure. But be certain that the roof and the walls are watertight before putting anything of value under the seat.

### A BOY SCOUT PATROL SHACK

The photograph of Fig. 547 shows a unique shack with attic, built by Clough Cullen and his patrol. Fig. 553 shows a plan and Fig. 554 shows a perspective of the framework



with principal dimensions. If you do not want to duplicate this shack, you will at least get ideas from the diagrams that will enable you to shape up a structure to your liking.

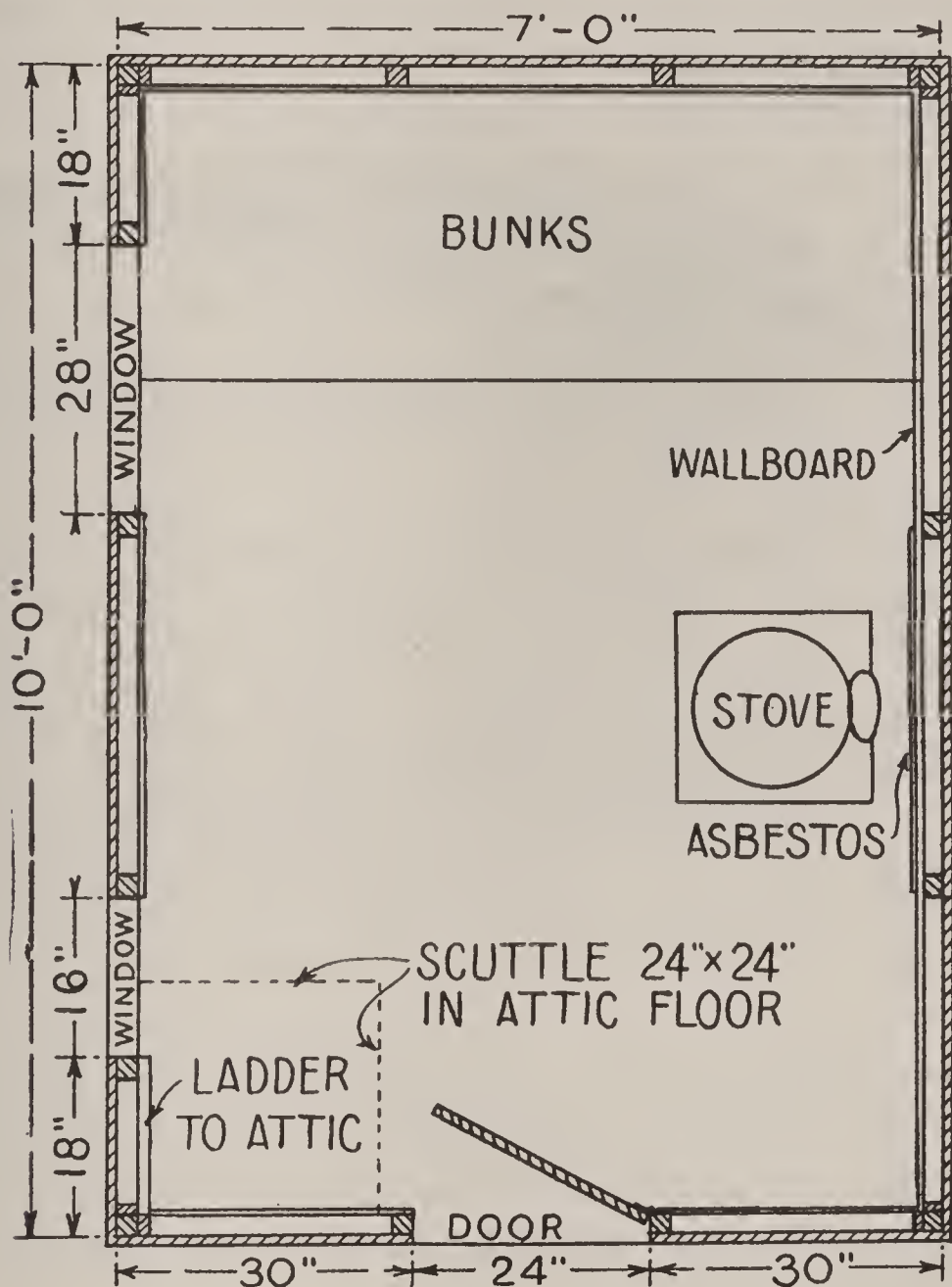

FIG. 553.—Plan of Patrol Shack Shown in Photograph of FIG. 547.

The Essentials of a Patrol Shack are a floor space large enough to accommodate 8 boys, tight walls and roof, good

light, and heat for winter. The shack illustrated has a ground area of 7 by 10 feet, its walls are lined inside with wallboard, the attic space has cross ventilation, making a cool lower story in warm weather, and there is a stove for heating in cold weather.

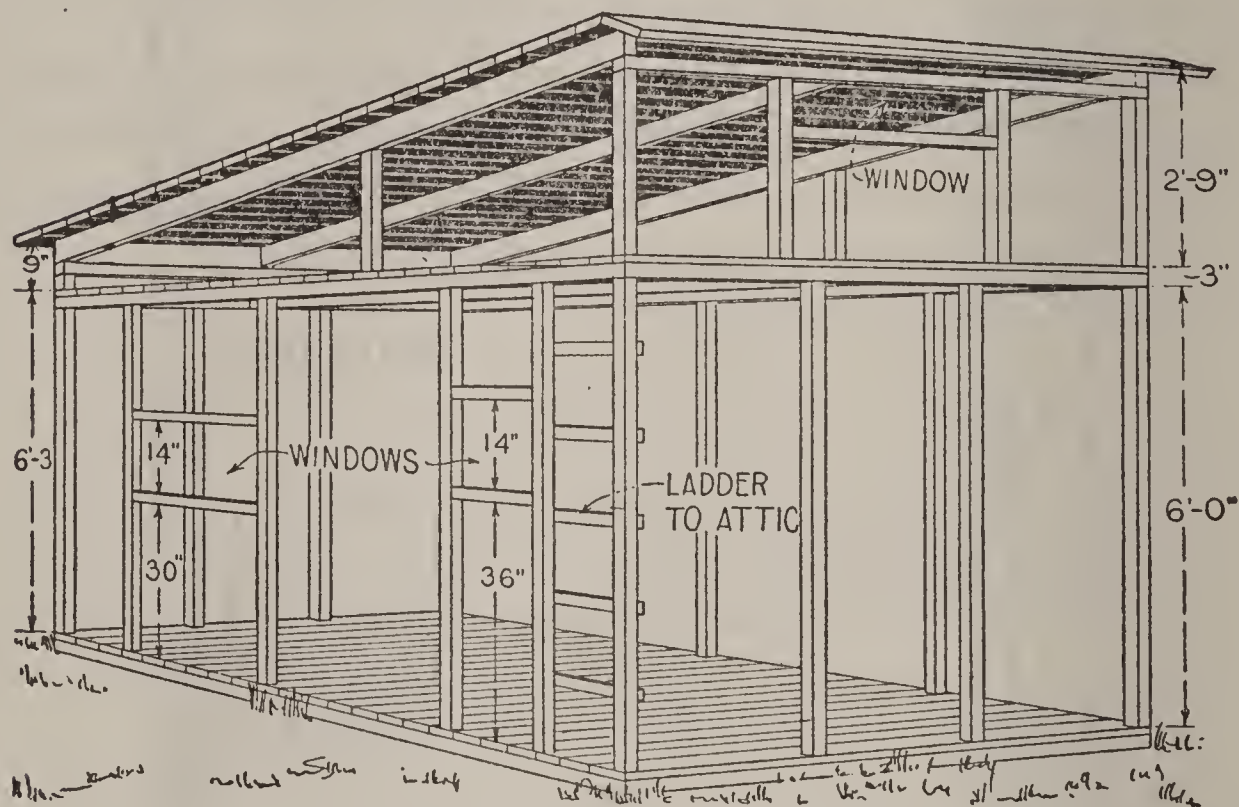

FIG. 554.—Framework Perspective.

A table, several chairs, a wall book-rack, and two bunks comprise the furniture. There are books, magazines, games and a radio set for entertainment, and, at last reports, the boys were installing a telegraph set for communication with scouts of another shack.

The Framework is clearly explained by plan and perspective. If you buy new material, you will save on the cost by using 2-by-2s instead of 2-by-4s for all short framework members. They will be strong enough for a small building.

After staking out the shack, lay the floor plates, then the floor boards. Then you will have a level platform on which to set up the wall studding. Spike the studs in place, brace them, and top them with the attic floor plates. Then lay the attic floor, with an opening at one corner for a scuttle, and upon this floor build up the wall framework to the height of the roof. A center double 2-by-4 rafter should be sufficient support for the attic floor and roof. But intermediate rafters may be set in for reinforcement.

**The Sheathing** for the walls of the shack illustrated was of new lumber. Run the sheathing across

**The Window Openings**, then cut the openings. Screens, with board shutters to keep out rain, will be sufficient for warm weather, but sash will be necessary for cold weather. If you can get second-hand window sash, arrange the wall studding so that they will fit between them. Wooden shutters with a good fit will be sufficient protection for the attic windows.

**Build a Batten Door** like that shown in Fig. 550.

**Lay the Roof** as described for the smaller shack, with a covering of roofing paper.

**Build a Ladder** to the attic by nailing 1-by-2s across the studs, in one corner, as shown in Fig. 554.

### INSULATION

If the shack is to be heated in winter, insulate the walls. Instead of buying wallboard or roofing paper, collect corrugated cartons, separate them at the corners, flatten them out, and tack the pieces to the inside of the walls and ceil-

ing. Protect the wall back of the stove with a sheet of asbestos or galvanized iron.

### BUNKS

should be provided if you intend to sleep out, and, of course, that is one-half of the fun of owning a shack. If you can get two old bedsprings, support them upon cleats and slats fastened to the walls at one end of the shack. Place one bedspring 16 inches above the floor, the other half-way between it and the ceiling.

### PAINTING

Whether you use new or old lumber, give the outside walls of your shack two coats of paint. One of the cheaper grades of paint will do.

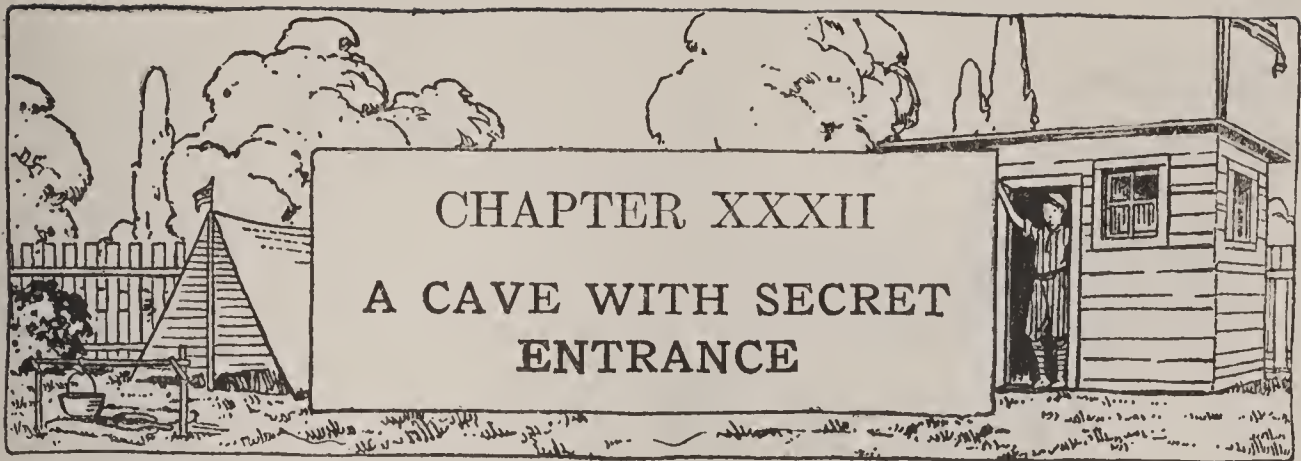

## CHAPTER XXXII

### A CAVE WITH SECRET ENTRANCE

You would give a good deal to own a cave, I know, and for a long time I have been planning to tell you how to make one like that shown in this chapter. This cave differs from what we generally think of as a cave. It is partly below ground and partly above. The reason for making it this way is that it is safer. Oftentimes the roof of an underground cave falls in burying its victims, and you must not take chances of being hurt. This cave is dry, light and well ventilated, and it has an interesting feature that some caves have—a secret entrance. The illustrations show where the entrance is, but don't give it away to a soul, except your brother or your chum, and then only upon his swearing to secrecy and promising to help you build the cave. When you allow friends to enter, blindfold them before conducting them in.

#### THE BUILDING MATERIAL

Except for a few 2-by-2s for the wall supports, you should not have to buy material for the above-ground portion of the cave, because crating material and box boards will do very well. On the site of a new building, you will find

many sizes of crating boards that the building contractor will gladly let you have, and at a plumbing shop, a paint

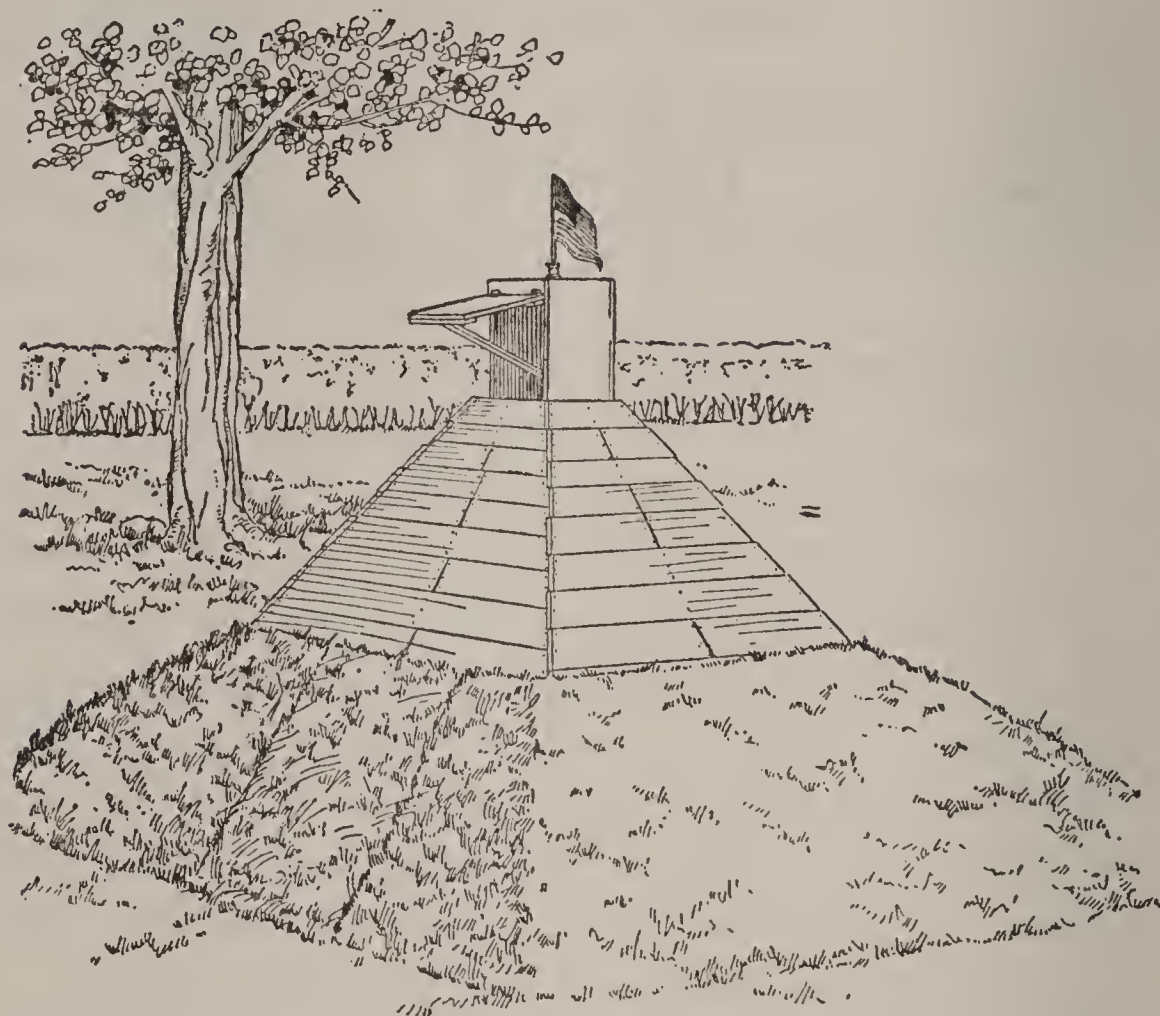

FIG. 555.—This Cave, Part Underground and Part Above, Has a Secret Entrance.

store and a hardware store, you can get discarded crating material.

#### THE SIZE OF THE CAVE

may be whatever you wish to make it. The cave in the illustrations has a floor 8 feet square. This is none too large, considering that the slanted walls cut down the head-room. Fig. 556 is a cross-section that shows how the completed cave will look inside.

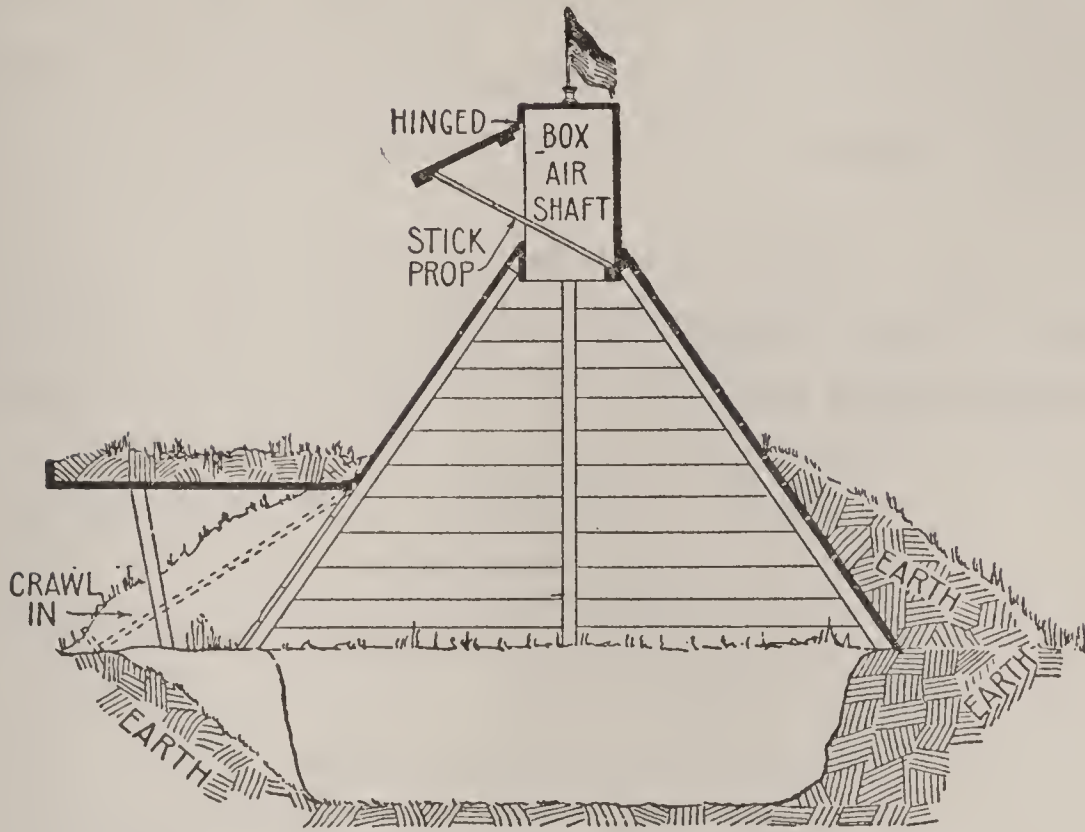

FIG. 556.—Cross-Section of Cave, Showing Secret Entrance.

### THE UNDERGROUND PORTION

First of all, stake out the four corners of the cave. Then dig a pit from 20 to 24 inches deep inside of this space (Fig.



FIG. 557.—Dig a Pit Like This for Underground Portion of Cave.

557). That is a deep hole, but you will need as much earth as you will dig out, to bank around the wooden walls. Trim

the sides of the pit straight. Fig. 557 shows how to cut away the bank of the pit at the cave entrance. You may leave this digging until after you have built

### THE ABOVE-GROUND PORTION

**The Walls.** Fig. 558 shows the front wall. Use a piece of 2-by-2 along each end, one in the center, and one each

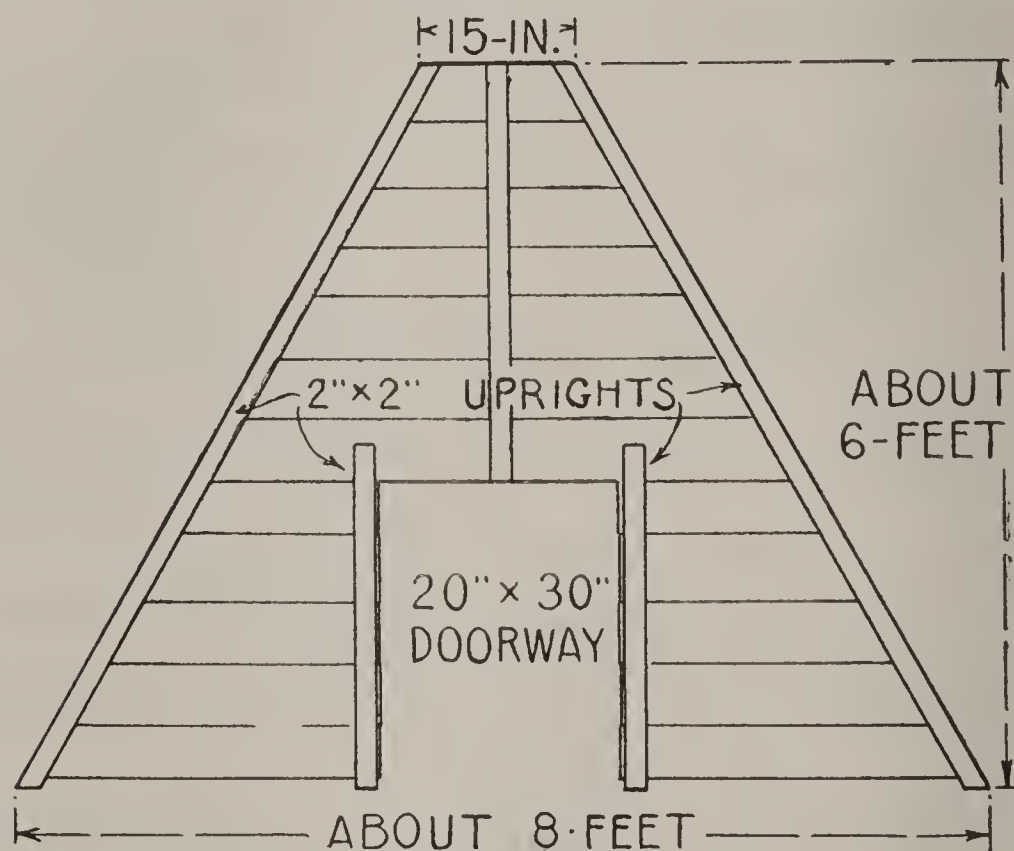

FIG. 558.—Detail of Front Wall.

side of the doorway. Start the wall by placing the main upright pieces upon the ground with ends correctly spaced, then fastening them temporarily with boards nailed across their ends. Board up this framework, then mark out the door opening and cut it. Build the rear wall of the same size.



Before setting up the walls, get a box about 14 inches wide and 14 inches deep. The length does not matter. This box is to fit between the walls at the peak, to form

**A Ventilator Shaft.** Remove one end of the box, nail a narrow board across the open top at each end, make a door out of the cover boards, and hinge the door to the box end that will be the upper part of the shaft. Cut a stick prop of the right length to hold open the ventilator door (Fig. 556). Nail a block of wood to the side of the box to support the lower end of the stick.

**To Set Up the Walls,** first stand the front and rear wall in the correct positions on opposite banks of the pit, and fasten their tops to the sides of the ventilator shaft box. Then nail boards across their end edges to complete the side walls. A center upright will be necessary to stiffen the side walls, and to nail short boards to. This is shown in the cross-section of Fig. 556.

**The Secret Entrance** is low, but the door must be 4 feet long so when it is closed it will slant as the earth banked around the walls. A detail of the door is shown in Fig. 559. Nail narrow boards to the edges as shown, to retain the earth and sod that are to conceal it. Fasten together the door boards with battens nailed across the under side. Hinge the door to the head of



FIG. 559.—Detail of Secret Entrance.

the doorway, and pivot a pair of stick legs to the sides to support it when it has been raised.

Make the Walls Watertight with building paper or roofing felt, or, lacking paper, tack pieces of old awnings, a tent, carpet or burlap bags to the walls.

#### OUTSIDE GRADING

When the walls have been completed, bank earth around them as shown in Fig. 555. It will be necessary to drive stakes at the entrance to keep the earth from sliding in. If you can get oats or grass seed, sow it over the banked earth, and before many days you will have a green carpet that will afford natural concealment. If you lack grass seed, use cuttings, weeds or straw to hide the entrance.

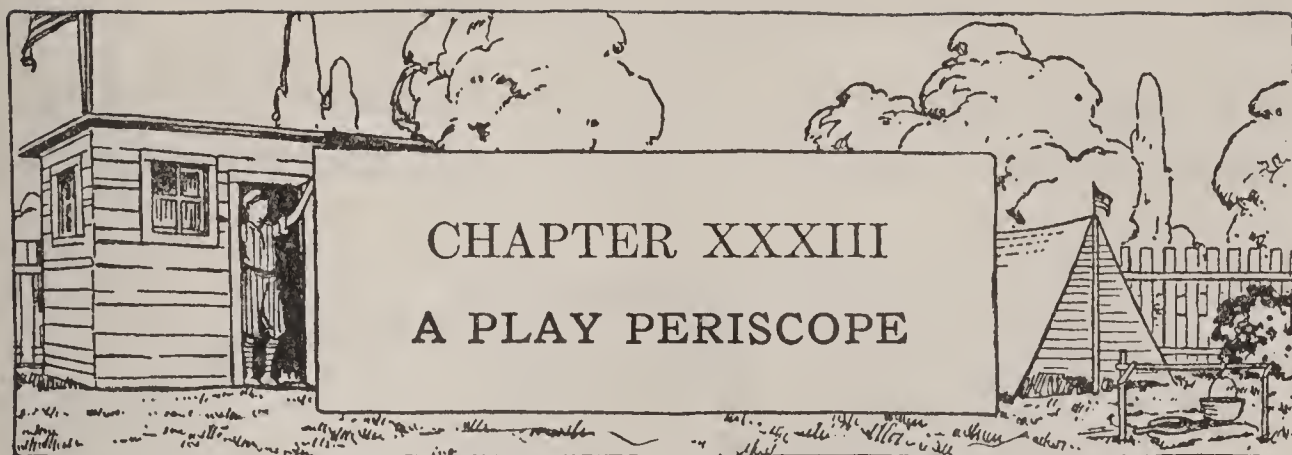

## CHAPTER XXXIII

### A PLAY PERISCOPE

As you know, a periscope is a long tube with mirrors inside, by which you can see what is going on above without exposing yourself to view. It is the submarine's eye when this craft is submerged. It is the trench fighter's means of watching for the enemy, in trench warfare.

There are several ways of having fun with the homemade periscope. First, in the back-yard cave, described in Chapter XXXII. The cave is built without a window, because caves do not have windows. But the ventilator shaft in its roof is an excellent lookout, and with the periscope raised as shown in Fig. 560, you will see out as plainly as though you were able to climb up into the shaft.

#### IMAGINE YOUR CAVE A SUBMARINE

submerged in mid-ocean, and if your imagination is strong, you will experience some of the thrills of submarine cruising. Again, imagine that your cave is an airplane, and that except for the periscope you are "flying blind." Here are

#### OTHER POSSIBILITIES FOR FUN

with the periscope. Use it to keep track of your pursuer

in a game of hide-and-go-seek. It will enable you to peek around corners (Fig. 561), over fence tops, and over mounds



FIG. 560.—Using the Periscope in Cave.

of earth and other places of concealment, without being seen, and to watch for an opportune time to dash out and away to the goal.

In winter, use it when defending your snow fort from attacking parties. Other uses will suggest themselves. I know a lad who discovered that a periscope long enough to top the fence of the local baseball field, afforded him a fuller view of the game than he could obtain through a

knot hole. Indeed, a giraffe has nothing on you, if you own a periscope.

### HOW THE PERISCOPE IS MADE

Fig. 562 shows the completed home-made periscope, and Fig. 563 is a cross-section of the box. Notice in the cross-section that the two mirrors are set at angles of 45 degrees, so when you look through the peep-hole into the lower mirror, you will see the reflection of the view projected through the front opening onto the upper mirror.



FIG. 561.—Playing Hide-and-Go-Seek With Periscope.

### THIS MATERIAL IS REQUIRED

to make the periscope. Box boards 18 inches long, two mirrors of the kind sold in ten-cent stores, a leather strap and nails.

The dimensions on the diagrams of Fig. 567 need not be followed closely. The mirrors you buy (Fig. 568) may require a wider or a deeper box, or they may permit making the box smaller. If you can find box boards longer than 18 inches, make a longer periscope. It will be a simple matter to change dimensions to suit the mirrors and box boards.

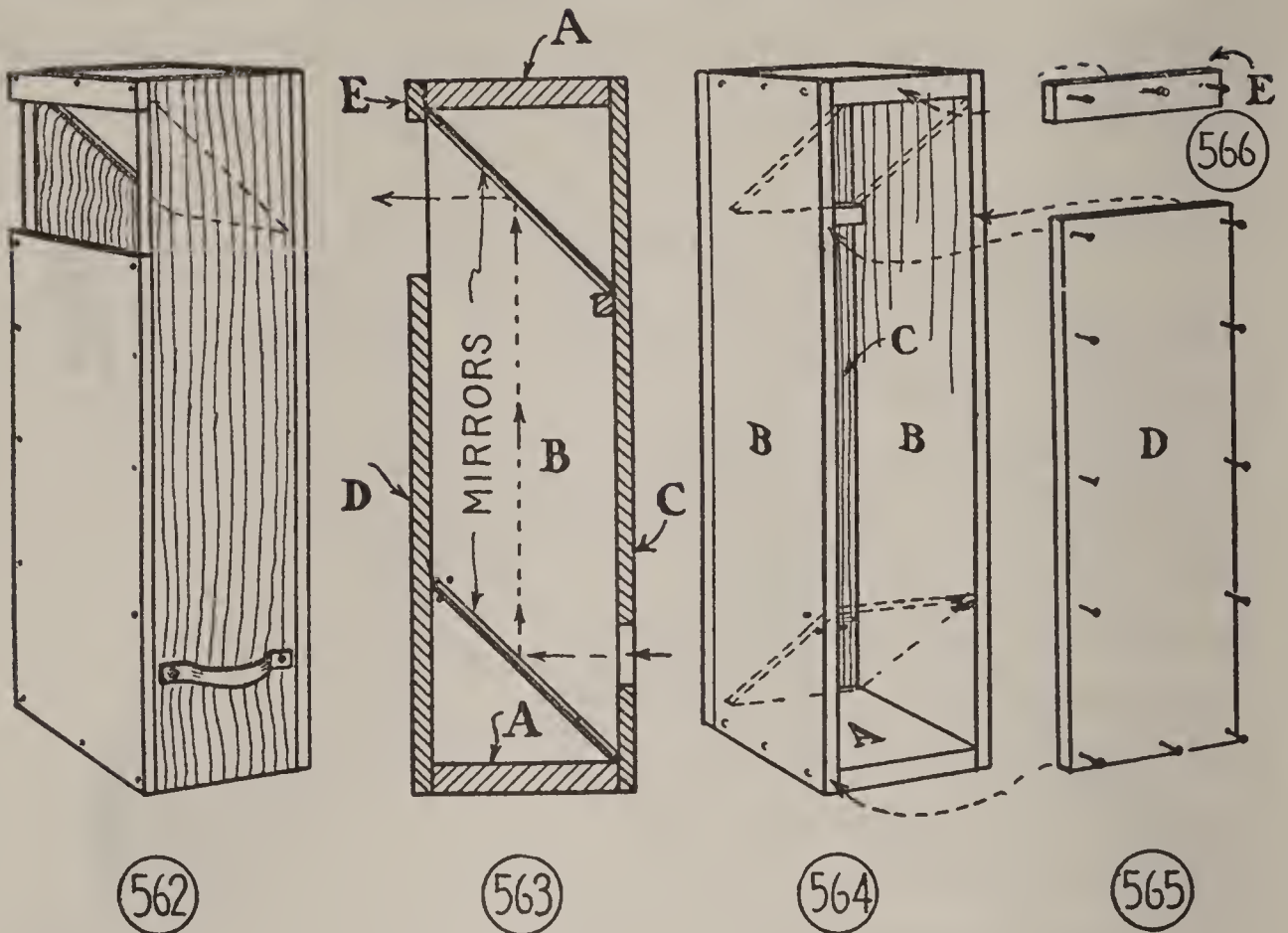

FIG. 562.—Completed Periscope.

FIG. 563.—Cross-Section of Periscope.

FIGS. 564-566.—Assembly Details.

### THE CONSTRUCTION IS SIMPLE

First, cut end pieces A and side boards B (Fig. 567) and nail boards B to the edges of ends A (Fig. 564). Back board C has the peep hole (Fig. 567). Cut the hole 2 inches in diameter, about 5 inches above the lower end. Unless you have a large bit, cut the hole with a coping-saw (Fig. 569). The hole doesn't have to be round, but if you describe a circle first, there is no reason why you cannot cut it round. If you haven't a small bit with which to start a hole to admit the saw blade, make a hole with a nail. Fasten back board C to the edges of ends A and sides B with nails.

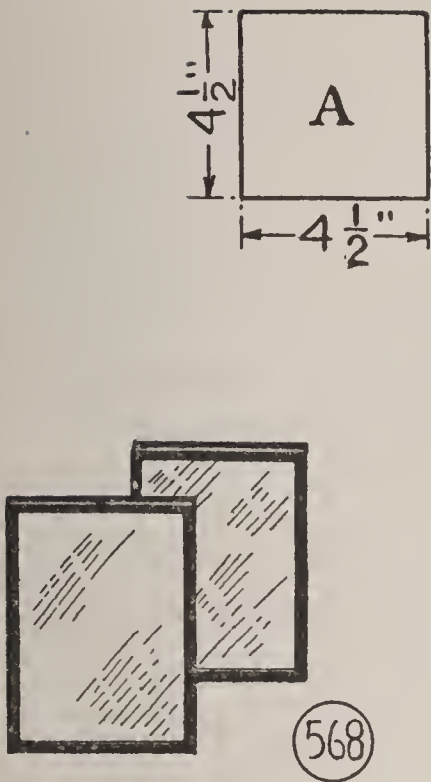

FIG. 568.—Mirrors.

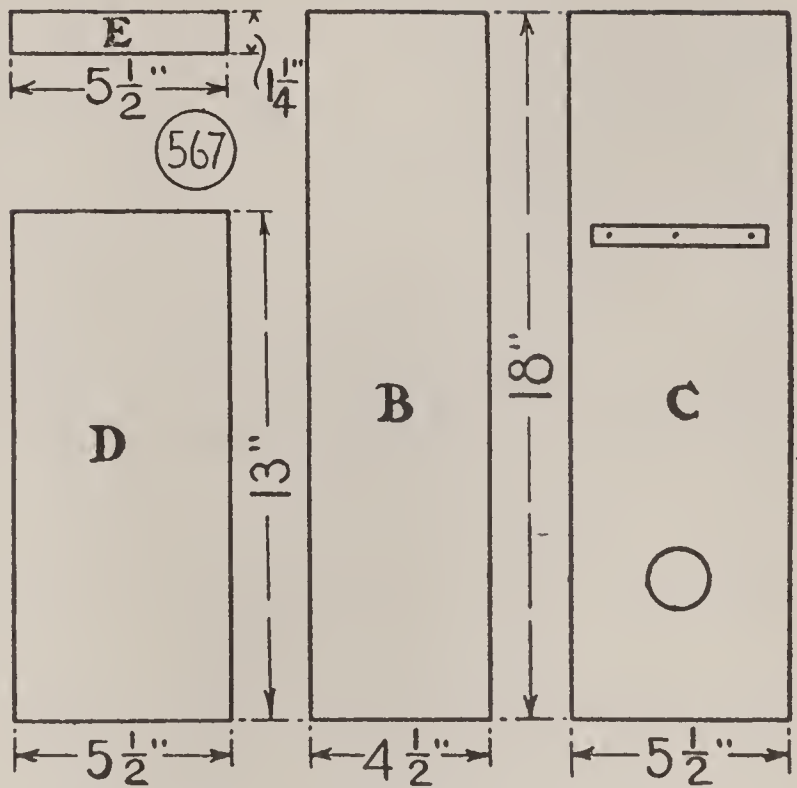

FIG. 567.—Patterns for Box.

Fit the Mirrors in position next. Tack a narrow cleat to back board C (Figs. 563, 564 and 567) to support the lower edge of the upper mirror, and nail the strip E (Figs. 566 and 567) across the front of the box to support the upper edge (Fig. 563). Let the lower edge of the lower mirror rest upon the box end, and support the upper edge on nails driven through the box sides, each side of the mirror frame, as indicated in Figs. 563 and 564.

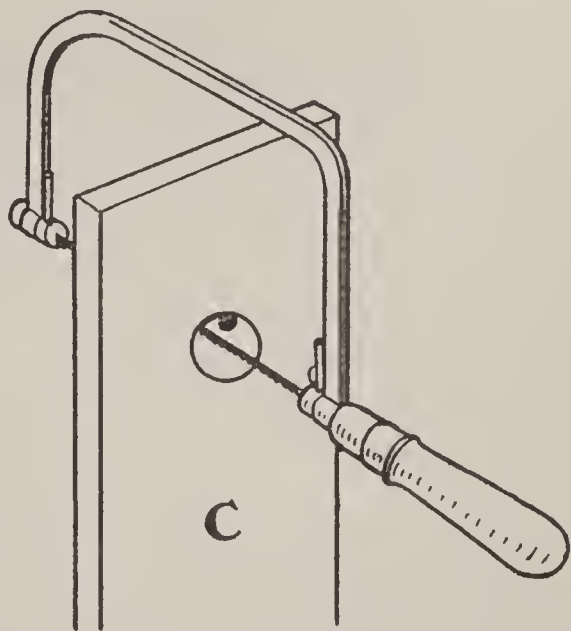

FIG. 569.—Cut Peep-Hole with Coping-Saw if You Haven't a Large Bit.

Complete the box by nailing front board D in place (Fig. 565), and tacking

**A Strap Handle** to each side near the lower end, as shown in Figs. 560 and 562.

#### PAINT THE INSIDE BLACK

before mounting the mirrors, to make the sides non-reflecting surfaces. Also paint the outside of the periscope.



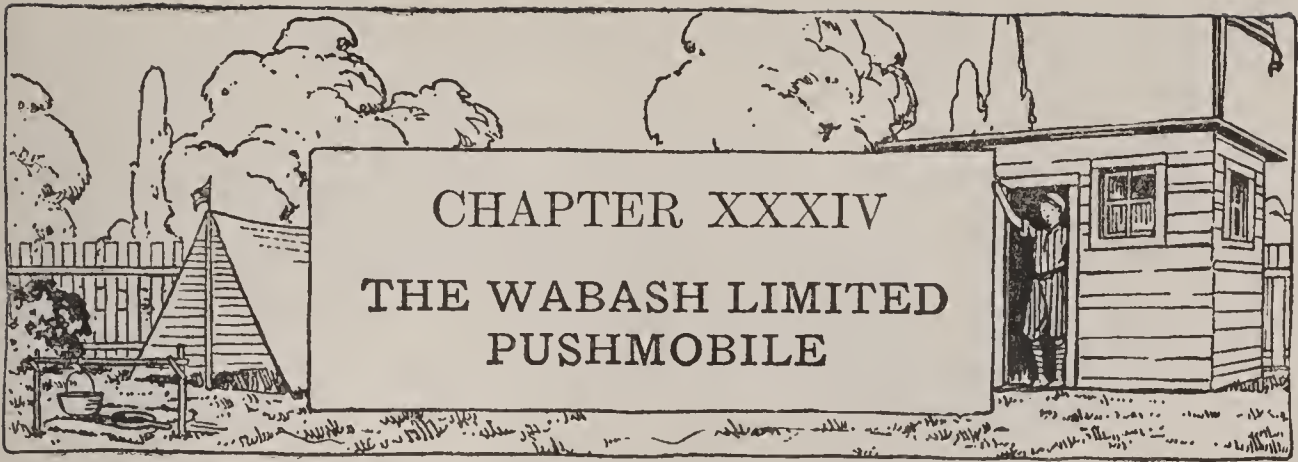

THE photographs opposite page 316 show one of the cleverest groups of boy-designed, boy-built vehicles that has come to my attention. These boy-size vehicles are a step between miniature models and the real thing. Building them is a hobby worthy of any boy's time and energy.

The railroad pushmobile in Fig. 570 was built by James and Aldwin Scott, Rowland Hardin and Charles Stevenson, the dump truck in Fig. 571 by the latter two boys, and the airplane pushmobile in Fig. 572 by James Scott.

In order that these examples of home-made vehicles may have an influence on the building of these and other types of rigs, I have made a record of them in the working diagrams of this and the two chapters that follow. Accept what you like, introduce your own ideas, and progress in the development of the home-made vehicle industry shall continue.

#### THE RAILROAD WORKING CAPITAL

at the disposal of the boy builders of the Wabash Limited consisted of a fund of patience, resourcefulness and ingenuity, a good sense of proportion, and a knack of assembling parts so they stay put.

### THE MATERIALS

did not cost a cent. Ten pairs of wheels, old boards and 2-by-4s, banana baskets, fruit crates, grocery boxes, tin cans, pans, stove pipe, and garden hose were used.

### THE TOOLS

used in building the Wabash Limited were few in number, but upon the publication of my newspaper articles descriptive of the model, officials of the Wabash Railroad presented each boy with a cabinet of twenty Stanley tools in recognition of his good work.

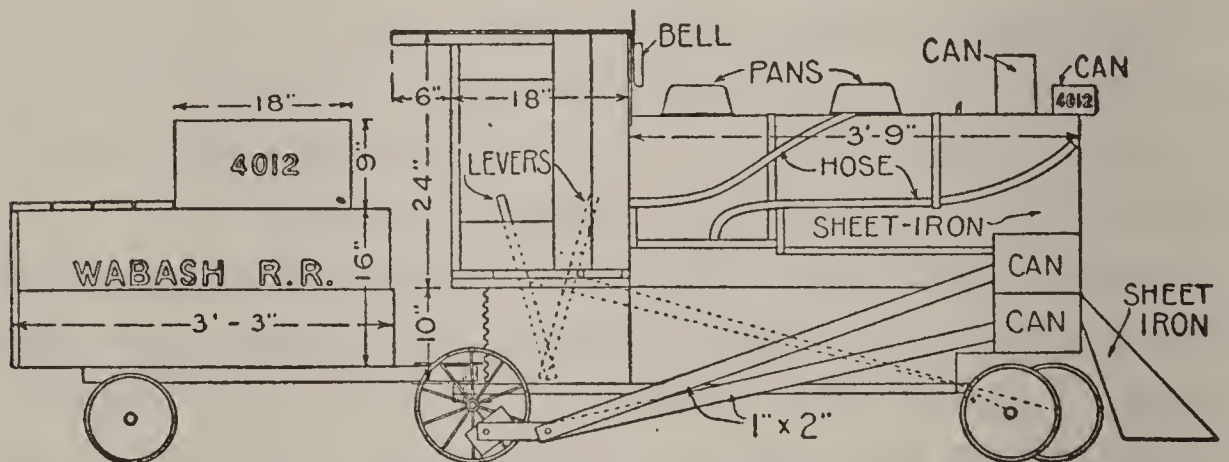

FIG. 573.—Side Elevation of Engine and Tender.

Fig. 573 shows a side view of

### THE LOCOMOTIVE

and Fig. 574 shows a head-on view. The first part built was

**The Chassis.** A 12-inch board 5 feet long was used for a reach (Fig. 575). The front end of this was cut away on each side, as shown, to provide for the turning of the



FIG. 570.—THE WABASH LIMITED PUSHMOBILE.



FIG. 571.—DUMP-TRUCK PUSHMOBILE.



FIG. 572.—AIRPLANE PUSHMOBILE.



wheels, and it was bolted to a 2-by-4 12 inches long, for the front wheel bolster. The rear end was nailed to a 1-by-4 board for the rear-wheel bolster.

The Wheel Axles were fastened with nails driven into the bolsters and bent over.

The Boiler Framework was built of two banana baskets fastened to a box 13 inches wide and 4 feet long, as shown in Fig. 576, then

The Boiler Jacket was formed of stove pipe, opened at the seams, flattened, bent to fit over the framework, and nailed to the box sides (Fig. 574). The boiler was mounted upon the chassis 10 inches above the reach board, with a 10-inch board fitted under each side to support it.

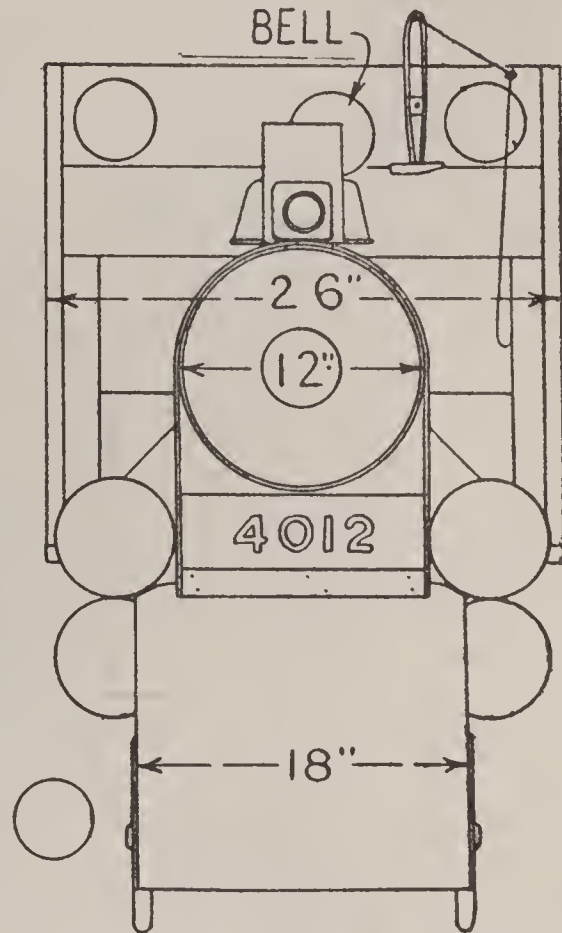

FIG. 574.—Head-on View of Engine.

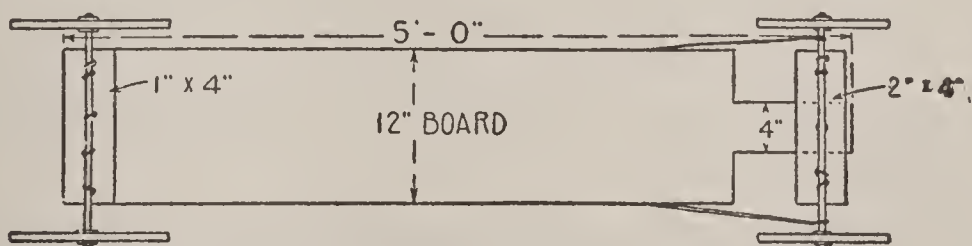

FIG. 575.—Plan of Engine Chassis.

The Cab has a base built out of a box 10 inches deep and 13 inches wide. The upper part was built to extend  $6\frac{1}{2}$

inches over each side of the box. Figs. 573 and 574 give the dimensions. The sides were made of  $\frac{7}{8}$ -inch boards, the roof of thin box boards.

The Driving Rods are ingenious. A block of wood was fastened to the spokes of each driving wheel, with bent-over nails. A short length of 1-by-2 was pivoted to the block with a nail, and two longer strips were bolted to the

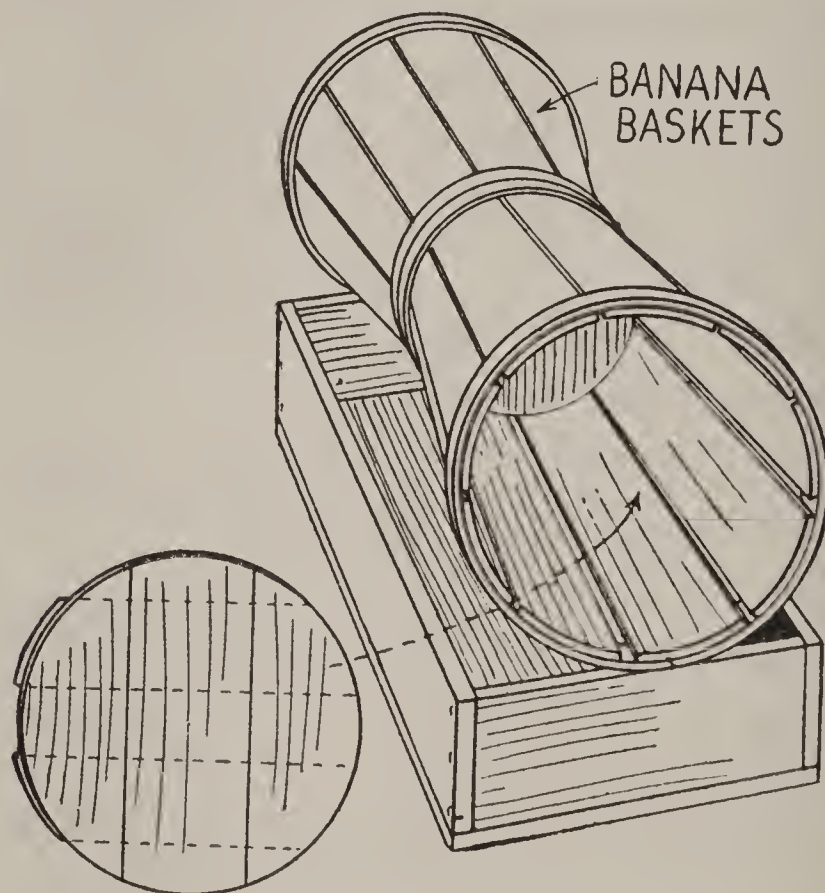

FIG. 576.—Detail of Engine-Boiler Framework.

end of the short piece (Fig. 573). Gallon-sized tin cans were used for

**The Cylinders.** One end of each was cut as shown in Fig. 577, then the two cans were mounted upon the chassis, as shown in Figs. 573 and 574, so the rods would slide back and forth in them.

The Steering Device is simple. Two stick levers were pivoted to the sides of the cab (Figs. 573 and 578), and ropes were run from them to the axle ends.

The Steam Dome and Sand Box were made of two sauce pans, inverted, and nailed to the top of the boiler.

The Stack was made of a coffee can 4 inches in diameter and 6 inches deep, and

The Headlight was made of a cocoa can.

Fig. 579 shows how

The Bell was made of the gong from an electric bell and a tack hammer,

with the hammer pivoted at its center to swing, and a cord attached to the handle and carried into the cab.

A Running Board was fastened on each side of the boiler, Steam and Water Pipes were formed of garden hose, and A Pilot was shaped out of stove pipe.

Inside of the cab are

Valves. One set was made of the head of a guitar (Fig. 580), others of worn-out faucets.

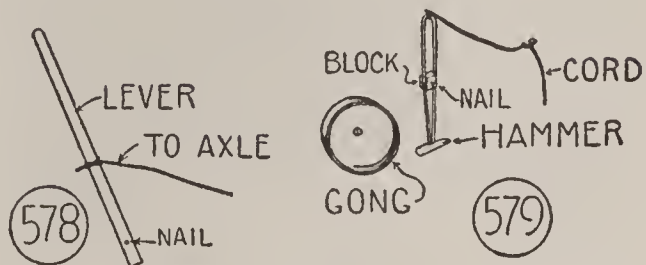
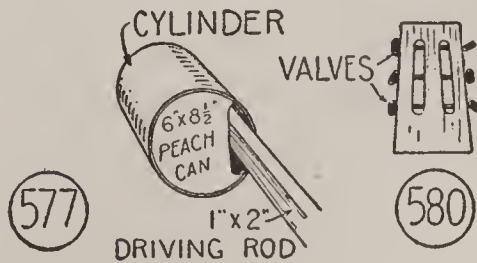

FIG. 577.—Detail of Cylinder and Driving Rod.

FIG. 578.—Detail of Steering Lever.

FIG. 579.—Detail of Bell.

FIG. 580.—Guitar Head Valves for Cab.

### THE TENDER

is a two-wheeled rig. Fig. 573 shows its length and height.

It is 21 inches wide. It was built like a cart, with high sides and part of the top boarded over.

### THE PULLMAN

with its observation platform is shown in detail in Fig. 581. It is 24 inches wide by the other dimensions given. This

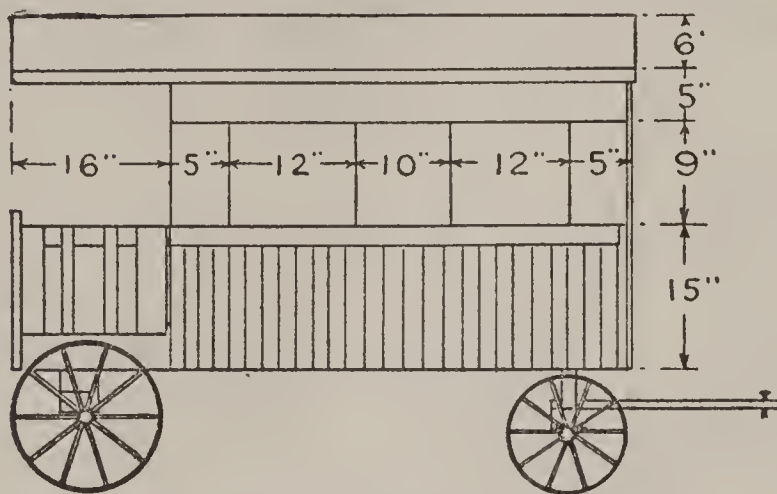

FIG. 581.—Side Elevation of Pullman.

car has four wagon wheels. It was built like an express wagon. Indeed, the Pullman body with observation platform might have been built to fit upon an express

wagon. Notice the bolt and shaft coupler.

### THE PAINT JOB

was not completed, because there wasn't enough paint, but what paint there was served to stripe parts to bring out details, and to letter the engine, tender and Pullman.



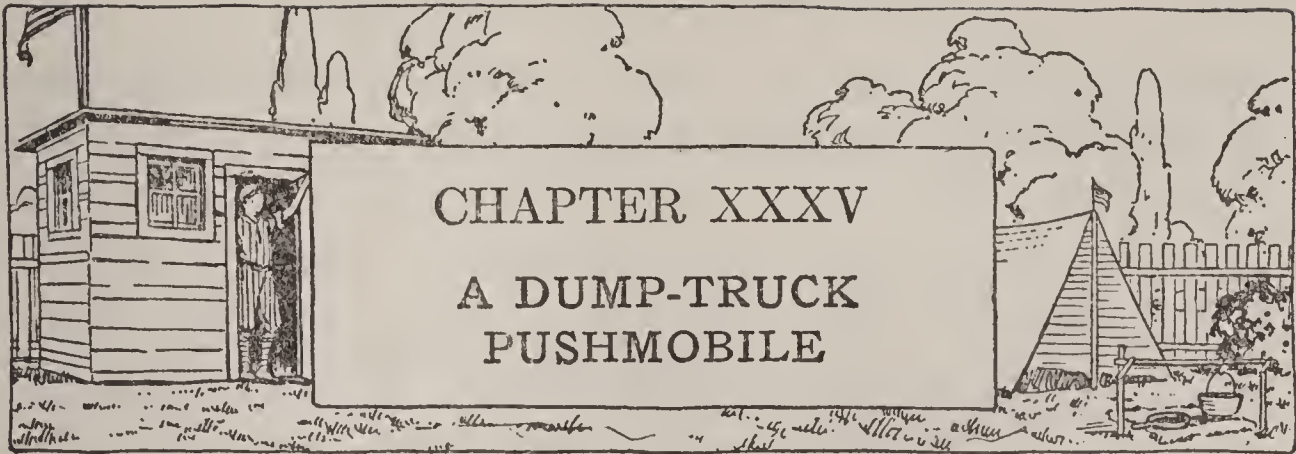

THIS new idea in pushmobiles is easy to carry out. It is the work of Charles Stevenson, shown in the photograph of Fig. 571, and of Roland Hardin. Both lads are enthusiastic model builders, and have no less than six types of wagons to their credit, besides a part ownership in the Wabash Limited pushmobile described in Chapter XXXIV. Collecting wagon wheels is one of their hobbies, and they own twenty pairs. No wonder, then, that it has been possible for them to equip the dump truck with double rear wheels. The boys are strong for reproducing details, as the photograph will convince you.

You will want to build one of these truck models. It will be different from any pushmobile owned in your neighborhood, and you will have great fun with it. I wish that you might see the original model, or my moving pictures which show the truck dumping a load of tin cans.

You will have your own ideas as to how this and that part should be built, and you can work out your own measurements for the parts altered, but the working diagrams will help you to shape up your plans.

Fig. 582 is a longitudinal section through the chassis,

hood, cab and truck, Fig. 583 is a plan of the under side of the chassis, Fig. 584 is a front elevation, Fig. 585 is a

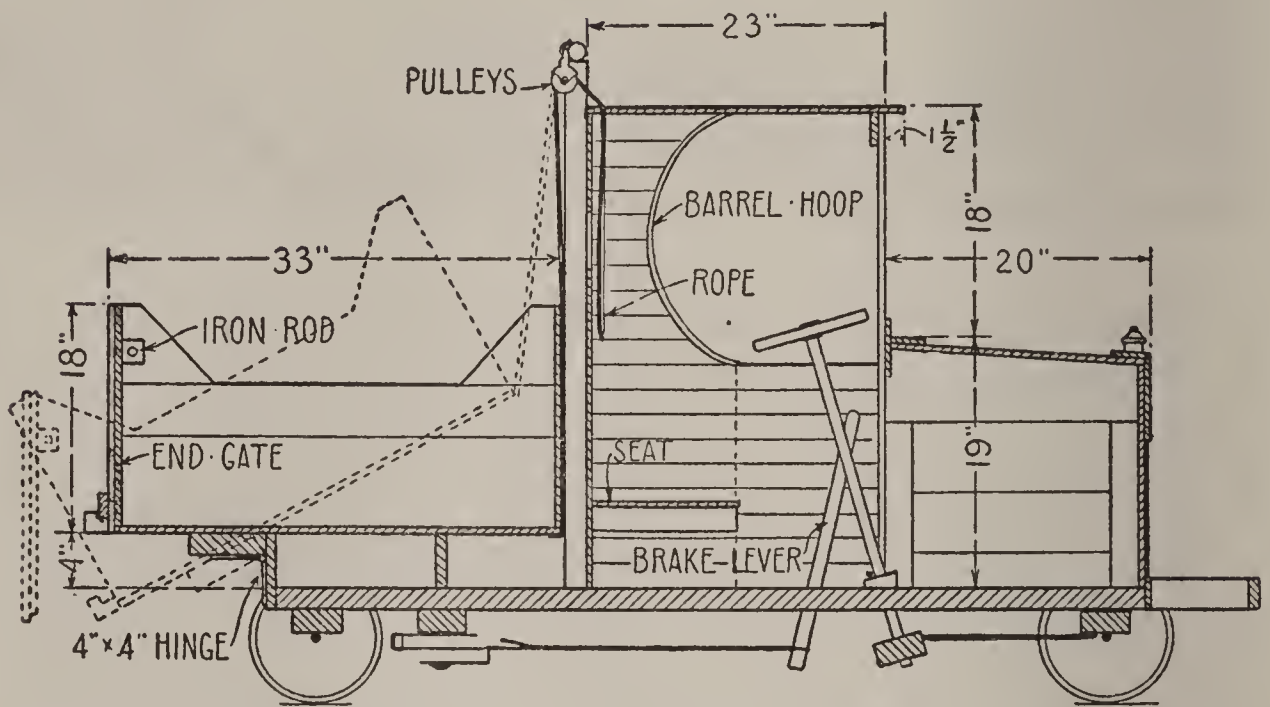

FIG. 582.—Side Elevation of Dump-Truck Pushmobile Shown in Photograph of Fig. 571.

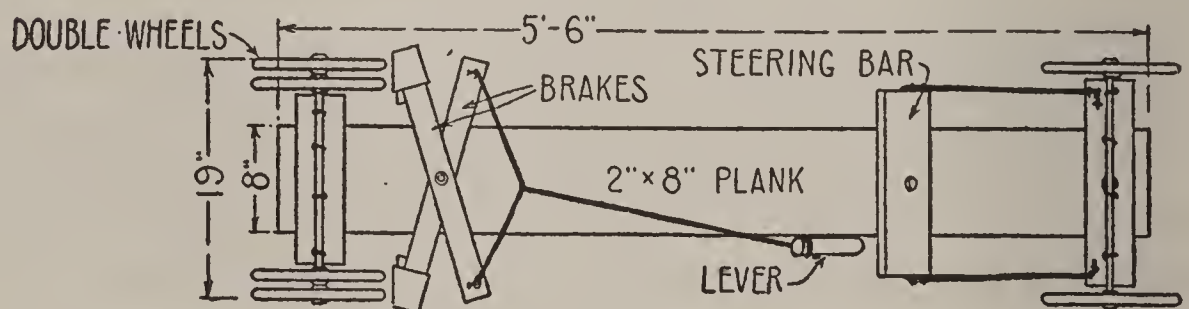

FIG. 583.—Plan of Under Side of Chassis.

detail of the steering gear, and Fig. 586 is a detail of the brakes.

### THE CHASSIS

was made of a 2-by-8 plank 5 feet 6 inches long, with the

rear wheel axle bolster spiked to the rear end, and the front wheel axle bolster pivoted with a carriage bolt to the front end. The bolsters were cut from a 2-by-4. The wheel axles were fastened to them with nails driven each side of the rods, then bent over. Staples would be better than nails.

**THE STEERING GEAR** shown in detail in Figs. 583 and 585, required a bar a trifle shorter than the axle bolsters, a broom handle steering shaft and a wagon wheel steering wheel. The shaft was run through a hole bored through the center of the steering bar, and fastened to the bar with a nail. A bearing block like that shown in Fig. 585 was used. A hole was bored through this block to admit the shaft, and the lower face was cut on a bevel to fit the chassis plank when the

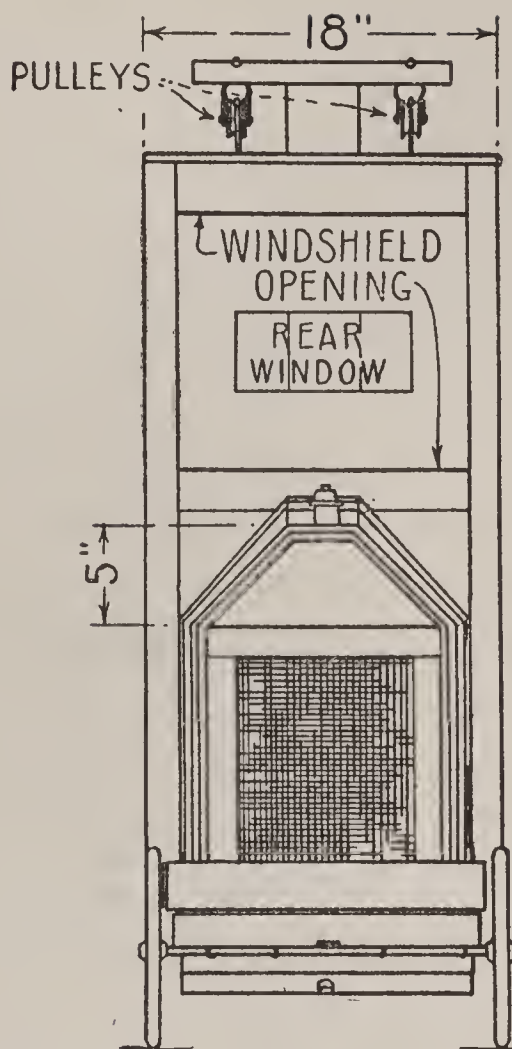

FIG. 584.—Front Elevation of Dump-Truck Pushmobile.

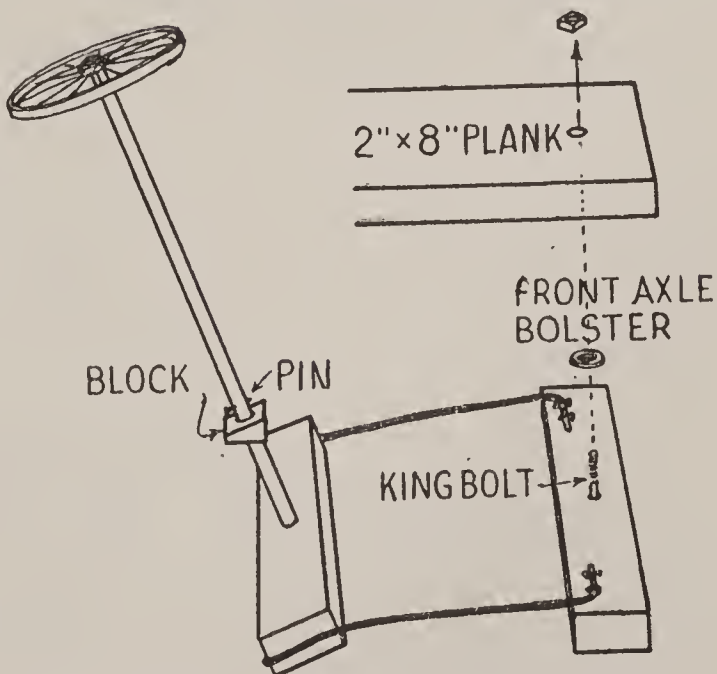

FIG. 585.—Detail of Steering Gear.

shaft had been set up with a rake to it, as shown in Fig. 582. The block was nailed to the chassis plank, and a spike was driven through the shaft for a pin to keep the shaft from slipping through the chassis plank. With the wheel, shaft and bar assembled, ropes were attached to nails driven into the bar and axle bolster, to complete the steering gear.

### THE BRAKING DEVICE

is ingenious. Two pieces of 1-by-2 were crossed at their centers and bolted to the chassis plank, as shown in Fig. 583, at the right distance from the rear wheels, so when one end of each bar is pulled forward the other end is drawn against the wheel. The braking end of each bar was fitted with a triangular block to make square contact with the wheel. The blocks were attached as shown in Fig. 586. The brake ends were covered with rubber from an old automobile tire tube.

Figs. 583 and 586 show how the brake bars were connected to the broom handle lever, and how the lever was pivoted to the edge of the chassis.

### THE TRUCK CAB

was built of box boards, with the curved side openings trimmed with barrel hoops. The seat was supported upon end cleats, as shown in Fig. 582.

### THE HOOD

was built of box boards. Figs. 582 and 584 show the details. A piece of wire mesh was set in the front for the radiator, and a tin can was nailed to the top for a cap.

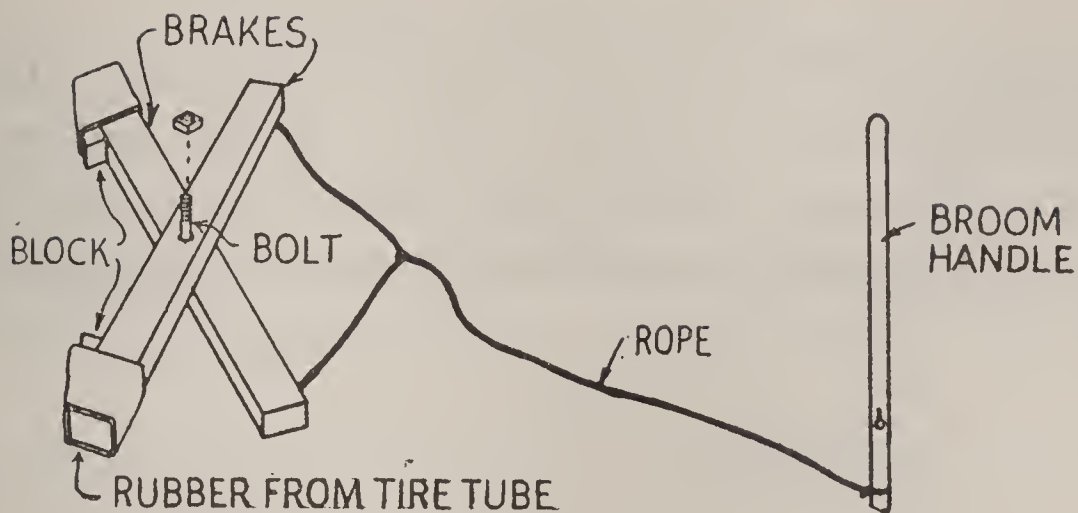

FIG. 586.—Detail of Brakes.

### THE TRUCK BOX

was made of a packing box. One end was removed, and its boards were fastened together with battens, then hung between the box sides, on an iron bar (Fig. 582) for the end gate. Two strips with notched ends were nailed to the box sides, and a stick was provided to reach across the back of the box and drop into the notches to lock the end gate.

The photograph of Fig. 571 shows the device for locking the box. It is a stick that slides between two wooden blocks that were nailed to the cab side. The stick end is pushed back over the block on the box to lock the box, and drawn forward to unlock it.

The truck box was supported upon blocking to raise it 4 inches above the chassis plank, as shown in the photograph and Fig. 582. A piece of 2-by-4 was nailed across the box bottom, then this was hinged to a piece of board nailed to the plank end.

### THE DUMPING HOIST

was made of a piece of 2-by-4 with a wooden bar nailed to its top (Figs. 582 and 584), a pair of pulleys fastened to the bar, and ropes attached to the box bottom, run up to and over the pulleys then down through a hole in the cab roof.

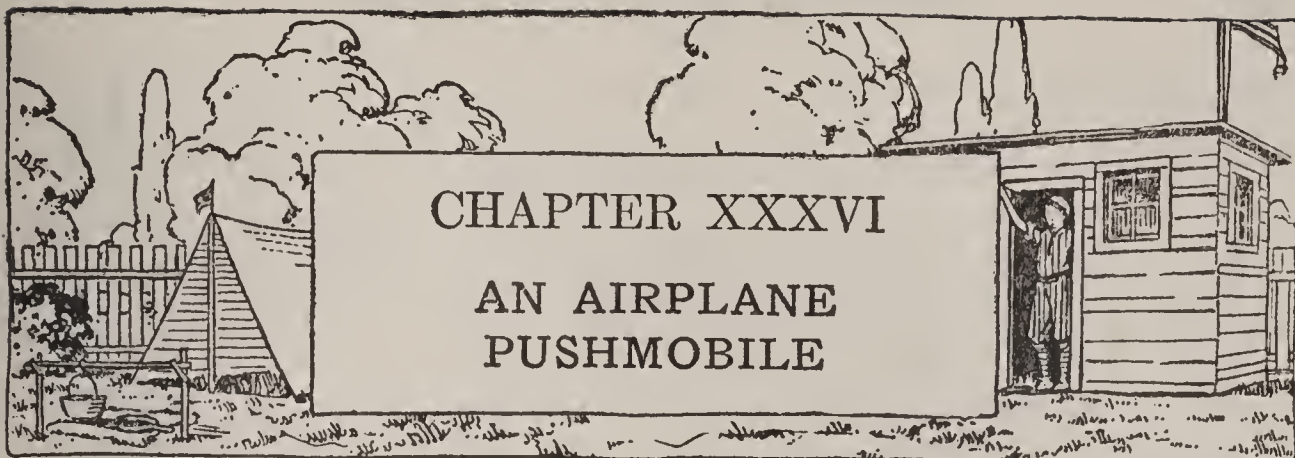

## CHAPTER XXXVI

### AN AIRPLANE PUSHMOBILE

SOME of you boys may be no more interested in the intricacies of miniature model-making than James Scott is. Toy railroads don't appeal to James. He wanted an engine large enough to ride in. He designed and helped to build the Wabash Limited pushmobile described in Chapter XXXIV. He would have none of the store automobiles. He built a dandy roadster pushmobile. He made several model airplanes, but they only whetted his ambition to own a model in which he might fly. Possibly he will never succeed in building a real ship. That lies in the far future. But he has progressed as far as building the large motorless monoplane pushmobile shown in the photograph of Fig. 572, and described in this chapter, and he is quite the proudest and most envied lad in the neighborhood. You would be, too, with such a model, and I am certain that you will decide to build one in your back yard. Pushed over the ground, with the wind turning its propeller, this model furnishes the realism and much of the thrill of the preliminaries to an actual taking off.

The general dimensions of James' airplane pushmobile are given on the accompanying working diagrams, but you

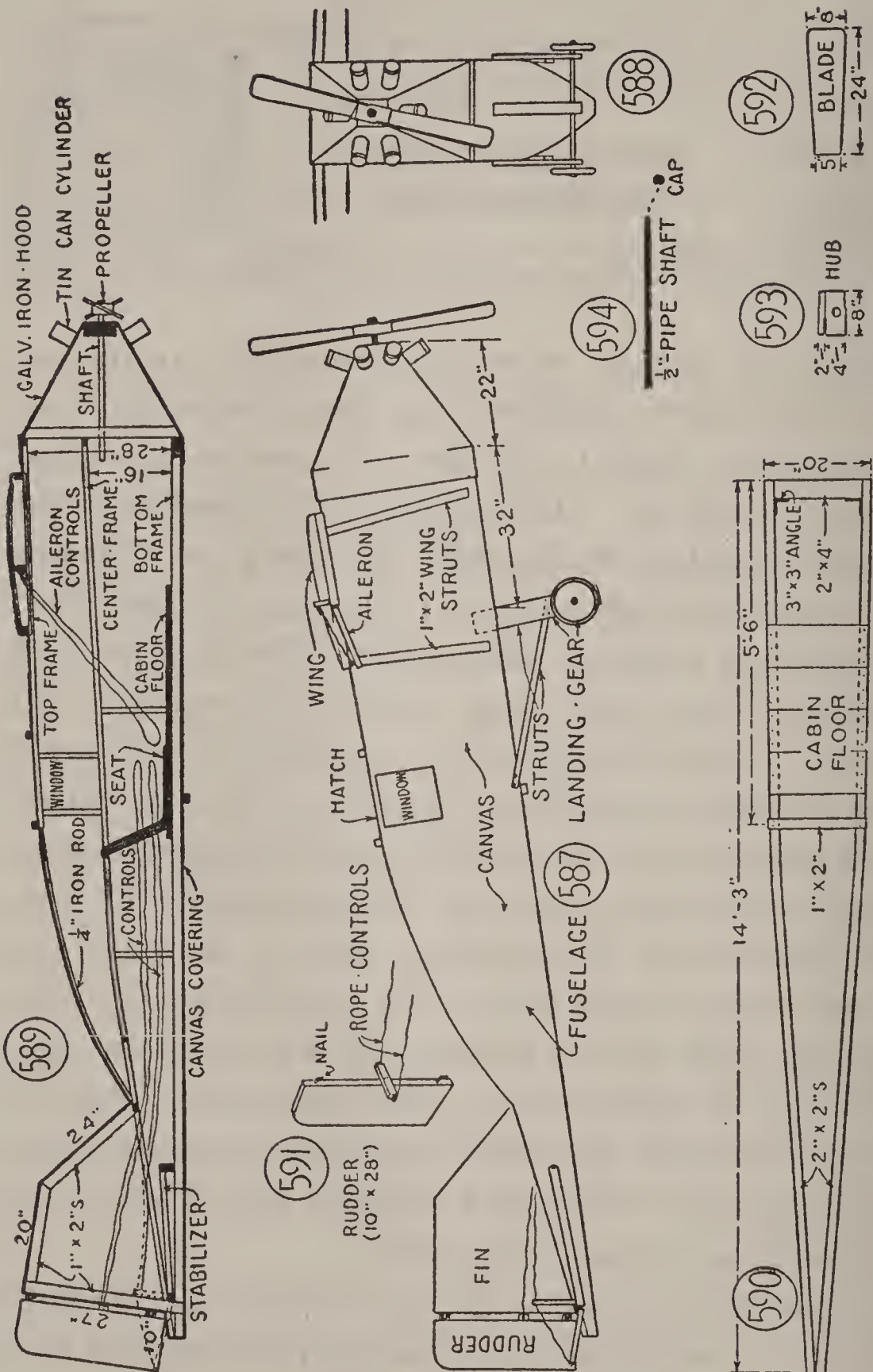

FIG. 587.—Side Elevation of Airplane Pushmobile (Shown in Photograph of Fig. 572.) FIG. 588.—Front Elevation. FIG. 589.—Longitudinal Section of Fuselage. FIG. 590.—Plan of Bottom Frame of Fuselage. FIG. 591.—Rudder Detail. FIG. 592.—Propeller Blade. FIG. 593.—Propeller Hub. FIG. 594.—Propeller Shaft.



can build a Ryan, a Curtiss or a Ford from the photographs and working drawings given in Chapter XI, or any other model that you want.

Fig. 587 shows a side elevation of James' model, Fig. 588 a front view, and Fig. 589 a longitudinal section of the fuselage.

### THE FUSELAGE

was started by making a bottom frame like that in Fig. 590. This was built of two 2-by-2s, a 1-by-2 and a 2-by-4. Then a duplicate frame was built of 1-by-1s for a center frame, shown in Fig. 589. The rear end of this frame was fastened to the bottom frame, the forward end to uprights, as shown. The top frame (Fig. 589) was curved two ways. The forward part of this was made by 1-by-1s, the rear portion of iron rods. The front ends of the rods were fitted in holes bored in the 1-by-1s, and the rear ends were fitted in holes bored in the center frame strips.

The Cabin Window was framed with upright strips, and The Hatchway was framed with cross strips.

To complete the fuselage framework, all corners were reinforced with iron angle braces, and a cowling of galvanized iron was shaped to fit over the nose.

### THE FIN

was built upon the tail of the fuselage, of three strips of 1-by-2 of the lengths marked in Fig. 589.

### THE RUDDER

was made of a board. Fig. 591 shows a detail of it. Two

nails were driven into the edge of the board, and bent to form pins, and a pair of screw-eyes were screwed into the fin frame to hook the pins into. A crosspiece with rope controls attached to its ends completed the rudder.

The donation of a discarded airplane propeller was James' good luck. But you can make one by cutting two board blades (Fig. 592) and fastening them in slots cut diagonally in the ends of a 2-by-4 hub (Fig. 593). Bore a hole through the hub, to admit the threaded end of a piece of iron pipe (Fig. 594), and screw a pipe cap to the threaded end to hold the propeller on the shaft. Run the shaft through holes in a block set in the nose of the fuselage, and through a hole in an upright placed 24 inches back of the block.

### THE MOTOR CYLINDERS

were made of tin cans. James used six cans, but there should be seven or nine. The cans were bolted to the cowling.

### THE WING

was made in two sections. A half plan of the wing framework is shown in Fig. 595. To give it proper camber, a strip of 1-by-3 was placed on edge for the center spar, a 1-by-2 was placed on edge for the leading-edge spar, and a 1-by-2 was set flat for the trailing-edge spar. The rear edge was cut away at the ends to admit two ailerons, as shown in Fig. 595, and pieces of board were set in and hinged to the center spar. The framework was then covered on both sides with thin boards.

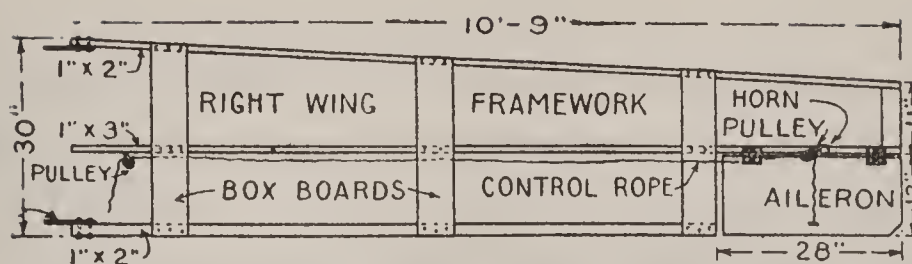

FIG. 595.—Half-Plan of Wing Framework.

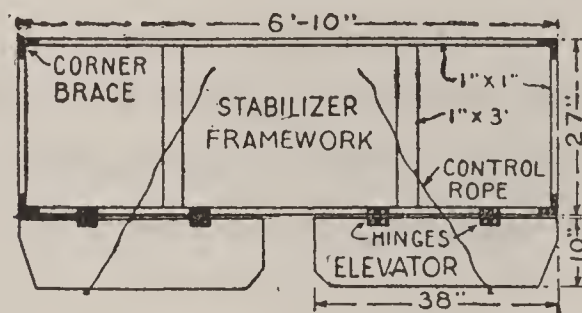

FIG. 596.—Half-Plan of Stabilizer Framework.

### THE STABILIZER

was built in one piece (Fig. 596), with a frame of 1-by-1s and 1-by-3s, and two boards hinged to it for elevators.

### THE LANDING-GEAR

was built of a pair of rubber-tired wheels, an iron axle, two 1-by-3 uprights and three diagonal struts, set up as shown in Figs. 587 and 588.

### THE COVERING

After the fuselage, wing, fin, and stabilizer frameworks had been completed, they were covered with canvas. A light-weight cotton duck will do, or, building paper, unbleached muslin or poultry feed bags.

### THE CABIN

is shown in the longitudinal section. Here you will see the controls for the ailerons, elevators and rudder. Rig up a joystick and pedals for operating the controls. The pilot's seat of the model illustrated was upholstered with leather from an old couch.

### PAINT THE SHIP

so that it will not look like a tramp outfit. James Scott used a battleship gray, with black lettering. Radiator aluminum paint will make an attractive finish.

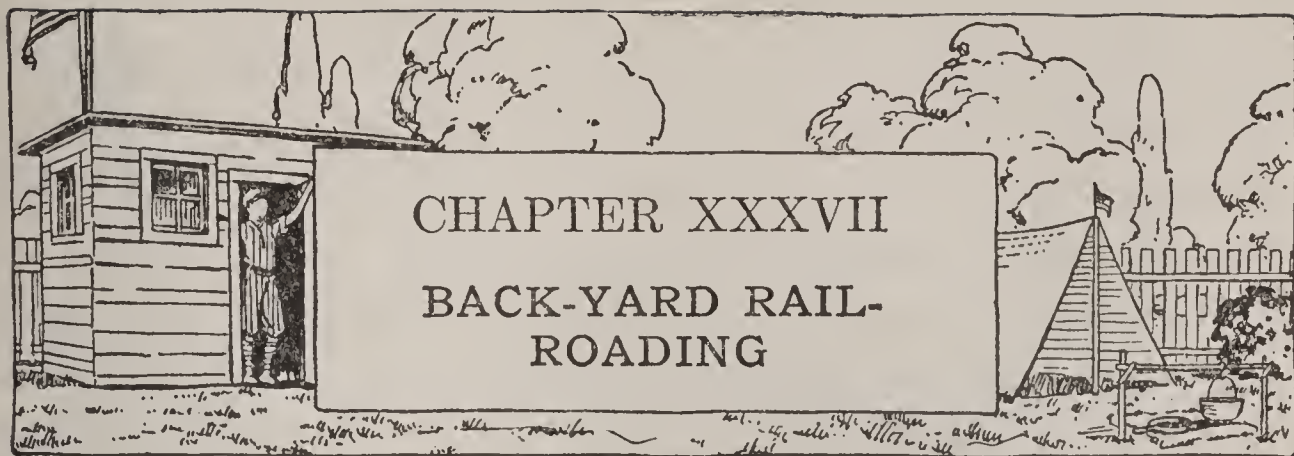

BUILDING model railroad systems is a recent development of an idea popular as long ago as when I was a lad. Present widespread interest has been brought about by the manufacture of nicely proportioned railroad equipment of American types, including practically everything to be found in modern railroad systems. When you get your hands on this real-looking stuff, you cannot resist the impulse to build a model, and once you have started, there is no telling how extensive the layout will be.

This modern toy railroad business makes us older boys wish that we were in our teens again, but years do not prevent our building models, and if at first we are not as agile in getting around on the ground, we can train into condition. Use a stop-watch on Dad, after you have got a good start on a back-yard model, and see how long he keeps out of the game.

Models that we built would seem crude to-day, but probably not more so than any vehicle setting of former days compared with one of the present time. An engine run by clockwork, cast-iron trains drawn by a string, were the best equipment available then. But you boys have electrical

railroads, exact models of real engines, trains, depots, bridges, signal systems and other accessories to select from, for which good fortune you are indebted to wide-awake American toy manufacturers.

Because the toy railroad catalogs are filled with wonderful equipment, however, do not feel that all this is essential to a good model. If you own track, engine, tender, several cars, a switch or two, and a transformer to connect to the house or garage electric current, or a battery of dry cells, consider yourself in luck. You can

#### MAKE ACCESSORIES

including a railroad station, water tank, signal tower, gates, bridge, tunnels, and culvert, and get lots of fun out of the work.

The photograph of Fig. 597 shows

#### A VILLAGE MODEL

built by Mr. Clyde Nolan, a model enthusiast, who has a dozen or more layouts to his credit. Notice how complete this model is, with its railroad viaduct to the right, in the background, tunnel entrance to the left, lake in the foreground with a concrete bridge across it, and business block of store buildings and a church. Besides being very complete, everything is in proportion. Exactness of detail is important.

The photograph of Fig. 598 shows

#### A ROCKY MOUNTAIN MODEL

built upon my studio lot. Besides the mountain creek with

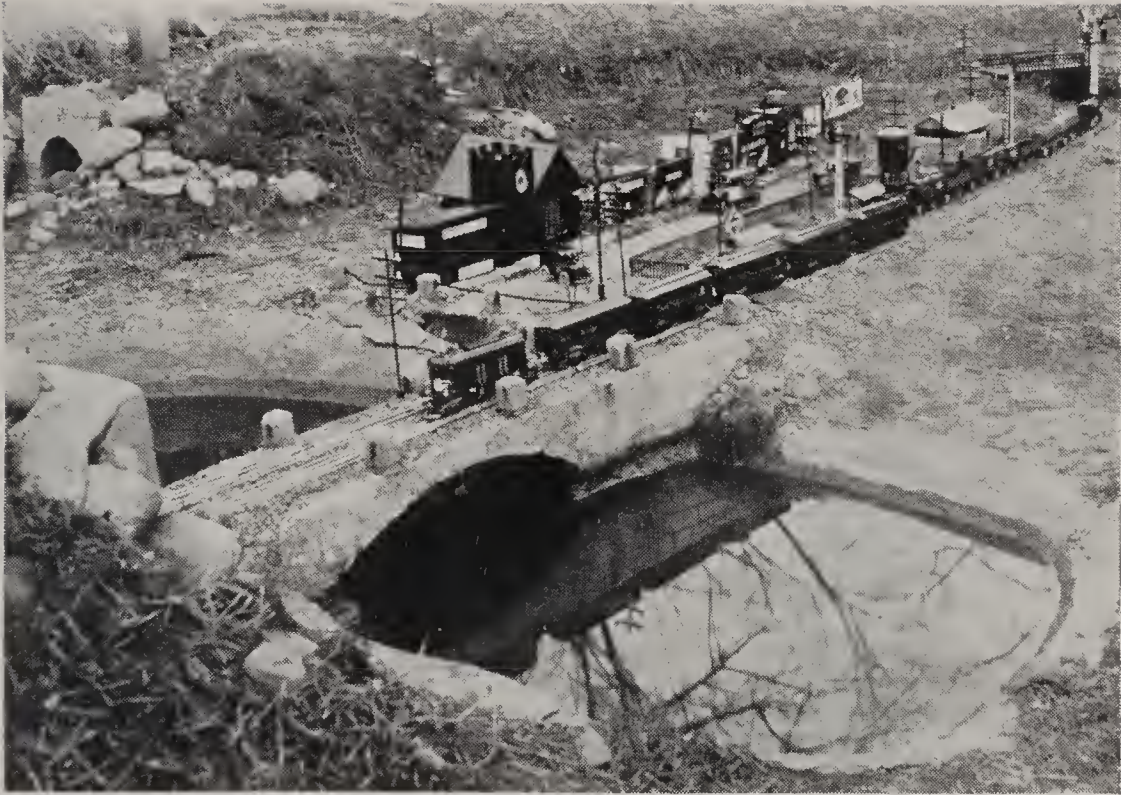

FIG. 597.—VILLAGE MODEL BUILT BY CLYDE NOLAN.



FIG. 598.—ROCKY MOUNTAIN MODEL BUILT BY AUTHOR.





railroad bridge and corduroy bridge, tunnel and railroad depot, shown in the picture, there are many developments on the hill not visible, which represent many hours of study and modelling.

It is not expected that you will want to copy either model, but you will get ideas from each, which will assist you in creating a model. Indeed, since the material in this chapter was published in my department in *The American Boy* several years ago, I have received many photographs from readers showing models in which the ideas have been incorporated.

If you have never attempted this form of model building,

#### START WITH A SIMPLE MODEL

like that shown in Fig. 599. Then add other features, and gradually develop it into a large model. That is what my reader Paul Baurle did, and a photograph which I have before me would indicate that his present model takes up the greater part of his back yard, and includes such features as a mountain range, tunnel, waterfall, creek, lake, quarry, village, buildings, lumber yard and railroad terminal.

One of the most interesting engineering problems is

#### BUILDING A MODEL LAKE

When I built my first model, cement was expensive, and no one thought of using it for model-building. So I contrived

**A Wash Tub Lake** by sinking a tub in the ground with

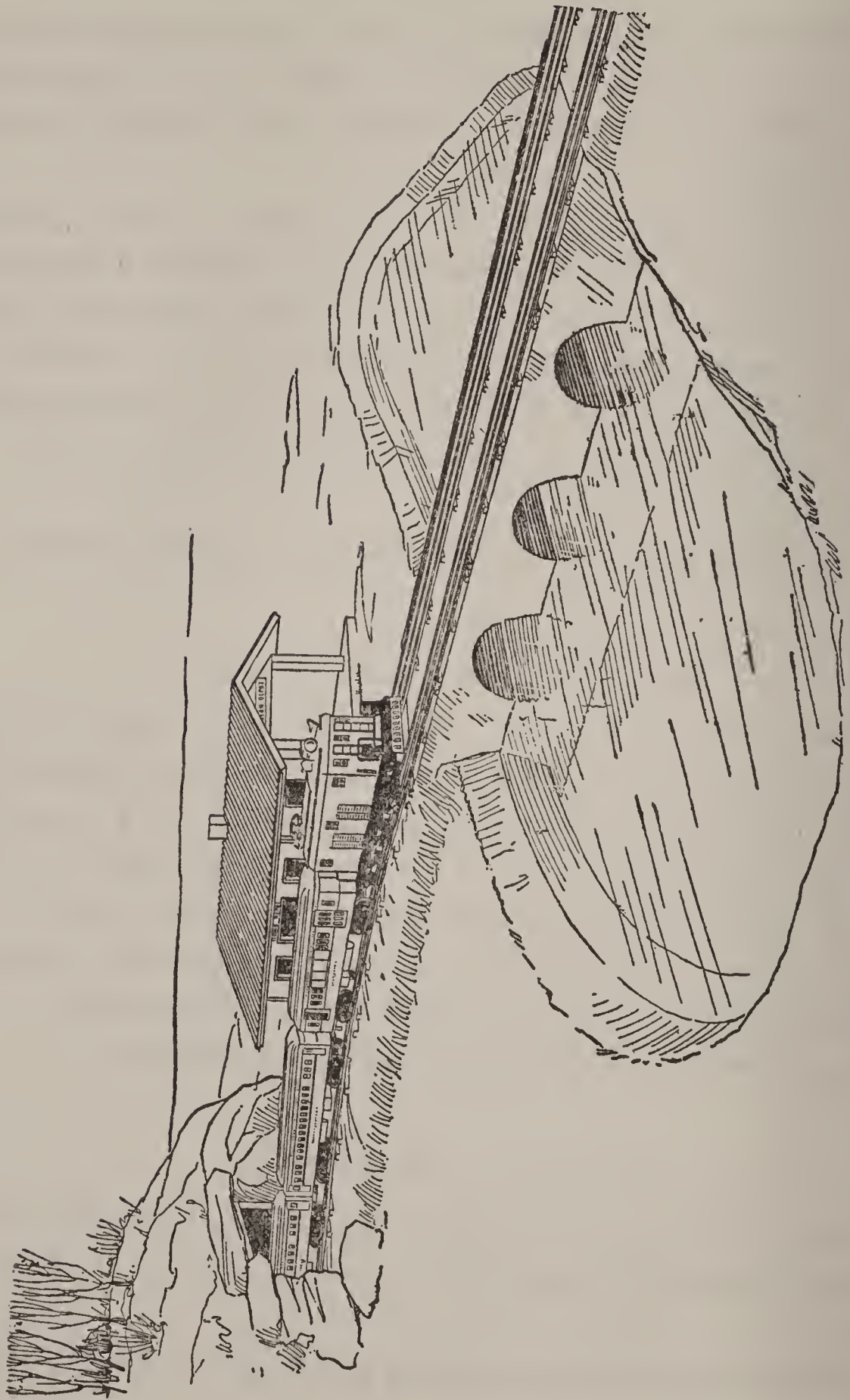

FIG. 599.—Start with a Simple Model Like This.

its rim level with the surface. If you use a tub, replace it with

**A Concrete Basin** as soon as you can get the material to cast one. One bag of cement, twice that quantity of sand, and twice as much crushed stone or clean gravel as sand, will build a basin 24 inches wide, 48 inches long, and 6 inches deep. Dig a hole irregular in shape, as shown in Fig. 599, and cast the basin in the manner described for the fish-pool in Chapter XXIV. Indeed, this may be used as a fish-pool.

#### A MOUNTAIN CREEK

like that in the photograph of Fig. 598 should be narrow and zigzag. Fig. 603 suggests what a cross-section of the creek may look like, with one bank ballasted for railroad roadbed.

The next engineering problem, after establishing the creek, is to throw

#### A RAILROAD BRIDGE

across it. If you will look in an encyclopedia, you will find pictures and descriptions of arched bridges, suspension bridges, cantilever bridges, box-girder bridges, trussed bridges and other types. You can build several kinds, if you want to.

#### A CONCRETE BRIDGE

like that shown in Fig. 599 is a good one and it is easy to build. It requires

**A Form** like that shown in Fig. 600. Cut two boards of

the shape shown in Fig. 601, to fit between the sides of the basin, as in Fig. 600, for the sides of the form. Alter the dimensions to suit your basin. The projections on the board ends should extend over the banks. Provide for

**The Arched Openings** by nailing three tin cans of No. 3 size to one of the side boards, as shown in Fig. 602.

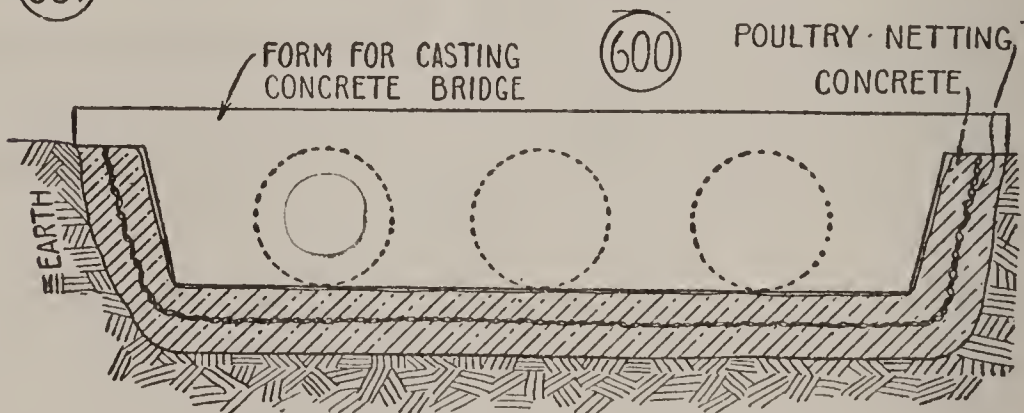
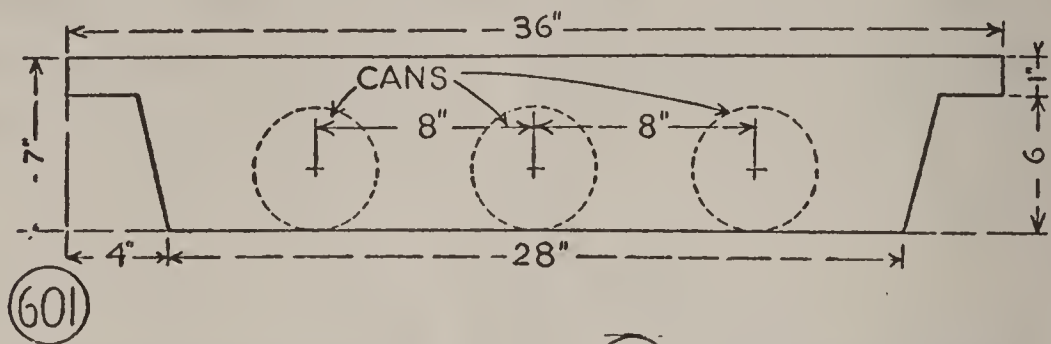

FIG. 600.—Cross-Section of Concrete Lake.  
FIG. 601.—Side of Form for Casting Lake.

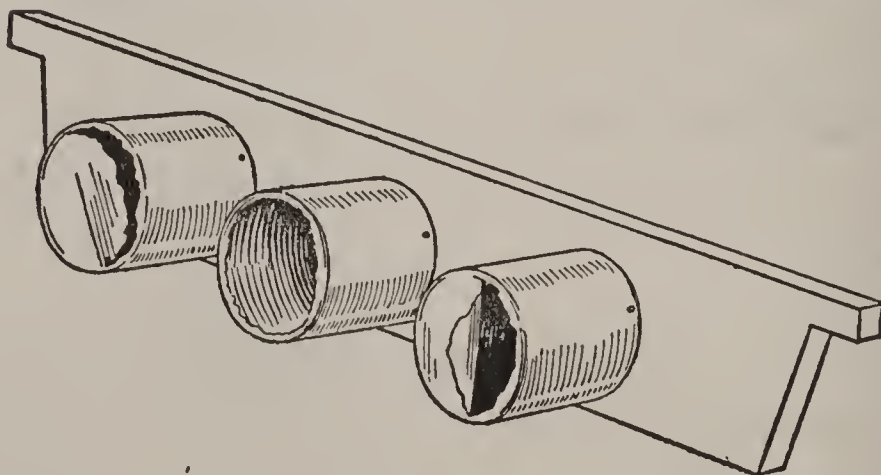

FIG. 602.—Side of Form with Cans Attached for Casting Arches.

Set the form in the basin, then wedge sticks between it and the ends of the basin to keep it from spreading when you pour the concrete.

Mix the Concrete somewhat sloppy so that the thin portion will run down at the sides and give the exposed surfaces a smooth finish. When you have poured and tamped the concrete and allowed it to set twenty-four hours, remove the form.

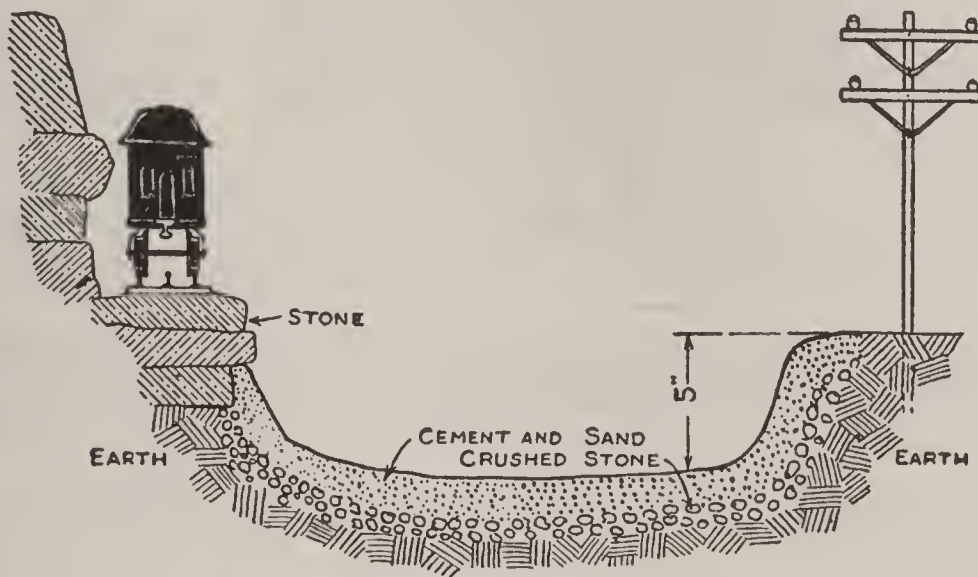

FIG. 603.—Cross-Section of Creek, with Ballasted Roadbed on Bank.

The photograph of Fig. 597 shows

#### A DIFFERENT DESIGN OF CONCRETE BRIDGE

The form for casting it will be the same as that for the bridge in Fig. 599, with the substitution of a piece of sheet metal for the tin cans. Lay iron rods or lengths of heavy wire in the form for reinforcement.

#### A BOX GIRDER TYPE OF BRIDGE

is shown in the photograph of Fig. 598, and in the detail

drawings of Figs. 604 to 609. It is an easy model to build. This one has three spans supported upon four abutments or

Piers. The center piers are tin cans with tapered sides, the kind that corned beef is packed in. Cans with square sides will do, if you cannot get the tapered ones.

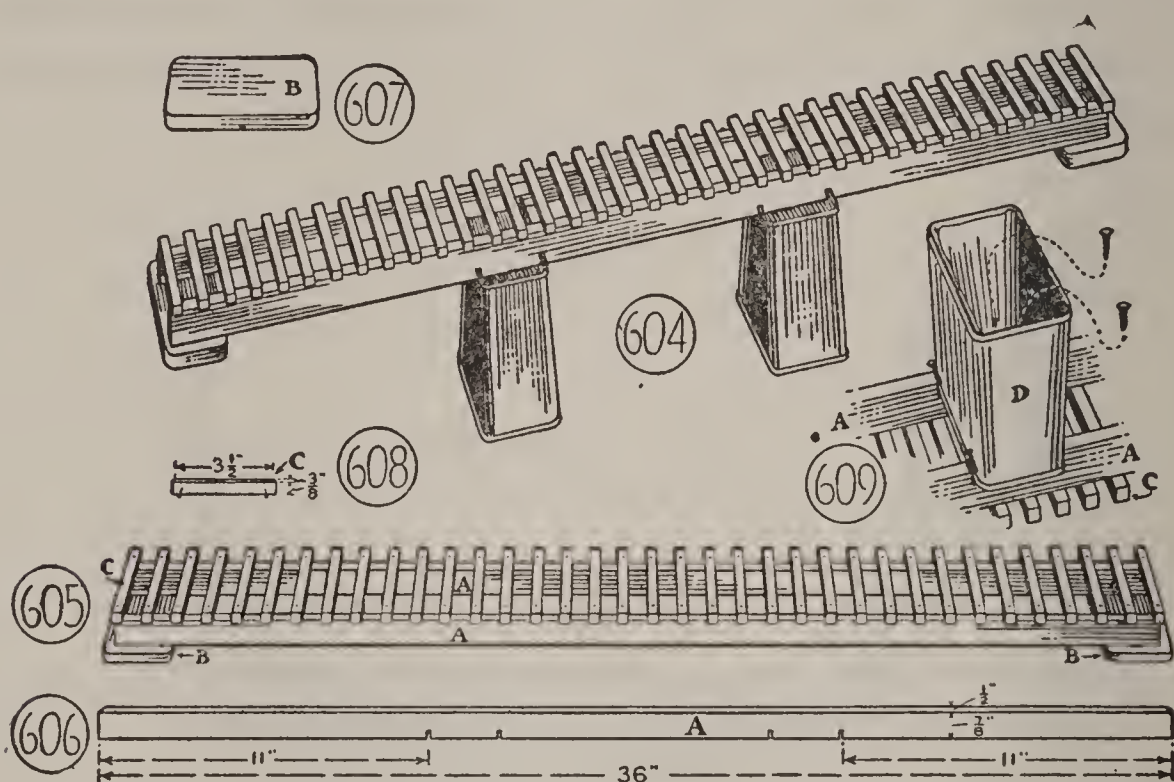

FIG. 604.—Box Girder Type of Bridge Used in Model in Photograph of FIG. 598.

FIG. 605.—Assembly of Girders, Pier Blocks, and Ties.

FIG. 606.—Girder.

FIG. 607.—Pier Block.

FIG. 608.—Tie.

FIG. 609.—Pressed-Beef-Can Pier.

The drawings show a bridge 36 inches long with The Roadbed  $3\frac{1}{2}$  inches wide. Fig. 605 shows a detail of the roadbed assembly. Cut two sticks of the size shown in Fig. 606 for

The Girders, and nail their ends to pier blocks B (Fig.

607). Cut the blocks of the same size as the can tops. Prepare

The Ties of the dimensions in Fig. 608. Cut them from box boards, or from tree branches whittled flat upon two sides. Space them at equal distances apart, along the girders. Use a block of wood  $\frac{5}{8}$ -inch wide for a spacing block. Nail the ties with 1-inch brads.

Fig. 606 shows how to cut notches in the under side of the girder strips for the rims of the tin-can piers to fit in. Fasten the cans to the girder strips with nails. Drive the nails through the ends and through the rims, as shown in Fig. 609.

Paint the piers white or gray to represent concrete, the girders white, red or black.

If you want to build

### A STEEL BRIDGE

use parts from a steel construction toy. You will find a design in your instruction book.

### A TRUSSED BRIDGE

of the corduroy type, common to the wagon road of the old West, is shown in the photograph of Fig. 598. Fig. 610 shows the complete bridge, and Figs. 611 and 612 show details of its parts.

Cut the Girders of the length, width and thickness of A (Fig. 611), from sticks, and cut

The Truss Members B, C and D from branches, of the right lengths to form trusses of the size shown.

Cut the Tie Rods E from heavy wire, and run them

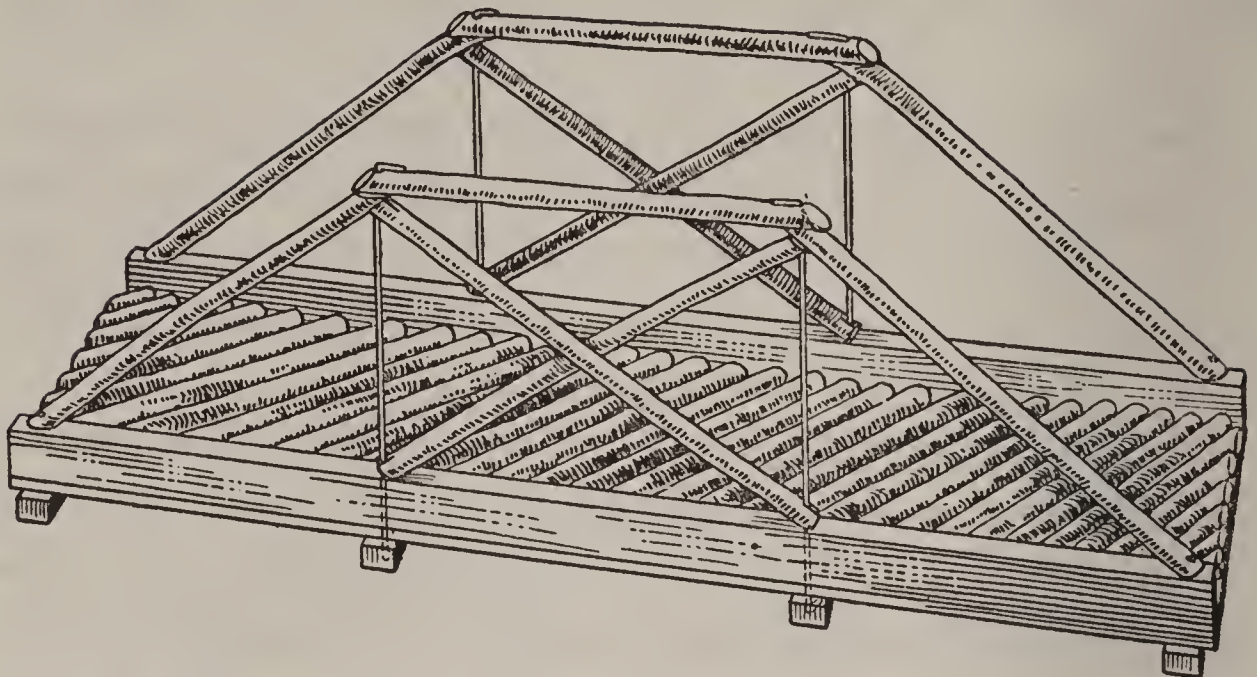

FIG. 610.—Trussed Bridge of Corduroy Type Used in Model in Photograph of FIG. 598.

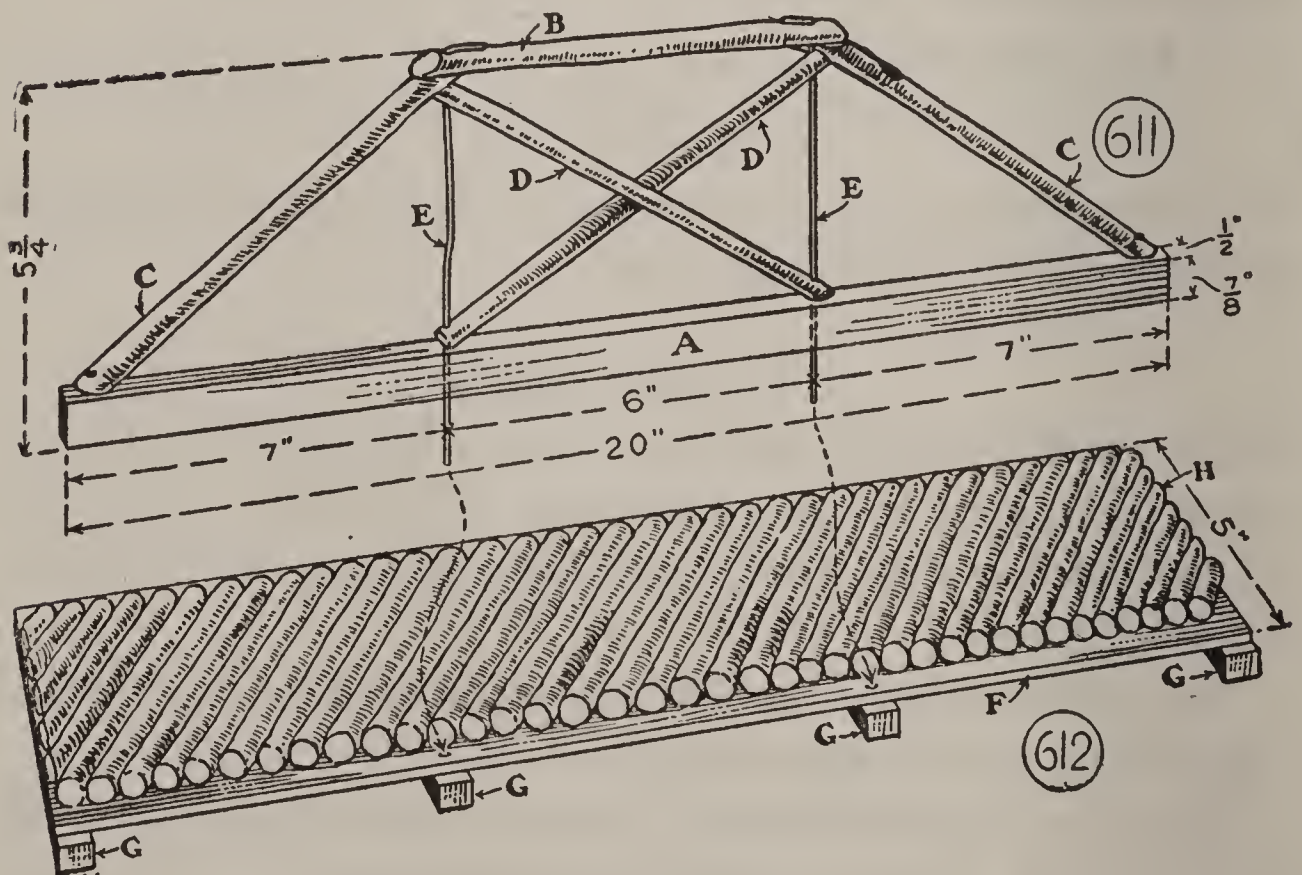

FIG. 611.—Side Truss of Corduroy Bridge.  
FIG. 612.—Roadbed.



through holes drilled in sticks A, B, and C. Notch the ends of struts D to fit over the tie rods. Bend over the rod tops to hold the members together.

Build the Roadbed of a board 5 inches wide and 20 inches long (F, Fig. 612). Nail the four cross beams G to the under side, one at each end, and two in line with the tie rods E. Nail the pieces of branches H diagonally across the upper surface. Drill holes through the roadbed and cross beams, stick the tie rods through the holes and bend the ends over.

Of course you will want to build

### A RAILROAD TUNNEL

for your electric train, like one of those shown in the models of Figs. 597, 598 and 599. This will be a simple problem in model engineering.

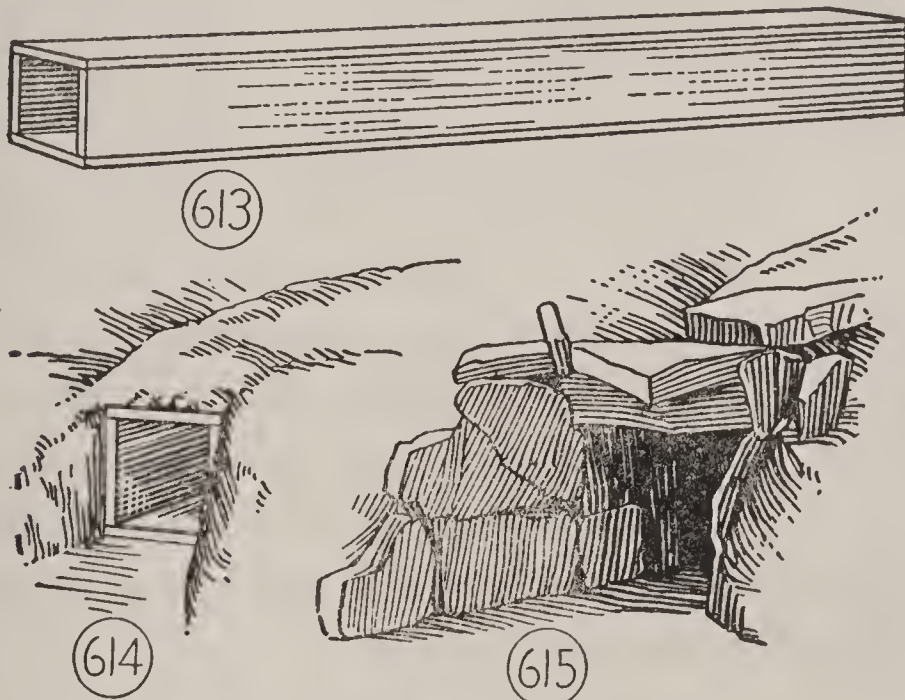

FIG. 613.—Box for Earth Tunnel.

FIG. 614.—Fill Earth Over Box Like This.

FIG. 615.—Stone Entrance.

Build a Box as long as you want the tunnel to be, and wide enough and high enough to admit your train and tracks (Fig. 613), then

Build a Mountain over it, of earth and stones (Fig. 614). The easiest way to

Finish the Entrances is to line them with pieces of stone, and place several large flat stones across the tops (Fig. 615). But you can build cement entrances like that in the photograph of Fig. 597, using a large tin can or pail in the form to cast a circular opening. Before the cement has set hard, remove the front of the form and mark off stone courses with a knife or trowel.

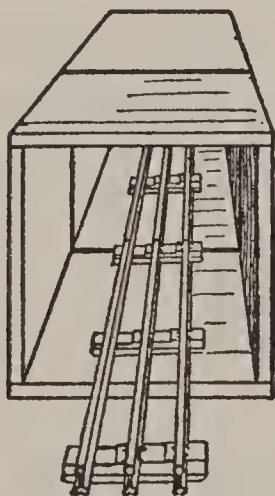

FIG. 616.—Grocery Boxes with Ends Removed Can Be Placed End to End for Tunnel Form.

Instead of building the wooden box tunnel, you can remove the ends of two or three grocery boxes and place the boxes end to end as shown in Fig. 616.

You must include

#### A RAILROAD DEPOT

in your model. Build one like that described in Chapter XL. Three layouts for the depot and tracks are shown in the photographs of Figs. 597 and 598, and in the drawing of Fig. 599. Do not neglect to take your tracks and other equipment indoors, or put them under cover, at night, unless they are rustproof. Parallel the tracks with

#### A TELEGRAPH LINE

as in the models of Figs. 597 and 598. Make

The Poles like that in Fig. 617, of dowel sticks or peeled branches, notched near the tops (Fig. 618) for crosstrees. Cut stick crosstrees (Fig. 619), make wire brackets (Fig.

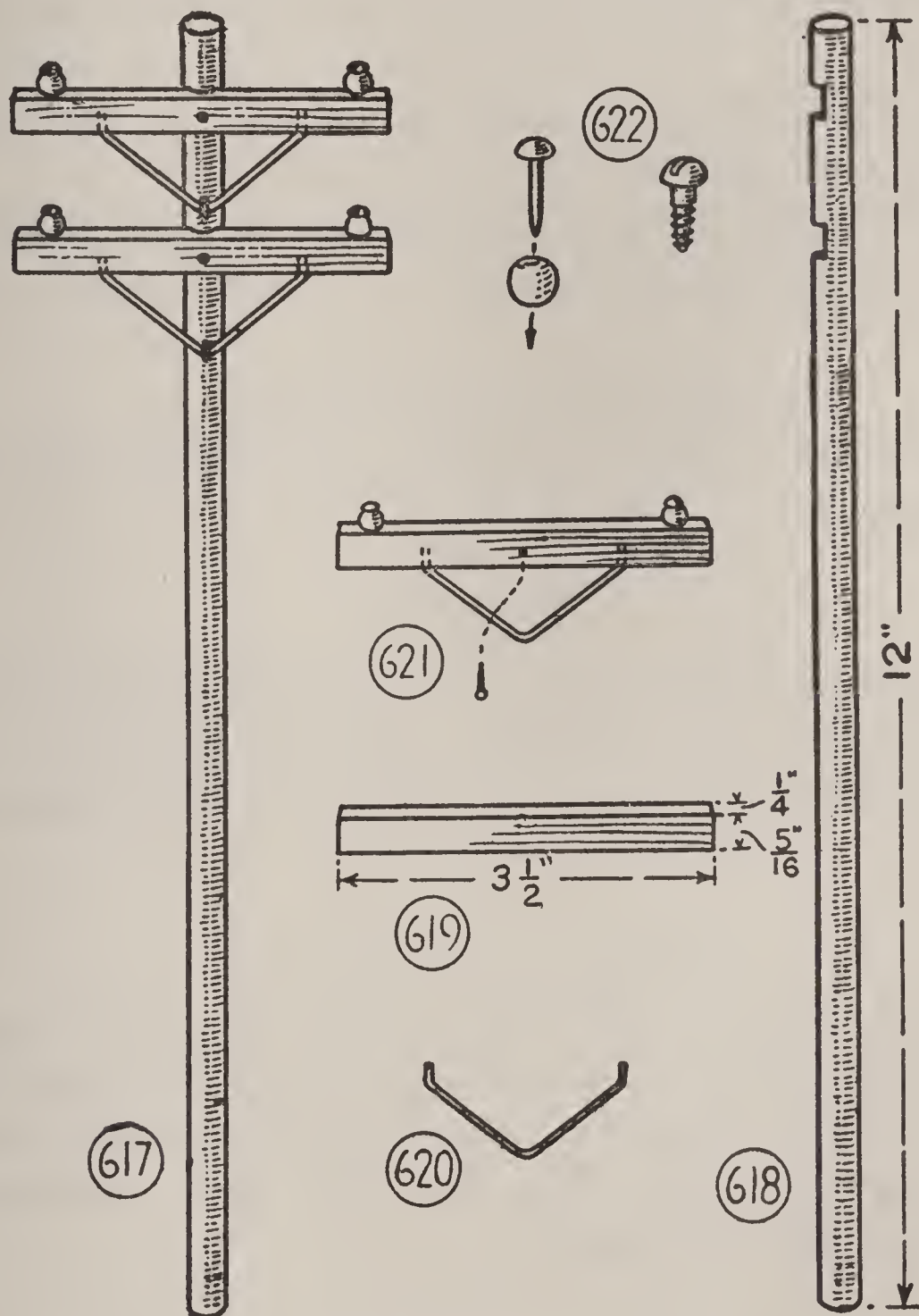

FIG. 617.—Telegraph Pole.  
 FIGS. 618—622.—Details of Pole, Crosstree, Bracket, and Insulator.

620), and stick the brackets in holes drilled in the cross-trees (Fig. 621). Make insulators of glass beads mounted on round-headed tacks or screws (Fig. 622). Nail the cross-trees to the poles, and fasten the wire braces with small staples.

Stick the ends of the poles far enough into the ground to stand erect, and for

**The Telegraph Wires** string fine wire, wrapping twine or heavy thread from pole to pole.

#### A RADIO TRANSMITTING STATION

should not be omitted, and if you have sufficient room, do not overlook

#### AN AIRPORT

with landing field, hangars, wind indicators, flood lights, and all of the other equipment. With air service and railroad service provided for, you will have a truly up-to-date model.

#### MATERIAL FOR SCENERY

can be picked up all about you. For the mountain model in the photograph of Fig. 598, I used large stones gathered along roadsides, smaller stones and pebbles picked up on a beach, earth excavated from the model creek, branches of arbor vitæ, spruce and pine.

#### TOY ANIMALS AND LIVE STOCK

were picked up in the nursery and in ten-cent stores, and

TOY AUTOMOBILES, AIRPLANES AND WAGONS  
of the right proportions were obtained from the same sources. You will be lucky if you have a small brother or sister from whom you can borrow accessories.

Lack of space prevents my giving

#### ADDITIONAL SUGGESTIONS

but where I have left off you can continue, drawing upon your imagination.



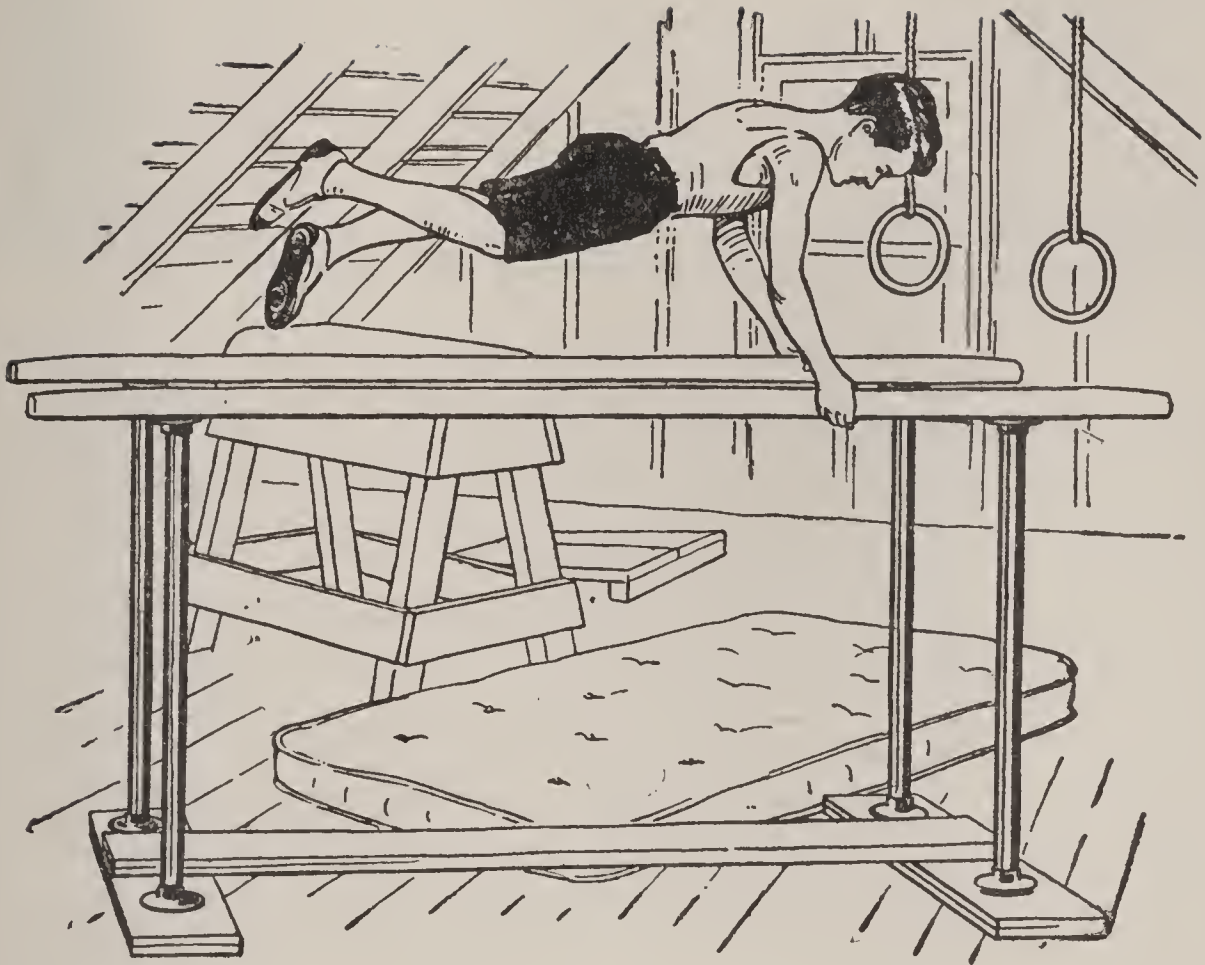

PART IV

Autumn Hobbies





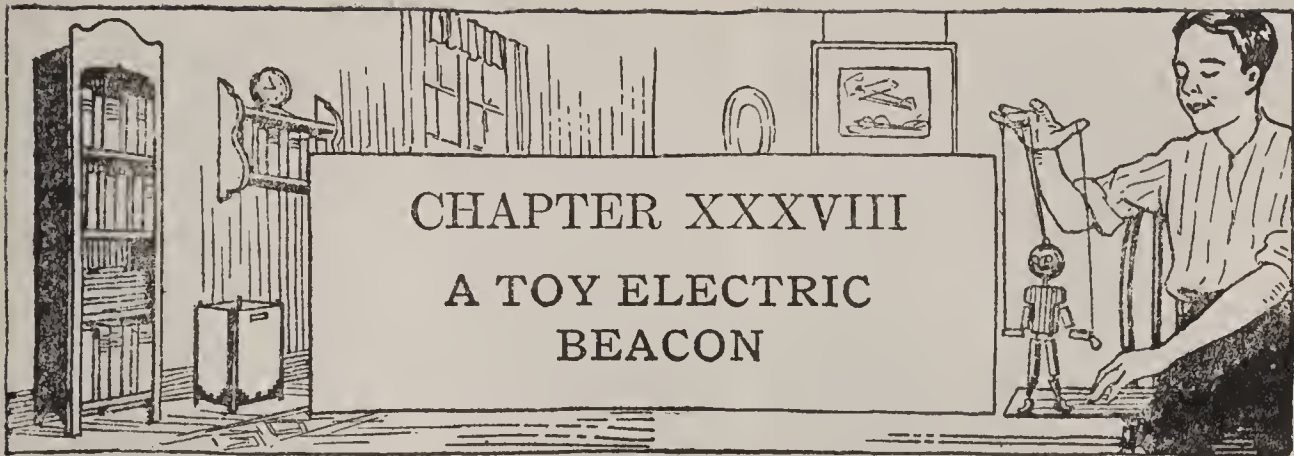

A BOY came to my studio for help in designing a model lighthouse which he had been hired to build for a store window. He didn't know how to build the tower, but had carefully and accurately figured how he was going to gear down the speed of a toy motor, to turn the lantern the right number of revolutions per minute to produce the proper intervals between flashes. We worked out a scheme for the tower, the model was successfully completed, and it proved a tremendous attraction for the merchant who had contracted for it.

Clever models for window displays are in demand; building them is fun. The work gives you a chance to draw upon your imagination, and to use your ingenuity. When you have established a reputation as a model-builder, you will find a ready market for all the models that you can produce. But to make a profit on your work, you must keep material costs as low as possible. Consequently, it is important to devise ways of attaining results in the most direct manner. In the instance of the lighthouse, it would have been simpler and cheaper for the lad to substitute a

flashing beacon for the revolving light, though from a mechanical standpoint the model might not have been so interesting to develop.

#### THE FLASHING BEACON

shown completed in the photograph of Fig. 623 was devised in my workshop. It is operated on an electric flasher of the kind used for electric signs. This beacon can be used indoors and out, in window displays, in playroom models and back-yard models. It is just the thing for

#### A PLAY HARBOR

built on the shore of the lake or creek on which you sail your boats, or for the lake of a back-yard model like that described in Chapter XXXVII.

It will be excellent also for

#### A MODEL AIRPORT BEACON

or for any model that you may plan for the back yard.

#### THE MATERIALS NEEDED

to build it are a dish-draining wire basket, wire cloth, an electric drop-cord, receptacle and plug, lamp bulb, electric flasher, screw-top jar, and enough plaster-of-Paris, or cement plaster, to cover the base and tower.

#### THE TOWER FRAMEWORK

is shown completed in the photograph of Fig. 624, and in detail in Fig. 627. First cut

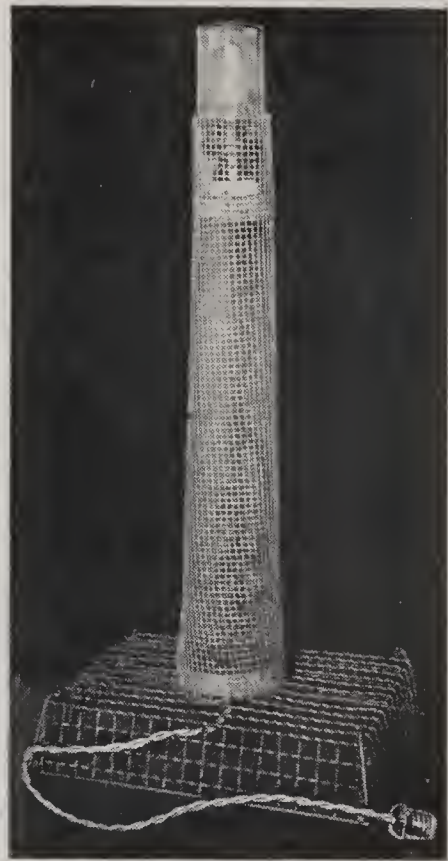

FIG. 623.—A SIGN-FLASHER OPERATES THIS TOY ELECTRIC BEACON.  
 FIG. 624.—FRAMEWORK OF BEACON.

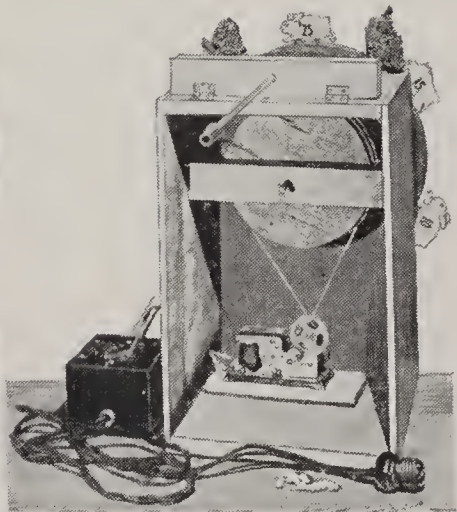
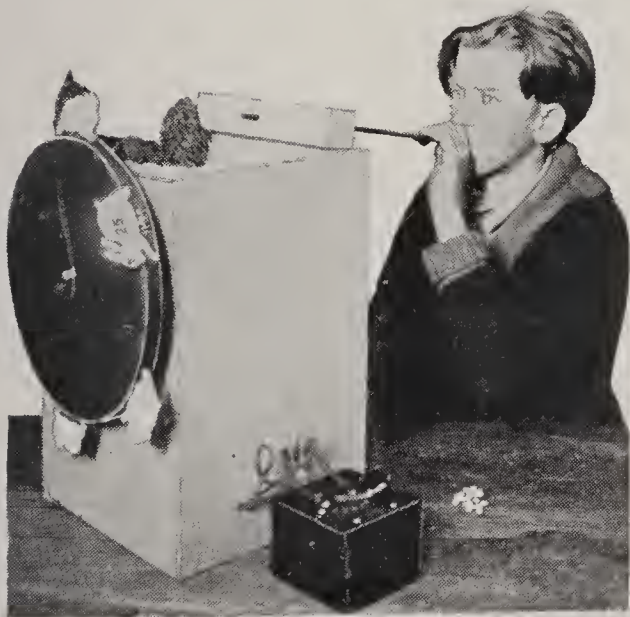

FIG. 625.—AN ELECTRIC TOY SHOOTING-GALLERY.  
 (See Chapter XXXIX.)  
 FIG. 626.—A TOY MOTOR MAKES THE TARGET RABBITS RUN.



Two Form Blocks of the diameters of A and B (Figs. 628 and 629), out of a board  $\frac{3}{4}$  inch thick. Use a coping-saw to cut them, and a file and sandpaper to smooth the cut edges. Bore two holes through block A and one through block B, to run the drop-cord through.

The Covering is of wire cloth with  $\frac{1}{4}$ -inch mesh. Buy it at the hardware store. Cut a piece of the shape and size shown in Fig. 630, for the sides of the tower, and shape it around the blocks A and B. Block A is to be set 3 inches from the top, and block B, flush with the bottom. Do not tack the wire cloth to the blocks until after you have installed the drop-cord and made the electrical connections.

THE BRIDGE AND RAILING are made of wire cloth. Cut and bend a strip of the form shown in Fig. 631, with the railing three meshes in height, the bridge platform two meshes in width, and a lap of 2 inches to fasten to the tower sides. After you have tacked the tower sides to its form blocks, wire the bridge and railing strip to the top.

THE TOWER BASE of my model is built upon a dish-draining

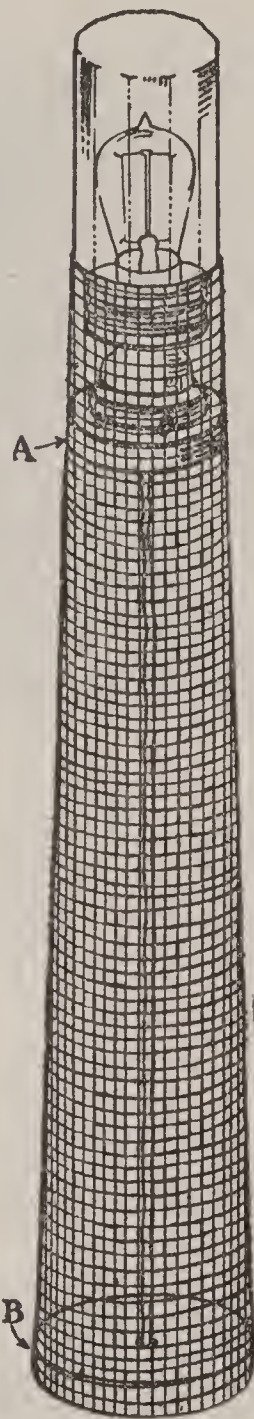
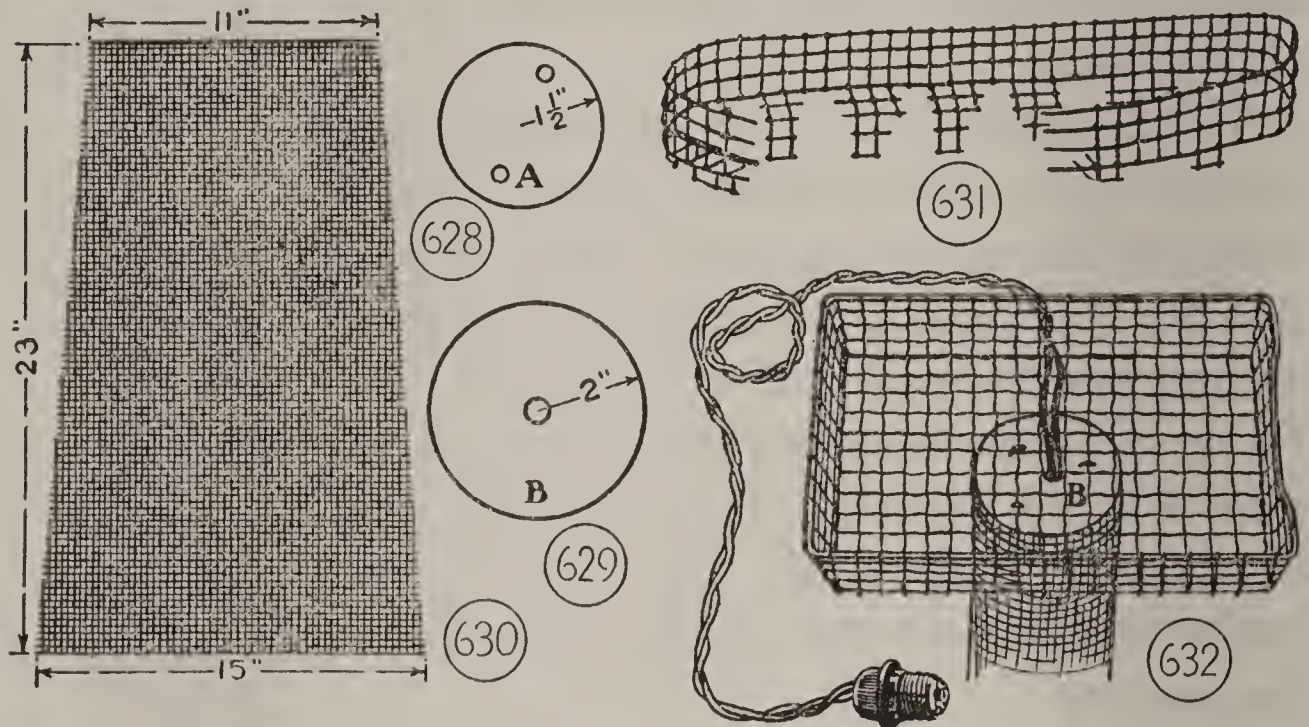

FIG. 627.—Detail of Tower Framework and Beacon.

wire basket (Fig. 624. You may use a board 10 or 12 inches square instead. Fasten block B of the tower to the basket, with staples (Fig. 632), or to a board base, with nails.



FIGS. 628 and 629.—Top and Bottom Blocks for Tower Framework.  
 FIG. 630.—Pattern for Wire Covering of Tower Framework.  
 FIG. 631.—Wire for Bridge and Railing.  
 FIG. 632.—Wire Basket for Base.

### THE ELECTRIC WIRING

must be done before you cover the tower framework, because the space will be too small to work in after the covering is on.

The Lamp Receptacle should be of the type with porcelain base, shown in Fig. 633. Run the wire ends of a 9-foot length of drop-cord through the holes in block A (Fig. 634), connect them to the binding-posts, screw the porcelain base to the block, and snap the brass cap into place.

Then slip the other end of the drop-cord through the hole in block B, and connect its wires to a plug (Fig. 632).

The Lantern is a mustard-jar with screw-cap (Fig. 635). The jar should approximate  $2\frac{3}{4}$  inches in diameter and 5 inches in height. Its neck opening should be at least  $1\frac{7}{8}$  inches in diameter, so that it will admit a small lamp bulb.

To install the lantern, cut an opening in the center of the screw-cap, with a can-opener, to admit the lamp receptacle (Fig. 636). Slip the cap over the receptacle, and solder the two together. Then screw the jar into its cap, and the lantern will be fastened securely, but it can be unscrewed and removed when necessary to gain access to the lamp.

A Small Bulb of the shape of Fig. 637 may slip through the jar neck. If you cannot get one that will fit, buy a slim straight-sided candelabra bulb. Take the jar to an electrical dealer and ask him to give you a bulb that will fit it.

The Flasher may be of the form shown in Fig. 638, made to screw into the lamp receptacle, or into the plug receptacle, or it may be of button form made to drop into the receptacle.

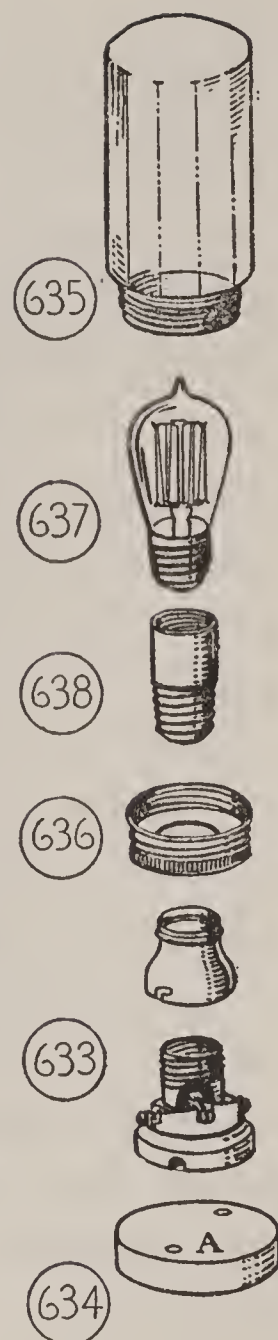

FIGS. 633 and 634.—Screw Lamp Receptacle to Top Block of Tower Framework.

FIG. 635.—Mustard-Jar Lantern.

FIG. 636.—Cut Mustard-Jar Screw-Cap to Fit over Lamp Receptacle.

FIG. 637.—Lantern Lamp.

FIG. 638.—Sign-Flasher for Flashing Beacon.

### THE OUTSIDE PLASTERING

of the tower and base may be of plaster-of-Paris, or cement and sand. Plaster-of-Paris is easier to get in small quantity. Paint stores carry it. Mix it with water, a little at a time. It sets rapidly, but you can delay the setting by adding one part of a saturated solution of borax to twelve parts of the water with which you mix the plaster. If you use cement, mix it with sand in the proportions of one part cement to two parts sand.

The base basket has large mesh, and the plaster or cement will not hold on the wires without additional support. Line the inside of the basket with cardboard. Sew the cardboard to the wires. You can remove it after the cement has set. The smaller mesh of the tower walls will not require the lining.

Apply plaster-of-Paris in one coat, cement in two coats. When the plaster has hardened, mark off a doorway at the base of the tower, and several windows above it, and scrape away the plaster inside of the marks. You can scrape away the plaster to the wire framework, or scrape it to a depth of  $\frac{1}{8}$  inch.

### FINISH THE TOWER

by smoothing off rough places in the plaster with sandpaper. Paint the bridge and railing, the door, and the window recesses, black.



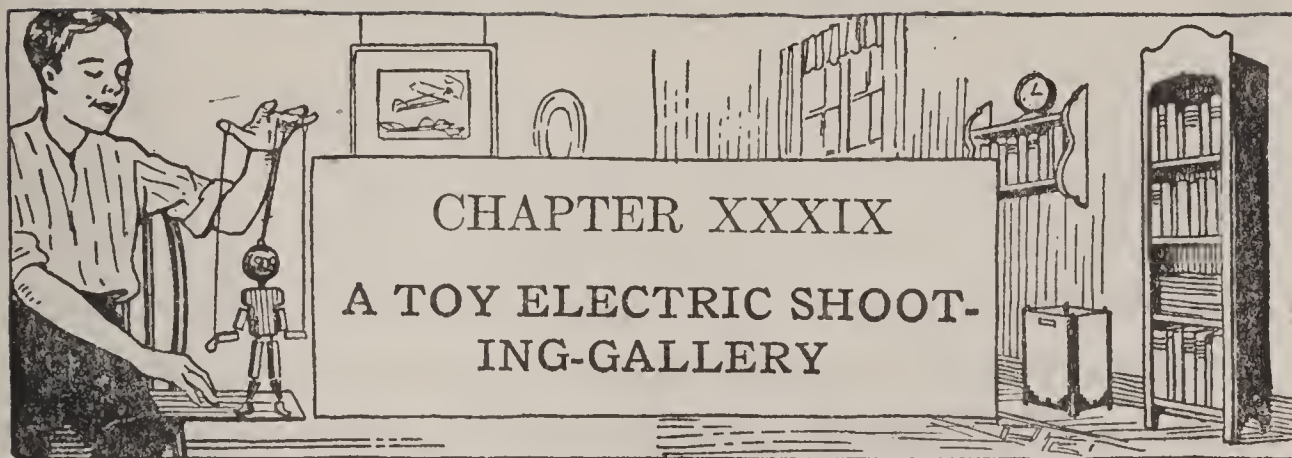

## CHAPTER XXXIX

### A TOY ELECTRIC SHOOTING-GALLERY

WHAT are you doing with that toy electric motor that you received last Christmas? Does it still come in for some of your attention, have you a genius for inventing new ways to use it, or have you lost interest in it? The photographs in Figs. 625 and 626, in Chapter XXXVIII, show a toy shooting-gallery with motor-driven targets that I designed and built to demonstrate an adaptation of the toy motor to a home-made toy. The idea may enable you to adjust your thinking-cap so that other interesting schemes will pop into your head.

You will have hours of fun with the toy shooting-gallery, the boys will become more frequent visitors to your home, and Dad will welcome a chance to match his skill with yours.

The photographs in Figs. 625 and 626, and the cross-section in Fig. 639 show

#### HOW IT WORKS

The rabbit targets are hinged to fall back when hit, and they right themselves automatically when the wheel upon which they are mounted makes a quarter revolution.

### THE BASE OF THE SHOOTING-GALLERY

is made of a grocery box. The box used for the model measures  $9\frac{1}{2}$  inches deep, 10 inches wide, and 15 inches long, which is quite large enough to house pulley, motor, and battery cells, or transformer. You may place the transformer inside the box. It was hooked up outside for the photographs, so that it might not conceal the motor.

### THE POWER PLANT

may be any type of toy motor. If its speed is geared down like most motors of steel construction toys, one 7-inch pul-

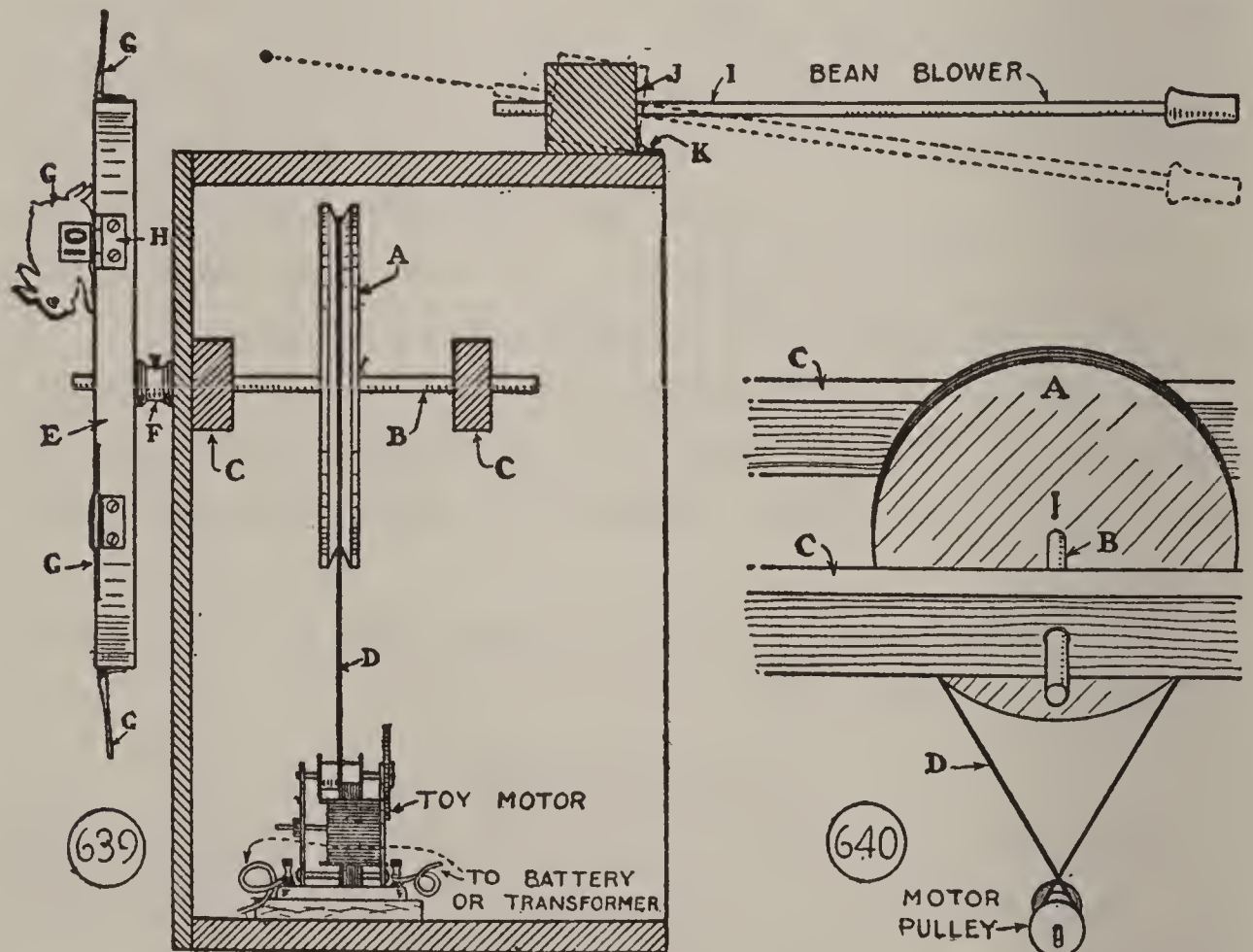

FIG. 639.—Cross-Section of Toy Electric Shooting-Gallery.  
FIG. 640.—Detail of Wooden Pulley.

ley-wheel mounted upon the target disk shaft and belted to the motor pulley (A, Fig. 639) will reduce the motor's speed sufficiently, but if the motor is without gearing, you will have to rig up additional pulleys.

### MAKING A WOODEN PULLEY

is easy. Describe the correct diameter upon a board, saw out the wheel with a coping-saw, and true up the rim with a file and sandpaper. It is important to cut accurately. Cut the rim groove of uniform depth with a rat-tail file.

### MOUNTING THE WHEEL

Bore a  $\frac{1}{4}$ -inch hole through the center of wooden pulley A for shaft B (Figs. 639 and 640). Use a  $\frac{1}{4}$ -inch dowel-stick or a stick whittled to this diameter for the shaft, and from a piece of 1-by-2 cut the two bearing-blocks C, of the right length to fit in the width of the box. Bore the shaft-hole through the center of the length of each block. Fasten the bearing-blocks between the box sides, 4 inches below the upper end, one block against the box bottom, the other one 4 inches away from it. It is important to mount the blocks on the same level, so that their shaft-holes will be opposite. Bore the shaft-hole through the box bottom, also. Fasten the pulley to the shaft with a brad (Fig. 640).

### BELT THE PULLEY TO THE MOTOR PULLEY

with a piece of hard wrapping-twine. Join the twine ends

with a small, firm knot, or cement them with the kind of cement used in model airplane construction.

### MOUNT THE MOTOR

upon a block of wood a trifle larger than the metal base, then screw one end of the block to the lower end of the box. Do not drive the screw home. Make the string pulley-belt tight enough to lift the unfastened end of the motor a trifle. Then the weight of the motor on the belt will take up the slack that will result from slight variations in the diameter of the home-made wheel and its groove.

### MAKE THE TARGET DISK

11 inches in diameter (E, Figs. 639 and 641), out of a 12-inch board. Spool F serves as a bearing. Nail it to the disk and drive a screw through it, for a set-screw, to fasten the disk to shaft B.

### THE RABBIT TARGETS

are shown in the large target detail (Fig. 641). A pattern marked off into squares is shown in Fig. 642. Draw a similar number of squares, with the lines spaced  $\frac{1}{4}$  inch apart, then

Draw the Rabbit Outline upon the squares, exactly as it appears upon the diagram squares. Make a tracing of the enlarged drawing, and transfer it five times upon cardboard. Go over the outlines with ink, color some brown and some black, and cut a trifle outside of the lines.

Mount the Targets with 1-inch hinges (H, Fig. 643).

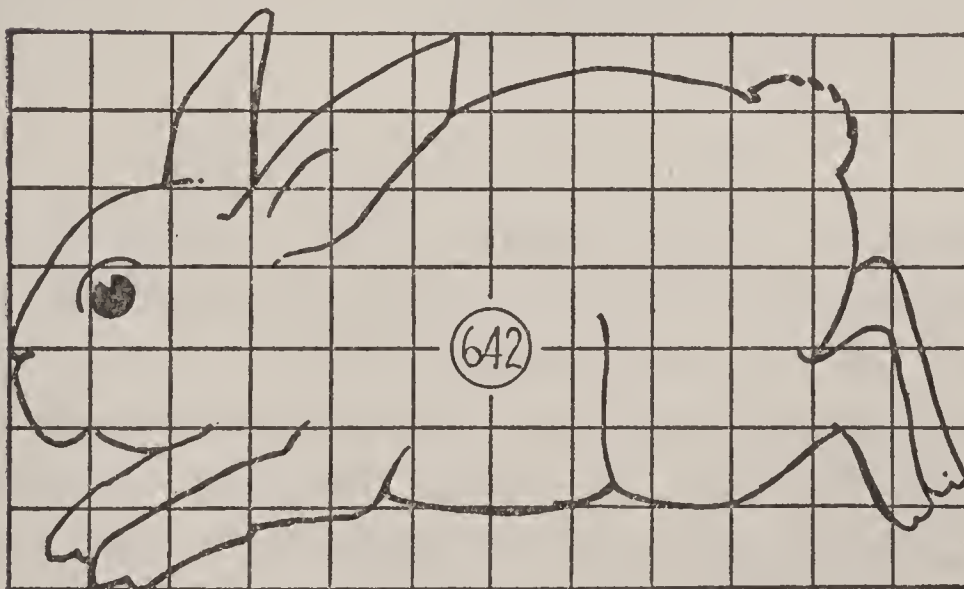
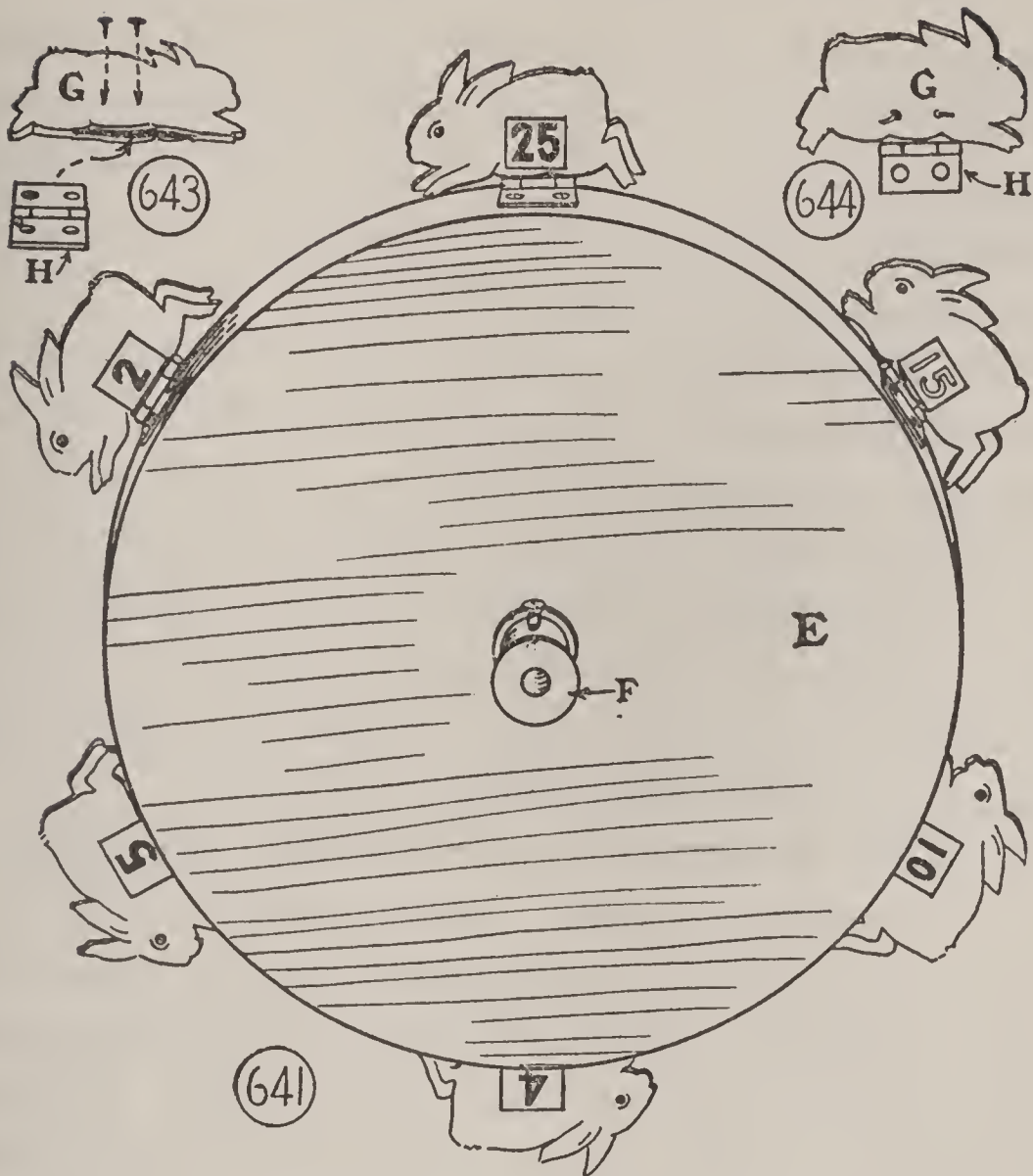

FIG. 641.—Detail of Target Disk.

FIG. 642.—Pattern for Rabbit Target.

FIGS. 643 and 644.—Details of Target Mounting.

Select hinges that open and close easily. Separate the plies of cardboard along the belly of each rabbit target, as shown in Fig. 643, to admit one flap of a hinge, and rivet together the cardboard and hinges, with small copper rivets or tacks driven through and clinched (Fig. 644).

Divide the circumference of the target disk into six parts, and screw the hinges to the rim at these points. By placing the hinges so that their pins rest upon the rim of the disk, the ease with which the targets drop when hit can be regulated by tightening or loosening the screws which hold the hinges to the rim. This is important, because if the screws are too loose, the targets will not stand up, and if they are too tight, the targets will not drop when hit.

**Cut Score Numbers** from a calendar, and paste them upon the targets as shown. Numbers 2, 4, 5, 10, 15, and 25 are a good selection of numbers to use. There should be one "bad-luck" target. Whoever hits this target should lose the number of points that it designates. If your calendar has Sunday or holiday dates in red, use one of the red figures for the bad-luck target.

### THE BEAN-BLOWER SHOOTER

is shown in the photographs and in Fig. 639. If bean-blowers are not in season when you build the shooting-gallery, use a hollow curtain-rod of the same diameter. Mount the bean-blower in a hole bored through a wooden block (J, Fig. 639), and pivot the block to the shooting-gallery base with a pair of hinges (K). The dotted lines in Fig. 639 indicate how block J must be tilted to give the

bean-blower the correct inclination to hit the targets. This will give you the range. You must time your blows so that the beans will hit the targets as they pass. You can substitute a sling-shot or an air-rifle for the bean-blower shooter, to make the shooting more difficult, and shoot from a mark several yards in front of the targets.

### FINISHING

When you have assembled the toy shooting-gallery, and adjusted its parts so that they work properly, take it down and finish it with paint. Bright colors are best for the job. Trees and shrubbery are mounted upon the base top of my shooting-gallery model, to make a good setting for the racing rabbits. Use pieces of sponge, stained with green paint. Glue them in place.

### RULES FOR SHOOTING AND SCORING

You may make your own rules for shooting and scoring, but I suggest that you allow each contestant five shots each turn, and that the winning score be 150 points.

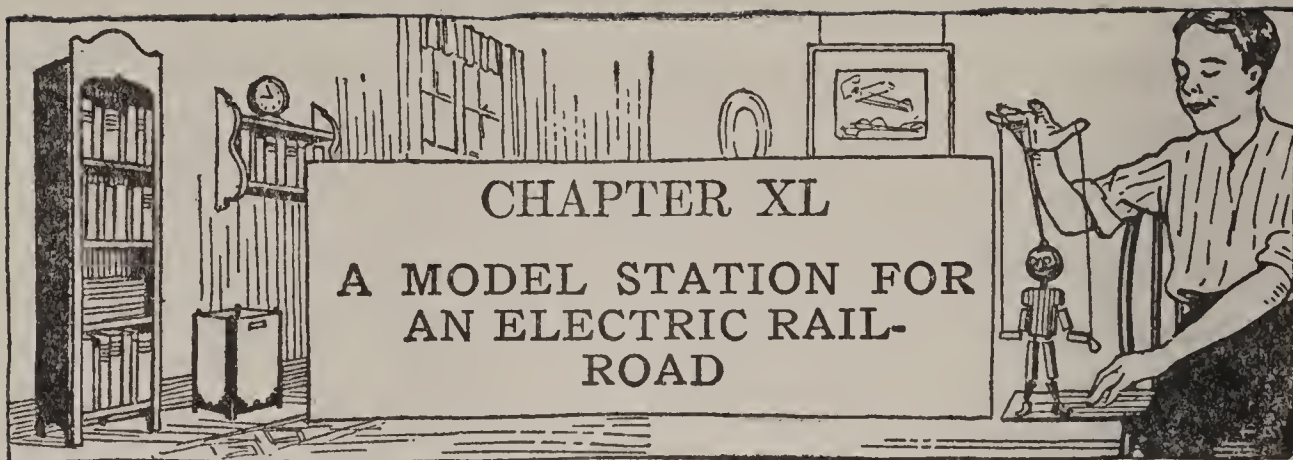

Your railroad equipment may include a station, but one is hardly enough for even a short line. Then there is that younger brother who may have a line of his own, and that cousin for whom you will soon need a gift for Christmas. The home-made suburban type of depot shown in Fig. 645, and described in this chapter, should answer the require-

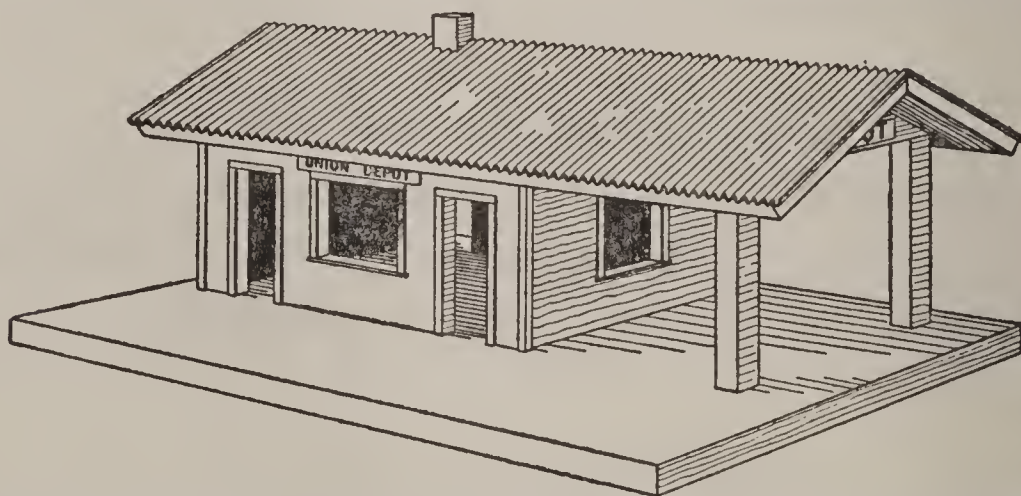

FIG. 645.—Completed Station and Platform for Electric Railroad.

ments of your own railroad or your brother's or cousin's, and you will find it easy to build.

IT REQUIRES A BOX  
about 11 inches long, 7 inches wide, and 5 inches deep, for



walls; two boards about 18 inches long and 5½ inches wide for the roof; corrugated strawboard for imitation roofing-tile, and a board about 12 inches wide and 18 inches long for the platform. A wooden starch-box approximates the dimensions given above. If you do not find one at home, your grocer will have a box that will do. If it is a trifle large, it will not matter. If it is much too large, cut it down.

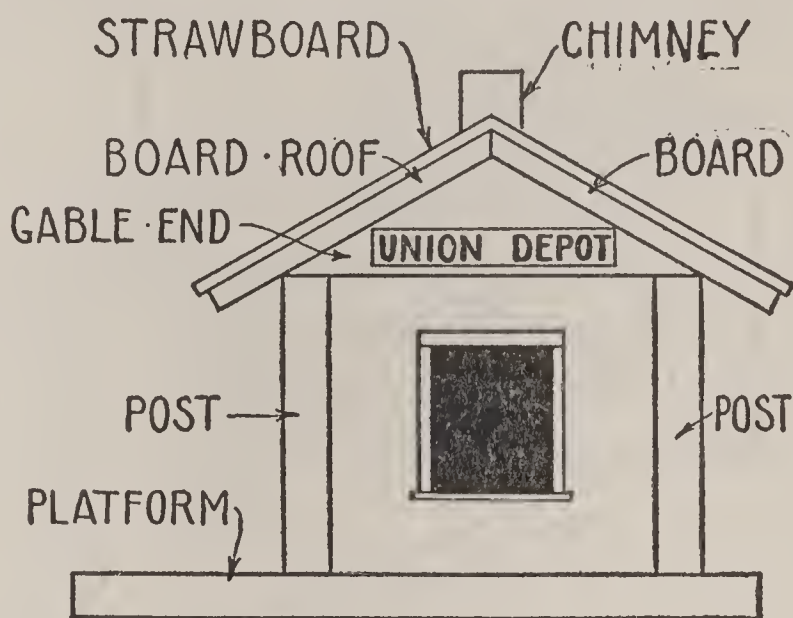

FIG. 646.—End Elevation of Station and Platform.

### CUT THE DOORS AND WINDOWS

in the box sides and ends, as shown in Fig. 647. Mark them with a ruler and pencil, then cut them with a coping-saw or a keyhole-saw. To admit the saw for cutting window-openings, bore small holes in the corners of the spaces marked out, then saw from corner to corner, as shown. You can save time by painting openings instead of cutting them, but cut openings look better, and you can improve them by hanging doors in the doorways and setting glass in the window-openings.

### TWO GABLE ENDS

are required to support the roof (Figs. 648 and 649). Make

them 2 inches high by a width equal to the width of the roof. Be careful to cut them alike. Nail them to the box bottom at the ends, as shown in Fig. 648.

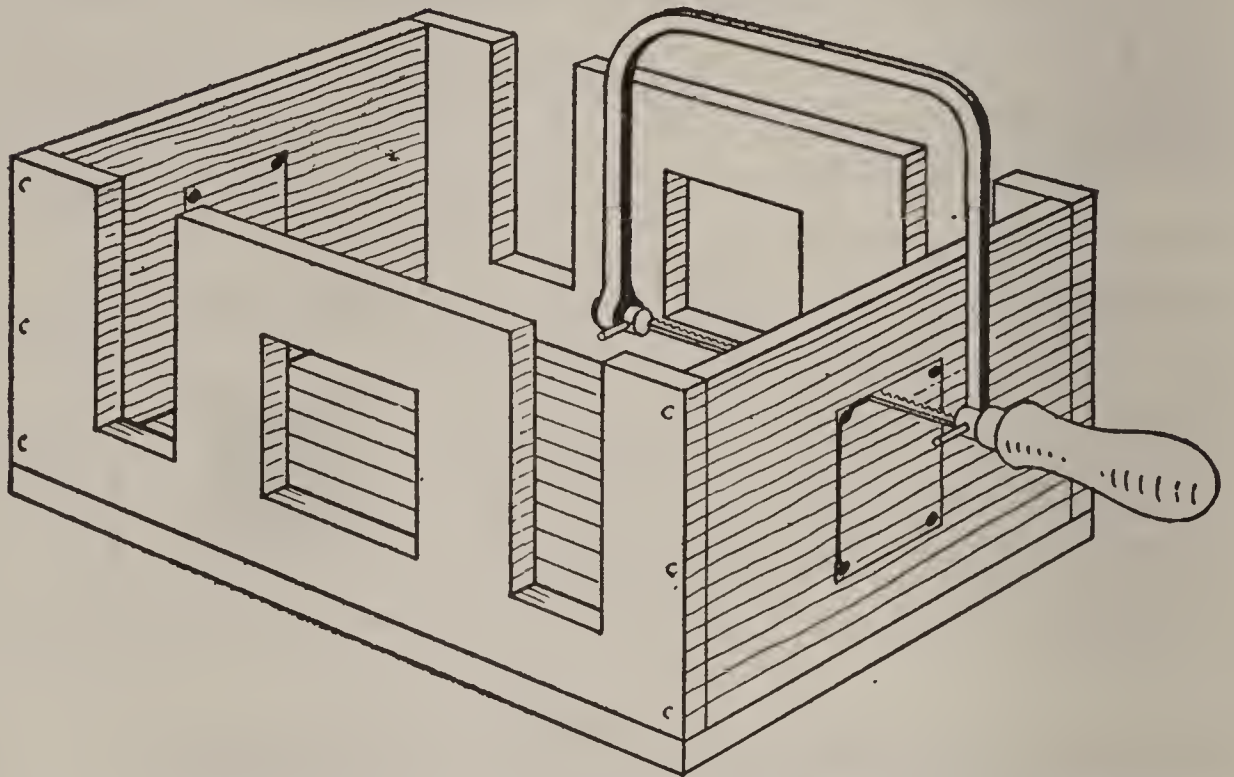
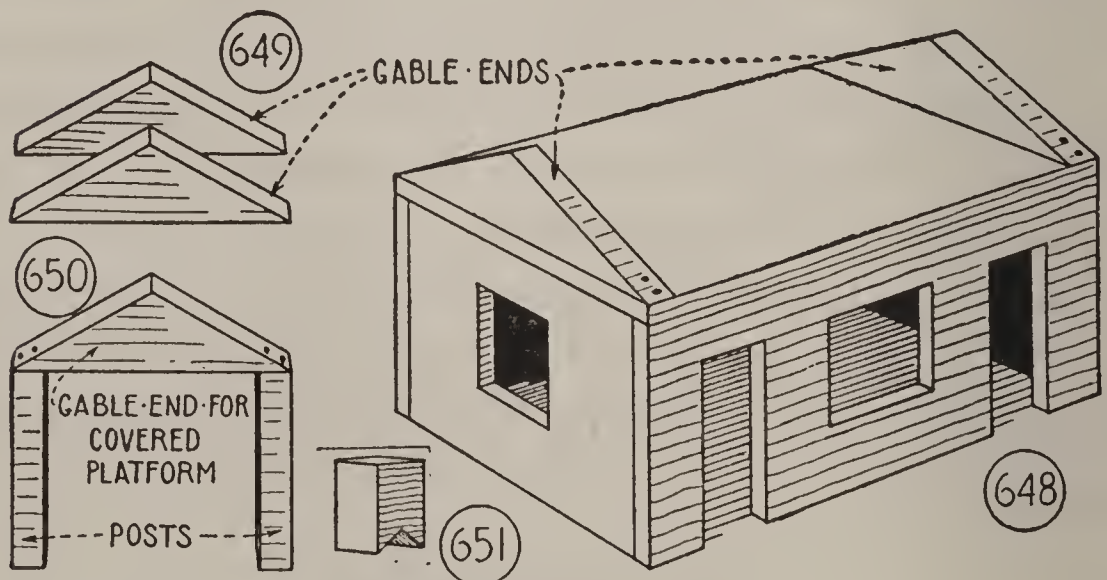

FIG. 647.—Cut Door- and Window-Openings with a Coping-Saw.



FIGS. 648 and 649.—Gable Ends.

FIG. 650.—Gable-End and Post Supports for Platform Roof.

FIG. 651.—Chimney Block.

### CUT TWO ROOF-BOARDS

of the right width to project  $1\frac{1}{4}$  inches over the side walls, and of the right length to project  $1\frac{1}{4}$  inches over one gable end and 6 inches over the other end. Whittle or plane off the upper edges to make them come together at the ridge, as shown in Fig. 646.

### MOUNT THE DEPOT UPON ITS PLATFORM

so that about 1 inch of the board projects along one side and end. Nail the walls to the platform. Prepare a third gable end to fit under the overhanging roof (Fig. 650), and cut two square sticks for posts to fit between the gable end and platform.

### CUT A CHIMNEY

like that in Fig. 651, with lower end notched to fit over the roof ridge, and nail it to the roof.

### TILE THE ROOF

with two pieces of corrugated strawboard. Cut them to fit the roof-boards with a slight overhang upon all sides, and glue and tack them in place.

### TRIM THE DOOR AND WINDOW OPENINGS

with narrow strips of cigar-box wood or other thin wood, as shown in Fig. 645. Fasten the strips with glue and brads.

### PAINT THE STATION

with yellow or green walls, red or green roof, red chimney,

and red or brown platform. Letter the name of the town upon each gable.

#### BUILD A FREIGHT-HOUSE

similar to the station, but omit the covered platform, and provide a large doorway in the center of the front.

#### BUILD A POWER-HOUSE

for the electric transformer or dry cells; or hinge or peg the station to its platform, and use it to conceal the power-plant.

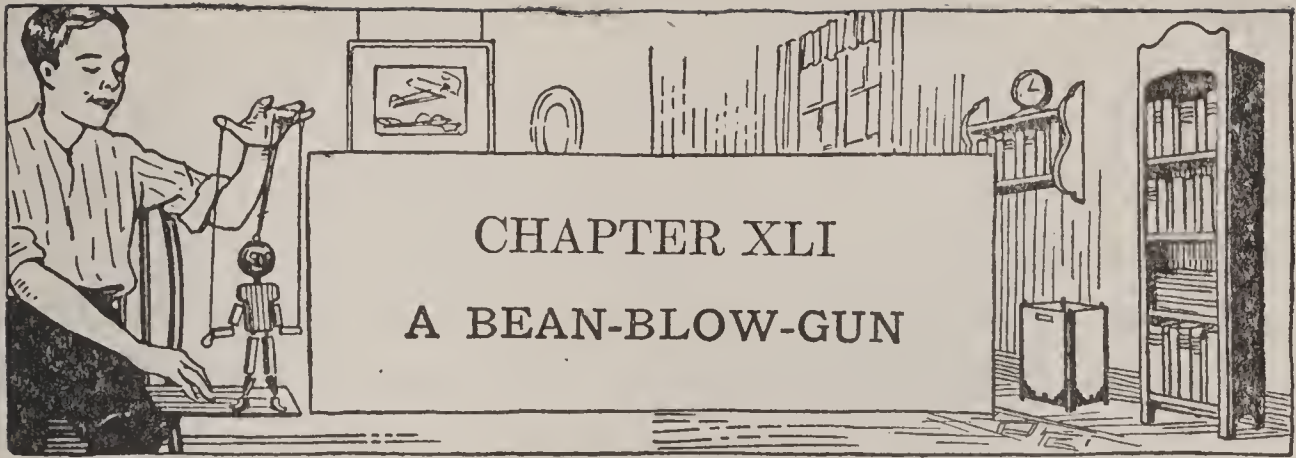

HERE is an interesting home-made gun designed to shoot beans at a target. It looks like a real gun, as you will see by the photograph of Fig. 652. Its barrel is built upon a tin bean-blower, which provides a smooth bore for the bean ammunition. The rubber-tubing extension, through which you blow, makes it possible to keep your eyes on the sights while you discharge the gun. You drop the beans into a magazine instead of feeding them into the tube with your mouth, as you would load a bean-blower. This keeps the beans dry, and they do not swell and clog the barrel.

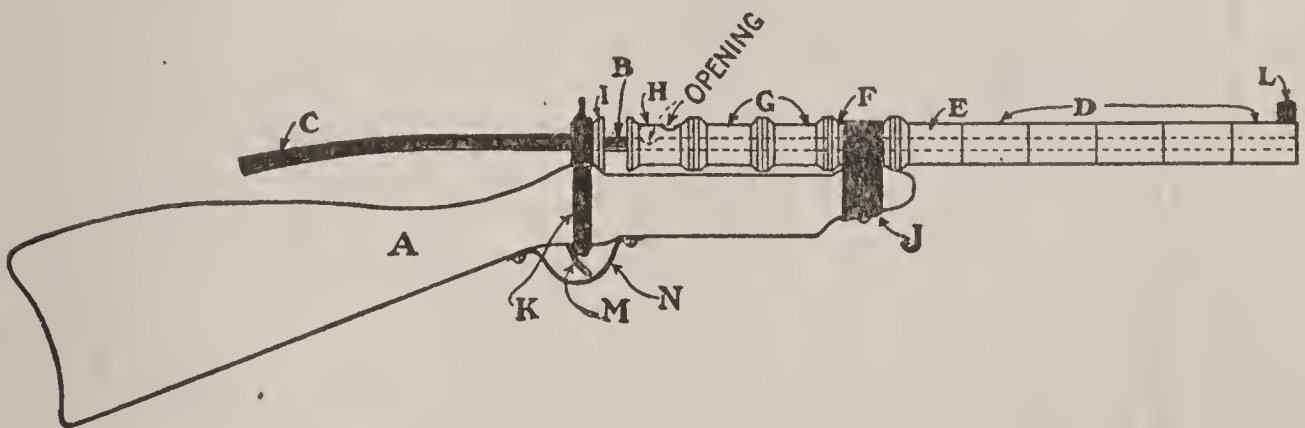

FIG. 656.—Detail of Completed Bean-Blow-Gun.

Fig. 656 shows a detail of the completed bean-blow-gun, with its parts lettered. First, prepare

## THE STOCK

by the pattern of Fig. 657. The squares on the pattern represent spaces  $\frac{1}{2}$  inch long and  $\frac{1}{2}$  inch wide upon the full-size pattern. To make your pattern, draw eighteen horizontal lines and six vertical lines upon a piece of board

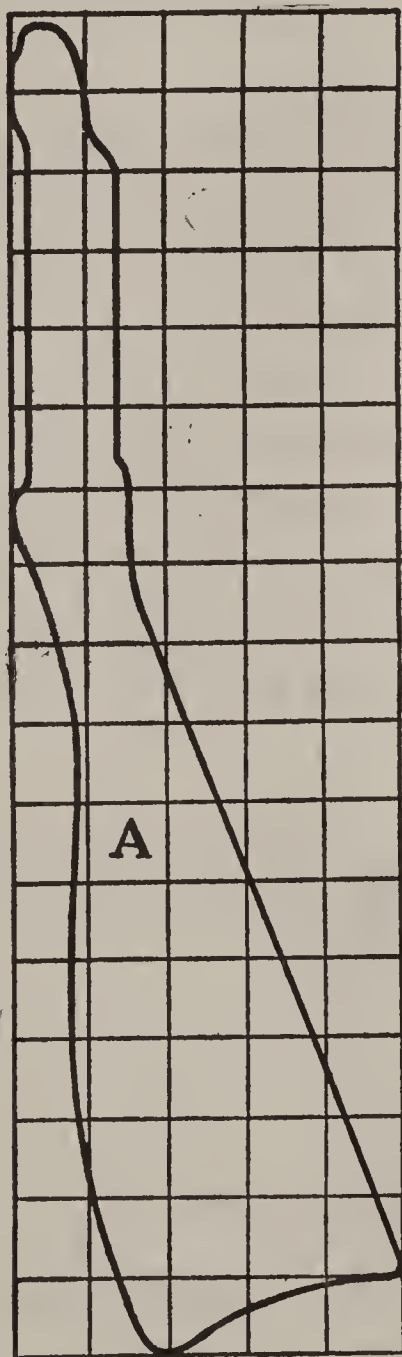

FIG. 657.—Pattern for Laying Out Stock.

$2\frac{1}{2}$  inches wide and  $8\frac{1}{2}$  inches long, then locate the curves and straight lines in the relative positions shown upon the small squares.

When you have laid out the stock, saw it out, round the edges with a plane or file, and smooth all surfaces with sandpaper.

## THE BARREL

If it is out of season for bean-blowers when you want to make the bean-blow-gun, use any metal tubing of  $\frac{1}{4}$ -inch diameter. You can find a hollow curtain-rod of the right size. The tube should measure 14 inches long. To prepare it for the gun, cut a hole in its side, 2 inches from one end, large enough for a bean to drop through (Fig. 658). Drive a dowel-stick, or a stick whittled to the right diameter, into the end of the tube, to support the tin, and cut the hole with a file.



FIG. 652.—THE BEAN-BLOW-GUN SHOOTS STRAIGHT TO THE BULL'S-EYE.



FIG. 653.—THE FEEDING-HENS TOY IS WORKED BY A PENDULUM. (See Chapter XLII.)

FIG. 654.—THE AIR-SPINNER ZOOMS TO GREAT HEIGHTS. (See Chapter XLIII.)

FIG. 655.—THE VIBRATING PLATFORM MAKES THE PUPPET DANCE. (See Chapter XLIV.)







Cut the Rubber-Tubing Extension of the length shown in Fig. 659.

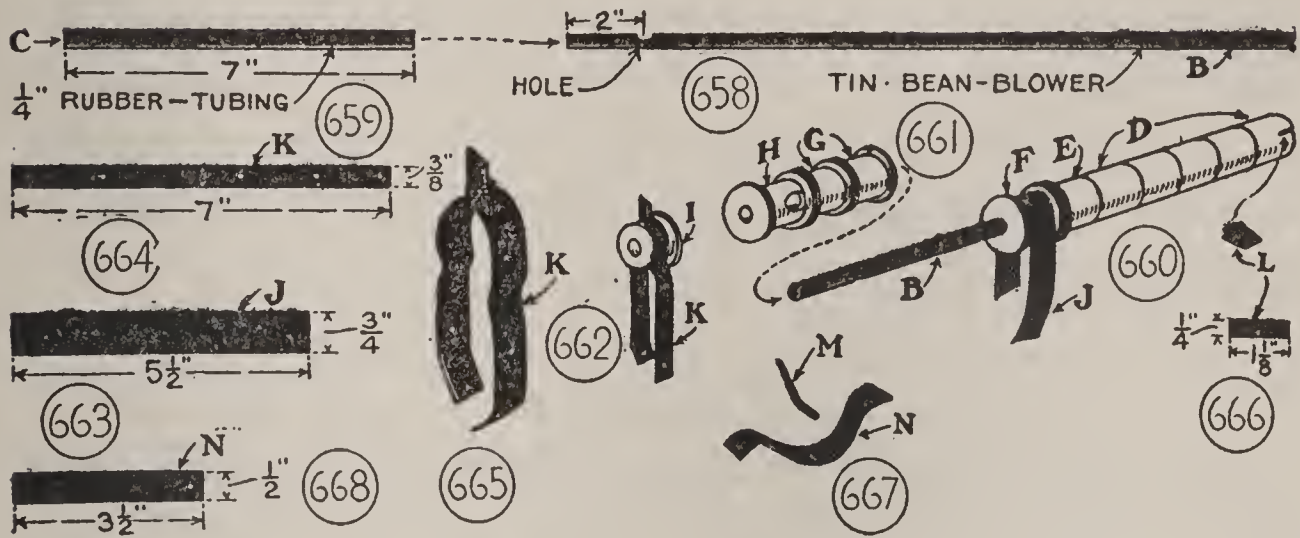

FIG. 658.—Bean-Blower Barrel.  
 FIG. 659.—Rubber-Tubing Extension.  
 FIG. 660.—Spool Casing for Barrel.  
 FIG. 661.—Spool Sliding-Sleeve.  
 FIGS. 662–666.—Details of Metal Straps and Sights.  
 FIGS. 667 and 668.—Details of Trigger and Trigger-Guard.

Encase the Bean-Blower from the muzzle to the stock, with spools of equal size (Fig. 660). Whittle off the flanges of five spools (D), whittle off one flange of a sixth spool (E), and leave both flanges on a seventh spool (F). Coat the spools with glue or cement, slip them over the end of the bean-blower, push them close together, and hold until the glue or cement has set.

### THE SLIDING SLEEVE

built up of three spools (G and H, Figs. 656 and 661), fits over the barrel next to spool F. Glue these spools end to end, but do not glue them to the bean-blower, because the sleeve must slide to open and close the opening between

the magazine and the firing chamber. Fasten half-spool I (Figs. 656 and 662) to the bean-blower  $\frac{3}{8}$  inch from spool H (Fig. 656). That should leave  $\frac{1}{2}$  inch at the end of the tube, to glue to the rubber-tubing extension. Cut a hole through spool H in the proper place so it will come directly over the hole in tube B when you slide the sleeve against spool I.

### THE ASSEMBLY

Assemble the barrel and stock, using straps J and K (Fig. 656) to bind them together. Cut the straps from a tin can, strap J of the size shown in Fig. 663, and strap K of the size shown in Fig. 664. Fold strap K in the middle, and twist the folded end into a tip like that shown in Fig. 662, for

**The Rear Sight.** Punch a small hole through the tip for a peep-sight. Tack or screw the tin straps to spools F and I (Figs. 660 and 661), bend their lower ends around the stock, and tack them to the stock.

**For the Front Sight** fold double a piece of tin of the size of L (Fig. 666), and drive it into a notch cut in the spool at the barrel muzzle.

**Make a Trigger** of a screw-hook bent into the shape of M (Fig. 667), and make a trigger guard of a plumber's pipe-strap, or a strip of tin bent into the shape of N, and punched for screws. Fig. 668 shows the size to cut the strip.

Glue or cement the rubber tubing to the end of the bean-blower.

## FINISHING

You will want to finish the bean-blow-gun. Stain the wood walnut color, then wax it, and paint the metal bands and sights black.

## HOW THE GUN WORKS

You will see by the diagrams how, when you close the chamber, by sliding the sleeve over to the positions shown in Fig. 656, and drop a bean into the magazine hole in sleeve-spool H, the bean rests on top of the bean-blower B, and how, when you open the chamber, by sliding the sleeve back, the bean drops into the bean-blower. Having dropped the bean into the firing-chamber, push the sleeve forward, then discharge the bean by blowing into the end of rubber tubing C.

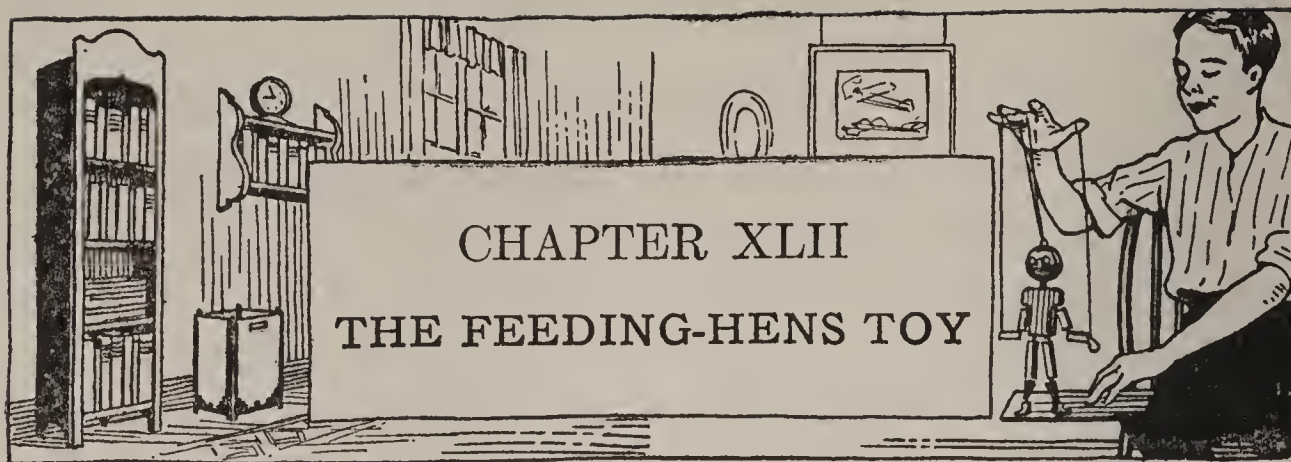

THIS pendulum toy, shown in the photograph of Fig. 653, in the preceding chapter, is a simple mechanical toy invented by a foreign toy-maker. To operate it, you hold the handle attached to the platform on which the five hens are mounted, and give the toy a slight rotary motion to cause the pendulum to swing in a circle. As the pendulum swings, the hens lower their heads, then raise them, simulating feeding. Cords from the pendulum run to tacks in the neck ends, and when these are taut, the heads are held erect as in Fig. 669, and when they are slack, the heads drop, as in Fig. 670.

### THE FIVE HENS

Cut blocks of the dimensions of A (Fig. 671), for  
**The Bodies**, and slot one end to receive the neck, the other end to receive the tail. Then shape them into the form shown in Fig. 672, with your jack-knife, a file, and sandpaper. Drill two small holes in which to stick

**The Legs.** Whittle pegs 1 inch long and  $\frac{1}{8}$  inch square for these, coat the ends with glue, and drive them into the holes drilled in the body.

The Head and Neck and the Tail (B and C, Fig. 673) may be cut out of cigar-box wood. Make a set of squares similar to those of the patterns, with the lines ruled  $\frac{1}{4}$  inch apart, and locate upon them the curves and straight lines

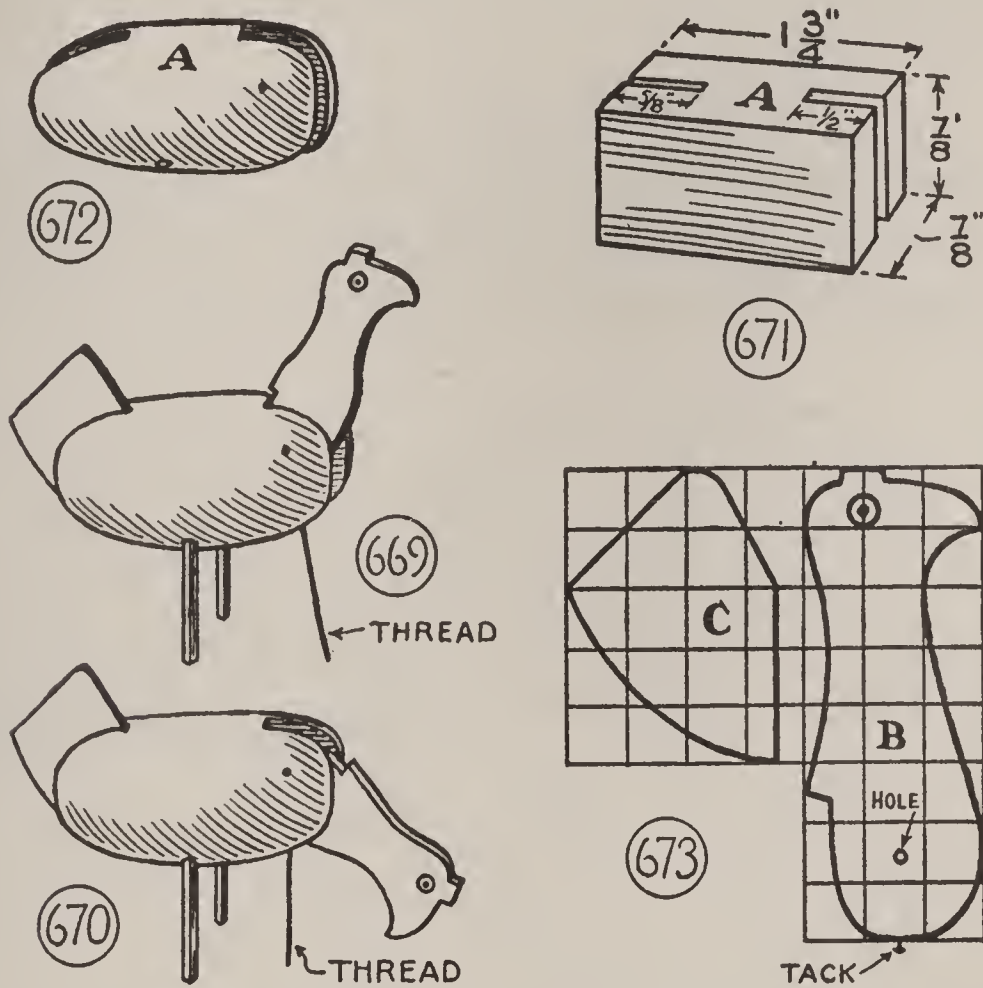

FIGS. 669 and 670.—Hens for the Toy Shown in the Photograph of FIG. 653 (opposite Page 370).

FIG. 671.—Body-Block Before Shaping.

FIG. 672.—Body-Block After Shaping.

FIG. 673.—Patterns for Head, Neck, and Tail.

of the patterns. Cut out the enlarged patterns, and use them to mark around on pieces of a cigar-box. Saw out the pieces with a coping-saw, or cut them with your knife.

Drill a small hole through the neck for a brad pivot, and drive a tack in the end, for attaching the pendulum cord.

When you have prepared the parts, pivot the neck in its slot in the body, and glue the tail in its slot. Drive the brad pivot in the right position to run through the hole in the neck.

### THE FEEDING PLATFORM

Cut the platform from a box board. Fig. 674 shows a plan. Describe the circle for the outer edge, then a circle with a radius of  $2\frac{1}{4}$  inches, on which to locate holes for the

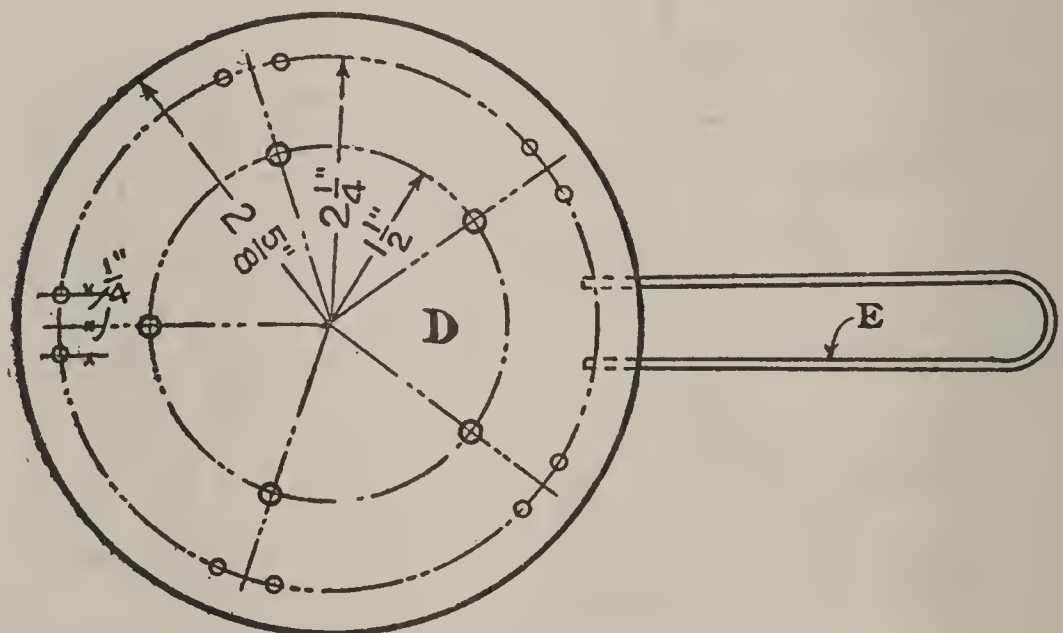

FIG. 674.—Pattern for Platform.

hens' legs, and an inner circle with a radius of  $1\frac{1}{2}$  inches on which to locate holes for the pendulum cords. Divide the inner circle into five equal parts, and each division point will be a center for a  $\frac{5}{16}$  inch hole. Draw radial lines from the center through the points, and locate holes for the hens' legs  $\frac{1}{4}$  inch to each side of these lines.

The Handle is a piece of heavy wire bent into a loop (E, Figs. 674 and 675). Drill holes in the edge of the platform, and drive the wire ends into them.

### THE PENDULUM

A spinning top makes the best-looking pendulum (Fig.

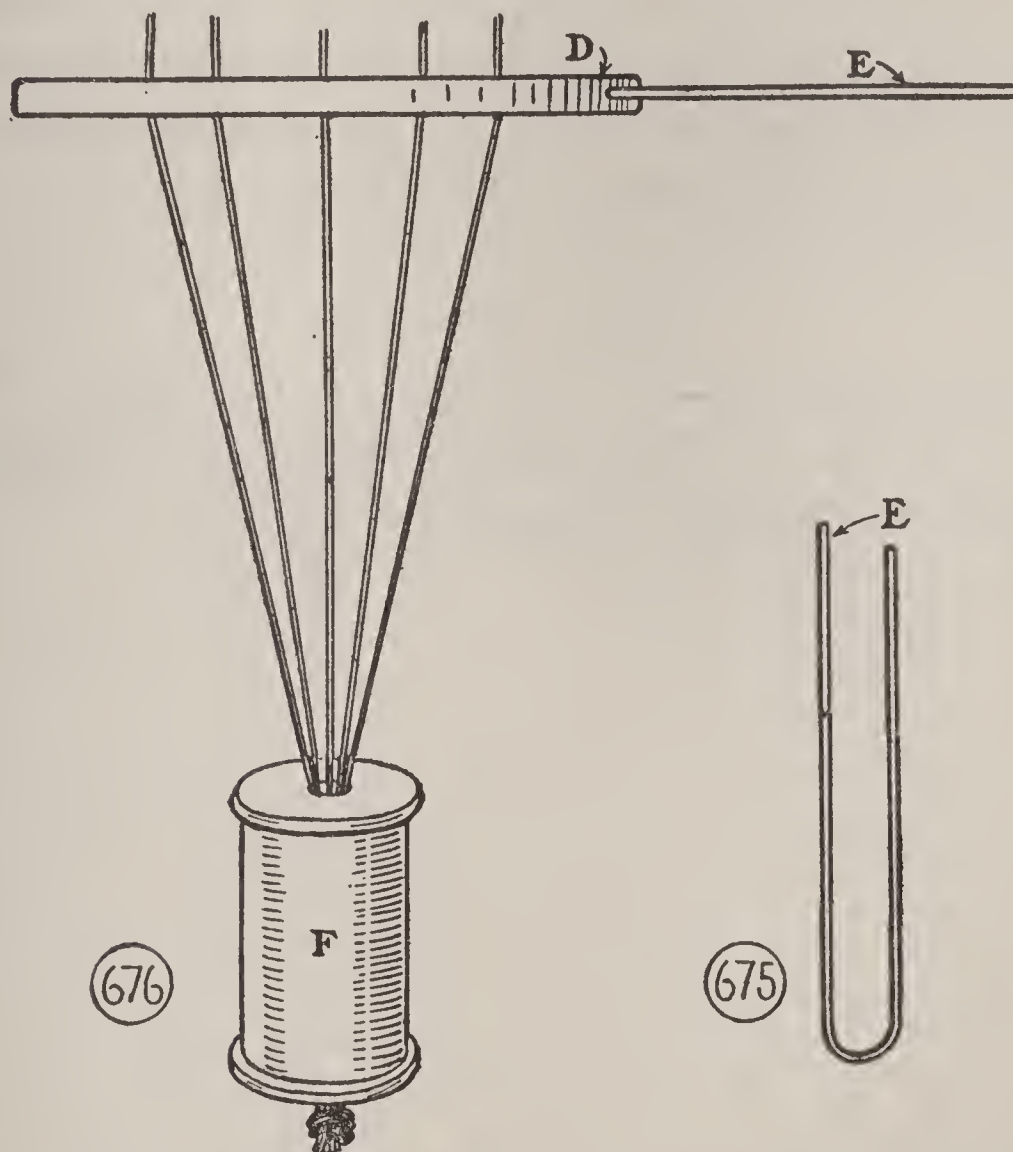

FIG. 675.—Detail of Wire Handle.

FIG. 676.—Detail of Spool Pendulum.

675), but a spool like that in Fig. 676 is the simplest rig.

Use a large spool unless you want to weight it by pouring its hole full of lead.

#### THE ASSEMBLY

To mount the hens, coat the leg-ends with glue, and stick them into the holes in the platform. Then tie heavy linen thread or light-weight wrapping-twine to the tacks in the neck ends, for the pendulum cords, run the cords through the holes in the platform, through the hole of the spool pendulum, and knot them. Make the distance between the pendulum and the platform about 5 inches.

#### FINISH THE TOY

as you like, with paint, stain, enamel, or lacquer. Bright colors are best. Indicate poultry feed upon the center of the platform by small daubs of yellow paint.



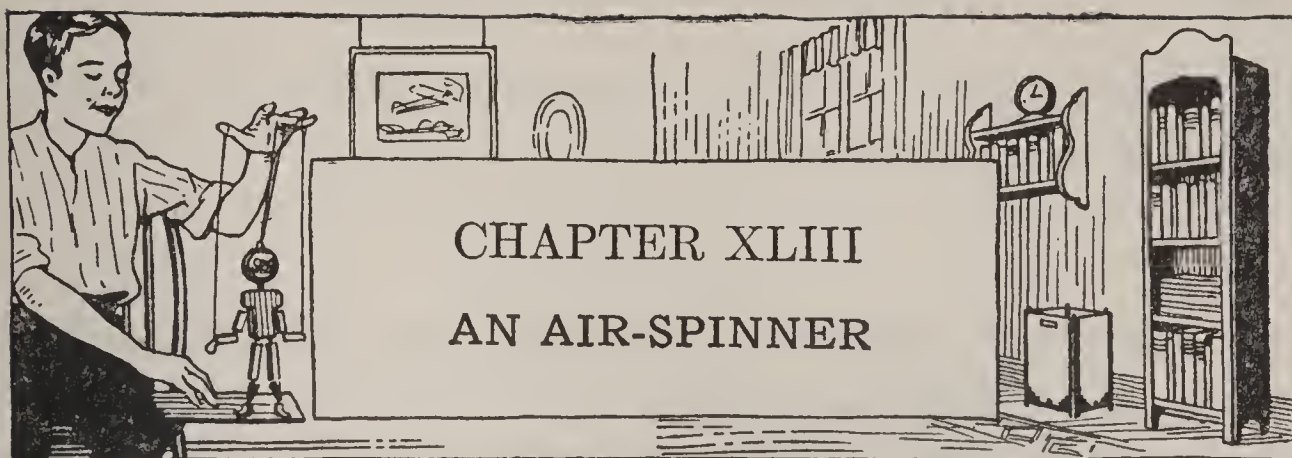

You can make the air-spinner rise perpendicularly, or spiral to the right or to the left, according to how you adjust its tips. It zooms until the spinning momentum has been expended, often to a surprising height, then slips back to earth.

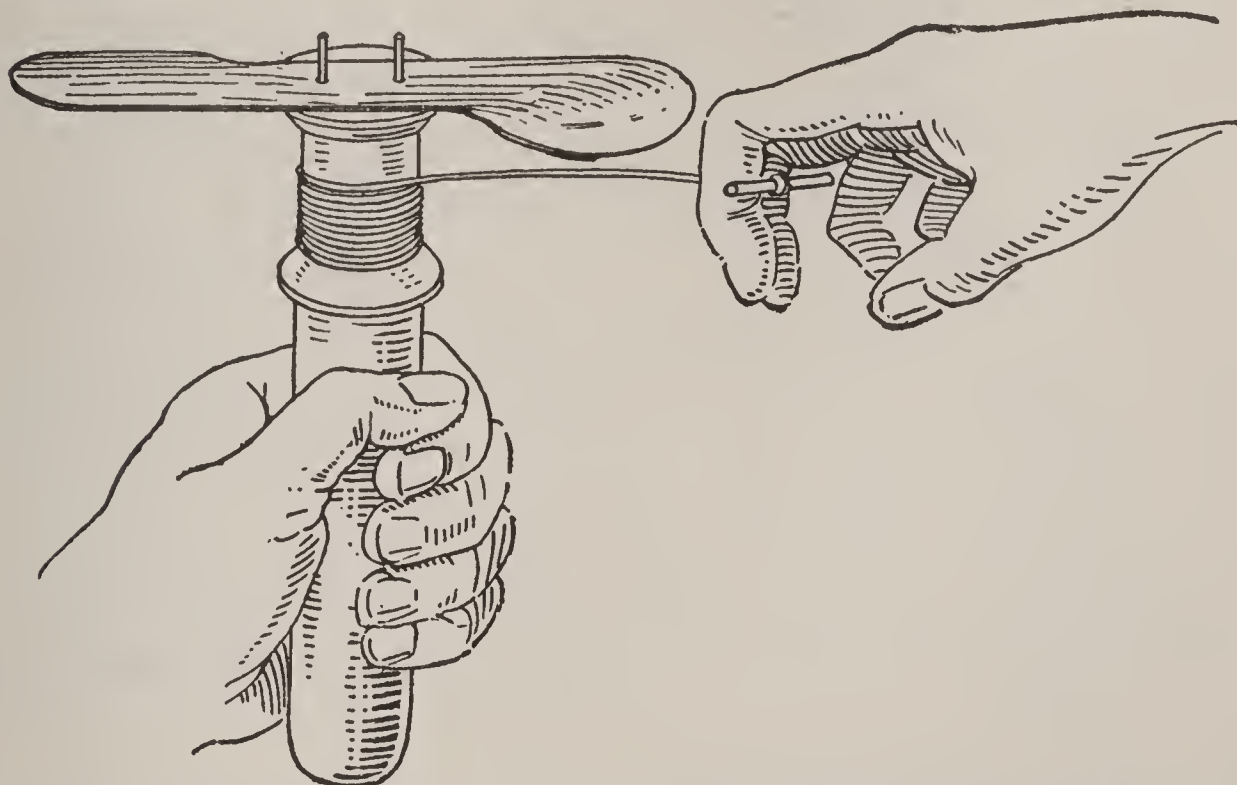

FIG. 677.—Launching the Air-Spinner Shown in the Photograph of FIG. 654 (opposite Page 370).

The completed toy and its spinning device are shown in

the photograph of Fig. 654, opposite page 370, and in Fig. 677 of the working diagrams.

#### FOR MATERIALS

get a large thread-spool (Fig. 678), a pair of phonograph needles (Fig. 679), a common nail 1 inch longer than the spool (Fig. 680), a broom-handle end 4 inches long

(Fig. 681), and a piece of tin cut from the side of a tin can.

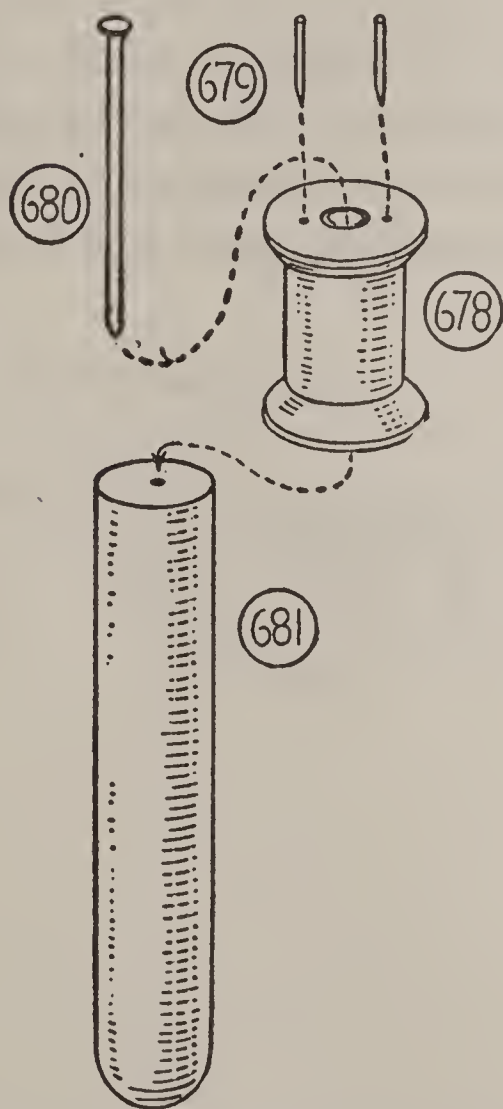

**THE SPINNING DEVICE** is assembled as indicated in Figs. 678 to 681. Drive the phonograph needles part way into the spool end, with a spacing from center to center of exactly  $\frac{1}{2}$  inch. Drill a hole in the end of the broom-handle, a trifle smaller than the nail, slip the nail through the spool, and drive it into the drilled hole. Trim the top edge of the spool-hole so that you can countersink the nail head.

FIGS. 678 and 679.—Spool and Phonograph Needles for Launching Device.

FIG. 680.—Nail Pivot for Spool.

FIG. 681.—Broom-Handle End for Handle.

#### THE SPINNER

is a piece of tin of the shape and size of the pattern in

Fig. 682. Make a tracing of the pattern, transfer it upon the piece of tin, cut out with a pair of tinsnips or old scissors, and drill the center holes a trifle larger than the needles.

When you have cut and drilled the spinner, bend down the tips as indicated in Fig. 682, then bend the spinner slightly at the center, so the straight edges will slant up from the center to the tips.

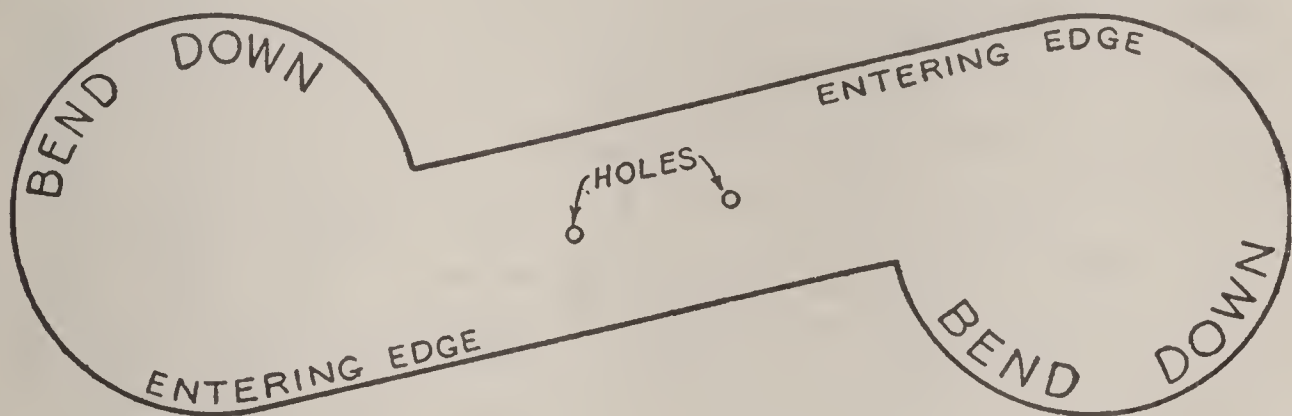
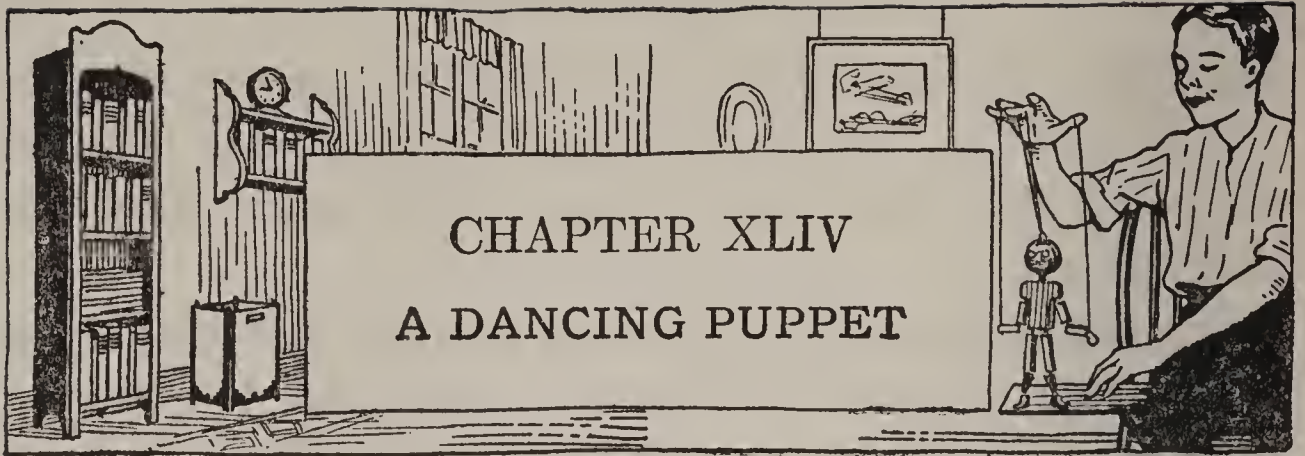

FIG. 682.—Full-Size Pattern for Air-Spinner.

#### TO LAUNCH THE AIR-SPINNER

place it upon the spinning device as shown in Fig. 677. Use cotton wrapping-twine for the spinning-cord. Wind it around the spool as you would wind the string upon a spinning-top. Tie a match or brad to the end for a grip, and pull with the right hand, while you hold the handle with the left hand.



INSTEAD of manipulating the feet of this puppet with strings, as you control the feet of the puppets in the following chapter, you make them dance by vibrating the dancing-platform with your fingers. The method is indicated by the photograph in Fig. 655, opposite page 370. Light tapping produces slow movements, fast, heavy tapping produces lively movements. With practice, you will become expert in handling the puppet, and can make it dance to the accompaniment of whistling, or music from the radio, phonograph, piano, and other instruments. This is a good toy for a Christmas gift for your younger brother or sister. But you will have as much fun playing with it as he or she will.

#### THE PUPPET

is of simple construction, as you will see by the diagram in Fig. 683.

Cut the Parts out of a box board  $\frac{3}{8}$  or  $\frac{1}{2}$  inch thick. You will find a coping-saw handy for the cutting, with a jack-knife and a file to finish the shaping of the hands and feet, and sandpaper to smooth the surfaces. Follow the

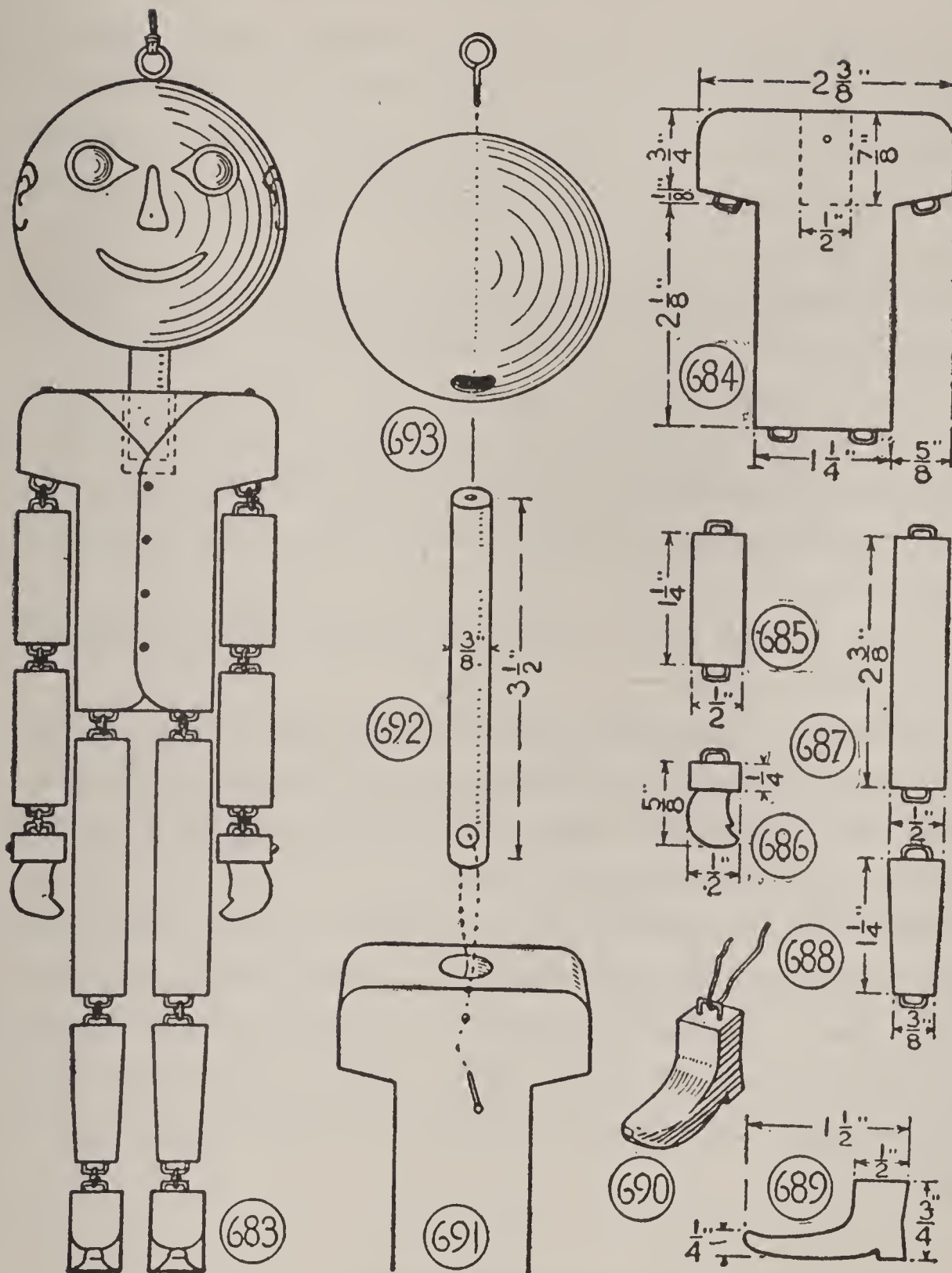

FIG. 683.—Puppet Shown in Photograph of Fig. 655 opposite Page 370.

FIG. 684.—Pattern for Body.

FIGS. 685 and 686.—Patterns for Arms and Hands.

FIGS. 687-689.—Patterns for Legs and Feet.

FIG. 690.—Detail of Shoe.

FIGS. 691 and 692.—Details of Neck.

FIG. 693.—Rubber-Ball Head.

pattern of Fig. 684 for the body block, Fig. 685 for the arm blocks, Fig. 686 for the hands, Fig. 687 for the upper portion of the legs, Fig. 688 for the lower portion of the legs, and Fig. 689 for the feet. Shape the toe of the shoes as shown in Fig. 690.

**Assemble the Parts** with heavy linen thread or cotton wrapping-twine. Drive tacks into the parts where you are to attach strings. The diagrams show the use of double-pointed tacks, but any kind with heads large enough to hold the strings will do. Tie the strings so that there will be enough length between the tacks to make the joints work freely.

Bore a  $\frac{1}{2}$ -inch hole  $\frac{7}{8}$  inch deep in the body (Figs. 683 and 691) to receive

**The Neck**, a piece of  $\frac{3}{8}$ -inch dowel-stick or stick whittled to this diameter,  $3\frac{1}{2}$  inches long (Fig. 692). Drill a  $\frac{3}{16}$ -inch hole through the stick near one end, slip this end into the body, and pivot with a brad.

**The Head** is a rubber ball (Fig. 693). Cut a hole in the ball, push the neck-stick through the hole as far as the opposite side of the ball, and screw a small screw-eye through the ball into the end of the stick. Drill a hole in the neck-stick so that the screw will drive in without splitting the stick.

#### FINISH THE PUPPET

with lacquer or enamel colors. It is easiest to finish the parts before assembling them. I used black for the head, hands, and feet of my model, red for the coat, green for the

trousers legs, and yellow for the stockings, then I drove tiny round-headed brass tacks into the coat for buttons, and made a collar of white paper, as shown by the photograph in Fig. 655. When the painted head had dried, I added eyes, nose, mouth, and ears, with white paint, then, when the white paint had dried, I drove round-headed brass nails through the eyes for pupils.

#### THE DANCING-PLATFORM

Use a shingle, or other thin piece of wood, or a piece of cardboard, for the platform. Rest one end of the platform upon a chair, and sit upon it to hold it, as shown by the photograph in Fig. 655.

#### TO MANIPULATE THE PUPPET

Tie a string or thread to the head screw-eye, to slip over the second finger of your left hand. Tie another string to each wrist of the puppet, and make loops in the ends, one to slip over your little finger, the other over your thumb. With the puppet thus supported by the left hand, use your right hand to vibrate the dancing-platform.

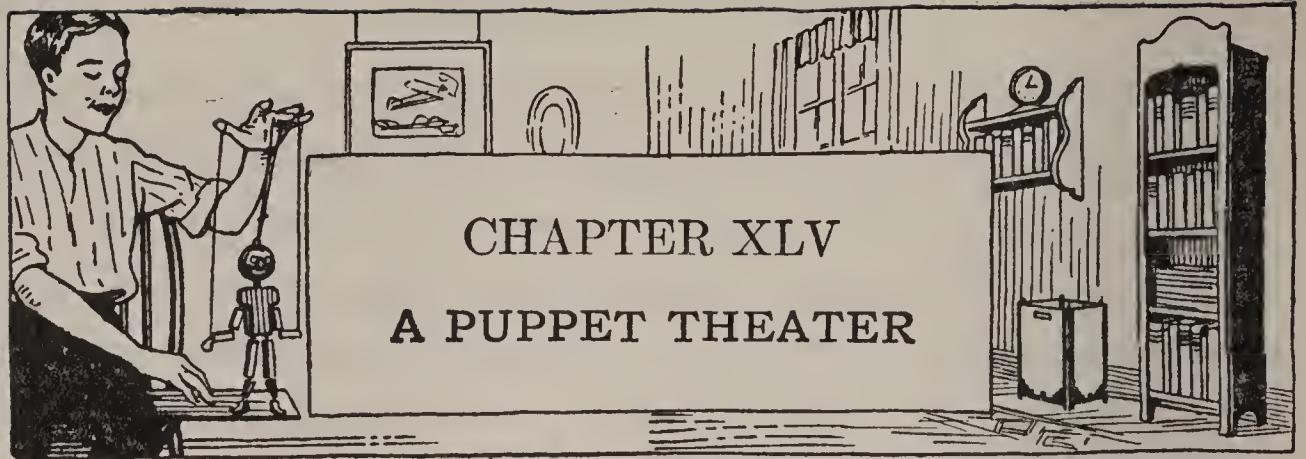

THIS might be a moving-picture theater as well as a puppet theater, if you or your chum should own a projector. A reel of pictures thrown upon the screen, while puppet scenery is being shifted, helps to sustain interest. I well remember the difficulty we boys used to have in preventing audiences from going back stage, or going home, during the long interval between acts. But that was before the advent of moving pictures. You fellows are lucky to be boys in this day and age.

There has been a revival of interest in puppet shows, of late, and a good show fills the house to capacity. Grown folks enjoy the shows as much as children do. But all the fun is not confined to the audience. Indeed, it is even more fun to make and operate the puppets. So, in this chapter, I shall give you suggestions for building a theater, making scenery, and preparing and operating puppets, and if you can interest two or three of your friends in taking up seriously the development of puppet shows this fall and winter, I promise that you will find the work a most delightful hobby.



First, build the theater. This should be portable, for no doubt you will want to exhibit at different places.

### THE DOORWAY THEATER

shown in Fig. 694 is of the right type for a portable theater. Since I first published the following plans and suggestions for building the theater, in my department in

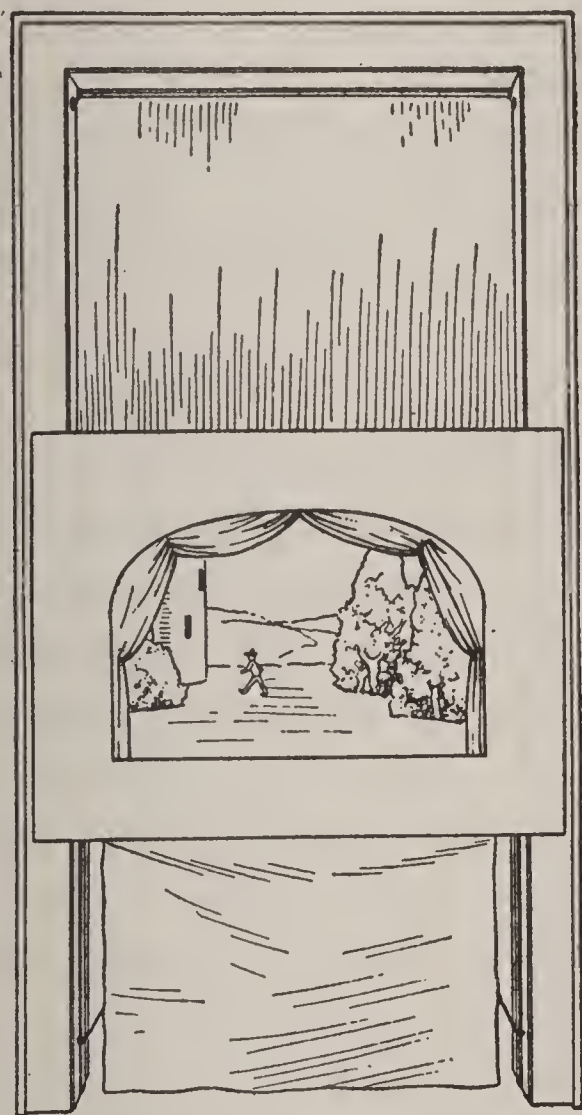

FIG. 694.—A Doorway Theater is Easy to Set Up.

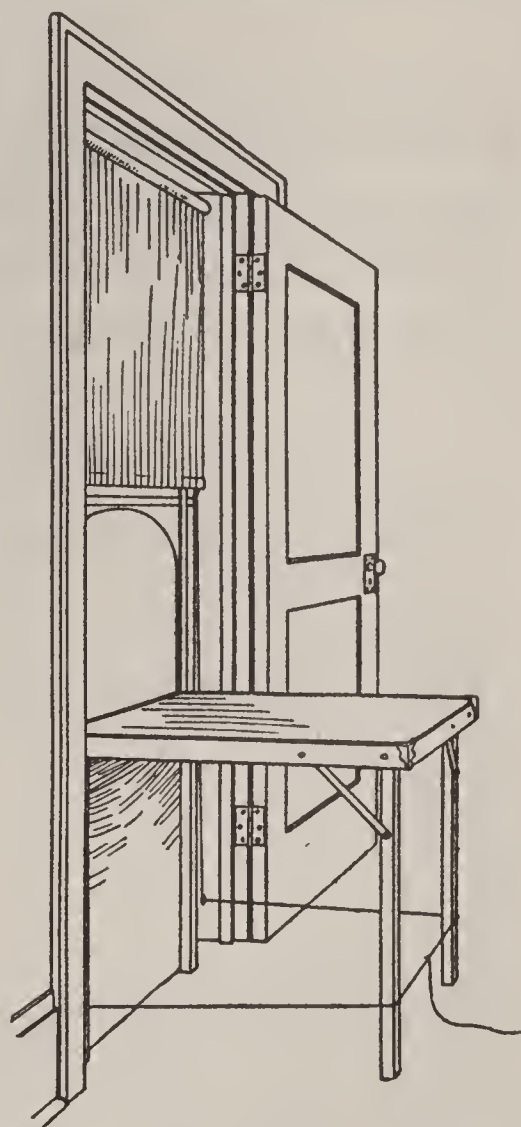

FIG. 695.—The Doorway Theater from Back Stage.

“Child Life,” the idea has received the indorsement of Tony Sarg, illustrator, cartoonist, and exponent of puppet

shows, who has won an international reputation for creating the most remarkable puppets in existence.

If you can set up the theater in a doorway, as shown, you will be saved the trouble of hanging curtains either side of it, to conceal what the audience should not see, including the operators, called the *puppeteers*. But if no doorway is available, you must resort to hangings.

### THE STAGE

of the doorway theater should be a card-table, or other small table, with a top about 28 inches square. Stand this in the doorway, as shown in Fig. 695. Then build the front of the stage, known as

### THE PROSCENIUM

Build a frame of four laths or lattice strips, crossed as

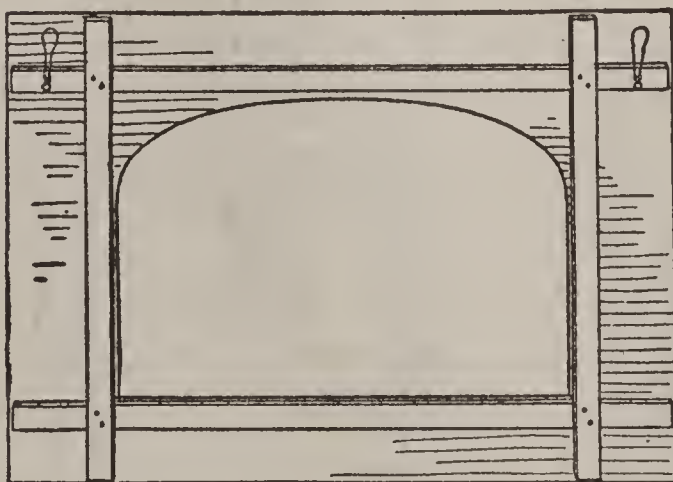

FIG. 696.—Build the Proscenium of Laths and Wallboard.

shown in Fig. 696, and cover the frame with a piece of wallboard. Saw out the center of the wallboard, to form an arched opening. Make the width of the opening the same as the width of the table, and the height 18 inches. Fasten loops

of string to tacks driven into the top frame-strip, near the ends, as shown in Fig. 696, and drive brads or glass-headed

push-pins into the door-casings to hang the loops on. From the front, the proscenium will appear as shown in Fig. 694.

Paint the Proscenium with radiator bronze, or decorate it with gold or silver stripes cut from wallpaper, and fill in between the stripes with lacquer.

### THE STAGE CURTAIN

is a window-shade of the right width to fit in brackets fastened to the door-jambs (Figs. 697-699). Possibly you will find an old shade in your storeroom. You can readily cut down one that is too wide, and if the material is torn too badly to patch, you can replace it with new shade-cloth or oilcloth. If you cannot find a shade or a roller at home, perhaps you can get one among the neighbors.

Screw the shade-brackets to the door-jambs near the door head, then the shade will serve the double purpose of stage-curtain and screen for the puppeteers.

**To Raise and Lower the**

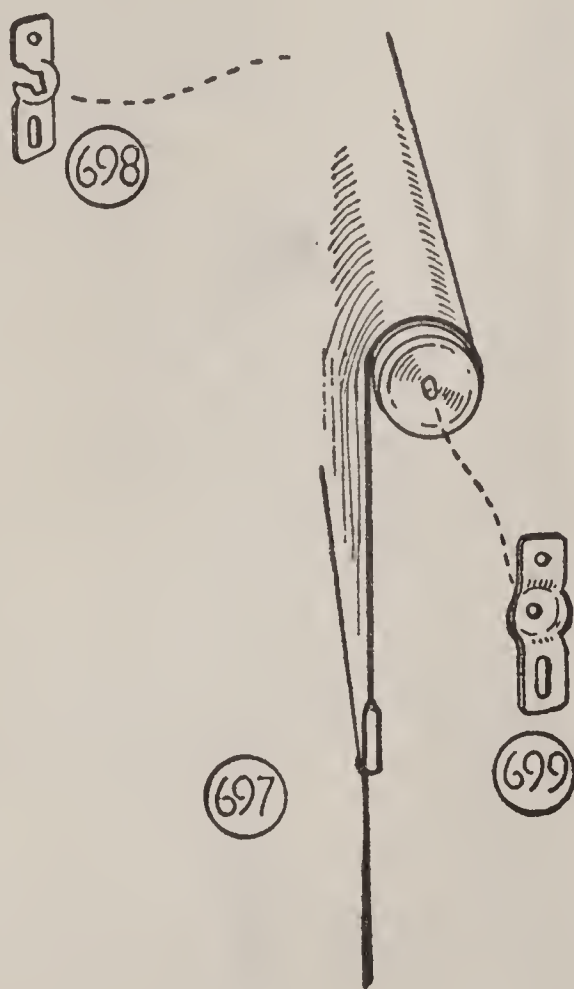

FIGS. 697-699.—Window-Shade Stage Curtain and Fixtures.

Curtain, there must be strings. Screw two screw-eyes into the stick in the hem of the shade, one near each end, tie a piece of wrapping-twine to each screw-eye, and run the strings through small screw-eyes screwed into the door-jambs near the floor (Fig. 695), then around the stage table legs, and tie the ends. Draw the shade to within an inch or so of the proscenium opening, before tying the strings.

### A PROSCENIUM DROP

should be provided in addition to the curtain. Make this of velour or other drapery material, and drape it around the proscenium, as shown in Fig. 694.

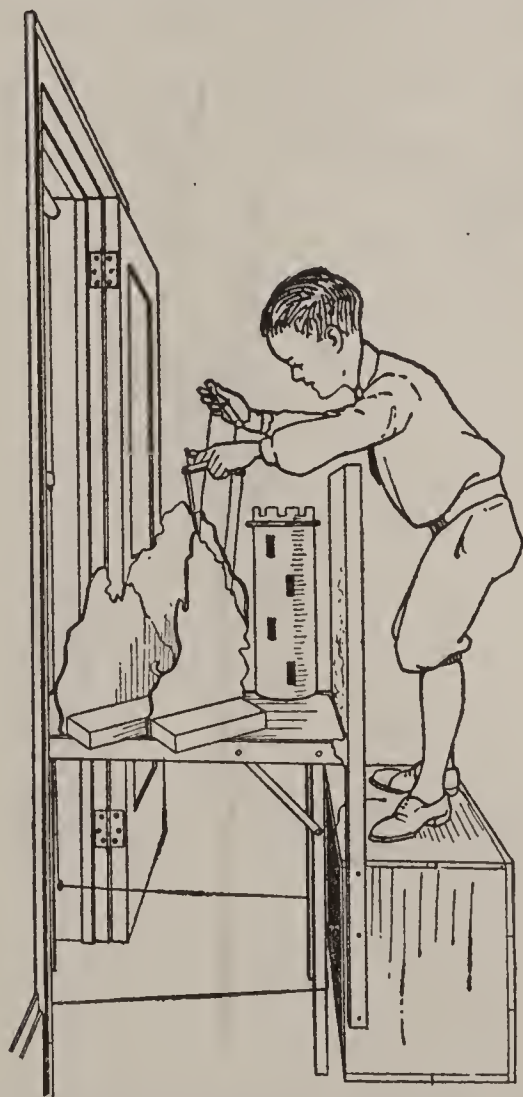

FIG. 700.—This is the Way the Puppeteer Controls a Puppet.

### STAGE-SETTINGS

Fig. 694 shows a simple setting, with one puppet on the stage. Fig. 700 shows the same setting, with the puppeteer manipulating the strings that control the puppet's movements. Suggestions for other settings will be found in Chapter XXIV of "The Boy Craftsman."

SCENERY AND PROPERTIES  
require cardboard, wrapping-

paper, blocks of wood, tacks and colored crayons. Scenery includes the *drops* and *wings* of a stage-setting. Properties include the smaller parts of a setting—towers, houses, garden, walls, furniture, and vehicles.

A Back Drop is shown in the diagram of Fig. 701. It is made of wrapping-paper. The upper two-thirds is colored

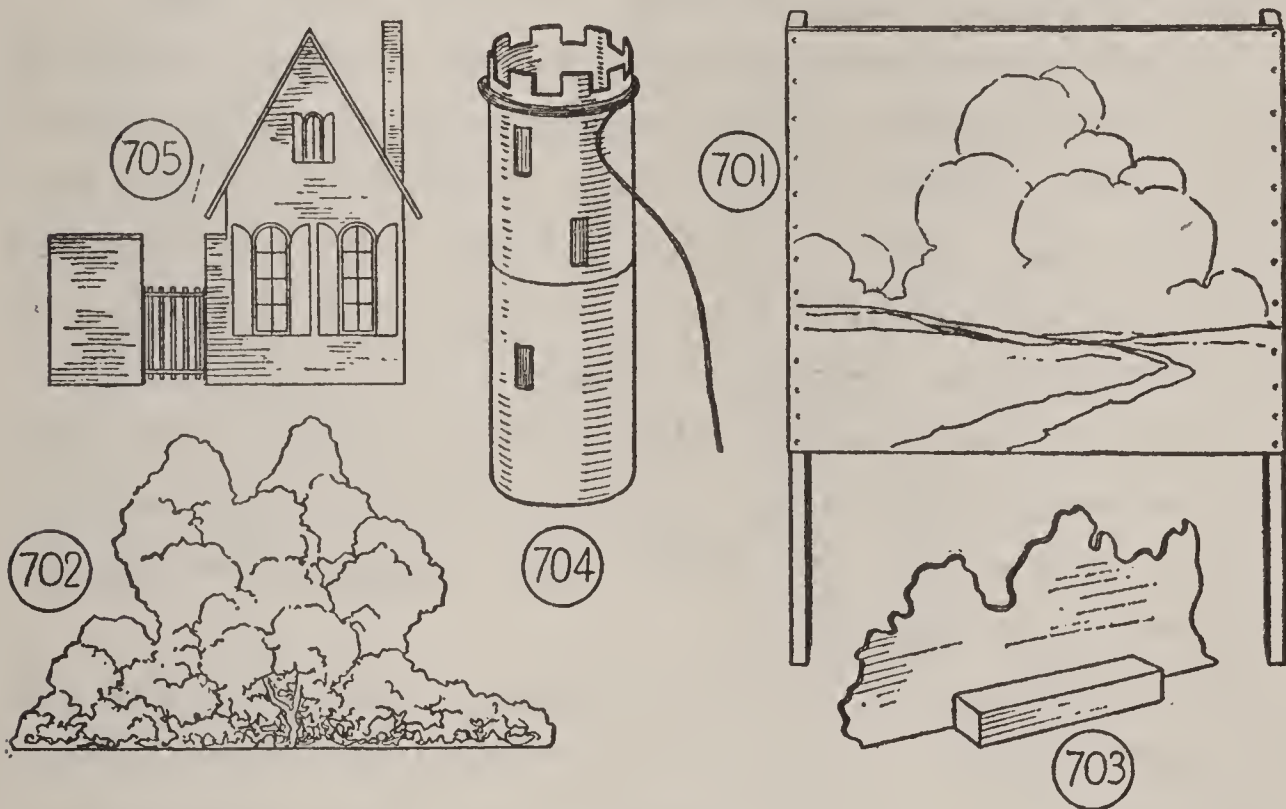

FIG. 701.—Back-Drop Frame.

FIG. 702.—Clump of Trees and Shrubbery for Wing.

FIG. 703.—Tack Small Scenery to Wooden Blocks, Like This.

FIG. 704.—Tower Built of Cartons, for Castle.

FIG. 705.—Cottage and Garden-Wall Wing.

blue for the sky, with white clouds. The lower one-third is made dark brown for ground. Sketch it out as shown, with a winding road at the center, or change the layout to suit your own ideas. Tack the drop to stick uprights, and

fasten these back of the stage to the puppeteers' platform, as shown in Fig. 700.

If it were not for wings and properties, the audience would see through the open sides of the stage. Fig. 702 shows a clump of

**Trees and Shrubbery.** Draw this upon box cardboard, cut it out, color it with green crayon, and shade it with black. Tack it to a base-block, as shown in Fig. 703.

**A Tower** for a scene including a castle is easy to make of two oatmeal cartons. Join the cartons end to end, as shown in Fig. 704. Notch the top carton to form the parapet battlements, and make a cornice molding of several turns of string, coated with glue, and wound around the carton. Cut window-openings, or indicate them with paint.

**A Cottage and Garden Wall** are shown in Fig. 705. Cut the window-openings and paste transparent paper over them. Then you can show light shining through the windows, in a night scene.

The making and coloring of scenery and properties will be easy for you boys who have worked with crayons and colored papers. Probably most of you have used them at school.

## PUPPETS

Small rag dolls make the best puppets for a puppet theater, although a loose-jointed doll like the dancing puppet described in the preceding chapter, will do very well for clowning. Tony Sarg uses

**Rag Dolls With Altered Joints**, like that shown in

Fig. 706. He opens the cloth at each joint, and removes some of the stuffing. Then he brings the cloth together and sews it. He does the same thing at the trunk, as indi-

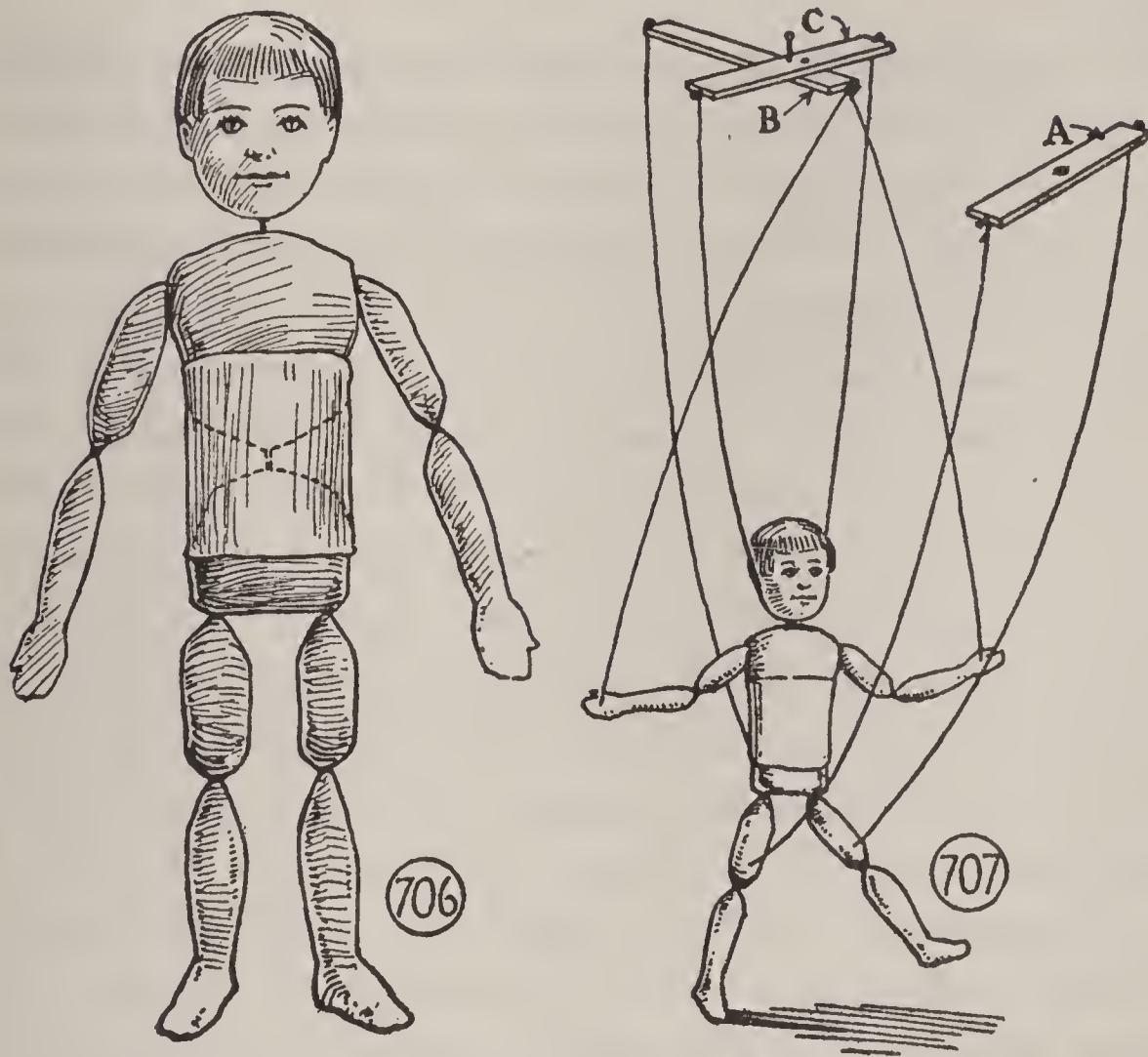

FIG. 706.—Rag Doll With Altered Joints, for Puppet.

FIG. 707.—Thread Controls, and Sticks for Supporting Them.

cated by dotted lines in Fig. 706. Then he sews a band of muslin around the waist.

If you haven't a sister from whom you can borrow dolls, small rag dolls are inexpensive enough to buy. Or, you can fasten small dolls' heads to home-made rag bodies. Ask

Mother to help you shape them. The puppets require several

**Changes of Costume.** You will be in luck if Mother or Sister will accept appointment to the position of wardrobe mistress.

Use **Paper Dolls**, if you cannot obtain help in shaping rag dolls. You can mount them as suggested in Chapter XXIV of "The Boy Craftsman." With characters from colored comics to select from, you have great possibilities for cardboard puppets.

**The Thread Controls** for puppets are shown in Fig. 707. Use fine linen thread. Attach a piece 24 inches long to each leg of the puppet, at the knee, and tie the free ends to tacks driven into the ends of a short stick (A). Cross two other sticks (B and C), nail them together, and drive a tack into both ends of each. Tie threads to the puppet's wrists, and join them to one of the tacks in crosspiece B. Fasten a thread to the back of the puppet, and join it to the second tack in crosspiece B. Fasten a thread to each ear, and tie the other ends to tacks in crosspiece C. A hole is shown in the center of stick A. This is provided so that the stick can be slipped over the nail in strip C, to combine the sticks.

### OPERATING THE PUPPETS

With the seven threads connected as shown, it is possible to put a puppet through any movements wanted, controlling the leg threads with the right hand, the other threads with the left hand.



Fig. 700 shows a puppeteer putting a puppet through his movements. Grocery boxes of different heights make good platforms.

### THE STAGE LIGHTING

Light the stage from the front and sides by floor lamps, or drop-cords, or both. It is easy to adjust these to get the desired effects. You can throw colored tissue-papers or silks over the lamps to produce colored lighting. Other suggestions for lighting will be found in "The Boy Craftsman."

### PUPPET PLAYS

You will probably find a book of puppet plays in your local public library. Fairy tales are always popular, because audiences are familiar with them. But after you have become expert in handling your puppets, you will have little difficulty in devising puppet scenarios of your own. A thrilling aviation story, or detective story can be built up from the day's news, or from a current magazine, and will "go across big." You will enjoy working up something along modern lines.



SOME boys whom I know make games their hobby. They have done so for several years. Both indoor and outdoor games are on their program. They plan games a season ahead, decide who is to play whom, and what and when, and play off this schedule in tournament style. Each boy of the group is more or less expert in his favorite games, but the best of calculations are often upset, and no one can predict who will be the season's champion of this game series, or of that, or who will be the all-round champion. As you may imagine, the boys get lots of fun out of their game tournaments.

If the game-tournament idea appeals to the boys in your hobby club, you will be interested in home-made equipment. There is little room, in this book of many hobbies, to devote to the subject, but you will find the following suggestions to your liking, I am sure, and you may supplement them with ideas from my book "Home-made Games and Game Equipment," which you will find in your public library. The book contains suggestions, also, for conducting game tournaments, and for making prize cups, medals, score indicators, and score books.

## TABLE TENNIS

Brought out as a fad when your Dad was a boy, table tennis has survived the fad period, and has established itself as one of our standard indoor games. Indeed, its popularity is greater now than ever before. Everybody enjoys it, and everybody can play it. It has the fascination of lawn tennis, but it is not as strenuous a game.

You can easily make every part of a table tennis outfit, except the balls.

The Court may be laid out upon a large library table (Fig. 708), or a dining table extended. If neither is available, buy a piece of wallboard 4 feet wide and 8 feet long,

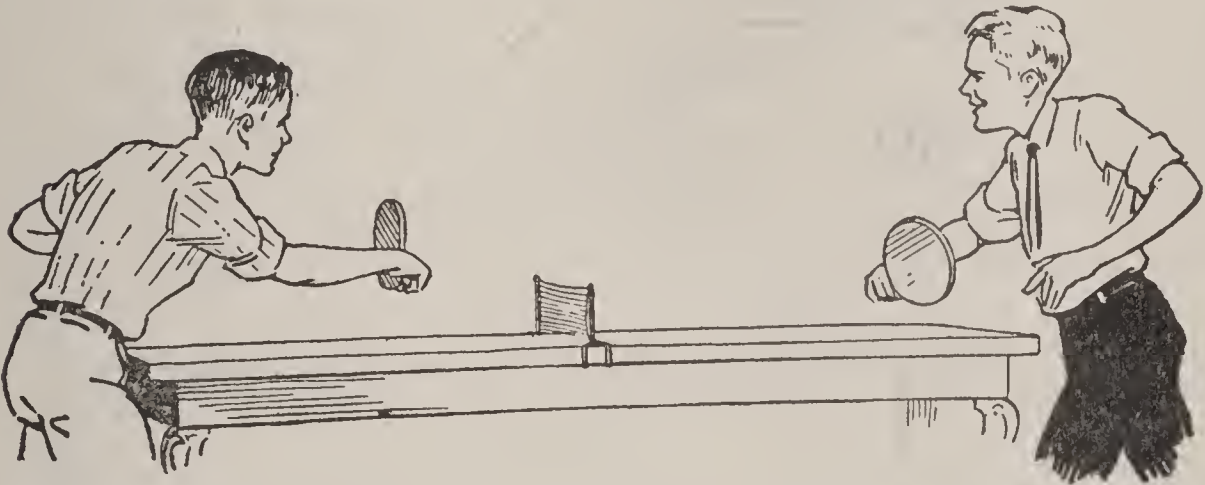

FIG. 708.—The Tennis-Court Can Be Laid Out Upon a Large Table, or Upon a Frame Covered With Wallboard.

and tack it to a frame made of 1-by-2 stock. Support the frame upon small tables, chair backs, boxes, or a pair of horses.

**Marking Out the Court.** You can mark out the court upon a table without injuring the finish, by use of a chalk line. Take a length of cotton line, and chalk it from end

to end. Give your partner one end of the string to hold, while you hold the other end. Lower the string to the surface of the table, at a point where you wish to mark a line, and while it is pulled taut, grasp it at its center, raise it 1 inch or so, and let it snap back to the surface. This will make a straight well-defined line that you can easily wash

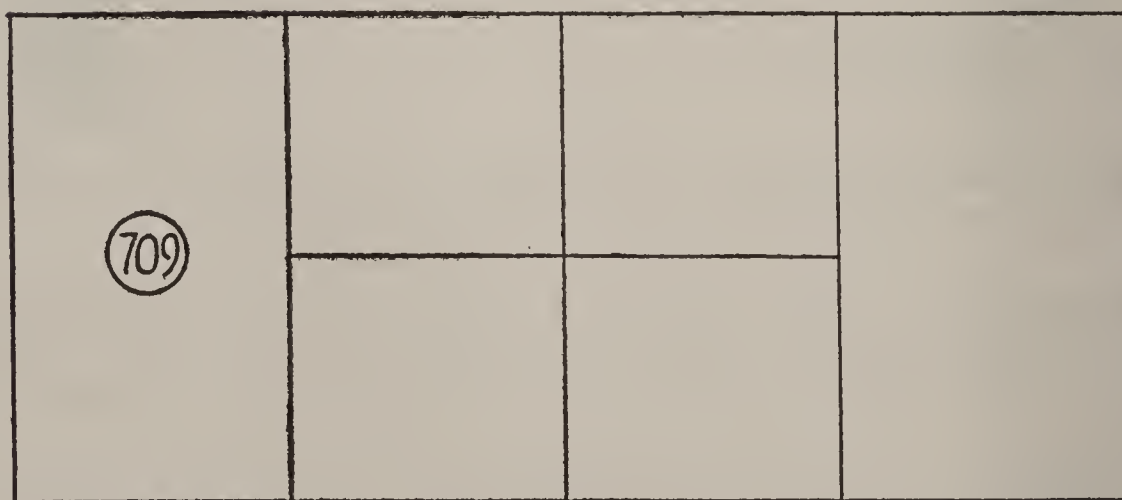
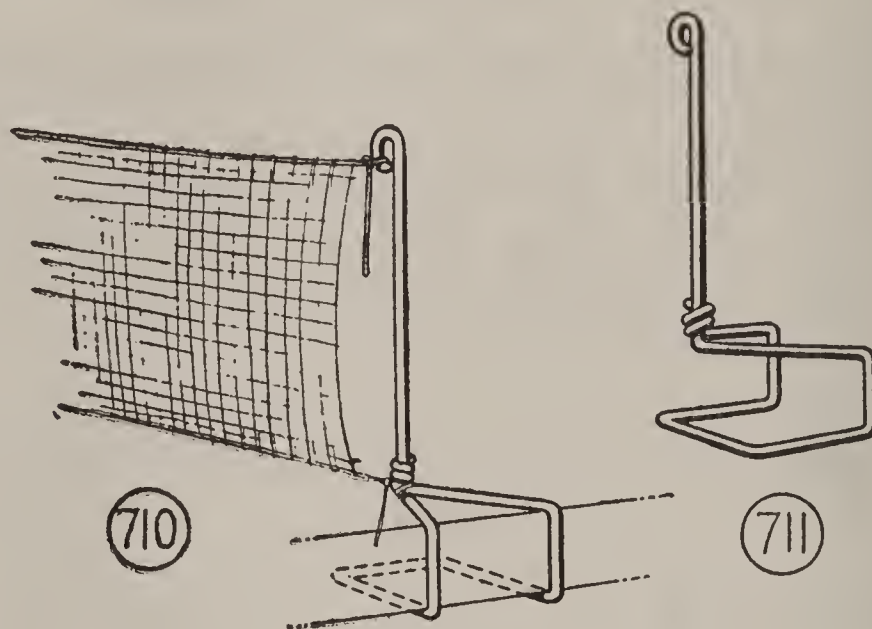

FIG. 709.—Layout for Table Tennis-Court.  
 FIG. 710.—Tennis Net and Post.  
 FIG. 711.—Detail of Wire Post.

off, when you are done playing. Fig. 709 suggests the layout of a table court.

A Wallboard Court may be marked off with crayon or with strips of gummed tape.

Make the Tennis Net of a strip of curtain net, marquisette, or other material. Bind the upper edge, and the lower edge, if need be, with tape, and cut the tape ends long enough to tie to the posts (Fig. 710).

The Tennis-net Posts. Figs. 710 and 711 are details of a tennis-net post. Make a pair of this type out of No. 8 wire, with the base shaped to grip the edge of the table with a snug fit. Fold pieces of blotter or cardboard over the table edges to keep the wire from marring the surface.

Make Tennis Rackets like that shown in Fig. 712. You may saw them out of box boards  $\frac{3}{8}$

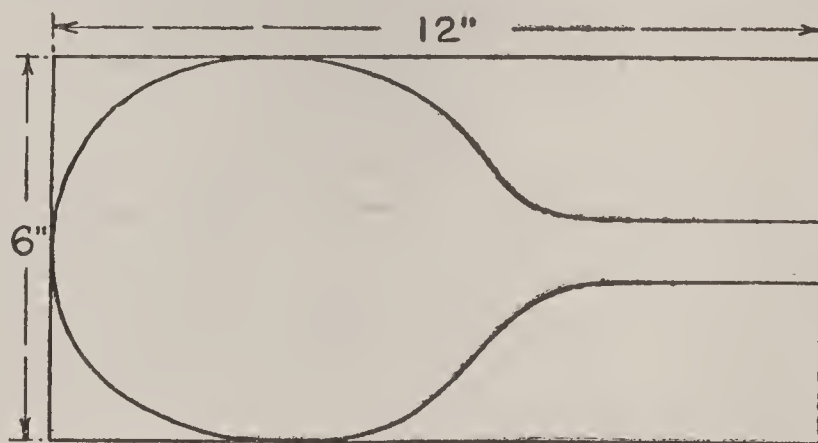

(713)

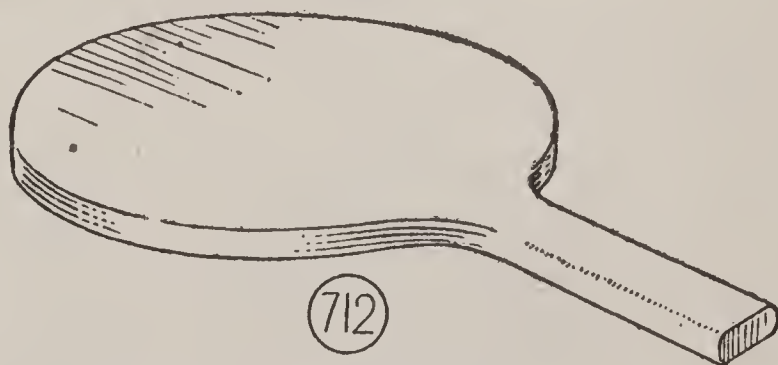

(712)

FIG. 712.—Tennis-Racket.

FIG. 713.—Diagram for Racket.

inch thick, but plywood is better, if you can get it, because it does not split or warp. You can reinforce box-board

rackets by gluing muslin over both surfaces. Mark out the rackets as shown in Fig. 713. When you have cut them, and smoothed their surfaces, finish with lacquer or wood stain.

**Table Tennis Balls** are of celluloid. You can substitute small rubber balls, but they are not nearly so good because of their weight. You can purchase celluloid balls wherever games are sold, and they are inexpensive.

**Rules for Table Tennis** are similar to those for the outdoor game, but you may make such changes in the regulations as your table court suggests.

#### A RING-TOSS TARGET

The big, brightly painted target shown in the photograph of Fig. 714 will be enjoyed by all the family, and especially by you, whose hands and eyes have been trained for straight tossing, by basket ball and other games. It will be a good investment of time to make the target, because you will use it the year round, indoors on winter evenings, and upon the lawn in summer.

Make the **Target** of a piece of wallboard 32 inches square. If a carpenter in the neighborhood hasn't a piece of the right size, you may have to buy a full-size sheet at the lumber yard, but whatever is left over will be useful for other models. The diameter of the target may be less, however, to suit a smaller piece of wallboard.

The **Target Face** is shown in the diagram of Fig. 718, with the radii for the bull's-eye and outer disks. Use a string with a brad or pin at one end for a center, and a

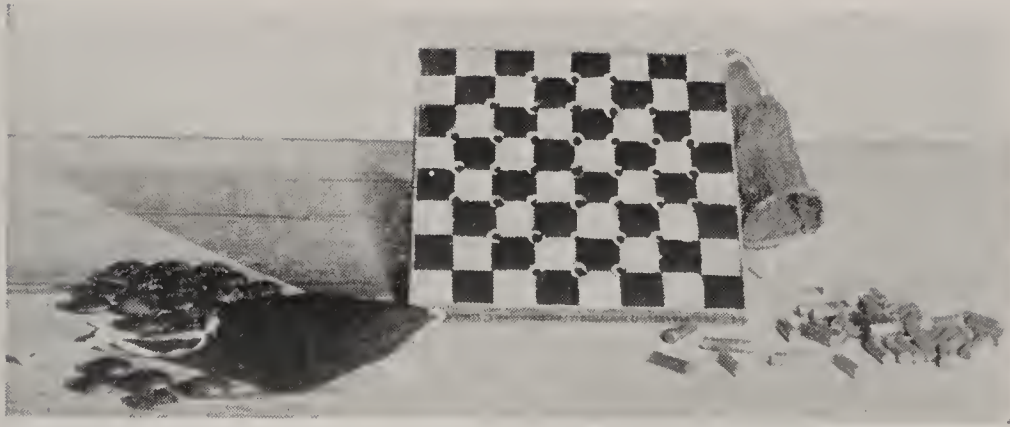

FIG. 715.—THE BOARD FOR CHECKERS AND SOLITAIRE IS OF CONVENIENT SIZE FOR TRAVELING.

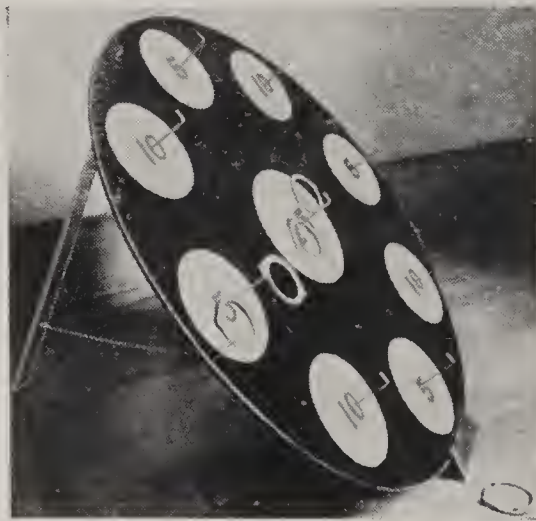

FIG. 714.—THIS RING-TOSS TARGET WILL BE USED INDOORS IN WINTER, AND ON THE LAWN IN SUMMER.

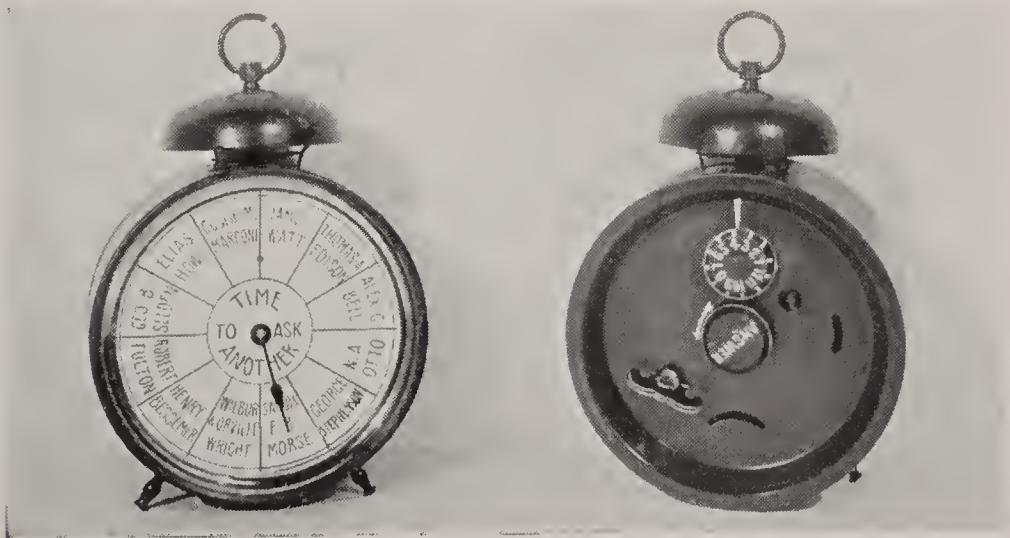

FIG. 716.—THE QUIZ CLOCK WILL FURNISH HOURS OF FUN.  
(See Chapter XLVII.)

FIG. 717.—THE QUIZ IS CONDUCTED BY MEANS OF THE "QUESTION" AND "ANSWER" KNOBS.





pencil slipped through a loop, at the other end, to describe three circles. Then locate centers for the outer disks, along the second circle, by means of a vertical line, a horizontal line, and two 45-degree lines, drawn through the center of the circle.

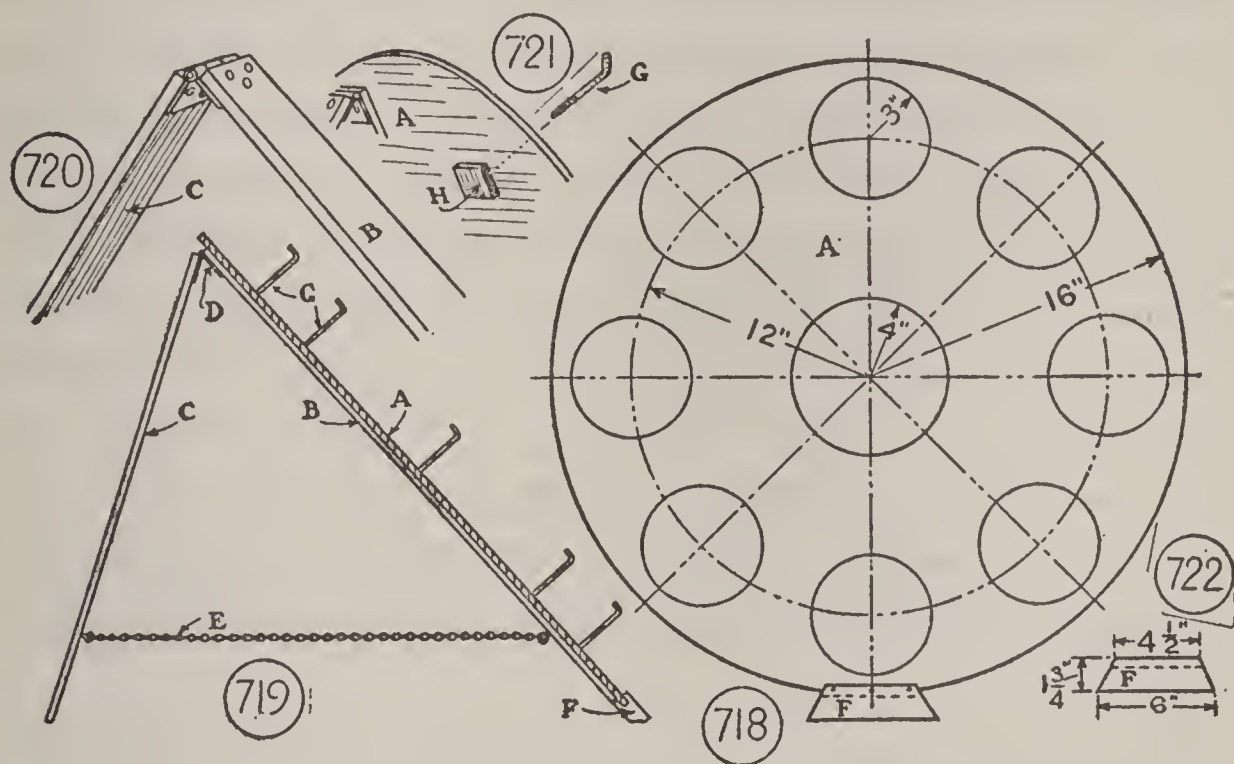

FIG. 718.—Diagram for Laying Out the Target Face.  
 FIG. 719.—Cross-Section of Target and Easel.  
 FIG. 720.—Detail of Easel.  
 FIG. 721.—Detail of Screw-Hook Pin.  
 FIG. 722.—Detail of Target Shoe Block.

Make the Easel of two pieces of lath or lattice strip (B and C, Figs. 719 and 720). Cut strip B, 30 inches long, and strip C, 26 inches long. Hinge the upper ends of the strips. Rivet the hinge flaps to the stick-ends as shown in Fig. 720. Rivet or screw strip B to the back of the target, along the center. Attach a check-chain of brass chain or strong cord to brass screw-eyes screwed into strips B and C, and the

easel will be complete, with the exception of the shoe (F, Figs. 718 and 719), for the target foot. Cut the shoe block, of the dimensions given in Fig. 722, slot its upper edge to receive the edge of the target, and glue and nail the block to the target.

Paint the **Target** with three coats of red enamel. Allow plenty of time for drying between applications. The enamel will conceal the target rings, but you can locate the centers quickly and redraw the circles. Trace the score numbers from a large calendar, or block them out with ruler or pencil. Center the numbers upon the disks. By the photograph in Fig. 714 you will see that the bull's-eye is marked "25," the outer disks "5" and "10." Outline the numbers with lead pencil, then fill in around the bull's-eye number with radiator bronze, and around the outer disk numbers with black enamel. That will leave the numbers red.

The **Target-pins** (G, Fig. 719) are brass hooks 3 inches long (Fig. 721). There are nine of them. Screw three hooks through the center, top, and bottom disks, into easel-strip B, and screw the other six hooks through the wall-board into small wooden blocks, like H in Fig. 721. Glue the blocks to the target back.

For **Tossing-rings**, use five preserve-jar rubbers.

#### RULES FOR TOSSING AND SCORING

Let the size of the room in which you use the target determine

**The Tossing-line.** Make handicap allowances to small

players. One good plan is to establish a close-up line, from which all players shall start, and then move the line back 12 inches or more after each ringer, until the end of the room has been reached.

**To Count the Score**, count for ringers the number of points indicated upon the bull's-eye and disks. Also, count points for rings that rest upon the disks at the end of a turn, as follows: 5 points for a ring that rests upon the bull's-eye, two points for a ring that rests upon a number 10 disk, and one point for a ring that rests upon a number 5 disk. Establish fifty or one hundred points as the game.

#### A CHECKER-SOLITAIRE BOARD

The photograph in Fig. 715 shows a small board of convenient size to pack in your trunk or suit-case when traveling, and large enough for home games. Little bags with draw-strings are fastened to the corners of the board, to hold the checker men and the solitaire pegs, when they are not in use.

Make the Board of  $\frac{5}{8}$ -inch or  $\frac{7}{8}$ -inch stock. Square up the block, plane the surfaces smooth, and plane a small bevel upon the edges. Then rub down with sandpaper.

**To Lay Out the Playing Surface**, measure off eight divisions of  $\frac{3}{4}$  inch along each edge, and connect opposite points with straight lines. The line intersections will be the centers for holes for the solitaire pegs, except three at each corner (Fig. 723).

**Bore the Peg Holes** at the thirty-seven intersections with

a  $\frac{1}{4}$ -inch bit, to a depth of  $\frac{3}{8}$  inch. Make holes with the point of a nail, for the point of the bit to start in.

When you have bored the peg holes, bevel their tops slightly with a countersink bit, or with your knife, and give all surfaces a final rubbing with sandpaper.

Finish the Board with lacquer or enamel. Lacquer is easy to apply on a small surface like the board, and its

(724)



(725)

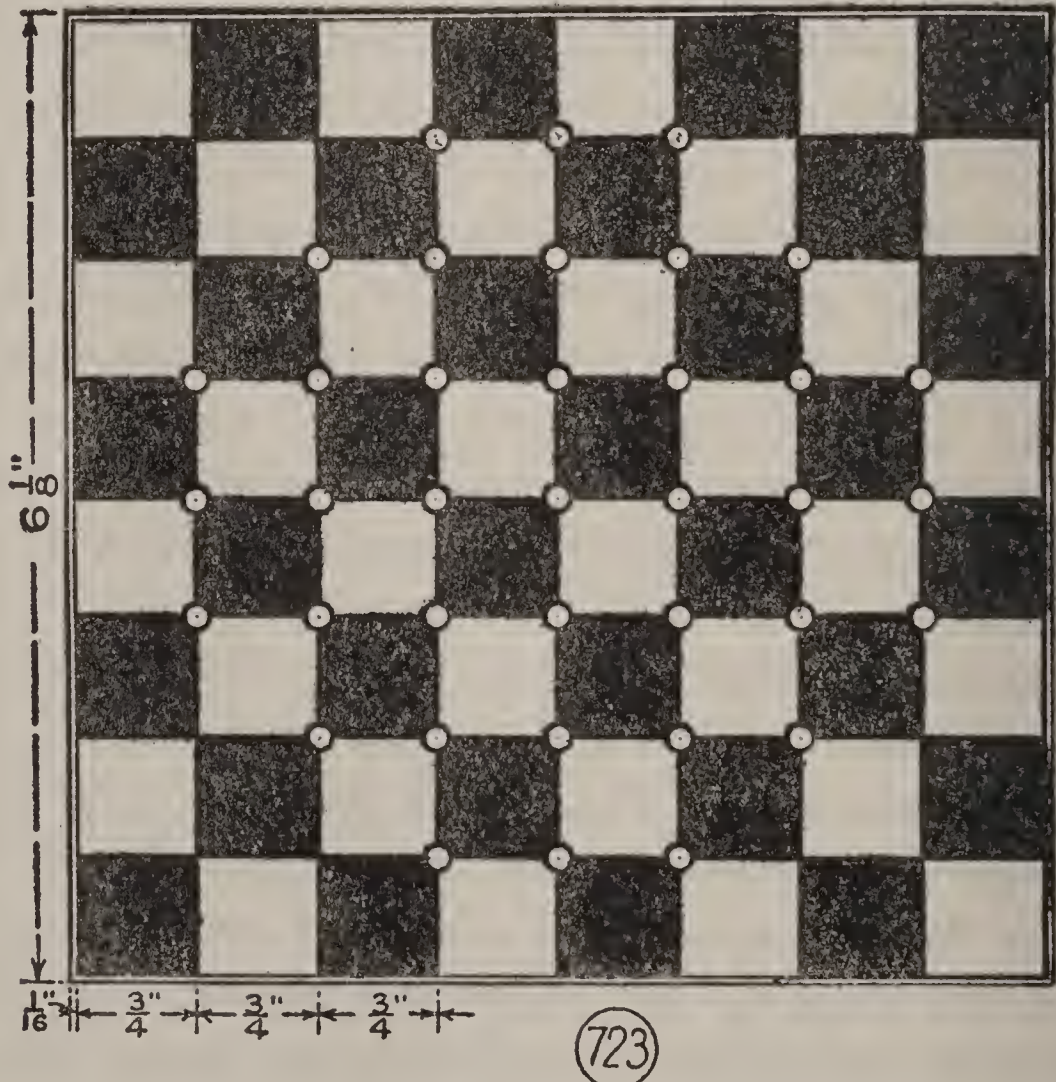
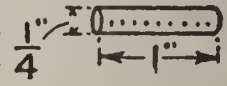

FIG. 723.—Diagram for Checker-Solitaire Board.

FIG. 724.—Button-Mold Checker Men.

FIG. 725.—Dowel-Stick Solitaire Pegs.

quick drying is in its favor. Lacquer the squares red and white, or black and white, and lacquer the edges of the board red or black. Use a medium-sized water-color brush for filling in the squares, and paint close to the lines, with care not to let the lacquer run over the lines.

**For Checker Men**, buy wooden button-molds  $\frac{3}{4}$  inch in diameter. Use them flat side down for men (Fig. 724), and with flat sides together for crowned men. Provide twenty-eight men. Lacquer half of the number one color, the other half another color. This number will provide two "spares" of each color.

**For Solitaire Pegs**, saw  $\frac{1}{4}$ -inch dowel-sticks into forty pieces 1 inch long (Fig. 725). This number will provide four "spares." Smooth up the surfaces of the pegs with sandpaper, then lacquer all alike, red or black.

**The Bags** to hold the checker men and solitaire pegs should be no larger than is necessary. The open end should be equipped with a draw-string for closing it. The bottom should have a short tape sewed to it to fasten it to the board. Give Mother or Sister the specifications. Either one can finish the bags in a few minutes on the sewing machine. Screw brass screw-eyes into two corners of the board and tie the bags to them.

### PLAYING RULES

Of course, you know how to play checkers. You may not know how to work the solitaire problems. There are several problems. One is to stick the pegs into all the holes but one. Then to jump the pegs, one at a time, removing each

peg jumped, until all the pegs but one have been removed. There are seven ways to do this. If you work long enough, you will surely discover one of the ways. The seven solutions, and two other problems and their solutions are illustrated and described in Chapter XX of "Home-made Games and Game Equipment."

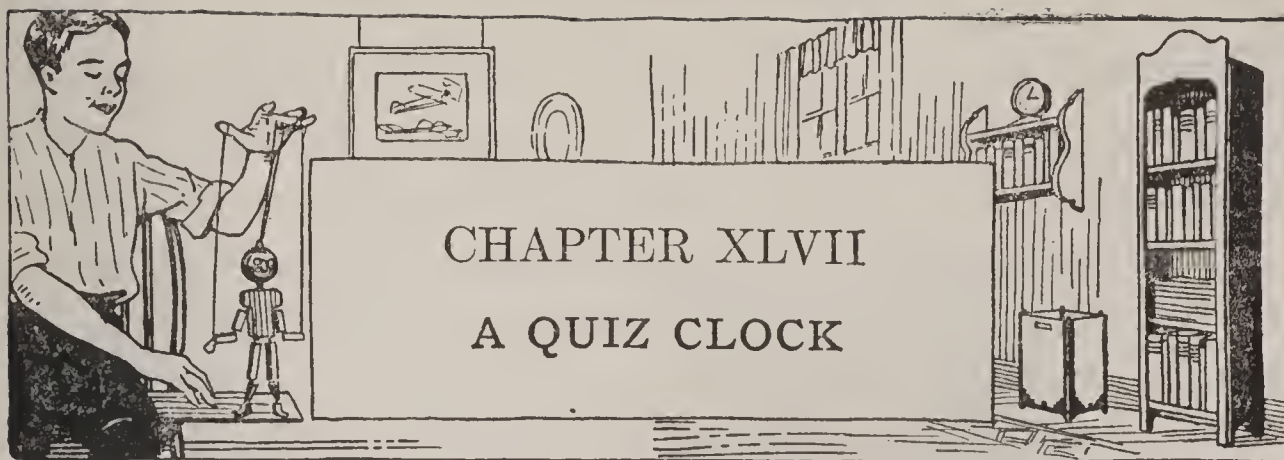

## CHAPTER XLVII

### A QUIZ CLOCK

THE popularity of games to determine how much you know, or how little you know, has brought forth devices, mechanically and electrically operated, that ask questions and give correct answers. The quiz clock, shown by the photographs in Figs. 716 and 717, opposite page 400, is my contribution to this field of entertainment, and it will cost you nothing to make. You will find it fun to assemble the quiz clock, and even more fun to prepare the cards with which to quiz.

Fig. 726 shows a detail of the front of the quiz clock, with an "answer" dial inserted, Fig. 727 shows the back of the clock, and the "question" and "answer" knobs with which you quiz. Since there isn't space on the clock case for a question card, you must make a separate card, like that in Fig. 733, and number the questions to correspond to the positions of the answers upon the answer dial.

#### THIS IS HOW THE QUIZ CLOCK WORKS

Referring to the question card in Fig. 733, which is suggested for the "inventors" card of your series, suppose that I ask, as a test question, "Who invented the Telegraph?"

You state who you think was the inventor. Then, I set the question-knob at the number opposite the question on the card (Fig. 733), which in this case is No. 4 (Fig. 727), and turn the answer-knob around and around until the alarm rings. Referring to the clock answer-dial, you find that the hand points to "Samuel F. B. Morse," and you know whether or not you answered my question correctly. Then, I turn the question-knob one point to the right, thus shutting off the alarm, and proceed with the next question.

When one set of questions has been answered, it requires but an instant to replace the answer-dial with another, in readiness to start the next quiz with the corresponding question-card.

#### A WORN-OUT CLOCK WILL DO

provided the alarm spring is intact, and usually that portion of a discarded clock is in good working order. If you cannot find a clock at home for the job, scout around among your relatives and friends. Probably one of them has a clock stowed away in a storeroom, and would be glad to let you have it.

#### TO PREPARE THE CLOCK

remove the glass, the alarm hand, and the minute hand (Fig. 726). So much for the face. Fig. 727 shows the remodeled back. Leave the alarm key on its post, but unscrew the time key, which is not needed, and slip off the alarm knob and the time knob, as you must fit these with larger heads.



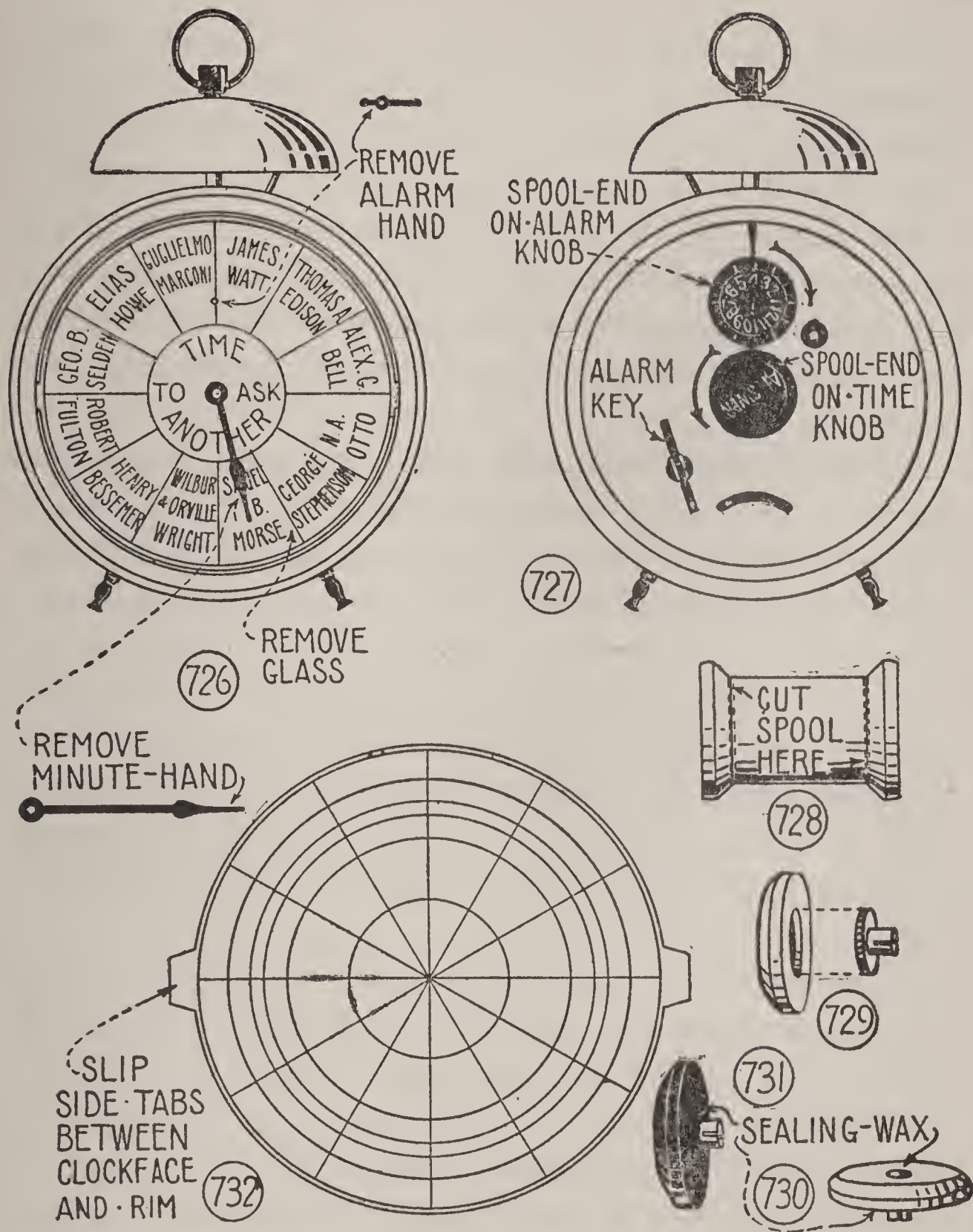

FIG. 726.—Remove Glass, Alarm-Hand, and Minute-Hand from Face.  
(See Photograph of Fig. 716 opposite Page 400.)

FIG. 727.—Remodel the Back of the Case, Like This.

FIGS. 728-731.—Details of Spool-End Knob-Heads.

FIG. 732.—Diagram of Answer-Dial Card.

**The Knob-heads** are spool ends. Get a spool with ends not larger than 1 inch in diameter (Fig. 728), or, for a small clock, use a spool with ends small enough to clear each other when they are mounted upon the clock posts.

The easiest way to cut off the ends of a spool is to slip two spools of equal diameter upon a dowel-stick, then hold one spool, while you saw the ends from the other spool. Cut the ends of equal thickness. Smooth the surfaces with sandpaper.

**To Mount the Knob-heads**, enlarge the holes in the spool ends with your knife, so that the heads of the clock knobs will set in flush with the wood, as indicated in Fig. 729. Then melt a stick of sealing-wax over a candle flame, and allow the wax to drip into the spool holes, and over the under side of the clock knob-heads, as indicated in Figs. 730 and 731. Level off the wax with a knife-blade, then, when it has hardened, sandpaper it smooth. Plug the knob stems with matches, to keep the wax from filling more than the upper part. The wax will bind the spool ends firmly to the knobs.

If, in the use of the quiz clock, the sealing-wax should break, and a spool end separate from the clock-knob, remelt the wax and cement the two together again. But there should be no chance of the parts separating, if, in the first place, you pile up enough wax upon the under side of the spool end and the clock knob-head, where indicated by the arrow in Fig. 731.

**Finish the Knob-heads** with paint, enamel, or lacquer. Black is best. Letter "Answer" upon the time knob-head.

Divide the rim of the alarm knob-head into twelve equal parts, and number these from 1 to 12 (Fig. 727). Use a small water-color brush and white paint for the lettering and numbering.

When the knobs are dry, push them onto their posts. Then, since the alarm knob must always be turned clockwise, and the time knob must always be turned counter-clockwise, paint two black arrows upon the back of the clock case, as shown in Fig. 727, to indicate the directions in which to turn the knobs. Also, paint a black arrow directly over the center of the alarm knob.

**Finish the Clock Case** with lacquer or enamel. My model is done in Chinese red, which makes an attractive job.

#### THE ANSWER-DIAL CARDS

must be cut a trifle smaller in diameter than the inner rim opening of the clock face, and must have two tabs, upon opposite edges, as shown upon the layout of Fig. 732, to slip between the clock face and rim. The tabs and two holes, for the alarm-hand and hour-hand posts to stick through, will hold the card in position.

Divide the card into twelve equal parts, as shown in Fig. 732, and describe circles between which to letter. In the center of the card, letter "Time to Ask Another."

If you own a typewriter, or have access to one, type the lettering on paper, cut it out, and paste it upon the card.

#### THE QUESTION CARDS

will look neater typewritten than hand-lettered, but if you

cannot type them, do the best job of lettering that you can. Fig. 733 suggests the form to use.

TIME · <u>WILL</u> · TELL	
WHO · INVENTED · THE _____	
WIRELESS · TELEGRAPH ?	NO. 10
AIRPLANE ?	.. 3
LOCOMOTIVE ?	.. 5
STEAM · ENGINE ?	.. 9
TELEGRAPH ?	.. 4
SEWING · MACHINE ?	.. 11
STEEL · PROCESS ?	.. 2
GAS · ENGINE ?	.. 6
TELEPHONE ?	.. 7
AUTOMOBILE ?	.. 12
MOVING-PICTURE · CAMERA ?	.. 8
STEAMBOAT ?	.. 1

FIG. 733.—Typewrite or Hand-Letter the Question Cards, Like This.

Preparing the questions and answers will furnish good fun for a group of you these autumn evenings. Let me hear how you develop the quiz-clock idea.

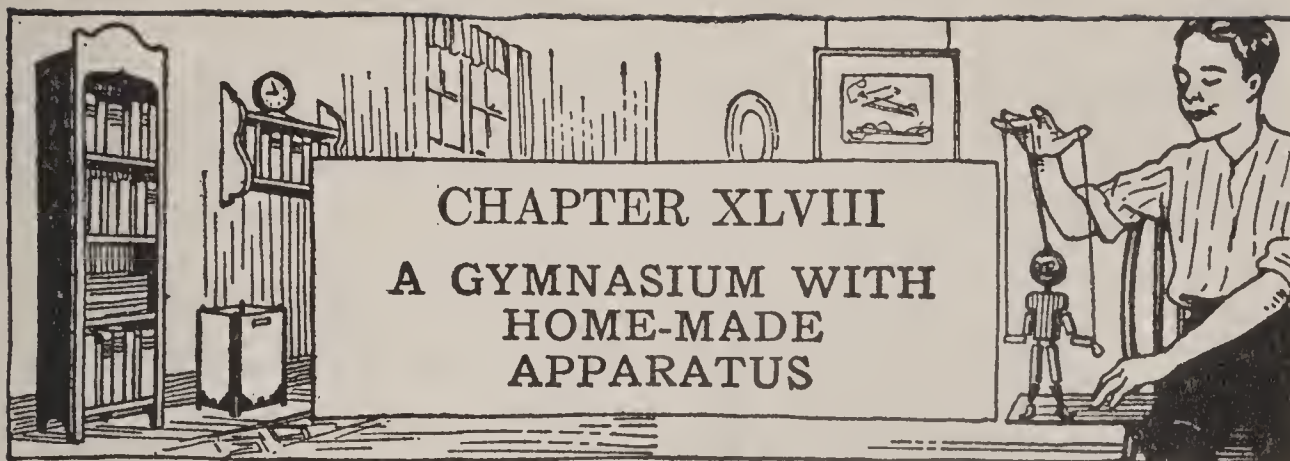

It will not require much talking to sell the idea of a gymnasium to your hobby club, and once enthusiasm is aroused, the success of the project should be assured. If the suggestion appeals to you, there are two ways to seek coöperation. One way is to show the fellows this chapter of home-made equipment which will doubtless interest them. The other way is to build one or two pieces of apparatus, then invite their inspection.

A gymnasium controlled by a group has advantages over one individually owned. There are more available sites to select from, and, what is quite as important, the cost of material for making equipment may be apportioned among the members, taken out of the club's funds, or raised through an entertainment.

#### WHERE TO LOCATE IT

One of the best locations for a gymnasium is

**A Barn Loft.** Lofts are not plentiful in these days of motor vehicles, but if you live in an old town, one among you may have the right sort of place. Many

**A Garage** could be adapted to the purpose, if the cars might be parked outside during gym periods.

A Basement with a high ceiling will do. I have known of a group rigging up an excellent gymnasium in a church basement. And don't forget that

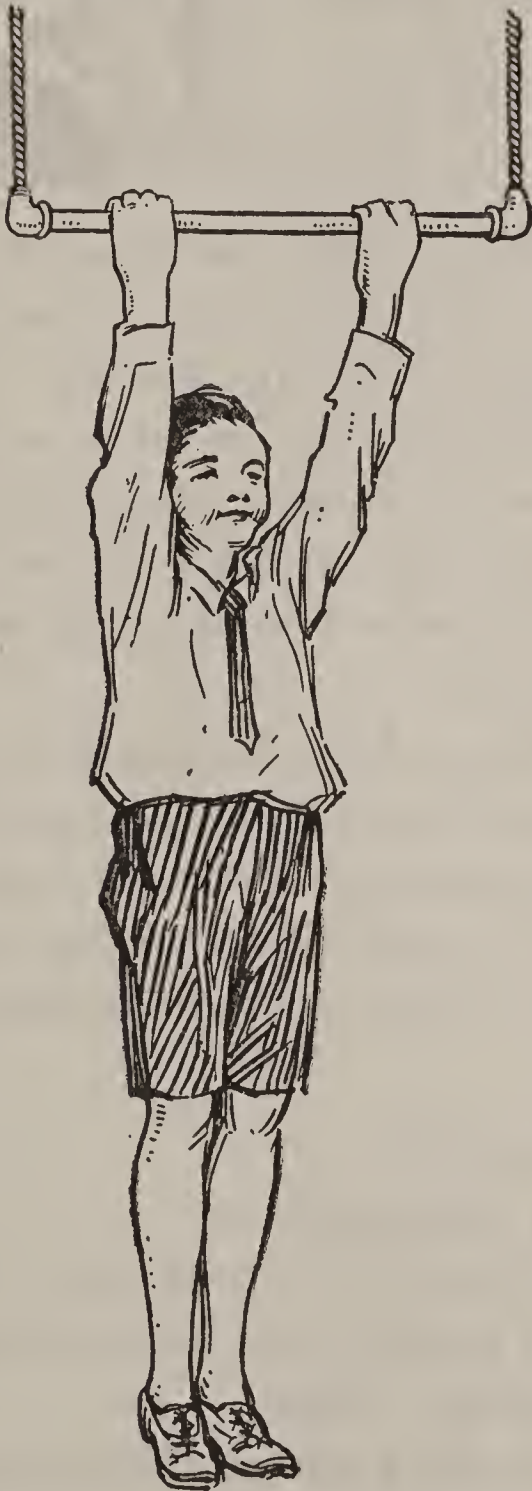

FIG. 734.—A Trapeze Will Be Used More Than Any Other Apparatus That You Put Up.

An Unfinished Attic presents great possibilities, if the roof is high enough. Here, there is plenty of room, and you have the exposed rafters from which to suspend a trapeze, rings and similar apparatus.

#### A TRAPEZE

will be used more than any other apparatus that you put up. Fig. 734 shows an excellent rig.

The Trapeze Bar is usually of hickory. Long bars are sometimes provided with steel cores. There is also the steel bar. Our model has a bar made of a piece of 1-inch iron pipe, 30 inches long (A, Fig. 735). One-inch pipe measures  $1\frac{1}{4}$  inches outside diameter. The ends of the pipe are threaded (Fig. 736), and a street-elbow pipe fitting

(B, Fig. 737) is screwed to each end to reduce the openings to the right size for the suspension rope.

The Suspension Ropes, straps, or chains, ordinarily are

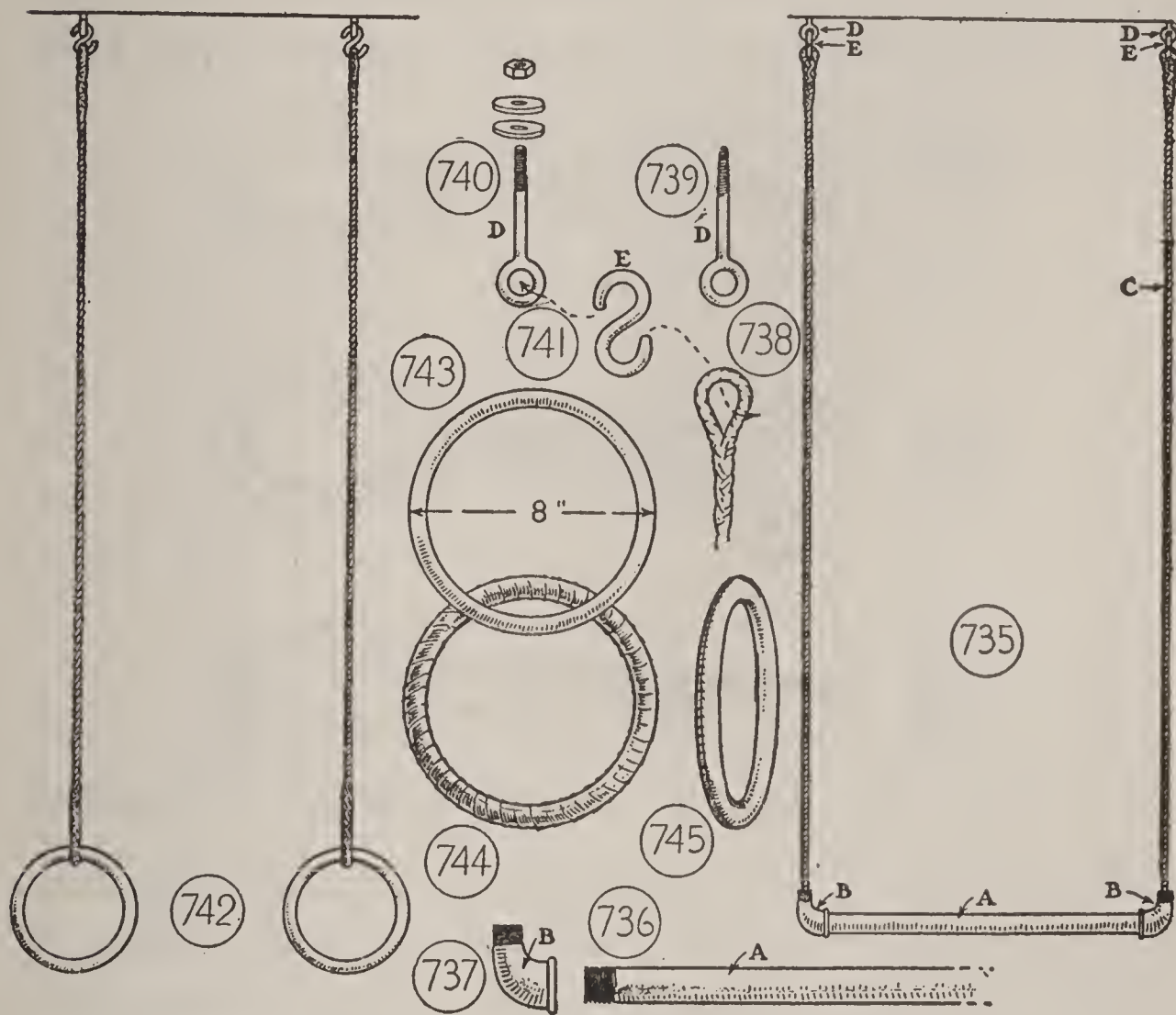
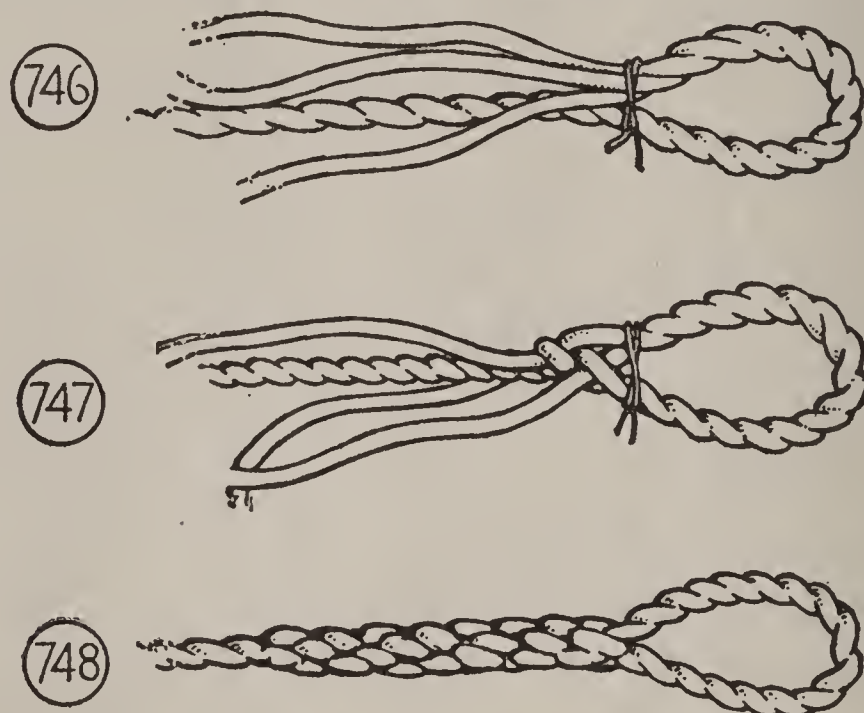

FIG. 735.—Completed Trapeze.  
 FIG. 736.—Iron-Pipe Trapeze-Bar.  
 FIG. 737.—Street-Elbow Bar End.  
 FIG. 738.—Eye-Splice on End of Suspension Rope.  
 FIG. 739.—Screw-Eye Hanger.  
 FIG. 740.—Eye-Bolt Hanger.  
 FIG. 741.—S-Hook Connector.  
 FIG. 742.—Completed Flying-Rings.  
 FIGS. 743-745.—Details of Rings.

attached to the bar ends. But in this model you will use

one rope and fish it through the bar and end fittings. Then you will splice eyes upon the rope ends, like that in Fig. 738. Buy rope  $\frac{1}{2}$  inch or  $\frac{3}{4}$  inch in diameter.

An Eye-Splice presents a simple problem in rope splicing. The three steps are shown in Figs. 746 to 748. First,



FIGS. 746-748.—Three Steps in Making an Eye-Splice on Rope-End.

untwist the rope end for a length of 8 or 9 inches, then form a loop above the untwisted ends, and bind with a string, as shown in Fig. 746. Next, take one of the untwisted ends, pass it over the strand next to it, and slip it under the next strand (Fig. 747). Pry the strands apart with a screwdriver to admit the strand end. Then pass the end over the next strand, and slip it under the strand next to that, and continue this weaving until the length of the rope end has been woven under. In the same way, weave the other untwisted rope ends, and if you do a neat job, the finished eye-splice will look like that shown in Fig. 748.



The Way to Suspend the Trapeze will depend upon the construction of the ceiling. The simplest hanger is a screw-eye of the form of D (Fig. 739),  $\frac{1}{2}$  inch in diameter and 4 or 5 inches long. You can screw a pair of these into a ceiling joist. But if there is an exposed beam overhead, it will be easier to bore holes through it, and use eye-bolts (Fig. 740). To connect the rope-eyes to the bolt-eyes, use hammock S-hooks (Fig. 741).

Height Adjustment has not been provided for. But if you will make the ropes long enough so that the bar will be as low as you will ever want it, you can make hitches to shorten them.

### FLYING RINGS

like the pair shown in the diagram of Fig. 742, and in the picture of Fig. 749, are in every modern gymnasium. They are as easy to rig as the trapeze.

The Pair of Rings should be of iron. Fig. 743 shows a ring 8 inches in diameter. Have a blacksmith make the pair out of  $\frac{3}{4}$ -inch rod, unless there is a forge in the school shop, where you can make them. You can pur-



FIG. 749.—Flying-Rings are as Easy to Rig as a Trapeze.

chase smaller rings, 5 or 6 inches in diameter, in the larger hardware stores. It is not essential to cover the rings, but the covering makes them easier to grasp. A two-ply wrapping of friction tape will serve the purpose (Fig. 744), but if you can locate a harness-maker, and can get leather about  $\frac{1}{16}$  inch thick, put it on over the wrapping of friction tape. Dampen the leather, and you will be surprised how easily you can shape it to the curved surfaces. Cut the leather into a strip of the right width to cover the rings without lapping. Bring the edges together upon the outer surface of the rings, and sew with stitches close together, as shown in Fig. 745.

**The Rope Hangers** must have eyes spliced on their ends. Form the lower eyes around the rings, as shown in Fig. 742. Suspend the ropes from screw-eyes or eye-bolts, in the manner described for the trapeze.

#### A HORIZONTAL BAR

or *turning-pole*, as most of you will prefer to call it, requires more space than the trapeze.

Fig. 750 shows a substantial apparatus that you can build easily. Its construction is shown in the details of Figs. 751 to 759.

**The Uprights** are of 1-inch iron pipe. Two lengths 7 feet long, with one end threaded, are needed (A, Fig. 751). You can buy them from a plumber or steam-fitter, and have them threaded at the shop. In addition to the pipe, you need two floor flanges (B, Fig. 752), for the lower ends of the uprights, to screw to the floor.

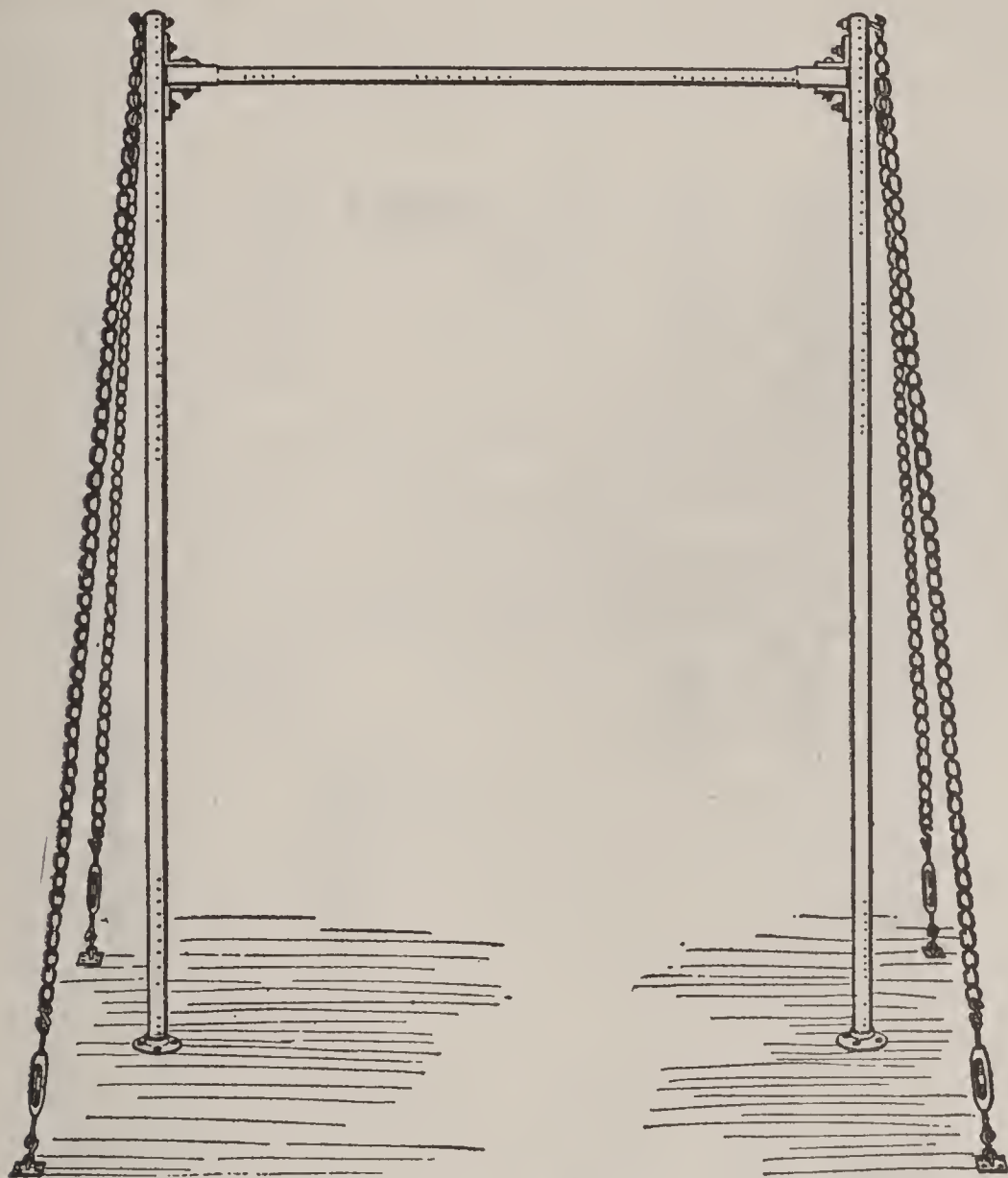

FIG. 750.—A Horizontal Bar Requires More Space Than a Trapeze.

The Bar Brackets (C, Figs. 751 and 753) are pieces of iron bar  $\frac{3}{8}$  inch thick and  $1\frac{1}{4}$  inches wide, bent into angles with legs  $2\frac{1}{2}$  inches long, and the vertical leg curved to fit against the pipe uprights. Maybe you can shape and drill these brackets at your school shop forge. If not, hunt up a blacksmith. He will charge little for shaping the four brackets, with two  $\frac{3}{8}$ -inch bolt holes in the vertical legs

and one  $\frac{3}{8}$ -inch hole in the horizontal legs. The holes must be located in the same positions on all brackets, be-

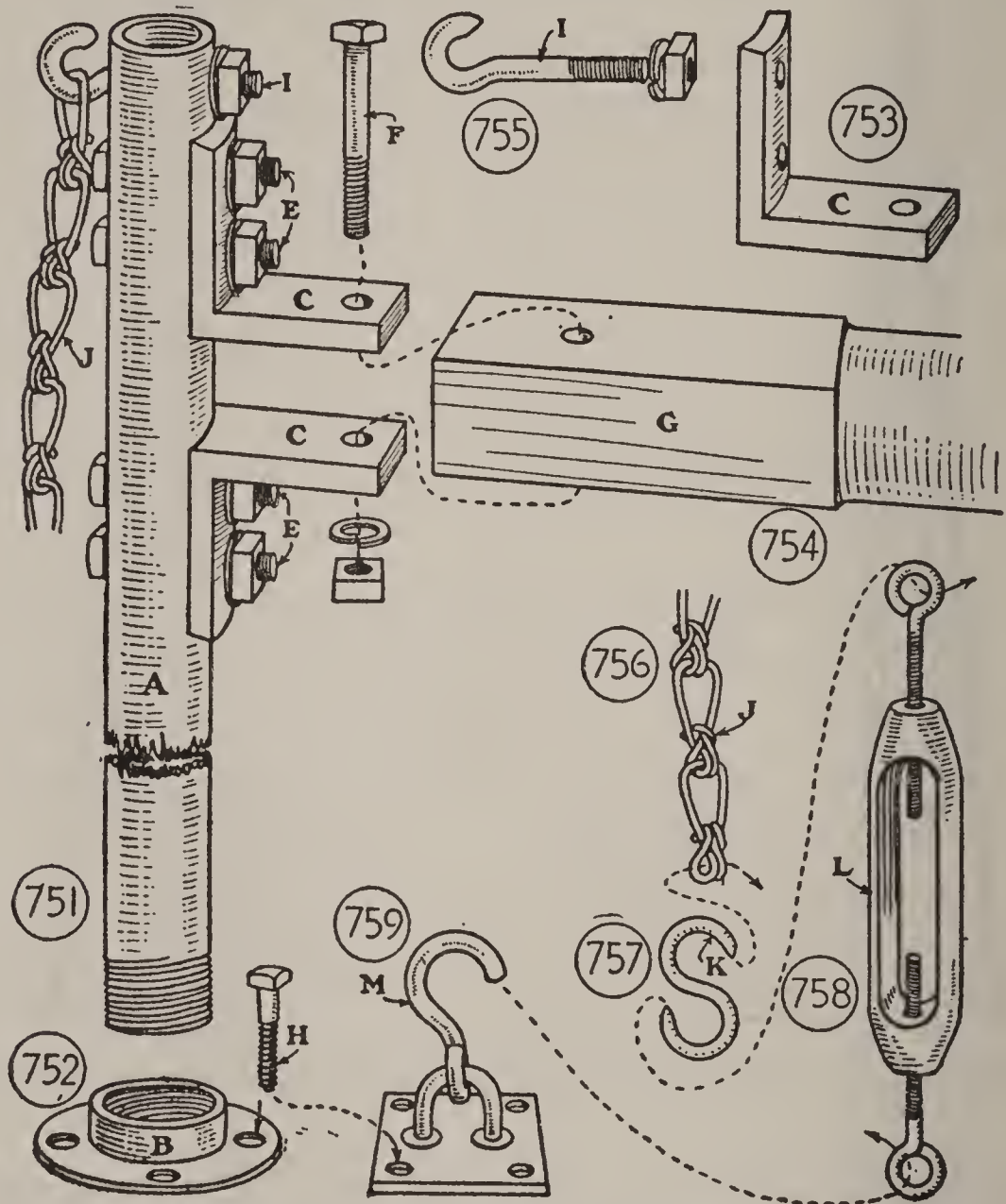

FIG. 751.—Detail of Upright.  
 FIG. 752.—Floor-Flange for Upright.  
 FIG. 753.—Detail of Bar-Bracket.  
 FIG. 754.—Bar End.  
 FIG. 755.—Hook-Bolt.  
 FIG. 756.—Chain-Stay.  
 FIG. 757.—S-Hook.  
 FIG. 758.—Turnbuckle.  
 FIG. 759.—Hammock-Hook.

cause the same spacing must be used for drilling holes through the pipe uprights and the bar.

If you have a metal drill, you can drill the pipe uprights for the attachment of the bar brackets. If you haven't a drill, call upon your plumber or blacksmith friend to do the job. Fig. 751 shows provision for only one position for the bar. If you want other adjustments, drill additional holes, or have them drilled, so that you can set the brackets at different heights. Use machine-bolts (E, Fig. 751) to attach the brackets.

**A Hickory Bar** 4 feet long will cost about \$3.00, at a sporting-goods store. But you can shape one yourself, if you can get a clear piece of hickory  $1\frac{1}{2}$  inches square. The ends of the bar should be square (G, Fig. 754). The diameter of the bar between ends should be  $1\frac{1}{4}$  inches.

Lacking a hickory bar, substitute

**An Iron Pipe Bar.** It will not be as smooth as the steel bar sold as regular equipment, but you can make it fairly smooth with a file and sandpaper.

Drill the bar ends to receive a  $\frac{3}{8}$ -inch bolt (F, Fig. 751).

**To Set Up the Bar,** slip the bar between the brackets and bolt it in place, then raise the uprights and screw down the floor flanges.

**Stay the Uprights** as shown in Fig. 750. Buy a pair of wrought-iron hook bolts (I, Fig. 755), 40 feet of hammock chain (J, Fig. 756), four wrought-iron S-hooks (K, Fig. 757), four turnbuckles (L, Fig. 758) and four iron hammock hooks (M, Fig. 759). Screw hooks M to the floor at points 3 feet in front and back of the floor flanges, 6

inches to the side, with lag screws about 2 inches long (H). Fasten bolts I through holes in the uprights. Slip the S-hooks K into the upper eyes of turnbuckles L, and slip the lower eyes of the turnbuckles over the floor hooks M. Then cut the hammock chain into lengths to extend from hook bolts I to S-hooks K, loop them over the hooks, and turn the turnbuckles to make the chains taut.

### PARALLEL BARS

are large, but there will be room for them in an attic gymnasium. The model shown in Fig. 760 is not difficult to build.

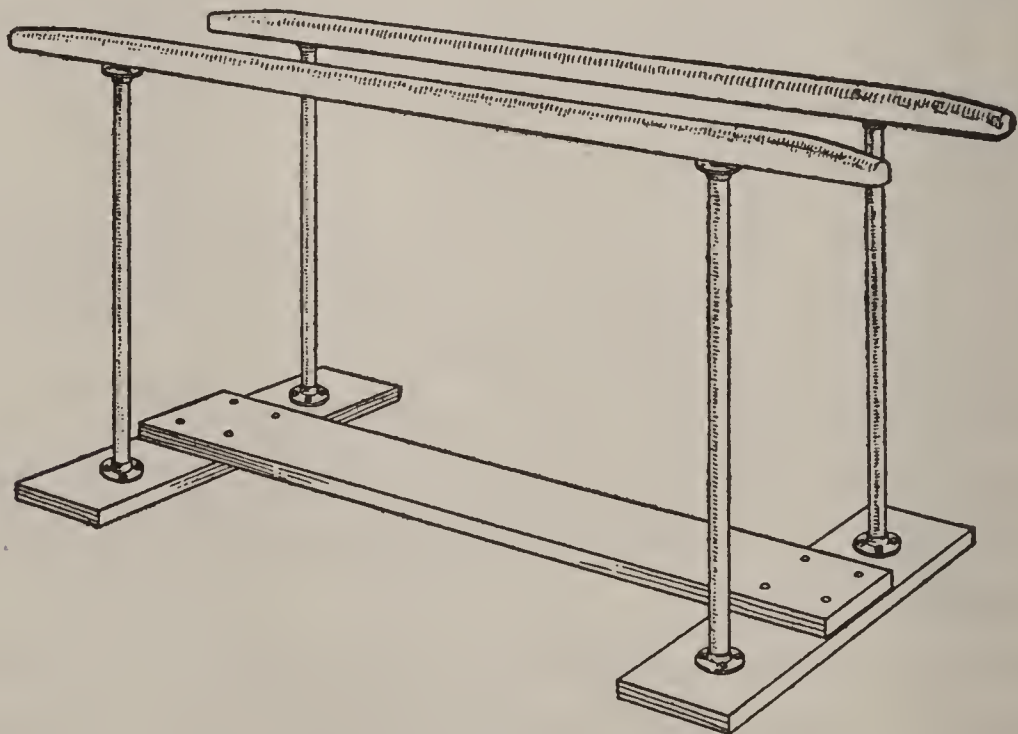

FIG. 760.—Probably There Will Be Room for the Parallel Bars in an Attic Gymnasium.

The Base has two end-plates 3 feet 6 inches long, cut from a 2-by-12 (A, Figs. 761 and 762), and a reach-plank

of the same size stock, 6 feet 3 inches long (B), that is spiked at its ends to plates A.

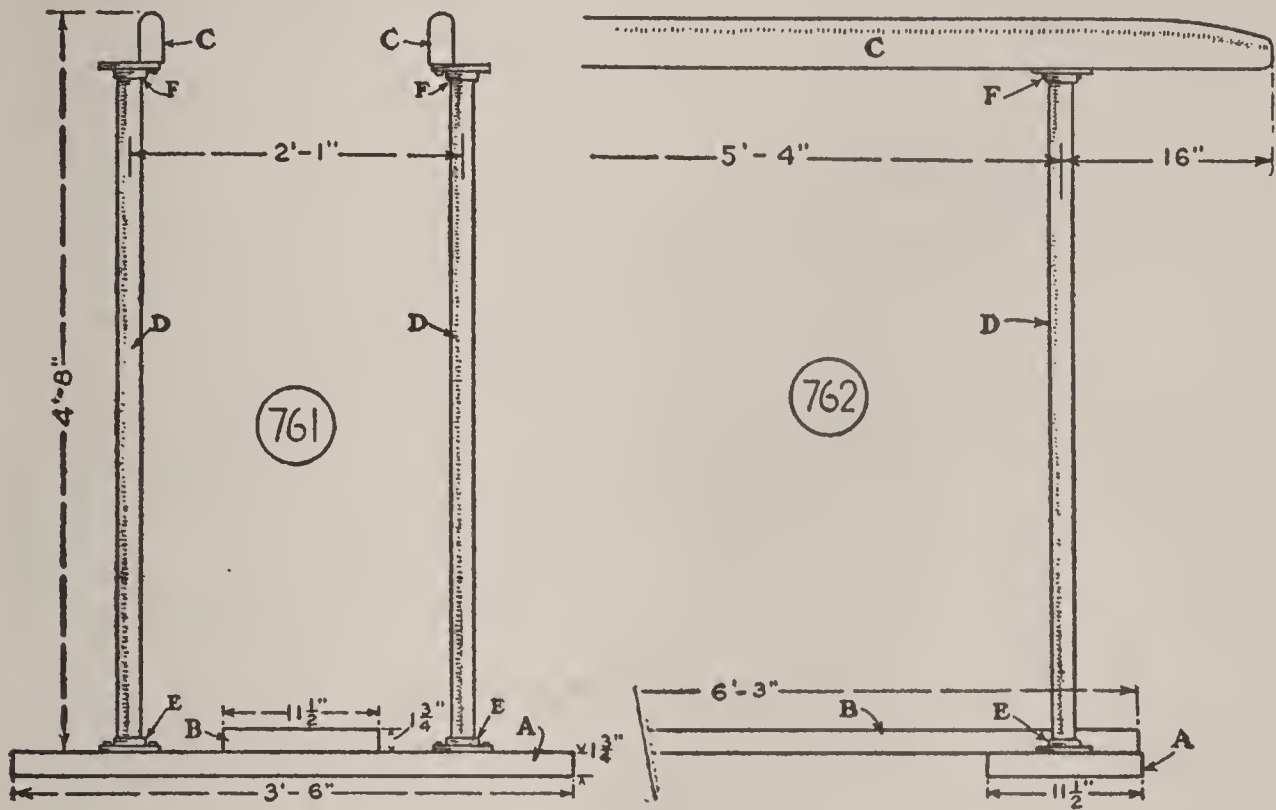

FIG. 761.—End Elevation of Parallel Bars.  
 FIG. 762.—One-Half Side Elevation.

The Bars are of spruce or pine 2-by-4 stock, 8 feet long (C, Figs. 761 and 762), with tops rounded as shown in the cross-section of Fig. 763, and ends tapered as shown in Fig. 764. Shape the bars with a draw-knife or plane, or both, then rub down the surfaces with sandpaper until they are as smooth as glass.

The Supports for the bars are 1½-inch iron pipe 4 feet 4 inches long (D, Fig. 766). Have a plumber or steam-fitter cut them for you, thread each end, and screw floor flanges to them (E and F, Figs. 765 and 766).

To Assemble the Apparatus, first screw floor flanges F

to the under side of the bars, with  $\frac{3}{8}$ -inch lag-screws  $2\frac{1}{2}$  inches long (G, Fig. 763). Lag-screws have square heads like machine-bolts, and you must turn them with a wrench.

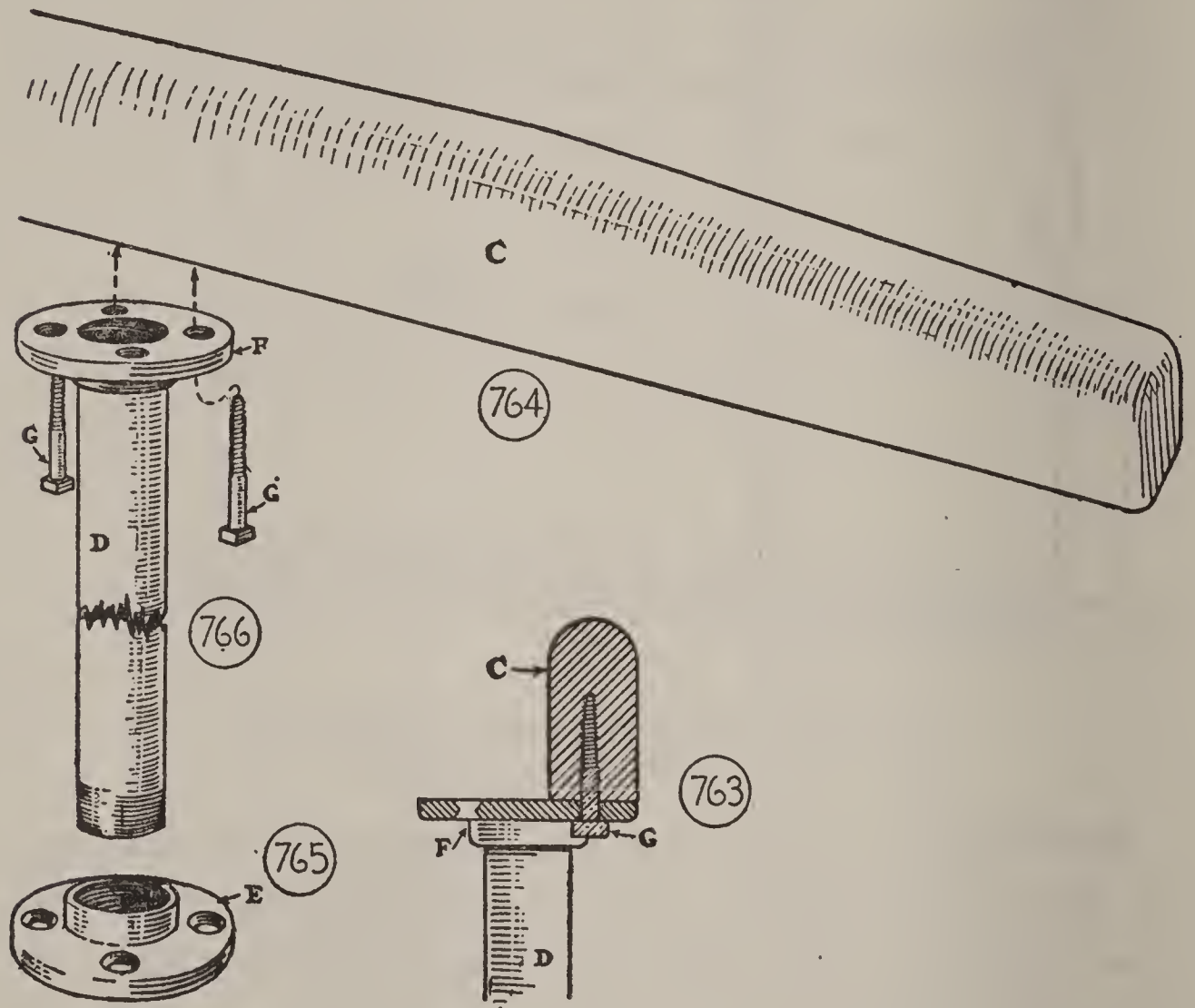

FIG. 763.—Cross-Section of Bar, Showing Pipe Floor-Flange Connection.  
 FIG. 764.—Detail of Tapered Bar End.  
 FIG. 765.—Floor-Flange for Upright Ends.  
 FIG. 766.—Iron-Pipe Upright with Floor-Flange on End.

To make them drive easily, bore holes  $\frac{3}{16}$  inch in diameter where they are to go, and soap the screw-threads. When you have screwed the floor flanges F to the bars, stand the supports upon plates A, with a spacing of 25 inches between



the centers of pipe uprights D (Fig. 761), and screw or bolt floor flanges E to plates A. Having mounted the supports, bolt reach-plank B to plates A. These bolts must be short enough for you to countersink the heads and nuts flush with the surfaces of the reach-plank and plates.

Finish the Woodwork of the parallel bars with yellow or gray paint, and wax the bars. Enamel the iron pipe supports and fittings black.

### MATS

You should have mats to place under your trapeze, parallel bars and other apparatus. An old mattress makes an excellent mat, and possibly you can find one. The covering will not stand rough usage, but you can add a second covering of No. 8 cotton duck, or heavy denim.

Burlap bags filled with straw and excelsior are better than no mat. Fill four or five bags, then lace them together, side by side, with wrapping-twine.

Your gymnasium will not be complete without

### A STRIKING-BAG PLATFORM

Fig. 767 shows how you can hang a platform from the ceiling-joists of a basement or porch, and you can use the same scheme in an attic with slanting rafters, by cutting one pair of hangers longer than the other pair.

Make the Platform 4 feet square. Fig. 768 shows a detail. Use three pieces of 2-by-4, placed flat, for battens (A), and matched boards for the covering. Cover the striking-face of the platform with wrapping-paper. Lap this

over the edges, and tack it. Then tack a piece of table oil-cloth over the paper.

Suspend the Platform about 2 inches above your head. This height will determine the length of

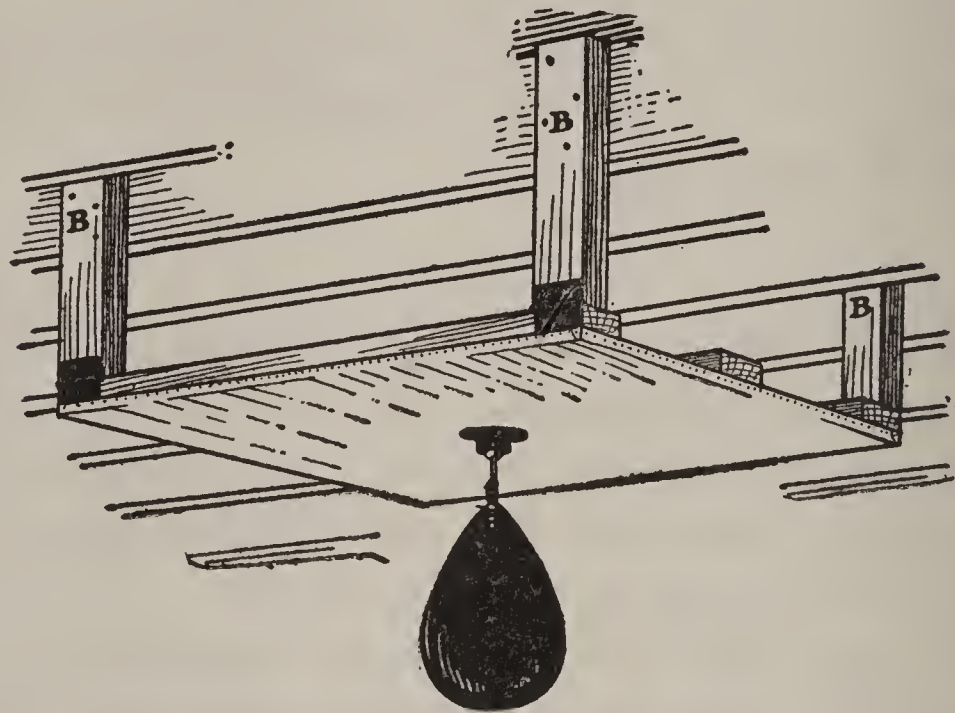

FIG. 767.—Hang This Striking-Bag Platform from the Ceiling-Joists.

**The Hangers.** As joists and rafters are usually spaced 16 inches or 24 inches from center to center, you should be able to spike the hangers directly to two of them (B, Fig. 767). Cut the hangers from a 2-by-4.

**Hinge the Platform** to the hangers, as shown in Fig. 767. If you use loose-pin hinges, you will have a portable platform that you can take down by withdrawing the pins, as indicated in Fig. 769. You may or may not care about this feature, but it is just as easy to hinge the platform to the hangers as to fasten it in any other way.

Screw the striking-bag attachment swivel to the center of

the platform. You can buy a one-piece ball-bearing swivel, or one of the detachable type shown in Fig. 770.

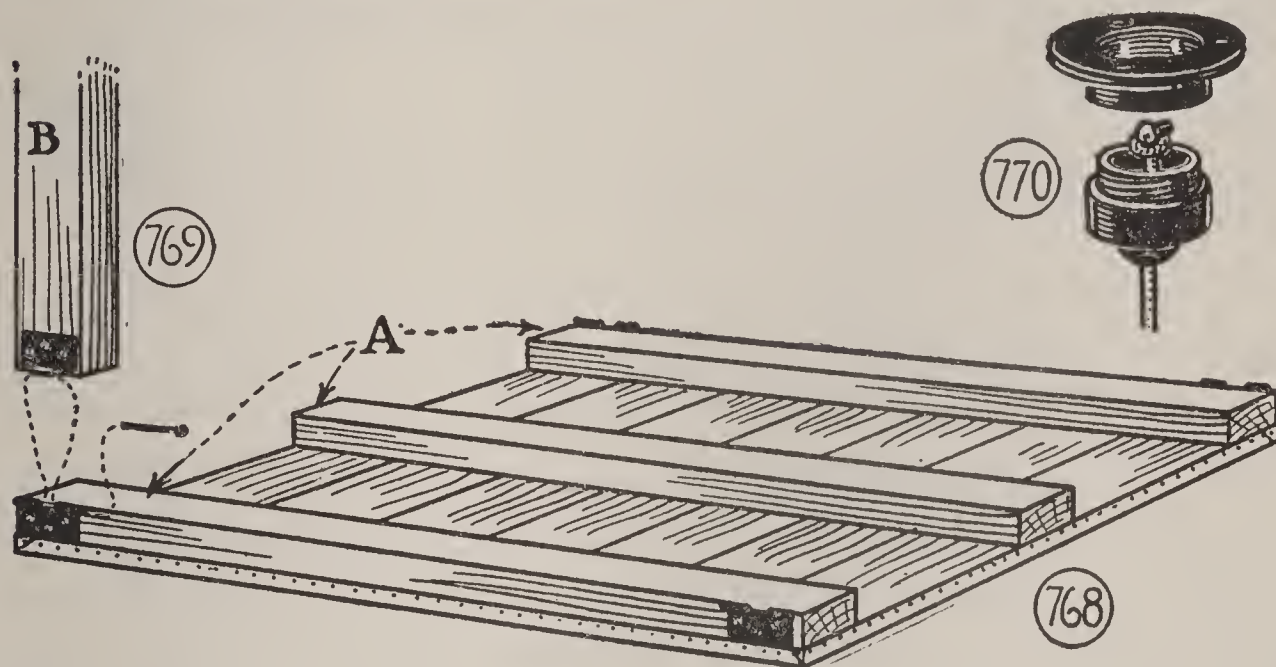

FIG. 768.—Detail of Striking-Bag Platform.

FIG. 769.—Hanger End, Showing Loose-Pin Hinge Connector.

FIG. 770.—Detachable Ball-Bearing Hanger for Striking-Bag.

### OTHER APPARATUS

Maybe you will have room for only one or two of the pieces of apparatus that I have described. Maybe you will have room for more. A *buck*, a *horse*, *jump standards*, *chest-weights*, *hitch-and-kick*, *horizontal ladder*, and *rope* for hand-over-hand climbing are equipment that you may want to add. You will find plans for some of this apparatus in Chapter X of "Handicraft for Handy Boys," and in Chapter XVIII of "The Boy Craftsman," and I believe that with the suggestions I have given, you can devise plans for anything else that you want.

You will have your own ideas about the arrangement of apparatus, and the making of *racks* for *dumb-bells*, *barbells*, and *wands*. I shall be interested in seeing a picture of your gymnasium when you have completed it.

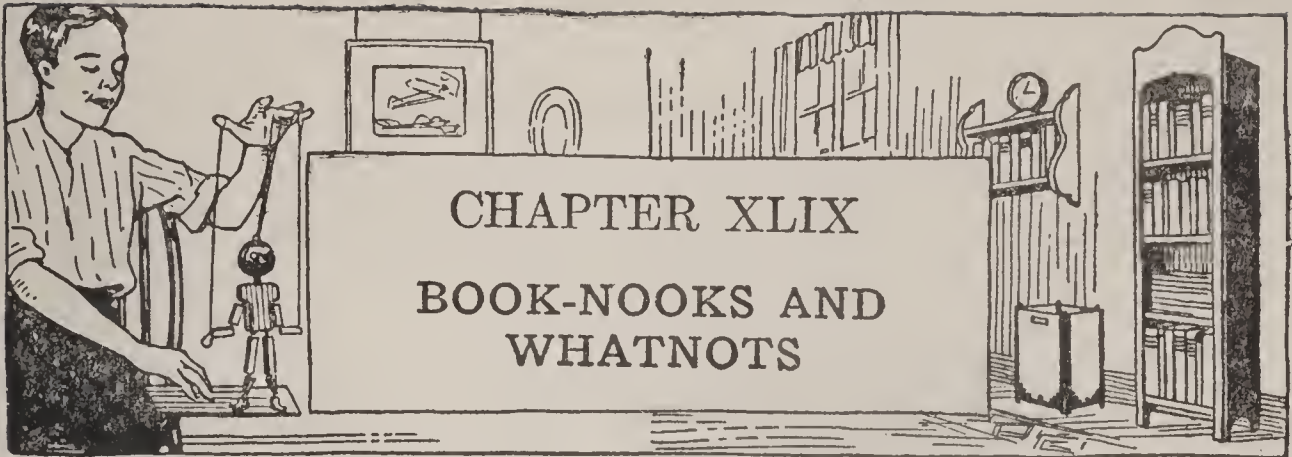

READING is one of the greatest of hobbies, and I have no doubt that it is one of yours, and that you have the start of a library which some day will be one of your most treasured possessions. What provision have you made for taking care of your books? Good books deserve good nooks to hold them in readiness for repeated readings, for reference, and for lending; and with a place for each book, and each book in its place, there is no need to hunt from pantry to coat closet for the book that you want, when you want it.

In this chapter, I have grouped a number of designs for book-racks and bookcases, small and large, and probably you will find among them what you need for your own books. Mother will discover an overflow unit for the home library, and Father will see the very rack he has wanted for his den. There are never too many book nooks in a household, the reverse is generally true. Bear this fact in mind, when you are looking about for something to make for a Christmas or a birthday gift. A well-built book-rack or bookcase will always be appreciated and will usually bring the response, "It is exactly what I have wanted."

There is nothing better than

## AN EXTENSION BOOK-RACK

to hold books in immediate use, on the library table or on your desk top. The model in Fig. 771 is very simple to

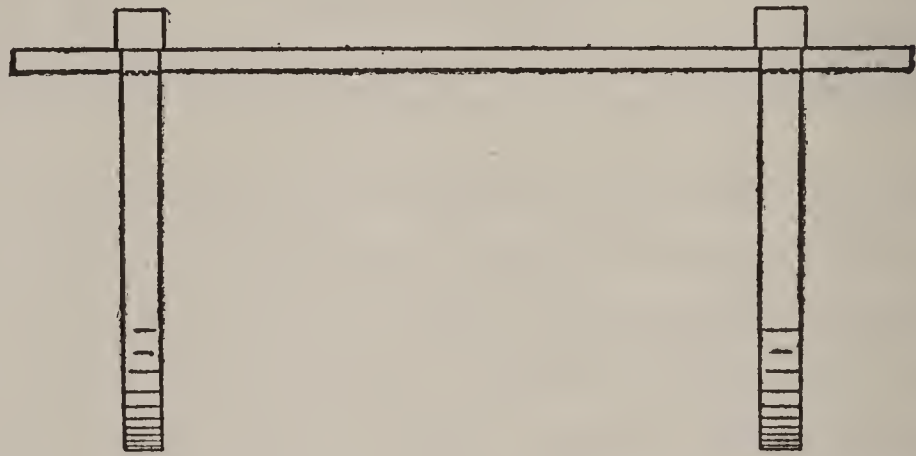

FIG. 771.—Side Elevation of Book-Rack Shown in Fig. 830.

make. A photograph of the rack is shown in Fig. 830. Working drawings of

The Parts are shown in Figs. 772 to 775. Cut two end pieces of the shape and size of the pattern in Fig. 772, out of  $\frac{5}{8}$ -inch or  $\frac{3}{4}$ -inch wood, two base blocks of the dimensions given in Figs. 773 and 774, and two slide strips of the size given in Fig. 775. If you intend to enamel or lacquer the surfaces, use pine, basswood or other wood with a close grain; if you want a stain-and-wax finish, use oak or other wood with open grain.

In Laying Out the end pieces, draw one-half of the pattern, make a tracing of it, lay it off on one side of the center line, and then reverse it for the other half. Be careful in sawing and finishing the tops of the end pieces to get them alike. A file will be handy for shaping the

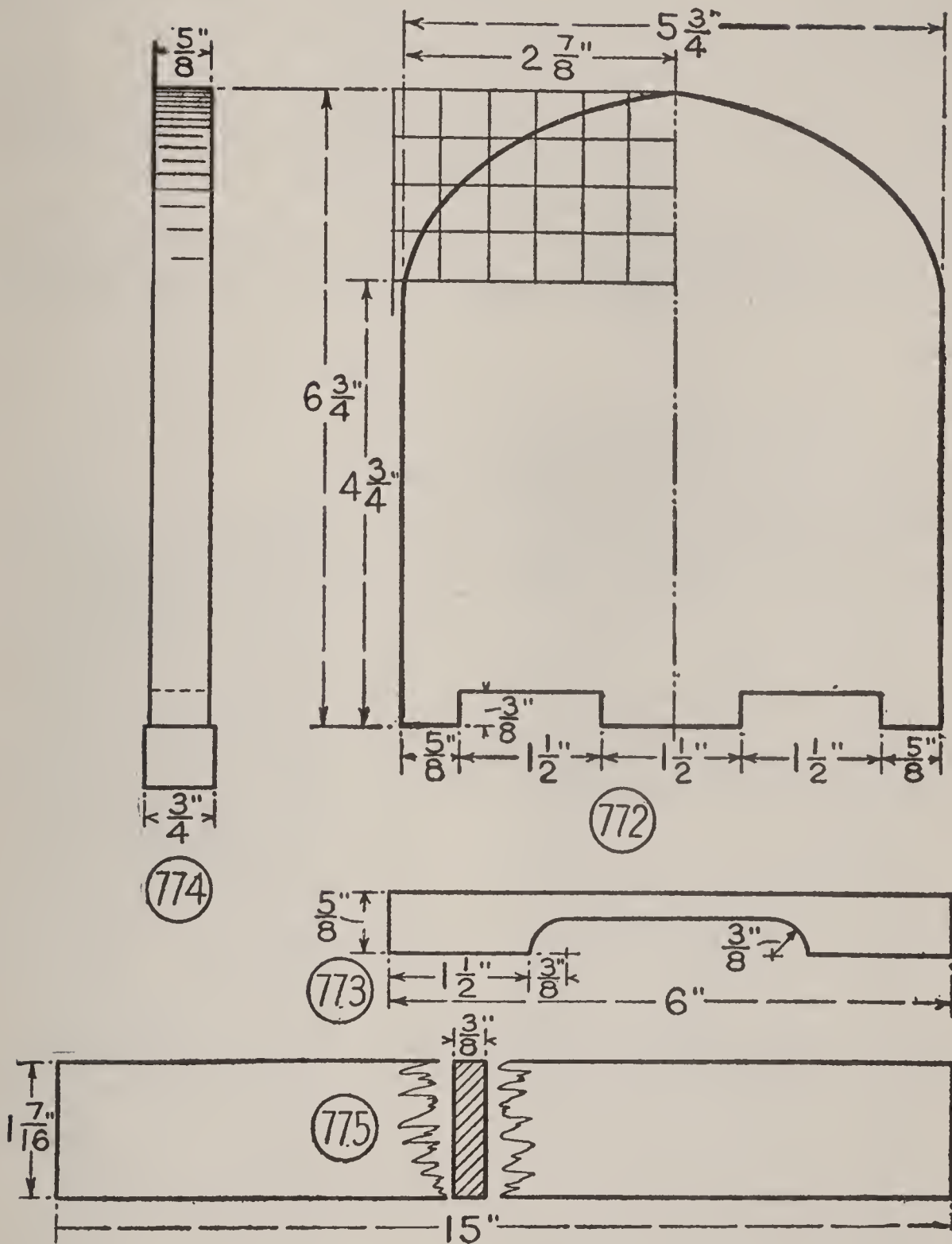

FIG. 772.—Book-Rack End.

FIG. 773.—Base Block.

FIG. 774.—Edge View of Completed Book-Rack End.

FIG. 775.—Slide Strip.

curved ends, after you have sawed them. Smooth all surfaces with sandpaper, and rub off the sharp edges.

To Assemble the rack, nail the base blocks to the end pieces (Fig. 774), and slip the slide strips into the notches cut for them.

When the parts have been finished, glue pieces of felt to the under side of the base blocks, or drive in rubber-headed tacks.

### A WALL-RACK

The photograph of Fig. 776 shows a type of rack now in vogue. Finished with one of the popular shades of red

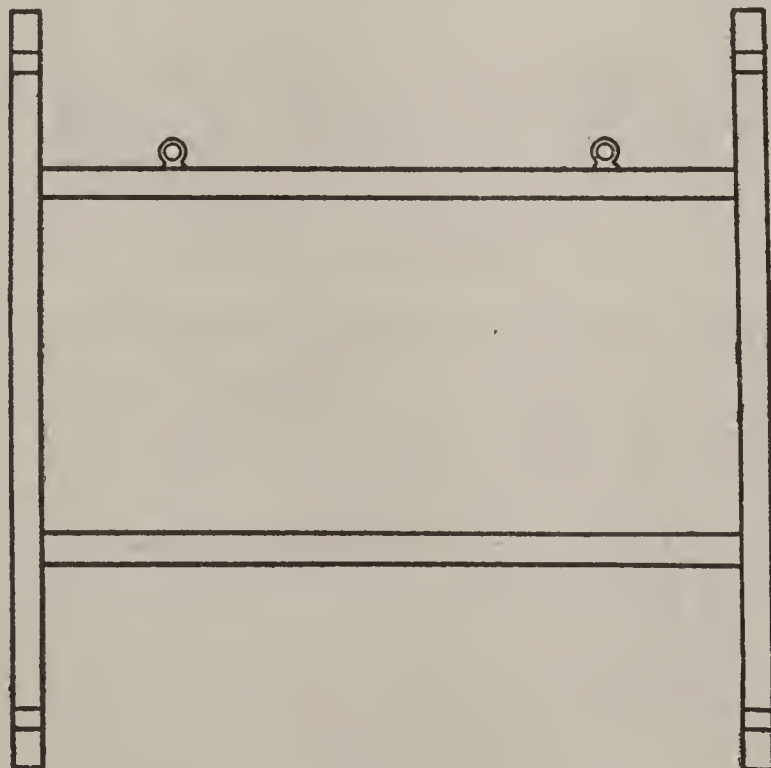

FIG. 779.—Front Elevation of Wall-Rack  
Shown in Fig. 776.

or green, it is a most attractive book-nook for a bedroom. The lower shelf will hold your school books or current reading, the top shelf will hold short books, or standardized volumes laid flat, or support a clock.

The Material used for this rack is  $\frac{3}{4}$  inch thick, but  $\frac{5}{8}$ -inch stock will do. Use soft pine, whitewood, basswood,





776

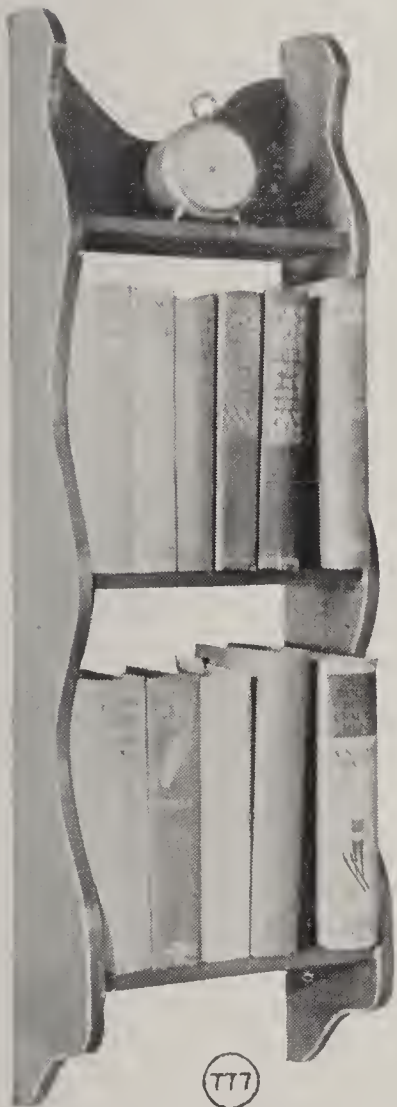

777



778

FIG. 776.—WALL BOOK-RACK. FIG. 778.—CORNER WHATNOT.  
FIG. 777.—ANOTHER WALL-RACK.



or other close-grained, easily-worked wood. An 8-inch board 8 feet long will contain enough material.

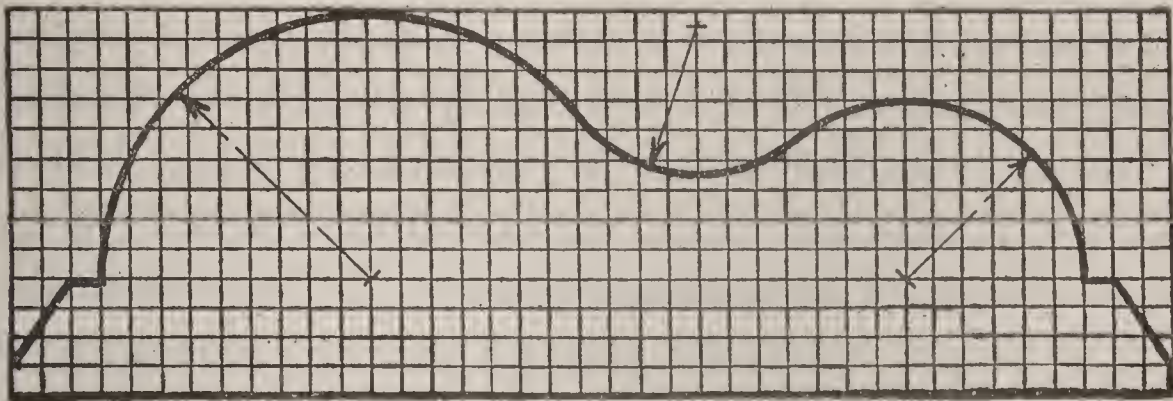

(781)



(785)

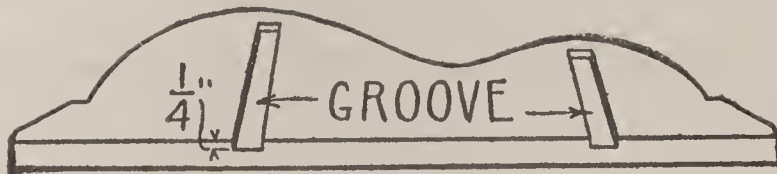

(782)

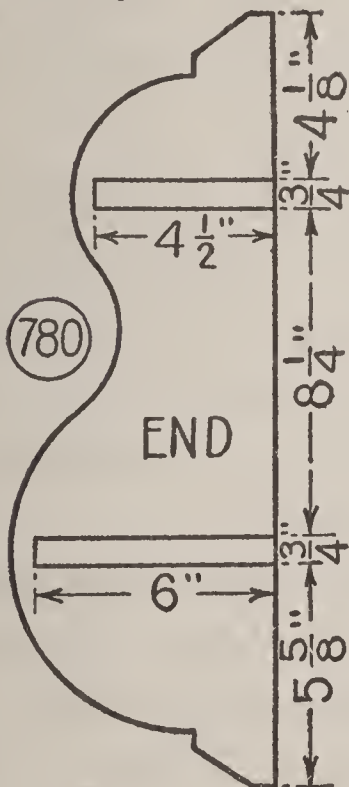

(780)

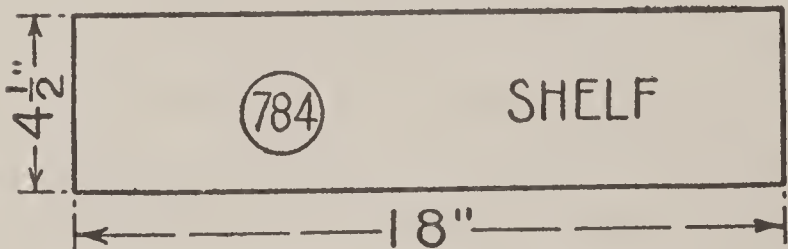

(784)

SHELF

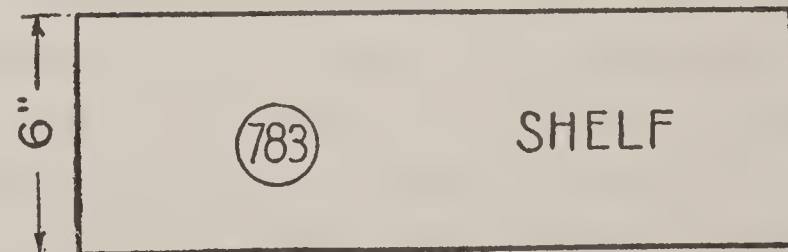

(783)

SHELF

FIGS. 780-782.—Details of End-Pieces.

FIGS. 783 and 784.—Shelves.

FIG. 785.—Metal Hanger.

Fig. 779 shows a front elevation of the rack, Figs. 780 to 782 are details of the ends, and Figs. 783 and 784 are shelf diagrams. First, lay out upon wrapping-paper

**A Pattern for the End-Pieces.** The pattern of Fig. 781 has been marked off into squares to aid you in enlarging it. Make a similar series of squares, drawing fourteen horizontal lines and forty vertical lines, spaced  $\frac{1}{2}$  inch apart. Then on the enlarged squares, lay off the outline, as it is shown upon the printed pattern. Describe the curves with a compass, with centers located where shown. When you have completed the outline, and made certain that it is correct, cut it out, and mark out two end-pieces upon the working material.

**Saw the Curves** with a coping-saw. Cut close to the outlines, then finish the sawed edges with a file, and smooth with sandpaper. Round the edges slightly, to remove their sharpness.

**Shelf-Grooves.** The end-pieces of the model have grooves for the shelves to fit in. These make stronger joints, and a more rigid job than butted ends. But you can use the butt-joint, if you are afraid to tackle the grooved joint; then reinforce it by screwing small iron brackets to the under side of the shelves and end-pieces.

Positions for the shelf-grooves are shown on the diagrams of Fig. 780. Lay them out, then cut down along the sides of the grooves with a chisel, and pare out the wood between. Make the depths of the grooves  $\frac{1}{4}$  inch. You can make the width of the grooves  $\frac{1}{2}$  inch, instead of making them equal to the thickness of the shelves, then cut

away the shelf ends so there will be  $\frac{1}{2}$  inch tongues to fit the grooves. This will form shoulders on the shelf ends that will add rigidity to the joints, provided that the work is done accurately.

Cut the Shelves of the dimensions given in Figs. 783 and 784. The given length allows  $\frac{1}{2}$  inch for fitting into the grooves of the end-pieces.

To Assemble the wall-rack, coat the shelf ends and the grooves of the end-pieces with glue, drive the joints together, nail with four-penny finishing-nails, and set the nail heads.

**Finishing.** If you have a sprayer and are practised in using it, finish your wall-rack with lacquer. But do not attempt to apply lacquer with a brush, on surfaces as large as those of the rack, because it dries so rapidly that it is difficult to cover without showing laps. It will be better to use one of the quick-drying enamels. You can get the same variety of shades of colors in enamels, as in lacquers, in small-sized cans, at the paint store.

Before applying the finish, putty nail holes, and smooth all surfaces thoroughly with medium and fine sandpaper.

When the last coat of finish has dried, screw a pair of brass hangers of the kind shown in Fig. 785, to the back of the upper shelf.

#### ANOTHER WALL-RACK

of simple lines, of a good size for a working library, or for favorite volumes, is shown in the photograph of Fig. 777. As this is a narrow rack

The Material for the ends and shelves may be  $\frac{3}{8}$  or  $\frac{1}{2}$  inch thick. Use soft pine, whitewood, basswood or other close-grained wood.

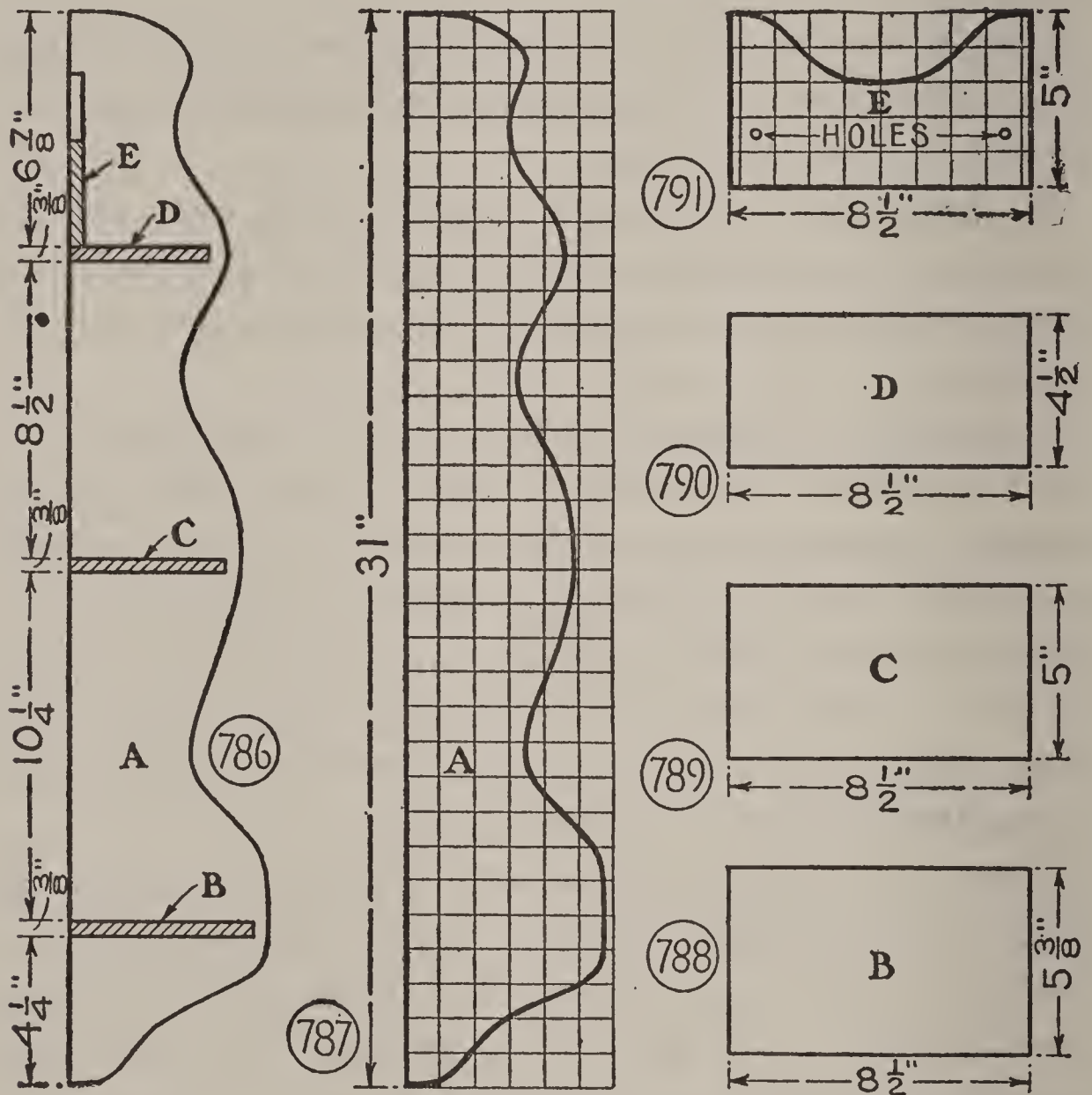

FIG. 786.—Cross-Section of Wall-Rack Shown in Fig. 777.

FIG. 787.—End-Piece.

FIGS. 788-790.—Shelves.

FIG. 791.—Shelf-Back.

Fig. 786 shows a cross-section of the rack, Fig. 787 shows a pattern for end-pieces A, Figs. 788 to 790 show dimen-

sions for shelves B, C, and D, and Fig. 791 shows a pattern for shelf-back E.

The Pattern for the Ends has been ruled off into squares to assist you in reproducing the curved edges. To make a full-sized pattern, rule off thirty-two horizontal lines and seven vertical lines, with a spacing of 1 inch. Then draw the curves across the large squares exactly as they are drawn across the small squares.

The Shelves are of equal length, but they vary in width (Figs. 788 to 790). Lay out shelf-back E by the pattern of Fig. 791, and bore a pair of hanger holes through it as indicated.

In Assembling the rack, use glue and three-penny finishing-nails. Locate the shelf positions in pencil upon the side-pieces, then there will be no chance of going wrong in nailing together the parts.

Finish the Rack as directed for the other wall-rack.

### A CORNER WHATNOT

Never since colonial days has the whatnot been as popular as it is now. The three-shelf corner model in the photograph of Fig. 778 is just the thing for Mother's bric-à-brac, and it is suited to bedroom or living-room. The top shelf might be used to support a clock.

The Turned Spindles of this whatnot are spools. Your first thought may be, "Where will you get so many spools?" There will be empty spools in Mother's work-basket. Relatives and friends will have a few. A dress-maker, or any one who specializes in fancy work will save

them for you. Broadcast your needs, and you will have more than you need before you realize it. My three-shelf model in the photograph has forty-eight spools, of uniform shape and size, but you may use two or three sizes, if you will arrange them so that the three spindles are alike.

You will need three  $\frac{1}{4}$ -inch dowel-sticks about 24 inches long on which to glue the spools, and six wooden button-molds 1 inch in diameter for caps for the three top and three bottom spools.

Fig. 792 is a plan of the rack. Fig. 793 is a pattern for **The Shelves**. You can cut these out of box-boards  $\frac{3}{8}$  inch thick and  $5\frac{3}{4}$  inches wide, a size easy to get. Select straight pieces that are free from knots and cracks. You may have to plane one or both sides of the boards, and rub them down with sandpaper. Prepare an accurate cardboard pattern. Be careful to make the inside corner square, and the outside corners alike. Locate centers for the dowel-stick holes, as shown, and describe arcs with a  $\frac{5}{8}$ -inch radius for the rounded corners. Cut the cardboard pattern, and use it to mark around in laying out the shelves upon the boards. Bore the  $\frac{1}{4}$ -inch dowel-stick holes before cutting the shelves, then there will be less danger of splitting the wood. After sawing the pieces, shape the corners with a file and sandpaper, and plane and sandpaper the straight edges.

**Finish the Parts** of the whatnot before assembling them. It saves working in and around the spools, skipping places, and making laps. Use either lacquer or enamel. You can readily apply brushing lacquer to the small surfaces. My



model was finished with enamel. I used two colors. Chinese vermilion for the shelves and eighteen spools, and black for the other thirty spools. The best way to hold

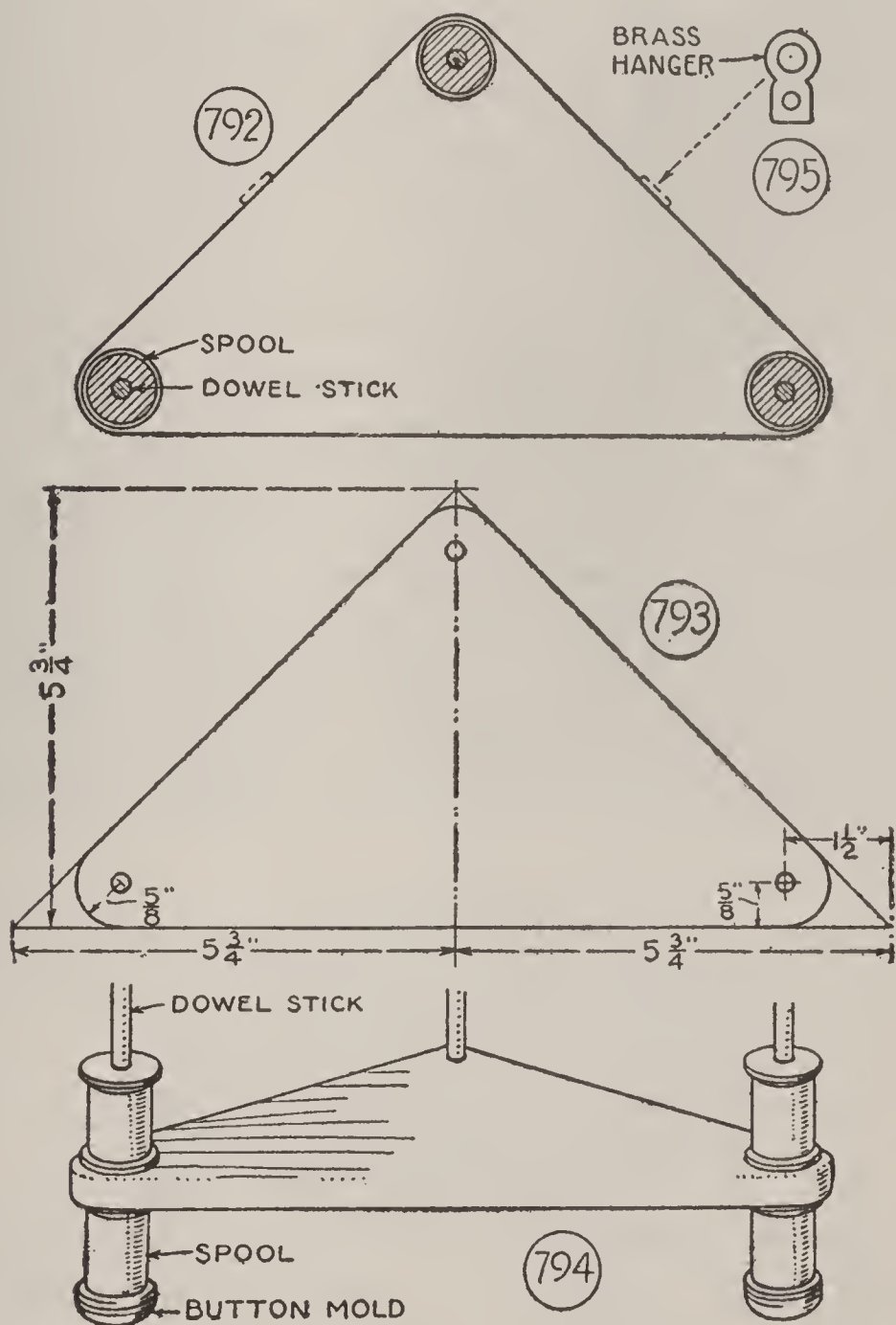

FIG. 792.—Plan of Whatnot Shown in Fig. 778.

FIG. 793.—Shelf.

FIG. 794.—Assembly Detail.

FIG. 795.—Metal Hanger.

spools for painting is to slip them onto the dowel-sticks, and twist a rubber-band around each stick end to keep the spools from slipping off. Apply three coats of lacquer or enamel to the shelves and spools. Sandpaper the surfaces lightly, between coats, with No. 00 sandpaper.

**To Assemble** the parts, run the three dowel-sticks through the holes in the bottom shelf, coat the stick ends with glue and slip a black spool over each (Fig. 794). Then coat the sticks with glue, and slip seven spools onto each, alternating the colors, with the first and seventh spool black. Apply the glue thickly, so that it will coat the sides of the spool-holes, and spread over the spool-ends. Add the middle shelf, then seven spools on each stick, the top shelf, and the top spool on each stick. Trim off the dowel-sticks even with the top and bottom spools, and glue and nail the button-molds to the spool ends for caps.

Stand the assembled whatnot upon the floor, place a weight upon the top shelf, and allow it to remain until the glue has had a chance to set.

Buy a pair of brass hangers like that in Fig. 795, at a hardware store, and screw them to the back edges of the top shelf where indicated in Fig. 792.

### A MODERNISTIC BOOK-TOWER

The skyscraper book-tower shown in the photograph of Fig. 796 is well adapted to a corner or narrow wall space. It is a small bookcase, but it has a surprising capacity, the result of the two open sides, which make it possible to slip books back of rows.



FIG. 796.—MODERNISTIC BOOK-TOWER.  
FIG. 797.—PIER CABINET AND WASTE-BASKET.  
FIG. 798.—FOOTSTOOL. (See Chapter L.)



Most furniture in the modernistic style looks simpler to build than is the case, and requires experience in joinery. But I have designed the tower with the thought that it may be your first project in cabinet making. Instead of rabbeting the joints, I have butted all parts, except the corner post, which I let into the corners of the shelves. With close attention to the diagrams and instructions, and careful workmanship, you will have no difficulty in turning out a satisfactory job.

**Material.** You may use either hard or soft wood for the book-tower, but you must consider the grain if you intend to lacquer or enamel the surfaces, as this must be closed like the grain in pine, whitewood or basswood, instead of open as in oak. You can buy the material at any lumber-yard. But make certain that what you get is dry. Tell the dealer the purpose for which you want it. If you can get pieces that are planed and sanded upon four sides, you will be saved much work. The stock should be  $\frac{3}{4}$  inch thick. Ten-inch boards, which usually measure about  $9\frac{1}{2}$  inches wide, will do for all parts except one of the back-boards, which must be  $10\frac{1}{4}$  inches wide. You will have to buy a 12-inch board for this piece, or glue a strip to one edge of a 10-inch board to make it of the correct width.

Fig. 799 shows a cross-section of the book-tower, Figs. 800 and 801 show

**The Back-Boards,** with the dimensions to cut them, and Figs. 802 and 803 show how to mark off the ends for cutting. When you have laid out the pieces, saw close to the lines, and cut out the pieces between the legs with a

copied-saw, or keyhole-saw. Plane the sawed edges smooth, trim the stepped ends with a chisel or file, or both, and smooth all surfaces with sandpaper. In the cutting,

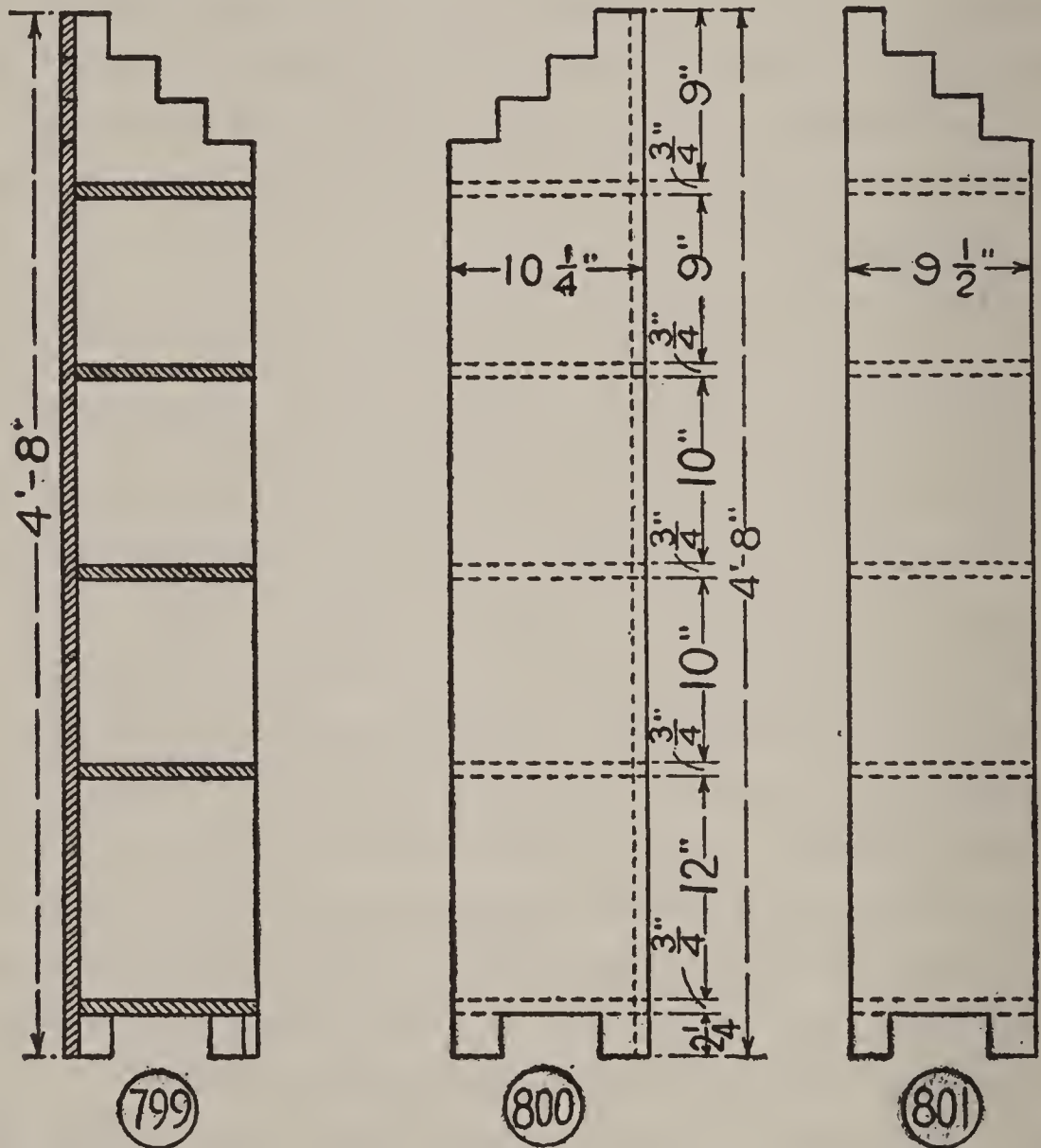

FIG. 799.—Cross-Section of Book-Tower Shown in Fig. 796.  
FIGS. 800 and 801.—Back-Boards.

work carefully to avoid splitting or chipping the wood along the edges. If you accidentally chip off a sliver, coat it with glue, and clamp it back into place.

You will see by the plan of Fig. 804 that one back-board is made  $\frac{3}{4}$  inch wider than the other, because it overlaps it.

**Cut Five Shelves** of the size shown in Fig. 805. Cut the corner notch exactly  $\frac{3}{4}$  inch square. It is important to cut the shelves with square corners, and to make the notches square.

**Cut the Corner-Post** of the size shown in Fig. 806.

**Assembling.** Use four-penny finishing-nails and glue for assembling the parts. Mark off the positions for the shelves upon the back-boards, as indicated by dotted lines in Figs. 800 and 801. Coat the edge of the board to

be lapped, and the edge of the board to lap, with glue, place them together and nail. In the same way, coat the edges

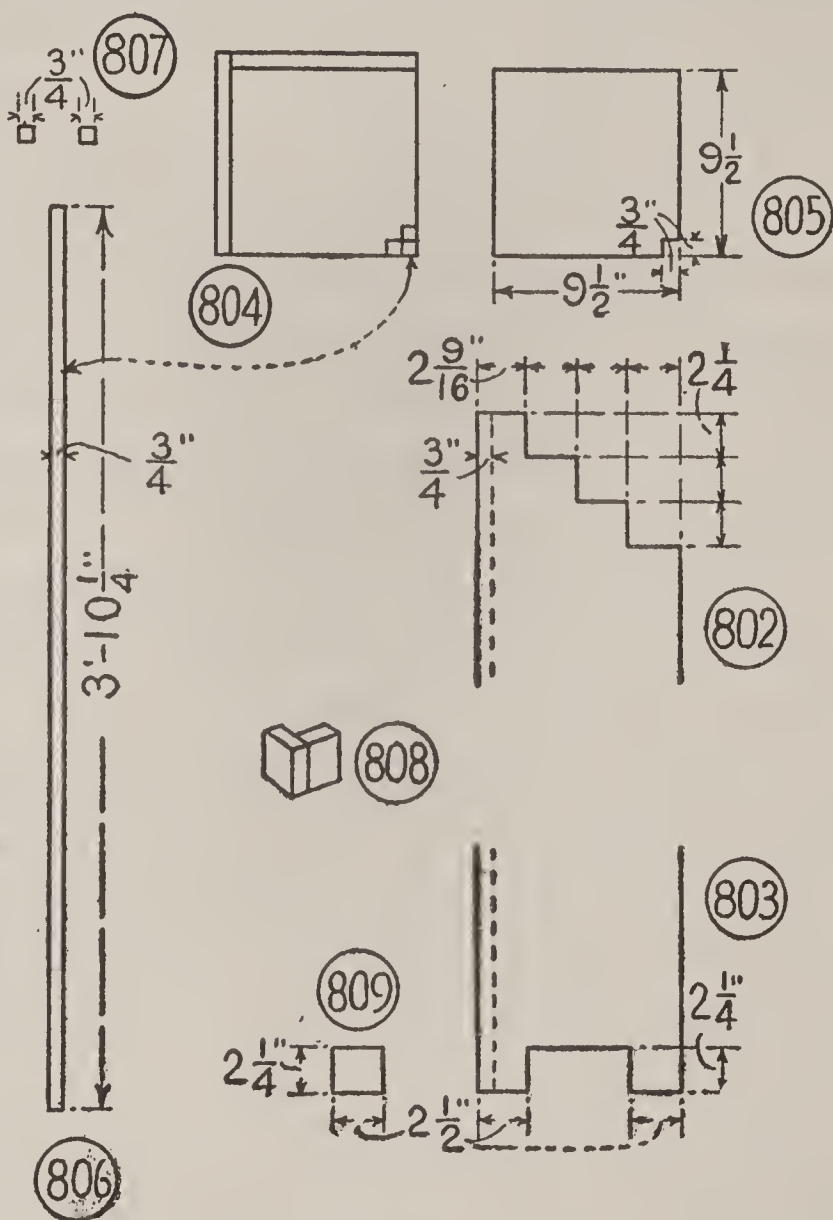

FIGS. 802 and 803.—Details of Ends of Back-Boards.

FIG. 804.—Plan of Book-Tower.

FIG. 805.—Shelf.

FIG. 806.—Corner-Post.

FIG. 807.—Corner-Post Blocks.

FIGS. 808 and 809.—Details of Base Blocks.

of the shelves with glue, fit them in place, and nail. The glue-coated shelf edges will slide out of place easily. Hold them between the guide-lines, while nailing, so that slipping will be prevented.

A little trimming may be necessary to make the corner-post fit in the shelf notches. Set the lower end of the strip flush with the under side of the bottom shelf. The upper end should then project  $1\frac{1}{2}$  inches above the top shelf. Glue and nail the corner-post to the shelves, checking up the shelf spacing, and making it the same at this corner as at the other corners.

Complete the top by fitting two blocks of wood  $\frac{3}{4}$  inch thick, wide and high (Fig. 807) against two sides of the corner post (Fig. 804).

Complete the base by fitting blocks under the bottom shelf, close to the projections, to make equal margins on all sides. Two blocks are required below the corner-post (Fig. 808), and one block at the other corners. Fig. 809 shows the width to cut the lapping blocks. The blocks lapped are  $\frac{3}{4}$  inch narrower.

When you have assembled the book-tower, go over it thoroughly. Trim off edges that are not exactly flush with one another, scrape off glue that has squeezed out of joints, set nail-heads, and rub down all surfaces.

**Finishing.** A quick drying enamel is preferable to brushing lacquer for this job, because lacquer dries too quickly to brush on without showing laps. Use three coats of enamel, and after each coat has dried, sand it lightly with No. 00 sandpaper to bring it to a smooth surface.



Two-tone work is the vogue for modernistic furniture. Green or a gun-metal gray, for the sides and shelves, with the edges done in silver, make good combinations.

### A PIER-CABINET

Tall and narrow, the pier-cabinet shown in the photograph of Fig. 797, requires little floor space. It is suited to any room in the house, not only for books, but also for glass, china and bric-à-brac.

The Material used for the sides, shelves and top of the cabinet is Norway pine, but any selected pine, whitewood, basswood, or other wood with close grain will do. Close-grained wood is best, if the cabinet is to be enameled. Two pieces of 1-by-10 8 feet long are sufficient for the job. Get sanded stock, if possible. It will save you the work of removing marks left by the circular-saw of the sawmill.

The back of my model is of wallboard, which is inexpensive and easily tacked on, but you can use a panel of plywood if you prefer it.

Fig. 810 of the diagrams shows the spacing of the cabinet shelves. Fig. 811 suggests closer spacing to provide an additional shelf. Fig. 812 is a cross-section of the cabinet with the parts lettered, and Figs. 813 to 816 are details of the parts.

Lay Out the Side-Boards by the diagram of Fig. 813. Make the half-circle cut in the lower end of each, to form feet, and cut away the front edge at the top, for face-board D to fit into.

The Top (B, Fig. 814) fits between face-board D and the back; therefore, it is narrower than

The Shelf-Boards, for which a pattern is given in Fig.

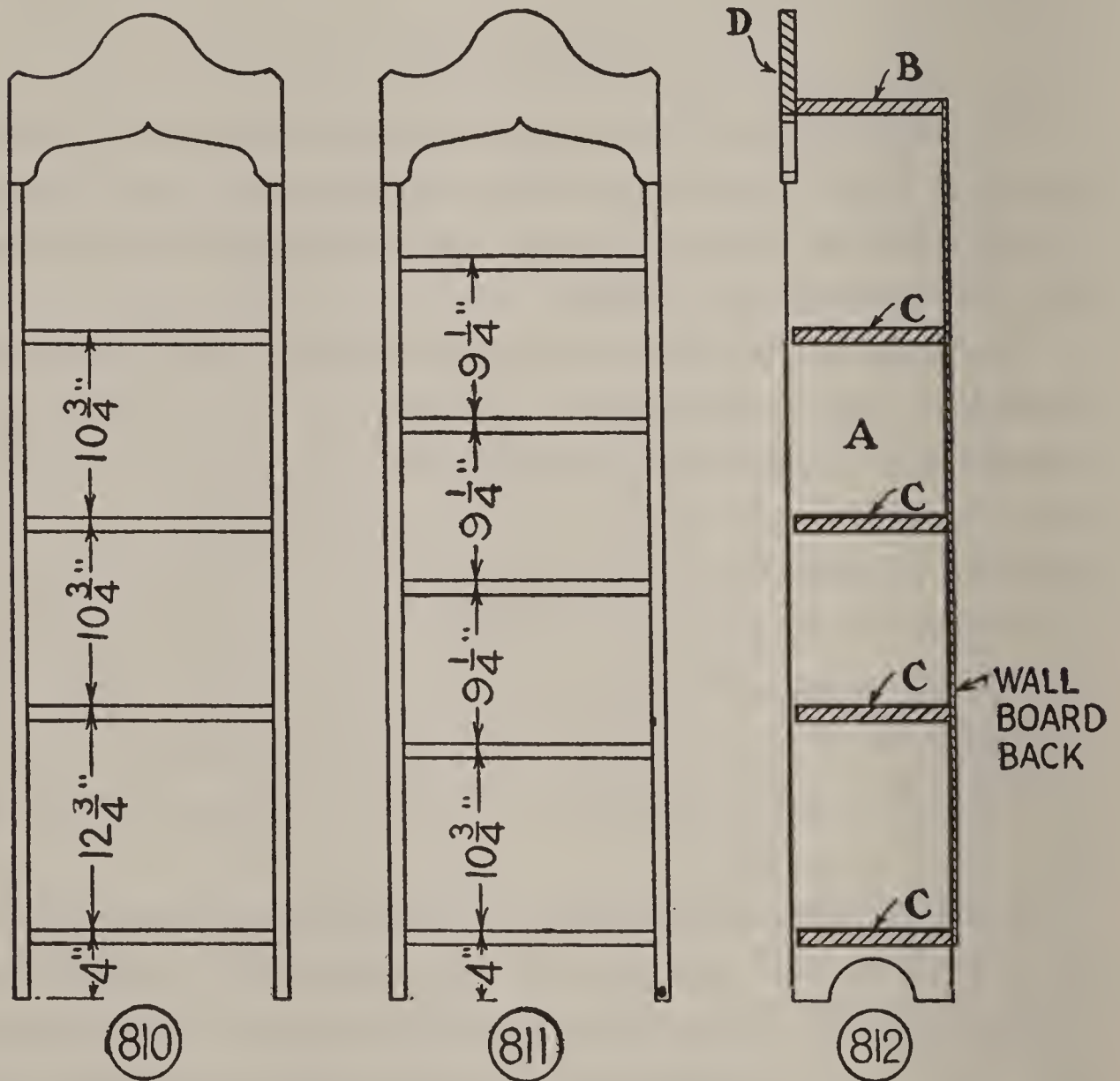

FIG. 810.—Front Elevation of Pier Cabinet Shown in Fig. 797.

FIG. 811.—Front Elevation Showing Spacing for Five Shelves.

FIG. 812.—Cross-Section of Cabinet.

814. Be careful, in cutting the shelves and top, to make them of equal length, and to make their corners square.

Lay Out the Face-Board by the diagram of Fig. 816. Notice that all of the curves may be described with a compass. Saw out the piece with a coping-saw, cutting close to the outline. Then smooth the edges with a wood-rasp and sandpaper. It is important to finish the curved edges

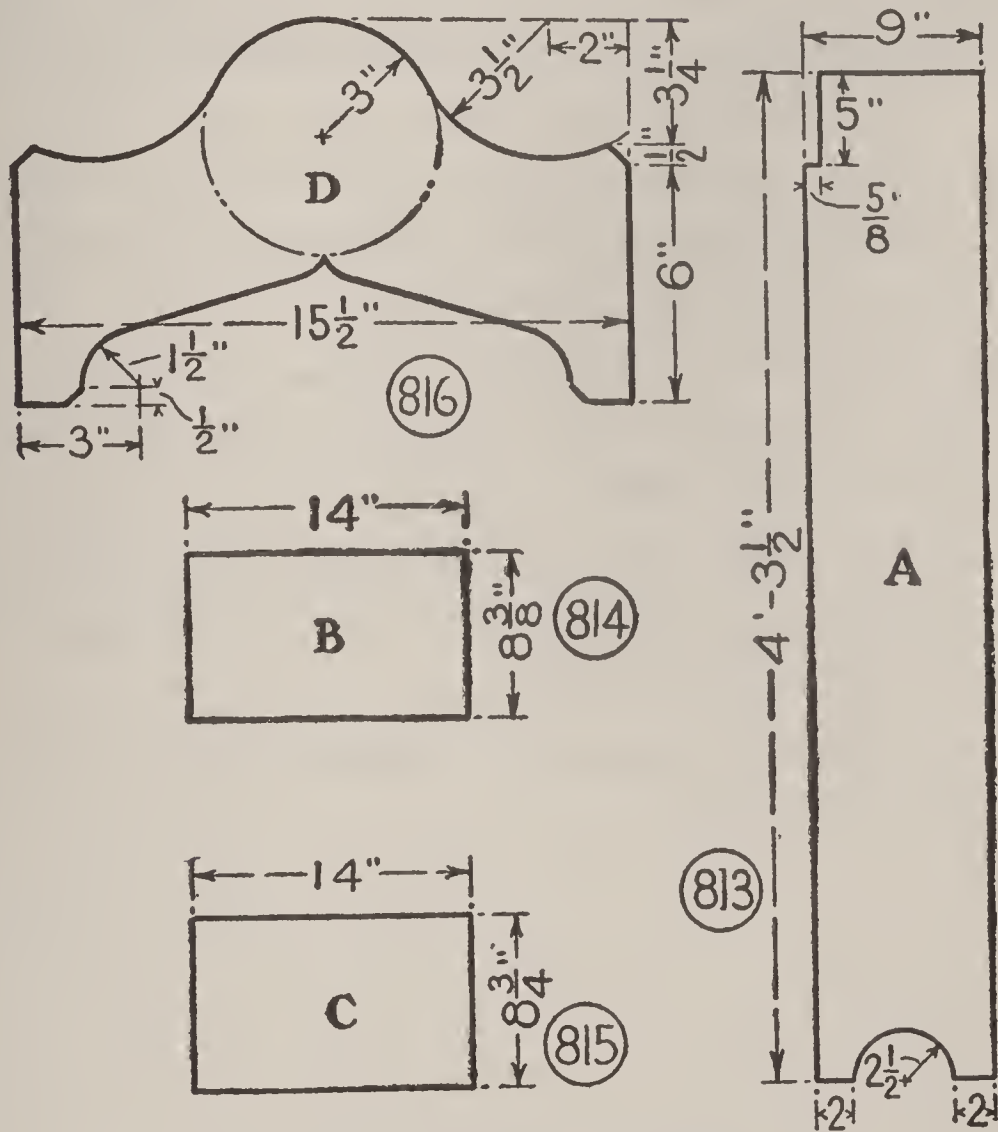

FIG. 813.—Side Board.

FIG. 814.—Top.

FIG. 815.—Shelf.

FIG. 816.—Face-Board.

carefully, because humps and hollows will show through a lacquer or enamel finish.

As you need only a narrow piece of

**Wallboard for the Back**, perhaps a neighborhood carpenter will have a strip large enough. If not, buy a sheet of it at the lumber yard. You can use what is left over, on another model.

**Assemble the Parts** with glue and four-penny finishing-nails. Mark off the positions for the shelves upon the side pieces. Coat the shelf ends with glue, and nail the side pieces to them. Then glue and nail face-board D in the notches cut for it. Drive nail-heads below the surface with a nail-set, in preparation for putty.

Fasten the wallboard back with glue and large-headed nails. When the glue has hardened, plane off the edges of the wallboard even with the cabinet sides, and sandpaper them smooth. Also, clean up all surfaces with sandpaper, and sandpaper the edges of the sides, shelves and face-board, to remove their sharpness.

**Finish the Cabinet** in the manner suggested for the modernistic book-tower.

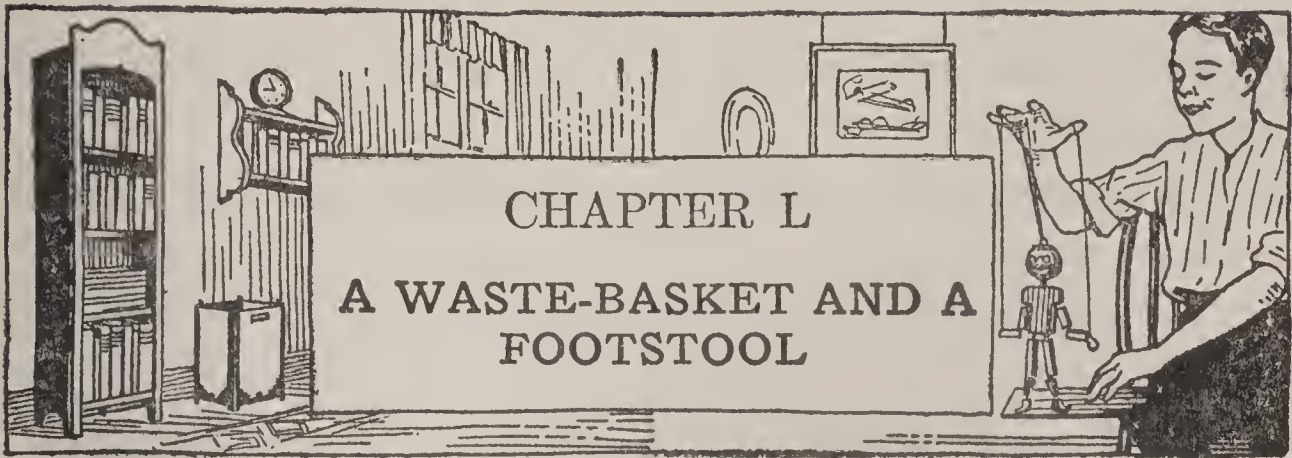

THERE is space for only a few ideas for home-made furniture in this book, but you boys whose hobby is making things for home, for gifts, and for sale, will find additional ideas in my other books. Waste-paper baskets and footstools are among the most useful medium-sized pieces of furniture that you can make, and the basket in the photograph of Fig. 797, and the stool in the photograph of Fig. 798, are practical models that are easy to make.

### THE WASTE-BASKET

in the photograph of Fig. 797 is an example of well-constructed wallboard furniture.

For Material you need five pieces of wallboard, four for sides and one for the bottom. Two of the sides (A, Fig. 817) must be cut  $\frac{1}{2}$  inch narrower than the other pair (B, Fig. 818), to allow for the overlapping of the former by the latter. The bottom (C, Fig. 819) is square. Be careful in laying out the pieces, to make the corners right angles, and in cutting, to saw close to, not on, the lines.

In addition to wallboard, you need four wooden corner-

posts  $\frac{3}{4}$  inch square (D, Fig. 820), and a bottom cleat (E, Fig. 821).

To Assemble the Basket, glue and nail the pair of nar-

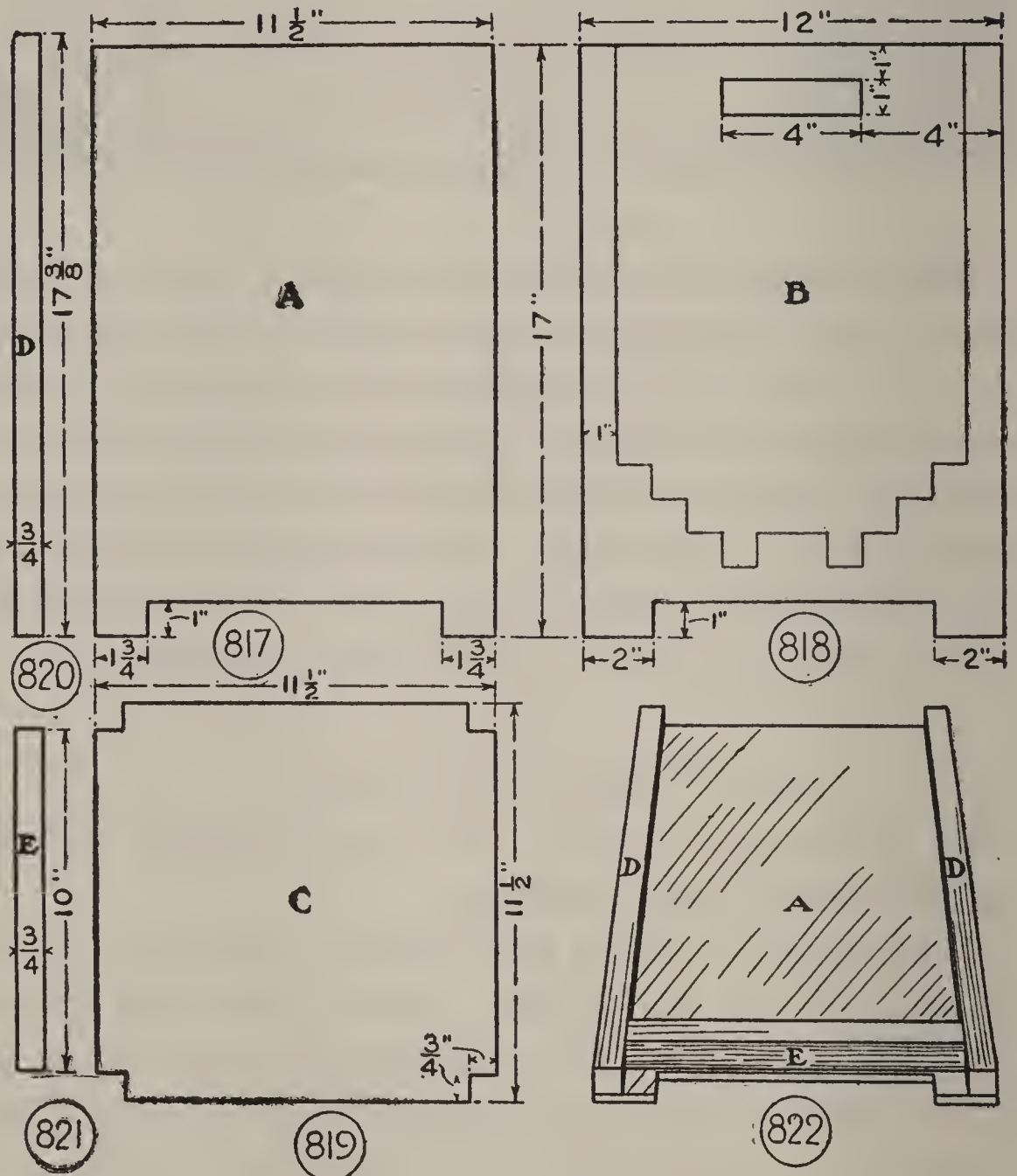

FIGS. 817 and 818.—Wallboard Sides for Waste-Basket Shown in Fig. 797.

FIG. 819.—Wallboard Bottom.

FIG. 820.—Wooden Corner-Post.

FIG. 821.—Bottom Cleat.

FIG. 822.—Assembly of Side, Posts, and Cleat.

row sides to the corner-posts, as shown in Fig. 822, and fasten two of the bottom cleats between the posts. Then glue and nail the other pair of sides to the corner-posts of the assembled frames, fasten the two remaining bottom cleats in place, and glue and nail the wallboard bottom to the upper face of the bottom cleats.

**Enamel the Basket.** The model in the photograph was finished with three coats of yellow enamel, then trimmed in black. The black was applied to the corner-posts, to a band 1 inch wide up each side of the corners, and to a stepped-up pattern laid out around the bottom, as shown on the pattern of Fig. 818. The pattern is simple, and effective in the contrasting color.

### THE FOOTSTOOL

The photograph of Fig. 798 shows a stool of generous size well adapted to sun porch or living-room. It is ideal for a fireside seat, too.

Fig. 823 of the diagrams is a cross-section of the stool.

Prepare a **Pattern for the Sides**, by enlarging the diagram shown in Fig. 824. Draw twenty horizontal lines and forty-one vertical lines, with a spacing of  $\frac{1}{2}$  inch, and you will have a series of squares similar to those of the diagram, but full-sized. Then reproduce the lines of the diagram upon the squares, exactly as shown.

Lay off the pattern four times upon a 10-inch board, which will measure about  $9\frac{1}{2}$  inches wide.

**Saw Out the Sides**, and smooth the curves with a file

and sandpaper. The ends of the boards must be mitered, to make trim corners (Fig. 825). The secret of making

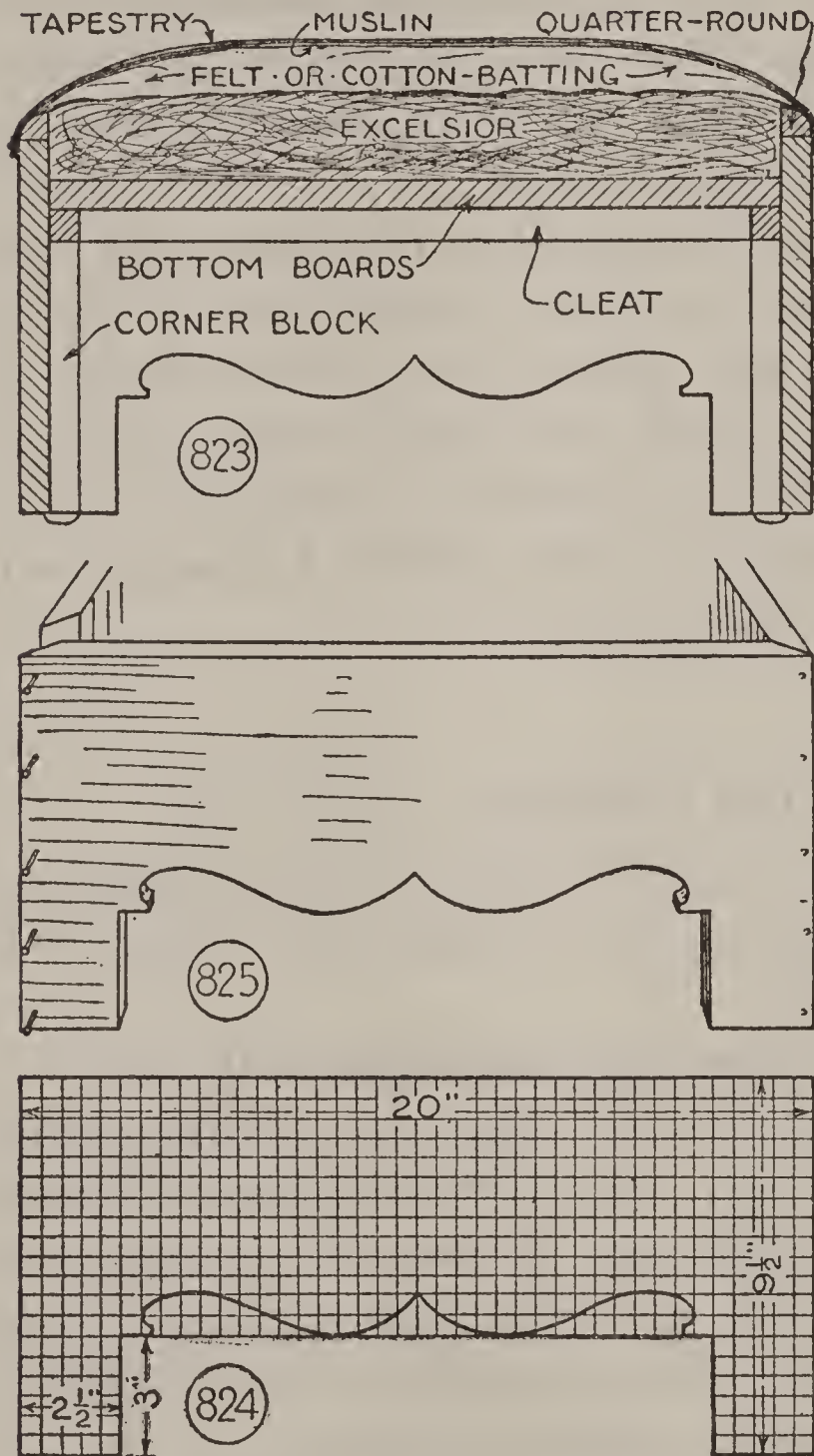

FIG. 823.—Cross-Section of Footstool Shown in Fig. 798.

FIG. 824.—Side.

FIG. 825.—Frame Assembly.

perfect miters is in laying them out accurately, and sawing exactly to the lines. You can correct slight imperfections with a plane, but it is generally more satisfactory to cut another piece than to attempt to correct a poorly cut miter.

To Assemble the Frame, coat the mitered ends of the sides with glue, and nail them together with 4-penny finishing-nails (Fig. 825). Then nail strips  $\frac{3}{4}$  inch square around the inside of the frame,  $1\frac{3}{4}$  inches below the top, for cleats to support the seat-



bottom boards (Fig. 823). Cut the bottom boards to make a snug fit between the sides of the frame, and nail them to the cleats. Glue and nail blocks to the inside corners (Fig. 823) to reinforce the mitered joints. Fasten quarter-round molding around the top of the frame, as shown in Fig. 823, to make a rounded rim for the upholstery filling.

For Upholstering the footstool, you need excelsior, felt, or cotton batting, muslin, or cambric, or other upholstery fabric, gimp braid, and tacks.

Dampen the excelsior and pack it into the top of the frame as solidly as you can. Place the felt or cotton batting over the excelsior. Spread the muslin over this, and tack it to the quarter-round molding on two opposite sides. With the cloth pulled taut, irregularities in the excelsior filling will show up. Locate these, and correct them by reducing the humps and filling out the hollows with excelsior. Then tack the other sides. It will probably require several readjustments to produce a top that is uniformly compact, and nicely rounded.

Finish the Frame with three coats of lacquer or enamel, then when the last coat has dried,

Tack the Top Covering Fabric in place. Fasten one edge, pull the material tightly over the muslin covering to the opposite side, and tack it; then pull the side edges taut, and tack them. Finish the edges of the material with gimp braid. Tack the braid with gimp tacks.

Drive domes-of-silence, or large rubber-headed screws into the leg ends, and the footstool will be completed.

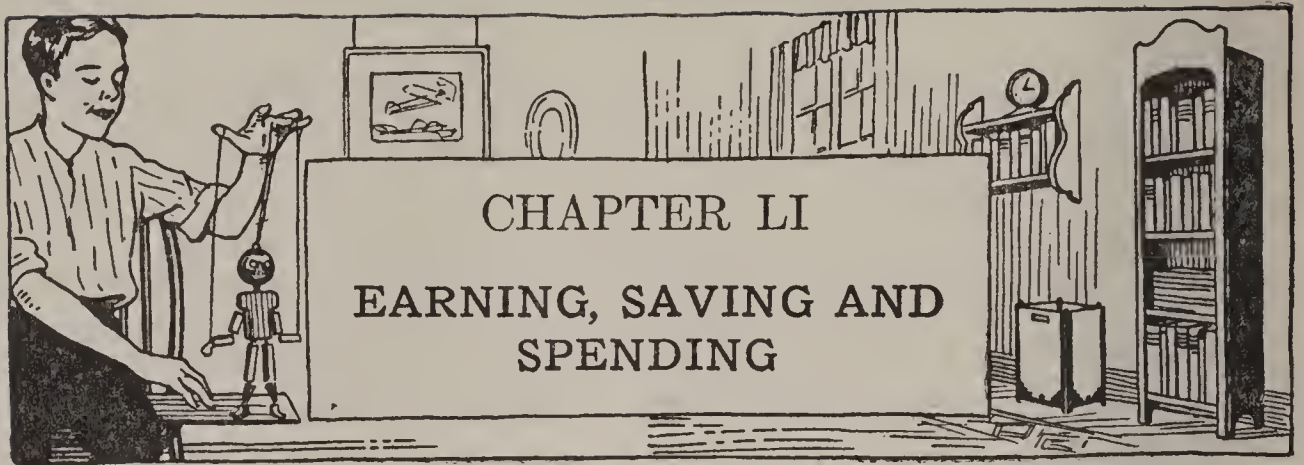

Now we come to a chapter of great importance, and if it spurs you on to do and to acquire bigger and better things, it will have accomplished its purpose.

Earning, saving, and spending are closely related to nearly every hobby that you may be interested in. Some boys adopt them as hobbies, but their real importance is in the furtherance of worth-while activities. Earn to save, and save to spend. This is becoming the accepted notion of a boy's rightful use of money. No one has more aptly expressed the thought than Henry Ford, who has said, "Of itself, money is the least valuable thing on earth. It is valuable only when it is used as a tool for self-improvement, or to accomplish some end. Saving, as it has been schooled into boys in the past, gives money too high a place, and, with some boys, saving takes the place of spending in a way that would increase earnings.

"A boy's job is not to accumulate dollars, but to use them to prepare himself with training, knowledge, and experience. If he saves, it should be with some such expenditure in view. So I say to boys, 'Spend your money! Spend it for things that will put you ahead of where you

were yesterday.' If I were bringing up a boy to-day, I would see to it that he had two things, and I would make his education center around them. He would have a shop in which he could work with tools, and he would have some money to spend—to invest in himself, in order to develop himself. A dollar put into a book might change the whole course of a boy's life. The same dollar put into a savings bank would at the end of a year yield four or five cents."

There is more of an incentive to earn money, and to save what you earn, when you have an objective. College, for one thing. Probably, you plan to earn your college expenses. But because college days are several years away, there will not be the urge to earn and to save now that there would be for a less distant objective.

Your earning, saving, and spending program might well center in your hobbies, with Dad's counsel in the matter of spending. Look to your hobbies as a possible source of guidance toward a successful career. Earn, save and spend money for equipment and materials that will enable you to pursue your hobbies to the fullest possible extent.

It is interesting to read in the autobiographies of successful men of their ambitions when boys, of their pursuit of hobbies, and of their struggle to obtain means to carry on these activities. Probably the foremost example in modern times is Thomas Edison. Young Edison at the age of ten set up a chemical laboratory in the cellar of his home; at twelve, he carried on experimental work on the train on which he was employed as newsboy and "candy

butcher” ; at fifteen, he printed and published a small newspaper, the first to be issued on a moving train; at sixteen, he was absorbed in the subject of electricity, and possessed telegraph instruments which he had built himself. Then, after several years of employment as telegrapher, at twenty-three, he received his first money, forty thousand dollars, for inventions. Until that time, Edison had spent all that he could earn and save, in the development of his ideas.

You probably have a better chance than Thomas Edison, the Wright Brothers, Henry Ford, and thousands of other successful men, of getting an early start in developing your genius, which Thomas Edison has said is “one per cent inspiration and ninety-nine per cent perspiration,” because of the better tools, machines, and hobby books that are available, and because of greater opportunities for earning money to buy materials and equipment.

The group of photographs of Figs. 826 to 830 show some of the hobby equipment that might be yours through your efforts in earning and saving money. Imagine the possibilities in the complete tool outfit (Fig. 826), in the electric bench lathe (Fig. 827), in the electric scroll-saw (Fig. 828), in the printing press (Fig. 829), and in the hobby library (Fig. 830). Such equipment as this will enable you to earn money for additional equipment. It will be an investment on which you will realize for years to come, and when you have attained success in the field of your choice, you will cherish it as Henry Ford cherishes his first lathe, at his Dearborn museum.

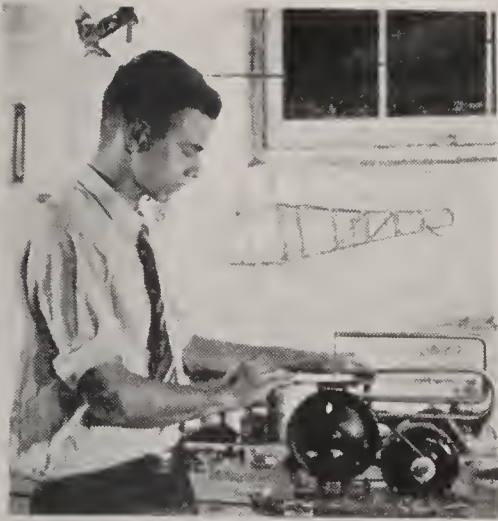

FIG. 828.—AN ELECTRIC  
SCROLL-SAW.



FIG. 827.—AN ELECTRIC BENCH-  
LATHE.



FIG. 829.—A PRINTING-PRESS.

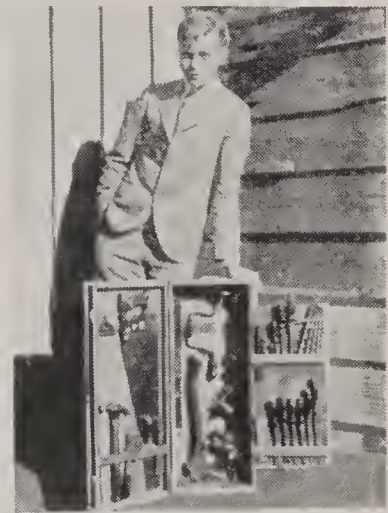

FIG. 826.—A CABINET  
OF FINE TOOLS.



FIG. 830.—A HOBBY LIBRARY.

EARN, SAVE, AND SPEND FOR SUCH EQUIPMENT AS THIS.



Select the equipment that will be of the greatest benefit in your chosen hobby, and do not be content until you have obtained it. Do not expect it to be given to you. If it is not worth working for, it is not worth having. If you are not capable of earning it, you are not capable of using it. If you haven't enough ambition to earn the purchase money, you haven't enough ambition to warrant its purchase.

There are many ways in which a boy can earn money, and I am certain that one or more of the following will appeal to you. These are offered not as a complete list, but as suggestions from my notebook, that have been followed and approved by boys.

#### MAKING THINGS TO SELL

Calendar-Boards	Egg-Racks
Stationery-Racks	Milk-Card Racks
Time-Card Racks	Window Refrigerator
Telephone-Card Directory	Recipe Cabinet
Post-Card Racks	Step-Ladder Stool
Candle-Sticks	Clothes-Line Reel
Spool-Holders	Kitchen Clock-Shelf
Whiskbroom-Holders	Pantry-Needs Board
Twine-Boxes	Pot-Cover Rack
Book-Ends	Pantry Bottle-Rack
Waste-Baskets	Flat-Iron Rest
Tabourets	Flat-Iron Rack
Plant-Stands	Knife-Box
Fireplace-Screens	Towel Roller
Shoe-Polishing Case	Scrub-Pail Platform
Necktie Racks	Ice-Pick and Ice-Chisel Rack
Birch-Bark Novelties	Window Ventilator
Leather Novelties	Clothes-Poles

Fly-Traps	Garden Dibbles
Rests for Hot Dishes	Garden Markers
Christmas-Tree Bases	Tomato-Racks
Christmas Wreaths	Concrete Lawn-Rollers
Sewing-Stand	Doll Furniture
Fancywork Frame	Doll-Houses
Fancywork Box	Toy Garages
Razor-Blade Knives	Toy Hangers
Bird-Houses	Toy Boats
Bird Feeding Shelters	Toy Wagons
Nesting-Material Racks	Toy Automobiles
Bird-Baths	Clockwork Toys
Fish-Pools	Cork Toys
Garden Seats	Pendulum Toys
Trellises	Electric Toys
Plant-Sticks	Kites
Bean-Poles	Model Airplanes
Seed Flats	Scale Model Airplanes
Plant Shields	Ship Models
Plant-Forcers	Picture Puzzles
Plant Hanging-Baskets	Game Boards
Window Plant-Boxes	

### PRINTING

Cards	Church and School Programs
Envelopes	Church and School Bulletins
Letter-Heads	A Boys' Paper
Fruit-Jar Labels	A Village History
Circulars	

### PAINTING

Signs	Weather-Vanes
Mail-Boxes	Windmills
Trellises	Fences
Plant-Boxes	Screens
Bird-Houses	Toys
Pet Shelters	Furniture
Poultry-houses	



## REPAIRING

Toys	Garden Hose
Furniture	Lawn-Mower
Baby Carriages	Window Screens
Electric Heating-Pads	Door and Window Locks
Electric Heaters	Bicycles
Electric Grills	Roller-Skates
Electric-Iron Cords	Sharpening Skates
Replacing Broken Drop-Cords, Sockets, and Plugs	Sharpening Knives
Replacing Fuse-Plugs	Soldering
Installing New Electric Bells, Push-Buttons, and Batteries	Installing Weather-Strips
Installing Bell-Transformer	Attaching Numbers to Screens and Storm-Sash
Renewing Faucet Washers	Putting Street Numbers Upon Houses and Garages
Renewing Sash-Cords	Rebinding Books
Reglazing Broken Windows	Cleaning Typewriters
Toilet Flushing-Tank	Operating a Doll Hospital

## PHOTOGRAPHY

Developing	Making Picture Post-Cards
Printing	Mounting and Lettering Photo Prints
Photographing Children	Making Freak Photographs
Photographing Pets	
Photographing Houses	

## GARDENING

Raising Vegetables	Watering Lawns
Raising Flowers	Picking Fruit
Whitewashing Trees	Weeding Gardens
Spraying Trees	Raking Leaves
Mowing Lawns	

## PETS

Caring for Pets During Own- ers' Vacations	Raising Poultry
Raising Goldfish	Raising Squabs
Raising Rabbits	Bee-Keeping

## SHOWS

Puppet	Neighborhood Circus
Magic	Pet
Magic-Lantern	Miniature Shooting-Gallery
Moving-Picture	

## SELLING

Fresh Fruit	Minnow, Worm, and Frog Bait
Roasted Peanuts	Picture Post-Cards
Popcorn	Automobile Road-Maps
Home-Made Candy	Old Newspapers, Magazines, Rags, and Bottles
Hot-Dogs	Daily Newspapers
Honey	Magazine Subscriptions
Maple Sugar and Syrup	Stamps for Collections
Spring-Water	
Fresh Eggs	

## SERVICES

Reporting for Local Newspaper	Erecting Aerials
Distributing Circulars	Storage Battery Service
Exchanging Library Books	Guarding Automobiles
Conducting Second-Hand Book Exchange	Washing Automobiles
Conducting Phonograph- Record Exchange	Washing Windows
Running Errands	Cleaning Basements
Taking Baggage to Depot	Cleaning Rugs
Caddyng	Removing Leaves from Roof Gutters
Paper and Magazine Route	Shovelling Snow
Renting Boats	Tending Furnaces
	Vacation Caretaker

You will find plans and instructions for making most of the things listed under "Making Things to Sell," in this and my other handicraft books; also suggestions for many of the money-earning ideas under the other group headings. Run through the indexes the next time that you go to your public library.

## INDEX

### A

Acetone, 46  
Adhesives, 44  
Aerial, A Radio, 134  
Aeronautics Scrapbook, 37  
A-Frame Model Airplane, 73  
Air Motor, 193  
Airplane, An Indoor-Duration Model, 59; A Twin-Pusher Model, 72; A Profile-Fuselage Model, 84; A Low-Wing Model, 95; A Scale Model, 106; A Contest Scale Model, 107; A "Spirit of St. Louis" Scale Model, 109; A Curtiss Army Hawk Scale Model, 112; A Ford Tri-Motor Scale Model, 119  
Airplane Dope, 46  
Airplane Model League of America, The, 4; 108  
Airplane Pushmobile, 327  
Airplane Tools, Model, 44  
Airplane Weather-Vane, 198  
Airport, A Model, 346  
Airport Beacon, A Model, 352  
Air-Spinner, 379  
American Bird-House League, The, 4  
Answer-Dial Cards, 411  
Aquarium, A Cracker-Box, 217  
Aquarium Castle, 222  
Aquarium Cement, 219  
Arrester, A Lightning-, 138  
Attic Room, 20  
Automatic Steering for Model Yacht, 171  
Automobile Cabinet, 284

### B

Back-Yard Railroading, 333  
Back-Yard Shacks, 294  
Back-Yard Zoo, 246  
Balsa, 47

Bamboo, 47; Shaping, 50  
Banana Oil, 46  
Bar, A Horizontal, 418  
Bar, A Trapeze, 414  
Barrel-Stave Skis, 148  
Barrel-Stave Sled, 146  
Bars, Parallel, 422  
Base for Ship Model, 132  
Batten Door, 264; 297  
Beacon, A Toy Electric, 351  
Bean-Blow-Gun, 369  
Bearing, Propeller, 48; 49; 66; 75; 89; 90; 101  
Bearings, 195; 196  
Bench, A Home-Made Work-, 9; A Packing-Box Work-, 14  
Bench-Stop, 14  
Bench Vise, 11  
Bird-Bath, A Tree-Stump, 233; A Rustic, 235; A Stone, 239  
Bird-Baths and A Fish-Pool, 233  
Bird-House, A Wren, 225; A Bluebird, 226; A Wren or Bluebird, 229  
Bird-Houses to Sell, 229  
Bird Nesting Material Depot, 231  
Bird-Sanctuary, 224  
Birds, A Winter Feeder for, 141  
Blow-Gun, A Bean-, 369  
Bluebird House, 226; 229  
Boat, A Model Sail, 163; A Model Motor, 177  
Boat, A Sharpie Outboard Motor, 269  
Book-Nooks and Whatnots, 429  
Book-Rack, An Extension, 430  
Book-Tower, A Modernistic, 440  
Bowl, A Dog's, 244  
Bowsprit, 130  
Box Furniture, 298  
Box-Girder Bridge, A Model, 339  
Boy Craftsman League, The, 4; 108

Boy Scout Museum, 208  
 Braking Device, A Pushmobile, 324  
 Bridge, A Model Railroad, 337; A  
 Concrete, 337; A Different De-  
 sign of, 339; A Box Girder, 339;  
 A Steel, 341; A Trussed, 341  
 Bridle, 191  
 Bulkheads, 127  
 Bunks, 312

## C

Cab, A Dump-Truck Pushmobile,  
 324  
 Cabin, A Model Airplane, 93; 105;  
 A Model Motor-Boat, 183; An  
 Airplane Pushmobile, 332  
 Cabinet, A Built-In, 23; A Speci-  
 men, 214; An Automobile, 284;  
 A Trek Cart, 286; A Pier, 445  
 Cage, An Exhibition, 248; A Nest-  
 ing Material, 232  
 Campfire Crane, 284  
 Campfire Pothooks, 284  
 Cannon, A Ship Model, 130  
 Canoe, A Canvas, 277  
 Canoe Headlight, 289  
 Cans, 75; 90; 102  
 Canvas Canoe, 277  
 Card-Index, 214  
 Carving a Hull, 165; 178  
 Carving Propellers, 69  
 Castle for Aquarium, 222  
 Cave with Secret Entrance, 303  
 Cells, Conyne Kite, 190  
 Cement Castle, An Aquarium, 222  
 Checker Men, 404  
 Checker-Solitaire Board, 403  
 Chest, A Treasure, 31  
 Chest Handles, 35  
 Chicken Coop, 252  
 Chicken House, 257  
 Clips, Wing, 67; 91; 102  
 Clock, Quiz, 407  
 Closets, Storage, 21  
 Club, A Hobby, 1  
 Club-House, 294  
 Club Library, 4  
 Clubroom, 3; Furnishing A, 19; An  
 Attic, 20  
 Club Workshop, 3

Cockpit, 281  
 Coconut Wren Hut, 225  
 Coin Collection, 209  
 Collection, A Stamp, 208; A Coin,  
 209; A Knot, 211; A Rock and  
 Mineral, 212; A Shell, 212; A  
 Leaf, 213; An Insect, 213; A  
 Photograph, 213  
 Concrete Base for Aerial Mast,  
 137  
 Concrete Model-Bridge, 337  
 Concrete Lake, 337  
 Concrete Pool, 235  
 Concrete Water Bowl, 244  
 Contest, A Model Airplane, 53  
 Contest Model Airplane Models,  
 107  
 Conyne Kite, 188  
 Coop, A Chicken, 250; 252  
 Court, A Table Tennis, 397  
 Covering A Canvas Canoe, 280  
 Covering A Kite, 191  
 Covers, Home-Made Scrapbook, 39  
 Cracker-Box Aquarium, 217  
 Crane, A Campfire, 284  
 Creek, A Model, 337  
 Cupboards, Work-Bench, 16  
 Curtain, A Puppet Theater, 389  
 Curtiss Army Hawk Scale Model  
 Airplane, 113  
 Cylinders, Airplane Weather-Vane,  
 202; Locomotive Pushmobile, 318;  
 Airplane Pushmobile Motor, 330.

## D

Dancing Puppet, 382  
 Depot, A Nesting-Material, 231; An  
 Electric Railroad, 343  
 Dihedral, 62; 77  
 Dog House, 240; A Barrel, 243  
 Doors, Cabinet, 24  
 Dope, Airplane, 46  
 Drawers, Cabinet, 216  
 Drilling Holes Through Paper, 41  
 Driving-Rods, 318  
 Drop, A Puppet Theater Proscen-  
 nium, 390; A Back, 391  
 Droppings-Board, 266  
 Drying-Reel, A Fishing-Line, 286  
 Dumping Hoist, 326

Dump-Truck Pushmobile, 321  
 Duration-Model Airplane, An In-  
 door, 59

## E

Earning, Saving and Spending, 454  
 Easel, A Ring-Toss Target, 401  
 Edison and His Boyhood Hobbies,  
 Thomas A., 455  
 Egg-Beater Propeller Winder, 81  
 Electric Beacon, A Toy, 351  
 Electric Shooting-Gallery, A Toy,  
 357  
 Elevator, A Model Airplane, 77;  
 112; An Airplane Weather-Vane,  
 200  
 Empennage, 64  
 Eye-Splice, 416

## F

Fan-Blades, Air Motor, 196  
 Feeder for Birds, A Winter, 141  
 Feeding-Hens Toy, 374  
 Files, Box, 26  
 File Scrapbook, 43  
 Fin, A Model Airplane, 65; 88;  
 100; 112; Airplane Pushmobile,  
 329  
 Fish Aquarium, 217  
 Fishing-Line Drying Reel, 286  
 Fish-Pond, 235  
 Fittings, Model Airplane Metal, 48  
 Fixtures, Poultry, 265  
 Flasher, A Toy Beacon, 355  
 Flat-Bottomed Boat, 269  
 Flying Line, A Kite, 191  
 Flying Rings, 417  
 Food-Containers, Poultry, 266  
 Footstool, 451  
 Ford Tri-Motor Scale Model Air-  
 plane, 119  
 Frames, Picture, 29  
 Freight-House, A Model, 368  
 Furniture, Box, 298  
 Fuselage, A Model Airplane, 87;  
 97; 109; 116; 119; An Airplane  
 Weather-Vane, 199; An Airplane  
 Pushmobile, 329

## G

Galleon Ship Model, 124  
 Game Equipment, 396  
 Garden, A Water, 235  
 Gardening, 459  
 Girders, Model Bridge, 340; 341  
 Gold-Fish Aquarium, 217  
 Grinding Skates, Hollow-, 154  
 Ground-Wire, 138  
 Gun, Bean-Blow-, 369  
 Gunwales, Canoe, 278  
 Gunwales, Flat-Bottomed Boat, 275  
 Gymnasium Apparatus, 413

## H

Handles, Chest, 35  
 Hanger, 90; 102  
 Harbor Beacon, A Play, 352  
 Headlight, A Canoe, 289; A Loco-  
 motive Pushmobile, 319  
 Hens Toy, The Feeding-, 374  
 Hinges, Double-Acting, 28  
 Hobby Club, 1  
 Hockey-Stick, An Ice, 152  
 Hollow-Grinding Skates, 154  
 Hood, 324  
 Hook, A Motor, 66; 90; 102; An  
 S-, 67; 80; 90; 102  
 Horizontal Bar, 418  
 House, A Club, 294; A Poultry, 257  
 Houses, Bird, 224  
 Hull, A Model Yacht, 165; A  
 Model Motor-Boat, 178  
 Hull, A Ship Model, 125  
 Hut, A Wren, 225; 229  
 Hutch, An Emergency, 247; A Rab-  
 bit, 248; A Convertible Coop or,  
 250

## I

Ice-Hockey Stick, 152  
 Ice Skatemobile, 144  
 Index, Card, 214  
 Index for Scrapbook, 43  
 Indoor-Duration Model Airplane,  
 59  
 Insect Collection, 213  
 Insulation, Aerial, 138; Shack, 302

## J

Japanese Tissue-Paper, 47

## K

Keel, A Model Yacht, 169; A Flat-Bottomed Boat, 274  
 Kennel, 240; A Barrel, 243  
 Kite-Line Reel, 192  
 Kites, A Great Rig In, 188  
 Kits, Model Airplane Material, 53; Model Yacht, 164  
 Knife, A Razor-Blade, 51  
 Knot-Board, 211

## L

Ladder for Shack, 301  
 Lake Model, 335  
 Landing-Gear, A Model Airplane, 49; 50; 91; 103; 112; An Airplane Weather-Vane, 203; An Airplane Pushmobile, 331  
 Lanterns, Ship Model, 129  
 Launching Model Airplanes, 71; 82  
 Lead-In, An Aerial, 138  
 Leaf Collection, 213  
 Letter-File Scrapbook, 43  
 Library, A Hobby Club, 4  
 Life-Preserver Vest, 281  
 Lightning-Arrester, An Aerial, 138  
 Lock, A Secret, 31; 34  
 Locomotive Pushmobile, 315  
 Longerons, 73  
 Low-Wing Model Airplane, 95

## M

Making Things to Sell, 457  
 Mast, A Model Yacht, 130; An Aerial, 135  
 Material-Kits, Model Airplane, 53  
 Mats, Gymnasium, 425  
 Metal Fittings, Model Airplane, 48; 66; 75; 89; 101  
 Mineral Collection, 212  
 Model, A Galleon Ship, 124  
 Model Airplane, An Indoor Duration, 59; A Twin Pusher Model, 72; A Profile-Fuselage Model, 84; A Low-Wing Model, 95; A Scale Model, 106; A Contest

Scale Model, 107; A "Spirit of St. Louis" Scale Model, 109; A Curtiss Army Hawk Scale Model, 112; A Ford Tri-Motor Scale Model, 119

Model Airplane Tools, 44  
 Model Airplane Tournaments, 53  
 Model Airport, 346  
 Model Creek, 337  
 Modeling A Snow Totem-Pole, 156  
 Model Lake, 335  
 Model Rocky Mountain, 334  
 Model Station for Electric Railroad, 364  
 Model Village, 334  
 Model Yacht, 163  
 Model Yacht Racing Association of America, The, 164  
 Mold, A Sharpie, 272  
 Molds, Canoe, 278  
 Motor, An Air, 193; A Toy Electric, 184  
 Motor-Base, A Model Airplane, 64; 86; 96  
 Motor-Boat, A Model, 177  
 Motor-Hook, 66; 90; 102  
 Motors, Model Airplane, 52; 70; 80; 92; 105  
 Mountain Model, 344  
 Museum, 206  
 Music-Wire, 48

## N

National Amateur Press Association, The, 4  
 Nest-Boxes, 266  
 Nesting-Material Depot, 231  
 Notebook Covers, Scrapbook, 38

## O

Oar Repairs, 290  
 Ogden Park Model Yacht Club, The, 164  
 Orange-Crate in Camp, 284  
 Outboard Motor-Boat, A Sharpie, 269

## P

Paddle, A Canoe, 281  
 Paddle Repairs, 290

- Painting, 27; 35; 130; 143; 146;  
 172; 187; 204; 221; 229; 232;  
 243; 244; 266; 275; 280; 303;  
 314; 320; 332; 341; 356; 363;  
 367; 373; 374; 384; 401; 410;  
 411; 425; 430; 435; 438; 439;  
 440; 444; 451; 453  
 Papering Model Airplanes, 47; 63;  
 65; 88; 99  
 Parallel-Bars, 422  
 Passe Partout Frame, 211  
 Patrol Shacks, 294; 299  
 Pendulum Toy, The Feeding-Hens,  
 374  
 Periscope, A Play, 309  
 Pets, 459  
 Photograph Album, 214  
 Photograph Collection, 213  
 Photography, 459  
 Picture-Frames, 29  
 Pier-Cabinet, 445  
 Piers, Model Bridge, 340  
 Pipe-Support, 204  
 Planting Water Garden, 239  
 Plays, Puppet, 395  
 Poles, Model Telegraph, 345  
 Pond, A Fish, 235  
 Pothooks, 284  
 Poultry Fixtures, 265  
 Poultry House, 257  
 Power-House, A Model, 368  
 Printing, 458  
 Profile-Fuselage Model Airplane,  
 84; A Low-Wing, 95  
 Propeller, A Model Airplane, 68;  
 79; 92; 104; A Model Motor-  
 Boat, 184; An Airplane Weather-  
 Vane, 201  
 Propeller Shaft, 67; 79; 90; 102  
 Propeller Winder, 81  
 Properties, Puppet Theater, 390  
 Proscenium, Puppet Theater, 388  
 Proscenium Drop, 390  
 Pulley, Wooden, 359  
 Pullman, A Pushmobile, 320  
 Puppet, A Dancing, 382  
 Puppet Plays, 395  
 Puppets for Puppet Theater, 392  
 Puppet Theater, 386  
 Pusher Model Airplane, 72  
 Pushmobile, The Wabash Limited,  
 315; A Dump-Truck, 321; An  
 Airplane, 327
- Q
- Question Cards, 411  
 Quiz Clock, 407
- R
- Rabbit-Hutch, 247; 248; 250  
 Rabbit Targets, Toy, 360  
 Rack, An Extension Book-, 430;  
 A Wall-, 432; Another Wall-,  
 435  
 Rackets, Table-Tennis, 399  
 Radio, Installing A, 134  
 Radio Broadcasting Station, A  
 Model, 346  
 Railroad Bridge, A Model, 337; A  
 Concrete, 337; A Different De-  
 sign of, 339; A Box Girder, 339;  
 A Steel, 341  
 Railroad Depot, A Model, 343  
 Railroading, Back-Yard, 333  
 Railroad Station, A Model, 364  
 Railroad Tunnel, 343  
 Razor-Blade Knife, 51  
 Reel, A Kite-Line, 192; A Fishing-  
 Line Drying, 286  
 Regattas, Rules for Model Yacht,  
 173  
 Repairing, 459  
 Ribbands, Canoe, 278  
 Ribs, Model Airplane, 62; 87; 99  
 Rigging a Model Yacht, 171  
 Rigging a Ship Model, 130  
 Rings, Flying, 417  
 Ring-Toss Targets, 400  
 Rock Collection, 212  
 Rocky Mountain Model, 334  
 Room, Furnishing Your, 19; An  
 Attic, 20; An Interesting, 29  
 Roosts, 265  
 Rubber-Strand Motors, 52; 70; 80;  
 92; 105  
 Rudder, A Model Airplane, 65; 88;  
 100; 112; A Model Yacht, 169;  
 A Model Motor-Boat, 185; An  
 Airplane Weather-Vane, 200; An  
 Airplane Pushmobile, 329

Runners, Sled, 147; 148  
 Runways, 249; 256; 265  
 Rustic Bird-Baths, 235

## S

Sail, A Skate, 149  
 Sailing With Skate Sail, 151  
 Sails, Galleon Ship Model, 130;  
 Model Yacht, 171  
 Sanctuary, A Bird, 224  
 Saving, 454  
 Scale Model Airplanes, 106  
 Scenery, Model, 346; Puppet Theater, 390  
 Scouting Scrapbook, 38  
 Scrapbooks, 37  
 Scratch-Shed, 257  
 Screen, A Folding, 27  
 Seat, A Window, 21  
 Seats, Boat, 275  
 Secret Doorways, 307  
 Selling, 460  
 Services, 460  
 Shacks, 294  
 Shaft, Propeller, 67; 79; 90; 102  
 Sharpie Outboard Motor-Boat, 269  
 Shelf for Models, 23  
 Shell Collection, 212  
 Shelves, Cabinet, 24  
 Shield, A Snowball, 158  
 Ship-Model, A Galleon, 124  
 Shock-Absorbers, 92; 104  
 S-Hook, 67; 80; 90; 102  
 Shooting-Gallery, A Toy Electric, 357  
 Shop Equipment, 17  
 Shows, 460  
 Shutters, Window, 298  
 Skatemobile, An Ice, 144  
 Skate-Sail, 149  
 Skates, Hollow-Grinding, 154  
 Skid, A Tail-, 203  
 Skis, Barrel-Stave, 148  
 Sled, A Barrel-Stave, 146  
 Snowball Shield, 158  
 Snow Totem-Pole, 156  
 Solitaire-Board, 403  
 Spars, Model Airplane, 62; 87; 98;  
 Model Yacht, 170  
 Specimen-Cabinet, 214

Spending, 454  
 Spinner, An Air, 379  
 Spinner-Cap, An Airplane Weather-Vane, 201  
 Spirit of St. Louis Scale Model Airplane, 109  
 Splice, An Eye-, 416; An Oar-Handle, 290  
 Sports Equipment, Winter, 144  
 Sports Scrapbook, 38  
 Stabilizer, A Model Airplane, 64; 88; 99; 112; 116; An Airplane Pushmobile, 331.  
 Stage, A Puppet Theater, 388  
 Stage-Lighting, Puppet Theater, 395  
 Stage-Settings, 390  
 Stamp Collection, 208  
 Stand, A Model Motor-Boat, 187  
 Station, A Model Railroad, 364  
 Steering, Automatic, 171  
 Stop, A Bench, 14  
 Striking-Bag Platform, 425  
 Struts, Model Airplane, 50  
 Superstructure, A Ship Model's, 127  
 Swivel Base, 204

## T

Table-Tennis, 397  
 Tail, A Model Airplane, 64; 88; 99; 116; An Air Motor, 197  
 Tail-Skid, 104; 204  
 Target, A Toy Rabbit, 360; A Ring Toss, 400  
 Telegraph Line, A Model, 344  
 Templets, 168; 180  
 Tender, A Pushmobile, 319  
 Tennis, Table, 397  
 Tent-Pole Pack, 282  
 Theater, A Puppet, 386  
 Thrust-Washers, 49; 67; 79; 90; 102  
 Tie-Rods, 341  
 Ties, Model Bridge, 341  
 Tiller, A Model Yacht, 170; A Model Motor-Boat, 185  
 Tissue-Paper, Japanese, 47  
 Tools, Model Airplane, 44  
 Totem-Pole, A Snow, 156  
 Tournaments, Model Airplane, 53



Tower, A Toy Beacon, 352; A Book-, 440  
 Trapeze, 414  
 Treasure-Chest, 31  
 Trek-Cart Cabinet, 286  
 Trestles for Rabbit Hutch, 250  
 Tri-Motor Scale Model Airplane, 119  
 Truck Pushmobile, 321  
 Trussed Bridge, 341  
 Tuning Model Airplanes, 70; 83; 93  
 Tunnel, A Model, 343  
 Twin-Pusher Model Airplane, 72

## V

Ventilator, A Kennel, 242; A Rabbit Hutch, 251; A Cave, 307  
 Vest, A Life-Preserver, 281  
 Village Model, 334  
 Vise, A Bench, 11; 17

## W

Wabash Limited Pushmobile, 315  
 Wallboard, 20  
 Wall-Rack, 432; 435  
 Washers, Thrust, 49; 67; 79; 90; 102  
 Wash-In, 63; 87  
 Wash-Tub Lake, 335  
 Waste-Basket and A Footstool, A 449  
 Water-Bowl, A Dog's, 244  
 Water Garden, 235

Waterproofing a Boat, 276  
 Weather-Vane, An Airplane, 198  
 Whatnot, A Corner, 437  
 Wheels, Model Airplane, 91; 104  
 Winder, A Propeller, 81  
 Windmill, 193; 198  
 Window-Seat, 21  
 Windows, Model Airplane, 93; 105; 119; Ship Model, 129  
 Window-Shutters, 298  
 Wing, Model Airplane, 60; 75; 87; 98; 109; 116; 122; Airplane Weather-Vane, 199; Airplane Pushmobile, 330  
 Wing-Clips, 67; 91; 102  
 Winter Feeder for Birds, 141  
 Winter-Sports Equipment, 144  
 Woods and Water Ideas, 282  
 Work-Bench, A Home-Made, 9; A Packing-Box, 14  
 Workshop, A Club, 3; A Model-Making, 8; An Outside, 8; A Garage, 8; A Porch, 9; Name for Your, 17; Equipment for A, 17  
 Wren-Hut, 225; 229

## Y

Yacht, A Model, 163  
 Yacht Regattas, Model, 173  
 Yards, 130  
 Yoke, 75

## Z

Zoo, A Back-Yard, 246

