

PUBLIC LIBRARY

THE ARCHITECT AND ENGINEER



JULY, 1920

PUBLISHED IN SAN FRANCISCO

35 cents per copy

\$2.50 a year



CLEAN, WELL-EQUIPPED TOILET and WASH ROOMS have a definitely beneficial effect upon the efficiency of workers. The Pacific line includes a wide variety of styles to fit every factory requirement --lavatories, toilets, urinals, tubs and drinking fountains.

PACIFIC
PLUMBING FIXTURES



For Sale by All Jobbers

OFFICES: 67 NEW MONTGOMERY STREET, SAN FRANCISCO.
FACTORIES: SAN PABLO AND RICHMOND, CALIFORNIA.



*The Botterill Automobile Co.'s New Salesroom
Salt Lake City, Utah
Covered with a PABCO 10 Year Roof*

Palliser and Hills
Architects
The Berrum Agency
Roofing Contractors

Demand Lasting Roof Protection

The constantly increasing number of buildings that are covered with Pabco Roofs is due to the demands of Architects, Engineers and Owners alike. They know that these roofs provide the highest type of permanent protection—and at a fair price.

PABCO ROOFS

Guaranteed for 10 and 20 years

Because of the high quality of materials, and the admitted superior method of construction, PABCO ROOFS cost slightly more than inferior roofs. Invariably, however, they prove cheaper in the long run, because of their *low cost per year of service.*

Write for Specifications and Complete Details

THE PARAFFINE COMPANIES, INC.
San Francisco, California
Manufacturers



Roofings, Felts
Building Papers
Wall-Board
Floor Covering
Industrial and
Marine Paints
Waterproofing
Materials
Box-Board
Paper Boxes
Fibre Containers

STEEL BARS

FOR
CONCRETE REINFORCEMENT

CORRUGATED
TWISTED
SQUARES
OR
ROUNDS
CUT
TO
LENGTH



FABRICATED
AND
INSTALLED
—
LUMP SUM
BIDS
ON
WORK
COMPLETE

Office, 444 MARKET STREET
Warehouse, 10th and Bryant Streets
Phone: Sutter 2720

“HYDRATITE” FOR WATERPROOFING AND HARDENING CONCRETE “HORNSTONE”

JK

**Kelly & Jones
Valves and Fittings
are Dependable**



**BYERS Genuine Wrought Iron
Pipe, Republic Steel Pipe, Com-
plete Line Plumbing Supplies.
Large stocks for prompt delivery**

**California Steam &
Plumbing Supply Co.**
671-679 Fifth St., cor. Bluxome
San Francisco, California



PIPE
 Valves & Fittings
STEAM & WATER SUPPLIES
 Heating Material
PLUMBING GOODS
 Pumps

GEORGE H. TAY COMPANY
 SAN FRANCISCO OAKLAND
 MISSION & SECOND STS. TENTH & HARRISON STS.
 TELEPHONE DOUGLAS 2240 TELEPHONE LAKESIDE 4200

Contractors Cannot Agree

as to percentage of labor and material saved in using

1 A RIB LATH

over other expanded metals; majority claim 20% saving — others more. Labor is high, material higher, 1 A RIB cuts down cost of both—present conditions demand your immediate investigation where metal lath is needed. Phone Market 8357.

Largest stock of fireproof material and reinforcing bars on the Pacific Coast.



Truscon Steel Company

CHAS. HOLLOWAY, JR., BRANCH MANAGER

527 Tenth Street, San Francisco

W. & J. SLOANE

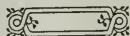

Carpetings Furniture

Rugs

Linoleum Window Shades

Wall Papers

Interior Decorations

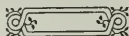

216-228 Sutter Street

Tel. Garfield 2838 San Francisco

THE BRUNSWICK-BALKE-COLLENDER
WHALE-BONE-ITE
WINDUP CLOSET SEAT

CUT SHOWS No. 23-9 SEAT
 C—WIND UP MECHANISM
 C—SEAT FROM CLOSING
 B—SEAT LEADERSHIP
 A—WIRE INS CAPSULE LAYER OF LAMINATION.
 THIS WIND UP SEAT.

CONSTRUCTION OF WHALE-BONE-ITE SEAT

Whale-bone-ite

has proven under tire and academic tests to be the best closet seat made.

Representative, also, of SLOAN VALVE COMPANY

EDWARD C. WHALEN
Monadnock Building
SAN FRANCISCO CALIF.



PROMETHEUS

The Electric Food and Plate Warmer

Wherever meals are cooked and served, in apartments, residences and institutions, Prometheus is a highly valued asset. The wireless heating units placed independently of the shelves keep food hot and tasty until ready to serve and cannot injure the finest china.

Write for information and list of installations

The Prometheus Electric Co.

Manufacturers

511 West 42d Street, New York

M. E. HAMMOND

217 Humboldt Bank Building, San Francisco

CLOW

Pound-foolish Clients

IN designing a new factory it happens frequently that the client wishes to effect economies in the most unwise places. One place in which the thought of economy should *never* enter, is in plumbing equipment. Nothing will do so much to promote contentment and insure productivity among the workers as the highest grade of sanitary equipment, wisely installed. Our long experience in this field enables us to assist architects, confronted by hesitant clients, with data drawn from the experience of other employers.

*A statement of your problem will
enlist our prompt co-operation*

Frederick A. Hamilton

Sales Agent

Show Rooms:

RIALTO BUILDING
SAN FRANCISCO



*New Municipal Building
and City Hall, New York City.*



Achievements to be proud of

WE are proud of the marvelous achievements of American Architects; proud of our share in their success; proud also that our

VAN DYKE DRAWING PENCILS

rank among America's foremost accomplishments.

Samples of your favorite degrees and an artist eraser sent upon request on your business stationery. Address us at 37 Greenpoint Avenue, Brooklyn, New York.

EBERHARD FABER

"The Oldest Pencil Factory in America"
NEW YORK



Van Dyke Drawing Pencils are made in 16 degrees, graduating from 6B softest, to 8H hardest.



P. Noble, Pres.
E. B. Noble, Vice-Pres.
A. E. Wilkins, Sec'y

Beam, Angle, Channels, and Universal
Mill Plates for immediate ship-
ment from stock

Pacific Rolling Mill Co.

SUPPLIERS OF

FABRICATED STRUCTURAL STEEL, Forgings,
Bolts, Rivets, Frogs, Switches, Cast Iron Castings

General Office and Works
17th and MISSISSIPPI STS., SAN FRANCISCO
Telephone Market 215

Phones: Garfield 2575 and 2576

WESTERN IRON WORKS

W. B. Morris, President

H. H. Morris, Vice-President

L. J. Gates, Secretary

STRUCTURAL IRON and STEEL CONTRACTORS

Beams, Channels, Angles, Plates and Steel
Wheelbarrows Carried in Stock

141-147 Beale Street and 132-148 Main Street
SAN FRANCISCO, CAL.

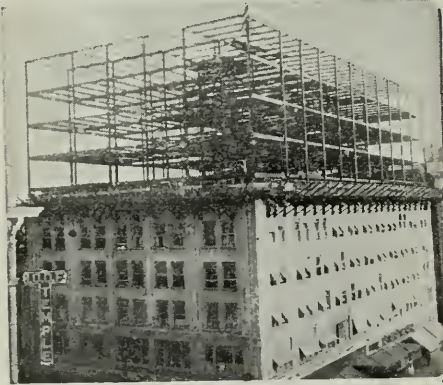

FORUM BUILDING, SACRAMENTO, CAL.
R. A. Herold, Architect

Progress Picture of the four story addition
to Sacramento's largest office building.

STRUCTURAL STEEL FABRI-
CATED AND ERECTED BY

The Palm Iron and Bridge Works

(Incorporated)

15th and R. Sts., Sacramento, Cal.

Cast Iron Stairs and Store Fronts

Bank and Office Railings, Elevator
Enclosures and Fire Escapes.

C. J. HILLARD CO., Inc.

Nineteenth and Minnesota Streets
Telephone Mission 1763

SAN FRANCISCO, CAL.

Architects' Specification Index

(For Index to Advertisements, see next page)

ARCHITECTURAL TERRA COTTA

Gladding, McBean & Company, Crocker Bldg., San Francisco.

Los Angeles Pressed Brick Company and United Materials Co., Crossley Bldg., San Francisco.

Livermore Fire Brick Works, Livermore, Cal.

ASBESTOS ROOFING, PACKING, ETC.

H. H. Robertson Co., Hobart Bldg., San Francisco.

H. W. Johns-Manville Co., San Francisco, Los Angeles and Portland, Ore.

AUTOMATIC SPRINKLERS

Grinnell Co. of the Pacific, 453 Mission St., San Francisco.

Scott Company, 243 Minna St., San Francisco.

Pacific Fire Extinguisher Co., 424 Howard St., San Francisco.

AUTOMOBILE INSURANCE

Bankers & Shippers Insurance Co. of New York, Insurance Exchange Bldg., San Francisco.

AWNINGS, TENTS, ETC.

W. A. Plummer, Front, at Pine St., San Francisco.

BANK FIXTURES AND INTERIORS

Fink & Schindler, 218 13th St., San Francisco.

C. F. Weber & Co., 985 Market St., San Francisco.

Home Mfg. Co., 543 Brannan St., San Francisco.

Mullen Manufacturing Co., 64 Rausch St., San Francisco.

Rucker-Fuller Desk Co., 677 Mission St., San Francisco.

Pacific Manufacturing Company, San Francisco, Oakland and Santa Clara.

BELTING AND PACKING

New York Belting and Packing Company, 519 Mission St., San Francisco.

Ralphs-Pugh Co., 530 Howard St., San Francisco.

H. N. Cook Belting Co., 401 Howard St., San Francisco.

BLACKBOARDS

C. F. Weber & Co., 985 Market St., San Francisco, Los Angeles and Reno, Nevada.

Beaver Blackboards and Greenboards, Rucker-Fuller Desk Company, Coast agents, 677 Mission St., San Francisco; also Oakland and Los Angeles.

BLINDS—VENETIAN AND DIFFUSELITE

J. G. Wilson Corporation, Metropolitan Bldg., Los Angeles; Waterhouse-Wilcox, Underwood Bldg., San Francisco.

Western Venetian Blind Co., Long Beach Ave., Los Angeles.

BOILERS

California Hydraulic Engineering & Supply Co., 70-72 Fremont St., San Francisco.

Franklin Water Tube Boiler, General Machinery and Supply Co., 39 Stevenson St., San Francisco.

Kewanee Water Supply System, Simonds Machinery Co., 117 New Montgomery St., San Francisco.

General Boilers Co., 322 Monadnock Bldg., San Francisco.

BONDS FOR CONTRACTORS

American Mutual Liability Insurance Co., Balboa Bldg., San Francisco.

Bonding Company of America, Kohl Bldg., San Francisco.

Bankers & Shippers Insurance Co. of New York, Insurance Exchange Bldg., San Francisco.

Globe Indemnity Co., 120 Leidesdorff St., San Francisco.

Fidelity & Casualty Co. of New York, Merchants Exchange Bldg., San Francisco.

Fidelity & Deposit Co. of Maryland, Insurance Exchange, San Francisco.

John H. Robertson, 621 First National Bank Building, San Francisco.

National Surety Co. of New York, 105 Montgomery St., San Francisco.

BRASS GOODS, CASTINGS, ETC.

H. Mueller Manufacturing Co., 635 Mission St., San Francisco.

BRICK—PRESSED, PAVING, ETC.

California Brick Company, Niles, Cal., and 604 Mission St., San Francisco.

Livermore Fire Brick Works, Niles, Cal.

Gladding, McBean & Company, Crocker Bldg., San Francisco.

Los Angeles Pressed Brick Co., Frost Bldg., Los Angeles.

United Materials Co., Crossley Bldg., San Francisco.

BRICK & CEMENT COATING

Armorite and Concreta, manufactured by W. P. Fuller & Co., all principal Coast cities.

The Paraffine Companies, Inc., 34 First St., San Francisco.

R. N. Nason & Co., 151 Potrero Ave., San Francisco.

Glidden Stuccolor Liquid Cement Coating. The Glidden Company, 123 Hooper St., San Francisco.

Wadsworth, Howland & Co., Inc., Boston, Mass., manufacturers of Bay State Brick & Cement Coating. Hambley & Son, agents, San Francisco and Los Angeles.

BRICK STAINS

Samuel Cabot Mfg. Co., Boston, Mass., agencies in San Francisco, Oakland, Los Angeles, Portland, Tacoma and Spokane.

Armorite and Concreta, manufactured by W. P. Fuller & Co., all principal Coast cities.

BUILDERS' HARDWARE

Joost Bros., agents for Russell & Erwin Hardware, 1053 Market St., San Francisco.

The Stanley Works, New Britain, Conn., represented in San Francisco and Los Angeles by John Rountree & Co.

Palace Hardware Company, Agents Corbin goods, 581 Market St., San Francisco.

Richards-Wilcox Mfg. Co., Aurora; Ewing-Lewis Co., 626 Underwood Bldg., San Francisco.

GRINNELL AUTOMATIC SPRINKLER GRINNELL COMPANY

OF THE PACIFIC

VALVES
PIPE and FITTINGS

ENGINEERS AND CONTRACTORS
453 Mission Street, San Francisco

CHEMICAL FIRE
EXTINGUISHERS
and FIRE ENGINES

When writing to Advertisers please mention this magazine.

An Index to the Advertisements

	Page		Page		Page
American Automatic Lock & Lift Co.	148	Golden Gate Ornamental Iron Co.	160	Palm Iron Works.....	6
American La France Fire Engine Co.	34	Grinnell Co.	7	Palmer & Petersen.....	142
American Mutual Liability Insurance Co.	10	Gunn Carle Company.....	2	Paraffine Companies, Inc.	1
American Mail Chute.....	32	Haines, Jones & Cadbury.....	123	Parker, K. E. Co., Inc.	144
American Marble & Mosaic Co.	44	Hamilton, F. A.	4	Petrium Sanitary Sink Co.	138
American Rolling Mill Co.	133	Hannah, J. D.	142	Phillips, Chas. T.	145
American Standard Oil Burner	43	Hammond, M. E.	4	Pitcher Door Hanger.....	33
American Window Glass Co.	42	Hauser Window Co.	26	Plummer, W. A.	129
Atlas Heating & Ventilating Co.	146	Haws Sanitary Drinking Faucet Co.	147	Pope & Talbot.....	15
Atlas Portland Cement Co.	125	Hicks-Judd Co.	151	Portland Lumber Co.	15
Austin Cube Mixer.....	153	Hillard, C. J., Co.	6	Power Construction Company	158
Bacon, Edward R., Co.	37	Hill, Hubbell & Company.....	149	Power & Pike Co.	152
Badt-Palk & Co.	145	Holbrook, Merrill & Stetson... ..	30	Prometheus Electric Co.	4
Baird-Bailhache Company	24	Holtzer-Cabot.....	20	Ralphs-Pugh Co.	34
Bankers & Shippers' Ins. Co.	159	Home Mfg. Co.	158	Ray Oil Burner.....	36
Barrett & Hilp.....	144	Hoosier Store.....	27	Raymond Granite Co.	160
Bass-Hueter Co. 3rd Cover	156	Hunt, Robt. W. & Co.	136	Redwood Mfg. Co.	42
Baxter, Reed.....	156	Hunter & Hudson.....	140	Reliance-Grant Elevator Equipment Co.	22
Beach-Robinson Co.	31	Ideal Heating & Engineering Co.	146	Rex Electric Engineering Co.	155
Beckwith, Herbert.....	145	Illinois Engineering Co.	146	Richards-Wilcox Mfg. Co.	35
Bittmann & Battée.....	20	Imperial Waterproofing.....	156	Ringius, John.....	160
Bowser & Co., S. F.	41	Inland Floor Co.	140	Roberts Mfg. Co.	129
Briminot Co.	22	James & Drucker.....	156	Robertson Co., H. H.	144
Browne-Langlais Company.....	155	Jarvis, T. P. Mfg. Co.	43	Robertson, John H.	150
Butte Electrical Equipment Co.	154	Johns-Manville Co.	10	Ruegg Bros.	150
Butte Electric & Mfg. Co.	155	Johnson, S. T.	43	Rucker-Fuller Desk Co.	140
Cabot, Samuel (Inc.).....	41	Johnson Service Co.	11	Ryan, M. E.	155
California Artistic Metal and Wire Co.	160	Joost Brothers.....	140	Safety Electric Co.	154
California Bldg. Material Co.	23	Kerner Incinerator Co.	21	Sampson Spot Cord.....	9
California Granite Co.	158	Key-hold Plaster Lath Co.	32	San Francisco Pioneer Varnish Works..... 3d Cover	146
California Hydraulic Engineering and Supply Co.	12	Kissel, I. R.	142	Scott Co.	160
California Paint Co.	14	Knittle-Cashel Co., Inc.	13	Schrader Iron Works.....	159
California Plastic Products Co.	36	Knowles, A.	160	Schwabacher-Frey Co.	24
California Redwood Ass'n.	122	Lange & Bergstrom.....	148	Sierra Electric Co.	4
California Steam and Plumbing Supply Co.	2	Larsen, Sampson & Co.	142	Sloane, W. & J.	12
Carter H. V. Motor Co.	157	Letlich, A.	146	Simmons, O. M. Co.	131
Cement Gun Construction Co.	134	Littlefield, R. W.	144	Simonds Machinery Co.	157
Central Iron Works.....	160	Livermore Fire Brick Works... ..	23	Smith-Booth-Usher Co.	144
Clinton Wire Lath.....	156	Los Angeles Pressed Brick Co.	141	Smith, Jas. F.	11
Clow & Sons.....	4	MacGruer & Simpson.....	151	Sommer, I. M.	31
Coleman, Alex.	146	MacRorie-McLaren Co.	152	Sonnenschein Bros.	24
Collman, A. D.	142	Magner Bros.	140	Spencer Elevator Co.	24
Cook Belting Co.	38	Mangrum & Otter.....	159	Spott Electrical Co.	138
Cowell Lime & Cement Co.	153	Marshall & Stearns Co.	33	Standard Varnish Works.....	22
Crane Co.	32	McCray Refrigerator Co.	140	Standard Fence Co.	145
Davis, R. J.	14	McLeran & Peterson.....	150	Stanley Works, The.....	121
Del Monte Properties Co.	28	McNab, H. N.	145	Stearns Contracting Co.	144
Detroit Steel Products Co.	44	Medusa Cement.....	29	St. Francis Hotel.....	131
Dieckman Hardwood Co.	132	Meese & Gottfried.....	134	Strable Mfg. Co.	39
Direct Line Telephone Co.	159	Meysers Electric Safety Switch Co., Inc.	154	Sunset Lumber Company.....	15
Dolan Wrecking & Construction Co.	158	Moline Heat.....	17	Tay Company, George H.	3
Dow-Herriman Co.	24	Montague Range & Furnace Co.	15	Taylor, F. A. & Co.	31
Drendell Elec. & Mfg. Co.	154	Monson Bros.	158	Tittle, H. S.	155
Dudfield Lumber Co.	21	Mortenson Construction Co.	160	Tormey Co.	140
Duncan, W. C.	144	Mott Co. of Calif.	18	Trost, Robt.	3
Dyer Bros.	22	Mueller Mfg. Co.	18	Truscon Steel Co.	143
Elevator Supplies Co.	150	Mullen Mfg. Co.	142	Tuec Cleaner.....	38
Ellery Arms Co.	156	Mushet Co., W. E.	148	Unit Construction Co.	142
Faber, Eberhard.....	5	Musto Sons Keenan Co.	13	United Electric Co.	143
Fess System Co.	43	Nason, R. N. & Co.	9	United Materials Co.	141
Fidelity & Casualty Co. of N.Y.	150	Nathan, Dohrmann Co.	151	U. S. Metal Products Co.	26
Fidelity & Deposit Co. of Maryland.....	150	National Mill & Lumber Co.	33	U. S. Steel Products Co.	40
Fink & Schindler Co., The.....	158	National Surety Co.	150	Van Fleet-Preear Co.	152
Fire Protection Products Co.	16	Nelson, James A.	148	Vermont Marble Co.	34
Flagg, Edwin H., Scenic Co.	158	Ne Page, McKenny Co.	155	Vukicevich & Bagge.....	144
Freeman Art Shop.....	31	Newbery Electric Co.	155	Vulcan Iron Works.....	32
Frigid Engineering Co.	122	New York Belting and Packing Co.	28	Vulcanite Roofing Co.	26
Fuller, W. P. Co.	19	Norris Co., L. A.	156	Wadsworth, Howland & Co., Inc	136
Garfield Company.....	153	Oak Flooring Mfgs' Ass'n.	130	Walter, D. N. & E. & Co.	145
Garnett, Young & Co.	20	Ocean Shore Iron Works.....	139	Waterhouse, Wilcox Co.	32
General Boilers Co.	18	Old Mission Portland Cement Co.	25	Wayne Oil Tank & Pump Co.	132
Gilley-Schmid Co.	156	Otis Elevator Co. Back Cover	25	Weber, C. F. & Co.	152
Gladding, McBean & Co.	153	Pacific Coast Steel Company.....	151	Wentworth, F. W.	140
Glidden Co.	35	Pacific Materials Co. 29-44	18	Western Blind & Screen Co.	137
Globe Electric Works.....	155	Pacific Fire Extinguisher Co.	18	Western Iron Works.....	6
Globe Indemnity Co.	150	Pacific Mfg. Co.	158	Western Office, Equipment Co.	34
Go-Sign & Letter Co.	145	Pacific Plumbing Fixtures. 2d Cover	158	Western Pipe and Steel Co.	30
		Pacific Porcelain Ware Co., 2d Cover	38	Wetenhall, W. S.	146
		Pacific Pump & Supply Co.	6	Whalen, E. C.	4
		Pacific Rolling Mills.....	38	White Bros.	120
		Palace Hardware Co.	38	Whitney Chemical Co.	149
				Wilson, J. G., Corp.	135
				Wilson, W. F., Co.	146
				Witt, G. E. Co.	44
				Zelinsky, D. & Sons.....	145

NASON'S OPAQUE FLAT FINISH

A FLAT WASH-
 ABLE OIL PAINT, made in soft Kalsomine tints—a practical article for WALLS, CEILINGS, Etc. Economical and Durable. Agency Tamm & Nolan Company's high grade Varnishes and Finishes, made on the Pacific Coast to stand our climatic conditions.

R. N. NASON & CO., Paint Makers

51 Potrero Ave.—SAN FRANCISCO—436 Market St.

PORTLAND
 SEATTLE
 LOS ANGELES

ARCHITECTS' SPECIFICATION INDEX—Continued

- BUILDING MATERIAL, SUPPLIES, ETC.**
 Pacific Materials Co., Underwood Bldg., San Francisco.
 Waterhouse-Wilcox Co., 523 Market St., San Francisco.
- CABINET MAKERS**
 Home Manufacturing Company, 543 Brannan St., San Francisco.
 Fink & Schindler Co., 218 13th St., San Francisco.
 Mullen Manufacturing Company, 64 Rausch St., San Francisco.
- CARPETS**
 W. & J. Sloane, 216-228 Sutter St., San Francisco.
- CASEMENT WINDOW HARDWARE**
 Richards-Wilcox Mfg. Co., Aurora, Ill., and Underwood Bldg., San Francisco.
- CASTINGS**
 Dow-Herriman Co., 140 Howard St., San Francisco.
- CEMENT**
 Atlas Portland Cement Co., New York and Chicago. (See advertisement for Coast Distributors.)
 Mt. Diablo, sold by Henry Cowell Lime & Cement Co., 2 Market St., San Francisco.
 Medusa White Portland Cement, manufactured by Sandusky Cement Co., represented in San Francisco by Pacific Building Materials Co., Underwood Bldg., San Francisco.
 Old Mission Portland Cement Co., Mills Building San Francisco.
- CEMENT EXTERIOR FINISH**
 Concrete, sold by W. P. Fuller & Co., all principal Coast cities.
 The Glidden Stucolor Liquid Cement Coating. The Glidden Company, 123 Hooper St., San Francisco.
 Samuel Cabot Mfg. Co., Boston, Mass., agencies Oakland, Los Angeles, Portland, Tacoma, Spokane; and Pacific Building Materials Co., 525 Market St., San Francisco.
 The Paraffine Companies, Inc., 34 First St., San Francisco.
- CEMENT EXTERIOR WATERPROOF PAINT**
 Armorite, sold by W. P. Fuller & Co., all principal Coast cities.
 Bay State Brick and Cement Coating, manufactured by Wadsworth, Howland Co., Boston, Mass.
 James Hambley & Son, Distributors, San Francisco and Los Angeles.
 Hill, Hubbell & Company, No. 1 Drumm St., San Francisco.
 Imperial Waterproofing, manufactured by Brooks & Doerr, Reed Baxter, agent, Merchants National Bank Bldg., San Francisco.
 Paraffine Paint Co., 34 First St., San Francisco.
 Medusa White Portland Cement, manufactured by Sandusky Cement Co., represented in San Francisco by Pacific Building Materials Co., 525 Market St., San Francisco.
- CEMENT FLOOR COATING**
 Fuller's Concrete Floor Enamel, made by W. P. Fuller & Co., San Francisco.
- Glidden Concrete Floor Dressing. The Glidden Company, 123 Hooper St., San Francisco.
- CEMENT GUN**
 Cement Gun Construction Company of California, 701 Balboa Bldg., San Francisco.
- CEMENT TESTS—CHEMICAL ENGINEERS**
 Robert W. Hunt & Co., 251 Kearny St., San Francisco.
- CHURCH INTERIORS**
 Fink & Schindler, 218 13th St., San Francisco.
 Mullen Manufacturing Company, 64 Rausch St., San Francisco.
 Home Manufacturing Company, 543 Brannan St., San Francisco.
- CHUTES—SPIRAL**
 Haslett Warehouse Co., 310 California St., San Francisco.
- CLAY PRODUCTS**
 Livermore Fire Brick Works, 604 Mission street, San Francisco.
 W. E. Mudgett Co., 502 Mission St., San Francisco.
 Gladding, McBean & Co., Crocker Bldg., San Francisco.
 United Materials Co., Crossley Bldg., San Francisco.
 Los Angeles Pressed Brick Co., Frost Bldg., Los Angeles.
- COLD STORAGE PLANTS**
 H. W. Johns-Manville Co., Second and Howard Sts., San Francisco.
 T. P. Jarvis Crude Oil Burning Co., 275 Connecticut St., San Francisco.
 Vulcan Iron Works, San Francisco.
- COMPRESSED AIR CLEANERS**
 United Electric Co., Canton, O., mfr. of Tuec Cleaner, sold by San Francisco Compressed Air Cleaning Co., Sutter and Stockton Sts., San Francisco.
 George H. Tay Company, Mission and Second Sts., San Francisco; 10th and Harrison Sts., Oakland.
- CONCRETE CONSTRUCTION**
 Barrett & Hilt, Sharon Bldg., San Francisco.
 Clinton Construction Co., 140 Townsend street, San Francisco.
 K. E. Parker Co., Inc., Clunie Bldg., San Francisco.
 Palmer & Petersen, Monadnock Bldg., San Francisco.
 I. M. Sommer, 401 Balboa Bldg., San Francisco.
 Steelform Contracting Company, 681 Market St., San Francisco.
- CONCRETE MIXERS**
 Austin Improved Cube Mixer. Stuart S. Smith, 625 Market Street, San Francisco.
 Foote and Jaeger mixers sold by Edward R. Bacon Co., 51 Minna St., San Francisco, also Los Angeles.
 Ransome mixers sold by the Garfield Co., Hearst Bldg., San Francisco.
- CONCRETE REINFORCEMENT**
 United States Steel Products Co., San Francisco, Los Angeles, Portland and Seattle.

SAMSON SPOT SASH CORD



SPOT IT BY THE SPOTS

Made of extra quality cotton yarn, firmly braided and smoothly finished. Carefully inspected and guaranteed free from all imperfections of braid and finish. → Can be distinguished at a glance by our trade-mark, the Colored Spots. Send for catalogue and samples.

Pacific Coast Agent, JOHN T. ROWNTREE, Inc., San Francisco and Los Angeles, Cal.

We have returned to our policy-holders annually for 33 years never less than 30% of the premium as a dividend. Dividends declared during 1919, \$2,017,893.

AMERICAN MUTUAL LIABILITY INSURANCE CO. OF BOSTON
Assets \$8,654,667 Surplus \$1,417,173

WORKMEN'S COMPENSATION, AUTOMOBILE, TEAMS AND PUBLIC LIABILITY INSURANCE

SAN FRANCISCO BRANCH OFFICE
1816 Balboa Building. Telephone Kearny 3202

N. F. Hesseltine, California Manager.

C. H. Gray, Assistant Manager.

ARCHITECTS' SPECIFICATION INDEX—Continued

- CONCRETE REINFORCEMENT (Continued)**
Twisted Bars. Sold by Gunn, Carle & Co., Inc., 444 Market St., San Francisco.
Clinton Welded Wire Fabric, L. A. Norris Co., 140 Townsend St., San Francisco.
Pacific Coast Steel Company, Rialto Bldg., San Francisco.
Steel bars sold by W. S. Wetenhall Co., 450 Irwin St., San Francisco.
Triangle Mesh Fabric. Sales agents, Pacific Materials Co., 525 Market St., San Francisco.
Truscon Steel Co., 527 Tenth St., San Francisco.
Badt Falk Co., Call-Post Bldg., San Francisco.
- CONDUITS**
Garnett, Young & Co., 612 Howard St., San Francisco.
- CONTRACTORS, GENERAL**
Barrett & Hulp, Sharon Bldg., San Francisco.
K. E. Parker Co., Inc., Clunie Bldg., San Francisco.
R. W. Littlefield, 357 12th St., Oakland.
Unit Construction Co., Phelan Bldg., San Francisco.
Larsen, Sampson & Co., Crocker Bldg., San Francisco.
J. D. Hannah, 142 Sansome St., San Francisco.
Chas. Stockholm & Son, Monadnock Bldg., San Francisco.
Herbert Beckwith, 323 Newton Ave., Oakland.
A. D. Collman, 110 Jessie St., San Francisco.
Clinton Construction Company, 140 Townsend St., San Francisco.
Monson Bros., 1907 Bryant St., San Francisco.
W. C. Duncan & Co., 526 Sharon Bldg., San Francisco.
A. Knowles, Call-Post Bldg., San Francisco.
T. B. Goodwin, 110 Jessie St., San Francisco.
Lange & Bergstrom, Sharon Bldg., San Francisco.
McLeran & Peterson, Hearst Bldg., San Francisco.
Robert Trost, 26th and Howard Sts., San Francisco.
I. M. Sommer, 401 Balboa Bldg., San Francisco.
- CONTRACTORS' EQUIPMENT**
Edward R. Bacon Co., 51 Minna St., San Francisco, and Los Angeles.
Garfield & Co., Hearst Bldg., San Francisco.
Smith, Booth-Usher Co., 60 Fremont St., San Francisco; 228 Central Ave., Los Angeles.
- CONTRACTORS' INSURANCE**
Bankers & Shippers Insurance Co. of New York, Insurance Exchange Bldg., San Francisco.
- CONVEYING MACHINERY**
Meese & Gottfried, San Francisco, Los Angeles, Portland and Seattle.
- CORK TILE, INSULATION, ETC.**
Van Fleet-Freear Co., Sharon Bldg., San Francisco.
- CRUSHED ROCK**
Coast Rock & Gravel Co., Call-Post Bldg., San Francisco.
- DAMP-PROOFING COMPOUND**
Armorite Damp Resisting Paint, made by W. P. Fuller & Co., San Francisco.
Glidden's Liquid Rubber. The Glidden Company, 123 Hooper St., San Francisco.
Hill, Hubble & Company, No. 1 Drumm St., San Francisco.
Imperial Waterproofing, mfrd. by Brooks & Doerr, Reed Baxter, agent, Merchants Na-
- tional Bank Bldg., San Francisco.
"Pabco" Damp-Proofing Compound, sold by Paraffine Co., 34 First St., San Francisco.
- DOOR HANGERS**
Pitcher Hanger, sold by National Lumber Co., 326 Market St., San Francisco.
Reliance Hanger, sold by Waterhouse-Wilcox Co., San Francisco; D. F. Fryer & Co., B. V. Collins, Los Angeles, and Columbia Wire & Iron Works, Portland, Oregon.
Stanley Works, New Britain, Conn. John Rountree, agent, Monadnock Bldg., San Francisco.
Richards-Wilcox Mfg. Co., Underwood Bldg., San Francisco.
- DRINKING FOUNTAINS**
Haws Sanitary Drinking Faucet Co., 1808 Harmon St. Berkeley, and C. F. Weber & Co., San Francisco and Los Angeles.
Crane Company, San Francisco, Oakland, and Los Angeles.
Pacific Porcelain Ware Co., 67 New Montgomery St., San Francisco.
George H. Tay Company, Mission and Second Sts., San Francisco; 10th and Harrison Sts., Oakland.
Haines, Jones & Cadbury Co., 857 Folsom St., San Francisco.
- DUMB WAITERS**
Spencer Elevator Company, 166 7th St., San Francisco.
M. E. Hammond, Humboldt Bank Bldg., San Francisco.
- ELECTRICAL CONTRACTORS**
Butte Electrical Equipment Company, 530 Folsom St., San Francisco.
Butte Electric & Manufacturing Co., 534 Folsom St., San Francisco.
Brown-Langlais Electrical Construction Co., 213 Minna St., San Francisco.
NePage, McKenny Co., 589 Howard St., San Francisco.
Newbery Electrical Co., 413 Lick Bldg., San Francisco.
Pacific Fire Extinguisher Co., 424 Howard St., San Francisco.
Globe Electric Works, 1959 Mission St., San Francisco.
M. E. Ryan, Redwood City, Calif.
Rex Electric & Engineering Co., 253 Minna St., San Francisco.
H. S. Tittle, 766 Folsom St., San Francisco.
Severin Electrical Company, 185 Stevenson St., San Francisco.
Spott Electrical Co., Sixteenth and Clay Sts., Oakland.
- ELECTRIC PLATE WARMER**
The Prometheus Electric Plate Warmer for residences, clubs, hotels, etc. Sold by M. E. Hammond, Humboldt Bank Bldg., San Francisco.
- ELECTRICAL SUPPLIES AND EQUIPMENT**
Sierra Electric Company, 515 Market St., San Francisco.
Garnett, Young & Co., 612 Howard St., San Francisco.
Butte Electrical Equipment Co., 530 Folsom St., San Francisco.
Safety Electric Company, 56-65 Columbia Square, San Francisco.

JOHNS-MANVILLE
SERVES IN CONSERVATION

Through

ASBESTOS and its ALLIED PRODUCTS



TEMPERATURE REGULATION

JOHNSON SERVICE COMPANY

(OF MILWAUKEE — ESTABLISHED 1885)

Manufacturers and Installers of **JOHNSON Heat CONTROL**

For schools, residences, hospitals, banks, public buildings, also canneries and all kinds of industrial plants—Hot water tank regulators, air and water reducing valves.

Rialto Bldg, SAN FRANCISCO Trust and Savings Bldg., LOS ANGELES

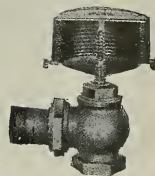

ARCHITECTS' SPECIFICATION INDEX—Continued

- ELECTRIC SUPPLIES & EQUIPMENT**—Cont.
Drendell Electrical & Mfg. Co., 1345 Howard St., San Francisco.
R. J. Davis, District Sales Agent, Century A. C. Motors and Fans, 171 Second St., San Francisco.
- ELEVATORS**
Otis Elevator Company, Stockton and North Point, San Francisco.
Spencer Elevator Company, 166 7th St., San Francisco.
- ELEVATOR EQUIPMENT**
Elevator Supplies Company, Inc., 186 Fifth St., San Francisco.
- ENGINEERS—CONSULTING, ELECTRICAL, MECHANICAL**
Chas. T. Phillips, Pacific Bldg., San Francisco.
Hunter & Hudson, Rialto Bldg., San Francisco.
- ELEVATOR DOOR HARDWARE**
Richards-Wilcox Mfg. Co., Underwood Bldg., San Francisco.
- FANS AND BLOWERS**
John Ringius, 252 Townsend St., San Francisco.
Ideal Heating & Engineering Co., 192 Erie St., San Francisco.
- FENCES—WIRE**
Standard Fence Construction Co., 77 O'Farrell St., San Francisco, and 310 12th St., Oakland.
- FILLING STATION EQUIPMENT**
S. F. Bowser & Co., Inc., 612 Howard St., San Francisco.
Wayne Oil Tank & Pump Co., 631 Howard St., San Francisco, 830 S. Los Angeles St., Los Angeles.
- FIRE ESCAPES**
Palm Iron & Bridge Works, Sacramento.
Western Iron Works, 141 Beale St., San Francisco.
Golden Gate Iron Works, 1541 Howard St., San Francisco.
- FIRE INSURANCE**
Bankers & Shippers Insurance Co., Insurance Exchange Bldg., San Francisco.
- FIRE SPRINKLERS—AUTOMATIC**
Grinnell Company, 453 Mission St., San Francisco.
Scott Company, 243 Minna St., San Francisco.
Pacific Fire Extinguisher Co., 424 Howard St., San Francisco.
- FIREPROOFING AND PARTITIONS**
Gladding, McBean & Co., Crocker Bldg., San Francisco.
Los Angeles Pressed Brick Co., Frost Bldg., Los Angeles.
Richards-Wilcox Mfg. Co., Aurora, Ill., and Underwood Bldg., San Francisco.
- FIRE RETARDING PAINT**
The Paraffine Companies, Inc., 34 First St., San Francisco.
Asbestos Paints, The Glidden Company, 123 Hooper St., San Francisco.
- FIXTURES—BANK, OFFICE, STORE, ETC.**
Home Manufacturing Company, 543 Brannan St., San Francisco.
The Fink & Schindler Co., 218 13th St., San Francisco.
Mullen Manufacturing Co., 64 Rausch St., San Francisco.
- C. F. Weber & Co., 985 Market St., San Francisco, and 210 N. Main St., Los Angeles, Cal.
- FLOOR TILE**
Mangrum & Otter, 827 Mission St., San Francisco.
- FLOOR VARNISH**
Bass-Hueter and San Francisco Pioneer Varnish Works, 816 Mission St., San Francisco.
Fifteen for Floors, made by W. P. Fuller & Co., San Francisco.
Standard Varnish Works, Chicago, New York and San Francisco.
R. N. Nason & Co., San Francisco and Los Angeles.
The Glidden Company, 123 Hooper St., San Francisco.
- FLOORS—HARDWOOD**
Inlaid Floor Company, 600 Alabama St., San Francisco.
Parrott & Co., 320 California St., San Francisco.
White Bros., Fifth and Brannan Sts., San Francisco.
Strable Manufacturing Company, 511 First St., Oakland.
- FLOORS—MASTIC**
Hill, Hubbell & Company, No. 1 Drumm St., San Francisco.
- FLUMES**
California Corrugated Culvert Co., West Berkeley, Cal.
- FRUIT DRYING MACHINERY**
Ideal Heating & Engineering Co., 192 Erie St., San Francisco.
Jas. A. Nelson, 517 Sixth St., San Francisco.
- FUEL OIL SYSTEMS**
S. F. Bowser & Co., Inc., 612 Howard St., San Francisco.
Wayne Oil Tank & Pump Co., 631 Howard St., San Francisco.
- FURNACES—WARM AIR**
Mangrum & Otter, 827 Mission St., San Francisco.
Montague Range and Furnace Co., 826 Mission St., San Francisco.
- FURNITURE—BUILT-IN**
Hoosier Kitchen Cabinet Store, Pacific Bldg., San Francisco.
- FURNITURE—SCHOOL, CHURCH, OFFICE, HOUSE, ETC.**
Home Manufacturing Company, 543 Brannan St., San Francisco.
C. F. Weber & Co., 985 Market St., San Francisco.
Rucker-Fuller Desk Co., 677 Mission St., San Francisco.
F. W. Wentworth & Co., 539 Market St., San Francisco.
Western Office Equipment Co., 467 Market St., San Francisco.
W. & J. Sloane, 216-228 Sutter St., San Francisco.
- GALVANIZED IRON WORK**
Power & Pike Co., 128 Beale St., San Francisco.
James A. Nelson, 517 Sixth St., San Francisco.
- GARAGE HARDWARE**
The Stanley Works, New Britain, Conn., represented in San Francisco, Los Angeles, Seattle by John T. Rowntree, Inc.

I. M. SOMMER

CONTRACTORS & ENGINEERS

Phone Kearny 4582

401 BALBOA BLDG., SAN FRANCISCO

KEWANEE GARBAGE BURNERS AND BOILERS	YEOMANS BILGE PUMPS EJECTORS HOUSE PUMPS	OVERHEAD CARRYING SYSTEMS
CALIFORNIA HYDRAULIC ENGINEERING & SUPPLY CO., 80 Fremont St., S. F.		

ARCHITECTS' SPECIFICATION INDEX—Continued

- GARAGE HARDWARE**—Continued.
Richards-Wilcox Mfg. Co., Aurora, Ill., and Underwood Bldg., San Francisco.
- GARBAGE CHUTES AND INCINERATORS**
Bradshaw Sanitary Garbage Chute, Bittmann & Battee, 745 Folsom St., San Francisco, sole agents for California.
Kerner Incinerator Co., 77 O'Farrell St., San Francisco.
California Hydraulic Engineering & Supply Co., 70-72 Fremont St., San Francisco.
- GAS STEAM RADIATORS—FUMELESS, ETC.**
Clow Gas Steam Radiators, F. A. Hamilton, Agent, 101 Rialto Bldg., San Francisco.
Ra-Do Fumeless Gas Radiators, manufactured and sold by Baird-Bailhache Co., 478 Sutter St., San Francisco.
- GLASS**
American Window Glass Co., represented by L. H. Butcher Co., 341 Montgomery St., San Francisco.
W. J. Fuller & Company, all principal Coast cities.
- GRADING, WRECKING, ETC.**
Dolan Wrecking & Construction Co., 1607 Market St., San Francisco.
- GRANITE**
California Granite Co., Gen. Contractors' Ass'n, San Francisco.
Raymond Granite Co., Potrero Ave. and Division St., San Francisco.
- GRAVEL AND SAND**
Coast Rock & Gravel Co., Call-Post Bldg., San Francisco.
Del Monte White Sand, sold by Del Monte Properties Co., Crocker Bldg., San Francisco.
- HARDWALL PLASTER**
Henry Cowell Lime & Cement Co., San Francisco.
- HARDWARE**
Joost Bros., agents for Russell & Erwin hardware, 1053 Market St., San Francisco.
The Stanley Works, New Britain, Conn.
Corbin hardware, sold by Palace Hardware Co., 581 Market St., San Francisco.
Richards-Wilcox Mfg. Co., Aurora, Ill., Ewing-Lewis Co., 626 Underwood Bldg., San Francisco.
- HARDWOOD LUMBER—FLOORING, ETC.**
Inlaid Floor Co., 600 Alabama St., San Francisco.
H. N. McNab, 2307 17th Ave., Oakland.
Parrott & Co., 320 California St., San Francisco.
White Bros., cor. Fifth and Brannan Sts., San Francisco.
Strable Manufacturing Company, First St., near Broadway, Oakland.
- HEATERS—AUTOMATIC—GAS**
Pittsburg Water Heater Co., 478 Sutter St., San Francisco.
George H. Tay Company, Mission and Second Sts., San Francisco; 10th and Harrison Sts., Oakland.
Ra-Do Fumeless Gas Heater, sold by Baird-Bailhache Company, 478 Sutter St., San Francisco.
- HEATING AND VENTILATING MATERIAL, ETC.**
Alex Coleman, 706 Ellis St., San Francisco.
Gilley-Schmid Company, 198 Otis St., San Francisco.
- Hateley & Hateley, Mitau Bldg., Sacramento.
Knittle-Cashel Co., Inc., 1820 Ellis St., San Francisco.
General Boilers Co., 332 Monadnock Bldg., San Francisco.
A. Lettich, 365 Fell St., San Francisco.
Mangrum & Otter, 827-831 Mission St., San Francisco.
Moline Heat, Hobart Bldg., San Francisco.
James & Drucker, 450 Hayes St., San Francisco.
James A. Nelson, 517 Sixth St., San Francisco.
Ideal Heating & Engineering Co., 192 Erie St., San Francisco.
Illinois Engineering Co., 563 Pacific Bldg., San Francisco.
William F. Wilson Co., 328 Mason St., San Francisco.
Pacific Fire Extinguisher Co., 424 Howard St., San Francisco.
Scott Company, 243 Minna St., San Francisco.
Mechanical Engineering & Supply Co., 908 7th St., Sacramento.
John Ringius, 252 Townsend St. (bet. Third and Fourth), San Francisco.
George H. Tay Company, Mission and Second Sts., San Francisco; 10th and Harrison Sts., Oakland.
O. M. Simmons Co., 115 Mission St., San Francisco.
- HOLLOW TILE BLOCKS**
Gladding, McBean & Co., San Francisco, Los Angeles, Oakland and Sacramento.
Los Angeles Pressed Brick Co., Frost Bldg., Los Angeles.
- HOSE—GARDEN, FIRE, ETC.**
Ralphs-Pugh Company, 530 Howard St., San Francisco.
- HOSPITAL FIXTURES**
Mott Company of California, 553 Mission St., San Francisco.
George H. Tay Company, Mission and Second Sts., San Francisco; 10th and Harrison Sts., Oakland.
- HOSPITAL SIGNAL SYSTEM**
Holtzer-Cabot system, represented by Bittmann & Battee, 745 Folsom St., San Francisco.
Chicago Signal Co., represented by Garnett, Young & Co., 612 Howard St., San Francisco.
- HOTELS**
St. Francis Hotel, Powell, Geary and Post Sts., San Francisco.
- ICE MAKING MACHINES**
Vulcan Iron Works, San Francisco.
- INGOT IRON**
"Armco" brand, manufactured by American Rolling Mill Company, Middletown, Ohio, and Monadnock Bldg., San Francisco.
- INSPECTIONS AND TESTS**
Robert W. Hunt & Co., 251 Kearny St., San Francisco.
- INSULATION**
Ebonite Boiler Kote, sold by California Plastic Products Co., 521 Sheldon Bldg., San Francisco.
- INCINERATORS**
Kerner Incinerator Co., 77 O'Farrell St., San Francisco.
- INTERIOR DECORATORS**
Beach-Robinson Co., 239 Geary St., San Francisco.

"The
Perfect
Automatic
Valve"

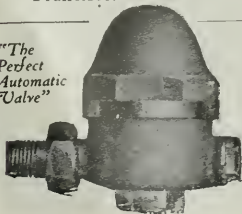

WILLIAM S. HAINES & CO.

Automatic Vacuum and Vapor Heating Systems

VENTO AUTOMATIC VALVES

"Everything for the Heating Engineer"

O. M. SIMMONS CO. 115 MISSION STREET
PACIFIC COAST REPRESENTATIVE SAN FRANCISCO
Phone: Douglas 5497

CLARENCE E. MUSTO, Pres.

JOSEPH B. KEENAN, Vice-Pres.

GUIDO J. MUSTO, Sec'y & Treas.

JOSEPH MUSTO SONS=KEENAN CO.Phone Franklin
—6365—**MARBLE**OFFICE AND MILLS:
535-565 North Point St.,
SAN FRANCISCO, CAL.**ARCHITECTS' SPECIFICATION INDEX—Continued**

- Sonnenschein Bros., 470 Sutter St., San Francisco.
- F. A. Taylor & Co., 251 Post St., San Francisco.
- The Torney Co., 1042 Larkin St., San Francisco.
- Freeman Art Shop, 386 Sutter St., San Francisco.
- W. & J. Sloane, 216 Sutter St., San Francisco.
- KITCHEN CABINETS**
Hoosier Kitchen Cabinet Store (O. K. Brown, Mgr.), Pacific Bldg., San Francisco.
- KITCHEN EQUIPMENT**
James A. Nelson, 517-19 Sixth street, San Francisco.
- LAMP POSTS, ELECTROLIERS, ETC.**
J. L. Mott Iron Works, 553 Mission St., San Francisco.
- LANDSCAPE GARDENERS**
MacRorie-McLaren Co., 141 Powell St., San Francisco.
- LATHING AND PLASTERING**
MacGruer & Simpson, Call-Post Bldg., San Francisco.
- A. Knowles, Call-Post Bldg., San Francisco.
- Jas. F. Smith, 273 Minna St., San Francisco.
- LATHING MATERIAL**
Pacific Materials Co., 525 Market St., San Francisco.
- Key-Hold Plaster Lath Co., Monadnock Bldg., San Francisco.
- Truscon Steel Co., Tenth St., near Bryant, San Francisco.
- LIGHT, HEAT AND POWER**
Great Western Power Company, Stockton St., near Sutter, San Francisco.
- LIGHTING FIXTURES**
Roberts Mfg Co., 663 Mission St., San Francisco.
- LIME**
Henry Cowell Lime & Cement Co., 2 Market St., San Francisco.
- LINOLEUM**
D. N. & E. Walter & Co., 562 Mission St., San Francisco.
- The Paraffine Companies, factory in Oakland; office, 34 First St., near Market, San Francisco.
- W. & J. Sloane, 216-228 Sutter St., San Francisco.
- LOCKERS—STEEL**
George H. Trask, Sacramento St., San Francisco, representing Durand Steel Lockers.
- LUBRICATING OIL STORAGE TANKS AND PUMPS**
S. F. Bowser & Co., Inc., 612 Howard St., San Francisco.
- LUMBER**
California Redwood Association, 216 Pine St., San Francisco.
- Dudfield Lumber Co., Palo Alto, Cal.
- Hart-Wood Lumber Co., Fifth and Berry Sts., San Francisco.
- Pacific Manufacturing Company, San Francisco, Oakland and Santa Clara.
- Pope & Talbot, foot of Third St., San Francisco.
- Portland Lumber Co., 16 California St., San Francisco.
- Sunset Lumber Company, First and Oak Sts., Oakland.
- MAIL CHUTES**
American Mailing Device Corp., represented on Pacific Coast by Waterhouse-Wilcox Co., 523 Market St., San Francisco.
- MANTELS**
Mangrum & Otter, 827-831 Mission St., San Francisco.
- MANUAL TRAINING EQUIPMENT**
Richards-Wilcox Mfg. Co., Ewing-Lewis Co., 626 Underwood Bldg., San Francisco.
- MARBLE**
American Marble and Mosaic Co., 25 Columbus Square, San Francisco.
- Joseph Musto Sons, Keenan Co., 535 N. Point St., San Francisco.
- Vermont Marble Co., Coast branches, San Francisco, Portland and Tacoma.
- METAL DOORS AND WINDOWS**
Fire Protection Products Co., 3117 20th St., San Francisco.
- Waterhouse-Wilcox Co., Inc., 523 Market St., San Francisco.
- U. S. Metal Products Co., 330 Tenth St., San Francisco.
- MILL WORK**
Dudfield Lumber Co., Palo Alto, Cal.
- Pacific Manufacturing Company, San Francisco, Oakland and Santa Clara.
- National Mill and Lumber Co., San Francisco and Oakland.
- The Fink & Schindler Co., 218 13th St., San Francisco.
- MOTORS AND FANS**
R. J. Davis, Dist. Sales Agent Century Motors and Fans, 171 Second St., San Francisco.
- OIL BURNERS**
American Standard Oil Burner Company, Berkeley.
- Fess System Co., 220 Natoma St., San Francisco.
- S. T. Johnson Co., 1337 Mission St., San Francisco.
- T. P. Jarvis Manufacturing Co., 275 Connecticut St., San Francisco.
- W. S. Ray Mfg. Co., 29 Spear St., San Francisco.
- G. E. Witt Co., 862 Howard St., San Francisco.
- OIL STORAGE AND DISTRIBUTING STATIONS**
S. F. Bowser & Co., Inc., 612 Howard St., San Francisco.
- Wayne Oil Tank & Pump Co., 631 Howard St., San Francisco; 830 S. Los Angeles St., Los Angeles.
- OFFICE EQUIPMENT**
Western Office Equipment Co., 467 Market St., San Francisco.
- F. W. Wentworth & Co., 539 Market St., San Francisco.
- ORNAMENTAL IRON AND BRONZE**
California Artistic Metal and Wire Co., 349 Seventh St., San Francisco.
- Palm Iron & Bridge Works, Sacramento.
- C. J. Hillard Company, Inc., 19th and Minnesota Sts., San Francisco.
- Schrader Iron Works, Inc., 1247 Harrison St., San Francisco.

KNITTLE-CASHEL CO., Inc.

HEATING CONTRACTORS

STEAM HEATING
HOT WATER HEATINGVENTILATING
POWER PLANTSGENERAL PIPE WORK
REPAIRING

1820-22 Ellis Street, San Francisco

Phone West 964



CAL-PA-CO

On Your Best Work Specify

CAL-PA-CO

DAMPSTOP (Outside)

WASHABLE WALL (Inside)

FOR CONCRETE BUILDINGS.

Everything Reliable in PAINT and VARNISH

CALIFORNIA PAINT COMPANY, OAKLAND, CALIF., U. S. A.

MANUFACTURERS SINCE 1865

SAN FRANCISCO OFFICE, MONADNOCK BUILDING

ARCHITECTS' SPECIFICATION INDEX—Continued**OVERHEAD CARRYING SYSTEMS**

California Hydraulic Engineering & Supply Co.,
70-72 Fremont St., San Francisco.
Richards-Wilcox Mfg. Co., Aurora, Ill., and
Underwood Bldg., San Francisco.

PAINT FOR STEEL STRUCTURES, BRIDGES, ETC.

The Paraffine Companies, Inc., 34 First St., San
cisco.
Anti-Rust Coatings. The Glidden Co., 123
Hooper St., San Francisco.
Premier Graphite Paint and Pioneer Brand Red
Lead, made by W. P. Fuller & Co., San Fran-
cisco.

Hill, Hubbell & Company, No. 1 Drumm St.,
San Francisco.

Wadsworth, Howland Co., makers of Bay State
Brick and Cement Coating, Boston, Mass.
Hambley & Son, Distributors in San Francisco
and Los Angeles.

PAINTING, TINTING, ETC.

I. R. Kissel, 1747 Sacramento St., San Fran-
cisco.

D. Zelinsky & Sons, San Francisco and Los
Angeles.

The Torrey Co., 681 Geary St., San Francisco.
Fick Bros., 475 Haight St., San Francisco.

PAINTS, OILS, ETC.

California Paint Company (see advertisement
above).

Magner Bros., 414-424 Ninth St., San Francisco.
Bass-Hueter Paint Co., Mission, near Fourth
St., San Francisco.

The Brininstool Co., Los Angeles, the Haslett
Warehouse, 310 California St., San Francisco.

The Glidden Company of California, 123 Hooper
St., San Francisco.

R. N. Nason & Company, San Francisco, Los
Angeles, Portland and Seattle.

W. P. Fuller & Co., all principal Coast cities.
"Satinette," Standard Varnish Works, 55 Stev-
enson St., San Francisco.

Palace Hardware Co., 581 Market St., San
Francisco.

PANELS AND VENEER

White Bros., Fifth and Brannan Sts., San Fran-
cisco.

PARTITIONS—FOLDING AND ROLLING

J. G. Wilson Corporation, 600 Metropolitan
Bldg., Los Angeles; Waterhouse-Wilcox Co.,
Underwood Bldg., San Francisco.

PENCILS

Eberhard Faber, Monadnock Bldg., San Fran-
cisco.

PIPE—STEEL AND WROUGHT IRON

Western Pipe & Steel Co., 444 Market St.,
San Francisco; 1758 N. Broadway, Los An-
geles.

George H. Tay Company, Mission and Second
Sts., San Francisco; 10th and Harrison Sts.,
Oakland.

PLASTER CONTRACTORS

A. Knowles, Call-Post Bldg., San Francisco.
MacGruer & Simpson, 540 Call-Post Bldg., San
Francisco.

James F. Smith, 273 Minna St., San Francisco.

PLUMBING CONTRACTORS

Alex Coleman, 706 Ellis St., San Francisco.

Gilley-Schmid Company, 198 Otis St., San
Francisco.

Hateley & Hateley, Mitau Bldg., Sacramento.

A. Lettich, 365 Fell St., San Francisco.

Scott Co., Inc., 243 Minna St., San Francisco.

Wm. F. Wilson Co., 328 Mason St., San Fran-
cisco.

PLUMBING FIXTURES, MATERIALS, ETC.

California Steam & Plumbing Supply Co., 671
Fifth St., San Francisco.

Jas. B. Clow, plumbing, Rialto Bldg., San Fran-
cisco.

Crane Co., San Francisco, Oakland, Los An-
geles.

Gilley-Schmid Company, 198 Otis St., San
Francisco.

Haines, Jones & Cadbury Co., 857 Folsom St.,
San Francisco.

H. Mueller Manufacturing Company, 635 Mis-
sion St., San Francisco.

Holbrook, Merrill & Stetson, 64 Sutter St., San
Francisco.

J. L. Mott Iron Works, D. H. Gulick, selling
agent, 553 Mission St., San Francisco.

Pacific Sanitary Manufacturing Co., 67 New
Montgomery St., San Francisco.

George H. Tay Company, Mission and Second
Sts., San Francisco; 10th and Harrison Sts.,
Oakland.

Wm. F. Wilson Co., 328 Mason St., San Fran-
cisco.

Whale-bone-ite Fixtures, sold by E. C. Whalen,
325 Monadnock Bldg., San Francisco.

POWER LAWN MOWERS

H. U. Carter Motor Co., 52 Beale St., San
Francisco.

POWER PLANTS

Knittle-Cashel Co., Inc., 1820 Ellis St., San Fran-
cisco.

POWER TRANSMITTING MACHINERY

Meese & Gottfried, San Francisco, Los Angeles,
Portland, Ore., and Seattle, Wash.

PUMPS

Chicago Pump Co., represented by Garnett,
Young & Co., 612 Howard St., San Francisco.

Dow-Herriman Company, 140 Howard St., San
Francisco; factory, Petaluma.

Simonds Machinery Co., 117 New Montgomery
St., San Francisco.

Ocean Shore Iron Works, 558 Eighth St., San
Francisco.

Pacific Pump & Supply Company, 851-853 Fol-
som St., San Francisco.

George H. Tay Company, Mission and Second
Sts., San Francisco; 10th and Harrison Sts.,
Oakland.

California Hydraulic Engineering & Supply Co.,
70 Fremont St., San Francisco.

PUMPS—HAND OR POWER, FOR OIL AND GASOLINE

S. F. Bowser & Co., Inc., 612 Howard St.,
San Francisco.

Dow-Herriman Co., 140 Howard St., San Fran-
cisco.

Wayne Oil Tank & Pump Co., 631 Howard St.,
San Francisco; 830 S. Los Angeles St., Los
Angeles.

R. J. Davis

District Sales
Agent*Century*A. C. Motors
and Fans

Complete stocks carried at: 171-173 Second St., San Francisco; 906 So. Hope St., Los Angeles



Yards { TRACY, CAL.
BRENTWOOD, CAL.

Phone KEARNY 2074

PORTLAND LUMBER COMPANY

A. J. RUSSELL, Agent

LUMBER

SIMPLEX SILOS
SAGINAW SPECIAL SHINGLES
*Ship Timbers, Oil Rigs and
Special Bills Cut to Order.*

16 California Street

San Francisco, Cal.

from tree to Consumer

Pine and Redwood Lumber

SASH DOORS AND MILL WORK

SUNSET LUMBER COMPANY

MANUFACTURERS — WHOLESALE AND RETAIL

Main Office and Yards:

FIRST AND OAK STREETS, OAKLAND

Phone Oakland 1820

POPE & TALBOT

Manufacturers, Exporters and Dealers in

Lumber, Timber, Piles, Spars, etc.

Office, Yards and Planing Mills

859-869 THIRD ST., SAN FRANCISCO, CAL.

Mills, Port Gamble, Port Ludlow and Utsalady, Washington

STORM KING and AMERICAN WARM AIR FURNACES

FURNACE FITTINGS AND REPAIRS

Montague Range & Furnace Company

327-329 JESSIE STREET

Phone Garfield 1422

826-830 MISSION STREET

SAN FRANCISCO, CALIF.

ARCHITECTS' SPECIFICATION INDEX—Continued

- PUMPS (Continued)**
George H. Tay Company, Mission and Second Sts., San Francisco; 10th and Harrison Sts., Oakland.
- REFRIGERATORS**
McCray Refrigerator Company, San Francisco office, Monadnock Bldg.
- REVERSIBLE WINDOWS**
Hauser Window Company, 157 Minna St., San Francisco.
- ROOFING CONTRACTORS**
Western Roofing Co., Inc., 420 15th St., San Francisco.
- ROOFING AND ROOFING MATERIALS**
Bender Roofing Company, Monadnock Bldg., San Francisco.
"Malthoid" and "Ruberoid," manufactured by Paraffine Companies, Inc., San Francisco.
United Materials Co., Crossley Bldg., San Francisco.
The Vulcanite Roofing Co., Texas and 16th Sts., San Francisco.
H. H. Robertson Co., Hobart Bldg., San Francisco.
- RUBBER TILING**
New York Belting and Packing Company, 518 Mission St., San Francisco.
- SAFETY TREADS**
Pacific Materials Co., 525 Market St., San Francisco.
- SAND**
Del Monte White Sand, Del Monte Properties Co., 401 Crocker Bldg., San Francisco.
- SCENIC PAINTING—DROP CURTAINS, ETC.**
The Edwin H. Flagg Scenic Co., 1638 Long Beach Ave., Los Angeles.
- SCHOOL FURNITURE AND SUPPLIES**
C. F. Weber & Co., 985 Market St., San Francisco; 512 S. Broadway, Los Angeles.
Rucker-Fuller Desk Company, 677 Mission St., San Francisco.
- SHEATHING AND SOUND DEADENING**
Samuel Cabot Mfg. Co., Boston, Mass., agencies in San Francisco, Oakland, Los Angeles, Portland, Tacoma and Spokane.
The Paraffine Companies, Inc., 34 First St., San Francisco.
- SHEET METAL WORK**
Jas. A. Nelson, 517 Sixth St., San Francisco.
Power & Pike Co., 128 Beale St., San Francisco.
- SHINGLE STAINS**
Bass-Huetter Paint Company, all principal Coast cities.
Cabot's Creosote Stains, sold by Pacific Building Materials Co., 525 Market St., San Francisco.
Fuller's Pioneer Shingle Stains, made by W. P. Fuller & Co., San Francisco.
Argonaut Shingle Stains. The Glidden Co., 123 Hooper St., San Francisco.
- SINKS—COMPOSITION**
Petrium Sanitary Sink Co., Fifth and Page Sts., Berkeley.
- SKYLIGHTS**
H. H. Robertson Co., Hobart Bldg., San Francisco.
Jas. A. Nelson, 517 Sixth St., San Francisco.
- STATIONERY AND SUPPLIES**
Schwabacher-Frey Stationery Co., 609 Market St., San Francisco.
- STEEL HEATING BOILERS**
California Hydraulic Engineering & Supply Co., 70-72 Fremont St., San Francisco.
General Boilers Co., 332 Monadnock Bldg., San Francisco.
- STEEL TANKS, PIPE, ETC.**
Ocean Shore Iron Works, 558 Eighth St., San Francisco.
Western Pipe & Steel Co., 444 Market St., San Francisco.
- STEEL AND IRON—STRUCTURAL**
Central Iron Works, 621 Florida St., San Francisco.
Dyer Bros., 17th and Kansas Sts., San Francisco.
Golden Gate Iron Works, 1541 Howard St., San Francisco.
Mortenson Construction Co., 19th and Indiana Sts., San Francisco.
Pacific Rolling Mills, 17th and Mississippi Sts., San Francisco.
Palm Iron & Bridge Works, Sacramento.
U. S. Steel Products Co., Rialto Bldg., San Francisco.
Schrader Iron Works, Inc., 1247 Harrison St., San Francisco.
Vulcan Iron Works, San Francisco.
Western Iron Works, 141 Beale St., San Francisco.
- STEEL PRESERVATIVES**
Hill, Hubbell & Company, No. 1 Drumm St., San Francisco.
- STEEL REINFORCING**
Badt-Falk & Co., Call-Post Bldg., San Francisco.
Pacific Coast Steel Company, Rialto Bldg., San Francisco.
Gunn, Carle & Co., Inc., 444 Market St., San Francisco.
Truscon Steel Co., 527 Tenth St., San Francisco.
W. S. Wetenhall Co., 725 Second St., San Francisco.
- STEEL ROLLING DOORS**
Kinnear Steel Rolling Door Co., Pacific Building Materials Co., agents, Underwood Bldg., San Francisco.
J. G. Wilson Corporation, 600 Metropolitan Bldg., Los Angeles.
- STEEL SASH**
Bayley-Springfield solid steel sash, sold by Pacific Materials Co., 525 Market St., San Francisco.
"Fenestra," solid steel sash, manufactured by Detroit Steel Products Company, Detroit, Mich. Direct factory sales office, Foxcroft Bldg., San Francisco.
U. S. Metal Products Company, 330 Tenth St., San Francisco.
- STEEL WHEELBARROWS**
Champion and California steel brands, made by Western Iron Works, 141 Beale St., San Francisco.
- SUMP AND BILGE PUMPS**
California Hydraulic Engineering & Supply Co., 70-72 Fremont St., San Francisco.
- SWITCHES**
Wemco Safety Switch, manufactured and sold by W. E. Musher Co., 502 Mission St., San Francisco.
- TANKS FOR OIL, GASOLINE, KEROSENE, ETC.**
S. F. Bowser & Co., Inc., 612 Howard St., San Francisco.
Wayne Oil Tank & Pump Co., 631 Howard St., San Francisco; 830 S. Los Angeles St., Los Angeles.
- TANKS—REDWOOD**
Redwood Manufacturers Co., Hobart Bldg., San Francisco.
- TELEPHONE AND ELECTRIC EQUIPMENT**
Bittmann & Battee, 745 Folsom St., San Francisco.
Direct Line Telephone Co., 320 Market St., San Francisco.

STEEL SASH — FIRE DOORS — SHEET METAL

Kalamein, Copper and Bronze Doors and Trim Sheet Metal Work of Every Description

FIRE PROTECTION PRODUCTS CO.

3117-3119 TWENTIETH STREET, Near Harrison, SAN FRANCISCO. Phone Mission 2607

ARCHITECTS' SPECIFICATION INDEX—Continued

- THEATER AND OPERA CHAIRS**
C. F. Weber & Co., 365 Market St., San Francisco.
Rucker-Fuller Desk Co., 677 Mission St., San Francisco.
- THERMOSTATS FOR HEAT REGULATION**
Johnson Service, Rialto Bldg., San Francisco.
- TILES, MOSAICS, MANTELS, ETC.**
Mangrum & Otter, 827-831 Mission St., San Francisco.
- TILE FOR ROOFING**
Gladding, McBean & Co., Crocker Bldg., San Francisco.
United Materials Co., Crossley Bldg., San Francisco.
- TRANSMISSION MACHINERY**
Meese & Gottfried Co., San Francisco, Los Angeles and Portland.
P. H. Reardon, 57 First St., San Francisco.
- VACUUM CLEANERS**
United Electric Company, Canton, O., manufacturers of Tuec Cleaners, sold in California by San Francisco Compressed Air Cleaning Co., Stockton and Sutter Sts., San Francisco.
- VALVES—PIPES AND FITTINGS**
California Steam & Plumbing Supply Co., 671 Fifth St., San Francisco.
Crane Radiator Valves, manufactured by Crane Co., Second and Brannan Sts., San Francisco.
Sloane Valves, sold by E. C. Whalen, 325 Monadnock Bldg., San Francisco.
Grinnell Co., 453 Mission St., San Francisco.
O. M. Simmons Co., 115 Mission St., San Francisco.
H. Mueller Mfg. Co., 635 Mission St., San Francisco.
W. E. Mushet Co., 502 Mission St., San Francisco.
George H. Tay Company, Mission and Second Sts., San Francisco; 10th and Harrison Sts., Oakland.
- VALVE PACKING**
N. H. Cook Belting Co., 317 Howard St., San Francisco.
- VARNISHES**
California Paint Company, 1797 Twelfth St., Oakland.
W. P. Fuller Co., all principal Coast cities.
R. N. Nason & Co., San Francisco, Los Angeles, Portland and Seattle.
S. F. Pioneer Varnish Works, 816 Mission St., San Francisco.
The Glidden Company, 123 Hooper St., San Francisco.
Standard Varnish Works, 55 Stevenson St., San Francisco.
- VENETIAN BLINDS, AWNINGS, ETC.**
C. F. Weber & Co., 985 Market St., San Francisco.
Western Blind & Screen Co., 2702 Long Beach Ave., Los Angeles.
- VENTILATORS**
H. H. Robertson Co., Hobart Bldg., San Francisco.
Power & Pike Co., 22-24 Main St., San Francisco.
- VITREOUS CHINAWARE**
Pacific Porcelain Ware Company, 67 New Montgomery St., San Francisco.
- WALL BEDS, SEATS, ETC.**
American Automatic Lock & Lift Co., 72 Fremont St., San Francisco. (Display at 77 O'Farrell street.)
Marshall & Stearns Co., 1154 Phelan Bldg., San Francisco.
- WALL BOARD**
"Amiwud" Wall Board, manufactured by The Paraffine Companies, Inc., 34 First St., San Francisco.
- WALL BOARD—Continued.**
"Liberty" Wall Board, manufactured by Key-Hold Plaster Lath Co., 148 Hooper St., San Francisco.
- WALL PAINT**
Nason's Opaque Flat Finish, manufactured by R. N. Nason & Co., San Francisco, Portland and Los Angeles.
San-A-Cote and Vel-va-Cote, manufactured by the Brininstool Co., Los Angeles.
- WALL PAPER AND DRAPERIES**
Beach-Robinson Co., 239 Geary St., San Francisco.
The Tormey Co., 681 Geary St., San Francisco.
W. & J. Sloane, 216-228 Sutter St., San Francisco.
Uhl Bros., San Francisco.
- WATERPROOFING FOR CONCRETE, BRICK, ETC.**
Armorite Damp Resisting Paint, made by W. P. Fuller & Co., San Francisco.
Bay State Brick & Cement Coating, manufactured by Wadsworth, Howland Co., Boston; Hambley & Son., Distributors for Northern and Southern California.
Imperial Waterproofing, mfrd. by Brooks & Doerr, Reed Baxter, agent, Merchants National Bank Bldg., San Francisco.
Pacific Materials Co., 525 Market St., San Francisco.
Samuel Cabot Mfg. Co., Boston, Mass., agencies in San Francisco, Oakland, Los Angeles, Portland, Tacoma and Spokane.
- WATER SUPPLY SYSTEMS**
Kewanee Water Supply System—Simonds Machinery Co., agents, 117 New Montgomery St., San Francisco.
Pacific Pump & Supply Company, 851-853 Folsom St., San Francisco.
- WHEELBARROWS—STEEL**
Western Iron Works, Beale and Main Sts., San Francisco.
- WHITE CEMENT**
"Atlas White," see coast agencies, page 127.
"Medusa White," sold by Pacific Materials Co., Underwood Bldg., San Francisco.
- WHITE ENAMEL**
"Gold Seal," manufactured and sold by Bass-Hueter Paint Co. All principal Coast cities.
Velvet White Enamel, The Glidden Company, 123 Hooper St., San Francisco.
"Silkenwhite," made by W. P. Fuller & Co., San Francisco.
"Satinette," Standard Varnish Works, 55 Stevenson St., San Francisco.
- WINDOW SHADES**
W. & J. Sloane, 216-228 Sutter St., San Francisco.
- WINDOWS, REVERSIBLE, CASEMENT, ETC.**
Hauser Window Co., 157 Minna St., San Francisco.
J. G. Wilson Corporation, 600 Metropolitan Bldg., Los Angeles; Waterhouse-Wilcox Co., Underwood Bldg., San Francisco.
- WIRE FABRIC**
U. S. Steel Products Co., Rialto Bldg., San Francisco.
Clinton Wire Lath, sold by L. O. Norris, 140 Townsend St., San Francisco.
- WIRE FENCE**
Standard Fence Co., 310 12th St., Oakland.
- WOOD MANTELS**
Fink & Schindler, 218 13th St., San Francisco.
Mangrum & Otter, 827 Mission St., San Francisco.

MOLINE HEAT

Hobart Building

San Francisco

TELEPHONE SUTTER 3818

MOTT PLUMBING FIXTURES

Architects and their clients are invited to visit our Showrooms, 553-555 Mission Street, San Francisco; D. H. Gulick, Sales Agent. Los Angeles Office, 1001 Central Building; J. R. Mayhew, Sales Agent.

Mott Company of California

MUELLER — BRASS GOODS

Recognized as the Standard of excellence in plumbing. It pays to use them, and other Mueller Brass Goods. *The first cost is practically their last cost.*

H. Mueller Mfg. Co.

635 MISSION STREET, SAN FRANCISCO, CAL.

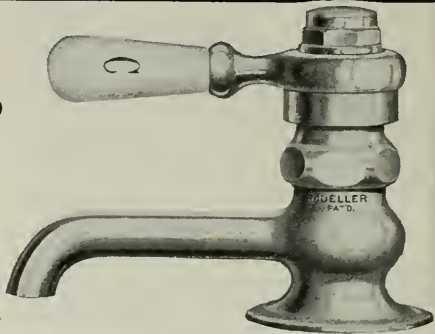

Automatic Fire Sprinklers

Protect your building and business from destruction by fire and reduce your Insurance Rate.

Pacific Fire Extinguisher Co.

FIRE PROTECTION ENGINEERS

424-440 HOWARD STREET
SAN FRANCISCO

MANUFACTURING PLANT
272 STEUART STREET

GENERAL BOILERS COMPANY

DEPARTMENT OF SALES

Manufacturers of

**Pacific Patented Steel Portable Double Return Tube
Low Pressure Steam and Hot Water Heating Boilers**

Pacific Steel Circulating Tanks

Pacific Steel Tank Heaters and Storage Tanks

General Office and Plant: WAUKEGAN, ILLS.

Sales Offices: 322 Monadnock Bldg., SAN FRANCISCO and 1310 South Hill St., LOS ANGELES,
CALIFORNIA.

A. W. MERRILL, Manager

There's a

Fuller Paint, Varnish, Stain or Enamel

for everything that needs preserving and beautifying.

And today, as during the past 70 years, the name "FULLER" means the same high standard in Paints, Varnishes, Stains, Enamels, etc.

During this long period of time, in all conditions of weather, season in and season out, FULLER Products have proven their superior lasting and beautifying qualities.

Thousands of homes and buildings have stood the test of time and the elements and are giving the maximum service through "FULLER Paint Protection."

For exteriors and interiors, the FULLER line meets every possible need.

There's a special FULLER product for everything that needs preserving and beautifying.

W. P. FULLER & CO.

Manufacturers

(70 Years)

CHICAGO
SILENT
SIGNAL
HOSPITAL
SYSTEMS

**GARNETT YOUNG
AND COMPANY**
Pacific Coast Sales Engineers
612 HOWARD STREET
SAN FRANCISCO, CAL.
Seattle - Los Angeles - Portland

Holtzer-Cabot

Hospital Silent Call Systems

HUNDREDS of hospitals all over the country are equipped with these efficient, time-saving Systems. In far-off China, Greece and other foreign countries also, there are hospitals installed with Holtzer-Cabot Systems. Representative architects invariably specify this system because of its Simplicity, Flexibility and Safety.

There is nothing in the walls but the wires—the whole of the operating mechanism is in the Locking Button; any station may be instantly changed by just plugging in another cord and button. This simple, safe locking button is exclusive to Holtzer-Cabot Systems.



BITTMANN & BATTEE, Inc., Agents

745 Folsom Street, San Francisco

Phone Douglas 4405

Homes Like This Have Banished Garbage Cans

by the installation of the

KERNER "Built-in-the-Chimney" INCINERATOR

This added refinement makes the home more livable, promotes sanitation, saves unnecessary steps and provides an effective means for the disposal of garbage, waste paper, paper boxes, faded flowers, in fact all household waste. There is no odor and the waste supplies its own fuel—THEREFORE, IT DOES NOT COST ONE PENNY TO OPERATE.



Owner, A. Getty, Wilshire and Hobart Sts., Los Angeles
Architect, T. B. Keim, Jr., Los Angeles



THE KERNER INCINERATOR

Is built into the base of the chimney when the house is erected.

Consumes no space on living floors: requires but little added masonry.

SANITARY CONVENIENT
ECONOMICAL ODORLESS

Kerner Incinerator Co.

77 O'Farrell St. Factory, 38 Stanford St.

SAN FRANCISCO

600 Metropolitan Building, Los Angeles.

See Page 1132 - Sweet's Catalog

Millwork Manufactured and delivered anywhere

Plans or Lists sent us for Estimates will
have Careful and Immediate Attention

DUDFIELD LUMBER

JNO. DUDFIELD
President and Manager

COMPANY

JOSEPH A. JURY
Secretary & Mill Supt.

Main Office, Yard and Planing Mill—PALO ALTO



Brininstool

San - a - Cote

(GLOSS—Can be Scrubbed)

AN INTERIOR WALL FINISH

For bath rooms, kitchens, hospitals, schools, office and public buildings. Ask dealers, owners, architects and contractors about this durable, sanitary, washable, economical wall covering. Brininstool makes a paint for every purpose, and every can purposely good.

THE BRININSTOOL CO., LOS ANGELES

COLOR GRINDERS AND PAINT MANUFACTURERS

Distributors—The Brininstool Co., 1174 Phelan Bldg., San Francisco, Cal.; The Brininstool Co., 222 Abington Bldg., Portland, Ore.; Schutz Paint Co., Fresno, Cal.; Schneider, Chappell & Jones, Sacramento, Cal.; Salt Lake Glass & Paint Co., Salt Lake City, Utah; Griffin Paint Co., Ogden, Utah; Campbell Hardware Co., First and Madison Sts., Seattle, Wash.; Imperial Valley Hardware Co., El Centro, Cal.; Imperial, Brawley, Seeley, Cal.; Spokane Hardware Co., Spokane, Wash.; Continental Paint Company, 328 South First St., San Jose, Cal.; Los Angeles Wallpaper & Paint Co., 525 So. Main St., Los Angeles, Cal.; H. A. Berger, 3838 13th St., San Diego, Cal.; H. L. Christian, Elythe, Cal.; Ezra Thayer, Phoenix, Ariz.; Miami Lumber & Supply Co., Miami, Ariz.



AN easy sliding door, whether it be in home, office, or public building, means convenience. No Architect can be at fault in specifying "Reliance" and "Grant" Ball Bearing Door Hangers.

RELIANCE-GRANT ELEVATOR EQUIPMENT CORP'N.

Pacific Coast Agents: **Park Avenue and 40th Street, New York**
 Waterhouse-Wilcox Co. San Francisco and Los Angeles, Cal.
 Columbia Wire & Iron Works Portland, Ore.
 D. E. Fryer & Co. Seattle, Spokane, Tacoma, Wash.; Great Falls, Mont.

FOR ALL FINISHING REQUIREMENTS



THE IMMACULATE WHITE ENAMEL

TRADE MARK
ELASTICA
 MARK
VARNISHES

Satinette
 TRADE MARK
ENAMEL

STANDARD VARNISH WORKS

GENERAL OFFICES: NEW YORK - 90 WEST STREET
 BRANCHES: LONDON - SAN FRANCISCO - PARIS - MELBOURNE

SAN FRANCISCO OFFICES & WAREHOUSE 55 STEVENSON STREET

Bungalow Building Blox

Hollow Building Tile
Hollow Partition Tile

California Brick Co.

604 Mission Street
San Francisco, Cal.

BRICK

Red Ruffled Face Brick
Paving Brick
Step and Walk
Brick

BRICK

Enamel Brick
Buff and Old Gold
Pressed Brick

Livermore Fire Brick Works

604 Mission Street
San Francisco, Cal.

Fire Brick and
Molded Fire Tile

Architectural Terra Cotta

Passenger and Freight Elevators



"MADE IN SAN FRANCISCO"

Factory and Warehouse, 166-180 Seventh Street, San Francisco. Phone Kearny 66

SPENCER ELEVATOR COMPANY

DOW ROTREX PUMP

For severe suction requirements

We also manufacture

TRIPLEX POWER PUMPS

and

CENTRIFUGAL PUMPS

We solicit your inquiries

DOW - HERRIMAN CO.

San Francisco Office, 140 Howard Street

Phone Garfield 612

Plant Petaluma Cal.

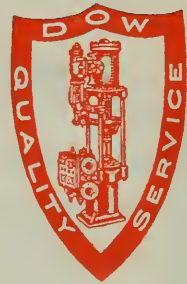

SIERRA ELECTRIC CO.

SAN FRANCISCO, CALA. U.S.A.

S. H. COUCH, Apartment, School and Industrial Telephones.

Federal Telephone and Telegraph Co., Magneto and Common Battery Telephones—Wireless Apparatus.

Roth Motor Company—Motors and Generators.

Schwarze Electric Co.—Bells and Horns.

Standard Electric Tool Company—Portable Drills and Grinders.

Palmer Electric Company—Safety Switches.

L. S. Brach Mfg. Co.—Telephone, Telegraph, Signal, Lightning Arresters.

SIERRA ELECTRIC COMPANY

SEATTLE BRANCH, 416 Maritime Bldg.

515 Market St., Douglas 94 or 95, SAN FRANCISCO

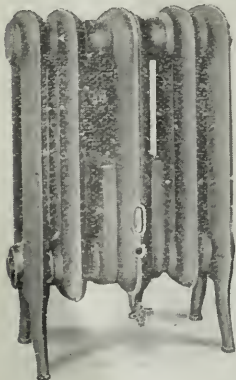

RA-DO ^{FUMELESS} GAS RADIATORS

ALL CAST IRON—3 Sizes (3, 5, and 7 Sections)

The Ideal "Year-Round" Heating System
For The Home—New or Old

Easiest and Cheapest to Install
Lowest Operating Cost

BAIRD - BAILHACHE COMPANY

MANUFACTURERS

478 Sutter St., San Francisco

Phone Sutter 6858

OLD MISSION PORTLAND CEMENT COMPANY



Each shipment of "OLD MISSION" Portland Cement is guaranteed not only to equal but to surpass all requirements of the standard specifications for Portland Cement as adopted by the U. S. Government and by the American Society for Testing Materials. A Guarantee Certificate is mailed with the bill of lading of each car, giving number of car, date packed, and number of barrels, over the signature of the chief chemist.

8000 SACKS DAILY

SALES OFFICE:

MILLS BLDG., SAN FRANCISCO

PHONE SUTTER 3075

PLANT:

SAN JUAN, CAL.

VULCANITE SLATE - SURFACED RED OR GREEN Famous for Quality ASPHALT ROOFING

A roofing that has been manufactured in eleven different factories in five different countries, covering a period of over 70 years.

A roofing that is patented in eight countries and which has been awarded the Gold Medal, and in some cases the Medal of Honor at International Expositions—is worth your consideration.

The Vulcanite Roofing Company

Roofing Division of the Beaver Board Companies

16TH AND TEXAS STREETS, SAN FRANCISCO, CAL.



Keep Down Insurance Premiums

SPECIFY

SAINO FIRE DOORS

Standard Automatic Sliding or Swinging Fire Doors.
Tested and Labeled by the Underwriters' Laboratories.

STEEL SASH AND HOLLOW METAL
UNDERWRITERS WINDOWS

U. S. METAL PRODUCTS CO.

326-338 Tenth Street, San Francisco



FITZGERALD MEMORIAL CHURCH,
SAN FRANCISCO

Chas. A. Haber, Architect.

IS EQUIPPED WITH

HAUSER REVERSIBLE WINDOWS

Will operate in any size
frame — wood or metal.

MANUFACTURED AND INSTALLED
— BY THE —

HAUSER WINDOW CO.

Office and Factory
157 Minna Street

Phone Kearny 3706
San Francisco, Cal.



Do You Want This Book in Your Files?

IT IS JUST OFF THE PRESS, and is FREE FOR THE ASKING. It contains full information and illustrations of the "PEERLESS" Built-ins besides a few splendid floor plans of houses and kitchens, as well as views of ideal kitchens worked out in our KITCHEN PLAN DEPARTMENT and tells you how to use this department in your lay-outs of house and apartment plans. *Don't wait—write for it today.*

Telephone ::
SUTTER 4122

THE HOOSIER STORE

821 Market Street, SAN FRANCISCO, CAL.



When writing to Advertisers please mention this magazine.

The Elevator Floor

whether in Office Building, Hotel or Department Store, is subjected to a great deal of wear and tear.

—SPECIFY—

INTERLOCKING RUBBER TILING

and you've provided your client's building with a Durable, Economical, Practical,

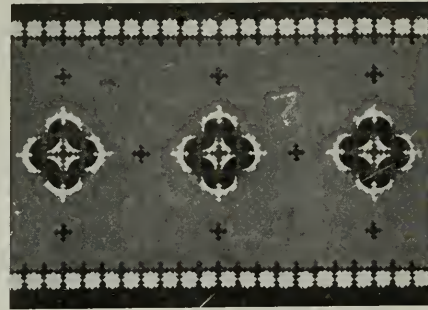

INTERLOCKING RUBBER TILING

material that is sure to give satisfaction. **Twenty tons installed in the Standard Oil Building, San Francisco.** Stock on hand for immediate delivery.



New York Belting and Packing Co.

NEW YORK

San Francisco Branch 519 MISSION ST. Phone Douglas 1837

Small booklet of designs mailed on request.



Perspective Pebble Beach Lodge. Lewis P. Hobart, Architect

The White Cement Finish is given added Beauty by the use of

DEL MONTE WHITE SAND

DEL MONTE PROPERTIES CO. 401 Crocker Bldg., San Francisco

Phone Sutter 6130



E. B. Homer, Architect.

Residence of Mrs. W. E. Brigham, Providence, R. I.

William Williams, Builder.

Beautiful for Years

MEDUSA
WHITE CEMENT
 WATERPROOFED



Also manufacturers of Medusa Water-proofing and Medusa Grey Portland Cement—Plain and Waterproofed

Pacific Coast Distributors

Pacific Materials Co., San Francisco, Cal.
 Riverside Portland Cement Company, Los Angeles, California.
 A. McMillan & Company, Portland, Ore.
 Galbraith & Company, Seattle, Washington

There's rare satisfaction in building homes that grow old gracefully—homes that *stay beautiful* through years of exposure.

You point to such creations with pride. And you again choose the building material that insures lasting charm.

MEDUSA White Cement (Stainless)

adds *permanent* beauty to stucco, terra cotta, stone and concrete work of all kinds. It is unexcelled for both exterior and interior use. Gives clean-cut, striking effects in trim or ornamentation.

Medusa White Cement is pure-white and non-staining. It preserves all the effectiveness of your designs and needs no renewal. The Medusa White Cement Book is full of interesting and practical material. May we send it to you?

The Sandusky Cement Company
 Department P
 Cleveland, Ohio

Bath Room Fixtures

A BATH ROOM should be just as true an expression of the owner's taste and individuality as any other room of the house.

No more is it considered a luxury, but an absolute necessity to your health and comfort.

Our fixtures reflect the finest ideas in design and construction as related to sanitation, utility and service.

To give this subject the attention it demands, you should visit our display rooms at 64 Sutter Street, San Francisco.

Holbrook, Merrill & Stetson

DEALERS IN

Plumbers' Supplies, Iron Pipe and Fittings, Metals, Steam, Water and Hot Air Heating Apparatus, Stoves, Ranges, Kitchen Utensils.

Show Room, 64 SUTTER STREET

Main Office and Warehouse,

Sixth, Townsend and Bluxome Streets, San Francisco



Designers - Fabricators - Erectors

General Plate Work

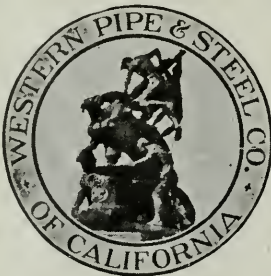

Hydro - Pneumatic Pressure Tanks —
Hemispherical Bottom Tanks and Towers
— Oil and Water Tanks — Oil Stills —
Pipe Lines—Smoke Stacks—Well Casing
— Rock Screens — "Western" Corru-
gated Culvert Pipe.

Western Pipe and Steel Company OF CALIFORNIA

444 MARKET STREET
SAN FRANCISCO

1758 NORTH BROADWAY
LOS ANGELES



**THE HOUSE
BEAUTIFUL**



THE interior of a Home should have those little touches of refinement that come with the co-operation of an experienced interior decorator.

CONSULT US

Decorative ideas, artistic framing, byamopa ware, floor lamps, table lamps, chair lamps, lamp shades, mirrors, candlesticks, decorated candles, book-ends, store window fixtures, odd furniture, pictures, Emma B. Freeman's Prints, pieces in unique colorings and indefinite carvings and other objects of art.

FREEMAN ART SHOP

386 SUTTER STREET
SAN FRANCISCO

Tel. Sutter 1593



Beach-Robinson Co.

Decorators and Furnishers

Carpets

Draperies

Furniture

Rugs

Wall Paper

Ranson E. Beach

239 Geary Street, 3d Floor

Union Square

Phone, Sutter 580

San Francisco, Cal.



ADD CHEER and COMFORT

to the Home by having a

WELL DESIGNED INTERIOR

Before Completing Your Plans, CONSULT

SONNENSCHN BROS.

INTERIOR DECORATORS

Furniture and Draperies Made to Order

Factory

718 NATOMA ST., Phone Market 1145

Show and Salesroom

470 SUTTER, ST., Phone Kearny 2051



*The Finishing Touch
of Right Building —*

F. A. TAYLOR CO.

251 Post St., San Francisco

Second Floor



Mercedes Bldg.

*Hand-made
Furniture,
Rugs,
Hangings,
Upholstering,
Decorating,
Wall Paper.*

The **GOLD MEDAL
MAIL CHUTE**



INSTALLED IN
THE NEW
SAN FRANCISCO
CITY HALL
AND THE
WHITE MARBLE
MERRITT
BUILDING,
LOS ANGELES

Given highest award at
Panama - Pacific International
Exposition, 1915.

Waterhouse-Wilcox Co.

California
Representatives

523 Market Street
SAN FRANCISCO

331 E. 4th Street.
LOS ANGELES

F. T. CROWE & CO.
Seattle, Wash.

THE J. McCracken Co.
Portland, Oregon

**American Mailing
Device
Corporation**

**LIBERTY
WALL BOARD**

MANUFACTURED BY
KEY-HOLD PLASTER LATH COMPANY



**MADE IN AMERICA
BY AMERICANS**

A Wall Board for Government Housing.
A Fibred Gypsum Plaster that will not
Shrink, Swell, Warp or Buckle.

Factory, 148 Hooper St., San Francisco, Cal.
Phone Market 5767.

Sales Office:
Monadnock Building, SAN FRANCISCO
Telephone Douglas 5889

**THE HEART OF A BUILDING
IS ITS PIPING EQUIPMENT**

A complete line for the Piping Features of Buildings—Power, Plumbing, Heating, Ventilating, Refrigerating, Vacuum-Cleaning, Gas, Water, etc.—is furnished by Crane Co. through the Plumbing and Heating trade.

The Architect, Engineer and Builder, or Investor, may enjoy, through the facilities of this Company, the distinct advantage of dealing entirely with one Competent and Responsible House.

Exhibit Rooms, Offices and Warehouses in San Francisco and Oakland and Fifty-one other cities.

CRANE CO.

1855—1918

**VALVES AND
FITTINGS**



**VULCAN
Refrigerating
and Ice Making
Machines**

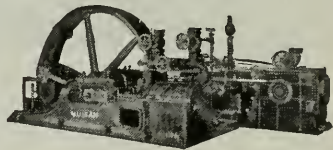

**Refrigerate Cold Storage Rooms
Make Pure Distilled Water Ice
Supply Cooled Drinking Water
Etc., Etc.**

Manufactured by

**VULCAN IRON WORKS
SAN FRANCISCO, CAL.**

PORTAL Economy Plan Service and PORTAL Quality Wall Beds

PORTAL wall-beds have received Highest Award wherever exhibited—an evidence of quality that should interest the Builder.

Patented oscillating arm permits the "Portal" bed to revolve in a foot less space than any other revolving bed—a good point to remember.

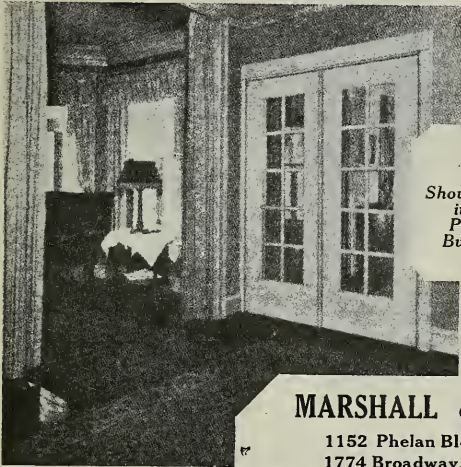

See Show Rooms in the Phelan Building



MARSHALL & STEARNS CO.

1152 Phelan Bldg.,
1774 Broadway,

San Francisco
Oakland

For the
Exacting Client

Pitcher Hangers

Give Satisfaction

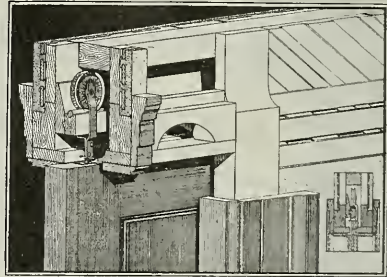

Smooth Running — Noiseless — Efficient
Inexpensive

MANUFACTURED BY

NATIONAL MILL & LUMBER CO.

318 Market Street, San Francisco, Cal.

Telephone Kearny 3620



IT'S not enough to say "Good For All Time" unless there is something back of it. ¶ There is in this case. ¶ Vermont Marble already has an unblemished record of over one hundred and fifty years. ¶ We know what it will do. It's not necessary to guess at it. ¶ And our quarries in Alaska and Texas are also proving themselves. ¶ So please don't think of "Good for All Time" as merely a happy phrase.

IT'S THE MARK OF A SERVICE.
It means exactly what it says.

VERMONT MARBLE COMPANY
PROCTOR, VERMONT
San Francisco - Portland - Tacoma

Fire Extinguishers

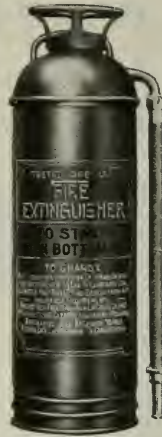

To adequately protect homes, offices, and factories install fire extinguishers at frequent intervals.

Specify

ALERT
NO. U.S. PAT. OFF.

Fire prevention and protection equipment of every description.

AMERICAN-LAFRANCE FIRE ENGINE COMPANY, Inc.

141 So. Hill St. 151 New Montgomery St.
Los Angeles San Francisco

16th and Marshall Sts.
Portland, Ore.

A Bargain in Files—

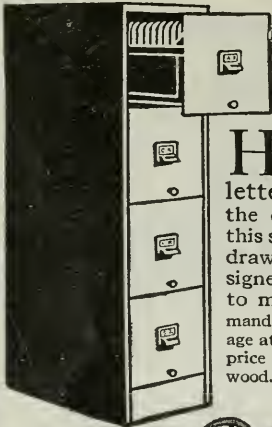

HOLDS 20,000 letters. That's the capacity of this special four-drawer file, designed and built to meet the demand for steel storage at less than the price of high grade wood. See it today.

Van Dorn
STEEL EQUIPMENT

Phone Douglas 1183

Western Office Equipment Co.
467 Market Street - San Francisco

Fire Protection

WE are equipped to furnish prices on **Fire Hose** for both inside and outside fire protection that will interest you. Estimates cheerfully given. Give us an opportunity to figure on your requirements.

AGENTS FOR

Childs' Approved and Labeled Fire Extinguishers and Chemical Fire Tanks

RALPHS-PUGH COMPANY

530-532 Howard St., San Francisco
Phone SUTTER 2886

FROM YOUR VIEWPOINT

Do you remember the first catalog you ever saw, with those grotesque wood cut prints and ridiculously exaggerated descriptions — everything presented from the maker's standpoint? In those days service had not entered the mind of the manufacturer. He made his goods his way, and sold them for his own benefit.

What a contrast in impressions and frank presentation obtains in the Richards-Wilcox' new catalog on

Distinctive Garage Door Hardware

Beginning with the front cover, handsomely displayed in full color, this catalog is built to accommodate the convenience of the person interested in garage door hardware.

Not a garage doorway condition is left unprovided for — not a personal taste overlooked.

Here are displayed hundreds of sets of distinctive fixtures for doors which operate inside and outside of the doorway — suitable for every conceivable condition — and all so lucidly

and completely compiled, so simply illustrated and so plainly detailed that the reader may select unerringly the exact set suited for his garage, his taste and his purse.

A copy of this beautiful book will be mailed to anyone interested in garage door hardware, on request.

Ask for Catalog OA-22.



Richards-Wilcox Mfg. Co.

"A Hanger for any Door that Slides."
 CHICAGO ST. LOUIS AURORA, ILLINOIS, U.S.A. BOSTON NEW YORK
 LOS ANGELES PHILADELPHIA LONDON, ONT. MINNEAPOLIS SAN FRANCISCO



For Any Surface

Use GLIDDEN Architectural Finishes and be assured of satisfaction. For inside and outside finishing, on flat or relief parts, on walls, ceilings, floors, etc., there's a Glidden Finish made just for the purpose.

GLIDDEN means *economy* consistent with highest quality. Finished panels and specific data on request.

THE GLIDDEN COMPANY

123 to 169 Hooper Street. Between 7th and 8th Streets
 San Francisco, Cal.

GLIDDEN

Velvet White Enamel

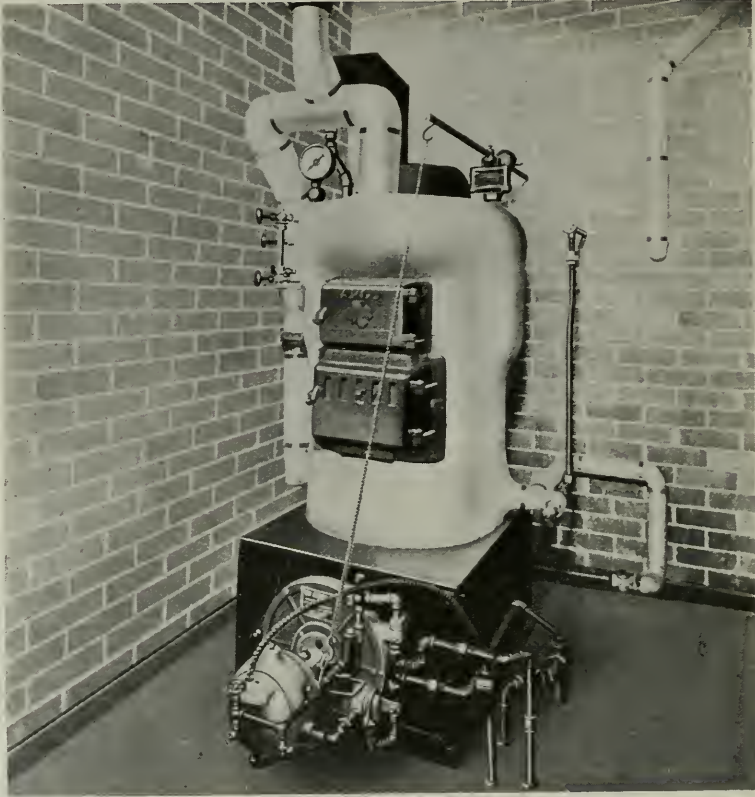

Equip the home with a Hot Water
or Steam Heating System and
RAY OIL BURNER

THE picture shows a recent installation in the Residence of Mr. M. E. Spiro in San Francisco. The RAY Equipment is adapted for both high and low pressure boilers in private homes and buildings of every type. Write for latest catalog.

W. S. Ray Manufacturing Co.

29 SPEAR STREET Phone Kearny 198 SAN FRANCISCO, CAL.

ROAD **MULTI FOOTE** PAVER

The State of California and the Multi Foote Paver lead the country in the construction of hard roads.

*Market St
San Francisco*

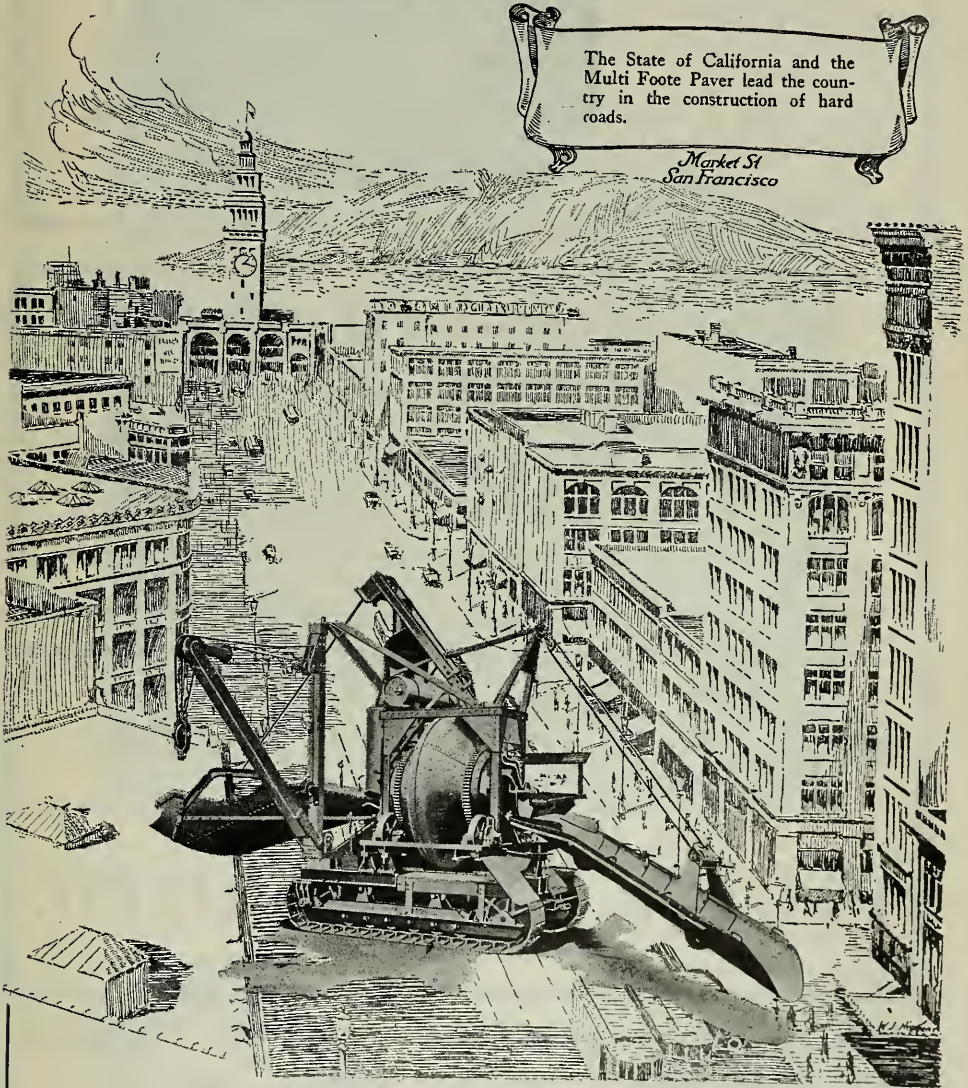

THE LAST WORD

FULL LENGTH TREAD AND BATCH-BOX DERRICK

EDWARD R. BACON COMPANY

165 Jefferson Street,
Los Angeles, California

51 Minna Street,
San Francisco, California

When writing to Advertisers please mention this magazine.

LEADER WATER SYSTEM

No country home is complete without this modern water system. Running water under pressure whenever and wherever needed. Convenient, economical, sanitary.

Pacific Pump & Supply Company, Distributors

851-853 Folsom Street
SAN FRANCISCO, CALIF.

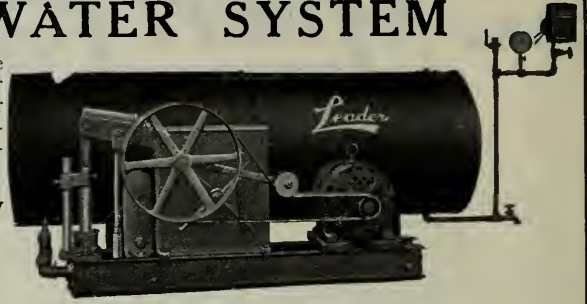

“SUNLIGHT’S THE GREATEST CHEER PRODUCER.”
“THE PAINT BRUSH COMES NEXT.”

UHL BROS., Inc.

SAN FRANCISCO

PORTLAND

LOS ANGELES

SEATTLE

OAKLAND



High Class

BUILDERS' HARDWARE
PALACE HARDWARE CO.

San Francisco's Leading Hardware Store

581 MARKET STREET

TELEPHONE SUTTER 6060



Pack your Radiator Valves with
Palmetto Twist Packing

It can be unstranded to fit any size valve. It does not get hard.

H. N. COOK BELTING CO.

401-433 Howard St.

San Francisco, Cal.



Whitthorne & Swan
Department Store
Building,
Oakland, California.
William Knowles,
Architect

MICHIGAN MAPLE FLOOR-
ING, laid in this building, is
admitted to be the last word in floor-
ing perfection.

WOLVERINE BRAND, a Michigan
product, has stood the test for years
and is extensively used in large
department stores.



Strable
Manufacturing Co.

HARDWOOD LUMBER

511-545 First Street,
OAKLAND, CAL.
Phone, Oakland 245

United States Steel Products Co.

Rialto Bldg., San Francisco

SELLERS of the products of the American Bridge Co., American Sheet and Tin Plate Co., American Steel and Wire Co., Carnegie Steel Co., Illinois Steel Co., National Tube Co., Lorain Steel Co., Shelby Steel Tube Co., Tennessee Coal, Iron and Railroad Co., Trenton Iron Co.

MANUFACTURERS OF

Structural Steel for Every Purpose—Bridges, Railway and Highway—"Triangle Mesh" Wire Concrete Reinforcement—Plain and Twisted Reinforcing Bars—Plates, Shapes and Sheets of Every Description—Rails, Splice Bars, Bolts, Nuts, etc.—Wrought Pipe, Trolley Poles—Frogs, Switches and Crossings for Steam Railway and Street Railway—"Shelby" Seamless Boiler Tubes and Mechanical Tubing—"Americore" and "Globe" Rubber Covered Wire and Cables—"Reliance" Weatherproof Copper and Iron Line Wire—"American" Wire Rope, Rail Bonds, Springs, Woven Wire Fencing and Poultry Netting—Tramways, etc.

United States Steel Products Co.

OFFICES AND WAREHOUSES AT
San Francisco - Los Angeles - Portland - Seattle

Include **BOWSER** ESTABLISHED 1863 Equipment In Your Filling Station Plans



Bowser Gasoline and Oil Storage Equipment is necessary to make the filling station complete.

You will find the finest stations everywhere are BOWSER equipped. Here the watchword is always safety,

accuracy and satisfaction, the certain result when BOWSER equipment is used.

Our literature will help you in your plans for storage equipment. Write or phone our nearest office.

S. F. BOWSER & CO., Inc.

Sales Offices
in all Centers

FORT WAYNE, INDIANA, U. S. A.

Representatives
Everywhere

San Francisco Office: 612 Howard Street. Telephone Douglas 4323



House at Cornwall-on-Hudson, N. Y. Finished with Old Virginia White. Rogers & Zogbaum, Architects, New York

Cabot's Old Virginia White

A Soft, Brilliant White for Shingles, Siding and Similar Woodwork. As Bright and Clean as New Whitewash, and as Lasting as Paint.

Architects and others have tried for years to get a paint that would give the same beautiful, brilliant white as new whitewash, and would also be durable and clean and not rub off like whitewash.

Old Virginia White is a shingle-stain compound that has solved the problem. It is as clean, cool and brilliant as fresh whitewash, and as lasting as paint; but it is not messy like whitewash, nor painty like paint, although it costs less and goes farther than paint.

Send for Sample Shingle and Circular showing other fine houses finished with Old Virginia White

SAMUEL CABOT, Inc., Mfg. Chemists, Boston, Mass.

Cabot's Creosote Stains, Stucco and Brick Stains, "Quilt," Mortar Colors, Dampproofing, Waterproofings, Conservo Wood Preservative, etc.

Pacific Materials Co., San Francisco

S. W. R. Dally, Seattle

The Waterhouse-Wilcox Co., Los Angeles

Timms, Cress & Co., Portland



CENTRAL HIGH SCHOOL, MINNEAPOLIS, MINN.

Architect, *William B. Ittner*Contractors, *Pike & Cook Co.*Glazed by *Forman, Ford & Co.*

**Completely equipped with American Window Glass Co.'s Double Strength AA Quality
First Choice of Leading Architects**

Because of its absolute dependability, American Window Glass has been used in many fine buildings. Our care in inspection practically eliminates all imperfections and assures uniformity in thickness.

American Window Glass Co., General Office, Pittsburgh, Pa.

DOMESTIC SALES OFFICES

New York, 220 Fifth Avenue
Chicago, 1011 Peoples Gas Building
Boston, Mass., 43 Tremont Street
San Francisco, Cal., 341 Montgomery Street
St. Louis, Mo., 1303 Syndicate Trust Building
Memphis, Tenn., 440 North Main St.
New Orleans, La., 904 Hennen Bldg.
Atlanta, Ga., 1408 Candler Building

EXPORT SALES OFFICES

Havana, Cuba, Apartado No. 930
Buenos Aires, Argentina
Mexico City, Mex., Apartado Postal No. 237
Barranquilla, Colombia
Bogota, Colombia
Valparaiso, Chile
Lima, Peru
Toronto, Canada, 205 Continental Life Building



The above Trade-Mark appears on every light

*Highest Quality**Finest Workmanship*

Remco Redwood Tanks

Underwriters — Standard — Specials

All dimensions and capacities

Towers Designed and Erected

For Prices, Data or Estimates Phone GARFIELD 1910

Redwood Manufacturers Company

SOLE MAKERS

Hobart Building, San Francisco

When writing to Advertisers please mention this magazine.

Fess System Turbine Fuel Oil Burner

The latest word in the science of burning fuel oil in an efficient and economical method

Ask for Bulletin No. 20

FESS SYSTEM CO., Inc.

1310 S. HILL ST.,
LOS ANGELES

218-220 Natoma Street, San Francisco

HOUSTON,
TEXAS

Member of the Oil Burners Manufacturers' Association of California.

JOHNSON'S ROTARY CRUDE OIL BURNER

Can be installed in any BOILER or FURNACE

Gives Satisfactory Results. Simple to Operate—
Automatic—Safe. Let us tell you more about this
Oil Burner.

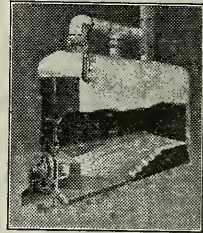

BURNER IN OPERATION

S. T. JOHNSON CO.

1337 Mission Street - San Francisco, Cal.
Ask for Bulletin No. 28 Phone Market 2759

Agencies: SEATTLE LOS ANGELES FRESNO SAN DIEGO SACRAMENTO
Member of the Oil Burners Manufacturers' Association of California.

OIL BURNER EQUIPMENTS

Low Pressure Air and Rotary Mechanical Atomizing Types

Refrigerating and Ice-Making Machines

Direct Expansion and Brine Circulating Systems

T. P. JARVIS MANUFACTURING CO.

CONTRACTING ENGINEERS AND MANUFACTURERS

275 Connecticut Street, San Francisco Phone Market 3397

Member of the Oil Burners Manufacturers' Association of California.



SIMPLICITY OF CONSTRUCTION together with
SUCCESSFUL and ECONOMIC OPERATION of

SIMPLEX BURNERS

reported by their many users, is the best recommenda-
tion we can furnish to those desiring crude oil burners.

American Standard Oil Burner

TRADE MARK

Phone BERKELEY 6389

Company FIFTH AND PARKER STREETS
BERKELEY, CALIFORNIA

Member of the Oil Burners Manufacturers' Association of California.



Pump Governors
 Oil Burner Governors
 Reducing Valves
 Safety Valves
 Oil Valves
 Blowoff Valves
 Boiler Feed Water
 Regulators

Oil Pumping Sets
 Little Giant Improved
 Oil Burners
 Duplex Oil Pumps
 Rotary Oil Pumps
 Oil Heaters
 Draft Gauges
 Boiler Feed Pumps

G. E. WITT CO., Inc.
ENGINEERS

Manufacturers and Distributors

862-864 HOWARD ST.

Phone Douglas 4404

SAN FRANCISCO, CAL.

REDUCTIONS IN PRICE
 ON ALL
CABOTS

“Quilt”
 “Creosote Shingle Stains”
 “Stucco Stains”
 “Brick Stains”, Etc.

KEARNY 3323

PACIFIC
MATERIALS CO.

525 MARKET ST., SAN FRANCISCO

A. F. EDWARDS, President
 J. M. FABBRIS, Vice-President

J. A. MACKENZIE
 Secretary

CHAS. F. EISELE } Asst. Managers
 J. RUBIOLLO }

AMERICAN
MARBLE & MOSAIC CO.

25-29 Columbia Square, San Francisco
 Telephone Market 5070

Factory on Canal, South San Francisco Telephone South San Francisco 161



DETROIT STEEL PRODUCTS CO., Detroit
 Direct Factory Branch, 68 Post Street, San Francisco Phone Sutter 1250

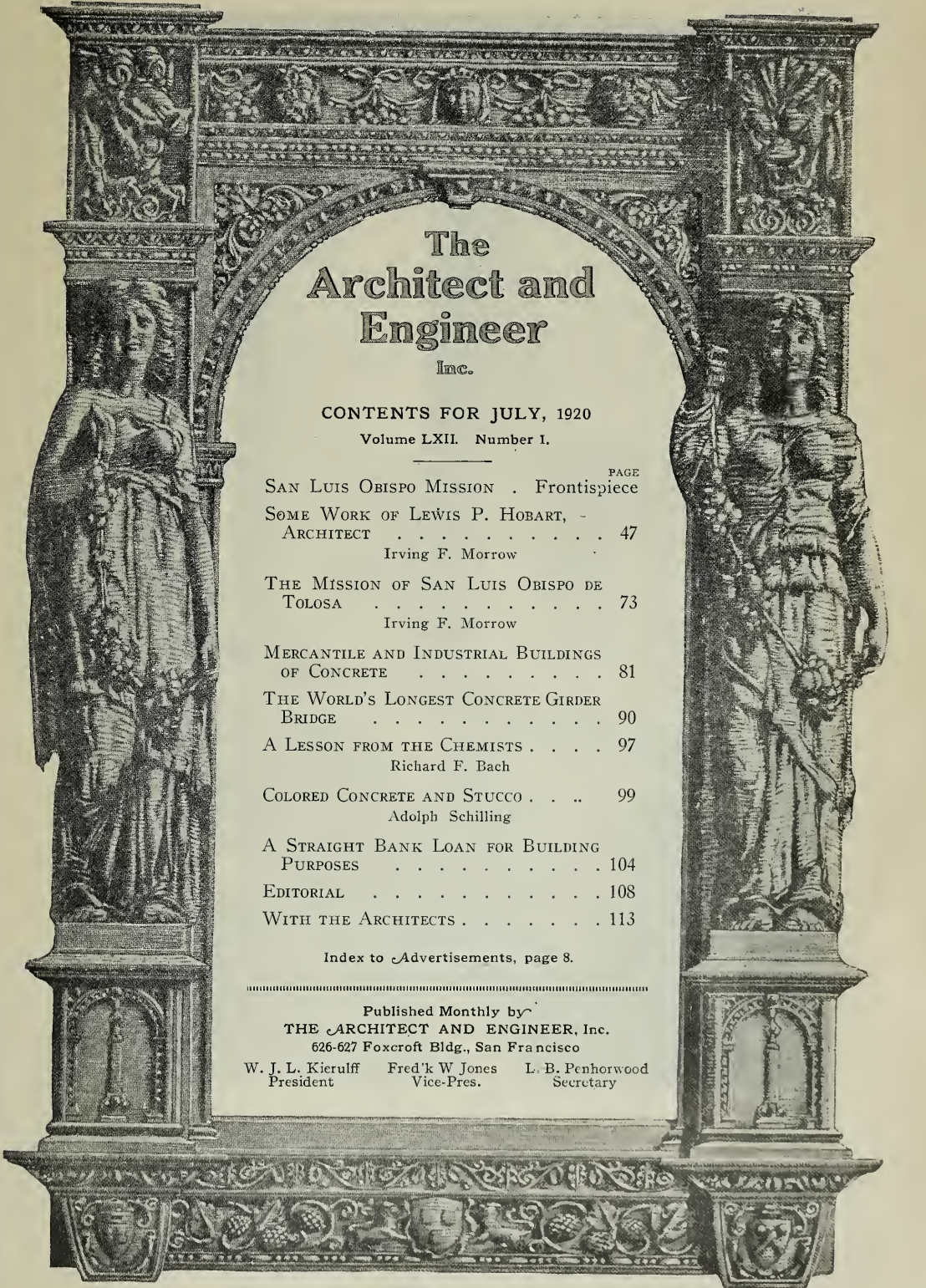

The Architect and Engineer

Inc.

CONTENTS FOR JULY, 1920

Volume LXII. Number 1.

	PAGE
SAN LUIS OBISPO MISSION . Frontispiece	
SOME WORK OF LEWIS P. HOBART, ARCHITECT	47
Irving F. Morrow	
THE MISSION OF SAN LUIS OBISPO DE TOLOSA	73
Irving F. Morrow	
MERCANTILE AND INDUSTRIAL BUILDINGS OF CONCRETE	81
THE WORLD'S LONGEST CONCRETE GIRDER BRIDGE	90
A LESSON FROM THE CHEMISTS	97
Richard F. Bach	
COLORED CONCRETE AND STUCCO	99
Adolph Schilling	
A STRAIGHT BANK LOAN FOR BUILDING PURPOSES	104
EDITORIAL	108
WITH THE ARCHITECTS	113

Index to Advertisements, page 8.

Published Monthly by
THE ARCHITECT AND ENGINEER, Inc.
626-627 Foxcroft Bldg., San Francisco

W. J. L. Kierulff Fred'k W Jones L. B. Penhorwood
President Vice-Pres. Secretary



SAN LUIS OBISPO MISSION — INTERIOR OF LOGGIA, NOW DESTROYED. (From an old photograph.)

SAN FRANCISCO
PUBLIC LIBRARY

+720.5 62

A724

157893

THE ARCHITECT AND ENGINEER

Vol. LXII.

SAN FRANCISCO, JULY, 1920

No. 1

Some Work of Lewis P. Hobart, Architect

By IRVING F. MORROW

RIDING on a day along a pleasant by-road of the San Francisco peninsula, my leisurely gaze was suddenly arrested by the glimpse of an architectural composition of more than usual freshness and charm. Every lover of architecture knows the feeling; of miles of mere building the effect is soporific; but the smallest fragment of wall which harbors a spark of the real stuff of life makes him sit up alert on the instant. This was a low tiled stucco building set at the back of a triangular walled pavement which occupied the gore between diverging roads. In a car of my own I should have straightaway halted and turned about for inspection; but riding, as is my wont, in that of a friend, I merely bent my neck to the wrenching point, and remarked, as we rounded a turn in the road, what an interesting building we had just passed. Too subtle a politeness does not pay; both gesture and remark passed unheeded, and we sped on. But the building I did not forget; and upon returning to the city I at once made inquiry to ascertain if Mr. Hobart had built a school in the vicinity I described. Let the reader decide whether this should be credited to my own perception or to Mr. Hobart's individuality. But coming, among the photographs here shown, upon the pictures of the Hillsborough District School, I enjoyed the dual surprise of recognition and identification. Also with the pictures returned the sense of freshness and charm I had felt the day I spun by on the road. This little building is a real delight. Its quiet and repose seem hardly to admit of analysis; yet, having a certain bulkiness in the gateway buttresses, it is carried out with exquisite grace and naturalness. Nor is its charm only, or even principally, for the passer-by. It suggests to me contented children; which is, perhaps, one of the highest as well as one of the rarest praises which can be accorded a school.

The Del Monte Lodge and the swimming pool and solarium at Hotel Del Monte are larger problems, and of greater intrinsic importance; but they as well breathe the same freshness and charm. In each case a natural situation of very rare beauty has been handled with delicacy and discretion. The

inevitable artificiality or formality in the life involved is reflected in a dominant note of contrast with the natural scene; not, however, at the expense of essential harmony. Our California landscapes embody varied and precious beauties. In the buildings which even of necessity obtrude upon them they deserve, though they seldom receive, the best that can be given. These structures under consideration really enhance the qualities of their respective settings for the purposes to which they are put. They are nice adaptations of means to

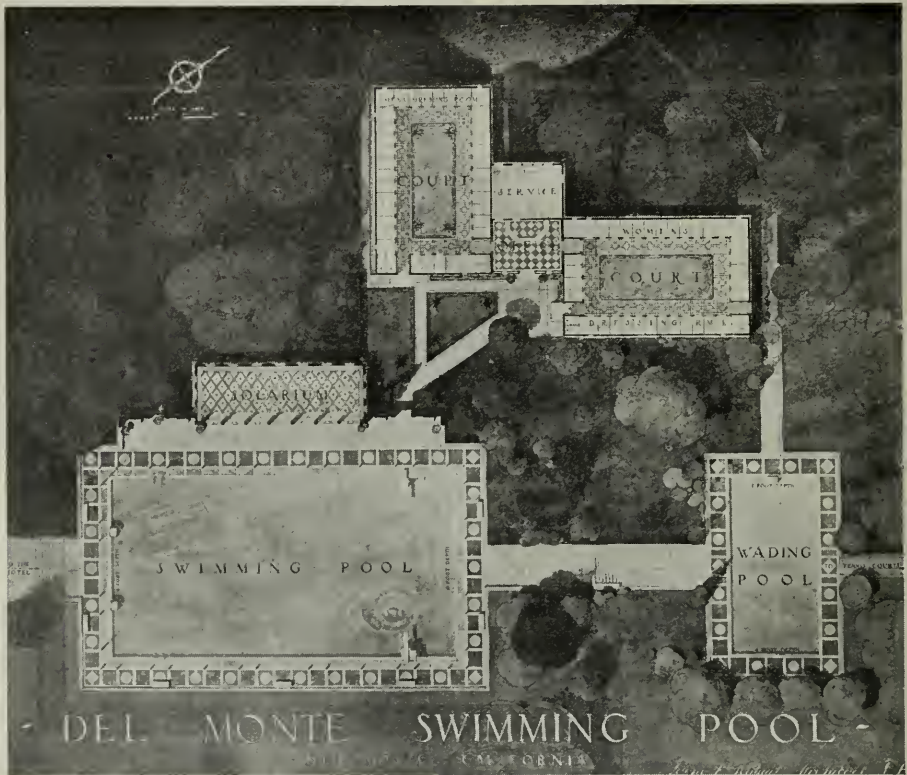

PLAN, SWIMMING POOL, HOTEL DEL MONTE

Lewis P. Hobart, Architect

all the conditions to be met, which is to say, they are real compositions. There are in them no unusual or novel elements or details; only those motifs which the progressive working of intelligent experience has pronounced "classic." But the familiar material is handled in a way to stimulate genuine pleasure. To mar the pleasure I felt myself, there was but one discordant note, which I so regretted that I own to having dissimulated in presenting one of the pictures which revealed it objectionably; I trimmed the photograph to obscure the unpleasant fact. I am therefore the more justified in dragging it forth with the light of the text. The colonnade along the ocean side of the garden at

Del Monte Lodge ends in a small triumphal-arch-like element. This balances a similar element on the building and toward the opposite end; but the conditions of its appearance in each case are so dissimilar that the correspondence is only theoretical; while its presence on the free end gives an unpleasant effect of a thing incomplete, awaiting subsequent additions. The swimming pool and solarium at Hotel Del Monte is a composition of fine quality. It is too reserved to be described as familiar; far too interesting to be called "monumental" as the term is generally applied. It is definite in expression and

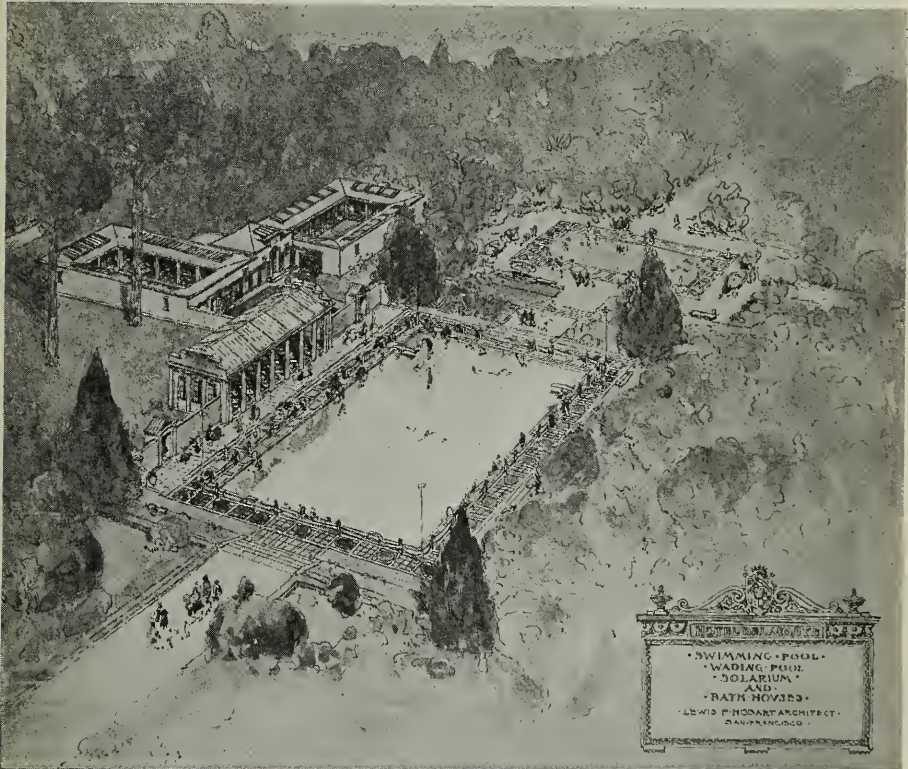

BIRD'S-EYE PERSPECTIVE, SWIMMING POOL, HOTEL DEL MONTE

Lewis P. Hobart, Architect

appropriate in feeling. Altogether, the inspection of these photographs was like a breath of fresh air blowing into the office.

It is commonly assumed that the countenance of the critic is one which habitually registers displeasure, and that his first movement, even prior to the opening of his typewriter, is the careful adjustment of a chip to his shoulder. Let me protest against this popular delusion. The critic is really looking out for a good time as well as anybody else; only he is seldom given the opportunity for so pleasant a time as he enjoyed in examining these illustrations. That, however, is his misfortune rather than his fault.



SWIMMING POOL, HOTEL DEL MONTE
LEWIS P. HOBART, ARCHITECT



SWIMMING POOL AND SOLARIUM, HOTEL DEL MONTE
LEWIS F. HOBART,
ARCHITECT



SWIMMING POOL AND SOLARIUM, HOTEL DEL MONTE
LEWIS P. HOBART,
ARCHITECT

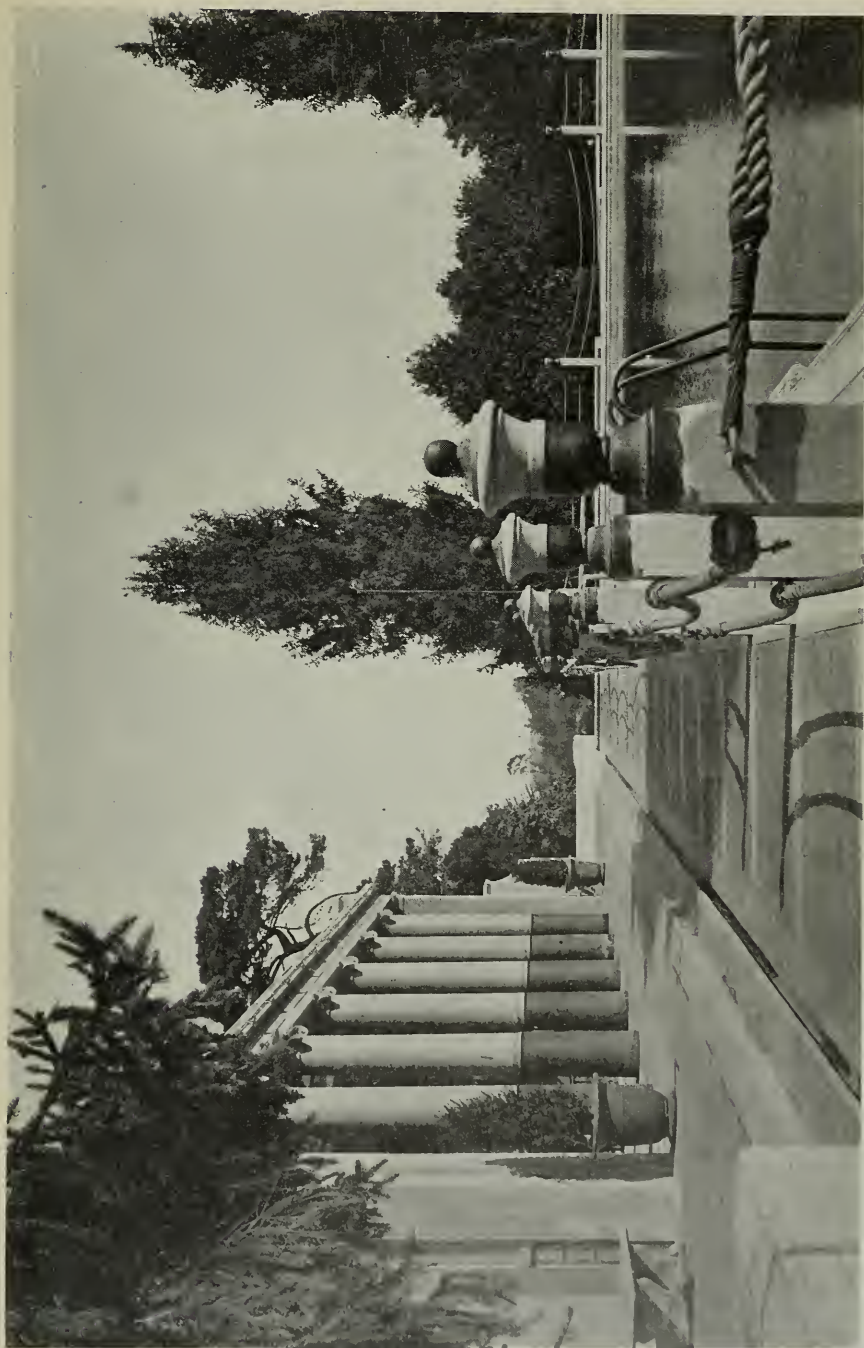

SWIMMING POOL AND SOLARIUM, HOTEL DEL MONTE
LEWIS P. HOBART,
ARCHITECT

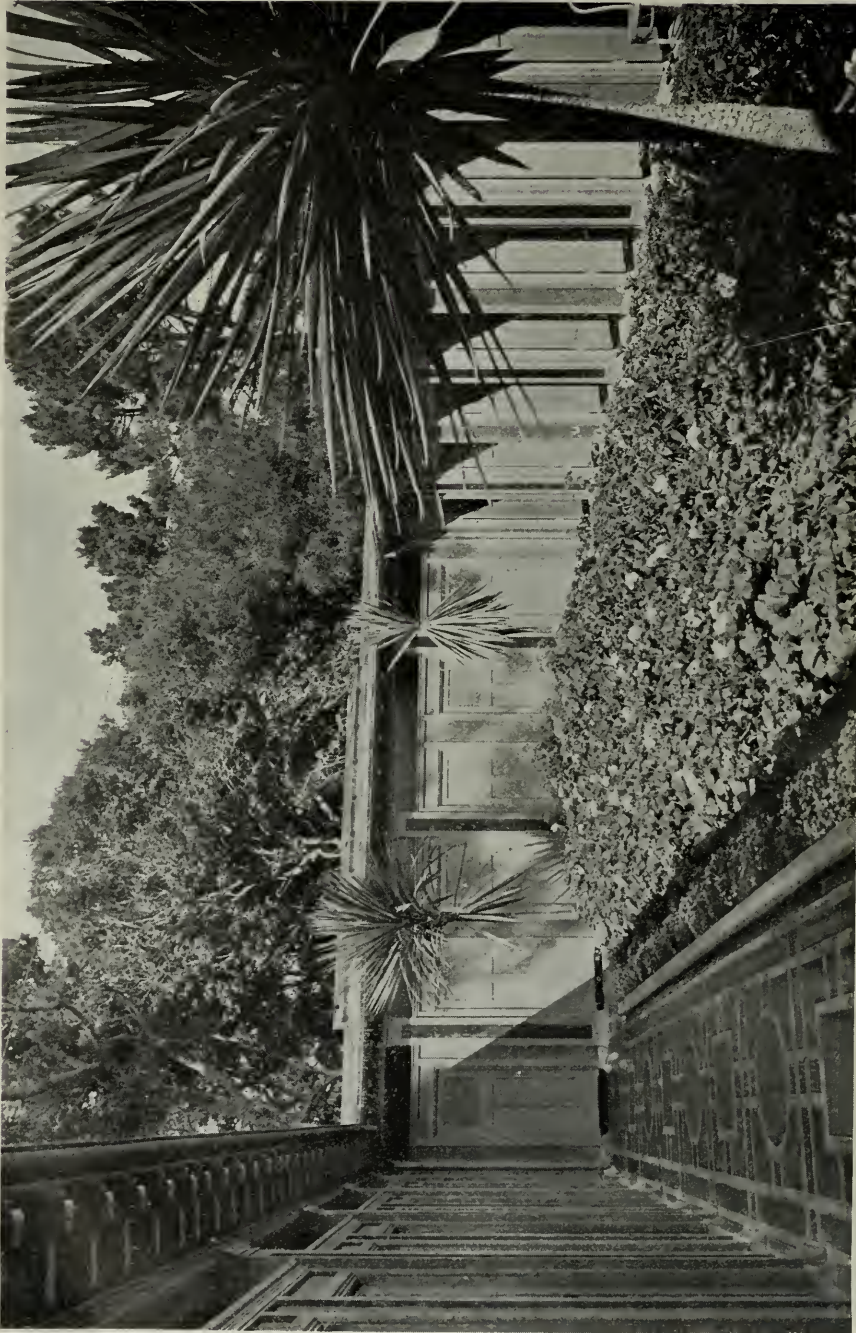

DRESSING ROOM COURT, SWIMMING POOL, HOTEL DEL MONTE
LEWIS P. HOBART,
ARCHITECT

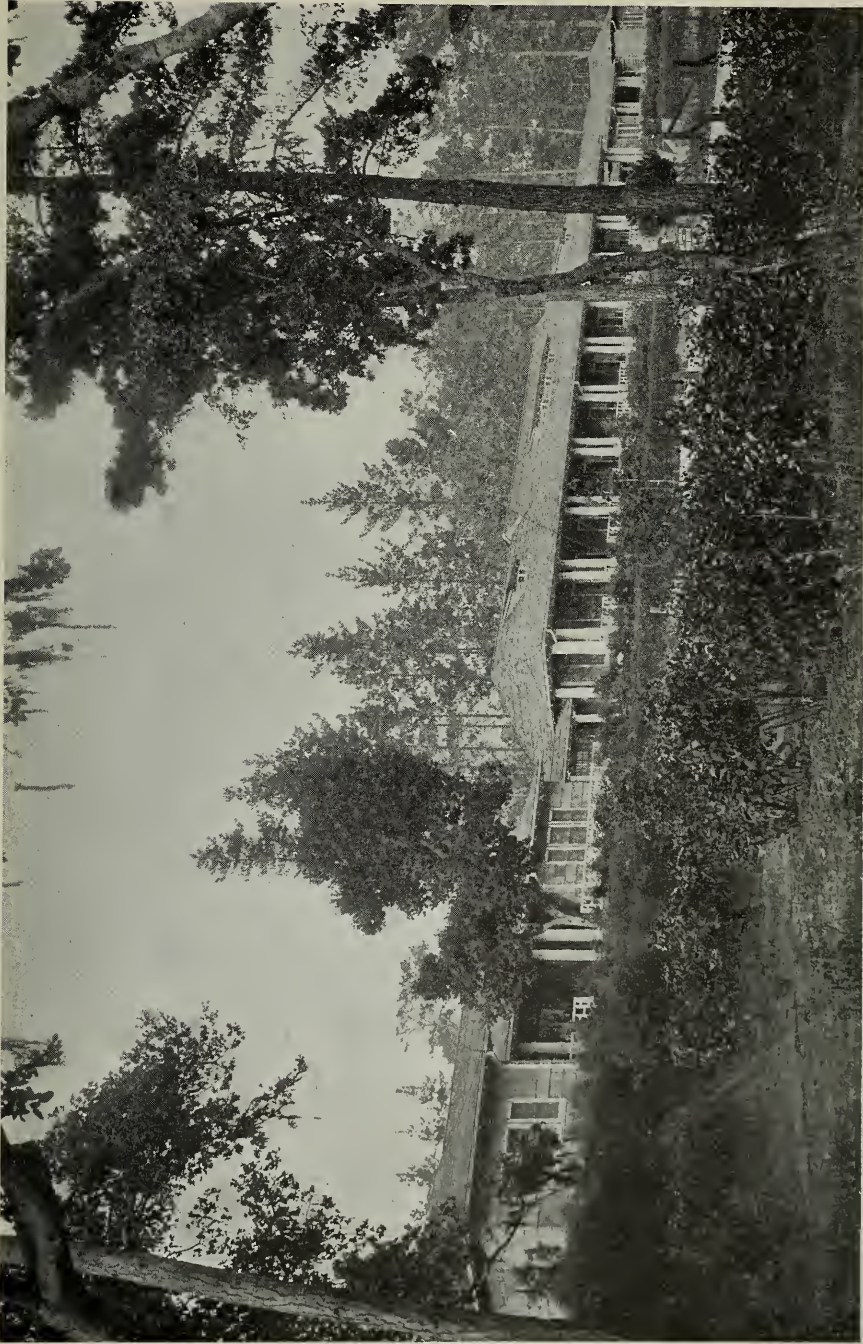

COTTAGES AT DEL MONTE LODGE, PEBBLE BEACH
LEWIS P. HOBART, ARCHITECT



DEL MONTE LODGE, PEBBLE BEACH
LEWIS P. HOBART, ARCHITECT

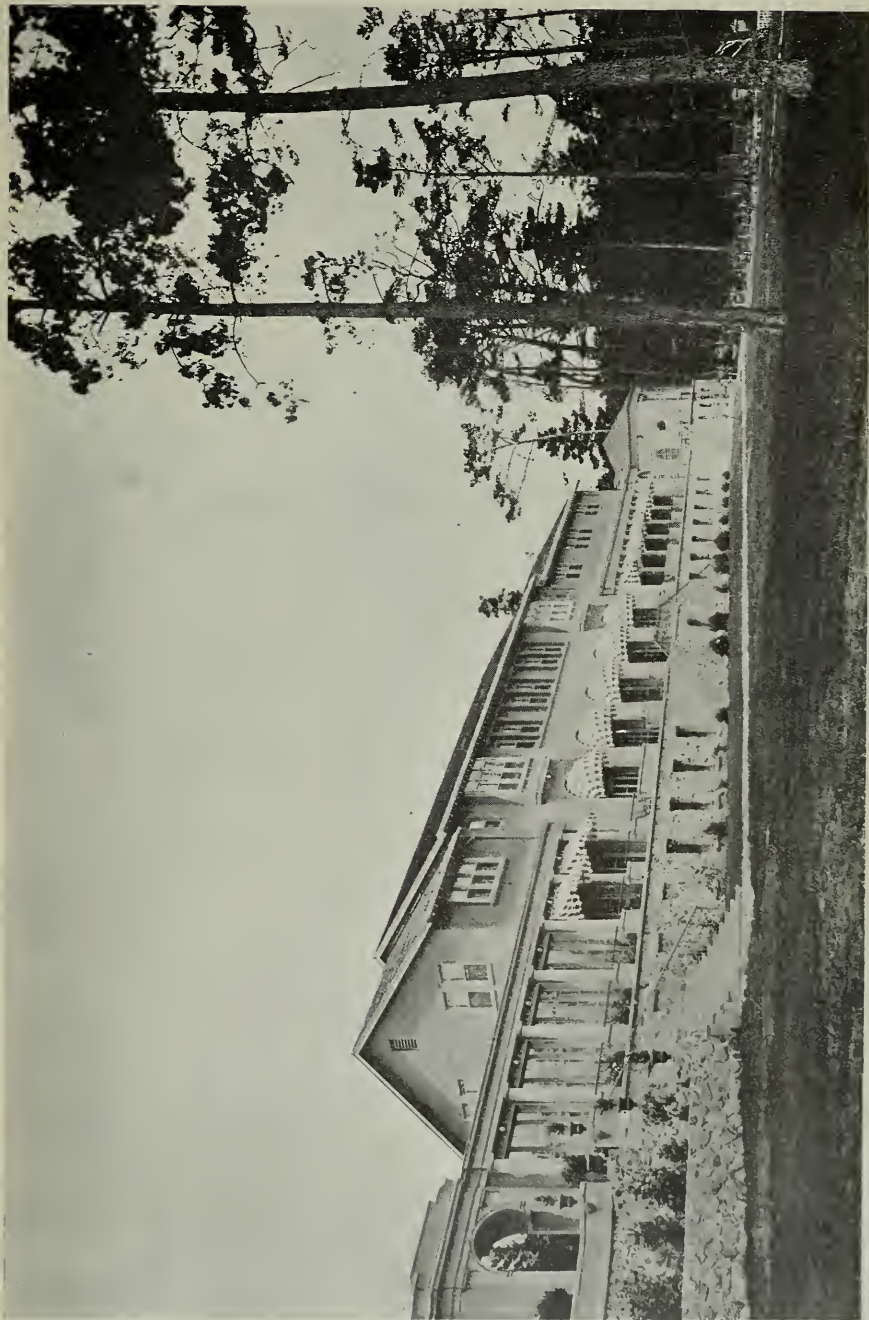

DEL MONTE LODGE, PEBBLE BEACH
LEWIS P. HOEART, ARCHITECT



DEL MONTE LODGE, PEBBLE BEACH
LEWIS P. HOBART, ARCHITECT



DEL MONTE LODGE, PEBBLE BEACH
LEWIS P. HOBART, ARCHITECT



ENCLOSED PORCH, DEL MONTE
LODGE, PEBBLE BEACH, CALIFORNIA
LEWIS P. HOBART, ARCHITECT



CORNER IN GARDEN, DEL MONTE
LODGE, PEBBLE BEACH
LEWIS P. HOBART, ARCHITECT

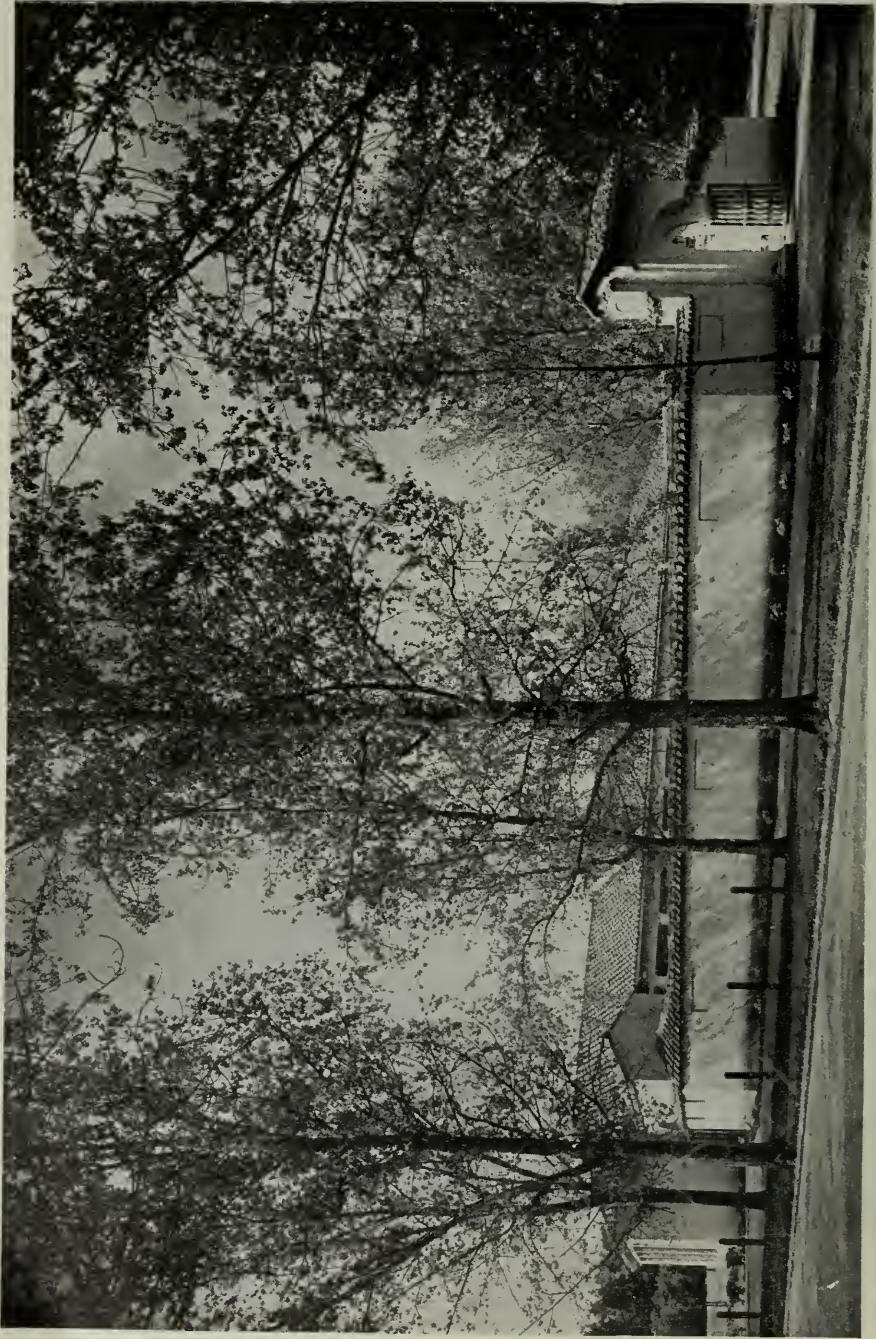

VIEW FROM THE ROAD, HILLSBOROUGH DISTRICT SCHOOL, HILLSBOROUGH LEWIS P. HOBART, ARCHITECT

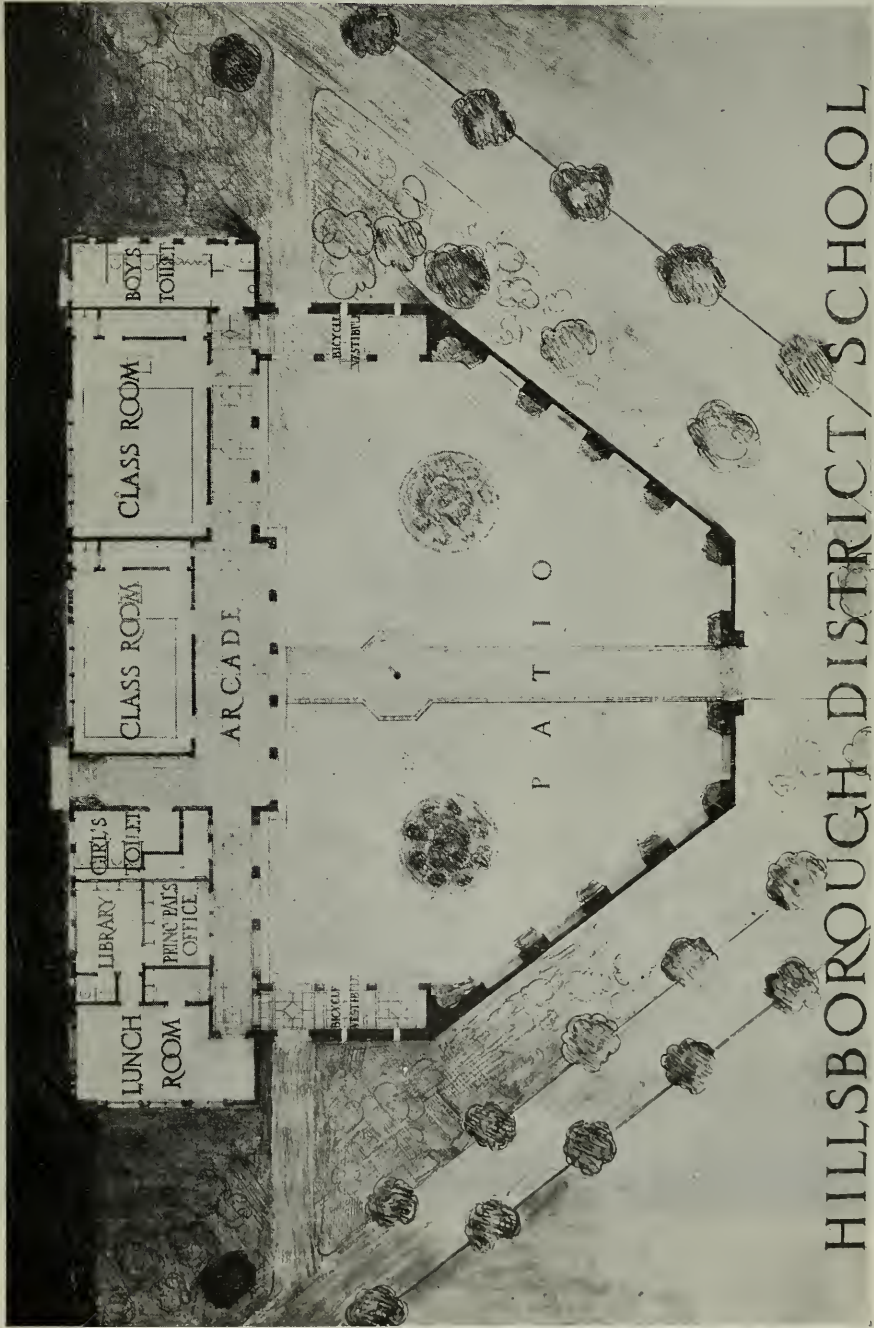

HILLSBOROUGH DISTRICT SCHOOL

PLAN, HILLSBOROUGH DISTRICT SCHOOL, HILLSBOROUGH ARCHITECT
LEWIS P. HOBART,

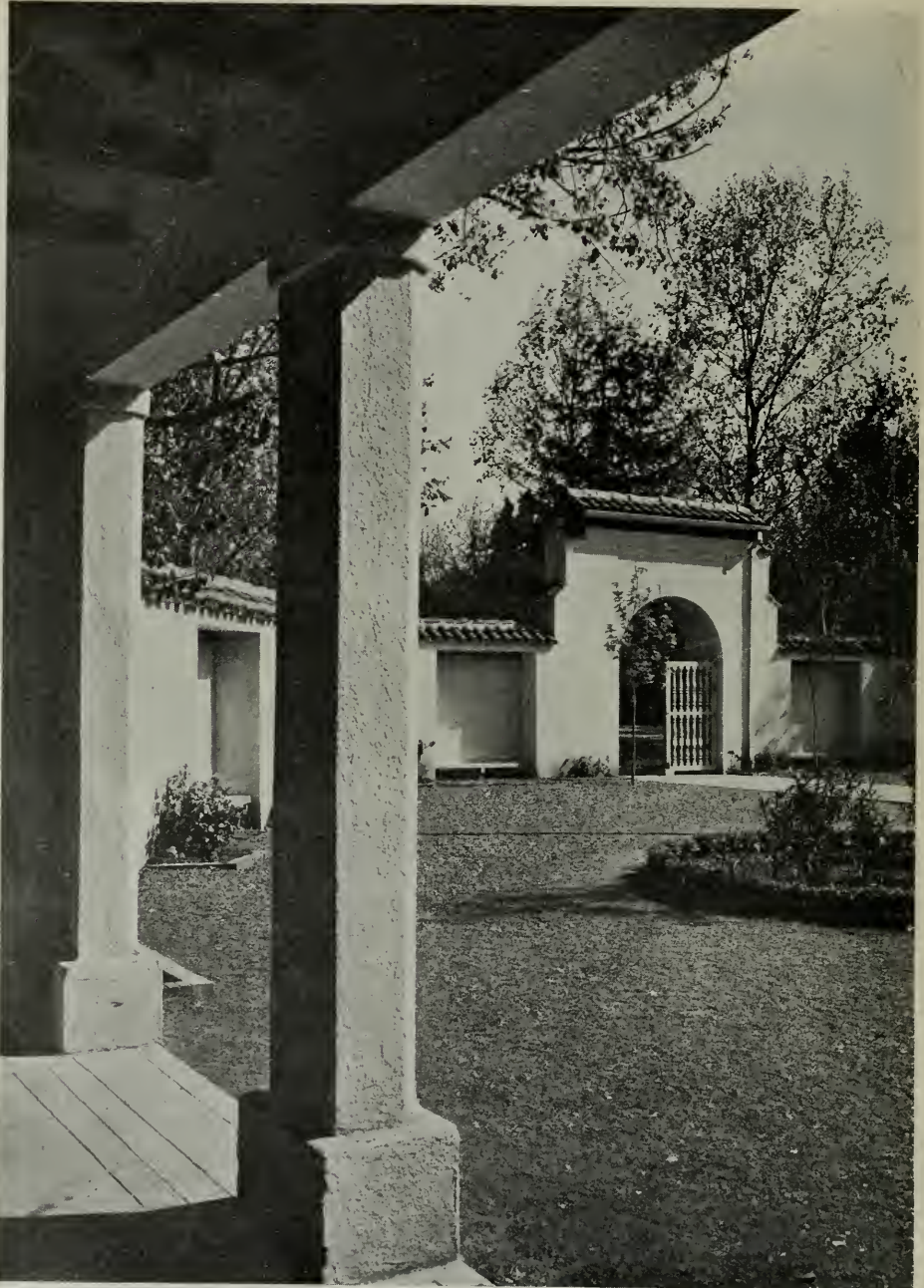

COURT, HILLSBOROUGH DISTRICT SCHOOL, HILLSBOROUGH
LEWIS P. HOBART, ARCHITECT



COURT, HILLSBOROUGH DISTRICT SCHOOL, HILLSBOROUGH
LEWIS P. HOBART, ARCHITECT



CHAPEL AND ADMINISTRATION BUILDING
ST. LUKE'S HOSPITAL, SAN FRANCISCO
LEWIS P. HOBART, ARCHITECT

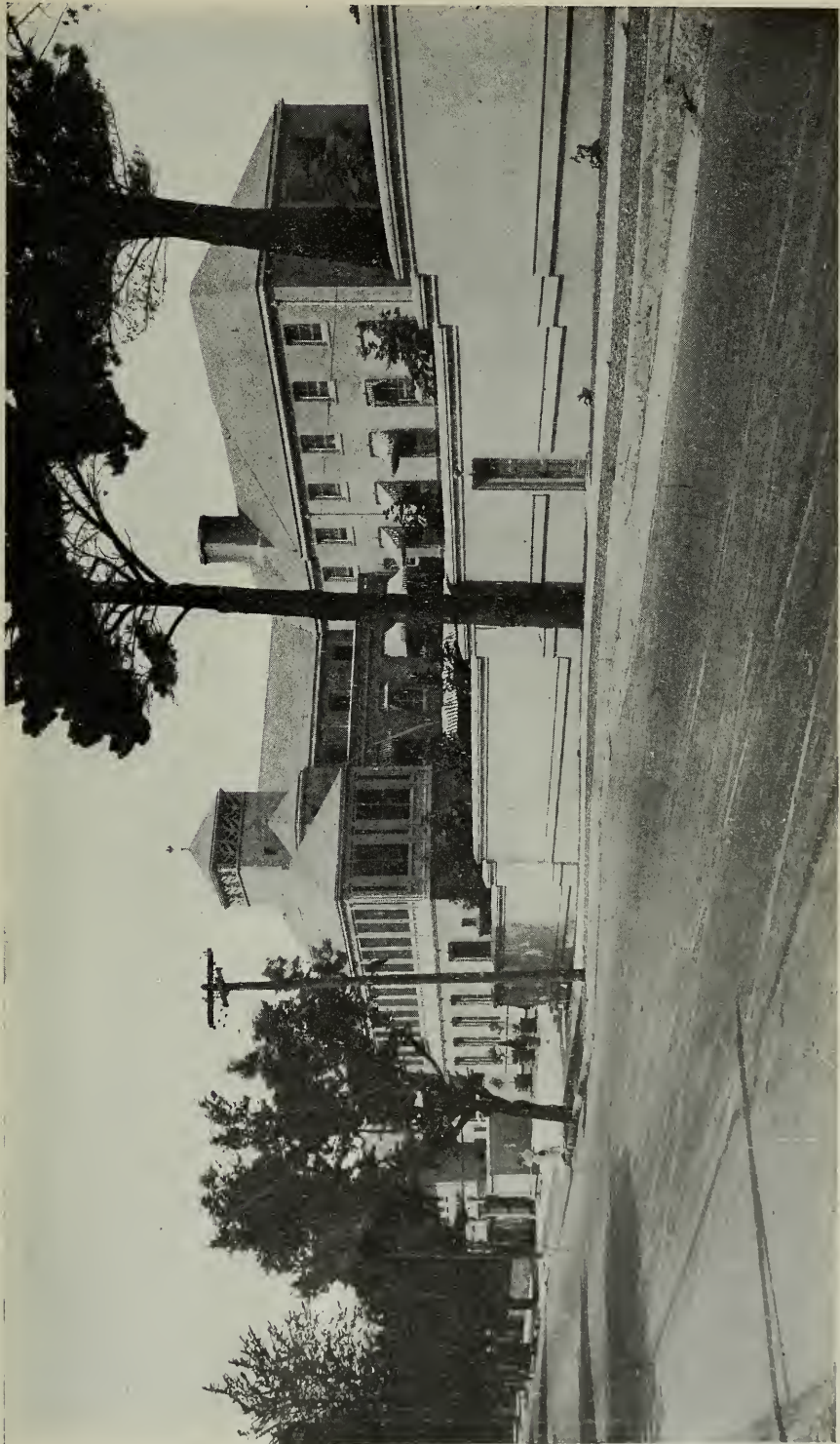

RED CROSS HOSPITAL, SAN MATEO, CALIFORNIA
LEWIS F. HOBART, ARCHITECT

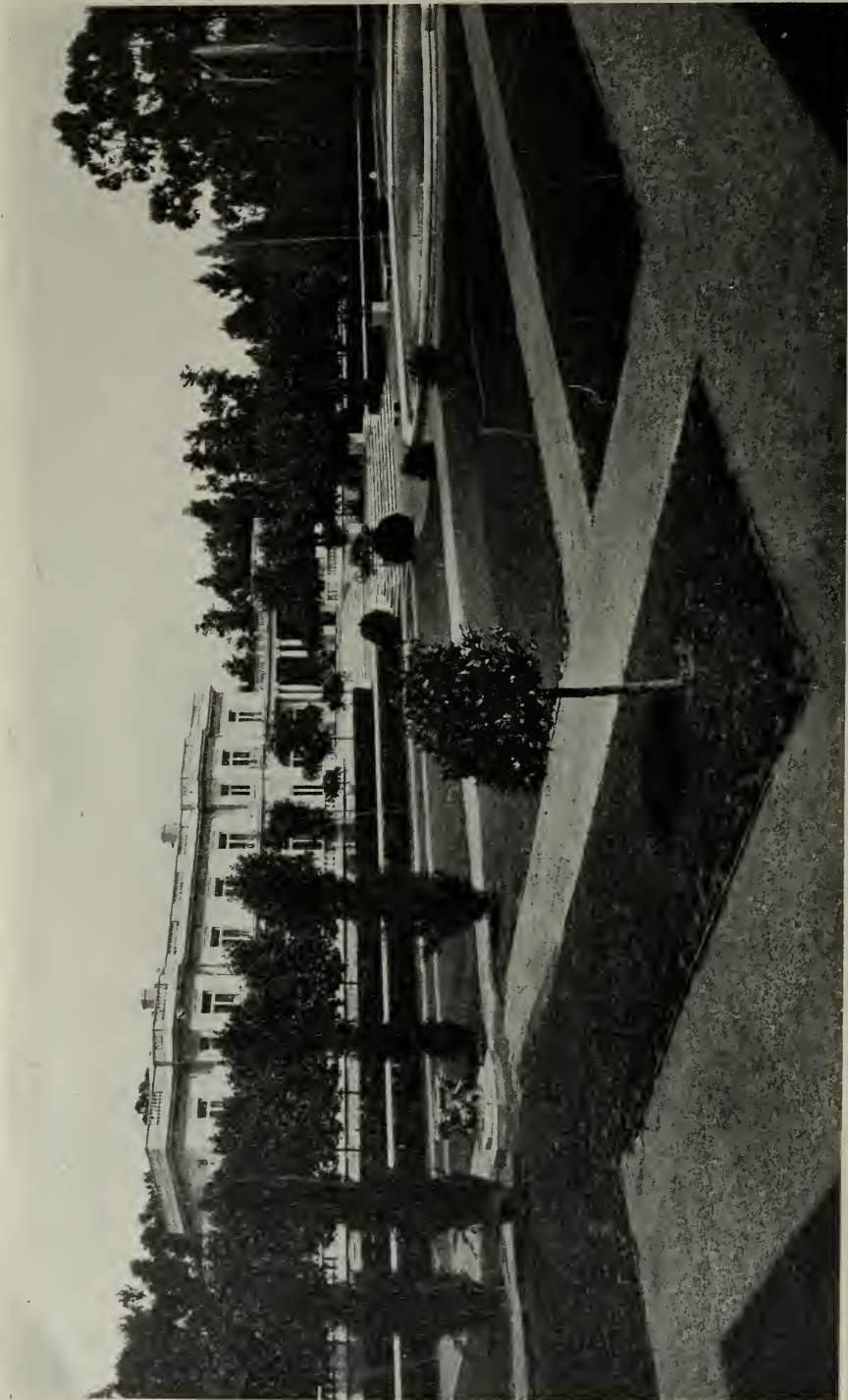

GENERAL VIEW, ESTATE OF GEO. A. NEWHALL, ESQ.
LEWIS P. HOBART, ARCHITECT



EAST ELEVATION, RESIDENCE OF THOS. DRISCOLL, ESQ.
BURLINGAME
LEWIS P. HOBART, ARCHITECT



ENTRANCE DETAIL, HOUSE OF THOS. DRISCOLL, ESQ.
LEWIS P. HOBART, ARCHITECT

Why House Building Must Increase

By WHARTON CLAY.

THE stability of the building industry is based, like every other industry, upon supply and demand. The increasing population demands more dwellings, and building will, unquestionably, continue; 1918 saw only 20,000 new houses built. There should have been twenty times that many.

Nineteen hundred and nineteen was some better, with 70,000 dwellings completed, according to the estimates by the U. S. Housing Corporation. But still the increase in population is far outstripping the building program for new houses. While in 1890, an average of 110.5 families occupied each 100 homes, today that figure has mounted to 121 families for every 100 dwellings. Hence, the present acute congestion.

With a conservative estimate of 27,900,000 families in 1925 the great housing shortage will continue unless building in all parts of the country increases to an extent unparalleled in the history of the construction business.

If only the current number of homes are constructed each year for the next five years 409,500 homes must be built, and the congestion will reach 129.6 families per hundred homes or 2 families in every fourth house.

Merely to keep up with the increasing number of families and in no way alleviate the present congestion 2,139,000 homes have to be constructed before 1926, while a return to the pre-war conditions of 115 families per 100 homes means the building of 3,340,000 dwellings in that period. When it is considered that in a town of 25,000 this construction program means 475 and 750 homes in five years respectively; the stability of the building industry becomes apparent.

The following table shows how, for the last three decades, the number of families in the country has exceeded the number of dwellings:

	Families	Dwellings
1890.....	12,690,152	11,483,318
1900.....	16,187,715	14,430,145
1910.....	20,255,555	17,895,845
1915.....	22,786,499	19,853,517
1916.....	23,292,887	20,263,051
1917.....	23,799,275	20,672,051
1918.....	24,305,662	20,808,562
1919.....	24,872,051	20,829,039
1920.....	25,319,443	20,900,000

* * *

Building Prices Will Stay Up After Other Prices Go Down

WITH the perceptible return of conditions of a fairly stabilized kind, prices of commodities are showing an inclination to rest about where they have been during the past few months—with the exception of the building material market. With this exception, other prices, and the price of labor in other lines is showing a tendency to remain firm where they have been for some time. The reason that building material and building labor still fluctuates, mostly upward, is twofold.

First, the call for building labor and supplies was never so great or concentrated at one time as at present, with every indication of an increasing volume for the middle of the present year. The second reason, which also is the reason why building activities have only now begun to approach their peak, is that building construction was one of the last of the great industries to get

started after war necessities were relieved. All things pertaining to real estate were slow in responding to the activity which otherwise prevailed in every other line of industry and trade. Real estate and building were the first to be scared to cover when war was imminent, and likewise, being the most conservative form of all investments, was the last to issue forth to daylight when the trouble was over. Hence the tardy rise in value of old buildings, the tardy rent increases, and the rise in building materials, which really for a time—say January to June, 1919—were not high as compared with other products, but are now finally getting up to a parity with other things. Vacant lots were the sole remaining commodity which refused to advance in price, but during the last few months the activity in improved real estate and the continuous building activity has caused the tension to relax and the prices of vacant lots are going upward. In some cases there has been an increase of 50 per cent over last summer's prices, and the market is getting firmer every week on this class of property. The activity in vacant property has a special significance. The transfers in nearly all cases, and the revival of interest in vacant lots means that those who are buying or making inquiries for vacant property have in mind only one thing—and that is to build. So that the whole situation is interwoven, and there is a definite reaction from one to another. A new and decided crush of work is again imminent for those in the building industry.

The problem that remains as concerns building is for the architects. They control the purchase of many tens of millions of dollars worth of material, and should keep their senses alert against methods of producers which might lead to profiteering on certain basic materials. There cannot be too much vigilance in this direction, as human nature is entirely too frail to resist the temptations to profiteer unnecessarily on the basic commodities which go into buildings. A brief list of basic products which should be watched are—cement, steel, gravel and sand, lumber, interior finish, plumbing, brick and roofing products.—Building Review, New Orleans.

* * *

A Work of Art

The Hartford Times and the city of Hartford are to be congratulated on the plans for the handsome building which the newspaper is to erect for its exclusive use on one of the most attractive sites in the city. On a large plot on Prospect street facing the Morgan memorial and the new municipal building, the Times building will have for its neighbors some of the finest architectural works in the city, and it will be worthy of its company. The most striking feature of the building will be its principal facade, including in its structure the six columns, two pilasters and a considerable portion of the colored glazed tiling which was removed from the Madison-avenue Presbyterian church (Dr. Parkhurst's church) in New York city, when it was torn down to make way for a sky-scraper. This church was the last and one of the best of the works of the late Stanford White and it will be a satisfaction to lovers of art everywhere that it is not to be entirely lost. In the Hartford building, of which Donn Barber is the architect, the rich green granite columns, originally of the Corinthian order, will be altered to the Doric. As a working newspaper plant, the Times building promises to be one of the best in the country. It will be roughly 65 feet deep by 165 feet long, three stories above grade in front and four stories in the rear, fireproof and with a maximum glass area. A mezzanine floor will afford visitors a convenient opportunity to see the presses at work.—Springfield Republican.



SAN LUIS OBISPO MISSION—ORIGINAL ENTRANCE AND FACADE TO CHURCH, AFTER REMOVAL OF ROOF TILES OVER BELFRY

(From a photograph reproduced by permission of Mr. Charles B. Turrill.)

The Mission of San Luis Obispo de Tolosa

By IRVING F. MORROW

“THE Mission of San Luis Obispo of the Tribe of the Tuhos, which is twenty-five leagues distant from the one above mentioned of San Antonio, also on the road to San Diego, was founded the first day of September of last year, 1772, on which day the place was blessed; we set up the Sacred Emblem of the Cross, sang the first mass, so tenderly we said it. As soon as the functions were finished we proceeded on our way to San Diego, where our two ships, at anchor, awaited us. A father whom I sent to Monterey to occupy my place wrote me a letter from my Mission. He said, ‘I arrived at the Mission of San Luis Obispo and found that Padre Cavaller had a well ordered house and was protected against rain; and they were making another, one-half of which was to serve as a church and the other half for the quarters of the boys. He is content with his Indians, with the result that they are very agreeable and loyal; if they had not been so the Mission could not have lasted.’ * * *

“The situation is excellent, an abundance of good land and good streams, timber and woods (most of the trees are elms and alder trees), and I hope by working hard that a beautiful and prosperous Mission will be created.”

In these words does Father Serra* describe the founding of the Mission which he himself dedicated to Saint Louis, Bishop of Toulouse. To relate the Mission’s subsequent history would be almost to repeat, in outline, that of every other establishment. There was the familiar laborious beginning, the same rise to opulence in the neighborhood of the turning of the century (when it harbored close to a thousand souls), the same long period of agricultural and industrial prosperity, the same decline and neglect accompanying the secularization just before the middle of the last century. But of all the Mission establishments in California there is perhaps none whose buildings have undergone greater vicissitudes.

* Serra, Representacion, 1773, a manuscript in the Bancroft Collection, University of California.

In 1776 burning arrows discharged upon the tule roof by hostile Indians during an attack resulted in the loss of the first buildings by fire. The undaunted Padres rebuilt, but on two succeeding occasions during the next ten years their buildings were again destroyed by fire. Three such unfortunate experiences apparently stimulated their ingenuity to contrive a roof covering more fireproof than tules. At any rate, it was at San Luis Obispo that were first made those terra-cotta roof tiles which were subsequently adopted at all of the Mission establishments, and have come to be regarded as one of the distinctive features of Mission architecture. In the nature of the case these tiles were technically inferior to current commercial products; they are fairly porous, and none too completely burned. But it is an impressive demonstration of the initiative and resourcefulness of the Padres that with their meagre facilities they were able to achieve practical results at all. From the æsthetic



SAN LUIS OBISPO MISSION—ORIGINAL CONDITION
(From an early photograph.)

standpoint their roofs were masterworks. The size and shape of the tiles exhibit that subtle variation inherent in honest hand workmanship; and the unequal burning results in a pleasant variation of color, which is also reinforced by the irregular clinging of minute mosses to the porous surfaces. The result is a roof of exquisite softness and richness of tone, an achievement which I believe to be quite impossible of reproduction today; for all the natural conditions which led to the distinctive qualities of these products have disappeared beyond recall from modern industry; and any attempt consciously to reproduce their eccentricities would end in the same futility that awaits every affectation. The more pity, then, that all of the original tiles have disappeared save over one small area of some twenty-five by fifty feet at the south end of the long arm of the building.

"A new church of adobes," says Lasuen,* "with a tile roof, was completed in 1793, and that same year a portico was added to its front." This fourth building, in the absence of any other indication, I take to be the present one.

* Lasuen, Informe of 1793, a manuscript in the Bancroft Collection, University of California.

But could the Padres today behold the Mission of San Luis Obispo de Tolosa, they would most assuredly show no recognition of their own handiwork. Decay and irreverent meddling have introduced change upon change, until now the structure stands stripped of every vestige of the romantic glamor associated with the period of the Spanish occupation. It is as forbidding spiritually, as poverty-stricken in æsthetic and emotional content, as the proverbial New England meeting house. It is the finished work of indifference collaborating with ignorance. A long series of transformations is revealed by successive documents; although I have had no opportunity to ascertain their exact dates, or even their precise order. Most obvious, but probably of least real importance, is the breaking up of the quadrangle. Reference to the plan will show that the line of buildings forming the south side of the enclosure has entirely disappeared, and that of the rear or west wing there remains but a small length of



SAN LUIS OBISPO MISSION—AFTER GRADING OF STREET, RECONSTRUCTION OF WALL TO CHURCH FORECOURT, AND REMOVAL OF TILES FROM BELFRY

(From a photograph.)

some forty feet lately used as a barn or stable. The front wall of this fragment is a rubble of golden stone, red tile, and gray mortar, beautiful in color and texture. These missing wings probably contained the living quarters of the Indians, the domestic services of the Mission, and certain of its industrial establishments. There is small likelihood that they embodied anything of more than ordinary architectural value; and their loss is of little practical consequence, since the remaining wings offer more than adequate space for the activities of the present parish church. It is probable that their passing was a slow disintegration covering a long period of neglect. Of more importance is the treatment which has been accorded the two wings which remain, and which from the beginning embraced the features constituting the Mission's real architectural claim. The street before the colonnaded loggia, which originally stood at a couple of steps below the floor inside, was early graded down to a level which averages four or five feet below the floor. This re-grading may have been inevitable in view of the desired development of the town's streets; although personally I believe that the block on which the Mission

stands will never be essential to vehicular traffic, and that the street might have been left at the old grade, with steps for pedestrians, in the European fashion, descending from it to the business streets below at the north. However, it is too late to discuss that now, for the work is done. But its effect on the architectural composition can be easily appreciated. The genial hospitality of the intimate Spanish loggia, mounted aloft upon a five-foot retaining wall, acquires something of the uneasy self-consciousness of homely domestic articles of former periods exposed for exhibition in a museum. However unfortunate all this, it may be admitted as inevitable under the conditions; nor is it fatal. But it seems to have been accomplished by another alteration equally unfortunate and less easily extenuated. The simple, dignified plaster walls and gate posts enclosing the little open fore-court to the church gave way to a rusticated stone wall topped by an open balustrade; a small change, it may seem, yet one entailing no inconsiderable loss of quiet charm. Changes also began to creep into the church proper. The open arched vestibule with belfry above, which formed the facade to the church, and whose walls seem to have been thinner than those of the nave, became weakened by earthquake. It was first deemed expedient to relieve the load on the walls by removing the roof tiles over this portion; but continued evidences of weakening finally led to the removal of the entire element back to the front wall of the nave. Architecturally this step was fatal. Not only was a stupid facade substituted for one of great charm, but the plane of the facade itself, receding along the upward-climbing gable line of the roof of the front wing, was left standing at a point where its eaves practically coincided with the ridge of the lower flanking roof. The resulting arrangement of lines is an ineptitude of which the Padres could never have been guilty. In addition, the destruction of the belfry necessitated a new housing for the three Mission bells; and with an uncanny insight for the incongruous, a trivial little wooden belfry was inserted at the most ill-considered point. Only three features now survived to perpetuate something of the picturesque spirit of the past — the colonnaded loggia, the tile roofs, and the plaster walls; and to their obliteration attention seems promptly to have been turned. The loggia was deliberately removed to increase the light on the interior; an admissible object, it may be owned, but one which slight ingenuity might have accomplished by measures less drastic. (I might note here in passing that, although all old documents show this loggia standing before only about two-thirds of the front facade, it was evidently incomplete, the architectural intention to extend it along the whole facade being unmistakable.) The tapestry-like tile roofs gave way to shingles. Why the little area above mentioned at the south end was spared, and what became of the large quantity of displaced tile, I do not pretend to say. Finally, the plastered adobe walls were boarded up in unsightly channel rustic and painted. This last is the only measure which can be condoned; plaster was undoubtedly scaling from the adobe, and without this protection, offensive as it is in appearance, the walls would unquestionably have suffered serious disintegration from storms. On the inside of the church a sleek, characterless tongue and groove sheathing was nailed on below the older ceiling. (The original ceiling, of course, must have rested on the top of the beams, as metal was one of the scarcest of the Padres' commodities, and nails were not available to fasten boards to the under sides of the beams.) The most recent addition was a transept, a brick structure of slight character, known locally as the annex, at the north side of the chancel. As if this tale of neglect and abuse were not sufficient for one building to endure, the Mission was but a few months back the scene of another fire. Newspaper reports at the time conveyed the impression that the entire structure had been demolished by the conflagration; so that it was with profound relief

that I verified with my own eyes that the damage had been confined to the destruction of the roof over nave and annex; even the original ceiling beams were but slightly charred, and burned to the point of impairment in not more than half a dozen instances.

Accepting the challenge of this culminating accident of a century and a quarter of misfortune, the citizens of San Luis Obispo have decided that their Mission, which is not only a local asset, but a part of the historical and cultural heritage of the people of California, is in its present condition an unworthy travesty of its former self. They have therefore organized to collect funds for its complete rehabilitation, all elements of the community uniting in an

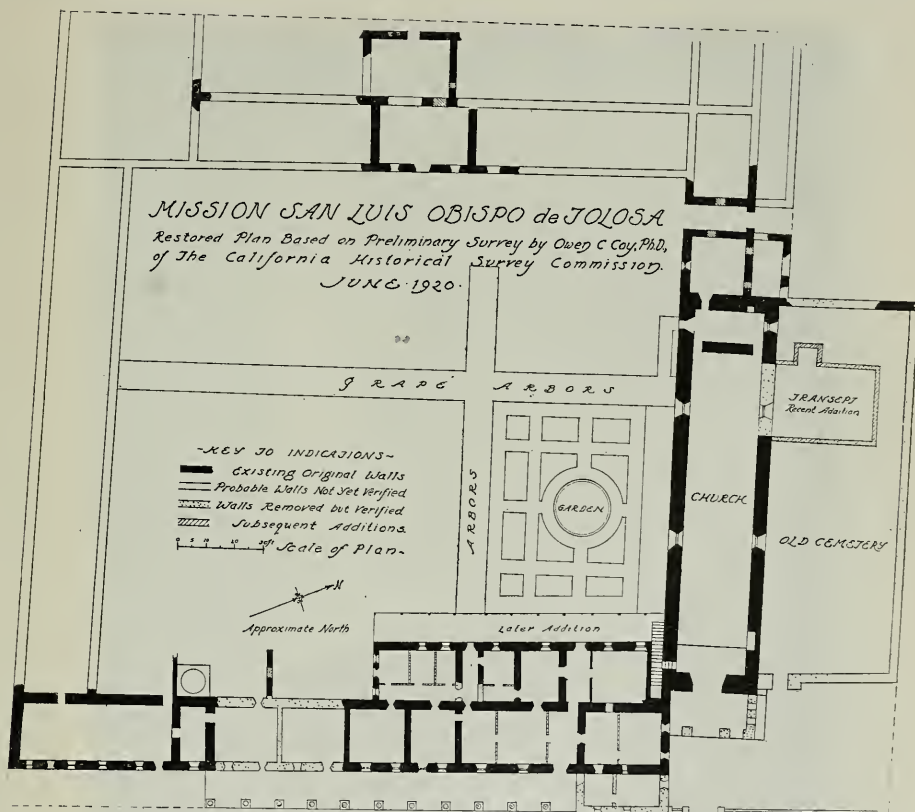

PLAN OF MISSION SAN LUIS OBISPO DE TOLOSA

Drawn from Preliminary Survey by Dr. Owen C. Coy of the California Historical Survey Commission.

effort which is strictly non-sectarian. Happily, throughout all the mischances I have recited, the Padres' original massive adobe walls remain structurally intact, unimpaired, as far as can be seen under the present conditions, save at one or two points which can be readily repaired. It is proposed, as money becomes available, to re-tile the entire roof, to rehabilitate the interior of the church, to rebuild the church vestibule and belfry, to remove the present belfry, to reconstruct the portico along the front, and to restore the entrance to the fore-court of the church. The accomplishment of this program will restore the surviving portions of the buildings as nearly to their condition in the days of full prosperity as is consistent with their legitimate present use;

and the Mission of San Luis Obispo, which has sunk to the position of least interesting of the extant Mission structures, will once more assume its rightful place as one of the most quietly charming, gracious, and poetic compositions of the Padres' legacy. I wish to state in passing that subscriptions in aid of this work will be gladly accepted, and may be forwarded to the San Luis Obispo Mission Restoration, Room 1, Wade Building, San Luis Obispo; to the Commercial Bank of San Luis Obispo; or to the Union National Bank of the same city.

There is today, I may add, no excuse for failure to restore these buildings in entire conformity with the conceptions of the original builders. In an



SAN LUIS OBISPO MISSION—THE CHURCH FROM THE ANNEX AFTER THE RECENT FIRE

article* published several months back, dealing with the general problem of Mission restoration, I expressed a hope for "the publication in adequate form of a complete and authoritative archæological and architectural record of the Missions, comprising pertinent early drawings and prints, the best obtainable photographs, drawings of their present state, and restored plans as far as the data for the making of such are obtainable." I have been glad, therefore, to learn since that time that work is actually in progress on substantially such a

* The Restoration of the California Missions—by Irving F. Morrow; Architect and Engineer, January, 1920.

program. The Legislature of California has appropriated funds to be used by the California Historical Survey Commission in furtherance of these ends, and work is being carried on under the direction of Dr. Owen C. Coy of the University of California. To date Mr. Coy's personal investigations have embraced San Diego, San Luis Obispo, Carmel, and Santa Cruz, as well as others of the Missions. The work, which is proceeding with great thoroughness, comprises excavations and investigations on the ground, surveys, and the collection of old documents. The Commission's results should be of inestimable value in restoration projects. On the historical side they are carried out with an accuracy and a completeness beyond the range of the architect's training or

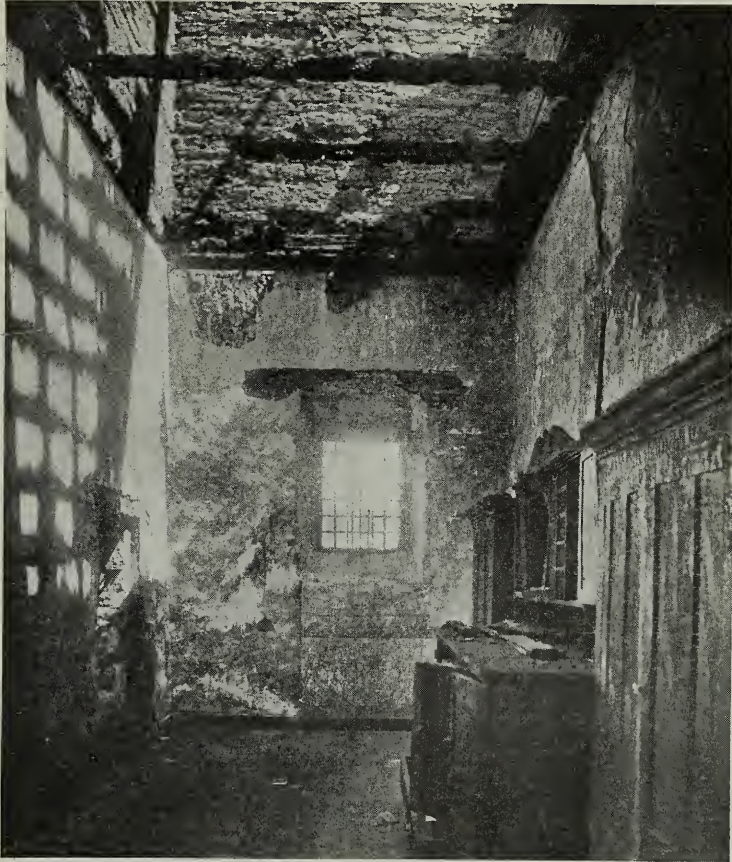

SAN LUIS OBISPO MISSION—SACRISTY AFTER THE RECENT FIRE

opportunity. It is the intention ultimately to publish these results, though none of the investigations has yet reached this point.

The plan of San Luis Obispo Mission here reproduced is (with the exception of the garden and a couple of modern additions, which I have added by eye) taken directly from Dr. Coy's preliminary data, which he has kindly permitted me to use. It should be stated that, while accurate as far as his investigations have gone, his survey is still incomplete. He has also been instrumental in directing me to old illustrations. The photograph of the original entrance and church facade is from the admirable collection of Mission data of Mr. Charles B. Turrill of San Francisco.



ASSEMBLY PLANT OF FORD MOTOR CO.,
CHICAGO. CONDROX CO., ENGINEERS

Mercantile and Industrial Buildings of Concrete*

BUSINESS executives confronted with the necessity of choosing a type of building that will best meet the needs of their industry consider every factor likely to affect the desirability of the proposed structure. Such features as fire-safeness and consequent low insurance, freedom from maintenance and depreciation, adaptability, speed of construction regardless of season, permanence, and sanitation are desirable factors. Each must be considered from the standpoint of its proper relative importance, although to many of them no definite money value can be given. Nevertheless, all are susceptible of being capitalized.

Today the merits and economies of mercantile and industrial buildings are judged largely in the cost accounting department. The annual balance sheets



CONCRETE FACTORY, ALUMINUM GOODS CO., NEWARK, N. J.
Lockwood, Green & Co., Engineers

will show that first cost of a structure is only one item and not necessarily of first importance. It is ultimate cost that will test and prove economy. Ultimate economy dictates the choice of that type of construction on which freedom from depreciation and maintenance, low insurance and favorable influence on production will, by comparison with some other type of construction, in a short time, more than compensate for any probable additional first cost.

Employes' welfare must be considered. Buildings which are sanitary, light, well ventilated and hence provide healthful quarters for workers, are certain to contribute to profits because of the contentment developed among the workers and the consequent reduction of labor turnover. A sense of security is felt by owners, operating officials and employes in the knowledge that the building which houses them and their industry is proof against destruc-

* Courtesy of the Portland Cement Association.



BUSH TERMINAL BUILDING, BROOKLYN, N. Y.
William Higginson, Architect

tion by fire, tornado and earthquake. It is worth money for owners and employes alike to know that none of these visitations can suddenly wipe out the industry on which they are dependent, with the resulting loss of time, money, patronage and prestige that may have taken years of endeavor to build up. Attainment of these desirable ends is certain to favorably influence financing and credits. Permanent, fireproof buildings are also of distinct advertising value to their owners. With concrete buildings, these desirable ends are secured in the fullest measure.



MILL OF THE NIAGARA SILK CO., NORTH TONAWANDA, N. Y.
G. Morton Wolf, Architect



FACTORY, NEW YORK CONSOLIDATED CORD CO., LONG ISLAND CITY, N. Y.
Ballinger & Perrot, Architects

A comparison of the initial cost of fireproof buildings will almost invariably show the low cost of the concrete structure. In many cases concrete buildings designed for heavy floor loads have been built for less than any other practicable type would have cost. Speaking of conditions in 1916, Arthur R. Lord, a consulting engineer of Chicago, said, in articles published in the *Cement World* for September and October, 1916: "Under normal market prices of materials, mill construction runs about 5 per cent cheaper than flat slab. Where lumber is cheap, the difference will be greater and, on the other hand, in certain cases flat slab construction has actually been built for the same first cost as mill construction." In the articles by Mr. Lord referred to, buildings of various types are placed in the following order as to first cost, beginning with the lowest in cost:

- Mill construction.
- Concrete flat slab.
- Concrete beam and slab.
- Structural steel, fireproofed.

Since 1916, however, marked changes have taken place in the materials and labor market, but the net result has been rather to reduce the difference in cost between mill construction and reinforced concrete instead of to increase it.

A modern concrete mercantile or industrial building of a certain size and type, built to serve a specific purpose, may, for example, cost \$200,000. A similar building equally modern in appointments, of the same size, built to serve the same purpose, but of another type of construction, may cost \$180,000. At first glance the intending builder might be tempted to favor the seemingly cheaper building, but when it can be shown that the first mentioned type costs



PACIFIC COAST SHREDDED WHEAT CO., OAKLAND
Lewis P. Hobart and C. H. Cheney, Architects
H. J. Brunner, Engineer

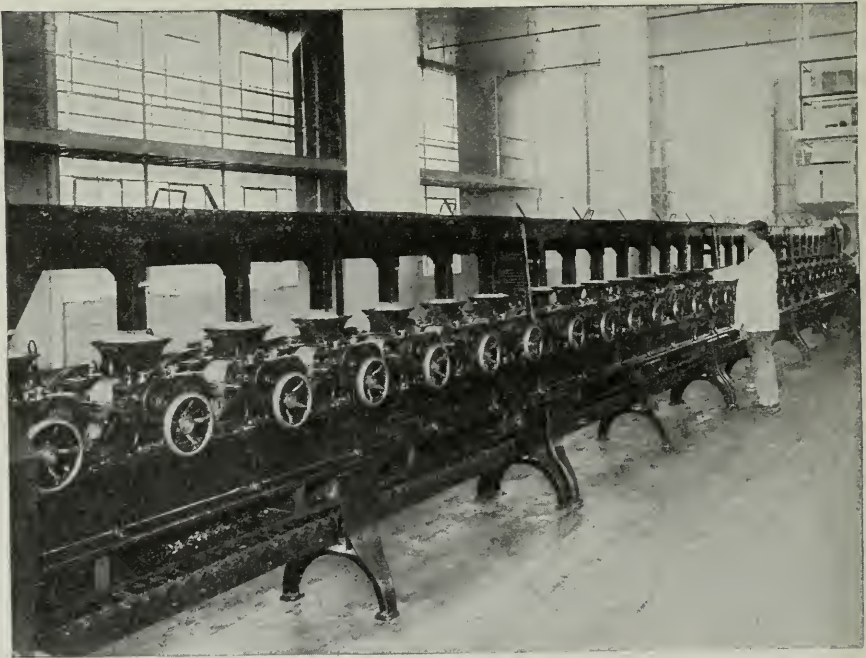

SHREDDING ROOM, PACIFIC COAST SHREDDED WHEAT CO., OAKLAND

several cents less per square foot of floor area, per annum, for interest, depreciation, insurance, repairs and all other annual charges than the building of lower initial cost, the difference in first cost loses its importance. Fortified with these facts, the industrial executive can hardly avoid adopting that type of construction for his buildings which will place his concern on the most profitable economic basis through the elimination of all avoidable annual charges.

It is not possible to anticipate every event that may delay the construction of a building. Fabrication and shipment of necessary materials may be interfered with, labor conditions may change so as to vitally affect progress and cost of construction. Thorough organization takes precautions to reduce many of these possible happenings to a minimum; nevertheless, the unforeseen frequently happens. If the intending builder has chosen concrete construction, many of these contingencies are eliminated or reduced to a minimum. Much of the necessary material required for concrete construction is usually near at hand. The structural parts of a concrete building are built in place. Distant shops and uncertain transportation need not be depended upon for their completion and delivery. Materials arrive in bulk and do not require special equipment for transportation; in fact, transportation is not a large item because the bulk of materials is usually near at hand. Motor trucks may do most of the hauling. Most of the labor required is of the less highly specialized kind. It can usually be obtained near where the building is going on. Practically all materials may be ordered as soon as preliminary requirements have been decided upon, thus disposing of any uncertainty as to the materials market. Equipment necessary to erect concrete buildings is of the simplest sort. There are no heavy structural members to be handled. Floors and columns are cast simultaneously and possibility of accident is reduced to a minimum.

An estimate of the first cost of a concrete building can be made with an unusual degree of accuracy. The owner thus secures the benefit of a minimum charge for contingencies in the contractor's bid or the benefit of low cost in a cost-plus contract.

One of the first things a business executive wants to know is how long it will take to build. Desire to immediately increase production, desire to meet an existing demand, desire to get invested capital earning money at the earliest possible moment have placed a new value, a premium, on speedy construction. The comparative simplicity of concrete construction and the availability of needed materials are reasons why concrete buildings may be quickly erected.

An estimate of the value of speedy construction from the standpoint of earlier occupancy and operation of newly-organized business may easily be made. To be conservative assume that two months may be saved in time of construction by using concrete. This will make possible a two months' earlier occupancy of the building and a like earlier active operation of the invested capital which would thereby be able to earn its interest during a period that would otherwise be a total loss. This shortening of the period of pre-occupancy idleness and the hastening of the end of the early development period is directly creditable to the greater speed of construction possible with concrete. The quicker turnover of the capital invested in construction equipment should also be taken into consideration. A saving of two months in each construction season means a considerably greater construction capacity without increase in crew or equipment.

Total loss by fire is unlikely to an industry housed in a concrete building. Contents may of course be damaged or destroyed, but records of big fires have shown that, even when such contents are of highly inflammable character, the injury sustained by concrete buildings is smaller and their salvage value higher than for buildings of any other type. In the case of total destruction of con-

tents, the concrete of the building seldom suffers more than minor injury, if any.

On a building subject to deterioration, maintenance and depreciation increase from year to year — in other words, no matter how carefully or systematically maintenance may be performed, the building can never be made as when new. Maintenance of those parts of a structure which can be replaced may be carried on indefinitely, but many of the most vital parts of a building are practically inaccessible, therefore do not permit easy replacement. Nor can such parts always be reached with treatments or coatings that would tend to prolong their useful life. It is therefore impracticable to maintain indefinitely buildings whose vital parts are subject to rust or rot.

Concrete grows stronger with age. Many city building departments recognize this by allowing greater loads to be placed on a concrete building several years old than would be permitted when the building was new. Because of their ability to resist the usual destructive agencies, concrete buildings require but

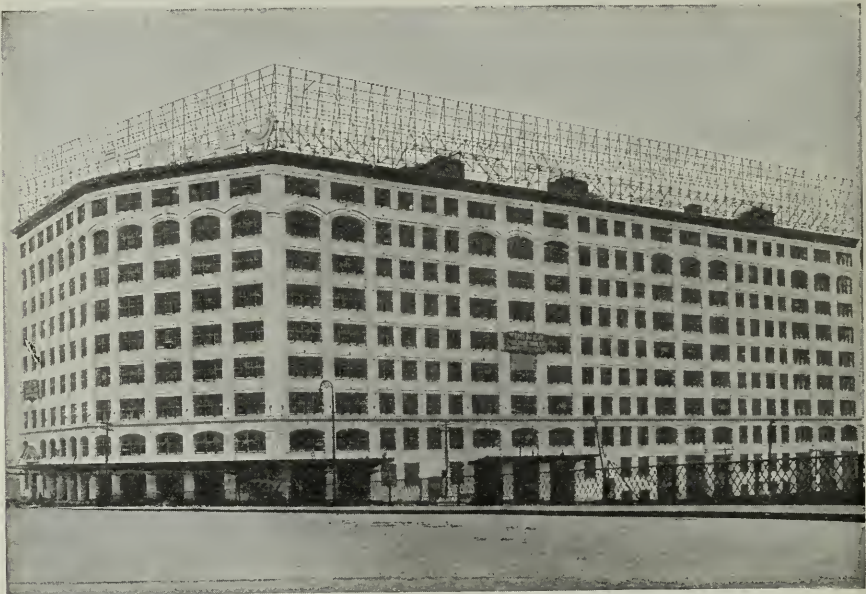

FACTORY OF LOOSE-WILES BISCUIT CO., LONG ISLAND CITY, N. Y.
William Higginson, Architect

little maintenance, and for all practical purposes are permanent. They do not require painting, there are no joints to be pointed up, no wornout or rotting structural parts to be removed and replaced, no sagging or warping of floors or floor beams. Concrete floors will wear indefinitely and their smooth, dense surface is easy to clean and keep clean. Germicidal or other cleansing solutions may be used on them without fear of injury. Concrete floors in a concrete building maintain their original level. Machinery mounted on them stays in adjustment longer, shafting keeps in line. The efficiency of concrete buildings therefore does not grow less with time, while in a building subject to deterioration there is the inevitable reduction in operating efficiency.

In comparing the economy of various types of buildings, maintenance may be taken as an average of 1 per cent per year of the cost of the building. When this charge is capitalized at 6 per cent it is seen that over \$16 more per \$100 original cost could be spent for a maintenance-free concrete building than

for one of depreciable type. Yearly maintenance, however, must be considered separate from gradual depreciation which, after a term of years, renders the structure unfit for use, regardless of the maintenance done on it.

As concrete buildings are now designed they have great reserve strength. The unit stresses used in designing them are very much below the stresses to which concrete may safely be subjected.

Any well-built concrete structure may be used for light manufacturing purposes or for an industry requiring operation of rapidly-moving machinery. Non-inflammable occupancy may change to inflammable occupancy, a mercantile building to a warehouse, a warehouse to a manufacturing plant, and vice versa. If the changes in environment are so radical as to preclude the profitable use of the building in its original location, it may be moved, provided its construction is such as to withstand the racking effects of moving without injury. Con-



WAREHOUSE, AUSTIN NICHOLS & CO., BROOKLYN, N. Y.
Cass Gilbert, Architect

crete buildings being monolithic possess the greatest possible rigidity. When necessary such buildings can be moved with the assurance that they will suffer no serious damage in the process. The expense of moving will be minimum since the great strength and monolithic nature of the structure permits moving it with greatest facility. Recently a three-story reinforced concrete building in Detroit used as an office building by the Hyatt Roller Bearing Co. was moved 450 feet, the full length of a city block and across street car tracks, while the office force carried on its work as usual. This work was done by the L. P. Friestedt Co. of Chicago at a cost of only 20 per cent of the original cost of the building. As the concrete building which can be moved does not suffer any ill effects from moving, its value as a usable structure is preserved and may actually even increase in the new location. Concrete buildings, therefore, are the type most likely to escape obsolescence.

Concrete buildings possess many qualities that make them most adaptable to practically any occupancy. It is difficult to express in dollars and cents the value of certain qualities inherent in a concrete building. It is evident that buildings in which people work should be sanitary. Sickness, poor health and generally low vitality of employes affect in a vital way their efficiency and therefore the efficiency of the business or industry. Concrete construction affords the utmost sanitation. Monolithic floors, columns and beams provide no recesses where filth may lodge. The dense, smooth surface of concrete is non-absorbent; cleansing solutions may be applied in any quantity to maintain surface cleanliness and concrete floors will protect lower stories from water damage. There are no interwall or interfloor spaces where rodents may lodge or nest, no hidden spaces inviting the accumulation of vermin, rubbish and filth to propagate disease germs.

While industrial buildings are primarily designed to serve in the best possible manner a certain definite use, they may, nevertheless, be made architecturally attractive at small expense. This will greatly improve their appearance. Ornament may easily be added in the form of concrete cornices, balustrades and raised or depressed panels. Proper attention given to the selection of aggregates, leading to special exterior finish, will result in pleasing effects. Stucco in considerable range of color may also be used as a surface finish.

Warmth and dryness are qualities desirable in all buildings. These may easily be obtained in a concrete building. In general, warmth and dryness depend on insulation. Even without the aid of insulating materials, concrete is a poor conductor of heat, and when used either with insulating membranes or by providing dead air spaces in walls possesses ideal insulating qualities. Both of these methods of securing insulation are easily carried out with concrete. The usual inside finish of furring, lathing and plaster furnishes the necessary insulation to prevent condensation of moisture on the walls and provides added resistance to the passage of heat or cold. No moisture passes through



WHEATENA CO., RAHWAY, N. J.
Willis & Goodwillie, Architects



SCHULZE BAKING CO., CHICAGO
W. W. Alschlager, Architect

dense, well-built concrete. Concrete buildings are easy to keep warm in cold weather and comfortably cool in warm weather.

An exceptional degree of security against loss of life from tornado, earthquake and explosions is provided by the practically indestructible monolithic concrete structure. Many cases are on record where concrete buildings have successfully withstood the effect of these destructive forces. The San Francisco earthquake and fire, the Baltimore fire, the munition ship explosion in Halifax Harbor, the Fergus Falls (Minn.) tornado, earthquake in San Domingo and Guatemala, and numerous other similar examples testify to the great resistance of concrete buildings against destruction or serious damage by the forces of Nature. Life and property are truly conserved by such structures. Their occupant's have the assurance at all times that they are enjoying the highest measure of protection against personal injury and loss.

* * *

The High Cost of Loafing

We are confronted by a condition, not a theory. Prices are high, and show tendency to go higher. Wages are high, with an upward trend. When prices rise, wages must follow; when wages go up, prices must keep pace. The wage-earner demands that prices drop while wages remain stationary or even continue to go up; the employer of labor has about given over hope of declining wages, but insists that prices must rise while wages stay put. And between the two millstones right in the dead center of the vicious circle are some millions of salaried workers who call upon Heaven to witness that whatever happens they must pay.—*Value World*.

The World's Longest Concrete Girder Bridge

TWO record-breaking concrete girder spans make up a new highway bridge across the Salt River in Humboldt County, California. Each span is 142 feet between centers of support, which is far in excess of the longest reinforced concrete girders hitherto built. Investigation shows no previous bridge girder over 75 feet span and few interior girders of even that length, though there is a record of roof girders in the Leonardt Warehouse in Los Angeles with spans of 102 feet.

Reinforced concrete girders were adopted for the Salt River bridge in preference to a concrete arch because of the greater clearance and lower cost of the girders. It was necessary on account of the location near the coast, where salt fogs are common, to have the steel protected against corrosion, so steel trusses were not considered in the design. It is stated that an arch bridge of the same length with solid rock abutments built under almost identical conditions in the same general location cost \$160 per lineal foot as against \$135 per lineal foot for the girder bridge.



VIEW OF HIGHWAY BRIDGE OVER SALT RIVER, HUMBOLDT COUNTY, CALIFORNIA
H. J. Brunnier, Engineer

Two views of the bridge accompany this article. The spans are identical. Each consists of two concrete girders 12 feet deep, carrying at 20-foot intervals (21-foot spans at each end) floor beams, between which the 5-inch concrete floor is carried on 9x20-inch reinforced concrete stringers spaced at the third points of the floor beams. The main section of the girder is 7 inches thick, enlarging by steps to 24 inches at the top and 18 inches at the bottom, and with pilasters opposite the floor beams stepping up to a maximum width of 30 inches and thickness of 18 inches.

Each main girder is figured as a straight girder loaded for floor-beam reaction. The steel, however, is continuous over the center pier, no expansion joint being provided at this point. The design was made for a uniform live-load of 70 pounds per square foot over the entire road surface or a 15-ton road roller, in accordance with the theory and tabulation in Ketchum's "Design of Highway Bridges." As classified in that text, this bridge would be classed "E—ordinary county highway bridges." Calculation of stresses under dead—and alive—load gives a maximum compression of 1100 pounds per square inch

and a maximum shear of 226 pounds per square inch in the main girders. Concrete is expected to carry only 60 pounds of the shear, steel being provided for the remainder. Calculated extreme fiber stresses of the steel in the girder range from 12,000 pounds in the top of the bottom flange to 16,000 pounds per square inch in the lower bar. The 21-foot stringers were stressed less than the main girders. Here the 15-ton road roller stresses govern, while in the design of the main girders the distributed load gave maximum stress. In the stringers the maximum fiber stress of the concrete is 350 pounds per square inch. In the steel a maximum fiber of 16,000 pounds per square inch was permitted and the shear is 145 pounds net section. Because of the likelihood of rusting and corrosion, too, it was decided not to use roller bearings to carry the expansion movement of the girders. Instead a thin sheet of asphalt was poured at each end and 4 inches latitude allowed for expansion and contraction.

The influence of concrete ship design and construction is noticeable in the layout of the reinforcement and in placing the concrete. Steel bars, it will be seen from the sections, have to be distributed closely through the flanges of the girders, and, as in the concrete ships, they are separated with spacers. Placing the concrete, too, was facilitated by the use of pneumatic hammer on the forms, as was done in the Government concrete ships.

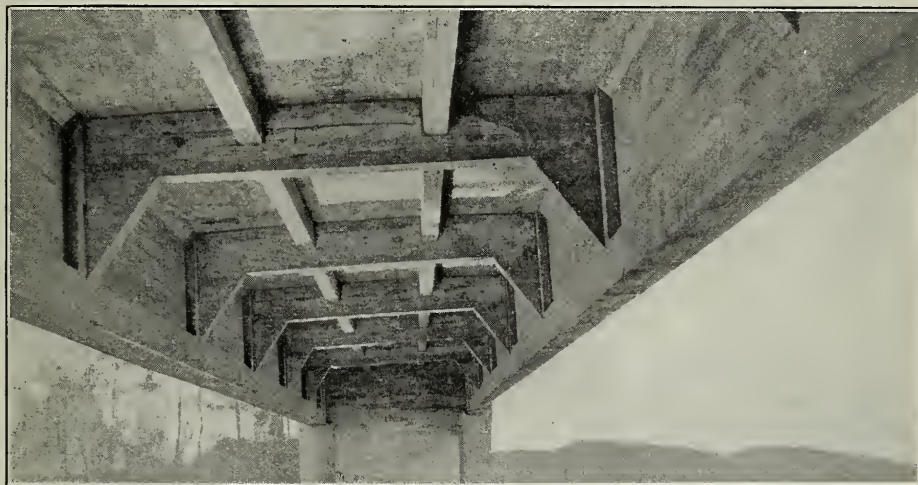

SHOWING STRUCTURAL DESIGN OF HIGHWAY BRIDGE OVER SALT RIVER

H. J. Brunner, Engineer

Reinforcement in the girders was built up to shape in the forms. An opening was left along the upper side of the bottom flange of the forms through which to place the bars below that level, and each layer was fastened as it was placed. The steel used in top and bottom flanges is all $1\frac{1}{8}$ -inch bars, plain rounds, which were delivered on the job in lengths up to 80 feet. In order to avoid the possibility of confusion in placing the steel and to insure a location of joints that would give a sufficient cross-section of continuous steel at any point, there was added to the blue-print an extra sheet on which was plotted the length and location of every longitudinal bar in top and bottom flanges.

In the bottom flange there are nine layers of six and five bars each. Each layer was numbered and the successive runs of bars in each layer were lettered. By laying off the length of these bars to scale, one above another, it was possible to tell at a glance where joints would come without interference, and conversely where to put the steel when the time came to sort it out and assemble it on the job. Thus on this special sheet not only was each run of steel identified by letter and number, but the exact length of each piece and its longitudinal

position were also specified. In order to secure the necessary amount of steel in all cross-sections without lap-joints, joints were broken at such intervals that such joints could be used in all runs and still maintain the required amount of steel in all sections.

The concrete was poured in five successive stages. The lower halves of the girders were poured first, then the floor system, and finally the upper halves. Under this plan suitable places for making joints could be reached at the end of each day's continuous pouring. Each half of each girder was poured in one day and the floor system was poured in four sections in one day each.

Two grades of concrete were used on the job, one for the girders and one for the floor slabs and floor system. In the girders there was used a 1:4 mix, with the aggregate consisting of $1\frac{1}{2}$ parts sand and $2\frac{1}{2}$ parts gravel, and gravel ranging from $\frac{3}{4}$ inch as a maximum down to $\frac{1}{4}$ inch, and the sand from $\frac{1}{4}$ inch to fines. In the floor system a 1: $1\frac{1}{2}$: $4\frac{1}{2}$ mix was used with the gravel up to $1\frac{1}{2}$ inch maximum size. The 1: $1\frac{1}{2}$: $2\frac{1}{2}$ mix was found to test from 2800 to 4200 pounds per square inch in 28 days.

The falsework consisted of ordinary driven pile bents with sway bracing, such as is used on railroad trestles. Square timber caps were used and above the caps the supports were shored up on shims so that the forms could be accurately lined up just before pouring concrete. The unsupported length of piles varied from 10 to 25 feet. The operations were carried on from one end of the bridge instead of both ends as was originally planned. This was due to the failure of the old bridge nearby, which prevented the contractor from delivering materials on the far side of the stream.

Using the design figures as stated before with a section modulus of 15, the center deflection of the girders for full load was calculated to be $2\frac{1}{16}$ inches. Six weeks after the forms had been removed a deflection of $1\frac{1}{4}$ inches in the center of the span was reported. Specifications called for 2-inch camber. The bridge was designed by Mr. H. J. Brunnier, consulting engineer, San Francisco. Mr. A. J. Logan is county surveyor of Humboldt county, California.

* * *

Charging for Estimates for Mill Work

Charging for estimates for mill work by planing mills is advocated by The Timberman, which says:

"Probably no branch of the lumber business has suffered more grievously from the besetting sin of being compelled to spend time and energy in estimating plans, often with no hope of ever getting the work, than has the average planing mill. Many of these estimates require a great deal of time and labor before a bid can be made. In some fair sized towns with half a dozen planing mills, the architect asks bids from each. Naturally only one concern can get the business. The other five have contributed their skill and energy for one purpose alone and that is to afford without cost to the prospective builder, a basis of comparison of values. The business invariably goes to the lowest bidder. This system is fundamentally wrong. It imposes an obligation on the planing mill, to provide an estimate, without cost, with no assurance of getting the order. A dozen jobs may be estimated without reward. The best talent in the business is required to figure out the detailed and often involved plans of the architect.

"The system should be changed at once. It is an imposition on the planing mill operator and an indirect charge on building which could be virtually wiped out if the planing mill men would organize and fix a reasonable charge on all estimates where the work was not awarded to them."

Building Prospects for 1920

By MORTON G. TUTTLE

Secretary, Aberthaw Construction Co., Boston, Mass.

FOR some time it has been possible to forecast from the returns of the first few months of the year the probable building volume for the entire year. Each spring this becomes an absorbing item among those interested in building, and many figures are prepared indicating the probable extent of construction work for the whole year.

It happens that the building figures for the first three months, during the years 1910 to 1919 inclusive, have amounted on the average to 18.26 per cent of the entire year's construction. If, therefore, we take this figure as about what may be expected from 1920, and consider that the total construction contracts reported by the F. W. Dodge Co. for the first three months of 1920 represents 18.26 per cent of what the entire year's work will bring forth, we may expect the reported figure of \$780,408,000 to be expanded to \$4,270,000,000 by December 31.

The magnitude of this total will be best appreciated when it is compared with building figures for preceding years. There have been only four years where the total has reached \$1,000,000,000, and only one year where it has exceeded \$1,700,000,000, the highest year completed being 1919, with \$2,560,000,000. The other high spots of the past decade are as follows:

1918	\$1,689,000,000
1917	1,618,000,000
1916	1,357,000,000
1915	940,000,000
1912	868,000,000

But it does not have to be emphasized that a million dollars of building today means far less than a million dollars of building meant five or ten years ago. Relative unit cost figures have been compiled, showing about how the comparison runs per unit bulk of building. And, to get a fair comparison with the 1920 program, it will be necessary to increase all the other figures up to 1920 prices. This means that the 1919 figures must be increased by about 7 per cent, 1918 figures by about 13 per cent, 1917 figures by 30 per cent, 1916 figures by 54 per cent, and previous years' by 80 per cent. Figured on the new basis, so that the amounts shown represent building volume and not merely depreciated dollars, we have the following comparison of building construction in the area east of the Missouri and north of the Ohio:

1920	\$4,270,000,000	estimated
1919	2,739,000,000	on 1920 prices
1918	1,909,000,000	on 1920 prices
1917	2,103,000,000	on 1920 prices
1916	2,090,000,000	on 1920 prices
1915	1,692,000,000	on 1920 prices
1912	1,562,000,000	on 1920 prices

It will be recognized that the figures immediately above have been corrected for all price differences, and that consequently they will represent the actual amount of building, all figured on the same unit costs which we are experiencing today.

The completion during 1920 of the stupendous building program outlined above will depend upon a number of factors. The press dispatches tell us that renewed strikes in Chicago have resulted in boosting the price of common building labor to \$1 per hour, and skilled labor to \$1.25 per hour.

The same press dispatch tells us that, because of these exorbitant figures, fully 50 per cent of the projected building construction in that city has been abandoned. Similar conditions through the country would cut hundreds of millions of dollars from the building operations which we might otherwise safely expect.

Even as it is, owners are hesitating long before going to the high cost of building, unless the structure is so urgently needed that they find they can recoup its cost by profits within a short period. As prospective profits do not govern in residence construction, it is only natural that the building of dwellings should lag far behind that of industrial and commercial buildings, because the monetary return in the case of the residence is not so easily traceable, nor can the cost be repaid by business profits.

Thirty years ago the United States had about 110 families to every 100 residences. Three years ago the figure was about 115 families to every 100 residences; today it is more than 121. This points to heavy overcrowding in some sections, and to the substitution of apartments and two-family houses for the single houses of our forefathers. To get back to conditions of 1917 would require the construction in the United States of more than 1,000,000 residences, and this without making any provision for expanding population. This means that the 1,000,000 would be in addition to the normal annual requirements of nearly 400,000 per year to take care of increasing population.

Because of the conditions outlined above, much delay may be expected in making up this back work. On the other hand, large projects, such as factories and commercial houses, will go ahead, regardless of conditions, so long as the increased cost of building can be passed eventually to the "ultimate consumer."

In the Great Central West District, from Ohio to Kansas and Minnesota, the record of the past 10 years shows that, on the average, 16.42 per cent of the entire year's building contracts are placed during the first three months. If that proportion is to hold good for 1920, then the \$229,233,000 of contracts up to April 1 will be expanded to \$1,396,000,000 before the end of December. The magnitude of this figure will be appreciated by two comparisons: with previous years' contracts in the entire area north of the Ohio River and east of the Missouri, including the heavy industrial region from Pennsylvania up through New England.

Compared with this year's prospective \$1,396,000,000, the highest previous figure of \$891,729,000 made in 1919 is far surpassed; and no other year ever provided over \$600,000,000 of contracts. When we compare with the entire area, last year gave \$2,560,000,000; 1918 and 1917, about \$1,650,000,000 each; 1916 showed \$1,357,000,000; and all previous years were below \$950,000,000. These figures are all on the basis of "dollars reported," without reference to the great increase in cost of building since 1915, or depreciation of the value of the dollar, whichever way one may choose to consider it. Figuring the contracts of previous years on the basis of 1920 prices, we have the following comparison for the Central West:

1920	\$1,396,000,000 estimated
1919	954,000,000 based on 1920 prices
1918	560,000,000 based on 1920 prices
1917	775,000,000 based on 1920 prices
1916	702,000,000 based on 1920 prices
1915	554,000,000 based on 1920 prices

No year previous to 1915 reported more than \$215,000,000 of construction in this territory; and even when figured up to present prices, none of them provided more than \$385,000,000. From these figures the immense building program now under way is at once apparent.

Houses Built of Rammed Earth

EARTH as a building material is no novelty. Bricks are baked earth, when the earth happens to be clay; adobe is unbaked clay, dried in the sun; sods are used by the peasantry of some countries overseas for the walls of their houses; dugouts in banks of earth were familiar to pioneers in the western United States. But ordinary earth, such as one may find in a field, would seem to be something new as an aid to housing. In the form known as "pise" or "cob," however, it was used long ago in Europe, and it is now suggested by a St. Louis architect, Mr. Thomas Crane Young, that it may be a factor in solving the problem of inexpensive building here, for cottages at least. The earth is employed just as concrete is—rammed into molds of frame and boards, which are afterward removed, leaving a hard wall. For moist climates, the walls would require waterproofing, of course. Mr. Young writes for the St. Louis Post-Dispatch the following discussion of the housing question, as it may be affected by this use of earthen construction:

"What has blocked the progress of every housing project in this country, as well as in Europe, is the hard fact that under present prices of labor and commonly used materials, it has proved impossible to build even the smallest and most modest six-room cottage for a sum which, with the cost of the necessary land, would make the total investment for a home economically possible for the ordinary workman or moderately salaried individual. Houses which five years ago could easily be built for \$4,000 or \$5,000 will now cost \$8,000 or \$10,000.

A Congressional committee, reporting on the war-housing activities of the United States Housing Corporation, states: 'Single houses in Bridgeport, Conn., cost \$7,263. The average for all houses was \$5,673.78.' It is not stated whether these houses represent a complete house or whether such necessary items as weather-stripping, electric fixtures, sidewalks, etc., were omitted. Probably no profit for the contractor nor cost of architectural service was included in these figures. And since the time when these houses were constructed the cost of building has advanced possibly as much as 25 per cent. . . .

"It can readily be seen that to pay rent or to own this home the occupant should have an income of at least \$3,500 per year. At \$1 per hour and working eight hours a day for three hundred days a year, one could earn only \$2,400, which is inadequate income for above basis of cost for rent.

"So far as one can learn, every new housing project yet planned or constructed either in this country or in Europe has been based on some form of tenement or the traditional story-and-a-half cottage, usually containing five or six rooms and constructed in the customary way of either brick, hollow clay tile, or wood. It would seem, therefore, if it is possible to beat the building game it will be necessary to evolve an entirely new type of house or find some cheaper material as a substitute. It might be possible to evolve the former if architects and builders could rid themselves of tradition and study the matter as though isolated in a country without the usual facilities of civilization and depend only upon their ingenuity and the materials which nature locally provides.

"In this way the Eskimo invented a cheap and comfortable dwelling built of ice; so did the early settlers in this country, who built of logs; and the early Spaniards and Indians of our Western States, who built of unbaked clay, or adobe. There are abundant examples of these earth dwellings in our own country which compare favorably with the usual forms of construction for durability, looks and comfort. The mission buildings in California are constructed of this material, as well as many dwellings still in use after more than a century of wear. In this connection, one wonders why no one thought to construct our war-cantonments and barracks of this material instead of the unsightly, uncomfortable and costly wooden shacks universally used.

"Adobe is a Spanish word from adobar (to plaster). It is nothing but air-dried brick, weatherproofed with plaster, and any traveler in Mexico or California knows that these buildings are as beautiful as any we produce in the same class.

"Many excellent plans for small cottages of the conventional American type have been developed by the United States Shipping Board and also by private architects, but as all of these have proved too costly to build, at least from a commercial standpoint, some new type of home will have to be devised in which every superfluous square inch of area and any unnecessary feature must be eliminated. Other possible economies may yet be found in new processes or materials as substitutes for present methods. Some years ago Mr. Edison led us to hope for much from his concrete house, but so far all forms of concrete have proved as costly at least as other forms of masonry.

"A recent number of the London Sphere calls attention to an old form of masonry called 'pise' or 'cob,' the use of which in housing projects is now being considered in England and

might be equally well applied to this country as an emergency substitute. The picturesque cottage in the illustration is of this construction.

"Sturgis's Dictionary of Architecture and Building describes it thus: 'A cheap masonry of compressed earth. The most suitable solid for the purpose is clayey, somewhat sandy loam and vegetable earth. It is mixed with straw or hay to prevent it from cracking when it dries. The wall is built in sections by means of a movable frame about three feet high and ten feet long, the two sides of which are of boards kept apart the thickness of the wall. This frame is placed on the wall and between the sides of the earth is rammed or beaten in four-inch layers. When this sort of box is full, it is taken apart and set up in another place—in some parts of France houses of two or three stories are built of 'pise.'

"The Sphere states: 'The earth hardens to an astonishing extent in the process of drying off; so much so that it is sometimes difficult to bore into it with an auger. . . . The outer surface of the pise wall can be color-washed or treated in various ways. Spraying with hot liquid tar has been tried successfully. The natural wall weathers in course of time to a very attractive color, and the outer surface itself withstands ordinary rain action and bad weather.'

"When properly waterproofed, there is no reason why these earthen buildings should not stand one climate as well as another, and certainly our variety of climate is not more severe than that of the British Islands or of France.

"At my suggestion, a firm of testing engineers of this city has agreed to make a few experiments concerning the use of earth masonry of this sort, which should prove much cheaper than any other, because it can be made by common, unskilled labor, of material found in nearly every community."

* * *

Items Contributing to High Cost of Lumber

IN 1913 men's wages in the lumber industry were \$28 to \$32 per month; in 1919 they were \$70 to \$85 per month (both being in addition to board and housing), according to the New Brunswick Lumbermen's Association in accounting for the high cost of lumber, as quoted by the U. S. consul at New Brunswick in Daily Commerce reports of the Bureau of Foreign and Domestic Commerce.

"In 1913," the article continues, "stumpage was \$1.50 and mileage \$8; today we pay \$3.50 stumpage, \$8 mileage and \$3.20 per mile for fire protection; also we have workmen's compensation for logging, river driving, rafting, milling and loading with a separate rate on each, and this still further adds to the cost; in addition, we have the heavy business Dominion war tax."

The cost of the principal supplies that enter into a logging operation has increased on an average of more than 100 per cent in 1920 as compared with 1913. This is true of flour which advanced from \$4.90 in 1913 to \$11.20 in 1920 and of many other food articles; of hay and oats, as well as of axes, saws and other similar equipment.

The logging engineer for one of the Montana districts of the Forest Service, as the result of an investigation in the larger band mills of the district, shows in detailed figures why manufactured lumber sells at \$40 a thousand feet or more though the timber is bought on the stump for from \$2 to \$5 a thousand. His report indicates that after the timber has been purchased on the stump at \$2 to \$5 per thousand, logging operations cost \$14 to \$20 a thousand. From the pond to the cars, including the manufacture of the rough lumber, the costs are \$11 to \$16 a thousand, these figures being based on records from mills sawing 600,000,000 feet of timber during the season of 1919.

* * *

San Francisco Builders to Celebrate

A get-together banquet will be held in August at the Palace hotel by the combined building interests of San Francisco. The purpose of the affair is to celebrate the recent merging of the Builders' Exchange and the Building Industries Association. A large attendance is anticipated.

A Lesson from*the Chemists

By RICHARD F. BACH*

OF all types of activity receiving direct stimulation from the war, none has so well profited by the present isolation of America as the science of chemistry. Official reports for the year preceding last June offer satisfactory information as to the growth of the dye-stuffs industry in America. Of aniline dyes, America imported in 1914 products to the value of \$7,241,406. and four years later exported similar products to the amount of \$7,296,080. There is a sermon in these figures. Four years have accomplished not only a complete neutralization of the former import figure, which may in this case be considered a negative figure on the thermometer of trade, but have in addition witnessed a positive gain above zero of an amount more than equivalent to the previous importations.

These coal tar dyes we formerly purchased from Germany. We now make essential colors sufficient for our own requirements and have begun to sell to other countries that have not so well profited by the opportunities of the war. In fact, latest reports show that our sales outside the United States are being made at a rate which would be represented by an annual figure of close to ten millions, and this does not account for the factor of acceleration.

For those interested in the industrial arts the initiative of the chemists offers pregnant suggestions. They have taken opportunity by the forelock, have assured American business in a very important field, have patriotically established America in a new branch of commerce, have assured to the American people a decided advantage in the way of American-made colors.

Can we say the same for American furniture, textiles, floor coverings and other industrial arts fields? Have they seen their opportunity or have they been careful to persuade themselves that business will be as usual after the war? Do industrial arts producers in these many fields fondly imagine that all of our friends the Allies will go out of business after the war? The same advantage which the chemists saw in America's isolation, our Allies have undoubtedly seen as a menace to their own commercial progress. There will be as many millions of mouths to feed in Europe, there will be as many artisans and workers capable of the highest type of tasteful execution as ever before; there will be put forth as a consequence the utmost efforts to reestablish European leadership in the industrial arts in the American market. The Allies saw three years of war before we entered the ranks; they had therefore three years' time in which to consider what to do when the war should end. As a consequence, it has ended more suddenly for us than for them, and the most terrific currents and cross-currents have begun to churn up the smooth course of our business life.

American manufacturers in the industrial arts fields must take advantage of their opportunity to improve their foothold in the markets of the world. American distributors must be convinced that the American public deserves the best; the American people must realize the plus quality of design in their own home furnishings. To this end the American schools must teach taste and appreciation rather than inane drawing without objective in execution. To this end schools of industrial art must be established. To this end we must make a beginning in training our own designers to provide for our own ends in our own way. To this end all of our manufacturers, designers, artisans, craftsmen, workmen, school children, and all who run and read, must find time to visit the museums, to take advantage of the enormous opportunities offered not only by the collections themselves but in the way of lectures, study rooms, photographs, publications, expert advice, and many other lines of direct educational usefulness. We have only to consider the work done by the Metro-

* Member of the staff of The Metropolitan Museum of Art, New York.

politan Museum in this connection to be assured of the immediate purpose which actuates our great museums. When the arts of peace will be called upon to restore balance, when these arts begin to function once more as a lode-stone of life, the work of the Metropolitan Museum will be rated high.

It is the high duty of craftsmen and women in the various arts of ancient lineage and of honorable history, in their effect upon the growth of civilization, to cherish constantly the ideal of absolute perfection of design and reliability of workmanship, and this duty, like the arts themselves, has changed progressively with each decade of time. In the year 1919 it has come to mean that handicraft in itself is not complete as an evidence of human progress in art. This handicraft must also exert its direct effect as a check upon machine manufacture, improving this by excellent example and by faithful practice. Nor should the craftsman wait for the manufacturer to come to him for suggestion; the obvious duty lies in the other direction. The craftsman in lace as in metal and other fields must convince the manufacturer, who must in all cases supply the mass requirements of the people generally, that only the best product in design and execution is good enough for America. The best workmanship and the best design will invariably remain in control of the handicraftsman, but unless he has demonstrated to the manufacturer engaged in mass production the guiding value of his craft as a standard he has performed but the tithe of his mission and his finest work must remain nothing more than a voice in the wilderness.

* * *

Ornamental Ironwork

ORNAMENTAL ironwork details are becoming increasingly popular, and the number of uses to which the material may be applied with decorative effect is almost unlimited.

In designing ornamental ironwork, "fussiness" should be avoided. Scrolls and other curlicues such as were common in this sort of work twenty-five or thirty years ago had best be avoided. Straight slender lines are characteristic of the material and should be used almost altogether, but a simple geometrical form at the ends or in the center of a panel is often used to overcome an appearance of stiffness. Small brass balls and knobs are often used over the corner posts. These, however, require frequent polishing and wrought iron is sometimes used instead.

For ordinary railings, balconies, and so forth, the balusters are usually made of $\frac{5}{8}$ -inch square bars and the posts are of $1\frac{1}{4}$ or $1\frac{1}{2}$ -inch hollow square tubing. The rails are usually made of $\frac{3}{4}$ -inch channels, the upper rail having a small moulded section fastened to the channel.

* * *

Central Refrigeration

The idea of a central heating plant is not so old but that even comparatively young men can remember when such installations were a novelty. Now the refrigerating machine is making headway, and the time is close at hand when it will be as difficult to rent or sell a building without a central refrigerating plant as it would be to rent or sell a stove heated building. The advantage of the refrigerating machine, however, in the matter of installations is that it can be readily installed in almost any building, though where intelligent provision is made for its place in the plans there is greater certainty of making a compact and easily accessible and controllable installation. Machines are now made that will be profitable to the user of even as small a quantity of ice as ten pounds a day, taking every factor into consideration. There are now sufficient users of such machines with experiences covering several years to satisfy the prospective buyer.

Colored Concrete and Stucco*

By ADOLPH SCHILLING

TO produce color effects, we may use gray or white portland cements, either by themselves, or mixed in certain proportions, adding to this, suitable pigments, but in many cases, the natural colored aggregates, sand, silica, pebble grits, marble and granite, will give excellent and more uniform results. It requires great skill and care to properly mix cement and color pigments without reducing the strength of the cement and still obtain uniform color effects.

The importance of mixing the pigment thoroughly with the cement, before adding the aggregates, should be understood by anybody attempting to make concrete in colors successfully on a large scale.

As a very simple method to test the proper amalgamation of the pigment with the cement, take a handful of the dry mixture, and press it under a sheet of stiff paper, this will produce an even surface of the material, and as long as this surface does not show absolute uniformity in color, the mixing is incomplete. If small specks of color show on the surface under this test, these same specks of unassimilated pigment will appear in the concrete. So far a very important factor that can be utilized for coloring concrete or cement has been given little or no attention, while very simple in its primary action, the successful application requires thorough understanding of the principle and medium employed.

The absorptive qualities of concrete during its stage of curing and seasoning offers opportunities for coloring concrete products by capillary action. By this method the color is deposited into the pores of the surface, amalgamating with the concrete into a permanent unit. The possibilities of this treatment are unlimited, based on knowledge of coloring values and good judgment not to impair the strength requirements of concrete. Coloring solution can be made to penetrate the surface of concrete six inches or more, if the object is immersed while in a very green state, but it is rarely necessary to penetrate more than $\frac{1}{32}$ to $\frac{1}{8}$ of an inch. This thoroughly fills all pores, gives the desired color effects and is less expensive. Every atom of coloring absorbed by the concrete reduces the strength of the solution; and as some of the coloring matter used is quite expensive, good judgment in allowing only the necessary absorption of coloring matter would be advisable from an economic standpoint. The sulphates of copper and iron are the most suitable to make solutions to color concrete by the capillary method.

The concrete to be colored can be treated after it is a week old. Concrete products used in construction and carrying loads should not be subjected to the coloring bath until the concrete has attained its required strength; as the filling of the pores in the concrete retards the action of curing by the usual methods. Coloring by absorption is effective on surfaces of concrete after it comes out of the mold, or after being treated with tools. Surfaces that have been colored by absorbing mineral or metallic colors, become more weather-proof and the action of the weather on the metallic colors is the same as on real metals, increasing the beauty of coloring by the usual oxidization noticed on bronze and copper. The surfaces of concrete treated by this method become so hard and dense that they will take a polish. I have treated such surfaces in the same manner as marble, granite and metal under polishing or buffing machines.

Our products made by wet cast methods, such as flower pots, vases and boxes, will hold water after the second day of casting and become so hard that when struck with a hammer, they ring like a metal bell; waterproofing

* Extracts of a paper read at the National Conference of Concrete House Construction.

compound helps, but is not essential to obtain this result. I consider that the thorough mixing of the proper amount of cement and water with graded aggregates is all important. Extensive tests made during the past three years with commercial waterproof paints, produced excellent results. Common concrete can be made very attractive by one or two coats and applied in stipple fashion, it will not impair the grain or texture, avoiding the undesirable effect of painted stone. This method is especially to be recommended for dry or semi-dry tamped concrete work, as the porous surface readily absorbs the waterproof liquid, and allows the pigment particles to fill the pores.

The color effect obtained in this manner is the most economical. It is a uniform color but does not give the richness and depth of shading that results by the immersion treatment in a metallic color bath. It has the advantage, however, of being applied where immersion is not practicable. I have obtained two and three-color effects by painting certain parts of an object, before subjecting same to the coloring bath, the parts so colored would not be affected by the color in the bath.

The artistic possibilities of such treatment are only limited by the color sense and taste of the craftsman. Using certain non-absorptive aggregates, their natural color can be retained, while the absorptive parts, especially the cement mortar will assume the desired color. In this treatment precaution must be taken in the use of acids in washing before immersion in the color bath, as the chemical action of the acids is liable to counteract the color values of the bath. Acid should not be employed on concrete treated with colors.

Long practice and tests will give the experience necessary to gain the full benefit of this process; I have spent nearly ten years to obtain the present results.

In the matter of surface finishes, considerable headway has been made, and most of the methods are well known to the progressive concrete man. Any surface treatment is preferable to leaving concrete as it comes from the mold.

* * *

London Puts Ban on Building

People in the United States who think they are suffering hardships in building will do well to reflect on conditions in London, Eng. Alfred Nutting, of the American consulate in that city, reports to the U. S. bureau of commerce that under the provision of the Housing Act of 1919, the London county council has stopped all alteration and remodeling work on buildings, notices having been served on some of the largest department stores. All labor and materials are urgently needed for construction of new dwellings.

An effective house building campaign in London, it is estimated, will require at least 45,000 skilled bricklayers. In all England there are now only 50,000 bricklayers as compared with 100,000 before the war. If the output of bricklayers, which decreased in England during the war, as in the United States, has not been appreciably raised these figures do not even approximate the real shortage in labor with which the city of London has to contend in building dwellings to relieve the housing shortage which has been most acute since the war.

Construction costs are relatively higher in England today than in the United States. If we were confronted by such a situation as exists in London we might indeed feel that we had something of which to complain. There has been scarcity of both labor and materials in some sections of the United States, but not to the extent that regulation of building by establishing priorities has even been considered for a moment. More building could have been done in this country since the war; we doubt if any community has pushed it to the limit.

What is a Competition?

WHAT is a competition? The architectural profession is vitally interested in a correct answer to this question. The American Institute of Architects has established a certain code which defines, more or less clearly, the status of competition in architectural problems, but apparently the conditions are not entirely clear in the minds of the members of the profession.

In the old days one of the first steps in solving an important problem was to invite certain architects to participate in a competition. In some instances all were paid and in others only the winner received compensation. In recent years, however, it has developed that the owner or a building operator would approach an architect and lay before him his building problem. The architect takes for granted that he is the only one thus approached. He will prepare the drawings and submit them to the owner, only to find that other architects have also submitted their drawings. Judicial authority has decided that this constitutes an unauthorized competition. Men have submitted sketches under these conditions who would under no consideration enter a competition.

What can be done to protect the architect against undeserved censure? The architect is called in conference with an owner. Theoretically he must ask the owner if any conferences have been held with other architects. If so, he must decline to confer further unless the owner first approaches the American Institute of Architects, asking that a competition be arranged.

Obviously the first architect approached would receive a negative answer to his inquiry. The next man might not be so ethical, and would refrain from asking questions. Under the recent decision the first man is as culpable as the second, although, in reality, the second man is the only one to enter in competition.

An owner asks an architect to prepare sketches for a project. Other architects hear of it and offer sketches. The owner is willing to receive suggestions so long as he is under no liability therefor. He is determined that if the construction proceeds, the architect he first approached shall execute the commission. Is this a competition? Is the first architect in any degree to be criticized for unprofessional conduct? Such conditions have existed. It is obviously unfair to the architectural profession and some changes should be made in any code which does not afford justice and equity. A good, healthy competition is sometimes desirable, but decisions as in the cases noted detract from the strength of the Institute and the loyalty of its members.

The Code of Ethics of the American Institute is a heritage of the days when the profession was individualistic. Building operations were carried on largely by individuals rather than by corporations. Each architect was identified, more or less closely, with certain clients. What is more natural under these conditions than that the profession should establish a code to prevent the unprincipled practice of "stealing a client" from another architect.

Nowadays all the major work is done by corporations or trusts composed of a number of men. The individual, both in real estate operations and in architecture, is not so prominent. What is more natural than that several directors of a trust should have friends in the profession and individually approach them for suggestions? If this is competition, the code should be amended.

A competition was recently held which was not disapproved by the American Institute and which was held in accordance with its rules. The building referred to was already designed from a structural standpoint by an engineer, and was final as to location of columns, windows spacing, floor heights, grades, etc. No latitude whatever was given to the architect to do anything except make an outside to fit the proposed building. Yet the competitors were invited to participate as architects.

If the tendency of modern times is to develop architects as dressmakers for engineer's frames, then the architect might as well give up his profession and strive to become an engineer in the newly accepted sense. If the architect values his profession, its ethics, its moral standards, its opportunities only to the extent of getting a "job," it might be for the best to give up architecture. He must have the fortitude and courage necessary to refuse to be made a mere draftsman unless he is prepared to acknowledge that his best work is done under the direction of some more capable executive.

Every architect, without doubt, remembers the attitude taken by the Government toward the architectural profession in the early war period, and how he was distinctly sidetracked by any one who called himself an engineer. If this condition is sought after by the architects as a whole, there is no better way to tell the Government and the business world that architecture is no longer an able, efficient, business-like profession than by assisting in just such problems as outlined above.

The profession has been criticized from the standpoint of its unbusiness-like methods, its overaccentuation of art and the ethical side. Recent events would seem to give the criticism weight.—Architectural Forum.

* * *

Safety First in Glass

WHAT should we do without glass? We regard it as one of the necessities of civilized life; yet under certain conditions, it can be almost as dangerous as a sharp knife in the hands of an irresponsible person.

Glass is a most useful servant; a utility of greatest convenience when conditions are normal, but when accidents occur causing glass to break and splinters to fly through the air, human life is endangered. Many a death and many a serious wound has resulted from flying pieces of broken glass.

Serious consequences are especially to be feared from the accidental breaking, in collision or otherwise, of automobile wind-shields, back and side curtain lights; street car doors and windows, railroad passenger car windows; locomotive cab windows; port hole and other window lights on ships; die cutting, grinding, polishing, loading and other types of machine guards; office and bank partitions; revolving doors; doors and windows generally in dwellings, stores, factories, etc.

Science has come to the rescue with a laminated glass consisting of two sheets of ordinary glass between which is interposed a thin sheet of pyroxylin plastic. Hydraulic pressure and the application of the proper degree of heat welds the glass and pyroxylin sheet together into a solid unit. The pyroxylin binder prevents any scattering of fragments in the event of violent breakage.

The transparency of the glass is reduced but $2\frac{1}{2}$ to 3 per cent by the insertion of the plastic sheet. This would never be noticed by the ordinary person not especially looking for a difference.

If life and accident insurance statistics were consulted to get a record of the vast number of accidents in the aggregate resulting from broken glass, it could readily be shown that the increased first cost of laminated glass to be used in exposed places where experience has proven accidents are most likely to happen, would be more than offset by savings in death and injury insurance payments, loss of wages due to lost time while recovering from wounds and damage to property. Then too, the suffering and disfigurement caused by cuts should be considered.

Laminated glass has its place in the world. As its virtues become known, it is undoubtedly going to be specified in many industries in which it is now unknown.

Architect Wins \$500,000 Suit

ANNOUNCEMENT has been made of the decision by the Court of Appeals in the suit brought by Mr. Allen H. Stem as surviving partner of Messrs. Reed & Stem, architects, and by the estate of Mr. Charles A. Reed, against Messrs. Whitney Warren and Charles D. Wetmore, of Warren & Wetmore, for an accounting of the moneys received by Warren & Wetmore for their work in connection with the Grand Central improvements, including the new station, the Biltmore Hotel and the Park Avenue viaduct over Forty-second street, New York City. The plaintiffs' share is expected to amount to about \$500,000.

The Court of Appeals upholds a judgment of the lower courts for Reed & Stem, but modifies it to exclude from the accounting everything relating to the Biltmore Hotel except one per cent of the cost of construction for the preparation of the preliminary plans. The contract between the plaintiffs and defendants, which described them as "associated architects" for the work upon such buildings as the New York Central might decide to erect, called for total compensation of four per cent, of which two per cent was the working plans and one per cent each for preliminary plans and supervision.

The associated architects devoted themselves to the construction work from 1904 to November 12, 1911, when Mr. Reed, who was the executive head of the work, died. Four days later Warren & Wetmore sent to Mr. William H. Newman, head of the Grand Central Terminal improvement, a proposed new contract similar to the first, except that Warren & Wetmore were described as the architects. The courts have found that this letter was written without any suggestion of the railroad company, and without the consent of the surviving member of Reed & Stem, but in response to the suggestion the railroad company terminated the first contract on December 31, 1911, and a new contract was made by which Warren & Wetmore were to complete the work and hold the railroad harmless for any claim that might be made by Reed & Stem.

The suit was based on allegations that because Warren & Wetmore took an illegal advantage of the trust relationship of the "associated architects," the firm of Reed & Stem was entitled to recover the amount it would have been entitled to if the original contract had been carried out. The case was heard before Justice Delehanty, who held that conduct of Warren & Wetmore was unfair and illegal and constituted a breach of trust. The Appellate Division sustained the opinion except the share of Reed & Stem for the Biltmore work was limited to three per cent on the cost of the hotel. The Court of Appeals now reduces this to one per cent.

The record of the case shows that the plans for the Forty-second street viaduct, as finally constructed, were drawn by Reed & Stem and caused them to be selected by the railroad company to share in the planning of the entire improvement. The plans were submitted in 1903 and the work was finished only a few months ago.

A fund of \$250,000 invested in Liberty Bonds has been awaiting the outcome of the case, and will be part of the payment to the plaintiff.—New York Times.

* * *

Memorial Club House

As a permanent memorial to the more than 3000 American officers who died in the world war, the Army and Navy Club of America, of 18 Gramercy Park, will establish in New York City, a \$3,000,000 service clubhouse, where, among other memorial features, the military record of every officer will be preserved for future generations.

A Straight Bank Loan for Building Purposes

IN these days of difficulty in obtaining straight building loans, at least one builder who does shake hands with the banker has recently used his credit to very good advantage. A brief story of what he did in the way of making use of his regular bank to assist him in his building projects will be of interest and perhaps will have the value of suggestion to others.

This particular builder, located in a middle western town near a large and expanding industrial plant, knew that there was a definite demand among executives of the plant for modern homes. He had some building material on hand, but was unable to get a building loan from the ordinary sources. He already had designs for a house to cost about \$7000 and had chosen a lot on which to place the house, having obtained an option at a cost of \$1000. His difficulty consisted of the fact that while the house was to cost \$7000 he had but \$3000 in cash.

After exhausting the usual means of obtaining building loan money, and feeling that his credit in the community was good, he went to his banker and stated the conditions, making a request for a loan of \$4000, giving his personal note with a statement of his realty and other assets. After some consideration the banker agreed to make the desired loan on the usual commercial basis.

The builder immediately went to the owner of the lot and offered him \$1200 for the lot if instead of cash he would take a mortgage on the land and the new house for one year at 6 per cent payable with full interest on thirty days' notice. This the owner of the land was entirely willing to do, and on this basis the land was transferred to the builder.

With his own \$3000 in cash he immediately started erection of the house, building being commenced in April, 1919. The money which he had carried the building until June, 1919, at which time he gave his first \$1000 note to the bank, receiving the proceeds in cash. This he repeated for the three following months — July, August and September — at which time the house was finished and he had borrowed on his personal note \$4000.

The house, being placed on the market for sale, was sold two months later in November for \$11,000, of which \$5000 was paid to the builder in cash and a first mortgage of \$6000 placed on the house, the \$1200 mortgage covering cost of land being paid off at this time with interest for one year. The builder immediately offered the first mortgage of \$6000 for sale at 10 per cent discount, and the mortgage was quickly purchased by a private investor, netting the builder \$5400 in cash. The six-month notes to the bank were also paid off as each fell due, the first being in November and following each month until the four were paid. Because of the lively demand for houses the builder took little risk in borrowing money for a short time on notes.

A statement of the actual cost of this operation and the net profit is as follows:

Cost of land	\$ 1,200
(Paid by giving mortgage one year 6% payable at will.)	
Interest paid on above amount, one year at 6%	72
Cost of building house	7,000
Interest paid on \$4,000 six-month loan from bank at 6% per annum ..	120
Discount given in cashing \$6,000 mortgage, 10%	600
Total cost of operation	\$ 8,992
The house was sold for	\$11,000
Total cost of operation	8,992
Net profit to builder	\$ 2,008

In this case through the co-operation of the bank a profitable operation was made possible for the builder. If the house had not been sold as soon as this it would not have been difficult to obtain a first mortgage loan on the completed house which would be sufficient to pay off the bank notes and the land purchase mortgage.—Builders' Journal.

* * *

Skyscrapers Here and Elsewhere

THE question is being hotly debated whether London and other English cities should now, in the interests of economical building, run to "skyscrapers" in the New York fashion. The latest convert to the idea is Sir Martin Conway, whose view it is that the East End of London should be "flattened and then up-ended," says a writer in the Manchester "Guardian." His supporters picture Whitechapel Road, for instance, as a series of green spaces, with buildings of 20 stories or so at intervals, which would amply house more than the present population. His critics do not hesitate to suggest that only his pre-eminence as a mountaineer can account for his wish to see the city landscapes dominated by such architectural peaks. The more serious opponents of the change hold that the real remedy for congested cities must be found in the development of garden suburbs, and that the building of skyscrapers would only retard a sane and healthy distribution of population. Some real good may come out of the controversy, for at least it sets people thinking of the essential character of the cities in which they dwell, and the form that changes in that character should take. The London building line is at present about 100 feet. Where that is exceeded it is by the spires and domes of great national and religious buildings. A general license to forego the limitation would alter the whole face of London, and buildings that are not less jewels because they are small, such as the Abbey and a score of lesser churches, would be dwarfed by vast commercial and residential structures.

New York is a freak city. It has made, in a wonderful way, the very most of its physical handicaps. It could not run to length and breadth, and it has therefore run to height. London, Edinburgh and Dublin are under no such limitations, and it will be an ill day for their distinctive beauty when a Woolworth Building looms over Princes Street or Piccadilly. On the other hand, there is something to be said on the æsthetic as well as the practical side for the solidly-built flats that distinguish Glasgow and Edinburgh, some parts of London, and almost all the great continental cities. So far as appearance counts, they afford a chance for architectural treatment, for dignified façades, and noble proportions, such as the cottage dwelling cannot have. From the point of view of convenience, run on the communal principle, with central heating, a restaurant, and a general domestic staff, they fill a want for which there is a growing demand in city life. Their ideal height will be dictated by the safe rule that it should not exceed the breadth of the road on which they stand. If that limitation be faithfully observed, building might in this country run to height more than it does, with both practical and artistic advantage.—S'one.

* * *

Oregon's Slogan Contest

The following slogan was awarded first prize out of a total of 1150 submitted, in the recent fire protective slogan contest in Oregon:

"Lumber, fuel, beauty, joy,
Forests furnish, fires destroy."

Argentina's Building Program

THERE is a large field for the sale of American construction materials in Argentina, according to a report just made public by the Bureau of Foreign and Domestic Commerce, Department of Commerce, and the investment of American capital in Argentine enterprises is an important factor in securing contracts.

Buenos Aires is in great need of first-class office buildings. Several departments of the government are being crowded out of their old quarters for lack of space and modern hotels and apartment houses of the American type are needed. With the return of normal conditions, many model homes for workingmen will also be erected in the suburbs of Buenos Aires. Notices appear in the newspapers of the capital from time to time inviting bids on various public construction enterprises. The time-limit for these is usually short, but if American firms were represented in Buenos Aires, they could secure many such contracts.

The National Council of Education has adopted a large building program for public schools. The plans to be completed in the next few years call for an expenditure of about \$8,500,000. The needs of various cities in the Province of Buenos Aires will call for the installation of sewerage and water systems in the near future at a total cost of about \$2,300,000.

The various provinces of Argentina have building programs independent of those of the central government, says the report, but also receive federal aid in the execution of many public works. Definite projects in which the central government plans to aid the provincial governments in the immediate future call for an expenditure of \$10,000,000 for sewerage and water systems alone.

Argentina has always been an excellent market for iron and steel products for construction purposes. Formerly the imports of cement were considerable, but a large cement plant is now in operation about 200 miles from Buenos Aires, owned by American interests. Lime of unsurpassed quality is found in many parts of Argentina, and the plaster of Paris used is produced chiefly in the country. Clay roofing tiles and roofing slate, and glazed wall and vitrified floor tiles are imported in considerable quantities. Some years ago, advertising campaigns were instituted to popularize felt roofing materials, but with only partial success. The chief competitor of this kind of roofing for industrial purposes is galvanized iron sheeting, for which there is good demand. In the past ten years many skeleton steel structures have been erected. Architects believe that reinforced concrete will be a strong competitor with this type in the future.

* * *

Housing Conditions in the United States

Since 1916 the number of families in this country has increased 2,026,000 while in the same period the number of dwellings has increased but 637,000. The following table from the June Stone & Webster Journal shows the conditions confronting the people of the United States better than words:

Year.	Families.	Dwellings.
1890	12,690,152	11,483,318
1900	16,187,715	14,430,145
1910	20,255,555	17,895,845
1915	22,786,499	19,853,517
1916	23,292,887	20,263,051
1917	23,799,275	20,672,051
1918	24,305,662	20,808,562
1919	24,872,051	20,829,039
1920	25,319,443	20,900,000

Decorative Value of Awnings

IN SELECTING awnings for a house one should carefully consider their decorative value. The appearance of a house may be easily spoiled by the addition of awnings that do not harmonize with the general appearance. The variety of colors and patterns in which they are offered often proves confusing and it usually requires careful judgment to select the ones most suitable for a given house. The same pattern or design should be used throughout.

The usual pattern is the familiar blue or brown stripe on a white ground, but almost any desired colors may be obtained. The stencil designs come in scores of patterns, but those based on the Greek fret are most popular. In general, striped awnings are suitable for brick or other dark toned buildings, while stencilled awnings are suitable for stucco or similar light toned ones. The scallops around the edges of awnings are also varied in pattern, but unless outlined with color, do not have much effect on the general appearance.

The durability of awnings is, of course, important and they should be bought from responsible dealers or manufacturers. All exposed hardware should be galvanized or otherwise protected against rust, the canvas should be new and of heavy weight, and the colors should be fast.

There are two principal types of awnings in general use: the hooded type which folds up against the wall at the top, and the roller type, which operates similarly to the ordinary roller shade. Some of the latter type may be operated from inside the room without opening the window or the screen. Further advantages that are claimed for the roller type are that they are more weather-proof; are not so noisy nor so likely to be damaged during high winds; do not form pockets for the accumulation of water and dirt when not in use, and are more durable.

Any ordinary type of plain or arched opening may be neatly fitted with awnings. Even casements opening out may be fitted with a special box type that allows the windows to be operated. This type of awning, however, has a clumsy appearance.

From a standpoint of appearance, it is better to have few rather than many awnings on a house. Windows under wide, overhanging eaves seldom need them and may often be omitted on north elevations.—National Builder.

* * *

Marriages and Houses

An average annually of 1,040,000 marriages in the United States as against 70,000 houses built in 1919, is the interesting contrast made by the manager of the St. Louis Housing Association at a recent address before the American Society of Mechanical Engineers. Only 20,000 houses were built in 1918 and 70,000 in 1919 according to this authority, who points out the need in this country of 3,340,000 additional houses. This association is building houses for workmen at cost, and suggests that similar associations be organized in every city to prevent house famine.

* * *

Hardwood Shortage

After many weeks spent in the southern lumber territory a special investigator for the National Council of Furniture Associations has reported to the council, so states a document issued by that association, that the hardwood lumber shortage was due to such adverse weather conditions that the mills could not be operated. He declared that he was satisfied that the manufacturers had done their utmost to increase the output but that they had met insurmountable obstacles.

THE Architect and Engineer

INCORPORATED

Founded 1905 by E. M. C. WHITNEY

W. J. L. KIERULFF - *President and Manager*
 FRED'K W. JONES - *Vice-Pres. and Editor*
 L. PENHORWOOD - *Secretary*
 T. C. KIERULFF - *Attorney*

ASSOCIATE EDITORS

IRVING F. MORROW - *Architectural Critic*
 W.M. B. GESTER, - *Inspection and Tests*
 O. P. SHELLEY, C. E. } *Fireproof Construction*
 F. W. FITZPATRICK, }
 T. RONNEBERG, C. E., - *Structural Steel*
 W. H. LOWE - *Roofs and Roofing*
 FRED'K N. WOODS, JR., - *Rock and Gravel*
 W. H. GEORGE - *Cement*
 WILBUR DAVID COOK, *Landscape Architecture*
 PAUL C. BUTTE - *Electrical Construction*
 CHAS. H. CHENEY - { *City Planning and*
 Book Reviews
 H. J. BRUNNIER - *Reinforced Concrete*
 I. W. FRICKE, - *School Equipment*
 C. H. WHITE - *Hardwood*
 WILL J. FRENCH, *Department of Safety*

Published Monthly in the Interest of the
 Architects, Structural Engineers, Contractors
 and the Allied Trades of the Pacific
 Coast by The Architect and Engineer Co.

BUSINESS OFFICE AND EDITORIAL ROOMS
 627-629 Foxcroft Building, San Francisco
 Telephone Douglas 1828

The publishers disclaim any responsibility for statements
 made in the advertisements of this magazine.

TERMS OF SUBSCRIPTION
 (Including postage) to all parts of the United States \$2.50
 per annum; to Canada 75c additional; to all Foreign points
 \$1 additional.

Vol. LXII. JULY, 1920 No. 1

FIRE LOSSES AND THE WOODEN SHINGLE

Contradictory and misleading statements as to fire causes are almost as numerous as those who make them if one may credit the fire reports printed in newspapers and other journals. In an address said to have been delivered at a recent convention with reference to wooden shingles it was stated that 90 per cent of all the fires in large cities originated from roofs; another so-called "authority" is quoted in the daily press as saying that 95 per cent of the fires in dwellings, where so many losses occur, start inside the house.

The sources of information for these two statements are of course not given but if one may trust the official reports of fire chiefs in the country as compiled by such magazines as "Fire and Water Engineering" (and this would seem to be as authoritative and unprejudiced a source as could be secured) the fire losses in 1917 and 1918

show that 3 per cent and 2.4 per cent respectively of the total losses are attributable to "sparks on roofs." Reports from the same sources for the first quarter of 1920 indicate a great preponderance of fires in congested and business districts of our cities. Of the \$67,000,000 fire loss during the first three months of 1920, \$57,000,000 was of public and business buildings and only about \$3,300,000 or about 5 per cent in dwellings. The greater part of the loss was therefore of buildings of fire-resistive or semi-fire-resistive construction and supposedly incombustible. It would appear that the great agitation directed in some places against shingle roofs and frame dwellings, might better be directed against the weaknesses in so-called incombustible construction, against carelessness and inadequate fire-fighting machinery.

Insufficient supervision by building departments of the greater part of new construction or installation of fire prevention equipment in public and business buildings, lack of efficient and consistent inspection of buildings after completion, as well as efficient building regulations are accountable for many of these preventable losses by fire which occur with seeming regularity.

BUILDING CHARACTER INTO WOOD AND STONE

At the recent third annual convention of the Northwest Master Builders Association, held in Portland, Oregon, President Parker, of the Portland branch of the association, said, in welcoming the delegates: "Let us remember in our work that we build more than buildings. We are building character, reputation for honesty and square dealing."

At the rebuilding of Solomon's Temple we are told that all the workers "did their work faithfully." They put themselves into it. They built character into the wood and stone and metals they fashioned. Mr. Parker echoes this idea. Character and reputation for honesty and square dealing should go into every structure, into every part of our work, says the editor of *Valve World*.

The chief aim in a building should be to have every part of it give to its owner the maximum of service, and this can be achieved only through all the workers engaged in it, either in preparing the materials or in assembling them, doing their work faithfully, keeping continually in mind as the guiding impulse that they are building more than a building, that they are building character and reputation for honesty and square dealing — building for service.

HAPHAZARD CONSTRUCTION OF HOMES

A prominent Ohio citizen was not especially enthusiastic about a building ordinance for his city, reports one of the field men of the National Lumber Manufacturers Association, until he inspected recently the construction of 32 houses out of a total of 42 now under erection in the town. The local dealer who is erecting these houses has violated nearly every possible law of good building. The foundations to grade are concrete poured dry and are cracked. From grade to sill cement blocks are set together without even a pretense of mortar in joints. He fills the joints inside and out after the building is up. The posts in the basement are misplaced. The spiked bearing member in his floor was in the way of a furnace pipe so he cut into the member and laid a short run pipe against the bearing member without any insulation. If the register above is shut off with a hot fire going and possibly children sleeping in the house, it would not take an expert to forecast the probable result. If a joist interfered with placing a register box, he would cut out the joist and use two by four headers spiked in. The woodwork was spiked to the flue — this alone being sufficient to condemn the structure so far as fire safety is concerned.

Even a novice in building laws can see the fire hazard in such houses and the urgent need of city building regulations which would not permit such careless construction. And yet if such a dwelling should be burned, many would thoughtlessly lay the old-time

blame upon frame construction or shingle roofs whereas the fault should be absolutely credited to the violation of almost every law of building known to the profession.

BUILDING RESTRICTIONS IN LONDON

"Luxury building" in London has now been extended to "any building contemplated or in the course of construction which may cause a shortage of labor or material for the provision of dwelling accommodation." The London City Council has served notices on a number of firms ordering work to cease on their premises in respect to rebuilding or alterations. Among the firms receiving such notice are some of the largest department stores.

The Chairman of the Building Control Committee of the London County Council is quoted in Daily Commerce Reports of the Bureau of Foreign and Domestic Commerce as saying that serious thought will be given before a ban is placed on the continuation of work in which highly skilled labor that would be of little use in the construction of dwelling houses is employed and if a building would be a source of enormous local revenue or result in increased employment or would help increase export trade, its construction would doubtless be permitted.

Notes and Comments

The story of a builder who followed the beaten track of building houses in Good Design rows, all alike, and who Helps to Sell failed because his houses A House were such slow sellers, eating up his profits in the interest, is given point in the way he came back through giving more attention to design and more care to planning, the charm of the individual design and convenience of plans selling his houses before he had them completed. Materials and their physical properties are the builder's province; design in materials and their sightly properties are the architect's province—but these

provinces merge in individual architect's and builders of the many-sided kind.

The builder of usual ability who works without an architect, declares the National Builder, may get away with it after a fashion, but he may lose as much or more than he saves not only immediately from defective planning, but in continuous loss due to uninteresting designing. So it cost the builder in the story the price of several failures to educate himself so that he could find him money in good design. Why would it not have been cheaper to get a good architect in the first place?

Wooden Houses Too Costly for England

ENGLAND'S great housing program will not draw heavily on American supplies of building materials, according to information gathered by W. Stanley Hollis, U. S. consul general at London, in a report to the U. S. Department of Commerce. Wooden houses cannot be built cheaply enough to supplant masonry structures and the exchange rate is unfavorable to the purchase of building materials from America. Mr. Hollis, in his report, says:

"Although much has appeared in the British press during the past few months in favor of the construction of large numbers of wooden buildings as a means of relieving the housing shortage, and although a considerable number of such houses may eventually be built here, in the opinion of experienced builders they will never become popular, for the reason that they are not suitable to the English climate. A type of wooden house, made to architects' plans and built from the ground up by experienced carpenters, with walls plastered and back-plastered, and of the type which can be kept warm by furnace, steam, or hot-water heating when the thermometer is below zero, might be popularized here if it could be built cheaper or quicker than a house of brick or stone after the British pattern; but this, according to the best practical authorities in the building trade in London, cannot be done at present.

"In the first place, the erection and finishing of a modern wooden house, after the best American pattern, calls for the labor of a considerable number of first-time carpenters. Now, at the present time, Great Britain is woefully short of carpenters, as over 200,000 of those who were available in 1914 were either killed or permanently disabled during the war. This shortage of carpenters can not be made good in the near future, inasmuch

as it takes a number of years to train a man into becoming a first-class carpenter.

"One of the largest London retail dry-goods merchants, whose name is a household word in Great Britain, with a view to doing his bit toward overcoming the housing shortage, and also to enable his own employees to secure houses at reasonable rates, and with no desire to make even a penny profit, recently acquired a large tract of land, with the intention of building thereon several hundred dwelling houses which could be let at reasonable rates.

"After going over all possible types of dwellings with one of the leading London builders and contractors, and going into the matter most thoroughly from all points of view, it was their unanimous conclusion that the best and cheapest type of dwelling which could be erected in a reasonable length of time would be one of brick and concrete, i. e., with brick pillars and concrete panels in between, to form the outer foundation walls. This particular contractor was asked by the writer to state to what extent American materials could be used in the construction of these buildings, and he replied that at present, owing to the high rate at which dollars are quoted in the English exchanges, he could not afford to buy even American structural steel, which he would have done had the exchange been at par or thereabouts. The present high freight rates on goods shipped from American to British ports also tend to restrict the importation into this country of bulky building materials."

Power Shortage on the Pacific Coast

IT may be that some day the East in general and Congress in particular will know and grasp the power situation on the Pacific Coast. They do not know it now. It is not unfair to say that the East has not the faintest conception, not to say adequate knowledge, of what the West has in the way of potential and developed power, nor does it realize how vital is power to the very life of this great and rapidly growing part of the country, says Power.

Agriculture and horticulture are the two great pursuits of the Coast from Seattle on the north to San Diego on the south. The average American, who knows more about Russia than he does about the San Joaquin and the Yakima valleys, cannot for the life of him see why a farm needs power other than that for the tractor and the Ford. He does not know that at this very writing every power company on the Coast is woefully overloaded furnishing electricity to farms and has booked so much farm business that the matter of delivery is a veritable nightmare to those responsible. This

is particularly true of California, though most of the plants in the Northwest also are overloaded with farm and lumber industry consumers.

At present the "rainy season" in California is practically over and there is a shortage of more than eight inches of rain. From a power standpoint this has created a desperate situation. Every kilowatt of steam-generating capacity that can be unearthed and set to work is eagerly sought. While it may be true that the question of reserve steam stations has not taken a new turn in the minds of engineers here, it is certain they are thinking about the question with an intensity which is more marked than ever. Oil is becoming so high in price that every day some additional engineer joins the ranks of those who are ready to look upon it as a prohibitive fuel. This oil is, of course, a California product, little or no Mexican oil having yet found use here. The natural gas available is of low heat value and heretofore so expensive that it found but small market in power plants. However, one large company in the southern part of the state is completing a large steam station using natural gas.

The serious power shortage may, nevertheless, have a happy ending in that it will direct such attention to the matter of fuels for steam stations that not only will there be a greater percentage of steam power, but the stations may become of such an efficient character both in design and operation that it will be worth while finding service for them that will be of regular instead of an emergency character. This much is certain—a given sum of money will go farther building steam stations to meet certain load conditions, the time element considered, than is true for hydro-electric developments.

The engineers of the Coast know better than outsiders can possibly know what is the solution of their power difficulties, but the problem is a Coast one in particular and a national one in general. It is this that the country as a whole should, but does not, realize.

Report of Eleventh Annual Convention of the American Federation of Arts

With a record attendance, the American Federation of Arts held its Eleventh Annual Convention at the Metropolitan Museum May 19th to 21st. Suiting its text to the occasion of the Metropolitan's Semi-centennial, the Federation devoted its sessions this year primarily to museums as factors in the growth of American culture.

For eleven years this national society, consisting of 225 affiliated chapters in 40 states, besides thousands of individual members, has been building up a reputation for solid service along lines of great value to the American people.

In all 44 exhibitions covering painting, sculpture, textiles, wall paper, etc., were circulated during the season now closing, these having reached 97 different communities. Last year there were only 30 exhibitions circulated, these reaching only 68 communities. And this success during 1919-1920 was achieved in the face of the hardest transportation conditions the country has ever faced, with strikes and embargoes without number. In addition there have been the untold obstacles of influenza epidemics and other causes to cancel listings.

Mr. Hodges Writes of Housing

Mr. Charles Edward Hodges, formerly of the firm of Hodges & Mitchell, architects, with offices in the Bankers Investment building, San Francisco, and at one time resident architect at Stanford University, is now practicing his profession in New York City. A recent number of the Touchstone magazine contains an article by Mr. Hodges on "Solving the High Cost of Small Homes." Mr. Hodges says in part:

Home builders today are face to face with the high cost of building construction. For some time, would-be owners of homes have postponed building in the hope that the present period of high construction cost would be materially lowered.

But the high level of cost for building material and labor shows no signs of dropping, indeed, forecasts at the present time indicate that it will be several years before a material reduction is effected in the abnormal price per square foot for all kinds of construction.

One of the largest items in residential construction is labor. Today, labor demands a good living wage—the skilled artisan has forced up wages to a point which would have been unbelievable a few years prior to the great war. This brings the man of average means to a Hobson's choice; he must either build under prevailing conditions or postpone, for a considerable period, his home-making plans. A country-wide congestion, arising from the wide-spread curtailment of construction during the war, has driven many a home seeker in desperation to an architect's office, with the certain feeling that he is going to get from one-third to one-half less than what he might have previous to the great world crisis. Some have given up all the cherished ideas which a would-be proprietor of a home brings into the architect's office, seeking to get something which will but distantly approximate what he might have had a few years ago. Others fall back on the stereotyped construction of suburban development schemes, seeking to overcome the increasing cost in taking somebody else's idea of a home in quantity lots.

Yet a third possibility remains—the systematic economization resulting from the most painstaking planning and construction of residences for the great middle class of professional and business men. This involves, at the present time, first: reduction of the foundation cost; second: simplifying and economizing of the plumbing; and third: securing an artistic yet simple exterior effect.

Personal

MR. R. T. JONES is now chief draftsman in the offices of Noerenberg & Johnson, architects, 761 Pacific Electric building, Los Angeles. Mr. Jones was until recently assistant professor of architecture at the University of Illinois.

American Institute of Architects

(ORGANIZED 1857)
OFFICERS FOR 1920-21

PRESIDENT.....HENRY H. KENDALL, Boston
FIRST VICE-PRESIDENT.....CHARLES A. FAVROT,
New Orleans, La.
SECOND VICE-PRESIDENT.....WM. B. FAVILLE,
San Francisco
SECRETARY.....W. STANLEY PARKER, Boston, Mass.
TREASURER.....D. EVERETT WAID, New York

San Francisco Chapter

PRESIDENT.....SYLVAIN SCHNAITTACHER
VICE-PRESIDENT.....ARTHUR BROWN, JR.
SECRETARY.....MORRIS M. BRUCE
Directors, WILLIAM MOOSER JNO. REID, JR.
WM. O. RAIGUEL CHAS. PETER WEEKS

Southern California Chapter

PRESIDENT.....EDWIN BERGSTROM
VICE-PRESIDENT.....HENRY F. WITHEY
SECRETARY.....R. GERMAIN HUBBY
TREASURER.....AUGUST WACKERBARTH

Executive Committee

A. M. EDELMAN ROBERT H. ORR S. B. MARSTON

Portland, Ore. Chapter

PRESIDENT.....W. C. KNIGHTON
VICE-PRESIDENT.....JOHN V. BENNES
SECRETARY.....FOLGER JOHNSON
TREASURER.....O. R. BEAN
TRUSTEES.....{ ELLIS F. LAWRENCE
JOSEPH JACOBBERGER

Washington State Chapter

PRESIDENT.....CHARLES H. ALDEN, Seattle
1ST VICE-PRESIDENT.....JAMES H. SCHACK, Seattle
2D VICE-PRESIDENT.....GEORGE GOVE, Tacoma
3D VICE-PRESIDENT.....L. L. RAND, Spokane
SECRETARY.....F. A. NARAMORE, Seattle
TREASURER.....EARL G. PARK, Seattle
DIRECTORS.....{ A. H. ALBERTSON
C. H. BEBB
G. C. FIELD

**California State Board of Architecture
NORTHERN DISTRICT.**

PRESIDENT.....CLARENCE R. WARD
SECRETARY-TREASURER.....SYLVAIN SCHNAITTACHER

Members

J. R. MILLER EDWARD GLASS J. J. DONOVAN
SOUTHERN DISTRICT.

PRESIDENT.....JOHN PARKINSON
SECRETARY-TREASURER.....A. M. EDELMAN

Members

W. H. WHEELER MYRON HUNT W. J. DODD

San Francisco Architectural Club

President.....Harry M. Michelson
Vice-President.....T. Pflueger
Secretary.....W. E. Baumberger
Treasurer.....James S. Cole
Directors—F. F. Amandes, N. Reinbertz, E. B. Hurt.

San Francisco Society of Architects

President.....W. C. HAYS
Vice-President.....LEWIS P. HOBART
Secretary-Treasurer.....H. H. GUTTFERSON
Directors.....{ GEO. A. LANSBURGH
JOHN REID, JR.

Washington State Society of Architects

PRESIDENT.....HENRY H. JAMES, Seattle
1ST VICE-PRES.CLAYTON D. WILSON, Seattle
2D VICE-PRES.JULIUS A. ZITTEL, Spokane
3D VICE-PRES.WATSON VERNON, Aberdeen
4TH VICE-PRES.RICHARD V. GOUGH, Okanogan
SECRETARY.....EDGAR BLAIR, Seattle
TREASURER.....L. L. MENDEL, Seattle
TRUSTEES:—H. H. JAMES, FRANK FOWLER, A. WARREN GOULD, W. J. JONES, R. H. ROWE, all of Seattle.

Pacific Coast Society of Landscape Architects

Chapter of American Society of Landscape Architects

PRESIDENT.....W. D. COOK, JR.
H. W. Hellman Bldg., Los Angeles, Calif.
VICE-PRESIDENT.....STEPHEN CHILD
Fairmont Hotel, San Francisco, Calif.
SECRETARY-TREASURER.....E. T. MISCHER
Henry Bldg., Portland, Oregon

Tacoma Society of Architects

PRESIDENT.....Roland E. Borhek
VICE-PRESIDENT.....Earl Dugan
SECRETARY AND TREASURER.....A. J. Russell

San Diego Architectural Association

PRESIDENT.....WM. TEMPLETON JOHNSON
VICE-PRESIDENT.....ROBERT HALLEY, JR.
SECRETARY-TREASURER.....E. C. DECKER

San Joaquin Valley Ass'n of Architects

PRESIDENT.....E. B. BROWN
VICE-PRESIDENT.....F. V. MAYO
SECRETARY-TREASURER.....JOSEPH LOSEKANY

**American Society of Civil Engineers
Southern California Association**

PRESIDENT.....GEO. G. ANDERSON
FIRST VICE-PRESIDENT.....H. W. DENNIS
SECOND VICE-PRESIDENT.....W. K. BARNARD
SECRETARY.....F. G. DESSERTY
TREASURER.....RALPH J. REED

DIRECTORS

GEO. G. ANDERSON
LOUIS C. HILL W. K. BARNARD
H. HAWGOOD RALPH J. REED
H. W. DENNIS F. G. DESSERTY

All communications should be addressed to Mr. Desserty, 511 Central building, Los Angeles.

San Francisco Association

PRESIDENT.....M. M. O'SHAUGHNESSY
1ST VICE-PRES.....W. L. HUBER
2ND VICE-PRES.....F. R. MUHS
SECRETARY AND TREASURER.....NATHAN A. BOWERS

BOARD OF DIRECTORS

W. L. HUBER
F. R. MUHS M. M. O'SHAUGHNESSY
E. J. SCHNEIDER NATHAN A. BOWERS

Address all communications to the secretary, 502 Rialto Bldg., San Francisco.

American Association of Engineers

PRESIDENT.....W. H. FINLEY, Chicago
FIRST VICE-PRESIDENT.....H. W. CLAUSEN, Chicago
SECOND VICE-PRESIDENT.....L. K. SHERMAN
SECRETARY, C. E. DRAYER, 29 S. LaSalle St., Chicago
ASS'T SECRETARY.....A. H. KROM
TREASURER.....JOHN ERICSON, Chicago

SAN FRANCISCO CHAPTER

PRESIDENT.....WILLIAM WOLLNER
FIRST VICE-PRESIDENT.....J. F. JOHNSTON
SECOND VICE-PRESIDENT.....W. H. PHELPS
TREASURER.....R. L. KESSING
SECRETARY.....A. G. MOTT

LOS ANGELES CHAPTER

PRESIDENT.....H. Z. OSBORNE, JR.
1ST VICE-PRESIDENT.....J. J. BACKUS
2D VICE-PRESIDENT.....H. L. SMITH
Permanent address, 625 Metropolitan Bldg., Los Angeles.

With the Architects

Building Reports and Personal Mention of Interest to the Profession

Bank to Have Large Quarters

The new quarters which the Anglo London Paris National Bank will occupy will probably cover more ground space than any other bank on the Pacific Coast. Besides the present building at the corner of Sansome and Sutter streets, the bank will erect an addition on property which it has purchased to the north and extending to the new twenty-one-story Standard Oil building at Bush and Sansome streets. The bank has leased the ground floor of the Standard Oil building, which will give it the entire Sansome street frontage from Sutter to Bush streets. Plans for the improvements are being prepared by Mr. George W. Kelham, architect in the Sharon building, San Francisco. Mr. Kelham is also making plans for a six-story Class "A" structure which the Standard Oil Company will build on Mission street, between First and Second streets, San Francisco, to accommodate the tenants of the present building at Bush and Sansome streets, which is to be razed to make room for the twenty-one-story building.

Jackling Plans Completed

Plans have been completed by Messrs. Bakewell & Brown, 251 Keary street, San Francisco, for Colonel D. C. Jackling's country house at Hillsborough, San Mateo county. The architects are now waiting for the owner's instructions to proceed with construction. Messrs. Bakewell & Brown are preparing working drawings for the Nurses' wing to the Stanford Hospital. It is to be of concrete, five stories, and will cost close to \$400,000.

Vallejo Hotel

The preparation of plans for the new Admiral hotel at Vallejo is now entirely in the hands of Engineers Heller & Wilson, 57 Post street, San Francisco. The building is to be Class "C" with brick exterior and will cost \$250,000. There will be 125 rooms, 65 per cent of which will have private baths. There will be one passenger and one freight elevator, steam heat and hot water. The site for the hotel is at Sonoma and Virginia streets. The project has been financed.

College Buildings

New college buildings are to be erected at Corvallis for the Oregon Agricultural College, from plans by Mr. John V. Bennes, Chamber of Commerce building, Portland. One building will be an addition to the gymnasium and will have a swimming pool. It will cost \$60,000. The other structure will be a three-story economics building and will cost \$100,000. Construction will be by day labor in charge of Mr. L. N. Travers, of Salem, Oregon. Other buildings planned by the college later on include a women's gymnasium, to cost \$250,000, and women's dormitory, to cost \$120,000.

Group of College Buildings

Mr. Leo J. Devlin, architect in the Pacific building, San Francisco, is busy on working drawings for a group of fire-proof concrete buildings which will be erected on a tract recently purchased in Los Altos, Santa Clara county, by St. Patrick's Seminary of Menlo Park. It is not the purpose to abandon the buildings at Menlo Park, for the present at least, but it is probable that the new college buildings in Los Altos will be operated as a branch institution of St. Patrick's Seminary. There will be about ten buildings.

Six-Story Apartment House

Mr. E. H. Denke, architect at 1317 Hyde street, San Francisco, has completed plans and bids have been taken and are under advisement for a six-story Class "C" apartment house to be erected on the southeast corner of Bush and Taylor streets, San Francisco, for Mr. A. Penziner, of 745 Baker street. The building will contain forty-eight apartments, and will represent an expenditure of \$200,000.

Addition to Berkeley Bank

The First National and Berkeley Bank of Savings is building a one-story concrete addition to its Telegraph avenue branch, from plans by Mr. James W. Plachek, of Berkeley. Mr. Plachek has also made plans for alterations to the bank's main building on Shattuck avenue, Berkeley, and for a two-story frame apartment house on College avenue, Berkeley, for Mr. E. Q. Turner.

Oakland Apartment Houses

Plans have been prepared by Mr. R. A. Hutchison, Albany block, Oakland, for a two-story frame apartment house at 36th street and Telegraph avenue, for Mr. M. P. Rose, and for a two-story, eight-room apartment house at 32d street and Telegraph avenue, Oakland, for the same owner. Mr. Hutchison has also made plans for an eight-room residence in the Claremont District, Berkeley, for Mr. L. R. Wilson, to cost \$9500.

Spanish Country Home

Mr. Albert Farr, architect in the Foxcroft building, San Francisco, has prepared plans for a large country house designed in the Spanish type of architecture, which will be built at Atherton, San Mateo county, for Mr. R. S. Moore of the Moore Shipbuilding Company. The house and outbuildings, including garage, tank house, swimming pool, etc., will occupy a fifteen-acre tract. The owner will spend \$60,000 on the improvements.

Two Theatre Contracts

Messrs. MacDonald & Kahn, construction engineers in the Rialto building, San Francisco, have been awarded contracts to erect a \$1,500,000 theatre and office building in Los Angeles for Marcus Loew and associates, from plans by Messrs. Weeks & Day and Reid Bros., of San Francisco, and for an \$800,000 theatre at Powell and Post streets, San Francisco, for the same theatrical interests, from plans by Messrs. Reid Bros.

Large Hospital Addition

Plans have been prepared by Messrs. Rigg & Vantyne, architects of Spokane, Washington, for a four-story addition to St. Luke's Hospital. The new wing will contain one hundred and forty-seven beds and will cost \$250,000.

Portland Warehouse

Plans have been completed by Messrs. Hoteling & Dougan, architects in the Elks building, Portland, Oregon, for a three-story mill construction warehouse to be built on East First street, Portland, at a cost of \$125,000.

\$35,000 English Residence

Mr. William E. Milwain, Albany block, Oakland, is preparing plans for a \$35,000 English house to be built for a client in Berkeley. Construction will be of brick and stucco and there will be twelve rooms and five baths.

Palo Alto School

A new elementary school building is to be built at Palo Alto providing a \$150,000 bond issue is carried. Plans for the building will be prepared by Mr. Chas. Sumner, architect of San Francisco.

Third Unit to Hospital Group

Plans are being completed in the office of Mr. Henry H. Meyers, Kohl building, San Francisco, for the third unit, consisting of three four-story reinforced concrete ward buildings to the Alameda County hospital group on Fourteenth avenue, East Oakland. The unit is expected to cost \$500,000.

Holbrook, Merrill & Stetson Building

Plans have been completed by Mr. George W. Kelham for a \$300,000 reinforced concrete warehouse which will be built on the northeast corner of Sixth and Townsend streets, San Francisco, for Holbrook, Merrill & Stetson. The P. J. Walker Building Company are the contractors.

Elks Building for Lewiston, Idaho

Plans have been prepared by Messrs. Richardson, Lovering & Nave of Lewiston, Idaho, for a three-story reinforced concrete lodge building for the Lewiston Elks. Building will be equipped with a gymnasium, swimming pool and lodge hall.

\$60,000 Residence

Plans have been completed by Messrs. Ward & Blohme, 454 California street, San Francisco, for an English country house for Mr. H. O. Harrison. It will be built on Junipero Serra Boulevard, and will cost \$60,000.

Bay Point Bank Building

Plans are being prepared by Mr. E. L. Norberg, Bankers Investment building, San Francisco, for a two-story concrete bank and office building for the First National Bank of Bay Point. The estimated cost is \$40,000.

San Francisco Residence

Mr. Alvin Davis will build a ten-room frame and plaster residence on Washington street, near Buchanan, San Francisco, from plans by Mr. S. L. Hyman, architect in the Crocker building, San Francisco.

\$200,000 School Building

Mr. John J. Roth, architect at the Atascadero Colony, near Paso Robles, California, is preparing plans for a reinforced concrete high school building to be built at Atascadero at a cost of \$200,000.

Oakland Warehouse

Plans have been completed by Messrs. Reed & Corlett of Oakland for a one-story concrete warehouse to be built on the Oakland waterfront for the Howard Company.

San Jose Residence

Messrs. Binder & Curtis, of San Jose, have prepared plans for a nine-room residence and garage to cost \$22,000 for Mr. R. H. Borchers of that city.

Architect for New Capitol of Nebraska

Mr. Bertram C. Goodhue of New York has been chosen architect for the new capitol of Nebraska. Out of a list of ten competitors who submitted plans he was chosen by a jury of three disinterested architects, Messrs. Waddy B. Wood of Washington, James Gamble Rogers of New York and Willis Polk of San Francisco. Their choice was confirmed by the members of the capitol commission comprising Governor S. R. McKelvie of Lincoln, William H. Thompson of Grand Island, William E. Hardy of Lincoln, Walter W. Head of Omaha, and George E. Johnson, state engineer. Mr. Thomas R. Kimball, advisory architect for the board, assisted the jury in its decision.

The successful competitor is to receive \$12,500 as a retainer. Ultimately he may receive a quarter of a million dollars, more or less, for his services. Unsuccessful competitors are to receive \$2000 each.

Those who entered the competition were: Messrs. Bertram C. Goodhue, New York; John Latenser & Son, Omaha; Ellery Davis, Lincoln; Bliss & Faville, San Francisco; H. Van Buren Magonigle, New York; John McDonald and Alan MacDonald, Omaha; McKim, Mead & White, New York; John Russel Pope, New York; Tracy & Swartwout, New York; Paul C. Cret and Zantzinger, Borrie & Medary, Philadelphia.

Mr. Goodhue, the choice of the jury and commission for architect, has already earned a national reputation as the designer of the new West Point buildings and the Princeton group of buildings. He was born at Pomfret, Conn., April 28, 1869. "Who's Who In America," says he studied architecture six and one-half years under Renwick. His firm later became architects for the reconstruction of buildings at the United States military academy. He has designed many churches, cathedrals, collegiate and public buildings of all kinds. He has been an extensive traveler and as an author issued Mexican Memories and contributed as an expert to a work on Spanish Colonial architecture in Mexico.

Alterations to Residence

Mr. William E. Milwain, Albany block, Oakland, has prepared plans for extensive alterations to the Lenox avenue residence of Mrs. M. A. Mikel. About \$10,000 will be expended in finishing off six apartments.

Concrete Apartment House

Mr. P. Righetti, Phelan building, San Francisco, has prepared plans for a two-story concrete store and apartment house to be erected on the south side of Turk street, west of Leavenworth, San Francisco, for Mrs. George A. Metcalf.

A. I. A. CHAPTER NEWS

Will Ignore Jurisdictional Awards

Southern California Chapter of the American Institute of Architects has refused to accept as binding upon its members any authority, action or decision of the Board of Jurisdictional Awards. This is the substance of a report submitted by a special committee to which the matter had been referred and adopted by the Los Angeles chapter at a special meeting June 25. The directors of the American Institute of Architects and every chapter of the Institute will be notified of the decision of the Southern California chapter. What action may be taken by the directors of the Institute cannot be forecasted. Under the agreement entered into by the Institute with organizations represented on the Board of Jurisdictional Awards any member of the Institute refusing to abide by the decisions of the board is liable to suspension. Responsibility for the next move has been passed up to the directors of the Institute.

The Board of Jurisdictional Awards was created to adjust disputes between crafts on questions of jurisdiction over work in the building trades. All parties to the agreement are bound to conform to its decisions. Delegates of the Southern California Chapter to the recent convention of the Institute at Washington, D. C., sought to present a protest against the Institute binding its members in such an agreement without having first submitted the question to them. They were ruled out of order.

Washington State Chapter

The 261st meeting was held Saturday, June 12, 1920, at the Tacoma Hotel, Tacoma, Washington.

The Educational Committee, through Mr. Loveless, made a progress report of the work of this committee, reporting a conference with Mr. R. W. Moore, Director of Manual Training in the Seattle Public Schools, that Messrs. Schack and Albertson had loaned to Mr. Moore (for use in the schools) drawings of small houses, and that Mr. Moore had advised that the course in architectural drawing in the public schools was being modified to meet the suggestions of the committee.

The Legislative Committee, through its Chairman, Mr. Baeder, spoke of a meeting of the Board of Architects' Examiners in Washington at the time of the Convention, and reported on the objection of the engineers to the architects' license law proposed by the Institute, which had subsequently been modified to remove this objection. Mr. Baeder also stated that architects' licenses should be renewed on June 12, 1920, but that an extension of 60 days had been made. He

also stated that the examination for architects would occur on July 6, 7 and 8, 1920.

The Chairman of the Committee on Chapter Branch Groups, Mr. G. C. Field, spoke of the meeting of the Spokane architects which he attended upon his return from the Washington Convention and his success in obtaining several applications for membership in the Chapter.

It was moved by Mr. Huntington, seconded by Mr. Gould, that a meeting of the Chapter be held in Spokane every three years, beginning with next year. Carried.

Mr. G. C. Field then read a joint report of the delegates (Messrs. Gould, Field and Baeder) to the 53rd Annual Convention in Washington, after Messrs. Field and Baeder related their impressions of the Convention. It was voted that a copy of the joint report be sent to each member of the Chapter.

The subject of the annual picnic was brought up, and Mr. Borhek suggested that the picnic be held on some other day than Sunday. Moved by Mr. Willatzen, seconded by Mr. Field, that a committee be appointed to arrange for this annual picnic. Carried.

Moved by Mr. Baeder, seconded by Mr. Huntington, that a vote of appreciation be extended to the Tacoma members of the Chapter for their hospitality.

F. A. MARAMORE, Secretary.

Architects Banqueted

About eighty Los Angeles architects were guests of the Metropolitan Building Exhibit management and exhibitors the last Thursday in June, at a turkey dinner, the chief purpose of the event being to celebrate the opening of the architectural display and drawings for which Miss Schmidt, the manager, has provided a permanent rack of sliding leaves on which the architects may hang examples of their work for the benefit of the public. After the dinner a program of speeches rounded out the evening, felicitations reflecting the esteem in which the exhibit is held being expressed by Messrs. John Parkinson, Myron Hunt, John C. Austin and R. G. Hubby, and by Chas. F. Lummis. Mr. A. F. Rosenheim read a paper and Walter R. Simons spoke on behalf of the exhibitors.

Architectural Club Member Honored

Mr. James A. Magee, architect in the Phelan building, San Francisco, an active member of the San Francisco Architectural Club since 1905, and for the past three years a member of the local Chapter of Architects, has been elected to membership in the American Institute of Architects. Mr. Magee received his architectural education in the Atelier of the Architectural Club and in the School of Architecture, University of California.

Memorial Auditorium for Los Angeles

A proposition to issue bonds to the amount of \$4,500,000 for the erection of a memorial auditorium in honor of the service men and women of the Army, Navy and Marine Corps of the United States on the Normal Hill Center site has been approved by the city council and the people will have an opportunity to vote upon it at state primary election in August. A sketch of the proposed building has been prepared by Messrs. John C. Austin and John Parkinson, architects of Los Angeles. If built according to the design, the building will be an imposing structure, 480 feet long and 200 feet deep, with a tower 246 feet high. It will contain an auditorium seating 12,000 persons with a stage large enough for any indoor spectacle, a smaller auditorium seating 1000, a banquet hall which will accommodate 2000 and club quarters exclusively for service men. The cost of the building is estimated at \$4,000,000, the remaining \$500,000 to be used in acquiring land on Flower street and furnishing approaches from four sides.

Woollett Defends Plans

Replying to the charges made by Mr. James L. McLaughlin, contractor for the new Chico High School, that the plans for the building were imperfect, Mr. John W. Woollett, of Woollett & Lamb, architects of the new building, in a statement, said the contractor had taken the job at a close figure; that he is attempting to secure "extras" to make a profit, and in order to discredit the architects, he has carried his case to the Board of Education. Woollett told McLaughlin, when the contract was awarded, that no "extras" would be included in the job.

\$350,000 Merced Hotel

Preliminary plans are being prepared by Mr. W. C. Hays, architect in the First National Bank building, San Francisco, for a three-story reinforced concrete hotel to be erected at Merced at an estimated cost of \$350,000. The new hostelry will be 300x150 feet and will have one hundred and fifty rooms.

Forest Hill Residence

Mr. J. Morgan has had plans prepared by Mr. Walter C. Falch, Hearst building, San Francisco, for a \$15,000 residence and garage at Forest Hill, San Francisco. Mr. Falch has also made plans for a one-story shingle bungalow to be built in Mill Valley for Mr. Samuel Hyman.

One Dollar Per Copy

The publishers will pay \$1.00 per copy for the Architect and Engineer for December, 1919—the Mission San Juan number.

With the Engineers

Reports from the Various Pacific Coast Societies,
Personal Mention, Etc.

Engineers Visit Hetch Hetchy Valley

ABOUT forty members of the San Francisco Section of the American Society of Civil Engineers and their friends made a trip to Hetch Hetchy valley June 12 to 15 under the able guidance of Mr. M. M. O'Shaughnessy, city engineer of San Francisco, and members of his staff. Most of the party left San Francisco by train on the morning of June 12, reaching Priest portal, the lower portal of the main 18-mile tunnel of the mountain division of the project, late in the afternoon. Here they were joined by others of the party, who had made the trip by automobile, and an inspection was made of the work at this portal. The heading has now progressed over a mile from the portal. That night was spent at Groveland. From here the entire party proceeded by train the next morning along the Hetch Hetchy railroad, making stops en route at the principal points where work is going on. At Big Creek, a shaft 575 feet deep has been completed, and headings are being driven each way from the shaft. The shaft at Second Garrotte was not visited, since it is some distance from the railroad.

At South Fork, where the aqueduct crosses the South Fork of the Tuolumne, one heading has been driven nearly a mile from the portal. At Early Intake, the upper end of the 18-mile tunnel, operations in the heading had been temporarily suspended because of water struck in the tunnel. The power-house, which uses water from Cherry Creek carried in three miles of flume, ditch and tunnel, is at this point. All the power used on the entire work is generated here, and a small surplus is sold. The stop at this point furnished plenty of thrills to the party, as the trip from the railroad to the river and back was made on a 3700-foot cable incline, most of it nearly as steep as the side of a house, and seeming to be a great deal steeper.

At Mather, the city's sawmill is situated, where all the lumber needed for the work is cut, off lands acquired by the city in connection with the project. The Damsite camp, at the end of the railroad, and overlooking Hetch Hetchy valley, was reached late in the afternoon, and the remaining daylight hours were spent admiring the scenery and fighting mosquitoes. Fortunately, the Hetch Hetchy mosquito does not work after

dark, or at least after the lights are out, which was a great relief to all concerned. An hour or so the following morning was spent at the damsite and the remainder of the day in a trip to Lake Eleanor, the return trip to Groveland made by train in the evening. The next morning, the 15th, those who did not make a side-trip into the Yosemite valley returned to San Francisco.

The following were present:

Charles Morser, Palo Alto.
Professor Charles B. Wing, Stanford University.
Professor Charles Derleth, Jr., University of California.
Professor Charles Gilman Hyde, University of California.
Francis Betts Smith, Consulting Engineer, San Francisco.
F. O. Shutts, Assistant City Engineer, San Francisco.
W. H. Popert, U. S. Steel Products Co., San Francisco.
A. Kempkey, Consulting Engineer, San Francisco.
W. B. Gester, Robt. W. Hunt & Co., San Francisco.
F. H. Tibbetts, Consulting Engineer, San Francisco.
H. D. Dewell, Consulting Engineer, San Francisco.
Ed. F. Haas, Consulting Engineer, San Francisco.
J. H. G. Wolf, Consulting Engineer, San Francisco.
Lieut. Collins McRae, Corps of Engineers, U. S. N., Mare Island.
Lieut. Thomas Shack, Corps of Engineers, U. S. N., Mare Island.
H. H. Hall, Engineer, Pipe Lines, Standard Oil Co., San Francisco.
C. H. Lee, State Water Commissioner, San Francisco.
Colonel Wm. Kelly, Corps of Engineers, U. S. A., San Francisco.
C. H. Snyder, Consulting Engineer, San Francisco.
W. H. Holmes, Stanford University.
C. J. Rhodin, Consulting Engineer, San Francisco.
A. A. Brown, California-Hawaiian Sugar Refining Co., Crockett, California.
A. T. Parsons, Editor "Metal Trades," San Francisco.
A. P. Denton, District Engineer, Portland Cement Association, San Francisco.
Jos. Meyerink, San Francisco.
J. B. Lippincott, Consulting Engineer, Los Angeles.
J. J. Walsh, San Francisco.
A. Swan, Lieut. Commander, U. S. N. (Retired).
Max W. Enderlein, Consulting Engineer, Hanford.
Albert Givan, Assistant State Engineer, Sacramento.
W. H. Kirkbride, Chief Engineer, Maintenance of Way, Southern Pacific, San Francisco.
E. H. Barkmann, Mo. Val. Bridge & Iron Co., Sacramento.
M. M. O'Shaughnessy, City Engineer, San Francisco.

J. M. Owens, Chairman, Excursion Committee,
Assistant City Engineer, San Francisco.

Mrs. F. O. Shutts, San Francisco.

Mrs. J. M. Owens, San Francisco.

W. W. Bruner, San Francisco.

Stanley Bent, Contractor, Bent Bros., Los Angeles.

Nelson A. Eckart, Construction Engineer, Hetch Hetchy Project, Groveland, California.

L. T. McAfee, Resident Engineer, Hetch Hetchy Dam.

Edward Noble, Pacific Rolling Mills Co., San Francisco.

To Push Organization Work

Dr. F. A. Newell, head of the department of civil engineering at the University of Illinois, and past president of A. A. E., was appointed director of field forces during the summer months, at the quarterly meeting of the board of directors of the American Association of Engineers on June 19. Dr. Newell will spend a large portion of his time in traveling and will assist the chapters in solving their problems of organization and expansion and assist them to prepare for rendering greater service.

The national employment committee was instructed to formulate a personnel card and prepare plans for the expansion of employment service.

Mr. H. W. Clausen, general office manager of the C. D. Osborn Co. of Chicago, was elected treasurer. The thanks of the association were ordered extended to Mr. John Ericson, the retiring treasurer, for his useful service.

A motion was passed that the association tender its good wishes to the American Federated Engineering Societies and that each member of the federated societies be invited to become a member of A. A. E. It was agreed that while the association might not be able to contribute to the federation's expenses it would be glad to join with it on matters of common interests.

The board accepted the report of the building trustees, announcing that three types of buildings are under consideration; one type costing three million dollars, another one, one and a half million, and the third five hundred thousand, and recommending that subscription blanks be sent to members as a means of determining the amount of money which may be raised.

Engineers Question Presidential Nominees

The American Association of Engineers has addressed a letter to the presidential nominees, in which the nominee is requested to give an answer to each of six questions. The complete letter follows:

Dear Sir:

At the Sixth Annual Convention of the American Association of Engineers a series of six questions was drafted, designed to bring out the position of nominees for President on subjects in which the engineer will be especially interested. A resolution was unanimously passed directing that these questions be sent.

The American Association of Engineers is composed of 18,000 professional engineers rather evenly distributed over the country. They wish to help maintain our government on a high plane of efficiency.

If you will kindly answer the following questions at your early convenience, steps will be taken to acquaint our members and the public with your answers:

1. Are you in favor of a National Department of Public Works, for the purpose of reducing and co-ordinating the present number of bureaus and commissions, and reducing the useless expenditures of money incident thereto?

2. Are you in favor of assembling and co-ordinating all the engineering and construction enterprises of the government (excepting the purely military works) in a department such as the National Department of Public Works, to the end that economy and efficiency will be obtained?

3. Do you favor the appointment of an engineer of recognized ability and unimpeachable character as a member of the Interstate Commerce Commission?

4. Do you favor the budget system of appropriation of public funds?

5. Do you favor the reclamation of waste lands by drainage, irrigation, flood control or other methods?

6. Do you favor giving the settler the advantage of procuring the land by a sound financial system, such as is provided by a rotating fund?

Cordially yours,

(Signed) C. E. DRAYER,
Secretary.

Examination for Senior Architect

The United States Civil Service Commission announces a civil service examination on August 3, for senior architect. Two vacancies in the Interstate Commerce Commission under the act providing for the valuation of the property of common carriers, for duty in the Central District, and vacancies in positions requiring similar qualifications throughout the United States, at entrance salaries ranging from \$2100 to \$2700 a year, will be filled from this examination, unless it is found in the interest of the service to fill any vacancy by reinstatement, transfer, or promotion.

The entrance salary within the range stated will depend upon the qualifications of the appointee as shown in the examination and the duty to which assigned. Appointees at annual compensation of \$2500 or less whose services are satisfactory may be allowed the temporary increase granted by Congress of \$20 a month.

Appointments to these positions will be principally for duty in the field, but some appointments may be made for duty in Washington, D. C. Appointees will be allowed necessary expenses when absent from headquarters in the discharge of official duties.

Designer and Builder Dead

Mr. Harry Chivers of Chivers Brothers, architects and builders, died at his home in Pacific Grove June 30, after a two years' illness. Mr. Chivers' native country was England, where members of his family reside. He was a member of Pacific Grove Lodge of Masons.

The Contractor

BUILDING CONSTRUCTION, BRIDGES AND
ROAD WORK

The Architect's Struggle

In addressing the Master Builders' convention recently held in Portland, a prominent architect stated that the architect has been fighting several years for existence, just as the contractor has been fighting for what little he gets. If this be true and many prominent architects will say it is, then isn't it about time for the public to be fully informed on the situation? Isn't it also about time that something be done to bring home to the public the value of the architect not only as a designer of buildings but as one whose business judgment and advice are very often sought and rarely ever rewarded? Will it soon be so that the architect by reason of economic stress must lay aside his ideals while he struggles for a bare existence? The objects of the interprofessional conference as enumerated are to "discover how to liberate the professions from the domination of selfish interest, both within and without the professions, to devise ways and means of better utilizing the professional heritage of knowledge and skill for the benefit of society, and to create relations between the professions looking toward these ends." That is an inspiring thought but self-preservation being the first law of nature, how is this ideal state to be brought about unless the public is given a true measure of the architect and other professional men? The engineer is making a successful fight for recognition. The architect with his professional skill, his ideals and conservative business judgment is essential to the welfare of society. Any plan of action that will bring his value home to society means a long step in advance for society itself.—Pacific Builder and Engineer.

More About the "Doughnut" House

Much interest is being taken in a hollow tile house that is being built on Fifty-fourth avenue, East Oakland, by Mr. A. A. Marshall, an Oakland contractor, who recently came to California from Detroit, Mich.

The tile, according to Marshall, permits the building of houses at approximately

20 per cent less expense than ordinary building costs. The hole in the tiling is filled with concrete after the tiles are all in place, making the whole structure rigid. Plaster is put on without laths.

Mr. Marshall came to Oakland as the representative of a Detroit, Mich., company, which proposed to erect 1000 bungalows for working men, but found the cost of labor and the usual building materials too high for profitable building of this type of home. Mr. Marshall decided to remain on the coast and experiment with the "doughnut" or tile structure, which, if successful, will be followed by the erection of many more similar buildings.

Eliminates Retained Percentage

Highway contractors in the State of Indiana have secured the consent of the State Highway Commission to advance to contractors engaged in building state highways, 100 per cent of the contract price per mile upon completion of each mile of road. Settlement on this basis will not be final, but will be subject to adjustment up till the time the whole is completed. The proportion advanced on each completed mile heretofore has been limited to 80 per cent.

Conferences held at Indianapolis between the highway contractors and the state highway commissioner during June, led to the adoption of the plan. The new arrangement must be approved by the State Board of Accounts before it can be put into effect.

Pencil Points

"Pencil Points" is the name of a new monthly publication from the press of the Architectural Review. It is published for the draftsman primarily and would seem to fill a need that has long been felt. The first issue contains much of practical value.

Hotel for Hanford

Mr. George C. Aydelotte, representing a syndicate of local business men, has secured title to the old Catholic church property at Hanford as a site for a \$200,000, six-story hotel of brick and concrete.

Passing of Mr. F. O. Engstrum

The many friends of Mr. F. O. Engstrum will be grieved to learn of his death which occurred at Newburn, North Carolina, June 14, last. Mr. Engstrum was 74. He was stricken with apoplexy on May 31.

Mr. Engstrum was one of the best known contractors on the Pacific Coast and at one time his company was under contract to erect buildings whose total cost ran well into the millions.

Mr. Engstrum was an expert in concrete construction. Just prior to his death he had been in Newburn supervising the construction of concrete ships for the U. S. Government, the Newport Shipbuilding Co., of which he was president, having the contract. As a building contractor he had specialized in reinforced concrete construction and it was largely for this reason he became interested in the building of concrete ships.

For more than a quarter of a century Mr. Engstrum was the head of a construction company bearing his name. During that period he operated on an extensive scale and built a large number of important structures in California. Among the larger buildings which he erected in Los Angeles are the International Bank building, Citizens National Bank building, Metropolitan building, Rosslyn Hotel, Clark Hotel, Majestic Theater, Walker Theater, Rex Arms apartments, the state building at Exposition Park, and the Polytechnic high school. He also built about 25 grade school buildings in Los Angeles. At San Diego he constructed the municipal stadium, Spreckles Theater building, Marston building, Timken building, Watts building, and the Union high school. Other building projects which he executed were: State normal school at San Jose, state hospital at Agnew, community buildings at Atascadero, Edi-

son power plant at Long Beach, Ocean Park and Santa Barbara bath houses. To this list might be added the Haas-Baruch wholesale building and many other buildings of lesser magnitude in Los Angeles, including hotels, apartments, mercantile buildings, warehouses and factories.

Mr. Engstrum not only possessed unusual business ability and great energy but his personality also attracted a host of friends. He was a Shriner and Elk, a member of the Jonathan, Athletic and Union League clubs, and the Knights of Pythias in Los Angeles.

He is survived by two sons, Messrs. F. E. Engstrum and Paul Engstrom, and a daughter, Mrs. H. W. Bryson.

Architect Wiseman Drowned

The architectural profession lost one of its younger members of promise in the tragic drowning of Mr. Thomas B. Wiseman of Bakersfield on July 4. Mr. Wiseman met his death in the Kern river, about fifteen miles above Kernville, after having swum across the river to a rock, reaching which he suddenly became exhausted, fell back into the water and was carried down stream before rescuers could reach him. He was 36 years old.

Mr. Wiseman secured his early architectural experience in the office of Messrs. Train & Williams, Los Angeles architects. He went to Bakersfield in 1909 as local manager for this firm, whose business in that city he purchased a year later. Mr. Wiseman designed a large number of buildings in Bakersfield and throughout the oil district.

For a time Mr. Wiseman was associated with Mr. Henry C. Smith of San Francisco in designing school houses in the southern part of the state. One of his last commissions was a school house at Madera, the plans for which were made by Mr. Wiseman in collaboration with Mr. Walter Parker, a San Francisco architect.

HARDWOOD HEADQUARTERS

ASH-BASSWOOD-BIRCH
AROMATIC RED CEDAR
COTTONWOOD-ELM-HOLLY
SOUTHERN RED GUM
HICKORY-LAUREL-MAPLE
OREGON MAPLE-PLAIN OAK
-QUARTERED OAK-
WYBROCK BENDING OAK
POPLAR--WALNUT



BOXWOOD-EBONY-IRONBARK
JENIRO-KOA-SPANISH CEDAR
LIGNUMVITAE-MAHOGANY
ROSEWOOD--TEAK-RED BEAN
SPOTTED GUM-CIRSIASSIAN WALNUT
LUMBER--TIMBER
HARDWOOD FLOORING
WYBRO VENEERED PANELS
DOWELS-TREENAILS-VENEERS

WHITE BROTHERS

FIFTH and BRANNAN STREETS
SAN FRANCISCO, CAL.

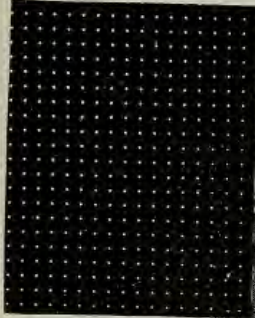

Hudson Terminal, New York City, N. Y. Equipped with The Stanley Works Ball Bearing Butts.

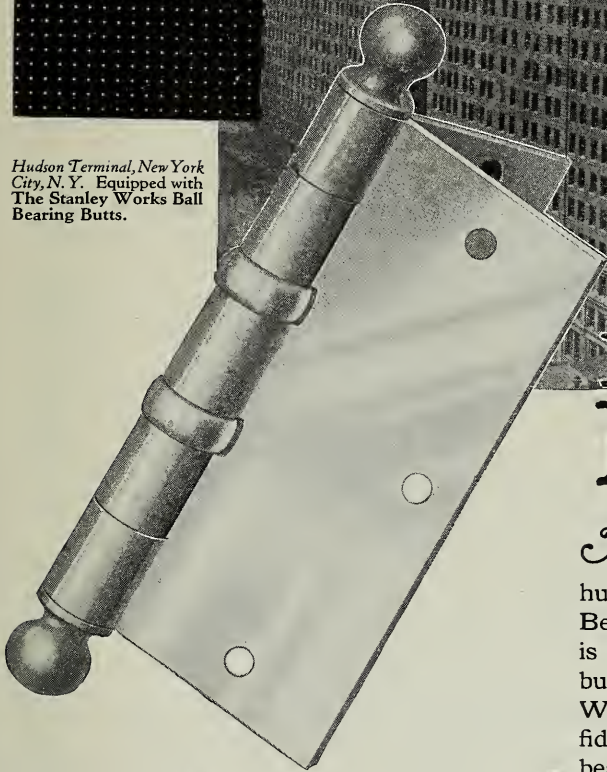

No. B B 239

BALL BEARING BUTTS

MORE and better service is obtained from the doors hung on The Stanley Works Ball Bearing Butts. This type of butt is used on the more prominent buildings throughout the country. Why, — because owners are confident that the high quality butt is best from an economical standpoint as well as the service it gives.

“Use The Stanley Works Ball Bearing Butts for Permanence.”

We have a book showing various types of Stanley Works Ball Bearing Butts. Ask for AE 7.

THE STANLEY WORKS

NEW YORK

NEW BRITAIN, CONN.

CHICAGO





Resists Fire

Freedom from pitch or resin gives California Redwood an unusual resistance to fire. For this reason Redwood construction, whether for home building, industrial, specialty, or engineering work, is long lasting.

Due to a natural preservative, Redwood also resists rot—a quality valuable in any industrial construction exposed to the elements or in contact with the ground.

CALIFORNIA REDWOOD
ASSOCIATION
San Francisco

California Redwood

Resists fire and rot

*Keep Abreast of the Times
by Recommending the*

FRIGID Refrigerating Plant

Frigid Refrigerating Plants are manufactured to give the best refrigerating service obtainable. Vertical or horizontal machines built to use either CO₂ or ammonia as refrigerants are designed, manufactured and installed by our skilled engineers and mechanics.

We repair, adjust or overhaul any style, size or make of refrigerating system or ice machine.

To Architects:

We will gladly cooperate with you in making estimates, recommendations and furnish information without charge. You owe it to yourself to avail yourself of this information—write today.

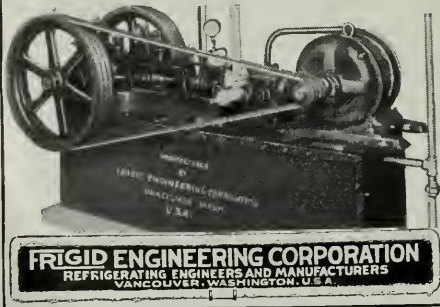

Big Equipment Order.

The Smith-Booth-Usher Co., dealers in contractors equipment, with offices and warehouses in San Francisco, Los Angeles and Taft, has been given an order by the Twohy Bros. Co., contractors, to furnish the entire Lakewood Road building equipment for the construction of \$4,000,000 worth of cement roads in Maricopa County, Arizona. This is said to be the largest single highway contract ever let in the United States.

The equipment consists of gasoline locomotives, steel track and cars, gasoline pavers with modern batch box transfers, boom and bucket discharge, road tamping and finishing machine, road sub-graders and tunnel traps.

All of the steel cars will have separate compartments for handling rock, sand and cement. In a word, this entire equipment will be the most modern installation of the latest type of Lakewood Road building equipment.

Some idea of the extensive operations of the Twohy Bros. Company may be had from the following interesting facts: In addition to their general contracting work, they own the Northwestern Car and Equipment Company of Seattle and the Pacific Car and Equipment Company of Portland. They contracted with the United States Government during the war to build twelve 9600-ton steel vessels, also 500 gondola all-steel cars for Government use. They erected the buildings at March Field, Riverside. Large portions of the Western Pacific and the Great Northern Railways were built by the Twohy Bros. Company as well as a portion of the San Diego and Arizona Railway.

The Lakewood Road Building plants are recognized as the most up-to-date road building equipment manufactured and sold in the United States. The value of good roads with easy grades is becoming more and more apparent to all who give the subject any serious consideration. Public sentiment is rapidly crystallizing in favor of concrete highways and the Board of Supervisors and the Highways Commissioners of Maricopa County are to be congratulated on their foresight and good judgment as well as the people of Maricopa County who voted in favor of the road bonds.

Another Cement Plant

Smith Emery & Co. of San Francisco are engaged in preliminary work for a new cement mill for California which will materialize as soon as the labor and material situation is a little more settled. The wet process will be used and the new mill will have a capacity of 2500 bbls. per day.

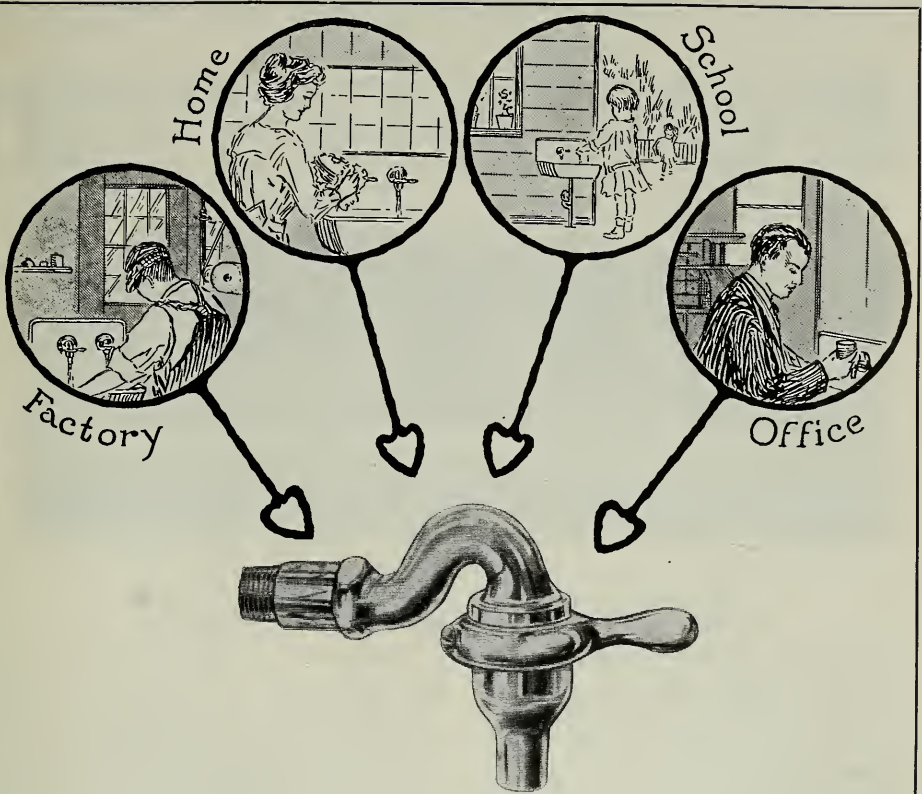

The
Hajoca "Quick" Faucet

is a distinct time-saver. It responds to a mere touch of the hand or even the wrist, with a thick, rapid-flowing, non-splashing stream. A real delight to the user in the home. Durable and simple in construction. Especially suitable for Wash Sinks in Packing Plants, Factories, etc.

SPECIFY
Hajoca "Quick" Faucets



HAINES, JONES & GADBURY Co.

MAKERS OF PLUMBING SUPPLIES

857 FOLSOM STREET, SAN FRANCISCO

PHILADELPHIA-NEW YORK-RICHMOND, VA.-SAVANNAH



FACTORY AND OFFICE BUILDING, SPENCER ELEVATOR COMPANY, SAN FRANCISCO

Spencer Elevator Company in New Quarters

THE Spencer Elevator Company, one of San Francisco's growing industries, has moved from 126-128 Beale street, where it began operations fourteen years ago, to its new home, 166-180 Seventh street, corner of Natoma, in a one-story brick building, 75x125 feet, designed to answer the needs of the company with ample offices and shop room on the ground floor and storage facilities in the basement.

With the completion of the Seventh street factory the Spencer Elevator Company enters upon a new era of industrial activity—an era that promises much for its management. Mr. F. M. Spencer, from whom the company takes its name, has been a tireless worker and the success of the Spencer machine must be credited to his thorough understanding of the manufacturing end and splendid business acumen.

That the company plays an important part in the up-building of San Francisco and the Bay Cities is evidenced by the contracts that recently have been let for both passenger and freight elevators.

The Chas. C. Moore loft building, under construction at First and Mission streets, will be equipped with five lifts—three freight and two passenger; the Hawley warehouse at Second and Bryant streets, being built by the Clinton Construction Company, will have four Spencer freight elevators; the Rattner apartments on Post street, will have one automatic passenger car; the Sherwin-Williams paint factory in Emeryville will have a Spencer hydro-electric; Robert Dalzell's new loft building just erected in Oakland by Palmer & Peterson, will be

equipped with two freight lifts; the new building at Sixth and Clara streets, for the Shields Estate, will have a large freight elevator. Orders are not confined to the local market. Recently two cars were shipped to Japan and one to Texas, which goes to show that the company's business is becoming nation-wide.

Amalgamation Parade

The amalgamation of the San Francisco Builders' Exchange and the Building Industries Association was made the occasion of a celebration Tuesday, June 29th, a large number participating. Formal ceremonies were preceded by a parade up Market street from Second to Third, and thence to the Exchange on Jessie street. Here speeches were made by Messrs. Chas. W. Gompertz, Henry Jacks, D. B. Farquharson, Supervisor Ralph McLeran, H. P. Stow, John Biller, Mr. Bergstrom, J. B. McSheehy, P. J. Lynch, and W. W. Watson.

The reception committee consisted of Messrs. C. M. Cadman, chairman, Alex Mennie, Jack Bender, L. J. Neal, J. A. Hart, Clarence Sand Pratt, D. J. Sullivan, Robert Grant, P. J. Lynch, Henry Jacks, Chas. Withington, Chas. Gompertz, Hermann Lawson, H. P. Stow, D. Zelinsky.

When the parade started, some wag rigged up a large board with the words "Wet Plank" boldly lettered on it, and carried it in the parade, to the amazement of the onlookers as well as the marchers. Many spectators confused the paraders with delegates to the Democratic convention, and for this reason the applause was not as spontaneous as it otherwise would have been.

DEPENDABILITY

ATLAS-WHITE is a true Portland Cement; pure white in color and therefore ideal for the finish coat of all-white stucco. Its higher accentuation of the values of color aggregates in the production of various color tones is still another reason for using Atlas-White—On The Job.

THE ATLAS PORTLAND CEMENT COMPANY

New York	Boston	Philadelphia	Birmingham
Chicago	Dayton	Des Moines	St. Louis

DISTRIBUTORS

J. S. Schirm Commercial Company
San Diego, Cal.
Oro Grande Lime & Stone Company
Los Angeles, Cal.
Santa Cruz Portland Cement
Company
Pacific Portland Cement Company
United Materials Company
San Francisco, Cal.
Langton Lime & Cement Company
Salt Lake City, Utah
Utah Sales Company Ogden, Utah
J. M. McCracken Company
Portland, Oregon
F. T. Crowe & Company
Seattle and Tacoma, Washington
Consolidated Supply Company
Spokane, Washington
Evans, Coleman & Evans, Ltd.
Vancouver and Victoria, B. C.
Canada

Upon request we will promptly send to architects one or all of three books: "Color Tones in Stucco," "Non-Staining Mortar for Pointing, Setting and Backing," "Cast Stone."



ATLAS WHITE

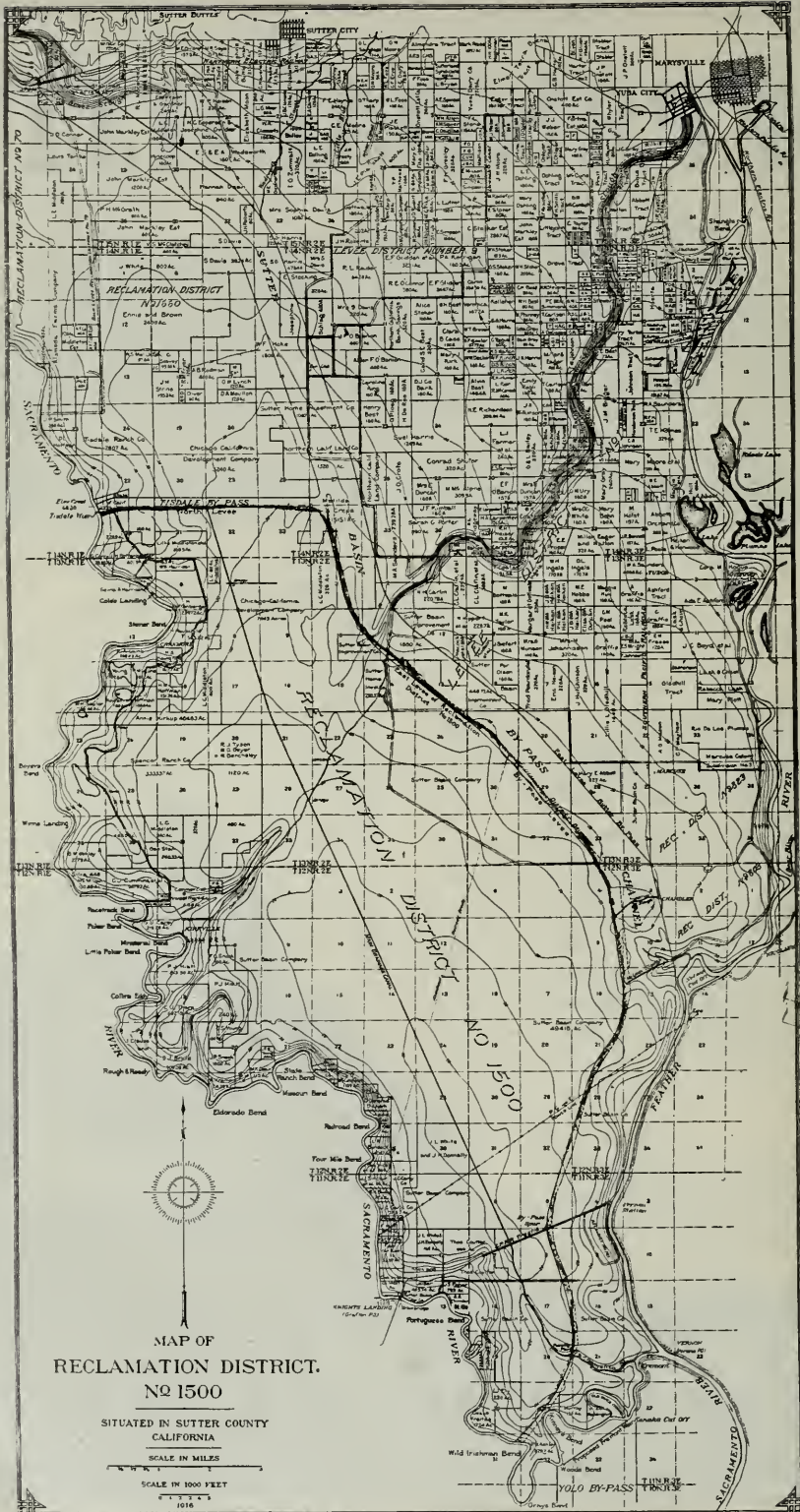

Draining and Irrigating Sutter County Lands*

A FACT, well known to engineers and construction men who have had experience with Pacific Coast reclamation projects, but rather new and surprising to many others, is that many of these developments embody a combination of drainage and irrigation operations with reference to the same areas of land. In the valley of the Sacramento River, in particular, hundreds of thousands of acres which in a natural state were tule-covered marshes, and at certain seasons deeply flooded, have been protected by dikes and levees from the flood waters, drained by canals and pumping plants, and finally provided with irrigation systems to enable the raising of many crops which would otherwise fail to thrive in our dry, California summers.

The accompanying map gives a good idea of a typical development of this character—Reclamation District No. 1500, situated on the east side of the Sacramento River and between that stream and



Reclamation District Camp, Sacramento River, and Armco Pipe

by means of main and lateral canals with plants at their lower extremities which pump the water back into the by-pass. The reclamation operations were started in 1912, and a total of five million dollars has been expended. Sixteen dredges were used. The levees are over sixty-two miles in length, and were practically closed in 1918.

The main drainage canal is 18.2 miles long and the lateral drainage canals total 252 miles. The main drainage pumping plant consists of six 50-inch Platt centrifugal pumps, direct connected to six 800-horsepower General Electric motors, capacity 1200 second feet or 539,000 gallons per minute. This pumping plant was constructed in the years 1913 and 1914.

Irrigation.—The irrigation system is the work of the Sutter Basin Company, of which Mr. George F. Maddock is general manager and Mr. R. L. Jones is engineer. It was started in 1919, and is now approaching completion. Its total cost is something over one million, seven hundred and fifty thousand dollars. It is called the Sutter Basin Mutual Water Company. A water right goes with the land.

The main canals, known respectively as East Canal, Main Canal, West Canal and Central Canal, are of a total length of 45.8 miles. The lateral irrigation canals



Tisdale Weir, North End of District 1500, at Flood Time

the Sutter Basin By-Pass, about forty miles northwest of Sacramento. This comprises a total reclaimed area of 63,250 acres, of which approximately 60,000 acres are cultivable. Practically all of this land lies between the low and high levels of the river and the by-pass, and normally would be flooded every time the river rose to any unusual levels.

The soil is extremely rich, and it is also easily worked and well adapted to grain, beans, and market vegetables as well as to alfalfa and some varieties of fruit. Rice is also becoming a very important crop. These facts have justified the expenditure of large sums for drainage and irrigation, the net result of which operations has been the addition of large areas of highly productive land to our food-producing acreages.

Protection and Drainage.—The tract is surrounded by levees, along the Sacramento River and the Tisdale and Sutter Basin By-Passes, and drainage is effected



Sutter Basin Roads—Threshing the Rice Crop (in Background)

* A description of the engineering works of California Reclamation District No. 1500 and the Sutter Basin Company. Engineering data supplied by Mr. R. L. Jones, Engineer, Sutter Basin Company.



IRRIGATION PUMP HOUSE AT THE NORTHWEST CORNER OF DISTRICT NO. 1500

total 138 miles. In constructing the irrigation canals as many as one thousand men, lodged in thirty camps, and working 950 head of stock, have been employed at one time.

The Tisdale Pumping Plant, at the north end of the district, consists of three 42-inch Byron Jackson centrifugal pumps, direct connected to three 250-horsepower General Electric motors, and three similar pumps, direct connected to three 300-horsepower General Electric motors. The total capacity is 730 second feet.

The Portuguese Bend Pumping Plant consists of two 24-inch Byron Jackson centrifugal pumps, direct connected to two 200-horsepower General Electric motors, and has a capacity at 25-foot head of 90 second feet.

The State Ranch Bend Pumping Plant operates one 23-inch Byron Jackson

pump, direct connected to one 200-horsepower General Electric motor. Its capacity is 40 second feet.

Irrigation structures include bridges, Armco corrugated pipe for carrying canals across drainage ways or other canals, various Calco and other types of gates and gate lifts and Armco metal flumes, and, of course, a considerable amount of concrete work. The total of irrigation structures is approximately four hundred and fifty.

The use of corrugated iron pipe in irrigation canals is found advantageous wherever it is desirable to have the ditch covered in order to have the use of the land above or to permit the passage of teams and tractors. Corrugated pipe can be rolled directly into a ditch which is already half full of water, and it has



ARMCO FLUME IN USE ON RECLAMATION DISTRICT NO. 1500

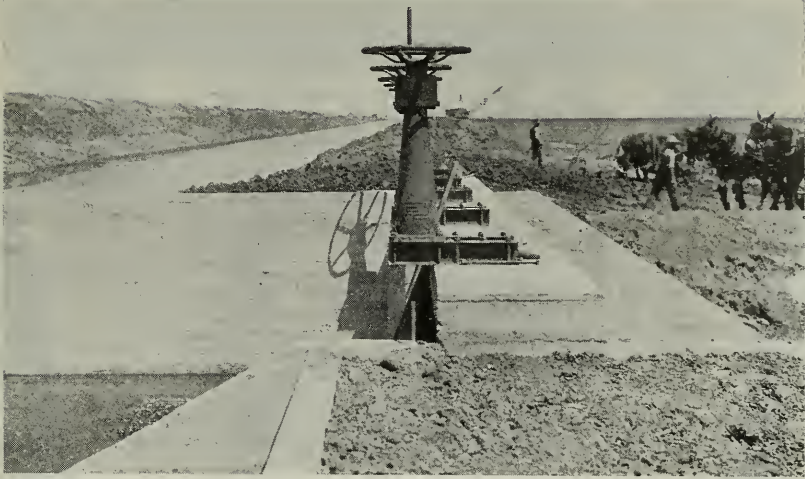

GATES AND CALCO PEDESTAL GATE STANDS, RECLAMATION DISTRICT
NO. 1500

enough flexibility to enable it to endure slight deformations, if necessary.

The gross area possible to cover by this irrigation system is 54,000 acres, net area about 51,000 acres.

Transportation Facilities.—A modern road system was one of the first necessities. Prior to 1912 transportation across the tract, during the flood season, was by motor boats. By the spring of 1920, ten miles of roadway had been graded and surfaced with gravel, and ninety miles had been graded. Eight miles are now being surfaced with water-bound macadam, and forty-five miles will be graded during the next six months. The drainage of these roads has been accomplished by the use of Armco corrugated pipe.

The Sutter Basin branch of the Southern Pacific runs through the property. There are six sidings and two terminals. At each siding warehouse facilities have been provided. Many more are in process of construction.

The land is divided into farms, ranging from small holdings up to several hundred and even thousand-acre tracts. Ultimately all of these will be cultivated by individuals or partnerships; and the Sutter Basin will become a prime source of food supplies.

This type of land development is worthy of careful study by engineers and investors, for there is no doubt that it will play a most important part in our future agricultural progress.



FORTY-EIGHT INCH ARMCO PIPE BEING INSTALLED IN IRRIGATION DITCH,
RECLAMATION DISTRICT NO. 1500

OAK FLOORS
(For Everlasting Economy)

In Industrial Buildings

OAK FLOORS present the needed resistance against wear. Their endurance means economy. Replacement costs are practically nil.

Their smooth, even surfaces of flint-like hardness aid in speeding inter-department transportation of materials and products. This means a profitable increase in production.

The lower grades of oak flooring meet all requirements in this type of construction and at a cost that is attractive. We should be glad to discuss this use of oak flooring with any inquiring architect.

OAK FLOORING MERSALLS, INC.
1036 ASHLAND BLOCK, CHICAGO, ILLINOIS

To Celebrate the 300th Anniversary of America's Origin

The year 1920 is doubly significant, historically. It marks the 300th anniversary of two important events which led to the founding of the Republic of the United States of America. One is the signing of the Mayflower Compact and the landing of the Pilgrims; and the other is the meeting of the first American legislative assembly.

On November 11, 1620, in the cabin of the Mayflower, a tiny bark lying off the Massachusetts coast, a little band of liberty-loving men, from "Brittania," entered into what history has styled the Mayflower Compact. This agreement bound the 41 adult males in the ship's company into a civil body politic for the better ordering, preserving, and furthering of their mutual ends. And it provided for such just and equal laws and offices as should be necessary for the general good of the colony.

Ten days later, so records Dr. Charles W. Eliot's inscription on the Pilgrim Memorial Monument at Provincetown, Mass., "the Mayflower, carrying 102 passengers, men and women and children, cast anchor in this harbor 67 days from Plymouth, England.

"This body politic, established and maintained on this bleak and barren edge of a vast wilderness, a state without a king or a noble, a church without a bishop or a priest, a democratic commonwealth, the members of which were

straitly tied to all care of each other's good, and of the whole by every one.

"With long-suffering devotion and sober resolution they illustrated for the first time in history the principles of civil and religious liberty and the practice of a genuine democracy."

Meantime, uninformed of the Pilgrims, fellow-colonists of Captain John Smith had met at "James City" (Jamestown), Virginia, for the first American Legislative Assembly. On July 30, 1619, they had thus broken ground for the foundation of the present democratic form of government in the United States.

This year (in 1920) these events are being commemorated in the United States, in England and in Holland. In August, the origin of the Pilgrim movement will be celebrated in England. And early in September, meetings will be held in Holland in memory of the Pilgrims' sojourn in that country.

Community Service (Incorporated), One Madison Avenue, New York, has drawn up suggestions for the use of communities planning to celebrate. These have been distributed for the use of schools, churches, clubs and general community groups throughout the United States and her territories. By writing to Community Service at the above address, individuals can secure valuable information and counsel regarding suitable plays, pageants, tableaux, recitations, ceremonials and music suitable for use in their communities.



The
ST. FRANCIS
One of the world's great hotels
Facing Union Square
SAN FRANCISCO CALIFORNIA

EXPRESSES MOST PLEASANTLY THE HOSPITALITY AND ANIMATION THAT ARE CHARACTERISTIC OF SAN FRANCISCO

Thos. J. Coleman,
Manager

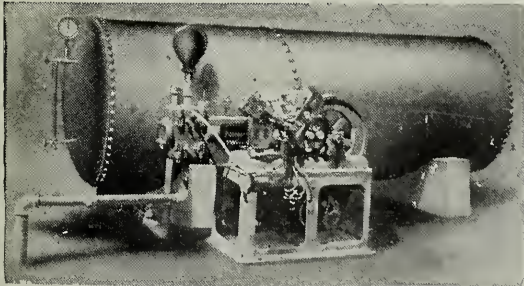

Kewanee Water System

Maintain your own Plant.
Small Operating Expense.
A Perfect Water Supply to
Country Homes, Hotels
and Parks.

Simonds Machinery Co.

117-121 Montgomery Street
SAN FRANCISCO
Phone Kearny 1457

OAK FLOORING

Clear Plain 5/16 x 2 sq. edge
@ \$200 Per M.

Select Plain 5/16 x 2 sq. edge
@ \$180 Per M.

ALSO

FOREIGN AND DOMESTIC
HARDWOODS

DIECKMANN HARDWOOD CO.

Beach and Taylor Sts., San Francisco, Cal.

Phone Franklin 2302

A Great Pump
in the Garage of a
Great American



Wayne
Liquid Storage Systems
for Garages, Stores, Factories,
Mills, Mines and Railways

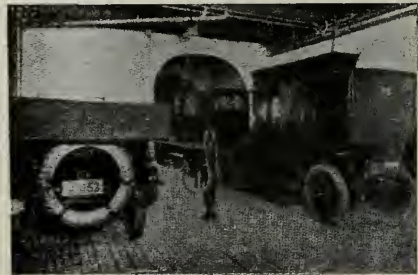

PICTURING the WAYNE installation in the garage of Mr. Andrew Carnegie at his town house, Ninety-first street and Fifth Avenue, New York City.

There is a Wayne System designed to meet the requirements of every type and every size of private garage.

Complete Information free upon request

WAYNE OIL TANK AND PUMP COMPANY

597 CANAL STREET, FORT WAYNE, IND.

San Francisco Office

631-633 HOWARD STREET
Phone GARFIELD 1350

Los Angeles Office

830 So. LOS ANGELES ST.
Phone MAIN 1600

Present Cost of Building Materials*

With Labor Wage Scale, Bonds, Etc.

THESE quotations are based on reliable information furnished by San Francisco material houses. Date of quotations, July 20, 1920.
 * All prices f. o. b. cars San Francisco or Oakland.

American Institute of Architects' Fees

New work—6 per cent minimum basis.
 Alterations—7 to 10 per cent as a minimum basis.

High class residence work—10 per cent as a minimum.

Bond—1½% amount of contract.

Brickwork—

Common, \$38.00 per 1000 laid.
 Face, \$70.00 per 1000 laid.
 Common, f. o. b. cars, \$18.00 plus cartage.
 Face, f. o. b. cars, \$45.50 per 1000, car-load lots.
 12x12x3 in., 10¼c. per square foot.
 12x12x4 in., 11¾c. per square foot.
 12x12x6 in., 16¼c. per square foot.
 Hod carriers, \$8.00 per day.
 Bricklayers, \$10.00 per day.
 Lime—\$2.40 per bbl.; per ton of 2000 lbs., \$18.50.

Composition Floors—30c. per sq. ft.
 Klingstone, 27c. to 65c. per foot.

Concrete Work (material at San Francisco bunkers)—

No. 3 rock.....\$2.25 per yd.
 No. 4 rock..... 2.40 per yd.
 Niles pea gravel..... 3.00 per yd.
 Niles gravel..... 2.25 per yd.
 Niles top gravel..... 2.50 per yd.
 City gravel..... 2.25 per yd.
 River sand..... 1.40 per yd.
 Bank sand..... 1.00 per yd.

Monterey White Sand—

Del Monte, \$1.25 to \$1.50 per ton.
 Fan Shell Beach, \$2.50 to \$3.00 per ton.
 Car lots, f. o. b. Lake Majella.
 Cement (f. o. b. cars).....\$3.88 per bbl.
 Rebate for sacks, 25c. each.
 Atlas "White".....\$9.50 per bbl.
 Medusa cement..... 9.50 per bbl.
 Forms.....\$60.00 per M

Wage—

Laborers.....\$6.00 per day
 Concrete workers..... 7.50 per day
 Cement finishers..... 9.00 per day

Dampproofing—

Two-coat work, 30c. per yard.
 Membrane waterproofing—4 layers of P.
 B. saturated felt, \$6.00 per square.
 Hot coating work, \$2.00 per square.
 WAGE—Roofers, \$9.00 per day.

Electric Wiring—\$8.00 to \$15.00 per outlet.

WAGE—Electricians, \$9.00 per day.

Elevators—

Prices vary according to capacity speed and type.
 Consult elevator companies.

Excavation—

\$2.00 per yard.
 Teams, \$12.00 per day.
 Trucks, \$30.00 to \$40.00 per day.
 Above figures are an average without water. Steam shovel work in large quantities, less; hard material, such as rock, will run considerably more.

Fire Escapes—

Ten-foot balcony, with stairs, \$100.00 per balcony.

Glass—

(Consult with manufacturers.)

21 ounce, 25c. per square foot.
 Plate, \$2.00 to \$5.00 per square foot.
 Art, \$1.00 up per square foot.
 Wire (for skylights), 40c. per square foot.
 Note.—Add extra for setting.
 WAGE—Glaziers, \$9.00 per day.

Heating—

Average, \$3.25 per sq. ft. of radiation.
 WAGE—Steamfitters, \$10.00 per day.

Iron

Cost of ornamental iron, cast iron, etc., depends on design.

Lumber—

Common (at building), \$48.00 per 1000 (average).

Common O. P. (select), \$98.00 per 1000 (average).

Flooring—

1x3 No. 1.....	\$121.00 per 1000
1x3 No. 2.....	113.00 per 1000
1x4 No. 1.....	116.00 per 1000
1x4 No. 2.....	113.00 per 1000
1x4 No. 3.....	106.00 per 1000
1x6 No. 1.....	121.00 per 1000
1x6 No. 2.....	118.00 per 1000
1¼x4 and 6 No. 1.....	121.00 per 1000
1¼x4 and 6 No. 2.....	116.00 per 1000
Slash grain, 1x4 No. 1....	90.00 per 1000
Slash grain, 1x4 No. 3....	85.00 per 1000
No. 1 common run to	
T. & G.	65.00 per 1000
Lath.....	9.00 per 1000

Shingles—

Redwood, No. 1.....\$1.60 per bdl.
 No. 2..... 1.50 per bdl.
 Red cedar..... 1.85 per bdl.
 (Add cartage to above)

Hardwood Floors—

Maple floor (laid and finished), 38c. per foot.

Factory grade floors (laid and finished), 30c. per foot.

Oak (quartered, finished), 57c per foot.

Oak (clear), 41c. per foot.

Oak (select), 39c. per foot.

Oak, quartered, sawed, clear, select, 48c.

WAGE—Floor layers, \$9.00 per day.

In flooring the usual grades of oak used are

	Grades	Quartered Sawed	Plain Sawed
5/16".....	Clear	"	"
	Select	"	"
1"x3"-13/16"x2¼".....	Clear	"	"
	Select	"	"
	No. 1 (very little used)		
7/8-inch plain oak.....			58c.
7/8-inch quarter sawed.....			70c.
Hardwood Floors (not laid)— Per M ft.			
5/16x2" sq. edge	Clear quartered oak.....		365.00
	Select quartered oak.....		295.00
	Clear plain oak.....		295.00
	Select plain oak.....		265.00

THE ARCHITECT AND ENGINEER

Hardwood Floors (not laid)—Continued

	Per M ft.
13/16x2¼" face Clear quartered oak.....	\$460.00
Select quartered oak.....	350.00
Clear plain oak.....	340.00
Select plain oak.....	305.00
Clear maple.....	280.00
Clear maple—white.....	310.00
13/16x3¼" face Clear maple.....	285.00
1¼x2¼" face Clear maple.....	290.00
¾x2" face Clear quartered oak.....	300.00
Select quartered oak.....	250.00
Clear plain oak.....	250.00
Select plain oak.....	215.00
Clear maple.....	235.00
Clear beech.....	225.00
Clear red beech.....	265.00

Veneered Panels—

24x60 in., ¼ in., 3-ply, 1 side:	Per ft.
Ash.....	31½c
Hungarian Ash.....	47c
Birch.....	31½c
Curly Birch.....	47c
Elm.....	29c
Jenifero (Genezero).....	45½c
Southern Red Gum (plain fig.).....	38½c
Otd. Southern Red Gum.....	47c
Hawaiian Koa.....	47c
Maple.....	29c
Birdseye Maple.....	57c
Mahogany.....	47c
Oregon Pine.....	23½c
Plain Oak.....	37½c
Quartered Oak.....	47c
Walnut.....	48c

Millwork—

O. P., \$180 per 1000. R. W., \$180 per 1000.	
Double hung box frame windows (average) with trim.....	\$10.50 each
Doors, includ. trim (single panel).....	15.00 each
Doors, including trim (five panel).....	\$12.00 each
Screen doors.....	5.50 each
Window screens.....	3.50 each
Medicine cases.....	5.00 each
Cases for kitchen pantries seven feet high, per lineal foot.....	10.00 each
Dining room cases same price, if not too elaborate,	
Flag poles, per foot.....	1.50
Labor—Rough carpentry, warehouse heavy framing, \$16.00 per 1000.	
For smaller work, average, \$23.00, \$30.00 per 1000.	
WAGE—Laborers, \$6.50 per day.	
Carpenters, \$9.00 per day.	

Marble—(Not set) add 60c up per ft. for setting

Columbia.....	\$1.75 sq. ft.
Alaska.....	1.75 sq. ft.
San Saba.....	2.90 sq. ft.
Tennessee.....	2.25 sq. ft.
Verde Antique.....	4.00 sq. ft.

Painting—

Two-coat work, 35c. per yard.	
Three-coat work, 45c. per yard.	
Whitewashing, 5c. per yard.	
Cold water paint, 10c. per yard.	
WAGE—Painters, \$8.50 per day.	

Patent Chimneys—

6-inch.....	\$1.50 lineal foot
8-inch.....	1.75 lineal foot
10-inch.....	2.25 lineal foot
12-inch.....	3.00 lineal foot

Pipe Casings—\$8.00 each.

Plastering—

Interior, on wood lath, 70c. per yard.	
Interior, on metal lath, \$1.25 per yard.	
Exterior, on brick or concrete, \$1.00 per yard.	
Portland White \$1.25 to \$1.50	

Interior on brick or terra cotta, 65c to 70c per yard.

Exterior, on metal lath, \$2.25 to \$2.50 per yard.

Wood lath, \$8.00 at yard per 1000.

Metal studding, \$1.00 to \$1.25 per yard.

Metal studding, with lath and plaster, \$2.00 per yard.

Galv. (metal lath), 38c. and up per yard, according to gauge.

Lime, f. o. b. warehouse, \$2.40 per bbl.

Hardwall plaster, \$21.00 per ton f. o. b. warehouse.

WAGE—Hod carriers, \$8.50 per day.

Plasterers, \$10.00 per day.

Plumbing—

From \$70.00 per fixture up, according to grade, quantity and runs.

WAGE—Plumbers, \$10.00 per day.

Reinforcing Steel—

Base price for less than car load lots, \$5.75 per 100 lbs.

Car load lots, \$5.50 per 100 lbs., f. o. b. San Francisco. (Mill delivery.)

Roofing—

Five-ply tar and gravel, \$7.50 per square for 30 squares or over.

Less than 30 squares, \$8.00 per square.

Tile, \$35.00 per square.

Redwood shingle, \$13.00 per sq. in place.

Cedar shingle, \$13.00 per square in place.

Reinforced Pabco roofing, \$8.25 per square.

WAGE—Roofers, \$8.00 to \$9.00 per day.

Rough Hardware—

Nails, per keg, \$7.10 base and very scarce.

Deafening felt, \$170.00 per ton.

Building paper, P. & B.,

1 ply, \$6.50 per 1000 ft. roll.

2 ply, \$9.75 per 1000 ft. roll.

3 ply, \$14.00 per 1000 ft. roll.

Sash cord,

(Sampson spot), \$2.50 per hank 100 feet.

Common, \$1.75 per hank 100 feet.

Sash weights, cast iron, \$80.00 per ton.

Skylights—

Copper, \$1.25 a square foot (not glazed).

Galvanized iron, 50c. a square foot (not glazed).

WAGE—Sheet metal workers, \$9.00 per day.

Store Fronts—

Kawneer copper bars for store fronts.

Corner, center and around sides, will average \$1.35 per lin. foot.

Structural Steel—\$150.00 per ton.

This quotation is an average for comparatively small quantities.

Light truss work higher; plain beam and column work in large quantities, less.

Steel Sash—

Fenestra, from S. F. stock, 45c. per sq. ft.

Fenestra, Plant shipment, 40½c. per sq. ft.

(Includes mullions and hardware.)

Tile—

White glazed, 80c. per foot.

White floor, 80c. per foot.

Colored floor tile, \$1.00 per foot.

Promenade tile, \$2.00 per sq. foot, laid.

Windows—

Metal \$2.00 a square foot



Build with Armco Iron -- Repair with It

If the roof of your building needs repairing, repair it so it won't need attention again for many years. MAKE IT A GALVANIZED ARMCO IRON ROOF. Use corrugated sheets of galvanized Armco Iron for the siding.

If you want your grain bins, silos, tanks and troughs, warehouses, sheds, etc., to last, see that these also are made of Armco Iron.

This wonderfully pure and even iron takes and holds a coat of galvanizing better than any other metal. The galvanizing adheres closely and because it is fused with the base metal does not crack or peel off.

Every product manufactured of galvanized sheet metal—plain or corrugated—will last longer if made of Armco Iron, for Armco Iron resists rust.

The American Rolling Mill Co.

The trademark ARMCO carries the assurance that products bearing that mark are manufactured by The American Rolling Mill Company with the skill, intelligence and fidelity associated with its products, and hence can be depended upon to possess in the highest degree the merit claimed for them. The trademark ARMCO is registered in the U. S. Patent Office.



Reg. U. S. Pat. Off.

Box 943, MIDDLETOWN, OHIO

Licensed Manufacturers under Patents granted to the International Metal Products Company

Pacific Coast Sales Office—10th and Bryant Streets, San Francisco; other Branch Offices in New York, Chicago, Pittsburgh, Cleveland, Detroit, St. Louis, Cincinnati, Atlanta, Washington, D. C. and Buffalo.

An ample stock of Armco Iron is carried at San Francisco Warehouse, Tenth and Bryant streets.

ARMCO IRON Resists Rust



CEMENT GUN

Will Make Your
Concrete Waterproof

Cement Gun Con-
struction Company

of California

701 Balboa Building,
San Francisco

For
DAMS
RESERVOIRS
TUNNELS
BULKHEADS
CANAL
LININGS
CEMENT
FLUMES
use the
Cement Gun
—
SPEED
ECONOMY
PERMANENCE

Concrete for Irrigation Work

Precast reinforced concrete slabs are being used to rebuild about 3000 gates, checks, drops and other small irrigation structures with 20 to 45 second feet capacity for the South San Joaquin Irrigation district, California. The slabs vary in size, the largest being 2x8 and 4x6 ft. and 2 in. thick. Joints between slabs are made tight by the use of beveled lugs on the edges fitting into channels. A 6x6 in. mesh No. 6 wire reinforcement is used. Slabs are cast in wooden trays at the casting yard in a gravel pit and are handled with a chain block traveling on an overhead rail. A crew of four men can erect two structures per day. Besides being about 25 per cent cheaper than monolithic concrete irrigation structures the slab structures are said to possess other advantages, being more quickly erected and more easily repaired.

State Highway Work Held Up

State highway day labor work, authorized or under way, involving approximately \$1,000,000 has been abandoned by the California highway commission pending developments in the matter of financing the work. The projects affected are in 21 counties and include grading on Myers Canyon grade and paving from Gravel wash to the north boundary in Imperial County; surface oiling in Kern County; Topeka surfacing between Visalia and Goshen in Tulare County; paving of small sections in Santa Barbara, San Luis Obispo and Monterey Counties; constructing concrete shoulders between Dehli and Stanislaus County line in Merced County, and stock piling of materials between Las Cruces and Zaca in Santa Barbara County. The force employed on paving in San Diego County between Tecate and the county line has been reduced.

Buy as Many Rooms as You Want

The following advertisement appeared in The Greenfield (Iowa) Press: "A. B.

Heaton is about to tear down his residence. He wants to sell any part or all of the residence before it's torn down. He will sell you three rooms or seven rooms, just as you want them. After the building is torn down he will not sell any of it. He is unable to find a place to store his furniture and if you need any furniture he will sell it. Come and see if you are interested, and come soon."

Architects Granted Certificates

At a meeting of the California State Board of Architecture, Northern District, held June 29th, the following were granted certificates to practice architecture in this State:

William G. Merchant, 806 Masonic Avenue, San Francisco; Stanton D. Willard, 795 Pine Street, San Francisco; Edgar B. Hunt, 521 Cottage Street, Oakland; John E. Norberg, 605 Howard Avenue, Burlingame; Carl A. Gustatson, 301 South Main Street, Kewanee, Ill.; Albert M. Cauldwell, 251 Kearny Street, San Francisco.



When writing to Advertisers please mention this magazine.

The
**J. G. WILSON
CORPORATION**

Rolling Steel Doors

Horizontal Rolling Wood Partitions

Vertical Rolling Wood Partitions

Folding Wood Partitions

Diffuselite Blinds

THE J. G. WILSON CORPORATION

Pacific Coast Office

600 Metropolitan Building, Los Angeles Calif.

Waterhouse-Wilcox Co., San Francisco
Theo. F. Snyder, San Diego
T. G. Bush & Co., Spokane
F. W. Farrington & Co., Portland & Seattle
Hawley-Richardson-Williams Co., Salt Lake City

SERVICE
TESTING
INSPECTION
CONSULTATION
PRODUCTION

**Structural and Engineering
 Materials**



Robert W. Hunt & Co.
 Engineers

**Chemical and Physical
 Testing Laboratories**

New York Chicago Pittsburgh
 St. Louis San Francisco Mexico City
 London Montreal



Residence of C. H. S. Littleton, 1350 Sq. Ft.
 Morlino St., Pasadena, Calif.

**BAY STATE
 COATING**

The heaviest rains can't beat through a Bay State Coated wall. Weather won't affect it. Bay State Brick and Cement Coating waterproofs all houses of brick, cement or stucco. It imparts a beauty that is distinctive and lasting. Choose from white or a range of colors. We will gladly send you a sample. Write for booklet No. 43. It shows many homes made beautiful with Bay State Brick and Cement Coating.



WADSWORTH, HOWLAND & CO., Inc.

Paint and Varnish Makers
 BOSTON, MASS.

Pacific Coast Representatives
JAMES HAMBLY & SON

San Francisco Los Angeles

Improved Sanitary Drinking Fountain

A vastly improved drinking fountain has just been perfected by the Haws Sanitary Drinking Faucet Co., Inc., of 1808 Harmon street, Berkeley, and the fixture will be placed on the market within a very short time, in fact the trade is already being taken care of for its urgent needs. The Haws sanitary drinking faucet was one of the first of this type of fixture to be manufactured, and, being a Pacific Coast product, it has been in demand for schools and public buildings in every section of the West. The new fountain will be catalogued as No. 7A. Its construction differs from the fountains now in use in that it is provided with an overhead cowl that prevents the drinker's lips from touching the source of supply. A slanting stream throws the water from right to left and away from the bubbler instead of shooting straight up and then falling back over the fountain head, as is the case with the old style fixture. The bowl is made of porcelain and is 13x8 inches over all. It is equipped with Mueller's self-closing valve and flow regulators.

GEO. H. DYER, President
 R. W. DYER, Vice-Pres.
 W. J. DYER, Sec'y

DYER BROS.
**GOLDEN WEST
 IRON WORKS**

(INCORPORATED)

**Structural Iron
 and
 Steel Contractors**

Ornamental Iron Work

Office and Works

17th and Kansas Streets
 SAN FRANCISCO, CAL.

Phone Market 134

**WESTERN
VENETIAN BLINDS**

ELIMINATE the unsightly awnings — Preserve the exterior beauty of your buildings by

Specifying

**WESTERN VENETIAN
BLINDS**

Some 1920 contracts for complete equipment:

- 12-story Mattie Building,
Fresno, California
- 9-story Pantages Building,
Los Angeles, California
- 7-story Marland Refining Bldg.
Ponca City, Oklahoma
- 10-story Trademens Bank Bldg.
Oklahoma City, Okla.
- 5-story Railway Exchange,
Muskogee, Oklahoma

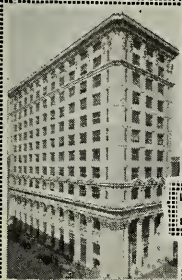

LOS ANGELES TRUST
AND SAVINGS BLDG.
LOS ANGELES, CAL.

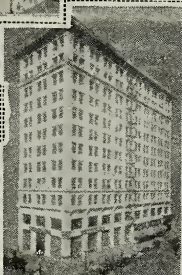

HAAS BLDG.
LOS ANGELES, CAL.



CITIZENS SAVINGS
BLDG.
PASADENA, CAL.



GLOBE GRAIN &
MILLING CO.
LOS ANGELES, CAL.



COUNTY COURT
HOUSE
WALLA WALLA, WASH.

When you consider the fact that **WESTERN VENETIAN BLINDS** take the place of both awning and window shade and will last practically as long as the building stands you'll realize that they are the logical equipment for modern buildings

WESTERN BLIND & SCREEN CO.
2704 LONG BEACH AVE.
LOS ANGELES CALIFORNIA

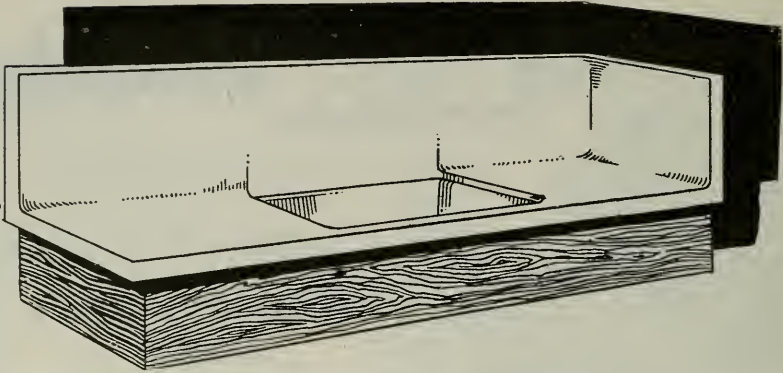

A Snow White Drain Board

PETRIUM SANITARY SINKS are made in Berkeley, California and are non-porous, non-absorbent and Lye-proof. The entire surface of the drainboard and back is covered with a composition, on which a smooth, glossy, snow white finish is applied mechanically leaving no crevice or corners in which dirt and grease can collect as where tile or wood is used. Can be installed in old as well as new homes.

PETRIUM SANITARY SINK COMPANY
 FACTORY AND OFFICE, WEST BERKELEY
 Agents in Principal Coast Cities

Send for booklet
 and Price List.

Oakland 540

The Largest Exclusive Electrical House in the State

MOTORS

BOUGHT — SOLD
 RENTED — REPAIRED

Lighting Fixtures

Manufactured

Construction

MAINTENANCE
 SUPPLIES

Estimates and engineering data cheerfully furnished

SPOTT ELECTRICAL CO.

Yours for Service

16th & CLAY STREETS

OAKLAND, CALIFORNIA

**FOR MODERN
STORE FRONTS**

Plummer's Disappearing Awnings

Are constructed with no outside attachments below awning recess. All mechanical parts entirely concealed. Send for Architects' Sheet showing specifications for recess construction, etc.

W. A. PLUMMER MFG. CO., 35-37 Front Street, San Francisco

JOHN TRAYNOR

CHARLES HARCOURT

OCEAN SHORE IRON WORKS

Manufacturers of Oil Tanks, Water Tanks, Pressure Tanks, Air Receivers, Feed Water Heaters, Breechings, Smoke Stacks, Water Pipe, Boilers, Retorts, Digestors, Pneumatic Pressure Tanks, Riveted or Oxy-Acetylene Welded Tanks, and dealers in Boilers, Tanks, Pumps, Engines, Machinery, Steel Plates, Shapes

Special Attention Given to Government and Export Orders

OCEAN SHORE IRON WORKS

Office and Works: 550-558 EIGHTH STREET, SAN FRANCISCO, CAL.

ROBERTS MANUFACTURING Co.

LIGHTING

ELECTRIC

INCANDESCENT

FIXTURES

APPLIANCES

LAMPS

WILLYS FARM LIGHTING
AND POWER PLANTS

663 Mission St.

San Francisco

THE TORMEY CO.

General
Painters

Phone Franklin
5-5-9-8

1042 Larkin St., San Francisco, Cal.

Alvaline, Cementoline
and other
Jones-Duncan Products

MAGNER BROTHERS
PAINT MAKERS

Telephone: Market 113
414-424 Ninth St. San Francisco

MCCRAY

SANITARY REFRIGERATORS

"Refrigerators for all Purposes"

OUR CATALOGS are yours for the asking—we want one or all of them in your files—No. 94 for Residences, No. 51 for Hotels, Restaurants and Clubs, No. 74 for Florists, No. 62 for Meat Markets, No. 71 for Grocers and Delicatessens.

MCCRAY REFRIGERATOR CO.
958 Lake Street Kendallville, Ind.
San Francisco Salesroom, 1054 Monadnock Bldg.

Alfred Gustafson, *Pres.* F. J. Gustafson, *Treas.*
Chas. A. Koenig, *Sec.* J. M. Reynolds, *Sales Mgr.*
Phone: Mission 1575-1576

4067 Watts St., Emeryville—*Phone* Piedmont 581

INLAID FLOOR CO.
Incorporated 1897

Manufacturers of
PLAIN AND ORNAMENTAL FLOORS
MACHINE FLOOR SANDING
Grilles and Weather Strips

600 ALABAMA STREET, AT 18TH ST.
SAN FRANCISCO

Phone Douglas 3224

Hunter & Hudson
ENGINEERS

Designers of Heating, Ventilating
and Wiring Systems. Mechanical
and Electrical Equipment of
Buildings.

703 Rialto Bldg., San Francisco, Cal.

BEAVER BLACKBOARD
BEAVER GREENBOARD

SCHOOL FURNITURE
AND SUPPLIES—
OFFICE, BANK AND
COURTHOUSE FURNITURE—
THEATRE AND
AUDITORIUM SEATING

Rucker-Fuller Desk Co.
677 Mission St., SAN FRANCISCO, CAL.
434 Higgins Bldg., LOS ANGELES, CAL.
432 - 14th Street - OAKLAND, CAL.

Business Systems
Office Furniture

F. W. WENTWORTH & CO.
Distributors for **LIBRARY BUREAU**
539 Market Street, San Francisco
LOS ANGELES OAKLAND SEATTLE

RUSSWIN
BUILDERS' HARDWARE

JOOST BROS., Inc.
SAN FRANCISCO AGENTS.

We Carry Complete Stock:
Fishing Tackle—Guns—Mechanics' Tools—
Paints—Crockery and Glassware—Stoves—
Household Goods. Telephone Market 891.

NO BRANCH STORE
Mazda Lamps Electric Goods



“FIRE!”

In the dead of night. You awake choking. Flames bar your way to the children's room. "Mother! Daddy!" You hear their screams through the smoke. Will they escape? Your blood freezes. Will you escape? Outdoors at last! — in night clothes. Mid-winter — and freezing cold. No place to go. Sparks have ignited the barn. Horses and cattle kicking in terror. You try to lead them out. A stampede. Will you escape their hoofs? No way to fight the fire. No one to help. Smoldering heaps of embers. HOMELESS!

Don't Live in Constant Fear of Chimney Fires!

Do you know that three or four out of every ten farmhouses that burn are set afire by leaky chimneys? Do you know that a chimney without flue lining is the biggest fire risk on your place?

Heat dries up the mortar. Chemicals in the soot crumble it. The mortar falls out and leaves holes through which the flames start a fire in your walls.

Or the soot gathers on the rough places inside the chimney, catches fire and drops sparks on the roofs — or the wind carries them toward the barn.

Fire Clay Flue Lining fireproofs a chimney from bottom to top — for a few dollars! Its smooth surface does not gather soot. This reduces the chance of flying sparks. Also it saves costly chimney sweepings. And the smooth, clean, leakless flue causes the chimney to draw better.

Out where you have no real way to fight a fire and where a fire usually means a total loss, take no unnecessary chances.

Protect your family and your home with chimneys that are lined from bottom to top with Fire Clay Flue Lining.

Sold by building material dealers in sizes to fit all chimneys. Write for free booklet, "HOW TO BUILD A SAFE CHIMNEY"

CLAY PRODUCTS ASSOCIATION

CHICAGO - PITTSBURG

(Los Angeles Pressed Brick Company, Los Angeles, Member)

FIRE CLAY FLUE LINING

A. D. COLLMAN

GENERAL CONTRACTING

Phone Sutter 3580

110 Jessie Street, San Francisco

I. R. KISSEL

Phone Franklin 548

Decorator, Painter and Paperhanger

1747 SACRAMENTO ST., Bet. Polk St. and Van Ness Ave., SAN FRANCISCO

ROBERT TROST

PHONE MISSION 2209

General Building ContractorWe Specialize in High Grade Work and Employ Skilled
Labor in every Branch of the Building Industry.26th and Howard Streets
SAN FRANCISCO

P. A. Palmer

Peter Petersen

W. L. Kelley

O. G. Hoas

PALMER & PETERSEN

Contracting Engineers

774-776 Monadnock Building

SAN FRANCISCO, CAL.

Phone Sutter 2581

LARSEN-SAMPSON CO.

BUILDING CONSTRUCTION

601 CROCKER BUILDING

SAN FRANCISCO

MULLEN MANUFACTURING CO.*BANK, STORE AND OFFICE FIXTURES—CABINET WORK OF
GUARANTEED QUALITY—CHURCH SEATING*

Office and Factory:

Telephone Market 8692

64 Rausch St., Bet. 7th and 8th Sts., San Francisco

UNIT CONSTRUCTION COMPANY

(INCORPORATED)

ENGINEERING AND CONSTRUCTION

Telephone Kearny 28

429-36 Phelan Building, SAN FRANCISCO

J. D. HANNAH

Contractor and Builder

OFFICE: 142 Sansome Street
San Francisco, Cal.

Telephone Douglas 3895

BUILDERS EXCHANGE, 180 JESSIE STREET



Hales
Department
Store
San Francisco,
Cal.
Reid Bros.,
Arch.

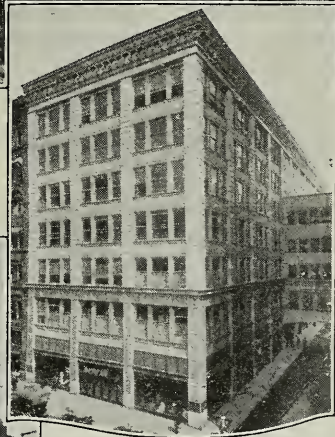
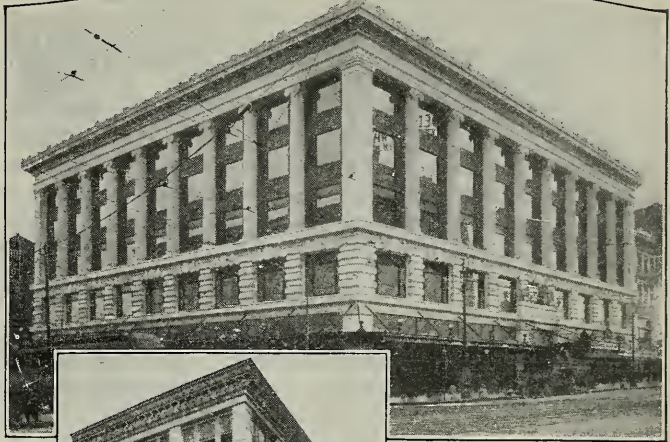

E. W. Edwards & Son
Rochester, N. Y.
Crandall & Strobel, Arch.



Warren M. Crosly
Dry Goods Co.
Topeka, Kansas
Frank C. Squires,
Arch.

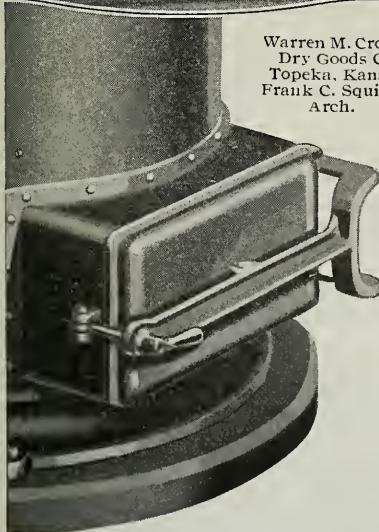

Are Indispensable In Store Buildings!

STOCKS of merchandise housed in any store building very often exceed the value of the building itself. Few kinds of goods sold in stores are immune to damage and losses from the dust blown in through windows and doors constantly opened or left open for ventilation.

Storekeepers everywhere have come to realize the value of the TUEC Stationary Suction Cleaning systems for the protection of their stocks.

Whether you are planning a new building for a store owner or to be rented to storekeeper tenants do not overlook this important item of equipment.

The comprehensive TUEC line (*five sizes*) meets the requirements of any store. Let us send you the names of the well-known TUEC equipped stores in your vicinity; also our Special Bulletin "The TUEC in the Store." Simply send us your name and address.

THE UNITED ELECTRIC CO., CANTON, O.
New York, Chicago, Cleveland, Atlanta, Ga., Portland, Ore., Toronto, Ont.

California Distributors } S. F. COMPRESSED AIR CLEANING CO., 397 Sutter Street San Francisco
BARKER BROS. 724 So. Broadway, Los Angeles

ASBESTOS PROTECTED METAL FOR ROOFING AND SIDING

HH ROBERTSON CO
 BUILDING PRODUCTS BUILDING PRODUCTS

FORMERLY ASBESTOS PROTECTED METAL COMPANY
 Hobart Building, San Francisco

Phone Garfield 522

K. E. PARKER COMPANY, Inc.
 GENERAL CONTRACTORS

Phone Sutter 5661

Room 515 Clunie Building, SAN FRANCISCO

R. W. LITTLEFIELD
 BUILDING CONSTRUCTION

357 12th Street, Room 9, Oakland, Cal.

Phone Lakeside 415

H. H. HILP, Jr.

J. FRANK BARRETT

BARRETT & HILP

CONCRETE CONSTRUCTION BUILDERS GENERAL CONTRACTORS

SHARON BUILDING, SAN FRANCISCO

TELEPHONE SUTTER 1168 or 1169

Res. Phone Mission 5049

JAMES F. SMITH — Plasterer

273 Minna Street, San Francisco

Phone KEARNY 740

Member Builders Exchange

STEELFORMS Signify ECONOMY, RAPIDITY, and EFFICIENCY

STEELFORM CONTRACTING COMPANY

STEELFORMS FOR
 CONCRETE
 BUILDINGS

C. B. Hopkins, C. E., Manager

681 Market Street, San Francisco

CONCRETE JOIST
 FLOOR
 CONSTRUCTION

W. C. DUNCAN & CO.

508 Sharon Bldg.

General Contractors

San Francisco

M. E. VUKICEVICH

SPENCER B. BAGGE

VUKICEVICH & BAGGE
 GENERAL CONTRACTORS

Phone Sutter 6700

Office, Builders Exchange, 180 Jessie St., San Francisco

245 Market St.
Kearny 2028

Standard Fence Co.

310 Twelfth St.
Oakland 475

WIRE AND IRON WORKS

DESIGNERS - BUILDERS
FACTORY PROTECTION FENCE
FIELD AND POULTRY FENCE
AVIARY AND TENNIS COURT FENCE

WIRE GRILL WORK
WIRE SCREEN
FLEXIBLE WIRE CONVEYOR BELT
WIRE SPECIALTIES

Steel Bars

FOR CONCRETE REINFORCEMENT
Cut to Length, Fabricated, Installed

BADT-FALK & CO.

Tel. Douglas 3466 346 Call-Post Bldg., 74 New Montgomery St., San Francisco

BUILDING DIRECTORIES

[INTERCHANGEABLE STEEL
LETTERS AND NUMBERS]

FOR OFFICE BUILDINGS, SCHOOLS, CAFETERIAS, Etc.
Bargains Lists for Auto Sales Companies. Sold Outright.

Go-Sign and Letter Manufacturing Co.

1106 Franklin Street Oakland, California

D. N. & E. WALTER & CO.

"SINCE 1858"

LINOLEUMS—CARPETS **LARGE STOCKS CARRIED**
Estimates furnished on request

562-572 MISSION STREET SAN FRANCISCO

Phone Merritt 668

H. N. McNAB

Hardwood Floors  Floor Sanding

2307 - 17th Ave. Oakland, Cal.

Res. Tel. Merritt 3600

HERBERT BECKWITH

Building Construction

Formerly with
ARTHUR ARLETT

323 Newton Ave.
Oakland

D. ZELINSKY & SONS

PAINTERS AND DECORATORS

420 TURK STREET, SAN FRANCISCO

CHARLES T. PHILLIPS

• CONSULTING ENGINEER •

PACIFIC BUILDING SAN FRANCISCO
HEATING VENTILATION WIRING ILLUMINATION

Ideal Air-Washers. Ideal Fruit-Dryers. Fan Systems for Heating, Cooling and Drying.

Ideal Heating and Engineering Co.

Air-Conditioning, Heating, Cooling and Drying

192 ERIE STREET

Phone Market 3708

SAN FRANCISCO

Atlas Heating and Ventilating Co., Inc.

ENGINEERS and CONTRACTORS

STEAM AND HOT WATER HEATING, FANS, BLOWERS,
FURNACES, POWER PLANTS--SHEET METAL WORK

Phone Douglas 378

Fourth and Freelon Sts., Bet. Bryant & Brannan, SAN FRANCISCO

Illinois Automatic Vacuum and Vapor Systems of Heating

"TWENTY-FIVE YEARS OF QUALITY"

ILLINOIS ENGINEERING COMPANY

JAS. I. KRUEGER, *Representative*

559-561 Pacific Building, San Francisco

Telephone: Kearny 3047

HEATING
VENTILATION

Automatic Sprinkler Systems
FLOOR AND WALL TILING

PLUMBING
SHEET METAL WORK

SCOTT CO., Inc.

SUCCESSOR TO JOHN G. SUTTON CO.

243 MINNA STREET

SAN FRANCISCO

ALEX COLEMAN

CONTRACTING PLUMBER

706 ELLIS ST., SAN FRANCISCO

Phone FRANKLIN 1006

WM. F. WILSON COMPANY

MODERN SANITARY APPLIANCES

Special Systems of Plumbing for Residences, Hotels, Schools, Colleges, Office Buildings, Etc.

Phone Sutter 357

328-330 Mason Street, San Francisco.

A. LETTICH

365 FELL ST., SAN FRANCISCO
Telephone — Park 234

Plumbing and Heating



REINFORCING BARS

Square, Twisted, Corrugated and Plain Round. Curb Plate Bars for Concrete Curbs and Guards

W. S. WETENHALL CO.

440 IRWIN STREET
SAN FRANCISCO, CAL. Phone Market 3815



Model No. 7A

*Chasing Rainbows?
No - Germs!*

HAWS IMPROVED SANITARY DRINKING FAUCET eliminates all possibility of contracting disease from dirty bulbs or unsanitary bowls. Provided with an overhead cowl, the drinker's lips never touch the source of supply. A slanting stream throws the water from right to left and away from the bubbler, instead of straight up to fall back over the fountain head. Recommended for Schools and Public Playgrounds. A type used extensively by the U. S. Government. *Manufactured by*

Haws Sanitary Drinking Faucet Co., Inc.

1808 Harmon Street, Berkeley

Phone Piedmont 3742

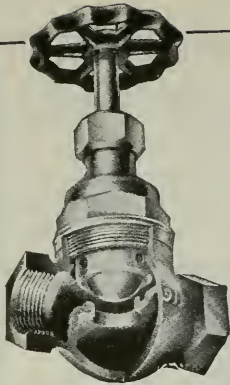

AMERICAN BALL VALVES

"Durable — therefore, Economical" — Stands the Severest Tests — Endorsed by the Leading Architects and Engineers of the Country. It is A PERFECT BALL-CLOSING VALVE.

W. E. MUSHET CO

SOLE AGENTS
Phone Sutter 4797



502 Mission Street
San Francisco, Cal.

DON'T NEGLECT YOUR HEATING SYSTEM.
THE BEST IS NONE TOO GOOD!

All kinds of Galvanized Iron Work — Furnaces, Pipes, Ventilators — Sheet Metal for Planing Mills, Fruit Dryers, Rice Mills. Kitchen Equipment, including Steam Tables, Sinks, Canopies, Urn Stands, Etc.

JAMES A. NELSON

Heating and Ventilating Contractor

Phone, Garfield 1959

517-519 SIXTH ST., SAN FRANCISCO

A. H. Bergstrom
Eric Lange

Phone Kearny 3526

LANGE & BERGSTROM

Building Contractors

(Established 1900)

207-210 SHARON BUILDING
San Francisco

TIMKEN BUILDING
San Diego

THE "CALIFORNIA" WALL BED

An Accomplishment in Design and Efficiency — Uses a minimum amount of space, all mechanical parts steel, a sturdily built standard bed, easily operated—Durable.

AMERICAN AUTOMATIC LOCK & LIFT CO.

Display Room: Building Material Exhibit, 77 O'Farrell Street, San Francisco

Office: 72 Fremont Street, San Francisco. Telephone Sutter 5712

Factory in Oakland

A GOOD FIELD FOR DISTRIBUTORS

Specify
**Whitney's Special
Magnesium Chloride**
(Crystals)

in your Composition Flooring

(Consult our Service Department)

WHITNEY CHEMICAL CO.
544 Market Street, San Francisco

MASTIC FLOORS

BITURINE COATINGS FOR STEEL

WATERPROOFING

Hill, Hubbell & Company

CONTRACTORS

SAN FRANCISCO

1000 Fife Building, No. 1 Drumm Street

LOS ANGELES
Marsh-Strong Building

SEATTLE
Grand Trunk Pacific
Dock

PORTLAND
Pittock Block



POSITIVE ELECTRIC INTERLOCK

(BAR LOCK TYPE)

Prevents Elevator Accidents Occurring at the Entrance Door

Approved by National Underwriters Laboratories—Meets requirements of Elevator Safety Orders of Industrial Accident Commission, State of California

ELEVATOR SUPPLIES COMPANY, Inc. 186 FIFTH STREET,
SAN FRANCISCO

Capital \$1,000,000

CALIFORNIA DEPARTMENT

Surplus \$1,122,000

THE FIDELITY AND CASUALTY COMPANY OF NEW YORK

Prompt Service for

BONDS AND CASUALTY INSURANCE

203-206 Merchants Exchange Building

SAN FRANCISCO, CAL.

ANY PLACE ANY TIME PROMPTLY "We Serve You"

JOHN H. ROBERTSON

Successor to Robertson & Hall
GENERAL INSURANCE

Phone Sutter 2750

621 First National Bank Building, San Francisco

CONTRACT BONDS

Fidelity and Surety Bonds of every kind.

C. K. BENNETT, Manager

FIDELITY AND DEPOSIT COMPANY OF MARYLAND

Telephone Kearny 1452

622 Insurance Exchange, San Francisco, Calif.

PACIFIC DEPARTMENT

Globe Indemnity Company

BONDS and CASUALTY INSURANCE for CONTRACTORS

FRANK M. HALL, formerly Robertson & Hall, Mgr.

120 Leidesdorff Street Phone Sutter 2280 SAN FRANCISCO

National Surety Company of New York

The World's Largest Surety Company

Assets over \$20,000,000

Pacific Coast Department: 105 MONTGOMERY ST., SAN FRANCISCO, CAL.

Frank L. Gilbert, Vice-President

Phone, Sutter 2636

PHONE DOUGLAS 2370

McLERAN & PETERSON

GENERAL CONTRACTORS

HEARST BUILDING

SAN FRANCISCO, CAL.

L. J. RUEGG

J. B. RUEGG

RUEGG BROS.

CONTRACTORS AND BUILDERS

Phone Douglas 1599

719 Pacific Building, SAN FRANCISCO



Steel ^{Open} ^{Hearth} Bars For Concrete Reinforcement

Square, Deformed and Cold Twisted, Plain Rounds and Squares

PACIFIC COAST STEEL COMPANY

General Office, Rialto Building, San Francisco. Phone Sutter 1564

Sales Office, Rialto Building, SAN FRANCISCO
 Sales Office, Union Oil Building, LOS ANGELES
 Sales Office..... SEATTLE, WASH.

ROLLING MILLS:
 SOUTH SAN FRANCISCO.....CAL.
 SEATTLE, WASH. PORTLAND, ORE.

Architects and Building Contractors :

THE Binding of Your Magazines
 and Periodicals is Our Specialty.
 Expert Plate and Map Mounting.

The HICKS-JUDD COMPANY, Inc.
 BOOKBINDERS
 51-65 First Street San Francisco, Cal.

George S. MacGruer }
 Robert M. Simpson } Members of Builders Exchange

MacGruer & Simpson

CONTRACTING PLASTERERS
 PLAIN AND ORNAMENTAL

Cement, Stucco and Artificial Stone

Phone Sutter 5688

540 Call-Post Building, San Francisco

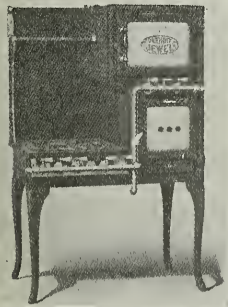

Detroit Jewel Gas Ranges

FOR HOME, RESTAURANT, HOTEL AND CLUB
 We carry a Full Line of Stock Sizes

SELLING AGENTS

NATHAN DOHRMANN CO.

Geary and Stockton Streets, San Francisco

PARMELEE-DOHRMANN CO.

436-444 S. BROADWAY, LOS ANGELES

THE HYLOPLATE BLACKBOARD

SCHOOL FURNITURE
AUDITORIUM SEATING

MAPS
GLOBES
ATLASSES

C. F. WEBER & CO.

985 Market Street
SAN FRANCISCO

222-224

S. Los Angeles St.
LOS ANGELES

100 W. Commercial
Row, RENO, NEV.

524 W. Washington
Street, PHOENIX, ARIZ.



LINOTILE

THE FLOOR
THAT'S BUILT
□ TO FIT □
THE ROOM

Furnished and
Installed by

Van Fleet-Freear Co.

61 New Montgomery Street
San Francisco, California
Telephone, Douglas 1227



BEAUTIFUL GARDEN
EFFECTS for the City
and Suburban Home

MacRORIE-McLAREN CO

Landscape Engineers
and General Nurserymen



Office
141 Powell Street
San Francisco

Nurseries at
Beresford,
San Mateo County

Sheet Metal Work

FOR BUILDINGS—

Gutters, Ventilators, Metal Covered
Doors, Skylights, Roofing, Tanks.

FOR MILLS AND FACTORIES—

Dust Collector Systems, Air and
Blow Pipes, Exhaust Hoods and
Pipe, Smoke Stacks, Hoppers, Bins,
Chutes, Metal Covered Shutters, etc.

Also manufacturers of Milk and
Cheese Vats of any size, Weigh Cans,
Wash Sinks, Ice Molds, Brine Tanks.

POWER & PIKE CO.

SHEET METAL WORKS

PLUMBERS
128 BEALE STREET

Telephone Douglas 1558 San Francisco

**MOUNT DIABLO CEMENT
COWELL SANTA CRUZ LIME**

ALL KINDS OF

BUILDING MATERIALS

HENRY COWELL LIME AND CEMENT CO.

Phone Kearny 2095

No. 2 MARKET STREET, SAN FRANCISCO

GLADDING, McBEAN & CO.

MANUFACTURERS CLAY PRODUCTS

CROCKER BUILDING, SAN FRANCISCO

WORKS, LINCOLN, CAL.

CONTRACTOR'S MACHINERY

RANSOME MIXERS

OSHKOSH MIXERS

INSLEY SPOUTING PLANTS

OSHKOSH EVEREADY SAW RIGS

INSLEY STEEL CARS and TRACKS

HOISTING BUCKETS, HOPPERS, GATES, ETC.

STEAM AND ELECTRIC HOISTS

NOVO GASOLINE HOISTS

EVERYTHING USED BY CONTRACTORS

CARRIED IN STOCK BY

GARFIELD & CO.

Hearst Building, San Francisco

Phone Sutter 1036

THE AUSTIN CUBE MIXER

The cube mixing principle, inside breaker rods, renewable drum plates, and long lasting qualities, combine to make the AUSTIN-CUBE the most highly efficient mixer in the concrete mixing service.

AUSTIN-CUBES are made in sizes adapted to every class of concrete mixing service. Special machines for road and street paving.

AUSTIN MACHINERY CORPORATION

Main Office, Railway Exchange, CHICAGO

Stuart S. Smith, 625 Market St., San Francisco.

Tom N. Nicholson, 743 Harvard Ave., Los Angeles

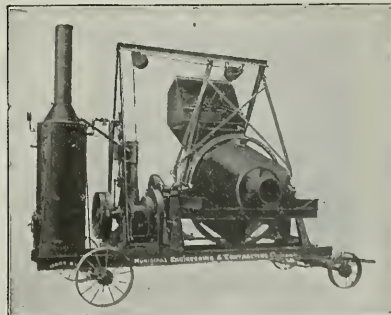

Telephone DOUGLAS 2046	<div style="border: 1px solid black; padding: 5px;"> <p style="font-size: small; margin: 0;">Butte Electrical Equipment Company</p> <h1 style="margin: 0;">BEECO</h1> <p style="font-size: x-small; margin: 0;">TRADE MARK - REG.</p> </div>	530 FOLSOM STREET
<p>CONTRACTORS FOR POWER LIGHTING AND INDUSTRIAL INSTALLATIONS</p> <p>For the convenience and guidance of our customers, we have adopted BEECO as our trade name.</p>		

SAFETY ELECTRIC COMPANY

MANUFACTURERS OF

SWITCHBOARDS SAFETY SWITCHES SAFETY CONTROLS		PANEL BOARDS SAFETY PANELS KNIFE SWITCHES
--	---	---

59-65 Columbia Square San Francisco, Calif.
Telephone Market 2949

<p>L. SIEBERT</p> <h2 style="margin: 0;">Drendell Electrical & Mfg. Co.</h2> <p style="font-size: small; margin: 5px 0;">Incorporated</p> <p style="margin: 5px 0;">SWITCHBOARDS, PANEL BOARDS, KNIFE SWITCHES, CABINETS, THEATRE INSTALLATIONS, PROTECTIVE POWER PANELS</p> <p style="margin: 5px 0;">1345-1353 Howard St., San Francisco</p>	<p>J. GENSLER</p> <p style="margin: 5px 0;">Telephone Market 1753</p>
--	---

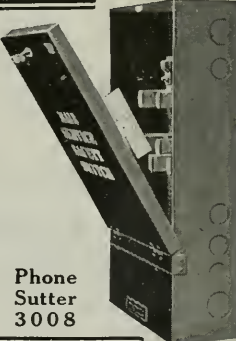
	<h2 style="margin: 0;">MEYERS</h2> <h3 style="margin: 0;">Electric Safety SWITCHES</h3> <p style="font-size: small; margin: 0;">EXTERNALLY OPERATED</p> <p style="font-size: x-small; margin: 0;">Switch on the right is controlled by Handle on Front of Door, allowing face of switch to be set flush with finish of wall.</p>	
<p>Knock outs on Top, Bottom and Side controlled by Handle on side of Box</p> <p>Meyers Electric Safety Switch Co., Inc. 247 Minna Street</p>		<p>Phone Sutter 3008</p>

BUTTE ELECTRIC & MFG. CO. DOUGLAS 145

(Paul C. Butte) at it since 1904
WIRING FOR BUILDINGS

534 Folsom Street

SAN FRANCISCO

H. S. TITTLE

CONTRACTING ELECTRICAL ENGINEER

766 FOLSOM ST., SAN FRANCISCO

Phone SUTTER 4278



To Be "Low Bidder" Not Always Our Aim.

Our most particular attention is given to prompt and skillful handling of all electrical work of any nature with "QUALITY AND SERVICE QUARANTEED."

Our nation-wide organization and large experience in this field assures you always of fair estimates and absolute satisfaction.

F. E. NEWBERY ELECTRIC CO.

163 Sutter St. (413 Lick Bldg.) San Francisco, Phone Sutter 521

San Francisco, Cal.

Oakland, Cal.

Los Angeles, Cal.

NE PAGE, McKENNY CO.

Electrical Engineers and Contractors

Phone Sutter 2369

589 Howard St., San Francisco, Cal.

Phone Market 2541

M. FLATLAND

GLOBE ELECTRIC WORKS

Estimates Furnished on Everything Electrical

ELECTRIC SUPPLIES

1959 Mission Street, bet. 15th and 16th

SAN FRANCISCO

E. E. BROWNE

Telephone Douglas 976

G. A. LANGLAIS

**BROWNE-LANGLAIS ELECTRICAL
 CONSTRUCTION COMPANY**

213 Minna Street

SAN FRANCISCO

M. E. RYAN

Electrical Contractor

Phones: Store, Red. 250J
 Residence, Red. 250M

216 Main Street
 REDWOOD CITY, CAL.

Thomas J. Bennett

Edward W. Lauer

Rex Electric and Engineering Co.

Contracting and Repairing

253 Minna Street

Telephone Sutter 2148

San Francisco

YOU KNOW that a building should be watertight and **WE KNOW** that it can be made so with

IMPERIAL WATERPROOFING

LOOK FOR  THE LABEL

If your building is leaking through the walls or around the windows, or if the Basement walls are wet below ground — call up SUTTER 978. IMPERIAL WATERPROOFING is manufactured by BROOKS & DOERR, 460 7th St., San Francisco

WATEREX REED BAXTER
DISTRIBUTOR

1002-04 Merchants National Bank Building,
Phone Sutter 978
SAN FRANCISCO, CAL.
3419 Broadway, OAKLAND, CAL.

CLINTON WELDED WIRE FABRIC AND LATH

The Perfect Support for Stucco and Interior Plaster. Complete Stock for Immediate Delivery. Steel Reinforcing Bars in Stock.

L. A. NORRIS CO.
140 Townsend Street

Phone Kearny 5375 San Francisco



HEATING-PLUMBING

COMPLETE PLUMBING AND HEATING SYSTEMS INSTALLED IN ALL CLASSES OF BUILDINGS ALSO POWER PLANTS

GILLEY-SCHMID CO., Inc.

198 OTIS STREET, SAN FRANCISCO.
Tel. MARKET 965

“BLAZING” THE TRAIL
We've been doing it for many years—giving the Sportsman Better Value for Quality than he ever before received. “Value at a Fair Price” in everything for the Sportsman.



583-85 MARKET ST
SAN FRANCISCO, CAL

SEND FOR CATALOG *The Sign of Quality*

C. H. GRAY

709 Balboa Building
Tel. Kearny 3202

Compensation, Liability and Automobile Insurance and Surety Bonds for California Contractors

C. DRUCKER

J. C. JAMES

JAMES & DRUCKER

PLUMBING—HEATING CONTRACTORS

Phone Market 275

450 Hayes Street
San Francisco

Ideal Power Lawn Mowers

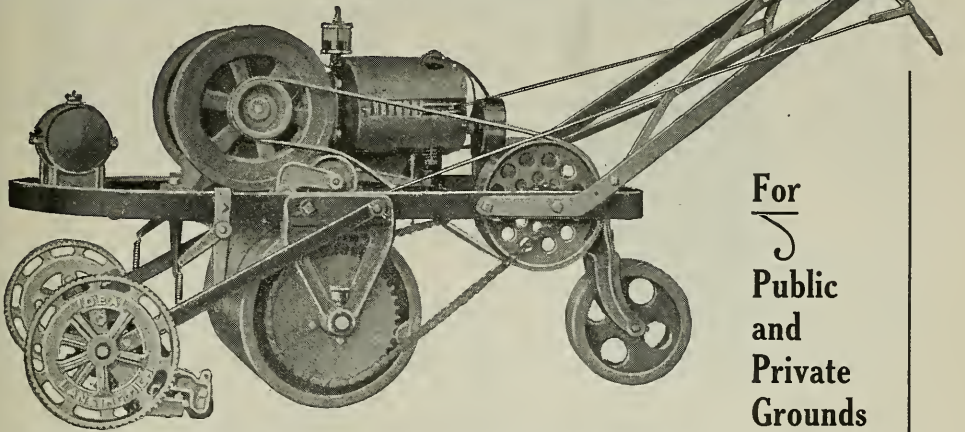

For
Public
and
Private
Grounds

IDEAL MOWERS insure velvety lawns—the clean, sure, easy way. Lawns are kept in perfect condition—the work is done quickly and easily by one man and at a minimum expense. The mower can be guided closely around flower beds, trees and walks. The roller levels all unsightly bumps, and does not mar the lawn with hoof-prints or mutilate the shrubbery, as is the case with horse-drawn mowers.

Ideal Mowers are a money-saving investment. They do away with several men and horses, and consume gas and oil only while working.

H. V. CARTER MOTOR CO. 52 BEALE STREET
SAN FRANCISCO, CAL.

SAVE TIME AND MONEY

by using a

BARBER - GREENE

SELF-FEEDING — SELF-PROPELLING

WAGON LOADER

OIL ENGINE OR MOTOR DRIVE

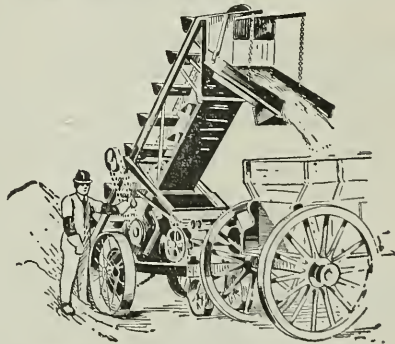

Many other labor saving machines are listed in our "Contractors' Catalog."

School and Theatre

STAGES AND EQUIPMENT

EDWIN H. FLAGG

SCENIC COMPANY, Inc.
400 Pantages Bldg., San Francisco, Cal.
1638 Long Beach Ave., Los Angeles, Cal.

The Granite Work on Eldorado County Courthouse; National Bank of D. O. Mills, Sacramento;—
and Sen. Nixon Mausoleum, Reno, WAS FURNISHED BY

CALIFORNIA GRANITE COMPANY

Phone Sutter 2646

STONE CONTRACTORS

Gen'l Contractors Ass'n, San Francisco
Quarries, Rocklin and Porterville

Main Office, Rocklin, Placer Co., Cal.
Telephone Main 82

POWER CONSTRUCTION CO.

INCORPORATED

CONTRACTING ENGINEERS

Preliminary Estimates Given in All Types
of Buildings, Towers and Bridges

SHARON BUILDING, SAN FRANCISCO
Phone Sutter 5478

A. C. SCHINDLER, President.

CHAS. F. STAUFFACHER, Secretary

THE FINK & SCHINDLER CO.

Manufacturers of INTERIOR WOODWORK AND FIXTURES
BANK, OFFICE AND STORE FITTINGS
SPECIAL FURNITURE

218-228 THIRTEENTH ST.
Bet. Mission and Howard Sts.

SAN FRANCISCO, CAL.
Telephone: Market 474

O. BAMANN, President

ERNEST HELD, Vice-President

HOME MANUFACTURING CO.

BANK, STORE AND OFFICE FITTINGS
FURNITURE AND HARDWOOD INTERIORS
CABINET WORK OF EVERY DESCRIPTION

543 and 545 BRANNAN ST. Phone Kearny 1514

San Francisco, Cal.

PACIFIC MANUFACTURING COMPANY

MILLWORK, SASH AND DOORS

Hardwood Interior Trim a Specialty

MAIN OFFICE:

SANTA CLARA, CAL.

SAN FRANCISCO.....177 Stevenson Street
OAKLAND.....1001 Franklin Street
BERKELEY.....2143 Center Street
SAN JOSE.....16 N. First Street

Dolan Wrecking & Construction Co.

(D. J. DOLAN)

Lumber, Lath, Nails, Shingles, Doors, Windows
and Plumbing Supplies, New and Second Hand

Phone Market 4264

Office and Yard, 1607-1639 MARKET ST., SAN FRANCISCO

MONSON BROS.

GENERAL CONTRACTORS

Telephone Market 2693

1908 Bryant Street, San Francisco

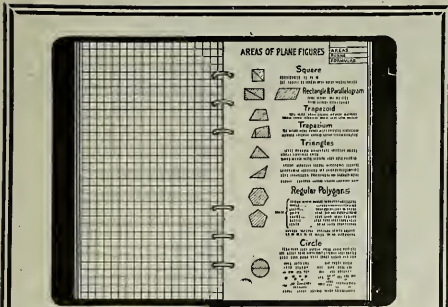

LEFAX
LEAF + FACTS
Pocket Cyclopedias

The facts that you want *instantly available* are not the same ones that some one else in your profession might desire. That's why LEFAX is made Loose Leaf. You file, in whatever order you wish, those sheets of facts that you want to have constantly at hand. If you wish, you may also file, in the same book, sheets for keeping data, for figuring, etc.

LEFAX sets cost but \$50c. and \$1.00. You cannot fully appreciate their handiness— their value—until you use them. Ask us about them.

SCHWABACHER-FREY STATIONERY CO.
PRINTERS LITHOGRAPHERS STATIONERS
611 Market Street San Francisco

Steam Heating and Ventilating

For Commercial and Public Buildings

Furnace Heating
For the Home

Mangrum & Otter, Inc.
827-831 Mission Street
Phone Kearny 3155 SAN FRANCISCO

DIRECT-LINE

Telephone Company
THEODORE HALL, Manager

Telephone and Electrical Engineers
Automatic Electric Company, Chicago
AUTOMATIC TELEPHONES and
AUTOMATIC ENUNCIATOR

Some of the Installations:

Baker, Hamilton-Pacific Co.; J. D. & A. B. Spreckels Securities Co.; California Packing Corporation; Sperry Flour Co., So. Vallejo.

TELAUTOGRAPH CORPORATION, New York
Some of the Installations:

Palace Hotel, Hotel St. Francis, Bank of California, California Hawaiian Sugar Refining Co., Crockett, Cal.

INSTALLATION AND MAINTENANCE OF ELECTRICAL AND TELEPHONE APPARATUS
Tel. Douglas 722 320 Market St., San Francisco

Mortgagor and Mortgagee Interests

Where a mortgagee insures his own interest at his own expense, payment of a loss before the mortgage is paid is not a payment on the mortgage, and, conversely, a mortgagor, insuring his separate interest, is entitled to the insurance proceeds, but, where the mortgagor effects insurance payable to the mortgagee as his interest may appear, the policy is for the benefit of both parties. *Sisk v. Rapuano*, Conn., 108 Atl., 858.

BANKERS & SHIPPERS INSURANCE COMPANY OF NEW YORK

OUR POLICIES ARE
TECHNICALLY CORRECT

Capital \$1,000,000
Policyholders' Surplus 2,381,000

FIRE AUTOMOBILE

Pacific Coast Department,
DIXWELL DAVENPORT,
Manager

INSURANCE EXCHANGE BLDG.
SAN FRANCISCO

FRANK M. BURNSIDE,
Manager Automobile

CALIFORNIA ARTISTIC METAL & WIRE CO.
 J. T. MCCORMICK, PRESIDENT
 ORNAMENTAL IRON AND BRONZE
 349-365 SEVENTH ST. SAN FRANCISCO

MORTENSON CONSTRUCTION CO.
 CONTRACTORS FOR STRUCTURAL STEEL AND IRON
 H. MORTENSON, PRES. CHAS. G. MORTENSON, VICE-PRES. AND MGR.
 OFFICE AND SHOPS: CORNER 19TH AND INDIANA STREETS
 PHONE: MISSION 5033 SAN FRANCISCO, CAL.

RAYMOND GRANITE COMPANY, Inc.
 Owning and operating at Knowles, Madera County, the largest Quarry in the world
 CONTRACTORS FOR STONE WORK
 Designers and Manufacturers of Exclusive Monuments and Mausoleums
 Main Office and Yard: No. 1 and 3 Potrero Avenue, San Francisco, California
 Also at Nos. 612-614 Homer Laughlin Building, Los Angeles

CAEN STONE  **A. KNOWLES**
 A refined, elegant, interior finish. CONTRACTOR and PLASTERER
 442 Call-Post Building San Francisco

THE GOLDEN GATE IRON WORKS
STRUCTURAL STEEL
 1541-1549 HOWARD STREET, BETWEEN 11th AND 12th STREETS
 Tel. Market 5445 San Francisco

Telephone Mission 58 A. A. Devoto, President
CENTRAL IRON WORKS, Inc.
 STRUCTURAL STEEL
 Office 2050 BRYANT STREET SAN FRANCISCO, CAL.

John Ringius Company, Inc. MANUFACTURERS OF
 Multivane Volume Fans and Steel Plate Blowers made to order, Sheet Metal Products
 any size, for Heating and Ventilating Plants in Theatres, Fans and Blowers
 Schools, Public Buildings, Etc.
 330 Ritch Street SAN FRANCISCO Phone Garfield 1108

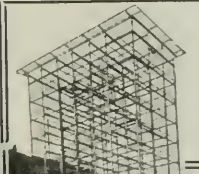
 **SCHRADER IRON WORKS, Inc.**
 STRUCTURAL STEEL CONTRACTORS
 Fire Escapes, Waterproof Trap Doors, Ornamental Iron Work
 1247-1249 HARRISON STREET SAN FRANCISCO, CAL
 Bet. 8th and 9th Telephone Market 337

THE
ARCHITECT AND
ENGINEER



LOS ANGELES NUMBER
AUGUST, 1920

PUBLISHED IN SAN FRANCISCO

This issue 50 cents

\$2.50 a year



HARMONY

WHEN an architect has created a home that is a combination of artistic good-taste and modern convenience, it is only natural that, in order to have everything in complete harmony, he specify

PACIFIC
PLUMBING FIXTURES



For Sale by All Jobbers

OFFICES: 67 NEW MONTGOMERY STREET, SAN FRANCISCO
FACTORIES: SAN PABLO AND RICHMOND, CALIFORNIA

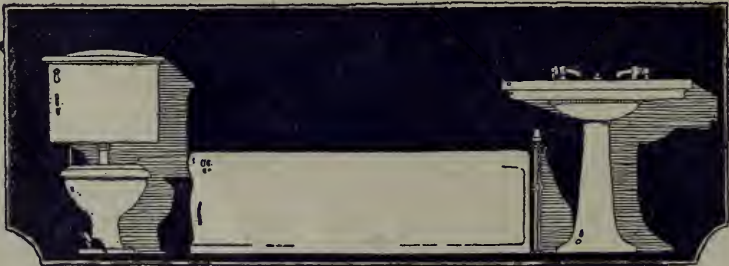



A PABCO Guarantee Protects You

Individual roofing contractors often give guarantees which they have every intention of maintaining. Unfortunately, however, as the result of death, failure, retirement from business, or other causes, they do not make good their guarantee.

PABCO 10 and 20 Year Roofs

Appeal to architects, engineers and owners because they carry the guarantees of The Paraffine Companies, Inc.—a \$6,000,000 institution with a record of thirty-six years of unquestioned integrity.

Moreover, PABCO Guaranteed Roofs eliminate annoyance and responsibility and, in the end, are less expensive because of their *low cost per year of service*.

Write for Specifications and
Complete Details

THE PARAFFINE COMPANIES, INC.
San Francisco, California

Lakeview Garage Lakeview, Oregon

Covered with a
PABCO 20Year Roof



Roofings—Felts
Building Papers
Floor Covering
Wall-Board
Waterproofing
Materials
Industrial and
Machine Paints
Electrical Varnishes and
Insulating Com-
pounds
Box-Board
Paper Boxes
Fibre Containers

"Each the standard
of its kind"

STEEL BARS

FOR
CONCRETE REINFORCEMENT

CORRUGATED
TWISTED
SQUARES
OR
ROUNDS
CUT
TO
LENGTH



FABRICATED
AND
INSTALLED
—
LUMP SUM
BIDS
ON
WORK
COMPLETE

Office, 444 MARKET STREET
Warehouse, 10th and Bryant Streets
Phone: Sutter 2720

“HYDRATITE” FOR WATERPROOFING AND HARDENING CONCRETE “HORNSTONE”

JK

Kelly & Jones
Valves and Fittings
are Dependable



BYERS Genuine Wrought Iron
Pipe, Republic Steel Pipe, Com-
plete Line Plumbing Supplies.
Large stocks for prompt delivery

California Steam &
Plumbing Supply Co.
671-679 Fifth St., cor. Bluxome
San Francisco, California



PIPE
Valves & Fittings
STEAM & WATER SUPPLIES
Heating Material
PLUMBING GOODS
Pumps

GEORGE H. TAY COMPANY
SAN FRANCISCO **OAKLAND**
 MISSION & SECOND STS. TENTH & HARRISON STS.
 TELEPHONE DOUGLAS 2240 TELEPHONE LAKESIDE 4200

Contractors Cannot Agree

as to percentage of labor and material saved in using

1 A RIB LATH

over other expanded metals; majority claim 20% saving — others more. Labor is high, material higher, 1 A RIB cuts down cost of both—present conditions demand your immediate investigation where metal lath is needed. Phone Market 8357.

Largest stock of fireproof material and reinforcing bars on the Pacific Coast.



Truscon Steel Company

CHAS. HOLLOWAY, JR., BRANCH MANAGER

527 Tenth Street, San Francisco

W. & J. SLOANE

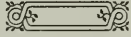

Carpetings Furniture
Rugs
Linoleum Window Shades
Wall Papers
Interior Decorations



216-228 Sutter Street
Tel. Garfield 2838 San Francisco

THE BRUNSWICK-BALNE-COLLERIE
WHALE-BONE-ITE
WHOLE CLOSET SEAT

CUT SHOWS No. 23-9 SEAT
D—WATER DISCHARGES IN CASE
C—WATER BECOMES CONDENSED
B—WATER IS COLLECTED
A—WATER THE COMPLETE LAYER OF LABORATORY
THIS TEST PROVES ITSELF

CONSTRUCTION OF WHALE-BONE-ITE SEAT

Whale-bone-ite

has proven under time and academic tests to be the best closet seat made.

Representative, also, of SLOAN VALVE COMPANY

EDWARD C. WHALEN
Monadnock Building
SAN FRANCISCO CALIF.



PROMETHEUS

The Electric Food and Plate Warmer

Wherever meals are cooked and served, in apartments, residences and institutions, Prometheus is a highly valued asset. The wireless heating units placed independently of the shelves keep food hot and tasty until ready to serve and cannot injure the finest china.

Write for information and list of installations

The Prometheus Electric Co.

Manufacturers

511 West 42d Street, New York

Showroom, **M. E. HAMMOND**
Mezzanine Floor Pacific Bldg., San Francisco

CLOW

AUTOMATIC CLOSETS

ARCHITECTS, as a class, are open-minded. That is why the Clow Automatic Closet has become so generally recognized. It has been specified in some of the largest industrial installations. There are at least three good reasons:

- 1.—Automatic flushing guarantees hygienic conditions.
- 2.—It is at least 40% more economical in the use of water than the manually operated type.
- 3.—The simplicity of its design and the care employed in its manufacture have made some amazing records in low cost of maintenance.

Frederick A. Hamilton

Sales Agent

Show Rooms:

RIALTO BUILDING
SAN FRANCISCO



Bath Room Fixtures

A BATH ROOM should be just as true an expression of the owner's taste and individuality as any other room of the house.

No more is it considered a luxury, but an absolute necessity to your health and comfort.

Our fixtures reflect the finest ideas in design and construction as related to sanitation, utility and service.

To give this subject the attention it demands, you should visit our display rooms at 64 Sutter Street, San Francisco.

Holbrook, Merrill & Stetson

DEALERS IN

Plumbers' Supplies, Iron Pipe and Fittings, Metals, Steam, Water and Hot Air Heating Apparatus, Stoves, Ranges, Kitchen Utensils.

Show Room, 64 SUTTER STREET

Main Office and Warehouse,

Sixth, Townsend and Bluxome Streets, San Francisco



Designers - Fabricators - Erectors

General Plate Work



Hydro - Pneumatic Pressure Tanks —
Hemispherical Bottom Tanks and Towers
— Oil and Water Tanks — Oil Stills —
Pipe Lines—Smoke Stacks—Well Casing
— Rock Screens — "Western" Corrugated Culvert Pipe.

Western Pipe and Steel Company OF CALIFORNIA

444 MARKET STREET
SAN FRANCISCO

1758 NORTH BROADWAY
LOS ANGELES

P. Noble, Pres.
E. B. Noble, Vice-Pres.
A. E. Wilkins, Sec'y

Beam, Angle, Channels, and Universal
Mill Plates for immediate ship-
ment from stock

Pacific Rolling Mill Co.

SUPPLIERS OF

**FABRICATED STRUCTURAL STEEL, Forgings,
Bolts, Rivets, Frogs, Switches, Cast Iron Castings**

General Office and Works
17th and MISSISSIPPI STS., SAN FRANCISCO
Telephone Market 215

Phones: Garfield 2575 and 2576

WESTERN IRON WORKS

W. B. Morris, President

H. H. Morris, Vice-President

L. J. Gates, Secretary

**STRUCTURAL IRON and
STEEL CONTRACTORS**

Beams, Channels, Angles, Plates and Steel
Wheelbarrows Carried in Stock

141-147 Beale Street and 132-148 Main Street
SAN FRANCISCO, CAL.



FORUM BUILDING, SACRAMENTO, CAL.
R. A. Herold, Architect

Progress Picture of the four story addition
to Sacramento's largest office building.

STRUCTURAL STEEL FABRI-
CATED AND ERECTED BY

**The Palm Iron and
Bridge Works**

(Incorporated)

15th and R. Sts., Sacramento, Cal.

Cast Iron Stairs and Store Fronts

Bank and Office Railings, Elevator
Enclosures and Fire Escapes.

C. J. HILLARD CO., Inc.

Nineteenth and Minnesota Streets
Telephone Mission 1763

SAN FRANCISCO, CAL.

Architects' Specification Index

(For Index to Advertisements, see next page)

ARCHITECTURAL TERRA COTTA

Gladding, McBean & Company, Crocker Bldg., San Francisco.

Los Angeles Pressed Brick Company and United Materials Co., Crossley Bldg., San Francisco.

Livermore Fire Brick Works, Livermore, Cal.

ASBESTOS ROOFING, PACKING, ETC.

H. H. Robertson Co., Hobart Bldg., San Francisco.

H. W. Johns-Manville Co., San Francisco, Los Angeles and Portland, Ore.

AUTOMATIC SPRINKLERS

Grinnell Co. of the Pacific, 453 Mission St., San Francisco.

Scott Company, 243 Minna St., San Francisco.

Pacific Fire Extinguisher Co., 424 Howard St., San Francisco.

AUTOMOBILE INSURANCE

Bankers & Shippers Insurance Co. of New York, Insurance Exchange Bldg., San Francisco.

AWNINGS, TENTS, ETC.

W. A. Plummer, Front, at Pine St., San Francisco.

BANK FIXTURES AND INTERIORS

Fink & Schindler, 218 13th St., San Francisco.

C. F. Weber & Co., 985 Market St., San Francisco.

Home Mfg. Co., 543 Brannan St., San Francisco.

Mullen Manufacturing Co., 64 Rausch St., San Francisco.

Rucker-Fuller Desk Co., 677 Mission St., San Francisco.

Pacific Manufacturing Company, San Francisco, Oakland and Santa Clara.

BELTING AND PACKING

New York Belting and Packing Company, 519 Mission St., San Francisco.

H. N. Cook Belting Co., 401 Howard St., San Francisco.

BLACKBOARDS

C. F. Weber & Co., 985 Market St., San Francisco, Los Angeles and Reno, Nevada.

Beaver Blackboards and Greenboards, Rucker-Fuller Desk Company, Coast agents, 677 Mission St., San Francisco; also Oakland and Los Angeles.

BLINDS—VENETIAN AND DIFFUSELITE

J. G. Wilson Corporation, Metropolitan Bldg., Los Angeles; Waterhouse-Wilcox, Underwood Bldg., San Francisco.

Western Venetian Blind Co., Long Beach Ave., Los Angeles.

BOILERS

California Hydraulic Engineering & Supply Co., 70-72 Fremont St., San Francisco.

Franklin Water Tube Boiler, General Machinery and Supply Co., 39 Stevenson St., San Francisco.

Kewanee Water Supply System, Simonds Machinery Co., 117 New Montgomery St., San Francisco.

General Boilers Co., 322 Monadnock Bldg., San Francisco.

BONDS FOR CONTRACTORS

American Mutual Liability Insurance Co., Balboa Bldg., San Francisco.

Bonding Company of America, Kohl Bldg., San Francisco.

Bankers & Shippers Insurance Co. of New York, Insurance Exchange Bldg., San Francisco.

Globe Indemnity Co., 120 Leidesdorff St., San Francisco.

Fidelity & Casualty Co. of New York, Merchants Exchange Bldg., San Francisco.

Fidelity & Deposit Co. of Maryland, Insurance Exchange, San Francisco.

John H. Robertson, 621 First National Bank Building, San Francisco.

National Surety Co. of New York, 105 Montgomery St., San Francisco.

BRASS GOODS, CASTINGS, ETC.

H. Mueller Manufacturing Co., 635 Mission St., San Francisco.

BRICK—PRESSED, PAVING, ETC.

California Brick Company, Niles, Cal., and 604 Mission St., San Francisco.

Livermore Fire Brick Works, Niles, Cal.

Gladding, McBean & Company, Crocker Bldg., San Francisco.

Los Angeles Pressed Brick Co., Frost Bldg., Los Angeles.

United Materials Co., Crossley Bldg., San Francisco.

BRICK & CEMENT COATING

Armorite and Concreta, manufactured by W. P. Fuller & Co., all principal Coast cities.

The Paraffine Companies, Inc., 34 First St., San Francisco.

R. N. Nason & Co., 151 Potrero Ave., San Francisco.

Glidden Stucco Liquid Cement Coating, The Glidden Company, 123 Hooper St., San Francisco.

Wadsworth, Howland & Co., Inc., Boston, Mass., manufacturers of Bay State Brick & Cement Coating.

Hambley & Son, agents, San Francisco and Los Angeles.

BRICK STAINS

Samuel Cabot Mfg. Co., Boston, Mass., agencies in San Francisco, Oakland, Los Angeles, Portland, Tacoma and Spokane.

Armorite and Concreta, manufactured by W. P. Fuller & Co., all principal Coast cities.

BUILDERS' HARDWARE

Joost Bros., agents for Russell & Erwin Hardware, 1053 Market St., San Francisco.

The Stanley Works, New Britain, Conn., represented in San Francisco and Los Angeles by John Rountree & Co.

Palace Hardware Company, Agents Corbin goods, 581 Market St., San Francisco.

Richards-Wilcox Mfg. Co., Aurora; Ewing-Lewis Co., 626 Underwood Bldg., San Francisco.

GRINNELL AUTOMATIC SPRINKLER GRINNELL COMPANY

OF THE PACIFIC

VALVES
PIPE and FITTINGS

ENGINEERS AND CONTRACTORS
453 Mission Street, San Francisco

CHEMICAL FIRE
EXTINGUISHERS
and FIRE ENGINES

When writing to Advertisers please mention this magazine.

An Index to the Advertisements

	Page		Page		Page
American La France Fire En- gine Co.	34	Haines, Jones & Cadbury	123	Palm Iron Works	6
American Mutual Liability Insurance Co.	10	Hamilton, F. A.	4	Palmer & Petersen	142
American Mail Chute	32	Hammond, M. E.	4	Paraffine Companies, Inc.	1
American Marble & Mosaic Co.	44	Hannah, J. D.	142	Parker, K. E. Co., Inc.	141
American Rolling Mill Co.	133	Hauser Window Co.	26	Petrum Sanitary Sink Co.	147
American Standard Oil Burner	43	Haws Sanitary Drinking Fau- cet Co.	138	Phillips, Chas. T.	145
American Window Glass Co.	42	Hicks-Judd Co.	151	Pitcher Door Hanger	33
Atlas Heating & Ventilating Co.	146	Hillard, C. J., Co.	6	Plummer, W. A.	138
Atlas Portland Cement Co.	125	Hill, Hubbell & Company	149	Pope & Talbot	15
Austin Machinery Corporation	153	Holbrook, Merrill & Stetson	5	Portland Lumber Co.	158
American Automatic Lock & Lift Co.	156	Holtzer-Cabot	20	Power Construction Company	158
Bacon, Edward R., Co.	153	Home Mfg. Co.	158	Prometheus Electric Co.	4
Baird-Falk & Co.	145	Hunt, Robt. W. & Co.	136	Raymond Granite Co.	160
Baird-Bailhache Company	24	Hunter & Hudson	140	Redwood Mfg. Co.	42
Bankers' & Shippers' Ins. Co.	128	Ideal Heating & Engineering Co.	146	Reliance-Grant Elevator Equip- ment Co.	22
Barrett & Hilp	144	Illinois Engineering Co.	146	Rex Electric Engineering Co.	155
Bass-Hueter Co.	3rd Cover	Imperial Waterproofing	32	Richards-Wilcox Mfg. Co.	35
Baxter, Reed	32	Inlaid Floor Co.	140	Roberts Mfg. Co.	159
Beach-Robinson Co.	31	James & Drucker	128	Robertson Co., H. H.	144
Beckwith, Herbert	145	Jarvis, T. P. Mfg. Co.	43	Robertson, John H.	150
Bittmann & Battee	20	Johns-Manville Co.	10	Ruegg Bros.	150
Bowser & Co., S. F.	41	Johnson, S. T.	43	Rucker-Fuller Desk Co.	140
Brimnool Co.	22	Johnson Service Co.	11	Ryan, M. E.	155
Browne-Langlais Company	155	Joost Brothers	140	Safety Electric Co.	154
Butte Electrical Equipment Co.	154	Kawneer Mfg. Co.	152	Sampson Spot Cord	9
Butte Electric & Mfg. Co.	155	Kawneer Co.	152	San Francisco Pioneer Varnish Works	3d Cover
Cabot, Samuel (Inc.)	41	Kerner Incinerator Co.	21	Scott Co.	146
California Artistic Metal and Wire Co.	160	Key-hold Plaster Lath Co.	32	Schrader Iron Works	160
California Bldg. Material Co. Back Cover		Kissel, I. R.	142	Schwabacher-Prey Co.	159
California Brick Co.	23	Knittle-Cashel Co., Inc.	13	Sloane, W. & J.	4
California Granite Co.	158	Knowles, A.	160	Simmons, O. M. Co.	12
California Hydraulic Engineer- ing and Supply Co.	12	Lange & Bergstrom	148	Simonds Machinery Co.	131
California Paint Co.	14	Larsen, Sampson & Co.	142	Smith-Booth-Usher Co.	157
California Redwood Ass'n.	122	Letch, A.	146	Smith, Jas. F.	144
California Steam and Plumb- ing Supply Co.	2	Liberty Electric Co.	156	Sommer, I. M.	11
Cement Gun Construction Co.	134	Littlefield, R. W.	144	Sonnenschein Bros.	31
Central Iron Works	160	Livermore Fire Brick Works	23	Spencer Elevator Co.	24
Clinton Wire Lath	34	Los Angeles Pressed Brick Co.	127	Spott Electrical Co.	156
Clo & Sons	4	MacGruer & Simpson	151	Standard Varnish Works	22
Coleman, Alex	146	MacKorie-McLaren Co.	152	Standard Electric Time Co.	30
Collman, A. D.	142	Magner Bros.	140	Standard Fence Co.	145
Cook Belting Co.	38	Mangrum & Otter	139	Stanley Works, The	121
Cowell Lime & Cement Co.	153	Marshall & Stearns Co.	35	Steelform Contracting Co.	144
Crane Co.	32	McGray Refrigerator Co.	27	St. Francis Hotel	131
Davis, R. J.	14	McLeran & Peterson	150	Strable Mfg. Co.	122
Del Monte Properties Co.	28	McNab, H. N.	145	Sunset Lumber Company	15
Detroit Steel Products Co.	44	Medusa Cement	29	Tay Company, George H.	3
Direct Line Telephone Co.	159	Meese & Gottfried	134	Taylor, F. A. & Co.	31
Dolan Wrecking & Construc- tion Co.	158	Meyers Electric Safety Switch Co., Inc.	154	Tittle, H. S.	155
Dow-Herriman Co.	148	Moline Heat	17	Tormey Co.	140
Drendell Elec. & Mfg. Co.	154	Montague Range & Furnace Co.	15	Trost, Robt.	142
Dudfield Lumber Co.	21	Monson Bros.	158	Truscon Steel Co.	3
Duncan, W. C.	144	Mortenson Construction Co.	160	Tuec Cleaner	135
Dyer Bros.	132	Mott Co. of Calif.	18	Uhl Bros.	38
Elevator Supplies Co.	150	Mueller Mfg. Co.	18	Unit Construction Co.	142
Ellery Arms Co.	128	Mullen Mfg. Co.	142	United Electric Co.	135
Faber, Eberhard	36	Musket Co., W. B.	148	United Materials Co.	127
Fess System Co.	43	Musto Sons Keenan Co.	13	U. S. Metal Products Co.	26
Fidelity & Casualty Co. of N.Y.	150	Nason, R. N. & Co.	9	U. S. Steel Products Co.	40
Fidelity & Deposit Co. of Mary- land	150	Nathan, Dohrmann Co.	151	Van Fleet-Freear Co.	152
Fink & Schindler Co., The	158	National Mill & Lumber Co.	33	Vermont Marble Co.	34
Fire Protection Products Co.	16	National Surety Co.	150	Vukicevich & Bagge	144
Flagg, Edwin H., Scenic Co.	158	Nelson, James A.	148	Vulcanite Roofing Co.	26
Freeman Art Shop	31	Ne Page, McKenny Co.	155	Wadsworth, Howland & Co., Inc.	136
Fuller & Goep.	24	Newbery Electric Co.	155	Walter, D. N. & E. & Co.	145
Fuller, W. P. Co.	19	New York Belting and Pack- ing Co.	28	Waterhouse, Wilcox Co.	32
Garfield Company	153	Norris Co., L. A.	34	Wayne Oil Tank & Pump Co.	33
Garnett, Young & Co.	20	Oak Flooring Mfgs' Ass'n.	129	Weber, C. F. & Co.	152
General Boilers Co.	18	Ocean Shore Iron Works	138	Wentworth, F. W.	140
Gilley-Schmid Co.	140	Old Mission Portland Cement Co.	25	Western Blind & Screen Co.	139
Gladding, McBean & Co.	138	Otis Elevator Co.	Back Cover	Western Iron Works	6
Glidden Co.	37	Pacific Coast Steel Company	151	Western Office, Equipment Co.	34
Globe Electric Works	155	Pacific Materials Co.	41-44	Western Pipe and Steel Co.	5
Globe Indemnity Co.	150	Pacific Fire Extinguisher Co.	18	Wetenhall, W. S.	146
Go-Sign & Letter Co.	145	Pacific Mfg. Co.	158	Whalen, E. C.	4
Golden Gate Ornamental Iron Co.	160	Pacific Plumbing Fixtures	2d Cover	White Bros.	120
Grinnell Co.	7	Pacific Porcelain Ware Co.	2d Cover	Whitney Chemical Co.	149
Gunn Carle Company	2	Pacific Pump & Supply Co.	38	Wilson, J. G., Corp.	139
		Pacific Rolling Mills	6	Wilson, W. F., Co.	44
		Palace Hardware Co.	38	Witt, G. E. Co.	44
				Wooden & Little	137
				Zelinsky, D & Sons	145

NASON'S OPAQUE FLAT FINISH A FLAT WASH-

ABLE OIL PAINT, made in soft Kalsomine tints—a practical article for WALLS, CEILINGS, Etc. Economical and Durable. Agency TAMM & NOLAN COMPANY'S high grade Varnishes and Finishes, made on the Pacific Coast to stand our climatic conditions.

R. N. NASON & CO., Paint Makers

51 Potrero Ave.—SAN FRANCISCO—436 Market St.

PORTLAND
SEATTLE
LOS ANGELES

ARCHITECTS' SPECIFICATION INDEX—Continued

- BUILDING MATERIAL, SUPPLIES, ETC.**
Pacific Materials Co., Underwood Bldg., San Francisco.
Waterhouse-Wilcox Co., 523 Market St., San Francisco.
- CABINET MAKERS**
Home Manufacturing Company, 543 Brannan St., San Francisco.
Fink & Schindler Co., 218 13th St., San Francisco.
Mullen Manufacturing Company, 64 Rausch St., San Francisco.
- CARPETS**
W. & J. Sloane, 216-228 Sutter St., San Francisco.
- CASEMENT WINDOW HARDWARE**
Richards-Wilcox Mfg. Co., Aurora, Ill., and Underwood Bldg., San Francisco.
- CASTINGS**
Dow-Herriman Co., 140 Howard St., San Francisco.
- CEMENT**
Atlas Portland Cement Co., New York and Chicago. (See advertisement for Coast Distributors.)
Mt. Diablo, sold by Henry Cowell Lime & Cement Co., 2 Market St., San Francisco.
Medusa White Portland Cement, manufactured by Sandusky Cement Co., represented in San Francisco by Pacific Building Materials Co., Underwood Bldg., San Francisco.
Old Mission Portland Cement Co., Mills Building San Francisco.
- CEMENT EXTERIOR FINISH**
Concreta, sold by W. P. Fuller & Co., all principal Coast cities.
Glidden Stucolor Liquid Cement Coating. The Glidden Company, 123 Hooper St., San Francisco.
Samuel Cabot Mfg. Co., Boston, Mass., agencies Oakland, Los Angeles, Portland, Tacoma, Spokane; and Pacific Building Materials Co., 525 Market St., San Francisco.
The Paraffine Companies, Inc., 34 First St., San Francisco.
- CEMENT EXTERIOR WATERPROOF PAINT**
Armorite, sold by W. P. Fuller & Co., all principal Coast cities.
Bay State Brick and Cement Coating, manufactured by Wadsworth, Howland Co., Boston, Mass. James Hambley & Son, Distributors, San Francisco and Los Angeles.
Hill, Hubbell & Company, No. 1 Drumm St., San Francisco.
Imperial Waterproofing, manufactured by Brooks & Doerr, Reed Baxter, agent, Merchants National Bank Bldg., San Francisco.
Paraffine Paint Co., 34 First St., San Francisco.
Medusa White Portland Cement, manufactured by Sandusky Cement Co., represented in San Francisco by Pacific Building Materials Co., 525 Market St., San Francisco.
- CEMENT FLOOR COATING**
Fuller's Concrete Floor Enamel, made by W. P. Fuller & Co., San Francisco.
- Glidden Concrete Floor Dressing. The Glidden Company, 123 Hooper St., San Francisco.
- CEMENT GUN**
Cement Gun Construction Company of California, 701 Balboa Bldg., San Francisco.
- CEMENT TESTS—CHEMICAL ENGINEERS**
Robert W. Hunt & Co., 251 Kearny St., San Francisco.
- CHURCH INTERIORS**
Fink & Schindler, 218 13th St., San Francisco.
Mullen Manufacturing Company, 64 Rausch St., San Francisco.
Home Manufacturing Company, 543 Brannan St., San Francisco.
- CHUTES—SPIRAL**
Haslett Warehouse Co., 310 California St., San Francisco.
- CLAY PRODUCTS**
Livermore Fire Brick Works, 604 Mission street, San Francisco.
W. E. Mushet Co., 502 Mission St., San Francisco.
Gladding, McBean & Co., Crocker Bldg., San Francisco.
United Materials Co., Crossley Bldg., San Francisco.
Los Angeles Pressed Brick Co., Frost Bldg., Los Angeles.
- CLOCKS—TIME**
Standard Electric Time Co., 461 Market St., San Francisco.
- COLD STORAGE PLANTS**
H. W. Johns-Manville Co., Second and Howard Sts., San Francisco.
T. P. Jarvis Crude Oil Burning Co., 275 Connecticut St., San Francisco.
- COMPRESSED AIR CLEANERS**
United Electric Co., Canton, O., mfr. of Tuec Cleaner, sold by San Francisco Compressed Air Cleaning Co., Sutter and Stockton Sts., San Francisco.
George H. Tay Company, Mission and Second Sts., San Francisco; 10th and Harrison Sts., Oakland.
- CONCRETE CONSTRUCTION**
Barrett & Hilp, Sharon Bldg., San Francisco.
Clinton Construction Co., 140 Townsend street, San Francisco.
K. E. Parker Co., Inc., Clunie Bldg., San Francisco.
Palmer & Petersen, Monadnock Bldg., San Francisco.
I. M. Sommer, 401 Balboa Bldg., San Francisco.
Steelform Contracting Company, 681 Market St., San Francisco.
- CONCRETE MIXERS**
Austin Improved Cube Mixer. Stuart S. Smith, 625 Market Street, San Francisco.
Foote and Jaeger mixers sold by Edward R. Bacon Co., 51 Minna St., San Francisco, also Los Angeles.
Ransome mixers sold by the Garfield Co., Hearst Bldg., San Francisco.
- CONCRETE REINFORCEMENT**
United States Steel Products Co., San Francisco, Los Angeles, Portland and Seattle.

SAMSON SPOT SASH CORD

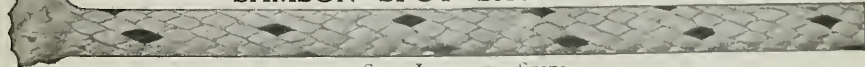

SPOT IT BY THE SPOTS

Made of extra quality cotton yarn, firmly braided and smoothly finished. Carefully inspected and guaranteed free from all imperfections of braid and finish. → Can be distinguished at a glance by our trade-mark, the Colored Spots. Send for catalogue and samples.

Pacific Coast Agent, JOHN T. ROWNTREE, Inc., San Francisco and Los Angeles, Cal.

We have returned to our policy-holders annually for 33 years never less than 30% of the premium as a dividend. Dividends declared during 1919, \$2,017,893.

AMERICAN MUTUAL LIABILITY INSURANCE CO. OF BOSTON

Assets \$8,654,667

Surplus \$1,417,173

WORKMEN'S COMPENSATION, AUTOMOBILE, TEAMS AND PUBLIC LIABILITY INSURANCE

SAN FRANCISCO BRANCH OFFICE

1816 Balboa Building. Telephone Kearny 3202

N. F. Hesselstine, California Manager.

C. H. Gray, Assistant Manager.

ARCHITECTS' SPECIFICATION INDEX—Continued

CONCRETE REINFORCEMENT (Continued)

Twisted Bars. Sold by Gunn, Carle & Co., Inc.
444 Market St., San Francisco.
Clinton Welded Wire Fabric, L. A. Norris Co.,
140 Townsend St., San Francisco.
Pacific Coast Steel Company, Rialto Bldg., San
Francisco.
Steel bars sold by W. S. Wetenhall Co., 450
Irwin St., San Francisco.
Triangle Mesh Fabric. Sales agents, Pacific
Materials Co., 525 Market St., San Francisco.
Truscon Steel Co., 527 Tenth St., San Fran-
cisco.
Badt Falk Co., Call-Post Bldg., San Francisco.

CONDUITS

Garnett, Young & Co., 612 Howard St., San
Francisco.

CONTRACTORS, GENERAL

Barrett & Hilp, Sharon Bldg., San Francisco.
K. E. Parker Co., Inc., Clunie Bldg., San
Francisco.
R. W. Littlefield, 357 12th St., Oakland.
Unit Construction Co., Phelan Bldg., San Francisco.
Larsen, Sampson & Co., Claus Spreckels Bldg.,
San Francisco.
J. D. Hannah, 142 Sansome St., San Francisco.
Chas. Stockholm & Son, Monadnock Bldg., San
Francisco.
Herbert Beckwith, 323 Newton Ave., Oakland.
A. D. Collman, 110 Jessie St., San Francisco.
Clinton Construction Company, 140 Townsend
St., San Francisco.
Monson Bros., 1907 Bryant St., San Francisco.
W. C. Duncan & Co., 526 Sharon Bldg., San
Francisco.

A. Knowles, Call-Post Bldg., San Francisco.
T. B. Goodwin, 110 Jessie St., San Francisco.
Lange & Bergstrom, Sharon Bldg., San Francisco.
McLeran & Peterson, Hearst Bldg., San Fran-
cisco.
Robert Trost, 26th and Howard Sts., San Francisco.
I. M. Sommer, 401 Balboa Bldg., San Francisco.

CONTRACTORS' EQUIPMENT

Edward R. Bacon Co., 51 Minna St., San Fran-
cisco, and Los Angeles.
Garfield & Co., Hearst Bldg., San Francisco.
Smith, Booth-Usher Co., 60 Fremont St., San
Francisco; 228 Central Ave., Los Angeles.

CONTRACTORS' INSURANCE

Bankers & Shippers Insurance Co. of New York,
Insurance Exchange Bldg., San Francisco.

CONVEYING MACHINERY

Meese & Gottfried, San Francisco, Los Angeles,
Portland and Seattle.

CORK TILE, INSULATION, ETC.

Van Fleet-Freear Co., Sharon Bldg., San Fran-
cisco.

CRUSHED ROCK

Coast Rock & Gravel Co., Call-Post Bldg., San
Francisco.

DAMP-PROOFING COMPOUND

Armorite Damp Resisting Paint, made by W. P.
Fuller & Co., San Francisco.
Glidden's Liquid Rubber. The Glidden Company,
123 Hooper St., San Francisco.
Hill, Hubbell & Company, No. 1 Drumm St.,
San Francisco.
Imperial Waterproofing. mfrd. by Brooks &

Doerr, Reed Baxter, agent, Merchants Na-
tional Bank Bldg., San Francisco.
"Pabco" Damp-Proofing Compound, sold by
Paraffine Co., 34 First St., San Francisco.

DOOR HANGERS

Pitcher Hanger, sold by National Lumber Co.,
326 Market St., San Francisco.
Reliance Hanger, sold by Waterhouse-Wilcox
Co., San Francisco; D. F. Fryer & Co., B. V.
Collins, Los Angeles, and Columbia Wire &
Iron Works, Portland, Oregon.
Stanley Works, New Britain, Conn. John
Rountree, agent, Monadnock Bldg., San Fran-
cisco.

Richards-Wilcox Mfg. Co., Underwood Bldg.,
San Francisco.

DRINKING FOUNTAINS

Haws Sanitary Drinking Faucet Co., 1808 Harmon St
Berkeley, and C. F. Weber & Co., San Fran-
cisco and Los Angeles.

Crane Company, San Francisco, Oakland, and
Los Angeles.

Pacific Porcelain Ware Co., 67 New Montgom-
ery St., San Francisco.

George H. Tay Company, Mission and Second
Sts., San Francisco; 10th and Harrison Sts.,
Oakland.

Haines, Jones & Cadbury Co., 857 Folsom St.,
San Francisco.

DUMB WAITERS

Spencer Elevator Company, 166 7th St., San
Francisco.

M. E. Hammond, Pacific Bldg., San Francisco.

ELECTRICAL CONTRACTORS

Butte Electrical Equipment Company, 530 Fol-
som St., San Francisco.

Butte Electric & Manufacturing Co., 534 Folsom
St., San Francisco.

Brown-Langlais Electrical Construction Co., 213
Minna St., San Francisco.

NePage, McKenny Co., 589 Howard St., San
Francisco.

Liberty Electric Company, 479 Sutter St., San
Francisco.

Newbery Electrical Co., 413 Lick Bldg., San
Francisco.

Pacific Fire Extinguisher Co., 424 Howard St.,
San Francisco.

Globe Electric Works, 1959 Mission St., San
Francisco.

M. E. Ryan, Redwood City, Calif.

Rex Electric & Engineering Co., 253 Minna St.,
San Francisco.

H. S. Tittle, 766 Folsom St., San Francisco.

Severin Electrical Company, 185 Stevenson St.,
San Francisco.

Spott Electrical Co., Sixteenth and Clay Sts.,
Oakland.

ELECTRIC PLATE WARMER

The Prometheus Electric Plate Warmer for
residences, clubs, hotels, etc. Sold by M. E.
Hammond, Pacific Bldg., San Francisco.

ELECTRICAL SUPPLIES AND EQUIPMENT

Garnett, Young & Co., 612 Howard St., San
Francisco.

Butte Electrical Equipment Co., 530 Folsom St.,
San Francisco.

Safety Electric Company, 56-65 Columbia
Square, San Francisco.

JOHNS-MANVILLE
SERVES IN CONSERVATION
Through
ASBESTOS and its ALLIED PRODUCTS



TEMPERATURE REGULATION

JOHNSON SERVICE COMPANY

(OF MILWAUKEE — ESTABLISHED 1885)

Manufacturers and Installers of **JOHNSON Heat Humidity CONTROL**

For schools, residences, hospitals, banks, public buildings, also canneries and all kinds of industrial plants—Hot water tank regulators, air and water reducing valves.

Rialto Bldg, SAN FRANCISCO Trust and Savings Bldg., LOS ANGELES

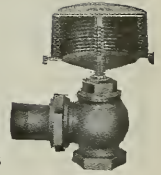

ARCHITECTS' SPECIFICATION INDEX—Continued

ELECTRIC SUPPLIES & EQUIPMENT—Cont.
Drendell Electrical & Mfg. Co., 1345 Howard St., San Francisco.

R. J. Davis, District Sales Agent, Century A. C. Motors and Fans, 171 Second St., San Francisco.

ELEVATORS

Otis Elevator Company, Stockton and North Point, San Francisco.

Spencer Elevator Company, 166 7th St., San Francisco.

ELEVATOR EQUIPMENT

Elevator Supplies Company, Inc., 186 Fifth St., San Francisco.

ENGINEERS—CONSULTING, ELECTRICAL, MECHANICAL

Chas. T. Phillips, Pacific Bldg., San Francisco.

Hunter & Hudson, Rialto Bldg., San Francisco.

ELEVATOR DOOR HARDWARE

Richards-Wilcox Mfg. Co., Underwood Bldg., San Francisco.

FANS AND BLOWERS

Ideal Heating & Engineering Co., 192 Erie St., San Francisco.

FENCES—WIRE

Standard Fence Construction Co., 77 O'Farrell St., San Francisco, and 310 12th St., Oakland.

FILLING STATION EQUIPMENT

S. F. Bowser & Co., Inc., 612 Howard St., San Francisco.

Wayne Oil Tank & Pump Co., 631 Howard St., San Francisco, 830 S. Los Angeles St., Los Angeles.

FIRE ESCAPES

Palm Iron & Bridge Works, Sacramento.

Western Iron Works, 141 Beale St., San Francisco.

Golden Gate Iron Works, 1541 Howard St., San Francisco.

FIRE EXTINGUISHERS

American La France Fire Engine Co., Inc., 151 New Montgomery St., San Francisco; Los Angeles and Portland.

FIRE INSURANCE

Bankers & Shippers Insurance Co., Insurance Exchange Bldg., San Francisco.

FIRE SPRINKLERS—AUTOMATIC

Grinnell Company, 453 Mission St., San Francisco.

Scott Company, 243 Minna St., San Francisco.

Pacific Fire Extinguisher Co., 424 Howard St., San Francisco.

FIREPROOFING AND PARTITIONS

Gladding, McBean & Co., Crocker Bldg., San Francisco.

Los Angeles Pressed Brick Co., Frost Bldg., Los Angeles.

Richards-Wilcox Mfg. Co., Aurora, Ill., and Underwood Bldg., San Francisco.

FIRE RETARDING PAINT

The Paraffine Companies, Inc., 34 First St., San Francisco.

Asbestos Paints. The Glidden Company, 123 Hooper St., San Francisco.

FIXTURES—BANK, OFFICE, STORE, ETC.

Home Manufacturing Company, 543 Brannan St., San Francisco.

The Fink & Schindler Co., 218 13th St., San Francisco.

Mullen Manufacturing Co., 64 Rausch St., San Francisco.

C. F. Weber & Co., 985 Market St., San Francisco, and 210 N. Main St., Los Angeles, Cal.

FLOOR TILE

Mangrum & Otter, 827 Mission St., San Francisco.

FLOOR VARNISH

Bass-Hueter and San Francisco Pioneer Varnish Works, 816 Mission St., San Francisco.

Fifteen for Floors, made by W. P. Fuller & Co., San Francisco.

Standard Varnish Works, Chicago, New York and San Francisco.

R. N. Nason & Co., San Francisco and Los Angeles.

The Glidden Company, 123 Hooper St., San Francisco.

FLOORS—HARDWOOD

Inlaid Floor Company, 600 Alabama St., San Francisco.

Parrott & Co., 320 California St., San Francisco.

White Bros., Fifth and Brannan Sts., San Francisco.

Strable Manufacturing Company, 511 First St., Oakland.

FLOORS—MASTIC

Hill, Hubbell & Company, No. 1 Drumm St., San Francisco.

FLUMES

California Corrugated Culvert Co., West Berkeley, Cal.

FRUIT DRYING MACHINERY

Ideal Heating & Engineering Co., 192 Erie St., San Francisco.

Jas. A. Nelson, 517 Sixth St., San Francisco.

FUEL OIL SYSTEMS

S. F. Bowser & Co., Inc., 612 Howard St., San Francisco.

Wayne Oil Tank & Pump Co., 631 Howard St., San Francisco.

FURNACES—WARM AIR

Mangrum & Otter, 827 Mission St., San Francisco.

Montague Range and Furnace Co., 826 Mission St., San Francisco.

FURNITURE—BUILT-IN

Hoosier Kitchen Cabinet Store, Pacific Bldg., San Francisco.

FURNITURE—SCHOOL, CHURCH, OFFICE, HOUSE, ETC.

Home Manufacturing Company, 543 Brannan St., San Francisco.

C. F. Weber & Co., 985 Market St., San Francisco.

Rucker-Fuller Desk Co., 677 Mission St., San Francisco.

F. W. Wentworth & Co., 539 Market St., San Francisco.

Western Office Equipment Co., 467 Market St., San Francisco.

W. & J. Sloane, 216-228 Sutter St., San Francisco.

GALVANIZED IRON WORK

James A. Nelson, 517 Sixth St., San Francisco.

GARAGE HARDWARE

The Stanley Works, New Britain, Conn., represented in San Francisco, Los Angeles, Seattle by John T. Rowntree, Inc.

I. M. SOMMER

CONTRACTORS & ENGINEERS

Phone Kearny 4582

401 BALBOA BLDG., SAN FRANCISCO

KEWANEE
GARBAGE BURNERS
AND
BOILERS

YEOMANS
BILGE PUMPS
EJECTORS
HOUSE PUMPS

OVERHEAD
CARRYING
SYSTEMS

CALIFORNIA HYDRAULIC ENGINEERING & SUPPLY CO., 80 Fremont St., S. F.

ARCHITECTS' SPECIFICATION INDEX—Continued

- GARAGE HARDWARE**—Continued.
Richards-Wilcox Mfg. Co., Aurora, Ill., and Underwood Bldg., San Francisco.
- GARBAGE CHUTES AND INCINERATORS**
Bradshaw Sanitary Garbage Chute, Bittmann & Battee, 745 Folsom St., San Francisco, sole agents for California.
Kerner Incinerator Co., 77 O'Farrell St., San Francisco.
California Hydraulic Engineering & Supply Co., 70-72 Fremont St., San Francisco.
- GAS STEAM RADIATORS—FUMELESS, ETC.**
Clow Gas Steam Radiators, F. A. Hamilton, Agent, 101 Rialto Bldg., San Francisco.
Ra-Do Fumeless Gas Radiators, manufactured and sold by Baird-Bailhache Co., 478 Sutter St., San Francisco.
- GLASS**
American Window Glass Co., represented by L. H. Butcher Co., 341 Montgomery St., San Francisco.
Fuller & Goepp, 32 Page St., San Francisco.
W. P. Fuller & Company, all principal Coast cities.
- GRADING, WRECKING, ETC.**
Dolan Wrecking & Construction Co., 1607 Market St., San Francisco.
- GRANITE**
California Granite Co., Gen. Contractors' Ass'n, San Francisco.
Raymond Granite Co., Potrero Ave. and Division St., San Francisco.
- GRAVEL AND SAND**
Coast Rock & Gravel Co., Call-Post Bldg., San Francisco.
Del Monte White Sand, sold by Del Monte Properties Co., Crocker Bldg., San Francisco.
- HARDWALL PLASTER**
Henry Cowell Lime & Cement Co., San Francisco.
- HARDWARE**
Joost Bros., agents for Russell & Erwin hardware, 1053 Market St., San Francisco.
The Stanley Works, New Britain, Conn.
Corbin hardware, sold by Palace Hardware Co., 581 Market St., San Francisco.
Richards-Wilcox Mfg. Co., Aurora, Ill., Ewing-Lewis Co., 626 Underwood Bldg., San Francisco.
- HARDWOOD LUMBER—FLOORING, ETC.**
Inlaid Floor Co., 600 Alabama St., San Francisco.
H. N. McNab, 2307 17th Ave., Oakland.
Parrott & Co., 320 California St., San Francisco.
White Bros., cor. Fifth and Brannan Sts., San Francisco.
Strable Manufacturing Company, First St., near Broadway, Oakland.
- HEATERS—AUTOMATIC—GAS**
Pittsburg Water Heater Co., 478 Sutter St., San Francisco.
George H. Tay Company, Mission and Second Sts., San Francisco; 10th and Harrison Sts., Oakland.
Ra-Do Fumeless Gas Heater, sold by Baird-Bailhache Company, 478 Sutter St., San Francisco.
- HEATING AND VENTILATING MATERIAL, ETC.**
Alex Coleman, 706 Ellis St., San Francisco.
- Gilley-Schmid Company, 198 Otis St., San Francisco.
Mechanical Engineering & Supply Co., Sacramento.
Hateley & Hateley, Mitau Bldg., Sacramento.
Knittle-Cashel Co., Inc., 1820 Ellis St., San Francisco.
General Boilers Co., 332 Monadnock Bldg., San Francisco.
A. Lettich, 365 Fell St., San Francisco.
Mangrum & Otter, 827-831 Mission St., San Francisco.
Moline Heat, Hobart Bldg., San Francisco.
James & Drucker, 450 Hayes St., San Francisco.
James A. Nelson, 517 Sixth St., San Francisco.
Ideal Heating & Engineering Co., 192 Erie St., San Francisco.
Illinois Engineering Co., 563 Pacific Bldg., San Francisco.
William F. Wilson Co., 328 Mason St., San Francisco.
Pacific Fire Extinguisher Co., 424 Howard St., San Francisco.
Scott Company, 243 Minna St., San Francisco.
Mechanical Engineering & Supply Co., 908 7th St., Sacramento.
John Ringius, 252 Townsend St. (bet. Third and Fourth), San Francisco.
George H. Tay Company, Mission and Second Sts., San Francisco; 10th and Harrison Sts., Oakland.
O. M. Simmons Co., 115 Mission St., San Francisco.
- HOLLOW TILE BLOCKS**
Gladding, McBean & Co., San Francisco, Los Angeles, Oakland and Sacramento.
Los Angeles Pressed Brick Co., Frost Bldg., Los Angeles.
- HOSPITAL FIXTURES**
Mott Company of California, 553 Mission St., San Francisco.
George H. Tay Company, Mission and Second Sts., San Francisco; 10th and Harrison Sts., Oakland.
- HOSPITAL SIGNAL SYSTEM**
Holtzer-Cabot system, represented by Bittmann & Battee, 745 Folsom St., San Francisco.
Chicago Signal Co., represented by Garnett, Young & Co., 612 Howard St., San Francisco.
- HOTELS**
St. Francis Hotel, Powell, Geary and Post Sts., San Francisco.
- INGOT IRON**
"Armo" brand, manufactured by American Rolling Mill Company, Middletown, Ohio, and Monadnock Bldg., San Francisco.
- INSPECTIONS AND TESTS**
Robert W. Hunt & Co., 251 Kearny St., San Francisco.
- INSULATION**
Ebonite Boiler Kote, sold by California Plastic Products Co., 521 Sheldon Bldg., San Francisco.
- INCINERATORS**
Kerner Incinerator Co., 77 O'Farrell St., San Francisco.
- INTERIOR DECORATORS**
Beach-Robinson Co., 239 Geary St., San Francisco.

"The
Perfect
Automatic
Valve"

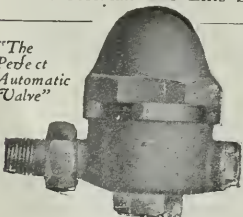

WILLIAM S. HAINES & CO.

Automatic Vacuum and Vapor Heating Systems

VENTO AUTOMATIC VALVES
"Everything for the Heating Engineer"

O. M. SIMMONS CO. 115 MISSION STREET
SAN FRANCISCO
PACIFIC COAST REPRESENTATIVE Phone: Douglas 5497

CLARENCE E. MUSTO, Pres.

JOSEPH B. KEENAN, Vice-Pres.

GUIDO J. MUSTO, Sec'y & Treas.

JOSEPH MUSTO SONS-KEENAN CO.Phone Franklin
6365**MARBLE**OFFICE AND MILLS:
535-565 North Point St.,
SAN FRANCISCO, CAL.**ARCHITECTS' SPECIFICATION INDEX—Continued**

- Sonnenschein Bros., 470 Sutter St., San Francisco.
- F. A. Taylor & Co., 251 Post St., San Francisco.
- The Torney Co., 1042 Larkin St., San Francisco.
- Freeman Art Shop, 386 Sutter St., San Francisco.
- W. & J. Sloane, 216 Sutter St., San Francisco.
- KITCHEN CABINETS**
Hoosier Kitchen Cabinet Store (O. K. Brown, Mgr.), Pacific Bldg., San Francisco.
- KITCHEN EQUIPMENT**
James A. Nelson, 517-19 Sixth street, San Francisco.
- LAMP POSTS, ELECTROLIERS, ETC.**
J. L. Mott Iron Works, 533 Mission St., San Francisco.
- LANDSCAPE GARDENERS**
MacRorie-McLaren Co., 141 Powell St., San Francisco.
- LATHING AND PLASTERING**
MacGruer & Simpson, Call-Post Bldg., San Francisco.
- A. Knowles, Call-Post Bldg., San Francisco.
- Jas. F. Smith, 273 Minna St., San Francisco.
- LATHING MATERIAL**
Pacific Materials Co., 525 Market St., San Francisco.
- Key-Hold Plaster Lath Co., Monadnock Bldg., San Francisco.
- Truscon Steel Co., Tenth St., near Bryant, San Francisco.
- LIGHT, HEAT AND POWER**
Great Western Power Company, Stockton St., near Sutter, San Francisco.
- LIGHTING FIXTURES**
Roberts Mfg Co., 663 Mission St., San Francisco.
- LIME**
Henry Cowell Lime & Cement Co., 2 Market St., San Francisco.
- LINOLEUM**
D. N. & E. Walter & Co., 562 Mission St., San Francisco.
- The Paraffine Companies, factory in Oakland; office, 34 First St., near Market, San Francisco.
- W. & J. Sloane, 216-228 Sutter St., San Francisco.
- LOCKERS—STEEL**
George H. Trask, Sacramento St., San Francisco, representing Durand Steel Lockers.
- LUBRICATING OIL STORAGE TANKS AND PUMPS**
S. F. Bowser & Co., Inc., 612 Howard St., San Francisco.
- LUMBER**
California Redwood Association, 216 Pine St., San Francisco.
- Dudfield Lumber Co., Palo Alto, Cal.
- Hart-Wood Lumber Co., Fifth and Berry Sts., San Francisco.
- Pacific Manufacturing Company, San Francisco, Oakland and Santa Clara.
- Pope & Talbot, foot of Third St., San Francisco.
- Portland Lumber Co., 16 California St., San Francisco.
- Sunset Lumber Company, First and Oak Sts., Oakland.
- MAIL CHUTES**
American Mailing Device Corp., represented on Pacific Coast by Waterhouse-Wilcox Co., 523 Market St., San Francisco.
- MANTELS**
Mangrum & Otter, 827-831 Mission St., San Francisco.
- MANUAL TRAINING EQUIPMENT**
Richards-Wilcox Mfg. Co., Ewing-Lewis Co., 626 Underwood Bldg., San Francisco.
- MARBLE**
American Marble and Mosaic Co., 25 Columbus Square, San Francisco.
- Joseph Musto Sons, Keenan Co., 535 N. Point St., San Francisco.
- Vermont Marble Co., Coast branches, San Francisco, Portland and Tacoma.
- METAL DOORS AND WINDOWS**
Fire Protection Products Co., 3117 20th St., San Francisco.
- Waterhouse-Wilcox Co., Inc., 523 Market St., San Francisco.
- U. S. Metal Products' Co., 330 Tenth St., San Francisco.
- MILL WORK**
Dudfield Lumber Co., Palo Alto, Cal.
- Pacific Manufacturing Company, San Francisco, Oakland and Santa Clara.
- National Mill and Lumber Co., San Francisco and Oakland.
- The Fink & Schindler Co., 218 13th St., San Francisco.
- MOTORS AND FANS**
R. J. Davis, Dist. Sales Agent Century Motors and Fans, 171 Second St., San Francisco.
- OIL BURNERS**
American Standard Oil Burner Company, Berkeley.
- Fess System Co., 220 Natoma St., San Francisco.
- S. T. Johnson Co., 1337 Mission St., San Francisco.
- T. P. Jarvis Manufacturing Co., 275 Connecticut St., San Francisco.
- W. S. Ray Mfg. Co., 29 Spear St., San Francisco.
- G. E. Witt Co., 862 Howard St., San Francisco.
- OIL STORAGE AND DISTRIBUTING STATIONS**
S. F. Bowser & Co., Inc., 612 Howard St., San Francisco.
- Wayne Oil Tank & Pump Co., 631 Howard St., San Francisco; 830 S. Los Angeles St., Los Angeles.
- OFFICE EQUIPMENT**
Western Office Equipment Co., 467 Market St., San Francisco.
- F. W. Wentworth & Co., 539 Market St., San Francisco.
- ORNAMENTAL IRON AND BRONZE**
California Artistic Metal and Wire Co., 349 Seventh St., San Francisco.
- Palm Iron & Bridge Works, Sacramento.
- C. J. Hillard Company, Inc., 19th and Minnesota Sts., San Francisco.
- Schrader Iron Works, Inc., 1247 Harrison St., San Francisco.

KNITTLE-CASHEL CO., Inc.

HEATING CONTRACTORS

STEAM HEATING
HOT WATER HEATINGVENTILATING
POWER PLANTSGENERAL PIPE WORK
REPAIRING

1820-22 Ellis Street, San Francisco

Phone West 964



On Your Best Work Specify

CAL-PA-CO DAMPSTOP (Outside)
WASHABLE WALL (Inside)

FOR CONCRETE BUILDINGS.

Everything Reliable in PAINT and VARNISH

CALIFORNIA PAINT COMPANY, OAKLAND, CALIF., U. S. A.
MANUFACTURERS SINCE 1865 SAN FRANCISCO OFFICE, MONADNOCK BUILDING

ARCHITECTS' SPECIFICATION INDEX—Continued

OVERHEAD CARRYING SYSTEMS

California Hydraulic Engineering & Supply Co.,
70-72 Fremont St., San Francisco.
Richards-Wilcox Mfg. Co., Aurora, Ill., and
Underwood Bldg., San Francisco.

**PAINT FOR STEEL STRUCTURES, BRIDGES,
ETC.**

The Paraffine Companies, Inc., 34 First St., San
cisco.
Anti-Rust Coatings. The Glidden Co., 123
Hooper St., San Francisco.
Premier Graphite Paint and Pioneer Brand Red
Lead, made by W. P. Fuller & Co., San Fran-
cisco.

Hill, Hubbell & Company, No. 1 Drumm St.,
San Francisco.

Wadsworth, Howland Co., makers of Day State
Brick and Cement Coating, Boston, Mass.
Hambley & Son, Distributors in San Francisco
and Los Angeles.

PAINTING, TINTING, ETC.

I. R. Kissel, 1747 Sacramento St., San Fran-
cisco.
D. Zelinsky & Sons, San Francisco and Los
Angeles.

The Tormey Co., 681 Geary St., San Francisco.
Fick Bros., 475 Haight St., San Francisco.

PAINTS, OILS, ETC.

California Paint Company (see advertisement
above).

Magner Bros. 414-424 Ninth St., San Francisco.
Bass-Hueter Paint Co., Mission, near Fourth
St., San Francisco.

The Brininstool Co., Los Angeles, the Haslett
Warehouse, 310 California St., San Francisco.

The Glidden Company of California, 123 Hooper
St., San Francisco.

R. N. Nason & Company, San Francisco, Los
Angeles, Portland and Seattle.

W. P. Fuller & Co., all principal Coast cities.
"Satinette," Standard Varnish Works, 55 Stev-
enson St., San Francisco.

Palace Hardware Co., 581 Market St., San
Francisco.

PANELS AND VENEER

White Bros., Fifth and Brannan Sts., San Fran-
cisco.

PARTITIONS—FOLDING AND ROLLING

J. G. Wilson Corporation, 600 Metropolitan
Bldg., Los Angeles; Waterhouse-Wilcox Co.,
Underwood Bldg., San Francisco.

PENCILS

Eberhard Faber, Monadnock Bldg., San Fran-
cisco.

PIPE—STEEL AND WROUGHT IRON

Western Pipe & Steel Co., 444 Market St.,
San Francisco; 1758 N. Broadway, Los An-
geles.

George H. Tay Company, Mission and Second
Sts., San Francisco; 10th and Harrison Sts.,
Oakland.

PLASTER CONTRACTORS

A. Knowles, Call-Post Bldg., San Francisco.
MacGruer & Simpson, 540 Call-Post Bldg., San
Francisco.

James F. Smith, 273 Minna St., San Francisco.

PLUMBING CONTRACTORS

Alex Coleman, 706 Ellis St., San Francisco.

Gilley-Schmid Company, 198 Otis St., [San Francisco
Hateley & Hateley, Mitau Bldg., Sacramento.
A. Lettich, 365 Fell St., San Francisco.
Scott Co., Inc., 243 Minna St., San Francisco.
Wm. F. Wilson Co., 328 Mason St., San Fran-
cisco.

PLUMBING FIXTURES, MATERIALS, ETC.

California Steam & Plumbing Supply Co., 671
Fifth St., San Francisco.
Jas. B. Clow, plumbing, Rialto Bldg., San Fran-
cisco

Crane Co., San Francisco, Oakland, Los An-
geles.

Gilley-Schmid Company, 198 Otis St., San
Francisco.

Haines, Jones & Cadbury Co., 857 Folsom St.,
San Francisco.

H. Mueller Manufacturing Company, 635 Mis-
sion St., San Francisco.

Holbrook, Merrill & Stetson, 64 Sutter St., San
Francisco.

J. L. Mott Iron Works, D. H. Gulick, selling
agent, 553 Mission St., San Francisco.

Pacific Sanitary Manufacturing Co., 67 New
Montgomery St., San Francisco.

George H. Tay Company, Mission and Second
Sts., San Francisco; 10th and Harrison Sts.,
Oakland.

Wm. F. Wilson Co., 328 Mason St., San Fran-
cisco.

Whale-bone-ite Fixtures, sold by E. C. Whalen,
325 Monadnock Bldg., San Francisco.

POWER LAWN MOWERS

H. U. Carter Motor Co., 52 Beale St., San
Francisco.

POWER PLANTS

Knittle-Cashel Co., Inc., 1820 Ellis St., San Fran-
cisco.

POWER TRANSMITTING MACHINERY

Meese & Gottfried, San Francisco, Los Angeles,
Portland, Ore., and Seattle, Wash.

PUMPS

Chicago Pump Co., represented by Garnett,
Young & Co., 612 Howard St., San Francisco.

California Hydraulic Engineering & Supply Co.,
70 Fremont St., San Francisco.

Dow-Herriman Company, 140 Howard St., San
Francisco; factory, Petaluma.

Simonds Machinery Co., 117 New Montgomery
St., San Francisco.

Ocean Shore Iron Works, 558 Eighth St., San
Francisco.

Pacific Pump & Supply Company, 851-853 Fol-
som St., San Francisco.

George H. Tay Company, Mission and Second
Sts., San Francisco; 10th and Harrison Sts.,
Oakland.

Wooden & Little, 33-41 Fremont St., San Fran-
cisco.

**PUMPS—HAND OR POWER, FOR OIL AND
GASOLINE**

S. F. Bowser & Co., Inc., 612 Howard St.,
San Francisco.

Dow-Herriman Co., 140 Howard St., San Fran-
cisco.

Wayne Oil Tank & Pump Co., 631 Howard St.,
San Francisco; 830 S. Los Angeles St., Los
Angeles.

R. J. Davis

District Sales
Agent

Century

A. C. Motors
and Fans

Complete stocks carried at: 171-173 Second St., San Francisco; 906 So. Hope St., Los Angeles



Yards { TRACY, CAL.
BRENTWOOD, CAL.

Phone KEARNY 2074

PORTLAND LUMBER COMPANY

A. J. RUSSELL, Agent

L U M B E R

SIMPLEX SILOS
SAGINAW SPECIAL SHINGLES
*Ship Timbers, Oil Rigs and
Special Bills Cut to Order.*

16 California Street

San Francisco, Cal.

from tree to Consumer

Pine and Redwood Lumber

SASH DOORS AND MILL WORK

SUNSET LUMBER COMPANY

MANUFACTURERS — WHOLESALE AND RETAIL

Main Office and Yards:

FIRST AND OAK STREETS, OAKLAND

Phone Oakland 1820

POPE & TALBOT

Manufacturers, Exporters and Dealers in

Lumber, Timber, Piles, Spars, etc.

Office, Yards and Planing Mills

859-869 THIRD ST., SAN FRANCISCO, CAL.

Mills, Port Gamble, Port Ludlow and Utsalady, Washington

**STORM KING and
AMERICAN WARM AIR FURNACES**

FURNACE FITTINGS AND REPAIRS

Montague Range & Furnace Company

327-329 JESSIE STREET

Phone Garfield 1422

826-830 MISSION STREET

SAN FRANCISCO, CALIF.

ARCHITECTS' SPECIFICATION INDEX—Continued

- PUMPS (Continued)**
George H. Tay Company, Mission and Second Sts., San Francisco; 10th and Harrison Sts., Oakland.
- REFRIGERATORS**
McCray Refrigerator Company, San Francisco office, Monadnock Bldg.
- REVERSIBLE WINDOWS**
Hauser Window Company, 157 Minna St., San Francisco.
- ROOFING CONTRACTORS**
Western Roofing Co., Inc., 420 15th St., San Francisco.
- ROOFING AND ROOFING MATERIALS**
Bender Roofing Company, Monadnock Bldg., San Francisco.
"Malthoid" and "Ruberoid," manufactured by Paraffine Companies, Inc., San Francisco.
United Materials Co., Crossley Bldg., San Francisco.
H. H. Robertson Co., Hobart Bldg., San Francisco.
- RUBBER TILING**
New York Belting and Packing Company, 518 Mission St., San Francisco.
- SAFETY TREADS**
Pacific Materials Co., 525 Market St., San Francisco.
- SAND**
Del Monte White Sand, Del Monte Properties Co., 401 Crocker Bldg., San Francisco.
- SASH CORD**
Samson Spot Sash Cord, John T. Rowntree, Pacific Coast Agent, San Francisco and Los Angeles.
- SCENIC PAINTING—DROP CURTAINS, ETC.**
The Edwin H. Flagg Scenic Co., 1638 Long Beach Ave., Los Angeles.
- SCHOOL FURNITURE AND SUPPLIES**
C. F. Weber & Co., 985 Market St., San Francisco; 512 S. Broadway, Los Angeles.
Rucker-Fuller Desk Company, 677 Mission St., San Francisco.
- SHEATHING AND SOUND DEADENING**
Samuel Cabot Mfg. Co., Boston, Mass., agencies in San Francisco, Oakland, Los Angeles, Portland, Tacoma and Spokane.
The Paraffine Companies, Inc., 34 First St., San Francisco.
- SHEET METAL WORK**
Jas. A. Nelson, 517 Sixth St., San Francisco.
- SHINGLE STAINS**
Bass-Hueter Paint Company, all principal Coast cities.
Cabot's Creosote Stains, sold by Pacific Building Materials Co., 525 Market St., San Francisco.
Fuller's Pioneer Shingle Stains, made by W. P. Fuller & Co., San Francisco.
Argonaut Shingle Stains. The Glidden Co., 123 Hooper St., San Francisco.
- SINKS—COMPOSITION**
Petrium Sanitary Sink Co., Fifth and Page Sts., Berkeley.
- SKYLIGHTS**
H. H. Robertson Co., Hobart Bldg., San Francisco.
Jas. A. Nelson, 517 Sixth St., San Francisco.
- STATIONERY AND SUPPLIES**
Schwabacher-Frey Stationery Co., 609 Market St., San Francisco.
- STEEL HEATING BOILERS**
California Hydraulic Engineering & Supply Co., 7A-72 Fremont St., San Francisco.
General Boilers Co., 332 Monadnock Bldg., San Francisco.
- STEEL TANKS, PIPE, ETC.**
Ocean Shore Iron Works, 558 Eighth St., San Francisco.
Western Pipe & Steel Co., 444 Market St., San Francisco.
- STEEL AND IRON—STRUCTURAL**
Central Iron Works, 621 Florida St., San Francisco.
Dyer Bros., 17th and Kansas Sts., San Francisco.
Golden Gate Iron Works, 1541 Howard St., San Francisco.
Mortenson Construction Co., 19th and Indiana Sts., San Francisco.
Pacific Rolling Mills, 17th and Mississippi Sts., San Francisco.
Palm Iron & Bridge Works, Sacramento.
U. S. Steel Products Co., Rialto Bldg., San Francisco.
Schrader Iron Works, Inc., 1247 Harrison St., San Francisco.
Western Iron Works, 141 Beale St., San Francisco.
- STEEL PRESERVATIVES**
Hill, Hubbell & Company, No. 1 Drumm St., San Francisco.
- STEEL REINFORCING**
Badt-Falk & Co., Call-Post Bldg., San Francisco.
Pacific Coast Steel Company, Rialto Bldg., San Francisco.
Gunn, Carle & Co., Inc., 444 Market St., San Francisco.
Truscon Steel Co., 527 Tenth St., San Francisco.
W. S. Wetenhall Co., 725 Second St., San Francisco.
- STEEL ROLLING DOORS**
Kinnear Steel Rolling Door Co., Pacific Building Materials Co., agents, Underwood Bldg., San Francisco.
J. G. Wilson Corporation, 600 Metropolitan Bldg., Los Angeles.
- STEEL SASH**
Bayley-Springfield solid steel sash, sold by Pacific Materials Co., 525 Market St., San Francisco.
"Fenestra," solid steel sash, manufactured by Detroit Steel Products Company, Detroit, Mich. Direct factory sales office, Foxcroft Bldg., San Francisco.
U. S. Metal Products Company, 330 Tenth St., San Francisco.
- STEEL WHEELBARROWS**
Champion and California steel brands, made by Western Iron Works, 141 Beale St., San Francisco.
- STORE FRONTS**
The Kawneer Company, West Berkeley, California.
- SUMP AND BILGE PUMPS**
California Hydraulic Engineering & Supply Co., 70-72 Fremont St., San Francisco.
- SWITCHES**
Wemco Safety Switch, manufactured and sold by W. E. Musher Co., 502 Mission St., San Francisco.
- TANKS FOR OIL, GASOLINE, KEROSENE, ETC.**
S. F. Bowser & Co., Inc., 612 Howard St., San Francisco.
Wayne Oil Tank & Pump Co., 631 Howard St., San Francisco; 830 S. Los Angeles St., Los Angeles.
- TANKS—REDWOOD**
Redwood Manufactures Co., Hobart Bldg., San Francisco.
- TELEPHONE AND ELECTRIC EQUIPMENT**
Bittmann & Battee, 745 Folsom St., San Francisco.
Direct Line Telephone Co., 320 Market St., San Francisco.

STEEL SASH — FIRE DOORS — SHEET METAL

Kalamein, Copper and Bronze Doors and Trim

Sheet Metal Work of Every Description

FIRE PROTECTION PRODUCTS CO.

3117-3119 TWENTIETH STREET, Near Harrison, SAN FRANCISCO.

Phone Mission 2607

ARCHITECTS' SPECIFICATION INDEX—Continued

THEATER AND OPERA CHAIRS

C. F. Weber & Co., 365 Market St., San Francisco.
Rucker-Fuller Desk Co., 677 Mission St., San Francisco.

THERMOSTATS FOR HEAT REGULATION

Johnson Service, Rialto Bldg., San Francisco.

TILES, MOSAICS, MANTELS, ETC.

Mangrum & Otter, 827-831 Mission St., San Francisco.

TILE FOR ROOFING

Gladding, McBean & Co., Crocker Bldg., San Francisco.
United Materials Co., Crossley Bldg., San Francisco.

TRANSMISSION MACHINERY

Meese & Gottfried Co., San Francisco, Los Angeles and Portland.

VACUUM CLEANERS

United Electric Company, Canton, O., manufacturers of Tucc Cleaners, sold in California by San Francisco Compressed Air Cleaning Co., Stockton and Sutter Sts., San Francisco.

VALVES—PIPES AND FITTINGS

California Steam & Plumbing Supply Co., 671 Fifth St., San Francisco.
Crane Radiator Valves, manufactured by Crane Co., Second and Brannan Sts., San Francisco.
Sloane Valves, sold by E. C. Whalen, 325 Monadnock Bldg., San Francisco.
Grinnell Co., 453 Mission St., San Francisco.
O. M. Simmons Co., 115 Mission St., San Francisco.
H. Mueller Mfg. Co., 635 Mission St., San Francisco.
W. E. Musket Co., 502 Mission St., San Francisco.
George H. Tay Company, Mission and Second Sts., San Francisco; 10th and Harrison Sts., Oakland.

VALVE PACKING

N. H. Cook Belting Co., 317 Howard St., San Francisco.

VARNISHES

California Paint Company, 1797 Twelfth St., Oakland.
W. P. Fuller Co., all principal Coast cities.
R. N. Nason & Co., San Francisco, Los Angeles, Portland and Seattle.
S. F. Pioneer Varnish Works, 816 Mission St., San Francisco.
The Glidden Company, 123 Hooper St., San Francisco.
Standard Varnish Works, 55 Stevenson St., San Francisco.

VENETIAN BLINDS, AWNINGS, ETC.

C. F. Weber & Co., 985 Market St., San Francisco.
Western Blind & Screen Co., 2702 Long Beach Ave., Los Angeles.

VENTILATORS

H. H. Robertson Co., Hobart Bldg., San Francisco.
Power & Pike Co., 22-24 Main St., San Francisco.

VITREOUS CHINAWARE

Pacific Porcelain Ware Company, 67 New Montgomery St., San Francisco.

WALL BEDS, SEATS, ETC.

Marshall & Stearns Co., 1154 Phelan Bldg., San Francisco.

WALL BOARD

"Amiwud" Wall Board, manufactured by The Paraffine Companies, Inc., 34 First St., San Francisco.
"Liberty" Wall Board, manufactured by Key-Hold Plaster Lath Co., 148 Hooper St., San Francisco.

WALL PAINT

Nason's Opaque Flat Finish, manufactured by R. N. Nason & Co., San Francisco, Portland and Los Angeles.
San-A-Cote and Vel-va-Cote, manufactured by the Brininstool Co., Los Angeles.

WALL PAPER AND DRAPERIES

Beach-Robinson Co., 239 Geary St., San Francisco.
The Tormey Co., 681 Geary St., San Francisco.
W. & J. Sloane, 216-228 Sutter St., San Francisco.
Uhl Bros., San Francisco.

WATERPROOFING FOR CONCRETE, BRICK, ETC.

Armorite Damp Resisting Paint, made by W. P. Fuller & Co., San Francisco.
Bay State Brick & Cement Coating, manufactured by Wadsworth, Howland Co., Boston; Hambley & Son., Distributors for Northern and Southern California.
Imperial Waterproofing, mfrd. by Brooks & Doerr, Reed Baxter, agent, Merchants National Bank Bldg., San Francisco.
Pacific Materials Co., 525 Market St., San Francisco.
Samuel Cabot Mfg. Co., Boston, Mass., agencies in San Francisco, Oakland, Los Angeles, Portland, Tacoma and Spokane.

WATER SUPPLY SYSTEMS

Kewanee Water Supply System—Simonds Machinery Co., agents, 117 New Montgomery St., San Francisco.
Pacific Pump & Supply Company, 851-853 Folsom St., San Francisco.

WHEELBARROWS—STEEL

Western Iron Works, Beale and Main Sts., San Francisco.

WHITE CEMENT

"Atlas White," see coast agencies, page 127.
"Medusa White," sold by Pacific Materials Co., Underwood Bldg., San Francisco.

WHITE ENAMEL

"Gold Seal," manufactured and sold by Bass-Hueter Paint Co. All principal Coast cities.
Velvet White Enamel. The Glidden Company, 123 Hooper St., San Francisco.
"Silkenwhite," made by W. P. Fuller & Co., San Francisco.
"Satinette," Standard Varnish Works, 55 Stevenson St., San Francisco.

WINDOW SHADES

W. & J. Sloane, 216-228 Sutter St., San Francisco.

WINDOWS, REVERSIBLE, CASEMENT, ETC.

Hauser Window Co., 157 Minna St., San Francisco.
The Kawneer Company, West Berkeley, California. (Simplex Fixtures.)
J. G. Wilson Corporation, 600 Metropolitan Bldg., Los Angeles; Waterhouse-Wilcox Co., Underwood Bldg., San Francisco.

WIRE FABRIC

U. S. Steel Products Co., Rialto Bldg., San Francisco.
Clinton Wire Lath, sold by L. O. Norris, 140 Townsend St., San Francisco.

WIRE FENCE

Standard Fence Co., 310 12th St., Oakland.

WOOD MANTELS

Fink & Schindler, 218 13th St., San Francisco.
Mangrum & Otter, 827 Mission St., San Francisco.

MOLINE HEAT

Hobart Building

San Francisco

TELEPHONE SUTTER 3818

MOTT PLUMBING FIXTURES

Architects and their clients are invited to visit our Showrooms, 553-555 Mission Street, San Francisco; D. H. Gulick, Sales Agent. Los Angeles Office, 1001 Central Building; J. R. Mayhew, Sales Agent.

Mott Company of California

MUELLER — BRASS GOODS

Recognized as the Standard of excellence in plumbing. It pays to use them, and other Mueller Brass Goods. *The first cost is practically their last cost.*

H. Mueller Mfg. Co.
635 MISSION STREET, SAN FRANCISCO, CAL.

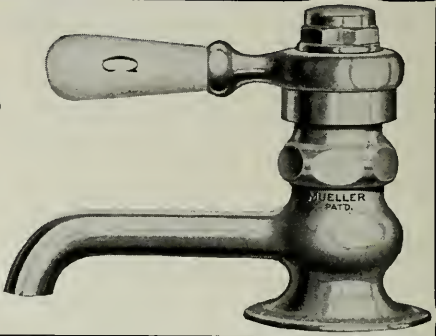

Automatic Fire Sprinklers

Protect your building and business from destruction by fire and reduce your Insurance Rate.

Pacific Fire Extinguisher Co.

FIRE PROTECTION ENGINEERS

424-440 HOWARD STREET
SAN FRANCISCO

MANUFACTURING PLANT
272 STEUART STREET

GENERAL BOILERS COMPANY

DEPARTMENT OF SALES

Manufacturers of

**Pacific Patented Steel Portable Double Return Tube
Low Pressure Steam and Hot Water Heating Boilers**

Pacific Steel Circulating Tanks

Pacific Steel Tank Heaters and Storage Tanks

General Office and Plant: WAUKEGAN, ILLS.
Sales Offices: 322 Monadnock Bldg., SAN FRANCISCO and 1310 South Hill St., LOS ANGELES,
CALIFORNIA. A. W. MERRILL, Manager

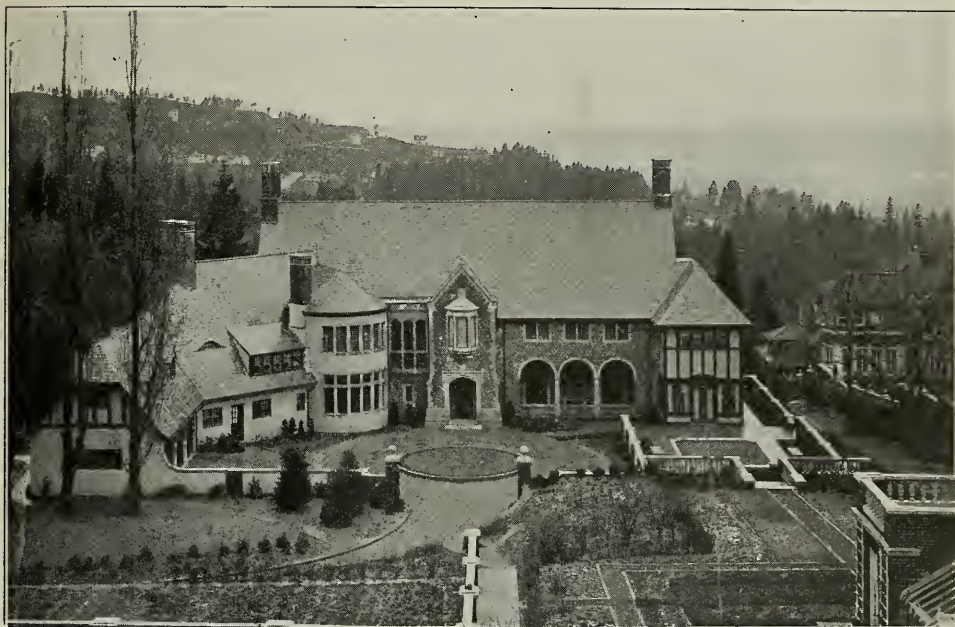

Residence of F. J. Cobb, Montgomery Drive, Portland, Oregon

A. E. Doyle, Architect
A. E. Chambers, Painter

Finished with Fuller's Silkenwhite Enamel
and Fuller's Forty for Finishing

FULLER'S Silkenwhite Enamel

For Interior and Exterior Use

The whitest, most lustrous and best wearing Enamel made. The perfect flowing properties of Silkenwhite eliminate laps and brush marks.

SILKENWHITE

Dries with a full, brilliant, intense white gloss, and produces a fine porcelain-like surface.

Manufactured by

W. P. FULLER & CO.

"Silkenwhite Enamel
is made in a Gloss and also a
perfect EGG-SHELL FINISH"

CHICAGO
SILENT
SIGNAL
HOSPITAL
SYSTEMS

GARNETT YOUNG
AND COMPANY

Pacific Coast Sales Engineers
612 HOWARD STREET
SAN FRANCISCO, CAL.
Seattle - Los Angeles - Portland

Holtzer-Cabot

Hospital Silent Call Systems

HUNDREDS of hospitals all over the country are equipped with these efficient, time-saving Systems. In far-off China, Greece and other foreign countries also, there are hospitals installed with Holtzer-Cabot Systems. Representative architects invariably specify this system because of its Simplicity, Flexibility and Safety.

There is nothing in the walls but the wires—the whole of the operating mechanism is in the Locking Button; any station may be instantly changed by just plugging in another cord and button. This simple, safe locking button is exclusive to Holtzer-Cabot Systems.



THE HOLTZER-CABOT ELECTRIC CO.
BOSTON, MASS.

BITTMANN & BATTEE, Inc., Agents

745 Folsom Street, San Francisco

Phone Douglas 4405

You Can Let Your Clients Say:

“Good Bye Garbage Man!”

by the installation of the

K E R N E R
 “Built-in-the-Chimney”
INCINERATOR

Successful domestic incineration is an accomplished fact in new homes and apartments that are equipped with the Kerner Incinerator. It burns all garbage and household waste, newspapers, wrapping paper, faded flowers without the use of any commercial fuel — not one penny for operating costs!

The dry waste thrown in the hopper door is lighted at intervals and in burning dries the wet waste so it also becomes fuel. Cans, bottles and other non-combustible matter are dried, sterilized and later dropped into the pit.

SANITARY CONVENIENT
 ECONOMICAL ODORLESS

Kerner Incinerator Co.

77 O'Farrell St. Factory, 38 Stanford St.

SAN FRANCISCO

600 Metropolitan Building, Los Angeles.

See Page 1132 — Sweet's Catalog



The Maley Four Flat Building
 551 So. Gramercy St., Los Angeles



**THE KERNER
 INCINERATOR**

Is built into the base of the chimney when the house is erected.

Consumes no space on living floors; requires but little added masonry.

**Millwork Manufactured
 and delivered anywhere**

Plans or Lists sent us for Estimates will
 have Careful and Immediate Attention

DUDFIELD LUMBER

JNO. DUDFIELD
 President and Manager

COMPANY

JOSEPH A. JURY
 Secretary & Mill Supt.

Main Office, Yard and Planing Mill — PALO ALTO



San - a - Cote

(GLOSS—Can be Scrubbed)

AN INTERIOR WALL FINISH

For bath rooms, kitchens, hospitals, schools, office and public buildings. Ask dealers, owners, architects and contractors about this durable, sanitary, washable, economical wall covering. Brininstool makes a paint for every purpose, and every can purposely good.

THE BRININSTOOL CO., LOS ANGELES

COLOR GRINDERS AND PAINT MANUFACTURERS

Distributors—The Brininstool Co., 1174 Phelan Bldg., San Francisco, Cal.; The Brininstool Co., 222 Abington Bldg., Portland, Ore.; Schutz Paint Co., Fresno, Cal.; Schneider, Chappell & Jones, Sacramento, Cal.; Salt Lake Glass & Paint Co., Salt Lake City, Utah; Griffin Paint Co., Ogden, Utah; Campbell Hardware Co., First and Madison Sts., Seattle, Wash.; Imperial Valley Hardware Co., El Centro, Cal.; Calexico, Imperial, Brawley, Seeley, Cal.; Spokane Hardware Co., Spokane, Wash.; Continental Paint Company, 328 South First St., San Jose, Cal.; Los Angeles Wall-paper & Paint Co., 525 So. Main St., Los Angeles, Cal.; H. A. Berger, 3838 13th St., San Diego, Cal.; H. L. Christian, Blythe, Cal.; Ezra Thayer, Phoenix, Ariz.; Miami Lumber & Supply Co., Miami, Ariz.

RELIANCE BALL BEARING DOOR HANGERS

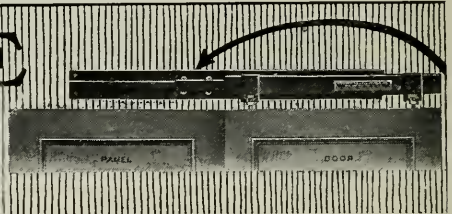

To get as near perfection as possible, use

“RELIANCE HANGERS” and “Reliance-Grant” Controllers

These insure fast service, practically noiseless and slamless doors.

Reliance-Grant Elevator Equipment Corp'n

PARK AVENUE AND 40TH STREET, NEW YORK

PACIFIC COAST AGENTS

Waterhouse-Wilcox Co.	- - - - -	San Francisco and Los Angeles, Cal.
Columbia Wire & Iron Works	- - - - -	Portland, Ore.
D. E. Fryer & Company	- - - - -	Seattle, Spokane, Tacoma, Wash. and Great Falls, Mont.

FOR ALL
FINISHING
REQUIREMENTS



THE
IMMACULATE
WHITE ENAMEL

TRADE
ELASTICA
MARK
VARNISHES

Satinette
TRADE MARK
ENAMEL

STANDARD VARNISH WORKS

GENERAL OFFICES: NEW YORK - 90 WEST STREET
BRANCHES: LONDON · SAN FRANCISCO · PARIS · MELBOURNE

SAN FRANCISCO OFFICES & WAREHOUSE, 55 STEVENSON STREET

Bungalow Building Blox

**Hollow Building Tile
Hollow Partition Tile**

California Brick Co.
604 Mission Street
San Francisco, Cal.

BRICK

**Red Ruffled Face Brick
Paving Brick
Step and Walk
Brick**

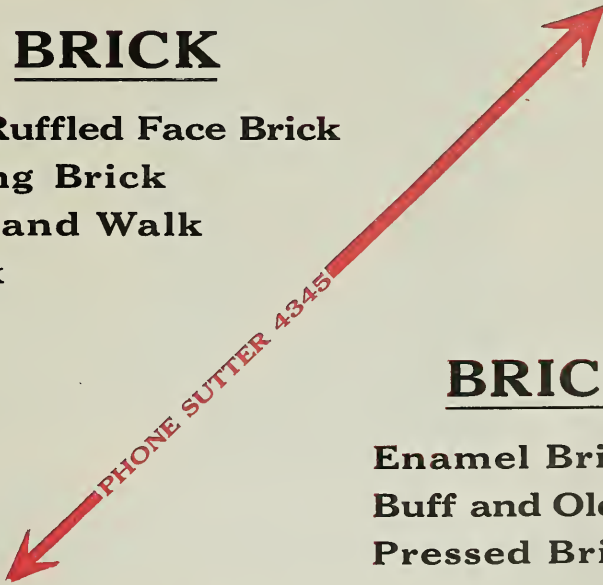

BRICK

**Enamel Brick
Buff and Old Gold
Pressed Brick**

Livermore Fire Brick Works
604 Mission Street
San Francisco, Cal.

**Fire Brick and
Molded Fire Tile**

Architectural Terra Cotta



FULLER & GOEPP

32 Page St.

Telephone Market 499

MANUFACTURERS OF

MIRRORS, ART AND LEADED GLASS

*Dealers in White Glass for Table Tops, Counter Tops,
Sink Backs & Etc.*

Passenger and Freight Elevators



"MADE IN SAN FRANCISCO"

Factory and Warehouse, 166-180 Seventh
Street, San Francisco. Phone Kearny 66

SPENCER ELEVATOR COMPANY

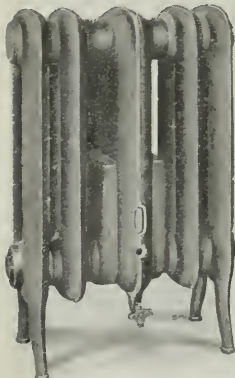

RA-DO ^{FUMELESS} GAS RADIATORS

ALL CAST IRON—3 Sizes (3, 5, and 7 Sections)

The Ideal "Year-Round" Heating System
For The Home—New or Old

Easiest and Cheapest to Install
Lowest Operating Cost

BAIRD - BAILHACHE COMPANY

MANUFACTURERS

478 Sutter St., San Francisco

'Phone Sutter 6858

OLD MISSION PORTLAND CEMENT COMPANY



Each shipment of "OLD MISSION" Portland Cement is guaranteed not only to equal but to surpass all requirements of the standard specifications for Portland Cement as adopted by the U. S. Government and by the American Society for Testing Materials. A Guarantee Certificate is mailed with the bill of lading of each car, giving number of car, date packed, and number of barrels, over the signature of the chief chemist.

8000 SACKS DAILY

SALES OFFICE:
MILLS BLDG., SAN FRANCISCO
PHONE SUTTER 3075

PLANT:
SAN JUAN, CAL.

VULCANITE SLATE - SURFACED RED OR GREEN FAMOUS FOR QUALITY ASPHALT ROOFING

A roofing that has been manufactured in eleven different factories in five different countries, covering a period of over 70 years.

A roofing that is patented in eight countries and which has been awarded the Gold Medal, and in some cases the Medal of Honor at International Expositions—is worth your consideration.

The Vulcanite Roofing Company

Roofing Division of the Beaver Board Companies

16TH AND TEXAS STREETS, SAN FRANCISCO, CAL.



Keep Down Insurance Premiums

SPECIFY

SAINO FIRE DOORS

Standard Automatic Sliding or Swinging Fire Doors.
Tested and Labeled by the Underwriters' Laboratories.

STEEL SASH AND HOLLOW METAL
UNDERWRITERS WINDOWS

U. S. METAL PRODUCTS CO.

326-338 Tenth Street, San Francisco



Building for
Goodyear Rubber Company,
San Francisco
A. M. Milwain, Architect

Plenty of light and good
ventilation made possible
by the use of

HAUSER WINDOWS

Manufactured and installed by

Hauser Window Company

157 MINNA STREET,
Phone Kearny 3706 SAN FRANCISCO

McCRAY

REFRIGERATORS FOR ALL PURPOSES

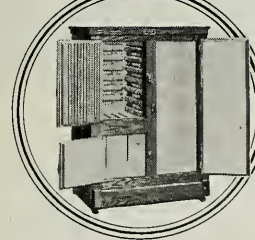
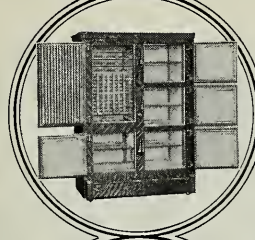
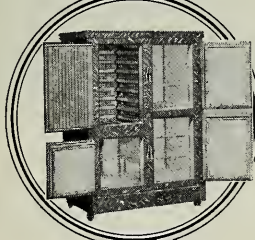
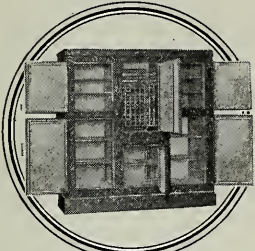

MANY of the leading architects and builders have long been specifying McCray Refrigerators—and they have the satisfaction of knowing that the McCray gives years and years of unequalled service.

McCray Refrigerators are different in construction from other refrigerators. They are the result of years of careful study by refrigeration engineers. Homes, hotels, clubs, hospitals, factory cafeterias, stores and markets from Maine to California have found by experience that the McCray is correct in principle—because cold, dry air in every compartment is assured.

Many architects are much interested in *machine refrigeration*—and in this connection it may well be noted that McCray Refrigerators can be arranged for either ice or mechanical refrigeration. Another special feature is the outside icing plan for residence refrigerators.

Our Service Department is always ready to co-operate with architects in the making of blue prints. The ideas and suggestions of our draftsmen are at your service. Let us assist you in drawing detailed specifications for McCray equipment.

Your Files should contain our new catalogs—No. 95 for Residences; No. 52 for Hotels, Restaurants, Clubs, Hospitals and Institutions; No. 71 for Grocery Stores; No. 63 for Markets; No. 74 for Florists.

"Look us up in Sweet's"

McCRAY REFRIGERATOR CO.

5062 LAKE STREET. KENDALLVILLE, INDIANA

Salesrooms in Principal Cities

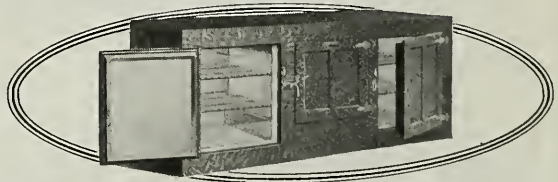

The Elevator Floor

whether in Office Building, Hotel or Department Store, is subjected to a great deal of wear and tear.

— SPECIFY —

INTERLOCKING RUBBER TILING

and you've provided your client's building with a Durable, Economical, Practical,

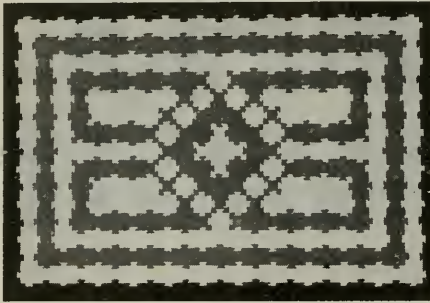

INTERLOCKING RUBBER TILING

material that is sure to give satisfaction. **Twenty tons installed in the Standard Oil Building, San Francisco.** Stock on hand for immediate delivery.



New York Belting and Packing Co.

NEW YORK

San Francisco Branch 519 MISSION ST. Phone Douglas 1837

Small booklet of designs mailed on request.

ATTRACTIVE HOMES

BEAUTIFUL Stucco Exteriors for Residential Work made possible by using a combination of

DEL MONTE
WHITE SAND

and

FAN SHELL
BEACH SAND

with

WHITE PORTLAND CEMENT



STUCCO RESIDENCE, SAN JOSE
Wm. H. Weeks, Architect

Del Monte Properties Co.

Phone Sutter 6130

401 Crocker Building, San Francisco



*Residence, Guilford Wood,
Denver, Colo., Medusa White
Exterior.*



*Manufacturers of Medusa
Waterproofing and Medusa
White and Grey Cement—
Plain and Waterproofed.*

Pacific Coast Distributors:
Pacific Materials Co., San
Francisco, California.
Riverside Portland Cement
Co., Los Angeles, California.
A. McMillan & Company,
Portland, Oregon.
Galbraith & Company,
Seattle, Washington.

Beautiful as the Day It Was Built

EVERY home builder seeks and cherishes the delightful charm and elegance of a white stucco house.

Stucco is moderate in cost and lends itself readily to the expression of the architect's vision.

Stucco made with Medusa Waterproofed White Cement is lasting in its beauty. Watertight through and through, it is proof against efflorescence and permanent in the purity of its white color.

To make sure that the buildings you design remain as beautiful as the day they were built, insist on Medusa Waterproofed White Cement.

The Sandusky Cement Company
Department P
Cleveland, Ohio

Electrical Time-keeping Devices

solves the time problem for Schools, Factories, Banks, Hospitals and other institutions in a most satisfactory manner. It does away with the nuisance of winding, setting and oiling individual clocks, maintains accurate and uniform time throughout the building, sounds opening and closing time automatically and, when properly made and installed, operates with the utmost reliability.



"STANDARD" ELECTRIC TIME SYSTEMS

have reached their present stage of high dependability through thirty-five years of use in hundreds of installations and having a direct branch office on the Pacific Coast is therefore in a position to render immediate service to its various installations throughout the Pacific Coast.

The Standard Electric Time Company

461 Market Street,
San Francisco, California

Telephone
SUTTER 241

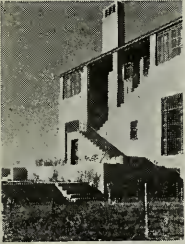

**THE HOUSE
BEAUTIFUL**



THE interior of a Home should have those little touches of refinement that come with the co-operation of an experienced interior decorator.

CONSULT US

Decorative ideas, artistic framing, byamopa ware, floor lamps, table lamps, chair lamps, lamp shades, mirrors, candlesticks, decorated candles, book-ends, store window fixtures, odd furniture, pictures, Emma B. Freeman's Prints, pieces in unique colorings and indefinite carvings and other objects of art.

FREEMAN ART SHOP

386 SUTTER STREET
SAN FRANCISCO
Tel. Sutter 1593



Beach-Robinson Co.

Decorators and Furnishers

Carpets

Draperies

Furniture

Rugs

Wall Paper

Ranson E. Beach

239 Geary Street, 3d Floor

Union Square

Phone, Sutter 580

San Francisco, Cal.



ADD CHEER and COMFORT
to the Home by having a
WELL DESIGNED INTERIOR
Before Completing Your Plans, CONSULT
SONNENSCHN BROS.

INTERIOR DECORATORS

Furniture and Draperies Made to Order

Factory

718 NATOMA ST., Phone Market 1145

Show and Salesroom

470 SUTTER ST., Phone Kearny 2051



*The Finishing Touch
of Right Building —*

F. A. TAYLOR CO.

251 Post St., San Francisco

Second Floor



Mercedes Bldg.

*Hand-made
Furniture,
Rugs,
Hangings,
Upholstering,
Decorating,
Wall Paper.*

The **GOLD MEDAL
MAIL CHUTE**

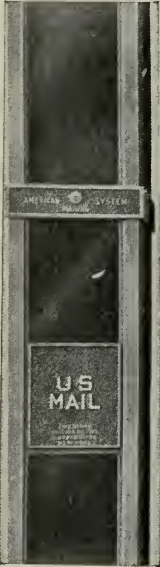

INSTALLED IN
THE NEW
SAN FRANCISCO
CITY HALL
AND THE
WHITE MARBLE
MERRITT
BUILDING,
LOS ANGELES

Given highest award at
Panama - Pacific Interna-
tional Exposition, 1915.

Waterhouse-Wilcox Co.

California
Representatives

523 Market Street
SAN FRANCISCO

331 E. 4th Street.
LOS ANGELES

F. T. CROWE & CO.
Seattle, Wash.

THE J. McCracken Co.
Portland, Oregon

**American Mailing
Device
Corporation**



**LIBERTY
WALL BOARD**

MANUFACTURED BY
KEY-HOLD PLASTER LATH COMPANY

A Fibered Gypsum Plaster that will not
shrink, warp or buckle.
Resists Fire, Moisture, Heat and Cold.
Key-hold plaster lath possesses a perfect
mechanical key—admitted for fire proof con-
struction in all classes of buildings.

KEY-HOLD PLASTER LATH CO.

Office and Factory
148 Hooper St. San Francisco
Phone Market 5767



CRANE

CAST IRON
BRASS
CAST STEEL
FERROSTEEL

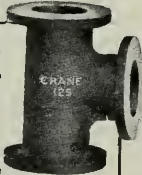

FLANGED FITTINGS

We have the largest line of patterns
for flanged fittings for low pressure,
standard, extra heavy, hydraulic, su-
perheated and extreme hydraulic pres-
sures, ranging in size from one-inch
to sixty-inch, and for working pres-
sures from fifty pounds to three thou-
sand pounds.

The dimensions of the low pressure,
standard and extra heavy fittings are
in accordance with the 1915 *American
Standard*.

Castings for special fittings also may
be made at a minimum expense owing
to our large equipment of special pat-
terns which may be altered at very low
cost.

CRANE CO.

PLUMBING SUPPLIES

2nd and Bran-
nan Sts., SAN
FRANCISCO.
348 9th Street
OAKLAND



YOU KNOW that a building
should be watertight and
WE KNOW that it can be
made so with

**IMPERIAL
WATERPROOFING**

LOOK FOR  THE LABEL

If your building is leaking through
the walls or around the windows, or
if the Basement walls are wet below
ground — call up SUTTER 978.

IMPERIAL WATERPROOFING
is manufactured by BROOKS &
DOERR, 460 7th St., San Francisco

**WATEREX REED BAXTER
DISTRIBUTOR**

1002-04 Merchants National Bank Building,
Phone Sutter 978
SAN FRANCISCO, CAL.
3419 Broadway, OAKLAND, CAL.

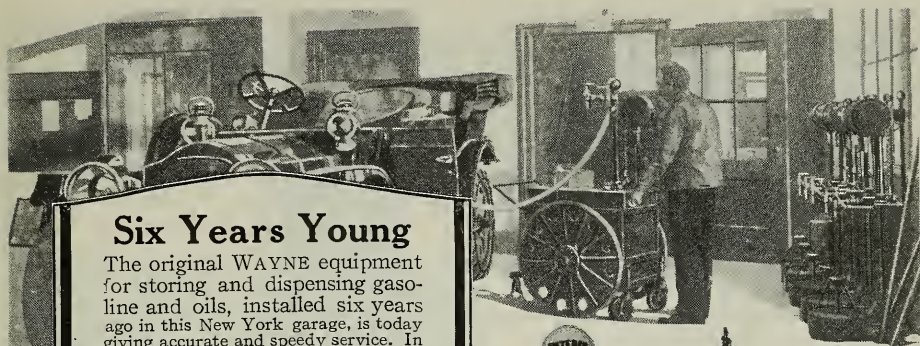

Six Years Young

The original WAYNE equipment for storing and dispensing gasoline and oils, installed six years ago in this New York garage, is today giving accurate and speedy service. In Wayne pumps the delicate adjustment essential for accuracy is combined with a durability that assures satisfaction for years and years.

There is a Wayne System for every need of the public garage. The service of Wayne engineers in advising and planning is yours without cost or obligation.

Wayne Oil Tank & Pump Co.
746 Canal St., Ft. Wayne, Ind.

San Francisco Office
631-633 Howard St.
Phone Garfield 1350

Los Angeles Office
830 S. Los Angeles St.
Phone Main 1600

REG. U.S. PAT. OFF. & TRADE MARK
Wayne
Liquid Storage Systems



Cut No. 230 One-gallon gasoline

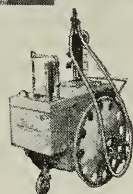

Cut No. 230 For Gas and Oil

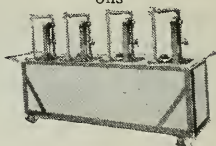

Cut No. 200 Lubricating oils

A SMOOTH RUNNING NOISELESS DOOR IS THE DELIGHT OF THE HOUSE-WIFE



J. A.

*Burkhalter Apartments,
Berkeley, California
James W. Plachek,
Architect.*

Your Apartment House will rent more readily and will STAY rented if it is equipped

— WITH —

PITCHER DOOR HANGERS

MANUFACTURED BY

NATIONAL MILL & LUMBER COMPANY

SAN FRANCISCO

LOS ANGELES



IT'S not enough to say "Good For All Time" unless there is something back of it. There is in this case. Vermont Marble already has an unblemished record of over one hundred and fifty years. We know what it will do. It's not necessary to guess at it. And our quarries in Alaska and Texas are also proving themselves. So please don't think of "Good for All Time" as merely a happy phrase.

IT'S THE MARK OF A SERVICE.
It means exactly what it says.

VERMONT MARBLE COMPANY
PROCTOR, VERMONT
San Francisco - Portland - Tacoma

Fire Extinguishers



To adequately protect homes, offices, and factories install fire extinguishers at frequent intervals.

Safely

ALERT
MFG. U.S. PAT. OFF.

Fire prevention and protection equipment of every description.

AMERICAN-LAFRANCE FIRE ENGINE COMPANY, Inc.

141 So. Hill St. 151 New Montgomery St.
Los Angeles San Francisco
16th and Marshall Sts.
Portland, Ore.

A Bargain in Files—

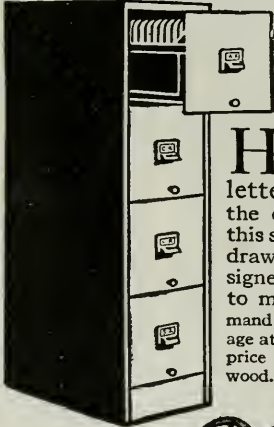

HOLDS 20,000 letters. That's the capacity of this special four-drawer file, designed and built to meet the demand for steel storage at less than the price of high grade wood. See it today.

Van Dorn
STEEL EQUIPMENT

Phone Douglas 1183
Western Office Equipment Co.
467 Market Street - San Francisco

EASY TO LAY

Great quantities of Clinton Electrically Welded Fabric can be laid in a very short time with absolute assurance that every strand of wire is in its proper position. It eliminates all the cost and trouble of spacing and wiring loose rods.

L. A. NORRIS COMPANY
140 Townsend St., San Francisco
Phone Kearny 5375



CLINTON
Electrically Welded Wire Fabric

Think of the Doorways in Your Homes!

Think of the beauty, convenience and economy you can impart to those doorways by providing them with

RICHARDS-WILCOX House DOOR HANGERS

The dining room doorway illustrated is only one example of a happy application of R-W House Door Hangers.

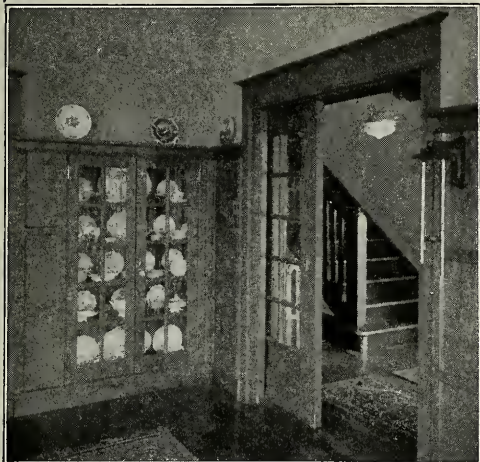

Closed, this doorway gives the artistic appearance of French doors. Note how the glass paneling harmonizes with the glass paneling of the cabinet doors.

Open, the door is out of the way and out of sight.

The pantry door is another example of a frequently difficult problem solved by R-W House Door Hardware.

There are others: Closet doors—parlor doors—hall doors.

Illustrated folder OF-13, entitled "Vanishing House Doors" and individual information sent without obligation.

Richards-Wilcox Mfg. Co.
 A Hanger for any Door that Slides.
 CHICAGO ST. LOUIS LOS ANGELES PHILADELPHIA
 AURORA, ILLINOIS, U.S.A.
 CLEVELAND INDIANAPOLIS LONDON, ONT.
 BOSTON NEW YORK MINNEAPOLIS SAN FRANCISCO

The Nation's Housing Conditions Demand ECONOMY in Building

Economy in expense and economy in space. Portal Wall Beds are timely space and cost savers meeting this national need. Everywhere architects and contractors who build wisely plan their apartments with



Crescent Apartments, Ellis and Hyde Streets, San Francisco
 Equipped with WALL BEDS

PORTAL WALL BEDS

MARSHALL & STEARNS CO.
 WALL BEDS

"Highest Award Always"

1152 Phelan Building
 San Francisco

1774 Broadway
 Oakland

*New Municipal Building
and City Hall, New York City.*



Achievements to be proud of

WE are proud of the marvelous achievements of American Architects; proud of our share in their success; proud also that our

VAN DYKE DRAWING PENCILS

rank among America's foremost accomplishments.

Samples of your favorite degrees and an artist eraser sent upon request on your business stationery. Address us at 37 Greenpoint Avenue, Brooklyn, New York.

EBERHARD FABER

"The Oldest Pencil Factory in America"
NEW YORK



Van Dyke Drawing Pencils are made in 16 degrees, graduating from 6B softest, to 8H hardest.

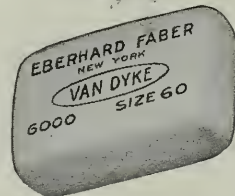

A Rich, Velvety White Enamel

—and a less expensive
enameling method

SET your enamel ideal high. Demand the richest, most delicate effect you can get. Meet the modern trend from the glaring, high-gloss enameled finish with Glidden Velvet White Enamel.

Glidden Velvet gives you the soft, smooth, semi-gloss finish—just the tone that harmonizes with the furnishings in the better homes.

Years of wear will prove its durability. Rub it or scrub it and it stands the test. A “prove it” panel will be sent you on request.

Glidden Velvet White Enamel is the true economy enamel. Apply only four coats instead of seven and there's no rubbing necessary. It's the most natural white enamel you can get.

THE GLIDDEN COMPANY

123 to 169 Hooper Street, Bet. 7th and 8th Sts., San Francisco

Factories

San Francisco Cleveland Toronto Reading

Branches

New York Chicago Kansas City Boston Pittsburgh London

STOCKS IN PRINCIPAL CITIES



When writing to Advertisers please mention this magazine.

UHL BROS., Inc.

DOMESTIC AND IMPORTED WALL PAPERS
UHL PAINTS—VARNISHES—ENAMELS

DISTRIBUTORS

Murphy Varnish Co's Architectural and Automobile } VARNISHES
EMAMELS

SAN FRANCISCO

OAKLAND

LOS ANGELES

PORTLAND

SEATTLE

LEADER WATER SYSTEM

No country home is complete without this modern water system. Running water under pressure whenever and wherever needed. Convenient, economical, sanitary.

Pacific Pump & Supply
Company, Distributors

851-853 Folsom Street
SAN FRANCISCO, CALIF.

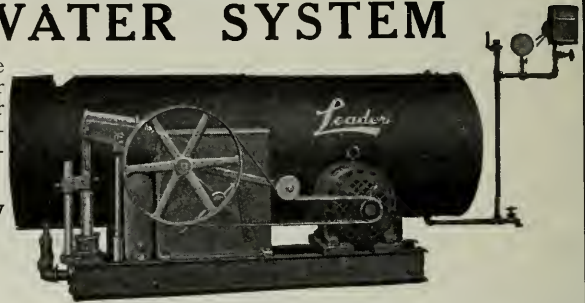

GOVERNMENT STANDARD



LOCKS AND BUILDERS'
HARDWARE

Will Equip 40 New Buildings
Air Defense Station, Presidio.

PALACE HARDWARE CO.

"San Francisco's Leading Hardware Store"

581 MARKET STREET. SUTTER 6060

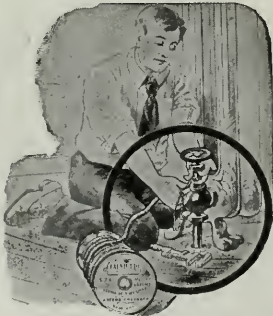

Pack your Radiator Valves with
Palmetto Twist Packing

It can be unstranded to fit any
size valve. It does not get hard.

H. N. COOK BELTING CO.

401-433 Howard St. San Francisco, Cal.

**WESTERN
VENETIAN
BLINDS**

ELIMINATE the unsightly awnings — Preserve the exterior beauty of your buildings by
Specifying

**WESTERN VENETIAN
BLINDS**

Some 1920 contracts for complete equipment:

- 12-story Mattie Building,
Fresno, California
- 9-story Pantages Building,
Los Angeles, California
- 7-story Marland Refining Bldg.
Ponca City, Oklahoma
- 10-story Tradesmens Bank Bldg.
Oklahoma City, Okla.
- 5-story Railway Exchange,
Muskogee, Oklahoma



LOS ANGELES TRUST
AND SAVINGS BLDG.
LOS ANGELES, CAL.

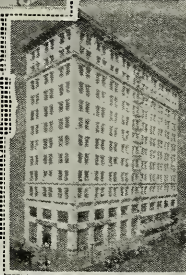

HAAS BLDG.
LOS ANGELES, CAL.



CITIZENS SAVINGS
BLDG.
PASADENA, CAL.



GLOBE GRAIN &
MILLING CO.
LOS ANGELES, CAL.



COUNTY COURT
HOUSE
WALLA WALLA, WASH.

When you consider the fact that **WESTERN VENETIAN BLINDS** take the place of both awning and window shade and will last practically as long as the building stands you'll realize that they are the logical equipment for modern buildings

WESTERN BLIND & SCREEN CO.
2704 LONG BEACH AVE.
LOS ANGELES CALIFORNIA

United States Steel Products Co.

Rialto Bldg., San Francisco

SELLERS of the products of the American Bridge Co., American Sheet and Tin Plate Co., American Steel and Wire Co., Carnegie Steel Co., Illinois Steel Co., National Tube Co., Lorain Steel Co., Shelby Steel Tube Co., Tennessee Coal, Iron and Railroad Co., Trenton Iron Co.

MANUFACTURERS OF

Structural Steel for Every Purpose—Bridges, Railway and Highway—"Triangle Mesh" Wire Concrete Reinforcement—Plain and Twisted Reinforcing Bars—Plates, Shapes and Sheets of Every Description—Rails, Splice Bars, Bolts, Nuts, etc.—Wrought Pipe, Trolley Poles—Frogs, Switches and Crossings for Steam Railway and Street Railway—"Shelby" Seamless Boiler Tubes and Mechanical Tubing—"Americore" and "Globe" Rubber Covered Wire and Cables—"Reliance" Weatherproof Copper and Iron Line Wire—"American" Wire Rope, Rail Bonds, Springs, Woven Wire Fencing and Poultry Netting—Tramways, etc.

United States Steel Products Co.

OFFICES AND WAREHOUSES AT
San Francisco - Los Angeles - Portland - Seattle

Planning the Private Garage

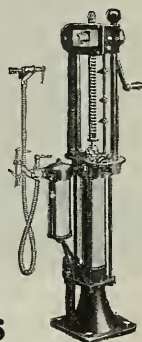
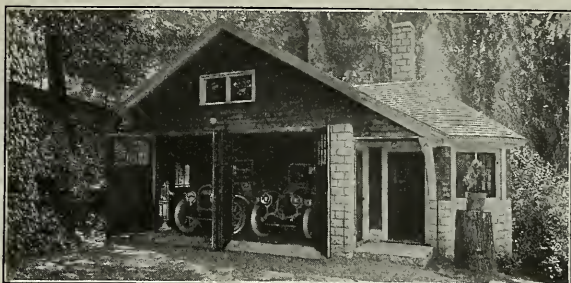

Bowser Oil and Gasoline Storage Systems

Are a necessity always, to make the garage complete — safe — convenient — and a saving proposition.

Bowser Equipment is Fire-Proof, Theft-Proof, Dirt-Proof and Loss-Proof. Because it is built to meet Underwriters' inspections — with every convenience and oil saving device.

Write or phone us at once for complete information.

S. F. BOWSER & CO., Inc.

FORT WAYNE, IND.

San Francisco Office: 612 Howard St. Telephone Douglas 4323
Sales Offices in All Centers — Representatives Everywhere



*Walls finished with Cabot's Old Virginia White
Roof finished with No. 346 Dark Gray Creosote Stain
Walter Boschen, Architect, St. Joseph, Mo.*

The soft, brilliant "whitewash white" of the Old Virginia White is particularly suitable for this type of house, and the rich greens and velvety dark gray stains harmonize perfectly for the roof, with the old New England dark green blinds.

Samples and information sent on request

SAMUEL CABOT, Inc., Mfg. Chemists, Boston, Mass.

Cabot's Creosote Stains, Waterproof Cement, and Brick Stain
"Quilt" Conservo Wood Preservative, Damp-Proofing
Protective Paints, Waterproofing, etc.

Pacific Building Materials Co., San Francisco
Waterhouse-Wilcox Co., Los Angeles

S. W. R. Dally, Seattle
Timms, Cress & Co., Portland

The Latest Country-house Color-schemes

An especially appropriate and harmonious exterior color-treatment has been developed for the dignified and beautiful type of country-house that our leading architects have now firmly established, in place of the fifty-seven varieties that have prevailed in recent years.

Cabot's Old Virginia White,
for the walls

Cabot's Creosote Stains, in
greens or dark gray, for the roofs

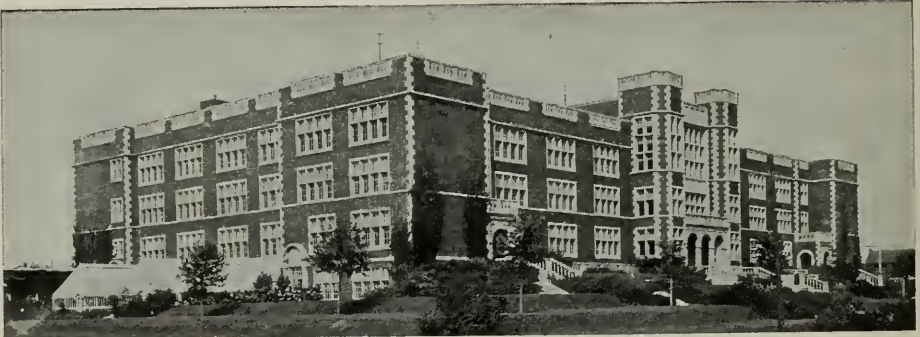

CENTRAL HIGH SCHOOL, MINNEAPOLIS, MINN.

Architect, *William B. Ittner*Contractors, *Pike & Cook Co.*Glazed by *Forman, Ford & Co.*

The above Trade-Mark
appears on every light

Completely equipped with American Window Glass Co.'s Double Strength AA Quality
First Choice of Leading Architects

Because of its absolute dependability, American Window Glass has been used in many fine buildings. Our care in inspection practically eliminates all imperfections and assures uniformity in thickness.

American Window Glass Co., General Office, Pittsburgh, Pa.

DOMESTIC SALES OFFICES

New York, 220 Fifth Avenue
Chicago, 1011 Peoples Gas Building
Boston, Mass., 43 Tremont Street
San Francisco, Cal., 341 Montgomery Street
St. Louis, Mo., 1303 Syndicate Trust Building
Memphis, Tenn., 440 North Main St.
New Orleans, La., 904 Hennen Bldg.
Atlanta, Ga., 1408 Candler Building

EXPORT SALES OFFICES

Havana, Cuba, Apartado No. 930
Buenos Aires, Argentina
Mexico City, Mex., Apartado Postal No. 237
Barranquilla, Colombia
Bogota, Colombia
Valparaiso, Chile
Lima, Peru
Toronto, Canada, 205 Continental Life Building

Highest Quality

Finest Workmanship

Remco Redwood Tanks

Underwriters — Standard — Specials

All dimensions and capacities

Towers Designed and Erected

For Prices, Data or Estimates Phone GARFIELD 1910

Redwood Manufacturers Company

SOLE MAKERS

Hobart Building, San Francisco

JOHNSON'S ROTARY CRUDE OIL BURNER

Can be installed in any BOILER or FURNACE

Gives Satisfactory Results. Simple to Operate—
Automatic—Safe. Let us tell you more about this
Oil Burner.

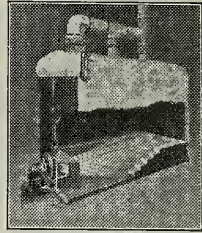

BURNER IN OPERATION

S. T. JOHNSON CO.

1337 Mission Street - San Francisco, Cal.

Ask for Bulletin No. 28

Phone Market 2759

Agencies: SEATTLE LOS ANGELES FRESNO SAN DIEGO SACRAMENTO

Member of the Oil Burners Manufacturers' Association of California.

Fess System Turbine Fuel Oil Burner

The latest word in the science of burning fuel
oil in an efficient and economical method

Ask for Bulletin No. 20

FESS SYSTEM CO., Inc.

1310 S. HILL ST.,
LOS ANGELES

218-220 Natoma Street, San Francisco

HOUSTON,
TEXAS

Member of the Oil Burners Manufacturers' Association of California.

OIL BURNER EQUIPMENTS

Low Pressure Air and Rotary Mechanical Atomizing Types

Refrigerating and Ice-Making Machines

Direct Expansion and Brine Circulating Systems

T. P. JARVIS MANUFACTURING CO.

CONTRACTING ENGINEERS AND MANUFACTURERS

275 Connecticut Street, San Francisco

Phone Market 3397

Member of the Oil Burners Manufacturers' Association of California.



SIMPLICITY OF CONSTRUCTION together with
SUCCESSFUL and ECONOMIC OPERATION of

SIMPLEX BURNERS

reported by their many users, is the best recommenda-
tion we can furnish to those desiring crude oil burners.

American Standard Oil Burner

TRADE MARK

Phone BERKELEY 6389

Company

FIFTH AND PARKER STREETS
BERKELEY, CALIFORNIA

Member of the Oil Burners Manufacturers' Association of California.



Pump Governors
 Oil Burner Governors
 Reducing Valves
 Safety Valves
 Oil Valves
 Blowoff Valves
 Boiler Feed Water
 Regulators

Oil Pumping Sets
 Little Giant Improved
 Oil Burners
 Duplex Oil Pumps
 Rotary Oil Pumps
 Oil Heaters
 Draft Gauges
 Boiler Feed Pumps

G. E. WITT CO., Inc.

ENGINEERS

Manufacturers and Distributors

862-864 HOWARD ST.

Phone Douglas 4404

SAN FRANCISCO, CAL.

CABOTS "QUILT"

SOUND DEADENING USED IN

Department School—Modesto.
 Lowell School—San Jose.
 Grammar School—Kingsburg.
 Horace Mann School—San Jose.
 Jefferson School—Fresno.
 Longfellow School—Fresno.

RECENT SALES

PACIFIC
MATERIALS CO.
 525 Market St. San Francisco

A. F. EDWARDS, President
 J. M. FABBRIS, Vice-President

J. A. MACKENZIE
 Secretary

CHAS. F. EISELE } Asst. Managers
 J. RUBIOLLO }

AMERICAN MARBLE & MOSAIC CO.

25-29 Columbia Square, San Francisco
 Telephone Market 5070

Factory on Canal, South San Francisco Telephone South San Francisco 161

Fenestra

SOLID STEEL WINDOWS

DETROIT STEEL PRODUCTS CO., Detroit

Direct Factory Branch, 68 Post Street, San Francisco

Phone Sutter 1250

The Architect and Engineer

Inc.

CONTENTS FOR AUGUST, 1920

Volume LXII. Number 2.

	PAGE
VIEW FROM DINING ROOM LOGGIA, JULIAN ELTINGE RESIDENCE, EDENDALE	Frontispiece
Pierpont and Walter S. Davis, H. F. Withey, Architects	
THE ARCHITECTURE AND LANDSCAPE ARCHITECTURE OF LOS ANGELES AND VICINITY	47
Frederick Jennings	
FINAL REPORT OF THE JURY TO SOUTHERN CALIFORNIA CHAPTER, A. I. A.	48
John W. Mitchell, John A. Comstock, Winsor Soule, J. T. Vawter, Chas. H. Cheney	
The Ten Most Notable Examples of Architecture in Los Angeles	49
(Illustrating the report of the Jury)	
The Five Most Notable Examples of Landscape Architecture in Los An- geles	77
(Illustrating the report of the Jury)	
The Five Most Notable Small Houses in Los Angeles	85
(Illustrating the report of the Jury)	
Honorable Mention of Other Notable Examples of Architecture and Landscape Architecture in Los Angeles	93
(Illustrating the report of the Jury)	
REPORT OF THE TWELFTH NATIONAL CON- FERENCE ON CITY PLANNING	98
Chas H. Cheney, City Planner	

Published Monthly by

THE ARCHITECT AND ENGINEER, Inc.

626-627 Foxcroft Bldg., San Francisco

W. J. L. Kierulff Fred'k W Jones L. B. Penhorwood
President Vice-Pres. Secretary



One of the five most notable examples of Landscape Architecture in Los Angeles, as selected by the recent Jury.

VIEW FROM DINING ROOM LOGGIA
RESIDENCE OF JULIAN ELTINGE, EDENDALE
PIERPONT AND WALTER S. DAVIS,
HENRY F. WITHEY, ARCHITECTS

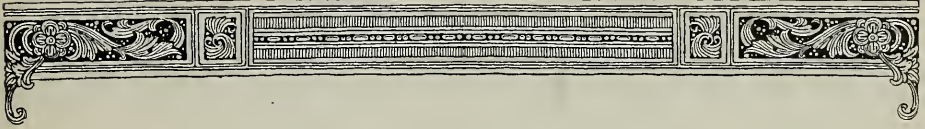

THE ARCHITECT AND ENGINEER

Vol. LXII.

SAN FRANCISCO, AUGUST, 1920

No. 2

The Architecture and Landscape Architecture of Los Angeles and Vicinity

By FREDERICK JENNINGS

It is doubtful whether many cities of this country can show as interesting a group of buildings and of as high a standard of architecture, as those selected in Los Angeles by the recent jury appointed by the Southern California Chapter of the American Institute of Architects. The reproductions in this number indicate to what a high degree the arts of Architecture and Landscape Architecture have been carried, which, as the jury says in its report, "augurs well for the advancement of these arts not only in California, but throughout the whole nation."

As was to be expected, the highest expression of architecture in Los Angeles was found to be in residence work. It is a city which has for many years been famous for its homes, and justly so. The interesting thing, however, is the great number of fine small houses found, showing that the architects of one city at least have discovered a way to turn their attention to small house architecture, in greater degree than seems to have been done in most of America.

Probably because the city has grown so fast and because of the great demand upon it for other public works, there has for a number of years been a noticeable lack of fine public buildings in Los Angeles. It is not surprising, therefore, that the jury found so few that could be listed as "most notable." In a great many cities the notable examples of architecture will include a considerable number of fine public structures, on which the best architects, those most capable of getting a remarkable result, are more often employed.

The greater the appreciation of and interest in good architecture the more of it we may expect throughout the country. And the decade we are entering seems likely to see greater advancement in the art of architecture, landscape architecture and sculpture than in any previous period of our history.

The following is the final report of the jury appointed by the Southern California Chapter, American Institute of Architects, to pass on the most notable examples of architecture and landscape architecture in Los Angeles*:

The Most Notable Examples of Architecture and Landscape Architecture in Los Angeles—(Final report of the jury)

To the Southern California Chapter of the American Institute of Architects:

The jury named by the Chapter to select, in its opinion, the ten most notable examples of architecture, the five most notable examples of landscape architecture, the three most notable examples of public sculpture, and the five most notable examples of small houses—all to be found within twenty miles of Los Angeles City Hall—met for six successive days from April 8th to 13th, 1920, inclusive. They visited in a body all parts of the city and vicinity, and carefully noted all buildings, parks, gardens and sculpture that seemed worthy of consideration.

Members of the Chapter had nominated 182 buildings, 43 gardens and parks and 9 sculptures, which they thought should be considered. These were viewed once, in some cases several times, and their relative merits weighed, with the exception of two residences, to which the jury, through some misunderstanding, was denied admission. In going over the prescribed area, the jury also noted 42 additional buildings and four additional gardens, which seemed worthy of equal consideration. With the field thus carefully reviewed we believe that few, if any, worthy buildings, gardens or sculptures in this area were overlooked and we have endeavored to give a strictly impartial judgment of what we saw.

Members of the jury are personally cognizant of the fact that some of the best work of a number of the most gifted and prominent members of the Chapter is to be found outside of the 20 miles radius here considered, but it was previously agreed that it was fairer to the public to limit the discussion to an area within the reach and acquaintance of most of the people of the city.

The jury's instructions were that "points of architecture to be considered are usefulness, arrangement, relation of exterior design to interior design, beauty, harmony of detail, setting, purpose, color and appropriateness." The size or cost of a structure did not unduly influence the decisions, and in fact it was most gratifying to find some of the most satisfactory designs in the smaller houses and gardens. Unfortunately people are often misled, on account of the massiveness or large cost of a structure, into thinking it is good architecture.

Aside from the points above mentioned, there is a special quality possessed by some structures, appealing to both architects and laymen—the elusive quality of charm—not easily definable, but which may be said to represent the soul of the building. A structure often embodies this quality even when it may be criticized on points of detail.

All types of buildings—commercial, industrial, educational, religious, public and semi-public—were compared as to which seemed to form, relatively, the highest expression of architecture. The final lists are made up of those deemed most notable, regardless of type or use.

Residence architecture in Los Angeles, as shown by the great number of fine examples mentioned below, is relatively of a higher standard, the jury believes, than that found in most cities of the country. Compared to other types of buildings here, residence design seems to have been carried to a greater perfection. Thus five of the ten most notable examples of architecture were found to be residences.

As in many cities, commercial buildings in Los Angeles do not seem, as yet, to have reached comparatively as high a standard of architecture as that shown in the residential work. After carefully surveying all buildings of the downtown area, the jury cannot place any business building among the most notable. Los Angeles also seems distinctly lacking in adequate or notable public structures, to which condition of affairs, however, the library and schools selected prove strong exceptions.

* It is much to be regretted that photographs were not available of the Residence at 1433 La Brea avenue, Hollywood, selected as one of the five most notable small houses, nor of the following buildings and gardens given honorable mention by the jury: The Eaton residence, Oak Knoll, and Stevens residence, on Oak Grove avenue, Pasadena, and the residence at 3823 West Seventh street, Los Angeles, of which Mr. Robert D. Farquhar was the architect; Beverly Station gardens, Beverly Hills, of which Mr. Myron Hunt was the architect and Mr. W. D. Cook the landscape architect; the Tapis Vert of the Huntington Estate gardens, Pasadena, of which Mr. Myron Hunt was the architect; residence at 1427 La Brea avenue, Hollywood, Mr. W. A. McCutcheon, designer; Residence at 434 Shatto street, Los Angeles; Residence at 7520 Hollywood boulevard, Hollywood, Mr. Edward H. Cline, architect; Bronson House court, 1739 North Bronson avenue, Hollywood; and Firenze House court, 5280 Sunset boulevard, Hollywood, Mr. W. J. Dodd, architect.

On the whole, the jury was much impressed with the extremely high character of architecture and landscape architecture found. It augurs well for the advancement of these arts, not only in California, but throughout the whole nation, which is bound to feel the influence of the work here. In the jury's opinion many of the buildings and gardens selected will compare most favorably with the very finest that this country has produced.

The jury regrets that it was unable to find any public sculpture within the prescribed area, that is, the twenty-mile circle of the Los Angeles City Hall, which it considered to be entitled to a first award of merit, judged by the high standards set by the artistic achievements of many great American sculptors—such as Augustus Saint Gaudens, Daniel Chester French, Frederick Macmonnies, George Gray Barnard, Paul Weyland Bartlett, Charles Henry Neuhaus, Tait McKenzie, or of others of similarly recognized ability and works. Therefore, any award in this class was omitted.

The Ten Most Notable Examples of Architecture in Los Angeles

The unanimous opinion of your jury is that the ten most notable examples of architecture are as follows (the order is alphabetical, no precedence having been awarded):

- Annandale Golf Club of Pasadena;
- Eltinge Residence, Edendale;
- Glover Residence, 327 S. Normandie street;
- Halliday Residence, Adelaide Drive, Santa Monica;
- Keeley Residence, 908 Oak Grove avenue, Pasadena;
- Lincoln Heights Library, Workman street and Avenue 26;
- Paxton Residence, Orange Grove avenue and State street, Pasadena;
- San Gabriel Mission, San Gabriel;
- Santa Monica High School, Santa Monica;
- State University, Southern Branch, Vermont avenue.

In considering the reasons for these selections, the jury has made brief note of each building, as follows:



ENTRANCE ANNANDALE GOLF CLUB,
PASADENA

Reginald D. Johnson, Architect

One of the ten most notable examples of Architecture in Los Angeles, as selected by the recent Jury.



ANNANDALE GOLF CLUB, PASADENA
Reginald D. Johnson, Architect

One of the ten most notable examples of Architecture in Los Angeles, as selected by the recent Jury.

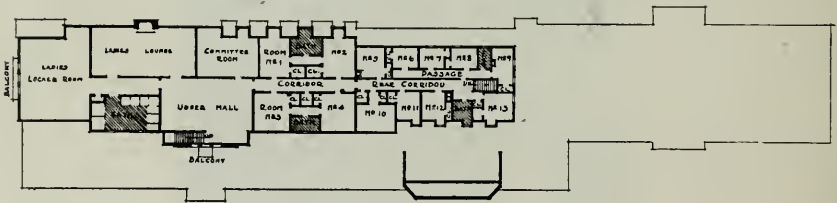

PLAN OF SECOND FLOOR

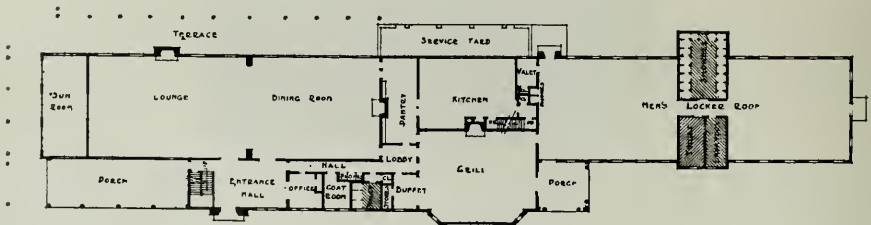

PLAN OF FIRST FLOOR

CLUB HOUSE FOR ANNANDALE GOLF CLUB ANNANDALE CALIFORNIA
REGINALD D. JOHNSON ARCHITECT PASADENA CALIFORNIA

SCALE FEET

Annandale Golf Club.—The simplicity and grace with which this building fits its site are its most notable points. It is in plaster finish and rather domestic in character. The long lines of roof recall the similar lines of the nearby ridges very pleasantly, and being on the crest of a small hill looking out over the links, the building commands attention at a distance. On closer view, the details of ornament, doors, windows, etc., are found to be admirable both in design and proportion. The entire place has an air of attractiveness that is stimulating. It seems to thoroughly express the Country Club idea. The mass and coloring of the building seems to melt harmoniously into the picturesque landscape of the Southern California hills covered with undergrowth.

On the interior, the large rooms are cheerful and inviting, opening spaciouly. It is noticeable that the decoration, used sparingly, is so placed as to count to the best advantage. Probably the most striking effect of all, however, is the pleasing impression of lack of formality everywhere, although the details of design on closer view follow, in general, the better formal traditions of renaissance architecture. The plan and arrangement of the rooms is excellent. The colors of exterior and interior are soft and restful, low in tone without lacking life. The building is, in fact, a notable example of Country Club architecture.



LIVING ROOM, JULIAN ELTINGE RESIDENCE, EDENDALE
Pierpont and Walter S. Davis, Henry F. Withey, Architects

One of the ten most notable examples of Architecture in Los Angeles, as selected by the recent Jury.



GARDEN FACADE, JULIAN ELTINGE RESIDENCE, EDENDALE PIERPONT AND WALTER S. DAVIS, HENRY F. WITHEY, ARCHITECTS

One of the ten most notable examples of Architecture in Los Angeles, as

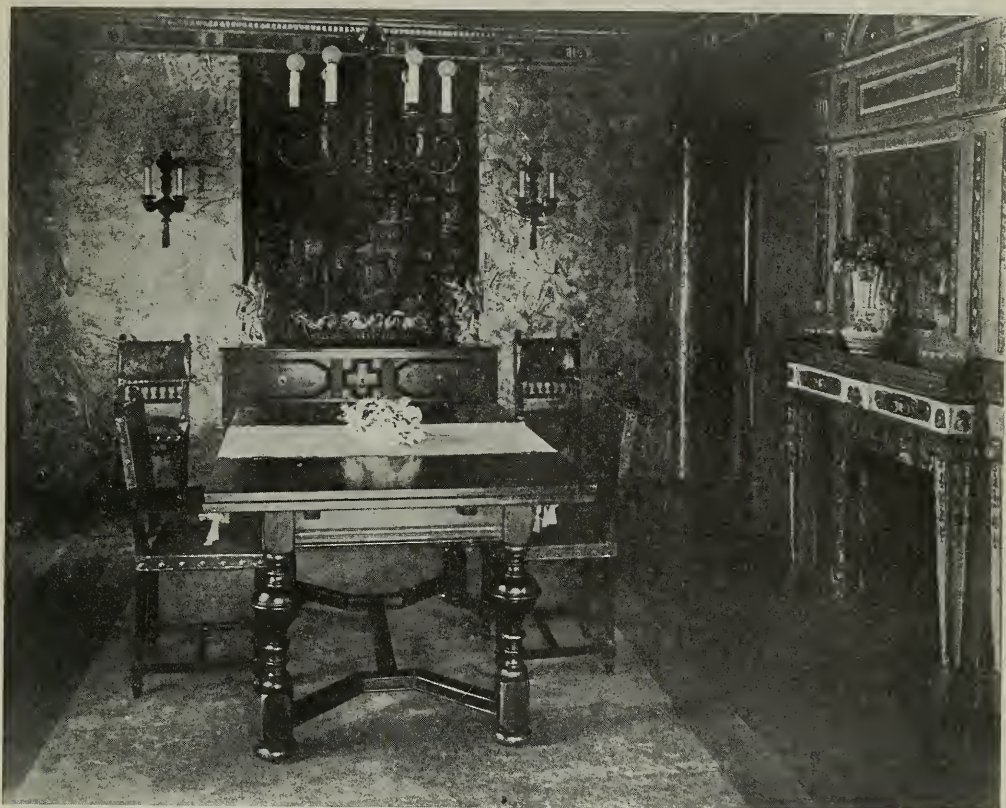

JULIAN ELTINGE RESIDENCE, EDENDALE
 Pierpont and Walter S. Davis, Henry F. Withey, Architects

One of the ten most notable examples of Architecture in Los Angeles, as selected by the recent Jury.

Eltinge House.—Here is a plaster house in Spanish style, designed in a bold yet happy manner bound to intrigue the senses and invite the interest of all lovers of architecture. Brilliant qualities of design are shown both inside and out and this building bids fair to long remain one of the most interesting in Southern California. The mellow golden yellow color of the exterior and the decoration of the interior walls must excite admiration. This house has strong character. It represents probably the best use of color that the jury found—full in tone and applied with masterly judgment to give the effect desired. The approach, setting and planting have all been arranged to make the most of a fine hilltop site and view, without obvious effort. Each detail of design in itself also has an individuality and beauty that evidences careful study and consistent execution. Rough plaster walls are brought into contrast with a few well placed iron grills, picked out in color.

Inside, the circular entrance hall with its winding staircase, niches and decorated ceiling is beautifully conceived and admirably executed. The large living room, the upper stair hall and a number of other rooms have each been designed with a boldness and life that is invigorating, the effect being tremendously heightened by the diaper patterns and stenciled designs on the rough plaster finish and then cleverly touched out and softened to give the mellowness generally only produced by age.

The jury believes that the success with which both house and garden have been handled reflects unusual credit, not only on the individual designer, but also on the whole profession as well, and is a remarkable effort in a style particularly adapted to this section.



ENTRANCE HALL AND STAIR, JULIAN ELTINGE RESIDENCE, EDENDALE
PIERPONT AND WALTER S. DAVIS, HENRY F. WITHEY, ARCHITECTS

One of the ten most notable examples
of Architecture in Los Angeles, as
selected by the recent Jury.



SOUTH APPROACH, JULIAN ELTINGE RESIDENCE, EDENDALE
PIERPONT AND WALTER S. DAVIS, HENRY F. WITHEY, ARCHITECTS

One of the ten most notable examples
of Architecture in Los Angeles, as
selected by the recent Jury.



RESIDENCE OF W. H. GLOVER
327 SOUTH NORMANDIE STREET
DE REMER & HEWITT, ARCHITECTS

One of the ten most notable examples
of Architecture in Los Angeles, as
selected by the recent Jury.

Glover Residence.—A good plaster house in Norman-French English composite style. It is quite different in type from the Eltinge Residence, and of a more formal treatment. In design, it follows no definite precedent but its character is distinctive. There is decided strength in the mass of the exterior, as well as much beauty. The plan is simple and the large rooms are well balanced. This residence seems to the jury to be well above the ordinary, even in comparison with the many other fine houses of different style, which have been given mention. It is refreshing in its original treatment, for a city residence on a constricted site.



RESIDENCE OF W. H. GLOVER, 327 SOUTH NORMANDIE STREET
De Remer & Hewitt, Architects

One of the ten most notable examples of Architecture in Los Angeles, as selected by the recent Jury.

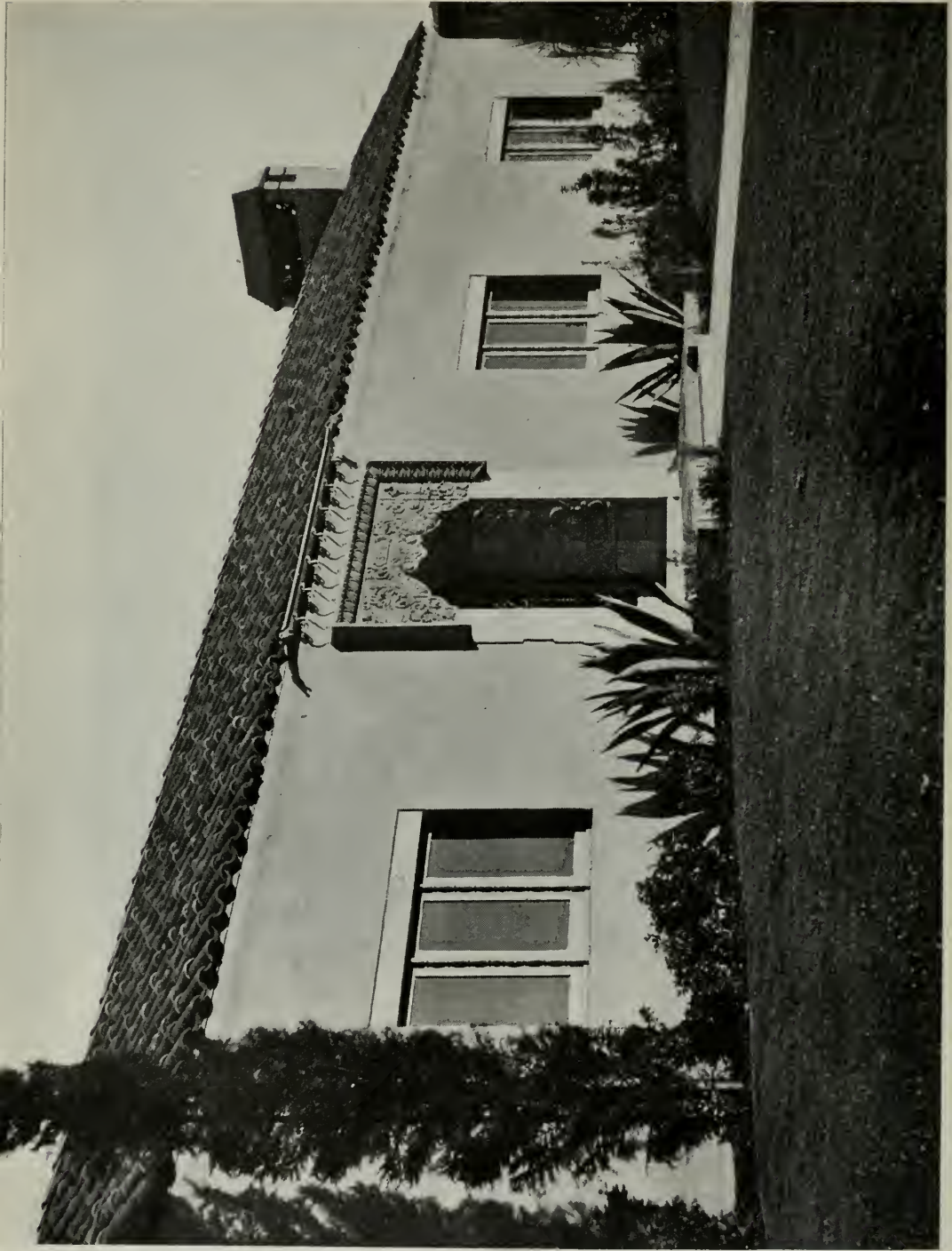

One of the ten most notable examples of Architecture in Los Angeles, as selected by the recent Jury.

HALLIDAY RESIDENCE, ADELAIDE DRIVE, SANTA MONICA. PIERPONT AND WALTER S. DAVIS, HENRY F. WITHEY, ARCHITECTS

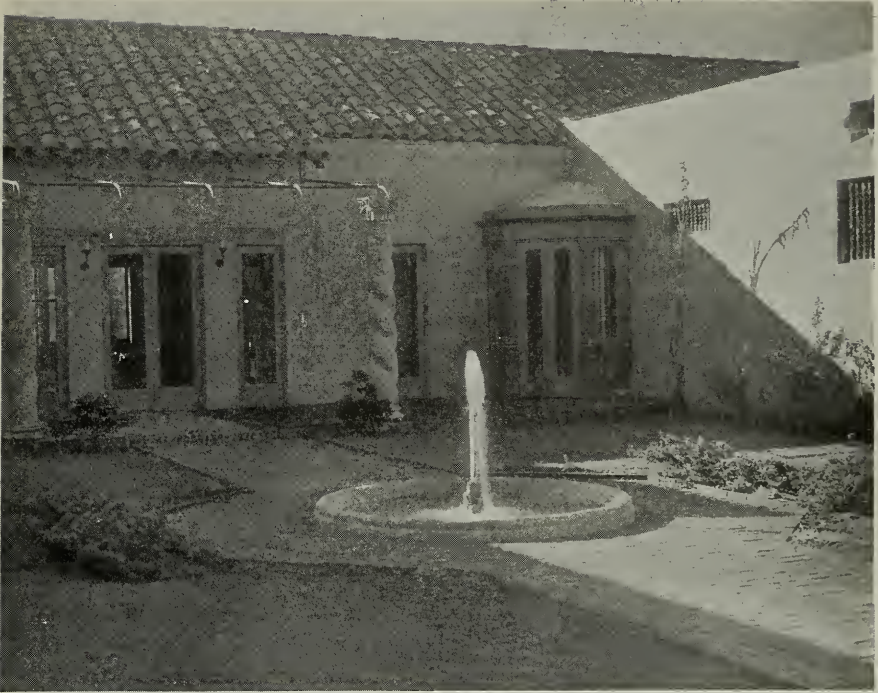

PATIO OF THE HALLIDAY RESIDENCE. SANTA MONICA
Pierpont and Walter S. Davis, Henry F. Withey, Architects

One of the ten most notable examples of Architecture in Los Angeles, as selected by the recent Jury.

Halliday Residence.—This is an attractive one-story house, in the Spanish style, built around an open patio or court. The exterior is a warm mauve color. The roof is of the mottled Spanish tile, now being made so well in California. Fullest opportunity has been taken by the architect to make the courtyard and garden a part of the house and the result has been most successful. The details of iron grills, windows, wooden window grills, etc., have been handled with the sure touch of an art of high character and the eye runs from detail to detail with delight. For comparatively so small a home, this residence is unusually successful in execution. The entrance doorway is a bit Churrigueresque, but the charm of color and refinement of detail of the mantels, mouldings and beamed ceiling of the living room and other interiors, are original and in rare artistic spirit.



RESIDENCE OF MRS. MARY KEELEY
908 OAK GROVE AVENUE, PASADENA
ROBERT D. FARQUHAR, ARCHITECT

One of the ten most notable examples
of Architecture in Los Angeles, as
selected by the recent Jury.

Keeley Residence.—A white Colonial residence of simple, yet dignified proportions, sitting comfortably to the ground. This is a good example of a more formal and refined type of residence architecture than is inspired from the Spanish style, yet on account of that, presenting less opportunity for the fire, life and play of color and shadow offered by the bright California sunshine. With its French windows and terraces, it fits well into its environment and shows the strong feeling for closer relation of house and garden, that seems so obviously a thing to be sought in this garden country.

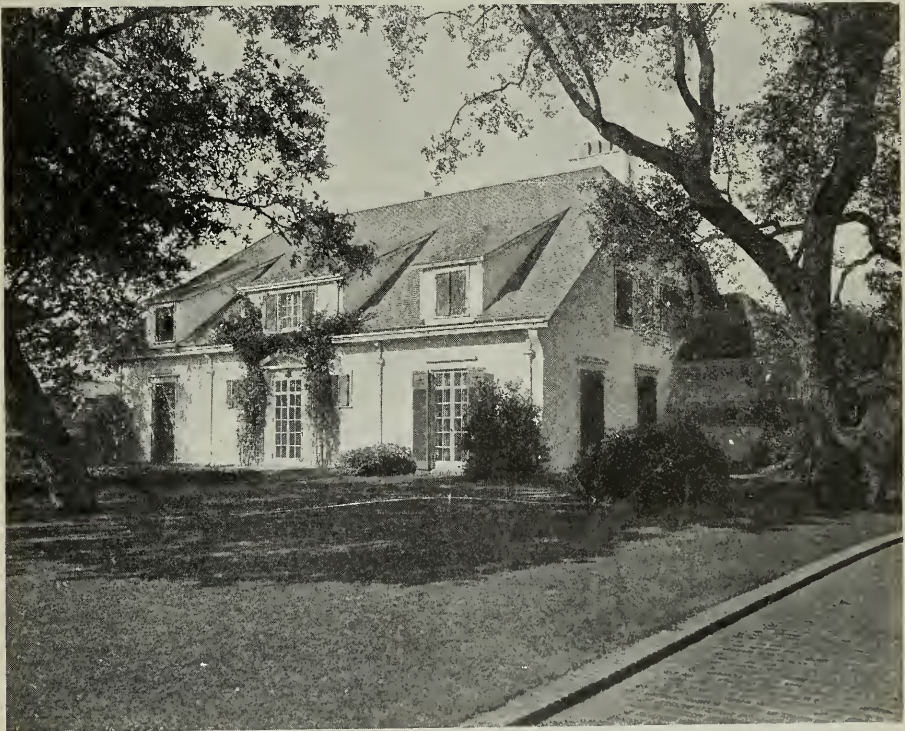

RESIDENCE OF MRS. MARY KEELEY, OAK GROVE AVENUE, PASADENA
Robert D. Farquhar, Architect

One of the ten most notable examples
of Architecture in Los Angeles, as
selected by the recent Jury.

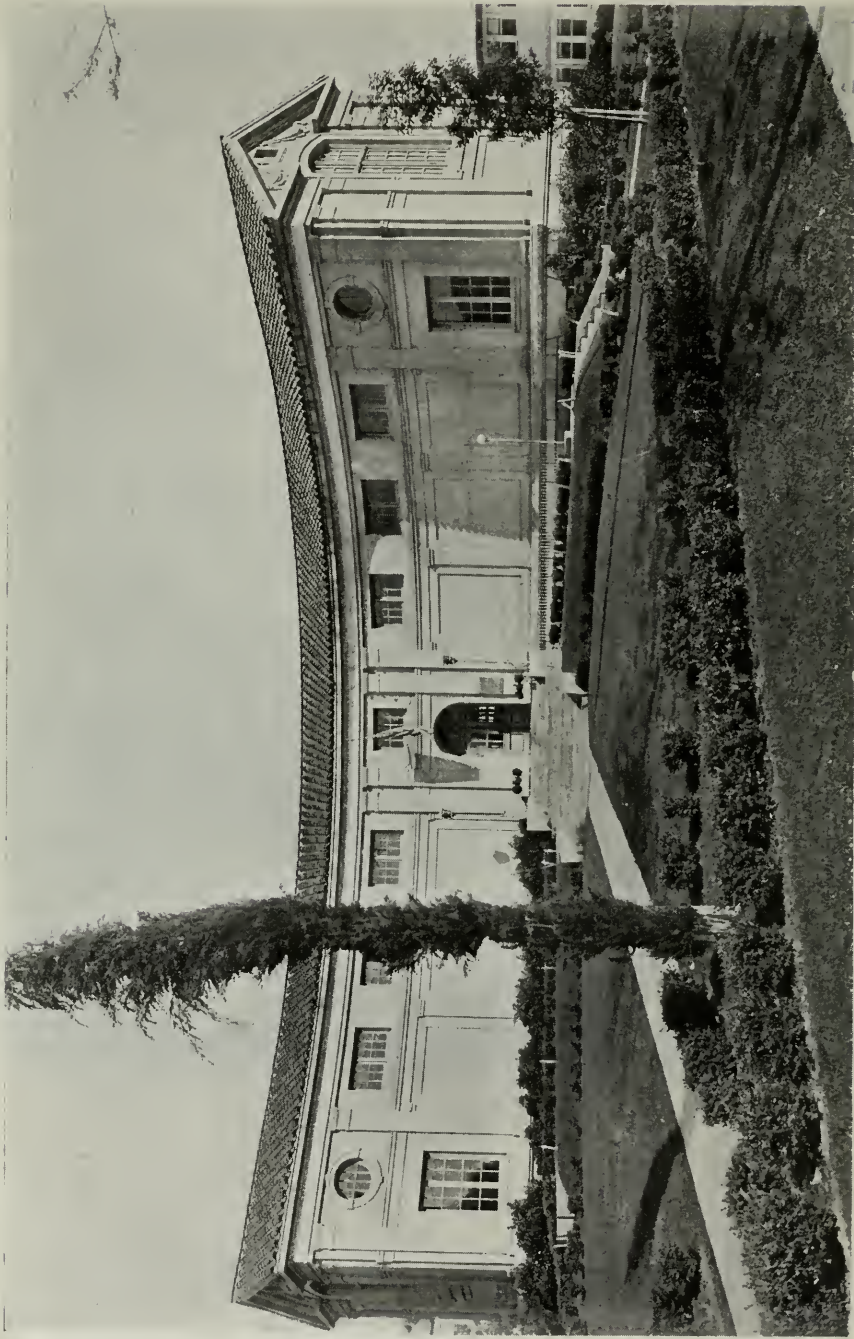

LINCOLN HEIGHTS BRANCH LIBRARY
WORKMAN STREET AND AVENUE 26
HIBBARD & CODY
ARCHITECTS

One of the ten most notable examples of Architecture in Los Angeles, as selected by the recent Jury.

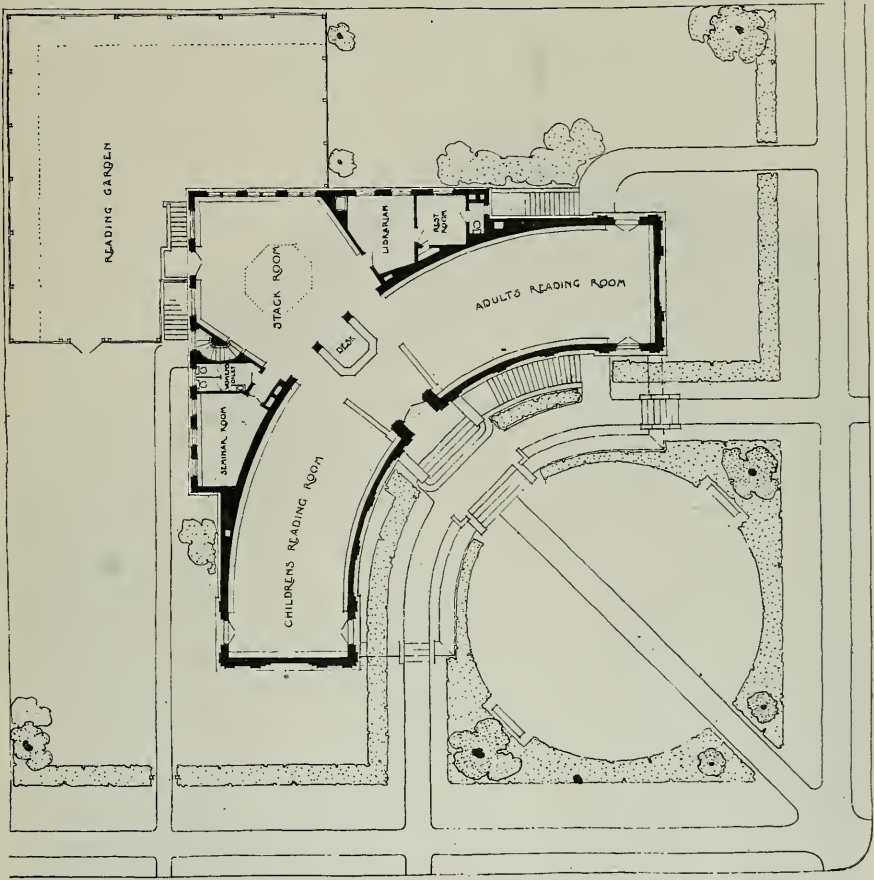

FLOOR PLAN OF LINCOLN HEIGHTS BRANCH LIBRARY
 Workman Street and Avenue 26
 Hibbard & Cody, Architects

One of the ten most notable examples of Architecture in Los Angeles, as selected by the recent Jury.

Lincoln Heights Library.—This branch library building was selected because of its most successful solution of an unusual quarter circle plan on a corner lot, and because of the dignity, large scale and good taste with which it is carried out. Looking into the curved facade, the building appears larger and more monumental than the ordinary structure of equal size as usually arranged. On the interior, the floor plan gives one attendant, opposite the main entrance, control and a clear view of the whole reading room and stacks, thus solving the library administration problem most economically and satisfactorily. This building will always be interesting to architectural students because of its unique scheme and well balanced elements of design in the facades.



END ELEVATION, LINCOLN HEIGHTS BRANCH LIBRARY
HIBBARD & CODY, ARCHITECTS

One of the ten most notable examples
of Architecture in Los Angeles, as
selected by the recent Jury.



READING ROOM, LINCOLN HEIGHTS BRANCH LIBRARY
HIBBARD & CODY, ARCHITECTS

One of the ten most notable examples
of Architecture in Los Angeles, as
selected by the recent Jury.



ENTRANCE, RESIDENCE OF C. F. PAXTON, ORANGE GROVE AVENUE, PASADENA
Reginald D. Johnson, Architect

One of the ten most notable examples of Architecture in Los Angeles, as selected by the recent Jury.

Paxton Residence.—This is a charming plaster house in the Spanish Renaissance style, a style now so generally being developed in and around Los Angeles. The Paxton Residence was selected from among a number of others, almost equally worthy of note, because of the pleasing manner in which it fits into its location under the trees, because of its interesting terrace on the south side and exterior staircase, and because its scale is intimate and homelike without a loss of dignity or of strength of design. The color of this house is to be commended, as deviating from the standard Spanish pink, and yet being most appropriate to the style and setting of the house.

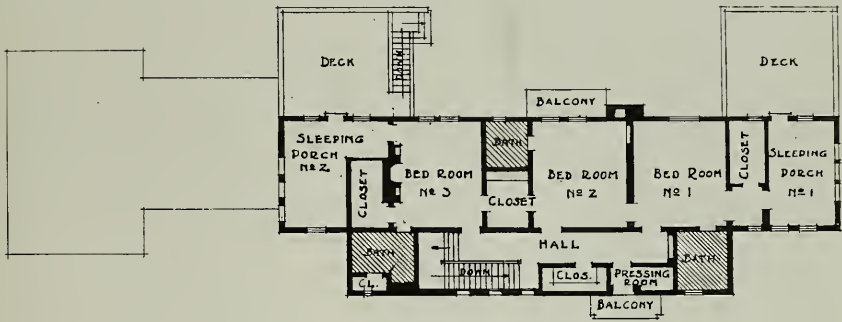

PLAN OF SECOND FLOOR

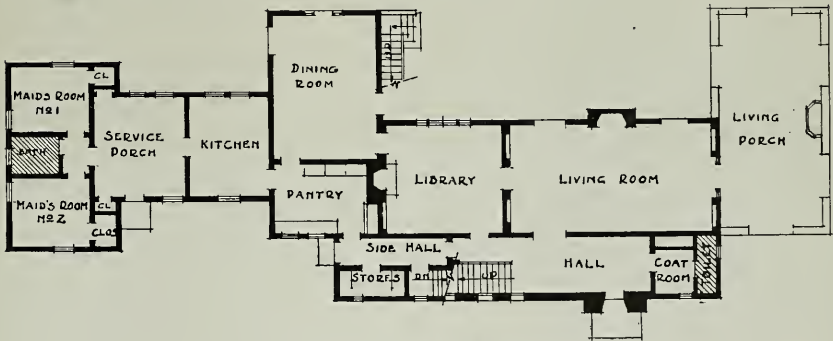

PLAN OF FIRST FLOOR

RESIDENCE FOR MR. C. F. PAXTON - PASADENA CALIFORNIA

REGINALD D. JOHNSON ARCHITECT - PASADENA CALIFORNIA

SCALE 1" = 2' 0" FEET

One of the ten most notable examples of Architecture in Los Angeles, as selected by the recent Jury.

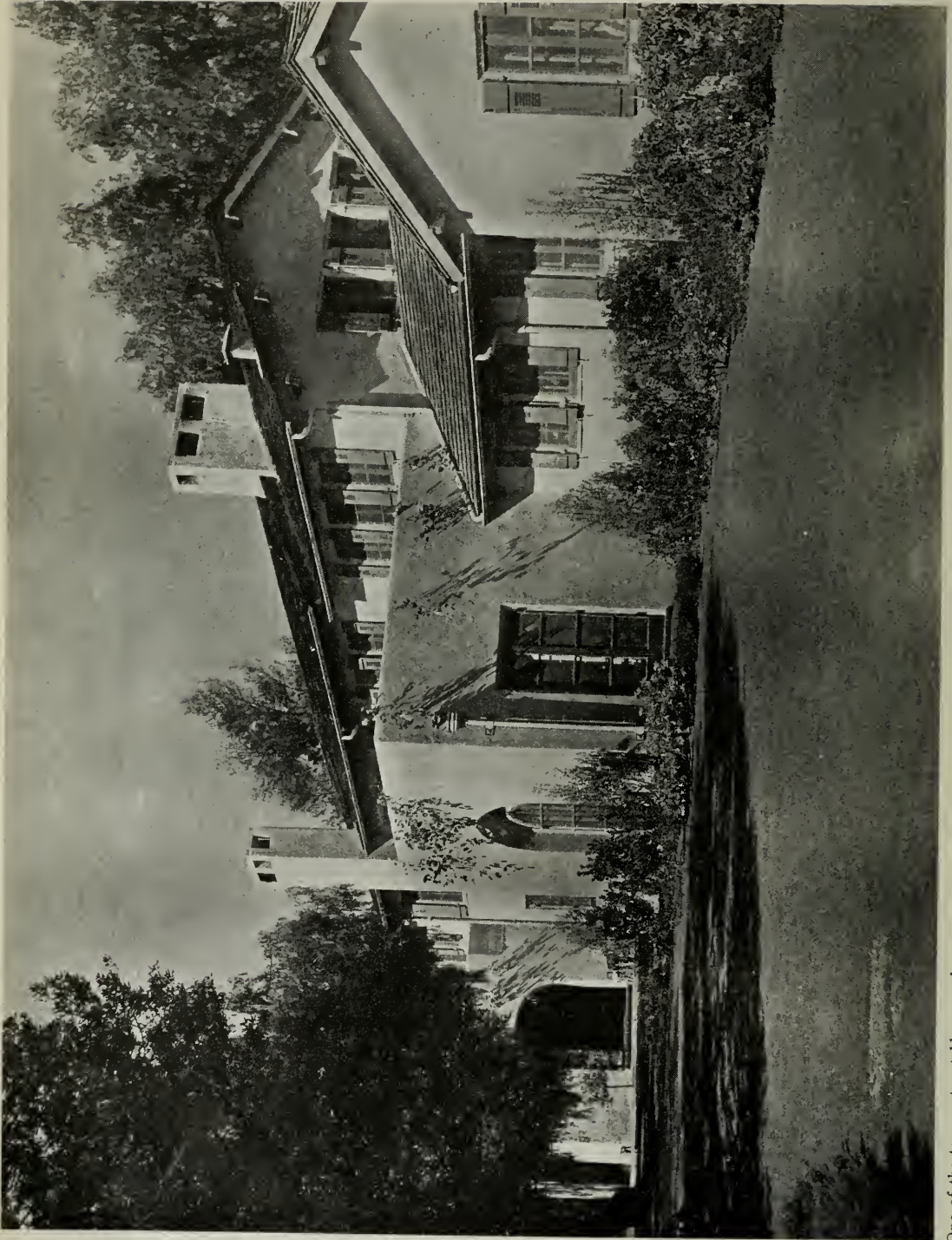

One of the ten most notable examples of Architecture in Los Angeles, as selected by the recent Jury.

VIEW FROM THE SOUTHEAST
RESIDENCE OF C. F. PAYTON, PASADENA
REGINALD D. JOHNSON, ARCHITECT



OUTSIDE STAIR, RESIDENCE OF C. F. PAXTON, PASADENA
Reginald D. Johnson, Architect

One of the ten most notable examples
of Architecture in Los Angeles, as
selected by the recent Jury.



BELFRY, SAN GABRIEL MISSION
SAN GABRIEL, CALIFORNIA
FOUNDED, SEPTEMBER 8, 1771

One of the ten most notable examples
of Architecture in Los Angeles, as
selected by the recent Jury.



CHURCH ENTRANCE AND BALCONY STAIRS, SAN GABRIEL MISSION
SAN GABRIEL, CALIFORNIA

San Gabriel Mission.—A Spanish Mission founded by the Franciscan Fathers in 1771, built of adobe brick and tile, baked on the premises. It is a beautiful and inspiring old pile that will ever live as one of the most interesting and notable examples of architecture in the vicinity of Los Angeles. Aside from its great historic interest, the sturdy proportions of its buttresses, tower, window openings and interior are eloquent reminders of a culture and art resulting from long ages of civilization in European countries, which, after all, is the background or foundation for whatever we may do here. Remembering that the Mission Fathers did not have any trained artisans but had to rely chiefly on half civilized Indian workmen, who could not run a moulding straight nor make dentils for the life of them, it is surprising how dignified and beautiful the resulting Mission buildings were. The belfry of San Gabriel is a rare detail of architecture to be cherished around the world. Any list of notable buildings in Los Angeles would be incomplete without inclusion of this historic monument.



HIGH SCHOOL, SANTA MONICA
Allison & Allison, Architects

One of the ten most notable examples of Architecture in Los Angeles, as selected by the recent Jury.

Santa Monica High School.—A large high school group, of brick buildings in early Italian style, effectively located on a hill dominating the whole city of Santa Monica, with a view far out to sea. The well developed ground plan has been so splendidly adapted to the site that the main elements of the group stand out in monumental form, the entrance doorway and square tower making a most fitting portal to the inner halls of learning. Fortunately the architect had the courage to place the main group at the back end of the site on the high ground, with the stadium and athletic field in front. The soft reddish tone of the bricks, which are laid up in patterns, gives a surprisingly rich texture to the wall surfaces, which is enhanced by the planting. On the whole, the jury feels that this is probably the most successful high school group in the West and any city should be proud to have attained it. Surely such a magnificent environment must have a perpetual influence on the youth who for four of the most formative years of their lives must spend the principal part of each day in it. So monumental and important is the effect of these buildings that it seems unfortunate that the City of Santa Monica has not opened up a parkway or vista on the center axis from the school down to Ocean Boulevard. Certainly few buildings in Southern California are likely to make a stronger impression on visitors, if this only be made visible to the great number who continually pass within a half mile, along the edge of the sea.



LOOKING TOWARD THE ADMINISTRATION BUILDING, UNIVERSITY OF CALIFORNIA,
SOUTHERN BRANCH (formerly Los Angeles State Normal School), VERMONT AVE.
Allison & Allison, Architects

One of the ten most notable examples
of Architecture in Los Angeles, as
selected by the recent Jury.

University of California—Southern Branch.—This group of brick buildings, formerly known as the "Los Angeles State Normal School," is in the early Italian style, leaning to Romanesque. It is notable architecture conceived in a big way and is probably the most harmonious and attractive group of college buildings in Southern California, if not in the West. Fortunately the buildings had the advantage of all being designed and constructed at the same time, under the direction of one architect. The group plan, which seems to have been well studied out in advance, placed the fifteen or more buildings so as to form a campus which is not so large as to lose the sense of intimacy or character, so often lacking in American collegiate institutions. The result is decidedly monumental and effective, showing the mass of the buildings to the best advantage. The architect fortunately emphasized the principal vistas. The octagonal tower and entrance portico of the main building are fine architecture—large in feeling, beautiful in proportion and monumental in result. It is to be hoped that as new buildings are added they will be kept rigidly to the same character and group plan.

Los Angeles has here a masterpiece of architecture of which it may well be proud.



LOOKING ACROSS THE CAMPUS, UNIVERSITY OF CALIFORNIA, SOUTHERN BRANCH
(Formerly Los Angeles State Normal School).
Allison & Allison, Architects



ENTRANCE TO THE ADMINISTRATION BUILDING, UNIVERSITY OF CALIFORNIA,
SOUTHERN BRANCH (formerly Los Angeles State Normal School)
Allison & Allison, Architects

One of the ten most notable examples
of Architecture in Los Angeles, as
selected by the recent Jury.

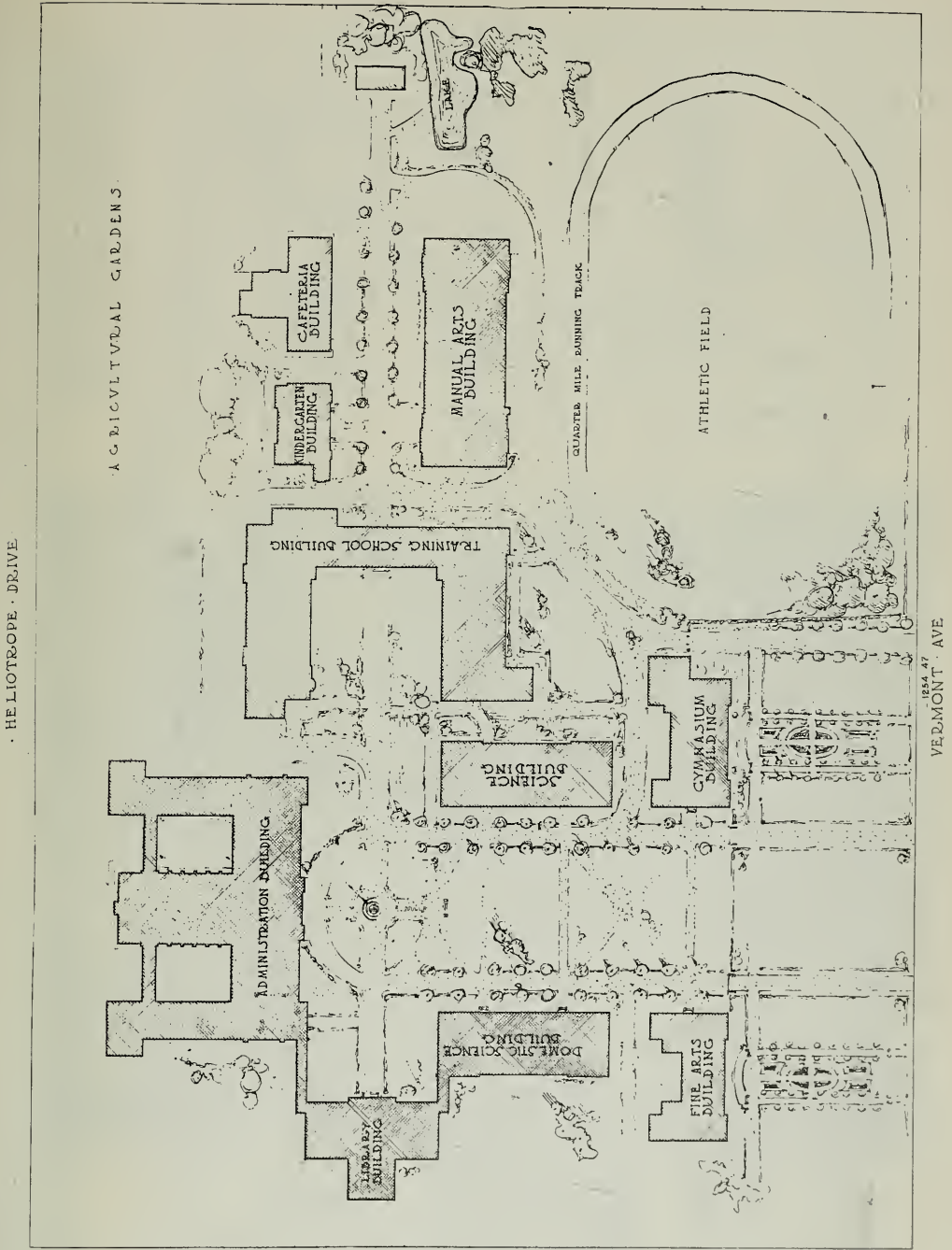

One of the ten most notable examples of Architecture in Los Angeles, as selected by the recent jury.

PLAN OF THE CAMPUS, UNIVERSITY OF CALIFORNIA, SOUTHERN BRANCH (Formerly Los Angeles State Normal School) ALLISON & ALLISON, ARCHITECTS

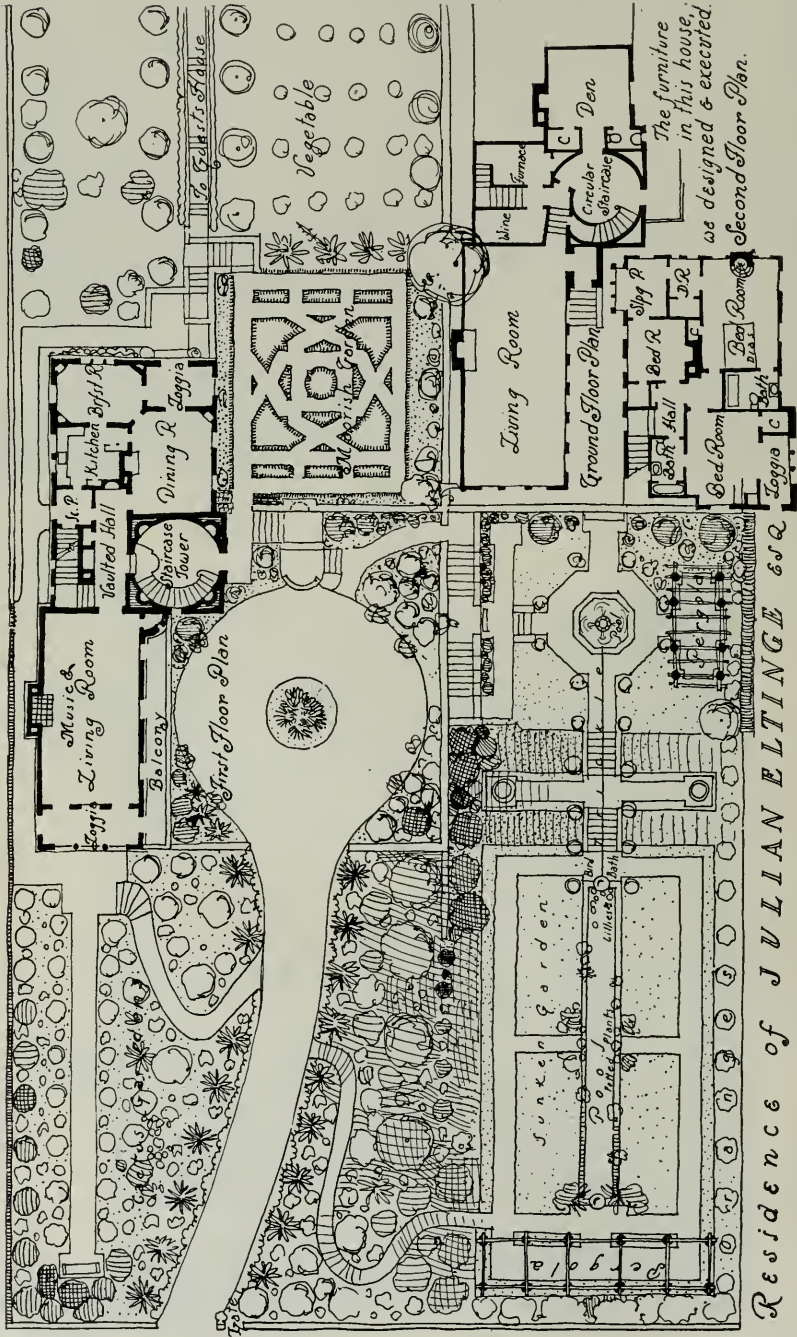

Residence of JULIAN ELTINGE 652

PLANS OF HOUSE AND GARDEN
 RESIDENCE OF JULIAN ELTINGE
 PIERPONT AND WALTER S. DAVIS
 H. F. WITHEY, ARCHITECTS

*The furniture
 in this house
 as designed & executed
 Second Floor Plan.*

One of the five most notable examples of
 Landscape Architecture in Los Angeles,
 as selected by the recent jury.

The Five Most Notable Examples of Landscape Architecture in Los Angeles

The five most notable examples of landscape architecture, in the unanimous opinion of the jury, are as follows, alphabetically arranged :

- Eltinge Garden, Baxter street, Edendale;
- Fuller Garden, San Raphaël Heights, Pasadena;
- Herbert Garden, Arroyo Drive, Pasadena;
- Murphy Italian Garden (in rear of residence), 2076 West Adams street, Los Angeles;
- Prentiss Garden, Hillcrest avenue, Pasadena.

Eltinge Garden.—A delightful small formal city garden in Spanish style, like the house, to which it forms a most admirable complement and setting. Containing about an acre of ground, and though only recently planted, this garden is most eminently successful in plan, massing of plants, arrangement of walks, fountain, pool and pérgola. It offers more harmony and restful effect to the visitor than many of the large estates and gardens viewed by the jury. It seemed that here landscape art had been carried to a very high point. The choice of plants is particularly appropriate and adapted to the production of the effect desired. This is quite in contrast with the "museum of many varieties" idea which has been so ruinous to the art of gardening in America. There is much hope for more real small garden design when a development as simple as this can be done so well.



ENTRANCE STEPS, GARDEN OF JULIAN ELTINGE, EDENDALE
 Pierpont and Walter S. Davis, H. F. Withey, Architects
 Planting by Chas. C. Adams, Landscape Architect

One of the five most notable examples of Landscape Architecture in Los Angeles, as selected by the recent Jury.

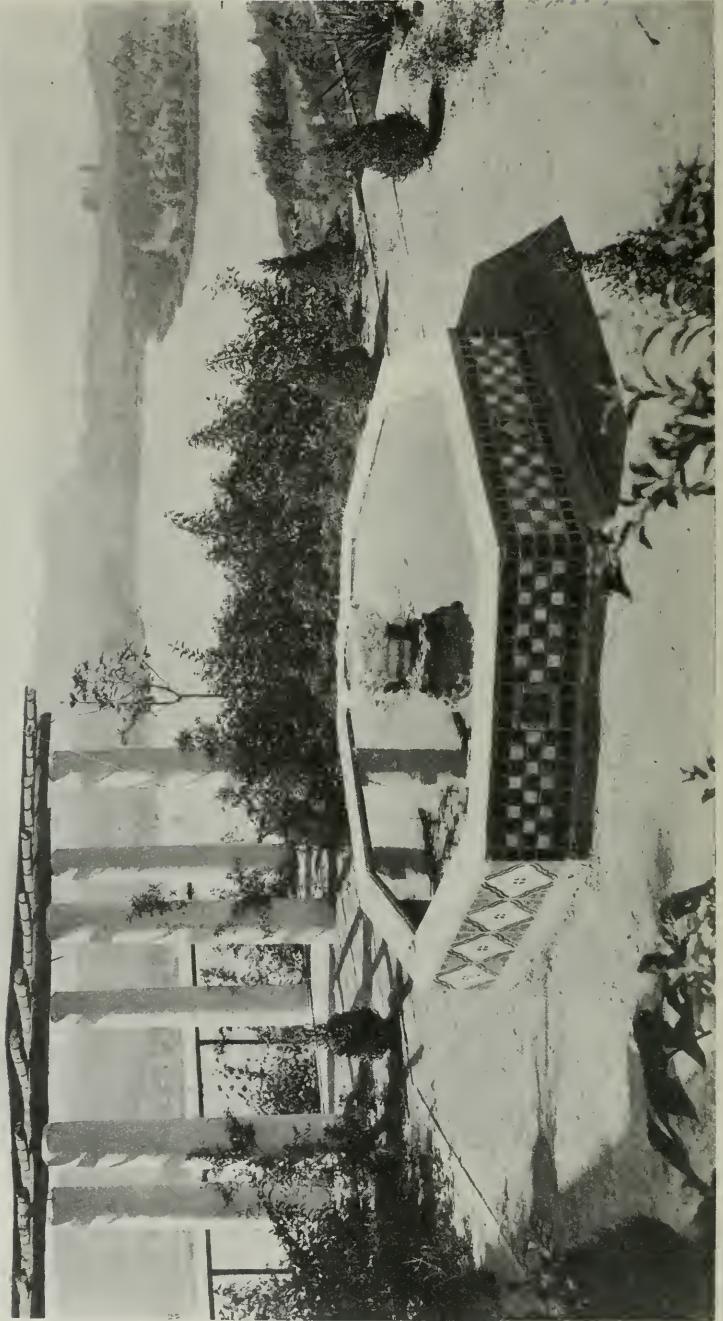

LOWER GARDEN, ELTINGE RESIDENCE, EDENDALE
PIERPONT AND WALTER S. DAVIS, H. F. WITHEY, ARCHITECTS
PLANTING BY CHAS. G. ADAMS, LANDSCAPE ARCHITECT

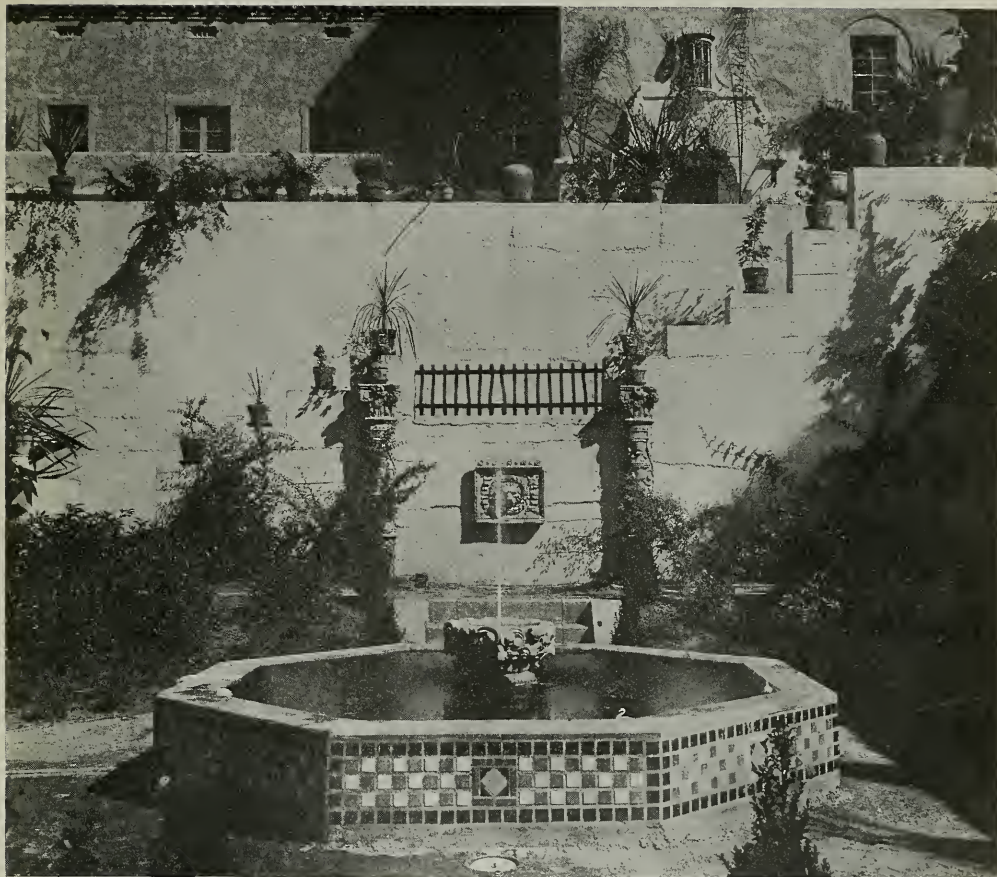

MOORISH FOUNTAIN, GARDEN OF JULIAN ELTINGE, EDENDALE
PIERPONT AND WALTER S. DAVIS, H. F. WITHEY, ARCHITECTS
PLANTING BY CHAS. G. ADAMS, LANDSCAPE ARCHITECT

One of the five most notable examples of
Landscape Architecture in Los Angeles,
as selected by the recent Jury.



VIEW FROM THE LOGGIA, FULLER GARDEN, PASADENA
Paul G. Thiene, Landscape Architect



LOOKING TOWARD THE HOUSE, FULLER GARDEN, PASADENA
Paul G. Thiene, Landscape Architect

One of the five most notable examples of Landscape Architecture in Los Angeles, as selected by the recent Jury.

Fuller Garden.—A rambling country garden of the so-called natural type, quite in contrast to the more formal arrangement of the smaller Eltinge Garden—yet with quite a distinct appeal. Here, in a few acres, trees, shrubs and flowers have been grouped with an art to rival nature and all worked in with judgment to produce open lawns and massed backgrounds in just the right proportion. While still a young garden, it gives great promise. Many older gardens seen might perhaps have displaced it on the list had they not seemed to have been altered and interrupted, with changes from the original complete design which impaired their attractiveness. This garden is full of charm and most refreshing in character.



GARDEN OF W. P. HERBERT, ARROYO DRIVE, PASADENA

One of the five most notable examples of Landscape Architecture in Los Angeles, as selected by the recent Jury.

Herbert Garden.—A small garden in the natural style, which makes the most of fine oaks and intelligent placing of an attractive house. Its open vistas and simple terraces express the feeling of home. It is all so pleasing, restful and harmonious as to invite leisure, and the masses of planting are warm in color. On the whole, this garden forms an admirable example of the landscape art of a simple country place.

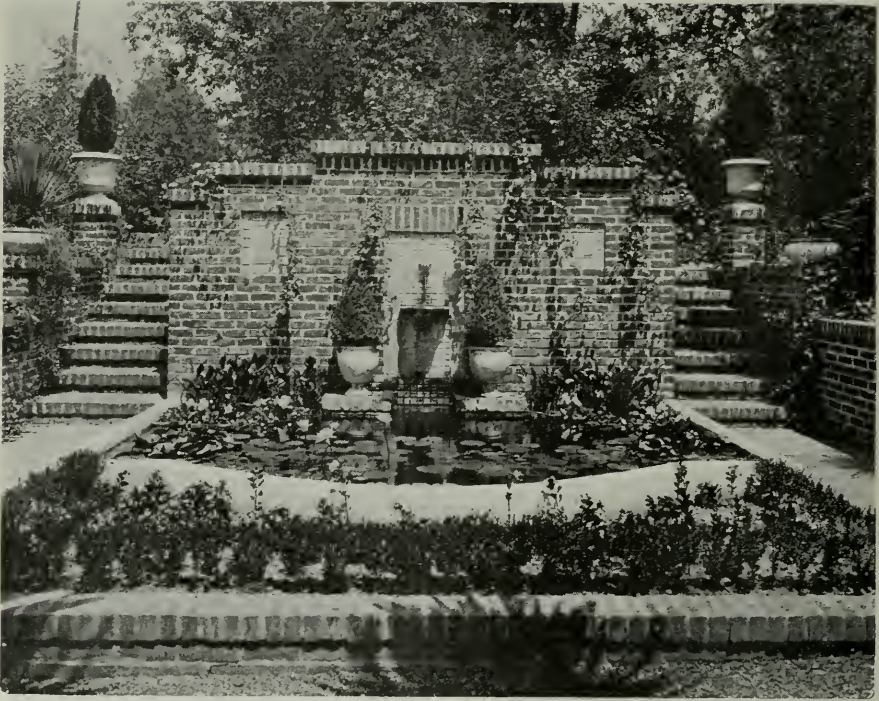

THE FOUNTAIN, GARDEN OF W. P. HERBERT, ARROYO DRIVE, PASADENA

One of the five most notable examples of Landscape Architecture in Los Angeles as selected by the recent Jury.

Murphy Garden.—A formal Italian garden of pleasing proportions, well planted, bordered with walls and balustrades and having an attractive pergola at the lower end. The planting has been most satisfactorily regulated to conform with the formal lines of the garden treatment, with just the right amount of accent at focal points. There are many exquisite points about it but the garden is somewhat detracted from by the house, which is not so successful in design.



THE FORMAL GARDEN, MURPHY RESIDENCE, WEST ADAMS STREET
Wilbur D. Cook, Landscape Architect



VIEW FROM THE LOGGIA, MURPHY RESIDENCE, WEST ADAMS STREET
Wilbur D. Cook, Landscape Architect

One of the five most notable examples of Landscape Architecture in Los Angeles, as selected by the recent Jury.



STEPS LEADING TO THE LOWER GARDEN
GARDENS OF MRS. FRANCIS F. PRENTISS, PASADENA
Greene & Greene, Architects

One of the five most notable examples of Landscape Architecture in Los Angeles, as selected by the recent Jury.

Prentiss Garden.—A very fine garden with formal features, showing a mixture of styles, but altogether charming in result. The planting of the area between the house and the street is here specially to be commended as developing in a most delightful way the expression of the architecture. A native ravine behind the house has been converted into a lower garden retreat of loveliest impression. Stairway, fountain and pool are so agreeably arranged as to give unusual interest, with surroundings of foliage into which all seems to fit most naturally. This is a garden to recall with pleasure.

The Five Most Notable Small Houses in Los Angeles

Good small houses are after all of paramount importance to Los Angeles, for this city is noted the world over as a city of small homes. Many are the compact, neatly designed houses to be seen in all parts of the city and a large number of them employ the art of building in a manner to merit calling them distinctly good architecture. Their attractiveness lies in good proportion, careful spacing of openings, and restrained use of detail and color.

The jury has found great pleasure in observing the increasing proportion of well designed small houses among those recently erected; and it considers the following five to be the most notable of those seen, alphabetically arranged:

- Bonestell Residence, 230 N. Ridgewood avenue;
- Davis Residence, 2114 Estrella avenue;
- Lyon Residence, 1907 Highland avenue, Hollywood;
- Residence, 1058 South Manhattan street;
- Residence, 1433 La Brea avenue.

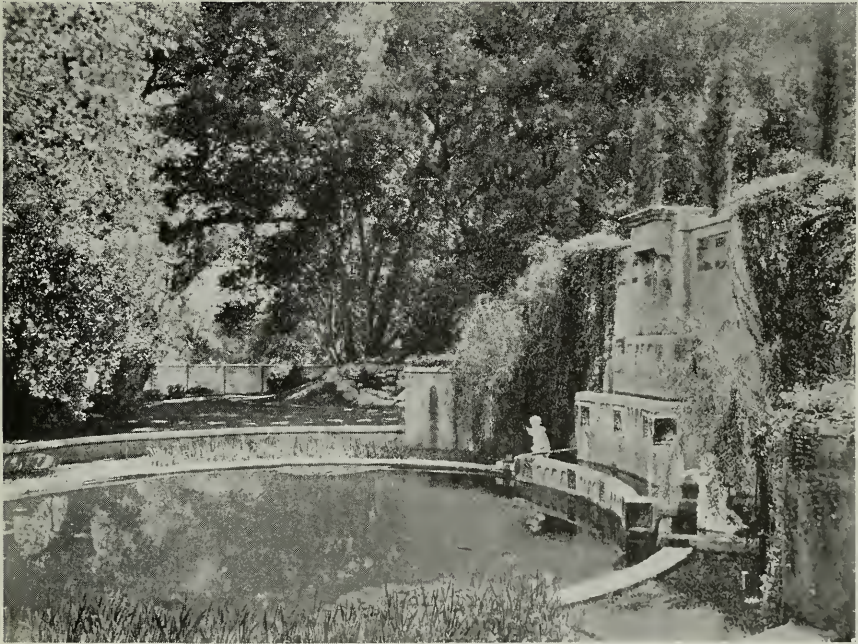

POOL IN THE LOWER GARDEN, GARDENS OF MRS. F. F. PRENTISS, PASADENA
Greene & Greene, Architects

One of the five most notable examples of
Landscape Architecture in Los Angeles,
as selected by the recent Jury.



BONESTELL RESIDENCE, 230 N. RIDGWOOD AVE.
Pierpont and Walter S. Davis, Henry F. Withey, Architects

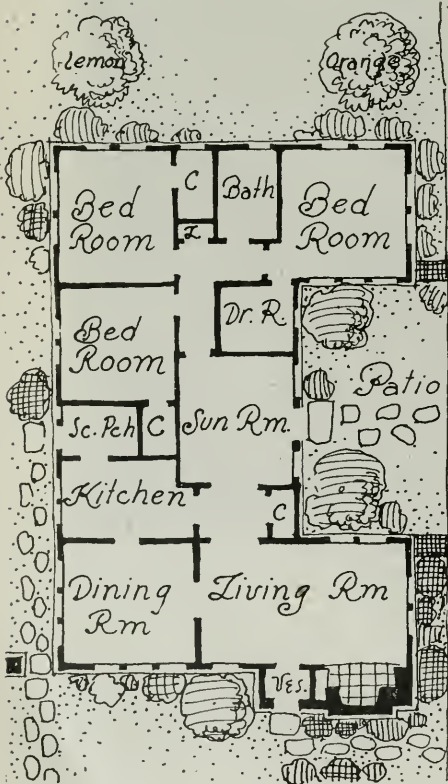

One of the five most notable examples of Small House Architecture in Los Angeles as selected by the recent Jury.

Bonstell Residence.—A Colonial type bungalow of somewhat different plan than the ordinary. The details in the living room, mantels, mouldings and decorations throughout, while of the simplest kind, make it an example of notable small house architecture.

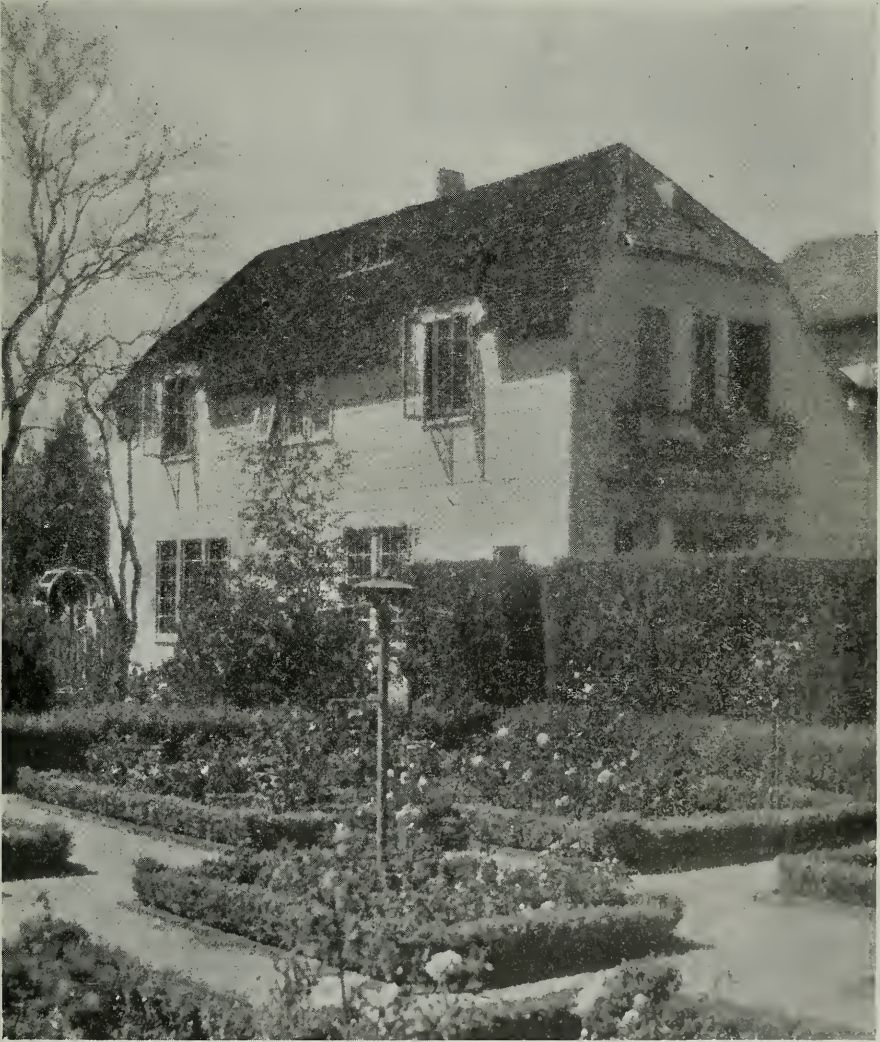

GARDEN VIEW, RESIDENCE OF MRS. PIERPONT DAVIS, ESTRELLA AVENUE
Pierpont Davis, Architect

One of the five most notable examples of Small House Architecture in Los Angeles, as selected by the recent Jury.

Davis Residence.—A modified Colonial cottage of fine proportion, in unusually good taste. The nice handling of roof, windows and doors and simple interior arrangements attract the attention and compel admiration. It is a modest home of a type of which there should be more in the West.

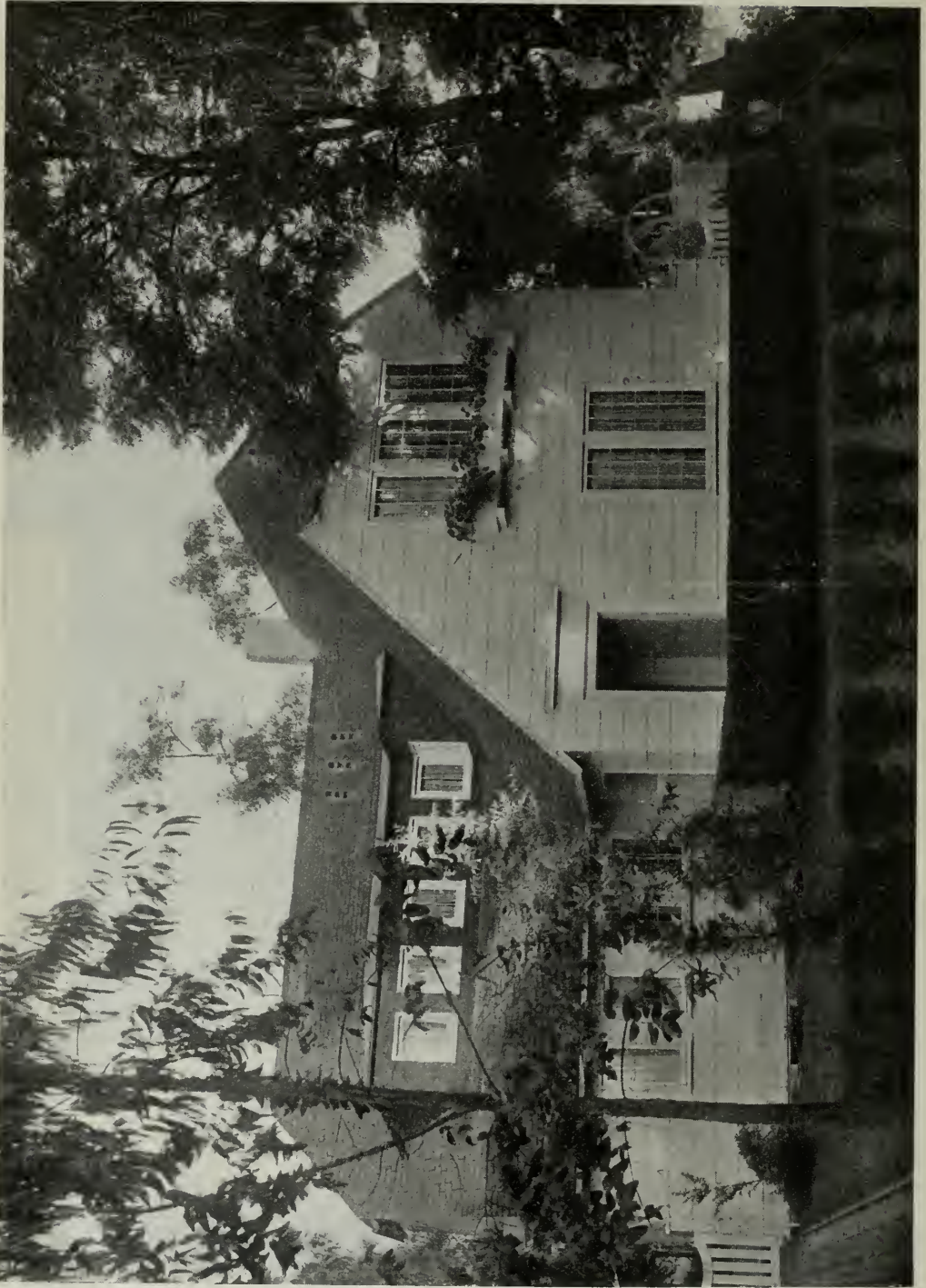

FACADE ON ESTRELLA AVENUE
RESIDENCE OF MRS. PIERPONT DAVIS
PIERPONT DAVIS, ARCHITECT

One of the five most notable examples of
Small House Architecture in Los Angeles,
as selected by the recent Jury.

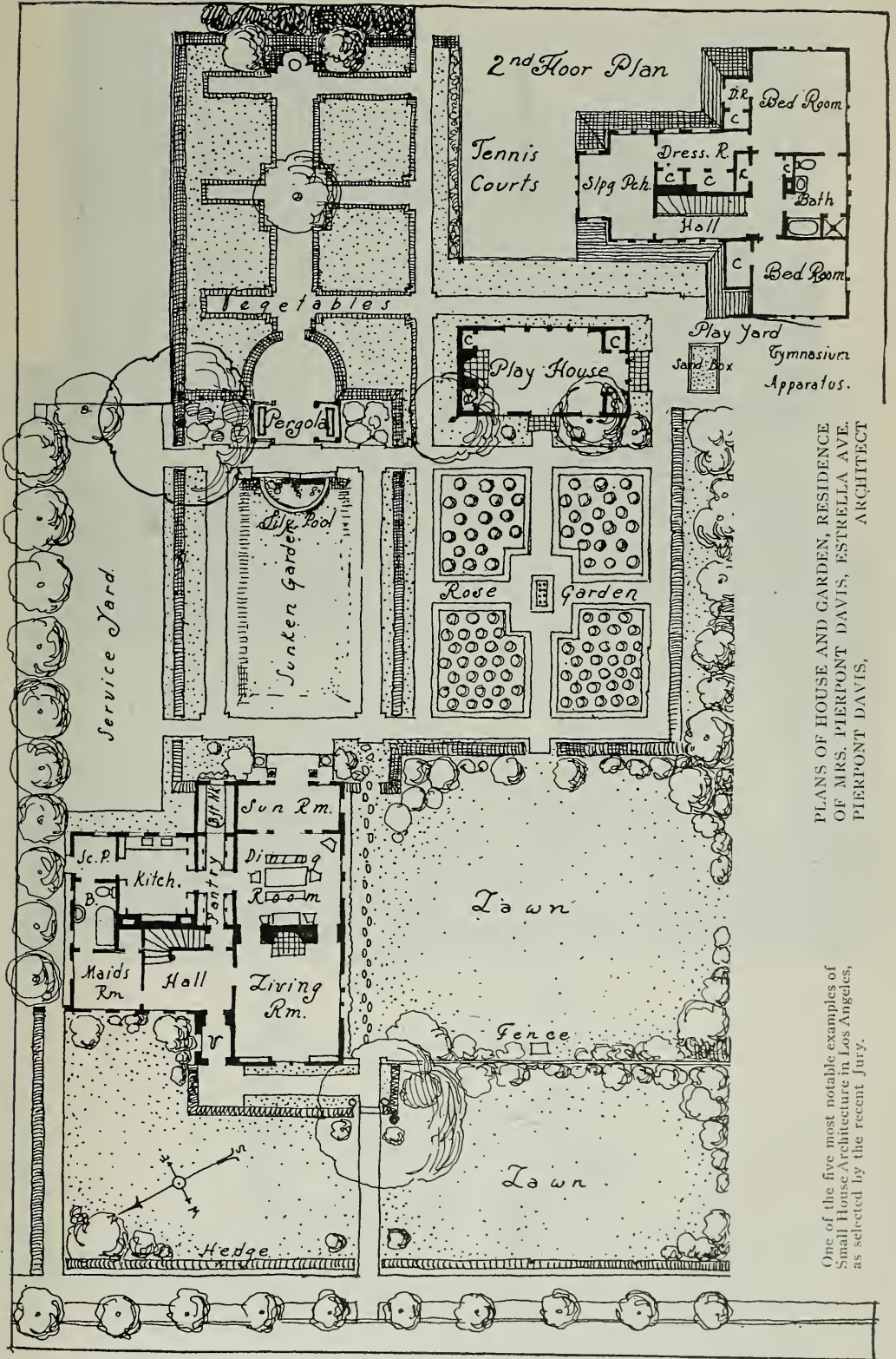

PLANS OF HOUSE AND GARDEN, RESIDENCE OF MRS. PIERPONT DAVIS, ESTRELLA AVE. PIERPONT DAVIS, ARCHITECT

One of the five most notable examples of Small House Architecture in Los Angeles, as selected by the recent Jury.



FRONT ELEVATION, LYON RESIDENCE, 1907 HIGHLAND AVE., HOLLYWOOD
 Pierpont and Walter S. Davis, H. F. Withey, Architects

One of the five most notable examples of Small House Architecture in Los Angeles, as selected by the recent Jury.

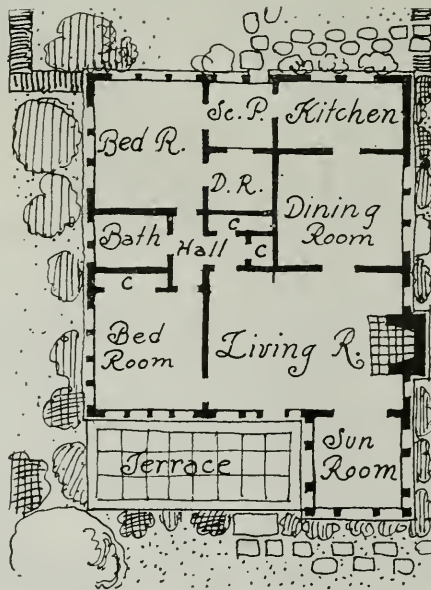

PLAN, LYON RESIDENCE, HOLLYWOOD

Lyon Residence.—A small bungalow in the English cottage style, handled more simply than the Davis residence, expressing in lesser degree but very definitely the same attractive qualities of design. Many other small houses were compared with this but they nearly all lacked that essential character and restraint so necessary to good architectural design. There is an intangible and restful quality of home about this building perhaps due to its small and intimate scale that distinguishes it from among many of the other small houses.



SIDE VIEW, LYON RESIDENCE, HOLLYWOOD
Pierpont and Walter S. Davis, H. F. Withey, Architects

One of the five most notable examples of
Small House Architecture in Los Angeles,
as selected by the recent Jury.



VIEW OF ENTRANCE, RESIDENCE AT 1058 S. MANHATTAN STREET
 Designed by Davidson Construction Co.

Residence at 1058 South Manhattan Street.—A plaster bungalow in Italian style of very distinct character. It represents marked advance in small house design.

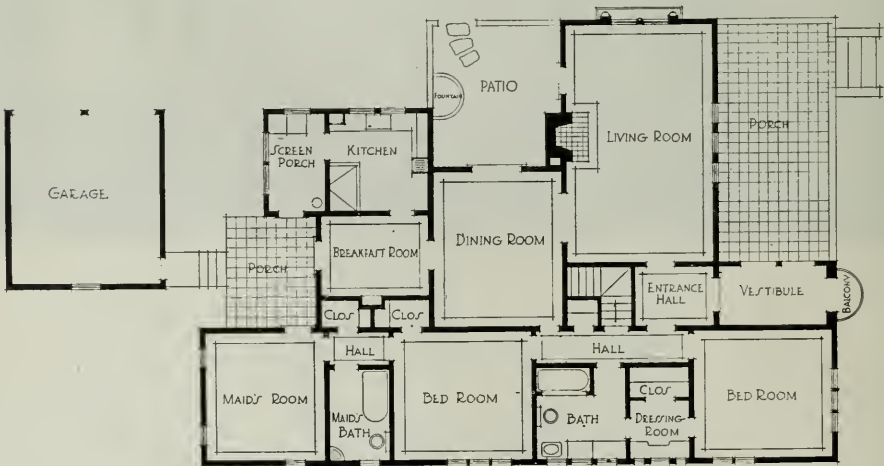

PLAN OF RESIDENCE AT 1058 S. MANHATTAN STREET
 Designed by Davidson Construction Co.

One of the five most notable examples of Small House Architecture in Los Angeles, as selected by the recent Jury.

Residence at 1433 La Brea Avenue.—Another plaster bungalow in Italian style, which in a different way, shows the result of study and restraint in handling.

These five small houses are remarkable for their design and good taste. There are undoubtedly others which the jury failed to find, but these set so high a standard as to well represent the city.

Honorable Mention of Other Notable Examples of Architecture and Landscape Architecture in Los Angeles

While the foregoing selections represent, in the opinion of your jury, the most notable examples of architecture, landscape architecture and small houses, there are a considerable number of other examples which are very worthy of note, and they have been awarded honorable mention, as follows:

Honorable Mention for Architecture—General:

Arcaded Store Building, 327 Colorado street, Pasadena;
 Arroyo Seco Bridge, Colorado street, Pasadena;
 Church of the Holy Faith, Inglewood;
 Eaton Residence, Oak Knoll, Pasadena;
 English Shops, 312 W. Colorado street, Pasadena;
 First National Bank Building, Beverly;
 Garden Court Garage, Hollywood;
 Garford Residence, Oak Knoll and Hill Crest avenue, Pasadena;
 Herbert Residence, Arroyo Drive, Pasadena;
 Keck Residence, 836 El Molino avenue, Pasadena;
 Post Office, Pasadena;
 Residence, 3836 West Seventh street;
 Savoy Hotel, Sixth street;
 Second Church of Christ, Scientist, W. Adams street;
 Stephens Residence, Oak Grove avenue, Pasadena;
 Thiers Residence, 596 Leslie avenue, Pasadena;
 Ynez School, Garvey avenue, Alhambra.

Honorable Mention for Landscape Architecture:

Beverly Station Gardens, Beverly;
 Davis Garden, 2114 Estrella avenue;
 Huntington Garden, Tapis Vert, Pasadena;
 Hinds Garden, 880 La Loma Road, Pasadena;
 Keeler Hawaiian Garden, La Brea avenue, Hollywood.

Honorable Mention for Architecture—Small Houses:

Double Residence, Crown Hill;
 Residence, 1427 La Brae avenue, Hollywood;
 Residence, 434 Shatto Place;
 Shrader Residence, 1927 Highland avenue, Hollywood;
 Flemish Farm House, 2414 Highland avenue, Hollywood;
 Muchmore Residence, 2402 Highland avenue, Hollywood;
 Residence, 7520 Hollywood boulevard, Hollywood;
 Residence, 1111 Western avenue;
 Residence, 1124 S. Manhattan Place;
 Bronson House Court, 1729 N. Bronson avenue, Hollywood;
 Firenze House Court, 5280 Sunset boulevard, Hollywood.

In Conclusion

It is impossible to conclude this report without special mention of three places visited by the jury which stand out preeminently as most charming and tasteful examples of unity between the house and its garden and landscape work. These places are the S. S. Hinds estate, 880 La Loma Road, Pasadena; the Garford estate, Oak Knoll and Hill Crest avenue, Pasadena; and the Herbert estate, Arroyo Drive, Pasadena. All three of these places, although differing greatly in size and method of development, possess a singular charm in the fact that the house and garden seem literally to be growths each of the other and the resultant effect produces that quality of unity and fitness which is the ultimate aim of all good design.

There has evidently been a marked advance in the number of notable examples of architecture and landscape architecture in the vicinity of Los Angeles during the past decade. While this bodes well for the future of these arts, the public in general must be made to know about them and to cultivate a taste for them before anything like a general demand for higher standards may be expected. That is the purpose, we understand, of having a jury report such as this at this time.

This report is made primarily for the benefit of laymen—not for architects. It is only relative in importance. The present selections of the jury are only valuable to help the layman to a better understanding of such things by giving him some definite examples with which to compare the other buildings he sees everywhere about him. They should serve him as a starting point in the cultivation of discrimination and taste in architecture. Any well selected group of buildings and gardens might serve this purpose, but this jury is unanimous that the lists here presented contain, in its judgment, the best examples for the Chapter to offer for such study.

It is not that the selections here made should be considered the last word on the subject. Friendly differences of opinion are to be expected and are perhaps a good thing if they only provoke greater discussion and interest in architecture. No jury can be infallible—your jury understands that fully, and feels sure that the members of the Chapter will also appreciate this fact and, in doing so, will set aside personal opinion until another as well or better qualified jury can substitute a similar determination for the benefit of laymen.

The time is ripe for interesting the ordinary man, if the architects, as a body, can only sufficiently lay aside their differences of opinion and organize public discussion of the things that are worth while in building design. We believe a common starting point such as this is all that is needed to give the layman outlet for a long pent-up desire for deeper understanding of architecture. We are in hearty sympathy with the Chapter in trying to work this out.

In conclusion, the jury respectfully offers the following definite suggestions:

1. That the Chapter work out with the Municipal Art Commission and secure the passage of a Charter amendment giving this Commission firmer control of the design of public structures and, particularly, of public sculpture, as in New York City, Philadelphia, and elsewhere. Accomplishment of this will do more in a large way to help the architecture of public buildings than any other one thing that the Chapter can do.
2. That the Chapter formally request the new City Planning Commission to undertake, as one of its items of work, a study of definite steps that will tend to improve the architecture and landscape architecture of private property in and near the city, thereby adding greatly to the attractiveness and value of the city to its inhabitants and to visitors.
3. That in 1925, or sooner, a new jury selection of the same items be repeated to see how far comparatively these arts have progressed, and particularly to serve as a further stimulus to public interest and discussion of better architecture.

And finally permit the jury to thank the members of the Chapter for the confidence reposed in it, in selecting us to undertake this most interesting task, embarrassing though it proved to be on account of the great number of very fine examples of architecture and landscape architecture which could not be premiated.

It was a privilege to serve you.

Respectfully submitted,

JOHN W. MITCHELL (Chairman).

JOHN A. COMSTOCK.

WINSOR SOULE, A. I. A.

J. T. VAWTER, A. I. A.,

CHAS. H. CHENEY, A. I. A. (Secretary).



ARCADED STORE, 327 COLORADO STREET, PASADENA
Marston & Van Pelt, Architects

Awarded honorable mention as a notable example of Architecture in Los Angeles by the recent Jury.



ARROYO SECO BRIDGE, PASADENA
Harrington, Howard and Ash, Engineers

Awarded honorable mention as a notable example of Architecture in Los Angeles by the recent Jury.



CHURCH OF THE HOLY FAITH, INGLEWOOD
Herbert Frohman and H. H. Martin, Architects

Awarded honorable mention as a notable example of Architecture in Los Angeles by the recent Jury.

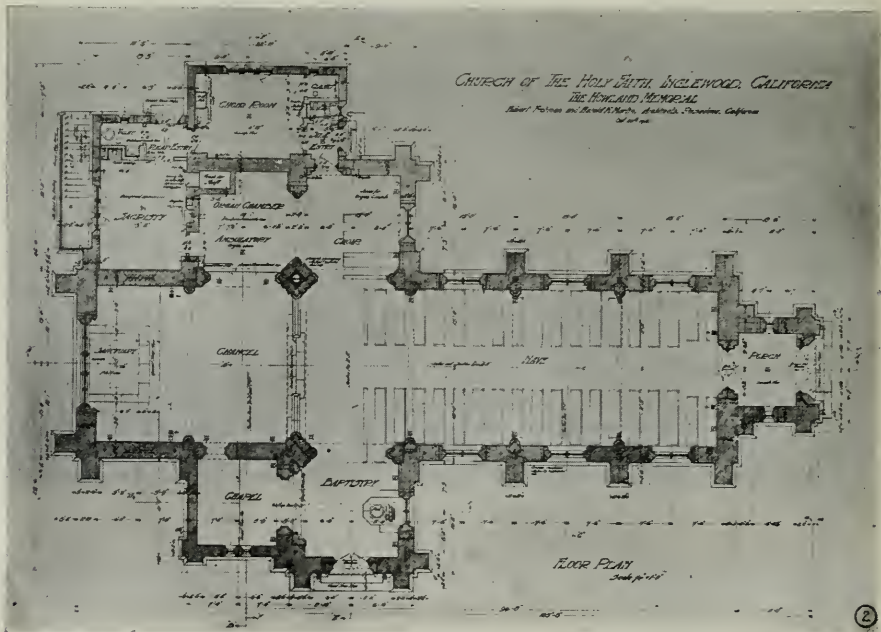

PLAN, CHURCH OF THE HOLY FAITH, INGLEWOOD
Herbert Frohman and H. H. Martin, Architects



TUDOR SHOPS, 312 W. COLORADO STREET, PASADENA
Designed by Kenneth A. Gordon

Awarded honorable mention as a notable example of Architecture in Los Angeles by the recent Jury.



INTERIOR TUDOR SHOPS, PASADENA
Designed by Kenneth A. Gordon



FIRST NATIONAL BANK, BEVERLY HILLS
Designed by Frank Meline

Awarded honorable mention as a notable example of Architecture in Los Angeles by the recent Jury.

Report of Twelfth National Conference on City Planning*

By CHAS. H. CHENEY, Delegate from the Portland, Spokane and Berkeley City Planning Commissions.

PRACTICAL means of unification of railroad terminals in cities, the advantage of zoning into business, residence and industrial districts, and stirring reports of progress actually made in carrying out city plans in many cities were the principal matters of interest at the Twelfth Annual Meeting of the National Conference on City Planning at Cincinnati April 19th to 22nd. The urban auto problem, and regional planning to tie in the suburbs and back-country of the city, were also very fully taken up, and with officials and planning experts of more than fifty cities on hand, and between two and three hundred present at each session, it was the liveliest and most constructive conference yet held, with much of value to all cities brought out in the discussions.

* Held at Cincinnati, April 19-22, 1920.



STREET VIEW OF THE GARFORD RESIDENCES, OAK KNOLL AVENUE, PASADENA
Marston & Van Pelt, Architects

Awarded honorable mention as a notable example of Architecture in Los Angeles by the recent Jury.

MARKED PROGRESS IN ZONING

Great progress in the zoning or districting of cities, as the first fundamental step in bringing order out of the usual haphazard development, was reported from places of all sizes and kinds, and from widely separated parts of the country. A short time ago the Pacific Coast seemed to be in the lead in such matters, but the war has aroused Eastern cities very generally to the pressing importance of planning more carefully in advance for industrial expansion, the housing of workers and the general improvement of all living and working conditions, and they are going about it now, in most thorough and businesslike fashion.

Experience of cities that have already adopted zone ordinances was described by representatives of New York City, St. Louis, Newark, Rochester, Niagara Falls, Alameda, Minneapolis, Berkeley, Los Angeles, and a number of smaller places. In every case the ordinances were reported as working well and in many instances were shown to have done a great deal for the city in attracting new industries, protecting homes, and helping business, as well as by stabilizing property values. Comprehensive zoning plans nearing process of completion were reported from Detroit, Philadelphia, Akron, Cleveland, Omaha, San Francisco, Portland, and Spokane. In addition the following cities are just starting their zoning: Washington, D. C., Chicago, Pittsburg, Dallas, St. Paul, Los Angeles (new comprehensive ordinance), Seattle, and many smaller cities.



GARDEN VIEW OF THE GARFORD RESIDENCES, PASADENA
Marston & Van Pelt, Architects

Awarded honorable mention as a notable example of Architecture in Los Angeles by the recent Jury.



RESIDENCE OF W. P. HERBERT, ARROYO DRIVE, PASADENA
Reginald D. Johnson, Architect

Awarded honorable mention as a notable example of Architecture in Los Angeles by the recent Jury.

ZONING BRINGS BIG INDUSTRIES TO ST. LOUIS

There can be little doubt that zoning has done a great deal for St. Louis. In passing through there I was shown in one district \$20,000,000 of new industrial plants, mostly still under construction, which they claim chose St. Louis instead of Chicago to locate in, because of the protection offered to industries in this new northwest industrial district. It is on the belt-line railroad and adjoining it are many miles of small workers' homes, established as residence zones under their ordinance of 1918.

After these new industries were well along I was told that speculators tried to have certain parts of the adjoining residence blocks changed to industrial zones, although not served with trackage, etc., but the industries immediately protested to the City Plan Commission and the City Council that one of their chief objects of locating in this section was to be sure of nearby protected home neighborhoods for their workers. Their contention was sustained and the residence districts kept as they are.

Officials and others in Chicago are very frank in the statement that on account of such losses to St. Louis and to other progressive cities of the Middle West they have come to see the importance of zoning and intend to push the preparation of a comprehensive ordinance immediately, a first appropriation of \$30,000 having been made for the work of their new Zoning Commission, now being appointed, during the balance of this year.

GETTING RESULTS IN CITY PLANNING

Detroit with a City Plan Commission that virtually controls the whole physical development of the city, and is said to have more power than any other commission in the country, has evolved a comprehensive city plan, on which much headway has been made, T. Glenn Phillips, consultant to the commission, announced in a discussion of Detroit's progress. This Commission outlined a park system plan as a result of which \$10,000,000 in bonds was voted last year, which will establish an elaborate system of playgrounds and playfields, and has made a complete map of the city property of Detroit to prevent the city condemning for its own use some of its own property, as had actually occurred in some cases. Out of 86 projects submitted by the Commission to City Council, 72 have been passed, he explained.



GARDEN COURT GARAGE, HOLLYWOOD
Designed by Frank Melrose

Awarded honorable mention as a notable example of Architecture in Los Angeles by the recent Jury.

RESULTS DUE TO ADEQUATE APPROPRIATIONS FOR CITY PLAN COMMISSIONS

The great practical results being obtained from city planning in Eastern cities can largely be traced to those commissions which have been supplied with adequate budget appropriations by their city councils. The following recent budgets are typical. They were given me by the delegates of these cities and are for the making of plans and educational work of the City Plan Commission only, including employment of expert help, secretary, draftsman, stenographer, printing, supplies, etc.

RECENT APPROPRIATIONS FOR CITY PLANNING COMMISSIONS

Detroit (population estimated 900,000) appropriated \$50,000 for 1919 and \$42,000 for 1920; St. Louis (population estimated 775,000) appropriated \$25,500 for 1917-18, \$24,270 for 1918-19, and \$19,160 for 1919-20; Cleveland (population estimated 750,000) appropriated \$24,000 for 1920; Cincinnati (population estimated 400,000) appropriated \$10,000 for 1920 with similar amount promised for 1921 and 1922. This has been supplemented by subscriptions of citizens, already amounting to \$25,000 and expected to reach \$70,000 this year, at the disposal of the City Plan Commission; Akron, Ohio (population estimated 150,000) appropriated \$19,000 for 1920; and St. Paul, Minn. (population estimated 225,000) appropriated \$25,000 for 1920.

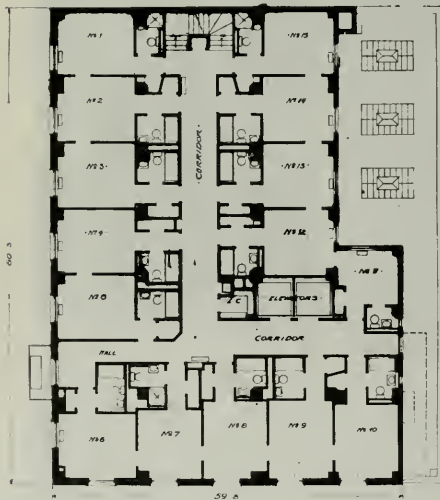

SAVOY HOTEL
LOS ANGELES CALIFORNIA

MORGAN WALLS & MORGAN
ARCHITECTS & ENGINEERS

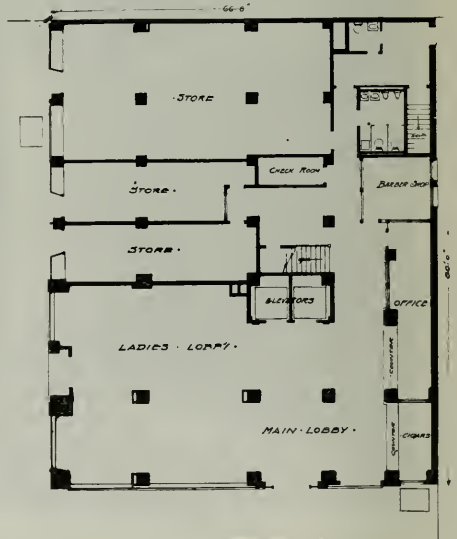

FIRST FLOOR PLAN

PLANS OF THE SAVOY HOTEL, SIXTH STREET
Morgan, Walls & Morgan, Architects

Awarded honorable mention as a notable example of Architecture in Los Angeles by the recent Jury.



Awarded honorable mention as a notable example of Architecture in Los Angeles by the recent Jury.

SAVOY HOTEL, SIXTH STREET
MORGAN, WALLS & MORGAN, ARCHITECTS



SECOND CHURCH OF CHRIST
SCIENTIST, WEST ADAMS ST.
A. F. ROSENHEIM, ARCHITECT

Awarded honorable mention as a
notable example of Architecture in
Los Angeles by the recent Jury.

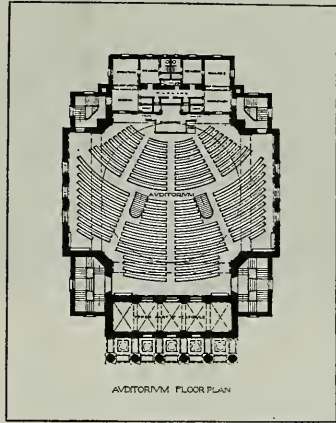
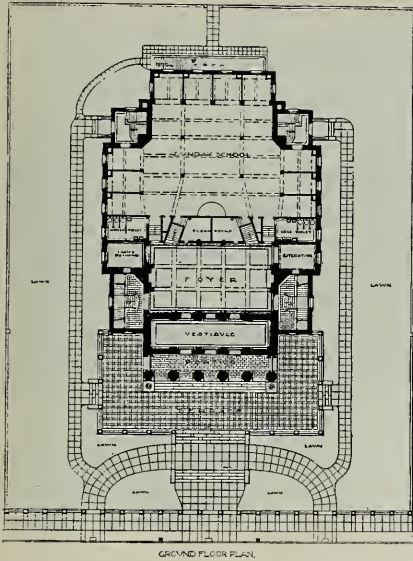

PLANS OF THE SECOND CHURCH OF CHRIST, SCIENTIST, WEST ADAMS STREET
A. F. Rosenheim, Architect

Awarded honorable mention as a notable example of Architecture in Los Angeles by the recent Jury.



POST OFFICE, PASADENA

Designed by the Supervising Architect, U. S. Treasury Department, Washington, D. C.

Awarded honorable mention as a notable example of Architecture in Los Angeles by the recent Jury.



HINDS GARDEN, LA LOMA ROAD, PASADENA
Howard & Smith, Landscape Architects

Awarded honorable mention as a notable example of Landscape Architecture in Los Angeles, by the recent Jury.

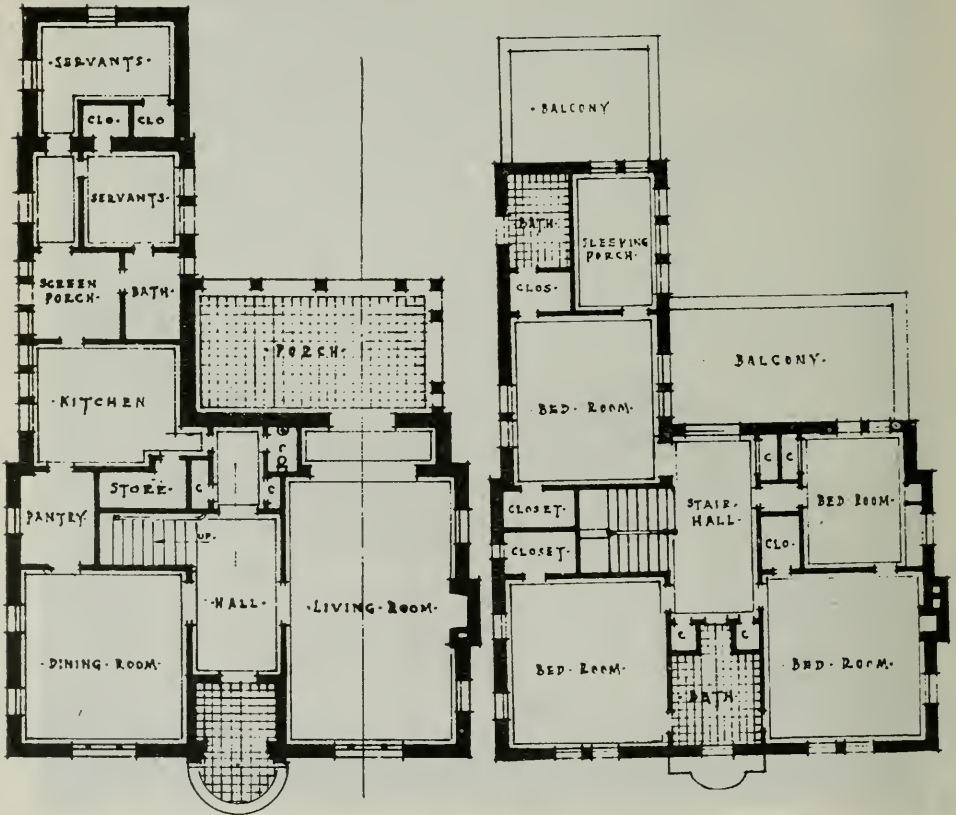

FIRST AND SECOND FLOOR PLANS
RESIDENCE OF BRIGGS C. KECK, OAK KNOLL, PASADENA
Reginald D. Johnson, Architect

Awarded honorable mention as a notable example of Architecture in Los Angeles by the recent Jury.



LOWER GARDEN AND POOL, HINDS GARDEN, PASADENA
Howard & Smith, Landscape Architects

Awarded honorable mention as a notable example of Landscape Architecture in Los Angeles, by the recent Jury.



RESIDENCE OF BRIGGS C. KECK, OAK KNOLL, PASADENA
Reginald D. Johnson, Architect

Awarded honorable mention as a notable example of Architecture in Los Angeles by the recent Jury.



RESIDENCE OF E. ROSCOE SHRADER, 1927 HIGHLAND AVENUE, HOLLYWOOD
Mead & Requa, Architects

Awarded honorable mention as a notable example of Small House Architecture in Los Angeles, by the recent Jury.

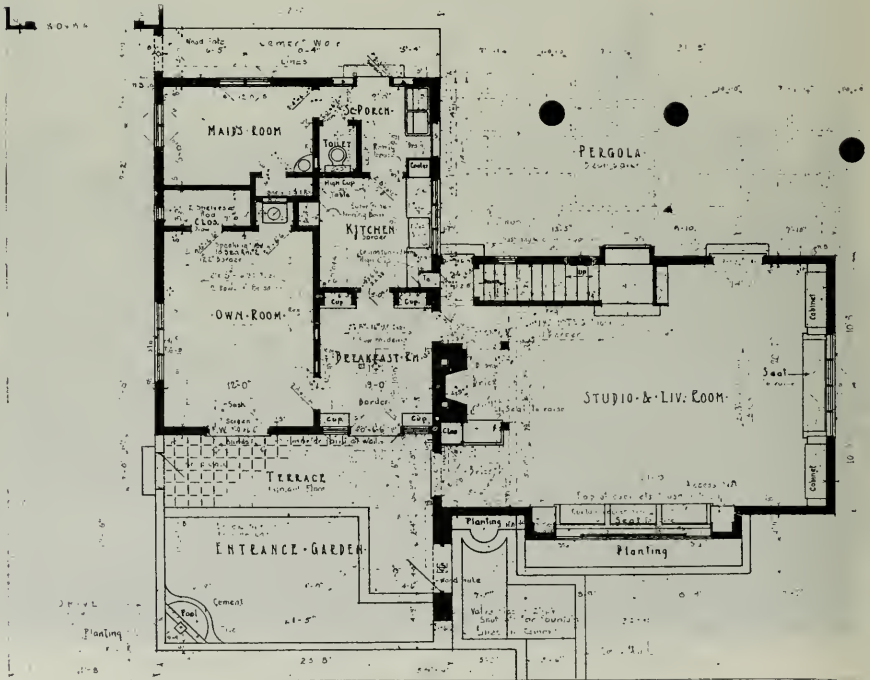

PLAN, RESIDENCE OF E. ROSCOE SHRADER
Mead & Requa, Architects



PATIO OF RESIDENCE OF E. ROSCOE SHRADER, HOLLYWOOD
Mead & Requa, Architects

Awarded honorable mention as a notable
example of Small House Architecture in
Los Angeles, by the recent Jury.



HAWAIIAN GARDEN OF F. C. KEELER, LA BREA AVENUE, HOLLYWOOD
Howard & Smith, Landscape Architects

Awarded honorable mention as a notable
example of Landscape Architecture in
Los Angeles, by the recent Jury.



FLEMISH FARMHOUSE, 2414 HIGHLAND AVENUE, HOLLYWOOD
Pierpont and Walter S. Davis, H. F. Withey, Architects

Awarded honorable mention as a notable example of Small House Architecture in Los Angeles, by the recent Jury.



YNEZ GRAMMAR SCHOOL, GARVEY AVENUE, ALHAMBRA
Allison & Allison, Architects

Awarded honorable mention as a notable example of Architecture in Los Angeles by the recent Jury.

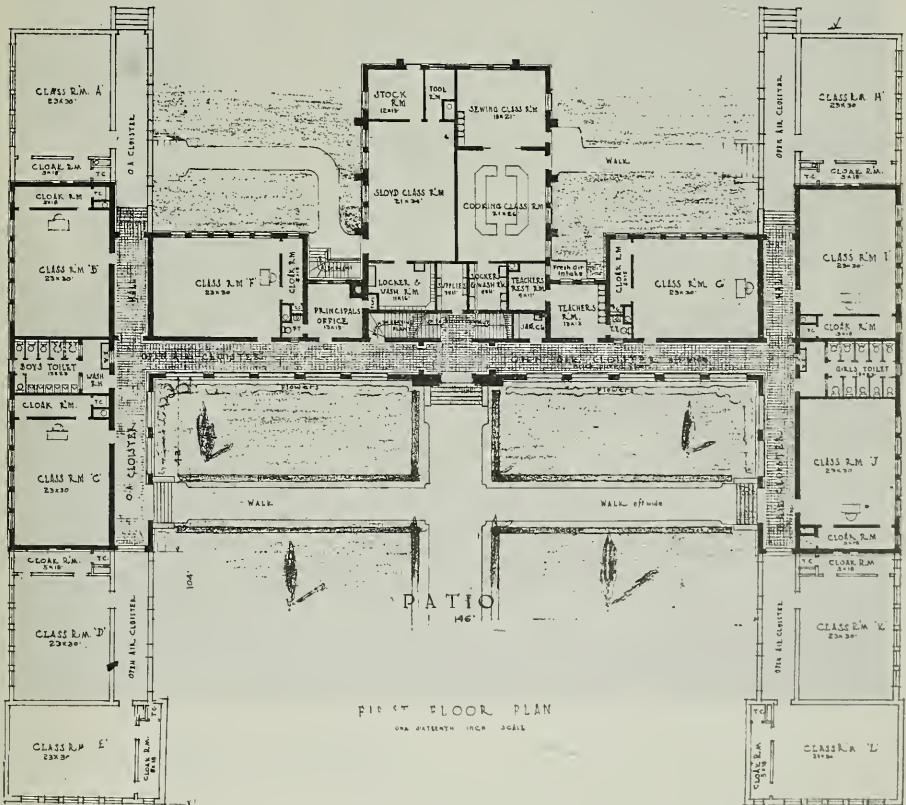
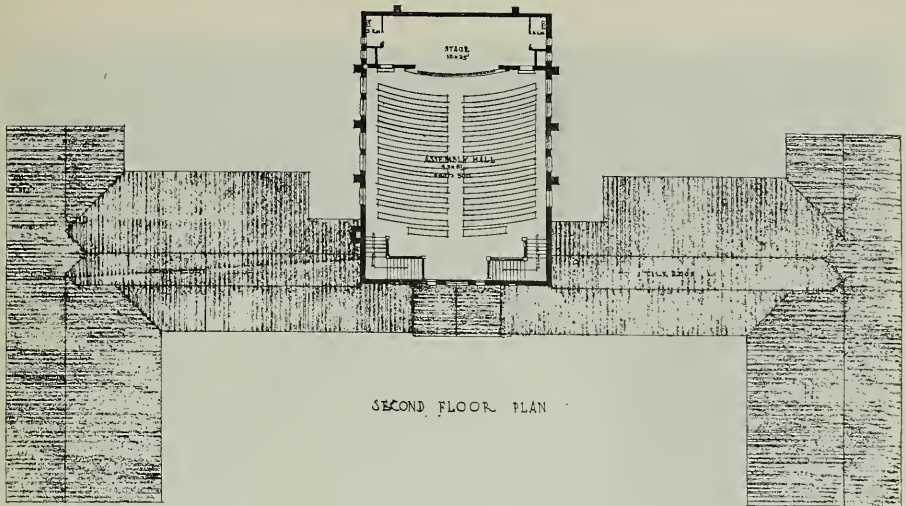

PLAN OF YNEZ GRAMMAR SCHOOL
GARVEY AVENUE, ALHAMBRA
ALLISON & ALLISON, ARCHITECTS

Awarded honorable mention as a notable example of Architecture in Los Angeles by the recent Jury.



RESIDENCE OF E. C. THIERS
596 LESLIE AVENUE, PASADENA
REGINALD D. JOHNSON, ARCHITECT

Awarded honorable mention as a notable example of Architecture in Los Angeles by the recent Jury.



GARDEN OF MRS. PIERPONT DAVIS, ESTRELLA, STREET
PIERPONT DAVIS, ARCHITECT

Awarded honorable mention as a notable example of Landscape Architecture in Los Angeles, by the recent Jury.



Awarded honorable mention as a notable example of Small House Architecture in Los Angeles, by the recent Jury.

RESIDENCE, 2402 HIGHLAND AVENUE, HOLLYWOOD
PIERPONT AND WALTER S. DAVIS, H. F. WITHEY, ARCHITECTS

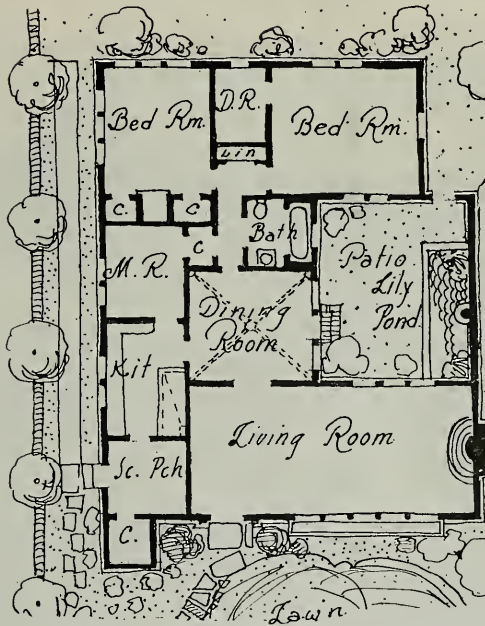

PLAN, RESIDENCE, 2402 HIGHLAND AVENUE, HOLLYWOOD
 Pierpont and Walter S. Davis, Henry F. Withey, Architects



DOUBLE RESIDENCE, CROWN HILL
 David J. Witmer, Architect

Awarded honorable mention as a notable example of Small House Architecture in Los Angeles, by the recent Jury.

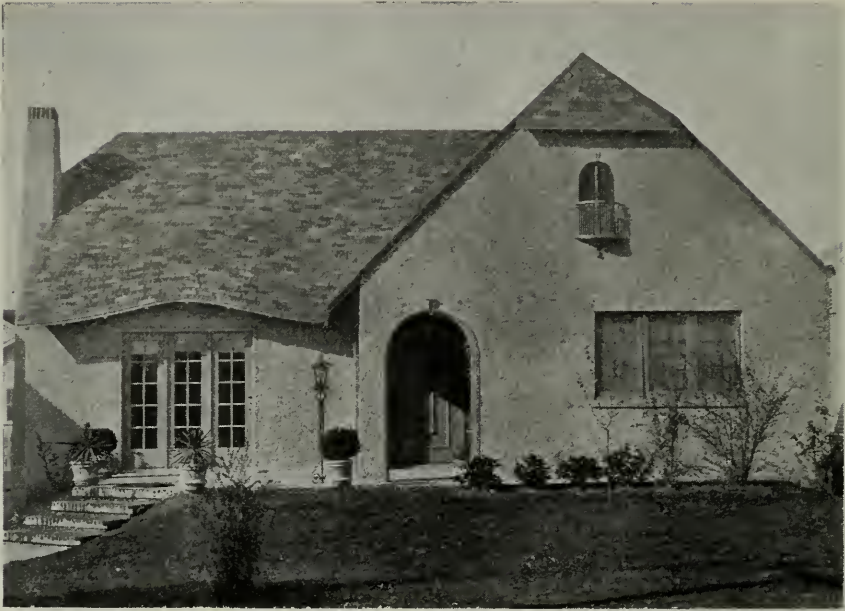

HOUSE AT 1111 SOUTH WESTERN AVENUE
 Designed by Davidson Construction Co.

Awarded honorable mention as a notable example of Architecture in Los Angeles by the recent Jury.

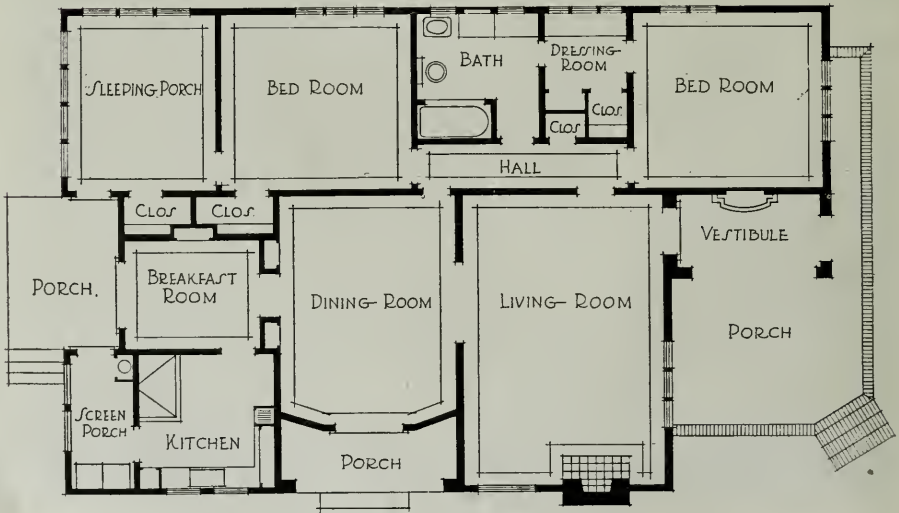

PLAN OF HOUSE AT 1111 SOUTH WESTERN AVENUE
 Designed by Davidson Construction Co.



PLAN OF RESIDENCE AT 1124 S. MANHATTAN STREET
Designed by Davidson Construction Co.

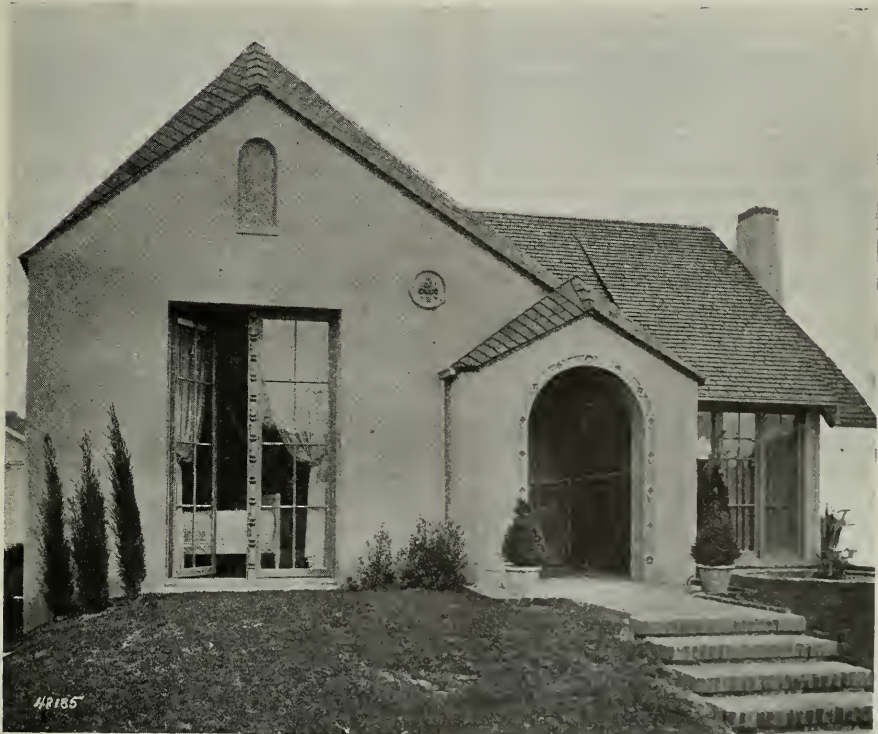

RESIDENCE AT 1124 S. MANHATTAN STREET
Designed by Davidson Construction Co.

Awarded honorable mention as a notable example of Small House Architecture in Los Angeles, by the recent Jury.

THE Architect and Engineer

INCORPORATED

Founded 1905 by E. M. C. WHITNEY

W. J. L. KIERULFF - *President and Manager*
 FRED'K W. JONES - *Vice-Pres. and Editor*
 L. PENHORWOOD - *Secretary*
 T. C. KIERULFF - *Attorney*

ASSOCIATE EDITORS

IRVING F. MORROW - *Architectural Critic*
 CHAS. H. CHENEY - *City Planning and Book Reviews*
 WILBUR DAVID COOK, *Landscape Architecture*
 WM. B. GESTER, - *Inspection and Tests*
 O. P. SHELLEY, C. E., } *Fireproof Construction*
 F. W. FITZPATRICK, }
 T. RONNEBERG, C. E., - *Structural Steel*
 W. H. LOWE - *Roofs and Roofing*
 FRED'K N. WOODS, JR., - *Rock and Gravel*
 W. H. GEORGE - *Cement*
 PAUL C. BUTTE - *Electrical Construction*
 H. J. BRUNNIE - *Reinforced Concrete*
 I. W. FRICKE, - *School Equipment*
 C. H. WHITE - *Hardwood*
 WILL J. FRENCH, *Department of Safety*

Published Monthly in the Interest of the Architects, Structural Engineers, Contractors and the Allied Trades of the Pacific Coast by The Architect and Engineer Co.

BUSINESS OFFICE AND EDITORIAL ROOMS
 627-629 Foxcroft Building, San Francisco
 Telephone Douglas 1828

The publishers disclaim any responsibility for statements made in the advertisements of this magazine.

TERMS OF SUBSCRIPTION
 (Including postage) to all parts of the United States \$2.50 per annum; to Canada 75c additional; to all Foreign points \$1 additional.

Vol. LXII. AUGUST, 1920 No. 2

GIVE THE LAYMAN A CHANCE

Some of the architects in Los Angeles, we understand, have been prone to disagree with the findings of the jury. That is to be expected. It seems probable to us that they would not all agree entirely with the selections of any jury, but is that the important thing?

We confess that we are very much in sympathy with the efforts of the Chapter of Architects in Los Angeles to give the layman a list of buildings, selected by men who should know something about it, with which to compare the other buildings of the city. In the present case a great deal of time and care seems to have been given to the subject and it is certainly a splendid thing that the members of the Chapter have so far laid aside their honest differences of opinion in order to give the ordinary man something definite to start with. The word of any jury selected by the Chapter is bound to have weight with the public.

The layman heretofore has had very little help from the architects as a profession, to guide him to a better understanding of some of the things that are worth while in buildings and gardens. We have had for many years many notable examples of architecture and landscape architecture among us, but the poor layman has always found it difficult, or well-nigh impossible, to get his friends among the architects to give him a definite list of buildings, all of which might be said to come up to a definite standard of some kind.

What we lack, or rather what the ordinary layman lacks, is an opportunity to get at standards of comparison, and these jury selections of the Los Angeles Chapter, and previously of the Portland Chapter, should go far toward helping him to more definite thought. Architecture must be thought about, talked about and cared about much more by the average man if we are to materially increase the number of really good buildings and gardens.

DIFFERENCE IN ARCHITECTURAL STYLES

Climate undoubtedly considerably affects the styles of architecture employed in any country. A comparison of the notable buildings of Portland, selected by a jury of the Oregon Chapter of Architects a year ago and published in the March, 1919, number of this magazine, with the recent selections in Los Angeles, shows how differently the two localities and their opposite climates have influenced the design of buildings. In Los Angeles, with its bright sunshine, the architects have been inspired more and more from the old-world architecture found under similar climatic conditions along the Mediterranean, while in Portland they seem to have been inspired more from the English and French styles, developed in the colder and more northerly weather of that part of Europe, corresponding in many ways to the northern states of this country.

Portland, perhaps because it is an older city, seems to have developed more public and business buildings of note than Los Angeles, but though

Portland is also known as a city of homes, only two residences were placed by the Portland jury among the first ten most notable examples of architecture in that city.

It would be interesting now to have a similar competent jury pick out the notable buildings of San Francisco and Seattle, in order that we might compare their progress with that of Los Angeles and Portland. We should be glad to give special numbers to publication of the results of such jury selections, as we have done for the two latter cities.

LOS ANGELES UNDERTAKES CITY PLANNING TOO

Los Angeles is taking seriously its new position as the largest city on the Coast, and has recently appointed a permanent City Planning Commission to work out a practical plan and regulations for guiding the city's growth along well thought out lines. Zoning, major street plans, park and boulevards systems, civic centers, railroads and transportation, and other city problems are to be planned in advance in order to make the most of the many million dollars of improvements which must go in in any event during the next two decades. At least that is the preliminary program of the new commission. Whether it will really procede to definite work immediately or fiddle around for a year or two, as some other City Planning Commissions have done, remains to be seen. We rather expect that Los Angeles is more progressive than that and that she will not permit half-way measures or periods of inaction in such an important matter.

CONGRATULATIONS

It is impossible to publish as fine a lot of buildings as are shown in this issue without publicly offering heartiest congratulations to the architects of Southern California on what they are accomplishing. We are glad to have this opportunity to do so, and also to thank the Southern California Chapter of the American Institute of Architects for bringing these buildings so authoritatively to public attention.

Much thanks is also due the members of the Chapter for assembling the excellent photographs for this issue.

ZONING OF APARTMENTS AGAIN UPHELD IN COURT

There has been much agitation and discussion in the recent zoning of Pacific Coast cities, as to whether the courts would sustain the limitation of apartment houses to certain established zones or districts. There is hardly a city of any size west of the Rocky Mountains, or throughout the country for that matter, that has not had bitter complaint from home owners in single-family home neighborhoods against the intrusion of flats and apartments where they are not only not wanted or necessary, but where they actually make the existing homes less desirable, less rentable and less salable.

While flats, apartments and hotels are certainly necessary at the center of the city and at conveniently located places in the outlying sections, city councils have more and more inclined to the view that they cannot be allowed to scatter indiscriminately through home neighborhood blocks. Alameda, Berkeley, Palo Alto, Portland and a number of other cities have in recent years established single family dwelling zones or taken means to restrict the location of apartment houses.

The following recent decision* in an Ohio court is therefore interesting, particularly as it states the case so clearly. In upholding an ordinance of a Cleveland suburb, which prohibited apartments in certain residential parts of the city, the court said:—

"It would seem that there could be no two opinions upon the proposition that the apartment house, or tenement, in a section of private residences, is a nuisance to those in its immediate vicinity. Under the evidence, and as a matter of common knowledge, of which the court may take judicial notice (16 Cyc. 582), it shuts off the light and air from its neighbors, it invades their privacy, it spreads smoke and soot throughout the neighborhood.

* Extract from opinion of Judge Kramer, in East Cleveland Zoning Case, State of Ohio, ex rel. Max Morris vs. C. M. Osborne, City Manager of the City of East Cleveland, in the Court of Common Pleas, County of Cuyahoga, State of Ohio, April 30, 1920.

The noise of constant deliveries is almost continuous. The fire hazard is recognized to be increased. The number of people passing in and out, render immoral practices therein more difficult of detection and suppression. The light, air and ventilation are necessarily limited, from the nature of its construction. The danger of the spread of infectious disease is undoubtedly increased, however little, where a number of families use a common hallway, and common front and rear stairways.

"The erection of one apartment house in a district of private homes would seriously affect only those persons living in the immediate vicinity thereof, but the common experience is, that the erection of one apartment drives out the single residences adjacent thereto, to make way for more apartments. The result is that, in time, and not a very great time, when one apartment is erected, the whole street is given over largely to apartment houses.

"With the growth of its population, it appears to be practically certain that unless restricted, the greater part of East Cleveland will be built up with apartments, and the home owners must choose either to adopt apartment life or abandon their depreciated property, and move out of the city or into its more remote parts.

"If the claim of the relator here is sound, a city of private homes, grass plots, trees and open spaces, with the civic pride and quality of citizenship which is usually found in such circumstances, is powerless to protect itself against the obliteration of its private residence districts, by apartments, which shut out the sun and sky from its streets, and one another, and are generally owned by those whose greatest interest is in the revenue that the building will produce. If such is the law, it must be conceded that it is unfortunate.

"The apartment house is, for many, a desirable convenience, and, for some, a necessity. They are a recognized necessity in cities of any size. Their erection should not be prohibited, and under this ordinance, are not prohibited. Private residences, with yards for play spaces, with grass, trees and flowers, are necessities for people with children, and as much a convenience to the people without children, who take an old-fashioned pride in owning their homes, as is the apartment to those who are willing to accept its restrictions, for its compensatory freedom from responsibilities. It is at least equally important to the community to preserve the private home for this class, as it is to provide the apartment for the first. Under this zoning ordinance, both the private home is preserved and the apartment house is provided.

"It seems eminently fair to restrict the apartment builder to a limited area, where his use of his property will do the least

damage to others, and to the community. The necessities or convenience of those who live in them will be served thus with the least sacrifice of the necessities and convenience of others. Whatever of the burden arising from apartments there are, will be borne by those whose purposes they serve, and not shifted to the other property owners of the city, to make their property unfit for use as a home."

* * *

"This court is therefore of the opinion, first, that the ordinance here in question is a valid exercise of the police power by the city of East Cleveland, under the authority of its charter; second, that it has not been shown that the classifications made under this ordinance are unreasonable, arbitrary, discriminatory and not uniform in operation.

"The petition of the relator therefore will be dismissed, and an exception given."

CITY PLANNING NOTES

Rochester, N. Y., is preparing to adapt the old canal bed of the Erie Canal to a suburban rapid transit system, with two passenger tracks and two freight tracks in the canal way, E. A. Fisher, Superintendent of City Planning in that city, announced. By charter provision this department has authority to establish zoning and other city planning regulations without interference of the city council. Zoning regulations were adopted in 1919.

Dallas, Texas, is spending \$6,500,000 for a new railroad terminal. The city was recently upheld by the Supreme Court in making the railroads abandon duplicate lines through the center of town.

Kingsport, Tenn., a town of 10,000 residents, was set up by Mr. John Nolen, city planning expert of New York, as a model city plan town. It has attracted wide attention because of its systematical methods of arranging the homes of workmen and the industrial plants, and a high standard of homes is one of the results, he said.

SPOKANE WILL SELECT ITS NOTABLE BUILDINGS

As we go to press the president of the Spokane City Plan Commission announces that a jury selected by the architects of that city is to name, about October 1st, the notable examples of architecture, landscape architecture, and sculpture within fifteen miles of Spokane City Hall. This magazine will be glad to make the report of this jury the subject of a special article, probably in November. Much interesting work has been done of late years in the Northwest, which we shall all be pleased to know more about.

With the Architects

Building Reports and Personal Mention of Interest to the Profession

Book on School Architecture

Mr. J. J. Donovan, former Supervising Architect of the Oakland schools, has completed the text for a practical treatise on school architecture, based upon his experience and study covering a period of fifteen years. The book will have twenty-eight chapters, seven hundred pages, 300 of which will be text matter. There will be approximately 750 illustrations. The first numbers are expected to be off the press in September.

Designing Richmond Schools

Mr. J. T. Narbett, of Richmond, has completed plans for two new school buildings in that city. One is a manual training building to cost \$40,000 for the high school and the other is a \$15,000 addition to the Grant school. Although the bonds have not been sold, provision has been made to finance construction of the more necessary buildings from funds now in the treasury.

Five Story Insurance Building

Plans have been completed by Mr. Horace G. Simpson, 110 Sutter street, San Francisco, for a five and one-story insurance office building to be erected on the site of the old Occidental Hotel at Bush and Montgomery streets, San Francisco. The owner is the California Pacific Title Insurance Company, and bids taken indicate that the structure will cost close to a quarter of a million dollars.

Designing Auto School Building

Mr. S. Heiman, 57 Post street, San Francisco, is completing working drawings for a three-story and basement reinforced concrete and brick automobile school building for the Butler School of Commerce. The site is the corner of Sutter and Larkin streets, San Francisco. Messrs. Dunn & Williams are the owners of the structure, which will cost \$110,000. Mr. Heiman is also preparing plans for a \$75,000 residence.

Granted Certificate to Practice

At the regular monthly meeting of the State Board of Architecture July 27th, Mr. Robert E. Backus of 1314 O Street, Sacramento, was granted a certificate to practice architecture in California.

Winners of Aquatic Park Competition

Prizes for drawings submitted to the San Francisco City Engineer's office for plans to be used in outlining the proposed aquatic park at the foot of Van Ness avenue have been awarded by the jury. The plans submitted by Messrs. Horace G. Colton and George M. Cantrell, jointly, and those of Mr. Ernest E. Weihe, were considered so excellent in points of merit, the committee could not decide between the two plans for first prize. It was therefore decided to combine the first and second prizes and divide it equally between the designers of the two plans. The amount totals \$450, which would make \$225 for each drawing.

The third prize of \$100 was won by Mr. Laurence A. Kruse, the fourth of \$50 to Mr. Ferdinand F. Amandes, and the fifth prize, also of \$50, goes to Mr. Walter E. Baumberger.

Store Fixture Work

Mr. Alfred Kuhn, Commercial building, San Francisco, is preparing plans for elaborate interior fixtures for Thompson's, Inc., a new candy store, which is to occupy a two-story building, from plans by Messrs. Reid Bros., on Post street, between Powell and Stockton streets, San Francisco. A notable feature will be a white marble staircase, extending from the first to the second floor. Mr. Kuhn is also making plans for new fixtures and store front at the old California Cafe on Powell street, near Ellis, San Francisco.

Designing \$75,000 Residence

Mr. W. H. Ratcliff, Jr., 1st National Bank building, Berkeley, is preparing plans for a \$75,000 residence and landscape work for Mr. Archibald Andrew, of Berkeley. The grounds will be extensively laid out at once, but construction of the house will probably not start until spring.

Alameda Bank Building

Mr. M. V. Politeo, 1st National Bank building, San Francisco, has completed plans, and figures have been taken for a one-story terra cotta addition to the Alameda National Bank. Building will cover ground area 150x60 feet.

Architect Foulkes Busy

Mr. Edward T. Foulkes, architect in the Crocker Building, San Francisco, is preparing plans for a seven story reinforced concrete addition to the Oakland Tribune Building at 13th and Franklin Streets, at an estimated cost of \$100,000. Mr. Foulkes is also preparing plans for a one story reinforced concrete Bank building to be erected at Livermore for the Bank of Italy. The structure will cost \$40,000 as will a branch Bank building for the same institution at Melrose, Alameda County, also being designed by Mr. Foulkes.

Alter Flats Into Apartments

Mr. A. H. Knowll, architect in the Hearst Building, San Francisco, has prepared plans for extensive alterations to a two story frame flat building on the west side of Divisadero Street, near Geary, San Francisco, and for remodeling a three story loft building on the west side of Twelfth Street near Market, San Francisco. About \$20,000 will be expended on the latter improvements.

Million Dollar Hotel

Preliminary plans are being prepared by Mr. Harold Cross, Merchants National Bank Building, Los Angeles, for a ten-story hotel at Atlantic and Ocean avenues, Long Beach, for Los Angeles capitalists. The estimated cost of the building is \$1,000,000.

San Jose Schools Being Figured

Additions to the various San Jose Schools, for which bonds were voted some time ago, are to be started in September from plans by local architects, including Messrs. Binder and Curtis, Chas. S. McKenzie, and Warren Skillings. Bids will be opened Tuesday, August 31.

Stockton Residence

Mr. William E. Milwain, Albany Block, Oakland, has let a contract to an Oakland contractor to build a two story frame and stucco residence in Stockton for Mr. C. A. Bachelder of the Holt Mfg. Company of that city, for \$16,000.

Architect For San Pablo School

Mr. James T. Narbett, 910 Macdonald avenue, Richmond, is the architect for the additions to the San Pablo school, for which \$35,000 bonds have been voted.

Designing Vallejo Church

Mr. E. C. Hemmings, of Sacramento and W. A. Jones of Vallejo, associated, are preparing plans for a \$60,000 edifice for the First Baptist Church of Vallejo.

Much Work at Atascadero

Mr. John J. Roth, building commissioner of the Atascadero Colony, has plans under way for a number of important projects, including a \$200,000 high school building for the Atascadero Union High School District and for which bonds have been voted and sold. There will be two buildings, one containing sixteen classrooms and manual training shops, the other an auditorium and gymnasium. For the Colony Holding Company, Mr. Roth is designing a community club house with auditorium, stage, swimming pool, bowling alleys, etc. Preliminary plans are also being made for a tourist hotel of one hundred rooms and which will cost \$250,000.

Fresno Church

Mr. Norman F. Marsh, 211 Broadway Central Bldg., Los Angeles, has been authorized to prepare complete working drawings for the new church building to be erected at Fresno for the Methodist Episcopal Church. It will contain a main auditorium to seat 800 people, Sunday school departments, social room, banquet rooms and kitchen equipment.

School Gymnasium

Mr. Herbert C. Howard, 619 Broadway Central Bldg., Los Angeles, has completed plans for the gymnasium to be erected at Franklin high school site. It will be one and two stories, 104x138 ft., and will contain a gymnasium with stage, showers, dressing rooms, class rooms and offices.

Brick Service Building

Messrs. Morgan, Walls & Morgan, 1124 Van Nuys Bldg., Los Angeles, are completing plans for a brick building, 100x150 ft., to be erected on Seventh Street, east of Alameda Street, Los Angeles, for J. B. Van Nuys. It will be the first unit of a service building for Chevrolet motor cars to be occupied by the General Motors Co.

Brick Factory Building

Mr. Richard D. King, 517 Van Nuys Bldg., Los Angeles, has completed plans for the erection of a 1-story brick factory building on Santa Fe Ave., near Ninth Street, Los Angeles, for Mrs. Kate Stamps.

Bank Building Plans Finished

Messrs. Weeks & Day, Phelan building, San Francisco, and architects of the new eighteen-story bank and office building to be erected at 10th and "J" streets, Sacramento for the Capitol National Bank, report that the plans are complete and ready for figures.

Passing of Louis T. Lenzen

Mr. Louis T. Lenzen, architect, passed away at his San Jose home July 24th after a brief illness of heart trouble, following a stomach ailment of more than a year's duration. He had attended to his practice, however, up to the end, and his many friends who had greeted him on the street a day or two previous were shocked to learn of his death. Mr. Lenzen was a native of San Jose and was 45 years old. His father, Mr. Theodore Lenzen, was a pioneer architect and builder, and upon his death a few years ago the son succeeded to the business and had designed a number of important structures. He was a member of San Jose Lodge of Elks and the local Parlor of Native Sons.

Personal

MR. MYRON HUNT and Mrs. Hunt have been taking a combined business and pleasure trip throughout the eastern cities. Mr. Hunt made a special investigation of new hospitals in connection with his commission to prepare plans for a large new building for the Pasadena Hospital Association. He also inspected the clay models being made in New York for the bronze doors which are to be installed in the new library building at San Marino for Mr. H. E. Huntington.

MR. WINSOR SOULE, of Santa Barbara, has returned to his practice after recovering from an operation performed at a Los Angeles hospital.

MR. JOSEPH L. STEWART, architect in the Claus Spreckels building, San Francisco, has resumed his practice after undergoing an operation in a San Francisco hospital.

Rebuilding Burned Town

San Francisco architects and engineers are participating in the rebuilding of the business center of Willows, California, which was wiped out by fire some weeks ago. Mr. B. G. McDougall is designing two new store buildings and repairing a two story business block for Mr. Frank Freeman, and Mr. Leland S. Rosener, construction engineer, is preparing plans for a reinforced concrete department store building for the Hochheimer Company. The latter will cost \$100,000 or more. The K. E. Parker Company, San Francisco contractors, will be in charge of the work.

Architects in New Offices

One of our Eastern subscribers, Mr. Morgan De Hite and Mr. Walter J. Ferguson, announce the removal of their offices to the Canal Bank Annex, 211 Camp street, New Orleans. The announcement further states that "our ideas are progressive, without being ultra. We endeavor to design for your permanent satisfaction—and this, we believe, is the only worth while way."

A. I. A. CHAPTER NEWS

San Francisco Chapter Meeting for June 17th, 1920

The regular monthly meeting of the San Francisco Chapter of the American Institute of Architects was held in the Architectural Club Rooms on Thursday, June 17th, 1920.

The meeting was called to order by Mr. Sylvain Schnaittacher, the President, at 3:30 p. m.

On account of the short time available, the reading of the Minutes of the last meeting was dispensed with.

COMMUNICATIONS

From the Central Bureau of the San Francisco Organization for the General Welfare and Rebuilding of San Francisco; from the Southern California Chapter in regard to a meeting in Santa Barbara. From Mr. C. H. Snyder in re Chapter affiliation with the Joint Council of the Engineering Societies of San Francisco.

The report of the Executive Committee in re the Sacramento Schools Competition and in re Tehama County Court House, was read and on motion duly seconded and carried, was ordered received.

The President made a report of progress in the matter of a revision of the City Building Laws and upon motion duly seconded and carried, the President was instructed to keep in close touch with the plans for revision of the laws.

On motion duly seconded and carried it was resolved that the Secretary be instructed to notify all members of the meeting in Santa Barbara with the Southern California Chapter.

In reply to the communication from the Joint Council of Engineering Societies of San Francisco, the President had written that after having consulted with the Board of Directors of the Chapter, would urge the Chapter to affiliate with that body.

On motion duly made and seconded, the Secretary was directed to advise the Central Council of the Builders Exchange that the Chapter heartily endorses the objects of that organization and would be pleased to have the architectural profession affiliated with the Council.

On motion duly seconded and carried, it was resolved that the Chapter will cooperate in every way possible in the work of the War Memorial Committee.

On motion duly seconded and carried, it was resolved that the Chapter approves the use of the Quantity Survey System for Estimating.

MORRIS M. BRUCE, Secretary.

Southern California Chapter

The Southern California Chapter of the American Institute of Architects held

its monthly meeting Tuesday evening, July 10 at the Jonathan Club. A number of important questions came up for discussion, including California Engineering Council and Architects Associated for Public Service. Several communications from the Institute pertaining to jurisdictional awards were read and discussed.

Another Outing For Los Angeles Architects

Los Angeles and Southern California architects have been enjoying a series of real treats this summer, their outing in San Diego and across the border into Mexico, being followed last month by a trip to El Capitan ranch, twenty miles north of Santa Barbara where they were the guests of Mr. Winsor Soule, architect in Santa Barbara, through whose influence permission was given the entire party to visit the extensive ranch. The outing lasted from Friday afternoon to Sunday afternoon and was participated in by 50 architects and their guests.

The members met at the Arlington Hotel, Santa Barbara, for dinner Friday evening and following the reunion proceeded to the camping grounds, arriving about 10:30 p. m. Here every arrangement had been made to provide for their comfort. Upon arriving at the camp the automobiles were halted at the command of Mr. Soule, officer of the day, while a number of boy scouts from Santa Barbara took charge of the baggage and deposited it in the proper tents and assigned the guests to their quarters. The tents were lighted by lanterns and the dining tables were lighted with an acetylene gas system.

The camp site was ideally situated in a grove of large oak and sycamore trees and only about two blocks from the ocean.

The idea of turning a Chapter meeting into an outing originated with President Edwin Bergstrom who has endeavored since assuming office, to make the meetings as entertaining as possible by providing an interesting program and holding the meetings in different places. The details of establishing and conducting the camp were handled by Messrs. L. F. Olson, superintendent for Edwin Bergstrom, Winsor Soule and Fred Ramirez of the Spanish Kitchen, Los Angeles, who acted as chef. Fred Ramirez makes a specialty of barbecues and providing for moving picture companies on location and furnished everything necessary for the comfort of the architects from ice water to drink to hot water for shaving. The menu included grape fruit, muskmelon, water melon, barbecued beef, broiled chickens, broiled fish, Spanish dishes, fruit, etc. The boy scouts carried the wood and water and made themselves generally useful.

The architects and their guests who participated in the outing included: Ed-

win Bergstrom, Henry F. Withey, Octavius Morgan, O. W. Morgan, A. M. Edelman, R. Gernain Hubby, Robert H. Orr, J. J. Backus, Stiles O. Clements, William Clarke, Wilbur D. Cooke, Geo. D. Hall, Charles E. Garstang, Alfred W. Rea, Harwood Hewitt, Frank D. Hudson, MacNeal Swazey, John W. Mitchell, Draper Brinckloe of Brooklyn, N. Y., William H. Wheeler of San Diego, E. L. Taylor, J. T. Zeller, J. L. Zeller, W. O. Raiguel, Henry M. Greene, Reginald Johnson, Callender Hewitt, S. B. Marston, Donald R. Wilkinson, Thaddeus Johnson, Winsor Soule, W. J. Dodd, L. F. Olson, H. C. Chambers, D. C. Allison, A. H. Avery and Magnus Johnson, Santa Barbara contractors; Fred Johnson, city manager of Santa Barbara; and J. Y. Parker of the Parker Brick Co. of Santa Barbara.

Architects Sue For Fee

Suit has been filed in the superior court at Modesto by Messrs. Walker & Eisen of Los Angeles, against the Thompson Co. to foreclose a lien for \$1506.95 on the Thompson department store property at Modesto. The building and fixtures for the store were designed by the architects who claim they were to receive a commission of 6 per cent on the cost of the work. They allege in their petition that \$4828.61 was paid on one contract and \$655.59 on the other and that the amount for which judgment is sought represents the unpaid balance.

Salinas Architects Busy

New work in the office of Messrs. Wyckoff and White at Salinas includes a \$22,000 school house for the San Justo school district; \$10,000 school building for the Fairhaven school district, \$10,000 Manual Training building at Hollister for the San Benito County High School District; residence and garage for Mr. W. E. Hickman at Watsonville and alterations to the W. H. Weeks building at Watsonville.

Paper Company To Build

The Independent Paper Stock Company will build a three story reinforced concrete paper sorting depot at Seattle and a warehouse at Portland, Oregon, from plans for Mr. Leland S. Rosener, C. E. Insurance Exchange Building, San Francisco.

Stockton School Building

Mr. Franklin Warner, Belding Building, Stockton, is preparing working drawings for a two story brick school building, containing sixteen rooms and auditorium, for the city of Stockton. The structure is estimated to cost \$160,000.

With the Engineers

Reports from the Various Pacific Coast Societies,
Personal Mention, Etc.

State Organization, A. A. E.

The California Chapters of the American Association of Engineers have just completed the formation of a State Organization. The name of this organization is The California Assembly of the American Association of Engineers. It consists of one delegate from each Chapter in the State. The officers elected are: Mr. T. E. Stanton of Sacramento, Pres.; Mr. Burdette E. Moody of Los Angeles, Vice President; Mr. Ralph E. Dodge, San Francisco, Secretary-Treasurer. The other delegates are: Mr. I. H. Tielman, Fresno; Mr. Arthur H. Adams, Long Beach; Mr. George S. Hinkley, Redlands; Mr. Thomas H. King, San Diego.

The State Assembly of the American Association of Engineers will handle all A. A. E. matters of state wide importance or those concerning matters of interest to several chapters. It will also co-ordinate the work of the different state chapters and will co-operate with other technical and civic organizations in advancing matters of mutual interest.

California, Oregon and Washington now have A. A. E. State Organization. California is the third state of the Union in point of A. A. E. membership.

Following are the secretaries of the various California Chapters and Clubs:

Mr. Jean L. Vincenz, P. O. Box 922, Fresno.

Mr. Arthur H. Adams, 125 E. Anaheim Street, Long Beach.

Mr. D. E. Godfrey, 625 Metropolitan Building, Los Angeles.

Mr. E. K. Albers, 1700 Merrill Ave., Los Angeles.

Mr. H. A. Lathrop, 1321 33rd Street, Sacramento.

Mr. M. A. Woods, 1063 Eleventh Street, San Bernardino.

Mr. Fred Grumm, 2604 "A" Street, San Diego.

Mr. F. W. Howard, Trinidad.

Engineers May Sign Drawings

Los Angeles city building ordinance has been amended to permit "responsible qualified engineers" to sign drawings for reinforced concrete buildings as well as certified architects. Members of the Los Angeles section of the American Society of Civil Engineers were active in securing this amendment, the matter being in the hands of a committee composed of Messrs. E. T. Flaherty, chairman; J. A. Griffin, M. C. Halsey, Blaine Noice and Robert T. Miller.

Notes of San Francisco Chapter, A. A. E.

The July meeting of San Francisco Chapter, American Association of Engineers, was addressed by Prof. C. D. Marx, head of Department of Civil Engineering at Stanford University and a past president of A. S. C. E. Professor Marx explained the proposed National Department of Public Works and gave a progress report of what has been done to promote this new department of Public Efficiency. The talk was thoroughly enjoyed by a large and enthusiastic audience. Immediately following the address the Public Affairs Committee introduced resolutions favoring passage of the Jones-Reavis Bill, which were adopted by the Chapter. Members of the San Francisco Chapter are urged to do everything in their power to secure the passage of this Bill by the next Congress.

The business portion of the meeting was largely devoted to a spirited debate on a resolution providing for the Chapter's endorsement of the initiative petition to place on the November ballot the proposition providing for an increase of the rate of interest on State Highway bonds to six per cent. The resolution failed to pass but the vote was very close.

The Program Committee had the good fortune to secure Mr. Walter B. Cole as the speaker for the August meeting. Mr. Cole is the manager of the Marchant Calculating Machine Company, and president of the Oakland Chamber of Commerce. His talk was on "The Relation of the Chapter to Civic Organizations."

The Union Construction Company of Oakland, California, invited the San Francisco Chapter to visit their plant on Saturday afternoon, August 21.

Pan-Pacific Scientific Congress

The Pan-Pacific Scientific Congress is in session from August 2d to August 20th in Honolulu. The Chicago Chapter of the American Association of Engineers will be represented by Miss Florence King a consulting engineer of Chicago. She bears the distinction of being the only woman member of the A. A. E. having a certified engineer's grade.

New Engineer For Butte County

Mr. H. H. Hume, of Chico, has been appointed county engineer by the supervisors of Butte County, to succeed Mr. M. C. Polk, who recently resigned.

A Million Dollar Dam That Does Not Hold Water

Several years ago a dam was built at Cedar Falls, Wash., to impound water for power purposes. The dam was not carried to bed rock, and, as had been predicted by experienced engineers, it failed to hold water. The city of Seattle, for whose municipal electric plant this dam had been constructed, then undertook to try to seal the bed of the valley for some distance above the dam, by sluicing clay into the basin. Now it is announced by J. D. Rose, the superintendent of the municipal electric plant, that the expenditure of \$400,000 in the attempt to stop the leakage with clay has been futile, and that the million dollar dam must be abandoned.

We venture to predict that the loss of this huge sum of money will never be charged to the depreciation reserve of the municipal plant. We understand that several years before Seattle undertook to build this dam, a private power company had investigated its site and had decided that a safe, watertight reservoir could not be built there except at a cost that would be profitable. Would it not be well for the engineers of Seattle to investigate the responsibility for this fiasco? The money that is lost can not be recovered, but perhaps the city can be protected against similar blunders in the future.—Engineering and Contracting.

Engineers Will Study Municipal Problems

The National Executive Committee of the American Association of Engineers will appoint twelve of the leading professional engineers to study the problems of civic administration of public works and report their findings to all Chapters as a guide to local engineers in the exercise of their duties as citizens and engineers.

American Society Civil Engineers

Mr. Arthur P. Davis, president of the American Society of Civil Engineers, was the guest of honor at a special meeting of Los Angeles section of the society held at the University Club Monday evening, August 2.

Addresses were made by Messrs. F. E. Weymouth, chief engineer of U. S. Reclamation Service; A. J. McCune, state engineer of Colorado; Mark Walker, president of Los Angeles Chapter, American Chemical Society; and Prof. R. W. Sorenson, president of Los Angeles Section, American Institute of Electrical Engineers.

Announcement was made of the death of Mr. Charles Clayton Huff, assistant engineer in the U. S. engineers' office, recently stationed at Ft. Rosecrans.

More Salary for State Employees

After eleven years' continuous service as Secretary of the State Department of Engineering, Mr. Earle Freeman sent in his resignation to State Engineer W. F. McClure, the past month, requesting that he be relieved from duty September 1.

Mr. Freeman has announced he will return to his old home in San Diego to engage in business for himself. His real reason for leaving the department is said to be based upon a denial of his application for increased pay in accordance with salary raises granted other employees of the department.

Total wage increases approved for the department, it is reported, will aggregate about \$12,000 per year.

The largest single increase of \$85 per month was granted to Mr. A. Givan, Chief Engineer of the Architectural Bureau. He was jumped from \$240 to \$325 per month.

Mr. J. W. Dutton, Superintendent of Construction, was given a wage advance of \$250 to \$325 a month.

Messrs. C. H. Kromer, Chief Structural Engineer, and C. F. Dean, Chief Architectural Designer, each were granted increases of \$50, jumping to positions paying \$325 per month.

Other changes made include:

Messrs. G. J. Adams, Deputy State Architect, increase from \$300 to \$325 per month; P. M. Norboe, Chief Assistant State Engineer, increase from \$300 to \$340 per month; G. M. Simonson, Chief Electrical Engineer, increase from \$225 to \$275 per month; R. E. Backus, Architectural Designer, increase from \$200 to \$225 per month.

Studios Buildings

The first moving picture studio to be built in the vicinity of San Francisco has been financed by the Golden Gate Studios Company, Hewes building, San Francisco, which has secured a desirable site in San Mateo county and has had plans prepared by Mr. A. G. Hamburg for a million dollar plant. There will be upwards of eighteen buildings, nine stages, an administration building, etc. The mission style of architecture is to be followed.

Dormitory at Pebble Beach

Messrs. Paul V. Tuttle and Arthur W. Angel, associate architects, 565 Light-house avenue, Pacific Grove, have prepared plans for a twelve-room dormitory to be built adjoining Pebble Beach Lodge in Monterey county, for the Del Monte Properties Company. The same architects have plans under way for a hollow tile high school group at Compton for which a bond issue of \$90,000 has been authorized.

The Contractor

BUILDING CONSTRUCTION, BRIDGES AND
ROAD WORK

Pacific Northwest—Associated General Contractors

Portland, Oregon

OFFICERS

President—Natt McDougall, A. Guthrie & Co., Portland, Ore.

Vice-President—R. E. Miller, Puget Sound Bridge & Dredge Co., Seattle, Wash.

Secretary-Treasurer—I. N. Day, A. D. Kern & Co., Portland, Ore.

Executive Secretary—J. D. MacVicar.

DIRECTORS

Natt McDougall, R. E. Miller, I. N. Day, E. Simpson, Albertson, Cornell Bros. & Simpson, Tacoma, Wash.; D. G. Munro, General Construction Co., Spokane, Wash.; A. E. Griffin, Stewart & Welch, Vancouver, B. C.; G. W. Gauntlett, Grays Harbor Construction Co., Hoquiam, Wash.; Fred T. Sherman, Independent Asphalt Paving Co., Seattle, Wash.; A. H. Toole, Clifton, Applegate & Toole, Spokane, Wash.; K. B. Kumpe, Warren Construction Co., Portland, Ore.; Charles Swigert, Pacific Bridge Co., Portland, Ore.

Southern California—Associated General Contractors

Los Angeles, Cal.

OFFICERS

President, Arthur Bent.

Vice-President, Clare L. Peck, of Leonard & Peck.

Treasurer, J. F. Atkinson.

Secretary, George A. Rogers, of Rogers Brothers Co.

EXECUTIVE COMMITTEE

Arthur Bent, Clare L. Peck, George A. Rogers, Godfrey Edwards, R. F. Ware, J. C. Edwards and Frank Foell.

General Contractors of San Francisco

OFFICERS

President, Henry Jacks.

1st Vice-President, John Biller.

2nd Vice-President, P. J. Lynch.

Treasurer, Charles Wright.

Secretary, E. T. Thurston.

DIRECTORS

Henry Jacks, John Biller, P. J. Lynch, Thomas Elam, Charles Wright, C. M. Moore, A. H. Wilhelm.

How Are We Going to Save the Roads?

By R. E. FULTON

Highway transportation as a public and commercial necessity has long ago received its certificate of economic justification. It has entered into the nation's scheme of things with the same wholeheartedness that characterized the railroads in their periods of development. It has found its place and is exercising a powerful influence toward shortening the gap between producer and consumer. It has reached the point, in fact, where its

extension must necessarily be restricted for the good of its own future and the future of the nation's transportation as a whole.

Legislators, highway engineers, and those intimately concerned with motor vehicle expansion realize that unless some measures restricting the use of motor trucks are enacted, this country's progress toward its ultimate state of highway perfection will be long drawn-out and tedious. Even after we have constructed a system of hard-surfaced national highways it will be necessary to provide revenues for their upkeep and maintenance. To this end, it is but equitable that those vehicles which cause the greatest amount of damage to the roads should be restricted in their use at the present time, and that in the future they should contribute the largest share toward road repair costs.

At this time, when legislation to accomplish this must necessarily assume definite form, to influence motor transportation for all time to come, it is vitally important that we make a far-reaching unbiased analysis to determine just where the basis of this restriction belongs. Not only must we save the roads, but we must do so if possible without sacrificing the increasing economies and conveniences that unquestionably would go with an expansion of motor transportation facilities.

There is a special field of transportation in which the motor truck is the only logical means of conveyance. How large a field it is, is shown by the fact that 300,000,000 tons of material were shipped by truck in 1919. Suppose this freight were transported in one-ton trucks. It would mean that 900,000,000 tons of traffic (including weight of vehicles and cargo) would pass over the roads of this country. If transported in 7 1-2 ton trucks the roads would have to bear only 600,000,000 tons of traffic. This is because the average one-ton truck carries two tons of vehicle weight for every ton of freight transported while in a 7 1-2 ton truck this ratio is reduced to less than one ton of vehicle weight for each ton of freight capacity. Regardless of what form restrictive legislation may take the total amount of material shipped in motor trucks in 1920 will obviously be greater than the total for 1919.

This country is suffering from various kinds of shortages but they are almost all directly the result of inadequate transportation. Since no other transportation agency can now take the place of the motor truck in its own recognized sphere, it is obvious that every heavy duty truck barred from the roads will be replaced by several smaller trucks. The result will be increased road wear and increased cost of transportation. As practically all products of the farm and factory make some part of their journey from producer to consumer in motor trucks, it is necessary to make sure there is no other alternative before framing legislation which will increase motor transportation costs.

There are many fields of short distance light delivery, in which the lighter truck is better adapted. However, when bulk hauling is considered, the light truck's greatest asset in comparison with its big brother is its speed. For a two-ton truck to transport material as economically as a heavy duty model it would be necessary for it to travel at three times the speed of the larger truck. Of course the light truck cannot do this but it does travel at a considerably higher normal speed. Its increased speed, however produces road wear in excess of that caused by the heavy truck in spite of the fact that the latter is accomplishing far more. It has been definitely proven that increased speed causes more rapid road wear than increased weight. It is not necessary that the heavy duty truck resort to destructive road speeds in order to furnish economical transportation.

Tire width bears an equally important relation to comparative road wear. A steam roller for example is about the heaviest vehicle which passes over a highway, yet because of its broad road bearing surface its effect on the roadway is beneficial rather than harmful. Likewise weight in a motor truck is destructive only when not accompanied by a sufficient width of tire. The fact is well-

established that a load of 800 pounds per inch of tire surface is not damaging to an ordinary roadway and the heavy duty truck is always built to conform to this requirement. A 7 1-2 ton truck has one inch of tire width for each 666 pounds of weight.

Highway engineers have long been concerned with the problem of determining a fair plan for motor truck legislation. The U. S. Bureau of Public Roads at Washington has conducted exhaustive tests to determine the real causes of road wear. The conclusions should certainly receive careful consideration from those interested in the preservation of this country's roads. The report of this test which appeared in the official "Public Roads" bulletin says that road impact is the real cause of road wear. Realizing this, the experiments were devoted to ascertaining the causes of road impact. Through these tests, it was decisively shown that unsprung weight is the controlling factor in road impact. Unsprung weight, by definition, is that part of a truck's total bulk which hits the road a direct solid blow undiminished by springs.

A Tip From Inside

In view of the report of the Cleveland Grand Jury, the following opinion boldly stated at the annual convention of the American Federation of Labor by John Donlin of Chicago, recently re-elected president of the Building Trades Department of that body, is worth noting.

"The wage-earner is just as much responsible for the high cost of living as any other agency," said Mr. Donlin in his annual report. "If every worker doing physical labor would insist that production equal pre-war times there would soon be a reduction in the price of commodities. The higher wages go and the more production falls off the more the worker is going to be hurt."

HARDWOOD HEADQUARTERS

ASH-BASSWOOD-BIRCH
AROMATIC RED CEDAR
COTTONWOOD-ELM-HOLLY
SOUTHERN RED GUM
HICKORY-LAUREL-MAPLE
OREGON MAPLE-PLAIN OAK
- QUARTERED OAK -
WYBROCK BENDING OAK
POPLAR--WALNUT



BOXWOOD-EBONY-IRONBARK
JENISERO-KOA-SPANISH CEDAR
LIGNUMVITAE-MAHOGANY
ROSEWOOD-TEAK-RED BEAN
SPOTTED GUM-CIRASSIAN WALNUT

WHITE BROTHERS

FIFTH and BRANNAN STREETS SAN FRANCISCO, CAL.

*Municipal Building
New York City*



*Others look for this
mark when pur-
chasing quality
merchandise. Why
not everyone.*

Equipped with

**THE STANLEY WORKS
BALL-BEARING
BUTTS**

Judges of material for
this quality building,
selected this quality
Butt.

THE STANLEY WORKS

New Britain, Conn.
Chicago New York

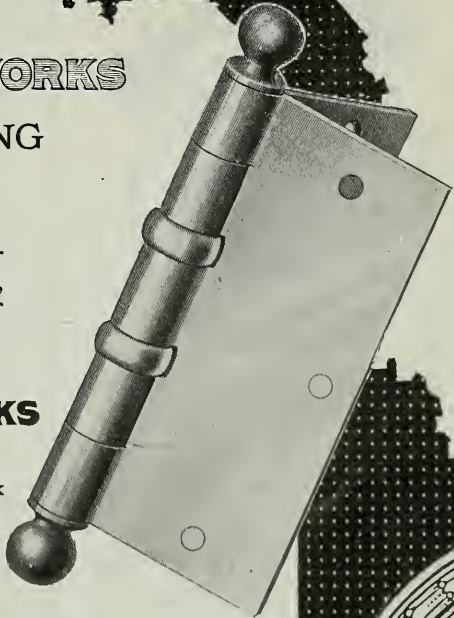



Resists Rot

Nature impregnates Redwood with a natural preservative that resists rot. Redwood lasts longer untreated than most woods when artificially preserved.

For all industrial construction, especially where exposed to the elements or in contact with the ground, Redwood is ideal.

Write for "Redwood Lives Forever," "California Redwood for the Engineer," and "Redwood Block Paving and Flooring."

CALIFORNIA REDWOOD
ASSOCIATION
San Francisco

California Redwood

Resists fire and rot

A FLOORING for discriminating Architects and Builders, and characteristically a Michigan product in every way, from the excellence of the wood itself to the superior millwork and careful grading.

Strable Mfg. Co.
HARDWOOD LUMBER
Phone, Oakland 245
511-545 FIRST STREET OAKLAND, CAL.

Open Shop Wins

The open shop plan of employment has been perpetuated for the city of New Orleans through the outcome of a controversy precipitated by strikes in the construction and metal trades industries to force a closed shop.

After a strike lasting three weeks, a satisfactory agreement was reached and signed with the carpenters under which open shop conditions will be preserved. The wage award adopted provides for a rate of 95 cents per hour from June 1 to December 1, 1920, and \$1.00 per hour from December 1 to June 1, 1921. The agreement provides that union carpenters shall not be discriminated against. The working conditions agreed to are those usually adopted, calling for a forty-four hour week with the customary overtime stipulations. It is agreed that all carpenters will be paid a uniform wage scale. For every five journeymen carpenters employed an apprentice carpenter will be allowed.

The agreement was reached as the result of the mediation of local architects after the carpenters had refused to work for the general contractors on the same wage basis as applied to public works. The Governor of Louisiana, after a conference with the carpenters employed on state work, particularly industrial canal and inner harbor work for the city of New Orleans—a \$20,000,000 project now in course of construction—proposed a rate of 90 cents for three months, 95 cents for three months thereafter, and \$1.00 per hour for one year additional. The contractors immediately agreed to pay the wage as stipulated, but the carpenters refused to return to private work on this basis and continued striking—with result as mentioned.

Central Council to Settle Labor Disputes

The following rules have been adopted by the new Central Council of the San Francisco Builders' Exchange and it is hoped through this Central Council to stabilize the wage question in the building trades and at least to present a united front of employers in controversies with union labor:

The name shall be "The Central Council of the Builders' Exchange." Place of business, City and County of San Francisco.

Objects

To promote the organization of the whole building business into one efficient institution for the various purposes, as herein set forth.

To adjust, by arbitration or otherwise, all differences between members and their employees; to foster the interests of all those engaged in the building business; to promote just and equitable principles in the conduct of their business; to discourage the peddling of bids; to advocate the opening of all bids in public; to bring about a standard form of bid and contract and to encourage mutual trading among members.

Membership

Any group of contractors, material men, or men engaged or affiliated with the building business,

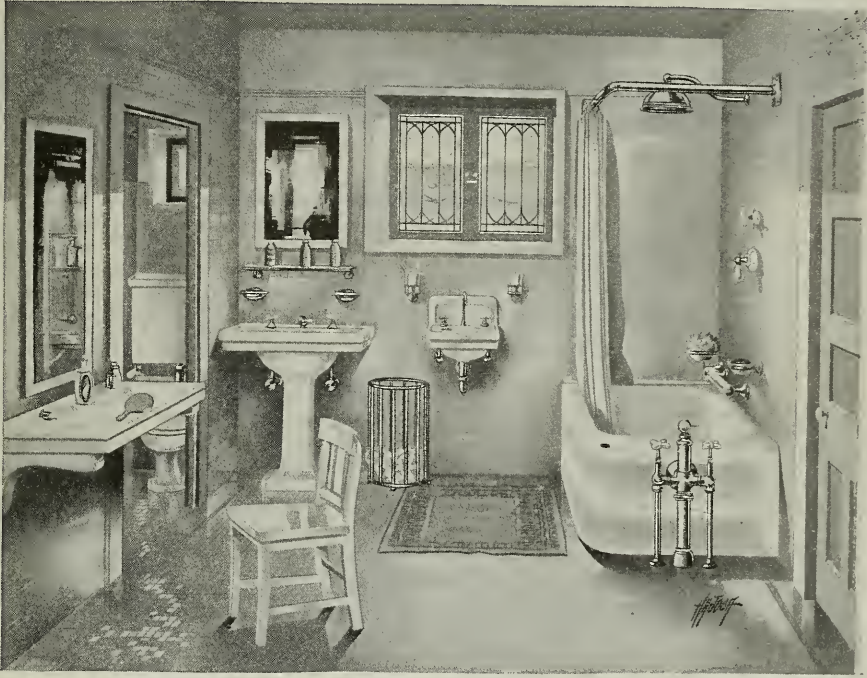

“HAJOCA” —The Bathroom of Refinement

BATHROOM FIXTURES, which you intend shall give you a lifetime of service, require thorough investigation and careful consideration.

This is the reason we constantly urge those about to build or remodel to visit our Showrooms. We know an inspection of Hajoca bathroom fixtures will impress you with their latest approved designs, their durability, their health-protecting features and their artistic beauty — a combination equally essential for humble home or luxurious residence.



HAINES, JONES & CADBURY Co.

MAKERS OF PLUMBING SUPPLIES

857 FOLSOM STREET, SAN FRANCISCO

PHILADELPHIA-NEW YORK-RICHMOND, VA.-SAVANNAH

composed of three or more, shall be eligible to representation in the Central Council and shall be entitled to one representative and one alternate. Anybody who is engaged in the building business, in which there are not three or more members, shall be represented by a representative at large, appointed by the President.

All applications must be approved by the particular trade organization interested and shall be referred to a membership committee and finally passed on by the whole body and shall be seated by a two-thirds majority of those present and voting.

Government

At the annual meeting a President and Vice Presidents shall be elected and a Secretary appointed. The President shall appoint the following standing committees: Joint Conference Committee with organized labor, of five; Committee on Rules, of three; Arbitration Committee, of three; Committee of Finance, of three; Membership Committee, of three; any further special committees necessary to properly conduct the affairs of the body.

Duties of Committees

The Joint Conference Committee shall take up all matters pertaining to labor in conformity with the findings of the Central Council.

Rules Committee shall, whenever the necessity arises, recommend the adoption of rules for the purpose of conducting the affairs of the Central Body.

Arbitration Committee shall adjudicate all disputes between crafts.

The Finance Committee shall approve all bills and recommend any expenditures necessary to properly conduct the affairs of the Central Body.

The Membership Committee shall approve all applications for membership, and, when necessary, shall organize all crafts who are not already organized.

The Board of Directors of the Builders' Exchange shall act as the Executive Committee of the Central Body, and its President shall be ex-officio a member of this body.

Quorum

Twenty-five members shall constitute a quorum and all questions shall require a two-thirds vote of the members present to be effective.

Agreements

Any new agreement between the various crafts and their employees shall be ratified by the Central Council.

The President, or Vice President, shall preside at all meetings and Roberts' Rules of Order shall govern.

Contractors as Choosers

There is plainly a declaration of independence in the new attitude of contractors in discussing specifications. The substance of this change is sensed more clearly than it can be defined, but its spirit challenges old practices so sharply that they must look to their defenses. The privileges, long ago appropriated by the engineer, of determining, without consulting him, the obligations of the contractor in building engineering works, is being squarely attacked.

Indicative of the new attitude of contractors is the fact that protests against requirements considered to be unfair, and pleas to the engineer to give these protests charitable consideration, are being replaced by evidence of unfairness and by argument that through unfairness the financial interests of the owner suffer equally with the profits of the contractor. In effect, the owner is being awakened by evidence and by an appeal to reason to the truth that he pays a high price for

every unfair requirement in or interpretation of specifications.

Conditions which are plain to all discourage the notion that the present attitude is likely to be temporary. Contractors are becoming more thoroughly organized and the strength of organization is being reflected in increased courage in calling for reforms in contracting practices. Large contracting organizations, directed by business and construction experts and employing large amounts of capital, are becoming increasingly dominant in the construction industry and with their growth is growing the determination to enforce the consideration of just reforms. Even in smaller organizations the same determination is begotten of the increasing extent to which engineers are taking control of their technical management. Finally, the determination to demand reforms is given power by conditions which are unique in engineering construction.

There is more construction pending than can be carried out by the contractors now in business. In highway work the condition is already acute. Large construction programs are certain to develop in the next two or three years on the railroads, in water power, building and public works. The shortage already apparent will be intensified.

A condition, therefore, is at hand which gives contractors power to choose the work which they will undertake. Naturally, they will exercise this privilege by refusing contracts which are least to their liking.

Co-operation and not resistance by the owner is the wise attitude, and this the engineer should encourage. On the other hand, the contractors themselves face a danger. Apparently they now have the whip hand and can dictate the terms under which they will work. Will they be drunk with power and become unfair? If they do, they will rue the day. Calling for fairness, they must be fair. Only so will justice be done.

Then, too, they must recognize that much of the complaint about unfairness is due to interpretation—a matter not possible of certain correction in all cases. In other words, it is absolutely impossible to define everything by specification—for engineering construction partakes of the nature of an art, not merely of a science. There is no use having contractors deceive themselves into believing that judgment of the man on the job can be eliminated. It can't be done.—Engineering News-Record.

Electroliers For Richmond

The Richmond Chamber of Commerce has started a drive for funds for installing ornamental electroliers along Macdonald avenue. It is expected that the merchants and light corporations will share in the expense.

DEPENDABILITY

ATLAS-WHITE
is the ideal cement for making Cast Stone—hard, weatherproof, durable stone—in pure white or an infinite variety of colors and textures, with a minimum labor of shaping, whether simply molded or richly ornamented.

THE ATLAS PORTLAND CEMENT COMPANY

New York	Boston	Philadelphia	Birmingham
Chicago	Dayton	Des Moines	St. Louis

DISTRIBUTORS

J. S. Schirm Commercial Company
San Diego, Cal
Oro Grande Lime & Stone Company
Los Angeles, Cal
Santa Cruz Portland Cement
Company
Pacific Portland Cement Company
United Materials Company
San Francisco, Cal
Langton Lime & Cement Company
Salt Lake City, Utah
Utah Sales Company
Ogden, Utah
J. M. McCracken Company
Portland, Oregon
F. T. Crowe & Company
Seattle and Tacoma, Washington
Consolidated Supply Company
Spokane, Washington
Evans, Coleman & Evans, Ltd.,
Vancouver and Victoria, B. C.,
Canada



ATLAS WHITE

United States Civil Service Examination For Building Estimator

The United States Civil Service Commission announces an open competitive examination for building estimator. A vacancy at the Picatinny Arsenal, Ordnance Department at Large, Dover, N. J., at \$1,800 to \$2,400 a year, and vacancies in positions requiring similar qualifications throughout the United States, at these or higher or lower salaries, will be filled from this examination, unless it is found in the interest of the service to fill any vacancy by reinstatement, transfer, or promotion.

After six months' satisfactory service appointees may be allowed the increase granted by Congress of \$20 a month.

The duties of the appointee will consist of making estimates on the cost of general building construction and maintenance, including labor, materials, and preparation of bills and material.

Applicants should at once apply for Form 1312, stating the title of the examination desired, to the Civil Service Commission, Washington, D. C., Secretary of the United States Civil Service Board, Customhouse, Seattle, Wash., and San Francisco.

Applications should be properly executed, excluding the medical and county officer's certificates, and must be filed with the Civil Service Commission, Washington, D. C., prior to the hour of closing business on September 7, 1920.

Austin Machinery Company Expands

The Austin Machinery Corporation of Chicago now embraces the following well known companies: The F. C. Austin Machinery Co., Inc., the Linderman Steel & Machine Co., the F. C. Austin Drainage Excavator Co, and the Municipal Engineering and Contracting Co. The Toledo Bridge and Crane Co. has also recently been included in this consolidation and it is quite likely that other large companies will be taken over in the near future, it is authoritatively stated.

The directors of the corporation are Messrs. Ralph Crews of the National City Company, New York; Clay H. Hollister, President, Old National Bank, Grand Rapids, Mich.; B. A. Linderman, President, Linderman Steel & Machine Co., Muskegon, Mich.; Samuel McRoberts, formerly Vice-President, National City Bank, New York; John R. Shaw, Vice-President, Canadian Manufacturers Assn., Woodstock, Ontario; C. A. Peckham, President, Toledo Bridge & Crane Co., Toledo, Ohio. Mr. B. A. Linderman is President of the Corporation.

The consolidation of so many interests means that the Austin Machinery Corporation will have every facility for turning out an enormous amount of high-class machinery for moving earth and mixing concrete.

The whole list of machinery will be put out under one trademark. This will cover all lines of manufacture, including industrial locomotive cars and batch boxes.

Increasing Use of Oak Floors

"Modern Oak Floors," is the name of an attractive brochure published by the Oak Flooring Manufacturers Association, 1014 Ashland Block, Chicago. The cover is done in colors and is highly artistic. The Company's trade mark appears on each page and it is set off with a decorative border which shows miniature scenes where oak floors are in use. The trade mark stands for quality and responsibility. The use of oak flooring is becoming more general throughout the country and a real home is no longer considered up-to-date unless one or more of its rooms are laid with hardwood floors. It is claimed by the manufacturers that the cost of oak floors is considerably less than the cost of sufficient good carpet to cover the same space. In buying oak floors it is well to avoid the mistake of selecting Japanese oak which is considered an inferior grade and lacks the wearing qualities of the American product. Owners of apartment houses find that apartments bring much higher rentals where the principal rooms have been laid with oak floors.

Hebrew Hospital

Working drawings are being prepared by Mr. S. L. Hyman, architect in the Crocker building, San Francisco, for a two-story reinforced concrete and brick hospital to be erected on Mission street near Silver avenue, San Francisco, for the Hebrew Hospital & Home for the Aged and Disabled. Approximately \$450,000 will be expended on the improvements.

Office Alterations and Bank Work

Mr. Morris M. Bruce, Flood building, San Francisco, has let a contract for \$15,000 for alterations to offices on the second floor of the Flood building. Mr. Bruce designed the new interior of the Growers Bank in San Jose, which recently opened its doors to a large patronage.

Store and Loft Building

Mr. W. D. Shea, 244 Kearny street, San Francisco, has prepared plans for a two-story Class "C" store and loft building on the south side of Mission street, west of Seventh, San Francisco, 75x85 feet, for Kathleen Farrell, to cost \$30,000.

Brick Garage

Messrs. W. C. Pennell and L. A. Smith, 204 Investment Bldg., Los Angeles, have prepared plans for a 1-story garage and shop building to be erected at 738-42 West Pico Street, for Drayer & Hanson.



"All chimneys, irrespective of which materials the walls are built, shall be lined with fire clay flue lining or with fire brick. The lining shall be made for the purpose and adapted to withstand high temperatures and the resultant gases from burning fuel." From "An Ordinance for Construction of Chimneys" recommended by the National Board of Underwriters, 1920.

Oust a Cruel "FIRE-BUG!"

Statistics show clearly that the most prolific "fire-bug" in residences is the *unlined* chimney. From one-fifth to one-third of the fires that endanger homes originate in chimneys. Fire Clay Flue Lining insures the safety of the families of your clients against the worst single cause of fires. A few dollars per chimney is all it costs. A trifle to include — an important thing to specify.

Write for a copy of the 1920 recommendations of the National Board of Fire Underwriters Committee on Construction of Buildings.

CLAY PRODUCTS ASSOCIATION

PITTSBURGH

CHICAGO

(Los Angeles Pressed Brick Co., Los Angeles, Member)

FIRE CLAY FLUE LINING

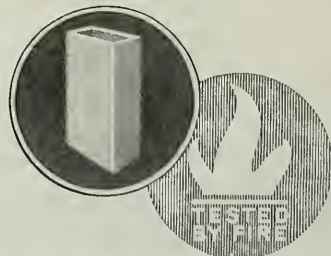

The Lumber Situation

Underproduction is still much in evidence in the lumber districts of Washington and Oregon and the car situation has not improved to any noticeable extent, according to a report issued by the West Coast Lumbermen's Association compiled from figures submitted by 129 reporting mills.

For the week ending July 24 production in the two States was 20 per cent below normal, orders were 20 per cent below production and 13 per cent above shipments. The car supply was approximately one-third of requirements.

The unshipped balance for transcontinental rail trade is 255,120,000 feet, approximately 7,504 carloads; unshipped domestic cargoes, 62,072,515 feet; unshipped export, 66,163,454 feet. Total of all unshipped business, 353,355,969 feet.

Moves to New Show Rooms

Mr. M. E. Hammond, representing The Prometheus Electric Company, manufacturers of electric food and plate warmers, has moved his office to the mezzanine floor of the Pacific building, San Francisco. Mr. Hammond also represents the Petrium Sanitary Sink Company, and has a full size petrium sanitary kitchen sink on display in the new show rooms.

Cafe Building

Mr. Wm. L. Woollett, 215 Wright & Callender Bldg., Los Angeles, has completed plans for a 1-story brick cafe building to be erected on Hope Street between Sixth and Seventh Streets, for Chas. F. De Long and Eugene Machtig, proprietors of Ye Bull Pen Inn, East Seventh Street, near Los Angeles Street.

Concrete Apartment House

Mr. Elmer Grey, 508 Wright & Callender Bldg., Los Angeles, has prepared preliminary plans for a 5-story and basement reinforced concrete apartment house to be erected at the corner of Ocean Blvd. and Virginia Court, Long Beach, for Frank P. Wright and Mrs. O. West, 643 Markwell Bldg. There will be 99 two and three-room apartments.

Factory Building

Mr. E. L. Mayberry, 468 Pacific Electric Building, Los Angeles, is preparing plans for repairing a portion of the factory building recently damaged by fire for the Brinstool Paint Co., Mateo and Palmetto Streets, Los Angeles.

WHY WORK?—Strike, and the world strikes with you; work, and you work alone.—Life.

Dealers Arrested for Selling Inflammable Stove Polish

In a crusade waged by the State Police against the selling of stove polish containing inflammable fluid, five storekeepers were summoned in court. The polish contained gasoline which emitted gas that flashes at a temperature less than 100 degrees.

DIXWELL DAVENPORT
Manager Pacific Coast Department

**BANKERS & SHIPPERS
INSURANCE COMPANY**
INSURANCE EXCHANGE BLDG.

SAN FRANCISCO
Telephone Kearny 3561

"BLAZING" THE TRAIL
We've been doing it for many years—giving the Sportsman Better Value for Quality than he ever before received. "Value at a Fair Price" in everything for the Sportsman.



SEND FOR CATALOG *The Sign of Quality*

G. DRUCKER

J. C. JAMES

JAMES & DRUCKER

**PLUMBING—HEATING
CONTRACTORS**

Phone
Market 275

450 Hayes Street
San Francisco

Construction Needs A Vital Domestic Issue

IN an open letter addressed to the chairman of the campaign committees of both the Republican and Democratic parties, General Manager R. C. Marshall, Jr., of the American Contractors Association, insists that the construction needs of the United States should be recognized as one of the most vital domestic issues of the coming political campaign. He points out that the business men of the country "will not be content with a discussion of international policies only, at a time when domestic problems are pressing for attention."

His letter places emphasis on the imperative need for a construction program that will adequately overcome the housing shortage and allow American industries to increase their facilities for production.

The present moment offers an opportunity for members to impress upon the political leaders of both parties the importance of keeping up with construction needs. The active participation of individual members in the effort to focus attention on the construction problem of the country will have real influence in bringing public opinion to bear on the issue.

After quoting the planks in each platform referring to constructive domestic legislation proposed, General Marshall indicates the need for careful consideration of the domestic problems involved in these planks, especially as they relate to the construction industry, which he lists second in importance only to problems relating to food and fuel.

The letter addressed to Chairman Hays of the Republican National Campaign Committee follows:

My dear Mr. Hays:

It is with interest that I note the attention given to the need for construction of various kinds in the platform recently adopted by the National Convention of the Republican Party.

In that document the Republican Party goes on record in favor of liberal appropriations for the construction of highways, the encouragement and development of water transportation and facilities, the restoration of railroad credit to furnish enlarged facilities, the promotion of water-power development, and the encouragement of home ownership and town-planning by the Federal Government. Every one of these problems touches a vital spot in the work of reconstruction which we are facing, in which construction, so long deferred, must play an important part.

When it is realized that the construction industry is second in importance only to agriculture in the United States, I believe it is not amiss to point out to you the need for giving this great organ of the body politic prime attention in the coming discussions of national issues preceding the presidential election.

The attention of the business men of the country will be focused on the analysis of the issues presented by the platform of the two great political parties more than in any election for some time past. Nor will they be content with a discussion of international policies only at a time when domestic problems are pressing for attention. For example we are facing during the present year a construction program estimated at the unprecedented total of \$4,000,000,000, and during the coming four or five years an annual

OAK FLOORS

(For Everlasting Economy)



Oak Floors for Homes of Moderate Cost

OAK FLOORS are sure to be the background for the fine furniture of the more costly homes, but the desirability of oak as the flooring material for homes of moderate cost is equal if not greater. Oak floors immediately raise this type of house out of the commonplace class and give the needed tone of distinction.

Many of our friends in the architectural profession are enthusiastic about this use of oak flooring. We are sure that all will find it helpful and that it will merit the praise of your clients.

OAK FLOORING *MORSE ASSN.*

1036 Ashland Block, Chicago



average which according to present indications will exceed that total. The problems of development, finance, transportation, production, and distribution of every kind involved in such a stupendous program include the most important questions of industry and government. Just at this time no other domestic problem—other than those related to the production and distribution of food and fuel—demands such careful consideration as those involved in the construction problems presented by the needs of the people.

It is in the hope that you as Chairman of the Republican National Committee will bring these facts home to the members of your organization who are at this time preparing for the discussion of the issues contained in your platform, that I am addressing you. I sincerely trust that they will make clear to the great representative body of men directly interested in the construction industry as well as to all citizens, every one of whom is indirectly affected by it, the steps which they propose to take to realize the aims referred to above as set forth in their platform.

Very truly yours,
R. C. MARSHALL, JR.
General Manager.

The Prevention of Elevator Accidents

By E. C. WOOD *

IN a recent issue of the "Literary Digest," Mr. J. L. Howe, of Stockton, California, comments at some length on the matter of elevator accidents. It appears that Mr. Howe's remarks were the outcome of a discussion which dealt with the dropping of elevator cars, and he hits the nail on the head. He lays much stress on the landing entrance accidents. Reliable statistics teach us that fully 70 per cent of the injuries received in passenger and freight elevator traveling are in connection with the openings to the elevator wellway. If we were to assume that such accidents were not preventable by physical means, the problem of elevator safety would coincide with that of general machinery safeguarding. It is a known fact that less than 50 per cent of industrial accidents can be prevented by the installation of mechanical guards. Educational safety propaganda can and must accomplish the remainder.

The elevator safety problem is different from practically all others. It is possible to prevent fully 90 per cent of all elevator accidents. The Industrial Accident Commission of the State of California has realized this by studying the several types of accidents. It is proposed to eliminate the landing entrance accidents by requiring suitable and effective interlocks operated by each door or gate. At present such apparatus is not required except where the elevator has been installed subsequent to October 1, 1916. Approximately 800 new elevators have been put into service since that date and no injuries resulting from the one principal cause have been reported as occurring on these elevators.

One must not misunderstand the foregoing. We are not to assume that an elevator made safe today will continue

*Chief Elevator Inspector, California Industrial Accident Commission.

to be so. One point must be conceded to those who see elevator accidents in terms of dropping cars, namely, that such an occurrence usually results in a serious calamity. An elevator car can drop and injure more persons in a few seconds than have been injured yearly through door accidents. Happily this has not been the case. Inspections have done much toward the prevention of this type of accident. In California, each cable is inspected periodically. Cable inspections are not infallible, but many impending disasters are prevented. All car-holding safety devices are tested by causing the safety to set when the car and capacity load are descending at full speed. In addition to this, each type of device is drop-tested and thoroughly examined for defective design and material. Countless criticisms have been made by the California Industrial Accident Commission and met by the manufacturers.

It would appear that the possibility of a car's falling an unsafe distance has been minimized. It is not claimed that these tests and inspections will prove infallible. It is a fact, however, that thorough inspections, tests, proper door safety devices and a general application of the California Elevator Code, will cause elevator travel to be 90 per cent safe, the remaining 10 per cent being a matter of "personal element," the one "bugbear" to the safety engineer.

Notes of Interest to Landscape Architects

Mr. Geo. D. Hall of Cook & Hall, Los Angeles, has returned from the East after a business trip of a month's duration.

The Hon. F. W. Blanchard has been unanimously elected to honorary membership in the Pacific Coast Chapter of the American Society of Landscape Architects. Mr. Blanchard is a Los Angeles man who has been much interested in the civic development of the city for many years.

Messrs. Cook and Hall report the development of a private estate for Mr. E. DeKoven Leffingwell at Granada Park, along Italian lines in co-operation with Mr. Reginald D. Johnson of Pasadena; also the remodelling of a private estate for Mr. Leffingwell at Sunny Slope, Cal., and the development of a private estate for Mr. E. C. Quimby at San Marino Pasadena, including sunken garden, water ramps, swimming pools, etc.

Group of Farm Houses

Mr. Henry C. Smith, Humboldt Bank building, San Francisco, has prepared plans for a group of frame farm houses to replace those recently destroyed by fire at Suisun, Solano county, on the ranch of Mr. William Pierce, Suisun. They will cost \$15,000.

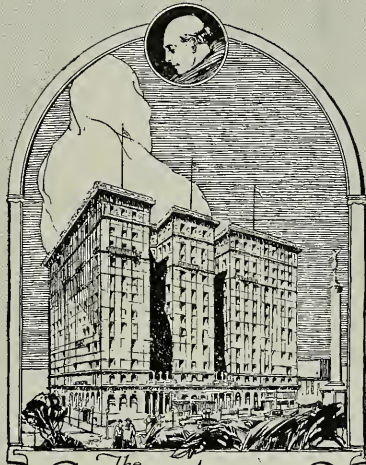

The
ST. FRANCIS
One of the world's great hotels
Facing Union Square
SAN FRANCISCO CALIFORNIA

EXPRESSES MOST PLEAS-
ANTLY THE HOSPITALITY
AND ANIMATION THAT
ARE CHARACTERISTIC
OF SAN FRANCISCO

Thos. J. Coleman
Manager

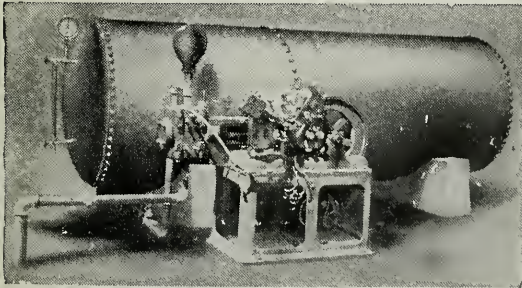

Kewanee Water System

Maintain your own Plant.
Small Operating Expense.
A Perfect Water Supply to
Country Homes, Hotels
and Parks.

Simonds Machinery Co.

117- 121 Montgomery Street
SAN FRANCISCO
Phone Kearny 1457

Some Sound Advice to the Prospective Builder

The Architect—What Is He? Why Employ Him? How Select Him?
How Deal With Him?*

PERSONS who have never employed an architect are apt to be at a loss as to the proper method of procedure, while many who have had some experience may not be familiar with the intricacies of architectural practice. They may not understand that architecture is a profession, calling for men of the highest integrity, business capacity and artistic ability; to command the respect and confidence as advisers, and to sustain a grave responsibility to the public. No one may have given them practical information as to the relations that should subsist between client and architect. Experience has shown that lack of information on this subject is one of the most fruitful causes of trouble in building. The following is a brief outline of vital elements in building operations:

1. The owner, who is to spend the money, as he does not and cannot know what he is buying, must trust the architect. Therefore he should first of all assure himself that the architect is worthy of his confidence; second, that he is fitted by study of economy in plan, construction, and material to discharge this grave responsibility; in short that he has the right to the professional title.

2. The owner's interests are to secure the most available service, suitable design, best construction, most economical expenditure of funds. These can only be obtained by employing, not as a luxury, but as a necessity, an expert, a competent and reliable architect. The owner will be most benefited by choosing an architect before deciding upon anything else connected with the building project (if possible even before fixing the building site and limit of expenditure); thereby gaining from start to finish the services of the expert's technical experience and knowledge in every phase of the problem.

3. Designing a building is a process of evolution. Nothing but the full working out of the problem can produce this. The architect's goal is to lead the client to the best solution of the problem in hand. He is a sort of clearing-house, in adjusting the multiplicity of ideas, wishes, needs, financial and other details. The best eventual scheme may be quite different from that which at the start was suggested by either owner or architect. The owner should get the benefit of his architect's best ideas and various solutions of the problem, not simply what is presented to catch the attention, and "get the job"; the complete services of an ex-

pert, not of a mere draftsman. "Blue prints" are not the sum and substance of this service.

4. Do not expect gratuitous competitive designs, any more than free diagnoses, prescriptions or briefs. Plans are not like merchandise, kept in stock, to fit all individual needs; the model plan exists only for its individual place and condition; each building requires special time, study and labor—the architect's capital.

5. The architect's practice is upon the same basis as that of the physician and the attorney; each is a profession, and selection should be on exactly the same principle, upon record for character, integrity, ability and fitness for the service.

6. To employ an architect on the basis of what he charges is usually wrong. It is almost always wrong when the "cheapest" man is selected. "Penny wise and

GEO. H. DYER, President
R. W. DYER, Vice-Pres.
W. J. DYER, Sec'y

DYER BROS.

GOLDEN WEST IRON WORKS

(INCORPORATED)

Structural Iron
and
Steel Contractors

Ornamental Iron Work

Office and Works

17th and Kansas Streets
SAN FRANCISCO, CAL.

Phone Market 134

* From a circular prepared by Mr. Eugene T. Taylor and distributed by the Iowa Chapter of the American Institute of Architects.

Present Cost of Building Materials*

With Labor Wage Scale, Bonds, Etc.

THESE quotations are based on reliable information furnished by San Francisco material houses. Date of quotations, August 20, 1920.
All prices f. o. b. cars San Francisco or Oakland.

American Institute of Architects' Fees

New work—6 per cent minimum basis.
Alterations—7 to 10 per cent as a minimum basis.

High class residence work—10 per cent as a minimum.

Bond—1½% amount of contract.

Brickwork—

Common, \$38.00 per 1000 laid.
Face, \$70.00 per 1000 laid.
Common, f. o. b. cars, \$18.00 plus cartage.
Face, f. o. b. cars, \$45.50 per 1000, car-load lots.
12x12x3 in., 10¼c. per square foot.
12x12x4 in., 11¼c. per square foot.
12x12x6 in., 16¼c. per square foot.
Hod carriers, \$8.00 per day.
Bricklayers, \$10.00 per day.
Lime—\$2.40 per bbl.; per ton of 2000 lbs., \$18.50.

Composition Floors—30c. per sq. ft.
Klingstone, 27c. to 65c. per foot.

Concrete Work (material at San Francisco bunkers)—

No. 3 rock \$2.60 per yd.
No. 4 rock 2.75 per yd.
Niles pea gravel 3.00 per yd.
Niles gravel 2.25 per yd.
Niles top gravel 2.50 per yd.
City gravel 2.25 per yd.
River sand 1.40 per yd.
Bank sand 1.00 per yd.

Monterey White Sand—

Del Monte, \$1.25 to \$1.50 per ton.
Fan Shell Beach, \$2.50 to \$3.00 per ton.
Car lots, f. o. b. Lake Majella.
Cement (f. o. b. cars) \$3.88 per bbl.
Rebate for sacks, 25c. each.
Atlas "White" \$9.50 per bbl.
Medusa cement 9.50 per bbl.
Forms \$60.00 per M

Wage—

Laborers \$6.00 per day
Concrete workers 7.50 per day
Cement finishers 9.00 per day

Dampproofing—

Two-coat work, 30c. per yard.
Membrane waterproofing—4 layers of P. B. saturated felt, \$6.00 per square.
Hot coating work, \$2.00 per square.
WAGE—Roofers, \$9.00 per day.

Electric Wiring—\$8.00 to \$15.00 per outlet.
WAGE—Electricians, \$9.00 per day.

Elevators—

Prices vary according to capacity speed and type.
Consult elevator companies.

Excavation—

\$2.00 per yard.
Teams, \$12.00 per day.
Trucks, \$30.00 to \$40.00 per day.
Above figures are an average without water. Steam shovel work in large quantities, less; hard material, such as rock, will run considerably more.

Fire Escapes—

Ten-foot balcony, with stairs, \$100.00 per balcony.

Glass—

(Consult with manufacturers.)
21 ounce, 25c. per square foot.
Plate, \$2.00 to \$5.00 per square foot.
Art, \$1.00 up per square foot.
Wire (for skylights), 40c. per square foot.
Note.—Add extra for setting.
WAGE—Glaziers, \$9.00 per day.

Heating—

Average, \$3.25 per sq. ft. of radiation.
WAGE—Steamfitters, \$10.00 per day.

Iron

Cost of ornamental iron, cast iron, etc., depends on design.

Lumber—

Common (at building), \$48.00 per 1000 (average).
Common O. P. (select), \$98.00 per 1000 (average).

Flooring—

1x3 No. 1 \$121.00 per 1000
1x3 No. 2 113.00 per 1000
1x4 No. 1 116.00 per 1000
1x4 No. 2 113.00 per 1000
1x4 No. 3 106.00 per 1000
1x6 No. 1 121.00 per 1000
1x6 No. 2 118.00 per 1000
1¼x4 and 6 No. 1 121.00 per 1000
1¼x4 and 6 No. 2 116.00 per 1000
Slash grain, 1x4 No. 1 90.00 per 1000
Slash grain, 1x4 No. 3 85.00 per 1000
No. 1 common run to
T. & G. 65.00 per 1000
Lath 9.00 per 1000

Shingles—

Redwood, No. 1 \$1.60 per bdl.
No. 2 1.50 per bdl.
Red cedar 1.85 per bdl.
(Add cartage to above)

Hardwood Floors—

Maple floor (laid and finished), 38c. per foot.
Factory grade floors (laid and finished), 30c. per foot.
Oak (quartered, finished), 57c per foot.
Oak (clear), 41c. per foot.
Oak (select), 39c. per foot.
Oak, quartered, sawed, clear, select, 48c.
WAGE—Floor layers, \$9.00 per day.
In flooring the usual grades of oak used are

Grades	Quartered Plain	
	Sawed	Sawed
5/16".....	Clear	"
	Select	"
1"x3"-13/16"x2¼".....	Clear	"
	Select	"
	No. 1 (very little used)	
¾-inch plain oak.....	58c.	
¾-inch quarter sawed.....	70c.	

Hardwood Floors (not laid)— Per M ft.

5/16x2" sq. edge Clear quartered oak..... 365.00
Select quartered oak..... 295.00
Clear plain oak 295.00
Select plain oak 265.00

* NOTE.—For country work add freight and cartage to prices given.

THE ARCHITECT AND ENGINEER

Hardwood Floors (not laid)—Continued

	Per M ft.
13/16x2¼" face Clear quartered oak.....	\$400.00
Select quartered oak.....	350.00
Clear plain oak.....	340.00
Select plain oak.....	305.00
Clear maple.....	280.00
Clear maple—white.....	310.00
13/16x3¼" face Clear maple.....	285.00
1½x2¼" face Clear maple.....	290.00
¾x2" face Clear quartered oak.....	300.00
Select quartered oak.....	250.00
Clear plain oak.....	250.00
Select plain oak.....	215.00
Clear maple.....	235.00
Clear beech.....	235.00
Clear red beech.....	265.00

Veneered Panels—

24x60 in., ¼ in., 3-ply, 1 side:	Per ft.
Ash.....	31½c
Hungarian Ash.....	47c
Birch.....	31½c
Curly Birch.....	47c
Elm.....	29c
Jenifero (Genezero).....	45½c
Southern Red Gum (plain fig.).....	38½c
Old Southern Red Gum.....	47c
Hawaiian Koa.....	47c
Maple.....	29c
Birdseye Maple.....	57c
Mahogany.....	47c
Oregon Pine.....	23½c
Plain Oak.....	37½c
Quartered Oak.....	47c
Walnut.....	48c

Millwork—

O. P., \$180 per 1000. R. W., \$180 per 1000.	
Double hung box frame windows (average) with trim.....	\$10.50 each
Doors, includ. trim (single panel).....	15.00 each
Doors, including trim (five panel).....	\$12.00 each
Screen doors.....	5.50 each
Window screens.....	3.50 each
Medicine cases.....	5.00 each
Cases for kitchen pantries seven feet high, per lineal foot.....	10.00 each
Dining room cases same price, if not too elaborate,	
Flag poles, per foot.....	1.50

Labor—Rough carpentry, warehouse heavy framing, \$16.00 per 1000.

For smaller work, average,	\$23.00,
\$30.00 per 1000.	
WAGE—Laborers, \$6.50 per day.	
Carpenters, \$9.00 per day.	

Marble—(Not set) add 60c up per ft. for setting

Columbia.....	\$2.05 sq. ft.
Alaska.....	2.05 sq. ft.
San Saba.....	3.65 sq. ft.
Tennessee.....	2.50 sq. ft.
Verde Antique.....	4.55 sq. ft.

Painting—

Two-coat work, 35c. per yard.	
Three-coat work, 45c. per yard.	
Whitewashing, 5c. per yard.	
Cold water paint, 10c. per yard.	
WAGE—Painters, \$8.50 per day.	

Patent Chimneys—

6-inch.....	\$1.50 lineal foot
8-inch.....	1.75 lineal foot
10-inch.....	2.25 lineal foot
12-inch.....	3.00 lineal foot

Pipe Casings—\$8.00 each.

Plastering—

Interior, on wood lath, 70c. per yard.	
Interior, on metal lath, \$1.25 per yard.	
Exterior, on brick or concrete, \$1.00 per yard.	
Portland White, \$1.25 to \$1.50.	

Interior on brick or terra cotta, 65c to 70c per yard.

Exterior, on metal lath, \$2.25 to \$2.50 per yard.

Wood lath, \$8.00 at yard per 1000.

Metal studding, \$1.00 to \$1.25 per yard.

Metal studding, with lath and plaster, \$2.00 per yard.

Galv. (metal lath), 38c. and up per yard, according to gauge.

Lime, f. o. b. warehouse, \$2.40 per bbl.

Hardwall plaster, \$21.00 per ton f. o. b. warehouse.

WAGE—Hod carriers, \$8.50 per day.

Plasterers, \$10.00 per day.

Plumbing—

From \$70.00 per fixture up, according to grade, quantity and runs.

WAGE—Plumbers, \$10.00 per day.

Reinforcing Steel—

Base price for less than car load lots, \$5.75 per 100 lbs.

Car load lots, \$5.50 per 100 lbs., f. o. b. San Francisco. (Mill delivery.)

Roofing—

Five-ply tar and gravel, \$7.50 per square for 30 squares or over.

Less than 30 squares, \$8.00 per square.

Tile, \$35.00 per square.

Redwood shingle, \$13.00 per sq. in place.

Cedar shingle, \$13.00 per square in place.

Reinforced Pabco roofing, \$8.25 per square.

WAGE—Roofers, \$9.00 per day.

Rough Hardware—

Nails, per keg, \$7.10 base and very scarce. Deafening felt, \$170.00 per ton.

Building paper, P. & B.,

1 ply, \$6.50 per 1000 ft. roll.

2 ply, \$9.75 per 1000 ft. roll.

3 ply, \$14.00 per 1000 ft. roll.

Sash cord,

(Sampson spot), \$2.50 per hank 100 feet.

Common, \$1.75 per hank 100 feet.

Sash weights, cast iron, \$80.00 per ton.

Skylights—

Copper, \$1.25 a square foot (not glazed).

Galvanized iron, 50c. a square foot (not glazed).

WAGE—Sheet metal workers, \$10.00 per day.

Store Fronts—

Kawneer copper bars for store fronts.

Corner, center and around sides, will average \$1.35 per lin. foot.

Structural Steel—\$150.00 per ton.

This quotation is an average for comparatively small quantities.

Light truss work higher; plain beam and column work in large quantities, less.

Steel Sash—

Fenestra, from S. F. stock, 45c. per sq. ft.

Fenestra, Plant shipment, 40½c. per sq. ft.

(Includes mullions and hardware.)

Tile—

White glazed, 80c. per foot.

White floor, 80c. per foot.

Colored floor tile, \$1.00 per foot.

Promenade tile, \$2.00 per sq. foot, laid.

WAGE—Tilersetters, \$9.00 per day.

Windows—

Metal, \$2.00 a square foot.

ARMCO IRON

ENAMELED PRODUCTS



SMOOTHLY BEAUTIFUL FOR KITCHEN USE

"What put the idea of Armco Iron Enameled Products in your mind?" asked the guest.

"My husband," the hostess replied. "He uses Armco Iron in the manufacture of various metal industrial products, and has had splendid success with it. You see, its purity and evenness make possible unusual durability.

"When my husband told me that there were stoves made with Armco Iron polished sheets and enameled parts, I decided to get one. I wrote the manufacturers of Armco Iron—The American Rolling Mill Company, of Middletown, Ohio—and they sent me the names and addresses of the firms that make such stoves, also of the

The trademark ARMCO carries the assurance that products bearing that mark are manufactured by The American Rolling Mill Company with the skill, intelligence and fidelity associated with its products, and hence can be depended upon to possess in the highest degree the merit claimed for them. The trademark ARMCO is registered in the U. S. Patent Office.



REG. U. S. PAT. OFF.

manufacturers of Armco Iron Enameled Kitchen Cabinets, Refrigerators, and Table-Tops.

"As you see, I now use all of these articles, and your own eyes tell you how smoothly beautiful and perfect they are. Because of the exceptional purity and evenness of Armco Iron, these kitchen products are remarkably free from occluded gases, seams, scars, cracks, spots, pinholes, and other defects, which in less carefully made enameled products show through the enameling and cause ugly spots and rough places.

"After my two years' experience with these products in my kitchen, I can heartily recommend them to every housewife."

THE AMERICAN ROLLING MILL CO. Box 943, MIDDLETOWN, OHIO

Licensed Manufacturers under Patents granted to the International Metal Products Company

Pacific Coast Sales Office—10th and Bryant Streets, San Francisco; other Branch Offices in New York, Chicago, Pittsburgh, Cleveland, Detroit, St. Louis, Cincinnati, Atlanta, Washington, D. C. and Buffalo.

ARMCO IRON Resists Rust



CEMENT GUN

Will Make Your
Concrete Waterproof

**Cement Gun Con-
struction Company**
of California

701 Balboa Building,
San Francisco

For

**DAMS
RESERVOIRS
TUNNELS
BULKHEADS
CANAL
LININGS
CEMENT
FLUMES**

use the
Cement Gun

**SPEED
ECONOMY
PERMANENCE**

pound foolish" applies most appropriately to this uneconomical method.

An incompetent man selling his service for a small fee may and often does waste a great deal of money in inefficient planning, unsafe and unscientific design, unwise specification of materials, and unimproved opportunity generally. An incompetent man as supervising architect is worse than useless as he has no accurate standards of his own but is at the mercy of the builder. A competent man by his services saves the client several times the amount of the architect's fee and often earns the undying gratitude of his client.

7. Architects, like doctors and lawyers, place different values upon their services, and their services likewise vary in merit and results. This should not confuse the owner—the best is likely to be the higher priced.

8. In merchandising one may buy calico or silk and pay accordingly, but there is only one kind of professional service that is worth paying for: that is the best of which the architect (or lawyer or doctor) is capable of giving. This means, generally, adherence to established standards of practice, and adequate fees. To underpay any man is to tempt him to be dishonest.

9. Make up your mind what you must have, then take the architect into your confidence as to the amount you are willing or able to expend; be perfectly frank with him. Do not try to set a price and refuse to relinquish terms and conditions which are bound to make your building cost more than you are willing to spend. Do not hurry. Take time enough on the preliminary sketches, so that you and the architect understand each other before the working drawings are started.

10. Do business only with a capable and honest contractor. Incompetence is as much to be avoided as dishonesty. "You cannot get blood out of a turnip," nor should you expect to get an honest building if the price asked is too low. Watch the work as much as you see fit,

but if you have employed an architect whom you can trust, rely upon him and save yourself time and worry. You can earn more at your own business than you can save by trying to shoulder the responsibility that properly belongs to the architect.

11. Do not violate the unwritten law which requires one head on a job. Let your instructions to the contractor be given through the architect. The contractor who comes to you with suggestions or to call your attention to real or fancied errors in the drawings or specifications should be referred to the architect. Make use of the architect's advice. That is what you are paying him for.

Do not mar your building by a wrong location, etc., or with incongruous decorations and furnishings. If you desire an effect of organic unity when the work is done, use the architect to that end.

12. Architectural service is the only form of reliable insurance that the client

TRANSMISSION EQUIPMENT

For Mill or Factory



Pulleys --	Shafting --	Gears --
Hangers --	Bearings --	Take Ups --
Sprockets --	Clutches --	Chain Belts --
Floor Stands	Belt Tighteners	Rope Sheaves

Meesco Short Center Drives

Meesco & Gottfried Company

ENGINEERS AND MANUFACTURERS
CONVEYING, ELEVATING, SCREENING
AND MECHANICAL POWER TRANSMITTING
MACHINERY

SAN FRANCISCO 560 Mission Street	SEATTLE 559 First Ave So	PORTLAND 67 Front Street	LOS ANGELES Garfield E 3rd St
-------------------------------------	-----------------------------	-----------------------------	----------------------------------

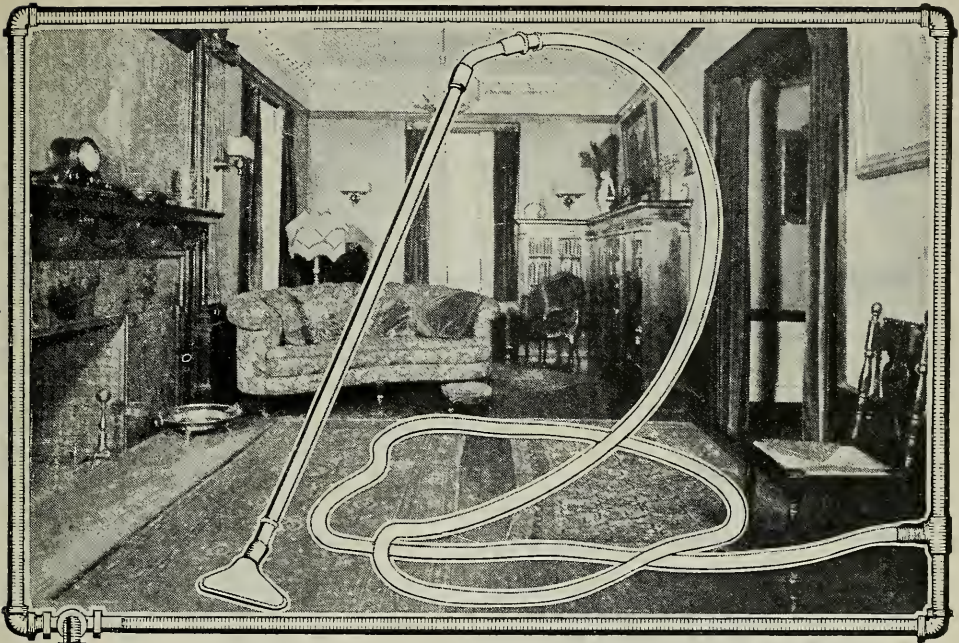

SIX WORDS THAT TELL IT ALL

**“Greatest in Efficiency
-Greatest in Value”**

There you have the whole secret of the remarkable success of the TUEC Stationary Suction Cleaner.

Judged from any standpoint the TUEC Fan-Type No. 260, $\frac{3}{4}$ -H.P. Model for buildings of ordinary size, is the biggest value ever offered in a stationary suction cleaner.

Simplicity of design is the keynote of the TUEC'S unmatched cleaning power, TUEC fan-type construction represents the latest and furthest advance in vacuum cleaner building. It costs less to maintain, requires less care, and is absolutely fool-proof and accident-proof.

Your knowledge of vacuum cleaners and air cleaning service is incomplete if you are not familiar with all the advantages of the TUEC.

Write for catalog and call on us for advisory service.

THE UNITED ELECTRIC CO. CANTON, OHIO
New York Chicago Cleveland Atlanta Portland, Ore.



S. F. COMPRESSED AIR CLEANING CO., 397 Sutter Street, San Francisco
BARKER BROS. 724 So. Broadway, Los Angeles—California Distributors

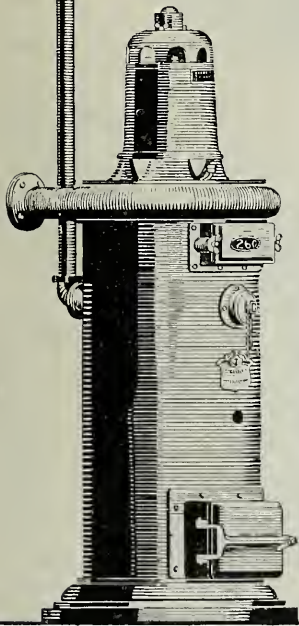

SERVICE
TESTING
INSPECTION
CONSULTATION
PRODUCTION

**Structural and Engineering
 Materials**



Robert W. Hunt & Co.
 Engineers

**Chemical and Physical
 Testing Laboratories**

New York Chicago Pittsburgh
 St. Louis San Francisco Mexico City
 London Montreal



*Residence of G. W. Wattles, Garden Front
 Hollywood, Calif.
 Myron Hunt & Elmer Grey, Architects*

Bay State Coating

Permanent beauty. That's the kind that one or two applications of Bay State Brick and Cement Coating imparts to all walls of brick, cement or stucco. It waterproofs them, too. No rain, sun, or storm affects its protection and lasting qualities.

Your choice of white or a range of colors. We will send you a sample of any tint you wish. Let us mail you Booklet No. 43. It shows a number of Bay State Coated Homes. Drop us a postal card today.

WADSWORTH, HOWLAND & CO.
 Incorporated

Paint and Varnish Makers
 Boston, Mass.

Pacific Coast Representatives

JAMES HAMBLY & SON

San Francisco

Los Angeles



may purchase which gives him the right to claim that he is getting what he pays for. An architect puts selling value into a building not only because the owner can claim for the building what the architect certifies it really is, but also from the intrinsic value resulting from a good design as compared with a poor one.

13. If you follow these few hints, in all that they imply, there is no reason why your structure should cost you a cent beyond the estimated price, or why it should cause you more worry than any ordinary business transaction.

Foreign Trade Service

The first Foreign Trade Service devoting its exclusive attention to the construction industry has been organized by the National Federation of Construction Industries, and is now in active operation with general offices in the Drexel Building, Philadelphia.

The work is being carried on by the Foreign Trade Division under the direction of Dr. J. T. Duryea, President of the Pierce, Butler and Pierce Manufacturing Corporation of New York City, who is Chairman of the Federation's Foreign Trade Committee.

One of the aims of the Foreign Trade Committee is to discover where the real opportunities lie for world trade in construction materials and machinery, and to aid in determining the best means of developing them. For this purpose a special and intensive study of each branch of the industry in all parts of the world is being made, and reports are being prepared at the Federation's headquarters.

The Federation is at present securing figures designed to show the relative costs and time of erecting office structures and warehouses in New York City and in London. It is well known that British trade and industry are seriously hampered for lack of proper office space and working facilities. By graphically showing at what cost American building methods may be adopted abroad, it is believed that a way may be opened to overcome this difficulty and at the same time bring about a considerable demand for the erection of American buildings and equipment.

A New Stanley Folder

A brand new folder illustrating set No. 1783 of the Stanley Works Garage Hardware is now ready for distribution to those interested. This is a real attractive folder, describing a set that is one of the more popular combinations for the better class of garage. It has the ball bearing hinges, foot and chain bolts and the 1774 Garage Door Holder. In fact, it has, as its makers state, every item of hardware for complete and serviceable equipment.

Readers of this magazine who would care to have a copy of this book, write for B12, the Stanley Works, New Britain, and it will be forwarded at once.

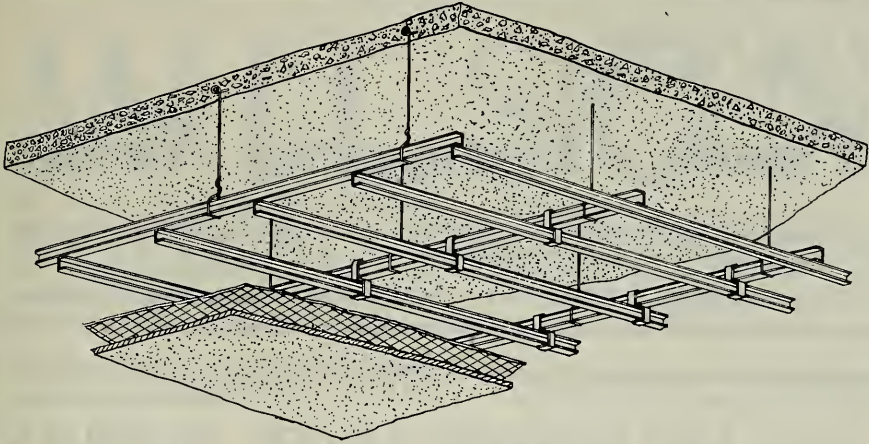

Yes, The U. S. Government Did Change Its Mind !

The specifications on the U. S. Government Building at Portland, Oregon, called for the tying together of the carrying bar and lathing bar with wire.

We submitted our system, and after an explanation of the S. S. System for fastening bars, the engineers and government officials were convinced that here at last is the perfect and economical system, and these reasons added weight in deciding.

It is a positive tie, no slipping or shearing. It is strong, Smith Emery test to 353 lbs. before failing.

It is fast, can be applied on the bench or on the scaffold.

Made for 1 inch carrying bar and $\frac{3}{4}$ inch lathing bar and $\frac{3}{4}$ inch carrying and $\frac{3}{4}$ inch lathing bar.

Can be used for wall furring as well as for ceiling work.

THE STEEL STUDDING COMPANY

1216 Folsom Street

San Francisco

Agents Wanted Everywhere

Also Manufacturers of

THE PRONG CHANNEL for Solid and Hollow Partitions

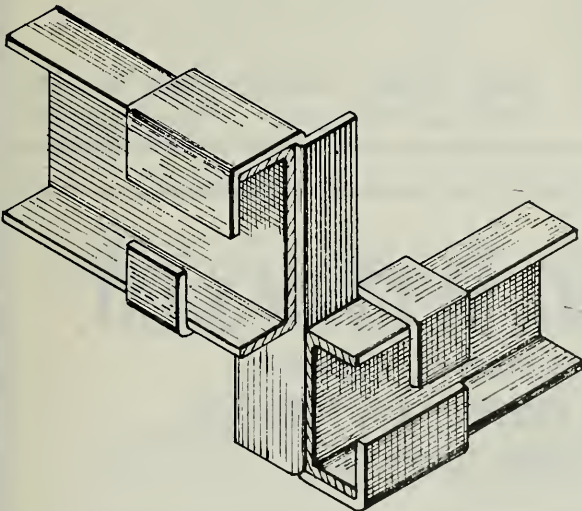
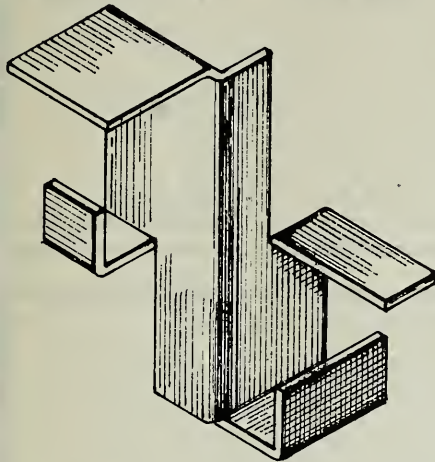

**FOR MODERN
STORE FRONTS**

Plummer's Disappearing Awnings

Are constructed with no outside attachments below awning recess. All mechanical parts entirely concealed. Send for Architects' Sheet showing specifications for recess construction, etc.

W. A. PLUMMER MFG. CO., 35-37 Front Street, San Francisco

JOHN TRAYNOR

CHARLES HARCOURT

OCEAN SHORE IRON WORKS

Manufacturers of Oil Tanks, Water Tanks, Pressure Tanks, Air Receivers, Feed Water Heaters, Breechings, Smoke Stacks, Water Pipe, Boilers, Retorts, Digestors, Pneumatic Pressure Tanks, Riveted or Oxy-Acetylene Welded Tanks, and dealers in Boilers, Tanks, Pumps, Engines, Machinery, Steel Plates, Shapes

Special Attention Given to Government and Export Orders

OCEAN SHORE IRON WORKS

Office and Works: 550-558 EIGHTH STREET, SAN FRANCISCO, CAL.

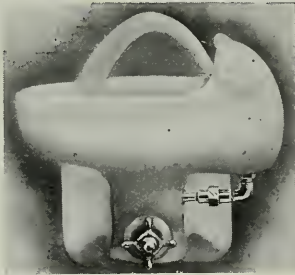

Model No. 7A.

NO GERMS HERE

HAWS IMPROVED SANITARY DRINKING FAUCET eliminates all possibility of contracting disease from dirty bulbs or unsanitary bowls. Provided with an overhead cowl, the drinker's lips never touch the source of supply. A slanting stream throws the water from right to left and away from the bubbler, instead of straight up to fall back over the fountain head. Recommended for Schools and Public Playgrounds. A type used extensively by the U. S. Government. Manufactured by

Haws Sanitary Drinking Faucet Co., Inc.
1808 Harmon Street, Berkeley Phone Piedmont 3742

GLADDING, McBEAN & CO.

MANUFACTURERS CLAY PRODUCTS

CROCKER BUILDING, SAN FRANCISCO

WORKS, LINCOLN, CAL.

WILSON

FOLDING PARTITIONS

For Schools, Clubs, Churches, Hotels,
Y. M. C. A. Buildings and Residences

STANDARDIZED BY THE FOLLOWING CITIES FOR THEIR PUBLIC SCHOOLS: New York; Philadelphia, Pa.; Cleveland, Ohio; Boston, Mass.; Harrisburg, Pa.; Bridgeport, Conn.; Waterbury, Conn.; Detroit, Mich.; Newark, N. J.; Cincinnati, Ohio; Providence, R. I., and Salt Lake City, Utah.

Also specified and used in the schools in Los Angeles, Calif.; Long Beach, Calif.; San Bernardino, Calif.; San Francisco, Calif.; Berkeley, Calif.; Monterey, Calif.; Portland, Ore.; Tacoma, Wash.; Seattle, Wash.; Eugene, Ore., and hundreds of other cities and towns throughout the United States. The standard partition for Y. M. C. A. buildings, as specified by the Building Bureau International Headquarters, New York. Hundreds of Sunday Schools equipped with Wilson Folding Partitions.

Send for catalogue to

PACIFIC COAST OFFICE

THE J. G. WILSON CORPORATION

600 Metropolitan Bldg., Los Angeles, Calif.

Also Manufacturers of

Diffuselite Blinds and Awnings

Rolling Partitions

Rolling Steel Doors

Western Agents at San Francisco, Portland, Seattle, Spokane, Salt Lake City

THE TORMEY CO.



1042 Larkin St., San Francisco, Cal.

Alvaline, Cementoline

and other

Jones-Duncan Products

MAGNER BROTHERS

PAINT MAKERS

Telephone: Market 113

414-424 Ninth St. San Francisco

HEATING-PLUMBING

COMPLETE PLUMBING AND
HEATING SYSTEMS INSTALLED
IN ALL CLASSES OF BUILDINGS
ALSO POWER PLANTS

GILLEY-SCHMID CO., Inc.

198 OTIS STREET, SAN FRANCISCO.

Tel. MARKET 965

Alfred Gustafson, *Pres.*, F. J. Gustafson, *Treas.*
Chas. A. Koenig, *Sec.*, J. M. Reynolds, *Sales Mgr.*
Phone: Mission 1575-1576

4067 Watts St., Emeryville—Phone Piedmont 581

INLAID FLOOR CO.

Incorporated 1897

Manufacturers of

PLAIN AND ORNAMENTAL FLOORS

MACHINE FLOOR SANDING

Grilles and Weather Strips

600 ALABAMA STREET, AT 18TH ST.
SAN FRANCISCO

Phone Douglas 3224

Hunter & Hudson

ENGINEERS

Designers of Heating, Ventilating
and Wiring Systems. Mechanical
and Electrical Equipment of
Buildings.

703 Rialto Bldg., San Francisco, Cal.

BEAVER BLACKBOARD BEAVER GREENBOARD

SCHOOL FURNITURE
AND SUPPLIES—

OFFICE, BANK AND

COURTHOUSE FURNITURE—

THEATRE AND

AUDITORIUM SEATING

Rucker-Fuller Desk Co.

677 Mission St., SAN FRANCISCO, CAL.

434 Higgins Bldg., LOS ANGELES, CAL.

432 - 14th Street - OAKLAND, CAL.

Business Systems Office Furniture

F. W. WENTWORTH & CO.

Distributors for **LIBRARY BUREAU**
539 Market Street, San Francisco
LOS ANGELES OAKLAND SEATTLE

RUSSWIN

BUILDERS' HARDWARE

JOOST BROS., Inc.

SAN FRANCISCO AGENTS.

We Carry Complete Stock:

Fishing Tackle—Guns—Mechanics' Tools—

Paints—Crockery and Glassware—Stoves—

Household Goods. Telephone Market 891.

NO BRANCH STORE

Mazda Lamps

Electric Goods

(SONNEBORN PRODUCTS)

Grind-Proof *and* Dust-Free Concrete Floors!

DUSTING WEARING CONCRETE FLOORS
ARE A THING OF THE PAST WHEREVER
ARCHITECTS HAVE SPECIFIED

Lapidolith

THIS liquid chemical has been flushed on 70,000,000 square feet of concrete floors old and new during the last two years alone. These lapidolized floors are now wearproof and dust-proof, because Lapidolith has completed the hydration of the Portland Cement and this Concrete is harder than granite.

Have you seen the results secured by the Lapidolith treatment? If not, let us refer you to a lapidolized floor near you. Thereafter you will specify Lapidolith on your old and new concrete work.

SONNEBORN PRODUCTS:

Cemcoat

the durable Mill White, Washable, of exceptional covering capacity, Gloss, Flat and Egg-shell, also all colors.

Lignophol

the modern wood preservative gives new life to old or new wooden floors.

Write for sample, literature and specification form

*Concrete for Permanence
Lapidolith for Dustlessness*

L. SONNEBORN SONS, Inc.

San Francisco

Los Angeles

Seattle

(SONNEBORN)

A. D. COLLMAN

GENERAL CONTRACTING

Phone Sutter 3580

110 Jessie Street, San Francisco

I. R. KISSEL

Phone Franklin 548

Decorator, Painter and Paperhanger

1747 SACRAMENTO ST., Bet. Polk St. and Van Ness Ave., SAN FRANCISCO

ROBERT TROST

PHONE MISSION 2209

General Building ContractorWe Specialize in High Grade Work and Employ Skilled
Labor in every Branch of the Building Industry.26th and Howard Streets
SAN FRANCISCO

P. A. Palmer

Peter Petersen

W. L. Kelly

PALMER & PETERSEN

Contracting Engineers

Monadnock Building

SAN FRANCISCO, CAL.

Phone Sutter 2581

LARSEN-SAMPSON CO.

BUILDING CONSTRUCTION

Claus Spreckels Building

SAN FRANCISCO

MULLEN MANUFACTURING CO.*BANK, STORE AND OFFICE FIXTURES—CABINET WORK OF
GUARANTEED QUALITY—CHURCH SEATING*

Office and Factory:

Telephone Market 8692

64 Rausch St., Bet. 7th and 8th Sts., San Francisco

UNIT CONSTRUCTION COMPANY

(INCORPORATED)

ENGINEERING AND CONSTRUCTION

Telephone Kearny 28

429-36 Phelan Building, SAN FRANCISCO

J. D. HANNAH

Contractor and Builder

OFFICE: 142 Sansome Street
San Francisco, Cal.Telephone Douglas 3895
BUILDERS EXCHANGE, 180 JESSIE STREET

HILDRETH & CO.
New York City

FALKENBURG & CO.
SEATTLE

R. E. Noble & Co.

Business Controlled by Abbot A. Hanks

Inspecting, Testing and Chemical
ENGINEERS AND CHEMISTS

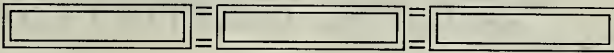

Phone, Kearny 3473

New Laboratories at
624 Sacramento Street
San Francisco, Calif.

OAK FLOORING

Clear Plain 5/16 x 2 sq. edge
@ \$200 Per M.

Select Plain 5/16 x 2 sq. edge
@ \$180 Per M.

ALSO

**FOREIGN AND DOMESTIC
HARDWOODS**

DIECKMANN HARDWOOD CO.

Beach and Taylor Sts., San Francisco, Cal.

Phone Franklin 2302

ASBESTOS PROTECTED METAL FOR ROOFING AND SIDING

HH ROBERTSON CO
 BUILDING PRODUCTS BUILDING PRODUCTS

FORMERLY ASBESTOS PROTECTED METAL COMPANY
 Hobart Building, San Francisco Phone Garfield 522

K. E. PARKER COMPANY, Inc.
 GENERAL CONTRACTORS

Phone Sutter 5661

Room 515 Clunie Building, SAN FRANCISCO

R. W. LITTLEFIELD
 BUILDING CONSTRUCTION

357 12th Street, Room 9, Oakland, Cal.

Phone Lakeside 415

H. H. HILP, Jr.

J. FRANK BARRETT

BARRETT & HILP

CONCRETE CONSTRUCTION BUILDERS GENERAL CONTRACTORS

SHARON BUILDING, SAN FRANCISCO

TELEPHONE SUTTER 1168 or 1169

Res. Phone Mission 5049

JAMES F. SMITH — Plasterer

273 Minna Street, San Francisco

Phone KEARNY 740

Member Builders Exchange

STEELFORMS Signify ECONOMY, RAPIDITY, and EFFICIENCY

STEELFORM CONTRACTING COMPANY

STEELFORMS FOR
 CONCRETE
 BUILDINGS

C. B. Hopkins, C. E., Manager

681 Market Street, San Francisco

CONCRETE JOIST
 FLOOR
 CONSTRUCTION

W. C. DUNCAN & CO.

508 Sharon Bldg.

General Contractors

San Francisco

M. E. VUKICEVICH

SPENCER B. BAGGE

VUKICEVICH & BAGGE
 GENERAL CONTRACTORS

Phone Sutter 6700

Office, Builders Exchange, 180 Jessie St., San Francisco

245 Market St. **Standard Fence Co.** 310 Twelfth St.
 Kearny 2028 **WIRE AND IRON WORKS** Oakland 475

DESIGNERS - BUILDERS WIRE GRILL WORK
 FACTORY PROTECTION FENCE WIRE SCREEN
 FIELD AND POULTRY FENCE FLEXIBLE WIRE CONVEYOR BELT
 AVIARY AND TENNIS COURT FENCE WIRE SPECIALTIES

Steel Bars FOR CONCRETE REINFORCEMENT
Cut to Length, Fabricated, Installed

BADT-FALK & CO.

Tel. Douglas 3466 346 Call-Post Bldg., 74 New Montgomery St., San Francisco

BUILDING DIRECTORIES [INTERCHANGEABLE STEEL
 LETTERS AND NUMBERS]
 FOR OFFICE BUILDINGS, SCHOOLS, CAFETERIAS, Etc.
 Bargains Lists for Auto Sales Companies. Sold Outright.

Go-Sign and Letter Manufacturing Co.

1106 Franklin Street Oakland, California

D. N. & E. WALTER & CO.
 "SINCE 1858"

LINOLEUMS—CARPETS LARGE STOCKS CARRIED
 Estimates furnished on request

562-572 MISSION STREET SAN FRANCISCO

Phone Merritt 668

H. N. McNAB

Hardwood Floors  Floor Sanding

2307 - 17th Ave. Oakland, Cal.

Res. Tel. Merritt 3600

HERBERT BECKWITH
Building Construction

Formerly with ARTHUR ARLETT 323 Newton Ave. Oakland

D. ZELINSKY & SONS
 PAINTERS AND DECORATORS

420 TURK STREET, SAN FRANCISCO

CHARLES T. PHILLIPS
 CONSULTING ENGINEER

PACIFIC BUILDING SAN FRANCISCO
 HEATING VENTILATION WIRING ILLUMINATION

Ideal Air-Washers. Ideal Fruit-Dryers. Fan Systems for Heating, Cooling and Drying.

Ideal Heating and Engineering Co.

Air-Conditioning, Heating, Cooling and Drying

192 ERIE STREET

Phone Market 3708

SAN FRANCISCO

Atlas Heating and Ventilating Co., Inc.

ENGINEERS and CONTRACTORS

STEAM AND HOT WATER HEATING, FANS, BLOWERS,
FURNACES, POWER PLANTS--SHEET METAL WORK

Phone Douglas 378

Fourth and Freelon Sts., Bet. Bryant & Brannan, SAN FRANCISCO

Illinois Automatic Vacuum and Vapor Systems of Heating

"TWENTY-FIVE YEARS OF QUALITY"

ILLINOIS ENGINEERING COMPANY

JAS. I. KRUEGER, *Representative*

559-561 Pacific Building, San Francisco

Telephone: Kearny 3047

HEATING
VENTILATION

Automatic Sprinkler Systems
FLOOR AND WALL TILING

PLUMBING
SHEET METAL WORK

SCOTT CO., Inc.

SUCCESSOR TO JOHN G. SUTTON CO.

243 MINNA STREET

SAN FRANCISCO

ALEX COLEMAN

CONTRACTING PLUMBER

706 ELLIS ST., SAN FRANCISCO

Phone FRANKLIN 1006

WM. F. WILSON COMPANY

MODERN SANITARY APPLIANCES

Special Systems of Plumbing for Residences, Hotels, Schools, Colleges, Office Buildings, Etc.

Phone Sutter 357

328-330 Mason Street, San Francisco.

A. LETTICH

365 FELL ST., SAN FRANCISCO
Telephone — Park 234

Plumbing and Heating



REINFORCING BARS

Square, Twisted, Corrugated and Plain Round. Curb Plate Bars for Concrete Curbs and Guards

W. S. WETENHALL CO.

440 IRWIN STREET
SAN FRANCISCO, CAL. Phone Market 3815



A RCHITECTS and OWNERS having occasion to specify Drain Boards for Apartment House and Residence work should first investigate the merits of **PETRIUM SANITARY SINKS** on display in the mezzanine floor of the Pacific Building, San Francisco, Cal., M. E. Hammond, agent.

It is a **Snow-white Drain Board!**

PETRIUM SANITARY SINKS are made in Berkeley, California and are non-porous, non-absorbent and Lye-proof. The entire surface of the drainboard and back is covered with a composition, on which a smooth, glossy, snow white finish is applied mechanically leaving no crevice or corners in which dirt and grease can collect as where tile or wood is used.

Can be installed in any home—new or old.

PETRIUM SANITARY SINK COMPANY

Factory and Office, West Berkeley

Agents in Principal Coast Cities

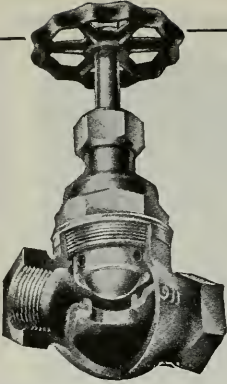

AMERICAN BALL VALVES

"Durable — therefore, Economical" — Stands the Severest Tests — Endorsed by the Leading Architects and Engineers of the Country. It is A PERFECT BALL-CLOSING VALVE.

W. E. MUSHET CO

SOLE AGENTS
Phone Sutter 4797



502 Mission Street
San Francisco, Cal.

**DON'T NEGLECT YOUR HEATING SYSTEM.
THE BEST IS NONE TOO GOOD!**

All kinds of Galvanized Iron Work — Furnaces, Pipes, Ventilators — Sheet Metal for Planing Mills, Fruit Dryers, Rice Mills. Kitchen Equipment, including Steam Tables, Sinks, Canopies, Urn Stands, Etc.

JAMES A. NELSON

Heating and Ventilating Contractor

Phone, Garfield 1959

517-519 SIXTH ST., SAN FRANCISCO

A. H. Bergstrom
Eric Lange

Phone Kearny 3526

LANGE & BERGSTROM

Building Contractors

(Established 1900)

207-210 SHARON BUILDING
San Francisco

TIMKEN BUILDING
San Diego

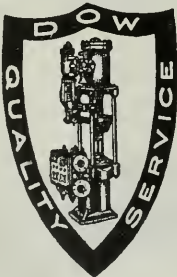

DOW ROTREX PUMP

For severe suction requirements

We also manufacture

TRIPLEX POWER PUMPS

and

CENTRIFUGAL PUMPS

We solicit your inquiries

DOW - HERRIMAN CO.

San Francisco Office, 140 Howard Street
Phone Garfield 612

Plant Petaluma Cal.

Specify
**Whitney's Special
Magnesium Chloride**
(Crystals)

in your Composition Flooring

(Consult our Service Department)

WHITNEY CHEMICAL CO.
544 Market Street, San Francisco

MASTIC FLOORS

BITURINE COATINGS FOR STEEL

WATERPROOFING

Hill, Hubbell & Company

CONTRACTORS

SAN FRANCISCO

1000 Fife Building, No. 1 Drumm Street

LOS ANGELES
Marsh-Strong Building

SEATTLE
Grand Trunk Pacific
Dock

PORTLAND
Pittock Block



POSITIVE ELECTRIC INTERLOCK

(BAR LOCK TYPE)

Prevents Elevator Accidents Occurring at the Entrance Door

Approved by National Underwriters Laboratories—Meets requirements of Elevator Safety Orders of Industrial Accident Commission, State of California

ELEVATOR SUPPLIES COMPANY, Inc. 186 FIFTH STREET,
SAN FRANCISCO

Capital \$1,000,000

CALIFORNIA DEPARTMENT

Surplus \$1,122,000

THE FIDELITY AND CASUALTY COMPANY OF NEW YORK

Prompt Service for

BONDS AND CASUALTY INSURANCE

203-206 Merchants Exchange Building

SAN FRANCISCO, CAL.

ANY PLACE ANY TIME PROMPTLY "We Serve You"
JOHN H. ROBERTSON

Successor to Robertson & Hall
GENERAL INSURANCE

Phone Sutter 2750

621 First National Bank Building, San Francisco

CONTRACT BONDS

Fidelity and Surety Bonds of every kind.

C. K. BENNETT, Manager

FIDELITY AND DEPOSIT COMPANY OF MARYLAND

Telephone Kearny 1452

622 Insurance Exchange, San Francisco, Calif.

PACIFIC DEPARTMENT

Globe Indemnity Company

BONDS and CASUALTY INSURANCE for CONTRACTORS

FRANK M. HALL, formerly Robertson & Hall, Mgr.

120 Leidesdorff Street Phone Sutter 2280 SAN FRANCISCO

National Surety Company of New York

The World's Largest Surety Company

Assets over \$20,000,000

Pacific Coast Department: 105 MONTGOMERY ST., SAN FRANCISCO, CAL.

Frank L. Gilbert, Vice-President

Phone, Sutter 2636

PHONE DOUGLAS 2370

McLERAN & PETERSON

GENERAL CONTRACTORS

HEARST BUILDING

SAN FRANCISCO, CAL.

L. J. RUEGG

J. B. RUEGG

RUEGG BROS.

CONTRACTORS AND BUILDERS

Phone Douglas 1599

719 Pacific Building, SAN FRANCISCO



Steel ^{Open} ^{Hearth} Bars For Concrete Reinforcement

Square, Deformed and Cold Twisted, Plain Rounds and Squares

PACIFIC COAST STEEL COMPANY

General Office, Rialto Building, San Francisco. Phone Sutter 1564

Sales Office, Rialto Building, SAN FRANCISCO
Sales Office, Union Oil Building, LOS ANGELES
Sales Office.....SEATTLE, WASH.

ROLLING MILLS:
SOUTH SAN FRANCISCO.....CAL.
SEATTLE, WASH. PORTLAND, ORE.

Architects and Building Contractors :

THE Binding of Your Magazines
and Periodicals is Our Specialty.
Expert Plate and Map Mounting.

The HICKS-JUDD COMPANY, Inc.
BOOKBINDERS
51-65 First Street San Francisco, Cal.

George S. MacGruer }
Robert M. Simpson } Members of Builders Exchange

MacGruer & Simpson

CONTRACTING PLASTERERS

PLAIN AND ORNAMENTAL

Cement, Stucco and Artificial Stone

Phone Sutter 5688

540 Call-Post Building, San Francisco

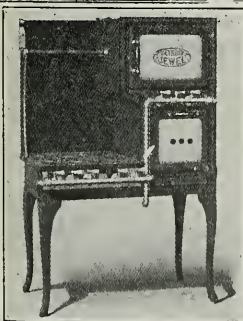

Detroit Jewel Gas Ranges

FOR HOME, RESTAURANT, HOTEL AND CLUB

We carry a Full Line of Stock Sizes

SELLING AGENTS

NATHAN DOHRMANN CO.

Geary and Stockton Streets, San Francisco

PARMELEE-DOHRMANN CO.

436-444 S. BROADWAY, LOS ANGELES

THE HYLOPLATE BLACKBOARD

SCHOOL FURNITURE
AUDITORIUM SEATING

MAPS
GLOBES
ATLASES

C. F. WEBER & CO.

985 Market Street
SAN FRANCISCO

222-224

S. Los Angeles St.
LOS ANGELES

100 W. Commercial
Row, RENO, NEV.

524 W. Washington
Street, PHOENIX, ARIZ.



LINOTILE

THE FLOOR
THAT'S BUILT
TO FIT
THE ROOM

Furnished and
Installed by

Van Fleet-Freear Co.

61 New Montgomery Street
San Francisco, California
Telephone, Douglas 1227



Formal Garden Effects

may be obtained on your Country
Estate within a period of two or
three years.

MacRORIE-McLAREN CO.

141 Powell Street, San Francisco
Telephone Douglas 4442

Kawneer

SIMPLEX

WEIGHTLESS
REVERSIBLE

WINDOW FIXTURES

MADE OF SOLID BRONZE

*f*_{or}

*Modern Hotels, Apartments,
Office Buildings, Schools,
Hospitals*

Entirely New Construction

Details Upon Request

**KAWNEER MFG.
COMPANY**

West Berkeley California

**MOUNT DIABLO CEMENT
COWELL SANTA CRUZ LIME**

ALL KINDS OF

BUILDING MATERIALS

HENRY COWELL LIME AND CEMENT CO.

Phone Kearny 2095

No. 2 MARKET STREET, SAN FRANCISCO

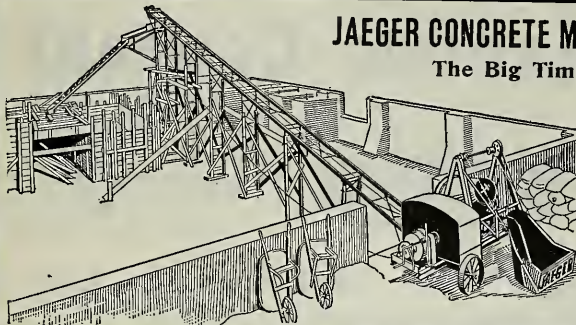

JAEGER CONCRETE MIXING AND PLACING PLANT

The Big Time and Money Saver

All Sizes and Models in Stock

Edward R. Bacon Co.

51 Minna St. 165 E. Jefferson St.
SAN FRANCISCO LOS ANGELES

CONTRACTOR'S MACHINERY

RANSOME MIXERS

OSHKOSH MIXERS

INSLEY SPOUTING PLANTS

OSHKOSH EVEREADY SAW RIGS INSLEY STEEL CARS and TRACKS

HOISTING BUCKETS, HOPPERS, GATES, ETC.

STEAM AND ELECTRIC HOISTS

EVERYTHING USED BY CONTRACTORS

CARRIED IN STOCK BY

GARFIELD & CO.

Hearst Building, San Francisco

Phone Sutter 1036

THE AUSTIN CUBE MIXER

The cube mixing principle, inside breaker rods, renewable drum plates, and long lasting qualities, combine to make the AUSTIN-CUBE the most highly efficient mixer in the concrete mixing service.

AUSTIN-CUBES are made in sizes adapted to every class of concrete mixing service.

Special machines for road and street paving.

AUSTIN MACHINERY CORPORATION

Main Office, Railway Exchange, CHICAGO

Stuart S. Smith, 625 Market St., San Francisco.
Tom N. Nicholson, 743 Harvard Ave., Los Angeles.

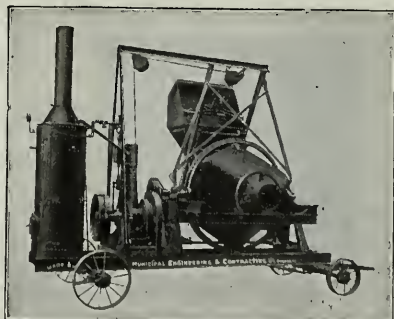

Telephone DOUGLAS 2046	Butte Electrical Equipment Company <h1>BEECO</h1> <small>TRADE MARK-REG.</small>	530 FOLSOM STREET
CONTRACTORS FOR POWER LIGHTING AND INDUSTRIAL INSTALLATIONS		
For the convenience and guidance of our customers, we have adopted BEECO as our trade name.		

<h1>SAFETY ELECTRIC COMPANY</h1>		
MANUFACTURERS OF		
SWITCHBOARDS SAFETY SWITCHES SAFETY CONTROLS		PANEL BOARDS SAFETY PANELS KNIFE SWITCHES
59-65 Columbia Square		San Francisco, Calif.
Telephone Market 2949		

L. SIEBERT	J. GENSLER
<h1>Drendell Electrical & Mfg. Co.</h1> Incorporated	
SWITCHBOARDS, PANEL BOARDS, KNIFE SWITCHES, CABINETS, THEATRE INSTALLATIONS, PROTECTIVE POWER PANELS	
1345-1353 Howard St., San Francisco	Telephone Market 1753

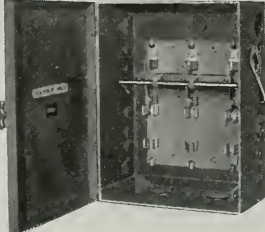
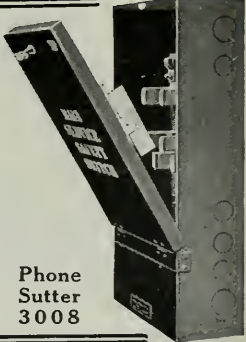
	<h1>MEYERS</h1> <h2>Electric Safety SWITCHES</h2>	
EXTERNALLY OPERATED		
Switch on the right is controlled by Handle on Front of Door, allowing face of switch to be set flush with finish of wall.		
Knock outs on Top, Bottom and Side controlled by Handle on side of Box	Meyers Electric Safety Switch Co., Inc. 247 Minna Street	
		Phone Sutter 3008

When writing to Advertisers please mention this magazine.

BUTTE ELECTRIC & MFG. CO. DOUGLAS 145
 (Paul C. Butte) at it since 1904
WIRING FOR BUILDINGS
 534 Folsom Street SAN FRANCISCO

H. S. TITTLE
 CONTRACTING ELECTRICAL ENGINEER
 766 FOLSOM ST., SAN FRANCISCO Phone SUTTER 4278

 **To Be "Low Bidder" Not Always Our Aim.**
 Our most particular attention is given to prompt and skillful handling of all electrical work of any nature with "QUALITY AND SERVICE GUARANTEED."
 Our nation-wide organization and large experience in this field assures you always of fair estimates and absolute satisfaction.
F. E. NEWBERY ELECTRIC CO.
 163 Sutter St. (413 Lick Bldg.) San Francisco, Phone Sutter 521

San Francisco, Cal. Oakland, Cal. Los Angeles, Cal.
NEPAGE, McKENNY CO.
Electrical Engineers and Contractors
 Phone Sutter 2369 589 Howard St., San Francisco, Cal.

Phone Market 2541 M. FLATLAND
GLOBE ELECTRIC WORKS
 Estimates Furnished on Everything Electrical
ELECTRIC SUPPLIES
 1959 Mission Street, bet. 15th and 16th SAN FRANCISCO

E. E. BROWNE Telephone Douglas 976 G. A. LANGLAIS
BROWNE-LANGLAIS ELECTRICAL CONSTRUCTION COMPANY
 213 Minna Street SAN FRANCISCO

M. E. RYAN
 Electrical Contractor
 Phones: Store, Red. 250J 216 Main Street
 Residence, Red. 250M REDWOOD CITY, CAL.

Thomas J. Bennett Edward W. Lauer
Rex Electric and Engineering Co.
 Contracting and Repairing
 253 Minna Street Telephone Sutter 2148 San Francisco

Oakland 540

The Largest Exclusive Electrical House in the State

MOTORS

BOUGHT — SOLD
RENTED — REPAIRED

Lighting Fixtures

Manufactured

Construction

MAINTENANCE
SUPPLIES

Estimates and engineering data cheerfully furnished

SPOTT ELECTRICAL CO.

Yours for Service

16th & CLAY STREETS

OAKLAND, CALIFORNIA

THE "CALIFORNIA" WALL BED

An Accomplishment in Design and Efficiency — Uses a minimum amount of space, all mechanical parts steel, a sturdily built standard bed, easily operated—Durable.

AMERICAN AUTOMATIC LOCK & LIFT CO.

Display Room: Building Material Exhibit, 77 O'Farrell Street, San Francisco

Office: 72 Fremont Street, San Francisco. Telephone Sutter 5712

Factory in Oakland

A GOOD FIELD FOR DISTRIBUTORS

E. W. Elliot

J. A. Grant

ELLIOT & GRANT

Contractors and Builders

Builders Exchange 180 Jessie St. San Francisco.

Phone Sutter 6700

CHAS. G. FRIES.

TELEPHONE SUTTER 5706

VICTOR A. KUEHN

LIBERTY ELECTRIC COMPANY

479 Sutter St. Electrical Contractors San Francisco, Cal.

WOODIN & LITTLE

PUMP HOUSE

**33 to 41 Fremont Street
SAN FRANCISCO, CAL.**

**PUMPS FOR EVERY
SERVICE AND USE**

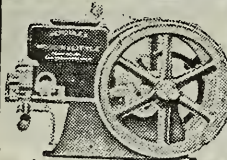

HERCULES GASOLINE ENGINES
From 1/2 to 12 Horse Power

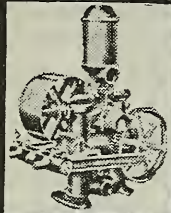

GOULDS PYRAMID POWER PUMP
All Sizes from 2 1/2 to 6 inch

P
U
M
P
S



CENTRIFUGAL PUMPS
All Sizes from 3/4 to 10 inch,
with self-aligning bearings

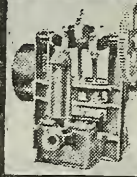

GOULDS TRIPLEX PUMPS
All Sizes

Centrifugal Power, Belt, Electricity,
Air, Vacuum, Ship, Spray, Oil, Mine,
Steam, Water Works, Wind Mill, Road
Sprinkling, Rotary, Rams, Hand, Deep
and Shallow Well Pumps, GOULDS
CELEBRATED TRIPLEX PUMPS.

W. & L. PNEUMATIC WATER SUPPLY SYSTEM

**PIPE, PIPE FITTINGS
BRASS GOODS, TANKS
GASOLINE ENGINES**

Send for Our Catalogue, Mailed Free
Inquire of Your Local Dealer for
Full Particulars

LAKEWOOD - MILWAUKEE CONCRETE MIXERS

ARE STURDY, HIGH SPEED, LABOR - SAVING MACHINES

Built in All Commercial Sizes. Driven by Kerosene Engine or Electric Motor.

COMPLETE STOCKS ON HAND



SMITH-BOOTH-USHER-Co.

SAN FRANCISCO-TAFT-LOS ANGELES

MACHINE TOOLS
WOODWORKING MACHINERY
ENGINES - MOTORS
AIR COMPRESSORS - PUMPS
POWER TRANSMISSION
OIL & MINING EQUIPMENT
CONSTRUCTION-INDUSTRIAL
ROAD MAKING MACHINERY
PIPE-FITTINGS-VALVES-SUPPLIES ETC.

CATALOG ON REQUEST

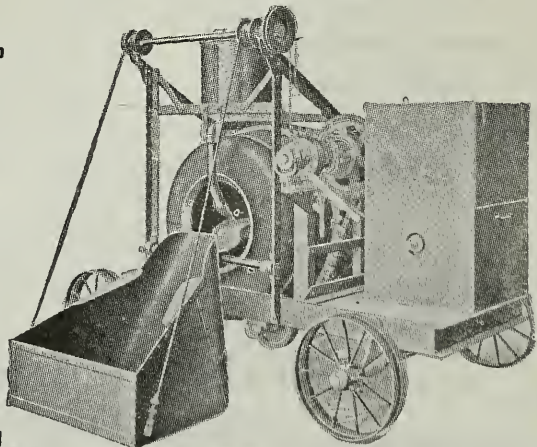

School and Theatre

STAGES AND EQUIPMENT

EDWIN H. FLAGG

SCENIC COMPANY, Inc.
400 Pantages Bldg., San Francisco, Cal.
1638 Long Beach Ave., Los Angeles, Cal.

The Granite Work on Eldorado County Courthouse; National Bank of D. O. Mills, Sacramento;—
and Sen. Nixon Mausoleum, Reno, WAS FURNISHED BY

CALIFORNIA GRANITE COMPANY

Phone Sutter 2646

STONE CONTRACTORS

Gen'l Contractors Ass'n, San Francisco
Quarries, Rocklin and Porterville

Main Office, Rocklin, Placer Co., Cal.
Telephone Main 82

POWER CONSTRUCTION CO.

INCORPORATED

CONTRACTING ENGINEERS

Preliminary Estimates Given in All Types
of Buildings, Towers and Bridges

SHARON BUILDING, SAN FRANCISCO
Phone Sutter 5478

A. C. SCHINDLER, President.

CHAS. F. STAUFFACHER, Secretary

THE FINK & SCHINDLER CO.

Manufacturers of INTERIOR WOODWORK AND FIXTURES
BANK, OFFICE AND STORE FITTINGS
SPECIAL FURNITURE

218-228 THIRTEENTH ST.
Bet. Mission and Howard Sts.

SAN FRANCISCO, CAL.
Telephone: Market 474

O. BAMANN, President

ERNEST HELD, Vice-President

HOME MANUFACTURING CO.

BANK, STORE AND OFFICE FITTINGS
FURNITURE AND HARDWOOD INTERIORS
CABINET WORK OF EVERY DESCRIPTION

543 and 545 BRANNAN ST. Phone Kearny 1514

San Francisco, Cal.

PACIFIC MANUFACTURING COMPANY

MILLWORK, SASH AND DOORS

Hardwood Interior Trim a Specialty

MAIN OFFICE:

SANTA CLARA, CAL.

SAN FRANCISCO.....177 Stevenson Street
OAKLAND.....1001 Franklin Street
BERKELEY.....2143 Center Street
SAN JOSE.....16 N. First Street

Dolan Wrecking & Construction Co.

(D. J. DOLAN)

Lumber, Lath, Nails, Shingles, Doors, Windows
and Plumbing Supplies, New and Second Hand

Phone Market 4264

Office and Yard, 1607-1639 MARKET ST., SAN FRANCISCO

MONSON BROS.

GENERAL CONTRACTORS

Telephone Market 2693

1908 Bryant Street, San Francisco

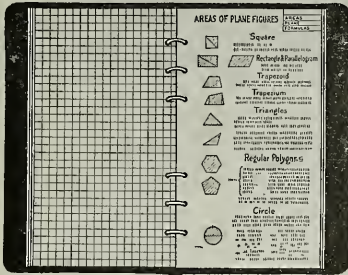

LEFAX

LEAF + FACTS

Pocket Cyclopedias

The facts that you want *instantly available* are not the same ones that some one else in your profession might desire. That's why LEFAX is made Loose Leaf. You file, in whatever order you wish, those sheets of facts that you want to have constantly at hand. If you wish, you may also file, in the same book, sheets for keeping data, for figuring, etc.

LEFAX sets cost but 50c, and \$1.00. You cannot fully appreciate their handiness—their value—until you use them. Ask us about them.

SCHWABACHER-FREY STATIONERY CO.
 PRINTERS LITHOGRAPHERS STATIONERS
 611½ Market Street San Francisco

Steam Heating and Ventilating

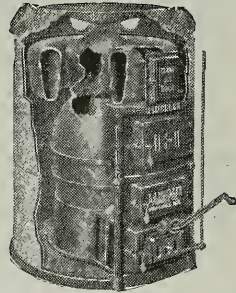

For Commercial and Public Buildings

Furnace Heating

For the Home

Mangrum & Otter, Inc.

827-831 Mission Street
 Phone Kearny 3155 SAN FRANCISCO

DIRECT-LINE

Telephone Company

THEODORE HALL, Manager



Telephone and Electrical Engineers

Automatic Electric Company, Chicago
 AUTOMATIC TELEPHONES and
 AUTOMATIC ENUNCIATOR.

Some of the Installations:

Baker, Hamilton-Pacific Co.; J. D. & A. B. Spreckels Securities Co.; California Packing Corporation; Sperry Flour Co., So. Vallejo.

TELAUTOGRAPH CORPORATION, New York

Some of the Installations:

Palace Hotel, Hotel St. Francis, Bank of California, California Hawaiian Sugar Refining Co., Crockett, Cal.

**INSTALLATION AND MAINTENANCE OF
 ELECTRICAL AND TELEPHONE APPARATUS**
 Tel. Douglas 722 320 Market St., San Francisco

ROBERTS MFG. CO.

Lighting Fixtures
 Electric Appliances
 Incandescent Lamps

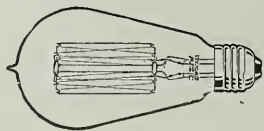

**WILLYS FARM LIGHTING
 AND POWER PLANTS**

663 Mission St., San Francisco

CALIFORNIA ARTISTIC METAL & WIRE CO.
 J. T. McCORMICK, PRESIDENT
 ORNAMENTAL IRON AND BRONZE
 349-365 SEVENTH ST. SAN FRANCISCO

MORTENSON CONSTRUCTION CO.
 CONTRACTORS FOR STRUCTURAL STEEL AND IRON
 H. MORTENSON, PRES. CHAS. G. MORTENSON, VICE-PRES. AND MGR.
 OFFICE AND SHOPS: CORNER 19TH AND INDIANA STREETS
 PHONE: MISSION 5033 SAN FRANCISCO, CAL.

RAYMOND GRANITE COMPANY, Inc.
 Owing and operating at Knowles, Madera County, the largest Quarry in the world
 CONTRACTORS FOR STONE WORK
 Designers and Manufacturers of Exclusive Monuments and Mausoleums
 Main Office and Yard: No. 1 and 3 Potrero Avenue, San Francisco, California
 Also at Nos. 612-614 Homer Laughlin Building, Los Angeles

CAEN STONE  **A. KNOWLES**
 A refined, elegant,
 interior finish. CONTRACTOR and PLASTERER
 442 Call-Post Building San Francisco

THE GOLDEN GATE IRON WORKS
STRUCTURAL STEEL
 1541-1549 HOWARD STREET, BETWEEN 11th AND 12th STREETS
 Tel. Market 5445 San Francisco

Telephone Mission 58 A. A. Devoto, President
CENTRAL IRON WORKS, Inc.
 STRUCTURAL STEEL
 Office 2050 BRYANT STREET SAN FRANCISCO, CAL.

J. W. BENDER ROOFING & PAVING CO.
 WATERPROOFING AND COMPOSITION ROOFING
 MASTIC AND BITUMEN PAVING
 110 Jessie Street San Francisco Telephone Douglas 4657

 **SCHRADER IRON WORKS, Inc.**
 STRUCTURAL STEEL CONTRACTORS
 Fire Escapes, Waterproof Trap Doors, Ornamental Iron Work
 1247-1249 HARRISON STREET SAN FRANCISCO, CAL
 Bet. 8th and 9th Telephone Market 337

PUBLIC LIBRARY

The
ARCHITECT &
ENGINEER



SEPTEMBER 1920

Published in San Francisco
35 cents a copy - \$2.50 a year



FAMOUS as were some of the baths
of Old Rome, no one would change to
the equipment of those days after know-
ing the convenience and rare beauty of

PACIFIC
PLUMBING FIXTURES.



For Sale by All Jobbers

Main Offices: 67 New Montgomery Street, San Francisco
Factories: San Pablo and Richmond, California
Branches: Portland, Los Angeles and Salt Lake City

THROUGH THE AGES



Albers Milling Co's Mill, Oakland, Calif.
Covered with a PABCO 10 Year Roof.

R.M. HENNINGSEN
ENGINEER

Avoid Roof "Bargains"

Not only disappointment and annoyance, but very often actual damage results when a building is covered with a cheap roof. Like most so-called "bargains," a cheap roof *falls short in service* and is, in the long run, far more expensive than a good roof.

PABCO ROOFS

Guaranteed for 10 and 20 Years, appeal to Architects, Engineers and owners because of high quality of materials, the method of construction, and because they are least expensive due to the low cost per year of service.

Write for Specifications and
Complete Details

THE PARAFFINE COMPANIES, INC.
San Francisco, California



- Roofings
- Felts
- Building Papers
- Floor Covering
- Wall-Board
- Waterproofing
Materials
- Industrial and
Marine Paints
- Electrical Varnishes
and Insulating
Compounds
- Box-Board
- Paper Boxes
- Fibre Containers

STEEL BARS

FOR
CONCRETE REINFORCEMENT

CORRUGATED
TWISTED
SQUARES
OR
ROUNDS
CUT
TO
LENGTH



FABRICATED
AND
INSTALLED
—
LUMP SUM
BIDS
ON
WORK
COMPLETE

Office, 444 MARKET STREET
Warehouse, 10th and Bryant Streets
Phone: Sutter 2720

“HYDRATITE” FOR WATERPROOFING AND HARDENING CONCRETE “HORNSTONE”

Look for this
Trademark



And if it's there don't worry
any more about your
Valves and Fittings

*Specify and
insist upon
having*

The Kelly & Jones Co.
Valves and Fittings
Byers Genuine
Wrought Iron Pipe
Republic Steel Pipe

Complete Line of Plumbing Supplies
Large Stocks for Prompt Delivery
Catalogue on request

**California Steam &
Plumbing Supply Co.**

671-679 Fifth Street, Corner Bluxome
SAN FRANCISCO, CALIFORNIA





PIPE
Valves & Fittings
STEAM & WATER SUPPLIES
Heating Material
PLUMBING GOODS
Pumps

GEORGE H. TAY COMPANY
SAN FRANCISCO OAKLAND
 MISSION & SECOND STS. TENTH & HARRISON STS.
 TELEPHONE DOUGLAS 2240 TELEPHONE LAKESIDE 4200

Contractors Cannot Agree

as to percentage of labor and material saved in using

1 A RIB LATH

over other expanded metals; majority claim 20% saving — others more. Labor is high, material higher, **1 A RIB** cuts down cost of both—present conditions demand your immediate investigation where metal lath is needed. Phone Market 8357.

Largest stock of fireproof material and reinforcing bars on the Pacific Coast.



Truscon Steel Company

CHAS. HOLLOWAY, JR., BRANCH MANAGER

527 Tenth Street, San Francisco

W. & J. SLOANE

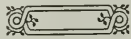

Carpetings Furniture
Rugs
Linoleum Window Shades
Wall Papers
Interior Decorations

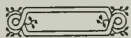

216-228 Sutter Street
Tel. Garfield 2838 San Francisco

THE BRUNSWICK-BALKE-COLLENDER
WHALE-BONE-ITE
CLOSET SEAT

CUT SHOWS NO. 23-9 SEAT
D—HALL GIGGLELY HINGE
C—HOLE HEAVY COUPLER
B—RUBS LEAKPROOF
A—NOTE THE COUPLER LAYER OF LUBRICATOR
FOR THE WOODEN SEAT

CONSTRUCTION OF WHALE-BONE-ITE SEAT

Whale-bone-ite

has proven under time and academic tests to be the best closet seat made.

Representative, also, of SLOAN VALVE COMPANY

EDWARD C. WHALEN
Monadnock Building
SAN FRANCISCO CALIF.



PROMETHEUS

The Electric Food and Plate Warmer

Wherever meals are cooked and served, in apartments, residences and institutions, Prometheus is a highly valued asset. The wireless heating units placed independently of the shelves keep food hot and tasty until ready to serve and cannot injure the finest china.

Write for information and list of installations

The Prometheus Electric Co.

Manufacturers
511 West 42d Street, New York

Showroom, **M. E. HAMMOND**
Mezzanine Floor Pacific Bldg., San Francisco

CLOW

AUTOMATIC CLOSETS

ARCHITECTS, as a class, are open-minded. That is why the Clow Automatic Closet has become so generally recognized. It has been specified in some of the largest industrial installations. There are at least three good reasons:

- 1.—Automatic flushing guarantees hygienic conditions.
- 2.—It is at least 40% more economical in the use of water than the manually operated type.
- 3.—The simplicity of its design and the care employed in its manufacture have made some amazing records in low cost of maintenance.

Frederick A. Hamilton

Sales Agent

Show Rooms:

RIALTO BUILDING
SAN FRANCISCO



WaterSavR FLUSHING VALVE

Non-Clogging, Self-Cleaning, Controlling By-Pass

NOTE
Controlling water is in two enclosed chambers and separated from the flushing water.

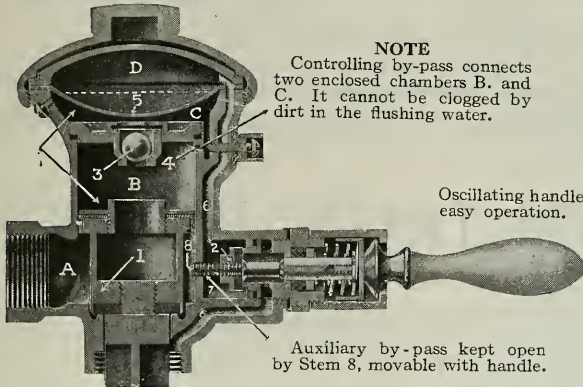

NOTE
Controlling by-pass connects two enclosed chambers B. and C. It cannot be clogged by dirt in the flushing water.

Oscillating handle easy operation.

Auxiliary by-pass kept open by Stem 8, movable with handle.

OPERATES EQUALLY AS WELL WITH DIRTY AS WITH CLEAN WATER

The by-pass is positively and automatically kept open and free of obstruction and cannot become clogged no matter how dirty the water may be.

Patented March 18, 1919

The controlling by-pass is enclosed in two chambers and cannot come into contact with dirt in the flushing water. At each flush, water passes alternately through the controlling by-pass thereby making it positively and automatically self-cleaning.

TiteSete Float Valve

For High and Low Pressures

IN SIZES UP TO 4 INCHES
Larger Sizes on special order

Remains Wide Open until desired Water Level is reached then Closes **POSITIVELY** without Water Hammer

Simple and Durable
Positive and Reliable



Self-Cleaning, Non-Clogging By-Pass

NATIONAL VALVE COMPANY

Phone Douglas 5093

23-25 MINNA ST., SAN FRANCISCO

P. Noble, Pres.
E. B. Noble, Vice-Pres.
A. E. Wilkins, Sec'y

Beam, Angle, Channels, and Universal
Mill Plates for immediate ship-
ment from stock

Pacific Rolling Mill Co.

SUPPLIERS OF

**FABRICATED STRUCTURAL STEEL, Forgings,
Bolts, Rivets, Frogs, Switches, Cast Iron Castings**

General Office and Works
17th and MISSISSIPPI STS., SAN FRANCISCO
Telephone Market 215

Phones: Garfield 2575 and 2576

WESTERN IRON WORKS

W. B. Morris, President

H. H. Morris, Vice-President

L. J. Gates, Secretary

**STRUCTURAL IRON and
STEEL CONTRACTORS**

Beams, Channels, Angles, Plates and Steel
Wheelbarrows Carried in Stock

141-147 Beale Street and 132-148 Main Street
SAN FRANCISCO, CAL.



FORUM BUILDING, SACRAMENTO, CAL.
R. A. Herold, Architect

Progress Picture of the four story addition
to Sacramento's largest office building.

**STRUCTURAL STEEL FABRI-
CATED AND ERECTED BY**

**The Palm Iron and
Bridge Works**

(Incorporated)

15th and R. Sts., Sacramento, Cal.

Cast Iron Stairs and Store Fronts

Bank and Office Railings, Elevator
Enclosures and Fire Escapes.

C. J. HILLARD CO., Inc.

Nineteenth and Minnesota Streets
Telephone Mission 1763

SAN FRANCISCO, CAL.

Architects' Specification Index

(For Index to Advertisements, see next page)

- ARCHITECTURAL TERRA COTTA**
 Gladding, McBean & Company, Crocker Bldg., San Francisco.
 Los Angeles Pressed Brick Company and United Materials Co., Crossley Bldg., San Francisco.
 Livermore Fire Brick Works, Livermore, Cal.
- ASBESTOS ROOFING, PACKING, ETC.**
 H. H. Robertson Co., Hobart Bldg., San Francisco.
 H. W. Johns-Manville Co., San Francisco, Los Angeles and Portland, Ore.
- AUTOMATIC SPRINKLERS**
 Grinnell Co. of the Pacific, 453 Mission St., San Francisco.
 Scott Company, 243 Minna St., San Francisco.
 Pacific Fire Extinguisher Co., 424 Howard St., San Francisco.
- AUTOMOBILE INSURANCE**
 Bankers & Shippers Insurance Co. of New York, Insurance Exchange Bldg., San Francisco.
- AWNINGS, TENTS, ETC.**
 W. A. Plummer, Front, at Pine St., San Francisco.
- BANK FIXTURES AND INTERIORS**
 Fink & Schindler, 218 13th St., San Francisco.
 C. F. Weber & Co., 985 Market St., San Francisco.
 Home Mfg. Co., 543 Brannan St., San Francisco.
 Mullen Manufacturing Co., 64 Rausch St., San Francisco.
 Rucker-Fuller Desk Co., 677 Mission St., San Francisco.
 Pacific Manufacturing Company, San Francisco, Oakland and Santa Clara.
- BELTING AND PACKING**
 New York Belting and Packing Company, 519 Mission St., San Francisco.
 H. N. Cook Belting Co., 401 Howard St., San Francisco.
- BLACKBOARDS**
 C. F. Weber & Co., 985 Market St., San Francisco, Los Angeles and Reno, Nevada.
 Beaver Blackboards and Greenboards, Rucker-Fuller Desk Company, Coast agents, 677 Mission St., San Francisco; also Oakland and Los Angeles.
- BLINDS—VENETIAN AND DIFFUSELITE**
 J. G. Wilson Corporation, Metropolitan Bldg., Los Angeles; Waterhouse-Wilcox, Underwood Bldg., San Francisco.
 Western Venetian Blind Co., Long Beach Ave., Los Angeles.
- BOILERS**
 California Hydraulic Engineering & Supply Co., 70-72 Fremont St., San Francisco.
 Franklin Water Tube Boiler, General Machinery and Supply Co., 39 Stevenson St., San Francisco.
 Kewanee Water Supply System, Simonds Machinery Co., 117 New Montgomery St., San Francisco.
 General Boilers Co., 322 Monadnock Bldg., San Francisco.
- BONDS FOR CONTRACTORS**
 American Mutual Liability Insurance Co., Balboa Bldg., San Francisco.
 Bonding Company of America, Kohl Bldg., San Francisco.
 Bankers & Shippers Insurance Co. of New York, Insurance Exchange Bldg., San Francisco.
 Globe Indemnity Co., 120 Leidesdorff St., San Francisco.
 Fidelity & Casualty Co. of New York, Merchants Exchange Bldg., San Francisco.
 Fidelity & Deposit Co. of Maryland, Insurance Exchange, San Francisco.
 John H. Robertson, 621 First National Bank Building, San Francisco.
 National Surety Co. of New York, 105' Montgomery St., San Francisco.
- BRASS GOODS, CASTINGS, ETC.**
 H. Mueller Manufacturing Co., 635 Mission St., San Francisco.
- BRICK—PRESSED, PAVING, ETC.**
 California Brick Company, Niles, Cal., and 604 Mission St., San Francisco.
 Livermore Fire Brick Works, Niles, Cal.
 Gladding, McBean & Company, Crocker Bldg., San Francisco.
 Los Angeles Pressed Brick Co., Frost Bldg., Los Angeles.
 United Materials Co., Crossley Bldg., San Francisco.
- BRICK & CEMENT COATING**
 Armorite and Concreta, manufactured by W. P. Fuller & Co., all principal Coast cities.
 The Paraffine Companies, Inc., 34 First St., San Francisco.
 R. N. Nason & Co., 151 Potrero Ave., San Francisco.
 Glidden Stucolor Liquid Cement Coating. The Glidden Company, 123 Hooper St., San Francisco.
 Wadsworth, Howland & Co., Inc., Boston, Mass., manufacturers of Bay State Brick & Cement Coating. Hambley & Son, agents, San Francisco and Los Angeles.
- BRICK STAINS**
 Samuel Cabot Mfg. Co., Boston, Mass., agencies in San Francisco, Oakland, Los Angeles, Portland, Tacoma and Spokane.
 Armorite and Concreta, manufactured by W. P. Fuller & Co., all principal Coast cities.
- BUILDERS' HARDWARE**
 Joost Bros., agents for Russell & Erwin Hardware, 1053 Market St., San Francisco.
 The Stanley Works, New Britain, Conn., represented in San Francisco and Los Angeles by John Rountree & Co.
 Palace Hardware Company, Agents Corbin goods, 581 Market St., San Francisco.
 Richards-Wilcox Mfg. Co., Aurora; Ewing-Lewis Co., 626 Underwood Bldg., San Francisco.

GRINNELL AUTOMATIC SPRINKLER GRINNELL COMPANY

OF THE PACIFIC

VALVES
PIPE and FITTINGS

ENGINEERS AND CONTRACTORS
453 Mission Street, San Francisco

CHEMICAL FIRE
EXTINGUISHERS
and FIRE ENGINES

When writing to Advertisers please mention this magazine.

An Index to the Advertisements

	Page		Page
American La France Fire Engine Co.	34	Haines, Jones & Cadbury	123
American Mutual Liability Insurance Co.	10	Hamilton, F. A.	4
American Mail Chute	32	Hammond, M. E.	4
American Marble & Mosaic Co.	44	Hannah, J. D.	142
American Rolling Mill Co.	134	Hauser Window Co.	26
American Standard Oil Burner	42	Haws Sanitary Drinking Faucet Co.	138
American Window Glass Co.	146	Hicks-Judd Co.	151
Atlas Heating & Ventilating Co.	157	Hillard, C. J., Co.	6
Austin Machinery Corporation	157	Hill, Hubbell & Company	149
American Automatic Lock & Lift Co.	153	Holbrook, Merrill & Stetson	147
Bacon, Edward R., Co.	157	Holtzer-Cabot	136
Badt-Falk & Co.	145	Home Mfg. Co.	158
Baird-Bailhache Company	24	Hoosier Store	27
Bankers' & Shippers' Ins. Co.	128	Hunt, Robt. W. & Co.	136
Barrett & Hilp	144	Hunter & Hudson	140
Bass-Hueter Co.	3rd Cover	Ideal Heating & Engineering Co.	146
Baxter, Reed	32	Illinois Engineering Co.	146
Beach-Robinson Co.	31	Imperial Waterproofing	32
Beckwith, Herbert	145	Inlaid Floor Co.	140
Bittmann & Battee	139	James & Drucker	128
Bowser & Co., S. F.	41	Jarvis, T. P. Mfg. Co.	43
Brinninstool Co.	22	Johns-Manville Co.	160
Browie-Langlais Company	155	Johnson, S. T.	43
Butte Electrical Equipment Co.	154	Johnson Service Co.	11
Butte Electric & Mfg. Co.	155	Joost Brothers	140
Cabot, Samuel (Inc.)	41	Kawneer Mfg. Co.	153
California Artistic Metal and Wire Co.	160	Kerner Incinerator Co.	21
California Bldg. Material Co.	Back Cover	Key-hold Plaster Lath Co.	32
California Brick Co.	23	Kissel, I. R.	142
California Granite Co.	158	Knittle-Cashel Co., Inc.	13
California Hydraulic Engineering and Supply Co.	10	Knowles, A.	160
California Paint Co.	14	Lange & Bergstrom	148
California Plastic Products Co.	137	Larsen, Sampson & Co.	142
California Redwood Ass'n.	122	Letlich, A.	146
California Steam and Plumbing Supply Co.	2	Liberty Electric Co.	156
Cement Gun Construction Co.	134	Littlefield, R. W.	144
Central Iron Works	160	Livermore Fire Brick Works	23
Clinton Wire Lath	34	Los Angeles Pressed Brick Co.	127
Clow & Sons	4	MacGruer & Simpson	151
Coleman, Alex.	146	MacRorie-McLaren Co.	152
Collman, A. D.	142	Magner Bros.	140
Cook Belting Co.	38	Mangrum & Otter	159
Cowell Lime & Cement Co.	153	Marshall & Stearns Co.	143
Crane Co.	152	McCray Refrigerator Co.	32
Davis, R. J.	14	McLeran & Peterson	150
Del Favero and Rasori	156	McNab, H. N.	145
Del Monte Properties Co.	28	Medusa Cement	29
Detroit Steel Products Co.	44	Meese & Gottfried	134
Dieckmann Hardwood Co.	12	Meyers Electric Safety Switch Co., Inc.	154
Direct Line Telephone Co.	159	Moline Heat	17
Dolan Wrecking & Construction Co.	158	Montague Range & Furnace Co.	15
Dow-Herriman Co.	148	Monson Bros.	158
Drendell Elec. & Mfg. Co.	154	Mortenson Construction Co.	160
Duffield Lumber Co.	21	Mott Co. of Calif.	18
Duncan, W. C.	144	Mueller Mfg. Co.	18
Dyer Bros.	132	Mullen Mfg. Co.	142
Elevator Supplies Co.	150	Mushet Co., W. E.	148
Ellery Arms Co.	128	Musto Sons Keenan Co.	13
Faber, Eberhard	36	Nason, R. N. & Co.	9
Fess System Co.	43	Nathan, Dohrmann Co.	151
Fidelity & Casualty Co. of N.Y.	150	National Mill & Lumber Co.	33
Fidelity & Deposit Co. of Maryland	150	National Surety Co.	150
Finck & Schindler Co., The	158	National Valve Co.	5
Fire Protection Products Co.	16	Nelson, James A.	148
Flagg, Edwin H., Scenic Co.	158	Ne Page, McKenny Co.	155
Freeman Art Shop	31	Newbery Electric Co.	155
Fuller & Goep	24	New York Belting and Packing Co.	28
Fuller, W. P. Co.	19	Norris Co., L. A.	34
Garfield Company	153	Oak Flooring Mfgs' Ass'n.	129
Garnett, Young & Co.	20	Ocean Shore Iron Works	138
General Boilers Co.	18	Old Mission Portland Cement Co.	25
Gilley-Schmid Co.	140	Otis Elevator Co.	Back Cover
Gladding, McBean & Co.	138	Pacific Coast Steel Company	151
Glidden Co.	37	Pacific Materials Co.	20-41-44
Globe Electric Works	155	Pacific Fire Extinguisher Co.	18
Globe Indemnity Co.	150	Pacific Mfg. Co.	158
Go-Sign & Letter Co.	145	Pacific Plumbing Fixtures	2dCover
Golden Gate Ornamental Iron Co.	160	Pacific Porcelain Ware Co.	2dCover
Grinnell Co.	7	Pacific Pump & Supply Co.	38
Gunn Carle Company	2	Pacific Rolling Mills	6
		Palace Hardware Co.	38
		Palm Iron Works	6
		Palmer & Petersen	142
		Paraffine Companies, Inc.	1
		Parker, K. E. Co., Inc.	144
		Petrium Sanitary Sink Co.	143
		Phillips, Chas. T.	145
		Pitcher Door Hanger	33
		Plummer, W. A.	138
		Pope & Talbot	15
		Portland Lumber Co.	15
		Portman, Frank	158
		Power Construction Company	156
		Prometheus Electric Co.	4
		Ray, W. S. Mfg. Co.	30
		Raymond Granite Co.	160
		Redwood Mfg. Co.	42
		Reliance-Grant Elevator Equipment Co.	22
		Rex Electric Engineering Co.	155
		Richards-Wilcox Mfg. Co.	35
		Roberts Mfg. Co.	159
		Robertson Co., H. H.	110
		Robertson, John H.	150
		Ruegg Bros.	150
		Rucker-Fuller Desk Co.	14
		Ryan, M. E.	15c
		Safety Electric Co.	154
		Sampson Spot Cord	9
		San Francisco Pioneer Varnish Works	3d Cover
		Scott Co.	146
		Schrader Iron Works	160
		Schwabacher-Frey Co.	159
		Sloane, W. & J.	4
		Simmons, O. M. Co.	12
		Simonds Machinery Co.	131
		Smith-Booth-Usher Co.	157
		Smith, Jas. F.	144
		Sommer, I. M.	144
		Sonneborn, L. Sons, Inc.	141
		Sonnenschein Bros.	31
		Spencer Elevator Co.	24
		Spott Electrical Co.	156
		Standard Varnish Works	22
		Standard Electric Time Co.	122
		Standard Fence Co.	145
		Stanley Works, The	121
		Steelwork Contracting Co.	144
		Steel Studding Co.	138
		St. Francis Hotel	131
		Strable Mfg. Co.	125
		Sunset Lumber Company	15
		Tay Company, George H.	3
		Taylor, F. A. & Co.	31
		Tittle, H. S.	155
		Torney Co.	140
		Trost, Robt.	142
		Truscon Steel Co.	3
		Tuec Cleaner	135
		Uhl Bros.	38
		Unit Construction Co.	142
		United Electric Co.	135
		United Materials Co.	127
		U. S. Metal Products Co.	26
		U. S. Steel Products Co.	40
		Van Fleet-Frear Co.	152
		Vermont Marble Co.	34
		Vukicevich & Bagge	144
		Vulcanite Roofing Co.	26
		Wadsworth, Howland & Co., Inc	136
		Walter, D. N. & E. & Co.	145
		Waterhouse, Wilcox Co.	32
		Wayne Oil Tank & Pump Co.	33
		Weber, C. F. & Co.	152
		Wentworth, F. W.	140
		Western Blind & Screen Co.	39
		Western Iron Works	6
		Western Office, Equipment Co.	34
		Western Pipe and Steel Co.	147
		Wetenhall, W. S.	4
		Whalen, E. C.	4
		White Bros.	120
		Whitney Chemical Co.	149
		Wilson, J. G., Corp.	39
		Wilson, W. F., Co.	146
		Witt, G. E. Co.	44
		Wooden & Little	132
		Zelinsky, D & Sons	145

NASON'S OPAQUE FLAT FINISH A FLAT WASH-

ABLE OIL PAINT, made in soft Kalsomine tints—a practical article for WALLS, CEILINGS, Etc. Economical and Durable. Agency TAMM & NOLAN COMPANY'S high grade Varnishes and Finishes, made on the Pacific Coast to stand our climatic conditions.

R. N. NASON & CO., Paint Makers

51 Potrero Ave.—SAN FRANCISCO—436 Market St.

PORTLAND
SEATTLE
LOS ANGELES

ARCHITECTS' SPECIFICATION INDEX—Continued

BUILDING MATERIAL, SUPPLIES, ETC.

Pacific Materials Co., Underwood Bldg., San Francisco.

Waterhouse-Wilcox Co., 523 Market St., San Francisco.

CABINET MAKERS

Home Manufacturing Company, 543 Brannan St., San Francisco.

Fink & Schindler Co., 218 13th St., San Francisco.

Mullen Manufacturing Company, 64 Rausch St., San Francisco.

CARPETS

W. & J. Sloane, 216-228 Sutter St., San Francisco.

CASEMENT WINDOW HARDWARE

Richards-Wilcox Mfg. Co., Aurora, Ill., and Underwood Bldg., San Francisco.

CASTINGS

Dow-Herriman Co., 140 Howard St., San Francisco.

CEMENT

Mt. Diablo, sold by Henry Cowell Lime & Cement Co., 2 Market St., San Francisco.

Medusa White Portland Cement, manufactured by Sandusky Cement Co., represented in San Francisco by Pacific Building Materials Co., Underwood Bldg., San Francisco.

Old Mission Portland Cement Co., Mills Building San Francisco.

CEMENT EXTERIOR FINISH

Concreta, sold by W. P. Fuller & Co., all principal Coast cities.

Glidden Stucolor Liquid Cement Coating. The Glidden Company, 123 Hooper St., San Francisco.

Samuel Cabot Mfg. Co., Boston, Mass., agencies Oakland, Los Angeles, Portland, Tacoma, Spokane; and Pacific Building Materials Co., 525 Market St., San Francisco.

The Paraffine Companies, Inc., 34 First St., San Francisco.

CEMENT EXTERIOR WATERPROOF PAINT

Armorite, sold by W. P. Fuller & Co., all principal Coast cities.

Bay State Brick and Cement Coating, manufactured by Wadsworth, Howland Co., Boston, Mass. James Hambley & Son, Distributors, San Francisco and Los Angeles.

Hill, Hubbell & Company, No. 1 Drumm St., San Francisco.

Imperial Waterproofing, manufactured by Brooks & Doerr, Reed Baxter, agent, Merchants National Bank Bldg., San Francisco.

Paraffine Paint Co., 34 First St., San Francisco.

Medusa White Portland Cement, manufactured by Sandusky Cement Co., represented in San Francisco by Pacific Building Materials Co., 525 Market St., San Francisco.

CEMENT FLOOR COATING

Fuller's Concrete Floor Enamel, made by W. P. Fuller & Co., San Francisco.

Glidden Concrete Floor Dressing. The Glidden Company, 123 Hooper St., San Francisco.

CEMENT GUN

Cement Gun Construction Company of California, 701 Balboa Bldg., San Francisco.

CEMENT TESTS—CHEMICAL ENGINEERS

Robert W. Hunt & Co., 251 Kearny St., San Francisco.

CHURCH INTERIORS

Fink & Schindler, 218 13th St., San Francisco.

Mullen Manufacturing Company, 64 Rausch St., San Francisco.

Home Manufacturing Company, 543 Brannan St., San Francisco.

CHUTES—SPIRAL

Haslett Warehouse Co., 310 California St., San Francisco.

CLAY PRODUCTS

Livermore Fire Brick Works, 604 Mission street, San Francisco.

W. E. Mushet Co., 502 Mission St., San Francisco.

Gladding, McBean & Co., Crocker Bldg., San Francisco.

United Materials Co., Crossley Bldg., San Francisco.

Los Angeles Pressed Brick Co., Frost Bldg., Los Angeles.

CLOCKS—TIME

Standard Electric Time Co., 461 Market St., San Francisco.

COLD STORAGE PLANTS

H. W. Johns-Manville Co., Second and Howard Sts., San Francisco.

T. P. Jarvis Crude Oil Burning Co., 275 Connecticut St., San Francisco.

COMPRESSED AIR CLEANERS

United Electric Co., Canton, O., mfr. of Tuec Cleaner, sold by San Francisco Compressed Air Cleaning Co., Sutter and Stockton Sts., San Francisco.

George H. Tay Company, Mission and Second Sts., San Francisco; 10th and Harrison Sts., Oakland.

CONCRETE CONSTRUCTION

Barrett & Hild, Sharon Bldg., San Francisco.

Clinton Construction Co., 140 Townsend street, San Francisco.

K. E. Parker Co., Inc., Clunie Bldg., San Francisco.

Palmer & Petersen, Monadnock Bldg., San Francisco.

I. M. Sommer, 401 Balboa Bldg., San Francisco.

Steelform Contracting Company, 681 Market St., San Francisco.

CONCRETE MIXERS

Austin Improved Cube Mixer. Stuart S. Smith, 625 Market Street, San Francisco.

Foote and Jaeger mixers sold by Edward R. Bacon Co., 51 Minna St., San Francisco, also Los Angeles.

Ransome mixers sold by the Garfield Co., Hearst Bldg., San Francisco.

CONCRETE REINFORCEMENT

United States Steel Products Co., San Francisco, Los Angeles, Portland and Seattle.

Twisted Bars. Sold by Gunn, Carle & Co., Inc., 444 Market St., San Francisco.

Clinton Welded Wire Fabric, L. A. Norris Co., 140 Townsend St., San Francisco.

Pacific Coast Steel Company, Rialto Bldg., San Francisco.

Steel bars sold by W. S. Wetenhall Co., 450 Irwin St., San Francisco.

Triangle Mesh Fabric. Sales agents, Pacific Materials Co., 525 Market St., San Francisco.

Truscon Steel Co., 527 Tenth St., San Francisco.

Badt Falk Co., Call-Post Bldg., San Francisco.

CONDUITS

Garnett, Young & Co., 612 Howard St., San Francisco.

CONTRACTORS, GENERAL

Barrett & Hild, Sharon Bldg., San Francisco.

K. E. Parker Co., Inc., Clunie Bldg., San Francisco.

R. W. Littlefield, 357 12th St., Oakland.

Unit Construction Co., Phelan Bldg., San Francisco.

We have returned to our policy-holders annually for 33 years never less than 30% of the premium as a dividend. Dividends declared during 1919, \$2,017,893.

AMERICAN MUTUAL LIABILITY INSURANCE CO. OF BOSTON
Assets \$8,654,667 Surplus \$1,417,173

WORKMEN'S COMPENSATION, AUTOMOBILE, TEAMS AND PUBLIC LIABILITY INSURANCE

SAN FRANCISCO BRANCH OFFICE

1816 Balboa Building. Telephone Kearny 3202

N. F. Hesselstine, California Manager.

C. H. Gray, Assistant Manager.

ARCHITECTS' SPECIFICATION INDEX—Continued

- CONTRACTORS, GENERAL—Continued**
Larsen, Sampson & Co., Claus Spreckels Bldg., San Francisco.
J. D. Hannah, 142 Sansome St., San Francisco.
Chas. Stockholm & Son, Monadnock Bldg., San Francisco.
Herbert Beckwith, 323 Newton Ave., Oakland.
A. D. Collman, 110 Jessie St., San Francisco.
Clinton Construction Company, 140 Townsend St., San Francisco.
Monson Bros., 1907 Bryant St., San Francisco.
W. C. Duncan & Co., 526 Sharon Bldg., San Francisco.
A. Knowles, Call-Post Bldg., San Francisco.
T. B. Goodwin, 110 Jessie St., San Francisco.
Lange & Bergstrom, Sharon Bldg., San Francisco.
McLeran & Peterson, Hearst Bldg., San Francisco.
Robert Trost, 26th and Howard Sts., San Francisco.
I. M. Sommer, 401 Balboa Bldg., San Francisco.
- CONTRACTORS' EQUIPMENT**
Edward R. Bacon Co., 51 Minna St., San Francisco, and Los Angeles.
Garfield & Co., Hearst Bldg., San Francisco.
Smith, Booth-Usher Co., 60 Fremont St., San Francisco; 228 Central Ave., Los Angeles.
- CONTRACTORS' INSURANCE**
Bankers & Shippers Insurance Co. of New York, Insurance Exchange Bldg., San Francisco.
- CONVEYING MACHINERY**
Meese & Gottfried, San Francisco, Los Angeles, Portland and Seattle.
- CORK TILE, INSULATION, ETC.**
Van Fleet-Freear Co., Sharon Bldg., San Francisco.
- CRUSHED ROCK**
Coast Rock & Gravel Co., Call-Post Bldg., San Francisco.
- DAMP-PROOFING COMPOUND**
Armorite Damp Resisting Paint, made by W. P. Fuller & Co., San Francisco.
Glidden's Liquid Rubber, The Glidden Company, 123 Hooper St., San Francisco.
Hill, Hubble & Company, No. 1 Drumm St., San Francisco.
Imperial Waterproofing, mfrd. by Brooks & Doerr, Reed Baxter, agent, Merchants National Bank Bldg., San Francisco.
"Pabco" Damp-Proofing Compound, sold by Paraffine Co., 34 First St., San Francisco.
- DOOR HANGERS**
Pitcher Hanger, sold by National Lumber Co., 326 Market St., San Francisco.
Reliance Hanger, sold by Waterhouse-Wilcox Co., San Francisco; D. F. Fryer & Co., B. V. Collins, Los Angeles, and Columbia Wire & Iron Works, Portland, Oregon.
Stanley Works, New Britain, Conn. John Rountree, agent, Monadnock Bldg., San Francisco.
Richards-Wilcox Mfg. Co., Underwood Bldg., San Francisco.
- DRINKING FOUNTAINS**
Haws Sanitary Drinking Faucet Co., 1808 Harmon St., Berkeley, and C. F. Weber & Co., San Francisco and Los Angeles.
Crane Company, San Francisco, Oakland, and Los Angeles.
Pacific Porcelain Ware Co., 67 New Montgomery St., San Francisco.
- George H. Tay Company, Mission and Second Sts., San Francisco; 10th and Harrison Sts., Oakland.
Haines, Jones & Cadbury Co., 857 Folsom St., San Francisco.
- DUMB WAITERS**
Spencer Elevator Company, 166 7th St., San Francisco.
M. E. Hammond, Pacific Bldg., San Francisco.
- ELECTRICAL CONTRACTORS**
Butte Electrical Equipment Company, 530 Folsom St., San Francisco.
Butte Electric & Manufacturing Co., 534 Folsom St., San Francisco.
Brown-Langlais Electrical Construction Co., 213 Minna St., San Francisco.
NePage, McKenny Co., 589 Howard St., San Francisco.
Liberty Electric Company, 479 Sutter St., San Francisco.
Newbery Electrical Co., 413 Lick Bldg., San Francisco.
Pacific Fire Extinguisher Co., 424 Howard St., San Francisco.
Globe Electric Works, 1959 Mission St., San Francisco.
M. E. Ryan, Redwood City, Calif.
Rex Electric & Engineering Co., 253 Minna St., San Francisco.
H. S. Tittle, 766 Folsom St., San Francisco.
Severin Electrical Company, 185 Stevenson St., San Francisco.
Spott Electrical Co., Sixteenth and Clay Sts., Oakland.
- ELECTRIC PLATE WARMER**
The Prometheus Electric Plate Warmer for residences, clubs, hotels, etc. Sold by M. E. Hammond, Pacific Bldg., San Francisco.
- ELECTRICAL SUPPLIES AND EQUIPMENT**
Garnett, Young & Co., 612 Howard St., San Francisco.
Butte Electrical Equipment Co., 530 Folsom St., San Francisco.
Safety Electric Company, 56-65 Columbia Square, San Francisco.
Drendell Electrical & Mfg. Co., 1345 Howard St., San Francisco.
R. J. Davis, District Sales Agent, Century A. C. Motors and Fans, 171 Second St., San Francisco.
- ELEVATORS**
Otis Elevator Company, Stockton and North Point, San Francisco.
Spencer Elevator Company, 166 7th St., San Francisco.
- ELEVATOR EQUIPMENT**
Elevator Supplies Company, Inc., 186 Fifth St., San Francisco.
- ENGINEERS—CONSULTING, ELECTRICAL, MECHANICAL**
Chas. T. Phillips, Pacific Bldg., San Francisco.
Hunter & Hudson, Rialto Bldg., San Francisco.
- ELEVATOR DOOR HARDWARE**
Richards-Wilcox Mfg. Co., Underwood Bldg., San Francisco.
- FANS AND BLOWERS**
Ideal Heating & Engineering Co., 192 Erie St., San Francisco.

KEWANEE
GARBAGE BURNERS
AND
BOILERS

YEOMANS
BILGE PUMPS
EJECTORS
HOUSE PUMPS

OVERHEAD
CARRYING
SYSTEMS

CALIFORNIA HYDRAULIC ENGINEERING & SUPPLY CO., 80 Fremont St., S. F.



TEMPERATURE REGULATION

JOHNSON SERVICE COMPANY

(OF MILWAUKEE — ESTABLISHED 1885)

Manufacturers and Installers of **JOHNSON Heat Humidity CONTROL**

For schools, residences, hospitals, banks, public buildings, also canneries and all kinds of industrial plants—Hot water tank regulators, air and water reducing valves.

Rialto Bldg, SAN FRANCISCO Trust and Savings Bldg., LOS ANGELES

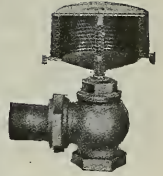

ARCHITECTS' SPECIFICATION INDEX—Continued

- FENCES—WIRE**
Standard Fence Construction Co., 77 O'Farrell St., San Francisco, and 310 12th St., Oakland.
- FILLING STATION EQUIPMENT**
S. F. Bowser & Co., Inc., 612 Howard St., San Francisco.
Wayne Oil Tank & Pump Co., 631 Howard St., San Francisco, 830 S. Los Angeles St., Los Angeles.
- FIRE ESCAPES**
Palm Iron & Bridge Works, Sacramento.
Western Iron Works, 141 Beale St., San Francisco.
Golden Gate Iron Works, 1541 Howard St., San Francisco.
- FIRE EXTINGUISHERS**
American La France Fire Engine Co., Inc., 151 New Montgomery St., San Francisco; Los Angeles and Portland.
- FIRE INSURANCE**
Bankers & Shippers Insurance Co., Insurance Exchange Bldg., San Francisco.
- FIRE SPRINKLERS—AUTOMATIC**
Grinnell Company, 453 Mission St., San Francisco.
Scott Company, 243 Minna St., San Francisco.
Pacific Fire Extinguisher Co., 424 Howard St., San Francisco.
- FIREPROOFING AND PARTITIONS**
Gladding, McBean & Co., Crocker Bldg., San Francisco.
Los Angeles Pressed Brick Co., Frost Bldg., Los Angeles.
Richards-Wilcox Mfg. Co., Aurora, Ill., and Underwood Bldg., San Francisco.
- FIRE RETARDING PAINT**
The Paraffine Companies, Inc., 34 First St., San Francisco.
Asbestos Paints, The Glidden Company, 123 Hooper St., San Francisco.
- FIXTURES—BANK, OFFICE, STORE, ETC.**
Home Manufacturing Company, 543 Brannan St., San Francisco.
The Fink & Schindler Co., 218 13th St., San Francisco.
Mullen Manufacturing Co., 64 Rausch St., San Francisco.
C. F. Weber & Co., 985 Market St., San Francisco, and 210 N. Main St., Los Angeles, Cal.
- FLOOR TILE**
Mangrum & Otter, 827 Mission St., San Francisco.
- FLOOR VARNISH**
Bass-Hueter and San Francisco Pioneer Varnish Works, 816 Mission St., San Francisco.
Fifteen for Floors, made by W. P. Fuller & Co., San Francisco.
Standard Varnish Works, Chicago, New York and San Francisco.
R. N. Nason & Co., San Francisco and Los Angeles.
The Glidden Company, 123 Hooper St., San Francisco.
- FLOORS—HARDWOOD**
Inlaid Floor Company, 600 Alabama St., San Francisco.
Parrott & Co., 320 California St., San Francisco.
White Bros., Fifth and Brannan Sts., San Francisco.
- Strable Manufacturing Company, 511 First St., Oakland.
- FLOORS—MASTIC**
Hill, Hubbell & Company, No. 1 Drumm St., San Francisco.
- FLOORS—DUST PROOF CEMENT**
L. Sonneborn Co., United Materials Co., San Francisco agents.
- FLUMES**
California Corrugated Culvert Co., West Berkeley, Cal.
- FLUSH VALVES**
National Valve Company, 23-25 Minna St., San Francisco.
- FRUIT DRYING MACHINERY**
Ideal Heating & Engineering Co., 192 Erie St., San Francisco.
Jas. A. Nelson; 517 Sixth St., San Francisco.
- FUEL OIL SYSTEMS**
S. F. Bowser & Co., Inc., 612 Howard St., San Francisco.
Wayne Oil Tank & Pump Co., 631 Howard St., San Francisco.
- FURNACES—WARM AIR**
Mangrum & Otter, 827 Mission St., San Francisco.
Montague Range and Furnace Co., 826 Mission St., San Francisco.
- FURNITURE—BUILT-IN**
Hoosier Kitchen Cabinet Store, Pacific Bldg., San Francisco.
- FURNITURE—SCHOOL, CHURCH, OFFICE, HOUSE, ETC.**
Home Manufacturing Company, 543 Brannan St., San Francisco.
C. F. Weber & Co., 985 Market St., San Francisco.
Rucker-Fuller Desk Co., 677 Mission St., San Francisco.
F. W. Wentworth & Co., 539 Market St., San Francisco.
Western Office Equipment Co., 467 Market St., San Francisco.
W. & J. Sloane, 216-228 Sutter St., San Francisco.
- GALVANIZED IRON WORK**
James A. Nelson, 517 Sixth St., San Francisco.
- GARAGE HARDWARE**
The Stanley Works, New Britain, Conn., represented in San Francisco, Los Angeles, Seattle by John T. Rowntree, Inc.
Richards-Wilcox Mfg. Co., Aurora, Ill., and Underwood Bldg., San Francisco.
- GARBAGE CHUTES AND INCINERATORS**
Bradshaw Sanitary Garbage Chute, Bittmann & Battee, 745 Folsom St., San Francisco, sole agents for California.
Kerner Incinerator Co., 77 O'Farrell St., San Francisco.
California Hydraulic Engineering & Supply Co., 70-72 Fremont St., San Francisco.
- GAS STEAM RADIATORS—FUMELESS, ETC.**
Clow Gas Steam Radiators, F. A. Hamilton, Agent, 101 Rialto Bldg., San Francisco.

ROBERTSON PROCESS METAL FOR ROOFING AND SIDING

HH ROBERTSON CO

BUILDING PRODUCTS

BUILDING PRODUCTS

FORMERLY ASBESTOS PROTECTED METAL COMPANY

Hobart Building, San Francisco

Phone Garfield 522

DIECKMANN HARDWOOD COMPANY

Office, Mill, Yards, and Dry Kilns
BEACH AND TAYLOR STS.
 SAN FRANCISCO, CAL.

PHONE FRANKLIN 2302

**Foreign & Domestic
 CABINET WOODS**

ARCHITECTS' SPECIFICATION INDEX—Continued

- GAS STEAM RADIATORS, ETC.**—Continued.
 Ra-Do Fumeless Gas Radiators, manufactured and sold by Baird-Bailhache Co., 478 Sutter St., San Francisco.
- GLASS.**
 American Window Glass Co., represented by L. H. Butcher Co., 341 Montgomery St., San Francisco.
 Fuller & Goepf, 32 Page St., San Francisco.
 W. P. Fuller & Company, all principal Coast cities.
- GRADING, WRECKING, ETC.**
 Dolan Wrecking & Construction Co., 1607 Market St., San Francisco.
- GRANITE**
 California Granite Co., Gen. Contractors' Ass'n, San Francisco.
 Raymond Granite Co., Potrero Ave. and Division St., San Francisco.
- GRAVEL AND SAND**
 Coast Rock & Gravel Co., Call-Post Bldg., San Francisco.
 Del Monte White Sand, sold by Del Monte Properties Co., Crocker Bldg., San Francisco.
- HARDWALL PLASTER**
 Henry Cowell Lime & Cement Co., San Francisco.
- HARDWARE**
 Joost Bros., agents for Russell & Erwin hardware, 1053 Market St., San Francisco.
 The Stanley Works, New Britain, Conn.
 Corbin hardware, sold by Palace Hardware Co., 581 Market St., San Francisco.
 Richards-Wilcox Mfg. Co., Aurora, Ill., Ewing-Lewis Co., 626 Underwood Bldg., San Francisco.
- HARDWOOD LUMBER—FLOORING, ETC.**
 Dieckmann Hardwood Company, Beach and Taylor Sts., San Francisco. (See advertisement above.)
 Inlaid Floor Co., 600 Alabama St., San Francisco.
 H. N. McNab, 2307 17th Ave., Oakland.
 Parrott & Co., 320 California St., San Francisco.
 White Bros., cor. Fifth and Brannan Sts., San Francisco.
 Strable Manufacturing Company, First St., near Broadway, Oakland.
- HEATERS—AUTOMATIC—GAS**
 Pittsburg Water Heater Co., 478 Sutter St., San Francisco.
 George H. Tay Company, Mission and Second Sts., San Francisco; 10th and Harrison Sts., Oakland.
 Ra-Do Fumeless Gas Heater, sold by Baird-Bailhache Company, 478 Sutter St., San Francisco.
- HEATING AND VENTILATING MATERIAL, ETC.**
 Alex Coleman, 706 Ellis St., San Francisco.
 Gilley-Schmid Company, 198 Otis St., San Francisco.
 Mechanical Engineering & Supply Co., Sacramento.
 Hateley & Hateley, Mitau Bldg., Sacramento. †
- Knittle-Cashel Co., Inc., 1820 Ellis St., San Francisco.
 General Boilers Co., 332 Monadnock Bldg., San Francisco.
 A. Lettich, 365 Fell St., San Francisco.
 Mangrum & Otter, 827-831 Mission St., San Francisco.
 Moline Heat, Hobart Bldg., San Francisco.
 James & Drucker, 450 Hayes St., San Francisco.
 James A. Nelson, 517 Sixth St., San Francisco.
 Ideal Heating & Engineering Co., 192 Erie St., San Francisco.
 Illinois Engineering Co., 563 Pacific Bldg., San Francisco.
 William F. Wilson Co., 328 Mason St., San Francisco.
 Pacific Fire Extinguisher Co., 424 Howard St., San Francisco.
 Scott Company, 243 Minna St., San Francisco.
 Mechanical Engineering & Supply Co., 908 7th St., Sacramento.
 John Ringius, 252 Townsend St. (bet. Third and Fourth), San Francisco.
 George H. Tay Company, Mission and Second Sts., San Francisco; 10th and Harrison Sts., Oakland.
 O. M. Simmons Co., 115 Mission St., San Francisco.
- HOLLOW TILE BLOCKS**
 Gladding, McBean & Co., San Francisco, Los Angeles, Oakland and Sacramento.
 Los Angeles Pressed Brick Co., Frost Bldg., Los Angeles.
- HOSPITAL FIXTURES**
 Mott Company of California, 553 Mission St., San Francisco.
 George H. Tay Company, Mission and Second Sts., San Francisco; 10th and Harrison Sts., Oakland.
- HOSPITAL SIGNAL SYSTEM**
 Holtzer-Cabot system, represented by Bittmann & Battee, 745 Pilsom St., San Francisco.
 Chicago Signal Co., represented by Garnett, Young & Co., 612 Howard St., San Francisco.
- HOTELS**
 St. Francis Hotel, Powell, Geary and Post Sts., San Francisco.
- INGOT IRON**
 "Armco" brand, manufactured by American Rolling Mill Company, Middletown, Ohio, and Monadnock Bldg., San Francisco.
- INSPECTIONS AND TESTS**
 Robert W. Hunt & Co., 251 Kearny St., San Francisco.
- INSULATION**
 Ebonite Boiler Kote, sold by California Plastic Products Co., 521 Sheldon Bldg., San Francisco.
- INCINERATORS**
 Kerner Incinerator Co., 77 O'Farrell St., San Francisco.
- INTERIOR DECORATORS**
 Beach-Robinson Co., 239 Geary St., San Francisco.

"The
 Perfect
 Automatic
 Valve"

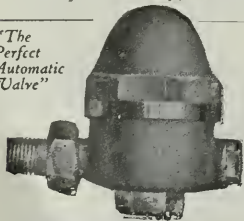

WILLIAM S. HAINES & CO.

Automatic Vacuum and Vapor Heating Systems

VENTO AUTOMATIC VALVES

"Everything for the Heating Engineer"

O. M. SIMMONS CO. 115 MISSION STREET
 SAN FRANCISCO

PACIFIC COAST REPRESENTATIVE

Phone: Douglas 5497

CLARENCE E. MUSTO, Pres.

JOSEPH B. KEENAN, Vice-Pres.

GUIDO J. MUSTO, Sec'y & Treas.

JOSEPH MUSTO SONS-KEENAN CO.Phone Franklin
—6365—**MARBLE**OFFICE AND MILLS:
535-565 North Point St.,
SAN FRANCISCO, CAL.**ARCHITECTS' SPECIFICATION INDEX—Continued**

- INTERIOR DECORATORS.**—Continued.
Sonnenschein Bros., 470 Sutter St., San Francisco.
The Tormey Co., 1042 Larkin St., San Francisco.
F. A. Taylor & Co., 251 Post St., San Francisco.
Freeman Art Shop, 386 Sutter St., San Francisco.
W. & J. Sloane, 216 Sutter St., San Francisco.
- KITCHEN CABINETS**
Hoosier Kitchen Cabinet Store (O. K. Brown, Mgr.), Pacific Bldg., San Francisco.
- KITCHEN EQUIPMENT**
James A. Nelson, 517-19 Sixth street, San Francisco.
- LAMP POSTS, ELECTROLIERS, ETC.**
J. L. Mott Iron Works, 553 Mission St., San Francisco.
- LANDSCAPE GARDENERS**
MacRorie-McLaren Co., 141 Powell St., San Francisco.
- LATHING AND PLASTERING**
MacGruer & Simpson, Call-Post Bldg., San Francisco.
A. Knowles, Call-Post Bldg., San Francisco.
Jas. F. Smith, 273 Minna St., San Francisco.
- LATHING MATERIAL**
Pacific Materials Co., 525 Market St., San Francisco.
Key-Hold Plaster Lath Co., Monadnock Bldg., San Francisco.
Truscon Steel Co., Tenth St., near Bryant, San Francisco.
- LIGHT, HEAT AND POWER**
Great Western Power Company, Stockton St., near Sutter, San Francisco.
- LIGHTING FIXTURES**
Roberts Mfg Co., 663 Mission St., San Francisco.
- LIME**
Henry Cowell Lime & Cement Co., 2 Market St., San Francisco.
- LINOLEUM**
D. N. & E. Walter & Co., 562 Mission St., San Francisco.
The Paraffine Companies, factory in Oakland; office, 34 First St., near Market, San Francisco.
W. & J. Sloane, 216-228 Sutter St., San Francisco.
- LOCKERS—STEEL**
George H. Trask, Sacramento St., San Francisco, representing Durand Steel Lockers.
- LUBRICATING OIL STORAGE TANKS AND PUMPS**
S. F. Bowser & Co., Inc., 612 Howard St., San Francisco.
- LUMBER**
California Redwood Association, 216 Pine St., San Francisco.
Dudfield Lumber Co., Palo Alto, Cal.
Hart-Wood Lumber Co., Fifth and Berry Sts., San Francisco.
Pacific Manufacturing Company, San Francisco, Oakland and Santa Clara.
Pope & Talbot, foot of Third St., San Francisco.
Portland Lumber Co., 16 California St., San Francisco.
- Sunset Lumber Company, First and Oak Sts., Oakland.
- MAIL CHUTES**
American Mailing Device Corp., represented on Pacific Coast by Waterhouse-Wilcox Co., 523 Market St., San Francisco.
- MANTELS**
Mangrum & Otter, 827-831 Mission St., San Francisco.
- MANUAL TRAINING EQUIPMENT**
Richards-Wilcox Mfg. Co., Ewing-Lewis Co., 626 Underwood Bldg., San Francisco.
- MARBLE**
American Marble and Mosaic Co., 25 Columbus Square, San Francisco.
Joseph Musto Sons, Keenan Co., 535 N. Point St., San Francisco.
Vermont Marble Co., Coast branches, San Francisco, Portland and Tacoma.
- METAL DOORS AND WINDOWS**
Fire Protection Products Co., 317 20th St., San Francisco.
Waterhouse-Wilcox Co., Inc., 523 Market St., San Francisco.
U. S. Metal Products Co., 330 Tenth St., San Francisco.
- MILL WORK**
Dudfield Lumber Co., Palo Alto, Cal.
Pacific Manufacturing Company, San Francisco, Oakland and Santa Clara.
National Mill and Lumber Co., San Francisco and Oakland.
The Fink & Schindler Co., 218 13th St., San Francisco.
Frank Portman, 1619-20 Mission St., San Francisco.
- MOTORS AND FANS**
R. J. Davis, Dist. Sales Agent Century Motors and Fans, 171 Second St., San Francisco.
- OIL BURNERS**
American Standard Oil Burner Company, Berkeley.
Fess System Co., 220 Natoma St., San Francisco.
S. T. Johnson Co., 1337 Mission St., San Francisco.
T. P. Jarvis Manufacturing Co., 275 Connecticut St., San Francisco.
W. S. Ray Mfg. Co., 29 Spear St., San Francisco.
G. E. Witt Co., 862 Howard St., San Francisco.
- OIL STORAGE AND DISTRIBUTING STATIONS**
S. F. Bowser & Co., Inc., 612 Howard St., San Francisco.
Wayne Oil Tank & Pump Co., 631 Howard St., San Francisco; 830 S. Los Angeles St., Los Angeles.
- OFFICE EQUIPMENT**
Western Office Equipment Co., 467 Market St., San Francisco.
F. W. Wentworth & Co., 539 Market St., San Francisco.
- ORNAMENTAL IRON AND BRONZE**
California Artistic Metal and Wire Co., 349 Seventh St., San Francisco.
Palm Iron & Bridge Works, Sacramento.
C. J. Hillard Company, Inc., 19th and Minnesota Sts., San Francisco.

KNITTLE-CASHEL CO., Inc.

HEATING CONTRACTORS

STEAM HEATING
HOT WATER HEATINGVENTILATING
POWER PLANTSGENERAL PIPE WORK
REPAIRING

1820-22 Ellis Street, San Francisco

Phone West 964



On Your Best Work Specify

CAL-PA-CO DAMPSTOP (Outside)
WASHABLE WALL (Inside)

FOR CONCRETE BUILDINGS.

Everything Reliable in PAINT and VARNISH

CALIFORNIA PAINT COMPANY, OAKLAND, CALIF., U. S. A.
MANUFACTURERS SINCE 1865 SAN FRANCISCO OFFICE, MONADNOCK BUILDING

ARCHITECTS' SPECIFICATION INDEX—Continued

- ORNAMENTAL IRON AND BRONZE.—Cont.
Schrader Iron Works, Inc., 1247 Harrison St., San Francisco.
- OVERHEAD CARRYING SYSTEMS
California Hydraulic Engineering & Supply Co., 70-72 Fremont St., San Francisco.
Richards-Wilcox Mfg. Co., Aurora, Ill., and Underwood Bldg., San Francisco.
- PAINT FOR STEEL STRUCTURES, BRIDGES, ETC.
The Paraffine Companies, Inc., 34 First St., San Francisco.
Anti-Rust Coatings. The Glidden Co., 123 Hooper St., San Francisco.
Premier Graphite Paint and Pioneer Brand Red Lead, made by W. P. Fuller & Co., San Francisco.
Hill, Hubbell & Company, No. 1 Drumm St., San Francisco.
Wadsworth, Howland Co., makers of Bay State Brick and Cement Coating, Boston, Mass. Hambley & Son, Distributors in San Francisco and Los Angeles.
- PAINTING, TINTING, ETC.
I. R. Kissel, 1747 Sacramento St., San Francisco.
D. Zelinsky & Sons, San Francisco and Los Angeles.
The Tormey Co., 681 Geary St., San Francisco.
Fick Bros., 475 Haight St., San Francisco.
- PAINTS, OILS, ETC.
California Paint Company (see advertisement above).
Magner Bros., 414-424 Ninth St., San Francisco.
Bass-Hueter Paint Co., Mission, near Fourth St., San Francisco.
The Brininstool Co., Los Angeles, the Haslett Warehouse, 310 California St., San Francisco.
The Glidden Company of California, 123 Hooper St., San Francisco.
R. N. Nason & Company, San Francisco, Los Angeles, Portland and Seattle.
W. P. Fuller & Co., all principal Coast cities. "Satinette," Standard Varnish Works, 55 Stevenson St., San Francisco.
Palace Hardware Co., 581 Market St., San Francisco.
- PANELS AND VENEER
White Bros., Fifth and Brannan Sts., San Francisco.
- PARTITIONS—FOLDING AND ROLLING
J. G. Wilson Corporation, 600 Metropolitan Bldg., Los Angeles; Waterhouse-Wilcox Co., Underwood Bldg., San Francisco.
- PENCILS
Eberhard Faber, Monadnock Bldg., San Francisco.
- PIPE—STEEL AND WROUGHT IRON
Western Pipe & Steel Co., 444 Market St., San Francisco; 1758 N. Broadway, Los Angeles.
George H. Tay Company, Mission and Second Sts., San Francisco; 10th and Harrison Sts., Oakland.
- PLASTER CONTRACTORS
A. Knowles, Call-Post Bldg., San Francisco.
MacGruer & Simpson, 540 Call-Post Bldg., San Francisco.
- James F. Smith, 273 Minna St., San Francisco.
- PLUMBING CONTRACTORS
Alex Coleman, 706 Ellis St., San Francisco.
Gilley-Schmid Company, 198 Otis St., San Francisco.
Hateley & Hateley, Mitau Bldg., Sacramento.
A. Lettich, 365 Fell St., San Francisco.
Scott Co., Inc., 243 Minna St., San Francisco.
Wm. F. Wilson Co., 328 Mason St., San Francisco.
- PLUMBING FIXTURES, MATERIALS, ETC.
California Steam & Plumbing Supply Co., 671 Fifth St., San Francisco.
Jas. B. Clow, plumbing, Rialto Bldg., San Francisco.
Crane Co., San Francisco, Oakland, Los Angeles.
Gilley-Schmid Company, 198 Otis St., San Francisco.
Haines, Jones & Cadbury Co., 857 Folsom St., San Francisco.
H. Mueller Manufacturing Company, 635 Mission St., San Francisco.
Holbrook, Merrill & Stetson, 64 Sutter St., San Francisco.
J. L. Mott Iron Works, D. H. Gulick, selling agent, 553 Mission St., San Francisco.
National Valve Company, 23-25 Minna St., San Francisco.
Pacific Sanitary Manufacturing Co., 67 New Montgomery St., San Francisco.
George H. Tay Company, Mission and Second Sts., San Francisco; 10th and Harrison Sts., Oakland.
Wm. F. Wilson Co., 328 Mason St., San Francisco.
- Whale-bone-ite Fixtures, sold by E. C. Whalen, 325 Monadnock Bldg., San Francisco.
- POWER LAWN MOWERS
H. U. Carter Motor Co., 52 Beale St., San Francisco.
- POWER PLANTS
Knittle-Cashel Co., Inc., 1820 Ellis St., San Francisco.
- POWER TRANSMITTING MACHINERY
Meese & Gottfried, San Francisco, Los Angeles, Portland, Ore., and Seattle, Wash.
- PUMPS
Chicago Pump Co., represented by Garnett, Young & Co., 612 Howard St., San Francisco.
California Hydraulic Engineering & Supply Co., 70 Fremont St., San Francisco.
Dow-Herriman Company, 140 Howard St., San Francisco; factory, Petaluma.
Simonds Machinery Co., 117 New Montgomery St., San Francisco.
Ocean Shore Iron Works, 558 Eighth St., San Francisco.
Pacific Pump & Supply Company, 851-853 Folsom St., San Francisco.
George H. Tay Company, Mission and Second Sts., San Francisco; 10th and Harrison Sts., Oakland.
Wooden & Little, 33-41 Fremont St., San Francisco.
- PUMPS—HAND OR POWER, FOR OIL AND GASOLINE
S. F. Bowser & Co., Inc., 612 Howard St., San Francisco.

R. J. Davis
District Sales
Agent

Century

**A. C. Motors
and Fans**

Complete stocks carried at: 171-173 Second St., San Francisco; 906 So. Hope St., Los Angeles



Yards { TRACY, CAL.
BRENTWOOD, CAL.

Phone KEARNY 2074

PORTLAND LUMBER COMPANY

A. J. RUSSELL, Agent

L U M B E R

SIMPLEX SILOS

SAGINAW SPECIAL SHINGLES

*Ship Timbers, Oil Rigs and
Special Bills Cut to Order.*

16 California Street

San Francisco, Cal.

from tree to Consumer

Pine and Redwood Lumber

SASH DOORS AND MILL WORK

SUNSET LUMBER COMPANY

MANUFACTURERS — WHOLESALE AND RETAIL

Main Office and Yards:

FIRST AND OAK STREETS, OAKLAND

Phone Oakland 1820

POPE & TALBOT

Manufacturers, Exporters and Dealers in

Lumber, Timber, Piles, Spars, etc.

Office, Yards and Planing Mills

859-869 THIRD ST., SAN FRANCISCO, CAL.

Mills, Port Gamble, Port Ludlow and Utsalady, Washington

STORM KING and AMERICAN WARM AIR FURNACES

FURNACE FITTINGS AND REPAIRS

Montague Range & Furnace Company

327-329 JESSIE STREET

Phone Garfield 1422

826-830 MISSION STREET

SAN FRANCISCO, CALIF.

ARCHITECTS' SPECIFICATION INDEX—Continued

- PUMPS (Continued)**
 Dow-Herriman Co., 140 Howard St., San Francisco.
 Wayne Oil Tank & Pump Co., 631 Howard St., San Francisco; 830 S. Los Angeles St., Los Angeles.
 George H. Tay Company, Mission and Second Sts., San Francisco; 10th and Harrison Sts., Oakland.
- REFRIGERATORS**
 McCray Refrigerator Company, San Francisco office, Monadnock Bldg.
- REVERSIBLE WINDOWS**
 Hauser Window Company, 157 Minna St., San Francisco.
- ROOFING CONTRACTORS**
 Western Roofing Co., Inc., 420 15th St., San Francisco.
- ROOFING AND ROOFING MATERIALS**
 Bender Roofing Company, Monadnock Bldg., San Francisco.
 "Malthoid" and "Ruberoid," manufactured by Paraffine Companies, Inc., San Francisco.
 United Materials Co., Crossley Bldg., San Francisco.
 H. H. Robertson Co., Hobart Bldg., San Francisco.
- RUBBER TILING**
 New York Belting and Packing Company, 518 Mission St., San Francisco.
- SAFETY TREADS**
 Pacific Materials Co., 525 Market St., San Francisco.
- SAND**
 Del Monte White Sand, Del Monte Properties Co., 401 Crocker Bldg., San Francisco.
- SASH CORD**
 Samson Spot Sash Cord, John T. Rowntree, Pacific Coast Agent, San Francisco and Los Angeles.
- SCENIC PAINTING—DROP CURTAINS, ETC.**
 The Edwin H. Flagg Scenic Co., 1638 Long Beach Ave., Los Angeles.
- SCHOOL FURNITURE AND SUPPLIES**
 C. F. Weber & Co., 985 Market St., San Francisco; 512 S. Broadway, Los Angeles.
 Rucker-Fuller Desk Company, 677 Mission St., San Francisco.
- SHEATHING AND SOUND DEADENING**
 Samuel Cabot Mfg. Co., Boston, Mass., agencies in San Francisco, Oakland, Los Angeles, Portland, Tacoma and Spokane.
 The Paraffine Companies, Inc., 34 First St., San Francisco.
- SHEET METAL WORK**
 Jas. A. Nelson, 517 Sixth St., San Francisco.
- SHINGLE STAINS**
 Bass-Hueter Paint Company, all principal Coast cities.
 Cabot's Creosote Stains, sold by Pacific Building Materials Co., 525 Market St., San Francisco.
 Fuller's Pioneer Shingle Stains, made by W. P. Fuller & Co., San Francisco.
 Argonaut Shingle Stains, The Glidden Co., 123 Hooper St., San Francisco.
- SINKS—COMPOSITION**
 Petrium Sanitary Sink Co., Fifth and Page Sts., Berkeley.
- SKYLIGHTS**
 H. H. Robertson Co., Hobart Bldg., San Francisco.
 Jas. A. Nelson, 517 Sixth St., San Francisco.
- STATIONERY AND SUPPLIES**
 Schwabacher-Frey Stationery Co., 609 Market St., San Francisco.
- STEEL HEATING BOILERS**
 California Hydraulic Engineering & Supply Co., 70-72 Fremont St., San Francisco.
 General Boilers Co., 332 Monadnock Bldg., San Francisco.
- STEEL TANKS, PIPE, ETC.**
 Ocean Shore Iron Works, 558 Eighth St., San Francisco.
 Western Pipe & Steel Co., 444 Market St., San Francisco.
- STEEL AND IRON—STRUCTURAL**
 Central Iron Works, 621 Florida St., San Francisco.
 Dyer Bros., 17th and Kansas Sts., San Francisco.
 Golden Gate Iron Works, 1541 Howard St., San Francisco.
 Mortenson Construction Co., 19th and Indiana Sts., San Francisco.
 Pacific Rolling Mills, 17th and Mississippi Sts., San Francisco.
 Palm Iron & Bridge Works, Sacramento.
 U. S. Steel Products Co., Rialto Bldg., San Francisco.
 Schrader Iron Works, Inc., 1247 Harrison St., San Francisco.
 Western Iron Works, 141 Beale St., San Francisco.
- STEEL PRESERVATIVES**
 Hill, Hubbell & Company, No. 1 Drumm St., San Francisco.
- STEEL REINFORCING**
 Badt-Falk & Co., Call-Post Bldg., San Francisco.
 Pacific Coast Steel Company, Rialto Bldg., San Francisco.
 Gunn, Carle & Co., Inc., 444 Market St., San Francisco.
 Truscon Steel Co., 527 Tenth St., San Francisco.
 W. S. Wetenhall Co., 725 Second St., San Francisco.
- STEEL ROLLING DOORS**
 Kinnear Steel Rolling Door Co., Pacific Building Materials Co., agents, Underwood Bldg., San Francisco.
 J. G. Wilson Corporation, 600 Metropolitan Bldg., Los Angeles.
- STEEL SASH**
 Bayley-Springfield solid steel sash, sold by Pacific Materials Co., 525 Market St., San Francisco.
 "Fenestra," solid steel sash, manufactured by Detroit Steel Products Company, Detroit, Mich. Direct factory sales office, Foxcroft Bldg., San Francisco.
 U. S. Metal Products Company, 330 Tenth St., San Francisco.
- STEEL WHEELBARROWS**
 Champion and California steel brands, made by Western Iron Works, 141 Beale St., San Francisco.
- STORE FRONTS**
 The Kawncer Manufacturing Company, West Berkeley, California.
- STUDDING—FIREPROOF STEEL**
 Steel Studding Company, 1216 Polson St., San Francisco.
- SUMP AND BILGE PUMPS**
 California Hydraulic Engineering & Supply Co., 70-72 Fremont St., San Francisco.
- SWITCHES**
 Wemco Safety Switch, manufactured and sold by W. E. Mushet Co., 502 Mission St., San Francisco.
- TANKS FOR OIL, GASOLINE, KEROSENE, ETC.**
 S. F. Bowser & Co., Inc., 612 Howard St., San Francisco.
 Wayne Oil Tank & Pump Co., 631 Howard St., San Francisco; 830 S. Los Angeles St., Los Angeles.
- TANKS—REDWOOD**
 Redwood Manufactures Co., Hobart Bldg., San Francisco.

STEEL SASH — FIRE DOORS — SHEET METAL

Kalamein, Copper and Bronze Doors and Trim Sheet Metal Work of Every Description

FIRE PROTECTION PRODUCTS CO.

3117-3119 TWENTIETH STREET, Near Harrison, SAN FRANCISCO. Phone Mission 2607

ARCHITECTS' SPECIFICATION INDEX—Continued

- TELEPHONE AND ELECTRIC EQUIPMENT**
Bittmann & Battee, 745 Folsom St., San Francisco.
Direct Line Telephone Co., 320 Market St., San Francisco.
- THEATER AND OPERA CHAIRS**
C. F. Weber & Co., 365 Market St., San Francisco.
Rucker-Fuller Desk Co., 677 Mission St., San Francisco.
- THERMOSTATS FOR HEAT REGULATION**
Johnson Service, Rialto Bldg., San Francisco.
- TILES, MOSAICS, MANTELS, ETC.**
Mangrum & Otter, 827-831 Mission St., San Francisco.
- TILE FOR ROOFING**
Gladding, McBean & Co., Crocker Bldg., San Francisco.
United Materials Co., Crossley Bldg., San Francisco.
- TRANSMISSION MACHINERY**
Meese & Gottfried Co., San Francisco, Los Angeles and Portland.
- VACUUM CLEANERS**
United Electric Company, Canton, O., manufacturers of Tucc Cleaners, sold in California by San Francisco Compressed Air Cleaning Co., Stockton and Sutter Sts., San Francisco.
- VALVES—PIPES AND FITTINGS**
California Steam & Plumbing Supply Co., 671 Fifth St., San Francisco.
Crane Radiator Valves, manufactured by Crane Co., Second and Brannan Sts., San Francisco.
National Valve Company, 23-25 Minna St., San Francisco.
Sloane Valves, sold by E. C. Whalen, 325 Mondrack Bldg., San Francisco.
Grinnell Co., 453 Mission St., San Francisco.
O. M. Simmons Co., 115 Mission St., San Francisco.
H. Mueller Mfg. Co., 635 Mission St., San Francisco.
W. E. Mushet Co., 502 Mission St., San Francisco.
George H. Tay Company, Mission and Second Sts., San Francisco; 10th and Harrison Sts., Oakland.
- VALVE PACKING**
N. H. Cook Belting Co., 317 Howard St., San Francisco.
- VARNISHES**
California Paint Company, 1797 Twelfth St., Oakland.
W. P. Fuller Co., all principal Coast cities.
R. N. Nason & Co., San Francisco, Los Angeles, Portland and Seattle.
S. F. Pioneer Varnish Works, 816 Mission St., San Francisco.
The Glidden Company, 123 Hooper St., San Francisco.
Standard Varnish Works, 55 Stevenson St., San Francisco.
- VENETIAN BLINDS, AWNINGS, ETC.**
C. F. Weber & Co., 985 Market St., San Francisco.
Western Blind & Screen Co., 2702 Long Beach Ave., Los Angeles.
- VENTILATORS**
H. H. Robertson Co., Hobart Bldg., San Francisco.
Power & Pike Co., 22-24 Main St., San Francisco.
- VITREOUS CHINAWARE**
Pacific Porcelain Ware Company, 67 New Montgomery St., San Francisco.
- WALL BEDS, SEATS, ETC.**
Marshall & Stearns Co., 1154 Phelan Bldg., San Francisco.
- WALL BOARD**
"Amiwud" Wall Board, manufactured by The Paraffine Companies, Inc., 34 First St., San Francisco.
- "Liberty" Wall Board, manufactured by Key-Hold Plaster Lath Co., 148 Hooper St., San Francisco.
- WALL PAINT**
Nason's Opaque Flat Finish, manufactured by R. N. Nason & Co., San Francisco, Portland and Los Angeles.
San-A-Cote and Vel-va-Cote, manufactured by the Brininstool Co., Los Angeles.
- WALL PAPER AND DRAPERIES**
Beach-Robinson Co., 239 Geary St., San Francisco.
The Tormey Co., 681 Geary St., San Francisco.
W. & J. Sloane, 216-228 Sutter St., San Francisco.
Uhl Bros., San Francisco.
- WATERPROOFING FOR CONCRETE, BRICK, ETC.**
Armorite Damp Resisting Paint, made by W. P. Fuller & Co., San Francisco.
Bay State Brick & Cement Coating, manufactured by Wadsworth, Howland Co., Boston; Hambley & Son., Distributors for Northern and Southern California.
Imperial Waterproofing, mfrd. by Brooks & Doerr, Reed Baxter, agent, Merchants National Bank Bldg., San Francisco.
Pacific Materials Co., 525 Market St., San Francisco.
Samuel Cabot Mfg. Co., Boston, Mass., agencies in San Francisco, Oakland, Los Angeles, Portland, Tacoma and Spokane.
- WATER SUPPLY SYSTEMS**
Kewanee Water Supply System—Simonds Machinery Co., agents, 117 New Montgomery St., San Francisco.
Pacific Pump & Supply Company, 851-853 Folsom St., San Francisco.
- WHEELBARROWS—STEEL**
Western Iron Works, Beale and Main Sts., San Francisco.
- WHITE CEMENT**
"Atlas White," see coast agencies, page 127.
"Medusa White," sold by Pacific Materials Co., Underwood Bldg., San Francisco.
- WHITE ENAMEL**
"Gold Seal," manufactured and sold by Bass-Hueter Paint Co. All principal Coast cities.
Velvet White Enamel. The Glidden Company, 123 Hooper St., San Francisco.
"Silkenwhite," made by W. P. Fuller & Co., San Francisco.
"Satinette," Standard Varnish Works, 55 Stevenson St., San Francisco.
- WINDOW SHADES**
W. & J. Sloane, 216-228 Sutter St., San Francisco.
- WINDOW SASH CORD**
Sampson Spot Cord, John T. Rowntree, Pacific Coast agents, San Francisco and Los Angeles.
- WINDOWS, REVERSIBLE, CASEMENT, ETC.**
Hauser Window Co., 157 Minna St., San Francisco.
The Kawneer Company, West Berkeley, California. (Simplex Fixtures.)
J. G. Wilson Corporation, 600 Metropolitan Bldg., Los Angeles; Waterhouse-Wilcox Co., Underwood Bldg., San Francisco.
- WIRE FABRIC**
U. S. Steel Products Co., Rialto Bldg., San Francisco.
Clinton Wire Lath, sold by L. O. Norris, 140 Townsend St., San Francisco.
- WIRE FENCE**
Standard Fence Co., 310 12th St., Oakland.
- WOOD MANTELS**
Fink & Schindler, 218 13th St., San Francisco.
Mangrum & Otter, 827 Mission St., San Francisco.

MOLINE HEAT

Hobart Building

San Francisco

TELEPHONE SUTTER 3818

MOTT PLUMBING FIXTURES

Architects and their clients are invited to visit our Showrooms, 553-555 Mission Street, San Francisco; D. H. Gulick, Sales Agent. Los Angeles Office, 1001 Central Building; J. R. Mayhew, Sales Agent.

Mott Company of California

MUELLER — BRASS GOODS

Recognized as the Standard of excellence in plumbing. It pays to use them, and other **Mueller** Brass Goods. *The first cost is practically their last cost.*

H. Mueller Mfg. Co.

635 MISSION STREET, SAN FRANCISCO, CAL.

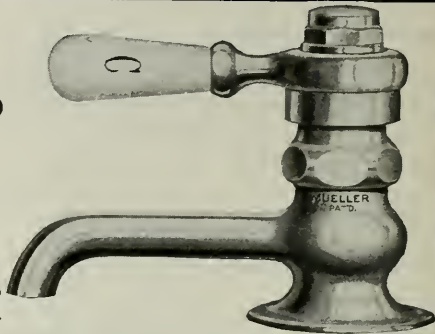

Automatic Fire Sprinklers

Protect your building and business from destruction by fire and reduce your Insurance Rate.

Pacific Fire Extinguisher Co.

FIRE PROTECTION ENGINEERS

424-440 HOWARD STREET
SAN FRANCISCO

MANUFACTURING PLANT
272 STEUART STREET

GENERAL BOILERS COMPANY

DEPARTMENT OF SALES

Manufacturers of

**Pacific Patented Steel Portable Double Return Tube
Low Pressure Steam and Hot Water Heating Boilers
Pacific Steel Circulating Tanks
Pacific Steel Tank Heaters and Storage Tanks**

General Office and Plant: WAUKEGAN, ILLS.

Sales Offices: 322 Monadnock Bldg., SAN FRANCISCO and 1310 South Hill St., LOS ANGELES, CALIFORNIA.

A. W. MERRILL, Manager



Home of Mr. C. L. Newton
 "Sea Cliff" Residential Section. Designed for Allen & Company by C. B. Bertz. Painted by Wm. Farrell & Company.

For Beauty and Permanency

The builders of "Sea Cliff" desired to erect homes that would express beauty and permanency. To carry out this desire they realized that only paints known for their quality and colorings should be used.

FULLER Paints and Varnishes

were chosen for expressing their ideas and for the qualities which make them especially adaptable to the climatic conditions of the Pacific Coast.

"Sea Cliff"

"Sea Cliff" overlooks the Golden Gate at Bakers Beach, extending from the Presidio west to Lincoln Park, and from California Street north to the Beach. Every home site has an unobstructed view of the Golden Gate and Marin County Hills.

"Fuller Products are made to meet all the requirements of your specifications."

W. P. FULLER & CO.
 Manufacturers

GARNETT YOUNG AND COMPANY

612 HOWARD STREET, SAN FRANCISCO

SEATTLE LOS ANGELES PORTLAND

Pacific Coast Sales Engineers

Chicago Pump Company

**House Pumps, Sewage Ejectors, Bilge Pumps,
Condensation Pumps.**

A FEW INSTALLATIONS:

Concord High SchoolConcord, California
Ames-Harris-Neville Bldg.....San Francisco, California
Levi Strauss Bldg.....San Francisco, California
John Muir SchoolBerkeley, California
California Hawaiian Sugar Refinery..Crockett, California
Solano HospitalFairfield, California
Arcata SchoolArcata, California

Chicago Signal Company

Silent Call Hospital Signal Systems.

A FEW INSTALLATIONS:

Multnomah County Hospital.....Portland, Oregon
St. Joseph HospitalAberdeen, Washington
Virginia Mason HospitalSeattle, Washington
Simon J. Murphy Hospital.....Whittier, California
Emanuel HospitalTurlock, California
Highland Hospital.....Alameda County, California
St. Francis Hospital Addition...San Francisco, California

Our Engineers Are At Your Service

Why Use Garbage Cans?



Owner, A. Getty, Wilshire and Hobart Sts., Los Angeles
 Architect, T. B. Keim, Jr., Los Angeles



THE KERNER INCINERATOR

*Is built into the
 base of the chimney
 when the house is erected.*

*Consumes no
 space on living
 floors: requires
 but little added
 masonry.*

Do you continue to use garbage and rubbish cans because you are satisfied? Or do you tolerate them because you think they are necessary evils? The

KERNER "Built-in-the-Chimney" INCINERATOR

has at last emancipated the home from these evils.

The only fuel used is the paper and other dry waste thrown in the hopper door. This in burning dries the wet waste so it also becomes fuel. Bottles, cans and other non-combustible matter are dried and sterilized and later dropped into the ash pit.

SANITARY
 ECONOMICAL

CONVENIENT
 ODORLESS

Kerner Incinerator Co. of San Francisco

77 O'Farrell St. Factory, 38 Stanford St.

600 Metropolitan Building, Los Angeles.

See Page 1132 - Sweet's Catalog

Millwork Manufactured and delivered anywhere

Plans or Lists sent us for Estimates will
 have Careful and Immediate Attention

DUDFIELD LUMBER

JNO. DUDFIELD
 President and Manager

COMPANY

JOSEPH A. JURY
 Secretary & Mill Supt.

Main Office, Yard and Planing Mill—PALO ALTO



Brininstool

San - a - Cote

(GLOSS—Can be Scrubbed)

AN INTERIOR WALL FINISH

For bath rooms, kitchens, hospitals, schools, office and public buildings. Ask dealers, owners, architects and contractors about this durable, sanitary, washable, economical wall covering. Brininstool makes a paint for every purpose, and every can purposely good.

THE BRININSTOOL CO., LOS ANGELES

COLOR GRINDERS AND PAINT MANUFACTURERS

Distributors—The Brininstool Co., 1174 Phelan Bldg., San Francisco, Cal.; The Brininstool Co., 222 Abington Bldg., Portland, Ore.; Schutz Paint Co., Fresno, Cal.; Schneider, Chappell & Jones, Sacramento, Cal.; Salt Lake Glass & Paint Co., Salt Lake City, Utah; Griffin Paint Co., Ogden, Utah; Campbell Hardware Co., First and Madison Sts., Seattle, Wash.; Imperial Valley Hardware Co., El Centro, Calexico, Imperial, Brawley, Seeley, Cal.; Spokane Hardware Co., Spokane, Wash.; Continental Paint Company, 328 South First St., San Jose, Cal.; Los Angeles Wallpaper & Paint Co., 525 So. Main St., Los Angeles, Cal.; H. A. Berger, 3838 13th St., San Diego, Cal.; H. L. Christian, Blythe, Cal.; Ezra Thayer, Phoenix, Ariz.; Miami Lumber & Supply Co., Miami, Ariz.

RELIANCE BALL BEARING DOOR HANGERS

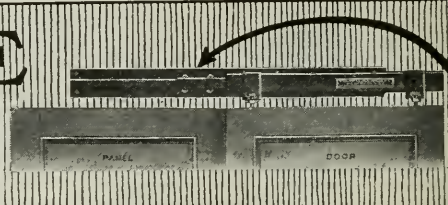

To get as near perfection as possible, use

“RELIANCE HANGERS” and “Reliance-Grant” Controllers

These insure fast service, practically noiseless and slamless doors.

Reliance-Grant Elevator Equipment Corp'n

PARK AVENUE AND 40TH STREET, NEW YORK

PACIFIC COAST AGENTS

Waterhouse-Wilcox Co.	San Francisco and Los Angeles, Cal.
Columbia Wire & Iron Works	Portland, Ore.
D. E. Fryer & Company	Seattle, Spokane, Tacoma, Wash. and Great Falls, Mont.

FOR ALL FINISHING REQUIREMENTS



THE IMMACULATE WHITE ENAMEL

TRADE MARK
ELASTICA
MARK
VARNISHES

Satinette
TRADE MARK
ENAMEL

STANDARD VARNISH WORKS

GENERAL OFFICES: NEW YORK - 90 WEST STREET
BRANCHES: LONDON - SAN FRANCISCO - PARIS - MELBOURNE

SAN FRANCISCO OFFICES & WAREHOUSE 55 STEVENSON STREET

When writing to Advertisers please mention this magazine.

Bungalow Building Blox

Hollow Building Tile
Hollow Partition Tile

California Brick Co.
604 Mission Street
San Francisco, Cal.

BRICK

Red Ruffled Face Brick
Paving Brick
Step and Walk
Brick

BRICK

Enamel Brick
Buff and Old Gold
Pressed Brick

Livermore Fire Brick Works
604 Mission Street
San Francisco, Cal.

Fire Brick and
Molded Fire Tile

Architectural Terra Cotta

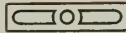

FULLER & GOEPP

32 Page St.
Telephone Market 499

MANUFACTURERS OF

MIRRORS, ART AND LEADED GLASS

*Dealers in White Glass for Table Tops, Counter Tops,
Sink Backs & Etc.*

Passenger and Freight Elevators



"MADE IN SAN FRANCISCO"

Factory and Warehouse, 166-180 Seventh
Street, San Francisco. Phone Kearny 66

SPENCER ELEVATOR COMPANY

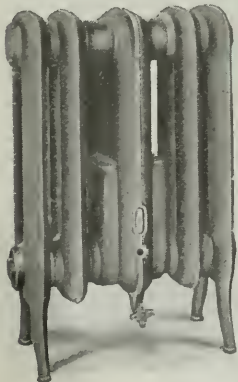

RA-DO FUMELESS GAS RADIATORS

ALL CAST IRON—3 Sizes (3, 5, and 7 Sections)

The Ideal "Year-Round" Heating System
For The Home—New or Old

Easiest and Cheapest to Install
Lowest Operating Cost

BAIRD - BAILHACHE COMPANY

MANUFACTURERS

478 Sutter St., San Francisco

'Phone Sutter 6858

OLD MISSION PORTLAND CEMENT COMPANY



Each shipment of "OLD MISSION" Portland Cement is guaranteed not only to equal but to surpass all requirements of the standard specifications for Portland Cement as adopted by the U. S. Government and by the American Society for Testing Materials. A Guarantee Certificate is mailed with the bill of lading of each car, giving number of car, date packed, and number of barrels, over the signature of the chief chemist.

8000 SACKS DAILY

SALES OFFICE:

MILLS BLDG., SAN FRANCISCO
PHONE SUTTER 3075

PLANT:

SAN JUAN, CAL.

VULCANITE SLATE - SURFACED Famous for Quality RED OR GREEN ASPHALT ROOFING

A roofing that has been manufactured in eleven different factories in five different countries, covering a period of over 70 years.

A roofing that is patented in eight countries and which has been awarded the Gold Medal, and in some cases the Medal of Honor at International Expositions—is worth your consideration.

The Vulcanite Roofing Company

Roofing Division of the Beaver Board Companies

16TH AND TEXAS STREETS, SAN FRANCISCO, CAL.



Keep Down Insurance Premiums

SPECIFY SAINO FIRE DOORS

Standard Automatic Sliding or Swinging Fire Doors.
Tested and Labeled by the Underwriters' Laboratories.

STEEL SASH AND HOLLOW METAL
UNDERWRITERS WINDOWS

U. S. METAL PRODUCTS CO.

326-338 Tenth Street, San Francisco

A Practical, Durable Window Fixture



Business College, Oakland, C.W. McCall, Architect

HAUSER WINDOW COMPANY

157 Minna Street, San Francisco, Cal.

easily operated,

Is a delight to the housewife. Equip the windows of your client's home,

Mr. Architect, with

HAUSER

Reversible
Window Fixtures

Manufactured and installed by

Telephone, Kearny 3706

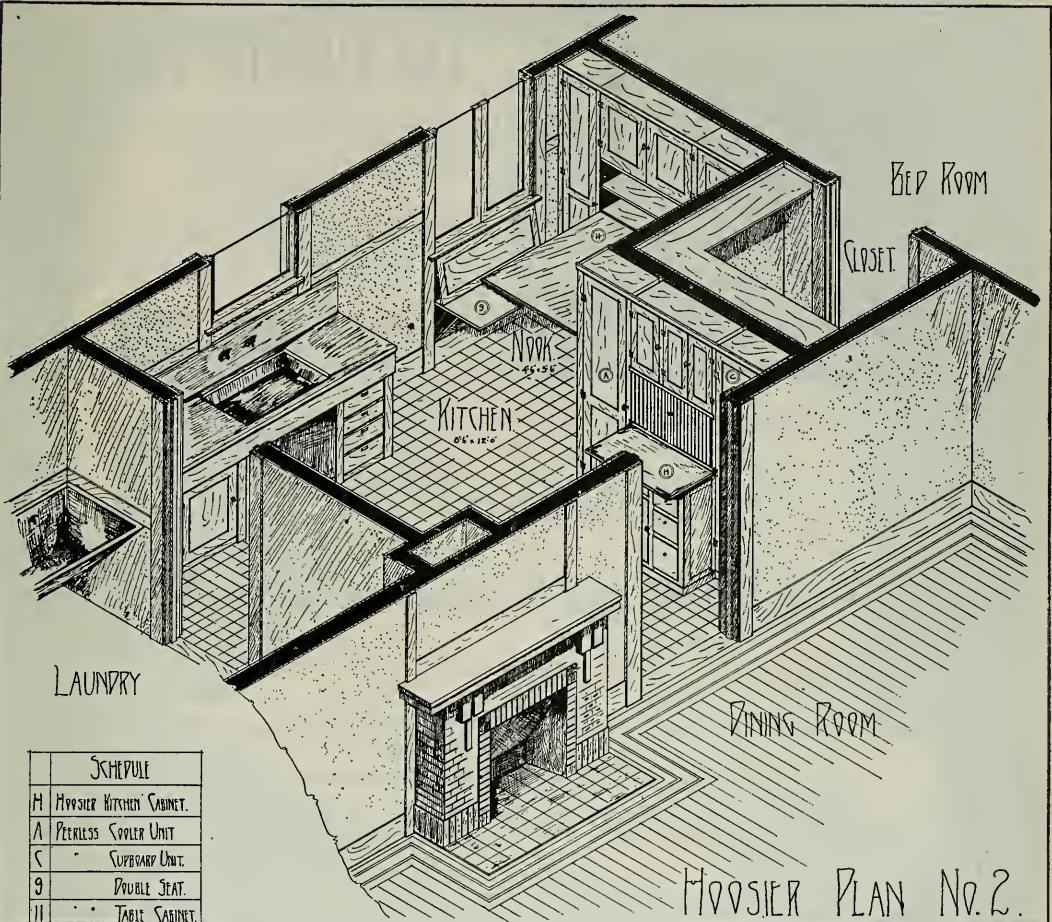

SCHEDULE	
H	HOOSIER KITCHEN CABINET.
A	PEERLESS SPOOLER UNIT
S	CUPBOARD UNIT.
9	DOUBLE SEAT.
H	TABLE CABINET.

ONE OF OUR MANY IDEAL KITCHEN PLANS

Your Housing Problem Solved

ARCHITECTS and Designers will Conserve Space in planning Apartments and Homes by following suggestions offered by our Kitchen PLAN DEPARTMENT. Our plans have been successfully incorporated in Housing Problems for the Shell Oil Company at Martinez and the Oliver Chilled Plow Works in 1000 houses.

Have you ordered your book of Built-in-Fixtures?
FREE on request.

THE HOOSIER STORE

Phone Sutter 4122

821 Market Street, San Francisco

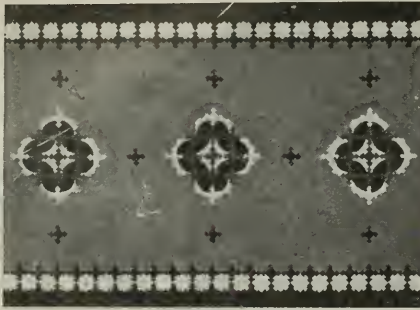

INTERLOCKING RUBBER TILING

material that is sure to give satisfaction. **Twenty tons installed in the Standard Oil Building, San Francisco.** Stock on hand for immediate delivery.

The Elevator Floor

whether in Office Building, Hotel or Department Store, is subjected to a great deal of wear and tear.

— SPECIFY —

INTERLOCKING RUBBER TILING

and you've provided your client's building with a Durable, Economical, Practical,



New York Belting and Packing Co.

NEW YORK

San Francisco Branch 519 MISSION ST. Phone Douglas 1837

Small booklet of designs mailed on request.

Stucco Homes and Apartments Appeal to the Home Seeker



THE Helbush Apartments shown above were designed by Architect E. E. Young of San Francisco. The exterior is covered with Klingstone, a stucco finish mixed with

FAN SHELL BEACH SAND

Always Clean and will not Crack

DEL MONTE PROPERTIES CO., 401 CROCKER BUILDING
Phone Sutter 6130 San Francisco

Charm That Endures

FRESH beauty and clean-cut neatness lend lasting distinction to well designed dwellings. Such results can be produced in either large or small homes by the artistic use of stucco made with

MEDUSA

WHITE CEMENT

WATERPROOFED

Stucco made with Medusa insures permanence and preserves its original whiteness through years of exposure. It can be delicately tinted if desired.

When you specify Medusa White Cement for all kinds of interior or exterior ornamental work you make certain of beauty, service and economy for your clients.

Our illustrated literature will interest you. Write for it.

THE SANDUSKY CEMENT COMPANY
Dept. P SANDUSKY, OHIO

Also manufacturers of Medusa Grey and Medusa White Portland Cement and Medusa Waterproofing

PACIFIC COAST DISTRIBUTORS

Pacific Materials Co., San Francisco, Calif.
Riverside Portland Cement Co., Los Angeles, Calif.
A. McMillan & Co., Portland, Oregon
Galbraith & Co., Seattle, Washington

Jose Balz Realty Co., Builders

Medusa Waterproofed White Stucco Finish

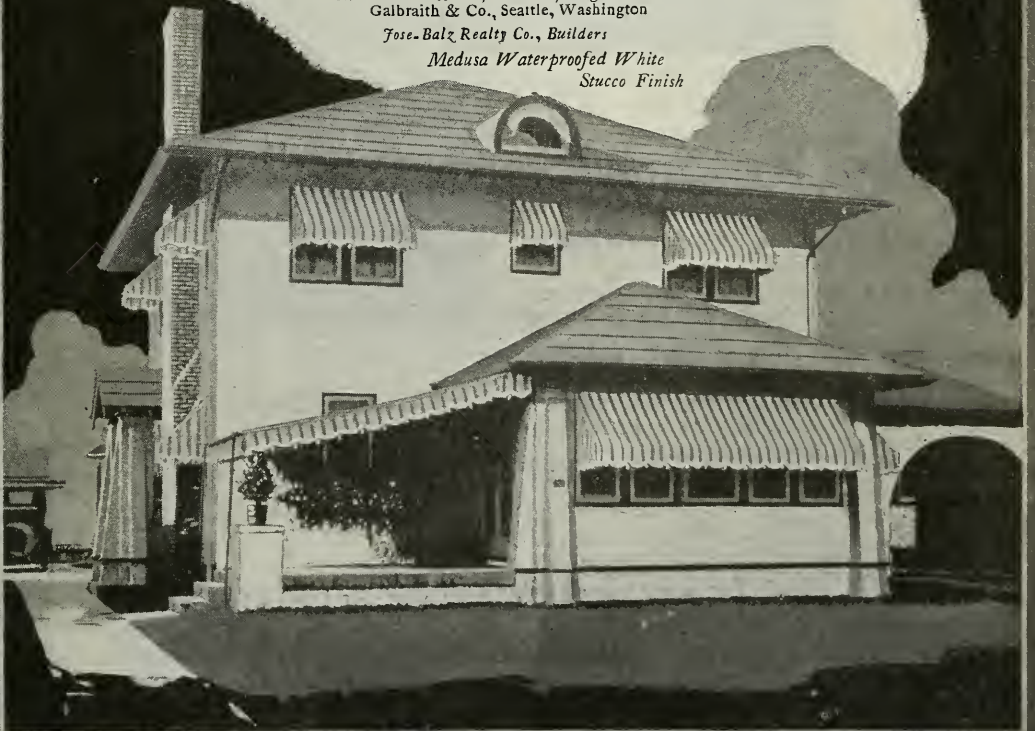

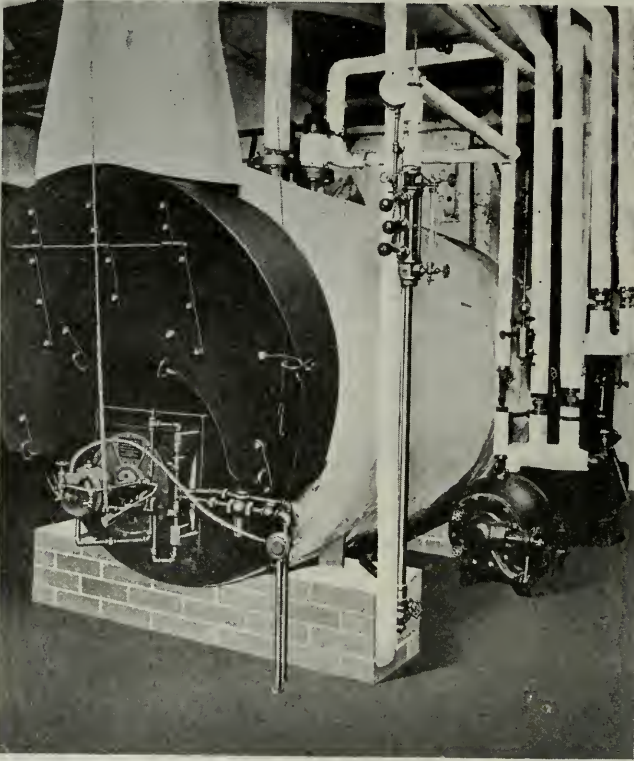

BOILER ROOM, BALBOA OFFICE BUILDING, SAN FRANCISCO

Ray Rotary Crude Oil Burner Pump Type

with tile lined swinging door, installed on the Scotch marine boiler shown in the picture, may be fitted to any make of boiler or furnace in dehydrating plants, fruit dryers, apartments and residences.

MANUFACTURED BY

W. S. Ray Manufacturing Co.

29 SPEAR STREET Phone Kearny 199 SAN FRANCISCO, CAL.

Branches in all Principal Coast Cities



**THE HOUSE
BEAUTIFUL**



THE interior of a Home should have those little touches of refinement that come with the co-operation of an experienced interior decorator.

CONSULT US

Decorative ideas, artistic framing, byamopa ware, floor lamps, table lamps, chair lamps, lamp shades, mirrors, candlesticks, decorated candles, book-ends, store window fixtures, odd furniture, pictures, Emma B. Freeman's Prints, pieces in unique colorings and indefinite carvings and other objects of art.

FREEMAN ART SHOP

386 SUTTER STREET
SAN FRANCISCO

Tel. Sutter 1593



Beach-Robinson Co.

Decorators and Furnishers

Carpets

Draperies

Furniture

Rugs

Wall Paper

Ranson E. Beach

239 Geary Street, 3d Floor

Union Square

Phone, Sutter 580

San Francisco, Cal.



ADD CHEER and COMFORT

to the Home by having a

WELL DESIGNED INTERIOR

Before Completing Your Plans, CONSULT

SONNENSCHN BROS.

INTERIOR DECORATORS

Furniture and Draperies Made to Order

Factory

718 NATOMA ST., Phone Market 1145

Show and Salesroom

470 SUTTER ST., Phone Kearny 2051



*The Finishing Touch
of Right Building —*

F. A. TAYLOR CO.

251 Post St., San Francisco

Second Floor



Mercedes Bldg.

*Hand-made
Furniture,
Rugs,
Hangings,
Upholstering,
Decorating,
Wall Paper.*

The GOLD MEDAL MAIL CHUTE



INSTALLED IN
THE NEW
SAN FRANCISCO
CITY HALL
AND THE
WHITE MARBLE
MERRITT
BUILDING,
LOS ANGELES

Given highest award at
Panama - Pacific Interna-
tional Exposition, 1915.

Waterhouse-Wilcox Co.

California
Representatives

523 Market Street
SAN FRANCISCO

331 E. 4th Street.
LOS ANGELES

F. T. CROWE & CO.
Seattle, Wash.

THE J. McCracken Co.
Portland, Oregon

American Mailing
Device
Corporation

LIBERTY WALL BOARD

MANUFACTURED BY
KEY-HOLD PLASTER LATH COMPANY



A Fibered Gypsum Plaster that will not
shrink, warp or buckle.

Resists Fire, Moisture, Heat and Cold.

Key-hold plaster lath possesses a perfect
mechanical key—admitted for fire proof con-
struction in all classes of buildings.

KEY-HOLD PLASTER LATH CO.

Office and Factory

148 Hooper St.

San Francisco

Phone Market 5767

MCCRAY REFRIGERATORS FOR ALL PURPOSES

It is our particular desire to
impress the Architects of
America with the fact that
McCray builds refrigerators
for all purposes. Thousands
of fine residences, hotels,
clubs, restaurants, factory
cafeterias, hospitals, stores and
markets depend on McCray
for efficient, economical re-
frigerator service.

MCCRAY REFRIGERATOR CO.
1054 Monadnock Bldg., San Francisco, Cal.
Home Office and Factory
Kendallville, Ind.

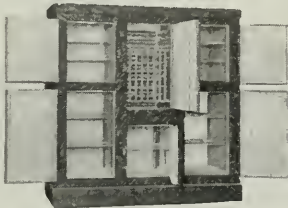

YOU KNOW that a building
should be watertight and

WE KNOW that it can be
made so with

IMPERIAL WATERPROOFING

LOOK FOR  THE LABEL

If your building is leaking through
the walls or around the windows, or
if the Basement walls are wet below
ground—call up SUTTER 978.

IMPERIAL WATERPROOFING
is manufactured by BROOKS &
DOERR, 460 7th St., San Francisco

WATEREX REED BAXTER
DISTRIBUTOR

1002-04 Merchants National Bank Building,
Phone Sutter 978

SAN FRANCISCO, CAL.

3419 Broadway, OAKLAND, CAL.

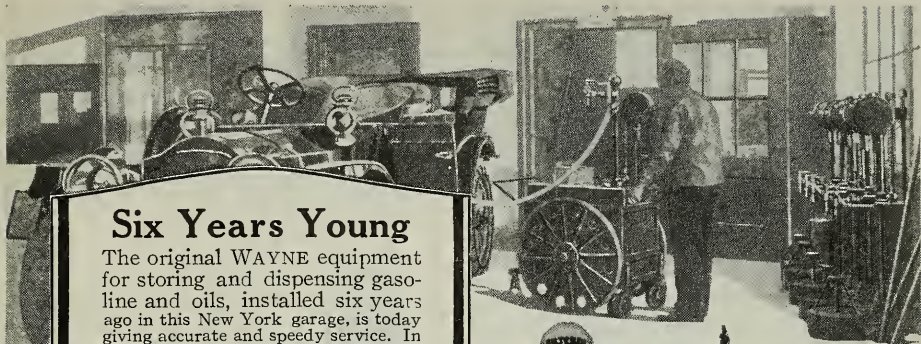

Six Years Young

The original WAYNE equipment for storing and dispensing gasoline and oils, installed six years ago in this New York garage, is today giving accurate and speedy service. In Wayne pumps the delicate adjustment essential for accuracy is combined with a durability that assures satisfaction for years and years.

There is a Wayne System for every need of the public garage. The service of Wayne engineers in advising and planning is yours without cost or obligation.

Wayne Oil Tank & Pump Co.
746 Canal St., Ft. Wayne, Ind.

San Francisco Office
631-633 Howard St.
Phone Garfield 1350

Los Angeles Office
830 S. Los Angeles St.
Phone Main 1600

Wayne
TRADE MARK
Liquid Storage Systems



Cut No. 230
For Gas and Oil

Cut No. 280
One-gallon gasoline

Cut No. 200
Lubricating oils

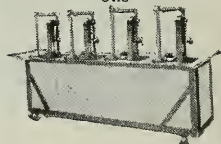

Pitcher Door Hangers



HUMPHREY APARTMENTS, SAN FRANCISCO
C. A. MEUSSDORFFER, Architect
Equipped with PITCHER HANGERS.

Give Service Satisfaction

Are Dependable Durable and Economical

No extra thickness of wall required. Installed in 5½ inch partitions. Specify sliding doors in place of swinging doors.

Manufactured by

National Mill and Lumber Company

 Kearny 3580

318 Market Street
SAN FRANCISCO

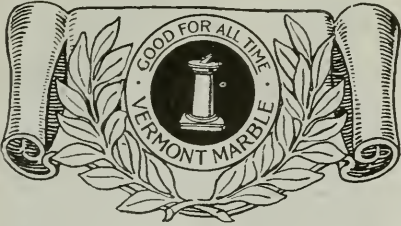

IT'S not enough to say "Good For All Time" unless there is something back of it. ¶ There is in this case. ¶ Vermont Marble already has an unblemished record of over one hundred and fifty years. ¶ We know what it will do. It's not necessary to guess at it. ¶ And our quarries in Alaska and Texas are also proving themselves. ¶ So please don't think of "Good for All Time" as merely a happy phrase.

IT'S THE MARK OF A SERVICE.
It means exactly what it says.

VERMONT MARBLE COMPANY
PROCTOR, VERMONT
San Francisco - Portland - Tacoma



A "LAFRANCE ALERT" Extinguisher Gives You The Benefit of 76 Years' Experience in Designing Fire Apparatus.

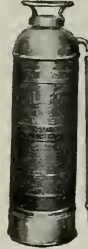

That is why they possess a degree of efficiency that makes them invaluable when called on for instant duty. One should be placed at every danger point in every building for thorough fire protection.

Write our nearest branch office for complete information

AMERICAN LAFRANCE FIRE ENGINE COMPANY, INC.

ELMIRA, N. Y.

Western Addresses

929 So. Hill St. 151 New Montgomery St.
Los Angeles, Calif. San Francisco, Calif.

A Bargain in Files—

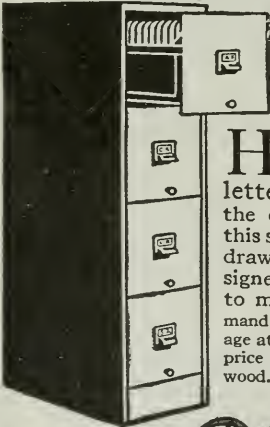

HOLDS 20,000 letters. That's the capacity of this special four-drawer file, designed and built to meet the demand for steel storage at less than the price of high grade wood. See it today.

Van Dorn
STEEL EQUIPMENT

Phone Douglas 1183

Western Office Equipment Co.
467 Market Street - San Francisco

CLINTON
WELDED WIRE
FABRIC AND LATH

The Perfect Support for Stucco and Interior Plaster. Complete Stock for Immediate Delivery. Steel Reinforcing Bars in Stock.

L. A. NORRIS CO.

140 Townsend Street

Phone Kearny 5375 San Francisco



A Toothsome Catch!

When you have gone out into the wilds of trade on a fishing trip for garage door hardware, and have tramped through the entanglements and underbrush of competitive garage hardware catalogs, and have suffered attacks from armies of mosquitos, deer flies and poison ivy, and have become sun burned by "also ran" garage door hardware, and have watchfully waited long hours,—and then finally you "strike"



Slidetite

(Patented)

The Last Word in Garage Door Hardware

Oh Boy! ain't it a grand and glorious sensation!!

"Slidetite" gives more service to the garage user than any other style of garage door hardware made. Embodies the greatest amount of economy, convenience and ornamental possibilities. Simple to install. Easy to operate. Readily adjustable.

Doors cannot sag. Stand where you open them without locks or holders. Close weather-tight. Add to the appearance of the building.

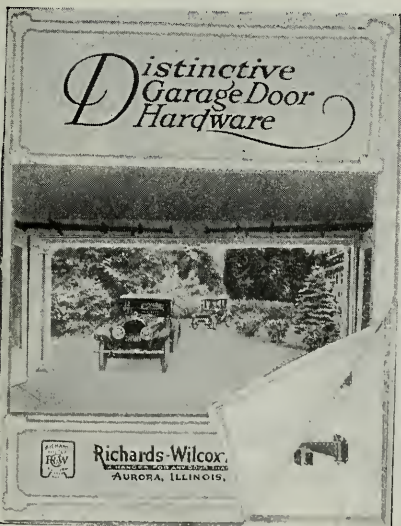

"Distinctive Garage Door Hardware" displays hundreds of sets of distinctive fixtures for garage doors that operate inside and outside the doorway, suitable for every conceivable doorway condition, every individual taste, and every purse.

Copy of this beautiful book will be mailed to anyone interested, on request. Ask for Catalog OA-22.

Unless you know "Slidetite," there are better fish in the sea of garage door hardware than you have ever caught.

Richards-Wilcox Mfg. Co.
"A Hanger for any Door that Slides."
 CHICAGO ST. LOUIS CLEVELAND INDIANAPOLIS BOSTON
 LOS ANGELES AURORA, ILLINOIS, U.S.A. NEW YORK
 PHILADELPHIA LONDON, ONT. MINNEAPOLIS SAN FRANCISCO

Starting the Day Right

"My first duty before setting down to the morning's work," said the architect, "is to look over my Van Dyke's; select the proper degrees for the task at hand and sharpen up."

"I use the Van Dyke Drawing Pencil, because, like a fine mechanical instrument it combines the best materials and highest skilled workmanship and it proves true to what ever test I put it."

"I'm sure you'll like it too."

Samples upon request on your business stationery. Please mention the degrees preferred. Address us at 37 Greenpoint Ave., Brooklyn, New York.

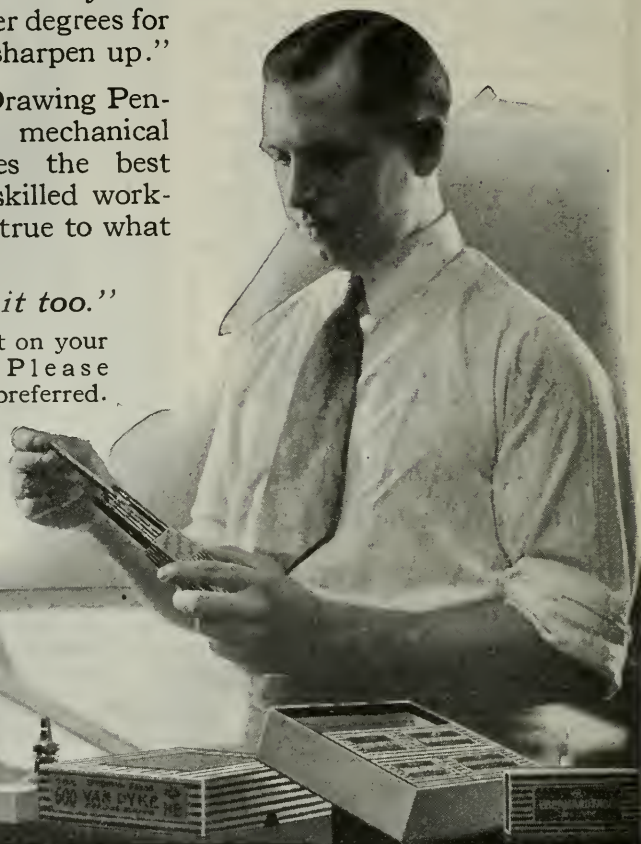

VAN DYKE DRAWING PENCILS

EBERHARD FABER
NEW YORK

VAN DYKE DRAWING PENCIL EBERHARD FABER U.S.A. 600-HB

Made in 16 degrees graduating from 6B, softest to 8H, hardest.

A Rich, Velvety White Enamel

—and a less expensive
enameling method

SET your enamel ideal high. Demand the richest, most delicate effect you can get. Meet the modern trend from the glaring, high-gloss enameled finish with Glidden Velvet White Enamel.

Glidden Velvet gives you the soft, smooth, semi-gloss finish—just the tone that harmonizes with the furnishings in the better homes.

Years of wear will prove its durability. Rub it or scrub it and it stands the test. A “prove it” panel will be sent you on request.

Glidden Velvet White Enamel is the true economy enamel. Apply only four coats instead of seven and there's no rubbing necessary. It's the most natural white enamel you can get.

THE GLIDDEN COMPANY

123 to 169 Hooper Street, Bet. 7th and 8th Sts., San Francisco

Factories

San Francisco Cleveland Toronto Reading

Branches

New York Chicago Kansas City Boston Pittsburg London

STOCKS IN PRINCIPAL CITIES

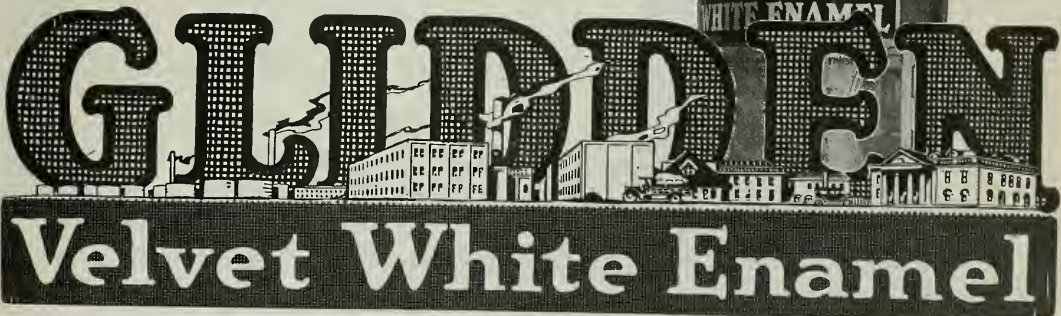

When writing to Advertisers please mention this magazine.

WALL PAPER

DOMESTIC AND IMPORTED

“FOR EVERY ROOM IN YOUR HOME”

UHL BROS., Inc.

PAINTS—VARNISHES—ENAMELS—PAINTERS SUPPLIES
DISTRIBUTERS— MURPHY'S LINE

LEADER WATER SYSTEM

No country home is complete without this modern water system. Running water under pressure whenever and wherever needed. Convenient, economical, sanitary.

**Pacific Pump & Supply
Company, Distributors**

851-853 Folsom Street
SAN FRANCISCO, CALIF.

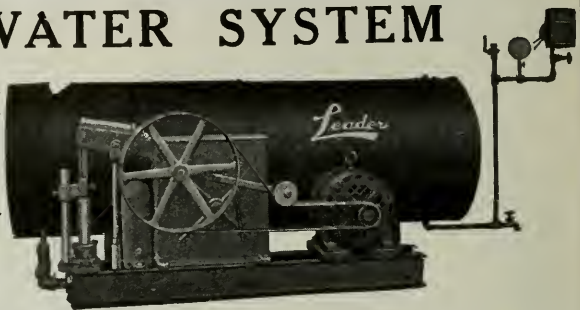

QUALITY HARDWARE



LOCKS AND BUILDERS'
HARDWARE

PALACE HARDWARE CO.

“San Francisco's Leading Hardware Store”

581 MARKET STREET. SUTTER 6060



Pack your Radiator Valves with
Palmetto Twist Packing

It can be unstranded to fit any
size valve. It does not get hard.

H. N. COOK BELTING CO.

401-433 Howard St. San Francisco, Cal.

**WESTERN
VENETIAN BLINDS
WESTERN**

ELIMINATE the unsightly awnings — Preserve the exterior beauty of your buildings by
Specifying

**WESTERN VENETIAN
BLINDS**

Some 1920 contracts for complete equipment:

- 12-story Mattie Building,
Fresno, California
- 9-story Pantages Building,
Los Angeles, California
- 7-story Marland Refining Bldg.
Ponca City, Oklahoma
- 10-story Trademens Bank Bldg.
Oklahoma City, Okla.
- 5-story Railway Exchange,
Muskogee, Oklahoma



LOS ANGELES TRUST
AND SAVINGS BLDG.
LOS ANGELES, CAL.

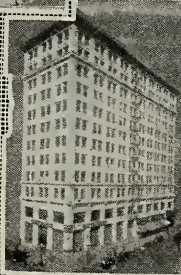

HAAS BLDG.
LOS ANGELES, CAL.

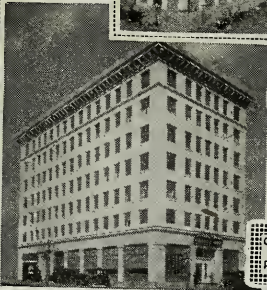

CITIZENS SAVINGS
BLDG.
PASADENA, CAL.



GLOBE GRAIN &
MILLING CO.
LOS ANGELES, CAL.



COUNTY COURT
HOUSE
WALLA WALLA, WASH.

When you consider the fact that **WESTERN VENETIAN BLINDS** take the place of both awning and window shade and will last practically as long as the building stands you'll realize that they are the logical equipment for modern buildings

WESTERN BLIND & SCREEN CO.
2704 LONG BEACH AVE.
LOS ANGELES CALIFORNIA

United States Steel Products Co.

Rialto Bldg., San Francisco

SELLERS of the products of the American Bridge Co., American Sheet and Tin Plate Co., American Steel and Wire Co., Carnegie Steel Co., Illinois Steel Co., National Tube Co., Lorain Steel Co., Shelby Steel Tube Co., Tennessee Coal, Iron and Railroad Co., Trenton Iron Co.

MANUFACTURERS OF

Structural Steel for Every Purpose—Bridges, Railway and Highway—"Triangle Mesh" Wire Concrete Reinforcement—Plain and Twisted Reinforcing Bars—Plates, Shapes and Sheets of Every Description—Rails, Splice Bars, Bolts, Nuts, etc.—Wrought Pipe, Trolley Poles—Frogs, Switches and Crossings for Steam Railway and Street Railway—"Shelby" Seamless Boiler Tubes and Mechanical Tubing—"Americore" and "Globe" Rubber Covered Wire and Cables—"Reliance" Weatherproof Copper and Iron Line Wire—"American" Wire Rope, Rail Bonds, Springs, Woven Wire Fencing and Poultry Netting—Tramways, etc.

United States Steel Products Co.

OFFICES AND WAREHOUSES AT

San Francisco - Los Angeles - Portland - Seattle

Specify **BOWSER** Storage For Indoors or Outdoors

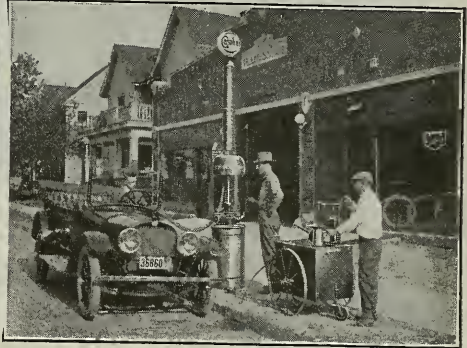
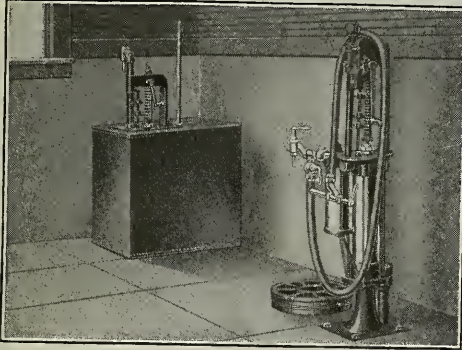

Bowser Storage Systems for Gasoline and Oil meet all requirements as to capacity, speed, or installation.

We are in position to help you in designing gasoline and oil storage for new or old buildings.

Write or phone us for literature or interview

S. F. BOWSER & CO., Inc.

Sales Offices
in all Centers

FORT WAYNE, INDIANA, U. S. A.

Representatives
Everywhere

San Francisco Office: 612 Howard Street. Telephone Douglas 4323



House at Cornwall-on-Hudson, N. Y. Finished with Old Virginia White. Rogers & Zogbaum, Architects, New York

Cabot's Old Virginia White

A Soft, Brilliant White for Shingles, Siding and Similar Woodwork. As Bright and Clean as New Whitewash, and as Lasting as Paint.

Architects and others have tried for years to get a paint that would give the same beautiful, brilliant white as new whitewash, and would also be durable and clean and not rub off like whitewash.

Old Virginia White is a shingle-stain compound that has solved the problem. It is as clean, cool and brilliant as fresh whitewash, and as lasting as paint; but it is not messy like whitewash, nor painty like paint, although it costs less and goes farther than paint.

Send for Sample Shingle and Circular showing other fine houses finished with Old Virginia White

SAMUEL CABOT, Inc., Mfg. Chemists, Boston, Mass.

Cabot's Creosote Stains, Stucco and Brick Stains, "Quilt," Mortar Colors, Dampproofing, Waterproofings, Conservo Wood Preservative, etc.

Pacific Materials Co., San Francisco
The Waterhouse-Wilcox Co., Los Angeles

S. W. R. Dally, Seattle
Timms, Cress & Co., Portland



CENTRAL HIGH SCHOOL, MINNEAPOLIS, MINN.

Architect, William B. Ittner

Contractors, Pike & Cook Co.

Glazed by Forman, Ford & Co.

Completely equipped with American Window Glass Co.'s Double Strength AA Quality
First Choice of Leading Architects

Because of its absolute dependability, American Window Glass has been used in many fine buildings. Our care in inspection practically eliminates all imperfections and assures uniformity in thickness.



The above Trade-Mark
appears on every light

American Window Glass Co., General Office, Pittsburgh, Pa.

DOMESTIC SALES OFFICES

New York, 320 Fifth Avenue
Chicago, 1011 Peoples Gas Building
Boston, Mass., 43 Tremont Street
San Francisco, Cal., 341 Montgomery Street
St. Louis, Mo., 1303 Syndicate Trust Building
Memphis, Tenn., 440 North Main St.
New Orleans, La., 904 Hennen Bldg.
Atlanta, Ga., 1408 Candler Building

EXPORT SALES OFFICES

Havana, Cuba, Apartado No. 930
Buenos Aires, Argentina
Mexico City, Mex., Apartado Postal No. 237
Barranquilla, Colombia
Bogota, Colombia
Valparaiso, Chile
Lima, Peru
Toronto, Canada, 205 Continental Life Building

Highest Quality

Finest Workmanship

Remco Redwood Tanks

Underwriters — Standard — Specials

All dimensions and capacities

Towers Designed and Erected

For Prices, Data or Estimates Phone GARFIELD 1910

Redwood Manufacturers Company

SOLE MAKERS

Hobart Building, San Francisco

When writing to Advertisers please mention this magazine.

JOHNSON'S ROTARY CRUDE OIL BURNER

Can be installed in any BOILER or FURNACE
 Gives Satisfactory Results. Simple to Operate—
 Automatic—Safe. Let us tell you more about this
 Oil Burner.

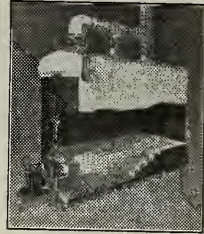

BURNER IN OPERATION

S. T. JOHNSON CO.

1337 Mission Street - San Francisco, Cal.
 Ask for Bulletin No. 28 Phone Market 2759

Agencies: SEATTLE LOS ANGELES FRESNO SAN DIEGO SACRAMENTO
 Member of the Oil Burners Manufacturers' Association of California.

Fess System Turbine Fuel Oil Burner

The latest word in the science of burning fuel
 oil in an efficient and economical method

Ask for Bulletin No. 20

FESS SYSTEM CO., Inc.

1310 S. HILL ST.,
 LOS ANGELES

218-220 Natoma Street, San Francisco

HOUSTON,
 TEXAS

Member of the Oil Burners Manufacturers' Association of California.

OIL BURNER EQUIPMENTS

Low Pressure Air and Rotary Mechanical Atomizing Types

Refrigerating and Ice-Making Machines

Direct Expansion and Brine Circulating Systems

T. P. JARVIS MANUFACTURING CO.

CONTRACTING ENGINEERS AND MANUFACTURERS

275 Connecticut Street, San Francisco

Phone Market 3397

Member of the Oil Burners Manufacturers' Association of California.

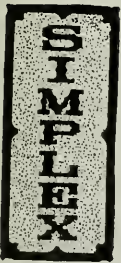

SIMPLICITY OF CONSTRUCTION together with
 SUCCESSFUL and ECONOMIC OPERATION of

SIMPLEX BURNERS

reported by their many users, is the best recommenda-
 tion we can furnish to those desiring crude oil burners.

American Standard Oil Burner

TRADE MARK

Phone BERKELEY 6389

Company

FIFTH AND PARKER STREETS
 BERKELEY, CALIFORNIA

Member of the Oil Burners Manufacturers' Association of California.



Pump Governors
 Oil Burner Governors
 Reducing Valves
 Safety Valves
 Oil Valves
 Blowoff Valves
 Boiler Feed Water
 Regulators

Oil Pumping Sets
 Little Giant Improved
 Oil Burners
 Duplex Oil Pumps
 Rotary Oil Pumps
 Oil Heaters
 Draft Gauges
 Boiler Feed Pumps

G. E. WITT CO., Inc.

ENGINEERS

Manufacturers and Distributors

862-864 HOWARD ST.

Phone Douglas 4404

SAN FRANCISCO, CAL.

CABOTS "QUILT"

SOUND DEADENING USED IN

Department School—Modesto.
 Lowell School—San Jose.
 Grammar School—Kingsburg.
 Horace Mann School—San Jose.
 Jefferson School—Fresno.
 Longfellow School—Fresno.

RECENT SALES

PACIFIC
 MATERIALS CO.
 525 Market St. San Francisco

A. F. EDWARDS, President
 J. M. FABBRIS, Vice-President

J. A. MACKENZIE
 Secretary

CHAS. F. EISELE } Asst. Managers
 J. RUBIOLLO }

AMERICAN MARBLE & MOSAIC CO.

25-29 Columbia Square, San Francisco
 Telephone Market 5070

Factory on Canal, South San Francisco Telephone South San Francisco 161

Fenestra

SOLID STEEL WINDOWS

DETROIT STEEL PRODUCTS CO., Detroit

Direct Factory Branch, 68 Post Street, San Francisco

Phone Sutter 1250



The Architect and Engineer Inc.

CONTENTS FOR SEPTEMBER, 1920

Volume LXII. Number 3.

	PAGE
UNION PASSENGER TERMINAL, AT THE PLAZA, LOS ANGELES . . . Frontispiece	
PROPOSED RAILROAD GRADE CROSSING ELIMINATION AND NEW PASSENGER AND FREIGHT TERMINALS FOR LOS ANGELES	47
UNIFICATION OF RAILROAD LINES AND SERVICE IN CITIES	59
ZONE PLAN FOR SAN FRANCISCO	65
SPANISH MISSION ARCHITECTURE IN RAILWAY PASSENGER STATIONS	75
Norman M. Stineman, C. E.	
ECONOMIC FEATURES OF ARCHITECTURE .	80
G. C. Field, Architect	
THE SPECIFICATION WRITER AND MANU- FACTURERS' LITERATURE	82
Louis R. Holske	
CONCRETE STORAGE TANKS	88
Robert Seth Lindstrom	
HOUSES: THE NEED	91
Arthur Gleason	
AN UNUSUAL ELEVATOR ACCIDENT . . .	106
E. C. Wood	
EDITORIAL	110
WITH THE ARCHITECTS	113

Published Monthly by

THE ARCHITECT AND ENGINEER, Inc.

626-627 Foxcroft Bldg., San Francisco

W. J. L. Kierulff Fred'k W. Jones L. B. Penhorwood
President Vice-Pres. Secretary

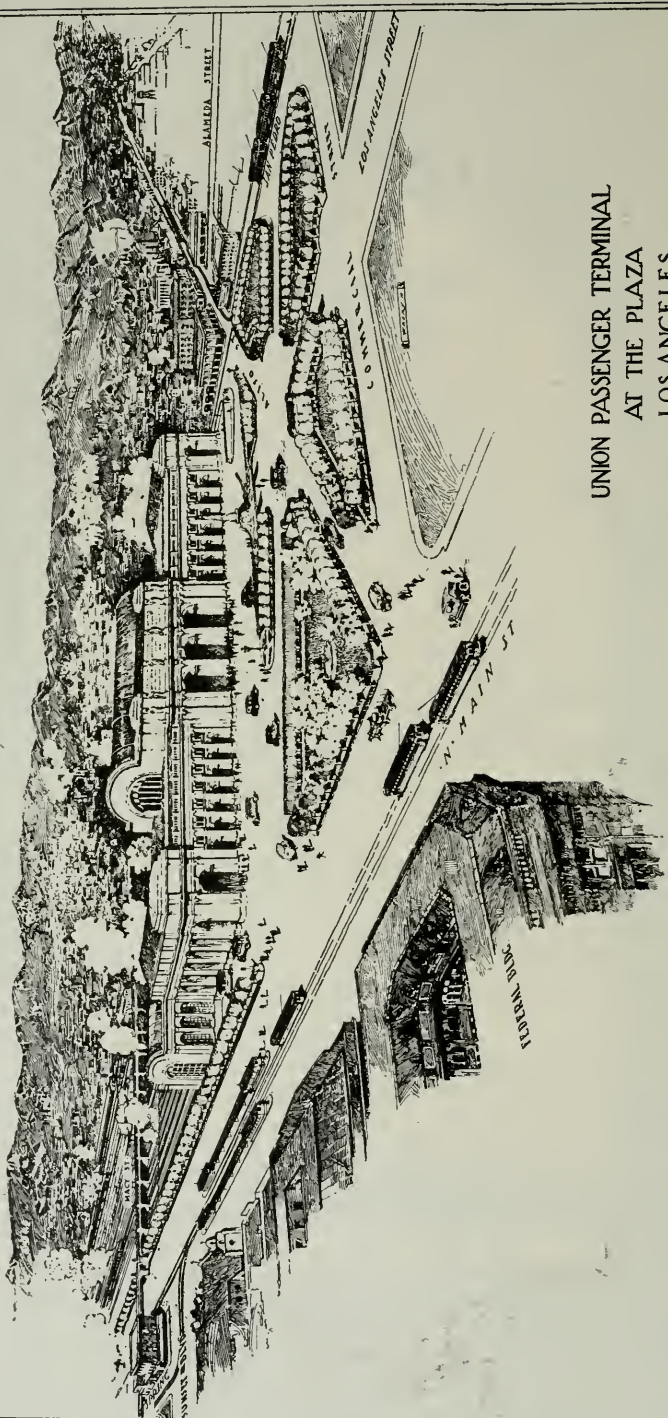

CASE AND PETERSON
ARCHITECTS

UNION PASSENGER TERMINAL AT THE PLAZA LOS ANGELES

SKETCH OF PROPOSED LOCATION RECOMMENDED BY ENGINEER RICHARD SACHSE OF THE STATE RAILROAD COMMISSION IN FINAL REPORT TO THE COMMISSION, JULY 31, 1919. (ADAPTED FROM UNION STATION, WASHINGTON, D. C.)

HOUSING AND CITY PLANNING NUMBER

THE
ARCHITECT
AND
ENGINEER

Vol. LXII.

SAN FRANCISCO, SEPTEMBER, 1920

No. 3

Proposed Railroad Grade Crossing Elimination and
New Passenger and Freight Terminals
for Los Angeles

THE California Railroad Commission has recently published the report of its chief engineer, Mr. Richard Sachse, on "Railroad Crossing Elimination and Passenger and Freight Terminals in Los Angeles."* This report is a large piece of work, and the proceeding before the Railroad Commission, of which this report is a part, is of vital interest to the City of Los Angeles and to the transportation interests.

In 1915 and 1916 several civic organizations of Los Angeles (Municipal League, Central Development Association, Civic Center Association) filed complaints asking the Commission to ameliorate the grade crossing situation within the city limits, to consolidate and unify the tracks of the various roads, to provide for a union passenger station and for better freight facilities, and to investigate thoroughly the entire transportation situation. Complaints were also filed by the cities of Pasadena, Alhambra, San Gabriel and South Pasadena and, in August, 1916, there were before the Commission seven formal proceedings and ten informal complaints.

The Commission began the hearing of these cases and consolidated them into one proceeding. The question of the Commission's jurisdiction was raised by the railroads and also by the City of Los Angeles, and the issue was taken before the Supreme Court of the State of California. This court confirmed the Com-

*"Railroad Grade Crossing and Terminal Investigation, Los Angeles, California Railroad Commission, Richard Sachse, Chief Engineer." 587 pages, 4 Vo., 26 tables, 200 colored and black and white maps, profiles, drawings and photographs. Copies can be secured by writing to the California Railroad Commission, San Francisco, California.

(Summary of report of Richard Sachse, Chief Engineer State Railroad Commission, prepared for this magazine by Mr. Sachse.)

mission's jurisdiction and placed the Commission under mandate to proceed with the various cases. The City of Los Angeles, the County of Los Angeles, and certain other interests were made parties to the proceeding, and investigation continued. The proceeding involves now all of the steam and electric railways entering into and operating in the City of Los Angeles (the Southern Pacific, the Santa Fe, the Los Angeles & Salt Lake, the Pacific Electric, and the Los Angeles Railway), the City of Los Angeles, the cities of Pasadena, Alhambra, San Gabriel, South Pasadena, San Dimas, El Monte, Pomona, Ontario, Sierra Madre, Colton, San Marino, San Pedro, Whittier, Santa Monica and Venice, the County of Los Angeles, and a large number of civic and commercial organizations. The Commission decided that, in order to have the necessary facts and data, a comprehensive engineering investigation of the entire problem should be made. The City of Los Angeles, alive to the importance of such an investigation, appropriated \$20,000.00 to defray part of the cost of the work.

In 1918 the federal government took over the operating control of the country's railroads, as a war measure, and Director General McAdoo announced as one of his policies the unification of terminal facilities.

Los Angeles was one of the cities whose terminals he wished to unify. He requested that the California Railroad Commission give him the benefit of its investigation and of its views in the Los Angeles grade crossing and terminal situation and, as a result, the Commission gave him two preliminary reports urging temporary unification during federal control. The larger investigation dealing with the permanent problems was continued during federal control and recently concluded. The matter is now before the Commission and an engineering conference has been appointed to study the report. In addition to the engineers of the Commission, there are in this conference, engineers of the City of Los Angeles and of the other cities mentioned above, engineers of the railroads, and engineers appointed by the various civic and commercial organizations interested in city planning and transportation problems. This conference is to make its report to the Commission prior to the next hearing set for August 15th. It is expected that the Commission will, thereafter, make a decision and an order.

The report of the Commission's engineers deals with four main subjects: grade crossing elimination, union passenger terminal, freight, electric interurban transit.

There is also involved, of course, much change, reconstruction and new construction of city streets, viaducts and bridges, and attention is called to the fact that, ultimately, the entire terminal plan and the entire transportation problem must be considered in its relation to the general subject of city planning. The report distinguishes between work to be done within the city limits of Los Angeles and that to be done outside the city limits. A program is laid down contemplating that the plan to be adopted will have to be carried out under the unit system in three steps: (a) Work to be commenced and carried out immediately, (b) Work to be carried out later, and (c) Work for the more distant future.

ELIMINATION OF GRADE CROSSINGS

The dominant factor in the entire problem is the grade crossing situation. Indeed this is one of the most serious questions facing Los Angeles today and a further postponement of the solution can only aggravate the situation and make the remedy more difficult and costly. With a population estimated at 600,000 in 1918, about 65,000,000 people every year cross the Los Angeles River and the

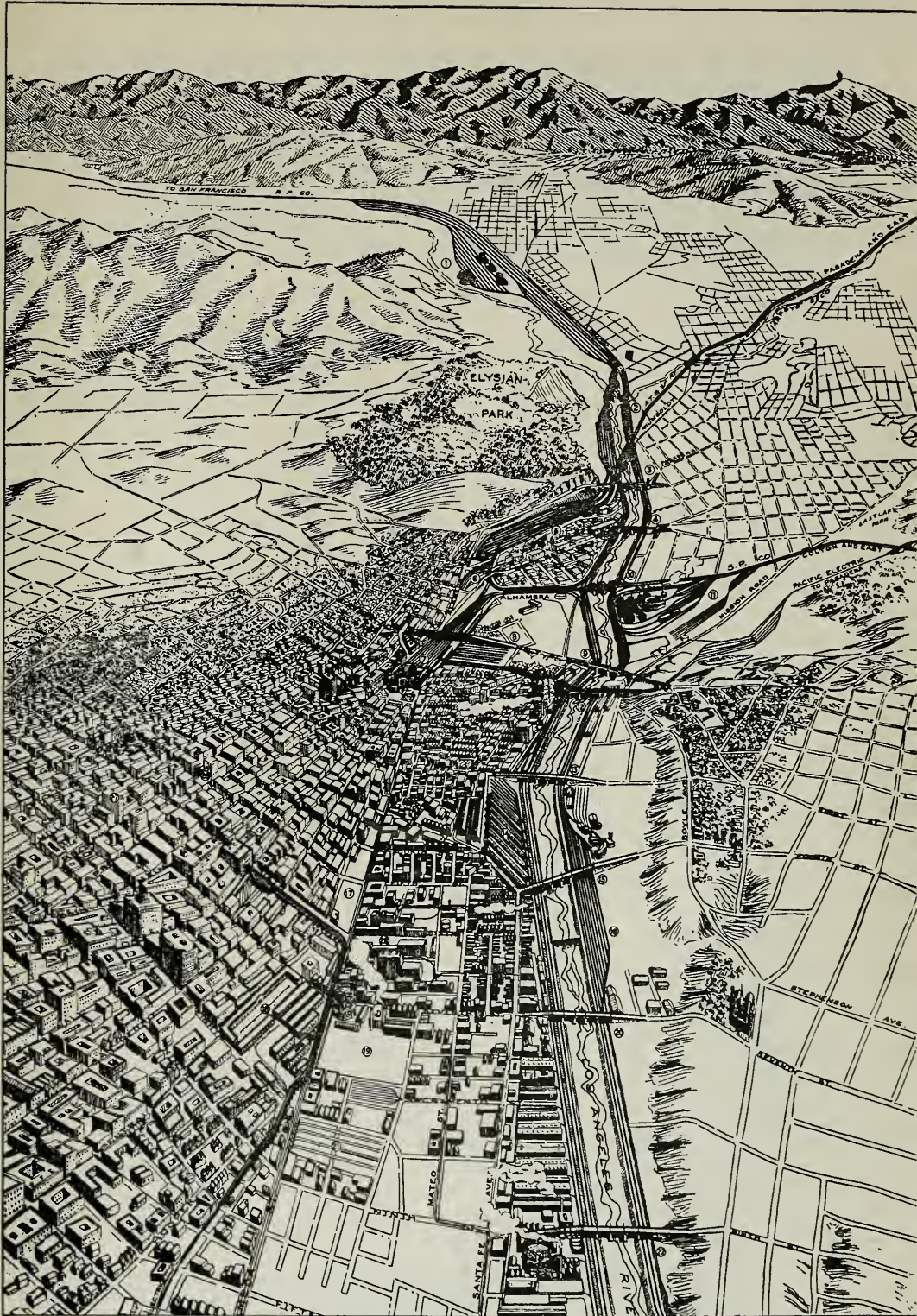

BIRD'S-EYE VIEW OF LOS ANGELES RAILROAD SITUATION
IN ACCORDANCE WITH RECOMMENDATIONS OF ENGINEER
R. SACHSE OF THE STATE RAILROAD COMMISSION, 1920

railroad tracks on both banks of the river. This movement is the equivalent to a going back and forth across the river every day of approximately one-third of the entire population.

The conditions on Alameda street, one of the main business thoroughfares of the city, are even worse. A total of 78,000,000 cross this street in its most congested portion (Spring to Ninth) every years, as follows :

	Per Annum
North of S. P. Arcade Station.....	59,000,000
South of S. P. Arcade Station.....	19,000,000
	<hr/>
Total	78,000,000

POPULATION

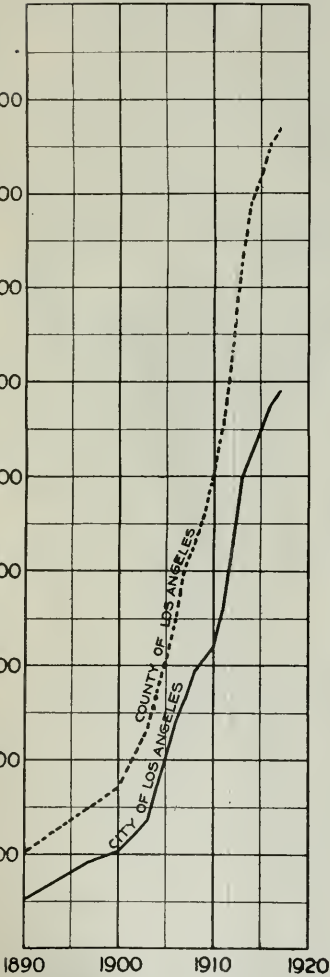

AREA

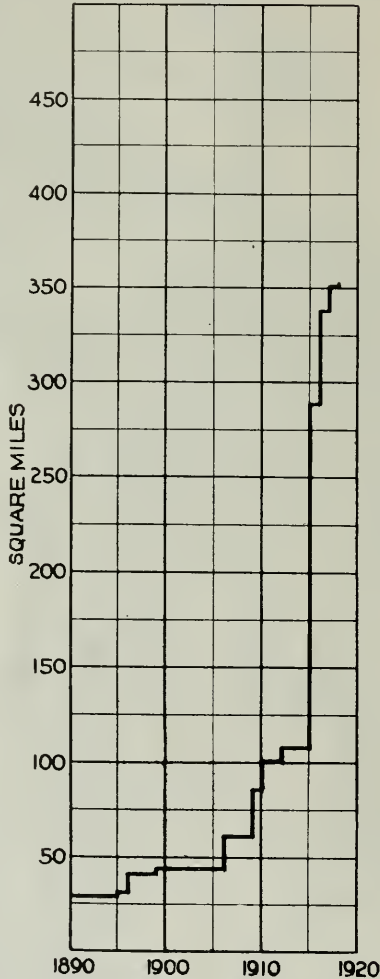

BANK CLEARINGS

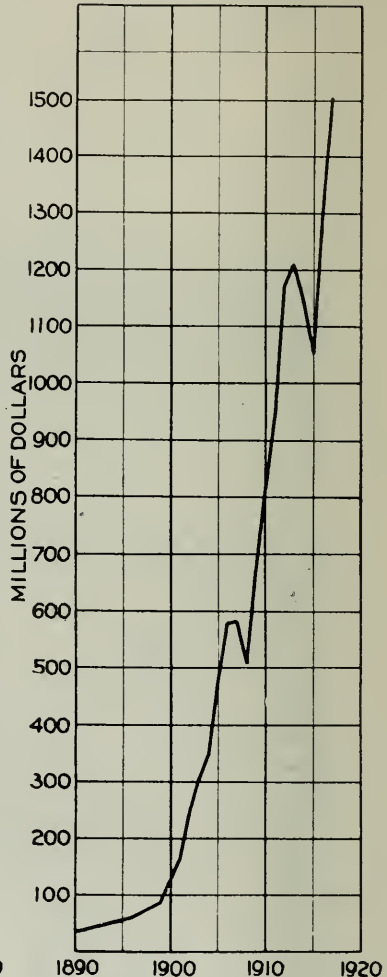

DIAGRAMS SHOWING GROWTH OF LOS ANGELES
(FROM REPORT OF ENGINEER RICHARD SACHSE
TO THE STATE RAILROAD COMMISSION)

This is approximately 214,000 people per day. Opposed to this stream of pedestrian and vehicular traffic there are 3,315 train movements each day: with a result that the street is closed by gates to traffic for 15 per cent of the daylight hours.

Again, on the lines of the Santa Fe and the Salt Lake and the Pacific Electric between Los Angeles and Pasadena, there are 128 dangerous grade crossings over important streets. Pasadena avenue, for instance, is crossed at grade several times although it is traversed by over 7,000 vehicles each day, 85 per cent of which are automobiles. Many accidents have occurred at these

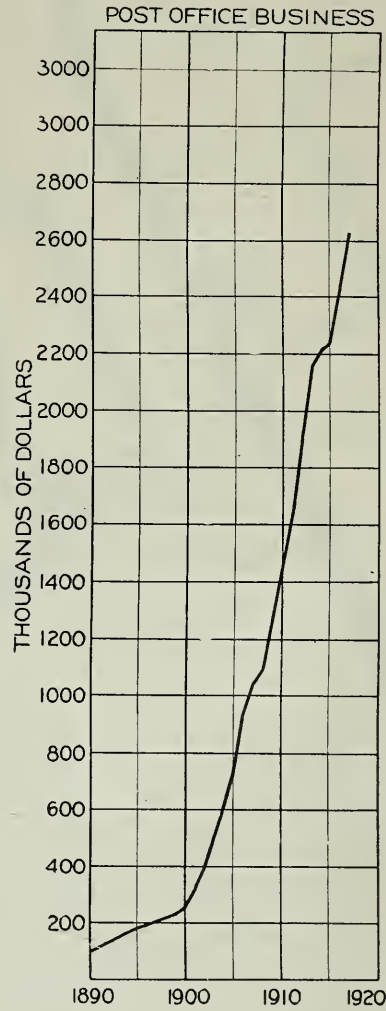
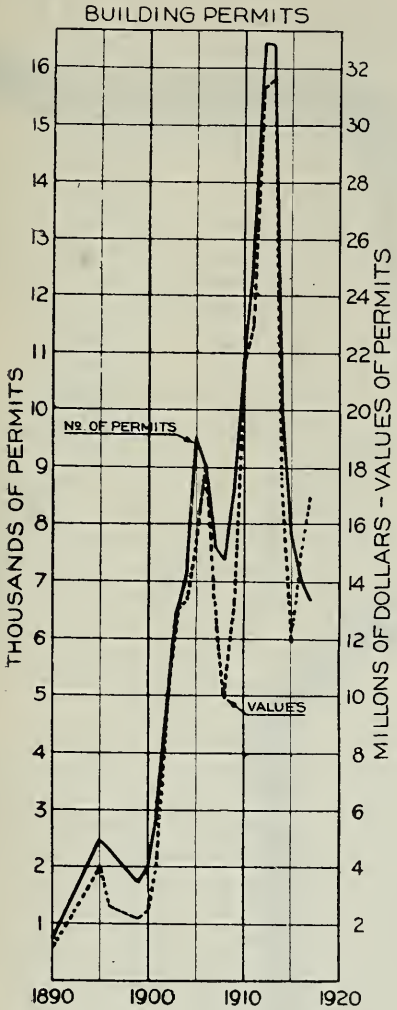

DIAGRAMS SHOWING GROWTH OF LOS ANGELES (FROM REPORT OF ENGINEER RICHLARD SACHSE TO THE STATE RAILROAD COMMISSION)

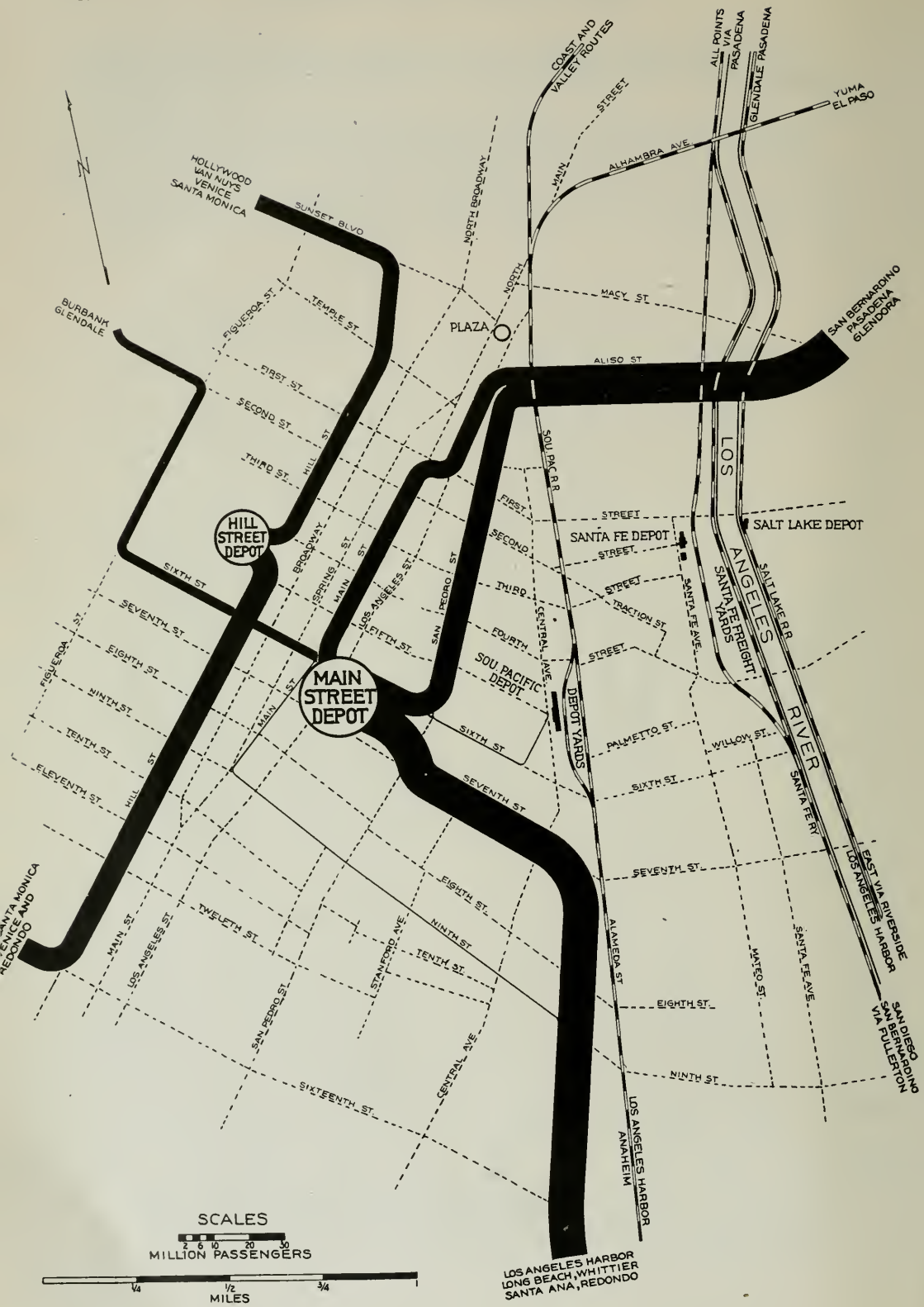

crossings and there is a serious delay to traffic. The Santa Fe has developed a plan to eliminate 61 street, eight electric railway and two steam railroad crossings, shortening, in addition, its line and reducing the gradients and curvature. The Santa Fe plan is approved in the report, and the recommendation is added that the Salt Lake and possibly the Pacific Electric should join in the construction and use of the new tracks, resulting in a partial or complete elimination of their present trackage.

The report recommends that the problem of grade crossing elimination should be considered as a whole and with a view to probable future developments rather than to use the much more expensive and less satisfactory method of dealing with the individual crossings in a piecemeal fashion. The following recommendations are made:

1. All grade crossings of the Santa Fe on the west bank and of the Salt Lake on the east bank should be eliminated by elevation of streets and depression of tracks on North Main, Macy, Aliso, East First, East Fourth, East Seventh and East Ninth streets.

2. The elimination of grade crossings on the Santa Fe between Los Angeles and Pasadena should be undertaken at once and the Salt Lake should remove its present tracks between the termini of the proposed new lines and use the new Santa Fe right of way.

3. If the Municipal rapid transit line of the City of Pasadena between Los Angeles and Pasadena should be built, that line should be constructed on the same right of way and roadbed.

UNION PASSENGER TERMINAL.

The report deals exhaustively with the question of whether or not a union passenger terminal is desirable in Los Angeles. Taking all things into consideration, the engineers were "convinced that a union station is desirable, provided it may be suitably located." The report states:

- "1. As a gateway to the city, Los Angeles prefers one adequate, convenient and beautiful entrance to several separate gateways, none of which can by themselves have all the advantages of a single union depot. This is a matter of civic pride and of city planning for the future. Los Angeles, by reason of its wonderful advantages as a tourist center and as a center of travel, is justified and sound, in our opinion, in making this consideration one of the first importance.

- "2. There will be increased convenience to passengers. Since mail, express and baggage is carried on passenger trains, it is more economical to handle this business at one station. Ten thousand dollars per annum would be saved in the handling of mail in a terminal post office. The express business amounts, in tonnage, to about one-fourth of the less than car-load freight business of Los Angeles and much would be saved by elimination of wagon haul between the various depots. This saving cannot readily be estimated in terms of money and is dependent on the location of the main depot. The more central the location, the greater the saving. Baggage is also transferred between the stations and—while of lesser importance in cost—increased convenience would result.

- "3. Grade crossing elimination would be simplified. When it is maintained that there is no necessity for a union station, it must be remembered that the retention of more than one station will necessitate greater expenditure for the elimination of grade crossings, and, pending complete separation, will result in more vehicular movements across tracks at grade.



THE PLAZA, LOS ANGELES

This circular park marks the center of the original city of Los Angeles at the time of its foundation in 1781. The new Union Depot is recommended by Engineer Sachse on the opposite side.

"4. Present passenger facilities of the Santa Fe and the Salt Lake stations are inadequate. Large capital expenditures must soon be incurred in any event to satisfy present and future needs. This is true to a lesser extent of the Southern Pacific Station also. A union depot will fill these needs better, permanently and at a relatively smaller cost than piecemeal construction by individual roads regardless of the problem as a whole. If the three steam roads now had satisfactory facilities, this argument would be of less importance. Under existing conditions, it is of prime importance.

"5. The topographical conditions and location of the railroads in Los Angeles are almost ideal and point definitely toward a union station. These natural conditions are such that a union station can be created with comparatively inexpensive connections between the roads at a relatively small capital expenditure. Long and costly approaches are eliminated and there is no doubt that the first cost will be relatively smaller than for a similar undertaking in other communities of equal importance in the United States.

"6. Centralization and consolidation would be particularly desirable from the point of view of unified operation of the railroads, whether under private or government ownership and control.

"The principal arguments against the establishment of a union station are:

"1. Los Angeles is not a through station. Practically all trains entering the city *terminate* there, and it is there that the majority of the passengers reach their destination. Only approximately 15 per cent of the total number of passengers transfer from one station to another.

"2. The first cost of any adequate union passenger terminal will be high and the saving in operating expenses will not alone warrant the resulting increase in fixed charges."



MAIN STREET, LOOKING NORTH FROM THE PLAZA, LOS ANGELES
All buildings in the immediate foreground lie within the proposed station zone.

A number of possible sites were studied and detailed plans and estimates were made for three: The Plaza site, the Santa Fe site and the Southern Pacific site. The report recommends that the Commission order the establishment of the union passenger station at the Plaza site substantially in accordance with the plan as developed.

FREIGHT

The question of economical handling of freight, although of even greater importance to the City than the question of passengers, is not at present in an unsatisfactory condition, and no radical changes are proposed. The most important of the recommendations made in this connection is the one urging the establishment of a union less than carload freight station at the Santa Fe avenue site from First to Seventh street, the present Santa Fe freight station to become a part of the union freight station.

The establishment of team yards along the east side of Alameda street is also recommended. The removal of tracks for industry purposes from Alameda street is not recommended at this time. For the future it is urged that:

1. New permits should not be granted for industrial tracks longitudinally in streets.
2. All tracks now longitudinally in streets be confined to use for industrial purposes only and be removed as soon as access to the industries served is otherwise obtained.
3. All spur tracks shall be built in a general easterly and westerly direction from the river banks and not across east and west streets, unless, by such construction, the crossing of more important north and south streets is avoided.

ELECTRIC INTERURBAN TRAFFIC

Another factor which has largely controlled the development of the Los Angeles territory but which must now be controlled by the facts of that very growth, is the question of electric railway traffic in the city.



FIRST LOS ANGELES RAILROAD STATION, BUILT IN 1869

The Los Angeles Railway, carrying, as it did in 1918, 130,538,704 passengers through the streets of Los Angeles, contributed to such an intolerable degree to the congestion of the downtown district that a special investigation, independent of this report, was made.

In regard to the Pacific Electric, drastic recommendations are made. The Pacific Electric is one of the largest and most important electric railway systems in the country and operates 1100 miles of tracks and serves fifty outlying towns and cities. In 1917 this road carried 35,000,000 passengers in and out of Los Angeles—thirteen times the number carried by the steam lines, which combined handled only 2,750,000 people. On December 31, 1917, there were over 1400 scheduled electric trains moving from the Pacific Electric depot. This splendid development has had a very serious effect on the traffic problem, however. The ratio of grade crossings between the electric and steam roads is hard to establish because of the lesser importance of some of the crossings. Besides the interference to traffic, the high speed of these interurban cars makes them a serious menace to life in the city. While the report does not deal with the problem of elimination of grade crossings in Los Angeles on the lines of the Pacific Electric (an entire elimination is impracticable at this time), this electric road is considered in the light of its relation to a union passenger station. The elimination of grade crossings on the most congested points on Main, San Pedro, Aliso and Seventh streets is taken up. Assuming the construction of a union passenger terminal at the Plaza, it is recommended that a subway be built from the Pacific Electric station at Sixth and Main streets northerly along Main street to and under the Union Passenger terminal, changing to an elevated railroad along Ramirez street and meeting the present line at the Aliso street bridge. The continuation of the present Pacific Electric elevated structure in the rear of its station is also recommended, elevating the Long Beach line to 14th street. The subway work along Main street should be undertaken within the next five years.

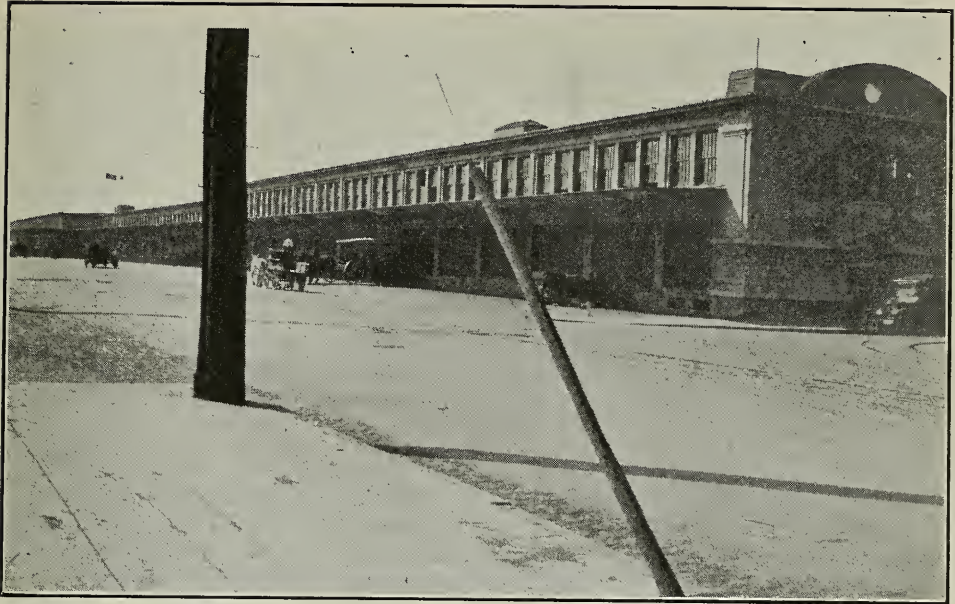

SANTA FE INBOUND FREIGHT SHED, LOS ANGELES

OTHER RECOMMENDATIONS

Secondary, though important, recommendations are made dealing with:

1. The continuation of a consolidated uptown ticket office.
2. Pairing of Southern Pacific and Salt Lake tracks between Los Angeles and Colton.
3. Installation of interlocking plant at Aliso street and the Los Angeles river.

ESTIMATED COST

The estimated capital expenditure (based on cost estimates for 1917-1918) for all recommendations is as follows:

Grade Crossing Elimination.....	\$11,488,933
Along Los Angeles river.....	\$4,593,042
Between Los Angeles and Pasadena.....	6,700,000
Butte street trackage	192,891
Union Passenger Terminal and Coach Yard.....	10,933,202
Union Freight Station	2,575,942
New Freight Yards	2,835,187
Double Track Operation of Southern Pacific and Salt Lake between Los Angeles and Colton	163,812
Team Yards	629,021
Additional Trackage, various locations.....	710,818
Subway and Elevated Construction (Pacific Electric).....	5,741,566
 Total	 \$35,051,481
Release Southern Pacific Station and Coach Yard Sites.....	2,818,036
 Net total	 \$32,233,445

Referring to this required capital, the chief engineer in his letter of transmittal of the report says:

“While a capital expenditure of over \$32,000,000 seems large, it should be remembered that this money is to be expended over a term of years. In any event, whether the foregoing recommendations are adopted or not, very large capital expenditures aggregating probably in the neighborhood of the sum estimated by us will be necessary in the near future if the transportation of Los Angeles is to keep pace with the growth and the industrial and business development of the city. The choice is not between a large expenditure if these recommendations are adopted and a small one if they are not: it is rather between an adequate and carefully planned development without wasteful expenditures and a haphazard growth dictated, in the main, by private interests, from the standpoint of each individual road. In either case the burden of capital and operating costs must, in the end, fall on the public.

“It is impossible to estimate in dollars the direct and indirect savings and benefits through the carrying out of these plans that will accrue to the railroads, to the passengers and to the shippers and also to the people and enterprises affected by transportation conditions. We have no hesitation in saying, however, that from the financial standpoint alone, the proposed expenditure is justified. In the larger aspect of city planning, there can be no doubt that the City of Los Angeles should use every effort to assist in the carrying out of these recommendations.”



NORTH BROADWAY BRIDGE, LOS ANGELES

This bridge across the Southern Pacific, Santa Fe, and Salt Lake lines marks the first comprehensive step of the city of Los Angeles in the permanent elimination of grade crossings.

About 17,000,000 people per year use this viaduct.

Unification of Railroad Lines and Service in Cities

[A Statement of Fundamental Principles]

THE importance of early unification of railroad lines and service in cities, and the prevention of further duplication and waste, has been for a long time appreciated by both the carriers and by city officials. To get at a common basis of solving the problem the National Conference on City Planning in 1919 appointed a committee to investigate, and their report was presented at the recent meeting in Cincinnati. This committee consisted of Mr. Nelson P. Lewis, Chief Engineer of the City of New York and President National Conference on City Planning; Col. William J. Wilgus, Chief Engineer, New York Central Railroad; Mr. E. P. Goodrich, Consulting Engineer, New York City; Mr. J. P. Newell, Consulting Engineer Public Service Commission of Oregon and Engineer Grand Trunk Arbitration Commission of the Canadian Government; and Mr. Charles H. Cheney, Consultant City Plan Commissions of Spokane, Portland and Berkeley.

The report is as follows:

1. Unified control and operation of all standard railroad lines within the limits of any city, is essential both to the requirements of modern business and to the convenience of the public. It should be brought about with as little delay as possible, at the same time providing opportunities for expansion both of trackage and terminals in connection with a well considered plan of city development. Means should be found and taken for persuading or compelling all railroads entering the city to connect up with such a unified system at the city limits. The entire question of railroad service should be considered as a whole, not with relation to one system or one part of the city only.
2. The present wasteful and needless duplication of lines and terminals inside of city limits cannot be permitted to continue. Many cities can show millions of dollars spent in unnecessary duplication of passenger stations when the same sums expended in added industrial lines would have increased both the business of the carriers and the prosperity of the city. This is a useless drain on the railroads, resulting in additional cost of operation, for which the public pays. It is a needless inconvenience to the public which can be remedied at comparatively small cost by proper co-operation in planning by both the city and the railroads. Voluntary action on the part of one road is not to be expected and generally impracticable. The city, with the aid of the State or National Government, holds an advantageous position to undertake bringing the railroads together with such intra-city unification.
3. All shippers within the city should be free from dependence on one road for cars. In some cities shippers now have to maintain needless additional warehouses on a second line in order to insure prompt delivery of cars on the first line. This is a wasteful expense which must be added to the cost of shipping and doing business, particularly where a perishable product is involved.
4. All spurs and industrial tracks within the city limits should be "common user" tracks, served by a belt line connected with all main lines entering the city, a fair pro rata return being made to the original owner of each line for such use.
5. Municipal ownership of intra-city lines is probably not necessary, provided there is unified control. Expansion of existing terminal companies to include all lines within city limits is probably the most economical, quickest and easiest method of accomplishing unification in most cities. New trunk lines should be allowed to hook on to the city terminal lines at the city limits, at any time in the future. This would provide for competitive lines through the

country without cutting the city into further pie-shaped sections or causing further blighted areas to property within a block or two of each side of the railroad right of way through a city, as at present.

6. Provision of complete modern business facilities is essential to all industries. Railroad service, while important, is not the only one of these facilities necessary. Protected industrial districts or zones appropriately and conveniently situated, free from hampering residential requirements, with wide heavy hauling pavements, high pressure fire protection, extra large sewers for industrial wastes, etc., as well as unlimited spur tracks, are necessary in any city of consequence, and many of the progressive cities of the country have already established such zones. The fullest co-operation between the city and the railroad is necessary to make the facilities in these zones most useful in the development of business. Once such zones are established, both railroads and shippers can feel safe in concentrating there large investments for permanent ultimate service, not otherwise justified.

7. One of the greatest opportunities for railroads to cut down expenses and freight rates is by simplification of terminals. On most of the big roads it costs as much to get a car of freight out of the city limits, as it does to haul it 250 miles or more on the main line. Some roads report as much as 35 per cent of their total freight cost in handling at terminals (from reports of O. W. R. & N. Railroad to Oregon Public Service Commission). This is by far the biggest single item to the railroads in their cost of doing business. A small saving, therefore, in terminal handling should effect a considerable amount of saving in freight cost and should be welcomed by railroads and shippers alike.

8. Whatever the origin of destination, a merchant or manufacturer should be able to receive and ship at the freight station which entails the shortest team haul.

9. Adequate expanded classification and freight yards must be provided in every city as part of its future plan and as an adjunct of industrial development. These yards should have long areas uninterrupted by grade crossings, and preferably be located at one side of or on the outskirts of the city, away from the probable expansion of business and main street traffic lines. Main railroad lines should be diverted around the city, and outside the city limits, wherever practicable, so that through freights and other through trains need not pass through the congested parts of the city. In light of the development of modern street transit, consideration should also be given to the possible advantages of relocating main passenger and freight stations away from the congested districts.

10. In cities which have water-borne commerce, whether coast or inland ports, rail and water terminals should be considered as a single rather than as separate problems; co-ordination of facilities for both methods of transportation should be insisted upon in the interest of the public and of the carriers themselves.

11. The relation of the railroad to the street system of the city should be carefully worked out. The value of the railroad to the prosperity and the very life of the city should be recognized. Wide heavy hauling pavements to freight terminals, docks and the industrial zones are equally essential and form a natural and important complement to the greatest use of railroad facilities. Direct and amply wide traffic thoroughfares should lead to all principal passenger and freight stations.

12. The elimination of grade crossings on both steam and electric rapid transit lines is essential to public safety and convenience, to prevent the inter-



SMALL HOUSE, LOS ANGELES
Pierpont and Walter S. Davis, H. F. Withey, Architects

ruption of traffic and for the proper conduct of business. The problem of grade crossing eliminations should be studied in the most comprehensive way and not in a piece-meal fashion, even though the execution of the work is to be carried out gradually.

13. The fullest co-operation should be given cities by the railroads in planting and improving the appearance of borders of rights of way, yards, bridges, viaducts, stations and terminals within the city limits. Much of the present damage to adjacent property values and rentals can be done away with in this manner at reasonably small expense, by closer working together of railroad officials.

14. These fundamental considerations in the Relation of Railroads to City Development we respectfully commend to railroad officials, City Plan Commissions, State Public Service Commissions, and to the distinguished members of the Interstate Commerce Commission, with the conviction that the grave questions of economy and public policy involved merit their fullest concurrence and co-operation.

* * *

I hate to be a kicker,
I generally stand for peace,
But the wheel that does the squeaking,
Is the wheel that gets the grease.

—Kipling.



GARDEN OF MRS. PIERPONT DAVIS
ESTRELLA STREET, LOS ANGELES
PIERPONT DAVIS, ARCHITECT

Awarded honorable mention as a notable example of landscape architecture in Los Angeles by the recent jury.



RESIDENCE OF MRS. MARY KEELEY, OAK GROVE AVENUE, PASADENA
Robert D. Farquhar, Architect

A Million Trees Planted

A TOTAL of 1,340,000 seedlings, principally Douglas fir, were planted on the forests of Oregon and Washington in the fiscal year ending June 30, according to a report which has just been completed by the United States forest service. The young trees, two years old, were planted on six Oregon forests and on only one in Washington, the Olympic National forest.

The seedlings are planted only on burned-over areas. Many more would have been planted but the forest service funds for the purpose are limited. The Oregon-Washington district planted a larger acreage, 2141, than in any year since 1915. The total acreage is an increase of 39 per cent over last year. The cost for the work was particularly high the past year, due to scarcity of labor and high wages. The planting is done largely in the fall.

The largest acreage was that on the Oregon national forest, which comprises the district from the Columbia river south to the north fork of the Santiam river. On Still creek 675 acres were planted, the majority Douglas fir, with some white pine, noble fir and silver fir. On the Cascade forest 400 acres of Douglas fir and some yellow pine were planted. An average of 600 seedlings were put in to the acre and 1200 of the yellow pine to the acre. The average cost per acre was \$10.89, about \$4.50 higher than the price paid in former years.

An average of a little more than 70 per cent of the seedlings planted survive during the year, the greatest loss being in the first two or three months.

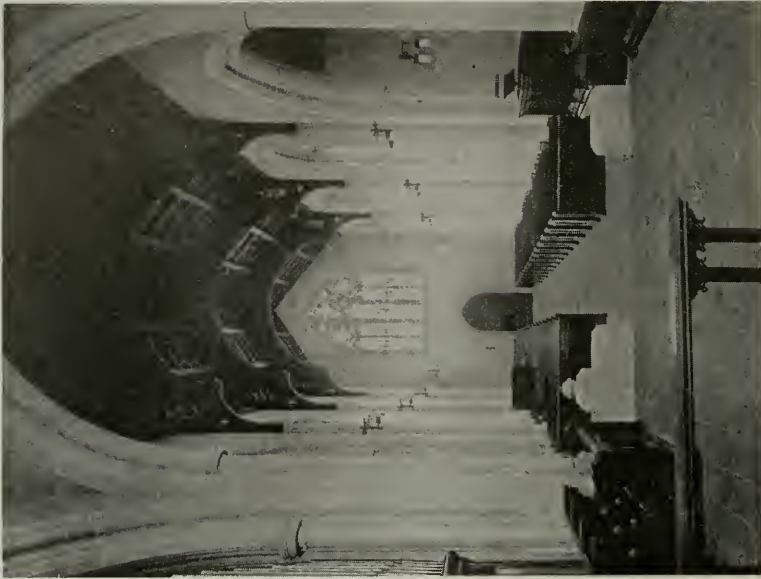

INTERIOR, CHURCH OF THE HOLY FAITH,
INGLEWOOD
Frohman and Martin, Architects

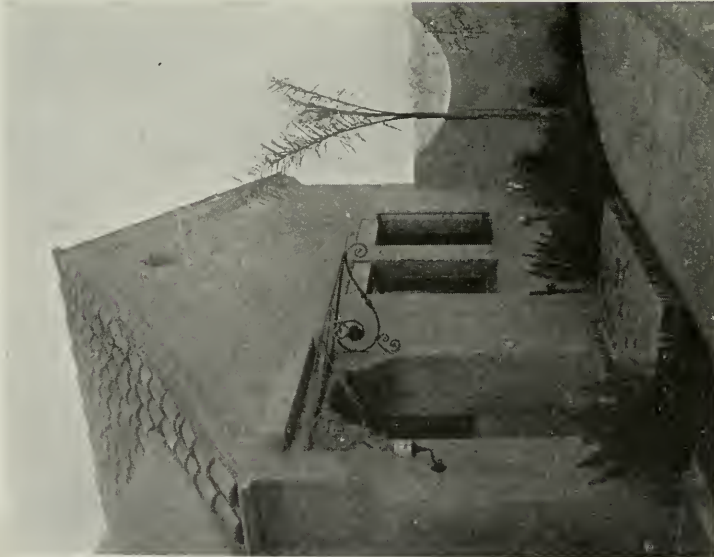

AUTOMOBILE ENTRANCE—HALLIDAY RESIDENCE,
SANTA MONICA
Pierpont and Walter S. Davis, H. F. Withey, Architects

Zone Plan for San Francisco

FOR a year past the San Francisco City Planning Commission has had under consideration the formulation of a zone plan for that city. Mr. M. M. O'Shaughnessy, City Engineer, placed at the disposal of the Commission the facilities of his department and assigned Mr. R. S. Woodward, of his staff, to take charge of the field work and the preparation of the necessary maps. The work involved a mass of detail. Every structure in the city had to be visited, its present use noted, and its construction, area and height listed.

The members of the San Francisco City Planning Commission are: Mr. Matt I. Sullivan, president; Mr. Frank I. Turner, vice-president; Mr. H. A. Mason, secretary; Mrs. Abbie E. Wilkins and Mr. Paul Scharrenberg.

The adoption of any zone plan should be supported by informed public opinion and every citizen should be impressed with the desirability of having a zoning system and comprehend the advantages to result therefrom.

The necessity of a zone plan has been concisely stated by Mr. Herbert S. Swan, who has had much to do with the zoning of New York and other Eastern cities. Mr. Swan writes on the matter as follows:

"Millions of dollars will be spent within the next few years on new buildings in every growing city in the United States. This money may just as well be spent toward the permanent upbuilding of the community as upon hit-or-miss, haphazard growth involving endless construction, demolition and reconstruction without ever achieving any degree of finality. It won't cost any more; indeed, it will cost considerably less, and at the same time it will produce a much better city to live in and to do business in for generations.

"The time to zone our city is now. Every year that is allowed to elapse without the adoption of zoning means that much less zoning in the end. Here is a quiet residential street improved with private dwellings. If zoned now, this street may be maintained for detached houses. Wait until next year to adopt a zoning scheme, and the erection of two or three tenements will place it in the tenement-house class. The erection of a factory or a garage may even put it in an industrial zone. We must have zoning to protect what we have.

"Mounting prices make it increasingly necessary to conserve the value of all buildings, old no less than new, from premature and avoidable depreciation.

"Zoning expresses the idea of orderliness in community development. Just as we have a place for everything in a well-ordered home, so we should have a place for everything in a well-ordered town. What should we think of a housewife who insisted on keeping her gas range in the parlor and her piano in the kitchen. Yet anomalies like these have become commonplace in our community housekeeping. In what city can we not find gas tanks next to parks, garages next to schools, boiler shops next to hospitals, stables next to churches, or funeral establishments next to dwelling houses? What would be considered insanity if practiced in the ordinary house is excused as an exercise of individual liberty when practiced in the city at large. And yet misplaced buildings are to be condemned much more than out-of-place pieces of furniture.

"The whole purpose of zoning is to encourage the erection of the right building in the right place. It protects the man who develops his property along proper lines against the man who develops his property along improper lines. Rightly understood, zoning means the substitution of an

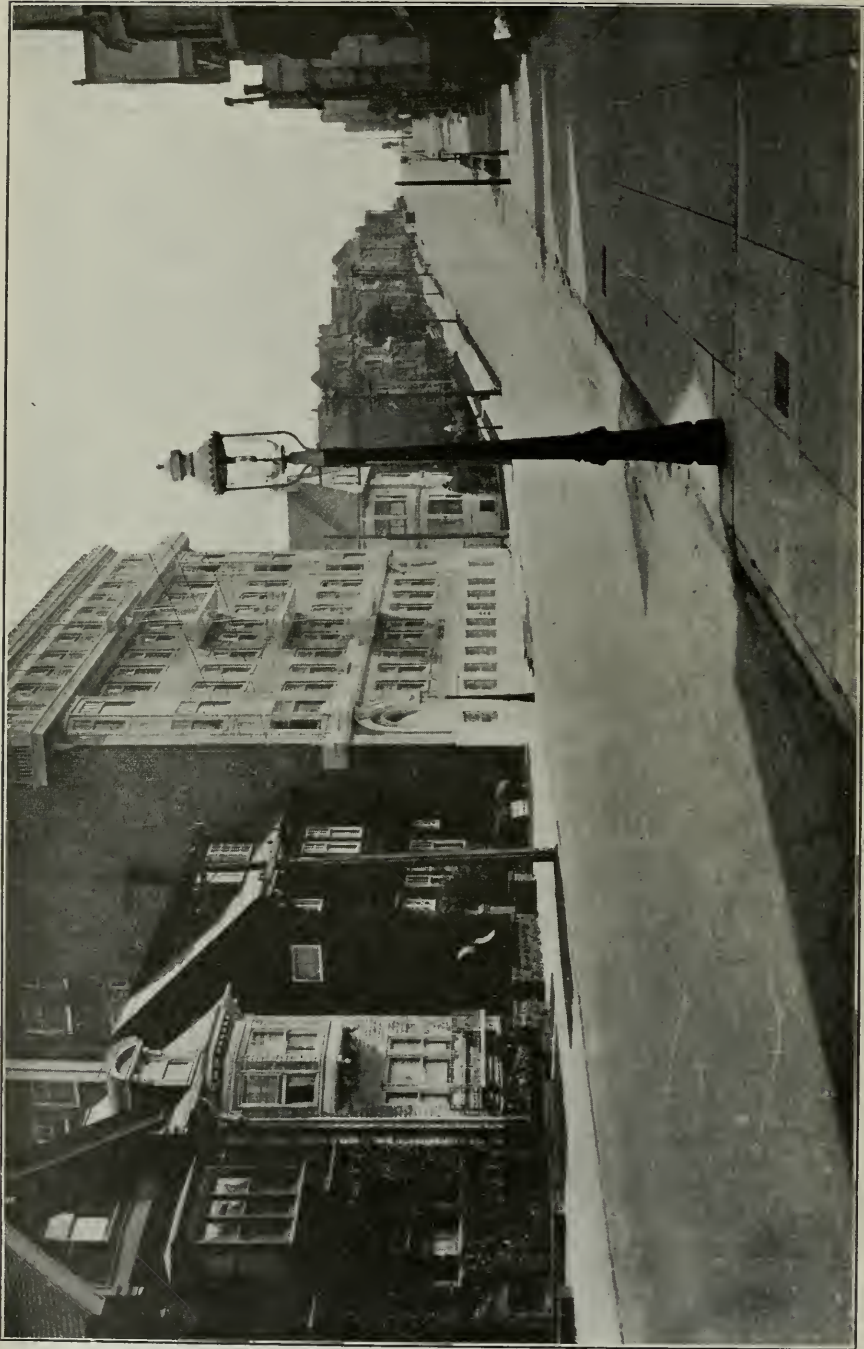

WASHINGTON STREET CROSSING OF LAUREL STREET, SAN FRANCISCO
An apartment house erected in a residential district and built up to the building line, thus taking away the sunlight and view from numerous houses.

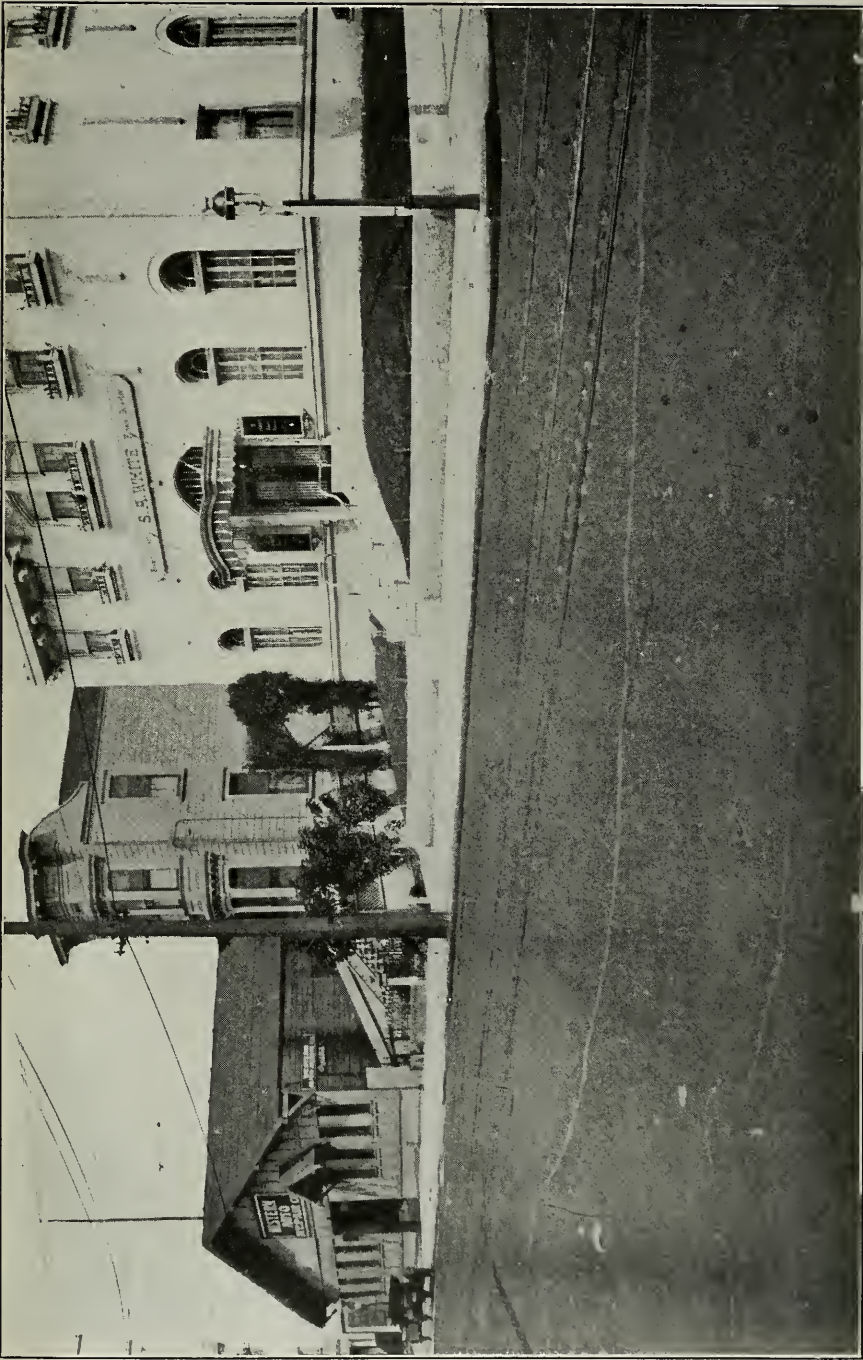

SUTTER STREET CROSSING PIERCE STREET, SAN FRANCISCO
Residence hemmed in on one side by a garage and on the other by an
undertaking establishment.

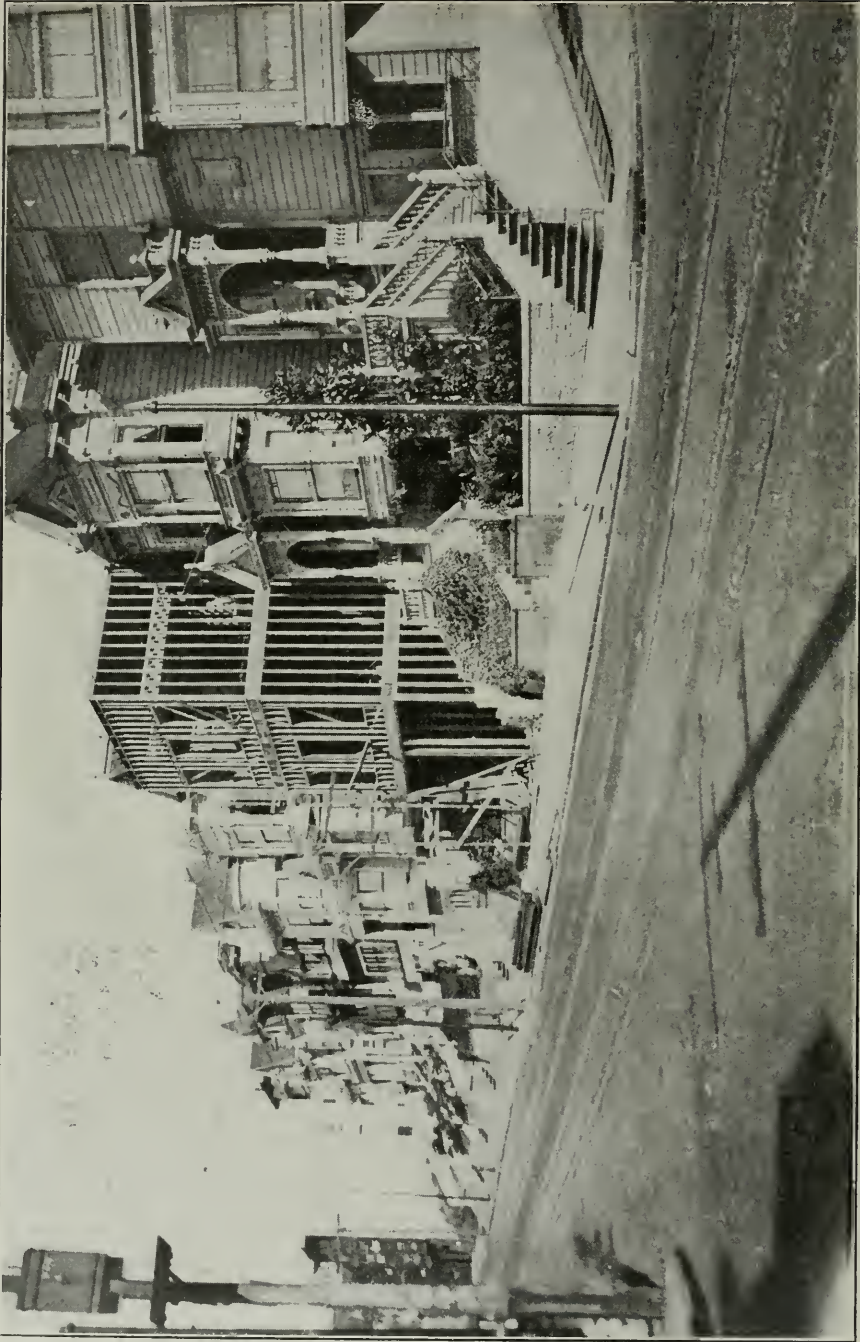

JACKSON STREET, BETWEEN BRODERICK AND BAKER, SAN FRANCISCO
Showing intrusion of established set back line in residence district.

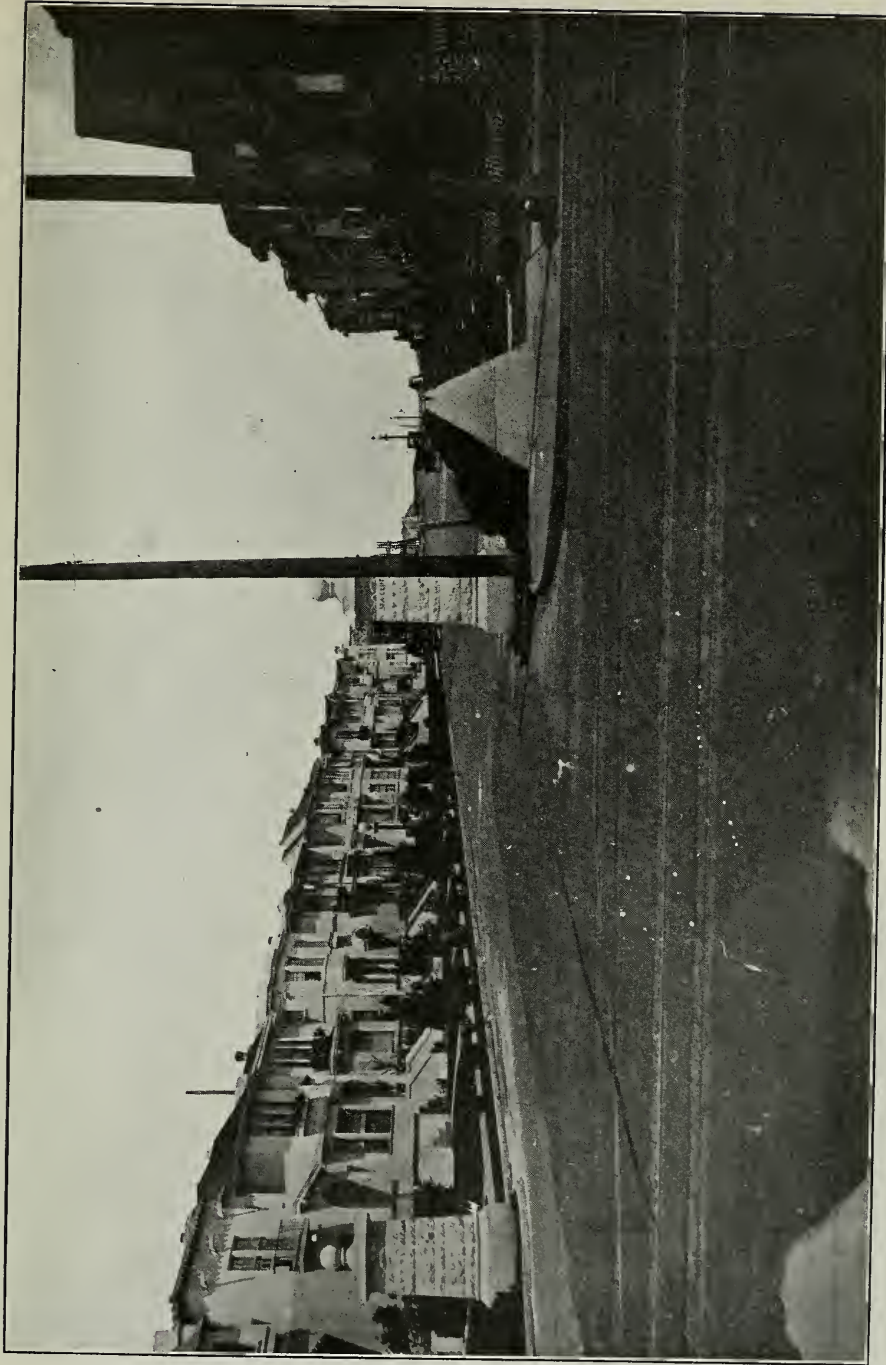

TWENTY-EIGHTH AVENUE, CALIFORNIA TO LAKE, SAN FRANCISCO
Showing the improvement of a block by constructing the houses on a set-back line

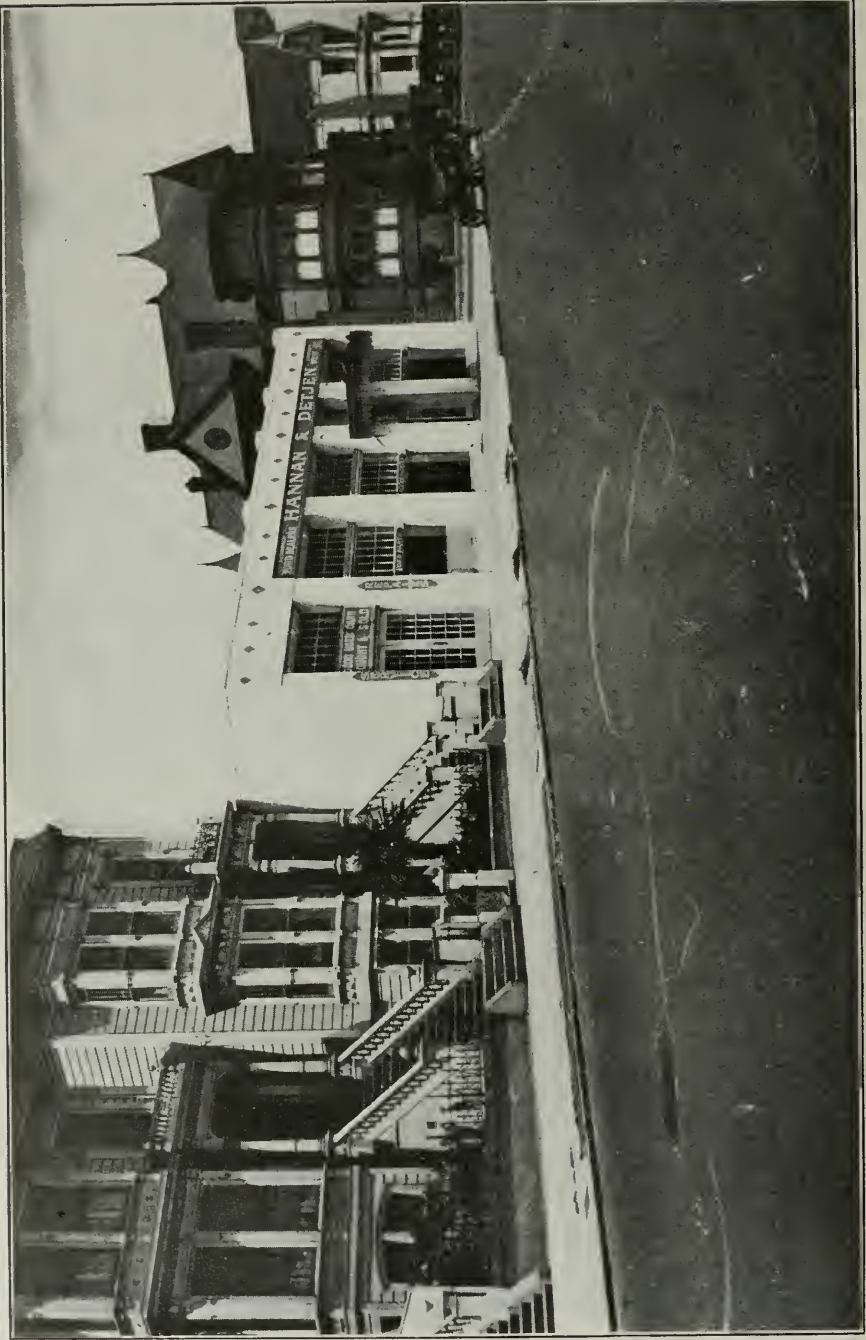

BAKER STREET CROSSING GROVE STREET, SAN FRANCISCO
In a residence district the erection of a garage should not have been tolerated

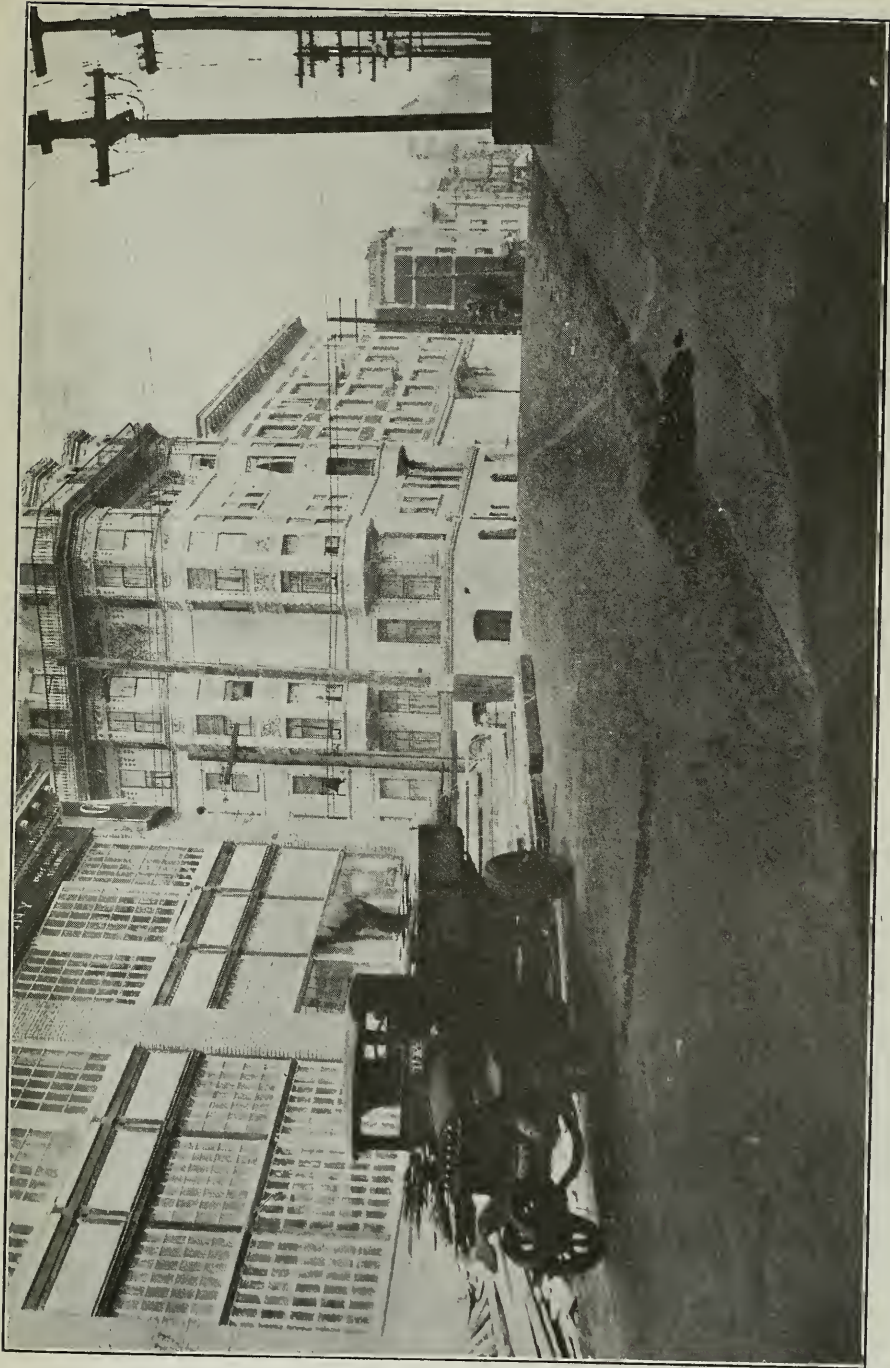

SUTTER STREET CROSSING GOUGH STREET, SAN FRANCISCO
A two-story factory building has just been erected on the left-hand corner, while the other three corners are now occupied by family hotels

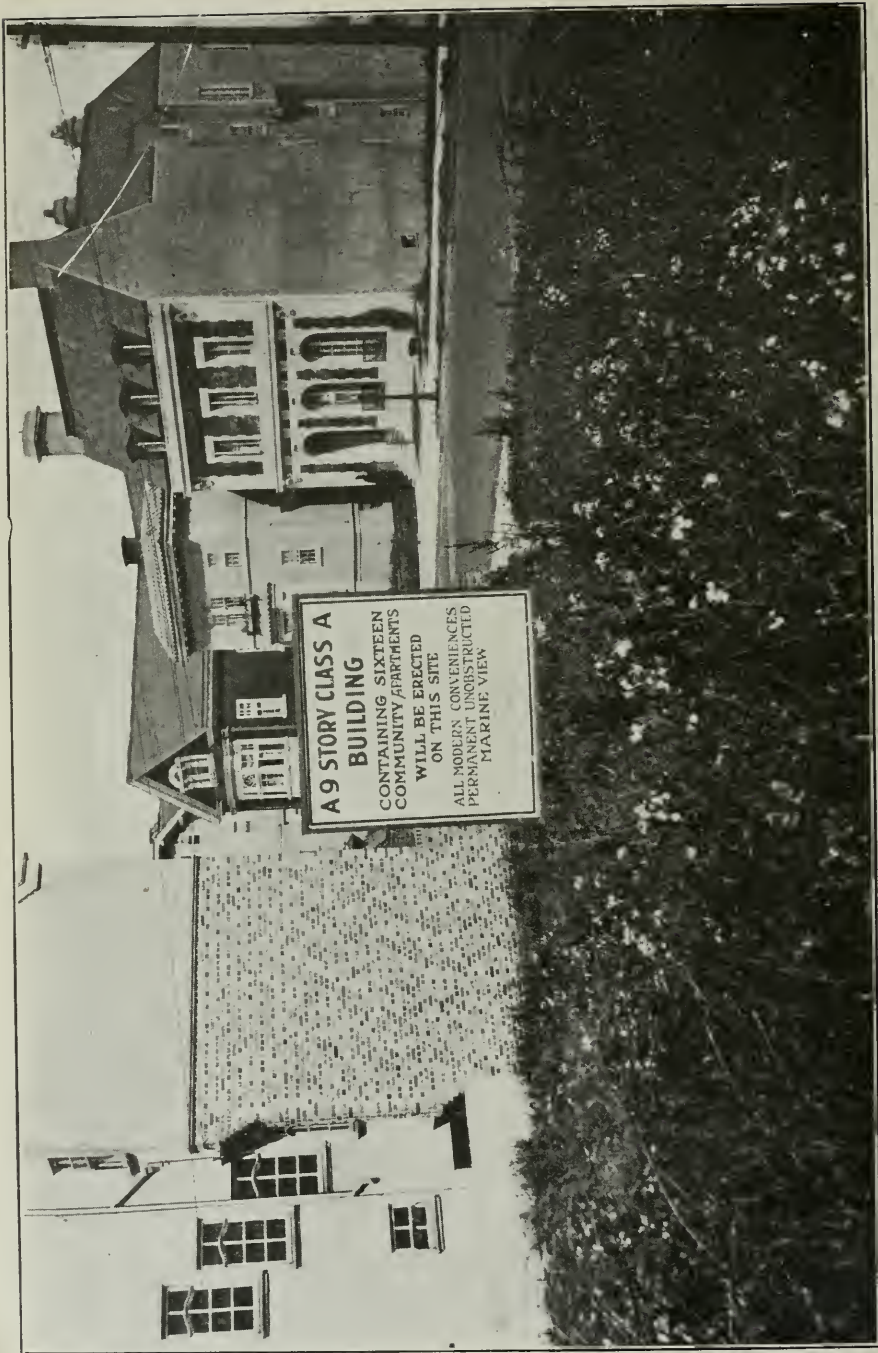

JACKSON STREET CROSSING LAUREL STREET, SAN FRANCISCO
The sign tells the story, while the houses in the background show the character of homes in the neighborhood.

economic, scientific, efficient community program of city building for wasteful, inefficient, haphazard growth."

In San Francisco there are but few single dwelling sections, outside of the residence tracts, that have been opened up lately and have their own building restrictions, and these are in constant danger of the encroachment of the apartment house. The only way that these districts can be protected is by zoning.

The apartment house is, of course, a necessity to the community and should have plenty of room in which to build. There is a large area tentatively zoned for the second residence section which will be given relief from the intrusion of businesses and garages. The conducting of a retail business in a dwelling district is, of course, a detriment to the adjoining property, for as a general rule, because of the lack of business in the dwelling section, the retail store is not a success, and eventually becomes idle, thus being an eyesore to the neighborhood.

The retail district is going to prosper when it is established along the lines of travel and business activity, and is not retarded by the factories and heavier industries.

In the light industrial section the erection of homes or tenements is permitted, but at the same time the use of a building for any trade or industry that is noxious or offensive by the emission of odor, gas, smoke or noises, is prohibited.

In the heavy industrial district the only restriction is the erection of single or group dwellings, for most of this land is naturally along the water front, on swamp lands, and on flat ground where railroad facilities are available, and it is evident that few people would desire to have their homes in an environment having its character fixed by stock yards, boiler shops, tanneries, chemical plants and railroad yards, etc.

The protection that is allowed other districts should also be given the heavy industrial district, and this is given them by the exclusion of dwellings, for once a number of dwellings are erected in a heavy industrial district, it is not long before the residents are clamoring for the abatement of the supposed nuisances which are a necessity to the life of the community.

The illustrations afford a means by which the reader may visualize the process that is now going on in San Francisco under the system that imposes no restrictions upon the use of property; that tamely acknowledges that a man may do with his own property that which pleases him regardless of its effect upon his neighbors or its results as affecting the public welfare.

The illustrations are typical of hundreds of localities in the city that have suffered from intrusions of various kinds; intrusions that have robbed citizens of sunlight and air; that have destroyed values as completely as war could have done. In fact, the present system invites an insidious warfare upon defenseless citizens, permitting a selfish impulse to find expression in an act that deprives good citizens of that which is theirs by nature and which the law should protect.

Time and time again citizens have protested against invasions in their neighborhoods but the officials have found themselves powerless to prevent catastrophes or afford relief.

*

*

*

If you can't laugh at the jokes of the age, laugh at the age of the jokes. Probably one joke in ten thousand makes people laugh.

How Automobiles Hold Up Building

A REAL estate man quoted in *The American Contractor* says the public is bidding against itself in keeping up the demand for luxuries, especially automobiles, when there is such acute need of labor and materials for building. As an instance of the motor industry's competition with building, the Building Commission of Chicago is credited with reporting "that agents of the automobile companies were in touch with plate-glass insurance people and were getting broken plate-glass windows, and that they were buying abandoned mirrors from bar-rooms, and that the automobile people had also bought two large plate-glass plants." The real estate authority continues:

The demand for sheet steel by the automobile industry has been so great that it has handicapped expanded metal-lath business and the price of wood lath has gone up from \$3.50 to \$23. It is said that almost the entire year's available supply of six-inch pipe has already been bought by the automobile industry. Labor, which formerly worked in the cement quarries in Bay City, Mich., in the summer and in the lumber-camps in the winter, has gone to the automobile industry in Detroit. One automobile concern alone is handling ten cars a day of freight into Chicago, while the building industry cannot get roofing material through to roof buildings partly constructed.

One automobile concern alone has \$100,000,000 worth of building construction on hand, and, while not deterred by the cost of construction, has been obliged to abandon part of its program because it was found that one of its projects was drawing labor, material, and capital from the other.

It has been shown that the composite index figure on building materials has gone up eighty-four points during the last year, which is an increase equal to the increase during the entire five years of the war. From a basis of one hundred at the beginning of the war it increased to 84 per cent. above pre-war levels in November, 1918, remaining at that level until March, 1919, and it now stands at 168 per cent. above pre-war levels.

While this is likely to fall in sympathy with any reaction in general business and the cessation of the purchase of luxuries, it is unreasonable to expect that it will fall below the level of last March, particularly if freight-rates are to be increased. It is reported that in order to pay 5½ per cent. on the capitalization of the railroads, freight rates will have to be almost doubled. Freight on building materials has already been increased 50 per cent., and if it is now doubled that construction industry will be compelled to pay \$3 for freight compared with \$1 which it paid in June, 1918, and this will be a very large factor in keeping up the price of building materials.

*

*

*

Improvement in Lighting Conditions

The general manager of the Electrical Testing Laboratories, Mr. Preston S. Miller, noting the statement by Mr. R. E. Simpson of the Travelers' Insurance Company that in 1910 23.8 per cent of accident claims in industrial establishments were due to improper or inadequate illumination, remarks:

"Mr. Simpson states that improvement in lighting conditions since 1910 has unquestionably reduced that proportion, but he feels it safe to estimate that 18 per cent of our industrial accidents today are due to ineffective lighting. On that basis he calculates that the services of 108,000 men for one year are lost annually because the illumination provided is not adequate for safety. When we think of the services of 108,000 men per year, we immediately see how important a matter that becomes in economic and productive significance.—Safety Engineering.



WESTERN PACIFIC DEPOT, SACRAMENTO
Willis Polk & Company, Architects

Spanish Mission Architecture in Railway Passenger Stations

By NORMAN M. STINEMAN, Assoc. M. Am. Soc. C. E.

CLASSIC architecture has been almost universally adopted for the design of monumental railway passenger stations in the large cities of the United States. For the smaller stations no predominant style has yet been adopted over the entire country; but in California and the Southwest the tendency has grown strongly toward the Spanish Mission type, with concrete and stucco as the materials in which the architect can best express himself.

To understand the adaptability of concrete and stucco to Spanish Mission architecture, it is necessary to consider the origin and the characteristics of this style. When the Spanish missionaries entered California by way of Mexico, they were unaccompanied by architects or artisans. In the construction of their missions they had to depend upon unskilled Indian labor, who utilized available material and worked with simple tools. Walls were constructed of adobe brick, covered with plaster. The missionaries quite naturally desired to follow the style of architecture familiar to them in Spain and Mexico, but because of the restrictions under which they labored, they were forced to modify the true Spanish architecture in the direction of simplicity. The characteristics of the Mission architecture thus developed are found in the low, spreading buildings, built in the form of a quadrangle around a large inner court; large, plain wall spaces; plain, semi-circular arches devoid of mouldings; low-pitched, tile-covered roofs with wide, projecting eaves and gable ends; belfries formed by the continuation of the walls above the roof and pierced by small arched openings to support the bells; turned wooden grilles on exposed first-story windows instead of the wrought iron grilles more commonly used in Spain; inner courts bordered by cloisters and arcades; and the entire absence of elaborate decoration. Simplicity was the key-note of this style, and Nature soon supplied the needed decoration in a most befitting manner by covering the walls and grounds with luxuriant vines, trees and shrubs.



PASSENGER STATION, DAVIS, CALIFORNIA
Engineering Department, Southern Pacific Company, Architects



PASSENGER STATION, VISALIA, CALIFORNIA
Engineering Department, Southern Pacific Company, Architects



PASSENGER STATION, MODESTO, CALIFORNIA
Engineering Department, Southern Pacific Company, Architects



PASSENGER AND FREIGHT DEPOT, WEST BERKELEY, CALIFORNIA
Engineering Department, Southern Pacific Company, Architects



SANTA FE PASSENGER STATION, STOCKTON

Concrete and stucco, like the plaster formerly used, are plastic materials and, therefore, well adapted to the Mission style of architecture. This is no doubt responsible for the fact that the use of concrete and stucco in architecture has advanced further in California and the Southwest than in other sections of this country. The extensive use of these materials in buildings designed after the Mission style trained architects and artisans in their use and led to their adoption where other types of architecture were involved.

It is not surprising that the Spanish Mission style has found favor with architects for small and medium-sized railway passenger stations. The facilities required in such buildings are nearly all placed on the main floor, necessitating a low building covering considerable ground area. This is one of the principal characteristics of Spanish Mission architecture. The series of arches, or arcades, another prominent characteristic, provide ample means for the passage of large numbers of people to and from the building and the trains. The wide projecting eaves furnish additional shelter from sun and rain. Last, but not least, the simplicity of the design and ease of construction insure moderate first cost.

Considering further that concrete construction produces a permanent, fireproof structure, low in maintenance, repair and insurance charges and immune against decay, the fortunate combination of material and style becomes at once apparent.

Some concrete examples are shown in the accompanying illustrations. The Atcheson, Topeka & Santa Fe station at Stockton is typical of the Spanish Mission style in its spreading outline, low-pitched tile roof, wide eaves, gable ends and plain semi-circular arches. Only in some minor details does it deviate from the Spanish Mission style. The station at Visalia, California, has the semi-circular arch openings and tile roof of the Spanish Mission. The large rectangular openings are logical modifications in recognition of modern construction methods. The small Western Pacific station at Nineteenth and K streets, Sacramento, stands in pleasant contrast to the stereotyped small stations too frequently found

in this country and Canada. The few elliptical arches and several less important details are deviations from the Mission style. The Santa Fe station at San Bernardino shows the Moorish influence in Spanish and Spanish Mission architecture.

These few examples are sufficient to illustrate the adaptability of concrete and stucco to Spanish Mission architecture. If such a building is to be a complete success, the architect must understand his materials; he must know the characteristics of the Mission style and the reasons for them, and he must adjust the material and the style to the practical purposes for which the building is intended.

* * *

Co-operative Plan Solves High Rent Problem

FOR many families seeking apartments and for corporations requiring increased office space to provide for business expansion, the co-operative plan of mortgage-free real estate ownership has helped solve the problem of soaring rents.

Present conditions in the money market make it practically impossible to finance large building operations except on the co-operative plan. This method has worked out successfully in the building and ownership of numerous apartment house dwellings in New York City during the last twenty years.

Under the co-operative ownership plan, a group of occupants, owning stock in a corporation and occupying space in the corporation's building, set aside a portion of the space for renting. The income from that part of the building not occupied by the stockholders is sufficient to afford a surplus over all operating expenses, insurance, and taxes.

When the corporation is organized, the stockholders purchase their space by paying a certain number of year's rent in advance. These payments defray the cost of construction of the building without dependence on the usual form of real estate mortgage. Figuring interest on his original investment at 6% and allowing 2% for amortization, the tenant owner will be able within approximately ten years to eliminate rent from the list of his annual fixed expenses. In addition to the saving in rent waste over a long period of years, the stockholder owns his office or his apartment, a tangible asset in itself.

The actuary of one of the large life insurance companies in New York has computed that a corporation purchasing under the co-operative plan office space renting for \$50,000 a year—the purchase price being \$350,000, the equivalent of seven years' rent—will be able to save \$1,116,606 in twenty years. It is possible for this same corporation to amortize its investment of \$350,000 in 9½ years and then save \$766,066 in rent waste over the balance of a twenty year period.

* * *

Starting with a Little Vacation

"I need a good office boy," said the manufacturer's agent, to the youthful applicant for a situation.

"What does the job pay, mister?"

"You'll get \$5 a week for the first two weeks, and \$9 a week after that."

"Well," replied the boy, "I'll start working for you the third week."—
Exchange.

Economic Features of Architecture

By G. C. FIELD, Architect, Seattle, Wash.

THE greater part of an architect's work is made up of a complex function which involves a high technical art in combination with an economic science. Only a very small portion of the money spent under his direction is used for purely artistic purposes. The success or failure of the majority of his work depends more upon its economic features than upon the purely architectural.

The architect's employer only realizes in a vague way that there is a certain value to the purely architectural features of the building, but few realize to what extent these features are carried throughout the entire development of a building's plans, and few owners realize, unless they have come in contact with highly trained architects, the great fund of information and deep study which they can give upon the economic side of any building project.

There are two principal theoretical requirements applicable to all modern buildings. First: That they shall be in harmony with their surroundings. Second: That their cost shall bear a proper proportion to the value of the land upon which they are built.

To speak of the purely architectural embellishments of a building, if we consider for a moment two buildings of equal accommodations, conveniences, and equally desirably located, if such were possible, one of them without architectural treatment and the other of good architectural design, it is an indisputable fact that the second one would earn more upon the investment than the first one, which is lacking in ornament. The architect of commercial and industrial buildings of today has in his possession as large a stock of classified and correlated facts pertaining to the economic phases of construction as he has upon the artistic part of his problems. It is of these economic facts that I wish to speak a moment. The client can receive advice at the inception of a building upon such subjects as: The proper proportion of the cost of a building to the value of land on which it is proposed to erect it. The owner may propose to erect a building which may be too costly for the site, by reason of the use of too costly materials or form of construction, raising the cost of accommodations above the average, or he may propose to erect what is termed a misplaced building. That is one which is out of harmony, or unsuited to its surroundings. This is frequently done through being erected in advance of the requirements of a neighborhood, though in the general line of growth it may become, in time, a proper type. Mistakes of this kind are a serious source of loss of capital in investments, and are very grave mistakes in growing cities, on account of the competition of later buildings.

The architect will advise his client upon the commercial life of a building, which may be quite a different period of time from the structural life. The structural life of a building may be terminated in any one of three ways: By natural decay, by destruction by fire or earthquake, or by the removal of the building. A building of which the structural life is far from terminated, reaches the limit of its commercial life when it becomes, through change and character of its location, or for any other reason, unfitted for the purposes for which it was erected, or is unable to earn a proper return on the land on which it stands.

The ownership of property appeals to many people, because it is something tangible, that they can see, and understand, thus differing from

securities, such as stocks and bonds, the value of which is difficult to grasp, causing many people to prefer to invest in something which cannot entirely disappear, even though it may show a diminishing return upon the investment.

There are a number of external factors influencing the commercial value of buildings, and these must be studied and given careful consideration in the development of a building project; the surrounding buildings, accessibility of the site, approach, transportation and topography, comparative value of the location of the entrances, width of the streets in addition to which, the possible different occupancies or utilizations of the building during its commercial life must be considered, and as the project approaches its more complete development, the operating equipment must be given considerable study, and the returns from the rentable parts of the building, being that which the entire investment is based upon, needs greater consideration than any other feature of the building. The result of consideration of cost of the various kinds of materials, the different forms of service and operating equipment, and the general architectural treatment in planning of a building is a compromise of conflicting requirements, and the most successful is therefore that which sacrifices the requirements of lesser importance in favor of those of more import.

Owners can receive advice upon such subjects as the best types of construction for various manufacturing processes, relative cost of fire and other forms of insurance for different types of construction and the municipal and insurance requirements pertaining to the safeguarding of life and property.

The owner who understands the value of an architect's service makes constant reference to him for opinions and advice upon a multitude of subjects, pertaining not only to the construction, but to the operating equipment of the building. Improvements of service and structural features can be suggested, insurance appraisals given, and many other forms of service rendered, of which many owners fail to take advantage. —Pacific Builder and Engineer.

* * *

Adobe Houses to Cut Building Costs?

ADOBE, the oldest known building material in Southern California, is due for a revival, according to Mr. John W. Chard, Santa Barbara architect. He asserts that if properly prepared this native material can be used to very considerably cut the cost of building.

"Experiments," says Mr. Chard, "have shown that adobe is the least affected by changes of temperature among all the building materials. Tests show that adobe bricks register no more than six degrees difference between February cold and extreme September heat. As a building material it is far stronger than is generally supposed, and develops a compressive strength as high as 400 pounds to the square inch.

"The proper plaster protection will insure an adobe wall against deterioration. Hard cement plaster thoroughly anchored into the walls and treated with an all-mineral waterproofing compound will give adobe walls great durability.

"Adobe is wet soil mixed with straw, cast into molds of required size and left to dry in the sun. As a building material adobe is everlasting, soundproof, nonconductive and fireproof, always of normal temperature, and is cool in summer and warm in winter."

The Specification Writer and Manufacturers' Literature

By LOUIS R. HOLSKE, in Pencil Points*

THE question, "In what form would the specification writers in architects' offices prefer to have on file data from manufacturers regarding materials and equipment?" is one that is important to every architect and specification writer, as well as to every manufacturer of building material and equipment. That it has not been satisfactorily answered is strange, in view of its importance.

At present, though specification writers endeavor to keep files of information issued by manufacturers, these files fall far short of being what they should be, for they are incomplete, inconvenient to refer to, and are very often lacking in the kind of data needed in preparing specifications.

It would seem desirable that all such printed matter should be of a size to permit its being placed in a letter file of standard size, that is, not larger than 8½ in. x 11 in. It should not be unduly bulky or inconvenient to handle.

Brochures, portfolios, and other elaborately gotten up pieces of printed matter on heavy paper with excessively wide margins, large type and showy illustrations occupy more space and are more difficult to keep in order than the information they contain usually warrants. This elaborate presentation may be right to put into the hands of the layman, it may make a selling appeal to the prospective home owner, but it is not what the specification writer wants to put into his files.

Much of the matter issued by manufacturers contains too much "selling talk." Pictures of buildings in which the materials or equipment have been used, photographs of the plant and of members of the organization may not be without interest, but they should have no place in a catalogue intended for filing by the specification writer. They encumber his files and the catalogue is likely to be discarded. The data needed should be compactly presented, the catalogue or leaflet should not only be of such size that it will go into the file, but it should take as little space as possible. The matter it contains should be so arranged that the information wanted can be found quickly.

Specifications issued by manufacturers are seldom usable to any considerable extent because they are, as a rule, written very closely about the manufacturer's product—if broader in character and better written they might be helpful. Picking out a bit of information here and there from a mass of useless material consumes a great deal of time and it would be much better if the needed data were concisely stated and well tabulated or indexed.

Aside from the faults in shape, size and makeup of much of the printed matter and in the arrangement of the data in it, there is an even more serious fault in the majority of cases, namely, the lack of much of the data needed. In addition to the dimensions required in providing space for an article of equipment, for instance, there should be measurements that will locate the article in connection with other work.

Full and complete data regarding the manufacturer's product should be given and it would be very helpful in many cases if there were brief notes on the correct practice in installing, or applying or employing the

* Mr. Holske is in charge of the preparation of specifications in the organization of McKim, Mead & White, architects, New York City.

equipment or material, as the case may be, in relation to the building itself or other equipment. For instance, the catalogue of a manufacturer of green houses might well state the usual height of the brick walls of such structures above the finished floor in addition to showing sections of the bars and giving the other details which are not usually included.

If manufacturers, who naturally wish to have data on their products in the hands of the men who write specifications, and architects and specification writers can be brought together in a discussion of this subject, much can be done to clear up this matter.

It is hoped that architects, specification writers and manufacturers will help in this discussion, giving any suggestions or thoughts they may believe will be helpful—the invitation is general, as will be the benefit from this discussion.

*

*

*

Increased Lumber Freight Rates Make Slight Difference in Home Building

THE increase in railroad freight rates authorized by the Interstate Commerce Commission has added only slightly to the value of lumber to the consumer and the home builder. The increase varies for different regions and it is estimated that it will average approximately $33\frac{1}{3}$ per cent so far as lumber is concerned. That means the addition of one-third to the cost of transportation, but since such expense is but a relatively small part of the total value of lumber which goes into a house it is not to be expected that it will materially affect the building of homes.

Lumber weighs anywhere from 2,000 to 3,500 pounds per thousand feet, according to the kind of wood and its degree of dryness. Much of the yellow pine coming into Chicago takes a rate of $32\frac{1}{2}$ cents per hundred pounds, so, in the case of lumber weighing, say, 2,800 pounds per thousand feet, the transportation cost amounts to \$9.10 per thousand. Douglas fir shipped from the Pacific Northwest to Chicago is hauled by the railroads at a charge of 60 cents per hundred pounds, so that the freight charges on a thousand feet of Douglas fir weighing, say 2,500 pounds, would amount to \$15. An increase of $33\frac{1}{3}$ per cent in the freight rate means adding about \$3 to the cost of transporting yellow pine from the South to Chicago and \$5 to the cost of Douglas fir from Oregon and Washington points to Chicago.

With yellow pine lumber selling at \$70 per thousand feet the old rate of transportation of \$9.10 per thousand feet formed 13 per cent of the total value. Under the new rate the cost of the railroad haul will be about 17 per cent of the value. In the case of Douglas fir selling in Chicago at \$70 per thousand feet the old freight charges formed 21 per cent of the value, while under the increased rate the freight haul will form 29 per cent.

The figures given apply to Chicago only, but they are illustrative in a general way to all sections of the country. The man who is going to build himself a home and who may use a total of twenty thousand feet of lumber in its construction, is not going to let the increase in the value of lumber due to the advance in the cost of transportation, deter him from carrying out his purpose. The added investment on twenty thousand feet of lumber would mean to the man in Chicago buying yellow

pine but \$60. On a house costing \$5,000 to build the increase of \$60 amounts to 1.2 per cent. Lumbermen generally do not believe that the home building movement of the country will lag by reason of the slight increase in the investment due to the coming advance in the cost of hauling building materials. Railroad economists insist that the higher revenues granted will improve the efficiency of the railroads to such an extent as to assist in minimizing transportation costs by cutting out the waste of delays, insufficient and poor equipment, and losses incident to poor service.

*
* *

The Hardwood Lumber Situation

There are two important factors which make for the uncertainty of the present hardwood lumber market. On one side, stocks at mill points are still way below the normal supply. There exists a real scarcity of hardwoods. Labor conditions continue abnormal, labor demanding as high a wage as ever for production. On the face, therefore, it would seem that the sudden drop in price is an artificial one—for the time being, at least, superinduced by the fact that the real big buyers of hardwoods, such as furniture and automobile factories, have slackened up considerably.

As long as the big buyers avoid the market, prices will fluctuate considerably. The present crop can be attributed to this cause more than to any other factor. How long it will obtain is difficult to predict.

It is not improbable, said a San Francisco dealer, that we may see prices go up again suddenly, should the big buyers resume activities on a larger scale. Meantime, it is curious to note how some items are affected more than others. For instance, Northern woods, such as maple, have not gone down in price, whereas Southern woods, particularly plain oak, quartered oak and gum, show a decided fall. Within the last thirty days quartered oak has gone down \$70.00 per 1000 feet, and plain oak \$20.00 per 1000. Southern red gum has been reduced \$40.00 per 1000, while maple flooring advanced a few days ago \$10.00 per 1000.

*
* *

To Distinguish Mahogany and Walnut from Red Gum.

IN the manufacture of furniture and cabinets a great deal of red gum is used as an imitation of mahogany or Circassian walnut. When red gum is properly finished, it can be made to look so much like either of these woods that only by very careful observation can the true be distinguished from the substitute. There is a very distinct difference, however, between red gum and mahogany or walnut. This difference lies in the size of the pores.

In mahogany, Circassian walnut and black walnut the pores are so large that they can be seen very distinctly on a smoothly-cut surface of the end grain, where they appear as minute openings smaller than pin holes but visible without magnification. On surfaced faces the pores appear as fine grooves, running parallel with the grain. They are even visible through the varnish, appearing as dark lines.

In red gum the pores are much smaller and can be seen only with a magnifying glass.

How the Seattle Plan for Prevention of Labor Troubles Has Worked

By F. R. SINGLETON, in Engineering and Contracting

SEATTLE today is practically a strikeless city.

Several months ago the story of how the Associated Industries of Seattle had broken the domination of radicals over the industries of that city, by a firm and successful stand for the open shop, was published broadcast throughout the United States. The employers of Seattle, banded together in the Associated Industries, declared their independence of restrictive union rule; stood for their right to hire their own men and the right of the employes to work, regardless of membership or lack of membership in a union; and established those rights by defeating a series of strikes to enforce unreasonable demands.

Back of this stand of the united employers of Seattle was the knowledge that the radical labor leaders had planned to practically take over the industries of Seattle and operate them, ostensibly in the interest of organized labor. Accordingly it was a fight for the perpetuation of industrial freedom in Seattle in which the whole United States was interested.

The story of the methods followed by the Associated Industries in defeating strikes and establishing the open shop; of the broadsides and other publicity in the daily newspapers to win public sentiment over to the "American Plan" of industry; of other phases of the struggle in which employers stood steadfast with unbroken ranks in the face of efforts to close their plants, was read with sympathetic interest by employers throughout the United States, and the Seattle plan of open shop campaign has been adopted in several notable instances since that time.

Naturally, the question has arisen in many minds: Will the Seattle plan endure? Will results be permanent and justify the struggle and expense entailed in putting it over?

Events of the past six months in Seattle justify answering this question in the affirmative. While many sections of this country are still troubled with destructive strikes and interference with production, Seattle today is free from strikes, harmony between employes and employers is on the increase, and the open shop has been established in every industry in which a strike has occurred.

When the story of Seattle's struggle to throw off the radical yoke was published, strikes in the building trades, the cleaning and dyeing and some minor industries, had been won, and the community thoroughly converted to the open shop idea, but several other strikes were still in progress, leaving the ultimate outcome in doubt. Since that time the employers have won out against the printers, one of the oldest and most powerful unions in Seattle; against the tailors and several other unions which saw fit to strike. Since August, 1919, every strike has been won completely by the employers and the open shop substituted for radical union domination.

Following a winter of comparative peace, radical union leadership attempted to force the issue again in the spring, in the hope of breaking the open shop movement. Attempts to force a new agreement with burdensome conditions on the baking industry late in April resulted in an open shop declaration by the master bakers, and a new strike which the employers won in short order. An abortive attempt was made to call out

the workers in the building trades on May 1, which amounted to nothing, for the building trades workers had their fill of strike last year. The defeat of the building trades strike, which lasted from August to November, 1919, was the first important victory of the Associated Industries and the occasion of the first open shop declaration. Since that victory, things have progressed in the building trades, accompanied by increased production. The majority of the union workers had accepted open shop conditions. They did not wish to go through another period of enforced idleness and so the efforts of union leaders to bring on another strike and overthrow the open shop were fruitless.

The most striking example of Seattle's freedom from the old-time radical domination, however, occurred on the Seattle water front. During the war, the local of the International Longshoremen's Association got a stranglehold on water front employment. Employers had practically nothing to say about the hiring of men, gangs of longshoremen and truckers being furnished by the union from the union list at the union hall. Although Seattle is a busy port, the union contained about twice as many men as there was full employment for. As a result, the work was often stretched out sufficiently to give a satisfactory measure of employment to all and the cost of handling cargo became inordinately high. Last fall, the employers succeeded in reaching a new agreement which abolished the list system, but early in May the I. L. A. served peremptory notice on employers of the re-establishment of the list system, thereby breaking the clause of their agreement requiring thirty days' notice of termination.

There is a large radical element in the Seattle local of the I. L. A. In fact, it was regarded as one of the last strongholds of radicalism, and a test of strength had been postponed as long as practicable by the employers, but the course of the union left no alternative but to declare open shop and fight it out. That action was taken by the employers. A surprising number of men responded to advertisements of work under the open shop. Within two weeks, work reached normal on the Seattle water front, and the I. L. A. declared the strike off under orders from the international officers who had refused to sanction the strike. As a result, there is a surplus of 1,000 to 1,500 men on the water front who will eventually have to find other work, for the employers are giving practically continuous employment to those who helped them out during the strike, and who wish to remain at work. Also the conservative element of the union has broken away from the radical leadership and is applying for a charter for a new local.

Also, Seattle escaped any interruption of freight service. While railway workers were striking in many sections of the country, the railway workers and switchmen refused to go out, even in sympathy with the longshoremen.

The Associated Industries has just held its second annual election. In one year of work it has changed Seattle from a radical-ridden and strike-disturbed city to one of the most peaceful and productive cities, from the commercial and industrial standpoint, in the United States. The defeat of the radicals has driven some thousands of them from the city, and Seattle is no longer the stronghold of the I. W. W. and a hotbed of soviet conspiracy.

Yes, the Seattle plan has proved a success. The Associated Industries, after an eventful year, is stronger in membership, finance and influence than ever before. It has followed consistently the declaration of a square

deal for the employes. In spite of the surplus of labor that has existed for several months with the decadence of the shipyards, its members have lived up to their pledge that wages would not be reduced until living costs receded. In some instances wages have been increased without any requests being made by the employes.

Seattle union men are not discriminated against in the operation of the open shop. Instead, the employers simply refuse to deal with the unions as such. The shop committee system is being worked out to give employes the representation promised them under the open shop. The policy of the Associated Industries is to give the employes such representation and fair treatment that the union is unnecessary to them.

That is why Seattle today is a strikeless city.

* * *

Will Benefit Building Industry

Increased freight rates will mean better transportation, more cars, and prompter shipments, which will be decidedly beneficial to the building industry. Prices may strengthen temporarily, but with the increased production and sure delivery of building materials which we foresee prices will gradually ease off.—American Builder.

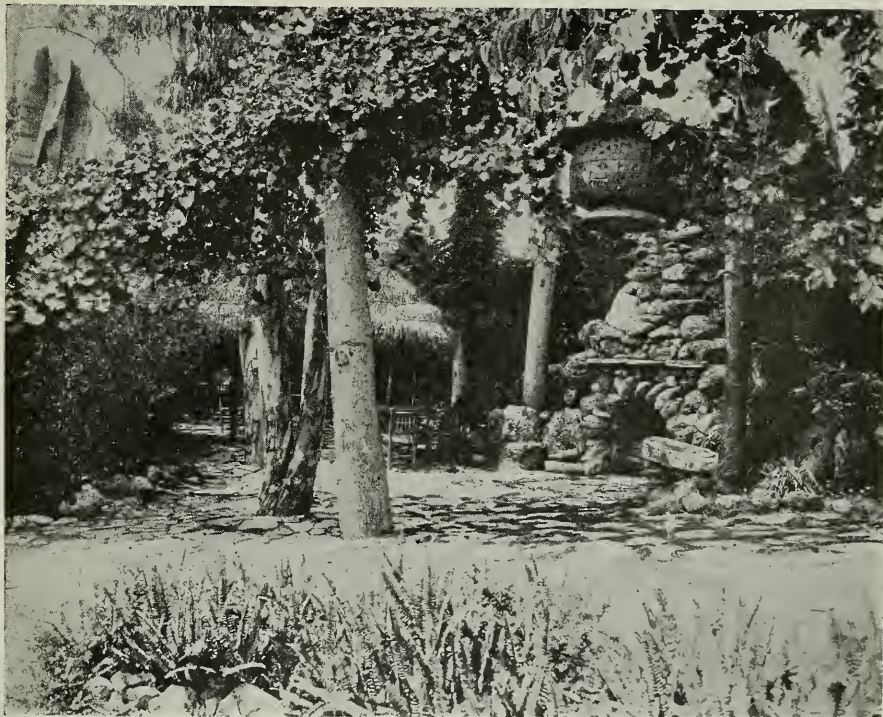

HAWAIIAN GARDEN OF F. C. KEELER, LA BREA AVENUE, HOLLYWOOD
Howard and Smith, Landscape Architects

Awarded honorable mention as a notable example of landscape architecture in Los Angeles by the recent jury.

Concrete Storage Tanks

By ROBERT SETH LINDSTRÖM

THE use of concrete as a material for the construction of tanks for the storage of liquids and fluids such as water, oils and products having a flowing nature, is ever increasing, due to the fact that concrete as a structural material has long since passed the state of experiment and is now universally adopted as one of the leading structural materials. For structural purposes, concrete both plain and reinforced, has by time proven to be non-deteriorating and wearproof material and so generally understood.

The materials entering into the construction of concrete tanks are cement, sand and aggregate mixed with water, together with structural reinforcement bedded into the concrete. Therefore, it is essential that these materials are selected for quality and grading that will produce a water and oil proof finished concrete tank.

The subject of waterproofing and oil proofing cement and concrete is very complex and may be accepted as a basis of wide divergence of opinions among chemists and others who have made exhaustive studies of cement and concrete waterproofing. Therefore, this branch of concrete tank construction requires the most careful consideration, especially in the field where the human element enters into the proportioning, mixing and placing of the concrete into the forms or moulds.

The term waterproofing, generally speaking, is the method employed for rendering concrete nonporous and dense, which divides itself into three divisions; the integral method, the membrane method and the surface coating method.

For the subject of this topic, we will consider the integral method or the absence of voids by selecting materials that will mix and create a density in the finished concrete tank that will be uniformly distributed throughout the walls and bottom of the tank. Therefore, it will become necessary to select only such materials as will guarantee good results, such as the quality and kind of cement, sand and aggregate and water to use.

Cement: The cement should be genuine Portland Brand ground to a fineness of 95 on a 200 mesh sieve. This quality of cement is called a "Reground Cement," which means passing through two stages of grinding until the cement has the fineness of talcum powder, thereby obtaining more colloidal efficiency, waterproofing value or cement glue than is obtained by standard specification for fineness of Portland Cement.

The calcareous matter or particles which do not pass through a 200 mesh sieve are incapable of complete crystallization and, therefore, valueless as a cementing material. The cement attacks the silica of the sand and aggregates and crystallizes into one solid mass in the process of crystallization, the finer the cement the less voids will appear in the completed mass or material called concrete.

The cement used for tank construction should be fresh new cement, as recent researches show that storage of cement where same is subjected to atmospheric changes create marked deterioration in the strength of the cement, due to absorption of atmospheric moisture causing a partial hydration which reduces the early strength of the concrete and prolongs the time of setting. These researches and tests were made on standard Portland Cement which showed the following losses from the original strength. Deterioration in strength with storage of Portland Cement from 3 months to 2 years time.

3 Month Storage in shed	80%	of original strength
6 " " " "	70%	" " "
1 Year " " "	61%	" " "
2 " " " "	40%	" " "

The cement giving the bond and final strength to the concrete should, therefore, be fresh and properly stored in a moistproof place.

The strength of concrete increases with the fineness of a given lot of cement for all mixes, consistencies, gradings of aggregate and ages of concrete.

Sand: The important characteristics of sand for use in concrete are durability, cleanliness and grading. By durability is meant sound, non-deteriorating particles of beads of grade known as torpedo sand, which is screened from gravel.

Cleanliness means free from vegetable or organic matter and grading is the sizes of particles having a certain percentage of coarse and fine grains, sharpness of sand is not absolutely necessary, too fine sand even if free from vegetable and organic matter should not be used. It makes a weaker concrete and requires more cement and a larger proportion of water. "Run of Bank" gravel should never be used. It should first be screened and correctly proportioned to determine the cleanliness of sand. The Colorimetric Test is a very practical and easy field test.

Method for Field Test: The field test consists of shaking the sand thoroughly in a dilute solution of sodium hydroxide (NaOH) and observing the resultant color after the mixture has been allowed to stand for a few hours. Fill a 12-ounce graduated prescription bottle to the 4½ ounce mark with the sand to be tested. Add a 3 per cent solution of sodium hydroxide until the volume of the sand and solution, after shaking, amounts to 7 ounces. Shake thoroughly and let stand for twenty-four hours. Observe the color of the clear liquid above the sand. A good idea of the quality of the sand can be formed earlier than twenty-four hours, although this period is believed to give best results.

If the solution resulting from this treatment is colorless, or has a light yellowish color, the sand may be considered satisfactory in so far as organic impurities are concerned. On the other hand, if a dark-colored solution is produced, the sand should not be used in high-grade work.

Aggregate. The aggregate may be of gravel, crushed limestone or other local aggregates equal to gravel or crushed limestone. If gravel is used, it should be graded from size that will pass through a ¾-inch ring down to size of sand used, and subjected to the same tests as to durability, cleanliness and grades as above suggested, for the sand.

If crushed limestone is used for aggregate, it should be graded from ¾-inch to ¼-inch in sizes and free from dust, loam and foreign matter, washed clean. Crushed limestone for concrete tank construction has been found to produce a more fire resistive concrete than when gravel has been used for the aggregate.

Proportions of Mix. For concrete tank construction the following proportions are recommended. One cubic foot reground cement, two cubic feet sand and three cubic feet of aggregate.

Water. The water for mixing concrete should be pure and free from oil, acid, alkali or organic matter and sufficient amount of water used on the mix to bring the mix into a consistency of pouring into forms.

Mixing. The concrete should be mixed by machine in a batch mixer of a type that will thoroughly mix cement, sand and aggregate into a uniform batch.

Pouring and Tamping. The batch should be poured into forms or moulds immediately after being properly mixed, then thoroughly spaded and tamped into place.

Reinforcement. The reinforcement should be so placed that the concrete will readily pour and entirely imbed the reinforcement steel as the tightness of the tank depends upon the dense coating around the steel. The steel should not be painted or coated, but clean, as the adhesion of the concrete to the steel depends upon the cleanliness of the steel.

Plaster Coat. After the forms have been removed, if any honeycombing or defect appears, the loose and porous portion should be removed and a coat of plaster filling all openings should be done while the tank is still green. This plaster coating should be of a mix consisting of one cubic foot of Reground Cement and two cubic feet of sand troweled to a smooth even finish.

Wetting Down. The tank, if exposed to heat or hot weather, should be wetted down while in the period of setting to prevent crazing of surface exposed to elements.

Expansion and Contraction. Expansion and contraction in concrete construction is caused by the expansion and contraction of the steel reinforcement and not in the concrete itself, as the concrete in the process of drying out and hardening naturally causes some shrinkage by the evaporation of the water and suction in the bonding and crystallization of cement with the sand and aggregate.

The term expansion applied to concrete is not correctly used, as expansion or breakage of bond in concrete is caused by the porousness of the concrete mix admitting moisture and water, which freezes and thaws causing expansion of the ice formed in the voids or minute opening in the concrete, also by the porousness of the concrete subjects the imbedded steel reinforcement to climatic changes and conditions.

Therefore, when reground cement is used with proper kinds of sand and aggregate, coupled with good workmanship, the density throughout the completed mix will prevent moisture and climatic condition from penetrating through the finished dense concrete and thereby practically do away with expansion and contraction of the steel reinforcement.

Pipe Openings. The weakest part of any tank construction material is at the openings left for filling and draining when metal pipes are used for this purpose, due to the expansion and contraction of the pipes, also the jar and friction caused by making pipe connections. Therefore, it is of great importance that the sleeve passing through the wall or floor of the tank is securely anchored into the concrete, and this can be accomplished by using a flange sleeve with prongs or long teeth in the center and extending into the concrete, the inner portion of the flange threaded its entire length, and a temporary screw cap for preventing the concrete coming in contact with the threaded portion of the sleeve. After the tank has set and dried out, remove the screw caps and insert an inner treaded pipe treaded the entire length, letting inner and outer ends project enough for the regular pipe connections.

* * *

“Hush-a-by Baby”

Hush-a-by, baby, on the tree top,
 When we can't buy the profits will stop;
 When the world's broke the prices will fall,
 And down will come business and prices and all.—Ex.

The Lack of Houses*

I.—HOUSES: THE NEED

By ARTHUR GLEASON

THERE is a national shortage of houses. Cities, towns, and villages suffer alike from the restriction of two years of war upon building. The Building Age says "A careful estimate, based on the most reliable available data, places the country's need at 500,000 homes." But a Chicago report to an architectural journal states that this one city is "short 75,000 to 100,000 homes." The admirable report of the Housing Committee of the Reconstruction Commission of the State of New York gives the need of apartments in New York City as 40,000. It is fair to say that the estimate of 500,000 as the national shortage is the strict minimum, immediately required to check congestion, eviction, and an un-American standard of living. The estimate does not include a constructive housing program. The present housing shortage may be traced back to 1907 when the cost of construction began to mount.

Building contracts, for the territory east of the Missouri and north of the Ohio Rivers, show for February of this year 42 per cent for industrial building, 20 per cent business, 20 per cent public work and utilities, 17 per cent residential buildings. The building figures for the year of 1919 show an increase in value over earlier years. But when the rise in costs is allowed for, the actual volume of building in December, 1919, amounts to about the same as in December, 1912, or 1913. And the tendency is toward commercial buildings rather than homes. Further, plans are not buildings. The New York Times of April 4 reports that of 94 plans filed in the Borough of the Bronx in 1919 for the construction of buildings containing 3,964 apartments, 14 were carried to completion — fewer than one-sixth of those planned.

As the Housing Committee of the New York Reconstruction Commission puts it: "Decent homes and wholesome environments in which to bring up children cost more than most workers can afford."

The simple fact is that the worker as a labor unit can be more easily disposed of in the flow of business than the worker as a person with human needs that include a home. The report of the United States Housing Corporation says: "Industrial plant investment, including the housing of machinery and of the workers during work hours, is relatively small as compared with the investment required properly to house and keep in working efficiency the workers and their families outside of work hours." Certain New York realty men state that rents will increase by 200 per cent within two or three years. And one of the wisest of them has said: "Rents will never get back to the pre-war basis. And there isn't any possibility of building enough houses within the next ten years." The housing problem includes:

The present shortage — an emergency.

The need of minimum standards in decency — "the pathological aspect of housing."

The need of good homes — a program of reconstruction.

Statistics of misery have determined much of our social policy, and the picturesque evils of foul tenements have been regarded as the housing problem. But by standardizing minima of decency, we do not build worthy homes for the whole community. We have studied and somewhat safeguarded the inarticulate poor, taking in tenants, doubling up families, and moving to lower grades of foulness. But a larger constructive plan of building has not been developed. "A mass of restrictive legislation, limited largely to the multiple

* Reprinted from *The Nation*, April 17 and April 24, 1920, by special permission of the publishers.

dwelling as a prevailing type"—taxes on enterprise, sabotage, government bureaucratic control or management of private business, state aid — these intrusions are not sufficient of themselves to build houses. As Edith Wood shows in her valuable but mistitled book, "The Housing of the Unskilled Wage Earner" (which envisages the entire problem and not that of the subnormal alone), one-third of the people of the United States are living under subnormal housing conditions, conditions which fall below a minimum standard. The 1910 census showed there were 20,255,000 families in the United States of whom 10,697,000 lived in rented houses.

Our actual housing system has tended to destroy the home, to penalize private property, and, in the stratum of the subnormal, to nationalize women. (See the investigations of Mr. George Kneeland for Mr. Rockefeller's Bureau of social hygiene.)

It was possible to say of the home building of five centuries ago that "every street had a Gothic profile." But the most accurate and brilliant summary of our deposit today is that of Emile Hovelague:

The monotonous succession of smoke-grimed cubes of brick, all similar and sordid, a symbol of the sordid similar lives they shelter; the endless lines of wretched homes which all over the greater industrial centers endlessly repeat, with the insistence of a maniac, their somber invariable rectangles, cluster on cluster, mile after dreary mile of mean and crushing hideousness, as though some spawn of insect life had settled there and swarmed. Is it in order to produce an architecture no higher than that of a coral reef, to bring into God's light such forms of life, such visions, such monotonies of hideous depression, that a society is born?

The individual home, self-contained, self-respecting, with its bit of garden and sunshine, and its touch of stillness and solitude, is perishing from the earth. Human life is not richer in dignity than in former times, but less rich. Town-blight, cramped quarters, foul air, canned food, herd life, have wrought their work till John Galsworthy says: "We do not realize the great deterioration of our stock; the squashed-in, stunted, disproportionate, commonized look of the bulk of our people. Ugliness has become a matter of course."

The buildings grow larger and higher, the rents increase, the rooms grow smaller, so that a typical modern nomad tenant can begin to see the walls close in on him, while he pays in proportion to the tightness of the squeeze.

Through no fault of its own, private enterprise, working for profits under price competition and price-fixing, with taxations, finds itself unable to build houses in sufficient numbers. This is not a New York situation, nor an American situation. It is not local. It is a universal crisis in the Western World. What I saw in London in January, I find in New York in April. Coventry, England, is in the same way as Buffalo, New York. The shortage of houses in Britain is at least half a million. Interventions by the Government in the last eleven years have only availed to make a bad situation worse. The next ten years may see a need of 1,630,000 dwellings, as Sir Kingsley Wood, Parliamentary Secretary to the Minister of Health, suggests.

Now, it is the duty of the business man, handling speculative money, to place it where the returns will be swift and "fat" (to quote a real estate owner). He is not in business for his health nor for the health of home-seekers. To expect business men to turn from sliding-scale profits to non-remunerative or fixed-return-on-capital services, is to ask them to yield the fortress of private enterprise. In recent days and up to the present moment, there has been more money in doing brokerage tricks with the existent supply of houses than in creating a new supply. Real estate men have been "starving" for eight years. And now, the last of business men, they enter the land of plenty. Long after food and clothing and the joys of life have soared to the sky and rewarded the good guessers who control their output, the land investor, land speculator, landlord,

and realty broker take their turn at taxing the community for their service as business men.

As the British Government Committee on Trusts showed, combinations prevail in nearly every branch of business for the purpose of regulating production and restricting competition, so as to restrict output; fixing a common price and controlling the price; delimiting markets. Into the market price of every important commodity there enters, at the various processes of its production and distribution, a series of profits that load it, a pyramid that weighs down like gravity. The final unhappy man who has to market the product is then called a profiteer. But he has merely tacked on his little tax to the dozen other taxes that began with the product when it was raw material and that attach themselves to it through its life journey. With land and the house upon it, the same piling of charges takes place — interest on interest, profits on profits — till the twentieth of an acre and its fragile building stagger under the necessary, legalized load. The final builder or broker pays taxes on his improvement and the land he has improved, “plus all the profits of three or four and sometimes as many as ten land speculators. An examination of the tax books of two Rhode Island cities has shown instances of increases in purchasing value of land from 100 to 650 per cent in less than fifteen years.” As Dr. Carol Aronovici, Director of Housing for the California State Commission of Immigration and Housing, says “The burden of final cost is placed upon the builder and the return upon this cost must be secured in rents which the tenant pays.”

The memorandum attached to the British trust report showed that 25 per cent of the materials that go to the building of an average house are subject to full control by combined business interests, and that 33 per cent more are partially controlled, for the purposes of so restricting output as to control prices. Such concerted organization and control relieve the associated business men from subjection to the “law of demand and supply” as regards the prices at which their products are sold to the consumer. Thus is created “a series of industrial monarchies or republics enjoying a sovereignty of their own as regards the amount they will allow to be produced and the prices at which they sell. Freedom from public control will then mean not free competition, but concerted or unified control by private interests.”

The total cost of cottages was then analyzed (excluding cost of the developed site), and it was found that of that total cost 40.74 per cent was labor and overhead, 14.64 per cent controlled building material, and 19.68 per cent partially controlled. An association, including 90 per cent of the manufacturers of one class of goods needed in the construction of workers' cottages, headed its rules thus:

(1) That object the Association has in view is that of raising and keeping up the price to the buyer of goods and articles made and (or) supplied by its members.

(2) This shall be done by means of pooling arrangements so controlling production that prices will rise naturally and inevitably, as they always must do when supply is brought into equilibrium with or is ever so little below demand.

To limit competition, to control and restrict output, to increase prices!

The Housing Committee of the Reconstruction Commission of the State of New York reports on this point:

It seems from such preliminary examinations as have been made that prices may be artificially maintained by a combination, expressed or implied, which certainly requires full investigation. If the Attorney General or the District Attorneys do not find that there is a crime, legislation should be enacted that will prevent the action of combinations that make it practically impossible to build houses, because of the artificial raising of prices and limiting of supply of essential materials.

This restriction of output by the business interests is not only legitimate, but necessary, because they cannot operate the system except under the inter-

action of prices and profits. If the charges which they make upon industry are disallowed, the whole structure of private enterprise would not only be endangered but destroyed. As the New York Times puts it, "A liberal margin of profit, adapted to the speculative chances involved, must be allowed to the real estate investor." It must. And his is only one of a dozen liberal margins of profit which the poor house must carry.

Now these charges (with labor charges, which will be referred to later), have fallen upon every item of American building material. The technical magazine *Factory* works out the costs in 1913 and 1919 of a typical six-room American dwelling. It finds a labor increase of 65 per cent and an increase in cost of materials of 71 per cent. This increase runs through every element of material — cinderfill, concrete foundation walls, waterproof painting, plastering.

This unavoidable sabotage of business men is for the moment revealed rather nakedly in the matter of housing which affects the comfort of fairly large numbers of persons. The accusation of profiteering has gone up against those particular men who control such commodities as houses and food. But this easy condemnation misses the fact that limitation of these commodities causes annoyance in a dramatic form, and that the same restriction of output and jockeying of the market in other commodities do not lead to mass meetings. So-called profiteering is merely the profit-making system (the necessary instrument of private business enterprise) at work on certain essential commodities, which, if produced in sufficient amount, would keep a population alive, comfortable, and quiet. Frederick L. Ackerman, who was chief of the Division of Town Planning and Housing Design of the United States Shipping Board, says:

What animates the speculator is the prospect of profits; hence if it chances that the building of habitations is likely to prove an agreeable speculative adventure, habitations become the medium of speculation. The significance to be found in this simple statement is that the house of the common man is a by-product. The system of price competition and investment for profit would not operate without a shortage and the high rents. If there were no shortage, the system spoken of as "modern business enterprise" would not function at all.

Not only that. The denunciation of the business man, carrying out the principles and practice of the last hundred years, which has created its own ethic, fails to include the worker. If the sabotage of the business man is almost universal, so is the sabotage of the worker. And unlike that of the business man, the worker's sabotage is not inevitable except as he chooses to make it so. For several generations he accepted his status as that of a commodity, and a minimum subsistence as his level in the cosmic scheme. The profit-making system is pivoted on his docility. It is only today that he begins to refuse to operate industry for an unrestricted profit-making system. By recurrent wage demands, by shortening hours, by "soldiering," by sectional strikes, he eats the profits out of industry. There will shortly come a time when business men will frankly come to the community and say they cannot operate the business system, because there are no profits in it. That day has arrived in the British coal mines and railways. It has apparently arrived in housing both in England and the United States. The house of today, as it tries to get itself built, is weighed down by an overlay of golden charges — taxes, profits, interest, every item of material, every stroke of labor.

Out of dim childhood we all remember the story of the little boy in the pageant who was selected to play the fairy prince. They overlaid his body with leaf gold, leaving no interstices through which his body could breathe. So he played the part of the happy prince, clad in his shining gold, sitting very stiffly. And at the end they found him dead.

II.—REMEDIES

There are no tidy optimistic little summaries possible on the housing situation. There is no overnight remedy. Banks, insurance companies, and large lending institutions "now show a great reluctance to make loans. They are in no mood for extending liberal credits on new homes. Other forms of building offer much better returns than does housing." And the bankers fear a shrinkage of values in houses.

For this problem — intricate, world-wide, increasing in severity — there is no panacea. But by pooling the experience of many peoples and many boldly-experimenting communities, the outlines of a housing policy emerge:

1. Land must be freed for community use.
2. The credit-power of the community must be placed behind the building of homes.
3. The network of business men's profits must be a little lifted from the building industry.
4. Town-planning must be recognized.
5. Transportation must relieve congestion.
6. Minimum standards must be set and maintained by rigid restrictive legislation.
7. In certain great cities (notably New York) some of the industries must be removed outside the city because the housing problem in such congested centers cannot be solved by more houses, nor additional transportation, since there is not room enough and land is too expensive.
8. Building material must be made available.
9. Community ownership and control of land and houses by copartnership tenancy societies must be made possible.
10. The private ownership of homes must be made possible.
11. Architects, and not speculative business men, must be made the "rightful masters in the task of providing shelter for man."
12. The sabotage of labor must be replaced by co-operation in public service.

Such is the large-scale policy for housing which experience suggests. Let us consider these twelve points in detail.

Land.—There is no question that F. T. Miller, president of the F. W. Dodge Company, is right when he says "The so-called unearned increment is the incentive to investment of savings in homes and real estate." But the attraction worked irregularly in that it tended to land speculating and the holding of land unoccupied. The Committee of the Reconstruction Commission of the State of New York says: "The increased values of land which result solely from the fact that individuals are crowded together are of no benefit to those who create them. This land increment, in most cases, is wasted in land speculation. * * * This increment is charged as a part of the cost of the house, either as rent or selling price." The remedy suggested by this Committee is: "Passage of an enabling act permitting cities to acquire and hold, or let, adjoining vacant lands, and if necessary to carry on housing. This legislation should be such as to permit conservation of the increment of land values for the benefit of the community creating it."

But no single remedy meets the situation. In the garden village of Sawyer Park (Williamsport, Pa.), the cost of raw land was \$636 an acre. To develop 24 acres cost approximately \$2,000 an acre (sewer, sidewalks, curbing, lighting, streets, planting, etc.). The heavy expense was not in the cost of the land, but in developing that land. If land were given away, the cost of development and building would still sometimes be prohibitive.

Money.—Housing is bound up with land, both are bound up with town-planning, and all three are bound up with our business system, and the obtaining of money. Money very properly goes where it finds friends. In house building it has been taxed, sabotaged, and profiteered till it has gone in other directions of speculative investment. A strong element in public opinion is in favor of temporarily relieving from taxation, in whole or part, real estate mortgages on residential properties up to some such amount as \$40,000, and of temporarily relieving new buildings from taxation. This remedy of tax exemption is the rendering of real estate money privileged. It is not a cure-all. Speculative money will turn to such forms of building investment as promise swift and large returns. This may mean increasing the congestion of large cities. The shortage of houses began long before the income tax troubled the investor. Industrial enterprises are paying profits and are expanding, although profits are taxed higher than realty mortgages.

In addition to tax-exemptions, Government aid takes three forms: Direct community action by state or municipal housing; loans to non-commercial housing companies at a low rate of interest (limited dividend public-welfare associations); loans to individual workingmen on such terms that they can build or acquire their own homes.

If taxes on mortgages, buildings and improvements are lessened, and a larger fraction of the rental value of land is taken by the community, there will still be a shortage of houses. Stewart Browne, president of the United Real Estate Owners' Association of New York, says "Unless the State or city takes a hand in new housing there will be mighty little new housing for workers in the next few years."

A majority of the Housing Committee of the New York Reconstruction Commission recommend a law providing local housing boards in places of over 10,000 and a central State housing agency, to assist in the preparation of housing laws, zoning ordinances, and the like. They further recommended the development of a means for using State credits to apply to housing at low rates of interest without loss to the State, and the enactment of a Constitutional amendment permitting extension of State credit on a large scale and at low rates to aid in the construction of moderate priced homes. This does not mean that the State itself shall build such homes. It does not mean the State is to own or operate houses. It does not mean that the State is to offer subsidy for the construction of houses. It does mean that the State shall be enabled to loan money on its credit to limited-dividend corporations or to individuals or to organizations of individuals to build houses of such standards, as to light and air, as the State or community may determine to be desirable, the rentals of such houses to be controlled and the loans to be secured by adequate mortgages. Exemption of the bonds of the State Land Bank from State and Federal taxation is also recommended. These recommendations have the backing of such men as Felix Adler, George Foster Peabody, Charles Proteus Steinmetz, and Abram I. Elkus.

Various suggestions have been made for tapping credit-power. Among such are: a national housing fund, to be allotted to States with housing commissions, and by them granted to municipalities, and to limited-dividend non-commercial housing companies (civic, philanthropic, co-operative, industrial); postal savings deposit loans to individual workingmen; an amendment of the Federal Reserve act, permitting national banks to make housing loans (an extension of already existent permissions), thus rendering two billion dollars available; an amendment of the Farm Loan act, permitting housing loans; State housing funds made available.

With this scheme, as Edith Wood sees it :

The lowest economic group will have rented houses or tenements provided by cities and housing companies. Individuals aspiring to home ownership, with an income not exceeding \$1,200, are to have the benefit of low interest rates and long-time payments made possible by the release of postal savings deposits. An overlapping group—say those with incomes from \$800 to \$1,500—might attain group ownership through copartnership methods, if they could be induced to try it. Those with incomes over \$1,200, debarred from the privileges of the postal savings deposits law, could have the same privileges as to time at the higher interest rate offered under the suggested amendment of the Farm Loan law. Persons with incomes of from \$1,500 to \$1,800 and over can get on very well under present building and loan association methods without special legislation in their behalf.

By the Massachusetts Homestead Commission, the State found it possible to appropriate money for the purchase of homes. Theirs is the first State housing enterprise in our country. Oklahoma has a law which authorizes the investment of certain state moneys in loans for building a home or paying off a mortgage on a home.

The United States Government entered the field of housing during the war. The Housing Corporation had a maximum program for housing 21,005 families. The average cost of the houses actually built was \$5,673.78.

The mutual building and loan associations have over four million individual members, and assets of nearly two billion dollars. By 1915, they had helped in building or acquiring over 700,000 houses. Their basic interest rate (with a few exceptions) is 6 per cent, and the completion of payment period is sixteen and one-half years. They have met the needs of the "black-coated proletariat" and the "salaried," rather than those of the unskilled worker.

Profits.—The rise in the cost of living is mainly not due to profiteering. It is due to a scarcity of goods, after war-waste heightened by currency-inflation and credit expansion, labor demands, and the whole business system of profit-making, including the dozen well-hidden charges that precede the final spectacular price, inaccurately dubbed profiteering. Until more goods are produced, there will be little alleviation. This is true in housing as in everything else. "The difference between the creative cost of the home and the ultimate cost to the owner and occupant ranges from 20 to 35 per cent of the purchase price." Added to these profits for promotion are the profits on each item of material. As Sir Eric Geddes, British Minister of Ways and Communications, put it: "In the past, private interest made for development, but today, I think I may say, it makes for colossal waste. We must forego the luxuries of competition, we must forego private interest and local interest in the interest of the state."

In Great Britain the employers and workers (representing about 600,000 persons) formed a Building Trades Parliament. A committee brought in a report, signed by all the trades unionists and by three out of eight of the employers. This report called for an end to be made of the profit-making system, in order that production might be for use instead of for profits upon investment. The Committee found a "disinclination of the operatives to make unrestricted profit for private employers." The remedies suggested were a fixed guaranteed return to capital, and a wage to management. This Building Trades Parliament and its report, declaring against the system of private enterprise for profits, received a series of sympathetic articles in the important American trade publication of the Associated General Contractors of America.

Town-Planning and Zoning.—And town-planning and housing are only a portion of the problem of community life, which also includes development of the land, agricultural production, and industrial efficiency. Town-planning has as yet dealt more with the city beautiful, the opening up of plazas and vistas,

the worthy placement of municipal buildings, than with transportation and housing. Several States have laws permitting cities to appoint official planning boards, and many cities are developing on lines of wise town-planning.

Zoning regulates and limits the height and bulk of buildings, and regulates and determines the area of courts, yards, and other open spaces. It divides the city into districts. It regulates and restricts the location of trades and industries and the location of buildings. It conserves property values, directs building development, is a security against nuisance, a guarantee of stability, and an attraction to capital. California, Illinois, Iowa, New Jersey, and New York have passed general laws permitting their cities to adopt zoning schemes.

Transportation.— Cheap rapid-transit is essential in solving the housing problem. Before the war, England was about to bring in a bill for a system of general transportation by means of light railways. Belgium has thirty-eight and one-half times as many miles of light railway in proportion to her area as Great Britain. This means that the worker can go from his factory to a home with a garden in the suburbs. Town-planning and cheap transportation will, in the long future, drain the slum dry and create garden communities. Fifty per cent of the Belgian population live in rural communes, although only 23 per cent of occupied persons are engaged in agriculture.

Legislation.— Among American names standing for effectual service in housing is that of Lawrence Veiller, secretary and director of the National Housing Association, author of "Housing Reform" and "A Model Housing Law" (revised edition of 1920). Upon his model housing law have been based the Housing Code of Michigan, applying to twenty-nine cities, the Minnesota Housing act, the Iowa Housing law. Many cities have ordinances based upon it. All the housing laws in the United States are based on the New York Tenement House law, the Veiller Model Tenement House law, or the Veiller Model Housing law.

Of the housing work of the Federal Government Mr. Veiller has written "The standards adopted by the Government for the housing of workers will have a potent influence upon the housing of the workingman in this country for many years to come." Among these standards are: The declaration against the tenement house as a means of housing workers; the requirements for light and ventilation, and through or cross ventilation; the declaration for adequate space between adjacent buildings and for adequate open space between the backs of buildings; the prohibition of living quarters in basements, cellars, barracks, bunk houses, and dormitories of the usual type.

Congestion.—In certain cities there is needed the distribution of population by the removal of industries from business centers to vacant land outside the congested area. New York City, for instance, is overcrowded. There is no room for many more houses. Subways make a slum out of a suburb, and increase the congestion. The general housing problem and the congestion of New York City are two very separate things. A year ago, when the clothing industry began to be dispossessed from Fifth Avenue, it had an opportunity to transfer itself to a new place outside the city. Instead it moved west two blocks. As long as industries huddle and breed in a city of limited area the crowding will increase. There is no real remedy until industry emigrates, leaving New York as a city of business. The housing problem of New York cannot be solved by more houses.

*

* *

WHY WORK?—Strike, and the world strikes with you; work, and you work alone.—Life.



*Portfolio of Some Recent Architecture in
San Francisco and Vicinity*

WALTER C. FALCH
JOHN K. BRANNER
JAMES W. PLACHEK



HOUSE IN FOREST HILL
Walter C. Falch, Architect

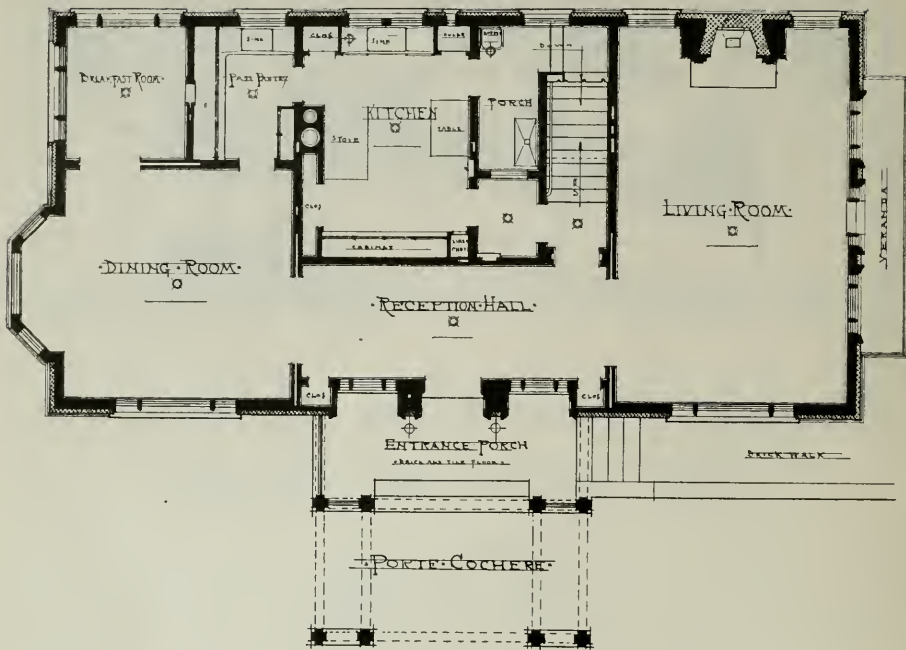

FIRST FLOOR PLAN, HOUSE IN FOREST HILL
Walter C. Falch, Architect

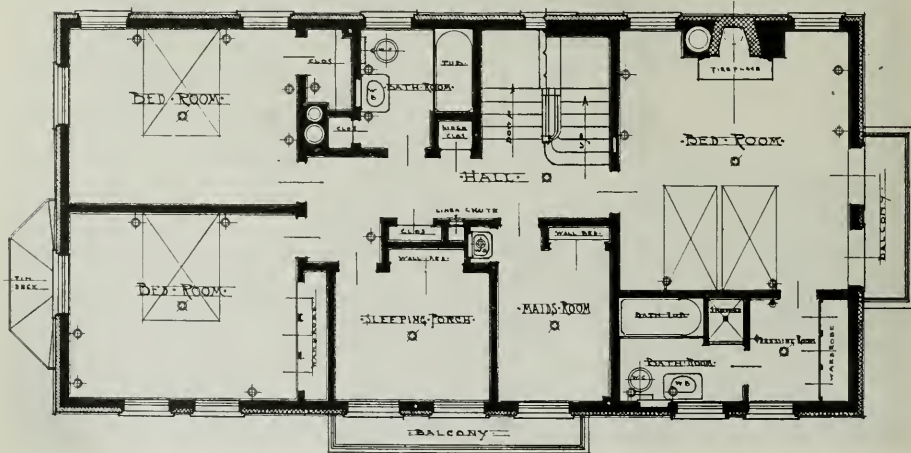

SECOND FLOOR PLAN, HOUSE IN FOREST HILL
Walter C. Falch, Architect

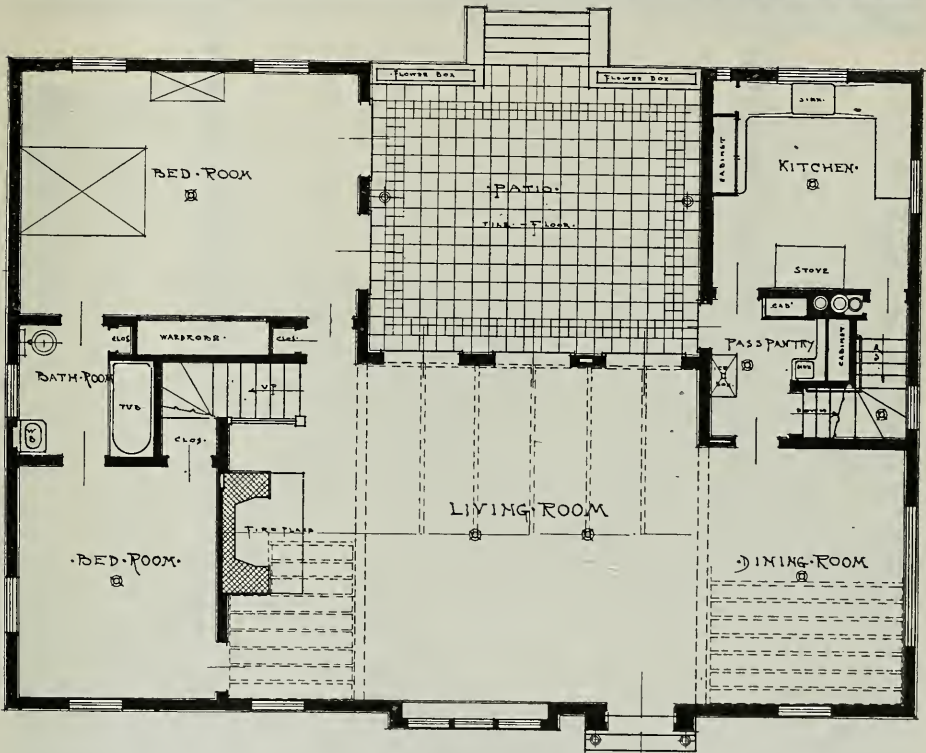

HOUSE FOR MR. H. ALLEN, FOREST HILL
Walter C. Falch, Architect

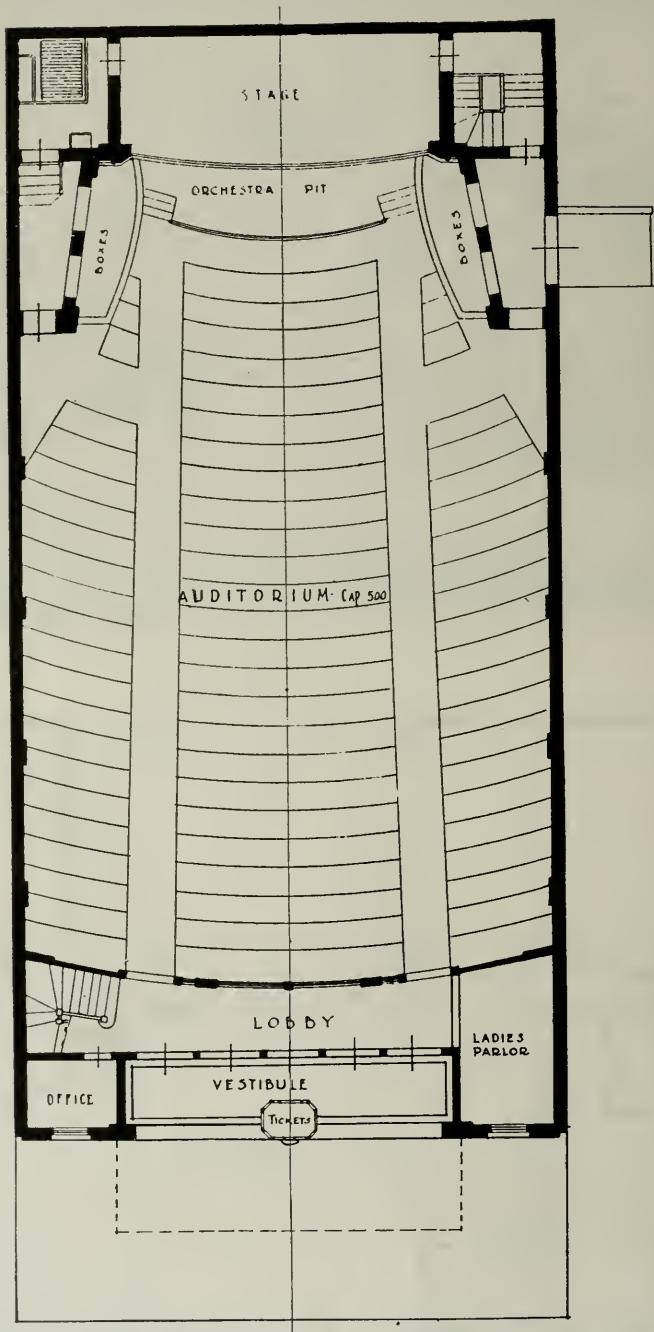

AUDITORIUM FLOOR PLAN, MAJESTIC THEATRE
BENICIA J. W. PLACHEK, ARCHITECT



FOYER, MAJESTIC THEATRE, BENICIA

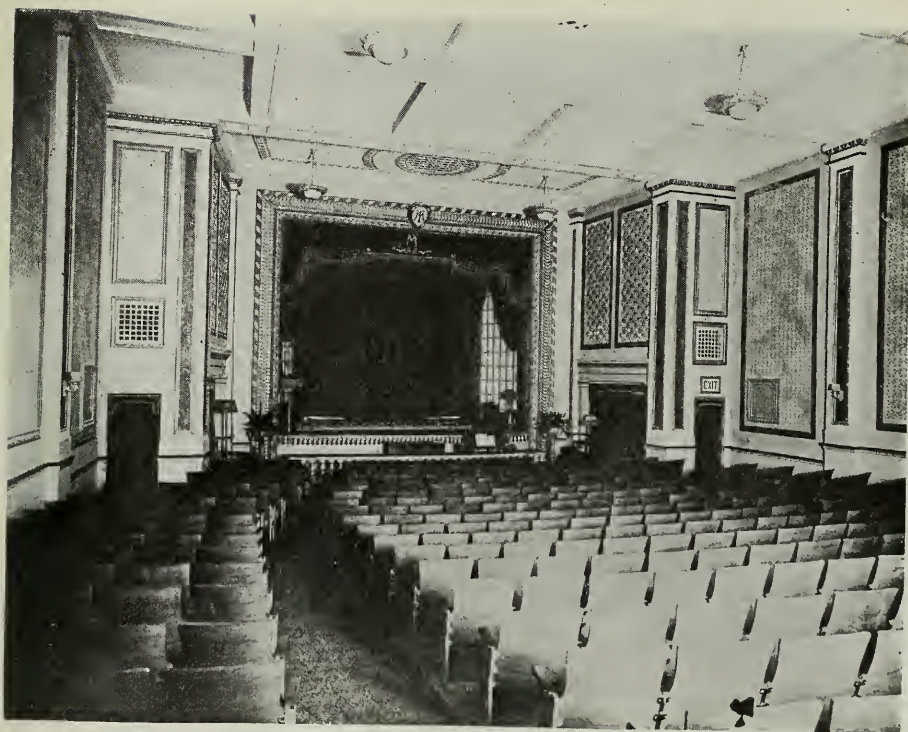

INTERIOR, MAJESTIC THEATRE, BENICIA
J. W. Plachek, Architect



ZETA PSI HOUSE, STANFORD UNIVERSITY
John K. Branner, Architect



ZETA PSI HOUSE, STANFORD UNIVERSITY
John K. Branner, Architect

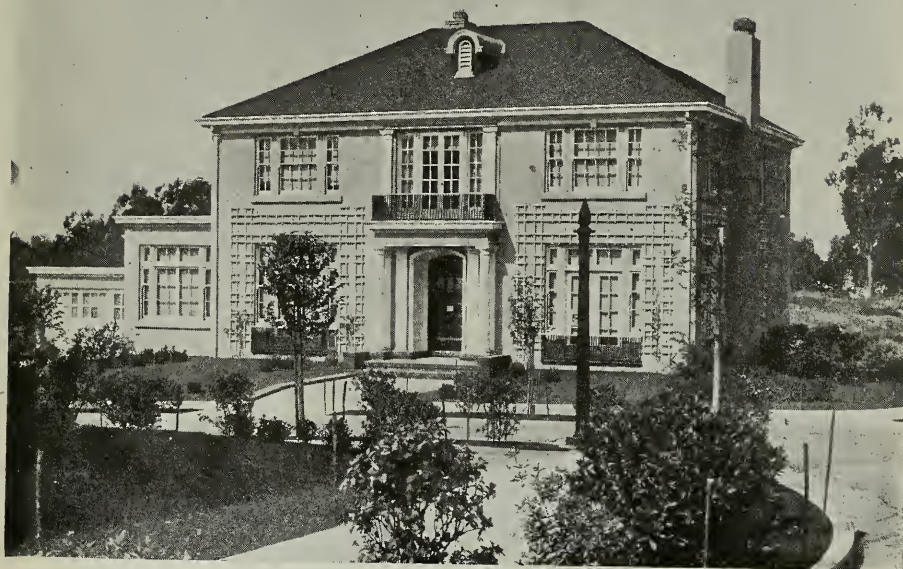

HOUSE FOR MR. J. A. QUEALY, FOREST HILL
Walter C. Falch, Architect



HOUSE FOR MR. J. MADISON, FOREST HILL
Walter C. Falch, Architect

Department of Safety

Conducted in the Interests of the Building
Public and with the Co-operation of the
California Industrial Accident Commission

An Unusual Elevator Accident

By E. C. WOOD, Chief Elevator Inspector

THE accompanying illustrations describe an uncommon but not infrequently possible type of fatal elevator accident.

A garage attendant was in the act of moving an automobile from the fifth to the first floor of a garage. It was his intention to drive up to the gate and wait for the elevator to come up from the second floor where it was standing. Unfortunately his brakes were unable to stop the automobile, with the result, the forward part of it crashed through the frail wooden gate, and overhung the landing threshold, being supported by the

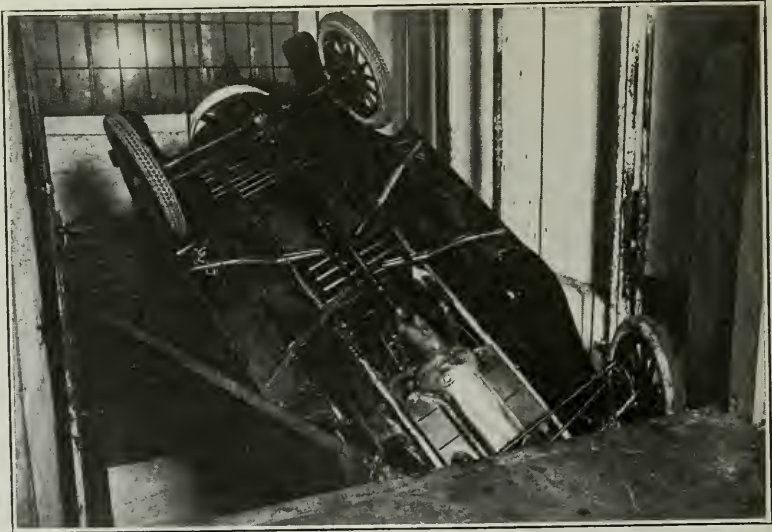

AUTOMOBILE TURNED TURTLE RESTING ON CROSSHEAD SCREEN

motor crank case. The attendant in endeavoring to alight from the automobile caused it to overbalance and plunge down the elevator shaft, fatally injuring himself.

It is fortunate that the construction of the car top was sufficiently strong to partially withstand the impact of the falling car as otherwise three other employees in close proximity would have suffered injury.

It is not contended that all elevator tops should be made strong enough to hold up falling automobiles or other heavy materials, but there are ways

and means of preventing this type of accident which is daily possible. Any elevator shaft opening, through which automobiles or similar conveyances pass, should be guarded by substantial metal doors. There is no more satisfactory form of enclosure or guard than the fire door. This appliance, whether it be single or double panel, can be made to serve as both safety and fire protection. Its construction is ordinarily very substantial and sufficient to stop a moderately moving automobile. It can be counterbalanced and interlocked in order to provide convenient operation as well as a desirable degree of safety.



STANDARD 3½ FOOT GATE THROUGH WHICH 1800 POUND AUTOMOBILE PLUNGED

We can not successfully educate the thousands of garage attendants who drive cars at lightning speed, on and off elevators, into narrow parking spaces, to be careful. Few if any of these men try the brakes before playing with thousands of dollars worth of automobiles. Failure of brakes and momentary loss of head, have sent more human beings to their graves than the German drive on Paris.

The remedy for the accident herein illustrated lies in providing substantial barricade in the form of landing entrance elevator doors. This barricade is more essential to the management of the garage than the bumpers he places on the front and rear of an automobile.

* * *

Unsafe Operation of Elevator Gates

By D. J. HARRIS, Elevator Inspector

The Elevator Safety Orders of the Industrial Accident Commission provide that all landing entrances of freight elevators shall be protected by gates or doors which shall begin to close automatically before the car platform has moved one foot from the landing. The accompanying illustration shows a very common practice of some employes—that is, to block these gates open with a stick or a nail, not realizing the danger to which they expose their fellow-workers and themselves.



To illustrate: "A" was employed by a furniture house as a receiving clerk. He was called from the basement to the sidewalk, to receive a case of goods from a drayman. He brought the car from the basement to the sidewalk, raised and blocked the gate open as he had been in the habit of doing. After receiving the case from the drayman he started to drag the case toward the elevator. In the meantime, unknown to him, another employe had taken the car to one of the upper landings. As he was dragging the box with his back toward the car, he did not perceive it had been moved, with the result that he backed into the open shaft, falling to the pit with the case, which he had instinctively held on to, a distance of fourteen feet, causing injuries which proved fatal.

* * *

The Flag Pole Hazard

A SHORT time ago a painter was sent up a flag pole to paint it. On reaching the top he took hold of the iron staff supporting the wooden ball. The staff bent over about 45 degrees and broke off just above the top of the flag pole.

The iron staff or rod was originally $\frac{3}{4}$ -inch in diameter, supporting a 10-inch diameter ball 20 inches above the top of the pole. Moisture collecting around the iron rod caused oxidization to set in, reducing the area of the rod to about $\frac{5}{16}$ of an inch in diameter. Where the rod was inserted into the top end of the pole, oxidization had also taken place, sufficiently to split the pole and the halyard ring, allowing more moisture to collect around the rod causing more rapid oxidization. The oxidization around the iron rod inside of the pole was nearly $\frac{5}{16}$ of an inch thick, and had enlarged the original $\frac{3}{4}$ -inch hole in the top of the pole to nearly 1 inch.

This pole had been up on a building nearly eight years. There are thousands of these poles and owing to the oxidization or rusting away of the iron rod or staff, which occurs at the very top end of the pole above the halyard ring, it is impossible to inspect them without going upon the pole to the very top.

American Institute of Architects

(ORGANIZED 1857)

OFFICERS FOR 1920-21

PRESIDENT.....HENRY H. KENDALL, Boston
 FIRST VICE-PRESIDENT.....CHARLES A. FAVROT,
 New Orleans, La.
 SECOND VICE-PRESIDENT.....WM. B. FAVILLE,
 San Francisco
 SECRETARY...W. STANLEY PARKER, Boston, Mass.
 TREASURER.....D. EVERETT WAID, New York

San Francisco Chapter

PRESIDENT.....SYLVAIN SCHNAITTACHER
 VICE-PRESIDENT.....ARTHUR BROWN, JR.
 SECRETARY.....MORRIS M. BRUCE
 Directors, WILLIAM MOOSER JNO. REID, JR.
 WM. O. RAIGUEL CHAS. PETER WEEKS

Southern California Chapter

PRESIDENT.....EDWIN BERGSTROM
 VICE-PRESIDENT.....HENRY F. WITHEY
 SECRETARY.....R. GERMAIN HUBBY
 TREASURER.....AUGUST WACKERBARTH

Executive Committee

A. M. EDELMAN ROBERT H. ORR S. B. MARSTON

Portland, Ore. Chapter

PRESIDENT.....W. C. KNIGHTON
 VICE-PRESIDENT.....JOHN V. BENNES
 SECRETARY.....FOLGER JOHNSON
 TREASURER.....O. R. BEAN
 TRUSTEES.....{ ELLIS F. LAWRENCE
 JOSEPH JACOBBERGER

Washington State Chapter

PRESIDENT.....CHARLES H. AIDEN, Seattle
 1ST VICE-PRESIDENT...JAMES H. SACK, Seattle
 2D VICE-PRESIDENT.....GEORGE GOVE, Tacoma
 3D VICE-PRESIDENT.....L. L. RAND, Spokane
 SECRETARY.....F. A. NARAMORE, Seattle
 TREASURER.....EARL G. PARK, Seattle
 DIRECTORS.....{ A. H. ALBERTSON
 C. H. BEBB
 G. C. FIELD

California State Board of Architecture

NORTHERN DISTRICT

PRESIDENT.....CLARENCE R. WARD
 SECRETARY-TREASURER...SYLVAIN SCHNAITTACHER

Members

J. R. MILLER EDWARD GLASS J. J. DONOVAN

SOUTHERN DISTRICT

PRESIDENT.....JOHN PARKINSON
 SECRETARY-TREASURER...A. M. EDELMAN

Members

W. H. WHEELER MYRON HUNT W. J. DODD

San Francisco Architectural Club

President.....Harry M. Michelson
 Vice-President.....T. Pfueger
 Secretary.....W. E. Baumberger
 Treasurer.....James S. Cole
 Directors—F. F. Amandes, N. Reinhertz, E. B. Hurt.

San Francisco Society of Architects

President.....W. C. HAYS
 Vice-President.....LEWIS P. HOBART
 Secretary-Treasurer.....H. H. GUTTERSON
 Directors.....{ GEO. A. LANSBURGH
 JOHN REID, JR.

Washington State Society of Architects

PRESIDENT.....HENRY H. JAMES, Seattle
 1ST VICE-PRES.CLAYTON D. WILSON, Seattle
 2D VICE-PRES.JULIUS A. ZITTEL, Spokane
 3D VICE-PRES.WATSON VERNON, Aberdeen
 4TH VICE-PRES.RICHARD V. GOUGH, Okanogan
 SECRETARY.....EDGAR BLAIR, Seattle
 TREASURER.....L. L. MENDEL, Seattle
 TRUSTEES:—H. H. JAMES, FRANK FOWLER, A. WARREN GOULD, W. J. JONES, R. H. ROWE, all of Seattle.

Pacific Coast Society of Landscape Architects

Chapter of Am. Society of Landscape Architects

PRESIDENT.....W. D. COOK, JR.
 H. W. Hellman Bldg., Los Angeles, Calif.
 VICE-PRESIDENT.....STEPHEN CHILD
 Fairmont Hotel, San Francisco, Calif.
 SECRETARY-TREASURER.....E. T. MISCHKE
 Henry Bldg., Portland, Oregon

Tacoma Society of Architects

PRESIDENT.....Roland E. Borhek
 VICE-PRESIDENT.....Earl Dugan
 SECRETARY AND TREASURER.....A. J. Russell

San Diego Architectural Association

PRESIDENT.....WM. TEMPLETON JOHNSON
 VICE-PRESIDENT.....ROBERT HALLEY, JR.
 SECRETARY-TREASURER.....E. C. DECKER

San Joaquin Valley Ass'n of Architects

PRESIDENT.....E. B. BROWN
 VICE-PRESIDENT.....F. V. MAYO
 SECRETARY-TREASURER.....JOSEPH LOSEKANY

American Society of Civil Engineers

Southern California Association

PRESIDENT.....GEO. G. ANDERSON
 FIRST VICE-PRESIDENT.....H. W. DENNIS
 SECOND VICE-PRESIDENT.....W. K. BARNARD
 SECRETARY.....F. G. DESSERTY
 TREASURER.....RALPH J. REED

DIRECTORS

LOUIS C. HILL W. K. BARNARD
 H. HAWGOOD RALPH J. REED
 H. W. DENNIS F. G. DESSERTY

All communications should be addressed to Mr. Desserty, 511 Central building, Los Angeles.

San Francisco Association

PRESIDENT.....M. M. O'SHAUGHNESSY
 1ST VICE-PRES.....W. L. HUBER
 2ND VICE-PRES.....F. R. MUHS
 SECRETARY AND TREASURER...NATHAN A. BOWERS

BOARD OF DIRECTORS

F. R. MUHS M. M. O'SHAUGHNESSY
 E. J. SCHNEIDER NATHAN A. BOWERS

Address all communications to the secretary, 502 Rialto Bldg., San Francisco.

American Association of Engineers

National Headquarters, 63 E. Adams St., Chicago

PRESIDENT.....L. K. SHERMAN
 FIRST VICE-PRESIDENT.....H. O. GARMAN
 SECOND VICE-PRESIDENT.....A. B. McDANIEL
 R. W. BARNES.....Portland
 FREDERIC BASS.....Minneapolis
 B. A. BERTENSHAW.....Cincinnati
 W. C. BOLIN.....Chicago
 RAYMOND BURNHAM.....Chicago
 C. E. DRAYER.....Secretary

SAN FRANCISCO CHAPTER

PRESIDENT.....WILLIAM WOLLNER
 FIRST VICE-PRESIDENT.....J. F. JOHNSTON
 SECOND VICE-PRESIDENT.....W. H. PHELPS
 TREASURER.....R. L. KESSING
 SECRETARY.....A. G. MOTT

Permanent address, 960 Pacific Bldg.

LOS ANGELES CHAPTER

PRESIDENT.....FRANK H. GAYNER
 FIRST VICE-PRESIDENT.....C. A. HEINZE
 SECOND VICE-PRESIDENT.....H. Z. OSBORNE, JR.
 SECRETARY.....D. E. GODFREY
 TREASURER.....E. H. MERRILL

Permanent address, 625 Metropolitan Bldg., Los Angeles.

THE
Architect and Engineer
INCORPORATED

Founded 1905 by E. M. C. WHITNEY

W. J. L. KIERULFF - *President and Manager*
 FRED'K W. JONES - *Vice-Pres. and Editor*
 L. PENHORWOOD - *Secretary*
 T. C. KIERULFF - *Attorney*

ASSOCIATE EDITORS

IRVING F. MORROW - *Architectural Critic*
 CHAS. H. CHENEY - *City Planning and Book Reviews*
 WILBUR DAVID COOK, *Landscape Architecture*
 WM. B. GESTER, - *Inspection and Tests*
 O. P. SHELLEY, C. E. } *Fireproof Construction*
 F. W. FITZPATRICK, }
 T. RONNEBERG, C. E., - *Structural Steel*
 W. H. LOWE - *Roofs and Roofing*
 FRED'K N. WOODS, JR., - *Rock and Gravel*
 W. H. GEORGE - *Cement*
 PAUL C. BUTTE - *Electrical Construction*
 H. J. BRUNNIER - *Reinforced Concrete*
 J. W. FRICKE, - *School Equipment*
 C. H. WHITE - *Hardwood*
 WILL J. FRENCH, *Department of Safety*

Published Monthly in the Interest of the
 Architects, Structural Engineers, Contractors
 and the Allied Trades of the Pacific
 Coast by The Architect and Engineer Co.

BUSINESS OFFICE AND EDITORIAL ROOMS
 627-629 Foxcroft Building, San Francisco
 Telephone Douglas 1828

The publishers disclaim any responsibility for statements
 made in the advertisements of this magazine.

TERMS OF SUBSCRIPTION
 (Including postage) to all parts of the United States \$2.50
 per annum; to Canada 75c additional; to all Foreign points
 \$1 additional.

Vol. LXII. SEPT., 1920 No. 3

A CONTRIBUTION TO ARCHITECTURE

"A valuable contribution to architecture," is the unanimous verdict of Architect and Engineer readers of the August issue, which illustrated some remarkably fine work of Los Angeles architects. The San Francisco and Bay city architects were loud in their praise of the work shown and many have expressed a keen desire to show the world some examples of the better class of architecture in Northern and Central California. Preliminary steps to this end already have been taken by the publishers of this magazine and further details of the plans will be announced shortly.

A GOOD RECEIPT IS WORTHLESS WITHOUT A GOOD COOK

The failure by fire of a reinforced concrete building is a signal to those who are interested in the proper development of this type of construction to

take notice of the causes of the failure and at the same time to take stock of the prevalent construction practice of the industry to determine by what course future failures are to be avoided, says Concrete.

The failure of the buildings of the Imperial Tobacco Company, Norfolk, Va., is the subject of a report by Mr. A. M. Schoen, chief engineer, South-eastern Underwriters Association, which has been issued in pamphlet form and given circulation among the members of the National Board of Fire Underwriters and of the American Concrete Institute.

The outstanding lesson of the whole matter bears on the old subject of adequate and competent inspection. No matter how good a design is or how perfect a set of specifications, if the job isn't done that way, the designs and specifications are just so much mental exercise for their authors.

WOOD CONSTRUCTION RESISTS CALIFORNIA QUAKES

Recent earthquakes in California have turned the attention of the nation generally to this type of misfortune and its results. In a general discussion of these earth tremors in the Scientific Monthly, Dr. Andrew H. Palmer has this to say with respect to the suitability of various types of construction to such conditions:

"San Francisco has learned its lesson in the matter of fire protection in a region of high seismicity. When that city was destroyed by fire in April, 1906, it was because the water mains had been broken by the earthquake and there was no water available for fire-fighting purposes. The water system has been reconstructed in such a way that an earthquake could not destroy its efficiency. But in the matter of building construction much is still to be learned. Steel-frame and reinforced concrete buildings will stand through a severe earthquake. Wooden buildings, too, will remain unharmed in destructive shocks, since they will yield to strains. Brick and concrete-block buildings are easily destroyed. But the most dangerous type of con-

struction is the primitive adobe, which is still in use among Mexicans and Indians. The lives lost in the Imperial Valley earthquake of June 22, 1915, resulted from the collapse of adobe buildings."

Notes and Comments

Leave it to Los Angeles if there is anything new under the sun to be developed. Read this from an Associated Press dispatch under a Los Angeles head line and published in an Eastern exchange:

What About a Lemon Pie of Concrete?

A lawn that is not a lawn, but looks like a lawn and is said by its owner to be better than a lawn—a waterless, mowerless, weedless, gopherless lawn—in short, a cement "lawn" painted grass green, has made its appearance in front of a Los Angeles bungalow.

Mrs. A. C. Woodward, inventor and owner, says it saves time, money and worry. She never has to water it, she never has to cut it, it is always dry enough to sit on—and it needs painting only once a year.

She has circular holes cut through the lawn and in them and along the edges she has flowers planted.

"I invented the cement lawn," she said, "because of trouble I had in getting a man to take care of my old grass lawn. It cost only \$65.

"You don't know what a blessing it is," she continued. "Do you know, I believe there would be much less unhappiness in married life if the husband would use a cement instead of a grass lawn, and so avoid having to come home after work and run an old lawn mower over the front yard every night."

From a landscape view-point our imagination fails to conjure a picture of this painted cement lawn that could possibly compare with nature's own beautiful mantle of greenery. And what a play-ground for Mrs. Woodward's children! Can you picture them romping over that artificial sward, their little bare feet patting the cold, green-painted concrete!

Several months ago the Architect and Engineer printed an abstract from a New Orleans paper, of Mr. Joseph Pennell's comments on the unsightly billboard. Because of Mr. Pennell's prominence in the world of art and design, much publicity has since been given his remarks by leading periodicals of the country. At the Eleventh Annual Convention of the American Federation of Arts Mr. Pennell further discoursed on the subject of signboards, the growth of which was declared by him to be debauching the taste of American citizens. Mr. Pennell's words were not minced nor was there any attempt by him to veil his sarcasm and contempt for some of the eyesores that are allowed to monopolize our vacant lots.

"Billboards," he said, "are ruining the landscape and the townscape. They are a danger to road users. They harbor dirt and indecency. As in all other countries laws must control them and, more important, be enforced." Mr. Pennell scored billboards as a menace to public taste, as eyesores in our cities, and as destroyers of countrysides. "The billboard people", declared the speaker, "have stolen the beauty of our country and to steal beauty is the same as to steal cash. They tell us the billboard people give the farmers a chance to earn a little money." Mr. Pennell went on to say that the pickpocket also picks pockets to earn money.

The speaker especially pointed out the danger of billboards on curves on highways and urged our citizens to boycott advertisers that use billboards. He had no mercy for the poster advertising people, calling them barbarians and vandals, and spoke of the effect of ugly signs on the growing minds of children. "For every one hundred going into the museum to enjoy paintings many thousand are on the street and absorbing the ugliness of the billboards." The speaker showed lantern slides of sketches made by himself of billboards and their effect on city streets and landscape.

Other speakers objected strongly to the billboard, while there were a few who chose the middle course, declaring that billboards were not bad because they were billboards but because they were poorly designed or poorly placed.

It was said that advertising as represented in billboards was an inflated industry; also that an industry representing so great an interest could never be destroyed unless by legislation as in the case of prohibition.

New methods of teaching, designed to remove "the malicious influence" which pure paper has upon the imagination of the student and to avoid mistakes which would stand as glaring faults through many generations, are now being employed in the School of Architecture of Columbia University.

The student is no longer restricted to one dimensional architecture, portrayed wholly on paper, but is required to construct models which bring into play the same skill and perspective demanded in the actual practice of the architectural profession. Model making as a means for construction in architecture is a long step in advance, according to the Columbia authorities who also say that the war has changed American standards of art.

"It has long been appreciated that the student of architecture is trained largely in feeling for one dimensional architecture, presented entirely upon paper, and in the form of a plain elevation drawing." Mr. H. Vandervoort Walsh of the Columbia Teaching Staff said in describing the system of model making now used to train Columbia architects.

"The student never has the opportunity which the practicing architect finds of observing his design completed in all three dimensions. This privilege only belongs to the architect who has secured his commission, and has had his building erected at the expense of his client. Many such architects have been astonished and surprised at mistakes in their design, due to the inability of drawings to fully represent the truth as it would appear in three dimensions. When the building is completed he has no opportunity of changing the form, and his mistake must

stand as a glaring fault through many generations.

"The student of Architecture who has the opportunity of designing a building or a group of buildings first on paper and then completing the same in the form of a model, has all the opportunities of observing the mistakes of his design without the cost of erecting the building. Moreover, he has removed the malicious influence which pure paper design has upon his imagination.

"Many a designer who has unusual skill in drawing and rendering, and who is blessed with an extremely fertile imagination is often able to mislead himself with his pictures and regard the thing he has erected on paper as beautiful architecture, while if it were constructed in three dimensions, in the form of a model, it would appear entirely absurd and ridiculous.

"The manner in which model making is carried on in the School of Architecture in Columbia University is extremely simple. A squad of students is given a problem as say, "A Club Colony in Florida." Each member of the squad then tries to solve this problem on paper according to his own ideas. These sketches are then judged by a jury consisting of the critics in design, and the best design is selected for the model. The students are then assigned to various parts of the model, some to making the landscape, others this building, and others that building of the group.

"The models of the buildings are constructed entirely of heavy illustration board. All elevations are drawn upon it, and minor projections, mouldings, windows, doors and ornamental features of this type are rendered not in the usual architectural manner, but with a very hard, contrasting technique, so that these features will stand out strongly and realistically in the completed model. Large projecting members like cornices, columns, chimneys and dormers, etc., are made from anything that the student may be clever enough to use.

"In fact, the ingenuity displayed in the construction of a model is one of the fascinating features of the work. As for landscape gardening, grass made from stained saw-dust, trees made from sponges, colonades made from tooth picks, water pools and fountains made from glass are a few suggestive ideas of the possibilities in these models."

Plumbers' License Act Invalid

The California state law providing for the licensing of plumbers has been declared unconstitutional by the appellate court which holds that it is not a proper exercise of police powers and that it is class legislation. Appeal to the supreme court will probably be made.

With the Architects

Building Reports and Personal Mention of Interest to the Profession

Appreciation

F. W. FITZPATRICK
CONSULTING ARCHITECT
Garland Building—58 E. Washington St.
Chicago

Sept. 2, 1920.

The Architect and Engineer,
626 Foxcroft Building,
San Francisco, California.

Gentlemen:—Just a word. Want to congratulate you. Been noticing of late—but too darned busy or old to say so 'til just now—that of all the architects' publications that come to my table in yours alone do I find anything refreshing, new, or interesting. True, of course, that's because the Coast fellows are pulling away from the hackneyed and doing clever original stunts, but, darn it, you're to be congratulated for being among them, urging them on, and having the sense to select from among that good stuff for your illustrations.

The other journals give us the same old stuff, measured works of the old masters or new buildings aping the old boys, classic churches, business blocks, dog kennels and all.

Go to it, man, you're doing things. Keep it up.

Sincerely,

F. W. FITZPATRICK.

\$1,000,000 in School Work

Mr. W. H. Weeks, 75 Post street, San Francisco, reports that he has prepared plans for new school buildings aggregating in value more than \$1,000,000. Construction is being delayed owing to inability to sell the bonds. In a number of cases, however, local banks have taken the bonds. In Piedmont the \$250,000 issue was sold without any difficulty and this was also the case in Santa Clara and Bishop.

Lane Hospital Addit'on

Messrs. Bakewell & Brown have completed plans for a nurses' wing to the Lane Hospital conducted by Stanford University at Clay and Webster streets, San Francisco. The building will be an eight story reinforced concrete structure, costing \$500,000. The structural plans were made by Mr. C. H. Snyder. Construction will be in charge of Mr. George Wagner.

To Rebuild Plant

The Mullen Manufacturing Company, whose cabinet works on Raisch street, San Francisco, were recently destroyed by fire, will rebuild on the site, the new plant to face Folsom street. Plans for a mill construction building are now being prepared by Mr. Alfred Kuhn, Commercial building, San Francisco.

Personals

MR. DONALD B. PARKINSON, son of Mr. John Parkinson, is now associated with his father in the practice of architecture, under the firm name of John Parkinson & Donald B. Parkinson, architects. Young Parkinson recently completed his studies at Massachusetts Institute of Technology where he was granted a degree of Bachelor of Science in the department of architecture.

MR. H. H. KEYES, formerly a member of the drafting force of Mr. F. D. Voorhees, Oakland architect, was a recent passenger on the steamship Columbia sailing for Manila where he will engage in the practice of architecture. For the past three years Mr. Keyes was employed in the engineering department of the Standard Oil Company, Richmond.

MR. SAM L. HYMAN has moved from the Crocker building to offices in the Foxcroft building, San Francisco.

MR. C. C. RITTENHOUSE is now located in room 317 Wilcox building, Los Angeles.

Architects Granted Certificates

At the last meeting of the California State Board of Architecture the following were granted certificates to practice architecture in this State:

Major Norton E. Wood, Fort Winfield Scott, San Francisco.

Sylvester A. Lesswing, 200 Bush Street, San Francisco, and 148 Duane Street, Redwood City.

Arthur Lamb, of Woollett & Lamb, Hagelstein Building, Sacramento.

Architect Members Voted

At a recent meeting of the Oregon Chapter of the American Institute of Architects, the following members were elected: Jamieson Parker, C. H. Wallwork, Wm. L. Smith, Milo S. Farwell, Earl L. Bryan, Knud A. Roald, James De Young, C. B. Martin, E. F. Gilstrap, G. K. Sharp, and F. C. Clark.

Architects of Seattle Bank

Mr. A. E. Doyle of Portland, Oregon, and Messrs. Bebb & Gould of Seattle have instructions to commence construction March 1st on the new building which will be erected for the Seattle National bank at Seattle. The structure will cost \$500,000.

Building Materials for Japan

Mr. Frederick Whitton, 369 Pine street, San Francisco, has been commissioned to represent the George A. Fuller Company in San Francisco. This company is building several large commercial structures in Tokyo for the Japan Oil Company. Much of the material, including terra cotta, ornamental iron, plumbing fixtures and mill work, will be supplied by San Francisco concerns.

This Office Keeps Busy

Mr. Smith O'Brien reports that his office is busy on a number of prospects that indicate no immediate cessation of building activity. A garage and market building recently have been erected from plans by Mr. O'Brien and contractors are now figuring on a concrete store building, 70x85, in the downtown district (Geary street) which is estimated to cost \$25,000.

\$150,000 School Building

A new frame school house will be built at Junipero Serra Boulevard near Ocean avenue, San Francisco, from plans by Mr. John Reid, Jr., City Architect. Funds for the building will be derived from the regular municipal budget. Besides twelve class rooms there will be domestic science and manual training shops and an auditorium.

Restaurant Building

Mr. E. E. Young, 251 Kearny street, San Francisco, has prepared plans for a two story and basement reinforced concrete building to contain a restaurant and private dining rooms on Powell street, south of Sutter, San Francisco, at a cost of \$60,000. Mr. John Condo is the owner.

Los Angeles Hospital

Mr. Herbert C. Howard, 619 Broadway Central building, Los Angeles, is preparing plans for a six story Class A hospital for the University Hospital Association, to be built on East Washington street at an estimated cost of \$600,000. There will be accommodations for 250 patients.

Two Bank Buildings

Plans have been completed by Mr. Edward T. Faulkes, Crocker building, San Francisco, for two branch buildings for the Bank of Italy, costing \$40,000 each. One will be at Melrose and the other at Livermore.

Merritt Terrace Houses

Two houses are to be built in Merritt Terrace, San Francisco, from plans by Mr. Walter C. Falch, Hearst building. Mr. George Merritt is the owner.

Y. M. I. to Build

The Young Men's Institute of California will erect new buildings at Los Angeles and San Jose.

British Columbia Architects

Under the terms of the British Columbia Architects Act of 1920, the lieutenant-governor-in-council recently appointed Messrs. Fox and Watkins of Victoria and Messrs. Mercer and Twizell of Vancouver and E. G. Matheson of the University of British Columbia as members of the first council of the Architectural Institute of British Columbia. At a meeting of the council Mr. Mercer was elected president, Mr. S. M. Eveleigh, treasurer, and Mr. I. L. Townley, secretary. The design submitted by Mr. Robert Kerr was unanimously selected as the official seal of the institute. The Council also selected a design for the seal to be used by the members of the institute. Under the regulations of the act all persons engaged in the practice of architecture must apply for registration.

Mr. A. H. Knoll Busy

Recent work in the office of Mr. A. H. Knoll, Hearst building, San Francisco, includes a two story and basement reinforced concrete loft building at Battery and Commercial streets, San Francisco, for Mr. Oliver Flayhaven to cost \$25,000, and alterations of frame flats into apartments for Mr. H. Roskamp at 1447 Divisadero street, at a cost of \$10,000.

Architects for Isleton School

Messrs. George C. Sellon & Company of Sacramento, are preparing plans for a large grammar school to be built at Isleton and to contain six class rooms, manual training, domestic science and an auditorium. A bond issue of \$100,000 has been authorized.

Bank Alterations

Mr. W. H. Weeks, 75 Post street, San Francisco, has completed plans for extensive alterations to the Security Savings Bank building, on Montgomery street, San Francisco. Safe deposit vaults will be placed in the basement.

Alterations to Residence

Mr. W. E. Milwain, Albany Block, Oakland, has prepared plans for alterations and additions to the San Leandro home of Mr. L. H. Bill, president of the Fageol Motors Company, Oakland.

Addition to Plant

The Fageol Motors Company will build a \$25,000 one-story steel and concrete addition to its manufacturing plant on the Foothill Boulevard, Oakland.

Alterations to Oakland Hotel

Plans are being prepared by Mr. Walter Mathews for alterations to the seventh floor of the Hotel Oakland. Improvements will cost approximately \$30,000.

January and April, 1906, Copies Wanted

Willis Polk & Company, building construction, are anxious to have a complete file of The Architect and Engineer for binding. Back numbers since the magazine commenced publication in 1905 have been furnished Mr. Polk, with the exception of the January and April numbers, 1906. Subscribers having these two copies will be paid 50 cents for each copy if they will send them to this office.

Sacramento Bank Building

Plans have been completed by Messrs. Weeks & Day, Phelan building, San Francisco, for an eighteen story Class "A" bank and office building at Seventh and "K" streets, Sacramento, for the Sacramento and San Joaquin Bank, of which Mr. J. M. Henderson is president. Bids for the construction of this structure, which will cost in excess of one million dollars, are now being taken.

Central America Residence

Plans are being prepared by Mr. S. Heiman, 57 Post street, San Francisco, for a large country house at San Salvador, Central America, for Mrs. R. Ruano. Construction will be of reinforced concrete with terra cotta tile roof. Most of the materials will be purchased in California. It is estimated the house will cost \$100,000.

Commercial Garage

Mr. Joseph L. Stewart, Claus Spreckels building, San Francisco, is completing drawings for a two story and basement commercial garage on Market street, near Brady. There will be accommodations for three hundred machines. Building will cost close to \$100,000.

One Million Dollar Catholic College

Plans are being completed by Mr. Leo J. Devlin, Pacific building, San Francisco, for a group of reinforced concrete educational buildings to be erected near Los Altos, Santa Clara county, for the Junior Catholic College. There will be nine buildings. Grading is now in progress.

\$20,000 Oakland Residence

Messrs. Reed & Corlett, Oakland Bank of Savings building, Oakland, are preparing plans for a \$20,000 English type home to be built on Sunnyslope avenue, Oakland, for Mr. C. W. Heyer, Jr., an Oakland builder with offices in the Dalziel building, Oakland.

Hollywood Hospital

Messrs. Hunt & Burns, Laughlin building, Los Angeles, are preparing plans for a two and three story Class "A" hospital for the Hollywood Hospital, Inc. The estimated cost is \$400,000.

Oakland Architects Busy

New work in the office of Messrs. Hutchinson and Mills, architects in the Albany block, Oakland, include alterations to two apartment houses to cost \$10,000 each; a three story frame building of five apartments to cost \$22,000; four flats costing \$13,000; a \$12,000 residence in Piedmont for Mrs. E. E. Stelle; two bungalows in Richmond for Mrs. T. C. Brown; a \$9,500 house in Piedmont for Mr. M. C. Vaughn and a concrete garage for Mr. A. Bosley.

Community Apartments

A four story concrete community apartment building to be erected at Long Beach is being promoted by Mr. A. St. Clair of Chicago. The building is to cost \$125,000 and will contain forty-seven apartments, single suites to be sold for \$1800 to \$2100 each and double suites at \$2600 to \$3500. The holding company will be known as the Ocean Home Owners' Apartment Corporation.

Architect Righetti Moves

Mr. Perseo Righetti, formerly of Righetti and Headman, architects of San Francisco, has moved his offices from the Phelan building to the Smidt building at 20 Geary street. New work in Mr. Righetti's office includes a two story and basement store and apartment house for Mr. Geo. A. Metcalf on Turk street, west of Leavenworth, San Francisco.

In Larger Offices

The Detroit Steel Products Company has moved its factory sales department, Pacific Coast branch, to larger and more desirable offices in the Foxcroft building, 68 Post street, San Francisco. Manager Clark's office looks out onto Post street, where he can find inspiration in the bustling crowds that pass during business hours.

Mercantile Building

Mr. A. A. Cantin, architect in the Foxcroft building, San Francisco, has prepared plans for a one story and basement Class A addition to a mercantile building on Commercial street, San Francisco. The improvements will cost \$60,000, the building being steel frame and covering ground area, 25 by 120 feet.

Residence Alterations

Mr. John K. Branner, 251 Kearny street, San Francisco, has prepared plans for alterations and additions to the Palo Alto residence of Mrs. Chas. Akers.

Parlier High School

Mr. Auton Johnson of Kingsburg is preparing plans for a new high school building at Parlier, to cost \$150,000.

LABOR MAXIMS BY WILLIS POLK

Being a Few Terse Paragraphs From the San Francisco Architect's Contribution to the Labor Day Edition of "Organized Labor."

THE strength of organized labor in the United States is somewhere between 3,000,000 and 5,000,000 of men, working, for the most part, under the eight-hour rule. Now as a concession to the general necessity for more production, and as a means of contributing to this end, would it not be wise for organized labor to offer, as an emergency proposal, to work an extra hour, of course, for regular pay? This could not fail to increase immediately and largely the volume of production, and so be an immense contribution to the general well-being. Incidentally it would tend vastly to the credit of organized labor if it should, by thus relieving a serious situation, make a notable contribution to the public welfare.

* * *

ASLACKER in the ranks of organized labor is an enemy of organized labor.

* * *

IT is possibly fair to say that the efficiency of labor at the present time only averages about 70 per cent—in other words, a loss of 30 per cent; whereas under normal conditions, efficiency has been the only difference between profit and loss.

* * *

"AN honest day's work for an honest day's pay" ought to be the slogan of both capital and labor.

* * *

THE trouble is that under stress of war and under the iniquitous cost-plus system of Government contracts, morale and discipline were tremendously lowered—most of us think as much as 30 to 50 per cent. This does not specially apply to building trades, but to labor at large. This condition must be rectified and labor must do it.

* * *

MOST men can do an easy job, but it takes a good man to do a hard job—and do it right.

* * *

LET efficiency be the watchword! Let construction rather than destruction be the order of the day!

* * *

IT is a fact that at the present time almost anything is a better investment than a building. Any banker can show you from 7 to 10 per cent for your money, but no architect can, if he is sincere, show you more than 5 to 6 per cent.

IF the unattainable could ensue, if the millenium really impends, if the laws of nature could be amended, if competition should cease to be the life of trade, then there would no longer be any baby shows. In the meantime let us make buildings the best security.

* * *

DDOUBLE pay for overtime is not consistent with the principles of organized labor—it saves at the spigot but wastes at the bung-hole; it sets up a false God; it invites worship at a false shrine. It possesses no economic value for either capital or labor; it is nothing more nor less than a demand for excess pay for normal product; it is the ultimate exemplification of the wiles of the short-change artist.

Do Not Recognize Schedule

Messrs. Houghtaling & Dougan, architects, Elks Club building, Portland, Oregon, have announced that they do not recognize the American Contractors Association's schedule of amounts or bonuses added to bids for each contractor figuring building construction and state further that they will not accept bids from any contractor who has signed and is held by American Contractors Association to add a bonus, which is to be paid unsuccessful bidders on work figured from their offices.

Oregon Board of Architects Meets

First annual meeting of the Oregon State Board of Architect Examiners was held recently at Portland. Officers were re-elected including Messrs. W. C. Knighton, Portland, president; J. E. Wicks, Astoria, vice-president; Morris H. Whitehouse, Portland, treasurer; and George A. Post, Portland, secretary. Lee A. Thomas, of Bend, Oregon, and Frank C. Clark, of Medford, are the other members of the board.

Portland Building

Mr. Earl G. Cash, architect, and Mr. A. H. Lamm, consulting engineer, Lewis building, Portland, have completed plans for the erection of a two-story structure to be built for Mr. J. M. Porter, Corvallis, at Twelfth and Glisan streets, Portland. It will be 100x100 feet in size, of concrete and mill construction.

Hood River Tourist Hotel

Mr. Morris H. Whitehouse, architect in the Railway Exchange building, Portland, is preparing preliminary plans for the proposed tourist hotel to be built on the Columbia river highway near Hood River by Messrs. Henry Teall, Simon Benson and others. The 40-room unit will cost \$40,000, exclusive of equipment. A rustic type of building is planned.

With the Engineers

Reports from the Various Pacific Coast Societies,
Personal Mention, Etc.

Graphic Building Costs

By C. E. PATCH,

Aberthaw Construction Co., Boston, Mass., in
Engineering and Contracting.

IN the construction of a concrete building, where accurate cost figures are kept for every part of the operation, with sub-divisions covering material, labor, etc., on each operation, a mass of statistics is built up which is of interest and value to the builder but almost unintelligible to the layman. To make this form of information more readily appreciable by those who are not "living with the subject" day by day, the accompanying sketch has been made.

22 per cent to the structural cost of the building. Here again each item is shown with height proportional to its cost, and to the costs in the main building.

In the building structure, as drawn, each item has a shaded portion at the left end. This portion represents the percentage of that item which was expended for direct labor by the contractor. The portion not shaded represents materials and other necessary expenses.

The drawing has been set up in the form of a manufacturing building with its adjoining power plant, in order to visualize more clearly the case under discussion. As the stories are added one by

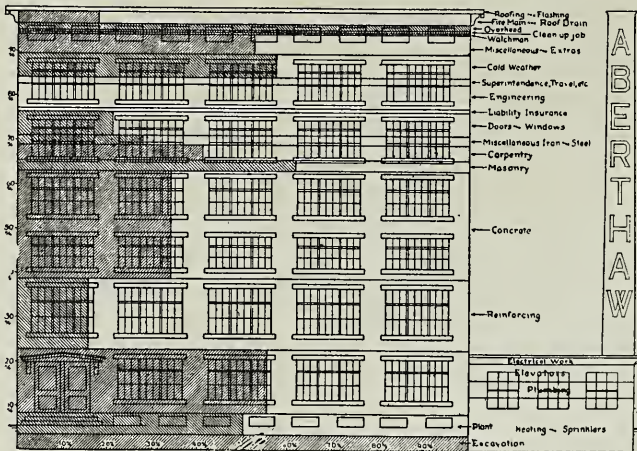

Illustration shows cost items entering into construction of a manufacturing building.

This shows the various elements placed one over the other in about the order in which they occur during the progress of the building. Each is proportional in height to the percentage which it represents of the total cost of the building. Thus, the excavation shown at the bottom is 3.05 per cent of the structural cost. The largest item of all—that of concrete—is 19.2 per cent of the total. At the right has been placed a power house, the height of which represents the percentage which the various sub-contracts bear to the structural cost of the building. The items covered here are electrical work, elevators, plumbing, heating and sprinklers, which all together add about

one, for the various materials as they are added, each structure is built up until finally, with the roof, we have reached 100 per cent of the total cost.

The percentage marks, shown at the left, give a ready measure of the extent of the several items in the particular building from which the present diagram was constructed. The various items of cost as represented in percentages are shown in the table. The first column of figures represents the item cost as compared with the total structural cost of the building. The second column of figures compares the item cost with the total cost of the building, including all sub-contracts for building equipment.

	Percentage referred to Structural cost of building.	Total cost including sub- contracts.
Concrete	24.0	19.2
Reinforcing	16.0	12.76
Forms	14.6	11.8
Engineering	5.5	4.50
Cold weather	5.2	4.25
Doors and windows	5.2	4.15
Plant	4.6	3.85
Miscellaneous and extras...	4.5	3.6
Excavation	3.7	3.05
Carpentry	3.7	3.05
Masonry	2.5	2.08
Fire main and roof drains...	2.3	1.95
Miscellaneous iron and steel	2.2	1.85
Overhead	1.56	1.28
Superintendence, travel, etc.	1.50	1.23
Roofing and flashing.....	1.36	1.12
Liability insurance	0.62	0.51
Watchman	0.54	0.45
Clean up job	0.42	0.35
Heating and sprinklers	59.7*	11.20
Plumbing	15.3*	2.93
Elevators	14.6*	2.86
Electrical work	10.4*	1.98

* Of total cost of equipment sub-contracts.

The Engineer—"A Man Who Can Conceive a Project and Make It of Record"

WHAT is an engineer? Is he a man who plods away patiently at a drawing board to produce a design of some machine, of some engineering problem, perhaps a railway proposition or a tunnel, either through a mountain or under a river; a great bridge, a steamship, a locomotive, or even a wheelbarrow? Is he an engineer, or is he simply a draftsman? Is he a toiler? Is he a man sufficiently educated to transfer to paper the ideas of others and under instructions to produce something that will guide the average workman in its construction? I do not regard men with those qualifications as engineers," declared Samuel N. Vauclain, president of the Baldwin Locomotive Works, at a conference of the Federated American Engineering Society.

"An engineer is a man who can see things, who is constructive in his thoughts, who can impart this knowledge to others, who can work not only one man on a drawing board but 20 men at drawing boards, and who can pass his ideas to them in a manner so satisfactory that they can be easily grasped. When these details are assembled from the many draftsmen who are employed you have a great and successful machine; you have a great or a successful proposition for building a railroad, for building a tunnel or a bridge; and on the number of men that such an engineer has got to handle depends the rapidity with which this project can be put before the people to whom it must be submitted before it can be constructed; because all engineers, such as we are, before we can do anything must have the money bags in our organization agree to find the cash to do it with. Therefore, if we get the right

idea of an engineer, an engineer who can not only conceive how things shall be done but can instruct assistants and subordinates clearly and thoroughly in such a manner that they can grasp his ideas and make them of record, then we can easily proceed to a short discussion of the executive in engineering.

"The true executive in engineering usually is called an optimist. It is very pleasant to be called an optimist. I have been referred to for years as an optimist. Now I am far from an optimist. I simply believe not so much in myself but in the other fellow. I have confidence in the engineers of this country. I have confidence in the engineers of Europe. I believe that these engineers can do things quite as well as I can, and perhaps a little better, so far as the scheming out of any particular contrivance may be concerned.

"But even should they not be capable of doing such, I feel that it is my duty to permit those men to enjoy and see successfully produced the results of their engineering skill, of their engineering knowledge, and not to undertake to change their views by substituting views of my own which would be counted as being even as good, perhaps far worse, after they have been put in actual practice."

Building Costs in New York

The New York Times gives a graphic illustration of the unprecedented rise since 1914 in the cost of materials and labor which pertain to building work in New York City.

Charles A. Chase, a member of the Mayor's Housing Committee, made an exhaustive study of the subject respecting the cost situation and finds that the advances in the prices of building materials range from 10 per cent to 366 $\frac{2}{3}$ per cent. The increased cost of but one item out of 115 is 10 percent, while the majority of the articles have advanced well over 100 per cent. Of the 115 items, 26 have advanced upwards of 200 per cent since 1914, and the rise in the cost of 14 items has been above 300 per cent.

Labor costs, he said, had gone up, but not nearly as much as material prices, the biggest advance in wages being granted to laborers, whose rate of pay had increased 300 per cent. Common labor in 1914 being paid 18 $\frac{3}{4}$ cents per hour were now receiving 75 cents per hour. Plumbers' laborers who got 25 cents in 1914 were now receiving \$1 per hour.

Twenty-two branches out of forty-nine listed received an increase of 100 per cent over the 1914 rate. The bricklayers in New York are the highest paid trade, the rate being \$1.25 per hour, the other trades nearly all receiving a dollar a day less.

Lumber of all kinds has advanced over 350 per cent and turpentine 300 per cent.

The Contractor

BUILDING CONSTRUCTION, BRIDGES AND
ROAD WORK

How to Estimate Interior Mill Work

By I. P. HICKS in National Builder

It is the custom with many contractors to send their plans to the mill to get figures on the mill work required. In one way this may be all right because many of the mills have expert estimators to go over the plans and take off the quantities.

To the inexperienced contractor this may be the safest plan, but who pays for this estimating? In all cases the mill man adds enough to the price to pay for the estimating and much more. The man who estimates for the mill has to play safe and make money for the mill; if he did not he could not hold his job as an estimator of mill work. They always add quite a margin above the actual figured cost. Of course we know that it is necessary for them to do this, for they must be sure that they have figured enough of everything and must figure some for contingencies.

However, the contractor who can take a set of plans and accurately take off the quantities of mill work required will be able to save a considerable amount of money on every job. The contractor can just as well figure to save the mill man's safety margin as not.

Many contractors think that taking off the quantities of mill work is such a tedious job that they do not care to undertake it, and then they are afraid that they will overlook some things and be the loser in the end. If you have a system in doing this work and follow it, you can make the work easy and do it with the full knowledge that your figures are right.

Mainly there are only three kinds of trim in general use. These are as follows: Mission style with just a heavy plain head casing. Cap mold trim with head casing, cap and cap mold and a fillet. Back band trim with casings and back band. Each one requires a little different figuring. Where the back band is used no plinth blocks are used and the side casings have to be figured longer, if mitred at the top allowance for this also has to be made. With cap trim you have to add enough of cap and mold to make the returns.

To show just how each should be figured so that the right amounts for each,

the proper lengths, the amounts that have to be added and that absolutely nothing shall be missed we will take a window and door openings of given sizes and figure the quantities for each of the different styles of trim.

We will take a window 24x28 two lights, size of opening will be 2 feet, 4 inches by 5 feet, 2 inches.

MISSION STYLE

	Amt. Added Inches.
2 side casings, 5 ft., 4 in. long.....	2
1 head casing, 3 ft., 6 in. long.....	14
1 stool, 3 ft., 6 in.....	14
1 apron, 3 ft., 4 in.....	12
1 head stop, 2 ft., 6 in.....	2
2 side stops, 5 ft., 4 in.....	2

CAP TRIM

2 side casings, 5 ft., 4 in.....	2
1 head casing, 3 ft., 4 in.....	12
1 cap mold, 3 ft., 10 in.....	18
1 head mold, 3 ft., 8 in.....	16
1 fillet, 3 ft., 6 in.....	14
1 stool, 3 ft., 6 in.....	14
1 apron, 3 ft., 4 in.....	12
1 apron mold, 3 ft., 8 in.....	16
1 head stop, 2 ft., 6 in.....	2
2 side stops, 5 ft., 4 in.....	2

Note: In some styles of cap trim the head mold and apron mold is not used. We put in all the items so that nothing shall be missed.

BACK BAND TRIM

	Amt. Added Inches.
2 side casings, 5 ft., 10 in.....	8
1 head casing, 3 ft., 4 in.....	12
1 stool, 3 ft., 6 in.....	14
1 apron, 3 ft., 4 in.....	12
1 head back band, 3 ft., 6 in.....	14
2 side pieces back band, 5 ft., 10 in....	8
1 head stop, 2 ft., 6 in.....	2
2 side stops, 5 ft., 4 in.....	2

We will now figure for a door opening by the same method. Take a door 2-8x 6-8, the opening will be 2 feet, 8 inches by 6 feet, 8 inches.

MISSION STYLE

	Amt. Added Inches.
Trim for one side.	
2 plinth blocks (supposed to be 10 inches long).	
2 side casings, 6 ft., 0 in.....	00
1 head casing, 3 ft., 10 in.....	14
1 head stop, 2 ft., 10 in.....	2
2 side steps, 6 ft., 10 in.....	2

CAP TRIM

2 plinth blocks, 10 in. long.....	00
2 side casings, 6 ft., 0 in.....	12
1 head casing, 3 ft., 8 in. long.....	18
1 cap mold, 4 ft., 2 in.....	16
1 head mold, 4 ft., 0 in.....	14
1 fillet, 3 ft., 10 in.....	2
1 head stop, 2 ft., 10 in.....	2
2 side stops, 6 ft., 10 in.....	

BACK BAND TRIM

2 side casings, 7 ft., 4 in. long.....	8
1 head casing, 3 ft., 8 in.....	12
1 head piece back band, 3 ft., 10 in....	14
2 side pieces back band, 7 ft., 6 in....	10
1 head stop, 2 ft., 10 in.....	2
2 side stops, 6 ft., 10 in.....	2

Bear in mind the following facts: That a window opening is nearly always 4 inches wider than the width of glass and 6 inches longer and the amounts we have added gives a plenty to cut on. Also remember that if you have twin windows or triple windows, you must add an additional 6 inches for each mullion as well as the width of the windows to all of the head and stool and apron trim. Don't forget that all doors except outside doors have to be cased up on both sides, so it takes double the amount for inside doors except for the stops.

Pay particular attention to the items listed in this article and the amounts we have added to work on. Be sure you figure the size of your openings right and be sure that you count up the number of openings of each size correctly, the ones that are cased on one side and those that are to be cased on both sides. It will pay you to take particular pains in carrying out this system.

It is well worth your attention, for in just a little figuring in this manner you can rely upon the exactness of your figures even better than if figured by the mill man and furthermore you will save yourself a good many dollars on the average job.

Contractor's Declaration of Independence

THERE is plainly a declaration of independence in the new attitude of contractors in discussing specifications. The substance of this change is sensed more clearly than it can be defined, but its spirit challenges old practices so sharply that they must look to their defenses, says the Engineering News-Record, which adds, "The privilege, long ago appropriated by the engineer, of determining, without consulting him, the obligations of the contractor in building engineering works, is being squarely attacked.

"Indicative of the new attitude of contractors is the fact that protests against requirements considered to be unfair and pleas to the engineer to give these protests charitable consideration, are being replaced by evidence of unfairness and by argument that through unfairness the financial interests of the owner suffer equally with the profits of the contractor. In effect, the owner, is being awakened by evidence and by an appeal to reason to the truth that he pays a high price for every unfair requirement in or interpretation of specifications.

"Conditions which are plain to all discourage the notion that the present attitude is likely to be temporary. Contractors are becoming more thoroughly organized and the strength of organization is being reflected in increased courage in calling for reforms in contracting practices. Large contracting organizations, directed by business and construction experts and employing large amounts of capital, are becoming increasingly dominant in the construction industry and with their growth is growing the determination to enforce the consideration of just reforms. Even in smaller organizations the same determination is begotten of the increasing extent to which engineers are taking control of their technical management. Finally, the

HARDWOOD HEADQUARTERS

ASH-BASSWOOD-BIRCH
AROMATIC RED CEDAR
COTTONWOOD-ELM-HOLLY
SOUTHERN RED GUM
HICKORY-LAUREL-MAPLE
OREGON MAPLE-PLAIN OAK
- QUARTERED OAK -
WYBROCK BENDING OAK
POPLAR--WALNUT



BOXWOOD-EBONY-IRONBARK
JENISERO-KOA-SPANISH CEDAR
LIGNUMVITAE-MAHOGANY
ROSEWOOD-TEAK-RED BEAN
SPOTTED GUM-CIRCISSIAN WALNUT

LUMBER--TIMBER
HARDWOOD FLOORING
WYBRO VENEERED PANELS
DOWELS-TREENAILS-VENEERS

WHITE BROTHERS

FIFTH and BRANNAN STREETS SAN FRANCISCO, CAL.

Service

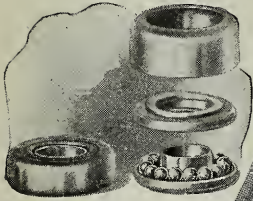

Non-detachable Ball Bearing Washers. 30 years of Continuous Service.

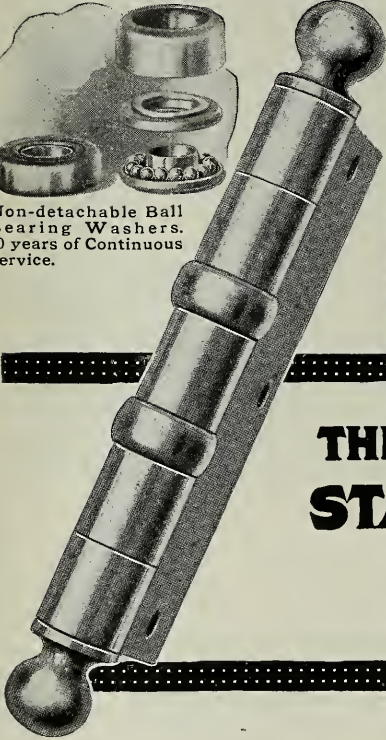
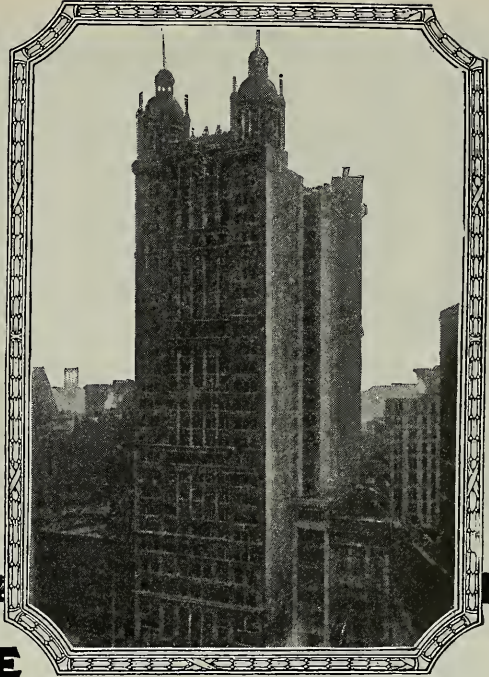

**THE
STANLEY WORKS
BALL BEARING
BUTTS**



*What Finer Recommendation
of a Sturdy Product.*

THE Park Row Building has been equipped with The Stanley Works Ball Bearing Butts since it was built, 30 years ago.

The doors are given real abuse every working day, but the Ball Bearing Butts do not complain and give their *service* today same as 30 years ago.

THE STANLEY WORKS

NEW BRITAIN, CONN.
NEW YORK CHICAGO



Durability

Redwood gives the best service for all industrial construction, especially where exposed to the elements or in contact with the ground.

Nature impregnates Redwood with a natural preservative that resists rot. Redwood lasts longer untreated than most woods when artificially preserved.

Write for "Redwood Lives Forever," "California Redwood for the Engineer," and "Redwood Block Paving and Flooring."

CALIFORNIA REDWOOD ASSOCIATION

San Francisco

California Redwood

Resists fire and rot

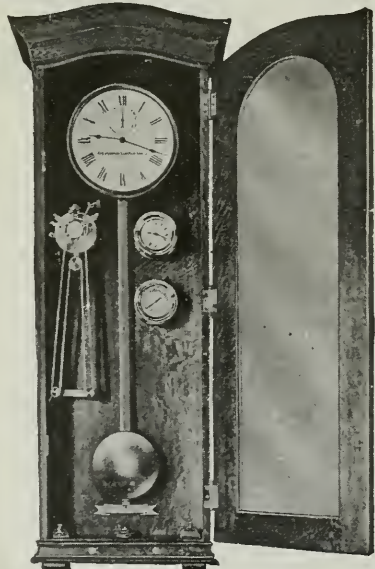

ELECTRICAL TIME-KEEPING DEVICES solves the time problem for schools, factories, banks, hospitals and other institutions. Specify "Standard" Electric Time Systems

The Standard Electric Time Company
461 Market St., San Francisco. Tel. Sutter 241

determination to demand reforms is given power by conditions which are unique in engineering construction.

"There is more construction pending than can be carried out by the contractors now in business. In highway work the condition is already acute. Large construction programs are certain to develop in the next two or three years on the railroads, in water power, building and public works. The shortage already apparent will be intensified.

"A condition, therefore, is at hand which gives contractors power to choose the work which they will undertake. Naturally, they will exercise this privilege by refusing contracts which are least to their liking."

High Cost of Building

PERHAPS the most serious phase of the industrial situation, the widest spread and with the largest continuing results, is found in the state of the building trades and in the enormous increase in the cost of building materials. For the resulting increase in the cost of building is not a temporary matter, as is the cost of food or of clothing, but is adding permanently to the cost of living of the world.

It is clear that if it now costs double to build a dwelling house what it did before the war, the rent for that house must be double what a fair price would formerly have been—otherwise there would be no incentive to build. It is clear also that this cost will be reflected in increased value of existing houses, as they will surely if gradually reach the level of the reproduction cost.

The world-wide shortage of housing is, of course, accompanied by a world-wide demand for the services of the building trades, and we find the building trades taking advantage of this situation to force heavy increases to wage scales that are already very high, and also in many cases we find a lamentable tendency to limit the output by distinct "laying down on the job."

The inevitable effect of this is to place a permanent additional burden on all men who live in houses or do business with men who live in houses.

The gravity of the situation is clear, and sane and right thinking leaders of the building trades will not fail to impress the men they represent with the truth that any extortionate demands they make are to be paid by other wage earners, and that fellow wage earners are really paying for all the shirking that is done, and paying for it a thousandfold.

For every man who rents a house or an apartment is beginning to realize that the increased cost of new building is inevitably and almost immediately reflected in increased value of existing buildings and

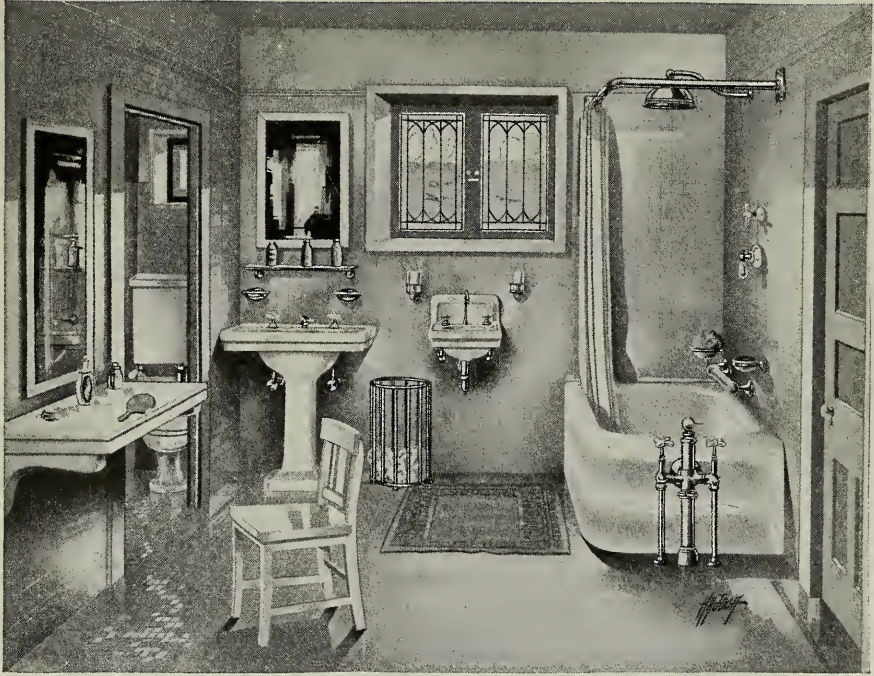

“HAJOCA” —The Bathroom of Refinement

BATHROOM FIXTURES, which you intend shall give you a lifetime of service, require thorough investigation and careful consideration.

This is the reason we constantly urge those about to build or remodel to visit our Showrooms. We know an inspection of Hajoca bathroom fixtures will impress you with their latest approved designs, their durability, their health-protecting features and their artistic beauty — a combination equally essential for humble home or luxurious residence.



HAINES, JONES & CADBURY Co.

MAKERS OF PLUMBING SUPPLIES

857 FOLSOM STREET, SAN FRANCISCO

PHILADELPHIA-NEW YORK-RICHMOND, VA.-SAVANNAH

consequently in increased rents, and having this fact in mind he is beginning further to realize that the factor of "inefficiency," so prominent at this time, is at his expense, and, that being so, he feels that the other fellow ought to give him an honest day's work for an honest day's pay.—Washington Post.

Wages in New York City

Wage rates in the building trades in New York City are reported periodically by the New York Building Council of the City. The following rates have been compiled from such reports. The last increase took effect May 1, 1920, and the present rate will remain in force until December 31, 1920; but it has been agreed between the parties that, if it is found before October 3 that the high cost of living continues, the employers will go into conference to consider the question of further increases. Except as otherwise noted the rates are based on eight hours' work per day, with a half holiday on Saturdays.

UNION WAGES IN THE PRINCIPAL BUILDING TRADES IN NEW YORK CITY—1914 AND 1920.

Occupation	Rates Per Day		Per Cent Increase
	1914	1920	
Asbestos workers, boiler felters, pipe coverers, insulators	\$4.75	\$9.00	89.5
Boilermakers	5.00	9.00	80.0
Carpenters and framers	5.00	9.00	80.0
Cement and concrete masons	5.00	9.00	80.0
Elevator constructors	5.28	9.00	70.5
Electrical workers	4.80	9.00	87.5
Engineers, stationary	4.50	9.00	100.0
Engineers, portable hoisting	6.00	9.50	58.3
Housesmiths, bridgemen and structural iron workers	5.00	9.00	80.0
Bronze, metal furniture and metal trim workers	5.00	9.00	80.0
Metallic lathers	5.00	9.00	80.0
Marble cutters and setters	5.50	9.00	63.6
Mosaic workers	4.50	8.00	77.8
Machinists of all descriptions	5.00	9.00	80.0
Plate and sheet glass glaziers	3.50	9.00	157.1
Plasterers, plain and ornamental	5.50	8.50	54.5
Plumbers and gas fitters	5.50	9.00	63.6
Painters	4.00	9.00	125.0
Riggers on machinery, dynamos, boilers	4.00	9.00	125.0
Roofers, tar, felt, composition, damp and water-proofers	4.25	8.00	88.2
Rockmen	2.50	7.00	180.0
Sheetmetal workers, copper-smiths, tinsmiths, metal roofers	5.00	9.00	80.0
Slate and tile roofers	5.00	9.00	80.0
Steam, hot water and general pipe fitters	5.50	9.00	63.6
Tile layers	5.50	9.00	63.6
Tunnel and subway constructors	3.75	8.00	113.3
Varnishers	4.00	9.00	125.0
Wood lathers	9.00

* 40 hours a week.

† Reprinted with permission from Bulletin No. 8, Wages in Various Industries and Occupations, A Summary of Wages, Movements, 1914-1920. Copyright 1920, Bureau of Applied Economics, Inc., Washington, D. C.

The Cost of Building

When the dollar buys a hundred cents worth, a carpenter, for instance, receives wages of about \$4 a day; when it buys 50 cents worth, he receives about \$8 a day. Really he is getting the same thing either way, but the blacksmith or the quarryman who wants a home of his own and is also getting wages on the same comparative basis, refuses to see it that way. He thinks he ought to have the \$8 a day, but the carpenter, the plumber, the painter, the lumberman and the mason ought to still be satisfied with the old \$4, in order that he, the blacksmith or the quarryman, might still buy the kind of house he wants for 4,000 of the 50-cent dollars he would pay for it.

It isn't difficult to make an intelligent, reasonable man see all this; in fact, most of them understand it now. Therefore, the time is ripe and all conditions favor a great home-building and home-owning campaign.—National Builder.

Architecture

ARCHITECTURE is that part of a rich man's home of which he knows the least, although it cost him the most," asserts Mr. Alexander Harvey, in Judge, and proceeds forthwith to make the following observations:

"A great architect is one who has been dead such a long time that he can be copied with impunity.

"A writer must be able to say many offensive things before he can become an authority on architecture.

"A school of architecture is a collection of men with the same unintelligible idea.

"Queen Anne knew nothing at all about the architecture of her period, in which respect she was no worse off than are the people who chatter about it today.

"Success in architecture can be achieved only through the medium of an appropriate vocabulary.

"A flourishing period of architecture in the past was fostered by the church. A flourishing period of architecture nowadays is fostered by the wives of millionaires.

"If bad architecture lasts long enough it becomes good.

"The most devoted lovers of the antique in architecture are the ghosts."

Engineers' National Conference on Employment

On November 12, 1920, in Chicago a National Conference on Engineering Employment will be held under the auspices of the American Association of Engineers. All employment managers of the large industries are expected to attend and participate in the solution of industrial relations problems affecting members of the engineering profession.



Apartment House
Taylor and Geary Streets
San Francisco
For Mr. I. Rosenberg
MR. JOSEPH CAHEN, Architect

"ACORN BRAND" Oak flooring used throughout this building (one of the newest type apartment houses in San Francisco), proved the finishing touch for the perfect completion of this abode of refinement and elegance.

"ACORN BRAND" Oak flooring produces a floor permanent and beautiful, and is admitted to be the acme of flooring perfection.



Strable Manufacturing Company

HARDWOOD LUMBER

511-545 First Street Oakland, California

Not How Much Will it Cost But How Much Will it Save

"I WON'T buy it," said the contractor, looking at a bit of needed equipment. "Why not?" asked the salesman.

"The cost is too great. Why, you are asking me twice as much as I would have paid five years ago for a similar piece of machinery. I won't buy it. That's my decision. It's final."

"All right," said the salesman, who was wise and knew human nature. "I'm not going to ask you to buy it. But when you get back to the office I wish you would sit down with a pencil, and do a little figuring."

"Don't figure how much money you might have saved by buying it five years ago. As a matter of fact you didn't buy it then, and pre-war costs do not enter into your problem at all. Your problem deals entirely with the present and the future."

"I want you to decide whether it would be a good investment NOW. Whether it would save you enough money NOW at present cost to pay for its installation. If you decide it isn't a good investment, don't buy it."

The contractor acted on this suggestion.

In the quiet of his office, after the "office help" had gone home, he reached certain conclusions.

First, he decided, that so far as human foresight can determine, prices are not going back to pre-war standards. Probably never. Have prices of labor ever returned to pre-war standards after any of the great wars of history? Prices of materials and of machinery are regulated by the cost of labor. Along in the 70's and 80's the development of modern labor-saving machinery resulted in quantity production that affected the price. Can we look forward to similar strides in the production of labor-saving machinery in the future? Probably not.

It will take not one generation, but two or three, to clear away the bond issues created by the war. As many of them expire they must be met by refunding bonds in one form or another.

Is there any likelihood of a complete deflation of currency to pre-war standards? Rather, is it not probable that new standards will be created?

The war is over. Pre-war prices is water over the dam, he concluded. Let's forget them.

Now, about the immediate future. It is true that as production catches up with consumption, and our railway snarl gets untangled, material and equipment prices will be regulated by the cost of production. In many instances they will be reduced. The law of supply and demand, which has forced them to great heights, will be in operation.

Then our friend, the contractor, thought about present labor costs, and though it made him wince to do it, he looked over the office records and saw what he is paying building mechanics and building laborers today.

He did a little figuring to determine how much work the equipment would do, and what it would save him on his payroll. He considered that not only have wages advanced, but there is a marked production decrease on the part of labor.

Suddenly he struck his desk a resounding blow with his fist.

"By the great corrugated concrete pipe," he exclaimed in a burst of denatured profanity, "I ought to be rated pretty close to zero in business judgment if I failed to buy that machine. It will cost me twice as much as it would have cost before the war, and it will save me three times as much money."—*Improvement Bulletin*.

State to Build Warehouse

The California State Board of Harbor Commissioners has adopted plans for new ship, rail and warehouse facilities contemplating an expenditure of \$2,230,000. The new warehouse is to be six stories in height and will provide storage capacity for 40,000 tons.

"The project is superior to anything in the United States," John H. McCallum, president of the board, announced. "It brings to this port the facilities for handling at the waterside all cargoes of seasonal freight, grain, cotton and the tropical pineapple and sugar at a minimum of cost for both domestic and for export movement. The largest ship may dock there and cargo may be put into storage at the harbor front."

Who Uses the Steel?

Steel is now used by this country at the rate of about thirty-five million tons a year—about twice the consumption of a dozen years since. Who uses it? Offhand, one would credit the big consumers—the railroads, the builders of skyscrapers, the fabricators of steel ships—with getting away with most of it. Yet an analysis by Chemical and Metallurgical Engineering (New York) does not bear out this idea. Most of the steel that we use—at least twenty-five of our thirty-five million tons—is consumed by miscellaneous industries for making all sorts of tools and machines, pipes, tanks, and articles that separately account for little of it but in bulk require an enormous mass of metal. We might therefore abolish the railroads, sink the navy, and go back to three-story brick or frame buildings, without affecting our use of steel by any very great figure.—*Literary Digest*.



"All chimneys, irrespective of which materials the walls are built, shall be lined with fire clay flue lining or with fire brick. The lining shall be made for the purpose and adapted to withstand high temperatures and the resultant gases from burning fuel." From "An Ordinance for Construction of Chimneys" recommended by the National Board of Underwriters, 1920.

Oust a Cruel "FIRE-BUG!"

Statistics show clearly that the most prolific "fire-bug" in residences is the *unlined* chimney. From one-fifth to one-third of the fires that endanger homes originate in chimneys. Fire Clay Flue Lining insures the safety of the families of your clients against the worst single cause of fires. A few dollars per chimney is all it costs. A trifle to include — an important thing to specify.

Write for a copy of the 1920 recommendations of the National Board of Fire Underwriters Committee on Construction of Buildings.

CLAY PRODUCTS ASSOCIATION

PITTSBURGH

CHICAGO

(Los Angeles Pressed Brick Co., Los Angeles, Member)

FIRE CLAY FLUE LINING

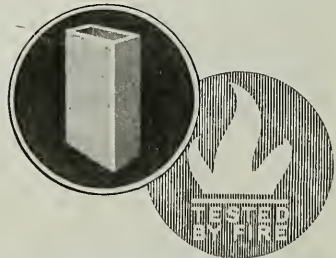

Necessity for Oil Conservation

Mr. Wm. F. Drew, a mechanical engineer with offices at 68 Post Street, San Francisco, has addressed the following interesting letter to Mr. H. C. Butler, State Power Administrator, Flood Building, San Francisco:

Dear Sir:—In view of the fact that the available supply of fuel oil is rapidly decreasing and the price increasing at a very rapid rate, I feel constrained to call your attention to the necessity for conservation in the use of this oil and the means by which such conservation can be accomplished.

Chemistry teaches us that there are certain defined hydrogen gases of a certain defined quantity or volume that are generated by the action of heat when applied to fuel oil that are not combustible unless brought into direct contact and mingled with a diffused and accurate volume of oxygen which can only be supplied by a certain accurate volume of fresh air.

A survey of some of the larger oil burning steam plants shows that there is no attempt made to utilize these hydrogen gases, but that they are forced out of the smoke stack by the draft of air from below the fire and thereby cause a waste of at least 15 per cent of the fuel oil which could be easily saved by a proper and accurate introduction of fresh air above the burning oil.

This also applies to all warship and other marine boilers, as is evidenced by the clouds of smoke from their stacks, for this smoke is nothing more or less than good fuel going to waste.

To give you an idea of the enormity of this waste, I will call your attention to what the records show as the approximate number of barrels of oil being consumed daily by electrical generating steam plants in Oakland and San Francisco.

In four plants in Oakland there is a total of approximately 4000 bbls. being consumed each day. In San Francisco four large plants consume a total of 7600 bbls. per day.

In the two cities there are 11,692 bbls. per day being consumed, of which at least 15 per cent is going up in smoke, and which could be saved by installing proper appliances. Thus we see being wasted 1753 bbls. of oil per day, 640,000 bbls. per year at \$2.00 per bbl., a total of \$1,280,000.00 per year.

If we were to use our knowledge of the chemical constituents of fuel oil and the gases generated from the burning of it in large plants in as intelligent a manner as is shown in the design of a certain patented oil burning heater, there would be no wicked waste of valuable gases and no smoke.

It seems to me that this is a matter worthy of your most serious consideration and official advice in rectifying.

Yours very truly,
Wm. F. DREW.

Human Nature and the Factory Building

No subject is so completely occupying the attention of the industrial executives as the study of the human element in relation to production.

Truscon Steel Company's publicity department has published for the benefit of the company's patrons an interesting book called "Human Nature and the Factory Building." It discusses the basic principles of modern industrial engineering and shows the very important relationship between the factory building and the human element in production.

The book is devoid of advertising, except such incidental reference as may appear under the illustrations. Its contents is made doubly interesting by numerous illustrations of modern factories, a feature that will appeal strongly to the manufacturer. Copies of this book will be furnished free to interested persons.

A surprisingly small number of people know the location of the fire alarm box nearest their homes or business, or the telephone number to be called. It would help greatly if a uniform fire telephone call could be agreed upon. The Dominion of Canada has adopted the number 100 as a universal fire call throughout the Dominion.

DIXWELL DAVENPORT
Manager Pacific Coast Department

BANKERS & SHIPPERS INSURANCE COMPANY

INSURANCE EXCHANGE BLDG.
SAN FRANCISCO

Telephone Kearny 3561

"BLAZING" THE TRAIL

We've been doing it for many years—giving the Sportsman Better Value for Quality than he ever before received. "Value at a Fair Price" in everything for the Sportsman.



SEND FOR CATALOG *The Sign of Quality*

C. DRUCKER

J. C. JAMES

JAMES & DRUCKER

PLUMBING—HEATING
CONTRACTORS

Phone
Market 275

450 Hayes Street
San Francisco

When writing to Advertisers please mention this magazine.

Does Plate Glass Fade?

SEVERAL years ago a contract was taken to supply a vertical installation of prisms in a store front of a haberdashery in the main business thoroughfare of Indianapolis, Ind. To install the prisms properly it was found necessary to cut off 5 feet from the top part of the plate-glass, which had been in position for a number of years and exposed to the sun's rays during much of the time, says a writer in the American Architect.

After the prisms had been installed the five-foot piece of plate-glass salvaged was thoroughly cleaned and polished and consigned to stock for resale. In the course of time this salvage piece was sold, to be used in a front window of a new residence in one of the principal streets in the fashionable residence section. The house was completed and the owner, having taken possession, was thoroughly enjoying the new home, when the family began to receive telephone calls of a rather puzzling and perplexing nature, asking the price and how quickly delivery could be effected in various quantities of Shirts Made to Order! A certain wag in the community called up the owner complaining that he, the owner, had made a mistake in building a shirt factory in that neighborhood, and that if he persisted in operating a factory in his residence, in all fairness and consideration to his neighbors, he should at least remove all advertising from his front window.

The daughter of the house, becoming thoroughly provoked and annoyed at what she presumed was a practical joke of some sort, proceeded to make an investigation on her own account, which resulted in the writer being requested to call at the house. He was greeted at the front door by Mr. Owner and asked whether the plate-glass furnished was really first grade or second hand. To the reply that, from a close inspection at that moment, it was a beautifully polished, high-grade piece of plate, and to all appearances absolutely without blemish, he assumed a knowing smile and asked me to walk down the street with him a short distance, when, turning abruptly at perhaps fifty paces, he asked me to look at the window. To my astonishment plainly legible at the particular angle at which we stood were the words: John Doe—Shirts Made to Order.

What seemed to be a phenomenon was easily explained. Previous to the plate-glass being removed from the show window of the haberdasher, there had been pasted to it white enameled letters, "John Doe—Shirts Made to Order." These letters being subjected to the direct rays of the sun for a period of years had prevented the fading of the glass (originally green) to a clear white, as was the case with that portion which was not immediately back of the opaque enameled let-

OAK FLOORS

(For Everlasting Economy)



Correcting a Common Error

FEW architects recommend any but oak floors when given carte blanche as to costs. But they often hesitate to specify oak floors when they would like to. A mistaken idea that oak floors are very costly prevails in many minds.

We recommend that costs be quoted by the room rather than by the thousand feet. The comparative low cost of oak floors is a big feature of our national advertising, upon which we receive many commendatory letters from architects.

OAK FLOORING *MERCADON*

1036 Ashland Block, Chicago, Ill.

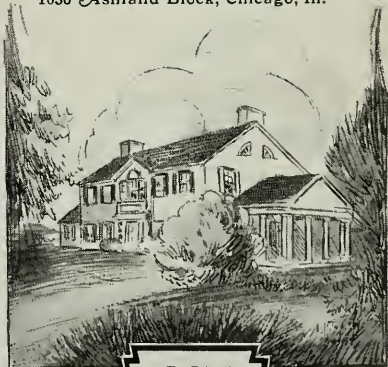

OAK

This trade-mark assures high quality and perfect grading.

FMA
USA



WAREHOUSE OF STRABLE MANUFACTURING COMPANY, OAKLAND

ters. The unfaded portion consequently stood out in contrast in its original green, but was not discernible except at a certain angle.

Hardwood Lumber Warehouse of Strable Manufacturing Company, Oakland

THE accompanying picture shows the office and warehouses of the Strable Manufacturing Company of Oakland, headquarters for Wolverine maple flooring and Acorn brand of oak flooring.

Some recent orders for these materials included fifteen car loads of Acorn brand for Peet Brothers' factory; three car loads of Wolverine for the National Paper Products Company, Stockton; car load for the California Cotton Mills in East Oakland and practically all the school buildings in the city of Oakland. Acorn brand of oak flooring has been used throughout the splendid new apartment house at Geary and Leavenworth streets, San Francisco, just completed from plans by Mr. Joseph Cohen.

Proper Street Lighting

By C. D. SALFIELD,

Chairman Street Lighting Committee, Haight and Ashbury Improvement Association.

THERE is hardly anything that adds so much to the desirability of a residential thoroughfare or a district of homes than well-lighted streets, and nothing detracts so much from an otherwise high-class residence district than poor street lighting.

This is particularly well illustrated in the Haight and Ashbury districts in San Francisco, the streets of which are, with two notable exceptions, very poorly lighted with out-of-date contrivances.

The exceptions are Buena Vista avenue, on the eastern slope of Buena Vista Park, and Ashbury Terrace. The first mentioned is probably the best lighted street in San Francisco. The superior lighting condi-

tions here were brought about by the progressive, far-sighted, wide-awake, public-spirited property owners along its line and in the vicinity.

They insisted upon the removal of the unsightly wooden poles, while the overhead wires were placed in conduits underground. Beautiful electroliers have replaced the old-time, unsightly lamp posts.

The property owners did nearly all of this, it should be noted, at their own expense, the city paying, as is customary, for the lighting. Not only were these beautiful electroliers set on the property side of this magnificent avenue, but they were placed on the Buena Vista Park side as well.

Of Ashbury Terrace the same may be said. Under the leadership of former Mayor P. H. McCarthy, a resident of the district and a member of this association, a great improvement was effected in the lighting of this district. The single standard electroliers were installed and they are in full harmony with the beautiful homes, lawns and gardens with which the neighborhood abounds. The electroliers are not quite so elaborate as those on Buena Vista avenue, but are very efficient and less expensive to operate. It is the opinion of experts in street lighting that this kind of lamp-post ought to be the standard for all of the Haight and Ashbury district and for all other residence sections.

In contradistinction to the foregoing well-lighted streets, Fell street, west of Baker, which was at one time considered the best lighted street in San Francisco, and of which the residents and property owners along its line to the entrance of Golden Gate Park felt justly proud, is now one of the poorest lighted streets in the city.

It started out well, soon after the closing of the Exposition, with three-globed, double-light Welsbach gasoliers of an exceptionally pleasing and artistic design, but had to submit at the very outset to a



The
ST. FRANCIS
 One of the world's great hotels
 Facing Union Square
 SAN FRANCISCO CALIFORNIA

EXPRESSES MOST PLEASANTLY THE HOSPITALITY AND ANIMATION THAT ARE CHARACTERISTIC OF SAN FRANCISCO

Thos. J. Coleman.
 Manager

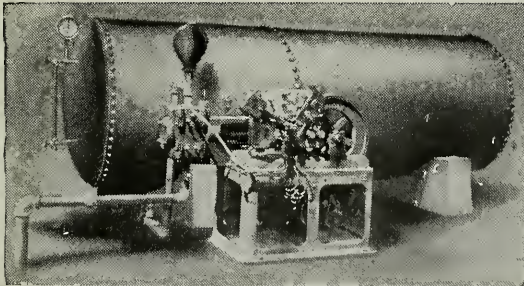

Kewanee Water System

Maintain your own Plant.
 Small Operating Expense.
 A Perfect Water Supply to
 Country Homes, Hotels
 and Parks.

Simonds Machinery Co.
 117- 121 Montgomery Street
 SAN FRANCISCO
 Phone Kearny 1457



WAREHOUSE OF STRABLE MANUFACTURING COMPANY, OAKLAND

ters. The unfaded portion consequently stood out in contrast in its original green, but was not discernible except at a certain angle.

Hardwood Lumber Warehouse of Strable Manufacturing Company, Oakland

THE accompanying picture shows the office and warehouses of the Strable Manufacturing Company of Oakland, headquarters for Wolverine maple flooring and Acorn brand of oak flooring.

Some recent orders for these materials included fifteen car loads of Acorn brand for Peet Brothers' factory; three car loads of Wolverine for the National Paper Products Company, Stockton; car load for the California Cotton Mills in East Oakland and practically all the school buildings in the city of Oakland. Acorn brand of oak flooring has been used throughout the splendid new apartment house at Geary and Leavenworth streets, San Francisco, just completed from plans by Mr. Joseph Cohen.

Proper Street Lighting

By C. D. SALFIELD,

Chairman Street Lighting Committee, Haight and Ashbury Improvement Association.

THERE is hardly anything that adds so much to the desirability of a residential thoroughfare or a district of homes than well-lighted streets, and nothing detracts so much from an otherwise high-class residence district than poor street lighting.

This is particularly well illustrated in the Haight and Ashbury districts in San Francisco, the streets of which are, with two notable exceptions, very poorly lighted with out-of-date contrivances.

The exceptions are Buena Vista avenue, on the eastern slope of Buena Vista Park, and Ashbury Terrace. The first mentioned is probably the best lighted street in San Francisco. The superior lighting condi-

tions here were brought about by the progressive, far-sighted, wide-awake, public-spirited property owners along its line and in the vicinity.

They insisted upon the removal of the unsightly wooden poles, while the overhead wires were placed in conduits underground. Beautiful electroliers have replaced the old-time, unsightly lamp posts.

The property owners did nearly all of this, it should be noted, at their own expense, the city paying, as is customary, for the lighting. Not only were these beautiful electroliers set on the property side of this magnificent avenue, but they were placed on the Buena Vista Park side as well.

Of Ashbury Terrace the same may be said. Under the leadership of former Mayor P. H. McCarthy, a resident of the district and a member of this association, a great improvement was effected in the lighting of this district. The single standard electroliers were installed and they are in full harmony with the beautiful homes, lawns and gardens with which the neighborhood abounds. The electroliers are not quite so elaborate as those on Buena Vista avenue, but are very efficient and less expensive to operate. It is the opinion of experts in street lighting that this kind of lamp-post ought to be the standard for all of the Haight and Ashbury district and for all other residence sections.

In contradistinction to the foregoing well-lighted streets, Fell street, west of Baker, which was at one time considered the best lighted street in San Francisco, and of which the residents and property owners along its line to the entrance of Golden Gate Park felt justly proud, is now one of the poorest lighted streets in the city.

It started out well, soon after the closing of the Exposition, with three-globed, double-light Welsbach gasoliers of an exceptionally pleasing and artistic design, but had to submit at the very outset to a



The
ST. FRANCIS
 One of the world's great hotels
 Facing Union Square
 SAN FRANCISCO CALIFORNIA

EXPRESSES MOST PLEAS-
 ANTLY THE HOSPITALITY
 AND ANIMATION THAT
 ARE CHARACTERISTIC
 OF SAN FRANCISCO

Thos. J. Coleman
 Manager

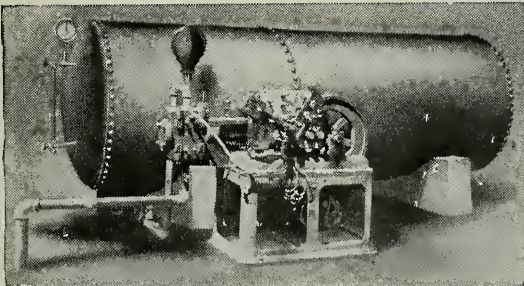

Kewanee Water System

Maintain your own Plant.
 Small Operating Expense.
 A Perfect Water Supply to
 Country Homes, Hotels
 and Parks.

Simonds Machinery Co.
 117-121 Montgomery Street
 SAN FRANCISCO
 Phone Kearny 1457

WOODIN & LITTLE

PUMP HOUSE

33 to 41 Fremont Street
SAN FRANCISCO, CAL.

PUMPS FOR EVERY SERVICE AND USE

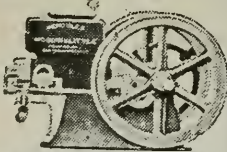

HERCULES GASOLINE ENGINES
From 1 1/2 to 12 Horse Power

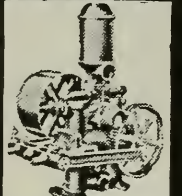

GOOLDS PYRAMID POWER PUMP
All Sizes from 2 1/2 to 6 Inch

PUMPS

Centrifugal Power, Bell, Electricity, Air, Vacuum, Ship, Spray, Oil, Mine, Steam, Water Works, Wind Mill, Road Sprinkling, Rotary, Rams, Hand, Deep and Shallow Well Pumps, GOOLDS CELEBRATED TRIPLEX PUMPS.

W. & L. PNEUMATIC WATER SUPPLY SYSTEM

PIPE, PIPE FITTINGS
BRASS GOODS, TANKS
GASOLINE ENGINES

Send for Our Catalogue, Mailed Free
Inquire of Your Local Dealer for Full Particulars

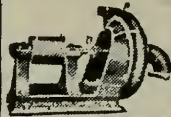

CENTRIFUGAL PUMPS
All Sizes from 1/2 to 10 Inch, with self-oiling bearings

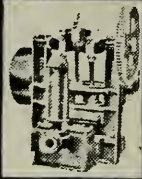

GOOLDS TRIPLEX PUMPS
All Sizes

spirit of jealousy and a streak of false economy, the top globe being removed soon after the gasoliers had been set.

Next, on account of our ill-advised municipal administration, thirty odd thousand dollars were cut from the street lighting fund in the budget, another piece of false economy and a political faux pas, another globe was removed, causing the gasoliers to look lopsided, so that at present this otherwise magnificent thoroughfare, and by all odds the most frequented auto drive in the city, has a very dilapidated, disgraceful appearance both by day and by night. What economy was there in it to remove the second globe. It surely saved no gas!

It is earnestly hoped that the lighting of Fell street will soon be restored to its old-time beauty. It would surely not cost to exceed a couple of dollars to put all of the globes back into their sockets and do away with the eyesore.

Page street and the streets adjacent thereto and crossing it are fairly well lighted by the old-fashioned Welsbach gas lamps, but to see the lamp lighter trot along these streets every evening in the gloaming for about an hour to finish his job of lighting with a torch reminds the few old citizens of the district of the days of 1849, or seventy years ago, when electric lights were unknown.

The cost of installation of up-to-date street lights is insignificant when one considers the benefits derived therefrom, and when compared to the cost of other street improvements, such as sewers, curbs, paving and sidewalks, any one of these having cost from 50 to 500 per cent more than what it would cost to put all of the wires in conduits underground, remove all of the ugly poles and provide artistic, up-to-date electroliers.

It is amazing, to say the least, that the property owners and residents of San

Francisco, along its most beautiful streets, well built up with pretty and expensive homes and all street work completed, will continue to put up with street lighting of

GEO. H. DYER, President
R. W. DYER, Vice-Pres.
W. J. DYER, Sec'y

DYER BROS.

GOLDEN WEST
IRON WORKS

(INCORPORATED)

Structural Iron
and
Steel Contractors

Ornamental Iron Work

Office and Works
17th and Kansas Streets
SAN FRANCISCO, CAL.

Phone Market 134

Present Cost of Building Materials*

With Labor Wage Scale, Bonds, Etc.

THESE quotations are based on reliable information furnished by San Francisco material houses. Date of quotations, September 20, 1920.
All prices f. o. b. cars San Francisco or Oakland.

American Institute of Architects' Fees

New work—6 per cent minimum basis.
Alterations—7 to 10 per cent as a minimum basis.

High class residence work—10 per cent as a minimum.

Bond—1½% amount of contract.

Brickwork—

Common, \$38.00 per 1000 laid.
Face, \$70.00 per 1000 laid.
Common, f. o. b. cars, \$18.00 plus cartage.
Face, f. o. b. cars, \$45.50 per 1000, carload lots.
12x12x3 in., 10¼c. per square foot.
12x12x4 in., 11¼c. per square foot.
12x12x6 in., 16¼c. per square foot.
Hod carriers, \$8.00 per day.
Bricklayers, \$10.00 per day.
Lime—\$3.25 per bbl.; carload, \$2.75 per bbl.

Composition Floors—30c. per sq. ft.

Concrete Work (material at San Francisco bunkers)—

No. 3 rock.....\$2.50 per yd.
No. 4 rock..... 2.75 per yd.
Niles pea gravel..... 3.25 per yd.
Niles gravel..... 2.50 per yd.
Niles top gravel..... 3.00 per yd.
City gravel..... 2.50 per yd.
River sand..... 1.65 per yd.
Bank sand..... 1.00 per yd.

Monterey White Sand—

Del Monte, \$1.25 to \$1.50 per ton.
Fan Shell Beach, \$2.50 to \$3.00 per ton.
Car lots, f. o. b. Lake Majella.
Cement (f. o. b. cars)....\$4.09 per bbl.
Rebate for sacks, 25c. each.
Atlas "White".....\$9.50 per bbl.
Medusa cement..... 9.50 per bbl.
Forms.....\$60.00 per M

Wage—

Laborers.....\$6.00 per day
Concrete workers..... 7.50 per day
Cement finishers..... 9.00 per day

Dampproofing—

Two-coat work, 30c. per yard.
Membrane waterproofing—4 layers of P. B. saturated felt, \$6.00 per square.
Hot coating work, \$2.00 per square.
WAGE—Roofers, \$9.00 per day.

Electric Wiring—\$8.00 to \$15.00 per outlet.

WAGE—Electricians, \$9.00 per day.

Elevators—

Prices vary according to capacity speed and type.
Consult elevator companies.

Excavation—

\$2.00 per yard.
Teams, \$12.00 per day.
Trucks, \$30.00 to \$40.00 per day.
Above figures are an average without water. Steam shovel work in large quantities, less; hard material, such as rock, will run considerably more.

Fire Escapes—

Ten-foot balcony, with stairs, \$100.00 per balcony.

Glass—

(Consult with manufacturers.)
21 ounce, 25c. per square foot.
Plate, \$2.00 to \$5.00 per square foot.
Art, \$1.00 up per square foot.
Wire (for skylights), 40c. per square foot.
Note.—Add extra for setting.
WAGE—Glaziers, \$9.00 per day.

Heating—

Average, \$3.25 per sq. ft. of radiation.
WAGE—Steamfitters, \$10.00 per day.

Iron

Cost of ornamental iron, cast iron, etc., depends on design.

Lumber—

Common (at building), \$48.00 per 1000 (average).

Common O. P. (select), \$98.00 per 1000 (average).

Flooring—

1x3 No. 1.....\$121.00 per 1000
1x3 No. 2..... 113.00 per 1000
1x4 No. 1..... 116.00 per 1000
1x4 No. 2..... 113.00 per 1000
1x4 No. 3..... 106.00 per 1000
1x6 No. 1..... 121.00 per 1000
1x6 No. 2..... 118.00 per 1000
1¼x4 and 6 No. 1..... 121.00 per 1000
1¼x4 and 6 No. 2..... 116.00 per 1000
Slash grain, 1x4 No. 1..... 90.00 per 1000
Slash grain, 1x4 No. 3..... 85.00 per 1000
No. 1 common run to
T. & G. 65.00 per 1000
Lath..... 9.00 per 1000

Shingles—

Redwood, No. 1.....\$1.60 per bdl.
No. 2..... 1.50 per bdl.
Red cedar..... 1.85 per bdl.
(Add cartage to above)

Hardwood Floors—

Maple floor (laid and finished), 38c. per foot.

Factory grade floors (laid and finished), 30c. per foot.

Oak (quartered, finished), 57c per foot.

Oak (clear), 41c. per foot.

Oak (select), 39c. per foot.

Oak, quartered, sawed, clear, select, 48c.

WAGE—Floor layers, \$9.00 per day.

In flooring the usual grades of oak used are

	Grades	Quartered Sawed	Plain Sawed
5/16"	Clear	"	"
	Select	"	"
1"x3"-13/16"x2¼"	Clear	"	"
	Select	"	"
	No. 1 (very little used)		
¾-inch plain oak.....			58c.
¾-inch quarter sawed.....			70c.

Hardwood Floors (not laid)—

5/16x2" sq. edge Clear quartered oak..... 365.00
Select quartered oak..... 295.00
Clear plain oak..... 295.00
Select plain oak..... 265.00

* NOTE.—For country work add freight and cartage to prices given.

Hardwood Floors (not laid)—Continued

	Per M ft.
13/16x2 1/4" face Clear quartered oak.....	\$460.00
Select quartered oak.....	350.00
Clear plain oak.....	340.00
Select plain oak.....	305.00
Clear maple.....	280.00
Clear maple—white.....	310.00
13/16x3 1/4" face Clear maple.....	285.00
1 1/8x2 1/4" face Clear maple.....	290.00
3/8x2" face Clear quartered oak.....	300.00
Select quartered oak.....	250.00
Clear plain oak.....	250.00
Select plain oak.....	215.00
Clear maple.....	235.00
Clear beech.....	225.00
Clear red beech.....	265.00

Veneered Panels—

24x60 in., 1/4 in., 3-ply, 1 side:	Per ft.
Ash.....	31 1/2c
Hungarian Ash.....	47c
Birch.....	31 1/2c
Curly Birch.....	47c
Elm.....	29c
Jeniseiro (Genzezo).....	45 1/2c
Southern Red Gum (plain fig.).....	38 1/2c
Qtd. Southern Red Gum.....	47c
Hawaiian Koa.....	47c
Maple.....	29c
Birdseye Maple.....	57c
Mahogany.....	47c
Oregon Pine.....	23 1/2c
Plain Oak.....	37 1/2c
Quartered Oak.....	47c
Walnut.....	48c

Millwork—

O. P., \$180 per 1000. R. W., \$180 per 1000.	
Double hung box frame windows (average) with trim.....	\$10.50 each
Doors, includ. trim (single panel).....	15.00 each
Doors, including trim (five panel).....	\$12.00 each
Screen doors.....	5.50 each
Window screens.....	3.50 each
Medicine cases.....	5.00 each
Cases for kitchen pantries seven feet high, per lineal foot.....	10.00 each
Dining room cases same price, if not too elaborate,	
Flag poles, per foot.....	1.50
Labor—Rough carpentry, warehouse heavy framing, \$16.00 per 1000.	
For smaller work, average, \$23.00, \$30.00 per 1000.	
WAGE—Laborers, \$6.50 per day.	
Carpenters, \$9.00 per day.	

Marble—(Not set) add 60c up per ft. for setting

Columbia.....	\$2.05 sq. ft.
Alaska.....	2.05 sq. ft.
San Saba.....	3.65 sq. ft.
Tennessee.....	2.50 sq. ft.
Verde Antique.....	4.55 sq. ft.

Painting—

Two-coat work, 35c. per yard.	
Three-coat work, 45c. per yard.	
Whitewashing, 5c. per yard.	
Cold water paint, 10c. per yard.	
WAGE—Painters, \$8.50 per day.	

Patent Chimneys—

6-inch.....	\$1.50 lineal foot
8-inch.....	1.75 lineal foot
10-inch.....	2.25 lineal foot
12-inch.....	3.00 lineal foot

Pipe Casings—\$8.00 each.

Plastering—

Interior, on wood lath, 70c. per yard.	
Interior, on metal lath, \$1.25 per yard.	
Exterior, on brick or concrete, \$1.00 per yard.	
Portland White, \$1.25 to \$1.50.	

Interior on brick or terra cotta, 65c to 70c per yard.	
Exterior, on metal lath, \$2.25 to \$2.50 per yard.	
Wood lath, \$8.00 at yard per 1000.	
Metal studding, \$1.00 to \$1.25 per yard.	
Metal studding, with lath and plaster, \$2.00 per yard.	
Galv. (metal lath), 38c. and up per yard, according to gauge.	
Lime, f. o. b. warehouse, \$2.40 per bbl.	
Hardwall plaster, \$21.00 per ton f. o. b. warehouse.	
WAGE—Hod carriers, \$8.50 per day.	
Plasterers, \$10.00 per day.	

Plumbing—

From \$70.00 per fixture up, according to grade, quantity and runs.	
WAGE—Plumbers, \$10.00 per day.	

Reinforcing Steel—

Base price for less than car load lots, \$5.75 per 100 lbs.	
Car load lots, \$5.50 per 100 lbs., f. o. b. San Francisco. (Mill delivery.)	

Roofing—

Five-ply tar and gravel, \$7.50 per square for 30 squares or over.	
Less than 30 squares, \$8.00 per square.	
Tile, \$35.00 per square.	
Redwood shingle, \$13.00 per sq. in place.	
Cedar shingle, \$13.00 per square in place.	
Reinforced Pabco roofing, \$8.25 per square.	
WAGE—Roofers, \$9.00 per day.	

Rough Hardware—

Nails, per keg, \$8.00 base and very scarce.	
Deafening felt, \$170.00 per ton.	
Building paper, P. & B.,	
1 ply, \$6.50 per 1000 ft. roll.	
2 ply, \$9.75 per 1000 ft. roll.	
3 ply, \$14.00 per 1000 ft. roll.	
Sash cord,	
(Sampson spot), \$2.50 per hank 100 feet.	
Common, \$1.75 per hank 100 feet.	
Sash weights, cast iron, \$80.00 per ton.	

Skylights—

Copper, \$1.25 a square foot (not glazed).	
Galvanized iron, 50c. a square foot (not glazed).	
WAGE—Sheet metal workers, \$10.00 per day.	

Store Fronts—

Kawneer copper bars for store fronts.	
Corner, center and around sides, will average \$1.35 per lin. foot.	

Structural Steel—\$150.00 per ton.

This quotation is an average for comparatively small quantities.	
Light truss work higher; plain beam and column work in large quantities, less.	

Steel Sash—

Fenestra, from S. F. stock, 45c. per sq. ft.	
Fenestra, Plant shipment, 40 1/2c. per sq. ft.	
(Includes mullions and hardware.)	

Tile—

White glazed, 80c. per foot.	
White floor, 80c. per foot.	
Colored floor tile, \$1.00 per foot.	
Promenade tile, \$2.00 per sq. foot, laid.	
WAGE—Tilesetters, \$9.00 per day.	

Windows—

Metal, \$2.00 a square foot.	
------------------------------	--

ARMCO

TRADE MARK

INGOT IRON

For 1600 Years this Iron Pillar Has Defied Rust

THE hot sun of India has beaten down upon it and it has been washed by torrential rains. Time has wiped out and re-made almost everything else around it, but the pillar stands and shows few signs of rust or corrosion.

It is an accident, a freak of nature—or else the old Hindoos had knowledge, used only in this case, which from then to modern times was utterly lost to the world.

Contrast this imperishable pillar with the thousands of tons of metal eaten by rust every year in this country alone.

In Armco Ingot Iron we have produced an iron that for commercial purposes is practically pure; that resists rust and is uniform in texture.

Because of the absence of harmful impurities, Ingot Iron will last longer than other irons. The qualities that give it endurance also make it an excellent material for welding purposes—gas welding and electric welding. It is also an ideal base for enameled table tops, stove doors, refrigerator linings, or any article that must receive a hard, extremely glossy enamel coating.

Our engineering and research departments are available at any time to any manufacturer who uses this class of metal for his products. They will gladly show him why he should use Armco Ingot Iron.

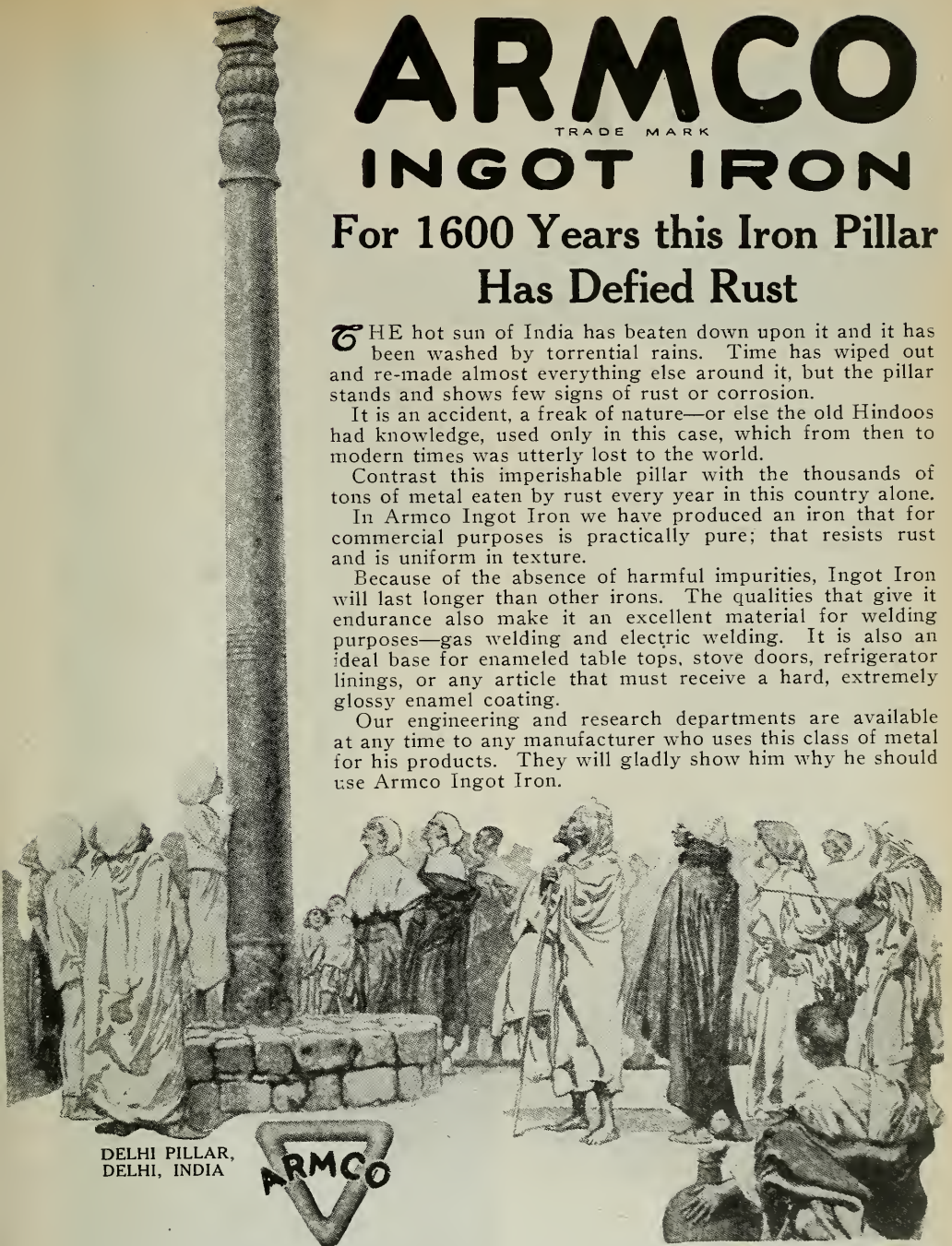

DELHI PILLAR,
DELHI, INDIA



THE AMERICAN ROLLING MILL COMPANY

Middletown, Ohio

*Licensed Manufacturers under Patents granted to the
International Metal Products Company*

Pacific Coast Sales Office—Tenth and Bryant Streets, San Francisco; other Branch Offices in New York, Chicago, Pittsburgh, Cleveland, Detroit, St. Louis, Cincinnati, Atlanta, Washington, D. C., and Buffalo.

CEMENT GUN

Will Make Your
Concrete Waterproof

Cement Gun Con-
struction Company

of California

701 Balboa Building,
San Francisco



For
DAMS
RESERVOIRS
TUNNELS
BULKHEADS
CANAL
LININGS
CEMENT
FLUMES

use the
Cement Gun

SPEED
ECONOMY
PERMANENCE

a sort that residents of small country towns would be ashamed of.

It is furthermore amazing to think that people will pay from \$2,000 to \$5,000 and more for a building lot and spend from \$5,000 to \$20,000 for a home and then be satisfied, seemingly, with rough, ungainly poles forty feet in height stuck into the sidewalk, four or more to the block, with a glimmering arc light near the top of one of the poles, when for less than the one hundredth part of the cost of a bare lot they could have decent, up-to-date illumination.

An example of how to get good street lighting is nearby Berkeley. Two years and a half ago proceedings were instituted to give the Claremont district, the finest residence district in the University City, a single lamp standard electric lighting service, with underground cable connections.

Some of the property owners could not understand how it could be done at a reasonable cost, and they, with the usual objectors to all improvements, raised the cry that it would cost at least a dollar a front foot, if not more.

The City Council finally agreed to take bids and not to consider any over 30 cents per front foot. A contract was finally let for 27 cents per front foot.

Today the entire district is well lighted and the property owners, even the strongest objectors originally, express themselves as well pleased.

Let us emulate Berkeley, even though the proper lighting of our streets should cost twice 27 cents per front foot. It is well worth it, for it will pay big in many ways. Houses that cannot be rented on poorly lighted streets will find permanent tenants and good ones at that where streets are well lighted.

The late lamented Theodore Roosevelt, when Police Commissioner of New York City, is quoted as having said "that one street lamp is equal to one policeman." And surely he was, at that time, in a position to know, being at the head of the Police Department of that great metropolis.

New Marysville Building Law

Contractors applying for permits to erect buildings in Marysville, will be required to make a sworn statement to the city assessor of the actual cost of the buildings, under the provisions of an ordinance passed by the city council. Heretofore many buildings were erected before a permit was sought and only a rough estimate of the cost was given.

\$15,000 Colonial House

Mr. Warren Perry of San Francisco has prepared plans for a \$15,000 seven room Colonial house to be built in Claremont for Dr. J. N. Force.

Standardization of Bathtubs Urged

Standardization of bathtubs, as a means of speeding up building, was urged at the convention of the American Society of Sanitary Engineers at St. Louis.

TRANSMISSION EQUIPMENT For Mill or Factory

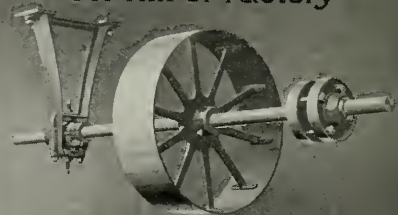

Pulleys - - - Shafts - - - Gears - - -
Hangers - - - Bearings - - - Take Ups - -
Sprockets - - - Clutches - - - Chain Belts -
Floor Stands - - - Belt Tighteners - - - Rope Sheaves

Meeseco Short Center Drives

Meeseco & Gottfried Company

ENGINEERS AND MANUFACTURERS
CONVEYING, ELEVATING, SCREENING
AND MECHANICAL POWER TRANSMITTING
MACHINERY

SAN FRANCISCO 560 Mission Street SEATTLE 67 Front Street LOS ANGELES
555 First Ave. So. San Pedro E. 3rd St.

When writing to Advertisers please mention this magazine.



Immediate Deliveries Guaranteed

Are your clients being held up by your inability to get delivery and to finish the installation of one or more vacuum cleaners?

The No. 260 TUEC Stationary Cleaner can be shipped in two packages by express to any point in the United States, as it does not exceed the express companies' maximum weight.

The No. 260 Fan-Type TUEC is large enough for any residence or flat building, and is equipped with a $\frac{3}{4}$ -h. p. universal motor.

Contrast its price with the price of the best $\frac{7}{8}$ -h. p., 430-lb. pump type machines and note the saving of \$40 on a TUEC.

We can ship your order for one or more TUEC 260s the same day we receive it.

Our Engineering Department will gladly advise you on any cleaning problem — without any obligations on your part.

The United Electric Co. CANTON, OHIO

New York Chicago Cleveland Atlanta Portland, Ore.

California Distributors

S. F. COMPRESSED AIR CLEANING CO.
397 Sutter Street, San Francisco

BARKER BROS.

724 So. Broadway, Los Angeles

Heavy Duty
Model

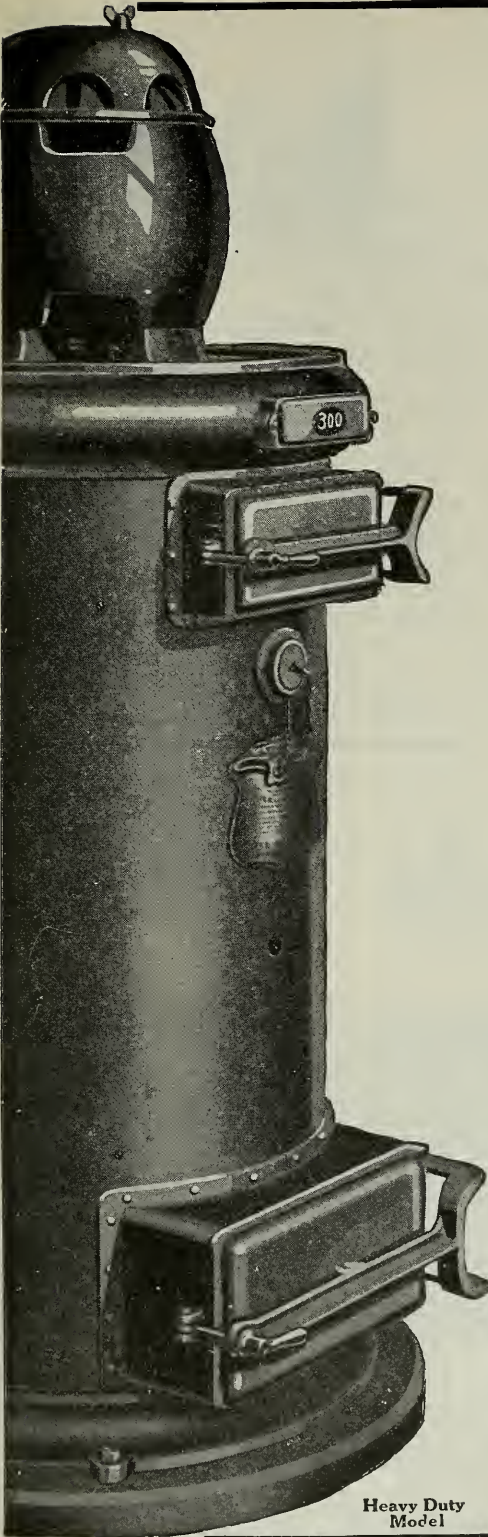

SERVICE
TESTING
INSPECTION
CONSULTATION
PRODUCTION

Structural and Engineering
Materials



Robert W. Hunt & Co.

Engineers

Chemical and Physical
Testing Laboratories

New York Chicago Pittsburgh
 St. Louis San Francisco Mexico City
 London Montreal



*Residence of Dr. Schiffman,
 505 So. Grand St., Pasadena, Calif.
 Dormell & Draubaugh, Ptrs.*



BAY STATE COATING

Charm and beauty belong to the home finished with Bay State Brick and Cement Coating. It waterproofs and weatherproofs all walls of brick, cement and stucco.

In white or colors. Send for a sample of your favorite tint and Booklet No. 43. It shows many Bay State Coated Homes. Bay State Liquid Paints and INOROUT Varnish fill every painting requirement.

WADSWORTH, HOWLAND & CO., Inc.

Paint and Varnish Makers
BOSTON, MASS.

Pacific Coast Representatives
JAMES HAMBLY & SON

San Francisco

Los Angeles



Holtzer-Cabot

Hospital Silent Call Systems

HUNDREDS of hospitals all over the country are equipped with these efficient, time-saving Systems. In far-off China, Greece and other foreign countries also, there are hospitals installed with Holtzer-Cabot Systems. Representative architects invariably specify this system because of its Simplicity, Flexibility and Safety.

There is nothing in the walls but the wires—the whole of the operating mechanism is in the Locking Button; any station may be instantly changed by just plugging in another cord and button. This simple, safe locking button is exclusive to Holtzer-Cabot Systems.



THE HOLTZER-CABOT ELECTRIC CO.
 BOSTON, MASS.

BITTMANN & BATTEE, Inc., Agents

745 Folsom Street, San Francisco

Phone Douglas 4405

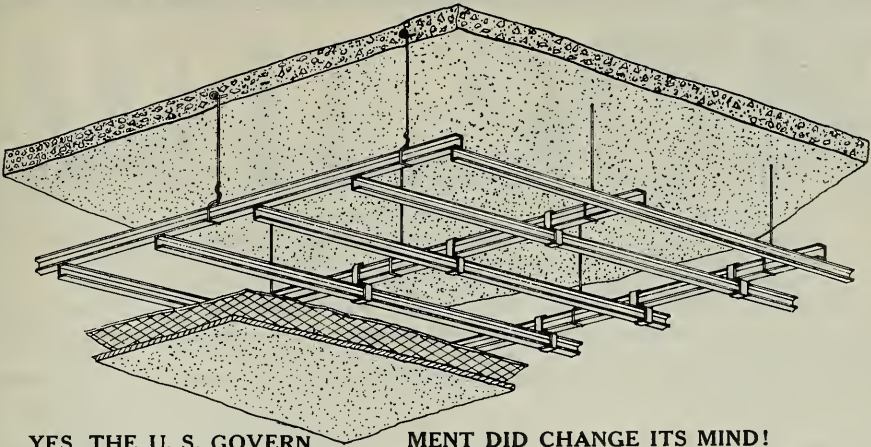

YES, THE U. S. GOVERNMENT DID CHANGE ITS MIND!

The specifications on the U. S. Government Building at Portland, Oregon, called for the tying together of the carrying bar and lathing bar with wire.

We submitted our system, and after an explanation of the S. S. System for fastening bars, the engineers and government officials were convinced that here, at last, is the perfect and economical system, and these reasons added weight in deciding.

It is a positive tie, no slipping or shearing.

It is strong, Smith Emery test to 353 lbs. before failing.

It is fast, can be applied on the bench or on the scaffold.

Made for 1 inch carrying bar and 3/4 inch lathing bar and 3/4 inch carrying bar and 3/4 inch lathing bar. Can be used for wall furring as well as for ceiling work.

THE STEEL STUDDING COMPANY

Also Manufacturers of

THE PRONG CHANNEL FOR SOLID AND HOLLOW PARTITIONS

Agents Wanted Everywhere

1216 Folsom Street, San Francisco

A TEN YEAR GUARANTEE

is back of this roof covering and it **costs less** than other roofing materials



2400 gallons used on the Fairmont Hotel, San Francisco.

Bekin's Warehouse is waterproofed with it.

The W. O. W. Building, Oakland, is roofed with it.

You make no mistake when you specify

LIQUID ASBESTOS PATCH-HOLE CEMENT

Write for sample and price list.

California Plastic Products Company

521 SHELDON BUILDING, SAN FRANCISCO, CALIFORNIA

**FOR MODERN
STORE FRONTS**

Plummer's Disappearing Awnings

Are constructed with no outside attachments below awning recess. All mechanical parts entirely concealed. Send for Architects' Sheet showing specifications for recess construction, etc.

W. A. PLUMMER MFG. CO., 35-37 Front Street, San Francisco

JOHN TRAYNOR

CHARLES HARCOURT

OCEAN SHORE IRON WORKS

Manufacturers of Oil Tanks, Water Tanks, Pressure Tanks, Air Receivers, Feed Water Heaters, Breechings, Smoke Stacks, Water Pipe, Boilers, Retorts, Digestors, Pneumatic Pressure Tanks, Riveted or Oxy-Acetylene Welded Tanks, and dealers in Boilers, Tanks, Pumps, Engines, Machinery, Steel Plates, Shapes

Special Attention Given to Government and Export Orders

OCEAN SHORE IRON WORKS

Office and Works: 550-558 EIGHTH STREET, SAN FRANCISCO, CAL.



Model No. 7A.

NO GERMS HERE

HAWS IMPROVED SANITARY DRINKING FAUCET eliminates all possibility of contracting disease from dirty bulbs or unsanitary bowls. Provided with an overhead cowl, the drinker's lips never touch the source of supply. A slanting stream throws the water from right to left and away from the bubbler, instead of straight up to fall back over the fountain head. Recommended for Schools and Public Playgrounds. A type used extensively by the U. S. Government. Manufactured by

Haws Sanitary Drinking Faucet Co., Inc.
1808 Harmon Street, Berkeley Phone Piedmont 3742

GLADDING, McBEAN & CO.

MANUFACTURERS CLAY PRODUCTS

CROCKER BUILDING, SAN FRANCISCO

WORKS, LINCOLN, CAL.

WILSON

ROLLING STEEL DOORS



PIER 33, SAN FRANCISCO

Equipped throughout with WILSON'S Big-4 Slat
 Withstand greatest wind pressure
 Heavily electrolyzed galvanized
 Very durable and easy to operate

40 years experience in manufacturing ROLLING STEEL DOORS

Pacific Coast
 Office:

The J. G. WILSON CORPORATION

600 Metropolitan Building

Los Angeles, Calif.

Also Manufacturers of

Diffuselite Blinds and Awnings Rolling Partitions
Folding Wood Partitions

Waterhouse-Wilcox Co.,	- - - - -	San Francisco
Theo. F. Snyder,	- - - - -	San Diego
T. G. Bush & Co.	- - - - -	Spokane
F. W. Farrington & Co.,	- - - - -	Portland & Seattle
Hawley-Richardson-Williams Co.,	- - - - -	Salt Lake City

THE TORMEY CO.

General
Painters

Phone Franklin
5-5-9-8

1042 Larkin St., San Francisco, Cal.

Alvaline, Cementoline

and other

Jones-Duncan Products

MAGNER BROTHERS

PAINT MAKERS

Telephone: Market 113
414-424 Ninth St. San Francisco

HEATING-PLUMBING

COMPLETE PLUMBING AND
HEATING SYSTEMS INSTALLED
IN ALL CLASSES OF BUILDINGS
ALSO POWER PLANTS

GILLEY-SCHMID CO., Inc.

198 OTIS STREET, SAN FRANCISCO.
Tel. MARKET 965

Alfred Gustafson, *Pres.* F. J. Gustafson, *Treas.*
Chas. A. Koenig, *Sec.* J. M. Reynolds, *Sales Mgr.*

Phone: Mission 1575-1576

4067 Watts St., Emeryville—Phone Piedmont 581

INLAID FLOOR CO.

Incorporated 1897

Manufacturers of
PLAIN AND ORNAMENTAL FLOORS
MACHINE FLOOR SANDING

Grilles and Weather Strips

600 ALABAMA STREET, AT 18TH ST.
SAN FRANCISCO

Phone Douglas 3224

Hunter & Hudson

ENGINEERS

Designers of Heating, Ventilating
and Wiring Systems. Mechanical
and Electrical Equipment of
Buildings.

703 Rialto Bldg., San Francisco, Cal.

BEAVER BLACKBOARD BEAVER GREENBOARD

SCHOOL FURNITURE

AND SUPPLIES—

OFFICE, BANK AND

COURTHOUSE FURNITURE—

THEATRE AND

AUDITORIUM SEATING

Rucker-Fuller Desk Co.

677 Mission St., SAN FRANCISCO, CAL.

434 Higgins Bldg., LOS ANGELES, CAL.

432 - 14th Street - OAKLAND, CAL.

Business Systems Office Furniture

F. W. WENTWORTH & CO.

Distributors for LIBRARY BUREAU
539 Market Street, San Francisco
LOS ANGELES OAKLAND SEATTLE

RUSSWIN

BUILDERS' HARDWARE

JOOST BROS., Inc.

SAN FRANCISCO AGENTS.

We Carry Complete Stock:

Fishing Tackle—Guns—Mechanics' Tools—

Paints—Crockery and Glassware—Stoves—

Household Goods. Telephone Market 891.

NO BRANCH STORE

Mazda Lamps

Electric Goods

(SONNEBORN PRODUCTS)

Grind-Proof *and* Dust-Free Concrete Floors!

**DUSTING WEARING CONCRETE FLOORS
ARE A THING OF THE PAST WHEREVER
ARCHITECTS HAVE SPECIFIED**

Lapidolith

THIS liquid chemical has been flushed on 70,000,000 square feet of concrete floors old and new during the last two years alone. These lapidolized floors are now wearproof and dust-proof, because Lapidolith has completed the hydration of the Portland Cement and this Concrete is harder than granite.

Have you seen the results secured by the Lapidolith treatment? If not, let us refer you to a lapidolized floor near you. Thereafter you will specify Lapidolith on your old and new concrete work.

SONNEBORN PRODUCTS:

Cemcoat

the durable Mill White, Washable, of exceptional covering capacity, Gloss, Flat and Egg-shell, also all colors.

Lignophol

the modern wood preservative gives new life to old or new wooden floors.

Write for sample, literature and specification form

*Concrete for Permanence
Lapidolith for Dustlessness*

L. SONNEBORN SONS, Inc.

San Francisco

Los Angeles

Seattle

(SONNEBORN)

A. D. COLLMAN

GENERAL CONTRACTING

Phone Sutter 3580

110 Jessie Street, San Francisco

I. R. KISSEL

Phone Franklin 548

Decorator, Painter and Paperhanger

1747 SACRAMENTO ST., Bet. Polk St. and Van Ness Ave., SAN FRANCISCO

ROBERT TROST

PHONE MISSION 2209

General Building ContractorWe Specialize in High Grade Work and Employ Skilled
Labor in every Branch of the Building Industry.26th and Howard Streets
SAN FRANCISCO

P. A. Palmer

Peter Petersen

W. L. Kelly

PALMER & PETERSEN**Contracting Engineers**

Monadnock Building

SAN FRANCISCO, CAL.

Phone Sutter 2581

LARSEN-SAMPSON CO.

BUILDING CONSTRUCTION

Claus Spreckels Building

SAN FRANCISCO

MULLEN MANUFACTURING CO.*BANK, STORE AND OFFICE FIXTURES—CABINET WORK OF
GUARANTEED QUALITY—CHURCH SEATING*

Telephone Market 8692

Office and Factory:
64 Rausch St., Bet. 7th and 8th Sts., San Francisco**UNIT CONSTRUCTION COMPANY**

(INCORPORATED)

ENGINEERING AND CONSTRUCTION

Telephone Kearny 28

429-36 Phelan Building, SAN FRANCISCO

J. D. HANNAH**Contractor and Builder**OFFICE: 142 Sansome Street
San Francisco, Cal.Telephone Douglas 3895
BUILDERS EXCHANGE, 180 JESSIE STREET

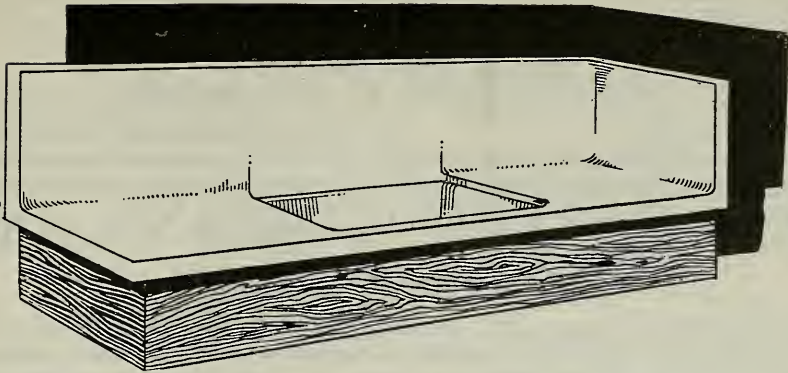

A Snow White Drain Board

PETRIUM SANITARY SINKS are made in Berkeley, California and are non-porous, non-absorbent and Lye-proof. The entire surface of the drainboard and back is covered with a composition, on which a smooth, glossy, snow white finish is applied mechanically leaving no crevice or corners in which dirt and grease can collect as where tile or wood is used.

Can be installed in any home—new or old.

PETRIUM SANITARY SINK COMPANY
 FACTORY AND OFFICE, WEST BERKELEY
 Agents in Principal Coast Cities

*Send for booklet
 and Price List.*

The High Cost of Building Material Is a Strong Argument for Economy

Architects may keep down the
 Cost by Economizing in Space

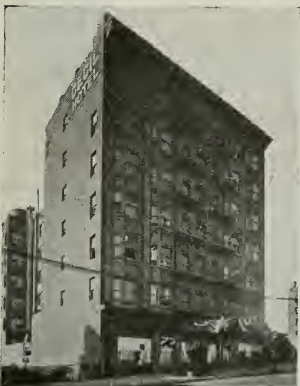

Hotel Cecil, San Francisco,
 Equipped with Wall Beds.

Portal Wall Beds

are timely space and cost savers,
 meeting a national need. Those who
 would build wisely in these days
 of soaring prices, provide for
PORTAL WALL BEDS

MARSHALL & STEARNS CO.

WALL BEDS

"HIGHEST AWARD ALWAYS"

1152 Phelan Building
 San Francisco

1774 Broadway
 Oakland

I. M. SOMMER**CONTRACTORS & ENGINEERS**

Phone Kearny 4582

401 BALBOA BLDG., SAN FRANCISCO

K. E. PARKER COMPANY, Inc.**GENERAL CONTRACTORS**

Phone Sutter 5661

Room 515 Clunie Building, SAN FRANCISCO

**R. W. LITTLEFIELD
BUILDING CONSTRUCTION**

357 12th Street, Room 9, Oakland, Cal.

Phone Lakeside 415

H. H. HILP, Jr.

J. FRANK BARRETT

BARRETT & HILP**CONCRETE CONSTRUCTION BUILDERS GENERAL CONTRACTORS**

SHARON BUILDING, SAN FRANCISCO

TELEPHONE SUTTER 1168 or 1169

Res. Phone Mission 5049

JAMES F. SMITH — Plasterer

273 Minna Street, San Francisco

Phone KEARNY 740

Member Builders Exchange

STEELFORMS Signify ECONOMY, RAPIDITY, and EFFICIENCY

STEELFORM CONTRACTING COMPANYSTEELFORMS FOR
CONCRETE
BUILDINGSC. B. Hopkins, C. E., Manager
681 Market Street, San FranciscoCONCRETE JOIST
FLOOR
CONSTRUCTION**W. C. DUNCAN & CO.**

508 Sharon Bldg.

General Contractors

San Francisco

M. E. VUKICEVICH

SPENCER B. BAGGE

VUKICEVICH & BAGGE**GENERAL CONTRACTORS**

Phone Sutter 6700

Office, Builders Exchange, 180 Jessie St., San Francisco

245 Market St. **Standard Fence Co.** 310 Twelfth St.
 Kearny 2028 **WIRE AND IRON WORKS** Oakland 475

DESIGNERS - BUILDERS
 FACTORY PROTECTION FENCE
 FIELD AND POULTRY FENCE
 AVIARY AND TENNIS COURT FENCE

WIRE GRILL WORK
 WIRE SCREEN
 FLEXIBLE WIRE CONVEYOR BELT
 WIRE SPECIALTIES

Steel Bars FOR CONCRETE REINFORCEMENT
 Cut to Length, Fabricated, Installed

BADT-FALK & CO.

Tel. Douglas 3466 346 Call-Post Bldg., 74 New Montgomery St., San Francisco

BUILDING DIRECTORIES [INTERCHANGEABLE STEEL
 LETTERS AND NUMBERS]

FOR OFFICE BUILDINGS, SCHOOLS, CAFETERIAS, Etc.
 Bargains Lists for Auto Sales Companies. Sold Outright.

Go-Sign and Letter Manufacturing Co.

1106 Franklin Street Oakland, California

D. N. & E. WALTER & CO.
 "SINCE 1858"

LINOLEUMS—CARPETS LARGE STOCKS CARRIED
 Estimates furnished on request

562-572 MISSION STREET SAN FRANCISCO

Phone Merritt 668

H. N. McNAB

Hardwood Floors  Floor Sanding

2307 - 17th Ave. Oakland, Cal.

Res. Tel. Merritt 3600

HERBERT BECKWITH
Building Construction

Formerly with ARTHUR ARLETT 323 Newton Ave. Oakland

D. ZELINSKY & SONS
 PAINTERS AND DECORATORS

420 TURK STREET, SAN FRANCISCO

CHARLES T. PHILLIPS
 CONSULTING ENGINEER

PACIFIC BUILDING SAN FRANCISCO
 HEATING VENTILATION WIRING ILLUMINATION

Ideal Air-Washers. Ideal Fruit-Dryers. Fan Systems for Heating, Cooling and Drying.

Ideal Heating and Engineering Co.

Air-Conditioning, Heating, Cooling and Drying

192 ERIE STREET

Phone Market 3708

SAN FRANCISCO

Atlas Heating and Ventilating Co., Inc.

ENGINEERS and CONTRACTORS

STEAM AND HOT WATER HEATING, FANS, BLOWERS,
FURNACES, POWER PLANTS--SHEET METAL WORK

Phone Douglas 378

Fourth and Freelon Sts., Bet. Bryant & Brannan, SAN FRANCISCO

Illinois Automatic Vacuum and Vapor Systems of Heating

"TWENTY-FIVE YEARS OF QUALITY"

ILLINOIS ENGINEERING COMPANY

JAS. I. KRUEGER, *Representative*

559-561 Pacific Building, San Francisco

Telephone: Kearny 3047

HEATING
VENTILATION

Automatic Sprinkler Systems
FLOOR AND WALL TILING

PLUMBING
SHEET METAL WORK

SCOTT CO., Inc.

SUCCESSOR TO JOHN G. SUTTON CO.

243 MINNA STREET

SAN FRANCISCO

ALEX COLEMAN

CONTRACTING PLUMBER

706 ELLIS ST., SAN FRANCISCO

Phone FRANKLIN 1006

WM. F. WILSON COMPANY

MODERN SANITARY APPLIANCES

Special Systems of Plumbing for Residences, Hotels, Schools, Colleges, Office Buildings, Etc.

Phone Sutter 357

328-330 Mason Street, San Francisco.

A. LETTICH

365 FELL ST., SAN FRANCISCO
Telephone - Park 234

Plumbing and Heating



REINFORCING BARS

Square, Twisted, Corrugated and Plain Round. Curb Plate Bars for Concrete Curbs and Guards

W. S. WETENHALL CO.

440 IRWIN STREET
SAN FRANCISCO, CAL. Phone Market 3815

GOODS OF QUALITY

A new syphon action closet at a moderate price that is not only ultra-efficient but pleasing in appearance and combining many new sanitary features.

On display at our show room—

64 Sutter Street, San Francisco

Main office and warehouse: Sixth, Townsend & Bluxome Sts.



Holbrook, Merrill & Stetson

Designers - Fabricators - Erectors

General Plate Work



Hydro - Pneumatic Pressure Tanks —
Hemispherical Bottom Tanks and Towers
— Oil and Water Tanks — Oil Stills —
Pipe Lines—Smoke Stacks—Well Casing
— Rock Screens — "Western" Corru-
gated Culvert Pipe.

Western Pipe and Steel Company

OF CALIFORNIA

444 MARKET STREET
SAN FRANCISCO

1758 NORTH BROADWAY
LOS ANGELES

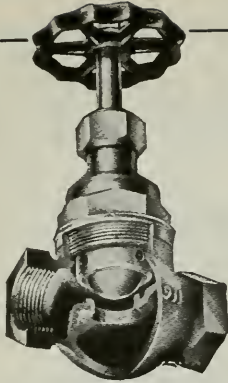

AMERICAN BALL VALVES

"Durable — therefore, Economical" — Stands the Severest Tests — Endorsed by the Leading Architects and Engineers of the Country. It is A PERFECT BALL-CLOSING VALVE.

W. E. MUSHET CO

SOLE AGENTS
Phone Sutter 4797



502 Mission Street
San Francisco, Cal.

**DON'T NEGLECT YOUR HEATING SYSTEM.
THE BEST IS NONE TOO GOOD!**

All kinds of Galvanized Iron Work — Furnaces, Pipes, Ventilators — Sheet Metal for Planing Mills, Fruit Dryers, Rice Mills. Kitchen Equipment, including Steam Tables, Sinks, Canopies, Urn Stands, Etc.

JAMES A. NELSON

Heating and Ventilating Contractor

Phone, Garfield 1959

517-519 SIXTH ST., SAN FRANCISCO

A. H. Bergstrom
Eric Lange

Phone Kearny 3526

LANGE & BERGSTROM

Building Contractors

(Established 1900)

207-210 SHARON BUILDING
San Francisco

TIMKEN BUILDING
San Diego

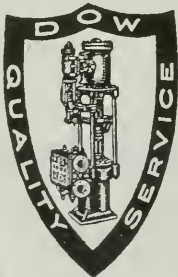

DOW ROTREX PUMP

For severe suction requirements

We also manufacture

TRIPLEX POWER PUMPS

and

CENTRIFUGAL PUMPS

We solicit your inquiries

DOW - HERRIMAN CO.

San Francisco Office, 140 Howard Street
phone Garfield 612

Plant Petaluma Cal.

Specify
**Whitney's Special
Magnesium Chloride**
(Crystals)

in your Composition Flooring

(Consult our Service Department)

WHITNEY CHEMICAL CO.
544 Market Street, San Francisco

MASTIC FLOORS

BITURINE COATINGS FOR STEEL

WATERPROOFING

Hill, Hubbell & Company

CONTRACTORS

SAN FRANCISCO

1000 Fife Building, No. 1 Drumm Street

LOS ANGELES
Marsh-Strong Building

SEATTLE
Grand Trunk Pacific
Dock

PORTLAND
Pittock Block



POSITIVE ELECTRIC INTERLOCK

(BAR LOCK TYPE)

Prevents Elevator Accidents Occurring at the Entrance Door

Approved by National Underwriters Laboratories—Meets requirements of Elevator Safety Orders of Industrial Accident Commission, State of California

ELEVATOR SUPPLIES COMPANY, Inc. 186 FIFTH STREET,
SAN FRANCISCO

Capital \$1,000,000

CALIFORNIA DEPARTMENT

Surplus \$1,122,000

THE FIDELITY AND CASUALTY COMPANY OF NEW YORK

Prompt Service for

BONDS AND CASUALTY INSURANCE

203-206 Merchants Exchange Building

SAN FRANCISCO, CAL.

ANY PLACE ANY TIME PROMPTLY "We Serve You"

JOHN H. ROBERTSON

Successor to Robertson & Hall

GENERAL INSURANCE

Phone Sutter 2750

621 First National Bank Building, San Francisco

CONTRACT BONDS

Fidelity and Surety Bonds of every kind.

C. K. BENNETT, Manager

FIDELITY AND DEPOSIT COMPANY OF MARYLAND

Telephone Kearny 1452

622 Insurance Exchange, San Francisco, Calif.

PACIFIC DEPARTMENT

Globe Indemnity Company

BONDS and CASUALTY INSURANCE for CONTRACTORS

FRANK M. HALL, formerly Robertson & Hall, Mgr.

120 Leidesdorff Street Phone Sutter 2280 SAN FRANCISCO

National Surety Company of New York

The World's Largest Surety Company

Assets over \$20,000,000

Pacific Coast Department: 105 MONTGOMERY ST., SAN FRANCISCO, CAL.

Frank L. Gilbert, Vice-President

Phone, Sutter 2636

PHONE DOUGLAS 2370

McLERAN & PETERSON

GENERAL CONTRACTORS

HEARST BUILDING

SAN FRANCISCO, CAL.

L. J. RUEGG

J. B. RUEGG

RUEGG BROS.

CONTRACTORS AND BUILDERS

Phone Douglas 1599

719 Pacific Building, SAN FRANCISCO



Steel ^{Open} ^{Hearth} Bars For Concrete Reinforcement

Square, Deformed and Cold Twisted, Plain Rounds and Squares

PACIFIC COAST STEEL COMPANY

General Office, Rialto Building, San Francisco. Phone Sutter 1564

Sales Office, Rialto Building, SAN FRANCISCO
Sales Office, Union Oil Building, LOS ANGELES
Sales Office.....SEATTLE, WASH.

ROLLING MILLS:
SOUTH SAN FRANCISCO.....CAL.
SEATTLE, WASH. PORTLAND, ORE.

Architects and Building Contractors :

THE Binding of Your Magazines
and Periodicals is Our Specialty.
Expert Plate and Map Mounting.

The HICKS-JUDD COMPANY, Inc.
BOOKBINDERS
51-65 First Street San Francisco, Cal.

George S. MacGruer }
Robert M. Simpson } Members of Builders Exchange

MacGruer & Simpson

CONTRACTING PLASTERERS
PLAIN AND ORNAMENTAL

Cement, Stucco and Artificial Stone

Phone Sutter 5688

540 Call-Post Building, San Francisco

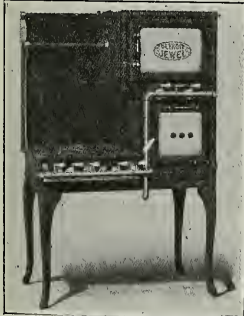

Detroit Jewel Gas Ranges

FOR HOME, RESTAURANT, HOTEL AND CLUB

We carry a Full Line of Stock Sizes

SELLING AGENTS

NATHAN DOHRMANN CO.

Geary and Stockton Streets, San Francisco

PARMELEE-DOHRMANN CO.

436-444 S. BROADWAY, LOS ANGELES

THE HYLOPLATE BLACKBOARD

SCHOOL FURNITURE
AUDITORIUM SEATING

MAPS
GLOBES
ATLASES

C. F. WEBER & CO.

985 Market Street
SAN FRANCISCO

222-224
S. Los Angeles St.
LOS ANGELES

100 W. Commercial
Row, RENO, NEV.

524 W. Washington
Street, PHOENIX, ARIZ.



LINOTILE

THE FLOOR
THAT'S BUILT
TO FIT
THE ROOM

Furnished and
Installed by

Van Fleet-Freear Co.

61 New Montgomery Street
San Francisco, California
Telephone, Douglas 1227



BEAUTIFUL GARDEN
EFFECTS for the City
and Suburban Home

MacRORIE-McLAREN CO

Landscape Engineers
and General Nurserymen



Office Nurseries at
141 Powell Street Beresford,
San Francisco San Mateo County

WASH in tempered running water by
installing

Crane "Sultana" Double Basin
Faucet
FOR NEW AND OLD INSTALLATIONS

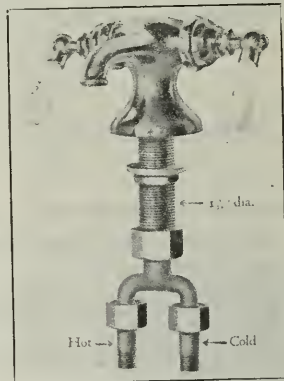

FOR HOME—OFFICE—FACTORY
"SULTANA" can be installed on practically
all lavatories cut for two basin faucets. It is
an ideal faucet to install when making alter-
ations.

CRANE CO.
PLUMBING SUPPLIES
SAN FRANCISCO AND OAKLAND

**MOUNT DIABLO CEMENT
COWELL SANTA CRUZ LIME**

ALL KINDS OF

BUILDING MATERIALS

HENRY COWELL LIME AND CEMENT CO.

Phone Kearny 2095

No. 2 MARKET STREET, SAN FRANCISCO

Kawneer

Factory
Berkeley, Calif.
Berkeley 8710

MANUFACTURING COMPANY
of California

San Francisco Office:
180 Jessie Street
Sutter 6700

Kawneer
Store-Fronts
All Metal Mouldings

Kawneer
Simplex Windows
Weightless & Reversible

CONTRACTOR'S MACHINERY

RANSOME MIXERS

OSHKOSH MIXERS

INSLEY SPOUTING PLANTS

OSHKOSH EVEREADY SAW RIGS INSLEY STEEL CARS and TRACKS

HOISTING BUCKETS, HOPPERS, GATES, ETC.

STEAM AND ELECTRIC HOISTS

EVERYTHING USED BY CONTRACTORS

CARRIED IN STOCK BY

GARFIELD & CO.

Hearst Building, San Francisco

Phone Sutter 1036

THE "CALIFORNIA" WALL BED

An Accomplishment in Design and Efficiency — Uses a minimum amount of space, all mechanical parts steel, a sturdily built standard bed, easily operated—Durable.

AMERICAN AUTOMATIC LOCK & LIFT CO.

Display Room: Building Material Exhibit, 77 O'Farrell Street, San Francisco

Office: 72 Fremont Street, San Francisco. Telephone Sutter 5712

Factory in Oakland

A GOOD FIELD FOR DISTRIBUTORS

Telephone DOUGLAS 2046	<div style="border: 1px solid black; padding: 5px;"> <p style="font-size: small; margin: 0;">Butte Electrical Equipment Company</p> <h1 style="margin: 0;">BEECO</h1> <p style="font-size: x-small; margin: 0;">TRADE MARK - REG.</p> </div>	530 FOLSOM STREET
<p>CONTRACTORS FOR POWER LIGHTING AND INDUSTRIAL INSTALLATIONS</p> <p>For the convenience and guidance of our customers, we have adopted BEECO as our trade name.</p>		

<h1 style="margin: 0;">SAFETY ELECTRIC COMPANY</h1> <p style="font-size: small; margin: 0;">MANUFACTURERS OF</p>		
SWITCHBOARDS SAFETY SWITCHES SAFETY CONTROLS		PANEL BOARDS SAFETY PANELS KNIFE SWITCHES
<p>59-65 Columbia Square San Francisco, Calif.</p> <p>Telephone Market 2949</p>		

L. SIEBERT	J. GENSLER
<h1 style="margin: 0;">Drendell Electrical & Mfg. Co.</h1> <p style="font-size: small; margin: 0;">Incorporated</p>	
<p>SWITCHBOARDS, PANEL BOARDS, KNIFE SWITCHES, CABINETS, THEATRE INSTALLATIONS, PROTECTIVE POWER PANELS</p>	
<p>1345-1353 Howard St., San Francisco Telephone Market 1753</p>	

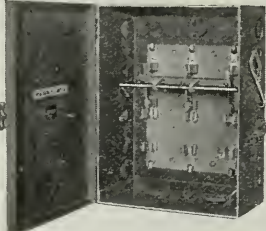
	<h1 style="margin: 0;">MEYERS</h1> <h2 style="margin: 0;">Electric Safety SWITCHES</h2> <p style="font-size: small; margin: 0;">EXTERNALLY OPERATED</p> <p style="font-size: x-small; margin: 0;">Switch on the right is controlled by Handle on Front of Door, allowing face of switch to be set flush with finish of wall.</p>	
<p>Knock outs on Top, Bottom and Side controlled by Handle on side of Box</p> <p>Meyers Electric Safety Switch Co., Inc. 247 Minna Street</p> <p style="text-align: right;">Phone Sutter 3008</p>		

When writing to Advertisers please mention this magazine.

BUTTE ELECTRIC & MFG. CO. DOUGLAS 145

(Paul C. Butte) at it since 1904

WIRING FOR BUILDINGS

534 Folsom Street

SAN FRANCISCO

H. S. TITTLE

CONTRACTING ELECTRICAL ENGINEER

766 FOLSOM ST., SAN FRANCISCO

Phone SUTTER 4278



To Be "Low Bidder" Not Always Our Aim.

Our most particular attention is given to prompt and skillful handling of all electrical work of any nature with "QUALITY AND SERVICE GUARANTEED."
Our nation-wide organization and large experience in this field assures you always of fair estimates and absolute satisfaction.

F. E. NEWBERY ELECTRIC CO.

163 Sutter St. (413 Lick Bldg.) San Francisco, Phone Sutter 521

San Francisco, Cal.

Oakland, Cal.

Los Angeles, Cal.

NE PAGE, McKENNY CO.

Electrical Engineers and Contractors

Phone Sutter 2369

589 Howard St., San Francisco, Cal.

Phone Market 2541

M. FLATLAND

GLOBE ELECTRIC WORKS

Estimates Furnished on Everything Electrical

ELECTRIC SUPPLIES

1959 Mission Street, bet. 15th and 16th

SAN FRANCISCO

E. E. BROWNE

Telephone Douglas 976

C. A. LANGLAIS

**BROWNE-LANGLAIS ELECTRICAL
CONSTRUCTION COMPANY**

213 Minna Street

SAN FRANCISCO

M. E. RYAN

Electrical Contractor

Phones: Store, Red. 250J
Residence, Red. 250M

216 Main Street
REDWOOD CITY, CAL.

Thomas J. Bennett

Edward W. Lauer

Rex Electric and Engineering Co.

Contracting and Repairing

253 Minna Street

Telephone Sutter 2148

San Francisco

Oakland 540

The Largest Exclusive Electrical House in the State

MOTORS

BOUGHT — SOLD
RENTED — REPAIRED

Lighting Fixtures

Manufactured

Construction

MAINTENANCE
SUPPLIES

Estimates and engineering data cheerfully furnished

SPOTT ELECTRICAL CO.

Yours for Service

16th & CLAY STREETS

OAKLAND, CALIFORNIA

CHAS. G. FRIES.

TELEPHONE SUTTER 5706

VICTOR A. KUEHN

LIBERTY ELECTRIC COMPANY

479 Sutter St. Electrical Contractors San Francisco, Cal.

POWER CONSTRUCTION CO.

INCORPORATED

CONTRACTING ENGINEERS

Preliminary Estimates Given in All Types
of Buildings, Towers and Bridges

SHARON BUILDING, SAN FRANCISCO
Phone Sutter 5478

SAMSON SPOT SASH CORD

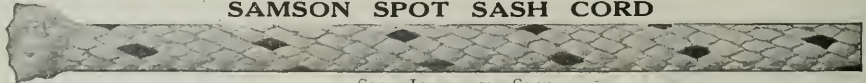

SPOT IT BY THE SPOTS

Made of extra quality cotton yarn, firmly braided and smoothly finished. Carefully inspected and guaranteed free from all imperfections of braid and finish. → Can be distinguished at a glance by our trade-mark, the Colored Spots. *Send for catalogue and samples.*

Pacific Coast Agent, JOHN T. ROWNTREE, Inc., San Francisco and Los Angeles, Cal.

S. RASORI, RES. 2042 TAYLOR ST.
PHONE FRANKLIN 6258

J. DEL FAVERO, RES. 1839 MASON ST.
PHONE FRANKLIN 9524

DEL FAVERO & RASORI

GENERAL CONTRACTORS

MEMBERS OF THE S. F. BUILDERS EXCHANGE AND THE BUILDING INDUSTRIES ASS'N

OFFICE:
110 JESSIE STREET

SAN FRANCISCO, CALIF.

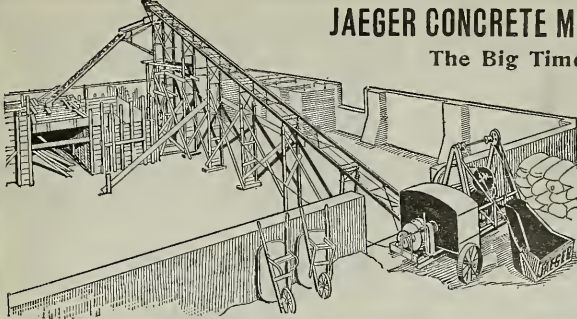

JAEGER CONCRETE MIXING AND PLACING PLANT
 The Big Time and Money Saver

All Sizes and Models in Stock

Edward R. Bacon Co.
 51 Minna St. 165 E. Jefferson St.
 SAN FRANCISCO LOS ANGELES

THE AUSTIN CUBE MIXER

The cube mixing principle, inside breaker rods, renewable drum plates, and long lasting qualities, combine to make the AUSTIN-CUBE the most highly efficient mixer in the concrete mixing service.

AUSTIN-CUBES are made in sizes adapted to every class of concrete mixing service. Special machines for road and street paving.

AUSTIN MACHINERY CORPORATION
 Main Office, Railway Exchange, CHICAGO
 Stuart S. Smith, 625 Market St., San Francisco.
 Tom N. Nicholson, 743 Harvard Ave., Los Angeles.

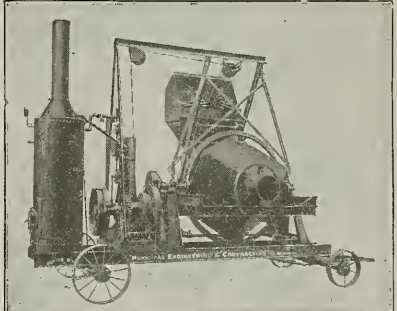

**LAKESWOOD - MILWAUKEE
 CONCRETE MIXERS**

ARE STURDY, HIGH SPEED, LABOR - SAVING MACHINES

Built in All Commercial Sizes. Driven by Kerosene Engine or Electric Motor.

COMPLETE STOCKS ON HAND



SMITH-BOOTH-USHER-Co.
 SAN FRANCISCO-TAFT-LOS ANGELES

MACHINE TOOLS
 WOODWORKING MACHINERY
 ENGINES - MOTORS
 AIR COMPRESSORS - PUMPS
 POWER TRANSMISSION
 OIL & MINING EQUIPMENT
 CONSTRUCTION-INDUSTRIAL
 ROAD MAKING MACHINERY
 PIPE-FITTINGS-VALVES-SUPPLIES ETC.

CATALOG ON REQUEST

When writing to Advertisers please mention this magazine.

School and Theatre

STAGES AND EQUIPMENT

EDWIN H. FLAGG

SCENIC COMPANY, Inc.
400 Pantages Bldg., San Francisco, Cal.
1638 Long Beach Ave., Los Angeles, Cal.

The Granite Work on Eldorado County Courthouse; National Bank of D. O. Mills, Sacramento;- and Sen. Nixon Mausoleum, Reno, WAS FURNISHED BY

CALIFORNIA GRANITE COMPANY

Phone Sutter 2646

STONE CONTRACTORS

Gen'l Contractors Ass'n, San Francisco
Quarries, Rocklin and Porterville

Main Office, **Rocklin, Placer Co., Cal.**
Telephone Main 82

FRANK PORTMAN

MILL AND CABINET WORK

Window Frames and Inside Finish A Specialty
Band Sawing, Sticking and Sand Papering

1618-20 MISSION STREET

SAN FRANCISCO

ALL KINDS OF
MOULDINGS
IN STOCK

Phone Park 6204

A. C. SCHINDLER, President.

CHAS. F. STAUFFACHER, Secretary

THE FINK & SCHINDLER CO.

Manufacturers of INTERIOR WOODWORK AND FIXTURES
BANK, OFFICE AND STORE FITTINGS
SPECIAL FURNITURE

218-228 THIRTEENTH ST.
Bet. Mission and Howard Sts.

SAN FRANCISCO, CAL.
Telephone: Market 474

O. BAMANN, President

ERNEST HELD, Vice-President

HOME MANUFACTURING CO.

BANK, STORE AND OFFICE FITTINGS
FURNITURE AND HARDWOOD INTERIORS
CABINET WORK OF EVERY DESCRIPTION

543 and 545 BRANNAN ST.

Phone Kearny 1514

San Francisco, Cal.

PACIFIC MANUFACTURING COMPANY

MILLWORK, SASH AND DOORS

Hardwood Interior Trim a Specialty

MAIN OFFICE:

SANTA CLARA, CAL.

SAN FRANCISCO.....177 Stevenson Street
OAKLAND.....1001 Franklin Street
BERKELEY.....2143 Center Street
SAN JOSE.....16 N. First Street

Dolan Wrecking & Construction Co.

(D. J. DOLAN)

Lumber, Lath, Nails, Shingles, Doors, Windows
and Plumbing Supplies, New and Second Hand

Phone Market 4264

Office and Yard, 1607-1639 MARKET ST., SAN FRANCISCO

MONSON BROS.

GENERAL CONTRACTORS

Telephone Market 2693

1908 Bryant Street, San Francisco

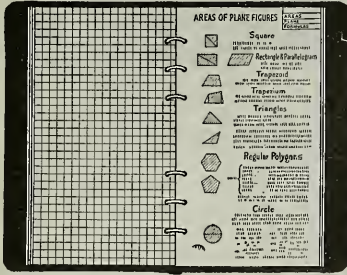

LEFAX
LEAF + FACTS
Pocket Cyclopedias

The facts that you want *instantly available* are not the same ones that some one else in your profession might desire. That's why LEFAX is made Loose Leaf. You file, in whatever order you wish, those sheets of facts that you want to have constantly at hand. If you wish, you may also file, in the same book, sheets for keeping data, for figuring, etc.

LEFAX sets cost but 50c. and \$1.00. You cannot fully appreciate their handiness—their value—until you use them. Ask us about them.

SCHWABACHER-FREY STATIONERY CO.
PRINTERS LITHOGRAPHERS STATIONERS
611 Market Street San Francisco

**Steam Heating
and Ventilating**

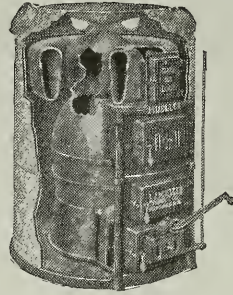

For Commercial and
Public Buildings

Furnace Heating
For the Home

Mangrum & Otter, Inc.
827-831 Mission Street
Phone Kearny 3155 SAN FRANCISCO

DIRECT-LINE

Telephone Company
THEODORE HALL, Manager



Telephone and Electrical Engineers
Automatic Electric Company, Chicago
AUTOMATIC TELEPHONES and
AUTOMATIC ENUNCIATOR

Some of the Installations:
Baker, Hamilton-Pacific Co.; J. D. & A. B. Spreckels Securities Co.; California Packing Corporation; Sperry Flour Co., So. Vallejo.

TELAUTOGRAPH CORPORATION, New York
Some of the Installations:
Palace Hotel, Hotel St. Francis, Bank of California, California Hawaiian Sugar Refining Co., Crockett, Cal.

**INSTALLATION AND MAINTENANCE OF
ELECTRICAL AND TELEPHONE APPARATUS**
Tel. Douglas 722 320 Market St., San Francisco

**ROBERTS
MFG. CO.**

Lighting Fixtures
Electric Appliances
Incandescent Lamps

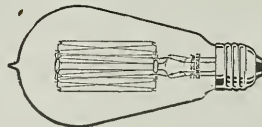

**WILLYS FARM LIGHTING
AND POWER PLANTS**

663 Mission St., San Francisco

CALIFORNIA ARTISTIC METAL & WIRE CO.
 J. T. McCORMICK, PRESIDENT
 ORNAMENTAL IRON AND BRONZE
 349-365 SEVENTH ST. SAN FRANCISCO

MORTENSON CONSTRUCTION CO.
 CONTRACTORS FOR STRUCTURAL STEEL AND IRON
 H. MORTENSON, PRES. CHAS. G. MORTENSON, VICE-PRES. AND MGR.
 OFFICE AND SHOPS: CORNER 19TH AND INDIANA STREETS
 PHONE: MISSION 5033 SAN FRANCISCO, CAL.

RAYMOND GRANITE COMPANY, Inc.
 Owing and operating at Knowles, Madera County, the largest Quarry in the world
 CONTRACTORS FOR STONE WORK
 Designers and Manufacturers of Exclusive Monuments and Mausoleums
 Main Office and Yard: No. 1 and 3 Potrero Avenue, San Francisco, California
 Also at 1350-Palmetto Street, Los Angeles

CAEN STONE  **A. KNOWLES**
 A refined, elegant, interior finish. CONTRACTOR and PLASTERER
 442 Call-Post Building San Francisco

THE GOLDEN GATE IRON WORKS
STRUCTURAL STEEL
 1541-1549 HOWARD STREET, BETWEEN 11th AND 12th STREETS
 Tel. Market 5445 SAN FRANCISCO

Telephone Mission 58 A. A. Devoto, President
CENTRAL IRON WORKS, Inc.
 STRUCTURAL STEEL
 Office 2050 BRYANT STREET SAN FRANCISCO, CAL.

JOHNS-MANVILLE
 SERVES IN CONSERVATION
 Through
ASBESTOS and its ALLIED PRODUCTS

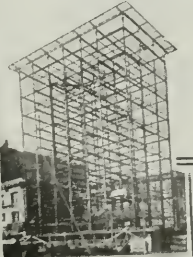
 **SCHRADER IRON WORKS, Inc.**
 STRUCTURAL STEEL CONTRACTORS
 Fire Escapes, Waterproof Trap Doors, Ornamental Iron Work
 1247-1249 HARRISON STREET SAN FRANCISCO, CAL
 Bet. 8th and 9th Telephone Market 337

THE
PUBLIC LIBRARY

The
ARCHITECT &
ENGINEER



OCTOBER 1920

Published in San Francisco
35 cents a copy - \$2⁵⁰ a year

Our enormous foreign business
is striking proof of the consistent
high quality of



PACIFIC
PLUMBING FIXTURES



For Sale by All Jobbers

Main Offices: 67 New Montgomery Street, San Francisco
Factories: San Pablo and Richmond, California
Branches: Portland, Los Angeles and Salt Lake City





*The First National Bank of
Fairfield, California
covered with a PABCO 20-Year Roof.*

The Banker's Preference

There are two reasons why so many bank buildings are covered with Pabco 10 and 20-year roofs.

1. Because the banker demands the permanent protection which these roofs provide.
2. Because he knows that a Pabco Roof is guaranteed by The Paraffine Companies, Inc.—an institution of unquestioned integrity.

PABCO 10 and 20-Year Roofs

are specified by architects and engineers and are demanded by owners because they provide permanent protection, at lowest cost per year of service.

Write for Specifications

THE PARAFFINE COMPANIES, Inc.

San Francisco

Engineering Department
Hermann Safe Co.
Designers



Roofings, Felts
Building Papers
Wall-Board
Floor Covering
Waterproofing
Materials
Industrial and Marine
Paints
Electrical Varnishes
and Insulating
Compounds
Box-Board
Paper-Boxes
Fibre Containers

STEEL BARS

FOR
CONCRETE REINFORCEMENT

CORRUGATED
TWISTED
SQUARES
OR
ROUNDS
CUT
TO
LENGTH



FABRICATED
AND
INSTALLED
—
LUMP SUM
BIDS
ON
WORK
COMPLETE

Office, 444 MARKET STREET
Warehouse, 10th and Bryant Streets
Phone: Sutter 2720

“HYDRATITE” FOR WATERPROOFING AND HARDENING CONCRETE “HORNSTONE”

Look for this
Trademark



And if it's there don't worry
any more about your
Valves and Fittings

*Specify and
insist upon
having*

The Kelly & Jones Co.
Valves and Fittings

Byers Genuine
Wrought Iron Pipe

Republic Steel Pipe

Complete Line of Plumbing Supplies
Large Stocks for Prompt Delivery
Catalogue on request

California Steam &
Plumbing Supply Co.

671-679 Fifth Street, Corner Bluxome
SAN FRANCISCO, CALIFORNIA





PIPE
 Valves & Fittings
STEAM & WATER SUPPLIES
 Heating Material
PLUMBING GOODS
 Pumps

GEORGE H. TAY COMPANY
SAN FRANCISCO OAKLAND
 MISSION & SECOND STS. TENTH & HARRISON STS.
 TELEPHONE DOUGLAS 2240 TELEPHONE LAKESIDE 4200

Contractors Cannot Agree

as to percentage of labor and material saved in using

1 A RIB LATH

over other expanded metals; majority claim 20% saving — others more. Labor is high, material higher, 1 A RIB cuts down cost of both—present conditions demand your immediate investigation where metal lath is needed. Phone Market 8357.

Largest stock of fireproof material and reinforcing bars on the Pacific Coast.



Truscon Steel Company

CHAS. HOLLOWAY, JR., BRANCH MANAGER

527 Tenth Street, San Francisco

W. & J. SLOANE

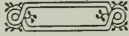

Carpetings Furniture
Rugs
Linoleum Window Shades
Wall Papers
Interior Decorations

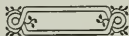

216-228 Sutter Street
Tel. Garfield 2838 San Francisco



A FLOORING for discriminating Architects and Builders, and characteristically a Michigan product in every way, from the excellence of the wood itself to the superior millwork and careful grading.

Strable Mfg. Co.

HARDWOOD LUMBER
Phone, Oakland 245
511-545 FIRST STREET OAKLAND, CAL



PROMETHEUS

The Electric Food and Plate Warmer

Wherever meals are cooked and served, in apartments, residences and institutions, Prometheus is a highly valued asset. The wireless heating units placed independently of the shelves keep food hot and tasty until ready to serve and cannot injure the finest china.

Write for information and list of installations

The Prometheus Electric Co.

Manufacturers
511 West 42d Street, New York

Showroom, **M. E. HAMMOND**
Mezzanine Floor Pacific Bldg., San Francisco

CLOW

Modern Heating

AS in lighting, the trend in heating is toward central station service. The wastefulness and high maintenance cost of individual heating plants is becoming understood by the public. At the same time gas — not as a supplementary but as the *main* source of heat—is being recognized. Architects, naturally in the forefront of all developments in such matters, ought to be thoroughly informed as to the scope and possibilities of the Gasteam Radiator. It is as revolutionary and far-reaching in its possibilities as concrete.

Frederick A. Hamilton

Sales Agent

Show Rooms:

RIALTO BUILDING
SAN FRANCISCO



TiteSete Float Valve

For High and Low Pressures

IN SIZES UP TO 4 INCHES
Larger Sizes on special order

Remains Wide Open
until desired Water Level
is reached then Closes
POSITIVELY without
Water Hammer

Simple and Durable
Positive and Reliable



Self-Cleaning,
Non-Clogging
By-Pass

NATIONAL VALVE COMPANY

Phone Douglas 5093

23-25 MINNA ST., SAN FRANCISCO

MASTIC FLOORS

BITURINE COATINGS FOR STEEL

WATERPROOFING

Hill, Hubbell & Company

CONTRACTORS

SAN FRANCISCO

1000 Fife Building, No. 1 Drumm Street

LOS ANGELES

Marsh-Strong Building

SEATTLE

Grand Trunk Pacific
Dock

PORTLAND

Pittock Block

E. B. Noble, Vice-Pres.
A. E. Wilkins, Sec'y

Beam, Angle, Channels, and Universal
Mill Plates for immediate ship-
ment from stock

Pacific Rolling Mill Co.

SUPPLIERS OF

**FABRICATED STRUCTURAL STEEL, Forgings,
Bolts, Rivets, Frogs, Switches, Cast Iron Castings**

General Office and Works
17th and MISSISSIPPI STS., SAN FRANCISCO
Telephone Market 215

Phones: Garfield 2575 and 2576

WESTERN IRON WORKS

W. B. Morris, President

H. H. Morris, Vice-President

L. J. Gates, Secretary

**STRUCTURAL IRON and
STEEL CONTRACTORS**

Beams, Channels, Angles, Plates and Steel
Wheelbarrows Carried in Stock

141-147 Beale Street and 132-148 Main Street
SAN FRANCISCO, CAL.

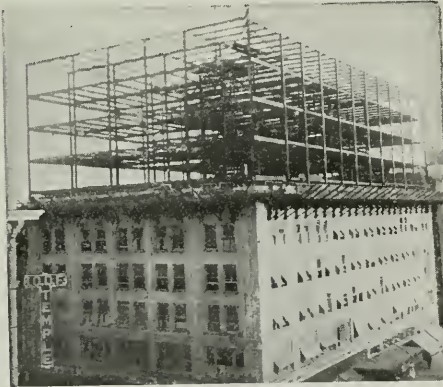

FORUM BUILDING, SACRAMENTO, CAL.
R. A. Herold, Architect

Progress Picture of the four story addition
to Sacramento's largest office building.

STRUCTURAL STEEL FABRI-
CATED AND ERECTED BY

**The Palm Iron and
Bridge Works**

(Incorporated)

15th and R. Sts., Sacramento, Cal.

Cast Iron Stairs and Store Fronts

Bank and Office Railings, Elevator
Enclosures and Fire Escapes.

C. J. HILLARD CO., Inc.

Nineteenth and Minnesota Streets
Telephone Mission 1763

SAN FRANCISCO, CAL.

Architects' Specification Index

(For Index to Advertisements, see next page)

ARCHITECTURAL TERRA COTTA

Gladding, McBean & Company, Crocker Bldg., San Francisco.

Los Angeles Pressed Brick Company and United Materials Co., Crossley Bldg., San Francisco.

Livermore Fire Brick Works, Livermore, Cal.

ASBESTOS ROOFING, PACKING, ETC.

H. H. Robertson Co., Hobart Bldg., San Francisco.

H. W. Johns-Manville Co., San Francisco, Los Angeles and Portland, Ore.

AUTOMATIC SPRINKLERS

Grinnell Co. of the Pacific, 453 Mission St., San Francisco.

Scott Company, 243 Minna St., San Francisco.

Pacific Fire Extinguisher Co., 424 Howard St., San Francisco.

AUTOMOBILE INSURANCE

Bankers & Shippers Insurance Co. of New York, Insurance Exchange Bldg., San Francisco.

AWNINGS, TENTS, ETC.

W. A. Plummer, Front, at Pine St., San Francisco.

BANK FIXTURES AND INTERIORS

Fink & Schindler, 218 13th St., San Francisco.

C. F. Weber & Co., 985 Market St., San Francisco.

Home Mfg. Co., 543 Brannan St., San Francisco.

Mullen Manufacturing Co., 64 Rausch St., San Francisco.

Rucker-Fuller Desk Co., 677 Mission St., San Francisco.

Pacific Manufacturing Company, San Francisco, Oakland and Santa Clara.

BELTING AND PACKING

New York Belting and Packing Company, 519 Mission St., San Francisco.

H. N. Cook Belting Co., 401 Howard St., San Francisco.

BLACKBOARDS

C. F. Weber & Co., 985 Market St., San Francisco, Los Angeles and Reno, Nevada.

Beaver Blackboards and Greenboards, Rucker-Fuller Desk Company, Coast agents, 677 Mission St., San Francisco; also Oakland and Los Angeles.

BLINDS—VENETIAN AND DIFFUSELITE

J. G. Wilson Corporation, Metropolitan Bldg., Los Angeles; Waterhouse-Wilcox, Underwood Bldg., San Francisco.

Western Venetian Blind Co., Long Beach Ave., Los Angeles.

BOILERS

California Hydraulic Engineering & Supply Co., 70-72 Fremont St., San Francisco.

Franklin Water Tube Boiler, General Machinery and Supply Co., 39 Stevenson St., San Francisco.

Kewanee Water Supply System, Simonds Machinery Co., 117 New Montgomery St., San Francisco.

General Boilers Co., 322 Monadnock Bldg., San Francisco.

BONDS FOR CONTRACTORS

American Mutual Liability Insurance Co., Balboa Bldg., San Francisco.

Bonding Company of America, Kohl Bldg., San Francisco.

Bankers & Shippers Insurance Co. of New York, Insurance Exchange Bldg., San Francisco.

Globe Indemnity Co., 120 Leidesdorff St., San Francisco.

Fidelity & Casualty Co. of New York, Merchants Exchange Bldg., San Francisco.

Fidelity & Deposit Co. of Maryland, Insurance Exchange, San Francisco.

John H. Robertson, 621 First National Bank Building, San Francisco.

National Surety Co. of New York, 105' Montgomery St., San Francisco.

BRASS GOODS, CASTINGS, ETC.

H. Mueller Manufacturing Co., 635 Mission St., San Francisco.

BRICK—PRESSED, PAVING, ETC.

California Brick Company, Niles, Cal., and 604 Mission St., San Francisco.

Livermore Fire Brick Works, Niles, Cal.

Gladding, McBean & Company, Crocker Bldg., San Francisco.

Los Angeles Pressed Brick Co., Frost Bldg., Los Angeles.

United Materials Co., Crossley Bldg., San Francisco.

BRICK & CEMENT COATING

Armorite and Concreta, manufactured by W. P. Fuller & Co., all principal Coast cities.

The Paraffine Companies, Inc., 34 First St., San Francisco.

R. N. Nason & Co., 151 Potrero Ave., San Francisco.

Glidden Stucolor Liquid Cement Coating. The Glidden Company, 123 Hooper St., San Francisco.

Wadsworth, Howland & Co., Inc., Boston, Mass., manufacturers of Bay State Brick & Cement Coating. Hambly & Son, agents, San Francisco and Los Angeles.

BRICK STAINS

Samuel Cabot Mfg. Co., Boston, Mass., agencies in San Francisco, Oakland, Los Angeles, Portland, Tacoma and Spokane.

Armorite and Concreta, manufactured by W. P. Fuller & Co., all principal Coast cities.

BUILDERS' HARDWARE

Joost Bros., agents for Russell & Erwin Hardware, 1053 Market St., San Francisco.

The Stanley Works, New Britain, Conn., represented in San Francisco and Los Angeles by John Rountree & Co.

Palace Hardware Company, Agents Corbin goods, 581 Market St., San Francisco.

Richards-Wilcox Mfg. Co., Aurora: Ewing-Lewis Co., 626 Underwood Bldg., San Francisco.

GRINNELL AUTOMATIC SPRINKLER GRINNELL COMPANY

OF THE PACIFIC

ENGINEERS AND CONTRACTORS
453 Mission Street, San Francisco

CHEMICAL FIRE
EXTINGUISHERS
AND FIRE ENGINES

VALVES
PIPE and FITTINGS

When writing to Advertisers please mention this magazine.

An Index to the Advertisements

	Page		Page		Page
American La France Fire Engine Co.	34	Gunn Carle Company	2	Palmer & Petersen	142
American Mutual Liability Insurance Co.	10	Haines, Jones & Cadbury	125	Paraffine Companies, Inc.	1
American Mail Chute	32	Hamilton, F. A.	4	Parker, K. E. Co., Inc.	144
American Marble & Mosaic Co.	44	Hammond, M. E.	4	Petrium Sanitary Sink Co.	143
American Rolling Mill Co.	28-29	Hannah, J. D.	142	Phillips, Chas. T.	145
American Standard Oil Burner	43	Hauser Window Co.	26	Pitcher Door Hanger	33
American Window Glass Co.	42	Haws Sanitary Drinking Faucet Co.	138	Plummer, W. A.	138
Atlas Heating & Ventilating Co.	146	Hicks-Judd Co.	151	Pope & Tabot.	15
Bacon, Edward R., Co.	157	Hillard, C. J., Co.	6	Portland Lumber Co.	15
Badt-Falk & Co.	145	Hill, Hubbell & Company	5	Portman, Frank.	158
Baird-Bailhache Company	24	Holbrook, Merrill & Stetson	147	Power Construction Company	156
Bankers' & Shippers' Ins. Co.	128	Home Mfg. Co.	158	Prometheus Electric Co.	4
Barrett & Hilp	144	Hunt, Robt. W. & Co.	133		
Bass-Hueter Co.	3rd Cover	Hunter & Hudson	140		
Baxter, Reed	32	Ideal Heating & Engineering Co.	146	Raymond Granite Co.	160
Beach-Robinson Co.	31	Illinois Engineering Co.	146	Redwood Mfg. Co.	42
Beckwith, Herbert	145	Imperial Waterproofing	32	Reliance-Grant Elevator Equipment Co.	22
Bowser & Co., S. F.	41	Inlaid Floor Co.	140	Rex Electric Engineering Co.	155
Brenner, John	136	James & Drucker	136	Roberts Mfg. Co.	159
Brininstool Co.	22	Jarvis, T. P. Mfg. Co.	43	Robertson Co., H. H.	11
Browne-Langlais Company	155	Johns-Manville Co.	160	Robertson, John H.	150
Butte Electrical Equipment Co.	154	Johnson, S. T.	43	Ruegg Bros.	150
Butte Electric & Mfg. Co.	155	Johnson Service Co.	11	Rucker-Fuller Desk Co.	140
		Joost Brothers	140	Ryan, M. B.	155
Cabot, Samuel (Inc.)	41	Kawneer Mfg. Co.	153	Safety Electric Co.	154
California Artistic Metal and Wire Co.	160	Kerner Incinerator Co.	21	Sampson Spot Cord.	156
California Bldg. Material Co.	Back Cover	Key-hold Plaster Lath Co.	32	San Francisco Pioneer Varnish Works	3d Cover
California Brick Co.	23	Kissel, I. R.	142	Scott Co.	146
California Granite Co.	146	Knittle-Cashel Co., Inc.	13	Schrader Iron Works	160
California Hydraulic Engineering and Supply Co.	10	Knowles, A.	160	Schwabacher-Frey Co.	159
California Paint Co.	14			Sloane, W. & J.	4
California Plastic Products Co.	137	Lange & Bergstrom	148	Simmons, O. M. Co.	12
California Redwood Ass'n.	136	Larsen, Sampson & Co.	142	Simonds Machinery Co.	131
California Steam and Plumbing Supply Co.	2	Letch, A.	146	Smith-Booth-Usher Co.	157
Cement Gun Construction Co.	134	Liberty Electric Co.	156	Smith, Jas. F.	144
Central Iron Works	160	Littfield, R. W.	144	Sommer, I. M.	144
Clinton Wire Lath	34	Livemore, Fire Brick Works	23	Sonnenschein Bros.	31
Clow & Sons	4	Los Angeles Pressed Brick Co.	127	Spencer Elevator Co.	24
Cobble Dick-Kibbe Glass Co.	136			Spott Electrical Co.	156
Coleman, Alex.	146	MacGruer & Simpson	151	Standard Varnish Works	22
Coolman, A. D.	142	MacRorie-McLaren Co.	152	Standard Electric Time Co.	136
Cook Belting Co.	38	Magner Bros.	140	Standard Fence Co.	145
Cowell Lime & Cement Co.	153	Mangrum & Otter	159	Stanley Works, The	123
Crane Co.	152	Marshall & Stearns Co.	143	Steffern Contracting Co.	144
		McCray Refrigerator Co.	32	Steel Studing Co.	137
Davis, R. J.	14	McLeran & Peterson	150	St. Francis Hotel	131
Del Favero and Rasori	156	McNab, H. N.	145	Strable Mfg. Co.	4
Del Monte Properties Co.	20	Medusa Cement	27	Sunset Lumber Company	15
Detroit Steel Products Co.	44	Meese & Gottfried	134		
Dieckmann Hardware Co.	12	Meyers Electric Safety Switch Co., Inc.	154	Tay Company, George H.	3
Direct Line Telephone Co.	159	Moline Heat	17	Taylor, F. A. & Co.	31
Dolan Wrecking & Construction Co.	158	Montague Range & Furnace Co.	15	Tittle, H. S.	155
Dow-Herriman Co.	148	Monson Bros.	142	Tormey Co.	140
Drendell Elec. & Mfg. Co.	154	Mortenson Construction Co.	160	Trost, Robt.	142
Durdfield Lumber Co.	158	Mott Co. of Calif.	18	Truson Steel Co.	3
Duncan, W. C.	144	Mueller Mfg. Co.	18	Tuec Cleaner	141
Dyer Bros.	132	Mullen Mfg. Co.	158		
		Mushet Co., W. E.	148	Uhl Bros.	38
Electric Outlet Co.	36-37	Musto Sons Keenan Co.	13	Unit Construction Co.	142
Elevator Supplies Co.	150	Nason, R. N. & Co.	9	United Electric Co.	141
Ellery Arms Co.	128	Nathan, Dohrmann Co.	151	United Materials Co.	127
		National Mill & Lumber Co.	33	U. S. Metal Products Co.	26
Faber, Eberhard	30	National Surety Co.	150	U. S. Steel Products Co.	40
Fess System Co.	43	National Valve Co.	5		
Fidelity & Casualty Co. of N.Y.	150	Nelson, James A.	148	Van Fleet-Freear Co.	152
Fidelity & Deposit Co. of Maryland	150	Ne Page, McKenny Co.	155	Vermont Marble Co.	34
Fink & Schindler Co., The	158	Newbery Electric Co.	155	Vukicevich & Bagge	144
Fire Protection Products Co.	16	New York Belting and Packing Co.	21	Vulcanite Roofing Co.	26
Flagg, Edwin H., Scenic Co.	158	Norris Co., L. A.	34		
Freeman Art Shop	31			Wadsworth, Howland & Co., Inc	133
Fuller & Goep.	24	Oak Flooring Mfgs' Ass'n.	129	Walter, D. N. & E. & Co.	145
Fuller, W. P. Co.	19	Ocean Shore Iron Works	138	Ward, Baldwin D.	140
		Old Mission Portland Cement Co.	25	Waterhouse, Wilcox Co.	32
Garfield Company	157	Otis Elevator Co.	Back Cover	Wayne Oil Tank & Pump Co.	33
Garnett, Young & Co.	20			Weber, C. F. & Co.	152
General Boilers Co.	18	Pacific Coast Steel Company	151	Wentworth, F. W.	128
Gilley-Schmid Co.	140	Pacific Materials Co.	27-41-44	Western Blind & Screen Co.	39
Gladning, McBean & Co.	138	Pacific Fire Extinguisher Co.	18	Western Iron Works	9
Glidden Co.	35	Pacific Mfg. Co.	158	Western Office, Equipment Co.	34
Globe Electric Works	155	Pacific Plumbing Fixtures	2d Cover	Western Pipe and Steel Co.	147
Globe Indemnity Co.	150	Pacific Porcelain Ware Co.	2d Cover	White Bros.	122
Go-Sign & Letter Co.	145	Pacific Pump & Supply Co.	38	Wilson, J. G., Corp.	139
Golden Gate Ornamental Iron Co.	160	Pacific Rolling Mills	6	Wilson, W. F., Co.	146
Grinnell Co.	7	Palace Hardware Co.	38	Witt, G. E. Co.	44
		Palm Iron Works	6	Wooden & Little	132
				Zelinsky, D. & Sons	145

NASON'S OPAQUE FLAT FINISH A FLAT WASH-

ABLE OIL PAINT, made in soft Kalsomine tints—a practical article for WALLS, CEILINGS, Etc. Economical and Durable. Agency TAMM & NOLAN COMPANY'S high grade Varnishes and Finishes, made on the Pacific Coast to stand our climatic conditions.

R. N. NASON & CO., Paint Makers

51 Potrero Ave.—SAN FRANCISCO—436 Market St.

PORTLAND
SEATTLE
LOS ANGELES

ARCHITECTS' SPECIFICATION INDEX—Continued

- BUILDING MATERIAL, SUPPLIES, ETC.**
Pacific Materials Co., Underwood Bldg., San Francisco.
Waterhouse-Wilcox Co., 523 Market St., San Francisco.
Johns-Manville Company, Second and Howard Sts., San Francisco.
- CABINET MAKERS**
Home Manufacturing Company, 543 Brannan St., San Francisco.
Fink & Schindler Co., 218 13th St., San Francisco.
Mullen Manufacturing Company, 64 Rausch St., San Francisco.
Frank Portman, 1618 Mission St., San Francisco.
- CARPETS**
W. & J. Sloane, 216-228 Sutter St., San Francisco.
- CASEMENT WINDOW HARDWARE**
Richards-Wilcox Mfg. Co., Aurora, Ill., and Underwood Bldg., San Francisco.
- CASTINGS**
Dow-Herriman Co., 140 Howard St., San Francisco.
- CEMENT**
Mt. Diablo, sold by Henry Cowell Lime & Cement Co., 2 Market St., San Francisco.
Medusa White Portland Cement, manufactured by Sandusky Cement Co., represented in San Francisco by Pacific Building Materials Co., Underwood Bldg., San Francisco.
Old Mission Portland Cement Co., Mills Building San Francisco.
- CEMENT EXTERIOR FINISH**
Concreta, sold by W. P. Fuller & Co., all principal Coast cities.
Glidden Stucolor Liquid Cement Coating. The Glidden Company, 123 Hooper St., San Francisco.
Samuel Cabot Mfg. Co., Boston, Mass., agencies Oakland, Los Angeles, Portland, Tacoma, Spokane; and Pacific Building Materials Co., 525 Market St., San Francisco.
The Paraffine Companies, Inc., 34 First St., San Francisco.
- CEMENT EXTERIOR WATERPROOF PAINT**
Armorite, sold by W. P. Fuller & Co., all principal Coast cities.
Bay State Brick and Cement Coating, manufactured by Wadsworth, Howland Co., Boston, Mass. James Hambley & Son, Distributors, San Francisco and Los Angeles.
Hill, Hubbell & Company, No. 1 Drumm St., San Francisco.
Imperial Waterproofing, manufactured by Brooks & Doerr, Reed Baxter, agent, Merchants National Bank Bldg., San Francisco.
Paraffine Paint Co., 34 First St., San Francisco.
Medusa White Portland Cement, manufactured by Sandusky Cement Co., represented in San Francisco by Pacific Building Materials Co., 525 Market St., San Francisco.
- CEMENT FLOOR COATING**
Fuller's Concrete Floor Enamel, made by W. P. Fuller & Co., San Francisco.
Glidden Concrete Floor Dressing. The Glidden Company, 123 Hooper St., San Francisco.
- CEMENT GUN**
Cement Gun Construction Company of California, 701 Balboa Bldg., San Francisco.
- CEMENT TESTS—CHEMICAL ENGINEERS**
Robert W. Hunt & Co., 251 Kearny St., San Francisco.
- CHURCH INTERIORS**
Fink & Schindler, 218 13th St., San Francisco.
Mullen Manufacturing Company, 64 Rausch St., San Francisco.
Home Manufacturing Company, 543 Brannan St., San Francisco.
- CHUTES—SPIRAL**
Haslett Warehouse Co., 310 California St., San Francisco.
- CLAY PRODUCTS**
Livermore Fire Brick Works, 604 Mission street, San Francisco.
W. E. Mushet Co., 502 Mission St., San Francisco.
Gladding, McBean & Co., Crocker Bldg., San Francisco.
United Materials Co., Crossley Bldg., San Francisco.
Los Angeles Pressed Brick Co., Frost Bldg., Los Angeles.
- CLOCKS—ELECTRIC TIME**
Standard Electric Time Co., 461 Market St., San Francisco.
- COLD STORAGE PLANTS**
H. W. Johns-Manville Co., Second and Howard Sts., San Francisco.
T. P. Jarvis Crude Oil Burning Co., 275 Connecticut St., San Francisco.
- COMPRESSED AIR CLEANERS**
United Electric Co., Canton, O., mfr. of Tuec Cleaner, sold by San Francisco Compressed Air Cleaning Co., Sutter and Stockton Sts., San Francisco.
George H. Tay Company, Mission and Second Sts., San Francisco; 10th and Harrison Sts., Oakland.
- CONCRETE CONSTRUCTION**
Barrett & Hilp, Sharon Bldg., San Francisco.
Clinton Construction Co., 140 Townsend street, San Francisco.
K. E. Parker Co., Inc., Clunie Bldg., San Francisco.
Palmer & Petersen, Monadnock Bldg., San Francisco.
I. M. Sommer, 401 Balboa Bldg., San Francisco.
Steelform Contracting Company, 681 Market St., San Francisco.
- CONCRETE MIXERS**
Foote and Jaeger mixers sold by Edward R. Bacon Co., 51 Minna St., San Francisco, also Los Angeles.
Ransome mixers sold by the Garfield Co., Hearst Bldg., San Francisco.
- CONCRETE REINFORCEMENT**
United States Steel Products Co., San Francisco, Los Angeles, Portland and Seattle.
Twisted Bars. Sold by Gunn, Carle & Co., Inc., 444 Market St., San Francisco.
Clinton Welded Wire Fabric, L. A. Norris Co., 140 Townsend St., San Francisco.
Pacific Coast Steel Company, Rialto Bldg., San Francisco.
Triangle Mesh Fabric. Sales agents, Pacific Materials Co., 525 Market St., San Francisco.
Truscon Steel Co., 527 Tenth St., San Francisco.
Badt-Falk Co., Call-Post Bldg., San Francisco.
- CONDUITS**
Garnett Young & Co., 612 Howard St., San Francisco.
- CONTRACTORS, GENERAL**
Barrett & Hilp, Sharon Bldg., San Francisco.
K. E. Parker Co., Inc., Clunie Bldg., San Francisco.
R. W. Littlefield, 357 12th St., Oakland.
Unit Construction Co., Pethan Bldg., San Francisco.
Larsen, Sampson & Co., Claus Spreckels Bldg., San Francisco.
J. D. Hannah, 142 Sansome St., San Francisco.
Chas. Stockholm & Son, Monadnock Bldg., San Francisco.

We have returned to our policy-holders annually for 33 years never less than 30% of the premium as a dividend. Dividends declared during 1919, \$2,017,893.

AMERICAN MUTUAL LIABILITY INSURANCE CO. OF BOSTON
Assets \$3,654,667 Surplus \$1,417,173

WORKMEN'S COMPENSATION, AUTOMOBILE, TEAMS AND PUBLIC
LIABILITY INSURANCE

SAN FRANCISCO BRANCH OFFICE

1816 Balboa Building. Telephone Kearny 3202

N. F. Hesselstine, California Manager.

C. H. Gray, Assistant Manager.

ARCHITECTS' SPECIFICATION INDEX—Continued

- CONTRACTORS, GENERAL—Continued
Herbert Beckwith, 323 Newton Ave., Oakland.
A. D. Collman, 180 Jessie St., San Francisco.
Clinton Construction Company, 140 Townsend St., San Francisco.
Monson Bros., 1907 Bryant St., San Francisco.
W. C. Duncan & Co., 526 Sharon Bldg., San Francisco.
A. Knowles, Call-Post Bldg., San Francisco.
T. B. Goodwin, 180 Jessie St., San Francisco.
Lange & Bergstrom, Sharon Bldg., San Francisco.
McLeran & Peterson, Hearst Bldg., San Francisco.
Robert Trost, 26th and Howard Sts., San Francisco.
I. M. Sommer, 401 Balboa Bldg., San Francisco.
Del Favero & Rasori, 180 Jessie St., San Francisco.
- CONTRACTORS' EQUIPMENT
Edward R. Bacon Co., 51 Minna St., San Francisco, and Los Angeles.
Garfield & Co., Hearst Bldg., San Francisco.
Smith, Booth-Usher Co., 60 Fremont St., San Francisco; 228 Central Ave., Los Angeles.
- CONTRACTORS' INSURANCE
Bankers & Shippers Insurance Co. of New York, Insurance Exchange Bldg., San Francisco.
- CONVEYING MACHINERY
Meese & Gottfried, San Francisco, Los Angeles, Portland and Seattle.
- CORK TILE, INSULATION, ETC.
Van Fleet-Freear Co., Sharon Bldg., San Francisco.
- CRUSHED ROCK
Coast Rock & Gravel Co., Call-Post Bldg., San Francisco.
- DAMP-PROOFING COMPOUND
Armorite Damp Resisting Paint, made by W. P. Fuller & Co., San Francisco.
Glidden's Liquid Rubber. The Glidden Company, 123 Hooper St., San Francisco.
Hill, Hubbell & Company, No. 1 Drumm St., San Francisco.
Imperial Waterproofing, mfrd. by Brooks & Doerr, Reed Baxter, agent, Merchants National Bank Bldg., San Francisco.
"Pabco" Damp-Proofing Compound, sold by Paraffine Co., 34 First St., San Francisco.
- DOOR HANGERS
Pitcher Hanger, sold by National Lumber Co., 326 Market St., San Francisco.
Reliance Hanger, sold by Waterhouse-Wilcox Co., San Francisco; D. F. Fryer & Co., B. V. Collins, Los Angeles, and Columbia Wire & Iron Works, Portland, Oregon.
Stanley Works, New Britain, Conn. John Rountree, agent, Monadnock Bldg., San Francisco.
Richards-Wilcox Mfg. Co., Underwood Bldg., San Francisco.
- DRINKING FOUNTAINS
Haws Sanitary Drinking Faucet Co., 1808 Harmon St., Berkeley, and C. F. Weber & Co., San Francisco and Los Angeles.
Crane Company, San Francisco, Oakland, and Los Angeles.
Pacific Porcelain Ware Co., 67 New Montgomery St., San Francisco.
George H. Tay Company, Mission and Second Sts., San Francisco; 10th and Harrison Sts., Oakland.
- Haines, Jones & Cadbury Co., 857 Folsom St., San Francisco.
- DUMB WAITERS
Spencer Elevator Company, 166 7th St., San Francisco.
M. E. Hammond, Pacific Bldg., San Francisco.
- ELECTRICAL CONTRACTORS
Butte Electrical Equipment Company, 530 Folsom St., San Francisco.
Butte Electric & Manufacturing Co., 534 Folsom St., San Francisco.
Brown-Langlais Electrical Construction Co., 213 Minna St., San Francisco.
NePage, McKenny Co., 589 Howard St., San Francisco.
Liberty Electric Company, 479 Sutter St., San Francisco.
Newbery Electrical Co., 413 Lick Bldg., San Francisco.
Pacific Fire Extinguisher Co., 424 Howard St., San Francisco.
Globe Electric Works, 1959 Mission St., San Francisco.
M. E. Ryan, Redwood City, Calif.
Rex Electric & Engineering Co., 253 Minna St., San Francisco.
H. S. Tittle, 766 Folsom St., San Francisco.
Severin Electrical Company, 185 Stevenson St., San Francisco.
Spot Electrical Co., Sixteenth and Clay Sts., Oakland.
- ELECTRIC PLATE WARMER
The Prometheus Electric Plate Warmer for residences, clubs, hotels, etc. Sold by M. E. Hammond, Pacific Bldg., San Francisco.
- ELECTRICAL SUPPLIES AND EQUIPMENT
Garnett Young & Co., 612 Howard St., San Francisco.
Butte Electrical Equipment Co., 530 Folsom St., San Francisco.
Electric Outlet Co., Inc., 119 West 40th St., New York.
Safety Electric Company, 56-65 Columbia Square, San Francisco.
Drendell Electrical & Mfg. Co., 1345 Howard St., San Francisco.
R. J. Davis, District Sales Agent, Century A. C. Motors and Fans, 171 Second St., San Francisco.
- ELEVATORS
Otis Elevator Company, Stockton and North Point, San Francisco.
Spencer Elevator Company, 166 7th St., San Francisco.
- ELEVATOR EQUIPMENT
Elevator Supplies Company, Inc., 186 Fifth St., San Francisco.
- ENGINEERS—CONSULTING, ELECTRICAL, MECHANICAL
Chas. T. Phillips, Pacific Bldg., San Francisco.
Hunter & Hudson, Rialto Bldg., San Francisco.
Baldwin D. Ward, 76 13th St., Oakland.
- ELEVATOR DOOR HARDWARE
Richards-Wilcox Mfg. Co., Underwood Bldg., San Francisco.
- FANS AND BLOWERS
Ideal Heating & Engineering Co., 192 Erie St., San Francisco.

KEWANEE
GARBAGE BURNERS
AND
BOILERS

YEOMANS
BILGE PUMPS
EJECTORS
HOUSE PUMPS

OVERHEAD
CARRYING
SYSTEMS

CALIFORNIA HYDRAULIC ENGINEERING & SUPPLY CO., 80 Fremont St., S. F.



TEMPERATURE REGULATION

JOHNSON SERVICE COMPANY

(OF MILWAUKEE — ESTABLISHED 1885)

Manufacturers and Installers of **JOHNSON Heat Humidity CONTROL**

For schools, residences, hospitals, banks, public buildings, also canneries and all kinds of industrial plants—Hot water tank regulators, air and water reducing valves.

Rialto Bldg, SAN FRANCISCO Trust and Savings Bldg., LOS ANGELES

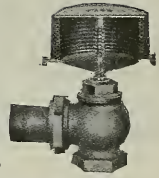

ARCHITECTS' SPECIFICATION INDEX—Continued

- FENCES—WIRE**
Standard Fence Construction Co., 245 Market St., San Francisco, and 310 12th St., Oakland.
- FILLING STATION EQUIPMENT**
S. F. Bowser & Co., Inc., 612 Howard St., San Francisco.
Wayne Oil Tank & Pump Co., 631 Howard St., San Francisco, 830 S. Los Angeles St., Los Angeles.
- FIRE ESCAPES**
Palm Iron & Bridge Works, Sacramento.
Western Iron Works, 141 Beale St., San Francisco.
Golden Gate Iron Works, 1541 Howard St., San Francisco.
- FIRE EXTINGUISHERS**
American La France Fire Engine Co., Inc., 151 New Montgomery St., San Francisco; Los Angeles and Portland.
- FIRE INSURANCE**
Bankers & Shippers Insurance Co., Insurance Exchange Bldg., San Francisco.
- FIRE SPRINKLERS—AUTOMATIC**
Grinnell Company, 453 Mission St., San Francisco.
Scott Company, 243 Minna St., San Francisco.
Pacific Fire Extinguisher Co., 424 Howard St., San Francisco.
- FIREPROOFING AND PARTITIONS**
Gladding, McBean & Co., Crocker Bldg., San Francisco.
Los Angeles Pressed Brick Co., Frost Bldg., Los Angeles.
Richards-Wilcox Mfg. Co., Aurora, Ill., and Underwood Bldg., San Francisco.
- FIRE RETARDING PAINT**
The Paraffine Companies, Inc., 34 First St., San Francisco.
Asbestos Paints, The Glidden Company, 123 Hooper St., San Francisco.
- FIXTURES—BANK, OFFICE, STORE, ETC.**
Home Manufacturing Company, 543 Brannan St., San Francisco.
The Fink & Schindler Co., 218 13th St., San Francisco.
Mullen Manufacturing Co., 64 Rausch St., San Francisco.
C. F. Weber & Co., 985 Market St., San Francisco, and 210 N. Main St., Los Angeles, Cal.
- FLOOR TILE**
Mangrum & Otter, 827 Mission St., San Francisco.
- FLOOR VARNISH**
Bass-Hueter and San Francisco Pioneer Varnish Works, 816 Mission St., San Francisco.
Fifteen for Floors, made by W. P. Fuller & Co., San Francisco.
Standard Varnish Works, Chicago, New York and San Francisco.
R. N. Nason & Co., San Francisco and Los Angeles.
The Glidden Company, 123 Hooper St., San Francisco.
- FLOORS—HARDWOOD**
Inlaid Floor Company, 600 Alabama St., San Francisco.
Parrott & Co., 320 California St., San Francisco.
White Bros., Fifth and Brannan Sts., San Francisco.
- Strable Manufacturing Company, 511 First St., Oakland.
- FLOORS—MASTIC**
Hill, Hubbell & Company, No. 1 Drumm St., San Francisco.
- FLOORS—DUST PROOF CEMENT**
L. Sonneborn Co., United Materials Co., San Francisco agents.
- FLUMES**
California Corrugated Culvert Co., West Berkeley, Cal.
- FLUSH VALVES**
National Valve Company, 23-25 Minna St., San Francisco.
- FRUIT DRYING MACHINERY**
Ideal Heating & Engineering Co., 192 Erie St., San Francisco.
Jas. A. Nelson, 517 Sixth St., San Francisco.
- FUEL OIL SYSTEMS**
S. F. Bowser & Co., Inc., 612 Howard St., San Francisco.
Wayne Oil Tank & Pump Co., 631 Howard St., San Francisco.
- FURNACES—WARM AIR**
Mangrum & Otter, 827 Mission St., San Francisco.
Montague Range and Furnace Co., 826 Mission St., San Francisco.
- FURNITURE—BUILT-IN**
Hoosier Kitchen Cabinet Store, Pacific Bldg., San Francisco.
- FURNITURE—SCHOOL, CHURCH, OFFICE, HOUSE, ETC.**
Home Manufacturing Company, 543 Brannan St., San Francisco.
C. F. Weber & Co., 985 Market St., San Francisco.
Rucker-Fuller Desk Co., 677 Mission St., San Francisco.
F. W. Wentworth & Co., 539 Market St., San Francisco.
Western Office Equipment Co., 467 Market St., San Francisco.
W. & J. Sloane, 216-228 Sutter St., San Francisco.
- GALVANIZED IRON WORK**
James A. Nelson, 517 Sixth St., San Francisco.
- GARAGE HARDWARE**
The Stanley Works, New Britain, Conn., represented in San Francisco, Los Angeles, Seattle by John T. Rowntree, Inc.
Richards-Wilcox Mfg. Co., Aurora, Ill., and Underwood Bldg., San Francisco.
- GARBAGE CHUTES AND INCINERATORS**
Kerner Incinerator Co., 77 O'Farrell St., San Francisco.
California Hydraulic Engineering & Supply Co., 70-72 Fremont St., San Francisco.
- GAS STEAM RADIATORS—FUMELESS, ETC.**
Clow Gas Steam Radiators, F. A. Hamilton, Agent, 101 Rialto Bldg., San Francisco.

ROBERTSON PROCESS METAL FOR ROOFING AND SIDING

HH ROBERTSON CO
BUILDING PRODUCTS

FORMERLY ASBESTOS PROTECTED METAL COMPANY

Hobart Building, San Francisco

Phone Garfield 522

DIECKMANN HARDWOOD COMPANY

Office, Mill, Yards, and Dry Kilns
BEACH AND TAYLOR STS.
 SAN FRANCISCO, CAL.

PHONE FRANKLIN 2302

**Foreign & Domestic
 CABINET WOODS**

ARCHITECTS' SPECIFICATION INDEX—Continued

- GAS STEAM RADIATORS, ETC.**—Continued.
 Ra-Do Fumeless Gas Radiators, manufactured and sold by Baird-Bailhache Co., 478 Sutter St., San Francisco.
- GLASS**
 American Window Glass Co., represented by L. H. Butcher Co., 341 Montgomery St., San Francisco.
 Cobbletick-Kibbe Glass Co., 175 Jessie St., San Francisco.
 Fuller & Goepf, 32 Page St., San Francisco.
 W. P. Fuller & Company, all principal Coast cities.
- GRADING, WRECKING, ETC.**
 Dolan Wrecking & Construction Co., 1607 Market St., San Francisco.
- GRANITE**
 California Granite Co., Gen. Contractors' Ass'n, San Francisco.
 Raymond Granite Co., Potrero Ave. and Division St., San Francisco.
- GRAVEL AND SAND**
 Coast Rock & Gravel Co., Call-Post Bldg., San Francisco.
 Del Monte White Sand, sold by Del Monte Properties Co., Crocker Bldg., San Francisco.
- GYMNASIUM EQUIPMENT**
 Ellery Arms Co., 583 Market St., San Francisco.
 A. G. Spalding & Bros., 158 Geary St., San Francisco.
- HARDWALL PLASTER**
 Henry Cowell Lime & Cement Co., San Francisco.
- HARDWARE**
 Joost Bros., agents for Russell & Erwin hardware, 1053 Market St., San Francisco.
 The Stanley Works, New Britain, Conn.
 Corbin hardware, sold by Palace Hardware Co., 581 Market St., San Francisco.
 Richards-Wilcox Mfg. Co., Aurora, Ill., Ewing-Lewis Co., 626 Underwood Bldg., San Francisco.
- HARDWOOD LUMBER—FLOORING, ETC.**
 Dieckmann Hardwood Company, Beach and Taylor Sts., San Francisco. (See advertisement above.)
 Inlaid Floor Co., 600 Alabama St., San Francisco.
 H. N. McNab, 2307 17th Ave., Oakland.
 Parrott & Co., 320 California St., San Francisco.
 White Bros., cor. Fifth and Brannan Sts., San Francisco.
 Strable Manufacturing Company, First St., near Broadway, Oakland.
- HEATERS—AUTOMATIC—GAS**
 Pittsburg Water Heater Co., 478 Sutter St., San Francisco.
 George H. Tay Company, Mission and Second Sts., San Francisco; 10th and Harrison Sts., Oakland.
 Ra-Do Fumeless Gas Heater, sold by Baird-Bailhache Company, 478 Sutter St., San Francisco.
- HEATING AND VENTILATING MATERIAL, ETC.**
 Alex Coleman, 706 Ellis St., San Francisco.
- Gilley-Schmid Company, 198 Otis St., San Francisco.
 Mechanical Engineering & Supply Co., Sacramento.
 Hateley & Hateley, Mitau Bldg., Sacramento.
 Knittle-Cashel Co., Inc., 1820 Ellis St., San Francisco.
 General Boilers Co., 332 Monadnock Bldg., San Francisco.
 A. Lettich, 365 Fell St., San Francisco.
 Mangrum & Otter, 827-831 Mission St., San Francisco.
 Moline Heat, Hobart Bldg., San Francisco.
 James & Drucker, 450 Hayes St., San Francisco.
 James A. Nelson, 517 Sixth St., San Francisco.
 Ideal Heating & Engineering Co., 192 Erie St., San Francisco.
 Illinois Engineering Co., 563 Pacific Bldg., San Francisco.
 William F. Wilson Co., 328 Mason St., San Francisco.
 Pacific Fire Extinguisher Co., 424 Howard St., San Francisco.
 Scott Company, 243 Minna St., San Francisco.
 Mechanical Engineering & Supply Co., 908 7th St., Sacramento.
 John Ringius, 252 Townsend St. (bet. Third and Fourth), San Francisco.
 George H. Tay Company, Mission and Second Sts., San Francisco; 10th and Harrison Sts., Oakland.
 O. M. Simmons Co., 115 Mission St., San Francisco.
- HOLLOW TILE BLOCKS**
 Gladding, McBean & Co., San Francisco, Los Angeles, Oakland and Sacramento.
 Los Angeles Pressed Brick Co., Frost Bldg., Los Angeles.
- HOSPITAL FIXTURES**
 Mott Company of California, 553 Mission St., San Francisco.
 George H. Tay Company, Mission and Second Sts., San Francisco; 10th and Harrison Sts., Oakland.
- HOSPITAL SIGNAL SYSTEM**
 Chicago Signal Co., represented by Garnett, Young & Co., 612 Howard St., San Francisco.
- HOTELS**
 St. Francis Hotel, Powell, Geary and Post Sts., San Francisco.
- INGOT IRON**
 "Armco" brand, manufactured by American Rolling Mill Company, Middletown, Ohio, and Monadnock Bldg., San Francisco.
- INSPECTIONS AND TESTS**
 Robert W. Hunt & Co., 251 Kearny St., San Francisco.
- INSULATION**
 Ebonite Boiler Kote, sold by California Plastic Products Co., 521 Sheldon Bldg., San Francisco.
- INCINERATORS**
 Kerner Incinerator Co., 77 O'Farrell St., San Francisco.
- INTERIOR DECORATORS**
 Beach-Robinson Co., 239 Geary St., San Francisco.

"The
 Perfect
 Automatic
 Valve"

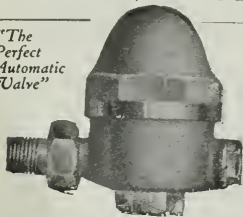

WILLIAM S. HAINES & CO.

Automatic Vacuum and Vapor Heating Systems

VENTO AUTOMATIC VALVES

"Everything for the Heating Engineer"

O. M. SIMMONS CO. 115 MISSION STREET
 SAN FRANCISCO

PACIFIC COAST REPRESENTATIVE

Phone: Douglas 5497

CLARENCE E. MUSTO, Pres.

JOSEPH B. KEENAN, Vice-Pres.

GUIDO J. MUSTO, Sec'y & Treas.

JOSEPH MUSTO SONS=KEENAN CO.Phone Franklin
—6365—**MARBLE**OFFICE AND MILLS:
535-565 North Point St.,
SAN FRANCISCO, CAL.**ARCHITECTS' SPECIFICATION INDEX—Continued****INTERIOR DECORATORS.—Continued.**

Sonnenschein Bros., 470 Sutter St., San Francisco.

The Tormey Co., 1042 Larkin St., San Francisco.

F. A. Taylor & Co., 251 Post St., San Francisco.

Freeman Art Shop, 386 Sutter St., San Francisco.

W. & J. Sloane, 216 Sutter St., San Francisco.

KITCHEN CABINETS

Hoosier Kitchen Cabinet Store (O. K. Brown, Mgr.), Pacific Bldg., San Francisco.

KITCHEN EQUIPMENT

James A. Nelson, 517-19 Sixth street, San Francisco.

LAMP POSTS, ELECTROLIERS, ETC.

J. L. Mott Iron Works, 553 Mission St., San Francisco.

LANDSCAPE GARDENERS

MacRorie-McLaren Co., 141 Powell St., San Francisco.

LATHING AND PLASTERING

MacGruer & Simpson, Call-Post Bldg., San Francisco.

A. Knowles, Call-Post Bldg., San Francisco.

Jas. F. Smith, 273 Minna St., San Francisco.

LATHING MATERIAL

Pacific Materials Co., 525 Market St., San Francisco.

Key-Hold Plaster Lath Co., Monadnock Bldg., San Francisco.

Truscon Steel Co., Tenth St., near Bryant, San Francisco.

LIGHT, HEAT AND POWER

Great Western Power Company, Stockton St., near Sutter, San Francisco.

LIGHTING FIXTURES

Roberts Mfg Co., 663 Mission St., San Francisco.

LIME

Henry Cowell Lime & Cement Co., 2 Market St., San Francisco.

LINOLEUM

D. N. & E. Walter & Co., 562 Mission St., San Francisco.

The Paraffine Companies, factory in Oakland; office, 34 First St., near Market, San Francisco.

W. & J. Sloane, 216-228 Sutter St., San Francisco.

LOCKERS—STEEL

George H. Trask, Sacramento St., San Francisco, representing Durand Steel Lockers.

LUBRICATING OIL STORAGE TANKS AND PUMPS

S. F. Bowser & Co., Inc., 612 Howard St., San Francisco.

LUMBER

California Redwood Association, 216 Pine St., San Francisco.

Dudfield Lumber Co., Palo Alto, Cal.

Hart-Wood Lumber Co., Fifth and Berry Sts., San Francisco.

Pacific Manufacturing Company, San Francisco, Oakland and Santa Clara.

Pope & Talbot, foot of Third St., San Francisco.

Portland Lumber Co., 16 California St., San Francisco.

Sunset Lumber Company, First and Oak Sts., Oakland.

MAIL CHUTES

American Mailing Device Corp., represented on Pacific Coast by Waterhouse-Wilcox' Co., 523 Market St., San Francisco.

MANTELS

Mangrum & Otter, 827-831 Mission St., San Francisco.

MANUAL TRAINING EQUIPMENT

Richards-Wilcox Mfg. Co., Ewing-Lewis Co., 626 Underwood Bldg., San Francisco.

MARBLE

American Marble and Mosaic Co., 25 Columbus Square, San Francisco.

Joseph Musto Sons, Keenan Co., 535 N. Point St., San Francisco.

Vermont Marble Co., Coast branches, San Francisco, Portland and Tacoma.

METAL DOORS AND WINDOWS

Fire Protection Products Co., 3117 20th St., San Francisco.

Waterhouse-Wilcox Co., Inc., 523 Market St., San Francisco.

U. S. Metal Products Co., 330 Tenth St., San Francisco.

MILL WORK

Dudfield Lumber Co., Palo Alto, Cal.

Pacific Manufacturing Company, San Francisco, Oakland and Santa Clara.

National Mill and Lumber Co., San Francisco and Oakland.

The Fink & Schindler Co., 218 13th St., San Francisco.

Frank Portman, 1619-20 Mission St., San Francisco.

MOTORS AND FANS

R. J. Davis, Dist. Sales Agent Century Motors and Fans, 171 Second St., San Francisco.

OIL BURNERS

American Standard Oil Burner Company, Berkeley.

Fess System Co., 220 Natoma St., San Francisco.

S. T. Johnson Co., 1337 Mission St., San Francisco.

T. P. Jarvis Manufacturing Co., 275 Connecticut St., San Francisco.

W. S. Ray Mfg. Co., 29 Spear St., San Francisco.

G. E. Witt Co., 862 Howard St., San Francisco.

OIL STORAGE AND DISTRIBUTING STATIONS

S. F. Bowser & Co., Inc., 612 Howard St., San Francisco.

Wayne Oil Tank & Pump Co., 631 Howard St., San Francisco; 830 S. Los Angeles St., Los Angeles.

OFFICE EQUIPMENT

Western Office Equipment Co., 467 Market St., San Francisco.

F. W. Wentworth & Co., 539 Market St., San Francisco.

ORNAMENTAL IRON AND BRONZE

California Artistic Metal and Wire Co., 349 Seventh St., San Francisco.

Palm Iron & Bridge Works, Sacramento.

C. J. Hillard Company, Inc., 19th and Minnesota Sts., San Francisco.

KNITTLE-CASHEL CO., Inc.**HEATING CONTRACTORS**

STEAM HEATING

HOT WATER HEATING

VENTILATING

POWER PLANTS

GENERAL PIPE WORK

REPAIRING

1820-22 Ellis Street, San Francisco

Phone West 964



On Your Best Work Specify

CAL-PA-CO DAMPSTOP (Outside)
WASHABLE WALL (Inside)
FOR CONCRETE BUILDINGS. Everything Reliable in PAINT and VARNISH

CALIFORNIA PAINT COMPANY, OAKLAND, CALIF., U. S. A.
MANUFACTURERS SINCE 1865 SAN FRANCISCO OFFICE, MONADNOCK BUILDING

ARCHITECTS' SPECIFICATION INDEX—Continued

ORNAMENTAL IRON AND BRONZE.—Cont.
Schrader Iron Works, Inc., 1247 Harrison St., San Francisco.

OVERHEAD CARRYING SYSTEMS
California Hydraulic Engineering & Supply Co., 70-72 Fremont St., San Francisco.
Richards-Wilcox Mfg. Co., Aurora, Ill., and Underwood Bldg., San Francisco.

PAINT FOR STEEL STRUCTURES, BRIDGES, ETC.

The Paraffine Companies, Inc., 34 First St., San Francisco.

Anti-Rust Coatings. The Glidden Co., 123 Hooper St., San Francisco.

Premier Graphite Paint and Pioneer Brand Red Lead, made by W. P. Fuller & Co., San Francisco.

Hill, Hubbell & Company, No. 1 Drumm St., San Francisco.

Wadsworth, Howland Co., makers of Bay State Brick and Cement Coating, Boston, Mass.
Hambley & Son, Distributors in San Francisco and Los Angeles.

PAINTING, TINTING, ETC.

I. R. Kissel, 1747 Sacramento St., San Francisco.

D. Zelinsky & Sons, San Francisco and Los Angeles.

The Tormey Co., 681 Geary St., San Francisco.
Fick Bros., 475 Haight St., San Francisco.

PAINTS, OILS, ETC.

California Paint Company (see advertisement above).

Magner Bros., 414-424 Ninth St., San Francisco.
Bass-Hueter Paint Co., Mission, near Fourth St., San Francisco.

The Glidden Company of California, 123 Hooper St., San Francisco.

R. N. Nason & Company, San Francisco, Los Angeles, Portland and Seattle.

W. P. Fuller & Co., all principal Coast cities.
"Satinette," Standard Varnish Works, 55 Stevenson St., San Francisco.

Palace Hardware Co., 581 Market St., San Francisco.

PANELS AND VENEER

White Bros., Fifth and Brannan Sts., San Francisco.

PARTITIONS—FOLDING AND ROLLING

J. G. Wilson Corporation, 600 Metropolitan Bldg., Los Angeles; Waterhouse-Wilcox Co., Underwood Bldg., San Francisco.

PENCILS

Eberhard Faber, Monadnock Bldg., San Francisco.

PIPE—STEEL AND WROUGHT IRON

Western Pipe & Steel Co., 444 Market St., San Francisco; 1758 N. Broadway, Los Angeles.

George H. Tay Company, Mission and Second Sts., San Francisco; 10th and Harrison Sts., Oakland.

PLAYGROUND EQUIPMENT

A. G. Spalding & Bros., 158 Geary St., San Francisco.

PLASTER CONTRACTORS

A. Knowles, Call-Post Bldg., San Francisco.

MacGruer & Simpson, 540 Call-Post Bldg., San Francisco.

James F. Smith, 273 Minna St., San Francisco.

PLUMBING CONTRACTORS

Alex Coleman, 706 Ellis St., San Francisco.
Gilley-Schmid Company, 198 Otis St., San Francisco.

Hateley & Hateley, Mitau Bldg., Sacramento.
A. Lettich, 365 Fell St., San Francisco.

Scott Co., Inc., 243 Minna St., San Francisco.
Wm. F. Wilson Co., 328 Mason St., San Francisco.

PLUMBING FIXTURES, MATERIALS, ETC.

California Steam & Plumbing Supply Co., 671 Fifth St., San Francisco.

Jas. B. Clow, plumbing, Rialto Bldg., San Francisco

Crane Co., San Francisco, Oakland, Los Angeles.

Gilley-Schmid Company, 198 Otis St., San Francisco.

Haines, Jones & Cadbury Co., 857 Folsom St., San Francisco.

H. Mueller Manufacturing Company, 635 Mission St., San Francisco.

Holbrook, Merrill & Stetson, 64 Sutter St., San Francisco.

J. L. Mott Iron Works, D. H. Gulick, selling agent, 553 Mission St., San Francisco.

National Valve Company, 23-25 Minna St., San Francisco.

Pacific Sanitary Manufacturing Co., 67 New Montgomery St., San Francisco.

George H. Tay Company, Mission and Second Sts., San Francisco; 10th and Harrison Sts., Oakland.

Wm. F. Wilson Co., 328 Mason St., San Francisco.

POWER PLANTS

Knittle-Cashel Co., Inc., 1820 Ellis St., San Francisco.

POWER TRANSMITTING MACHINERY

Meese & Gottfried, San Francisco, Los Angeles, Portland, Ore., and Seattle, Wash.

PUMPS

Chicago Pump Co., represented by Garnett, Young & Co., 612 Howard St., San Francisco.

California Hydraulic Engineering & Supply Co., 70 Fremont St., San Francisco.

Dow-Herriman Company, 140 Howard St., San Francisco; factory, Petaluma.

Simonds Machinery Co., 117 New Montgomery St., San Francisco.

Ocean Shore Iron Works, 558 Eighth St., San Francisco.

Pacific Pump & Supply Company, 851-853 Folsom St., San Francisco.

George H. Tay Company, Mission and Second Sts., San Francisco; 10th and Harrison Sts., Oakland.

Wooden & Little, 33-41 Fremont St., San Francisco.

PUMPS—HAND OR POWER, FOR OIL AND GASOLINE

S. F. Bowser & Co., Inc., 612 Howard St., San Francisco.

R. J. Davis

District Sales Agent

Century

A. C. Motors and Fans

Complete stocks carried at: 171-173 Second St., San Francisco; 906 So. Hope St., Los Angeles



Yards { TRACY, CAL.
BRENTWOOD, CAL. Phone KEARNY 2074

PORTLAND LUMBER COMPANY
A. J. RUSSELL, Agent
LUMBER
SIMPLEX SILOS
SAGINAW SPECIAL SHINGLES
*Ship Timbers, Oil Rigs and
Special Bills Cut to Order.*

16 California Street San Francisco, Cal.

from tree to Consumer

Pine and Redwood Lumber
SASH DOORS AND MILL WORK
SUNSET LUMBER COMPANY
MANUFACTURERS — WHOLESALE AND RETAIL
Main Office and Yards:
FIRST AND OAK STREETS, OAKLAND Phone Oakland 1820

POPE & TALBOT
Manufacturers, Exporters and Dealers in
Lumber, Timber, Piles, Spars, etc.
Office, Yards and Planing Mills
859-869 THIRD ST., SAN FRANCISCO, CAL.
Mills, Port Gamble, Port Ludlow and Utsalady, Washington

**STORM KING and
AMERICAN WARM AIR FURNACES**
FURNACE FITTINGS AND REPAIRS
Montague Range & Furnace Company
327-329 JESSIE STREET Phone Garfield 1422 826-830 MISSION STREET
SAN FRANCISCO, CALIF.

ARCHITECTS' SPECIFICATION INDEX—Continued

- PUMPS (Continued)**
 Dow-Herriman Co., 140 Howard St., San Francisco.
 Wayne Oil Tank & Pump Co., 631 Howard St., San Francisco; 830 S. Los Angeles St., Los Angeles.
 George H. Tay Company, Mission and Second Sts., San Francisco; 10th and Harrison Sts., Oakland.
- REFRIGERATORS**
 McCray Refrigerator Company, San Francisco office, Monadnock Bldg.
- REVERSIBLE WINDOWS**
 Hauser Window Company, 157 Minna St., San Francisco.
- ROOFING CONTRACTORS**
 Western Roofing Co., Inc., 420 15th St., San Francisco.
- ROOFING AND ROOFING MATERIALS**
 Bender Roofing Company, Monadnock Bldg., San Francisco.
 "Malthoid" and "Ruberoid," manufactured by Paraffine Companies, Inc., San Francisco.
 United Materials Co., Crossley Bldg., San Francisco.
 H. H. Robertson Co., Hobart Bldg., San Francisco.
- RUBBER TILING**
 New York Belting and Packing Company, 518 Mission St., San Francisco.
- SAFETY TREADS**
 Pacific Materials Co., 525 Market St., San Francisco.
- SAND**
 Del Monte White Sand, Del Monte Properties Co., 401 Crocker Bldg., San Francisco.
- SASH CORD**
 Samson Spot Sash Cord, John T. Rowntree, Pacific Coast Agent, San Francisco and Los Angeles.
- SCENIC PAINTING—DROP CURTAINS, ETC.**
 The Edwin H. Flagg Scenic Co., 1638 Long Beach Ave., Los Angeles.
- SCHOOL FURNITURE AND SUPPLIES**
 C. F. Weber & Co., 985 Market St., San Francisco; 512 S. Broadway, Los Angeles.
 Rucker-Fuller Desk Company, 677 Mission St., San Francisco.
- SHEATHING AND SOUND DEADENING**
 Samuel Cabot Mfg. Co., Boston, Mass., agencies in San Francisco, Oakland, Los Angeles, Portland, Tacoma and Spokane.
 The Paraffine Companies, Inc., 34 First St., San Francisco.
- SHEET METAL WORK**
 Jas. A. Nelson, 517 Sixth St., San Francisco.
- SHINGLE STAINS**
 Bass-Hueter Paint Company, all principal Coast cities.
 Cabot's Creosote Stains, sold by Pacific Building Materials Co., 525 Market St., San Francisco.
 Fuller's Pioneer Shingle Stains, made by W. P. Fuller & Co., San Francisco.
 Argonaut Shingle Stains. The Glidden Co., 123 Hooper St., San Francisco.
- SINKS—COMPOSITION**
 Petrium Sanitary Sink Co., Fifth and Page Sts., Berkeley.
- SKYLIGHTS**
 H. H. Robertson Co., Hobart Bldg., San Francisco.
 Jas. A. Nelson, 517 Sixth St., San Francisco.
- STATIONERY AND SUPPLIES**
 Schwabacher-Frey Stationery Co., 609 Market St., San Francisco.
- STEEL HEATING BOILERS**
 California Hydraulic Engineering & Supply Co., 70-72 Fremont St., San Francisco.
 General Boilers Co., 332 Monadnock Bldg., San Francisco.
- STEEL TANKS, PIPE, ETC.**
 Ocean Shore Iron Works, 558 Eighth St., San Francisco.
 Western Pipe & Steel Co., 444 Market St., San Francisco.
- STEEL AND IRON—STRUCTURAL**
 Central Iron Works, 621 Florida St., San Francisco.
 Dyer Bros., 17th and Kansas Sts., San Francisco.
 Golden Gate Iron Works, 1541 Howard St., San Francisco.
 Mortenson Construction Co., 19th and Indiana Sts., San Francisco.
 Pacific Rolling Mills, 17th and Mississippi Sts., San Francisco.
 Palm Iron & Bridge Works, Sacramento.
 U. S. Steel Products Co., Rialto Bldg., San Francisco.
 Schrader Iron Works, Inc., 1247 Harrison St., San Francisco.
 Western Iron Works, 141 Beale St., San Francisco.
- STEEL PRESERVATIVES**
 Hill, Hubbell & Company, No. 1 Drumm St., San Francisco.
- STEEL REINFORCING**
 Badt-Falk & Co., Cal-Post Bldg., San Francisco.
 Pacific Coast Steel Company, Rialto Bldg., San Francisco.
 Gunn, Carle & Co., Inc., 444 Market St., San Francisco.
 Truscon Steel Co., 527 Tenth St., San Francisco.
- STEEL ROLLING DOORS**
 Kinnear Steel Rolling Door Co., Pacific Building Materials Co., agents, Underwood Bldg., San Francisco.
 J. G. Wilson Corporation, 600 Metropolitan Bldg., Los Angeles.
- STEEL SASH**
 Bayley-Springfield solid steel sash, sold by Pacific Materials Co., 525 Market St., San Francisco.
 "Fenestra," solid steel sash, manufactured by Detroit Steel Products Company, Detroit, Mich. Direct factory sales office, Foxcroft Bldg., San Francisco.
 U. S. Metal Products Company, 330 Tenth St., San Francisco.
- STEEL WHEELBARROWS**
 Champion and California steel brands, made by Western Iron Works, 141 Beale St., San Francisco.
- STORE FRONTS**
 The Kawneer Manufacturing Company, West Berkeley, California.
 Zouri Safety Sash Bars—Cobbledick-Kibbe Glass Company, 175 Jessie St., San Francisco.
- STUDDING—FIREPROOF STEEL**
 Steel Studding Company, 1216 Folsom St., San Francisco.
- SUMP AND BILGE PUMPS**
 California Hydraulic Engineering & Supply Co., 70-72 Fremont St., San Francisco.
- SWITCHES**
 Wemco Safety Switch, manufactured and sold by W. E. Mushet Co., 502 Mission St., San Francisco.
- TANKS FOR OIL, GASOLINE, KEROSENE, ETC.**
 S. F. Bowser & Co., Inc., 612 Howard St., San Francisco.
 Wayne Oil Tank & Pump Co., 631 Howard St., San Francisco; 830 S. Los Angeles St., Los Angeles.
- TANKS—REDWOOD**
 Redwood Manufactures Co., Hobart Bldg., San Francisco.

STEEL SASH — FIRE DOORS — SHEET METAL

Kalamein, Copper and Bronze Doors and Trim

Sheet Metal Work of Every Description

FIRE PROTECTION PRODUCTS CO.

3117-3119 TWENTIETH STREET, Near Harrison, SAN FRANCISCO.

Phone Mission 2607

ARCHITECTS' SPECIFICATION INDEX—Continued

- TELEPHONE AND ELECTRIC EQUIPMENT**
Bittmann & Battee, 745 Folsom St., San Francisco.
Direct Line Telephone Co., 320 Market St., San Francisco.
- THEATER AND OPERA CHAIRS**
C. F. Weber & Co., 365 Market St., San Francisco.
Rucker-Fuller Desk Co., 677 Mission St., San Francisco.
- THERMOSTATS FOR HEAT REGULATION**
Johnson Service, Rialto Bldg., San Francisco.
- TILES, MOSAICS, MANTELS, ETC.**
Mangrum & Otter, 827-831 Mission St., San Francisco.
- TILE FOR ROOFING**
Gladding, McBean & Co., Crocker Bldg., San Francisco.
United Materials Co., Crossley Bldg., San Francisco.
- TRANSMISSION MACHINERY**
Meese & Gottfried Co., San Francisco, Los Angeles and Portland.
- VACUUM CLEANERS**
United Electric Company, Canton, O., manufacturers of Tucc Cleaners, sold in California by San Francisco Compressed Air Cleaning Co., Stockton and Sutter Sts., San Francisco.
- VALVES—PIPES AND FITTINGS**
California Steam & Plumbing Supply Co., 671 Fifth St., San Francisco.
Crane Radiator Valves, manufactured by Crane Co., Second and Brannan Sts., San Francisco.
National Valve Company, 23-25 Minna St., San Francisco.
Grinnell Co., 453 Mission St., San Francisco.
O. M. Simmons Co., 115 Mission St., San Francisco.
H. Mueller Mfg. Co., 635 Mission St., San Francisco.
W. E. Mushet Co., 502 Mission St., San Francisco.
George H. Tay Company, Mission and Second Sts., San Francisco; 10th and Harrison Sts., Oakland.
- VALVE PACKING**
N. H. Cook Belting Co., 317 Howard St., San Francisco.
- VARNISHES**
California Paint Company, 1797 Twelfth St., Oakland.
W. P. Fuller Co., all principal Coast cities.
R. N. Nason & Co., San Francisco, Los Angeles, Portland and Seattle.
S. F. Pioneer Varnish Works, 816 Mission St., San Francisco.
The Glidden Company, 123 Hooper St., San Francisco.
Standard Varnish Works, 55 Stevenson St., San Francisco.
- VENETIAN BLINDS, AWNINGS, ETC.**
C. F. Weber & Co., 985 Market St., San Francisco.
Western Blind & Screen Co., 2702 Long Beach Ave., Los Angeles.
- VENTILATORS**
H. H. Robertson Co., Hobart Bldg., San Francisco.
- VITREOUS CHINAWARE**
Pacific Porcelain Ware Company, 67 New Montgomery St., San Francisco.
- WALL BEDS, SEATS, ETC.**
Marshall & Stearns Co., 1154 Phelan Bldg., San Francisco.
- WALL BOARD**
"Amiwud" Wall Board, manufactured by The Paraffine Companies, Inc., 34 First St., San Francisco.
"Liberty" Wall Board, manufactured by Key-Hold Plaster Lath Co., 148 Hooper St., San Francisco.
- WALL PAINT**
Nason's Opaque Flat Finish, manufactured by R. N. Nason & Co., San Francisco, Portland and Los Angeles.
San-A-Cote and Vel-va-Cote, manufactured by the Brininstool Co., Los Angeles.
- WALL PAPER AND DRAPERIES**
Beach-Robinson Co., 239 Geary St., San Francisco.
The Torney Co., 681 Geary St., San Francisco.
W. & J. Sloane, 216-228 Sutter St., San Francisco.
Uhl Bros., San Francisco.
- WATERPROOFING FOR CONCRETE, BRICK, ETC.**
Armortite Damp Resisting Paint, made by W. P. Fuller & Co., San Francisco.
Bay State Brick & Cement Coating, manufactured by Wadsworth, Howland Co., Boston; Hambley & Son., Distributors for Northern and Southern California.
Imperial Waterproofing, mfrd. by Brooks & Doerr, Reed Baxter, agent, Merchants National Bank Bldg., San Francisco.
Pacific Materials Co., 525 Market St., San Francisco.
Samuel Cabot Mfg. Co., Boston, Mass., agencies in San Francisco, Oakland, Los Angeles, Portland, Tacoma and Spokane.
- WATER SUPPLY SYSTEMS**
Kewanee Water Supply System—Simonds Machinery Co., agents, 117 New Montgomery St., San Francisco.
Pacific Pump & Supply Company, 851-853 Folsom St., San Francisco.
- WHEELBARROWS—STEEL**
Western Iron Works, Beale and Main Sts., San Francisco.
- WHITE CEMENT**
"Atlas White," see coast agencies, page 127.
"Medusa White," sold by Pacific Materials Co., Underwood Bldg., San Francisco.
- WHITE ENAMEL**
"Gold Seal," manufactured and sold by Bass-Hueter Paint Co. All principal Coast cities.
Velvet White Enamel. The Glidden Company, 123 Hooper St., San Francisco.
"Silkenwhite," made by W. P. Fuller & Co., San Francisco.
"Satinette," Standard Varnish Works, 55 Stevenson St., San Francisco.
- WINDOW SHADES**
W. & J. Sloane, 216-228 Sutter St., San Francisco.
- WINDOW SASH CORD**
Sampson Spot Cord, John T. Rowntree, Pacific Coast agents, San Francisco and Los Angeles.
- WINDOWS, REVERSIBLE, CASEMENT, ETC.**
Hauser Window Co., 157 Minna St., San Francisco.
The Kawneer Company, West Berkeley, California. (Simplex Fixtures.)
J. G. Wilson Corporation, 600 Metropolitan Bldg., Los Angeles; Waterhouse-Wilcox Co., Underwood Bldg., San Francisco.
- WIRE FABRIC**
U. S. Steel Products Co., Rialto Bldg., San Francisco.
Clinton Wire Lath, sold by L. O. Norris, 140 Townsend St., San Francisco.
- WIRE FENCE**
Standard Fence Co., 310 12th St., Oakland.
- WOOD MANTELS**
Fink & Schindler, 218 13th St., San Francisco.
Mangrum & Otter, 827 Mission St., San Francisco.

MOLINE HEAT

Hobart Building

San Francisco

TELEPHONE SUTTER 3818

MOTT PLUMBING FIXTURES

Architects and their clients are invited to visit our Showrooms, 553-555 Mission Street, San Francisco; D. H. Gulick, Sales Agent. Los Angeles Office, 1001 Central Building; J. R. Mayhew, Sales Agent.

Mott Company of California

MUELLER — BRASS GOODS

Recognized as the Standard of excellence in plumbing. It pays to use them, and other Mueller Brass Goods. *The first cost is practically their last cost.*

H. Mueller Mfg. Co.

635 MISSION STREET, SAN FRANCISCO, CAL.

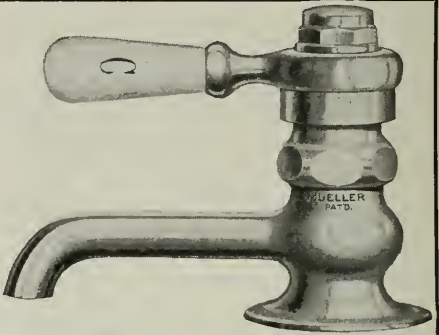

Automatic Fire Sprinklers

Protect your building and business from destruction by fire and reduce your Insurance Rate.

Pacific Fire Extinguisher Co.

FIRE PROTECTION ENGINEERS

424-440 HOWARD STREET
SAN FRANCISCO

MANUFACTURING PLANT
272 STEUART STREET

GENERAL BOILERS COMPANY

DEPARTMENT OF SALES

Manufacturers of

**Pacific Patented Steel Portable Double Return Tube
Low Pressure Steam and Hot Water Heating Boilers**

Pacific Steel Circulating Tanks

Pacific Steel Tank Heaters and Storage Tanks

General Office and Plant; WAUKEGAN, ILLS.

Sales Offices: 322 Monadnock Bldg., SAN FRANCISCO and 1310 South Hill St., LOS ANGELES, CALIFORNIA.

A. W. MERRILL, Manager

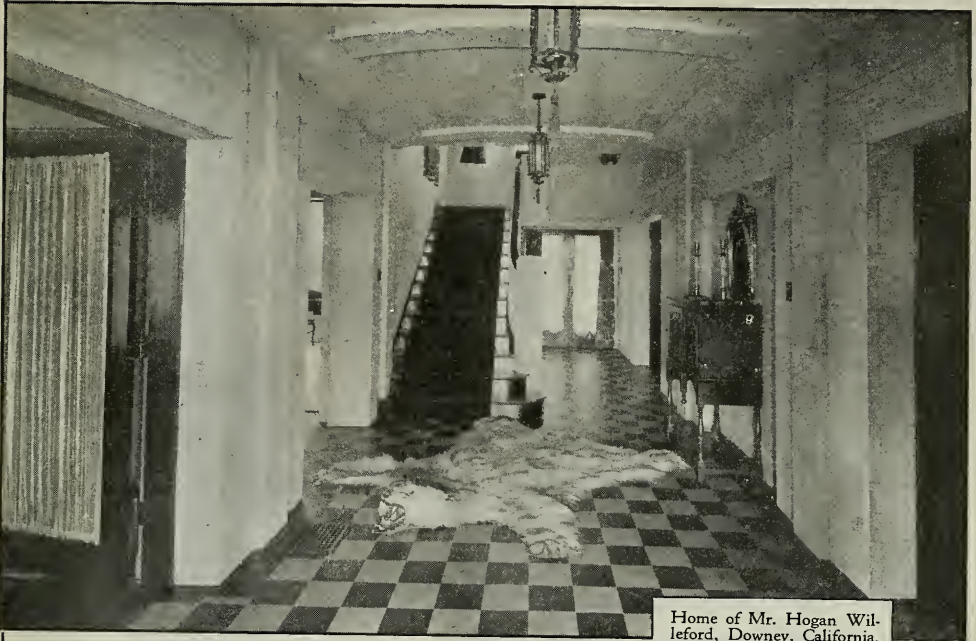

Home of Mr. Hogan Wil-
lford, Downey, California.
Designed and built by Mr.
H. H. Whiteley.

Quality Varnishes

"FULLER VARNISHES AND ENAMELS" and "QUALITY" are synonymous. They stand for the same thing—excellent materials, beautiful tones and richness in finishing.

FULLER VARNISHES AND ENAMELS produce the sleek glossy surface and soft tones that harmonize with the interior furnishing of the finest homes.

Combined with "QUALITY" in Fuller Products is the one other essential of all interior finishes—"DURABILITY." This combination will meet every test of beauty and service.



W. P. FULLER & CO.

MANUFACTURERS

*"When Quality and Durability
are required Fuller Products
meet the test."*

CHICAGO PUMP COMPANY

House Pumps Sewage Ejectors Bilge Pumps
 Condensation Pumps



Garnett Young and Company

612 Howard Street, San Francisco

SEATTLE

LOS ANGELES

PORTLAND

THERE is something Cheery about a White Cement House that appeals to the owner. Possibly that is why Stucco Homes have predominated in California in recent years.

DEL MONTE WHITE SAND

and

FAN SHELL BEACH SAND

used with a White Cement make a perfect stucco finish.

DEL MONTE PROPERTIES CO.

401 Crocker Building

Phone Sutter 6130

San Francisco



Makes Garbage Burn Itself

The K E R N E R "Built-in-the-Chimney" INCINERATOR

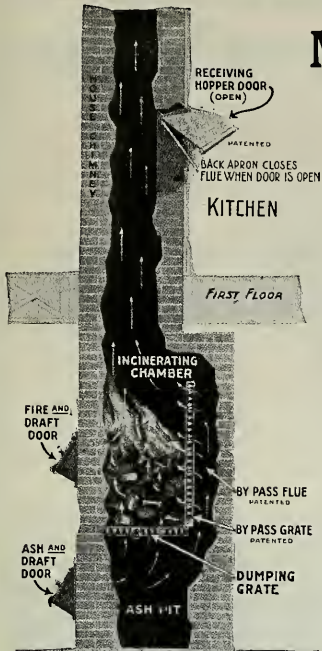

requires no coal, gas or any other fuel other than the dry waste deposited in the handy little hopper door. All you need do is to throw the garbage, waste paper, tincans, bottles and other refuse in the hopper door — and occasionally light the incinerator in the basement.

The dry waste burns readily and, in burning dries the wet waste so it also becomes fuel. Bottles and tin cans are dried, sterilized and later dropped into the ash pit.

SANITARY—ECONOMICAL—CONVENIENT—ODORLESS

Kerner Incinerator Co.

77 O'Farrell St. Factory, 38 Stanford St.

San Francisco

Patented Aug. 25, 1914; May 18, 1919

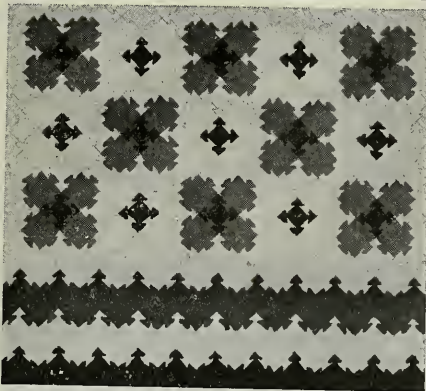

INTERLOCKING RUBBER TILING

material that is sure to give satisfaction. Twenty tons installed in the Standard Oil Building, San Francisco. Stock on hand for immediate delivery.

The Elevator Floor

whether in Office Building, Hotel or Department Store, is subjected to a great deal of wear and tear.

— SPECIFY —

INTERLOCKING RUBBER TILING

and you've provided your client's building with a Durable, Economical, Practical,



New York Belting and Packing Co.

NEW YORK

San Francisco Branch 519 MISSION ST. Phone Douglas 1837

Small booklet of designs mailed on request.



Brininstool

San - a - Cote

(GLOSS—Can be Scrubbed)

AN INTERIOR WALL FINISH

For bath rooms, kitchens, hospitals, schools, office and public buildings. Ask dealers, owners, architects and contractors about this durable, sanitary, washable, economical wall covering. Brininstool makes a paint for every purpose, and every can purposely good.

THE BRININSTOOL CO., LOS ANGELES

COLOR GRINDERS AND PAINT MANUFACTURERS

Distributors—The Brininstool Co., 1174 Phelan Bldg., San Francisco, Cal.; The Brininstool Co., 222 Abington Bldg., Portland, Ore.; Schutz Paint Co., Fresno, Cal.; Schneider, Chappell & Jones, Sacramento, Cal.; Salt Lake Glass & Paint Co., Salt Lake City, Utah; Griffin Paint Co., Ogden, Utah; Campbell Hardware Co., First and Madison Sts., Seattle, Wash.; Imperial Valley Hardware Co., El Centro, Cal.; Calexico, Imperial, Brawley, Seeley, Cal.; Spokane Hardware Co., Spokane, Wash.; Continental Paint Company, 328 South First St., San Jose, Cal.; Los Angeles Wall-paper & Paint Co., 525 So. Main St., Los Angeles, Cal.; H. A. Berger, 3838 13th St., San Diego, Cal.; H. L. Christian, Blythe, Cal.; Ezra Thayer, Phoenix, Ariz.; Miami Lumber & Supply Co., Miami, Ariz.

RELIANCE BALL BEARING DOOR HANGERS

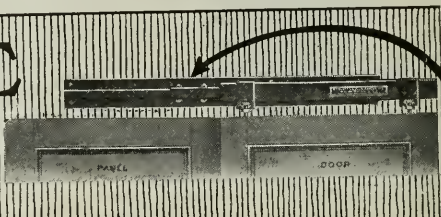

To get as near perfection as possible, use

RELIANCE "HANGERS" and "Reliance-Grant" Controllers

These insure fast service, practically noiseless and slamless doors.

Reliance-Grant Elevator Equipment Corp'n

PARK AVENUE AND 40TH STREET, NEW YORK

PACIFIC COAST AGENTS

Waterhouse-Wilcox Co. San Francisco and Los Angeles, Cal.
 Columbia Wire & Iron Works Portland, Ore.
 D. E. Fryer & Company Seattle, Spokane, Tacoma, Wash. and Great Falls, Mont.

FOR ALL
FINISHING
REQUIREMENTS



THE
IMMACULATE
WHITE ENAMEL

TRADE
ELASTICA
MARK
VARNISHES

Satinette
TRADE MARK
ENAMEL

STANDARD VARNISH WORKS

GENERAL OFFICES: NEW YORK - 90 WEST STREET
 BRANCHES: LONDON - SAN FRANCISCO - PARIS - MELBOURNE

SAN FRANCISCO OFFICES & WAREHOUSE 55 STEVENSON STREET

When writing to Advertisers please mention this magazine.

Bungalow Building Blox

Hollow Building Tile
Hollow Partition Tile

California Brick Co.

604 Mission Street
San Francisco, Cal.

BRICK

Red Ruffled Face Brick
Paving Brick
Step and Walk
Brick

BRICK

Enamel Brick
Buff and Old Gold
Pressed Brick

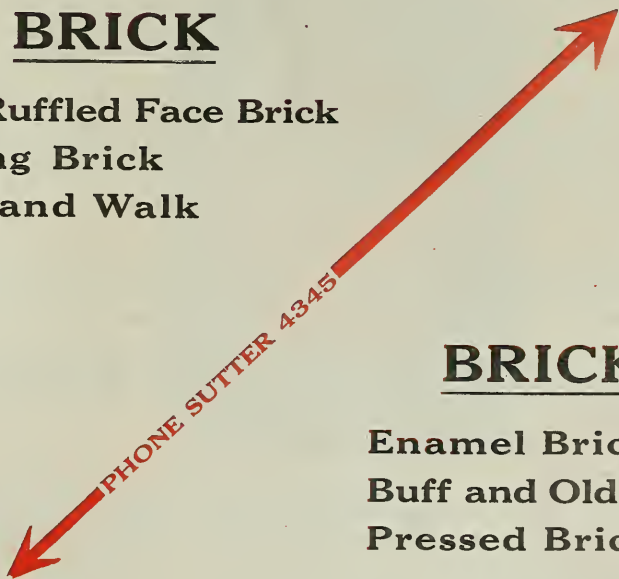

Livermore Fire Brick Works

604 Mission Street
San Francisco, Cal.

Fire Brick and
Molded Fire Tile

Architectural Terra Cotta

GLASS

FULLER & GOEPP

32 Page Street, San Francisco. Telephone Market 499
PRIVATE EXCHANGE CONNECTING ALL DEPARTMENTS

MANUFACTURERS OF

MIRRORS, ART AND LEADED GLASS

Dealers in **WHITE** Glass for Table Tops, Counter Tops, Sink
Backs & Etc. Complete Stock — Prompt Deliveries.

Passenger and Freight Elevators



"MADE IN SAN FRANCISCO"

Factory and Warehouse, 166-180 Seventh
Street, San Francisco. Phone Kearny 66

SPENCER ELEVATOR COMPANY

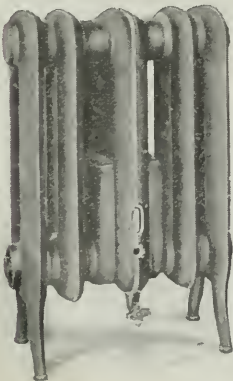

RA-DO ^{FUMELESS} GAS RADIATORS

ALL CAST IRON—3 Sizes (3, 5, and 7 Sections)

The Ideal "Year-Round" Heating System
For The Home—New or Old

Easiest and Cheapest to Install
Lowest Operating Cost

BAIRD - BAILHACHE COMPANY

MANUFACTURERS

478 Sutter St., San Francisco

'Phone Sutter 6858

OLD MISSION PORTLAND CEMENT COMPANY



Each shipment of "OLD MISSION" Portland Cement is guaranteed not only to equal but to surpass all requirements of the standard specifications for Portland Cement as adopted by the U. S. Government and by the American Society for Testing Materials. A Guarantee Certificate is mailed with the bill of lading of each car, giving number of car, date packed, and number of barrels, over the signature of the chief chemist.

8000 SACKS DAILY

SALES OFFICE:

MILLS BLDG., SAN FRANCISCO

PHONE SUTTER 3075

PLANT:

SAN JUAN, CAL.

VULCANITE

Famous for Quality



ADAPTABILITY

The Vulcanite Roofing Company

16th and Texas Sts.
San Francisco, Cal.

Roofing Division of the Beaver Board Companies

FAMOUS FOR QUALITY

Los Angeles, Cal.
Portland, Ore.
Seattle, Wash.



Keep Down Insurance Premiums

SPECIFY

SAINO FIRE DOORS

Standard Automatic Sliding or Swinging Fire Doors.
Tested and Labeled by the Underwriters' Laboratories.

STEEL SASH AND HOLLOW METAL
UNDERWRITERS WINDOWS

U. S. METAL PRODUCTS CO.

326-338 Tenth Street, San Francisco

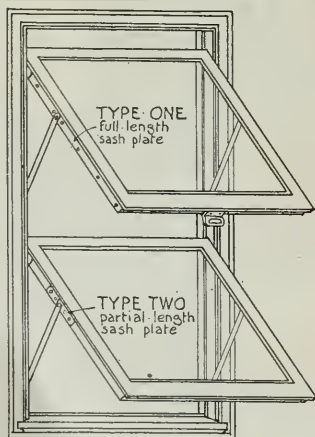

Hauser Reversible Windows

The Ideal Window is one that will operate in any size frame—wood or metal—the HAUSER is such a window—easy to install—a positive protection against rain, dust and wind.

Hauser Window Company

OFFICE AND FACTORY

157 Minna St. (Phone Kearny 3706) San Francisco



Joyce Residence,
Beverly Hills, California
Medusa White Cement
Stucco
Frank Meline, Designer
and Builder



*Manufacturers of Medusa
White and Medusa Grey
Cement — plain and water-
proofed—and Medusa Water-
proofing paste and powder.*

Pacific Coast Distributors:
Pacific Materials Co., San
Francisco, California.
Riverside Portland Cement
Co., Los Angeles, California.
A. McMillan & Company,
Portland, Oregon.
Galbraith & Company,
Seattle, Washington.

A Charming Residence in Beautiful Surroundings

BATHED in California sunshine, against the green background of foliage, amid the foothills of the Coast Range, this artistic pure white stucco residence gives an impression of perfect taste.

Whether in the mild climate of the Pacific Coast, the more rigorous temperatures of the New England States or in the equator heat of the Canal Zone, Medusa Waterproofed White Stucco residences will be found always in perfect taste—an ornament to any landscape.

In the city or the country and with any type of architecture, stucco of Medusa Waterproofed White Portland Cement is the ideal material, of unquestioned durability and unlimited artistic value.

The Sandusky Cement Company
Department P
Cleveland, Ohio

MEN OF

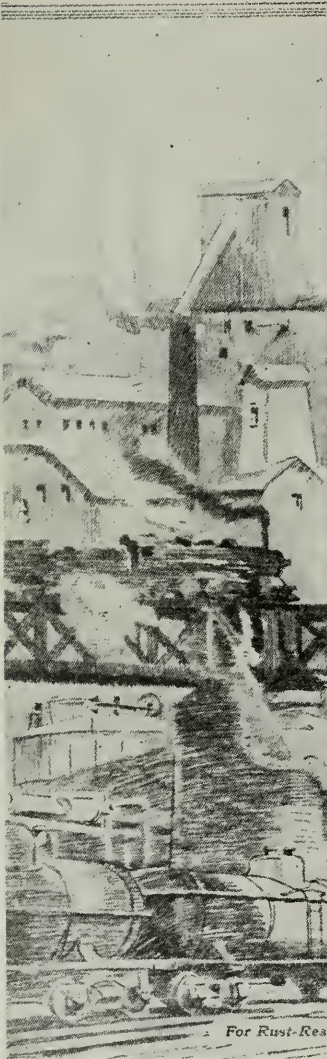
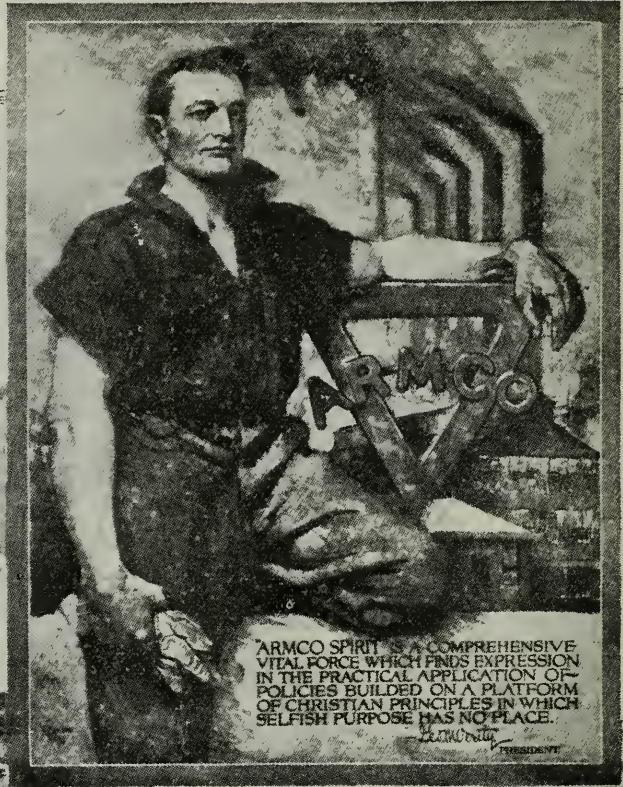

For Rust-Resistance

An ample stock of **ARMCO IRON** is carried at

When writing to Advertisers please mention this magazine.

ARMCO

THERE is a direct relationship between the spirit that moves men to work and the results they accomplish.

Scientific knowledge and Armco manufacturing processes are not *wholly* responsible for the quality of Armco products.

The human organization, the creative brains of our engineers, the skilled hands of Armco workers are guided by the principles of the institution.

So that you may know the products made of ARMCO Ingot Iron, the blue triangle—our trade mark and signature — is placed upon them by the manufacturer.

The American Rolling Mill Company

Middletown, Ohio

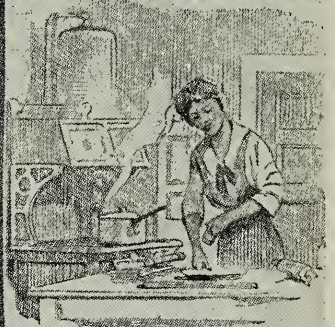

For Enameled Products

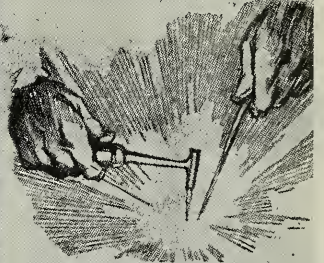

For Welding

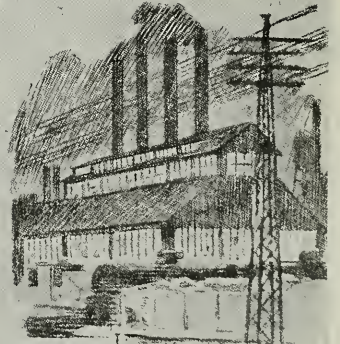

For Electrical Conductivity

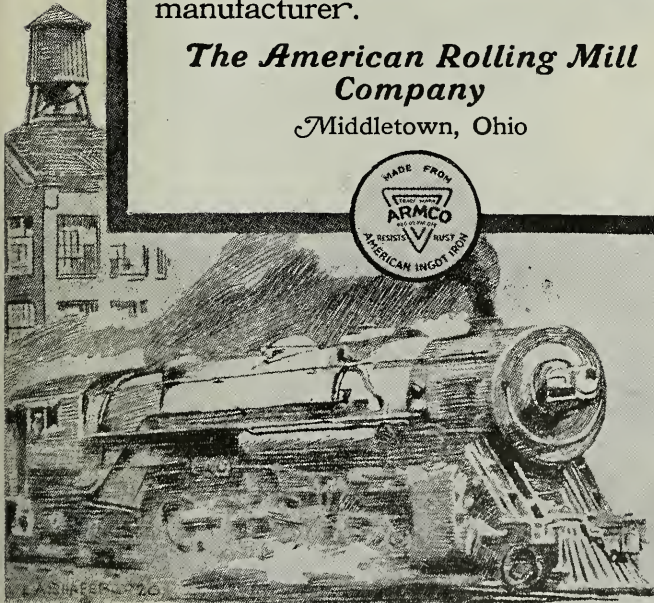

San Francisco. Sales office, 10th & Bryant Sts.

When writing to Advertisers please mention this magazine.

Starting the Day Right

"My first duty before sitting down to the morning's work," said the architect, "is to look over my Van Dyke's; select the proper degrees for the task at hand and sharpen up."

"I use the Van Dyke Drawing Pencil, because, like a fine mechanical instrument it combines the best materials and highest skilled workmanship and it proves true to what ever test I put it."

"I'm sure you'll like it too."

Samples upon request on your business stationery. Please mention the degrees preferred. Address us at 37 Greenpoint Ave., Brooklyn, New York.

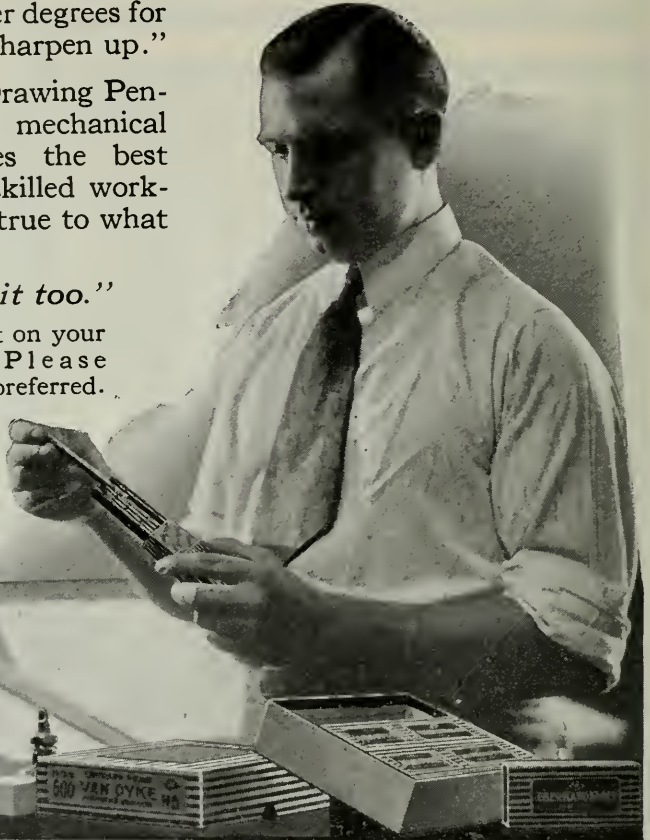

VAN DYKE DRAWING PENCILS

EBERHARD FABER
NEW YORK

VAN DYKE DRAWING PENCIL EBERHARD FABER U.S.A. 600-HB

Made in 16 degrees graduating from 6B, softest to 8H, hardest.



THE HOUSE BEAUTIFUL



THE interior of a Home should have those little touches of refinement that come with the co-operation of an experienced interior decorator.

CONSULT US

Decorative ideas, artistic framing, byamopa ware, floor lamps, table lamps, chair lamps, lamp shades, mirrors, candlesticks, decorated candles, book-ends, store window fixtures, odd furniture, pictures, Emma B. Freeman's Prints, pieces in unique colorings and indefinite carvings and other objects of art.

FREEMAN ART SHOP

386 SUTTER STREET
SAN FRANCISCO

Tel. Sutter 1593



Beach-Robinson Co.

Decorators and Furnishers

Carpets

Draperies

Furniture

Rugs

Wall Paper

Ranson E. Beach

239 Geary Street, 3d Floor

Union Square

Phone, Sutter 580

San Francisco, Cal.

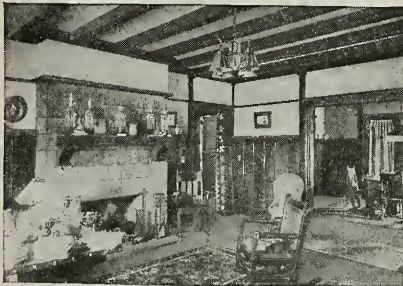

ADD CHEER and COMFORT
to the Home by having a

WELL DESIGNED INTERIOR

Before Completing Your Plans, CONSULT

SONNENSCHN BROS.

INTERIOR DECORATORS

Furniture and Draperies Made to Order

Factory

718 NATOMA ST., Phone Market 1145

Show and Salesroom

470 SUTTER ST., Phone Kearny 2051



*The Finishing Touch
of Right Building —*

F. A. TAYLOR CO.

251 Post St., San Francisco

Second Floor



Mercedes Bldg.

*Hand-made
Furniture,
Rugs,
Hangings,
Upholstering,
Decorating,
Wall Paper.*

The **GOLD MEDAL
MAIL CHUTE**



INSTALLED IN
THE NEW
SAN FRANCISCO
CITY HALL
AND THE
WHITE MARBLE
MERRITT
BUILDING,
LOS ANGELES

Given highest award at
Panama - Pacific Interna-
tional Exposition, 1915.

Waterhouse-Wilcox Co.

California
Representatives

523 Market Street
SAN FRANCISCO

331 E. 4th Street.
LOS ANGELES

F. T. CROWE & CO.
Seattle, Wash.

THE J. McCRACKEN CO.
Portland, Oregon

**American Mailing
Device
Corporation**



**LIBERTY
WALL BOARD**

MANUFACTURED BY
KEY-HOLD PLASTER LATH COMPANY

A Fibered Gypsum Plaster that will not
shrink, warp or buckle.
Resists Fire, Moisture, Heat and Cold.
Key-hold plaster lath possesses a perfect
mechanical key—admitted for fire proof con-
struction in all classes of buildings.

KEY-HOLD PLASTER LATH CO.

Office and Factory
148 Hooper St. San Francisco
Phone Market 5767

McCRAY
REFRIGERATORS
FOR ALL PURPOSES

It is our particular desire to
impress the *Architects of
America* with the fact that
McCray builds refrigerators
for all purposes. Thousands
of fine residences, hotels,
clubs, restaurants, factory
cafeterias, hospitals, stores and
markets depend on McCray
for efficient, economical re-
frigerator service.

McCRAY REFRIGERATOR CO.
1054 Monadnock Bldg., San Francisco, Cal.
Home Office and Factory
Kendallville, Ind.

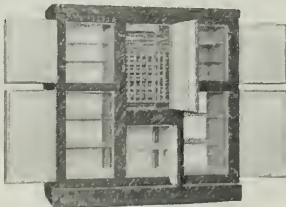

YOU KNOW that a building
should be watertight and
WE KNOW that it can be
made so with

**IMPERIAL
WATERPROOFING**

LOOK FOR  THE LABEL

If your building is leaking through
the walls or around the windows, or
if the Basement walls are wet below
ground — call up SUTTER, 978.
IMPERIAL WATERPROOFING
is manufactured by BROOKS &
DOERR, 460 7th St., San Francisco

WATEREX REED BAXTER
DISTRIBUTOR

1002-04 Merchants National Bank Building,
Phone Sutter 978
SAN FRANCISCO, CAL.
3419 Broadway, OAKLAND, CAL.

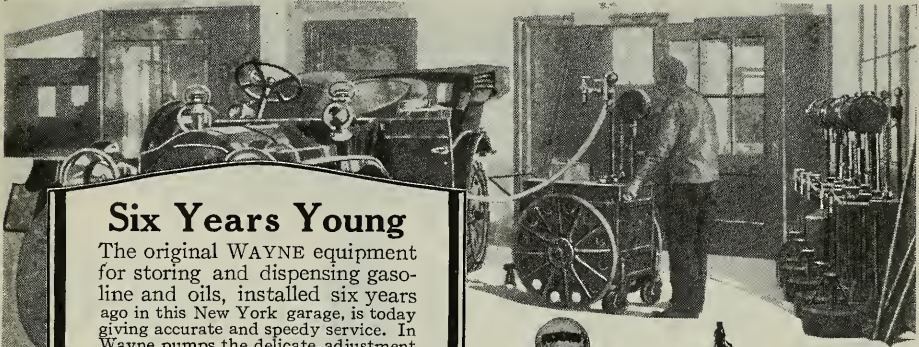

Six Years Young

The original WAYNE equipment for storing and dispensing gasoline and oils, installed six years ago in this New York garage, is today giving accurate and speedy service. In Wayne pumps the delicate adjustment essential for accuracy is combined with a durability that assures satisfaction for years and years.

There is a Wayne System for every need of the public garage. The service of Wayne engineers in advising and planning is yours without cost or obligation.

Wayne Oil Tank & Pump Co.
746 Canal St., Ft. Wayne, Ind.

San Francisco Office 631-633 Howard St. Phone Garfield 1350	Los Angeles Office 830 S. Los Angeles St. Phone Main 1600
---	---

REG. U. S. TRADE MARK
Wayne
Liquid Storage Systems

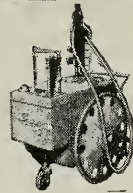

Cut No. 230
For Gas and Oil

Cut No. 280
One-gallon gasoline

Cut No. 200
Lubricating oils

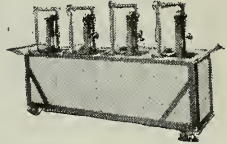

For the
Exacting Client

Pitcher Hangers

Give Satisfaction

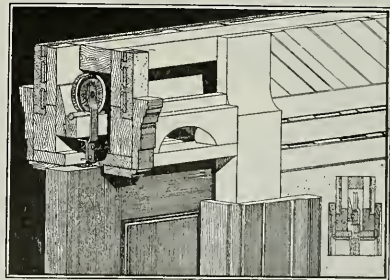

Smooth Running — Noiseless — Efficient
Inexpensive

MANUFACTURED BY

NATIONAL MILL & LUMBER CO.

318 Market Street, San Francisco, Cal.

Telephone Kearny 3626



IT'S not enough to say "Good For All Time" unless there is something back of it. ¶ There is in this case. ¶ Vermont Marble already has an unblemished record of over one hundred and fifty years. ¶ We know what it will do. It's not necessary to guess at it. ¶ And our quarries in Alaska and Texas are also proving themselves. ¶ So please don't think of "Good for All Time" as merely a happy phrase.

IT'S THE MARK OF A SERVICE.
It means exactly what it says.

VERMONT MARBLE COMPANY
PROCTOR, VERMONT
San Francisco - Portland - Tacoma



**A "LAFRANCE ALERT"
Extinguisher Gives You
The Benefit of 76 Years'
Experience in Designing
Fire Apparatus.**



That is why they possess a degree of efficiency that makes them invaluable when called on for instant duty. One should be placed at every danger point in every building for thorough fire protection.

Write our nearest branch office for complete information

AMERICAN LAFRANCE FIRE ENGINE COMPANY, INC.

ELMIRA, N. Y.

Western Addresses

929 So. Hill St. 151 New Montgomery St.
Los Angeles, Calif. San Francisco, Calif.

A Bargain in Files—

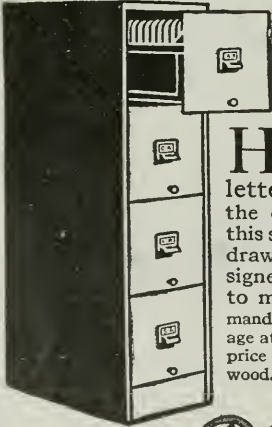

HOLDS 20,000 letters. That's the capacity of this special four-drawer file, designed and built to meet the demand for steel storage at less than the price of high grade wood. See it today.

Van Dorn
STEEL EQUIPMENT

Phone Douglas 1183

Western Office Equipment Co.
467 Market Street - San Francisco

EASY TO LAY
Great quantities of Clinton Electrically Welded Fabric can be laid in a very short time with absolute assurance that every strand of wire is in its proper position. It eliminates all the cost and trouble of spacing and wiring loose rods.

L. A. NORRIS COMPANY
140 Townsend St., San Francisco
Phone Kearny 5375

CLINTON
Electrically Welded Wire Fabric

A Rich, Velvety White Enamel

—and a less expensive
enameling method

SET your enamel ideal high. Demand the richest, most delicate effect you can get. Meet the modern trend from the glaring, high-gloss enameled finish with Glidden Velvet White Enamel.

Glidden Velvet gives you the soft, smooth, semi-gloss finish—just the tone that harmonizes with the furnishings in the better homes.

Years of wear will prove its durability. Rub it or scrub it and it stands the test. A “prove it” panel will be sent you on request.

Glidden Velvet White Enamel is the true economy enamel. Apply only four coats instead of seven and there's no rubbing necessary. It's the most natural white enamel you can get.

THE GLIDDEN COMPANY

123 to 169 Hooper Street, Bet. 7th and 8th Sts., San Francisco

Factories

San Francisco Cleveland Toronto Reading

Branches

New York Chicago Kansas City Boston Pittsburgh London

STOCKS IN PRINCIPAL CITIES



When writing to Advertisers please mention this magazine.

The ELECTRIC



New and Far-Reaching Possibilities in Lighting Await the Architectural Profession

IN spite of wonderful progress in the design and construction of buildings, the art of electric lighting hitherto has remained relatively limited and inflexible.

The principal limiting factor has been the inadequacy and inelasticity of the present electric outlet.

Placing necessary outlets for lighting has been hedged about by constructional limitations and by the necessity of finishing every outlet with a permanent and immovable fixture.

Lighting, the most intangible of all forms of decoration, has had to be studied without the benefit of experimentation.

Long before the stage at which the real study of decorations becomes possible, lighting arrangements have had to be predetermined.

The Electric Outlet Company will make it possible for the architectural profession to change this condition.

By a new simplification the door is opened to a lighting development that will benefit every architect.

This simplification will make it possible to provide, at reasonable expense, electric outlets in all the places where they may ever be needed, in homes, offices, stores, hotels, clubs and other buildings.

It will place at the architect's disposal almost unlimited possibilities in lighting harmony and efficiency.

It will make the technique of lighting so flexible that determination of lighting arrangements need not be made in advance of finished construction and decoration.

OUTLET *Company*

It will make electric outlets more useful than they have ever been before.

It will not only make possible the manipulation of lighting within wide artistic and practical limits, but also provide for the use of many other electrical conveniences wherever and whenever they may be desired.

The Electric Outlet Company by means of a comprehensive and continuous advertising campaign will educate the public to the advantages of more electric outlets.

It will show them the convenience and the artistic possibilities of changeable, flexible lighting.

It will demonstrate the charm of adapting lighting to individual tastes.

It will emphasize the desirability of having lighting arrangements harmonize perfectly with other furnishings and decorations.

It will promote the wider use of all kinds of electrical conveniences through the availability of standardized electric outlets.

The benefits from this campaign of education will be felt by all members of the architectural profession.

This story is of vital importance to everyone connected with the architectural profession and the electrical industry.

More details will be given in succeeding advertisements in this publication.

ELECTRIC OUTLET COMPANY, Inc.
119 West 40th St., New York City.



Use UHL'S FLOOR PAINT

"DURABLE SEMI-GLOSS FINISH"

UHL BROS., Inc.

DISTRIBUTORS

MURPHY VARNISHES AND ENAMELS

SAN FRANCISCO

OAKLAND

LOS ANGELES

PORTLAND

SEATTLE

LEADER WATER SYSTEM

No country home is complete without this modern water system. Running water under pressure whenever and wherever needed. Convenient, economical, sanitary.

**Pacific Pump & Supply
Company, Distributors**

851-853 Folsom Street
SAN FRANCISCO, CALIF.

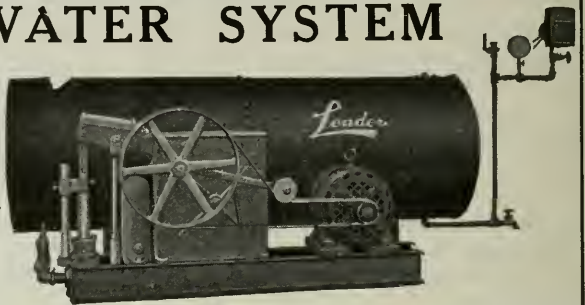

QUALITY HARDWARE



LOCKS AND BUILDERS'
HARDWARE

PALACE HARDWARE CO.

"San Francisco's Leading Hardware Store"

581 MARKET STREET. SUTTER 6060



Pack your Radiator Valves with
Palmetto Twist Packing

It can be unstranded to fit any
size valve. It does not get hard.

H. N. COOK BELTING CO.

401-433 Howard St.

San Francisco, Cal.

**WESTERN
VENETIAN BLINDS
WESTERN**

ELIMINATE the unsightly awnings — Preserve the exterior beauty of your buildings by
Specifying

**WESTERN VENETIAN
BLINDS**

Some 1920 contracts for complete equipment:

- 12-story Mattie Building,
Fresno, California
- 9-story Pantages Building,
Los Angeles, California
- 7-story Marland Refining Bldg.
Ponca City, Oklahoma
- 10-story Tradesmens Bank Bldg.
Oklahoma City, Okla.,
- 5-story Railway Exchange,
Muskogee, Oklahoma



LOS ANGELES TRUST
AND SAVINGS BLDG.
LOS ANGELES, CAL.



HAAS BLDG.
LOS ANGELES, CAL.

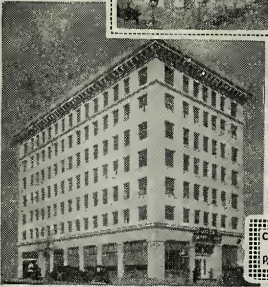
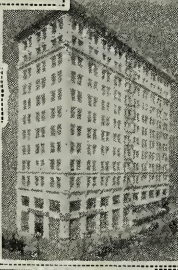

CITIZENS SAVINGS
BLDG.
PASADENA, CAL.



CLOSE GRAY &
MILLING CO.
LOS ANGELES, CAL.



COUNTY COURT
HOUSE
WALLA WALLA, WASH.

When you consider the fact that **WESTERN VENETIAN BLINDS** take the place of both awning and window shade and will last practically as long as the building stands you'll realize that they are the logical equipment for modern buildings

WESTERN BLIND & SCREEN CO.

2704 LONG BEACH AVE.
LOS ANGELES CALIFORNIA

United States Steel Products Co.

Rialto Bldg., San Francisco

SELLERS of the products of the American Bridge Co., American Sheet and Tin Plate Co., American Steel and Wire Co., Carnegie Steel Co., Illinois Steel Co., National Tube Co., Lorain Steel Co., Shelby Steel Tube Co., Tennessee Coal, Iron and Railroad Co., Trenton Iron Co.

MANUFACTURERS OF

Structural Steel for Every Purpose—Bridges, Railway and Highway—"Triangle Mesh" Wire Concrete Reinforcement—Plain and Twisted Reinforcing Bars—Plates, Shapes and Sheets of Every Description—Rails, Splice Bars, Bolts, Nuts, etc.—Wrought Pipe, Trolley Poles—Frogs, Switches and Crossings for Steam Railway and Street Railway—"Shelby" Seamless Boiler Tubes and Mechanical Tubing—"Americore" and "Globe" Rubber Covered Wire and Cables—"Reliance" Weatherproof Copper and Iron Line Wire—"American" Wire Rope, Rail Bonds, Springs, Woven Wire Fencing and Poultry Netting—Tramways, etc.

United States Steel Products Co.

OFFICES AND WAREHOUSES AT
San Francisco - Los Angeles - Portland - Seattle

Planning the Private Garage

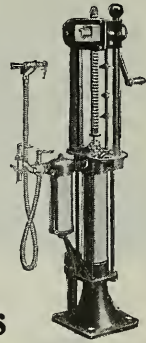
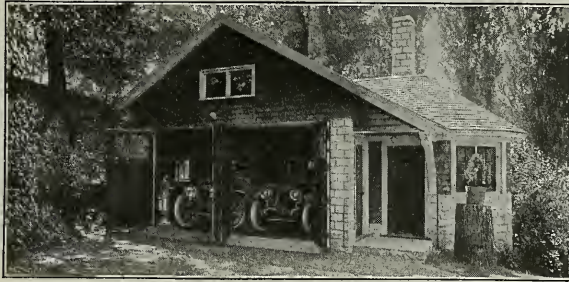

Bowser Oil and Gasoline Storage Systems

Are a necessity always, to make the garage complete — safe — convenient — and a saving proposition.

Bowser Equipment is Fire-Proof, Theft-Proof, Dirt-Proof and Loss-Proof. Because it is built to meet Underwriters' inspections — with every convenience and oil saving device.

Write or phone us at once for complete information.

S. F. BOWSER & CO., Inc.
FORT WAYNE, IND.

San Francisco Office: 612 Howard St. Telephone Douglas 4323
Sales Offices in All Centers — Representatives Everywhere



*Walls finished with Cabot's Old Virginia White
Roof finished with No. 316 Dark Gray Creosote Stain
Walter Boschen, Architect, St. Joseph, Mo.*

The Latest Country-house Color-schemes

An especially appropriate and harmonious exterior color-treatment has been developed for the dignified and beautiful type of country-house that our leading architects have now firmly established, in place of the fifty-seven varieties that have prevailed in recent years.

Cabot's Old Virginia White,
for the walls

Cabot's Creosote Stains, in
greens or dark gray, for the roofs

The soft, brilliant "whitewash white" of the Old Virginia White is particularly suitable for this type of house, and the rich greens and velvety dark gray stains harmonize perfectly for the roof, with the old New England dark green blinds.

Samples and information sent on request

SAMUEL CABOT, Inc., Mfg. Chemists, Boston, Mass.

Cabot's Creosote Stains, Waterproof Cement, and Brick Stain
"Quilt" Conservo Wood Preservative, Damp-Proofing
Protective Paints, Waterproofing, etc.

Pacific Building Materials Co., San Francisco
Waterhouse-Wilcox Co., Los Angeles

S. W. R. Dally, Seattle
Timms, Cress & Co., Portland

Theo. F. Snyder, San Diego, Cal.



CENTRAL HIGH SCHOOL, MINNEAPOLIS, MINN.

Architect, William B. Ittner

Contractors, Pike & Cook Co.

Glazed by Forman, Ford & Co



The above Trade-Mark appears on every light

Completely equipped with American Window Glass Co.'s Double Strength AA Quality First Choice of Leading Architects

Because of its absolute dependability, American Window Glass has been used in many fine buildings. Our care in inspection practically eliminates all imperfections and assures uniformity in thickness.

American Window Glass Co., General Office, Pittsburgh, Pa.

DOMESTIC SALES OFFICES

- New York, 220 Fifth Avenue
- Chicago, 1011 Peoples Gas Building
- Boston, Mass., 43 Tremont Street
- San Francisco, Cal., 341 Montgomery Street
- St. Louis, Mo., 1303 Syndicate Trust Building
- Memphis, Tenn., 440 North Main St.
- New Orleans, La., 904 Hennen Bldg.
- Atlanta, Ga., 1408 Candler Building

EXPORT SALES OFFICES

- Havana, Cuba, Apartado No. 930
- Buenos Aires, Argentina
- Mexico City, Mex., Apartado Postal No. 237
- Barranquilla, Colombia
- Bogota, Colombia
- Valparaiso, Chile
- Lima, Peru
- Toronto, Canada, 205 Continental Life Building

Highest Quality

Finest Workmanship

Remco Redwood Tanks

Underwriters — Standard — Specials

All dimensions and capacities

Towers Designed and Erected

For Prices, Data or Estimates Phone GARFIELD 1910

Redwood Manufacturers Company

SOLE MAKERS

Hobart Building, San Francisco

When writing to Advertisers please mention this magazine.

JOHNSON'S ROTARY CRUDE OIL BURNER

Can be installed in any BOILER or FURNACE

Gives Satisfactory Results. Simple to Operate—
Automatic—Safe. Let us tell you more about this
Oil Burner.

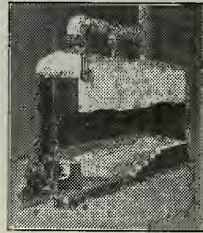

BURNER IN OPERATION

S. T. JOHNSON CO.

1337 Mission Street - San Francisco, Cal.

Ask for Bulletin No. 28

Phone Market 2759

Agencies: SEATTLE LOS ANGELES FRESNO SAN DIEGO SACRAMENTO
Member of the Oil Burners Manufacturers' Association of California.

Fess System Turbine Fuel Oil Burner

The latest word in the science of burning fuel
oil in an efficient and economical method

Ask for Bulletin No. 20

FESS SYSTEM CO., Inc.

1310 S. HILL ST.,
LOS ANGELES

218-220 Natoma Street, San Francisco

HOUSTON,
TEXAS

Member of the Oil Burners Manufacturers' Association of California.

OIL BURNER EQUIPMENTS

Low Pressure Air and Rotary Mechanical Atomizing Types

Refrigerating and Ice-Making Machines

Direct Expansion and Brine Circulating Systems

T. P. JARVIS MANUFACTURING CO.

CONTRACTING ENGINEERS AND MANUFACTURERS

275 Connecticut Street, San Francisco

Phone Market 3397

Member of the Oil Burners Manufacturers' Association of California.



SIMPLICITY OF CONSTRUCTION together with
SUCCESSFUL and ECONOMIC OPERATION of

SIMPLEX BURNERS

reported by their many users, is the best recommenda-
tion we can furnish to those desiring crude oil burners.

American Standard Oil Burner

TRADE MARK

Phone BERKELEY 6389

Company

FIFTH AND PARKER STREETS
BERKELEY, CALIFORNIA

Member of the Oil Burners Manufacturers' Association of California.



Pump Governors
 Oil Burner Governors
 Reducing Valves
 Safety Valves
 Oil Valves
 Blowoff Valves
 Boiler Feed Water
 Regulators

Oil Pumping Sets
 Little Giant Improved
 Oil Burners
 Duplex Oil Pumps
 Rotary Oil Pumps
 Oil Heaters
 Draft Gauges
 Boiler Feed Pumps

G. E. WITT CO., Inc.

ENGINEERS

Manufacturers and Distributors

862-864 HOWARD ST.

Phone Douglas 4404

SAN FRANCISCO, CAL.

Preserve Your Concrete Floors



By the use of "VITRIFYX" you can at small expense, stop dusting and abrasion, prevent absorption of oil or water and protect from dilute acids.

**PACIFIC
 MATERIALS CO.**
 525 Market St., San Francisco

A. F. EDWARDS, President
 J. M. FABBRIS, Vice-President

J. A. MACKENZIE
 Secretary

CHAS. F. EISELE } Asst. Managers
 J. RUBIOLO }

AMERICAN MARBLE & MOSAIC CO.

25-29 Columbia Square, San Francisco
 Telephone Market 5070

Factory on Canal, South San Francisco Telephone South San Francisco 161

Fenestra

SOLID STEEL WINDOWS

DETROIT STEEL PRODUCTS CO., Detroit

Direct Factory Branch, 68 Post Street, San Francisco

Phone Sutter 1250



The Architect and Engineer

Volume LXIII. Number 1.

CONTENTS FOR OCTOBER, 1920

	PAGE
HOUSE OF MR. EDWIN J. SYMMES, ALAMEDA Frontispiece	
Edwin J. Symmes, Architect	
SOME SMALL HOUSES OF THE EAST BAY CITIES	47
Irving F. Morrow	
ARCHITECTURE AND THE MOTION PICTURE	66
William I. Garren, Architect	
THE PLANNING OF THEATRES AND AUDITORIUMS	71
Edwin H. Flagg	
COMPETITION FOR \$3,000,000 CLUBHOUSE	81
THE SPECIFICATION WRITER AND THE MANUFACTURERS' LITERATURE	89
Louis R. Holske	
CUTTING STEPS IN THE SKYSCRAPER	93
F. W. Fitzpatrick	
CONCRETE STEPS EASY TO BUILD	97
WHEN WILL BUILDING COSTS BE LOWER?	99
CHIMNEY AND FIREPLACE CONSTRUCTION	104

Published Monthly by

THE ARCHITECT AND ENGINEER, Inc.

626-627 Foxcroft Bldg., San Francisco

W. J. L. Kierulff Fred'k W. Jones L. B. Penhorwood
President Vice-Pres. Secretary



HOUSE OF MR. EDWIN J. SYMMES, ALAMEDA, CALIFORNIA
EDWIN J. SYMMES, ARCHITECT

EAST BAY HOUSE NUMBER

Some Notable Homes in Oakland, Berkeley and Alameda

THE ARCHITECT AND ENGINEER

Vol. LXIII.

SAN FRANCISCO, OCTOBER, 1920

No. 1

Some Small Houses of the East Bay Cities

By IRVING F. MORROW

HOUSE-HUNTING is the greatest of fun. To the evicted tenant in quest of new quarters this will seem such arrant perversity that I hasten to protest that I mean another kind of house-hunting. His is an experience I have known only vicariously, through such media as distracted friends and comic papers. By house-hunting I mean just ferreting about in search of seemly houses, untroubled by considerations of vacancy or rent. Compared with the sterner kind, involved as it is with landlords and real-estate agents and personal uncertainty and other things not wholly agreeable, this may seem an innocuous and academic undertaking. I repeat, however, that it is a source of never-failing interest and pleasant surprises, provided only that you have good weather and a good machine. You start out with a nonchalant avoidance of preconceptions. This may make it a bit hard on the driver. For such questions as, "Where do we go?" or "Which way do we turn?" you have only unilluminating replies like, "I don't know," or "It makes no difference." This seems to foist upon the driver the responsibility for finding good architecture (a burden, I admit, unwonted and in no sense justified). But the imposition is only apparent. Presently, glancing down a side street, you catch a glimpse of a fleeting doorway or gable, whereupon you call, "Turn to the right," or "to the left," with an unconcern as complete as if you were quite unaware that the corner were already passed. After all, suppose you do have to proceed another block to turn about, who knows but that that block may contain some priceless, or at least valuable, architectural pearl? There will be plenty of rest for the driver while you set up the camera and hunt favorable points of view. Sometimes you

discover in the morning a composition which must be revisited for an afternoon sun, or you may happen in the afternoon upon something which should have been photographed with morning light. Then there are piquant uncertainties as to what you will get when the pictures are developed. (I have often wondered if a practical certainty as to how things are going to turn out must not deprive the professional photographer of much of the zest of adventure.) Pictures play such unexpected tricks. Sometimes things in which you had shown the keenest delight fail lamentably to register on the plate so much as a sug-



HOUSE FOR MR. H. C. TAFT, OAKLAND, CALIFORNIA
Bakewell & Brown, Architects

gestion of the source of your interest. Even such accidents may be instructive. They set you to thinking on the problems of the inter-relation of pure form and its more evanescent accompaniments. Colors and textures and the impalpable aspects of environment are all realities, though not subject to photographic representation.

It was, in fact, in just this happy-go-lucky manner that the collection of domestic architecture here illustrated was gathered together. All of the work is from the cities on the east shore of San Francisco bay. It was decided to show only houses of small or moderate size, of fairly recent construction, and in any case to exclude work previously published or well known. Outside of

these limitations, the only principle of selection was that a jury consisting of the author and the editor happened along at the right time to take a picture, and felt moved to do so. Even more uncertain factors of chance influenced the inclusions; for pictures by which some store had been set in several instances, turned out unworthy of reproduction. Obviously, therefore, the collection disclaims the slightest pretence to being complete or in any way representative. It is rather what an observant visitor might chance upon in the course of an aimless automobile ramble.

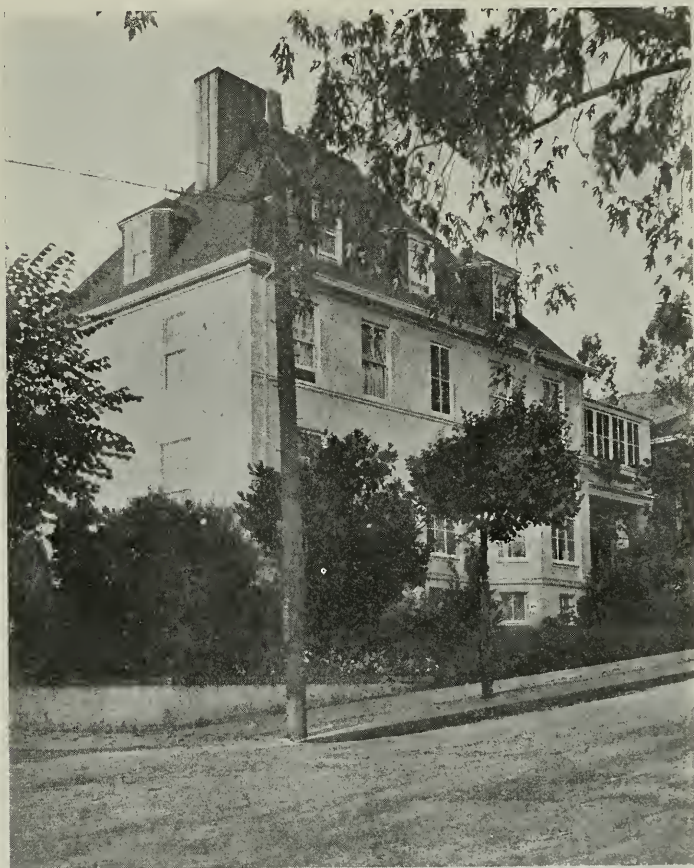

HOUSE IN BERKELEY, CALIFORNIA
Bakewell & Brown, Architects

It is an illuminating comment on the architectural level attained by a community that so casual a gleaning can yield results of such distinct interest. We have advanced beyond the day when examples of meritorious architecture had to be listed and sought out, as well as the day when only houses of size and pretention were worthy of attention. The present collection is not hand-picked; which means that anywhere else you might turn in the better quarters of our cities you stand an equal chance of encountering architecture equally good. A community where it is so easy to make up an attractive magazine portfolio must be a not unattractive place in which to live. And that, after all, is the most important aspect of the matter.



HOUSE OF H. S. RIGLEY, CLAREMONT, CALIFORNIA



HOUSE FOR MRS. N. W. EDWARDS, OAKLAND, CALIFORNIA
Wm. E. Milwain, Architect

(See plan on page 53.)

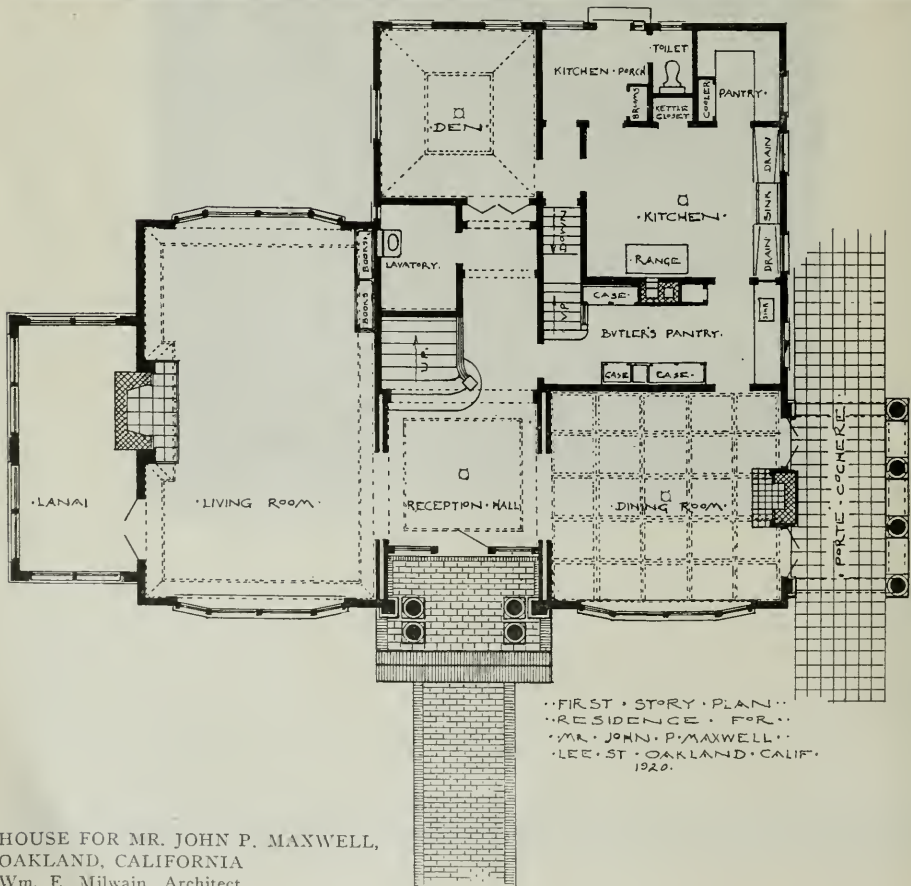

HOUSE FOR MR. JOHN P. MAXWELL,
 OAKLAND, CALIFORNIA
 Wm. E. Milwain, Architect



HOUSE IN OAKLAND, CALIFORNIA
C. W. McCall, Architect

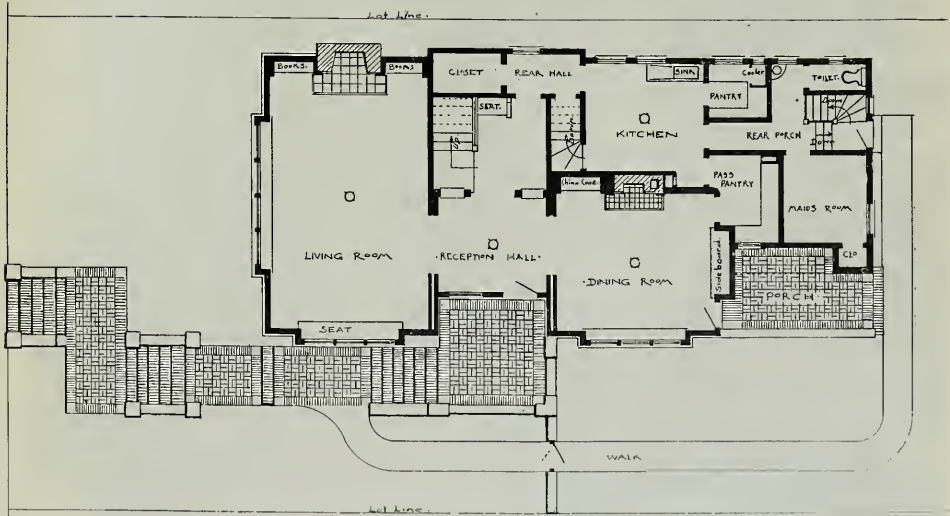

PLAN—HOUSE FOR MRS. N. W. EDWARDS, OAKLAND, CALIFORNIA
Wm. E. Milwain, Architect

(See page 51.)

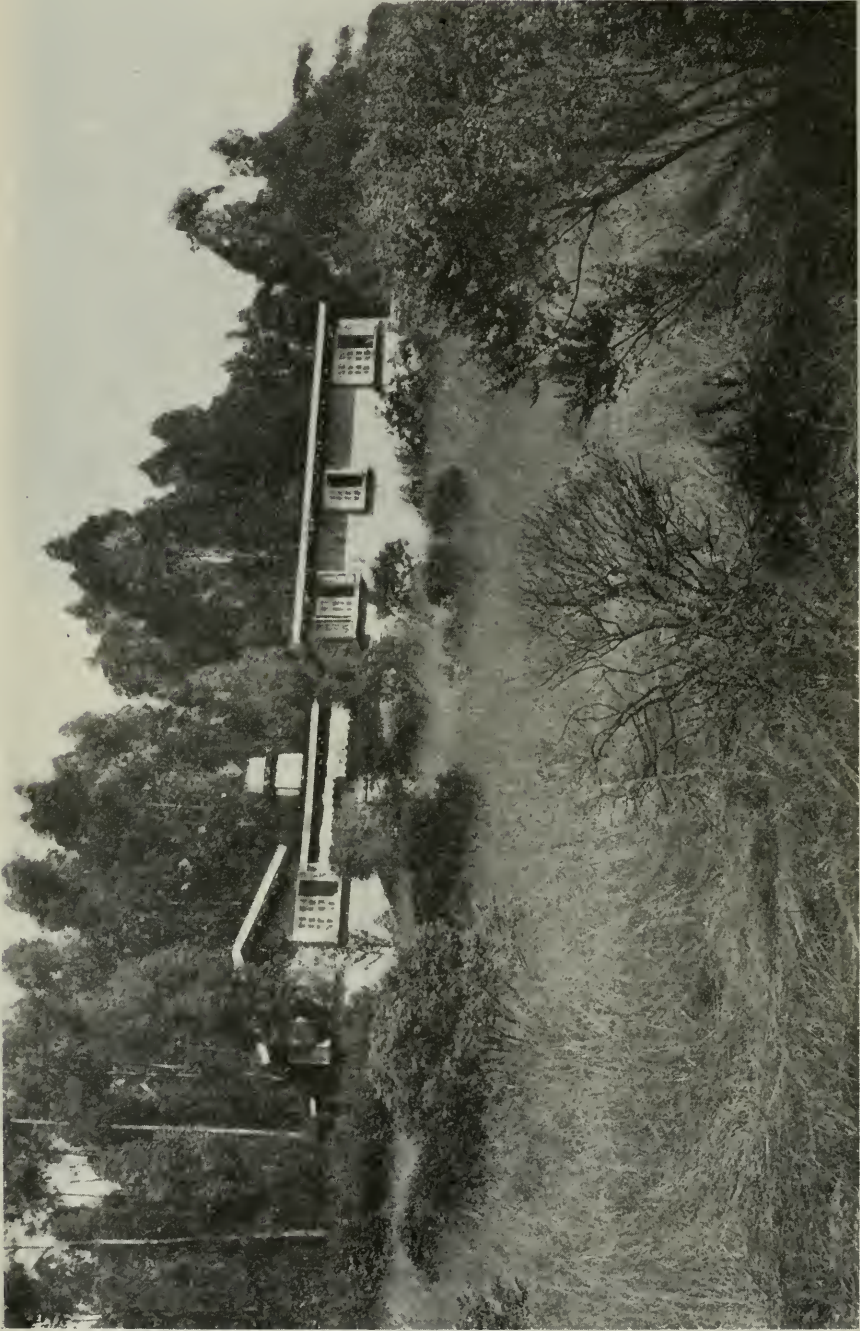

HOUSE FOR MR. CIJAS, W. FORE, PIEDMONT, CALIFORNIA
LOUIS CHRISTIAN MULLGARDT, ARCHITECT

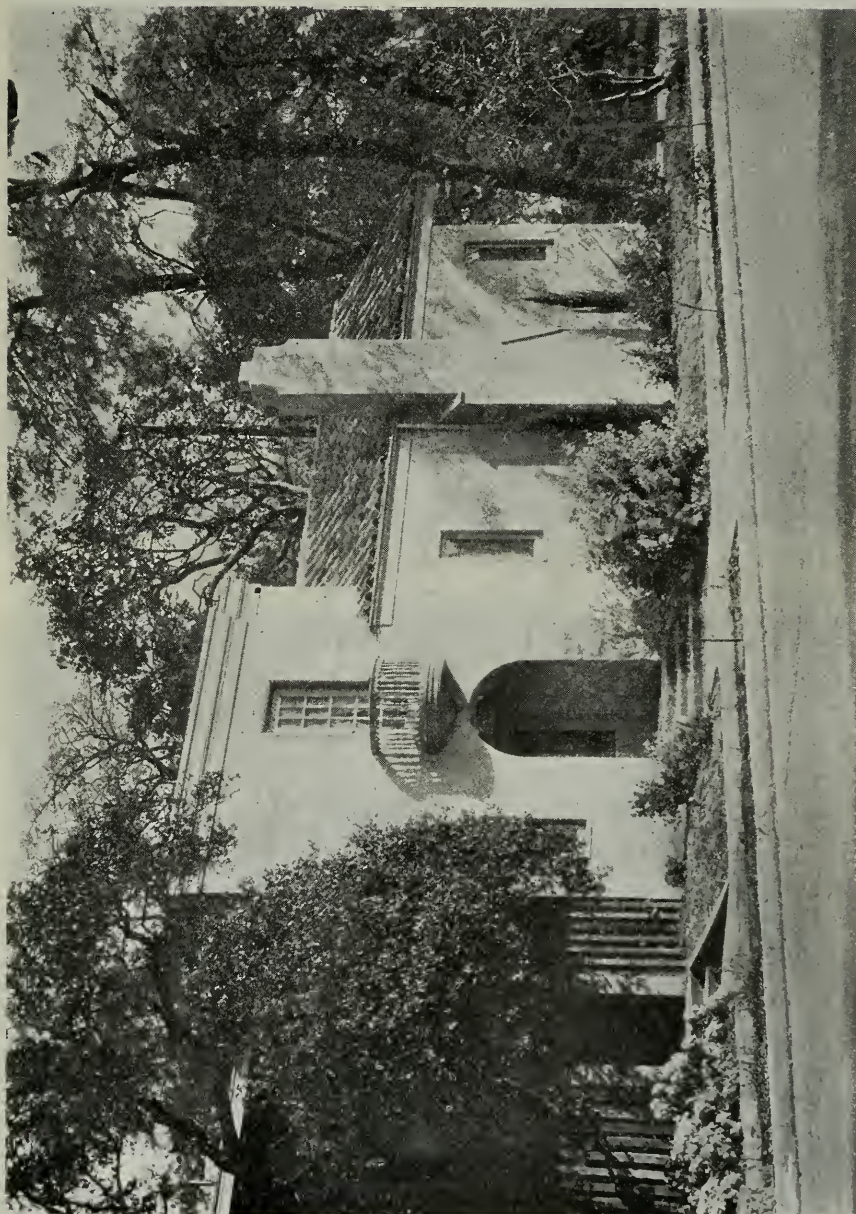

HOUSE OF MR. EDWIN J. SYMMES, ALAMEDA, CALIFORNIA
EDWIN J. SYMMES, ARCHITECT



HOUSE OF MRS. W. W. PHILLIPS, PIEDMONT
Designed by V. W. Houghton's



HOUSE IN PIEDMONT, CALIFORNIA
Wm. E. Milwain, Architect



LIVING ROOM, HOUSE OF MRS. W. W. PHILLIPS, PIEDMONT



STAIRCASE HALL, HOUSE OF MRS. W. W. PHILLIPS, PIEDMONT



HOUSE FOR MR. A. H. MARKWART, OAKLAND, CALIFORNIA
Wm. C. Hays, Architect

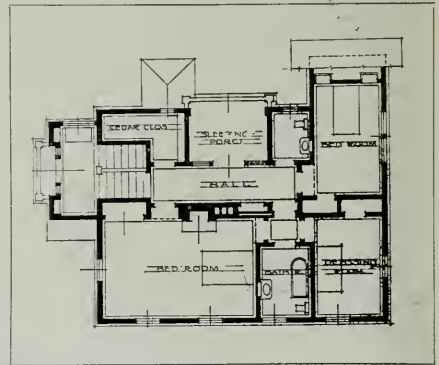
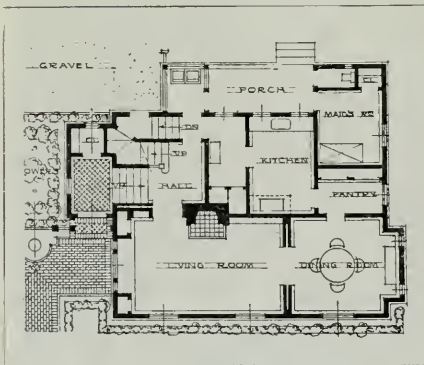

PLAN, HOUSE FOR MR. A. H. MARKWART, OAKLAND, CALIFORNIA
Wm. C. Hays, Architect

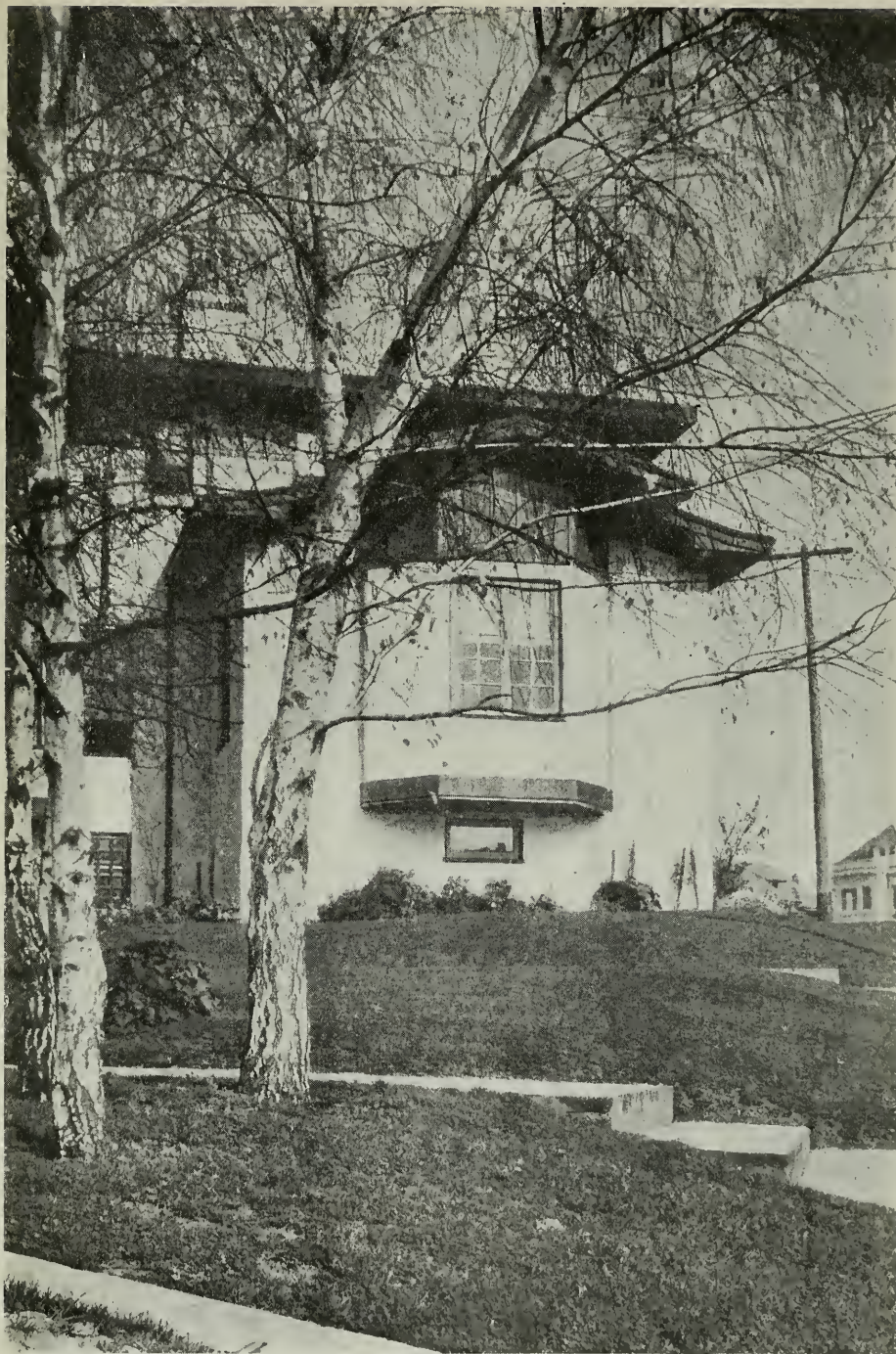

HOUSE OF MR. IRVING F. MORROW, OAKLAND, CALIFORNIA
WM. C. HAYS AND ABE APPLETON, ASSOCIATE ARCHITECTS



HOUSE FOR DR. G. C. THOMPSON, ALAMEDA, CALIFORNIA
Wm. C. Hays, Architect

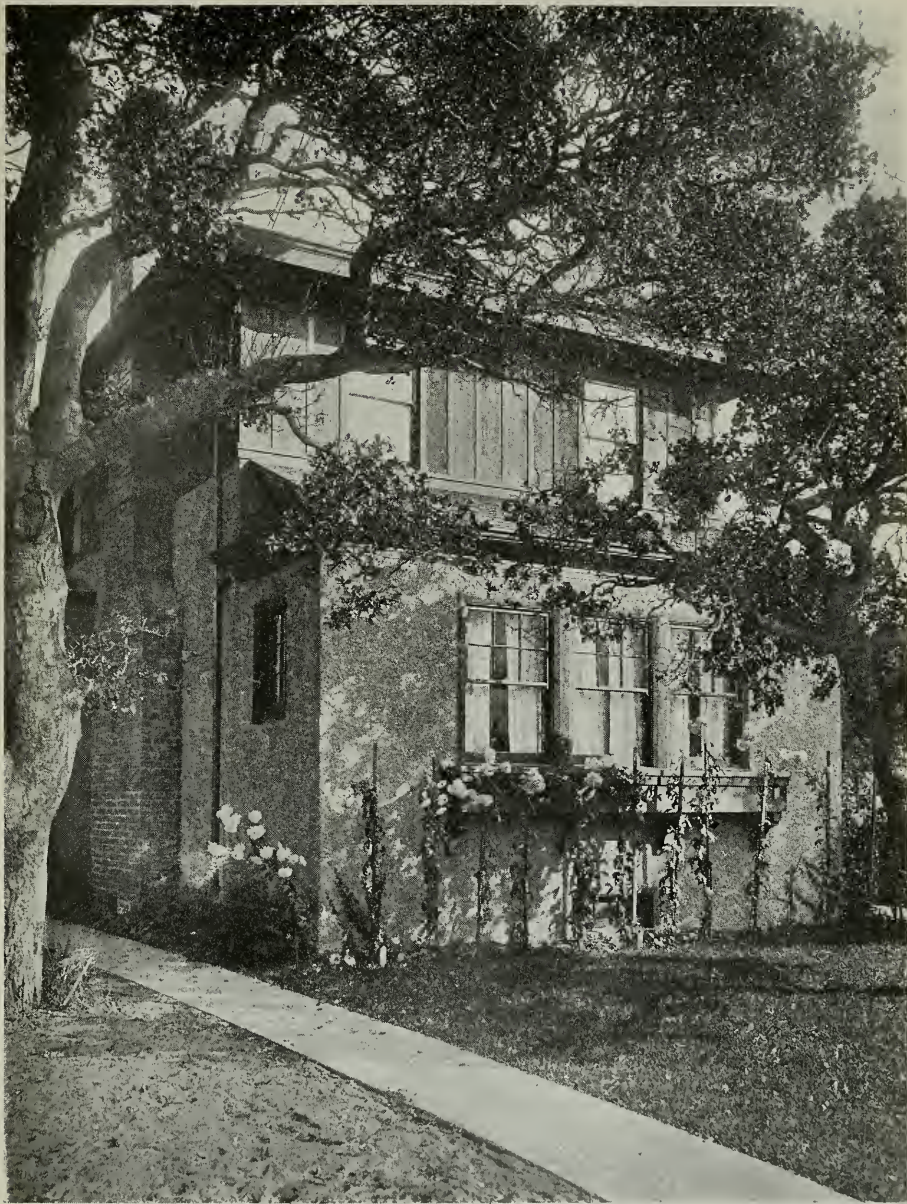

HOUSE FOR DR. G. C. THOMPSON
ALAMEDA, CALIFORNIA
WM. C. HAYS, ARCHITECT



HOUSE OF MRS. HENRY ATKINS, PIEDMONT, CALIFORNIA
DESIGNED BY VICKERY, ATKINS & TORREY



HOUSE OF MRS. HENRY ATKINS, PIEDMONT, CALIFORNIA
DESIGNED BY VICKERY, ATKINS & TORREY

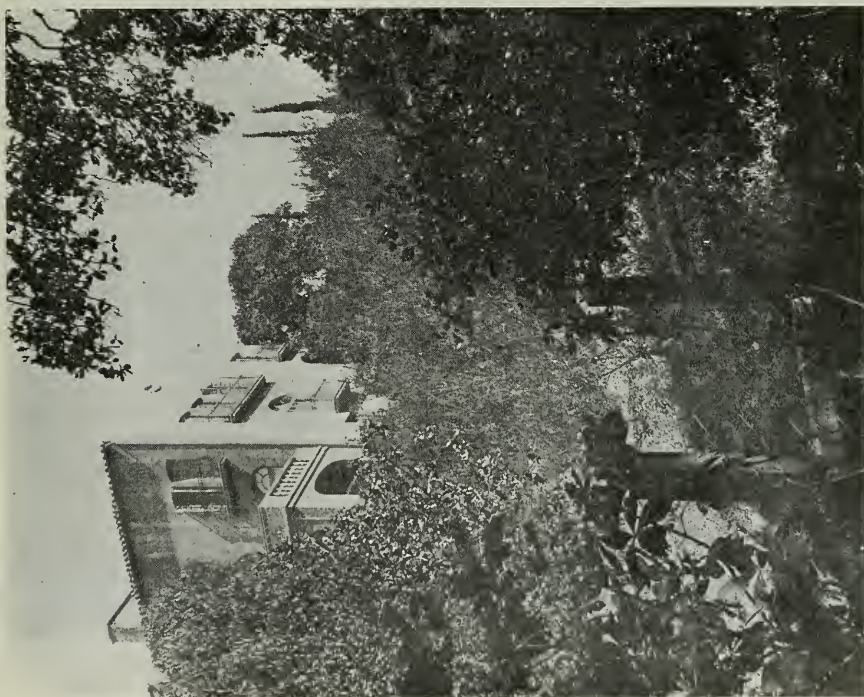



HOUSE OF JOHN DENNIS, CLAREMONT, CALIFORNIA
Designed by John Dennis



HOUSE FOR MR. W. E. SCHIRMER, OAKLAND, CALIFORNIA
Schirmer, Bugbee & Co., Architects



HOUSE AT CHABOT OBSERVATORY, OAKLAND, CALIFORNIA
Reed & Corlett, Architects



HOUSE FOR MRS. J. INGERSOLL, OAKLAND, CALIFORNIA
Hugh C. White, Architect

Architecture and the Motion Picture

By WILLIAM I. GARREN, Architect

WHEN does the production of the motion picture become an art and what does the public want. To the public who enjoy good art, music or drama the average motion picture is a sad disappointment; until a producer or producers shall be known by the class of article they present for show, there is no alternative for the public except to go to a theatre in spite of what may have previously been shown and take a chance. There are producers who strive to do the best that talent or money will allow, and recent years have seen the industry working for the development of motion pictures as an art.

What makes the picture good? This is not an old question nor one to be answered without reservations. To the average producer the good picture is



COTTAGE IN A SCOTCH VILLAGE. SET BY GOLDWYN PRODUCING CORPORATION

one that sells or, is what the public wants; how often promoters, producers or financiers mistake what the public tolerates or accepts, through indifference or inability to dictate, for what it might better enjoy or benefit by. Of the spoken drama it has oft been quoted, "the play's the thing"; if such is the case, in the medium of photography it must equally be true, in a general way, the picture's the thing. In the instance of the motion picture we mean the art of photographic composition in action or movement. There must first of all be a scenario or story such as will permit of a highly artistic composition and will leave to the artistic director a free hand to compose his film. Moving masses properly arranged in pictorial composition, pleasing to the eye and successively related by story, will create in the production of the film a picture worthy of its possibilities and properly deserving to be called an art.

Let us trace some of the progressive steps of the film industry and see how it has advanced. The first use of any great discovery is usually the novelty of

seeing it work. The discovery in this case was that by passing a number of pictures of objects in different positions rapidly before the eye the effect of continuous movement could thus be reproduced. This probably explains that in the earliest pictures audiences enjoyed merely to see anything move on the screen, just as one might now more enjoy the act of talking by phone from San Francisco to New York than the actual conversation. During this period of novelty the picture passed through the era of long chases with running crowds and fastly moving vehicles, often reversing the action of the film to the keen delight of the audience. These chases, however, gave to the picture life and action and even today no great comedy is complete without a crowd running into the Italian banana wagon man. The novelty of merely viewing the film having passed, the next period, as with any discovery, is that of illusion or doing tricks with the new toy. During this era we had the great fairy and genii and ghost pictures;



THE TOWN OF LEXINGTON IN 1860, SET BY GOLDWYN PRODUCING CORPORATION

marvelously clad persons, in weird caverns, appeared and disappeared in clouds of smoke and color and audiences sat open-mouthed in wonder at these spectacles. This type of film today is produced only for children, but the art of illusion forms a most important part in the field of imitation and reproduction as well as being used with the double negative. As audiences tired of these early pictures, no avenue was open to the producers except to develop what they had. At this juncture the great cowboy and Indian plots came forward; it was indeed a great advance for the film, taking it to the open stage of nature where it truly belonged and with earth, sky, water and fire forming the great sets, impossible to reproduce, the picture found its finest quality, pictorial composition. Today the large studio plants of the country are working for achievements which years of experience have taught the public will recognize and appreciate, thereby giving a prestige to the producer such as is sought by artists, artisans



A VILLAGE IN SCOTLAND, SET BY GOLDWYN PRODUCING CORPORATION

and commercial establishments the world over. The modern picture combines the action that is paramount, the illusion of artificial reproduction that deceives yet does not excite and the pictorial composition of setting, and with individuals or groups moving about telling a story the eye of the audience is carried through tenements and palaces, mountains and plains, living the life of the world's peoples and their habits. The motion picture is truly an art. It requires good music to accompany it as does the dance, and in its best productions it yields aesthetic enjoyment, satisfying at nominal charges thousands of people who can visit its screens.

The architect will find in the motion picture a vast field of architectural reproduction or imitation partly removed from scenic art, yet not the art of the



THE DRESSING ROOMS AND STAGES, GOLDWYN STUDIOS, LOS ANGELES



AN INN IN THE BURNS' COUNTRY, SCOTLAND, BY GOLDWYN PRODUCING CORPORATION

utilitarian structure. We plainly see that the structures we build as time goes on truly interpret to posterity the lives we live and lead, for in these pictures of today no play or story could be produced without completely in every detail surrounding the actors with the architectural style of the period of the story. The studio must include almost an entire building industry, for aside from the administrative, advertising, and technical departments the larger work is that of construction. At the studios of the Goldwyn Producing Corporation, which is here illustrated, there is embodied in the plant large carpenter and scenic shops; adjoining is a mill complete to construct houses, churches and street scenes in huge proportions. A cabinet shop manufactures, builds and finishes all furniture used, mostly all of which is of good design and construction; a



GLASS AND ENCLOSED STAGES AND EXTERIOR SET, GOLDWYN STUDIOS, LOS ANGELES

staff shop is engaged in sculpture and modeling and moulds are turning out columns, vases, and human figures. A model shop is developing miniatures of trains, ships and fixtures; these models are photographed where it might be expensive or unattainable to get an original, and are used in picturing objects supposedly at a great distance. Painting and paperhanging is an important work, for most effects of surfaces and shadows are secured by painting. The electrical shops are attending to the power and light for the plant; a great many of the modern pictures are photographed in closed stages under artificial light. A landscape and nursery department furnishes flowers and potted plants and gardens for the numerous sets.

The photographic department is highly technical and perhaps primary in importance, for here lies the success or failure of the film. Each day the nega-

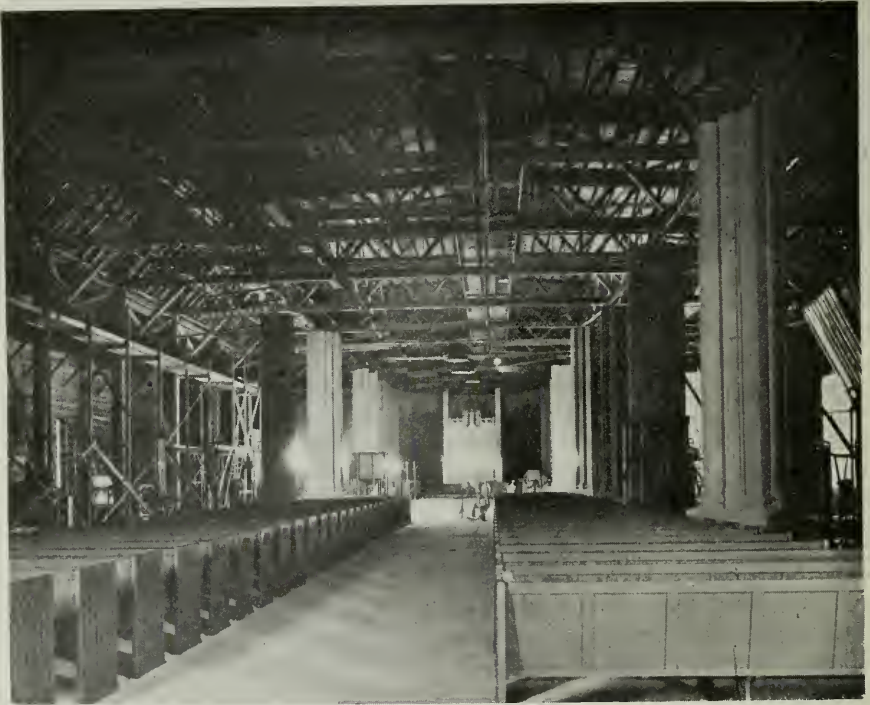

FALSEWORK FOR CATHEDRAL SET IN "EARTHBOUND"

tive of the work done is finished and actors and directors sit and view with regret or satisfaction the results of their endeavors. There are in addition hundreds of dressing rooms, costuming rooms, tailor shops, restaurants and premises catering to the hundreds of people that participate in the making of the film. The stages are mostly of glass, although a later type is entirely enclosed; each is large enough for five or six interior sets and in one case a stage was given over entirely to reproduce the interior of the cathedral here illustrated. About the properties are scattered sets showing street scenes, Venetian canal scenes, houses the world over, all in plaster, wood and canvas painted.

The studios of these picture plants are in themselves small cities, quite human in all of their working parts and toiling by sun or lamp to mimic the lives of the people and their habits.

The Planning of Theatres and Auditoriums

A Frank Criticism of Present Methods of Some Architects who Profess to be Competent Designers

By EDWIN H. FLAGG*

THE recent impetus given theatre and school auditorium and stage construction throughout the United States shows a greater proportionate advance than any other single building program, with a possible exception of the temporary rush of military housing at the outbreak of the world war. And even in this war program there were two or more theatres projected for every encampment.

The resultant "crop" turned out upon the country hundreds of auditoriums and stages that in most instances have proved sorry examples of modern play-house design.

Why this is so need not be as pertinent a part of these suggestions as to advise remedies to correct the evils. What is most glaringly apparent to those who have for many years been careful students of the matter is the apparent failure of designers to treat the simple problems in a manner that would accomplish most satisfactory results. A few suggestions which are herein set forth may be summed up briefly as follows:

Auditoriums must be arranged to allow every patron to see and hear the presentation of the show (pictures, dramatic, musical or spectacular) with maximum comfort, satisfaction and safety.

Stages must be adjuncts thereto, constructed and incorporated to permit the "presentation" most satisfactorily, practically and economically.

With a factor of safety at least equal to the most stringent that is provided for any other building.

Regardless of the views of the original builders, subsequent, if not the first users, will, as has been invariably the case, install more or less scenery and theatrical properties on the stage. That this scenery is of the most fragile and combustible nature there is no doubt.

Proper safeguards, assuring against this ever-present element of danger to audience, actors and workers should be adopted.

Means must be provided to adequately allow for both temporary and permanent installation, and quick operation of whatever scenery, paraphernalia and properties are likely to be required.

Every conceivable form and type of arrangement of the various details has been tried out under all existing conditions of practical usage. Those forms that prove meritorious are retained—the unsatisfactory ones eliminated. Certain other forms or details, though very few, are matters of either opinion, special class of building, or presentation desired, necessitating certain requirements; or geographical location where only certain building materials were available, advisable or more economical.

These suggestions are based on the practical and actual working out of all of the existing plans and methods in use both in America and abroad, supplemented by careful study of every source of information, many that are not open to general research; and, on results of experiments carried on at different times and places. But when one comes to

* First of a series of articles on Theatre Design, Seating and Stage Equipment, etc.

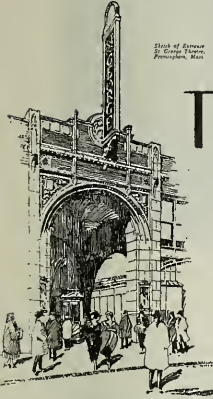

Sketch of interior
of Grand Theatre,
Providence, Mass.

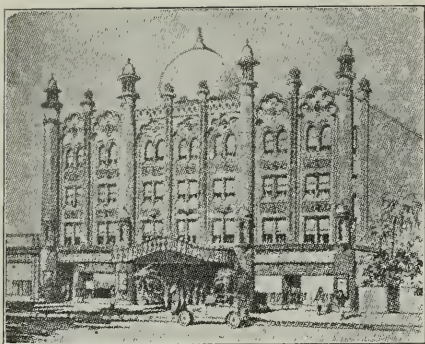

New Hollywood Theatre, Los Angeles
A. B. Rosenthal, Architect
Gore Bros, Sole Lessors



Stage and Orchestra, Rialto Theatre, New York

examine the works in such places as the New York and other municipal Public Libraries, to which everybody can easily obtain access, it is astonishing to note the quantity of substantial materials which have remained undetected.

Vital scientific rules for sight lines and stage construction that lend themselves to every size and shape of auditorium and stage have been perfected and used for a generation or more and they have since lain dormant for years while most architects nowadays struggle blindly and finally work out and adopt something not nearly as good.

The vital subject of perfect acoustics which, until recently, has been held to be either an elusive or accidental property at best, has at last been conquered and is now a matter of knowledge duly arranged and systematized through the genius of the late Prof. Wallace Sabin of Harvard University.

Next we have lessons to be derived from the results of a plan of ideal stage lighting by Prof. Fortuni of Berlin. His suggestions should be followed seriously.

In the matter of simplicity in play presentation we find enthusiastic sponsors in Messrs. Gordon Craig, Sam Hume, Max Littman and the Russian school, where the stage is hung entirely in draperies or blank wings and arches; or unconventional or grotesque flat paintings, and little or no properties, the stage illuminated fantastically—in some cases, carrying the whole idea to a fanatical exaggeration.

And the utilization, in spite of considerable criticism to the contrary, for both the highest and best artistically and commercially of everything attempted in the dramatic field, the results of Mr. Max Reinhardt, Mr. David Belasco and Mr. Oliver Morosco show the student the utmost.

Volumes on most, if not all, of the above are available. While many of these books are by competent authorities, there are other works by inexperienced theorists or well-meaning but mis-informed writers which contain both good and poor information.

Some of the present-day problems which call for new methods of treatment are: Improved illuminants; methods of remote control of both power and light; requirements of different audiences, localities or conditions; divergence of shows and the ascendancy of pictures; the incor-

porating of complete stages in school auditoriums with their individual requirements; community and neighborhood theatres; all call for new methods of treatment.

* * *

One of the most important works on the subject from which evolution and progress may be traced from earliest times down to the present is "An Account of Theatres and Their Appurtenances," by Mr. J. P. Collier, published in London by Mr. Wm. Clewes in 1881. It is the earliest compilation of any records of the kind we have where appurtenances were employed.

The first dramatic stages were those of the Greeks of about the year 600 B. C. These consisted of a saucer-like natural depression on a hill side, with one-third of the saucer broken off and filled out with a platform, elevated to the level of the eyes of those seated in the lowest of the stepped-up benches extending around the sides of the saucer.

The flat central portion of the saucer section was even then called the Orchestra and was used by the maskers or performers when they were not pantomiming or declaiming on the stage.

The stage was divided longitudinally by a wall, through which openings were cut. In front of this wall all of the acting was done. The space back of the wall was called the "skene" and in front of it the "proskenion."

In the Roman theatre of 100 A. D. we see this same arrangement, excepting that one-half, instead of two-thirds of the saucer shape is used for the seating space, or the same arrangement as the "Greek" theatre at Berkeley.

Practically the same names of these divisions of the Greek theatre were used by the Romans—"postscaenium" (back of the scenes) and "pro-scaenium" (in front of the scenes). Our "Orchestra" seats and "Pro-skenium" arch is handed down almost intact.

There was practically nothing corresponding to either the Greek or Roman Theatre, (unless it be the always existent and similar arrangement of theatres found in the interior of China), during the dark ages until the Renaissance.

Among the earliest theatres of record in England were the "Bull," "Curtain," and "Globe," in London.

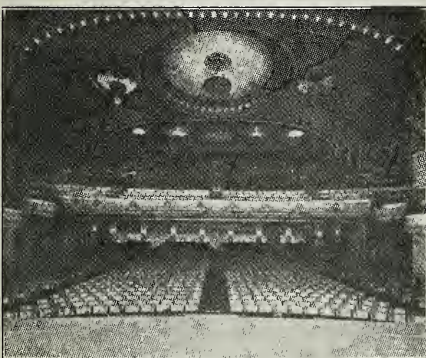

Palace Theatre, Cincinnati
Geo. L. Rapp, Architect

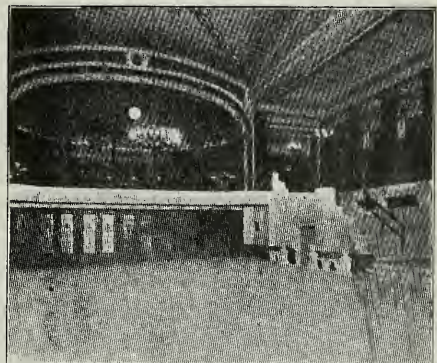

Lobby, Strand Theatre, Brooklyn, New York

These were reported by travelers to represent from the distance, high towers. This impression was caused by the circular roofs over the single large dressing room that was located above the stage.

The audience brought their own stools or stood in an open to the sky enclosure in front of the stage proper. Later, semi-circular stepped elevations were added and these were covered, still leaving the central portion open.

Illumination was had by means of candles across the front of the stage, "which required constant snuffing," and two large candles which were held in brackets let down from above. A similar theatre to this was in vogue in Massachusetts in the sixteenth century.

And the English custom of dispensing from a keg of ale placed in the center of the enclosure was also imported—the custom if not the ale. Painted scenery was used in the early Greek theatres practically from their inception. Backgrounds being hung between the pilasters of the wall dividing the "proskenion" from the "skene." Evidently it was that fact that gave these earliest divisions of the stage their respective names.

From the beginning down to the present there has been a striving to simulate or suggest nature in connection with the rendering of theatrical performances.

It was this that led to the introduction of more modernly painted scenery in England, which innovation was quickly copied in French theatres about the year 1660. Previously, scenes and properties were described by declaimers or lines of the play or pantomimed as in ancient Chinese dramas and as is still done by them to a great extent down to this day.

The Chinese were doubtless the originators of the folding screen idea variously accredited to certain German and English reformers and opposers to the so-called present-day realistic school.

From 1660 until 1750 the theatre improved both as to providing comfort for the audience and adequacy of stage and appurtenances.

Sachs says, "There is little difference between the London stage of 1750 and that of today (1880).

That meant stalls, ground floor divided into many sections, horse shoe shaped balcony and gallery, stage boxes, deep circular aprons and footlights extending out sometimes twelve or fifteen feet in front of the drop curtain and the stage slanting upwards from footlights to back wall.

In America, it was McElfatrick who changed all this and gave us the level stage, straight stage front and footlights, who eliminated stage boxes and gave us the parabolic (saucer-shaped) ground floor, undivided from front to rear.

He also established sight lines—for the front of the parquet, 3 feet 10 inches below the level of the stage. The level of the parquet where it touches the orchestra pit must be not less than 3 feet 6 inches and not more than 4 feet below the level of the stage. Any level less than 3 feet 6 inches will make bad sight lines unless every row of seats can be at least three inches higher than the row in front of it, and anything over four feet will shut off the view of the stage floor from those in the front seats. The balcony risers should be on a line, which extended would intersect the front curtain line six feet below the level of the stage.

While the majority of representative theatres throughout the country have followed this rule and are correct, it is through an investigation of the many theatres that have not followed it that a proper appreciation of

its value is realized. Owing to the fact that the errors are apparent to their discerning patrons and irritating to all others, the names of these theatres are not mentioned as horrible examples, as this would make the present lessees suffer for the mistakes of the architects.

In America, despite the defiant opposition of religious sects, many theatres sprung up in New York and other cities of New England about 1760.

The first play of which there is any record of having been written in America was "Androboros," by Governor Hunter in 1714.

About 1770 Major Andre, besides being an actor of note, painted his own scenery and by strange coincidence, some of this was used later by a theatre manager by the name of Dunlop in his great production of "Andre," as settings depicting the place where Andre himself had been captured as an English spy.

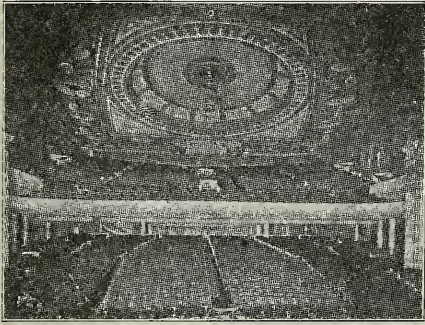

Interior Capital Theatre, New York

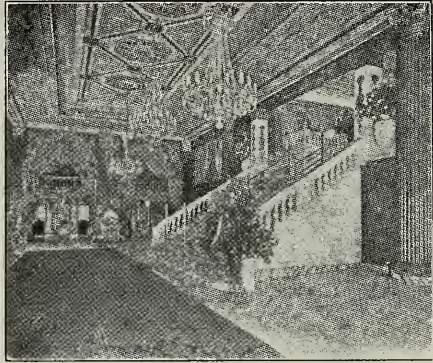

The Famous Grand Staircase
Capital Theatre, New York

Our theatre of this period and until McElfrick's time was copied from England and the Continent.

But the conflagrations that frightened the Europeans to extensively alter the plans of their theatres, and ultimately, not only to protect against fire and panic, but incorporate wonderful innovations for elaborate and exceptionally realistic scenes, and the means to change them quickly, were taken up by the Americans only in part and in isolated cases.

This series of fires of which mention is made elsewhere in this article culminated in the Ring Theatre fire in Vienna in 1881 in which 450 lives were lost.

Although there were many notable fires subsequently, it was this Ring Theatre fire which spurred the ingenuity of the foremost theatre engineers, mechanics and promoters to perfect a theatre which would unite safety, comfort and adequacy.

The most successful of these were the results of the ultimately incorporated Asphalia syndicate type of theatre of which the Auditorium in Chicago is the nearest example we have in this country.

The Asphalia was the first showing of a level stage in Europe.

The model was built first for exhibition purposes and shown in Berlin in 1889 and in Vienna in 1892.

The Court Theatre in Vienna used this idea practically throughout. The stage was a series of sections operated by hydraulic rams.

Settings could be made in a large space under the stage, rolled onto these "elevators" and raised to the stage level, where they could either stay where they were during a scene or be rolled to another position.

The customary loft or flies was present in this model from which all leg and solid drops or "Cloths" as they are called in England, were hung to be lowered as required to fit the scenes of the piece.

Revolving stages were in vogue in Europe then, the same as the one in the Ye Liberty Theatre in Oakland, California, in which the flies are stationary but the main central portion of the stage turns, allowing several settings to be made at one time and almost instantly revolved into full view of the audience.

This was designed and built by Mr. Harry Bishop, who later designed and built in the Bishop Playhouse, a revolving stage over which the entire gridiron and flies revolved.

The Denham, in Denver, Colorado, is an example of an old European idea where several sections of the stage, on large platforms, can be previously "set" and rolled on and off the entire space usually occupied by a stage setting, requiring only a few moments to make a complete change of scene and having many advantages and few drawbacks.

The management of the theatre in Wiesbaden, the Court, had their orchestra arranged to be raised and lowered as desired on a hydraulic lift similar to that used in Tally's Broadway Theatre in Los Angeles, and of late incorporated in many recently built theatres.

But in spite of these few adaptations of European stages, and these only in part, the great majority of American theatres have been merely copies—shells, garishly ornate and unnecessarily inadequate.

Robt. Grau in his "The Stage of the 20th Century," says: "Europe has learned long ago that theatre and stage engineering is a profession acquired not from books but from practice."

America does not understand it that way and intrusts its theatre designs to architects, who build theoretically, not practically. By the latter I mean they do not keep up to date as to requirements or opportunities, as they are not engaged in the productions of plays.

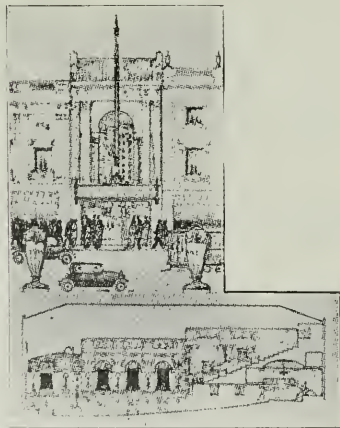

Allen Theatre, Montreal
Facade and Perfect Floor Lines,
by C. Howard Crane of Detroit

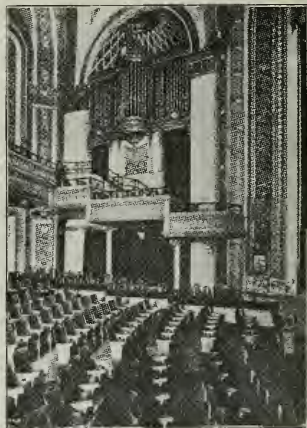

Boxes and Organ Arrangement
State Lake Theatre

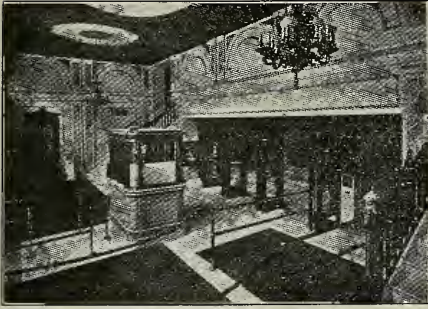

Lobby and Box Office, State Lake Theatre,
Chicago

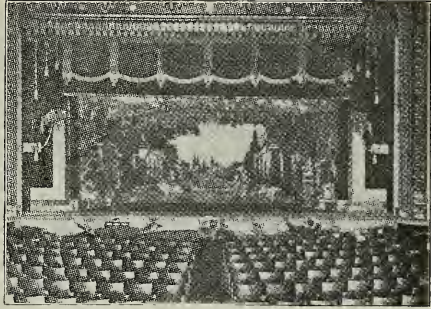

Stage, State Lake Theatre, Chicago
C. W. & Geo. L. Rapp and G. Albert Lansburgh,
Associate Architects

The actors themselves, from the beginning, have always made the most successful playwrights. Why should not the producers, where they have made a serious and conscientious study of this special subject, be the most successful theatre builders?

An European authority, Mr. Edwin O. Sachs, leading English architect, says: "Any architect approaching the subject (theatre planning) must realize this work demands more careful blending of architecture, painting and sculpture, with, at the same time, the satisfaction of 'INNUMERABLE PRACTICAL REQUIREMENTS HOSTILE TO HIS BEST EFFORTS AT PERFECTION OF DESIGN.'" The capitals are mine.

It is this, what the architect thinks is against his making the most attractive design, that sways him many times unconsciously to design what he thinks is more beautiful instead of what is most practical.

It is like an automobile builder saying he could design a more attractive car if he could put the radiator in the rear or the steering wheel in the steerage, but when he really has the subject under control he finds that obstreperous points blend into one another, or of necessity must be a certain way and he works out a system adapted to fit them.

There are many examples of this blending of technical requirements into a perfect harmony in late theatres, notably Keith's Theatre in Syracuse, New York; The Strand in New York City, and in an entirely different style, in Grauman's, Los Angeles, or even in a less degree in the Rialto and Capital Theatres in New York City.

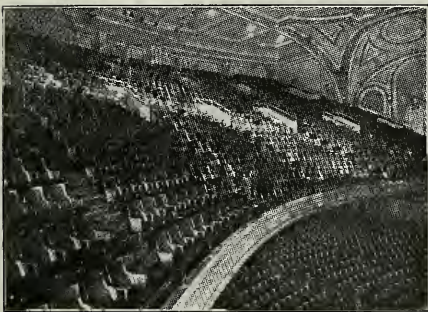

Balcony, State Lake Theatre, Chicago
C. W. & Geo. L. Rapp and G. Albert Lansburgh,
Associate Architects

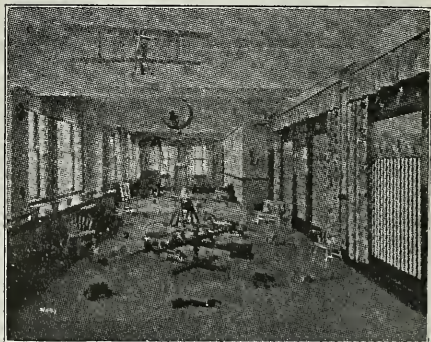

Children's Playroom and Nursery
State Lake Theatre, Chicago

The architect must be complete master of the entire subject to satisfactorily swing the whole interior into a peaceful, flowing, harmonious composition without sacrificing a single detail considered necessary to the most practical operation of the theatre itself.

While this degree of perfection has been attained in certain theatres throughout the country, over more or less areas in the buildings, it is very seldom that this is true of the entire plant.

The Strand Theatre in New York City is a most perfect example of harmonious blending of curves, uniting or rather making, the ornamentation fit the requirements of space available. But this applies wholly to the "front of the house"—the auditorium, promenade, lobby, etc.—and not the space back of the proscenium, and to the whole to meet all the requirements of a motion picture theatre exclusively. This house is located on what is probably the most valuable footage in the world—the corner of Seventh avenue and 42d street, at the foot of Longacre Square, and a stone's throw from Broadway. Necessarily every inch of space has to count. And still what appears to be a commodious foyer and promenade is provided for in a big transverse elliptical gallery, with rotunda above supported by columns and reached by elaborate stairways; all of this is in what would ordinarily be waste space.

The auditorium is laid out similarly only that the ellipse is lengthways of the room, and pairs of columns, equidistant along the side walls, on nearing the stage end, where the oval curve would naturally begin, complete the effect by utilizing the space at the apex of the oval between the two pairs of columns with the entablature for the proscenium arch. Back of this proscenium frame is situated the picture screen. The single right and left spaces remaining between the pairs of columns where the oval starts at the side walls, and between that and the columns forming the proscenium, are used for atmospheric or decorative pictures as desired. The orchestra is in practically the same position it occupied in the old Greek and Roman Theatres, a half-circle in front of the stage. It is in the perfect co-ordination seemingly of every line in the interior that gives such a feeling of utter satisfaction with the arrangement and ornamentation.

The California theatres in both San Francisco and Los Angeles, the Newman Theatre in Kansas City and many others too numerous to mention, where the effect of the whole is a smooth, harmonious blending of curves, making a unity of both practicability and beauty in design, applies only to the auditorium side of the proscenium.

An authority says, "But—and this must never be forgotten—the architectural rendering of the auditorium, and above all the ceiling, must harmonize with the proscenium."

In planning a theatre, other matters besides space must be considered; for example, the question of upholstering, furnishing, particular type of performance and purpose to which the theatre is to be put—the character of the audiences—whether they are noisy or quiet. But we do not need to go to the extreme in certain details in this country that has been found advisable in some other parts of the world, as for instance, the requirements mentioned in the following letter received a short time ago by "Variety," the New York theatrical weekly:

Mr. Edward B. Kinsila, a New York architect, here on a second visit and en route to China, is quoted as saying that "Japan in its construction of picture theatres is considerably behind the rest of the world. Although the attendance at its poorly constructed theatres is large and the prices demanded for admission to the best seats are high, yet

people pay them. So far there has been no appeal made for the patronage of the better element." This Mr. Kinsila attributes to the fault of the management in failing to provide the essential comforts necessary to attract such patronage.

To build an enormous theatre in Japan that would seat over 5,000 people, as does the Capitol, recently built in New York, is out of the question, because the theatres of a country should be expressive of that country.

In Japan the manner of showing motion pictures is different from that of the Western world. There the audience gathers its knowledge of the play from the declamation of the tale by the professional reader engaged for the task. Managers and public alike in Japan are at the mercy of the reader for the proper appreciation of the play. This fact alone limits the capacity of an auditorium to one within the sound of his voice. Acoustics teach that the human voice is capable of projecting distinguishable words without expansion only about 75 feet.

Theatres also must give more comforts to patrons. When they enter, Japanese remove their shoes. The base of the stairways should be cleared of footwear and the same placed in a recess at one side. The presence of awaiting footgear might cause the people in time of excitement to stumble and fall and thereby create a serious obstacle for those following.

New builders entering the field with their first or even subsequent theatres, hardly ever realize all of the objections to be overcome or the many advantages that theatres in other parts of the countries have incorporated as well as an expert, who has made all of these innovations a constant study. Or know nearly as much as a producer who has worked with the stage mechanics of a generation or two ago when melodrama was in its prime, or even earlier, when massive, simulating effects had to be produced mechanically with only the crude materials then at hand. Nowadays, with automobiles, aeroplanes, motion pictures and their almost unlimited scope for showing on the screen, the utmost in melodramatic realism, there has not been the necessity for these effects; in fact, for the past few years there has been a constant striving towards imaginative theatre settings, the actors using as a background blank walls or draperies. It is in this renaissance of dramatic and spectacular productions that stages are called upon to supply atmospheric prologues to pictures or allegorically depict in even a more spectacular manner, than ever before, stage productions that will most profitably continue to stimulate interest in these constantly increasing big capacity theatres.

A similar decadence to what has existed in the past ten years before the last great strides in spectacular productions occurred, prior to 1870, when, as one writer put it in a book published in 1878, stating that stage reform was necessary, "That in the seventeenth and eighteenth centuries, the queer, the grotesque and the non-natural were the ideals of the decorative artists, and the transformations were spectral forms, flying dragons, fairies, will-o'-the-wisps and the like, were their best stock in trade."

It is in this going round a circle, that has given us, for the past few years, these queer stage settings, for which there has been no reason, excepting the apparent distortant imaginings of some so-called artistic geniuses and their imitators; now the pendulum is swinging back to the natural and rational expression in stage decoration as in everything else.

It was due to this somewhat similar enlightened realization among producers about fifty years ago that a demand was felt for mechanism and paraphernalia for more closely and correctly simulating nature that led to the invention and installation of many really wonderful innovations that have not been surpassed as far as mechanical ingenuity goes and only improved upon through the adaptation of electrical appliances.

It is a fact, however, in connection with these improvements and appurtenances, we have of late really deteriorated, not gone back because

it was considered advantageous artistically, but solely because the expense involved was considered unnecessary.

The growing popularity and promised profits of the theatre set up strong competition on account of so many entering the field.

And as a theatre building encompassing all these accessories cost considerably more and took up more space than the ordinary playhouse, the builders have omitted them.

It is further a fact that the houses that did incorporate more or less of these advantages were not until recently among the financial successes. As for example the Century Theatre, New York, the New York Hippodrome, the Chicago Auditorium or the Oakland, California, Liberty Theatre. The old Grand Opera House in San Francisco, operated by Mr. Walter Morosco, father of Mr. Oliver Morosco, had quite an adequately equipped stage and was very successful a generation ago.

But it seems that nowhere now are any such stages even faintly comprehended by theatre builders. This conclusion is arrived at, not by looking only at the results, but by talks with both the representative and lesser architects and builders throughout the country.

Of necessity they, the architects, are a great many times deterred from doing even what they would like to do in the way of introducing admirable details, by owners or managers, who, knowing only the immediate causes and results, "of the business," demand theatres planned accordingly.

The architects themselves are to be blamed to a great extent for this situation on account of the feeling of "giving the man who pays for it what he wants," instead of trying to put him right at the possible expense of losing him to some less conscientious practitioner.

Many times the architect, on becoming disheartened, proceeds with the plans strictly under the owner's orders, copying this bit from one theatre, and that from another, usually incorporating all the existing errors and sometimes originating others, which in turn were subsequently copied by some other imitators.

When an expert is called into consultation with an architect and to illustrate a point, the expert explains the fallacy of some certain constantly recurring error, the architect will confidently state that he would, under no circumstances, ever make that mistake; still, he will insist on doing something else equally absurd, saying he does not see the necessity of doing it differently; in spite of his admitted unfamiliarity with the subject.

There is unquestionably a greater amount of money squandered in perpetrating impossible auditoriums and stages, than in any other building program. A little investigation as intelligently directed as in other types of buildings, would unmistakably save owners much annoyance and expense and would result in a much better standard of theatre construction.

* * *

"Shine, Mister?"

Speaking of things in general, there is a little story in one sentence going the rounds that will bear analysis as a shrewd comment on the present state of the nation:

The office boy sought out "the chief," who was in a back room shining his own shoes—and interrupted that operation to borrow a dime to buy a shoe-shine for himself.—Concrete.

Competition for \$3,000,000 Clubhouse

LEADING architects of the country will be asked to submit competitive drawings of the \$3,000,000 clubhouse the Army and Navy Club of America is to build in New York in memory of the 3,500 officers who died in the war. The memorial will be a national one, dedicated to the commissioned men in all branches of the service who made the supreme sacrifice.

Messrs. Charles Dana Gibson, Edwin Howland Blashfield, Henry Bacon and Benjamin Morris, with Admiral Bradley A. Fiske, president of the club, form the committee appointed to select the design for the building.

Notable contributions have been made to American art and architecture by members of the committee on design. Mr. Edwin Howland Blashfield decorated the great central dome of the Library of Congress. His war posters attracted international attention. His most recent important work was the design for the government's certificate of honor issued for every man who died or was wounded in service during the war.

The impressive Lincoln Memorial at Washington was designed by Mr. Henry Bacon. He formerly was a member of the firm of McKim, Mead & White. He is a member of the National Institute of Arts and Letters, and the National Academy of Design.

Mr. Benjamin Morris was the architect for the Junius Spencer Morgan Memorial at Hartford, the Westchester County Court House at White Plains, and is the designer of the new Cunard building at 25 Broadway, New York. He is president of the Society of Beaux Arts Architects.

Mr. Charles Dana Gibson is known throughout the world as an illustrator. He has a wide personal acquaintance among artists and architects. "Life" was recently purchased by Mr. Gibson and he is now its publisher.

The new clubhouse will be centrally located and will serve not only as a monument to the men who died, but also as a home for living officers, active or retired, in the army, navy or state militia. Civilians interested in nation's defence are also eligible for associate membership.

The committee on design will decide the rules governing the competitive drawings the club will request of all the leading architects. Only tentative plans have been decided on, but interesting features of the new building are included in these.

The memorial feature will probably take the form of a central court or hall with bronze paneled walls where the names of those who made the supreme sacrifice will be engraved.

The present clubhouse at 18 Gramercy Park has long been unsuited for entertaining the hundreds of officers who annually come to New York. During the war members found it very inadequate. Naval officers of this and the other allied countries were entertained at the New York Yacht Club, but Army officers in New York during those trying days found hotels overcrowded and themselves without a home to which they could go for suitable accommodations.

In the new clubhouse there will be at least 400 bedrooms. A large dormitory furnished with cots will also be provided for use on special occasions when the city is crowded with service men.

There also will be a large assembly hall and small rooms for meetings of patriotic societies. Women friends of members, or women relatives of the deceased men will find a dining room and reception room for their exclusive use. Other features to be found in a modern clubhouse will be included in the plans.

Does Architecture Need a Salesman?*

By EMORY STANFORD HALL

DOES Architecture need a salesman? Yes, architecture needs a salesman, and it is the duty of architects to provide one. Will architects shirk a plain duty to their fellowman? Mr. Sidney Webb, in an address before the Royal Institute of British Architects, among other things, said, "I hope I am not saying anything too hard, but practically the brain-working professions began as the body servants of the rich, and they have not yet sufficiently realized that it is their duty to have developed out of that to become the servants of the community; they have not yet managed to make their service available for the whole of the community which needs their service." Mr. Webb's clear, succinct statement referring to the beginning and early practice of the professions is a most apt statement of the case as it applies to the early history of the practice of architecture; but it is likewise true, to a large extent, with reference to present-day practice. Architects have been slow, in common with members of other professions, to come to a full understanding of their duty to the community. This sloth, in the fullest appreciation of community obligation, while operating against the best interests of the community, has also tended to bring this and the other professions into disrepute. No single class of society can long disregard its plain duty to the community without suffering a lack of that public confidence which is so essential to the highest degree of efficiency in service.

Architects had the confidence and patronage of a considerable clientele which gave them a certain degree of material prosperity; a prosperity which befuddled their reasoning capacity to such an extent as to allow them to come to believe that they were secure in their aloofness from the common need. A false security which they are now beginning to realize through seeing much patronage towards which they had assumed proprietary rights going to others. How have architects acquired these notions, and what has brought about the change, can best be studied by an analysis of the development of Western civilization during the last century.

America has been passing through a more or less chaotic state. Society has not been well balanced, leveling influences have not been fully developed. There has been a lack of perspective. These conditions have been fruitful ground for the development of dominant individualism. Enormous individual fortunes have been able to grow in a night. Many have suddenly found themselves possessed of great wealth without the culture essential to its wise use. This lack of culture, on the part of the principal patrons of the professions has operated against wise choice in the selection of professional assistance. It is not strange that a class which has acquired large wealth without a long, meritorious struggle would be inclined to judge their professional advisers by the same standards that had obtained in their own advance. Men without balancing culture, who had won wealth by sharp tricks or by chance, found no difficulty in convincing themselves that they were made of some superior sort of clay. It was so easy, why any one with brains could be rich, see what I have done; and the converse, any one that is not rich, or does not operate on a large scale, must be lacking in mental capacity.

In face of these conditions the so-called professional man said, "What is the use?" "Bluff" is the word. In the presence of such ignorance, how could the architect be expected to obtain recognition of real merit in service.

* From The Architectural Record.

It was sure to be the architect who could show the largest and highest buildings; the biggest office force; and the richest clients who would be preferred with such a clientele. Technically meritorious performances and equipment did not enter into consideration. The rich man wanted an architect as smart as himself, and to determine this, looked to his, the architect's, seeming material prosperity, not to his technical worth.

Now, of course, competent architects know that it requires less dexterity in practice to plan skillfully and supervise the erection of a stereotype skyscraper office building than it does to work out correctly the complicated and much involved details of many a building of very inferior magnitude; but neither the rich client nor the public understand this, and for that reason, while willing to pay largely for small service on a big project, were unwilling to pay even a living fee for large and very valuable service on small projects.

This attitude on the part of the employing public has tended to divorce the architect from much service where the exercise of his best skill would be of inestimable public value. The factory and the housing problem demand the finest skill of the most diligent and perfectly trained architects; but since the simplest work pays the largest profit, and complex work of small magnitude pays little or no profit, the latter class of work is not sought by the salesman architect, and cannot be assumed by the professional architect, without serious peril to his economic existence.

It may be observed that in the profession of medicine, the physician is able to make his rich patients pay the bills of the poor, and he is able to live on the average. In architectural practice the salesman architect secures all of the highly profitable business, and leaves the professional architect the complex and difficult middle magnitude work where there can be only a mere living fee with no surplus for the service of the poor. Therefore, the poor get no service, for the salesman architect neither has the disposition nor the ability to render such service, and the professional architect, despite willingness, because of economic limitations, is unable to render gratuitous service. Now the principles of economics make it perfectly clear that no service, no matter how desirable, can be rendered to the public without the public paying a living remuneration to those rendering that service, and since no remuneration for any sort of service can be secured from a democratically governed public, except that public is first convinced of the necessity and value of that service, and since it requires the medium of salesmanship to convince the public, then would it not seem that it is a public duty on the part of the architects to employ a salesman in order that the poor as well as the rich, may have the gospel of the value of architectural service preached into them.

Looking at this question from another angle: within the last few years material changes have come about in society structure. Socialistic propaganda is beginning to have its effect; the world war, through which we have just passed, was but an echo of these teachings. We say we have fought to make the world safe for democracy. "Down with the Kaiser," does not mean the elimination of the Prussian royal household or even of the Prussian military system—it means, to a considerable extent, the death of dominant individualism and the pre-eminence of class or vocational socialism, not general socialism.

The people are done with kings either of property or nations, and have found that by organizing themselves, so as to have control of an essential commodity, they can force wealth to its knees. Projects of magnitude will no longer depend for execution upon the will of the rich; but the small man,

by joining himself with others, will be able to dictate the success or failure of almost any project.

From a strictly selfish standpoint, therefore, it behooves the architect to curry favor with collective small folk. Now these small folk are too numerous to be cultivated in the same fashion as was so effective with the rich man. Trained in the school of adversity, these folk have learned to judge men on intrinsic worth. They want to know the possibilities of performance. They are being influenced less and less, as the years go by, by the flummery of social prestige and the glamour of tawdry display. What they want to know is what service they can secure that will be of greatest benefit to them.

In place of selecting their professional adviser through personal acquaintanceship, or even directly at all, they will have recourse to the use of some system of collective bargaining. An expert corporate purchasing agent or a collective buyer will be the medium of contract for service, and service will be rated on that person's idea of its economic value. Under these conditions only those who employ the services of the skilled salesman can hope to present adequately the value of professional service.

Since no architect, who can show the highest degree of technical skill in his profession, can possibly be possessed of either time or sufficient skill as a salesman to present adequately his case to the expert purchasing agent representative of a class of collective bargainers, it becomes plainly evident that the architect must, eventually, make use of the expert salesman if they would preserve their identity as a class. For in case they do not make use of such salesman service to convincingly present their claims for consideration they must expect the function which they now perform to fall into the hands of other classes less fitted for that service, but classes which are now making the largest use of expert salesmanship, particularly the great contracting and engineering corporations, which are nothing more nor less than aggregations of brain workers who make use of highly perfected and unusually skilled sales organizations.

With longer training and superior attainment, architects need not fear the competition of the so-called engineering and contracting corporation, provided they are willing to lay aside the dignity and prejudice which has grown out of the necessity of generations of individual patronage on the part of the rich and the powerful, and make use of modern sales methods. There should be no confusion in understanding. In no sense is it advocated that the architect himself should become a salesman. Either he would be a very poor salesman or a very poor architect; and since merit in commodity is essential to the exercise of the best skill in salesmanship, the architect must devote his entire energy to perfecting his technical skill in order that the salesman may have a good case to present.

Professional codes proscribe advertising in any form as unethical and prejudicial to the best interests of a profession; yet advertising is the handmaiden of the salesman, for commercial experience clearly demonstrates that honest educational advertising is an essential factor in salesmanship. Is it time, then, to do away with established codes, wipe the slate clean, and start over again? Is it expedient for the individual architect to employ advertising in laudation of his individual attainment? It hardly seems so—there were well founded reasons which led originally to the promulgation of the code. These reasons have not been eliminated.

All professional service is personal service, and laudatory reference to it by the producer is equivalent to personal boasting, often rated as exaggerated egoism, and a practice which is always objectionable. Since it is

difficult; if not impossible, to escape this objectionable feature in the presentation of the merits of the service of a single individual, it would appear that the only way open to the accomplishment of desired results is for the profession to present its merits to the public by the employment, through its professional societies and associations, of salesmen or organizations who will present the merits of architecture and the necessity of making use of the assistance of expert practitioners.

This method of procedure will, no doubt, necessitate radical changes in architectural practice. Practice will need to be brought up to a uniformly high standard, for if individual merit is to be advocated collectively, then all of the individuals forming the collection must at least have attained minimum standards of qualification for service. The problem of adjusting to new conditions is necessarily complex. It cannot be undertaken hastily; it needs serious thought and constructive criticism.

Conceding that good architecture is essential to the welfare of all, then the public must be made to know what is for their own good and by continuous reminding not allowed to forget. Recent events serve only to prove that it is not sufficient for the public to know its needs, but it must always have those needs forced to its observing attention. Witness the report of the Hughes' Committee on Soldiers' Benefit Insurance, a large percentage of the policies lapsing, not because of lack of funds to pay premiums, nor because of a lack of knowledge as to the value of insurance, but because the men were not continuously followed up and impressed with their duty, as in the case of private insurance where salesmen are paid premiums for keeping policies in force.

These observations force the conclusion that all architects should become members of local and state societies, and either directly or through affiliation with local societies, members and supporters of the American Institute of Architects, and this society should be provided with funds and institute a nation-wide educational campaign for the purpose of acquainting every one with the essential value of architectural service.

* * *

Encouraging Invention

THE Patent Office at Washington was instituted, presumably, to encourage invention as well as to protect inventors. According to Mr. Aaron Hardy Hulm, in the Nation's Business, it really does little of either. Mr. Hulm points out that "the patent office is about the only Government bureau with which one is compelled to deal through an expert representative." For every employee of the Patent Office there are about five patent attorneys whose work relates directly or indirectly to the work of the office.

It is practically impossible for an inventor to deal directly with the Government, comments the Valve World. He has to secure the services of an attorney. And after he receives his patent, he often has to fight in the courts at his own cost to protect it. The system is antiquated, expensive, inefficient and inadequate.

It would seem that the nation most prolific in inventions would offer full encouragement to inventors, make it easy for them to have their inventions officially approved and, if patentable, provide ready means of protecting the patent. Mr. Hulm offers suggestions for betterment, that are worthy of consideration. We cannot imagine any suggestion that would make conditions much worse than they are or of smaller credit to our national ingenuity and progressiveness.

Estimating the Selling Price of a Suburban Residence

A NEW YORK architect was recently called upon to render a somewhat unusual service for a client for whom he had designed a large suburban residence which was constructed in 1913. The client stated that for the needs of his present family the house was too large and felt that now was an advisable time to sell and build a smaller house for himself. He was somewhat at a loss, however, to determine what selling price to put on the house, as he did not wish to put it in the hands of a real estate agent until he had set a definite sales price.

In considering the sale of the average building, whether an investment building or a small home, market conditions largely govern sales value; but in the case of a suburban residence the sale price is largely governed by a personal element represented by the buyer's opinion, and in today's market it is apparent that as a rule two large suburban houses containing approximately the same cubic footage and with apparently equal land value will vary over 20 per cent in selling price. This is undoubtedly due to individual demand and to general conditions of the community. It is evident, therefore, that the owner's decision rather than market value must largely govern the price.

The method used by the architect in determining a fair selling price for this house is interesting and may prove of value to others who must face the same problem from time to time, or who through sound business judgment may encourage the sale of houses built some years ago for clients. In this case the selling price was estimated as follows:

To the cost of the land was added the cost of improvements. The complete cost of the house and outbuildings was then computed from the architect's files, and to this total was added one-half of the increase in replacement value of the house. It was felt that this addition represented a saving to the buyer in proportion to the cost of building a new house, and also provided for any depreciation in the building. To the total thus gained a reducible margin of 10 per cent was added, as in the average case of the sale of a house of this type the quoted selling price is not fixed, but is open to offer on the part of the buyer. The tabulation of this individual cost estimate is as follows:

Cost of land (thirty acres)	\$12,000
Improvements, including roads, landscape, planting, etc.....	14,000
Cost of house and outbuildings	90,000
One-half increase in replacement value (estimating 100 per cent increase in building cost)	45,000
	<hr/>
	\$161,000
10 per cent reducible margin.....	16,100
	<hr/>
Selling price of house	\$177,100

The determination on a definite selling price places the broker in a much better position to make a sale than a general commission to get an offer, which is quite an ordinary proceeding on the part of an owner of this class of property. The estate in question was not mortgaged, and the owner stated his willingness to leave a mortgage of \$100,000 at 5 per cent if this proved an inducement to the purchaser. In this manner there was presented a clean-cut selling proposition fair to all parties to the transaction.—Exchange.

Expansion Joints in Large Concrete Buildings

SOME interesting information on the above subject is given by Mr. G. W. Maker of the Aberthaw Construction Company in the September Successful Methods, from which we quote as follows:

Some engineers advise that expansion joints should be provided every 100 feet to take care of the contraction and expansion of structures built of concrete. However, there can be found in nearly every city of magnitude concrete structures 300 feet long constructed without expansion joints which have successfully withstood the changes due to variations in temperature and humidity. These structures indicate that if proper attention is paid to the method of reinforcement the difficulty can be overcome within wider limits than 100 feet.

Examples can be found of structures 400 feet long that have shown no severe cracks after having passed through the intense heat of two summers and the severe cold of winter.

In general, however, for buildings over three stories high and over 300 feet long, expansion joints should be provided. These joints should completely separate the buildings one from the other so that the different units will be free to move independently and of their own accord. This should preferably be done by means of double columns and double beams. The columns may rest upon the same footing as the movement would be practically negligible below the ground.

The adjacent column and beam should be cast after the forms for the first have been removed. In order to prevent the weather from coming through the space between the outside wall columns and the roof beams, metal diaphragm should be provided of either sheet lead or copper. This should be bent in the form of a "V" so as to allow it to expand as the two different units of the building move. The joints at the floor level should be protected by angle guards which prohibit the edge of the concrete from being broken. Sliding plates should be provided to prevent the dirt from sifting through to the floor below.

Another method of accomplishing this same result in providing a successful weather stop for the columns is to cast two grooves in the first section approximately 3 inches by 3 inches and coating with paint or pitch. In building the next section a tongue is formed by the concrete entering the grooves previously left.

* * *

Glass Bath in New "Luxury" House

IN house fixtures in London a novelty is the glass bath. It has been introduced by Mr. Paul Poiret, the dress designer, who is going in also for household decoration in order that his gowns might have worthy settings. Despite many other attempts at the aesthetic bathtub, none have come up to Poiret's for beauty as well as utility.

Many folks seeking domestic luxury in their ablutions, have pounced on the idea of a marble bathtub, only to return a verdict that it was "cold and uncomfortable." Some plutocrats have even gone so far as to use a gold or silver bath, but these have been pronounced bad form, and certainly they haven't been approved very extensively by the "best people."

Poiret would seem to have solved a problem which has baffled many, for his bath is of translucent green, and the walls of its shrine decorated with fishes. A shell acts as light diffuser and there is a sea-foam frieze.

This glass bath is to be the finishing touch to what is already described as the "most colorful house in London."

Wage Scale — San Francisco, August 1, 1920

	Journey- men	Helpers	Over- time	Days per week
Asbestos workers	\$ 8.50		1½	Holidays double time
Bricklayers	10.00	\$7.50	2	
Carpenters	9.00	8.00	2	
Cement finishers	9.00	8.00	2	
Concrete workers	7.50		2	
Electrical workers No. 6.....	9.00		2	Foremen \$9.50
Electrical fix. hangers.....	8.00		2	
Elevator constrs.....	8.50	6.00	2	6-day week
Engineers, stationary	8.00		1½	6-day week
Engineers, hoist. & port.....	9.00		1½	
Glass workers	8.50		2	
Housemovers and derrickmen..	8.00		2	
Housesmiths, arch. iron.....	7.00	4.75	2	
Housesmiths, erect. steel S. & D..	7.00		2	
Housesmiths, reinf. con.....	8.50		2	Ala. Co. rate \$1.00 higher
Iron wkrs., bridge & struct.....	9.00		2	
Laborers (common)	6.50		2	6-day week
Lathers	9.00		2	
Marble set. & Carv. No. 375....	8.00	6.00	2	
Cutters No. 25.....	7.50		2	
Bed rubbers No. 9.....	7.00		2	6-day week
Pol. & fin. No. 9.....	6.50		2	6-day week
Millmen, P. M. dept.....	7.50		2	
Millmen, S. & D. dept.....	6.50		2	
Millwrights	9.00		2	
Model makers	9.00		1½	Sun. & Hol. double time
Casters	8.00		1½	Sun. & Hol. double time
Modelers & sculptors	8.50		2	
Mosaic and terrazo wkrs.....	8.50	6.50	2	
Painters	8.50		2	
Var. & pol. (shop).....	7.50		2	
Var. & pol. (out.).....	8.50		2	
Pile drvs. & whrf. bldrs.....	9.00		2	
Plasterers	10.00	8.50	2	5-day week
Plumbers	10.00		2	
Roofers	9.00		2	Foremen add \$1.00
Sign painters	10.00	8.00	2	
Sprinkler fitters	10.00		2	
Steam fitters	10.00	4.50	2	
Metal sheet workers.....	10.00		2	
Stair builders	9.00		2	
Steam shovel eng., per mo.....	240.00			6-day week
Steam shovel cranemen, per mo..	200.00			6-day week
Steam shovel firemen, per mo....	165.00			6-day week
Stone cutters, soft, No. 25.....	8.00		1½	Holidays double time
Stone cutters, granite	8.00			
Stone setters, soft	9.00			
Stone setters, granite	8.50			
Stone handlers & hse. mvrs.....	8.00			
Tile setters	9.00	6.00	2	
Wood carvers	8.00		2	

The Specification Writer and the Manufacturers' Literature

By LOUIS R. HOLSKE in Pencil Points

PART II.

TO provide a basis for the systematic discussion of the question, "In what form would the specification writers in architects' offices prefer to have on file data from manufacturers regarding materials and equipment?" an attempt will be made in succeeding issues to indicate the information specification writers need regarding each class of building material and equipment.

In your last issue, the general requirements that apply to all catalogue information for the use of the specification writer, were outlined. Such matters as the form of the catalogues or other literature most suitable for filing, the character of the data, etc., were gone into.

Now, the various classes of building materials and equipment will be taken up one after another in succeeding issues. So far as possible, this will be done in the order in which the materials appear in the building during the process of construction, the classification being made on this basis to embrace all types of buildings.

The object in view is to make as clear a statement as possible of what the architect and the specification writer need, what information the manufacturer can give that will be of assistance. It is quite possible that in doing this we may overlook some articles or classes of materials which should be mentioned and it is hoped that much valuable matter will be added to that which will be brought out in these pages in relation to the data needed on each class of materials. In fact, it is the writer's main purpose to bring out the thoughts and the experiences of others, to bring the architects, specification writers and manufacturers together in a discussion of this question as it relates to each class of materials or equipment in order that a fund of information and ideas may be contributed, from which helpful conclusions may be drawn.

In the first group to be discussed will be masonry work and foundations, brick work, water-proofing and fire-proofing, structural steel and miscellaneous metal work and building stones.

The next group considered will take in hollow steel, including trim, furniture, medicine closets, etc., hollow metal windows and the hardware suitable for use with hollow metal work. Associated with the latter group will be the metal covered work. Roofing, including all materials in general use, will next be taken up for discussion. Inside work, marbles, tiling, mill work, rough and finished, carpentry and painting will be included in another great class. Heating and plumbing will be taken up in a separate class.

While the writer will endeavor to cover these various classes with as much thoroughness as possible, he will depend upon the responses from others to supply the most helpful matter needed to make the discussion of the question of real value.

Some manufacturers have already done much toward putting the data relating to their products into convenient form for the use of the specification writer and have made a serious effort to supply the kind of data needed. The results of these efforts afford suggestions which should not be overlooked in any discussion having for its purpose the improvement of the manufacturers' literature in general from the standpoint of the specification writer. With these exceptions the need for improvement is great. If the needs of the specification writer can be made clear the manufacturer will benefit as well as everyone else.

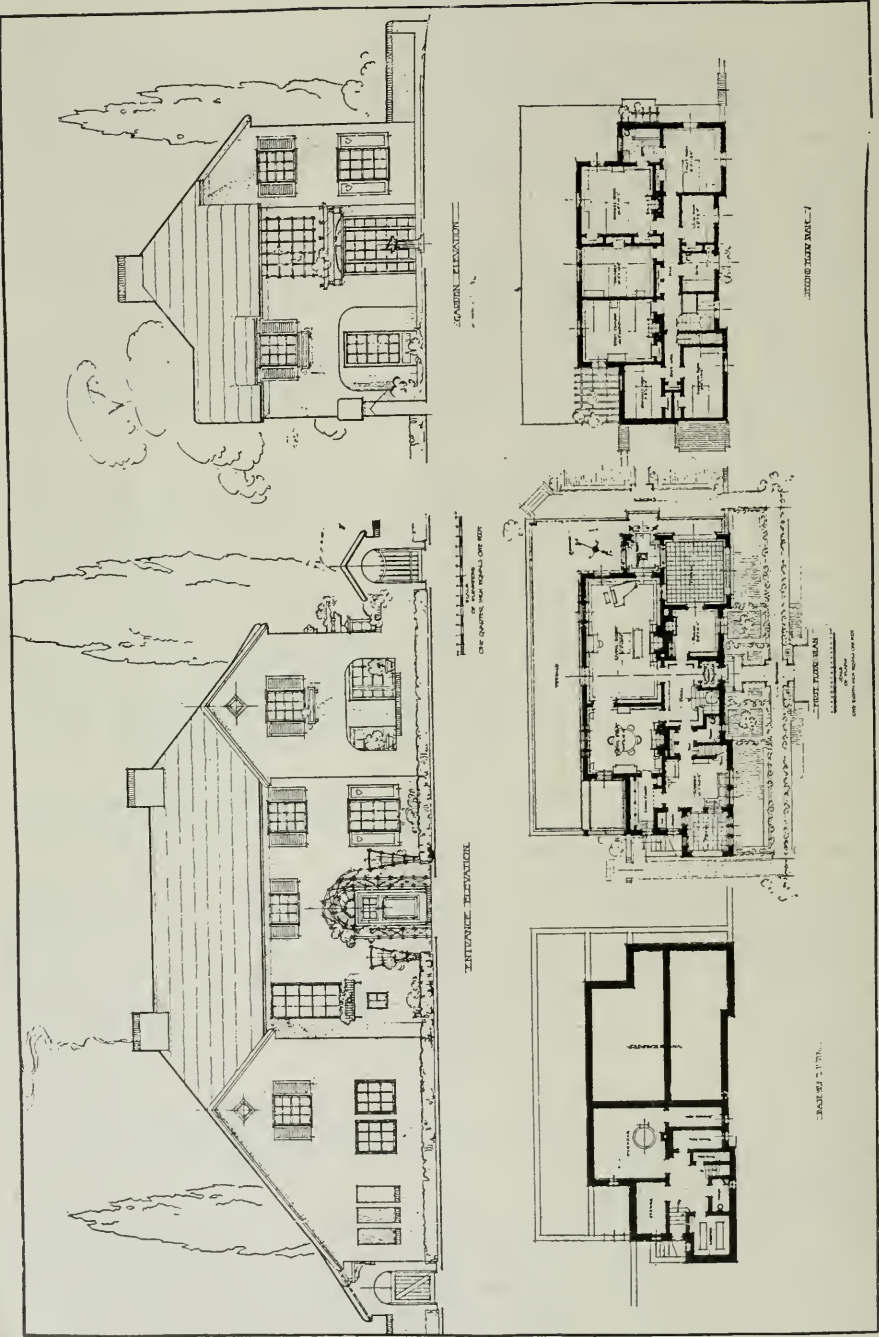

ELEVATION AND PLANS FOR TWO STORY PLASTER HOUSE

The Lack of Houses*

By ARTHUR GLEASON

II.—REMEDIES

(Concluded from the September issue of *The Architect and Engineer*, page 98.)

IT is to meet such a need that the English Garden City idea was projected. The Garden City is a self-contained community with its own industries, land owned in common, density of population limited, and the community surrounded by a belt of agricultural land.

Building Material.—Building materials (in all grades of building) have advanced to 136 per cent above pre-war levels. This is connected with the forestry situation and the tariff. There is a scarcity of lumber, monopoly prices upon it, and a protective duty (in spite of downward revisions) on importations. There are tariff restrictions on such building material as hollow tile. The sabotage of labor affects the price of every item. The sabotage of business men is equally in evidence. If the situation were to grow acute enough, with angry, dispossessed tenants, unhealthy slum-dwellers, and factories idle because of no housing for workers, then there would perforce arise public control of building materials, exactly as the British Government controlled food during the war and now controls building material. But any such drastic action here is improbable in the immediate future.

Copartnership Tenancy Societies.—Group ownership of large areas of land and of houses is one important solution. Copartnership tenancy societies enable the members to become part owners of the community by investing in the company stock. The member lives in a house, whose rent is based on expense for use, instead of on land-and-house-scarcity, manipulated by private enterprise for profits. The unearned increment of land value is used for decreasing rents and bettering the public services of the community. The member is in possession of his home for as long a time as he holds his investment in the company stock. In Britain there are eighty co-operative tenancy societies of the limited-dividend, non-commercial type. Some of them are creating garden suburbs. One British company of copartnership tenants in nine years increased its assets from \$250,000 to \$30,000,000.

Home Ownership.—The results of private enterprise in building have been to destroy individual ownership of and property in homes. The 1920 census will probably show that almost 60 per cent of our people are tenants. Mr. Miller of the F. W. Dodge Company says "Legislation promoting wider ownership of property can alone call forth the energy necessary for the maximum of production." He advocates the solution of the urban housing problem by placing long-term banking facilities at the disposal of the would-be home owner. The American Federation of Labor has called on Congress for "a plan by which the Government may build model homes for workers, and to establish a system of credits by which workers may build their own homes."

Architects.—Manual laborers and business men cannot give standards. The architect must again be master of the job as he used to be in the era of noble building. Professor Alfred Zimmern once said to me: "Only the artists can give our industrial workers a standard. Masons and bricklayers are no more qualified to design a house than navvies are to decide on how a bridge is to be built. The bridge will tumble and the house will be ugly."

Modern business enterprise directs industry through the machine, and controls production through the profit making system. The architect is the hired servant of the business man. "Suppose," says the *Journal of the*

* Reprinted from *The Nation*, April 17 and April 24, 1920, by special permission of the publishers.

American Institute of Architects, "that the way out does lie in the guild principle, under which architect and workman combine to control the industry rightfully theirs. It would mean emancipation for architecture, and why should we fear to be emancipated?"

Labor.— The workers have withdrawn their efficiency. This passive strike against the business system of machine industry for profits began early in this century in England. More recently it spread through the United States, where it is less consciously directed. Even before the war in Britain, the building trades were in wreckage. The necessary incentive of profits for business men did not, unfortunately, furnish an incentive for the 600,000 workers. It increasingly had the opposite effect of making the workers, who watched its operations in price-fixing and restriction of output, imitate the methods. They, too, turned to sabotage. They made profits in house building impossible. Since the war, in both Great Britain and America, the workers have gone to repair work and to the construction of industrial and commercial premises. Industrial inflation can stand considerable sabotage and still pay profits. But house building cannot.

In January of this year the Manchester building trade operatives made an offer to the City Council to build the houses needed at a lower price than that of speculative builders. They offered their labor power in place of tangible securities as a basis of credit. They asked the authorities for the necessary raw materials and money for wages and overhead. Building material is under the control of the Ministry of Health. The workers pledged themselves to find architects, directors, and other technical men.

There are two important matters in this proposal. One is the new conception of group credit based upon the power to produce, in contrast to bank credit based upon the purchasing power of gold. The position of the administrator, technician, architect, and surveyor, is the other matter of moment. Unless adequate representation and freedom are given to the non-manual functions, the guild will prove as sterile as business enterprise. Private building of homes has failed. The State has not succeeded. Now comes labor with an interesting proposal. Its success will depend on the recognition it gives the architect.

The Nineteenth Century concerned itself with supplying an incentive to keep the business man at work. The problem of the Twentieth Century is to find those sources of motive which will draw out the productive power of the manual worker and the technical man. When the architect and the workman are enlisted, houses will be built. The credit-power of the community, based on productive capacity, will back their co-operative effort. Profits are not indispensable. But houses are.

*
*
*

Portland, Oregon, Competition

A competition is being held at Portland, Oregon, for the proposed \$1,000,000 Cathedral for the Oregon Consistory No. 1.

Mr. Wm. Gray Purcell, architect, 812 Spalding building, Portland, has been appointed architectural advisor and has charge of the details in preparing the program.

The architects who have been selected to enter the competition are: Messrs. Richard Martin, Jr., E. M. Lazarus, Edward A. Miller, A. N. Haley, W. C. Knighton, Morris Whitehouse, Albert Sutton and H. A. Whitney, the last two mentioned being partners, practicing under the firm name of Sutton & Whitney.

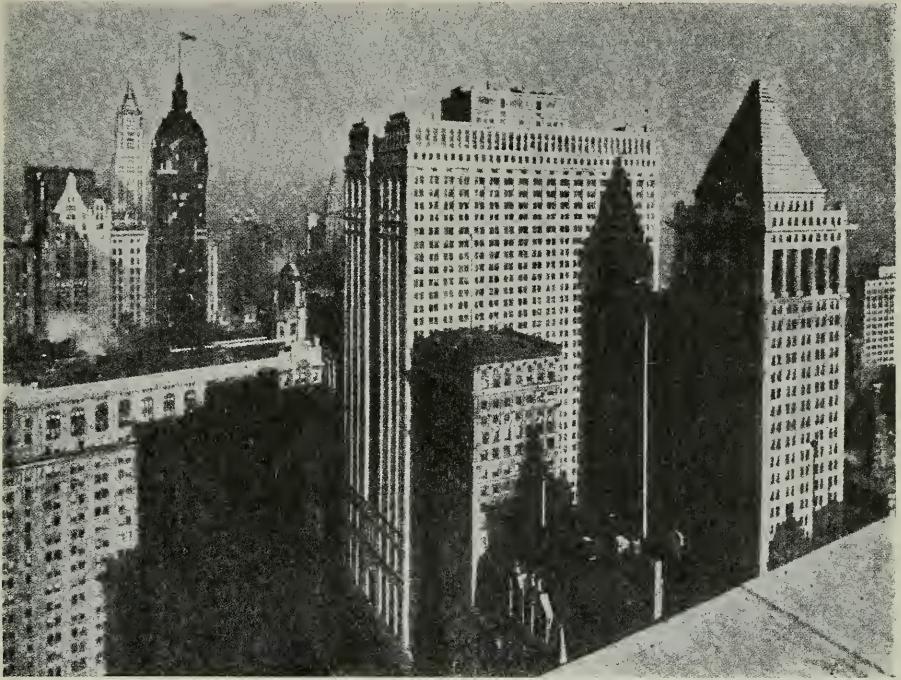

All sunlight is cut off from the narrow streets on which New York skyscrapers stand; and the shadows tall buildings throw on each other add to the gloom.

Cutting Steps in the Skyscraper

By F. W. FITZPATRICK, Consulting Architect*

SHALL we go on building skyscrapers? Sweden prohibits anything that looks like a skyscraper. London may allow two stories more than is now legal height, but even that is doubtful. Paris will not have any. It is in this country, where every town of ten thousand persons must have a twelve-storied building or be entirely out of the running, that there is the liveliest interest in the skyscraper problem.

New York insists upon skyscrapers; Chicago is not so sure but that they are unhygienic, light obscuring, unsightly and somewhat unnecessary. San Francisco is now building three 15-story structures and announcement is made that January 1st the Standard Oil Company will erect a 26-story office building, the tank roof of which will tower 85 feet above the Hobart building, at present reputed to be the tallest structure in San Francisco.

But everyone concedes that in congested cities it is absolutely necessary to build upwards since but little lateral expansion is possible.

Many cities have established two hundred feet as the maximum height of buildings. There is even a tendency to reduce that. It is generally acknowledged that the ultra-tall building is not necessary, is not profitable, is a detriment to the artistic appearance of a city, and has no reason for existence at this late day except as an advertising medium.

New York has made a concession to good sense in recently adopting the scheme of the "stepped-back" building I first advocated years ago, but could

* Revised by the author for this magazine from a contribution by him to Popular Science Monthly.

induce no city to adopt at the time. The plan permits the erection of a building up to a certain height on the street line. To go higher the owner must step back the front of his building in order to allow a greater width of "street in the air." Successive "set-backs" until the roof is attained would insure the admission of air and sunshine to the constantly shadowed streets below.

Some skyscrapers, for example, cast a shadow covering nearly eight acres. The Adams Express building, New York, which is 424 feet high, casts a shadow 875 feet in length; the Equitable building, which is 493 feet high, one 1,018 feet in length; the Singer Tower, which is 540 feet high, one 1,127 feet in length, and the Woolworth Tower, which is 791 feet high, one 1,635 feet in length.

Some skyscrapers cast shadows from a sixth to a third of a mile in length on surrounding property. Thus the Equitable building's shadow at noon on December 21, is about one-fifth of a mile in length; it completely envelops an area of 7.59 acres. Yet the ground area of the Equitable building is only 1.14 acres.

The shadow cuts off all sunshine from the Broadway facade of the United States Realty building, which is 21 stories high. The New York Title & Mortgage Company building, 14 stories high, and the Washington Life Insurance building, 19 stories high, are both completely shaded. The south side of the Singer Tower is shaded to a height of 27 stories. The nearest part of the City Investing building, 400 feet away, is in shadow for 24 of its 26 stories. Even part of the New York Telephone building, north of Cortlandt street is shadowed by the Equitable building.

Cedar street, the street immediately north of the Equitable building, has an average width of 34 feet between Broadway and Nassau street. The height of the Equitable building is $14\frac{1}{2}$ times the width of this street. On a north and south street of this width in New York, uniformly improved on both sides with buildings having a height equal to that of the Equitable building, only 9.31 per cent of the windows would receive any direct sunshine at noon on the shortest day in the year.

On the north and south streets only the windows nearest the top for a distance equal to 1.35 times the width of the street would receive direct sunshine at noon on December 21 at New York (40 degrees north latitude). The windows in the first 34 stories nearest the ground would receive absolutely no direct sunlight. Direct sunlight would only enter these windows in the four stories nearest the top. Not a single window within 447 feet of the street level would receive a ray of direct sunshine.

The Equitable building is, of course, an extreme case. But even in much lower buildings a considerable number receive absolutely no direct sunshine at the winter solstice. Up to a height equal to 1.35 times the width of such a street all the windows receive some sunshine. If the street, however, is improved with buildings one and one-half times the street width in height, only 90 per cent of the windows obtain direct sunshine.

The editor of *The Architect and Engineer* has asked me how high I would dare to construct a building with the material and skill available today. The progression is interesting. People will walk up to a third story, therefore that is the limit of unelevated buildings. When once you have to install an elevator in a four-story structure, very little additional cost is involved in building seven stories. Build more than eight stories, and you may as well plan for ten; if for ten, then for fifteen, etc. Above twenty you find yourself in an entirely new order of construction, and wind pressure. Thirty and forty-story buildings are wasteful. Structures over forty stories in height belong to the class of freaks.

If I could locate a building in the wilderness, upon rock at least seventy-five feet thick in a region where there had never been an earthquake, and if I could

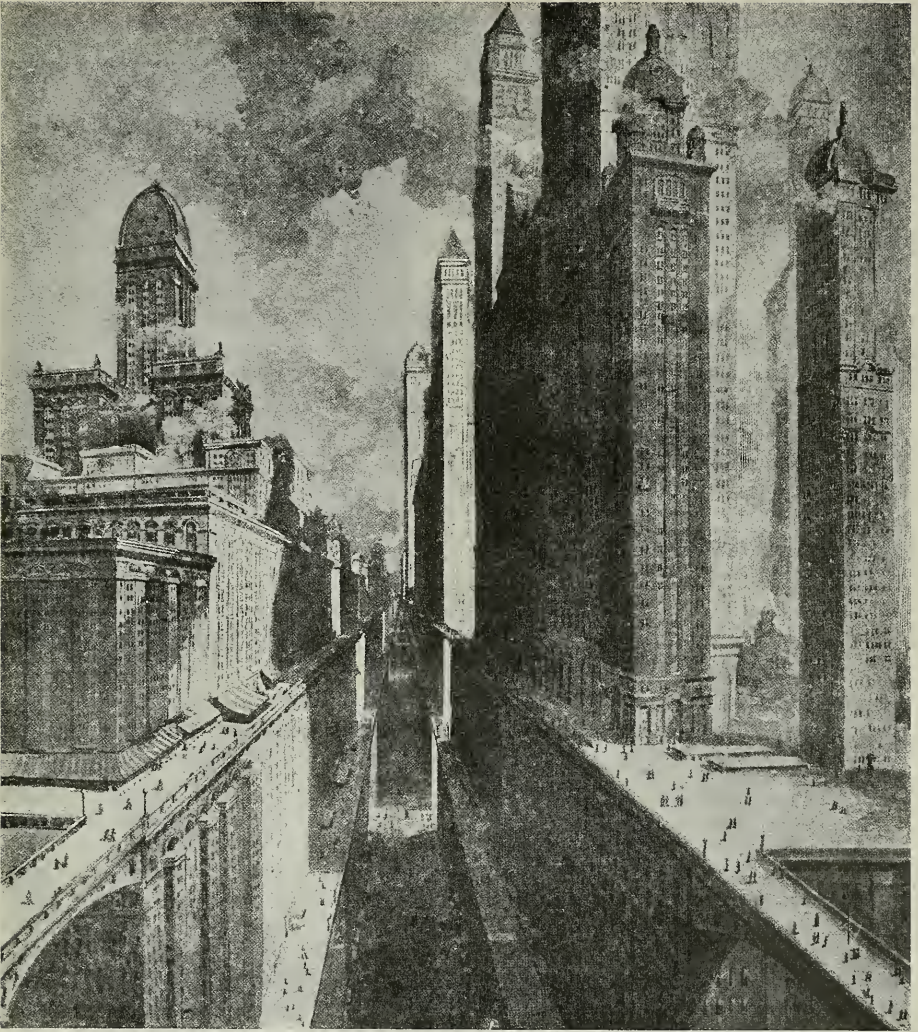

THE "STEPPED-BACK" SKYSCRAPER AND THE THIRTY-STORY SIDEWALK

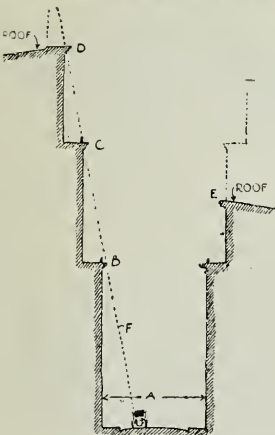

To the left is a diagram illustrating Mr. Fitzpatrick's proposed "stepped-back" skyscraper construction to reduce shadows. Down at the bottom is the existing street, A. The first level, B, is established where all buildings that are to be higher must be receded. The dotted line F, prolonged from the center of the street to B upwards, establishes the levels C, D, etc., at which the buildings must again be receded to permit the desired amount of sunlight and air to reach the street and the opposite buildings. A building may be roofed at an intermediate point, E.

In the picture above Mr. Fitzpatrick's scheme is visualized on the left-hand side. The right-hand side of the picture shows the shadows cast by the present type of sheer skyscraper construction, some of which cover nearly eight acres. It is doubtful if municipalities will permit real estate owners to build structures taller than those that now shut out light and air from the streets below.

disregard the matter of elevators or of rooms encumbered with wind bracing I am quite sure that a structure 4,000 feet high could be built on a base 400 feet square.

We don't know how steel or wind behaves at that height, but we can fairly calculate from what we do know about lower structures.

It is strange, that although the tallest buildings are in New York, the tall structure did not originate there but is a product of the West. Undoubtedly the skyscraper was thought of, perhaps discussed, prior to the first publication of the idea in the West, but the fact remains that nothing was written about it until 1884.

In 1889 Architect Janney of Chicago designed and built the first actual steel framed so-called "skyscraper" wherein the outer walls were but curtain walls supported on steel work at each story. New York then took hold and now the highest structures in the world are there.

Strange to relate, however, and somewhat of a vindication of the reasoning of the kind of '83, buildings much over twenty-five stories are more valuable as advertising media than as building investments. The structures of twenty-five stories or so, reasonably located, all pay well, while the huge, overgrown fellows produce a rather unattractive return. An occasional skyscraper may act as a tower in the landscape, but objection has developed—and rightly—to their multiplication.

* * *

Wooden Doors Dating Back to Middle Ages

AMONG the famous doors of history are the carved wooden doors of the church of Santa Sabina, Rome, depicting in relief, scenes from the Old and New Testament. These are one of the most remarkable examples of early Christian sculpture extant.

In the earliest times, as in Babylon, doors swung on sockets instead of hinges. In Roman days wooden doors were decorated with bronze and inlaid, and throughout the Middle Ages richly carved doors of wood adorned the churches. In the Gothic period, wooden doors were decorated with wrought iron hinges which were often elaborated into intricate ornamentation covering a large part of the door. The doors of the cathedral of Notre Dame in Paris of the 13th century, are the finest examples of this class. During the Renaissance in Germany and France elaborately carved doors were among the most beautiful products of wood sculpture.

Some of the old English doors were formed of narrow planks placed side by side and in dwelling houses generally, in the Middle Age, the doors were small and fairly simple, meant for strictly practicable purposes and often provided with some means of defense. The doors of the Norman period were round-headed, while with the 13th century, came the doorway with the pointed arch and later the flattened arch.

In the case of interior doors, splendid old polished mahogany doors were important features in some old English homes and there were old oak doors of wonderful beauty, especially when found in oak panelled rooms.

Haphazard selection of doors of the ready-made variety should not be allowed in the building of a fine home, but the doors should be designed by the architect who builds the structure that they may be in keeping with the general style of the house. Upon the attractiveness and distinction of the door and doorway depends the visitor's first impression of the home he is about to enter.

Concrete Steps Easy to Build

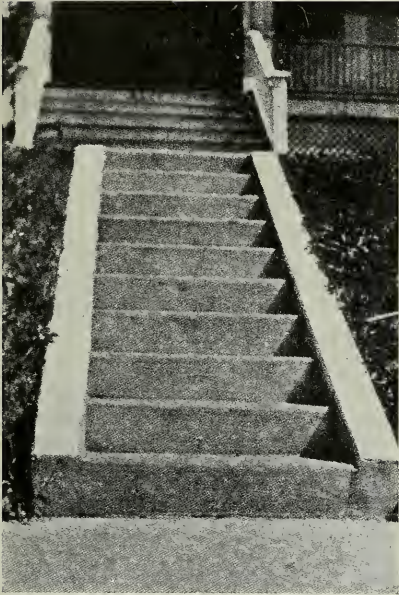

Concrete steps add to the attractiveness of the entrance as well as to the safety and permanence.

ONE desirable detail of every house is steps at the front and rear entrances which will last. Changing moisture conditions contribute to rapid depreciation of wood steps because naturally they are in contact with the soil. The home owner is sure that concrete steps will give service indefinitely without need of any maintenance such as is necessary to temporary construction.

Details of form construction for simple concrete steps such as might be used at the side or rear entrance of the average home are shown in an accompanying drawing. Steps of this kind resting on well compacted earth require no reinforcing.

Forms consist of planks held firmly in place by means of 1 by 4-inch cross pieces against the side walls which are built first. To the planks are nailed short 1 by 4's the length of which is such that they come within two inches of the treads. An added advantage in riser construction is given by sloping these pieces back, thus making an attractive looking step which provides a safety factor not present in most types. Cross planks, usually of one-inch material and eight inches high, are nailed to these to make the riser forms.

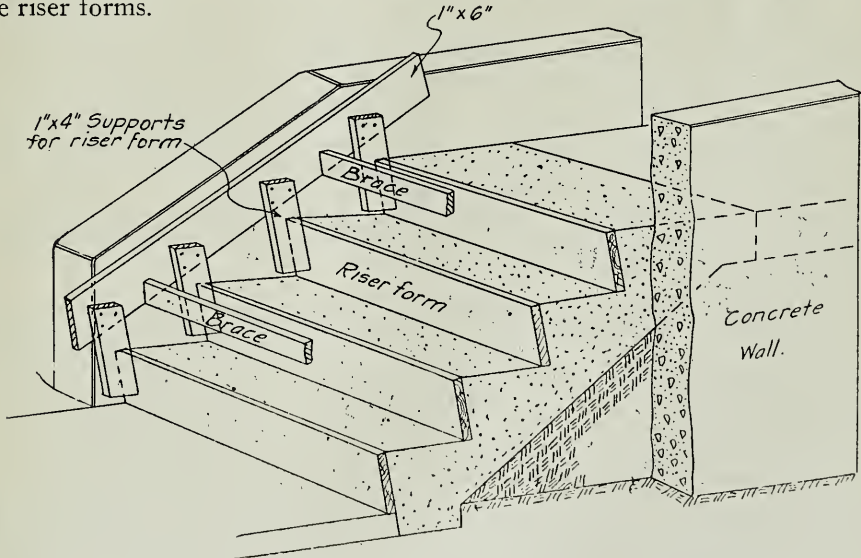

Simple design which can be adapted to any number of concrete steps

For steps of this kind it is best to use concrete mixed in the proportion of one sack of Portland cement to 2 cubic feet of sand to 4 cubic feet of pebbles or

crushed stone. Forms may be removed as soon as the concrete has acquired sufficient strength to be self-sustaining. The steps may be given a finished surface by using a steel trowel after any small depressions which might be found have been filled with a cement grout.

The concrete should be kept moist by frequent sprinklings for a week or 10 days after removal of forms. A covering of earth or straw, kept wet will accomplish the same purpose. At the end of this time they may be safely put into use.—Concrete Builder.

* * *

The "Tax on Sales" Proposition

THE French Government has decided to place a tax of one per cent on every business transaction. The fact that this is practically the "tax on sales" measure that lately was urged upon our own Congress makes this action by the French Government of uncommon interest.

France is availing herself of this rational method in order to avoid a tax on capital. No country safely can afford to absorb the capital that is needed to keep its industries going. Yet that is what we are doing in the United States through the inequitable and destructive excess profits tax. The tax collector is steadily swallowing up new capital, resulting in the paralyzation of new industries and the withholding of investment in new industrial propositions.

The practical politicians in Washington thus far have failed to favor the proposed "tax on sales," but they did not hesitate—in order to provide funds for a soldiers' bonus—to suggest a heavy retroactive tax on profits made during the war, a proposal utterly iniquitous and ruinous. Commenting on this feature of the wild economical vagaries of some of our lawmakers, the Boston Herald says:

It would be a virtual confiscation of property and would involve a wide departure from all sound principles of taxation. Excess profits were taxed heavily during the war and these taxes were paid without serious complaint. Whatever profits were left after this taxation were either distributed to shareholders or put back into the business. Much of the capital with which the business of the country is now carried on came in this way. Any retroactive levy at this time would disorganize business to an extent that no one can accurately measure. It would destroy the foundations on which trade and industry rest by reaching back and taking, in ex-post facto fashion, those earnings of capital to which an implied exemption had been given. It is inconceivable that Congress will seriously consider any such mad proposal. * * * If our congressmen think that any form of taxation will not, in the long run, have exactly the same effect as a tax on retail sales, they are mistaken. Whatever the channel of taxation may be, the ultimate incidence is always the same, and the public as a whole bears the burden.

The excess profits tax is iniquitous and destructive. The proposed tax on sales would be just and constructive and adequate for all necessary purposes. The danger as to what Congress may do in the matter of taxation is temporarily averted. But after this political campaign is over and the selected lawmakers reassemble in Washington, no one can predict with even a remote approach to probability what will be done by them.

This is why the work of selecting our next company of lawmakers is so highly important to every one of us. It is essential to the welfare of the Nation that we send to Washington next November only such men as will keep the National good in mind, men who will be conservative and constructive, men who will labor to manage the vast business of the Nation along well-proved economic lines and with an eye single to getting the greatest good for the greatest number of our whole body of citizenry.—Valve World.

When Will Building Costs Be Lower?*

THESE are three conditions which might bring about a reduction in building costs:

1. A reduction in demand.
2. Reduction in wages of labor.
3. A reduction in price of building materials.

A reduction in the demand for additional construction is highly improbable, in view of the present shortage of building space which has resulted from a slowing down of commercial and industrial building during the period of the war.

An inspection of the accompanying figures will bring out clearly the fact that the country at large is short about three and a half billion dollars' worth of normal building construction, and until this shortage is made up there will surely be continued and increasing demand for space.

As to the hope for a reduction in building costs due to a reduction in wages paid to labor, it does not seem probable that the laboring man will be content to accept any reduction in the size of his pay envelope. His attitude is rather to force wages to higher planes, and an inspection of the diagrams which follow will show that the wages of the building trades throughout the United States, as well as in New York City, have risen steadily during the past seven years. Still labor is dissatisfied and restless. The hope for a reduction in the cost of building materials rests very largely on the hope for a reduction in wages, because, for every dollar spent for brick, cement or steel which goes into a building, from 85 to 90 per cent of such price ultimately goes back to the laborer who dug the clay, mined the coal, burned the brick, ground the cement, rolled the steel, and transported all of them over railroad lines to the site of the work and built them into the structure. Until these related wages go down, therefore, it is not reasonable to expect any substantial reduction in the price of building materials.

Some idea of the increase in the prices of the principal building materials during the past seven years is given by diagrams on following pages. That this increase is by no means at an end is evidenced by the increase in prices of these materials since the first of January, 1920. In New York, the price of brick has risen from \$25 to \$33 per thousand; lumber from \$58 to \$72 per thousand feet, B. M.; steel from \$95 to \$135 per ton; and other materials in like manner.

In view of the building shortage in the United States, there seems little hope for a reduction in building costs due to reduced demand. With the present attitude of labor, there seems less chance for a reduction in building costs due to lower wages; and with this same attitude affecting 90 per cent of the cost of building materials there seems small chance for a reduction in the price of the latter. The country is so far underbuilt that prices have become subsidiary to necessity.

We know of no other major influence which can bring a marked or immediate reduction in building costs, and our mature judgment is that there will be no substantial reduction for several years to come.

Our advice to our clients, in view of this whole situation, is that if they need additional building facilities, and the conditions of their business justify the expenditure, it is far wiser to build now and enjoy the benefit of the improvements than to wait and lose the use of this money-making space for several years, and then build at costs which may be even higher than those of the present time.

* A study of conditions, made for the George A. Fuller Company, by the Fuller Industrial Engineering Corporation, New York City. From the September Bulletin of the Associated General Contractors of America.

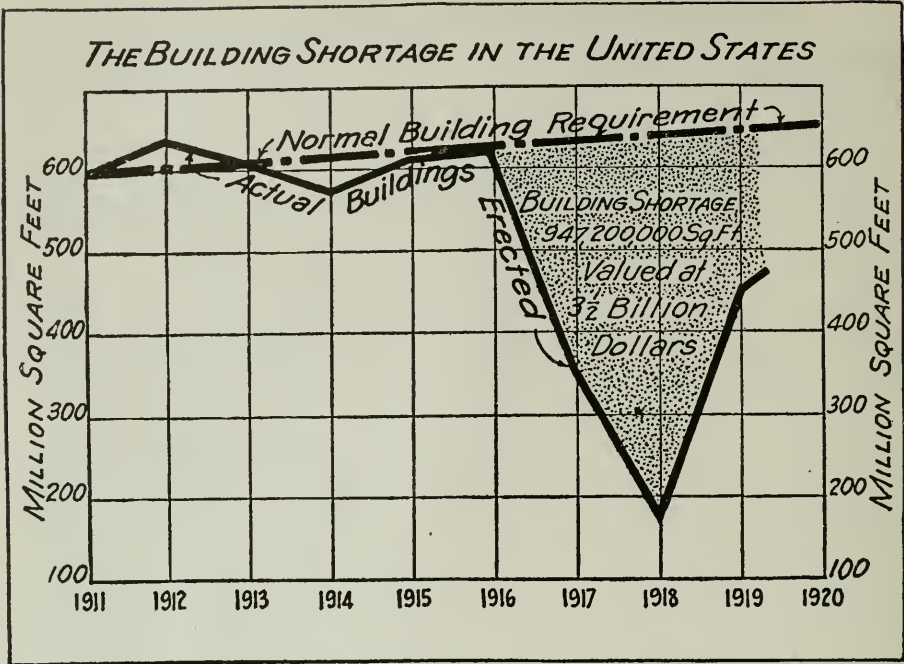

GRAPHIC DESCRIPTION OF NORMAL BUILDING REQUIREMENTS, 1911-1919

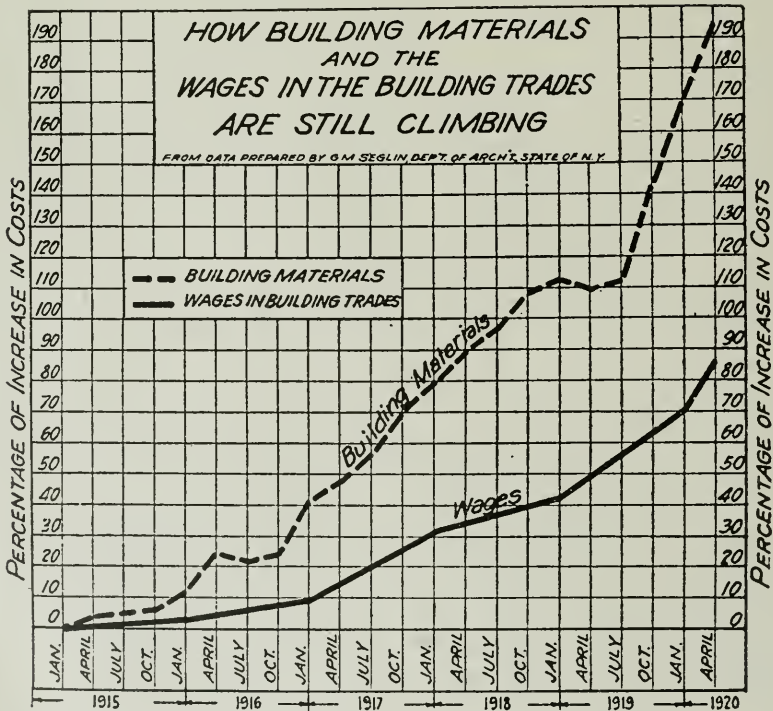

THESE FIGURES ARE THE BASIS OF THE GRAPHIC CHART ABOVE, SHOWING THE SHORTAGE OF BUILDING

THE BUILDING SHORTAGE IN THE UNITED STATES

The records of new building construction in the cities of the United States, from 1911 to 1919, inclusive, as published by Forbes Magazine, show the following figures:

Year	Cost of Building Constructed	Average Cost per Square Foot	Square Feet Built
1911.....	\$ 962,499,700	\$1.59	605,300,000
1912.....	1,027,515,200	1.63	630,400,000
1913.....	980,971,600	1.61	609,300,000
1914.....	891,845,500	1.55	575,400,000
1915.....	931,937,300	1.52	613,100,000
1916.....	1,137,160,900	1.82	642,800,000
1917.....	816,941,000	2.27	358,500,000
1918.....	492,163,900	2.65	185,700,000
1919.....	1,467,821,300	3.20	458,600,000

The low average cost per square foot of building constructed, shown in the above table, is due to the high percentage of floor space which consists of the cheapest kind of factory construction, amounting to little more than sheds. The average cost per square foot of modern factories of reinforced concrete, or other fireproof material, as well as of first-class office buildings and hotels, is much higher, the range being from \$3.50 to \$10.50 per square foot, depending upon the character of structure and its location.

For the years 1911 to 1914, inclusive, the estimated average amount of new building was equivalent to 605,100,000 square feet of floor space per annum. In 1918 less than one-third of this amount was done, and, even in 1919, in spite of the large money expenditure, the amount of building done was 146,500,000 square feet below this figure. Hence it is clear that ever since the end of 1916 the available building space has been running further and further behind requirements.

Owing to the increase in population, at least 10 per cent more floor space is required to be built annually than before the war. Otherwise expressed, we ought to have built about 650,000,000 feet annually during the past three years, or nineteen hundred and fifty million (1,950,000,000) square feet in all. We actually built only about 1,002,800,000 square feet, and this leaves a shortage of 947,200,000 square feet. At the present time, we are building at the rate of about 550,000,000 feet per annum.

Thus we see that in order to make up during this present year the existing shortage of housing space we would have to construct dwellings, factories and offices having an aggregate floor space of about 1,597,200,000 square feet, or almost as much as we ever built in any three past years.

The chart reproduced here illustrates graphically the normal building requirements in the United States from 1911 to the end of 1919, the actual building operations completed during those years and the resulting shortage which this country is now facing. It appears, therefore, that we are about 18 to 21 months behind in our building program, and that the total amount of building operations during the next few years must not only rise to the average normal yearly requirements but must exceed those requirements sufficiently to make up the shortage which accumulated during the past three years. With this shortage to be overcome, there is no likelihood of a decrease in building operations, but on the contrary there is every reason to expect an increasing demand for some years to come.

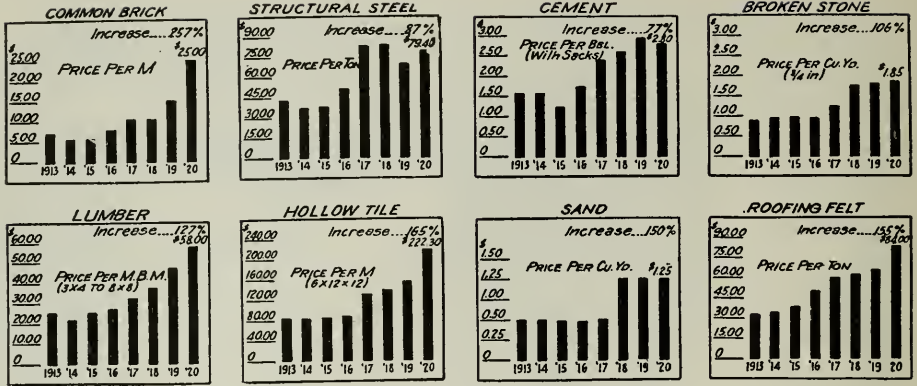

PRICES OF BUILDING MATERIALS IN NEW YORK FROM 1913 TO 1920

HOW LONG WILL THE HIGH COST OF BUILDING CONTINUE?

The prices of building materials and labor are controlled by economic law—supply and demand. The present abnormal demand for building materials is due to curtailment in the normal amount of building during the war; to a 10 per cent increase in population since the war began; to a shifting of population from rural to urban centers, where thousands of men and women were attracted by war wages, which have increased, in many cases, since the war ended.

The labor shortage is due to the practical suspension of immigration since 1914; in a small measure to the return of foreign workmen to their own countries; to the stimulation of all manufacturing industries brought about by war conditions abroad; and very largely to the development in this country of entirely new industries, on a very large scale, such as dye manufacturing and ship building.

Authorities agree that high building costs will continue for some time. They recognize, however, that any general financial depression will ultimately affect the costs of materials and labor, but feel that the decline in building costs will be small, and slow to follow the downward trend of other commodities, because of the great demand for building space which must continue until the shortage due to the war has been eliminated.

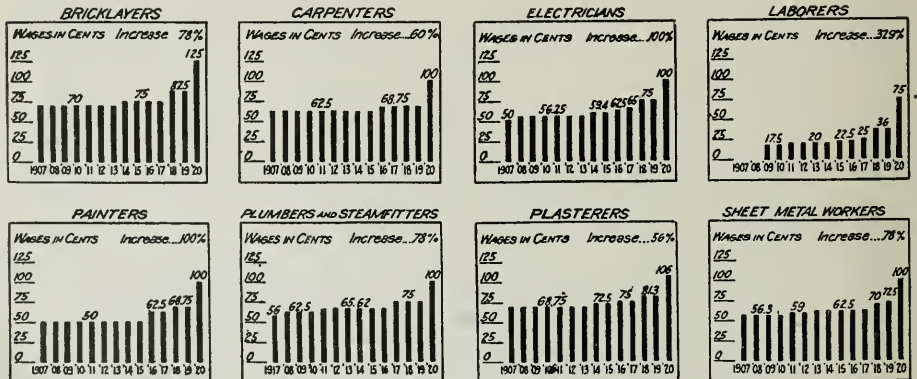

HOURLY WAGES OF PRINCIPAL BUILDING TRADES IN NEW YORK CITY, 1907 TO 1920

None of them anticipates a return to the low pre-war levels, and far-sighted executives are perfecting their plans and having exhaustive engineering reports made for the betterment of conditions in their factories, so that they can immediately take advantage of any lower costs which may momentarily prevail during the period of readjustment.

Many manufacturers, who see in the present prices obtained for their products an opportunity to write off the increased cost of new building, are going forward with their construction work, and are thus relieving their cramped factory conditions, securing greater production and lowering factory costs.

* * *

Building in France

BUILDING is the chief industry of France today. Necessity, rather than inclination is the cause, for every Frenchman yearns for the day when the shrill factory whistles, and the smoke of foundries will proclaim that once more her industries, paralyzed and crippled by the ravages of war, have been rehabilitated.

But shelter must be provided first for thousands of families, living now in temporary shacks, or barracks, donated to the French people by the American Red Cross, and ancient buildings and historic cathedrals, which have withstood the shock of war, must be strengthened as to tottering foundations, and caving roofs.

The almost insuperable obstacles under which the French carpenter and builder struggles, however, can scarcely be imagined by those who have not viewed the chaos that prevails in the devastated area. One of the first and most tedious preliminaries consists of building extensive scaffoldings and safety zones, in order that the workmen may not risk unnecessary dangers from crumbling walls. Dangers of unexploded shells and grenades have always been reckoned with, and cannot be well anticipated.

A widespread shortage of metals, together with idle factories, has caused the price of all hardware to soar, so that nails and staples are used as sparingly as possible. In their place the ubiquitous telephone wire, which the armies of both sides left, knee deep, upon the fields of Flanders, is employed. The wire is strung or woven about the uprights and lateral timbers of the scaffolding so skilfully that the resulting structure will bear up almost any amount of weight, and is as trig and trim as a ship's rigging.

The same hardware shortage has made many of the French workmen dependent upon the largess of the American Red Cross for their tools. For the most part saws, hammers, planes and chisels are their only equipment. Yet so thorough-going is the French workman in all that he undertakes, and so painstakingly has he learned his trade, that his handiwork endures for years. "Safety First" is one of his mottoes. He never sacrifices safety to speed, nor ventures upon a high platform until he has assured himself that the scaffolding is substantial.

For material, the builders must either utilize the debris which lies in endless heaps all about them, or spend prodigally of their slender means for the precious lumber, most of which is imported. Yet at that, the lumber shortage is not so acute as that of other building materials, inasmuch as solution of the transportation difficulties will soon provide France with adequate lumber. But the bricks and hewn stones cannot be provided for building until the industries of France have been restocked and equipped with machinery to replace that stolen by the Germans.

Chimney and Fireplace Construction

THE preponderance of fires reported as being caused from defective flue construction greatly emphasizes the necessity for more and greater care in the construction of chimneys. It has been made plainly apparent from investigations of the causes of fires, that the proper construction of chimneys, particularly with regard to their proximity to wooden frames and finish, has been carelessly if not maliciously overlooked.

No better means by which to prescribe the manner in which chimneys and fireplaces should be constructed can be had, than to quote from Chapter V of Standard Building Ordinances*:

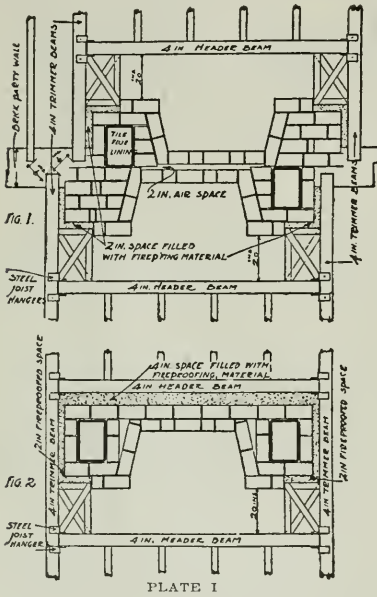

PLATE I

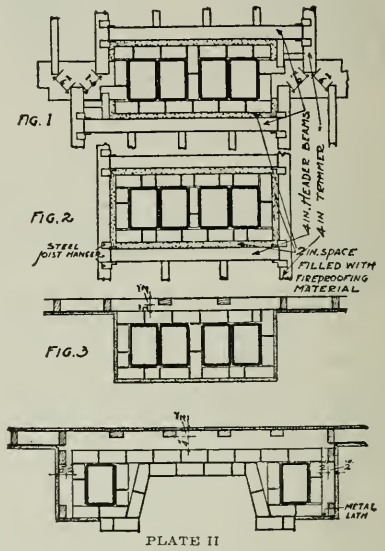

PLATE II

Fig. 1—Method of building two fireplaces back-to-back in a brick party wall to secure proper spacing between ends of floor joists. The space between backs can be filled if desired.

Fig. 2—Floor framing around a single fireplace. Note filling between framing and brickwork which serves both as insulator and firestop.

PLATE II

Fig. 1—Floor framing around chimney in a party wall to secure proper space between ends of floor joists.

Fig. 2—Ordinary floor framing around a chimney. All timbers 2 inches clear of brickwork and space filled with fireproofing material.

Fig. 3—Stud partition across back of a chimney showing proper method of arranging studs.

Fig. 4—Stud partition across back of a fireplace and around the ends of the chimney breast, showing proper method of arranging studs.

Chimneys and Fireplaces. Except as herein provided, all chimneys in every building hereafter erected, altered or rebuilt shall be constructed of brick, stone or reinforced concrete. No masonry chimney shall have walls less than 8 inches thick unless it be lined on the inside with well burned terra cotta or fire clay chimney tile set in Portland cement mortar, in which case the wall shall not be less than 4 inches thick. The lining shall be continuous from the bottom of the flue to its extreme height.

Every smoke flue contained in a chimney hereafter erected shall have an area of at least 64 square inches, except that terra cotta flue linings 7 inches by 7 inches rectangular or 8-inch diameter inside dimensions, may be used.

* Copies of Standard Building Ordinances ready for adoption by cities with populations ranging from five to thirty thousand may be had upon request from the Architectural and Building Code Service of the National Lumber Manufacturers' Association, Chicago, Ill.

No chimney shall be corbeled out more than 8 inches from a brick wall, and such corbeling shall consist of at least five courses of brick. No one course shall project more than 1½ inches. See Plate IV.

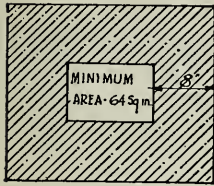

Solid Masonry.

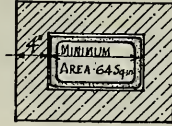

Brick with Flue Lining.

Cross Sections of Flues.
PLATE III

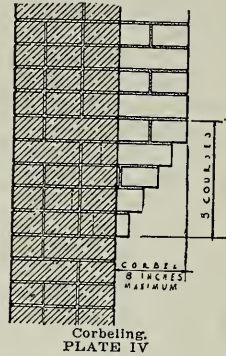

Corbeling.
PLATE IV

Brick set on edge shall not be permitted in chimney construction.

Chimneys of all low-pressure boilers, or furnaces, also the smoke flues for baker's ovens, large cooking ranges, large laundry stoves, and all flues used for similar purposes shall be at least 8 inches in thickness and be lined continuously on the inside with well-burned terra cotta or fire clay chimney tile set in Portland cement mortar. All such chimneys shall be capped with terra cotta, stone, concrete or cast iron.

The smoke flue of every high pressure steam boiler, and every appliance producing a corresponding temperature in a flue, if built of brick, stone, reinforced concrete or other approved masonry, shall have walls not less than 12 inches thick, and the inside 4 inches of such walls shall be firebrick, laid in Portland cement mortar for a distance of at least 25 feet from the point where the smoke connection of the boiler enters the flue.

All chimneys shall project at least 3 feet above the point of contact with a flat roof, or 2 feet above the ridge of a pitched roof.

Portland cement mortar only shall be used in the construction of chimneys their entire length.

No chimney in any building shall have wooden supports of any kind. Supports shall be incombustible and shall rest upon the ground or the foundation.

All chimneys which are dangerous from any cause shall be repaired and made safe, or taken down.

Metal smokestacks may be permitted for boilers, furnaces and similar apparatus where large hot fires are used, provided they have a clearance from all combustible material of not less than one-half the diameter of the stack, but not less than 15 inches unless the combustible material be properly guarded by loose fitting metal shields, in which case the distance shall be not less than 12 inches. Where such a stack passes through a roof, it shall be guarded by a galvanized iron ventilating thimble extending from at least 9 inches below the underside of the ceiling or roof beams to be at least 9 inches above the roof, and the radius of the ventilating thimble shall be at least 18 inches greater than that of the smokestack. Metal smokestacks shall not be permitted to pass through floors.

The fireback of every fireplace hereafter erected shall be not less than 8 inches in thickness of solid brickwork, nor less than 12 inches of stone lined with firebrick. When a grate is set in a fireplace a lining of brick at least 2 inches in thickness shall be added to the firebrick; or soapstone, tile or cast iron may be used, if solidly backed with brick or concrete.

All flue-holes when not in use shall be closed with tight-fitting metal covers.

Ashes shall be kept in metal or other incombustible receptacles provided for

the purpose. When the ash pit is located in a basement or cellar, enclosing walls and cover shall consist of at least 4 inches of brick or concrete.

Flues to be cleaned. All flues in every building shall be cleaned and all rubbish removed, and the flues left smooth on the inside upon the completion of the building. Once each year all flues shall be properly cleaned from top to bottom.

The worst single cause of fires is the defective chimney and to overcome the tremendous losses sustained therefrom, it is essential that architects, engineers, contractors and building superintendents should exercise extreme care, not only in proper design but also in the actual construction of all chimneys and flues.

* * *

The Architect's Personality on the Job

IN the army and navy, a system has grown up of creating artificial respect on the part of the enlisted men and inferior officers for the office or men higher up. In straight commercial life the workers (equivalent in this case to the rank and file of enlisted men in military life) are not bound by the iron and inflexible requirements of military law, hence the executives in straight commercial life (in this case the equivalent of the commissioned officers in the army and navy) must be able to direct and manage their operations successfully without the aid of any artificial distinctions or hedging-in methods.

In civil life an executive or "boss" must stand or fall on his own merits, and will not have success unless he has either one of two things—a lovable personality or is a master of his business. In either case men will do for him more and better things than for men lacking these attributes. Men can not be fooled by a substitute for either of these qualities. In this case "four-flushing" is impossible, except on first acquaintance. After that, if the "boss" does not grow bigger and better in the eyes of the subordinate, he will fail in securing the best results from subordinates who feel that way about him. The "boss" must improve on closer acquaintance. Familiarity must breed more admiration and respect, rather than contempt. The days of the executive are numbered whose presence is not welcomed on the job by every worker, especially by the workers who know him best.

This success in handling men is, as before said, merely a matter either of personality or knowledge or mastery of one's work. Every worker in that work—as in the broad field of architecture, with its endless ramifications — must feel a respect for the directing personality if the best results are to be obtained. This respect cannot be artificially created, except as it is done in the navy and army by sheer brute force of the articles of military law. To the civil worker, the creation of artificial respect for a high officer, by various elaborate means, is evidence of a weakness in ability in the average military and naval executive, and it may be concluded that by the word "ability" is implied everything requisite, in which personality or tactfulness would be one of the important factors. In other words, a really able executive must necessarily have a forceful personality, have a certain loveableness in addition to sheer technical knowledge and experience. Without this he can succeed only with the assistance of rigid military law back of him. During the war there were thousands of officers no doubt who could never exercise any executive power in civil life, but were successful in war because behind them were the piled up resources to enforce their commands, of the entire army, of the Congress and the billions of money that the American people were called on to pay. It would seem that almost anybody could succeed under such magnificently ideal conditions.

But these magnificently ideal factors are lacking in straight commercial activities, in every-day architectural work, for example, and to succeed without them requires something superior in the directing mind. That is why the architect who mistakenly carries onto the job the inflexible ideas of army discipline shows a further deficiency or lack of ability by so doing, for were he alert to the factors involved in the case he would quickly distinguish between protected authority and authority which must depend solely on his own merits for success. He may "get by" with it while on the job, but when he leaves the works he will take with him the contemptuous thoughts of the workers and when out of hearing their feelings will be as freely expressed as they may feel the conditions warrant them in doing so.

The successful architect will not depend on the creation around him of an artificial aura or halo, a supposed dignity that makes him respected in spite of his merits, but will get his ideas across to the workers by more real and permanent means. Just dealing, and a recognition of the right of the individual, a recognition of the skill and good intentions of each man on the job, will gain for him a better constructed piece of work, and in the end build good will with labor and make for a more satisfied clientele. For the right kind of an architect may expect that into his buildings under these conditions will be put a little more skill by the workman, a little more thought and study, a little more sympathy for the intent of the architect, a little more understanding of the thing which once was only a dream figment in the architect's brain, and a little more sweat.

Personality can hardly be acquired, it is true, but weak points can be strengthened, and those who have not this quality may as well quit the profession—they will never be more than mediocre products—either that, or get into some department of architecture where personality has no place.

—Building Review.

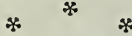

Immense Sums Invested in Movie Theatres

AS a sign of the times, an expression of the mood of a people, the taste of a public, the need for diversion, there is nothing more significant than the multiplicity of theatres, large and small, that are going up throughout the country, says a writer in *Architecture*. Hardly a small town but has its playhouse, usually devoted to the movies and that they are proving a profitable investment is evidenced by the fact that, more than any kind of building, they seem easily financed. The movies have driven out plays from many famous old houses that were once the homes of the legitimate, the largest of new houses are given over to the movies, either with or without accompanying vaudeville or some musical entertainment. In New York there are more than 650 theatres in the greater city, and more are under construction. The amount of money already appropriated for new amusement houses in New York alone amounts, we are informed, to something like \$25,000,000.

The architecture of the theatre seems to be very much specialized and the problems involved call for trained experts in this particular field. The plans vary with the needs of particular localities and purposes, but the fundamental consideration seems the using of spaces to permit of the largest unobstructed seating capacity and the easy inflow and exit of changing audiences, combined with requirements of safety.

One of the great contributing factors in theatre construction of today is the use of reinforced concrete arches. Some of the spaces covered in this way are amazing in their daring and knowledge of the engineering problems involved.

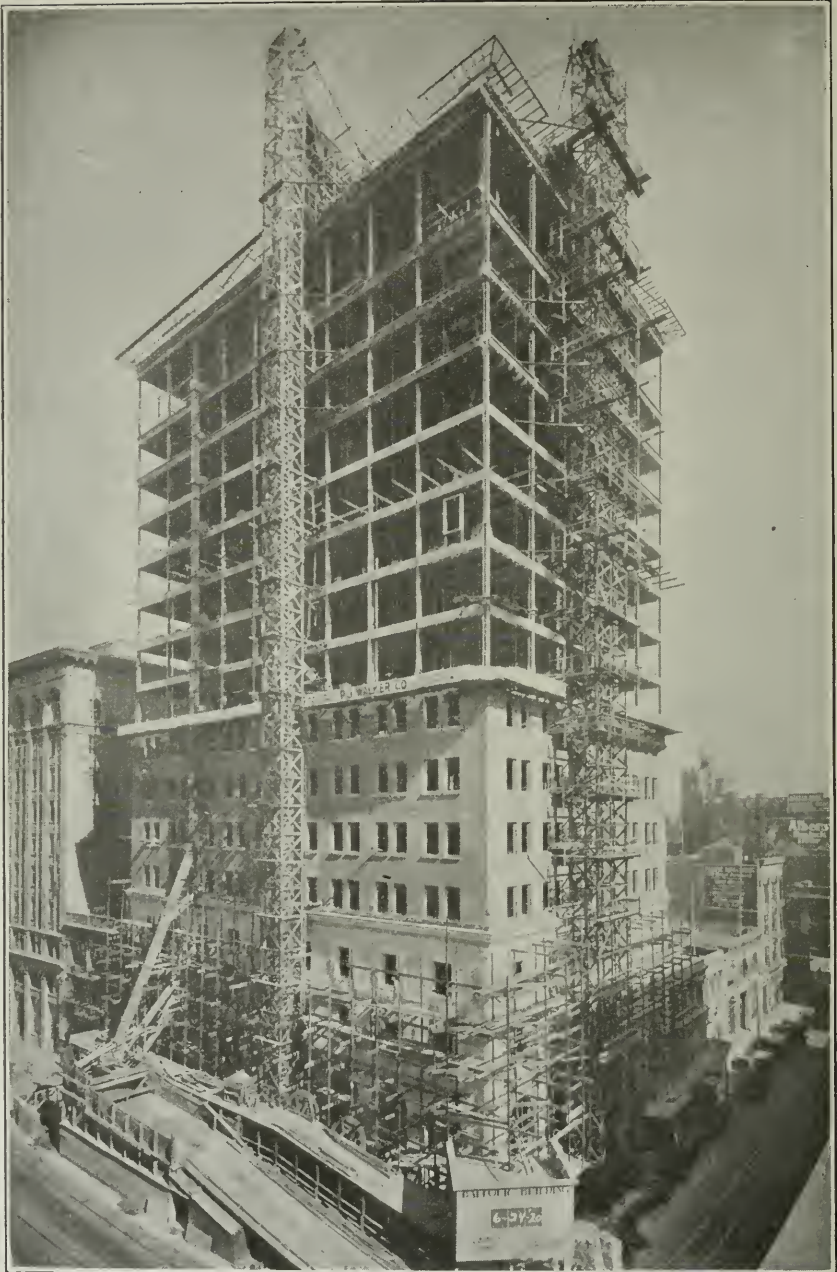

BALFOUR BUILDING, SAN FRANCISCO
GEO. W. KELHAM, ARCHITECT
Substantially constructed towers for hoisting material. Note landings with safety railings and safety suspended scaffolds.

Department of Safety

Conducted in the Interests of the Building
Public and with the Co-operation of the
California Industrial Accident Commission

Preventing Accidents on Building Construction

By J. J. ROSEDALE, Construction Engineer

THE Balfour building, under construction in San Francisco, is breaking all records for speed and the prevention of accidents. Every effort is being made by the contractors to comply with the California Industrial Accident Commission's safety requirements.

The insurance companies are surprised at the low cost of compensation paid out on this job. Up to July 15, 1920, there were only eight slight injuries on this building, and a total of \$725 was paid out for compensation. This structure has surely stricken out the rule from the casualty companies' books that a building more than ten stories in height must lose a life for every story above the tenth floor.

Early in November, 1919, wrecking of the old building and clearing of the site for the new building started, and on February 9, 1920, the steel erection was started for this fifteen-story building. There are numerous rumors among the big contractors in California that this building will beat all previous records on the coast for time of completion.

The building was 70 per cent completed on July 15, 1920, and is expected to be ready for occupancy by November 1, 1920.

Cost of Safeguarding Workers on Building

Planking floors	\$3,500
Guarding machinery	500
Guarding stairways	300
Two towers, including cages and landings.....	2,550
Guarding two elevator shafts	300
250 feet of safety suspended scaffold.....	2,200
Outriggers' scaffold to protect workmen and the public from falling materials.....	350

The total cost of safeguarding 170 workers for the period of twelve months on this job is \$9,700, or \$57.05 per man. These excellent results were accomplished through frequent inspections by the Department of Safety and the cooperation of contractors and employees.

* * *

Safety Belt Saves Life of Line Worker

The safety belt he was wearing probably saved the life of Mr. Will White, lineman employed by the Pacific Gas and Electric Company at Marysville, California. While stringing wires on a pole he came in contact with a wire carrying 2,300 volts, and as he fell free from the wire his belt held him suspended. Another lineman cut the live wire and two others climbed the pole and lowered White with a rope. Holes were burned in White's trousers above the knees. White's brother was electrocuted while working on a pole about a year ago.—San Francisco Examiner.

THE Architect and Engineer

INCORPORATED

Founded 1905 by E. M. C. WHITNEY

W. J. L. KIERULFF - *President and Manager*
 FRED'K W. JONES - *Vice-Pres. and Editor*
 L. PENHORWOOD - *Secretary*
 T. C. KIERULFF - *Attorney*

ASSOCIATE EDITORS

IRVING F. MORROW - *Architectural Critic*
 CHAS. H. CHENEY - *City Planning and Book Reviews*
 WILBUR DAVID COOK, *Landscape Architecture*
 WM. B. GESTER, *Inspection and Tests*
 O. P. SHELLEY, C. E., *Fireproof Construction*
 F. W. FITZPATRICK, }
 T. RONNEBERG, C. E., - *Structural Steel*
 W. H. LOWE - *Roofs and Roofing*
 FRED'K N. WOODS, JR., - *Rock and Gravel*
 W. H. GEORGE - *Cement*
 PAUL C. BUTTE - *Electrical Construction*
 H. J. BRUNNIER - *Reinforced Concrete*
 J. W. FRICKE, - *School Equipment*
 C. H. WHITE - *Hardwood*
 WILL J. FRENCH, *Department of Safety*

Published Monthly in the Interest of the
 Architects, Structural Engineers, Contractors
 and the Allied Trades of the Pacific
 Coast by The Architect and Engineer Co.

BUSINESS OFFICE AND EDITORIAL ROOMS
 627-629 Foxcroft Building, San Francisco
 Telephone Douglas 1828

The publishers disclaim any responsibility for statements
 made in the advertisements of this magazine.

TERMS OF SUBSCRIPTION
 (Including postage) to all parts of the United States \$2.50
 per annum; to Canada 75c additional; to all Foreign points
 \$3 additional.

Vol. LXIII. Oct., 1920 No. 1

THE BUILDING SITUATION IN SAN FRANCISCO

We read that the Central Council of the San Francisco Builders' Exchange, which is composed of a number of prominent contractors, has declined to grant any further wage increases. The union plasterers, for example, recently asked for a raise of \$2 a day, making their pay \$12 instead of \$10. The request was refused, as were similar demands from other crafts of the building industry.

It remains to be seen how effective the builders are going to make their latest stand. If they pull together and decline to be coerced into granting further increases on the ground that the zenith of high wages has been reached, there is some hope for the future, but if, on the other hand, the contractors do not stand "pat," if they continue to grant increases despite written agreements with their men—it would be folly to expect any material betterment in existing conditions.

If things are allowed to go on as they have been going the past year, there is small likelihood of an immediate building revival.

Contractors who have been paying bonuses over the union wages have done more to lower the efficiency of labor than they have any idea; and this practice must cease if normal conditions are to be restored.

With the fall of prices in commodities and foodstuffs there is no longer excuse for the labor unions to renew their demands every two or three months for more pay. They should stand by agreements with their employers, at least until the expiration of these contracts. For some time past a contract has been taken about as seriously as was a certain historic treaty that its maker characterized as a "mere scrap of paper."

With a demand for more building, unparalleled since the great fire, San Francisco, and all California for that matter, will see a tremendous building revival if labor will be content to give an honest eight hours' working day for a livable wage. Ample capital will be forthcoming with a stabilization of prices and a definite, permanent wage basis. Transportation facilities are going to adjust themselves very shortly and the shortage of material is already being overcome. To meet public needs building must resume its normal activities.

Latest developments in the San Francisco labor situation provide for arbitration of differences between the unions and their employers. Well and good, if this arbitration is for a definite, specified time. If it is only a temporary understanding it will be but a question of a short while when we will have another disagreement and conditions will be as deplorable as ever.

BUILD RIGHT

Primarily "good design" has, among architects, grown to mean attractive, well-proportioned buildings representing some "period," the plans of which are arranged to meet the demands of occupancy while the features of "structural" design are usually given but secondary consideration.

It is not uncommon to hear the designer or architect remark, upon learning that no building regulations exist: "I am glad of that, now we can go ahead as we wish without restrictions." This either indicates a decided lack of appreciation of the value of legitimate restrictions to building or else inadequate knowledge of the methods of their application. In either case it is the wrong spirit and tends to impede not only the progress of legitimate building, but of the architectural profession as well.

Designs should, when drawn, include as much, if not more, of the practical as of the theoretical, since the proper application of one should be dependent upon the other. For example: A professor of design in a school of architecture was insistent upon placing a ten-ton money vault directly in the center of a second-story room the size of which was 50x80, with no intermediate supports. This gentleman acquired a national reputation as a designer of well proportioned and beautiful exteriors, but his knowledge of the application of practical design was decidedly lacking.

Few architects know, neither do they care, how much it may cost a client to maintain a building after its completion. The proper distribution of radiation of heat pipes is often left to the heater man who uses his best business judgment to underbid the other fellow and after securing the job tries to see how much profit he can make. In the meantime the owner has to spend one or two hundred dollars more a year for coal, or perhaps his house may burn up because the heat pipes were not located properly with relation to combustible material.

In the mad scramble for dollars, safety and legitimate economy are forgotten, our great annual fire loss continues, building laws exist in but two hundred of our 1,400 larger cities, and the architects and builders are permitted to build as they see fit, without regard for safety.

It requires but a small amount of reasoning to see why every town and city should be supplied with ordinances regulating the construction of build-

ings. Build your town for the future as you would your own business. Restrict the types of construction in the congested districts to fire safe buildings. Have plenty of space, air and light surrounding each dwelling in the uncongested districts for health and fire protection.

Notes and Comments

Domestic Engineering has an editorial under the above heading. It claims that a grave injustice is being done the plumber by cartoonists and writers in newspapers and national magazines "who continually knock the plumber."

Our contemporary thinks it is "time to call a halt" on this sort of humor. We agree that the time has arrived, but who is going to call "Halt"? Who is going to tell the editor, who has had a personal experience with a certain brand of plumber, that such a fellow does not exist and that the personnel of the industry must not be lampooned further?

The halt will be called by the plumbers themselves when they decide to call themselves something more in keeping with their craft and its importance to society. According to an old proverb: "A person with a bad name is already half hanged." And the Good Book tells us that "a good name is rather to be chosen than great riches." Change the bad name. Choose a good name.

Sister Anne is Hoping

The Chamber of Commerce of the United States, Washington, D. C., recently sent out the following:

Building construction is very much the same here as in the remainder of the country. It has practically come to a standstill because of being tied hand and foot by high prices and the unreliability and uncertainty of labor, high prices and scarcity of material, and the almost impossibility of financing any construction. The Sister Anne of Hope is sitting upon the housetop of expectancy, scanning the distant horizon for that little cloud of dust which shall announce the stability of labor, the lowered costs of construction, the possibility of getting building material, and the loosening of credit, that are needed for the resumption of activity in this great and important industry.

American Institute of Architects

(ORGANIZED 1857)
OFFICERS FOR 1920-21

PRESIDENT.....HENRY H. KENDALL, Boston
FIRST VICE-PRESIDENT.....CHARLES A. FAVROT,
New Orleans, La.
SECOND VICE-PRESIDENT.....WM. B. FAVILLE,
San Francisco
SECRETARY....W. STANLEY PARKER, Boston, MASS.
TREASURER.....D. EVERETT WAID, New York

San Francisco Chapter

PRESIDENT.....SYLVAIN SCHNAITTACHER
VICE-PRESIDENT.....ARTHUR BROWN, JR.
SECRETARY.....MORRIS M. BRUCE
Directors, WILLIAM MOOSER JNO. REID, JR.
WM. O. RAIGUEL CHAS. PETER WEEKS

Southern California Chapter

PRESIDENT.....EDWIN BERGSTROM
VICE-PRESIDENT.....HENRY F. WITHEY
SECRETARY.....R. GERMAIN HUBBY
TREASURER.....AUGUST WACKERBARTH
Executive Committee
A. M. EDELMAN ROBERT H. ORR S. B. MARSTON

Portland, Ore. Chapter

PRESIDENT.....W. C. KNIGHTON
VICE-PRESIDENT.....JOHN V. BENNES
SECRETARY.....FOLGER JOHNSON
TREASURER.....O. R. BEAN
TRUSTEES.....{ ELLIS F. LAWRENCE
JOSEPH JACOBBERGER

Washington State Chapter

PRESIDENT.....CHARLES H. ALDEN, Seattle
1ST VICE-PRESIDENT.....JAMES H. SCHACK, Seattle
2D VICE-PRESIDENT.....GEORGE GOVE, Tacoma
3D VICE-PRESIDENT.....L. L. RAND, Spokane
SECRETARY.....F. A. NARAMORE, Seattle
TREASURER.....EARL G. PARK, Seattle
DIRECTORS.....{ A. H. ALBERTSON
C. H. BEBB
G. C. FIELD

California State Board of Architecture

NORTHERN DISTRICT

PRESIDENT.....CLARENCE R. WARD
SECRETARY-TREASURER.....SYLVAIN SCHNAITTACHER

Members

J. R. MILLER EDWARD GLASS J. J. DONOVAN

SOUTHERN DISTRICT

PRESIDENT.....JOHN PARKINSON
SECRETARY-TREASURER.....A. M. EDELMAN

Members

W. H. WHEELER MYRON HUNT W. J. DODD

San Francisco Architectural Club

President.....Harry M. Michelson
Vice-President.....T. Pflueger
Secretary.....W. E. Baumberger
Treasurer.....James S. Cole
Directors—F. F. Amandes, N. Reinhertz, E. B. Hurt.

San Francisco Society of Architects

President.....W. C. HAYS
Vice-President.....LEWIS P. HOBART
Secretary-Treasurer.....H. H. GUTTERSON
Directors.....{ GEO. A. LANSBURGH
JOHN REID, JR.

Washington State Society of Architects

PRESIDENT.....HENRY H. JAMES, Seattle
1ST VICE-PRES.CLAYTON D. WILSON, Seattle
2D VICE-PRES.JULIUS A. ZITTEL, Spokane
3D VICE-PRES.WATSON VERNON, Aberdeen
4TH VICE-PRES. ...RICHARD V. GOUGH, Okanogan
SECRETARY.....EDGAR BLAIR, Seattle
TREASURER.....L. L. MENDEL, Seattle
TRUSTEES—H. H. JAMES, FRANK FOWLER, A. WARREN GOULD, W. J. JONES, R. H. ROWE, all of Seattle.

Pacific Coast Society of Landscape Architects

Chapter of Am. Society of Landscape Architects
PRESIDENT.....W. D. COOK, JR.
H. W. Hellman Bldg., Los Angeles, Calif.
VICE-PRESIDENT.....STEPHEN CHILD
Fairmont Hotel, San Francisco, Calif.
SECRETARY-TREASURER.....E. T. MISCHIE
Henry Bldg., Portland, Oregon

Tacoma Society of Architects

PRESIDENT.....Roland E. Borhek
VICE-PRESIDENT.....Earl Dugan
SECRETARY AND TREASURER.....A. J. Russell

San Diego Architectural Association

PRESIDENT.....WM. TEMPLETON JOHNSON
VICE-PRESIDENT.....ROBERT HALLEY, JR.
SECRETARY-TREASURER.....E. C. DECKER

San Joaquin Valley Ass'n of Architects

PRESIDENT.....E. B. BROWN
VICE-PRESIDENT.....F. V. MAYO
SECRETARY-TREASURER.....JOSEPH LOSEKANY

**American Society of Civil Engineers
Southern California Association**

PRESIDENT.....GEO. G. ANDERSON
FIRST VICE-PRESIDENT.....H. W. DENNIS
SECOND VICE-PRESIDENT.....W. K. BARNARD
SECRETARY.....F. G. DESSERTY
TREASURER.....RALPH J. REED

DIRECTORS

LOUIS C. HILL GEO. G. ANDERSON
W. K. BARNARD
H. HAWOOD RALPH J. REED
H. W. DENNIS F. G. DESSERTY
All communications should be addressed to Mr. Desserty, 511 Central building, Los Angeles.

San Francisco Association

PRESIDENT.....M. M. O'SHAUGHNESSY
1ST VICE-PRES.....W. L. HUBER
2ND VICE-PRES.....F. R. MUHS
SECRETARY AND TREASURER.....NATHAN A. BOWERS

BOARD OF DIRECTORS

W. L. HUBER
F. R. MUHS M. M. O'SHAUGHNESSY
E. J. SCHNEIDER NATHAN A. BOWERS
Address all communications to the secretary, 502 Rialto Bldg., San Francisco.

American Association of Engineers

National Headquarters, 63 E. Adams St., Chicago

PRESIDENT.....L. K. SHERMAN
FIRST VICE-PRESIDENT.....H. O. GARMAN
SECOND VICE-PRESIDENT.....A. B. MCDANIEL
R. W. BARNES.....Portland
FREDERIC BASS.....Minneapolis
B. A. BERTENSHAW.....Cincinnati
W. C. BOLIN.....Chicago
RAYMOND BURNHAM.....Chicago
C. E. DRAVER.....Secretary

SAN FRANCISCO CHAPTER

PRESIDENT.....WILLIAM WOLLNER
FIRST VICE-PRESIDENT.....J. F. JOHNSTON
SECOND VICE-PRESIDENT.....W. H. PHELPS
TREASURER.....R. L. KESSING
SECRETARY.....A. G. MOTT

Permanent address, 960 Pacific Bldg.

LOS ANGELES CHAPTER

PRESIDENT.....FRANK H. GAYNER
FIRST VICE-PRESIDENT.....C. A. HEINZE
SECOND VICE-PRESIDENT.....H. Z. OSBORNE, JR.
SECRETARY.....D. E. GODFREY
TREASURER.....E. H. MERRILL
Permanent address, 625 Metropolitan Bldg., Los Angeles.

With the Architects

Building Reports and Personal Mention of Interest to the Profession

Architect Hobart Busy

New work in the office of Mr. Lewis P. Hobart, Crocker building, San Francisco, includes a three-story reinforced concrete dwelling for the Jesuit Fathers on Fulton street and for which a contract has been awarded for \$102,500 to W. C. Duncan & Co.; alterations and additions for the Firemen's Fund Insurance Company; four houses at Pebble Beach, ranging in price from \$20,000 to \$40,000, and alterations to the country house at Pebble Beach of Col. John H. Poole.

Y. W. C. A. Buildings

Miss Julia Morgan, architect in the Merchants Exchange building, San Francisco, is preparing plans for recreation and dormitory buildings for the Y. W. C. A. at Fresno, and for an association building at Honolulu. Miss Morgan has completed plans for a Community Center building to be erected on Milvia street, Berkeley, for the Calvary Presbyterian Church.

Designing Fraternity House

Mr. H. H. Gutterson, 78 Post street, San Francisco, is preparing plans for a fraternity house for the Delta Kappa Epsilon in Piedmont Place, Berkeley. Construction will be in charge of Mr. Frederick Whitton. Mr. Gutterson has completed plans for a large country house at Los Altos for Mr. C. H. Blake to cost \$60,000.

Farm Buildings

Mr. Robert H. Orr, Van Nuys building, Los Angeles, is preparing plans for a group of fifteen hollow tile and frame ranch buildings for the Azusa Foothill Citrus Association. The same architect has revised plans for a brick fire house and jail at Pomona to cost \$60,000.

Bank Building

Messrs. Reed and Corlett, architects in the Oakland Bank of Savings building, Oakland, are preparing plans for a one-story reinforced concrete bank building for the Commercial Bank of Patterson. About \$50,000 will be expended on the improvements.

Personal

Mr. J. C. ALLISON, chief engineer and general manager of the Palo Verde Joint Levee District, has placed his resignation in the hands of the new board of directors, which is said to be committed to a different policy from that adopted by the old board by whom Mr. Allison was retained. The resignation has not been accepted and efforts will be made to find ground for a compromise.

Mr. RALPH WHITAKER, for three years city engineer of Bakesfield, has resigned to accept a position with a cement company at San Diego. Mr. R. H. Hubbard, former assistant city engineer, has been appointed to fill the vacancy.

Mr. HARRY E. HUDSON, architect, has opened offices at 7619 Aurora avenue, Seattle. He was formerly a member of the firm of Hudson Brothers, architects, American Bank building, which firm has been dissolved.

Mr. CHARLES CHEVALLEZ, who has practiced architecture in Seattle for the past seven years, is making a tour of Europe and at present is in Switzerland.

Mr. LLOYD ALDRICH, county engineer of Sonoma county, has resigned.

Mr. D. C. COLLMAN has moved to the French Bank building, San Francisco.

Berkeley School Construction

The entire Berkeley bond issue for new school buildings has been purchased, largely by individual capitalists and banks, and the Berkeley school construction program, as originally planned, will now be carried out. Contracts let on the Lincoln and Garfield schools will stand and construction is now under way.

Plans are finished for the Jefferson school and high school gymnasium and bids will be called for shortly.

Architect Hays has been instructed to complete drawings for the Hawthorne school, to cost \$90,000, and for Longfellow school, to cost \$50,000.

Sacramento Schools

Preliminary plans for the new Sacramento High School and the Elmhurst and El Dorado schools have been approved by the Board of Education.

Two Big Elevator Contracts

Two of the largest elevator contracts to be awarded in San Francisco in years were let during the past month, one to the Otis Elevator Company for installing a battery of nine cars in the new Standard Oil building at a contract price of \$386,000, and the other to the Spencer Elevator Company for eleven freight elevators in the six-story concrete warehouse of the Southern Pacific Company for \$90,000. In connection with the Standard Oil installation it is interesting to note that the contract price of \$386,000 is more than the original cost of the Sharon building. The new Standard Oil building will be twenty-one stories high.

Oakland Architect Busy

Mr. W. J. Wilkinson, formerly with Mr. Edgar Mathews and now practicing architecture independently with offices in the First Trust building, Oakland, has a large volume of prospective work on the boards, including two private hospitals costing \$60,000 and \$40,000 each, a hotel in Madera, a Masonic temple, two store and loft buildings, a warehouse and thirty cottages. Plans have been completed by the same architect for the new Oakland Labor Temple, construction of which will start in the spring.

Passing of Mrs. C. P. Weeks

Mr. Charles Peter Weeks, senior member of the architectural firm of Weeks & Day, San Francisco and Los Angeles, has the sympathy of the profession in the death, September 28th, of his wife, Ora Crawford Weeks, daughter of Mr. John K. Crawford. Mrs. Weeks was 40 years of age, a woman of beautiful character, and beloved by a wide circle of friends.

Big Sugar Warehouse

The construction department of the California-Hawaiian Sugar Refining Company at Crockett, Mr. A. A. Brown, chief engineer, is preparing plans for a two-story steel concrete and brick warehouse having 120,000 square feet and which will cost \$600,000.

Laboratory Building

Mr. John Galen Howard, First National Bank building, San Francisco, is preparing plans for a two-story reinforced concrete office and laboratory building, 110 by 144, for the Union Oil Company, Los Angeles.

Three Methodist Churches

Mr. W. J. Wythe, Central Bank building, Oakland, has completed plans for Methodist churches to be built at Byron, Escalon and Riverbank.

Montana Architects Meet

The Montana Association of Architects met at Bozeman in annual session on August 28th. The meeting continued throughout the day and adjourned for a trip through the Yellowstone Park, ending with another session at Old Faithful Inn on August 30th. The convention was well attended and was called together by Mr. Chandler Cohagen of Billings, president of the association at the college. The first speaker was Dean E. B. Norris of the Engineering department.

In the afternoon Prof. W. R. Plew, of the college, gave a talk on architectural engineering and after a discussion it was suggested by the association that it was to the interest of both the college and the association to make out a program of lectures for the architectural students. Mr. A. B. Ingals gave an interesting stereopticon lecture on steam and hot water heating. Mr. James Mills, of Great Falls, spoke of the benefits to be gained by closer cooperation between the architects and the electrical contractors and the desire of the latter to elevate their profession. Mr. Fred Powers, of Bozeman, talked on the false economy of cheap construction of buildings in Montana, where winter heating was an important item and poor construction involves a loss of heat and the burning of more fuel.

A committee consisting of Messrs. C. C. Cohagen, W. V. Marshall and Fred F. Wilson met with Dean Norris and Prof. Plew and went over the course in architectural engineering at the college for changes.

\$300,000 Portland Hospital

Mr. Ernest Kroner, architect, 301 Spalding building, Portland, Oregon, is preparing plans for three buildings to be built for the Emanuel Hospital at Commercial and Stanton streets, Portland, at a cost of \$300,000.

The hospital group will include a six-story Class A hospital building to be constructed of reinforced concrete with face brick front; a four-story nurses' home of ordinary construction, using brick walls, and a fireproof power house.

Store and Office Building

Messrs. Walker and Eisen, Hibernian building, Los Angeles, are preparing plans for a four-story brick store and office building to be erected on Western avenue, near Sixth street, Los Angeles, for Dr. L. E. Ford. The building will cost \$85,000.

Gymnasium Building

Mr. Ralph P. Morrell of Stockton has prepared plans for a frame gymnasium to cost \$10,000 for the Ripon High School district.

Santa Rosa Country Club

Plans have been finished by Mr. Albert Farr, architect in the Foxcroft building, San Francisco, for a club building for the Santa Rosa Country Club. Construction will be frame and native stone, and the cost is estimated at \$30,000.

Mr. Farr has let contracts for a large country house at Atherton, San Mateo county, for Mr. R. S. Moore, president of the Moore Shipbuilding Company.

San Francisco Apartment Houses

Mr. C. O. Clausen, Hearst building, has completed plans for six apartments to be built in the Park Presidio District and which embody many new ideas in apartment house construction. Mr. Clausen has also made plans for a three-story frame apartment house to be built on the northeast corner of Fourteenth avenue and Anza street, for Mr. Charles A. Johnson.

Vallejo Hotel

The firm of Heller and Wilson having dissolved partnership, the preparation of plans for the proposed Admiral Hotel at Vallejo has been given to Mr. Chas. E. J. Rogers, architect in the Phelan building, San Francisco. The building is to be six stories high, constructed of reinforced concrete and will cost in the neighborhood of \$250,000.

Addition to Business Building

A one-story addition is to be built to the five-story store and loft building at Grant avenue and Tillman alley, San Francisco, from plans by Mr. Herman Barth. Mrs. W. W. Young is the owner and Hirsch and Kaye are the lessees. Construction will not start until spring.

\$250,000 Court House

The supervisors of Chelan county, at Wenatchee, Washington, have appropriated \$254,000 for the construction of a new court house. They have appointed an architect and announcement is made that construction will start this fall.

Christian Science Churches

Four new Christian Science churches are projected in the Bay regions, two in Oakland, one in Alameda, from plans by Mr. Carl Werner, and one in San Francisco from plans by Mr. Walter C. Falch.

Jack London Memorial Library

Plans are being prepared by Mr. Harry Merritt of Glenn Ellen for a stone and concrete library which will be erected in Glenn Ellen as a memorial to the late story writer, Jack London.

City Planning Commissions

Whittier is to have a city planning commission, the city trustees having passed an ordinance for the appointment of one consisting of one member of the board of trustees, the city engineer, the city attorney and two citizens. The mayor will be a member ex-officio. The commission will act in an advisory capacity on all matters affecting city planning.

San Jose is also going to have a city plan, and Mr. Ernest Curtiss, the architect, has been appointed a member of the committee to draw up a suitable ordinance.

Parish House and Bank Building

Mr. B. G. McDougall, architect in the Alta building, San Francisco, has been commissioned to prepare plans for a new parish house for St. James Episcopal church, Los Angeles. Later an auditorium will be built. Mr. McDougall is also making drawings for a reinforced concrete bank building at Pittsburg, for the Contra Costa County bank. About \$75,000 will be expended on the building and fixtures.

San Jose Garages

Mr. John H. Powers, San Francisco architect, is preparing plans for an \$80,000 automobile sales building and garage at San Jose.

Mr. Charles McKenzie has completed plans for a \$16,000 concrete garage in the same city.

Auto Assembling Plant

The Scripps-Booth Company of California will erect a \$250,000 assembling plant near the Chevrolet factory in East Oakland. The P. J. Walker Company has been commissioned to put up the building and construction will start this fall.

Moving Picture Studios

The W. C. Duncan Company has been given the contract to build a group of Mission type moving picture studio buildings at San Mateo for the Pacific Studios Company. The improvements will cost \$500,000.

Gilroy Masonic Temple

Mr. William Radke of Gilroy submitted the low bid to erect a Masonic temple and moving picture theatre at Gilroy, from plans by Messrs. Reid Bros., California-Pacific building, San Francisco, for about \$90,000.

Alterations to Club Building

Mr. H. G. Simpson, 110 Sutter street, San Francisco, is preparing plans for extensive alterations to the clubhouse of the McCloud Country Club at McCloud, Siskiyou county.

A. I. A. CHAPTER NEWS

THE OFFICIAL MINUTES

San Francisco Chapter, A. I. A.

The regular monthly meeting of the San Francisco Chapter of the American Institute of Architects was held in the rooms of the San Francisco Architectural Club, 77 O'Farrell street, on Thursday evening, September 16, 1920, at 7:30 p. m.

MINUTES

The minutes of the meetings held on April 15th and June 17th were read and approved. No meeting was held in May owing to a lack of a quorum. No meetings were held during the months of July and August owing to the summer vacation.

REPORTS OF STANDING COMMITTEES

Executive Committee.—During the summer months the Board of Directors held two meetings. The principal matters to come before these meetings on which action was taken are as follows:

The Chapter was invited to become a member of the Joint Council of the Engineering Societies of San Francisco and it was suggested that the Chapter join the Council, as many matters of mutual interest may thus be thrashed out. The expense is \$3.00 per month.

The consideration of revisions to the building laws permitting improved conditions of loading and design for reinforced concrete construction, and several other matters came up for passage before the Supervisors at a meeting held on Monday night, August 16th.

After some correspondence with Mr. William Otis Raiguel relative to retaining his Chapter membership, but resigning from the Institute, the Board of Directors sent a communication to the Secretary of the Institute, Mr. Wm. Stanley Parker, recommending that Mr. Raiguel's resignation from the Institute be accepted and in accordance with the by-laws of the Chapter Mr. Raiguel is entitled to retain his membership in the Chapter.

GENERAL BUSINESS

Communications.—From Mr. E. C. Kemper, Executive Secretary of the Institute relative to the application of Mr. Edwin J. Symmes as an Institute member and one relative to the National Fire Protection Association; from Mr. Wm. Stanley Parker, Secretary of the A. I. A., relative to the same matter and one in re Congress of the Building Industry; from Mr. R. Germain Hubby, Secretary of the Southern California Chapter, A. I. A., enclosing copy of resolution relating to the procedure and action of the American Institute of Architects in the matter of Jurisdictional Awards; from California Housing and Building Institute enclosing Supplement to

Progress Report No. 4, and Circular Letters Nos. 5 and 6; from the Central Council of the Builders' Exchange enclosing minutes of Arbitration Committee; from the Central Bureau of San Francisco Organizations for the General Welfare and Upbuilding of San Francisco, asking the Chapter to become a member of this organization.

In the matter of the communication from Mr. Wm. Stanley Parker in re National Fire Protection Association, the following resolution, on motion duly seconded, was carried:

RESOLVED, That the Chapter endorses the action suggested in the report of the Board of Directors of the Institute that the Chapter should appoint committees to cooperate with building departments and fire chiefs in the matter of approval of plans and inspection of buildings, to the end that fire hazards may be reduced and that a copy of this resolution be sent to the Board of Supervisors of San Francisco.

In this connection Mr. Mooser reported to the Chapter that he is a member of the Board of Directors of the local Chapter of the National Fire Protection Association.

In the matter of the communication from the Southern California Chapter in re the Institute's action in connection with Jurisdictional Awards, it was the sense of the meeting that the Chapter cannot express an opinion on the matter at present, and that the Southern California Chapter be so notified.

The communication from the Central Bureau of San Francisco Organizations was referred to the Board of Directors for action.

On motion duly made, seconded and carried, the report of the Nominating Committee was ordered received and filed.

Mr. Coxhead offered a resolution proposing a means of financing the Institute, which on motion was ordered received with instructions that it be printed and distributed to the members, and action deferred until the Annual Meeting.

REPORT OF THE NOMINATING COMMITTEE

The report of the Nominating Committee was read, as follows:

To the President and Members of the San Francisco Chapter, American Institute of Architects.

Dear Sirs:—Your Nominating Committee begs leave to make the following report as to its findings in the matter of nominations for officers and directors for the coming Chapter year, to be elected in October:

For President, Mr. G. A. Applegarth.
For Vice-President, Mr. E. A. Coxhead.
For Secretary, Mr. J. S. Fairweather.
For Directors, Messrs. Sylvain Schnaittacher, Morris M. Bruce, George W. Kelham (to fill unexpired term of Mr. Wm. O. Raiguel, resigned).

Respectfully submitted,
(Signed) W. B. FAVILLE,
J. W. DOLLIVER,
WM. MOOSER, Chairman.

ADJOURNMENT

There being no further business before the Chapter, the meeting adjourned at 8:30 p. m.

MORRIS M. BRUCE, Secretary.

With the Engineers

Reports from the Various Pacific Coast Societies, Personal Mention, Etc.

Presidential Nominees Answer Engineers' Interrogations

SENATOR W. G. HARDING and Governor James M. Cox of Ohio have both made replies to list of questions submitted them by the American Association of Engineers. The questions were drafted at a recent annual convention of the American Association of Engineers and submitted to both presidential candidates in August.

The questions asked were as follows:

1. Are you in favor of a National Department of Public Works, for the purpose of reducing and coordinating the present number of bureaus and commissions, and reducing the useless expenditures of money incident thereto?
 2. Are you in favor of assembling and coordinating all the engineering and construction enterprises of the government (excepting the purely military works) in a department such as the National Department of Public Works, to the end that economy and efficiency will be obtained?
 3. Do you favor the appointment of an engineer of recognized ability and unimpeachable character as a member of the Inter-State Commerce Commission?
 4. Do you favor a progressive and constructive program of conservation and development of our natural resources?
 5. Do you favor the budget system of appropriation of public funds?
 6. Do you favor the reclamation of waste lands by drainage, irrigation, flood control or other methods?
- Do you favor giving the settler the advantage of procuring the land by a sound financial system such as is provided by a rotating fund?

To those questions the following letters have been received:

State of Ohio, Executive Department,
Columbus, August 13, 1920.

Mr. L. K. Sherman, President,
American Association of Engineers,
63 East Adams street, Chicago, Ill.

Dear Mr. Sherman:

My reply to every one of the questions you ask is unequivocally "Yes." Time will not permit, nor do I consider it proper, that I answer the ordinary questionnaire. My past record and public utterances must be sufficient, however, as in the case of your letter, the reply to questions asked and my record and public announcements are one and the same. I therefore take great pleasure in making this statement.

With every good wish, I am,

Yours very truly,
JAMES M. COX.

Marion, Ohio, August 9, 1920.

Mr. C. E. Drayer, Secretary,
American Association of Engineers,
63 Adams street, Chicago, Ill.

My dear Mr. Drayer:

Your letter to Mr. Christian of August 4th has been brought to my attention.

It is not an easy matter for me to make a detailed reply to the inquiries conveyed in your letter and I do not care to enter into a categorical reply to questionnaires, no matter how friendly they may be and no matter how reputable and high standing is the source from which they come.

My theory of a campaign is, that a man's candidacy ought to be based on the formal and public utterances, though, of course, we are all of us informal enough to discuss informally many of the problems which are in the minds of various groups of our American citizenship.

I have had up the matter of the Department of Public Works in some personal interviews and quite agree with you that the question is an exceedingly interesting and important one. I fear I should be unworthy of public confidence if I ventured to decide so important and far-reaching a question without the very fullest study. It involves the reorganization of several departments. Undoubtedly, there is necessity for this, but I should be very reluctant to unalterably commit myself to it without the very fullest of understanding.

You may be interested to know that I have already sent for the Congressional hearings on this particular question.

I may say, in a general way, that I think very well of the appointment of an engineer on the Interstate Commerce Commission and I have always spoken heartily in favor of a progressive and constructive program of conservation. I am sure you know that I favor the budget system and a very forward policy relating to reclamation and irrigation.

Very sincerely yours,
W. G. HARDING.

These letters are published to the engineering profession by the American Association of Engineers in furtherance of its policy of forwarding the public interest by the means at its command.

The Association believes that the six questions asked the two principal candidates for the presidency of the United States are of great importance to the American people and it has requested those candidates to announce their stand upon the policies involved, in order that the electorate may be informed definitely upon them. Engineers are in a position to give sound thought to certain matters of public policy and hope to be able to safeguard the interests of the public in those matters with which engineers are by the nature of their calling familiar. It should be distinctly understood that the political activities of the American Association of Engineers are non-partisan and that the association places the interests of the people of the United States ahead of party, ahead of the interests of the engineering profession itself.

The Engineer and the Painter vs. the Architect

MR. WYNDHAM LEWIS, the British artist, recently criticized the modern architect very severely and somewhat unjustly. Nevertheless, there is food for thought in at least a part of his utterances, as, for example:

The painter and the engineer could buy him (the architect) out, going into partnership, and produce what would be neither a world of boxes on the one hand, as it would be if the engineer controlled house construction, nor of silly antique fakes on the other, as happens when the architect has his sweet and horrible way.

Let us banish absolutely the stylistic architectural rubbish. But even as to the shaping of the box or series of boxes let the artist be used.

We hear a great deal of rubbish talked about the skyscraper. The skyscraper, for the most part, is a tall box. So far it has been nothing but that; except where, as in the Schiller Theater building in Chicago, and the famous Woolworth buildings, some dreadful intervention of art has converted it into an acre-high advertisement of the modern architect's faculty.

It has been a fashion lately to admire the skyscraper in its purely engineering forms, and other forms of quite plain engineering construction. But a box is always a box, however high. And when you think of the things that could have been done by a liaison of the artist's fancy, once more, with all those works of engineering genius, you wonder that there is not one single example which one can quote of such a structure.

Mr. Lewis is not very definite in pointing out how much of a part the "painter" should play in his suggested association with the structural engineer, but the following quotation indicates that the "painter" should do more than decorate the surface of the building with suitable color.

If you say that the design and ornament over the body of the building is the same as the clothes on a man's back, there is still something to be said about the naked shape of the man or even for his skeleton. The nature of the body or of the skeleton will decide what the character of the clothes must be. So the artist should come in long before he usually does, or give a new consciousness to the shaping of the skeleton of the engineer. This should be invariable, not occasional; that is, when the first painters or sculptors have been used for this purpose, instead of the horrible stock architect.

The question naturally arises as to a "painter's" ability to "shape the skeleton" more artistically than it is ordinarily shaped by an architect. Would not a "painter" capable of artistic design of the "skeleton" be in reality less a painter and more an architect? Is not Mr. Lewis vainly striving to make the terms "painter" and "artist" synonymous?

It seems to us that what Mr. Lewis is really attacking is not the architect in general but the imitative and conventional architect. Such an attack may with equal force be directed against the average artist, whatever his class, whether painter, musical composer, sculptor or architect; and the following picture will therefore be quite as true of the average "art man" of one class as of another:

He gushes about everything he sees. He is enraptured at the curious clumsy country print found on the lodging house wall; at the beauty of cheap china ornaments, a stupid chair, a staring, mean, pretentious little sea-side house. When with any-

body, he will titter or blink or faintly giggle when his attention is drawn to such a winning and lovely object. I am, you will perceive, drawing a picture of the English variety of art man. The most frequently used epithet will be "jolly" for the beautiful; and the pursuit will invariably be described as "fun." So we have before us, all said and done, a very playful fellow indeed, who quite enters the spirit of this "amusing" life, and who is as true a "sportsman" as any red-coated squire; only for the pursuit of "jolly" little objects like stuffed birds, apples or plates, areas of decayed wallpaper, and the form of game that he wishes rather smirkingly and haughtily to devour, he must be as cunning, languid, and untidy as his distinguished fellow-sportsman is alert, hearty, and colored like a letter-box.

For stalking a stuffed bird you have, in the first place, to be a little bit dead yourself.—Engineering and Contracting.

Engineers in Membership Campaign

Fourteen hundred members of the American Association of Engineers have signed intention slips which pledge them to obtaining five new members each before the end of 1920. The 1920 membership campaign commenced on September 15th and will last until October 30th. A banner is offered to the Chapter obtaining the greatest number of members and another banner to the Chapter having the greatest per cent of increase in membership. Other banner prizes are offered in the four divisions into which chapters are grouped according to size. Individual prizes are to be given to the thirteen members obtaining the greatest number of applications.

The ten chapters having the most intention slip men are:

Chicago	119
New York	86
Mich. S. A.	76
San Francisco	56
S. W. Territory	53
Los Angeles	32
Twin City	30
Boston	24
Cleveland	20
Washington, D. C.	18

The Women's Engineering Society

RUNNING across the foregoing title in Engineering (London) "gives us pause." The Society was organized in 1920 and it has just held its first annual meeting.

This is one of the outgrowths of the war. Women then stood energetically and efficiently by the side of man in practically all of the skilled trades and in most of the professions. Return of peace conditions forced many of them out of industry and out of the professions and back to former modes of livelihood. But enough of them were left who did not consider it fair that they should not be allowed to continue in their new positions and these have organized a regular engineering society. They are publishing the Woman Engineer, have a club room in Dover street, London, and a library where technical books and papers may be read and consulted.

We are informed that several of the institutions of engineers in Great Britain have opened their doors to women, and we may expect before long to find the woman engineer as common as the woman physician and making a name for herself as well in the one profession as in the other.—Valve World.

Early Next Year a Good Time to Build

By E. H. NORBLOM, President of the Minneapolis Builders' Exchange.

STATISTICS show that prices for building have advanced less than most other things. Prices for lumber have declined, and it is generally believed that any reductions in prices that may be expected for several years will take place between now and early spring. It is stated on good authority, that from 75 to 80 per cent of the cost of building material represents labor. This includes mining of coal used in manufacturing, transporting, handling and hauling. It is, therefore, obvious that until there is a reduction in wages, building material will not be much cheaper. No one expects a decline in wages until the cost of living comes down. It would, therefore, be a mistake to unnecessarily delay building, as the present shortage would then become more acute.

Many of the best informed men in the industry believe that early next year will be a good time to build, because material will then be available, labor will be plentiful, and prices will be stabilized.

When the United States entered the war the building industry was the first to be affected. A large number of men who had been engaged in construction work entered the army, others were employed by firms manufacturing war material, and a large number entered shipbuilding plants. Architects and engineers entered the service in different departments, so that from early in 1917 up to the end of the war, building was in a continuous decline. During 1918, all non-essential building was prohibited by the government, and the manufacturers of building material were required to sign pledges that they would not furnish their commodities, except for essential buildings.

This curtailment of building created a shortage from which the country is suffering today.

The prices for building materials, the uncertainty of obtaining them, the high wages and strikes have caused considerable depression in building. At present there are a number of large buildings under construction, many of which are nearing completion. A few new ones are now in contemplation, and some residences are being built, but building is far below normal for this time of the year. The uncertainty of obtaining material and the uncertainty of labor demands must

be removed before building will be resumed to any marked degree.

There is no reason to believe, however, that the small amount of building at this time will enable manufacturers to replace their depleted stocks; and with increased freight rates, which have recently been granted by the interstate commission, the railroads will be able to give improved service. With material available in sufficient quantities to insure completion of projects undertaken, it is still necessary to ascertain the attitude of labor before a general building movement can develop. Prospective builders will not start work until they have reasonable assurance that their buildings will not be tied up by strikes. Contractors cannot make intelligent bids, unless they have definite information as to the cost of material and labor.

Passing of Mr. Patrick Noble

Mr. Patrick Noble, president of the Pacific Rolling Mill Company, San Francisco, died October 2d following an illness of three weeks. He was 71 years old.

Mr. Noble came to San Francisco via Capt Horn when 19 years old, just as the Pacific Rolling Mill Company was being formed. First engaged as clerk, he later became manager and then its president. About 1893 he furnished the steel for the Mills building, and he was connected with the early development of the cable roads. In 1889 and 1890 he served as Supervisor.

He was interested in many charitable causes, served for many years as president of the Humane Society and was a member of the Bohemian and Transportation clubs.

He leaves a widow, a son and a daughter. The son is Vice-President Edward B. Noble of the Pacific Rolling Mill Company.

To Amend Height Limit

Among the proposed amendments to the Los Angeles city charter to be voted upon at the November election is the following:

Proposed Charter Amendment "J"—That Section 30-a of Article III of the Charter be amended to read as follows:

Sec. 30-a. No building or any part thereof of a height exceeding 150 feet shall be erected within that portion of the city described as follows: Bounded on the north by Temple street, on the east by San Pedro street, on the south by Pico street and on the west by Figueroa street; and no building or any part thereof of a height exceeding 150 feet shall be erected in any portion of the city outside of said district unless authorized by an ordinance passed by two-thirds vote of the Council.

This amendment is proposed primarily to aid the Globe Grain & Milling Co. to erect a grain elevator, which its engineers say must be 208 feet high to make it practicable. If the company is permitted to erect the elevator it will mean an outlay of \$2,000,000 on a new industrial plant for Los Angeles.

The Contractor

BUILDING CONSTRUCTION, BRIDGES AND
ROAD WORK

Building Prospects in Middle West

By F. E. DAVIDSON,*

President of the Illinois Society of Architects.

THE only change since our last issue in the building situation is the further postponement of many large projects, a continued increase in the cost of practically all materials entering into any structure and a further advance in bankers' commission charges for building loans.

Many owners who have had complete plans and specifications for important work prepared are ready to proceed notwithstanding the present high building costs if they could secure any assistance from the banking interests in financing; but with United States bonds selling in the open market at prices netting the investor over 6 per cent; with foreign government bonds selling at prices netting better than 8 per cent, with securities of first class industries realizing from 9 per cent to 12 per cent, there is practically no money available for building operations.

Perhaps one way to temporarily stimulate the construction of buildings of all classes would be to amend the present Income Tax Law and exempt from taxation for a period of say five years, all moneys invested in new buildings. This exemption, if granted, would make first mortgage securities more attractive to investors and would undoubtedly result in large sums being immediately placed at the disposal of builders.

It is a peculiar circumstance that notwithstanding the great falling off in the amount of work contracted for in Chicago and vicinity that the cost of almost all building materials are continually advancing.

The Editor recently addressed a letter to a representative contractor in each of the various building trades doing work in Chicago. This letter being as follows:

"The writer as Editor of the Bulletin is collecting data as a basis for a short article on 'building costs.'

"Will you do me the courtesy of replying at once and advising me of the percentage or amount of increases or decreases that have occurred since August

1 in the cost of building materials used by you, and oblige?"

A tabulation of the replies received follows:

Material	Increase	Decrease
Cement	16¾%	
Torpedo sand	6¼%	
Bank sand	6¼%	
Stone or gravel	6¼%	
Lime	8%	
Carney's cement	15%	
Flue lining	30%	
Tile coping	30%	
Plaster board	14%	
Fire brick	25%	
Hydrated lime	5%	
Pyrobar	8%	
Waterproofing cement	20%	
Partition tile	2½%	
Reinforcing steel	12%	
Structural timber		10%
Form lumber	5½%	
Structural steel and iron	3%	
Cut stone	17½%	per cu. ft.
Plastering materials	10%	
Ornamental iron	11%	
Boiled oil		20%
Turpentine		24%
Soil pipe	8%	
Pumps	10%	
Magnesia pipe covering	5%	
Asbestos cement	10%	
Vitrified asbestos fibre blocks	25%	
Cast-iron water pipe	5%	
Cast-iron pipe fittings	8%	
Sewer pipe	10%	
Castings for heating and power boilers	10%	
Plumbing enameled ware	10%	
Plumbing brass goods	5%	to 38½%
Black and galvanized malleable fittings	9%	to 52%
Plumbers' shop tools	5½%	
Assembled plumbing fixtures	16¾%	3%
Cast-iron basins, etc.	12%	
Lead pipe per hundred	55	per lb.

Where no increases or decreases are noted, we are advised that prices quoted today are the same as those of August 1st. (In this connection it might be noted that the present selling price of wrought iron pipe is only 6¾ per cent greater than it was three years ago, while the cost of plumbers' earthenware has increased over 300 per cent during the same period of time.)

Owners contemplating building are advised that there are practically no available stocks of most building supplies, and that delays in any building project are bound to occur due to the impossibility of contractors securing materials as they will be required for any building operation to proceed in an orderly manner.

Owners are further advised that under present circumstances that they are con-

* Reprinted from the Illinois Society of Architects' Bulletin for September, 1920.

fronted with the certainty of there being further delays in construction due to the jurisdictional claims of the Chicago union labor trades. As a matter of history, there have been more strikes reported during the past sixty days than ever before in a like period in the history of Chicago. Responsibility for this condition should be placed where it belongs, which is with the Contractors' Association of Chicago. For some reason the carpenters' and masons' associations have refused to affiliate with the Building Construction Employers' Association, and the Building Construction Employers' Association has refused to affiliate with the carpenters and masons. Thus the two big associations are not working together and are apparently unable or unwilling to unite and agree upon a plan of action which could and would control the labor situation in a short time. The situation complained of has been corrected in other cities by the united efforts of all the interests interested in building, and it will never be corrected in Chicago until all employers' associations are united under one management with a strong guiding hand, an autocrat if you will, who must be given the power to act.

At present building operations which should be consummated in a period of, say four months, now require eight or ten months to complete, notwithstanding all the efforts of the architect and contractor for improvement.

Owners contemplating building are advised that it is the Editor's opinion that building material costs will continue to be enhanced for many months and that there is no prospect of any immediate lowering of building costs. In fact, building costs will probably increase for at least two years more.

Standard Lengths, Sizes and Quality of Lumber as Related to Economic Design

SINCE labor has become a most significant factor in the cost of building, and since there are certain established standards of lengths and sizes, as well as significant differences in grades of lumber, it is important that the use of these standard lengths, sizes and grades be intelligently applied to the design of buildings for the purpose of reducing the cost of construction where possible.

In designing the floor plan of a building, the fact that standard lengths of joists are multiples of two feet, 4 feet to 24 feet inclusive, should be an important consideration in determining the widths and lengths of each room.

Odd lengths, such as joists 9, 11, 13, and 15 feet, not commonly carried in stock, are charged as the next longer even length and cut at the lumber yard before delivery, or delivered in the next longer even length, necessitating cutting

by the carpenter on the job. The waste here is obvious, both in material and in labor, and could easily be avoided by careful design.

A building does not necessarily have to be an even number of feet in width in its over all dimension. Take, for example, a brick building, which is built 24 feet wide with 12-inch walls. Joists which are 24 feet long can be used, but at least 16 inches must be cut from the ends to have the proper extension of the joist ends in the brick wall, whereas, if the building had been built 25 feet 4 inches wide, 24-foot joists could have been used with no waste, or by decreasing the width but 8 inches, 20-foot joists could have been used.

When designing heights of stories, whether in braced or balloon frame, ordinary or other types of construction in which wooden studs are used, standard lengths are quite as important a consideration as joists, and economy may be practiced with the same result. To be sure, 9-foot and 11-foot lengths may be cut from 18-foot and 22-foot lengths, respectively, but why necessitate even this amount of additional labor when avoidable?

Whether the schedule of lumber ordered be large or small, if the material listed be of standard instead of odd lengths, a material saving, as well as more prompt delivery is assured.

It should also be remembered that whenever the size of lumber is given in whole numbers, such as, 2x4, 2x6, 2x8, etc., standard commercial or nominal sizes are meant; but whenever the size is given as $1\frac{3}{8} \times 3\frac{3}{8}$, $1\frac{3}{8} \times 5\frac{3}{8}$, $1\frac{3}{8} \times 7\frac{1}{2}$, etc., actual sizes are meant, and stresses should always be based on actual size of material used.

In the selection of materials, particularly of timbers and wooden beams to be used in building, care should be exercised to select good, sound materials, free from rot, large or loose knots, shakes or any imperfections whereby the strength may be impaired, and of such size and dimensions as are required for the kind of building erected.

Upon ascertaining from your lumber dealer the prices per 1,000 feet of several sizes and lengths of lumber, it is a simple problem in mathematics to determine whether it will be more economical to use sixteen lengths of 2x8-inch joists, 16 inches on centers in the floor construction under a certain room, or to use twelve lengths of 2x10-inch joists, 20 inches on centers, for the same purpose, and similarly, of two lengths of 2x4-inch studs 8 feet long, can be used more economically than one length 16 feet long and answer the same purpose. Care should also be exercised in the design of roofs, so that the pitch of the roof and the projection of the cornice or eaves is so arranged as

to use even lengths of materials for rafters.

As the flooring of porches is generally laid at right angles to the house proper, the width of the porch should be such that material here will cut also to the best advantage.

If these few points are adopted by architects, engineers and contractors, to make more efficient the design and application of lumber in building, much waste can be avoided and a considerable reduction in cost of construction will result.

Substitute for Frosted Glass

All kinds of glass are scarce on the markets, and frosted glass is particularly hard to get now.

A makeshift substitute that isn't bad at all if properly applied, consists in bushing on the plain glass a coat of ordinary flat wall paint, afterwards stippling it with a stiff brush to give it uniform appearance and eliminate the brush marks.

In factories and other places that do not call for de luxe appointments, this painting of windows in place of frosted glass will answer permanently and save considerable money, for the glass is not only scarce, but it is high in price at present.—Ex.

San Francisco Atelier

The San Francisco Architectural Club atelier for the season 1920-21 has been started under very favorable circumstances and with a larger membership than usual. Mr. F. Frederic Amandes is the massier. Two different classes have been organized. The course is free, except for a nominal fee of two dollars required by the New York Institute.

The schooling is conducted through the generosity of San Francisco architects who are graduates of the Beaux Arts School of Paris, and can give the necessary instructions.

Paver Lays 5,000 Brick Per Hour

In paving the Prunytown Pike, near Grafton, W. Va., according to Successful Methods, Mr. John W. Martin, a negro, laid 600 lin. feet of 16-foot brick road in eight hours. In doing this he placed 42,000 brick weighing 10½ pounds each. He was served by 22 convict laborers carrying brick and by laborers placing brick on carrying boards. On Armistice Day, working on a street in Grafton and limited by lack of sufficient carriers, he placed 15,000 bricks in two hours and 40 minutes. It is stated that he can at any time place 90 bricks in 30 seconds.

May Get Big Factory

The Berger-Carter Co., 365 Market street, San Francisco, one of the largest jobbers of fruit canning machinery in the world and which maintains warehouses in San Francisco and a factory at Hayward, is seriously considering a proposition to locate in San Jose. The removal of the Hayward factory is contingent upon the San Jose Chamber of Commerce guaranteeing spur track facilities. It is proposed to erect one or more large buildings.

Has Back Numbers for Sale

Editor The Architect and Engineer,
San Francisco, California.

I have a complete set of The Architect and Engineer, starting with the October, 1906, number, which I would like to dispose of. They are in first-class condition and I will dispose of them at 10 cents per copy, not delivered.

If you know of any one in need of these numbers, it is a good opportunity to get them.

Very truly, W. W. HANSCOM,
848 Clayton street, San Francisco.

Death of Walter E. Rice

Mr. Walter E. Rice, who had been connected with the office of Mr. Myron Hunt for several years, died at the Pasadena hospital on September 9th. He was for several years head draftsman in the office of Mr. Reginald Johnson at Pasadena. Mr. Rice began architectural work in the office of Mr. Clifton Sturgis in Boston, Mass.

HARDWOOD HEADQUARTERS

ASH-BASSWOOD-BIRCH
AROMATIC RED CEDAR
COTTONWOOD-ELM-HOLLY
SOUTHERN RED GUM
HICKORY-LAUREL-MAPLE
OREGON MAPLE-PLAIN OAK
- QUARTERED OAK -
WYBROCK BENDING OAK
POPLAR--WALNUT



BOXWOOD-EBONY-IRONBARK
JENISERO-KOA-SPANISH CEDAR
LIGNUMVITAE-MAHOGANY
ROSEWOOD-TEAK-RED BEAM
SPOTTED GUM-CIRCISSIAN WALNUT
LUMBER--TIMBER
HARDWOOD FLOORING
WYBRO VENEERED PANELS
DOWELS-TREENAILS-VENEERS

WHITE BROTHERS

FIFTH and BRANNAN STREETS SAN FRANCISCO, CAL.

Service

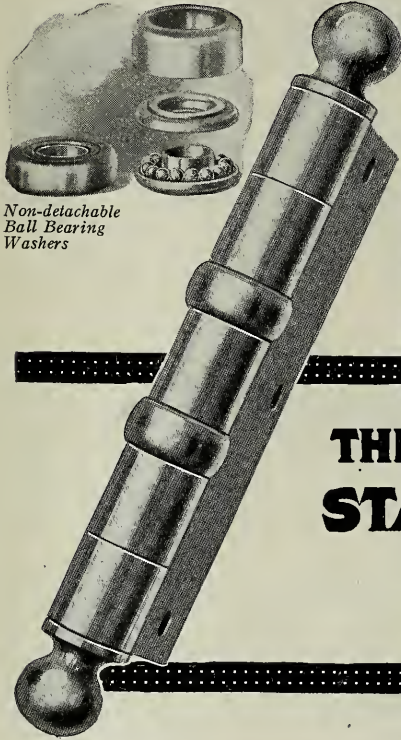

Non-detachable
Ball Bearing
Washers



THE STANLEY WORKS BALL BEARING BUTTS



Hotel Sherman, Chicago, Ill.

- ¶ The modern hotel demands more than the usual service from its doors.
- ¶ Swinging constantly from kicks, bumps and all sorts of abuse, the butts are subjected to real work.
- ¶ This organization is pleased to state this hotel is equipped with The Stanley Works Ball Bearing Butts — The service of the butts are entirely satisfactory.

We have ready for distribution to architects, an architectural service sheet AE-10 featuring Storm Sash Hardware which will be mailed on request.

THE STANLEY WORKS

NEW BRITAIN, CONN.

NEW YORK — Branch Offices — CHICAGO

Optimism

From Oliver Brothers', recognized financial authorities, current comment letter of August, 1920, is taken the following optimistic view of business conditions—financial and industrial, by the Smith-Booth-Usher Company, San Francisco and Los Angeles, and mailed to their customers throughout the Pacific Coast:

Judge Gary, on his departure for a three months' vacation abroad recently expressed the opinion that the business outlook is now better than it has been for the last six years,—that the worst of our dangers are behind us and with proper consideration for the workers and the public, business should continue to prosper.

A banker's view: According to a recent interview, he says the law of supply and demand will prevent a business depression this year.

A business depression comes when the world's shelves are filled with goods.

That condition does not exist at home or abroad with the possible exception of the clothing business.

Railroads must spend hundreds of millions for new equipment and extensions.

Our housing problem is as serious as our transportation. We need a million new houses in this country.

We are producing 10,000,000 tons of coal a week, which we normally consume.

We are facing serious shortage due to inadequate transportation system, and heavy export demands.

Oil production is not keeping pace with the demands.

Steel companies are behind with orders on their books, and with prospective orders from railroads and building trades and farm machinery people, etc., it is believed that they will be able to operate at capacity for many months.

Business depression does not and cannot mean greater production.

Greater production obviously is what we need and must have.

A business depression simply means the world is resting.

There is too much work to be done for us to take a rest now.

Urge Vote for Amendment Twelve

The students at the University of California have signed an appeal to the people of the state to support on November 2nd, Amendment 12, which will give the University a steady, permanent income.

Following is a copy of the resolutions which deserve the endorsement of the public:

WHEREAS, The University of California in all its branches has increased in student enrollment since 1910 more than 200 per cent, making the University the largest university in America; and

WHEREAS, Class rooms available for general use have increased only 20 per cent, and other university equipment has been added to in proportion far below the increase in the number of its students; and

WHEREAS, As a result of this crisis, classes are so overcrowded, rooms so inadequate, teachers so few, that students no longer have an opportunity to obtain instruction of the high grade for which the University should stand, and the teaching force, the faculty experts engaged in agricultural, commercial and industrial surveys and investigations of paramount importance to the state as a whole, are unable to serve the people as they should; and

WHEREAS, The only three solutions suggested to meet the present crisis are (1) to so enfeeble the University's services as to keep it within the bounds of an uncertain and sporadic income: (2)

to charge tuition; (3) to adopt a permanent, progressive plan, embodied in Amendment 12, providing for a steady income proportionate to the wealth of the state; and

WHEREAS, The first two of these solutions are not in accord with the ideals of the people of this great state in providing for a democratic and free institution; and

WHEREAS, The plan provided by Amendment 12 is in accord with these ideals in that it (1) gives our University an assured future; (2) keeps the control of the University in the hands of the people through the State Legislature, and (3) maintains the ideals of free higher education for which California has stood for fifty consecutive years.

Be it therefore resolved, That we, students of the University of California from San Francisco county, do hereby urge that the people of California relieve the crisis which at present is responsible for conditions that are a discredit to the University and to the state, by supporting with all their loyalty and with all their power, the passage of Amendment 12, which is to be voted upon November 2nd.

For the students of San Francisco county.

JOHN E. MCCARTHY.

Los Angeles Chapter Meets

Following out the plan of meeting in nearby cities inaugurated by President Bergstrom, the Southern California Chapter, American Institute of Architects, met at Long Beach for its September meeting. More than twenty Long Beach architects and representative men from the building industry of that city were present to meet the Los Angeles architects.

Following the dinner, which was at the Elks Clubhouse, a short business session was held. President Bergstrom announced that Mr. Richard S. Requa of San Diego had been elected to Institute membership and that Messrs. H. C. Chambers and C. E. Noerenberg, of Los Angeles, to Chapter associate membership.

Messrs. W. J. Dodd and Frank D. Hudson established an enviable reputation as an entertainment committee. Mr. John W. Mitchell acted as chairman of the entertainment section of the evening and introduced the artists.

Mr. Mitchell called upon Colonel A. C. Knowles, United States Army, to relate some details of the war.

Mr. Charles Wakefield Cadman, noted composer, played a number of his compositions and Mr. James W. Foley, poet, humorist and writer, entertained the audience with a humorous talk. Messrs. W. Horace Austin and G. F. Deatherage of Long Beach had charge of the local arrangements for the evening.

The next meeting of the Chapter will be held in Los Angeles and the program will be in charge of Messrs. A. B. Benton and Chas. F. Lummis.

The guests of the Chapter were: Col. A. C. Knowles, Charles Wakefield Cadman, James W. Foley, Harold Proctor, Chas. H. Cheney and Leroy A. Cowan.

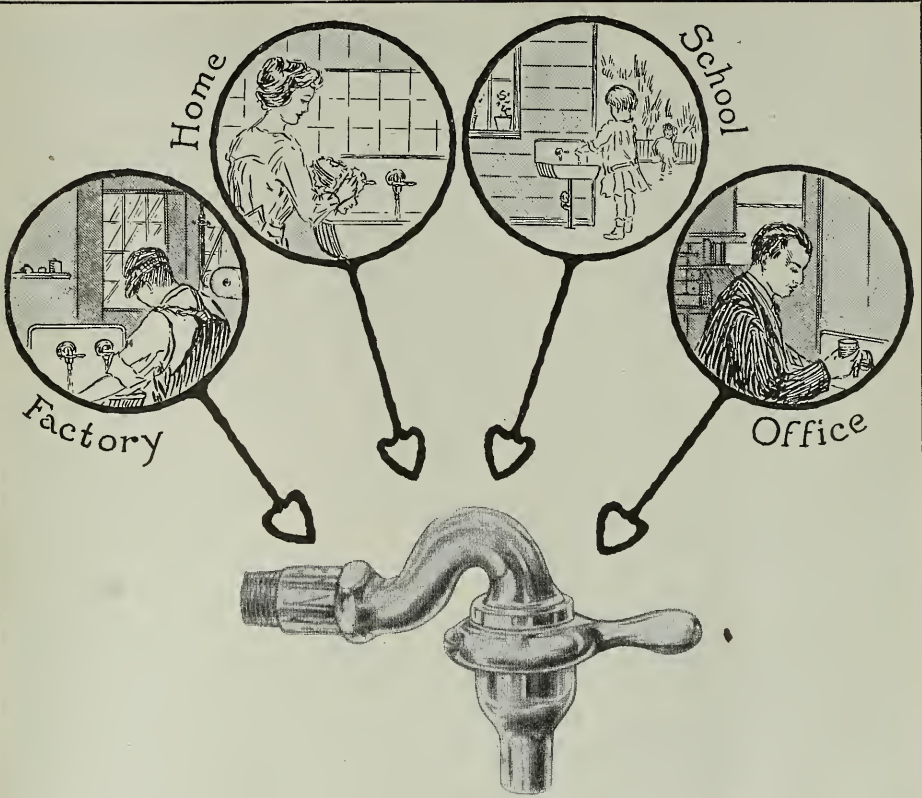

The
Hajoca "Quick" Faucet

is a distinct time-saver. It responds to a mere touch of the hand or even the wrist, with a thick, rapid-flowing, non-splashing stream. A real delight to the user in the home. Durable and simple in construction. Especially suitable for Wash Sinks in Packing Plants, Factories, etc.

SPECIFY
Hajoca "Quick" Faucets



HAINES, JONES & CADBURY Co.
 MAKERS OF PLUMBING SUPPLIES
 857 FOLSOM STREET, SAN FRANCISCO
 PHILADELPHIA-NEW YORK-RICHMOND, VA.-SAVANNAH

Contract Arrangements for Building Schools

Editor The Architect and Engineer:

At the present time there are at least five different forms or kinds of contract in use for building work. They are called the "Lump Sum Contract," the "Percentage Contract," the "Cost Plus a Fixed Sum Contract," the "Emergency Contract," and the "Cost Plus Fixed Sum With Bonus or Penalty Contract."

After much reading for years in several prominent magazines, enquiry among builders and careful study of these various forms, we believe the last named in *far the best to use*, certainly for us at the present time.

Various advantages and objections will be pointed out later on, but first let us have a clear view of this best of all forms known today,—the "Cost Plus Fixed Sum With Bonus or Penalty Contract."

First of all, plans and specifications are worked out as full and complete as needed to carefully inform all bidders of the kinds, qualities and amounts of the work to be done.

Then, by the best practice, full *Bills of Quantities* are made out, so that all bidders shall work on the same basis, simply adding their prices in detail and footing up the totals.

This removes the big main source of the common omissions, mistakes and other variations in bids, which in the past have differed surprisingly even up to 100 per cent on the same building.

With this plan, figures received will be much more nearly alike and other very important matters can be more fairly judged, such as the character, ability and other qualities of the contractor to be chosen. (See another paper on this subject.)

Then in order that all bidders shall know from the start what the form of contract is to be, it is written in the Specifications as follows:

Every bid shall state a fixed sum (aside from net costs) for which the Contractor will execute the work complete (as indicated by plans and specifications). This sum to be his sole compensation for his part in the work and the use of his organization and equipment (all needed) not to be augmented by commission, discount, rebate or other profit, hidden or known.

Every bid shall also include a careful estimate of the net cost of the work to the contractor (aside from his organization and equipment); this estimate and bid shall consist of (or be accompanied with) complete bills of quantities with prices of materials and labor attached, to be used for reference by contractor and owner or architect, to facilitate part payments and settlements, or any changes, and to help keep account of actual costs.

Then it is provided that if the actual cost of the work is *less* than the estimate, the difference saved shall be divided between the owner and contractor, in the proportion of $\frac{1}{3}$ to contractor and $\frac{2}{3}$ to the owner.

Also if the actual cost is *greater* than the estimate, the excess shall be borne by owner and contractor in like proportions ($\frac{1}{3}$ by contractor and $\frac{2}{3}$ by owner), the contractor's part being deducted from his fixed sum compensation mentioned above.

This shall apply to each separate general contract. It shall also apply to each sub-contract as between the sub-contractor and his general contractor.

Also if any contractor with his men or any of them, choose to organize a co-operative plan under the same rules, for doing any of his contract work; it is very likely to be approved and encouraged by the management.

(The main purpose of this arrangement is to bring about actual friendly *co-operation*, in mutual confidence and helpfulness, in place of opposition of private interests.)

It is provided that if the costs be increased by fault of contractor or his men, such as neglect, carelessness, known wilful act, continuous loafing or correction of faulty work; he shall bear the loss due to such fault without the owner sharing it.

It is also provided that if the cost is increased by fault or act of the owner, such as failure to pay agreed-on installments as due, or changes after work affected is under way, or unreasonable delay in deciding what to do; the loss due to this condition shall be borne by the owner without the contractor sharing it. (All as nearly as can be

estimated and made practicable in either case.) Daily or frequent reports of work done, with its cost, shall be made to owner or his agent, as a check on any trouble liable to arise, before details and circumstances are forgotten.

* * *

Forms of contract for building work are now under intensive study and discussion all over the country and in Europe; in architectural and building magazines, in societies and gatherings of representative building men, in the newspapers and between persons interested.

The old form of "Lump Sum" Contract, though for fifty years a bar to worse evils, has been the instrument of immeasurable damage or ruin to good building work, to owners, to contractors, to material men, to workmen, to tenants and to all people concerned or affected.

Its evils became so notorious, so outrageous and intolerable that before the war, many good men quit the building business in disgust, many owners and officials regarded the business with aversion and dread, and architects, obliged to use the "lump sum" method, were so hated and feared by contractors, that to this day, builders either refuse to bid at all or add a large percentage just to guard against the name of "Architect" borne by the man who represents the owner in that capacity, even when plans call for only a medium grade of work.

Accounts of losses and ruinous effects are legion and well known, though they can only be fully realized when compared with what might have been under better conditions.

Now during and since the War, the old lump sum contract has passed or is passing out of use generally, all over the country and over sea as well, and the above named improved forms of contract have come into use.

They all have special merits and various degrees of improvement over the old way; but the best of all is the form shown herewith.

It seems to include all the merits of the others, avoids objections to them and adds besides the immense and far-reaching advantage of *co-operation*.

Under it the purposes and the interests of the owner and the contractor are the same—namely to carry out the plan for a fine building in the best way they can *together* manage at moderate cost. There is nothing to gain by scheming and bucking against each other.

Under the old lump sum contract large amounts of time, life and effort were wasted by the owner and architect on one side in watching, striving and fighting to get the contractor to do a good job as planned, while he on the other side was scheming and squirming and camouflaging to squeeze out a profit or a poor living, or save himself and his family from ruin. All this instead of working together to do a good job, for the needs and better welfare of all concerned.

Results very commonly were so bad they are painful to remember and should only be lightly referred to if at all as a background of contrast with what we expect and what should develop from now on.

They were demoralizing to the whole community, and in the case of schools were and would especially be a very bad example to set before children, as they contradict the best instructions given them.

Quoting from Mr. W. H. Hall of San Francisco, in 1907:

"This best system does not tend to make gamblers of contractors, nor conduce to 'skinning' of work, as the lump sum system does. It does not conduce to under-estimating, or to running up the cost of work, as the percentage system does.

It does not conduce to neglect of the work, as the percentage and cost plus fixed sum systems do. It does not conduce to antagonism between owner and contractor or architect and contractor, as all the other systems do.

"This system puts a premium on good faith, energy and special ability in the contractor, for the owner's benefit as well as the contractor's profit, and it puts a penalty on bad faith, neglect and incompetency in the contractor, for the owner's protection. But it does not penalize the contractor for what he cannot reasonably foresee, nor beyond the limit of his profit in any ordinary case.



INSURANCE DID NOT SAVE THIS HOME

THE architect and builder are better able to prevent disaster by fire than any insurance agent. The architect builds fire insurance into the house; the agent merely writes it on paper.

FIRE CLAY FLUE LINING

specified by leading architects, used by reputable builders and required by ordinance of National Board of Fire Underwriters prevents 30% of residence fires by making it impossible for flames to reach woodwork through defective flues, and by preventing burning soot and sparks on the roof. For a very few dollars it *really* insures the results of your labor and the homes of your clients.

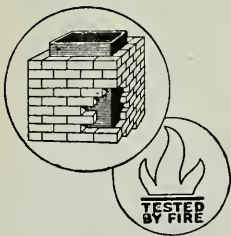

*Copy of the 1920 Chirney Ordinance
proposed by the National Board of
Fire Underwriters free on request.*

CLAY PRODUCTS ASSOCIATION
PITTSBURGH CHICAGO

(Los Angeles Pressed Brick Co., Los Angeles, Member)

"The principle of this system of contract agreement is distinctly right, in the honest interest of all concerned.

"All that can be said against it is that its application may be inconvenient in some cases and under some business conditions."

It may call for more work in accounts, by owner or some one for him.

It gives opportunity for as much interest and watchful care as the proper officials choose to give to the work as it goes along. Improvements can be made or items eliminated without impairing the contract or exciting antagonism. This is especially the case when all "quantities" are carefully estimated beforehand, with detailed prices attached.

And the great benefits need not and should not stop with owners and contractors. When *workmen* begin to see and realize these much better conditions, and feel even a little of the stimulating good spirit, of helpful co-operation, which this plan is adapted to call out; there will be an immense relief from the old deadly, degrading and ruinous feelings of being driven, exploited, impoverished and suppressed (or kicked out on a triviality, which is worse) until the result is slow murder inch by inch.

Seeing the opportunity to really share in more and better work they will feel encouraged to do it and get the benefits, also to help guard against losses which they will share if they do not do their best.

We will see some speeding up, now so sorely needed, more interest and more pride in quality of results, more sense of responsibility and a growing unity of feeling and effort for the welfare of all, and a fading of the cause of strikes.

Yet the owners, the city, the people, are protected no less than before but really a great deal better than before.

Opinions may differ on the most fair proportion to use in sharing of savings or losses. Half and half is used and seems fair for small sums. But if excess costs come to 20 per cent of estimated cost, the contractor loses the whole of his 10 per cent compensation and has nothing for all his work, care and expense in erecting the building. This is one extreme.

On the other extreme, in a recent article in an eastern magazine, it is urged to use whatever percentage the saving or loss is of the whole estimated cost; that is, if contractor saves (or loses) say 10 per cent of estimated cost, then he gains (or loses) 10 per cent of that saving (or loss) the other 90 per cent being for the owner.

But on a school estimated at \$100,000, for a saving of \$100, which is $\frac{1}{10}$ of 1 per cent on 100,000, he would have *ten cents* for his extra care—too trivial for a second thought. So this rule clearly is inadequate for small amounts.

Somewhere between these extremes should be the best rule.

But now, as the owner bears the greater burden of cost, also gets the greater benefit in the finished building, he should have the greater proportion of saving or loss.

In view of all these things, it seems most fair and equitable to provide a sharing of two to one: $\frac{2}{3}$ for owner and $\frac{1}{3}$ for contractor; whereby contractor gains $\frac{1}{3}$ of all savings or loses $\frac{1}{3}$ of all extra costs; which is a good, effective incentive to do his best in either case, and it eliminates the excessive gambling risks.

LOUIS COWLES, Architect,
Santa Rosa, California.

The Word "Gentleman" Is Defined This Way:

A man who is clean, both outside and inside; who neither looks up to the rich nor down to the poor; who can lose without squealing and win without bragging; who is considerate of women, children and old people; who is too brave to lie, too generous to cheat, and who takes his share of the world and lets other people have theirs.—Anonymous.

When writing to Advertisers please mention this magazine.

THE CITY MUST PAY DAMAGES CAUSED BY DYNAMITING

The decision of the Supreme Court of Georgia is that although the Atlanta Fire Department had authority under the law to destroy dwellings during the big fire of 1917, by dynamiting them to prevent the spread of the conflagration, the city is liable for damages to the owners of the property for its value.

DIXWELL DAVENPORT
Manager Pacific Coast Department

BANKERS & SHIPPERS INSURANCE COMPANY

INSURANCE EXCHANGE BLDG.
SAN FRANCISCO
Telephone Kearny 3561

"BLAZING" THE TRAIL

We've been doing it for many years—giving the Sportsman Better Value for Quality than he ever before received. "Value at a Fair Price" in everything for the Sportsman.



SEND FOR CATALOG

The Sign of Quality

Business Systems Office Furniture

F. W. WENTWORTH & CO.

Distributors for LIBRARY BUREAU
539 Market Street, San Francisco
LOS ANGELES OAKLAND SEATTLE

Mueller Factories Run Overtime

The annual pilgrimage of the Pacific Coast salesmen of the H. Mueller Manufacturing Company to the Eastern factories proved of exceptional interest this year, because it afforded an opportunity for all to visit the company's three factories—one at Port Huron, Mich.; one at Decatur, Ill., and the third at Sarnia, Ontario. All these plants are running on full time in an endeavor to keep pace with orders. The company is employing something like 2600 hands and every effort has been made to maintain a high standard of efficiency through a fair basis of wages and hour schedule. A gratifying feature of the gathering, according to Mr. Thos. F. Leary, manager of the San Francisco house, was the reports from the Coast branches of increased business during the past year. The San Francisco office did 100 per cent more business, and some of the other Coast cities reported increases equally gratifying. Mr. Leary says there is nothing to the rumors that numerous stock orders have been cancelled; on the contrary, bona fide orders have been on the increase with them.

Standard Steel Buildings

A new, attractive book has just been issued by the Truscon Steel Company of Detroit on "Standard Buildings." The contents speak so well for themselves that comments are hardly necessary.

The book shows the present-day possibilities in standard steel buildings. All the numerous types of buildings available are shown, including buildings one, two, three and four bays wide, monitor types, sawtooth, leantos, etc.

In the buildings of the pitch-roof type, spans vary from 6 to 100 feet, and lengths any multiples of two feet. Sawtooth buildings come in standard bays of any number of units in each direction. The book is profusely illustrated with actual photographs of buildings in use.

Leading industrial and commercial companies have used the Truscon steel building very extensively. Photographs show them in use as warehouses, foundries, heat-treating buildings, machine shops, cafeterias, factory garages, hospitals, railroad shops, express buildings, etc.

Los Angeles Second

Los Angeles ranked second among the cities of the United States in building for the month of August, 1920—a truly remarkable showing.

New York City with its five boroughs reported a total of \$29,492,230, while Los Angeles came next with \$6,970,312, more than \$1,000,000 ahead of Chicago, which ranked third. San Francisco, thirteenth in the list with a total of \$1,517,916, was second among the Pacific Coast cities, while Seattle, seventeenth in the list with \$1,204,330, was third among the coast cities.

OAK FLOORS

(For Everlasting Economy)

How Our Educational Work Helps You

YOU would probably specify Oak Floors on all jobs if left to yourself. You realize that they are the best, as well as the most economical, in the end.

One objective of our advertising is to correct the mistaken idea many laymen have that Oak Floors are a costly proposition. Another is to get the trade to quote prices by the room, instead of by the thousand feet, thus making sales easier.

We get many letters from members of the building professions and trades showing that our associational work along such lines is helping them materially.

OAK FLOORING MFRS. ASSN.

1036 ASHLAND BLOCK, CHICAGO, ILLINOIS

OAK

OAK



PLANT OF THE DUDFIELD LUMBER COMPANY, PALO ALTO

Lumber Company Expands

The above picture shows the office building and planing mill of the Dudfield Lumber Company at Palo Alto. This company has enjoyed continuous growth since it entered the building field some years ago, and today its mill and yards are the largest in that territory, extending from San Francisco to San Jose. The president and manager is Mr. John Dudfield, and the secretary and mill superintendent is Mr. Joseph A. Jury, both well known and experienced men in the lumber business.

Two Hollow Tile Residences

Mr. Frank Lloyd Wright, 522 Laughlin building, Los Angeles, has prepared plans for two hollow tile residences on Olive Hill, Vermont avenue and Hollywood boulevard, for Aline, Barnsdall. The houses will contain ten rooms and three bathrooms each. Mr. Wright is also preparing plans for other buildings to be erected on the property, which comprises twelve acres.

To Protect the Highways

A movement to secure state legislation to protect the improved highways from the wear and tear to which they are subjected by the enormous and constantly increasing motor traffic, was inaugurated at a conference called by the supervisors of Kings county and held at Hanford recently. The supervisors of Merced, Fresno, King, Tulare, Kern, San Bernardino and Los Angeles counties were represented. Delegates from the automobile and motor truck associations were also present. Uniform regulations for traffic loads on highways in all counties are considered not only desirable but necessary in view of the fact that county regulations are in many cases at variance.

Bulletin Boards for Varied Purposes

The Go Sign and Letter Company, 1106 Franklin street, Oakland, reports that it is receiving many inquiries and orders from school architects for its De Luxe bulletin boards, and a number of churches, too have introduced the boards as a means of making announcements for services and meetings to be held during the week.

The manner in which these interchangeable steel boards are constructed makes them superior to many similar devices on the market. Unlike the ordinary interchangeable signs the background of bars is pressed from solid sheets of steel. This makes them far more attractive and durable than ordinary boards which have backgrounds constructed of single bars linked together.

The background is treated with imported enamel, baked to a temperature of over 400 degrees. Regardless of the amount of wear received, they will not scratch.

The frames are made of oxidized copper, mahogany, Circassian walnut, enamel, brass, natural and fumed oak.

The letters and numerals furnished are packed in imitation leather compartment cases. The letters stand out in bold relief, as they are handsomely lithographed in white. They catch the eye of the passing public whether they are on your side of the street or not. The signs can easily be read by people in street cars or automobile.

There is hardly a line of business which cannot use to profitable advantage these bulletin boards. But aside from the commercial advantage of the boards, there is the great array of church boards, baseball score boards, bulletins for lodges and societies, and building directory boards.



The
ST. FRANCIS
One of the world's great hotels
Facing Union Square
SAN FRANCISCO CALIFORNIA

EXPRESSES MOST PLEASANTLY THE HOSPITALITY AND ANIMATION THAT ARE CHARACTERISTIC OF SAN FRANCISCO

Thos. J. Coleman,
Manager

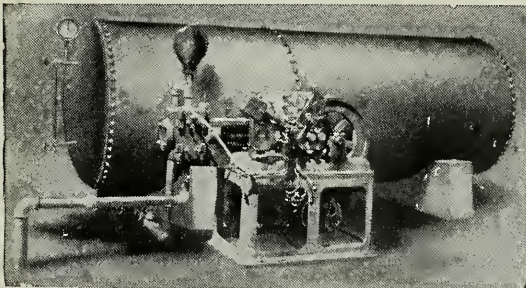



Kewanee Water System

Maintain your own Plant.
Small Operating Expense.
A Perfect Water Supply to
Country Homes, Hotels
and Parks.

Simonds Machinery Co.

117-121 Montgomery Street

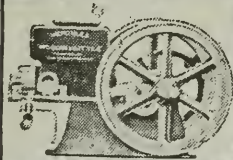
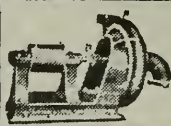
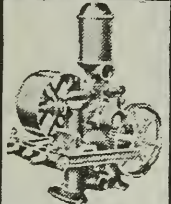
SAN FRANCISCO
Phone Kearny 1457

WOODIN & LITTLE		
PUMP HOUSE		
33 to 41 Fremont Street SAN FRANCISCO, CAL.		
PUMPS FOR EVERY SERVICE AND USE		
 HERCULES GASOLINE ENGINES From 1/2 to 12 Horse Power	P U M P S	 CENTRIFUGAL PUMPS All sizes from 1/2 to 10 inch, with self-oiling bearings
 GOULDS PYRAMID POWER PUMP All Sizes from 2 1/2 to 6 inch	W. & L. PNEUMATIC WATER SUPPLY SYSTEM PIPE, PIPE FITTINGS BRASS GOODS, TANKS GASOLINE ENGINES	 GOULDS TRIPLEX PUMPS All Sizes
Send for Our Catalogue, Mailed Free Inquire of Your Local Dealer for Full Particulars.		

Making Highways Ornamental As Well As Useful*

By JOHN A. HAZELWOOD,
Chairman, Wisconsin Highway Commission.

OF all the constructive work that is done, there is none that counts more in obtaining good results than the planning and preparation that goes before the actual performance. We realize that good roads lie at the basis of social institutions and the associational life of every community. Good and attractive highways can not possibly be obtained unless they are planned.

The period of achievement in the road work is not over, but we are entering upon new phases of the problem, mainly because we are seeing things in this motorized age in a different light. We are in a new era of social development and national growth and the question is not whether we shall continue to expand, but how we are to expand. On some things we have spent too much time and wealth and on others we have spent too little. Those things upon which we have wasted too much are easy to criticise because we see the mistakes, but those things upon which we have spent too little may have caused great losses, although they are not especially apparent. Wealth is produced not from the existence of natural resources, but from the conversion of natural resources into some form of human use. The aesthetic phase of road betterment does convert natural resources into forms of human enjoyment and should be encouraged.

It is not enough to build good roads, it is not enough to maintain good roads, it is vitally important when we build and maintain good roads that we beautify them. Roads without embellishments,

such as trees, shrubs, and flowers, are ugly and prosaic. It is not enough to consider only the financial side of roads; it is our duty to consider as well the joy

GEO. H. DYER, President
R. W. DYER, Vice-Pres.
W. J. DYER, Sec'y

DYER BROS.

GOLDEN WEST IRON WORKS

(INCORPORATED)

Structural Iron
and
Steel Contractors

Ornamental Iron Work

Office and Works

17th and Kansas Streets
SAN FRANCISCO, CAL.

Phone Market 134

* A paper presented at the convention of the American Association of State Highway Officials.

that man receives traveling upon them. Any progressive and self-respecting community ought not to allow a mercenary spirit to cause it to disregard the work of beautifying highways. Rural forces should make "Scenic betterment" one of their slogans. All over the New England states we find, in connection with trolley lines, comfort stations with trees, shrubs, and flowers about them, cared for at the expense of the railway companies. We find in many of our cities small parks with shrubbery and flower beds about the railroad depots. These companies do these things because they know they are rewarded for so doing. Rest rooms and comfort stations at regular intervals along the roads add greatly to the joy and comfort of traveling.

We have been careless and thoughtless in the past. We have permitted the woodman's ax to destroy the trees we have admired as bits of forest scenery.

We should plant trees, shrubbery, and flowers along our highways. What a splendid opportunity we have for getting good results from nut-bearing and fruit-bearing trees systematically planted and cared for along the public highways of this country. The expense of planting trees, shrubbery, and flowers along our roads and caring for them calls for only a small expenditure of funds. We should realize that each passing year will add to our pleasure if trees and shrubbery are planted and protected. Little do we realize the returns obtained from this class of service which are not considered in Wall street or listed in Bradstreet.

We all admire a home with trees, shrubbery, flowers, and trailing vines about it. We know the pleasure that is excited in hearts by these adornments. We can not help but feel sorry for those who are obliged to occupy homes where no attention is given to plants, to flowers, and to trees. A little attention to flowers and trees will transform ugly lawns into spots of beauty. We can not look upon a beautiful tree or a cluster of shrubbery without forgetting a grouch and getting an inspiration for higher thinking. The shade and the freshness of trees along the roads running out of any village or city are needed now more than ever before. Concrete roads and hard-surfaced roads of all kinds are cold and need some softening effect.

Beauty and profits usually do not go hand in hand. However, beauty is oft-times combined with utility and this is true in road building. One can note at a glance whether a road has had the touch of an artist. A curved road is much better adapted to artistic landscape than a straight one. If to this curved road are added the touches of the tree, the shrub, the flower, we have pleasing associates as we travel along. It does not take a landscape gardener to tell whether

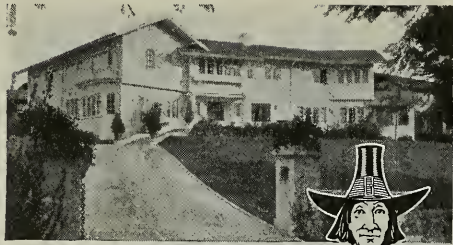

... H. S. Lutetion, 1350 Sq. Ft.
... Cortino St., Pasadena, Calif.

BAY STATE COATING

The heaviest rains can't beat through a Bay State Coated wall. Weather won't affect it. Bay State Brick and Cement Coating waterproofs all houses of brick, cement or stucco. It imparts a beauty that is distinctive and lasting. Choose from white or a range of colors. We will gladly send you a sample. Write for booklet No. 43. It shows many homes made beautiful with Bay State Brick and Cement Coating.



WADSWORTH, HOWLAND & CO., Inc.

Paint and Varnish Makers

BOSTON, MASS.

Pacific Coast Representatives

JAMES HAMBLY & SON

San Francisco

Los Angeles

SERVICE

TESTING
INSPECTION
CONSULTATION
PRODUCTION

Structural and Engineering
Materials



Robert W. Hunt & Co.
Engineers

Chemical and Physical
Testing Laboratories

New York Chicago Pittsburgh
St. Louis San Francisco Mexico City
London Montreal



CEMENT GUN

Will Make Your
Concrete Waterproof

**Cement Gun Con-
struction Company**

of California
701 Balboa Building,
San Francisco

For
DAMS
RESERVOIRS
TUNNELS
BULKHEADS
CANAL
LININGS
CEMENT
FLUMES
use the
Cement Gun
—
SPEED
ECONOMY
PERMANENCE

thought and attention has been exercised in connection with highway construction.

We are all interested in civic art. We like to put our best foot forward. Civic art means a constant endeavor to secure in our public works the maximum of utility combined with the maximum of beauty. Cities have realized the importance of this and have given large attention to parks, playgrounds, and boulevards. In fact, proper attention to roadsides means a substantial addition to the value of adjoining property. Concrete macadam, and gravel roads particularly need the protecting shade of trees.

We know that many European countries have spent and are spending large sums of money in planting and caring for trees along the highways. Many trees along highways are apple, plum and cherry, and from these large profits are annually obtained. The southern counties of the United States have given some attention to the matter of beautifying the sides of roads. The counties, particularly of Florida, have expended lots of money in beautifying their highways. Los Angeles county, California, spends annually \$7,000 a year for the purpose of planting and taking care of roses along the highways.

The beautification of one country road in Los Angeles county has recently been completed. The road, which is known as the Sherman Way, extends 28 miles through an agricultural district near the city of Los Angeles. The district was originally embraced in a 47,000-acre ranch, which was taken over by a real-estate company, and about three years ago the work of beautifying the road was undertaken. It was completed last winter and the road formally turned over to the county, which in future will maintain it. The beautification has consisted of the planting of rosebushes and trees along the roadside. The rosebushes are planted at intervals of 7 feet along each side of the road. The different varieties of roses are grouped together. In all, there are

approximately 80,000 rosebushes. The total cost of this work was practically \$100,000.

Many other counties in California are annually spending large sums of money in beautifying their highways. These investments are paying well, and the counties that have had this experience in beautifying their roads realize this and intend to continue to expend money on landscape work.

We have been a little careless in the road game of late. Many road builders have destroyed beauty by permitting the careless cutting out on the side of roads of the blackberry, the hazel brush, the wild rose, and the wild crab and thorn apple. The transformation of many roads by our so-called professional road builders from the rustic, beautiful drive to the barren highway seems almost brutal. In many cases everything has been grubbed out. Bare spots mark the

TRANSMISSION EQUIPMENT

For Mill or Factory



Pulleys - - -	Shafing - - -	Gears - - - -
Hangers - - -	Bearings - - -	Take Ups - - -
Sprockets - -	Clutches - - -	Chain Belts - -
Floor Stands	Belt Tighteners	Rope Sheaves

Meeseco Short Center Drives

Mees & Gottfried Company

ENGINEERS AND MANUFACTURERS
CONVEYING, ELEVATING, SCREENING
AND MECHANICAL POWER TRANSMITTING
MACHINERY.

SAN FRANCISCO 560 Mission Street	SEATTLE 555 First Ave So	PORTLAND 67 Front Street	LOS ANGELES 447 Pico & E 3rd St
-------------------------------------	-----------------------------	-----------------------------	------------------------------------

places where beauty went up in smoke and flame. This change from the beautiful to the ugly has not been called for and should not have been permitted.

One distracting thing along the country highway is that of advertising. We see the billboard destroy the beauty of many pretty glens and beautiful curves. The greed of advertisers has destroyed many beauty spots by putting up advertisements. This destruction of beauty has been somewhat handled through city ordinances issuing permits or licenses. Women's clubs in our cities have done much in the matter of curbing landscape destruction by billboards. Little has been done in rural districts to restrict such advertising.

It seems that the most effective way of handling the question is the exacting of a tax. I believe we could drive away much of our advertising on billboards that can reach the eye of the traveling public. In order not to be unduly hard on those who have already erected their billboards, half or quarter the rate may be charged them until they take them down or have them repainted. This is one of the effective ways of handling this manner of destroying the beauty of our highways.

Every highway commission should employ a landscape artist. Delaware has already taken that step. There should be a landscape artist abroad in the land. Nothing counts like expert advice and direction in the handling of important problems. We can not afford to let this matter of rural planning continue to be worked out under our indifferent amateur policy if we wish to make our roads ornamental as well as useful.

We all enjoy a beautiful road and drive. Nothing is more pleasing to pass over than a road stretching ahead, running by farmhouses, wayside schools, churches, and villages. The automobile has crowded two, three, and even four hours into one hour as compared with the horse-drawn means of transportation. A road seems to have moods and whims. Sometimes it stretches on and on onto infinite space; sometimes the eye loses it in some wistful curve; sometimes it loiters in sunny vale.

Some one said, "The important thing to me about a road, as about life, is not that it comes from somewhere and goes somewhere, but that it is livable where it goes." The invitation to explore the unknown road is very alluring. The unknown road as it winds along is a perpetual revelation of beauty. One person rightly says that he greets a new road with almost as much pleasure as a new person and usually parts with it with rather more reluctance. It is curious, indeed, how closely roads are linked with humanity; how warmly companionable they are. A public road talks business all

the time. It tells us new things about everything that appears in a panoramic view on the roadside. It tells about the farm houses and the type of farming that is being carried on by the farmers. It is one of the most important and interesting of all of man's wonderful institutions.

We never receive our friends in our woodshed and break bread with them in a corner of the kitchen, using our ordinary linen, silverware, and dishes, but we receive them and entertain them in the most comfortable rooms in our home. We dine them in our most pleasant room and we use our best linen, silverware and dishes. What for? Why, for the very purpose of impressing upon them that we are maintaining good homes. Our visitors are usually our friends. They bless us and make us happy and contented. Therefore, we are justified in spending a great deal of money in providing attractive lawns, beautiful entrances, and pleasant homes. The portals, the gateways, the entrances to our community homes are the highways.

Many of our cities understand the value of having inviting boulevards and streets for guests to enter. Large attention is given to the main entrance to commercial and residential centers. They beautify the streets with park rows, with trees, hedges, shrubbery and flowers so that visitors may feel more welcome. Rural communities should take the same interest in their roads. They should not only build and maintain roads but they should beautify them to give their friends a good impression of their homes.

We find many so-called self-styled "practical men" who do not realize the importance of beautifying country highways. Lloyd-George said that there is nothing more fatal to a people than it should narrow its vision to only material things. We need beautiful streets and highways to stimulate the imagination and exalt the vision of our people. We know that good roads mean good schools, education, and prosperity and that bad roads mean poor schools, ignorance, and poverty. Beautiful roads are silent education. Each beautiful thing makes a good and lasting impression upon the plastic mind of man, and when we consider that an ugly road makes the opposite impression we should realize our responsibility in the matter of adornment of our highways.

Sperry Flour Buildings

Mr. M. C. Couchot, structural engineer in the French Bank building, San Francisco, has prepared plans for new buildings for the Sperry Flour Company in Los Angeles and Santa Barbara. Mr. Couchot made the engineering plans for the new Southern Pacific warehouse now under construction by the Dinwiddie Company at Third and Berry streets, San Francisco.

ZOURI SAFETY SASH BARS
 Accepted by the Insurance Underwriters for Safety Setting of Plate Glass used in Store Front Construction.
COBBLEDICK-KIBBE GLASS CO.
 175 JESSIE ST. WASHINGTON AT THIRD ST.
 SAN FRANCISCO, CAL. OAKLAND, CAL.

C. DRUCKER J. C. JAMES
JAMES & DRUCKER
 Plumbing—Heating Contractors
 Phone Market 275 450 Hayes Street, San Francisco, Cal.

CHAS. STOCKHOLM & SONS
 GENERAL CONTRACTORS
 849 MONADNOCK BUILDING Phone DOUGLAS 4657 SAN FRANCISCO

J. W. BENDER ROOFING & PAVING CO.
 WATERPROOFING AND COMPOSITION ROOFING
 MASTIC AND BITUMEN PAVING
 110 Jessie Street San Francisco Telephone Douglas 4657



Resists Fire
 Freedom from pitch or resin gives California Redwood an unusual resistance to fire. For this reason Redwood construction, whether for home building, industrial, specialty, or engineering work, is long lasting.
 Due to a natural preservative, Redwood also resists rot—a quality valuable in any industrial construction exposed to the elements or in contact with the ground.
 CALIFORNIA REDWOOD ASSOCIATION
 San Francisco

California Redwood
Resists fire and rot

TIME CLOCKS



SCHOOLS must have uniform time to secure efficient results. They also need automatic sounding of the program Bells synchronized with the clocks.
 All "Standard" Electric Time Equipments are guaranteed against any electrical or mechanical defects for a period of one year from date of installation. Specifications, blue prints and other information will be gladly furnished architects, engineers or officials for planning and installing "Standard" systems. Let us cooperate with you for securing the best results.

STANDARD ELECTRIC TIME COMPANY
 461 MARKET STREET
 Phone Sutter 241 SAN FRANCISCO

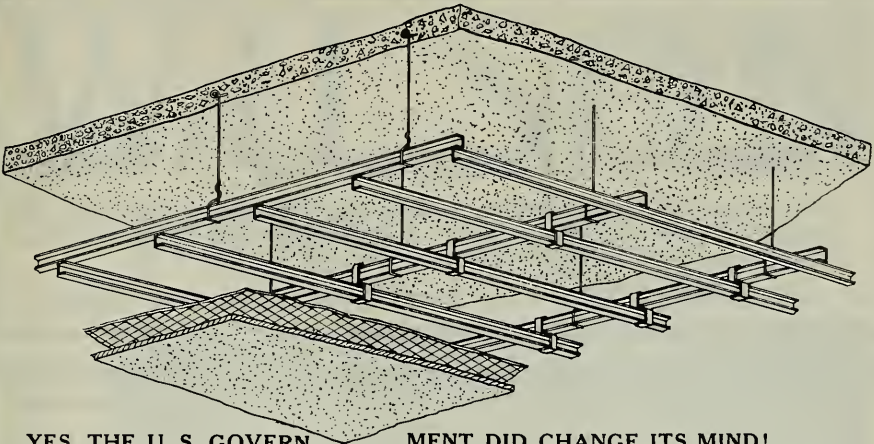

YES, THE U. S. GOVERNMENT DID CHANGE ITS MIND!

The specifications on the U. S. Government Building at Portland, Oregon, called for the tying together of the carrying bar and lathing bar with wire.

We submitted our system, and after an explanation of the S. S. System for fastening bars, the engineers and government officials were convinced that here, at last, is the perfect and economical system, and these reasons added weight in deciding.

It is a positive tie, no slipping or shearing.

It is strong, Smith Emery test to 353 lbs. before failing.

It is fast, can be applied on the bench or on the scaffold.

Made for 1 inch carrying bar and 3/4 inch lathing bar and 3/4 inch carrying bar and 3/4 inch lathing bar. Can be used for wall furring as well as for ceiling work.

THE STEEL STUDDING COMPANY

Also Manufacturers of

THE PRONG CHANNEL FOR SOLID AND HOLLOW PARTITIONS

Agents Wanted Everywhere

1216 Folsom Street, San Francisco

A TEN YEAR GUARANTEE

is back of this roof covering and it **costs less** than other roofing materials



2400 gallons used on the Fairmont Hotel, San Francisco.

Bekin's Warehouse is waterproofed with it.

The W. O. W. Building, Oakland, is roofed with it.

You make no mistake when you specify

LIQUID ASBESTOS PATCH-HOLE CEMENT

Write for sample and price list.

California Plastic Products Company

521 SHELDON BUILDING, SAN FRANCISCO, CALIFORNIA

**FOR MODERN
STORE FRONTS**

Plummer's Disappearing Awnings

Are constructed with no outside attachments below awning recess. All mechanical parts entirely concealed. Send for Architects' Sheet showing specifications for recess construction, etc.

W. A. PLUMMER MFG. CO., 35-37 Front Street, San Francisco

JOHN TRAYNOR

CHARLES HARCOURT

OCEAN SHORE IRON WORKS

Manufacturers of Oil Tanks, Water Tanks, Pressure Tanks, Air Receivers, Feed Water Heaters, Breechings, Smoke Stacks, Water Pipe, Boilers, Retorts, Digestors, Pneumatic Pressure Tanks, Riveted or Oxy-Acetylene Welded Tanks, and dealers in Boilers, Tanks, Pumps, Engines, Machinery, Steel Plates, Shapes

Special Attention Given to Government and Export Orders

OCEAN SHORE IRON WORKS

Office and Works: 550-558 EIGHTH STREET.

SAN FRANCISCO, CAL.

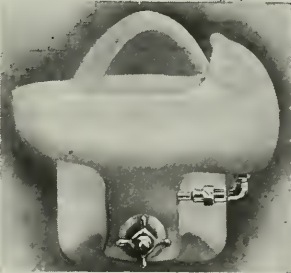

Model No. 7A.

NO GERMS HERE

HAWS IMPROVED SANITARY DRINKING FAUCET eliminates all possibility of contracting disease from dirty bulbs or unsanitary bowls. Provided with an overhead cowl, the drinker's lips never touch the source of supply. A slanting stream throws the water from right to left and away from the bubbler, instead of straight up to fall back over the fountain head. Recommended for Schools and Public Playgrounds. A type used extensively by the U. S. Government. Manufactured by

Haws Sanitary Drinking Faucet Co., Inc.
1808 Harmon Street, Berkeley Phone Piedmont 3742

GLADDING, McBEAN & CO.

MANUFACTURERS CLAY PRODUCTS

CROCKER BUILDING, SAN FRANCISCO

WORKS, LINCOLN, CAL.

WILSON

**FOLDING PARTITIONS
CASEMENTS
WARDROBE FRONTS**

One big room out of three small ones—or three rooms out of one.



A Wilson installation in Los Angeles Standard School Buildings.



Read below what Mr. C. B. J. Snyder, Architect and Supt. of N. Y. City Schools, says in an article in *American Architect*:

"... Folding Partitions are an important factor in school house design. There are certain conditions which require the enlargement of a room temporarily and by the use of these partitions this is accomplished.

"Also the value of a folding partition depends largely on its soundproof qualities and easy working, and it is necessary to exercise great care in the manufacture and erection.

"Wilson Folding Partitions have been the standard for New York City Schools for several years."

Pacific Coast Office: **The J. G. WILSON CORPORATION** Los Angeles, Calif.
600 Metropolitan Building

Also Manufacturers of

Diffuselite Blinds and Awnings **Rolling Partitions** **Rolling Steel Doors**
Waterhouse-Wilcox Co., San Francisco Theo. F. Snyder, San Diego T. G. Bush & Co., Spokane
F. W. Farrington & Co., Portland and Seattle Hawley-Richardson-Williams Co., Salt Lake City

THE TORMEY CO.

General
Painters

Phone Franklin
5-5-9-8

1042 Larkin St., San Francisco, Cal.

Alvaline, Cementoline

and other

Jones-Duncan Products

MAGNER BROTHERS
PAINT MAKERS

Telephone: Market 113

414-424 Ninth St. San Francisco

HEATING-PLUMBING

COMPLETE PLUMBING AND
HEATING SYSTEMS INSTALLED
IN ALL CLASSES OF BUILDINGS
ALSO POWER PLANTS

GILLEY-SCHMID CO., Inc.

198 OTIS STREET, SAN FRANCISCO.

Tel. MARKET 965

Alfred Gustafson, *Pres.* F. J. Gustafson, *Treas.*
Chas. A. Koerig, *Sec.* J. M. Reynolds, *Sales Mgr.*
Phone: Mission 1575-1576

4067 Watts St., Emeryville—Phone Piedmont 581

INLAID FLOOR CO.

Incorporated 1897

Manufacturers of

PLAIN AND ORNAMENTAL FLOORS

MACHINE FLOOR SANDING

Grilles and Weather Strips

600 ALABAMA STREET, AT 18TH ST.
SAN FRANCISCO

Phone Douglas 3224

Hunter & Hudson

ENGINEERS

Designers of Heating, Ventilating
and Wiring Systems. Mechanical
and Electrical Equipment of
Buildings.

703 Rialto Bldg., San Francisco, Cal.

BEAVER-BLACKBOARD BEAVER GREENBOARD

SCHOOL FURNITURE

AND SUPPLIES—

OFFICE, BANK AND

COURTHOUSE FURNITURE—

THEATRE AND

AUDITORIUM SEATING

Rucker-Fuller Desk Co.

677 Mission St., SAN FRANCISCO, CAL.

434 Higgins Bldg., LOS ANGELES, CAL.

432 - 14th Street - OAKLAND, CAL.

ELECTRICAL MECHANICAL

BALDWIN DREW WARD

Consulting Engineer
Power and Industrial Plants

Associate Member A. I. E. E.

76 Eleventh St. Oakland, Cal.

RUSSWIN

BUILDERS' HARDWARE

JOOST BROS., Inc.

SAN FRANCISCO AGENTS.

We Carry Complete Stock:

Fishing Tackle—Guns—Mechanics' Tools—
Paints—Crocery and Glassware—Stoves—
Household Goods. Telephone Market 891.

NO BRANCH STORE

Mazda Lamps

Electric Goods

Present Cost of Building Materials*

With Labor Wage Scale, Bonds, Etc.

THESE quotations are based on reliable information furnished by San Francisco material houses. Date of quotations, October 20, 1920.
All prices f. o. b. cars San Francisco or Oakland.

American Institute of Architects' Fees

New work—6 per cent minimum basis.
Alterations—7 to 10 per cent as a minimum basis.

High class residence work—10 per cent as a minimum.

Bond—1½% amount of contract.

Brickwork—

Common, \$38.00 per 1000 laid.
Face, \$70.00 per 1000 laid.
Common, f. o. b. cars, \$18.00 plus cartage.
Face, f. o. b. cars, \$45.50 per 1000, carload lots.
12x12x3 in., 10¼c. per square foot.
12x12x4 in., 11¾c. per square foot.
12x12x6 in., 16¼c. per square foot.
Hod carriers, \$8.00 per day.
Bricklayers, \$10.00 per day.
Lime—\$3.25 per bbl.; carload, \$2.75 per bbl.

Composition Floors—30c. per sq. ft.

Concrete Work (material at San Francisco bunkers)—

No. 3 rock.....\$2.50 per yd.
No. 4 rock.....2.75 per yd.
Niles pea gravel.....3.25 per yd.
Niles gravel.....2.50 per yd.
Niles top gravel.....3.00 per yd.
City gravel.....2.50 per yd.
River sand.....1.65 per yd.
Bank sand.....1.00 per yd.

Monterey White Sand—

Del Monte, \$1.25 to \$1.50 per ton.
Fan Shell Beach, \$2.50 to \$3.00 per ton.
Car lots, f. o. b. Lake Majella.
Cement (f. o. b. cars)....\$4.09 per bbl.
Rebate for sacks, 25c. each.
Atlas "White".....\$9.50 per bbl.
Medusa cement.....9.50 per bbl.
Forms.....\$60.00 per M
Wage—
Laborers.....\$6.00 per day
Concrete workers.....7.50 per day
Cement finishers.....9.00 per day

Damproofing—

Two-coat work, 30c. per yard.
Membrane waterproofing—4 layers of P. B. saturated felt, \$6.00 per square.
Hot coating work, \$2.00 per square.
WAGE—Roofers, \$9.00 per day.

Electric Wiring—\$8.00 to \$15.00 per outlet.

WAGE—Electricians, \$9.00 per day.

Elevators—

Prices vary according to capacity speed and type.
Consult elevator companies.

Excavation—

\$2.25 per yard.
Teams, \$12.00 per day.
Trucks, \$30.00 to \$40.00 per day.
Above figures are an average without water. Steam shovel work in large quantities, less; hard material, such as rock, will run considerably more.

Fire Escapes—

Ten-foot balcony, with stairs, \$100.00 per balcony.

Glass— (Consult with manufacturers.)

21 ounce, 30c. per square foot.
Plate, \$2.00 to \$3.50 per square foot.
Art, \$1.00 up per square foot.
Wire (for skylights), 45c. per square foot.
Obscure glass, 30c. per square foot.
Note.—Add extra for setting.
WAGE—Glaziers, \$9.00 per day.

Heating—

Average, \$3.25 per sq. ft. of radiation.
WAGE—Steamfitters, \$10.00 per day.

Iron

Cost of ornamental iron, cast iron, etc., depends on design.

Lumber—

Common (at building), \$40.00 per 1000 (average).
Common O. P. (select), \$75.00 per 1000 (average).

Flooring—

1x3 No. 1.....\$100.00 per 1000
1x3 No. 2.....96.00 per 1000
1x4 No. 1.....95.00 per 1000
1x4 No. 2.....92.00 per 1000
1x4 No. 3.....80.00 per 1000
1x6 No. 1.....100.00 per 1000
1x6 No. 2.....97.00 per 1000
1¼x4 and 6 No. 1.....100.00 per 1000
1¼x4 and 6 No. 2.....95.00 per 1000
Slash grain, 1x4 No. 2.....75.00 per 1000
Slash grain, 1x4 No. 3...60.00 per 1000
No. 1 common run to
T. & G.50.00 per 1000
Lath.....9.00 per 1000

Shingles—

Redwood, No. 1.....\$1.60 per bdl.
No. 2.....1.50 per bdl.
Red cedar.....1.85 per bdl.
(Add cartage to above)

Hardwood Floors—

Maple floor (laid and finished), 38c. per foot.
Factory grade floors (laid and finished), 30c. per foot.
Oak (quartered, finished), 57c per foot.
Oak (clear), 41c. per foot.
Oak (select), 39c. per foot.
Oak, quartered, sawed, clear, select, 48c.
WAGE—Floor layers, \$9.00 per day.
In flooring the usual grades of oak used are

	Grades	Quartered	Plain
		Sawed	Sawed
5/16"	Clear	"	"
	Select	"	"
1"x3"-13/16"x2¼"	Clear	"	"
	Select	"	"
	No. 1 (very little used)		
¾-inch plain oak.....			58c.
¾-inch quarter sawed.....			70c.

Hardwood Floors (not laid)— Per M ft.

5/16x2" sq. edge Clear quartered oak.....365.00
Select quartered oak.....295.00
Clear plain oak.....295.00
Select plain oak.....265.00

* NOTE.—For country work add freight and cartage to prices given.

Hardwood Floors (not laid)—Continued

	Per M ft.
13/16x2 1/4" face Clear quartered oak.....	\$460.00
Select quartered oak.....	350.00
Clear plain oak.....	340.00
Select plain oak.....	305.00
Clear maple.....	280.00
Clear maple—white.....	310.00
13/16x3 1/4" face Clear maple.....	285.00
1 1/2x2 1/4" face Clear maple.....	290.00
3/8x2" face Clear quartered oak.....	300.00
Select quartered oak.....	250.00
Clear plain oak.....	250.00
Select plain oak.....	215.00
Clear maple.....	235.00
Clear beech.....	225.00
Clear red beech.....	265.00

Veneered Panels—

24x60 in., 1/4 in., 3-ply, 1 side:	Per ft.
Ash.....	31 1/2c
Hungarian Ash.....	47c
Birch.....	31 1/2c
Curly Birch.....	47c
Elm.....	29c
Jeniserö (Genczero).....	45 1/2c
Southern Red Gum (plain fig.).....	38 1/2c
Otd. Southern Red Gum.....	47c
Hawaiian Koa.....	47c
Maple.....	29c
Birdseye Maple.....	57c
Mahogany.....	47c
Oregon Pine.....	23 1/2c
Plain Oak.....	37 1/2c
Quartered Oak.....	47c
Walnut.....	48c

Millwork—

O. P., \$150 per 1000. R. W., \$150 per 1000.	
Double hung box frame windows (average) with trim.....	\$10.50 each
Doors, includ. trim (single panel).....	15.00 each
Doors, including trim (five panel).....	\$12.00 each
Screen doors.....	5.50 each
Window screens.....	3.50 each
Medicine cases.....	5.00 each
Cases for kitchen pantries seven feet high, per lineal foot.....	10.00 each
Dining room cases same price, if not too elaborate, Flag poles, per foot.....	1.50
Labor—Rough carpentry, warehouse heavy framing, \$16.00 per 1000.	
For smaller work, average, \$23.00, \$30.00 per 1000.	
WAGE—Laborers, \$6.50 per day.	
Carpenters, \$9.00 per day.	

Marble—(Not set) add 60c up per ft. for setting

Columbia.....	\$2.05 sq. ft.
Alaska.....	2.05 sq. ft.
San Saba.....	3.65 sq. ft.
Tennessee.....	2.50 sq. ft.
Verde Antique.....	4.55 sq. ft.

Painting—

Two-coat work, 35c. per yard.
Three-coat work, 45c. per yard.
Whitewashing, 5c. per yard.
Cold water paint, 10c. per yard.
WAGE—Painters, \$8.50 per day.

Patent Chimneys—

6-inch.....	\$1.50 lineal foot
8-inch.....	1.75 lineal foot
10-inch.....	2.25 lineal foot
12-inch.....	3.00 lineal foot

Pipe Casings—\$8.00 each.

Plastering—

Interior, on wood lath, 70c. per yard.
Interior, on metal lath, \$1.25 per yard.
Exterior, on brick or concrete, \$1.00 per yard.
Portland White, \$1.25 to \$1.50.

Interior on brick or terra cotta, 65c to 70c per yard.

Exterior, on metal lath, \$2.25 to \$2.50 per yard.

Wood lath, \$8.00 at yard per 1000.

Metal studding, \$1.00 to \$1.25 per yard.

Metal studding, with lath and plaster, \$2.00 per yard.

Galv. (metal lath), 38c. and up per yard, according to gauge.

Lime, f. o. b. warehouse, \$2.40 per bbl.

Hardwall plaster, \$21.00 per ton f. o. b. warehouse.

WAGE—Hod carriers, \$8.50 per day.

Plasterers, \$10.00 per day.

Plumbing—

From \$70.00 per fixture up, according to grade, quantity and runs.

WAGE—Plumbers, \$10.00 per day.

Reinforcing Steel—

Base price for less than car load lots, \$5.75 per 100 lbs.

Car load lots, \$5.50 per 100 lbs., f. o. b. San Francisco. (Mill delivery.)

Roofing—

Five-ply tar and gravel, \$7.50 per square for 30 squares or over.

Less than 30 squares, \$8.00 per square.

Tile, \$35.00 per square.

Redwood shingle, \$13.00 per sq. in place.

Cedar shingle, \$13.00 per square in place.

Reinforced Pacbo roofing, \$8.25 per square. WAGE—Roofers, \$9.00 per day.

Rough Hardware—

Nails, per keg, \$8.00 base and very scarce.

Deafening felt, \$170.00 per ton.

Building paper, P. & B.,

1 ply, \$6.50 per 1000 ft. roll.

2 ply, \$9.75 per 1000 ft. roll.

3 ply, \$14.00 per 1000 ft. roll.

Sash cord,

(Sampson spot), \$2.50 per hank 100 feet.

Common, \$1.75 per hank 100 feet.

Sash weights, cast iron, \$80.00 per ton.

Skylights—

Copper, \$1.25 a square foot (not glazed).

Galvanized iron, 50c. a square foot (not glazed).

WAGE—Sheet metal workers, \$10.00 per day.

Store Fronts—

Kawneer copper bars for store fronts.

Corner, center and around sides, will average \$1.35 per lin. foot.

Zouri bar, \$1.25 per lin. foot.

Zouri Underwriters' Specification sash, \$1.60 per lin. foot.

Structural Steel—\$150.00 per ton.

This quotation is an average for comparatively small quantities.

Light truss work higher; plain beam and column work in large quantities, less.

Steel Sash—

Fenestra, from S. F. stock, 45c. per sq. ft.

Fenestra, Plant shipment, 40 1/2c. per sq. ft. (Includes mullions and hardware.)

Tile—

White glazed, 80c. per foot.

White floor, 80c. per foot.

Colored floor tile, \$1.00 per foot.

Promenade tile, \$1.00 per sq. foot, laid.

WAGE—Tilers, \$9.00 per day.

Windows—Metal, \$2.00 a square foot.

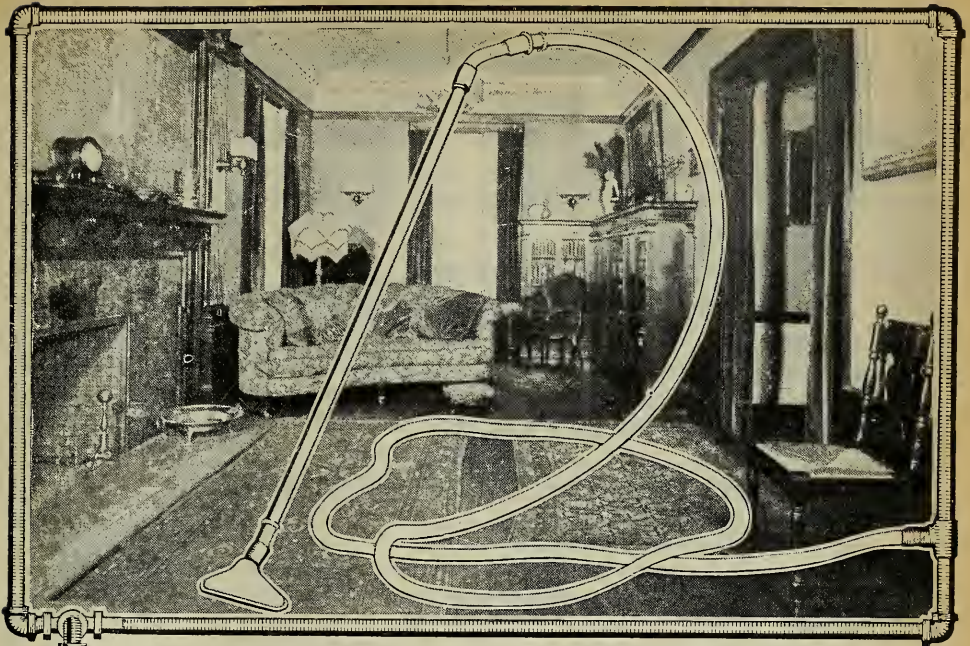

SIX WORDS THAT TELL IT ALL

**“Greatest in Efficiency
-Greatest in Value”**

There you have the whole secret of the remarkable success of the TUEC Stationary Suction Cleaner.

Judged from any standpoint the TUEC Fan-Type No. 260, $\frac{3}{4}$ -H. P. Model for buildings of ordinary size, is the biggest value ever offered in a stationary suction cleaner.

Simplicity of design is the keynote of the TUEC'S unmatched cleaning power, TUEC fan-type construction represents the latest and furthest advance in vacuum cleaner building. It costs less to maintain, requires less care, and is absolutely fool-proof and accident-proof.

Your knowledge of vacuum cleaners and air cleaning service is incomplete if you are not familiar with all the advantages of the TUEC.

Write for catalog and call on us for advisory service.

THE UNITED ELECTRIC CO.
New York Chicago Cleveland

CANTON, OHIO
Atlanta Portland, Ore.



S. F. COMPRESSED AIR CLEANING CO., 397 Sutter Street, San Francisco
BARKER BROS., 724 So. Broadway, Los Angeles—California Distributors

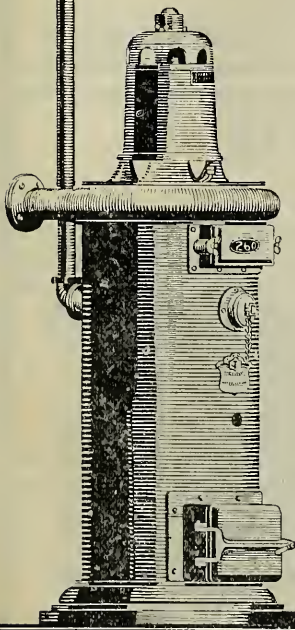

A. D. COLLMAN

GENERAL CONTRACTING

Phone Sutter 4858

546-48 Monadnock Building, San Francisco

I. R. KISSEL

Phone Franklin 548

Decorator, Painter and Paperhanger

1747 SACRAMENTO ST., Bet. Polk St. and Van Ness Ave., SAN FRANCISCO

ROBERT TROST

PHONE MISSION 2209

General Building ContractorWe Specialize in High Grade Work and Employ Skilled
Labor in every Branch of the Building Industry.26th and Howard Streets
SAN FRANCISCO

P. A. Palmer

Peter Petersen

W. L. Kelly

PALMER & PETERSEN

Contracting Engineers

Monadnock Building

SAN FRANCISCO, CAL.

Phone Sutter 2581

LARSEN-SAMPSON CO.

BUILDING CONSTRUCTION

Claus Spreckels Building

SAN FRANCISCO

MONSON BROS.

GENERAL CONTRACTORS

Telephone Market 2693

1908 Bryant Street, San Francisco

UNIT CONSTRUCTION COMPANY

(INCORPORATED)

ENGINEERING AND CONSTRUCTION

Telephone Kearny 28

429-36 Phelan Building, SAN FRANCISCO

J. D. HANNAH

Contractor and Builder

OFFICE: 142 Sansome Street
San Francisco, Cal.

Telephone Douglas 3895

BUILDERS EXCHANGE, 180 JESSIE STREET

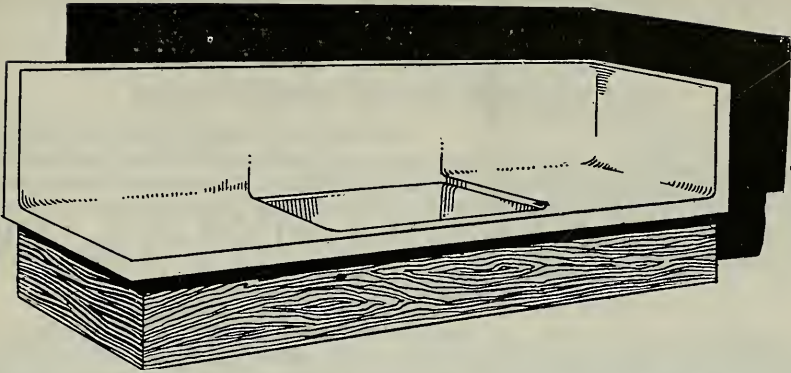

A Snow White Drain Board

PETRIUM SANITARY SINKS are made in Berkeley, California and are non-porous, non-absorbent and Lye-proof. The entire surface of the drainboard and back is covered with a composition, on which a smooth, glossy, snow white finish is applied mechanically leaving no crevice or corners in which dirt and grease can collect as where tile or wood is used.

Can be installed in any home—new or old.

PETRIUM SANITARY SINK COMPANY
 FACTORY AND OFFICE, WEST BERKELEY
 Agents in Principal Coast Cities

*Send for booklet
 and Price List.*

The High Cost of Building Material Is a Strong Argument for Economy

Architects may keep down the
 Cost by Economizing in Space



Hotel Cecil, San Francisco,
 Equipped with Wall Beds.

Portal Wall Beds

are timely space and cost savers,
 meeting a national need. Those who
 would build wisely in these days
 of soaring prices, provide for
PORTAL WALL BEDS

MARSHALL & STEARNS CO.

WALL BEDS

"HIGHEST AWARD ALWAYS"

1152 Phelan Building
 San Francisco

1774 Broadway
 Oakland

I. M. SOMMER,**CONTRACTORS & ENGINEERS**

Phone Kearny 4582

401 BALBOA BLDG., SAN FRANCISCO

K. E. PARKER COMPANY, Inc.**GENERAL CONTRACTORS**

Phone Sutter 5661

Room 515 Clunie Building, SAN FRANCISCO

R. W. LITTLEFIELD
BUILDING CONSTRUCTION

357 12th Street, Room 9, Oakland, Cal.

Phone Lakeside 415

H. H. HILP, Jr.

J. FRANK BARRETT

BARRETT & HILP**CONCRETE CONSTRUCTION BUILDERS GENERAL CONTRACTORS**

SHARON BUILDING, SAN FRANCISCO

TELEPHONE SUTTER 1168 or 1169

Res. Phone Mission 5049

JAMES F. SMITH — Plasterer

273 Minna Street, San Francisco

Phone KEARNY 740

Member Builders Exchange

STEELFORMS Signify ECONOMY, RAPIDITY, and EFFICIENCY

STEELFORM CONTRACTING COMPANYSTEELFORMS FOR
CONCRETE
BUILDINGSC. B. Hopkins, C. E., Manager
681 Market Street, San FranciscoCONCRETE JOIST
FLOOR
CONSTRUCTION**W. C. DUNCAN & CO.**

508 Sharon Bldg.

General Contractors

San Francisco

M. E. VUKICEVICH

SPENCER B. BAGGE

VUKICEVICH & BAGGE
GENERAL CONTRACTORS

Phone Sutter 6700

Office, Builders Exchange, 180 Jessie St., San Francisco

245 Market St. **Standard Fence Co.** 310 Twelfth St.
 S. F. Kearny 2028 **WIRE AND IRON WORKS** Oakland 475

DESIGNERS - BUILDERS WIRE GRILL WORK—WIRE SCREEN
 FACTORY PROTECTION FENCE FLEXIBLE WIRE CONVEYOR BELT
 AVIARY AND TENNIS COURT FENCE WIRE SPECIALTIES

320 North Los Angeles Street, Los Angeles, Cal. Phone 67188

Steel Bars FOR CONCRETE REINFORCEMENT
 Cut to Length. Fabricated. Installed

BADT-FALK & CO.

Tel. Douglas 3466 346 Call-Post Bldg., 74 New Montgomery St., San Francisco

BUILDING DIRECTORIES [INTERCHANGEABLE STEEL
 LETTERS AND NUMBERS]

FOR OFFICE BUILDINGS, SCHOOLS, CAFETERIAS, Etc.
 Bargains Lists for Auto Sales Companies. Sold Outright.

Go-Sign and Letter Manufacturing Co.

1106 Franklin Street Oakland, California

D. N. & E. WALTER & CO.
 "SINCE 1858"

LINOLEUMS—CARPETS LARGE STOCKS CARRIED
 Estimates furnished on request

562-572 MISSION STREET SAN FRANCISCO

Merritt 668

H. N. McNAB

Hardwood Floors  Floor Sanding

2307 - 17th Ave. Oakland, Cal.

Res. Tel. Merritt 3600

HERBERT BECKWITH
Building Construction

Formerly with ARTHUR ARLETT 323 Newton Ave.
 Oakland

D. ZELINSKY & SONS

PAINTERS AND DECORATORS

420 TURK STREET, SAN FRANCISCO

CHARLES T. PHILLIPS
CONSULTING ENGINEER

PACIFIC BUILDING SAN FRANCISCO
 HEATING VENTILATION WIRING ILLUMINATION

Ideal Air-Washers. Ideal Fruit-Dryers. Fan Systems for Heating, Cooling and Drying.

Ideal Heating and Engineering Co.

Air-Conditioning, Heating, Cooling and Drying

192 ERIE STREET

Phone Market 3708

SAN FRANCISCO

Atlas Heating and Ventilating Co., Inc.

ENGINEERS and CONTRACTORS

STEAM AND HOT WATER HEATING, FANS, BLOWERS,
FURNACES, POWER PLANTS--SHEET METAL WORK

Phone Douglas 378

Fourth and Freelon Sts., Bet. Bryant & Brannan, SAN FRANCISCO

Illinois Automatic Vacuum and Vapor Systems of Heating

"TWENTY-FIVE YEARS OF QUALITY"

ILLINOIS ENGINEERING COMPANY

JAS. I. KRUEGER, *Representative*

559-561 Pacific Building, San Francisco

Telephone: Kearny 3047

HEATING
VENTILATION

Automatic Sprinkler Systems
FLOOR AND WALL TILING

PLUMBING
SHEET METAL WORK

SCOTT CO., Inc.

SUCCESSOR TO JOHN G. SUTTON CO.

243 MINNA STREET

SAN FRANCISCO

ALEX COLEMAN

CONTRACTING PLUMBER

706 ELLIS ST., SAN FRANCISCO

Phone FRANKLIN 1006

WM. F. WILSON COMPANY

MODERN SANITARY APPLIANCES

Special Systems of Plumbing for Residences, Hotels, Schools, Colleges, Office Buildings, Etc.

Phone Sutter 357

328-330 Mason Street, San Francisco.

A. LETTICH

365 FELL ST., SAN FRANCISCO

Telephone — Park 234

Plumbing
and Heating

The Granite Work on Eldorado County Courthouse; National Bank of D. O. Mills, Sacramento;—
and Sen. Nixon Mausoleum, Reno, WAS FURNISHED BY

CALIFORNIA GRANITE COMPANY

Phone Sutter 2646

STONE CONTRACTORS

Gen'l Contractors Ass'n, San Francisco
Quarries, Rocklin and Porterville

Main Office, Rocklin, Placer Co., Cal.
Telephone Main 82

GOODS OF QUALITY

A new syphon action closet at a moderate price that is not only ultra-efficient but pleasing in appearance and combining many new sanitary features.

On display at our show room—

64 Sutter Street, San Francisco

Main office and warehouse: Sixth, Townsend & Bluxome Sts.



Holbrook, Merrill & Stetson

Designers - Fabricators - Erectors General Plate Work



Hydro - Pneumatic Pressure Tanks —
Hemispherical Bottom Tanks and Towers
— Oil and Water Tanks — Oil Stills —
Pipe Lines—Smoke Stacks—Well Casing
— Rock Screens — “Western” Corru-
gated Culvert Pipe.

Western Pipe and Steel Company OF CALIFORNIA

444 MARKET STREET
SAN FRANCISCO

1758 NORTH BROADWAY
LOS ANGELES

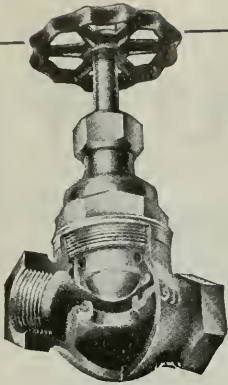

AMERICAN BALL VALVES

"Durable — therefore, Economical" — Stands the Severest Tests — Endorsed by the Leading Architects and Engineers of the Country. It is A PERFECT BALL-CLOSING VALVE.

W. E. MUSHET CO

SOLE AGENTS

Phone Sutter 4797



502 Mission Street
San Francisco, Cal.

**DON'T NEGLECT YOUR HEATING SYSTEM.
THE BEST IS NONE TOO GOOD!**

All kinds of Galvanized Iron Work — Furnaces, Pipes, Ventilators — Sheet Metal for Planing Mills, Fruit Dryers, Rice Mills. Kitchen Equipment, including Steam Tables, Sinks, Canopies, Urn Stands, Etc.

JAMES A. NELSON

Heating and Ventilating Contractor

Phone, Garfield 1959

517-519 SIXTH ST., SAN FRANCISCO

A. H. Bergstrom
Eric Lange

Phone Kearny 3526

LANGE & BERGSTROM

Building Contractors

(Established 1900)

207-210 SHARON BUILDING
San Francisco

TIMKEN BUILDING
San Diego

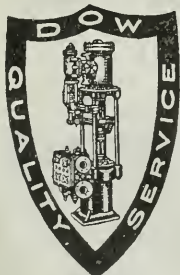

DOW ROTREX PUMP

For severe suction requirements

We also manufacture

TRIPLEX POWER PUMPS

and

CENTRIFUGAL PUMPS

We solicit your inquiries

DOW - HERRIMAN CO.

San Francisco Office, 140 Howard Street
phone Garfield 612 Plant Petaluma Cal.

Vacuum Pipeless Furnace

The Perfect Heating Plant



"VACUUM" HEATING & VENTILATING PRINCIPLE
SHOWING- CONTINUOUS AIR CIRCULATION

Installed in one day in new or old homes, stores or public buildings.

Heats entire building with one register—no piping.

One-third fuel bill saved.

Over 50,000 now in use

Write, telephone or call for our Heating Engineer

Vacuum Pipeless Furnace Co.

523 Monadnock Building, San Francisco

Market Street, Below Third Street.

Telephone Sutter 5469



POSITIVE ELECTRIC INTERLOCK

(BAR LOCK TYPE)

Prevents Elevator Accidents Occurring at the Entrance Door

Approved by National Underwriters Laboratories—Meets requirements of Elevator Safety Orders of Industrial Accident Commission, State of California

ELEVATOR SUPPLIES COMPANY, Inc. 186 FIFTH STREET,
SAN FRANCISCO

Capital \$1,000,000

CALIFORNIA DEPARTMENT

Surplus \$1,122,000

THE FIDELITY AND CASUALTY COMPANY OF NEW YORK

Prompt Service for

BONDS AND CASUALTY INSURANCE

203-206 Merchants Exchange Building

SAN FRANCISCO, CAL.

ANY PLACE ANY TIME PROMPTLY "We Serve You"

JOHN H. ROBERTSON

Successor to Robertson & Hall

GENERAL INSURANCE

Phone Sutter 2750

621 First National Bank Building, San Francisco

CONTRACT BONDS

Fidelity and Surety Bonds of every kind.

C. K. BENNETT, Manager

FIDELITY AND DEPOSIT COMPANY OF MARYLAND

Telephone Kearny 1452

622 Insurance Exchange, San Francisco, Calif.

PACIFIC DEPARTMENT

Globe Indemnity Company

BONDS and CASUALTY INSURANCE for CONTRACTORS

FRANK M. HALL, formerly Robertson & Hall, Mgr.

120 Leidesdorff Street

Phone Sutter 2280

SAN FRANCISCO

National Surety Company of New York

The World's Largest Surety Company

Assets over \$20,000,000

Pacific Coast Department: 105 MONTGOMERY ST., SAN FRANCISCO, CAL.

Frank L. Gilbert, Vice-President

Phone, Sutter 2636

PHONE DOUGLAS 2370

McLERAN & PETERSON

GENERAL CONTRACTORS

HEARST BUILDING

SAN FRANCISCO, CAL.

L. J. RUEGG

J. B. RUEGG

RUEGG BROS.

CONTRACTORS AND BUILDERS

Phone Douglas 1599

719 Pacific Building, SAN FRANCISCO

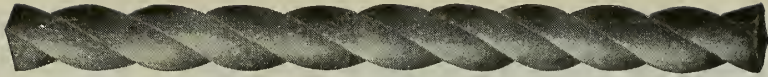

Steel ^{Open} ^{Hearth} Bars ^{For Concrete} ^{Reinforcement}

Square, Deformed and Cold Twisted, Plain Rounds and Squares

PACIFIC COAST STEEL COMPANY

General Office, Rialto Building, San Francisco. Phone Sutter 1564

Sales Office, Rialto Building, SAN FRANCISCO
Sales Office, Union Oil Building, LOS ANGELES
Sales Office..... SEATTLE, WASH.

ROLLING MILLS:
SOUTH SAN FRANCISCO.....CAL.
SEATTLE, WASH. PORTLAND, ORE.

Architects and Building Contractors:

THE Binding of Your Magazines
and Periodicals is Our Specialty.
Expert Plate and Map Mounting.

The HICKS-JUDD COMPANY, Inc.
BOOKBINDERS

51-65 First Street San Francisco, Cal.

George S. MacGruer }
Robert M. Simpson } Members of Builders Exchange

MacGruer & Simpson

CONTRACTING PLASTERERS
PLAIN AND ORNAMENTAL

Cement, Stucco and Artificial Stone

Phone Sutter 5688

540 Call-Post Building, San Francisco

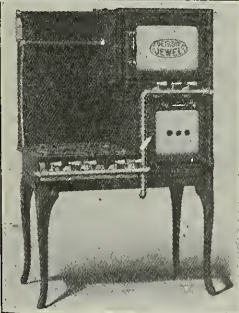

Detroit Jewel Gas Ranges

FOR HOME, RESTAURANT, HOTEL AND CLUB

We carry a Full Line of Stock Sizes

SELLING AGENTS

NATHAN DOHRMANN CO.

Geary and Stockton Streets, San Francisco

PARMELEE-DOHRMANN CO.

436-444 S. BROADWAY, LOS ANGELES

THE HYLOPLATE BLACKBOARD

SCHOOL FURNITURE
AUDITORIUM SEATING

MAPS
GLOBES
ATLASES

C. F. WEBER & CO.

985 Market Street
SAN FRANCISCO

222-224

S. Los Angeles St.
LOS ANGELES

100 W. Commercial
Row, RENO, NEV.

524 W. Washington
Street, PHOENIX, ARIZ.



LINOTILE

THE FLOOR
THAT'S BUILT
TO FIT
THE ROOM

Furnished and
Installed by

Van Fleet-Frear Co.

61 New Montgomery Street
San Francisco, California
Telephone, Douglas 1227



Formal Garden Effects

may be obtained on your Country
Estate within a period of two or
three years.

MacRORIE-McLAREN CO.

141 Powell Street, San Francisco
Telephone Douglas 4442

THE HEART OF A BUILDING IS ITS PIPING EQUIPMENT

A complete line for the Piping Features of Buildings—Power, Plumbing, Heating, Ventilating, Refrigerating, Vacuum-Cleaning, Gas, Water, etc.—is furnished by Crane Co. through the Plumbing and Heating trade.

The Architect, Engineer and Builder, or Investor, may enjoy, through the facilities of this Company, the distinct advantage of dealing entirely with one Competent and Responsible House.

Exhibit Rooms, Offices and Warehouses in San Francisco and Oakland and Fifty-one other cities.

CRANE CO.

1855—1918

VALVES AND
FITTINGS



MOUNT DIABLO CEMENT COWELL SANTA CRUZ LIME

ALL KINDS OF

BUILDING MATERIALS

HENRY COWELL LIME AND CEMENT CO.

Phone Kearny 2095

No. 2 MARKET STREET, SAN FRANCISCO

Kawneer

Factory
Berkeley, Calif.
Berkeley 8710

MANUFACTURING COMPANY
of California

San Francisco Office:
180 Jessie Street
Sutter 6700

Kawneer
Store-Fronts
All Metal Mouldings

Kawneer
Simplex Windows
Weightless & Reversible

SHOP and COMPARE

— *that's the only true test of values*

Furnishings for the home of distinctive style are featured in this shop at prices that will bear the strictest comparison.

FURNITURE

FLOOR
COVERINGS

John Breunler Co.
of San Francisco
281 Geary Street, S. F.



DRAPERIES

INTERIOR
DECORATORS

Telephone DOUGLAS 2046	<div style="border: 1px solid black; padding: 5px; margin: 0 auto; width: 80%;"> Butte Electrical Equipment Company <h1 style="margin: 0;">BEECO</h1> <small>TRADE MARK-REG.</small> </div>	530 FOLSOM STREET
CONTRACTORS FOR POWER LIGHTING AND INDUSTRIAL INSTALLATIONS		
For the convenience and guidance of our customers, we have adopted BEECO as our trade name.		

<h1 style="margin: 0;">SAFETY ELECTRIC COMPANY</h1>		
<small>MANUFACTURERS OF</small>		
SWITCHBOARDS SAFETY SWITCHES SAFETY CONTROLS		PANEL BOARDS SAFETY PANELS KNIFE SWITCHES
59-65 Columbia Square		San Francisco, Calif.
Telephone Market 2949		

L. SIEBERT	J. GENSLER
<h1 style="margin: 0;">Drendell Electrical & Mfg. Co.</h1>	
<small>Incorporated</small>	
SWITCHBOARDS, PANEL BOARDS, KNIFE SWITCHES, CABINETS, THEATRE INSTALLATIONS, PROTECTIVE POWER PANELS	
1345-1353 Howard St., San Francisco	Telephone Market 1753

	<h1 style="margin: 0;">MEYERS</h1> <h2 style="margin: 0;">Electric Safety SWITCHES</h2> <p style="margin: 0;">EXTERNALLY OPERATED</p> <p style="margin: 0; font-size: small;">Switch on the right is controlled by Handle on Front of Door, allowing face of switch to be set flush with finish of wall.</p>	
Knock outs on Top, Bottom and Side controlled by Handle on side of Box Meyers Electric Safety Switch Co., Inc.	247 Minna Street	Phone Sutter 3008

BUTTE ELECTRIC & MFG. CO. DOUGLAS 145

(Paul C. Butte) at it since 1904
WIRING FOR BUILDINGS

534 Folsom Street

SAN FRANCISCO

H. S. TITTLE

CONTRACTING ELECTRICAL ENGINEER

766 FOLSOM ST., SAN FRANCISCO

Phone SUTTER 4278



To Be "Low Bidder" Not Always Our Aim.

Our most particular attention is given to prompt and skillful handling of all electrical work of any nature with "QUALITY AND SERVICE GUARANTEED."

Our nation-wide organization and large experience in this field assures you always of fair estimates and absolute satisfaction.

F. E. NEWBERY ELECTRIC CO.

163 Sutter St. (413 Lick Bldg.) San Francisco, Phone Sutter 521

San Francisco, Cal.

Oakland, Cal.

Los Angeles, Cal.

NE PAGE, McKENNY CO.

Electrical Engineers and Contractors

Phone Sutter 2369

589 Howard St., San Francisco, Cal.

Phone Market 2541

M. FLATLAND

GLOBE ELECTRIC WORKS

Estimates Furnished on Everything Electrical

ELECTRIC SUPPLIES

1959 Mission Street, bet. 15th and 16th

SAN FRANCISCO

E. E. BROWNE

Telephone Douglas 976

C. A. LANGLAIS

**BROWNE-LANGLAIS ELECTRICAL
 CONSTRUCTION COMPANY**

213 Minna Street

SAN FRANCISCO

M. E. RYAN

Electrical Contractor

Phones: Store, Red. 250J
 Residence, Red. 250M

216 Main Street
 REDWOOD CITY, CAL.

Thomas J. Bennett

Edward W. Lauer

Rex Electric and Engineering Co.

Contracting and Repairing

253 Minna Street

Telephone Sutter 2148

San Francisco

Oakland 540

The Largest Exclusive Electrical House in the State

MOTORS

BOUGHT — SOLD
RENTED — REPAIRED

Lighting Fixtures
Manufactured

Construction

MAINTENANCE
SUPPLIES

Estimates and engineering data cheerfully furnished

SPOTT ELECTRICAL CO.

Yours for Service

16th & CLAY STREETS · OAKLAND, CALIFORNIA

CHAS. G. FRIES.

TELEPHONE SUTTER 5706

VICTOR A. KUEHN

LIBERTY ELECTRIC COMPANY

479 Sutter St. Electrical Contractors San Francisco, Cal.

POWER CONSTRUCTION CO.

INCORPORATED

CONTRACTING ENGINEERS

Preliminary Estimates Given in All Types
of Buildings, Towers and Bridges

SHARON BUILDING, SAN FRANCISCO
Phone Sutter 5478

SAMSON SPOT SASH CORD

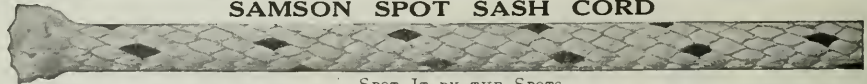

SPOT IT BY THE SPOTS

Made of extra quality cotton yarn, firmly braided and smoothly finished. Carefully inspected and guaranteed free from all imperfections of braid and finish. → Can be distinguished at a glance by our trade-mark, the Colored Spots. *Send for catalogue and samples.*

Pacific Coast Agent, JOHN T. ROWNTREE, Inc., San Francisco and Los Angeles, Cal.

S. RASORI, RES. 2042 TAYLOR ST.
PHONE FRANKLIN 6258

J. DEL FAVERO, RES. 1839 MASON ST.
PHONE FRANKLIN 9524

DEL FAVERO & RASORI

GENERAL CONTRACTORS

MEMBERS OF THE S. F. BUILDERS EXCHANGE AND THE BUILDING INDUSTRIES ASS'N

OFFICE:
110 JESSIE STREET

SAN FRANCISCO, CALIF.

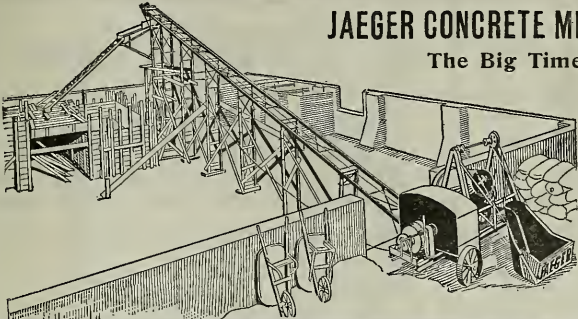

JAEGER CONCRETE MIXING AND PLACING PLANT
The Big Time and Money Saver

All Sizes and Models in Stock

Edward R. Bacon Co.
51 Minna St. 165 E. Jefferson St.
SAN FRANCISCO LOS ANGELES

CONTRACTOR'S MACHINERY

RANSOME MIXERS OSHKOSH MIXERS
INSLEY SPOUTING PLANTS
OSHKOSH EVEREADY SAW RIGS INSLEY STEEL CARS and TRACKS
HOISTING BUCKETS, HOPPERS, GATES, ETC.
STEAM AND ELECTRIC HOISTS

EVERYTHING USED BY CONTRACTORS
CARRIED IN STOCK BY

GARFIELD & CO.

Hearst Building, San Francisco Phone Sutter 1036

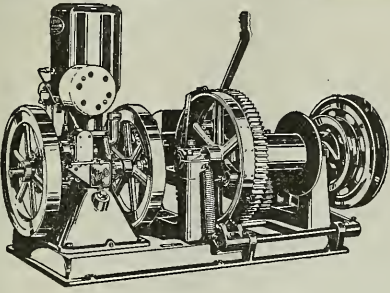

NOVO ENGINES

ALWAYS
SATISFY

BUILT IN SIZES
1½ TO 15 H. P.

We have a Hoist for every requirement of
the Mine, Factory or Contractor.

NOVO HOIST -- TYPE T.

NOVO OUTFITS
comprise Contractor's Pumps—Hoists
Compressors—Saw Rigs, Etc.



STOCKS ALWAYS ON HAND

SMITH-BOOTH-USHER-CO.

PUMPS — ENGINES — MOTORS — MACHINERY — SUPPLIES

San Francisco Taft Los Angeles
50-60 Fremont St. Sutter 952 Supply Row 228 Central Ave. M2695

When writing to Advertisers please mention this magazine.

School and Theatre

STAGES AND EQUIPMENT

EDWIN H. FLAGG

SCENIC COMPANY, Inc.
400 Pantages Bldg., San Francisco, Cal.
1638 Long Beach Ave., Los Angeles, Cal.

MILLWORK Manufactured and Delivered Anywhere

Plans or Lists sent us for Estimates will have Careful and Immediate Attention.

Jno. Dudfield, Pres.
and Manager

DUDFIELD LUMBER CO.

Joseph A. Jury,
Sec'y & Mill Supt.

MAIN OFFICE, YARD AND PLANING MILL — PALO ALTO, CALIFORNIA

FRANK PORTMAN

MILL AND CABINET WORK

Window Frames and Inside Finish A Specialty
Band Sawing, Sticking and Sand Papering

1618-20 MISSION STREET

SAN FRANCISCO

ALL KINDS OF
MOULDINGS
IN STOCK

Phone Park 6204

A. C. SCHINDLER, President.

CHAS. F. STAUFFACHER, Secretary

THE FINK & SCHINDLER CO.

Manufacturers of INTERIOR WOODWORK AND FIXTURES
BANK, OFFICE AND STORE FITTINGS
SPECIAL FURNITURE

218-228 THIRTEENTH ST.
Bet. Mission and Howard Sts.

SAN FRANCISCO, CAL.
Telephone: Market 474

O. BAMANN, President

ERNEST HELD, Vice-President

HOME MANUFACTURING CO.

BANK, STORE AND OFFICE FITTINGS
FURNITURE AND HARDWOOD INTERIORS
CABINET WORK OF EVERY DESCRIPTION

543 and 545 BRANNAN ST.

Phone Kearny 1514

San Francisco, Cal.

PACIFIC MANUFACTURING COMPANY

MILLWORK, SASH AND DOORS

Hardwood Interior Trim a Specialty

MAIN OFFICE:

SANTA CLARA, CAL.

SAN FRANCISCO.....177 Stevenson Street
OAKLAND.....1001 Franklin Street
BERKELEY.....2143 Center Street
SAN JOSE.....16 N. First Street

MULLEN MANUFACTURING CO.

BANK, STORE AND OFFICE FIXTURES—CABINET WORK OF
GUARANTEED QUALITY—CHURCH SEATING

Telephone Market 8692

Office and Factory:

64 Rausch St., Bet. 7th and 8th Sts., San Francisco

Dolan Wrecking & Construction Co.

(D. J. DOLAN)

Lumber, Lath, Nails, Shingles, Doors, Windows
and Plumbing Supplies, New and Second Hand

Phone Market 4264

Office and Yard, 1607-1639 MARKET ST., SAN FRANCISCO

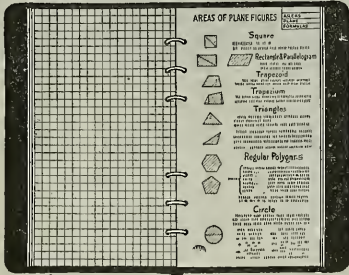

LEFAX
LEAF + FACTS
Pocket Cyclopedias

The facts that you want *instantly available* are not the same ones that some one else in your profession might desire. That's why LEFAX is made Loose Leaf. You file, in whatever order you wish, those sheets of facts that you want to have constantly at hand. If you wish, you may also file, in the same book, sheets for keeping data, for figuring, etc.

LEFAX sets cost but 50c. and \$1.00. You cannot fully appreciate their handiness— their value—until you use them. Ask us about them.

SCHWABACHER - FREY STATIONERY CO.
PRINTERS LITHOGRAPHERS STATIONERS
611 Market Street San Francisco

**Steam Heating
and Ventilating**



For Commercial and
Public Buildings

Furnace Heating
For the Home

Mangrum & Otter, Inc.
827-831 Mission Street
Phone Kearny 3155 SAN FRANCISCO

TIME AND THE P. A. X.

TIME was a use-
less factor in the
Eocene period.

But since the period
when giant dinosa-
urs roamed the
earth Man has ap-
peared and with
him has come his
institutions, built
up thru the applica-
tion of his thought

to his experiences.
Time has become
more and more valu-
able, until today
man reckons in
seconds.

**The manager who can
save seconds wins suc-
cess for his Institution.**

**Time is money.
Save both.**

Let our experienced engineers show
you how "A Pair of Wires and a Dial"*
can help you decrease your overhead.

" TALK DON'T WALK "

**DIRECT-LINE
TELEPHONE COMPANY**

Telephone Electrical Engineers

THEODORE HALL, Manager
320 MARKET STREET, SAN FRANCISCO
Phone Douglas 722

* A most interesting Book of Business Re-
manances, founded on facts, sent on request.

**ROBERTS
MFG. CO.**

Lighting Fixtures
Electric Appliances
Incandescent Lamps

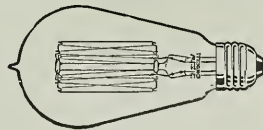

WILLYS FARM LIGHTING
AND POWER PLANTS

663 Mission St., San Francisco

CALIFORNIA ARTISTIC METAL & WIRE CO.
 J. T. MCCORMICK, PRESIDENT
 ORNAMENTAL IRON AND BRONZE
 349-365 SEVENTH ST. SAN FRANCISCO

MORTENSON CONSTRUCTION CO.
 CONTRACTORS FOR STRUCTURAL STEEL AND IRON
 H. MORTENSON, PRES. CHAS. G. MORTENSON, VICE-PRES. AND MGR.
 OFFICE AND SHOPS: CORNER 19TH AND INDIANA STREETS
 PHONE: MISSION 5033 SAN FRANCISCO, CAL.

RAYMOND GRANITE COMPANY, Inc.
 Owing and operating at Knowles, Madera County, the largest Quarry in the world
 CONTRACTORS FOR STONE WORK
 Designers and Manufacturers of Exclusive Monuments and Mausoleums
 Main Office and Yard: No. 1 and 3 Potrero Avenue, San Francisco, California
 Also at 1350-Palmetto Street, Los Angeles

CAEN STONE  **A. KNOWLES**
 A refined, elegant, interior finish. CONTRACTOR and PLASTERER
 442 Call-Post Building San Francisco

THE GOLDEN GATE IRON WORKS
STRUCTURAL STEEL
 1541-1549 HOWARD STREET, BETWEEN 11th AND 12th STREETS
 Tel. Market 5445 San Francisco

Telephone Mission 58 A. A. Devoto, President
CENTRAL IRON WORKS, Inc.
 STRUCTURAL STEEL
 Office 2050 BRYANT STREET SAN FRANCISCO, CAL.

JOHNS-MANVILLE
 SERVES IN CONSERVATION
 Through
ASBESTOS and its ALLIED PRODUCTS

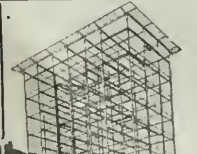
 **SCHRADER IRON WORKS, Inc.**
 STRUCTURAL STEEL CONTRACTORS
 Fire Escapes, Waterproof Trap Doors, Ornamental Iron Work
 1247-1249 HARRISON STREET SAN FRANCISCO, CAL.
 Bet. 8th and 9th Telephone Market 337

SAN FRANCISCO
PUBLIC LIBRARY

The
ARCHITECT &
ENGINEER



NOVEMBER 1920

Published in San Francisco
35 cents a copy - \$2⁵⁰ a year



Progressing with the West

WE have kept step with the growth of the West. In all the world there are no better fixtures than

PACIFIC
PLUMBING FIXTURES



For Sale by All Jobbers

Main Offices: 67 New Montgomery Street, San Francisco
Factories: San Pablo and Richmond, California
Branches: Portland, Los Angeles and Salt Lake City



Chosen Because of Dependability

a. Many theatres in the West are covered with PABCO 10 and 20-year roofs, because both the architects and the owners, realizing the necessity of only first class construction throughout, insist on the roof of *proven* dependability.

PABCO 10 and 20-Year Roofs

b. Eliminate responsibility and annoyance, and are less expensive than cheap roofs, because of their *low cost per year of service*.

Write for Specifications and Complete Details

THE PARAFFINE COMPANIES, INC.
San Francisco, California

*New Lyceum Theatre, San Francisco
Covered with a PABCO 10 Year Roof.*



Roofings—Felts
Building Papers
Floor Covering
Wall-Board
Waterproofing
Materials
Industrial and
Marine Paints
Box-Board
Paper Boxes
Fibre Containers

Reid Bros.
Architects

Cantley Roofing Co.
Roofing Contractors



STEEL BARS

FOR
CONCRETE REINFORCEMENT

CORRUGATED
TWISTED
SQUARES
OR
ROUNDS
CUT
TO
LENGTH



FABRICATED
AND
INSTALLED
—
LUMP SUM
BIDS
ON
WORK
COMPLETE

Office, 444 MARKET STREET
Warehouse, 10th and Bryant Streets
Phone: Sutter 2720

“HYDRATITE” FOR WATERPROOFING AND “HORNSTONE”
HARDENING CONCRETE

Look for this
Trademark



And if it's there don't worry
any more about your
Valves and Fittings

*Specify and
insist upon
having*

The Kelly & Jones Co.
Valves and Fittings

Byers Genuine
Wrought Iron Pipe

Republic Steel Pipe

Complete Line of Plumbing Supplies
Large Stocks for Prompt Delivery
Catalogue on request

California Steam &
Plumbing Supply Co.

671-679 Fifth Street, Corner Bluxome
SAN FRANCISCO, CALIFORNIA





PIPE
 Valves & Fittings
STEAM & WATER SUPPLIES
 Heating Material
PLUMBING GOODS
 Pumps

GEORGE H. TAY COMPANY
SAN FRANCISCO OAKLAND
 MISSION & SECOND STS. TENTH & HARRISON STS.
 TELEPHONE DOUGLAS 2240 TELEPHONE LAKESIDE 4200

Contractors Cannot Agree

as to percentage of labor and material saved in using

1 A RIB LATH

over other expanded metals; majority claim 20% saving — others more. Labor is high, material higher, 1 A RIB cuts down cost of both—present conditions demand your immediate investigation where metal lath is needed. Phone Market 8357.

Largest stock of fireproof material and reinforcing bars on the Pacific Coast.



Truscon Steel Company

CHAS. HOLLOWAY, JR., BRANCH MANAGER

527 Tenth Street, San Francisco

W. & J. SLOANE

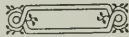

Carpetings Furniture
Rugs
Linoleum Window Shades
Wall Papers
Interior Decorations

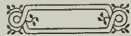

216-228 Sutter Street
Tel. Garfield 2838 San Francisco

TIME CLOCKS

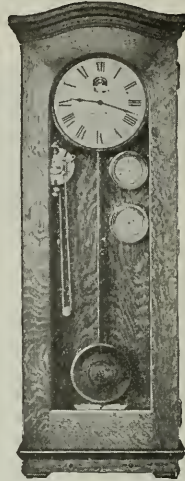

SCHOOLS must have uniform time to secure efficient results. They also need automatic sounding of the program Bells synchronized with the clocks.

All "Standard" Electric Time Equipments are guaranteed against any electrical or mechanical defects for a period of one year from date of installation. Specifications, blue prints and other information will be gladly furnished architects, engineers or officials for planning and installing "Standard" systems. Let us cooperate with you for securing the best results.

STANDARD ELECTRIC TIME COMPANY

461 MARKET STREET
Phone Sutter 241 SAN FRANCISCO



PROMETHEUS

The Electric Food and Plate Warmer
Wherever meals are cooked and served, in apartments, residences and institutions, Prometheus is a highly valued asset. The wireless heating units placed independently of the shelves keep food hot and tasty until ready to serve and cannot injure the finest china.

Write for information and list of installations

The Prometheus Electric Co.

Manufacturers
511 West 42d Street, New York

Showroom, M. E. HAMMOND
Mezzanine Floor Pacific Bldg., San Francisco

CLOW

Modern Heating

AS in lighting, the trend in heating is toward central station service. The wastefulness and high maintenance cost of individual heating plants is becoming understood by the public. At the same time gas — not as a supplementary but as the *main* source of heat—is being recognized. Architects, naturally in the forefront of all developments in such matters, ought to be thoroughly informed as to the scope and possibilities of the Gasteam Radiator. It is as revolutionary and far-reaching in its possibilities as concrete.

The subject is fully covered in our booklet. Let us send you a copy.

Frederick A. Hamilton

Sales Agent

Show Rooms:

RIALTO BUILDING
SAN FRANCISCO



WaterSavR FLUSHING VALVE

Non-Clogging, Self-Cleaning, Controlling By-Pass

NOTE
Controlling water is in two enclosed chambers and separated from the flushing water.

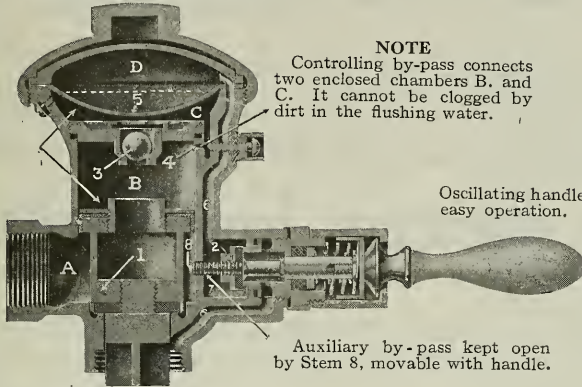

NOTE
Controlling by-pass connects two enclosed chambers B. and C. It cannot be clogged by dirt in the flushing water.

Oscillating handle easy operation.

Auxiliary by-pass kept open by Stem 8, movable with handle.

OPERATES EQUALLY AS WELL WITH DIRTY AS WITH CLEAN WATER

The by-pass is positively and automatically kept open and free of obstruction and cannot become clogged no matter how dirty the water may be.

Patented March 18, 1919

NATIONAL VALVE COMPANY

Phone Douglas 5093

23-25 MINNA ST., SAN FRANCISCO

MASTIC FLOORS

BITURINE COATINGS FOR STEEL

WATERPROOFING

Hill, Hubbell & Company

CONTRACTORS

SAN FRANCISCO

1000 Fife Building, No. 1 Drumm Street

LOS ANGELES
Marsh-Strong Building

SEATTLE
Grand Trunk Pacific
Dock

PORTLAND
Pittock Block

E. B. Noble, President
A. E. Wilkins, Vice-Pres.

Beam, Angle, Channels, and Universal Mill
Plates for immediate shipment from stock

Pacific Rolling Mill Co.

SUPPLIERS OF

FABRICATED STRUCTURAL STEEL, Forgings,
Bolts, Rivets, Frogs, Switches, Cast Iron Castings

General Office and Works
17th and MISSISSIPPI STS., SAN FRANCISCO
Telephone Market 215

Beams
Channels
Angles
Plates

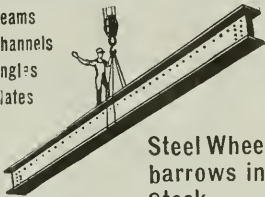

Steel Wheel-
barrows in
Stock

Western Iron Works

W. B. MORRIS, Pres. H. H. MORRIS, V.-P. L. J. GATES, Sec.

STRUCTURAL IRON AND
STEEL CONTRACTORS

141-147 Beale St. and 132-148 Main St. SAN FRANCISCO

Phones: GARFIELD 2575--2576

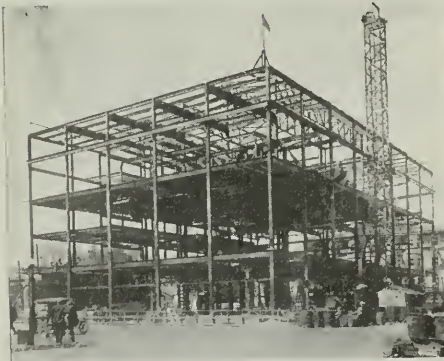

STEEL FRAME, MASONIC TEMPLE,
Sacramento. R. A. HEROLD, Architect.

STRUCTURAL STEEL
(600 tons) Fabricated and
Erected by

THE PALM IRON AND
BRIDGE WORKS (Incorporated)
15th and R Streets, Sacramento, Cal.

Cast Iron Stairs and Store Fronts

Bank and Office Railings, Elevator
Enclosures and Fire Escapes.

C. J. HILLARD CO., Inc.

Nineteenth and Minnesota Streets
Telephone Mission 1763

SAN FRANCISCO, CAL.

Architects' Specification Index

(For Index to Advertisements, see next page)

- ARCHITECTURAL TERRA COTTA**
Gladding, McBean & Company, Crocker Bldg., San Francisco.
Los Angeles Pressed Brick Company and United Materials Co., Crossley Bldg., San Francisco.
Livermore Fire Brick Works, Livermore, Cal.
- ASBESTOS ROOFING, PACKING, ETC.**
H. H. Robertson Co., Hobart Bldg., San Francisco.
H. W. Johns-Manville Co., San Francisco, Los Angeles and Portland, Ore.
- AUTOMATIC SPRINKLERS**
Grinnell Co. of the Pacific, 453 Mission St., San Francisco.
Pacific Fire Extinguisher Co., 424 Howard St., San Francisco.
- AUTOMOBILE INSURANCE**
Bankers & Shippers Insurance Co. of New York, Insurance Exchange Bldg., San Francisco.
- AWNINGS, TENTS, ETC.**
W. A. Plummer, Front, at Pine St., San Francisco.
- BANK FIXTURES AND INTERIORS**
Fink & Schindler, 218 13th St., San Francisco.
C. F. Weber & Co., 985 Market St., San Francisco.
Home Mfg. Co., 543 Brannan St., San Francisco.
Mullen Manufacturing Co., 64 Rausch St., San Francisco.
Rucker-Fuller Desk Co., 677 Mission St., San Francisco.
Pacific Manufacturing Company, San Francisco, Oakland and Santa Clara.
- BELTING AND PACKING**
New York Belting and Packing Company, 519 Mission St., San Francisco.
H. N. Cook Belting Co., 401 Howard St., San Francisco.
Smith-Booth-Usher Co., San Francisco and Los Angeles.
- BLACKBOARDS**
C. F. Weber & Co., 985 Market St., San Francisco, Los Angeles and Reno, Nevada.
Beaver Blackboards and Greenboards, Rucker-Fuller Desk Company, Coast agents, 677 Mission St., San Francisco; also Oakland and Los Angeles.
- BLINDS—VENETIAN AND DIFFUSELITE**
J. G. Wilson Corporation, Metropolitan Bldg., Los Angeles; Waterhouse-Wilcox, Underwood Bldg., San Francisco.
Western Venetian Blind Co., Long Beach Ave., Los Angeles.
- BOILERS**
California Hydraulic Engineering & Supply Co., 70-72 Fremont St., San Francisco.
Franklin Water Tube Boiler, General Machinery and Supply Co., 39 Stevenson St., San Francisco.
Kewanee Water Supply System, Simonds Machinery Co., 117 New Montgomery St., San Francisco.
- General Boilers Co., 322 Monadnock Bldg., San Francisco.
- BOOK BINDERS**
Abbott-Brady Printing Corp'n, 460 Fourth St., San Francisco.
- BONDS FOR CONTRACTORS**
American Mutual Liability Insurance Co., Balboa Bldg., San Francisco.
Bonding Company of America, Kohl Bldg., San Francisco.
Bankers & Shippers Insurance Co. of New York, Insurance Exchange Bldg., San Francisco.
Globe Indemnity Co., 120 Leidesdorff St., San Francisco.
Fidelity & Casualty Co. of New York, Merchants Exchange Bldg., San Francisco.
Fidelity & Deposit Co. of Maryland, Insurance Exchange, San Francisco.
John H. Robertson, 621 First National Bank Building, San Francisco.
National Surety Co. of New York, 105' Montgomery St., San Francisco.
- BRASS GOODS, CASTINGS, ETC.**
H. Mueller Manufacturing Co., 635 Mission St., San Francisco.
- BRICK—PRESSED, PAVING, ETC.**
California Brick Company, Niles, Cal., and 604 Mission St., San Francisco.
Livermore Fire Brick Works, Niles, Cal.
Los Angeles Pressed Brick Co., Frost Bldg., Los Angeles.
United Materials Co., Crossley Bldg., San Francisco.
- BRICK & CEMENT COATING**
Armorite and Concreta, manufactured by W. P. Fuller & Co., all principal Coast cities.
The Paraffine Companies, Inc., 34 First St., San Francisco.
R. N. Nason & Co., 151 Potrero Ave., San Francisco.
Wadsworth, Howland & Co., Inc., Boston, Mass., manufacturers of Bay State Brick & Cement Coating, Hambley & Son, agents, San Francisco and Los Angeles.
- BRICK STAINS**
Samuel Cabot Mfg. Co., Boston, Mass., agencies in San Francisco, Oakland, Los Angeles, Portland, Tacoma and Spokane.
Armorite and Concreta, manufactured by W. P. Fuller & Co., all principal Coast cities.
- BUILDERS' HARDWARE**
Joost Bros., agents for Russell & Erwin Hardware, 1053 Market St., San Francisco.
The Stanley Works, New Britain, Conn., represented in San Francisco and Los Angeles by John Rountree & Co.
Palace Hardware Company, Agents Corbin goods, 581 Market St., San Francisco.
Richards-Wilcox Mfg. Co., Aurora; Ewing-Lewis Co., 626 Underwood Bldg., San Francisco.

GRINNELL AUTOMATIC SPRINKLER GRINNELL COMPANY

OF THE PACIFIC

VALVES
PIPE AND FITTINGS

ENGINEERS AND CONTRACTORS
453 Mission Street, San Francisco

CHEMICAL FIRE
EXTINGUISHERS
and FIRE ENGINES

An Index to the Advertisements

	Page		Page		Page
Abbott-Brady Printing Corp.	151	Gunn Carle Company	2	Paraffine Companies, Inc.	1
American La France Fire Engine Co.	135	Haines, Jones & Cadbury	129	Parker, K. E. Co., Inc.	144
American Mutual Liability Insurance Co.	10	Hamilton, P. A.	4	Petrium Sanitary Sink Co.	135
American Mail Chute	32	Hammond, M. E.	4	Phillips, Chas. T.	145
American Marble & Mosaic Co.	44	Hannah, J. D.	142	Pitcher Door Hanger	33
American Rolling Mill Co.	141	Hauser Window Co.	26	Plummer, W. A.	138
American Standard Oil Burner	43	Haws Sanitary Drinking Faucet Co.	138	Pope & Talbot	15
American Window Glass Co.	42	Hillard, C. J., Co.	6	Portland Lumber Co.	15
Atlas Heating & Ventilating Co.	146	Hill, Hubbell & Company	5	Portman, Frank	158
Bacon, Edward R., Co.	157	Holbrook, Merrill & Stetson	147	Power Construction Company	136
Badt-Falk & Co.	145	Home Mfg. Co.	158	Prometheus Electric Co.	4
Baird-Bailhache Company	24	Hoosier Store	20	Ray, W. S., Mfg. Co.	133
Bankers' & Shippers' Ins. Co.	34	Hunt, Robt. W. & Co.	130	Raymond Granite Co.	152
Barrett & Hilp	144	Hunter & Hudson	140	Redwood Manufacturing Co.	42
Bartlett, John M.	136	Ideal Heating & Engineering Co.	146	Reliance-Grant Elevator Equipment Co.	22
Bass-Hueter Co.	3rd Cover	Illinois Engineering Co.	146	Rex Electric Engineering Co.	155
Baxter, Reed	32	Imperial Waterproofing	32	Richards-Wilcox	35
Beach-Robinson Co.	31	James & Drucker	146	Ringsins, John	136
Beckwith, Herbert	145	Jarvis, T. P. Mfg. Co.	43	Roberts Mfg. Co.	159
Bowser & Co., S. F.	41	Johns-Manville Co.	152	Robertson Co., H. H.	11
Breuner, John	130	Johnson, S. T.	43	Robertson, John H.	150
Brininstool Co.	22	Johnson Service Co.	11	Ruegg Bros.	150
Browie-Langlais Company	155	Joost Brothers	140	Rucker-Fuller Desk Co.	140
Butte Electrical Equipment Co.	154	Kawneer Mfg. Co.	143	Ryan, M. E.	155
Butte Electric & Mfg. Co.	155	Kerner Incinerator Co.	21	Safety Electric Co.	154
Cabot, Samuel (Inc.)	41	Key-hold Plaster Lath Co.	32	Sampson Spot Cord	136
California Artistic Metal and Wire Co.	152	Kissel, I. R.	142	San Francisco Pioneer Varnish Works	3d Cover
California Bldg. Material Co.	Back Cover	Knittle-Cashel Co., Inc.	13	Scott Co.	146
California Brick Co.	23	Knowles, A.	152	Schrader Iron Works	152
California Granite Co.	146	Lange & Bergstrom	148	Schwabacher-Frey Co.	159
California Hydraulic Engineering and Supply Co.	10	Leiter, E. T. & Son	136	Sloane, W. & J.	4
California Paint Co.	14	Liberty Electric Co.	136	Simmons, O. M. Co.	12
California Plastic Products Co.	137	Littlefield, R. W.	144	Simonds Machinery Co.	131
California Redwood Ass'n.	153	Livemore Fire Brick Works	23	Smith-Booth-Usher Co.	157
California Steam and Plumbing Supply Co.	2	Los Angeles Pressed Brick Co.	127	Smith, Jas. F.	144
Cement Gun Construction Co.	134	MacGruer & Simpson	151	Sommer, I. M.	144
Central Iron Works	152	MacRorie-McLaren Co.	153	Sonnenschein Bros.	30
Clinton Wire Lath	34	Magner Bros.	140	Spencer Elevator Co.	24
Clow & Sons	4	Mangrum & Otter	159	Spott Electrical Co.	156
Cobbedick-Kibbe Glass Co.	136	Marshall & Stearns Co.	156	Standard Varnish Works	22
Coleman, Alex.	146	McCray Refrigerator Co.	32	Standard Electric Time Co.	4
Collman, A. D.	142	McLeran & Peterson	150	Standard Fence Co.	145
Cook Belting Co.	38	McNab, H. N.	145	Stanley Works, The	123
Cowell Lime & Cement Co.	143	Medusa Cement	27	Stelform Contracting Co.	144
Crane Co.	153	Meese & Gottfried	134	Steel Studing Co.	137
Davis, R. J.	14	Meyers Electric Safety Switch Co., Inc.	154	St. Francis Hotel	131
Del Favero and Rasori	142	Moline Heat	17	Stockholm, Chas. & Son	136
Del Monte Properties Co.	20	Montague Range & Furnace Co.	15	Strable Mfg. Co.	28
Detroit Steel Products Co.	44	Monson Bros.	142	Sunset Lumber Company	15
Dieckmann Hardware Co.	12	Mortenson Construction Co.	152	Tay Company, George H.	3
Direct Line Telephone Co.	159	Mott Co. of Calif.	18	Taylor, F. A. & Co.	31
Dolan Wrecking & Construction Co.	158	Mueller Mfg. Co.	18	Tittle, H. S.	155
Dow-Herriman Co.	148	Mullen Mfg. Co.	158	Tormey Co.	140
Drendell Elec. & Mfg. Co.	154	Mushet Co., W. E.	148	Trost, Robt.	142
Dudfield Lumber Co.	158	Musto Sons Keenan Co.	13	Trusco Steel Co.	3
Duncan, W. C.	144	Nason, R. N. & Co.	9	Tuec Cleaner	141
Dyer Bros.	26	Nathan, Dohrmann Co.	151	Uhl Bros.	38
Electric Outlet Co.	36-37	National Mill & Lumber Co.	33	Unit Construction Co.	142
Elevator Supplies Co.	150	National Sarey Co.	150	United Electric Co.	149
Ellery Arms Co.	140	National Valve Co.	5	United Materials Co.	127
Fess System Co.	43	National Terra Cotta Society	125	U. S. Metal Products Co.	26
Fidelity & Casualty Co. of N.Y.	150	Nelson, James A.	148	U. S. Steel Products Co.	40
Fidelity & Deposit Co. of Maryland	150	Ne Page, McKenny Co.	155	Van Fleet-Freear Co.	143
Fink & Schindler Co., The	158	Newbery Electric Co.	155	Vermont Marble Co.	34
Fire Protection Products Co.	16	New York Belting and Packing Co.	21	Vukicevich & Bagge	144
Flagg, Edwin H., Scenic Co.	158	Norris Co., L. A.	34	Wadsworth, Howland & Co., Inc.	135
Freeman Art Shop	31	Oak Flooring Mfgs' Ass'n	132	Walter, D. N. & E. & Co.	145
Fuller & Goep	24	Ocean Shore Iron Works	138	Ward, Baldwin D.	140
Fuller, W. P. Co.	19	Old Mission Portland Cement Co.	25	Waterhouse, Wilcox Co.	32
Garfield Company	157	Otis Elevator Co.	160	Wayne Oil Tank & Pump Co.	33
Garnett, Young & Co.	20	Pacific Coast Steel Company	151	Weber, C. F. & Co.	153
General Boilers Co.	18	Pacific Materials Co.	27-41-44	Westworth, F. W.	130
Gilley-Schmid Co.	140	Pacific Fire Extinguisher Co.	143	West Coast Porcelain Co.	Back Cover
Gladding, McBean & Co.	138	Pacific Mfg. Co.	158	Western Blind & Screen Co.	39
Globe Electric Works	155	Pacific Plumbing Fixtures	2d Cover	Western Iron Works	6
Globe Indemnity Co.	150	Pacific Porcelain Ware Co.	2d Cover	Western Office, Equipment Co.	34
Go-Sign & Letter Co.	145	Pacific Pump & Supply Co.	38	Western Pipe and Steel Co.	147
Golden Gate Ornamental Iron Co.	152	Pacific Rolling Mills	6	White Bros.	122
Grinnell Co.	7	Palace Hardware Co.	38	Wilson, J. G. Corp.	139
		Palm Iron Works	6	Wilson, W. F. Co.	146
		Palmer & Petersen	142	Witt, G. E. Co.	44
				Zelinsky, D & Sons	145

Nason's Opaque Flat Finish

A Flat Washable Oil Paint, made in soft Kalsomine tints—a practical article for Walls, Ceilings, Etc. Agency for Tamm & Nolan Company's High Grade VARNISHES and FINISHES, made on the Pacific Coast to stand our climatic conditions.

R. N. NASON & CO. Paint Makers
151 Potrero Ave.—436 Market St., San Francisco—Portland-Seattle-Oregon

ARCHITECTS' SPECIFICATION INDEX—Continued

- BUILDING MATERIAL, SUPPLIES, ETC.**
Pacific Materials Co., Underwood Bldg., San Francisco.
Waterhouse-Wilcox Co., 523 Market St., San Francisco.
Johns-Manville Company, Post and Mason Sts., St. Francisco.
- CABINET MAKERS**
Home Manufacturing Company, 543 Brannan St., San Francisco.
Fink & Schindler Co., 218 13th St., San Francisco.
Mullen Manufacturing Company, 64 Rausch St., San Francisco.
Frank Portman, 1618 Mission St., San Francisco.
- CARPETS**
W. & J. Sloane, 216-228 Sutter St., San Francisco.
John Breuner Co., 281 Geary St., San Francisco.
- CASEMENT WINDOW HARDWARE**
Richards-Wilcox Mfg. Co., Aurora, Ill., and Underwood Bldg., San Francisco.
- CASTINGS**
Dow-Herriman Co., 140 Howard St., San Francisco.
- CEMENT**
Mt. Diablo, sold by Henry Cowell Lime & Cement Co., 2 Market St., San Francisco.
Medusa White Portland Cement, manufactured by Sandusky Cement Co., represented in San Francisco by Pacific Building Materials Co., Underwood Bldg., San Francisco.
Old Mission Portland Cement Co., Mills Building San Francisco.
- CEMENT EXTERIOR FINISH**
Concreta, sold by W. P. Fuller & Co., all principal Coast cities.
Samuel Cabot Mfg. Co., Boston, Mass., agencies Oakland, Los Angeles, Portland, Tacoma, Spokane, and Pacific Building Materials Co., 525 Market St., San Francisco.
The Paraffine Companies, Inc., 34 First St., San Francisco.
- CEMENT EXTERIOR WATERPROOF PAINT**
Armorite, sold by W. P. Fuller & Co., all principal Coast cities.
Bay State Brick and Cement Coating, manufactured by Wadsworth, Howland Co., Boston, Mass. James Hampley & Son, Distributors, San Francisco and Los Angeles.
Hill, Hubbell & Company, No. 1 Drumm St., San Francisco.
Imperial Waterproofing, manufactured by Brooks & Doerr, Reed Baxter, agent, Merchants National Bank Bldg., San Francisco.
Paraffine Paint Co., 34 First St., San Francisco.
Medusa White Portland Cement, manufactured by Sandusky Cement Co., represented in San Francisco by Pacific Building Materials Co., 525 Market St., San Francisco.
- CEMENT FLOOR COATING**
Fuller's Concrete Floor Enamel, made by W. P. Fuller & Co., San Francisco.
- CEMENT GUN**
Cement Gun Construction Company of California, 701 Balboa Bldg., San Francisco.
- CEMENT TESTS—CHEMICAL ENGINEERS**
Robert W. Hunt & Co., 251 Kearny St., San Francisco.
- CHURCH INTERIORS**
Fink & Schindler, 218 13th St., San Francisco.
Mullen Manufacturing Company, 64 Rausch St., San Francisco.
Home Manufacturing Company, 543 Brannan St., San Francisco.
- CHUTES—SPIRAL**
Haslett Warehouse Co., 310 California St., San Francisco.
- CLAY PRODUCTS**
Livermore Fire Brick Works, 604 Mission street, San Francisco.
W. E. Musket Co., 502 Mission St., San Francisco.
Gladding, McBean & Co., Crocker Bldg., San Francisco.
United Materials Co., Crossley Bldg., San Francisco.
Los Angeles Pressed Brick Co., Frost Bldg., Los Angeles.
- CLOCKS—ELECTRIC TIME**
Standard Electric Time Co., 461 Market St., San Francisco.
- COLD STORAGE PLANTS**
H. W. Johns-Manville Co., Post and Mason Sts., San Francisco.
T. P. Jarvis Crude Oil Burning Co., 275 Connecticut St., San Francisco.
- COMPRESSED AIR CLEANERS**
United Electric Co., Canton, O., mfr. of Tuec Cleaner, sold by San Francisco Compressed Air Cleaning Co., Sutter and Stockton Sts., San Francisco.
George H. Tay Company, Mission and Second Sts., San Francisco; 10th and Harrison Sts., Oakland.
- CONCRETE CONSTRUCTION**
Barrett & Hilp, Sharon Bldg., San Francisco.
Clinton Construction Co., 140 Townsend street, San Francisco.
K. E. Parker Co., Inc., Clunie Bldg., San Francisco.
Palmer & Petersen, Monadnock Bldg., San Francisco.
I. M. Sommer, 401 Balboa Bldg., San Francisco.
Steelform Contracting Company, 681 Market St., San Francisco.
- CONCRETE MIXERS**
Foote and Jaeger mixers sold by Edward R. Bacon Co., 51 Minna St., San Francisco, also Los Angeles.
Ransome mixers sold by the Garfield Co., Hearst Bldg., San Francisco.
Smith-Booth-Usher Co., San Francisco and Los Angeles.
- CONCRETE REINFORCEMENT**
United States Steel Products Co., San Francisco, Los Angeles, Portland and Seattle.
Twisted Bars. Sold by Gunn, Carle & Co., Inc., 444 Market St., San Francisco.
Clinton Welded Wire Fabric, L. A. Norris Co., 140 Townsend St., San Francisco.
Pacific Coast Steel Company, Rialto Bldg., San Francisco.
Triangle Mesh Fabric. Sales agents, Pacific Materials Co., 525 Market St., San Francisco.
Truscon Steel Co., 527 Tenth St., San Francisco.
Badt-Falk Co., Call-Post Bldg., San Francisco.
- CONDUITS**
Garnett Young & Co., 612 Howard St., San Francisco.
- CONTRACTORS, GENERAL**
Barrett & Hilp, Sharon Bldg., San Francisco.
K. E. Parker Co., Inc., Clunie Bldg., San Francisco.
R. W. Littlefield, 357 12th St., Oakland.
Unit Construction Co., Phelan Bldg., San Francisco.
J. D. Hannah, 142 Sansome St., San Francisco.
Chas. Stockholm & Son, Monadnock Bldg., San Francisco.
John M. Bartlett, 357 Twelfth St., Oakland.
E. T. Leiter & Son, Call-Post Bldg., San Francisco.

We have returned to our policy-holders annually for 33 years never less than 30% of the premium as a dividend. Dividends declared during 1919, \$2,017,893.

AMERICAN MUTUAL LIABILITY INSURANCE CO. OF BOSTON
Assets \$8,654,667 Surplus \$1,417,173

WORKMEN'S COMPENSATION, AUTOMOBILE, TEAMS AND PUBLIC LIABILITY INSURANCE

SAN FRANCISCO BRANCH OFFICE

1816 Balboa Building. Telephone Kearny 3202

N. F. Hesseltine, California Manager.

C. H. Gray, Assistant Manager.

ARCHITECTS' SPECIFICATION INDEX—Continued

- CONTRACTORS, GENERAL—Continued**
Herbert Beckwith, 323 Newton Ave., Oakland.
A. D. Collman, 546 Monadnock Bldg., San Francisco.
Clinton Construction Company, 140 Townsend St., San Francisco.
Monson Bros., 1907 Bryant St., San Francisco.
W. C. Duncan & Co., 526 Sharon Bldg., San Francisco.
A. Knowles, Call-Post Bldg., San Francisco.
T. B. Goodwin, 180 Jessie St., San Francisco.
Lange & Bergstrom, Sharon Bldg., San Francisco.
McLeran & Peterson, Hearst Bldg., San Francisco.
Robert Trost, 26th and Howard Sts., San Francisco.
I. M. Sommer, 401 Balboa Bldg., San Francisco.
Del Favero & Rasori, 180 Jessie St., San Francisco.
- CONTRACTORS' EQUIPMENT**
Edward R. Bacon Co., 51 Minna St., San Francisco, and Los Angeles.
Garfield & Co., Hearst Bldg., San Francisco.
Smith, Booth-Usher Co., 60 Fremont St., San Francisco; 228 Central Ave., Los Angeles.
- CONTRACTORS' INSURANCE**
Bankers & Shippers Insurance Co. of New York, Insurance Exchange Bldg., San Francisco.
- CONVEYING MACHINERY**
Meese & Gottfried, San Francisco, Los Angeles, Portland and Seattle.
- CORK TILE, INSULATION, ETC.**
Van Fleet-Freear Co., Sharon Bldg., San Francisco.
- CRUSHED ROCK**
Coast Rock & Gravel Co., Call-Post Bldg., San Francisco.
- DAMP-PROOFING COMPOUND**
Armorite Damp Resisting Paint, made by W. P. Fuller & Co., San Francisco.
Hill, Hubbell & Company, No. 1 Drumm St., San Francisco.
Imperial Waterproofing, mfrd. by Brooks & Doerr, Reed Baxter, agent, Merchants National Bank Bldg., San Francisco.
"Pabco" Damp-Proofing Compound, sold by Paraffine Co., 34 First St., San Francisco.
- DOOR HANGERS**
Pitcher Hanger, sold by National Lumber Co., 326 Market St., San Francisco.
Reliance Hanger, sold by Waterhouse-Wilcox Co., San Francisco; D. F. Fryer & Co., B. V. Collins, Los Angeles, and Columbia Wire & Iron Works, Portland, Oregon.
Stanley Works, New Britain, Conn. John Rountree, agent, Monadnock Bldg., San Francisco.
Richards-Wilcox Mfg. Co., Underwood Bldg., San Francisco.
- DRINKING FOUNTAINS**
Haws Sanitary Drinking Faucet Co., 1808 Harmon St., Berkeley, and C. F. Weber & Co., San Francisco and Los Angeles.
Crane Company, San Francisco, Oakland, and Los Angeles.
Pacific Porcelain Ware Co., 67 New Montgomery St., San Francisco.
George H. Tav Company, Mission and Second Sts., San Francisco; 10th and Harrison Sts., Oakland.
- Haines, Jones & Cadbury Co., 857 Folsom St., San Francisco.
- DUMB WAITERS**
Spencer Elevator Company, 166 7th St., San Francisco.
M. E. Hammond, Pacific Bldg., San Francisco.
- ELECTRICAL CONTRACTORS**
Butte Electrical Equipment Company, 530 Folsom St., San Francisco.
Butte Electric & Manufacturing Co., 534 Folsom St., San Francisco.
Brown-Langlais Electrical Construction Co., 213 Minna St., San Francisco.
NePage, McKenny Co., 589 Howard St., San Francisco.
Liberty Electric Company, 479 Sutter St., San Francisco.
Newbery Electrical Co., 413 Lick Bldg., San Francisco.
Pacific Fire Extinguisher Co., 424 Howard St., San Francisco.
Globe Electric Works, 1959 Mission St., San Francisco.
M. E. Ryan, Redwood City, Calif.
Rex Electric & Engineering Co., 253 Minna St., San Francisco.
H. S. Tittle, 766 Folsom St., San Francisco.
Severin Electrical Company, 185 Stevenson St., San Francisco.
Spot Electrical Co., Sixteenth and Clay Sts., Oakland.
- ELECTRIC PLATE WARMER**
The Prometheus Electric Plate Warmer for residences, clubs, hotels, etc. Sold by M. E. Hammond, Pacific Bldg., San Francisco.
- ELECTRICAL SUPPLIES AND EQUIPMENT**
Garnett Young & Co., 612 Howard St., San Francisco.
Butte Electrical Equipment Co., 530 Folsom St., San Francisco.
Electric Outlet Co., Inc., 119 West 40th St., New York.
Safety Electric Company, 56-65 Columbia Square, San Francisco.
Drendell Electrical & Mfg. Co., 1345 Howard St., San Francisco.
R. J. Davis, District Sales Agent, Century A. C. Motors and Fans, 171 Second St., San Francisco.
- ELEVATORS**
Otis Elevator Company, Stockton and North Point, San Francisco.
Spencer Elevator Company, 166 7th St., San Francisco.
- ELEVATOR EQUIPMENT**
Elevator Supplies Company, Inc., 186 Fifth St., San Francisco.
- ENGINEERS—CONSULTING, ELECTRICAL, MECHANICAL**
Chas. T. Phillips, Pacific Bldg., San Francisco.
Hunter & Hudson, Rialto Bldg., San Francisco.
Baldwin D. Ward, 76 13th St., Oakland.
- ELEVATOR DOOR HARDWARE**
Richards-Wilcox Mfg. Co., Underwood Bldg., San Francisco.
- FANS AND BLOWERS**
Ideal Heating & Engineering Co., 192 Erie St., San Francisco.

KEWANEE
GARBAGE BURNERS
AND
BOILERS

YEOMANS
BILGE PUMPS
EJECTORS
HOUSF PUMPS

OVERHEAD
CARRYING
SYSTEMS

CALIFORNIA HYDRAULIC ENGINEERING & SUPPLY CO., 80 Fremont St., S. F.



TEMPERATURE REGULATION

JOHNSON SERVICE COMPANY

(OF MILWAUKEE — ESTABLISHED 1885)

Manufacturers and Installers of **JOHNSON Heat Humidity CONTROL**

For schools, residences, hospitals, banks, public buildings, also canneries and all kinds of industrial plants—Hot water tank regulators, air and water reducing valves.

Rialto Bldg, SAN FRANCISCO Trust and Savings Bldg., LOS ANGELES

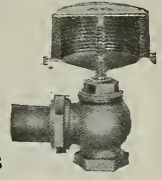

ARCHITECTS' SPECIFICATION INDEX—Continued

FENCES—WIRE

Standard Fence Construction Co., 245 Market St., San Francisco, and 310 12th St., Oakland.

FILLING STATION EQUIPMENT

S. F. Bowser & Co., Inc., 612 Howard St., San Francisco.
Wayne Oil Tank & Pump Co., 631 Howard St., San Francisco, 830 S. Los Angeles St., Los Angeles.

FIRE ESCAPES

Palm Iron & Bridge Works, Sacramento.
Western Iron Works, 141 Beale St., San Francisco.
Golden Gate Iron Works, 1541 Howard St., San Francisco.

FIRE EXTINGUISHERS

American La France Fire Engine Co., Inc., 151 New Montgomery St., San Francisco; Los Angeles and Portland.

FIRE INSURANCE

Bankers & Shippers Insurance Co., Insurance Exchange Bldg., San Francisco.

FIRE SPRINKLERS—AUTOMATIC

Grinnell Company, 453 Mission St., San Francisco.
Pacific Fire Extinguisher Co., 424 Howard St., San Francisco.

FIREPROOFING AND PARTITIONS

Gladding, McBean & Co., Crocker Bldg., San Francisco.
Los Angeles Pressed Brick Co., Frost Bldg., Los Angeles.
Richards-Wilcox Mfg. Co., Aurora, Ill., and Underwood Bldg., San Francisco.

FIRE RETARDING PAINT

The Paraffine Companies, Inc., 34 First St., San Francisco.

FIXTURES—BANK, OFFICE, STORE, ETC.

Home Manufacturing Company, 543 Brannan St., San Francisco.
The Fink & Schindler Co., 218 13th St., San Francisco.
Mullen Manufacturing Co., 64 Rausch St., San Francisco.
C. F. Weber & Co., 985 Market St., San Francisco, and 210 N. Main St., Los Angeles, Cal.

FLOOR TILE

Mangrum & Otter, 827 Mission St., San Francisco,

FLOOR VARNISH

Bass-Hueter and San Francisco Pioneer Varnish Works, 816 Mission St., San Francisco.
Fifteen for Floors, made by W. P. Fuller & Co., San Francisco.
Standard Varnish Works, Chicago, New York and San Francisco.
R. N. Nason & Co., San Francisco and Los Angeles.

FLOORS—HARDWOOD

Parrott & Co., 320 California St., San Francisco.
White Bros., Fifth and Brannan Sts., San Francisco.
Strable Manufacturing Company, 511 First St., Oakland.

FLOORS—MASTIC

Hill, Hubbell & Company, No. 1 Drumm St., San Francisco.

FLOORS—DUST PROOF CEMENT

L. Sonneborn Co., United Materials Co., San Francisco agents.

FLUMES

California Corrugated Culvert Co., West Berkeley, Cal.

FLUSH VALVES

National Valve Company, 23-25 Minna St., San Francisco.

FRUIT DRYING MACHINERY

Ideal Heating & Engineering Co., 192 Erie St., San Francisco.
Jas. A. Nelson, 517 Sixth St., San Francisco.

FUEL OIL SYSTEMS

S. T. Johnson Co., 1337 Mission St., San Francisco.
S. F. Bowser & Co., Inc., 612 Howard St., San Francisco.
Wayne Oil Tank & Pump Co., 631 Howard St., San Francisco.

FURNACES—WARM AIR

Mangrum & Otter, 827 Mission St., San Francisco.
Montague Range and Furnace Co., 826 Mission St., San Francisco.

FURNITURE—BUILT-IN

Hoosier Kitchen Cabinet Store, Pacific Bldg., San Francisco.

FURNITURE—SCHOOL, CHURCH, OFFICE, HOUSE, ETC.

Home Manufacturing Company, 543 Brannan St., San Francisco.
C. F. Weber & Co., 985 Market St., San Francisco.
Rucker-Fuller Desk Co., 677 Mission St., San Francisco.
F. W. Wentworth & Co., 539 Market St., San Francisco.
W. & J. Sloane, 216-228 Sutter St., San Francisco.

GALVANIZED IRON WORK

James A. Nelson, 517 Sixth St., San Francisco.

GARAGE HARDWARE

The Stanley Works, New Britain, Conn., represented in San Francisco, Los Angeles, Seattle by John T. Rowntree, Inc.
Richards-Wilcox Mfg. Co., Aurora, Ill., and Underwood Bldg., San Francisco.

GARBAGE CHUTES AND INCINERATORS

Kerner Incinerator Co., 77 O'Farrell St., San Francisco.
California Hydraulic Engineering & Supply Co., 70-72 Fremont St., San Francisco.

GAS STEAM RADIATORS—FUMELESS, ETC.

Clow Gas Steam Radiators, F. A. Hamilton, Agent, 101 Rialto Bldg., San Francisco.

ROBERTSON PROCESS METAL FOR ROOFING AND SIDING

HH ROBERTSON CO
BUILDING PRODUCTS

FORMERLY ASBESTOS PROTECTED METAL COMPANY

Hobart Building, San Francisco

Phone Garfield 522

When writing to Advertisers please mention this magazine.

DIECKMANN HARDWOOD COMPANY

Office, Mill, Yards, and Dry Kilns
BEACH AND TAYLOR STS.
 SAN FRANCISCO, CAL.
 PHONE FRANKLIN 2302

**Foreign & Domestic
 CABINET WOODS**

ARCHITECTS' SPECIFICATION INDEX—Continued

- GAS STEAM RADIATORS, ETC.**—Continued.
 Ra-Do Fumeless Gas Radiators, manufactured and sold by Baird-Bailhache Co., 478 Sutter St., San Francisco.
- GLASS**
 American Window Glass Co., represented by L. H. Butcher Co., 341 Montgomery St., San Francisco.
 Cobblestick-Kibbe Glass Co., 175 Jessie St., San Francisco.
 Fuller & Goepf, 32 Page St., San Francisco.
 W. P. Fuller & Company, all principal Coast cities.
- GRADING, WRECKING, ETC.**
 Dolan Wrecking & Construction Co., 1607 Market St., San Francisco.
- GRANITE**
 California Granite Co., Gen. Contractors' Ass'n, San Francisco.
 Raymond Granite Co., Potrero Ave. and Division St., San Francisco.
- GRAVEL AND SAND**
 Coast Rock & Gravel Co., Call-Post Bldg., San Francisco.
 Del Monte White Sand, sold by Del Monte Properties Co., Crocker Bldg., San Francisco.
- GYMNASIUM EQUIPMENT**
 Ellery Arms Co., 583 Market St., San Francisco.
 A. G. Spalding & Bros., 158 Geary St., San Francisco.
- HARDWALL PLASTER**
 Henry Cowell Lime & Cement Co., San Francisco.
- HARDWARE**
 Joost Bros., agents for Russell & Erwin hardware, 1053 Market St., San Francisco.
 The Stanley Works, New Britain, Conn.
 Corbin hardware, sold by Palace Hardware Co., 381 Market St., San Francisco.
 Richards-Wilcox Mfg. Co., Aurora, Ill., Ewing-Lewis Co., 626 Underwood Bldg., San Francisco.
- HARDWOOD LUMBER—FLOORING, ETC.**
 Dieckmann Hardwood Company, Beach and Taylor Sts., San Francisco. (See advertisement above.)
 Inlaid Floor Co., 600 Alabama St., San Francisco.
 H. N. McNab, 2307 17th Ave., Oakland.
 Parrott & Co., 320 California St., San Francisco.
 White Bros., cor. Fifth and Brannan Sts., San Francisco.
 Strable Manufacturing Company, First St., near Broadway, Oakland.
- HEATERS—AUTOMATIC—GAS**
 Pittsburg Water Heater Co., 478 Sutter St., San Francisco.
 George H. Tay Company, Mission and Second Sts., San Francisco; 10th and Harrison Sts., Oakland.
 Ra-Do Fumeless Gas Heater, sold by Baird-Bailhache Company, 478 Sutter St., San Francisco.
- HEATING AND VENTILATING MATERIAL, ETC.**
 Alex Coleman, 706 Ellis St., San Francisco.
- Gilley-Schmid Company, 198 Otis St., San Francisco.
 Hateley & Hateley, Mitau Bldg., Sacramento.
 Knittle-Cashel Co., Inc., 1820 Ellis St., San Francisco.
 General Boilers Co., 332 Monadnock Bldg., San Francisco.
 Mangrum & Otter, 827-831 Mission St., San Francisco.
 Moline Heat, Hobart Bldg., San Francisco.
 James & Drucker, 450 Hayes St., San Francisco.
 James A. Nelson, 517 Sixth St., San Francisco.
 Ideal Heating & Engineering Co., 192 Erie St., San Francisco.
 Illinois Engineering Co., 563 Pacific Bldg., San Francisco.
 William F. Wilson Co., 328 Mason St., San Francisco.
 Pacific Fire Extinguisher Co., 424 Howard St., San Francisco.
 Scott Company, 243 Minna St., San Francisco.
 Mechanical Engineering & Supply Co., 908 7th St., Sacramento.
 John Ringius, 252 Townsend St. (bet. Third and Fourth), San Francisco.
 George H. Tay Company, Mission and Second Sts., San Francisco; 10th and Harrison Sts., Oakland.
 O. M. Simmons Co., 115 Mission St., San Francisco.
- HOLLOW TILE BLOCKS**
 Gladding, McBean & Co., San Francisco, Los Angeles, Oakland and Sacramento.
 Los Angeles Pressed Brick Co., Frost Bldg., Los Angeles.
- HOSPITAL FIXTURES**
 Mott Company of California, 553 Mission St., San Francisco.
 George H. Tay Company, Mission and Second Sts., San Francisco; 10th and Harrison Sts., Oakland.
- HOSPITAL SIGNAL SYSTEM**
 Chicago Signal Co., represented by Garnett, Young & Co., 612 Howard St., San Francisco.
- HOTELS**
 St. Francis Hotel, Powell, Geary and Post Sts., San Francisco.
- INGOT IRON**
 "Armo" brand, manufactured by American Rolling Mill Company, Middletown, Ohio, and Monadnock Bldg., San Francisco.
- INSPECTIONS AND TESTS**
 Robert W. Hunt & Co., 251 Kearny St., San Francisco.
- INSULATION**
 Ebonite Boiler Note, sold by California Plastic Products Co., 521 Sheldon Bldg., San Francisco.
- INCINERATORS**
 Kerner Incinerator Co., 77 O'Farrell St., San Francisco.
- INTERIOR DECORATORS**
 Beach-Robinson Co., 239 Geary St., San Francisco.

"The
 Perfect
 Automatic
 Valve"

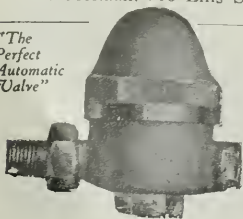

WILLIAM S. HAINES & CO.

Automatic Vacuum and Vapor Heating Systems

VENTO AUTOMATIC VALVES

"Everything for the Heating Engineer"

O. M. SIMMONS CO.

PACIFIC COAST REPRESENTATIVE

115 MISSION STREET
 SAN FRANCISCO

Phone: Douglas 5497

CLARENCE E. MUSTO, Pres.

JOSEPH B. KEENAN, Vice-Pres.

GUIDO J. MUSTO, Sec'y & Treas.

JOSEPH MUSTO SONS=KEENAN CO.Phone Franklin
—6365—**MARBLE**OFFICE AND MILLS:
535-565 North Point St.,
SAN FRANCISCO, CAL.**ARCHITECTS' SPECIFICATION INDEX—Continued**

- INTERIOR DECORATORS.**—Continued.
John Breuner Co., 281 Geary St., San Francisco.
Sonnenschein Bros., 470 Sutter St., San Francisco.
The Tormey Co., 1042 Larkin St., San Francisco.
F. A. Taylor & Co., 251 Post St., San Francisco.
Freeman Art Shop, 386 Sutter St., San Francisco.
W. & J. Sloane, 216 Sutter St., San Francisco.
- KITCHEN CABINETS**
Hoosier Kitchen Cabinet Store (O. K. Brown, Mgr.), Pacific Bldg., San Francisco.
- KITCHEN EQUIPMENT**
James A. Nelson, 517-19 Sixth street, San Francisco.
- LAMP POSTS, ELECTROLIERS, ETC.**
J. L. Mott Iron Works, 553 Mission St., San Francisco.
- LANDSCAPE GARDENERS**
MacRorie-McLaren Co., 141 Powell St., San Francisco.
- LATHING AND PLASTERING**
MacGruer & Simpson, Call-Post Bldg., San Francisco.
A. Knowles, Call-Post Bldg., San Francisco.
Jas. F. Smith, 273 Minna St., San Francisco.
- LATHING MATERIAL**
Pacific Material Co., 525 Market St., San Francisco.
Key-Hold Plaster Lath Co., 148 Hooper St., San Francisco.
Truscon Steel Co., Tenth St., near Bryant, San Francisco.
- LIGHT, HEAT AND POWER**
Great Western Power Company, Stockton St., near Sutter, San Francisco.
- LIGHTING FIXTURES**
Roberts Mfg Co., 663 Mission St., San Francisco.
- LIME**
Henry Cowell Lime & Cement Co., 2 Market St., San Francisco.
- LINOLEUM**
D. N. & E. Walter & Co., 562 Mission St., San Francisco.
The Paraffine Companies, factory in Oakland; office, 34 First St., near Market, San Francisco.
W. & J. Sloane, 216-228 Sutter St., San Francisco.
- LOCKERS—STEEL**
George H. Trask, Sacramento St., San Francisco, representing Durand Steel Lockers.
- LUBRICATING OIL STORAGE TANKS AND PUMPS**
S. F. Bowser & Co., Inc., 612 Howard St., San Francisco.
- LUMBER**
California Redwood Association, 216 Pine St., San Francisco.
Dudfield Lumber Co., Palo Alto, Cal.
Hart-Wood Lumber Co., Fifth and Berry Sts., San Francisco.
Pacific Manufacturing Company, San Francisco, Oakland and Santa Clara.
Pope & Talbot, foot of Third St., San Francisco.
Portland Lumber Co., 16 California St., San Francisco.
Sunset Lumber Company, First and Oak Sts., Oakland.
- MAIL CHUTES**
American Mailing Device Corp., represented on Pacific Coast by Waterhouse-Wilcox Co., 523 Market St., San Francisco.
- MANTELS**
Mangrum & Otter, 827-831 Mission St., San Francisco.
- MANUAL TRAINING EQUIPMENT**
Richards-Wilcox Mfg. Co., Ewing-Lewis Co., 626 Underwood Bldg., San Francisco.
Smith-Booth-Usher Co., San Francisco and Los Angeles.
- MARBLE**
American Marble and Mosaic Co., 25 Columbus Square, San Francisco.
Joseph Musto Sons, Keenan Co., 535 N. Point St., San Francisco.
Vermont Marble Co., Coast branches, San Francisco, Portland and Tacoma.
- METAL DOORS AND WINDOWS**
Fire Protection Products Co., 3117 20th St., San Francisco.
Waterhouse-Wilcox Co., Inc., 523 Market St., San Francisco.
U. S. Metal Products Co., 330 Tenth St., San Francisco.
- MILL WORK**
Dudfield Lumber Co., Palo Alto, Cal.
Pacific Manufacturing Company, San Francisco, Oakland and Santa Clara.
National Mill and Lumber Co., San Francisco and Oakland.
The Fink & Schindler Co., 218 13th St., San Francisco.
Frank Portman, 1619-20 Mission St., San Francisco.
- MOTORS AND FANS**
R. J. Davis, Dist. Sales Agent Century Motors and Fans, 171 Second St., San Francisco.
- OIL BURNERS**
American Standard Oil Burner Company, Berkeley.
Fess System Co., 220 Natoma St., San Francisco.
S. T. Johnson Co., 1337 Mission St., San Francisco.
T. P. Jarvis Manufacturing Co., 275 Connecticut St., San Francisco.
W. S. Ray Mfg. Co., 29 Spear St., San Francisco.
G. E. Witt Co., 862 Howard St., San Francisco.
- OIL STORAGE AND DISTRIBUTING STATIONS**
S. F. Bowser & Co., Inc., 612 Howard St., San Francisco.
S. T. Johnson Co., 1337 Mission St., San Francisco.
Wayne Oil Tank & Pump Co., 631 Howard St., San Francisco; 830 S. Los Angeles St., Los Angeles.
- OFFICE EQUIPMENT**
C. F. Weber Co., 985 Market St., San Francisco.
Rucker-Fuller Co., 677 Mission St., San Francisco.
F. W. Wentworth & Co., 539 Market St., San Francisco.

KNITTLE-CASHEL CO., Inc.

HEATING CONTRACTORS

STEAM HEATING
HOT WATER HEATINGVENTILATING
POWER PLANTSGENERAL PIPE WORK
REPAIRING

1820-22 Ellis Street, San Francisco

Phone West 964



On Your Best Work Specify
CAL-PA-CO DAMPSTOP (Outside)
 WASHABLE WALL (Inside)
 FOR CONCRETE BUILDINGS. *Everything Reliable in PAINT and VARNISH*
CALIFORNIA PAINT COMPANY, OAKLAND, CALIF., U. S. A.
 MANUFACTURERS SINCE 1865 SAN FRANCISCO OFFICE, MONADNOCK BUILDING

ARCHITECTS' SPECIFICATION INDEX—Continued

ORNAMENTAL IRON AND BRONZE

California Artistic Metal and Wire Co., 349 Seventh St., San Francisco.
 Palm Iron & Bridge Works, Sacramento.
 C. J. Hillard Company, Inc., 19th and Minnesota Sts., San Francisco.

ORNAMENTAL IRON AND BRONZE.—Cont.
 Schrader Iron Works, Inc., 1247 Harrison St., San Francisco.

OVERHEAD CARRYING SYSTEMS

California Hydraulic Engineering & Supply Co., 70-72 Fremont St., San Francisco.
 Richards-Wilcox Mfg. Co., Aurora, Ill., and Underwood Bldg., San Francisco.

PAINT FOR STEEL STRUCTURES, BRIDGES, ETC.

The Paraffine Companies, Inc., 34 First St., San Francisco.
 Premier Graphite Paint and Pioneer Brand Red Lead, made by W. P. Fuller & Co., San Francisco.

Hill, Hubbell & Company, No. 1 Drumm St., San Francisco.

Wadsworth, Howland Co., makers of Bay State Brick and Cement Coating, Boston, Mass.
 Hambley & Son, Distributors in San Francisco and Los Angeles.

PAINTING, TINTING, ETC.

I. R. Kissel, 1747 Sacramento St., San Francisco.

D. Zelinsky & Sons, San Francisco and Los Angeles.

The Tormey Co., 681 Geary St., San Francisco.
 Fick Bros., 475 Haight St., San Francisco.

PAINTS, OILS, ETC.

California Paint Company (see advertisement above).

Magner Bros., 414-424 Ninth St., San Francisco.
 Bass-Iueter Paint Co., Mission, near Fourth St., San Francisco.

R. N. Nason & Company, San Francisco, Los Angeles, Portland and Seattle.

W. P. Fuller & Co., all principal Coast cities.
 "Satinette," Standard Varnish Works, 55 Stevenson St., San Francisco.

Palace Hardware Co., 581 Market St., San Francisco.

PANELS AND VENEER

White Bros., Fifth and Brannan Sts., San Francisco.

PARTITIONS—FOLDING AND ROLLING

J. G. Wilson Corporation, 600 Metropolitan Bldg., Los Angeles; Waterhouse-Wilcox Co., Underwood Bldg., San Francisco.

PENCILS

Eberhard Faber, Monadnock Bldg., San Francisco.

PIPE—STEEL AND WROUGHT IRON

Western Pipe & Steel Co., 444 Market St., San Francisco; 1758 N. Broadway, Los Angeles.

George H. Tay Company, Mission and Second Sts., San Francisco; 10th and Harrison Sts., Oakland.

PLAYGROUND EQUIPMENT

A. G. Spalding & Bros., 158 Geary St., San Francisco.

PLASTER CONTRACTORS

A. Knowles, Call-Post Bldg., San Francisco.
 MacGruer & Simpson, 540 Call-Post Bldg., San Francisco.

James F. Smith, 273 Minna St., San Francisco.

PLUMBING CONTRACTORS

Alex Coleman, 706 Ellis St., San Francisco.
 Gilley-Schmid Company, 198 Otis St., San Francisco.

Hateley & Hateley, Mitau Bldg., Sacramento.
 Scott Co., Inc., 243 Minna St., San Francisco.
 Wm. F. Wilson Co., 328 Mason St., San Francisco.

PLUMBING FIXTURES, MATERIALS, ETC.

California Steam & Plumbing Supply Co., 671 Fifth St., San Francisco.

Jas. B. Clow, plumbing, Rialto Bldg., San Francisco.

Crane Co., San Francisco, Oakland, Los Angeles.

Gilley-Schmid Company, 198 Otis St., San Francisco.

Haines, Jones & Cadbury Co., 857 Folsom St., San Francisco.

H. Mueller Manufacturing Company, 635 Mission St., San Francisco.

Holbrook, Merrill & Stetson, 64 Sutter St., San Francisco.

J. L. Mott Iron Works, D. H. Gulick, selling agent, 553 Mission St., San Francisco.

National Valve Company, 23-25 Minna St., San Francisco.

Pacific Sanitary Manufacturing Co., 67 New Montgomery St., San Francisco.

George H. Tay Company, Mission and Second Sts., San Francisco; 10th and Harrison Sts., Oakland.

West Coast Porcelain Company, San Francisco.

Wm. F. Wilson Co., 328 Mason St., San Francisco.

POWER PLANTS

Knittle-Cashel Co., Inc., 1820 Ellis St., San Francisco.

POWER TRANSMITTING MACHINERY

Meese & Gottfried, San Francisco, Los Angeles, Portland, Ore., and Seattle, Wash.

PUMPS

Chicago Pump Co., represented by Garnett, Young & Co., 612 Howard St., San Francisco.

California Hydraulic Engineering & Supply Co., 70 Fremont St., San Francisco.

Dow-Herriman Company, 140 Howard St., San Francisco; factory, Petaluma.

Simonds Machinery Co., 117 New Montgomery St., San Francisco.

Ocean Shore Iron Works, 558 Eighth St., San Francisco.

Pacific Pump & Supply Company, 851-853 Folsom St., San Francisco.

George H. Tay Company, Mission and Second Sts., San Francisco; 10th and Harrison Sts., Oakland.

PUMPS—HAND OR POWER, FOR OIL AND GASOLINE

S. F. Bowser & Co., Inc., 612 Howard St., San Francisco.

R. J. Davis

District Sales Agent

Century

A. C. Motors and Fans

Complete stocks carried at: 171-173 Second St., San Francisco; 906 So. Hope St., Los Angeles



Yards { TRACY, CAL.
BRENTWOOD, CAL.

Phone KEARNY 2074

PORTLAND LUMBER COMPANY

A. J. RUSSELL, Agent

LUMBER

SIMPLEX SILOS
SAGINAW SPECIAL SHINGLES
*Ship Timbers, Oil Rigs and
Special Bills Cut to Order.*

16 California Street

San Francisco, Cal.

from tree to Consumer

Pine and Redwood Lumber

SASH DOORS AND MILL WORK

SUNSET LUMBER COMPANY

MANUFACTURERS — WHOLESALE AND RETAIL

Main Office and Yards:

FIRST AND OAK STREETS, OAKLAND

Phone Oakland 1820

POPE & TALBOT

Manufacturers, Exporters and Dealers in

Lumber, Timber, Piles, Spars, etc.

Office, Yards and Planing Mills

859-869 THIRD ST., SAN FRANCISCO, CAL.

Mills, Port Gamble, Port Ludlow and Utsalady, Washington

STORM KING and AMERICAN WARM AIR FURNACES

FURNACE FITTINGS AND REPAIRS

Montague Range & Furnace Company

327-329 JESSIE STREET

Phone Garfield 1422

826-830 MISSION STREET

SAN FRANCISCO, CALIF.

ARCHITECTS' SPECIFICATION INDEX—Continued

- PUMPS (Continued)**
 Dow-Herriman Co., 140 Howard St., San Francisco.
 S. T. Johnson Co., 1337 Mission St., San Francisco.
 Wayne Oil Tank & Pump Co., 631 Howard St., San Francisco; 830 S. Los Angeles St., Los Angeles.
 George H. Tay Company, Mission and Second Sts., San Francisco; 10th and Harrison Sts., Oakland.
- REFRIGERATORS**
 McCray Refrigerator Company, San Francisco office, Monadnock Bldg.
- REVERSIBLE WINDOWS**
 Hauser Window Company, 157 Minna St., San Francisco.
- ROOFING CONTRACTORS**
 Western Roofing Co., Inc., 420 15th St., San Francisco.
- ROOFING AND ROOFING MATERIALS**
 Bender Roofing Company, Monadnock Bldg., San Francisco.
 "Malthoid" and "Ruberoid," manufactured by Paraffine Companies, Inc., San Francisco.
 United Materials Co., Crossley Bldg., San Francisco.
 H. H. Robertson Co., Hobart Bldg., San Francisco.
- RUBBER TILING**
 New York Belting and Packing Company, 518 Mission St., San Francisco.
- SAFETY TREADS**
 Pacific Materials Co., 525 Market St., San Francisco.
- SAND**
 Del Monte White Sand, Del Monte Properties Co., 401 Crocker Bldg., San Francisco.
- SASH CORD**
 Samson Spot Sash Cord, John T. Rowntree, Pacific Coast Agent, San Francisco and Los Angeles.
- SCENIC PAINTING—DROP CURTAINS, ETC.**
 The Edwin H. Flagg Scenic Co., 1638 Long Beach Ave., Los Angeles.
- SCHOOL FURNITURE AND SUPPLIES**
 C. F. Weber & Co., 985 Market St., San Francisco; 512 S. Broadway, Los Angeles.
 Rucker-Fuller Desk Company, 677 Mission St., San Francisco.
- SHEATHING AND SOUND DEADENING**
 Samuel Cabot Mfg. Co., Boston, Mass., agencies in San Francisco, Oakland, Los Angeles, Portland, Tacoma and Spokane.
 The Paraffine Companies, Inc., 34 First St., San Francisco.
- SHEET METAL WORK**
 Jas. A. Nelson, 517 Sixth St., San Francisco.
- SHINGLE STAINS**
 Bass-Hueter Paint Company, all principal Coast cities.
 Cabot's Creosote Stains, sold by Pacific Building Materials Co., 525 Market St., San Francisco.
 Fuller's Pioneer Shingle Stains, made by W. P. Fuller & Co., San Francisco.
 Argonaut Shingle Stains. The Glidden Co., 123 Hooper St., San Francisco.
- SINKS—COMPOSITION**
 Petrium Sanitary Sink Co., Fifth and Page Sts., Berkeley.
- SKYLIGHTS**
 H. H. Robertson Co., Hobart Bldg., San Francisco.
 Jas. A. Nelson, 517 Sixth St., San Francisco.
- STATIONERY AND SUPPLIES**
 Schwabacher-Frey Stationery Co., 609 Market St., San Francisco.
- STEEL HEATING BOILERS**
 California Hydraulic Engineering & Supply Co., 70-72 Fremont St., San Francisco.
 General Boilers Co., 332 Monadnock Bldg., San Francisco.
- STEEL TANKS, PIPE, ETC.**
 Ocean Shore Iron Works, 558 Eighth St., San Francisco.
 S. T. Johnson Co., 1337 Mission St., San Francisco.
 Western Pipe & Steel Co., 444 Market St., San Francisco.
- STEEL AND IRON—STRUCTURAL**
 Central Iron Works, 621 Florida St., San Francisco.
 Dyer Bros., 17th and Kansas Sts., San Francisco.
 Golden Gate Iron Works, 1541 Howard St., San Francisco.
 Mortenson Construction Co., 19th and Indiana Sts., San Francisco.
 Pacific Rolling Mills, 17th and Mississippi Sts., San Francisco.
 Palm Iron & Bridge Works, Sacramento.
 U. S. Steel Products Co., Rialto Bldg., San Francisco.
 Schrader Iron Works, Inc., 1247 Harrison St., San Francisco.
 Western Iron Works, 141 Beale St., San Francisco.
- STEEL PRESERVATIVES**
 Hill, Hubbell & Company, No. 1 Drumm St., San Francisco.
- STEEL REINFORCING**
 Badt-Falk & Co., Call-Post Bldg., San Francisco.
 Pacific Coast Steel Company, Rialto Bldg., San Francisco.
 Gunn, Carle & Co., Inc., 444 Market St., San Francisco.
 Truscon Steel Co., 527 Tenth St., San Francisco.
- STEEL ROLLING DOORS**
 Kinnear Steel Rolling Door Co., Pacific Building Materials Co., agents, Underwood Bldg., San Francisco.
 J. G. Wilson Corporation, 600 Metropolitan Bldg., Los Angeles.
- STEEL SASH**
 Bayley-Springfield solid steel sash, sold by Pacific Materials Co., 525 Market St., San Francisco.
 "Fenestra," solid steel sash, manufactured by Detroit Steel Products Company, Detroit, Mich. Direct factory sales office, Foxcroft Bldg., San Francisco.
 U. S. Metal Products Company, 330 Tenth St., San Francisco.
- STEEL WHEELBARROWS**
 Champion and California steel brands, made by Western Iron Works, 141 Beale St., San Francisco.
- STORE FRONTS**
 The Kawneer Manufacturing Company, West Berkeley, California.
 Zouri Safety Sash Bars—Cobbledick-Kibbe Glass Company, 175 Jessie St., San Francisco.
- STUDDING—FIREPROOF STEEL**
 Steel Studding Company, 1216 Folsom St., San Francisco.
- SUMP AND BILGE PUMPS**
 California Hydraulic Engineering & Supply Co., 70-72 Fremont St., San Francisco.
- SWITCHES**
 Wemco Safety Switch, manufactured and sold by W. E. Mushet Co., 502 Mission St., San Francisco.
- TANKS FOR OIL, GASOLINE, KEROSENE, ETC.**
 S. F. Bowser & Co., Inc., 612 Howard St., San Francisco.
 Wayne Oil Tank & Pump Co., 631 Howard St., San Francisco; 830 S. Los Angeles St., Los Angeles.

STEEL SASH — FIRE DOORS — SHEET METAL

Kalamein, Copper and Bronze Doors and Trim Sheet Metal Work of Every Description

FIRE PROTECTION PRODUCTS CO.

3117-3119 TWENTIETH STREET, Near Harrison, SAN FRANCISCO. Phone Mission 2607

ARCHITECTS' SPECIFICATION INDEX—Continued

- TANKS—REDWOOD**
Redwood Manufactures Co., Hobart Bldg., San Francisco.
- TELEPHONE AND ELECTRIC EQUIPMENT**
Bittmann & Battee, 745 Folsom St., San Francisco.
Direct Line Telephone Co., 320 Market St., San Francisco.
- THEATER AND OPERA CHAIRS**
C. F. Weber & Co., 365 Market St., San Francisco.
Rucker-Fuller Desk Co., 677 Mission St., San Francisco.
- THERMOSTATS FOR HEAT REGULATION**
Johnson Service, Rialto Bldg., San Francisco.
- TILES, MOSAICS, MANTELS, ETC.**
Mangrum & Otter, 827-831 Mission St., San Francisco.
- TILE FOR ROOFING**
Gladding, McBean & Co., Crocker Bldg., San Francisco.
United Materials Co., Crossley Bldg., San Francisco.
- TRANSMISSION MACHINERY**
Meese & Gottfried Co., San Francisco, Los Angeles and Portland.
- VACUUM CLEANERS**
United Electric Company, Canton, O., manufacturers of Tuec Cleaners, sold in California by San Francisco Compressed Air Cleaning Co., Stockton and Sutter Sts., San Francisco.
- VALVES—PIPES AND FITTINGS**
California Steam & Plumbing Supply Co., 671 Fifth St., San Francisco.
Crane Radiator Valves, manufactured by Crane Co., Second and Brannan Sts., San Francisco.
National Valve Company, 23-25 Minna St., San Francisco.
Grinnell Co., 453 Mission St., San Francisco.
O. M. Simmons Co., 115 Mission St., San Francisco.
H. Mueller Mfg. Co., 635 Mission St., San Francisco.
W. E. Mushet Co., 502 Mission St., San Francisco.
George H. Tay Company, Mission and Second Sts., San Francisco; 10th and Harrison Sts., Oakland.
- VALVE PACKING**
N. H. Cook Belting Co., 317 Howard St., San Francisco.
- VARNISHES**
California Paint Company, 1797 Twelfth St., Oakland.
W. P. Fuller Co., all principal Coast cities.
R. N. Nason & Co., San Francisco, Los Angeles, Portland and Seattle.
S. F. Pioneer Varnish Works, 816 Mission St., San Francisco.
Standard Varnish Works, 55 Stevenson St., San Francisco.
- VENETIAN BLINDS, AWNINGS, ETC.**
C. F. Weber & Co., 985 Market St., San Francisco.
Western Blind & Screen Co., 2702 Long Beach Ave., Los Angeles.
- VENTILATORS**
H. H. Robertson Co., Hobart Bldg., San Francisco.
- VITREOUS CHINAWARE**
Pacific Porcelain Ware Company, 67 New Montgomery St., San Francisco.
- WALL BEDS, SEATS, ETC.**
Marshall & Stearns Co., 1154 Phelan Bldg., San Francisco.
- WALL BOARD**
"Amiwud" Wall Board, manufactured by The Paraffine Companies, Inc., 34 First St., San Francisco.
"Liberty" Wall Board, manufactured by Key-Hold Plaster Lath Co., 148 Hooper St., San Francisco.
- WALL PAINT**
Nason's Opaque Flat Finish, manufactured by R. N. Nason & Co., San Francisco, Portland and Los Angeles.
San-A-Cote and Vel-va-Cote, manufactured by the Brininstool Co., Los Angeles.
- WALL PAPER AND DRAPERIES**
Beach-Robinson Co., 239 Geary St., San Francisco.
The Torrey Co., 681 Geary St., San Francisco.
W. & J. Sloane, 216-228 Sutter St., San Francisco.
Uhl Bros., San Francisco.
- WATERPROOFING FOR CONCRETE, BRICK, ETC.**
Armorite Damp Resisting Paint, made by W. P. Fuller & Co., San Francisco.
Bay State Brick & Cement Coating, manufactured by Wadsworth, Howland Co., Boston; Hambley & Son., Distributors for Northern and Southern California.
Imperial Waterproofing, mfrd. by Brooks & Doerr, Reed Baxter, agent, Merchants National Bank Bldg., San Francisco.
Pacific Materials Co., 525 Market St., San Francisco.
Samuel Cabot Mfg. Co., Boston, Mass., agencies in San Francisco, Oakland, Los Angeles, Portland, Tacoma and Spokane.
- WATER SUPPLY SYSTEMS**
Kewanee Water Supply System—Simonds Machinery Co., agents, 117 New Montgomery St., San Francisco.
Pacific Pump & Supply Company, 851-853 Folsom St., San Francisco.
Smith-Booth-Usher Co., San Francisco and Los Angeles.
- WHEELBARROWS—STEEL**
Western Iron Works, Beale and Main Sts., San Francisco.
- WHITE CEMENT**
"Atlas White," see coast agencies, page 127.
"Medusa White," sold by Pacific Materials Co., Underwood Bldg., San Francisco.
- WHITE ENAMEL**
"Gold Seal," manufactured and sold by Bass-Hueter Paint Co. All principal Coast cities.
"Silkenwhite," made by W. P. Fuller & Co., San Francisco.
"Satinette," Standard Varnish Works, 55 Stevenson St., San Francisco.
- WINDOW SHADES**
W. & J. Sloane, 216-228 Sutter St., San Francisco.
- WINDOW SASH CORD**
Sampson Spot Cord, John T. Rowntree, Pacific Coast agents, San Francisco and Los Angeles.
- WINDOWS, REVERSIBLE, CASEMENT, ETC.**
Hauser Window Co., 157 Minna St., San Francisco.
The Kawneer Company, West Berkeley, California. (Simplex Fixtures.)
J. G. Wilson Corporation, 600 Metropolitan Bldg., Los Angeles; Waterhouse-Wilcox Co., Underwood Bldg., San Francisco.
- WIRE FABRIC**
U. S. Steel Products Co., Rialto Bldg., San Francisco.
Clinton Wire Lath, sold by L. O. Norris, 140 Townsend St., San Francisco.
- WIRE FENCE**
Standard Fence Co., 310 12th St., Oakland.
- WOOD MANTELS**
Fink & Schindler, 218 13th St., San Francisco.
Mangrum & Otter, 827 Mission St., San Francisco.

MOLINE HEAT

Hobart Building

San Francisco

TELEPHONE SUTTER 3818

MOTT PLUMBING FIXTURES

Architects and their clients are invited to visit our Showrooms, 553-555 Mission Street, San Francisco; D. H. Gulick, Sales Agent. Los Angeles Office, 1001 Central Building; J. R. Mayhew, Sales Agent.

Mott Company of California

MUELLER — BRASS GOODS

Recognized as the Standard of excellence in plumbing. It pays to use them, and other Mueller Brass Goods. *The first cost is practically their last cost.*

H. Mueller Mfg. Co.

635 MISSION STREET, SAN FRANCISCO, CAL.

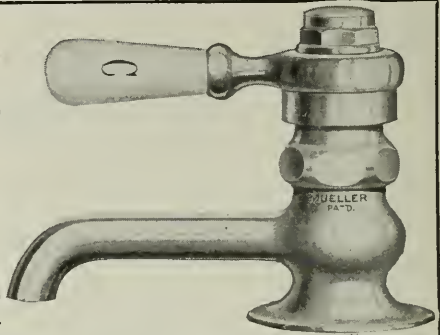

GENERAL BOILERS COMPANY

DEPARTMENT OF SALES

A. W. MERRILL, Manager

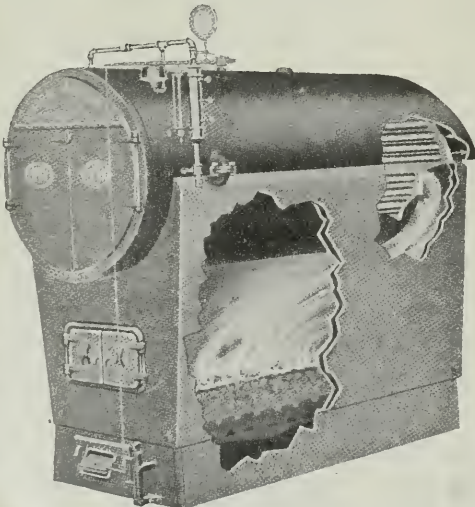

MANUFACTURERS of
Pacific Patented Steel
Portable Double Return Tube
— Low Pressure Steam and
Hot Water Heating Boilers
— Pacific Steel Circulating
Tanks — Pacific Steel Tank
Heaters and Storage Tanks.

General Office and Plant:
WAUKEGAN, ILLS.

Sales Offices: 322 Monadnock Building, San Francisco and 1310 South Hill St.,
Los Angeles, California.



Lake Tahoe Fish Hatchery, near Tahoe City, Calif. Designed by Mr. George B. McDougall, California State Architect. Mr. Matt Green, Builder.

An Old Proverb Refuted

"*Beauty is only skin deep*" runs the old proverb. True, in many instances. When the government built in the High Sierras, it sought a man-made product which would preserve as well as beautify. The quest was successful.

FULLER'S PIONEER SHINGLE STAINS

possess both properties. Containing the exact amount of creosote, which our seventy years of experience have taught us is correct — our stains **DO** preserve all structures from the ravages of Time. Pigments — the experimentation of years — carefully chosen by those who know — are incorporated in these stains, resulting in those rich, subdued tones whose artistry is a delight to every architect, builder and home-owner.



"*Beauty is more than skin-deep with Pioneer Shingle Stains.*"

W. P. FULLER & CO.

MANUFACTURERS

70 YEARS

CHICAGO PUMP COMPANY

House Pumps Sewage Ejectors Bilge Pumps
 Condensation Pumps

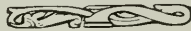

Garnett Young and Company

612 Howard Street, San Francisco

SEATTLE

LOS ANGELES

PORTLAND



DEL MONTE
 Lewis P. Hobart

Pebble Beach Lodge, Monterey Co. Lewis P. Hobart, Architect

The White Cement Finish is given added Beauty
 by the use of

DEL MONTE WHITE SAND

DEL MONTE PROPERTIES CO. 401 Crocker Bldg., San Francisco

Phone Sutter 6130

Makes Garbage Burn Itself

The **KERNER** "Built-in-the-Chimney" INCINERATOR



Patented Aug. 25, 1914; May 18, 1919

requires no coal, gas or any other fuel other than the dry waste deposited in the handy little hopper door. All you need do is to throw the garbage, waste paper, tincans, bottles and other refuse in the hopper door — and occasionally light the incinerator in the basement.

The dry waste burns readily and, in burning dries the wet waste so it also becomes fuel. Bottles and tin cans are dried, sterilized and later dropped into the ash pit.

SANITARY—ECONOMICAL—CONVENIENT—ODORLESS

Kerner Incinerator Co.

77 O'Farrell St. Factory, 38 Stanford St.

San Francisco

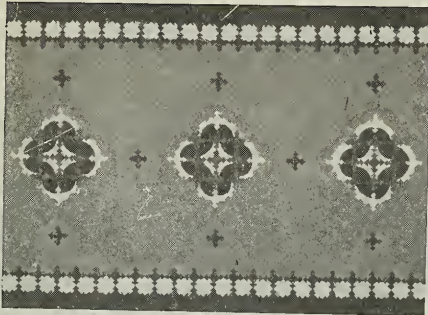

INTERLOCKING RUBBER TILING

material that is sure to give satisfaction. **Twenty tons** installed in the **Standard Oil Building, San Francisco.** Stock on hand for immediate delivery.

New York Belting and Packing Co.

NEW YORK

San Francisco Branch 519 MISSION ST. Phone Douglas 1837

Small booklet of designs mailed on request.

The Elevator Floor

whether in Office Building, Hotel or Department Store, is subjected to a great deal of wear and tear.

— SPECIFY —

INTERLOCKING RUBBER TILING

and you've provided your client's building with a Durable, Economical, Practical,





Brininstool

San - a - Cote

(GLOSS—Can be Scrubbed)

AN INTERIOR WALL FINISH

For bath rooms, kitchens, hospitals, schools, office and public buildings. Ask dealers, owners, architects and contractors about this durable, sanitary, washable, economical wall covering. Brininstool makes a paint for every purpose, and every can purposely good.

THE BRININSTOOL CO., LOS ANGELES

COLOR GRINDERS AND PAINT MANUFACTURERS

Distributors—The Brininstool Co., 1174 Phelan Bldg., San Francisco, Cal.; The Brininstool Co., 223 Abington Bldg., Portland, Ore.; Schutz Paint Co., Fresno, Cal.; Schneider, Chappell & Jones, Sacramento, Cal.; Salt Lake Glass & Paint Co., Salt Lake City, Utah; Griffin Paint Co., Ogden, Utah; Campbell Hardware Co., First and Madison Sts., Seattle, Wash.; Imperial Valley Hardware Co., El Centro, Cal.; Calexico, Imperial, Brawley, Seeley, Cal.; Spokane Hardware Co., Spokane, Wash.; Continental Paint Company, 328 South First St., San Jose, Cal.; Los Angeles Wall-paper & Paint Co., 525 So. Main St., Los Angeles, Cal.; H. A. Berger, 3838 13th St., San Diego, Cal.; H. L. Christian, Elythe, Cal.; Ezra Thayer, Phoenix, Ariz.; Miami Lumber & Supply Co., Miami, Ariz.

RELIANCE BALL BEARING DOOR HANGERS

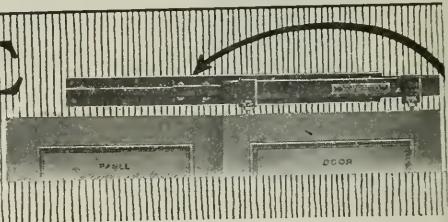

To get as near perfection as possible, use

RELIANCE "HANGERS" and "Reliance-Grant" Controllers

These insure fast service, practically noiseless and slamless doors.

Reliance-Grant Elevator Equipment Corp'n

PARK AVENUE AND 40TH STREET, NEW YORK

PACIFIC COAST AGENTS

Waterhouse-Wilcox Co.
Columbia Wire & Iron Works
D. E. Fryer & Company

San Francisco and Los Angeles, Cal.
Portland, Ore.
Seattle, Spokane, Tacoma, Wash. and Great Falls, Mont.

FOR ALL
FINISHING
REQUIREMENTS



THE
IMMACULATE
WHITE ENAMEL

TRADE
ELASTICA
MARK
VARNISHES

Satinette
TRADE MARK
ENAMEL

STANDARD VARNISH WORKS

GENERAL OFFICES: NEW YORK - 90 WEST STREET
BRANCHES: LONDON - SAN FRANCISCO - PARIS - MELBOURNE

SAN FRANCISCO OFFICES & WAREHOUSE 55 STEVENSON STREET

When writing to Advertisers please mention this magazine.

Bungalow Building Blox

Hollow Building Tile
Hollow Partition Tile

California Brick Co.

604 Mission Street
San Francisco, Cal.

BRICK

Red Ruffled Face Brick
Paving Brick
Step and Walk
Brick

BRICK

Enamel Brick
Buff and Old Gold
Pressed Brick

Livermore Fire Brick Works

604 Mission Street
San Francisco, Cal.

Fire Brick and
Molded Fire Tile

Architectural Terra Cotta

GLASS

FULLER & GOEPP

32 Page Street, San Francisco. Telephone Market 499
PRIVATE EXCHANGE CONNECTING ALL DEPARTMENTS
MANUFACTURERS OF

MIRRORS, ART AND LEADED GLASS

Dealers in **WHITE** Glass for Table Tops, Counter Tops, Sink
Backs & Etc. Complete Stock — Prompt Deliveries.

Passenger and Freight Elevators



"MADE IN SAN FRANCISCO"

Factory and Warehouse, 166-180 Seventh
Street, San Francisco. Phone Kearny 66

SPENCER ELEVATOR COMPANY



RA-DO ^{FUMELESS} _{GAS} RADIATORS

ALL CAST IRON -- 3 Sizes (3, 5, and 7 Sections)

The Ideal "Year-Round" Heating System
For The Home—New or Old

Easiest and Cheapest to Install
Lowest Operating Cost

BAIRD - BAILHACHE COMPANY

MANUFACTURERS

478 Sutter St., San Francisco

'Phone Sutter 6858

OLD MISSION PORTLAND CEMENT COMPANY



Each shipment of "OLD MISSION" Portland Cement is guaranteed not only to equal but to surpass all requirements of the standard specifications for Portland Cement as adopted by the U. S. Government and by the American Society for Testing Materials. A Guarantee Certificate is mailed with the bill of lading of each car, giving number of car, date packed, and number of barrels, over the signature of the chief chemist.

8000 SACKS DAILY

SALES OFFICE:

MILLS BLDG., SAN FRANCISCO

PHONE SUTTER 3075

PLANT:

SAN JUAN, CAL.

GEO. H. DYER, President

R. W. DYER, Vice-Pres.

W. J. DYER, Sec'y

DYER BROTHERS

Golden West Iron Works, Inc.

Structural Iron and Steel Contractors

ORNAMENTAL IRON WORK

Office and works:
17th and KANSAS STREETS

SAN FRANCISCO, CAL.
Phone Market 134



Keep Down Insurance Premiums

SPECIFY

SAINO FIRE DOORS

Standard Automatic Sliding or Swinging Fire Doors.
Tested and Labeled by the Underwriters' Laboratories.

STEEL SASH AND HOLLOW METAL
UNDERWRITERS WINDOWS

U. S. METAL PRODUCTS CO.

326-338 Tenth Street, San Francisco

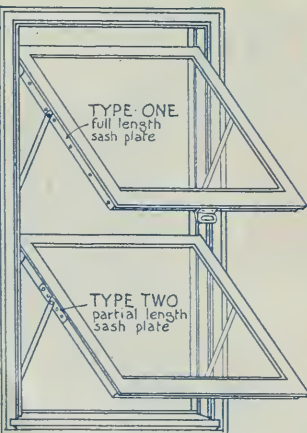

Hauser Reversible Windows

The Ideal Window is one that will operate in any size frame—wood or metal—the HAUSER is such a window—easy to install—a positive protection against rain, dust and wind.

Hauser Window Company

OFFICE AND FACTORY

157 Minna St. (Phone Kearny 3706) San Francisco



Country Residence U. S.
Senator James D. Phelan,
Santa Clara County, Cal.
Wm. Curlett & Son, Archts.

Unstained Beauty

MEDUSA White Stainless Cement makes stucco work permanently beautiful and non-staining. Eight years' exposure to weather has not affected the clean, white freshness of the handsome country place shown in the above illustration.

Medusa White Stainless Cement prevents discoloration by weather action. It preserves the beauty of the most striking effects in building trim and ornamentation, whether snow white or delicately tinted. Satisfaction in stucco work depends upon *lasting beauty*—specify Medusa White Stainless Cement for your own satisfaction and that of your clients.

There is an illustrated booklet describing the typical uses of Medusa Non-staining White Cement. May we send it to you?

The Sandusky Cement Company
Department P
Cleveland, Ohio



*Manufacturers of Medusa
White and Medusa Grey
Cement — plain and water-
proofed—and Medusa Water-
proofing paste and powder.*

Pacific Coast Distributors:
Pacific Materials Co., San
Francisco, California.
Riverside Portland Cement
Co., Los Angeles, California
A. McMillan & Company,
Portland, Oregon.
Galbraith & Company,
Seattle, Washington.



BUILDING FOR MANHEIM & MAZOR, OAKLAND.
B. J. JOSEPH, ARCHITECT.
BARRETT & HILP, CONTRACTORS.

MICHIGAN MAPLE FLOORING laid in this building, is enduring; assures harmony.

¶ The perfection of a modern Department Store is individualized by Maple Flooring.

¶ "WOLVERINE BRAND," a Michigan product, is superior in its manufacture.



Phone, Oakland 245

STRABLE HARDWOOD COMPANY

FORMERLY

Strable Manufacturing Co.

511-545 First Street,
OAKLAND, CAL.

HARDWOOD LUMBER
HARDWOOD FLOORING

This
Peerless Breakfast Nook — \$51.



A TABLE CABINET for the Kitchen with two drop seats — can be installed in a space 5 ft. 4 by 6 feet — an ideal arrangement, where comfort is desired and space is limited. For private residences and apartment houses. Architects will find this Cabinet both *practical* and *economical*.

PLANS AND SPECIFICATIONS ON REQUEST

THE HOOSIER STORE

O. K. BROWN, Manager

Phone Sutter 4122

821 Market Street, San Francisco

SONNEBORN PRODUCTS



Grind-Proof *and* Dust-Free Concrete Floors!

DUSTING WEARING CONCRETE FLOORS
ARE A THING OF THE PAST WHEREVER
ARCHITECTS HAVE SPECIFIED

Lapidolith

THIS liquid chemical has been flushed on 70,000,000 square feet of concrete floors old and new during the last two years alone. These lapidolized floors are now wearproof and dust-proof, because Lapidolith has completed the hydration of the Portland Cement and this Concrete is harder than granite.

Have you seen the results secured by the Lapidolith treatment? If not, let us refer you to a lapidolized floor near you. Thereafter you will specify Lapidolith on your old and new concrete work.

SONNEBORN PRODUCTS:

Cemcoat

the durable Mill White, Washable, of exceptional covering capacity, Gloss, Flat and Egg-shell, also all colors.

Lignophol

the modern wood preservative gives new life to old or new wooden floors.

Write for sample, literature and specification form

*Concrete for Permanence
Lapidolith for Dustlessness*

L. SONNEBORN SONS, Inc.

San Francisco

Los Angeles

Seattle

SONNEBORN



**THE HOUSE
BEAUTIFUL**



THE interior of a Home should have those little touches of refinement that come with the co-operation of an experienced interior decorator.

CONSULT US

Decorative ideas, artistic framing, byamopa ware, floor lamps, table lamps, chair lamps, lamp shades, mirrors, candlesticks, decorated candles, book-ends, store window fixtures, odd furniture, pictures, Emma B. Freeman's Prints, pieces in unique colorings and indefinite carvings and other objects of art.

FREEMAN ART SHOP

386 SUTTER STREET
SAN FRANCISCO

Tel. Sutter 1593



Beach-Robinson Co.

Decorators and Furnishers

Carpets

Draperies

Furniture

Rugs

Wall Paper

Ranson E. Beach

239 Geary Street, 3d Floor

Union Square

Phone, Sutter 580

San Francisco, Cal.



ADD CHEER and COMFORT
to the Home by having a
WELL DESIGNED INTERIOR

Before Completing Your Plans, CONSULT

SONNENSCHN BROS.

INTERIOR DECORATORS

Furniture and Draperies Made to Order

Factory

718 NATOMA ST., Phone Market 1145

Show and Salesroom

470 SUTTER ST., Phone Kearny 2051

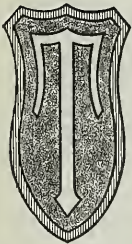

*The Finishing Touch
of Right Building —*

F. A. TAYLOR CO.

251 Post St., San Francisco

Second Floor



Mercedes Bldg.

*Hand-made
Furniture,
Rugs,
Hangings,
Upholstering,
Decorating,
Wall Paper.*

The GOLD MEDAL MAIL CHUTE



INSTALLED IN
THE NEW
SAN FRANCISCO
CITY HALL
AND THE
WHITE MARBLE
MERRITT
BUILDING,
LOS ANGELES

Given highest award at
Panama - Pacific International
Exposition, 1915.

Waterhouse-Wilcox Co.

California
Representatives

523 Market Street
SAN FRANCISCO

331 E. 4th Street,
LOS ANGELES

F. T. CROWE & CO.
Seattle, Wash.

THE J. McCracken Co.
Portland, Oregon

**America Mailing
Device
Corporation**



LIBERTY WALL BOARD

MANUFACTURED BY
KEY-HOLD PLASTER LATH COMPANY

A Fibered Gypsum Plaster that will not
shrink, warp or buckle.

Resists Fire, Moisture, Heat and Cold.

Key-hold plaster lath possesses a perfect
mechanical key—admitted for fire proof con-
struction in all classes of buildings.

KEY-HOLD PLASTER LATH CO.

Office and Factory

148 Hooper St.

San Francisco

Phone Market 5767

McCRAY REFRIGERATORS FOR ALL PURPOSES

It is our particular desire to impress the *Architects of America* with the fact that McCray builds refrigerators for all purposes. Thousands of fine residences, hotels, clubs, restaurants, factory cafeterias, hospitals, stores and markets depend on McCray for efficient, economical refrigerator service.

McCRAY REFRIGERATOR CO.
1054 Monadnock Bldg., San Francisco, Cal.
Home Office and Factory
Kendallville, Ind.

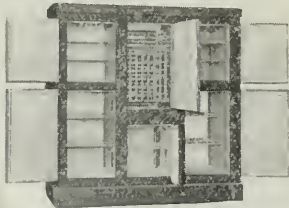

YOU KNOW that a building
should be watertight and
WE KNOW that it can be
made so with

IMPERIAL WATERPROOFING

LOOK FOR  THE LABEL

If your building is leaking through the walls or around the windows, or if the Basement walls are wet below ground—call up SUTTER 978

IMPERIAL WATERPROOFING is manufactured by BROOKS & DOERR, 460 7th St., San Francisco

WATEREX REED BAXTER
DISTRIBUTOR

1002-04 Merchants National Bank Building,
Phone Sutter 978
SAN FRANCISCO, CAL.
3419 Broadway, OAKLAND, CAL.

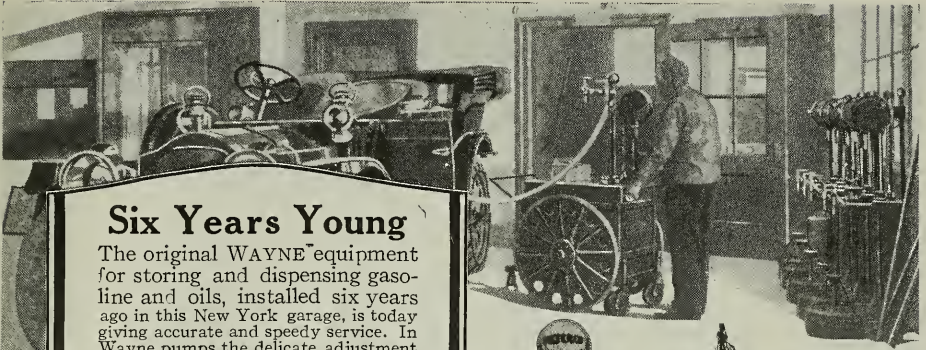

Six Years Young

The original WAYNE equipment for storing and dispensing gasoline and oils, installed six years ago in this New York garage, is today giving accurate and speedy service. In Wayne pumps the delicate adjustment essential for accuracy is combined with a durability that assures satisfaction for years and years.

There is a Wayne System for every need of the public garage. The service of Wayne engineers in advising and planning is yours without cost or obligation.

Wayne Oil Tank & Pump Co.
746 Canal St., Ft. Wayne, Ind.

San Francisco Office 631-633 Howard St. Phone Garfield 1350
Los Angeles Office 830 S. Los Angeles St. Phone Main 1600

Wayne
Liquid Storage Systems

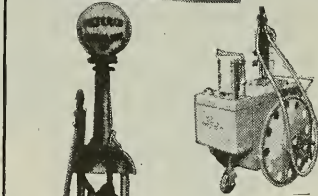

Cut No. 230 For Gas and Oil



Cut No. 280 One-gallon gasoline



Cut No. 200 Lubricating oils

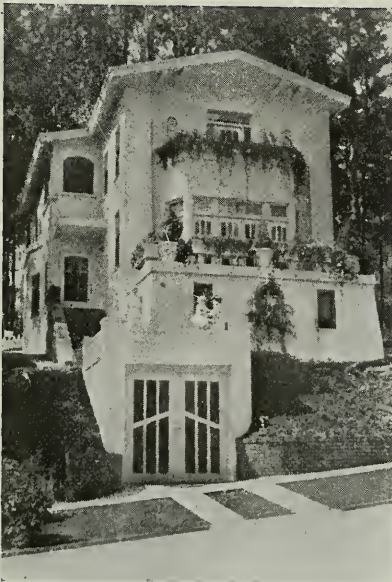

This House Designed by Architects Heiman-Schwartz is Equipped with PITCHER HANGERS.

A Smooth Running Noiseless door hanger is a delight to the discriminating housewife.

A Pitcher

Hanger is an asset to Every Home, Apartment House and Hotel. Manufactured by

NATIONAL MILL & LUMBER COMPANY

318 Market Street
San Francisco

Telephone Kearny 3626



IT'S not enough to say "Good For All Time" unless there is something back of it. ¶ There is in this case. ¶ Vermont Marble already has an unblemished record of over one hundred and fifty years. ¶ We know what it will do. It's not necessary to guess at it. ¶ And our quarries in Alaska and Texas are also proving themselves. ¶ So please don't think of "Good For All Time" as merely a happy phrase.

IT'S THE MARK OF A SERVICE.
It means exactly what it says.

VERMONT MARBLE COMPANY

PROCTOR, VERMONT

San Francisco - Portland - Tacoma

WHEN WRITING INSURANCE

on buildings in course of construction be sure and include the clause permitting it to be occupied. In the State of New York a policy was written on building in process of construction and when completed and occupied was destroyed by fire. The court construed the policy to apply only while it was being constructed.

DIXWELL DAVENPORT
Manager Pacific Coast Department

BANKERS & SHIPPERS INSURANCE COMPANY

INSURANCE EXCHANGE BLDG.
SAN FRANCISCO
Telephone Kearny 3561

A Bargain in Files—

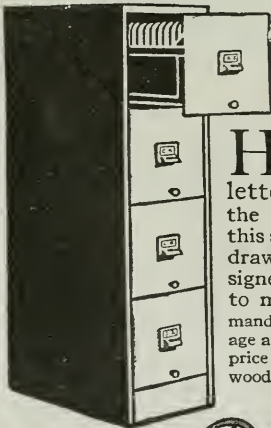

HOLDS 20,000 letters. That's the capacity of this special four-drawer file, designed and built to meet the demand for steel storage at less than the price of high grade wood. See it today.

Van Dorn
STEEL EQUIPMENT

Phone Douglas 1183

Western Office Equipment Co.
467 Market Street - San Francisco

CLINTON

WELDED WIRE
FABRIC AND LATH

The Perfect Support for Stucco and Interior Plaster. Complete Stock for Immediate Delivery. Steel Reinforcing Bars in Stock.

L. A. NORRIS CO.

140 Townsend Street

Phone Kearny 5375 San Francisco



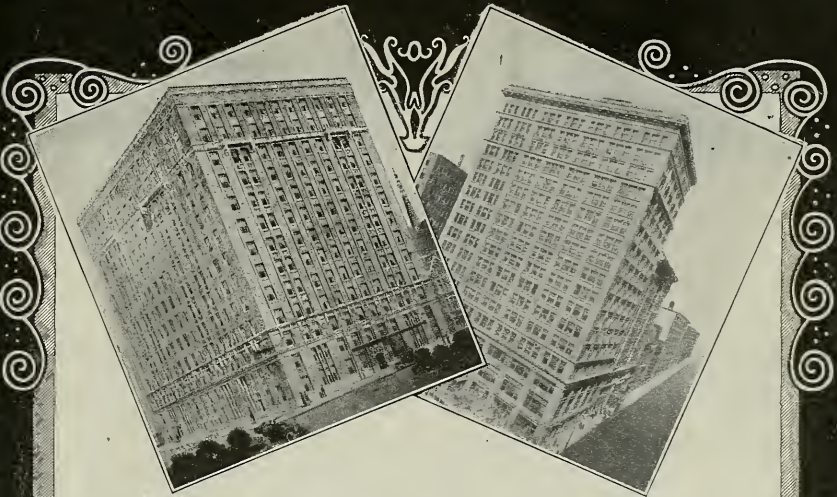

Performance *More Eloquent than Promises*

A FEW OF THE THOUSANDS OF "IDEAL"-
EQUIPPED BUILDINGS

Hotel Breton Hall.....	New York, N. Y.
Palace Theatre	New York, N. Y.
Prince George Hotel.....	New York, N. Y.
St. Anthony Hospital.....	Chicago, Ill.
Guger Building	Indianapolis, Ind.
Radison Hotel	Minneapolis, Minn.
Union Station	St. Paul, Minn.
Court House	Sioux City, Iowa.
Spaulding Hotel	Duluth, Minn.
First National Bank Building.....	Des Moines, Iowa.
Arlington Hotel	Washington, D. C.
Caheen Building	Birmingham, Ala.
Shawnee Hotel	Springfield, Ohio
Herald Building	Lexington, Kentucky
Big Four R. R. Office Building.....	Cincinnati, Ohio
Delco Company Building.....	Dayton, Ohio
Union Trust Building	Cincinnati, Ohio
Farmers & Merchants National Bank.....	Stockton, Cal.

Do years of faithful service by "Ideal" Elevator Door Equipment installed in these representative buildings interest you in knowing more about "Ideal" hardware? If so, allow us to send you, without obligation, illustrated catalog A-21, "Ideal Elevator Door Equipment and Checking Devices."

Richards-Wilcox Mfg. Co.
A Hanger for any Door that Slides.

CHICAGO	AURORA, ILLINOIS, U.S.A.	BOSTON
ST. LOUIS	CLEVELAND	INDIANAPOLIS
LOS ANGELES	LONDON, ONT.	MINNEAPOLIS
PHILADELPHIA		SAN FRANCISCO

The Door Hanger Institution

R-W "Ideal" Elevator Door Equipment

The ELECTRIC



Lighting, the most intangible of all forms of decoration, has had to be studied without the benefit of experimentation

THE architect has always realized the vital importance of lighting.

But up to now he has been greatly handicapped by the fact that he must not only plan the lighting scheme *before* his structure is built—but that the lighting arrangements, once built in, cannot be changed without considerable trouble and expense.

So lighting, the most intangible of all forms of decoration, has had to be studied without the benefit of experimentation.

In other words, the lack of a standardized electric outlet has proved to be the determining factor in *limiting* the development of electric lighting.

But now this much needed standardized electric outlet has been developed, and the limiting conditions that have hampered the architect are about to pass. His problem has been solved—solved simply—solved successfully—solved economically—and solved satisfactorily.

His work will be made easier. He will be able to plan electrically finished buildings, divorcing the selection and placing of “fixtures” from the wiring, and putting it where it belongs, in the field of interior decoration.

It will no longer be necessary for electric fixtures to be placed at each outlet. Their selected locations and their

OUTLET *Company*

particular design and form need not be determined until the decoration of the room and the arrangement of the furniture is decided upon.

And as furnishings and decorative schemes are changed the lighting plan can be changed to suit, for fixtures can be moved without the services of an electrician—without wiring—without fuss or muss.

Clients will be quick to appreciate the charm of changeable lighting—to value the convenience and economy of flexible lighting—to utilize artistic suggestions because they will now be practical.

Architects can specify as many outlets as they deem advisable. People will want them because they can be finished inexpensively. They will be safe and inconspicuous when not in use—always ready for instant use—because wherever there is an outlet they may have light or current whenever they want it.

The Electric Outlet Company will spread the news of this standard lighting outlet to the general public through a comprehensive and continuous advertising campaign.

This news is of vital importance to everyone—and to the architect in particular. A complete description of the standard lighting outlet will appear in an early issue of this publication.

ELECTRIC OUTLET CO., Inc.
119 West 40th St., New York City



USE

UHL'S DIAMOND FLOOR WAX

1—3—5-lb. Cans. A Finishing Wax of best quality in Paste Form

UHLSEATTLE
OAKLAND
PORTLAND
LOS ANGELES
SAN FRANCISCO**BROS.**

"WALL PAPER" - "PAINTS"

LEADER WATER SYSTEM

No country home is complete without this modern water system. Running water under pressure whenever and wherever needed. Convenient, economical, sanitary.

**Pacific Pump & Supply
Company, Distributors**

851-853 Folsom Street
SAN FRANCISCO, CALIF.

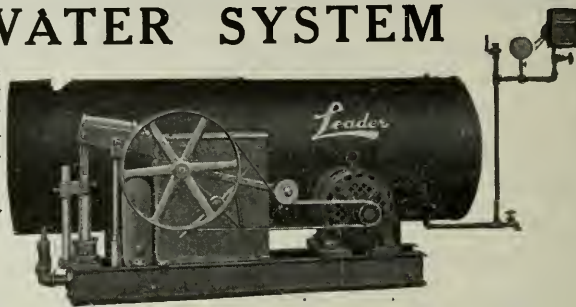
**QUALITY HARDWARE**

LOCKS AND BUILDERS'
HARDWARE

PALACE HARDWARE CO.

"San Francisco's Leading Hardware Store"

581 MARKET STREET. SUTTER 6060



Pack your Radiator Valves with
Palmetto Twist Packing

It can be unstranded to fit any size valve. It does not get hard.

H. N. COOK BELTING CO.

401-433 Howard St. San Francisco, Cal.

**WESTERN
VENETIAN BLINDS
WESTERN**

ELIMINATE the unsightly awnings — Preserve the exterior beauty of your buildings by *Specifying*

**WESTERN VENETIAN
BLINDS**

Some 1920 contracts for complete equipment:

- 12-story Mattie Building,
Fresno, California
- 9-story Pantages Building,
Los Angeles, California
- 7-story Marland Refining Bldg.
Ponca City, Oklahoma
- 10-story Trademens Bank Bldg.
Oklahoma City, Okla..
- 5-story Railway Exchange,
Muskogee, Oklahoma

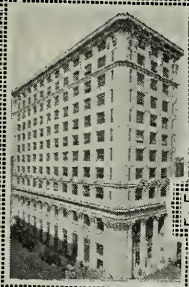

LOS ANGELES TRUST
AND SAVINGS BLDG.
LOS ANGELES, CAL.



HAAS BLDG.
LOS ANGELES, CAL.

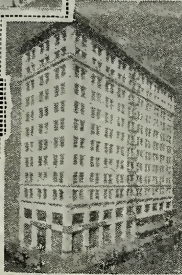

CITIZENS SAVINGS
BLDG.
PASADENA, CAL.



GLOBE GRAIN &
MILLING CO.
LOS ANGELES, CAL.



COUNTY COURT
HOUSE
WALLA WALLA, WASH.

When you consider the fact that **WESTERN VENETIAN BLINDS** take the place of both awning and window shade and will last practically as long as the building stands you'll realize that they are the logical equipment for modern buildings

WESTERN BLIND & SCREEN CO.

2704 LONG BEACH AVE.
LOS ANGELES CALIFORNIA

United States Steel Products Co.

Rialto Bldg., San Francisco

SELLERS of the products of the American Bridge Co., American Sheet and Tin Plate Co., American Steel and Wire Co., Carnegie Steel Co., Illinois Steel Co., National Tube Co., Lorain Steel Co., Shelby Steel Tube Co., Tennessee Coal, Iron and Railroad Co., Trenton Iron Co.

MANUFACTURERS OF

Structural Steel for Every Purpose—Bridges, Railway and Highway—"Triangle Mesh" Wire Concrete Reinforcement—Plain and Twisted Reinforcing Bars—Plates, Shapes and Sheets of Every Description—Rails, Splice Bars, Bolts, Nuts, etc.—Wrought Pipe, Trolley Poles—Frogs, Switches and Crossings for Steam Railway and Street Railway—"Shelby" Seamless Boiler Tubes and Mechanical Tubing—"Americore" and "Globe" Rubber Covered Wire and Cables—"Reliance" Weatherproof Copper and Iron Line Wire—"American" Wire Rope, Rail Bonds, Springs, Woven Wire Fencing and Poultry Netting—Tramways, etc.

United States Steel Products Co.

OFFICES AND WAREHOUSES AT

San Francisco - Los Angeles - Portland - Seattle

Specify **BOWSER** Storage For Indoors or Outdoors

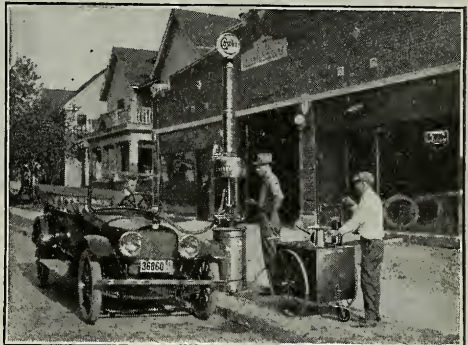
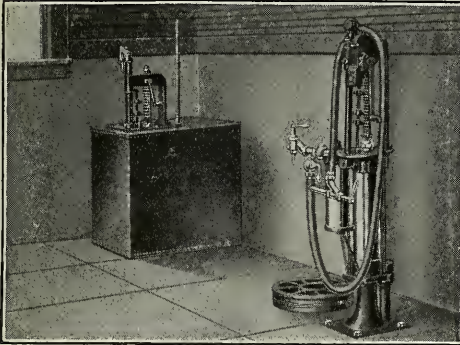

Bowser Storage Systems for Gasoline and Oil meet all requirements as to capacity, speed, or installation.

We are in position to help you in designing gasoline and oil storage for new or old buildings.

Write or phone us for literature or interview

S. F. BOWSER & CO., Inc.

Sales Offices
in all Centers

FORT WAYNE, INDIANA, U. S. A.

Representatives
Everywhere

San Francisco Office: 612 Howard Street. Telephone Douglas 4323



House at Cornwall-on-Hudson, N. Y. Finished with Old Virginia White. Rogers & Zogbaum, Architects, New York

Cabot's Old Virginia White

A Soft, Brilliant White for Shingles, Siding and Similar Woodwork. As Bright and Clean as New Whitewash, and as Lasting as Paint.

Architects and others have tried for years to get a paint that would give the same beautiful, brilliant white as new whitewash, and would also be durable and clean and not rub off like whitewash.

But paint was always "painty" — hard, cold and heavy. Old Virginia White is a shingle-stain compound that has solved the problem. It is as clean, cool and brilliant as fresh whitewash, and as lasting as paint; but it is not messy like whitewash, nor painty like paint, although it costs less and goes farther than paint.

Send for Sample Shingle and Circular showing other fine houses finished with Old Virginia White

SAMUEL CABOT, Inc., Mfg. Chemists, Boston, Mass.

Cabot's Creosote Stains, Stucco and Brick Stains, "Quilt," Mortar Colors, Dampproofing, Waterproofings, Conservo Wood Preservative, etc.

Pacific Materials Co., San Francisco
The Waterhouse-Wilcox Co., Los Angeles

S. W. R. Dally, Seattle
Timms, Cress & Co., Portland



CENTRAL HIGH SCHOOL, MINNEAPOLIS, MINN.

Architect, William B. Ittner

Contractors, Pike & Cook Co.

Glazed by Forman, Ford & Co



The above Trade-Mark
appears on every light

**Completely equipped with American Window Glass Co.'s Double Strength AA Quality
First Choice of Leading Architects**

Because of its absolute dependability, American Window Glass has been used in many fine buildings. Our care in inspection practically eliminates all imperfections and assures uniformity in thickness.

American Window Glass Co., General Office, Pittsburgh, Pa.

DOMESTIC SALES OFFICES
New York, 220 Fifth Avenue
Chicago, 1011 Peoples Gas Building
Boston, Mass., 43 Tremont Street
San Francisco, Cal., 341 Montgomery Street
St. Louis, Mo., 1303 Syndicate Trust Building
Memphis, Tenn., 440 North Main St.
New Orleans, La., 904 Hennen Bldg.
Atlanta, Ga., 1408 Candler Building

EXPORT SALES OFFICES
Havana, Cuba, Apartado No. 930
Buenos Aires, Argentina
Mexico City, Mex., Apartado Postal No. 237
Barranquilla, Colombia
Bogota, Colombia
Valparaiso, Chile
Lima, Peru
Toronto, Canada, 205 Continental Life Building

Highest Quality

Finest Workmanship

Remco Redwood Tanks

Underwriters — Standard — Specials

All dimensions and capacities

Towers Designed and Erected

For Prices, Data or Estimates Phone GARFIELD 1910

Redwood Manufacturers Company

SOLE MAKERS

Hobart Building, San Francisco

JOHNSON'S ROTARY CRUDE OIL BURNER

Can be installed in any BOILER or FURNACE
 Gives Satisfactory Results. Simple to Operate—
 Automatic—Safe. Let us tell you more about this
 Oil Burner.

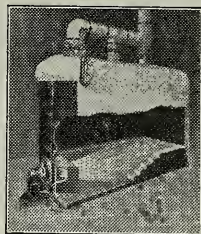

BURNER IN OPERATION

S. T. JOHNSON CO.

1337 Mission Street - San Francisco, Cal.

Ask for Bulletin No. 28 Phone Market 2759

Agencies: SEATTLE LOS ANGELES FRESNO SAN DIEGO SACRAMENTO
 Member of the Oil Burners Manufacturers' Association of California.

Fess System Turbine Fuel Oil Burner

The latest word in the science of burning fuel
 oil in an efficient and economical method

Ask for Bulletin No. 20

FESS SYSTEM CO., Inc.

1310 S. HILL ST.,
 LOS ANGELES

218-220 Natoma Street, San Francisco

HOUSTON,
 TEXAS

Member of the Oil Burners Manufacturers' Association of California.

OIL BURNER EQUIPMENTS

Low Pressure Air and Rotary Mechanical Atomizing Types

Refrigerating and Ice-Making Machines

Direct Expansion and Brine Circulating Systems

T. P. JARVIS MANUFACTURING CO.

CONTRACTING ENGINEERS AND MANUFACTURERS

275 Connecticut Street, San Francisco

Phone Market 3397

Member of the Oil Burners Manufacturers' Association of California.



SIMPLICITY OF CONSTRUCTION together with
 SUCCESSFUL and ECONOMIC OPERATION of

SIMPLEX BURNERS

reported by their many users, is the best recommenda-
 tion we can furnish to those desiring crude oil burners.

American Standard Oil Burner

TRADE MARK

Phone BERKELEY 6389

Company

FIFTH AND PARKER STREETS
 BERKELEY, CALIFORNIA

Member of the Oil Burners Manufacturers' Association of California.



Pump Governors
Oil Burner Governors
Reducing Valves
Safety Valves
Oil Valves
Blowoff Valves
Boiler Feed Water
Regulators

Oil Pumping Sets
Little Giant Improved
Oil Burners
Duplex Oil Pumps
Rotary Oil Pumps
Oil Heaters
Draft Gauges
Boiler Feed Pumps

G. E. WITT CO., Inc.

ENGINEERS

Manufacturers and Distributors

862-864 HOWARD ST.

Phone Douglas 4404

SAN FRANCISCO, CAL.

"The White House"



has had the concrete floors in its new garage and warehouse at Fulton and Laguna Sts. treated with VITRIFIX and the wood floors with VITRIFYL. There will be no dust on any "White House" merchandise.



**PACIFIC
MATERIALS CO.**

525 Market St., San Francisco

A. F. EDWARDS, President
J. M. FABBRIS, Vice-President

J. A. MACKENZIE
Secretary

CHAS. F. EISELE } Asst. Managers
J. RUBIOLLO }

AMERICAN MARBLE & MOSAIC CO.

25-29 Columbia Square, San Francisco

Telephone Market 5070

Factory on Canal, South San Francisco Telephone South San Francisco 161

DETROIT STEEL PRODUCTS CO., Detroit

Direct Factory Branch, 68 Post Street, San Francisco

Phone Sutter 1250



The Architect and Engineer

Volume LXIII. Number 2.

CONTENTS FOR NOVEMBER, 1920

HOUSE OF MR. ROBERT S. ATKINS, SAN FRANCISCO	Frontispiece
J. F. DUNN, Architect	
A NEW ARCHITECTURAL POLICY	PAGE 47
IRVING F. MORROW	
TWO UNUSUAL SAN FRANCISCO HOUSES	61
J. F. DUNN, Architect	
CONSTRUCTION OF FUTURE HIGHWAY PAVEMENTS	68
R. M. MORTON	
NEW FEDERAL RESERVE BANK, SAN FRANCISCO	71
PUBLIC OPINION AND CITY PLANNING PROGRESS	73
JOHN NOLEN	
A SERMONETTE	80
F. W. FITZPATRICK	
AN APARTMENT HOUSE BUILT LIKE A CITY	82
AMERICAN PLAN TO REBUILD REIMS	89
THE SPECIFICATION WRITER	92
LEWIS R. HOLSKE	
SLOW DECLINE SEEN IN BUILDING COSTS	96
H. A. WHITNEY, Architect	
CO-OPERATION AMONG ENGINEERS	102
F. H. NEWELL, C. E.	

Published Monthly by

THE ARCHITECT AND ENGINEER, Inc.

626-627 Foxcroft Bldg., San Francisco

W. J. L. Kierulff Fred'k W. Jones L. B. Penhorwood
President Vice-Pres. Secretary

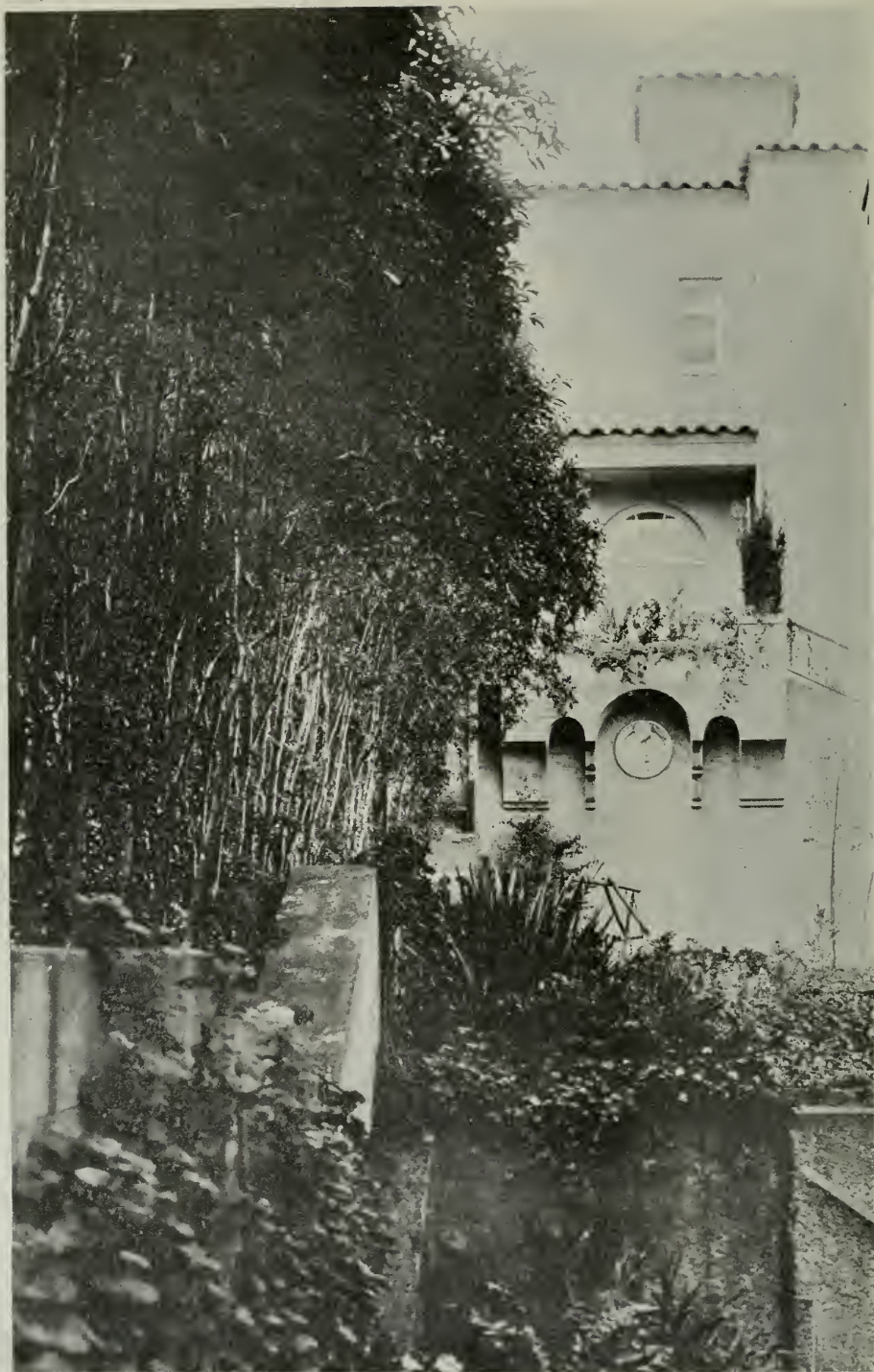

(See Page 67)

HOUSE FOR MR. ROBERT S. ATKINS, SAN FRANCISCO, CALIFORNIA. J. F. DUNN, ARCHITECT

THE
ARCHITECT
AND
ENGINEER

Vol. LXIII.

SAN FRANCISCO, NOVEMBER, 1920

No. 2

A New Architectural Policy

By IRVING F. MORROW

OF course it will scandalize the orthodox. Not Messrs. Woollett & Lamb's architecture—do not misunderstand me there! That is in no wise a subject of scandal. It is, on the contrary, distinctly meritorious. It is conceived by a sane and open mind, and worked up by a well trained one. It is equally aware of the human aspects of its problems and of the course of tradition, and is, essentially, not unorthodox itself. It is, in short, the sort of solid, average work which is indispensable in the formation of a background for a more genuine and more general architectural appreciation—sound, careful, but unoppressed by irrelevant precedents. Such manifestations are always reassuring.

Then why my concern for the orthodox? Well, what I really had in mind was not the way in which Messrs. Woollett & Lamb do their work, but the way they get it. But there is no use beating further about the bush. Let it be said plainly and be over with—Messrs. Woollett & Lamb are advertising. And lest, out of charity, it be assumed that they have merely been innocently inveigled into paying a pittance to some mercenary newspaper for the insertion of their name in the real-estate section, let me hasten to add that deliberately and with malice prepense they are working out a carefully planned advertising campaign.

This from a reputable firm of architects! Goodness knows, disreputable architects have often enough advertised, and we have become reconciled to the practice in their case—I suspect that the truly orthodox might hold that advertising *ipso facto* renders an architect disreputable. But for the sake of a point which occurred to me let us note that Messrs. Woollett & Lamb have not quite yet entered upon their intensive campaign; which leaves us an opportunity to give them the benefit of the doubt and consider them still technically reputable. For such weak-kneed liberality I shall probably be considered hopelessly old-fashioned. We

know what an aggressive Department of Justice would do. It would ignore as irrelevant the fact that the defendants may have as yet committed no overt act, and convict on intent. In case of doubt an intent to commit crime can be supplied on the ground that they would have had one if only given the time; although in the present instance I would not even need to provide the intent. I have the defendants' open confession, freely given and without reservations. Yet the evidence is withheld temporarily in the interests of that point I wished to make, and for the purpose of which one must assume the defendants to be technically innocent. And the point is this: We have grown accustomed to advertising by certain ques-

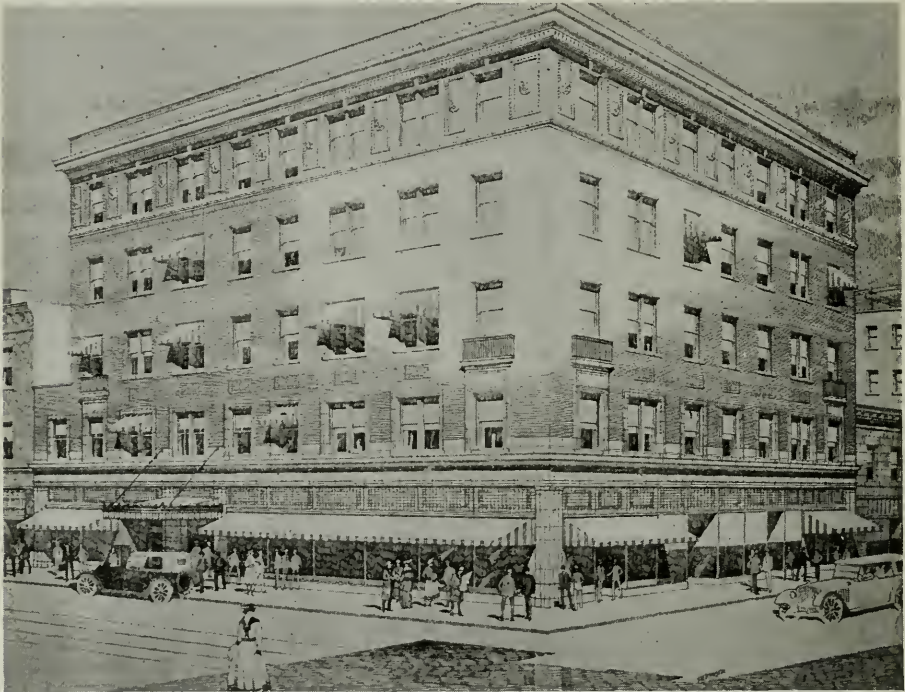

PHYSICIANS' BUILDING, SACRAMENTO, CALIFORNIA.
Woollett & Lamb, Architects.

tionable practitioners, and we let them go their ways (realizing, I suppose, that they will do so in any case); but when qualified architects advertise we register surprise, if not pain. Is such discrimination justified? Admitting the effectiveness of advertising in arousing a public demand for goods, why should we condone the stimulatoin of such a demand for admittedly inferior work, and deplore it in the case of admittedly capable work? Is it not of vital importance to the development of a sound public attitude toward architecture that work such as that of Messrs. Woollett & Lamb should prosper and increase at the expense of frankly ill-designed and unstudied building? Why should the shvster be allowed a demonstrable advantage denied to the reputable practitioner?

Allowed, did I say, and *denied*? One finds himself employing the words quite naturally and unconsciously. And yet who should allow or deny to us such personal privileges? Enter the religion of professionalism. To the orthodox, investigation concerning the revealed code of professional ethics is as impious as was inquiry into the nature of the physical universe to the religious orthodox of former days. The code of professional ethics says, Thou shalt not advertise; so we don't.

At least we don't call it by that name. We are never found refusing space and recognition in newspapers. For such service and attention most other parties (except criminals and politicians) expect to pay, and



BRET HARTE HOTEL, GRASS VALLEY, CALIFORNIA.
Woollett & Lamb, Architects.

do pay, stipulated fees. Our position is peculiar. We need and appreciate newspaper notices, but the priesthood forbids our paying our own money for them. Therefore, we argue, they should be carried for their news value. The distinction is not in the result, but in the motive and method. A paid notice is advertising, which is illegitimate; the same notice acquired without expense on our part is publicity. No sensitive mind can miss the superior distinction of the latter term.

But as to that code of professional ethics. What is professional ethics? A divine revelation reposed in the American Institute of Architects? We live (supposedly) in a rational age; we need not for that reason decry faith, but we can at least apply reason to the problem. Let us turn to

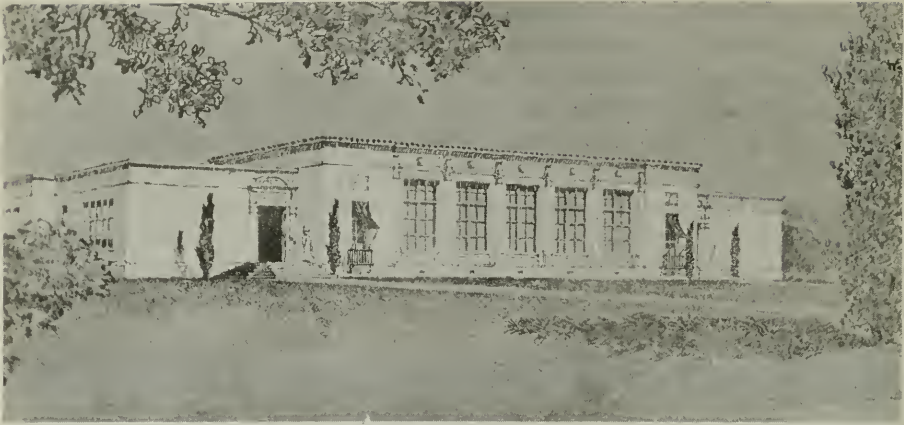

SKETCH FOR SCHOOL.
Woollett & Lamb, Architects.

the dictionary. There we learn that, considered as a general branch of human knowledge, ethics is "the science of right conduct and character; the science which treats of the nature and grounds of moral obligation and of the rules which ought to determine conduct in accordance with this obligation; the doctrine of man's duty in respect to himself and the rights of others"; and in a more specific sense it is "a particular system of principles and rules concerning moral obligations and regard for the rights of others". Moral obligation, respect for one's self, and a regard for the rights of others—these seem to be the essential factors involved. The real question, then, should be, Does advertising violate our moral obligations, our self respect, or a proper regard for the rights of others? It is difficult to find any moral obligation pertinent to the case other than the universal obligation of truth. Due respect for the same virtue, as well as

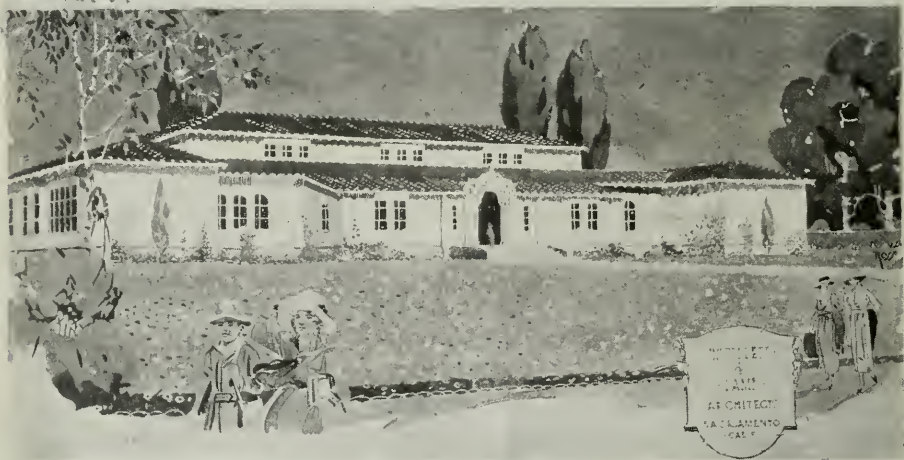

SKETCH FOR SCHOOL.
Woollett & Lamb, Architects.

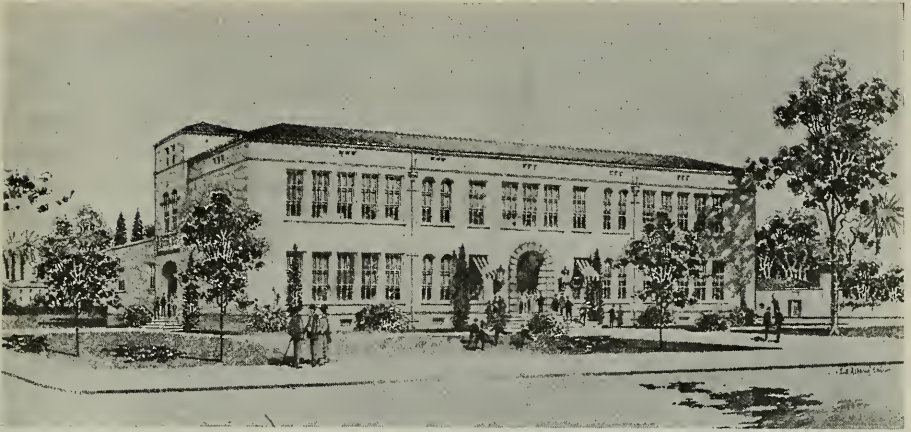

GRAMMAR SCHOOL, ORLAND, CALIFORNIA.
Woollett & Lamb, Architects.

elementary taste, would seem to safeguard any rights which others could claim in the matter. One's self respect should be amply protected by a scrupulous observance of good taste and dignity of bearing. Of course there are ways and ways of advertising. But were an architect to indulge in personalities or extravagant, misleading, or false statements, or other forms of poor taste or untruth, the problem presented would be none other than the common one of falsehood and bad taste wherever met. There is no less urgent necessity for eradicating these evils from all advertising whatsoever. Representative commercial organizations in every city are engaged in trying to do so. It matters not whether one be selling soap, automobiles, candy, or professional services—they should be fairly and squarely sold, cleanly and without misrepresentation. Why should what is honest and in good taste be unethical? Indeed, it can only



PRIMARY SCHOOL, JEFFERSON SCHOOL DISTRICT, CALIFORNIA.
Woollett & Lamb, Architects.

be so in respect to a code of ethics arbitrarily framed and imposed, instead of developed in the light of reality. Architecture is truly an art and a profession; but if it is to be other than a pastime, it must also be a business. An architect who feels that proper professional conduct is incompatible with incurring expense to increase his practice is assuredly under no obligation to advertise. But it is hardly reasonable to insist that every other architect must therefore make a like voluntary renunciation. It is conceivable that judicious advertising may further the sale of good architecture as against bad, and at a smaller expenditure of waste effort. In

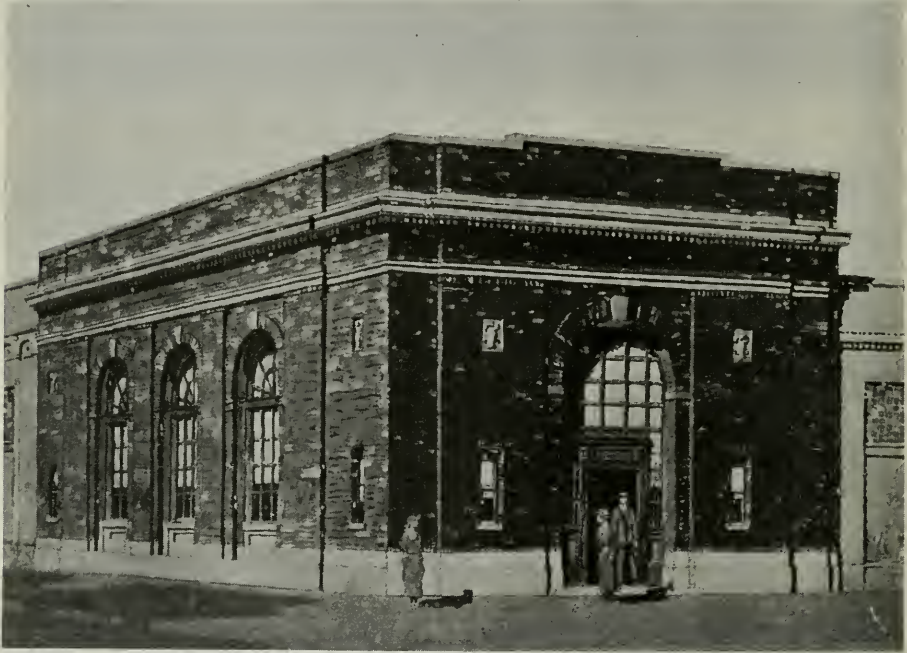

BANK AT ORLAND, CALIFORNIA.
Woollett & Lamb, Architects.

thus serving the business of architecture it should render the art and the profession at large its debtors.

Now as to that confession I alluded to near the beginning. Messrs. Woollett & Lamb are entering into no ill-considered or haphazard venture. They have carefully mapped out their plan of campaign and fortified themselves with reasons therefor. Perhaps I should modify the latter clause. It may convey the impression that they are morally on the defensive, which is an unjust implication. They are clear in their own minds as to the legitimacy of their course, and merely state the reasons which have led them into a position for which they make no apology. As a preliminary venture they acquired a booth at the recent Orland fair and lined its walls with examples of their work. The photographs reveal

this booth as sufficiently impeccable in taste to appease the most captious. Of course there are table and chairs in the center, where someone in attendance may have engaged the visitor in parley; and we have no record of what may have passed under these circumstances. But there would seem to be no reason to assume the need of a dictaphone to check the legitimacy of Messrs. Woollett & Lamb's activities. It would surely be unreasonable, given the taste they have shown in their architecture, to look for any lapse from decorum in their method of bringing it to public attention. For the future they propose the insertion of periodical paid

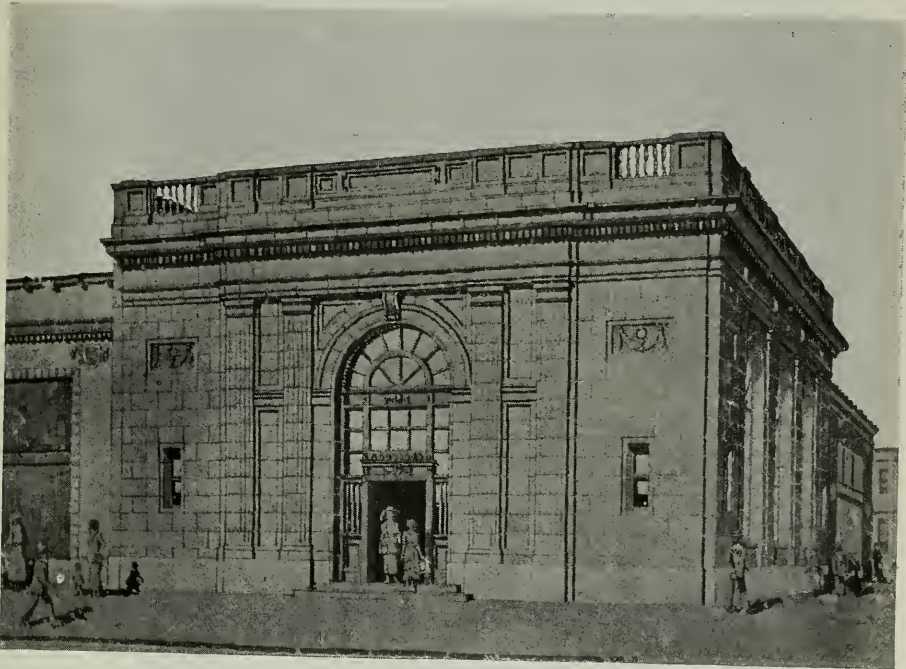

BANK AT MONTAGUE, CALIFORNIA.
Woollett & Lamb, Architects.

advertisements in a prominent Sacramento newspaper, which shall illustrate work from their office executed or under construction, set forth facts appertaining thereto of value or interest to the public, and identify their name therewith. It seems like an innocuous undertaking, devoid of any likelihood of harm. If thereby they can increase throughout the Sacramento Valley and foothill towns the volume of work such as they are doing, it can hardly fail to prove beneficial to the cause of architecture at large, as well as to the business of their own particular firm. It will be interesting to know the result of their experiment.

Of course the orthodox will be scandalized by so open a flouting of accepted authority and precedent. In fact, that is what makes them orthodox.

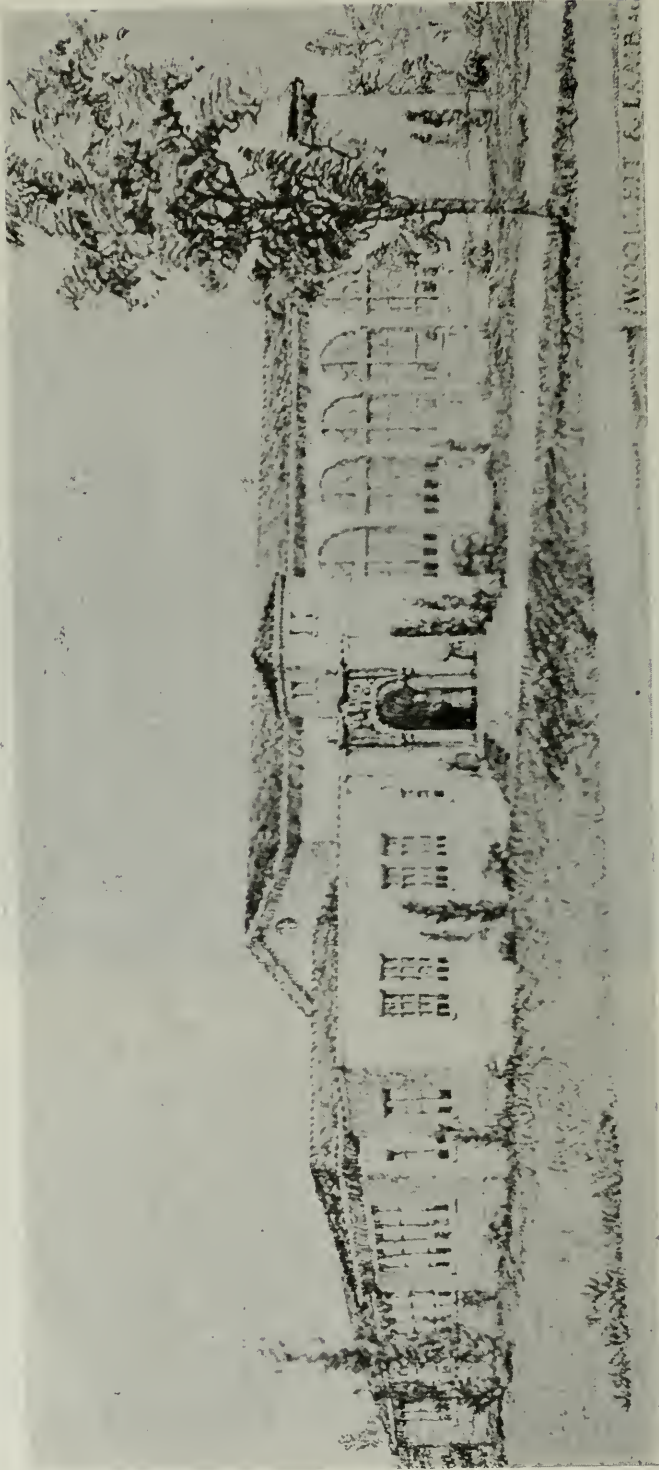

SKETCH FOR A GRAMMAR SCHOOL
WOOLLETT & LAMB, ARCHITECTS

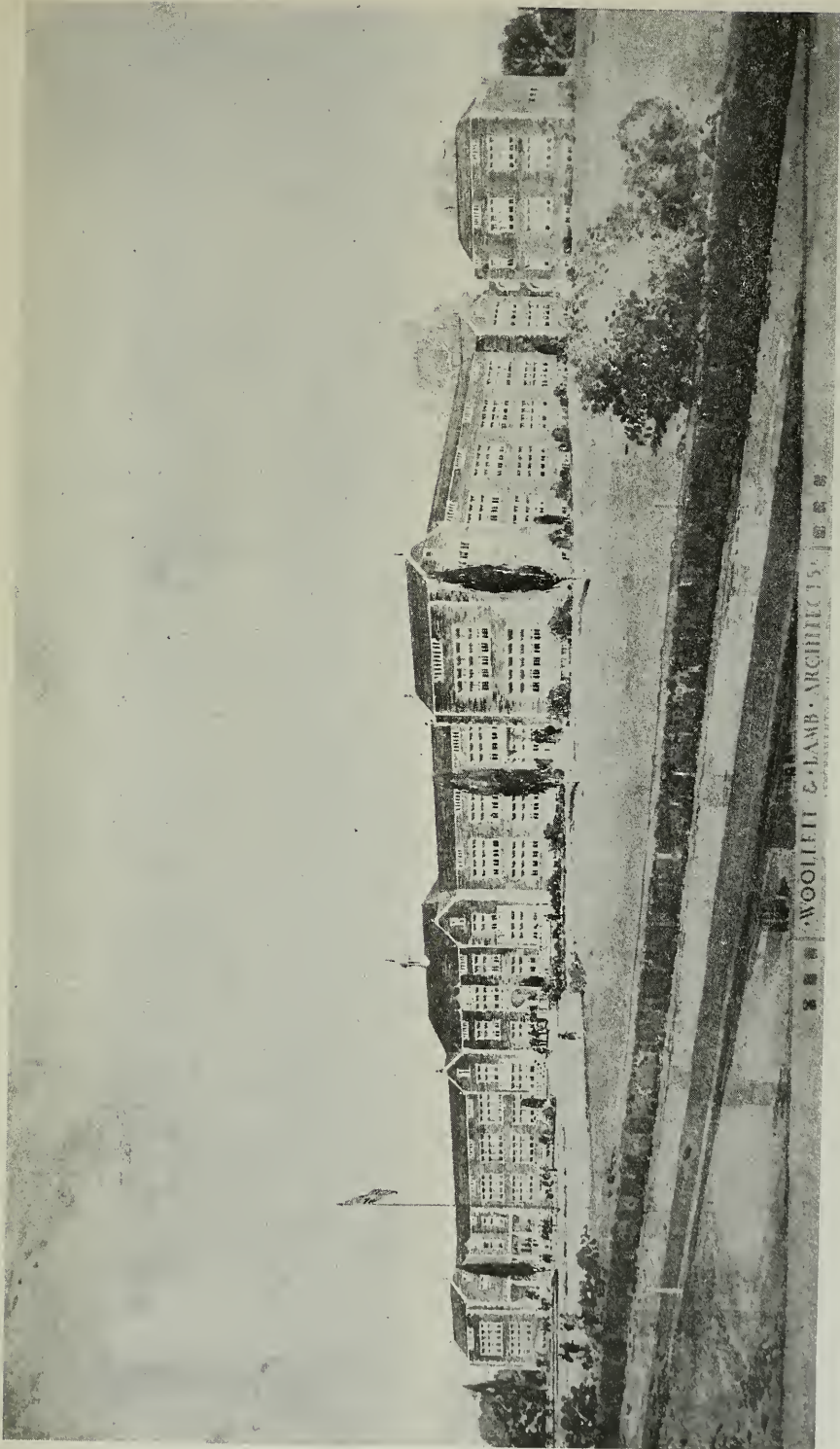

HIGH SCHOOL, CHICO, CALIFORNIA
WOOLLETT & LAMB, ARCHITECTS

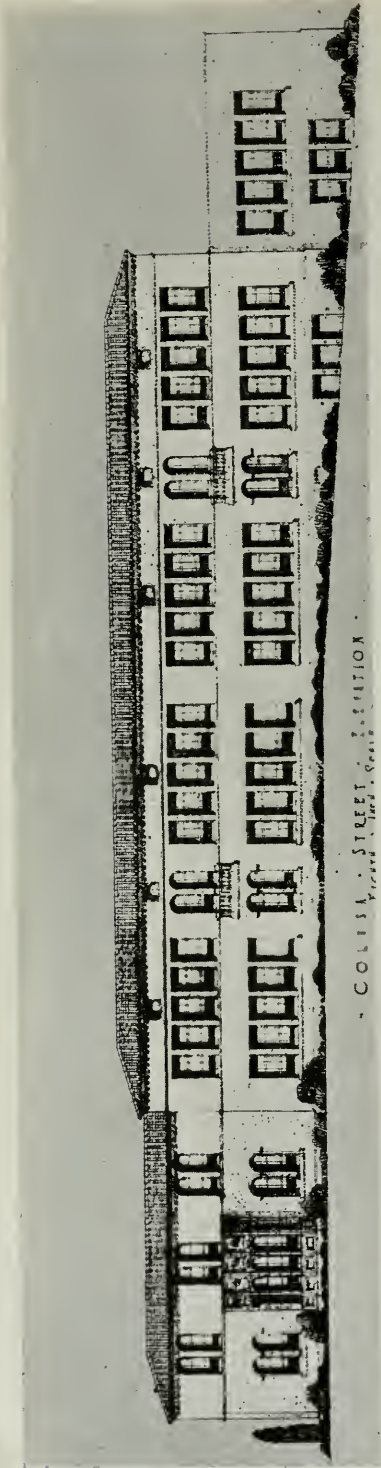

COLUSA STREET ELEVATION
Viewed from East

COLUSA STREET ELEVATION.

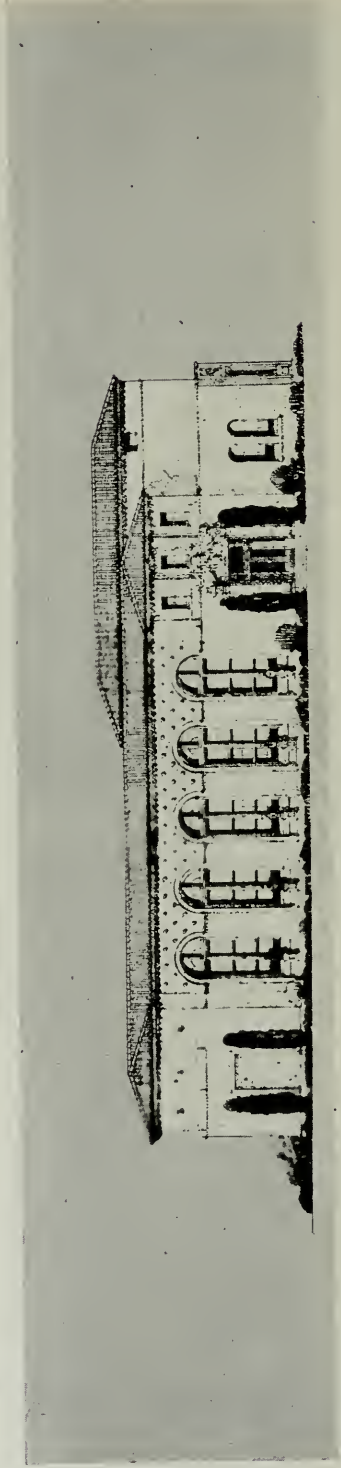

CAPITOL STREET ELEVATION.
GRAMMAR SCHOOL, VALLEJO, CALIFORNIA.
Woollett & Lamb, Architects.

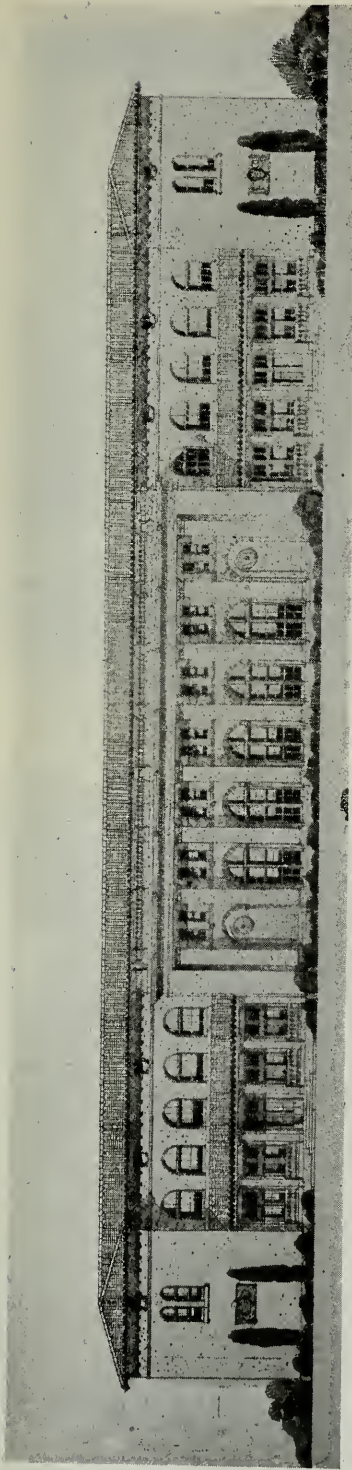

HIGH SCHOOL, GRIDLEY, CALIFORNIA.
WOOLLETT & LAMB, ARCHITECTS.

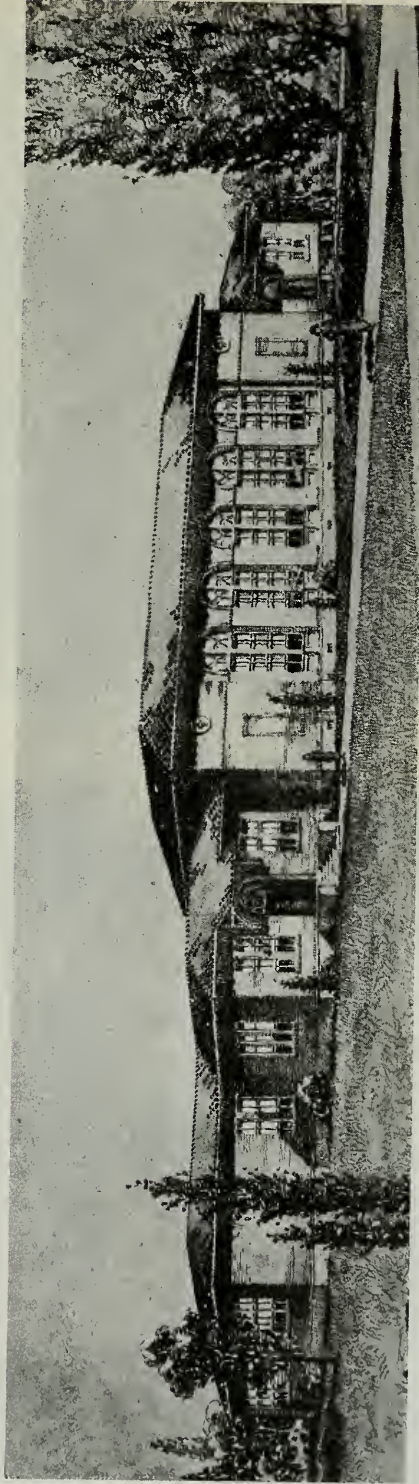

SKETCH FOR SCHOOL BUILDING
WOOLLETT & LAMB, ARCHITECTS



HOUSE FOR HOLLAND LAND CO., CLARKSBURG, CALIFORNIA
Woollett & Lamb, Architects.



WAREHOUSE, CAPITAL VAN & STORAGE CO., SACRAMENTO, CALIFORNIA
Woollett & Lamb, Architects.



BOOTH OF WOOLLETT & LAMB, ARCHITECTS, AT ORLAND FAIR.



BOOTH OF WOOLLETT & LAMB, ARCHITECTS, AT ORLAND FAIR.



BANK AND OFFICE BUILDING
SACRAMENTO, CALIFORNIA
WOOLLETT, & LAMB, Architects

Two Interesting San Francisco Houses

THE two buildings by Mr. J. F. Dunn illustrated herewith are of unusual interest, not only because they possess beauty in conjunction with very definite character, but because they serve notice that the appalling stupidity of mile upon dreary mile of San Francisco streets is due less to the admitted difficulty, even unreasonableness, of many of the conditions imposed, than to sheer incompetence and dearth of ideas. The problems are, respectively, a private house and an apartment house, both built upon



INTERIOR, APARTMENT FOR MR. NATHAN L. BELL, SAN FRANCISCO.
J. F. Dunn, Architect.

steep and narrow lots. The limitations and handicaps which commonly render such buildings offensive to eye and deadening to spirit have been frankly envisaged, and imagination and ingenuity have impressed them into the actual service of interesting and individual conceptions. A city need not be stupid, even in the face of a faulty lay-out; and a practical object lesson is more convincing than pages of argument.

The house for Mr. Robert S. Atkins is built on a lot 28 and 117 feet, raised to a great height above the sidewalk level. By placing the building to one side of the lot, the free space has been in effect treated with an existing garden on the adjoining property, and the house, although on an interior lot,

has been given the advantages of a corner exposure. This has permitted the placing of the main entrance at the center, instead of at the end of the plan, thereby allowing much more freedom in arrangement, and preserving a fine view over the Palace of Fine Arts, San Francisco Bay, and the hills of Marin County.

The apartment for Mr. Nathan L. Bell is in a way a more noteworthy achievement, as it is an alteration job. The original building, of the vintage of 1895, was typical of endless blocks of San Francisco houses, built well, but assuredly none too wisely. It was encumbered with a ten thousand dollar mortgage, and when rented scarcely paid interest and taxes. The



BUILDING BEFORE REMODELING
Apartments for Mr. Nathan L. Bell, San Francisco

altered building contains five apartments provided with first-class modern equipment; which, leased for three years, yield a yearly return of \$10,700. The architectural transformation has been no less convincing than the financial one. The street views breathe charm and distinction, untainted by the musty odor of alteration. The interesting lattice dome serves the double purpose of effectively terminating the passage from street to entrance, and of screening this passage from adjoining windows of the apartments as well as from unsightly constructions on property beyond. The interior view shows that the rooms of these old houses can really be made livable for people of taste.—I. F. M.



APARTMENTS FOR MR. NATHAN L. BELL,
SAN FRANCISCO. J. F. DUNN, ARCHITECT

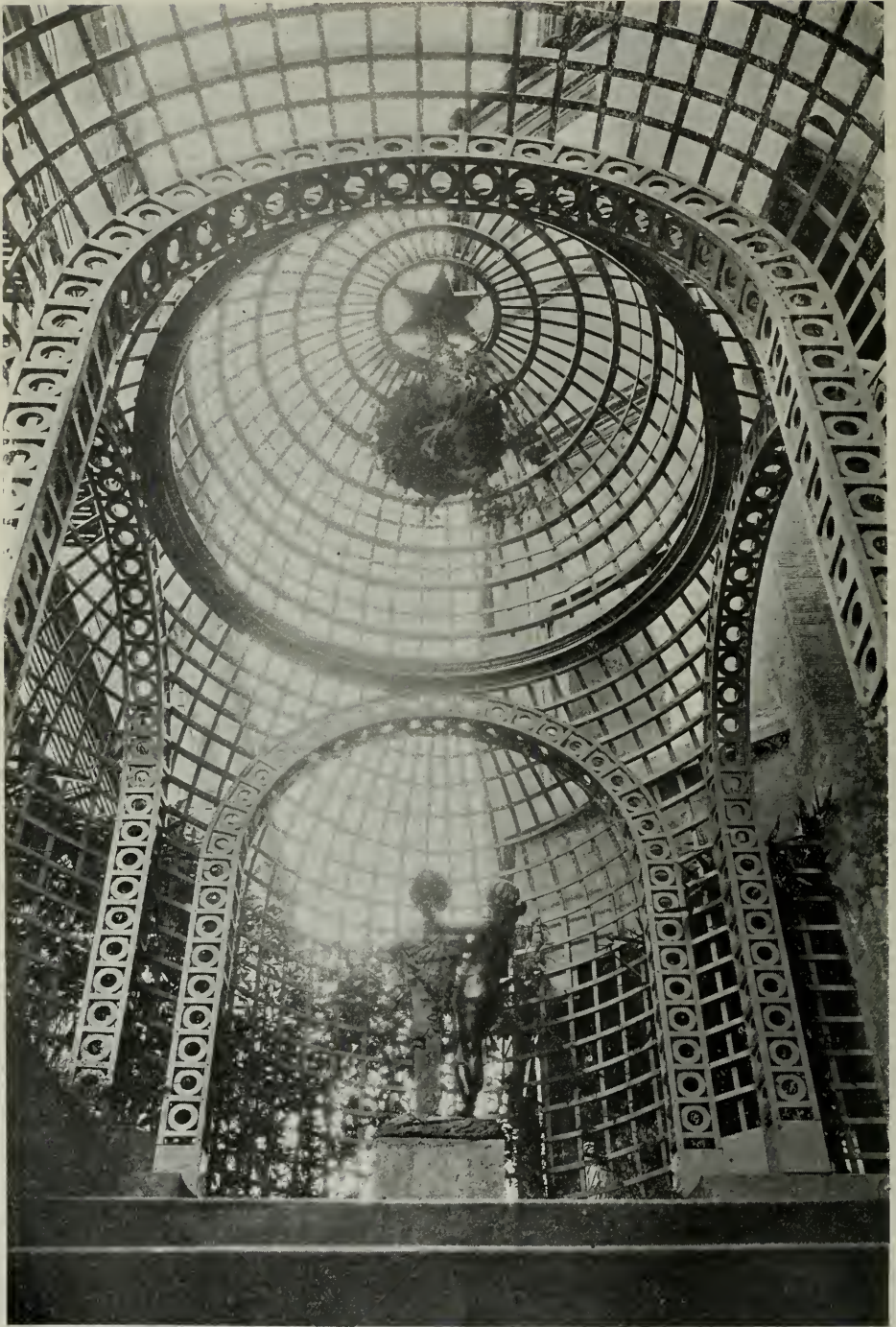

LATTICE IN ENTRANCE PASSAGE, APARTMENTS FOR MR. NATHAN L. BELL, SAN FRANCISCO. J. F. DUNN, ARCHITECT



ENTRANCE, APARTMENTS FOR MR. NATHAN L. BELL, SAN FRANCISCO. J. F. DUNN, ARCHITECT



APARTMENTS FOR MR. NATHAN L. BELL.
SAN FRANCISCO. J. F. DUNN, ARCHITECT



(See Frontispiece)

HOUSE FOR MR. ROBERT S. ATKINS, SAN FRANCISCO.
J. F. DUNN, ARCHITECT

Construction of Future Highway Pavements

By R. M. MORTON, Highway Engineer of Sacramento County

THE concrete road has gained such popularity during the last five years that now it is the general type used for highway construction in California. This popularity is due to many advantageous features. Concrete as a foundation offers a rigidity and bridging power which is not so successfully obtained in any other type of base; as a wearing surface it is hard and resistant to the abrasion of traffic; it is smooth, which makes it very acceptable to the automobilists; it offers slight resistance to traction in hot weather, which makes it a favorite among those who use the highways for heavy hauling. These qualities, coupled with the ease of installation and the low maintenance cost, render it popular with highway engineers. In brief, the concrete pavement comes nearer fulfilling all of the requirements of the theoretically perfect pavement than any other type which can be installed at the same cost.

The rise to favor of the concrete pavement in California is due to the construction work of the California Highway Commission. Near the beginning of the expenditure of the first state highway bond issue of \$18,000,000, the state adopted concrete as the standard type of pavement for main line roads. This action, with the announcement of standard width and thickness, was generally greeted with disfavor by engineers, contractors and laymen, but the Highway Commission stood by their decision. After two years' work by the state, public sentiment changed, and today the concrete pavement is the generally accepted standard.

STATE STANDARDS OF WIDTH AND THICKNESS

The success of the concrete pavement, both as a foundation and wearing surface, has been demonstrated in California, not only by the excellent work of the state, but by magnificent roads constructed by various counties under county bond issues. However, it has been pretty thoroughly demonstrated during the past five years that concrete construction must not be too narrow nor too thin. The four-inch thickness, which proved adequate for all traffic at the time this standard was adopted, is now giving signs of being inadequate for the increasing demands made upon it by the increasing number of maximum size trucks.

The necessity for regulation of truck traffic is recognized by all highway officials, and unless strict regulatory measures for loading are enforced in California, we must expect that some earlier built pavements will suffer serious damage.

Not only in thickness, but in width, is the type deficient—that is, on main traveled highways. Without doubt there are many miles of secondary roads where a width of fifteen (15) feet will accommodate the traffic with ease for many years, but on the main arteries, present conditions point to the necessity for greater widths. Our main line concrete pavements must be constructed not less than six (6) inches in thickness and not less than twenty (20) feet in width, in order to keep abreast of future traffic requirements.

EARLY CONCRETE PAVEMENTS

There are several early examples of concrete pavements in California. The first development along this line known to the writer, was a pavement known as bitucrete—several sample sections of which were laid in 1910-1911. A section was laid in San Mateo county, just north of Redwood City, on the main highway; another in Kern county, and another in San Joaquin county on the Farmington road, about four miles from the city of Stockton. This last section was laid under the direction of the writer.

This pavement was a development of the oil macadam types, which were being generally installed at that time, and consisted of a concrete base, with

rocks imbedded upon the surface, sufficiently close together to create "pockets." These "pockets" were to retain the asphaltic road oil and screenings which were applied to the surface after the concrete had cured. Briefly, the principle of the pavement was an oil macadam wearing surface on a concrete foundation. This pavement never attained any degree of popularity, although the section in San Joaquin county, about three-eighths of a mile in length, was used for about five years with very little maintenance.

Adjoining this experimental pavement in San Joaquin county, an unsurfaced concrete pavement was laid in 1910 of 1:2½:5 mixture of concrete five (5) inches thick and twelve (12) feet wide. The surface remained intact, except for the appearance of transverse cracks, for as long as it remained adequate for the track. San Joaquin county has now widened all of this experimental pavement to twenty (20) feet, and surfaced it with Warrenite.

In 1910, the highway commission of San Joaquin county prepared specifications, advertised and received bids on upwards of fifty (50) miles of concrete pavements. The figures submitted were so much in excess of the average amount provided in the San Joaquin bond issue of 1909 for highway construction, that it was deemed advisable to reject the bids and build less costly pavements of the oil macadam type.

STRENGTH OF CALIFORNIA CONCRETE PAVEMENTS

With the co-operation of the California Highway Commission in the furnishing of a calyx core drilling outfit and permitting the use of the laboratory at Sacramento, the Sacramento County Highway Commission has undertaken the obtaining and testing of sample cores of concrete cut from all of the pavements installed to date in Sacramento county. The age of the samples varies from three months to three and one-half years, and when the full set of tests is completed, it should furnish interesting and valuable data for the guidance of highway engineers. Practically all of the concrete pavements in this county have been mixed in the proportions of 1:2½:5, and with few exceptions the materials used are California cements, Yuba river sands, and coarse aggregate from the crushing of the dredger mining deposits east of Sacramento.

Breaks on fifty-six (56) samples obtained from about forty-one (41) miles of highway are available at the present time. Eight (8) samples could not be broken at a stress of 50,000 pounds—the capacity of the compression machine. To obtain average results, however, it has been assumed that these samples would break at 55,000 pounds.

Engineers exercise the greatest care in the selection of the aggregates and in the inspection of the field work of laying concrete pavements, but tests made on actual samples cut from the pavements themselves are eloquent in their testimony as to how well the engineer's work has been done:

Road No.	Length in Miles	No. Samples	Age in Days		Low Break lbs.	High Break lbs.	Aver Comp lbs.	Remarks
			Min.	Max.				
1	6.08	9	210	485	2044	3459	2653	2 samples not broken.
6	1.75	2	545	575	2610	2655	2633	
7	3.66	4	490	550	2579	3459	2949	1 sample not broken.
8	3.33	4	575	605	2988	3459	3161	1 sample not broken.
9	4.56	5	550	600	1635	3459	2997	2 samples not broken.
11	6.40	7	455	575	2220	3459	2816	2 samples not broken.
**14 (Grand Island)	13.50	21	45	275	1698	2956	2244	{ High break 275 days old. { Low break 50 days old.
14 (Randall Island)	1.67 40.95	4 56	575	600	2296	2925	2603	

**Rock from San Francisco Bay; sand from Sacramento River.

A close study of the individual breaks entering into the above table shows that there is a great increase of strength in the period from thirty (30) to three hundred (300) days of age.

The sample showing the low strength on Highway No. 9 had an uncured appearance in the lower half of the sample—the indications were that the concrete had been placed on a dusty and unwatered subgrade.

Measurements of the samples, which were $4\frac{1}{2}$ inches in diameter, show that generally the pavement is slightly thicker than required by the specifications, and rarely is a sample found which shows a deviation of more than one-eighth ($\frac{1}{8}$) inch below the required thickness of pavement.

It would seem desirable to the writer that an elaborate study of the strength of pavements already installed in the state should be made by means of obtaining core samples, and a tabulation made of the materials and other conditions surrounding their construction. It would be highly desirable and entirely feasible in the future to proportion the ingredients of the concrete with reference to the materials to be used on each job, so as to give a certain definite strength.

SUB-GRADES, DRAINAGE AND SURFACING

A study of the concrete pavements at present installed in the state shows that a large percentage of the failures are due to inadequate foundations. In localities where heavy soil is encountered, especially red or black adobe, the concrete pavement constitutes a somewhat better base than broken stone, but such a soil will finally disintegrate even a concrete slab. Even on soils generally classed with those furnishing good foundation, sufficient attention has not been paid to the proper construction of the sub-grade by thorough settling and compacting with water. In order to insure permanence of the construction, the foundation on heavy soils should be especially prepared by preliminary layers of gravel, crushed rock or sand, and steel reinforcement should be employed in the concrete.

Usually adobe sub-grade is encountered on flat country where drainage conditions are difficult, but road builders must learn that standing water along a road is the worst enemy of the foundation, and provisions must be made, in spite of expense, to get the water away from the road.

At the present time, in view of the rapidity with which horse drawn traffic and steel tires are being withdrawn from the highways, it seems to the writer that the protection of the concrete with a wearing surface is unnecessary. As evidence that rubber tires do not damage the concrete, there are many unsurfaced concrete highways on which the original trowel marks can still be seen after several years of traffic. It is not too late to apply a surfacing after signs of abrasions are observed, and any project of highway construction in California need not necessarily include surfacing for the concrete. The most economic results will be attained if the cost of the surfacing is expended for heavier foundations, and wider and thicker concrete.

* * *

Lumber for Sewing Machines

About sixty million feet of lumber are used annually in the manufacture of sewing machines. Oak and red gum each supply nearly one-third of this lumber, and yellow poplar and black walnut each a little more than one-eighth, the balance being made up of tupelo, chestnut, cottonwood, maple, basswood, birch, sycamore, mahogany, yellow pine and redwood. Tops of sewing machines are usually made of hardwood veneers such as oak or walnut, or of other woods stained to imitate mahogany. The sewing machine industry is centered largely in Indiana and Illinois.

Public Opinion and City Planning Progress

By JOHN NOLEN, City Planner

TO stimulate interest and make clear the need of city planning is an important part of the task of establishing new ideals and new standards. It is a publicity job, this work of making intelligible to the public generally what city planning really means. We must aim to get all who are interested in their community to see the planning of the city in its simple, practicable and financially advantageous outlines.

The making of public opinion for city planning is like making public opinion for pretty much anything else. It is done through the newspapers, by public exhibitions of plans, by moving pictures, if they can be made available, by the printing of reports, pamphlets and popular leaflets, by public meetings, illustrated lectures, the use of the stereomotorgraph and attractoscope, and free and wide discussion. One important thing to discuss is the financial results of city plans—that in a big sense, city planning pays. That might be the first appeal. The second appeal is almost opposite. It is the appeal to sentiment, to idealism, to loyalty to one's own community. It is surprising how quickly business organizations, such as Chambers of Commerce and Boards of Trade, respond on the ground that city planning promotes the city's welfare. The third appeal is to the imagination. It is the need of actual plans. It is necessary to visualize as graphically and attractively as possible various proposals for improvement, especially as related in comprehensive schemes. The final appeal is that of an object lesson, something actually done, even though it is but a small part of the general plan. This involves the execution of a park, a playground, a garden suburb, a viaduct, a better type of bridge, a union station, a civic center—some feature, but with reference to the whole plan. Such an object lesson will often convince the most skeptical, even those whom the other appeals do not reach.

It is sometimes said that city planning schemes are not carried out. To some extent this statement is true. The execution of comprehensive city plans requires time—often a generation; also money—large sums; also authority—sometimes a change in the state laws or even a change in the state constitution; also the formation of favorable public opinion. Horace Bushnell, in his agitation for the first city public park in the United States, said, "Many things must be carefully prepared, as carefully watched, and persistently pushed, by the man who will get any city public into and through a great public improvement. Wearied, and worried, and hindered, he must never sleep, never be beaten, never desist, and if, by a whole five years of toil, he get his work on far enough to become an interest in itself, and take care of itself, he does well, and there may rest."

The answers received from a questionnaire sent out recently to more than a score of cities, uniformly emphasizes the same conclusions with regard to the success or failure of city planning proposals. Careful examination of the responses shows that the degree of success is dependent on a regard for and adherence to certain principles. The solution of the whole problem seems to lie in diplomatic, carefully planned, and if need be, a long extended campaign of education aimed to reach not only the well informed and prominent elements of the community, but also the laboring classes and the public at large. In other words, the success of the commissions, from replies which were received, may be graded by the progress of such campaigns of education in their towns and cities.

To one who is familiar with the natural and formidable obstacles to the execution of comprehensive city planning projects and the progress that has been made already, the astonishing thing is that so much has been done, especially in the smaller places. In some cases, as for example, Glen Ridge, N. J., and Walpole, Mass., virtually all the proposals have been carried out, or are definitely authorized for execution. In other cases, even though the city plan commissions were not able at the time to get the approval of their recommendations, the plans have been partially executed by the city council or other public authority. The words of Daniel H. Burnham have often proved true: "A logical diagram, once recorded, will never die, but long after we are gone will be a living thing, asserting itself with ever growing insistency." Furthermore, the city planning movement, it should be recalled, is still in its initial stages. Its merits are not yet clearly understood by the general public, and very little money is available for the making of careful plans, based upon reliable surveys, and the publicity necessary "to sell" those plans to the people for whom they were prepared.

With the possible exception of Chicago, no town or city in the United States has yet taken city planning seriously. Chicago's methods have been more logical, more persistent, and more systematic than those of any other city. The whole story is convincingly presented in Walter D. Moody's recently issued book, entitled "What of the City?" by A. C. McClurg & Company, with the subtitle, "America's Greatest Issue—City Planning, What It Is, and How to Go About It to Achieve Success." Some of the main facts to record in the program to "put across" Chicago's City Plan are the following:—

1. The printing of the report on "The Plan of Chicago" at a cost of \$85,000. This was in the form of a beautiful octavo volume, the very finest example of printers' craftsmanship. It contained 164 pages, and 134 drawings, charts and pictures, including 15 full page, six-color drawings painted by the famous artist, Jules Guerin.

2. The publication of a booklet entitled "Chicago's Greatest Issue—An Official Plan." The basis of this publication was the de luxe Chicago Plan book, issued by the Commercial Club. Many of the drawings of the parent book were adapted to the smaller one. Its 93 pages, carrying the 328 names of the members of the Commission, representing every walk of life in the city, told the story of the Plan of Chicago to all the people in simple, easily comprehended, everyday language. 165,000 copies were issued and distributed at a cost of \$18,000. These were delivered to every property owner of the city, and to persons paying a rental of \$25 per month and over. "Chicago's Greatest Issue" was sent, on request, all over the civilized world.

3. A notable pamphlet was printed and issued, entitled "Fifty Million Dollars for Nothing." It showed the people of Chicago how they could obtain 1,300 acres of lake front parks, playgrounds and watercourses by utilizing the waste material of the city. It pointed out that by so doing, the city could secure in twelve years park lands ready for development, and worth fifty million dollars, at no cost whatever to the taxpayers.

4. There were many other special pamphlets and reports, but to cap all, the Commission issued a publication entitled "Chicago's World-wide Influence in City Planning." It was an effort to "keep the home fires burning" with community confidence and devotion to its own plan as it was regarded by the rest of the world. This was a compilation of comments and requests for Chicago Plan literature from hundreds of experts,

civic workers, municipal authorities, libraries, schools and public-spirited citizens, received by the Commission from all over the world.

5. Following the signing of the armistice in the great war, and the announcement of the reconstruction platform of the Chicago Plan Commission, to which the Chicago newspapers devoted twelve columns, an appeal was made to the clergy of the city to preach from their pulpits upon the humanitarian benefits of the Plan of Chicago. The Commission's "Seed Thoughts for Sermons" pointed out the close harmony between the social work in the churches and the benefits in the plan. This document, together with a resolution, and the reconstruction platform, was sent to every clergyman in Chicago.

6. As a direct result of the admonition, "Establish the Plan of Chicago with the people," a school text book was printed, entitled "Wacker's Manual of the Plan of Chicago." This came as an inspiration. The Plan of Chicago text book was adopted by the Chicago Board of Education in 1912. The first issue was 15,000 copies. It was used as a part of the curriculum of the eighth grade courses. The school authorities followed the wish of the Plan Executive, whose conviction it was that a larger number of students could thus be reached. It was believed, too, that there was value in an appeal to the children at their most impressionable age. More than 50,000 copies of Wacker's Manual have been published for the current needs of the school.

7. After the school book came the Lecture Bureau. A popular lecture, showing more than 200 pictures of twenty-four countries of the world, was most carefully prepared, and critics say it compares favorably with the popular lectures of the day delivered by professional speakers. The Board of Education placed the assembly halls of the schools at the disposal of the Plan officials without price. How to attract the people to the Plan of Chicago lectures was the task. The difficulties, however, were finally overcome. As many as 150,000 circular announcements of the lectures were mailed to citizens in a single season. Nearly a hundred school lectures were delivered in one year. The schools were selected in order, and to equitably cover the city. This method was continued from year to year, and during the first seven years of the Commission, nearly four hundred lectures were delivered. 175,000 people have been directly reached with the Plan message; that is, one in every fourteen residents of Chicago.

8. One of the chief aids to the effective publicity for the Plan of Chicago was a motion picture campaign. This consisted of a two-reel feature entitled "A Tale of One City." It contrasted the Plan proposals with existing conditions, and was interspersed with scenes of human interest and attraction about Chicago. The reels were shown in more than sixty Chicago theatres to an estimated audience of more than 150,000 people. The opening was at the Majestic Theatre to an audience which packed the house to capacity, and was as representative as a Grand Opera occasion.

9. The most valuable medium of all for publicity for the Plan of Chicago has been the newspapers. Publishers, editors, reporters, feature writers and cartoonists have cooperated intelligently, heartily and generously to carry to the people of the city the great ideas and the far-reaching benefits contained in Chicago's Plan. One of the papers prints daily at the top of its editorial column its platform, which contains a persistent endorsement of the Chicago Plan, and an appeal for its support. As Wendell Philipps has well said: "The newspaper is parent, school, college, pulpit, theatre, example, counselor, all in one. Every drop of our blood is colored by it. Let me make the newspapers and I care not who makes the religion and the laws."

This is not by any means the whole story of Chicago's publicity, but here are given the nine main points. Chicago's publicity campaign on its great Plan has been big, far-reaching, inspiring and effective. Behind the conception of a city plan is recognized the necessity to stir the hearts of men, and to inspire in their minds that desire for better city conditions which are the fruits of well-executed city planning. Finally, it shows how it is necessary to awaken the people to the need of city planning, and how they can be moved to action.

One question remains. Assuming that a publicity campaign is an indispensable feature of a city planning program, how can that campaign be best organized and carried out? Should the work be inaugurated and directed by the city planner, by the city government, by the city plan commission, or by some other body? The city planner is not a professional publicity man, and he is often—in fact, usually—not a citizen of the city for which the plan is prepared. It would seem that his contribution would necessarily be limited to the preparation, in as popular a form as possible, of his plans and reports, together with, perhaps, a personal presentation of those plans and reports to a public audience. After that, his active participation in a local educational campaign would be of doubtful expediency.

The city authorities, especially the city plan commission, should be relied upon wherever there is a well organized city planning agency, to outline, direct and execute the educational campaign that must accompany any large city planning program. In no other way can the presentation be wide enough nor the discussion authoritative and far-reaching. The city planning authorities, however, cannot hope to be thoroughly effective unless they can secure the active coöperation of the voluntary social, civic and other groups of citizens. The whole public can be effectively reached only by the assistance of Chambers of Commerce, women's clubs, labor unions, Y. M. C. A., churches and other organizations to which the people of the city are accustomed in their daily life to look for information and guidance.

* * *

Engineer Defends Architects

IN a communication replying to a recent editorial in the Engineering News-Record on "What Is Art?" Mr. N. H. Holmes, an engineer of Boston, Mass., says:

It does the engineer no good to sneer at "art" or architects, because of isolated examples of bad design. The public is coming more and more to understand that rarely does the engineer put into his design the grace and beauty that the well trained architect can give. Hence the ever growing demand that architects, landscape gardeners, sculptors, etc., be consulted on great public works.

Up to about twenty years ago, engineers or "practical builders" designed nearly all the factories and industrial plants. For that time they were very good buildings, indeed, and served their purposes most satisfactorily but nothing has ever equalled them as a class in sheer depressing and dreary ugliness. Today, architects almost always design these buildings, very often as subordinates to engineers. In spite of occasional examples of poor taste, these buildings are generally at least pleasing, and are often beautiful.

This difference from the old type of factory was not attained by the more common use of terra cotta, steel sash, etc. It lies in the general proportions of major and subordinate masses, the groupings of openings, the correct location of good ornamental design and a studied color scheme; all things of which the great majority of engineers have a very vague understanding.

The writer believes there is glory enough for all in large work, and that the engineer can no more enter the field of the architect than an architect can do engineering.

Applying the Co-operative Method of Financing to Inexpensive Types of Apartment Buildings

AS interest in the idea of co-operative apartment house financing is becoming national in its aspect, it is but natural that this interest should take definite form in a consideration of the possibilities of applying the co-operative idea to the financing of moderate cost apartment houses. The great wave of co-operative financing of apartment houses and office buildings which has found its center in New York has, to a certain extent, been developed in high cost buildings; but in view of the number of inquiries in regard to this question, it will undoubtedly interest architects and speculative builders to know that there is no reason why the co-operative method of financing should not be applied to less expensive types of buildings. In fact a number of such buildings have been recently developed in and near New York, and while sufficient time has not yet elapsed to determine the ultimate success of the proposition this method has been successful to the point of making it possible to design a number of buildings.

The basic elements of co-operative building ownership do not preclude the application of this principle to moderate cost buildings, except in the limitation of promoters' fees. In fact it might be said that as the inducement to the promoter is greater in developing high cost buildings it is but natural that real estate activity of this kind should be directed chiefly toward the promotion of the more expensive types of apartment dwellings. Possibly this is why the co-operative plan has been applied, in most instances, to costly developments.

On the other hand, there is a great need of studied application of the co-operative principle in the development of apartment units costing in gross figures not over \$8,000 per family. In order to give some idea how a comparatively inexpensive co-operative project can be developed it may be interesting to know of a simple development of this nature which is now being successfully carried out, in so far as the financing is concerned, and which promises to be successful from the tenants' side.

For the development of the operation in question it was first determined that in a rapidly growing industrial city there were a number of families who would be interested in buying an apartment on the co-operative plan provided the cash payment were not too high. It was further learned that as far as a building loan was concerned co-operation might be expected either from a financing corporation, definitely developed to aid in meeting the housing shortage, or from an insurance company which had set aside a certain amount of money to assist in solving the housing problem.

The first step was to work out sketch plans and to outline specifications for an apartment building simple in design and equipped and planned to include every possible economy, but at the same time providing comfortable dwelling quarters for a class of people represented by the employes of local factories. Having determined that the element of financing and demand could be definitely counted upon, the advancing of the necessary equity to carry out this project was undertaken by a group of business men representing employers of labor, and others interested in meeting the local housing shortage.

The general figures on this project were worked out somewhat in this manner:

1—That a building should be constructed providing ten apartments averaging six rooms each at a cost of \$6,500 per family, consequently making the total cost of the building \$65,000. The building in question is a four-story, walk-up apartment having simple modern conveniences.

2—That suitable land for the location of this building should be obtained for \$5,000.

3—That a mortgage loan, bearing an amortization clause as later described, could be obtained, amounting to 60 per cent of the cost of land and building or 60 per cent of \$70,000, being a building and first mortgage loan of \$42,000, 20 per cent of which was to be paid off over a period of five years. This meant in simple figures that, adding a profit of \$500 per family for those who financed the equity in this building, each apartment might be put on the market for purchase at \$7,500 made up as:

Pro rata cost of building.....	\$6,500
Pro rata cost of land.....	500
Pro rata allowance for profit.....	500
	\$7,500

Of this amount the advancement of \$4,200 as part of the building loan was assured, leaving an actual cost balance of the difference between \$7,000 and \$4,200, or \$2,800 per family, this being the amount of equity advanced by the promoting group.

Having completed the details of the operation thus far a stock company was formed representing the equity in the sales price of the building,—the sales price as given being \$75,000; the first mortgage being \$42,000, and the original owners having agreed to allow a second mortgage of \$15,000 to be paid off on an amortization plan by those who purchased stock carrying occupancy privilege in the building.

From the viewpoint of the buyer, therefore, an apartment in this building could be purchased for the gross price of \$7,500 of which \$4,200 represented a pro rata share in the first mortgage, and \$1,500 represented a pro rata share in the second mortgage, which is to be paid off in five years. Taking this total of \$5,700 it is found that the purchaser of an apartment must pay \$1,800 in cash for which he receives one-tenth of the stock of the corporation carrying with it the perpetual leasehold privileges for one apartment. Having paid \$1,800 the tenant has assumed these liabilities which might be termed owner's annual rental:

Interest on first mortgage of \$4,200 at 6%.....	\$252
Interest on second mortgage of \$1,500 at 6%.....	90
Amortization of 20% of first mortgage over 5 years, or 20% of \$840	168
Amortization of second mortgage over 5 years.....	300
Pro rata cost of maintenance and service charges.....	300
	\$1,110

In this total of \$1,110 the items of \$168 and \$300 representing amortization payments cannot be figured as actual rental, but are actually installments on the purchase of the apartment and consequently represent savings. Therefore the actual rental of the apartments approximates \$642 or about \$54 a month, which is actually decreased by the cessation of interest on the amortization payments until, at the end of five years, the owner of one-tenth of the stock representing the tenancy of one apartment actually pays as a rental charge:

Interest on reduced first mortgage, \$3,360 at 6%.....	\$201.60
Second mortgage has been paid off	
Cost of maintenance and service charges.....	300.00
Owner's rental, after fifth year.....	\$501.60

or approximately \$40 per month, to which must be added any repairs which the owner may wish to make to his own apartment, as the owner always assumes interior repairs and decoration in the co-operative plan.

No item is included, of course, on money invested as this interest is returned in the form of reduced rental cost.

In the purchasing of apartments as here outlined the purchaser's viewpoint is that by paying an annual amount, not exceeding normal rental in the locality, he is obtaining the use of an apartment and at the same time buying his share in the building in the same manner that furniture might be purchased on the installment plan.

From the viewpoint of the developers of this project, each is receiving interest on his money and a profit of \$500 on a \$2,800 five-year interest bearing investment, at the same time helping in the relief of the housing situation.

In later issues we expect to give detailed examples of actual operations where the co-operative idea has been applied to the development of inexpensive types of apartment houses. It is plainly evident that the co-operative apartment of comparatively inexpensive type can be developed for the family which can afford a moderate cash payment, and a low but definite investment each year over a period of years until amortization or indebtedness has been cleared off.

Another method of developing an operation of this type is, of course, getting together a group of future tenants who will do the necessary financing, thus eliminating the middleman who first provides the equity. This requires a larger amount of capital per family for immediate investment, unless it is possible to borrow second mortgage money, paying relatively high fees which may be distributed over the first few years as owner's rental.

In general, however, the successful co-operative developments carried out thus far have included a promoting entity of some sort, which for the sake of profit has either carried out the operation and then sold stock, or has been the actuating force to bring together a group of prospective tenants, receiving a promoter's fee which has been made chargeable to building costs.—The Architectural Forum.



Fireplace in a Southern California Home.

A Sermonette

By F. W. FITZPATRICK

NEAR my home they started months ago building a rather pretentious house, a stucco on wood affair. I noticed that work lagged, then ceased altogether several weeks ago. Not being overly curious I paid no further attention to it, supposing money had run out or that there was some other good reason for the stoppage.

Then one day, coming into town, I noticed renewed activity and that there was a lot of a certain much-advertised metal lath being delivered. Then I was curious and asked the contractor what the delay had been. Why, of course, the metal lath had just arrived. The architect would have no other, and they wanted to do the plastering and stucco work at the same time, hence the absolute stoppage of building for six weeks of the best building weather.

This suggested to me a text for a sermonette to my brethren, the architects.

We hear much lament about the architects not receiving the consideration that is their due: the usurping of their power, prestige, authority, popularity and what not by the engineers; the awarding of building contracts direct to big construction companies with an architect as an adjunct rather than a monarch of all he surveys, as of old. This lament was especially loud and insistent during the war. To put it plainly, the Government gave all the plums to the engineers and flatly ignored the architects.

Well, is not the reason fully illustrated in this little episode of the delayed house?

Our profession is one in which art and business should be most intimately linked and few of us ever dream of the linking. We are hide-bound in our ideas, non-progressive, ultra-conservative and absolutely non-adaptable to varying circumstances. And of all times when we needed and need versatility and adaptability it was during the War and is Now.

Our friend of the house made his plans, wrote his specifications and awarded his contracts in the old and easy and eminently respectable way. He specified what he knew or had been told was good and let it go at that. Did he find out if this or that material was immediately available and at what price? Not he. There was his specification and it was up to the contractor to get what was specified. What wotted he?

Curiosity being well aroused I've been inquiring among friends, architects, engineers, contractors, here and in many of the other cities about this matter of delay and of high cost and have come to the conclusion that the architects are blameable for a very considerable share of both evils. Their cursed non-adaptability.

Why didn't that chap of the delayed house use some other metal lath? A live fellow would have put on three or four layers of chicken wire rather than waste the summer waiting for that particular order of stuff.

The average architect sits serenely in his office and writes specifications and never flickers an eye as to whether he can get this, that or the other thing. And was there ever a time when more things were off the market?

Perhaps because I'm more engineer than architect, but I can't write a specification in the solitude of my study. I have to go down into the marts of trade and see what is obtainable and at once and then I buy it and build with the stuff and forget all about the iron-clad specification of yore. Result: in a pretty busy time of it I've not been delayed a day for material.

I may like such or such texture brick for such or such a building, but if it's not easy to get—not promises but real brick that I can see—then we'll use something else. Why fuss about it or why pay exorbitant prices for special stuff when ordinary things are high enough?

We're doing some building in a lower lake city. Awhile ago there was a railroad embargo on freight. All the fellows sat around with their tongues out, they couldn't get cement through and not a bit of it in town, all their work tied up, and that city was building right merrily. We chartered a boat and shipped a boat load of cement from another lake city, kept our building going and indeed sold some cement to the local supply company that had a contract to furnish us with it! Why couldn't the other fellows do the same? First and foremost they didn't think of it and secondly, in many instances, the cement specified was not gettable where we got ours. Blamed old inelastic specifications.

The architects do not seem to have wakened up to the fact that these be new times, a new era, conditions we've not been up against before. They would love to do things the old way, but somehow or another conditions and times refuse to be molded into pre-cast architectural forms to suit our conveniences. The writing on our wall is "Switch over, wake up, realize these are new times, or go into the discard!"

Cost of construction has jumped up amazingly, even in the past few months, freight rates up, wages boosted a couple of times, men doing less work for more pay and all that, besides all of which money is not the same value it was sometime back, the country is full of it and not full of the things it used to buy so, presto, its purchasing value has diminished muchly—as all fellows who had any savings or old money know only too well.

But nevertheless and notwithstanding there hasn't been the jump in building many of us think. Or to put it another way, one can build today, using the things of today, as artistically and well as of yore and at not as great a difference in cost as most of us imagine.

For instance, here's a bank building planned and estimated some months ago at \$860,000, then held up until lately when bids came in at \$1,158,000. That's a specific case where plans and all facts came to my attention. In a general way I know of scores of similar instances.

Well, now then, my contention is that in the first place the building more than probably couldn't have been built for \$860,000 when plans *were* made. We're all most hopeful estimators. Secondly, contractors are figuring abominably high right now for no one knows what may happen tomorrow or next week. Indeed, a man is a fool to enter into a contract except on a most princely margin for contingencies. Most of the big work is being done on cost-plus basis anyway, for that very reason. And thirdly, I'll aver that as handsome and thorough a bank as planned can be built for very considerably less than \$1,158,000 today. The style of the work, the materials specified, bronzes and fine marbles, are all of yesterday. To get them today is in some cases impossible and in others simply spells delay and costing more than they are really worth.

* * *

The Decorative Value of Screens

THE possibilities of decorative value in screens are practically unlimited. In tone and living hue they may be of sufficient brilliance to give the necessary note of color or dash of sharp contrast to a whole room that might otherwise be dull and uninteresting. As to material, they may be made of almost anything that has any quality, decorative or severely practical, to commend it.

The whole idea underlying the use of screens is that they should serve some practical purpose, or be frankly decorative in aim. Occasionally they fulfill both functions, and when they can be made to do this, so much the better. Of course it ought to go without saying that, even where the reason for using a screen is purely practical, one should not fail to make it decorative also.

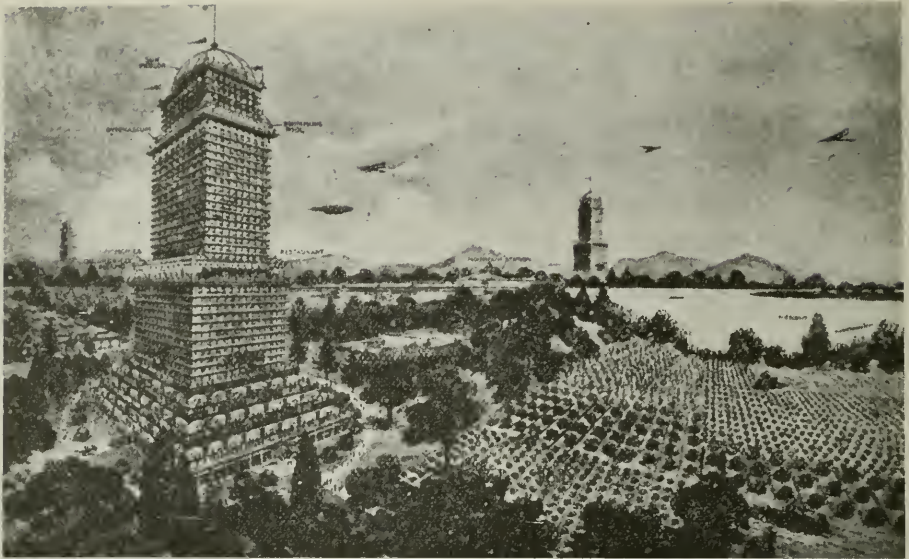

AEROPLANE VIEW OF APARTMENT HOUSE OF THE FUTURE.
Designed to Accommodate 2,000 Families.

An Apartment House Built Like A City

Just as we smiled as we read the weird tale of Jules Verne's "Twenty Thousand Leagues Under the Sea," so we smile and question its plausibility when we read in Science and Invention the imaginative story of an apartment house of the future that is to constitute the home of 2,000 families—a "self-contained" house that is a veritable city in itself with every conceivable accommodation for its tenants. The author offers his "dream" as a possible relief to our future housing congestion, and who knows but that some day it will become a reality?

By H. GERNSBACK

THE housing problem which confronts the majority of people at this time, is not only a condition that prevails in the United States, but is universal all over the globe. No new construction to speak of has taken place while the population has increased anywhere from 10 to 20 per cent.

The average human being prefers the suburbs to the city. He lives in the city because he has to for business and economic reasons, as well as for the sake of convenience. The man who lives in the suburbs gets fresh air, and fresh produce, while his children have ample room to play; moreover, he has more room than his city brother. Against this it is charged that he has no convenience to speak of. He has to attend to his furnace, he has trouble in getting his coal, and he cannot buy all the things he requires in the little suburb or country place in which he resides. This makes for expensive transportation of small quantities of goods or other necessities. Moreover, in the average country town, there are few amusement places where a man may take his family. In the larger villages, to be sure, we have moving picture houses and the like, but in this case the village approaches again to the city size with all its congestion, higher rents, etc.

Why not move the city bodily into the country, taking all of the city conveniences with you, yet having all of the country conveniences, but neither the inconveniences of the city, nor the inconveniences of the country.

Imagine a big co-operative building set up in the midst of the country, close to the woods if you wish, near a lake or a stream, and not too far away from a rapid transit railway station within commuting distance from the city, let us say twenty to thirty miles from any one of our large cities. Picture a 40 or 50-story building, housing, let us say 2,000 families. From the illustration, it will be noted that there are two distinct sections to this building. The bottom stories are given over exclusively to business, while the upper stories are for residential purposes only. The entire building is self-contained. By the words "self-contained" is meant that the building is like a city unto itself.

The 2,000 families living in this building will give enough business to the business section to keep it going on a profitable basis. Whether you wish to buy a steak or a pound of nails, whether you desire a hair cut or to cash a check at the bank, whether you wish your vacuum cleaner repaired, whether your clock needs fixing, whether you wish ice-cream soda, whether you need your chair upholstered, or whether you require a dentist, or a chiropodist, or wish the latest magazine, or whether your wife wants a new dress, or if you need a prescription filled—all of these and more are to be had right in the house. The business section will give good service and sell you merchandise or services vastly cheaper for the following reasons:

In the first place, the cost of delivery is practically nil. You will not see a boy with his delivery wagon and horse nor a push-cart, for that matter, in this co-operative building. Consequently the cost of delivery is at a minimum. All goods sold to tenants of the co-operative house are distributed by means of dumb-waiters, the same as is done now in up-to-date apartment houses. Suppose you wish to order a porterhouse steak. You lift up the hook of your telephone and the house central will connect you with the butcher you patronize. You will give him your name and apartment number. He takes the order, and within fifteen minutes you have your steak via an electric operated dumb-waiter. Your wife will not have much marketing to do, and she will not have to run around in a hot sun or blasting cold, wasting one or two hours of her time to buy the various things for the table. Note also from the butcher's or grocer's standpoint that all he has to do is to step into the hallway where the dumb-waiter shafts are located; all he has to do then is to place the goods on the dumb-waiter and press a button which rings a bell in your apartment. The dumb-waiter automatically stops at your apartment, and no other one. You take off the goods, push another button and the dumb-waiter goes down, ready for the next customer.

How do we establish the various trades people in such a co-operative building? In a very simple manner. First, we could readily fill the stores and business places of such a house without much trouble, once they were assured that they were to have a community of 6,000 souls to serve exclusively. But we do better. The management of the house will allow these trades people to have their places of business rent free as a great inducement. This is done for two purposes. First to reduce the cost of the merchandise or service rendered, and second to make them anxious to stay in such a community. In order to make things interesting, our co-operative building will have two competing lines of trade. In other words, there will not be more than two butchers, two drug stores, two hardware stores, two electricians, etc. The reason is simple. If there was only one, he might not give such good service as if he had a little competition. It will also tend to keep prices at their correct level. Of course, the management or the board of directors or the "mayor" of the house—if you wish to call him such—will see to it that the two butchers or the two hardware stores do not enter into a combine in order to exploit the tenants. This is also

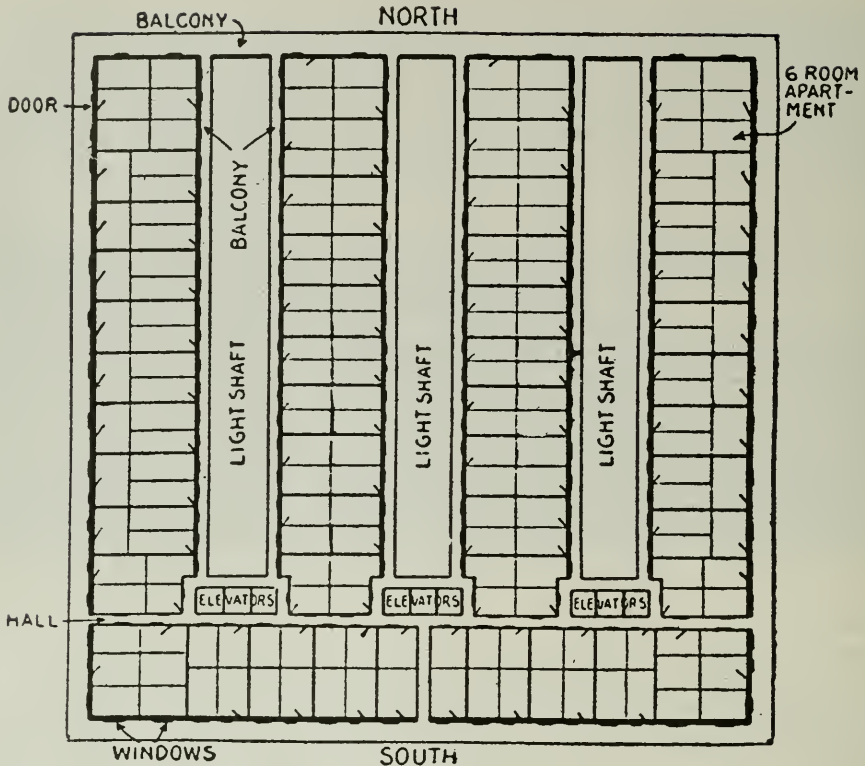

Typical Floor Plan, Apartment House to Accommodate 2,000 Families.

the reason why no rent is charged the trades people. They have no permanent lease. If the management of the co-operative house finds that unfair practices are used, the trades people can be dispossessed at once on short notice. All these things will tend to keep prices down and service up; far better than is the case today in the average community, where things are handled very loosely, and only for the benefit of the trades people themselves.

As for the goods and supplies themselves, these of course come by train direct from the city, and here again we have a saving. Take your present butcher in the city. He buys from the wholesaler, who himself maintains a distributing station. It means a double handling. Your butcher on the other hand in our co-operative building buys his goods directly from the big distributing centers, and they come by train and are therefore hauled only once. Another saving. All this saving goes to the tenants who therefore will be enabled to buy their supplies, goods, etc., at more reduced figure than is possible now.

Coming to the apartments, these are laid out in such a manner, that all of the rooms have sufficient light and air. By studying the ground plan of one of the floors, a great innovation will be noted. All elevator halls lead to the outside balcony running around the house on every floor. Access to any apartment is had only by way of balcony from the outside. No door opens inside of the house.

An important feature of the co-operative apartments is that they are all built on what is now called the "California plan" unless the tenant wishes it otherwise. The California plan means that there are no actual bed rooms in the apartment. We have nothing but living rooms, dining rooms, parlor, etc., but no real bed room. The idea is simply that the bed swings back into a small alcove, which also is used for dressing purposes. Beds at the present time take up a lot of room unnecessarily and all of this is done away with. Such apartments, with disappearing beds and with the efficiency of extra rooms, are actually in use in all of our large cities where room is at a premium.

Turning to the kitchen we will have many conveniences. The present housewife, particularly when she has no help to fall back upon, becomes a drudge and slave to her work. No more washing dishes for her; our apartment will have a steam-operated dish washer, which not only washes the dishes, but dries them from the heat of the steam, and the dishes, forks, knives, et cetera, come out sterilized and perfectly dry and clean. Our kitchen besides the usual hot and cold water has running ice water as most up-to-date hotels have now. Nor is there ice in the ice-box. Instead there is a "snake" which supplies freezing cold at any time day and night. If you wish ice, all you need do is to place a dish of water inside the ice-box, and within three hours ice is formed. Make ice-cream the same way.

All apartments are of course steam and electrically heated in the winter time, and here again the management will make a big saving for the reason that it is easier to buy coal in twenty carload lots than buying it by the truck load. Furthermore, the distributing charge again is low, for there is no expensive city trucking. Indeed, a railroad siding runs right into the basement of the house via a short "subway," so as not to mar the surroundings of the place. The coal is delivered from the railroad cars direct into the coal bins of the house. The cars being dumped automatically, the handling charges are therefore reduced to the minimum. Ashes and refuse are returned on the same cars. If the house is located near a stream, things will be even better, for then all electricity can be derived by hydro-electric power and the building need not be dependent upon a central power plant nor have to generate its own electricity by burning expensive coal.

An innovation in this co-operative house is that each floor is surrounded with an opaque glass bottomed balcony. If you wish exercise, and do not wish to go down to terra firma, you can run a short marathon around the apartments of your floor. Of course, children can play here as well, if the weather permits, and there will not be any dust, either. The balcony in the evening is lighted up electrically so you can walk around, or if you care, place a steamer chair outside your parlor, and take the air. The glass bottom is necessary so as not to cut off any light from the apartments below.

Due to the fact that most of the apartments are so high up, there will be little bother with either dust or insects. It is well known that neither of these rise very high in the air. The absence of dust, particularly is a boon to the housewife.

Of course, all other conveniences of the city are had in this house. We have our own theater, a first-class moving picture house accommodating 2,000 people at one time. We have our gymnasium, our open air dining rooms in the summer time and closed in the winter time; our skating rinks, our indoor tennis courts, dance hall, swimming pools, and finally on the top our conservatory de luxe with its own weather bureau. Natural plants and a fairy garden all by itself, as well as a roof garden and a small restaurant all rolled into one. Here is where we can entertain our friends, or if we have been sick

we can convalesce in the sun parlor with or without our attending trained nurse, supplied from the house hospital.

As for the tenants themselves, for many reasons it would be desirable that the apartments should be sold outright as is now done in our great cities. In other words, you do not rent your apartment any longer—you buy it outright, and then of course you can do anything in it you wish—making any alterations that you care to, etc. It is just like buying your own house. You understand that you will have to pay for your electric light, elevator service and other services, and taxes, just as you would have to pay were you to own your own house.

As to the outside, it will be seen that we are right in the midst of the country: farmers are all about us tilling the soil and selling the produce at low cost to our own trades people and there is no middleman or distributor that costs money. We get fresh corn, fresh potatoes, fresh fruit, etc., without the usual expensive storage and without hauling them over great distances. Consequently the price is astonishingly low.

Outside, we also have a co-operative garage where all the automobiles of the tenants are housed. Further, we have the children's playground as will be noted, and the tennis court as well as golf links are not missing. We also have a flying field so if you own your own airplane, you can land right at home. If you have neither automobile nor airplane, you can take the auto buses or airplanes that run to the city station and which bring you to the city and to your office in less than a quarter of an hour.

Let us suppose some syndicate with a capital of seven or eight million dollars would erect such a building or for that matter half a dozen of them in the suburbs of either New York or Chicago. Have you any doubt that these houses would not be filled to capacity within two days?

* * *

Unit Type Apartment House

WHEN Bridgeport, Connecticut, began work on the solution of her housing problem it was found that one of the most needful types of buildings was the apartment house. It was wisely held that an important phase of housing is that which concerns newly married couples who have not had sufficient time to establish a permanent home.

It was learned that the "floating" worker was recruited not only from the single men, but that the young married class also is a large contributor to the ranks of workers who are constantly moving from job to job.

In view of the deplorable housing conditions that surround these young people in every congested community,—conditions that are fostered by the housekeeping rooms and the "three decker" tenements that are common to almost all such communities,—it was arranged to make an experiment. It was decided to build groups of sightly, convenient and inexpensive apartment houses that would offer young couples a temporary home until they could accumulate enough funds to move into their own houses.

It has long been understood that this first period of married life is of vast importance in determining the formation of family habits. It is also understood that homelife gives a reasonably accurate index as to contentment, in other words the worker who lives in a slipshod house will reflect his environment; his work will suffer and he is always on the go, hunting a better job. Granting that his job isn't all that is to be desired, if his home

is an exceptionally pleasing one he will think several times before sacrificing it on account of a more or less petty dissatisfaction with his job. In this he will often be influenced by his wife.

These apartments at Bridgeport are very successful in influencing young people to stay on the job. They permit their tenants to retain their self respect while saving for a real home, and because of their clean, wholesome and attractive atmosphere they offer a stimulus toward the formation of valuable family habits. In other words the apartments bridge the gap between the more or less dependent circumstances of the young worker during the first few years of married life and the later years when his growing family and his natural desires lead him to think of a real home of his own.

In building these apartments only three types of plans are utilized. These consist of three, four and five room units that offer considerable flexibility of arrangement to provide for variety in the appearance of the buildings and also permit various sizes and shapes of ground to be properly utilized. The architect was Mr. R. Clipston Sturgis, of Boston.

The walls are of common brick with rowlock arches over the windows. The second story windows of the 5-room apartments have a more ornamental character produced with stucco panels and a wooden balcony treatment. The bay windows in some of the second room apartments also add interest. The entrances are of wood and are well designed.

It will be noted that in all cases the apartments are but two rooms deep, thus avoiding the use of air shafts and other disagreeable features of ordinary tenement houses. Each apartment has a private porch and the inevitable clothes line has been provided, but this feature is supplied by one of the compact swinging bracket types which do not disfigure the rear of the buildings as do the long dangling clothes lines stretched in the rears of most tenements.

The areas in the rear of the apartments is made sightly by shrubbery, trees and grass, and offer a play space for children that is a decided contrast to the dangerous and unhealthful conditions existing around most tenements, and many high grade apartments for that matter. In one case a large playground has been provided for the larger children of the neighborhood. The familiar saying, "A Queen Anne front and a Mary Ann back" certainly doesn't apply to these buildings.

That this plan of giving each room a pleasant outlook onto generous air and light spaces is entirely practicable for almost any building of this type is shown by the fact that the U-shaped units facing the streets and containing 18 apartments are adaptable for use on lots only 100 feet in depth; the units in rows parallel to the street may be used on lots only 50 feet deep. The buildings as used in this development give a density of almost 40 families per acre gross, which from an economic standpoint, compares favorably with the density of population of ordinary "three-decker" districts.

The heating plant is contained in a separate building.—National Builder.

* * *

Ancient Architecture

The first Housing Problem must have been solved by Noah's Ark.



FEUDAL HALL, RUMANIA.

Used by the American Red Cross during the World War as a storehouse.



SUMMER HOME OF NICHOLAS, MONTENEGRO,

Used as a distributing station for relief supplies by the American Red Cross.



ITALIAN VILLA, NEAR FLORENCE,
Used as a hospital by the American Red Cross during the World War.

American Plan to Rebuild Reims

REIMS, the thirteenth-century cathedral city of France, ruthlessly ruined by Germany in the war, is to be reconstructed on the city-plan completed by Mr. George B. Ford, an American architect and city-planning expert of New York. American writers immediately discover a reciprocity of service to France for that of L'Enfant's plans accepted more than a century ago for Washington, our capital city. Mr. Ford reports that 80,000 people are now trying to live in Reims, where there are only 2,000 repairable houses for 30,000 persons; 9,000 out of 14,000 buildings were completely destroyed; the mutilated Cathedral is under a temporary wooden roof protected by tar-paper. We find Mr. Ford's own words regarding his city-plan, as quoted by Mr. William L. Chenery in the New York Times Book Review and Magazine, most enlightening:

"Our problem was to design an industrial city which will probably ultimately have a population of 300,000 and at the same time to preserve the charm of the old city and in particular to retain the historic monuments and the characteristic architecture. With these two dominant motives the plan calls for the building of four new divisions, north, south, east, and west of the original city, together with the creation of great thoroughfares to unify the entire community. In the creation of these new divisions, and indeed in the rebuilding of the original city, the effort has been made to incorporate those new features of municipal life which have proved their worth in the United States and elsewhere.

"In the center of the city the purpose has been to group the development about the historic places and to connect these with the newer parts of the future city. The fact that so large a proportion of buildings are beyond repair has made it practicable to lay out through streets and to create open spaces. Thus, for example, behind the Cathedral a large open space which will be of great service in showing Notre Dame to better advantage, has been planned.

"From this park runs a great avenue through the city. This passes through the Place du Forum, which dates back to Roman times. Adjoining the forum will be a large building to be used as the meeting-place of public and private bodies, while in the forum itself open-air meetings may be held. The broad avenue extends across the city from the library to the city hall, and intersecting this central highway are other broad streets which run through the city.

"A central market and a civic center in the heart of the city are also proposed.

"In each of the four new divisions branch markets and smaller community centers are included. Each of these is designed for industrial development and for workmen's houses. In the eastern division a new port and a large freight station with railroad yards are provided for. Throughout the city new parks and playgrounds will be established and every school will be connected with a playground, a system almost unknown in France. About the city local community centers have been arranged. In the center of the city a new passenger station is planned.

"Industries, transportation by the canal and railroads, homes, schools, public buildings, streets, and avenues are grouped in such a way as to make life as comfortable as possible. Connected with the local community centers will be public baths, libraries, and dispensaries. The height of buildings will be limited by the width of streets. The work will be done as the money becomes available. The national Government will undertake a part of the expense; how large a part is not yet determined. Now that the plan has been completed, the work will be done by French architects, engineers, and other technical men. With so many experts there is no necessity for technical assistance in the problem of actual construction."

Mr. André Hallays, a French contributor to *L'Illustration* (Paris), protests against "a foreigner being empowered to fix for all time the features of the city in which the kings of France were crowned!" And, again, "of course, Mr. Ford treated Reims like a town in the Far West." But this sounds like an echo from the deadlocked competition in plans by French architects under the new town-planning law. The city authorities finally called on Mr. Ford, who had reported to the French organization, *La Renaissance des Cités*, on plans for some 200 towns. After two public hearings his plan for Reims was adopted successively by the city, the departmental commission, and the national commission at Paris, thus running a gauntlet of characteristically French organization for artistic achievement in reconstructing devastated areas. "The plan had the benefit of the fullest and best obtainable French expert advice," writes Mr. David Lloyd in the *New York Evening Post*. "Reims has been studied in France in its every aspect as few towns have ever been studied anywhere, and 'le plan Ford' has profited freely by the consequent thorough and affectionate erudition." Mr. Lloyd further replies to the French criticism:

"If the American has treated Reims with some of the devotion that has been lavished on towns of our West and Far West he might have done worse. The suggestion that he has mistaken the project for one in the Far West is a little hot and hasty.

"Reims today is a manufacturing city of about 120,000 population, the most important center of its region. From the north and northwest it draws on coal and iron deposits. The automobile industry, among others, was, before the war, thriving. The old dominant fortified town at the crossing of two great Roman roads, north and south and east and west, receives its freight today by five railroads and a system of canals. Mr. Ford's plan, in brief, provides urban circulation for a future 300,000 population."

* * *

A 2,000-Year Old Definition of An Engineer

In a recent address before the Western Society of Engineers, Mr. John W. Alvord, past president of the society, gave a definition of an engineer made by Marcus Vitruvius, who wrote 150 years B. C.

"He should be a good writer, a skillful draughtsman, versed in geometry and optics, expert at figures, acquainted with history, informed on the principles of natural and moral philosophy, somewhat of a musician, not ignorant of the sciences, both of law and physics, nor of the motions, laws and relations to each other of the heavenly bodies. * * * Moral philosophy will teach him to be above meanness in his dealings and to avoid arrogance. It will make him just, compliant and faithful to his employer and what is of highest importance, it will prevent avarice gaining an ascendancy over him, for he should not be occupied with thoughts of filling his coffers, nor with the desire of grasping everything in the shape of gain, but by the gravity of his manners and a good character, should be careful to preserve his dignity."

Charging Commissions on Commissions

SOME architects have been faced with the question by the owners, since cost-plus work has begun to prevail, as to whether the architect's charge should be based on the direct cost of material and labor only, or on those items plus the general contractor's overhead and profit percentages. The architect works on the basis of a fee based on the cost of the building, and as the cost-plus system surely includes contractors' profits in the cost, there is no technical or legal reason why the architect should not base his commission on the commissions of others as well. From a moral standpoint he is even more entitled to be considered as worthy of his hire. The architect is the first in the field on a building project and the last man at the finish. He must untangle all tangles. His sole interest is to get for the owner the best building possible, while doing justice to the contractor at the same time. So that of all agents engaged in a building operation the architect has the most disinterested standpoint.

The general contractor collects a percentage fee on a great many items which he expends no effort on, and for which he makes no monetary outlay, but as this would be the case with him on a lump-sum contract, there is no essential difference on a cost-plus contract in the architect asking his fee on every item which goes into the cost of the structure.

The single advantage accruing out of the whole cost-plus cost system is that architects now, more than ever before, and owners for the first time, scrutinize the itemized cost of their buildings carefully, and a tendency is beginning to show of a more careful analysis of planning, sizes, qualities and a differentiating between essential and non-essential factors.

Of all who work on a job, the architect goes into the subject the most deeply. The studies he makes and much of his work in the final result is not included in the cost of the building, and therefore he does not collect any fee, this extra professional work by the architect more than offsets such fees as may come to him when he collects his percentage on the contractor's percentage. There is a way to gauge the contractor's performance, but the work done by the architect eludes any measuring process. And if that day should come when the architect declines, as does the contractor, to abide by anything but the precise letter of the law, rather than interpret it in terms of spirit as well as material content, it will be a sad day for architecture, and if architecture should enter upon sad days it means that it will be still sadder for all who are engaged as members of the widely diversified building industry. The keynote of the arch is the architect. The rise and the fall of the art, the business, depends on his interpretation of his own duties to society. He has always proved worthy of his hire.—
Building Review.

* * *

Architects' Difficult Task

Besides desiring to know the relative costs between different kinds of houses, the architect is constantly confronted with the problem of approximating the cost before he starts his plans. His client comes to him and tells him that he wants a house to cost about \$12,000, and then asks how much of a house can be had for this sum, says a writer in *Architecture*.

In order to approximate this figure, the architect must use the cubic-foot system of estimates. Now, while formerly this system was fairly accurate, today it is almost impossible to give a snap judgment as to cost on the cubic-foot basis. The only safe way is to take the cost of last month's houses and add about 20 per cent, say some contractors. Others say it cannot be done at all.

The Specification Writer and the Manufacturers' Literature

By LOUIS R. HOLSKE in Pencil Points

PART III.

PERHAPS if the manufacturer in preparing his catalogue matter would place himself in the position of the architect who is planning a building and endeavor to follow the architect's line of thought, catalogues that would be more useful would result. In arriving at this decision that a certain article is desirable in the building which he is planning the architect must first obtain as full an understanding of the article as possible, and it is the purpose of the catalogue, presumably, to supply him with the data he needs in judging the results obtainable by the use of the article in question, in gauging the expenditure involved, and the limitations of the article and other matters that govern his decision.

The first question the architect wants answered is usually in regard to the space required to accommodate an article under consideration. This is important, for often a great deal of ingenuity is required in assigning space for all the articles of equipment needed. The space requirements include, of course, the necessary clearance space on all sides.

Next, the requirements of the article in its relation to all other work must be considered. Does it require foundations, steam, water or gas or electric connections? How and where are such connections made, and many other points which vary with different articles.

While the characteristics of basic mason's material such as Portland cement, lime, concrete aggregates and common brick are familiar to architects, a few remarks on the information needed by the architect may be helpful.

Portland Cement—Although producers generally manufacture to meet with standard requirements of the American Society for Testing Materials, the architect is interested in knowing whether the particular cement under consideration is slow or quick setting and also its fineness.

Hydrated Lime—The architect would be interested in knowing whether it is a high calcium or magnesium lime.

Concrete Aggregates—The crushing strength, the nature of the stone, and if a limestone, some assurances backed by authorities that it will not disintegrate.

Common Brick—This is a material with which the architect is familiar and its examination for quality is a matter of routine of superintendence.

There are other materials classed as mason's materials, namely, concrete binders, mortar colors, nailing compounds, face, enamel and paving brick, hollow tile, terra cotta wall copings, and flashing blocks, flue linings, spot grounds, each of which may be considered in its relation to what the architect wants to know.

Concrete Binders—The nature of the ingredients composing the binder, authentic tests of its strength per square inch, at various periods up to two years.

Mortar Colors—Nature of the material in each case, its permanence or non-fading qualities and the safe maximum quantity permissible to use without injury to the mortar.

Nailing Compounds—The nature of the ingredients of the mixture and assurance of freedom from saw-dust or wood flour. An authentic test of its holding power with wire and with cut nails, to what materials it will bond, the minimum thickness usable. What is its condition at the lapse of two years. Can an old floor be removed and a new one laid without replacement of the compound?

Face Brick—Quality, size, surface or texture, colors.

Enameled Brick—Size, colors, what special shapes are made.

Paving Brick—Quality, size, colors, vitrified or hard-burned.

Hollow Tile—A complete list of sizes and shapes with illustrations. In what grades of material are they manufactured, hard-burned, semi-porous or porous.

Terra Cotta Wall Copings—A list of sizes manufactured. Quality, whether salt glazed or hard-burned.

Flashing Blocks—Illustrations of shapes manufactured properly figured—quality.

Flue Linings—A list of sizes manufactured.

Spot Grounds—Size, necessary spacing for light and heavy duty, developed by tests. Mortar mixture for setting.

* * *

New Method of Laying Brick Pavement

A 500-FOOT section of three-inch wire-cut-lug brick is now under construction in Edgar county, Illinois. The wire-cut-lug brick, which is being furnished by the Danville Brick Company, Danville, Illinois, is identical with regulation brick of this type, with the exception that it is three inches in depth instead of four inches. It is claimed, however, that this slight change of one inch in depth dimension opens a new field in highway construction without a loss in efficiency.

It is claimed that three-inch brick effects a saving of fully 25 per cent in material, freight and haulage.

The three-inch wire-cut-lug brick, above referred to, is laid on a four-inch wet concrete mortar and is thoroughly filled with 1-to-1 cement grout filler.

The road is first graded and thoroughly rolled, then steel forms are so placed as to mark the edges of the roadway. A concrete mixer makes the concrete into a plastic mud and deposits it right between the forms and it is then cut off and shaped up by a large steel template, which leaves the base about four inches deep. Within two feet behind this template comes a second template and in this space is a quantity of sand and cement mixed 1-to-1, and the second template is one-eighth inch higher than the first one, leaving behind the second template a perfectly smooth floor on which the brick are immediately laid. The brick are then rolled with a light roller and thoroughly filled with the usual high-grade cement filler before the base has had time to set.

The cement in the whole road sets up together, forming a seven-inch "brick-slab" pavement, solid from top to bottom. The contractor reports there is a great saving of labor in the consolidation of this work. The advantage to the cement lies in this: First, the large body of wet cement forming the base is protected by a complete covering of brick and is compelled to dry more slowly; and second, the cement filler being connected with the body of wet concrete below, is by capillary attraction from below kept wet and also compelled to cure slowly, these two ideas tending to give the concrete a slower and better curing process. This makes a roadway composed mostly of cement but having a brick wearing surface. In short, it is laid just like a tile floor and might properly be called a vitrified brick veneer, and since under heavy traffic a good paving block has been known to wear off the top less than one-eighth inch in twenty-five years, this new type of brick ought to meet every requirement of the highest grade of pavement.—Municipal Engineering.

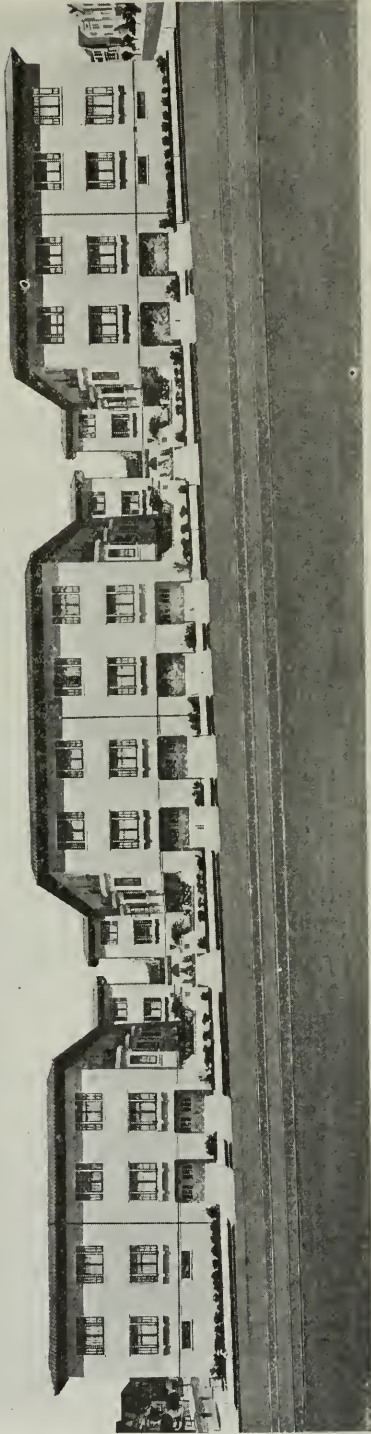

APARTMENT HOUSE FOR MR. A. HAASE.
SAN FRANCISCO, C. O. CLAUSEN, ARCHITECT.

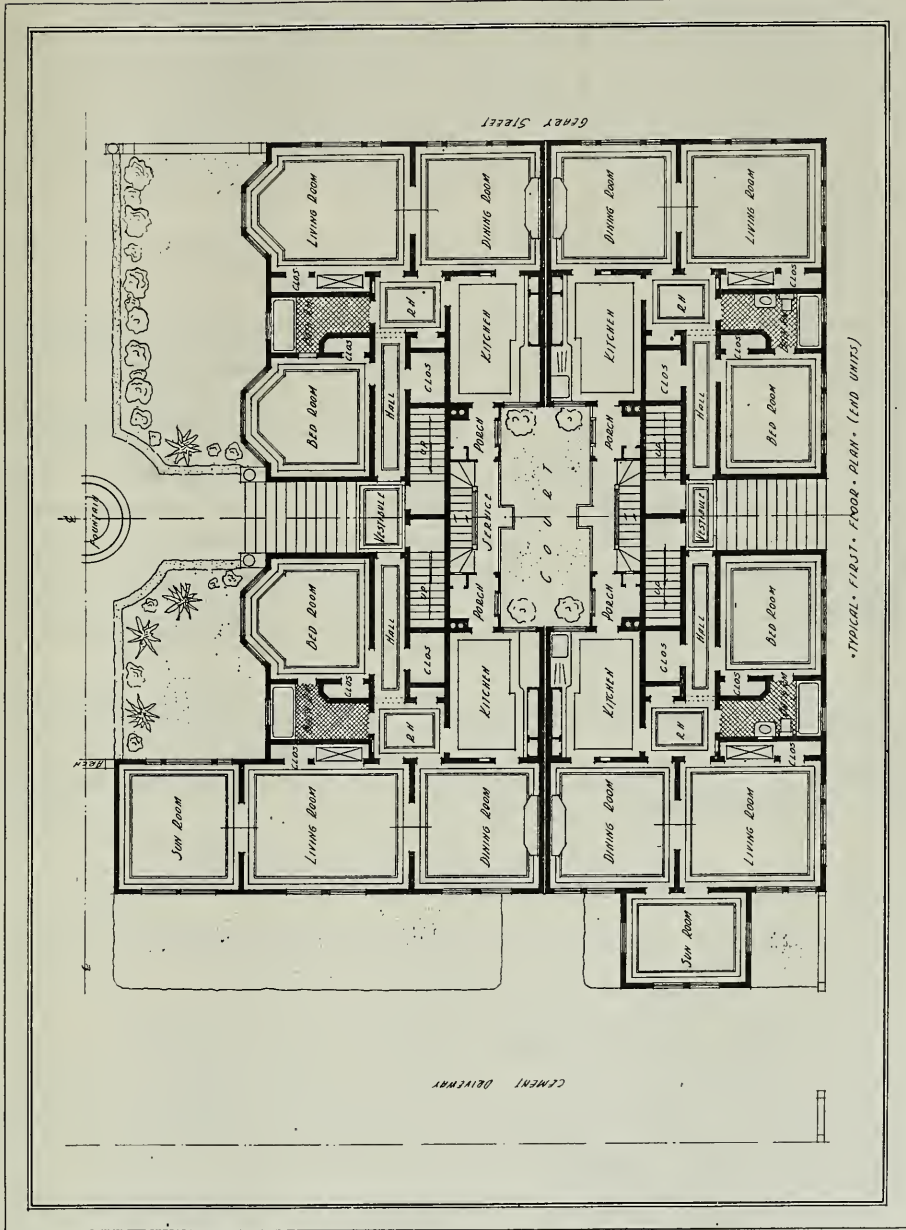

APARTMENT HOUSE FOR MR. A. HAASE,
SAN FRANCISCO, C. O. CLAUSEN, ARCHITECT.

Slow Decline Seen in Building Costs

AFTER an investigation covering building conditions and costs of building materials in all parts of the country and after thorough study of the rise of the price level, Mr. H. A. Whitney, of the firm of Sutton & Whitney, Portland, Ore., before that city's Building Owners' & Managers' Association, recently stated that building costs are not due to fall for at least two years and that the decline will be slow. A further conclusion was that a new price level must be accepted as an established fact and that the old prices of 1914 are gone for good. Mr. Whitney's findings and forecast for the future are graphically shown in the accompanying chart, which illustrates the fluctuation in the amount of building since 1910, and the increase in the cost of building and the cost of living since that time, and also forecasts the probable tendencies along these lines up to 1930.

In showing the comparative increase in the cost of living and building, Mr. Whitney says: "I have prepared a chart covering the last ten years. One line

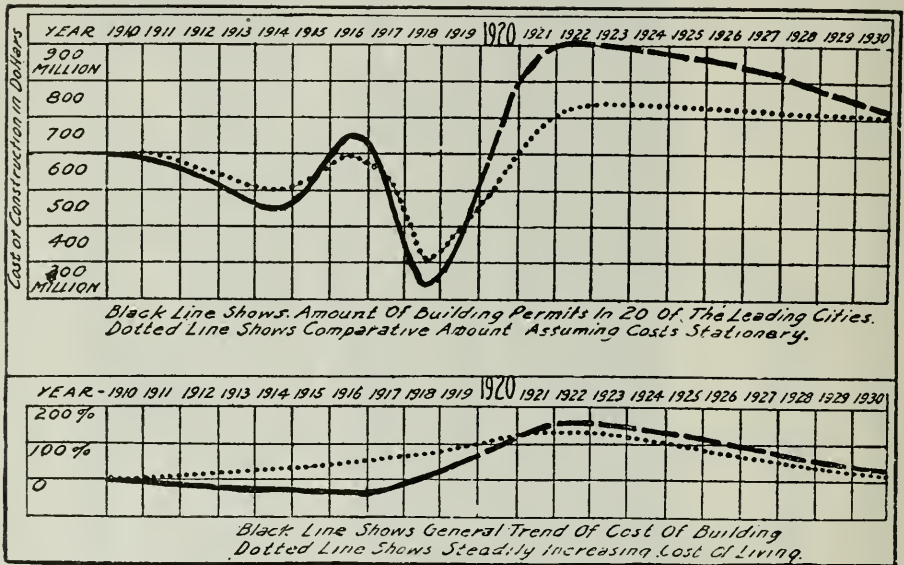

shows the constantly increased cost of living, while another shows the cost of building. This latter line shows that the cost of building fell off materially during the war and only two years ago did it equal the high level of 1910-11-12. Last year showed a marked increase in cost because of increased labor costs. In a finished building between 80 and 90 per cent of the total cost is attributed to labor. Therefore, the peak of the present building material price advance can only be reached when there comes a final settlement of labor wage scales.

"You will note that the cost of living has increased something over 100 per cent over 1910, while construction costs only increased about 75 per cent up to the beginning of the present year.

"I have been rash enough to plot both curves on for the next ten years. From present indications living costs will continue to rise for some time. Now it is evident that the curve of a living costs must come down and cut the ascending curve of building costs before the latter line can flatten out. In the near future the demand for building materials will probably overshadow supply so

completely that the price advance will continue unabated for two or three years. It now takes about six months to fill an order for any material using steel or iron. Plate glass is extremely scarce on account of its increased use in automobile construction and it will be at least three years before the glass manufacturers will have caught up with the demand.

"The upper curve shows the amount of building construction in 20 leading cities of the United States for the last ten years. You will note that construction fell off considerably in 1914-1915, went up in 1916 on account of pre-war activity, then fell off in 1918, after the war and has since been rising sharply. The other line shows that the actual amount of building construction, assuming costs had remained stationary.

"The government has estimated that the country is at least two billion dollars behind on building construction. You will, therefore, see that the projected curve for the next ten years must be high enough to take care of this extra construction as well as the average construction. A steady increase in population will also mean that the average amount of construction must also increase. Of course these curves are based on the assumption of a gradual return to normal conditions throughout the world.

"There are at least three reasons why these curves must flatten out gradually rather than go to a peak followed by a sudden drop.

"First—Scarcity of funds. Insurance companies, ordinarily heavy investors in this field, have bought large amounts of liberty bonds. Individual investors have been disposed to get out of the mortgage market. Savings banks have funds available for building, but they are disposed to be conservative and are unwilling to accept, as a rule, a valuation as much over the 1912 level as increased building costs would seem to require. They also operate under a legal limit as to the amount which they can place upon first mortgages. I might remark here that I interviewed several of the leading bankers of Portland and found that they were disposed to be conservative and indicated that they would not loan as large a percentage of the cost of a building as formerly. Building and loan companies have been called upon heavily for funds, but have not been able to meet the demands upon them.

"Secondly—The labor shortage will restrict the amount of building. Laborers have been leaving the United States at the rate of 1,000 a day for the last year, yet in spite of this shortage the federation of labor is trying to have immigration restricted.

"Thirdly—The shelves are bare of all materials. We are therefore driven to the inevitable logical conclusion that existing prices will not decline and that these prices express a new and substantially permanent level upon which present and future business must be conducted."

* * *

New Type of Brick Wall Construction

The Los Angeles city council has approved an amendment to the city building ordinance, allowing the use of a 8-in. hollow wall built of solid brick. In this construction bricks are laid on edge, giving a 2-in. section on either side of a 4-in. air space, and are bonded together with header brick, laid on edge, 8 in. apart, in every course. Following the ordinary method of laying brick the leaders give a Flemish bond. The ordinance requires that such walls be laid with mortar composed of 3 parts of rich lime mortar and 1 part of cement. They may be used only in 1-story buildings where the height of the story does not exceed 9 ft., erected outside fire limits Nos. 1, 2, 3 and 4. Three courses of solid brick wall are required at the top under all ceiling and roof joists. The length of the wall, unless supported laterally, is limited to 24 feet.

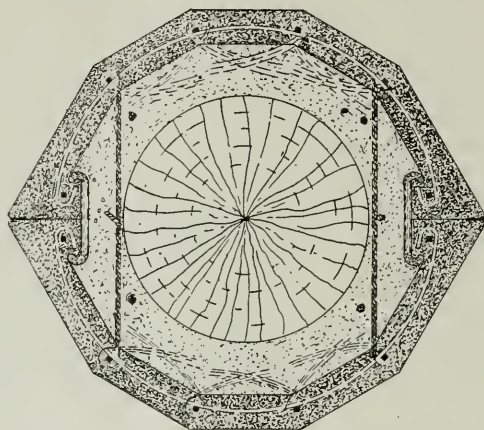
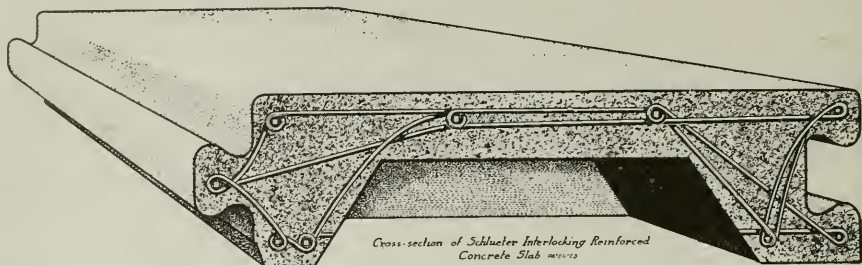

Cross Section of Wooden Pile Concreted by Schlueter System.

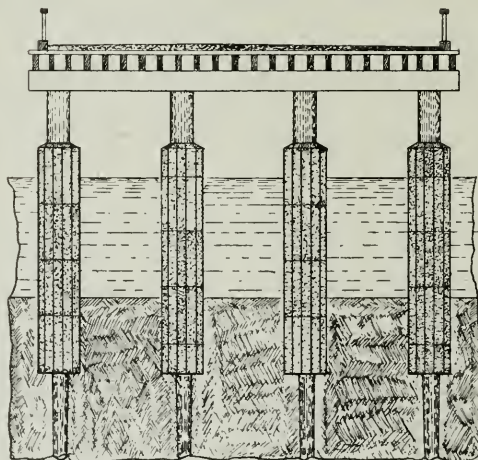

Bent of Wooden Piles Concreted by the Schlueter System.

New Method of Concreting Wooden Piles

A NEW method of concreting wooden piles to reinforce and preserve them has been devised by Mr. Henry W. Schlueter, a Los Angeles engineer, whose system is being used in the construction of the new sea wall at Long Beach. It frequently happens that in wooden piers a few scattered piles are damaged by teredos or wakened by decay of the wood and it is necessary to replace or strengthen them to save the structure. Replacing piles under such conditions is expensive and often difficult. Mr. Schlueter's method of reinforcing and preserving such piles obviates some of the difficulties of this work and makes it possible to do it at a small cost. He estimates the cost at about \$2.00 to \$2.50 per lin. foot of piling concreted, this figure being subject to slight fluctuations depending upon the character of the work and availability of materials.

Mr. Schlueter's first experiments in concreting wooden piles were made with a sheet iron form as a container for the concrete. This was not found to be satisfactory because the concrete when so placed could not be reinforced and the sheet iron form soon rusted away allowing the concrete to disintegrate. His new method involves the use of a precast reinforced concrete form, or circular shell, cast in two sections and in units of three feet or less. These forms are reinforced with vertical steel bars and horizontal wire wrapping fastened to the bars with wire stirrups which project on the inside of the form and are imbedded in the grout between the form and the pile. Where the sections join there is an interlocking flange on the inside of the form over which a clamp is fastened, holding the two sections together. There are also stay wires on the inside of the forms which are joined at the ends and twisted to hold the forms in place when they are first set up. The accompanying illustrations show a cross section of a concrete pile and a bent of concrete piles.

All the concreting work is done from a scaffold swung beneath the pier. The bottom forms are placed first, one being a full length unit and the other a half length unit so that the entire series of forms are staggered when placed, the horizontal joints on each side being the middle of the forms on the other side. Boards are fastened on the bottom of the first forms and a canvas flap encircling the wooden pile is attached to the boards at the rim of the form. When the pouring of the concrete grout is started the canvas is forced down and makes a tight bottom so that the concrete will not seep through.

The concrete grout is poured as each unit of the form is set in place, the grouted form being dropped down as the work proceeds. When the form reaches the sand it is jettied down to a point below the scouring line. The work is performed quickly and the entire form is placed before the concrete grout begins to set so all voids inside the form are filled and the wooden pile is entirely covered.

A rich concrete mixture is used for the forms, making it dense and impermeable so that the reinforcing steel will be protected from corrosion by the salt water. The grout consists of 40 parts of cement to 60 parts of sand, no coarse aggregate being used, so that it will pack in solidly, leaving no voids. The ends of the form units are smooth, making a tight horizontal joint, and strips of felt are placed in the outer edges of the vertical joints to make them tight. The forms are approximately $1\frac{3}{4}$ inches thick and the grouting space is sufficient to give a minimum of 5 inches of concrete around the entire length of the pile to be protected.

Ordinarily the concreting will not extend above a height to which protection is needed. However, it may be carried higher and a concrete girder may be cast on top of each bent, making a reinforced concrete structure to support the deck. Mr. Schlueter has applied for patents covering all the principal features of his method.

Contractor's Plant for Concrete Work

ONE of the chief problems facing the superintendent of construction on reinforced concrete work, according to the report submitted by the special committee on contractor's plant at the recent annual convention of the American Concrete Institute at Chicago, is the study of requirements as to the operating plant and the arrangement of this plant so that the work may be carried on in an economical manner both as to cost and time. This is true of any kind of construction work, but the problem is a more difficult one when concrete is to be the medium of construction, because due probably to the enormous growth of the concrete industry within a comparatively few years, the committee found that there is far less of a standard in the design and arrangement of construction equipment for concrete work than for structural steel, brick and other forms of construction which have been in vogue for a longer period of time.

The committee recognized that each job needs individual study and that definite recommendations cannot be made as to plant layout that would be equally useful on two pieces of work without adaptation to the exact conditions of each. "It is possible, however," states the report, "by a careful study of the work that has been done for the determination of the most successful operating plants, to make definite recommendations as to how the problem should be approached so that the procedure may be uniform for all work. In a general way, an increase in the outlay for plant and its installation causes a decrease in the daily operating cost of the work, and the problem is to find the economical relation between the money invested in plant installation and the amount saved thereby."

In comparing the usual layouts, the committee found the following general items entering into the cost of the work. These items when distributed over the amount of work to be done give the unit cost of the same:

1. Cost of plant chargeable to job (material only).
2. Cost of installation and taking down (labor only).
3. Cost of maintenance (labor and material).
4. Cost of operation (labor and material).

Item one represents the difference between the purchase price of the machinery and materials and the salvage value of the same at the end of the job. Item two is the labor cost of installing and taking down the plant and auxiliary structures. Item three is the value of labor and materials used to maintain the plant. Item four would be the labor and material costs of operating the plant, including the cost of labor actually employed in receiving materials and placing concrete as well as that used in operating the plant. The combination of these four general items, which gives a minimum total, represents, according to the committee report, what will probably turn out to be the most suitable layout for the job in question, unless special conditions have to be given undue consideration.

* * *

The Rich Contractor

It is said that a certain contractor well known throughout Ohio, who started out poor twenty years ago, has retired with a comfortable fortune of \$50,000. This money was acquired through industry, economy, conscientious effort to give full value, indomitable perseverance, and the death of an uncle who left him \$49,999.50.

Largest Concrete Building

THE largest concrete building ever erected on Manhattan Island is now being built at 395 Hudson street, New York. The building, partly an 11-story office building and warehouse and partly a five-story and basement warehouse, will occupy the entire block surrounded by Hudson, West Houston, Greenwich and Clarkson streets. The construction will cover an area 338 by 200 feet and will be throughout of reinforced concrete with the exception of a veneer of brick on the exterior walls. The work is being done by the Turner Construction Company; McKenzie, Voorhees & Gmelin are the architects.

This operation furnishes a most interesting side light on the trend of building design in the greater city. For many years it has been an accepted fact that reinforced concrete was an ideal building material for industrial buildings, but loft buildings, apartment houses, office buildings and institutional buildings have still been built almost exclusively of structural steel, brick, stone and terra cotta. With the present labor and material price situation, the economy in favor of reinforced concrete is so big that many people, who through prejudice or inertia, had refused to consider reinforced concrete, are now turning to this material as the only way out of their difficulties.

The building is of a type which up to a year or so ago, would have been built of structural steel. Today it is going ahead, the largest building of its kind, or reinforced concrete without any structural steel involved at all. There are many office and loft buildings, twelve stories or less in height, which could be efficiently, economically and expeditiously built of reinforced concrete at this time. This building will be occupied by the Western Electric Co. and the New York Telephone Co.—Concrete.

* * *

What It Means to Discount Bills

Discount your bills. Should you not have the money in your business to enable you to do this, increase your capital in some manner. By the following table observe the great advantage to be gained in paying cash. By reason of the recent war more money has been put in circulation than ever before, and there is no reason why the nation should not get on a cash basis. It is merely a habit of mankind that we don't need, and a bad habit, too. More human misery is brought through the lack of money than for any other reason. This can all be overcome if we would keep ourselves within our means, and to do this more satisfactorily is to pay cash for our wants.

1 per cent, 10 days, net 30 days.....	18 per cent
2 per cent, 10 days, net 30 days.....	36 per cent
3 per cent, 10 days, net 30 days.....	54 per cent
3 per cent, spot cash, net 30 days.....	36 per cent
5 per cent, 10 days, net 30 days.....	90 per cent
6 per cent, 10 days, net 30 days.....	108 per cent
8 per cent, 10 days, net 30 days.....	142 per cent
3 per cent, 10 days, net 60 days.....	216 per cent
2 per cent, 10 days, net 60 days.....	142 per cent
3 per cent, 10 days, net 60 days.....	24 per cent
5 per cent, 30 days, net 4 months.....	20 per cent
3 per cent, 30 days, net 60 days.....	36 per cent

—New Orleans Item.

Co-Operation Among Engineers*

By DR. F. H. NEWELL,

President American Association of Engineers.

WHAT does co-operation mean? We have used the word frequently; I have discussed it often and have tried to bring about co-operation among engineering bodies. It means merely a working together effectively. While such working together is theoretically the wise, the most obvious thing to do, practically it is one of the most difficult things to bring about because of the tendency of men and organizations to segregate rather narrowly in order to secure higher efficiency; to work along narrow and narrower lines and to keep clear of all entanglements tending to divert their attention.

Our problem, and the one we wish to discuss this morning is how best we may co-operate and for what reason we should co-operate.

The reason is obvious. It is primarily and fundamentally in order that we as intelligent men, as citizens, may benefit personally. There is no use getting away from that. There is a reasonable and necessary selfishness running through our plans, yet that selfishness, while we recognize it, is not the beginning nor the end of the problem. An intelligently directed selfishness may bring the highest results to the whole community.

All engineers to a certain extent are men of vision, they are idealists, and we can all agree that to put over a successful idea you must have a near as well as a remote object. We might as well admit first as last that we begin primarily with the conception that by co-operation we intend to help ourselves and help our associates. In doing that we are not losing sight of the fact that in helping ourselves we must help the community and the public at large. Moreover, anything that helps us but is to the detriment of the public we must not tolerate. I want it clearly understood that while starting with the primary assumption that all incentive to co-operation must be founded upon a desire to help ourselves, yet it must not be developed in such a way as to interfere with our great ideals. It must lead to the best result for the common good. I put this proposition to you frankly, because in all our plans we must not let anything interfere with the ultimate good of the community as a whole; helping ourselves intelligently and wisely to help the community at large.

How can we do it?

The Engineering Council representing the officers of the founder societies is at work as one of the results of these attempts at co-operation, but because of its form of organization it cannot be as effective as a less cumbersome device. It has no power to enforce or carry out its conclusions, being simply a council dependent on the good will of the separate societies and on the personality of its agents. We may theorize about the efficiency of different forms of organizations, as to how best to organize men; but experience shows that some of these schemes which look well on paper may not work out, because they do not appeal to the peculiar spirit of our people.

To illustrate my point, we formerly elected the U. S. Senators by the vote of the state legislatures, but as you know there was a feeling that the Senate thus chosen was not well selected. It was a representative

* From an address before the Ohio Association of Technical Societies.

body that was the choice of other representative bodies. This second-hand delegation of power never seemed to work right. A similar criticism is made against any council chosen in this way.

Here is perhaps a more striking illustration of how this kind of co-operation does not satisfy. Before the present constitution of the United States was adopted we had a loose confederation of the states; each state voluntarily co-operated or attempted to co-operate with every other state, the result you know was disastrous. By great good fortune the people of the United States were led to adopt the present form of constitution without which we probably never would have existed as a nation. Theoretically the old way of co-operation among states was perhaps ideal, practically it did not work. Under our constitution we are citizens of the United States first, last and all the time. We are not citizens of the United States because we are citizens of Ohio or because we are citizens of Columbus, but we are citizens of the United States and elect our representatives directly to the United States Congress.

Similarly, plans for co-operation among engineering societies have not worked out practically where the citizenship or the membership is represented not directly, but by a body chosen as the result of a second or third delegation of power. We want the power to go directly from each citizen or member to the responsible parties.

Because of the recognition of this principle we have started in another form of co-operation; a conclusion reached by going all around the circle, by trying different things and finally reaching this result. Parenthetically I wish to say here that this summer I have spent much time in traveling from the Atlantic to the Pacific, from the Canadian line to Mexico, visiting town after town, talking with engineers in their offices and in their meetings, much as I am talking now, getting acquainted and urging them to co-operate and to get together along the line where every individual man will be represented in a national body, not indirectly through a local organization, which in turn delegates its power, but as members of one civic body, engineers and architects, and that is the American Association of Engineers. I hope you will be patient while I exploit this, not as the only organization, but as the form of organization that I think is going to win. The final outcome may not be in the name of the American Association of Engineers, but it will be some form of organization of engineers and architects which working directly will achieve the result to which we are looking forward.

What is it we desire to do? We want to improve the condition of the engineer and the architect. We want to improve his condition financially, mentally, spiritually, as a citizen, as a man and as a member of a group of trained workers. That is why we are trying to co-operate, subordinating the interest of the individual to the interests of all humanity, and yet in our enthusiasm for these higher things, not forgetting that the man down in the ranks must have his fair share and proper treatment if we are going to have a strong organization. That is what we are working to do in our co-operation.

Some will say at once, and this issue should be met squarely, "These advocates of the A. A. E. are attempting to establish a glorified laboring union." In reply I may state that I do not hold any brief for labor unions. They can take care of themselves; they are well able to do so. But I do desire to point out certain differences between the kind of organization needed to secure co-operation among brain workers and the labor unions.

In the first place the American Association of Engineers is an incorporated body. It is a responsible body. It differs from a labor union in that respect because whatever it does, whatever it agrees to are matters for which it is responsible. As you know the prime element of labor unions is irresponsibility. Of course there are all kinds of labor unions, as there are all kinds of churches. With some people labor unionism is a religion. Men have given their lives for the labor union. Many of them have done great and good work, others have not, but the danger today to society exists because these labor unions are irresponsible bodies and cannot be held to any agreement into which they enter.

This is an age of organization. The unorganized man is not effective in performing his duties or securing his rights nor is he able to preserve the rights of others. The question before us as engineers and architects, brain workers, is not whether we shall organize, but as to what kind of organization we shall create. Shall we enter an organization that is incorporated, that is responsible, or shall we continue to organize the small groups of technical men to discussing technical topics and tabooing all the vital questions of society?

A noted preacher recently said, "Some boys go to hell because there is no other place for them to go." Today in the unorganized or disorganized condition among engineers and architects we are forcing men into labor unions because we are not freely admitting them into our specialized societies. The great body of these plain men that I have described as the non-commissioned officers of the army of engineers, the draftsmen, the surveyors, the checkers, these are the men we are forcing into labor unions. That is where my interest lies in this great co-operative movement, namely to get those men organized into a body that is responsible for its acts, a body in which every man feels that responsibility legally as well as morally, and keep them out of the irresponsible labor union that is eagerly seeking them.

That is the condition we are facing. It is not a theory. It is a fact that unless we do co-operate in a sane, definite, business-like way, meeting the present conditions of society as they are, this is going to come about in a very few years. That is why I am so intensely interested in upbuilding an organization that will keep these men as I have said, in a responsible body led and officered by natural leaders, men to whom they can look with respect.

That is what I mean by ultimate co-operation among engineers and architects. We have worked through and beyond this idea of forming small societies of civil engineers and of mechanical engineers and so on with the idea of then getting them to work together, and somehow out of that same combination produce a powerful organization. This idea does not work under present economic conditions. For efficiency we must have an organization in which every man is a member just as much as he is a citizen of the United States. That does not prevent his being an active citizen or member of his technical society, any more than your citizenship in the United States prevents you from being a good citizen of Ohio or of Columbus. In fact, it strengthens it; but the two citizenships are independent and function without any interference with each other.

There is in the world a shortage of all goods, every necessity of life, and the only right thing we can do is to increase production and organize to fight every movement that there is to keep down production, and at the same time accompany that effort by seeing to it that a proper compensation is given to all men who are engaged in that increased production.

How are we going to do it? Are you going to organize a union and

call a strike to get more money? We say most emphatically we are not. In the case of men who are thinking, it is not necessary to do that. While so-called capitalistic organizations may organize a lockout, or the labor unions may organize a strike, we believe we can accomplish permanent good, not by force or intimidation, but by using the weapons that every intelligent man should use: common sense, argument and reason.

Under present conditions of depreciated currency, where money is worth half or less than half of what it was before the war, and where the value of currency has dropped, the readjustment to meet the altered condition of our standard of value must be met gradually and wisely. And how can it be met? Only by presenting our claims honestly, sincerely and convincingly.

Certain engineers in municipal, public and railroad employ, relatively to the value of money, are getting less than the amount to which they are entitled, less than the amount on which they have been accustomed to live and the amount which they should spend to be good American citizens. The thing to do is to present that fact, without the alternative of threats of going on strike, but as intelligent men, educating the public and the people concerned.

We have followed that course. It is not a question of whether results can be had in that way; they have been attained. Such a course is not as spectacular as it is to call a strike, but in the end it accomplishes the result, and it is done in a way that preserves the self-respect of all the men and a proper appreciation of the dignity of their profession.

We must get together in some form of organization, effective primarily for the benefit of these men, but ultimately looking forward to that larger benefit to humanity. On this basis alone can an organization long exist. We cannot survive permanently if we adopt a low moral plane, if we organize for ourselves exclusively; but if we desire to endure and to have the respect of the public and to put the men of education and experience where they belong, the engineers and architects must be organized and their organization founded on deep principles which will benefit the public and the human race.

* * *

Investing Time

AN advertisement of a well-known educational institution states the following interesting, but often overlooked, fact:

"Has anyone ever told you that, in one respect, you are as rich as Rockefeller, as well off as Schwab and J. P. Morgan? Well, you are. When you were born Nature deposited to your credit in the Bank of Life a great big ample capital of Time. You have all the time there is—twenty-four hours each day. In that one thing, you are as rich as the wealthiest man in the world."

A logician might put the matter thus: Material wealth is measured by a standard called money. Time is money. Therefore, if you have all the time there is you have all the money there is.

Substantially that logic is sound. The vast majority of human beings exchange their time for money. Investing time, therefore, is simply a matter of intelligent exchange. It is in the hands of every man to make a minute or an hour or a day or a week earn more for him by the simple process of exchanging more of his time for more money. The more he gives the more is he likely to get.

Invest your time wisely, generously, thriftily; save it as you would money, avoid wasting it as you would avoid wasting money. You will find it at once the most fascinating and the most profitable thing in the world.

Are You a Trained Observer?

THERE is a world of difference between casual observation and systematic, purposeful observation. A careful scientific observer can learn more in a few months about a given subject than the average man learns in a lifetime about it. The difference lies mainly in two factors: (1) The relative concentration of attention, and (2) the analysis and comparison of data.

In December we abstracted a paper by Mr. Ernest Coxhead of San Francisco on "Training the Architect by Direct Method." One of his most suggestive statements was this:

The power to visualize architecture is not to be developed to any extent merely by seeing things, or by gaining fleeting impressions, but by observation, focused and concentrated upon the object in general, and in detail, by actual contact with the building and by means of measured drawings and sketches and notes, further impressing upon the mind the observations made. The essence of the direct method then lies in taking the student to architecture and confronting him with it in three dimensions, life-size, as opposed to the atelier method of focusing his attention upon mere documentary representation of the actual building. In the latter case his sense of scale is undeveloped, his ideas of proportion remain distorted, and, by laborious mental effort, he sometimes is able to construct in his mind from the documentary study of plan, elevation, and section what the subject of study, or something akin to it, is in the reality.

Mr. Coxhead is emphasizing the "direct method," or the "field work method," of training architects, with particular reference to developing a sense of proportion. We quote him, however, for another purpose, namely to emphasize the value of "observation, focused and concentrated upon the subject."

When an engineer is asked to state his experience in a given field we are all prone to give undue weight to the number of years of his experience. Rarely do we undertake to measure the degree of his concentration of observation during those years. Yet without concentration of observation, mere personal presence among suitable surroundings adds little to any man's knowledge. During the last 200 years men have learned more about natural laws than during all the countless centuries before, not because modern man has a better brain than his ancestors, but because he has employed better methods of studying nature. In like manner a well trained young engineer may learn more in 10 years than an ill trained engineer has learned in 50.

More and more do educators realize that their main functions are, first, to arouse ambition, and, second, to instill lasting habits of carefully observing, reading and reasoning. It seems to us that engineering societies should also endeavor to strengthen such habits. To this end it will be wise to have classes in scientific observing, classes in systematic reading, classes in memorizing, and classes in logic. Call them classes in applied psychology, if you please, to differentiate them from classes whose main object it is to impart information rather than to develop mental habits.

It does not suffice to know what to do and how to do it. Men must be habituated by long practice, usually under mental trainers, to act in accordance with the principles to which they readily give lip service.—Engineering and Contracting.

* * *

Criticism of New York's Victory Architecture

A rather violent school of New York thought holds that the lath-and-plaster Victory arch at Fifth avenue and Twenty-third street should be pulled down and forgotten as soon as possible. Another school, principally led by those who had one or more hands in the making of the arch, think

that it should be perpetuated in marble. The chances are that the fuss will be continued until the arch falls of its own weight and blocks the street.

Those who dislike the arch hold that its art is of the early Tweed era. Also that it spoils the fine vista down Fifth avenue, or up Fifth avenue, as you will. Also that the arch is a heritage from Roman wars and victories, and that it symbolizes the yoke set upon the neck of a conquered people. Also that if the American people is to monument its achievements in the war that its artists should be able to devise an American form of art expression.

"The depth bomb was an American invention," say these persons, "and the depth bomb finished the submarine, which at one time threatened to finish the war. The American invention of the airplane was the one big new thing in the war. It would be rather a pity if the American artists are forced to fall back on an art form that was old 2,000 years ago."—Exchange.

* * *

A Seventeenth Century New England Frame House

ONE of the best preserved houses of the earlier Colonial period in New England is the "Parson Capen House" in Topsfield, Mass., built in 1683 by the Rev. Joseph Capen and described in the latest bulletin of the Society for the Preservation of New England Antiquities. The house is now owned by the local historical society and was carefully restored in 1913 by its secretary. This house was well built, even for its day, and it possesses architectural embellishments unknown in other existing dwellings of that period. The second story widely overhangs the first in front, the garret floors project at either end and all are supported by ornamental wooden brackets. The overhang is a form of timber construction common in old English work and seems to have been done solely for its architectural effect. Beside the front door and under the gables are brackets that help to support the overhang.

The framework of these houses was usually of oak, though sometimes of pine and made of heavy timbers mortised and tenoned together and held in place by wooden pins. Their joints were hewn with much skill by men who worked as their medieval forefathers had done. The foundation timbers rested on an underpinning of field stones, laid without mortar.

The timbers of the framing in the Parson Capen house are of course very old, and the original newel and turned balusters of oak are still in place. Much of the interior woodwork, however, and all of the shingles and clapboards are restored. This restoration serves to show how the houses of the early period looked when fresh from the hands of the builders. Under the northern ends of the "summer beams"—which is one of the curious features in the Parson Capen House—being girts spanning the rooms, is incised with a chisel the date, "July ye 8th, 1683," so that the exact date when the "frame" was raised is known.

* * *

Los Angeles Chapter Nominates Officers

Mr. Edwin Bergstrom, president of the Southern California Chapter of the American Institute of Architects, has been renominated for the presidency, as have Mr. H. F. Withey, vice-president, and Mr. R. Germain Hubby, secretary. The committee expressed regret that the by-laws of the organization, which provide that officers shall not serve more than two years consecutively, made it impossible to renominate Mr. August Wackerbarth, treasurer, and Mr. Robert H. Orr, director. The committee nominated Mr. D. C. Allison for director and Mr. Robert H. Orr for treasurer. The election will be held in December.

Depreciation—As an Apartment House Problem

By THOS. J. CHRISTAT, Secretary Apartment House Owners
and Managers Association, San Francisco.

THE matter of depreciation is a question which should receive the attention of all owners of apartment houses. It is a question of particular interest at this time when realty values are passing through a period of readjustment and the fixing of the worth of an improvement is perplexing owners.

While the subject is one upon which widely divergent opinions may be obtained, there are, however, certain fundamental principles which are controlling factors and which should be clear to all.

Capital invested in improved real estate is partly in the land—which is a fixture which will last as long as time itself, and, if wisely selected, should enhance in value. The balance is taken by the improvements or buildings which are perishable, which must eventually disappear and the capital represented be lost unless sufficient rents are obtained to pay fixed charges and interest and to create sufficient reserve to offset the cost of the buildings.

The forces tending to destroy and render unfit the buildings for profitable usage are those of depreciation. There is a physical deterioration, which is the natural wearing out of the structural elements composing the building. In addition, a second and greater factor conspiring to bring improvements to a scrap heap is economic depreciation or obsolescence. It is evident that a building has a physical life determined by the composite endurance of the brick, timber, steel and other material of the make-up. Many attempts have been made to derive a scale of percentage which could be used as an approximate guide in determining the physical life and economic life of different classes of buildings.

The highly developed small unit apartment house, with all manner of specialized built-in furniture and devices particularly designed to please the passing whim of transient tenants, is a one utility and must, by its limitation, be a structure in which obsolescence is very heavy.

A great many tenants who rent apartments never take any interest in this matter, and if we go back over the years 1915, 1916 and 1917 we will find that those who built apartment houses never figure on obsolescence, and the result was they thought they were making 6 per cent on their investment. Later, when repairs had to be made, they found they were deceiving themselves, and some received only 2 per cent, others 3 per cent and 4 per cent, but none over 5 per cent, and it was necessary for our local banks to take over a great many of these houses because the owners could not meet the interest on the mortgage.

A great many lessees are paying \$8, \$9 and \$10.50, others \$12.50 and \$15 per room. When you figure the cost of furnishing these rooms, you will find that today it is 300 per cent more than it was in 1915. For instance, a two-room apartment in 1915 was furnished for \$200; today the same two rooms cost \$575. Carpet which formerly sold for \$1.95 per yard now costs \$5.50 per yard, 300 per cent more. Study the following comparisons of prices between 1915 and 1920 and see how all other furnishings have gone up, up, up.

Sheets—1915, \$9.25 dozen; 1920, \$30.50 dozen; 300 per cent.

Pillow slips—1915, \$1.85 dozen; 1920, \$6.25 dozen; 300 per cent.

Bed spreads—1915, \$1.50 each; 1920, \$3.50 each; 150 per cent.

Cotton face towels—1915, 85 cents dozen; 1920, \$3.25 dozen; 250 per cent.

Cotton bath towels—1915, \$2.75 dozen; 1920, \$7.50 dozen; 300 per cent.

Blankets—1915, \$3.50 each; 1920, \$7.50 each; 110 per cent.

Comforters—1915, \$12.00 dozen; 1920, \$33.00 dozen; 200 per cent.

Other cotton and linen goods in proportion.

After a general survey of a number of houses we find 70 per cent cost furnishings must be replaced in a period of five years.

Steam heat—Enjoyed a *flat rate* of 60 cents per thousand pounds con., now priced at \$2.50 per thousand, or 250 per cent raise.

Fuel oil—In 1915, average 65 cents per barrel, now \$1.75 per barrel, 270 per cent increase.

Labor—Average increase in labor, janitor, maids, etc., 100 per cent.

Upkeep—Plumbing work, etc., 1915, \$1.00 per hour; 1920, \$1.75 per hour. Material, from 150 per cent to 300 per cent. Painting, papering and other items, 100 per cent increase. Taxes, 25 per cent increase. Insurance, accident, raised 400 per cent. Garbage, raised 250 per cent. Incidentals, raised 100 per cent.

And then—Average raised rents—about 25 per cent. A great many of the apartment houses here only get the original rents which prevailed 1912, 1913 and 1914. If these houses were not 100 per cent full today they would not be able to continue in business.

* * *

Praises Western States Architecture

(From the Architectural Review for October.)

THE Architect and Engineer, San Francisco, August.

The number is entitled the Los Angeles number and is a remarkably interesting one, the examples of architecture being well chosen for their merit and being well illustrated. The architecture of the Western Coast states has always been better than that of the Middle West, less exaggerative and eccentric, less theoretically and aggressively "new," and with much more artistic charm, and more hamonious in general character. This may be due to a climate which ameliorates crudities, and a possibility to use concrete and stucco surfaces which are broad and simple, or to the villa traditions of Italy and Spain of studied classic proportions. Probably all three causes exist and in addition the refinements of good taste which accrue to those who have made California a home because of its natural beauty. There is little doubt but what Beaux Arts projects of adolescent students are tempered by sanity in this work, and the stupidities of English Victorian work have not affected it. The examples reproduced are in general highly commendable. The Lincoln Heights Library by Hibbard & Cody is designed with a deliberate *parti-pris* which seems to us a mistaken one, and an echo of school work. A concave form in plan is essentially a terminal feature and requires flanking masses as in the court of the Casa de Papa Giulis of which this is slightly reminiscent. This building appears like a quarter of a circular court and therefore is incomplete. The broken pediment and the arches at the ends are not in harmony with the rest of the design, being the Musée de Luxemburg type, while the remainder is of simpler and better stuff.

* * *

The Eve of a Building Revival

San Francisco and the Bay cities are unquestionably on the eve of a building revival, the likes of which has not been seen in years. By March or April we expect to find architects and contractors overwhelmed with work. All signs point that way. The demand for more buildings is already keenly felt. Labor conditions will adjust themselves shortly; prices will soon be at a stationary level, and banking interests will be prepared to make liberal loans for construction purposes.

THE
Architect and Engineer

INCORPORATED
Founded 1905 by E. M. C. WHITNEY

W. J. L. KIERULFF - *President and Manager*
 FRED'K W. JONES - *Vice-Pres. and Editor*
 L. B. PENHORWOOD - *Secretary*
 T. C. KIERULFF - *Attorney*

ASSOCIATE EDITORS

IRVING F. MORROW - *Architectural Critic*
 CHAS. H. CHENEY - *City Planning and Book Reviews*
 WILBUR DAVID COOK, *Landscape Architecture*
 WM. B. GESTER, *Inspection and Tests*
 O. P. SHELLEY, C. E., *Fireproof Construction*
 F. W. FITZPATRICK, *Structural Steel*
 T. RONNEBERG, C. E., *Roofs and Roofing*
 W. H. LOWE - *Rock and Gravel*
 FRED'K N. WOODS, JR., *Cement*
 W. H. GEORGE - *Electrical Construction*
 PAUL C. BUTTF - *Reinforced Concrete*
 H. J. BRUNNIER - *School Equipment*
 I. W. FRICKE, *Hardwood*
 C. H. WHITE, *Department of Safety*
 WILL I. FRENCH, *Department of Safety*

Published Monthly in the Interest of the Architects, Structural Engineers, Contractors and the Allied Trades of the Pacific Coast by The Architect and Engineer, Inc.

BUSINESS OFFICE AND EDITORIAL ROOMS
 627-629 Foxcroft Building, San Francisco
 Telephone Douglas 1828

Los Angeles Representative: Bert Butterworth Agency, Citizens Bank Building, Los Angeles.
 Portland office: 210 Stock Exchange Building, Portland, Oregon.

The publishers disclaim any responsibility for statements made in the advertisements of this magazine.

TERMS OF SUBSCRIPTION
 (Including postage) to all parts of the United States \$2.50 per annum; to Canada 75c additional; to all Foreign points \$1 additional

Vol. LXIII. Nov., 1920 No 2

TO ENCOURAGE HOME BUILDING

A movement is on foot in New York City to restrict commercial building, not only in order to divert building materials and labor to dwelling construction but because, in many cases, the erection of commercial structures results in the tearing down of dwellings and the eviction of families. One such project recently in New York would have resulted in the eviction of 1450 families. At present the city's commercial building program shows the huge total of \$79,000,000 in contracts let. If this is permitted to take priority over house building the absorption of labor, materials and transportation facilities will make home construction practically impossible.

Dr. Copeland, New York City Commissioner of Health, says that something must be done and done quickly in New York City to relieve the housing situation which is intensely acute. He states that New York City health

laws are being winked at by the Health department itself, in many cases, to avoid putting in the streets thousands of tenants who are overcrowding apartments and other buildings.

Before the Senate Committee on Reconstruction and Production Dr. Copeland approved the British plan of stimulating building by selling "housing bonds" guaranteed not only by municipalities but also by the government. He suggests that buyers be urged to take the housing bonds "in the name of civilization" as they bought Liberty Bonds in the name of patriotism.

The congestion described in New York is an excellent barometer of housing conditions throughout the country. California is no exception. With prices tumbling speculators and owners should get busy and build. But they should not make the mistake that some investors have made by building cheap homes—bungalows that are little more than thrown together and which, at best, will last their owners not more than five years. These dwellings are an eye-sore architecturally, not to mention their poorly planned interiors and cheap, flimsy type of construction. Second-hand plumbing, leaky roofing material, discarded imperfect glass, cheap paint and poor millwork all combine to make these so-called homes more of a plague to the community than a benefit. We are loath to admit that such dwellings have been built in Oakland and down the peninsula as far as Santa Cruz and Watsonville, and it seems that in some of these towns the banking interests are supporting the promoters to the extent of advancing them 60 per cent of the cost. The houses are sold for \$3,000 and \$4,000 on the installment plan. Architects who have investigated say the houses are a disgrace and will fall to pieces before the owners get them paid for. If we are going to build homes to relieve the housing congestion, let us build them right and if local inspection is inadequate, let us have a State Board to pass on all plans before permitting construction to proceed.

Notes and Comments

The downward march of prices has reached hardwoods, and most items show quite drastic reductions. Quartered oak, plain oak, gum, hickory and ash and all Southern woods have dropped from \$30 to in some cases \$75 per M. The Northern woods such as birch and maple have not had such sweeping cuts, but they have eased off to quite a degree. Flooring in oak and maple is now quoted at comparatively reasonable rates and the declines in these commodities should have its effect on building.

It is hardly possible that prices of hardwoods can ever go to the pre-war level. Few people have ever expected this. Many producers of hardwood claim that the present prices are below their cost of production. This is in a measure substantiated by the fact that a number of sawmills are closing down; their owners stating that they cannot run their plants at a profit on the prevailing wholesale prices. Be this as it may, the reductions are apparently very welcome to all concerned. They place the hardwood business on a more solid foundation.

* * *

The high crest of prices to which all building commodities had surged was bound to cause a corresponding reaction, and now that this has taken place, general business should flow along in more even and conservative channels. The inflated prices have been deflated. The wise wholesalers are making corresponding reductions to their customers in the prices of the goods they have on hand and are striving to take the greater part of their losses this year. The excellent business enjoyed in all lines at high prices for the first nine or ten months of 1920 has placed most business concerns in a position to stand the very considerable loss entailed by the drop in prices of stock on hand. By taking

this loss this year—that is, by selling their stocks on the basis of the present low prices and not on the basis of the high prices which they paid for them—they will still have a profitable year and be ready to do business next year on the new levels, with a clean sheet to work upon. In other words, by cleaning house now, prices and everything else connected with business should become stabilized by the commencement of the new year.

All of which would seem to bring out the idea that now is a good time to buy or build, manufacture or make repairs.

To Oakland and Berkeley by Electric Submarine Cable

Editor The Architect and Engineer,
San Francisco, California:—

Mr. Know-it-all will now roar: "Another fool proposition." Not long ago he made the same remark about wireless telegraphy. Years ago the same gentleman said reproduction of the human voice was absurd; "Some fool physicians say they can see through the human arm;" Motion pictures were a "phantasy of a disordered brain;" "Flying through the air may be a reality when we are dead, not before;" Harnessing the ocean's power "an impossibility;" Storage of electricity from the air "a dream."

An Express Cable from Market street to points across the bay is not only possible but will be built, unless "interests" prevent it. The people want quick transportation and must have it or San Francisco will have to remain second city on the Pacific Coast.

Friend husband telephones friend wife in Oakland, ten miles away: "I will catch the 5:10 Cable and be there in twenty minutes to dinner."

This cable will be laid above ground, where you "attach yourself" at Market street; plunging under the waters of the bay it reappears near the Oakland mole and goes its merry way to the centre of that city. During the trip you peruse the evening paper, seated on upholstered Pullmanlike cushions or on harder morning rush seats.

This "cable" is fourteen feet in dimensions and the hole through the centre through which electricity "shoots" you is twelve feet in diameter, allowing the passage of a train not impeded by air ahead, capable of seating twelve hundred each trip.

The cable will be free to act for itself from Market street to the centre of Oakland. It will lie on the bottom and will be made and installed without interruption to shipping. It will weigh tens of millions of pounds and will take probably ten months to get in service (Uncle Sam and the State Commission being willing). It will be lined with heavy metal and covered with a conglomerate through which water cannot pass and will be harder each year for the next ten thousand years and made to withstand treble the natural water pressure per inch. The trains will not run on ordinary wheels, to break and get "hot boxes," but glide on greased roller-bearing surfaces, propelled by several interchangeable electric systems to avoid the remotest possibility of "trouble" holding a train for ten seconds under the bay. Instead of the rattle-te-bang of the present electric cars it will glide almost noiselessly, and the slight depression in the centre will not be felt.

EADS & BEACH, Construction Engineers.

Temporary address: 211 O. T. Johnson building, Los Angeles.

Repartee:—"We need brains in this business, 'I know' you do. The business shows it, sir."

American Institute of Architects

(ORGANIZED 1857)

OFFICERS FOR 1920-21

PRESIDENT.....HENRY H. KENDALL, Boston
 FIRST VICE-PRESIDENT.....CHARLES A. FAVROT,
 New Orleans, La.
 SECOND VICE-PRESIDENT.....WM. B. FAVILLE,
 San Francisco
 SECRETARY....W. STANLEY PARKER, Boston, Mass.
 TREASURER.....D. EVERETT WAID, New York

San Francisco Chapter

PRESIDENT.....G. A. APPELEGARTH
 VICE-PRESIDENT.....EARNEST A. COXHEAD
 SECRETARY-TREASURER.....J. S. FAIRWEATHER

DIRECTORS

SYLVAIN SCHNAITACHER, for three years.
 MORRIS M. BRUCE, for three years.
 GEORGE W. KELHAM (to fill the unexpired term
 of Mr. Wm. Otis Raiguel, resigned).

Southern California Chapter

PRESIDENT.....EDWIN BERGSTROM
 VICE-PRESIDENT.....HENRY F. WITHEY
 SECRETARY.....R. GERMAIN HUBBY
 TREASURER.....AUGUST WACKERBARTH

Executive Committee

A. M. EDELMAN ROBERT H. ORR S. B. MARSTON

Portland, Ore. Chapter

PRESIDENT.....W. C. KNIGHTON
 VICE-PRESIDENT.....JOHN V. BENNES
 SECRETARY.....FOLGER JOHNSON
 TREASURER.....O. R. BEAN
 TRUSTEES.....{ ELLIS F. LAWRENCE
 JOSEPH JACOBBERGER

Washington State Chapter

PRESIDENT.....CHARLES H. ALDEN, Seattle
 1ST VICE-PRESIDENT.....JAMES H. SCHACK, Seattle
 2D VICE-PRESIDENT.....GEORGE GOVE, Tacoma
 3D VICE-PRESIDENT.....L. L. RAND, Spokane
 SECRETARY.....F. A. NARAMORE, Seattle
 TREASURER.....EARL G. PARK, Seattle
 DIRECTORS.....{ A. H. ALBERTSON
 C. H. BEBB
 G. C. FIELD

California State Board of Architecture

NORTHERN DISTRICT

PRESIDENT.....CLARENCE R. WARD
 SECRETARY-TREASURER.....SYLVAIN SCHNAITACHER

Members

J. R. MILLER EDWARD GLASS J. J. DONOVAN

SOUTHERN DISTRICT

PRESIDENT.....JOHN PARKINSON
 SECRETARY-TREASURER.....A. M. EDELMAN

Members

W. H. WHEELER MYRON HUNT W. J. DODD

San Francisco Architectural Club

President.....Harry M. Michelson
 Vice-President.....T. Pfueger
 Secretary.....W. E. Baumberger
 Treasurer.....James S. Cole
 Directors—F. F. Amandes, N. Reinhertz, E. B. Hurt.

San Francisco Society of Architects

President.....W. C. HAYS
 Vice-President.....LEWIS P. HOBERT
 Secretary-Treasurer.....H. H. GUTTERSON
 Directors.....{ GEO. A. LANSBURGH
 JOHN REID, JR.

Washington State Society of Architects

PRESIDENT.....HENRY H. JAMES, Seattle
 1ST VICE-PRES.CLAYTON D. WILSON, Seattle
 2D VICE-PRES.JULIUS A. ZITTEL, Spokane
 3D VICE-PRES.WATSON VERNON, Aberdeen
 4TH VICE-PRES.RICHARD V. GOUGH, Okanogan
 SECRETARY.....EDGAR BLAIR, Seattle
 TREASURER.....L. L. MENDEL, Seattle
 TRUSTEES—H. H. JAMES, FRANK FOWLER, A. WARREN GOULD, W. J. JONES, R. H. ROWE, all of Seattle.

Pacific Coast Society of Landscape Architects

Chapter of Am. Society of Landscape Architects

PRESIDENT.....W. D. COOK, JR.
 H. W. Hellman Bldg., Los Angeles, Calif.
 VICE-PRESIDENT.....STEPHEN CHILD
 Fairmont Hotel, San Francisco, Calif.
 SECRETARY-TREASURER.....E. T. MISCHÉ
 Henry Bldg., Portland, Oregon

Tacoma Society of Architects

PRESIDENT.....Roland E. Borhek
 VICE-PRESIDENT.....Earl Dugan
 SECRETARY AND TREASURER.....A. J. RUSSELL

San Diego Architectural Association

PRESIDENT.....WM. TEMPLETON JOHNSON
 VICE-PRESIDENT.....ROBERT HALLEY, JR.
 SECRETARY-TREASURER.....E. C. DECKER

San Joaquin Valley Ass'n of Architects

PRESIDENT.....E. B. BROWN
 VICE-PRESIDENT.....F. V. MAYO
 SECRETARY-TREASURER.....JOSEPH LOSEKANY

American Society of Civil Engineers

Southern California Association

PRESIDENT.....GEO. G. ANDERSON
 FIRST VICE-PRESIDENT.....H. W. DENNIS
 SECOND VICE-PRESIDENT.....W. K. BARNARD
 SECRETARY.....F. G. DESSERTY
 TREASURER.....RALPH J. REED

DIRECTORS

GEO. G. ANDERSON W. K. BARNARD
 LOUIS C. HILL RALPH J. REED
 H. HAWGOOD F. G. DESSERTY
 I. W. DENNIS
 All communications should be addressed to Mr Dessery, 511 Central building, Los Angeles.

San Francisco Association

PRESIDENT.....M. M. O'SHAUGHNESSY
 1ST VICE-PRES.....W. L. HUBER
 2ND VICE-PRES.....F. R. MUHS
 SECRETARY AND TREASURER.....NATHAN A. BOWERS

BOARD OF DIRECTORS

W. L. HUBER
 F. R. MUHS M. M. O'SHAUGHNESSY
 E. J. SCHNEIDER NATHAN A. BOWERS
 Address all communications to the secretary, 502 Rialto Bldg., San Francisco.

American Association of Engineers

National Headquarters, 63 E. Adams St., Chicago

PRESIDENT.....L. K. SHERMAN
 FIRST VICE-PRESIDENT.....H. O. GARMAN
 SECOND VICE-PRESIDENT.....A. B. MCDANIEL
 R. W. BARNES Portland
 FREDERIC BASS Minneapolis
 B. A. BERTENSHAW Cincinnati
 W. C. BOLIN Chicago
 RAYMOND BURNHAM Chicago
 C. E. DRAYER.....Secretary

SAN FRANCISCO CHAPTER

PRESIDENT.....WILLIAM WOLLNER
 FIRST VICE-PRESIDENT.....J. F. JOHNSON
 SECOND VICE-PRESIDENT.....W. H. PHELPS
 TREASURER.....R. L. KESSING
 SECRETARY.....A. G. MOTT
 Permanent address, 960 Pacific Bldg.

LOS ANGELES CHAPTER

PRESIDENT.....FRANK H. GAYNER
 FIRST VICE-PRESIDENT.....C. A. HEINZE
 SECOND VICE-PRESIDENT.....H. Z. OSBORNE, JR.
 SECRETARY.....D. E. GODFREY
 TREASURER.....E. H. MERRILL
 Permanent address, 625 Metropolitan Bldg., Los Angeles.

With the Architects

Building Reports and Personal Mention of Interest to the Profession

Personal

MR. A. W. MERRILL, sales manager for the General Boilers Company in this territory, has recovered from a severe illness and is back at his desk in the company's coast headquarters, 322 Monadnock building, San Francisco. Mr. Merrill recently returned from Los Angeles where his company maintains a Southern California branch at 1310 South Hill street.

MR. FRANK SPENCER, president and manager of the Spencer Elevator Company, San Francisco, recently enjoyed his first visit to the Eastern states. He was accompanied by Mrs. Spencer. The convention of Elevator manufacturers at Toledo was an objective point.

MR. EDGAR A. MATHEWS and MR. HORACE G. SIMPSON, architects, announce their association for the practice of architecture. Office will for the present be located in the Call building, New Montgomery street, San Francisco.

MR. W. HASTINGS, architect, formerly of Everett, Washington, is now associated with Wallace & Bush, construction engineers, of San Jose.

Much Church Work in Prospect

There are prospects that church construction throughout the state will be unusually active during the coming year. Money will be available after the first of the year from many of the large demonstrations, including the Methodists and Christian Science congregations. Mr. Carl Werner has been commissioned to prepare plans for a \$200,000 edifice for the Fourth Church of Christ, Scientist. Mr. Robert H. Orr of Los Angeles, is preparing plans for a \$135,000 brick veneer church for the First Christian Church of Stockton, and Mr. W. J. Wythe has made preliminary plans for a large edifice to cost \$500,000 or more for the Methodist Episcopal Church at Leavenworth and McAllister streets, San Francisco.

Berkeley Apartment House

Plans have been completed and a contract has been let by Mr. W. H. Ratcliff, Jr., for a three-story frame and plaster apartment house on Durant street, near College avenue, Berkeley, for Mrs. Bowie.

Oakland Architects Busy

Messrs. Schirmer-Bugbee Company, 527 Thayer building, Oakland, have plans on the boards for several large country residences, including one at Los Gatos for Mr. W. W. Garthwaite, Oakland, banker; one for Mr. Jackson at Los Gatos, and a large bungalow for Mr. H. S. Scott at Ross. Preliminary drawings are being made for two apartment houses in Oakland, one to cost in excess of \$100,000.

Los Angeles Stadiums

Plans are being prepared by Messrs. John Parkinson and Donald B. Parkinson, 420 Title Insurance building, Los Angeles, for a stadium 600x400 to seat 32,000 people for the University of Southern California.

An immense stadium is also planned by the Pasadena Rose Festival Committee at Pasadena. The structure will accommodate 60,000 people.

Tower for Mission Inn

Mr. Frank Miller, proprietor of the famous Riverside Mission Inn, is planning another new feature in the form of a tower 200 ft. high and a ball room of Spanish architecture to be erected at the Sixth and Main street corner of the hotel grounds. The tower will be called the Tower of Seville. Mr. A. B. Benton, architect, of Los Angeles, an authority on Spanish and Mission architecture, has prepared sketches for the proposed improvement.

Piedmont Manor Residence

Messrs. Meyer & Johnson, architects in the Bankers Investment building, San Francisco, have prepared plans for a one-story and basement frame and stucco bungalow to be built in Piedmont Manor, Oakland, for Mr. Louis Hilborn, an attorney in the Crocker building, San Francisco.

Women's Club Building

Plans are being prepared by Mr. Ralph P. Morrell of Stockton, for a \$35,000 hollow tile club building for the Lodi Women's Club at Lodi.

Portland Temple Competition

The following interesting paragraphs are taken from the program of an architectural competition being conducted in Portland, Oregon, for a Masonic temple:

The architect selected by the Jury of Awards will be delegated to prepare plans and specifications for the structure and to supervise the construction.

Any additional architects selected to enter the competition will be announced on October 15. The board of trustees agrees that no architect will be admitted to the competition to whom they are not willing to award the commission in event he is the winner of the competition.

The Jury of Awards will include: The three members of the Board of Trustees, Mr. P. S. Malcom and an architect to be selected from a list furnished by the professional advisor.

The Board of Trustees agrees that the jury shall have authority to make the award and its decision shall be final. And a selection shall be made from the list of competitors providing a design is submitted which conforms with the requirements. The professional advisor will examine the plans and report to the jury of any deviations from the program. Selection shall be made by secret ballot and the successful architect will not be known until the selection of the design has been agreed upon. Competitors ranking second in selection will receive an award of \$600 and third will receive \$400. No features embodied in the unsuccessful designs will be used without the permission of the architect.

No sum of money is set as the probable cost due to the uncertain building costs and the indefinite time as to when actual construction will be undertaken. Architects are given the information that the building shall consist of 2,000,000 cubic feet of cubical contents.

The building is to be constructed of brick and terra cotta. Stone is not to be contemplated except as an un moulded and undecorated base course and the use of such stone shall not extend above the lowest window sills.

Architects are warned against designs of a stone type being transformed into brick and terra cotta. In the use of the terra cotta, the jury will not recognize the conventional assumption that terra cotta is necessarily a material calling for a high degree of ornamentation or special surface treatment.

The general interior construction of all floors will be reinforced concrete. The roofs may be of joist or timber construction with the exterior covering the fire resistive surface.

Plans will include a cathedral hall with balcony to seat 2500 persons; entrance lobby of liberal proportions, coat and toilet rooms, stage and property rooms, organ, ante rooms, small hall, library lounge, all of which will be on the main floor. The lower floor will include banquet and ballroom, refreshment room and kitchen, janitor's apartment and furnace and fan room.

\$350,000 San Jose Theatre

Mr. Chas. S. McKenzie, architect of San Jose, is preparing working drawings for Beatty's American Theatre in San Jose. The new moving picture house will be constructed of reinforced concrete and will seat 1,500 persons. It will have an immense pipe organ, stage, scenery and special lighting equipment. The owners say they intend to spend \$350,000 on the building and furnishings.

Richmond Wharf and Warehouse

Plans are being drawn by City Engineer H. G. Chapman of Richmond for extensions to the Municipal pier and additional warehouses.

Says High Prices Will Continue

There will be no material decline in building costs for the next ten years in the opinion of Mr. Edwin Bergstrom, president of Southern California Chapter, American Institute of Architects, who addressed the Los Angeles Realty Board at its October meeting. Mr. Bergstrom based his prediction on the great building shortage throughout the country and labor conditions.

He illustrated his address by charts showing the volume and cost of building year by year from 1910 to 1920. The present shortage in building is estimated at 1,065,000,000 sq. ft. based on the annual average of building between 1910 and 1914. Between 1910 and 1914 the average cost of building was \$1.62 sq. ft. In 1915 the average cost dropped to \$1.52 per sq. ft. In 1919 the cost rose to \$3.20 sq. ft. and during the early part of 1920 it mounted to \$3.50.

Mr. Bergstrom stated the cost of building materials in Los Angeles had increased about 155 per cent between 1914 and 1920. If building activities are resumed on a large scale he predicted new high levels may be reached.

San Jose Architects Busy

Messrs. Wolfe and Higgins, San Jose architects, report being exceptionally busy for the winter construction period. Plans have been drawn for two large country houses at Mt. Eden for the Oliver Brothers, one to cost \$30,000 and the other \$20,000; alterations to the St. James hotel, San Jose; a \$15,000 automobile machine shop for John H. Graves and several small dwellings in Santa Clara county.

Adopts American Plan

The Judson Manufacturing Company of Oakland announces that its plant will be run on the American plan. This is the first move made in the Bay district, outside the shipyards, to break away from the closed shop. The American plan has been in effect at the shipyards for several months.

Vallejo Water Plant

The city of Vallejo has voted bonds amounting to \$1,250,000 for improvements to the municipal water supply, including construction of a concrete dam and pipe line in Gordon Valley. Plans are being prepared by City Engineer T. D. Kilkenny.

Country School Building

Mr. Hugh Y. Davis, of Stockton, is preparing plans for a \$40,000 school house for the Denair School District, Stanislaus county.

Oakland School Programme

Something more than \$1,000,000 of the Oakland school bond issue has recently been sold, making available that much money for immediate construction work. Contracts are being let at the rate of two school buildings a week, which will enable the board of education to make some progress in the long deferred construction work.

Insurance Office Building

Mr. A. H. Knoll, architect in the Hearst building, San Francisco, has completed plans for a \$40,000 Class "C" reinforced concrete insurance office building to be erected on the southwest corner of Montgomery and Clay streets. The design is classic with sandstone and plate glass front.

Native Sons' Club Building

The Native Sons' Athletic Club of San Francisco will erect a \$100,000 building on Mason street near Geary, from plans being prepared by Mr. W. B. Gebhardt, who has offices with Mr. Alfred Henry Jacobs in the French Bank building, San Francisco.

Dormitory at Palo Alto

Messrs. Bakewell & Brown, of San Francisco, have completed plans for a three-story reinforced concrete men's dormitory to be erected on the campus at Stanford University, Palo Alto. The building will cost \$175,000.

Oxnard School to Be Re-Figured

All bids have been rejected for the construction of a new high school building at Oxnard, Ventura county, and the architects, Messrs. Allison & Allison, Hibernian building, Los Angeles, will call for new bids the first of the year.

\$45,000 Residence

Messrs. Bliss & Faville, Balboa building, San Francisco, have completed plans for a handsome two-story and basement frame and stucco residence to be built in Sea Cliff, San Francisco, for Mr. Ney Wolfskill at a cost of \$45,000.

Alterations to Cliff House

Extensive alterations are being made to the historic Cliff House on the Great Highway, from plans by Mr. C. O. Clausen. The building has been leased to Roberts Bros.

Warehouses Planned

The George W. McNear Company has purchased additional waterfront land at Martinez and it is understood the company will spend \$100,000 or more in warehouse and dock construction.

Informal School Competition

The following architectural firms participated in an informal competition for a new school building for the Penitentiary School District, near San Jose:

Leo J. Devlin, San Francisco.
Henry C. Smith, San Francisco.
E. L. Norberg, San Francisco.
Wolfe & Higgins, San Jose.
Warren Skillings, San Jose.
Binder & Curtiss, San Jose.

\$25,000 Apartment House

Mr. Warren Skillings of San Jose has completed plans for a two-story \$25,000 frame apartment house for Mr. H. M. Garcia to be erected at 10th and San Antonio streets, San Jose. The building will contain eight apartments of three rooms each.

Work of Los Angeles Architects

The work of Messrs. Morgan, Walls and Morgan, well known Los Angeles architects, will be shown in the January number of The Architect and Engineer. The entire issue will be taken up with illustrations of buildings designed by this firm in the past ten or twelve years.

Lancaster High School

Mr. John C. Austin, 1125 Baker-Detwiler building, Los Angeles, has completed plans for new buildings to be erected at the High School site at Lancaster for the Antelope Valley Union High School District. Bonds in the sum of \$200,000 have been voted and sold.

Alhambra High School

The board of supervisors has sold the \$112,000 bond issue of the Alhambra High School District. Messrs. Allison & Allison, 1405 Hibernian building, Los Angeles, are the architects and will prepare plans for a new commercial building to be erected at the High School site.

Fresno Bank Building

The Fidelity Bank & Trust Co. has purchased an additional lot on Mariposa street, Fresno, giving it a site 80x125 ft. for its new building. It will be of the sky-scraper type and plans are being prepared by R. F. Felchlin & Co., Fresno.

Open Los Angeles Office

Messrs. Weeks and Day, architects in the Phelan building, San Francisco, will open permanent offices in Los Angeles in addition to the offices maintained in San Francisco and Sacramento.

Sunol School Building

The school district at Sunol, in Niles canyon, is to have a fine new school building. Competitive plans by San Francisco, Oakland and San Jose architects have been submitted.

American Institute of Architects
THE OFFICIAL MINUTES

San Francisco Chapter

The annual meeting of the San Francisco Chapter of the American Institute of Architects was held in the Architectural Club Rooms, 77 O'Farrell street, on Thursday evening, October 21st. The meeting was called to order by the president, Mr. Sylvain Schnaittacher, at 8 p. m.

MINUTES

The minutes of the meeting held on September 16th, 1920, were read and approved.

STANDING COMMITTEES

Two reports from standing committees were read. Mr. John Bakewell, Jr., chairman of the committee on education, submitted a written report which was ordered read, and on motion duly seconded and carried. A copy of the report was ordered sent to the Institute on Education and also to Professor John Galen Howard of the Department of Architecture at the University of California and to Mr. Harry Michelsen, president of the San Francisco Architectural Club. Mr. John J. Donovan, as chairman of the committee on legislation, made a written report on the progress of this committee which was ordered read and placed on file.

REPORTS OF OFFICERS

The president read his annual report which was ordered received and placed on file.

The secretary read the annual report of the board of directors and of the secretary, both of which were ordered received and placed on file.

GENERAL BUSINESS

From Mr. William Stanley Parker, secretary of the A. I. A., enclosing copy of pamphlet concerning War Memorials; one in re proposed changes in the Schedule of Charges; one relative to Community Planning, from Mr. John Irwin Briest, chairman on committee on Community Planning, A. I. A., regarding the lecture on Community Planning; from Mr. William Stanley Parker, secretary of the A. I. A., asking for a report from this chapter in re Draftsmen's Unions; from Mr. E. C. Kemper, executive secretary of the A. I. A., stating that the resignation of Mr. William Otis Raiguel as an Institute member would be acted upon at the board meeting on November 19, 1920; from Mr. T. B. McGuinniss, assistant clerk of the Board of Supervisors, thanking the chapter for letter relating to co-operation with city officials in building construction to prevent fire hazards; from Mr. John J. Donovan relative to his committee on legislation, and calling attention to the revision of the present registration law which is to

be presented at the coming session of the Legislature; from Mr. Joshua H. Vogel asking for his assignment to the Washington State Chapter, A. I. A.; from California Housing and Building Institute enclosing Progress Report No. 7; from National Fire Protection Association in re annual meeting to be held in San Francisco June 7, 8 and 9, 1921; from Mr. Ernest Coxhead in re Southern California Chapter, A. I. A., forming an Association for Public Service.

Mr. Bruce, for a committee appointed to confer with the directors of the Central Council of the Builders' Exchange on the relations of the Chapter to the Central Council, reported progress, but that no meeting has yet been held with the directors.

NEW BUSINESS

On motion, duly seconded and carried, a letter from Mr. Parker in re "Schedule of Charges" and "Draftsmen's Union" was ordered referred to the executive committee.

On motion, duly seconded and carried, the resolution offered by Mr. Coxhead in re Chapter finance was ordered referred to the board of directors.

On motion, duly seconded and carried, the chair was instructed to appoint a committee to obtain from the Engineers a draft of their proposed registration law and distribute copies to the Chapter members and to confer with the Engineers on the proposed law and report at the next meeting of the Chapter.

Mr. Schnaittacher spoke in re to the proposed revision of the registration law.

Mr. Mooser spoke in behalf of the Building and Housing Institute, and urged the co-operation of the Chapter members.

A vote of thanks was tendered to the administration of last year for their services during the year.

UNFINISHED BUSINESS

On motion duly seconded and carried, the resolution offered by Mr. Coxhead in re financing of the institute was adopted, and a copy was ordered sent to the secretary of the institute.

ELECTION OF OFFICERS

The next order of business being the election of officers for the ensuing year, the secretary was directed to cast the ballot for the regular nominees, whereupon the chair announced that the following had been elected to serve the Chapter for the ensuing year:

President.....Mr. G. A. Applegarth
Vice-President...Mr. Ernest A. Coxhead
Sec'y-Treasurer...Mr. J. S. Fairweather
Directors: Mr. Sylvain Schnaittacher, for three years.

Mr. Morris M. Bruce, for three years.
Mr. George W. Kelham (to fill the unexpired term of Mr. Wm. Otis Raiguel, resigned).

Subject to approval,

MORRIS M. BRUCE, Secretary.

With the Engineers

Reports from the Various Pacific Coast Societies,
Personal Mention, Etc.

An Argument for "Sanitary Engineer"

By ROBERT VESSEY, in Valve World

WHILE I realize that it will require time, patience, and perseverance (as all good things do), still I trust that the day is not far distant when the old and worn out term "plumber" will be eliminated, and in its stead, the more dignified, elevating, and proper term "Sanitary Engineer" instituted.

This subject is of importance to the future of all engaged in the sanitary craft, not only as a means of elevating the business to a proper plane and eliminating old prejudices and jokesters, but really applying a truly descriptive term to the craft, the word *plumb* meaning straight, or *plumbum* as translated from the Latin meaning lead. The name plumber being a coined word for lead worker, certainly does not apply to present day methods, this much we all know.

A proper analysis of the situation under present conditions will show that the only true term to apply would be sanitary engineer, as in the first place through the installation of such fixtures as supply the water to permit of bathing, sprinkling the streets, flushing, washing or in any way contributing to the hygiene of the people, and as a means of carrying off the filth and refuse through sewage is considered a sanitary measure; and this being the prime factor the term "sanitary" is certainly properly placed. It is also a certain fact that with such strict laws, codes, ordinances and technicalities which must be adhered to, the fact that he must have the knowledge to read and work from plans, specifications, blue prints, must serve a term of apprenticeship, stand an examination before obtaining a license and after acquiring this store of knowledge he must have exceptional engineering skill to perform his duties, especially in the installation of fixtures and engineering work in our great hotels and office buildings of today, my idea is that such a man is an engineer in every sense of the word, and as such, no better and no other name should be applied.

In the old days when there was no recognized need for sanitary laws, rules and regulations the term "plumber" was no doubt practical, but under Twentieth Century methods it is obsolete.

There has been much discussion on this very important subject, with the result that up to the present writing no one has been able to come forward with a real reason why the term "Sanitary Engineer" should not be adopted, while the fact is very evident that the term should be adopted, "and without delay."

It is a source of real satisfaction to me to note that we have two progressive states and a few progressive cities that have taken the lead for the betterment of the craft and have adopted the term sanitary engineer. The two states are Indiana and Tennessee, the former being known as The Indiana Society of Sanitary Engineers and the latter The Tennessee Sanitary Engineers' Association. Personally I prefer the former style and would like to see this style standardized for each state and if adopted throughout the country to be known as the National Society of Sanitary Engineers. And in this connection I would suggest that the inspectors be known as sanitary inspectors, the journeymen as sanitary fitters, while the man who is engaged in strictly repair work could be known as a "sanitary crafter" or have a sign reading "Sanitary Repairs and Fittings."

A publicity campaign would quickly acquaint the public with the new terms as applied to each branch of the craft, and while I realize that these terms sound odd and peculiar to you, think what it will mean to the future of your business which has been the butt for so-called jokes, cartoonists, cheap actors and such like. However, the changing of the name must be accompanied by more constructive business methods else very little will have been accomplished. Let us open the way for more progress and uplift which will be a long stride in the right direction.

I have made every effort to have the term "Sanitary Engineer" adopted since 1913 and I trust that with the momentum which the movement has acquired there will be no let-up until it has been generally adopted.

American Society of Civil Engineers
SOUTHERN CALIFORNIA SECTION

Southern California Section, American Society of Civil Engineers, voted unanimously at its October meeting to join

in the formation of the proposed California Engineering Council.

By unanimous vote the section also approved the proposal that the American Society of Civil Engineers become a charter member of the Federated American Engineering Societies. Action followed an earnest appeal by G. G. Anderson, member of the joint conference committee, for the support of the members on the proposed affiliation.

A committee consisting of Messrs. E. R. Bowen, E. A. Bayley, J. A. Griffin, G. C. Fitzgerald and F. G. Dessery was appointed to co-operate with the Portland Cement Association in the preparation of standard specification for cement concrete pipe.

Mr. Hawgood called attention to efforts which are reported being made to remove from office State Engineer W. F. McClure, asserting that this effort is for selfish motives. The matter was referred to the president and officers of the section with full authority to take such action as they deem proper.

Mr. H. W. Dennis read a paper giving the results of a study of stream flow with particular reference to a comparison between the flow as observed at two points on the Kern river and a method of adapting the records of flow at one point to another point on the same stream. Stereopticon pictures were used to illustrate his discussion of the subject.

* * *

SEEK NEW MEMBERS

The San Francisco Chapter of the American Association of Engineers is taking part in a national campaign to enlist 10,000 new members. This new association has 21,000 members and includes all of the progressive elements of the profession. It is the engineer's business organization as distinguished from the various technical associations known as the founder societies. Applications will be received at 960 Pacific building.

* * *

NEVADA CHAPTER

Nevada Chapter, American Association of Engineers, has been organized with about 70 members. Mr. H. W. Loy is president; Mr. H. F. Holly, vice-president, and Mr. L. V. Campbell, secretary. The headquarters of the chapter are at Carson City but a service bureau has been opened at Reno under the direction of Mr. A. A. Horwege.

The A. A. E. schedule of salaries for engineers in municipal service was approved by the American Society for Municipal Improvements at the recent convention of that body in St. Louis.

* * *

ANNUAL ELECTION

The annual election of the San Francisco Chapter, American Association of Engineers, will be held December 7.

The officers to be elected are president, first vice-president, second vice-president, secretary, treasurer, representatives for the Joint Council and representatives for the State Assembly.

* * *

VOTES TO RAISE DUES

By a vote of 75 to 8, Los Angeles Chapter, American Association of Engineers, declared in favor of increasing the dues of all members except student members from \$10 to \$15 per year and for a division or dues under the proposed Burnham classification. The vote was taken at a meeting held at the Chamber of Commerce building on October 8, in response to a call from national headquarters for a referendum on both propositions.

Los Angeles Chapter, which is now the second largest in the United States, with 606 paid-up members and 223 applications pending, was responsible for the referendum, being the first to suggest it.

* * *

SANTA CRUZ ENGINEERS' CLUB

A club of the American Association of Engineers will be organized at once in Santa Cruz. All engineers residing in that general vicinity should make inquiry of Mr. H. O. Beck, Temporary President, who will furnish them with information concerning the new Club.

* * *

TO ENTER NEW FIELD

The San Francisco Chapter of the American Association of Engineers has organized a Service Bureau, with headquarters at 960 Pacific building, to act as a clearing house for engineering positions of every nature.

The bureau is in touch with all employers of engineers in the Bay region, and as soon as it receives notice of an opening for an engineer, it sends around a man whose experience and qualifications as on file with the Bureau are best suited to the requirements of the position.

This service is free to all A. A. E. members, and fills a longfelt need in the engineering profession. An engineer seeking a position has formerly been compelled to make the rounds of all employers of engineers, and often spend days locating a position which he could have found immediately through the Service Bureau.

V. D. COUSINS.

Climate and the Dairy Farm

The committee on ventilation of farm buildings of the American Society of Agricultural Engineers is making a study of the proper housing conditions for stock in different parts of the United States and Canada.

As the cow is the source of heat in the dairy barn it follows that the construction and ventilation of the barns must be

different in the northern part of the country than in the southern to maintain the proper temperature and sanitary conditions of the air.

An article under the head of "Climatic Dairy Barns," by Messrs. W. B. Clarkson and C. S. Whitnah is published in the October number of the society's journal, "Agricultural Engineering." The authors have divided the country into four well defined zones, based on sustained low temperatures in the winter months, and outline the proper type of barn in its relation to the temperature of the different zones.

New York Greets California

A HANDSOME bouquet is extended to the so-called California type of apartments by the Sun and New York Herald in the following editorial in a recent issue:

From California Mr. Whitney Warren, the New York architect, has adopted and adapted a type of apartment which he believes will go a long way toward solving, or at least bettering, living conditions in this city. Mr. Warren's firm has designed an apartment house for New York in which, as he says, "the California type of apartment, by which convertible living and dining rooms are also used as sleeping rooms, gives twenty-four hours a day service." This fashion of interior domestic architecture in which beds appear where escritoires and buffets stood is now fairly familiar to all those who know the California of today. Its origin is probably due to the need for convenience in homes of the bungalow type so numerous in that state. Its practicability has been demonstrated. And now it receives the compliment of being borrowed by the East, an event rarely occurring in art, where movements are nearly always from East to West.

What Mr. Warren proposes is to have the new type of New York apartment home centre around a large living room. On either side of its fireplace he would have alcove sleeping rooms with dressing rooms behind them, these rooms being cut off from the main room by doors that would fold back into the jambs during the day. Kitchen and butler's pantry would be separate rooms communicating with one end of the central room only through the pantry. One end of this room would be used for dining, "a discreet use of screens," as he says, preventing "any disturbance of the occupants by the table preparation." To a degree this idea of dining and living room in one has been adopted in many modern country houses in the East and in a few New York apartments, chiefly by artists. But in the structure designed by Mr. Warren is to be found the first instance of this alcove idea. It may help to remedy the over-crowded conditions in New York.

Orpheum Contracts Awarded

Contracts have been let during the past month for the construction of million dollar Orpheum theater and office buildings in San Francisco and Los Angeles, from plans by Mr. G. Albert Lansburgh, Gunst building, San Francisco, who will also design the new Orpheum in Oakland.

Santa Maria Hospital

Preliminary plans have been prepared by Mr. W. C. Hays, 1st National Bank building, San Francisco, for a \$50,000 private hospital at Santa Maria for Dr. Coblenz of that city.

Criticism of Mr. Lindstrom's Article on Concrete Storage Tanks

Editor The Architect and Engineer,
San Francisco, California:—

I have read with a great deal of interest the article entitled "Concrete Storage Tanks," by Mr. Robert Seth Lindstrom, in the September, 1920, issue of The Architect and Engineer. . . . The following remarks are offered in the line of constructive criticism and I trust that they will be accepted in that light.

Statements which appear through the entire article show the shallowness of it. For instance, although I have seen and heard of many kinds of portland cement, I have yet to hear of the "Portland Brand." Neither have I ever heard of the cement attacking the silica of the sand and aggregates. Mention is also made of the fact that "the reinforcement should be so placed that the concrete would readily pour." Although these are small items they indicate various fallacies.

Although I might enumerate numerous other points there are two which are all too obvious. In the third paragraph mention is made that "concrete tank construction requires most careful consideration, especially in the field where the human element enters into the proportioning, mixing and placing of the concrete." It would seem as though "Reground Cement" should eliminate all such troubles. In other words, just as satisfactory results could be obtained with common labor as with skilled concrete workers. To cap this, provision is made for plastering porous spots or defects that appear. It also seems that the only time when concrete need be wet down is in case that it is exposed to heat or hot weather. Experience has proven that one of the fundamentals in securing good, sound, durable concrete is proper curing.

If Mr. Lindstrom's ideas on expansion and contraction due to temperature changes are correct, he has succeeded in overthrowing absolutely every theory and experiment dealing with concrete. So far as I have ever been able to determine heat is transmitted by molecular motion. This is in no way dependent upon the porosity of the concrete. I believe that many experiments have shown and definitely proved that there is a coefficient of expansion in concrete regardless of whether there is any moisture present or not.

Undoubtedly you will receive other criticisms of this article should other engineers or architects consider it worth the trouble. For my own part I trust that you will see fit to make some comment in your next issue upon the article in order that those of our profession who have not made up their minds as to the proper construction of concrete tanks may not be misled.

Yours truly, E. G. SWANSON,
518 Peoples Gas Building,
Chicago, Illinois.

Vallejo School Buildings

Plans have been completed by Messrs. William H. Weeks of San Francisco and Woollett & Lamb, of Sacramento, for high and grammar school buildings to be erected at Vallejo under a recently authorized bond issue. Contractors are now figuring the work.

Bank Alterations

Mr. John H. Powers, 460 Montgomery street, San Francisco, has prepared plans for alterations to the banking rooms of the Italian American Bank at Montgomery and Sacramento streets, San Francisco. Improvements will cost \$15,000.

January and April, 1906, Copies Wanted

The publishers will pay 75 cents a copy for the Architect and Engineer dates of January and April, 1906.

The Contractor

BUILDING CONSTRUCTION, BRIDGES AND
ROAD WORK

Contractors Should Advertise Their Business

"NO sir, I can't tell you the contractor's name," answered the laborer. "I have been working here two weeks and I have never heard it. 'Big Bill' is what they call the walking boss. He gives us the pay envelopes, but all they have on them is our name and the amount due."

We had been travelling for more than 10 miles along a road that was being rebuilt, having made several detours only to come back to the main road to find it torn up again. Not a sign either at the detours or upon any of the machinery being used. The work had modern equipment upon it and seemed to be going on with vim, but never a sign or name to show who was the contractor.

At last under a shade tree we saw a young man resting. He was the state highway inspector, so we stopped to quizz him and learned that two contractors were doing this road job. He gave the name of each and we found that both were well known in several states as successful road builders. Yet, neither deemed it of sufficient importance to have his name painted on his equipment or upon his detour signs.

Contrast this with other road companies, who have their names on all machinery with the machine's serial number. Every mixer, boiler, wagon, truck, roller and all small machines owned by up-to-date contractors have signs on them and their names and numbers kept bright. Besides, on telegraph poles and in other prominent places large signs are used telling the world the name of the man who is doing the job.

Signs indicating that the road is closed or pointing out a detour bear the same inscription. The large signs on the poles are left after the construction is finished and act as an advertisement for years, many times causing a demand from communities for similar roads.

Nearly every one in business today agrees that advertising pays. A construction job always attracts the attention of the thousands who pass by, yet it is surprising how few are the contractors who take advantage of this wonderful opportunity for publicity.

Many men working for contractors do not know their employer's name, as in the case of the man referred to in the beginning of this article. The writer in visiting hundreds of jobs throughout the country has found laborers and foremen who did not know the name of their employer. Little wonder that many such men care little for their employer's interest and whether or not honest work is done or money is made. Just as the laborer stated, the contractor cared so little about making his identity known to his employees that he did not have his name printed on his pay envelopes. In conducting large operations it is almost impossible for a contractor to know all of his employees, but it is an easy matter for him to be known to all of his men if not by sight, at least by name and reputation. Signs on the machinery and on the work not only serve as an advertisement to the public but also acquaint the employees with the employer. They give the men in the organization a certain pride in the work. They even lead many of the best men to speak of the work as "our job" and refer to the contractor by name, thus teaching them to speak in terms of "we" and "us." This means much in these days. It means loyalty to the contractor and pride in the job.

Every man is interested in his pay envelope, and although some few empty it and throw it away instantly, yet the majority carry it away, sometimes keeping a part of their money in it for days. If an "ad" on a letter envelope is of value, surely one on a pay envelope can give returns. This envelope gives an easy means of communication with the employee and if a different message is carried to them each week, it helps in the work of building up morale.

The contractor's name and address can always be on the envelope, leaving the rest of the space on the two sides available for talks on safety first principles, on the interest the contractor has in his men, where savings accounts can be opened, store accounts run, how mistakes in pay can be corrected, how and

where doctors can be obtained in case of injury or sickness, how men can secure promotion and a hundred other messages that will strengthen the relation between employer and employee.

The cost of this is little. It can be divided between the contractor and others such as savings banks, insurance agents, dentists, doctors, store keepers and others. The envelopes can be printed or the message put on with a rubber stamp, a manifold machine or other duplicating apparatus. An office boy or clerk in spare time can work up thousands of envelopes. It means advertising a business to employees and through them to others.

Another means of advertising is that of identification buttons or pins used by the men. These can bear the contractor's name and also distinguishing colors. Many workmen keep these on their hats or coats even when they are not working, thus advertising their employer.

Cost and time reports also should bear the name of the contractor. This is some help in advertising. Envelopes that are used to send reports, payrolls, letters and other things from the job to the contractor's office should bear the name of the firm and the address printed upon them in large type. This not only prevents letters from being lost or delayed but likewise assists in making the contractor better known.

No matter what kind of a structure is being built, it is a wise policy for a contractor to place a sign board upon the work. If there are several avenues of approach, a sign should be placed at each one. In building construction it is an easy matter to use a sign, as it can be attached to the building or scaffold or on the barrier built around the structure, the fence barrier being used for a large sign or for a number of them.

For large engineering jobs it is generally necessary to erect posts to hold the signs, but at times they can be attached to trees, poles and other things already there.

High concrete hoisting towers afford an excellent place to display signs.

The wording of signs is important. If possible, the wording should be such as either to call special attention of the public by some catch phrase or else to carry some special message that may be the means of obtaining future business. It is also advisable to give by means of a sign the name of the job being built. If the two signs are combined in one, the objection to this is that the sign cannot be used again except by repainting, so it is advisable to use two signs, one for the structure, which must be repainted, and the other for the contractor, which can be used over again on other jobs.

Another means of advertising is by photographs of work either finished or

under way. Of course, such photographs labeled and framed look well in a contractor's office, but are seen only by the few who go there.

Articles descriptive of jobs and published in the trade papers form another way of advertising a contractor's work. New or unusual methods or time-saving features are always of interest to engineers and editors, the latter generally publishing these articles and paying their usual rates for them. Advertising of this kind may mean little locally unless followed up, but it is national advertising.

A contractor's business can be advertised successfully through the engineering and trade papers. To obtain the best results, more than a publicity card should be carried. In other words, the "ad" should tell a story. This can be done with photographs or reading matter or combinations of the two.

(Half tone plates, showing a different building each month in architectural and engineering magazines, would give contractors distinctive advertising possible in no other way.)

* * *

A story of speed, or saving money, of special service, of a good form of contract, of a job of magnitude or a combination of several of these features will prove of value.

A well-illustrated book or pamphlet always is attractive and much can be told in an impressive manner. Most of those who receive a copy will keep it and even years after it is published jobs will be procured by it. Naturally such books are expensive to publish.

As for the advertisement, it is well worded and as it tells a story of service and shows long experience, it is bound to get new business.

Some newspapers in many of our cities are now catering to contractors and construction engineers for advertisements. The space is small, barely sufficient for a publicity card, and appears once a week. This kind of advertising would amount to but little but for the fact that a page or more of reading matter accompanies the "ads." In this space the newspaper is glad to publish interviews with contractors or prepared statements as to labor conditions, the cost of building, the troubles of the contractor, and many other things regarding construction and building. This part gives publicity to the contractor.

These are some of the various means of advertising a contractor's business and today it is well understood that if a man is to increase the amount of his business steadily and quickly, he must do advertising according to modern methods and ideas.—Contract Record.

Should the Builder Be Licensed?

By O. W. ROSENTHAL

The builder—the contractor who supervises the actual transformation of money into building—is the agent of the man who spends the money and the public which uses the finished building. To each of these he is obligated.

Today there are no recognized qualifications which a man must have before undertaking the responsibilities of a builder. Any man can go into the contracting business.

Architects and engineers must qualify for their work; doctors and lawyers must give convincing proof of their fitness but the man who does the

actual work in building may go at this work with no experience and no theoretical knowledge.

Mr. O. W. Rosenthal, president of the O. W. Rosenthal-Cornell Company, of Chicago, in the American Contractor, offers an affirmative answer to the question, "Should the Builder Be Licensed?" He points out the public interest which inheres in the question and suggests some of the inevitable social wastage in a system where a man may be a baker or a barber today and tomorrow blossom forth a builder with few if any qualifications. Read his article:

THAT the protection of the public against unscrupulous, dishonest, inefficient, and careless persons must necessarily be a primary consideration, is unquestioned.

The efforts of the state to give to the public this protection have brought about a supervision of private industry that to many seems extreme. It, however, is generally admitted that in most instances some supervision or control is necessary.

The necessity for state control in the practice of medicine, pharmacy, dentistry, law, architecture and engineering of banks and the sale of securities, and of the many other branches over which the state has extended its supervision is unquestioned by any who have given the matter thought.

There have been no acts passed by our legislature that would have been productive of greater good than those for the control of architecture and engineering, had they gone one step farther and enacted some legislation for the control of the builder. As the matter now stands, the protection is incomplete and largely fails of its purpose.

The registration of architects and engineers leaves no question that the legislature is alive to the hazardous nature of a building operation and recognizes its public character.

The mechanics' lien law, the workmen's compensation act, and the many precautionary measures for the protection of the workingman and the public

which are left for enforcement to the state factory inspector are further evidence that our law makers realize the perilous and unusual character of a building operation.

The various building codes and sanitary measures give further assurance that every effort is being made to safeguard the public health and welfare, but the one great fundamental protection to which the public, the workingman, the future occupant of the building, the investor, and the seller of materials is entitled, is control of those who practice the art of building by a license board created by the state. A license board with power so broad that it could demand of anyone desiring to engage in the practice of building that he give satisfactory evidence of his ability to practice the art in the best and most efficient manner. A board with the power of revocation of licenses.

The registration of architects and engineers assures the public that the codes will be adhered to so far as the design is concerned, and that the architecture and engineering will be sane and safe, but the execution of the design is in the hands of an unregistered builder who has never been required to give evidence of his ability to carry on successfully so dangerous and important and so public an undertaking.

The enforcement of the various codes covering a building operation must of necessity be perfunctory and left largely

HARDWOOD HEADQUARTERS

ASH-BASSWOOD-BIRCH
AROMATIC RED CEDAR
COTTONWOOD-ELM-HOLLY
SOUTHERN RED GUM
HICKORY-LAUREL-MAPLE
OREGON MAPLE-PLAIN OAK
- QUARTERED OAK -
WYBROCK BENDING OAK
POPLAR--WALNUT



BOXWOOD-EBONY-IRONBARK
JENISERO-KOA-SPANISH CEDAR
LIGNUMVITAE-MAHOGANY
ROSEWOOD-TEAK-RED BEAN
SPOTTED GUM-CIRCISSIAN WALNUT
LUMBER--TIMBER
HARDWOOD FLOORING
WYBRO VENEERED PANELS
DOWELS-TREENAILS-VENEERS

WHITE BROTHERS

FIFTH and BRANNAN STREETS

SAN FRANCISCO, CAL.

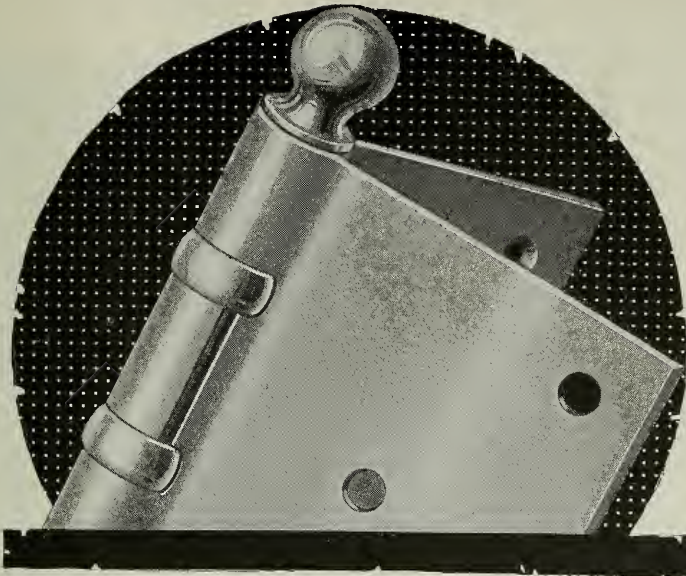

NON-DETACHABLE
BALL BEARING
WASHERS

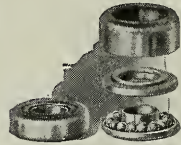

THE STANLEY WORKS

BALL-BEARING BUTTS

POSITIVE SERVICE

is obtained when this type of Stanley Works Butt is specified.

The Ball Bearing Washers do the work. They carry the load of the door and successfully too, every day where they are employed.

We have ready for distribution to architects, an architectural service sheet AE-11 featuring Storm Sash Hardware which will be mailed on request. Write at once for it.

THE STANLEY WORKS

New Britain, Conn.

Chicago

New York



For more than three-quarters of a century this mark has appeared on dependable products. Look for it when specifying Wrought Steel Hardware.

When writing to Advertisers please mention this magazine.

to the honor of the builder when building is at its height. Where an infraction of the code is discovered, the work is stopped temporarily or the correction is ordered. The penalties are absolutely insufficient. The architect and engineer do not necessarily supervise the execution of the design. The responsibility resting upon the builder is one that should be placed only upon the shoulders of one who has given evidence of the necessary ability, and who is under state control.

There is expressed everywhere throughout our statutes the feeling that control of building is regarded as of extreme importance. Yet the efforts to control as evidenced by the various building and sanitary codes, the mechanics' lien law, the workmen's compensation act, the architect's and engineers' registration acts, and the various safety measures fail of complete potency so long as the builder (the one who carries on the actual construction of the building) is not directly answerable to the state.

The economic waste and the loss of life due to incompetence, inefficiency, and lack of moral responsibility would be surprising could the facts be known. The factors of safety employed by architects and engineers, based of course largely upon experience, is based not entirely upon the uncertainty of materials and the natural carelessness of the craftsman, but also upon the inefficiency and the lack of even reasonable, to say nothing of thorough supervision or knowledge on the part of the builder. What seems to be an excessive cost of liability insurance and contractors' bonds also is due largely to these conditions.

Public welfare demands that fraud and collusion practiced in connection with building operations be stopped, and this can be done only by state control.

The question of the efficacy of the mechanics' lien law as it is now drawn, and which is intended as protection against the unscrupulous or careless builder, will not be important when the interest of the seller of materials, the investor, and the public are protected by the state control of the builder.

There are many engaged in the practice of building who are wholly unequipped by experience, temperament, or a sense of moral responsibility to engage in so dangerous and difficult a profession. To permit others to engage in the practice without making an effort to ascertain their fitness would indeed be a mistake.

We are at the present time facing a most unusual situation as regards a lack of building in the face of a most unprecedented need of buildings of every description. It can reasonably be expected that this condition will soon be corrected, and with the revival of building operations the public should be protected from

the dishonest, incompetent, inefficient and irresponsible builder.

It is almost unbelievable that any one without previous experience can engage in so dangerous a profession and be answerable to no one. Under our present laws one can be a doctor, a lawyer, a butcher, or a baker today, and a builder tomorrow, for no reason other than he so wills it, with no previous experience, without control, and without regard to the interests of the public. This is not a healthy condition, and should not be permitted.

The honest builders of this state should be in favor of any legislation that will eliminate the unscrupulous builder who evades the building codes, and in many other ways conspires to defraud the public with no regard for the dangers of such a practice.

Consequent to the establishment of such a board will be a great moral awakening in the building profession. A better understanding of the duties and obligations of those engaged in the practice will result. The tendency of many builders to put up the building at a profit, regardless, will be greatly lessened. It will cause to be established a code of ethics and will compel obedience. It will bring about a recognition of the real standards of the profession, and the public, the workingman, the architect, the engineer, and the seller of materials will be reassured when it is known that the art of building is in the hands of competent builders who are under the control of a state board which has the power to enforce its rulings.

The establishment of this board is a public necessity.

Not Entitled to Reimbursement

Because there was no formal agreement the comptroller has ruled that Gutleben Bros. of San Francisco, are not entitled to reimbursement for \$5748.28 paid for transporting materials used by them on a contract for the construction of a naval radio station at Seward, Alaska, in 1917. Gutleben Bros., were third lowest bidders on the contract and accepted it when awarded to them a month later, on representation of the Navy Department that it "would assist in transportation" but contractors' check for \$1000 would be confiscated if they refused to take the contract. The comptroller held that the government's agreement to assist had been fulfilled when it secured reduced transportation charges for the contractors.

Y. W. C. A. Building

Miss Julia Morgan, Merchants Exchange building, San Francisco, is preparing preliminary plans for the proposed new Y. W. C. A. building in Pasadena. Miss Wilhelmina Loos is general secretary of the association.

A CAMPAIGN for BETTER UNDERSTANDING



Copyright 1920 by
National Terra Cotta Society

Drawing by
Hugh Ferriss

THE WOOLWORTH BUILDING
CASS GILBERT, ARCHITECT

EVERY Architect knows that the profession of architecture calls for more than design, supervision, engineering and all else that goes to create a building.

The profession of Architecture calls for BETTER UNDERSTANDING of its aims on the part of the general public.

The Public should share the Architect's vision—should appreciate the ideals as well as the problems which enter into architecture.

To bring about this better understanding, National Terra Cotta Society has planned a series of full page advertisements in "The Literary Digest."

It is the purpose of the advertisements not only to increase public admiration for the Architect and his judgment, but to set forth, as well, the practical and aesthetic qualities of Terra Cotta as an architectural material of permanence, beauty and profit.

Every Architect is earnestly invited to read this unusual series of advertisements.

National Terra Cotta Society is a bureau of service and information operating for the Terra Cotta manufacturers of the United States. Its publications cover not only the technical and structural use of the material but show, as well, examples of its application to buildings of various types.

Brochures of specific value, as indicated by their titles, will be sent to Architects on request:

The School The Theatre The Garage The Store The Bank

These brochures consist of a selection of illustrations, with text and comment, showing representative Terra Cotta buildings of the respective types.

Terra Cotta—Standard Construction

A Valuable Technical Reference Work for Architects and Engineers.

TERRA COTTA

Permanent Beautiful Profitable

When writing to Advertisers please mention this magazine.

The Toughness of Corrugated Pipe

By H. McDOWELL WENTWORTH



Armo corrugated pipe leading from concrete wall at edge of highway underneath railroad tracks.

ONE of the principal reasons for the rapid increase in the use of corrugated pipe is its peculiar adaptability to service conditions. In thousands of instances all over the country, it is giving long continued service under conditions which speedily ruin other excellent forms of pipe and masonry. This it accomplishes by virtue of the elasticity or toughness conferred by the corrugations. It is an interesting fact and one of great practical importance that the particular form which multiplies the strength of metal cylinders so surprisingly also enables them to endure bending through considerable limits without injury or noticeable deformation and to absorb all the changes resulting from expansion and contraction of their material.

A very large portion of the inhabited area of the United States is composed of alluvial valleys and plains. The subsoil of such regions, while highly favorable to agriculture, offers certain difficulties in the construction of highways and railroads through its tendency to shift and settle under the weight of fills and traffic. It is not practicable to excavate deeply at all intersecting water courses and drainage ways and lay solid and unchanging foundations for masonry, since these places are so numerous that such a course would involve extravagant outlays. Therefore a culvert pipe which has toughness or resiliency as well as strength is extremely useful.

The accompanying drawing shows a corrugated pipe, newly installed, and again after two or three years' service under conditions which are duplicated thousands of times over and from one end



2. Location of corrugated siphon carrying drainage water under irrigation canal. No trouble from expansion and contraction although firmly anchored at both ends.



INSURANCE DID NOT SAVE THIS HOME

THE architect and builder are better able to prevent disaster by fire than any insurance agent. The architect builds fire insurance into the house; the agent merely writes it on paper.

FIRE CLAY FLUE LINING

specified by leading architects, used by reputable builders and required by ordinance of National Board of Fire Underwriters prevents 30% of residence fires by making it impossible for flames to reach woodwork through defective flues, and by preventing burning soot and sparks on the roof. For a very few dollars it *really* insures the results of your labor and the homes of your clients.

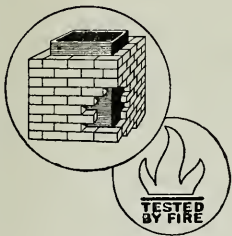

Copy of the 1920 Chicago Ordinance proposed by the National Board of Fire Underwriters free on request.

CLAY PRODUCTS ASSOCIATION
PITTSBURGH CHICAGO

(Los Angeles Pressed Brick Co., Los Angeles, Member)

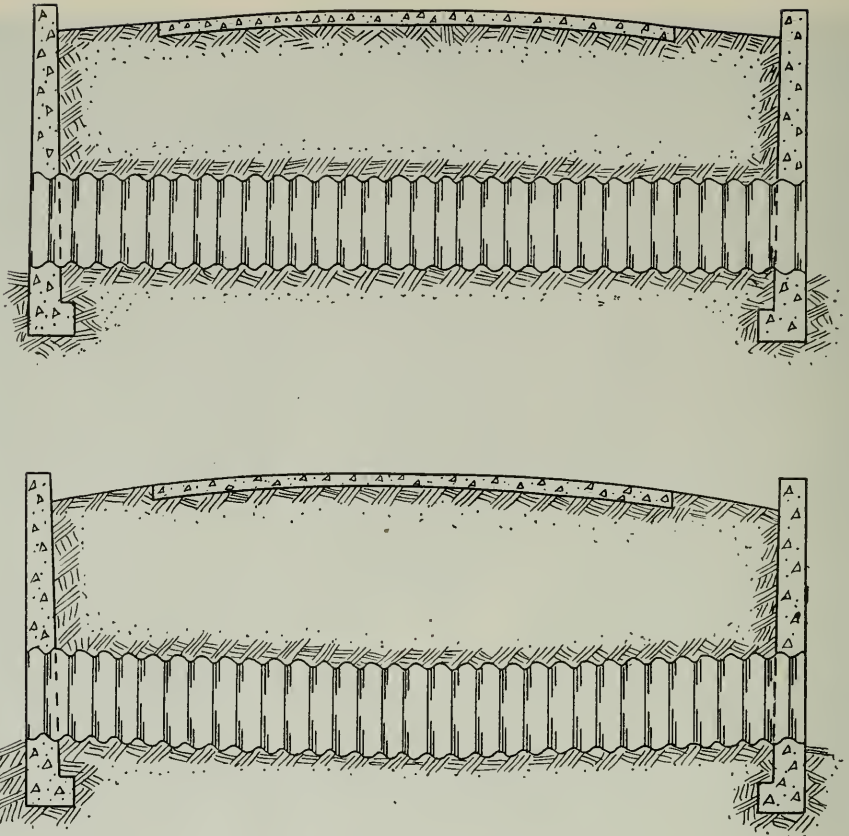

YIELDING FOUNDATION

CROSS SECTION OF A HIGHWAY, SHOWING A CORRUGATED PIPE IN A SETTLING FILL.

of the country to the other. It might be said that this indicates faulty road building, and that the highway base should be so constructed as not to permit any such settlement. But every practical highway engineer or supervisor knows that we have thousands of miles of improved highways whereon such requirements cannot be met, to say nothing of a million miles or more of unimproved earth roads. And many highway foundations which were considered absolutely rigid ten years ago are now yielding and settling under the tremendous onslaughts of the motor trucks.

The point of importance is that when a highway foundation around a corrugated culvert shifts or settles, the culvert settles with it, without suffering any noticeable injury. Of course, it is not ideal for a culvert pipe to be several inches lower in the middle than at either end; but such a condition is much to be preferred to a breakdown of the entire structure; and under these conditions a break must surely occur if the pipe is of rigid material.

Another way in which the elasticity of corrugated pipe operates to advantage is

in the absorption of the volume changes resulting from changes of temperature. Not only ordinary road culverts but long lines of corrugated pipe are often installed with both ends rigidly embedded in concrete, and with no special provision in the way of expansion joints. Experience demonstrates that the expansion and contraction accompanying summer and winter conditions is perfectly accommodated by the corrugations, and that no damage is to be feared in the form of loosening or fracturing at the piers or abutments.

In regions where the winters are severe, it often happens that a corrugated pipe is full of water at the time of a hard freeze and this water soon becomes a solid block of ice. Other forms of pipe are almost certainly ruptured if this occurs, but here again the corrugated form proves a safety device, allowing the pipe to expand sufficiently to care for the increased volume of its contents. At least one instance is known of a corrugated pipe which has been frozen solidly in this way every winter for seven or eight years, and which is still in good condition.

For like reasons, the heaving of the

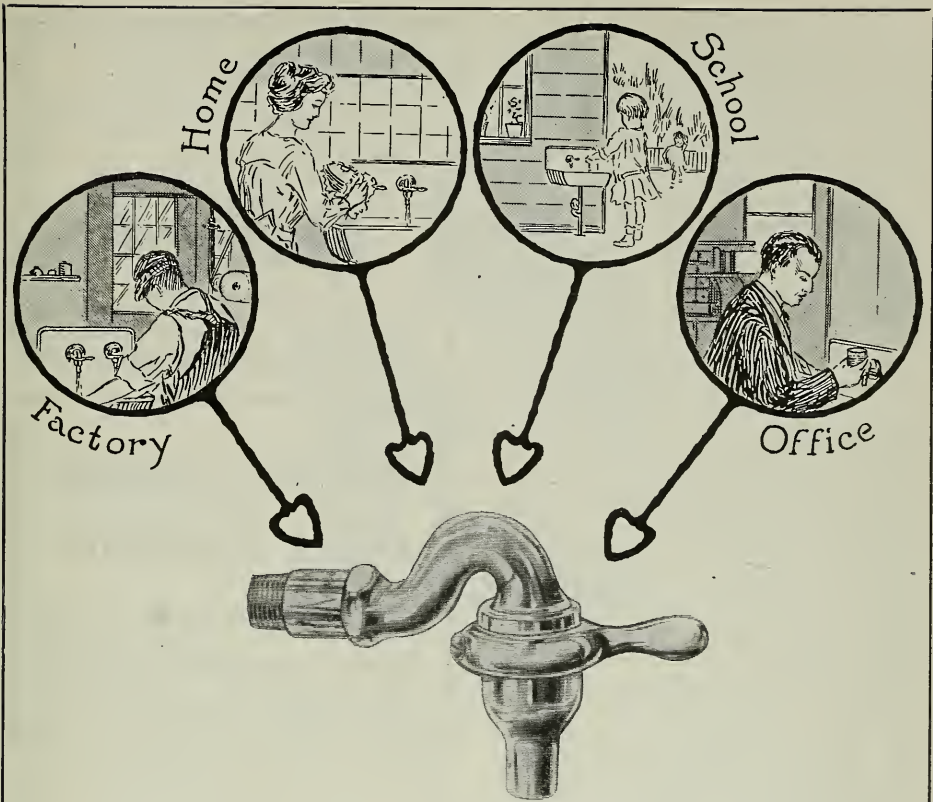

The
Hajoca "Quick" Faucet

is a distinct time-saver. It responds to a mere touch of the hand or even the wrist, with a thick, rapid-flowing, non-splashing stream. A real delight to the user in the home. Durable and simple in construction. Especially suitable for Wash Sinks in Packing Plants, Factories, etc.

SPECIFY
Hajoca "Quick" Faucets



HAINES, JONES & CADBURY Co.
 MAKERS OF PLUMBING SUPPLIES
 857 FOLSOM STREET, SAN FRANCISCO
 PHILADELPHIA-NEW YORK-RICHMOND, VA.-SAVANNAH

ground about corrugated pipes by frost or by earthquakes produces no noticeable effect upon them unless the movements are extremely violent. Certain geological formations are so unstable that highways and railroads built upon them actually slide from their locations with a glacier-like motion of several inches each year. For the drainage ways through such embankments nothing serves so well as corrugated pipe. It is apparent from all experience that the quality of resiliency is one of the prime merits of this form of conduit.

Statement of the Ownership, Management, Circulation, etc.

(Required by the Act of Congress of August 24, 1912),

Of The Architect and Engineer, published monthly at San Francisco, California, for October 1st, 1920. State of California, City and County of San Francisco.—ss.

Before me, a Notary Public in and for the State and county aforesaid, personally appeared W. J. L. Kierulff, who, having been duly sworn according to law, deposes and says that he is the Manager and Publisher of The Architect and Engineer, Inc., and that the following is, to the best of his knowledge and belief, a true statement of the ownership, management, etc., of the aforesaid publication for the date shown in the above caption, required by the Act of August 24, 1912, embodied in section 443, Postal Laws and Regulations, to wit:

1. That the names and addresses of the publisher, editor, managing editor, and business managers are:

Publisher.....W. J. L. KIERULFF
627 Foxcroft Bldg., San Francisco

Editor.....F. W. JONES
627 Foxcroft Bldg., San Francisco

Business Manager.....W. J. L. KIERULFF
2. That the owners are: W. J. L. Kierulff, 627 Foxcroft Bldg., San Francisco; F. W. Jones, 627 Foxcroft Bldg., San Francisco; L. B. Penhorwood, 627 Foxcroft Bldg., San Francisco.

3. That the known bondholders, mortgagees, and other security holders owning or holding 1 per cent or more of total amount of bonds, mortgages, or other securities are: None.

4. That the two paragraphs next above, giving the names of the owners, stockholders, and security holders, if any, contain not only the list of stockholders and security holders as they appear upon the books of the company but also, in cases where the stockholder or security holder appears upon the books of the company as trustee or in any other fiduciary relation, the name of the person or corporation for whom such trustee is acting, is given; also that the said two paragraphs contain statements embracing affiant's full knowledge and belief as to the circumstances and conditions under which stockholders and security holders who do not appear upon the books of the company as trustees, hold stock and securities in a capacity other than that of a bona fide owner; and this affiant has no reason to believe that any other person, association, or corporation has any interest direct or indirect in said stock, bonds, or other securities than as so stated by him.

W. J. L. KIERULFF, Manager.

Sworn to and subscribed before me this 28th day of September, 1920.

[SEAL]

NETTIE HAMILTON,
Notary Public in and for the City and County
of San Francisco, State of California.

(My commission expires February 15, 1921.)

Engineer Addresses Down Town Ass'n

Dr. B. M. Rastall, of New York, was speaker at a luncheon meeting of the Down Town Association, his topic being "City Building."

Shop and Compare—that's the only true test of values.

Furnishings for the home of distinctive style are featured in this shop at prices that will bear the strictest comparison.

John Breuner & Co.
of San Francisco

281 GEARY STREET

Furniture
Floor Coverings

Draperies
Interior Decorations

**Business Systems
Office Furniture**

F. W. WENTWORTH & CO.

Distributors for LIBRARY BUREAU
539 Market Street, San Francisco
LOS ANGELES OAKLAND SEATTLE

SERVICE

TESTING
INSPECTION
CONSULTATION
PRODUCTION

**Structural and Engineering
Materials**



Robert W. Hunt & Co.
Engineers

**Chemical and Physical
Testing Laboratories**

New York Chicago Pittsburgh
St. Louis San Francisco Mexico City
London Montreal



The
ST. FRANCIS
One of the world's great hotels
Facing Union Square
SAN FRANCISCO CALIFORNIA

EXPRESSES MOST PLEASANTLY THE HOSPITALITY AND ANIMATION THAT ARE CHARACTERISTIC OF SAN FRANCISCO

Thos. J. Coleman,
Manager

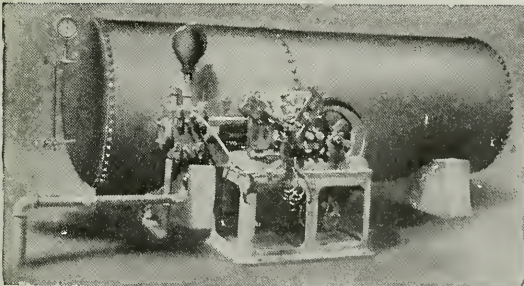

Kewanee Water System

Maintain your own Plant.
Small Operating Expense.
A Perfect Water Supply to
Country Homes, Hotels
and Parks.

Simonds Machinery Co.

117-121 Montgomery Street
SAN FRANCISCO
Phone Kearny 1457

Something New in Gasoline Pumps

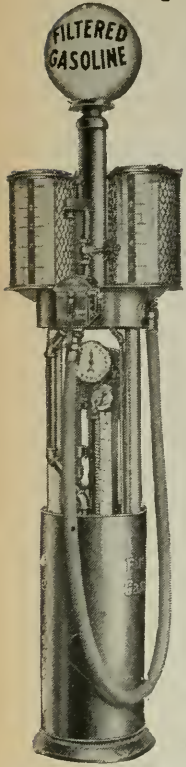

THE Wayne Oil Tank & Pump Company has recently published an interesting Bulletin which illustrates and describes in detail a distinctly new idea in gasoline pump design, operation and service.

After exhaustive tests under actual working conditions, the company has placed this model on the market in the belief that it answers a long felt need for gasoline pump buyers and sellers alike.

A cut of this pump is shown herewith.

The following excerpts from the Bulletin give an idea of the improved device:

Every drop of gasoline delivered into the glass containers has been previously, accurately, mechanically measured once and mechanically checked three times. Positive, sealed quantity gauges in the glass containers visibly verify the measure.

A common cause for error in visible pumps is due to what is called "parallax." "Parallax" is the apparent changing of the relative position of the pointers and graduations due to the observer looking at them from different angles. Such graduations should be on the inside of the

glass containers. Wayne eliminates parallax by doing this.

The Wayne Five-Way Valve prevents the return of any gasoline to the underground tank while either container is being filled or emptied; none can be discharged from a container while it is being filled; none can be siphoned from a customer's car tank. The hose is completely drained after each delivery. There is no overflow pipe. If you turn the Serve Lever to the Right Serve you must turn the Fill Lever to the Left Fill Position or vice-versa. Turning the Fill Lever to Drain Position drains both containers.

Sparks, short circuits and fires are prevented as no motors are used. Explosive vapors are absent in the glass containers. The liquid in the glass containers may be returned to the underground tank at any time, except when delivery is being made to the customer, the drain pipe closing automatically. Any leak in the pipe lines is immediately noticeable by short measurement.

One glass container may be filled while the other is being emptied. No waits are necessary. This increases sales. It can be operated as rapidly as any power pump. No extra pipes and fittings other than those required for an ordinary pump. It is delivered as an assembled unit.

The gasoline is filtered, free from air and contains full power and mileage-giving qualities. The pump can be locked in or out of service, thus protecting the owner against fraud. The glass containers can be quickly and easily removed without affecting the measurement at all.

Architects' Meeting.

The possibility of holding the next annual convention of the American Institute of Architects in Los Angeles was discussed at the meeting of the Southern California Chapter Tuesday evening, Nov. 9, at the City Club.

OAK FLOORS

(For Everlasting Economy)



Why Anything But Oak Flooring?

TO overcome the mistaken idea many laymen have that Oak Flooring is costly, we are doing a great deal of educational work—through advertising and direct-by-mail—telling the people how Oak Flooring really costs less than good carpets.

There is an appropriate grade of Oak Flooring for every floor requirement, and we will be glad to give you any information along these lines you may desire.

OAK FLOORING MFRS. ASSN.
1036 Ashland Block, Chicago, Ill.



This trade-mark assures high quality and perfect grading.

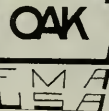

Present Cost of Building Materials*

With Labor Wage Scale, Bonds, Etc.

THESE quotations are based on reliable information furnished by San Francisco material houses. Date of quotations, October 20, 1920.
All prices f. o. b. cars San Francisco or Oakland.

American Institute of Architects' Fees

New work—6 per cent minimum basis.
Alterations—7 to 10 per cent as a minimum basis.

High class residence work—10 per cent as a minimum.

Bond—1½% amount of contract.

Brickwork—

Common, \$38.00 per 1000 laid.
Face, \$70.00 per 1000 laid.
Common, f. o. b. cars, \$18.00 plus cartage.
Face, f. o. b. cars, \$45.50 per 1000, carload lots.
12x12x3 in., 10¼c. per square foot.
12x12x4 in., 11¾c. per square foot.
12x12x6 in., 16¼c. per square foot.
Hod carriers, \$8.00 per day.
Bricklayers, \$10.00 per day.
Lime—\$3.25 per bbl.; carload, \$2.75 per bbl.

Composition Floors—30c. per sq. ft.

Concrete Work (material at San Francisco bunkers)—

No. 3 rock.....\$2.50 per yd.
No. 4 rock..... 2.75 per yd.
Niles pea gravel..... 3.25 per yd.
Niles gravel..... 2.50 per yd.
Niles top gravel..... 3.00 per yd.
City gravel..... 2.50 per yd.
River sand..... 1.65 per yd.
Bank sand..... 1.00 per yd.

Monterey White Sand—

Del Monte, \$1.25 to \$1.50 per ton.
Fan Shell Beach, \$2.50 to \$3.00 per ton.
Car lots, f. o. b. Lake Majella.
Cement (f. o. b. cars)....\$4.09 per bbl.
Rebate for sacks, 25c. each.
Atlas "White".....\$9.50 per bbl.
Medusa cement..... 9.50 per bbl.
Forms.....\$60.00 per M
Wage—
Laborers.....\$6.00 per day
Concrete workers..... 7.50 per day
Cement finishers..... 9.00 per day

Dampproofing—

Two-coat work, 30c. per yard.
Membrane waterproofing—4 layers of P.
B. saturated felt, \$6.00 per square.
Hot coating work, \$2.00 per square.
WAGE—Roofers, \$9.00 per day.

Electric Wiring—\$8.00 to \$15.00 per outlet.

WAGE—Electricians, \$9.00 per day.

Elevators—

Prices vary according to capacity speed and type.
Consult elevator companies.

Excavation—

\$2.25 per yard.
Teams, \$12.00 per day.
Trucks, \$30.00 to \$40.00 per day.
Above figures are an average without water. Steam shovel work in large quantities, less hard material, such as rock, will run considerably more.

Fire Escapes—

Ten-foot balcony, with stairs, \$100.00 per balcony.

Glass—(Consult with manufacturers.)

21 ounce, 30c. per square foot.
Plate, \$2.00 to \$3.50 per square foot.
Art, \$1.00 up per square foot.
Wire (for skylights), 45c. per square foot.
Obscure glass, 30c. per square foot.
Note.—Add extra for setting.
WAGE—Glaziers, \$9.00 per day.

Heating—

Average, \$3.25 per sq. ft. of radiation.
WAGE—Steamfitters, \$10.00 per day.

Iron

Cost of ornamental iron, cast iron, etc., depends on design.

Lumber—

Common (at building), \$40.00 per 1000 (average).
Common O. P. (select), \$75.00 per 1000 (average).

Flooring—

1x3 No. 1.....\$100.00 per 1000
1x3 No. 2..... 96.00 per 1000
1x4 No. 1..... 95.00 per 1000
1x4 No. 2..... 92.00 per 1000
1x4 No. 3..... 80.00 per 1000
1x6 No. 1..... 100.00 per 1000
1x6 No. 2..... 97.00 per 1000
1¼x4 and 6 No. 1..... 100.00 per 1000
1¼x4 and 6 No. 2..... 95.00 per 1000
Slash grain, 1x4 No. 2... 75.00 per 1000
Slash grain, 1x4 No. 3... 60.00 per 1000
No. 1 common run to
T. & G. 50.00 per 1000

Lath..... 9.00 per 1000

Shingles—

Redwood, No. 1.....\$1.60 per bdle.
No. 2..... 1.50 per bdle.
Red cedar..... 1.85 per bdle.
(Add cartage to above)

Hardwood Floors—

Maple floor (laid and finished), 40c. per foot.

Factory grade floors (laid and finished), 30c. per foot.

Oak (quartered, finished), 65c. per foot.

¾ Oak (clear), 39c per foot (plain).

¾ Oak (select), 37c. per foot (plain).

¾ Oak, quartered, sawed, clear, 45c.

WAGE—Floor layers, \$10.00 per day.

In flooring the usual grades of oak used are

	Grades	Quartered Sawed	Plain Sawed
5/16".....	Clear	45	39
	Select	41	37
1"x3"-13/16"x2¼"....	Clear	65	50
	Select	55	45

No. 1 (very little used)

Hardwood Floors (not laid)— Per M ft.

5/16x2" sq. edge	Clear quartered oak.....	245.00
	Select quartered oak.....	195.00
	Clear Plain oak.....	190.00
	Select plain oak.....	170.00

* NOTE.—For country work add freight and cartage to prices given.

Hardwood Floors (not laid)—Continued

		Per M ft.
13/16x2 1/4" face	Clear quartered oak.....	\$280.00
	Select quartered oak.....	230.00
	Clear plain oak.....	215.00
	Select plain oak.....	175.00
	Clear maple.....	220.00
13/16x3 1/4" face	Clear maple.....	250.00
	Clear maple.....	220.00
1 1/8x2 1/4" face	Clear maple.....	220.00
	Clear maple.....	220.00
3/8x2" face	Clear quartered oak.....	215.00
	Select quartered oak.....	170.00
	Clear plain oak.....	155.00
	Select plain oak.....	140.00
	Clear maple.....	165.00

Veneered Panels—

24x60 in., 1/4 in., 3-ply, 1 side:	Per ft.
Ash.....	31 1/2c
Hungarian Ash.....	47c
Birch.....	31 1/2c
Curly Birch.....	47c
Elm.....	29c
Jenisero (Genezero).....	45 1/2c
Southern Red Gum (plain fig.).....	38 1/2c
Qtd. Southern Red Gum.....	47c
Hawaiian Koa.....	47c
Maple.....	29c
Birdseye Maple.....	57c
Mahogany.....	47c
Oregon Pine.....	23 1/2c
Plain Oak.....	37 1/2c
Quartered Oak.....	47c
Walnut.....	48c

Millwork—

O. P., \$150 per 1000. R. W., \$150 per 1000.	
Double hung box frame windows (average) with trim.....	\$10.50 each
Doors, includ. trim (single panel).....	15.00 each
Doors, including trim (five panel).....	\$12.00 each
Screen doors.....	5.50 each
Window screens.....	3.50 each
Medicine cases.....	5.00 each
Cases for kitchen pantries seven feet high, per lineal foot.....	10.00 each
Dining room cases same price, if not too elaborate, flag poles, per foot.....	1.50

Labor— Rough carpentry, warehouse heavy framing, \$16.00 per 1000.

For smaller work, average, \$23.00, \$30.00 per 1000.

WAGE—Laborers, \$6.50 per day.

Carpenters, \$9.00 per day.

Marble—(Not set) add 60c up per ft. for setting

Columbia.....	\$2.05 sq. ft.
Alaska.....	2.05 sq. ft.
San Saba.....	3.65 sq. ft.
Tennessee.....	2.50 sq. ft.
Verde Antique.....	4.55 sq. ft.

Painting—

Two-coat work, 42c. per yard.
Three-coat work, 55c. per yard.
Whitewashing, 6c. per yard.
Cold water paint, 10c. per yard.
WAGE—Painters, \$8.50 per day.

NOTE—Accessibility and conditions cause wide variance of costs.

Patent Chimneys—

6-inch.....	\$1.50 lineal foot
8-inch.....	1.75 lineal foot
10-inch.....	2.25 lineal foot
12-inch.....	3.00 lineal foot

Pipe Casings—\$8.00 each.

Plastering—

Interior, on wood lath, 80c. per yard.
Interior, on metal lath, \$1.50 per yard.
Exterior, on brick or concrete, \$1.35 per yard.

Portland White, \$1.75 to \$2.00.

Interior on brick or terra cotta, 65c to 75c. per yard.

Exterior, on metal lath, \$2.50 to \$3.00 per yard.

Wood lath, \$8.00 at yard per 1000.

Metal studding, \$1.25 to \$1.50 per yard.

Metal studding, with lath and plaster, \$2.25 per yard.

Galv. (metal lath), 38c. and up per yard, according to gauge.

Lime, f. o. b. warehouse, \$3.25 per bbl.

Hardwall plaster, \$24.00 per ton, f. o. b. warehouse.

WAGE—Hod carriers \$9.00 per day.

Plasterers, \$11.00 per day.

Plumbing—

From \$70.00 per fixture up, according to grade, quantity and runs.

WAGE—Plumbers, \$10.00 per day.

Reinforcing Steel—

Base price for less than car load lots, \$5.75 per 100 lbs.

Car load lots, \$5.50 per 100 lbs., f. o. b. San Francisco. (Mill delivery.)

Roofing—

Five-ply tar and gravel, \$7.50 per square for 30 squares or over.

Less than 30 squares, \$8.00 per square.

Tile, \$35.00 per square.

Redwood shingle, \$13.00 per sq. in place.

Cedar shingle, \$13.00 per square in place.

Reinforced Pacbo roofing, \$8.25 per square. WAGE—Roofers, \$9.00 per day.

Rough Hardware—

Nails, per keg, \$7.50 base and very scarce.

Deafening felt, \$170.00 per ton.

Building paper, P. & B.,

1 ply, \$6.50 per 1000 ft. roll.

2 ply, \$9.75 per 1000 ft. roll.

3 ply, \$14.00 per 1000 ft. roll.

Sash cord,

(Sampson spot), \$3.00 per hank 100 feet.

Common, \$1.75 per hank 100 feet.

Sash weights, cast iron, \$80.00 per ton.

Skylights—

Copper, \$1.25 a square foot (not glazed).

Galvanized iron, 50c. a square foot (not glazed).

WAGE—Sheet metal workers, \$10.00 per day.

Store Fronts—

Kawneer copper bars for store fronts.

Corner, center and around sides, will average \$1.35 per lin. foot.

Zouri bar, \$1.25 per lin. foot.

Zouri Underwriters' Specification sash, \$1.60 per lin. foot.

Structural Steel—\$150.00 per ton.

This quotation is an average for comparatively small quantities.

Light truss work higher; plain beam and column work in large quantities, less.

Steel Sash—

Fenestra, from S. F. stock, 45c. per sq. ft.

Fenestra, Plant shipment, 40 1/2c. per sq. ft. (Includes mullions and hardware.)

Tile—

White glazed, 80c. per foot.

White floor, 80c. per foot.

Colored floor tile, \$1.00 per foot.

Promenade tile, \$1.00 per sq. foot, laid.

WAGE—Tilers, \$9.00 per day.

Windows—Metal, \$2.00 a square foot.

Ray Rotary Crude Oil Burners

Used from Coast to Coast by those who know



Apartment House, Taylor and Geary Streets, San Francisco, for Mr. I. Rosenberg.
Mr. JOSEPH CAHEN, *Architect.*

The Steam and Hot Water Boilers
in this Building are Equipped with

RAY ROTARY CRUDE OIL BURNERS

MANUFACTURED BY

W. S. Ray Manufacturing Co.

29 SPEAR STREET, SAN FRANCISCO, CALIFORNIA

Phone Kearny 199

Branches in all Principal Coast Cities

When writing to Advertisers please mention this magazine.



CEMENT GUN

Will Make Your
Concrete Waterproof

Cement Gun Con-
struction Company

of California

701 Balboa Building,
San Francisco

For
DAMS
RESERVOIRS
TUNNELS
BULKHEADS
CANAL
LININGS
CEMENT
FLUMES
use the
Cement Gun
—
SPEED
ECONOMY
PERMANENCE

McCray Refrigerators in California

Mr. A. J. Moore, California State manager of the McCray Refrigerator Company, with headquarters in the Monadnock building, San Francisco, recently returned from an Eastern trip which took him to the company's factory at Kendallville, Ind., and then on to New York and Philadelphia. Mr. Moore reports that his factory is rushed with orders and is preparing to materially increase its output the coming year. McCray refrigerators are in demand from one end of the coast to the other, and in California there has been a steady increase in the sales, according to Mr. Moore. One of the largest installations of recent record is a three-compartment storage cooler in the O'Connor sanitarium in San Jose. It is equipped to take care of dairy products, vegetables and fresh meat. The interior of the three storage compartments is lined with white opal glass, and the floor is of tile. The shelving, meat racks and meat hangers are of steel. The exterior of the whole cooler is of highly polished furniture oak, while the hardware used is of a special McCray design of solid brass, triple nickel plated.

The following is a partial list of McCray installations in California:

Alameda County Hospital, Oakland, California.
Arroyo Sanitarium, Livermore, California.
Veterans' Home, Yountville, California.
Post Supply, U. S. Presidio, San Francisco.
Sherman, Clay & Co., San Francisco.
Trania's, San Francisco.
Santa Clara County Hospital, San Jose, California.
O'Connor Sanitarium, San Jose, California.
Modesto Sanitarium, Modesto, California.
Southern Pacific R. R. Co., San Francisco.
Madera Sanitarium, Madera, California.
Fresno County Hospital, Fresno, California.
Belmont School, Belmont, California.
Matsonia Steamship Co., San Francisco.
Hotel Jeffery, Salinas, California.
Standard Oil Company, San Francisco.
C. A. Thayer, Summit Apartments, San Francisco.
Colonel Sidney Cloman, residence, Burlingame.
Robert Conniston, residence, Honolulu.
H. F. Wiggins, residence, Modesto.
Captain Frank P. Helm, residence, San Francisco.
Frank E. Murphy, residence, Stockton.
J. A. Chase, residence, San Jose.
Mrs. A. B. Clark, residence, Fresno.
F. M. Doak, residence, Rutherford.
W. E. Everett, residence, Rutherford.
M. C. Parker, residence, Bakersfield.
Roy Elliott, residence, Berkeley.

Rev. Father Murray, residence, Belmont.
H. R. Brown, residence, Sacramento.
Mrs. S. E. Heckscher, residence, San Francisco.
Wm. Templeton Johnson, residence, San Diego.
C. A. Gaines, residence, Lindsay.
Frank Gurnsey, residence, Stockton.
A. M. Noble, residence, Stockton.
Chas. Manthey, residence, Stockton.
Wm. C. Van Antwerp, residence, Burlingame.
Horace Orear, residence, San Francisco.
Capt. Fritz Oleson.
Ray Lyman Wilbur, Stanford University residence.
I. Helman, residence, Los Angeles.
F. D. McPherson, residence, Los Angeles.
R. L. Hinkley, residence, Los Angeles.
R. S. Atkins, residence, San Francisco.

Awarded Two Contracts

The Unit Construction Company, Phelan building, San Francisco, have been awarded two large contracts by Messrs. Chamberlain & Proctor. One is for a four-story reinforced concrete garage on Stevenson street, near New Montgomery, from plans by Messrs. O'Brien Bros., and the other is a two-story loft building on Sutter street, from plans by Willis Polk and Company.

TRANSMISSION EQUIPMENT

For Mill or Factory

Pulleys - - - Shafting - - - Gears - - -
Hangers - - - Bearings - - - Take Ups - -
Sprockets - - - Clutches - - - Chain Belts -
Floor Stands - - - Belt Tighteners - - - Rope Shaaves

Meesco Short Center Drives

Mees & Gottfried Company

ENGINEERS AND MANUFACTURERS

CONVEYING, ELEVATING, SCREENING
AND MECHANICAL POWER TRANSMITTING
MACHINERY

SAN FRANCISCO 642 Meesco Street SEATTLE 555 First Ave So PORTLAND 67 Front Street LOS ANGELES 607 1/2 4th St

LA FRANCE SAFETY DEVICES

FOR EVERY INDUSTRY

Your Responsibility



When you specify AMERICAN-LAFRANCE equipment, no matter whether it be an extinguisher, chemical engine, nozzles, hose, hose reels or any other number of this great line, produced by the world's largest manufacturer of fire equipment, you can be confident that you have recommended apparatus that will prove its worth the first time danger threatens.

WRITE OUR NEAREST BRANCH OFFICE FOR COMPLETE INFORMATION

AMERICAN-LAFRANCE FIRE ENGINE COMPANY, INC.

ELMIRA, N. Y.



San Francisco, Calif.
151 New Montgomery St.

Los Angeles, Calif.
929 South Hill St.

Portland, Ore.
A. B. Long



Residence of Dr. Schiffman
505 So. Grand St., Pasadena, Calif.
Dormell & Draubaugh, Ptrs.



BAY STATE COATING

Charm and beauty belong to the home finished with Bay State Brick and Cement Coating. It waterproofs and weatherproofs all walls of brick, cement and stucco.

In white or colors. Send for a sample of your favorite tint and Booklet No. 43. It shows many Bay State Coated Homes. Bay State Liquid Paints and INOROUT Varnish fill every painting requirement.



WADSWORTH, HOWLAND & CO., Inc.

Paint and Varnish Makers
BOSTON, MASS.

Pacific Coast Representatives

JAMES HAMBLY & SON
San Francisco Los Angeles

Your Client, Mr. Architect Demands

Snow White Brilliance

Upon a Smooth Surface

☞ Petrium Sanitary Sinks answer every requirement. They are non-porous, non-absorbent and lye-proof. There are no crevices or corners to catch the dirt and grease. ☞ Therefore Specify this sink.

☞ Can be installed in any home or apartment — new or old. A California product.

Send for our Booklet and Price List

**Petrium Sanitary Sink
Company**

Factory and Office, West Berkeley



When writing to Advertisers please mention this magazine.

ZOURI**SAFETY SASH BARS**

Accepted by the Insurance Underwriters for Safety Setting of Plate Glass used in Store Front Construction.

COBBLEDICK-KIBBE GLASS CO.175 JESSIE ST. WASHINGTON AT THIRD ST.
SAN FRANCISCO, CAL. OAKLAND, CAL.**POWER CONSTRUCTION CO.**

INCORPORATED

CONTRACTING ENGINEERSPreliminary Estimates Given in All Types
of Buildings, Towers and BridgesSHARON BUILDING, SAN FRANCISCO
Phone Sutter 5478**CHAS. STOCKHOLM & SONS****GENERAL CONTRACTORS**

849 MONADNOCK BUILDING Phone DOUGLAS 4657 SAN FRANCISCO

John Ringius Company, Inc.

MANUFACTURERS OF

Multivane Volume Fans and Steel Plate Blowers made to order,
any size, for Heating and Ventilating Plants in Theatres,
Schools, Public Buildings, Etc.**Sheet Metal Products****Fans and Blowers**

330 Ritch Street

SAN FRANCISCO

Phone Garfield 1108

JOHN M. BARTLETT**GENERAL CONTRACTOR**Office
357 - 12th ST., OAKLANDPhone Lakeside 6750
Res. Phone Berkeley 6884W**E. T. LEITER & SONS****BUILDING CONSTRUCTION**

412 CALL-POST BUILDING Phone SUTTER 1980 SAN FRANCISCO

CHAS. G. FRIES.

TELEPHONE SUTTER 5706

VICTOR A. KUEHN

LIBERTY ELECTRIC COMPANY

479 Sutter St. Electrical Contractors San Francisco, Cal.

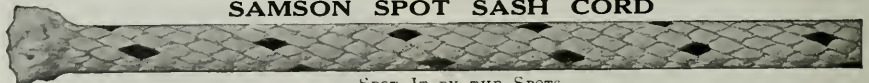
SAMSON SPOT SASH CORD

SPOT IT BY THE SPOTS

Made of extra quality cotton yarn, firmly braided and smoothly finished. Carefully inspected and guaranteed free from all imperfections of braid and finish. Can be distinguished at a glance by our trade-mark, the Colored Spots. Send for catalogue and samples.

Pacific Coast Agent, JOHN T. ROWNTREE, Inc., San Francisco and Los Angeles, Cal.

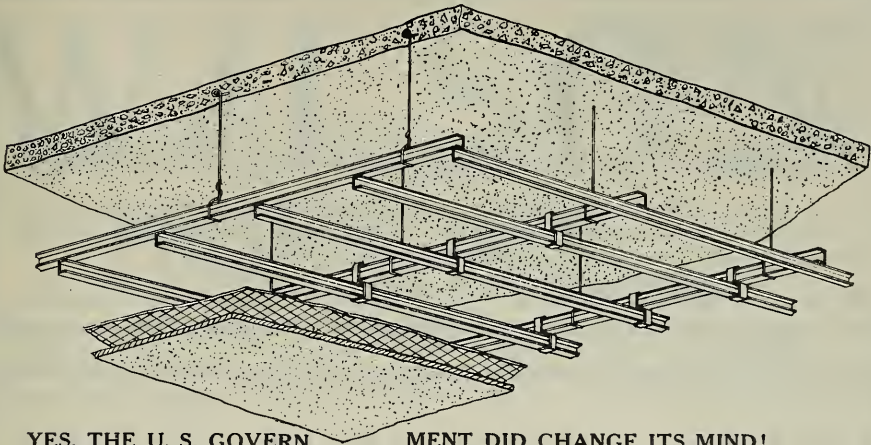

YES, THE U. S. GOVERNMENT DID CHANGE ITS MIND!

The specifications on the U. S. Government Building at Portland, Oregon, called for the tying together of the carrying bar and lathing bar with wire.

We submitted our system, and after an explanation of the S. S. System for fastening bars, the engineers and government officials were convinced that here, at last, is the perfect and economical system, and these reasons added weight in deciding.

It is a positive tie, no slipping or shearing.

It is strong, Smith Emery test to 353 lbs. before failing.

It is fast, can be applied on the bench or on the scaffold.

Made for 1 inch carrying bar and 3/4 inch lathing bar and 3/4 inch carrying bar and 3/4 inch lathing bar. Can be used for wall furring as well as for ceiling work.

THE STEEL STUDDING COMPANY

Also Manufacturers of

THE PRONG CHANNEL FOR SOLID AND HOLLOW PARTITIONS

Agents Wanted Everywhere

1216 Folsom Street, San Francisco

A TEN YEAR GUARANTEE

is back of this roof covering and it **costs less** than other roofing materials



2400 gallons used on the Fairmont Hotel, San Francisco.

Bekin's Warehouse is waterproofed with it.

The W. O. W. Building, Oakland, is roofed with it.

You make no mistake when you specify

LIQUID ASBESTOS PATCH-HOLE CEMENT

Write for sample and price list.

California Plastic Products Company

521 SHELDON BUILDING, SAN FRANCISCO, CALIFORNIA

When writing to Advertisers please mention this magazine.

**FOR MODERN
STORE FRONTS**

Plummer's Disappearing Awnings

Are constructed with no outside attachments below awning recess. All mechanical parts entirely concealed. Send for Architects' Sheet showing specifications for recess construction, etc.

W. A. PLUMMER MFG. CO., 35-37 Front Street, San Francisco

JOHN TRAYNOR

CHARLES HARCOURT

OCEAN SHORE IRON WORKS

Manufacturers of Oil Tanks, Water Tanks, Pressure Tanks, Air Receivers, Feed Water Heaters, Breechings, Smoke Stacks, Water Pipe, Boilers, Retorts, Digestors, Pneumatic Pressure Tanks, Riveted or Oxy-Acetylene Welded Tanks, and dealers in Boilers, Tanks, Pumps, Engines, Machinery, Steel Plates, Shapes

Special Attention Given to Government and Export Orders

OCEAN SHORE IRON WORKS

Office and Works: 550-558 EIGHTH STREET, SAN FRANCISCO, CAL.

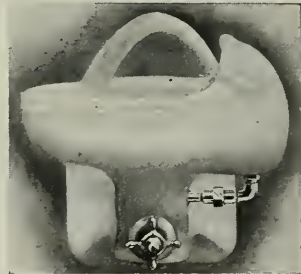

Model No. 7A.

NO GERMS HERE

HAWS IMPROVED SANITARY DRINKING FAUCET eliminates all possibility of contracting disease from dirty bulbs or unsanitary bowls. Provided with an overhead cowl, the drinker's lips never touch the source of supply. A slanting stream throws the water from right to left and away from the bubbler, instead of straight up to fall back over the fountain head. Recommended for Schools and Public Playgrounds. A type used extensively by the U. S. Government. Manufactured by

Haws Sanitary Drinking Faucet Co., Inc.
1808 Harmon Street, Berkeley Phone Piedmont 3742

GLADDING, McBEAN & CO.

MANUFACTURERS CLAY PRODUCTS

CROCKER BUILDING, SAN FRANCISCO

WORKS, LINCOLN, CAL.

WILSON

**FOLDING PARTITIONS
CASEMENTS
WARDROBE FRONTS**

For **SCHOOLS, Clubs, Churches, Hotels,
Y. M. C. A. Buildings and Residences**

An average of 100 square feet of floor space is saved in each class room by installing **WILSON** Wardrobes

AN ADDED FEATURE IN SCHOOL HYGIENE

A great reduction can be made in building costs by the use of **WILSON PRODUCTS.**

A SCHOOL WARDROBE

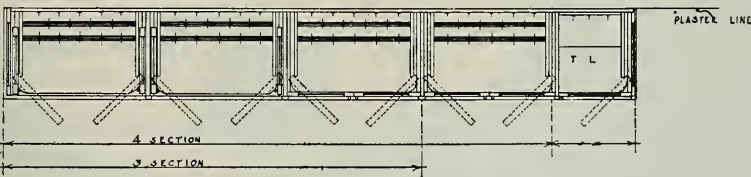
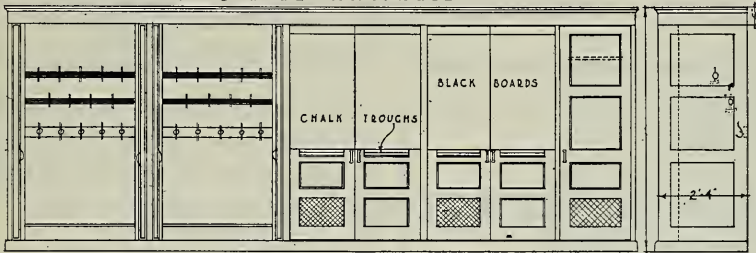

PACIFIC COAST OFFICE

The J. G. WILSON CORPORATION

600 Metropolitan Bldg., Los Angeles, Calif.

Also Manufacturers of

Diffuselite Blinds and Awnings

Rolling Partitions

Rolling Steel Doors

Western Agents at San Francisco, Portland, Seattle, Spokane, Salt Lake City

When writing to Advertisers please mention this magazine.

THE TORMEY CO.

General
Painters

Phone Franklin
5-5-9-8

1042 Larkin St., San Francisco, Cal.

Alvaline, Cementoline
and other
Jones-Duncan Products

MAGNER BROTHERS
PAINT MAKERS

Telephone: Market 113
414-424 Ninth St. San Francisco

HEATING-PLUMBING

COMPLETE PLUMBING AND
HEATING SYSTEMS INSTALLED
IN ALL CLASSES OF BUILDINGS
ALSO POWER PLANTS

GILLEY-SCHMID CO., Inc.

198 OTIS STREET, SAN FRANCISCO.
Tel. MARKET 965

"BLAZING" THE TRAIL
We've been doing it for many years—giving the Sportsman Better Value for Quality than he ever before received. "Value at a Fair Price" in everything for the Sportsman.

The
Elery Arms
Company

583-85 MARKET ST
SAN FRANCISCO, CAL.

SEND FOR CATALOG *The Sign of Quality*

Phone Douglas 3224

Hunter & Hudson
ENGINEERS

Designers of Heating, Ventilating
and Wiring Systems. Mechanical
and Electrical Equipment of
Buildings.

703 Rialto Bldg., San Francisco, Cal.

BEAVER BLACKBOARD
BEAVER GREENBOARD

SCHOOL FURNITURE
AND SUPPLIES—
OFFICE, BANK AND
COURTHOUSE FURNITURE—
THEATRE AND
AUDITORIUM SEATING

Rucker-Fuller Desk Co.

677 Mission St., SAN FRANCISCO, CAL.
434 Higgins Bldg., LOS ANGELES, CAL.
432 - 14th Street - OAKLAND, CAL.

ELECTRICAL MECHANICAL

BALDWIN DREW WARD
Consulting Engineer
Power and Industrial Plants

Associate Member A. I. E. E.

76 Eleventh St. Oakland, Cal.

RUSSWIN
BUILDERS' HARDWARE

JOOST BROS., Inc.
SAN FRANCISCO AGENTS.

We Carry Complete Stock:
Fishing Tackle—Guns—Mechanics' Tools—
Paints—Crockery and Glassware—Stoves—
Household Goods. Telephone Market 891.

NO BRANCH STORE
Mazda Lamps Electric Goods

ARMCO

TRADE MARK

INGOT IRON

The Desert Shall Bloom as a Garden

ACRE by acre the American arid lands are being reclaimed. The hot, dry sand becomes fertile soil when the life-giving water is brought to it.

Sometimes the water must be carried for miles into the desert. Wooden flumes rot and leak. Ordinary sheet-metal flumes may rust quickly, but "ARMCO" Ingot Iron flumes are coming into general use.

They cannot rot and the metal is so pure that it successfully resists the rust that would soon eat its way through the flume and waste the precious water.

The service life of flumes made from this pure iron is many times the life of wooden or of other sheet-metal flumes. And it is a matter of pride to us to be able to share in the splendid work of making farms on the desert.

"ARMCO" Ingot Iron is good for any purpose where rust must be fought. Write for full information.

The American Rolling Mill Company

Middletown, Ohio

"ARMCO" INGOT IRON RESISTS RUST



An ample stock of ARMCO Iron is carried at San Francisco Warehouse, Tenth and Bryant Streets.



A. D. COLLMAN

GENERAL CONTRACTING

Phone Sutter 4858

546-48 Monadnock Building, San Francisco

I. R. KISSEL

Phone Franklin 548

Decorator, Painter and Paperhanger

1747 SACRAMENTO ST., Bet. Polk St. and Van Ness Ave., SAN FRANCISCO

ROBERT TROST

PHONE MISSION 2209

General Building ContractorWe Specialize in High Grade Work and Employ Skilled
Labor in every Branch of the Building Industry.26th and Howard Streets
SAN FRANCISCO

P. A. Palmer

Peter Petersen

W. L. Kelly

PALMER & PETERSEN**Contracting Engineers**

782-796 Monadnock Building

SAN FRANCISCO, CAL.

S. RASORI, RES. 2042 TAYLOR ST.
PHONE FRANKLIN 6258J. DEL FAVERO, RES. 1839 MASON ST.
PHONE FRANKLIN 9524**DEL FAVERO & RASORI**

GENERAL CONTRACTORS

MEMBERS OF THE S. F. BUILDERS EXCHANGE AND THE BUILDING INDUSTRIES ASS'N

OFFICE:
110 JESSIE STREET

SAN FRANCISCO, CALIF.

MONSON BROS.

GENERAL CONTRACTORS

Telephone Market 2693

1908 Bryant Street, San Francisco

UNIT CONSTRUCTION COMPANY

(INCORPORATED)

ENGINEERING AND CONSTRUCTION

Telephone Kearny 28

429-36 Phelan Building, SAN FRANCISCO

J. D. HANNAH

Contractor and Builder

OFFICE: 142 Sansome Street
San Francisco, Cal.Telephone Douglas 3895
BUILDERS EXCHANGE, 180 JESSIE STREET

**MOUNT DIABLO CEMENT
COWELL SANTA CRUZ LIME**

ALL KINDS OF

BUILDING MATERIALS

HENRY COWELL LIME AND CEMENT CO.

Phone Kearny 2095

No. 2 MARKET STREET, SAN FRANCISCO

Automatic Fire Sprinklers

Protect your building and business from destruction by fire and reduce your Insurance Rate.

Pacific Fire Extinguisher Co.

FIRE PROTECTION ENGINEERS

424-440 HOWARD STREET
SAN FRANCISCO

MANUFACTURING PLANT
272 STEUART STREET

LINOTILE

“The Floor that’s Built to Fit the Room”

Furnished and Laid by

VAN FLEET-FREEAR CO.

Telephone :
Douglas 1227

61 New Montgomery Street
San Francisco, California

Kawneer

Factory
Berkeley, Calif.
Berkeley 8710

MANUFACTURING COMPANY
of California

San Francisco Office:
180 Jessie Street
Sutter 6700

Kawneer
Store-Fronts
All Metal Mouldings

Kawneer
Simplex Windows
Weightless & Reversible

I. M. SOMMER

CONTRACTORS & ENGINEERS

Phone Kearny 4582

401 BALBOA BLDG., SAN FRANCISCO

K. E. PARKER COMPANY, Inc.

GENERAL CONTRACTORS

Phone Sutter 5661

Room 515 Clunie Building, SAN FRANCISCO

R. W. LITTLEFIELD

BUILDING CONSTRUCTION

357 12th Street, Room 9, Oakland, Cal.

Phone Lakeside 6750

H. H. HILP, Jr.

J. FRANK BARRETT

BARRETT & HILP

CONCRETE CONSTRUCTION BUILDERS GENERAL CONTRACTORS

SHARON BUILDING, SAN FRANCISCO

TELEPHONE SUTTER 1168 or 1169

Res. Phone Mission 5049

JAMES F. SMITH — Plasterer

273 Minna Street, San Francisco

Phone KEARNY 740

Member Builders Exchange

STEELFORMS Signify ECONOMY, RAPIDITY, and EFFICIENCY

STEELFORM CONTRACTING COMPANY

STEELFORMS FOR
CONCRETE
BUILDINGS

C. B. Hopkins, C. E., Manager
681 Market Street, San Francisco

CONCRETE JOIST
FLOOR
CONSTRUCTION

W. C. DUNCAN & CO.

508 Sharon Bldg.

General Contractors

San Francisco

M. E. VUKICEVICH

SPENCER B. BAGGE

VUKICEVICH & BAGGE

GENERAL CONTRACTORS

Phone Sutter 6700

Office, Builders Exchange, 180 Jessie St., San Francisco

245 Market St. **Standard Fence Co.** 310 Twelfth St.
 S. F. Kearny 2028 **WIRE AND IRON WORKS** Oakland 475

DESIGNERS - BUILDERS
 FACTORY PROTECTION FENCE
 AVIARY AND TENNIS COURT FENCE
 320 North Los Angeles Street, Los Angeles, Cal. Phone 67188

WIRE GRILL WORK—WIRE SCREEN
 FLEXIBLE WIRE CONVEYOR BELT
 WIRE SPECIALTIES

Steel Bars FOR CONCRETE REINFORCEMENT
Cut to Length, Fabricated, Installed

BADT-FALK & CO.

Tel. Douglas 3466 346 Call-Post Bldg., 74 New Montgomery St., San Francisco

BUILDING DIRECTORIES [INTERCHANGEABLE STEEL
 LETTERS AND NUMBERS]

FOR OFFICE BUILDINGS, SCHOOLS, CAFETERIAS, Etc.
 Bargains Lists for Auto Sales Companies. Sold Outright.

Go-Sign and Letter Manufacturing Co.

1106 Franklin Street Oakland, California

D. N. & E. WALTER & CO.
 "SINCE 1858"

LINOLEUMS—CARPETS LARGE STOCKS CARRIED
 Estimates furnished on request

562-572 MISSION STREET SAN FRANCISCO

Phone Merritt 668

H. N. McNAB

Hardwood Floors  Floor Sanding

2307 - 17th Ave. Oakland, Cal.

Res. Tel. Merritt 3600

HERBERT BECKWITH
Building Construction

Formerly with ARTHUR ARLETT 323 Newton Ave.
 Oakland

D. ZELINSKY & SONS

PAINTERS AND DECORATORS

420 TURK STREET, SAN FRANCISCO

CHARLES T. PHILLIPS
CONSULTING ENGINEER

PACIFIC BUILDING SAN FRANCISCO
 HEATING VENTILATION WIRING ILLUMINATION

Ideal Air-Washers. Ideal Fruit-Dryers. Fan Systems for Heating, Cooling and Drying.

Ideal Heating and Engineering Co.

Air-Conditioning, Heating, Cooling and Drying

192 ERIE STREET

Phone Market 3708

SAN FRANCISCO

Atlas Heating and Ventilating Co., Inc.

ENGINEERS and CONTRACTORS

STEAM AND HOT WATER HEATING, FANS, BLOWERS,
FURNACES, POWER PLANTS--SHEET METAL WORK

Phone Douglas 378

Fourth and Freelon Sts., Bet. Bryant & Brannan, SAN FRANCISCO

Illinois Automatic Vacuum and Vapor Systems of Heating

"TWENTY-FIVE YEARS OF QUALITY"

ILLINOIS ENGINEERING COMPANY

JAS. I. KRUEGER, *Representative*

559-561 Pacific Building, San Francisco

Telephone: Kearny 3047

HEATING
VENTILATION

FLOOR AND WALL TILING

PLUMBING
SHEET METAL WORK

SCOTT CO., Inc.

SUCCESSOR TO JOHN G. SUTTON CO.

243 MINNA STREET

SAN FRANCISCO

ALEX COLEMAN

CONTRACTING PLUMBER

706 ELLIS ST., SAN FRANCISCO

Phone FRANKLIN 1006

WM. F. WILSON COMPANY

MODERN SANITARY APPLIANCES

Special Systems of Plumbing for Residences, Hotels, Schools, Colleges, Office Buildings, Etc.

Phone Sutter 357

328-330 Mason Street, San Francisco.

C. DRUCKER

J. C. JAMES

JAMES & DRUCKER

Plumbing—Heating Contractors

Phone Market 275

450 Hayes Street, San Francisco, Cal.

The Granite Work on Eldorado County Courthouse; National Bank of D. O. Mills, Sacramento;—
and Sen. Nixon Mausoleum, Reno, WAS FURNISHED BY

CALIFORNIA GRANITE COMPANY

Phone Sutter 2646

STONE CONTRACTORS

Gen'l Contractors Ass'n, San Francisco
Quarries, Rocklin and Porterville

Main Office, Rocklin, Placer Co., Cal.
Telephone Main 82

Bath Room Fixtures

A BATH ROOM should be just as true an expression of the owner's taste and individuality as any other room of the house.

No more is it considered a luxury, but an absolute necessity to your health and comfort.

Our fixtures reflect the finest ideas in design and construction as related to sanitation, utility and service.

To give this subject the attention it demands, you should visit our display rooms at 64 Sutter Street, San Francisco.

Holbrook, Merrill & Stetson

DEALERS IN

Plumbers' Supplies, Iron Pipe and Fittings, Metals, Steam, Water and Hot Air Heating Apparatus, Stoves, Ranges, Kitchen Utensils.

Show Room, 64 SUTTER STREET

Main Office and Warehouse,

Sixth, Townsend and Bluxome Streets, San Francisco



Designers - Fabricators - Erectors

General Plate Work



Hydro - Pneumatic Pressure Tanks —
Hemispherical Bottom Tanks and Towers
— Oil and Water Tanks — Oil Stills —
Pipe Lines — Smoke Stacks — Well Casing
— Rock Screens — "Western" Corru-
gated Culvert Pipe.

Western Pipe and Steel Company

OF CALIFORNIA

444 MARKET STREET
SAN FRANCISCO

1758 NORTH BROADWAY
LOS ANGELES

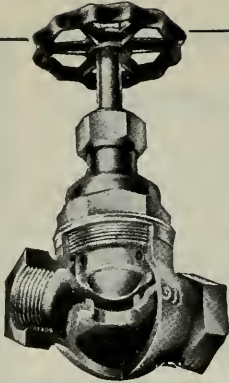

AMERICAN BALL VALVES

"Durable — therefore, Economical" — Stands the Severest Tests — Endorsed by the Leading Architects and Engineers of the Country. It is A PERFECT BALL-CLOSING VALVE.

W. E. MUSHET CO

SOLE AGENTS
Phone Sutter 4797



502 Mission Street
San Francisco, Cal.

DON'T NEGLECT YOUR HEATING SYSTEM.
THE BEST IS NONE TOO GOOD!

All kinds of Galvanized Iron Work — Furnaces, Pipes, Ventilators — Sheet Metal for Planing Mills, Fruit Dryers, Rice Mills. Kitchen Equipment, including Steam Tables, Sinks, Canopies, Urn Stands, Etc.

JAMES A. NELSON

Heating and Ventilating Contractor

Phone, Garfield 1959

517-519 SIXTH ST., SAN FRANCISCO

A. H. Bergstrom
Eric Lange

Phone Kearny 3526

LANGE & BERGSTROM

Building Contractors

(Established 1900)

207-210 SHARON BUILDING
San Francisco

TIMKEN BUILDING
San Diego

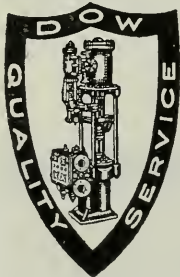

DOW ROTREX PUMP

For severe suction requirements

We also manufacture

TRIPLEX POWER PUMPS

and

CENTRIFUGAL PUMPS

We solicit your inquiries

DOW - HERRIMAN CO.

San Francisco Office, 140 Howard Street
phone Garfield 612

Plant Petaluma Cal.

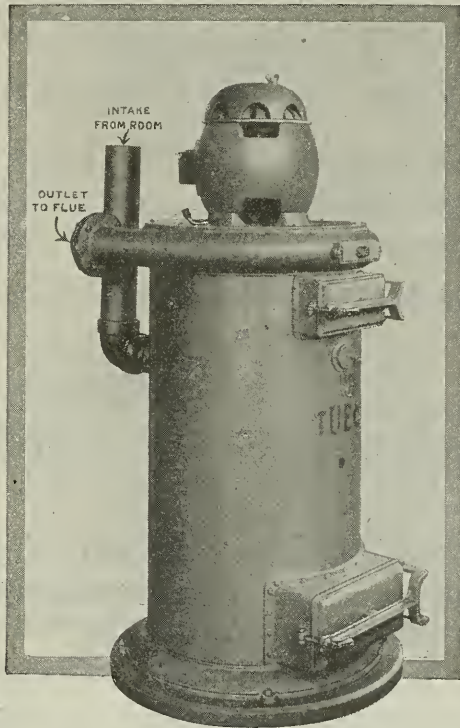

TUEC STATIONARY CLEANER.

THE cleaner that reduces building maintenance expense by keeping floors, walls, stairways, merchandise and other stocks, carpets, furniture and furnishings free from dust and dirt. No other cleaning device or dust removal method is so thorough, efficient, and economical. Investigate yourself and invite your client to do so. Write for our free catalog and full information.

THE UNITED ELECTRIC CO.

CANTON, OHIO.

Canadian Plant: Toronto, Ont.

California Distributors

S. F. COMPRESSED AIR CLEANING CO.
397 Sutter Street, San Francisco

BARKER BROS.
724 S. Broadway, Los Angeles



POSITIVE ELECTRIC INTERLOCK

(BAR LOCK TYPE)

Prevents Elevator Accidents Occurring at the Entrance Door

Approved by National Underwriters Laboratories—Meets requirements of Elevator Safety Orders of Industrial Accident Commission, State of California

ELEVATOR SUPPLIES COMPANY, Inc. 186 FIFTH STREET,
SAN FRANCISCO

Capital \$1,000,000

CALIFORNIA DEPARTMENT

Surplus \$1,122,000

THE FIDELITY AND CASUALTY COMPANY OF NEW YORK

Prompt Service for

BONDS AND CASUALTY INSURANCE

203-206 Merchants Exchange Building

SAN FRANCISCO, CAL.

ANY PLACE ANY TIME PROMPTLY "We Serve You"

JOHN H. ROBERTSON

Successor to Robertson & Hall

GENERAL INSURANCE

Phone Sutter 2750

621 First National Bank Building, San Francisco

CONTRACT BONDS

Fidelity and Surety Bonds of every kind.

C. K. BENNETT, Manager

FIDELITY AND DEPOSIT COMPANY OF MARYLAND

Telephone Kearny 1452

622 Insurance Exchange, San Francisco, Calif.

PACIFIC DEPARTMENT

Globe Indemnity Company

BONDS and CASUALTY INSURANCE for CONTRACTORS

FRANK M. HALL, formerly Robertson & Hall, Mgr.

120 Leidesdorff Street Phone Sutter 2280 SAN FRANCISCO

National Surety Company of New York

The World's Largest Surety Company

Assets over \$20,000,000

Pacific Coast Department: 105 MONTGOMERY ST., SAN FRANCISCO, CAL.

Frank L. Gilbert, Vice-President

Phone, Sutter 2636

PHONE DOUGLAS 2370

McLERAN & PETERSON

GENERAL CONTRACTORS

HEARST BUILDING

SAN FRANCISCO, CAL.

L. J. RUEGG

J. B. RUEGG

RUEGG BROS.

CONTRACTORS AND BUILDERS

Phone Douglas 1599

719 Pacific Building, SAN FRANCISCO

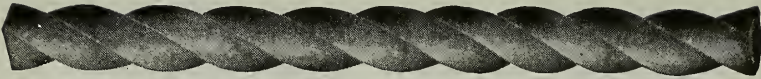

Steel ^{Open} ^{Hearth} Bars For Concrete Reinforcement

Square, Deformed and Cold Twisted, Plain Rounds and Squares

PACIFIC COAST STEEL COMPANY

General Office, Rialto Building, San Francisco. Phone Sutter 1564

Sales Office, Rialto Building, SAN FRANCISCO
 Sales Office, Union Oil Building, LOS ANGELES
 Sales Office, SEATTLE, WASH.

ROLLING MILLS:
 SOUTH SAN FRANCISCO, CAL.
 SEATTLE, WASH. PORTLAND, ORE.

Architects and Building Contractors!

The HICKS-JUDD COMPANY, Inc., and SUNSET PUBLISHING HOUSE
 have consolidated under the name of
 ABBOTT-BRADY PRINTING CORPORATION
 460 Fourth Street, San Francisco, Calif.

THE Binding of Magazines and Periodicals
 will continue as one of Our Specialties;
 also Expert Plate and Map Mounting.

Reprinting of The Architect and Engineer Advertisements for Circular or File Use

George S. MacGruer }
 Robert M. Simpson } Members of Builders Exchange

MacGruer & Simpson

CONTRACTING PLASTERERS

PLAIN AND ORNAMENTAL

Cement, Stucco and Artificial Stone

Phone Sutter 5688

540 Call-Post Building, San Francisco

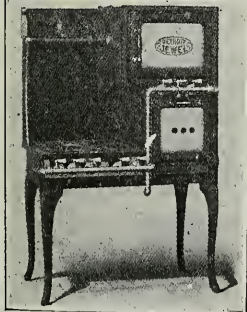

Detroit Jewel Gas Ranges

FOR HOME, RESTAURANT, HOTEL AND CLUB

We carry a Full Line of Stock Sizes

SELLING AGENTS

NATHAN DOHRMANN CO.

Geary and Stockton Streets, San Francisco

PARMELEE-DOHRMANN CO.

436-444 S. BROADWAY, LOS ANGELES

CALIFORNIA ARTISTIC METAL & WIRE CO.
 J. T. McCORMICK, PRESIDENT
 ORNAMENTAL IRON AND BRONZE
 349-365 SEVENTH ST. SAN FRANCISCO

MORTENSON CONSTRUCTION CO.

CONTRACTORS FOR STRUCTURAL STEEL AND IRON

H. MORTENSON, PRES. CHAS. G. MORTENSON, VICE-PRES. AND MGR.

OFFICE AND SHOPS: CORNER 19TH AND INDIANA STREETS

PHONE: MISSION 5033

SAN FRANCISCO, CAL.

RAYMOND GRANITE COMPANY, Inc.

Owning and operating at Knowles, Madera County, the largest Quarry in the world

CONTRACTORS FOR STONE WORK

Designers and Manufacturers of Exclusive Monuments and Mausoleums

Main Office and Yard: No. 1 and 3 Potrero Avenue, San Francisco, California

Also at 1350-Palmetto Street, Los Angeles

**CAEN
STONE**

A refined, elegant,
interior finish.



A. KNOWLES

CONTRACTOR and PLASTERER

442 Call-Post Building

San Francisco

**THE GOLDEN GATE IRON WORKS
STRUCTURAL STEEL**

1541-1549 HOWARD STREET, BETWEEN 11th AND 12th STREETS
 Tel. Market 5445 San Francisco

Telephone Mission 58

A. A. Devoto, President

CENTRAL IRON WORKS, Inc.
 STRUCTURAL STEEL

Office 2050 BRYANT STREET

SAN FRANCISCO, CAL.

**JOHNS-MANVILLE
SERVES IN CONSERVATION**
 Through
ASBESTOS and its ALLIED PRODUCTS

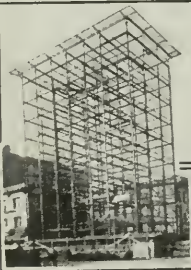

SCHRADER IRON WORKS, Inc.

STRUCTURAL STEEL CONTRACTORS

Fire Escapes, Waterproof Trap Doors, Ornamental Iron Work

1247-1249 HARRISON STREET
 Bet. 8th and 9th.

SAN FRANCISCO, CAL
 Telephone Market 337

THE HYLOPLATE BLACKBOARD

SCHOOL FURNITURE
AUDITORIUM SEATING

MAPS
GLOBES
ATLASES

C. F. WEBER & CO.

985 Market Street
SAN FRANCISCO

222-224

S. Los Angeles St.
LOS ANGELES

100 W. Commercial
Row, RENO, NEV.

524 W. Washington
Street, PHOENIX, ARIZ.



**BEAUTIFUL GARDEN
EFFECTS** for the City
and Suburban Home

MacRORIE-McLAREN CO.

Landscape Engineers
and General Nurserymen



Office Nurseries at
141 Powell Street Beresford,
San Francisco San Mateo County

Resists Rot

Nature impregnates Redwood with a natural preservative that resists rot. Redwood lasts longer untreated than most woods when artificially preserved.

For all industrial construction, especially where exposed to the elements or in contact with the ground, Redwood is ideal.

Write for "Redwood Lives Forever," "California Redwood for the Engineer," and "Redwood Block Paving and Flooring."

CALIFORNIA REDWOOD
ASSOCIATION
San Francisco

California Redwood

Resists fire and rot

WASH in tempered running water by installing
Crane "Sultana" Double Basin Faucet
FOR NEW AND OLD INSTALLATIONS

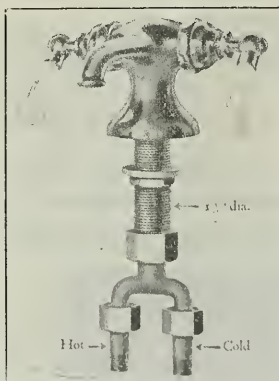

FOR HOME — OFFICE — FACTORY
"SULTANA" can be installed on practically all lavatories cut for two basin faucets. It is an ideal faucet to install when making alterations.

CRANE CO.
PLUMBING SUPPLIES
SAN FRANCISCO AND OAKLAND

Telephone DOUGLAS 2046	Butte Electrical Equipment Company BEECO <small>TRADE MARK - REG.</small>	530 FOLSOM STREET
CONTRACTORS FOR POWER LIGHTING AND INDUSTRIAL INSTALLATIONS		
For the convenience and guidance of our customers, we have adopted BEECO as our trade name.		

<h1>SAFETY ELECTRIC COMPANY</h1>		
MANUFACTURERS OF		
SWITCHBOARDS SAFETY SWITCHES SAFETY CONTROLS		PANEL BOARDS SAFETY PANELS KNIFE SWITCHES
59-65 Columbia Square	San Francisco, Calif.	
Telephone Market 2949		

L. SIEBERT	J. GENSLER
<h1>Drendell Electrical & Mfg. Co.</h1>	
Incorporated	
SWITCHBOARDS, PANEL BOARDS, KNIFE SWITCHES, CABINETS, THEATRE INSTALLATIONS, PROTECTIVE POWER PANELS	
1345-1353 Howard St., San Francisco	Telephone Market 1753

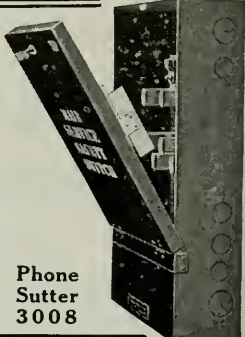
	<h1>MEYERS</h1> <h2>Electric Safety SWITCHES</h2>	
Knock outs on Top, Bottom and Side controlled by Handle on side of Box	EXTERNALLY OPERATED Switch on the right is controlled by Handle on Front of Door, allowing face of switch to be set flush with finish of wall.	Phone Sutter 3008
Meyers Electric Safety Switch Co., Inc. 247 Minna Street		

When writing to Advertisers please mention this magazine.

BUTTE ELECTRIC & MFG. CO. DOUGLAS 145

(Paul C. Butte) at it since 1904

WIRING FOR BUILDINGS

534 Folsom Street

SAN FRANCISCO

H. S. TITTLE**CONTRACTING ELECTRICAL ENGINEER**

766 FOLSOM ST., SAN FRANCISCO

Phone SUTTER 4278

**To Be "Low Bidder" Not Always Our Aim.**

Our most particular attention is given to prompt and skillful handling of all electrical work of any nature with "QUALITY AND SERVICE GUARANTEED."
 Our nation-wide organization and large experience in this field assures you always of fair estimates and absolute satisfaction.

F. E. NEWBERY ELECTRIC CO.

163 Sutter St. (413 Lick Bldg.) San Francisco, Phone Sutter 521

San Francisco, Cal.

Oakland, Cal.

Los Angeles, Cal.

NEPAGE, McKENNY CO.*Electrical Engineers and Contractors*

Phone Sutter 2369

589 Howard St., San Francisco, Cal.

Phone Market 2541

M. FLATLAND

GLOBE ELECTRIC WORKS

Estimates Furnished on Everything Electrical

ELECTRIC SUPPLIES

1959 Mission Street, bet. 15th and 16th

SAN FRANCISCO

E. E. BROWNE

Telephone Douglas 976

C. A. LANGLAIS

**BROWNE-LANGLAIS ELECTRICAL
CONSTRUCTION COMPANY**

213 Minna Street

SAN FRANCISCO

M. E. RYAN**Electrical Contractor**Phones: Store, Red. 250J
Residence, Red. 250M216 Main Street
REDWOOD CITY, CAL.

Thomas J. Bennett

Edward W. Lauer

Rex Electric and Engineering Co.**Contracting and Repairing**

253 Minna Street

Telephone Sutter 2148

San Francisco

Oakland 540

The Largest Exclusive Electrical House in the State

MOTORS

BOUGHT — SOLD
RENTED — REPAIRED

Lighting Fixtures

Manufactured

Construction

MAINTENANCE
SUPPLIES

Estimates and engineering data cheerfully furnished

SPOTT ELECTRICAL CO.

Yours for Service

16th & CLAY STREETS

OAKLAND, CALIFORNIA

The Nation's Housing Conditions Demand ECONOMY in Building

Economy in expense and economy in space. Portal Wall Beds are timely space and cost savers meeting this national need. Everywhere architects and contractors who build wisely plan their apartments with



Crescent Apartments, Ellis and Hyde Streets, San Francisco
Equipped with WALL BEDS

PORTAL WALL BEDS

MARSHALL & STEARNS CO
WALL BEDS

"Highest Award Always"

1152 Phelan Building ..
San Francisco

1774 Broadway
Oakland

When writing to Advertisers please mention this magazine.

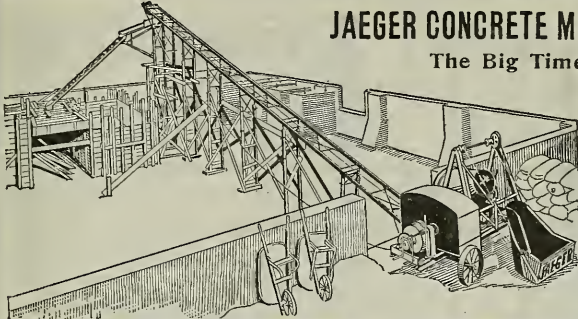

JAEGER CONCRETE MIXING AND PLACING PLANT
 The Big Time and Money Saver

All Sizes and Models in Stock

Edward R. Bacon Co.
 51 Minna St. 165 E. Jefferson St.
 SAN FRANCISCO LOS ANGELES

CONTRACTOR'S MACHINERY

RANSOME MIXERS OSHKOSH MIXERS
 INSLEY SPOUTING PLANTS
 OSHKOSH EVEREADY SAW RIGS INSLEY STEEL CARS and TRACKS
 HOISTING BUCKETS, HOPPERS, GATES, ETC.
 STEAM AND ELECTRIC HOISTS

EVERYTHING USED BY CONTRACTORS
 CARRIED IN STOCK BY
GARFIELD & CO.
 Hearst Building, San Francisco Phone Sutter 1036

**LAKWOOD - MILWAUKEE
 CONCRETE MIXERS**

ARE STURDY, HIGH SPEED, LABOR - SAVING MACHINES

Built in All Commercial Sizes. Driven by Kerosene Engine or Electric Motor.

COMPLETE STOCKS ON HAND



SMITH-BOOTH-USHER CO.
 SAN FRANCISCO-TAFT-LOS ANGELES

MACHINE TOOLS
 WOODWORKING MACHINERY
 ENGINES - MOTORS
 AIR COMPRESSORS - PUMPS
 POWER TRANSMISSION
 OIL & MINING EQUIPMENT
 CONSTRUCTION-INDUSTRIAL
 ROAD MAKING MACHINERY
 PIPE-FITTINGS-VALVES-SUPPLIES ETC.

CATALOG ON REQUEST

School and Theatre
STAGES AND EQUIPMENT

EDWIN H. FLAGG **SCENIC COMPANY, Inc.**
400 Pantages Bldg., San Francisco, Cal.
1638 Long Beach Ave., Los Angeles, Cal.

MILLWORK Manufactured and Delivered Anywhere

Plans or Lists sent us for Estimates will have Careful and Immediate Attention.

Jno. Dudfield, Pres. and Manager **DUDFIELD LUMBER CO.** Joseph A. Jury, Sec'y & Mill Supt.

MAIN OFFICE, YARD AND PLANING MILL — PALO ALTO, CALIFORNIA

FRANK PORTMAN
MILL AND CABINET WORK

Window Frames and Inside Finish A Specialty
Band Sawing, Sticking and Sand Papering

1618-20 MISSION STREET SAN FRANCISCO Phone Park 6204

ALL KINDS OF
MOULDINGS
IN STOCK

A. C. SCHINDLER, President. CHAS. F. STAUFFACHER, Secretary

THE FINK & SCHINDLER CO.
Manufacturers of INTERIOR WOODWORK AND FIXTURES
BANK, OFFICE AND STORE FITTINGS
SPECIAL FURNITURE

218-228 THIRTEENTH ST. SAN FRANCISCO, CAL.
Bet. Mission and Howard Sts. Telephone: Market 474

O. BAMANN, President ERNEST HELD, Vice-President

HOME MANUFACTURING CO.
BANK, STORE AND OFFICE FITTINGS
FURNITURE AND HARDWOOD INTERIORS
CABINET WORK OF EVERY DESCRIPTION

543 and 545 BRANNAN ST. Phone Kearny 1514 San Francisco, Cal.

PACIFIC MANUFACTURING COMPANY
MILLWORK, SASH AND DOORS

Hardwood Interior Trim a Specialty

MAIN OFFICE: SAN FRANCISCO.....177 Stevenson Street
SANTA CLARA, CAL. OAKLAND.....1001 Franklin Street
BERKELEY.....2143 Center Street
SAN JOSE.....16 N. First Street

MULLEN MANUFACTURING CO.
BANK, STORE AND OFFICE FIXTURES—CABINET WORK OF
GUARANTEED QUALITY—CHURCH SEATING

Office and Factory:
Telephone Market 8692 64 Rausch St., Bet. 7th and 8th Sts., San Francisco

Dolan Wrecking & Construction Co.
(D. J. DOLAN)

Lumber, Lath, Nails, Shingles, Doors, Windows
and Plumbing Supplies, New and Second Hand

Phone Market 4264 Office and Yard, 1607-1639 MARKET ST., SAN FRANCISCO

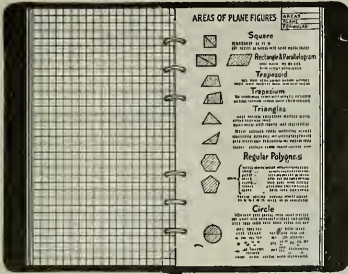

LEFAX

LEAF + FACTS

Pocket Cyclopedias

The facts that you want *instantly available* are not the same ones that some one else in your profession might desire. That's why LEFAX is made Loose Leaf. You file, in whatever order you wish, those sheets of facts that you want to have constantly at hand. If you wish, you may also file, in the same book, sheets for keeping data, for figuring, etc.

LEFAX sets cost but 50c. and \$1.00. You cannot fully appreciate their handiness—their value—until you use them. Ask us about them.

SCHWABACHER-FREY STATIONERY CO.
 PRINTERS LITHOGRAPHERS STATIONERS
 611 Market Street San Francisco

Steam Heating and Ventilating



For Commercial and Public Buildings

Furnace Heating
 For the Home

Mangrum & Otter, Inc.

827-831 Mission Street

Phone Kearny 3155 SAN FRANCISCO

"Talk — Don't Walk"

Baker, Hamilton & Pacific Co.; California Packing Corporation; J. Barth & Company; Robert Dollar Company; Bass-Hueter Paint Co.; Sperry Flour Company, So. Vallejo; J. D. & A. B. Spreckles Securities Co.

WHY are the above firms using the AUTOMATIC PRIVATE TELEPHONE SYSTEM?

BALFOUR, GUTHRIE Co.; HOWARD AUTOMOBILE COMPANY; U. S. MARINE HOSPITAL KNOW WHY, and are also installing the AUTOMATIC PRIVATE TELEPHONE SYSTEM.



DIRECT-LINE TELEPHONE COMPANY

Telephone Electrical Engineers

THEODORE HALL, MANAGER

320 MARKET STREET, SAN FRANCISCO

Phone Douglas 722

Have you read "A Pair of Wires and A Dial?"

ROBERTS MFG. CO.

Lighting Fixtures
 Electric Appliances
 Incandescent Lamps

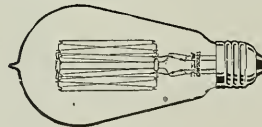

WILLYS FARM LIGHTING AND POWER PLANTS

663 Mission St., San Francisco

Washed Gravel and Sand

Quality For Concrete Construction *Service*

Thoroughly Washed and Accurately Graded—An Ideal Concrete Aggregate



View of Plant at Niles

California Building Material Co.

Plants at Eliot and Niles, Cal.

500 Call Building, San Francisco

Otis Elevators

THE Architect or Engineer can specify "Otis Elevators" assured that the responsibility of the Otis Elevator Company extends beyond satisfactory installation. Buildings equipped with Otis Elevators enjoy the advantage of the prompt service and careful inspection rendered by any of our hundred offices. Such service means your clients' gratitude.

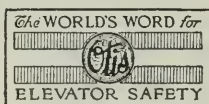

Otis Elevator Company

Offices in All Principal Cities of the World
2300 Stockton Street, San Francisco, Calif.

The
ARCHITECT &
ENGINEER



DECEMBER 1920

Published in San Francisco
35 cents a copy - \$2.50 a year



The final touch of refinement

is added by the installation of the Pacific Vitreous China Built-in Bath Spout.

It eliminates those bothersome metal faucets that must be constantly polished.

The Pacific Bath Spout completes the pure white effect, so desired in bath installations.

By also specifying the Pacific Vitreous China Outlet — illustrated — you carry the white color scheme to completion.

These fixtures were invented and patented by the manufacturers of



PACIFIC **PLUMBING FIXTURES**

For Sale by All Jobbers

Main Offices: 67 New Montgomery Street, San Francisco
Factories: San Pablo and Richmond, California

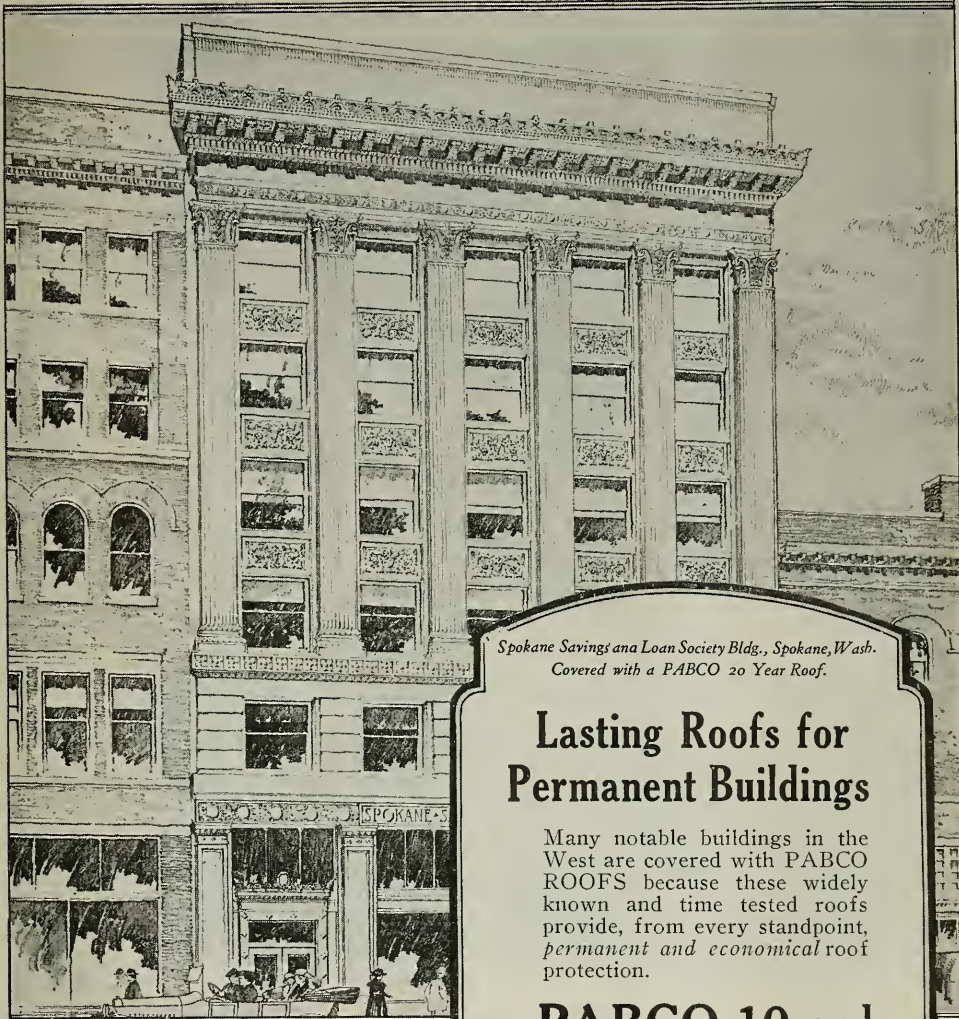

*Spokane Savings and Loan Society Bldg., Spokane, Wash.
Covered with a PABCO 20 Year Roof.*

Lasting Roofs for Permanent Buildings

Many notable buildings in the West are covered with PABCO ROOFS because these widely known and time tested roofs provide, from every standpoint, *permanent and economical* roof protection.

PABCO 10 and 20-Year Roofs

Because of the high quality of materials used, and the admitted superior method of construction, PABCO ROOFS cost slightly more than inferior and short lived roofs. Invariably, however, they prove cheaper in the long run, because of their *low cost per year of service*.

Write for Specifications and Complete Details

THE PARAFFINE COMPANIES, INC.
San Francisco, California

▲ FREDERICK WESTCOTT ▲
▲ ARCHITECT ▲

Roofings—Felts
Building Papers
Floor Covering
Wall-Board
Waterproofing
Materials
Industrial and
Marine Paints
Box-Board
Paper Boxes
Fibre Containers

STEEL BARS

FOR
CONCRETE REINFORCEMENT

CORRUGATED
TWISTED
SQUARES
OR
ROUNDS
CUT
TO
LENGTH



FABRICATED
AND
INSTALLED
—
LUMP SUM
BIDS
ON
WORK
COMPLETE

Office, 444 MARKET STREET
Warehouse, 10th and Bryant Streets
Phone: Sutter 2720

"HYDRATITE" FOR WATERPROOFING AND HARDENING CONCRETE "HORNSTONE"

Look for this
Trademark



And if it's there don't worry
any more about your
Valves and Fittings

*Specify and
insist upon
having*

The Kelly & Jones Co.
Valves and Fittings

Byers Genuine
Wrought Iron Pipe

Republic Steel Pipe

Complete Line of Plumbing Supplies
Large Stocks for Prompt Delivery
Catalogue on request

California Steam &
Plumbing Supply Co.

671-679 Fifth Street, Corner Bluxome
SAN FRANCISCO, CALIFORNIA



When writing to Advertisers please mention this magazine.



Getting ready for the party

Elexits

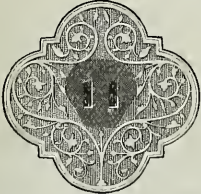

"Places for Lights"

THE FINISHING touches before the guests arrive! A bowl of flowers placed here—a chair moved a little there! And that dark corner brightened up by plugging the new wall fixtures—which "dad" just brought—into two of the numerous and convenient "places for lights."

ELECTRIC OUTLET COMPANY

Inc.

119 West 40th St., New York City

This picture enlarged on heavy mat paper with caption, furnished ready for framing upon receipt of \$5.00. Send check with order.

W. & J. SLOANE

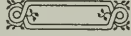

Carpets and Furniture
Rugs
Linoleum Window Shades
Wall Papers
Interior Decorations



216-228 Sutter Street
Tel. Garfield 2838 San Francisco

TIME CLOCKS

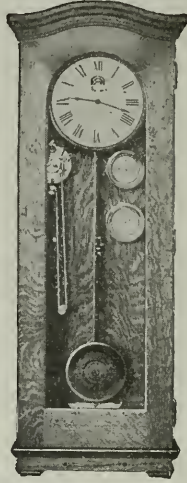

SCHOOLS must have uniform time to secure efficient results. They also need automatic sounding of the program Bells synchronized with the clocks.

All "Standard" Electric Time Equipments are guaranteed against any electrical or mechanical defects for a period of one year from date of installation. Specifications, blue prints and other information will be gladly furnished architects, engineers or officials for planning and installing "Standard" systems. Let us cooperate with you for securing the best results.

STANDARD ELECTRIC TIME COMPANY

461 MARKET STREET
Phone Sutter 241 SAN FRANCISCO



PROMETHEUS

The Electric Food and Plate Warmer

Wherever meals are cooked and served, in apartments, residences and institutions, Prometheus is a highly valued asset. The wireless heating units placed independently of the shelves keep food hot and tasty until ready to serve and cannot injure the finest china.

Write for information and list of installations

The Prometheus Electric Co.

Manufacturers

511 West 42d Street, New York

Showroom, M. E. HAMMOND

Mezzanine Floor Pacific Bldg., San Francisco

CLOW

Modern Heating

AS in lighting, the trend in heating is toward central station service. The wastefulness and high maintenance cost of individual heating plants is becoming understood by the public. At the same time gas — not as a supplementary but as the *main* source of heat—is being recognized. Architects, naturally in the forefront of all developments in such matters, ought to be thoroughly informed as to the scope and possibilities of the Gasteam Radiator. It is as revolutionary and far-reaching in its possibilities as concrete.

The subject is fully covered in our booklet. Let us send you a copy.

Frederick A. Hamilton

Sales Agent

Show Rooms:

RIALTO BUILDING
SAN FRANCISCO





How
VAN DYKE
DRAWING PENCILS
 are graded

OCCASIONALLY, we find a man who has apparently forgotten that **VAN DYKE DRAWING PENCILS** are made in 16 degrees and who has been using a certain degree when another would have served him better. Have you been doing the same thing?

ASK for **VAN DYKE** by name at your stationer's.

SAMPLES of any degrees upon request on your business stationery. Address us at Monadnock Bldg., San Francisco, Cal.

EBERHARD FABER
 "The Oldest Pencil Factory In America"
 NEW YORK



E. B. Noble, President
A. E. Wilkins, Vice-Pres.

Beam, Angle, Channels, and Universal Mill
Plates for immediate shipment from stock

Pacific Rolling Mill Co.

SUPPLIERS OF

FABRICATED STRUCTURAL STEEL, Forgings,
Bolts, Rivets, Frogs, Switches, Cast Iron Castings

General Office and Works
17th and MISSISSIPPI STS., SAN FRANCISCO
Telephone Market 215

Beams
Channels
Angles
Plates

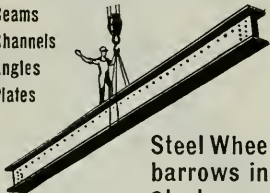

Steel Wheel-
barrows in
Stock

Western Iron Works

W. B. MORRIS, Pres. H. H. MORRIS, V.-P. L. J. GATES, Sec.

STRUCTURAL IRON AND
STEEL CONTRACTORS

141-147 Beale St. and 132-148 Main St. SAN FRANCISCO

Phones: GARFIELD 2575-2576

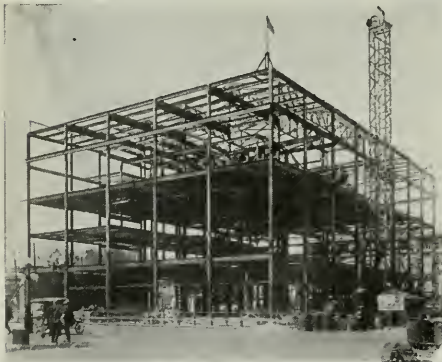

STEEL FRAME, MASONIC TEMPLE,
Sacramento. R. A. HEROLD, Architect.

STRUCTURAL STEEL
(600 tons) Fabricated and
Erected by

THE PALM IRON AND
BRIDGE WORKS (Incorporated)
15th and R Streets, Sacramento, Cal.

Cast Iron Stairs and Store Fronts

Bank and Office Railings, Elevator
Enclosures and Fire Escapes.

C. J. HILLARD CO., Inc.

Nineteenth and Minnesota Streets
Telephone Mission 1763

SAN FRANCISCO, CAL.

Architects' Specification Index

(For Index to Advertisements, see next page)

ARCHITECTURAL TERRA COTTA

Gladding, McBean & Company, Crocker Bldg., San Francisco.

Livermore Fire Brick Works, Livermore, Cal.

ASBESTOS ROOFING, PACKING, ETC.

H. H. Robertson Co., Hobart Bldg., San Francisco.

H. W. Johns-Manville Co., San Francisco, Los Angeles and Portland, Ore.

AUTOMATIC SPRINKLERS

Grinnell Co. of the Pacific, 453 Mission St., San Francisco.

Pacific Fire Extinguisher Co., 424 Howard St., San Francisco.

AUTOMOBILE INSURANCE

Bankers & Shippers Insurance Co. of New York, Insurance Exchange Bldg., San Francisco.

AWNINGS, TENTS, ETC.

W. A. Plummer, Front, at Pine St., San Francisco.

BANKS

First National Bank, Post and Montgomery streets, San Francisco.

BANK FIXTURES AND INTERIORS

Fink & Schindler, 218 13th St., San Francisco.

C. F. Weber & Co., 985 Market St., San Francisco.

Home Mfg. Co., 543 Brannan St., San Francisco.

Mullen Manufacturing Co., 64 Rausch St., San Francisco.

Rucker-Fuller Desk Co., 677 Mission St., San Francisco.

Pacific Manufacturing Company, San Francisco, Oakland and Santa Clara.

BELTING AND PACKING

New York Belting and Packing Company, 519 Mission St., San Francisco.

H. N. Cook Belting Co., 401 Howard St., San Francisco.

Smith-Booth-Usher Co., San Francisco and Los Angeles.

BLACKBOARDS

C. F. Weber & Co., 985 Market St., San Francisco, Los Angeles and Reno, Nevada.

Beaver Blackboards and Greenboards, Rucker-Fuller Desk Company, Coast agents, 677 Mission St., San Francisco; also Oakland and Los Angeles.

BLINDS—VENETIAN AND DIFFUSELITE

J. G. Wilson Corporation, Metropolitan Bldg., Los Angeles; Waterhouse-Wilcox, Underwood Bldg., San Francisco.

Western Venetian Blind Co., Long Beach Ave., Los Angeles; C. F. Weber & Co., San Francisco.

BOILERS

California Hydraulic Engineering & Supply Co., 70-72 Fremont St., San Francisco.

Franklin Water Tube Boiler, General Machinery and Supply Co., 39 Stevenson St., San Francisco.

Kewanee Water Supply System, Simonds Machinery Co., 117 New Montgomery St., San Francisco.

General Boilers Co., 322 Monadnock Bldg., San Francisco.

BOOK BINDERS

Abbott-Brady Printing Corp'n, 460 Fourth St., San Francisco.

H. S. Crocker Co., 565 Market St., San Francisco.

BONDS FOR CONTRACTORS

American Mutual Liability Insurance Co., Balboa Bldg., San Francisco.

Bonding Company of America, Kohl Bldg., San Francisco.

Bankers & Shippers Insurance Co. of New York, Insurance Exchange Bldg., San Francisco.

Globe Indemnity Co., 120 Leidesdorff St., San Francisco.

Fidelity & Casualty Co. of New York, Merchants Exchange Bldg., San Francisco.

Fidelity & Deposit Co. of Maryland, Insurance Exchange, San Francisco.

John H. Robertson, 621 First National Bank Building, San Francisco.

National Surety Co. of New York, 105' Montgomery St., San Francisco.

BRASS GOODS, CASTINGS, ETC.

H. Mueller Manufacturing Co., 635 Mission St., San Francisco.

BRICK—COMMON, PRESSED, PAVING, ETC.

California Brick Company, Niles, Cal., and 604 Mission St., San Francisco.

Livermore Fire Brick Works, Niles, Cal. Los Angeles Pressed Brick Co., Frost Bldg., Los Angeles.

United Materials Co., Crossley Bldg., San Francisco.

Cannon & Co., Sacramento; and Chronicle Bldg., San Francisco.

BRICK & CEMENT COATING

Armorite and Concreta, manufactured by W. P. Fuller & Co., all principal Coast cities.

The Paraffine Companies, Inc., 34 First St., San Francisco.

R. N. Nason & Co., 151 Potrero Ave., San Francisco.

Wadsworth, Howland & Co., Inc., Boston, Mass., manufacturers of Bay State Brick & Cement Coating. Hambley & Son, agents, San Francisco and Los Angeles.

BRICK STAINS

Samuel Cabot Mfg. Co., Boston, Mass., agencies in San Francisco, Oakland, Los Angeles, Portland, Tacoma and Spokane.

Armorite and Concreta, manufactured by W. P. Fuller & Co., all principal Coast cities.

BUILDERS' HARDWARE

Joost Bros., agents for Russell & Erwin Hardware, 1053 Market St., San Francisco.

The Stanley Works, New Britain, Conn., represented in San Francisco and Los Angeles by John Rountree & Co.

Palace Hardware Company, Agents Corbin goods, 581 Market St., San Francisco.

Richards-Wilcox Mfg. Co., Aurora; Ewing-Lewis Co., 626 Underwood Bldg., San Francisco.

GRINNELL AUTOMATIC SPRINKLER GRINNELL COMPANY

OF THE PACIFIC

ENGINEERS AND CONTRACTORS
453 Mission Street, San Francisco

VALVES
PIPE and FITTINGS

CHEMICAL FIRE
EXTINGUISHERS
and FIRE ENGINES

An Index to the Advertisements

Page		Page		Page	
151	Abbott-Brady Printing Corp.	152	Golden Gate Orn'tal Iron Co.	1	Paraffine Companies, Inc.
135	American La France Fire Engine Co.	7	Grinnell Co.	144	Parker, K. E. Co., Inc.
10	American Mutual Liability Insurance Co.	2	Gunn Carle Company	141	Petrium Sanitary Sink Co.
32	American Mail Chute	129	Haines, Jones & Cadbury	145	Phillips, Chas. T.
44	American Marble & Mosaic Co.	4	Hamilton, F. A.	33	Pitcher Door Hanger
133	American Rolling Mill Co.	4	Hammond, M. E.	138	Plummer, W. A.
43	American Standard Oil Burner	142	Hannah, J. D.	15	Pope & Tabbot
42	American Window Glass Co.	26	Hauser Window Co.	158	Portland Lumber Co.
146	Atlas Heating & Ventilating Co.	138	Haws Sanitary Drinking Faucet Co.	136	Portman, Frank
157	Bacon, Edward R., Co.	6	Hillard, C. J., Co.	4	Powder Construction Company
145	Badt-Falk & Co.	36	Hill, Hubbell & Company	152	Prometheus Electric Co.
24	Baird-Bailhache Company	147	Holbrook, Merrill & Stetson	42	Raymond Granite Co.
34	Bankers' & Shippers' Ins. Co.	158	Home Mfg. Co.	22	Redwood Manufacturing Co.
144	Barrett & Hilp	130	Hunt, Robt. W. & Co.	136	Reliance-Grant Elevator Equipment Co.
136	Bartlett, John M.	140	Hunter & Hudson	155	Rex Electric Engineering Co.
3rd Cover	Bass-Hueter Co.	146	Ideal Heating & Engineering Co.	136	Ringius, John
32	Baxter, Reed	146	Illinois Engineering Co.	159	Roberts Mfg. Co.
31	Beach-Robinson Co.	32	Imperial Waterproofing	11	Robertson Co., H. H.
145	Beckwith, Herbert	146	James & Drucker	150	Robertson, John H.
41	Bowser & Co., S. F.	43	Jarvis, T. P. Mfg. Co.	150	Ruegg Bros.
130	Breuner, John	152	Johns-Manville Co.	140	Rucker-Fuller Desk Co.
22	Brinstool Co.	43	Johnson, S. T.	155	Ryan, M. E.
155	Browie-Langlais Company	110	Johnson Service Co.	154	Safety Electric Co.
154	Butte Electrical Equipment Co.	140	Joost Brothers	136	Sampson Spot Cord
41	Cabot, Samuel (Inc.)	143	Kawneer Mfg. Co.	3d Cover	San Francisco Pioneer Varnish Works
152	California Artistic Metal and Wire Co.	21	Kerner Incinerator Co.	146	Scott Co.
160	California Bldg. Material Co.	32	Key-hold Plaster Lath Co.	152	Schrader Iron Works
23	California Brick Co.	142	Kissel, I. R.	159	Schwabacher-Frey Co.
146	California Granite Co.	13	Knittle-Cashel Co., Inc.	4	Sloane, W. & J.
10	California Hydraulic Engineering and Supply Co.	152	Knowles, A.	12	Simmons, O. M. Co.
14	California Paint Co.	148	Lange & Bergstrom	131	Simonds Machinery Co.
137	California Plastic Products Co.	136	Leiter, E. T. & Son	157	Smith-Booth-Usher Co.
153	California Redwood Ass'n.	136	Liberty Electric Co.	144	Smith, Jas. F.
2	California Steam and Plumbing Supply Co.	144	Littlefield, R. W.	144	Sommer, I. M.
37	Cannon & Co.	23	Livermore Fire Brick Works	31	Sonnenschein Bros.
134	Cement Gun Construction Co.	127	Los Angeles Pressed Brick Co.	24	Spencer Elevator Co.
135	Central Electric Co.	151	MacCruer & Simpson	156	Spott Electrical Co.
152	Central Iron Works	153	MacRorie-McLaren Co.	22	Standard Varnish Works
4	Clow & Sons	140	Magner Bros.	4	Standard Electric Time Co.
136	Cobble-dick-Kibbe Glass Co.	159	Mangrum & Otter	145	Standard Fence Co.
146	Coleman, Alex	141	Marshall & Stearns Co.	123	Stanley Works, The
142	Coleman & Spedel	32	McCray Refrigerator Co.	144	Steelform Contracting Co.
38	Cook Belting Co.	150	McLeran & Peterson	137	Steel Studding Co.
143	Cowell Lime & Cement Co.	145	McNab, H. N.	131	St. Francis Hotel
153	Crane Co.	27	Medusa Cement	136	Stockholm, Chas. & Son
29	Crocker, H. S. Co.	134	Meese & Gottfried	135	Strable Mfg. Co.
14	Davis, R. J.	17	Moline Heat	15	Sunset Lumber Company
142	Del Pavero and Rasori	15	Montague Range & Furnace Co.	35	Tay Company, George H.
20	Del Monte Properties Co.	142	Monson Bros.	31	Taylor, F. A. & Co.
44	Detroit Steel Products Co.	152	Mortenson Construction Co.	155	Tittle, H. S. & Co.
12	Dieckmann Hardwood Co.	18	Mott Co. of Calif.	140	Torney Co.
159	Direct Line Telephone Co.	18	Mueller Mfg. Co.	142	Trost, Robt.
158	Dolan Wrecking & Construction Co.	18	Mullen Mfg. Co.	30	Truscon Steel Co.
154	Drendell Elec. & Mfg. Co.	148	Mushet Co., W. E.	149	Tuec Cleaner
158	Dudfield Lumber Co.	13	Musto Sons Keenan Co.	38	Uhl Bros.
144	Duncan, W. C.	9	Nason, R. N. & Co.	142	Unit Construction Co.
35	Dunham, C. A. Co.	151	Nathan, Dohrmann Co.	149	United Electric Co.
26	Dyer Bros.	156	National Magnesite Co.	127	United Materials Co.
3	Electric Outlet Co.	33	National Mill & Lumber Co.	26	U. S. Metal Products Co.
150	Elevator Supplies Co.	150	National Surety Co.	40	U. S. Steel Products Co.
140	Ellery Arms Co.	36	National Valve Co.	143	Van Fleet-Freear Co.
5	Faber, Eberhard	125	National Terra Cotta Society	34	Vermont Marble Co.
43	Fess System Co.	148	Nelson, James A.	144	Vukicevich & Bagge
150	Fidelity & Casualty Co. of N.Y.	155	Ne Page, McKenny Co.	135	Wadsworth, Howland & Co., Inc.
150	Fidelity & Deposit Co. of Maryland	155	Newbery Electric Co.	145	Walter, D. N. & E. Co.
158	Fink & Schindler Co., The	21	New York Belting and Packing Co.	140	Ward, Baldwin D.
16	Fire Protection Products Co.	34	Norris Co., L. A.	32	Waterhouse, Wilcox Co.
158	Flagg, Edwin H., Scenic Co.	132	Oak Flooring Mfgs' Ass'n.	33	Wayne Oil Tank & Pump Co.
31	Freeman Art Shop	138	Ocean Shore Iron Works	153	Weber, C. F. & Co.
24	Fuller & Goepf	25	Old Mission Portland Cement Co.	130	Wentworth, F. W.
19	Fuller, W. P. Co.	160	Otis Elevator Co.	39	Western Blind & Screen Co.
157	Garfield Company	151	Pacific Coast Steel Company	6	Western Electric Safety Mfg. Co.
20	Garnett, Young & Co.	27-41-44	Pacific Materials Co.	154	Western Iron Works
18	General Boilers Co.	143	Pacific Fire Extinguisher Co.	6	Western Office, Equipment Co.
140	Gilley-Schmid Co.	158	Pacific Mfg. Co.	147	Western Pipe and Steel Co.
138	Gladding, McBean & Co.	2dCover	Pacific Plumbing Fixtures	122	White Bros.
155	Globe Electric Works	2dCover	Pacific Porcelain Ware Co.	139	Wilson, J. G., Corp.
150	Globe Indemnity Co.	38	Pacific Pump & Supply Co.	146	Wilson, W. F., Co.
145	Go-Sign & Letter Co.	6	Pacific Rolling Mills	44	Witt, G. E. Co.
		38	Palace Hardware Co.	142	Zelinsky, D. & Sons
		6	Palm Iron Works		
		142	Palmer & Petersen		

Nason's Opaque Flat Finish

A Flat Washable Oil Paint, made in soft Kaisomine tints—a practical article for Walls, Ceilings, Etc. Agency for Tamm & Nolan Company's High Grade VARNISHES and FINISHES, made on the Pacific Coast to stand our climatic conditions.

R. N. NASON & CO. Paint Makers
151 Potrero Ave.—436 Market St., San Francisco—Portland-Seattle-Oregon

ARCHITECTS' SPECIFICATION INDEX—Continued

BUILDING MATERIAL, SUPPLIES, ETC.

Pacific Materials Co., Underwood Bldg., San Francisco.

Waterhouse-Wilcox Co., 523 Market St., San Francisco.

Johns-Manville Company, Post and Mason Sts., St. Francisco.

CABINET MAKERS

Home Manufacturing Company, 543 Brannan St., San Francisco.

Fink & Schindler Co., 218 13th St., San Francisco.

Mullen Manufacturing Company, 64 Rausch St., San Francisco.

Frank Portman, 1618 Mission St., San Francisco.

CARPETS

W. & J. Sloane, 216-228 Sutter St., San Francisco.

John Breuner Co., 281 Geary St., San Francisco.

D. N. & E. Walter, Mission near Second street, San Francisco.

CASEMENT WINDOW HARDWARE

Richards-Wilcox Mfg. Co., Aurora, Ill., and Underwood Bldg., San Francisco.

CEMENT

Mt. Diablo, sold by Henry Cowell Lime & Cement Co., 2 Market St., San Francisco.

Medusa White Portland Cement, manufactured by Sandusky Cement Co., represented in San Francisco by Pacific Building Materials Co., Underwood Bldg., San Francisco.

Old Mission Portland Cement Co., Mills Building San Francisco.

CEMENT EXTERIOR FINISH

Concreta, sold by W. P. Fuller & Co., all principal Coast cities.

Samuel Cabot Mfg. Co., Boston, Mass., agencies Oakland, Los Angeles, Portland, Tacoma, Spokane; and Pacific Building Materials Co., 525 Market St., San Francisco.

The Paraffine Companies, Inc., 34 First St., San Francisco.

CEMENT EXTERIOR WATERPROOF PAINT

Armorite, sold by W. P. Fuller & Co., all principal Coast cities.

Bay State Brick and Cement Coating, manufactured by Wadsworth, Howland Co., Boston, Mass. James Hambley & Son, Distributors, San Francisco and Los Angeles.

Hill, Hubbell & Company, No. 1 Drumm St., San Francisco.

Imperial Waterproofing, manufactured by Brooks & Doerr, Reed Baxter, agent, Merchants National Bank Bldg., San Francisco.

Paraffine Paint Co., 34 First St., San Francisco.

Medusa White Portland Cement, manufactured by Sandusky Cement Co., represented in San Francisco by Pacific Materials Co., 525 Market St., San Francisco.

CEMENT FLOOR COATING

Fuller's Concrete Floor Enamel, made by W. P. Fuller & Co., San Francisco.

CEMENT GUN

Cement Gun Construction Company of California, 701 Balboa Bldg., San Francisco.

CEMENT TESTS—CHEMICAL ENGINEERS

Robert W. Hunt & Co., 251 Kearny St., San Francisco.

CHURCH INTERIORS

Fink & Schindler, 218 13th St., San Francisco.

Mullen Manufacturing Company, 64 Rausch St., San Francisco.

Home Manufacturing Company, 543 Brannan St., San Francisco.

CHUTES—SPIRAL

Haslett Warehouse Co., 310 California St., San Francisco.

CLAY PRODUCTS

Cannon & Co., Sacramento; and Chronicle Bldg., San Francisco.

Livermore Fire Brick Works, 604 Mission street, San Francisco.

W. E. Mushet Co., 502 Mission St., San Francisco.

Gladding, McBean & Co., Crocker Bldg., San Francisco.

United Materials Co., Crossley Bldg., San Francisco.

Los Angeles Pressed Brick Co., Frost Bldg., Los Angeles.

CLOCKS—ELECTRIC TIME

Standard Electric Time Co., 461 Market St., San Francisco.

COLD STORAGE PLANTS

H. W. Johns-Manville Co., Post and Mason Sts., San Francisco.

T. P. Jarvis Crude Oil Burning Co., 275 Connecticut St., San Francisco.

COMPRESSED AIR CLEANERS

United Electric Co., Canton, O., mfr. of Tucc Cleaner, sold by San Francisco Compressed Air Cleaning Co., Sutter and Stockton Sts., San Francisco.

George H. Tay Company, Mission and Second Sts., San Francisco; 10th and Harrison Sts., Oakland.

CONCRETE CONSTRUCTION

Barrett & Hilp, Sharon Bldg., San Francisco.

Clinton Construction Co., 140 Townsend street, San Francisco.

K. E. Parker Co., Inc., Clunie Bldg., San Francisco.

Palmer & Petersen, Monadnock Bldg., San Francisco.

I. M. Sommer, 401 Balboa Bldg., San Francisco.

Steelform Contracting Company, 681 Market St., San Francisco.

CONCRETE MIXERS

Foote and Jaeger mixers sold by Edward R. Bacon Co., 51 Minna St., San Francisco, also Los Angeles.

Ransome mixers sold by the Garfield Co., Hearst Bldg., San Francisco.

Smith-Booth-Usher Co., San Francisco and Los Angeles.

CONCRETE REINFORCEMENT

United States Steel Products Co., San Francisco, Los Angeles, Portland and Seattle.

Twisted Bars. Sold by Gunn, Carle & Co., Inc., 444 Market St., San Francisco.

Clinton Welded Wire Fabric, L. A. Norris Co., 140 Townsend St., San Francisco.

Pacific Coast Steel Company, Rialto Bldg., San Francisco.

Triangle Mesh Fabric. Sales agents, Pacific Materials Co., 525 Market St., San Francisco.

Truscon Steel Co., 527 Tenth St., San Francisco.

Badt-Falk Co., Call-Post Bldg., San Francisco.

CONDUITS

Garnett Young & Co., 612 Howard St., San Francisco.

CONTRACTORS, GENERAL

Barrett & Hilp, Sharon Bldg., San Francisco.

K. E. Parker Co., Inc., Clunie Bldg., San Francisco.

R. W. Littlefield, 357 12th St., Oakland.

Unit Construction Co., Phelan Bldg., San Francisco.

J. D. Hannah, 142 Sansome St., San Francisco.

Chas. Stockholm & Son, Monadnock Bldg., San Francisco.

John M. Bartlett, 357 Twelfth St., Oakland.

E. T. Leiter & Son, Call-Post Bldg., San Francisco.

We have returned to our policy-holders annually for 33 years never less than 30% of the premium as a dividend. Dividends declared during 1919, \$2,017,893.

AMERICAN MUTUAL LIABILITY INSURANCE CO. OF BOSTON

Assets \$8,654,667 Surplus \$1,417,173

WORKMEN'S COMPENSATION, AUTOMOBILE, TEAMS AND PUBLIC LIABILITY INSURANCE

SAN FRANCISCO BRANCH OFFICE

1816 Balboa Building. Telephone Kearny 3202

N. F. Hesselstine, California Manager.

C. H. Gray, Assistant Manager.

ARCHITECTS' SPECIFICATION INDEX—Continued

- CONTRACTORS, GENERAL—Continued**
Herbert Beckwith, 323 Newton Ave., Oakland.
Collman & Speidel, 546 Monadnock Bldg., San Francisco.
Clinton Construction Company, 140 Townsend St., San Francisco.
Monson Bros., 1907 Bryant St., San Francisco.
W. C. Duncan & Co., 526 Sharon Bldg., San Francisco.
A. Knowles, Call-Post Bldg., San Francisco.
T. B. Goodwin, 180 Jessie St., San Francisco.
Lange & Bergstrom, Sharon Bldg., San Francisco.
McLeran & Peterson, Hearst Bldg., San Francisco.
Robert Trost, 26th and Howard Sts., San Francisco.
I. M. Sommer, 401 Balboa Bldg., San Francisco.
Del Favero & Rasori, 180 Jessie St., San Francisco.
- CONTRACTORS' EQUIPMENT**
Edward R. Bacon Co., 51 Minna St., San Francisco, and Los Angeles.
Garfield & Co., Hearst Bldg., San Francisco.
Smith, Booth-Usher Co., 60 Fremont St., San Francisco; 228 Central Ave., Los Angeles.
- CONTRACTORS' INSURANCE**
Bankers & Shippers Insurance Co. of New York, Insurance Exchange Bldg., San Francisco.
- CONVEYING MACHINERY**
Meese & Gottfried, San Francisco, Los Angeles, Portland and Seattle.
- CORK TILE, INSULATION, ETC.**
Van Fleet-Freear Co., Sharon Bldg., San Francisco.
- CRUSHED ROCK**
Coast Rock & Gravel Co., Call-Post Bldg., San Francisco.
- DAMP-PROOFING COMPOUND**
Armorite Damp Resisting Paint, made by W. P. Fuller & Co., San Francisco.
Hill, Hubbell & Company, No. 1 Drumm St., San Francisco.
Imperial Waterproofing, mfrd. by Brooks & Doerr, Reed Baxter, agent, Merchants National Bank Bldg., San Francisco.
"Pabco" Damp-Proofing Compound, sold by Paraffine Co., 34 First St., San Francisco.
- DOOR HANGERS**
Pitcher Hanger, sold by National Lumber Co., 326 Market St., San Francisco.
Reliance Hanger, sold by Waterhouse-Wilcox Co., San Francisco; D. F. Fryer & Co., B. V. Collins, Los Angeles, and Columbia Wire & Iron Works, Portland, Oregon.
Stanley Works, New Britain, Conn. John Rountree, agent, Monadnock Bldg., San Francisco.
Richards-Wilcox Mfg. Co., Underwood Bldg., San Francisco.
- DRINKING FOUNTAINS**
Haws Sanitary Drinking Faucet Co., 1808 Harmon St. Berkeley, and C. F. Weber & Co., San Francisco and Los Angeles.
Cranie Company, San Francisco, Oakland, and Los Angeles.
Pacific Porcelain Ware Co., 67 New Montgomery St., San Francisco.
George H. Tay Company, Mission and Second Sts., San Francisco; 10th and Harrison Sts., Oakland.
- Haines, Jones & Cadbury Co., 857 Folsom St., San Francisco.
- DUMB WAITERS**
Spencer Elevator Company, 166 7th St., San Francisco.
M. E. Hammond, Pacific Bldg., San Francisco.
- ELECTRICAL CONTRACTORS**
Butte Electrical Equipment Company, 530 Folsom St., San Francisco.
Butte Electric & Manufacturing Co., 534 Folsom St., San Francisco.
Brown-Langlais Electrical Construction Co., 213 Minna St., San Francisco.
Central Electric Company, 185 Stevenson street, San Francisco.
NePage, McKenny Co., 589 Howard St., San Francisco.
Liberty Electric Company, 479 Sutter St., San Francisco.
Newbery Electrical Co., 413 Lick Bldg., San Francisco.
Pacific Fire Extinguisher Co., 424 Howard St., San Francisco.
Globe Electric Works, 1959 Mission St., San Francisco.
M. E. Ryan, Redwood City, Calif.
Rex Electric & Engineering Co., 253 Minna St., San Francisco.
H. S. Tittle, 766 Folsom St., San Francisco.
Severin Electrical Company, 185 Stevenson St., San Francisco.
Spott Electrical Co., Sixteenth and Clay Sts., Oakland.
- ELECTRIC PLATE WARMER**
The Prometheus Electric Plate Warmer for residences, clubs, hotels, etc. Sold by M. E. Hammond, Pacific Bldg., San Francisco.
- ELECTRICAL SUPPLIES AND EQUIPMENT**
Garnett Young & Co., 612 Howard St., San Francisco.
Butte Electrical Equipment Co., 530 Folsom St., San Francisco.
Electric Outlet Co., Inc., 119 West 40th St., New York.
Safety Electric Company, 56-65 Columbia Square, San Francisco.
Drendell Electrical & Mfg. Co., 1345 Howard St., San Francisco.
R. J. Davis, District Sales Agent, Century A. C. Motors and Fans, 171 Second St., San Francisco.
Western Electric Safety Mfg. Co., Inc., 247 Minna street, San Francisco.
- ELEVATORS**
Otis Elevator Company, Stockton and North Point, San Francisco.
Spencer Elevator Company, 166 7th St., San Francisco.
- ELEVATOR EQUIPMENT**
Elevator Supplies Company, Inc., 186 Fifth St., San Francisco.
- ENGINEERS—CONSULTING, ELECTRICAL, MECHANICAL**
Chas. T. Phillips, Pacific Bldg., San Francisco.
Hunter & Hudson, Rialto Bldg., San Francisco.
Baldwin D. Ward, 76 13th St., Oakland.

KEWANEE
GARBAGE BURNERS
AND
BOILERS

YEOMANS
BILGE PUMPS
EJECTORS
HOUSE PUMPS

OVERHEAD
CARRYING
SYSTEMS

CALIFORNIA HYDRAULIC ENGINEERING & SUPPLY CO., 80 Fremont St., S. F.



TEMPERATURE REGULATION

JOHNSON SERVICE COMPANY

(OF MILWAUKEE — ESTABLISHED 1885)

Manufacturers and Installers of **JOHNSON Heat Humidity CONTROL**

For schools, residences, hospitals, banks, public buildings, also canneries and all kinds of industrial plants—Hot water tank regulators, air and water reducing valves.

Rialto Bldg, SAN FRANCISCO Trust and Savings Bldg., LOS ANGELES

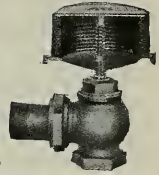

ARCHITECTS' SPECIFICATION INDEX—Continued

- ELEVATOR DOOR HARDWARE**
Richards-Wilcox Mfg. Co., Underwood Bldg., San Francisco.
- FANS AND BLOWERS**
Ideal Heating & Engineering Co., 192 Erie St., San Francisco.
- FENCES—WIRE**
Standard Fence Construction Co., 245 Market St., San Francisco, and 310 12th St., Oakland.
- FILLING STATION EQUIPMENT**
S. F. Bowser & Co., Inc., 612 Howard St., San Francisco.
Wayne Oil Tank & Pump Co., 631 Howard St., San Francisco, 830 S. Los Angeles St., Los Angeles.
- FIRE ESCAPES**
Palm Iron & Bridge Works, Sacramento.
Western Iron Works, 141 Beale St., San Francisco.
Golden Gate Iron Works, 1541 Howard St., San Francisco.
- FIRE EXTINGUISHERS**
American La France Fire Engine Co., Inc., 151 New Montgomery St., San Francisco; Los Angeles and Portland.
- FIRE INSURANCE**
Bankers & Shippers Insurance Co., Insurance Exchange Bldg., San Francisco.
- FIRE SPRINKLERS—AUTOMATIC**
Grinnell Company, 453 Mission St., San Francisco.
Pacific Fire Extinguisher Co., 424 Howard St., San Francisco.
- FIRE RETARDING PAINT**
The Paraffine Companies, Inc., 34 First St., San Francisco.
- FIXTURES—BANK, OFFICE, STORE, ETC.**
Home Manufacturing Company, 543 Brannan St., San Francisco.
The Fink & Schindler Co., 218 13th St., San Francisco.
Mullen Manufacturing Co., 64 Rausch St., San Francisco.
C. F. Weber & Co., 985 Market St., San Francisco, and 210 N. Main St., Los Angeles, Cal.
- FLOOR TILE**
Mangrum & Otter, 827 Mission St., San Francisco.
- FLOOR VARNISH**
Bass-Hueter and San Francisco Pioneer Varnish Works, 816 Mission St., San Francisco.
Fifteen for Floors, made by W. P. Fuller & Co., San Francisco.
Standard Varnish Works, Chicago, New York and San Francisco.
R. N. Nason & Co., San Francisco and Los Angeles.
- FLOORS—HARDWOOD**
Parrott & Co., 320 California St., San Francisco.
White Bros., Fifth and Brannan Sts., San Francisco.
Strable Manufacturing Company, 511 First St., Oakland.
- FLOORS—MASTIC**
Hill, Hubbell & Company, No. 1 Drumm St., San Francisco.
- FLOORS—DUST PROOF CEMENT**
L. Sonneborn Co., United Materials Co., San Francisco agents.
- FLUMES**
California Corrugated Culvert Co., West Berkeley, Cal.
- FLUSH VALVES**
National Valve Company, 23-25 Minna St., San Francisco.
- FRUIT DRYING MACHINERY**
Ideal Heating & Engineering Co., 192 Erie St., San Francisco.
Jas. A. Nelson, 517 Sixth St., San Francisco.
- FUEL OIL SYSTEMS**
S. T. Johnson Co., 1337 Mission St., San Francisco.
S. F. Bowser & Co., Inc., 612 Howard St., San Francisco.
Wayne Oil Tank & Pump Co., 631 Howard St., San Francisco.
- FURNACES—WARM AIR**
Mangrum & Otter, 827 Mission St., San Francisco.
Montague Range and Furnace Co., 826 Mission St., San Francisco.
- FURNITURE—BUILT-IN**
Hoosier Kitchen Cabinet Store, Pacific Bldg., San Francisco.
- FURNITURE—SCHOOL, CHURCH, OFFICE, HOUSE, ETC.**
Home Manufacturing Company, 543 Brannan St., San Francisco.
C. F. Weber & Co., 985 Market St., San Francisco.
Rucker-Fuller Desk Co., 677 Mission St., San Francisco.
F. W. Wentworth & Co., 539 Market St., San Francisco.
W. & J. Sloane, 216-228 Sutter St., San Francisco.
- GALVANIZED IRON WORK**
James A. Nelson, 517 Sixth St., San Francisco.
- GARAGE HARDWARE**
The Stanley Works, New Britain, Conn., represented in San Francisco, Los Angeles, Seattle by John T. Rowntree, Inc.
Richards-Wilcox Mfg. Co., Aurora, Ill., and Underwood Bldg., San Francisco.
- GARBAGE CHUTES AND INCINERATORS**
Kerner Incinerator Co., 77 O'Farrell St., San Francisco.
California Hydraulic Engineering & Supply Co., 70-72 Fremont St., San Francisco.
- GAS STEAM RADIATORS—FUMELESS, ETC.**
Clow Gas Steam Radiators, F. A. Hamilton, Agent, 101 Rialto Bldg., San Francisco.

ROBERTSON PROCESS METAL FOR ROOFING AND SIDING

HH
BUILDING
PRODUCTS

ROBERTSON CO
BUILDING
PRODUCTS

FORMERLY ASBESTOS PROTECTED METAL COMPANY

Hobart Building, San Francisco

Phone Garfield 522

When writing to Advertisers please mention this magazine.

DIECKMANN HARDWOOD COMPANY

Office, Mill, Yards, and Dry Kilns
BEACH AND TAYLOR STS.
 SAN FRANCISCO, CAL.
 PHONE FRANKLIN 2302

**Foreign & Domestic
 CABINET WOODS**

ARCHITECTS' SPECIFICATION INDEX—Continued

- GAS STEAM RADIATORS, ETC.**—Continued.
 Ra-Do Fumeless Gas Radiators, manufactured and sold by Baird-Bailhache Co., 478 Sutter St., San Francisco.
- GLASS**
 American Window Glass Co., represented by L. H. Butcher Co., 341 Montgomery St., San Francisco.
 Cobblestick-Kibbe Glass Co., 175 Jessie St., San Francisco.
 Fuller & Goepf, 32 Page St., San Francisco.
 W. P. Fuller & Company, all principal Coast cities.
- GRADING, WRECKING, ETC.**
 Dolan Wrecking & Construction Co., 1607 Market St., San Francisco.
- GRANITE**
 California Granite Co., Gen. Contractors' Ass'n, San Francisco.
 Raymond Granite Co., Potrero Ave. and Division St., San Francisco.
- GRAVEL AND SAND**
 Coast Rock & Gravel Co., Call-Post Bldg., San Francisco.
 Del Monte White Sand, sold by Del Monte Properties Co., Crocker Bldg., San Francisco.
- GYMNASIUM EQUIPMENT**
 Ellery Arms Co., 583 Market St., San Francisco.
 A. G. Spalding & Bros., 158 Geary St., San Francisco.
- HARDWALL PLASTER**
 Henry Cowell Lime & Cement Co., San Francisco.
- HARDWARE**
 Joost Bros., agents for Russell & Erwin hardware, 1053 Market St., San Francisco.
 The Stanley Works, New Britain, Conn.
 Corbin hardware, sold by Palace Hardware Co., 581 Market St., San Francisco.
 Richards-Wilcox Mfg. Co., Aurora, Ill., Ewing-Lewis Co., 626 Underwood Bldg., San Francisco.
- HARDWOOD LUMBER—FLOORING, ETC.**
 Dieckmann Hardwood Company, Beach and Taylor Sts., San Francisco. (See advertisement above.)
 Inlaid Floor Co., 600 Alabama St., San Francisco.
 H. N. McNab, 2307 17th Ave., Oakland.
 Parrott & Co., 320 California St., San Francisco.
 White Bros., cor. Fifth and Brannan Sts., San Francisco.
 Strable Manufacturing Company, First St., near Broadway, Oakland.
- HEATERS—AUTOMATIC—GAS**
 Pittsburg Water Heater Co., 478 Sutter St., San Francisco.
 George H. Tay Company, Mission and Second Sts., San Francisco; 10th and Harrison Sts., Oakland.
 Ra-Do Fumeless Gas Heater, sold by Baird-Bailhache Company, 478 Sutter St., San Francisco.
- HEATING AND VENTILATING MATERIAL, ETC.**
 C. A. Dunham Co., Sheldon Building, San Francisco.
- Alex Coleman, 706 Ellis St., San Francisco.
 Gilley-Schmid Company, 198 Otis St., San Francisco.
 Hateley & Hateley, Mitau Bldg., Sacramento.
 Knittle-Cashel Co., Inc., 1820 Ellis St., San Francisco.
 General Boilers Co., 332 Monadnock Bldg., San Francisco.
 Mangrum & Otter, 827-831 Mission St., San Francisco.
 Moline Heat, Hobart Bldg., San Francisco.
 James & Drucker, 450 Hayes St., San Francisco.
 James A. Nelson, 517 Sixth St., San Francisco.
 Ideal Heating & Engineering Co., 192 Erie St., San Francisco.
 Illinois Engineering Co., 563 Pacific Bldg., San Francisco.
 William F. Wilson Co., 328 Mason St., San Francisco.
 Pacific Fire Extinguisher Co., 424 Howard St., San Francisco.
 Scott Company, 243 Minna St., San Francisco.
 Mechanical Engineering & Supply Co., 908 7th St., Sacramento.
 John Ringius, 252 Townsend St. (bet. Third and Fourth), San Francisco.
 George H. Tay Company, Mission and Second Sts., San Francisco; 10th and Harrison Sts., Oakland.
 O. M. Simmons Co., 115 Mission St., San Francisco.
- HOLLOW TILE BLOCKS**
 Cannon & Co., plant at Sacramento; office in Chronicle Bldg., San Francisco.
 Gladding, McBean & Co., San Francisco, Los Angeles, Oakland and Sacramento.
 Los Angeles Pressed Brick Co., Frost Bldg., Los Angeles.
- HOSPITAL FIXTURES**
 Mott Company of California, 553 Mission St., San Francisco.
 George H. Tay Company, Mission and Second Sts., San Francisco; 10th and Harrison Sts., Oakland.
- HOSPITAL SIGNAL SYSTEM**
 Chicago Signal Co., represented by Garnett, Young & Co., 612 Howard St., San Francisco.
- HOTELS**
 St. Francis Hotel, Powell, Geary and Post Sts., San Francisco.
- INGOT IRON**
 "Armo" brand, manufactured by American Rolling Mill Company, Middletown, Ohio, and Monadnock Bldg., San Francisco.
- INSPECTIONS AND TESTS**
 Robert W. Hunt & Co., 251 Kearny St., San Francisco.
- INSULATION**
 Ebonite Boiler Kote, sold by California Plastic Products Co., 521 Sheldon Bldg., San Francisco.
- INCINERATORS**
 Kerner Incinerator Co., 77 O'Farrell St., San Francisco.
- INTERIOR DECORATORS**
 Beach-Robinson Co., 239 Geary St., San Francisco.

"The
 Perfect
 Automatic
 Valve"

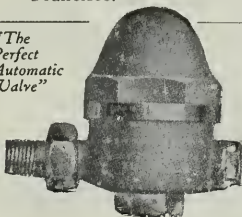

Haines Heating Systems

ASSURE

Heating Satisfaction

O. M. SIMMONS CO.

115 Mission St., San Francisco
 Phone: Douglas 5497

CLARENCE E. MUSTO, Pres. JOSEPH B. KEENAN, Vice-Pres. GUIDO J. MUSTO, Sec'y & Treas.

JOSEPH MUSTO SONS-KEENAN CO.

Phone Franklin
—6365—

MARBLE

OFFICE AND MILLS:
535-565 North Point St.,
SAN FRANCISCO, CAL.

ARCHITECTS' SPECIFICATION INDEX—Continued

- INTERIOR DECORATORS.**—Continued.
John Breuner Co., 281 Geary St., San Francisco.
Sonnenschein Bros., 470 Sutter St., San Francisco.
The Tormey Co., 1042 Larkin St., San Francisco.
F. A. Taylor & Co., 251 Post St., San Francisco.
Freeman Art Shop, 386 Sutter St., San Francisco.
W. & J. Sloane, 216 Sutter St., San Francisco.
- KITCHEN CABINETS**
Hoosier Kitchen Cabinet Store (O. K. Brown, Mgr.), Pacific Bldg., San Francisco.
- KITCHEN EQUIPMENT**
James A. Nelson, 517-19 Sixth street, San Francisco.
- LAMP POSTS, ELECTROLIERS, ETC.**
J. L. Mott Iron Works, 553 Mission St., San Francisco.
- LANDSCAPE GARDENERS**
MacRorie-McLaren Co., 141 Powell St., San Francisco.
- LATHING AND PLASTERING**
MacGruer & Simpson, Call-Post Bldg., San Francisco.
A. Knowles, Call-Post Bldg., San Francisco.
Jas. F. Smith, 273 Minna St., San Francisco.
- LATHING MATERIAL**
Pacific Materials Co., 525 Market St., San Francisco.
Key-Hold Plaster Lath Co., 148 Hooper St., San Francisco.
Truscon Steel Co., Tenth St., near Bryant, San Francisco.
- LIGHT, HEAT AND POWER**
Great Western Power Company, Stockton St., near Sutter, San Francisco.
- LIGHTING FIXTURES**
Roberts Mfg Co., 663 Mission St., San Francisco.
- LIME**
Henry Cowell Lime & Cement Co., 2 Market St., San Francisco.
- LINOLEUM**
D. N. & E. Walter & Co., 562 Mission St., San Francisco.
The Paraffine Companies, factory in Oakland; office, 34 First St., near Market, San Francisco.
W. & J. Sloane, 216-228 Sutter St., San Francisco.
- LOCKERS—STEEL**
George H. Trask, Sacramento St., San Francisco, representing Durand Steel Lockers.
- LUBRICATING OIL STORAGE TANKS AND PUMPS**
S. F. Bowser & Co., Inc., 612 Howard St., San Francisco.
- LUMBER**
California Redwood Association, 216 Pine St., San Francisco.
Dudfield Lumber Co., Palo Alto, Cal.
Hart-Wood Lumber Co., Fifth and Berry Sts., San Francisco.
Pacific Manufacturing Company, San Francisco, Oakland and Santa Clara.
Pope & Talbot, foot of Third St., San Francisco.
Portland Lumber Co., 16 California St., San Francisco.
- Sunset Lumber Company, First and Oak Sts., Oakland.
- MAIL CHUTES**
American Mailing Device Corp., represented on Pacific Coast by Waterhouse-Wilcox Co., 523 Market St., San Francisco.
- MANTELS**
Mangrum & Otter, 827-831 Mission St., San Francisco.
- MANUAL TRAINING EQUIPMENT**
Richards-Wilcox Mfg. Co., Ewing-Lewis Co., 626 Underwood Bldg., San Francisco.
Smith-Booth-Usher Co., San Francisco and Los Angeles.
- MARBLE**
American Marble and Mosaic Co., 25 Columbus Square, San Francisco.
Joseph Musto Sons, Keenan Co., 535 N. Point St., San Francisco.
Vermont Marble Co., Coast branches, San Francisco, Portland and Tacoma.
- METAL DOORS AND WINDOWS**
Fire Protection Products Co., 3117 20th St., San Francisco.
Waterhouse-Wilcox Co., Inc., 523 Market St., San Francisco.
U. S. Metal Products Co., 330 Tenth St., San Francisco.
- MILL WORK**
Dudfield Lumber Co., Palo Alto, Cal.
Pacific Manufacturing Company, San Francisco, Oakland and Santa Clara.
National Mill and Lumber Co., San Francisco and Oakland.
The Fink & Schindler Co., 218 13th St., San Francisco.
Frank Portman, 1619-20 Mission St., San Francisco.
- MOTORS AND FANS**
R. J. Davis, Dist. Sales Agent Century Motors and Fans, 171 Second St., San Francisco.
- OIL BURNERS**
American Standard Oil Burner Company, Berkeley.
Fess System Co., 220 Natoma St., San Francisco.
S. T. Johnson Co., 1337 Mission St., San Francisco.
T. P. Jarvis Manufacturing Co., 275 Connecticut St., San Francisco.
W. S. Ray Mfg. Co., 29 Spear St., San Francisco.
G. E. Witt Co., 862 Howard St., San Francisco.
- OIL STORAGE AND DISTRIBUTING STATIONS**
S. F. Bowser & Co., Inc., 612 Howard St., San Francisco.
S. T. Johnson Co., 1337 Mission St., San Francisco.
Wayne Oil Tank & Pump Co., 631 Howard St., San Francisco; 830 S. Los Angeles St., Los Angeles.
- OFFICE EQUIPMENT**
C. F. Weber Co., 985 Market St., San Francisco.
Rucker-Fuller Co., 677 Mission St., San Francisco.
F. W. Wentworth & Co., 539 Market St., San Francisco.

KNITTLE-CASHEL CO., Inc.

HEATING CONTRACTORS

STEAM HEATING
HOT WATER HEATING

VENTILATING
POWER PLANTS

GENERAL PIPE WORK
REPAIRING

1820-22 Ellis Street, San Francisco

Phone West 964



CAL-PA-CO

On Your Best Work Specify

CAL-PA-CO

DAMPSTOP (Outside)

WASHABLE WALL (Inside)

FOR CONCRETE BUILDINGS.

Everything Reliable in PAINT and VARNISH

CALIFORNIA PAINT COMPANY, OAKLAND, CALIF., U. S. A.
MANUFACTURERS SINCE 1865 SAN FRANCISCO OFFICE, MONADNOCK BUILDING

ARCHITECTS' SPECIFICATION INDEX—Continued

ORNAMENTAL IRON AND BRONZE

California Artistic Metal and Wire Co., 349 Seventh St., San Francisco.
Palm Iron & Bridge Works, Sacramento.
C. J. Hillard Company, Inc., 19th and Minnesota Sts., San Francisco.

ORNAMENTAL IRON AND BRONZE.—Cont.

Schrader Iron Works, Inc., 1247 Harrison St., San Francisco.

OVERHEAD CARRYING SYSTEMS

California Hydraulic Engineering & Supply Co., 70-72 Fremont St., San Francisco.
Richards-Wilcox Mfg. Co., Aurora, Ill., and Underwood Bldg., San Francisco.

PAINT FOR STEEL STRUCTURES, BRIDGES, ETC.

The Paraffine Companies, Inc., 34 First St., San Francisco.
Premier Graphite Paint and Pioneer Brand Red Lead, made by W. P. Fuller & Co., San Francisco.
Hill, Hubbell & Company, No. 1 Drumm St., San Francisco.
Wadsworth, Howland Co., makers of Bay State Brick and Cement Coating, Boston, Mass.
Hambley & Son, Distributors in San Francisco and Los Angeles.

PAINTING, TINTING, ETC.

I. R. Kissel, 1747 Sacramento St., San Francisco.
D. Zelinsky & Sons, San Francisco and Los Angeles.
The Tormey Co., 681 Geary St., San Francisco.
Fick Bros., 475 Haight St., San Francisco.

PAINTS, OILS, ETC.

California Paint Company (see advertisement above).
Magner Bros., 414-424 Ninth St., San Francisco.
Bass-Hueter Paint Co., Mission, near Fourth St., San Francisco.
R. N. Nason & Company, San Francisco, Los Angeles, Portland and Seattle.
W. P. Fuller & Co., all principal Coast cities.
"Satinette," Standard Varnish Works, 55 Stevenson St., San Francisco.
Palace Hardware Co., 581 Market St., San Francisco.

PANELS AND VENEER

White Bros., Fifth and Brannan Sts., San Francisco.

PARTITIONS—FOLDING AND ROLLING

J. G. Wilson Corporation, 600 Metropolitan Bldg., Los Angeles; Waterhouse-Wilcox Co., Underwood Bldg., San Francisco.

PENCILS

Eberhard Faber, Monadnock Bldg., San Francisco.

PIPE—STEEL AND WROUGHT IRON

Western Pipe & Steel Co., 444 Market St., San Francisco; 1758 N. Broadway, Los Angeles.
George H. Tay Company, Mission and Second Sts., San Francisco; 10th and Harrison Sts., Oakland.

PLAYGROUND EQUIPMENT

A. G. Spalding & Bros., 158 Geary St., San Francisco.

PLUMBING CONTRACTORS

Alex Coleman, 706 Ellis St., San Francisco.
Gilley-Schmid Company 198 Otis St., San Francisco
Hateley & Hateley, Mitau Bldg., Sacramento.
Scott Co., Inc., 243 Minna St., San Francisco.
Wm. F. Wilson Co., 328 Mason St., San Francisco.

PLUMBING FIXTURES, MATERIALS, ETC.

California Steam & Plumbing Supply Co., 671 Fifth St., San Francisco.
Jas. B. Clow, plumbing, Rialto Bldg., San Francisco
Crane Co., San Francisco, Oakland, Los Angeles.
Gilley-Schmid Company, 198 Otis St., San Francisco.
Haines, Jones & Cadbury Co., 857 Folsom St., San Francisco.
H. Mueller Manufacturing Company, 635 Mission St., San Francisco.
Holbrook, Merrill & Stetson, 64 Sutter St., San Francisco.

J. L. Mott Iron Works, D. H. Gulick, selling agent, 553 Mission St., San Francisco.
National Valve Company, 23-25 Minna St., San Francisco.
Pacific Sanitary Manufacturing Co., 67 New Montgomery St., San Francisco.

George H. Tay Company, Mission and Second Sts., San Francisco; 10th and Harrison Sts., Oakland.
West Coast Porcelain Company, San Francisco.
Wm. F. Wilson Co., 328 Mason St., San Francisco.

POWER PLANTS

Knittle-Cashel Co., Inc., 1820 Ellis St., San Francisco.

POWER TRANSMITTING MACHINERY

Meese & Gottfried, San Francisco, Los Angeles, Portland, Ore., and Seattle, Wash.

PUMPS

Chicago Pump Co., represented by Garnett, Young & Co., 612 Howard St., San Francisco.
California Hydraulic Engineering & Supply Co., 70 Fremont St., San Francisco.
Simonds Machinery Co., 117 New Montgomery St., San Francisco.
Ocean Shore Iron Works, 558 Eighth St., San Francisco.
Pacific Pump & Supply Company, 851-853 Folsom St., San Francisco.
George H. Tay Company, Mission and Second Sts., San Francisco; 10th and Harrison Sts., Oakland.

PUMPS—HAND OR POWER, FOR OIL AND GASOLINE

S. F. Bowser & Co., Inc., 612 Howard St., San Francisco.

R. J. Davis

District Sales
Agent

A. C. Motors
and Fans

Complete stocks carried at: 171-173 Second St., San Francisco; 906 So. Hope St., Los Angeles



Yards { TRACY, CAL.
BRENTWOOD, CAL.

Phone KEARNY 2074

PORTLAND LUMBER COMPANY

A. J. RUSSELL, Agent

LUMBER

SIMPLEX SILOS

SAGINAW SPECIAL SHINGLES

*Ship Timbers, Oil Rigs and
Special Bills Cut to Order.*

16 California Street

San Francisco, Cal.

from tree to Consumer

Pine and Redwood Lumber

SASH DOORS AND MILL WORK

SUNSET LUMBER COMPANY

MANUFACTURERS — WHOLESALE AND RETAIL

Main Office and Yards:

FIRST AND OAK STREETS, OAKLAND

Phone Oakland 1820

POPE & TALBOT

Manufacturers, Exporters and Dealers in

Lumber, Timber, Piles, Spars, etc.

Office, Yards and Planing Mills

859-869 THIRD ST., SAN FRANCISCO, CAL.

Mills, Port Gamble, Port Ludlow and Utsalady, Washington

STORM KING and AMERICAN WARM AIR FURNACES

FURNACE FITTINGS AND REPAIRS

Montague Range & Furnace Company

327-329 JESSIE STREET

Phone Garfield 1422

826-830 MISSION STREET

SAN FRANCISCO, CALIF.

ARCHITECTS' SPECIFICATION INDEX—Continued

- PUMPS** (Continued)
 S. T. Johnson Co., 1337 Mission St., San Francisco.
 Wayne Oil Tank & Pump Co., 631 Howard St., San Francisco; 830 S. Los Angeles St., Los Angeles.
 George H. Tay Company, Mission and Second Sts., San Francisco; 10th and Harrison Sts., Oakland.
- RADIATOR TRAPS**
 C. A. Dunham Co., Sheldon Bldg., San Francisco.
- REFRIGERATORS**
 McCray Refrigerator Company, San Francisco office, Monadnock Bldg.
- REVERSIBLE WINDOWS**
 Hauser Window Company, 157 Minna St., San Francisco.
- ROOFING AND ROOFING MATERIALS**
 Bender Roofing Company, Monadnock Bldg., San Francisco.
 "Malthoid" and "Ruberoïd," manufactured by Paraffine Companies, Inc., San Francisco.
 United Materials Co., Crossley Bldg., San Francisco.
 H. H. Robertson Co., Hobart Bldg., San Francisco.
- RUBBER TILING**
 New York Belting and Packing Company, 518 Mission St., San Francisco.
- SAFETY TRENDS**
 Pacific Materials Co., 525 Market St., San Francisco.
- SAND**
 Del Monte White Sand, Del Monte Properties Co., 401 Crocker Bldg., San Francisco.
- SASH CORD**
 Samson Spot Sash Cord, John T. Rowntree, Pacific Coast Agent, San Francisco and Los Angeles.
- SCENIC PAINTING—DROP CURTAINS, ETC.**
 The Edwin H. Flagg Scenic Co., 1638 Long Beach Ave., Los Angeles.
- SCHOOL FURNITURE AND SUPPLIES**
 C. F. Weber & Co., 985 Market St., San Francisco; 512 S. Broadway, Los Angeles.
 Rucker-Fuller Desk Company, 677 Mission St., San Francisco.
- SHEATHING AND SOUND DEADENING**
 Samuel Cabot Mfg. Co., Boston, Mass., agencies in San Francisco, Oakland, Los Angeles, Portland, Tacoma and Spokane.
 The Paraffine Companies, Inc., 34 First St., San Francisco.
- SHEET METAL WORK**
 Jas. A. Nelson, 517 Sixth St., San Francisco.
- SHINGLE STAINS**
 Bass-Hueter Paint Company, all principal Coast cities.
 Cabot's Creosote Stains, sold by Pacific Building Materials Co., 525 Market St., San Francisco.
 Fuller's Pioneer Shingle Stains, made by W. P. Fuller & Co., San Francisco.
 Argonaut Shingle Stains. The Glidden Co., 123 Hooper St., San Francisco.
- SINKS—COMPOSITION**
 Petrium Sanitary Sink Co., Fifth and Page Sts., Berkeley.
- SKYLIGHTS**
 H. H. Robertson Co., Hobart Bldg., San Francisco.
 Jas. A. Nelson, 517 Sixth St., San Francisco.
- STATIONERY AND SUPPLIES**
 Schwabacher-Frey Stationery Co., 609 Market St., San Francisco.
 H. S. Crocker Co., 565 Market street, San Francisco.
- STEEL HEATING BOILERS**
 California Hydraulic Engineering & Supply Co., 70-72 Fremont St., San Francisco.
 General Boilers Co., 332 Monadnock Bldg., San Francisco.
- STEEL TANKS, PIPE, ETC.**
 Ocean Shore Iron Works, 558 Eighth St., San Francisco.
 S. T. Johnson Co., 1337 Mission St., San Francisco.
 Western Pipe & Steel Co., 444 Market St., San Francisco.
- STEEL AND IRON—STRUCTURAL**
 Central Iron Works, 621 Florida St., San Francisco.
 Golden Gate Iron Works, 1541 Howard St., San Francisco.
 Mortenson Construction Co., 19th and Indiana Sts., San Francisco.
 Pacific Rolling Mills, 17th and Mississippi Sts., San Francisco.
 Palm Iron & Bridge Works, Sacramento.
 U. S. Steel Products Co., Rialto Bldg., San Francisco.
 Schrader Iron Works, Inc., 1247 Harrison St., San Francisco.
 Western Iron Works, 141 Beale St., San Francisco.
- STEEL PRESERVATIVES**
 Hill, Hubbell & Company, No. 1 Drumm St., San Francisco.
- STEEL ROLLING DOORS**
 Kinnear Steel Rolling Door Co., Pacific Building Materials Co., agents, Underwood Bldg., San Francisco.
 J. G. Wilson Corporation, 600 Metropolitan Bldg., Los Angeles.
- STEEL SASH**
 Bayley-Springfield solid steel sash, sold by Pacific Materials Co., 525 Market St., San Francisco.
 "Fenestra," solid steel sash, manufactured by Detroit Steel Products Company, Detroit, Mich. Direct factory sales office, Foxcroft Bldg., San Francisco.
 U. S. Metal Products Company, 330 Tenth St., San Francisco.
 Truscon Steel Company, 527 Tenth street, San Francisco.
- STEEL WHEELBARROWS**
 Champion and California steel brands, made by Western Iron Works, 141 Beale St., San Francisco.
- STORE FRONTS**
 The Kawneer Manufacturing Company, West Berkeley, California.
 Zouri Safety Sash Bars—Cobbledick-Kibbe Glass Company, 175 Jessie St., San Francisco.
- STUDDING—FIREPROOF STEEL**
 Steel Studding Company, 1216 Folsom St., San Francisco.
- SUMP AND BILGE PUMPS**
 California Hydraulic Engineering & Supply Co., 70-72 Fremont St., San Francisco.
- SWITCHES**
 Wemco Safety Switch, manufactured and sold by W. E. Mushet Co., 502 Mission St., San Francisco.
 Western Electric Safety Switch Co., Inc., 247 Minna street, San Francisco.
- TANKS FOR OIL, GASOLINE, KEROSENE, ETC.**
 S. F. Bowser & Co., Inc., 612 Howard St., San Francisco.
 Wayne Oil Tank & Pump Co., 631 Howard St., San Francisco; 830 S. Los Angeles St., Los Angeles.

STEEL SASH — FIRE DOORS — SHEET METAL

Kalamein, Copper and Bronze Doors and Trim Sheet Metal Work of Every Description

FIRE PROTECTION PRODUCTS CO.

3117-3119 TWENTIETH STREET, Near Harrison, SAN FRANCISCO. Phone Mission 2607

ARCHITECTS' SPECIFICATION INDEX—Continued

- TANKS—REDWOOD**
Redwood Manufacturers Co., Hobart Bldg., San Francisco.
- TELEPHONE AND ELECTRIC EQUIPMENT**
Direct Line Telephone Co., 320 Market St., San Francisco.
- THEATER AND OPERA CHAIRS**
C. F. Weber & Co., 365 Market St., San Francisco.
Rucker-Fuller Desk Co., 677 Mission St., San Francisco.
- THERMOSTATS FOR HEAT REGULATION**
Johnson Service, Rialto Bldg., San Francisco.
- TILES, MOSAICS, MANTELS, ETC.**
Mangrum & Otter, 827-831 Mission St., San Francisco.
- TILE FOR ROOFING**
Cannon & Co., Sacramento; and Chronicle Bldg., San Francisco.
Gladding, McBean & Co., Crocker Bldg., San Francisco.
United Materials Co., Crossley Bldg., San Francisco.
- TRANSMISSION MACHINERY**
Meese & Gottfried Co., San Francisco, Los Angeles and Portland.
- VACUUM CLEANERS**
United Electric Company, Canton, O., manufacturers of Tucc Cleaners, sold in California by San Francisco Compressed Air Cleaning Co., Stockton and Sutter Sts., San Francisco.
- VALVES—PIPES AND FITTINGS**
California Steam & Plumbing Supply Co., 671 Fifth St., San Francisco.
Crane Radiator Valves, manufactured by Crane Co., Second and Brannan Sts., San Francisco.
National Valve Company, 23-25 Minna St., San Francisco.
Grinnell Co., 453 Mission St., San Francisco.
O. M. Simmons Co., 115 Mission St., San Francisco.
H. Mueller Mfg. Co., 635 Mission St., San Francisco.
W. E. Mushet Co., 502 Mission St., San Francisco.
George H. Tay Company, Mission and Second Sts., San Francisco; 10th and Harrison Sts., Oakland.
- VALVE PACKING**
N. H. Cook Belting Co., 317 Howard St., San Francisco.
- VARNISHES**
California Paint Company, 1797 Twelfth St., Oakland.
W. P. Fuller Co., all principal Coast cities.
R. N. Nason & Co., San Francisco, Los Angeles, Portland and Seattle.
S. F. Pioneer Varnish Works, 816 Mission St., San Francisco.
Standard Varnish Works, 55 Stevenson St., San Francisco.
- VENETIAN BLINDS, AWNINGS, ETC.**
C. F. Weber & Co., 985 Market St., San Francisco.
Western Blind & Screen Co., 2702 Long Beach Ave., Los Angeles.
- VENTILATORS**
H. H. Robertson Co., Hobart Bldg., San Francisco.
- VITREOUS CHINAWARE**
Pacific Porcelain Ware Company, 67 New Montgomery St., San Francisco.
West Coast Porcelain Manufacturers, Rialto Building, San Francisco.
- WALL BEDS, SEATS, ETC.**
Marshall & Stearns Co., 1154 Phelan Bldg., San Francisco.
- WALL BOARD**
"Amiwud" Wall Board, manufactured by The Paraffine Companies, Inc., 34 First St., San Francisco.
"Liberty" Wall Board, manufactured by Key-Hold Plaster Lath Co., 148 Hooper St., San Francisco.
- WALL PAINT**
Nason's Opaque Flat Finish, manufactured by R. N. Nason & Co., San Francisco, Portland and Los Angeles.
San-A-Cote and Vel-va-Cote, manufactured by the Brininstool Co., Los Angeles.
- WALL PAPER AND DRAPERIES**
Beach-Robinson Co., 239 Geary St., San Francisco.
The Torney Co., 681 Geary St., San Francisco.
W. & J. Sloane, 216-228 Sutter St., San Francisco.
Uhl Bros., San Francisco.
- WATERPROOFING FOR CONCRETE, BRICK, ETC.**
Armorite Damp Resisting Paint, made by W. P. Fuller & Co., San Francisco.
Bay State Brick & Cement Coating, manufactured by Wadsworth, Howland Co., Boston; Hambley & Son., Distributors for Northern and Southern California.
Imperial Waterproofing, mfrd. by Brooks & Doerr, Reed Baxter, agent, Merchants National Bank Bldg., San Francisco.
Pacific Materials Co., 525 Market St., San Francisco.
Samuel Cabot Mfg. Co., Boston, Mass., agencies in San Francisco, Oakland, Los Angeles, Portland, Tacoma and Spokane.
- WATER SUPPLY SYSTEMS**
Kewanee Water Supply System—Simonds Machinery Co., agents, 117 New Montgomery St., San Francisco.
Pacific Pump & Supply Company, 851-853 Folsom St., San Francisco.
Smith-Booth-Usher Co., San Francisco and Los Angeles.
- WHEELBARROWS—STEEL**
Western Iron Works, Beale and Main Sts., San Francisco.
- WHITE CEMENT**
"Medusa White," sold by Pacific Materials Co., Underwood Bldg., San Francisco.
- WHITE ENAMEL**
"Gold Seal," manufactured and sold by Bass-Hueter Paint Co. All principal Coast cities.
"Silkenwhite," made by W. P. Fuller & Co., San Francisco.
"Satinette," Standard Varnish Works, 55 Stevenson St., San Francisco.
- WINDOW SHADES**
W. & J. Sloane, 216-228 Sutter St., San Francisco.
- WINDOW SASH CORD**
Sampson Spot Cord, John T. Rowntree, Pacific Coast agents, San Francisco and Los Angeles.
- WINDOWS, REVERSIBLE, CASEMENT, ETC.**
Hauser Window Co., 157 Minna St., San Francisco.
The Kawnear Company, West Berkeley, California. (Simplex Fixtures.)
J. G. Wilson Corporation, 600 Metropolitan Bldg., Los Angeles; Waterhouse-Wilcox Co., Underwood Bldg., San Francisco.
- WIRE FABRIC**
U. S. Steel Products Co., Rialto Bldg., San Francisco.
Clinton Wire Lath, sold by L. O. Norris, 140 Townsend St., San Francisco.
- WIRE FENCE**
Standard Fence Co., 310 12th St., Oakland.
- WOOD MANTELS**
Pink & Schindler, 218 13th St., San Francisco.
Mangrum & Otter, 827 Mission St., San Francisco.

MOLINE HEAT

Hobart Building

San Francisco

TELEPHONE SUTTER 3818

MOTT PLUMBING FIXTURES

Architects and their clients are invited to visit our Showrooms, 553-555 Mission Street, San Francisco; D. H. Gulick, Sales Agent. Los Angeles Office, 1001 Central Building; J. R. Mayhew, Sales Agent.

Mott Company of California

MUELLER — BRASS GOODS

Recognized as the Standard of excellence in plumbing. It pays to use them, and other **Mueller Brass Goods**. *The first cost is practically their last cost.*

H. Mueller Mfg. Co.

635 MISSION STREET, SAN FRANCISCO, CAL.

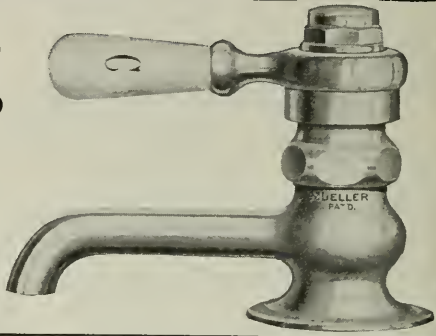

GENERAL BOILERS COMPANY

DEPARTMENT OF SALES

A. W. MERRILL, Manager

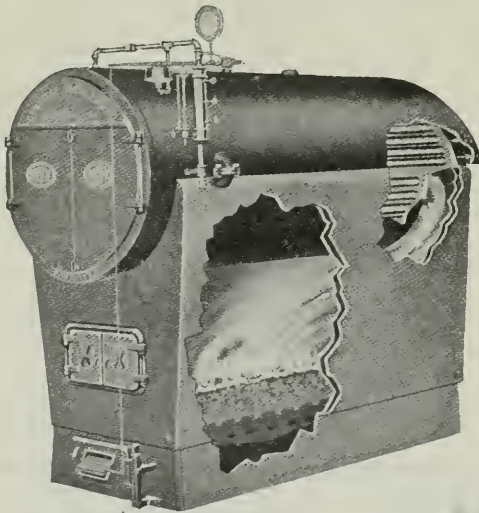

MANUFACTURERS of Pacific Patented Steel Portable Double Return Tube — Low Pressure Steam and Hot Water Heating Boilers — Pacific Steel Circulating Tanks — Pacific Steel Tank Heaters and Storage Tanks.

General Office and Plant:
WAUKEGAN, ILLS.

Sales Offices: 322 Monadnock Building, San Francisco and 1310 South Hill St., Los Angeles, California.



State Supreme Court and Library Building, Salem, Oregon
 Architect W. C. Knighton, formerly State Architect, Portland, Oregon

LASTING IMPRESSIONS

THE State Supreme Court and Library Building of Oregon does, of necessity, represent the people of Oregon. It crystallizes Oregon's conception of how its highest tribunal of justice should be housed.

The architect, who created this building, was confronted with not only a state, but a national problem. His ideas were the culmination of those necessary to convince the casual out-of-state visitor, as well as the citizens of the commonwealth—that this edifice faithfully portrayed the architectural ideals of Oregon. His efforts have been notably successful.

To secure the proper decorative treatment — FULLER'S VARNISHES and allied products were used — Particularly, "FORTY FOR FINISHING," which fulfilled the exacting requirements of dignity and character.

W. P. FULLER & Co.

Since 1849

PAINT AND VARNISH
 MANUFACTURERS

*"Fuller's Paints
 and Varnishes court
 investigation."*

"CHICAGO"
SILENT
SIGNAL
HOSPITAL
SYSTEMS

Garnett Young and Company

Pacific Coast Sales Engineers

612 Howard Street, San Francisco

SEATTLE

LOS ANGELES

PORTLAND



SOME STRIKING DESIGNS in Plaster Houses are to be found on the Pacific Coast. Many of them have been made possible by the use of **Del Monte White Sand** and White Portland Cement. **DEL MONTE WHITE SAND** and **FAN SHELL BEACH SAND** sold by leading building material dealers from Los Angeles to Vancouver, B. C. Prompt Deliveries.

Del Monte Properties Co.

Telephone Sutter 6130

401 Crocker Building, San Francisco



HERE IS SHOWN THE HANDY HOPPER DOOR OF

The
KERNER
"Built-in-the-Chimney"
INCINERATOR

which burns all garbage without a penny of cost. Into it is put all waste—everything from kitchen refuse to tin cans, and bottles.

The material deposited falls down the chimney flue to the incinerator built into the base of the chimney. Here it is ignited and burns itself up. The dry waste in burning dries the wet waste so it, too, can burn.

SANITARY — ECONOMICAL — CONVENIENT — ODORLESS

KERNER INCINERATOR CO.

77 O'Farrell St. SAN FRANCISCO Factory, 38 Stanford St.

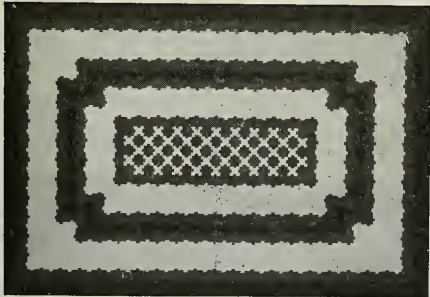

INTERLOCKING RUBBER TILING

material that is sure to give satisfaction. **Twenty tons installed in the Standard Oil Building, San Francisco.**
Stock on hand for immediate delivery.

New York Belting and Packing Co.

NEW YORK

San Francisco Branch 519 MISSION ST. Phone Douglas 1837

Small booklet of designs mailed on request.

The Elevator Floor

whether in Office Building, Hotel or Department Store, is subjected to a great deal of wear and tear.

— SPECIFY —

INTERLOCKING RUBBER TILING

and you've provided your client's building with a Durable, Economical, Practical,





Brininstool

San - a - Cote

(GLOSS—Can be Scrubbed)

AN INTERIOR WALL FINISH

For bath rooms, kitchens, hospitals, schools, office and public buildings. Ask dealers, owners, architects and contractors about this durable, sanitary, washable, economical wall covering. Brininstool makes a paint for every purpose, and every can purposely good.

THE BRININSTOOL CO., LOS ANGELES

COLOR GRINDERS AND PAINT MANUFACTURERS

Distributors—The Brininstool Co., 1174 Phelan Bldg., San Francisco, Cal.; The Brininstool Co., 222 Abington Bldg., Portland, Ore.; Schutz Paint Co., Fresno, Cal.; Schneider, Chappell & Jones, Sacramento, Cal.; Salt Lake Glass & Paint Co., Salt Lake City, Utah; Griffin Paint Co., Ogden, Utah; Campbell Hardware Co., First and Madison Sts., Seattle, Wash.; Imperial Valley Hardware Co., El Centro, Calexico, Imperial, Brawley, Seeley, Cal.; Spokane Hardware Co., Spokane, Wash.; Continental Paint Company, 328 South First St., San Jose, Cal.; Los Angeles Wall-paper & Paint Co., 525 So. Main St., Los Angeles, Cal.; H. A. Berger, 3838 13th St., San Diego, Cal.; H. L. Christian, Blythe, Cal.; Ezra Thayer, Phoenix, Ariz.; Miami Lumber & Supply Co., Miami, Ariz.

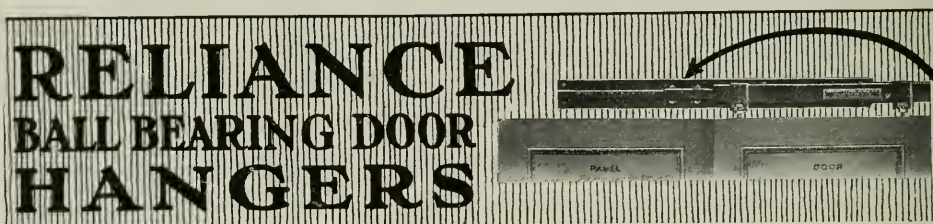

RELIANCE BALL BEARING DOOR HANGERS

To get as near perfection as possible, use

RELIANCE "HANGERS" and "Reliance-Grant" Controllers

These insure fast service, practically noiseless and slamless doors.

Reliance-Grant Elevator Equipment Corp'n

PARK AVENUE AND 40TH STREET, NEW YORK

PACIFIC COAST AGENTS

Waterhouse-Wilcox Co. - - - - - San Francisco and Los Angeles, Cal.
Columbia Wire & Iron Works - - - - - Portland, Ore.
D. E. Fryer & Company - - - - - Seattle, Spokane, Tacoma, Wash. and Great Falls, Mont.

FOR ALL
FINISHING
REQUIREMENTS



THE
IMMACULATE
WHITE ENAMEL

TRADE
ELASTICA
MARK
VARNISHES

Satinette
TRADE MARK
ENAMEL

STANDARD VARNISH WORKS

GENERAL OFFICES: NEW YORK - 90 WEST STREET
BRANCHES: LONDON - SAN FRANCISCO - PARIS - MELBOURNE

SAN FRANCISCO OFFICES & WAREHOUSE 55 STEVENSON STREET

When writing to Advertisers please mention this magazine.

Bungalow Building Blox

Hollow Building Tile
Hollow Partition Tile

California Brick Co.
604 Mission Street
San Francisco, Cal.

BRICK

Red Ruffled Face Brick
Paving Brick
Step and Walk
Brick

BRICK

Enamel Brick
Buff and Old Gold
Pressed Brick

Livermore Fire Brick Works
604 Mission Street
San Francisco, Cal.

Fire Brick and
Molded Fire Tile

Architectural Terra Cotta

GLASS

FULLER & GOEPP

32 Page Street, San Francisco. Telephone Market 499
PRIVATE EXCHANGE CONNECTING ALL DEPARTMENTS

MANUFACTURERS OF

MIRRORS, ART AND LEADED GLASS

Dealers in **WHITE** Glass for Table Tops, Counter Tops, Sink
Backs & Etc. Complete Stock — Prompt Deliveries.

Passenger and Freight Elevators



"MADE IN SAN FRANCISCO"

Factory and Warehouse, 166-180 Seventh
Street, San Francisco. Phone Kearny 66

SPENCER ELEVATOR COMPANY



RA-DO ^{FUMELESS} GAS RADIATORS

ALL CAST IRON—3 Sizes (3, 5, and 7 Sections)

The Ideal "Year-Round" Heating System
For The Home—New or Old

Easiest and Cheapest to Install
Lowest Operating Cost

BAIRD - BAILHACHE COMPANY

MANUFACTURERS

478 Sutter St., San Francisco

'Phone Sutter 6858

OLD MISSION PORTLAND CEMENT COMPANY



Each shipment of "OLD MISSION" Portland Cement is guaranteed not only to equal but to surpass all requirements of the standard specifications for Portland Cement as adopted by the U. S. Government and by the American Society for Testing Materials. A Guarantee Certificate is mailed with the bill of lading of each car, giving number of car, date packed, and number of barrels, over the signature of the chief chemist.

8000 SACKS DAILY

SALES OFFICE:

MILLS BLDG., SAN FRANCISCO

PHONE SUTTER 3075

PLANT:

SAN JUAN, CAL.

GEO. H. DYER, President

R. W. DYER, Vice-Pres.

W. J. DYER, Sec'y

DYER BROTHERS

Golden West Iron Works, Inc.

Structural Iron and Steel Contractors

ORNAMENTAL IRON WORK

Office and works:
17th and KANSAS STREETS

SAN FRANCISCO, CAL.
Phone Market 134



Keep Down Insurance Premiums

SPECIFY

SAINO FIRE DOORS

Standard Automatic Sliding or Swinging Fire Doors.
Tested and Labeled by the Underwriters' Laboratories.

STEEL SASH AND HOLLOW METAL
UNDERWRITERS WINDOWS

U. S. METAL PRODUCTS CO.

326-338 Tenth Street, San Francisco

Hauser Reversible



Window Fixtures

THIS Modern Apartment House in San Francisco designed by Architect E. E. Young, is equipped with the Hauser Type Fixture. *Manufactured and installed by*

Hauser Window Co.

157 Minna Street,
SAN FRANCISCO

Phone
Kearny 3706



As Good as New

*Residence of Edward Weitz,
Des Moines, Ia. Vorse,
Kraetsch & Kraetsch,
Architects. Chas. Weitz
Sons, General Contractors.*



FRESH and bright as if finished yesterday—but this attractive home was built five years ago. What's the secret?

Notice the mortar joints. They're as clean-cut and white as the day they were laid. And the flower vases, trim and spotless, play their part.

Medusa Stainless Waterproofed White Cement—that's the answer.

Face brick laid in that material was specified by the architects, Messrs. Vorse, Kraetsch & Kraetsch of Des Moines. The foundation walls were back-plastered with cement waterproofed with Medusa Waterproofing Paste. The work was done by Chas. Weitz Sons, Contractors.

The stainless quality and permanence of Medusa products recommend them to architects and builders of fine structures. We'll gladly aid in making up the cement specifications. The Medusa Cement booklets describe the products fully.

THE SANDUSKY CEMENT COMPANY
Department P. Cleveland, Ohio

Pacific Coast Distributors

Pacific Materials Co., San Francisco
A. McMillan & Co., Portland

Galbraith & Co., Seattle
Riverside Portland Cement Co., Los Angeles

THE GENERAL MANAGER OF A BIG OAKLAND LUMBER COMPANY

sat in his office the other morning and turning to his head salesman inquired rather irritably:

“What’s the matter with our sales? Our competitors next door seem to be putting it over on us lately.”

“Can’t account for it,” replied the salesman, “we have been following up all the leads in the daily papers.”

Tips from the daily papers! How can the manager of a big corporation blame his salesmen if that’s the kind of information he buys for them.

Newspaper information about new building projects is invariably from one week to one year old.

The live lumber dealer, material man and contractor is willing to pay for genuine advance information. The Architect and Engineer supplies that information to its advertisers daily.

Write for sample and rates.

The Architect and Engineer Inc.

Phone Douglas 1828

627 Foxcroft Building, San Francisco



How Do Customers Judge Your Firm?

JUST as the manner and appearance of your employees command respect or disapproval from outsiders, so your office equipment tells the visitor whether or not to expect an orderly, reliable and established business organization.

Accustomed as you are to your surroundings, just try for a moment to see them through the critical eyes of a business prospect. Are you satisfied or does it leave you with some misgivings?

"Good people"—so goes the silent message from office to caller when you are equipped with Globe-Wernicke Filing Cases, Fire Proof Safes, Bookcases and the proper kind of desk accessories.

Globe-Wernicke office fixtures, steel or wood, besides comprising the most complete line of office equipment manufactured, are outstandingly the best from a standpoint of design and utility.

Perhaps the appearance of *your* office could be improved. A bookcase added, or a modern filing case for your records may help your particular business to run smoothly and assist in favorably impressing the visiting "outsiders."

The H. S. Crocker Company maintains a complete stock of Globe-Wernicke fixtures ready for your inspection.

Send today for catalogue

H. S. CROCKER CO., INC.

565-571 Market Street, San Francisco

Los Angeles

1444 Broadway, Oakland

Sacramento

How Daylight Helps Workmen Do More and Better Work

DAYLIGHT and fresh air are powerful aids to production. The stimulus of plenty of light and fresh air is reflected in greater volume and accuracy of output, with diminished wastage. Operatives enjoy better health, are freer from eye-strain, lose fewer days through sickness. Labor turnover is reduced—output is noticeably increased. All of this is accomplished with Truscon Daylight Sash.

Truscon Daylight Engineers At Your Service

The daylighting of modern factories requires not alone intimate knowledge of steel sash, but also a broad understanding of all phases of modern construction. A pioneer in permanent building methods, Truscon's experience includes 30,000 buildings of all types. Truscon Daylight Engineers offer an exceptional service in planning the most effective daylighting of your building.

Largest stock of fireproof material and reinforcing bars on the Pacific Coast.

TRUSCON STEEL COMPANY

CHAS. HOLLOWAY, JR., Branch Manager

527 Tenth Street, San Francisco

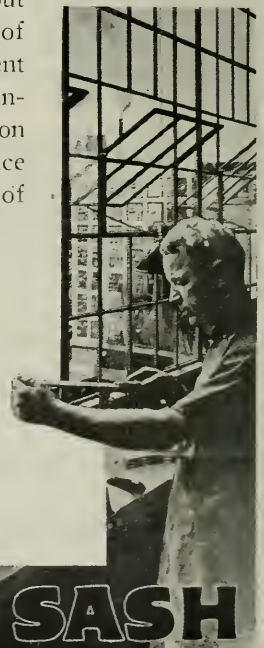

TRUSCON DAYLIGHT SASH

When writing to Advertisers please mention this magazine.



THE HOUSE BEAUTIFUL



THE interior of a Home should have those little touches of refinement that come with the co-operation of an experienced interior decorator.

CONSULT US

Decorative ideas, artistic framing, bybompa ware, floor lamps, table lamps, chair lamps, lamp shades, mirrors, candlesticks, decorated candles, book-ends, store window fixtures, odd furniture, pictures, Emma B. Freeman's Prints, pieces in unique colorings and indefinite carvings and other objects of art.

FREEMAN ART SHOP

386 SUTTER STREET
SAN FRANCISCO

Tel. Sutter 1593



Beach-Robinson Co.

Decorators and Furnishers

Carpets

Draperies

Furniture

Rugs

Wall Paper

Ranson E. Beach

239 Geary Street, 3d Floor

Union Square

Phone, Sutter 580

San Francisco, Cal.



ADD CHEER and COMFORT
to the Home by having a

WELL DESIGNED INTERIOR

Before Completing Your Plans, CONSULT

SONNENSCHN BROS.

INTERIOR DECORATORS

Furniture and Draperies Made to Order

Factory

718 NATOMA ST., Phone Market 1145

Show and Salesroom

470 SUTTER ST., Phone Kearny 2051



*The Finishing Touch
of Right Building —*

F. A. TAYLOR CO.

251 Post St., San Francisco

Second Floor



Mercedes Bldg.

*Hand-made
Furniture,
Rugs,
Hangings,
Upholstering,
Decorating,
Wall Paper.*

The GOLD MEDAL MAIL CHUTE



INSTALLED IN
THE NEW
SAN FRANCISCO
CITY HALL
AND THE
WHITE MARBLE
MERRITT
BUILDING,
LOS ANGELES

Given highest award at
Panama - Pacific International
Exposition, 1915.

Waterhouse-Wilcox Co.
California
Representatives
523 Market Street
SAN FRANCISCO

331 E. 4th Street.
LOS ANGELES

F. T. CROWE & CO.
Seattle, Wash.

THE J. McCracken Co.
Portland, Oregon

**American Mailing
Device
Corporation**



**LIBERTY
WALL BOARD**

MANUFACTURED BY
KEY-HOLD PLASTER LATH COMPANY

A Fibered Gypsum Plaster that will not
shrink, warp or buckle.
Resists Fire, Moisture, Heat and Cold.
Key-hold plaster lath possesses a perfect
mechanical key—admitted for fire proof con-
struction in all classes of buildings.

KEY-HOLD PLASTER LATH CO.
Office and Factory
148 Hooper St. San Francisco
Phone Market 5767

McCRAY
**REFRIGERATORS
FOR ALL PURPOSES**

It is our particular desire to
impress the Architects of
America with the fact that
McCray builds refrigerators
for all purposes. Thousands
of fine residences, hotels,
clubs, restaurants, factory
cafeterias, hospitals, stores and
markets depend on McCray
for efficient, economical re-
frigerator service.

McCRAY REFRIGERATOR CO.
1054 Monadnock Bldg., San Francisco, Cal.
Home Office and Factory
Kendallville, Ind.



YOU KNOW that a building
should be watertight and
WE KNOW that it can be
made so with

**IMPERIAL
WATERPROOFING**

LOOK FOR  THE LABEL

If your building is leaking through
the walls or around the windows, or
if the Basement walls are wet below
ground—call up SUTTER 978.
IMPERIAL WATERPROOFING is
manufactured by BROOKS &
DOERR, 460 7th St., San Francisco

**WATEREX REED BAXTER
DISTRIBUTOR**
1002-04 Merchants National Bank Building,
Phone Sutter 978
SAN FRANCISCO, CAL.
3419 Broadway, OAKLAND, CAL.

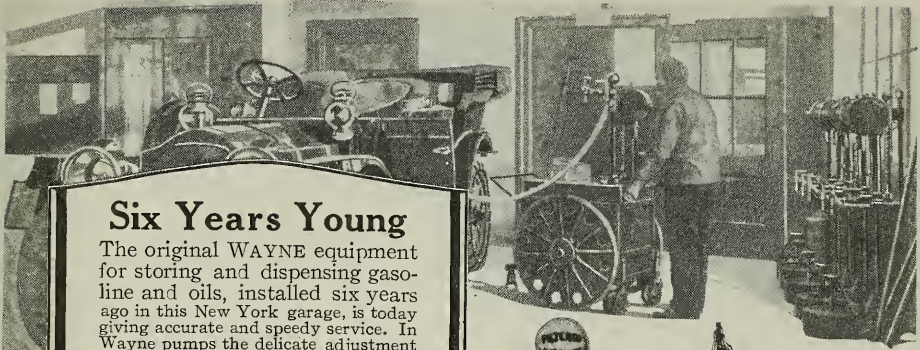

Six Years Young
 The original WAYNE equipment for storing and dispensing gasoline and oils, installed six years ago in this New York garage, is today giving accurate and speedy service. In Wayne pumps the delicate adjustment essential for accuracy is combined with a durability that assures satisfaction for years and years.
 There is a Wayne System for every need of the public garage. The service of Wayne engineers in advising and planning is yours without cost or obligation.
Wayne Oil Tank & Pump Co.
 746 Canal St., Ft. Wayne, Ind.
 San Francisco Office 631-633 Howard St. Phone Garfield 1350
 Los Angeles Office 830 S. Los Angeles St. Phone Main 1600
Wayne
REG. U. S. TRADE MARK
Liquid Storage Systems

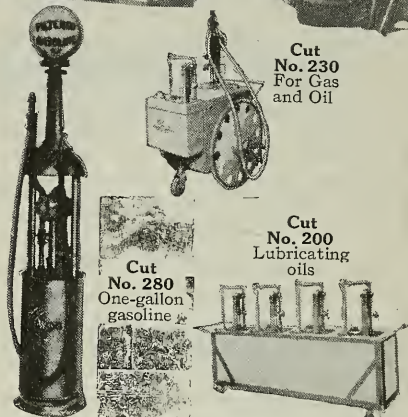

Cut No. 230
For Gas and Oil

Cut No. 280
One-gallon gasoline

Cut No. 200
Lubricating oils

PITCHER DOOR HANGERS



Specified in this Apartment House by Mr. A. H. Knoll, Architect, because of their simplicity, quiet running qualities and dependability.

MANUFACTURED BY

NATIONAL MILL & LUMBER CO.

318 Market Street
 SAN FRANCISCO

Apartment House of Mr. Antone Rulfs
 Geary Street, San Francisco

Phone Kearny 3620



IT'S not enough to say "Good For All Time" unless there is something back of it. ¶ There is in this case. ¶ Vermont Marble already has an unblemished record of over one hundred and fifty years. ¶ We know what it will do. It's not necessary to guess at it. ¶ And our quarries in Alaska and Texas are also proving themselves. ¶ So please don't think of "Good For All Time" as merely a happy phrase.

IT'S THE MARK OF A SERVICE.
It means exactly what it says.

VERMONT MARBLE COMPANY
PROCTOR, VERMONT
San Francisco - Portland - Tacoma

WHERE A MORTGAGEE INSURES

his own interest at his own expense, payment of a loss before the mortgage is paid is not a payment of the mortgage, and conversely, a mortgagor, insuring his separate interest, is entitled to the insurance proceeds, but where the mortgagor effects insurance, payable to the mortgagee as his interest may appear, the policy is for the benefit of both parties. *Sisk vs. Rapuano, Conn., 108 Atl. 858.*

DIXWELL DAVENPORT
Manager Pacific Coast Department

**BANKERS & SHIPPERS
INSURANCE COMPANY**
INSURANCE EXCHANGE BLDG.
SAN FRANCISCO
Telephone Kearny 3561

A Bargain in Files—

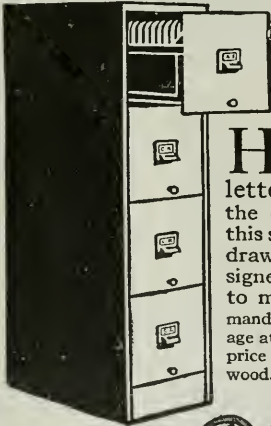

HOLDS 20,000 letters. That's the capacity of this special four-drawer file, designed and built to meet the demand for steel storage at less than the price of high grade wood. See it today.

Van Dorn
STEEL EQUIPMENT

Phone Douglas 1183
Western Office Equipment Co.
467 Market Street - San Francisco

EASY TO LAY

Great quantities of Clinton Electrically Welded Fabric can be laid in a very short time with absolute assurance that every strand of wire is in its proper position. It eliminates all the cost and trouble of spacing and wiring loose rods.

L. A. NORRIS COMPANY
140 Townsend St., San Francisco
Phone Kearny 5375



CLINTON
Electrically Welded Wire Fabric

Cross-Section of No. 2 Trap

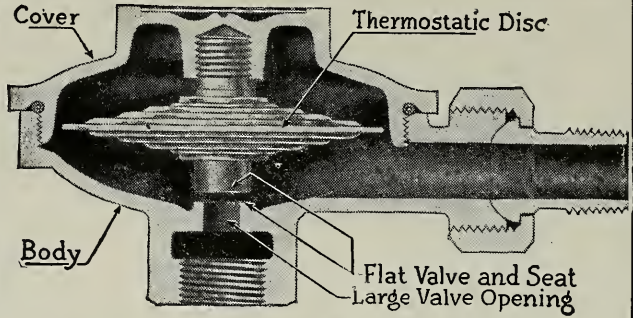

The DUNHAM Radiator Trap

All that the perfect radiator trap should do, the Dunham does. Witness its progress from its advent in 1903. Is it not true that today, the thermostatic hollow disc type trap is the leader? The Dunham was the **first** of this type. And so correct were the original traps that after 17 years of continuous service many of them still are operating with the promise of working indefinitely. Nor has the fundamental principle of the Dunham Trap been changed since 1903. You who advocate standardization know what this signifies.

The DUNHAM
REG. TRADE-MARK
HEATING SERVICE

If you have not received your copy of "The Dunham Hand Book," please advise us at once. We believe that you will find it very helpful in many ways.

LOS ANGELES
600 Metropolitan Bldg.
PORTLAND
410 Board of Trade Bldg.

C. A. DUNHAM CO.
SAN FRANCISCO, 524 Sheldon Bldg.
Administration Office, CHICAGO, ILL.

SEATTLE
206 First Ave. South
SPOKANE
405 Sherwood Bldg.



TAY PIPE
Valves & Fittings
STEAM & WATER SUPPLIES
Heating Material
PLUMBING GOODS
Pumps

GEORGE H. TAY COMPANY
SAN FRANCISCO OAKLAND
MISSION & SECOND STS. TENTH & HARRISON STS.
TELEPHONE DOUGLAS 2240 TELEPHONE LAKESIDE 4200

TiteSete Float Valve

For High and Low Pressures

IN SIZES UP TO 4 INCHES
Larger Sizes on special order

Remains Wide Open
until desired Water Level
is reached then Closes
POSITIVELY without
Water Hammer

Simple and Durable
Positive and Reliable



Self-Cleaning,
Non-Clogging
By-Pass

NATIONAL VALVE COMPANY

Phone Douglas 5093

23-25 MINNA ST., SAN FRANCISCO

MASTIC FLOORS

BITURINE COATINGS FOR STEEL

WATERPROOFING

Hill, Hubbell & Company

CONTRACTORS

SAN FRANCISCO

1000 Fife Building, No. 1 Drumm Street

LOS ANGELES
Marsh-Strong Building

SEATTLE
Grand Trunk Pacific
Dock

PORTLAND
Pittock Block

CANNON & CO

Clay Products

Denison Interlocking Tile

"THEREFORE when we build, let us think that we build forever. Let it not be for present delight, nor for present use alone, let it be such work as our descendants will thank us for, and let us think, as we lay stone on stone, that a time is to come when those stones will be held sacred because our hands have touched them, and that men will say as they look upon the labor and wrought substance of them, 'See! this our forefathers did for us.'" This is the spirit of Denison Interlocking Tile.

Factory Sacramento Calif
San Francisco Office 1605-6-7 Chronicle Bldg
Phone Kearny 5908

USE
UHL'S DIAMOND FLOOR WAX
 1—3—5-lb. Cans. A Finishing Wax of best quality in Paste Form

UHL SEATTLE OAKLAND PORTLAND LOS ANGELES SAN FRANCISCO **BROS.**
 "WALL PAPER" - "PAINTS"

LEADER WATER SYSTEM

No country home is complete without this modern water system. Running water under pressure whenever and wherever needed. Convenient, economical, sanitary.

Pacific Pump & Supply Company, Distributors

851-853 Folsom Street
 SAN FRANCISCO, CALIF.

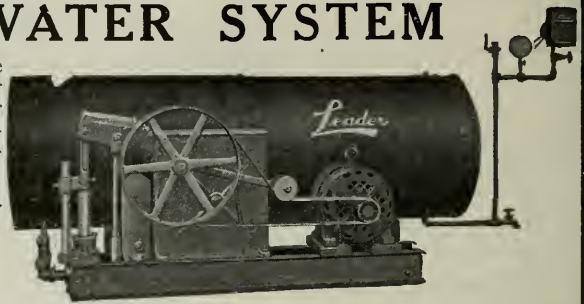

QUALITY HARDWARE



LOCKS AND BUILDERS'
 HARDWARE

PALACE HARDWARE CO.

"San Francisco's Leading Hardware Store"

581 MARKET STREET. SUTTER 6060



Pack your Radiator Valves with
Palmetto Twist Packing

It can be unstranded to fit any size valve. It does not get hard.

H. N. COOK BELTING CO.

401-433 Howard St.

San Francisco, Cal.

WESTERN VENETIAN BLINDS

ELIMINATE the unsightly awnings — Preserve the exterior beauty of your buildings by
Specifying

**WESTERN VENETIAN
BLINDS**

Some 1920 contracts for complete equipment:

- 12-story Mattie Building,
Fresno, California
- 9-story Pantages Building,
Los Angeles, California
- 7-story Marland Refining Bldg.
Ponca City, Oklahoma
- 10-story Trademens Bank Bldg.
Oklahoma City, Okla..
- 5-story Railway Exchange,
Muskegee, Oklahoma



LOS ANGELES TRUST AND SAVINGS BLDG. LOS ANGELES, CAL.

HAAS BLDG. LOS ANGELES, CAL.

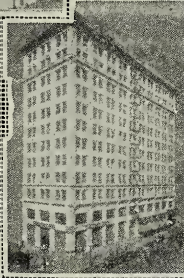

CITIZENS SAVINGS BLDG. PASADENA, CAL.



GLOBE GRAIN & MILLING CO. LOS ANGELES CAL.



COUNTY COURT HOUSE WALLA WALLA, WASH.

When you consider the fact that **WESTERN VENETIAN BLINDS** take the place of both awning and window shade and will last practically as long as the building stands you'll realize that they are the logical equipment for modern buildings

WESTERN BLIND & SCREEN CO.
2704 LONG BEACH AVE.
LOS ANGELES CALIFORNIA

United States Steel Products Co.

Rialto Bldg., San Francisco

SELLERS of the products of the American Bridge Co., American Sheet and Tin Plate Co., American Steel and Wire Co., Carnegie Steel Co., Illinois Steel Co., National Tube Co., Lorain Steel Co., Shelby Steel Tube Co., Tennessee Coal, Iron and Railroad Co., Trenton Iron Co.

MANUFACTURERS OF

Structural Steel for Every Purpose—Bridges, Railway and Highway—"Triangle Mesh" Wire Concrete Reinforcement—Plain and Twisted Reinforcing Bars—Plates, Shapes and Sheets of Every Description—Rails, Splice Bars, Bolts, Nuts, etc.—Wrought Pipe, Trolley Poles—Frogs, Switches and Crossings for Steam Railway and Street Railway—"Shelby" Seamless Boiler Tubes and Mechanical Tubing—"Americore" and "Globe" Rubber Covered Wire and Cables—"Reliance" Weatherproof Copper and Iron Line Wire—"American" Wire Rope, Rail Bonds, Springs, Woven Wire Fencing and Poultry Netting—Tramways, etc.

United States Steel Products Co.

OFFICES AND WAREHOUSES AT

San Francisco - Los Angeles - Portland - Seattle



Accuracy and Safety with **BOWSER** Piston Type Measuring Pumps

Gasoline users demand Accurate Measurement and Safety from any danger of fire and explosion. The 35 years' consistent record of Accuracy and Safety of Bowser pumps fulfills this demand.

ACCURACY of Bowser pumps is determined positively by mechanical means. The Piston Type Pump is arranged to permit EXACTLY the same amount to be repeatedly discharged.

SAFETY—There is no possibility of breakage or spilling of gasoline with Bowser pumps to endanger lives and property. There has never been a fire caused by a Bowser pump.

S. F. BOWSER & COMPANY, Inc.

FORT WAYNE, INDIANA

San Francisco Office: 612 HOWARD STREET

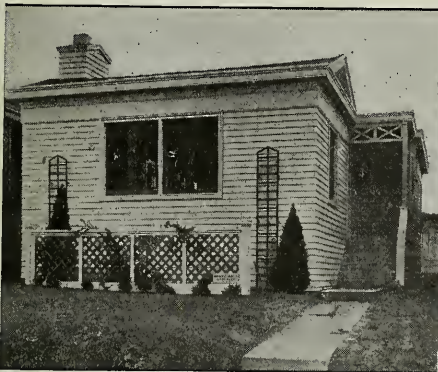

Cabot's Old Virginia White on Siding and Trim

Cabot's Old Virginia White on Trim

Morrow & Garren, Architects, San Francisco

CABOT'S OLD VIRGINIA WHITE—The Modern Architectural Outside White

The clean, brilliant "whitewash white" effect of Old Virginia White has real distinction. It is a softer and yet a brighter white than paint, and its texture and color-values are essentially different in character from the heavy, hard paint coating. This makes it especially appropriate for the modern "Colonial," because it gives the house at once the aspect of well-groomed old age—a result that it would take years to accomplish with paint.

CABOT'S OLD VIRGINIA TINTS

This softness and textural quality have led many of the leading architects to call for the same compound in tints, and Cabot's Old Virginia Tints are now made in a wide variety of delicate shades. The tones are almost pastel-like in quality, and the effects produced are most unique and pleasing. Send for Samples.

SAMUEL CABOT, Inc., Manufacturing Chemists, BOSTON, MASS.

Pacific Building Materials Co., San Francisco
Waterhouse-Wilcox Co., Los Angeles

S. W. R. Dally, Seattle
Timms, Cress & Co., Portland

Theo. F. Snyder, San Diego, Cal.

When writing to Advertisers please mention this magazine.



CENTRAL HIGH SCHOOL, MINNEAPOLIS, MINN.

Architect, William B. Ittner

Contractors, Pike & Cook Co.

Glazed by Forman, Ford & Co



The above Trade-Mark
appears on every light

Completely equipped with American Window Glass Co.'s Double Strength AA Quality
First Choice of Leading Architects

Because of its absolute dependability, American Window Glass has been used in many fine buildings. Our care in inspection practically eliminates all imperfections and assures uniformity in thickness.

American Window Glass Co., General Office, Pittsburgh, Pa.

DOMESTIC SALES OFFICES
New York, 220 Fifth Avenue
Chicago, 1011 Peoples Gas Building
Boston, Mass., 43 Tremont Street
San Francisco, Cal., 341 Montgomery Street
St. Louis, Mo., 1303 Syndicate Trust Building
Memphis, Tenn., 440 North Main St.
New Orleans, La., 904 Hennen Bldg.
Atlanta, Ga., 1408 Candler Building

EXPORT SALES OFFICES
Havana, Cuba, Apartado No. 930
Buenos Aires, Argentina
Mexico City, Mex., Apartado Postal No. 237
Barranquilla, Colombia
Bogota, Colombia
Valparaiso, Chile
Lima, Peru
Toronto, Canada, 205 Continental Life Building

Highest Quality

Finest Workmanship

Remco Redwood Tanks

Underwriters — Standard — Specials

All dimensions and capacities

Towers Designed and Erected

For Prices, Data or Estimates Phone GARFIELD 1910

Redwood Manufacturers Company

SOLE MAKERS*

Hobart Building, San Francisco

When writing to Advertisers please mention this magazine.

JOHNSON'S ROTARY CRUDE OIL BURNER

Can be installed in any BOILER or FURNACE

Gives Satisfactory Results. Simple to Operate—
Automatic—Safe. Let us tell you more about this
Oil Burner.

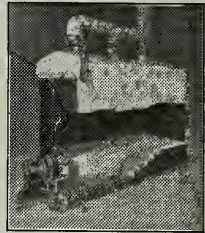

BURNER IN OPERATION

S. T. JOHNSON CO.

1337 Mission Street - San Francisco, Cal.

Ask for Bulletin No. 28 Phone Market 2759

Agencies: SEATTLE LOS ANGELES FRESNO SAN DIEGO SACRAMENTO
Member of the Oil Burners Manufacturers' Association of California.

Fess System Turbine Fuel Oil Burner

The latest word in the science of burning fuel
oil in an efficient and economical method

Ask for Bulletin No. 20

FESS SYSTEM CO., Inc.

1310 S. HILL ST.,
LOS ANGELES

218-220 Natoma Street, San Francisco

HOUSTON,
TEXAS

Member of the Oil Burners Manufacturers' Association of California.

OIL BURNER EQUIPMENTS

Low Pressure Air and Rotary Mechanical Atomizing Types

Refrigerating and Ice-Making Machines

Direct Expansion and Brine Circulating Systems

T. P. JARVIS MANUFACTURING CO.

CONTRACTING ENGINEERS AND MANUFACTURERS

275 Connecticut Street, San Francisco

Phone Market 3397

Member of the Oil Burners Manufacturers' Association of California.

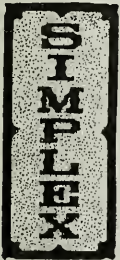

SIMPLICITY OF CONSTRUCTION together with
SUCCESSFUL and ECONOMIC OPERATION of

SIMPLEX BURNERS

reported by their many users, is the best recommenda-
tion we can furnish to those desiring crude oil burners.

American Standard Oil Burner

TRADE MARK

Phone BERKELEY 6389

Company

FIFTH AND PARKER STREETS
BERKELEY, CALIFORNIA

Member of the Oil Burners Manufacturers' Association of California.



Pump Governors
 Oil Burner Governors
 Reducing Valves
 Safety Valves
 Oil Valves
 Blowoff Valves
 Boiler Feed Water
 Regulators

Oil Pumping Sets
 Little Giant Improved
 Oil Burners
 Duplex Oil Pumps
 Rotary Oil Pumps
 Oil Heaters
 Draft Gauges
 Boiler Feed Pumps

G. E. WITT CO., Inc.

ENGINEERS

Manufacturers and Distributors

862-864 HOWARD ST.

Phone Douglas 4404

SAN FRANCISCO, CAL.

"The White House"



has had the concrete floors in its new garage and warehouse at Fulton and Laguna Sts. treated with VITRIFYX and the wood floors with VITRIFYL. There will be no dust on any "White House" merchandise.

**PACIFIC
 MATERIALS CO.**
 525 Market St., San Francisco

A. F. EDWARDS, President
 J. M. FABBRIS, Vice-President

J. A. MACKENZIE
 Secretary

CHAS. F. EISELE } Asst. Managers
 J. RUBIOLLO }

AMERICAN MARBLE & MOSAIC CO.

25-29 Columbia Square, San Francisco
 Telephone Market 5070

Factory on Canal, South San Francisco Telephone South San Francisco 161

Fenestra

SOLID STEEL WINDOWS

DETROIT STEEL PRODUCTS CO., Detroit

Direct Factory Branch, 68 Post Street, San Francisco

Phone Sutter 1250



The Architect and Engineer

CONTENTS FOR DECEMBER, 1920

STREET VIEW OF AN INDUSTRIAL VIL- LAGE NEAR YOUNGSTOWN, OHIO . . .	Frontispiece
HERDING & BOYD, Architects	PAGE
TWO TOWN PLANNING PROJECTS IN ARIZONA, HERDING & BOYD, Architects	43
IRVING F. MORROW	
THE BUSINESS CONDUCT OF AN ARCHI- TECT'S OFFICE	'88
A. H. GREGG	
SCHEME TO TUNNEL SAN FRANCISCO BAY	93
THE SPECIFICATION WRITER AND THE MANUFACTURER'S LITERATURE	97
LOUIS R. HOLSKA	
TWO GARAGE ELEVATIONS	99-100
JOSEPH L. STEWART, Architect	
BACK PLASTERED CEMENT STUCCO PROVES STRONGEST FOR EXTERIOR WALL CONSTRUCTION	101
SKILLED MECHANICS NEEDED	105
CONCRETE FOR RESIDENCES	108
E. B. GOODELL, JR.	
FINLAND DEVELOPS ITS OWN ARCHI- TECTURE	109

.....
The price of this issue (Special Christmas Housing
Number) IS 50c A COPY
.....

Published Monthly by

THE ARCHITECT AND ENGINEER, Inc.

626-627 Foxcroft Bldg., San Francisco

W. J. L. Kierulff Fred'k W. Jones L. B. Penhorwood
President Vice-Pres. Secretary



The
Season's Greetings
1920 - 1921



Strable Hardwood Company,
formerly Strable Manufactur-
ing Company of Oakland,
California, extends to its
architect friends and patrons,
the compliments of the season,
and a happy and prosperous
New Year.

Strable Hardwood Company
G. H. Brown, President



STREET VIEW OF AN INDUSTRIAL VILLAGE, NEAR YOUNGSTOWN, OHIO
HERDING AND BOYD, ARCHITECTS, ENGINEERS AND TOWN PLANNERS

Frontispiece
The Architect and Engineer
for December, 1920

THE ARCHITECT AND ENGINEER

Vol. LXIII.

SAN FRANCISCO, DECEMBER, 1920

No. 3

Two Town Planning Projects in Arizona, Herding & Boyd, Architects

By IRVING F. MORROW

TIME was when City Planning meant an adventure in the Grand Style. It was an affair of colonnades, vistas, monuments. For the cultured but untechnical onlooker the impressive delivery of the term evoked visions of vast civic centers and vanishing perspectives down interminable boulevards. The most disparate structures might be assembled in these civic center plazas, unassociated save by the common enthusiasm which inflated their grandiose orders; and avenues might sweep majestically between unimportant points without other justification than the magnificence of their width. If the layman was uncritical of the logic of this undeniably impressive but often misplaced display, the architect was certainly no conspicuous object-lesson of sanity. The profession, in fact, was obsessed by the monumental. The only quality rated at its face value was the one which should reasonably deserve the most careful scrutiny—pretension. Many a modest-sized city and town fell into line and employed a City Planning Expert. Most of them in due time became the proud possessors of elaborate plans which smothered whatever natural or potential individuality may have been theirs under an impressive but irrelevant monumentality. The most fortunate thing about most of these plans is that after the Chamber of Commerce banquets at which they were exposed, their influence was confined to folders for the delectation of tourists. Had they been with any consistence actually carried out, these towns would have become uniformly pretentious and devoid of the salt of personality.

It was inevitable that there should be a reaction from this conception of city planning as an excuse for the grandiose but characterless. So complete was it, in fact, that the newer school is sometimes almost ostentatious in discarding the former term and substituting the more modest sounding "town planning." But the change of name is genuinely symbolical of the altered point of view. The watchwords are today utility and human charm. Nor can there be a serious doubt that the results are more amenable to ordinary human uses. Surely if there is any realm in which there is justification for the contention that beauty must be based in the last analysis on utility, it is in the physical organization of the communities in which

people are congregated. As a place physically, morally and mentally healthful, a town must provide for traffic, transportation, sanitation, comfort, industry, education, recreation. The satisfaction of these and other similar fundamental practical considerations is a *sine qua non*. Civic beauty can not be considered as an abstract end in itself above, or even beside these. It must be derived as an incident to the adequate and natural solution of these utilitarian problems. In an age which prides itself upon rationality, it is really intolerable that a city should develop either by chance, with reference to no standards, or designedly with reference to irrelevant standards.

The two mining towns which Messrs. Herding & Boyd have planned for Arizona admirably exemplify the rational attitude toward the subject. Straining for effect for its own sake is abolished, but every native peculiarity

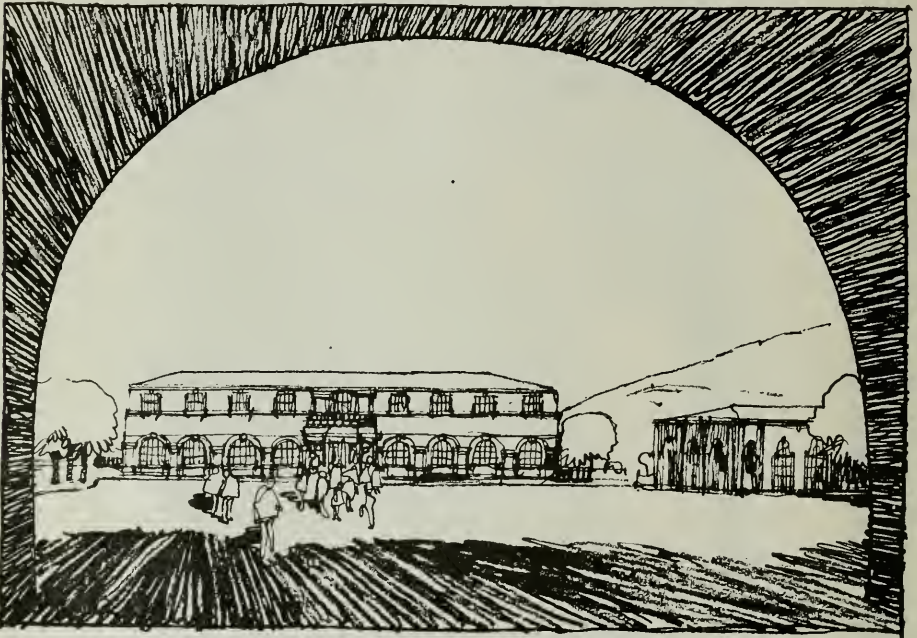

THE SCHOOL GROUNDS, MINING TOWN NEAR JEROME, ARIZONA
Herding & Boyd, Architects

is seized upon and made to yield its particular beauty. Careful studies of the site, the relations to the surrounding country, the prospective uses of the towns, the nature of their inhabitants, and other vital practical concerns determine the lines of the developments and the forms of their expressions. In the Clarkdale plan the architects were hampered by a town already existing. Its layout and partial construction were of the nature unfortunately common to small American towns—purposeless, characterless, impractical, stupid. Sympathy and understanding have overcome as far as may be the initial mistakes, and indicated the proper course for a logical and harmonious development. The mining town near Jerome, Arizona, is, on the other hand, an out and out creation. The result of the freedom here enjoyed is a conception of interest and individuality. The town is laid out with due consideration for the various factors which must inevitably domi-

nate its life; it is, in fact, determined by them. Yet it very cleverly avoids the pitfalls of the stock, the arbitrary, the ready-made. Its appearance is that of a community which has grown naturally and of an inner impulse throughout the course of years. It is invested, in addition, with a flexibility which will permit it to be constructed gradually, according to its growing needs, as well as to adjust its development readily to requirements which must inevitably change as to detail along with the course of its growth.

The graphical presentations of the ideas deserve a special word of mention. They offer a curious combination of decorative and realistic qualities which is decidedly piquant. Mr. Herding's pen, pencil, and brush all wander over the paper with a nonchalance which, superficially at least, at times seems



THE SITE OF THE MINING TOWN NEAR JEROME, ARIZONA

equivalent to carelessness. It is only after realizing the unerring precision with which his facts are invariably set forth that one appreciates that it all must have been strictly under the control of foresight and intelligence. It is both novel and refreshing to see matter-of-fact subjects like plans and elevations of miners' dwellings presented with an effect distinctly decorative, yet sacrificing thereby nothing of their essential architectural accuracy. Most of these drawings have had to undergo a considerable over-reduction to bring them within the compass of the magazine page. The water colors, in flat, opaque color on heavily tinted boards, have in addition had to bear the transcription to one color.

The reports which Messrs Herding & Boyd have written on the Mining Town near Jerome, Arizona, the Typical Miner's House, in conjunction with this scheme, and the Replanning of Clarkdale, Arizona, set forth clearly the essential facts in regard to these projects, and leave little else to be said. These three reports therefore follow in their entirety:



BIRDSEYE VIEW, MINING TOWN NEAR JEROME, ARIZONA
HERDING & BOYD
ARCHITECTS

I. — Design of Mining Town Near Jerome, Arizona

By HERDING & BOYD, Architects, Engineer and Town Planners

GENERAL STATEMENT

THIS report covering the construction of a mining town to be located near Jerome, Arizona, has been prepared to accompany our construction proposal which embraces a complete town plan, the layout of streets, sewers and sidewalks, the design of houses and the construction of this development.

In making a detailed study of the requirements of this town we have been brought in close contact with the general conditions of the Jerome district, the



VIEW IN AMERICAN TOWN, MINING TOWN NEAR JEROME, ARIZONA

Herding & Boyd, Architects

sources of labor supply, annual labor turnover, the living and social conditions of the community, and it is only in the belief that the operating management of these properties will share in our general views that we have gone beyond the strict limits of a construction proposal and have undertaken a partial survey of the living and social conditions which surround these properties.

You are confronted with a situation in which your assets, consisting of large deposits of copper, will have their commercial value impaired unless mining can be carried on at a reasonable cost. The largest item of cost is undoubtedly the

direct labor cost which can only be controlled by an adequate supply of high grade labor working under satisfactory conditions, well housed and located in a permanent town.

The population of the town of Jerome varies from six thousand to fourteen thousand people, the majority of whom live in overcrowded and unsanitary surroundings which have been brought about by a lack of plan covering the growth of this community, or of adequate provision for the social welfare of this community other than the fine results that have been obtained in connection with your hospital service.



VIEW EAST ON LOWER STREET OF DETAILED DEVELOPMENT
WEST OF PUBLIC PLAZA, MINING TOWN NEAR JEROME, ARIZONA
Herding & Boyd, Architects (See pages 54 and 55)

The condition of unrest which has pervaded the copper mining districts of the Country during the past few years cannot be entirely accounted for by a spirit of radicalism. It has been undoubtedly increased by a floating supply of undesirable labor and failure to provide living conditions which will attract to this industry a high type of labor which will be permanently satisfied with the general wage and living conditions of the industry.

With the natural restrictions on immigration and the possibility of national legislation limiting immigration, the industries of this Country are facing a

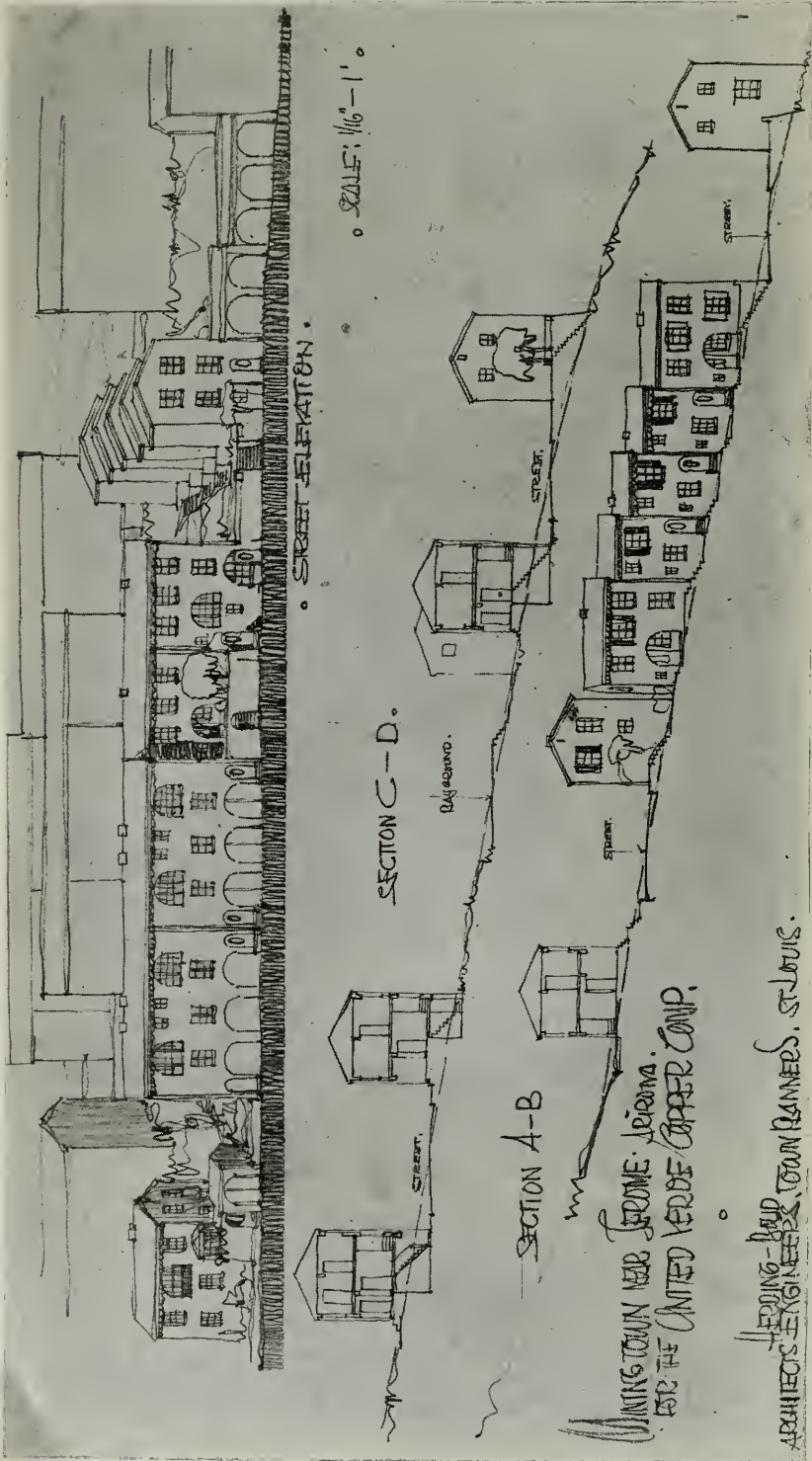

SECTIONS OF DETAILED DEVELOPMENT WEST OF PUBLIC PLAZA, MINING TOWN NEAR JEROME, ARIZONA
HERDING & BOYD ARCHITECTS

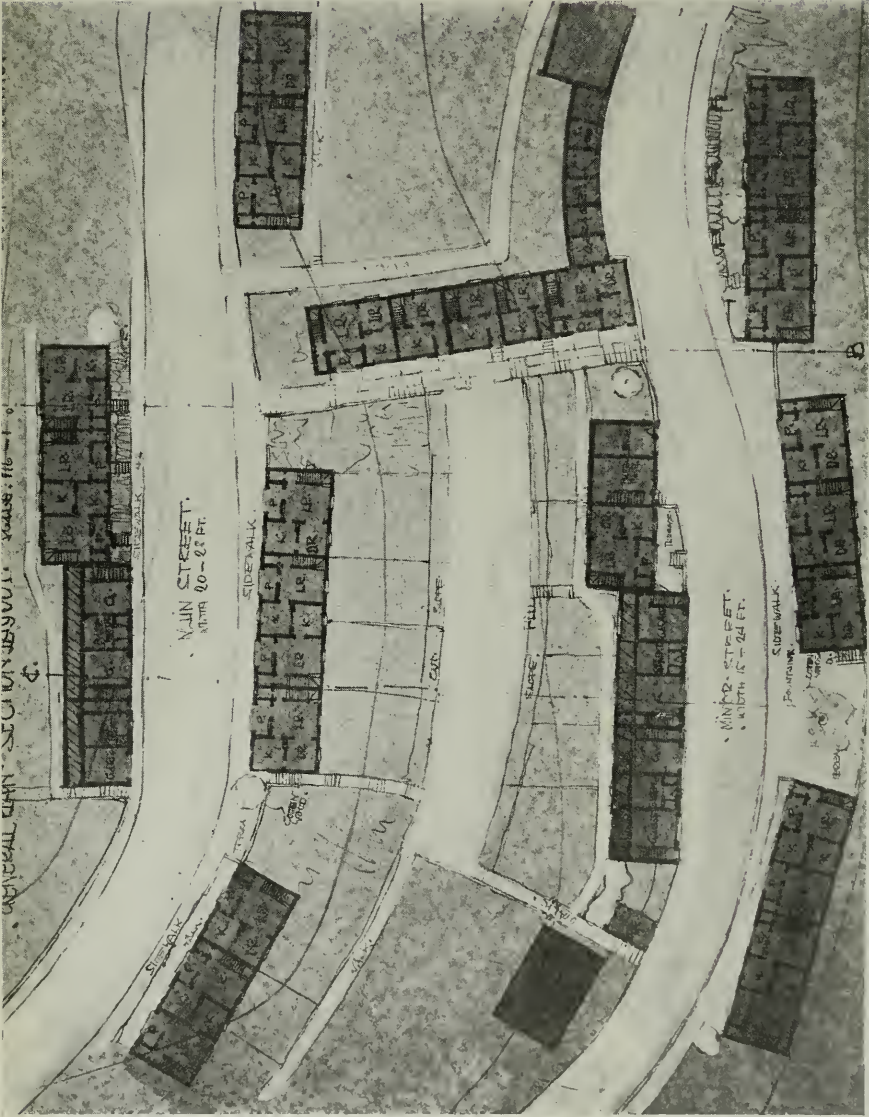

PLAN OF DETAILED DEVELOPMENT WEST OF PUBLIC PLAZA, MINING TOWN NEAR JEROME, ARIZONA
HERDING & BOYD ARCHITECTS



CROSS SECTION THROUGH WEST ENDS OF AMERICAN AND MEXICAN TOWNS, SHOWING SCHOOLHOUSE AND CHURCH, MINING TOWN NEAR JEROME, ARIZONA
HERDING & BOYD, ARCHITECTS



CROSS SECTION AT PUBLIC PLAZA OF MAIN TOWN, MINING TOWN NEAR JEROME ARIZONA
HERDING & BOYD, ARCHITECTS (See page 67)

serious labor shortage, which will result in acute competition for the available labor supply, either in the form of higher wages or the providing of better living conditions, or a combination of both.

It is with these ideas in view that we have designed the industrial town illustrated in this report to be constructed in connection with your new mining operation.

THE TOWN PLAN

This town has been laid out for an ultimate population of approximately 500 families, together with public buildings to serve the spiritual, material, and recreational need of such a community.



VIEW WEST ON LOWER STREET OF DETAILED DEVELOPMENT WEST OF PUBLIC PLAZA, MINING TOWN NEAR JEROME, ARIZONA
Herding & Boyd, Architects (See pages 54 and 55)

It is now proposed to construct something over one hundred houses and two dormitories to meet your immediate requirements, these houses being divided between the Mexican and the American section of the development.

The general layout of streets, public places, sewer and water systems, together with roadways leading to Jerome and Clarkdale have been made with the ultimate requirements in mind in order that no expense incurred at this time will result in increased financial expenditure through lack of foresight in the original town plan.



GROUP OF HOUSES ON THE JEROME ROAD, SOUTHWEST CORNER OF TOWN, MINING TOWN NEAR JEROME, ARIZONA
Herding & Boyd, Architects

The structure of the town and street layout has been formulated by closely following the existing contour and general conditions of the site and developing a type of house designed to meet the actual conditions of this particular town site.

The accompanying illustrations give a birdseye view of the town development showing the natural segregation between the Mexican and American sections of the town with the school houses and playgrounds as a natural connecting link.

At the western end of the town site a location has been found for an adequate ball field by utilizing the interior of the railroad loop giving sufficient

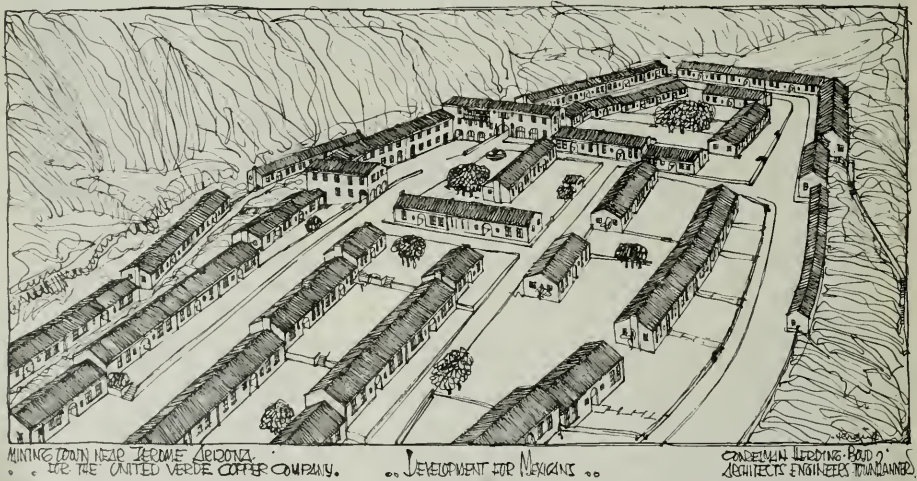

BIRDSEYE VIEW OF MEXICAN VILLAGE, LOOKING EAST, MINING TOWN NEAR JEROME, ARIZONA
Herding & Boyd, Architects

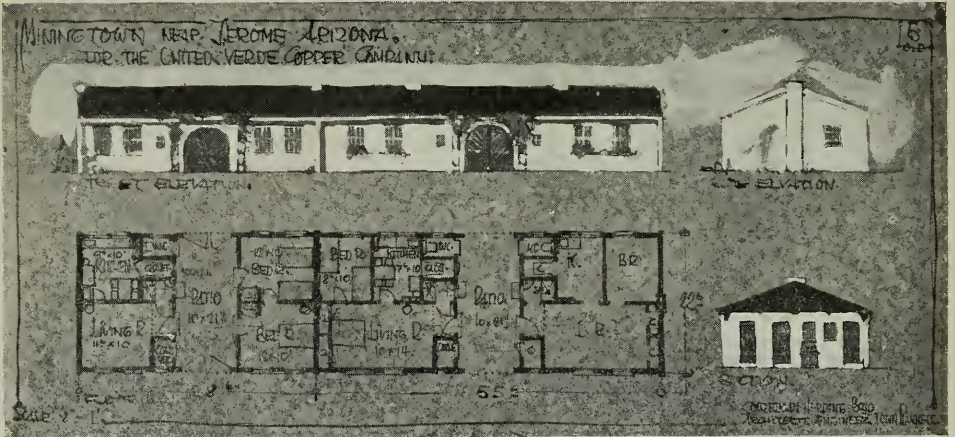

PATRIOTYPE OF MEXICAN HOUSES, MINING TOWN NEAR JEROME, ARIZONA
Herding & Boyd, Architects

space for a baseball field and an opportunity to erect a grandstand on the railroad embankment at a minimum expense. There will be a comparatively small amount of grading and filling in connection with this work which is amply justified, as there is no other location for a ball field within six or seven miles of either this town site or of Jerome.

ENGINEERING FEATURES

Attention is called to the cross sections of the town site which graphically shows the use to which this very rough land has been put and the exceedingly small amount of cut or fill that is required to carry out these plans.

The light dotted line shown in these cross sections represents the existing grade which has been utilized for cellar space on the upper side of the roadway, any excavated material being used as fill on the lower side of the roadway so as to meet steam shovel operation.

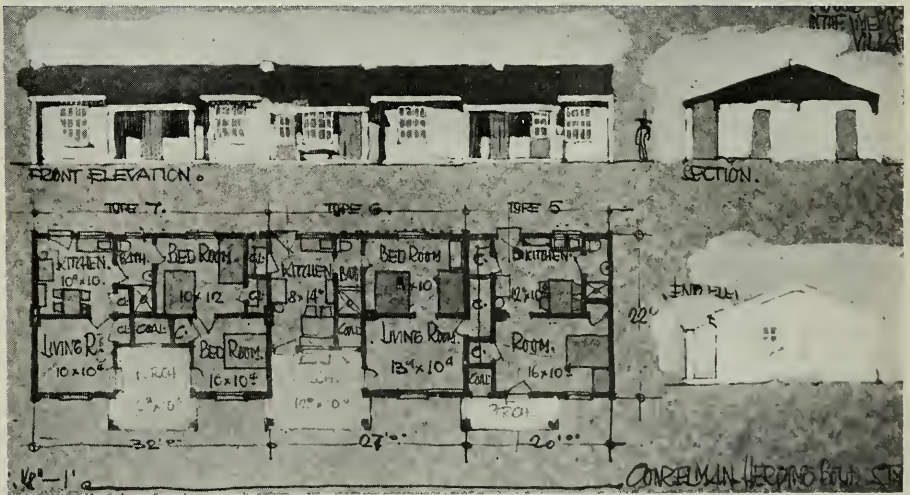

REVISED MEXICAN HOUSES, MINING TOWN NEAR JEROME, ARIZONA
Herding & Boyd, Architects

The only fill of consequence is in the proposed school area and is to be utilized to develop a playground and athletic field connecting the Mexican and American sections to the town.

Special care has been given to drainage, which is an item of considerable importance due to the comparatively large area and the rocky character of the ground. The natural gullies are preserved, and wherever possible have been improved and in some cases advantageously used to irrigate groups of cottonwood trees, which should be set out in this development.

Wherever the need of pathways will justify the expense, these have been laid out in the form of concrete stairways.

The street layout illustrated in both cross sections and plan has been designed to control through traffic which is regulated by the general arrangement

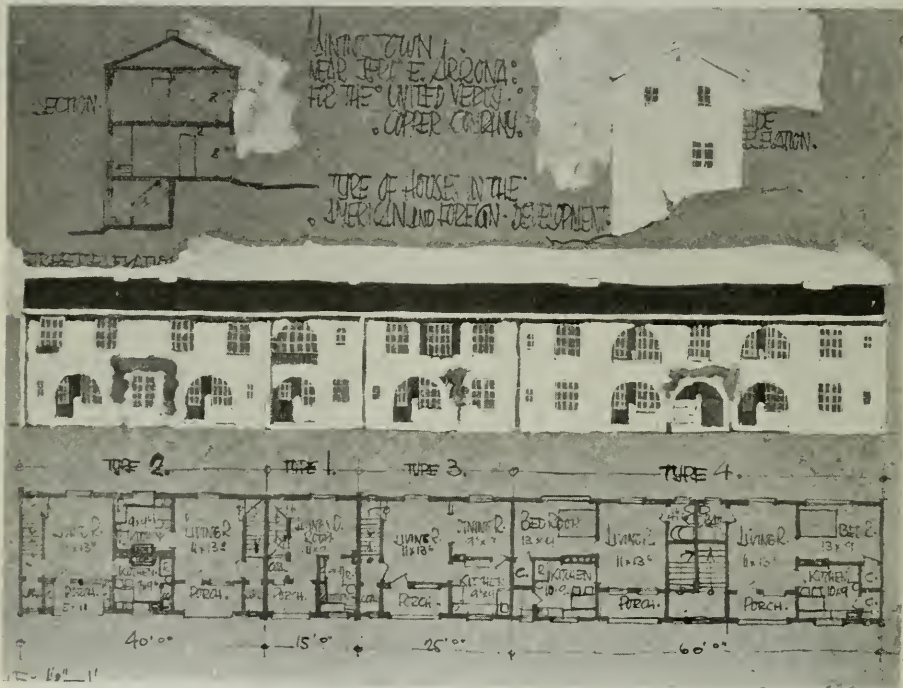

TYPICAL AMERICAN HOUSES, FIRST FLOOR PLAN AND STREET ELEVATION,
MINING TOWN NEAR JEROME, ARIZONA

Herding & Boyd, Architects

of the houses and town plan. The minor streets have been designed for the purpose of community passage ways rather than as highways, and will be low in cost and maintenance.

The streets have been increased over the minimum width on the low grade through streets, especially on turns and intersections where the need of garages and parking space has been provided. The grouping of the houses along the streets is done with the idea of obtaining interesting and picturesque street views without violating the principles of practicability which in a development of this character necessitates the simplest and most direct architectural work in order that construction cost may be held to the minimum. These results can only be obtained through a basic town design which contemplates the actual architectural treatment to be adopted in the construction operation.

Wherever possible, with little expense, there are children's playgrounds arranged in the rear of the houses, with direct and easy access. Garages are provided for in the plan at suitable locations. This is an increasing factor in town-planning, and individual garages can be worked in easily and in harmony with these houses.

Coal, wood, and ice are handled directly from the street without entering the house, while provision has been made in a similar way for garbage disposal.

THE MEXICAN VILLAGE

Our preliminary house designs for the Mexican Village consisted of typical patio houses with modern improvements, but this design upon being submitted to our Engineering Department proved to be more expensive than the limit of

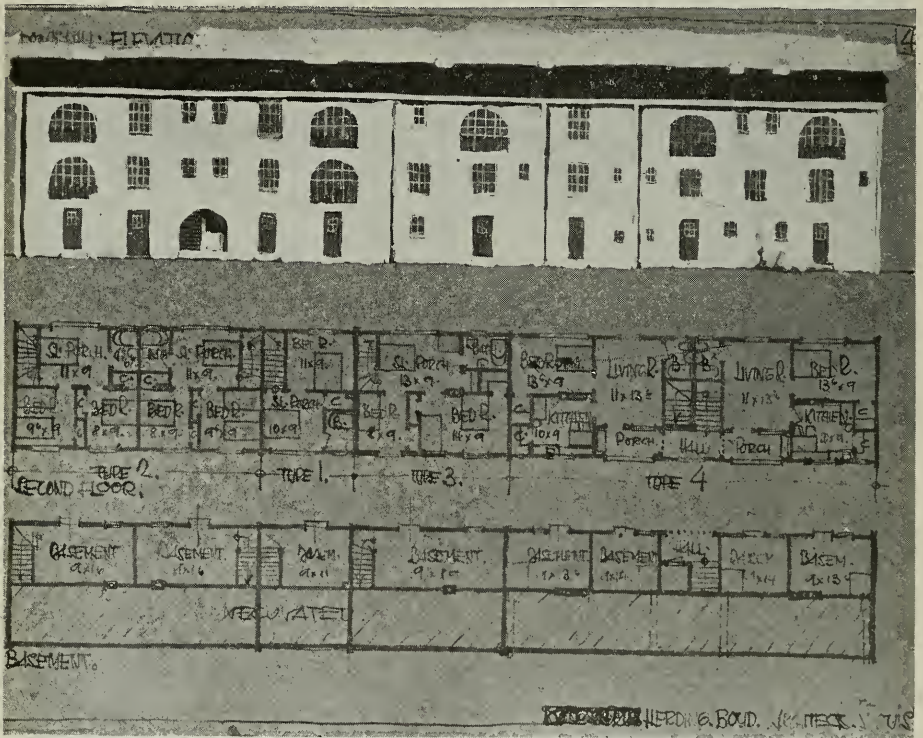

TYPICAL AMERICAN HOUSES, BASEMENT AND SECOND FLOOR PLANS AND REAR ELEVATION, MINING TOWN NEAR JEROME, ARIZONA

Herding & Boyd, Architects

cost which had been set for this type of house. These designs are therefore shown in the accompanying illustration merely as a matter of interest. The revised type of Mexican house is somewhat smaller but contains the same modern features and can be constructed with considerable less cost than the patio type.

The Mexican section has been provided with streets and walks, a large village square with shops, dormitories, and reservation for a clubhouse or a community house. It is considered important to provide some features which will stimulate the social life of this section of the village, and we have given special consideration to these features.

TYPICAL HOUSE DESIGNS

The designs adopted for this community have been made with the idea of providing a practical, attractive, and healthy home of fireproof construction, built of permanent materials. We have been influenced in the designs adopted, by the topography of the land, the climate, customs of the people to be housed, and the community life and spirit which must be developed in an isolated community in order to provide for anything beyond mere existence; and also by the need of suiting a standardized concrete construction. (Precast concrete slabs, Unit Method.)

The houses are generally of a long and narrow type, as the steep ground slopes offer a practical limitation of approximately 20 feet in the width of a house in order to reduce expense in further excavation or filling work. They are two stories high, the first floor containing the living rooms, the second floor

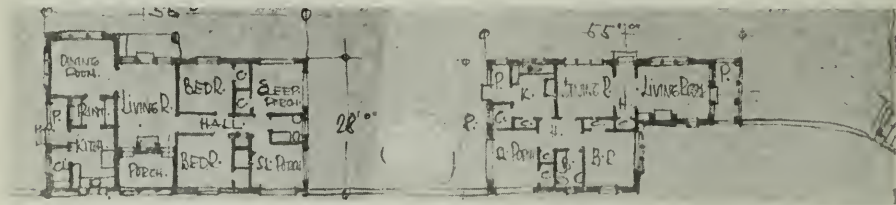

DETACHED HOUSES IN AMERICAN TOWN, MINING TOWN NEAR JEROME, ARIZONA
Herding & Boyd, Architects

the bedrooms, sleeping porch and bath. A basement is provided, running the full width of the house and approximately one-half of the depth on the downhill side, as this area provides a natural basement, in most cases without excavation. The houses range from three, four, five to six rooms, all being provided with bath, a front porch, and many of the houses have been designed with sleeping porches.

The houses in the officials' section are to be of individual design in accordance with the particular location and type of house required. These are 30 in number, all detached, of bungalow type. They are grouped around a hilltop at the east end of the town. The center is leveled and developed into a playground with easy access from the town. They all are located to offer an unobstructed view into valleys below.

REVISED HOUSE DESIGNS

We present the original designs submitted for your town, together with a re-design of the houses which contemplates the use of the basements on the downhill portion of the houses which have been re-arranged into two room and bath apartments.

This re-arrangement has been thought necessary by your operating department in order to bring the capital outlay to a point where your income from rentals would care for both capital outlay and operating expenses.

The revised designs have been submitted to your operating department and have been approved by them as to cost and facilities.

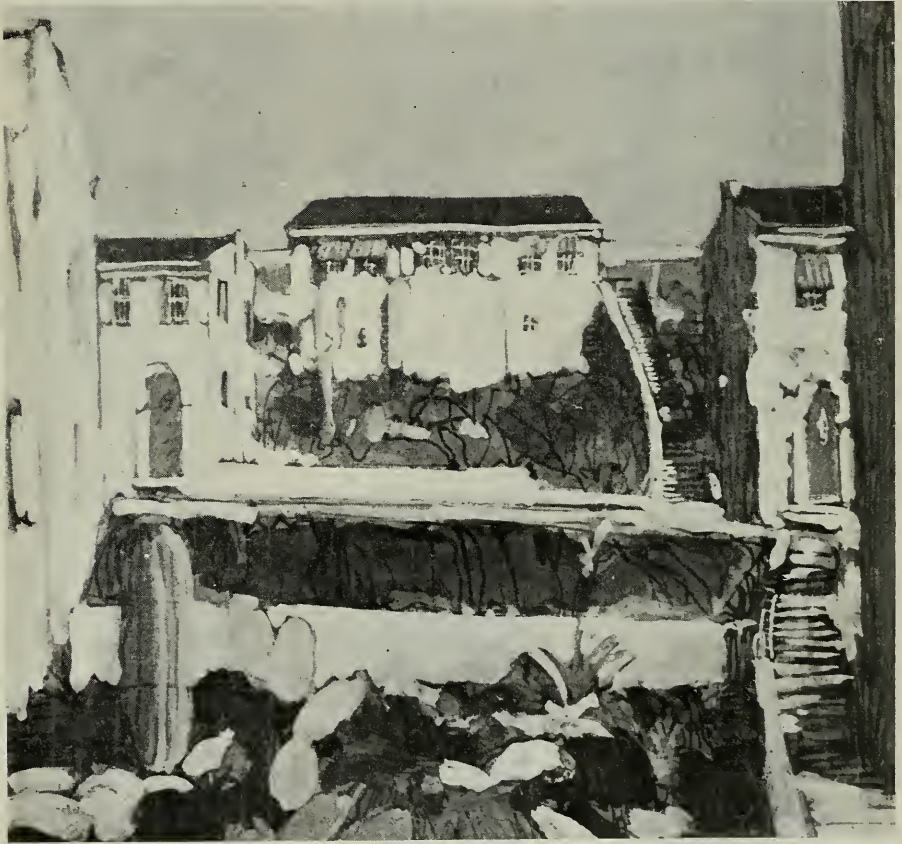

HOUSES IN THE AMERICAN SECTION, MINING TOWN NEAR JEROME, ARIZONA
Herding & Boyd, Architects

We regret the necessity of changing these houses from a one family dwelling into an apartment house, as this arrangement will not provide your employees with the best type of housing suitable for their requirements. We firmly believe that it would be to your advantage to adhere to the original type of house design, and to meet general costs such as policing, refuse collection, street maintenance, and other matters indirectly related to housing as an item of general overhead expense, rather than to attempt to collect it through increased rentals or by cutting down the facilities that are offered to your employees. From the standpoint of money involved, this is a comparatively small outlay,

MINING TOWN NEAR JEROME ARIZ
 FOR THE UNITED VERDY
 COPPER COMP.
 HOUSE 4. REVISED
 FOR 6 FAMILIES.

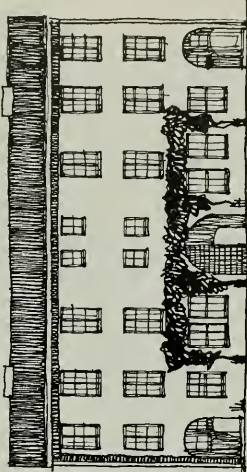

DOWN-HILL ELEVATION

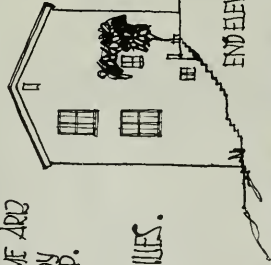

END ELEV.

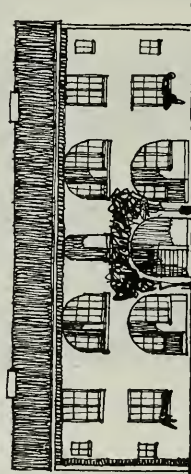

STREET ELEVATION

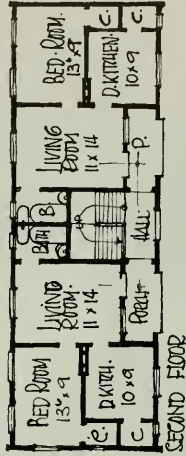

SECOND FLOOR

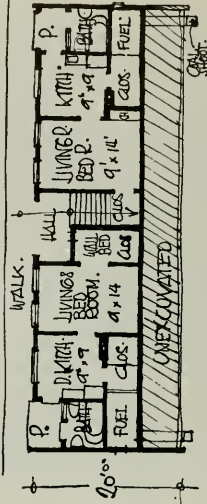

FIRST FLOOR

SCALE 1/4" = 100'

HERDING AND BOYD, ARCHITECTS OF TULSA, OKLA.

REVISED AMERICAN HOUSES, MINING TOWN NEAR
 JEROME, ARIZONA HERDING & BOYD, ARCHITECTS

MINING TOWN
NEAR JEROME, ARIZONA.
FOR THE
UNITED VEEDER-CORP. CO.
TYPE 10.
6 FAMILY HOUSE.

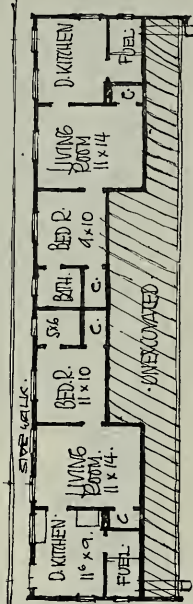
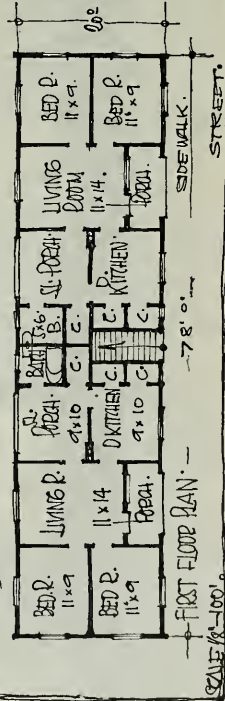
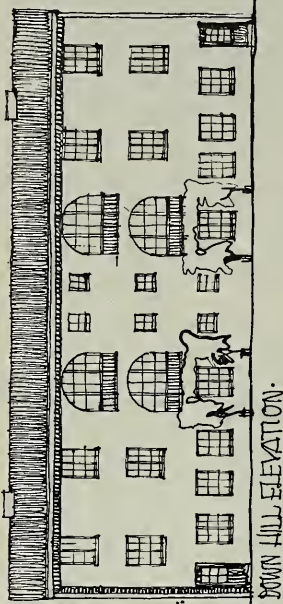
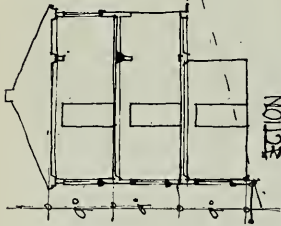

HERDING & BOYD, ARCHITECTS AND ENGINEERS

REVISED AMERICAN HOUSES, MINING TOWN NEAR JEROME, ARIZONA HERDING & BOYD, ARCHITECTS

MINING TOWN NEAR JEROME ARIZONA FOR THE UNITED VERDY COPPER COMPANY.

REVISED MEXICAN HOUSES.



DOWN HILL ELEVATION

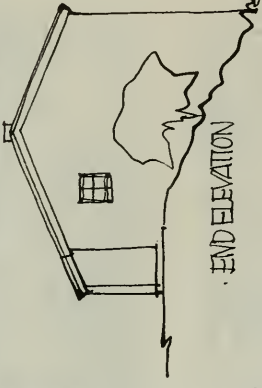

END ELEVATION

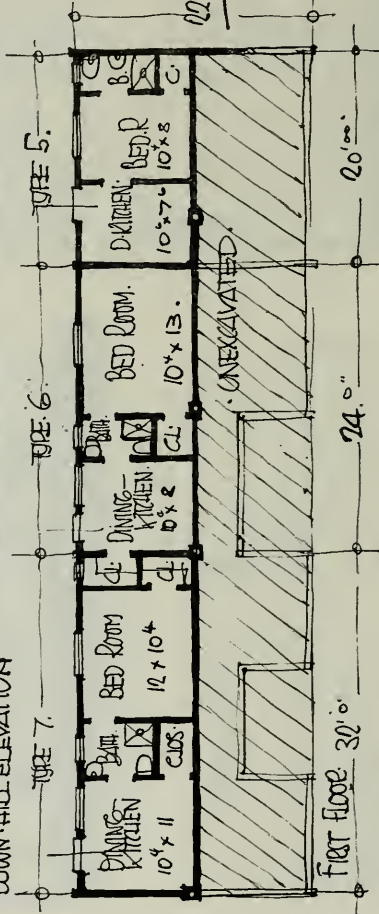

First floor 30' 0"

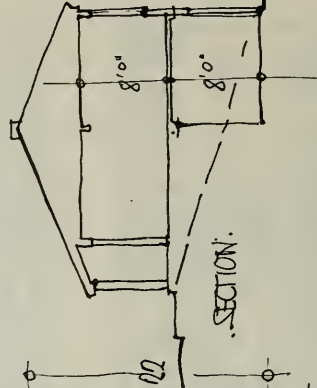

SECTION

HERDING AND BOYD ARCHITECTS AND TOWN PLANNERS.

REVISED MEXICAN HOUSES, MINING TOWN NEAR JEROME, ARIZONA HERDING & BOYD, ARCHITECTS

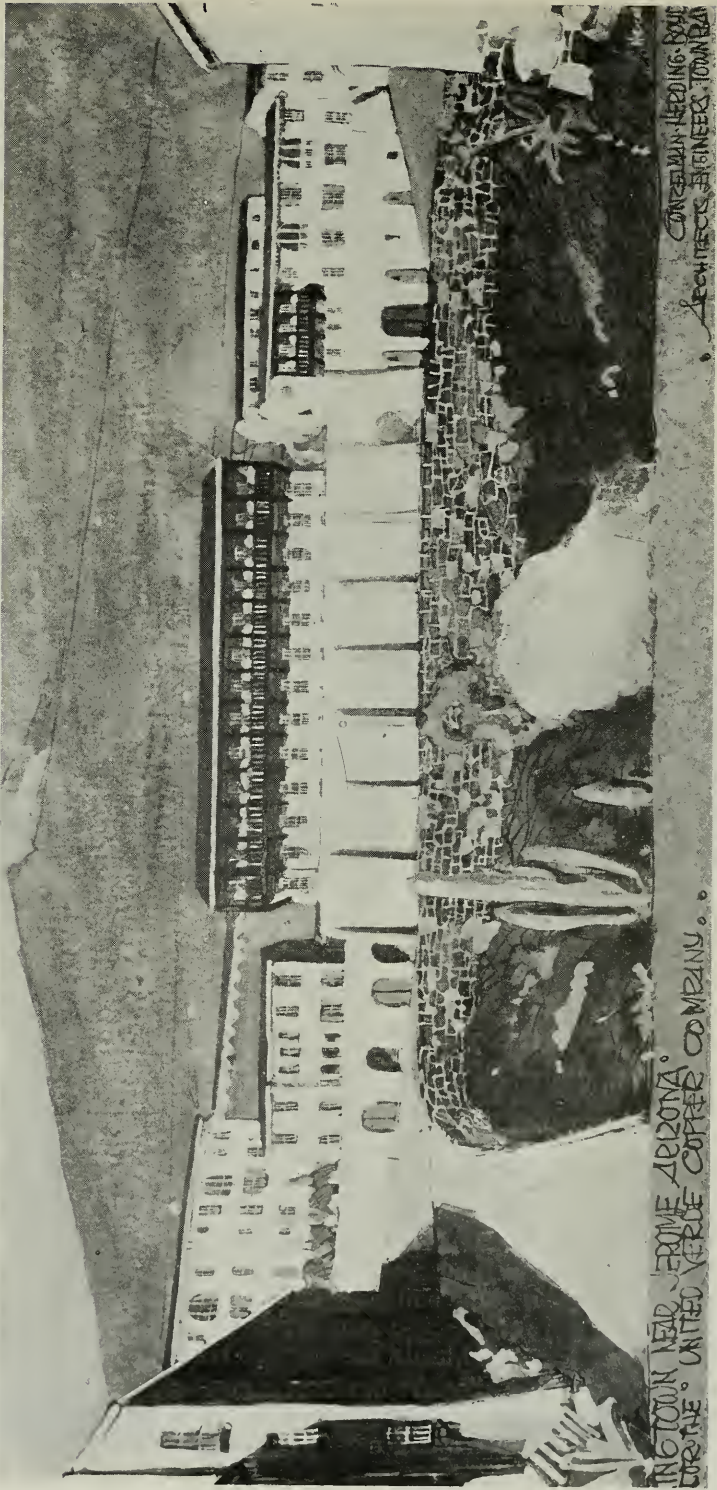

PUBLIC PLAZA IN AMERICAN SECTION, MINING TOWN NEAR JEROME, ARIZONA — HERDING & BOYD, ARCHITECTS (See page 56, lower illustration)

but when these items are assessed against a small section of a town it can only be done at a sacrifice to the value of the community.

COMMUNITY FEATURES

Public Square in the main town has been established at the head of an intersecting ravine, as this point is centrally located and naturally results from three intersecting roadways. On the upper side of the plaza, a clubhouse or dormitory structure has been provided for and provision has also been made for a few stores, although most of the purchasing of this community will be done through the shopping district of Jerome.

It is proposed to develop this ravine and the slopes into a rock garden with a stone wall to form the Public Square Terrace.

The landscaping through the town is confined to the use of local plants which require little or no care. The local plant life offers wonderful possibilities for decorative effects in mass planting and graduation of color.



PUBLIC SQUARE IN MEXICAN VILLAGE, MINING TOWN NEAR JEROME, ARIZONA
Herding & Boyd, Architects

This illustration* shows one of several special types of houses that have been introduced at certain points to increase the picturesque viewpoint. Our present proposal does not contemplate the construction of any of these special features, it being our idea to undertake the fundamental requirements in the first operation and to consider several of these special features at such time as the development of the town will warrant this expenditure.

We have reserved an exceptionally well located site for church purposes, within easy access to both the Mexican and American sections of the town, upon a site which is not well adapted for housing. With moderate terracing, grading, and grouping of church buildings, school house, a gymnasium, and ball field, these features will form a civic center, and the reservation of these sites at this time will enable their ultimate use upon an economic basis.

The Spanish type of architecture has been carried out in all of these structures, and emphasis is placed upon the necessity of providing attractive church facilities, especially for your large element of Mexican labor.

*Reproduced on cover.

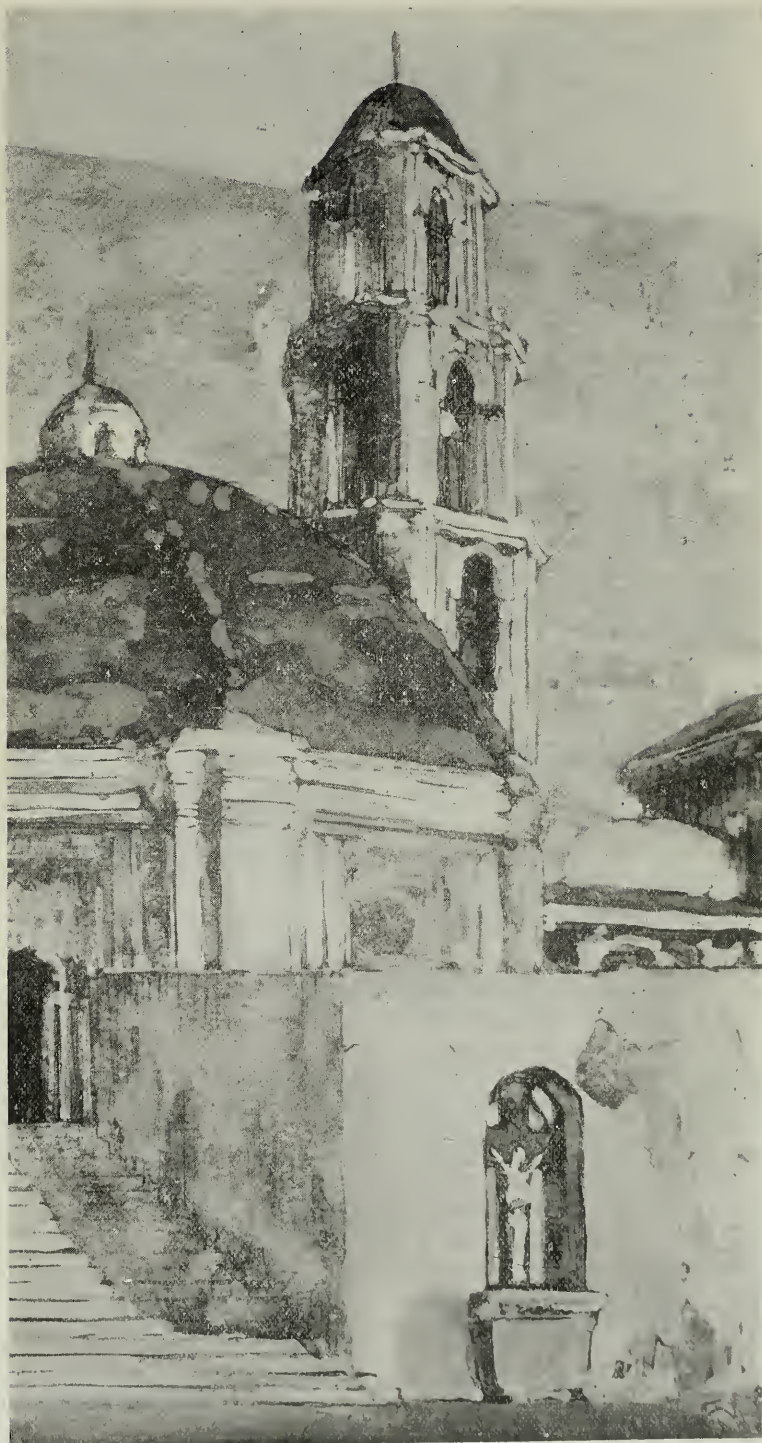

CHURCH, MINING TOWN NEAR JEROME, ARIZONA
HERDING & BOYD, ARCHITECTS

II. — Suggestion for a Typical Miner's House

WHAT MAKES A HOME?

The ideal home is the practical, healthy, attractive, one-family-house. It is practical, if the general arrangements are useful and time-saving; if the rooms are of the proper size and have sufficient wall space to properly place furniture; if closets, pantries, shelves and other features are arranged for, and if fuel, ice, and garbage can be handled conveniently and sanitarily. Also if some kind of a room or space is provided where the many-sided rough handwork connected with a household can be done, and if there is near the house a fenced-in private yard.

These practical arrangements together with good construction make the healthy house. It should be built of fire-resisting material to insure not only safety, but a bug and worm-proof house, as well as one that is cool in summer and warm in winter. There should be no place hidden from direct light and air.

The plumbing of the house must be completely installed. The boiler connected with the sink, wash basin, bath, and the washtub, or these installations will never be used properly.

The practical house will always be attractive if designed in good proportion, in harmony with its surroundings, and is finished in pleasing colors.

It is not necessary that the house be detached, but it has to be a one-family-house, giving privacy from ground to roof, including the yard or garden.

All these needs should not be omitted on account of the costs. The saving should be done in another way. The house will cost 400 to 500 dollars less if built in groups. This will also considerably reduce the costs of the developing work. It means less roadways, sidewalks, sewers, etc., and as in our case, less retaining walls and grading. The land can be used with more economy and the town also be made more attractive.

A HOUSE FOR A MINER'S FAMILY

To illustrate the points mentioned, I have worked out a type of a house on those conditions, and at the same time made it to suit Jerome climate and our town site. This design differs from our original house design, type No. 3, about only in these utilities which I have worked in and which I consider indispensable in the modern and permanent dwelling.

There is no doubt that a home of this design will set a standard in mining communities. The first costs may run somewhat higher than the everyday type, but the return will be better labor. It will make happy, healthy, contented families in an attractive, permanent town which will need little upkeep and will require practically no repairs.

I am showing here only one house type. In a town of a size and population as in our case, various types are needed, some smaller, some larger and having different numbers of rooms, etc. It is only a matter of study to do that and combining the same utilities with the prevailing conditions.

This house is 26x18 ft., the long side being the street side, the short one the end or division wall. It is set directly to the 4-6 foot sidewalk. The street along is for service as well as for traffic. On one end of the house is a coal and wood chute to the basement; on the other, just outside of the kitchen door, the underground garbage receiver.

On the first floor are a well-sized porch, kitchen, and the living room. The kitchen is of sufficient size and so arranged that it can be used as a dining kitchen. The ice box is near the outside door to afford easy access for ice delivery. The sink has good light, the pantry is directly ventilated. The range and boiler are near the chimney with a hood above. A shelf is sug-

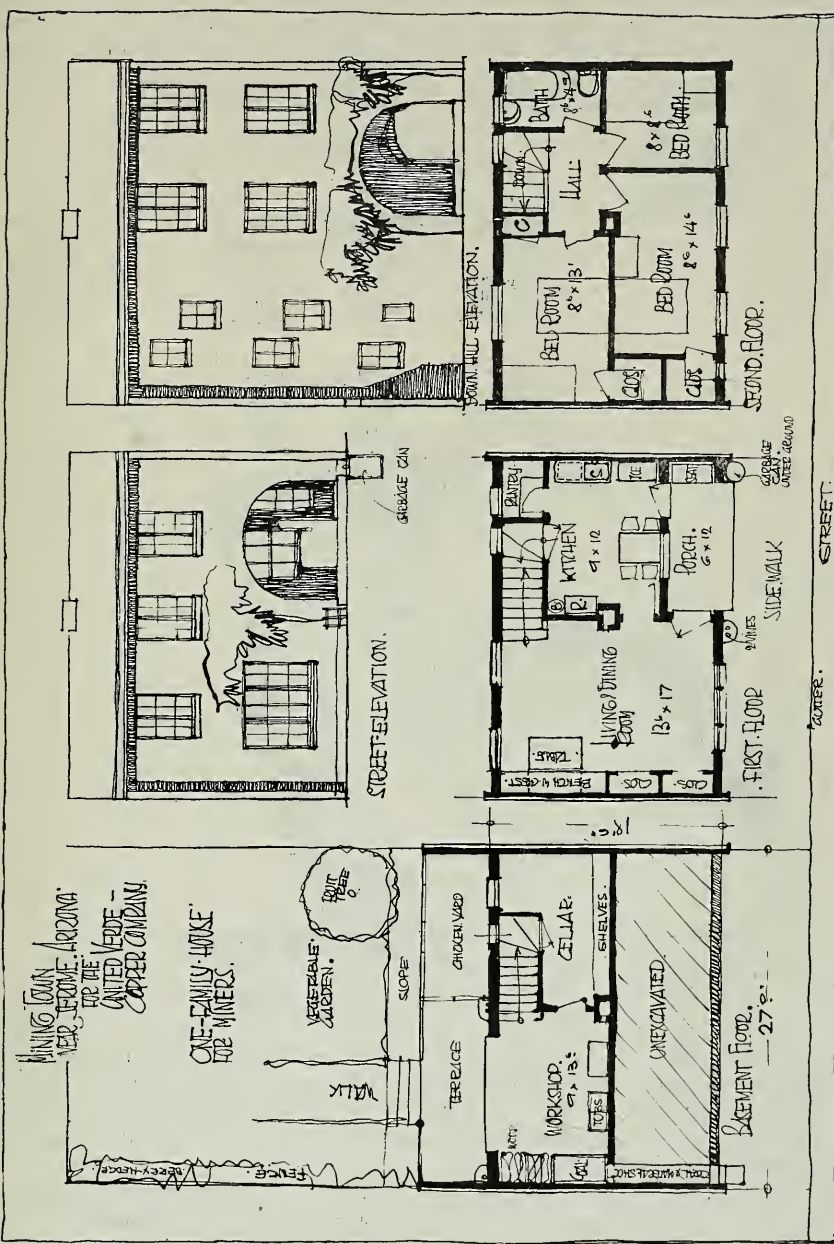

MINING TOWN
NEAR JEROME, ARIZONA.
FOR THE
UNITED LEAD-
COPPER COMPANY!

ONE-FAMILY HOUSE
FOR MINERS.

HERDING AND BOYD, ARCHITECTS AND ENGINEERS.

MODEL MINER'S HOUSE, DEVELOPED IN CONNECTION WITH THE PLAN FOR TOWN NEAR JEROME, ARIZONA

HERDING AND BOYD, ARCHITECTS

gested to run along the wall over sink and ice box. The living room, as the main room of the house, is large and well lighted and aired. It has two closets; also a bench with a chest underneath and a shelf on door height.

On the second floor are bedrooms and the bathroom. This floor area is usually turned into two rooms and ba'h, but as this is insufficient for the average family with boys and girls, it is certainly better to make three smaller bedrooms than two larger ones. All that is needed is a small, practical room giving space for the absolutely necessary furniture, for conveniently moving

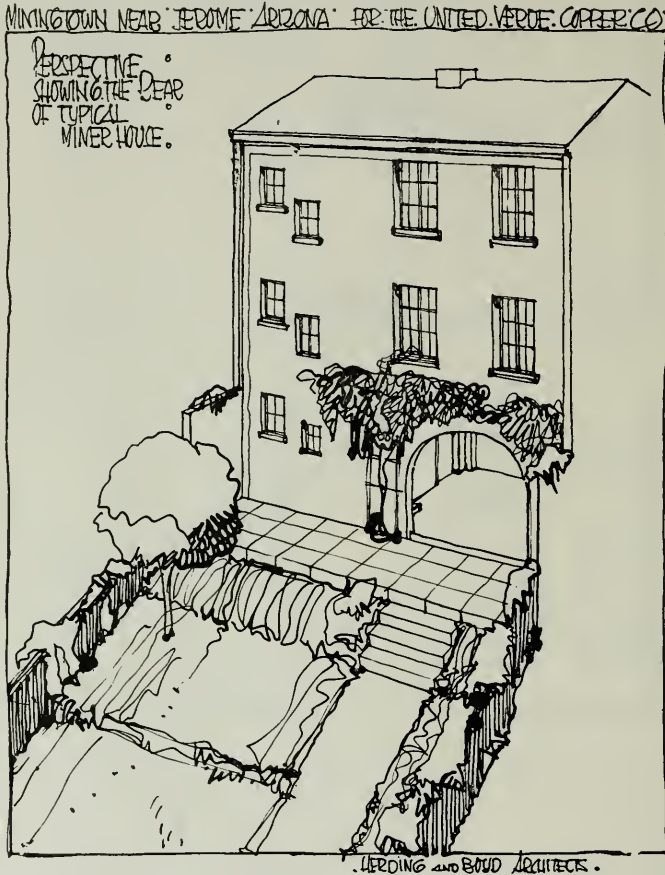

MODEL MINER'S HOUSE, DEVELOPED IN CONNECTION WITH
THE PLAN FOR TOWN NEAR JEROME, ARIZONA
Herding & Boyd, Architects

around and for closets. This will also prevent overcrowding and will make these rooms exclusively sleeping quarters. Sleeping porches are not a need in the permanent, low-cost house in Jerome climate. A narrow house with the arrangements for good ventilation, good sized windows and transoms over door will insure agreeable bedrooms.

The basement floor on the downhill side provides a cellar and a workshop. Here is a laundry tub, a coal bin, wood storage, space for a workbench, etc. It is the idea to induce the miner to occupy his leisure hours here in a useful way, to his liking. A terrace is just behind and is made private by having the end walls of the house protrude. A chicken yard can be worked in here easily, or a stable for some small domestic animals.

The families are given a chance to work a garden in the allotted fenced-in space directly behind the house and terrace. We have many proofs, over the Jerome hills, that it is possible to grow fruit and vegetables.

Very correctly, the tenants are judged by the upkeep of their surroundings. The good ones are greatly in minority, and the only reason for this is that the larger part of our laboring classes are without vision. They cannot see the possibilities and cannot grasp the proper means of improving their homes and surroundings. Some try, forced by need, but usually or always do so by impairing the general scheme. Therefore, we must finish the houses and the towns and leave for the tenant only such things to do as he cannot help making right. For instance, if one wants to make a garden porch, he can do it with a few wires between the protruding walls and some vines, and has, with those simplest means, a pleasant feature. An opening to the space under the boxed-in basement stairs would suggest using this as a chicken house, and by simply screening the terrace corner, a chicken run can be made. There are still many other little things for the tenant to do where he can express individuality but cannot injure the general effect, precaution against this having been taken in the design.

III. — Town Plan for Clarkdale, Arizona

THE PROBLEM :

The problem to be solved in creating a town plan for Clarkdale is twofold. We have first to connect the existing upper and lower towns to form a unified whole, and second, to direct the growth of this town structure according to an orderly and preconceived plan.

At present the two existing sections of the town are divided from one another by a barren stretch of hillside, the only connection between the two being Main Street. The upper town consists of a distinctly better class of dwellings than the earlier settlement. The business district of the community is in the upper town. Except for one boarding house, the lower town is devoted entirely to private residences, containing no provisions for general community needs.

The streets of the two present unrelated settlements are laid out at right angles in checkerboard pattern. In the lower town particularly the effect of the streets and houses is monotonous. The houses themselves, while they do not express poverty or cheapness of construction, do indicate complete lack of taste in design, and absence of imagination. The streets are disproportionately wide in their relation to the size and heights of the cottages bordering them, and cross streets are run north and south until cut short by the rapidly changing contours of the ground. This arrangement of the streets gives an effect of abruptness and rawness which further detracts from the appearance of the present development. The ends of the north and south streets are in all cases unfinished and unsightly. Main Street between Broadway and Ninth is cut into the hillside so deeply as to leave on the south an unfinished steep cutting and on the north a sharp embankment ending in an unsightly gully. It is unfortunate that the store buildings lining Main Street between Ninth and Tenth have been built on such narrow frontage and with such unnecessary depth. Besides giving these structures an unsightly appearance, this congestion cuts off needed light and air. With the price of land in the community a factor of minor importance it has been a great mistake to crowd these business structures as though in a high priced limited city district. (See plan and note, page 82.)

We would take occasion to note the recent development of a dozen houses at the south end of Sunset Boulevard. The design and grouping of these houses form a welcome relief from the prevailing monotony of the present settlement. However, even these houses can have but little logical relationship



PRESENT PLAN OF CLARKDALE, ARIZONA

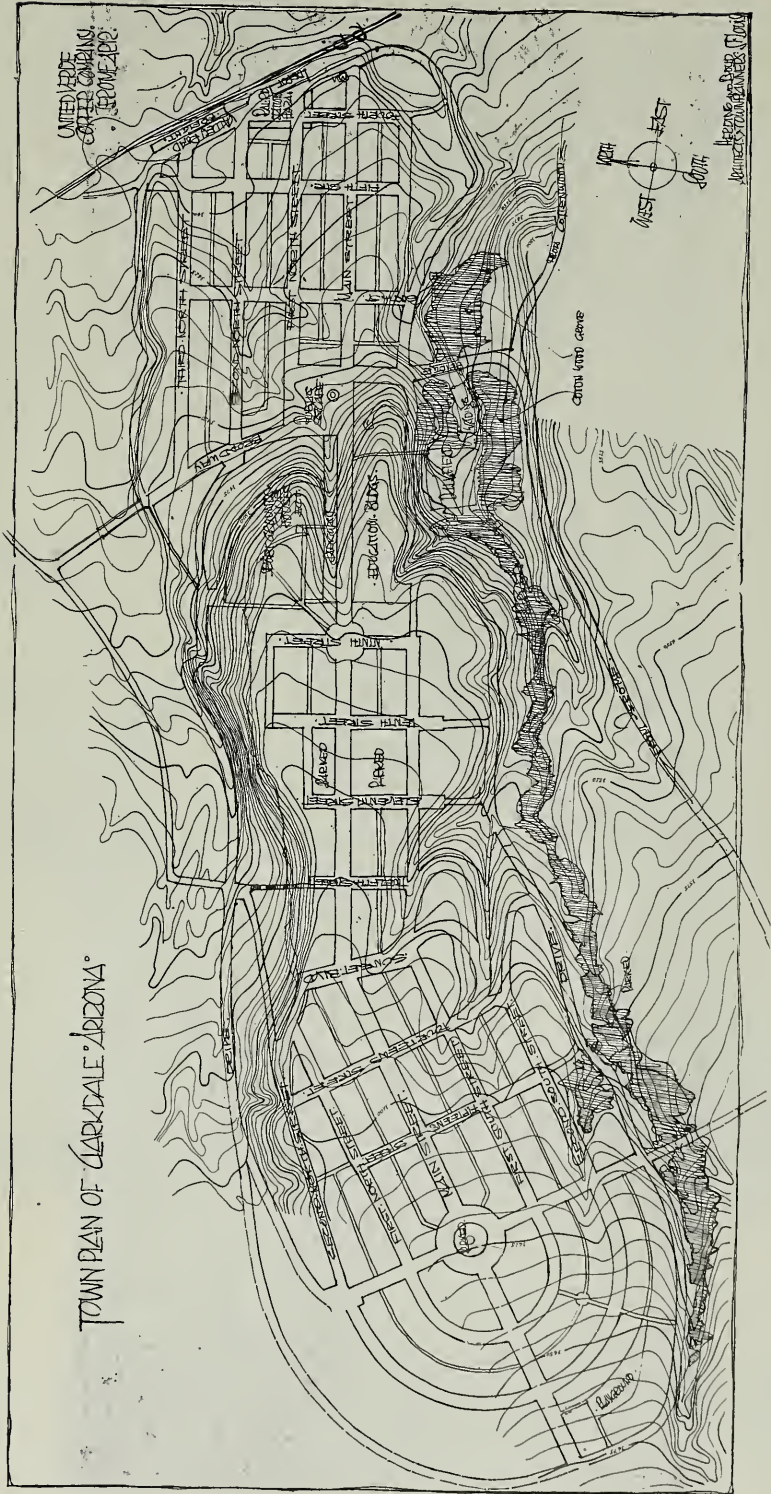

TOWN PLAN OF CLARKDALE, ARIZONA

REDEVELOPED PLAN OF CLARKDALE, ARIZONA
HERDING & BOYD
ARCHITECTS

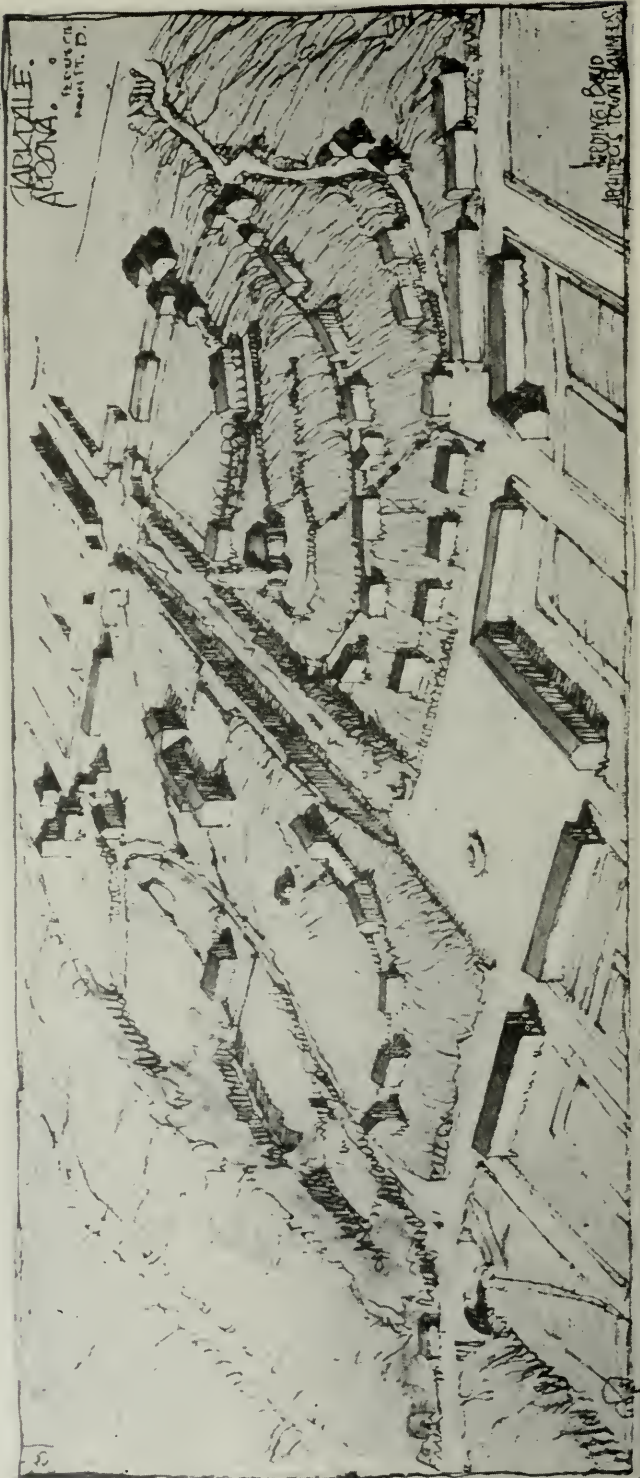

BIRDS-EYE VIEW LOOKING WEST FROM PUBLIC SQUARE, CLARKDALE, ARIZONA. HERDING & BOYD, ARCHITECTS

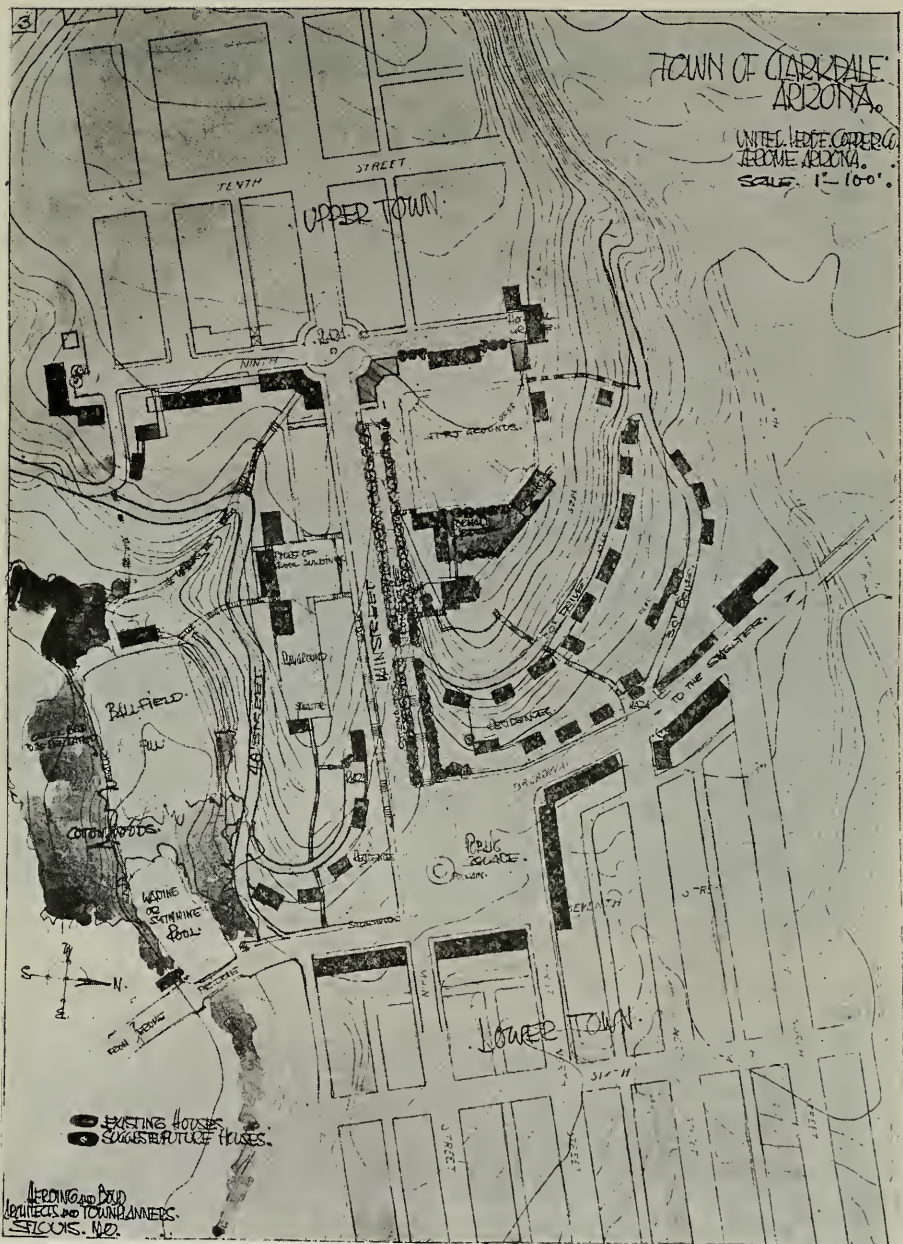

DETAILED PLAN OF CENTER OF TOWN, CLARKDALE ARIZONA
HERDING & BOYD, ARCHITECTS

to any comprehensive plan for the development of the community, and while good in themselves serve rather to bar the way for a unified extension project.

A very attractive structure is the new Improvement building and Post Office on the northeast corner of Main and Ninth Streets. This, like the development at the end of Sunset Boulevard, is individually good from the architectural point of view, and has the further advantage of suggesting an excellent solution for the treatment of this corner in the town plan. Unfortunately, however, this building is balanced on the opposite corner of this street intersection by the uncompromising squareness and bareness of the Miller store building. To complete the proper treatment of this street intersection the Miller store should be cut back to a radius at the street corner corresponding but opposite to the arcade treatment of the Improvement building. The two remaining corners at this intersection should be developed similarly. Not only the building line but also the curb line should be brought back to complete the circle indicated. This treatment will produce a harmonious and attractive town feature which will break the monotony of Main Street very effectively. If this treatment is not followed out, however, the new Improvement building will

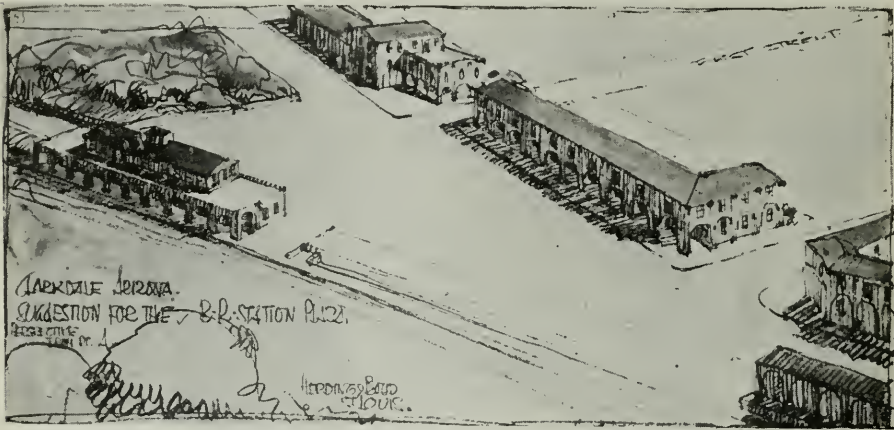

RAILROAD STATION AND PLAZA, LOOKING WEST, CLARKDALE, ARIZONA
Herding & Boyd, Architects

always look a stranger and its really meritorious architectural effect will be wasted.

Clarkdale being a Company town, the size of which may be expected to be limited to a population of some 5,000, its growth is entirely within the control of the United Verde Copper Company. This offers an excellent opportunity to the town-planner to work out a coherent unified community project, having due regard to harmony and beauty as well as the proper distribution of the essential utilities. Such treatment is most important, owing to the location of the town at the future junction of the Jerome and Santa Fe railroads, a situation which will bring into it a considerable floating population consisting of visitors as well as employees of the Company who must enter the Jerome mining fields through its gates. Advantage should be taken of the opportunity offered here for making this entrance as imposing and as attractive as possible.

The solution of the problem is to a certain extent governed by the fact that water supply, sewage and other utilities are established, and we have, therefore, only to consider the development of a community from the standpoints of unity, coherence and the esthetic values. This must be done by providing proper traffic channels by rearranging present streets and adding new ones, and

by the introduction of plazas to direct and divert the traffic. In connection with this development, sites must be apportioned and structures planned to provide for the recreational, educational and spiritual needs of the community.

THE SOLUTION :

These plans have been drawn with a view of taking advantage, in so far as it is practicable, of the present development and thus making the layout economical as well as attractive. The town center lies between the upper and lower settlements, at the foot of the hillside. This is the natural geographical location. The Public Square is shown formed by Main Street, First Street, Broadway and a new bridge approach. The Square is the converging point of the inbound vehicular traffic from Jerome and Cottonwood, the smelter and the local traffic of the town. Egress from the city toward the north leads out of the Square along Broadway. The ever-increasing volume of automobile and truck traffic demands a large unbroken plaza at this point to avoid damming action as the incoming and local streams meet and cross and rearrange themselves. In its relation to the traffic stream through the town the public square might be lik-

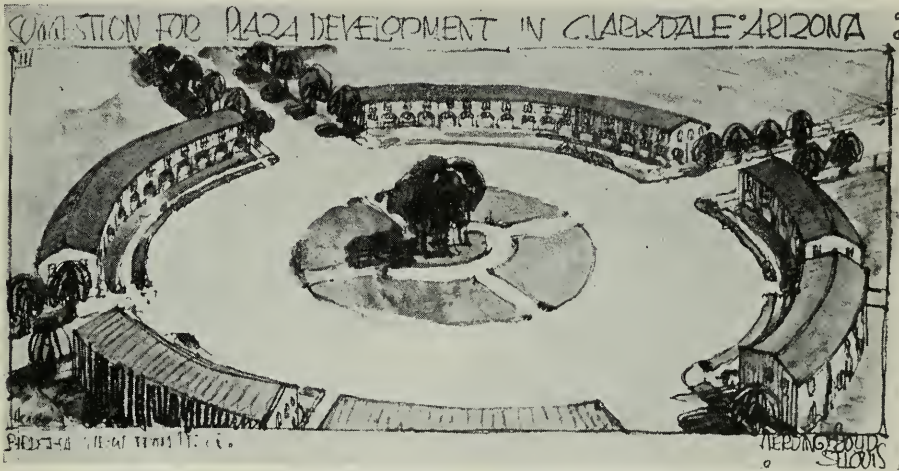

THE PLAZA IN THE WEST END, CLARKDALE, ARIZONA
Herding & Boyd, Architects

ened to a settling basin. To avoid confusion in this plaza a kiosk or gasoline station should be installed where indicated for the double purpose of regulating the traffic and serving the needs of incoming motor vehicles. In connection with this arrangement it is suggested to omit the present stretch of Seventh Street between First and Third to the north of the Square entirely. There is no need for this street and it will serve only to confuse unfamiliar incoming traffic from the southwest and east, bound for the north, all of which traffic should be carried on Broadway. The most congested trend of local traffic will be east and north of the public square toward the railroad to which ready egress is offered from the converging point of the Public Square by Main Street and First Street. Sixth and Main Streets will be the center of the future commercial development of the town.

The railroad station should be located as shown at the end of First Street at the intersection of Fourth Street and the valley road and a plaza should be laid out adjacent to the station at the axis of First Street continued.

Beginning at the station and ending at the station a circuit drive is proposed to encircle the entire town. This will serve to remove the objection of the

unfinished street ends referred to in the preceding section of this report and will also furnish a convenient connection between the various parts of the development, besides providing a pleasure drive circling the foot of the hills. To develop this driveway properly a sidewalk should be laid out on the town side of the drive and all building should be confined to this side of the walk. This walk should be at least six feet wide and the circuit drive itself should be a 24-foot roadway of concrete or macadam.

From the junction of the Jerome and Cottonwood highways south of the town, the road is to be carried across the narrow valley west of the south end of Sixth Street over a bridge. This approach is suggested to eliminate the dangerous and wasteful horseshoe curve by which this highway now enters the town following the contours of this gully. The gully west of the proposed bridge should be partially filled and utilized as a ball field and wading pool. The gully along the north side of Main Street between the Improvement building and the Public Square should be graded to form a promenade for pedestrians only. This would serve the utilitarian purpose of providing a safe foot passage,



DORMITORY FOR SOUTH END OF FIFTH STREET, CLARKDALE, ARIZONA
Herding & Boyd, Architects

free from traffic interference, west of the Public Square, and would also remove the objectionable feature of the sharp fill on the north side of Main Street at this point, referred to in the preceding section. Both borders of this parkway should be lined with cottonwood trees to form a pleasing landscape border both to relieve the unbroken stretch of Main Street and to provide shade and beauty to the parkway or promenade. The slope of the ground between the promenade and the playgrounds and clubhouse should be terraced and rectified. Attention should be paid to the provision of irrigation for the greenery along the promenade.

The detailed plan and birdseye view further illustrate the development which is proposed to link together the upper and lower town. The plateau northeast of the Ninth Street plaza should be laid out as an athletic field, the center of which should be the axis of the arcade of the Development building. At the farther end of this athletic field and also centering on the arcade axis the clubhouse should be located. Adjoining the clubhouse and sport grounds to the east the formal gardens should be laid out, and below the gardens and facing the promenade and Main Street it is suggested that a church be built. This location readily lends itself to development as the common social center of the community. On the south plateau across Main Street the present school should

be extended as the needs of the town require. East of the school site a natural location for a playground stretches toward the valley. To complete the grouping of the civic center it is also suggested that sites for additional public or semi-public buildings be reserved along Ninth Street north and south of the plaza. At the north end of Ninth Street a hospital group should be extended from the present Emergency Operating building and so grouped as to form a closure for the vista north from the plaza. This in turn should be balanced by the erection of a public hall or perhaps a moving picture theatre at the south end of Ninth Street centering on the axis of the street and facing the plaza. Another suggested location for an Auditorium is the southeast corner of the plaza where this edifice should be developed in a similar architectural spirit to the Improvement building. With whatever buildings the plaza at Ninth Street should be surrounded, it is essential that the treatment of the Improvement building be repeated. Further, as indicated above, the building line surrounding the plaza should be a continuation of the circumference of which the face of the arcade of the Improvement building forms an arc. The curb line and sidewalk should



HOSPITAL GROUP TO FACE NINTH STREET, CLARKDALE, ARIZONA
Herding & Boyd, Architects

be brought back to correspond with this line. This is essential not only for the effect of symmetry and beauty but to provide traffic room and temporary parking space at this important center.

The detailed plan further explains the treatment of the recreation area west of the new bridge approach to the public square and south of Main Street at the head of the gully. At comparatively small expense the head of the gully can be filled to form an excellent ball field. The planting of cottonwoods around the lower end of the field and about the wading pool will add greatly to the attraction and comfort of this development. The contour of the ground adapts itself readily to this proposed treatment, and relatively little grading will be necessary. The feasibility of this scheme is further increased by the fact that this gully is a natural drainage area, thus making the supply of water for the wading pool a comparatively simple matter. The recreation area is conveniently located, not only to the school building and civic center, but to the residence portion of the town. Precautions must be taken, however, to provide emergency overflow drainage for the valley to accommodate the occasional floods during the rainy season.

In the treatment of the Public Square it is suggested that the east side be built up in stores as this will prove to be the business center of the lower town. On the north, apartment blocks to accommodate the employees of the stores

and of the railroad could be built to advantage. The blocks of stores and apartments should be treated somewhat in the Mexican style with sidewalk arcades and balconies. The slope west of the square and north of the athletic field should be used for the erection of detached houses of a better class, as the surroundings and outlook are capable of a very attractive development. Driveways giving access to this area leading into Main Street and Broadway are indicated.

Any future development of Main Street and First Street between the Public Square and the railroad station should be planned to form a pleasing entrance to the town, as these stretches of street will afford the incoming stranger his first impression of Clarkdale.

The general plans with the birdseye views and perspectives embodied in this report will serve to further illustrate the proposed solution of this town site problem. The drawings and sketches should be followed closely in studying this report. The general birdseye view indicates the proposed developments of the playgrounds to the left, the promenade along Main Street in the

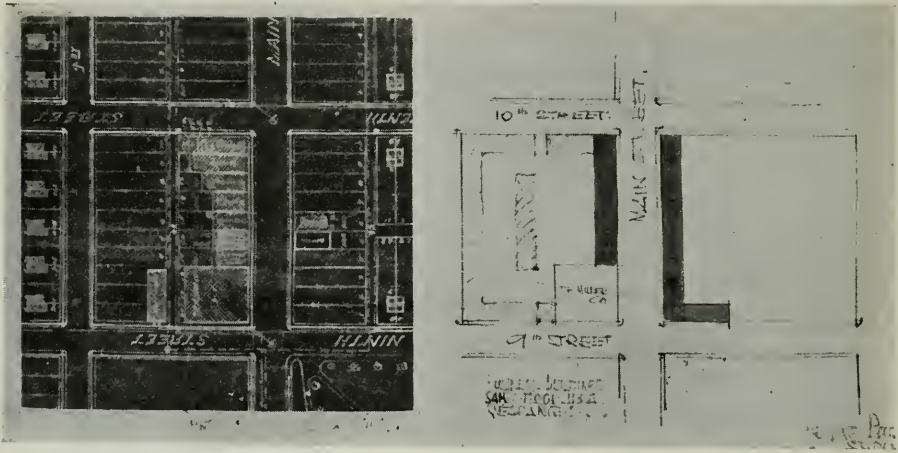

COMPARATIVE DEVELOPMENTS* OF BUSINESS ON MAIN STREET BETWEEN NINTH AND TENTH STREETS, CLARKDALE, ARIZONA
Herding & Boyd, Architects

center, and the athletic field, formal gardens, library and church on the plateau to the right with the Ninth Street plaza in the background.

The station should be by all means on the town side of the railroad and on the axis of First Street. At the end of First North Street and Fourth Street a plaza should be developed surrounding the station on the west and south. This plaza and First and Main Streets in the vicinity of the plaza should be built up with hotels, restaurants and shops. The treatment of the blocks facing the plaza is suggested in the Mexican style. A hotel and restaurant building is indicated on Fourth Street at the southwest corner of the plaza. This arrangement will bring First Street into more prominence than at present, making it in fact the main traffic artery between the railroad station and the Public Square, at which point local traffic will be offset into Main Street. It is therefore important that the development of houses along First Street should be carefully controlled as indicated in the body of the report preceding.

*The plat on left shows present lot layout and building development; on right is shown what could have been done with the same area and practically for same cost. In a privately owned town it is of special importance to make the best showing with the relatively few public buildings, shops, etc., that it needs. As the cost of land is of minor importance, these buildings should be arranged along the street having a depth of not more than fifty feet. This will insure also proper light and air. The interior can be better arranged, the exterior more attractively treated and the value in the general town picture will be immensely enhanced.

HIGH SCHOOL DEVELOPMENT, JEROME, ARIZONA

BIRDSEYE VIEW, 1921

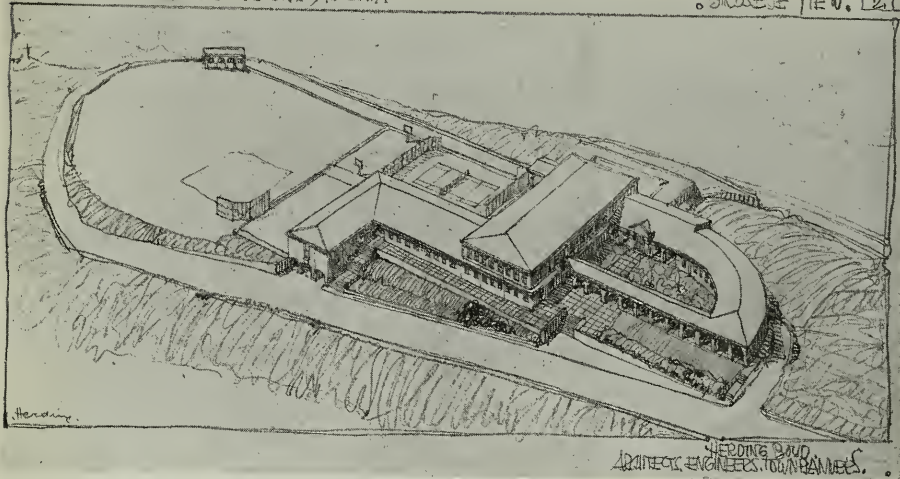

HIGH SCHOOL, JEROME, ARIZONA, BIRDSEYE VIEW
Herding & Boyd, Architects

HIGH SCHOOL DEVELOPMENT
JEROME, ARIZONA.
LAYOUT PLAN.

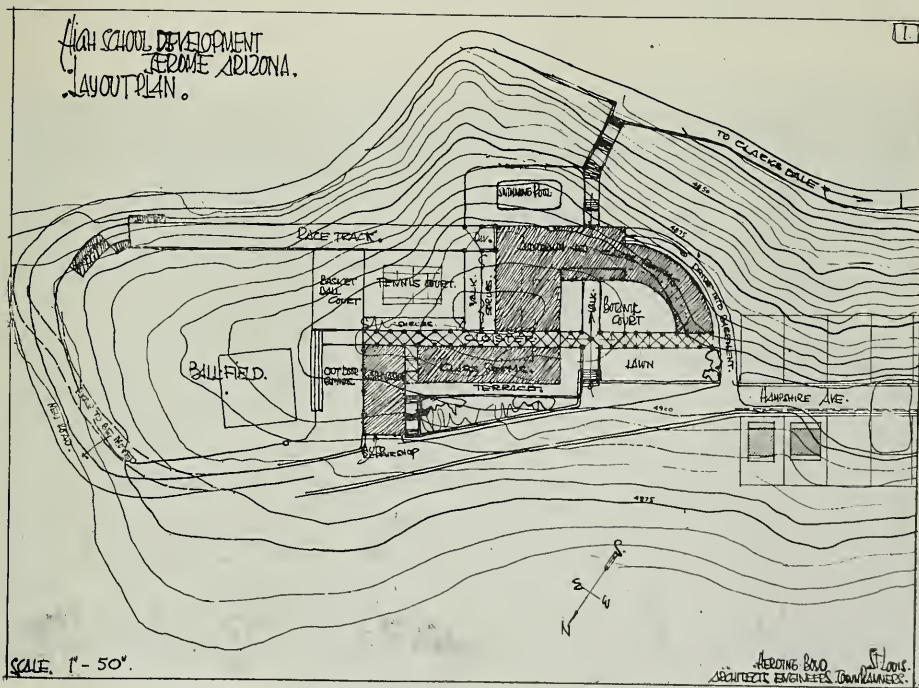

PLAN, HIGH SCHOOL, JEROME, ARIZONA
Herding & Boyd, Architects

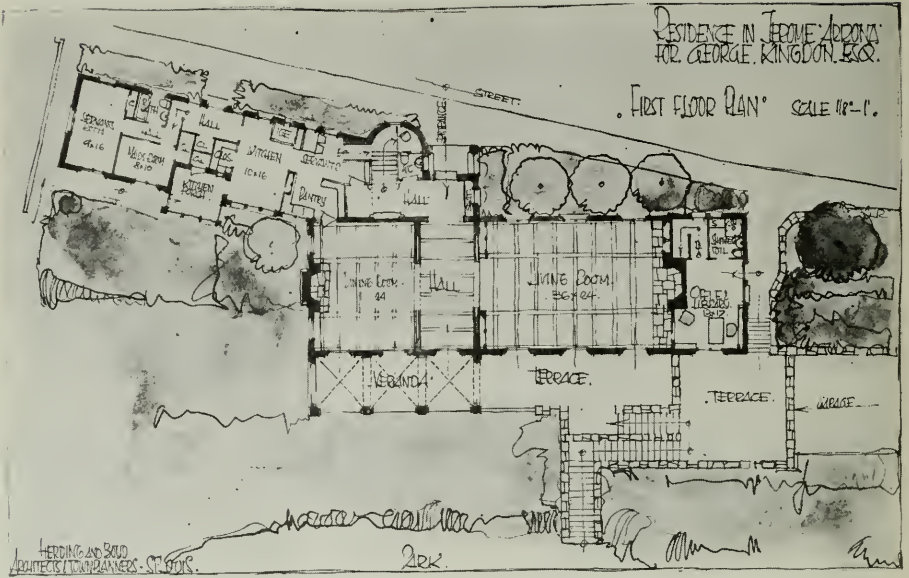

FIRST FLOOR PLAN, HOUSE FOR GEORGE H. KINGDON, ESQ., JEROME, ARIZONA
Herding & Boyd, Architects (See page 87)

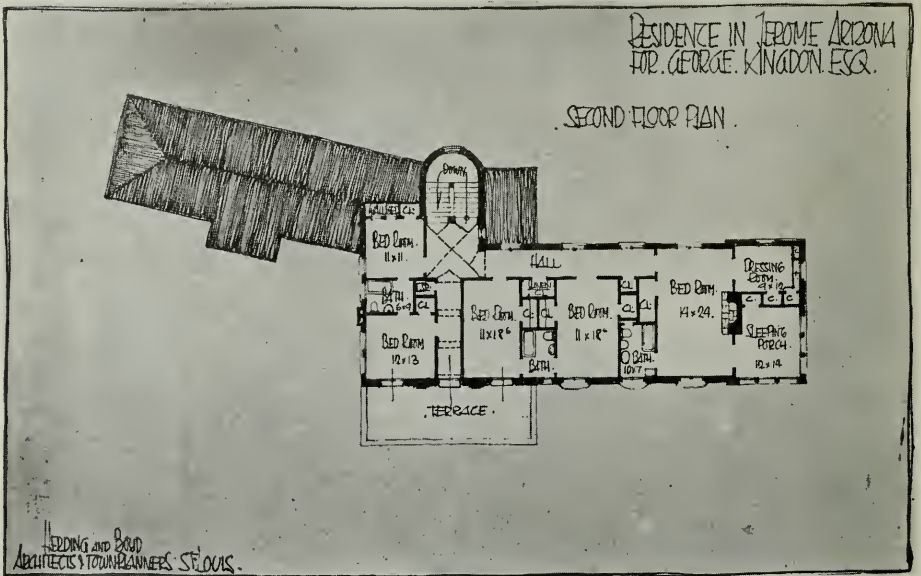

SECOND FLOOR PLAN, HOUSE FOR GEORGE H. KINGDON, ESQ., JEROME, ARIZONA
Herding & Boyd, Architects

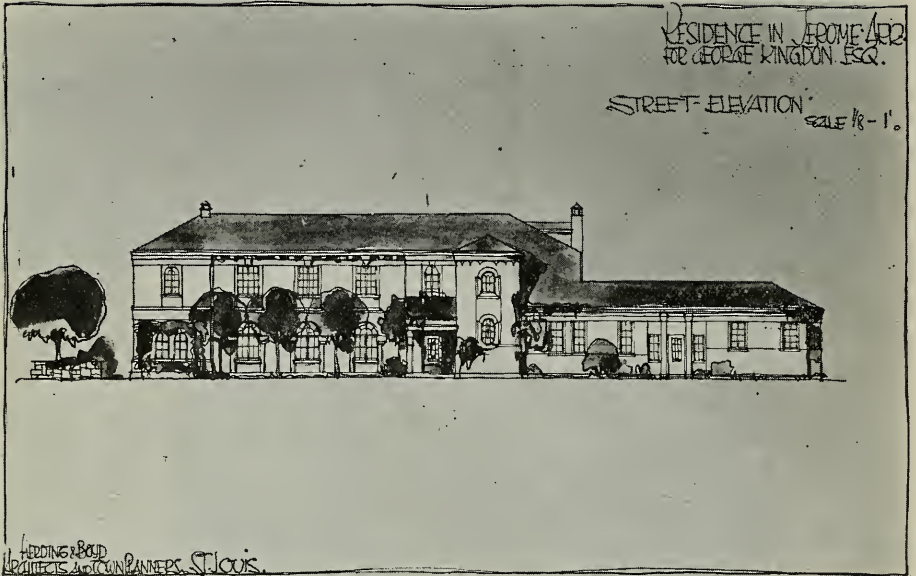

HOUSE FOR GEORGE H. KINGDON, ESQ., JEROME, ARIZONA
Herding & Boyd, Architects



HOUSE FOR GEORGE H. KINGDON, ESQ., JEROME, ARIZONA
Herding & Boyd, Architects



STUDY FOR HILLSIDE DEVELOPMENT IN JEROME,
ARIZONA
HERDING & BOYD, ARCHITECTS



PARTIAL VIEW OF THE TOWN OF JEROME, ARIZONA, PRESENT CONDITION

IV. — Study for Jerome, Arizona

The town of Jerome, Arizona, with a population of some 9000 inhabitants, is practically hanging on a steep mountain side. Its dwellings are mostly of a temporary character and the design in general the typical home one can find in the 30- to 40-foot lot of any town or city. This not seldom conditions the rear of the first floor to be four or five stories above the grade, resulting in most abnormal and bad living quarters. The layout of the town approaches the checkerboard pattern—and needless to say the uphill streets never can serve their purpose.

The town is growing planless, and tremendous sums have to be spent for grading and cutting, retaining walls, etc., and a great many unsatisfactory conditions always come up from lack of co-operation in lot development.

The town has, among others, a schoolhouse problem. As the buildings, streets, plazas, etc., under Jerome conditions are too intimately bound up with the nature of the site, this problem can only be solved properly together with a replanning scheme for the entire town.

Therefore, the architects have prepared, aside from authorized schoolhouse study, a preliminary development of a part of Jerome. The sketch on opposite page is one of those studies, giving a vision of the town section taken in by above photograph.

V.—Residence for Mr. George H. Kingdon, Jerome, Arizona

(See pages 84 and 85)

This is a study for a residence on a steep hillside near Jerome, Arizona. The two roads above the proposed building are existing, also the level ground and retaining wall, on the down-hill side. The plan is developed to meet the approach of the intersecting streets and to take advantage of a superb view into the Verde River Valley.

* * *

Housing Question Becomes More Acute

The housing situation becomes more acute from day to day and unemployment appears to be growing. Unemployment in a period of high rents and discomforting housing conditions is not a condition to be viewed without anxiety. From the banker's standpoint the organization of so many corporations to engage in housing finance ought to inspire some anxiety, also.

The Business Conduct of An Architect's Office*

By A. H. GREGG

IN starting a discussion on such an important subject as the Business Conduct of an Architect's Office, it might be well to consider first the general policy which should be established as a basis for all dealings with clients, contractors and staff, and then to consider some of the details of office administration and office system, which may assist in producing good work, and in carrying it out in the most business-like manner.

To begin with, the general policy should be based on the highest standard of ethics. While honorable dealing with all with whom we come in contact is the first essential and the honorable man should have no difficulty in determining the right course to pursue, it might be well to repeat a few basic principles.

First he must be convinced in his own mind that he is qualified to give good service and that there will be no slighting of his duties. An architect cannot be all-wise but if, for instance, his knowledge of heating engineering is deficient he should employ a heating engineer to assist him, rather than to take a chance on a system of his own devising which may or may not be effective.

Another basic principle is that the client's interests demand that the architect be entirely unbiased in any matter in which his judgment is required. It is therefore the invariable rule that no pecuniary advantage accrue to the architect through the employment of any contractor or the use of any special materials. He should not be interested as a stockholder or otherwise in any company manufacturing building materials or have any other business relations that may in any way bias his judgment where the client's interests are concerned.

Contractor Should Have Fair Treatment

Another principle that should be enunciated is that while the client's interests are the architect's first consideration, it is equally important that the contractor be given the fairest treatment.

Leaving the strict rulings required in matters of right and wrong, questions of policy often arise, particularly with the younger architects, which deserve consideration. The first of these may naturally be the matter of business getting, particularly as regards the establishment of a practice, and the methods that may be adopted in securing clients. The old idea for the beginner was to trust to one's friends for a start or to enter competitions, where budding genius may hope to be recognized by the public.

Undoubtedly, personality has much to do with the success of a business man or a professional man. A well-educated man, with ability to talk intelligently and entertainingly with any one, a good mixer, such a man has attributes worthy of emulation. At the same time, ability to do is of more importance than ability to talk, and the class of architect who rather glories in his lack of technical knowledge, and who claims the one distinction of being a business getter, usually has a short-lived career. The reason for this is that while he may have associated with him men who can do the work, his own methods are almost inevitably misleading and opposed to the prospective client's interests, as in his efforts to secure work he may mislead him as to the class of building that will suit his requirements, its probable cost, etc., in a way that may not be discovered until too late.

Assuming, however, that the architect is a capable architect, there seems no reason why he should not offer his services to any individual or

*An address before the London Convention of The Ontario Association of Architects.

corporation requiring the services of an architect, provided, of course, the field is believed to be clear and no effort is being made to take business from another. It must be remembered, however, that many an architect has hurt his reputation by approaching a man of conservative character, who is instantly antagonized by what he considers an unwarranted effort to forcibly establish business relationship.

In the same way the policy of an architect as regards advertising may be discussed. To my mind an architect has a perfect right to display his name on any building he may be erecting, or he may advertise in the daily papers or by circular or booklet, but the question still arises and must be settled by the individual, are such methods advantageous in the long run?

Group Advertising for Architects.

Group advertising, however, probably makes an appeal to the building public which cannot be obtained by individual advertising, and the campaign recently inaugurated by the association should have beneficial results for the members generally and should therefore have general support. Such advertising should educate the public as to the services rendered by architects, and thus enlarge their clientele, and it is probably one of the most effective ways of combatting the encroachment by contractors, engineers and construction companies on the legitimate field of the architect. Such a propaganda should tend to stabilize the position of the architect and the service he renders, and with the hard-headed business man it may do much to root out the old idea of the architect as an artistic dilettante, utterly impossible as a man of affairs.

Mention has been made of competition with contractors, engineers, etc., and in this connection I wish only to say a word in passing, as this subject has been pretty fully dealt with at other conventions. From time immemorial, I believe architects have suffered in this way, and if we had the statistics, I believe it could be proved that never has there been such a large proportion of building enterprises of all classes entrusted to trained architects as there is today. To make present-day conditions better, I believe the real remedy lies with the architects, who with better and more efficient organizations can prove to the building public that even the most commercial and matter-of-fact buildings should be entrusted to their care. They should see that the architect, who has no interests but the client's to further, who with his all-around training can approach the subject from the artistic, structural and business standpoints, is the man in whom the greatest confidence can be placed. As I have said, I believe the remedy lies with ourselves, but even if at some future period this class of work were entirely lost to architects, trained architects will even then be required for classes of work such as public buildings, fine residences, etc., and if such a condition arises the architect should then surely be entitled to, and be able to secure, a remuneration for this more difficult work which will enable him to live as well as other professional men.

Architects and Draughtsmen.

In regard to the relationship between an architect and his draughtsmen, I should like to emphasize one matter which I believe should receive more and more the attention of architects, and that is the improvement of the status of the draughtsmen.

Under the ordinary system, the draughtsman with ambition, as soon as he believes himself qualified, is desirous of starting off for himself, often to the utter dismay of his chief. Should this be so? If a young man can get business for himself, could not arrangements be made whereby he

could continue with his former employer to their mutual advantage? In all large cities do not our law firms work on such a system? It is an interesting study to note the changes that take place in the firm names of large legal organizations. Junior partners are constantly being added, some, I believe, on a salary, and some with an interest in the business. The older members of the firm rely more and more on them, and more and more clients find their way to the junior's office, until in good time, the former chief retires, and a former assistant takes his place. Such a system cannot of course be made workable in all cases, but what I believe is that a good draughtsman should be given something to look forward to and that with larger and better organizations, many a draughtsman could be saved from a life of drudgery or from the often disastrous effort to start "on his own" in competition with the larger and better known firms.

While dealing with the relationship between the firm and the staff, two other matters might be mentioned, one the matter of overtime and the other that of vacations. While these are matters to be settled by each architect for himself, it seems to me that no harm can be done by general discussion and, as far as possible, having all our offices run on the same system.

As to overtime, the less the better, and the better the office administration usually the less overtime is required. When it is absolutely necessary to have men working overtime, I believe the general custom is to pay time and a half, this overtime only being allowed, however, when by order of the firm.

As to vacations, the allowance of two weeks' vacation is a common practice, applying to employees who have been in the office for a full year. A "vacation earned" account is sometimes written up on some fixed date, say May 30th, and a proportional vacation allowed for any period of service over six months. If less than six months no vacation is allowed during the season, although the time due may be credited either for future delivery in holidays or in cash.

Internal Administration of Architect's Office.

The internal administration of an architect's office is a subject upon which much thought may well be expended. The many branches of service that are embraced in the practice of architecture today demand a carefully thought-out system through which clients, contractors and the architect himself will be assured that their several interests are being taken care of in the most economical and efficient manner. It is true that an architect's work cannot be systematized like that of a factory turning out thousands of similar articles day by day and there is no need to crush artistic individuality, but it has been pretty well proven that a well organized office, carried on in a business-like manner and with the minimum loss of time and energy, can produce the best artistic as well as utilitarian results. Proper subdivision of work, proper records of all building operations, proper accounting, proper records of office costs, proper filing systems are all essentials, and in the following remarks some suggestions will be made on these subjects as a basis for discussion and comparison.

In the first place, all system introduced should be of the simplest character and suited to the size of the office and to the character of work done. Some very large offices may have many departments—business, designing, draughting, engineering, building supervision, interior decoration, etc., etc.—but for the purposes of this paper we will consider the average office, with say two or three members of the firm and any number up to twenty-five or thirty employees.

As to general administration, it is usually found in such an office that the members of the firm have each developed along structural, designing or business lines, and will naturally oversee these general departments of work accordingly.

In the draughting room a head draughtsman is essential, who will have a general knowledge of all that is going on, will see that all men are kept busy and be the advisor of the other draughtsmen when necessary. Under the head of draughtsman, different draughtsmen may be made "job captains," a system effectually employed in many moderately sized offices. By this system one man is given general charge of some one building with one or more assistants under him. He has made or knows every drawing connected with that building, occasionally inspects the work in progress and is in a position to answer questions of his chief, the owner or the builder, regarding that particular building.

The filing system in an architect's office requires much attention. In our own office, we use a standing file for 1-8 inch and 1 1-4 inch scale plans, when desired to keep them flat, boxes 4-inch by 8-inch by 24-inch with flaps at end, and set in cabinet for folded details and pigeon holes for current and old plans when rolled or placed in tubes.

All boxes and pigeon holes are, of course, numbered, and the drawings in each may be instantly found by reference to the "plan file book."

The record of drawings made may conveniently be kept in a loose leaf book with ruled pages having headings giving numbers, "date," "draughtsman," "scale," "to whom delivered," etc. Card indexes are used in some offices, but it seems utterly hopeless to expect a card system to be kept up properly when different parties have to make entries. Of course, if a filing clerk is employed the card indexes may be advantageously adopted, and in this case there will be a separate card for each drawing with full record.

In keeping records of drawings made, it is most important that special entries are made when plans or details are revised, as this is a fruitful cause of trouble. Our rules are that a revised drawing is given the old number with a letter added as 120A, a new entry made and "revised" marked in red ink at the first entry.

In numbering drawings our plan is to give first a building number, then number all 1-8 inch or 1-4 inch scale drawings from 1 to 100 and all large scale or detail drawings from 101 up.

Bookkeeping Methods.

As to office accounts, two sets of books should be kept—one for the personal accounts, dealing with monies actually passing through the architect's hands, and the other for building accounts for which certificates are issued.

For the personal accounts a simple and complete system can be installed with general ledger, cash journal and petty cash books. All cash received should be deposited in the firm's bank account, and all disbursements represented by firm cheques, and all these transactions should be recorded in the cash journal which may be classified so that disbursements may be divided by columns into such divisions as office expense, wages, drawing materials, etc., the totals at the end of the month being posted into the ledger.

If a simple double ledger entry system of bookkeeping is adopted, the ledger can be made to show exactly at the end of the year the amount earned, etc. To do this "loss and gain" and "assets and liabilities" balances are found. In order to determine the assets it will be necessary to

open a special "commissions accrued" account to show amounts earned at the end of the year but not actually received.

To avoid too many cheques and too many entries in the cash journal, a cheque may be issued periodically to the keeper of the petty cash who pays all salaries and makes all petty disbursements which are duly recorded in the petty cash book.

For the building accounts probably the simplest and best method is to have a "building ledger," preferably on the loose leaf system. In such a ledger an account is opened with each contractor, one or more on each page with the building title at the head. The contractor is then credited with the amount of his contract and debited with each certificate issued; the account being duly closed when all entries of extras and deductions are made and final certificate issued.

Office Costs.

The keeping of office costs is as necessary in an architect's office as in any other business. To do this every draughtsman should be provided with printed time cards or books, and enter therein the actual time spent on the various buildings from day to day. These cards should be handed into the office weekly or monthly for entry in the "time record" book. In order to complete this record it is necessary to record any time spent by members of the firm in the draughting room which should be noted in their office diaries and duly recorded in the "time record" book.

In addition to draughting room costs, it is of course necessary to ascertain from the office ledger the percentage of overhead expenses—rent, stenographers' salaries, office and draughtsmen's supplies, etc.—to draughtsmen's time.

I might emphasize the necessity of keeping written records of all important matters, such as orders for extras, memoranda of important conversations, building reports, etc., etc.

As to building reports, we have found printed forms ruled with headings for "date," "superintendent," "time," and "report," very handy. The current reports are then kept in an alphabetical file hung in the office where any one superintending work may enter his report as soon as he returns to the office.

Another important matter which should be on record is the agreement as to fees, and at the outset of all work there should be a clear written understanding with clients as to the fees to be charged. This understanding may be a formal contract in the case of large undertakings and of necessity when dealing with corporations whose contracts have to be under seal, or in ordinary cases it may be in the form of a letter, with the institute schedule enclosed.



Seek Broader Architects' License Law

A meeting of architects' representatives from the various states having license laws was held at St. Louis, November 18, for the purpose of securing the adoption, if possible, of a uniform license law for architects that may be put into effect in various states. Considerable friction has resulted from administration of the present laws. One of the chief reasons for this friction comes from the fact that the laws of the different states contain the provision that an architect moving to another state is required to pass a new examination. The meeting at St. Louis was held for the purpose of eliminating this section.

Scheme to Tunnel San Francisco Bay

THE project of Admiral Joseph L. Jayne to make a viaduct crossing from Oakland to Yerba Buena Island, which is having the support of leading San Francisco business men, is not a new one. Some years ago Mr. F. W. Fitzpatrick, a consulting architect and engineer of Chicago, published in the *Architect and Engineer* a scheme to tunnel the bay which, if carried out at that time, would undoubtedly have proved of immense benefit to the transbay cities, and would have cost about one-half what the project would entail at this time. It is hoped the plan will be carried to consummation, and it can be authoritatively stated that there will be no royalty to pay Mr. Fitzpatrick, as his patents and all those controlled by him have long since expired.

For those not familiar with the Fitzpatrick scheme, the following interesting data is given by him:

"Where there is very deep water, such as an ocean inlet, to cross, a body 250 or more feet deep, of course the difficulties for a submarine tube multiply. Long spindle-legged concrete or stone anchors or "supporting piers" have to be built unless the tube is to rest upon the bottom. In the latter case the approach grades are bored under the bottom, and in the former case the construction of such piers a hundred feet or so high and all under water is an undertaking of considerable magnitude. But in shallow water this subaqueous bridge is ideal.

"One of the first projects of this kind seriously considered was the narrow crossing of the canal at Duluth.

"The canal at this point cuts a long strip of sandy shoal that would have been an admirable and much needed freight terminal. But the authorities were frightened by its novelty.

"There is a crossing there now, an aerial bridge that took every bit of ingenuity I possessed to get approved by the War Department, and that affords only a crossing for vehicles and pedestrians.

"The scheme is ideal for the crossing from San Francisco to Oakland, where in the seven miles of water there is no greater depth than seventy-five feet.

"It is generally recognized that something must be done to relieve the railroad isolation that now grips San Francisco and handicaps its terminal railway business. About seven years ago the newspapers and local engineers were quite enthusiastic about this subaqueous bridge crossing, but politics and lack of funds and the war prevented the plan from being actually realized.

"Divested of all technical details and terms, my 'subaqueous bridge' crossing consists merely in lowering a previously built tube into place, either right on the bottom of the waterway or raised above the bottom on piers. It is the simplest, the most effective, the most cheaply maintained and least expensive water crossing.

"My plans are for a concrete tube, made in sections ashore, as we build concrete ships. Sections about three hundred feet long are the more easily handled. They are square, large enough for a double track provision being made for drain and ventilating pipes, electric wires, etc. Each section has a temporary bulkhead at the ends and is launched as you would a ship, and towed to the point where it is to be sunk in a trench previously dredged, or on piers built in place.

"To sink the tube section the bulkheads are knocked out. The water fills the tube, and it sinks, directed by divers, into its proper place. The

Diagram on the left shows Mr. Fitzpatrick's plan to prevent the tube from floating off from the anchor piers.

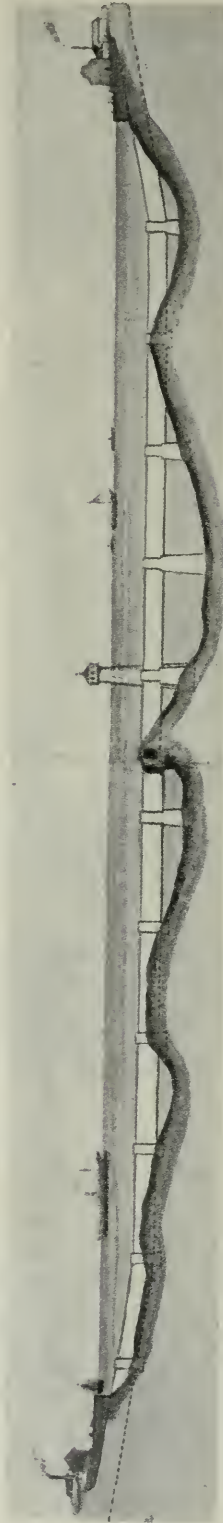
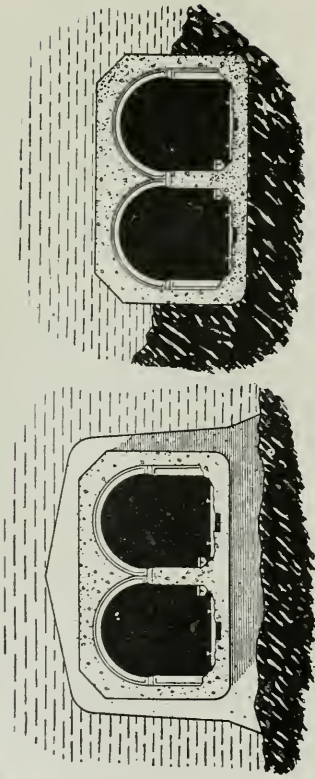

At intervals there will be lighthouse-like vent-towers projecting out of the water to aid in ventilation. The concrete tubes are to be built in sections ashore, towed to the proper place, and sunk into position on the piers. With the ends of the tube sections temporarily closed for transit, the tubes could be towed like large scows, as shown on page 92.

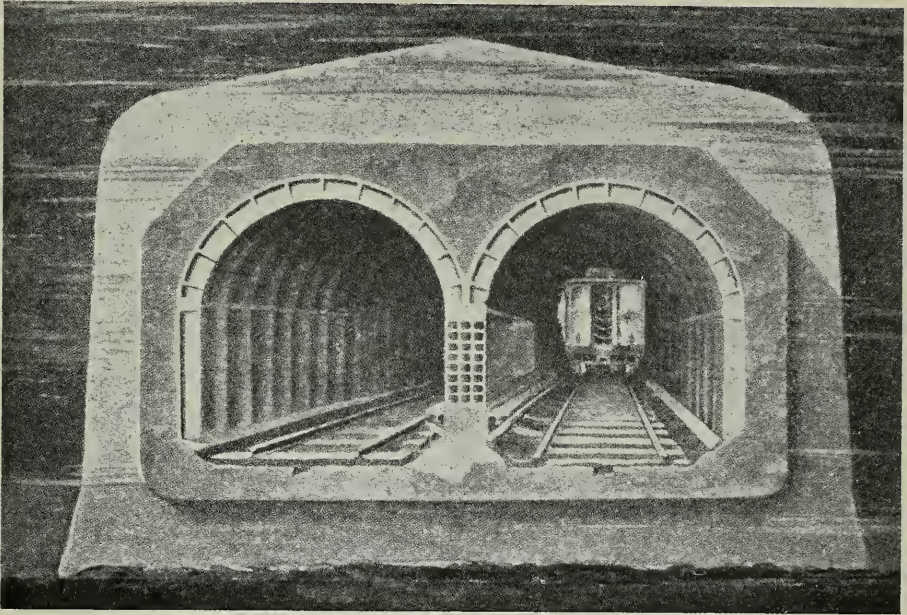

That Mr. Fitzpatrick's scheme is not impracticable is shown by this picture of the process carried out in building the portion of the New York subway that goes underneath the Harlem River. In this case the sections were built of steel instead of concrete; but they were sunk, as Mr. Fitzpatrick advocates, in a carefully prepared trench.



"My subaqueous bridge crossing consists merely in lowering a previously built tube into place, either right on the bottom of the waterway or raised above the bottom on piers," says Mr. Fitzpatrick.

ends are fastened to the other sections. Another and another section is lowered. When all are in place the water is pumped out, the connections perfected, tracks laid, lights, ventilation, and drainage installed.

"Your 'subaqueous bridge' is complete and ready for operation—the cheapest and best water crossing ever devised, one not subject to winds and storms like a bridge, nor disturbed by currents or tides, nor painfully bored underground. If the traffic becomes too great for two tracks, another double-track tube is laid alongside the first, and another and another later on, as needed. Thus the 'subaqueous bridge' can develop without in any way disturbing the first tube or its traffic.

"The joints in these tubes are so devised that when the two sections are butted together the easing into exact location is automatic. Tighten one line of bolts and the juncture is as solid and water-tight as any part of the structure.

"At the ends of the tunnel or 'subaqueous bridge' the approaches lead through open cuts or troughs exactly as one would expect for the regular bored tunnel under a waterway bottom."

* * *

Residence Design

THE following paragraphs are quoted from an article printed under the title, "Render Unto Caesar," in the October issue of *The Charette*, a monthly journal published by The Pittsburgh Architectural Club.

"There has always seemed to exist a sentiment that monumental architecture must of necessity call for genius of a higher character than residence architecture. This is a viewpoint which we have felt bound to combat rather stoutly at times, for personally the two forms have seemed to require totally different moods of mind, and the obvious fact that the residence is a less important work measured in mere terms of mass, does not seem admissible as an argument against its superior artistic worth. The predilection of the architect would rather seem the factor in judging the respective merits of the minds of designers in the two phases of building. It may be readily granted that the house calls for a more delicate taste than the public building and perhaps renders it more or less true that the ranks of residential architects of ability count more men of less vigorous imagination than will be found in an equal number of similarly competent monumental designers. Yet when a man of great imaginative power elects residential architecture as his medium, the result is only to be expected, namely, the emergence of an astonishingly fine manner. But whatever may be the merits of the controversy, we may concede that while residence work may not be as severe a test of the mental stamina of the designer, it is in fact the most exacting trial of taste in the art, for it is there that the refinement of cultivated races may be most readily displayed. The test of civilization is the intellectual refinement of the individual, and the most individual of the works of man is his house. There will be found a fair reflection of his manners, and his manners are the measure of his development. The hall-mark of progress in the slow ascent from savagery is increasing reserve. A gentleman is quiet, a lady is serene. It is that quality which proves him farthest removed in spirit from the primitive, where self glorification was the delight and attribute of the warrior, bragging his bleeding kill. The glistened palace of the parvenue is the twentieth century skull heap of the twentieth century hunter of heads. No person of any refinement of mind would suffer himself to be paraded by his house. Such persons among the people will demand quietness in the character of their homes, whether they discriminate further or not."

The Specification Writer and the Manufacturers' Literature

PART IV

By LOUIS R. HOLSKE, in Pencil Points

THE articles listed below are not mason's materials, but inasmuch as they are customarily set by masons they will be considered in this division, each in its relation to "What the architect wants to know," without special effort to arrange them in the order in which they are usually set in the building. They are as follows: steel windows of various types, underwriter's scuppers, shutter eyes, curb bars, window chains, safety bolts, safety treads, fireplace dampers, ash traps, coal chutes, clean-out doors, milk and package receivers, coal-hole frames and covers for sidewalk lift openings.

Steel Windows—Full-size sections of jamb, head, sill and transom of each type, embracing the sash, and of meeting rails in case of double-hung sash. A detail of muntins in the sash. If carried in stock, a list of sizes, the points of measurement, indicated by dimension lines on the details. A detail of mullion construction. A statement as to material, rolled steel sections, heavy gauge sheet steel or a combination of both. Quality of hardware, rough and finishing. Hardware finish—details of operating hardware. Is the priming coat applied in the shop? In the case of shallow reveals, just how can window cleaner safety bolts be accommodated? An illustration of the possible application of shades on the inside.

Underwriter's Supplies—A detail showing the pitch and method of hinging valve, material of valve. How is the ill effect of corrosion avoided at the hinge point? How is hinge protected against the weather? For what thickness of walls are they made?

Shutter Eyes—The architect would be interested in knowing the size, thickness of casting and the manner of reinforcing the side carrying the eye on steel shutters.

Curb Bars—A full-size section of the bar showing the method of anchoring. The spacing of the anchors. The method used in galvanizing, whether hot dip, electro plate or Sherardizing.

Window Cleaner's Safety Bolts—Material of bolts. Illustrations of different types, minimum area of cross section of each type.

Safety Treads—Sections, either full-size or to scale, of the different forms made by the manufacturer, showing methods of anchoring. Description of non-slip material and base used. Manner of attaching or incorporating non-slip material to or with base. Reliable tests for durability.

Fireplace Dampers—Plan and section drawn to scale which will enable the architect to determine readily the splay of the jambs, and the height and angle of the dome. A list of sizes made, the points of measurement indicated by dimension lines on the drawing; the thickness of metal of the front of dome and front flange.

Ash Traps—Plan and sections to scale, properly figured, including a figure for the projection of the top of the flange beyond the body of the trap.

Coal Chutes—A plan and section of each type, drawn to scale and properly figured. A list of sizes made, the points of measurement indicated by dimension lines in the drawing. An illustration and description of the locking device. Adaptability to walls of various thicknesses.

Clean-out Doors—A list of sizes manufactured along with a large-scale section of the frame, showing the point of measurement, and the methods of anchoring. The locking device.

Milk and Package Receivers—Details of the inner and outer frames, showing method of anchoring to masonry. The sizes manufactured, the points of measurement indicated by dimension lines on the detail. Adaptability to walls of various thicknesses. An illustration and description of the automatic locking device.

Wall Garbage Receiver—This, being a device similar to the milk and package receiver, same kind of information is required.

Coal Hole Frames and Covers—Regarding the flush type, the architect would be interested in knowing the size, form of frame, shape of cheeks, guards, manner of hinging cover, how the cover and framework are made non-slipping, and whether any attempt at drainage has been made.

Sidewalk Lift Frame and Cover—A section of frame and cover, how drainage is provided for; how slipping is provided against on frame and cover; manner of hinging and material at hinges. What guards are provided to prevent persons from falling in when the cover is open? What stays are provided to hold the cover in position when open?

There are many other items which might be discussed in this division, but the writer believes that the principles involved have been illustrated sufficiently to make their application clear in the preparation of data on all materials and equipment under this head, with the purpose of supplying the facts the specification writer needs.

* * *

Tax Exemptions on Houses in Two States

Two states have passed laws exempting new buildings used for housing from taxation. The New Jersey law provides that taxes shall not, with certain exceptions, be levied on buildings built within five years. The New York law, which was approved September 27, went into effect immediately. It places the responsibility of exempting new dwellings from taxation on the local legislative bodies, as follows:

“The legislative body of a county, or the legislative body of a city with the approval of the board of estimate and apportionment, if there be one in such city, or the governing board of a town, village or school district may determine that until January 1, 1932, new buildings therein, planned for dwelling purposes exclusively, except hotels, shall be exempt from taxation for local purposes other than for assessments for local improvements during construction and so long as used or intended to be used exclusively for dwelling purposes, or if a building of four stories or more in height, used exclusively for dwelling purposes above the ground floor, provided construction was completed since April 1, 1920, or, if not so completed, that construction be commenced before April 1, 1922, and completion for occupancy be effected within two years after such commencement, or if now in course of construction within two years after this section takes effect.”

* * *

Why?

Twenty-five bank building projects were reported throughout the United States in a single week last month. If building at present construction costs is such folly from a sound business viewpoint, will some one please explain why it is that for the last six weeks from ten to twenty-five bank building projects have been gotten under way each week? If it is good business for the banks to build new structures, why is it unsound to lend money on other building projects?—American Contractor.

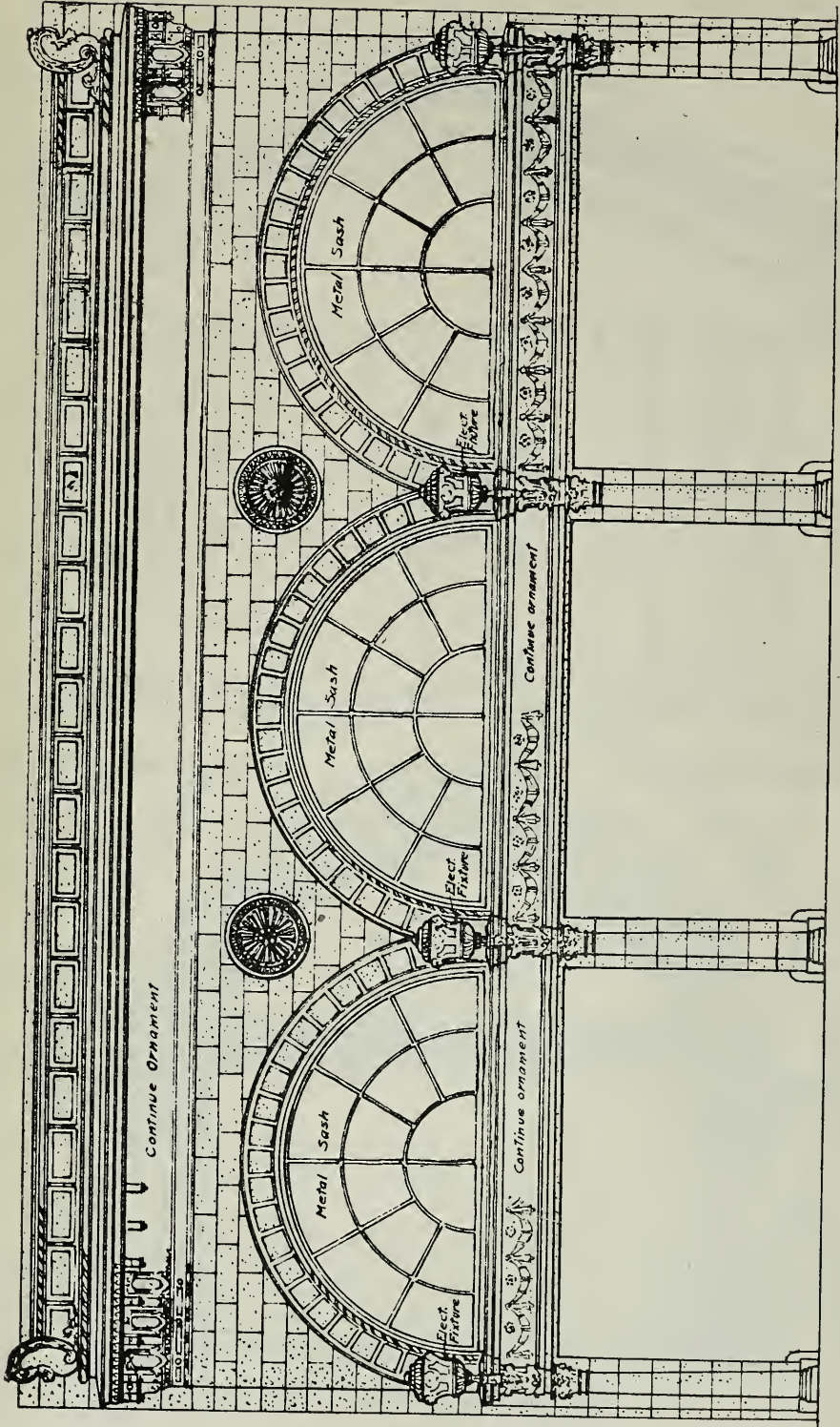

GARAGE FOR MR. MORTIMER FLEISHACKER, SAN FRANCISCO
JOSEPH L. STEWART
ARCHITECT

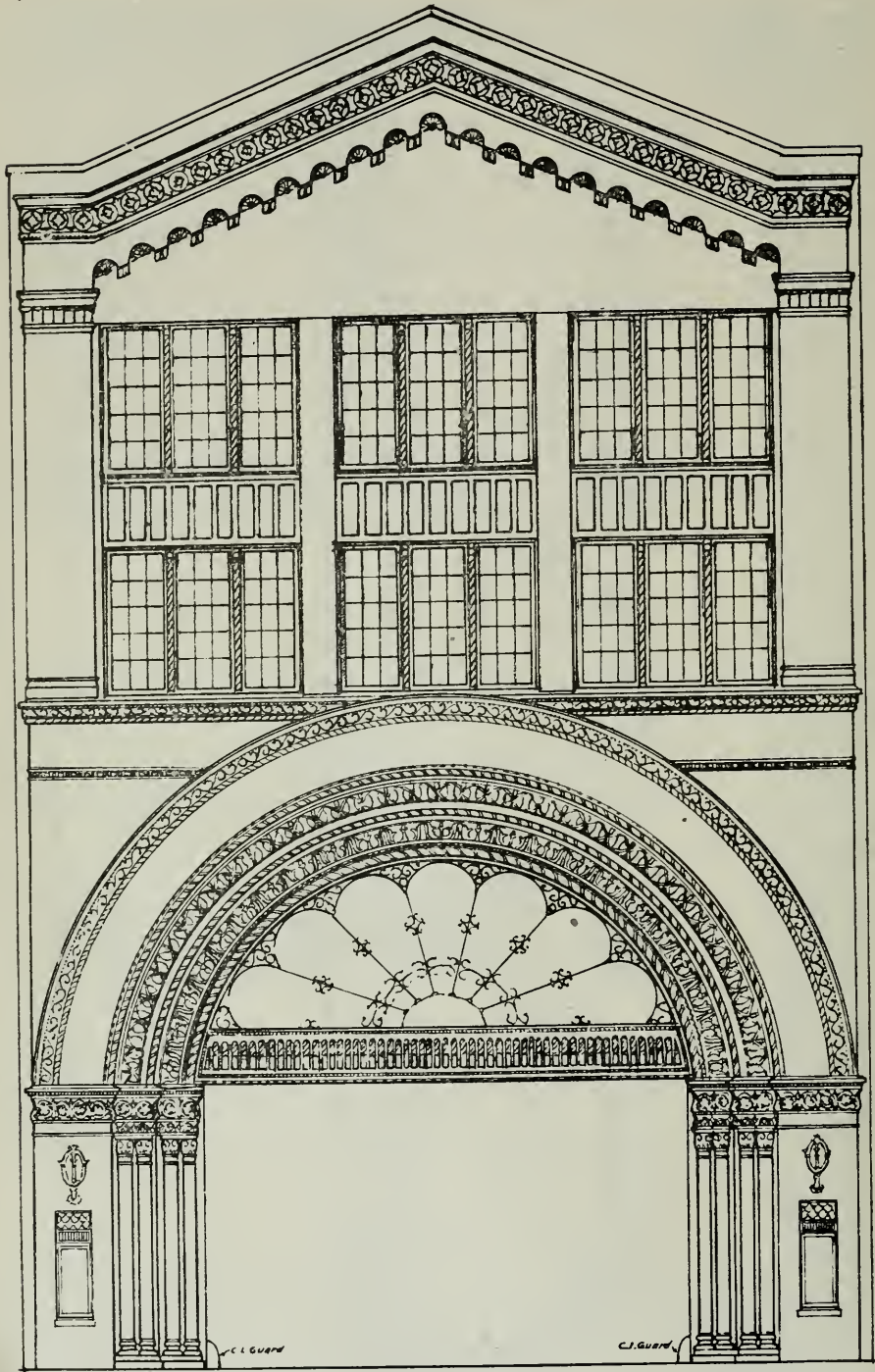

GARAGE FOR MR. THOMAS McDOUGALL, SAN FRANCISCO
JOSEPH L. STEWART ARCHITECT

Back Plastered Cement Stucco Proves Strongest for Exterior Wall Construction

THE following tests on distortion of exterior wall sections are timely and interesting.

Since the United States Bureau of Standards found that the back-plastered metal lath form of stucco construction was the only one on which they could give a 100 per cent rating on frame structures, the Associated Metal Lath Manufacturers have endeavored to educate the building fraternity to an appreciation of this. It has been an up-hill job, and yet this form of stucco construction is said to have proved time and time again to be more satisfactory and not a little cheaper than drop-siding or masonry.

Chicago, Ill., July 22, 1920.

Associated Metal Lath Manufacturers,
Edison Building, Chicago, Ill.

Gentlemen:

We submit herewith our report on distortion tests of wall sections which we have just completed.

The samples tested were designated in your letter of April 27, 1920, and conform in detail to the following descriptions:

1. Back-plastered stucco on metal lath—Back-plaster on metal lath furred out by 3/16-inch pencil rods on 2-inch by 4-inch wood studding with 11/16-inch Portland cement stucco on outside, back plastered with 11/16-inch Gypsum plaster, making 1 3/4-inch from inside surface of back-plaster to outside surface of stucco. On the inside 1 1/4-inch Gypsum plaster; each wood stud toenailed to sill at top and bottom with two 10-penny nails.

2. Siding and Sheathing—Ordinary wood construction, metal lath and Gypsum plaster 1 1/4-inch thick on inside, and sheathing and drop siding 1 3/4-inch thick in outside. Each stud toenailed to sill at top and bottom with two 10-penny nails. Each piece of sheathing nailed to each stud with two 10-penny nails, and each piece of drop siding nailed with one 4-penny nail.

3. Stucco on Metal Lath Over Sheathing—Same as ordinary wood construction except that in place of the drop siding 11/16-inch of Portland cement stucco on metal lath was used, furred out with 3/16-inch pencil rods laid on ordinary building paper stretched over the siding.

4. Stucco over 6-inch Hollow Clay Tile—Six-inch hollow clay tile covered on outside with 7/8-inch Portland cement stucco and on inside with 7/8-inch Gypsum plaster.

The purpose of these tests was to secure data in regard to the behavior of the different wall sections when under load, and the strength shown by each to resist such loading. Particularly it was desired to observe the behavior of the inside plastered surface to note such cracking, crushing, or falling away of the plaster as might occur under the load. Similar observations were also made on the stucco in the samples using this type of construction.

All the samples used in these tests measured 42-inches by 42-inches outside dimensions. The thicknesses of course varied, depending upon the character of the construction, and were as follows:

Construction—	Thickness (Inches)
Back-plastered Stucco on Metal Lath.....	6 5/16
Siding and Sheathing	6 3/4
Stucco on Metal Lath Over Sheathing.....	7 15/16
Stucco Over Six-inch Hollow Clay Tile.....	7 3/4

In making these tests the sample was placed in an upright position on the bed of the testing machine, resting on one of its short edges. The load was then applied vertically downward on the diagonally opposite edge. It will be noted that with the sample in this position the studs are not vertical but at an angle of about 45 degrees with the vertical. Thus the studs are not loaded like a long column in compression, but the load is rather a combination of compression, cross bending, and shear. Unless the plastered surface is exceedingly rigid such a stress should produce cracks which would cause the plaster to fall away.

RESULTS OF TESTS

BACK-PLASTERED STUCCO ON METAL LATH

No effect was noted until the load reached 10,000 pounds, at which cracks appeared in both plaster and stucco near top and bottom corners of the sample. At a load of 14,200 pounds the sample was destroyed by the failure of the interior framework of 2-inch by 4-inch. The metal lath was torn from the studs, due to the failure of the latter, but the greater part of the plaster remained unbroken except for cracking and crushing around the edges.

SIDING AND SHEATHING

Plaster slightly crushed at top and bottom corners and a crack produced about 12 inches long near the top corner at a load of 5460 pounds. Sample destroyed by failure of interior framework at a load of 8800 pounds.

STUCCO ON METAL LATH OVER SHEATHING

Small cracks appeared in both plaster and stucco near top and bottom corners at a load of 9100 pounds. Sample destroyed by failure of interior framework at a load of 10,800 pounds.

STUCCO OVER 6-INCH HOLLOW CLAY TILE

Tile, plaster, and stucco crushed at top and bottom corners, and a crack about 15 inches long produced in plaster just above center of sample at a load of 8000 pounds. Sample crushed so that tiles fell apart at a load of 9600 pounds.

One point of importance to be noted from these tests is the manner in which the plaster held together, even when the supporting framework was completely destroyed. This was noticeable in all the samples tested, and is doubtless due to the monolithic character of the metal lath and plaster construction.

These tests show further that the strength of a wall to resist such load does not depend entirely upon the character of the framework, but is affected to a considerable extent by the nature of the wall surface materials. Note that the only structural difference between sample number 3 and sample number 2 of this report lies in the substitution of Portland cement stucco on metal lath in place of the drop siding. A reference to the above results shows that sample 3 is considerably stronger than sample number 2, thus indicating that stucco on metal lath has greater structural strength than the siding.

Further, the back plastered construction comprising back-plastered stucco having a total thickness of 1 3/4 inches on the outside of the wall and Gypsum plaster 1 1/4 inches thick on the inside, shows greater strength than any of the others, although the interior framework is the same. This increase in strength is due to the monolithic character of the stucco and plaster and to the absence of wood in the wall surface. Wood, such as sheathing or wood lath, tends to crack and split under the load and thus hasten the destruction of the wall. On the other hand stucco or plaster on metal lath acts like as a single piece of material, thus adding to the strength and rigidity of the wall.

Respectfully submitted,

G. F. GEBHARDT,
Per J. C. Peebles.

Testing Engineer: J. C. Peebles.

* * *

Day Labor in Road Construction

THE chief highway engineer of Oregon is quoted as saying that the State cannot do work as cheaply as the contractor. This will be interesting to California contractors in view of the fact that there has been a good deal of talk lately about the day labor method of doing public work. In speaking at a dinner of the Contractors' Association of the Pacific Northwest, Mr. Herbert Nunn, chief engineer of the Oregon Highway Commission, said:

"We are doing everything that is fair and honest by the contractor. We are giving estimates of completed work so as to cut down the retained percentage. We would make most of the changes in the contracts and specifications demanded by the contractors if we were permitted by law to do so. The basic law under which we are obliged to work must first be changed by appropriate legislation. We are convinced that it is impossible for us to handle work as economically as the contractor. The contractor is entitled to a clear specification so that he can submit an intelligent bid. He is entitled to a sure and fair profit. We believe every hazard should be eliminated that it is possible to eliminate."

“What Can Be Done About the Housing Crisis”*

FOR many years before the war housing conditions had been gradually improving, rentals were low and the death rate in one of our great cities, New York, had fallen to 12 per thousand.

During the war the building industry which had been generally normal was suppressed by the government and came to a standstill in November, 1918, and it was about 4 per cent normal in December, 1918.

Within the first year after the armistice, the rate of building again approached normal, but during the second year after the armistice, building once more came to a standstill through governmental interference and through high prices caused largely by popular demand for consumables and luxuries.

In answer to the question, “What can be done about the housing crisis?” Without going into particulars, I would reply, “Reverse so far as you can the unfortunate chain of events which caused the crisis.”

Of these events the following may be mentioned:

On October 2, 1917, Judge Lovett issued Priority Order No. 2 denying the use of open top cars for the transportation of building materials.

In the spring of 1918 Secretary McAdoo urged that all but “necessary” building be stopped.

The Capital Issues Committee restricted credit for the banking industry.

The Labor Department and the War Industries Board allocated labor and materials for war uses.

In June, 1918, the freight rates on building materials were increased on an average of 50 per cent, while freight rates on other commodities were increased on an average of 25 per cent.

In September, 1918, the War Industries Board inaugurated a system of permits through which construction was brought to a standstill.

It was not until March, 1919, that the Treasury Department released restrictions on credit for new construction.

In March, 1919, the Department of Commerce inaugurated a system for fixing prices which halted construction work.

In April, 1919, the Director General of Railroads refused to purchase cars, rails and coal at the prices approximated by the Department of Commerce and to this action may be traced a part of our present transportation difficulties.

In the winter of 1919 and the spring of 1920 the demand for luxuries and consumable commodities was so great that the price of building materials and labor was raised above the purchasing power of the construction industry.

In the spring of 1920, transportation of building materials became increasingly difficult.

On June 2, 1920, priority orders were issued reserving open top cars for the use of coal. These priority orders have succeeded one another until the twentieth or twenty-first was issued on October 8th, canceling permits for the movement of any materials save coal to the Northwest. Within two weeks most of these orders were canceled, and yet the coal shortage persists in certain sections of the country and it is still most difficult to move building materials.

On August 26, 1920, the freight rates on building materials were increased an additional 40 per cent.

During the war no extensions were made to our railroads, and rolling stock was allowed to become depleted and scattered throughout the country.

Since the beginning of the war the cost of transportation to the building industry has increased about 140 per cent, the cost of fuel some 300 per cent and labor 100 per cent.

*From report of Senate Committee on Reconstruction and Production, Senator William M. Calder, Chairman, 29 West Thirty-ninth Street, New York City.

Coastwise rates were raised higher than all-rail rates, our railroads are overburdened and our coastwise shipping left idle.

During the past two years, as well as during the war, no effort has been made toward the development of inland waterways and terminals.

Regular and irregular strikes and "vacations" had added to the transportation congestion.

After the Fuel Administration was discontinued on April 1, 1920, restrictions on the export of coal were released simultaneously with the beginning of the coal year and with the beginning of an abnormal foreign demand.

Priority car service orders without adequate police supervision and without regulation of price or export have permitted coal speculation of an unprecedented character. It is the opinion of many that the anti-profiteering laws have not been wisely enforced. A meeting of the coal operators was held in Cleveland at the suggestion of the Attorney General on Tuesday, October 26th, with certain limitations and assurances, and resulted in a resolution of the coal operators to co-operate with the Attorney General in the enforcement of fair practices.

Unlike some foreign countries, the United States has no long-term banking system to supplement its short-term commercial system. During the war long-term securities were forced upon commercial banks and long-term deposits were used by commercial banks for short-term loans.

During the war tax-exempt securities increased two and a half times, and they now amount to nearly fourteen billion dollars. The greater attractiveness of these tax-exempt securities has drawn credit from its former capital investment.

During the war our taxes were greatly increased and excess profits taxes were placed to check war profiteering, and these excess profits taxes were not repealed at the time governmental regulation of prices was discontinued.

Private as well as governmental action is necessary to reverse this chain of events. Business must play fair, labor must be efficient and the citizenry must be thrifty, buying only essential commodities and investing in things that have lasting value and earning power.

There is no royal road by the way of governmental subsidy and regulation. Rent regulation will not build houses and governmental subsidy cannot absorb ever increasing costs due to inefficient labor, irregular transportation, and coal and material speculation. The government is not capable of supporting its citizenry. Police power and subsidy which are necessary in an emergency must be resorted to only under extraordinary circumstances lest part of the people be made dependents. The building industry may be likened to a man who has been jostled into the quicksand by his companions—his companions may pull him out but cannot be expected to support him ever afterward.

We had willing buyers and renters of houses and we have willing sellers of land and raw materials, and we have land and raw materials in abundance; but transportation, fuel and labor are costly and scarce and capital is looking toward more promising investment.

The government may remove some of the barriers which keep buyers and sellers apart. In fact, this is an obligation upon the federal, state and municipal governments, each within its own jurisdiction.

As a primary undertaking the government may insure the regular and cheap delivery of raw materials necessary to reduce the cost of the manufacture of building materials.

Skilled Mechanics Needed

By EARL F. STOKES

ONE of the greatest problems facing the building trades industries today, and one that is fast becoming serious, is the apprentice situation, and unless the master builders get together and force the issue of more apprentices the building industries are going to experience a dearth of good mechanics for years to come. Even now from all over the country we hear the wail for good mechanics—"Give us good mechanics and we can increase production"—but where are these mechanics to come from with but few shops and firms employing apprentices?

What must be done? First the master builders must get in touch with the locals and agree upon a system governing apprentices; then they, in turn, should ask the co-operation of the industrial night schools in working out courses to insure proper training of apprentices. You will find the heads of vocational training schools in your city very glad to co-operate.

One of the reasons that we do not have more young men seeking apprenticeships in the building trades is that they offer them no particular inducement and another reason is the lack of interest taken by the employer in the apprentice.

A young man at work likes to be encouraged, and unless he is he soon gets into a rut. One way to encourage him would be to have a monthly report card; give him credit for what he does and let him see his progress. If he is 50 per cent efficient in hanging doors, sash or whatsoever at the end of this month, next month he is surely going to try to improve his standing if he is ambitious. If he makes no improvement then it is to the employer's interest to get rid of him.

Too often we find employers and foremen putting apprentices to work digging ditches, etc. What could be more discouraging than continually being forced to do this kind of work when in reality it is laborers' work? The employer would be far ahead if he employed laborers for that work and kept his apprentices on the work that they should be doing. Then, too, we often find foremen who may be excellent mechanics themselves, but who are not able to intelligently impart their knowledge. Because a man is an expert in his line is no assurance that he is a good teacher, and therefore it is not always the fault of the apprentice that he does not make good. Going further into the matter, why would it not benefit the master builders to have classes for foremen, say one night a week, where a capable teacher could be provided to instruct the foremen how to handle apprentices?

This apprentice situation is of such vital importance to the welfare of the building trades' future that it is worthy of serious consideration by every master builder in the country. Therefore, if we expect to accomplish the end we set out to gain, we must make the proposition we have to sell attractive and really, in the end, it is a salesman's proposition—the builders are selling the young man a trade.

* * *

Carpenters Study Architecture

Thirty carpenters are taking a course in architecture at the University of Oregon, Eugene. The class is held every Friday evening by Professor Percy P. Adams of the architectural department. Two courses—graphic statics and estimating—are being given and a majority of the men are taking both courses.

Radium—A New Element in the Safety Movement

By ARTHUR ROEDER

RADIUM, the most mysterious and most powerful element known to science, which has the greatest power of all discovered sources of energy, has now been linked with the safety movement and will lend its power to the prevention of avoidable accidents. So great is its power that one gram is sufficient to raise a ton of water from the freezing to the boiling point. If one ton of it were harnessed to a ship equipped with 1,500 horsepower engines, the ship would be propelled at the rate of fifteen knots an hour for thirty years.

Radium is best known to the world through its curative properties in the treatment of cancer and through its commercial value in making radium luminous material. The power of radium was made known only a few years ago through the efforts of a Polish woman scientist, and a French and an American professor. Radium now treats thousands of cases of cancer annually, preventing death and eliminating a great deal of suffering.

Radium's role in industry as a life saver is less spectacular, but perhaps even more important than it is as a therapeutic agent. The great mass of accidents in factories, in mines and in other industrial institutions where darkness is a creator of danger, are being eliminated through the newest invention of science—radium luminous material. Radium illuminated watches are familiar articles. The same material that illuminates these is now being employed in great factories on all power line switches where fumbling might mean electrocution to the operator.

High pressure gauges, which are installed as an insurance against dangers are deprived of a great deal of their safety value through inconstant lighting. Their dependability as indicators is increased tremendously through making them safe twenty-four hours a day by the application of radium luminous material, which is invariably luminous in the dark. Steam gauges and water gauges of all sorts are making use of radium to increase safety.

Electric switches are often set in places which are unlit. This includes electric lighting equipment which is usually visible only after the light it controls has been turned on. A spot of radium luminous material on the bottom or switch makes them easily located in the dark, so that in emergency they may quickly be made use of.

Likewise, a fire alarm or a fire extinguisher is deprived of a good deal of its efficiency through being invisible in the dark. Radium luminous material acts as a quick locator for them. Telephones which are often necessarily found quickly in the dark in emergencies, various emergency call bells, and revolvers are made more useful through the application of undark. Gun sights, illuminated, insure accuracy of aim in the dark. The need of luminating poison bottles, so that they may stand out warningly in the dark has been demonstrated too often to need further dwelling on. An interesting safety device is the safe combination whose dial is radium luminated, so that no artificial light need be used for it.

The industrial uses of radium luminous material are many. Bolts that are necessarily attached to the dark under-portions of machines and equipment are being touched with dabs of this luminous material, with a consequent great saving of bloodshed. In mines where the carrying of oil lamps or the placing of electric lighting equipment is not feasible, radium has been found to be a boon to humanity. There are dark corners in the dark underground channels which miners must traverse; corners where danger lurks—these are made safe through the unvarying luminosity of radium.

While radium is the most valuable element in the world—a gram of radium which is about a thimbleful, costs \$120,000, as opposed to \$150 for an ounce of platinum—so powerful is it when mixed with other materials that even the minutest particle is effective in making material self-luminous for years. It is this quality which makes radium luminous material commercially possible.

The great value of radium is due to its scarcity, and to the great difficulty in isolating it after it has been found. Much of the radium of the world is now found in America, in carnotite fields. A great portion of this comes from the Undark Radium mines in the Paradox Valley of Colorado.

The ore is found in narrow seams in the ground. It is sorted and packed in 100-pound sacks and transported sixty miles to the nearest railroad station on the backs of burros and mules. Thence it is shipped in carload lots 2,900 miles across the continent to an extraction plant in Orange, N. J.

Two hundred fifty tons of ore treated with an equal amount of chemicals and water yields one gram, which is about the size of a pinhead.

The power of radium lies in the penetrating character of its rays, which disintegrate and travel at the rate of 3,000 miles a quarter of a second.

In addition to the use of radium luminous material on machinery in industrial plants, it is used extensively for the marking of any corner or spot which should be visible in the dark. Angles of tables and chairs, corners in rooms, numbers to indicate cubby holes or doorways on which there is no other illumination are touched with a spot of undark. Even the valuable electric torch increases its efficiency when it has a touch of radium on it so that it can be reached instantly in an emergency in the dark.

The employment of radium to help solve our medical and industrial problems of life safety is as yet in the first stages of its development. What the future will bring no one knows.

* * *

Lumber Cut of 788 Identical Sawmills—1918-1919

A preliminary comparative report on the cut of lumber for 1919, compiled in co-operation with the Forest Service, Department of Agriculture, has been issued by Director Sam L. Rogers, Bureau of the Census, Department of Commerce.

The statement shows the production of lumber for the years 1918 and 1919 by 788 large identical mills which reported a total cut of five million feet or more annually in either one or both of these years.

This group of large mills normally produces more than one-third of the total lumber cut of the United States. The mills are located in thirty-four states and, therefore, introduce into this comparison elements of the production conditions in practically all lumber regions of importance. Since their total cut as reported in 1919 differs by only three-tenths of one per cent from that of 1918, it appears reasonable to forecast that the lumber cut of the United States in 1919 will vary from that of 1918 by only a relatively small quantity.

Notwithstanding the termination of hostilities and the unprecedented advance of prices which began in 1919, and which normally might have been expected to stimulate production, it is apparent that other factors, such as labor troubles, transportation difficulties, unfavorable weather, and financial stresses were sufficient to restrict the output to the approximate level of the preceding year.

* * *

Tallest Concrete Structure

According to an Eastern exchange, the Arcade building in St. Louis is the tallest concrete building in the world, being seventeen stories in height above ground with two additional stories beneath the surface.

Concrete for Residences

By E. B. GOODELL, Jr., Architect, in *House Beautiful*

CONCRETE houses are in their infancy, and are comparatively untried. There have been many experiments—some successful and others decided failures. There seems to be no reason why concrete should not prove an admirable building material for the small house. It has proved its worth in many fields. Factories, garages, bridges and stadia have been made to fulfill all their requirements when built almost entirely of concrete. One of the finest examples is the Harvard Stadium—a structure which is a modern architectural monument. Why not more concrete houses?

There have been difficult problems to overcome in adapting concrete to housework. Forms are expensive as ordinarily used, and the bracing necessary for holding floor forms in a rigid position until after the initial set of the concrete is considerable. Water-proofing has been another difficult problem.

While the practical construction of concrete houses must still be considered as in the experimental state, there are conclusions which may lead to a perfect solution of the inexpensive house.

A combination of concrete walls throughout with common wooden joist construction of floors and wooden roof rafters does away with the expensive floor slab work which requires a steel reinforcement and expensive forms.

The outside walls should have an air-space—for example, a seven-inch wall made of two solid three-inch concrete walls and a one-inch air-space. This air-space insures dryness and is the most effective and cheapest damp-proofing. It also helps to keep cold out and heat in. With the air-space as described, plaster can be applied directly onto the inside of the concrete without danger of stains from seeping moisture.

The use of a very dry mixture, so that forms can be moved and used again only a few hours after the concrete has been poured into them, saves wood. Every saving in lumber in form-work is a great stride, with lumber at its present cost and the probable future shortage.

There is a splendid house in Boston where concrete has been used almost entirely. The architraves around windows and doors, all floors and practically all ornamental details are of concrete. The house is a decided success architecturally, but it was very expensive. This house, while its system of construction is not practical and could not be economically adapted to small-house work, does prove that concrete need be neither cold, ugly nor barren. The house is rich in its detail, pleasing in color, and the interior (due in a large measure, to be sure, to furnishings) is warm and homelike.

As precedent for designing concrete houses the architect can look to the domestic work of any country and find inspiration. Wherever plaster has been used on masonry, the problem has been similar.

* * *

Lumber Drops But May Soar Again Soon

Lumber producers assert that their product has reached its lowest possible level. We may safely say that by spring these prices will rebound. Other construction materials remain practically stationary, except for temporary fluctuations. No spectacular recessions are expected. Waiting for further reductions means inaction, non-production and expensive delays, when much-needed building projects should be going forward.



APARTMENT HOUSE AT HELSINGFORS, IN THE FINNISH STYLE OF ARCHITECTURE
 Photographed by the American Red Cross

Finland Develops Its Own Architecture

FOR years Finland possessed no architecture of its own. Finnish architectural students not only sought their training abroad but were forced to remain abroad for a livelihood. Stone was a luxury which few could afford. Only the public buildings were of stone. The wood-built towns were so frequently swept by fire that all desire for architectural beauty was destroyed. German and Italian architecture prevailed, and though great art upheavals swept other countries, Finland remained untouched.

Then came an increase of material wealth and with the increase Finland began to develop a few building ideas of its own. Today there are structures of granite and stone, and though German influence is still strong, the Finns have adopted a plainness and simplicity of style characteristic of themselves. Finnish architecture has a wealth of proportion and massiveness, with a lavishness of original ornament. Though simplicity usually prevails, sometimes a freakish shape is given to towers, spires and corners.

On all sides, from the buildings housing the headquarters of the American Red Cross and those in which more than 10,000 Russian refugees have been cared for, to the buildings in the pretty Helsingfors Boulevardsgatan, may be seen the beginning of Finnish architecture. Granite and stone, together with bricks covered with plaster, produce beautiful and fantastic ornamentation.

Dwellings or Lollipops?

If the disappearance of cottage pudding is because of the shortage of cottages, says The Review of Boston, is the high cost of lumber due to the vast quantities of it now being used in making lollipop handles? Probably, and while we use our lumber in making cheap sweets we cannot expect to have cheap suites.—Exchange.

THE Architect and Engineer

INCORPORATED

Founded 1905 by E. M. C. WHITNEY

W. J. L. KIERULFF - *President and Manager*
FRED'K W. JONES - *Vice-Pres. and Editor*
L. B. PENHORWOOD - *Secretary*
T. C. KIERULFF - *Attorney*

ASSOCIATE EDITORS

IRVING F. MORROW - *Architectural Critic*
CHAS. H. CHENEY - *City Planning and Book Reviews*
WILBUR DAVID COOK, *Landscape Architecture*
WM. B. GESTER, - *Inspection and Tests*
O. P. SHELLEY, C. E. } *Fireproof Construction*
F. W. FITZPATRICK, }
T. RONNEBERG, C. E., - *Structural Steel*
W. H. LOWE - *Roofs and Roofing*
FRED'K N. WOODS, JR., - *Rock and Gravel*
W. H. GEORGE - *Cement*
CHAS. FELIX BUTTE *Electrical Construction*
H. J. BRUNNIER - *Reinforced Concrete*
J. W. FRICKE, - *School Equipment*
C. H. WHITE - *Hardwood*
WILL J. FRENCH, *Department of Safety*

Published Monthly in the Interest of the Architects, Structural Engineers, Contractors and the Allied Trades of the Pacific Coast by The Architect and Engineer, Inc.

BUSINESS OFFICE AND EDITORIAL ROOMS

627-629 Foxcroft Building, San Francisco
Telephone Douglas 1828

Los Angeles Representative: Bert Butterworth Agency, Citizens Bank Building, Los Angeles.

Portland office: 210 Stock Exchange Building, Portland, Oregon.

The publishers disclaim any responsibility for statements made in the advertisements of this magazine.

TERMS OF SUBSCRIPTION

(Including postage) to all parts of the United States \$2.50 per annum; to Canada 75c additional; to all Foreign points \$1 additional.

Vol. LXIII. Dec., 1920 No. 3

THE AMERICAN PLAN BEST— LET'S GET BUSY

The spirit of fair play must dominate in industrial relations if there is to be industrial peace and a prosperous development of American life.

Anything less than absolute industrial justice must react, as it often has in the past, to the detriment of the man or men who have been guilty of injustices. Unfortunately it seems to be written in the scheme of things that most square men who play the game fairly, suffer from the economic mistakes and misdeeds of others.

American labor must be well paid if American industries are to prosper. America is a nation of workers. Contrary to the patter of certain radicals there is in America no great leisure class. The workers are the consumers. The consumers cannot spend money unless they receive it. Restricted earnings mean re-

stricted buying capacity, and that in turn means restricted production, and when that happens we put the reverse English on the "vicious circle" about which we have all been so concerned in the last year or two. Carried to its logical conclusion, restricted earnings would mean want and suffering in a land of plenty.

Workers should all be well, even liberally paid. An American worker should be able to earn enough to meet all his expenses, while living on a comfortable American scale, raise his family according to American standards, educate his children, and have an adequate amount left over for rainy days and old age.

No one will quarrel with this as a general proposition. The trouble lies in the fact that there is no unanimity of opinion as to what constitutes a comfortable livelihood and a fair amount of recreation. There are many different standards, but by the exercise of common sense it ought to be possible to find a happy medium between grinding penury and wasteful extravagance.

For his own sake each man ought to be an individualist in his work. He ought to give to his employer in his working hours the best product of his brawn and his brain. Healthy Americanism should have no patience with any theory of restricted output. It is unfair to the employer and the employe. It works injustice to both.

Labor has the right to organize. It has the right to bargain collectively. But it has not the right to say to employers: "You shall not employ this man because he does not belong to our union."

The principle of the open shop is right and just. It is growing in strength because it is sanely American, and it has the sentiment of the general public behind it. The shop closed to union men is not an open shop. It is an autocratic and unfair attitude which says that a man shall not work in a shop because he belongs to an organization of his fellows. It is not a policy that would

tend to create a fair understanding between employers and workers.

Every man, says a writer in the Builders' Guide, ought to be employed on his merits, and to the employer should be reserved the right to discharge any man who is incompetent or who will not do a fair day's work.

This is very true. The American plan has been tried in Seattle and in Los Angeles and has proved a success. San Francisco industries and employers of building mechanics should try out the American plan—the sooner the better, and when this is done and our bankers quit their pessimism, architects and builders will have no complaint about not having enough work to keep them busy.

RAVAGES OF THE MARINE BORER

The destructive teredo has been raising havoc with wooden piles all along the San Francisco Bay and engineers are exerting themselves in an effort to find a pile that will resist the ravages of this "pesky" parasite, yet at the same time will not involve too great an expenditure. Concrete piles seem to be the best solution thus far. An idea of how much damage is being done by this marine borer may be had from the following clippings taken at random from recent news publications:

MARE ISLAND—The causeway, which is now being repaired by employes of the Public Works Department of Mare Island as a result of damage caused by the teredo, has cost the Government nearly \$400,000. The yard has some \$116,000 with which to make the needed repairs, and if the teredo remains in local waters after the heavy rains it is quite likely that arrangements will be made to install concrete piers. The causeway was authorized during the war and is 3000 feet in length, and a bascule lift in the center allows warships and other craft to pass up and down the channel.

VALLEJO—The Monticello Steamship Company has a piledriver at work installing some piling at Maine street dock to take the place of the piling that has been damaged by the teredo. The electric railroad people are preparing to install some seventy piles alongside their wharf this month, according to City Engineer T. D. Kilkenny. The city wharf

at the foot of Virginia street is to be inspected again to see if the teredo has damaged the outer piles, and in the meantime all heavy loads will be kept off the landing place.

* * *

At Port Costa the Southern Pacific Company is replacing its wharves which have been virtually ruined by the teredo. And the same conditions have been found to exist at Martinez.

Commenting on the subject the Chronicle finds that it needs no survey of the worm-eaten piles to know that concrete is the final answer to the teredo. "As for wood," concludes the Chronicle, "you may dope, you may paint the piles as you will, but the teeth of the shipworm will gnaw at them still. Indeed, so unequal has been the success of creosoting wooden piles that a strong suspicion has arisen that instead of poisoning the teredo, creosote is merely an appetizer."

It is claimed that concrete resists decay far beyond the endurance of any wood that grows. Once put down, if the job is properly done, it lasts, and on public works, like water front piers, the concrete stands up indefinitely.

Notes and Comments

This is culled from Mr. Bert Taylor's "Linotype or Two," in the San Francisco Chronicle:

"Benjamin Bills will talk on 'What Many Architects Lack' at 6 P. M."—Art note.

We fancy that what they lack at that hour, or a little later, is a judicious combination of Gordon dry and vermouth.

One million weddings were celebrated in the United States in 1919 but only 70,000

A Million Weddings and *70,000 New Homes* new homes were erected — 400,000

short of the actual needs. In 1890 an average of 110.05 families occupied each 100 homes. Today there are 125 families for each 100 homes and no re-

(Continued on page 126)

American Institute of Architects
(ORGANIZED 1857)
OFFICERS FOR 1920-21

PRESIDENT.....HENRY H. KENDALL, Boston
FIRST VICE-PRESIDENT.....CHARLES A. FAVROT,
New Orleans, La.
SECOND VICE-PRESIDENT.....WM. B. FAVILLE,
San Francisco
SECRETARY...W. STANLEY PARKER, Boston, Mass.
TREASURER.....D. EVERETT WAID, New York

San Francisco Chapter

PRESIDENT.....G. A. APFLEGARTH
VICE-PRESIDENT.....EARNEST A. COXHEAD
SECRETARY-TREASURER.....J. S. FAIRWEATHER
DIRECTORS
SYLVAIN SCHNAITACHER, for three years.
MORRIS M. BRUCE, for three years.
GEORGE W. KELHAM (to fill the unexpired term
of Mr. Wm. Otis Raiguel, resigned).

Southern California Chapter

PRESIDENT.....EDWIN BERGSTROM
VICE-PRESIDENT.....HENRY F. WITHEY
SECRETARY.....R. GERMAIN HUBBY
TREASURER.....ROBERT H. ORR
Executive Committee
A. M. EDELMAN D. C. ALLISON S. B. MARSTON

Portland, Ore. Chapter

PRESIDENT.....W. C. KNIGHTON
VICE-PRESIDENT.....JOHN V. BENNES
SECRETARY.....FOLGER JOHNSON
TREASURER.....O. R. BEAN
TRUSTEES.....{ ELLIS F. LAWRENCE
JOSEPH JACOBBERGER

Washington State Chapter

PRESIDENT.....CHARLES H. ALDEN, Seattle
1ST VICE-PRESIDENT.....JAMES H. SCHACK, Seattle
2D VICE-PRESIDENT.....GEORGE GOVE, Tacoma
3D VICE-PRESIDENT.....L. L. RAND, Spokane
SECRETARY.....F. A. NARAMORE, Seattle
TREASURER.....EARL G. PARK, Seattle
DIRECTORS.....{ A. H. ALBERTSON
C. H. BEBB
G. C. FIELD

California State Board of Architecture
NORTHERN DISTRICT

PRESIDENT.....CLARENCE R. WARD
SECRETARY-TREASURER.....SYLVAIN SCHNAITACHER
Members
J. R. MILLER EDWARD GLASS J. J. DONOVAN

SOUTHERN DISTRICT

PRESIDENT.....JOHN PARKINSON
SECRETARY-TREASURER.....A. M. EDELMAN
Members
W. H. WHEELER MYRON HUNT W. J. DODD

San Francisco Architectural Club

PRESIDENT.....Harry M. Michelson
VICE-PRESIDENT.....T. Pflueger
SECRETARY.....W. E. Baumberger
TREASURER.....James S. Cole
DIRECTORS—F. F. Amandes, N. Reinhertz, E. B.
Hurt.

San Francisco Society of Architects

PRESIDENT.....W. C. HAYS
VICE-PRESIDENT.....LEWIS P. HOBART
SECRETARY-TREASURER.....H. H. GUTTERSON
DIRECTORS.....{ GEO: A. LANSBURGH
JOHN REID, JR.

Washington State Society of Architects

PRESIDENT.....HENRY H. JAMES, Seattle
1ST VICE-PRES.CLAYTON D. WILSON, Seattle
2D VICE-PRES.JULIUS A. ZITTEL, Spokane
3D VICE-PRES.WATSON VERNON, Aberdeen
4TH VICE-PRES.RICHARD V. GOUGH, Okanogan
SECRETARY.....EDGAR BLAIR, Seattle
TREASURER.....L. L. MENDEL, Seattle
TRUSTEES—H. H. JAMES, FRANK WENDEL, A. WARREN GOULD, W. J. JONES, R. H. ROWE, all of Seattle.

American Society of Landscape Architects

Pacific Coast Chapter

PRESIDENT.....W. D. COOK, JR.
H. W. Hellman Bldg., Los Angeles, Calif.
VICE-PRESIDENT.....STEPHEN CHILD
Fairmont Hotel, San Francisco, Calif.
SECRETARY-TREASURER.....E. T. MISCHKE
Henry Bldg., Portland, Oregon

Tacoma Society of Architects

PRESIDENT.....Roland E. Borhek
VICE-PRESIDENT.....Earl Dugan
SECRETARY AND TREASURER.....A. J. Russell

San Diego Architectural Association

PRESIDENT.....WM. TEMPLETON JOHNSON
VICE-PRESIDENT.....ROBERT HALLEY, JR.
SECRETARY-TREASURER.....E. C. DECKER

San Joaquin Valley Ass'n of Architects

PRESIDENT.....E. B. BROWN
VICE-PRESIDENT.....F. V. MAYO
SECRETARY-TREASURER.....JOSEPH LOSEKANY

American Society of Civil Engineers
Southern California Association

President.....H. W. Dennis
First Vice-President.....R. J. Reed
Second Vice-President.....F. D. Howell
Treasurer.....E. R. Bowen
Secretary.....F. G. Dessery
DIRECTORS—H. W. Dennis, Ralph J. Reed,
F. D. Howell, E. R. Bowen, F. G. Dessery, G. G.
Anderson, W. K. Barnard.
Address all communications to Secretary F. G.
Dessery, 619-20 Central building.

San Francisco Association

PRESIDENT.....M. M. O'SHAUGHNESSY
1ST VICE-PRES.....W. L. HUBER
2ND VICE-PRES.....F. R. MUHS
SECRETARY AND TREASURER.....NATHAN A. BOWERS
BOARD OF DIRECTORS
W. L. HUBER
F. R. MUHS M. M. O'SHAUGHNESSY
E. J. SCHNEIDER NATHAN A. BOWERS
Address all communications to the secretary, 502
Rialto Bldg., San Francisco.

American Association of Engineers

National Headquarters, 63 E. Adams St., Chicago
PRESIDENT.....L. K. SHERMAN
FIRST VICE-PRESIDENT.....H. O. GARMAN
SECOND VICE-PRESIDENT.....A. B. MCDANIEL
R. W. BARNES.....Portland
FREDERIC BASS.....Minneapolis
B. A. BERTENSHAW.....Cincinnati
W. C. BOLIN.....Chicago
RAYMOND BURNHAM.....Chicago
C. E. DRAYER.....Secretary

SAN FRANCISCO CHAPTER

PRESIDENT.....WILLIAM WOLLNER
FIRST VICE-PRESIDENT.....J. F. JOHNSTON
SECOND VICE-PRESIDENT.....W. H. PHELPS
TREASURER.....R. L. KESSING
SECRETARY.....A. G. MOTT
Permanent address, 960 Pacific Bldg.

LOS ANGELES CHAPTER

PRESIDENT.....FRANK H. GAYNER
FIRST VICE-PRESIDENT.....C. A. HEINZE
SECOND VICE-PRESIDENT.....H. Z. OSBORNE, JR.
SECRETARY.....D. E. GODFREY
TREASURER.....E. H. MERRILL
Permanent address, 625 Metropolitan Bldg.,
Los Angeles.

With the Architects

Building Reports and Personal Mention of Interest to the Profession

Praise for Mr. Hobart's Work

From the Architectural Review.

The Architect and Engineer, San Francisco, July, is largely devoted to the work of Mr. Lewis P. Hobart, including the Del Monte Lodge and Swimming Pool, the Hillsborough District School, Administration Buildings, St. Luke's Hospital, San Francisco, the Red Cross Hospital, San Mateo, and two residences. Mr. Irving F. Morrow, in writing of them, states his pleasure as a critic in seeing them. They are the work of an artist, admirable, and could form an object lesson for those who in their desire to be spontaneous become absurd. They are well composed, devised, proportioned, detailed and designed, and in no case are excessive in any direction—they are delightful. There is also an illustrated article upon industrial buildings of concrete.

Stadium for Stanford University

Stanford University trustees have authorized construction of a \$750,000 concrete stadium to accommodate 60,000 people. Messrs. Bakewell & Brown, architects for the University, will prepare the plans. The University of California needs a stadium as badly as Stanford, as was evidenced when thousands were turned away from the big Thanksgiving football game. Here would be a splendid opportunity for some wealthy Californian, philanthropically inclined, to perpetuate his name for many years to come, by building a stadium and making a gift of it to the University.

Two Commercial Garages

Mr. Joseph L. Stewart, architect in the Claus Spreckels building, San Francisco, has completed plans for two large commercial garages to be built in San Francisco. Both buildings are of unusual design as indicated by the elevations shown elsewhere in this issue. One of the buildings is a four-story reinforced concrete structure, which will be erected on the south side of Market street, 125 feet east of Ninth, San Francisco, at an estimated cost of \$175,000. Mr. Thomas McDougall is the owner. The other building is for Mr. Mortimer Fleischhacker and is being erected on Market street, near Brady, at a cost of \$100,000.

Personal

MESSRS. McDONALD and KAHN, construction engineers, are erecting a building for themselves on Montgomery street, between Sutter and Bush, San Francisco. They expect to occupy their new home early in the spring. Their offices at present are in the Rialto building.

MR. ARTHUR BROWN, JR., returns this month from extensive travels abroad that have consumed the greater part of the year. Mr. Brown was accompanied by Mrs. Brown. Mr. Brown is junior member of the San Francisco architectural firm of Bakewell & Brown.

MR. ARTHUR BUGBEE, architect, has moved from the Sharon building, San Francisco, to room 318 in the remodeled building at 26 Montgomery street. Mr. Bugbee's new phone number is Sutter 5012.

MR. F. E. QUAIL has been appointed county engineer of San Joaquin County at a salary of \$5000 per year. Mr. Quail was county surveyor and his new appointment was made under the provisions of the Reams law.

Le Brun Scholarship Competition

The executive committee of the New York Chapter of the American Institute of Architects, as trustees of the traveling scholarship founded by Pierre L. LeBrun, announces a competition for the selection of a beneficiary, and calling for drawings to be delivered about January 15, 1921. Under the terms of the award \$1,400 is available for an architect or architectural draftsman resident in the United States to aid him in paying the expenses of an European trip lasting not less than six months.

Addition to Bank Building

The Bank of Italy will build a \$125,000 addition to its building at Temple and Spring streets, Los Angeles, from plans by Mr. Albert C. Martin.

Swimming Tank

The Fresno City Park Commissioners have recommended the construction of a large community swimming tank with dressing rooms and lockers at Roeding Park.

Architect T. P. Ross Busy

Mr. T. Paterson Ross, 310 California street, San Francisco, has recently awarded a contract amounting to approximately \$60,000 to the American Marble and Mosaic Company for marble work in the mausoleum of the Forest Lawn Memorial Park Association, Los Angeles. Mr. Ross has also let a contract for \$8,700 for alterations and additions to Mr. John Tonningsen's store at Twenty-second and Mission streets, San Francisco. Plans have been completed by the same architect for a three-story frame apartment house to be erected at Fourth and Irving streets, San Francisco, for M. Cohen, and for a one-story, eight-room bungalow in Westwood Park, for Mr. E. Ketjen.

Architect Schwartz Busy

New work in the office of Mr. Mel I. Schwartz, Nevada Bank building, San Francisco, includes a two-story frame and stucco office building and apartments, 27½x132-8 on Sacramento street, west of Octavia, San Francisco, for Dr. Albert Abrams, and a one-story reinforced concrete store building on Post street, west of Leavenworth, San Francisco, for Pauline Schoenberg.

San Luis Obispo Schools

A bond election for \$373,000 has been called at San Luis Obispo for new schools and additions. Messrs. John J. Donovan of Oakland and Orville L. Clark of Bakersfield and San Luis Obispo have been commissioned to prepare the plans.

Informal Competition Decided

The plans of Messrs. Wolfe & Higgins, architects of San Jose, for a one-story reinforced concrete school building for the Penitencia School near San Jose, have been selected in an informal competition. Construction of the building, which will cost \$70,000, will be started early in the spring.

Pasadena Hospital

Mr. Myron Hunt of Los Angeles is completing working drawings for a four-story Class "A" hospital for the Pasadena Hospital Association. The building will accommodate from eighty to one hundred patients.

Another San Francisco Theatre

Plans are being prepared by Mr. T. L. Pflueger, associated with Mr. J. R. Miller, architect in the Lick building, San Francisco, for a Class "A" reinforced concrete theatre to be built on Castro street, between Seventeenth and Eighteenth streets, San Francisco, for Nasser Bros.

New Sacramento Bank

The new Merchants National Bank to be established in Sacramento after the first of the year and which is to have suitable banking quarters, has elected Mr. Norman De Vaux, well-known San Francisco and Oakland automobile man, Vice-President, and Mr. Chas. Heeseman, a director. The President of the company is Mr. J. H. Stephens of Sacramento. The new Bank will be situated on the Cavanaugh property on the corner of the alley east side of Seventh Street, J and K Streets, directly behind the Post Office Building.

Designing Packing Plant

The plans for the \$200,000 office building to be built jointly by the California Peach Growers and Associated Raisin Co. at Fresno are being prepared by Messrs. Glass and Butner, 427 Cory building, Fresno, and Hearst building, San Francisco. The same architects are also preparing plans for a \$250,000 packing house for the California Peach Growers. The engineering and mechanical plans are being prepared by Messrs. Hunter and Hudson, Rialto building, San Francisco. Construction is to be of reinforced concrete.

Two Seattle Apartment Houses

Mr. William Bruce of Seattle has completed plans for two large community apartment buildings to cost \$750,000. One of the buildings is for Mr. George Boole and will be 128x142, eight stories high and constructed of white terra cotta or brick. There will be 30 apartments. The other building is for Mrs. Anna C. Boyd and will be ten stories, 120x120 of fireproof construction and will contain 57 apartments.

\$1,000,000 San Pedro Apartments

Mr. John G. Evans, San Pedro, has prepared plans for a 7-story Class "A" apartment house to be erected at Tenth and Leland streets, San Pedro, for himself. Mr. Evans is a contractor, formerly of New York. The building will contain 102 apartments, of 3, 4 and 6 rooms and will cost \$1,000,000. There will also be 30 single rooms.

Sacramento Canning Plant

Announcement is made in Sacramento that a permit has been issued to start construction of the first unit of the \$200,000 cannery for the Sacovalley Meat Canning & Provision Company. Construction will be of reinforced concrete and brick—the first story of concrete and the second of brick. The architect is Mr. Clarence C. Cuff, Ochener building, Sacramento.

Dies of Apoplexy

Mr. Carrol H. Brown, for many years a practicing architect in Los Angeles, died suddenly of apoplexy at his ranch, Sierra Madre Villa, Nov. 18. He had been helping a man on the ranch who was clearing away some rocks, during the afternoon, and it is believed the stroke was brought on by over exertion.

Mr. Brown was born at Champaign, Ill., in 1861, and came to Los Angeles about 40 years ago. Mr. Brown was the architect for the Stimson office building at Third and Spring streets, which at the time it was erected, was one of the largest and finest business structures in the city. His last important architectural work was the Puente high school. He was at one time a member of Southern California Chapter, American Institute of Architects.

Surviving are his widow and a son, Groff S. Brown, a newspaper man of Pasadena, a daughter, two brothers, Mr. Edgar B. Brown, an architect of Stockton, and Mr. G. S. Brown of Santa Barbara.

Masonic Temples

Mr. Carl Werner, architect in the Humboldt bank building, San Francisco, is preparing plans for a \$200,000 Masonic Temple to be built at San Jose and another at Bakersfield. Plans for the Stockton temple have been completed by Mr. Werner and constructions will start early in the year.

Designing Ferry Slips

Mr. H. J. Brunner, C. E., Sharon building, San Francisco, is designing the ferry slips, pier, etc., for the Golden Gate Ferry Co., which is to operate an automobile ferry from North Beach, San Francisco, to Marin County.

Government Hospital

Mr. W. A. O. Munsell, 414 Stimson building, Los Angeles, has completed plans for two two-story reinforced concrete hospital buildings to be erected at the Soldiers' Home, Sawtelle.

Brick Warehouse

Mr. W. H. Crim, Jr., 425 Kearny street, San Francisco, has completed plans for a four-story Class "C" warehouse to be built on Brannan street, near Eighth, for the Western Pacific Railway Company.

Certificate to Practice

On November 30th, 1920, at the regular meeting of the California State Board of Architecture, Mr. James Somerville Dean of 1351 40th street, Sacramento, was granted a certificate to practice architecture in this State.

Oakland Apartment House

Plans have been completed by Mr. C. W. McCall, Central Bank building, Oakland, for a three-story frame and plaster apartment house to contain twelve, two and three-room apartments for Mr. John Westphal of 1933 Harrison street, Oakland. The building will cost \$51,000.

Lodge Room Alterations

Messrs. Sidney B. & Nobel Newsom, architects in the Nevada Bank building, San Francisco, are preparing plans for alterations to the lodge rooms of the Oakland Moose. Improvements will include a gymnasium. The same architects are designing a two-story brick veneer residence to be built in Piedmont at an estimated cost of \$25,000.

Portland Elks Building

Messrs. Hotaling & Dougan, Henry building, Portland, have completed plans for a four-story Class "A" lodge building for the Portland Lodge of Elks to cost \$650,000.

Wants Books on Architecture

Mr. C. E. Azurdia, Department of Civic Design, University of Liverpool, writes that he would like to get in communication with publishers in the United States of architectural books, such as the History of Architecture, Construction, Theories, Housing Schemes, Town Planning and allied subjects.

Alterations to Store

Mr. William Mooser, Nevada Bank building, San Francisco, has let segregated contracts for extensive alterations to Ohlandt & Buck's store at 966-970 Market street, San Francisco. The improvements will cost in the neighborhood of \$30,000.

San Mateo Residence

Mr. Thomas M. Edwards, Commercial building, San Francisco, has completed plans and awarded a contract for a handsome \$25,000 country residence to be erected in the Homestead Tract, San Mateo, for Mr. Antone Borel of San Francisco.

Passing of Carl W. Regnart

Mr. Carl W. Regnart, for the past few years San Francisco manager of the Pacific Manufacturing Company, died suddenly Wednesday, December 1, following a stroke. Mr. Regnart became manager of the San Francisco office of the Pacific Manufacturing Company upon the resignation of Mr. D. O. Druffel. He was 35 years old and esteemed by a wide circle of acquaintances.

American Institute of Architects OFFICIAL MINUTES OF COAST CHAPTERS

WASHINGTON STATE CHAPTER.

Two Hundred Sixty-third Meeting.

Minutes of the 263rd meeting, held Thursday, November 4, 1920, 6:30 p. m., at Blanc's. Present: Alden, presiding; Albertson, Baeder, Bell, Cote, Constable, Field, Gould, Gove, Huntington, Knox, Lovless, Myers, Naramore, Sexsmith.

Minutes of previous meetings were read and approved.

A letter was read from the Master Builders' Association in acknowledgment of Chapter action regarding opening of bids.

A letter was read from Dennis A. Nichols regarding his appointment to membership in the Chapter.

Mr. Myers reported for Committee on Education that several meetings were held with teachers of High School Drawing. He stated that the committee was planning to come before the school board with plans to improve the type of work being done by the high school departments of drawing.

Mr. Baeder reporting for the Committee on Legislation announced that Mr. Alden would attend a meeting of State Boards of Architect Examiners, to be held at St. Louis November 17th and 18th, and that any proposed changes in laws for the licensing of architects will be deferred until after that time.

Mr. Alden spoke on the proposed building code for school buildings in the State of Washington, and suggested that a special committee should be appointed to handle our report on the proposed law. Mr. Baeder made a motion, seconded by Mr. Naramore, to refer the proposed law to a special committee. Carried. Mr. Naramore emphasized the need of a more comprehensive law than that proposed.

Mr. Albertson, speaking for the Committee on Ordinances, said that the committee was making progress in regard to the ordinance for the construction of portable booths for movie project.

Mr. Field, reporting for the Committee on Public Information, read a letter from Mr. William Stanley Parker with reference to a campaign of public information to be conducted nationally by the Institute. The letter dealt particularly with publicity in the press and suggested ways of obtaining greater publicity for the profession by that means. Several members present, at the request of Mr. Field, promised to write articles of general interest on phases of architectural service which could be edited and run in the local newspapers.

Mr. Gould, on Community Planning, reported that his committee was planning a campaign along the following three plans:

1. Collecting all the available material on community planning and digesting it.
2. Collecting local material of work either proposed or executed, to be used as examples of what might be done in Seattle or environs. Mr. Gould asked the members present to submit any material of this nature they may have at hand for review by the committee.
3. Publicity work on Community Planning through the Chapter Committee on Public Information.

Mr. Vogel, reporting for the Committee on Farm Buildings, said that the State had been divided into three districts, namely, Inland Empire, Fruit District and Coast, for the study of the problem of architectural service to the farmers. In an interesting manner he outlined the work that this committee hopes to do and contrasted it with the work now being done by a service bureau in Spokane.

Mr. Alden introduced Mr. H. L. Cunliffe, Quantity Surveyor, who gave an interesting talk on the methods pursued in England in quantity survey and detailed the methods as conducted by his office in Seattle. Discussion followed by the Chapter. Mr. Vogel moved and Mr. Gould seconded that the Chapter Committee on Quantity Survey make recommendations for Chapter action

on a specific proposal for the use of quantity survey for Chapter members and present the proposal to the Chapter for its action. Carried.

It was moved and carried that the amendments to the by-laws previously proposed should be voted upon separately.

Mr. Alden spoke in some detail regarding the work of the Zoning Commission of the City of Seattle. General discussion followed, in which the members present seemed to feel that greater publicity should be given the work of the Zoning Commission to the end that greater sympathy might be expected from the commercial organizations of Seattle. Mr. Huntington moved and Mr. Gould seconded a motion that a committee of three be appointed as Chapter Committee on Zoning to aid wherever possible the work of the Zoning Commission by publicity co-operation, etc. Carried.

Mr. Albertson moved and Mr. Baeder seconded that a vote of thanks be extended to Mr. Naramore for his services as secretary of the Chapter.

Mr. Huntington moved, Mr. Baeder seconded, that a committee on arrangements for the annual meetings be formed. Carried.

Adjourned, 10:15.

H. O. SEXSMITH,
Acting Secretary.

Architects Hold Two Meetings

The Southern California Chapter of the American Institute of Architects held two meetings at the City Club on Tuesday evening, Dec. 14. One was a special meeting called by President Bergstrom to consider and rectify all errors in the constitution and by-laws so as to make Southern California safe for architects. The other was the regular monthly meeting at which officers were elected for next year.

Architect W. J. Wythe Busy

New work in the office of Mr. W. J. Wythe, architect in the Central Bank building, Oakland, includes preliminary sketches for a large Methodist church at Modesto; working drawings for new Methodist churches at Escalon and Byron, and a brick veneer chapel and gymnasium for St. Paul's Methodist church in Oakland.

Addition to Hotel

Messrs. Miller & Warnecke, Perry building, Oakland, are preparing plans for a three-story brick addition to the Hotel Taylor, Paso Robles. The same firm has completed drawings for altering a two-story frame flat building at Castro and Eighteenth streets, San Francisco, into modern apartments. Mr. Chas. F. Gross is the owner.

Auto Sales Building

Plans have been prepared in the office of Mr. James W. Plachek, of Berkeley, for a one-story brick and tile auto sales building and garage to be erected at Broadway and Mather streets, Oakland, for Mr. W. C. Morse. The cost is estimated at \$25,000.

With the Engineers

Reports from the Various Pacific Coast Societies,
Personal Mention, Etc.

The Newer Branches of Engineering

JUST why it is we do not know, but engineering seems to be getting more popular. Perhaps it is the free advertising which Mr. Herbert Hoover has given the profession, or possibly the Federated American Engineering Societies is having some influence. But, anyway, an engineer is no longer considered one who runs an engine, just as a chemist is no longer merely a soda-water clerk.

The latest is Real Estate Engineering, or, as the pioneers in the profession call it, Property Management Engineering. This is the heading of an advertisement occupying the entire last page of the New York Tribune of Oct. 26. The advertisement goes on to say that engineers are scientists who know the facts about materials with which they work and who must not merely guess. They must also have the ability to put their knowledge to practical use. That is just the way the officials of the company running this ad feel about the handling of real estate. Hence the title. They admit that the question as to what Property Management Engineering means has been asked them many times, and we do not wonder.

Mr. Julian Street, in his interesting little satire on the modern advertising man, just published under the title "Sunbeans, Inc.," follows the career of Mr. H. Bell Brown from newspaper reporter through his "induction" into the profession of advertising engineering. It would seem that he was cut out for it. Either he learned with a speed hardly short of miraculous, or else advertising engineering may be mastered in a much shorter space of time than engineering in the commoner branches. Had he, for example, become an automobile engineer, a constructing engineer, or a civil engineer, instead of an advertising engineer, and progressed as rapidly, he would have been building motor cars, skyscrapers, steel bridges, or railroads within a year.

We are glad to see engineering becoming so popular, but we hope that the new-coming class will not totally supplant the old. No doubt Soup Engineering and Baked Bean Engineering will soon be featured in the advertising pages of our popular magazines. At present, as is well known from the advertisements, our beans are baked by chemists, who analyze each bean as it goes into the

can. Why wouldn't a good engineer be fitted to superintend the ovens, or, as they might be termed, roasting furnaces? Or even—but this is too much to expect—a good cook?—Engineering and Mining Journal.

A. A. E. to Have New Quarters

At the meeting of Los Angeles Chapter, American Association of Engineers, Nov. 19, it was decided by a practically unanimous vote to secure new quarters in the new Union League Club building at Third and Hill streets. A committee was appointed to make arrangements with the Union League Club for rooms. This committee consists of Messrs. H. Z. Osborne, Jr., chairman; W. W. Patch and D. E. Godfrey.

Considerable discussion was given to the matter of urging the appointment of Dr. Frederick H. Newell as Secretary of the Interior in the new federal administration. A resolution was adopted requesting California's senators and representatives to use their influence to secure the cabinet portfolio for Dr. Newell. A telegram was also sent to President-Elect Harding endorsing Dr. Newell for Secretary of the Interior.

Engineers Elect New Officers

Mr. G. Chester Brown, Chief Mining Engineer for California Industrial Accident Commission, was elected President of the local Chapter of the American Association of Engineers at the annual election December 7th. Mr. Brown has served as an engineer for the Associated Oil Co., City and County of San Francisco, American Mines Company, Guggenheim Syndicate, Spokane Mining Co., East Side Canal Co., and since 1915 as the chief mining expert for the California Industrial Accident Commission.

Other engineers of note will serve on the Board of Directors as follows:

Mr. Frederick J. Amweg, Consulting Engineer, San Francisco.

Mr. R. E. Dodge, Office Engineer, San Francisco Division, California State Highway.

Mr. L. D. Howland, Sales Engineer, C. C. Moore & Co.

Mr. A. G. Mott, Assistant Engineer, Southern Pacific Co.

Mr. W. H. Phelps, Assistant Division Engineer, Southern Pacific Co.

Mr. P. E. Dufour, Interstate Commerce Commission, San Francisco.

Mr. W. S. Wollner, General Safety,

Fire Prevention and Welfare Agent, Northwestern Pacific Railroad Co.

The Chapter has 646 members of the total of 25,000 in the United States. It is the engineers' business organization, formed to enable the engineers to render efficient public service.

The new officers purpose taking an active part in State and local affairs and will voice their opinions on engineering problems as a guide to their fellow citizens in deciding local issues of a technical character. The various professional associations and civic bodies are invited to command the services of the American Association of Engineers in the solution of any civic problems which, on account of their technical character, are difficult to analyze without the aid of the engineer.

Pile Driver for Sinking 200 Feet Concrete Piles

From *The Engineer*, London, June 11, 1920.

DURING the execution of the foundation work for a large reinforced concrete bridge in Sweden it was found necessary to provide for piles up to 200 feet in length in order to reach solid bottom, the circumstances being such as to prevent the driving of shorter piles with subsequent building up and re-driving.

The bridge, which is 300 feet long and connects Ropsten and Lidings, is constructed with a number of 50-foot spans, each of which is supported on piles varying in length from 75 feet to 200 feet. The depth of water is about 60 feet and the bottom consists of soft soil for a distance of about 80 feet down, after which firm ground is encountered. A considerable part of the pile is thus unsupported, which necessitated ample dimensions to prevent buckling. Moreover, as the whole of the driving operations had to be carried out from the surface of the water the designers were faced with the difficulty of providing a pile 200 feet long which was of sufficient stiffness to be handled and driven, and which would yet allow of easy transport to a floating pile-driver. The problem was solved by constructing the piles as circular tubes between 3 feet and 4 feet diameter, reinforced with steel and built in a specially constructed dry dock, from which they could be floated out to the pile-driver. After driving they were filled with concrete.

The pile-driver, which, of course, had to be specially designed for the purpose, is mounted on four floating caissons built of reinforced concrete. The equipment is provided with pumping machinery for trimming during the handling and pitching of the piles. This trimming arrangement was also utilized to tilt the pile frame in order to drive the piles to a certain inclination, as required by the de-

signers. In addition to the trimming pumps, force pumps were provided for actual driving purposes, two water jets being carried along the whole length of the piles diametrically opposite one an-

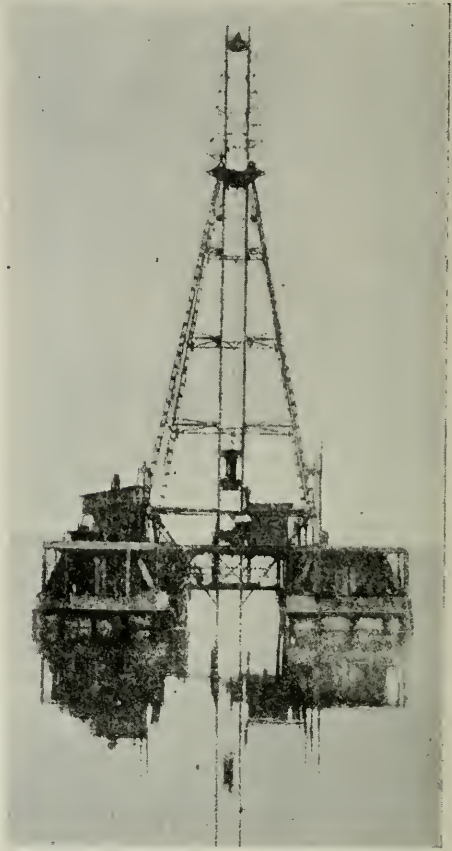

Floating Pile Driver for 200 Feet Long Reinforced Concrete Piles.

other. Hydraulic hose, specially armored to support the weight due to the considerable length of hose filled with water, was obtained.

On account of the height of the pile-driver special precautions had to be taken against wind pressure, and a very broad base is provided so as to minimize the effects of wind tilting. The leaders are of the sliding type and admit of being lowered below water to a considerable depth, while guide rollers are fitted so as to keep the circular piles in place during the driving. The weight of the hammer was about 10 tons.

The whole of the pile frame was designed and built by Messrs. Christiani and Nielson, 25 Victoria street, Westminster, London, England, in connection with the design and execution of the reinforced concrete work of the bridge above and for which they were responsible.



Electrical Department

Present Tendency in Street Lighting

THE present trend in street lighting and illumination was outlined as follows in a report of the Committee on Street Lighting submitted last month at the annual convention of the American Society for Municipal Improvements:

There is a tendency in the larger cities to install on the principal thoroughfare, or thoroughfares, usually the main thoroughfare of the city, what is known as high power lamps, either the gas filled, or, in exceptional cases, the luminous arc.

New installations have just been made on Broadway in the city of Los Angeles, at Saratoga Springs, N. Y., at New Orleans and at San Francisco. These installations are composed of ornamental iron poles carrying one or more lamps at the top. Considerable height has been added to the poles, in some cases 27 feet, in contrast with lower candlepower units installed heretofore.

There is a tendency to substitute for residential lighting a lantern neatly designed to replace the round globe which has been so extensively used heretofore. There is an advantage in the lantern in that when a glass becomes broken it is not as expensive as the replacement of the globe. As an illustration; an 8x18 globe costs at this time approximately \$7.50, the 8x16 nearly \$5. Therefore it is easily seen that the replacement of one or two panels in a lantern is much less expensive and, furthermore, the lantern is a change and when of proper design is very artistic.

Greater effort is being put forth in designing street lighting systems artistically. This refers to the standards as well as the lamp equipment. In former years our street lighting systems were anything but artistic, and some of them very cumbersome and unsightly. These are all giving way to the more modern artistically designed equipment.

Practically all street lighting heretofore has been on the series system. There is a tendency, however, to install multiple systems. The thing that stands in the way of the increased use of the multiple system is the problem of controlling the system, i. e., turning the lights on and off in a way that will not only be economical but dependable. The

constant-potential multiple system with proper control offers considerable advantage over the old constant-current series system. It has greater flexibility in the number of lamps, the elimination of station apparatus, taking advantage of the use of constant-potential transformers already in service for commercial purposes, power factor practically unity. It seems that the tendency will be for an increased extension of constant-potential multiple systems except where special systems are required for white-way lighting.

The practice on the part of municipal officials today is to spend more money for street illumination. In this connection frequent comparison as to the cost of street lighting on the per capita basis is made, but it does not tell the whole story. The true comparison is the number of watts per mile of street or the candlepower per mile of street. Then, too, the rate paid for electrical energy must be taken into consideration.

The tendency in the past has been to illuminate one down-town street, or the business section and leave the residential section unprotected. There is a clamor for electric street illumination to replace the inadequate gas lighting of the past age. Changes are being made as fast as the old contracts expire. It is difficult for gas illumination to compete with first-class electric street illumination.

In changing over street-lighting systems from gas to electric, in many cases the old iron lamp-post can be used by substituting a neat and artistic top casting carrying the necessary socket, receptacles and glassware. This will save considerable expense in the installation of an ornamental street-lighting system in a residential section in the replacement of gas lighting. This has been done in Chicago with good effect.

More money is being appropriated for street lighting than in the past because of the fact that it is now realized that a well-lighted thoroughfare is a great aid to the protection of the inhabitants of our cities, a great aid to the police department and fire department and furthermore, greatly adds to the safety in these days of the advanced use of motor-propelled vehicles.

The Contractor

BUILDING CONSTRUCTION, BRIDGES AND
ROAD WORK

General Contractors Discuss Segregation of Bids

SEGREGATION of contracts for work on public buildings was the chief subject considered by Los Angeles Chapter, Associated General Contractors of America, at the regular meeting, Nov. 18. This method of letting work has been a matter of considerable concern to the general contractors, as they regard it as encroaching upon the field of the general contractor and having a tendency to ultimately greatly restrict the scope of their operations.

In order that its members might learn the views of architects doing work by segregated contracts, the Chapter had extended an invitation to Mr. J. E. Allison, senior member of the architectural firm of Allison & Allison, to address them on this subject. Mr. Allison said he was pleased to have an opportunity to talk over the matter with the members of the Chapter, as many persons entertained an erroneous idea of his attitude toward contractors. His chief reason, he stated, for segregating contracts, was the difficulty which the firm has experienced in getting responsible and experienced general contractors to bid on their work.

Under the state law contracts for public work must be let to the lowest responsible bidder. Invariably city and county attorneys ruled that ability to furnish a bond is the only test of responsibility under this law. It unfortunately had been possible, Mr. Allison said, for men lacking the essential qualifications of a general contractor, to secure bonds. When contracts were let to such persons the only thing to which they gave consideration in letting sub-contracts was the matter of price. The man who offered to do the work the cheapest was selected and it was left to the architects to get the best they could out of the sub-contractors. To remedy this situation the practice of segregating contracts had been resorted to, Mr. Allison said. This method gave the architects and owners direct control over the contractors on every part of the work. It was true, he said, the test of responsibility was the same under the law, as when a general contract was let.

Mr. Allison explained his firm's method of segregating the work. On a building costing \$100,000 or more it was usually divided into about 15 contracts, the principal one embracing the excavation, concrete and carpentry work. Sometimes the masonry was included in this contract, but generally if it was a large item, it was made a separate contract. On smaller buildings the principal contract sometimes included everything except plumbing and heating. Whether other parts of the work were segregated depended upon the character of the work and relative importance of the different items.

Mr. Allison stated that his firm had erected about 25 school buildings by segregated contracts and declared that this method had given uniformly satisfactory results and had enabled them to erect better buildings. Plans and specifications were made so complete and definite, he said, that each contractor knew just what part of the work he had to perform and there was no conflict or delays, the buildings being completed in schedule time.

Mr. Allison said he did not wish to place himself in the position of appearing to interfere in the general contractor's business, but he believed they would profit more by taking only that part of the work which they do themselves. He had no objection to the letting of a general contract if he could be assured of having responsible general contractors, such as those who are members of the Chapter, on the job. However, it is impossible to select contractors, under the existing law. Any person who demands a set of plans and specifications on a public building, can secure them and the work must be let to the lowest bidder who can furnish a bond.

When Mr. Allison had concluded his address he stated he would answer any questions and there was an informal discussion of the subject. This brought out the views of the contractors who maintained that the real general contractor is not a broker, but knows and understands all parts of the work and is

better qualified than anyone else to take care of it. He is more than a carpenter or a mason. In order to execute the work quickly and satisfactorily he must have control of at least all those parts which overlap the work which he does himself.

Over Billion Dollars Available for Road Construction in 1921

HIGHWAY Contractors need have no fear that road building will be delayed next year for lack of funds. The final Federal Aid appropriation of \$75,000,000, which will be available next season, together with the state and county bond issues, direct levies and revenue, will raise the total available sum to more than a billion dollars, says The National Contractors' Association Bulletin. The sources of these funds are shown in the table below.

Of the total sum thus available, probably not more than half will be actually expended during the coming year, according to the Bureau of Public Roads. A large portion of the bond issues were approved only recently and the time necessary to prepare plans and secure approval of the projects will doubtless limit the expenditures. More significant considerations, however, from the standpoint of contractors who have invested heavily in road building, are the following factors that no prospective bidder can safely neglect:

1. Supply of labor and materials.
2. Transportation service.
3. The economic principle of suppressing public works in time of business expansion or prosperity.
4. The probable volume of private construction.

The first two of these factors are old acquaintances, but their connection with economic principles and private construction will bear close scrutiny from now until June. Judging from this year's experience, the material supply appears doubtful, and since the recent creation of well functioning highway departments in most states, thousands of men formerly engaged in construction work are now employed in maintenance. Transportation is improving, but little hope is entertained that it can also stand the strain of a boom in both public and private construction.

The belief is firmly expressed in many quarters that if both public works and private projects go forward in the volume now predicted, a shortage of materials, labor and transportation with attending increase of prices, will be the inevitable result. Whether both classes of construction will be pushed or whether one will be suppressed, are questions to which answers are not yet available.

The location of extensive work may be ascertained from the following table:

FUNDS AVAILABLE FOR HIGHWAY CONSTRUCTION, 1921

Total Federal Aid Appropriations..	\$ 275,000,000
Forest Road Appropriations.....	14,000,000
State Bond Issues	543,000,000
County Bond Issues	362,000,000
Direct Levies and Revenue (estm.)..	200,000,000

Total	\$1,394,000,000
Less total of projects completed or under construction	264,000,000

Available for new construction, 1921 \$1,130,000,000

**STATE BOND ISSUES
1918 (Partly Expended)**

Illinois	\$ 60,000,000
Pennsylvania	50,000,000

1919 (Partly Expended)

California	40,000,000
Oregon	12,500,000
Nevada	1,000,000
South Dakota	4,500,000
Wyoming	2,800,000
Maine	10,000,000
Michigan	50,000,000
Utah	4,000,000

1920 (New Appropriations)

Alabama	25,000,000
Idaho	2,000,000
Oregon	10,000,000
Colorado	5,000,000
Maryland	3,000,000
Minnesota	75,000,000
West Virginia	50,000,000
Missouri	60,000,000
Virginia (Legislature to fix).....	(50,000,000)
New Jersey Vehicular Tunnel.....	29,000,000

Total State Bond Issues Available for 1921\$543,800,000

COUNTY BOND ISSUES, 1920

Alabama	\$ 5,000,000
Arizona	8,400,000
Arkansas	2,400,000
California	24,635,000
Colorado	
Florida	1,515,000
Georgia	15,245,000
Indiana	7,373,000
Illinois	8,862,845
Iowa	18,475,000
Kansas	50,000
Kentucky	1,700,000
Louisiana	5,850,000
Maine	
Michigan	2,300,000
Minnesota	12,800,000
Mississippi	15,773,000
Missouri	13,504,000
Montana	6,283,000
Nebraska	3,000,000
Nevada	1,200,000
New Jersey	
New Mexico	200,000
North Carolina	13,609,000
Oklahoma	1,158,000
Oregon	9,696,704
Pennsylvania	21,337,553
Rhode Island	8,500,000
South Dakota	
Tennessee	7,185,000
Texas	86,023,000
Vermont	2,766,000
Washington	8,225,000
West Virginia	7,039,200
Wisconsin	36,525,000
Wyoming	2,800,000

Total County Bond Issues.....\$361,971,537

Concerning Foundations Built on the Sands

By CHAS. R. GOW

AN unexpected body of sand, discovered in the course of an excavation job, has brought grief to many Northwestern contractors. Sub-surface conditions very frequently spell the difference between profit and loss on the job.

Fine wet sand has often been considered the bane of the contractor in sub-surface work, yet as a matter of fact fine wet sand, in its normal condition, will sustain as great a foundation load as coarse grained sands. The aversion to using wet sand as a bearing material has its chief basis upon the fact that we usually see such sand in its abnormal and not its normal state.

Some years ago I had occasion to construct some pier foundations upon coarse wet sand. The test borings indicated a firm layer of sand, but when the excavation had progressed to this point it was found by the inspector that he could readily force a rod into the soil for a considerable depth. Because of this apparent instability, I advised that the excavation be carried deeper until satisfactory material was encountered. The foreman suspended work for the time being and allowed the ground water to rise in the pit to its normal level. Upon attempting again to demonstrate the soft quality of sand by means of the same rod, the inspector was surprised to find that he could make no impression upon the surface of the sand now that there was no longer an upward flow through it.

It is largely because of the fact that we are obliged ordinarily to produce an unnatural condition in wet sand in order to expose and examine it, that so many people assume this to be its natural state, while the contrary is in reality true.

A perusal of the building regulations of the several large cities will show that fine wet sand and "quicksand" are al-

lowed bearing values of from one-half to two tons, while coarse sands are allotted much higher values. It has been the writer's experience in making tests upon the fine wet sands that they will carry quite as much load as the coarser sands provided the ground water stands at its normal level.

The chief danger in using such materials for foundation loads lies in the possibility of future excavations being made in the immediate neighborhood which may be carried to a lower depth than that of the foundations referred to, in which case there may be a flow of surrounding soil toward the new opening, thus undermining the foundations. Such damage however, will occur whatever may be the unit loading upon the soil.

I never hesitated to recommend loadings as high as four tons per square foot upon sand which, during the excavation process, permitted the workmen to sink to their knees in it. Nor has there ever been to my knowledge any observable settlement in such cases.

A distinction is often made between fine sand which is confined and that which is unconfined. The surrounding of a foundation site with tight sheeting is useful in preventing subsequent lateral displacement in the event of adjacent excavations being made, but it does not increase the bearing value. If the material is a pure sand it will not flow under pressure alone except under excessive loading. In the case of those sands containing a considerable quantity of clay this may not be true. It is not easily possible to determine how much, if any, clay is contained in a fine sand. The individual grains of sand may and usually are so small as to give the mass which they form the general appearance of clay. A microscope may be required in such case to determine accurately whether the particles are of sand or clay. Generally speaking, fine sands containing a considerable quantity of clay will not show the characteristic behavior of quicksand.

HARDWOOD HEADQUARTERS

ASH-BASSWOOD-BIRCH
AROMATIC RED CEDAR
COTTONWOOD-ELM-HOLLY
SOUTHERN RED GUM
HICKORY-LAUREL-MAPLE
OREGON MAPLE-PLAIN OAK
-QUARTERED OAK-
WYBROCK BENDING OAK
POPLAR-WALNUT



BOXWOOD-EBONY-IRONBARK
JENISERO-KCA-SPANISH CEDAR
LIGNUMVITAE-MAHOGANY
ROSEWOOD-TEAK-RED BEAN
SPOTTED GUM-CIRSIASIAN WALNUT

LUMBER-TIMBER
HARDWOOD FLOORING
WYBRO VENEERED PANELS
DOWELS-TREENAILS-VENEERS

WHITE BROTHERS

FIFTH and BRANNAN STREETS

SAN FRANCISCO, CAL.



The Season's Greetings.

The sincere wish of this organization is that during the year 1921 our customers will enjoy the same pleasant business relationship with us as we have had with them the passing year.

**Stanley
Tools**



THE STANLEY WORKS

NEW BRITAIN, CONNECTICUT

NEW YORK

BRANCH OFFICES

CHICAGO

Before deciding to utilize fine sand as a foundation for permanent structures, consideration should be given to the future possibility of its becoming saturated under a head which may produce quicksand.

The writer recalls a case in which some mill buildings were built upon fine sand on the high bank of a river. Later a power dam was constructed at a still higher elevation above the mill site and in the course of time the water impounded behind the dam found its way under the dam and into the fine sand which formed the foundation of the mill buildings. This condition was unknown until the pressure broke through to the river, undermining one of the buildings and causing its complete collapse. It should be noted, however, that in this, as in all similar failures, the sand under the foundation flowed to a lower level.

Ready to Follow the Market

With the advice, "buy what you need, not what you want, but if you need it, buy it," comes an announcement to the trade from Smith-Booth-Usher Co., of a readiness to follow the market, and a guarantee of prices against decline up to February 1, 1921.

"Today we are ready to follow the market," President H. P. Usher writes in his monthly trade letter. "At this time, we are without lower prices on any leading lines of goods; in fact, from our side our counting that such reductions cannot occur until the mill and factory unfilled orders are largely reduced, and only when a real reduction in cost of base materials such as iron, steel, etc., may be effective.

"Because our business may be described as not one of 'staples' but rather of 'specials', covering well-known lines of goods, which we distribute exclusively, we cannot be classed as the prime factory in price making. Truthfully speaking, our resale prices on many lines are practically established by our factories.

"However, evidencing our good-will, we will now guarantee our prices against our own price declines, (and we have but one price, found in our printed price sheets) up to February 1, 1921."

Liberal stocks is another policy announcement made by Mr. Usher at this time. "No effort has been spared in this direction," the sales letter continues, "even to the point of renewing stocks from distant jobbers, when unable to secure our supplies from regular factory sources.

"We shall continue this policy unchanged, confident that our trade will appreciate same and benefit most by being able to get what they want, when they want it."

State Highway Program

A substantial program of State highway construction is guaranteed for 1921 by the passage of Amendment No. 9.

This amendment, however, does not become effective until five days after certification by the Secretary of State, who will not be able to effect a complete and official canvass of the November 2 vote much before December 1. Thereafter the new State highway finance board consisting of Governor Stephens, State Treasurer Richardson, State Controller Chambers, Marshall DeMotte, Chairman of the State Board of Control, and N. D. Darlington, Chairman of the California Highway Commission, must meet, fix a prevailing interest rate and offer for sale such an amount of bonds as needed by the State Highway Department to meet existing obligations and provide for new work. This operation will consume not less than sixty days, as the bond sale advertisement will take thirty days and printing and signing bonds will take an equal amount of time.

Probably February 1 will be as early a day as new contracts safely may be let, but in the interim the department will work on its program of work for the next year. Every section of unconstructed highway cannot be built the first year. There is a four year program ahead and what work is done immediately will be distributed fairly throughout the State.

Shearing Stresses in Reinforced Concrete Beams

There is no subject in reinforced concrete design that presents so many interesting features as the shearing stresses in beams. A phase of it to which considerable study is now being given is the rigid connection of this shear reinforcement. A valuable contribution to this discussion is a book by Mr. H. S. Rogers, B. Sc., C. E. Mr. Rogers has devoted considerable time to the study as well as the practical design of reinforced concrete. He is now connected as Professor of Hydraulics and Structural Mechanics with one of the universities of Oregon.

The book "Shearing Stresses in Reinforced Concrete Beams", gives a complete analytical comparison between loose stirrup designs and beams reinforced with rigidly connected shear members. Some of the subjects discussed are: Requirements of Beam Design, Cost of Steel and of Handling, Stress Lines, Designing of Shear Members and Anchorage of Shear Members. Discussions and tables of many tests are also given. The two appendixes discuss the Anchorage of Web Reinforcement and Bond Stress.



TAKING the PUBLIC into PARTNERSHIP

Even on Michigan Avenue, Chicago's famous lake-front boulevard, you easily recognize the Railway Exchange Building as a landmark. It is faced entirely with light cream enamel Terra Cotta.

Drawing by Hugh Ferriss

Copyright, 1920, by
National Terra Cotta Society

RAILWAY EXCHANGE
BUILDING
Chicago, Ill.

D. H. BURNHAM & CO., Architects.

AS popular appreciation of Architecture grows and expands, the work of the architect becomes easier and more pleasant.

Today there is a wider and increasingly more intelligent appreciation of design—tomorrow the architect will find his work aided by a greater public appreciation of the advantages of certain building materials.

Through the advertising pages of *The Literary Digest*, every month, National Terra Cotta Society is acquainting the public—owners, investors, tenants, committee members—with those inherent properties of Terra Cotta which are familiar to every architect.

In this series of advertisements in *The Literary Digest*, which every architect is earnestly invited to read, it will be shown by picture and text that Terra Cotta is a building material permanent, beautiful and profitable.

National Terra Cotta Society is a bureau of service and information operating for the Terra Cotta manufacturers of the United States. Its publications cover not only the technical and structural use of the material but show, as well, examples of its application to buildings of various types.

Brochures of specific value, as indicated by their titles, will be sent to Architects on request:

The School The Theatre The Garage The Store The Bank

These brochures consist of a selection of illustrations, with text and comment, showing Terra Cotta buildings of the respective types.

Terra Cotta—Standard Construction

A Valuable Technical Reference Work for Architects and Engineers

TERRA COTTA

Permanent Beautiful Profitable

When writing to Advertisers please mention this magazine.

Mr. Rogers' book on Shearing Stresses in Reinforced Concrete Beams is published by the Engineering Department of the Truscon Steel Co. at Youngstown, Ohio. Copies of this book will be furnished free to interested persons.

The San Francisco Labor Situation

THE LABOR crisis in San Francisco has been temporarily averted by an agreement between the Central Council of the Builders' Exchange and the Building Trades Council to arbitrate the entire question of wages, hours and conditions in the building industry, all workmen meanwhile are to return to work at the agreed wage scale in effect on August 1st, subject to the stipulation that the wages of plasterers shall be \$11.00 per day and of plasterers' hod-carriers \$9.00 per day, with the proviso that the contracting plasterers will be protected by the Building Trades Council against loss on old contracts figured at lower wages. It is understood that in adjusting wages the arbitrator shall consider primarily the relative cost of living, the existing wage scale to have only such influence in determining the new wage scale as the arbitrator may see fit to give it.

The agreement is understood to accord the arbitrator full latitude in making such adjustments of the relative wages as between crafts as he may deem just in the light of the required skill and conditions of employment; and it is provided that, pending arbitration work throughout the State of California under the jurisdiction of the Building Trades Council shall proceed as usual without prejudice to any person or persons on either side connected with the building industry.

Under this agreement work is proceeding smoothly. There is, however, a considerable shortage of workmen in certain trades, notably of roofers, plasterers and bricklayers, being a direct result of the practical exclusion of apprentices for years past by the unions.

Building material prices have a downward tendency, although brick, cement, lime and plaster are firm. There is no material change in the transportation situation.

Modern Theatre Equipments

Mr. Charles Felix Butte, head of the Butte Electrical Equipment Company of San Francisco, has prepared a series of articles for this magazine dealing with modern theatre equipments on the Pacific Coast. The first article will appear in the January issue and will be illustrated with interior views of the New Lyceum and Mission theatres designed by Messrs. Reid Bros., architects, of San Francisco.

Notes and Comments

(Concluded from page 111)

lief is in sight. With a conservative estimate of 27,900,000 families in the United States by 1925, at least 500,000 homes must be built and then the building program would be on a small scale. At these figures the country would only have 129.06 families for each 100 homes.

If something is not done to remedy the situation by 1926, with the increasing number of families, 2,200,000 dwellings will be necessary. The erection of 3,400,000 homes by 1926 will be necessary if the country returns to pre-war conditions of 115 families for each 100 homes.

In certain cities in New York state the shortage of homes is so great that parents, who have searched in vain for new quarters, are, as a last resort, seeking to place their children in institutions or boarding houses. County welfare authorities have received hundreds of requests in recent months for accommodations for the children of parents who though in very comfortable circumstances cannot find rentable houses for their families.

California Highway Commission Prefers Contract to Day Labor Work

In re-establishing active highway construction, the California Highway Commission will pursue its definite policy of doing work by contract rather than by day labor work wherever possible.

The reason for this policy is obvious. The State highway organization is capable of doing twice the volume of contract work that it could do under day labor because of the enormous detail imposed by the latter method of operating. Therefore, the commission never undertakes by day labor a job large enough to warrant advertising for contract or where a fair bid is presented.

Contractor Wins Suit

After long litigation the J. M. Dogan Company, a contracting firm that formerly maintained offices in San Francisco and now located in Portland, Ore., has been awarded judgment in full against Klamath County, Oregon, for a balance of \$92,000 due on the County Court house building.



"All chimneys, irrespective of which materials the walls are built, shall be lined with fire clay flue lining or with fire brick. The lining shall be made for the purpose and adapted to withstand high temperatures and the resultant gases from burning fuel." From "An Ordinance for Construction of Chimneys" recommended by the National Board of Underwriters, 1920.

Oust a Cruel "FIRE-BUG!"

Statistics show clearly that the most prolific "fire-bug" in residences is the *unlined* chimney. From one-fifth to one-third of the fires that endanger homes originate in chimneys. Fire Clay Flue Lining insures the safety of the families of your clients against the worst single cause of fires. A few dollars per chimney is all it costs. A trifle to include — an important thing to specify.

Write for a copy of the 1920 recommendations of the National Board of Fire Underwriters Committee on Construction of Buildings.

CLAY PRODUCTS ASSOCIATION

PITTSBURGH

CHICAGO

Los Angeles Pressed Brick Co., Los Angeles, Member

FIRE CLAY FLUE LINING

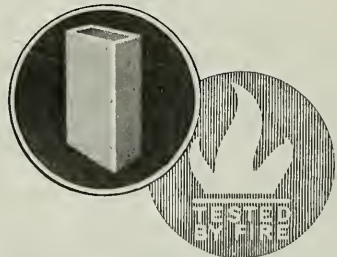



DOOR HUNG ON STANLEY BALL BEARING BUTTS IN THE PACIFIC GAS AND ELECTRIC COMPANY'S BUILDING, SAN FRANCISCO

1500-lb. Doors Hung on Stanley Butts

WITH the steady growth in the size of buildings, doors have been brought more and more into the limelight as extremely vital factors in construction. It is interesting to note how the door butt has measured up to the ever increasing demands that have been made upon it.

Architects and builders realize that they cannot expect the public to have any consideration for the door butts, which,

in fact, the public neither notices nor recognizes as the "works" of the door. They are, however, giving considerably more thought to the selection of butts, and are quick to report notable achievements made by the products of their choice.

"It might interest you to know," writes Mr. Ivon C. Frickstad, architectural assistant for the Pacific Gas and Electric Company, San Francisco, "that The Stanley Works number 851, ball bearing,

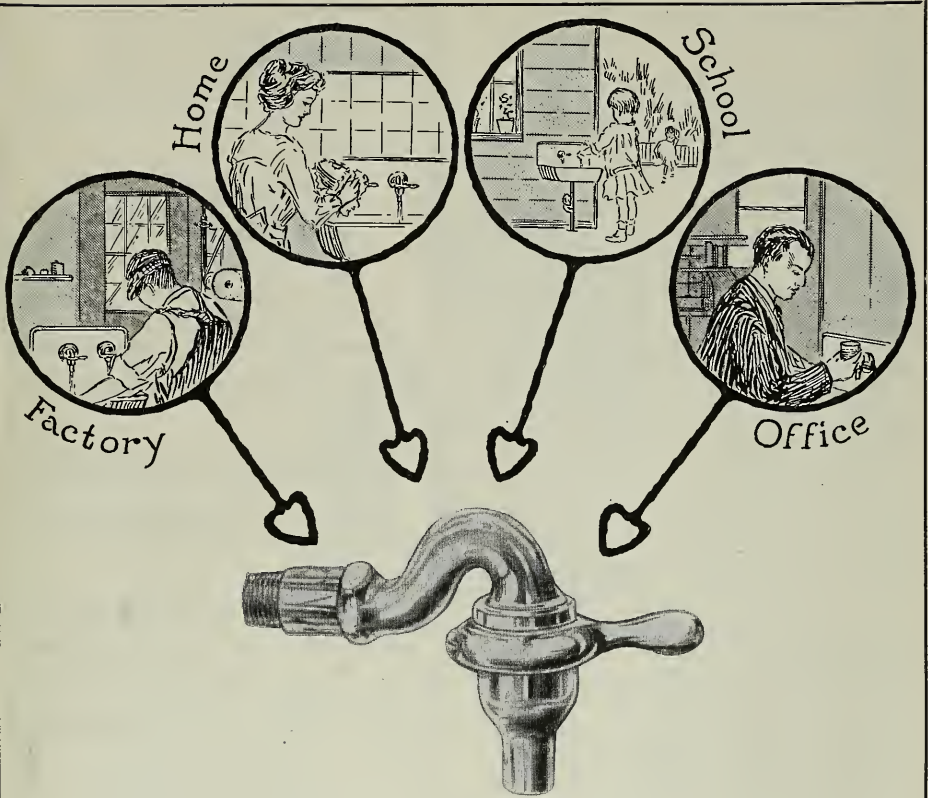

The
Hajoca "Quick" Faucet

is a distinct time-saver. It responds to a mere touch of the hand or even the wrist, with a thick, rapid-flowing, non-splashing stream. A real delight to the user in the home. Durable and simple in construction. Especially suitable for Wash Sinks in Packing Plants, Factories, etc.

SPECIFY
Hajoca "Quick" Faucets



HAINES, JONES & CADBURY Co.

MAKERS OF PLUMBING SUPPLIES

857 FOLSOM STREET, SAN FRANCISCO

PHILADELPHIA-NEW YORK-RICHMOND, VA.-SAVANNAH

huskies back of him, ready to jerk him out of the way in case anything happened.

8"x10", plain steel butts with which we hung extra heavy doors in our electric sub-station 'E' in San Francisco are today swinging as easily and true as the day they were hung, which was a little over a year ago.

"I might add for information that owing to the requirements of all interests considered it was necessary to construct doors which were 6 feet wide by 10 feet 6 inches high by 7¼ inches thick and weighing approximately 1500 pounds, which are hung with three butts per door, iron plates and straps were bolted in the door while under construction to which the butts were fastened, the jamb of the door is also of iron.

"These doors are in constant use and at the present time are the only ones giving real satisfaction."

No. 851 is a standard butt of the Stanley line, which includes butts for use on every door from light French windows to heavy vault doors.

"Armco" In Moving Pictures

SOMETHING which the naked eye cannot see—the boiling of an incandescent mass of molten metal in an open hearth furnace—is shown in closest detail in motion pictures recently filmed at the Middletown, Ohio, plants of The American Rolling Mill Company. This "movie" is soon to start on a tour of technical schools, engineering societies, and sales conventions where the study of results in modern metallurgy is of paramount interest.

Comparatively few laymen have ever seen the sight of metal heated to 3000 degrees Fahrenheit. It is too hot in the vicinity of the boiling metal in the interior of the open hearth furnaces for the comfort of most visitors, and the intense light emanating from the livid mass is too blinding for the naked eye. Heretofore only through specially colored glasses has the human eye beheld what iron looks like when it is hot enough to flow like water.

When the Rothacker Film Company of Chicago was selected to make the "Armco" picture, the movie concern was told it had an opportunity to make a record.

"A close-up scene of boiling iron has never been obtained," they said. "Steel men say it can't be done."

Cameraman Tiry H. Miller was given the task and the results are even more than could have been expected.

Veteran steel workmen were thrilled when Miller set up his camera. Would he stick it out? Would the heat crack the camera lens or set fire to the explosive film inside? The cameraman did not know it at the time, but there were two

Shop and Compare—that's the only true test of values.

Furnishings for the home of distinctive style are featured in this shop at prices that will bear the strictest comparison.

John Breuner & Co.
of San Francisco

281 GEARY STREET

Furniture
Floor Coverings

Draperies
Interior Decorations

Business Systems Office Furniture

F. W. WENTWORTH & CO.

Distributors for LIBRARY BUREAU
539 Market Street, San Francisco
LOS ANGELES OAKLAND SEATTLE

SERVICE

TESTING

INSPECTION

CONSULTATION

PRODUCTION

Structural and Engineering
Materials



Robert W. Hunt & Co.

Engineers

Chemical and Physical
Testing Laboratories

New York Chicago Pittsburgh
St. Louis San Francisco Mexico City
London Montreal

When writing to Advertisers please mention this magazine.



The
ST. FRANCIS
 One of the world's great hotels
 Facing Union Square
 SAN FRANCISCO CALIFORNIA

EXPRESSES MOST PLEASANTLY THE HOSPITALITY AND ANIMATION THAT ARE CHARACTERISTIC OF SAN FRANCISCO

Thos. J. Coleman,
 Manager

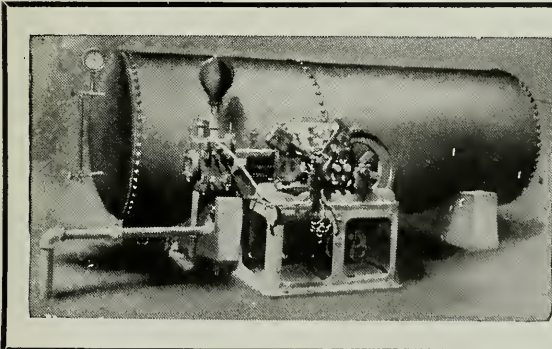

Kewanee Water System

Maintain your own Plant.
 Small Operating Expense.
 A Perfect Water Supply to
 Country Homes, Hotels
 and Parks.

Simonds Machinery Co.

117-121 Montgomery Street
 SAN FRANCISCO
 Phone Kearny 1457

After the film was developed, the cameraman felt well repaid. He had obtained a scene which, according to one motion picture trade paper, makes him peer of industrial cinematographers.

The first big showing of the picture was to 10,000 people on a big out-of-doors screen, at Middletown, Ohio, on National "Armco" Day. Later it will make the rounds of conventions. Eventually it will be shown in the plants of Armco customers who fabricate this pure iron into stoves, ranges, refrigerators, culverts and a hundred and one other needs of the twentieth century.

An empty electric light socket is all that the customer will need to supply for the salesman to show the amazing picture on the wall of his office.

Various manufacturers are already emphasizing in their advertising that "Armco" Ingot Iron goes into their products. This will grow more general as the picture eventually reaches out to millions of Americans through educational and non-theatrical exhibitors, such as schools, churches, Y. M. C. A.'s, etc. These splendid realistic pictures have marked a new "high spot" in the development of industrial films for trade and educational purposes.

Cannon & Company Opens San Francisco Office

After six years of success in the manufacture of face brick, Denison Interlocking tile and clay products, Cannon & Co. of Sacramento have opened offices at 1605-6-7 Chronicle building, San Francisco, with the intention of serving the Bay regions. The new branch will be in charge of Mr. Willis E. Huson, who for the past eight years has been associated with Mr. Louis Christian Mullgardt, architect. It is the policy of Cannon & Co. to make their San Francisco offices and display rooms of real service to architects and builders.

Denison Interlocking tiles, manufactured by Cannon & Co., are being used extensively throughout the Sacramento Valley. California is rapidly recognizing what the East has for many years known, that Denison Interlocking tiles are a most efficient and economical building material for all kinds of structures. They are especially appropriate for climatic conditions in California and lend themselves most attractively to California landscape.

Interlocking tile is not the sole product of Cannon & Co. A most interesting face brick in a wide range of colors and of a texture similar to Travertine, is manufactured in both Roman and common brick sizes. This material was designed to meet the frequently expressed wishes of architects, who have long voiced a desire for a face brick of interesting texture and color but one

OAK FLOORS

(For Everlasting Economy)



The Penalty of a Mistaken Idea

THE almost universal use of oak floors where the best of everything is specified demonstrates their superiority. But when the prospective builder of moderate means hears oak flooring quoted by the thousand feet he often assumes it to be a luxury he cannot afford.

We are constantly advertising the *economy* as well as the beauty and durability of oak floors and have been assured by architects that this work contributes to their success in creating satisfied and delighted clients. We believe we can aid you still further, if you will write us.

OAK FLOORING MERS. ASSN.
1036 Ashland Block, Chicago



Present Cost of Building Materials*

With Labor Wage Scale, Bonds, Etc.

THESE quotations are based on reliable information furnished by San Francisco material houses. Date of quotations, December 20, 1920.
All prices f. o. b. cars San Francisco or Oakland.

American Institute of Architects' Fees

New work—6 per cent minimum basis.
Alterations—7 to 10 per cent as a minimum basis.

High class residence work—10 per cent as a minimum.

Bond—1½% amount of contract.

Brickwork—

Common, \$38.00 per 1000 laid.
Face, \$70.00 per 1000 laid.
Common, f. o. b. cars, \$18.00 plus cartage.
Face, f. o. b. cars, \$45.50 per 1000, carload lots.
12x12x3 in., 10¼c. per square foot.
12x12x4 in., 11¾c. per square foot.
12x12x6 in., 16¼c. per square foot.
Hod carriers, \$8.00 per day.
Bricklayers, \$10.00 per day.
Lime—\$3.25 per bbl.; carload, \$2.75 per bbl.

Composition Floors—30c. per sq. ft.

Concrete Work (material at San Francisco bunkers)—

No. 3 rock.....\$2.50 per yd.
No. 4 rock..... 2.75 per yd.
Niles pea gravel..... 3.25 per yd.
Niles gravel 2.50 per yd.
Niles top gravel..... 3.00 per yd.
City gravel 2.50 per yd.
River sand 1.65 per yd.
Bank sand 1.00 per yd.

Monterey White Sand—

Del Monte, \$1.25 to \$1.50 per ton.
Fan Shell Beach, \$2.50 to \$3.00 per ton.
Car lots, f. o. b. Lake Majella.
Cement (f. o. b. cars)....\$4.09 per bbl.
Rebate for sacks, 25c. each.
Atlas "White"\$9.50 per bbl.
Medusa cement 9.50 per bbl.
Forms\$60.00 per M

Wage—
Laborers\$6.00 per day
Concrete workers 7.50 per day
Cement finishers 9.00 per day

Dampproofing—

Two-coat work, 30c. per yard.
Membrane waterproofing—4 layers of P. B. saturated felt, \$6.00 per square.
Hot coating work, \$2.00 per square.
WAGE—Roofers, \$9.00 per day.

Electric Wiring—\$8.00 to \$15.00 per outlet.

WAGE—Electricians, \$9.00 per day. For conduit work, knob and tube average \$4.50 outlet.

Elevators—

Prices vary according to capacity speed and type. Consult elevator companies.

Excavation—

\$2.25 per yard.
Teams, \$12.00 per day.
Trucks, \$30.00 to \$40.00 per day.
Above figures are an average without water. Steam shovel work in large quantities, less; hard material, such as rock, will run considerably more.

Fire Escapes—

Ten-foot balcony, with stairs, \$100.00 per balcony.

Glass—(Consult with manufacturers.)

21 ounce, 30c. per square foot.
Plate, \$2.00 to \$3.50 per square foot.
Art, \$1.00 up per square foot.
Wire (for skylights), 45c. per square foot.
Obscure glass, 30c. per square foot.
Note.—Add extra for setting.
WAGE—Glaziers, \$9.00 per day.

Heating—

Average, \$3.25 per sq. ft. of radiation.
WAGE—Steamfitters, \$10.00 per day.

Iron

Cost of ornamental iron, cast iron, etc., depends on design.

Lumber—

Common (at building), \$36.00 per 1000 (average).
Common O. P. (select), \$65.00 per 1000 (average).

Flooring—

1x3 No. 1.....\$87.00 per 1000
1x3 No. 2..... 78.00 per 1000
1x4 No. 1..... 84.00 per 1000
1x4 No. 2..... 81.00 per 1000
1x4 No. 3..... 74.00 per 1000
1x6 No. 1..... 85.00 per 1000
1x6 No. 2..... 92.00 per 1000
1¼x4 and 6 No. 1..... 90.00 per 1000
1¼x4 and 6 No. 2..... 89.00 per 1000
Slash grain, 1x4 No. 2..... 71.00 per 1000
Slash grain, 1x4 No. 3..... 55.00 per 1000
No. 1 common run to
T. & G..... 54.00 per 1000
Lath 7.50 per 1000

Shingles—

Redwood, No. 1.....\$1.20 per bdl.
No. 2..... 1.10 per bdl.
Red cedar 1.30 per bdl.
(Add cartage to above)

Hardwood Floors—

Maple floor (laid and finished), 40c. per foot.
Factory grade floors (laid and finished), 30c. per foot.
Oak (quartered, finished), 65c. per foot.
¾ Oak (clear), 39c. per foot (plain).
¾ Oak (select), 37c. per foot (plain).
¾ Oak, quartered, sawed, clear, 45c.
WAGE—Floor layers, \$10.00 per day.

In flooring the usual grades of oak used are

	Grades	Quartered Sawed	Plain Sawed
5/16"	Clear	45	39
	Select	41	37
1"x3"-13/16"x2¼"	Clear	65	50
	Select	55	45
	No. 1 (very little used)		

Hardwood Floors (not laid)— Per M ft.

5/16x2" sq. edge Clear quartered oak. ...\$245.00
Select quartered oak..... 207.00
Clear Plain oak..... 150.00
Select plain oak..... 125.00

THE ARCHITECT AND ENGINEER

Hardwood Floors (not laid)—Continued

	Per M ft.
13/16x2 1/4" face Clear quartered oak.....	\$290.00
Select quartered oak.....	200.00
Clear plain oak.....	200.00
Select plain oak.....	175.00
Clear maple.....	177.50
Clear maple—white.....	250.00
13/16x3 1/4" face Clear maple.....	177.50
1 1/8x2 1/4" face Clear maple.....	177.50
3/8x2" face Clear quartered oak.....	215.00
Select quartered oak.....	160.00
Clear plain oak.....	150.00
Select plain oak.....	130.00
Clear maple.....	122.50

Veneered Panels—

24x60 in., 3/4 in., 3-ply, 1 side:	Per ft.
Ash.....	28c
Hungarian Ash.....	42 1/4c
Birch.....	28c
Curly Birch.....	42c
Elm.....	26c
Jeniseo (Genezero).....	41c
Southern Red Gum (plain fig.).....	34 1/2c
Otd. Southern Red Gum.....	42 1/4c
Hawaiian Koa.....	42 1/4c
Maple.....	26c
Birdseye Maple.....	51 1/2c
Mahogany.....	42 1/4c
Oregon Pine.....	14c
Plain Oak.....	33 1/2c
Quartered Oak.....	42 1/4c
Walnut.....	43 1/4c

Millwork—

O. P., \$150 per 1000. R. W., \$140 per 1000.	
Double hung box frame windows (average) with trim.....	\$9.50 each
Doors, includ. trim (single panel).....	\$13.50 each
Doors, including trim (five panel).....	\$11.00 each
Screen doors.....	5.00 each
Window screens.....	3.50 each
Medicine cases.....	5.00 each
Cases for kitchen pantries seven feet high, per lineal foot.....	7.50 each
Dining room cases same price, if not too elaborate....	7.50 each
Flag poles, per foot.....	1.50
Labor—Rough carpentry, warehouse heavy framing, \$13.00 per 1000.	
For smaller work, average, \$21.00 to \$28.00 per 1000.	
WAGE—Laborers, \$6.50 per day.	
Carpenters, \$9.00 per day.	

Marble—(Not set) add 60c up per ft. for setting

Columbia.....	\$2.05 sq. ft.
Alaska.....	2.05 sq. ft.
San Saba.....	3.65 sq. ft.
Tennessee.....	2.50 sq. ft.
Verde Antique.....	4.55 sq. ft.

Painting—

Two-coat work, 42c. per yard.	
Three-coat work, 55c. per yard.	
Whitewashing, 6c. per yard.	
Cold water paint, 10c. per yard.	
WAGE—Painters, \$8.50 per day.	

NOTE—Accessibility and conditions cause wide variance of costs.

Patent Chimneys—

6-inch.....	\$1.50 lineal foot
8-inch.....	1.75 lineal foot
10-inch.....	2.25 lineal foot
12-inch.....	3.00 lineal foot

Pipe Casings—\$8.00 each.

Plastering—

Interior, on wood lath, 80c. per yard.	
Interior, on metal lath, \$1.50 per yard.	
Exterior, on brick or concrete, \$1.35 per yard.	
Portland White \$1.75 to \$2.00.	

Interior on brick or terra cotta, 65c to 75c. per yard.

Exterior, on metal lath, \$2.50 to \$3.00 per yard.

Wood lath, \$8.00 at yard per 1000.

Metal studding, \$1.25 to \$1.50 per yard.

Metal studding, with lath and plaster, \$2.25 per yard.

Galv. (metal lath), 38c. and up per yard, according to gauge.

Lime, f. o. b. warehouse, \$3.25 per bbl. Hardwall plaster, \$24.00 per ton, f. o. b. warehouse.

WAGE—Hod carriers \$9.00 per day.

Plasterers, \$11.00 per day.

Plumbing—

From \$70.00 per fixture up, according to grade, quantity and runs.

WAGE—Plumbers, \$10.00 per day.

Reinforcing Steel—

Base price for less than car load lots, \$5.75 per 100 lbs.

Car load lots, \$5.50 per 100 lbs., f. o. b. San Francisco. (Mill delivery.)

Roofing—

Five-ply tar and gravel, \$7.50 per square for 30 squares or over.

Less than 30 squares, \$8.00 per square.

Tile, \$35.00 per square.

Redwood shingle, \$13.00 per sq. in place.

Cedar shingle, \$13.00 per square in place.

Reinforced Pabco roofing, \$8.25 per square. WAGE—Roofers, \$9.00 per day.

Rough Hardware—

Nails, per keg, \$7.50 base and very scarce. Deafening felt, \$170.00 per ton.

Building paper, P. & B.,

1 ply, \$6.50 per 1000 ft. roll.

2 ply, \$9.75 per 1000 ft. roll.

3 ply, \$14.00 per 1000 ft. roll.

Sash cord,

(Sampson spot), \$3.00 per hank 100 feet)

Common, \$1.75 per hank 100 feet.

Sash weights, cast iron, \$80.00 per ton.

Skylights—

Copper, \$1.25 a square foot (not glazed). Galvanized iron, 50c. a square foot (not glazed).

WAGE—Sheet metal workers, \$10.00 per day.

Store Fronts—

Kawneer copper bars for store fronts. Corner, center and around sides; will average \$1.35 per lin. foot.

Zouri bar, \$1.25 per lin. foot.

Zouri Underwriters' Specification sash,

\$1.60 per lin. foot.

Structural Steel—\$145.00 per ton.

This quotation is an average for comparatively small quantities.

Light truss work higher; plain beam and column work in large quantities, less.

Steel Sash—

Fenestra, from S. F. stock, 45c. per sq. ft.

Fenestra, Plant shipment, 40 1/2c. per sq. ft. (Includes mullions and hardware.)

Tile—

White glazed, 80c. per foot.

White floor, 80c. per foot.

Colored floor tile, \$1.00 per foot.

Promenade tile, \$1.00 per sq. foot, laid.

WAGE—Tilers, \$9.00 per day.

Windows—Metal \$2.00 a square foot

ARMCO AMERICAN INGOT IRON

TRADE MARK

FOR ENAMELED PRODUCTS



Scene in the hospital of The American Rolling Mill Co.

Where *Every* Precaution is Taken

The doctors and nurses work with gloved hands, guarded mouths, sterilized instruments—and enameled-iron equipment.

There would be grave danger if the enameled surface of a basin should chip and the fragment be carried by a sponge to an open wound; therefore all hospital enameled equipment should have a base of ARMCO Ingot Iron.

This iron is so pure, so smooth and even in texture, it takes a coat of enameling with a sheer, beautiful gloss — and holds it.

The advantage of Armco enameled ware in the home for kitchen use, and particularly for cooking, is just as great as in the hospital. The next time you purchase enameled ware ask the salesman if it is made with ARMCO Ingot Iron.

Our laboratory and research departments are at the disposal of manufacturers of enameled equipment of all kinds.

The American Rolling Mill Co.

Middletown, Ohio



ARMCO Ingot Iron RESISTS RUST

The trade-mark ARMCO carries the assurance that products bearing that mark are manufactured by the American Rolling Mill Company with the skill, intelligence, and fidelity associated with its products, and hence can be depended upon to possess in the highest degree the merit claimed for them. The trade-mark ARMCO is registered in the U. S. Patent Office.

An Ample Stock ARMCO IRON is carried at the San Francisco Warehouse, Tenth and Bryant Streets.

When writing to Advertisers please mention this magazine.



CEMENT GUN

Will Make Your
Concrete Waterproof

**Cement Gun Con-
struction Company**

of California

701 Balboa Building,
San Francisco

For
DAMS
RESERVOIRS
TUNNELS
BULKHEADS
CANAL
LININGS
CEMENT
FLUMES
use the
Cement Gun
—
SPEED
ECONOMY
PERMANENCE

in which the texture is distinctly architectural and inherent and not an imitation of fabrics.

Those interested in building will find a visit to the San Francisco display rooms profitable and interesting.

Electric Switch Company Changes Name

After January 1st the Meyers Electric Safety Switch Company, Inc., will change its name to the Western Electric Safety Manufacturing Company. Mr. Charles F. Parker, manager of the company, reports that his concern has had a very successful year and plans have been made to handle an increased volume of business in 1921. The company's factory is at 247 Minna street, where a large force of skilled mechanics is employed. The company specializes in the manufacture of enclosed externally operated safety switches, metal switch and cut-out boxes and safety switch boards.

No Lump Sum in Greece

IN the case of contracts for public works in Greece it would be hazardous for an American contractor to make a tender of a fixed amount for a given piece of construction work on account of delays arising from a variety of causes quite beyond the control of the contractor, states Mr. Arthur Hugh Frazier, Charge d' Affaires, Athens, in a recent consular report. On the basis of an opinion from an experienced American representative, he believes that the only satisfactory contract for an American firm to make would be on the basis of the actual cost, plus a percentage.

Colonial Houses

Messrs. Hutchinson and Mills, Albany block, Oakland, have prepared plans for a two-story Colonial house to be built in Piedmont for Mr. George F. Longsdorf. Plans have also been drawn by the same architects for an \$8,500 Colonial house for Mr. M. P. Rose, Oakland builder.

Faith

Them thet haz gits,
Them that haint haint,
An him thet haz gits from
Them thet haint.

Man wants but litl here
B-low,
An gits a dam site les.

After pleasure folleys pain,
Every cloud is lined with rain.
Nothin aint!

—Ned Thatcher.

HOLIDAY
GREETINGS
TO OUR FRIENDS
AND PATRONS

We pray the prayer the Easterners
do.
May the peace of Allah abide with you,
Wherever you stay, wherever you go,
May the beautiful palms of Allah grow,
Through days of labor and nights of rest,
The love of good Allah make you blest,
So we greet you today as the Easterners do,
May the peace of Allah abide with you.

Meesse & Gottfried Company
ENGINEERS AND MANUFACTURERS
SAN FRANCISCO SEATTLE PORTLAND-LOS ANGELES

**LA FRANCE SAFETY DEVICES
FOR EVERY INDUSTRY**

**Consider Fire Protection
in Making Your Plans**

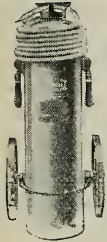

If you are planning a factory provide a space for a LaFrance No. 20 Chemical Engine, for it is simple in construction and easy to operate. It contains twenty gallons of fluid forty times as effective as water for extinguishing fires. It is made by the world's largest manufacturer of fire apparatus, with a full knowledge of what is best for effective fire fighting.

Write for complete information in regard to this and our other appliances, such as Hose, Hose Racks, Reels, Nozzles, Axes and many others.

AMERICAN LA FRANCE FIRE ENGINE COMPANY, INC.

ELMIRA, N. Y.

929 South Hill Street,
Los Angeles, Calif.



151 New Montgomery
Street, San Francisco,
Calif.



Residence of G. W. Wattles, Garden Front
Hollywood, Calif.
Myron Hunt & Elmer Grey, Architects

Bay State Coating

Permanent beauty. That's the kind that one or two applications of Bay State Brick and Cement Coating imparts to all walls of brick, cement or stucco. It waterproofs them, too. No rain, sun, or storm affects its protection and lasting qualities.

Your choice of white or a range of colors. We will send you a sample of any tint you wish. Let us mail you Booklet No. 43. It shows a number of Bay State Coated Homes. Drop us a postal card today.

WADSWORTH, HOWLAND & CO.
Incorporated

Paint and Varnish Makers
Boston, Mass.

Pacific Coast Representatives

JAMES HAMBLY & SON
San Francisco Los Angeles



A FLOORING for discriminating Architects and Builders, and characteristically a Michigan product in every way, from the excellence of the wood itself to the superior millwork and careful grading.

Strable Mfg. Co.

HARDWOOD LUMBER

Phone, Oakland 245

511-545 FIRST STREET OAKLAND, CAL.

WIRING

Some of Our Installations:

- | | |
|----------------------|---------------------|
| Hotel Whitcomb | Children's Hospital |
| Flood Building | Calif. Land Shows |
| Rialto Building | Capital Nat. Bank, |
| Medical Supply De- | Sacramento |
| pot, Mare Island | Portola Decorations |
| National Carbon | Schoolhouses and |
| Company's Factory. | Firehouses in Oak- |
| Crocker Estate Bldg. | land and S. F. |



185 Stevenson Street, San Francisco
Phone Douglas 4832

ZOURI**SAFETY SASH BARS**

Accepted by the Insurance Underwriters for Safety Setting of Plate Glass used in Store Front Construction.

COBBLEDICK-KIBBE GLASS CO.

175 JESSIE ST.

SAN FRANCISCO, CAL.

WASHINGTON AT THIRD ST.

OAKLAND, CAL.

POWER CONSTRUCTION CO.

INCORPORATED

CONTRACTING ENGINEERSPreliminary Estimates Given in All Types
of Buildings, Towers and BridgesSHARON BUILDING, SAN FRANCISCO
Phone Sutter 5478**CHAS. STOCKHOLM & SONS****GENERAL CONTRACTORS**

849 MONADNOCK BUILDING Phone DOUGLAS 4657 SAN FRANCISCO

John Ringius Company, Inc.

MANUFACTURERS OF

Multivane Volume Fans and Steel Plate Blowers made to order,
any size, for Heating and Ventilating Plants in Theatres,
Schools, Public Buildings, Etc.**Sheet Metal Products****Fans and Blowers**

330 Ritch Street

SAN FRANCISCO

Phone Garfield 1108

JOHN M. BARTLETT**GENERAL CONTRACTOR**

Office

357 - 12th ST., OAKLAND

Phone Lakeside 6750

Res. Phone Berkeley 6884W

E. T. LEITER & SONS**BUILDING CONSTRUCTION**

412 CALL-POST BUILDING Phone SUTTER 1980 SAN FRANCISCO

CHAS. G. FRIES.

TELEPHONE SUTTER 5706

VICTOR A. KUEHN

LIBERTY ELECTRIC COMPANY

479 Sutter St. Electrical Contractors San Francisco, Cal.

SAMSON SPOT SASH CORD

SPOT IT BY THE SPOTS

Made of extra quality cotton yarn, firmly braided and smoothly finished. Carefully inspected and guaranteed free from all imperfections of braid and finish. → Can be distinguished at a glance by our trade-mark, the Colored Spots. Send for catalogue and samples.

Pacific Coast Agent, JOHN T. ROWNTREE, Inc., San Francisco and Los Angeles, Cal.

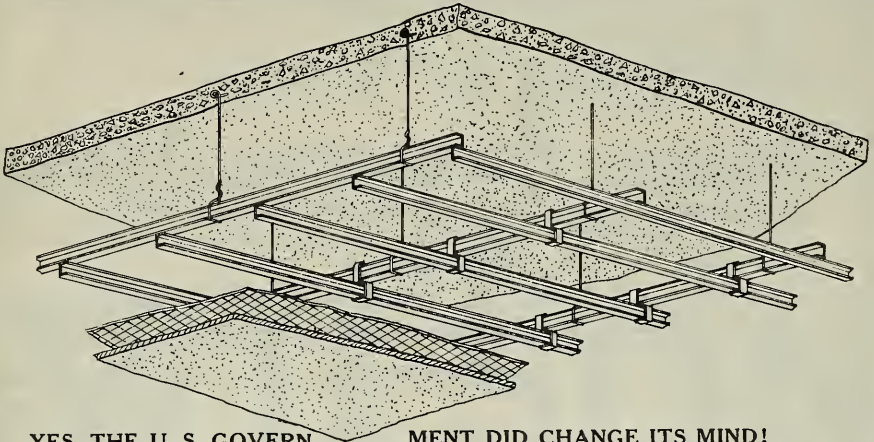

YES, THE U. S. GOVERNMENT DID CHANGE ITS MIND!

The specifications on the U. S. Government Building at Portland, Oregon, called for the tying together of the carrying bar and lathing bar with wire.

We submitted our system, and after an explanation of the S. S. System for fastening bars, the engineers and government officials were convinced that here, at last, is the perfect and economical system, and these reasons added weight in deciding.

It is a positive tie, no slipping or shearing.

It is strong, Smith Emery test to 353 lbs. before failing.

It is fast, can be applied on the bench or on the scaffold.

Made for 1 inch carrying bar and 3/4 inch lathing bar and 3/4 inch carrying bar and 3/4 inch lathing bar. Can be used for wall furring as well as for ceiling work.

THE STEEL STUDDING COMPANY

Also Manufacturers of

THE PRONG CHANNEL FOR SOLID AND HOLLOW PARTITIONS

Agents Wanted Everywhere

1216 Folsom Street, San Francisco

A TEN YEAR GUARANTEE

is back of this roof covering and it **costs less** than other roofing materials



2400 gallons used on the Fairmont Hotel, San Francisco.

Bekin's Warehouse is waterproofed with it.

The W. O. W. Building, Oakland, is roofed with it.

You make no mistake when you specify

LIQUID ASBESTOS PATCH-HOLE CEMENT

Write for sample and price list.

California Plastic Products Company

521 SHELDON BUILDING, SAN FRANCISCO, CALIFORNIA

When writing to Advertiser's please mention this magazine.

**FOR MODERN
STORE FRONTS**

Plummer's Disappearing Awnings

Are constructed with no outside attachments below awning recess. All mechanical parts entirely concealed. Send for Architects' Sheet showing specifications for recess construction, etc.

W. A. PLUMMER MFG. CO., 35-37 Front Street, San Francisco

JOHN TRAYNOR

CHARLES HARCOURT

OCEAN SHORE IRON WORKS

Manufacturers of Oil Tanks, Water Tanks, Pressure Tanks, Air Receivers, Feed Water Heaters, Breechings, Smoke Stacks, Water Pipe, Boilers, Retorts, Digestors, Pneumatic Pressure Tanks, Riveted or Oxy-Acetylene Welded Tanks, and dealers in Boilers, Tanks, Pumps, Engines, Machinery, Steel Plates, Shapes

Special Attention Given to Government and Export Orders

OCEAN SHORE IRON WORKS

Office and Works: 550-558 EIGHTH STREET, SAN FRANCISCO, CAL.



Model No. 7A.

NO GERMS HERE

HAWS IMPROVED SANITARY DRINKING FAUCET eliminates all possibility of contracting disease from dirty bulbs or unsanitary bowls. Provided with an overhead cowl, the drinker's lips never touch the source of supply. A slanting stream throws the water from right to left and away from the bubbler, instead of straight up to fall back over the fountain head. Recommended for Schools and Public Playgrounds. A type used extensively by the U. S. Government. Manufactured by

Haws Sanitary Drinking Faucet Co., Inc.
1808 Harmon Street, Berkeley Phone Piedmont 3742

GLADDING, McBEAN & CO.

MANUFACTURERS CLAY PRODUCTS

CROCKER BUILDING, SAN FRANCISCO

WORKS, LINCOLN, CAL.

SAVE MONEY
on
SCHOOL BUILDINGS

By Specifying

WILSON

**SCHOOL
WARDROBES**

Equipped with Blackboards and Chalk Rails
DISAPPEARING DOORS

Send for further information to

The J. G. WILSON CORPORATION

MANUFACTURERS OF
WILSON FOLDING PARTITIONS ROLLING PARTITIONS
ROLLING STEEL DOORS AND FOLDING CASEMENTS

Pacific Coast Office:

600 Metropolitan Building

Los Angeles, Calif.

Also Manufacturers of

DIFFUSELITE BLINDS AND AWNINGS

Waterhouse-Wilcox Co., San Francisco

Theo. F. Snyder, San Diego

T. G. Bush & Co., Spokane

F. W. Farrington & Co., Portland and Seattle

Hawley-Richardson-Williams Co., Salt Lake City



FOLDING PARTITION

When writing to Advertisers please mention this magazine.

THE TORMEY CO.

General
Painters

Phone Franklin
5-5-9-8

1042 Larkin St., San Francisco, Cal.

Alvaline, Cementoline
and other
Jones-Duncan Products

MAGNER BROTHERS
PAINT MAKERS

Telephone: Market 113
414-424 Ninth St. San Francisco

HEATING-PLUMBING

COMPLETE PLUMBING AND
HEATING SYSTEMS INSTALLED
IN ALL CLASSES OF BUILDINGS
ALSO POWER PLANTS

GILLEY-SCHMID CO., Inc.
198 OTIS STREET, SAN FRANCISCO.
Tel. MARKET 965

"BLAZING" THE TRAIL
We've been doing it for many years—giving the Sportsman Better Value for Quality than he ever before received. "Value at a Fair Price" in everything for the Sportsman.

The
Elery Arms
Company

583-85 MARKET ST
SAN FRANCISCO, CAL

SEND FOR CATALOG *The Sign of Quality*

Phone Douglas 3224

Hunter & Hudson
ENGINEERS

Designers of Heating, Ventilating
and Wiring Systems. Mechanical
and Electrical Equipment of
Buildings.

703 Rialto Bldg., San Francisco, Cal.

BEAVER BLACKBOARD
BEAVER GREENBOARD
SCHOOL FURNITURE
AND SUPPLIES—
OFFICE, BANK AND
COURTHOUSE FURNITURE—
THEATRE AND
AUDITORIUM SEATING

Rucker-Fuller Desk Co.
677 Mission St., SAN FRANCISCO, CAL.
434 Higgins Bldg., LOS ANGELES, CAL.
432 - 14th Street - OAKLAND, CAL.

ELECTRICAL MECHANICAL

BALDWIN DREW WARD
Consulting Engineer
Power and Industrial Plants

Associate Member A. I. E. E.

76 Eleventh St. Oakland, Cal.

RUSSWIN
BUILDERS' HARDWARE
JOOST BROS., Inc.
SAN FRANCISCO AGENTS.
We Carry Complete Stock:
Fishing Tackle—Guns—Mechanics' Tools—
Paints—Crocery and Glassware—Stoves—
Household Goods. Telephone Market 891.

NO BRANCH STORE
Mazda Lamps Electric Goods

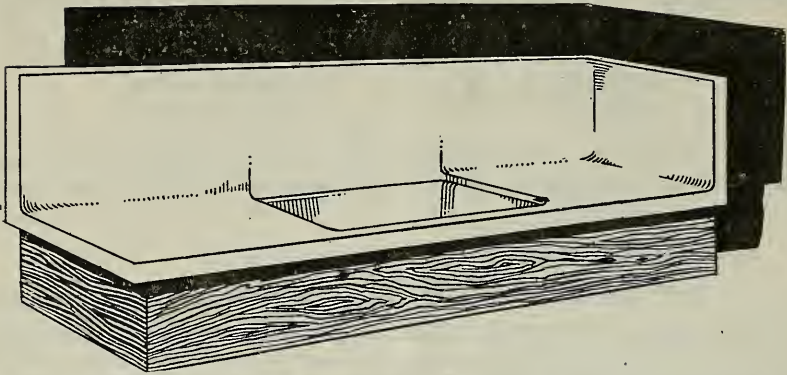

A Snow White Drain Board

PETRIUM SANITARY SINKS are made in Berkeley, California and are non-porous, non-absorbent and Lye-proof. The entire surface of the drainboard and back is covered with a composition, on which a smooth, glossy, snow white finish is applied mechanically leaving no crevice or corners in which dirt and grease can collect as where tile or wood is used.

Can be installed in any home—new or old.

PETRIUM SANITARY SINK COMPANY
 FACTORY AND OFFICE, WEST BERKELEY
 Agents in Principal Coast Cities

*Send for booklet
 and Price List.*

The High Cost of Building Material Is a Strong Argument for Economy

Architects may keep down the
 Cost by Economizing in Space



Hotel Cecil, San Francisco,
 Equipped with Wall Beds.

Portal Wall Beds

are timely space and cost savers, meeting a national need. Those who would build wisely in these days of soaring prices, provide for **PORTAL WALL BEDS**

MARSHALL & STEARNS CO.

WALL BEDS

"HIGHEST AWARD ALWAYS"

1152 Phelan Building
 San Francisco

1774 Broadway
 Oakland

A. D. COLLMAN

P. F. SPEIDEL

COLLMAN AND SPEIDEL**GENERAL
CONTRACTING****CONSTRUCTION
ENGINEERS**

Telephone SUTTER 4858

MONADNOCK BUILDING, SAN FRANCISCO

I. R. KISSEL

Phone Franklin 548

Decorator, Painter and Paperhanger

1747 SACRAMENTO ST., Bet. Polk St. and Van Ness Ave., SAN FRANCISCO

ROBERT TROST

PHONE MISSION 2209

General Building ContractorWe Specialize in High Grade Work and Employ Skilled
Labor in every Branch of the Building Industry.26th and Howard Streets
SAN FRANCISCO

P. A. Palmer

Peter Petersen

W. L. Kelly

PALMER & PETERSEN**Contracting Engineers**

782-796 Monadnock Building

SAN FRANCISCO, CAL.

S. RASORI, RES. 2042 TAYLOR ST.
PHONE FRANKLIN 6258J. DEL FAVERO, RES. 1839 MASON ST.
PHONE FRANKLIN 9524**DEL FAVERO & RASORI**
GENERAL CONTRACTORS

MEMBERS OF THE S. F. BUILDERS EXCHANGE AND THE BUILDING INDUSTRIES ASS'N

OFFICE:
110 JESSIE STREET

SAN FRANCISCO, CALIF.

MONSON BROS.**GENERAL CONTRACTORS**

Telephone Market 2693

1908 Bryant Street, San Francisco

UNIT CONSTRUCTION COMPANY

(INCORPORATED)

ENGINEERING AND CONSTRUCTION

Telephone Kearny 28

429-36 Phelan Building, SAN FRANCISCO

J. D. HANNAH**Contractor and Builder**OFFICE: 142 Sansome Street
San Francisco, Cal.

Telephone Douglas 3895

BUILDERS EXCHANGE, 180 JESSIE STREET

**MOUNT DIABLO CEMENT
COWELL SANTA CRUZ LIME**
ALL KINDS OF
BUILDING MATERIALS

HENRY COWELL LIME AND CEMENT CO.

Phone Kearny 2095

No. 2 MARKET STREET, SAN FRANCISCO

Automatic Fire Sprinklers

Protect your building and business from destruction by fire and reduce your Insurance Rate.

Pacific Fire Extinguisher Co.

FIRE PROTECTION ENGINEERS

424-440 HOWARD STREET
SAN FRANCISCO

MANUFACTURING PLANT
272 STEUART STREET

LINOTILE

“The Floor that’s Built to Fit the Room”

Furnished and Laid by

VAN FLEET-FREEAR CO.

Telephone :
Douglas 1227

61 New Montgomery Street
San Francisco, California

Kawneer

Factory
Berkeley, Calif.
Berkeley 8710

MANUFACTURING COMPANY
of California

San Francisco Office :
180 Jessie Street
Sutter 6700

Kawneer
Store-Fronts
All Metal Mouldings

Kawneer
Simplex Windows
Weightless & Reversible

I. M. SOMMER,**CONTRACTORS & ENGINEERS**

Phone Kearny 4582

401 BALBOA BLDG., SAN FRANCISCO

K. E. PARKER COMPANY, Inc.**GENERAL CONTRACTORS**

Phone Sutter 5661

Room 515 Clunie Building, SAN FRANCISCO

R. W. LITTLEFIELD
BUILDING CONSTRUCTION

357 12th Street, Room 9, Oakland, Cal.

Phone Lakeside 6750

H. H. HILP, Jr.

J. FRANK BARRETT

BARRETT & HILP**CONCRETE CONSTRUCTION BUILDERS GENERAL CONTRACTORS**

SHARON BUILDING, SAN FRANCISCO

TELEPHONE SUTTER 1168 or 1169

Res. Phone Mission 5049

JAMES F. SMITH — Plasterer

273 Minna Street, San Francisco

Phone KEARNY 740

Member Builders Exchange

STEELFORMS Signify ECONOMY, RAPIDITY, and EFFICIENCY

STEELFORM CONTRACTING COMPANYSTEELFORMS FOR
CONCRETE
BUILDINGSC. B. Hopkins, C. E., Manager
681 Market Street, San FranciscoCONCRETE JOIST
FLOOR
CONSTRUCTION**W. C. DUNCAN & CO.**

508 Sharon Bldg.

General Contractors

San Francisco

M. E. VUKICEVICH

SPENCER B. BAGGE

VUKICEVICH & BAGGE
GENERAL CONTRACTORS

Phone Sutter 6700

Office, Builders Exchange, 180 Jessie St., San Francisco

245 Market St. **Standard Fence Co.** 310 Twelfth St.
 S. F. Kearny 2028 **Oakland 475**

WIRE AND IRON WORKS

DESIGNERS - BUILDERS
 FACTORY PROTECTION FENCE
 AVIARY AND TENNIS COURT FENCE
 320 North Los Angeles Street, Los Angeles, Cal. Phone 67188

WIRE GRILL WORK—WIRE SCREEN
 FLEXIBLE WIRE CONVEYOR BELT
 WIRE SPECIALTIES

Steel Bars **FOR CONCRETE REINFORCEMENT**
Cut to Length, Fabricated, Installed

BADT-FALK & CO.

Tel. Douglas 3466 346 Call-Post Bldg., 74 New Montgomery St., San Francisco

BUILDING DIRECTORIES [INTERCHANGEABLE STEEL
 LETTERS AND NUMBERS]

FOR OFFICE BUILDINGS, SCHOOLS, CAFETERIAS, Etc.
 Bargains Lists for Auto Sales Companies. Sold Outright.

Go-Sign and Letter Manufacturing Co.

1106 Franklin Street **Oakland, California**

D. N. & E. WALTER & CO.
 "SINCE 1858"

LINOLEUMS—CARPETS **LARGE STOCKS CARRIED**
 Estimates furnished on request

562-572 MISSION STREET **SAN FRANCISCO**

Phone Merritt 668

H. N. McNAB

Hardwood Floors  Floor Sanding

2307 - 17th Ave. **Oakland, Cal.**

Res. Tel. Merritt 3600

HERBERT BECKWITH
Building Construction

Formerly with **ARTHUR ARLETT** 323 Newton Ave.
Oakland

D. ZELINSKY & SONS

PAINTERS AND DECORATORS

420 TURK STREET, **SAN FRANCISCO**

CHARLES T. PHILLIPS
CONSULTING ENGINEER

PACIFIC BUILDING SAN FRANCISCO
 HEATING VENTILATION WIRING ILLUMINATION

Ideal Air-Washers. Ideal Fruit-Dryers. Fan Systems for Heating, Cooling and Drying.

Ideal Heating and Engineering Co.

Air-Conditioning, Heating, Cooling and Drying

192 ERIE STREET

Phone Market 3708

SAN FRANCISCO

Atlas Heating and Ventilating Co., Inc.

ENGINEERS and CONTRACTORS

STEAM AND HOT WATER HEATING, FANS, BLOWERS,
FURNACES, POWER PLANTS--SHEET METAL WORK

Phone Douglas 378

Fourth and Freelon Sts., Bet. Bryant & Brannan, SAN FRANCISCO

Illinois Automatic Vacuum and Vapor Systems of Heating

"TWENTY-FIVE YEARS OF QUALITY"

ILLINOIS ENGINEERING COMPANY

JAS. I. KRUEGER, *Representative*

559-561 Pacific Building, San Francisco

Telephone: Kearny 3047

HEATING
VENTILATION

FLOOR AND WALL TILING

PLUMBING
SHEET METAL WORK

SCOTT CO., INC.

SUCCESSOR TO JOHN G. SUTTON CO.

243 MINNA STREET

SAN FRANCISCO

ALEX COLEMAN

CONTRACTING PLUMBER

706 ELLIS ST., SAN FRANCISCO

Phone FRANKLIN 1006

WM. F. WILSON COMPANY

MODERN SANITARY APPLIANCES

Special Systems of Plumbing for Residences, Hotels, Schools, Colleges, Office Buildings, Etc.

Phone Sutter 357

328-330 Mason Street, San Francisco.

C. DRUCKER

J. C. JAMES

JAMES & DRUCKER

Plumbing—Heating Contractors

Phone Market 275

450 Hayes Street, San Francisco, Cal.

The Granite Work on Eldorado County Courthouse; National Bank of D. O. Mills, Sacramento;—
and Sen. Nixon Mausoleum, Reno, WAS FURNISHED BY

CALIFORNIA GRANITE COMPANY

Phone Sutter 2646

STONE CONTRACTORS

Gen'l Contractors Ass'n, San Francisco
Quarries, Rocklin and Porterville

Main Office, Rocklin, Placer Co., Cal.
Telephone Main 82

Bath Room Fixtures

A BATH ROOM should be just as true an expression of the owner's taste and individuality as any other room of the house.

No more is it considered a luxury, but an absolute necessity to your health and comfort.

Our fixtures reflect the finest ideas in design and construction as related to sanitation, utility and service.

To give this subject the attention it demands, you should visit our display rooms at 64 Sutter Street, San Francisco.

Holbrook, Merrill & Stetson

DEALERS IN



Plumbers' Supplies, Iron Pipe and Fittings, Metals, Steam, Water and Hot Air Heating Apparatus, Stoves, Ranges, Kitchen Utensils.

Show Room, 64 SUTTER STREET
Main Office and Warehouse,
Sixth, Townsend and Bluxome Streets, San Francisco

Designers - Fabricators - Erectors

General Plate Work



Hydro - Pneumatic Pressure Tanks —
Hemispherical Bottom Tanks and Towers
— Oil and Water Tanks — Oil Stills —
Pipe Lines—Smoke Stacks—Well Casing
— Rock Screens — "Western" Corrugated Culvert Pipe.

Western Pipe and Steel Company OF CALIFORNIA

444 MARKET STREET
SAN FRANCISCO

1758 NORTH BROADWAY
LOS ANGELES

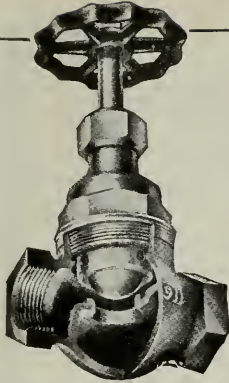

AMERICAN BALL VALVES

"Durable — therefore, Economical" — Stands the Severest Tests — Endorsed by the Leading Architects and Engineers of the Country. It is A PERFECT BALL-CLOSING VALVE.

W. E. MUSHET CO

SOLE AGENTS
Phone Sutter 4797



502 Mission Street
San Francisco, Cal.

**DON'T NEGLECT YOUR HEATING SYSTEM.
THE BEST IS NONE TOO GOOD!**

All kinds of Galvanized Iron Work — Furnaces, Pipes, Ventilators — Sheet Metal for Planing Mills, Fruit Dryers, Rice Mills. Kitchen Equipment, including Steam Tables, Sinks, Canopies, Urn Stands, Etc.

JAMES A. NELSON

Heating and Ventilating Contractor

Phone, Garfield 1959

517-519 SIXTH ST., SAN FRANCISCO

A. H. Bergstrom
Eric Lange

Phone Kearny 3526

LANGE & BERGSTROM

Building Contractors

(Established 1900)

207-210 SHARON BUILDING
San Francisco

TIMKEN BUILDING
San Diego

TELEPHONE MISSION 1105

Pacific Foundry Company

CONTRACTORS' SUPPLIES

Hand Hot Rollers, Tamping Irons,
Smoothing Irons, Sewer Fittings

Send for Bulletins

18th and Harrison Sts., San Francisco

C. DRUCKER

J. C. JAMES

JAMES & DRUCKER

PLUMBING—HEATING
CONTRACTORS

Phone
Market 275

450 Hayes Street
San Francisco

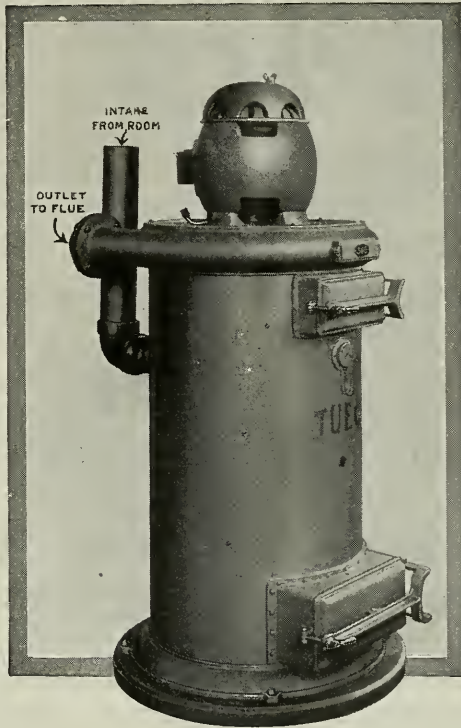

TUEC STATIONARY CLEANER.

THE cleaner that reduces building maintenance expense by keeping floors, walls, stairways, merchandise and other stocks, carpets, furniture and furnishings free from dust and dirt. No other cleaning device or dust removal method is so thorough, efficient, and economical. Investigate yourself and invite your client to do so. Write for our free catalog and full information.

THE UNITED ELECTRIC CO.
CANTON, OHIO.

Canadian Plant: Toronto, Ont.

California Distributors

S. F. COMPRESSED AIR CLEANING CO.
397 Sutter Street, San Francisco

BARKER BROS.
724 S. Broadway, Los Angeles



POSITIVE ELECTRIC INTERLOCK

(BAR LOCK TYPE)

Prevents Elevator Accidents Occurring at the Entrance Door

Approved by National Underwriters Laboratories—Meets requirements of Elevator Safety Orders of Industrial Accident Commission, State of California

ELEVATOR SUPPLIES COMPANY, Inc. 186 FIFTH STREET,
SAN FRANCISCO

Capital \$1,000,000

CALIFORNIA DEPARTMENT

Surplus \$1,122,000

THE FIDELITY AND CASUALTY COMPANY OF NEW YORK

Prompt Service for

BONDS AND CASUALTY INSURANCE

203-206 Merchants Exchange Building

SAN FRANCISCO, CAL.

ANY PLACE ANY TIME PROMPTLY "We Serve You"

JOHN H. ROBERTSON

Successor to Robertson & Hall

GENERAL INSURANCE

Phone Sutter 2750

621 First National Bank Building, San Francisco

CONTRACT BONDS

Fidelity and Surety Bonds of every kind.

C. K. BENNETT, Manager

FIDELITY AND DEPOSIT COMPANY OF MARYLAND

Telephone Kearny 1452

622 Insurance Exchange, San Francisco, Calif.

PACIFIC DEPARTMENT

Globe Indemnity Company

BONDS and CASUALTY INSURANCE for CONTRACTORS

FRANK M. HALL, formerly Robertson & Hall, Mgr.

120 Leidesdorff Street

Phone Sutter 2280

SAN FRANCISCO

National Surety Company of New York

The World's Largest Surety Company

Assets over \$20,000,000

Pacific Coast Department: 105 MONTGOMERY ST., SAN FRANCISCO, CAL.

Frank L. Gilbert, Vice-President

Phone, Sutter 2636

PHONE DOUGLAS 2370

McLERAN & PETERSON

GENERAL CONTRACTORS

HEARST BUILDING

SAN FRANCISCO, CAL.

L. J. RUEGG

J. B. RUEGG

RUEGG BROS.

CONTRACTORS AND BUILDERS

Phone Douglas 1599

719 Pacific Building, SAN FRANCISCO

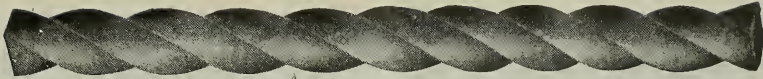

Steel ^{Open} ^{Hearth} Bars For Concrete Reinforcement

Square, Deformed and Cold Twisted, Plain Rounds and Squares

PACIFIC COAST STEEL COMPANY

General Office, Rialto Building, San Francisco. Phone Sutter 1564

Sales Office, Rialto Building, SAN FRANCISCO
 Sales Office, Union Oil Building, LOS ANGELES
 Sales Office, SEATTLE, WASH.

ROLLING MILLS:
 SOUTH SAN FRANCISCO, CAL.
 SEATTLE, WASH. PORTLAND, ORE.

Architects and Building Contractors!

The HICKS-JUDD COMPANY, Inc., and SUNSET PUBLISHING HOUSE
 have consolidated under the name of
 ABBOTT-BRADY PRINTING CORPORATION
 460 Fourth Street, San Francisco, Calif.

THE Binding of Magazines and Periodicals
 will continue as one of Our Specialties;
 also Expert Plate and Map Mounting.

Reprinting of The Architect and Engineer Advertisements for Circular or File Use

George S. MacGruer } Members of Builders Exchange
 Robert M. Simpson }

MacGruer & Simpson

CONTRACTING PLASTERERS
 PLAIN AND ORNAMENTAL

Cement, Stucco and Artificial Stone

Phone Sutter 5688

540 Call-Post Building, San Francisco

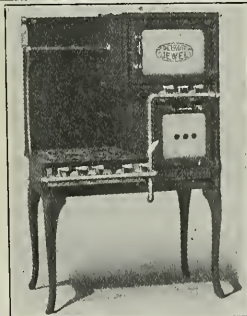

Detroit Jewel Gas Ranges

FOR HOME, RESTAURANT, HOTEL AND CLUB

We carry a Full Line of Stock Sizes

SELLING AGENTS

NATHAN DOHRMANN CO.

Geary and Stockton Streets, San Francisco

PARMELEE-DOHRMANN CO.

436-444 S. BROADWAY, LOS ANGELES

CALIFORNIA ARTISTIC METAL & WIRE CO.
 J. T. McCORMICK, PRESIDENT
 ORNAMENTAL IRON AND BRONZE
 349-365 SEVENTH ST. SAN FRANCISCO

MORTENSON CONSTRUCTION CO.
 CONTRACTORS FOR STRUCTURAL STEEL AND IRON
 H. MORTENSON, PRES. CHAS. G. MORTENSON, VICE-PRES. AND MGR.
 OFFICE AND SHOPS: CORNER 19TH AND INDIANA STREETS
 PHONE: MISSION 5033 SAN FRANCISCO, CAL.

RAYMOND GRANITE COMPANY, Inc.
 Owning and operating at Knowles, Madera County, the largest Quarry in the world
 CONTRACTORS FOR STONE WORK
 Designers and Manufacturers of Exclusive Monuments and Mausoleums
 Main Office and Yard: No. 1 and 3 Potrero Avenue, San Francisco, California
 Also at 1350-Palmetto Street, Los Angeles

CAEN STONE  **A. KNOWLES**
 A refined, elegant, interior finish. CONTRACTOR and PLASTERER
 442 Call-Post Building San Francisco

THE GOLDEN GATE IRON WORKS
STRUCTURAL STEEL
 1541-1549 HOWARD STREET, BETWEEN 11th AND 12th STREETS
 Tel. Market 5445 SAN FRANCISCO

Telephone Mission 58 A. A. Devoto, President
CENTRAL IRON WORKS, Inc.
 STRUCTURAL STEEL
 Office 2050 BRYANT STREET SAN FRANCISCO, CAL.

JOHNS-MANVILLE
 SERVES IN CONSERVATION
 Through
ASBESTOS and its ALLIED PRODUCTS

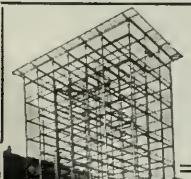
 **SCHRADER IRON WORKS, Inc.**
 STRUCTURAL STEEL CONTRACTORS
 Fire Escapes, Waterproof Trap Doors, Ornamental Iron Work
 1247-1249 HARRISON STREET SAN FRANCISCO, CAL.
 Bet. 8th and 9th Telephone Market 337

THE HYLOPLATE BLACKBOARD

SCHOOL FURNITURE
AUDITORIUM SEATING

MAPS
GLOBES
ATLASES

C. F. WEBER & CO.

985 Market Street
SAN FRANCISCO

222-224
S. Los Angeles St.
LOS ANGELES

100 W. Commercial
Row, RENO, NEV.

524 W. Washington
Street, PHOENIX, ARIZ.



California Redwood BLOCK PAVING

California Redwood Blocks, dipped in asphaltum, stand heavy traffic—outlive asphalt, brick or concrete.

Noiseless, dustless, sanitary. Reasonable in first cost and have longer life—maintenance practically nothing.

Redwood contains a *natural* preservative—no artificial preservative required.

Resists rot and fire, permanent in shape.

Redwood Block Flooring used in the Palace Hotel, Union Iron Works, Moore & Scott Iron Works, all of San Francisco.

Write for free booklet and full information.

CALIFORNIA REDWOOD
ASSOCIATION
San Francisco.

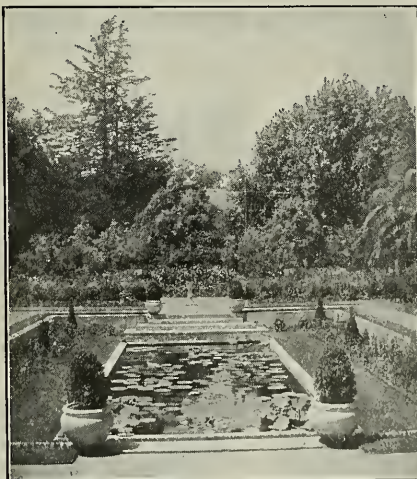

Formal Garden Effects

may be obtained on your Country Estate within a period of two or three years.

MacRORIE-McLAREN CO.

141 Powell Street, San Francisco
Telephone Douglas 4442

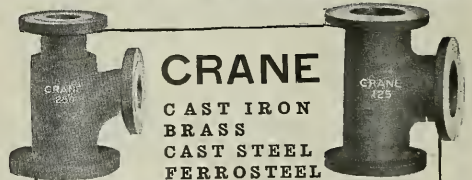

CRANE

CAST IRON
BRASS
CAST STEEL
FERROSTEEL

FLANGED FITTINGS

We have the largest line of patterns for flanged fittings for low pressure, standard, extra heavy, hydraulic, superheated and extreme hydraulic pressures, ranging in size from one-inch to sixty-inch, and for working pressures from fifty pounds to three thousand pounds.

The dimensions of the low pressure, standard and extra heavy fittings are in accordance with the 1915 *American Standard*.

Castings for special fittings also may be made at a minimum expense owing to our large equipment of special patterns which may be altered at very low cost.

CRANE CO.

PLUMBING SUPPLIES

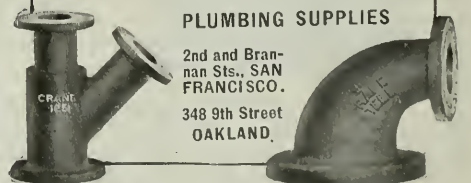

2nd and Bran-
nan Sts., SAN
FRANCISCO.

348 9th Street
OAKLAND.

Telephone
DOUGLAS
2046

Butte Electrical Equipment Company

BEECO

TRADE MARK - REG.

530
FOLSOM
STREET

CONTRACTORS FOR POWER LIGHTING
AND INDUSTRIAL INSTALLATIONS

For the convenience and guidance of our customers,
we have adopted BEECO as our trade name.

SAFETY ELECTRIC COMPANY

MANUFACTURERS OF

SWITCHBOARDS
SAFETY SWITCHES
SAFETY CONTROLS



PANEL BOARDS
SAFETY PANELS
KNIFE SWITCHES

59-65 Columbia Square

San Francisco, Calif.

Telephone Market 2949

L. SIEBERT

J. GENSLER

Drendell Electrical & Mfg. Co.

Incorporated

SWITCHBOARDS, PANEL BOARDS, KNIFE SWITCHES,
CABINETS, THEATRE INSTALLATIONS,
PROTECTIVE POWER PANELS

1345-1353 Howard St., San Francisco

Telephone Market 1753



Knock outs on Top, Bottom and Side
controlled by Handle on side of Box

MEYERS Electric Safety SWITCHES

EXTERNALLY OPERATED

Switch on the right is controlled by
Handle on Front of Door, allowing
face of switch to be set flush with
finish of wall.

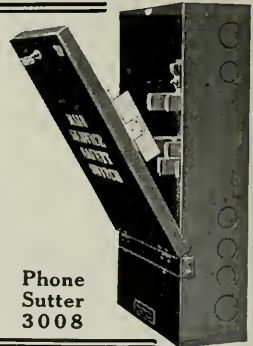

Phone
Sutter
3008

Western Electric Safety Mfg. Co., Inc. 247 Minna Street

BUTTE ELECTRIC & MFG. CO. DOUGLAS 145

(Paul C. Butte) at it since 1904

WIRING FOR BUILDINGS

534 Folsom Street

SAN FRANCISCO

H. S. TITTLE**CONTRACTING ELECTRICAL ENGINEER**

766 FOLSOM ST., SAN FRANCISCO

Phone SUTTER 4278

**To Be "Low Bidder" Not Always Our Aim.**

Our most particular attention is given to prompt and skillful handling of all electrical work of any nature with "QUALITY AND SERVICE GUARANTEED."

Our nation-wide organization and large experience in this field assures you always of fair estimates and absolute satisfaction.

F. E. NEWBERY ELECTRIC CO.

163 Sutter St. (413 Lick Bldg.) San Francisco, Phone Sutter 521

San Francisco, Cal.

Oakland, Cal.

Los Angeles, Cal.

NE PAGE, McKENNY CO.*Electrical Engineers and Contractors*

Phone Sutter 2369

589 Howard St., San Francisco, Cal.

Phone Market 2541

M. FLATLAND

GLOBE ELECTRIC WORKS

Estimates Furnished on Everything Electrical

ELECTRIC SUPPLIES

1959 Mission Street, bet. 15th and 16th

SAN FRANCISCO

E. E. BROWNE

Telephone Douglas 976

C. A. LANGLAIS

**BROWNE-LANGLAIS ELECTRICAL
CONSTRUCTION COMPANY**

213 Minna Street

SAN FRANCISCO

M. E. RYAN**Electrical Contractor**Phones: Store, Red. 250J
Residence, Red. 250M216 Main Street
REDWOOD CITY, CAL.

Thomas J. Bennett

Edward W. Lauer

Rex Electric and Engineering Co.**Contracting and Repairing**

253 Minna Street

Telephone Sutter 2148

San Francisco

Oakland 540

The Largest Exclusive Electrical House in the State

MOTORS

BOUGHT — SOLD
RENTED — REPAIRED

Lighting Fixtures

Manufactured

Construction

MAINTENANCE
SUPPLIES

Estimates and engineering data cheerfully furnished

SPOTT ELECTRICAL CO.

Yours for Service

16th & CLAY STREETS

OAKLAND, CALIFORNIA

KLINGSTONE

WILL NOT CRACK

Modern Flooring Requirements

¶ In this day of modern building construction, sanitary and fireproof requirements are sought by the architect in building specifications.

Klingstone Sanitary Flooring Rates 82%

—Cork tile, 72%; linoleum, 70%; oak or maple, 63%; white pine 62%; marble, 52%; rubber tile, 49%; clay tile, 43%; terrazo 43%; Portland Cement concrete, 42%; common brick rating 25%. — ¶ KLINGSTONE SANITARY FLOORING is being extensively used in modern office buildings, schools, hospitals, factories, churches, railroad cars, steamships, hotels, public buildings, theatres, banks, stores, restaurants, cafes, garages, dairies, creameries, high-class residences and apartment houses.

¶ **GUARANTEE.** — We rigidly guarantee our KLINGSTONE Sanitary Flooring, and where applied according to our printed specifications, will replace, free of charge, any defective material, including labor for installing same.

NATIONAL MAGNESITE PRODUCTS CORPORATION

833 MARKET STREET, SAN FRANCISCO

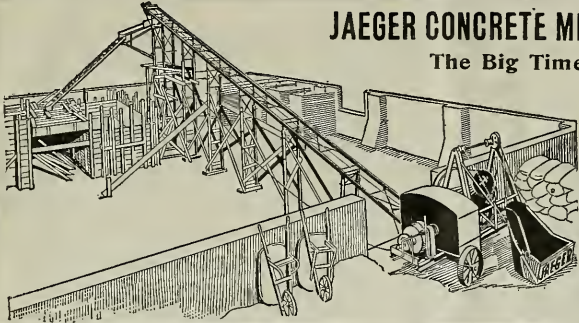

JAEGER CONCRETE MIXING AND PLACING PLANT
 The Big Time and Money Saver

All Sizes and Models in Stock

Edward R. Bacon Company

51 Minna St. 165 E. Jefferson St.
 SAN FRANCISCO LOS ANGELES

CONTRACTOR'S MACHINERY

RANSOME MIXERS OSHKOSH MIXERS
 INSLEY SPOUTING PLANTS
 OSHKOSH EVEREADY SAW RIGS INSLEY STEEL CARS and TRACKS
 HOISTING BUCKETS, HOPPERS, GATES, ETC.
 STEAM AND ELECTRIC HOISTS

EVERYTHING USED BY CONTRACTORS
 CARRIED IN STOCK BY

GARFIELD & CO.

Hearst Building, San Francisco Phone Sutter 1036

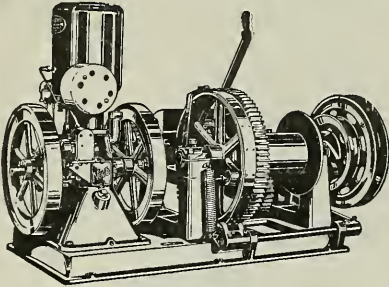

NOVO HOIST -- TYPE T.

NOVO ENGINES

ALWAYS
SATISFY

BUILT IN SIZES
 1½ TO 15 H. P.

We have a Hoist for every requirement of
 the Mine, Factory or Contractor.

NOVO OUTFITS
 comprise Contractor's Pumps—Hoists
 Compressors—Saw Rigs, Etc.



STOCKS ALWAYS ON HAND

SMITH-BOOTH-USHER-CO.

PUMPS — ENGINES — MOTORS — MACHINERY — SUPPLIES

San Francisco 50-60 Fremont St. Sutter 952
 Taft Supply Row
 Los Angeles 228 Central Ave. M2695

School and Theatre

STAGES AND EQUIPMENT

EDWIN H. FLAGG

SCENIC COMPANY, Inc.
400 Pantages Bldg., San Francisco, Cal.
1638 Long Beach Ave., Los Angeles, Cal.

MILLWORK Manufactured and Delivered Anywhere

Plans or Lists sent us for Estimates will have Careful and Immediate Attention.

Jno. Dudfield, Pres.
and Manager

DUDFIELD LUMBER CO.

Joseph A. Jury,
Sec'y & Mill Supt.

MAIN OFFICE, YARD AND PLANING MILL — PALO ALTO, CALIFORNIA

FRANK PORTMAN

MILL AND CABINET WORK

Window Frames and Inside Finish A Specialty
Band Sawing, Sticking and Sand Papering

1618-20 MISSION STREET

SAN FRANCISCO

ALL KINDS OF
MOULDINGS
IN STOCK

Phone Park 6204

A. C. SCHINDLER, President.

CHAS. F. STAUFFACHER, Secretary

THE FINK & SCHINDLER CO.

Manufacturers of INTERIOR WOODWORK AND FIXTURES
BANK, OFFICE AND STORE FITTINGS
SPECIAL FURNITURE

218-228 THIRTEENTH ST.
Bet. Mission and Howard Sts.

SAN FRANCISCO, CAL
Telephone: Market 474

O. BAMANN, President

ERNEST HELD, Vice-President

HOME MANUFACTURING CO.

BANK, STORE AND OFFICE FITTINGS
FURNITURE AND HARDWOOD INTERIORS
CABINET WORK OF EVERY DESCRIPTION

543 and 545 BRANNAN ST.

Phone Kearny 1514

San Francisco, Cal.

PACIFIC MANUFACTURING COMPANY

MILLWORK, SASH AND DOORS

Hardwood Interior Trim a Specialty

MAIN OFFICE:

SANTA CLARA, CAL.

SAN FRANCISCO.....177 Stevenson Street
OAKLAND.....1001 Franklin Street
BERKELEY.....2143 Center Street
SAN JOSE.....16 N. First Street

MULLEN MANUFACTURING CO.

BANK, STORE AND OFFICE FIXTURES—CABINET WORK OF
GUARANTEED QUALITY—CHURCH SEATING

Telephone Market 8692

Office and Factory:

64 Rausch St., Bet. 7th and 8th Sts., San Francisco

Dolan Wrecking & Construction Co.

(D. J. DOLAN)

Lumber, Lath, Nails, Shingles, Doors, Windows
and Plumbing Supplies, New and Second Hand

Phone Market 4264

Office and Yard, 1607-1639 MARKET ST., SAN FRANCISCO

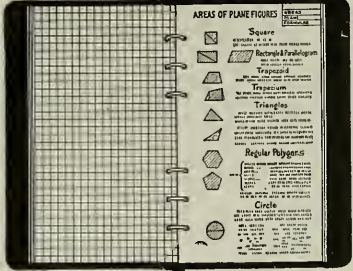

LEFAX
LEAF + FACTS
Pocket Cyclopedias

The facts that you want *instantly available* are not the same ones that some one else in your profession might desire. That's why LEFAX is made Loose Leaf. You file, in whatever order you wish, those sheets of facts that you want to have constantly at hand. If you wish, you may also file, in the same book, sheets for keeping data, for figuring, etc.

LEFAX sets cost but 50c. and \$1.00. You cannot fully appreciate their handiness—their value—until you use them. Ask us about them.

SCHWABACHER-FREY STATIONERY CO.
PRINTERS LITHOGRAPHERS STATIONERS
611 Market Street San Francisco

Steam Heating and Ventilating



For Commercial and Public Buildings

Furnace Heating
For the Home

Mangrum & Otter, Inc.
827-831 Mission Street
Phone Kearny 3155 SAN FRANCISCO

"Talk — Don't Walk"

Baker, Hamilton & Pacific Co.; California Packing Corporation; J. Barth & Company; Robert Dollar Company; Bass-Hueter Paint Co.; Sperry Flour Company, So. Vallejo; J. D. & A. B. Spreckles Securities Co.

WHY are the above firms using the AUTOMATIC PRIVATE TELEPHONE SYSTEM?

BALFOUR, GUTHRIE CO.; HOWARD AUTOMOBILE COMPANY; U. S. MARINE HOSPITAL KNOW WHY, and are also installing the AUTOMATIC PRIVATE TELEPHONE SYSTEM.



DIRECT-LINE TELEPHONE COMPANY
Telephone Electrical Engineers
THEODORE HALL, MANAGER
320 MARKET STREET, SAN FRANCISCO
Phone Douglas 722

Have you read "A Pair of Wires and A Dial?"

ROBERTS MFG. CO.

Lighting Fixtures
Electric Appliances
Incandescent Lamps



WILLYS FARM LIGHTING AND POWER PLANTS

663 Mission St., San Francisco

Washed Gravel and Sand

Quality For Concrete Construction *Service*

Thoroughly Washed and Accurately Graded—An Ideal Concrete Aggregate



View of Plant at Niles

California Building Material Co.

Plants at Eliot and Niles, Cal.

500 Call Building, San Francisco

Otis Elevators

THE Architect or Engineer can specify "Otis Elevators" assured that the responsibility of the Otis Elevator Company extends beyond satisfactory installation. Buildings equipped with Otis Elevators enjoy the advantage of the prompt service and careful inspection rendered by any of our hundred offices. Such service means your clients' gratitude.

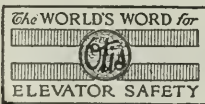

Otis Elevator Company

Offices in All Principal Cities of the World
2300 Stockton Street, San Francisco, Calif.

