

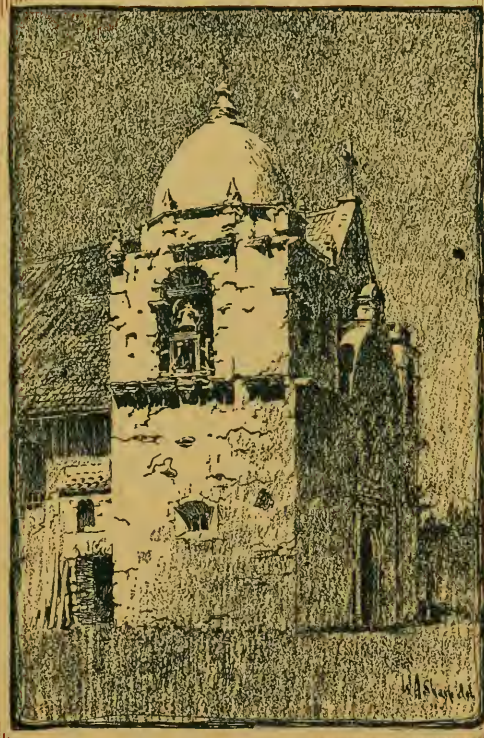

SAN FRANCISCO  
PUBLIC LIBRARY

THE  
**ARCHITECT & ENGINEER**  
OF  
CALIFORNIA  
· PACIFIC COAST STATES ·



25c a Copy  
\$1.50 a Year

Published by the **THE ARCHITECT & ENGINEER CO.**

621 Monadnock Bldg.  
San Francisco  
Vol. XXIV. No 1

Entered at the Post Office, San Francisco, as second class matter.

FLOORS

ROOFS

NOTE CONTINUOUS BOND

CEILING

SIDWALKS

PARTITIONS

# CLINTON

FIRE-PROOFING SYSTEM

FABRIC WIRE LATH

CLINTON FIREPROOFING  
OF CALIFORNIA  
CONTRACTORS FOR  
FIREPROOFING

L. A. NORRIS CO.  
WESTERN SALES AGENTS  
FOR CLINTON FIRE-  
PROOFING MATERIALS

SEATTLE                      SAN FRANCISCO                      LOS ANGELES

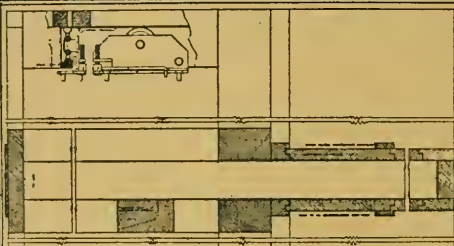

**THIS HANGER**  
CAN be put in  $3\frac{3}{4}$ " partition, a great saving of space and 50 per cent of labor and material.

Specified by All Leading Architects.

The new patent hanger with double track, upper and lower, which cannot bind in any way, with side adjustment.

## Pacific Ballbearing Door Hanger Co.

Phone Kearny 1039                      959-961 Howard St., San Francisco

# MEURER BROS. CO.



## AMERICAN MADE ROOFING PLATES

Four Guaranteed Brands  
Unexcelled in Quality and Coating  
None Better — Few Equal

A. H. McDONALD, Pacific Coast Manager

630 THIRD STREET                      Office and Warehouse                      SAN FRANCISCO

# The Day Has Past

When the Pacific Coast Owner,  
Architect or Builder must use  
an Eastern made Elevator simply  
because it is Eastern made

The Van Emon Electric Elevator  
is BETTER than any Eastern machine made

---

---

## Van Emon Elevators

ARE USED BY:

Hale Bros., Inc., Eiler's Music Co.,  
Sterling Furniture Company,  
W. W. Montague & Company,  
Chas. M. Plum & Company.

---

---

## Heavy Duty Freight Elevators

BUILT AND INSTALLED BY

## Van Emon Elevator Co.

FOR

Baker & Hamilton - - 5,000 Lbs.  
Harron, Rickard & McCone 12,000 "  
Henshaw, Bulkley & Co. 12,000 "  
Studebaker Bros. - 8,000 "



# WATERPROOFING WISDOM



PERMANENCY

is shown by  
the use of



ECONOMY

# CERESIT

paste. Same is simply added to the water used in mixing concrete and mortar. With the water, the **CERESIT** paste penetrates to all parts of the **concrete** and **mortar** and assures a **permanent water- and damp-proof** job.

No expert help required; no scientific and expensive mixing.

**CERESIT** is not an experiment, but has been used with complete success on hundreds of tanks, pits, foundations, dams and bridges. It has been employed not only by the U. S. Government, but by practically every government in the civilized world. **More than 5,000,000 cubic feet of concrete and mortar have been waterproofed with CERESIT in 1909.** The use of **CERESIT** is complete assurance against the penetration of moisture or dampness, even under high pressure, as encountered in dam work, etc.

Ask for our free book. It is money in your pocket to know about this excellent material.

## CERESIT WATERPROOFING CO.

PACIFIC COAST REPRESENTATIVES

## PARROTT & CO.

SAN FRANCISCO LOS ANGELES PORTLAND

## JULIEN A. BECKER CO.

413 BAILEY BLDG., SEATTLE, WASH.

MAIN OFFICE, 446 COMMERCIAL NATIONAL BANK BLDG., CHICAGO, ILL.



Masons' Suspended Platforms Worked Individually as Units

## Lay your Bricks at any Story and at any Height with Perfect Safety

A Device for Conserving Human Life and Limb  
that Appeals to Contractor and Owner. Reduces  
Possibility of Accident Claims to a Minimum.

**The Patent Scaffolding Company**  
**PARROTT & CO.**

**Building Materials & Equipment.**  
San Francisco, Seattle, Los Angeles.

**Waterproofing Specialists**  
Tacoma, Portland, Spokane

When writing to Advertisers mention this Magazine.



# Building Materials

*These Three Are Permanent  
and Beautiful*

“RENO WHITE” PLASTER, a product of the Western Gypsum Co. that is beautiful, hard and lasting.

DEL MONTE WHITE SAND, to be used with Medusa and other white cement to make a beautiful white stone finish on concrete and artificial stone buildings.

“MEDUSA WHITE PORTLAND CEMENT,” a new and beautiful product adapted to ornamental artificial stone work of the highest grade.

**F.T.CROWE & Co.**  
**Jobbers and Dealers**

SEATTLE, PORTLAND, TACOMA, SPOKANE.

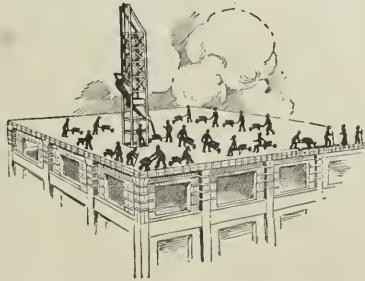

THE OLD WAY

- 1—COST TO WHEELBARROW OR CART CONCRETE, \$1 TO \$1.76 PER YARD.
- 2—SLOW AND CONGESTED, 8 TO 10 YARDS PER HOUR.
- 3—LOSS OF INITIAL SET, VARIABLE MULTILITHIC CONSTRUCTION.
- 4—CAUSES SEPARATION, AIDS LA TENGE.
- 5—DAMAGES FLOOR TILE, DISPLACES STEEL AND SPILLS CONCRETE.
- 6—EXPENSIVE SCAFFOLDING, RUNWAYS AND STAGING.
- 7—TAMPING.

## CONCRETE APPLIANCES COMPANY

LICENSEE'S  
OF

### GRAVITY SYSTEM

DISTRIBUTING CONCRETE  
LOS ANGELES

Buildings now being constructed by the Gravity System:

- WILSON BUILDING, San Francisco, Cal.
- FERGUSON BUILDING, Los Angeles
- UNION LEAGUE BUILDING, Los Angeles
- IVANS BUILDING, Los Angeles
- EXPOSITION BUILDING FOR THE STATE AGRICULTURAL PARK, Los Angeles
- SWEETWATER DAM, San Diego, Cal.
- WAREHOUSE FOR GENERAL ELECTRIC COMPANY, Los Angeles
- EDISON ELECTRIC CO., 3 Warehouses, Long Beach
- SPECKELS THEATRE AND OFFICE BLDG., San Diego

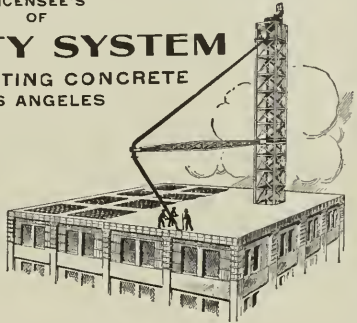

THE NEW WAY

- 1—COST FOR DELIVERING CONCRETE, 26 TO 60 CENTS PER CUBIC YARD
- 2—RAPID AND EFFICIENT, 26 TO 40 CUBIC YARDS PER HOUR.
- 3—OBTAIN INITIAL SET, HOMODENOUS MONOLITHIC CONSTRUCTION.
- 4—UNIFORM CONCRETE OBTAINS LA TENGE.
- 5—NO LOSS OF FLOOR TILE, DISPLACEMENT OF STEEL OR SPILLING.
- 6—SAVES SCAFFOLDING, RUNWAYS AND STAGING.
- 7—NO TAMPING.

### WILLIAM B. HOUGH COMPANY

EXCLUSIVE AGENTS  
HOME OFFICES  
CHICAGO, ILL.

DETROIT

MINNEAPOLIS

ST. LOUIS

DES MOINES

INDIANAPOLIS

PACIFIC COAST REPRESENTATIVES

## PARROTT & COMPANY

SAN FRANCISCO  
SEATTLE

TACOMA  
SPOKANE

PORTLAND  
LOS ANGELES



# Medusa WHITE PORTLAND CEMENT



*St. Mary's Hospital, San Francisco*

*D. H. Burnham & Co., Architects*

FACED WITH  
MEDUSA WHITE PORTLAND CEMENT

## HIGH TESTING - STAINLESS

### The Building Material Co. INC.

583 MONADNOCK BUILDING,  
SAN FRANCISCO

## ARCHITECTS' SPECIFICATION INDEX

(For Index to Advertisements, see page 117)

- ARCHITECTURAL AND ORNAMENTAL STEEL AND IRON WORK**  
 Western Iron Works, 141-147 Beale St., S. F.  
 Pacific Rolling Mills, 17th and Mississippi Sts., S. F.  
 Dyer Bros., 17th and Kansas Sts., S. F.
- ARCHITECTURAL MODELERS**  
 S. Tomasello & Co., 122 Tenth St., near Mission, S. F.  
 Callaghan & Manetta, 344 10th St., S. F.  
 C. Menzer & Son, 862 Howard St., S. F.
- ARCHITECTURAL TERRA COTTA**  
 Steiger Terra Cotta and Pottery Works, Mills Bldg., S. F.  
 Gladding, McBean & Company, Crocker Bldg., S. F.
- ASBESTOS-PROTECTED METAL**  
 P. J. Knudsen Company, Pacific Coast Agents, 214 Front St., S. F.
- AUTOMATIC FREIGHT ELEVATOR DOORS**  
 Boyd & Moore, 356 Market St., S. F.
- BANK FIXTURES**  
 M. G. West Company, 353 Market St., S. F.  
 J. A. M. Johnson, Monadnock Bldg., S. F.  
 C. F. Weber & Co., 365 Market St., San Francisco and 210 N. Main St., Los Angeles, Cal.  
 Weary & Alford Co., 303 Union Trust Bldg., S. F.
- BANK INTERIORS**  
 Weary & Alford Co., 303 Union Trust Bldg., S. F.
- BELTING, PACKING, ETC.**  
 H. N. Cook Belting Co., 317-319 Howard St., S. F.  
 Goodyear Rubber Co., 587 Market St., S. F.
- BLACKBOARDS**  
 Whitaker & Ray Wiggins Co., 776 Mission St., S. F.; 209 E. Seventh St., Los Angeles.  
 C. F. Weber & Co., 365 Market St., S. F.
- BOILERS**  
 Simonds Machinery Co., 12 Natoma St., S. F.
- BRICK AND CEMENT COATING**  
 Wadsworth Howland & Co., Inc. (See Adv. for Pacific Coast Agents.)
- BRICK**  
 Gladding, McBean & Company, Crocker Bldg., S. F.  
 Golden Gate Brick Co., 660 Market St., S. F.  
 Diamond Brick Co., Balboa Bldg., S. F.  
 Los Angeles Pressed Brick Co., Frost Bldg., Los Angeles  
 Northern Clay Company, Auburn, Wash.  
 Steiger Terra Cotta and Pottery Works, Mills Bldg., S. F.  
 Vallejo Brick & Tile Co., Monadnock Bldg., S. F.
- BRICK STAINS**  
 Samuel Cabot Mfg. Co., Boston, Mass., agencies in San Francisco, Oakland, Los Angeles, Portland, Tacoma and Spokane.
- BRIDGE CONTRACTORS**  
 San Francisco Bridge Co., Monadnock Bldg., S. F.
- BUILDERS' HARDWARE**  
 Reading Hardware sold by Brittain & Co., San Francisco  
 Russell & Erwin Mfg. Co., Commercial Bldg., S. F.
- BUILDERS' SUPPLIES**  
 Boyd & Moore, 356 Market St., S. F.  
 Waterhouse & Price, 59 Third St., S. F.
- CAPITALS, MOLDINGS, ETC.**  
 Western Builders' Supply Co., 680 Mission St., S. F.
- CASEMENT WINDOWS**  
 The Bexhill Casement Window Co., Mills Bldg., S. F.
- CEMENT**  
 Blanc Stainless Cement Co., Allentown, Pa.  
 Standard Supply Co., First St. and Broadway, Oakland  
 Pacific Portland Cement Co., Pacific Bldg., S. F.  
 Western Building Material Co., 430 California St., S. F.  
 The Building Material Co., "Medusa White Portland", 587 Monadnock Bldg., S. F.  
 Boyd & Moore, 356 Market St., S. F.  
 Standard Portland Cement Co. and Santa Cruz Portland Cement Co., Crocker Bldg., S. F.
- CEMENT AND PLASTER BLOCKS**  
 Dodds' Interlocking Block Company, 356 Market St., S. F.
- CEMENT AND PLASTER CONTRACTORS**  
 Callaghan & Manetta, 344 Tenth St., S. F.  
 D. Ross Clarke, 708 Pacific Bldg., S. F.  
 C. Menzer & Son, 862 Howard St., S. F.  
 A. Knowles, 985 Folsom St., S. F.
- CEMENT EXTERIOR WATERPROOF COATING**  
 "Blanc," manufactured by Blanc Stainless Cement Company, Allentown, Pa.  
 Protectorine, Black, White and Colorless, Boyd & Moore, 356 Market St., S. F.  
 Bay State Brick and Cement Coating, made by Wadsworth, Howland & Co. [See distributing agents on page 19.]
- CEMENT TESTS**  
 Robert W. Hunt & Co., 418 Montgomery St., S. F.  
 Pacific Laboratories, Inc., 558 Market St., S. F.  
 Smith, Emery & Co., 651 Howard St., S. F.
- CEMENT EXTERIOR FINISH**  
 Medusa White Portland Cement, California Agents, The Building Material Co., Inc., 587 Monadnock Bldg., S. F.  
 "La Farge" sold by Waterhouse & Price, 59 Third St., S. F.  
 Blanc Stainless Cement Co., Allentown, Pa. [See color insert for Coast distributors.]  
 Bay State Brick and Cement Coating, made by Wadsworth, Howland & Co. [See list of distributing agents on page 119.]  
 Samuel Cabot Mfg. Co., Boston, Mass., agencies in San Francisco, Oakland, Los Angeles, Portland, Tacoma and Spokane.
- CEMENT FLOOR COATING**  
 Bay State Brick and Cement Coating, made by Wadsworth, Howland & Co. [See list of distributing agents on page 119.]
- CHEMICAL ENGINEERS**  
 Robert W. Hunt & Co., 418 Montgomery St., S. F.  
 Smith, Emery & Co., 651 Howard St., S. F.  
 Pacific Laboratories, Inc., 558 Market St., S. F.

## A. L. YOUNG MACHINERY CO.

Hoisting Engines, Derricks, Concrete Mixers, Barrows and Carts,  
 Portable Saw Tables, Swing and Band Saws—in Stock

26-28 FREMONT STREET

SAN FRANCISCO, CAL.



Sunday News Bldg., E. C. Hemmings, Architect Sacramento Haub Bldg., R. A. Herold, Architect

**RANSOME CONCRETE COMPANY**  
**BUILDERS**  
**MECHANICS' INSTITUTE BUILDING, SAN FRANCISCO**

Rust-resisting—Anti-corrosive

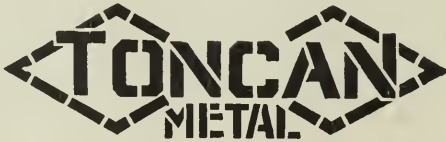

**Black and Galvanized Sheets**

will resist corrosion under conditions that destroy iron and steel. Durability, Ductility and Price considered it is the logical material for roofing, siding and all formed products.

*Write for Samples, Prices and "Corrosion Text Book"*

CARRIED IN STOCK IN SAN FRANCISCO BY

**The Berger Manufacturing Company**  
**OF CALIFORNIA**

1120-22-24-26 Mission Street  
 San Francisco, Cal.

320 San Fernando Building  
 Los Angeles, Cal.



# WE MAKE BLUE PRINTS

DAY OR NIGHT—RAIN OR SHINE

**EUGENE DIETZGEN CO.,** 18 FIRST STREET  
SAN FRANCISCO

Architects' Supplies      Surveying Instruments

## ARCHITECTS' SPECIFICATION INDEX—Continued

- CHIMNEY BUILDERS**  
Dresser, McDonnell & Co., 39-49 Isis St., S. F.
- CHURCH FURNITURE**  
C. F. Weber & Co., 365 Market St., S. F.
- COLD STORAGE INSULATION**  
Neposnet Waterdyke Felt and Compound, manufactured by F. W. Bird & Son, East Walpole, Mass.; sold by Parrott & Co., 320 California St., S. F.  
Hydrex Felt, Boyd & Moore, Agents, 356 Market St., S. F.
- CONCRETE CONSTRUCTION**  
Peterson, Nelson & Co., Inc., 407 Pine St., S. F.  
A. Lynch & Co., 185 Stevenson St., S. F.  
Esterly Construction Co., Berkeley, Cal.  
Bluxome & Co., Monadnock Bldg., S. F.  
Foster & Vogt, Mechanics Bank Bldg., S. F.
- CONCRETE FOUNDATIONS**  
Peterson, Nelson & Company, Russ Bldg., S. F.
- CONCRETE MIXERS**  
Foot Concrete Mixers, Monadnock Bldg., S. F.  
Coltrin Concrete Mixers, N. J. Morehouse, Western Agent, Waterloo, Iowa; J. L. Mery Eng. Co., Monadnock Bldg., S. F.; V. W. Mason, St. Johns, Ore.  
F. T. Crowe & Co., Seattle, Tacoma, Spokane and Portland  
Chicago Improved Cube Mixer, Pacific Coast Offices, 789 Folsom St., S. F., and F. T. Crowe & Co., Portland and Seattle
- CONCRETE POURING APPARATUS**  
Concrete Appliances Co., Los Angeles; Parrott & Co., Coast Representatives, San Francisco, Portland, Seattle
- CONCRETE REINFORCEMENT**  
The Kahn System, Agents in San Francisco, Los Angeles, Portland and Seattle.  
Clinton Fireproofing System, L. A. Norris, Monadnock Bldg., S. F.
- Corrugated Bars sold by**  
John B. Leonard, C. E. Sheldon Bldg., S. F.  
International Fabric & Cable, represented by Western Builders' Supply Co., 680 Mission St., S. F.
- Twisted Bars sold by**  
Woods & Huddart, 356 Market St., S. F.  
Plain and Twisted Bars, sold by Baker & Hamilton, San Francisco, Los Angeles and Sacramento.
- CONCRETE SURFACING**  
"Concreta" sold by W. P. Fuller & Co., S. F.  
"Alkacene" Liquid Concrete—Boyd & Moore, 356 Market St., S. F.  
Concrete, Worden-Meecker Varnish Co., S. F.—Oakland
- CONCRETE SURFACING—Continued**  
Glidden Liquid Cement, manufactured by Glidden Varnish Company, Whittier, Coburn Co., San Francisco and Los Angeles, Pacific Coast Distributors.
- CONTRACTORS, GENERAL**  
E. D. Crowley Co., 127 Montgomery St., S. F.  
W. H. Bagge & Son, Inc., 3528 Sacramento St., S. F.  
Esterly Construction Co., Berkeley, Cal.  
F. O. Engstrum Co., Fifth and Seaton Sts., Los Angeles  
Henning & Burke, 242 Russ Bldg., S. F.  
Hoyt Bros., Builders' Exchange, S. F., and Santa Rosa Ransome Concrete Co., Mechanics Institute Bldg., S. F.  
Gutleben Bros., 944 Monadnock Bldg., S. F.  
Henning & Burke, 242 Russ Bldg., S. F.  
Rickon-Ehrhart Eng. & Const. Co., 1859 Geary St., S. F.  
Geo. H. Stoffels & Co., 830 Pacific Bldg., S. F.  
Williams Bros. & Henderson, 351 Monadnock Bldg., S. F.
- CORKBOARD INSULATION**  
Armstrong Cork Co., 693 Mission St., S. F.
- CORK CARPET**  
"B. & M. Cork Carpet," Boyd & Moore, Agents, 356 Market St., S. F.
- CORNER BEAD**  
"Prescott" sold by Boyd & Moore, 356 Market St., S. F.  
Union Metal Corner Company, 206 Summer St., Boston, represented on the Pacific Coast by Waterhouse & Price.
- DAMP-PROOFING COMPOUND**  
Liquid Stone Paint Co., Inc., Laird & Sinclair and Lilley & Thurston Co., Agts., S. F.  
Boyd & Moore, 356 Market St., S. F.  
"Pabco" Damp Proofing Compound sold by Paraffine Paint Co., 38 First St., S. F.  
H. D. Samuel Co., Monadnock Bldg., S. F.  
"Protectorine," Compound, sold by Boyd & Moore, 356 Market St., S. F.  
Parrott & Co., agents for Genasco Positive Seal Damp Proof Paint.
- DAMP PROOFING FOR BRICK WALLS**  
"Imperial" Waterproofing, sold by Baker Bros., San Francisco; Braun Chemical Co., Los Angeles; W. O. Stamps, Portland, and B. W. Gaisford, Seattle, Wash.
- DISAPPEARING BEDS**  
Holmes Disappearing Bed Company, 687 Monadnock Bldg., S. F.
- DOOR OPENER**  
G. Rischmuller, Builders' Ex., S. F., 842 37th St., Oakland

Specify...

For Plastering

**HOLMES DIAMOND SANTA CRUZ LIME**

PHONE KEARNY 2220

Guaranteed Against Pitting or Popping

The Holmes Lime Co.,  
Monadnock Bldg., San Francisco

When writing to Advertisers mention this Magazine.



## ARCHITECTS' SPECIFICATION INDEX—Continued

## DOOR HANGERS—Continued

Johns Door Hanger Manufacturing Company,  
832-838 Folsom street, S. F.

## DOORS—FREIGHT ELEVATOR

"Cross" Counterbalance Automatic, Boyd &  
Moore, Agents.....356 Market St., S. F.

## DOORS—METAL

M. G. West Company, 353 Market St., S. F.  
Waterhouse & Price.....59 Third St., S. F.

## DOORS—WAREHOUSE

"Cross" Horizontal Folding Doors, Boyd &  
Moore, Agents.....356 Market St., S. F.

## DUMB WAITERS

Energy Dumb Waiters, Boyd & Moore,  
Agents.....356 Market St., S. F.  
Wells & Spencer Machine Company,  
173 Beale St., S. F.

## ELECTRICAL CONTRACTORS

Electric Appliance Co., 726 Mission St., S. F.  
The Turner Co.....278 Natoma St., S. F.  
Central Electric Co.....185 Stevenson St., S. F.  
Butte Engineering Co.....683 Howard St., S. F.  
Jno. G. Sutton Co.....229 Minna St., S. F.  
Pacific Fire Extinguisher Company,  
507 Montgomery St., S. F.

## ELEVATORS

Van Emon Elevator Co., 54 Natoma St., S. F.  
Wells & Spencer Machine Co.,  
173 Beale St., S. F.

## ELEVATOR CARS

Cleveland Art Metal Co., Boyd & Moore,  
Agents.....356 Market St., S. F.

## ELEVATORS, SIGNALS, FLASHLIGHTS AND DIAL INDICATORS

Elevator Supply & Repair Co.,  
593 Market St., S. F.

## ENGINEERS

John B. Leonard.....Sheldon Bldg., S. F.  
W. W. Breite.....Clunie Bldg., S. F.  
F. J. Amweg.....700 Marston Bldg., S. F.

## EXPRESS CALL SYSTEM

Elevator Supply & Repair Co.,  
593 Market St., S. F.

## FILING CASES—METAL

M. G. West Company, 353 Market St., S. F.

## FIRE EXTINGUISHERS

Goodyear Rubber Company,  
587-591 Market St., S. F.  
Pacific Fire Extinguisher Co.,  
507 Montgomery St., S. F.

## FIREPROOF PARTITIONS

Dodds' Interlocking Block Co.,  
356 Market St., S. F.

## FIREPROOFING

Gladding, McBean & Company,  
Crocker Bldg., S. F.  
Roebing Construction Co., Crocker Bldg., S. F.

## FIRE PROTECTION

Goodyear Rubber Company,  
587-589 Market St., S. F.

Highest Awards Grand Medal Paris 1900

Exclusive Designs  
Finest Workmanship

**United Glass Works**

INCORPORATED  
H. R. HOPPS, PRESIDENT

**Art Stained Glass**

TELEPHONES

FRANKLIN 1763 HOME J 1763

115 Turk Street

San Francisco

## FIRE PROTECTION—SPRINKLER SYSTEM

Jno. G. Sutton Co.....229 Mission St., S. F.  
Pacific Fire Extinguisher Company, 507 Mont-  
gomery St., San Francisco; Branch Offices,  
Portland, Seattle and Spokane.

## FLOOR VARNISH

Bass-Hueter and S. F. Pioneer Varnish Works,  
816 Mission St., S. F.  
Standard Varnish Works,  
Chicago, New York and S. F.  
Worden-Meeker Varnish Co., S. F.—Oakland

## FLOORS—COMPOSITION AND TILE

"Kompolite".....350 Mills Bldg., S. F.

## FOUNDATION CONTRACTORS

Loeke Foundation Company,  
1107 Crocker Bldg., S. F.

## GARAGE EQUIPMENT—

Bowser Gasoline Tanks and Outfit, S. F.  
Bowser & Co.....612 Howard St., S. F.

## GARBAGE CHUTES

Bradshaw Garbage Chute, sold by C. T. Jacob-  
son.....524 Pine St., S. F.

## GLASS—PRISM, ART, ETC.

Thomas & Schneider Art Glass Co.,  
610 Howard St., S. F.  
California Art Glass Works,  
768 Mission St., S. F.  
United Glass Co.....115 Turk St., S. F.

## GRAVEL, SAND AND CRUSHED ROCK

Bay Development Co.....153 Berry St., S. F.  
California Bldg., Material Co.,  
Pacific Bldg., S. F.  
Grant Gravel Co.....87 Third St., S. F.  
Del Monte White Sand, sold by Pacific Im-  
provement Co.....Crocker Bldg., S. F.

*Specify a  
California  
Marble...*

**"PORTOLA"**

A DELICATE BUFF BEAUTIFULLY MARKED  
THE THING FOR BANK INTERIORS, VESTIBULES AND  
HOTEL CORRIDORS SAMPLES ON APPLICATION

**THE COLUMBIA MARBLE CO.**

268 MARKET ST. SAN FRANCISCO

QUARRIES FINISHING PLANT  
COLUMBIA, CALIFORNIA 17TH & MISSOURI STS., SAN FRANCISCO

# SAN FRANCISCO BRIDGE COMPANY

INCORPORATED 1884

## ENGINEERS AND CONTRACTORS

Dredging, Pile Driving, Wharves, Piers  
Foundations, Breakwaters, Rock Work  
Concrete, Pipe Lines, Sewers, Bridges  
Steel Work

865 Monadnock Building  
San Francisco, Cal.

Agents for C. W. Hunt Company's Labor Saving Devices  
and Ambursen Hydraulic Construction Company's Dams

### ARCHITECTS' SPECIFICATION INDEX—Continued

#### HARDWOOD FLOORING

Boyd & Moore.....356 Market St., S. F.  
Dieckmann Hardwood Co.,  
244 California St., S. F.  
Parrott & Co.....320 California St., S. F.  
White Bros. Cor. Fifth and Brannan Sts., S. F.

#### HARDWOOD LUMBER

Dieckmann Hardwood Co., Welch Bldg., S. F.  
Niehaus & Co.....548 Brannan St., S. F.  
Stable Mfg. Co.,  
First St., betw. Washington & Clay, Oakland  
White Bros.,  
Cor. Fifth and Brannan Sts., S. F.  
Parrott & Co.....320 California St., S. F.

#### HARDWOOD PANELS

White Bros. Cor. Fifth and Brannan Sts., S. F.  
Niehaus & Co.....548 Brannan St., S. F.

#### HARD WALL PLASTER

Standard Supply Company,  
First St. and Broadway, Oakland  
Reno Hard Wall Plaster, sold by Western  
Building Material Co.,  
430 California St., S. F.  
Empire Hard Wall Plaster Co.,  
Pacific Bldg., S. F.

#### HEATERS—AUTOMATIC

Hart Heater Co., State Savings Bank Bldg.,  
13th and Franklin Sts., Oakland  
Hoffman Heater, sold by Holbrook, Merrill  
& Stetson, San Francisco and Los Angeles.  
Humphrey Co.,  
565 N. Rose St., Kalamazoo, Mich.  
Pittsburg Water Heater sold by Tbos. Thieben  
& Co.....585 Mission St., S. F.

#### HEATING AND VENTILATING

The Turner Co.....278 Natoma St., S. F.  
Machinery and Electrical Co.,  
351-353 N. Main St., Los Angeles  
Pacific Fire Extinguisher Company,  
507 Montgomery St., S. F.  
Mangrum & Otter, Inc., 507 Mission St., S. F.  
Gilley-Schmid Co., Inc.,  
Thirteenth and Mission Sts., S. F.  
Jno. G. Sutton Co.....229 Minna St., S. F.  
Pacific Blower & Heating Co.,  
17th St., betw. Mission and Valencia, S. F.  
Geo. W. Schmitt Heating and Ventilating  
Co.....1160 Webster St., Oakland

#### HINGES

Stanley's Ball-Bearing Hinges, Stanley Co.,  
New Britain, Conn.

#### ICE MAKING MACHINES

Triumph Ice Machine Co., H. F. Lyon, Agent,  
581 Monadnock Bldg., S. F.

#### IMITATION STONE

C. Menzer & Son.....862 Howard St., S. F.

#### INSPECTIONS AND TESTS

Robert W. Hunt & Co.,  
418 Montgomery St., S. F.  
Pacific Laboratories, Inc.,  
558 Market St., S. F.  
Smith, Emery & Co., Inc.,  
651 Howard St., S. F.

#### INSURANCE

David Duncan .....340 Sansome St., S. F.

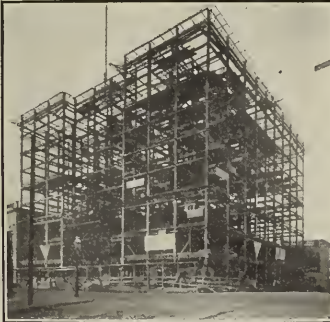

Steel Frame of Y. M. C. A.  
Building, San Francisco  
McDougall Bros.  
Architects

ANOTHER OF OUR BUILDINGS

## STEEL

For this Class A Structure Furnished and  
Erected by

## DYER BROS.

Largest and Best Equipped  
Plant on the Pacific Coast

MAIN OFFICE AND WORKS

17th and KANSAS STREETS  
SAN FRANCISCO, CAL.

Phone, Market 134 Home Phone M 3933

# WELLS AND SPENCER MACHINE CO.

F. M. SPENCER, SUCCESSOR

173-177 BEALE ST., SAN FRANCISCO

REPRESENTING

## WESTERN ELEVATOR COMPANY

REPAIRS, INSPECTIONS AND DUMB WAITERS

TELEPHONES: KEARNY 664  
HOME J 1124

### ARCHITECTS' SPECIFICATION INDEX—Continued

#### INTERIOR DECORATING

L. Tozer & Son Co., 228 Grant Ave., S. F.  
Schastey & Vollmer, 1930 Van Ness Ave., S. F.  
Richard Arenz Co., 335 East Fourth St., Los Angeles

#### JOIST HANGERS

A. C. Wocker, 1370 Sutter St., S. F.  
Western Builders' Supply Co., 680 Mission St., S. F.

#### KITCHEN EQUIPMENT

John G. IIs & Co., 827 Mission St., S. F.

#### LEAD

"Selby," manufactured by National Lead Co., 840 Merchants' Exchange Bldg., S. F.

#### LIFTING JACKS

M. G. West Company, 353 Market St., S. F.

#### LIME

Standard Supply Co., First St. and Broadway, Oakland  
Holmes Lime Company, Mutual Savings Bank Bldg., S. F.  
Western Lime & Cement Co., 268 Market St., S. F.

#### LIGHTING FIXTURES

Adams & Holoopeter, 745 Mission St., S. F.  
J. F. Kelly Company, 723 7th St., Oakland  
Century Electric Co., 13th and Clay Sts., Oakland, Cal.

#### LOCKERS—METAL

Hart & Cooley Co., Boyd & Moore, Agents, 356 Market St., S. F.  
M. G. West Company, 353 Market St., S. F.

#### LUMBER

Columbia Lumber Co., Portuguese-American Bank Bldg., S. F.  
Santa Fe Lumber Co., Seventeenth and De Haro Sts., S. F.

#### MACHINERY AND MACHINERY SUPPLIES

Machinery and Electrical Co., 351 N. Main St., Los Angeles

#### MANTELS

Mangrum & Otter, 561 Mission St., S. F.  
W. W. Montague & Co., 557 Market St., S. F.  
The J. F. Kelly Co., 723-731 7th St., Oakland

#### MARBLE

Columbia Marble Co., 268 Market St., S. F.

#### MASONRY CONTRACTORS

Farrell & Reed, Gunst Bldg., S. F.

#### MASONS

Ferdinand Wagner, 609 Waller St., S. F.

#### METAL AND STEEL LATH

Roebling Construction Co., Crocker Bldg., S. F.

#### METAL CEILING

San Francisco Metal Stamping & Corrugating Co., Treat Ave. and 19th St., S. F.  
San Francisco Cornice Co., Inc., 1140 Bryant St., S. F.  
Berger Manufacturing Company, 1120 Mission St., S. F.

#### METAL DOORS AND WINDOWS

M. G. West Company, 523 Market St., S. F.  
Waterhouse & Price, 59 Third St., S. F.  
San Francisco Cornice Company, 1140 Bryant St., S. F.

#### METAL SHINGLES

Meurer Bros., J. A. McDonald, Pacific Coast Agent, Third, near Townsend St., S. F.  
San Francisco Metal Stamping & Corrugating Co., Treat Ave. and 19th St., S. F.  
San Francisco Cornice Co., Inc., 1140 Bryant St., S. F.

#### OIL BURNING PLANTS

Fess System Company, Inc., 125-129 Hayes St., S. F.

#### OPERA CHAIRS

C. F. Weber & Co., 365 Market St., S. F.  
Whittaker & Ray-Wiggin Co., San Francisco and Los Angeles.

#### ORNAMENTAL IRON AND BRONZE

Western Builders' Supply Co., Representing The L. Schreiber & Sons Co., Cincinnati  
J. G. Braun, Chicago and New York  
Sartorius Co., Inc., 16th and Utah Sts., S. F.  
C. Farrenkopf & Sons, 623 Minna St., S. F.  
Industrial Ornamental Iron and Wire Works, 552 Noe St., S. F.  
C. J. Hillard Company, Inc., 211-215 Eighth St., S. F.

#### PAINT FOR CEMENT

Worden-Meeker Varnish Co., S. F.—Oakland  
Vitreolite Cold Water Paint, sold by Boyd & Moore, 356 Market St., S. F.  
Bay State Brick and Cement Coating—Made by Wadsworth, Howland & Co. (Inc.). See adv. in this issue for Pacific Coast agents.  
Adamant Cement, Brick and Plaster Coating. Made by Parker, Preston & Co., Inc.  
Samuel Cabot Mfg. Co., Boston, Mass., agencies in San Francisco, Oakland, Los Angeles, Portland, Tacoma and Spokane.

#### PAINT FOR STEEL STRUCTURES

Detroit Superior Graphite Paint, manufactured by Detroit Graphite Company, C. W. Pike Company, Coast Sales Agents, 22 Battery street, San Francisco.

#### PAINTS, OILS, ETC.

Bass-Hueter Paint Company, Mission, near Fourth St., S. F.  
Worden-Meeker Varnish Co., S. F.—Oakland  
Paraffine Paint Co., 38-40 First St., S. F.  
Glidden Varnish Co., Cleveland, Ohio, represented by Whittier-Coburn Co., S. F. and Los Angeles  
Standard Varnish Works, represented by W. P. Fuller & Co., S. F. and Los Angeles

#### PAVING BRICK

Los Angeles Pressed Brick Co., Frost Bldg., Los Angeles  
Vallejo Brick & Tile Co., Mills Bldg., S. F.

#### PHOTOGRAPHY

Gabriel Moulin, 153 Kearny St., S. F.

#### PILE DRIVING

San Francisco Bridge Co., Monadnock Bldg., S. F.

#### PIPE FOR SEWERAGE

Gladding, McBean & Company, Crocker Bldg., S. F.

## M. G. West Company, Engineers

BANK EQUIPMENT

### THE MOSLER SAFE COMPANY

Fire and Burglar Proof Vaults, Safes and Safe  
Deposit Boxes, Steel Filing Devices and Fire  
Proof Doors, Lifting Jacks for all Purposes

353 MARKET STREET

SAN FRANCISCO, CAL.

**Opera  
Chairs**

**Buy Steel Construction every time  
IT LASTS ALWAYS**

For Blackboard use "Olmstead Artificial Slate." Every architect wanting the best will specify this. Get our catalogues and prices

**WHITAKER & RAY-WIGGIN CO.**

776 MISSION STREET  
San Francisco

209 E. SEVENTH STREET  
Los Angeles

**School  
Desks**

**ARCHITECTS' SPECIFICATION INDEX—Continued**

**PLASTERING CONTRACTORS**

A. Knowles.....985 Folsom St., S. F.  
D. Ross Clarke.....708 Pacific Bldg., S. F.  
Hanley & McCulloch,  
378 Monadnock Bldg., S. F.

**PLUMBING**

The Turner Co.....278 Natoma St., S. F.  
Fisher & Wolfe Co.....207 Tehama St., S. F.  
J. E. O'Mara.....447 Minna St., S. F.  
Alex. Coleman.....706 Ellis St., S. F.  
Jno. G. Sutton Co.....229 Minna St., S. F.  
Oscar L. Zeis.....456 E. 16th St., Oakland  
Carl Doell & Co.....467 22d St., Oakland  
Kiernan & O'Brien.....1754 Mission St., S. F.  
Thos. J. Ford.....1213 Octavia St., S. F.

**PLUMBING APPLIANCES**

Brown's Gasket, sold by Sanitary Plumbing  
Appliance Co.....412 Sheldon Bldg., S. F.

**PLUMBING FIXTURES**

Crane Co.....Second and Brannan Sts., S. F.  
Geo. H. Tay Co.....617 Mission St., S. F.  
Haines, Jones & Cadbury Co.,  
851-859 Folsom St., S. F.  
N. O. Nelson Mfg. Co.....978 Howard St., S. F.  
406 E. 4th St., Los Angeles  
J. L. Mott Iron Works, D. H. Gulick, selling  
agent.....135 Kearny St., S. F.

**PLUMBING SUPPLIES**

California Steam & Plumbing Supply Co.,  
Fifth and Bluxome Sts., S. F.

**POTTERY**

Steiger Terra Cotta and Pottery Works,  
Mills Bldg., S. F.

**PUMPS, MACHINERY, ETC.**

Simonds Machinery Co., 12 Natoma St., S. F.

**RAILROADS**

Southern Pacific Co. ....Flood Bldg., S. F.

**REFRIGERATING PLANTS**

Duval Dairy Supply Co., 201 Drumm St., S. F.

**ROLLING DOORS, SHUTTERS, PARTITIONS,  
ETC.**

C. F. Weber & Co.....365 Market St., S. F.

**ROOFING AND ROOFING MATERIALS**

Ford & Malott,  
Mariposa St., at Iowa St., S. F.  
Genasco Ready Roofing, sold by Parrott &  
Co.....320 California St., S. F.  
"Ferroinelaev," the Brown Hoisting Machinery  
Co., Coast Agent, Chas. A. Levy,  
Balboa Bldg., S. F.

Pioneer Roll Paper Co.....Los Angeles  
Mackenzie Roof Co., 425 15th St., Oakland  
Western Builders' Supply Co.,  
680 Mission St., S. F.

H. D. Samuel Company,  
1054 Monadnock Bldg., S. F.

W. H. Wilson & Co.....42 Natoma St., S. F.

**ROOFING TIN**

"Scott's Extra Coated," manufactured by Follansbee Bros. Co.....Pittsburg, Pa.

**RUBBER TILING AND MATTING**

Goodyear Rubber Co.....587 Market St., S. F.

**SAFES**

M. G. West Co.....523 Market St., S. F.

**SAND**

Del Monte White Sand, sold by Pacific Improvement Company,

SASH CORD Main office, Crocker Bldg., S. F.

"Puritan" Cord, Manufactured by

Puritan Cordage Mills, Louisville, Ky.

Samson Cordage Works, Manufacturers of

Solid Braided Cords and Cotton Twines,  
88 Broad St., Boston, Mass.

**SCHOOL FURNITURE AND SUPPLIES**

C. F. Weber & Co.....365 Market St., S. F.

210 N. Main St., Los Angeles

Whitaker & Ray-Wiggin Co., 776 Mission St.,  
S. F.; 209 E. Seventh St., Los Angeles.

**SCAGLIOLA**

California Scagliola Co., F. Mayer,  
68-70 Clara St., S. F.

**SHEATHING AND SOUND DEADENING**

Samuel Cabot Mfg. Co., Boston, Mass., agencies in San Francisco, Oakland, Los Angeles,  
Portland, Tacoma and Spokane.

**SHEET METAL WORK**

Abrahamson & De Gear, 655 McAllister St., S. F.

Berger Mfg. Co.....1120 Mission St., S. F.

**SHINGLE STAINS**

W-M Shingle Stain, Worden-Meeker Varnish  
Co.....S. F.—Oakland

Cabot's Creosote Stains, sold by Waterhouse  
& Price, San Francisco, Los Angeles and  
Portland.

**SLATERS' CEMENT**

Western Builders' Supply Co., Representing  
Clinton Metallic Paint Co., Clinton, N. Y.

**STABLE STALLS AND FIXTURES**

Howe Scale Co.....143 Main St., S. F.

Duval Dairy Supply Co., 201 Drumm St., S. F.

**STAINLESS CEMENT**

Bianc Stainless Cement Co., Levensaler &  
Preston, Inc., San Francisco; Quartz Glass  
& Manufacturing Co., Los Angeles; John  
Brooke & Co., Inc., Seattle, Wash.

**STANDARD SCALES**

George A. Riggs, rep. The Howe Scale Co.,  
143-149 Main St., S. F.

**STEEL AND IRON—STRUCTURAL**

Boyd & Moore.....356 Market St., S. F.

Woods & Huddart.....356 Market St., S. F.

Pacific Rolling Mills,  
17th and Mississippi Sts., S. F.

Western Iron Works.....125 Beale St., S. F.

Brode Iron Works.....621 Howard St., S. F.

Dyer Bros.....17th and Kansas Sts., S. F.

Mortenson Construction Co.,  
19th and Indiana Sts., S. F.

**STEEL BARS FOR CONCRETE REINFORCE-  
MENT**

Jno. B. Leonard.....Sheldon Bldg., S. F.

Woods & Huddart.....356 Market St., S. F.

Baker & Hamilton, 4th and Brannan Sts., S. F.

**STEEL MOULDINGS FOR STORE FRONTS**

J. G. Braun, 537 W. 35th St., N. Y., and  
322 S. Paulina St., Chicago

WM. H. FORD

Telephone Market 1596

W. H. MALOTT

**FORD & MALOTT**

**FELT, ASPHALT AND GRAVEL ROOFING CONTRACTORS**

"FIBRESTONE" MAGNESITE, FLOORING ASPHALT FLOORS AND SIDEWALKS

Office and Yard: Mariposa, at Iowa St., San Francisco Members Builders' Exchange, Builders' Association



## ARCHITECTS' SPECIFICATION INDEX—Continued

- STORE FRONTS**  
Kawneer System of Glass Setting, manufactured by Kawneer Mfg. Co., Coast agencies at San Francisco, Portland, Ore., Spokane and Seattle, Wash.
- SURVEYORS**  
Sanborn & Carinson....251 Kearny St., S. F.
- TAPESTRY AND BRONZE**  
Euenee Glaeuzer & Co., 705 Fifth Ave., New York
- TILES, MOSAICS, MANTELS, ETC.**  
Mangrum & Otter....561 Mission St., S. F.  
Mosaic Tile Co., Zanesville, Ohio,  
228 Eighth St., S. F.  
W. W. Montague, 557-563 Market St., S. F.  
The J. F. Kelly Co., 723-731 7th St., Oakland
- TILE FOR ROOFING**  
Gladding, McBean & Company,  
Crocker Bldg., S. F.
- VACUUM CLEANERS**  
Mechanical Dust Suction Company,  
301 Merchants' Exchange, S. F.  
S. F. Compressed Air Cleaning Co.,  
Sutter and Stockton Sts., S. F.
- VALVE PACKING**  
"Palmetto Twist," sold by H. N. Cook Belting Co.,.....317 Howard St., S. F.
- VAULTS—FIREPROOF**  
M. G. West Company, 353 Market St., S. F.
- VENETIAN BLINDS, AWNINGS, ETC.**  
C. F. Weber & Co.,...365 Market St., S. F.
- VENEERS**  
Dieckmann Hardwood Co.,  
Welch Bldg., 244 California St., S. F.  
White Bros. Cor. Fifth and Brannan Sts., S. F.
- VITRIFIED CLAY PIPE**  
Steiger Terra Cotta and Pottery Works,  
Mills Bldg., S. F.
- WAINSCOTING**  
"Kompolite",.....350 Mills Bldg., S. F.
- WALL BEDS**  
The Turner Wall Bed Co.,  
Mission, near Fifth, S. F.  
Marshall & Stearns Co.,  
1154 Phelan Bldg., S. F.
- WATERPROOF FINISHES**  
"Trus-Con" Finish, sold by Western Lime & Cement Co.,.....268 Market St., S. F.
- WATERPROOFING FOR CONCRETE, ETC.**  
"Ceresit," manufactured by the Ceresit Waterproofing Co., sold by Parrott & Co., San Francisco, Los Angeles and Portland, and Julien A. Becker Co., Seattle, Wash.  
The Building Material Co., Inc.,  
587 Monadnock Bldg., S. F.  
Parrott & Co.,.....320 California St., S. F.  
Hydrex Felt and Engineering Co., Boyd & Moore, Agents,.....356 Market St., S. F.  
Te-Pe-Co Waterproofing, sold by H. G. Clinton, 34 Ellis St., S. F.; Bass Hueter Paint Co., Pacific Coast Distributors.  
Samuel Cabot Mfg. Co., Boston, Mass., agencies in San Francisco, Oakland, Los Angeles, Portland, Tacoma and Spokane.  
"Imperial" Waterproofing, sold by Baker Bros., San Francisco; Braun Chemical Co., Los Angeles; W. O. Stamps, Portland, and B. W. Gaisford, Seattle, Wash.
- WATER SUPPLY**  
Kewance System, Simonds Machinery Co., sole agents,....12 and 14 Natoma St., S. F.
- WEATHER STRIP**  
Monarch Metal Weather Strip, Boyd & Moore, Agents,.....356 Market St., S. F.
- WHITE ENAMEL FINISH**  
Velvo-Tone, Worden-Mecker Varnish Co.,  
S. F.—Oakland  
"Satinette," W. P. Fuller & Co.,  
S. F. and all principal Coast cities
- WHITE PORTLAND CEMENT**  
Blanc Stainless Cement Co., Levensaler & Preston, Inc., San Francisco; Quartz Glass & Manufacturing Co., Los Angeles; John Brooke & Co., Inc., Seattle, Wash.
- WINDOWS, REVERSIBLE, ETC.**  
Soule Reversible Window Co.,  
1061 Mission St., S. F.  
Dean Reversible Window Co.,  
551 Brannan St., S. F.  
Hipolito Screen & Sash Co.,  
634 Maple Ave., Los Angeles  
Tabor Sash Fixture Co., Boyd & Moore, Agents,.....356 Market St., S. F.
- WOOD FINISH**  
Bridgeport Wood Finishing Co.,  
New Milford, Conn.



This Half Brick was subjected to over 150,000 pounds pressure, equal to 30,000 for the Whole Brick (15,000 per square inch) absorption test thirteen one hundredth of one per cent. Test made by Engineering Department City of San Francisco.

Monadnock Building, SAN FRANCISCO, CAL.

TELEPHONE KEARNY 4314

## VALLEJO BRICK AND TILE COMPANY

Consolidated

MANUFACTURERS OF

## PAVING BRICK

SEWER BRICK AND  
OTHER VITRIFIED  
CLAY PRODUCTS.

WORKS AT

VALLEJO, SOLANO CO.

CALIFORNIA

TELEPHONE VALLEJO 242

## ARCHITECTURAL FAIENCE

Faience Tiles for Exterior and Interior Decorations. Mantel Facings — Complete Mantels. Equipped to Execute Designs of Architects and Decorators. Special Designs by our own Artists

**Los Angeles Pressed Brick Co.**

404-414 FROST BLDG. SECOND AND BROADWAY LOS ANGELES

## NORTHERN CLAY COMPANY

MANUFACTURERS OF

ARCHITECTURAL TERRA COTTA  
**FIRE BRICK**  
AND CLAY PRODUCTS

MAIN OFFICE AND FACTORIES, - AUBURN, WASHINGTON

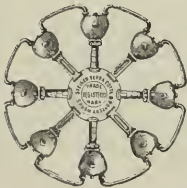

## STEIGER TERRA COTTA AND POTTERY WORKS

ARCHITECTURAL TERRA COTTA, PRESSED BRICK, SEWER PIPE  
CHIMNEY PIPE, FLUE LINING, FIRE BRICK  
MANTEL TILE, ACID WARES

FACTORY SOUTH SAN FRANCISCO  
SAN MATEO CO.

YARD: 18TH AND DIVISION STS.  
SAN FRANCISCO

MAIN OFFICE: 729 MILLS BUILDING

TELEPHONE DOUGLAS 3010

SAN FRANCISCO, CAL.

## GLADDING, McBEAN & Co.

MANUFACTURERS CLAY PRODUCTS

CROCKER BLDG. SAN FRANCISCO

WORKS. LINCOLN, CAL.

# PERFECT WALL BEDS HALEY SEAT BEDS

PERFECT CONCEALED & TURNER BED CO.  
862 MISSION ST. SAN FRANCISCO, CAL.

YOU HAVE SEEN THAT

## RED RED-FACE BRICK

Cherry, Red, Wine. Here is where they GET THEM

### DIAMOND BRICK COMPANY

True Colors. Many Shades. Various Textures.  
Moderate Prices.

SALES OFFICE  
909 BALBOA BUILDING

TELEPHONE DOUGLAS 1909  
SAN FRANCISCO



THE ELYSIUM  
The Largest and Finest  
Skating Palace in the  
World is Water-  
proofed with

## TE-PE-CO

July 8, 1909.

THE NATIONAL WATERPROOF CO.,

Gentlemen:— We are pleased to state that the *Te-Pe-Co* Waterproofing that we used on the entire concrete exterior and plaster walls of our Elysium Building about three years ago has proven absolutely satisfactory. Yours very truly,

THE HUMPHREY CO.,

per H. J. Humphrey, Sec. & Treas.

DISTRIBUTORS FOR THE PACIFIC COAST

## BASS-HUETER PAINT CO.

SAN FRANCISCO, SEATTLE, PORTLAND AND LOS ANGELES

H. G. CLINTON, SALES AGENT, 34 ELLIS ST., SAN FRANCISCO

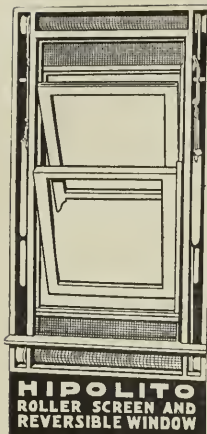

Reversible  
Window and  
Self-  
Regulating  
Roller  
Screens

**HIPOLITO SCREEN & SASH CO.**

634-38 MAPLE AVENUE  
LOS ANGELES, CAL.

DEAN REVERSIBLE WINDOW CO. INC.

STAND INSIDE  
WHILE CLEANING  
"DEAN"  
REVERSIBLE  
WINDOWS

THEY SLIDE UP & DOWN  
& TURN INSIDE OUT  
PERFECT SAFETY  
PERFECT VENTILATION  
NO DRAUGHTS

FACTORY 551-555 BRANNAN ST

SAN FRANCISCO, CAL.  
Phone, Kearny 1516

OVER  
500,000  
TONS

of Structural Steel Painted with

"SUPERIOR GRAPHITE  
PAINT"

DETROIT GRAPHITE COMPANY  
PAINT MAKERS  
DETROIT, MICHIGAN, U. S. A.

C. W. PIKE COMPANY  
PACIFIC COAST SALES AGENTS  
22 BATTERY ST.  
SAN FRANCISCO, CAL.  
TELEPHONE, KEARNY 4303

**Architects  
and Owners**

We have Something Better in Re-  
versible Sash Single Casement.  
French Sash, Single Pivot Sash,  
Double-hung Reversible Sash ::  
Call and be convinced of their  
absolute Simplicity and Perfect  
Mechanism :: :: :: :: :: :: ::  
Absolutely Water Tight :: :: ::  
Write for Attractive Booklet with  
Full Particulars :: :: :: :: :: ::

**SOULE REVERSIBLE  
WINDOW COMPANY**

OFFICE AND DISPLAY ROOM  
1061 MISSION STREET SAN FRANCISCO, CAL.



**BOWSER**

## The Standard Gasoline Outfit for Public or Private Garages

It's Fire-proof, Leak-proof and Evaporation-proof. That means Safety, Profit and High Test Gasoline.

All Styles, Sizes and Prices  
— Direct Lift, Long Distance and Portable types.

Recommended by Architects, Endorsed by Owners and tested by time.

*IT'S THE PIONEER.*

because it fulfils every requirement. No measures — No funnels. You pump the gasoline directly into the car without exposure or possibility of explosion. **WE MAKE THE LOWEST PRICED OUTFITS AND WE MAKE THE BEST.**

Special Information for Architects. Just ask for booklet No. 107 for details.

### S. F. BOWSER & CO

INCORPORATED

FORT WAYNE, IND.

Western Office, 612 HOWARD STREET  
SAN FRANCISCO, CAL.



## SOMETHING NEW IN A GAS WATER HEATER



The accompanying cut is something New in a Tank Heater

**T**HIS is a double Copper Coil Heater with Union Nut Connections on each coil. This is the only double coil Tank Heater on the market with independent connections, the use of which permits the removal of either coil without interfering with the other coil.

This Heater is considered the most efficient Tank Heater on the Market. Give it a trial.

We are represented in the West by the following:  
**HOLBROOK, MERRILL & STETSON**  
San Francisco and Los Angeles, Calif.  
**CRANE COMPANY**  
Seattle and Tacoma, Wash.  
**CRANE COMPANY, Vancouver, B. C.**

The Hoffman Heater Company, Factory and General Offices,  
Lorain, Ohio, U. S. A.



**THE TOZER COMPANY**  
**Interior Decorators**

Wall Papers and Fabrics of Character  
and Distinctiveness

*We Design, Decorate and Furnish Interiors of all Kinds*

The Leading Architects and Builders our References

Correspondence and Enquiries Solicited

228 Grant Ave. (24 floor, next to White House)      187 Twelfth Street  
San Francisco      Oakland

MANY of the Finest Buildings Constructed in San Francisco since the Fire are furnished throughout with Reading Hardware Company's High Grade Builders' Hardware.

REPRESENTED BY

**Brittain & Co.**  
INCORPORATED

PACIFIC COAST DISTRIBUTERS

Market and Mason Sts., San Francisco

Phones: Pacific, Douglas 2040—Home,

C-2040 and C-2060

908 Broadway, Oakland

Phones: Oakland 1185

Home, A-3395

## BEXHILL WINDOWS

Used Exclusively  
in this Building

BEXHILL Patent Casement Windows are weather proof and will not rattle. No Racks, Wheels, Pulleys or Cords. Can be adjusted to any position and firmly locked.



SAUNDERS BUILDING, SAN FRANCISCO

## BEXHILL CASEMENT CO.

MILLS BUILDING, SAN FRANCISCO

## GLIDDEN

WATERPROOF

## LIQUID CEMENT

GIVES TWO VALUES

**WATERPROOFS--DECORATES**



1. It gives highly efficient positive damp proof protection to concrete walls.
2. It gives a highly decorative effect to the structure both inside and out, because it obliterates the mottled effect in color tones found in all concrete buildings, and as it is made in various shades it can be used to produce various pleasing color tones to the building, without adding a cent of expense to the damp proofing process.

It is made in a variety of practical shades, including imitation of Bedford Sandstone, Colonial and Pompeian Buffs and Pure White.

Its use assures a thoroughly damp proof wall at a minimum expense and a pleasing decorative effect obtainable on concrete structures in no other way except at greatly added cost for special materials. Booklet with specifications on request.

THE GLIDDEN VARNISH CO.

FACTORIES—Cleveland, Ohio; Toronto, Ont.

BRANCHES—New York, St. Louis, Chicago



## HOT WATER SERVICE

The quickest, cheapest and most dependable is secured only from a **HUMPHREY'S INSTANTANEOUS GAS BATH WATER HEATER.**

Light the gas and out pours hot water—about as easy to secure as cold—almost as cheap: a big hot bath, **TWO CENTS.** Always ready, no repairs, makes bathing a pleasure.

Positively Guaranteed.  
Sold Everywhere. Ask your Plumber.  
Handsome Catalog No. 11. Free on request.

**HUMPHREY CO.**

565 N. Rose St.

Kalamazoo, Mich.



Building for Central Oakland Light & Power Co.  
*Long & Hoyt, Engineers*

*The Roof and Walls of this Building are Metal Lath and Cement Plaster over Steel Frame.*

Executed by

# A. KNOWLES

Plastering, Modeling, Metal Partitions, Fabrous Ceilings and Decorations ££ ££ ££

**985 FOLSOM ST., SAN FRANCISCO**

PHONE DOUGLAS 3451



St. Patrick, Apostle of Ireland  
Installed in St. Mary's Church, San Francisco

## California Art Glass Works

WILLIAM SCHROEDER, PRES.

MEMORIAL WINDOWS A SPECIALTY

Staining Crystalizing Binding and  
Embossing Beveling Cutting

TEL. HOME J 2662

768 MISSION ST., SAN FRANCISCO

## EUGENE GLAENZER & CO.

705 FIFTH AVENUE,  
NEW YORK

### Antique Works of Art

Garden Ornaments,  
Mantels, Furniture,  
Tapestries, Bronzes,  
Paintings by Masters

*Gardens and Interiors  
Designed* 



A NATIVE SON BEAR IN SHEET METAL BY

## San Francisco Metal Stamp- ing and Corrugating Company

Stamped and Spun  
Sheet Metal Ornaments

Statue Work, Mission Tile, Art Metal Ceilings

554-556 TREAT AVE., Near Nineteenth St.  
(OPPOSITE MISSION FOUNDRY)

PHONES:  
MISSION 2421  
HOME M-3428

SAN FRANCISCO,  
CALIFORNIA

## HOTEL VICTORIA Chicago

In the Heart of  
wholesale, retail  
and theatrical  
district.

Fireproof Construction

Remodeled and refurbished at an  
expense of over \$150,000.

OPPOSITE LA SALLE  
DEPOT

Cor. Clark and Van Buren Sts.

ELMER C. PUFFER,  
Managing Director.

## San Francisco Cornice Co., Inc.

### OUR SPECIALTIES

Underwriter metal windows,  
fire doors, shutters and hard-  
ware. Fine copper doors,  
Kalamein work, Interior trim,  
Copper fronts, Architectural  
sheet metal work, Cornices,  
Tin roofing, Old Mission and  
S. Spanish tile, Steel ceilings  
(our own stamping), Orna-  
mental work.

1140 BRYANT STREET, Cor. DORE  
San Francisco, California



# CRUDE OIL

is NOW burned by TWO methods,  
the FESS SYSTEM and the other

WE have passed the stone age. In the new year of 1911 you will find in the improved FESS SYSTEM, the only advanced science of burning oil.

We eliminate the use of a complicated air compressor, numerous adjusting valves, and the noise of combustion. This system is operated with 75% less power and produces a smokeless fire; in fact the advantages are so numerous that it must be seen to be appreciated. We can convince the most skeptical that the problem of burning crude oil for heating purposes has at last been solved.

ARCHITECTS ARE ESPECIALLY INVITED TO CALL AND WITNESS A DEMONSTRATION

**FESS SYSTEM COMPANY, Inc.**

125 HAYES STREET, SAN FRANCISCO

Architects Specify

# NILES CRUSHED ROCK

BEST BY TEST

There is None Better on the Market  
Write for Sample and Information

**CALIFORNIA BUILDING  
MATERIAL COMPANY**

714-716 Pacific Bldg.  
SAN FRANCISCO, CAL.

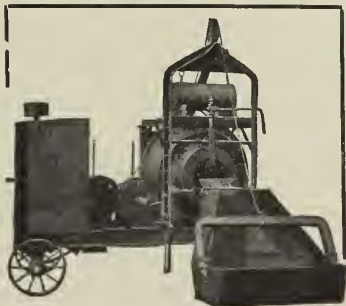

No. 0 Foote Batch Mixer with Power Loading Skip, Automatic Water Tank and Gasoline Engine.

## "EVERY FOOTE A MIXER"

Batch and Continuous Mixers

In Stock for Immediate Delivery  
BRIGGS' CONCRETE SPREADER CARTS  
HOTCHKISS METAL SIDEWALK FORMS  
Send for Catalog No. 4.

**Foote Concrete Machinery Co.**

R. E. BACON, REPRESENTATIVE  
999 MONADNOCK BLDG., SAN FRANCISCO, CAL.  
PHONE DOUGLAS 1380

We are Pacific Coast Agents for

## JAMES SANITARY BARN EQUIPMENT

Which is the Latest and Best in that Line

WHEN figuring plans for new Barns or when remodeling old ones, we would be glad to receive your inquiries. Catalogs may be had for the asking.

**DE LAVAL DAIRY SUPPLY CO.**

DRUMM AND SACRAMENTO STREETS  
SAN FRANCISCO, CAL.



Residences of Geo. L. Payne and Mrs. Eugene Lent, Pacific Avenue, San Francisco  
*C. P. Moore Building Company, Contractors. Nathaniel Blaisdell, Architect*

PRESSED BRICK WALLS OF THESE SPLENDID  
 RESIDENCES WATERPROOFED WITH

# IMPERIAL WATERPROOFING

A Home Product — Made in California

The attention of the Delegates to the 44th Annual Convention of the American Institute of Architects, in session in San Francisco is called to the advantages of IMPERIAL WATERPROOFING

IMPERIAL is a white mineral solution.

IMPERIAL is indestructible by climatic changes, acids, etc.

IMPERIAL is an absolute cure and preventative against moisture.

IMPERIAL will prevent efflorescence, bloom or alkali from appearing on walls.

IMPERIAL will resist the severest water pressure when mixed with sand and cement.

Manufactured by K. C. T. WATERPROOFING CO., Inc.

## BAKER BROTHERS

Builders' Exchange Bldg.

SAN FRANCISCO, CAL.

BRAUN - CHEMICAL CO.

BRAUN BUILDING  
 LOS ANGELES, CAL.

W. O. STAMPS

PORTLAND, ORE.

“QUALITY COUNTS”

# WESTERN BUILDERS' SUPPLY CO.

ESTABLISHED 1902

680 MISSION STREET

SAN FRANCISCO, CAL.

TELEPHONE KEARNY 1991

INTERIOR WOOD FINISH ORNAMENTS  
(ART MOULDINGS, CARVINGS, ETC.)

HIPOLITO EVEN TENSION SCREENS  
(FOR GOOD HOUSES)  
CONVENIENT, DURABLE, NON-RUSTING

STANDARD METAL CORNER BEAD

GOLDEN WEST VULCANITE ROOFING

“ENAMETILE” (METAL ENAMEL WAINSCOTING)  
(SANITARY, INTERLOCKING)



LANE JOIST HANGERS  
POST CAPS AND BASES

REPRESENTING

DECORATORS' SUPPLY CO., CHICAGO, ILL.



ARCHITECTURAL ORNAMENTS

IN WOOD, COMPOSITION AND CEMENT

EXTERIOR AND INTERIOR

CAPITALS AND BRACKETS

TO MATCH OAK, MAHOGANY, REDWOOD, ETC.

Four Large Catalogs (Furnished Registered Architects)

CAPITALS AND BRACKETS  
WOOD GRILLES

EXTERIOR COMPOSITION AND PLASTER  
COMPOSITION TO MATCH WOOD

For Information apply 680 Mission Street



## “SUN-PROOF” PAINTS

MILWAUKEE

“Pitcairn Aged Varnish”

NEWARK

GOES FARTHEST WEARS LONGEST

**PROPERLY LAID WITH GALVANIZED CUT NAILS THE  
REDWOOD SHINGLE WILL LAST FOR A LIFE TIME**

SPECIFY

# REDWOOD SHINGLES

A CALIFORNIA PRODUCT

## CLEAR REDWOOD SHINGLES

are all Vertical Grain, and  
being free from pitch makes  
them practically fire-proof

Properly Dried Redwood Shingles will not Swell, Shrink nor Warp



*Lafarge*

## Will Not Stain

Limestone, Granite or Marble—  
The Best Cement for Exterior  
Stucco Construction. Also  
EXTRA WHITE LAFARGE for  
use with Light Brick, Terra  
Cotta, White Granite or Marble  
and White Stucco Exteriors

**NON-STAINING CEMENT CO.**

156 FIFTH AVENUE, NEW YORK  
Sole Agents for the United States and Canada

**WATERHOUSE & PRICE CO.**

SAN FRANCISCO

SEATTLE PORTLAND OAKLAND LOS ANGELES

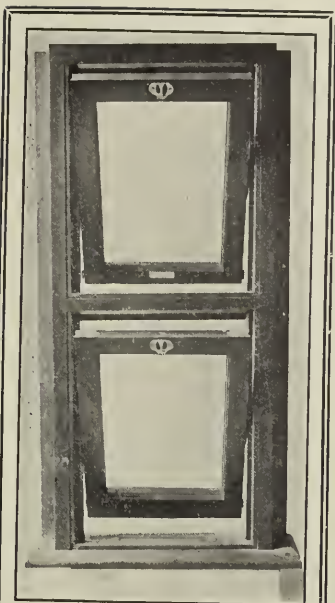

Double Hung Reversible Window,  
Style "A" Fixtures.

Manufactured by

## Tabor Sash Fixture Co.

TABOR Patent Strip and  
Fixtures for all types of  
Revolving, Reversible, Re-  
movable, Horizontal and  
Vertical Pivoted Sash, Case-  
ment Sash and Transoms.

### Boyd & Moore

*Sole Agents for Northern California*

356 MARKET STREET  
SAN FRANCISCO

*Telephone Kearny 2386*

## Notice to Architects

We are about to put on the  
market a new product which  
we have trade marked

# Amiwud

It is a stiff pulp board and  
made to imitate hardwood.

Amiwud can be nailed  
to studding, avoiding the  
necessity of lathing and  
plastering.

Many artistic and deco-  
rative designs for interior  
finishing can be made of  
Amiwud — cheaply  
and without difficulty —  
most anyone can do it.

We have demonstrated the  
value of Amiwud in  
our own place of business,  
where it is on display.

Call at our general offices  
and see what can be done  
with Amiwud.

### The PARAFFINE PAINT CO.

34 FIRST STREET, SAN FRANCISCO



TELEPHONE, MARKET 6468

HOME PHONE, J 2376

# C. J. HILLARD CO., Inc.

MANUFACTURERS OF

## Ornamental Iron, Brass and Bronze Work

Bank and Office Railings. Elevator Enclosures and Cars.  
Cast Iron Stairs and Store Fronts. Wire Work. Fire Escapes.

211-213-215-217 8th Street  
Between Howard and Folsom

San Francisco, Cal.

### FINISHES FOR CONCRETE SURFACES

Ordinary paints, when used on concrete, peel, crack and wear off.  
Trus-Con Finishes become part of the concrete, resist wear and are waterproof.

**Trus-Con Floor Enamel** is dampproof, stain-proof, and prevents the formation of concrete dust on cement floors. Produces a tile-like surface which resists wear and is easily cleaned by mopping. Furnished in a variety of colors.

**Trus-Con Wall Finishes** make walls absolutely dampproof and allow the masonry to retain its natural texture, preserving its beautiful grain and replacing its cheerless monotony with delicate artistic tints.

Tell us condition and size of surface to be finished and we will send *free trial sample. Booklet and Color Card free.*

## Western Lime & Cement Co.

DISTRIBUTORS OF

CHEMICAL



PRODUCTS

268 MARKET STREET  
SAN FRANCISCO, CAL.

# J. G. BRAUN

537-541 W. 35TH STREET, NEW YORK  
615-621 S. PAULINA STREET, CHICAGO

CARRIES A COMPLETE STOCK OF

## Steel Mouldings for Store Fronts Elevator Enclosures, Etc.



Plain and Ornamental Sash Bars, Leaves, Rosettes  
Pickets and Ornamental Rivets, Square Root  
Angle Iron from  $\frac{3}{8}$ " x  $\frac{3}{8}$ " x 1-10" Upwards

Square Tubing for Elevators, Elevator  
Enclosures and Office Railings



Catalog to Architects, Architectural Iron  
Works and Builders only on Application

### PATENT SHEET METAL SHEARS PUNCHING MACHINES

All parts, including the main body, are made of forged steel, which makes these tools far superior to any made from cast steel. The Punch Machines are made from steel plates. All movable parts are steel forgings. All parts which can be are tempered. The Eccentric pillar blocks are made with independent steel rings. Some of these Machines also have Shears for cutting Angle, Tee or Flat Iron.

WRITE FOR CATALOG  
AND PRICES

OVER 900  
MACHINES  
SOLD



P. NOBLE, PRESIDENT      H. C. BANKS, VICE-PRESIDENT      THOMAS ROLPH, SECRETARY

## Pacific Rolling Mill Co.

TELEPHONE MARKET 215

SUPPLIERS OF

### STRUCTURAL STEEL

FORGINGS, BOLTS, RIVETS, FROGS, SWITCHES

### CAST IRON

GENERAL OFFICE AND WORKS      SALES OFFICE  
 17TH & MISSISSIPPI STS.      SAN FRANCISCO      908 CROCKER BUILDING



## Sartorius Company, Inc.

### Ornamental Iron & Bronze.



· ELEVATOR ENCLOSURES & CABS · METAL STORE FRONTS ·  
 · STAIRS · RAILINGS · BANK ENCLOSURES & RAILINGS ·  
 · BRONZE TABLETS & NAME PLATES · ANDIRONS · ETC ·  
 · TELE-MARKET 1529 · SAN FRANCISCO · WORKS 15TH & VTAH STS

W. B. MORRIS, President      H. M. WRIGHT, Vice-President      L. J. GATES, Secretary

## WESTERN IRON WORKS

### STRUCTURAL IRON and STEEL CONTRACTORS

Gas Holders, Vault Linings, Jails, Fire Escapes, Beams, Channels, Angles  
and Steel Wheelbarrows Carried in Stock

Phones: Kearny 575      141-147 BEALE STREET      SAN FRANCISCO, CAL.  
 J 1259      132-148 MAIN STREET



## SAN FRANCISCO COMPRESSED AIR CLEANING CO.

### VACUUM CLEANER SYSTEM

Compressed Air System  
 Combined Vacuum and Compressed Air Systems  
 Stationary Plants  
 Portable Apparatus

AGENTS      OFFICE  
 THE McCRUM HOWELL COMPANY      South East corner Sutter and Stockton Streets  
 RICHMOND VACUUM CLEANERS      San Francisco  
 DUNTLEY MANUFACTURING CO.      TELEPHONE KEARNY 5852  
 CHICAGO, ILLS.

When it comes to specifying a **DOOR HANGER** you must take into consideration these essential points:

**Permanency, Smooth Action,  
Absence of Noise, Economy**

## THE JOHNS HANGER

Embodies all of these Features. Used in Hundreds of Hotels, Apartment Houses, Flats and Residences and giving Satisfaction

**Strictly a California Product**

**The Johns Hanger Manufacturing Co.**

832-838 Folsom Street

San Francisco, Cal.

## DISAPPEARING DOORS

A Great Labor and Space Saving Device

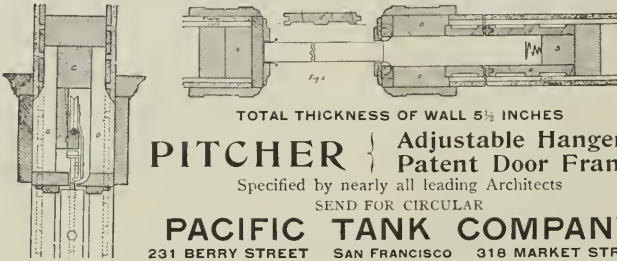

TOTAL THICKNESS OF WALL 5 1/2 INCHES

**PITCHER** } Adjustable Hangers  
Patent Door Frames

Specified by nearly all leading Architects

SEND FOR CIRCULAR

**PACIFIC TANK COMPANY**

231 BERRY STREET SAN FRANCISCO 318 MARKET STREET

## "RELIANCE" HANGERS MOVE SILENTLY

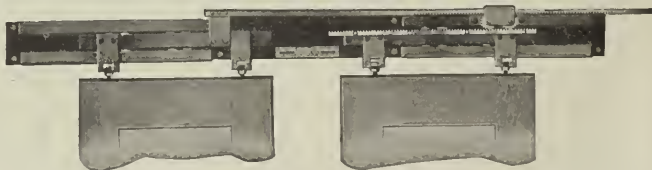

This cut shows "Double Gear" Opening Device

**THEY** are Strong, Durable and Easy Running. The Best Architects always Specify them for the Best Buildings. See a working model in the office of any of our numerous agents—or study them in action on the elevator doors of any High Class Building.

**Reliance Ball Bearing Door Hanger Co., 1 Madison Ave., New York**

**PACIFIC COAST AGENTS**

San Francisco: SARTORIUS Co., Inc., Fifteenth & Utah Sts. Seattle: D. E. FRYER & Co.  
Los Angeles: LOUIS R. BEDELL, 1108 Story Building Portland: PORTLAND WIRE & IRON WORKS

FRED J. H. RICKON, C. E.  
Member A. M. Soc. C. E.

R. EHRHART, C. E.

# RICKON-EHRHART ENGINEERING & CONSTRUCTION CO.

Civil Engineers and Contractors

Phone West 1300

1859 GEARY ST., SAN FRANCISCO

ALFRED FOWLE, President

JOS. R. WHALEN, Secretary and Treasurer

## CALIFORNIA STEAM AND PLUMBING SUPPLY CO.

SANITARY PLUMBING  
FIXTURES



WATER, STEAM AND  
GAS SUPPLIES

FIFTH AND BLUXOME STREETS

SAN FRANCISCO, CAL.

## CRANE COMPANY

Second & Brannan Sts.  
SAN FRANCISCO

High Grade . . .

### PLUMBING SUPPLIES

Steam and Hot Water Heating  
PIPE, VALVES, FITTINGS

Power Plant and Water Works Materials

STEAM SPECIALTIES

## N. O. NELSON MFG. CO.

### PLUMBING SUPPLIES



978 Howard Street  
San Francisco

406 E. 4th Street  
Los Angeles

**DIECKMANN****HARDWOOD**

HARDWOODS  
 CABINET WOODS  
 HARDWOOD FLOORING

**COMPANY**

OFFICE, 244 CALIFORNIA STREET  
 MILL AND YARD, FOOT OF TAYLOR STREET

**SAN FRANCISCO, CAL.**

TILING  
 MANTELS  
 GRATES



N. B. HERNDON,  
 TREASURER

A. S. MANGRUM,  
 PRESIDENT AND MANAGER

CHAS. C. HANLEY  
 SECRETARY

**MANGRUM & OTTER**

INCORPORATED

**FURNACE AND STEAM HEATING****HOTEL AND KITCHEN OUTFITS**

Stoves, Ranges, Refrigerators, Tin and Enameled Ware

Telephone Kearny  
 3155

561-563 MISSION ST.  
 SAN FRANCISCO

**WEARY & ALFORD COMPANY****Bank Interiors and Equipment**

OF THE HIGHER CLASS

H. H. WINNER, Pacific Coast Representative

303 Union Trust Building

SAN FRANCISCO

**CONCRETE REINFORCEMENT**  
**STEEL BARS** FLATS, ROUNDS, SQUARES & TWISTED

**BANDS, HOOPS AND WIRE**

ALL SIZES IN STOCK

**WOODS & HUDDART**

356 MARKET STREET

SAN FRANCISCO, CAL.



# Cold TWISTED STEEL BARS

(Square, Round and Flat) for Reinforcing Concrete



OUR STOCK IS COMPLETE IN ALL SIZES

## BAKER & HAMILTON

SAN FRANCISCO

SACRAMENTO

LOS ANGELES

# The Architect and Engineer

Terms of Subscription,  
\$1.50 per Year

of California

Single Copies,  
25 Cents

## Pacific Coast States

Issued monthly in the interests of Architects, Structural Engineers, Contractors and the Allied Trades of the Pacific Coast.

## Contents for February

### MISSION NUMBER

	PAGE
Arthur Burnett Benton - - - - -	<i>Frontispiece</i>
The California Mission and its Influence Upon Pacific Coast Architecture - -	35
<i>Arthur B. Benton, Architect</i>	
<small>Illustrated with Engravings of Prominent Missions, the Mission Inn at Riverside and the Arlington Hotel, Santa Barbara.</small>	
The Forty-Fourth Annual Convention of the American Institute of Architects -	76
Working for the Redwood Shingle - - - - -	93
A Good Word for Bricks - - - - -	94
A New Safety Device Used on the Hearst Building - - - - -	95
American Style of Architecture is Coming - - - - -	97
Among the Architects - - - - -	98
Editorial - - - - -	102
Heating and Lighting - - - - -	104
The Broadening Field of the Plumber - - - - -	104
<i>Andrew Young</i>	
Single Pipe Plumbing - - - - -	105
Recent Patents Granted Pacific Coast inventors - - - - -	105
A Good Word for Corrugated Iron Culverts - - - - -	109
By the Way - - - - -	112

(For Index to Advertisers see Pages 121-124)



*Arthur Burnett Benton*

Frontispiece  
The Architect and Engineer  
Mission Number  
February  
1911.

720.5

Ar 24<sup>24</sup>

63660

THE

## Architect and Engineer

Of California

VOL. XXIV.

FEBRUARY, 1911.

No. 1.

## The California Mission and Its Influence Upon Pacific Coast Architecture

ONE of the numerous treats enjoyed by the delegates to the recent convention of the American Institute of Architects, held in San Francisco, was the illustrated lecture on the California Mission by Architect Arthur B. Benton of Los Angeles, whose work in Mission architecture has been most successfully developed in the Glenwood Inn\* at Riverside and the Arlington Hotel\*\*, under construction at Santa Barbara. Much space is given in this issue of *The Architect and Engineer* to illustrate these two notable structures, which are unquestionably among the best examples of the genuine Mission type that we have in modern architecture.—EDITOR.

By ARTHUR BURNETT BENTON, Architect



THE twenty-one Franciscan Missions of Alta, California, with their several Asistencias or outposts, rank in architectural importance with the historic buildings of our Colonial period of the Atlantic coast. They lack for us the consummate interest attaching to the ancient buildings, enriched by the traditions of the founders of the American Republic, and monumental of its early development, and of our forefathers whose influence, so dominant in the Colonial and Revolutionary periods, is still so persistent in shaping our national life; but these old Missions are speaking witnesses of the introduction into our borders of a type of civilization with different ideals, whose full influence on our territorial expansion and the customs of our people can not be rightly estimated until the development of the Southwest shall have approached more nearly that of the Mississippi valley and the Eastern coast.

Certain it is that this great region, destined to be one of the most populous within our limits, owes vastly more to the Spanish occupation than our people have now the wit to perceive or the courtesy to acknowledge. The historic importance of the Missions will become more apparent

\*Architecturally, the Inn is an adaptation of the ancient Spanish methods of building as practiced by the Mission Padres, the pioneers of civilization in California, to the diversified requirements of a modern hotel. The owner, Mr. Frank A. Miller, desired not only to perpetuate the spirit of the old architecture, but also to embody in his building details of construction and ornamentation as found in the Missions, for their own beauty and historic interest, regardless of their special fitness for modern uses.

\*\*This hotel was built to replace the historic Arlington, destroyed by fire. One wing of the old building that escaped destruction has been remodeled, the frame structure inclosed in brick walls, concrete floors placed over the wooden ones and the interior arrangements greatly modified. The new buildings are of fireproof construction. Pillars and floor and roof slabs are hollow, with outside and inner walls of brick. All partitions are of brick. Towers, buttresses and bays have cement plaster finish, and belts formed by floor slabs are also plastered. The wall panels have the brick exposed and these are stained with oil stains.



*Entrance to Carmel Mission, Monterey*

with the passing years, and I am confident that with the growth of appreciation of the virtues of the Mission builders as pioneers of civilization in the wilderness, will come a better realization of the architectural excellencies of their works, not, indeed, comparable in design or in execution with the best buildings of the populous cities of Mexico and South America, or with the best of our Eastern Colonial work, but nevertheless, to my thinking, possessing characteristics most admirable in their consistent emphasis of a high ideal in their design and in their very noble use of many base and common materials in their construction, for I take it that ideality and adaptation to environment are fundamental architectural virtues which may, under some conditions, overrank even academic correctness and the niceties of perfected construction.

To appreciate Mission architecture we must know the history of their founding and have a clear conception of the extraordinary isolation of their locations at the time of their construction. Fifty years after the



*Doorway, Carmel Mission, Monterey*

Columbus discovery, in the year 1542, one Juan Rodriguez Cabrillo, a Portuguese navigator in the employment of Spain, discovered and to some extent explored the coast of Alta California. The hardships endured by the sailors of his two small vessels, and Cabrillo's death through accident on San Miguel, one of the Santa Barbara Channel islands, were disheartening. The expedition, moreover, neither found gold nor an easterly passage to the Atlantic, nor a mainland connection with Asia, which three quests were the precious fleeces for which Spanish Argonauts of the sixteenth century sailed the North Pacific, and no further expeditions were sent to California for many years.

In 1579, Sir Francis Drake came this way and had he founded a colony of sturdy Englishmen like those of Jamestown and Plymouth, how different would have been the problem of the Pacific today! But he, too, was in





*Bell Tower, Carmel Mission, Monterey*

quest of gold, not in mines but aboard rich Spanish galleons from Mexico to the Orient. Afterward, in 1602-3, the second Spanish exploration of the Upper California coast was undertaken by General Don Sebastian Vizcaino, with a principal object of finding a safe harbor for vessels sailing from the Philippines to New Spain. According to his own report, he went as far as 42 degrees north, or the present northern limit of California, and returned to Mexico, recommending the improvement of the harbor of Monterey. Later, for more than one hundred and fifty years, the native Indians—here more numerous than anywhere else in what is now the territory of the United States—dwelt, conditioned more favorably for the struggle for existence than their contemporaries east of the Rockies, without molestation from white settlers.

It was not the love of gold nor the desire for territorial expansion that at length proved the chief incentive for the settlement of white men in California. Her pioneers were animated by that great fervor of missionary zeal kindled by St. Francis of Assisi. Their quest was the souls of the heathen; their ambition, the enlargement of Christendom. When, in 1769, Padre Junipero Serra, President of the Missions of Lower California, led his party of pioneers from Villicata, in Lower California, to San Diego Bay, it was through hardships that would have been unsurmounted by a less courageous captain. At San Diego he found the naval expedition which had been four months making its way from La Paz, a distance of but 700 miles, an indication of the difficulties of navigation with the poor ships and inaccurate charts of the time.

After the arrival of the Spaniards, there were numerous deaths by sickness. The Indians, at first friendly, became for a time hostile and had to be placated, but on July 16, 1769, the Mission of San Diego was

founded and civilization in Alta California had its beginning. In June, 1770, the second Mission, San Carlos de Monterey, was established. Before Junipero's death in 1784, seven other Missions—San Antonio de Padua, San Gabriel Archangel, San Luis Obispo de Tolosa, Francisco de Assisi (Dolores), San Juan Capistrano, Santa Clara and San Buena Ventura—were founded.

The physical difficulties encountered in this work, extending over six hundred miles of wilderness, with its nearest outpost seven weeks' journey from the older settlements, could have been conquered by none but most indomitable spirits. The success of their endeavors was phenomenal. La Perouse, a French naval commander, who visited California in 1786, states that at that time there were five thousand one hundred and forty-three Indians in the Missions of Upper California. That they were not held in subjection by force is evidenced by the record of the same officer, that at the time there were but two hundred and eighty-two soldiers and about one hundred officers and friars, all told, in both Upper and Lower California, extending over a distance of eight hundred leagues. "The friars were stationed, by twos, from sixty to one hundred miles apart."

There can be no doubt that Junipero Serra was an ideal missionary and pioneer, and while none of the great stone churches were built during his lifetime, the ruins of the adobe buildings of the earliest period are convincing proofs of his skill as a builder. He was of Spanish birth, a most ardent Franciscan, and one of the best men of his time. He lies buried in the church of San Carlos, Carmel Bay, Monterey.

By 1804, nineteen Missions were established and "a man might ride from San Diego to Monterey by easy stages, spending each night as guest at a Mission establishment." In 1812, a series of earthquakes brought widespread disaster to the Missions, but they were rebuilt on a larger scale than before. In a few years thereafter their wealth had grown to vast proportions. Agriculture and grazing were the principal sources of income, but at all the Missions, manufacturing establishments of various sorts were also in operation. At many places massive stone churches were erected, and large monasteries surrounded by shops and dwellings, constituting populous towns of several thousand inhabitants. The padres were wonderfully successful in civilizing the Indians, and while there were instances of cruelty by the one and revenge and reprisal by the other of these partners in the upbuilding of the new commonwealth, it seems certain that harmony prevailed to a degree far greater than in any similar effort at colonization with whose record I am familiar.

The administration of the Missions was by the friars, under a prefect, or president, who was responsible to the Franciscan College of San Fernando in Mexico. A general purchasing agent was kept in the City of Mexico and there were shipping agencies at convenient ports. The income of the Missions was derived from the sale of products and from the "Pius Fund," originally belonging to the Jesuit order, but on the suppression of that order, seized by the Spanish government and held in trust for the Missions. The government required that at the expiration of ten years the Indians of the Missions should be formed into communities, or pueblos, when the Missions would become the parish churches. The plan was good, but ten years was far too short a time in which to prepare the Indians for the independence of the pueblo.

Very early the pueblos of Los Angeles and San Jose were founded by the Spanish government and what was known as "Presidial Pueblos" had gradually grown up around the Missions San Diego and Monterey,



*Interior of Chapel, Carmel Mission, Monterey*

Santa Barbara and San Francisco. In these, persons not in sympathy with the missionaries' work and jealous of their control, both civilians and soldiers, increased in numbers, and the military authorities often opposed their measures to those of the friars.

In 1813, the Spanish government passed an act of secularization, which was not, however, enforced. In the quarrel over Mexican independence, the Missions remained loyal to Spain and many friars left the country rather than take the oath of allegiance to the Mexican government when finally established. The political situation under the new Republic in California was worse even than it was in Mexico, although that seems hard of belief, and the Missions suffered greatly.

In 1834, the Governor of California, acting on orders from Mexico, issued the edict for their secularization, and for the "emancipation of the Indians." The Indians, however, "should be obliged to join in such labors



*Mission of San Luis Rey*



*Outer Corridor, San Juan Capistrano Mission*

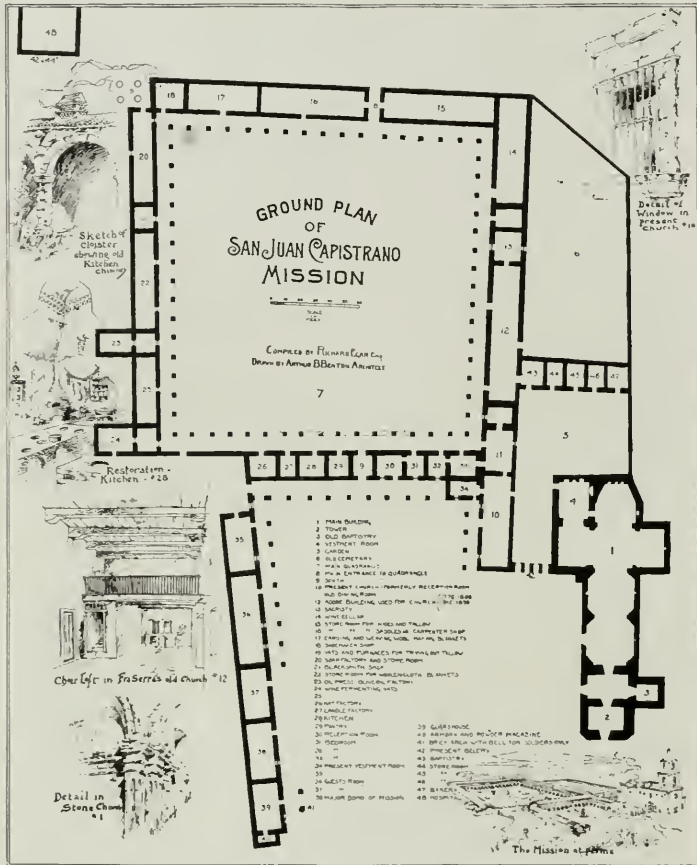

Ground Floor Plan, Restoration of Capistrano Mission  
Arthur B. Benton, Architect

of the community as are indispensable in the judgment of the political chief."

Out of one hundred and sixty families at San Diego, but ten were willing to accept of this "emancipation." One-half the movable property was to be divided among the "emancipated persons," each head of family to be given four hundred square yards of land. Everything else was to be put in the hands of the administrators subject to the federal government, which was to provide for the support of the fathers left in charge of the church and the church properties. "These laws," says Dwinelle in his





*Santa Barbara Mission*

history, "whose ostensible purpose was to convert the missionary establishments into Indian pueblos, their churches into parish churches, and to elevate the Christianized Indians to the rank of citizens, were executed in such manner as to result in the plunder and complete ruin of the Missions and the demoralization and dispersion of the Indians."

For years after the secularization act was passed, each governor used his own devices for making all he could out of the Missions, renting them, dividing them for use of colonists and selling them. In 1834, there were from 20,000 to 30,000 Indians in the Missions. In six years their numbers had shrunk to 6,000 and the livestock from 800,000 to 6,300. When the United States took possession of the country, many Mission lands were held by squatters, without right or title. After litigation, the United States courts made what restoration was practicable of the old churches and some fragment of the Mission lands to the Roman Catholic Church.

For many of these facts I am indebted to Helen Hunt Jackson's book, entitled "Glimpses of California and the Missions," which I commend to

*San Gabriel Mission*

those desirous of obtaining a short, sympathetic and, I believe, a trustworthy account of the Mission period of California history.

Any intelligent consideration of the architecture of the Missions without a right conception of the character of their builders is impossible. Their founders were Franciscan friars, vowed to poverty, to works of charity, to celibacy. In their architecture, as in their lives, the secular was always subordinated to the religious. They built no marts of commerce, no courts of justice, no halls of government, no palatial dwellings, no cities. All their architectural aspirations were centered in their churches. Even where the monasteries were large, as at San Fernando and Santa Barbara, they contained no great or ornate apartments. The chambers were plain cells. In the churches, on the contrary, were employed all the art and ornamentation within the compass of the builders, supplemented by extensive importations from Mexico, Spain and the Orient.

The most prominent characteristics of the Mission ground plans were their spacious patios, their long cloisters, their deliberate perspectives, all of which are inherent in those types of architecture derived from the Italian Renaissance. It is frequently asserted by writers on the Missions, that their architecture obtains from Moorish sources. That there are traces of Moorish influence, as is common in much of the architecture of Spain, is true, but that Christian zealots should deliberately adopt the architecture of their worst infidel enemies is inconceivable, even if it were not historically certain that the Renaissance style of architecture, introduced from Italy, was the prevailing fashion in Spain at the end of the fifteenth century, when America was discovered; was carried to all the Spanish colonies by the conquerors, and was an especial favorite of the Roman Church everywhere. In common with the ecclesiastical buildings of Mexico,



Arthur B. Benton  
- Architect -  
- Santa Barbara, California -

The Arlington  
Santa Barbara, California

The Arlington Hotel, Santa Barbara, California. Photo of Motel

Arthur B. Benton, Architect

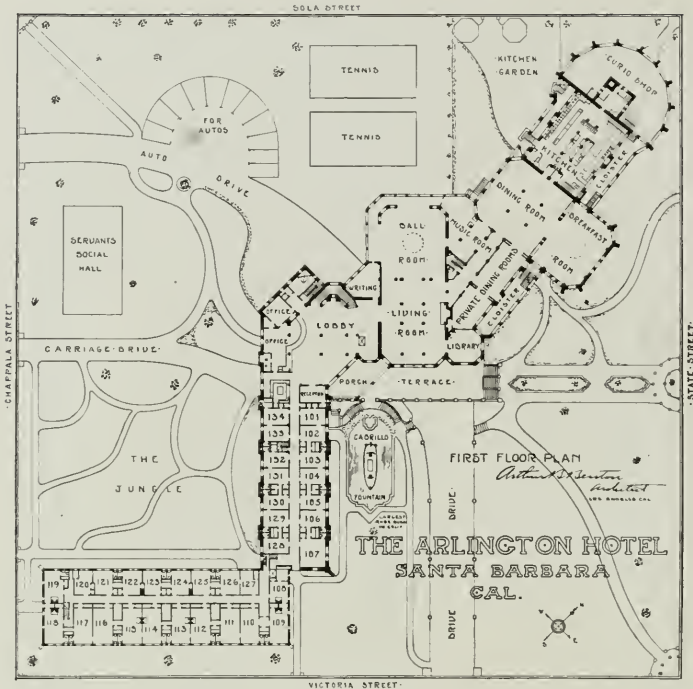

Main Floor Plan, Arlington Hotel, Santa Barbara  
Arthur B. Benton, Architect

Florida, Texas and Arizona, the Alta California Mission buildings, in their principal architectural features, as well as in their ornamentation, follow the Renaissance; often it is true but lamely, judged by the standard of the schools.

The California Missions are unique among the Spanish buildings of the Americas, by their simplicity, often approaching in this respect the severity and the charm of the arcades and unbroken wall masses of the early Romans. When I consider that they were the work of laborers largely derived from the native Indian tribes under the direction of friars more often than of highly skilled architects, if, indeed, there were any professional architects whatever; when I see their great diversity in design without violent departure from type, their moderation where one might expect redundancy, their enrichment where we are accustomed to find poverty, I am not critical as to the crudeness of some of their detail, nor impatient with their departure from fixed rules of classic proportions, but I am rather amazed at their exhibition of the fundamental principles of design and their freedom from those architectural vulgarisms from which this generation has yet to be delivered.



Image Maker at Capistrano Mission

It is evident that the men who built the Missions loved architecture, as few love it now, for its own sake. Who was there then to admire but the barbarians? As a means wherewith to retain their hold on the highest conventions of civilization and as an expression of that faith for which they had put all that most men count dear behind them. I can imagine no lesser motives that could have produced in the California wilderness of the early eighteenth century such stupendous architectural works as the greater of the masonry churches or that would have almost immediately rebuilt the Missions in better form than before after the widespread destruction wrought by the earthquakes of 1812.

The principal churches of the Missions now standing were all built prior to the year 1820, or within fifty years of the founding of the first Mission at San Diego. San Carlos, at Monterey, was dedicated in 1797; San Gabriel Archangel, near Los Angeles, was completed in 1800; the





*General Panoramic View of Glenwood Mission Inn, Riverside*



*Dining Room Mission Inn, Riverside*



California

Arthur B. Benton, Architect



View in Dining Room, Mission Inn

church at San Luis Rey, in 1802; at San Juan Capistrano, in 1806; at San Fernando, in 1818; the present church at Santa Barbara, to replace the one destroyed in 1812, in 1820; the Plaza church at Los Angeles, built by Neophytes from San Gabriel and San Luis Rey, in 1822, and rebuilt in 1861.

The sites for the Missions were admirably chosen, always in picturesque as well as fertile locations. One who makes a modern pilgrimage to the ancient buildings will visit some of the most beautiful of the California valleys. The Missions were generally some miles inland, but not far from a harbor. Their exact location was largely determined by an adequate water supply. Their irrigation works are of considerable extent and the conduits, reservoirs and ornamental basins built of tiles and of stone are, many of them, in excellent condition to this day. The basins were often very elaborate in design, with intricate star-shaped plans and excellent carved work and plaster ornamentation.

The constructive materials for the buildings varied with their location. The first buildings were of posts and interwoven brush, with thatched roofs, not differing greatly from the native Indian dwellings. In some places these were followed by frame buildings with plastered walls. But doubtless the earlier buildings were generally of adobe sun-dried bricks, in which straw or other binder was incorporated. Their foundations were of stone or burnt clay brick, as adobe too near to grade will rapidly disintegrate from absorption of ground dampnesses. The adobe brick were laid in mortar of the same material. Adobe arches are common; also wood lintels of sycamore, willow and pine.

Thatch was used for roofing to some extent, but all permanent buildings were covered with terra-cotta tiles generally very large and heavy, two layers of which were placed on timber rafters and roof lath, where they were retained by their own weight. I have not seen evidence of nailing or other securing of them. No knowledge of truss construction seems to have been possessed by the builders, as rafter ends were placed directly on the walls and ridge poles upheld by struts bearing on the centers of the ceiling beams. These were often reinforced by corbels and bolsters at the ends and sometimes at the centers.

Timbers were tied together by thongs of raw hide, which in drying contracted with such power as to hold fast for over a century these great timbers. This hide was used for most purposes for which we use nails and bolts, and also in place of chains for the hanging of bells and other weights. The ceilings of major rooms were of hewn plank laid on top of the ceiling beams, and of minor rooms of tile laid on rafters very close together, or of the native bamboo, woven together with rawhide strands. Both tile and rush ceilings made a very good appearance.

Many of the ceilings and the plastered interior walls were frescoed in brilliant colors. At San Miguel Mission, near Paso Robles, the design is of pomegranates and morning glories, while the chancel decoration is derived from the scallop shell.

Window openings were very few and small, and closed with wooden shutters. Many of the doors were of interesting design, with curved and molded flutings. Hinges and locks were not generally conspicuous, the former especially being often almost invisible, although strong and serviceable. Floors were of burnt clay tile or of hewn planks. The clay tile were square, oblong, or elongated diamond shapes and sometimes laid in patterns.

There was much cutting and shaping of corbel ends. Turned and sawed woodwork of good design was common and iron grill and railing



*Pergola along West Wing, Mission Inn*



*Street Side of East Wing, Mission Inn*



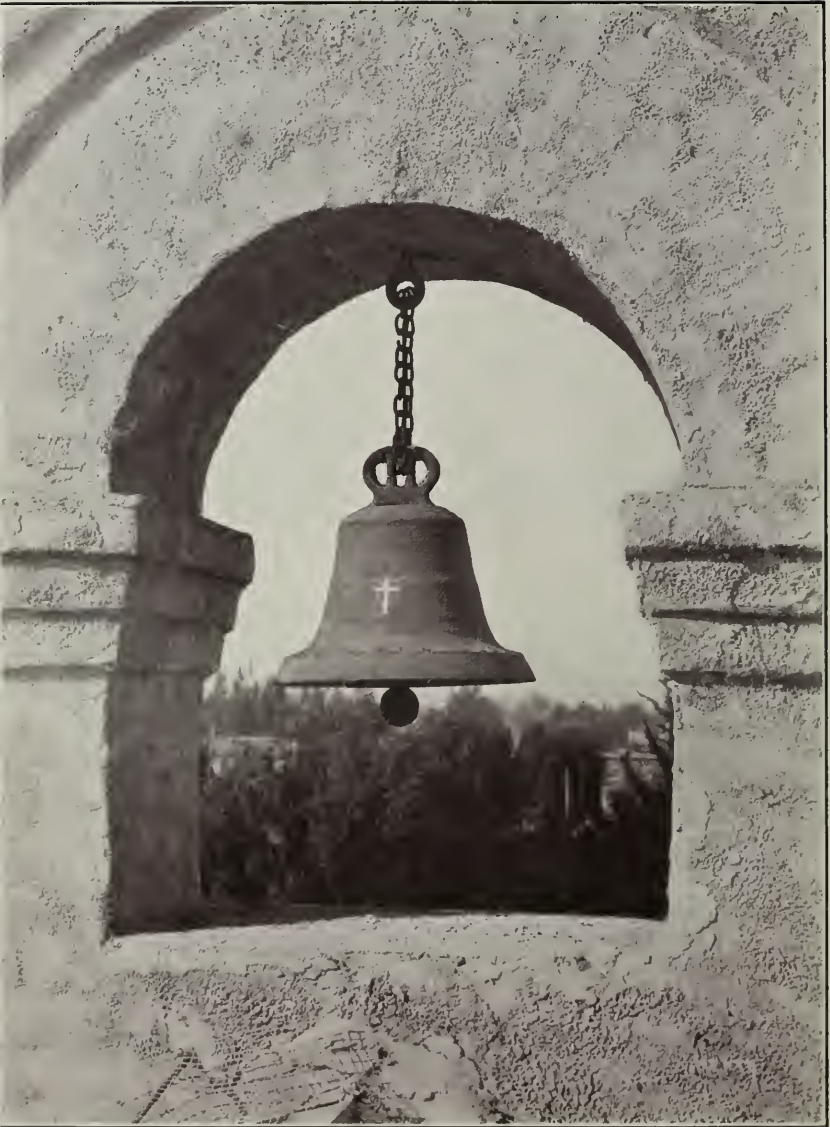

*Old Mission Bell in Top of Facade, South Front, Mission Inn, Riverside*





Lynch  
San Francisco Cal.

St. Catherine's Well  
Glewood Hotel, Riverside Cal.

373

St. Catherine's Well, Mission Inn

work was most admirable in its refinement. What remains of altar reredos and accessories is of elaborate Renaissance design and heavily gilded. Dolores Chapel, in San Francisco, contains very interesting examples.

Many statues of wood overlaid with enamel and gilding, and old paintings still remain.

Candlesticks and altar vessels were of the precious metals and vestments for the priests and altars approached those of Mexico in their richness. Fonts, piscinas, holywater stoups and niches were handsomely carved and decorated even in the adobe churches.

The stone churches, as at San Luis Rey, San Juan Capistrano, Monterey, San Gabriel and Santa Barbara were generally constructed of sandstone. In some places, as at San Juan Capistrano, it is of inferior quality for the support of the great weights required. Many of the roofs were of vaulted construction, partly of stone, as the ancient nave roof at San Carlos now entirely disappeared, or of tile and concrete as at San Juan Capistrano. Here the tiles are of the old Roman pattern, laid in projecting rings, not truly vaulted. The mortar is exceedingly hard and the great domes are in excellent condition in spite of what nature and man has done to destroy them, for the greater portion of this church was blown down with gunpowder to make room for a projected church which was never built.

I have been unable to discover accounts of the methods of preparing limes or cements for mortar. It is related that in the building of Santa Barbara church the lime was obtained from boulders; that sea sand was not used, but stream gravel; that the "mash" was formed and then laid aside for several months, added to and stirred from time to time until properly tempered.

In the stone churches there was much elaboration of door stiles and lintels and of pilasters and cornices. The workmanship is generally crude, but in some instances, as at the Presidio church and San Carlos Mission at Monterey, mouldings and flutes are very well cut. The mouldings and turned work show a fair knowledge of classic detail treated with a freedom to be expected, and frequently by its departure from rule the more interesting, as showing the possibility of a free rendering of the classic with but very few lapses into the vulgarisms with which our modern ordinary work is so unfortunately overloaded.

The prominent characteristics of the exteriors of the Missions, aside from those of the ground plan which I have mentioned, and the predominance of the churches over all other of the buildings, are the towers, the fractable gables and the cloisters.

The towers differ from their Spanish and Mexican prototype in their extreme massiveness, their simplicity of detail, and in their common, almost universal, domed terminations. Their great massiveness—in some there are six feet of wall thickness in the upper stories—is doubtless due to the destruction of earlier buildings by earthquake; their simplicity, I think, to the temperament of their Franciscan builders. As for the reason of the preference of the builders for domes over pyramidal roofs or steeples, I will not hazard an opinion.

The recession of stories is a treatment of frequent occurrence in English and German, as well as in Spanish Colonial architecture of the 17th and 18th centuries. Fractable gables are also common in the same architectural era in Northern as well as in Southern Europe and in the Americas. The roof construction of the Missions made this form of gable the easiest termination for rafters and tiling, and also the simplest way of giving



*Inside of Campanile, Showing Mission Chimes*

proper contrast and architectural support to the towers. The curvatures of these gables are an interesting study in design, exhibiting as they do some of the subtleties of ancient mouldings.

The cloisters were mostly of burned brick of various patterns not hard enough to resist wind erosion unless plastered. Arches were usually semi-circular, but as the preserving of uninterrupted vistas was evidently carefully considered, the spacing of piers was frequently irregular, and elliptical arches intersperse with the round ones. Circular brick pillars supporting veranda beams sometimes occur. The roofs of the cloisters were originally almost always flat, with parapet walls and native asphaltum roofs laid on boards. In several of the Missions, as at San Fernando, the flat decks have later been covered by raising the walls to the main buildings and extending their roofs over the cloisters.

The monastery kitchens, with vaulted roofs and latticed tile chimneys, were interesting features, as were the domed ovens and the fireplaces, but



*Father Servo Raising One of the Mission Bells, Glenwood Mission Inn, Riverside  
George Stone, Artist*

the latter were generally small and with little adornment, all richness being always reserved for the churches.

The following description of one Mission will give an idea of their arrangement:

"San Luis Rey Church was 160 feet long, 50 feet wide and 60 feet high, with walls four feet thick. The tower held eight bells. There were 256 arches to the cloisters. The quadrilateral was 450 feet square, or about 5 acres in area. The interior court was ornamented with trees and fountains. Upon the cloisters opened the dormitories of the monks, of



Painting at Mission Inn  
By George Stone

major-domo and of travelers, small workshops, schoolrooms and storerooms. The schoolrooms and hospitals were in the most quiet situations. The young Indian girls dwelt in monasteries and were called nuns. The Indian children mingled in school with those of the white colonists. Those who distinguished themselves in the carpenter shops or at other skilled labor, were made overseers. Surrounding these buildings were the adobe and reed dwellings of the Indian families."

All of the California voyagers and travelers speak highly of the gen-





*Perspective of Monastery. Latest Addition to Glenwood Mission Inn*



*View of Old Adobe, Mission Inn*



General Floor Plan, Glenwood Mission Inn, River side  
Arthur B. Benton, Architect



*Main Entrance to the Cloister, Mission Inn*

erous hospitality of the friars, so that guest rooms must have been many, if simple.

The Mission bells were probably nearly all imported from Mexico or from Spain. Those having the crown at the top are said to be from the royal bell foundry at Barcelona. Furniture was also imported. Much of it would look well in place in our Eastern Colonial dwellings. Some was from the Orient. But little was of the fashion of that now called "Mission" furniture. A delicacy of treatment characterized ornamental metal work and furnishings, indicating a nice perception of that fitness of design to purpose which is the eternal standard of architectural art.

Within the limits of this paper it is impossible to do more than to barely mention some characteristics of the Missions which are worthy of much consideration. I can assure you this field of study is a rich one for the architect, with many unsuspected leadings toward the great schools



*Music Room in the Cloister, Mission Inn*

of design, but chiefly interesting to me as the most consistent architectural development of a half century duration with which I am familiar, at least of modern times.

The presence of such buildings in California from its earliest occupation by any large population of civilized people, could not fail to greatly influence its architecture. That its influence has not been greater is due to the small growth of cities until the time of the American occupation, and since to the demand for wooden buildings as the cheapest and easiest of construction and the most susceptible of all manner of architectural eccentricities of design and elaboration. Until within the last twenty years our cities were wooden cities to an extent very rarely equaled in any other country.



South Front from Court, Mission Inn, Riverside

Arthur B. Benton, Architect



The development of the lumber industry and the very rapid increase in population made this "wooden era" the natural development for the times. When the buildings of the Columbian Exposition at Chicago started a new classic revival throughout the country, the people of California were just beginning to realize its possibilities for rapid growth and to plan for permanent buildings. The models of classic architecture at hand in the ancient Missions were copied by all sorts of designers and their designs executed in various materials, but mostly in lath and plaster and staff. Of many of these, I believe it may be justly said, as was noted by Thomas Jefferson of the early buildings of the Virginia towns: "Their one redeeming quality is that their construction is of so pitiful a nature that posterity will have no opportunity for criticism." That, however, is true of many of our buildings in the East as well as in the West, and in other styles than "Mission."

The Missions having singular simplicity of design, would naturally need to be variously "enriched" to meet the architectural refinement of a generation which can manufacture staff at a few cents a yard, and whose duplication of classic ornament is as easy today as was the jig-saw creations of a few years ago. There has been, however, a growing appreciation of the Mission with the growing interest throughout the country in all good architecture, and it has doubtless had large influence on California architects toward better design.

There have been many intelligent attempts to follow the Mission architects, but it is not an easy road for the modern designer. Sixteen-inch walls will not give the effect of six-foot ones. Walls pierced by many windows will not have the repose of unbroken masses. Ordinary building sites forbid long perspectives or spacious patios. Milled woodwork, machine iron work and stock hardware can not surprise and charm as do their ancient substitutes.

It is possible to adapt some of the Mission architecture to our modern uses without too much sacrifice of the utilities. It is better to try and conceive of the workings of that spirit pervading the minds and souls of the old padres, which made them able in the midst of manifold labors to take of the clay, the local stone, the sparse timber, the green hide and the rushes at hand, to train wild savages to skill and obedience, and to build in so little space of time, buildings warm in winter and cool in summer, pleasing in architecture, comfortable to the bodies and satisfying to the souls of several generations of men. When we can grasp this we will not need their works as a copy, but will rejoice in them as an inspiration and build our highest aspirations into structures commensurate with our opportunities, as they did with theirs.

While we are learning to do that, we may well go to the same sources from which they must have obtained their insight into architectural design, and study the early Renaissance, and the architectural developments which preceded it. Not that florid, decadent Renaissance, with its senseless ornament and unmeaning symbolism, which so appeals to the architecturally uneducated, but a type simple enough to be gradually enriched with a symbolism growing out of our own national and local history, and expressive of the ideals of our own times.

In doing this we will certainly find much in our own work resembling that of the Mission padres, as we see in theirs much that speaks of the art of Spain and Italy.

In my own work in the so-called "Mission" style, for secular buildings, I have found as much help, or more, in the study of the buildings of Lom-

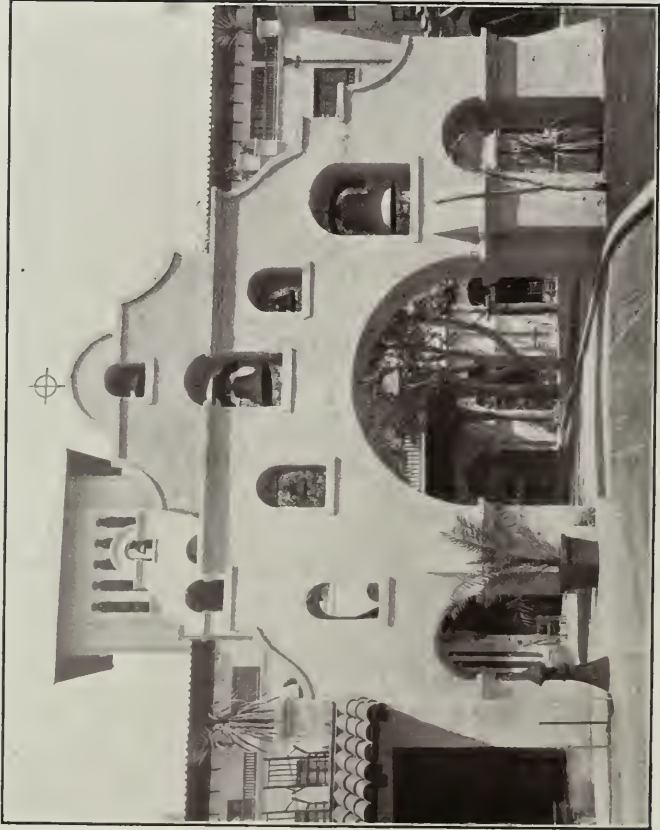

*Elevation of Campanile, Showing Entrance to Lobby, Mission Inn, Riverside*



*South Balcony, Mission Inn*



*View of Mission Arcade Outside of Inn*



*View of Court from Corner of East Wing, Showing Comonile in Distance*



*View of South Front from East Balcony, Mission Inn*



*The Garden of Bells, Mission Inn*



*Music Room and Cloister, Mission Inn*





*View of Mission Inn Through Arcade*



*View of Campanile from Balcony*



*Pergola on South Front,  
Mission Inn*



*View of Entrance to Lobby,  
Mission Inn*



*Front of East Wing from Street, Mission Inn*

bardy and of the Italian towns as of the California Missions, because of their ecclesiastical character, excepting that in designing arcades, towers, and large gables, I have believed it right to make as fairly close copies—avowedly duplications—as was compatible with the character of the buildings of which they were to form a part, because the Missions are with appalling swiftness falling to decay and unless their ruin is checked will soon be beyond the possibility of repair, and excepting in copies there will be few remnants to show what they were in their prime.

I have referred to the spoilation of the Missions by Mexican politicians and American squatter occupation. When they were recovered by the church, the Indian populations had been dispersed and there was no immediate practical use to which the buildings in isolated situations could be put. The titles of some had passed beyond recovery. Some of the most important, which are still in use, have suffered greatly from the honest padres in charge, who have whitewashed old frescoes, torn down arches, and sold the brick for a song, replaced leaky tile roofs with shingles or corrugated iron, thrown away old doors of quaint workmanship and put in their place common mill-made ones, ceiled over the old beams with tongue and grooved ceiling, and done to the old Mission work the same despite that was suffered by so much of the Eastern Colonial work, not so long ago but that we may readily remember its doing. The spirit of our age is such as to make it difficult for it to comprehend the thoughts and ideals of such men as the Franciscans of the seventeenth century. The modern padres are no more to blame for their want of appreciation than many others of this day with wider opportunities for culture. They have often the excuse of sharp constructural necessity to be met, with little money for meeting it.

There have been efforts for the restoration and preservation of the Missions by organizations outside the church. The "Landmark's Club" in the South, the "Historical Landmark's Society" in the North, the "Native Sons" and "Native Daughters," and others have spent some thousands of dollars in replacing roofs, repairing walls, and underpinning foundations, and by their work much irreparable damage has been, for the time, averted. For many years I have been the secretary of the "Landmark's Club." Its work has been preservative, rather than restorative.

A most serious danger to the life of the old buildings is the rotting of the roof timbers, which are now worm-eaten. The great weight of the tile and the unscientific construction of the roof supports, make the ruin great when the roof falls. Adobe walls, when their tops are exposed to rains, crumble rapidly. The immense roofs at San Juan Capistrano, San Fernando, and of the church at Pala, have been removed by the "Landmark's Club," new timbers placed and the tile reset in as nearly the old way as is practicable. This with some other repairs has consumed seven or eight thousand dollars. Some artists have waxed indignant at the "vandalism" of the club in "destroying," as they term it, the picturesqueness of the Missions by stopping the holes in the roofs and otherwise prolonging their existence. We have had to do some things not in tune with the old spirit, because of lack of money and of workmen who could do the old work, but as far as we could we have kept to the old methods.

After very careful consideration and long experience in this work, I am convinced that the preservation or speedy destruction of the remnants of the Mission buildings, depends on the action of the Roman Catholic Church in whom their title vests. Of my own knowledge I can say that



*West Wing, Mission Inn, Riverside*

the Bishops of the church and many of its clergy, have always given encouragement and aid to the Landmark's Club and other agencies working for the preservation of the Missions, and that some of the largest money contributions have come from members of that communion. I am informed that the church spent large sums in the United States Courts to regain possession from squatters and other usurpers of title. I am fully cognizant that in the present active work of the church there is no place for the greater number of the Missions, as the Indians are dispersed and surrounding populations are non-Catholic, or the Missions are isolated from all local support. It must be apparent however, that the preservation of the Missions and their partial restoration for their picturesqueness and historical value, if it is to be done at all, must be under the direction of men of rare architectural insight, and well informed in the history of the Missions, the customs and services of the Church, the characteristics of the





*The Crypt Banquet Room, Mission Inn*

Indians and Mexican builders, and with a fine appreciation of the archaeological value of the smallest departure in the construction of the Mission builders, from our modern ways.

For want of such supervision, the work or repair necessary from time to time, in such Missions as Santa Barbara and San Luis Rey, which are still in use as churches and monasteries, is mostly modern and fatal to their distinctive character. This process is natural in the absence of skilled supervision, and with economy of expense to be considered. It is none the less destructive and deplorable, and will in a short while, if continued go far to ruin the best preserved of the Mission buildings.

Without doubt the repair and extension of the buildings of the Missions now in use in harmony with the spirit and **letter** of their first builders would eventually prove a most profitable investment for the church, especially as large sums could be raised outside the church membership, if assurance could be had that they would be spent intelligently, I mean, of course, archaeologically intelligently.

Those ruined Missions, practically abandoned by the church, should be sold or leased for a long time to an organization chartered by the State, governed by commissioners selected for eminent fitness, whose character would command the largest confidence.

I should hesitate to speak so confidently had I not for the last fifteen years, given much thought to this problem. I hope that great church, whose missionaries doubtless saved California from English or Russian occupation, and whose padre's lives and works are a romance in the history of a country whose annals are none too rich in romance, will soon realize that not only it but the State and Nation will be much the poorer if these great monuments of the founding of this commonwealth of California are suffered to go the way they are so swiftly going. To do that which must be done to save them will require hundreds of thousands of dollars, but I know of great sums that will be made available if the donors can be assured that



*Tea Room in Old Adobe, Mission Inn*



*Parlor in Mission Inn, Riverside*

restorations will be consistently made and their future safety guaranteed. Without these assurances the church must assume the whole burden of restoration and preservation or most of the responsibility for further destruction.

The commercial value of the Missions is nearly as great as their architectural and historic worth. They advertise the State as nothing else can. They give a touch of that romantic and historical atmosphere which is the lure that draws the people of our new America by thousands to the Old World, whose people have long ago learned the money value of a monument of the olden times. Our railroads, than whom we have no better advertisers, have their Mission folders, Mission stations and now their Mission cars. Our Mission hotels are proving how great the demand by tourists for something "different" from the conventional. But the real Missions are left to crumble into shapeless rubbish heaps or to the destructive alterations of unthinking repairers. This is a situation which architects more than others will appreciate and strive to change.

I count it a high privilege to speak to the Institute on a subject so sure to command your attention as the history of these Missions which so enrich the valleys by our Western sea, whose nomenclature fits the softened majesty of our mountains as their walls and towers do the vivid sunlight of our southern land, and whose design and fashioning remind us that noble architecture is not dependent for its making on the competitions growing out of congested populations or the ostentations of individual or public pride, but that at its best it is the natural expression of the lives of men wise in their appreciation of the culture of the past, skillful in its adaptation to their present needs, mindful of their obligation to pay to the future their debt to the past, and inspired by a realization of those lasting glories which do inhabit all great buildings.

\*  
\* \* \*

## Have They Gone Out of Business?

Please discontinue our advertisement. Business is so poor we feel we must cut down expenses wherever possible. Later on we may possibly resume our advertising.

The above is the substance of a letter received by the Architect and Engineer two months ago from a San Francisco house that represents half a dozen Eastern agencies of well known building materials. This firm, like some others, has hoodwinked itself into believing that it is so well known that to keep its name before the architects and contractors in dull times is but a waste of money. Listen here to the sequel:

The Architect and Engineer.

Gentlemen:—Will you kindly give me the name of a San Francisco firm that handles — — goods. I used to see their advertisement in your book. Have looked over my last copy from the first page to the last but can find no mention of their name. Have they gone out of business? (Signed — — Architect.

\*  
\* \* \*

### Truth Is Best.

Farmer—Here is a letter from city folks answerin' our ad, Mirandy. They want ter know if there's a bath in the house. What'll I tell 'em?

His wife—Tell 'em the truth. Tell 'em if they need a bath, they'd better take it afore they come.

## The 44th Annual Convention of the American Institute of Architects

**T**HE 44th annual convention of the American Institute of Architects was held in San Francisco, January 16-21. The attendance exceeded all expectations, the meetings proved of great interest and value and the entertainment features eclipsed anything of the kind ever attempted at any previous convention. Some of the delegates, in their enthusiasm, declared if they could have their way they would bring the gathering to the Coast every year. The San Francisco architects certainly did themselves proud and proved to be splendid entertainers. Nothing was overlooked in planning for the comfort and pleasure of the visitors.

As to the convention, one familiar face in particular was missed—that of Mr. Cass Gilbert, formerly President of the Institute. He was prevented at the last moment from attending, but he sent a warm telegram that conveyed his deep interest in the organization and his love for Californians. The business sessions were taken up largely with the reading of committee reports—some of them very valuable; others not so important and much too long, and this latter evil was the subject of a discussion which may result in the elimination of much routine matter at future conventions. The reports of the Committees on Competitions, Conservation and Education are reprinted practically in full, as is the excellent address of President Irving K. Pond. The convention re-elected the old board of officers, with the exception of three new directors, one of whom is Mr. Alfred F. Rosenheim of Los Angeles.

**T**HE address of the president, Mr. Irving K. Pond, was listened to with much interest. Mr. Pond said in part:

The fact that the forty-fourth annual convention of the American Institute of Architects is about to enter upon its deliberations in this great city of the Coast carries with it an implication of the age and the wide geographical importance of this body, which has its permanent headquarters in the nation's capital city. The simplest statement to be made concerning the Institute is that it has been in existence for more than fifty years and embraces in its membership practicing architects throughout the broad extent of the United States. Another simple statement, and just as little liable to be questioned, is that the Institute's service of fifty-three years has been honorable and that in its membership is represented the highest type of practitioner in a given community. That is the proud record, the fact of which is recognized within the Institute, though its real significance be not altogether comprehended in the profession and by the laity.

On three phases of the Institute's intimate concern I propose to dwell at this time. These phases embrace (1) certain of the Institute's relations to the building public as represented by the client; (2) the Institute's attitude as affecting the profession; and (3) the family relation within the Institute. The first and second affect the public; the third is more intimate. Matters bearing upon these three phases are to be discussed and legislated upon during the convention, hence the president's especial interest in them at this time.

The Institute has a large life, an ever-widening circle of influence which brings it into intimate relations with affairs of national, municipal and civic import, and every move of the Institute in this field, I believe, has

been altruistic in its spirit and entirely unselfish in its nature, though ulterior motives have been ascribed to it by those who knew, or might have known better. The Institute has elevated its own standards and increased its own stature and incidentally that of the profession by setting up the standards it is endeavoring to reach. The ideals and achievements of the Institute were set before the architects of this city and of the Coast a little over a year ago by my illustrious predecessor in office, Mr. Cass Gilbert, and with a power of fervor and fluency given to but few men. Though the sound of his voice has hardly died away and his words are yet a living memory, I am in no way relieved of my responsibility of restating certain principles and dwelling upon certain ideals at this time.

I touch firstly upon that phase which embraces the Institute's relation to the client, that is, that portion of the general public which comes into direct business contact with the architect. It is a fairly safe proposition that one may question the sincerity, if one grants the intelligence of him who imputes to the Institute ulterior motives. In those cases it is safe to question the honesty as well as the sincerity of him who imputes such motives to the Institute. However, recriminations are futile; more is to be gained by frank statement and argument, and, indeed, reaffirmation of principles will vitalize the profession and enlighten the laity.

It is the province of the Institute to deal broadly and in detail with the principals underlying the science of building and the ideals underlying the art of design. To these is added by the very character of the work the necessity of taking cognizance of the ethics of business, for the Institute, like the architect, cannot today, even if it would, sit aloof from intimate contact with the mighty current of commercial endeavor, but must be a factor in the great world of affairs. Commercial instinct gives way in the Institute to business idealism, but this strengthens rather than weakens the business capacity of the high-minded practitioner. A frank recognition of fact, just here, can do no harm; not all of the high-minded practitioners in this country are enrolled in the Institute's membership, though all would find a congenial atmosphere here. There are to be found now and again within the Institute body members who are not high minded practitioners though their number is at any time very small, and the possibility of their accomplishing injury to the Institute very slight. The most high-minded may at times make mistakes in judgment—that is but human—but the consensus of judgment within the Institute may be relied upon ever to raise the standard of ideals. It is this very certainty which gives the Institute its acknowledged standing and authority in the community, for high standing and wide authority it has in spite of the fact (or is it because of the fact?) that its membership includes less than one-fifth of the number of the so-called practicing architects in the United States. The Institute would gladly welcome to its fold every high-minded practitioner of the art of architecture. The Institute desires within its ranks no one who is not willing to make sacrifices for the good, not of the Institute, but of the profession.

The officers of the Institute are urged constantly to widen the bounds and to take in every practitioner in the country upon the idea that there is strength in numbers. This is a most mistaken idea, for while numbers may add *avoidsupois*, it is moral stamina which counts in the initiation and inculcation of ideals. It is not the policy of the Institute to marry a man to reform him—the man must be formed and well formed when he presents himself. The Institute seeks the man of ideals and seeks to aid him in the advancement of his ideals. No loyal member is in any sense coerced,



but upholds the standards of the Institute because he recognizes in them a concrete and definite presentment of his own personal ideals of the ethics of practice. Not every man is born, Minerva like, full-armed, but has to gain his equipment and ideals by increments through such avenues of experience and such educational agencies as may exist about him. Among these avenues and agencies are schools, ateliers, draughtsmen's clubs, architectural leagues, architects' business associations, and the like, and the Institute encourages the formation and fosters the existence of all such agencies, knowing well that they are developing men of moral fibre and professional strength who later will seek to associate themselves with the Institute body. The work of the Institute is such that it required within its ranks men of the finest moral fibre and such men only. I have known in more than one instance of a man of sub-normal ethical sense and of questionable ethical practice to seek or to urge an affiliation with the Institute because of the prestige such affiliation would ensure. The Institute does not want him. It is more concerned in elevating the standards of professional ethics and in unfurling the banners of beauty than in giving social standing or professional prestige to any individual, however worthy he may be. Nevertheless, as I have had occasion to say recently, the mere fact of the existence of the American Institute of Architects is an asset to any practicing architect in the United States, and raises his social and professional status, whether he be a member of the organization or not. It was a realization of what the Institute really means to the profession and to the individual which led me personally, as it has led many another man, to associate myself with it and lend such assistance as I might. The Institute represents a moral principle and that principle is just as valid at the poles as it is at the equator, is just as vital at long. 5 deg. E. of Washington as at long. 47 deg. W. of Washington, and it appeals with just the same force to the man of one locality as of another. When the principle for which the Institute stands is generally accepted and generally acted upon in our relations with our fellow men the American Institute of Architects will need no longer to be a militant standard bearer but will become a purely social organization. I imagine, however, that it will be some time before the Institute will be free to stack its banners in a museum case.

The first great principle upon which the Institute stands is that of justice and fairness in so far as it is given to man to realize these seeming abstractions. In the Code of Ethics, in the Competition Code, in the cognizance it takes of all professional activities, the Institute stands for fair play as between man and man, absolute frankness and fairness of dealing between architects in their professional relations, absolute integrity and fairness in the dealings between architect and client and between client and architect. The Code of Ethics, formulated only a few years ago, was but a clear statement of certain principles of conduct and of professional practice which had been the inner guide of the best men of the profession for years and had been more or less nebulous always in the minds of many of the others. The Competition Code, although a more recent expression, dealt with matter which has been long upon the Institute's horizon, and is of equal value to the public and the architect. The competition exists for the benefit of the client primarily, almost exclusively. It is that he may get a good plan, or, what is better, discover the architect peculiarly fitted to handle the problem; or it is that the client may conform to law; or it is that the client may relieve himself of the responsibility of choice, or that he may give the commission to a favorite under the pretext of fair play. In any case the competition is to the direct advantage of the client, and

only incidentally to the advantage of the individual architect. It is to the material disadvantage of the competing architects unless they be paid individually the value of their time. If the owner is sincere in instituting his competition he will find the paid competition to be logical and of economic advantage, as it will put him in the possession of special powers which will be of the highest assistance to him in the materialization of his schemes, and for the possession of which he may well afford to pay something beyond, a great deal beyond, the recognized minimum value which the Institute places upon such services. No fair-minded man, or corporation, or community which is seeking to gain the highest architectural service for itself can logically object to having its competition hedged about by such conditions as will guarantee fairness and justice, and it is only such conditions that the Institute seeks to suggest. Out of its vast experience the Institute has succeeded in formulating a code which will effect the desired result, and with slight modifications will be made susceptible of general application.

As ex-officio member I have been in close touch with the work of the various Committees during the past year, and I want to speak right here a word in praise of the loyalty and devotion of the members of this Committee representation. The Standing Committee on Competitions and especially its chairman, Mr. Frank Miles Day, and its temporary chairman, Mr. Carrere, acting in Mr. Day's absence, have carried a burden of work with a courage and tact and devotion to its interests which entitles them to the deepest gratitude of the Institute.

One resolution of instruction offered, enthusiastically received and immediately adopted at the last convention brought into activity not only the Standing Committee on Competitions, but also the Committee on Practice and finally the Judiciary Committee; and this leads me to remark upon the disciplinary function of the Institute. I am now in no way voicing the opinion of any committee, nor in any way presaging its actions, but am expressing my own idea as to the Institute's proper stand at the present time. There are cases when it is absolutely necessary for the Institute to act upon disciplinary lines, and in those cases the committees and the board will accept the unpleasant responsibility placed upon them; but the Institute is not a disciplinary machine heartlessly overriding sincere and self-respecting members. The Institute cannot afford to be a soulless martinet insisting on the pound of flesh, but it must recognize in every instance the desire on the part of the member to do the right and just thing, and also recognize those surrounding conditions which seem at times almost to make an infraction of rules necessary in a given case. The American Institute of Architects can find little cause for discipline when there does not inhere in the action a wrong or an unfairness toward a fellow man. Where, as for instance in this Competition Code, lines still remain to be tested, disciplinary force must move slowly; yet even here there have been infractions which cannot pass unnoticed.

One of the mandates of the Competition Code which has seemed to work a hardship is that involving an acceptance of the Institute's schedule of charges. If every member of the Institute felt way down in his heart that the Institute's schedule was perfectly logical, or that a flat charge in all cases of six per cent or any per cent were absolutely just, this mandate would impose no hardship in its application; but the schedule of charges is like the tariff; everybody knows that it is unjust, yet everybody dreads to meddle with it for fear of upsetting established conditions. A logical tariff does not apply to the same rate to all articles but discriminates between

articles of necessity and of luxury, articles of educational value and articles which will degrade, articles which will bring moral and aesthetic pleasure, and articles which will inflict moral and spiritual wounds. A logical schedule of charges will differentiate between buildings which are merely of structural import and call for the most part for the application of the merely ordinary methods of construction, and those which call into play all the physical and spiritual resources, all of the material and aesthetic capabilities of the architect. Any generally stated percentum of the commercial value might distinctly overpay the architect in one case and even more certainly underpay him in another. In my opinion to be logical and just a schedule of rates must take cognizance of types of building and must consider the range of values within those types. I shall suggest a careful study of this subject of schedules by the Board, not with the idea of upsetting the present status, but with the idea that the Board shall present at some future (not too future) convention a logical solution of the question. This suggestion is made hesitatingly and with a full knowledge of the work which might be entailed upon some loyal and already overworked member of the Institute. The Institute's schedule should express the just minimum which the work of men fitted to be members of the Institute should command, and this work is in the nature of things of higher quality than the average produced outside of Institute membership. This is why, referring again to competitions, it imposes no hardship on one instituting a competition for a work which demands the highest professional skill in its production, to demand that he pay the recognized just and equitable minimum Institute rates.

It was absolutely impossible for me to conclude this address without some slight reference to that paramount ideal which colors and sways the entire range of architectural being, that ideal upon which and for which the Institute really exists, as, wanting which there is no architecture, and that is the ideal of beauty. It must sway in the relations between architect and client, it must color the fraternal intercourse between architects, it must govern in the realm of education. A structure through which the spirit of beauty does not shine forth is not architecture, it is a clod. The American Institute of Architects must concern itself with an American expression of beauty. This is not cant; it is the plain statement of a philosophical truth. We are not Americans if we do not express the American ideal. There is an American ideal as reflected in our governmental forms, or there is no America. This ideal develops with our growth, but it is none the less concrete. As nature has dealt bountifully, prodigally even, with us in the varied settings she has furnished for our monuments, in the varied materials she has furnished for their construction; as destiny has dealt bountifully, prodigally even, with us in the varied minds, with the varied backgrounds of experience and history, it has furnished to conceive these monuments and place them in their appropriate settings, we are not worthy workers in our art unless we accept these factors and bend them to the true American expression. Our American ideal need not, must not be expressed monotonously along narrow lines, but must expand broadly under varied skies, under climatic extremes, under varied ethnic and social impulses unified by one American spirit. This must be if we are to be true to our aesthetic ideal. California is one phase of America, as New England is another, as Manhattan is another, these phases are to be harmonized and not confused, to be nurtured and developed and not swept aside for some manifestation of exotic growth. The American Institute of Architects is deeply concerned in the ethics of business and the profession, in

the science of business and the profession, but its passion must be for that beauty which inheres in architecture.

The report of the Committee on Allied Arts contained some splendid thoughts on color and its relation to the fine arts in general and to architecture in particular. Owing to lack of space the report is withheld for publication until the March number of this magazine.

#### Report of the Board of Directors.

The Board reports that the Institute has now 1,084 members as follows: Fellows, 311; Associates, 615; Honorary, 772; Corresponding Members, 86.

Since the last report of the Board six Fellows and thirty Associates have been elected.

The Board recommends for advancement to Fellows the following Associates: George C. Nimmons, Illinois Chapter; Milton B. Medary, Jr., and Thomas M. Kellogg, Philadelphia Chapter; Arthur B. Benton, Southern California Chapter; Wm. B. Stratton, Michigan Chapter; Frank W. Ferguson, Arthur Little, Harry J. Carlson, Boston Chapter; John A. Dempwolf, South Pennsylvania Chapter; W R B Willcox, Washington State Chapter; Robert Maynicke, John Beverly Robinson, Phillip Sawyer, D. Everett Waid, Robert D. Kohn, New York Chapter; Aaron M. Gove, Colorado Chapter.

Two new Chapters have been organized within the past year, one in New Orleans, Louisiana, the other in the State of Indiana. Both of these Chapters have already taken active part in the betterment of the profession in their localities.

The Ninth International Congress of Architects will be held in Rome during the month of October, 1911. At past international congresses the Institute has been an active factor and the Board thinks it particularly desirable that the Institute should be well represented at the coming Congress, as the subject of foreign schools in Rome has been given a place on the program. The American Institute of Architects has fostered the American Academy in Rome and the Board desires an adequate presentation of the aims and achievements of the Academy at this coming Congress.

The Institute labored consistently for many years for the establishment of a Government Bureau of the Fine Arts. This position was supported by President Roosevelt, but, being unable to establish a Bureau of the Fine Arts, he attempted to accomplish the result by the establishment of a Commission of the Fine Arts. This was done in the last year of his administration. Even this, however, was found not to be practicable under the law and President Taft, also being in sympathy with the aims of the Institute, has caused to be created through Act of Congress a Commission of similar character, but one whose authority is limited to advice, without the power of vote or initiative. This Commission consists of the following: Daniel H. Burnham, Cass Gilbert, Daniel C. French, Thomas Hastings, Frank D. Millet, Charles Moore and F. L. Olmsted.

From this beginning and through the continued activities of the Institute, the Board may reasonably expect a further advance.

The Board of Directors, as instructed by the last convention, has issued a Circular of Advice, relative to the conduct of competitions and a Code governing the members of the Institute. Some twenty thousand copies have been distributed. The Standing Committee on Competitions

has organized the necessary machinery to put the circular into effect. The Board is gratified and even surprised by the support given to this document, both by owners and architects and by the consequent raising of competition standards throughout the country. That the Code should fail in some cases to apply accurately and that it should meet with adverse criticisms was to be expected, but, on the whole, it has proved of great service. A new edition is now being published by authority of the Board to correct points that have been justly criticized, and the Board anticipates a general adoption of the principles of this circular throughout the country.

The Circular of Advice and Canons of Ethics adopted at the last Convention has been circulated very extensively to all members of the American Institute of Architects and to others who are interested in the relations between architect and contractor and owner. Members of the Institute are urged to familiarize themselves with this document, which is of great value as a statement of the principles in which the Institute believes.

The Board of Directors at their last meeting voted unanimously to recommend to the Institute the conferring of the gold medal of the Institute on George B. Post of New York, who, for the past fifty years has given his great energy and ability to all questions relating to the advancement of the profession.

The L'Enfant Memorial, which the American Institute of Architects was instrumental in securing, to commemorate the man who designed the plan for Washington City, has been erected in Arlington Cemetery and will be unveiled some time in the spring, when the Institute should be represented by its officers or some proper committee.

#### **Committee on Report of Board of Directors.**

The Committee on the report of the Board of Directors submitted the following in regard to membership:

Your committee is thoroughly in accord with the Board of Directors in the belief that the membership of the Institute should comprise only those practitioners who hold its own high ethical standards, but it believes that a larger proportion of those who are Chapter members should become members of the Institute. Approximately 27 per cent of the practicing architects of the United States are members of Chapters and of this number something less than two-thirds are members of the Institute. A reasonable probationary period of Chapter membership is desirable, but it should be the aim of the Chapters to encourage their members to ally themselves with and lend the weight of their influence to the national body. Your Committee therefore recommends that the Board of Directors take such steps as will bring forcibly to the attention of the Chapters their duty to the Institute in this respect.

#### **A Government Bureau of the Fine Arts.**

But little more than three years ago, the President of the United States appointed a Commission of the Fine Arts and the Congress promptly nullified its influence by legislative enactment. Within the past year, the Congress has itself established such a Commission and the President has appointed its members. While it must be a source of regret that the authority of the Commission has been limited to advice and that it has not the veto power, the great progress that has been made in so brief a period gives abundant promise of further progress in the near future.

Your Committee endorses most heartily the attitude of the Board in respect to Competitions. For years, competitions and questions as to



the propriety of their conduct in relation thereto on the part of members of the Institute have been sources of serious concern to those who value most highly the Institute's ethical ideals. The Code adopted in principle by the last Convention and made operative by the Board, has accomplished more in the ten months since its promulgation than was accomplished in all the previous years of sporadic outbreaks of altruistic and ineffectual rhetoric. The Board has found, as was to have been expected, that the Code as formulated has failed to apply accurately in individual cases. It has considered adverse criticism and formulated amendments to meet such criticisms as seemed to it to be justified by experience and a new edition of the Code is promised at an early date.

Your Committee confidently believes that while momentarily more difficult of application in the smaller and more remote communities, it will eventually be of enormous assistance to practitioners in such communities in educating their public to the standards of the most advanced. Your Committee therefore recommends that no action be taken by the Convention which will lower the standards set by the Code in the slightest particular, relying upon the Board to modify and clarify the Code from time to time as experience in its workings shall point the way, for it must be borne in mind that the Board is the nerve-center of the Institute body, and, therefore, better able than the representatives of any given locality to express and make effective measures for the Institute's general good.

#### Chapter Work Encouraging.

The report of the Committee on the Reports of Chapters showed that many of the leading cities in the United States have called upon the organization for advice and co-operation in matters affecting the beautification of cities, architecturally and otherwise.

The report states in part:

"In addition to the usual routine work, considerable effort seems to have been made to bring the chapters into closer relation with the various municipal and State authorities, and in some cases with excellent results.

"In the Boston Chapter a committee was appointed to make an inventory of works of art in private collections in Boston and vicinity, and a record of buildings of unusual interest; which will be of great value to the laymen as well as to the profession.

"In New York an earnest protest of the chapter has probably saved the City Hall (one of New York's historic monuments), from being dwarfed by the proposed new court house, which it was proposed to erect on the City Hall site.

"In Philadelphia, the Chapters' Committee on the "Preservation of Historic Monuments" has persuaded the municipal authorities that the successful restoration of historic buildings, can best be obtained through co-operation with the Chapter, and the Mayor of this city has appointed the Chapter's Committee to restore Congress Hall, one of the most important of the State House group in Independence Square, and has placed the City Photographer at the disposal of this committee for the purpose of photographing any other buildings in the city desired by the committee.

"In addition to this the Committee has also been authorized to design the lamp standards for the lighting of Independence Square.

"In the late trial of the Architect for the State Capitol building at Harrisburg, the Attorney General of the State called upon the Chapters for expert testimony to refute statements made by the defense, concerning the practice of architecture, which statements if permitted to stand unchallenged would have seriously injured the profession in the eyes of the public.

Subsequently, five architects from the chapter testified in rebuttal, and the verdict was in favor of the State.

"The Washington State Chapter has urged the appointment of a Municipal Plans Commission, and has had one of its members appointed to this Commission.

"The Michigan Chapter is founding a school of design in Detroit, and expects to have in hand very shortly the funds necessary for this purpose.

"In a number of cities, the Municipal authorities have called upon the chapters of the Institute for assistance in revising the building laws.

"Your Committee believes much prestige has been gained by the profession through the efforts of the chapters to render assistance to the various State and Municipal authorities, and strongly recommends that all the chapters of the Institute be urged to offer assistance to the Municipal authorities in their respective cities in all matters pertaining to architectural work.

"We believe that this course of procedure will create a favorable impression in the lay mind, whereas, criticism by the Institute or the Chapters of Architectural work after it has been done by the various municipalities, results in most cases, in criticism of the profession by the laymen.

"Your Committee also recommends that all Chapters of the Institute be urged to appoint committees for the 'Preservation of Historic Buildings.' We believe this to be particularly important in the East, where the old Colonial landmarks are repeatedly disappearing."

### Committee on Conservation.

The Committee of the American Institute of Architects on the Conservation of Natural Resources reported as follows:

The Committee of the American Institute of Architects on the Conservation of Natural Resources reported as follows:

That a wide and increasingly active interest in the subject exists among the officers and members of the Institute. The Committee believes that few, if any, of the great national organizations touch the subject of Conservation at so many points, or are more vitally interested in its wise and efficient progress, or can be more directly helpful in the application of the principles of Conservation in a great series of important industries.

The construction of modern buildings either for residential or business purpose involves the use in one form or another of practically the entire list of materials included under the general understanding of the term the "Natural resources" of the country, excepting only agricultural land and food stuffs; and in common with all other thinking citizens, the architects realize that the continued prosperity of the building interests is in the long run dependent upon the wise use of these resources. Exact statistics of the great building industry of the country are not obtainable; but somewhat extended inquiry recently made led to an approximate estimate of the amount of money expended upon buildings in the United States per annum at an average of not less than one thousand millions of dollars, practically all of which passes under the hands of the architects in the specifications of materials to be used and in certification as to quality and cost.

Among the materials used are metals, including iron and its various products in rolled steel, sheet metal, pipe, castings, machinery, etc. Copper, lead, graphite, zinc, nickel, silver and even gold. Lumber in enormous quantities and of all kinds. Clay products, such as brick, terra cotta, roofing tiles, drain tiles, floor tiles and porcelain. Stone, including granite, marble, limestone, sandstone and other quarry products. Cement, lime, sand, glass, oils, gums, hemp, bitumen, asphalt, asbestos, barytes and many other materials, woven cotton, linen, wool and other fibres. The use of coal and water power, and above all that greatest of all resources of the nation, the labor of man both skilled and unskilled. The above but briefly suggests the variety and extent of the interests represented in modern building. Therefore the profession of architecture represented by the American Institute of Architects has a most real interest in this great topic, and can, and does wield a very potent influence upon the use of the products of mine, quarry, factory and field. It has been stated with a large measure of truth, that if the architects will study the economic use of lumber and specify or permit the use of short lengths such as two foot and four foot lengths as against 13 feet and 14 feet lengths, where such are structurally permissible, that one-fourth of the lumber cut per annum could be saved, without lessening the amount of labor used in building. If the architects specify concrete to the exclusion of steel, the steel market is affected; if brick or clay products, the cement market is affected; if copper or sheet iron or lead or tile or slate or pitch, or even thatched straw for roofing instead of shingles, the number of shingles used is correspondingly reduced. It is obvious that if the architects will substitute clay products, concrete or steel for lumber now used in building, no more effective method of conserving our lumber supply could be devised.

Materials used in building are not necessarily lost to the future, however. On the contrary, a certain class of materials, such as steel and other metals, are thus preserved though temporarily withdrawn from use. Who shall say that other needs

and other customs of building of a future time will not be as different from ours as ours are from those of former times, and it is not wholly fantastic to prophecy that the skyscrapers of today may not become the iron mines of tomorrow.

The architects are only indirectly employers of labor, but as such they can more fairly, and with less self interest than any other class, observe the conditions under which labor in the building trades is employed. Your Committee believes that the great annual losses by reason of accidents to men engaged in the building trades are largely preventable. That the strict enforcement of laws governing the construction of scaffolding, hoisting apparatus, derricks and other machinery used in quarrying, manufacturing and building, should be passed where they do exist, and should be rigorously enforced everywhere. That mechanics and laborers should be taught not to take unnecessary risks and should suffer their fair share of blame if they do, but they should be encouraged by the public authorities in all reasonable demands for the opportunity to pursue their avocations without unnecessary hazard to life and limb.

The architects believe in the conservation of buildings once they are erected, and to this end that fireproof construction should be adopted wherever possible. In all American cities today fire is a constant menace, and the annual loss from this cause both in life and property is appalling. The strict enforcement of wise building laws, will largely prevent this loss; but some concession in taxation to those erecting fireproof buildings might be found feasible, whereby a premium would be made to these owners of buildings who contribute to the greater safety of life and property by erecting fireproof structures, or on the other hand an increase of taxation might be made on those erecting buildings which endanger the lives and property of their neighbors and whose flimsy structures make necessary the present large public expenditure for fire department service in our cities.

This Committee, in common with those who have from the beginning promoted the cause of Conservation, believes in the use of our natural resources, not in their abuse; in their equitable distribution and development in the hands of the people or in the hands of the Government, not in locking them up in the hands of a few. That if corporate capital can develop them better than individual capital, then that it should be so done only under restrictions that will safeguard the interests of the people and be subject to governmental control and limitation; while at the same time giving the capital engaged absolute assurance of protection, security and reasonable profit.

This Committee believes that use does not mean waste or loss nor does it mean that reckless spendthrift policy which would squander in a generation, or less, the vast natural resources of this nation, or permit these resources to be monopolized.

The American Institute of Architects is heartily in sympathy with the principle of the conservation of our natural resources—and will do its part to advance these principles.

### **Report on Competition.**

The Standing Committee on Competitions, Frank Miles Day, chairman, offered the following report:

The Institute in its Canons of Ethics declares that it is unprofessional conduct for any member to take part in any competition, the terms of which are not in harmony with the principles approved by the Institute. In consonance with the Canon and as a means of applying it in practice, the Institute at its forty-third Annual Convention resolved that it should be held unprofessional for any member to take part in any competition, the program of which has not received the formal approval of the Institute. It, therefore, became necessary for the Board of Directors accurately to state the Institute's principles. Owing to the frequent discussions which had taken place at conventions and in view of the several resolutions adopted by the Institute and the substantial agreement among members as to the provisions essential for the proper conduct of a competition, the difficulty of formulating these principles was less than had been anticipated. The statement of them took the form of a Circular of Advice Relative to the Conduct of Competitions and a code stating the provisions regarded by the Institute as essential to every program. This document was ready by the end of March and the Standing Committee on Competitions and a subcommittee in and for the territory of each Chapter were charged with the duty of giving the approval of the Institute to programs in consonance with its provisions.

As this system has now been in operation nine months it may be well for this Committee to briefly summarize the results as seen by it. The fact that a standard has been set up has proven of the greatest value in helping members to resist the temptation of taking part in competitions. The Circular and Code have been inval-

able in strengthening the hands of Professional Advisers. Owners have learned for the first time that the idea of equitable agreements with competitors is not a mere form of words, but that it must be given legal force if they wish members of the Institute to compete. The general tone of competition has been raised and their number diminished. Many cases have come to the attention of this Committee in which programs which otherwise would have contained highly inequitable provisions have been and are being brought into harmony with the principles of the Institute. In other cases when it became clear to owners that without legally binding themselves to treat the competitors and winners with fairness, they could not secure designs from members, they have abandoned the idea of a competition and have followed the basic principle of the Circular of Advice by directly selecting and appointing an architect. It is highly gratifying to know that not only have members stood loyally by the Institute in its efforts to improve competition practice but those architects who are not members of the Institute have in several cases refused to compete unless the program was brought up to its standard.

It seems rather surprising that in less than a year a new system should have effected a perceptible improvement in practice. Knowledge of the Institute's effort has been slow to reach architects generally. Many members have still a rather hazy idea of the contents of the Circular and Code and owners generally cannot be expected to know of its existence. It is, therefore, reasonably to be expected that with a wider knowledge of the Institute's attitude and with increasing respect for its authority, the next year will show an advance still greater than the year just passed. The Institute is winning the battle for decent competition not by exhorting members to an ideal standard of conduct, but by laying down a few just and reasonable principles to which the owner must conform if he wishes to have the ablest architects as competitors.

Turning from these general considerations to the Circular of Advice and Code, it is gratifying to find that the Board has been willing to modify that document as frequently as experience has pointed the way. In June the Board added a definition of a competition and made a few other changes. At the Board meeting in October the Code was referred to this Committee and the Committee on Practice for a comprehensive revision, which was to be submitted to the Board. At the January meeting of the Board this report was carefully considered and with two exceptions was approved. The chief changes were in the arrangement and wording of the document which was much improved. A new clause relating to the owner's choice of competitors and another relating to the legality of procedure were added and the Code was clearly separated from the Circular.

The Board did not endorse individual approval in place of the approval of the Committee, nor exceptions to the schedule of charges; on the ground that both were liable seriously to weaken the force of the Code, but it did, however, approve of excepting certain cases from the operation of the Code.

When the Document was written, the Board felt that as the Tarsney Act had been passed largely through the efforts of the Institute and as the Treasury Department had conducted its competitions under that Act with fairness and ability, it was well to exempt such competitions from the Code. It is highly gratifying to know that in the recent competition for three departmental buildings, the propriety of the Institute's new rate has been recognized by the Government; but in other respects it was far below the standard set by the Institute and this, owing to its disregard of the very provisions the Institute deems essential.

The Institute requires a professional adviser. In this case such an adviser was not in charge. Probably it was due largely to lay control that so large a number were invited, and that the jury should have been appointed so late, and without an opportunity to study the programme in advance.

In consequence of the great number invited, the cost to the profession was quite out of proportion to the result obtained and it is doubtful whether the Government received as good material to choose from as would have resulted from a smaller list and a better conducted competition. The Institute should, in the judgment of your Committee, use its influence to improve the conditions of competitions held by the Government under the Tarsney Act.

Returning to the general subject of the Institute's present attitude toward competitions, it is interesting to note that the Joint Committee above named, having made a most exhaustive examination of the whole subject and having carefully considered the Code and all the objections to it of which it could learn, reported as follows:

"The Committee was of the opinion that the action of the last convention has been of the highest value to the profession; that the Circular of Advice has greatly diffused a knowledge of the proper way of holding competitions and that the mandatory character of the Code has in a few months brought about such an improvement

in the conduct of its members as no academic discussion or statement of principles could have brought about in years. The committee was unanimous that the Institute's attitude and the Code itself were sound and right and that the only changes needed were of procedure and detail.

"As there had come from several quarters objection to the mandatory features of the Code and expressions of a desire that the Code should be declared to be purely advisory, the Committee, after discussion, reached the conclusion that while it might be possible ultimately to give such a character to the Code, it was premature to attempt, for the present, to effect any considerable improvement in the conduct of competitions by a mere declaration of principles. In other words, the Institute should stand not merely for good intentions but as it does, for good intentions carried into practice."

### Report of the Committee on Education.

For several years this Committee has devoted itself to the development of a working theory of architectural education; of a plan for a consistent scheme for such education; and of a general statement of the principles that should control our activities in this direction and form the goal of all our endeavors. This modest ambition was achieved and brought to a conclusion, to the satisfaction at least of the Committee, in its report of last year, and, as was indicated in this same document, the Committee of this year has now taken up the concrete and practical aspect of the case, beginning at the beginning, which is, not the student, but the working draughtsman.

There is more of justification in this action than mere theory. This Committee does not conceive that it possesses a mandate from the Institute to scrutinize too curiously the chosen methods of education followed by the several schools of architecture, nor to act as a censor or as an advocate. The most it is privileged to do is to obtain, if possible, from the Institute itself, endorsement of the general principles it lays down: To bring these principles, so fortified, to the attention of the schools, and to leave the adjustment of any resulting difference to the individual and corporate conscience. In the case of the draughtsman, the ambitious office-boy, and the night-school grind, this inhibition does not exist. Their development is sporadic, their education casual, their resources small, or nil, while their only avowed friends, the club classes and ateliers, the night-schools and correspondence schools and Y. M. C. A. courses, are so diverse in their nature and practices, so irresponsible in some cases and deficient in adequate direction in others, that the boy himself is unable to distinguish the good, which is very notable, from the bad which is, unfortunately, equally conspicuous.

Yet the testimony of nearly all architects is to the effect that from this very class come frequently the most efficient men, and this in spite of the great disadvantages under which they labor. To increase the few opportunities now offered; to assure efficient direction in place of a well meaning incapacity; to round out the fine work now being done in drawing and design by such organizations as the Beaux Arts Society, The Philadelphia T Square Club and the Boston Architectural Club, by equally authoritative training in history, mathematics and construction, has been the object of the Committee of this year.

Specifically an effort has been made to stretch what we know as "University Extension," until it covers architectural education. Through its Secretary the Committee put itself in communication with a number of the principal colleges and schools of architecture in America, it placed its case clearly before the authorities in charge of extension work, and the professors of architecture, and in every case, without exception, it met with promises of co-operation that were conditioned only by financial or personal limitations. Briefly the position assumed was that extension work for architectural draughtsmen should be taken up wherever they existed in sufficient numbers and in the near vicinity of a college; that the course should include drawing, design, history, mathematics and construction; that there should be no duplication of activity, but that whatever drawing and design were already being taught acceptably by other agencies these should be recognized and if possible given some financial assistance; that the courses should be in the evening, that the fees should be nominal, and that wherever possible, there should be co-ordination and parallelism of development in such subjects as design, construction and the history of architecture.

From the first Professor Egbert of Columbia University entered enthusiastically into the scheme of the Committee, giving invaluable assistance at every point, and finally establishing in a central locality in New York, courses in Applied Mathematics, the History of Architecture, Construction, the Elements of Architecture, Architectural Drawing, Shades and Shadows, Ancient Architectural History and the History



of Architectural Ornament. On October 22nd, there were seventy-three enrolled students, all engaged in active and enthusiastic work. On that date Professor Egbert reported, "We are entirely satisfied with the undertaking, feeling, however, disappointed that our expenses have been so high as to cause a loss in this department of extension teaching."

On inquiring into the matter, we found that much of the large expense was due to the rental equipment of admirable rooms in the Engineering Societies Building, and that an increase of forty in the number of students would have made the venture self-supporting. We believe this increase can be effected next year by a little effort on the part of the architects—who after all are even more benefitted than the draughtsmen themselves—and we shall recur to this matter a little later.

In Philadelphia, the University of Pennsylvania has established extension courses in Mathematics, including Algebra, Trigonometry and the Mechanics of Architecture; Graphics, comprising Descriptive Geometry, Shades and Shadows and Perspective; History, ancient, mediæval and renaissance, with Historic Ornament and Construction, including Stereotomy. This course will extend through two years, Construction coming in the second year. The work is carried on in consultation with the local Chapter of the Institute and the T Square Club; the registration is satisfactory and the results successful in the highest degree.

In Boston the work of giving this sort of instruction is being carried out this year, as it has been for the past ten or fifteen years, by the Architectural Club, with no assistance, except some financial support by the Society of Architects. Its courses are not modeled on the exact lines laid down by the Committee, but are a continuation of the scheme that has been in operation, with variations, for some years, covering instruction in design in connection with the Society of Beaux Arts Architects, and separate classes in construction, drawing from life, free hand drawings, history and French, together with preliminary course in drawing to fit the younger boys for entrance into the preliminary design problems of the Society of Beaux Arts Architects. It is felt that the authorities in the architectural schools at Harvard and Technology are in cordial sympathy with the principles of extending university extension work to cover this field as outlined above, but owing to special conditions it was impossible for actual work to be begun this season. It is hoped that next year the work of the club will be supported by this sort of co-operation on the part of the organized educational agencies. The Committee feels that with work actively under way in New York and Philadelphia, and a prospect of improved conditions in Boston that a beginning has been made that should not be allowed to lapse, but should receive hearty support of all architects and be extended to Chicago, San Francisco and Detroit, and even to some of the smaller cities, where college faculties are available. The University of Michigan is making arrangements to establish in Detroit courses in design, construction and the history of architecture. The University of Ohio is interested and asking further information, and altogether the results, both in accomplishment and promise, are far beyond anything anticipated by the Committee.

This much we have accomplished: The issue rests, not with the Committee, but with the architects. The Universities and Colleges have declared their interest and some of them have put the theories of the Committee into practice; the work will continue if there is an adequate supply of men; this supply is dependent on the interest the architects show in their assistants, on their realization that they owe them something besides their weekly wage, and on their recognition of the fact that they themselves profit more than their draughtsmen through the increased efficiency that is the result of supplementary education. This Committee desires to urge on all the members of the Institute the duty of a personal solicitude for the welfare of their employes, and the necessity of urging all those who may lack the advantages of scholastic and professional training, to take advantage of every educational opportunity that may be offered them, both by local architectural clubs, and extension courses, when they exist. The day is gone by when the cold-blooded relationship of buyers and sellers of labor was all there was between architect and draughtsman, and instead is a new vision of the vital community of interest that holds them together. This new relationship is put into practical form whenever the architect makes it his business to interest himself in the education of his men, giving them every assistance towards, and opportunity for, obtaining every educational advantage that is at hand. This Committee recommends to the Board of Directors the sending of a direct appeal to every member of the Institute to interest himself in the education of those of his assistants who need such education, and it urges further that the Board bring the matter of extension courses in architectural education to the attention of the several Chapters that they may bring their influence to bear upon the schools and colleges within their territory toward the establishing of such courses wherever, at present, they do not exist.

Judging from the results already achieved, and the interest that has been accorded in schools and colleges not as yet quite prepared to put in practical operation a plan that commands their avowed sympathy, the educational agencies now maintained by the schools of architecture and the independent classes are to be supplemented by a third, the extension courses for draughtsmen. The question at once arises whether some graded plan of study and some system of credits which will serve in a measure to standardize all extra-university study should not receive the formal endorsement of the Institute. This Committee is of the opinion that such a course would be logical and is ultimately inevitable, but it is not prepared to indicate the general lines of such a plan of study, or lay down the principles of such a scheme of credits, neither is it ready to suggest the agencies through which this scheme of standardization should be effected. The Architectural League put forth in November, 1909, precisely such a scheme of standardization, and is now engaged in working out the details and endeavoring to put the plan into operation. We believe it would be well to await the results of this effort, as there is no object in duplicating activities, though the Education Committee of next year should be ready to co-operate with the League in this particular direction.

This Committee submits the results of its labors toward the establishment of university extension work for draughtsmen as its contribution to this year's work of the Institute, but it can not be content with a mere statement of accomplished facts, it is impelled to go further and indicate the part this work—extended and improved—should play in the general policy of the Institute itself.

In the first place, we wish to emphasize with all possible earnestness the duty and the privilege all architects have to increase the efficiency and strengthen the future prospects of their men through all the educational opportunities that are offered them. The relation between the architect and the draughtsman is peculiarly intimate and susceptible of a degree of fellowship unusual in similar associations. This we all realize and the history of architectural practice in America is full of unforgettable instances that have made the lives of both employer and employed immeasurably richer than would have been possible under more formal or commercial relations. With the enormous increase of professional activity during the last decade some of us have tended to forget this in the press of unexampled responsibilities, while the multiplication of hitherto unthoughtof educational agencies has served to release the architect from the responsibilities that lay on him before. Actually these things have increased that responsibility instead of minimizing it. Nothing can ever take the place of personal relations as the greatest educational agency in the world, while the very multiplicity of schools and classes and ateliers has created for the draughtsman the need for advice and assistance that did not exist before. There is much in the old "apprentice system" still in vogue in England, which commends it, and for this very reason we had hoped to make a definite report on this matter as affecting the practice of architecture in America, but we do not feel that our investigations have gone far enough. We are strongly impelled, however, to urge the members of the Institute to take that personal interest in their draughtsmen that can only mean so much to both parties to the contract; to urge upon those who need it, the educational opportunities offered by the schools, classes and clubs in their vicinity, and to make possible, wherever they can, participation in their benefits. There are many great manufacturers in the United States, who in employing draughtsmen, stipulate that they themselves shall pay tuition for those same draughtsmen in evening schools where instruction is given on lines that will prove beneficial to the employes and therefore to the employers. Now, it may be neither desirable, nor possible, for architects to go so far as to pay tuition fees, but at least they can support all local centers of instruction, bring them to the attention of their draughtsmen, urge their use, advise as between one another, and as to the respective value for each individual case, of the several classes, and offer all possible assistance in the matter of opportunity of times and hours to those who wish to better their own conditions and the service they render their employer by continuing the education that, for a well rounded man, must be co-terminous with his life.

In the second place we wish to lay down a general principle that should govern the educational work of the Institute and all other architectural organizations in America, offering it, not for blind acceptance, but for discussion.

The ultimate object of the Institute, as we understand it, is to increase the efficiency and usefulness of the members of the profession, to raise ever higher the standard of their work, to exalt the profession itself, and the Institute, which is architecture in corporate form, to a point where it is recognized by the public at large as equally august with the other learned professions, and equally able to act and speak with authority and finality. The advance toward this ideal since the Institute came into being is almost unexampled, and for a large part of this the

credit belongs to the Institute itself. The very wonderful work must go on, and will go on, but a concrete and definite object is desirable as the natural end to which we are tending. Is not this the establishing of the American Institute of Architects on a solid basis where it will be recognized on all hands as the final judge of the efficiency of its members, where membership will mean, ipso facto, the right to practice, and where the license of the State will be simply the official endorsement of a man "admitted to practice" by his peers?

At present in some states any man can practice as an architect if he can pay for his sign; in others he submits his artistic, educational and practical qualifications to a political board of judges, the standards varying as between State and State, the judicial ability of the board as between one politician and another. We do not condemn the State licensing system, we simply assert that it is an indifferent substitute for a more competent licensing power that at present has insufficient recognition—the Institute itself. In Germany where bureaucracy is remarkably vigorous, State licensing is imperative, but our kinship is more close with England and France, and there the architectural profession as a whole is pretty well recognized as the power that is competent to judge of the efficiency of its members. In England, membership in the R. I. B. A. is practically a *sine qua non* for any practitioner; in France, while membership in the *Societe Centrale* is perhaps not quite so essential, it is nevertheless the greatest guarantee of an architect's ability. The American Institute of Architects should hold the same position here, and when it does the question of State licensing will take care of itself—for it will no longer be necessary.

Now, it seems to us that one reason why the Institute does not comprise in its membership every competent architect in the United States, every architect who is fit to practice architecture, is that the student and the draughtsman do not early enough realize the position they occupy towards the profession as a whole. A few eminent men, not practicing for themselves, are admitted to membership in the Institute when they have reached mature years, but the rank and file are either isolated units without friends and without companions, or they are members of voluntary associations; of draughtsmen, by draughtsmen, for draughtsmen. The result is that both in school and in the office they know nothing of the Institute except as a vague and more or less august assemblage of elderly practitioners from whom they are severed by the entire diameter of being, and the self-closing door of the private office. They grow up sufficient unto themselves, and membership in the Institute, when it is achieved through the initiative of one already of the elect, comes as something of a shock, not as the inevitable accomplishment of destiny.

This we believe to be wrong, and we are convinced that the solution of many difficulties lies in catching the student or the draughtsman young and bringing him up in some form of close contact with the Institute so that when he comes to practice, membership therein will seem as inevitable to him as the painting of his name on an office door.

Granting the justice of this argument, the solution is, we admit, not wholly conspicuous; there seem three alternatives. First: The creation of a series of "minor orders" in the Institute itself, "Probationer" for all students at the very outset of their educational work, "Student" when they take up actual work, and from this grade advancement would be to that of a regular member of the Institute. Second: Some form of alliance with the Architectural League whereby it becomes the junior branch of the Institute, carrying on, under proper direction, the educational and training functions of the Institute, membership in the League becoming practically compulsory for all students and draughtsmen. Third: The opening of the local Chapters to students and draughtsmen through similar grades of junior membership, the local affiliation giving no rights and privileges in the national body, but leading inevitably to it.

Each of these schemes has its advocate in this Committee, but no one of them is able as yet to convince the others of the superior virtue of his plan; moreover, the question is so far reaching it seems to us to demand discussion by the Convention rather than the formulating of a specific solution by a Committee and its possible acceptance without mature debate. As a Committee we are, however, so convinced of the prime necessity of establishing some form of relationship, at the earliest possible moment, between the Institute and the students and draughtsmen, that we ask for some consideration of the three schemes already outlined.

As for the first project, the opening of the Institute itself to the widest junior membership, the idea of its advocates is that the moment a boy joins the architectural club of his college, or town, he should be enrolled as a "Probationer" of the Institute, paying a very nominal fee. His name would appear in the necessarily very mutual membership lists of the Institute, he would be taught through his

college or club the influence of the Institute and the ethical aspect of the profession, as well as its artistic and practical sides. Many names would be dropped from the Institute lists from time to time whether through abandonment of an architectural career by a Probationer, or through his failure, after a certain time, to present himself for advancement to the next highest rank of student. This latter grade would be open to those who had graduated from a school of architecture, or could present a certificate of definite work accomplished in a club, or atelier, or office. From the rank of student, advancement would be to the grade of member of the Institute.

The second plan aims at the same end of bringing students and draughtsmen into close association with the organized profession, at the very outset of their career, but its upholders advocate a graded membership in a great junior society, bearing a similar relation to the Institute the Architectural Association does to the R. I. B. A. This would relieve the Institute of a vast amount of clerical work inevitable under the first scheme, putting it on the junior society. The Architectural League of America might be a possible nucleus for such a society, but were it to become this it would of course have to be radically reorganized, ceasing to be a federation of clubs and becoming an organization where membership was open to individuals only. It would be self-governing, but as it would naturally have assigned to it all the educational functions of the Institute, its administration of these would be under the direction of the Committee on Education of the Institute, acting with the mandate of the Board of Directors.

The third scheme finds its prototype in the Boston Society of Architects, which has a dual personality, since it is also a Chapter of the Institute. All the local members of the Institute are members of the Boston Society of Architects, but not all the members of the Society are members of the Institute. About half the roll of the Boston Society is made up of junior members, who are supposed to be draughtsmen, though some of them, on becoming full fledged architects, are a little dilatory in asking to be advanced to full membership. The monthly meetings are open to all, but only regular members can vote or hold office, though they can speak and serve on committee. The monthly attendance varies between forty and one hundred, and frequently half those present are junior members.

We believe the fact that the Boston Chapter has always been one of the largest and most active, and was actually, until a few years ago, the largest in America, only recently having been passed by New York, is due to this far-sighted policy of admitting draughtsmen, even though these were not, and could not be, members of the Institute. Should it be considered unwise to accept either of the two plans already described, we would urge on the several Chapters serious consideration of the policy of admitting non-members of the Institute, and particularly draughtsmen, to junior membership. When such junior organizations as the T Square Club and the Boston Architectural Club exist side by side with the Chapters, classes of membership corresponding to the Probationer and the Apprentice, named above, would not be necessary, but even here we are of the opinion that closer contact between the two organizations would be both possible and desirable. Particularly we would urge that at one meeting each year the junior society should be entertained by the senior, and that such a meeting should be devoted to consideration of the ethical aspects of the profession and the significance and importance of the paramount authority over all architectural practitioners—the Institute.

In conclusion, we beg to emphasize once more the key-note of our report; the solidarity of the architectural profession, architects, draughtsmen and students; the community of interests that binds them together rather as fellow workers than as employers and employed; the necessity of unending education and the duty of each architect to see that his men get enough of it and of the right kind; the need of establishing an intimate bond between the Institute and every student and draughtsman at the very beginning of his career; the bringing into membership with the Institute of every decent and honorable practitioner in the U. S. and finally the raising of the Institute itself to a point where it will command, where now it only deserves, universal recognition as the authoritative and definitive expression of the architectural profession in the U. S.

New Jersey has the honor already of recognizing the Institute as a power competent to judge of the ability of its members, and under the Licensing Law in that State a license to practice is issued to any member of the Institute without examination or other scrutiny. This is as it should be. All we ask is that the other sovereign commonwealths of the Union grant the same recognition, and that the Institute itself becomes the inevitable goal of every practitioner until every competent and right-minded architect is enrolled on its lists of membership, and none others. When this time arrives, as soon it must, state licensing will become unnecessary and the American Institute of Architects will have achieved the exalted

and universally recognized position that belongs to it by right by reason of its history, its standards and its personnel.

#### **Institute Endorses Art Commission Plans for San Francisco.**

The following resolutions were adopted:

"WHEREAS, the San Francisco Chapter of the American Institute of Architects has been brought to the notice of this Convention for its approval or commendation, a resolution recommending the creation in San Francisco of a municipal commission for the purpose of developing a comprehensive plan for municipal betterment along practical and economical lines, and

"WHEREAS, such recommendation to the people of San Francisco by the San Francisco Chapter is in conformity with the highest aims of the Institute and would, if adopted, be of great benefit to the City, therefore, be it

"RESOLVED, that this Convention hereby approves and endorses the above referred to action of the San Francisco Chapter."

#### **Officers Elected.**

The following officers were elected: President, Irving K. Pond, Chicago; first vice-president, Walter Cook, New York; second vice-president, E. N. Wheelwright, Boston; secretary-treasurer, Glenn Brown, Washington, D. C.; directors to serve for three years: A. F. Rosenheim, Los Angeles; Thomas Kimball, Omaha; Milton M. Medary, Philadelphia. There was a spirited contest for the choice of directors, New York, Chicago, Cleveland and St. Louis presenting candidates against those selected.

#### **The Banquet.**

The convention ended with a banquet at the Fairmont Hotel on Thursday evening and it proved a fitting conclusion to one of the most successful meetings held by the Institute. The banquet was a complimentary one given by the San Francisco Chapter to the visiting delegates and to especially invited guests—men prominent in public and private life, attorneys, physicians and representatives of the press. The tables were prettily decorated and an orchestra furnished music the entire evening.

Architect Wm. Mooser, president of the San Francisco Chapter, acted as toastmaster, and delivered the opening address.

The essence of his talk was that the East was beginning to care more for beauty, while the West had still the strength of utilitarianism in building. He paid a graceful tribute to the representatives of both parts of the country, and told his hearers of some of the advantages that must accrue from the gathering together of representative architects in a city like San Francisco, where for nearly five years the best efforts of her architects have been to rebuild a city that should combine beauty with usefulness.

Ex-Governor James N. Gillett was then introduced and in his happy and masterful way welcomed the guests and drew a word picture wherein he portrayed all men as architects who in their own way were planning their own moral edifices and closed with a brilliant reference to the Almighty, whose handiwork fashioned the Yosemite with its domes, pillars and walls of primeval granite.

James D. Phelan was the next speaker. Always brilliant and versatile, Mr. Phelan was specially interesting. In part he said that all the world loves art, which was but frozen music, and mankind everywhere bows to creative genius. His address was punctured with several witty stories, which admirably illustrated the points he scored.



President Irving K. Pond of the American Institute of Architects was presented with a handsome floral piece when he was called upon to speak. He read a telegram from President Taft, in which the chief executive of the nation expressed his thanks for the assistance rendered by the commission of fine arts and the aid given by architects in public work generally. The "Star Spangled Banner" was sung by all present at the banquet board. Pond spoke briefly of the ethics and ideals of architecture and expressed the thanks of the convention to the city of San Francisco.

Telegrams were read by the toastmaster from Senator George C. Perkins, Senator Newlands of Nevada, Congressman Julius Kahn, Governor Hiram W. Johnson, John M. Carriere of New York and Albert Pissis.

C. Grant La Farge, one of the foremost of New York architects, spoke at length of the influences tending to affect modern architecture. He paid a special tribute to the Japanese as the originators of the few basic elements that have found their way into the architecture of the modern school.

Charles W. Hornick, of *The Call*, spoke on the subject of the relation of journalism to architecture.

Bishop William Ford Nichols declared that the "skyline" was the most important phase of architecture, and on this subject based a declaration that the ordinary skyline was a "fever chart of hurry and push." He pleaded that a note of religious feeling find its way into the architecture of the present day, and that this dominate rather than the artistic or esthetic.

President Benjamin Ide Wheeler of the University of California spoke briefly of modern architecture as compared with that of ancient days. He complimented the architects upon their selection of San Francisco as a meeting place.

Ralph Adams Cram of Boston spoke of the opportunities that the exposition would bring to the San Francisco architects.

"We see in San Francisco," he said, "the most remarkable restoration of vitality that American history has ever recorded. The opportunity offered by your disaster has not been lost, but has not been taken advantage of to the greatest extent.

"If the government decides that the great exposition shall be held in the city having every conceivable claim upon that honor, once more will that opportunity come to you architects of San Francisco."

Professor C. B. Wing of Stanford University welcomed the guests on behalf of the University.

Frank T. Shea paid a glowing tribute to the pioneer architects of the West.

By popular acclaim Willis Polk was called for, and in responding dwelt at length upon the benefits of the Burnham Plan as a system upon which San Francisco should construct its public and semi-public buildings.

\* \* \*

## Working for the Redwood Shingle

THE campaign which the Redwood Shingle Association has launched in an effort to have California architects specify the redwood shingle in preference to others, first because it is a home product, and second because the shingle is fire-proof, or nearly so, is already accomplishing results. Architects who specify "redwood shingles" are urged to see that their specifications are carried out and that the contractor does not substitute some other brand. Mr. E. E. Skinner, president of the Redwood Shingle Association, has addressed letters to the Mayor of San Francisco, the California Home Industry League, Chamber of Commerce, San Fran-

cisco Chapter of the American Institute of Architects, and various other organizations, calling attention to the merits of the redwood shingle and requesting the co-operation of each society in promoting its use.

The following letter was addressed to Mayor P. H. McCarthy:

San Francisco, Cal., Nov. 19, 1910.

Hon. P. H. McCarthy, Mayor, San Francisco, Cal.

Dear Sir.—I desire to address you in relation to the strict regulations in force in your city in regard to the use of shingles upon the roofs of the frame buildings in San Francisco.

As the representative of the Redwood Shingle Manufacturers of Humboldt County, I have been engaged for some time past in investigating the cause of the falling off of the consumption of this California product in San Francisco and elsewhere.

In your city I met with this statement: "The shingle business is killed as a result of the fact that the city requires the use of patent roofing on frame buildings in almost every section of the city."

I presume the reason that the administration has taken the position it has in relation to shingled houses is that it believes that patent roofings offer the greater resistance against fire. While this may be true in the case of most woods used in the manufacture of shingles it certainly is not true in the case of the California Redwood which is used for this purpose.

A close inquiry into the fire resisting qualities of the redwood shingle must show that it is as near fire proof as any wood, or prepared roofing, used. That patent roofings will burn is easily demonstrated by applying a lighted match to the edge of a piece of it; so will a redwood shingle burn, but it is a hard job to make it do so.

In districts in our State where buildings are covered with redwood shingles fires igniting on roofs are very rare.

Had the home town of the writer (Eureka) been built of any other material than redwood it would have been burned long ago.

Fires do not spread in that town for the reason that it is built of redwood and shingled with redwood shingles. A building there may be destroyed from an internal fire but its next door neighbor, a few feet away, is easily saved.

These being the true conditions, do you wonder that the manufacturers of California redwood shingles should be anxious that your administration should aid in building up and maintaining this California industry by adopting less stringent regulations in relation to the use of redwood shingles upon the roofs of your frame buildings?

I trust that I may have your advice as to the advisability of placing this matter before the members of your Board of Supervisors.

Very sincerely yours,

E. E. SKINNER, President Redwood Shingles Assn.

The Mayor's reply follows:

Mr. E. E. Skinner,

Elks' Club, City.

November 21, 1910.

Dear Sir.—I am directed by the Mayor to acknowledge receipt of your communication of November 19th and to state that the restrictions you refer to have been created and enforced upon the positive demand of the Board of Underwriters of this city. Inasmuch as this question would seem to seriously involve the matter of insurance rates, it would appear that the very clear arguments which you have put forth might well be submitted for the consideration of the underwriters. The Mayor has carefully noted your remarks upon this subject and should you at a later date decide to bring the matter before the Board of Supervisors he will be glad, indeed, to again take up the subject with that body.

Yours very truly,

(Signed) E. C. LEFFINGWELL,

Mayor's Secretary.

The following letter was addressed to the Secretary of the Merchants Association by the Home Industry Committee of San Francisco Chapter of the American Institute of Architects:

December 23, 1910.

Mr. L. M. King, Secretary, The Merchants Association, City.

Dear Sir.—Your favor of the 29th ult., to the San Francisco Chapter of the American Institute of Architects, with its enclosure of Nov. 14th, 1910, from the Redwood Shingle Association, relative to the promotion of the use of redwood shingles for building purposes in San Francisco, has been referred to the committee on Home Industry League & Commercial Bodies of the San Francisco Chapter A. I. A.

That committee begs to say in reply that architects are agreed upon the excellent qualities of redwood shingles for building purposes in their lasting qualities, fire-resisting qualities, economy and other directions, but that these do not at all times determine public tastes; public prejudice for or against the desire for a certain effect in a color scheme, etc., are important factors to which of necessity the architect must give consideration.

Public taste, always uncertain, is created and fostered, particularly in matters pertaining to the materials of construction, by successful advertising on the part of the producer and the impulse gained from such advertising is slow to wane when once it has successfully supplanted something else. This is the case in the matter of cypress and cedar shingles as against redwood shingles, when the light-colored shingles lend themselves more readily to the present practice of various hues and tints of stain than do the dark colored redwood shingles.

The Chapter of Architects is in hearty accord with every effort to strengthen and stimulate home industry, and to this end will aid in the particular subject under consideration where possible to do so; we feel, however, that the initiative must necessarily come from the producer—he must excite public attention.

Very truly yours,

COMMITTEE ON HOME INDUSTRY LEAGUE AND  
COMMERCIAL BODIES, S. F. CHAPTER A. I. A.

(Signed) HENRY A. SCHULZ, Chairman.

\* \* \*

## American Style of Architecture is Coming, Declares Magonigle

**A**MONG the distinguished guests present at the 44th annual meeting of the American Institute of Architects held in San Francisco the past month was Mr. H. Van Buren Magonigle, the successful competitor in the contest of designs for the Fulton Memorial Water Gate, in which more than sixty plans were submitted. Mr. Magonigle in an interview, had something of interest to say in regard to the progress of American architecture.

"Has the American style of architecture arrived? Not yet, I think, but it will come in good time. It will have to be developed, and developed unconsciously. It's hard to say what it will be like, when it does get here, but I should say that it will have all the best elements in the architectures that have gone before, just as the race has all the best elements in the best races of the world to date. It is coming, though, without a doubt, and coming much more quickly than similar products of the olden days. In the twenty-five years in which I have been in touch with it, vast strides have been made in architecture here. The architectural magazines bear witness to this, and the facilities for education at the time when I first entered an office cannot begin to compare with the facilities of today.

"It is, of course, trite to say that things move quickly these days, and that the development in architecture goes ahead like the rest. But it is none the less true. At the time of the Renaissance, communication between countries, and even between parts of countries, was slow. News traveled slowly, and the results of experiments and innovations went at the same pace. Today it is very different. With the camera, the halftone and all the different methods of reproduction, ideas are imitated and absorbed and assimilated almost as soon as they are brought forth. In this country we are drawing on the rest of the world.

"I don't mean that we are consciously imitating any particular person or set of persons. But if we see anything good we use it. If we see anything which gets the results we desire better than the methods we have used before, why, then we are out for it all the time. I think that in that sort of way the American style of architecture will be developed."



*Suspended Platforms Worked Individually as Units*

## A New Safety Device Used on the Hearst Building

IT IS not generally known that there is being used on the new Hearst building, now under construction in San Francisco, a safety device for carrying a scaffold which was awarded the "Scientific American medal at the permanent Exposition of Safety, held in the Engineering Societies' building, in New York City recently. This device is handled in California by Parrott & Company.

The high building has brought its own problems, which are only now being solved in many instances. The erection of each of the modern skyscrapers has taken its toll in human lives, while masons and bricklayers were working on wooden scaffolds supported by horses and cantilevers. Abroad, particularly in France and Germany, a building being erected is surrounded by a forest of timbers supporting the scaffolding. In this country time is everything, and builders will not go to the expense of such rather useless constructions. In five years in New York alone there were 600 deaths caused by falls from new buildings, while 177 deaths were caused by falls from scaffolds alone. Since the introduction of the new form of scaffold, there have been no fatal accidents where it is in use. In the last two years

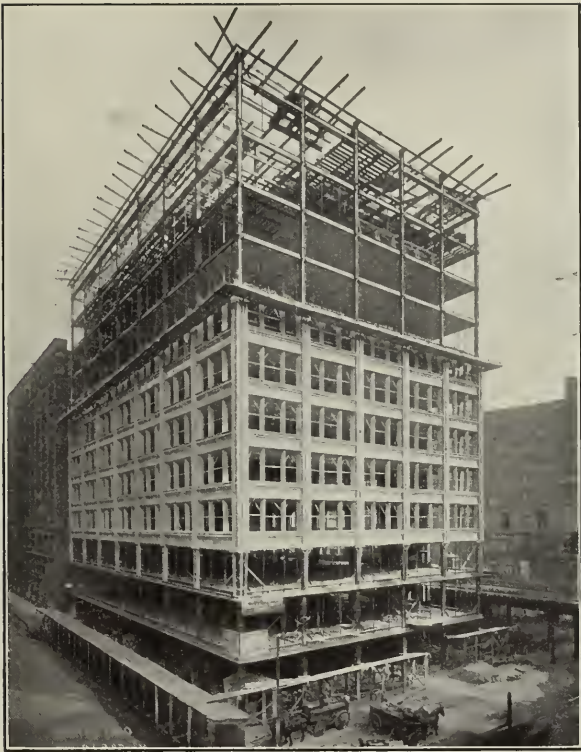

*Safety Platforms at Top of Eighth Floor*

319 buildings were erected with its aid, and 8,265 machines were employed, and the men were all unharmed.

The construction will be readily understood by reference to the engraving. The scaffold is interrupted so as to make sections ten feet long. At the ends of each section of planking are a pair of winches secured to a horizontal iron beam serving to support the planks. The winches are composed of a drum around which wire rope is roved, and the necessary supporting members. The upper end of the wire rope is secured to an outrigger by an anchor bolt, thus serving to support the scaffold. To the drums are secured ratchet wheels. A level serves to actuate a pawl, which raises or lowers the scaffold by means of the ratchets which serve to turn the drum which winds up the cables. As the sections are small, one man can raise his section very quickly by a few strokes of the four levers at each corner. The speed is very considerable, and permits workmen to operate in sections, which is often important when material does not arrive, or where there are many openings. One of our engravings shows a building with part of the brick work in place and a scaffold warped up at an angle. The great danger in scaffolding is in the use of imperfect and worn-out material, and for this reason with the present device inspections are constant, and all worn parts are replaced at the end of each job.



# Among the Architects

## American Institute of Architects (ORGANIZED 1857)

Next Convention in Washington

### OFFICERS FOR 1911-12

PRESIDENT.....IRVING K. POND, Chicago  
 FIRST VICE-PRESIDENT...WALTER COOK, New York  
 SECOND VICE-PRESIDENT..F. M. WHEELWRIGHT,  
 Boston  
 SECRETARY AND TREASURER....\*GLENN BROWN,  
 Washington, D. C.  
 AUDITORS... { JAMES G. HILL, Washington, D. C.  
 { ROBERT STEAD, Washington, D. C.

### Board of Directors for 1910-11

For Three Years—Cass Gilbert, New York;  
 Ralph Adams, Cram, Boston; John Galen Howard,  
 San Francisco.

For Two Years—Frank C. Baldwin, Detroit,  
 Mich.; \*S. B. P. Trowbridge, New York, N. Y.;  
 John M. Carrere, New York, N. Y.

For One Year—Thomas R. Kimball, Omaha,  
 Neb.; Milton B. Medary, Philadelphia; Alfred F.  
 Rosenheim, Los Angeles.

\*Executive Committee.

### San Francisco Chapter

PRESIDENT.....WILLIAM MOOSER  
 VICE-PRESIDENT.....G. B. McDUGALL  
 SECRETARY-TREASURER...SYLVAIN SCHNAITTACHER  
 TRUSTEES..... { JAMES W. REID  
 { ALBERT PISSIS

### Southern California Chapter

PRESIDENT.....FRANK D. HUDSON  
 VICE-PRESIDENT.....R. B. YOUNG  
 TREASURER.....AUGUST WACKERBARTH  
 SECRETARY.....FERDINAND PARMENTIER

### Board of Directors

FRANK L. STIFF OCTAVIUS MORGAN  
 ARTHUR B. BENTON JOHN C. AUSTIN  
 R. B. YOUNG

## California State Board of Architecture

### NORTHERN DISTRICT.

PRESIDENT.....WILLIAM CURETT  
 SECRETARY-TREASURER.....LIONEL DEANE  
 MEMBERS..... { WM. CURETT  
 { JOSEPH C. NEWSOME  
 { CLARENCE R. WARD

### SOUTHERN DISTRICT.

PRESIDENT.....JOHN P. KREMPFEL  
 SECRETARY-TREASURER.....FRED H. ROEHRIG  
 MEMBERS..... { OCTAVIUS MORGAN  
 { SUMNER P. HUNT  
 { WM. S. HERRARD

## Washington State Chapter, A. I. A.

### OFFICERS FOR 1910-11

PRESIDENT.....DAVID J. MYERS  
 SECRETARY.....W. R. B. WILCOX  
 TREASURER.....C. R. ALDEN

## Architectural League of the Pacific Coast

Next Convention, Los Angeles

### OFFICERS FOR 1910-11

PRESIDENT.....ALFRED F. ROSENHEIM  
 Los Angeles, Cal.  
 VICE-PRESIDENT.....E. F. LAWRENCE  
 Portland, Or.  
 SECRETARY.....JOHN KREMPFEL  
 Los Angeles, Cal.  
 TREASURER.....W. R. B. WILCOX  
 Seattle, Wash.

## San Francisco Architectural Club

### OFFICERS FOR 1911.

PRESIDENT.....ERNEST H. HILDEBRAND  
 VICE-PRESIDENT.....TOBIAS BRABWALD  
 SECRETARY.....JOHN G. DRACHUR  
 TREASURER.....ALBERT L. LAPACHET  
 AUGUST G. HEADMAN  
 DIRECTORS..... FREDERICK II. MEYER

## Los Angeles Architectural Club

### OFFICERS FOR 1910-11

PRESIDENT.....MYRON HUNT  
 VICE-PRESIDENT.....FRANK L. STIFF  
 SECRETARY.....H. E. BEAN  
 TREASURER.....OTTO JANSSEN

## Portland Architectural Club

### OFFICERS FOR 1910-11

PRESIDENT.....ELLIS F. LAWRENCE  
 VICE-PRESIDENT.....DAVID L. WILLIAMS  
 SECRETARY.....FRED ALYN  
 TREASURER.....JOHN M. HATTON

## Oakland Architectural Club

PRESIDENT.....HART WOOD  
 VICE-PRESIDENT.....E. B. MEAD  
 SECRETARY-TREASURER.....W. J. WILKINSON

### Directors

JOHN G. HOWARD LOUIS C. MULLGARDT  
 OSWALD SPIER C. E. RICHARDSON

## John Knox Taylor Capitulates.

California building materials will be used  
 in Federal buildings in this State in the  
 future, according to intimations in a letter  
 received recently by the Merchants' Associa-  
 tion from John Knox Taylor, supervising  
 architect of the Treasury Department, in  
 Washington.

The letter was forwarded to State Min-  
 ister Anburn, who appealed recently to  
 President Taft.

The letter says: "Should contractors for  
 buildings in California or any adjoining  
 State, submit for approval any material  
 produced in California which meets the con-  
 tract requirements, it will be very promptly  
 approved."

The Home Industry League has been  
 prominent in the movement to gain this  
 right.



*The New Fresno Hotel, Fresno, California  
Edward T. Foulkes, Architect*

#### Landscape Work.

Wilbur D. Cook Jr., of Los Angeles, is completing plans for landscaping and improving Agricultural Park. The work will include sunken gardens, fountains, walks, pergolas, colonnades, etc. The cost will be over \$100,000. A large part of the work will consist of excavating, grading, brick, cement and artificial stone work. Under a contract with the Sixth District Agricultural Park association, the city is required to expend \$10,000 each year in improving the property.

#### Concrete Hospital Buildings.

Santa Rosa is to have a splendid group of county hospital buildings. They will be of reinforced concrete and will represent an expenditure of \$200,000 or more. Preliminary plans have been made by Architect J. W. Dolliver, of San Francisco, who designed the recently completed Santa Rosa court house.

#### Million Dollar Concrete Dam.

It is stated on good authority at Reno, that work will be started inside of 30 days on a great concrete dam 15 miles west of Fallon for the Truckee-Carson Irrigation project. Estimated cost \$1,250,000. More than 200 men will be employed on the job for two years.

#### Designing Many Bungalows.

Architect F. D. Wolfe, of San Jose has made plans for several attractive bungalows to be erected this spring. One is for Mrs. N. O'Connor, to be erected on Clayton avenue, San Jose, another is for Mrs. Gertrude Huff, of Palo Alto, and a third is for Mrs. Fatjo of Santa Clara. The latter will be an eight room house in the mission style and will cost \$5,000.

#### Modesto to Have Carnegie Library.

Andrew Carnegie has donated \$12,500 towards a library building for Modesto, which swells the fund available to \$35,000 and insures the immediate construction of a fine building. City Clerk Walter Thompson is a member of the committee. W. H. Weeks is the architect.

#### McCormick to Build.

E. O. McCormick, passenger traffic manager of the Southern Pacific with offices in the Flood building, San Francisco, is to build a fine country home at Montecito, near Santa Barbara.

#### Parker and Kenyon Busy.

Architects Parker and Kenyon of San Francisco have prepared plans for a \$25,000 bank building for the Citizens Bank of Winters and the Plumas County High School to cost \$45,000.

**Big Casino for Santa Monica.**

Architect A. F. Rosenheim, of Los Angeles, is preparing working plans for a brick casino to be built at the northeast corner of Ocean avenue and Colorado street, Santa Monica, for the Anheuser-Busch Brewing Association. The building will be 100x150 feet and there will be a concrete basement under the entire structure. The exterior walls will be faced with brick laid in diaper patterns with plastered panels between the windows. The main portion of the building fronting on Ocean avenue will contain a dining room 50x100 feet having a 20-foot ceiling with fumed oak beams, English quarry tile floor, enameled brick dado and walls faced with pressed brick of different colors laid in patterns. Over the dining room will be a roof garden 50x100 feet, with reinforced concrete floor laid on wood trusses, of the Howe pattern and enclosed with movable glass screens and covered with canvas on a metal frame.

**Theater and Office Building.**

The erection of a 14-story theater and office building on the east side of Broadway between Seventh and Eighth streets, Los Angeles, for William Garland, Union Trust building, is assured by the closing of a lease by William Kerckhoff and associates for the entire building. The lessees have sublet the proposed theater to the Belasco Theater company and the ground floor and three floors immediately above to the Pacific Light & Power Company. Plans will be prepared by Architects Morgan, Walls & Morgan, and work will be started as soon as the leases expire. Sketches of the proposed building have been made by the architects and show an ornate structure 180 feet in height with mansard roof complying with the city ordinances. The building will have a steel frame with terra cotta front and finish and equipment of the highest class. The theater will seat about 1500 persons.

**Useful Cement Book.**

The 1911 edition of the directory of Portland Cement manufacturers is out and is replete with information of value to any one interested in the cement, gypsum and lime products. This directory is a pocket edition, size 3x5 inches, 260 pages, one quarter inch thick, bound in flexible leather cover, gilt edges, and in fact a very fine little book in every respect; it is very useful and very handy. Price \$1.00. Cement Era Co., Chicago, Ill.

**Herold Gets Sacramento Masonic Temple**

Architect R. A. Herold, of Sacramento, who drew the plans for the new court house in that city has been selected by the Masonic Hall Association of Sacramento to prepare the plans for a \$200,000 temple to be erected by the Masons of the Capitol City at Twelfth and J streets.

**Polytechnic School at Riverside**

Architect Norman F. Marsh of Los Angeles has been commissioned to prepare plans for a series of buildings for the Polytechnic High School at Riverside. Bonds to the amount of \$250,000 have been issued and sold. There will be five buildings in the group, one and two stories high with reinforced concrete walls and floors and possibly steel frame. The buildings will include an administration building, auditorium, science and agriculture building, manual arts building, gymnasium and power plant. Lyman Evans is chairman of the Riverside Board of Education.

**Will Use California Marble**

After many conferences and effective campaigning on the part of the Home Industry League and the State Mineralogist, the Lindgren company and the Board of Supervisors of Sacramento county, have decided to substitute California marble for Vermont marble, which is considered a great victory for the champions of the home industry movement, and is believed to be the commencement of a general movement on the part of the California and Pacific Coast architects and contractors to use the home product in preference to the Eastern goods.

**Personal**

Mr. Wilhelm K. Winterhalter wishes to announce the opening of a Consulting Agricultural office at Room 302, Wright and Callender Building. Attention will be given to agricultural investigations, development of lands, soil improvements, irrigation and drainage problems, farm management and agricultural accounting.

Architect John B. Nicholson, until recently associated in business with Architect I. H. Seehorn, after an enforced retirement for three months due to illness, has again taken up the active practice of his profession and has opened an office in the Wright and Callender building, Los Angeles.

C. R. Brawner, civil engineer, is now located at 324 Higgins building, Los Angeles. The late R. G. Miller was also to have occupied the same quarters and the business left unfinished at the time of his death will be handled from this office.

Architect J. Martyn Haenke is a recent addition to the list of practicing certified architects of Los Angeles. Mr. Haenke practiced for a time in San Francisco. He is located in suite 310 Central Building.

Mr. Daniel H. Burnham of Chicago has been elected an honorary corresponding member of the Royal Institute of British Architects.

Mr. Joseph H. Coté announces his removal to new offices in the Haight Building, Seattle, Wash.

### Two Notable Exhibitions.

Both the San Francisco and Los Angeles Architectural Clubs timed their annual exhibitions so they would come during the visit to the Coast of the Eastern delegates to the American Institute Convention. The two exhibitions were viewed with great interest by the visitors and while neither exhibition was as large or as satisfactory as last year's, still the general run of work shown was of a higher standard than ever before and the selections showed that the exhibition committees were extremely critical in their judgments. The San Francisco exhibit was held in the club rooms and it is estimated several thousand persons viewed the work. The top floor of the Forrester building was utilized for the Los Angeles show.

Special effort was made on the part of the committees in charge to secure architectural drawings of merit. Particularly interesting were the splendid Copley prints, Blashfield's drawings and other works of art.

With the close of the Los Angeles exhibition a banquet was held at Hamburger's. Architect A. F. Rosenheim acting as toastmaster. Architect W. S. Eames of St. Louis delivered an address.

### New Building for Medford.

Medford, which is close to the California border line, will be the scene of much building this spring. Following is a partial list:

Page Hotel—Four-story pressed brick.

Hotel Medford—Five-story granite and pressed brick.

Masonic Temple—Three-story pressed brick and granite.

Jackson St. School—Three-story pressed brick.

Queen Ann School—Three-story pressed brick.

St. Mark's Church—Granite.

First M. E. Church building.

### Porterville Concrete Hotel.

Architect B. G. McDougall of San Francisco has prepared plans for a two story hotel to be erected at Main and Olive streets for Anton Kenda, a Porterville capitalist. The building will be of reinforced concrete, Mission style, with metal tile cornice. Rooms will be arranged single and en suite and will accommodate 100 guests. There will be a large dining room, sample rooms and two stores. The estimated cost is \$40,000.

### Modesto Municipal Theatre

There is a movement on foot in Modesto for a municipal playhouse, and present indications are that the project will materialize. Architect Bernard Joseph of San Francisco has offered his services and is at work on plans for a splendid theatre to seat 1,000 persons.

### Menlo Country Club.

A tract of about 120 acres of land lying on the Woodside road, about two miles from Redwood City, has been purchased by the Menlo Country Club for its exclusive use, and already plans on an extensive scale are in progress for improving the grounds, and the erection of a clubhouse, which will be one of the most pretentious country clubhouses in the vicinity of San Francisco. It will cost in the neighborhood of \$100,000. The officers and directors of the club are as follows: Beach Thompson, president and director; E. W. Hopkins, vice-president; J. B. Croyell, Jas. L. Flood, J. A. Folger, Alex. Hamilton, Timothy Hopkins, J. Henry Meyer, Leroy Nichols and S. E. Slade.

### Competition for Northwestern University, Chicago-Evanston, Ill.

The trustees of Northwestern University have appointed a committee with power to procure a general plan for its campus at Evanston and to appoint an architect for buildings now projected at a cost of three hundred and fifty thousand dollars (\$350,000.00). This the committee will do through a competition which has been approved by the American Institute of Architects through its Illinois Chapter, and will be conducted by Professor Warren P. Laird. It will be restricted to twelve architects of whom four have been especially invited, while eight will be selected from the open field. To the former, and those three among the latter rated by the jury as best, will be paid each a fee of five hundred dollars (\$500.00) and traveling expenses incurred in an inspection of the site; such fee, in the case of the appointed architect, to apply on account of his fee as architect of the work. The jury will consist of the adviser and two other architects chosen by the competitors from among five or more nominees selected by the adviser. The appointed architect will receive one thousand dollars (\$1,000.00) for the use of his general plan in addition to the fee of six per cent on the work. The competition will close April 15, 1911. All communications are to be addressed to Warren P. Laird, Architectural Adviser, University of Pennsylvania, Philadelphia, Pa.

### Successful Competition for Government Buildings.

According to press dispatches the successful competitors for the three buildings which the Government will erect in Washington are as follows:

Building for Department of Commerce and Labor, York & Sawyer, New York.

Building for the State Department, Arnold W. Brunner, New York.

Building for the Department of Justice, Donn Barber, New York.

## THE Architect and Engineer OF CALIFORNIA

Member of California Periodical Publishers' Association

Published Monthly in the interests of the  
Architects, Structural Engineers, Con-  
tractors and the Allied Trades of the  
Pacific Coast by the Architect and En-  
gineer Company.

### OFFICES

621 Monadnock Building - San Francisco  
Telephone Douglas 1828  
Builders' Exchange, Oakland  
Room 234-223 West 2nd St., Los Angeles

### TERMS OF SUBSCRIPTION

(Including postage) to all parts of the United States \$1.50  
per annum; to Canada 50c additional; to all Foreign points  
\$1 additional.

Vol. XXIV. FEBRUARY, 1911. No. 1

### ASSOCIATE EDITORS

MORRIS KIND, C. E.	Cement
WM. B. GESTER,	
JNO. B. LEONARD, C. E.,	<i>Reinforced Concrete</i>
LOREN E. HUNT, C. E.	} <i>Inspection</i> and Tests
ATHOL McBEAN	} <i>Brick, Tile and Terra</i>
W. E. DENNISON	} <i>Cotta</i>
HOWARD FROST,	
W. W. BREITE, C. E.	} <i>Structural Steel and</i> <i>Iron</i>
FRANK SOULE	} <i>Masonry Engineering</i>
G. B. ASHCROFT, C. E.	} <i>Artificial Stone</i>
W. J. WATSON	} <i>Roofs and Roofing</i>
J. R. D. MACKENZIE	} <i>Heating and</i> <i>Ventilating</i>
F. H. BRYANT	
WILLIAM ADAMS,	} <i>Decorative Lighting</i>
C. WALTER TOZER	} <i>Interior Decoration</i>
WILBUR DAVID COOK,	} <i>Landscape Architecture</i>
T. C. KIERULFF	} <i>Legal Points</i>
F. W. FITZPATRICK,	} <i>Fireproof Construction</i>
PAUL C. BUTTE	} <i>Electrical Construction</i>
C. W. WHITNEY	} <i>Building Construction</i>

### ARCHITECTURAL

Fred H. Meyer	J. C. Austin
Edward T. Foulkes	F. D. Hudson
Alfred F. Rosenheim	Sumner P. Hunt
G. Albert Lansburgh	C. Sumner Greene
Jas. W. Reid	Ralph W. Hart
Clinton Day	James Seadler
Kenneth MacDonal. Jr.	Maxwell G. Bugbee
Houghton Sawyer	Clayton D. Wilson
John G. Howard	Americo Coxhead
Arthur Brown, Jr.	Harrison Albright
M. V. Politeo	John Parkinson
T. J. Welsh	W. J. Cuthbertson
Chas. P. Weeks	A. W. Smith
Chas. F. Whittlesey	T. Patterson Ross
Octavius Morgan	William H. Weeks
W. A. Newman	Chas. W. Dickey
H. Alban Reeves	Henry C. Smith

### CONTRIBUTORS

Merritt Reid	Hon. Jas. D. Phelan
William Curlett	J. T. Walsh, C. E.
Albert Fissie	Chas. Havens
Edgar A. Mathews	Smith O'Brien
Julius E. Kraft	H. F. Starbuck
Geo. A. Dodge	Nathaniel Blaisdell
John C. Pelton	W. T. Bliss
Herman Barth	William Mooser
Arthur O. Johnson	Geo. H. Wyman
Herbert E. Law	Robert Morgeneier

E. M. C. WHITNEY Manager  
FREDERICK W. JONES Managing Editor

In recent years there has been a growing sentiment among architects, engineers and the public in general that a limit ought to be set to the height of buildings, particularly in narrow and crowded thoroughfares. This sentiment never reached further than the discussion stage until a few weeks ago, when Chicago, by a vote of 58 to 2, set a limit of 260 feet as the maximum height to which buildings can be extended. The advocates of a restricted skyline for buildings were in favor of a 200-foot limit, but compromised with the opposition sooner than have the measure defeated.

Whether this provision of the code is finally accepted and upheld by the courts, into which sooner or later it will find its way, is hard to say. It is particularly appropriate, however, that Chicago, the originator of the steel-frame skyscraper, should be the first to set a limit to its height.

That there should be a limit to the height of buildings very few will deny. What that limit should be is the question that will call forth a diversity of opinions. One plan has been suggested of proportioning the height of buildings according to the width of the streets. Another to step back the fronts of buildings at certain levels or heights.

One phase of the tall building craze which has not been discussed by the press is the tendency of wealthy men to want to erect the highest building in their home town, that it may stand as a family monument. We have had two such instances on the Pacific Coast only recently. In Seattle a 28-story skyscraper has been proposed by a millionaire property owner, while in Los Angeles a wealthy resident wanted to put up a 15-story building, which would be the highest business structure in that city. The Council declined to change the Building Laws permitting the construction of this building, concluding that the existing limit of 150 feet for straight walls and 30 feet additional for a mansard roof was sufficient to answer present requirements. As a result, the man



who was to build a family monument may invest his money elsewhere or for some other purpose.

This problem of high buildings is one not easily solved. In big cities where the population is congested and where there is a demand for office room, the tall building would seem to be entirely feasible, but this notion of putting up a skyscraper where there is no demand for such a building, simply to gratify the whim or vanity of a millionaire, seems absurd and foolhardy. After all, though, it's no ones loss but the owner's if the building fails to yield him an income, and if he is wealthy, he probably would not worry over such a trifling matter as a few hundred empty offices.

There are many churches throughout England which are without tower or spire, but there are few churches which can boast of having a tower and spire side by side. One of these is the parish church of Ormskirk, in Lancashire. The tower is built over the porch at the west end, and the spire is placed as closely as possible to it. The origin of this architectural freak has not been ascertained, but there is a tradition to the effect that when Orme, the Saxon pirate from whom the town derives its name, decided to construct a kirk, or church, as an expiatory offering for his evil deeds his two daughters quarreled over the design for the structure. One determined to have a tower; the other was equally resolved to have a steeple. As neither of them would give way the pirate chief acceded to both their wishes, and the curious may see the tower and spire still keeping watch side by side on the surrounding country.

#### Historic Table Used at the Convention

An historic old table, famed as the one upon which the ratification of the Treaty of Ghent, which closed the War of 1812, was signed by President James Madison and a commission of which Henry Clay was one of the members, was lent by Mrs. Alfred Hunter Voorhies, of San

Francisco, to whom the table has descended, to the American Institute of Architects for use during the annual convention.

When the national assembly was called to order the president's gavel fell upon one of the most valuable and historic heirlooms in the city, and upon the close of the convention the massive piece of old mahogany was again removed to the Voorhies home on Van Ness avenue to take its place with one of the city's most interesting collections of old furniture outside of a museum.

The table first figured in history when, upon the destruction of the White House by fire in 1814, President Madison established the executive offices of the nation in the old "Octagon," a colonial mansion in Washington, D. C., now owned by the American Institute of Architects. It was in the library upstairs that the famous Treaty of Ghent was soon thereafter signed by Madison, Henry Clay the while standing at his elbow.

Shortly afterward, upon the rehabilitation of the White House, the table passed into the possession of George Ogle Taylor, of Forngaux, King George county, Virginia, and about twelve years ago Mrs. Voorhies became its owner.

The table is of massive construction and made with the care and thoroughness of the hand manufacture of a century ago. It is circular, four feet in diameter and on a revolving pedestal. Twelve drawers, the labels made of ivory, are ranged around the under edge and a section of the top lifts up to form a rack for papers or for music.

#### Praise for the Pacific Coast Architect. Editor The Architect and Engineer:

Before getting into my regular mail I had to glance over your January number and I want to congratulate you. It is a bully number and stands out in marked contrast to many of your contemporaries. Some of these actually make one shiver, you hear the rattle of dry bones when you open the book, its fossilization complete and perfect. What the hink does the architect of today care whether the Tower of Pisa leans 14 inches or 18 inches and how the measurements were so accurately taken! Page upon page of supposedly valuable space wasted in that kind of rot!

Your illustrations are particularly bully. There's some snap and go out there, the architects seem to be designing something, there is character, some diversity, it isn't the same old hackneyed stuff we are being fed upon back here. I almost regret that I am not out there with you folks where you are actually doing things. Keep up the good work, you are all right.

Hastily,  
F. W. FITZPATRICK.

# HEATING AND LIGHTING

## Plumbing and Electrical Work

### The Broadening Field of the Plumber.\*

**T**HIRTY years ago in many cities the plumber was the standing joke of the press—and it was deserved. But with the advent of the Master Plumbers' Association came the awakening. Just and equitable trade relations were established between the plumber and the manufacturer. The local associations by lectures, open meetings and their local support of trade schools and activity in the enactment of laws conserving the public health, won for themselves the support of the citizens in their communities, and today the plumber is the one mechanic that makes it possible for cities to exist.

Without plumbing and drainage your giant buildings would be but monuments to the plague-ridden dead and dying within their walls. Sanitary enactments fostered by you have bettered the condition of those who by poverty or circumstances are compelled to occupy the cheaper tenements in our cities, and in time will lift them from their purgatory to the paradise of healthful living and environment. It should never be forgotten by our law-makers that insanitary conditions of any part of the community are a menace to the whole; that a sickly and diseased population engenders and propagates vice and crime. The criminal's nursery is in the insanitary quarters of every large city.

It is not so many years ago when the mansion of the wealthy was noted for a collection of paintings, elaborate frescoes or quaint furniture; but mark the change; your skill and the taste and genius of the manufacturer have made the bath room the show room of the house. In Cuba and Panama you have eliminated that scourge of years, yellow fever. Practical sanitary work will give to millions yet unborn reclaimed lands that shall blossom as the rose.

Then love your trade. No Crusader of old ever had a nobler mission than yours. In all this work you have taken the picture and by your fertile brains and cunning hands have made of it a reality for the benefit of mankind. There is still work to be done: the removal of garbage in many cities is crude, insani-

tary, unsightly and disease-breeding. Garbage can be removed as readily as any other waste. The city of Chicago in the past three years has appropriated nearly \$1,000,000 for the removal of garbage. A part of the garbage is burned, the rest, as in the past, is used as filling for abandoned clay or quarry-holes, the land when filled being built upon. Imagine, if you can, the disease-breeding possibilities of this condition. The remedy for this condition is to place the practical sanitary work of cities in the hands of the sanitary expert, who by education and practical training is fitted for the work. This department should not be an appendage to a department with a physician at its head, but should be free and untrammelled in its work in conserving the health of the community; its head should have the power of appointments and discharge.

We are warned of the disease-breeding house-fly, while we maintain 500,000 garbage cans, each one an incubator for its propagation. The remedy—practical men for practical work. The intentions of the medical men as health department heads are no doubt good, but hell is paved with good intentions.

I hope upon my next visit to your city to see a garbage opening at each sink, self-sealing, where the garbage can be placed and whisked to a garbage barge at your street ends on the river, and from there taken to a place of treatment and returned to the soil as a fertilizer. This system has possibilities in connection with vacuum cleaning of streets and the deposit and disposition of street sweepings.

I hope some of the inventive minds in the association will solve this problem of cities before the next convention. A bill is now before Congress for the purposes of creating a National Board of Health. Should it pass, see to it that some practical men are upon the board. If you see your power, this end can be attained. This association by virtue of its work should be represented on that board in your own community. Take an active part in its government. Your training in your business and through knowledge of a city's sanitary needs would make your services invaluable.

We should broaden our activities. Let us take some of our superfluous revent-

\*Extracts from address of Andrew Young at recent National Convention of Master Plumbers in Chicago.

pipings and turn them into filtered, purified air supplies, through which, by the pressure of a button, a wholesome supply of air can be poured into the premises at will, other pipes carrying away the contaminating air at the floor line. A vacuum system points the way as to the disposal of garbage and impure air.

**Single Pipe Plumbing**

A severe test was given recently to the single pipe system of plumbing installed according to the plans of Architect Irving J. Gill in the beautiful new home of Mrs. Charles L. Tutt at Coronado.

The test was conducted by City Health Officer Dr. R. Larini and Louis Ferrea, city plumbing inspector, and proved satisfactory in every way to these San Diego officials.

The single pipe system of plumbing is the one local architects are endeavoring to have the city authorities adopt for use in San Diego. They desire to have the plumbing ordinance revised, making it optional to the builder whether he shall use the single or double pipe system.

The master and journeymen plumbers, it is said, are bitterly opposed to the use of the single pipe system for the reason that it requires about one-half as much labor and material as the double pipe system. The architects want the new system because they claim it is about 50 per cent cheaper to install.

Architect Gill obtained a special permit from the Coronado officials to put this system in the Tutt residence to determine its merits. It is a single pipe system, using anti-siphon centrifugal traps.

The test consisted of flushing all fixtures and emptying a four-ounce bottle of oil of peppermint into the head sewer pipe or vent, and then pouring in two quarts of hot water. This immediately created dense fumes of oil of peppermint. If there were any leaks in the system they could be detected easily by the vapors escaping into the house. The work also was given other tests, but the plumbing withstood every one, not a single flaw being found. The plumbing was accepted without criticism.

"The San Diego board of health and plumbing inspector would do well to inspect this system and adopt it for the residence section of San Diego," said Architect Gill. "It is much cheaper to install and maintain than the double pipe system now in use, and every bit as good. These are very important items to the small home builder because it is the man building the home who is compelled to stand this extra expense."—San Diego Union.

**Recent Patents Relating to Building Construction**

Material for this department is compiled expressly for the Architect and Engineer by Watson & Boyden, patent and trade-mark lawyers and solicitors, 918 F street, Washington, D. C., and to them all inquiries in regard to patents, trademarks, copyrights, etc., and litigation affecting the same should be addressed.

A complete printed copy of the specification and drawing of any United States patent in print will be sent, postpaid, to any address for ten cents.

Elijah D. McDonald, of Los Angeles, Cal.—Reinforced-Concrete Pile.

979,529. Patented Dec. 27, 1910.

This invention relates to concrete piles and seeks to provide means whereby such piles may be readily sunk into a sand or clay bed by means of the action of a jet of water. To this end the bottom of the pile is provided with a depending flange surrounding the edge thereof and projecting below the footings so as to form an enclosed space beneath the pile. Into this space a jet of water is fed through the pipe 11, while suction is maintained through the outlet pipe 12, so that as fast as the material is loosened by the action of the jet it is carried away and a hole thus produced into which the pile sinks.

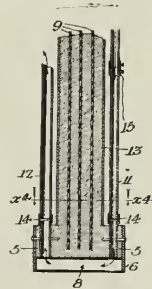

Henry Harrild, of Spokane, Wash.—Window-Screen.

980,519. Patented Jan. 3, 1911.

This invention is an improvement in window screens. It consists in providing a pair of alined strips on each side of the window frame, such strips being formed of angle irons and having one flange adapted to be secured to the window frame and the other flange adapted to enter a groove in the edge of the screen. This latter flange is upset as indicated at A5 in order to produce sufficient friction to hold the screen in adjusted position. The lower pair of strips are pivoted at the top so that they can be swung to the position shown in dotted lines for the insertion of the screen.



Family Club Interior  
Ward & Blohme, Architects

## DREYFUS BROS.

CONTRACTORS

Interior Work a Specialty

339 Montgomery Street  
San Francisco, Cal.

Phone Douglas 3667

Home Phone C 3667



No. 980,519

Lloyd Douglas, of Los Gatos, Cal.—Bracket  
Seat.

980,618.

Patented Jan. 3, 1911.

The object of this invention is to provide an improved seat for builders' use on roofs. The seat comprises a metal section 1 and a pair of side sections 2 and 3 hinged thereto, said sections being sup-

ported by means of foldable interlocked brace rods 11, 16, 21, etc., such rods having prongs 13 adapted to bite into the roof to prevent slipping.

Frank M. Brown, of Salem, Ore.—Window-  
Sash.

981,374.

Patented Jan. 10, 1911.

This invention relates to window sash construction and its object is to cheapen the cost of manufacture of such sashes. To this end the mortising and tenoning of the bars or mullions of the sash is obviated and instead the bars are connected by simply boring one or more holes in the molding of one set of bars to fit the ends of the sections of the other set of bars, which are cut off square. As shown in the illustration 3 and 7 indicate the grooved molding which is bored at 8 to form a socket for the reception of the other bars such as 6, such bars having lateral flanges 10 and 11 adapted to lie in notches 9 formed at either side of the socket 8. For a better understanding of this improved construction reference should be had to the complete patent.

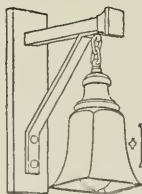

## ADAMS AND HOLLOPETER

INC

MAKERS OF

HIGH GRADE LIGHTING FIXTURES

745 MISSION STREET

SAN FRANCISCO CAL.

TELEPHONE

DOUGLAS 1773

JOHN P. YOUNG  
WILLIAM ADAMS  
FRANK ADAMS  
W. H. HOLLOPETER

# High Grade Electrical Installation Work

**Butte Engineering & Electric Co.**  
683 - 687 Howard Street  
San Francisco

PAUL C. BUTTE  
C. F. BUTTE

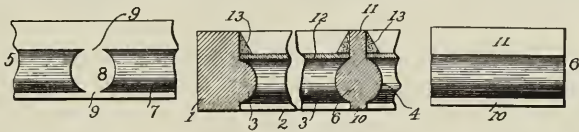

No. 981,374

Josef Graef, of Everett, Wash.—Window-  
Pane Fastener. Patented Jan. 10, 1911.  
981,411.

The object of this invention is to produce  
an improved fastening means for window  
panes by the use of which the employment

of putty may be obviated. The fastening  
device consists of a metallic strip folded  
upon itself and provided with depending  
prongs which may be driven into the win-  
dow sash in such a manner that the folded  
edge of the strip engages the pane. A



## Forty Years of Experience

Enables us to offer the Architect, Builder or Contractor the most durable, lasting and workable roofing tin that has ever been produced. There is **no guess work**. No **uncertainty** in the manufacture of

### SCOTT'S EXTRA COATED ROOFING TIN

It is the result of years of time, labor, experience and research, culminating in The **Follansbee Hammered Open Hearth** process. The only process that gives you a tough yet pliable and practically indestructible product. A Roofing Tin that is adapted to all conditions and a **perfect protection** against wind, water or fire.

Write for "TIN TRUTH" and learn the truth.

**FOLLANSBEE BROS. CO., PITTSBURG, PA.**  
Only Manufacturers Hammered Open Hearth Roofing Tin in America.

Pacific Coast Trade supplied through our San Francisco Branch in charge  
of **GEORGE S. LACY**, Marvin Building. Phone Douglas 4497.



# ELECTRIC APPLIANCE COMPANY

726-730 MISSION STREET  
SAN FRANCISCO, CAL.

## HIGH GRADE CONSTRUCTION MATERIAL

---

" GALVADUCT " CONDUIT (WHITE)

" LORICATED " CONDUIT (BLACK)

" PACKARD " INCANDESCENT LAMPS

" NEW WRINKLE " PULL AND KEY SOCKETS

" PERKINS " PUSH BUTTON SWITCHES

" COUCH & SEELEY " TELEPHONES

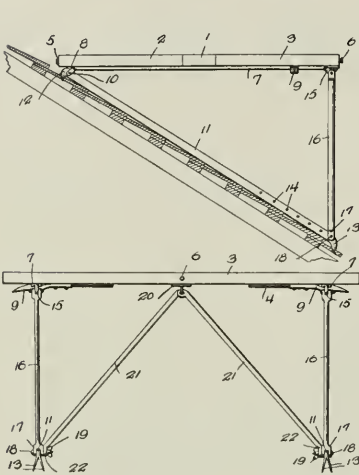

No. 980,618

cushion or packing strip of rubber or pulp is shaped to conform to the inner surface of the metallic strip and is placed between the same and the pane.

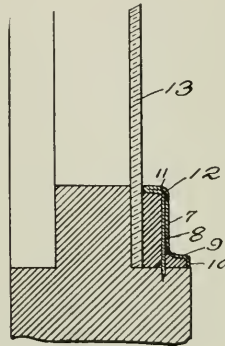

No. 981,411

**A. W. KENNEDY,**  
BUSINESS MANAGER

**CHAS. HART,**  
SUPT. AND INVENTOR

## THE HART HEATER CO.

MANUFACTURERS OF

### THE QUEEN GAS WATER HEATER

### THE HART COMBINATION HOT WATER BOILER

Instantaneous — Economical — Clean.  
Copper coils insure perfect circulation.



OFFICE  
406 Thirteenth St. **OAKLAND, CAL.**

PHONE OAKLAND 7421

FACTORY  
526 Seventh Street  
PHONE OAKLAND 2581

**Successful Exhibition at University of California.**

The fifth annual exhibition of the Architectural Association of the University of California was held in January and was well attended. The work shown included designs in water color and pen and ink, clay modeling from life, and a generous display of work done by the alumni. Mr. Geo. Jay Adams was in charge of the exhibit, which was one of the most successful ever held at the University.

**A Good Word for Corrugated Iron Culverts**

Editor The Architect and Engineer:

Dear Sir.—An injustice has been done us in an article headed: "Condemn Corrugated Iron Culverts," and published in the December number of your magazine. Under the circumstances, we feel sure that you will be willing to investigate this subject and set it right. The metal culverts used by the San Diego County Highway Commission have been purchased from us.

Our culverts are not manufactured from the so-called galvanized iron, which is in reality steel, but from Galvanized American Ingot Iron 99.94% pure, which is accepted by the leading chemists and engineers of this country to be superior in rust resisting qualities to that of any metal that has ever been manufactured in commercial quantities.

Before the discovery of the cheap process of the manufacture of steel, iron was used for many of the purposes that were later filled with steel. We all can remember how much better the iron of that time withstood corrosion than the steel of today. The iron of that time did not always run even, but in every case where the iron of that time has withstood corrosion and remains in good shape, an analyses shows it to be an exceptionally pure grade of iron for that time.

Dr. Cushman of the Bureau of Public Roads, Department of Agriculture, clearly brought out the fact that the purer and more homogeneous the metal, the less the corrosion, and recommended that

H. H. FISHER, President  
G. H. McNISSICK, Secy.

Phone Kearny 4410

**FISHER & WOLFE CO.**  
**Plumbing, Steam and Gas Fitting**

TINNING AND GENERAL JOBBING

207-209 Tehama St., Near Third St., San Francisco

R. J. O'BRIEN T. F. KIERNAN

**KIERNAN & O'BRIEN**  
**PLUMBERS**

ESTIMATES FURNISHED

1754 MISSION STREET, Bet. 13th-14th  
SAN FRANCISCO, CAL.

Builders' Association, Box 149 Phone Market 2517

Phone West 1327

**THOMAS J. FORD**

PLUMBING  
and HEATING

1213 Octavia Street San Francisco, Cal.

**PLUMBING**  
and **HEATING**  
**J. E. O'Mara**

449 MINNA ST.  
Phone, Douglas 3421

Business Phones  
Oakland 3524  
Home A 1344

Residence Phones  
Pied. 637  
Home 3648

**CARL DOELL & Co.**

PLUMBING AND  
GAS FITTING

467 Twenty-second Street  
Residence, 557 31st Street Between Broadway and Telegraph

**we  
want  
your  
elec-  
trical  
work**

**BECAUSE**

**We know we  
can please you**

We are pleasing a good number of architects and contractors who insist on prompt service and first class work.

We get their business because our prices are fair, and they know they can depend upon us.

**CENTRAL ELECTRIC CO.**

185 STEVENSON ST.

SAN FRANCISCO

PHONE, DOUGLAS 387



An Up-to-Date Bath Room

**HEATING, PLUMBING  
AND POWER PLANTS**

Complete Systems Installed in all  
Classes of Buildings. ☛ Defective  
Systems overhauled and corrected

**GILLEY-SCHMID CO., Inc.**

198 WEST MISSION STREET

SAN FRANCISCO

PHONE MARKET 985

mills endeavor to eliminate impurities. The American Rolling Mill Company, Middletown, Ohio, from whom we buy every pound of material that we use, worked along this line with the result that they have succeeded in so far eliminating impurities that American Ingot Iron contains only six one-hundredths of one per cent, making it a purer and better metal than even the best of iron used many years ago, which has through service shown that it withstood corrosion. Tests indicate that American Ingot Iron will last not only fifty years, but probably a great deal longer.

We believe there is no question of strength in the minds of those who have travelled over these culverts, but in this connection we make an absolute guarantee that any culverts that we build will carry any fills placed on them or any loads that travel over them. This great strength is due to the corrugations, which make them twenty-nine times as strong as a plain tube of the same weight material.

We have nothing to say against concrete construction when all essentials are carefully carried out, as concrete work may be made permanent. However, there are many chances for failure in concrete work and one needs to no more than glance at the sidewalks of many cities where this work is out in view to see what a large percentage of failures actually occur. In the culverts that we build absolutely no chances are taken, as they are all built exactly alike and are of such construction as have been proved by actual tests to always handle the travel. Any of the culverts supplied by us to the San Joaquin County Highway Commission will never cost a cent for repairs during the life time of any of us. On the other hand we have sold many culverts to take the place of broken concrete work.

American Ingot Iron has been specified by most of the leading engineers of the country, which includes those of the largest railroad systems and in the U. S. Government Service, as well as those of highway commissions and general practice. These men have made a study of the metal before specifying the material to be supplied. American Ingot Iron is produced by a more expensive process than steel and naturally costs considerably more, so that there would be an increase of many thousands of dollars in our profits during the year, were we to use steel. However, we are in business, not for a year, but for many years to come, and it would be suicidal on our part to use anything but the best material that can be purchased.

Yours very truly,

CALIFORNIA CORRUGATED CULVERT CO.

By H. W. Force.

**PACIFIC BLOWER & HEATING CO.**

3261 Seventeenth Street, (near Mission) San Francisco

Specialists in **HOT AIR HEATING**

Torrid Zone and Pacific Furnaces for Schools, Theaters, Residences, Etc.

**HAVE YOU TRIED TO GET IT IN OAKLAND?**

ELECTRICAL SUPPLIES AND FIXTURES, ANDIRONS,  
FIRE SETS, PORTABLE LAMPS, MOTORS AND DYNAMOS

**CENTURY ELECTRIC AND FIXTURE CO.**

PHONES...Oak 911; A-2911

**THIRTEENTH AND CLAY STREETS**

Phone West 7000

All Work Guaranteed

**ALEX COLEMAN**  
**PLUMBER**

706 ELLIS STREET

SAN FRANCISCO, CAL.

Phone Oakland 1753

I. A. COOKE, MANAGER

**THE J. F. KELLY COMPANY**

(INCORPORATED)

MANTELS, GRATES and TILES

Fire Sets, Andirons, Fenders and Portable  
Baskets, Floor and Wall Tiling in  
Original and Artistic Effects

723-731 Seventh Street, Cor. Brush St.  
OAKLAND, CAL.

Phone Merritt 3555

Estimates Furnished

**OSCAR L. ZEIS**  
**PLUMBING AND TINNING**

♦♦♦♦ JOBGING A SPECIALTY ♦♦♦♦

456 East Sixteenth Street

Oakland, Cal.

**GEO. W. SCHMITT HEATING AND VENTILATING CO.**

**HOT AIR MERCHANTS**

Heating of Residences and Public Buildings  
SHEET METAL WORK

1160 WEBSTER STREET  
Oakland, Cal.

HEATING

ELECTRICAL WORK  
AUTOMATIC SPRINKLERS

PLUMBING

VENTILATION

SHEET METAL WORK

**JOHN G. SUTTON CO.**

229 MINNA STREET

SAN FRANCISCO

Manufacturers of Abrahamson's Patent Ventilators, Galvanized Iron Cornices and Skylights. Repairing a Specialty

**Abrahamson & DeGear, Inc.**  
**Sheet Metal Works**

Tin and Galvanized Iron Roofing, Heating and  
Ventilating, Registers and Ventilating Facings

655 McALLISTER ST.

Phones, Market 2898  
Home S 1857 San Francisco, Cal.

# By the Way

Some Industrial Information Worth the While

## Asbestos Protected Metal

A handsomely illustrated catalog has just been published by the Asbestos Protected Metal Company of Canton, Mass., and represented on the Coast by P. J. Knudsen Company, 214 Front street, San Francisco. The book contains a view of the San Francisco Sulphur Company's plant, the roof of which is covered with Asbestos Protected Metal, thereby making it impervious to the attack of moisture, penetrating acids or coal gases.

The following facts are taken from the catalogue:

"The value of roofing and siding materials is determined by the length of time they will give satisfactory protection to buildings and their contents. We have produced a material practical in its make-up, possessing individual characteristics, merit and serviceability hitherto unobtainable.

"Asbestos Protected Metal is applicable to a wide variety of service, as roofing, siding, and interior sheathing, and for fire proofing in buildings of all kinds. It overcomes all the defects so apparent in the various grades of other materials used for roofing and siding, and at the same time possesses certain unique characteristics which make it superior to them all.

"Asbestos Protected Metal has proved itself impervious to the destructive action of extreme weather conditions in all climates and at the same time is not affected by sulphurous gases, extreme condensation, varying temperatures, and such

conditions, which are disastrous to the serviceability of its competitors.

"The only Asbestos Roofing that has received the approval of the Bureau of Buildings of the Borough of Manhattan (New York City) is Asbestos Protected Metal."

## Cabot's Quilt Reaches the South Pole

The North Pole having been discovered by an American, other nations are hastening toward the South Pole. From England Capt. Scott sailed last June on an expedition which has been carefully planned to follow up the great progress made by Lieut. Shackleton, and from Japan another start has been made.

Capt. Scott has the most complete outfit ever carried on such an expedition, including ice-automobiles and specially made portable houses which can be quickly set up to protect his men from the terrible cold.

These two items were worked out under Capt. Scott's personal supervision. The houses must be as absolutely cold-proof as possible, and yet must be light in weight for ease of handling. After careful investigation Cabot's Sheathing Quilt was chosen for insulating these huts. The latter, including walls, floors and roofs, were lined with two layers of Cabot's double-fly quilt.

In one of its latest circulars the Samuel Cabot Company, sole manufacturers, Boston, Mass., gives the following interesting facts:



*Southern Pacific Co.'s New Depot, Tulare, Cal. D. J. Patterson, Architect*

**T**HIS cut shows the new depot now being built at Tulare and which is being faced with "**Golden Gate Sandstone**" Brick made of sand and lime at our Antioch factory. We also sold the Del Monte (white Monterey) sand, red brick and crushed rock for this building. *Do you ever buy sand, rock or gravel in carload lots?* If you need any sand, rock or gravel for any interior points such as Tulare, Fresno, Sacramento, Richmond, etc., let us quote you and submit samples, for we can not only ship from our Antioch pit but we are able to supply you from a pit in the San Joaquin Valley as well as a convenient point in the Sacramento Valley. **GOLDEN GATE BRICK CO.,** C. F. PRATT, Manager, 660 Market St., Opposite Palace Hotel



"Cabot's Quilt is made like carpet lining, but it is a matting of cured eel-grass, which will never rot, will never harbor insects or vermin and will retard the spread of fire. One layer of quilt is as warm as ten layers of the best and most expensive papers, and is incomparably warmer than common papers. It costs about half as much as back-plastering, but it is twice as good, and is permanent, while back-plastering goes to pieces in a short time, and lets in the cold.

"Quilt is the greatest money saver that can be used in a house. It will save enough fuel in two average winters to pay its whole cost, and it will make the house more comfortable and doctor's bills smaller for all time. It will keep out the heat in summer and keep it in in winter. Roofs and walls lined with it are practically wind, frost and sun-proof. It costs less than one cent a foot, and it is the best investment that you can make in building your house, because if you build a cold house it will always be a drain on your purse for fuel.

"Quilt is good for all kinds of buildings. It is used in large quantities for insulating ice and cold storage houses, and it is the most effective sound-deadener made. Immense quantities are used for deadening sound in the floors and partitions of schoolhouses, lodge-rooms, hotels, apartments, etc."

**Rohlfs Goes East.**

J. C. Rohlfs, manager of the marine department of the Standard Oil Company, and a director of the Dodd's Interlocking Block Company of San Francisco, is in New York buying ships for oil carrying in the coast trade. Rohlfs probably will stay in Gotham three months.

Rohlfs installed the wireless telegraph outfits on the oil carrying ships of the Standard Oil Company, and is said to have gone East to assist in the selection of vessels which will be used on this coast.

His departure is taken as an indication that the oil corporation plans to strengthen its position here with more and better equipped ships.

**THE ROEBLING CONSTRUCTION CO.'S**

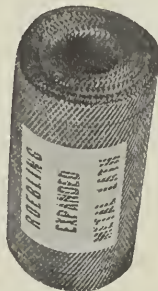

System of FIRE PROOFING and EXPANDED METAL LATH

HOME INDUSTRY  
Made in San Francisco

EXPANDED metal lath manufactured in rolls 150' long, 25" and 33" wide, or sheets if desired, plain, painted or galvanized. Crimped metal lath and wire lath for exterior plastering.

Everything in the lath line for architect, owner, plasterer and lather. Information, prices and samples cheerfully given.

OFFICES: Nos. 623-626 CROCKER BLDG.  
SAN FRANCISCO

Phones—Home C-4312; Kearny 2222

Factory and Warehouse: No. 476 Eighth St.

**Mackenzie Roof Co.**



425 15th St., Oakland  
Phone Oakland 3461

**HARDWOODS**

The Largest Stock WEST OF CHICAGO

**WHITE BROTHERS**

FIFTH AND BRANNAN STREETS, SAN FRANCISCO

# SMITH, EMERY & COMPANY, Inc.

INSPECTING AND TESTING ENGINEERS  
AND CHEMISTS

651 HOWARD STREET  
SAN FRANCISCO

245 SO. LOS ANGELES STREET  
LOS ANGELES

INSPECTORS OF

## IRON, STEEL, CEMENT

REPRESENTED AT

SEATTLE  
NEW YORK

SAN DIEGO  
CHICAGO

PUEBLO  
PHILADELPHIA

BIRMINGHAM  
MONTREAL

PITTSBURG  
GLASGOW

### Reorganization of Smith, Emery & Company

Smith, Emery & Company, engineers and chemists, announce the completion of a reorganization of their business, made necessary by its rapid growth and development. The capital stock has been increased to \$100,000, and the latest bookkeeping and filing systems have been installed.

The Los Angeles establishment, which has hitherto been a separate corporation, under the name of Smith-Emery Company, now becomes a part of Smith, Emery & Company, the parent organization.

The personnel of the directing forces of the firm are now: A. L. Emery, president; Emory E. Smith, vice-president and general manager; E. O. Slater, second vice-president and manager, Los Angeles; M. T. MacDonald, secretary; B. R. Putnam, treasurer and manager mining department; W. C. Bass, manager Mining Department, Los Angeles; Duncan Anderson, chief chemist; Frank Riordan, superintendent Cement Department; A. E. Roberts, designing engineer.

The laboratories and offices of the company occupy the entire building at 651-3 Howard Street, San Francisco, and the Los Angeles branch occupies the entire building and lot, owned by the company, at 245 South Los Angeles Street, in that city.

The firm has at present on its regular staff twenty-two engineers, chemists, and assistants, and a staff of six associate engineers, and has extensive Eastern, Canadian and European connections.

Smith, Emery & Company is unquestionably playing an important part in the development of the large construction and manufacturing businesses of the State.

### White Brothers Bring Down Their Season's Cut

White Brothers, the big hardwood house at Fifth and Brannan Streets, San Francisco, have, within the last few weeks brought down from their Petaluma saw mill three immense barc loads of dry lumber.

This represents their last seasons cut and consists of oak, mahogany, jenisero,

Spanish cedar, ash, teak and sonokling.

This lumber was sawed the first part of 1910 and has been piled on sticks and the soft Petaluma zephyrs have done their work well. Petaluma is an ideal spot for drying lumber as the warm winds that sweep down through the valley, season the lumber effectively and impart to it a certain mellowness which can never be attained in lumber which is kiln-dried direct from the saw. Jenisero especially is a most refractory wood and usually warps and twists to a very great extent when kiln-dried; the jenisero, however, which is dried by the Petaluma winds remains as straight and flat as the day it was sawed. Another great advantage of the Petaluma climate for drying hardwoods is the fact that the wind contains no dust and the lumber dries clean.

### Are Using Ingot Iron Culverts.

The California Corrugated Culvert Company has recently sold the Highway Commission of San Diego County a large bill of American Ingot Iron culverts, which shows conclusively that this county has not discarded the iron culvert for the concrete. The same company is supplying the Los Angeles County Highway Commission with material for use in the roads that they are building under the bond issue of \$3,500,000 and the Highway Commission of San Joaquin County for use in the roads they are building under bond issue of \$1,250,000, as well as the leading railroads and large irrigation projects, all of whom are employing engineers of the highest standing. The company also has sold the U. S. Government material for roads in the Yosemite National Park, under specifications drawn by the U. S. Engineer in charge, and throughout the United States, in the Panama Canal zone and in our island possessions. U. S. engineers have often specified and are using large quantities of American Ingot Iron culverts.

### New County Jail.

Lassen county is to have a fine stone or brick jail to cost \$30,000. Notice for bids is now being published. The county seat is at Susanville.

INVESTIGATE  
**HOLMES' Disappearing BEDS**

687 Monadnock Building, San Francisco, California

**KEUFFEL & ESSER CO. OF NEW YORK**

48-50 Second Street, San Francisco, Cal.



**PAYZANT BLOCK LETTERING PENS**

Particularly adapted for lettering Architects' and Engineers' Drawings; Form letters at a single stroke, and produce smooth lines of even width. Work can be done in ONE QUARTER OF THE TIME needed with the fine-pen method. Made in six graded sizes.

Write for Descriptive Circular.

Producers of Clean, Fresh-Water

**GRAVEL  
 AND SAND**

QUALITIES

- "GRADED"
- "CRUSHED"
- "ROOFING"
- "TOPPING"

CAPACITY, 3000 TONS PER DAY

Plants at Eliot, near Pleasanton and Healdsburg

**Grant Gravel  
 Company**

OFFICES  
**WILLIAMS BUILDING**  
 3d and Mission Sts.

Phones: Pacific, Douglas 3078  
 Home, J 1982

**San Francisco**

Make inquiry ANYWHERE as to the reputation of **BLUXOME & CO.**, 532 Monadnock Building, San Francisco, for high class workmanship and fair dealing in plain or Reinforced Concrete Construction.

### Use of White Lead

Pure white lead reaches the painter in the form of a thick paste. It has been thoroughly ground and the pigment is extremely fine. All that is necessary is to thin the white lead paste down with pure linseed oil and necessary thinners, and color to suit any particular purpose desired.

Pure white lead has a natural affinity for pure linseed oil. The linseed oil and white lead combine into one perfect product—paint—just as sugar and water combine into syrup. Because of this perfect combination of linseed oil and white lead the house painted with a pure white lead mixture is certain to be well protected; and a beautiful job results. When pure white lead is used there is an entire absence of cracking and scaling paint.

Pure white lead paint wears long and evenly, no burning or scraping of the old paint is required when a new coat of paint is applied over the old white lead coat. Pure white lead has been the standard of paint excellence for hundreds of years and will continue as the best paint material because of its ability to give the most exacting service and to maintain under the most violent elemental disturbances a fabric of undiminished depth and surface solidity.

Pure white lead wears defiantly against such enemies as unseasoned wood, prevailing gases, if any, and a great multitude of forces inimical to its appearance and durability. While it is not always successful in resisting the advances of these untoward and disturbing conditions, it invariably wages a good fight and surrenders without discredit.

### Malthoid in China

As an instance of the wide field for California manufactured products, the editor's eye the other day, in the Daily Consular and Trade Reports, saw the following report of Vice-Consul C. L. L. Williams, writing from Newchwang, China, on Rubber Roofing in Manchuria:

"Several brands of 'rubber' roofing have been placed on the local market, but one special brand, Malthoid, has been found to sell best. Rubber roofing is hardly adapted to the style of architecture employed by the Chinese, but the Japanese, of whom there are large numbers in Manchuria, use it extensively. The popular brand mentioned was at one time handled by an American company, but latterly the agency has passed into the hands of a Japanese company at Dalny, who do a large business in it at the following prices for double rolls of 216 square feet: One-half ply, \$4.75; 1 ply, \$6.25; 2 ply, \$8; 3 ply, \$10.

"Other roofings have been offered at

## BRIDGEPORT STANDARD WOOD FINISHES

### SERVICE

Good SERVICE is a broad term as applied to wood finishes. It begins with ease of application — it ends with beauty and the lasting qualities of the wood finish.

If you want to recommend wood finishes that give the best possible SERVICE in all respects, specify the use of—

## Bridgeport Standard Wood Finishes

Bridgeport Standard Wood Finishes are practical finishes—simple to use, easy to spread, great in covering capacity.

They develop the natural beauty of the wood and *never* cloud, obscure or raise the grain.

And they give an elastic, tough finish that looks good at the start and stays good with the years.

We have hundreds of letters from Architects, Property Owners, and Furniture, Piano and Car Building concerns who use Bridgeport Standard Wood Finishes which verify and emphasize this statement.

We would like to place tangible proof of the good SERVICE of Bridgeport Standard Wood Finishes in your hands.

#### Write for Sample Panels

We will be very glad to mail you on request a neat compact case of sample panels showing numerous wood finishes in new and staple effects. You will find them useful and PRACTICAL.

### Whittier-Coburn Co.,

San Francisco and Los Angeles

Agents for the Pacific  
Coast.

THE BRIDGEPORT CO.  
WOOD FINISHING  
NEW MILFORD, CONN.  
NEW YORK. CHICAGO. WASHINGTON.

ROBERT W. HUNT

JNO. J. CONE

JAS. C. HALLSTED

D. W. MCNAUGHER

**ROBERT W. HUNT & CO., Engineers****BUREAU OF INSPECTIONS, TESTS AND CONSULTATIONS**

NEW YORK LONDON CHICAGO PITTSBURG ST. LOUIS MONTREAL MEXICO CITY

418 MONTGOMERY ST., SAN FRANCISCO

Inspection of Rails and Fastenings, Cars, Locomotives, Pipes, Bridges, Buildings, Etc.

**CEMENT TESTING AND INSPECTION****Reports and Estimates on Properties and Processes**

much lower prices, but no sales resulted. One brand was quoted as follows: One ply, \$3.90; 2 ply, \$5.50; 3 ply, \$6.75."

The manufacturers of Malthoid, the Paraffine Paint Company, are now among the large roofing and paint makers of the world and find markets for their products wherever modern construction methods are in vogue.

Just now the company is introducing through its extensive agencies, under the name "Amiwud," a very attractive imitation of hardwoods made from pulp board. Amiwud is made up to imitate several varieties of oak, mahogany and jenisero and is manufactured in various thicknesses and weights, in heavy grained, heavy plain without grain, light grained and thin grained, the latter for covering wood and other mouldings or patching.

Amiwud is designed to take the place of lath, plaster and wall paper for walls and ceilings of any type of building, new or remodeled. It is sold ready for application, and may be nailed to the studing of a new wall or ceiling or put on an old one over the plaster. In its manufacture the makers aimed to create a product that could be used in the home, office or factory, that would deaden sound and keep out heat and cold, that would not crack or discolor, or wear out easily, and that cannot be shaken down by explosions or earthquake.

**Good Masonry.**

One of San Francisco's most successful firms in masonry contracting is Farrell & Reed, with offices in the Gunst building at Third and Mission streets. Walter N. Reed, the junior member of the firm is so well known to the building trades of San Francisco, that he needs no introduction. When an architect or an owner wants a first-class mason on the job he sends for Reed. The masonry work of the Orpheum theater building, Lansburgh and Joseph, architects, was done by this firm as was the Newhall or White Investment Company's building, the stately office structure on California street designed by Architect Louis Hobart. Several of the buildings that were illus-

trated in the November Architect and Engineer, designed by Architects Reid Bros., were erected by Farrell & Reed.

**THE STANDARD  
SUPPLY CO.****Building Materials****Agents for NEPHI  
HARDWALL PLASTER****Oakland, :: :: California****AMERICAN ROTARY VALVE CO.**

L. J. WHITE

S. I. WAILES

(Morehead Vacuum Cleaning System)

Complete Stationary Vacuum Cleaning  
Plants for Hotels, Office Buildings,  
Theaters, Apartment Houses,  
Schools and Residences

**702 BALBOA BUILDING  
Phone Sutter 607  
SAN FRANCISCO**

W. H. Henning

J. J. Burke

Phone Douglas 2298

**HENNING & BURKE****General Contractors**

Room 242 Russ Bldg.

San Francisco



# HARDWOOD

and **PANELS**  
**EDW. F. NIEHAUS & CO., Inc.**

548 TO 570 BRANNAN STREET  
 Between Fourth and Fifth Sts.  
 SAN FRANCISCO, CALIFORNIA

BRANCH YARDS { TRACY, CAL.  
 MAYFIELD, CAL.

PHONES { LUMBER EX. 30  
 MARKET 1485

## SANTA FE LUMBER COMPANY

DEALERS IN WHOLESALE AND RETAIL

### LUMBER

Large Timbers and Special Bills to Order      Kiln Dried Oregon Pine Finish

Main Yard on SOUTHERN PACIFIC, WESTERN PACIFIC, SANTA FE  
 17th and De Haro Streets      ::      ::      SAN FRANCISCO, CAL.

## STRABLE MANUFACTURING CO.

MANUFACTURERS OF

### HARDWOOD FLOORING AND LUMBER

"TOFCO BRAND"

Quartered and Plain Sawn White and Red Oak Flooring. Has No Equal.

OFFICE AND YARDS, FIRST ST., BET. WASHINGTON AND CLAY, OAKLAND, CAL.

# BEAVER BOARD

A Unique and Distinctive Finish

## SUPERIOR TO PLASTER

DURABLE - EFFICIENT - ECONOMICAL

THE LILLEY & THURSTON CO., 82 2nd St., San Francisco

Kearny 1783

Home J 4385

## WALTER HOUGH

**Building  
Construction**

**503 Market Street**

**San Francisco**

**California**

### Imperial Waterproofing

The F. W. Braun Chemical Company, 906 East Third Street, Los Angeles, has acquired the sole agency for the sale of Imperial Waterproofing in Southern California, Nevada, Arizona and New Mexico. This stroke of business diplomacy was accomplished after a thorough examination of the merits of the composition and the reports of their laboratory showing that it was composed solely of chemically pure ingredients.

Imperial Waterproofing during the comparatively short period that it has been on the market has proven beyond doubt that it is a very superior and durable article for treating brick, stone, concrete and plaster surfaces, thereby making them impervious to moisture.

One of the best practical examples of the value of Imperial Waterproofing was in the treatment of the tunnel on the County Court House grounds in Los Angeles. Before this work was commenced the walls were reeking with foul smelling seepage and slime, and it was with considerable doubt that the board of supervisors agreed to the proposal of the manufacturers to make the tunnel waterproof.

Besides the F. W. Braun Company, Imperial Waterproofing is handled on the Coast by Baker Brothers, San Francisco, and W. O. Stamps of Portland, Ore.

### More Inferior Lime From the Cowell Company

Complaints of "popping" lime made by the Cowell Lime & Cement Company continue to be heard.

Recently suit was instituted in San Jose against Fred A. Figel, the local

agent of the Cowell Company, by W. H. Jones, a plaster contractor who did some partition work in the Agnew State Hospital buildings. Engineer Nat Ellery refused to accept the job and the general contractor, F. O. Engstrom, held up Jones' pay in consequence. Then followed the suit against Figel by Jones, who claims to have been furnished an inferior brand of lime. The amount sued for is \$2,011.35, the contract price, and \$5,000 as damages to the contractor's business because of the condemnation of the work.

## BAY STATE BRICK AND CEMENT COATING



It safeguards concrete, brick and stucco from the ravages of dampness, prevents hair cracking, overcomes the monotonous gray tones or spotted appearance of cement, can be used as a finishing plaster on concrete walls instead of the ordinary finishing plaster. Applied on ceiling over delicate machinery it will not drop off. It does not destroy the distinctive texture of concrete.

Write at once for book and color card mentioning this medium.

### WADSWORTH, HOWLAND & CO., Inc.

PAINT AND VARNISH MAKERS  
AND LEAD CORRODERS

82 - 84 Washington St., Boston, Mass.

Distributing Agents:—Hiram W. Wadsworth, Chamber of Commerce Building, Pasadena, Cal.; Timms, Cress & Co., Portland, Ore.; F. T. Crowe & Co., Spokane, Seattle, Tacoma, Wash.



Cover  
Your

## ROOF with ELATERITE

ELATERITE DRILL TOP or CLOTH TOP DECKING

MAKES AN IDEAL DECK FLOOR AND ROOF

THESE HIGH GRADE PRODUCTS MADE ONLY IN DENVER, COLO.

**THE WESTERN ELATERITE ROOFING CO.**

PACIFIC COAST AGENCY, 413 FIFTEENTH ST., OAKLAND



# WORDEN-MEEKER VARNISH CO.

Products of Uniform Quality

**PAINTS, OILS, VARNISHES, STAINS**

**EGG SHELL FINISH**

A Flat Varnish Not Requiring Rubbing

*Architects will find our  
Line Unequaled*

**SAN FRANCISCO .. OAKLAND**

P. P. MOORE

G. D. BOYD

## Boyd & Moore

HYDREX WATERPROOFING SYSTEM. ENAMELED BRICK. "TABOR"  
REVERSIBLE SASH FIXTURES (SEE PAGE 129). "VAN KANNEL"  
REVOLVING DOORS. "ENUPHYL" ORNAMENTAL BRONZE.  
"CROSS" HORIZONTAL FOLDING DOORS  
"CROSS" COUNTER-BALANCE FREIGHT ELEVATOR DOORS  
"ENERGY" DUMB WAITERS.  
"H. & C." METAL LOCKERS.

**356 Market Street**

**SAN FRANCISCO**

E. F. HENDERSON

W. M. WILLIAMS

CHAS. WILLIAMS

## Williams Bros. & Henderson

**BUILDING CONTRACTORS**

PHONES: KEARNY 2401  
J-2401

**351 MONADNOCK BUILDING**  
SAN FRANCISCO

## FREDERICK J. AMWEG

**CIVIL ENGINEER**  
MEM. AM SOC. C. E.

**700-705 MARSDON BLDG. SAN FRANCISCO, CAL.**

**ADVISORY ENGINEER**

*and*

**MANAGER OF BUILD-  
ING OPERATIONS.**

**BUILDER OF**  
KERN COUNTY COURT  
HOUSE, BAKERSFIELD,  
CALIFORNIA

An Index to the Advertisements

Page	Page	Page
Abrahamson & De Gear.....111	Gilley-Schmid Co.....110	Pacific Fire Extinguisher Co.....125
Adams & Holloper.....106, 150	Glaenzler, Eugene & Co.....22	Pacific Laboratories.....133
American Rotary Valve Co.....117	Gladding, McBean & Co.....15	Pacific Improvement Co. 4th Cover
Amweg, Frederick J.....120	Glidden Varnish Co.....20	Pacific Rolling Mills.....29
Arenz, Richard Co.....132	Golden Gate Brick Co.....112	Pacific Tank Co.....30
	Golden Gate Structural and Or-	Pacific Tel. & Tel. Co.....136
	namental Iron Works.....134	Paraffine Paint Co.....27
Bagge, W. H., & Son, Inc.....141	Goodyear Rubber Co.....138	Parrott & Co.....2, 3, 5
Baker Bros.....24	Grant Gravel Co.....115	Perfect Concealed and Turner
Baker & Hamilton.....33	Gutleben Bros.....141	Bed Company.....16
Bass-Hueter Paint Co.....16		Petersen, H. L.....142, 164
Bay Development Co.....141	Haines, Jones & Cadbury Co.....131	Peterson, Nelson Co.....128
Berger Manufacturing Co.....8	Hanley & McCulloch.....145	Pike, C. W. Company.....17
Bexhill Casement Co.....20	Hart Heater Co., The.....108	Pioneer Paper Co.....151
Blanc Stainless Cement Co.....	Hemming & Burke.....117	
Colored Insert	Hillard, C. J., Co.....28	Ransome Concrete Co.....8
Bluxome & Co.....115	Hipolito Screen & Sash Co.....17	Redwood Shingles.....26
Boswall, Wallace C.....145	Hoffman Heater Co.....18	Reliance Ball-Bearing Door
Bowler & Co., S. F.....18	Holbrook, Merrill & Stetson Co.....18	Hanger.....30
Boyd & Moore.....27, 120, 140, 143	Holmes Disappearing Bed Co.....115	Rickon-Ehrhart Co.....31
Braun, J. G.....28	Holmes Lime Co.....9	Rischmuller, G.....145
Braun, Williams & Russell, Inc. 133	Hotel Victoria.....22	Roebling Construction Co.....113
Breite, W. W.....132	Hough, Walter.....119	Russell & Erwin Mfg. Co.....149
Bridgeport Wood Finishing Co. 116	Howe Scale Co.....142	
Brittain & Co.....19	Hoyt Bros.....132	Samuel, H. D., Co.....126
Brode Iron Works.....134	Humphrey Co.....21	Samson Cordage Works.....141
Brown Hoisting Machinery Co.....	Hunt, Robt. W. & Co.....117	San Francisco Bridge Co.....11
The.....147		S. F. Comp. Air Cleaning.....29
Building Material Co., The, Inc. 6	Ils, John G., & Co.....133	S. F. Cornice Co.....22
Butte Engineering Co.....107	Industrial Ornamental Iron &	S. F. Metal Stamping and Cor-
	Wire Works.....134	rugating Co.....22
	Ione Sandstone Company.....132	S. F. Pioneer Varnish Works.....152
Cabot, Samuel (Incorporated) 148		Sanborn & Corinson.....134
California Art Glass Works.....21	Jacobsen, C. T.....151	Santa Cruz Portland Cement Co.
California Bldg. Materials Co.....23	Johnson, J. A. M.....132	Santa Fe Lumber Co.....118
California Corrugated Culvert	Johns-Hanger Mfg. Co., The... 30	Colored Insert
Co.....Colored Insert		Sanitary Plumbing Appliance
California Photo Engraving Co. 145	Kawneer Manufacturing Co.....130	Co.....133
California Scagliola.....150	Kelly, J. F. Co.....111	Sartorius Co.....29
California Steam and Plumbing	Keuffel & Esser Co.....115	Scarritt & Clark.....133
Supply Co.....31	Kiernan & O'Brien.....109	Schastey & Vollmer.....134, 149
Callaghan & Manetta.....150	Knowles, A.....21	Schmitt, Geo. W.....111
Central Electric Co.....110	Knudsen, P. J., Co.....138	Simonds Machinery Co.....133
Century Electric & Fixture Co.....111	Kompolite.....137	Smith, Emery & Co.....114
Clarke, D. Ross.....145	Liquid Stone Paint Co.....148	Southern Pacific Co.....146
Clinton Fireproofing Co.....2d cover	Lilley & Thurston Co.....148	Soule Reversible Window Co... 17
Coleman, Alex.....111	Locke Foundation Co.....111	Standard Portland Cement Cor-
Columbia Lumber Co.....133	Los Angeles Pressed Brick Co... 15	poration.....Colored Insert
Columbia Marble Co.....10	Lynch & Co., A.....128	Standard Supply Co.....117
Cook, H. N. Belting Co.....137		Standard Varnish Works.....129
Corrugated Bar Co.....	Machinery and Electrical Co.,	Stanley Works.....135
Inside Back Cover	Front Cover	Steiger Terra Cotta & Pottery
Crane Company.....18, 31	Mackenzie Roof Co.....113	Works.....15, 172
Crowe, F. T. & Co.....4	Mangrum & Otter.....32	Stoffels, Geo. H. & Co.....142
Crowley, E. D. Co.....141	Marshall & Stearns Co.....123	Strable Manufacturing Co.....118
	Master Builders Co.....126	Sutton John G., Co.....111
	Menzer, C. & Son.....150	
Dean Reversible Window Co... 17	Meurer Bros.....	Tay, George H.....131
De Laval Dairy Supply Co.....23	Inside Front Cover	Thieben & Co., Jos.....140
Diamond Brick Co.....16	Mosaic Tile Co., The.....	Thomas & Schneider Art Glass
Dieckmann Hardwood Co.....32	Montague & Co., W. W.....125	Company.....144
Dietzgen, Eugene Co.....9, 133	Mortenson Construction Co.....134	Tomasello, S. & Co.....123
Doell, Carl & Co.....109	Mott Iron Works.....141	Tozer Company.....19
Dreyfus Bros.....106	Moulin, Gabriel.....157	Triumph Ice Machine Co.....135
Duncan, David.....145	Mt. Diablo Construction Co. 134	Trussed Concrete Steel Co.....139
Dyer Bros.....11	Municipal Eng. & Con. Co.....135	Turner Company.....125
	Murphy Mfg. Co.....132	
Elam & Son, Thomas.....141	National Lead Co..Colored Insert	Union Metal Corner Co.....147
Electric Appliance Co.....108	Natamos Consolidated of Cal. 136	United Glass Works.....10
Elevator Supply and Repair Co. 135	Nelson, N. O., Mfg. Co.....31	
Engstrum, F. O. Co.....142	Nevada Gypsum Co., The.....	Vallejo Brick and Tile Co.....14
Esterly Construction Co.....145	Colored Insert	Van Emon Elevator Co.....1
	Niehau & Co., Edw. F.....118	
Farrell & Reed.....139	Northern Clay Co.....15	Wadsworth, Howland & Co.....119
Farrenkopf & Sons, C.....134		Wagner, Ferdinand.....132
Fee, Grant.....145	O'Mara, J. E.....109	Wanted, Concrete Mixer.....124
Fernald Co., The.....123		Waterhouse & Price Co.....
Fess System Co.....23	Pacific Ball-bearing Door-Han-	.....26, 144, 147
Fisher & Wolfe Company.....109	ger Co.....Inside Front Cover	Weary & Ahford Co.....32
Follansbee Bros. Co.....107	Pacific Blower & Heating Co.....111	Weber, C. F. & Co.....144
Footo Concrete Machinery Co. 23	Pacific Portland Cement Co.,	Wells & Spencer Machine Co. 12
Ford & Malott.....13	Con., The.....Colored Insert	West, M. G. Company.....12
Ford, Thomas J.....109		Western Building Material Co.
Fox, John L.....132		.....4th cover
Fuller, W. P. Co.....129, 131		



*Laying "Kompolite" in Erie Railroad's Fruit Auction Room, Pier 20, New York*

## The Floor Problem Solved

The problem of floors, which confronts the architect of today, is a serious one. With the inadequate mediums at their command they are at a loss to devise a floor that will be durable enough to stand the strain of modern traffic and at the same time soft and warm enough to the tread to be suitable for the interior finish of buildings.

The Kompolite Company have succeeded in perfecting just such a flooring, which at the same time is of such an excellent appearance that it is used in New York's handsome private residences.

Architects and builders will be pleased to learn that the Kompolite Company, of 132 Nassau Street, New York, has completed arrangements for the formation of a sub-company to supply the large demand for this product in California, Washington and Oregon, under the name of The Kompolite Company of the Pacific Coast.

The officers of the local company are: President, Mr. A. M. Bergevin, capitalist; vice-president, Mr. H. L. Mack, resident partner of the New York Banking House of Ehrlich & Co.; treasurer, Mr. W. J. Ehrlich, of Ehrlich & Co.; directors, Mr. George Bos, of Lewis P. Hobart, architects, Crocker Bldg., San Francisco; Mr. John G. Walter, treasurer of D. N. & E. Walter, San Francisco; Mr. Samuel Jaros, president of Kompolite Company, New York; Mr. H. Steinbach, of Imperial Oil Company, San Francisco, and the

president, vice-president and treasurer.

The association of men as well known in San Francisco as Messrs. Bergevin, Mack, Bos and Walter is sufficient guarantee that the affairs of the company will be ably handled.

For the benefit of those who have not seen Kompolite, it should be stated that it is nearly as soft, warm and light as wood. It will take and hold a screw as readily as wood; it is as quiet to the tread as linoleum; it is waterproof, fireproof, vermin-proof, non-porous, and sanitary; it is laid in any color or design; it is guaranteed to neither crack nor bulge; and it has repeatedly been demonstrated to outwear cement, concrete, terrazzo, tile, or any similar material.

Floors laid nearly four years ago in various garages and stables in New York are as good today as when they were first laid.

Kompolite has already been specified for several important jobs in California. The company has the contract to lay all the floor space in the auditorium and corridors of the Orpheum Theater now being built in Los Angeles. This contract was awarded after the architect, Mr. G. A. Lansburgh, had satisfied himself by personal inspection of the work in New York that Kompolite would do all that is claimed for it.

Some of the most prominent jobs done by the Kompolite Company in the East are:

Norfolk High School, Norfolk, Va.,



SOMETHING ENTIRELY NEW

# OSCILLATING PORTAL WALL BEDS

**MARSHALL & STEARNS CO.**

1154 PHELAN BUILDING

SAN FRANCISCO, CAL.

floors in all class rooms, halls and stair treads, comprising over 60,000 square feet.

Erie Railroad Fruit Auction Room, Pier 20, New York.

New York Edison Company, over 10,000 feet in various rooms in building on Pearl Street, Brooklyn.

Borden's Condensed Milk Company, seven milk depots in New York.

Commercial Cable Building, 20 Broad Street, New York, main hall crossed daily by over 60,000 people.

Roosevelt Hospital, New York, various rooms in the Vanderbilt Clinic.

Lehigh & Hudson Railway, all floors in depot at Warwick, N. Y.

Garage of Daniel G. Reid, president Rock Island Railroad.

Bernheimer & Schwartz Brewery, New York: The 1000-ton coal bunker is lined with Kompolite.

Cafe Martin, New York (formerly Cafe de l'Opera), kitchen, servants' dining room and 40 bath rooms.

Cushman's Restaurant and Bakery, Fourth Avenue, New York.

Larimore & Company, druggists, 1 West Forty-sixth Street, New York.

The Kompolite Company has contracts or is specified for work in the Kings County Hospital, The Mirror Candy Factory being erected by the Trinity Corporation, the Simms Magneto Factory, Bloomfield, N. J., the Rochester depot of the New York Central Railroad, the Cleveland depot of the New York, Chi-

cago and St. Louis Railroad, the Washington Irving High School, New York; the East Orange High School, East Orange, N. J.; the Glen Cove High School, Long Island, the Grace George Theater, New York; the Bushwick Theater, Brooklyn; four new public schools in Newark, N. J., and any number of smaller jobs in private houses, restaurants and apartments in and around New York.

While there are, of course, no finished jobs in San Francisco, the Kompolite Company has at its office, No. 349 Mills Building, a large number of samples showing how Kompolite is laid on wood, concrete, cement, or compressed cork.



Model for Orpheum Marquise

**S. TOMASELLO & CO.**

ARCHITECTURAL MODELERS

METAL PATTERNS FOR CHANDELIERS  
 PLASTER ORNAMENTS WAX AND PLASTER PATTERNS  
 COMPOSITION AND CEMENT BRONZE TABLETS  
 SCALE MODELS TELEPHONE PARK 6133  
 STUDIO: 122 10TH ST., NEAR MISSION, SAN FRANCISCO

PHONE: KEARNY 263

# THE FERNALD CO.

REPRESENTING THE

NORTHWESTERN EXPANDED METAL CO., OF CHICAGO

MANUFACTURERS OF

## KNO-BURN DIAMOND MESH METAL LATH

EXPANDED  
 IN GALVANIZED, BLACK AND PAINTED

Our Galvanized Lath is Galvanized after Expanding and Cutting

The only Galvanized Lath worthy of the name

OFFICE AND WAREHOUSE:

248 TEHAMA ST., BET. 3D & 4TH  
 SAN FRANCISCO, CAL.

ADVERTISERS' INDEX - Continued from Page 121

Western Builders' Supply Co. 25, 166  
 Western Elaterite Roofing..... 119  
 Western Iron Works..... 29  
 Western Lime and Cement Co. 28  
 Whitaker & Ray-Wiggin Co. 13  
 White Bros. .... 113

White, S. A..... 137  
 Whittier, Coburn Co..... 24, 116  
 Williams Bros. & Henderson... 120  
 Wilson, W. H. & Co..... 128  
 Wittman, Lyman & Co..... 125  
 Wocker, A. C..... 144

Woods & Huddart..... 1  
 Worden-Meeke Varnish Co. 120, 128  
 Young Machinery Co., A. L.... 7  
 Zeis, Oscar L..... 111



Something New Just Out  
 This No. 25 Automatic Heater is the latest addition to the extensive line of

water heaters manufactured by The Hoffman Heater Company of Lorain, Ohio.

This heater supplies a long-felt want and is suitable for cottages, bungalows or small apartments. It is automatic and will supply hot water to any fixture in the house.

This heater is made to either set on brackets or on the floor as space will permit, is small and neat, and supplies 2½ gallons of hot water per minute, which is sufficient for a small family.

This heater is also very inexpensive and gives the best of satisfaction.

For additional details, price list, etc., address Messrs. Holbrook, Merrill & Stetson, San Francisco and Los Angeles.

**WANTED**

CONCRETE MIXER, with or without power. State size, make, age, condition, price and where can be seen.

Address Box H, Architect and Engineer.

**WAINWRIGHT GALVANIZED STEEL CORNER BAR**

For Protecting Edges of Concrete Curbs, Steps, Columns, Etc.

The only **Concrete Edge Protector** offered to the effective contracting public

WAINWRIGHT PATENTS—March 9, 1897, November 22, 1898, May 5, 1903, March 26, 1907, August 29, 1907, August 2, 1910.

This bar has been in public use for more than ten years as the main feature of the

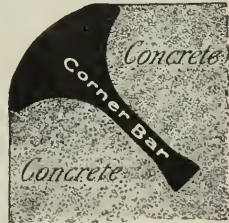

**WAINWRIGHT STEEL-BOUND CONCRETE CURB**

THE BEST IN THE WORLD

**OVER THREE MILLION FEET**

In use in more than three hundred cities in the United States

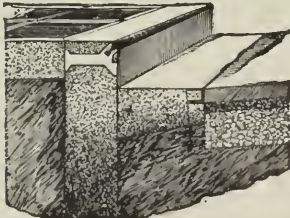

ABSOLUTELY NON-BREAKABLE  
 CHEAPER THAN GRANITE

Handsome than Granite and much stronger.  
 Continuous in Construction, hence Never Out of Line.  
**GALVANIZED STEEL CORNER BAR** Prevents Chipping or Breaking on Edges.

This Curb is Mechanically Perfect and Unequaled for Curved Corners.

**THIS CURB WILL STAND HARDER USE AND LAST TEN TIMES AS LONG AS PLAIN CONCRETE CURBING.**

**CONTRACTORS** can make money by laying this curb.

**CITY ENGINEERS** can save money by specifying it

**ARCHITECTS** are invited to read pages 242 and 243 "Sweet's Index."

**METAL PARTS FOR SALE**

SEND FOR COPYRIGHTED BOOKLET NO. 16

**STEEL PROTECTED CONCRETE CO.**

REAL ESTATE TRUST BUILDING  
 PHILADELPHIA, PA.



# PACIFIC FIRE EXTINGUISHER CO.

## ENGINEERS AND CONTRACTORS

Heating and Ventilating, Electrical Instal-  
lations, Fire Extinguishing Apparatus

### THE GRINNELL AUTOMATIC SPRINKLER

Main Office : 507 MONTGOMERY STREET, SAN FRANCISCO, CAL.  
 { 217-218 Colman Building.....Seattle, Wash.  
 Branch Offices { 504-505 McKay Building.....Portland, Ore.  
 { 703 Paulsen Building.....Spokane, Wash.

# HEATING

Eminent Physicians, Scientists and Heating and  
Ventilating Engineers say that the only correct  
method of heating is by the indirect

## WARM AIR FURNACE

which supplies fresh, pure air, the most important element in sustaining life.

# W. W. MONTAGUE & CO.

HEADQUARTERS FOR HEATING APPARATUS OF ALL KINDS

557 - 563 MARKET STREET, Opp. Sutter SAN FRANCISCO, CAL.

W. J. TURNER,  
PRESIDENT

D. TURNER,  
SEC'Y & TREAS.

# THE TURNER COMPANY

PLUMBING, HEATING, VENTILATING  
AND ELECTRICAL CONTRACTORS

TELEPHONE SUTTER 1059

278-280 NATOMA STREET  
SAN FRANCISCO, CAL.

Phone Market 746

# WITTMAN, LYMAN & CO.

PLUMBING and GAS FITTING  
HOT WATER and STEAM HEATING

315 POLK STREET  
Bet. McAllister and Fulton Sts.

SAN FRANCISCO, CAL.

### Imitation Door Hanger May Involve Architects and Owners in Law Suit

Editor the Architect and Engineer:

It has recently come to our attention that the Pitcher patented sliding door frames for 5½ inch walls, which are advertised in your journal and which are being specified heavily by nearly all prominent architects, are being copied and that there is a very frail imitation now on the market, which contractors are endeavoring to put into buildings as a substitute for our patented frame. In most cases we think this is being done without the knowledge of the architect or owner and we are taking steps through our attorney to stop such infringement and wish to give notice through your journal that all manufacturers and users of our patented frame are doing so at their own risk and are making themselves liable for royalties and considerable expense in defending suits. Such infringements will be prosecuted by us to the full limit.

The architects of this city have treated us very courteously and we have received many favors from them in specifying our patented hardware and our patented frames and we do not wish to take any steps that would cause inconvenience or trouble to their clients without first publishing the facts of such infringements and giving due warning to architects, contractors and owners. There is one case in particular, we might mention, where these imitation frames can be found and we will leave it to any architect or builder as to whether they offer any comparison as to strength or durability with the Pitcher Patented Frame. This particular job is on the north side. It is not the loss of business that would hurt us so much as the injury to the patented disappearing door system for single partitions with 4 inch studs that we are advertising, by having a substitute of such poor construction placed on the market.

Kindly notify all of your customers whether they be architects, contractors or owners of buildings to beware of imitations and infringements upon the Pitcher Sliding Door Hangers and Frames that are now on the market and that if they use the same it will be at their own risk.

Yours truly,

PACIFIC TANK & PIPE CO.,  
Manufacturing Dept.,  
By E. C. Pitcher, Mgr.

## Patch them up!

**YOUR Concrete Floors can be patched with 'Master Builders Concrete Filler.'**

**This 'Filler' will form a perfect bond with the old Concrete.**

**When applied it becomes the hardest part of the flooring.**

**Worn places can be filled and made perfectly smooth.**

**'Master Builders Concrete Filler' can be applied over an entire Floor and it will stand an endless amount of heavy trucking without any effect.**

**'Master Builders Filler' is a mineral powder and is mixed with cement and sand.**

**When applied on a wall (dry or damp) it will make it absolutely watertight.**

**Also used for Acid Vats, Concrete Tanks, Concrete Roofs.**

**Not affected by acids.**

**Write us for particulars.**

Manufactured only by

## The Master Builders Co.

1054 Monadnock Building

San Francisco

California

## Upright Roller Bed Latest Space and Money Saver

There seems to be no limit to the constantly increasing popularity of the concealed or wall bed. Owners of apartment houses, flats and even private homes where space is limited have found the wall bed an indispensable fixture. As built today it is sanitary, safe, convenient, and a space and money saver. There are a number of different types of wall beds. This article has particular reference to the Upright Roller Bed, manufactured by the Perfect Concealed and Turner Bed Company of San Francisco.

In this particular bed the company claims it has developed something entirely new, combining the best features of all the other types, with additional advantages of its own, such as:

1. Saves a closet door.
2. Takes no more space than a wall bed and gives closet room.
3. Can be placed anywhere in room.
4. Not necessary to move the bed to enter the closet.
5. Looks like and is a regular bed when in use.
6. No legs on front of bed.
7. Bed is completely concealed by regular stock doors, not by excessively wide panels.
8. No indication of opening when bed is in use.
9. Absolutely sanitary. No woodwork attached.

Attractive display rooms have been fitted up on the second floor of the building at 862 Mission street, San Francisco, and here



*Showing Bed in Upright Position with Doors Open*

a number of types may be seen in operation. Each bed has a different wall fixture, including couch, window seat, bureau, library desk, buffet, etc. These fixtures are not merely ornamental—all may be put to practical use. They may be finished in any kind of wood from Oregon pine to the most expensive hardwoods.

The Upright Roller Bed differs very



*Showing Bed Hidden by Stock Doors*



*Showing Bed Ready for Use*



materially from the ordinary wall bed in that it can be released from its fastener after being lowered from the wall, and may be rolled to any part of the room like any other bed. With the bed rolled to some other part of the room the opening in the wall may be used for a dresser, clothes closet, etc.

Architects, builders and all interested are cordially invited to visit the company's display rooms and witness a practical demonstration of the Upright Roller Bed. The fact that it possesses the features of other beds, but is far less expensive, are arguments which the promoters maintain can not be very well overlooked.

## Johns Door Hanger Establishes Plant in San Francisco

It is not generally known that the Johns sliding door hanger is now being manufactured in San Francisco by a company headed by Mr. Richard Fahy, for more than twenty years in the contracting business in the Bay City and vicinity. There are few architects in San Francisco who have not heard of Mr. Fahy and those who have had business dealings with him as well as those who have not, speak well of him. It, therefore, will interest these men and a great many others to learn of Mr. Fahy's association with the well-known Johns hanger.

For years the manufacturing plant of the Johns hanger was situated in East Oakland. Some three or four months ago the building and part of the machinery were destroyed by fire. The proprietor, not caring to re-establish the business, sold his interests to the new company which brought the plant to San Francisco and established the business at 832-838 Folsom street in a building 75 x 75 feet with abundant yard and storage room. Considerable new machinery has been installed and with the full force at work the capacity of the plant is equal to 2500 sets of hangers per month.

As a contractor Mr. Fahy built many prominent business structures and apartment houses in San Francisco before the fire. Immediately following the conflagration he had no less than eighteen buildings under construction at one time and on this work he employed more than 100 skilled carpenters. Among the buildings erected after the fire are the Western Union Telegraph building at Montgomery and Pine streets, the two large apartment houses at the corner of Jones and Jackson and Jones and Washington streets, the Goplevick building on Sansome near California street, and many others.

The Johns hanger was formerly handled in San Francisco by the San Francisco Hardware Company and heretofore has never been pushed any to speak of. It is claimed to be the best hanger on the market today for the money. An imitation hanger is now being sold and the parties handling it are likely to have a suit on their hands as they are known to be using identically the same track as the Johns patent. Among the strong points claimed for the Johns hanger is the fact that it possesses

All Orders Promptly Attended to

Old Roofs Repaired and Warranted

**W. H. WILSON & CO.**  
ASPHALTUM AND COMPOSITION  
ROOFERS

42 and 44 Natoma Street, Bet. First and Second Sts.

SAN FRANCISCO

CHAS. PETERSON, President

CHAS. H. NELSON, Vice-President

J. V. WESTERLUND, Secretary

**PETERSON, NELSON & CO., Inc.**  
CONCRETE CONTRACTORS

Artificial Stone Work of all Kinds

Phones: Douglas 1113  
Home C 1831

OFFICE: 407 PINE STREET  
Builders Association Box 327

San Francisco, Cal.

Telephone Douglas 121

Residence 291 15th Avenue. Telephone Pacific 929

**A. LYNCH & CO.**

ARTIFICIAL STONE PAVEMENT  
and CONCRETE CONSTRUCTION

Estimates Given on all Kinds of Concrete Work

Office: Builders' Exchange Building, 185 Stevenson Street

SAN FRANCISCO, CAL.

## THE ART IN ARCHITECTURE

Artistic merit in Architecture depends to a certain extent upon color. On account of the importance of this factor, too much care cannot be exercised in attaining desired tones.

To produce artistic color results in interior finishing, the preservation of the beautiful, natural figure of the wood is a vital consideration. For really artistic, modern, exclusive color effects, STANDARD VARNISH WORKS' Kleartone Stains are a constant revelation to the architect as well as his clients.

Not only does the architect have the regular up-to-date shades, but he also has our unique service in securing special, out-of-the-ordinary tones. This effective assistance makes it possible for every architect to stamp every piece of his work with his own individuality and personality.

White enamel work has a peculiar charm and richness. Our Satinette White Enamel proves its superiority wherever it is used on church, residence, office building and public institution. It does not turn yellow, it is easily cleaned and does not crack. It may be finished with a dull, flat effect or rich gloss. Satinette Undercoat should always be used for priming and undercoats for Satinette White Enamel work.



### ARCHITECTURAL FINISHES

Elastica Floor Finish for floors, Elastica No. 1 for outside work, Elastica No. 2 for inside work, Flatline Cabinet Finish for flat, dull finish, Kleartone Stains for beautiful color effects, Satinette White Enamel flat and gloss for both interior and exterior work and our other Architectural Finishes always more than meet expectations.

These Finishes give results that make high-class, artistic work possible. They make it possible for wood finishing to contribute in an unusual degree to the Art in Architecture.

## STANDARD VARNISH WORKS

NEW YORK, CHICAGO, LONDON, BERLIN, BRUSSELS, MELBOURNE

### W. P. FULLER & CO.

DISTRIBUTORS FOR THE PACIFIC COAST AND HAWAIIAN ISLANDS

Canadian Branch: International Varnish Co., Limited, Toronto

a one and one-half inch adjustment which permits the raising or lowering of a door that much. The ordinary hanger, so it is claimed, has an adjustment leeway of but half an inch. The hanger is made entirely of steel. The track is made of maple, is rigid and easily adjusted.

A door can never jump the track when equipped with the Johns patent. The guide keeps it in perfect alignment and it is impossible for it to swing out or work up and off the track. It is an extremely simple contrivance yet almost powerful in its strength. Although the average door weighs less than 100 pounds the company will guarantee to attach 1000 pounds to the fixture without causing it to spring. All the hangers are ball-bearing.

Shipments will be made to any point in the United States and reliable agencies are wanted everywhere. Only the other day the company shipped an order of 650 sets to the Marshall & Wells Company of Portland, Ore.

### Pouring Concrete by Gravity.

Contractors are beginning to realize the tremendous advantages of using the gravity system for pouring the concrete in the construction of large structures made of this material. The saving to the contractor is estimated at anywhere from 5 to 20 per cent. Parrott & Company, the Coast representatives of the Concrete Appliances Company, licensees of the gravity system throughout the United States, have arranged for the pouring of 150,000 yards of green concrete by gravity in the construction of a great dam for the Washington State Water Power Company.

It is understood that the system will be used in pouring the foundations, curtain walls, floors and roof of the temporary municipal city hall in San Francisco. Messrs. Heller and Wilson are the engineers of this building and Wright, Rushford and Cahill are the architects. More than 20,000 barrels of cement are to be used on this structure.

### Will Build Country Mansion.

It is reported that P. C. Hale, of Hale Bros., will this Spring begin the construction of a splendid country home on his 50-acre estate at Woodside in San Mateo county.

### H. F. Eckert.

H. F. Eckert, for the past 27 years a civil engineer of San Francisco, died January 4, 1911, of typhoid fever. Mr. Eckert was 52 years of age, a native of Germany, and leaves a widow and a daughter 18 years of age. Eckert was of a sunny, optimistic disposition and those who knew him personally will remember him with feelings of friendship.

# THIS CORNER BAR IS ONLY ONE PART OF

## *The* **Kawneer System** *of Store Fronts*

The same principles are carried out in every member that bears directly upon the glass. The spring friction grip insures glass safety—the grip is continuous, not intermittent, and the face piece and spring (made of yielding metal) allow sufficiently for contraction and expansion of the glass. Walk through the business district of your own city and notice the glass breakages. Now go one step further and figure out the cause. It is very evident that glass breaks invariably in settings that do not allow for contraction and expansion.

The sash is also of great importance in a store front construction.

Send for our Booklet No. 4 and learn about Kawneer No. 30 sash. That is the one that has entirely revolutionized store fronts. It enables you to regulate ventilation and drainage. It's done simply by a V-shaped slide built in the gutter. By moving it back and forth (operated from the inside of the window) you open and close the vent holes—that gives proper ventilation and drainage in Winter and a dust-tight sash in Summer.

Because the Kawneer System is made entirely of either solid copper, brass, bronze or aluminum, it lasts. It will not require repairs nor paint. The attractive appearance is permanent.

Kawneer Service is another element that should appeal to you. Combine that with the other "make good" features and you have a store front construction unequalled. The Kawneer System is the original metal store front construction.

Our new 1911 Booklet No. 4 has just been received from our printers and it's one that will be of interest to you. It contains mighty good information and plenty of photographic reproductions of Kawneer fronts, showing them in actual use. Simply drop a card with your address and be sure to mention Booklet No. 4.



No. 5 Corner Bar, Full Size

#### BRANCH OFFICES

Portland, Ore.  
San Francisco  
Spokane  
Los Angeles  
Seattle  
Vancouver, B. C.  
and all other  
large cities.

## KAWNEER MFG. CO.

Factory and General Offices

Niles, Michigan

# CONCRETA

*A Damp-Proof Coating for  
Surfaces of Concrete  
or Brick*

CONCRETA is a Reliable Paint Specialty prepared expressly for coating Cement, Plaster and Brick Walls. Its wearing properties are unexcelled.

It is much superior to ordinary oil paints for this special class of work.

CONCRETA works freely and covers more surface than any other Cement Coating.

Its economy, durability and sanitary properties make it an unequalled coating for use in Mills and Factories of concrete or brick construction.

WRITE AND MENTION THIS MAGAZINE TO

## W. P. FULLER & CO.

MANUFACTURERS

SAN FRANCISCO, CALIFORNIA



"Hygienic" Drinking Fountain  
For other styles see samples in our show rooms  
851-859 Folsom St., San Francisco, Cal.  
Circular sent on request.

**HAINES, JONES & GADBURY Co.**  
MAKERS OF PLUMBING SUPPLIES  
1130-1144 RIDGE AVENUE PHILADELPHIA  
BRANCHES - SAVANNAH AND SAN FRANCISCO



GEORGE H. TAY CO.  
SAN FRANCISCO, CAL.

HIGH GRADE

# Plumbing Fixtures

SOLD UNDER OUR

"Gold Label Guarantee"

Affords a Form of Insurance  
Equally Pleasing to Owner,  
Architect and Plumber : : :

Call at our showrooms for particulars

617 Mission Street San Francisco

**W. W. BREITE, C. E.***Structural Engineer*

Designs and Details of

All Classes of Metallic Structures

702-704-706 CLUNIE BUILDING  
California and Montgomery Sts.**SAN FRANCISCO CALIFORNIA****MALTHE**  
**DAMP-PROOF PAINT**  
**MALTHE**

(Trade Mark Reg.)

Proven BEST by Every Test

**JOHN L. FOX**

TELEPHONE KEARNY 3515

207 MONADNOCK BUILDING SAN FRANCISCO, CAL.

DR. W. J. HANNA, PRES.  
H. J. HARRISON, VICE-PRES.  
R. M. BEEBEE, SEC'Y-TREAS.**IONE SANDSTONE CO.**RED, WHITE AND VARIEGATED  
**BUILDING STONE**ROOM 532 OCHSNER BUILDING  
SACRAMENTO, CAL.

TELEPHONE 9833 R

QUARRY, AMADOR COUNTY

Telephone Market 3989

**Ferdinand Wagner****MASON  
and  
BUILDER**ESTIMATES FURNISHED ON ALL KINDS  
OF WORK

609 Waller Street - San Francisco

**DEWEY PATENT  
DISAPPEARING BEDS**ALL KINDS OF WALL BEDS  
AND CABINET BEDS

MANUFACTURED BY

**THE MURPHY MANUFACTURING COMPANY**  
919 O'FARRELL STREET  
SAN FRANCISCO, CAL.**J. A. M. JOHNSON CO.**Bank and Office  
**EQUIPMENT**Room 519 Monadnock Bldg.  
Tel. Sutter 741 SAN FRANCISCO**HOYT BROS.****CONTRACTORS**

of Northern California make a specialty of

**PUBLIC BUILDINGS**BUILDERS' EXCHANGE  
SAN FRANCISCO

SANTA ROSA, CAL.

MAIN 2615

HOME F 2615

**Richard Arenz Co.**  
**Painting and Decorating**

DISTRIBUTORS

SOUTHERN CALIFORNIA

FOR

PARKER, PRESTON & CO'S  
ART IN SHINGLE STAINS. WEATHER  
PROOF AND WATERPROOF  
COATINGS335 EAST FOURTH STREET  
Near San Pedro Street, LOS ANGELES, CAL.





The Value of a System of  
**FLAT VERTICAL FILING**

For Drawings, Tracings  
and Blue Prints

UNTIL YOU HAVE USED IT

Write for Catalog BF

**Eugene Dietzgen Co.** 18 First St.  
San Francisco



H. M. SCARRITT

W. A. CLARK

**SCARRITT & CLARK**

Foundations, Retaining  
Walls, Cement Walks  
and Floors....

Dealers in CRUSHED BRICK

GENERAL CONTRACTORS

REINFORCED CONCRETE CONSTRUCTION OFFICE, YARD AND BUNKERS:

TELEPHONE FRANKLIN 1804 TURK AND JONES STS.

**JOHN G. ILS & CO.**

Kitchen Equipments

and Installations

827-829 MISSION STREET SAN FRANCISCO, CAL.

OUR SPECIALTY IS FRENCH RANGES (Brick Set)

**BROWN'S GASKET**

A New Sanitary Plumbing Device to Pre-  
vent the Escape of Water and Sewer Gas.

DEADENS NOISE OF FLUSHING

Order from Your Jobber

**Sanitary Plumbing  
Appliance Co., Inc.**

412 Sheldon Bldg., First and Market Sts.  
Tel. Sutter 1476 SAN FRANCISCO, CAL.

BOILERS

ENGINES

TANKS

PUMPS

CONDENSERS

**BRAUN, WILLIAMS & RUSSELL, Inc.**

503 Market Street, San Francisco :: Telephone DOUGLAS 5356

**MECHANICAL ENGINEERS AND CONSTRUCTORS**

Representatives ALBERGER CONDENSER CO. MINNEAPOLIS STEEL AND MACHINERY CO. ROBB-MUMFORD BOILER CO.

**SIMONDS MACHINERY CO.**

**PUMPING MACHINERY**

Sole Agents KEWANEE WATER SUPPLY CO.

Phones, Kearay 1457  
Home J 3467

12 and 14 Natoma Street, Near First, San Francisco

**THE PACIFIC LABORATORIES, Incorporated**

MINING ENGINEERS, CHEMISTS AND METALLURGISTS

Inspectors of Steel, Cement, Building Materials and Construction Work

MAIN OFFICE AND LABORATORIES

558 MARKET STREET, SAN FRANCISCO, CAL.

PHONE DOUGLAS 3678

**COLUMBIA LUMBER CO.**

LUMBER OF ALL DESCRIPTIONS IN STOCK OR CUT TO ORDER

Main Office—BEACH STREET, Between Taylor and Mason, San Francisco, Calif.

Telephones, Kearny 323 — Home C 4545

Mill—South Bend, Wash.

Yard—Block bounded by Beach, North Point, Taylor, Mason

R. J. BRODE, PROPRIETOR TEL. KEARNY 2464

**BRODE IRON WORKS**  
MANUFACTURERS OF  
**STRUCTURAL STEEL** ORNAMENTAL  
IRON WORK

OFFICE AND WORKS BET. SECOND AND THIRD STS.  
621-625 HOWARD STREET SAN FRANCISCO, CAL.

MEMBER OF TECHNICAL SOCIETY ALL SURVEY NOTES SAVED



**SANBORN & CORINSON**  
Successors to C. S. TILTON  
**Surveyors and Civil Engineers**

Phone Douglas 366 Home Phone C 2741 251 KEARNY ST., Charleston Bldg., Room 406  
SAN FRANCISCO

**MORTENSON CONSTRUCTION CO.**

CONTRACTORS FOR STRUCTURAL STEEL AND IRON  
H. MORTENSON, PRES. CHAS. G. MORTENSON, VICE-PRES. AND MGR.

OFFICE AND SHOPS: CORNER 19TH AND INDIANA STREETS  
PHONES: MISSION 5D33—HOME M 3918 SAN FRANCISCO, CAL.

**INDUSTRIAL**  IRON, BRASS & BRONZE WORK  
**ORNAMENTAL IRON**  WIRE GUARDS  
and **WIRE WORKS**  BANK & OFFICE  
RAILINGS  
FOLDING  
GATES

JOHN NORDGREN  
MANAGER  
552 NOE STREET  
SAN FRANCISCO, CAL.  
PHONE MISSION 6237

**C. FARRENKOPF & SONS**  
**ARCHITECTURAL IRON WORKS**

Grill Work, Stair Rails, Fire Escapes, Elevator Cars, Bank and  
Office Counter and Enclosure Work, Sash Bars, Store Fronts

Phone Market 2145 623 MINNA STREET, near 7th, SAN FRANCISCO, CAL.

C. S. HOFFMAN L. W. FLEIGNER

**GOLDEN GATE STRUCTURAL and ORNAMENTAL IRON WORKS**

Structural Works, 107-109 Eleventh Street  
Ornamental Iron, Wire Works and Office, 1479 Mission Street, San Francisco  
Pacific Telephone, Market 5445 Home Phone J1815

**REINFORCED CONCRETE CONSTRUCTION**

Contracts Taken for Foundation Work, Fireproofing and Complete Structures.  
No Contract Too Small or Too Large. Our Motto: "One Good Job Deserves Another."

**Mt. Diablo Concrete Construction Co.**

W. E. Charbonneau, President E. Nelson, Treasurer F. E. McCoy, Secretary  
Telephone, Sutter 1227 Offices, 211-213 No. 185 Stevenson St., San Francisco

**SCHASTEY & VOLLMER** | **Designers**  
1930 Van Ness Avenue | and  
Telephone Franklin 2729 SAN FRANCISCO, CAL. | **Decorators**

# STANLEY'S BALL BEARING HINGES

In Wrought Bronze or Steel

Nothing else so good for Hanging Doors.

No wearing down, no creaking, no need of oiling

— For sale by —  
Hardware Dealers

Attractive Literature Free

**THE STANLEY WORKS**  
NEW BRITAIN, CONN.

# ARMSTRONG ELECTRIC SIGNALS

for Passenger and Freight Elevators

MECHANICAL FLOOR INDICATORS FOR ELEVATORS

Automatic Freight Door Operating Mechanism, Expressman Call System, Fire-proof Steel Curtains for Theatres.

## Elevator Supply and Repair Co.

GEO. A. MESICK,  
Pacific Coast Manager

BALBOA BLDG. SAN FRANCISCO

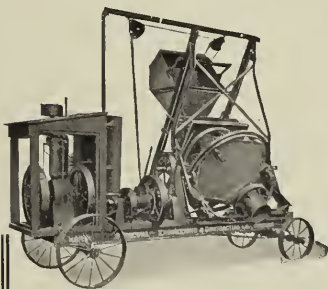

## Chicago Improved Cube Concrete Mixer

MANUFACTURED BY

**MUNICIPAL ENGINEERING & CONTRACTING CO.**

Main Office, Railway Exchange,  
CHICAGO, ILL.

San Francisco Agents, Lansing Wheelbarrow Co., 789 Folsom St.

P. B. ENGH, 345 Pacific Electric Bldg., Los Angeles  
Special Sales Representative for Southern California

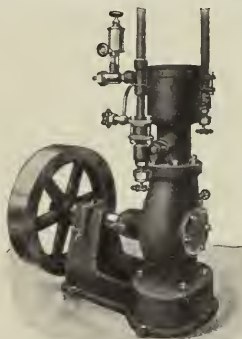

We build and install Ice Making and Refrigerating Machinery of any capacity

## Triumph Ice Machine Co.

H. F. LYON, Western Representative  
581 Monadnock Building, San Francisco.

## SAVING TIME *by* TELEPHONE



WHEN a man feels the necessity of being in two places at the same time he goes to the nearest telephone and sends his voice.

It is not exactly the same thing, but when a man talks hundreds of miles in opposite directions from the same Bell Telephone, it is about as good.

In the daily use of the telephone a man travels all over town by wire in a few minutes. It is just as easy to travel all over the state and other states by means of the universal Long Distance Service of the Bell System.



### The Pacific Telephone & Telegraph Co.

*Every Bell Telephone is the Center of the System*



# NATOMAS ROCK

A CRUSHED ROCK that is absolutely free of sand, clay or other foreign matter, very hard and very tough, without flaw or seam. Unequaled for concrete or macadam work. Inquiries and trial orders solicited.

## Natomas Consolidated of California,

Rock Crushing Department,

203 Hagelstein Building,

SACRAMENTO, CAL.

**WHAT IS MORE TROUBLESOME THAN TO PACK RADIATOR VALVES**

**Y**OU never seem to have the right size packing. Because there is no active rod travel through the stuffing box the packing sets and gets hard, and the valves leak more or less when opened or closed.

**PALMETTO TWIST**

can be unstranded and any size valve packed from one spool. It cannot burn — its all asbestos. Does not get hard — because a perfect lubricant is forced into each strand. Use **PALMETTO TWIST** on all the valves, and you will not have to repack so often. We will send you a sample spool **FREE**. Just to prove this.

**H. N. COOK BELTING CO.**

317-319 Howard Street

SAN FRANCISCO

CALIFORNIA



K  
O  
M  
P  
O  
L  
I  
T  
E  
F  
L  
O  
O  
R  
S

SANITARY

**FLOORS WITHOUT FLAWS**

**A PERFECT FLOOR** should have at least these four qualifications: It should be **BEAUTIFUL** and **DURABLE**, **SANITARY** and **FIRE-PROOF**. Those manufactured by the **KOMPOLITE CO.** have all these qualities, and at the same time many more which render them ideal for use in **Hospitals, Churches, Factories, Steamships, Schools, Theatres, Public Buildings, Lofts, Garages, Private Houses, Etc.**

**TAKES AND HOLDS AN ORDINARY SCREW**

**FACTORIES:**  
SAN FRANCISCO  
NEW YORK

**OFFICES:** 337 MILLS BLDG.  
SAN FRANCISCO  
132 NASSAU ST.  
NEW YORK

**TELEPHONE: SUTTER 272**

**Architects! Contractors!**

**W**E are trying to introduce **DES MOINES ELATERITE** products, using a new base for paints — which gives results that cannot be obtained with any other base. *Give it a trial.* We know we can satisfy you. If you have any special conditions to meet for **Waterproofing, Acid or Alkali, Climate on any kind of a surface,** send for us. We have special mixtures for each. Also plaster bond, marine and heat resisting paints.

**S**PECIFY Lupton Steel Sash steel and copper Skylight, and Fireproof windows, for the **BEST** construction. We want *inquiries* from *Contractors* for steel and Reinforcing Materials, Steel Ceiling and special paints, also for *any kind of machinery.* You will find it to your advantage to get my prices.

I have the Cheapest and Best Rock and Ore Crusher on the market, and also Oil Burning Apparatus, and the Best Bar Bender made.

**S. A. WHITE** 375 MONADNOCK BLDG.  
SAN FRANCISCO  
Phone, Sutter 1575



# GOODYEAR'S FIRE PROTECTION

FOR OFFICE BUILDINGS, FACTORIES AND RESIDENCES

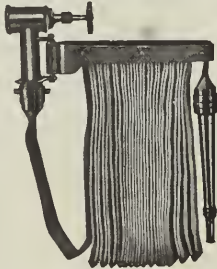

ESTIMATES FURNISHED

All Styles Swinging Hose Reels. "Eclipse" Swinging Hose Rack, with Goodyear Special Valve. Acme Fire Extinguishers, Approved and Labeled. Always Ready for Use. Rubber Matting, Mats, Rubber Tiling, etc. Eureka's Rubber Lined Cotton Hose and Unlined Linen Hose. Specify "Eureka's Best," "20th Century" or "Worthy" for an Underwriter's Approved Linen Fire Hose.



## GOODYEAR RUBBER CO.

R. H. PEASE, President

587-589-591 Market St.  
San Francisco

61-63-65-67 Fourth St.  
Portland, Oregon



Crusher House and Ore Conveyor, Goldfield Consolidated Mines Company.

## P. J. KNUDSEN COMPANY

214 Front St., San Francisco

SOLE AGENTS FOR

ASBESTOS PROTECTED METAL COMPANY

Canton, Massachusetts

## THE CHEAPEST REINFORCEMENT AND BEST

The superiority of the Kahn Trussed Bar has never been questioned, so that we can say "cheapest" and be understood. Considered strictly from a dollars-and-cents standpoint you are losing money by buying any other bar. Remember that in the Kahn Trussed Bar the shear members are formed from the flanges of the main bar which are ordinarily wasted,—that you save all of the expense of handling a large number of loose stirrups — that you secure absolute safety and strength against fire, shock or careless workmanship, — that rigid connection makes beams 20% stronger.

### INSIST ON RIGID CONNECTION OF SHEAR MEMBERS



## KAHN TRUSSED BARS

Other Kahn System Products include:

Hy-Rib, a self-centering reinforcement for Roofs, Floors, Walls, Partitions and Ceilings; Rib Metal, for Conduits and Slabs; Built-up Column Hooping; Cup-Bars, Straight or Bent; Rib Lath and Rib Studs, for Plaster and Stucco; United Steel Sash for Fireproof Windows; Trus-Con Products, for Waterproofing and Finishing Concrete.

Write for catalogues or call upon one of the men listed below.

### Trussed Concrete Steel Company

689 Trussed Concrete Building, Detroit, Michigan

SAN FRANCISCO, Felix Kahn,  
304 Macdonough Building.

PORTLAND, ORE., J. A. Currey,  
1009 Board of Trade Building.

LOS ANGELES, J. E. Heber,  
703 Central Building.

SEATTLE, WASHINGTON,  
Arthur T. Nelson, 836 Henry Bldg.



## FARRELL & REED

MASONS and GENERAL CONTRACTORS

Cut Shows Facade of New Orpheum Theatre, San Francisco. G. Albert Lansburgh, Architect

Stone and Terra Cotta Work and Terra Cotta Partitions by **Farrell & Reed**

Office 9th Floor, Gunst Bldg.  
Third and Mission Sts.  
Phone Sutter 450 San Francisco

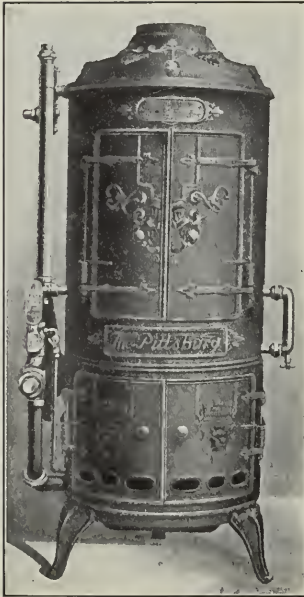

The Standard of Perfection

# PITTSBURG AUTOMATIC WATER HEATERS

also

Storage System and House Heaters

Most Efficient and Economical Gas  
Water Heaters Manufactured

## JOS. THIEBEN & CO

SOLE AGENTS

667 Mission Street  
SAN FRANCISCO

Phones: Kearny 3762

Home J-3762

# DODD'S INTERLOCKING BLOCKS

USED IN THIS BUILDING

*A*

*Fire Proof  
Germ Proof  
and Inexpensive  
Partition  
Will not Warp  
Make an Absolutely  
True Surface*

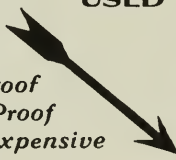

INVESTIGATE

## BOYD & MOORE

SALES AGENTS

356 Market St. San Francisco

Sheldon Bldg. San Francisco. B. G. McDougall, Architect

# BAY DEVELOPMENT COMPANY GRAVEL - SAND - ROCK

Telephones, K 5313 -- J 3535 153 BERRY ST., SAN FRANCISCO

C. T. GUTLEBEN

DAN GUTLEBEN

## GUTLEBEN BROTHERS

CONTRACTORS ARCHITECTURAL AND  
ENGINEERING CONSTRUCTION

PHONE KEARNY 4640 927 MONADNOCK BLDG., SAN FRANCISCO

E. D. CROWLEY, PRESIDENT

S. A. JUBB, SECRETARY

## E. D. CROWLEY CO.

CONSTRUCTING ENGINEERS

EXPERTS IN REINFORCED  
CONCRETE CONSTRUCTION

PHONE DOUGLAS 982

127 MONTGOMERY STREET  
SAN FRANCISCO

THOMAS ELAM  
GROVER C. ELAM

Phone Kearny 4700

## THOMAS ELAM & SON

GENERAL CONTRACTORS

Office, Builders' Exchange, 180 Jessie Street

San Francisco, Cal.

## LOCKE FOUNDATION CO.

CONTRACTING ENGINEERS

CONCRETE AND CEMENT WORK

1107 CROCKER BUILDING

Phone Kearny 2608

SAN FRANCISCO, CAL.

## THE J. L. MOTT IRON WORKS —OF— NEW YORK

D. H. GULICK, Selling Agent for Pacific Coast

135 KEARNY ST.

Phone, West 6894

SAN FRANCISCO

## SAMSON SPOT SASH CORD

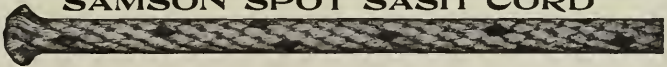

Guaranteed free from all imperfections of braid or finish. Can always be distinguished by our trade mark, the colored spots. Send for samples, tests, etc. SAMSON CORDAGE WORKS, BOSTON, MASS.  
Pacific Coast Agent. JOHN T. ROWNTREE, 1075 Monadnock Bldg., San Francisco and 501 Equitable Savings Bank Bldg., Los Angeles

## W. H. BAGGE & SON, INC.

BUILDING CONSTRUCTION

TELEPHONE KEARNY 4749  
ESTABLISHED 1889

3528 SACRAMENTO STREET  
SAN FRANCISCO, CAL.

F. O. ENGSTRUM, PRESIDENT  
F. E. ENGSTRUM, VICE-PRESIDENT

TELEPHONES :  
MAIN 3046-A-1969

H. W. BRYSON, MANAGER  
WM. MCKAY, SUPERINTENDENT

## **F. O. ENGSTRUM COMPANY, Inc.**

### **CONTRACTORS**

WHOLESALE DEALERS IN

LUMBER, BRICK, LIME, CEMENT, GLASS, SASH  
DOORS, PAINTS AND ELECTRICAL SUPPLIES

MAIN OFFICES, MILL, WAREHOUSE AND YARDS: EAST FIFTH AND SEATON STREETS, LOS ANGELES

## **FISKE'S**

### **FANCY IRON STABLE STALLS and STABLE FIXTURES**

Samples on exhibition. We would be pleased to have you call and examine these goods and give us an opportunity to quote prices.

## **HOWE SCALE COMPANY**

GEO. A. RIGG, MANAGER

143-149 MAIN STREET  
PHONE KEARNY 31

SAN FRANCISCO, CAL.

## **H. L. PETERSEN**

### **REINFORCED CONCRETE CONSTRUCTION**

Artificial Stone Sidewalks, Concrete Walls,  
: : Foundations, Tanks, Reservoirs, Etc. : :

Rooms 322-24, 62 POST ST.

SAN FRANCISCO

## **GEO. H. STOFFELS & CO.**

### **BUILDERS**

830 PACIFIC BUILDING

SAN FRANCISCO, CAL.





*Geo. W. Kelham, Supervising Architect*

*Trowbridge & Livingston, Architects*

## **Palace Hotel, Deep Basement and Sidewalks Waterproofed with**

# **HYDREX**

**MEMBRANE SYSTEM**

Plans, Specifications and Estimates Furnished

---

**SOLE REPRESENTATIVES FOR CALIFORNIA**

## **BOYD & MOORE**

**356 Market Street**

**San Francisco**

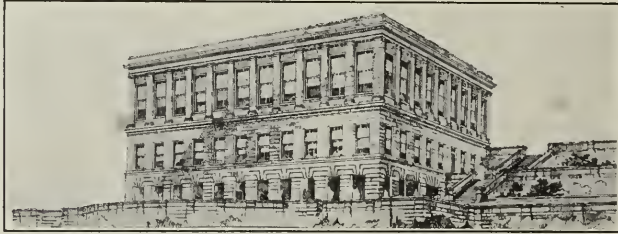

CLIFF HOUSE, San Francisco. Reid Bros., Architects. Interior Decoration by  
A. C. WOCKER, DECORATOR, 1820 Sutter Street, San Francisco



The "Triumph" Desk

## C. F. WEBER & CO.

**Manufacturers of SEATING FOR ALL PUBLIC BUILDINGS**

School Desks, Church Pews, Opera Chairs, Hall Seating, Bank Furniture, Lodge Furniture and Equipment, P. O. Cabinets. Also Venetian Blinds, Rolling Wood Partitions, School and Church Bells, Maps, Map Cases, Globes.

Manufacturers of *Hyloplate* Blackboards, in use in nearly all School Buildings.

Ask for booklet "Good Blackboards"; also "Hand Book of Seating." They are FREE to Architects.

Offices: 365-367 Market St., San Francisco. 210-212 North Main St., Los Angeles



Art Glass Panel in Dunn's Cafe, San Francisco

From the Studio of  
**THOMAS & SCHNEIDER**  
ART GLASS CO.

610-12 Howard Street San Francisco



Artificial Stone as Granite, Sandstone,  
Marble. Special Capitals in Classic  
and Modern Designs

## Architectural Decorating Co.

F. J. HAHN, Manager  
1255 FIRST AVENUE SOUTH,  
SEATTLE, WASHINGTON

Manufacturers of

## ARTISTIC RELIEF DECORATIONS

For Exterior and Interior Use  
Thousands of Different Models in Stock

## Waterhouse & Price Co.

SAN FRANCISCO  
OAKLAND LOS ANGELES SEATTLE PORTLAND

No Modern Flat or Apartment House  
is Complete without—

RISCHMULLER'S IMPROVED LIQUID  
DOOR CHECK AND SPRING as well as  
RISCHMULLER'S PATENT DOOR OPENER  
and CLOSER.

HOME INDUSTRY  
Details on Application

**G. RISCHMULLER**  
BUILDERS' EXCHANGE  
San Francisco

842 37th St. - - OAKLAND

Phone Douglas 1763

**GRANT FEE**  
**GENERAL CONTRACTOR**

**Business Buildings and Heavy  
Construction a Specialty**

Office:  
682 Monadnock Bldg. SAN FRANCISCO

Member of Builders' Exchange  
and Builders' Association

**D. ROSS CLARKE**  
**PLASTERING and CEMENT CONTRACTOR**

**Ornamental Plastering and Cement Plastering  
or Reinforced Concrete a Specialty**

**EXTERIOR CEMENTING DONE  
IN WHITE OR CREAM COLOR**

OFFICE:  
708 PACIFIC BUILDING

ESTABLISHED 1865

C. H. Franklin, Mgr. & Atty.

**THE FRANKFORT Marine Accident and Plate Glass  
INSURANCE COMPANY**  
OF FRANKFORT-ON-THE-MAIN, GERMANY  
INSURANCES TRANSACTED

United States Department, 100 William Street, New York  
LIABILITY:—Employers, Public, Teams, General, Land-  
lords, Elevator, Vessel Owners, Contingent, Druggists and  
Physicians. Burglary. Workmen's Collective. Individual  
Accident and Health. Industrial Accident and Health.

TRUSTEES

RICHARD DELAFIELD, Pres. of National Park Bank.  
ERNST THALMANN, of Ladenburg, Thalmann & Co.  
STUVVESANT FISH, 52 Wall St, New York.

DAVID DUNCAN, General Agent, Pacific Coast Dep't.  
340 SANSOME STREET, SAN FRANCISCO, CAL.  
Agents wanted for unoccupied territory

**Esterly**

**Construction Co.**

Incorporated

**CEMENT AND CONCRETE  
CONTRACTORS**

2136 CENTER STREET  
BERKELEY, CAL.

PHONE PACIFIC 1822

**WALLACE C. BOSWALL**

**CONTRACTOR AND SUPERIN-  
TENDENT OF CONSTRUCTION  
STORE AND SALOON FITTINGS**

58 BOYCE STREET  
SAN FRANCISCO

JOBGING PROMPTLY WORK OF ALL KINDS  
ATTENDED TO DONE ON PERCENTAGE

H. W. HANLEY  
P. J. McCULLOCH

Phone Douglas 2446

**HANLEY & McCULLOCH**

**CONTRACTING PLASTERERS**



378 MONADNOCK BUILDING  
SAN FRANCISCO, CALIFORNIA

**WE HAVE MOVED  
to 121 SECOND ST.  
SAN FRANCISCO, CAL.**

**CALIFORNIA PHOTO  
ENGRAVING COMPANY**  
PHONES - SUTTER 789; HOME, J 2705

DOUBLE  
DAILY  
SERVICE

ON THE

# SUNSET ROUTE

Between San Francisco, Los Angeles, New Orleans and East via the Road of a Thousand Wonders, Southern California Orange Groves and El Paso with its Mexico border scenes.

# SOUTHERN PACIFIC

TICKET OFFICES:

Flood Building, Palace Hotel,  
Market Street Ferry Depot,  
Third & Townsend Sts. Depot,  
Broadway & 13th St., Oakland.

**Hannon "OUTERSITE" Metal Picture Moulding** (patented)  
**Hannon ORNAMENTAL Metal Picture Moulding** (patented)



**Hannon Ornamental  
 Metal Picture Moulding**

Showing Bracket inserted into "OUTERSITE" and HANNON METAL PICTURE MOULDING attached thereto.

**UNION METAL CORNER CO.**  
 MANUFACTURERS, BOSTON, MASS.

**"Outersite"  
 Plastered**

Showing Hook Inserted  
 Hook can be placed  
 wherever desired.

OR

**Hannon "Outersite"  
 Metal Picture Moulding**

[An Invisible moulding]  
 Above section shows "Outersite" applied to wood lath (upper half) and to wire (lower half). Can be used on any kind of fire proof construction. "Outersite" is doubly hot-galvanized. Made in one length only—10 ft.

**WATERHOUSE & PRICE CO.**  
 SAN FRANCISCO      PORTLAND  
 LOS ANGELES      OAKLAND

**Ferroidncave** The **IDEAL CONSTRUCTION**

For ROOFS, SIDE WALLS, ARCH and FLAT FLOORS, STAIRWAYS, PARTITIONS, TANKS, SILOS  
 Economical, Light, Fireproof, Great Strength, Simple in Construction, Requires no Centering, Permanent



Ferroidncave was used for Roof of this Garage

**The BROWN HOISTING MACHINERY CO., Cleveland, O.**  
 Ferroidncave Agent for California, CHAS. A. LEVY, 244 Balboa Building, San Francisco

When writing to Advertisers mention this Magazine.



MYRON HUNT &  
ELMER GREY  
Architects  
Los Angeles



Stained with  
Cabot's  
Shingle Stain

## CABOT'S CREOSOTE SHINGLE STAINS

THE ORIGINAL AND STANDARD STAINS

Distinguishable by their soft depth and freshness of color, richness of tone, and durability. No muddy or greasy effects, no blackening, no washing off. They have stood the test more than twenty-five years.

Cabot's Sheathing and Deafening "Quilt." Cabot's Waterproof Cement Stains. Conservo Wood Preservative. Cabot's Waterproof Brick Stains.

**Samuel Cabot, Inc., Sole Manufacturers, Boston, Mass.**

Agents { Waterhouse & Price Co., San Francisco and Oakland, Cal.  
P. H. Mathews Paint House, Los Angeles  
Timms, Cress & Co., Portland, Oregon  
S. W. R. Dally, Seattle, Tacoma and Spokane

# DAMP PROOF YOUR BRICK AND CONCRETE WALLS

**FIRE PROOF**

USE



## LIQUID STONE

It will keep walls Dry and Insure a Water Tight Structure. Liquid Stone is a Paint made from Stone and applied to the surface with an ordinary Paint Brush.

Used on the Walls of the San Francisco Y. M. C. A. Building, MacDougall Bros., Architects.

**WATER PROOF**

## THE LIQUID STONE PAINT CO., Inc.

MAIN OFFICE, 306 CHRONICLE BLDG.  
PHONE DOUGLAS 250

LAIRD & SINCLAIR AND LILLEY & THURSTON CO.  
AGENTS  
SAN FRANCISCO, CAL.



HADDAM DESIGN



WARREN DESIGN

**RUSSELL & ERWIN MFG. CO.**  
NEW BRITAIN, CONN.

464-411 Commercial Building, San Francisco

NEW YORK

PHILADELPHIA

CHICAGO

LONDON, ENG

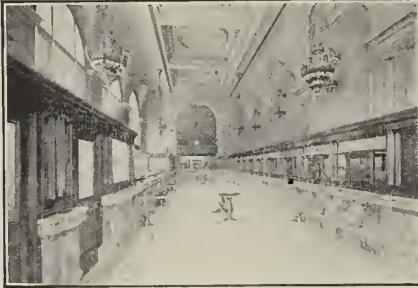

Interior of Banking Room, London Paris National Bank, San Francisco  
Albert Pissis Architect

Plain and Ornamental  
**PLASTER Work**

BY

**Callaghan  
& Manetta**



334 Tenth Street

SAN FRANCISCO, CAL.

# CALIFORNIA SCAGLIOLA CO

WE GUARANTEE  
ALL OUR HIGH  
GRADE IMPORTED  
MARBLE IMITATIONS  
TO BE PERFECT  
WITH THE VERY  
FINEST EVER-  
LASTING  
FRENCH  
POLISH.

OFFICE & YARD  
**68-70 CLARA STREET**  
BETWEEN 3<sup>RD</sup> & 4<sup>TH</sup> STREETS  
**SAN FRANCISCO, CAL.**

THE MOST  
ELEGANT  
INTERIOR  
ARTISTIC MARBLE  
DECORATIONS  
IN ALL COLORS  
LOWEST PRICES  
SAMPLES ESTIMATES  
CHEERFULLY  
FURNISHED

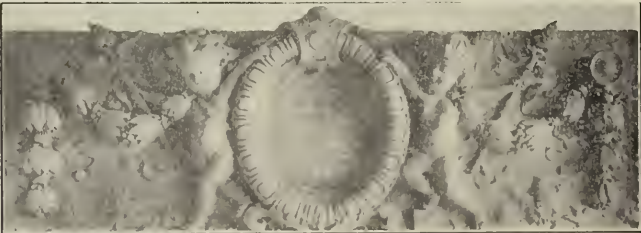

Produced in Caen Stone

Expert in the manufacture of Caen Stone and Graphito; also Fire and Waterproof Composition for the exterior of all kinds of frame buildings, etc. (Patent applied for.) Also the Menzer Interlocking Fire-proof Partition Wall Block

**C. MENZER & SON**

DESIGNERS AND ARCHITECTURAL SCULPTORS

862 HOWARD ST., SAN FRANCISCO



best by every test

**T**HE Popularity of Pioneer Roofing is due to its wearing qualities. We want to go on record right here and now with the positive assertion that a "Pioneer Roof" will outlast two ordinary roofs. The first cost is little if any more than you would have to pay for roofing of inferior quality. And once a "Pioneer Roof" is on, there is no further cost. It requires no paint or repairs. Address Dept. 23.

**Booklet and Samples**

The Pioneer Paper Company has issued a 32 page Roofing Booklet, a copy of which, together with samples of Roofing, will be mailed upon request. Address Dept. 23.

**PIONEER PAPER COMPANY**

247-251 SO. LOS ANGELES ST., LOS ANGELES, CAL.

**GABRIEL MOULIN**

Maker of

**Photographs**

**FOR ADVERTISING AND  
COMMERCIAL PURPOSES**

**153 Kearny Street  
Wiley B. Allen Building  
San Francisco**

**Telephone Douglas 4969**

**THE BRADSHAW SANITARY  
GARBAGE CHUTE PATENTED**

Absolutely sanitary, odorless, germ, fly, and rat proof. Labor and Cost in disposing of garbage reduced to a minimum. Particularly designed for apartment houses, flats, hospitals, hotels and residences.

**First Cost the Only Cost**

**T**HE BRADSHAW SANITARY GARBAGE CHUTE can be applied to old as well as new buildings. It extends from basement to roof and is thoroughly ventilated. As the door is opened to receive the garbage an automatic sprinkler thoroughly flushes the chute. The garbage can has a wire screen bottom allowing the water to percolate through to the cess pool where it is trapped to the sewer. It is hermetically sealed, thus preventing all dust and odors and shutting off any food supply for rats or domestic animals. This system reduces to a minimum or entirely eliminates janitor service now required for the disposal of garbage. The chute is made of heavy galvanized sheet metal and iron castings. It is installed complete ready to connect to sewer and service pipes, and is guaranteed. The mechanical arrangements are so simple as to be absolutely fool-proof and out of the reach of small children. A complete chute is in full operation at our office, 524-26 Pine St.

Our chute can be installed at a very moderate price and **THE FIRST COST IS THE ONLY COST.** No expense for maintenance or wear and tear after it is in operation.

For full particulars prices, etc., address

**BILL & JACOBSEN,  
524-26 Pine Street,  
San Francisco, Cal.**

**Phones  
Kearny 1790  
Home C 6603**





# HUETER'S

## Superior Architectural

and

# FLOOR VARNISHES

¶ The Varnishes to Use and include in Your Specifications.

KEEP THESE IN MIND

HUETER'S INTERIOR WOOD FINISH  
 HUETER'S COLUMBIAN FLOOR  
 HUETER'S ELASTIC EXTERIOR  
 HUETER'S INTERIOR SPAR  
 HUETER'S MATT LAC (Rubbed Effect)

There are No Better Varnishes Made for the Purpose.

MANUFACTURED BY

## S. F. PIONEER VARNISH WORKS

E. L. HUETER, Proprietor

ESTABLISHED 1857

WORKS, - SAN FRANCISCO, CAL.

MAIN OFFICE,

816 MISSION STREET

Los Angeles Office and Warehouse,

333 to 343 East Second Street

Portland Office and Warehouse,

191 Second Street

Seattle Office and Warehouse,

91 Spring Street





SAN FRANCISCO  
PUBLIC LIBRARY

THE

# ARCHITECT & ENGINEER

OF  
CALIFORNIA

PACIFIC COAST STATES



Published by **THE ARCHITECT & ENGINEER CO.**

621 Monadaock Bld  
San Francisco  
Vol. XXIV. No

25c a Copy  
\$1.50 a Year

Entered at the Post Office, San Francisco, as second class matter.

FLOORS

ROOFS

NOTE CONTINUOUS BOND

CLINTON  
FIRE-PROOFING SYSTEM

FABRIC WIRE LATH

SIDEWALKS

Ceilings

PARTITIONS

CLINTON FIREPROOFING OF CALIFORNIA CONTRACTORS FOR FIREPROOFING

L. A. NORRIS CO. WESTERN SALES AGENTS FOR CLINTON FIRE-PROOFING MATERIALS

SEATTLE SAN FRANCISCO LOS ANGELES

**THIS HANGER**  
CAN be put in  $3\frac{3}{4}$ " partition, a great saving of space and 50 per cent of labor and material.  
Specified by All Leading Architects.  
The new patent hanger with double track, upper and lower, which cannot bind in any way, with side adjustment.

**Pacific Ballbearing Door Hanger Co.**  
Phone Kearny 1039 959-961 Howard St., San Francisco

**MEURER BROS. CO.**  
**UNIQUE SHINGLES**

All straight lines. No broken joints. Has a perfect lock and is water-tight even on a low pitch.

**A. H. McDONALD,** PACIFIC COAST MANAGER  
Office and Warehouse  
630 THIRD STREET  
SAN FRANCISCO

UNIQUE SHINGLE



VIEW OF MACHINERY ROOM—PACIFIC ELECTRIC RY. BUILDING, LOS ANGELES  
SHOWING FOUR CONTROLLER BOARDS

# 8 VAN EMON 8 ELEVATORS

WERE INSTALLED IN H. E. HUNTINGTON'S  
BUILDING OVER SIX YEARS AGO. 'RUN-  
NING NIGHT AND DAY AND GIVING PER-  
FECT SATISFACTION.

☞ THESE ELEVATORS CARRY OVER 14,000 PASSENGERS DAILY ☞

(Patronize Your Home Company)

# CONCRETE APPLIANCES COMPANY

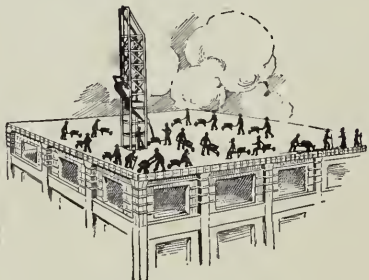

THE OLD WAY

- 1—COST TO WHEELBARROR OR CART CONCRETE, \$1 TO \$1.75 PER YARD.
- 2—SLOW AND CONGESTED, 8 TO 15 YARDS PER HOUR.
- 3—LOSS OF INITIAL SET, VARIABLE MULTILITHIC CONSTRUCTION.
- 4—CAUSES SEPARATION. AIDS LA TENGE.
- 6—DAMAGES FLOOR TILE, DISPLACES STEEL AND SPILLS CONCRETE.
- 6—EXPENSIVE SCAFFOLDING, RUNWAYS AND STAGING.
- 7—TAMPING.

LICENSORS  
OF  
**G-Y SYSTEM**  
OF CONVEYING AND  
DISTRIBUTING  
CONCRETE  
—  
LOS ANGELES

Patent Nos.

948719  
948723  
948746

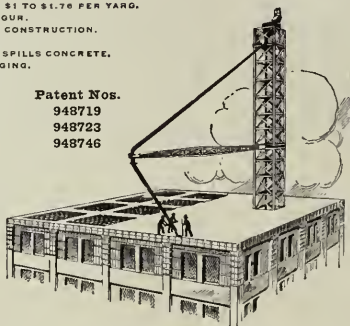

THE NEW WAY

- 1—COST FOR DELIVERING CONCRETE, 25 TO 30 CENTS PER CUBIC YARD
- 2—RAPID AND EFFICIENT, 25 TO 40 CUBIC YARDS PER HOUR.
- 3—OBTAIN INITIAL SET, HOMOGENEOUS MONOLITHIC CONSTRUCTION.
- 4—UNIFORM CONCRETE OBIVIATES LA TENGE.
- 6—NO LOSS OF FLOOR TILE, DISPLACEMENT OF STEEL OR SPILLING.
- 6—SAVES SCAFFOLDING, RUNWAYS AND STAGING.
- 7—NO TAMPING.

Buildings now being constructed  
by the Gravity System:

WILSON BUILDING, San Francisco, Cal.  
FERGUSON BUILDING, Los Angeles  
UNION LEAGUE BUILDING, Los Angeles  
COLUMBIA HOSPITAL BUILDING, Los Angeles  
EXPOSITION BUILDING FOR THE STATE AGRICULTURAL  
PARK, Los Angeles  
SWEETWATER DAM, San Diego, Cal.  
WAREHOUSE FOR GENERAL ELECTRIC COMPANY, Los  
Angeles  
EDISON ELECTRIC CO., 3 Warehouses, Long Beach  
SPRECKELS THEATRE AND OFFICE BLDG., San Diego

WILLIAM B. HOUGH COMPANY  
EXCLUSIVE AGENTS

HOME OFFICES  
CHICAGO, ILL.

DETROIT

MINNEAPOLIS

ST. LOUIS

DES MOINES

INDIANAPOLIS

PACIFIC COAST REPRESENTATIVES

## PARROTT & COMPANY

SAN FRANCISCO  
SEATTLE

TACOMA  
SPOKANE

PORTLAND  
LOS ANGELES

When writing to Advertisers mention this Magazine.



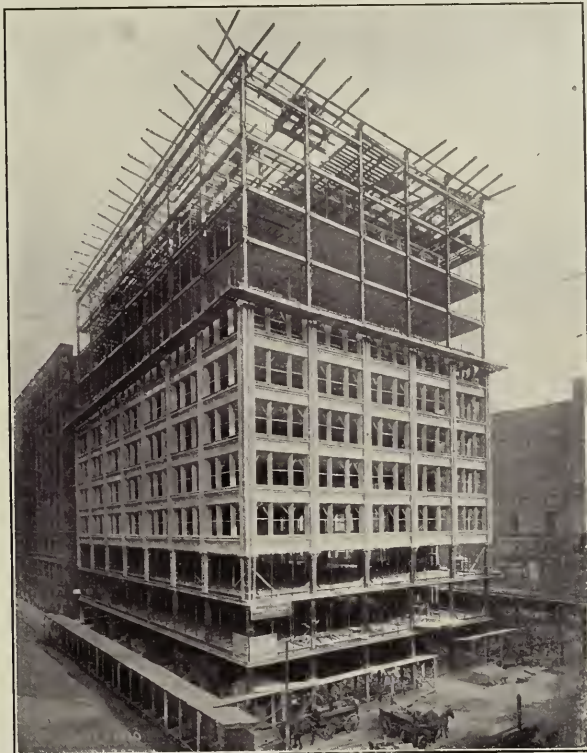

Safety Platforms at Top of Eighth Floor

## Lay your Bricks at any Story and at any Height with Perfect Safety

A Device for Conserving Human Life and Limb  
that Appeals to Contractor and Owner. Reduces  
Possibility of Accident Claims to a Minimum.

**The Patent Scaffolding Company**  
**PARROTT & CO.**

**Building Materials & Equipment.**  
San Francisco. Seattle. Los Angeles.

**Waterproofing Specialists**  
Tacoma. Portland. Spokane





# Building Materials

*These Three Are Permanent  
and Beautiful*

“RENO WHITE” PLASTER, a product of the Western Gypsum Co. that is beautiful, hard and lasting.

DEL MONTE WHITE SAND, to be used with Medusa and other white cement to make a beautiful white stone finish on concrete and artificial stone buildings.

“MEDUSA WHITE PORTLAND CEMENT,” a new and beautiful product adapted to ornamental artificial stone work of the highest grade.

**F.T.CROWE & Co.**  
**Jobbers and Dealers**

SEATTLE, PORTLAND, TACOMA, SPOKANE.

# WATERPROOFING WISDOM



PERMANENCY

is shown by  
the use of



ECONOMY

# CERESIT

paste. Same is simply added to the water used in mixing concrete and mortar. With the water, the CERESIT paste penetrates to all parts of the concrete and mortar and assures a permanent water- and damp-proof job.

No expert help required; no scientific and expensive mixing.

CERESIT is not an experiment, but has been used with complete success on hundreds of tanks, pits, foundations, dams and bridges. It has been employed not only by the U. S. Government, but by practically every government in the civilized world. More than 5,000,000 cubic feet of concrete and mortar have been waterproofed with CERESIT in 1909. The use of CERESIT is complete assurance against the penetration of moisture or dampness, even under high pressure, as encountered in dam work, etc.

Ask for our free book. It is money in your pocket to know about this excellent material.

## CERESIT WATERPROOFING CO.

PACIFIC COAST REPRESENTATIVES

## PARROTT & CO.

SAN FRANCISCO LOS ANGELES PORTLAND

### JULIEN A. BECKER CO.

413 BAILEY BLDG., SEATTLE, WASH.

MAIN OFFICE, 446 COMMERCIAL NATIONAL BANK BLDG., CHICAGO, ILL.

# Medusa

White Portland Cement  
Water Proof Compound



CONCRETE SWIMMING TANK, UNIVERSITY OF CALIFORNIA BERKELEY, CAL.

WATERPROOFED WITH MEDUSA COMPOUND

HIGH-TESTING  
STAINLESS



ABSOLUTELY PERMANENT  
RESULTS

The Building Material Co. INC.  
583 MONADNOCK BLDG, SAN FRANCISCO.

## ARCHITECTS' SPECIFICATION INDEX

(For Index to Advertisements, see page 117)

- ARCHITECTURAL AND ORNAMENTAL STEEL AND IRON WORK**  
 Western Iron Works, 141-147 Beale St., S. F.  
 Pacific Rolling Mills,  
 17th and Mississippi Sts., S. F.  
 Dyer Bros., 17th and Kansas Sts., S. F.  
 Central Iron Works, 621 Florida St., S. F.
- ARCHITECTURAL MODELERS**  
 S. Tomasello & Co.,  
 122 Tenth St., near Mission, S. F.  
 Callaghan & Manetta, 344 10th St., S. F.  
 C. Menzer & Son, 862 Howard St., S. F.
- ARCHITECTURAL TERRA COTTA**  
 Steiger Terra Cotta and Pottery Works,  
 Mills Bldg., S. F.  
 Gladding, McBean & Company,  
 Crocker Bldg., S. F.
- ASBESTOS-PROTECTED METAL**  
 P. J. Knudsen Company, Pacific Coast Agents,  
 214 Front St., S. F.
- AUTOMATIC FREIGHT ELEVATOR DOORS**  
 Boyd & Moore, 356 Market St., S. F.
- BANK FIXTURES**  
 M. G. West Company, 353 Market St., S. F.  
 J. A. M. Johnson, Monadnock Bldg., S. F.  
 C. F. Weber & Co., 365 Market St., San Francisco, and 210 N. Main St., Los Angeles, Cal.  
 Weary & Alford Co.,  
 303 Union Trust Bldg., S. F.
- BANK INTERIORS**  
 Weary & Alford Co.,  
 303 Union Trust Bldg., S. F.
- BELTING, PACKING, ETC.**  
 H. N. Cook Belting Co.,  
 317-319 Howard St., S. F.  
 Goodyear Rubber Co., 587 Market St., S. F.
- BLACKBOARDS**  
 Whitaker & Ray-Wiggin Co., 776 Mission St., S. F.; 209 E. Seventh St., Los Angeles.  
 C. F. Weber & Co., 365 Market St., S. F.
- BOILERS**  
 Simonds Machinery Co., 12 Natoma St., S. F.
- BRICK AND CEMENT COATING**  
 Wadsworth Howland & Co., Inc. (See Adv. for Pacific Coast Agents.)
- BRICK**  
 Gladding, McBean & Company,  
 Crocker Bldg., S. F.  
 Golden Gate Brick Co., 660 Market St., S. F.  
 Diamond Brick Co., Balboa Bldg., S. F.  
 Los Angeles Pressed Brick Co.,  
 Frost Bldg., Los Angeles  
 Northern Clay Company, Auburn, Wash.  
 Steiger Terra Cotta and Pottery Works,  
 Mills Bldg., S. F.  
 Vallejo Brick & Tile Co.,  
 Monadnock Bldg., S. F.
- BRICK STAINS**  
 Samuel Cabot Mfg. Co., Boston, Mass., agencies in San Francisco, Oakland, Los Angeles, Portland, Tacoma and Spokane.
- BRIDGE CONTRACTORS**  
 San Francisco Bridge Co.,  
 Monadnock Bldg., S. F.
- BUILDERS' HARDWARE**  
 Reading Hardware sold by Brittain & Co.,  
 San Francisco  
 Russell & Erwin Mfg. Co.,  
 Commercial Bldg., S. F.
- BUILDERS' SUPPLIES**  
 Boyd & Moore, 356 Market St., S. F.  
 Waterhouse & Price, 59 Third St., S. F.
- CAPITALS, MOLDINGS, ETC.**  
 Western Builders' Supply Co.,  
 680 Mission St., S. F.
- CASEMENT WINDOWS**  
 The Bexhill Casement Window Co.,  
 Mills Bldg., S. F.
- CEMENT**  
 Blanc Stainless Cement Co., Allentown, Pa.  
 Standard Supply Co.,  
 First St. and Broadway, Oakland  
 Pacific Portland Cement Co., Pacific Bldg., S. F.  
 Western Building Material Co.,  
 430 California St., S. F.  
 The Building Material Co., "Medusa White Portland", 587 Monadnock Bldg., S. F.  
 Boyd & Moore, 356 Market St., S. F.  
 Standard Portland Cement Co. and Santa Cruz Portland Cement Co., Crocker Bldg., S. F.
- CEMENT AND PLASTER BLOCKS**  
 Dods' Interlocking Block Company,  
 356 Market St., S. F.
- CEMENT AND PLASTER CONTRACTORS**  
 Callaghan & Manetta, 344 Tenth St., S. F.  
 D. Ross Clarke, 708 Pacific Bldg., S. F.  
 C. Menzer & Son, 862 Howard St., S. F.  
 A. Knowles, 985 Folsom St., S. F.
- CEMENT EXTERIOR WATERPROOF COATING**  
 "Blanc," manufactured by Blanc Stainless Cement Company, Allentown, Pa.  
 Protectorine, Black, White and Colorless,  
 Boyd & Moore, 356 Market St., S. F.  
 Bay State Brick and Cement Coating, made by Wadsworth, Howland & Co. [See distributing agents on page ]
- CEMENT TESTS**  
 Robert W. Hunt & Co.,  
 418 Montgomery St., S. F.  
 Smith, Emery & Co., 651 Howard St., S. F.
- CEMENT EXTERIOR FINISH**  
 Medusa White Portland Cement, California Agents, The Building Material Co., Inc.,  
 587 Monadnock Bldg., S. F.  
 "La Farge" sold by Waterhouse & Price,  
 59 Third St., S. F.  
 Blanc Stainless Cement Co., Allentown, Pa. [See color insert for Coast distributors.]  
 Bay State Brick and Cement Coating, made by Wadsworth, Howland & Co. [See list of distributing agents on page 119.]  
 Samuel Cabot Mfg. Co., Boston, Mass., agencies in San Francisco, Oakland, Los Angeles, Portland, Tacoma and Spokane.
- CEMENT FLOOR COATING**  
 Bay State Brick and Cement Coating, made by Wadsworth, Howland & Co. [See list of distributing agents on page 119.]
- CHEMICAL ENGINEERS**  
 Robert W. Hunt & Co.,  
 418 Montgomery St., S. F.  
 Smith, Emery & Co., 651 Howard St., S. F.

## A. L. YOUNG MACHINERY CO.

Hoisting Engines, Derricks, Concrete Mixers, Barrows and Carts,  
 Portable Saw Tables, Swing and Band Saws—in Stock

26-28 FREMONT STREET

SAN FRANCISCO, CAL.



HOME MARKET, SAN FRANCISCO. CHAS. S. KAISER, ARCHITECT

## **RANSOME CONCRETE COMPANY**

### **BUILDERS**

**MECHANICS' INSTITUTE BUILDING, SAN FRANCISCO**  
**328 J STREET, SACRAMENTO**

Rust-resisting—Anti-corrosive



**Black and Galvanized Sheets**

will resist corrosion under conditions that destroy iron and steel. Durability, Ductility and Price considered it is the logical material for roofing, siding and all formed products.

*Write for Samples, Prices and "Corrosion Text Book"*

CARRIED IN STOCK IN SAN FRANCISCO BY

**The Berger Manufacturing Company**  
**OF CALIFORNIA**

1120-22-24-26 Mission Street  
 San Francisco, Cal.

320 San Fernando Building  
 Los Angeles, Cal.





# WE MAKE BLUE PRINTS

DAY OR NIGHT--RAIN OR SHINE

**EUGENE DIETZGEN CO.,** 18 FIRST STREET  
SAN FRANCISCO

**Architects' Supplies      Surveying Instruments**

## ARCHITECTS' SPECIFICATION INDEX—Continued

### COLD STORAGE INSULATION

Neponset Waterdyke Felt and Compound, manufactured by F. W. Bird & Son, East Walpole, Mass.; sold by Parrott & Co., 320 California St., S. F.  
Hydrex Felt, Boyd & Moore, Agents, 356 Market St., S. F.

### CONCRETE APPLIANCES

A. L. Young Machinery Co., 26 Fremont St., S. F.

### CONCRETE CONSTRUCTION

Peterson, Nelson & Co., Inc., 407 Pine St., S. F.  
A. Lynch & Co., 185 Stevenson St., S. F.  
Esterly Construction Co., Berkeley, Cal.  
Bluxome & Co., Monadnock Bldg., S. F.

### CONCRETE FOUNDATIONS

Peterson, Nelson & Company, Russ Bldg., S. F.

### CONCRETE MIXERS

Foot Concrete Mixers, Monadnock Bldg., S. F.  
Coltrin Concrete Mixers, N. J. Morehouse, Western Agent, Waterloo, Iowa; J. L. Mery Eng. Co., Monadnock Bldg., S. F.; V. W. Mason, St. Johns, Ore.  
F. T. Crowe & Co., Seattle, Tacoma, Spokane and Portland  
Chicago Improved Cube Mixer, Pacific Coast Offices, 789 Folsom St., S. F., and F. T. Crowe & Co., Portland and Seattle  
A. L. Young Machinery Company, 26 Fremont St., S. F.

### CONCRETE POURING APPARATUS

Concrete Appliances Co., Los Angeles; Parrott & Co., Coast Representatives, San Francisco, Portland, Seattle

### CONCRETE REINFORCEMENT

The Kahn System, Agents in San Francisco, Los Angeles, Portland and Seattle.  
Clinton Fireproofing System, L. A. Norris, Monadnock Bldg., S. F.  
Corrugated Bars sold by John B. Leonard, C. E. Sheldon Bldg., S. F.  
International Fabric & Cable, represented by Western Builders' Supply Co., 680 Mission St., S. F.  
Twisted Bars sold by Woods & Huddart, 356 Market St., S. F.  
Plain and Twisted Bars, sold by Baker & Hamilton, San Francisco, Los Angeles and Sacramento.

### CONCRETE SURFACING

"Concrete" sold by W. P. Fuller & Co., S. F.  
"Alkacene" Liquid Concrete—Boyd & Moore, 356 Market St., S. F.

### CONCRETE SURFACING—Continued

Concrete, Worden-Mecker Varnish Co., S. F.—Oakland  
Glidden Liquid Cement, manufactured by Glidden Varnish Company, Whittier, Cobern Co., San Francisco and Los Angeles, Pacific Coast Distributors.

### CONTRACTORS, GENERAL

E. D. Crowley Co., 127 Montgomery St., S. F.  
W. H. Bagge & Son, Inc., 3528 Sacramento St., S. F.  
Esterly Construction Co., Berkeley, Cal.  
F. O. Engstrum Co., Fifth and Seaton Sts., Los Angeles  
Hansen & Johnson, Inc., 3 Mission St. S. F.  
Henning & Burke, 242 Russ Bldg., S. F.  
Walter Hough Company, 503 Market St., S. F.  
Hoyt Bros., Builders' Exchange, S. F., and Santa Rosa  
Ransome Concrete Co., Mechanics Institute Bldg., S. F.  
Gutleben Bros., 944 Monadnock Bldg., S. F.  
Rickon-Ehrhart Eng. & Const. Co., 1859 Geary St., S. F.  
Scarritt & Clark, Turk and Jones Sts., S. F.  
Geo. H. Stoffels & Co., 830 Pacific Bldg., S. F.  
Williams Bros. & Henderson, 351 Monadnock Bldg., S. F.

### CONCRETE MACHINERY

Wallace Concrete Machinery Co., represented by The Lilley & Thurston Co., 82 2nd St., S. F.

### CONCRETE REINFORCEMENT

Triangle Mesh Fabric, Sales Agents, The Lilley & Thurston Co., 82 2nd St., S. F.

### CORNER BEAD

"Prescott" sold by Boyd & Moore, 356 Market St., S. F.  
Union Metal Corner Company, 206 Summer St., Boston, represented on the Pacific Coast by Waterhouse & Price.

### CRUSHED ROCK

Natomas Consolidated of California, 203 Hagelstein Bldg., Sacramento, Cal.

### DAMP-PROOFING COMPOUND

John L. Fox, 207 Monadnock Bldg.  
Liquid Stone Paint Co., Inc., Laird & Sinclair and Lilley & Thurston Co., Agts., S. F.  
Boyd & Moore, 356 Market St., S. F.  
"Pabco" Damp Proofing Compound sold by Paraffine Paint Co., 38 First St., S. F.  
H. D. Samuel Co., Monadnock Bldg., S. F.  
"Protectorine," Compound, sold by Boyd & Moore, 356 Market St., S. F.  
Parrott & Co., agents for Genaseo Positive Seal Damp Proof Paint.

Specify...

For Plastering

**HOLMES DIAMOND SANTA CRUZ LIME**

PHONE KEARNY 2220

Guaranteed Against Pitting or Popping

The Holmes Lime Co.,  
Monadnock Bldg., San Francisco

When writing to Advertisers mention this Magazine.

## ARCHITECTS' SPECIFICATION INDEX—Continued

- DAMP PROOF PAINTS**  
John L. Fox.....207 Monadnock Bldg., S. F.
- DAMP PROOFING FOR BRICK WALLS**  
"Imperial" Waterproofing, sold by Baker Bros., San Francisco; Braun Chemical Co., Los Angeles; W. O. Stamps, Portland, and B. W. Gaisford, Seattle, Wash.  
John L. Fox.....207 Monadnock Bldg., S. F.
- DISAPPEARING BEDS**  
Holmes Disappearing Bed Company,  
687 Monadnock Bldg., S. F.
- DOOR OPENER**  
G. Rischmuller.....Builders' Ex., S. F.  
842 37th St., Oakland
- DOOR HANGERS**  
Johns Door Hanger Manufacturing Company,  
832-838 Folsom street, S. F.  
Pacific Ballbearing Door Hanger Co.,  
959 Howard St., S. F.  
Pitcher Hanger, sold by Pacific Tank Company.....231 Berry St., S. F.  
Reliance Hanger, sold by Sartorius Co., S. F.; D. F. Fryer & Co., Louis R. Bedell, Los Angeles, and Portland Wire & Iron Works.
- DOORS—FREIGHT ELEVATOR**  
"Cross" Counterbalance Automatic, Boyd & Moore, Agents.....356 Market St., S. F.
- DOORS—METAL**  
M. G. West Company, 353 Market St., S. F.  
Waterhouse & Price.....59 Third St., S. F.
- DOORS—WAREHOUSE**  
"Cross" Horizontal Folding Doors, Boyd & Moore, Agents.....356 Market St., S. F.
- DUMB WAITERS**  
Energy Dumb Waiters, Boyd & Moore, Agents.....356 Market St., S. F.  
Wells & Spencer Machine Company,  
173 Beale St., S. F.
- ELECTRICAL CONTRACTORS**  
Electric Appliance Co., 726 Mission St., S. F.  
The Turner Co.,.....278 Natoma St., S. F.  
Central Electric Co., 185 Stevenson St., S. F.  
Butte Engineering Co., 683 Howard St., S. F.  
Jno. G. Sutton Co.,.....229 Minna St., S. F.  
Pacific Fire Extinguisher Company,  
507 Montgomery St., S. F.
- ELEVATORS**  
Van Emon Elevator Co., 54 Natoma St., S. F.  
Wells & Spencer Machine Co.,  
173 Beale St., S. F.
- ELEVATOR CARS**  
Cleveland Art Metal Co., Boyd & Moore, Agents.....356 Market St., S. F.
- ELEVATORS, SIGNALS, FLASHLIGHTS AND DIAL INDICATORS**  
Elevator Supply & Repair Co.,  
593 Market St., S. F.
- ENGINEERS**  
John B. Leonard.....Sheldon Bldg., S. F.  
W. W. Breite.....Clunie Bldg., S. F.  
F. J. Amweg.....700 Marston Bldg., S. F.
- EXPRESS CALL SYSTEM**  
Elevator Supply & Repair Co.,  
593 Market St., S. F.

Highest Awards Grand Medal Paris 1900  
Exclusive Designs  
Finest Workmanship

## United Glass Works

INCORPORATED  
H. R. HOPPS, PRESIDENT

Art Stained Glass

TELEPHONES

FRANKLIN 1763 HOME J 1763

115 Turk Street

San Francisco

- FILING CASES—METAL**  
M. G. West Company, 353 Market St., S. F.
- FIRE EXTINGUISHERS**  
Goodyear Rubber Company,  
587-591 Market St., S. F.  
Pacific Fire Extinguisher Co.,  
507 Montgomery St., S. F.
- FIREPROOF PARTITIONS**  
Dodds' Interlocking Block Co.,  
356 Market St., S. F.
- FIREPROOFING**  
Gladding, McBean & Company,  
Crocker Bldg., S. F.  
Roebling Construction Co., Crocker Bldg., S. F.
- FIRE PROTECTION**  
Goodyear Rubber Company,  
587-589 Market St., S. F.
- FIRE PROTECTION—SPRINKLER SYSTEM**  
Jno. G. Sutton Co.,.....229 Mission St., S. F.  
Pacific Fire Extinguisher Company, 507 Montgomery St., San Francisco; Branch Offices, Portland, Seattle and Spokane.
- FLOOR VARNISH**  
Bass-Hueter and S. F. Pioneer Varnish Works,  
816 Mission St., S. F.  
Standard Varnish Works,  
Chicago, New York and S. F.  
Worden-Meeker Varnish Co., S. F.—Oakland
- FLOORS—COMPOSITION AND TILE**  
"Kompolite".....350 Mills Bldg., S. F.
- FOUNDATION CONTRACTORS**  
Locke Foundation Company,  
1107 Crocker Bldg., S. F.
- GARAGE EQUIPMENT—**  
Bowser Gasoline Tanks and Outfit, S. F.  
Bowser & Co.,.....612 Howard St., S. F.

Specify a  
California  
Marble...



## "PORTOLA"

A DELICATE BUFF BEAUTIFULLY MARKED  
THE THING FOR BANK INTERIORS, VESTIBULES AND  
HOTEL CORRIDORS SAMPLES ON APPLICATION

### THE COLUMBIA MARBLE CO.

268 MARKET ST., SAN FRANCISCO

QUARRIES FINISHING PLANT  
COLUMBIA, CALIFORNIA 17TH & MISSOURI STS., SAN FRANCISCO

# SAN FRANCISCO BRIDGE COMPANY

INCORPORATED 1884

## ENGINEERS AND CONTRACTORS

Dredging, Pile Driving, Wharves, Piers  
Foundations, Breakwaters, Rock Work  
Concrete, Pipe Lines, Sewers, Bridges  
Steel Work

865 Monadnock Building  
San Francisco, Cal.

Agents for C. W. Hunt Company's Labor Saving Devices  
and Ambursen Hydraulic Construction Company's Dams

### ARCHITECTS' SPECIFICATION INDEX—Continued

#### GARBAGE CHUTES

Bradshaw Garbage Chute, sold by C. T. Jacobson.....524 Pine St., S. F.

#### GLASS—PRISM, ART, ETC.

Thomas & Schneider Art Glass Co.,  
610 Howard St., S. F.  
California Art Glass Works,  
768 Mission St., S. F.  
United Glass Co.....115 Turk St., S. F.

#### GRAVEL, SAND AND CRUSHED ROCK

Bay Development Co.....153 Berry St., S. F.  
California Bldg., Material Co.,  
Pacific Bldg., S. F.  
Grant Gravel Co.....87 Third St., S. F.  
Del Monte White Sand, sold by Pacific Improvement Co.....Crocker Bldg., S. F.

#### HARDWOOD FLOORING

Boyd & Moore.....356 Market St., S. F.  
Dieckmann Hardwood Co.,  
244 California St., S. F.  
Parrott & Co.....320 California St., S. F.  
White Bros., Cor. Fifth and Brannan Sts., S. F.

#### HARDWOOD LUMBER

Dieckmann Hardwood Co., Welch Bldg., S. F.  
Niehaus & Co.....548 Brannan St., S. F.  
Strable Mfg. Co.,  
First St., betw. Washington & Clay, Oakland  
White Bros.,  
Cor. Fifth and Brannan Sts., S. F.  
Parrott & Co.....320 California St., S. F.

#### HARD WALL PLASTER

Standard Supply Company,  
First St. and Broadway, Oakland  
Reno Hard Wall Plaster, sold by Western Building Material Co.,  
430 California St., S. F.  
Empire Hard Wall Plaster Co.,  
Pacific Bldg., S. F.

#### HARDWOOD PANELS

White Bros., Cor. Fifth and Brannan Sts., S. F.  
Niehaus & Co.....548 Brannan St., S. F.

#### HEATERS—AUTOMATIC

Hart Heater Co., State Savings Bank Bldg.,  
13th and Franklin Sts., Oakland  
Hoffman Heater, sold by Holbrook, Merrill & Stetson, San Francisco and Los Angeles.  
Humphrey Co.,  
365 N. Rose St., Kalamazoo, Mich.  
Pittsburg Water Heater sold by Thos. Tbieben & Co.....585 Mission St., S. F.

#### HEATING AND VENTILATING

The Turner Co.....278 Natoma St., S. F.  
Machinery and Electrical Co.,  
351-353 N. Main St., Los Angeles  
Pacific Fire Extinguisher Company,  
507 Montgomery St., S. F.  
Mangrum & Otter, Inc., 507 Mission St., S. F.  
Gilley-Schmid Co., Inc.,  
Thirteenth and Mission Sts., S. F.  
Jno. G. Sutton Co.....229 Minna St., S. F.  
Pacific Blower & Heating Co.,  
17th St., betw. Mission and Valencia, S. F.  
Geo. W. Schmitt Heating and Ventilating Co.....1160 Webster St., Oakland

TELEPHONE { MISSION 139  
MISSION 59

HOME PHONE M 1841

A. A. DEVOTO, PRESIDENT



OFFICE AND WORKS

621-651 FLORIDA ST.

BETWEEN HARRISON AND BRYANT, 18TH AND 19TH  
SAN FRANCISCO, CALIF.

**WELLS AND SPENCER MACHINE CO.**

F. M. SPENCER, SUCCESSOR

173-177 BEALE ST., SAN FRANCISCO

REPRESENTING:

**WESTERN ELEVATOR COMPANY**

REPAIRS, INSPECTIONS AND DUMB WAITERS

TELEPHONES: KEARNY 664  
HOME J 1124**ARCHITECTS' SPECIFICATION INDEX—Continued**

- HINGES**  
Stanley's Ball-Bearing Hinges, Stanley Co.,  
New Britain, Conn.
- ICE MAKING MACHINES**  
Triumph Ice Machine Co., H. F. Lyon, Agent,  
581 Menadnock Bldg., S. F.
- IMITATION STONE**  
C. Menzer & Son.....862 Howard St., S. F.
- INSPECTIONS AND TESTS**  
Robert W. Hunt & Co.,  
418 Montgomery St., S. F.  
Smith, Emery & Co., Inc.,  
651 Howard St., S. F.
- INSURANCE**  
David Duncan .....340 Sansome St., S. F.
- INTERIOR DECORATING**  
L. Tozer & Son Co., 228 Grant Ave., S. F.  
Schastey & Vollmer., 1930 Van Ness Ave., S. F.  
Richard Arenz Co.,  
335 East Fourth St., Los Angeles  
A. C. Woeker.....1370 Sutter St., S. F.
- JOIST HANGERS**  
Western Builders' Supply Co.,  
680 Mission St., S. F.
- KITCHEN EQUIPMENT**  
John G. Iis & Co.....827 Mission St., S. F.
- LIME**  
Standard Supply Co.,  
First St. and Broadway, Oakland  
Holmes Lime Company,  
Mutual Savings Bank Bldg., S. F.  
Western Lime & Cement Co.,  
268 Market St., S. F.
- LIGHTING FIXTURES**  
Adams & Hollopeter....745 Mission St., S. F.  
J. F. Kelly Company, 723 7th St., Oakland
- LOCKERS—METAL**  
Hart & Cooley Co., Boyd & Moore, Agents,  
356 Market St., S. F.  
M. G. West Company, 353 Market St., S. F.
- LUMBER**  
Columbia Lumber Co.,  
Portuguese-American Bank Bldg., S. F.  
Santa Fe Lumber Co.,  
Seventeenth and De Haro Sts., S. F.
- MACHINERY AND MACHINERY SUPPLIES**  
Machinery and Electrical Co.,  
351 N. Main St., Los Angeles  
A. L. Young Machinery Company,  
26 Fremont St., S. F.
- MANTELS**  
Mangrum & Otter.....561 Mission St., S. F.  
The J. F. Kelly Co., 723-731 7th St., Oakland
- MARBLE**  
Columbia Marble Co.....268 Market St., S. F.
- MASONRY CONTRACTORS**  
Farrell & Reed.....Gunst Bldg., S. F.  
Ferdinand Wagner.....609 Waller St., S. F.
- METAL AND STEEL LATH**  
Roebling Construction CoCrockett Bldg., S. F.
- METAL CEILING**  
San Francisco Metal Stamping & Corrugating  
Co.....Treat Ave. and 19th St., S. F.  
San Francisco Cornice Co., Inc.,  
1140 Bryant St., S. F.  
Berger Manufacturing Company,  
1120 Mission St., S. F.
- METAL DOORS AND WINDOWS**  
M. G. West Company, 523 Market St., S. F.  
Waterhouse & Price.....59 Third St., S. F.  
San Francisco Cornice Company  
1140 Bryant St., S. F.
- METAL SHINGLES**  
Meurer Bros., J. A. McDonald, Pacific Coast  
Agent.....Third, near Townsend St., S. F.  
San Francisco Metal Stamping & Corrugating  
Co.....Treat Ave. and 19th St., S. F.  
San Francisco Cornice Co., Inc.,  
1140 Bryant St., S. F.
- OIL BURNING PLANTS**  
Fess System Company, Inc.,  
125-129 Hayes St., S. F.
- OPERA CHAIRS**  
C. F. Weber & Co....365 Market St., S. F.  
Whitaker & Ray-Wiggin Co., San Francisco  
and Los Angeles.
- ORNAMENTAL IRON AND BRONZE**  
Golden Gate Structural & Ornamental Iron  
Works.....1479 Mission St., S. F.  
Western Builders' Supply Co., Representing  
The L. Schreiber & Sons Co., Cincinnati  
J. G. Braun.....Chicago and New York  
Sartorius Co., Inc.....16th and Utah Sts., S. F.  
C. Farrenkopf & Sons....623 Minna St., S. F.  
Industrial Ornamental Iron and Wire Works,  
552 Noe St., S. F.  
C. J. Hillard Company, Inc.,  
211-215 Eighth St., S. F.
- PAINT FOR CEMENT**  
Worden-Meeker Varnish Co...S. F.—Oakland  
Vitreous Cold Water Paint sold by Boyd &  
Moore.....356 Market St., S. F.  
Bay State Brick and Cement Coating—Made  
by Wadsworth, Howland & Co. (Inc.). See  
adv. in this issue for Pacific Coast agents.  
Adamant Cement, Brick and Plaster Coating.  
Made by Parker, Preston & Co., Inc.  
Samuel Cabot Mfg. Co., Boston, Mass., agencies  
in San Francisco, Oakland, Los Angeles,  
Portland, Tacoma and Spokane.
- PAINT FOR STEEL STRUCTURES**  
Detroit Superior Graphite Paint, manufactured  
by Detroit Graphite Company, C. W. Pike  
Company, Coast Sales Agents, 22 Battery  
street, San Francisco.
- PAINTS, OILS, ETC.**  
Bass-Hueter Paint Company,  
Mission, near Fourth St., S. F.  
Worden-Meeker Varnish Co...S. F.—Oakland  
Paraffine Paint Co.....38-40 First St., S. F.

**M. G. West Company, Engineers****BANK EQUIPMENT****THE MOSLER SAFE COMPANY**Fire and Burglar Proof Vaults, Safes and Safe  
Deposit Boxes, Steel Filing Devices and Fire  
Proof Doors, Lifting Jacks for all Purposes**353 MARKET STREET  
SAN FRANCISCO, CAL.**

**Opera  
Chairs**

**Buy Steel Construction every time  
IT LASTS ALWAYS**

For Blackboard use "Olmstead Artificial Slate." Every architect wanting the best will specify this. Get our catalogues and prices

**WHITAKER & RAY-WIGGIN CO.**

276 MISSION STREET  
San Francisco

209 E. SEVENTH STREET  
Los Angeles

**School  
Desks**

**ARCHITECTS' SPECIFICATION INDEX—Continued**

- PAINTS, OILS, ETC.—Continued.**  
Glidden Varnish Co., Cleveland, Ohio, represented by Whittier-Coburn Co., S. F. and Los Angeles  
Standard Varnish Works, represented by W. P. Fuller & Co., S. F. and Los Angeles
- PAVING BRICK**  
Los Angeles Pressed Brick Co., Frost Bldg., Los Angeles  
Vallejo Brick & Tile Co., Mills Bldg., S. F.
- PHOTOGRAPHY**  
Gabriel Moulin, 153 Kearny St., S. F.
- PILE DRIVING**  
San Francisco Bridge Co., Monadnock Bldg., S. F.
- PIPE FOR SEWERAGE**  
Gladding, McBean & Company, Crocker Bldg., S. F.
- PLASTERING CONTRACTORS**  
A. Knowles, 985 Folsom St., S. F.  
D. Ross Clarke, 708 Pacific Bldg., S. F.  
Hanley & McCulloch, 378 Monadnock Bldg., S. F.
- PLUMBING**  
The Turner Co., 278 Natoma St., S. F.  
Fisher & Wolfe Co., 207 Tehama St., S. F.  
J. E. O'Mara, 447 Minna St., S. F.  
Alex. Coleman, 706 Ellis St., S. F.  
Jno. G. Sutton Co., 229 Minna St., S. F.  
Oscar L. Zeis, 456 E. 16th St., Oakland  
Kiernan & O'Brien, 1754 Mission St., S. F.  
Thos. J. Ford, 1213 Octavia St., S. F.
- PLUMBING APPLIANCES**  
Brown's Gasket, sold by Sanitary Plumbing Appliance Co., 412 Sheldon Bldg., S. F.
- PLUMBING FIXTURES**  
Crane Co., Second and Brannan Sts., S. F.  
Geo. H. Tay Co., 617 Mission St., S. F.  
Haines, Jones & Cadbury Co., 851-859 Folsom St., S. F.  
N. O. Nelson Mfg. Co., 978 Howard St., S. F.  
406 E. 4th St., Los Angeles  
J. L. Mott Iron Works, D. H. Gulick, selling agent, 135 Kearny St., S. F.
- PLUMBING SUPPLIES**  
California Steam & Plumbing Supply Co., Fifth and Bluxome Sts., S. F.
- POTTERY**  
Steiger Terra Cotta and Pottery Works, Mills Bldg., S. F.
- PUMPS, MACHINERY, ETC.**  
Simonds Machinery Co., 12 Natoma St., S. F.
- RAILROADS**  
Southern Pacific Co., Flood Bldg., S. F.
- REFRIGERATING PLANTS**  
Duval Dairy Supply Co., 201 Drumm St., S. F.
- ROLLING DOORS, SHUTTERS, PARTITIONS, ETC.**  
C. F. Weber & Co., 365 Market St., S. F.  
Lilley & Thurston, 82 Second Street, S. F.
- ROOFING TIN**  
"Scott's Extra Coated," manufactured by Follansbee Bros. Co., Pittsburg, Pa.  
Meurer Bros. Co., A. H. McDonald, Coast Representative, 628 Third St., S. F.
- ROOFING AND ROOFING MATERIALS**  
Ford & Malott, Mariposa St., at Iowa St., S. F.  
Genasco Ready Roofing, sold by Parrott & Co., 320 California St., S. F.  
"Ferroinclave," the Brown Hoisting Machinery Co., Coast Agent, Chas. A. Levy, Balboa Bldg., S. F.  
Pioneer Roll Paper Co., Los Angeles  
Mackenzie Roof Co., 425 15th St., Oakland  
Western Builders' Supply Co., 680 Mission St., S. F.  
H. D. Samuel Company, 1054 Monadnock Bldg., S. F.  
W. H. Wilson & Co., 42 Natoma St., S. F.  
Meurer Bros. Co., A. H. McDonald, Coast Representative, 628 Third St., S. F.
- RUBBER TILING AND MATTING**  
Goodyear Rubber Co., 587 Market St., S. F.
- SAFES**  
M. G. West Co., 523 Market St., S. F.
- SAND**  
Del Monte White Sand, sold by Pacific Improvement Company.
- SASH CORD** Main office, Crocker Bldg., S. F.  
"Puritan" Cord, manufactured by Puritan Cordage Mills, Louisville, Ky.  
Samson Cordage Works, Manufacturers of Solid Braided Cords and Cotton Twines, 88 Broad St., Boston, Mass.  
Silver Lake A Sash Cord, represented by Sanford Plummer, 149 New Montgomery St., S. F.
- SCHOOL FURNITURE AND SUPPLIES**  
C. F. Weber & Co., 365 Market St., S. F.  
210 N. Main St., Los Angeles  
Whitaker & Ray-Wiggin Co., 776 Mission St., S. F.; 209 E. Seventh St., Los Angeles.
- SCAGLIOLA**  
California Scagliola Co., F. Mayer, 68-70 Clara St., S. F.
- SHEATHING AND SOUND DEADENING**  
Samuel Cabot Mfg. Co., Boston, Mass., agencies in San Francisco, Oakland, Los Angeles, Portland, Tacoma and Spokane.
- SHEET METAL WORK**  
Abrahamson & De Gear, 655 McAllister St., S. F.  
Burger Mfg. Co., 1120 Mission St., S. F.  
Dunlevy & Gettle, 79 City Hall Ave., S. F.
- SHINGLE STAINS**  
W-M Shingle Stain, Worden-Meeker Varnish Co., S. F.—Oakland  
Cabot's Creosote Stains, sold by Waterhouse & Price, San Francisco, Los Angeles and Portland.
- SLATERS' CEMENT**  
Western Builders' Supply Co., Representing Clinton Metallic Paint Co., Clinton, N. Y.

WM. H. FORD

Telephone Market 1596

W. H. MALOTT

**FORD & MALOTT**

**FELT, ASPHALT AND GRAVEL ROOFING CONTRACTORS**  
"FIBRESTONE" MAGNESITE, FLOORING ASPHALT FLOORS AND SIDEWALKS

Office and Yard: Mariposa, at Iowa St., San Francisco Members Builders' Exchange. Builders' Association



## ARCHITECTS' SPECIFICATION INDEX—Continued

- STABLE STALLS AND FIXTURES**  
Howe Scale Co. .... 143 Main St., S. F.  
Duval Dairy Supply Co., 201 Drumm St., S. F.
- STAINLESS CEMENT**  
Blanc Stainless Cement Co., Levensaler & Preston, Inc., San Francisco; Quartz Glass & Manufacturing Co., Los Angeles; John Brooke & Co., Inc., Seattle, Wash.
- STANDARD SCALES**  
George A. Riggs, rep. The Howe Scale Co., Market St., S. F.
- STEEL AND IRON—STRUCTURAL**  
Boyd & Moore. .... 356 Market St., S. F.  
Woods & Huddart. .... 356 Market St., S. F.  
Pacific Rolling Mills,  
17th and Mississippi Sts., S. F.  
Western Iron Works. .... 125 Beale St., S. F.  
Brode Iron Works. .... 621 Howard St., S. F.  
Dyer Bros. .... 17th and Kansas Sts., S. F.  
Mortenson Construction Co.,  
19th and Indiana Sts., S. F.  
Central Iron Works, 621 Florida St., S. F.
- STEEL BARS FOR CONCRETE REINFORCEMENT**  
Jno. B. Leonard. .... Sheldon Bldg., S. F.  
Woods & Huddart. .... 356 Market St., S. F.  
Baker & Hamilton, 4th and Brannon Sts., S. F.
- STEEL MOULDINGS FOR STORE FRONTS**  
J. G. Braun, 537 W. 35th St., N. Y., and  
322 S. Paulina St., Chicago
- STORE FRONTS**  
Kawneer System of Glass Setting, manufactured by Kawneer Mfg. Co., Coast agencies at San Francisco, Portland, Ore., Spokane and Seattle, Wash.
- SURVEYORS**  
Sanborn & Carinson. .... 251 Kearny St., S. F.
- TAPESTRY AND BRONZE**  
Eugene Glaenzer & Co., 705 Fifth Ave., New York
- TERRA COTTA CHIMNEY PIPE**  
Dunlevy & Gettle. .... 79 City Hall Ave., S. F.
- TILES, MOSAICS, MANTELS, ETC.**  
Mangrum & Otter. .... 561 Mission St., S. F.  
Mosaic Tile Co., Zanesville, Ohio,  
228 Eighth St., S. F.  
The J. F. Kelly Co., 723-731 7th St., Oakland
- TILE FOR ROOFING**  
Gladding, McBean & Company,  
Crocker Bldg., S. F.
- TIN PLATES**  
Meurer Bros. Co., A. H. McDonald, Coast Representative. .... 628 Third St., S. F.
- VACUUM CLEANERS**  
S. F. Compressed Air Cleaning Co.,  
Sutter and Stockton Sts., S. F.  
American Rotary Valve Co.,  
702 Balboa Bldg., S. F.
- VALVE PACKING**  
"Palmetto Twist," sold by H. N. Cook Belting Co. .... 317 Howard St., S. F.
- VAULTS—FIREPROOF**  
M. G. West Company, 353 Market St., S. F.
- VENETIAN BLINDS, AWNINGS, ETC.**  
C. F. Weber & Co. .... 365 Market St., S. F.
- VENEERS**  
Dieckmann Hardwood Co.,  
Welch Bldg., 244 California St., S. F.  
White Bros. Cor. Fifth and Brannon Sts., S. F.
- VENTILATORS AND SHEET IRON**  
Meurer Bros. Co., A. H. McDonald, Coast Representative. .... 628 Third St., S. F.
- VITRIFIED CLAY PIPE**  
Steiger Terra Cotta and Pottery Works,  
Mills Bldg., S. F.
- WAINSCOTING**  
"Kompolite" ..... 350 Mills Bldg., S. F.
- WALL BEDS**  
The Turner Wall Bed Co.,  
Mission, near Fifth, S. F.  
Marshall & Stearns Co.,  
1154 Phelan Bldg., S. F.
- WATERPROOF FINISHES**  
"Trus-Con" Finish, sold by Western Lime & Cement Co. .... 268 Market St., S. F.
- WATERPROOFING FOR CONCRETE, ETC.**  
"Ceresit," manufactured by the Ceresit Waterproofing Co., sold by Parrott & Co., San Francisco, Los Angeles and Portland, and Julien A. Becker Co., Seattle, Wash.  
The Building Material Co., Inc.,  
587 Monadnock Bldg., S. F.  
Parrott & Co. .... 320 California St., S. F.  
Hydrex Felt and Engineering Co., Boyd & Moore, Agents. .... 356 Market St., S. F.  
Te-Pe-Co Waterproofing, sold by H. G. Clinton, 34 Ellis St., S. F.; Bass Hueter Paint Co., Pacific Coast Distributors.  
Samuel Cabot Mfg. Co., Boston, Mass., agencies in San Francisco, Oakland, Los Angeles, Portland, Tacoma and Spokane.  
"Imperial" Waterproofing, sold by Baker Bros., San Francisco; Braun Chemical Co., Los Angeles; W. O. Stamps, Portland, and B. W. Gaisford, Seattle, Wash.
- WATER SUPPLY**  
Kewanee System, Simonds Machinery Co., sole agents. .... 12 and 14 Natoma St., S. F.
- WEATHER STRIP**  
Monarch Metal Weather Strip, Boyd & Moore, Agents. .... 356 Market St., S. F.
- WHITE ENAMEL FINISH**  
Velvo-Tone, Worden-Meeker Varnish Co., S. F.—Oakland  
"Satinette," W. P. Fuller & Co., S. F. and all principal Coast cities
- WHITE PORTLAND CEMENT**  
Blanc Stainless Cement Co., Levensaler & Preston, Inc., San Francisco; Quartz Glass & Manufacturing Co., Los Angeles; John Brooke & Co., Inc., Seattle, Wash.
- WINDOWS, REVERSIBLE, ETC.**  
Dean Reversible Window Co.,  
551 Brannan St., S. F.  
Hipolito Sereen & Sash Co.,  
634 Maple Ave., Los Angeles  
Soule Reversible Window Co.,  
1061 Mission St., S. F.  
Tabor Sash Fixture Co., Boyd & Moore, Agents. .... 356 Market St., S. F.
- WOOD FINISH**  
Bridgeport Wood Finishing Co.,  
New Milford, Conn.

ARCHITECTS OWN DESIGNS CARRIED  
OUT AT MODERATE COST

DESIGNS SUITED TO EVERY STYLE  
OF ROOM

FIRE HOODS  
HOUSE HARDWARE  
SUNDIALS  
FIRE IRONS

**The Palmer Shop, Inc.**  
MAKERS OF ARTISTIC ELECTRIC FIXTURES

1345  
SUTTER STREET  
PHONE  
FRANKLIN 4719

# ARCHITECTURAL FAIENCE

Faience Tiles for Exterior and Interior Decorations. Mantel Facings — Complete Mantels. Equipped to Execute Designs of Architects and Decorators. Special Designs by our own Artists

## Los Angeles Pressed Brick Co.

404-414 FROST BLDG.      SECOND AND BROADWAY      LOS ANGELES

# NORTHERN CLAY COMPANY

MANUFACTURERS OF

## ARCHITECTURAL TERRA COTTA FIRE BRICK AND CLAY PRODUCTS

MAIN OFFICE AND FACTORIES, - AUBURN, WASHINGTON

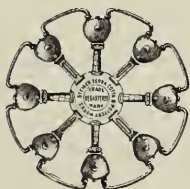

## STEIGER TERRA COTTA AND POTTERY WORKS

ARCHITECTURAL TERRA COTTA, PRESSED BRICK, SEWER PIPE  
CHIMNEY PIPE, FLUE LINING, FIRE BRICK  
MANTEL TILE, ACID WARES

FACTORY: SOUTH SAN FRANCISCO  
SAN MATEO CO.

YARD: 18TH AND DIVISION STS.  
SAN FRANCISCO

MAIN OFFICE: 729 MILLS BUILDING

TELEPHONE DOUGLAS 3010

SAN FRANCISCO, CAL.

# GLADDING, Mc BEAN & Co.

MANUFACTURERS CLAY PRODUCTS

## CROCKER BLDG. SAN FRANCISCO

WORKS, LINCOLN, CAL.

# PERFECT WALL BEDS HALEY SEAT BEDS

**PERFECT CONCEALED & TURNER BED CO.**  
862 MISSION ST. SAN FRANCISCO, CAL.



CLIFF HOUSE, San Francisco. Reid Bros., Architects. Interior Decoration by  
A. C. WOCKER, DECORATOR, 1370 Sutter Street, San Francisco



This Half Brick was subjected to over 150,000 pounds pressure, equal to 300,000 for the Whole Brick (15,000 per square inch); absorption test thirteen one-hundredth of one per cent. Test made by Engineering Department City of San Francisco.

**Monadnock Building, SAN FRANCISCO, CAL.**

TELEPHONE KEARNY 4314

## VALLEJO BRICK AND TILE COMPANY

Consolidated

MANUFACTURERS OF

## PAVING BRICK

SEWER BRICK AND  
OTHER VITRIFIED  
CLAY PRODUCTS.

WORKS AT

**VALLEJO, SOLANO CO.**

CALIFORNIA

TELEPHONE VALLEJO 242

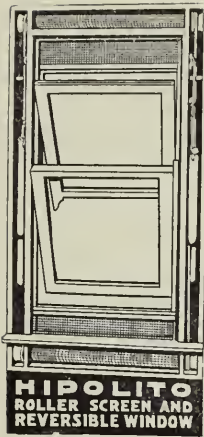

Reversible  
Window and  
Self-  
Regulating  
Roller  
Screens

**HIPOLITO SCREEN & SASH CO.**

634-38 MAPLE AVENUE  
LOS ANGELES, CAL.

DEAN REVERSIBLE WINDOW CO. INC.



**SAN FRANCISCO, CAL.**

Phone, Kearny 1516

OVER  
500,000  
TONS

of Structural Steel Painted with

"SUPERIOR GRAPHITE  
PAINT"

**DETROIT GRAPHITE COMPANY**  
PAINT MAKERS

DETROIT, MICHIGAN, U. S. A.

**C. W. PIKE COMPANY**

PACIFIC COAST SALES AGENTS

22 BATTERY ST.

**SAN FRANCISCO, CAL.**

TELEPHONE, KEARNY 4303

We are Pacific Coast Agents for

**JAMES SANITARY  
BARN EQUIPMENT**

Which is the Latest and Best in that Line

WHEN figuring plans for new Barns  
or when remodeling old ones, we  
would be glad to receive your inquiries.  
Catalogs may be had for the asking.

**DE LAVAL DAIRY SUPPLY CO.**

DRUMM AND SACRAMENTO STREETS  
SAN FRANCISCO, CAL.

**BOWSER**

## The Standard Gasoline Outfit for Public or Private Garages

It's Fire-proof, Leak-proof and Evaporation-proof. That means Safety, Profit and High Test Gasoline.

All Styles, Sizes and Prices  
—Direct Lift, Long Distance and Portable types.

Recommended by Architects, Endorsed by Owners and tested by time.

*IT'S THE PIONEER.*

because it fulfils every requirement. No measures — No funnels. You pump the gasoline directly into the car without exposure or possibility of explosion. WE MAKE THE LOWEST PRICED OUTFITS AND WE MAKE THE BEST.

Special Information for Architects. Just ask for booklet No. 107 for details.

# S. F. BOWSER & CO

INCORPORATED

FORT WAYNE, IND.

Western Office, 612 HOWARD STREET  
SAN FRANCISCO, CAL.

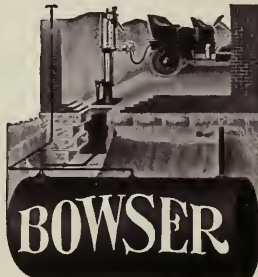

## RECOMMEND AND INSTALL "HOFFMAN Automatic Gas Water Heaters"

AND SATISFY YOUR CUSTOMERS



They are simple in construction, high in efficiency and sold at a reasonable price. These are three of the most essential points.

If you are not already using the "HOFFMAN" see your jobber and get prices, they will surprise you.

We are represented in the West by the following:

HOLBROOK, MERRILL & STETSON  
San Francisco and Los Angeles, Calif.

CRANE COMPANY  
Seattle and Tacoma, Wash.

CRANE COMPANY  
Vancouver, B. C.

**The Hoffman Heater Company** Factory and General Offices  
Lorain, Ohio, U. S. A.



**THE TOZER COMPANY**

**Interior Decorators**

Wall Papers and Fabrics of Character  
and Distinctiveness

*We Design, Decorate and Furnish Interiors of all Kinds*

The Leading Architects and Builders our References

Correspondence and Enquiries Solicited

228 Grant Ave. (2d Floor, Next to White House)      187 Twelfth Street  
San Francisco      Oakland



## Perfection Gas

## Steam Radiators

**E**NDORSED by Architects and Physicians as the most healthful and convenient. Will heat a room 20x20 to 70 degrees, consuming at full capacity only 12 feet of gas per hour. ☐ Each heater fitted with patented Water Tank and Filler, Steam Coils, Air Vent and Safety Valve, forming a complete and independent heater. ☐ Made in two styles: To set against a flat wall or recess in mantel. : : : :

## Jos. Thieben & Co.

SELLING AGENTS

667 Mission Street      Phones      San Francisco.  
Keamy 3762; Home J-3762

Write for Catalog and Prices



## THE VARNISH TO SPECIFY

# A

Thoroughly Satisfied Client is an Architect's Best Asset.

It means more Business for Him Every Time. A Well Built and Finished Interior Goes a Long Way to Impress the Owner with the Architect's Genius.

The Wood Finish, Therefore, Must Not be Neglected.

A Superior Varnish is Necessary to Insure a Satisfactory Finish

Specify HUETER'S ARCHITECTURAL and FLOOR VARNISHES.

Manufactured by

### S. F. PIONEER VARNISH WORKS

ESTABLISHED 1857

E. L. HUETER, Proprietor

WORKS SAN FRANCISCO, CAL.  
MAIN OFFICE, 816 MISSION ST.

Los Angeles Office and Warehouse,  
333 to 343 East Second St.

Portland Office and Warehouse,  
191 Second Street

Seattle Office and Warehouse,  
91 Spring Street

## GLIDDEN

WATERPROOF

## LIQUID CEMENT

### GIVES TWO VALUES

**WATERPROOFS--DECORATES**



1. It gives highly efficient positive damp proof protection to concrete walls.
2. It gives a highly decorative effect to the structure both inside and out, because it obliterates the mottled effect in color tones found in all concrete buildings, and as it is made in various shades it can be used to produce various pleasing color tones to the building, without adding a cent of expense to the damp proofing process.

It is made in a variety of practical shades, including imitation of Bedford Sandstone, Colonial and Pompeian Buffs and Pure White.

Its use assures a thoroughly damp proof wall at a minimum expense and a pleasing decorative effect obtainable on concrete structures in no other way except at greatly added cost for special materials. Booklet with specifications on request.

### THE GLIDDEN VARNISH CO.

FACTORIES—Cleveland, Ohio; Toronto, Ont.

BRANCHES—New York, St. Louis, Chicago

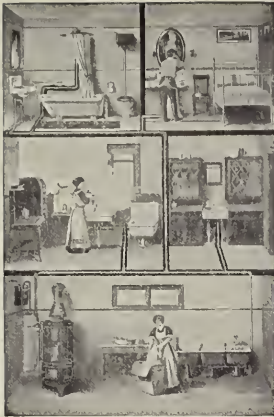

## PERFECT HOT WATER SERVICE

to all parts of a building can be secured cheaply and without bother of any kind from a **HUMPHREY AUTOMATIC INSTANTANEOUS Gas Water Heater**. It is as dependable as the following of day by night. Open a faucet — hot water pours out. Guaranteed exactly as claimed. Write for Catalog to

## HUMPHREY CO.

565 N. ROSE STREET, KALAMAZOO, MICH., U. S. A.

### PACIFIC COAST AGENTS

The Gas & Electric Appliance Co., 443 Sutter St., San Francisco  
 J. E. Miranda, - - - - - 1313 Broadway, Oakland  
 The Independent Gas Appliance Co., 604 S. Hill St., Los Angeles



Building for Central Oakland Light & Power Co.  
*Long & Hoyt, Engineers*

The Roof and Walls of this Building are Metal Lath and Cement Plaster over Steel Frame.

Executed by

## A. KNOWLES

Plastering, Modeling, Metal Partitions, Fabrous Ceilings and Decorations ££ ££ ££

985 FOLSOM ST., SAN FRANCISCO

PHONE DOUGLAS 3451



St. Patrick, Apostle of Ireland  
 Installed in St. Mary's Church, San Francisco

## California Art Glass Works

WILLIAM SCHROEDER, PRES.

MEMORIAL WINDOWS A SPECIALTY

Staining Crystalizing Binding and  
 Embossing Beveling Cutting

TEL HOME J 2652

768 MISSION ST., SAN FRANCISCO

## EUGENE GLAENZER & CO.

705 FIFTH AVENUE,  
NEW YORK

### Antique Works of Art

Garden Ornaments,  
Mantels, Furniture,  
Tapestries, Bronzes,  
Paintings by Masters

PARIS, 5 RUE SCRIBE



Statue of Sheet Metal

## San Francisco Metal Stamping and Corrugating Company

STAMPED AND SPUN  
SHEET METAL  
ORNAMENTS,  
STATUE WORK,  
MISSION TILE

554-556 TREAT AVE.  
NEAR NINETEENTH ST.

Phone Mission 2421  
Home Phone M-3428

SAN FRANCISCO,  
CALIFORNIA

## HOTEL VICTORIA Chicago

In the Heart of  
wholesale, retail  
and theatrical  
district.

Fireproof Construction

\$1.00 AND UP PER DAY

Remodeled and refurbished at an  
expense of over \$150,000.

OPPOSITE LA SALLE  
DEPOT

Cor. Clark and Van Buren Sts.

ELMER C. PUFFER,  
Managing Director.

## San Francisco Cornice Co., Inc.

### OUR SPECIALTIES

Underwriter metal windows,  
fire doors, shutters and hard-  
ware. Fine copper doors,  
Kalamein work, Interior trim,  
Copper fronts, Architectural  
sheet metal work, Cornices,  
Tin roofing, Old Mission and  
S. Spanish tile, Steel ceilings  
(our own stamping), Orna-  
mental work.

1140 BRYANT STREET, Cor. DORE  
San Francisco, California

# CRUDE OIL

is NOW burned by TWO methods,  
the FESS SYSTEM and the other

WE have passed the stone age. In the new year of 1911 you will find in the improved FESS SYSTEM, the only advanced science of burning oil.

We eliminate the use of a complicated air compressor, numerous adjusting valves, and the noise of combustion. This system is operated with 75% less power and produces a smokeless fire; in fact the advantages are so numerous that it must be seen to be appreciated. We can convince the most skeptical that the problem of burning crude oil for heating purposes has at last been solved.

ARCHITECTS ARE ESPECIALLY INVITED TO CALL AND WITNESS A DEMONSTRATION

**FESS SYSTEM COMPANY, Inc.**

125 HAYES STREET, SAN FRANCISCO

Architects Specify

# NILES CRUSHED ROCK

BEST BY TEST

There is None Better on the Market  
Write for Sample and Information

**CALIFORNIA BUILDING  
MATERIAL COMPANY**

714-716 Pacific Bldg.  
SAN FRANCISCO, CAL.



No. 0 Foote Batch Mixer with Power Loading Skip, Automatic Water Tank and Gasoline Engine.

## "EVERY FOOTE A MIXER"

Batch and Continuous Mixers

In Stock for Immediate Delivery  
BRIGGS' CONCRETE SPREADER CARTS  
HOTCHKISS METAL SIDEWALK FORMS  
Send for Catalog No. 4.

**Foote Concrete Machinery Co.**

R. E. BACON, REPRESENTATIVE  
999 MONADNOCK BLDG., SAN FRANCISCO, CAL.  
PHONE DOUGLAS 1380

## Architects and Owners

We have Something Better in Re-  
versible Sash Single Casement.

French Sash, Single Pivot Sash,

Double-hung Reversible Sash :: ::

Call and be convinced of their

absolute Simplicity and Perfect

Mechanism :: :: :: :: :: :: :: ::

Absolutely Water Tight :: :: :: ::

Write for Attractive Booklet with

Full Particulars :: :: :: :: :: ::

**SOULE REVERSIBLE  
WINDOW COMPANY**

OFFICE AND DISPLAY ROOM

1061 MISSION STREET

SAN FRANCISCO, CAL.





THE LEWIS P. HOBART RESIDENCE, EL CERRITO PARK, SAN MATEO, CAL.

FURNISHED THROUGHOUT WITH

## RUSSWIN HARDWARE

BY

JOOST BROS.

1274 MARKET STREET, SAN FRANCISCO

---

## RUSSELL & ERWIN MFG. CO.

NEW BRITAIN, CONN.

404-411 Commercial Bldg., 833 Market St.  
San Francisco, California

Telephone Kearny 1370

NEW YORK

PHILADELPHIA

CHICAGO

LONDON, ENG.

**“QUALITY COUNTS”**

# WESTERN BUILDERS' SUPPLY CO.

ESTABLISHED 1902

**680 MISSION STREET**

**SAN FRANCISCO, CAL.**

TELEPHONE KEARNY 1991

INTERIOR WOOD FINISH ORNAMENTS  
(ART MOULDINGS, CARVINGS, ETC.)

HIPOLITO EVEN TENSION SCREENS  
(FOR GOOD HOUSES)  
CONVENIENT, DURABLE, NON-RUSTING

STANDARD METAL CORNER BEAD

GOLDEN WEST VULCANITE ROOFING

“ENAMETILE” (METAL ENAMEL WAINSCOTING)  
(SANITARY, INTERLOCKING)



REPRESENTING

**DECORATORS' SUPPLY CO., CHICAGO, ILL.**



**ARCHITECTURAL ORNAMENTS**

IN WOOD, COMPOSITION AND CEMENT

EXTERIOR AND INTERIOR

**CAPITALS AND BRACKETS**

TO MATCH OAK, MAHOGANY, REDWOOD. ETC.

**Four Large Catalogs (Furnished Registered Architects)**

CAPITALS AND BRACKETS  
WOOD GRILLES

EXTERIOR COMPOSITION AND PLASTER  
COMPOSITION TO MATCH WOOD

For Information apply 680 Mission Street



## “SUN-PROOF” PAINTS

MILWAUKEE

“Pitcairn Aged Varnish”

NEWARK

**GOES FARTHEST WEARS LONGEST**

# American Ingot Iron



*"Rust-Resisting"*



## Corrugated Road Culverts

Made in continuous lengths ready to install without any interruption to traffic.

Pure Iron Resists Corrosion while Common  
Steel Rusts Quickly when placed in the ground.

We use exclusively American Ingot Iron—99.94% Pure in all our construction.

**CALIFORNIA CORRUGATED CULVERT CO.**  
LOS ANGELES WEST BERKELEY



*Lafarge*

## Will Not Stain

Limestone, Granite or Marble—  
The Best Cement for Exterior  
Stucco Construction. Also  
EXTRA WHITE LAFARGE for  
use with Light Brick, Terra  
Cotta, White Granite or Marble  
and White Stucco Exteriors

**NON-STAINING CEMENT CO.**

156 FIFTH AVENUE, NEW YORK  
Sole Agents for the United States and Canada

**WATERHOUSE & PRICE CO.**

SAN FRANCISCO

SEATTLE PORTLAND OAKLAND LOS ANGELES



Design Gonda

A NEW DESIGN IN

# Reading Hardware

Represented by

**Brittain & Co.**  
INCORPORATED

Market and Mason Sts.	908 Broadway
SAN FRANCISCO	OAKLAND
Doug. 2040	Oak. 1185
C-2040	A-3395

# Notice to Architects

---

We are about to put on the market a new product which we have trade marked

# Amiwud

It is a stiff pulp board and made to imitate hardwood.

**Amiwud** can be nailed to studding, avoiding the necessity of lathing and plastering.

Many artistic and decorative designs for interior finishing can be made of **Amiwud** — cheaply and without difficulty — most anyone can do it.

We have demonstrated the value of **Amiwud** in our own place of business, where it is on display.

Call at our general offices and see what can be done with **Amiwud**.

**The PARAFFINE PAINT CO.**  
 34 FIRST STREET, SAN FRANCISCO



THE ELYSIUM  
The Largest and Finest  
Skating Palace in the  
World is Water-  
proofed with

**TE-PE-CO**

July 8, 1909.

THE NATIONAL WATERPROOF CO.,

Gentlemen:— We are pleased to state that the *Te-Pe-Co* Waterproofing that we used on the entire concrete exterior and plaster walls of our Elysium Building about three years ago has proven absolutely satisfactory.

Yours very truly,

THE HUMPHREY CO.,

per H. J. Humphrey, Sec. & Treas.

DISTRIBUTORS FOR THE PACIFIC COAST

**BASS-HUETER PAINT CO.**

SAN FRANCISCO, SEATTLE, PORTLAND AND LOS ANGELES

H. G. CLINTON, SALES AGENT, 34 ELLIS ST., SAN FRANCISCO

**J. G. BRAUN**

537-541 W. 35TH STREET, NEW YORK  
615-621 S. PAULINA STREET, CHICAGO

CARRIES A COMPLETE STOCK OF

**Steel Mouldings for Store Fronts**

**Elevator Enclosures, Etc.**



Plain and Ornamental Sash Bars, Leaves, Rosettes  
Pickets and Ornamental Rivets, Square Root  
Angle Iron from  $\frac{3}{8}$ "x $\frac{3}{8}$ "x1-16" Upwards

Square Tubing for Elevators, Elevator  
Enclosures and Office Railings



Catalog to Architects, Architectural Iron  
Works and Builders only on Application

**PATENT SHEET METAL SHEARS PUNCHING MACHINES**

All parts, including the main body, are made of forged steel, which makes these tools far superior to any made from cast steel. The Punch Machines are made from steel plates. All movable parts are steel forgings. All parts which can be are tempered. The Eccentric pillar blocks are made with independent steel rings. Some of these Machines also have Shears for cutting Angle, Tee or Flat Iron.

WRITE FOR CATALOG  
AND PRICES

**OVER 900  
MACHINES  
SOLD**





P. NOBLE, PRESIDENT      H. C. BANKS, VICE-PRESIDENT      THOMAS ROLPH, SECRETARY

# Pacific Rolling Mill Co.

TELEPHONE MARKET 215

SUPPLIERS OF

## STRUCTURAL STEEL

FORGINGS, BOLTS, RIVETS, FROGS, SWITCHES

## CAST IRON

GENERAL OFFICE AND WORKS  
17TH & MISSISSIPPI STS.

SAN FRANCISCO

SALES OFFICE  
908 CROCKER BUILDING



# Sartorius Company, Inc.

· Ornamental Iron & Bronze ·



· ELEVATOR ENCLOSURES & CABS · METAL STORE FRONTS ·  
· STAIRS · RAILINGS · BANK ENCLOSURES & RAILINGS ·  
· BRONZE TABLETS & NAME PLATES · ANDIRONS · ETC ·  
· TELE · MARKET 1529    · SAN FRANCISCO ·    WORKS 15TH & VTAH STS

W. B. MORRIS, President      H. M. WRIGHT, Vice-President      L. J. GATES, Secretary

# WESTERN IRON WORKS

## STRUCTURAL IRON and STEEL CONTRACTORS

Gas Holders, Vault Linings, Jails, Fire Escapes, Beams, Channels, Angles  
and Steel Wheelbarrows Carried in Stock

Phones: Kearny 575  
J 1259

141-147 BEALE STREET    SAN FRANCISCO, CAL.  
132-148 MAIN STREET

TELEPHONE, MARKET 6468

HOME PHONE, J 2376

# C. J. HILLARD CO., Inc.

MANUFACTURERS OF

## Ornamental Iron, Brass and Bronze Work

Bank and Office Railings.      Elevator Enclosures and Cars.  
Cast Iron Stairs and Store Fronts.    Wire Work.    Fire Escapes.

211-213-215-217 8th Street  
Between Howard and Folsom

San Francisco, Cal.

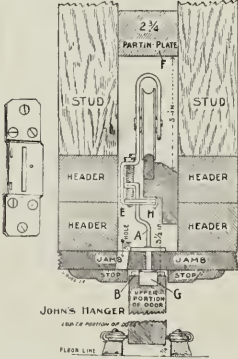

When it comes to specifying a **DOOR HANGER** you must take into consideration these essential points:

**Permanency, Smooth Action,  
Absence of Noise, Economy**

## THE JOHNS HANGER

Embodies all of these Features. Used in Hundreds of Hotels, Apartment Houses, Flats and Residences and giving Satisfaction

Strictly a California Product

## The Johns Hanger Mfg. Co.

832-838 Folsom Street, San Francisco, Cal.

### WHAT IS MORE TROUBLESOME THAN TO PACK RADIATOR VALVES

**YOU** never seem to have the right size packing. Because there is no active rod travel through the stuffing box the packing sets and gets hard, and the valves leak more or less when opened or closed.

#### PALMETTO TWIST

can be unstranded and any size valve packed from one spool. It cannot burn — its all asbestos. Does not get hard — because a perfect lubricant is forced into each strand.

Use **PALMETTO TWIST** on all the valves, and you will not have to repack so often.

We will send you a sample spool **FREE**. Just to prove this.

### H. N. COOK BELTING CO.

317-319 Howard Street

SAN FRANCISCO CALIFORNIA



## “RELIANCE” HANGERS

are the Strongest  
and the Easiest  
Running Hangers  
Made



For proof of this seemingly extravagant claim, we can refer you to more than 500 of the largest and best buildings in the country where these Hangers have been in use for years—and are giving entire satisfaction. Send for a catalog, or look in “SWEET’S” or visit the office of any of our

PACIFIC COAST AGENTS

SAN FRANCISCO.....SARTORIUS COMPANY, Fifteenth and Utah Streets  
SEATTLE.....D. E. FRYER & CO., 305 Lumber Exchange  
LOS ANGELES.....LOUIS R. BEDELL, 1108 Story Building  
PORTLAND... PORTLAND WIRE AND IRON WORKS, Second and Everett Streets

**RELIANCE BALL BEARING DOOR HANGER CO., 1 Madison Avenue, New York City**

FRED J. H. RICKON, C. E.  
Member A. M. Soc. C. E.

R. EHRHART, C. E.

# RICKON-EHRHART ENGINEERING & CONSTRUCTION CO.

Civil Engineers and Contractors

Phone West 1300

1859 GEARY ST., SAN FRANCISCO

ALFRED FOWLE, President

JOS. R. WHALEN, Secretary and Treasurer

## CALIFORNIA STEAM AND PLUMBING SUPPLY CO.

SANITARY PLUMBING  
FIXTURES



WATER, STEAM AND  
GAS SUPPLIES

FIFTH AND BLUXOME STREETS

SAN FRANCISCO, CAL.

# CRANE COMPANY

Second & Brannan Sts.  
SAN FRANCISCO

High Grade . . .

## PLUMBING SUPPLIES

Steam and Hot Water Heating  
PIPE, VALVES, FITTINGS

Power Plant and Water Works Materials

STEAM SPECIALTIES

# N. O. NELSON MFG. CO.

## PLUMBING SUPPLIES



978 Howard Street  
San Francisco

406 E. 4th Street  
Los Angeles

**DIECKMANN**  
**HARDWOOD**  
**COMPANY**

HARDWOODS  
 CABINET WOODS  
 HARDWOOD FLOORING

---

OFFICE, 244 CALIFORNIA STREET  
 MILL AND YARD, FOOT OF TAYLOR STREET

**SAN FRANCISCO, CAL.**

A. S. MANGRUM, PRES. AND MGR. CHAS. C. HANLEY, SEC'Y AND TREAS.

**MANGRUM & OTTER**  
 (INCORPORATED)

**TILING MANTELS  
 GRATES**

**FURNACE AND  
 STEAM HEATING**

HOTEL AND KITCHEN OUTFITS  
 Stoves, Ranges, Refrigerators, Tin and Enameled Ware

Telephone, Kearny 3155 561-563 Mission St., San Francisco

**WEARY & ALFORD COMPANY**

Bank Interiors and Equipment  
 OF THE HIGHER CLASS

H. H. WINNER, Pacific Coast Representative

303 Union Trust Building SAN FRANCISCO

**CONCRETE REINFORCEMENT  
 STEEL BARS** FLATS, ROUNDS, SQUARES & TWISTED

BANDS, HOOPS AND WIRE  
 ALL SIZES IN STOCK

**WOODS & HUDDART**

356 MARKET STREET SAN FRANCISCO, CAL.

# Cold TWISTED STEEL BARS (Square, Round and Flat) for Reinforcing Concrete



OUR STOCK IS COMPLETE IN ALL SIZES

## BAKER & HAMILTON

SAN FRANCISCO

SACRAMENTO

LOS ANGELES

# The Architect and Engineer of California Pacific Coast States

Terms of Subscription.  
\$1.50 per Year

Single Copies  
25 Cents

Issued monthly in the interests of Architects, Structural Engineers, Contractors and the Allied Trades of the Pacific Coast.

## Contents for March

	PAGE
Louis Christian Mullgardt, Architect - - - - -	<i>Frontispiece</i>
Color in Architecture— <i>Louis Christian Mullgardt</i> - - - - -	35
To Prevent Dusting or Easy Abrasion of Improperly Laid Concrete Floors - - - - -	41
<i>Albert Moyer, C. E.</i>	
The Use of Reinforced Concrete in Sao Francisco and Vicinity - - - - -	43
<i>John B. Leonard, C. E.</i>	
Illustrated	
Fees of Architects - - - - -	62
"Fire"— <i>Charles H. Merriam</i> - - - - -	63
Architect's Piracy - - - - -	69
Suburban Architecture <i>Thomas Hastings, Architect</i> - - - - -	70
An Attractive Country Bank Building - - - - -	71
Illustrated	
Successful Design for Druid's Hall Building - - - - -	73
Illustrated	
The Lighting of Large Halls— <i>Dr. Robert Grimshaw</i> - - - - -	75
Illustrated	
The Iron Trades Agreement - - - - -	81
Brick Versus Frame Houses - - - - -	82
Largest Steel Truss in California for Native Sons' Building— <i>E. S. Chew, C. E.</i> - - - - -	84
Illustrated	
Honolulu's New Y. M. C. A. Building - - - - -	87
Testing Portland Cement— <i>Emory E. Smith</i> - - - - -	88
The Life of Metal Lath - - - - -	89
Evolution of the Corrugated Iron Culvert— <i>Perry Van Horn</i> - - - - -	90
Illustrated	
Teakwood for interior Decoration— <i>C. H. White</i> - - - - -	94
Illustrated	
Improving Trade Conditions - - - - -	97
Among the Architects - - - - -	98
Editorial - - - - -	102
Heating and Lighting - - - - -	104
By the Way - - - - -	112





*LOUIS CHRISTIAN MULLGARDT, Architect*

Frontispiece  
The Architect and Engineer  
March, 1911

THE  
Architect and Engineer  
Of California  
Pacific Coast States

VOL. XXIV.

MARCH, 1911.

No. 2.

Color in Architecture\*

By LOUIS CHRISTIAN MULLGARDT, Architect.

THE Committee on Allied Arts, in its annual report of 1908, defined broadly its conception of the nature of architecture and its relation to the allied arts. Also, the relation of art to the life of the people, and, its position relative to that of government influence.

In 1909 the Committee on Allied Arts defined its conception of the exact relationship existing between architecture and one of its most closely allied arts—that of sculpture.

It is intended in this report to note to what extent color is related to the fine arts in general, and to architecture in particular. Also to show that color strongly manifests itself in every one of the fine arts.

There is perhaps more color in our present day architecture than some of us are conscious of. The reason why we are not conscious of it is partly due to the confusion of colors which exists in many of our solidly built up settlements. Nearly every building is different in color mass from that of its neighbors. Then also, we frequently introduce intense or discordant color in large masses. This is in reality garish, but we don't realize it, because we have become accustomed to it.

Nevertheless, a large intense or discordant color mass tends to nullify any neighboring refined color scheme.

What, for instance, could be more violent than a large mass of red, and yet, how commonly we see it in architecture.

What chance would a refined scheme of color in architecture have by the side of a mass of intense color, be it red, green, blue, or something else?

Perhaps we would find upon investigation that much intense color in our present day architecture is inadvertently acquired.

Some people wear red underwear, not because it is red, but because it is flannel.

Thus it may be, that we have inadvertently acquired some of the violent masses of color in architecture because we want the material, and the color is an unpremeditated incident in the result.

Color is a most elusive, evanescent element in our realm of observation.

At times we find color to be as material in substance as our bodies are.

At times we find color as spiritual as the breezes that blow. We see material color of every hue being brought forth by Mother Earth, and we note the beautiful spiritual color which the sun imprints in bowed form upon the raindrops.

In the art of music, we hear color in music's tonal runs—the trilling of

\*Read before the American Institute of Architects at its Forty-fourth Annual Meeting held in San Francisco in January, 1911.

the instruments, or the wonderful florid decorations produced by a glorious voice. We hear it where single syllables are sung in two or more tones or cadences and we speak of it as colorature or tone coloring in the art of music.

In the art of etching or engraving, altho' recognized as arts in monochrome, we find color accents in tonal values, which we also term colorature, as in music. Every good etching or engraving suggests true color to the mind's eye as clearly as if it were really present in the picture, and this is termed color value in etching or engraving.

In the art of prose, poetry, and the rhetorical phase of stage art and oratory, color manifests itself in inflection, cadence, modulation of voice, consonant with sense conveyed epigrammatically, and this is called color in rhetoric.

In the art of painting, as in architecture and sculpture, it becomes a material demonstration, it is a fact here, which requires no further defining or proof. The color is manifestly there.

We note a certain relationship existing in the matter of color in all of the fine arts. Therefore it is fair to assume that we can learn much thro' observing their relative application that we may better understand the correct principles involved, when applying the same to our art.

We note two fundamental methods according to which color is used in architecture.

The first method consists of a deliberate use of broad color masses which are generally made to appear as an embodied constituent in the structure.

The second method is that of treating a structural design to a florid color decoration in detailed ornament, with or without the broad massing of color.

The first method is a consistent integral part of the physical structure. The second method is in the nature of pure ornament, applied, even tho' it has been made a part of the physical structure. It is nevertheless a decoration and does not represent an essential in the structure's makeup.

In the two methods broadly referred to, we have color in mass, and color as ornament. These two fundamental principles are again subdivided into various methods in their application.

Sometimes broad masses of color, or detailed ornament, or both, are applied after walls are structurally complete.

Every instance where color is applied as a thin non-structural skin after the architectural structure is complete, such work is purely decorative in character, and is thereby distinguished from the art of building in color, which method is distinctly constructive in character, and therefore purely architectural because it is an inherent part of the structure.

If, for instance, color is applied as a pigment, stain, metal foils, mosaic, or similar materials, then it does not differ from the character of decorative art.

If, on the contrary, color is embodied in the structural material out of which a building is being built, either in mass coloring or detailed ornament, then we are building in color, as distinguished from decorating in color.

Colors possess a comparative element which is suggestive of physical strength or weakness, vigor or delicacy.

The so-called pastel colors which are commonly used in the art of dry painting, such as colored chalks, are peculiarly expressive of great delicacy.

This effect of delicacy is principally due to these pastel colors being ground in white chalk, consequently the element of white prevails, and as white is essentially evanescent in effect, it tends to remove the element of

strength in color, and substitutes an effect of weakness, or changes an expression of vigor into delicacy.

It is conclusive that all colors which have a strong infusion of white, lack in elemental quality expressive of physical strength. Therefore, such colors should be used in an architectural composition with due regard to the principle of physical strength in color.

If, for example, a structure several stories high and laminated in character, is to embody two mass colors, one above the other, in laminated form, in such instances it would seem logical to consider the relative physical strength of color, and thereby guard the artistic result quite as much as to guard the relative strength and carrying efficiency of the materials piled one above the other in stratified form.

As a matter of course, there can be no set rules covering the precise relation and use of color in architecture because they are so variable, nevertheless, there are many fundamental principles which are generally applicable.

For instance, take a structure of numerous stories, wherein the major superimposed mass is of a rich, dark red or purplish brick so commonly used:— imagine this heavy mass of dark color supported upon a lamination of one or two stories of white marble or granite.

The mass of red is, to be sure, being carried by a white material which our scientific knowledge tells us is harder in texture, but the suggestion conveyed to the eye due to relative color strengths is on the order of beautiful female Caryatides, determinedly, stolidly, but not gracefully supporting an entablature upon the crowns of their heads.

It stands to reason that colors must be placed relative to their carrying efficiency, if they are to fulfil the natural requirements of the unconscious eye of mankind, which has inherited certain fundamental laws.

It is not natural to support a great mass of strong heavy color on a weaker and lighter one, whereas, a color expressive of superior strength is appropriate under a mass of lighter color. This is a consistent rule, most effectually illustrated by the natural law of the prevailing deeper, stronger color tones, which we find below the line of the horizon, and from which vaults the ethereal canopy of the sky.

Color is most seductive and illusive. It appears to be everywhere except in white and black, and even these outcasts of nondescript origin borrow from their surroundings instantly, where there is the slightest chance for them to reflect a new tone out of their neighbor's complexion.

Then again, each color appears changed in its tonal value the instant that a new color neighbor is introduced into the field of vision.

Color possesses a distinct element of temperature. We speak of colors which are fundamentally red or yellow as warm colors, and those which are fundamentally blue, as cool colors. The eye is at once conscious of the influence of color as regards temperature and the effect conveys a distinct physical sensation.

It would seem to be an indiscreet and hazardous expedient to deliberately or by inference advocate a more extensive use of color in architecture.

Instead of advocating the use of more color, it would seem proper to strongly advise curbing the prevailing custom of using too much intense color, and substituting a more refined and judicious application of it.

Architecture, viewed from the standpoint of a constructive art, has one most vital constituent which does not enter into the more limited scope of any

other branch of the fine arts; that constituent is physical weight tending to destroy.

Neither music, painting, poetry, or even sculpture possess within themselves this element of physical weight.

Architecture alone has this element of physical weight in expression as well as in reality, and unless it is properly provided against, both in its physical construction and its visual expression, in that case we have failed in our purpose of good design, and the result is essentially imperfect.

A color treatment applied to the exterior surface of a structure, which presents an appearance suggestive of skin-grafting, generally lacks the firm and all-important requisite demanded by this element of physical weight.

Anything, which gives the impression of insecurity in architecture, fails of its purpose to be good architecture.

A structure which is sufficiently large and imposing to inherit the architectural element of visual weight, must of necessity present an appearance of perfect homogeneity in its construction.

It must have the appearance which is clearly manifested by the human form divine, wherein the cuticle is essentially an integral part of the structure, and not something which has the appearance of being applied, after the body was constructed.

A field, or large mass of color applied in the nature of faience, tile or thin slabs of any conventional building material, and which in its application fails to express the principle of homogeneity in construction, may in some instances suggest an inherent tendency for that structure to fall.

The mere suggestion of instability in architecture, even though it does not exist physically, is nevertheless sufficient to jeopardize charm of design.

Physical weight is an inherent primary element in architecture, the evidence of which even the untrained eye unconsciously telegraphs to the senses. Therefore, it is of vital importance that a design possess the elements of strength in appearance, both as regards color and method of application, to provide an antidote to resist this element of physical weight, which is the antithesis of strength in design.

The Alhambra—at Granada—palace of the Red Pasha, affords us a most interesting example of the influence of polychrome, combined with sculptural detail, as applied to architecture. The inner courts are enriched with the most delicate marble columns, exquisitely carved, supporting arcades and wall masses, which, if compared with any other accepted architectural style, would be pronounced utterly disproportionate.

It is most interesting to note how the effect of superincumbent weight has been practically eliminated by means of a gorgeous application of the most intricate and delicate elaboration.

The heavy walls supported by these slender columns have been treated with an endless variety of Arabesque patterns and Moslem inscriptions, interwoven like a fabric out of the sculptor's and decorator's art in polychrome.

Herein we find a representative style, quite its own, because it graphically illustrates how effectual delicacy of sculptural detail, combined with polychrome, will tend to make a disproportionate mass in super-structure look ethereally proportionate under the most adverse condition respecting the element of weight in architecture.



Polychrome in architecture was well understood in the days of our classic forebears. Greece is accredited with having carried the art of color application to its highest artistic perfection. It was frequently applied to sculpture as well as to architecture. The use of colors in statuary became more or less conventionalized. For example, men's flesh was represented by a dark brown otherwise red color, whereas the flesh of women was represented in white or yellow.

Architecture has a marked parallel characteristic to sculpture, in the sense of proportionate massing, termed composition.

Without proper massing partial failure in design is certain, because proportion is a fundamental requisite, which, if once lost in the structural element, can only be partially rescued by means of a polychromatic treatment in design.

Sculpture in reality parallels architecture most closely, when independent and complete in itself, as an integral composition.

Again, sculpture, when applied to architecture, becomes an integral part thereof, because it is embodied into the physical and spiritual elements of an architectural entity, quite as color is, when similarly applied.

In Greek architecture the entablature was strongly accented. The triglyphs and metopes, aside from being carved, were also colored, usually in brilliant shades of blue, red and gold.

Sometimes broad wall surfaces back of columns were in color, whereas the columns were left in natural marble, though sometimes tinted lightly, and further ornamented with meander and other conventional designs in bright colorings and gold.

A building in polychrome is in some respects comparable to a painting in parti-color, because here we have a complete expression of the object, in shade and color, regardless of the physical structure back of it.

A building in monotone may more properly be said to find its prototype in the art of etching; herein the entire surface is treated in a solitary basic color of lights, shades and shadows.

Every building, whether in polychrome or monotone, is influenced by its surroundings, and also affects its surroundings into an altered state of existence. It must be observed that no building can be regarded as complete in itself, and that every building must serve to fulfil a beneficial, otherwise a detrimental, effect upon its surroundings. It is either Appropriate or inappropriate to the place which it occupies, all depending upon the design.

The proportion of a structure is subject to the effect of optical change in its apparent length, width or height through a judicious use of polychrome, otherwise by means of varying shades of a single color.

The apparent length of a building may be increased through the introduction of a horizontal color scheme in its architectural laminations.

As opposed to this, its apparent height may be increased by inverting the contrast of color or shade values in its vertical growth.

It is, indeed, quite impossible to avoid the use of color in architecture, since everything which is not positively white or black, has the element of color in it.

Color may express truth, or hide the real nature of whatever it covers, like a cloak would a queen, or as the sheep's skin did the wolf, in one of Aesop's fables.

It was Aristotle who, in reflecting upon the comparative merits of culture and religion, requested to be enlightened as to which one of these two, culture or religion, was the true architectonic or master-art, which prescribes to all the other arts and occupations of life their proper functions.

Sir Charles Thomas Newton, England's archaeologist, writes that "We must consider architecture as the great law which has in all time regulated the growth and affected the form of painting and sculpture, until they have attained a certain period in their development, which enables them to free themselves from its influences."

There are innumerable examples of the deliberate use of color as applied to architecture, in the orient.

It is an accepted tradition that the peoples who inhabit the oriental sections of the globe have constantly, through succeeding ages, manifested a natural tendency toward artistic variety in the use of color.

This is not alone in their architecture and sculpture, but also in their apparel, and in the many other objects with which humanity surrounds itself.

It will be observed that this evident tendency toward the artistic use of color was almost invariably accentuated by the predominating masses of lighter shades, of which the building walls were constituted, in every thickly populated community.

Such walls are usually in tints approximating white most closely, and, because white accentuates all other color values most effectually, therefore, it is fair to assume that our impression of the extensive use of color in the orient is due to a judicious, rather than an extravagant use of color. The color used shows to better advantage, because of the prevailing lighter tints approximating white in their architecture.

This is true of India with its "Gem of Buildings," Taj-Mahal, predominating in light color, with its beautiful mosaics in stone, of flower motifs and arabesques, rendered in various colors of agate, bloodstone and jasper—resembling the Alhambra in the delicacy of its lace-like tracery, and Santa Sophia in its solidity.

Assyria, Turkey, Greece, Italy, Egypt, including all the north coast of Africa bordering on the Mediterranean—then Spain and its South American colonies, and Mexico, are all in the same category.

Florida and California, with their oriental atmosphere, show a natural tendency in that direction, partly due to early Spanish influence, but largely because the climatic conditions call for it. The occidental has not fully awakened to this fact as yet, but he will as is proven by the more extensive use of the lighter tints approaching white in the walls which he builds today.

We are beginning to realize that it is the white wall which makes the blue sky seem more blue than it was, and that the red roof is more red. In this are the first signs of an awakening, which will prove to be the forerunner to an ultimate acceptance of the complete gamut of color.

After all, architecture, however much abused by its true worshippers, or its pretenders, is destined to always remain the guiding spirit of the allied arts. She is mother to them all, and, in turn, is sanctified by them, as a true mother is blessed by her beloved children.

They depend upon her embraces, her enveloping comforts, love, sympathy and protection—she shields them all.

Architecture's soul inspiring grandeur makes them stronger, more beautiful, sublime. She is their alma mater.

Retrospectively, architecture existed in embryo like the oak tree in the earth, like rock in molten lava, like music in the rippling brook, and the roar of the winds and the sea.

All Nature's sounds are music in embryo, requiring man to translate them.

All the world's visible substance is painting and sculpture in embryo, requiring man to translate it.

All the world's spirit is poetry, requiring man to translate it.

Man developed from a state of embryo, and became heir to all these things.

Man developed—he grew from an unshaped embryo into primitive man, and with his development—in accordance with divine law—became master over the spirit lying dormant within the tree, the rock, the sound of the brook, and of the visible and invisible elements, which he must interpret into the purposes for which they are intended.

Man is empowered to develop them into the arts of sculpture, painting, music, poetry, architecture. They constitute his property, his most sublime enjoyment, his greatest heritage.

\* \* \*

## To Prevent Dusting or Easy Abrasion of Improperly Laid Concrete Floors

By ALBERT MOYER, Assoc. Am. Soc. C. E.

**C**EMENT floors, particularly in office buildings or warehouses, which do not have the advantage of obtaining the necessary moisture from the atmosphere as do outside floors and sidewalks on which the dew falls at night, if not properly protected and kept damp, become prematurely dry and are therefore more or less porous and weak, causing easy abrasion under foot traffic, or what is commonly known as dusting.

Care should be exercised in keeping such floors damp by covering with wet sand, wet hay or straw, for a week or more, until the floor has properly hardened. If this has not been done and the floors are found to dust under foot traffic, the following remedy will be found very easy to accomplish, economical and effective.

Wash the floor thoroughly with clean water, scrubbing with a stiff broom or scrubbing brush, removing all dirt and loose particles. Allow the surface to dry, and then apply a solution of one part water-glass (sodium silicate) of 40 degrees Baume, and 3 to 4 parts of water, the proportion of water depending upon the porosity of the concrete. The denser the concrete the weaker the solution required. Stir well, and apply this mixture with a brush (a large white-wash brush with a long handle will be found the most economical). Do not mix a greater quantity than you can use in an hour.

If this solution is sufficiently thin, it will penetrate the pores of the concrete. Allow the concrete surface thus treated to dry. As soon as dry, wash off with clean water, using a mop. Again allow surface to dry and apply the solution as before. Allow to dry and again wash off with clean water, using a mop. As soon as the surface is again dry, apply the solution as before. If the third coat does not flush to the surface apply another coat as above.

The sodium silicate which remains on the surface, not having come in contact with the other alkalis in the concrete, is readily soluble in water and can therefore be easily washed off, thus evening up the color and texture of the floor. That which has penetrated into the pores, having come in contact with the other alkalis in the concrete, has formed into an insoluble and very hard material, hardening the surface, preventing dusting and adding materially to the wearing value of the floor.



*Hotel San Marco San Francisco. Built Entirely of Reinforced Concrete  
MacDonall & Applegarth Architects*



*American Music Hall, San Francisco. Steel Frame and Concrete Walls  
Henry Ives Cobb, Architect*

## The Use of Reinforced Concrete in San Francisco and Vicinity\*

By JOHN B. LEONARD, C. E.

**I**N order to properly appreciate the use of reinforced concrete in San Francisco and vicinity at the present time, it is essential to understand the conditions existing in this territory immediately previous to the great earthquake of San Francisco in 1906. By vicinity, the writer refers to that portion of California that is within the radius of 150 miles of San Francisco.

Municipal Laws of San Francisco.—Prior to April 18, 1906, the building laws of the city of San Francisco were so framed that they did not permit the construction of an all reinforced concrete building. They did allow the use of reinforced concrete for foundation work, sidewalk walls and floor slabs. Architects were also allowed the use of reinforced concrete, intermediate beams in a structural steel frame, and this device had been resorted to in two or three instances. There were many buildings in which reinforced concrete floor slabs were used, and also concrete fireproofing for the columns, but a large portion of the practice used tile for floor and fireproofing purposes.

The advocates of reinforced concrete, however, were making a very strenuous fight to secure permission to construct of this material, and their efforts would undoubtedly have secured favorable results in a short time.

San Francisco being the metropolis, was then, as it is today, the guide

\*Delivered before the Seventh Annual Convention of the National Association of Cement Users, New York, December, 1910. Mr. Leonard's address is the Sheldon Building, San Francisco. The illustrations accompanying this paper have been selected by the publishers as typical all-concrete or semi-reinforced concrete structures erected in San Francisco and vicinity since 1906.



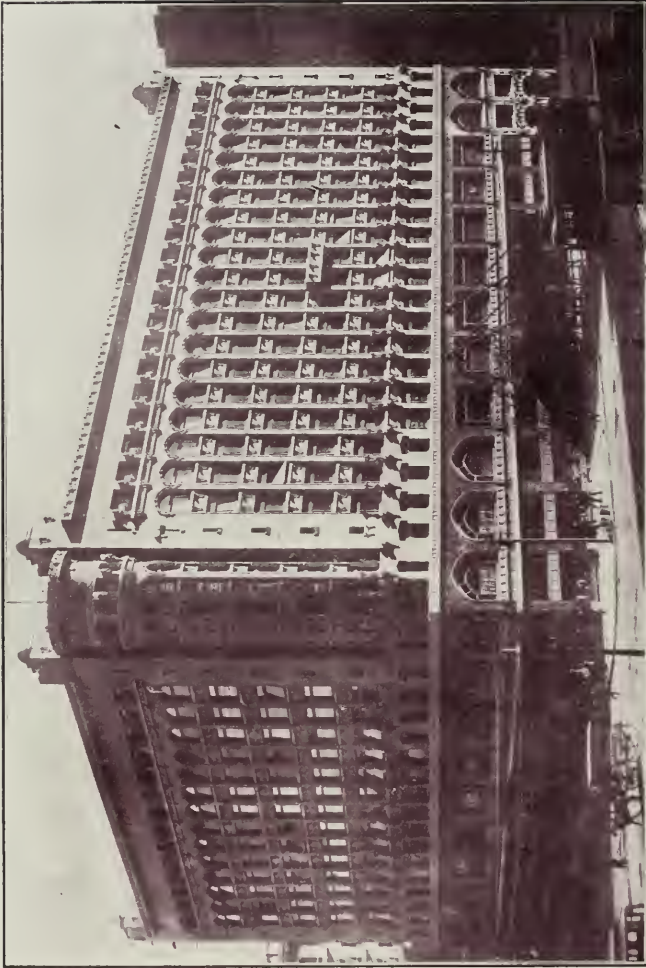

*Pacific Building, San Francisco. One of the First All-Concrete Structures to be Erected in San Francisco after the Fire. This is One of the Largest Concrete Office Buildings in the World  
Charles F. Whittelsey, Architect*

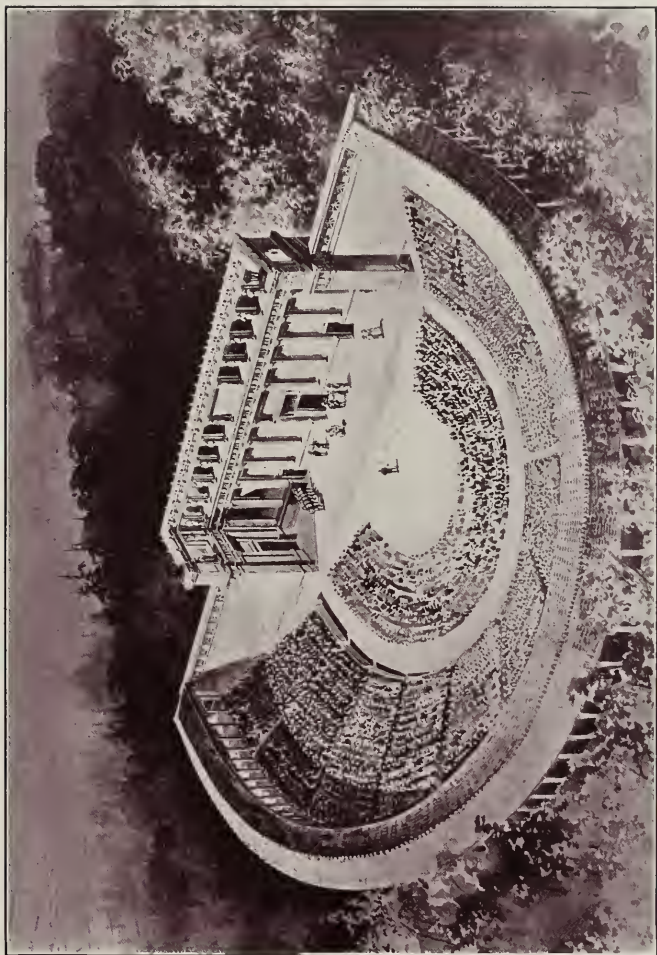

John Galen Howard, Architect

The Greek Theater, University of California, Berkeley, Cal. Built Entirely of Concrete



*Temporary City Hall, San Francisco. Contract for the Concrete Work Alone Amounted to Nearly \$200,000. Foundations, Curtain Walls, Floors and Roof Are All of Concrete Wright, Rushforth & Cohill, Architects*

for the smaller interior cities and villages in all essential matters pertaining to building construction.

**THE EFFECT OF EARTHQUAKE ON REINFORCED CONCRETE BUILDINGS.**—Owing to the building laws of San Francisco denying the privilege of constructing reinforced concrete buildings in the city limits there was no completed building of this type in San Francisco at time of the earthquake and fire. There was one building just being constructed. The owner had never received an official permit for the erection of this building, but being confident of the merits of reinforced concrete, intended to abide by the issue in the courts. The structure was intended for storage purposes, and was to be six stories high. The footings, columns, girders, floor and roof slabs were to be of reinforced concrete, and the enclosing walls of brick. At the time of our great disaster the second floor had been completed and forms were up for the third floor, also the curtain walls were up nearly to the third floor.

The building was not subjected to any intense fire, but it was in a section of the city that suffered severely from the earthquake. An examination of the building a few days after the disaster showed that the brick curtain walls had suffered considerably, but that the reinforced concrete portion of the structure was entirely sound. The faults in the curtain walls have since been corrected and the building carried on to completion in reinforced concrete.

At the Leland Stanford, Jr. University, located at Palo Alto, about 30 miles south of San Francisco, in the Santa Clara valley, and but a few miles from the famous fault line, there existed a reinforced concrete building that was constructed some 23 years ago. This building, known as the Museum building, had a length of about 300 feet and a depth of about 50 feet and is two stories high. The construction was entirely of reinforced concrete, consisting of interior columns, girders, beams and floors and enclosed with concrete bearing walls. The enclosure walls, however, were not reinforced except at the floor levels, the space between the floor levels consisting of plain concrete.



*Pacific Telephone Building, San Jose. Steel Frame and Concrete Walls*



*Montgomery Hotel, San Jose. An All-concrete Structure, Reinforced with Deformed Steel Bars. This Building Is Nearing Completion and Will Cost Close to \$200,000  
William Binder, Architect*





Successful Competitive Design for Olympic Club Building, San Francisco  
Reinforced Concrete Foundations, Swimming Tank and Fireproofing  
Parr & Bauer, Architects



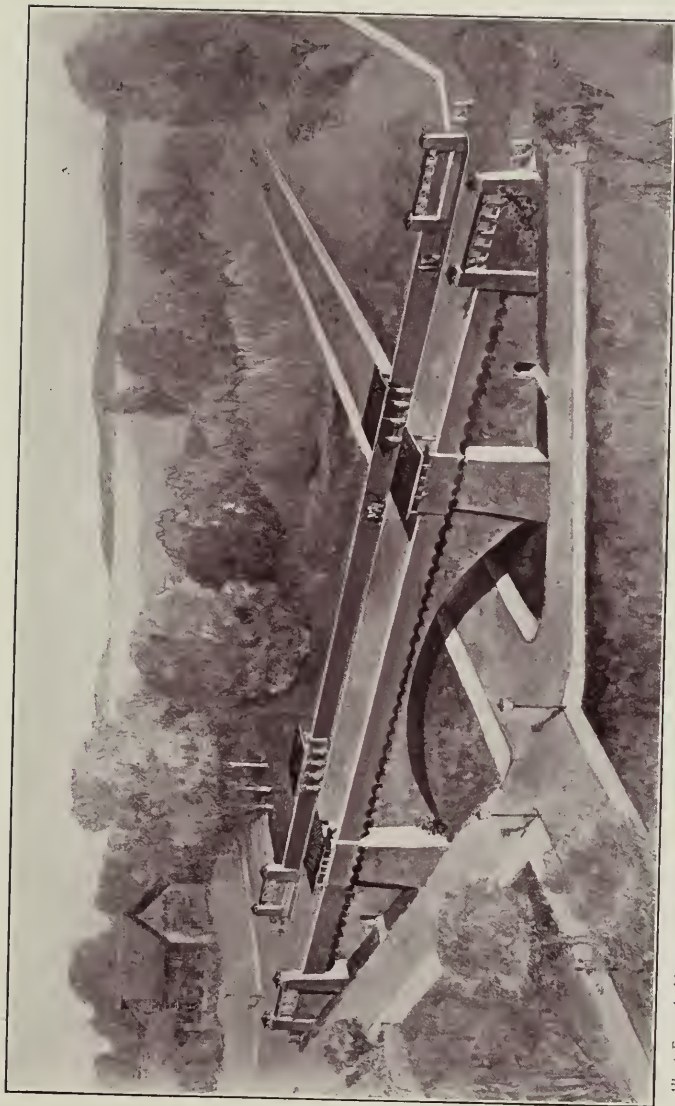

Albert Fary, Architect

An Attractive Suburban Concrete Bridge at Piedmont, Cal.

John B. Leonard, Engineer

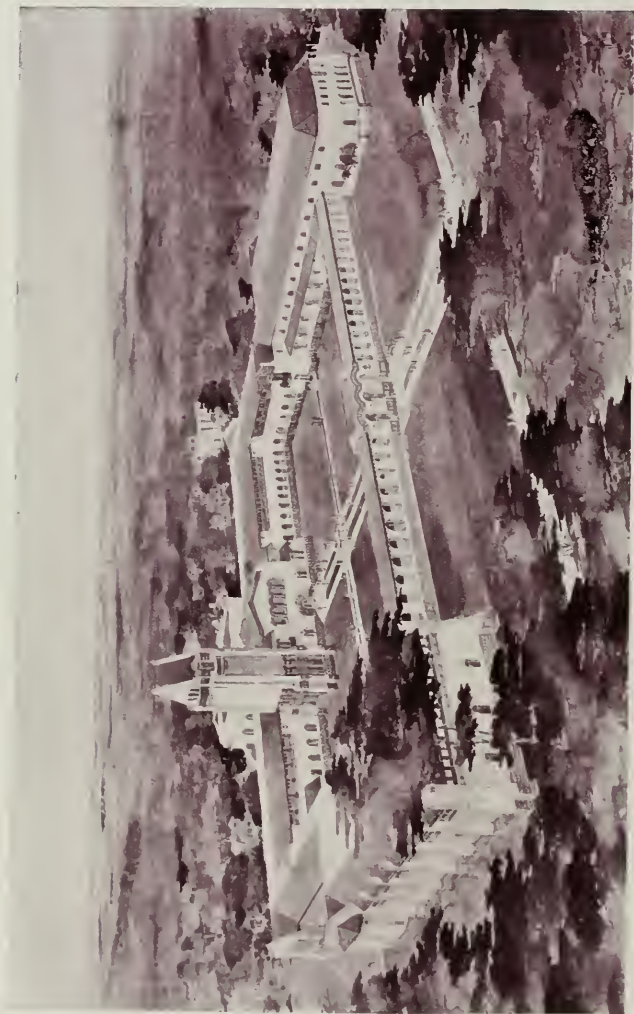

*Birds-eye View of San Jose State Normal School, All the Buildings Are of Reinforced Concrete with Brick and Tile Decorations*



Tower and Main Entrance, San Jose State Normal School. This Building Is Roofed with Red Clay Tile. The Exterior Treatment of Concrete Walls Is Pebble Dash and Faience Tile



*Tillmann & Bendel Building, San Francisco. One of the First Concrete Buildings for Wholesale Purposes Completed after the Fire. The Kahn System of Reinforcement Is Used  
MacDonald & Applegarth, Architects.*

Shortly after the completion of the building, as was to be expected, shrinkage cracks appeared in some of the walls. Recent observers have mistaken these shrinkage cracks for earthquake cracks, but there is ample testimony of unquestionable character to prove that they were in existence years before the earthquake occurred.

It became the writer's privilege about a month after the shock to make a thorough and minute examination of the structure in company with an engineer and an architect. Because of our realization of the important part that reinforced concrete would probably take in the reconstruction of the stricken section, our examination was made with unusual care. At the completion of this task it was the unanimous opinion that this structure had suffered no structural damage from the earthquake. It was not subjected to any fire test. Columns, girders and floors showed no cracks or defects of any character whatever. The only item of damage that could be found in the building at all was a hole that had been punctured in one of the floors, this puncture being caused by the falling of a piece of statuary.

That this building had been subjected to a severe vibratory motion was evident in the main entrance. This entrance had a marble wainscoting about four feet high, and the floor was covered with chips and dust caused by the grinding of the edges of the marble used in the wainscoting. Some of the chips were as large as the thumb nail.

There was just being completed an addition to the Museum building. This was almost ready for occupancy. The construction of the new work consisted of brick bearing walls and concrete floors, the concrete floors being supported by steel girders and columns. All the new work was badly wrecked by the earthquake. It is interesting to know that the University authorities had abandoned the reinforced concrete construction and resorted to this type as being safer. The alarm was caused by the shrinkage cracks that existed in the main Museum building.

This building certainly possesses for advocates of reinforced concrete more interest than any structure in this vicinity, on account of the unquestionable severe ordeal through which it has passed. It will convince all fair minded persons that a properly constructed reinforced concrete building of such dimensions is a safe and sound structure for earthquakes of as great magnitude as that which occurred in California in 1906. It was the intention and object of Governor Stanford when he authorized the construction of this building to have on the campus a structure, whose strength and durability would be the maximum that could be obtained. That he succeeded, can be doubted by no one who saw the campus after the earthquake.

The writer has heard it stated, and is informed, that this statement exists in print, that the Memorial Arch at the Leland Stanford, Jr. University was a reinforced concrete structure and that it was a complete wreck. I take this opportunity to refute this statement in so far as it pertains to reinforced concrete; the arch was a wreck, but it was constructed of brick.

Fire Resisting Qualities of Reinforced Concrete.—One of the great misfortunes for us is that there did not exist at the time of the fire an all reinforced concrete building in San Francisco. Such information as was gleaned from the San Francisco fire on this subject was derived wholly from the behavior of the concrete floors and fireproof columns in some of our steel frames. As in all other places, good, bad and indifferent concrete work had been done, so that the results must of necessity be variable in character. The same faults of workmanship existed, no doubt, in the buildings in which tile was the fireproofing element.

When San Francisco faced the problem of rebuilding, it was a source of astonishment to those interested in construction to see the attention and investigation that was being given to reinforced concrete by the laymen. The public opinion became so strong for this material that the Board of Supervisors were compelled to recognize its merits and permit its use for all building operations.

Its superior fire resisting qualities were recognized by comparing the general condition of such buildings as had used concrete with those which had used tile. The result is that today in San Francisco concrete has been used as fireproofing for the steel frame buildings almost exclusively. There is but one case in the city in which tile was used.

Up to June 30, 1910, there had been issued in San Francisco permits for 132 reinforced concrete buildings. Several permits have been issued since, so that the number to date can safely be taken as over 140. Of this number, 128 are completed structures and being occupied, eight more will be completed within two months, and the balance within six months. The private capital invested in buildings in San Francisco from April, 1906, to June 30, 1910, as shown by the official reports of the California Development Board is as follows:

Class A (steel frames).....	105	\$23,467,260
Class B (reinforced concrete).....	132	9,059,371
Class C (mill constructed).....	1,739	53,597,631
Frame .....	15,844	63,701,643
Alterations .....	9,491	11,302,231
	27,311	\$161,128,136
Addition of 15 per cent for under valuation.....		24,169,220
Total expended to January 1, 1910.....		\$185,297,356
Municipal work inclusive of bond issue (city work applies to only contracts actually awarded before January 1, 1910).....		6,150,371
Total .....		\$191,447,727



*Reinforced Concrete Garage for the  
White Automobile Company  
MacDonald & Applegarth, Architects*



*Reinforced Concrete Bridge, Santa  
Clara County, Cal.  
J. G. McMillan, Engineer*



*Concrete Bridge at Ross, Marin County, Cal.  
John B. Leonard, Engineer*



*Showing Method of Building Concrete Coissons for Pier Improvements, San Francisco Water Front*



*James D. Phelan Building, San Francisco  
Fireproofed Throughout with Concrete. Exterior of Terra Cotta Tile  
William Curlett & Son, Architects*



*Sacramento Hotel, Sacramento, Col. An All-Reinforced Concrete Structure  
Sellon & Hemmings, Architects*



*Y. M. C. A. Building, San Francisco, Steel Frame and Reinforced Concrete Walls  
McDougall Bros., Architects*



*Residence, San Francisco. Unique Design in the Indian Pueblo Style.  
Exterior of Rough Pebble Cement  
Chas. F. Whittlesey, Architect*

The concrete buildings constructed have been built by a most conservative capital. Because of the known conservatism of the company, I mention in particular the Southern Pacific Railroad Hospital. This structure cost the railroad about \$550,000 and was built of reinforced concrete exclusively.

The concrete buildings in San Francisco have been constructed in the face of one very great obstacle. For some reason, unknown to the writer, the banks have absolutely declined to negotiate loans for this type of construction. Many owners have built in structural steel, where they would have used reinforced concrete but for this difficulty.

STATE OF CALIFORNIA.—The State of California through the State Engineers Department, Nat C. Ellery, engineer, has used reinforced concrete very extensively in the replacing of such State buildings as were destroyed by the earth-



quake. The State Insane Asylum situated at Agnews, a place 20 miles from the Leland Stanford, Jr. University, has been rebuilt of reinforced concrete. The old structures were entirely demolished by the earthquake, having been built of brick with timber interiors.

Very extensive additions to the State Penitentiary at San Quentin, situated on the bay but a few miles from San Francisco, were made of the same material.

STATE BOARD OF HARBOR COMMISSIONERS.—The State Board of Harbor Commissioners are a body of men who control the improvements of the harbor of San Francisco, and are appointed by the Governor for this specific purpose. Since 1906 they have used reinforced concrete very extensively in the construction of wharves. Piers 36-38 and 40 are founded on concrete cylinder piers, which support a series of steel girders. These girders are encased in concrete, and on them rests a reinforced concrete slab which supports the entire traffic of the wharf. Pier 54, which is now under construction and nearly completed, is supported by concrete cylinders. The floor system of this pier, however, consists of a series of girders, beams and slabs, all of which are constructed entirely of reinforced concrete. This is the last pier constructed by the Board of Harbor Commissioners, but they now have in preparation plans for another one that will incorporate the same type of construction as Pier 54. These four piers have a floor area of about 360,000 square feet, and cost about \$1,090,000.

It is beyond question that our State Board of Harbor Commissioners are being guided by their experiences and investigations in the selection of reinforced concrete for permanent structures on the water front of San Francisco.

SAN FRANCISCO.—The City of San Francisco has shown its confidence in reinforced concrete in a very emphatic manner. It is well known to you all, no doubt, that the great fire of San Francisco was made possible because of the breaking of the water supply pipes on the marsh just south of the city, thus leaving our fire department without any water to combat the conflagration. Before a rebuilt city could be made safe, it was patent to all that some device must be used to protect the city in case the supply pipes should again be broken. It was finally decided to build storage cisterns distributed throughout the city at proper intervals. There have been 80 of these cisterns built in San Francisco, and all of them are constructed of reinforced concrete.

In the new sewer system, for which bonds have been voted in the sum of \$5,000,000, reinforced concrete is being used exclusively where the sewers are of sufficient size to warrant. There has already been expended in these reinforced concrete sewers \$1,500,000, and the balance of the bond money will be used for this same type.

The County Infirmary building is built of reinforced concrete, and in the steel frame buildings that have been constructed by the city, it is used exclusively for the fireproofing and floor constructions.

COSTS.—For the purpose of conveying to you an idea of the relative costs of a reinforced concrete building, and a structural steel frame building, San Francisco is selected as the location of the structure. The prices existing here for labor and material at the present time are as follows:

Cement workers:	
Laborers .....	per day, \$ 4.00
Finishers .....	per day, 6.00
Housesmith:	
Inside workmen .....	per day, 4.00
Outside workmen .....	per day, 5.00
Carpenters .....	per day, 5.00
The cement is worth.....	per bbl. delv., 1.90
Form lumber .....	per M., 15.00
Gravel or sand .....	per yard, 1.35
Crushed rock .....	per yard, 1.50
Reinforcing steel .....	per ton, 50.00



*Reinforced Concrete City Hall, Berkeley, Cal.*

*Rakevell & Brown, Architects*

The building selected is one of six stories and basement, with a floor area of 10,400 square feet on each floor, and a cubiture of 1,088,000 cubic feet. As actually constructed, the frame is of steel with reinforced concrete foundations, basement walls, floor slabs, and intermediate beams. The curtain walls are of brick. The total contract price for the brick work, concrete work and steel frame was about \$104,000. This figure was considered very low. The cost of a reinforced concrete frame and curtain walls under the same conditions would not be more than \$86,000. A concrete building would have made a saving of \$18,000, or a little more than seventeen (17) per cent. It must be borne in mind, however, that the steel frame building had intermediate reinforced concrete beams, which, of course, reduces its cost to a minimum, thus making the above comparison as favorable to steel as possible.

BRIDGES.—Previous to 1906 and within the territory included in this discussion, there was but one reinforced concrete bridge of any magnitude. This one was a structure consisting of ten 75-foot spans, built by interior counties for highway purposes. This bridge caused considerable inclination among the county officials to weigh more carefully the merits of concrete bridges. By persistent efforts the concrete men are being able to gradually convince the authorities that the extra cost of concrete bridges over steel is money well expended. The result is that there exists today over 50 reinforced concrete county bridges, ranging in magnitude from 35 to 130-foot spans in a section that four years ago contained but one. There is now being constructed by one of the interior counties a bridge consisting of seven 195-foot 6-inch spans.

The county surveyors, who, under the laws of the State of California, control the designing of bridges for the counties except through a special act of the Board of Supervisors, are rapidly becoming advocates of the use of reinforced concrete. The bridges that have been built in the interior, which embrace flat slabs, girders and arches have done an immense work toward educating the people to understand the possibilities and utility of this material. Two counties of California have, through their Board of Supervisors, and by resolutions of the latter, committed themselves to the use of reinforced concrete for bridge purposes wherever possible.

\*

\*                      \*

## Value of Wire Glass

A report of much interest, as indicating the value of wire glass when used as a fire retardent, has recently been made in connection with a fire which occurred in a lumber yard in St. Louis. It appears that two buildings, one equipped with windows glazed with wire glass set in metal frames, and the other with ordinary window frames and glass, were equally exposed to the fire. Each building was provided with automatic sprinklers. The building in which the windows were protected with wire glass was little damaged, as but three sprinkler heads were opened by the heat on the third floor, and one on the second floor. The wire glass held intact, although the great heat radiated through it sufficiently to ignite wood more than fifteen inches away from the glass. This incipient blaze was, however, extinguished by the sprinklers. In the building lighted by windows glazed with ordinary glass, 117 sprinkler heads were opened, and while the water from them prevented complete loss of the building or contents by fire, considerable damage resulted from the flood of water poured out by the sprinklers.

## Fees of Architects

THE American Institute of Architects allows 6 per cent for complete architectural services, including sketches, working drawings and details, taking of figures, letting of contracts, superintendence of the construction and the payment of all contractors' bills. The Institute, however, recommends a higher scale for residence and alteration work. Most architects adopt a sliding scale, 7 to 8 per cent for work amounting to less than \$10,000 and 6 per cent for all work over that amount.

An architect in *Country Life in America* says 10 per cent straight for all residence work should be charged. This is the amount of clear profit usually figured upon by the contractor. The architect has kept careful count of the time spent on all work turned out of his office, and by an empirical rule based on the salaries of the draughtsmen employed, this time is reduced to office hours. He figures that to retain an income of \$5,000 a year there should be a gross receipt of \$3 for each office hour expended on a building. Perhaps to expect an income of \$5,000 a year is presumptuous in as humble a member of society as an architect. To quote the architect:

"Of eight houses recently completed, the lowest return was \$1.75 an office hour, and the highest \$3.19, with an average of \$2.28. Remodeling jobs at 10 per cent commission will return higher. My office is run in a very economical way and the maximum salary paid is \$25 a week.

"Possibly we make one set of sketches; more likely we make five or six. Consultations with our clients last usually from 8 to 11:30 p. m., and we cheerfully give up our evenings because our client tactfully informs us that he is too busy during the day to waste any time talking about plans. Finally the plans are completed and are changed back and forth and back again, each time patiently and for nothing. The specifications are also completed. An owner should realize that an architect is not a necromancer. He is just as dependent as the owner or the contractor. He can not by a wave of his wand or his pencil make a \$10,000 house cost \$5,000. An owner can say, 'Here is \$6,000; do the best you can for me,' or he can say, 'I want so and so; keep the price as low as you can.' But he can not say, 'I want so and so and I wont pay a cent over \$6,000 for it.' Maybe he can get it, and maybe he can't. The contractor determines that question.

"The architect will make mistakes, but small wonder. Did you ever stop to consider what an architect must know? First, the artistic side; here we must start with a certain amount of God-given talent. To design properly an architect must have or thinks he must have exact and intimate knowledge of the great styles of architecture. This knowledge is usually acquired in four years of arduous study at school, either at home or abroad. Furthermore, he must know something—no, he must know a great deal—about the following professions: Civil engineering, the design of beams, trusses, etc., mechanical engineering for heating and power plants, sanitary engineering for plumbing, electrical engineering for wiring, etc.

"To construct his building he must have exact and minute knowledge of each of the twelve or more trades that enter into it. This is essential for efficient superintendence and it comprises, for instance, knowledge of characteristics of all kinds of woods, the properties of all varieties of building stone, the strengths of the different mixtures of concrete, properties of plaster and methods of manufacture, the same of slate, sheet metal, hardware, glass, tile, paints, stains and varnishes, plumbing goods, boilers, radiators, etc. Not only that, but he must be acquainted with the prices of these articles. He must be a business man for he lets all your contracts and pays by certificate all your bills, and he must have a knowledge of building law because under the laws of most states mechanics liens may be levied by contractors, sub-contractors, and yet after all—artist, engineer, builder, financier, lawyer, though he be—it avaieth him nothing if he can not get the job."

## "Fire"

By CHARLES H. MERRIAM.

**F**IRE has been called the most important element of the universe. Without that great and constant conflagration, the sun, the surfaces of our own and other planets would change in form and life,—as we comprehend it, would cease.

The flame of the match, properly applied to fuel which is properly safeguarded, makes for light and heat and health and happiness, for industry and for progress, and all the material welfare which we enjoy.

The flame of the match or any other source of heat energy, improperly or carelessly or thoughtlessly or wantonly applied, often results in the destruction of property and in death.

The sun showers the blessings of its light and heat upon all portions of the earth, and many of us believe that none is more favored in this regard for the comfort of mankind than the zone in which lies America.

And if in America there is a section which in all seasons, and year after year, enjoys in a greater degree than any other the benefits of equitable and constant service from the sun, that section is California.

And yet America leads the world in the destruction of life and property through loss by fire, and California has had the task of replacing created resources representing the largest values wiped out of existence at one time and place in the history of the world.

America's fire waste averages two hundred and fifty millions of dollars per year for the last five years, being a loss of about \$30,000 for each hour.

The loss per capita in America is approximately eight times as great as the average per capita loss in European countries. We destroy more property by fire than do any four nations of Europe.

Each loss by fire is a drain upon the material resources of the country, irrecoverable through collection of insurance. For that which the individual destroys by fire, under insurance taxation, the nation must pay.

America's greatest contribution to the fire waste is, however, her men, her women and her children, burned alive as sacrifices to the ignorance, carelessness and greed of her citizens. Those who perished at the Iroquois Theatre at Chicago, on the steamer "General Slocum" at New York, in the hall at Boyertown, at the school in Collingswood, in the mine at Cherry, and more recently in lesser numbers at many other places, leave us the remembrance of their cries and the horrors which they suffered. These appeal to us much more strongly than the money loss, be it ever so large.

In his symbolic piece "The Bluebird," which is playing in many languages in many theatres in many countries, Maeterlinck shows to us two little children in search of happiness, accompanied by various animals and elements, among which are Fire and Water and Bread. Fire, as a hot-tempered gentleman, is continually interrupting the proceedings with ill-considered remarks. Water, as a lachrymose damsel, often threatens to put him out, but never quite succeeds. It remains for Bread, in the last scene of the last act, to properly characterize him. He says, "This is the trouble with Fire; he was not properly raised." Coming from Bread, the remark is particularly pat. And what a fund of philosophy it contains! Fire, the servant of man, through man's carelessness, becomes his master. Fire, the child of man, brought into life at man's command, being left, through man's neglect, to pursue its own whims, immediately turns to evil ways and destroys man and his works.

\*Paper read before the Thirty-fifth Annual Meeting of the Fire Underwriters of the Pacific of San Francisco, January, 1911.



How can we ever be expected to control ourselves if we cannot properly control so small a thing as the flame of a match? How may we be expected to do our full duty toward our neighbor when "I didn't know" or "I was careless" is sufficient plea to relieve us from responsibility in the matter of burning our neighbor's home.

An inquest after every fire, and laws penalizing carelessness resulting in fire losses, have been suggested, and these would be servicable. They would do more than penalize—they would teach. They would instruct the man on the jury as well as the prisoner. And they would also instruct the people generally who have been accustomed to extend sympathy rather than criticism toward the individual who permits his property to burn.

Instruction on fire hazards given to children at schools would tend to relieve the next generation of much of the shame attached to ours.

Fire marshal laws are well administered in many of the States.

Proper building laws and suitable ordinances governing explosives and combustibles are enforced in some of the cities.

Insurance companies are lending their aid in a united effort to reduce the fire waste and prevent conflagrations, for otherwise they cannot do a safe business at popular prices.

The Credit Men's Associations throughout the country are interesting themselves in the matter, realizing that a dependable insurance is necessary to a sound credit.

In several of the larger cities separate high pressure water systems for fire purposes have been installed and have proved successful.

In some cities, fire departments are divorced from politics, well disciplined, and furnished with modern apparatus.

These and other efforts by certain of the constituted authorities, by a few private interests, and by some semi-public associations are worthy of emulation by others.

Preachers and politicians often emphasize the importance of bringing responsibility home to the individual, and while I do not wish to preach, and am nothing of a politician, it may be pertinent to inquire if each one of us is doing his share as an individual toward the reduction of the fire waste. Do we permit the use of parlor matches in our homes? Do we employ safe and sane methods in our celebrations of the Fourth? Are we mindful of our property and the lives of our families in arranging Christmas decorations and displays? Are the cellars and closets of our houses kept cleared of accumulation of combustibles?

Have we studied the hazards of the heating and lighting systems in our own homes? And have we equipped our houses with proper fire appliances?

The force of a good example by all the insurance men of the country would have a tremendous potency for good, and would enable them to talk a little more forcefully to their neighbors about their duties in this matter.

Collectively, insurance companies and agents are doing a great deal of real benefit—enormously more than any other single interest.

The National Board of Fire Underwriters has prepared a model Building Code, which it distributes freely to officers of all municipalities who can be interested. It employs expert fire protection engineers who visit all of the principal cities of the country and make extensive reports on conflagration conditions.

In Chicago it has built Laboratories where tests are made and reports issued on various devices, materials, systems and appliances having a bearing on the fire hazard. This institution, the Underwriters' Laboratories, has erected and occupies what is generally believed to be the best model

of fire-proof building construction in America, and up to the present time over 5,000 reports on various subjects and appliances coming before it have been promulgated. The findings of these reports are generally accepted by the authorities throughout the United States and Canada.

The Laboratories have inaugurated a system of inspection at factories turning out fire appliances, and attach to the goods themselves their manifest of approval whereby the appliances best suited for use can be readily recognized wherever found. At the present time the Laboratories are labeling at the rate of twenty million devices, materials and appliances per year.

This volume having been reached within the comparatively brief space of five years, proves that the public is quite ready to indicate its preference to receive something real for its money in this line, as in food products and medicine and milk.

The Laboratories' labeling system is ideal in that the people who do the certifying have a financial interest, presumably equivalent to that of the purchaser, in the ability of the labeled article to properly perform its designed functions.

I will cite a few instances where a system of this kind would prove serviceable:

Seven years ago a man put ten cents worth of baking soda in a five-cent tin tube. He sold it for three dollars as a fire extinguisher to use in the stage chamber of the Iroquois Theatre in Chicago. At a Christmas pantomime this great chamber was hung with flimsy draperies representing fairyland. One of these draperies was ignited by a spark from an electric lamp representing a moon. The operator testified that the fire in its incipency could have easily been extinguished by a small stream of water, but the unreal extinguisher being at hand, he waved it as directed, expecting the magic wand to be effective in such surroundings. Unfortunately, there was nothing "make-believe" about the fire, and the result was and always will be very real to the families and the friends of over six hundred women and children whose lives were sacrificed that a man might make a profit of two dollars. I have not heard that the faker was punished. One of his confreres offering the same line of goods recently received the endorsement of a leading official of a great State, who, in lessons he had prepared for the instruction of school children and until their limitations were called to his attention, recommended these appliances as suitable for general use.

Of course, there must be some talking point and an item of reality in connection with all such appliances. The so-called dry powder fire extinguisher will quickly and dramatically subdue a small quantity of gasoline burning in a cuspidor, and it will act similarly with certain other small fires in confined spaces. The point is, we do not have many gasoline fires in cuspidors; we cannot educate our fires to meet the limitations of the specialty extinguisher.

Certain brands of so-called rubber covered wire, conducting that subtle form of energy, electricity, through the concealed spaces of our houses are sold for about the price of the copper they contain. If any real rubber is used in their coverings the fact has escaped the observation of a number of enlightened investigators.

In fire hose, the arteries and veins of our fire departments, we find manufacturers making a monstrous mystery of their wares, analysis proving them rotten or unfit for use, and gossips busy with tales of scandal about the reasons why inferior hose is delivered when superior is supposed to be paid for from the public treasuries.

But the same degree of acumen which brings profit from unfair dealings is rewarded in larger measure if applied to legitimate trade, and fakes in the fire appliance line are going out of fashion. Beginning with an annual output of a few thousand certified fire appliances, we now have an annual volume of twenty million. Manufacturers and dealers, buyers and users, the constituted authorities and underwriters' boards, the financial interests, and departments of the National Government are all lending their aid and earnest co-operation to this movement.

Real fire windows, real fire doors and shutters, and various excellent forms of building materials are being installed; fire extinguishing appliances with their fittings and appurtenances are being constructed in accordance with recognized standards; electrical fittings of all kinds are being properly safe-guarded, and the hazards of many gas and oil using devices are being reduced to a minimum.

Perhaps no single agency has had a greater influence in making for these improved conditions than the National Fire Protection Association, an organization unique, I believe, in listing ninety of the principal National Institutes, Societies, Associations and Insurance Boards in America as active members. During the fifteen years of its existence, this Association has worked constantly for conservation of the created resources of America. It believes that the fire waste is of great importance as affecting the material welfare of the nation as a whole, and that it is of direct obligatory and pecuniary interest to each one having families to protect and property to preserve for his family's use.

An index to the printed records of this Association, issued last month, indicates several thousand items under the headings of fire protection and fire prevention, to which it has devoted its attention.

In the specifications coming under the jurisdiction of this Association, possibly the one best known is the National Electrical Code, which covers the safeguarding of electrical equipment, and which has been adopted as the law of more municipalities and the standard of a greater number of other organizations with authority than any other single set of engineering specifications in existence today.

Another publication covers rules for automatic sprinkler installations, outlining in detail the methods to be followed in equipping buildings with this most useful and successful extinguishing agent. Publications of a similar character, which have been distributed in editions of many thousands, and which are freely used by property owners, architects, insurance boards and others interested, include specifications for the construction and installation of fire doors and fire windows, fire shutters, electrical signaling systems affecting the fire hazard, valves and hydrants, hose, suggestion for organizing private fire departments, and various forms of building construction.

Specifications for safeguarding hazardous appliances and systems coming under the general head of Explosives and Combustibles have been issued, including films for moving picture machines, systems for storing fluids which at ordinary temperatures give off inflammable vapors, acetylene gas machines, gasoline vapor gas lighting machines, lamps and systems, engines and stoves, rules for waste cans, ash cans, refuse barrels, fire pails and safety cans for benzine and gasoline, storage and use of fuel oil, kerosene oil pressure systems, and also suggestion for protection against lightning. \* \* \* \*

We feel that the fire waste is a national, not a sectional question. The East helps bear the losses of the West and the West those of the East. The

burning of New York this year or next year would cause a greater calamity than did the burning of San Francisco, from which, with the aid of the nation, you have so wonderfully recovered.

The significance of the Fire Waste is apparent and the remedies are at hand. I recite no new truth and I prescribe no untried or sensational cures for the ills we all recognize. The evil and uncontrolled spirit of the flame has taken a greater toll of human life and is responsible for a greater destruction of property than all the wars of recent years. Therefore, let us defend ourselves, using practical methods of proven value. I submit the following:

- Fire Inquests.
- Instruction in the Public Schools.
- Rigid Building Laws.
- Explosives and Combustibles Safeguarded.

Departments of Public Safety divorced from politics and furnished with modern apparatus.

Enforce the National Electrical Code and Exclude the Parlor Match.

Fire Marshal Laws.

Eradicate Conflagration Conditions.

Never be careless of the dangers of fire, and do not permit those about you to be careless of the dangers of fire.

Separate high pressure water systems for fire services where conditions warrant.

Educate the public.

I wish this poor cyptogram were less simple, that it might be read more than once. I could wish it more sensational, that it might attract attention. But the greatest doctrine ever given to the world has gained nothing during nineteen hundred years by attempts to distort it, and in this matter the greatest amount of lasting benefit may perhaps come from stating the facts as we know them, and recommending as frequently as possible practical relief measures of established value.

\* \* \*

## Honor for San Francisco Student

**C.** I. HARRISON, draftsman for Bakewell & Brown, the San Francisco architects, has received special distinction from the New York Society of Beaux Arts Architects, having been awarded a medal for the excellence of an archaeological problem, "A Temple to Flora," which he worked out recently in the atelier of Architect Arthur Brown, Jr. A reproduction of the drawing is shown on page 68 of this issue.

\* \* \*

## Concrete Houses for Workmen

It is reported that the Civic Improvement Association of Los Angeles will erect, as an experiment, fifty concrete houses for Mexican laborers and their families. Each house is to be built on a separate plot of ground and will have modern plumbing installed. It is proposed to assign a gardener and a nurse to the district that the occupants of the houses may be taught to take full advantage of their improved conditions.



A Temple to Flora

This Rendering Received Special Mention by the New York Society,Beaux Arts

Designed by C. I. Harrison.



## Architects' Piracy

**S**TEALING of a design by an architect is a most serious breach of professional ethics. In fact there is no other violation which so undermines the work of an architect. Unfortunately, the culprit usually escapes. Plans are accepted and the defeated architect, rather than create trouble, withdraws, leaving success and added glory to his unfair competitor.

The crime of stealing designs evidences itself in different forms and consequently in different degrees of guilt. The most common and one which even good architects are often guilty of, is so-called "adapting of ideas." Thus the New York Herald, Madison Square Garden Tower, Pilgrims' Monument at Providence and many other accepted pieces of American architecture are adaptations, pure and simple, of European buildings.

The practice of "adapting ideas" must, of course, not be confused with following definite styles of architecture or erecting buildings in keeping with certain periods. Styles are perfectly legitimate provided an honest effort is made to create something new. In school architecture there has not been so much of the "adapting of ideas" as of following styles. The Tudor, the Georgian, the Italian and Spanish Renaissance, the earlier Gothic, simplified to an extreme, have occupied the attention of architects of schools.

The most criminal form of architects' piracy is bold-faced stealing of a design and submitting it as an original for acceptance. This occurs frequently in smaller districts where school boards wish to carry local favor by cultivating home talent. The results so far as the local school board is concerned are usually disastrous, in that the steal rarely fits local conditions.

A Far West newspaper recently blazed the story of an excellent school building, just completed, in a town we will call X. Naturally the newspaper story was clipped by the building news service companies throughout the country. A Middle West architect was one day surprised to find in his reports this newspaper story with photograph and floor plans the identical duplicate of a building he had completed two years previous. Upon charging the architect with the steal, a complete confession was made in the very first answer with a check for fifty dollars as "hush money" to save his reputation with the school board.

An Illinois architect, about three years ago, submitted plans and specifications in a Michigan school house competition. After sifting down a large number of architects and plans, the school board finally became deadlocked between the Illinois architect and another who had for years been considered the city's architect. A long fight ensued until finally the board selected another architect, who happened to be doing some work in the city during the contest. The Illinois architect, in the meantime, took his defeat philosophically, awaiting only the return of his plans to terminate the matter. After several months his plans were returned from a distant city instead of the Michigan town where the competition had been held. The plans adopted by the school board were almost identical with the plans submitted by the Illinois architect, while the front elevation differs only in a few minor details. The building stands as a monument to a school board's ignorance and an architect's steal.

Architects' piracy is becoming, day by day, a greater crime because of the high professional ideals fought for by such bodies as the American Institute of Architects. Standards as high as those of the lawyer and doctor are set for the members of the profession. And yet abuses are common. Necessarily where men of so great a variety of professional education are involved this is to be expected. Nevertheless, piracy must be branded as unprofessional and cannot be condemned in language too strong.

One steal ought to condemn an architect with a superintendent or a school board. Crookedness in submitting a design may be taken as a standard of moral responsibility. A preliminary piece of rottenness will make others plausible and often possible. The architect who steals ought to be ostracized by the profession, and ought to be branded by every school board as the man who will always be undesirable.

[From The School Board Journal]

## Suburban Architecture

By THOMAS HASTINGS, Architect.\*

ONE of the most important causes of the unsatisfactory features of suburban architecture about New York is the lack of respect for the traditions that used to be handed down from one generation to another in old times and were adhered to by the builders of our country houses. Perhaps these houses were not especially interesting as architecture, but they contained principles which could be of great value to us if they were applied in suburban architecture today.

One of the most important principles that was, as a matter of course, passed from one generation to another, was that one dimension must in the plan of an ordinary suburban or country house dominate the plan. Yet in the modern rather inexpensive house that we put up today, the requirements are generally such that it makes a house built on the plan of a square. Its height is about the same as its depth and its width. Thus its three dimensions are all equal as an artistic principle of construction. The ordinary house with two or three rooms on the ground floor, for example, has its width the same as its depth. Two floors make its height about the same. The result is a square which looks as if it could be rolled down hill. When one sees a row of them, there is almost an irresistible desire to knock over the first one and see if all the rest would not fall over in the same way.

The old fashioned house of fifty or one hundred feet was always either planned so as to be wider and deep, or vice versa. So one of these two dimensions dominated. When you go to the country your attention will be called to a very simple little house, which is very wide and shallow, or wide and narrow. Here the ridge of the roof has a direction to take, whereas, in the other case, with no dimension dominating, there is no general direction for the roof ridge to take. It could just as well run one way as another. The little farm house that is long and shallow, looks better on the landscape. This is a serious principle of composition, one of the first principles handed down from one generation to another.

These new suburban houses are generally too complicated. They would save money by making them simpler and building them of masonry—concrete, brick, rough stone, or anything instead of wood. By saving money in simplifying them, they could build them of permanent material and make them in addition, more artistic. There are usually enough ideas wrought into one of these wooden houses to build a dozen. The old houses we admire so much are always very simple and therefore more interesting.

One very important factor in making a suburban house look well, is the way it is placed on the grounds. As a rule, a man buys a small parallelogram of ground. He makes a path of another parallelogram around it. He puts a house, another parallelogram, inside of the outline of this lot. None of them is in any relation to each other. If he would only remember that with a small site, if he would put his house on one side or the other instead of having a fringe of ground around it, he would have a considerable piece of ground on one or the other side, or at the front or back. He could have a little garden and he could have a little approach. Then the house and the grounds would immediately become more interesting in their relation to each other.

\* Member of the firm of Carrere & Hastings, New York. Extracts from an interview in the *Builder's Guide*



Commercial Bank Building, San Luis Obispo, Cal.  
Righetti & Headman, Architects

## An Attractive Country Bank Building

THE accompanying illustrations show the exterior and interior of the remodeled Commercial Bank building at San Luis Obispo, designed by Architects Righetti and Headman of San Francisco. The interior equipment of the bank has been carried out in a most attractive manner, the architects having the co-operation of the J. A. M. Johnson Company, specialists in bank furnishings and fittings.

The interior finish is mahogany and white Italian marble, with verde antique base fixtures and bronze metal work.

The directors' room is made up of beautiful panels of mahogany.

Besides the general banking room, president's office, etc., there is a cozy room for the women patrons of the bank. This room is furnished with comfortable chairs, writing desks and other conveniences.

There is also a special consulting room for the accommodation of clients.

A convenient arrangement of rooms intended for the use of clients who have occasion to use the safety deposit vaults is in the form of specially locked rooms which are equipped with automatic closing devices and signals that will show whether a room is occupied or not, so that after a person passes through the door the same is automatically closed and cannot be reopened except by an attendant in charge whose business it is to see that nothing has been left behind by the client. Access to the rooms of the safe deposit vaults is made through a door controlled by an electrical device operated by a button behind the counter of the banking room.

The latest in desks, chairs and office appliances has been added to the bank's equipment and nothing has been left undone which will assist the management and employees of the bank to give clients prompt and efficient service.

The vault work and safe deposit boxes are of the newest and most modern type, being burglar proof as well as fireproof.

The second floor is taken up entirely with offices. The building is steam heated.



*Interior Commercial Bank Building, San Luis Obispo, Cal.*



*Interior Commercial Bank Building, San Luis Obispo, Cal.*



Tognazzini Mausoleum, San Luis Obispo, Cal.

Righetti &amp; Headman, Architects

## Successful Design for Druids' Hall Building

THE accompanying perspective and floor plan of a lodge building won first prize in a recent competition held by the Druid's Hall Association of San Francisco. The design is by Architect E. P. Antonovich, and calls for a three-story and basement structure in the Italian Renaissance style of architecture. The street elevation will be faced with white mat glazed terra cotta. The interior will contain the general offices of the order, a large ball room, various lodge rooms, kitchen, dining room, library, lounging room, etc. The building will cost approximately \$65,000. Others who received mention in the competition were Architects Burki and Dolliver, Henry C. Smith and J. C. Flugger.

Druids' Hall Building, San Francisco  
E. P. Antonovich, Architect



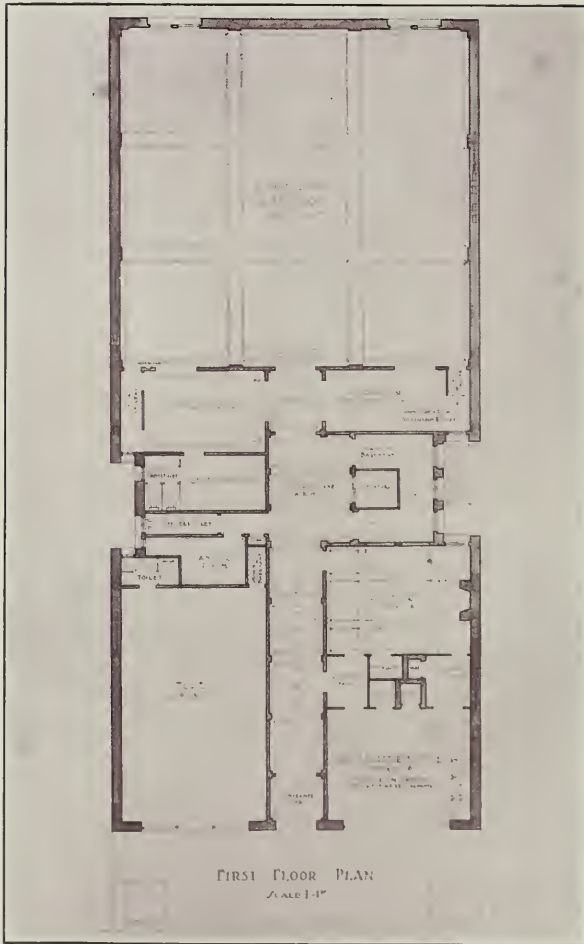

First Floor Plan, Drums' Hall Building  
E. P. Antonovich, Architect



Fig. 1.—Court Theater, Cassel

## The Lighting of Large Halls

By DR. ROBERT GRIMSHAW, in *The Illuminating Engineer*

**I**N lighting large halls, such as are used for concerts, banquets, etc., the special conditions demand special consideration. The illumination must be strong enough to be cheerful and inspiring, yet blind no one; and there must not be so much heat generated as to make the guests or others uncomfortable. Not only the table, stage, etc., but also the ceiling must be well lighted, else the effect will verge on the funereal. It is desirable that the lights develop no combustion gases which would render the air less healthful and also serve to depress those breathing it. The lamps should be noiseless, as sizzling or frying, sputtering or roaring, renders either conversation or public speaking difficult, and detracts from the pleasure of a musical entertainment not only by interfering with the tones themselves, but by "putting out" the soloists. The tone of the light must be such as to bring out to advantage the complexions and toiles of the ladies, and enhance the color effects of the general decoration of the hall. Add to this the desirability of having plentiful light, regularly distributed and generated at low cost and with no danger from fire, and the problem seems sufficiently complicated to make the decision one requiring considerable knowledge, experience, judgment and thought.

To comply in every particular with this rather exacting set of requirements, there seems to be available but one source of light—namely, electricity—but this is applied in many and very various manners in the way of both arc and incandescent lamps, differently placed and arranged in private and public buildings.



*Fig. 2.—A Wine Restaurant*



*Fig. 3.—Auditorium, Court Theater, Cassel*



Fig. 4.—Concert Hall at Bad Neuenahr

The table herewith, on the authority of Professor Wedding and taken from *The Elektrotechnische Zeitschrift*, gives data furnished by the Siemens & Halske Company of Berlin, concerning the effects on the air in the rooms of their tantalum lamps in comparison with other sources of illumination, incidentally giving some interesting data concerning the heat and carbonic acid evolved by human beings:

Source	Evolved hourly	
	Kilogram-Calories	CO <sub>2</sub> Liters
Petroleum .....	36,400	530
Alcohol incandescent .....	16,300	2,770
Auer von Welsbach gas .....	11,000	1,130
Compressed gas .....	6,480	670
Lucas lamp .....	7,820	810
Millenium lamp .....	5,770	595
Carbon filament incandescent .....	3,990	.....
Tantalum .....	1,340	.....
Pure carbon arc .....	950	27
Flaming carbon arc .....	200	12
Human beings per head .....	75	14

As far as the effects of the light on the natural colors is concerned the various kinds of electric light have the advantage over the average gas lights; either the tantalum or the ordinary carbon arc light revealing the most delicate shades in full beauty and correct value.

Without going to great expense it is possible to get by means of electricity the highest degree of illumination; and as far as safety from danger by fire is concerned this source is claimed to be well ahead of all others. There are few



*Fig. 5.—Imperial Palace, Strassburg*

instances of modern banquet halls being lighted other than by electricity. In times gone by there were employed great—shall I say candelabra?—as in the foyer of the Court Theater in Cassel, Figure 1; but in striving not to detract attention from the beauty of the ceiling, and also not to limit the view from the galleries downwards, these ceiling fixtures were gradually diminished in size and conspicuousness. Nowadays special favor is shown towards fixtures with incandescent lamps in one or more wreaths on the ceiling, as in Figure 2, which shows the dining-room of a wine restaurant. Very often there are recessed in the ceiling immense crystal basins, or pendants, in which the lamps are contained, as in the auditorium of the Cassel Theater above mentioned, Figure 3, and in the concert hall at Bad Neuenahr, Figure 4; or tubular lamps, hidden in the cornice, diffuse a soft mild light on the ceiling and in the hall. It is often, however, desirable to add a few lateral wall branches in order to impart to the hall a cheerful, pleasant appearance, as in the foyer of the Cassel Theater, Figure 1, and the Imperial Palace in Strassburg, Figure 5.

Lighting by means of incandescent lamps requires, by reason of the great number of lamps necessary and the high price of artistic fixtures, somewhat higher outlay than for arc lamps. Further, the changing of numerous incandescent bulbs where ladders are requisite is troublesome, and it is, therefore,





Fig. 6.—Mozart Hall, New Theater, Berlin

recommended to arrange heavy overhead fixtures so that they can be raised and lowered as a body, which calls for building in special hoisting appliances. Arc lamps have the further great advantage, that they are more economical of current than the incandescent types. The cost of current for flaming arc lamps is only about one-fifth that of the best filament bulbs, the consumption per specific effect with arc lamps being about 0.2, with metal filament incandescent lamps from 1.2 to 1.5 watts per hemispherical Hefner candle. In Germany the average cost of carbons and attention, including the Government tax, which need not trouble Americans, for flaming arc lamps are about 0.1 to 0.2 pfennigs, or, say, 0.02 to 0.048 United States per 100 Hefner candles per hour burned; whereas, for replacing metal filament incandescent bulbs ("pears," the Germans call them) it is much higher.

These considerations often influence the architect or the owner to light the halls with arc lamps.

As a rule, these (the lamps, not the owners) are hung in the hall itself, and the newer lamps are of the half-enclosed pure carbon ("Bivolta") type, with carbons above or beside one another. In specially well-ventilated halls such as are built nowadays, with technically perfect ventilating appliances like the famous Mozart Hall in the New Theater, Berlin, Figure 6, or in ballrooms and dancing halls of summer restaurants, arc lamps of the "effective" type may be used directly in the hall.

Under all circumstances the use of the flaming arc lamp is to be recommended where the hall has top lights or a glass roof.



Fig. 7



Fig. 8

The flaming arc lamp is then hung from the glass roof exactly as in show window lighting. In both instances it is possible to choose the same type of lamp, one with no casing, but only a small bell of clear glass, Figure 7. To facilitate attention, either the lamp should be arranged so as to be capable of being drawn to one side for attention or the caretaker should have a small carriage running on a track in the iron frame of the glass roof, and by which he can get at the lamps. As a rule, the real top light consists of ground glass, the glass ceiling of the hall being of either clear or colored ribbed glass. In music halls it should be the lower surface of the glass which is ribbed to improve the acoustics.

Many architects avoid having windows in halls, their object being to keep out the street noises. In some cases, however, where there are windows these are filled with decorative glass, and it is desirable to take advantage of this at night; then such windows should have outside of them either flaming arc lights with oblique total reflectors, say, of the Hrabowski type, Figure 8, or searchlights from an opposite wing of the same building, as is done in the Imperial Palace in Strassburg.

Exactly this last example shows clearly that electric lighting by means of powerful sources is inferior to none in the ability to produce tasteful and magnificent effects in immense buildings.

## The Iron Trades Agreement

**T**HE controversy between the California Metal Trades Association and the Iron Trades Council, has resulted in a form of agreement, which has been accepted and signed by both sides and which reads as follows:

"AGREEMENT: Made this ninth day of November, 1910, between the CALIFORNIA METAL TRADES ASSOCIATION and THE IRON TRADES COUNCIL OF SAN FRANCISCO.

"First—The terms of this agreement shall run from November 9th, 1910, until November 9th, 1913.

"Second—The wages provided for in the former agreement shall be in force for the full term of this agreement.

"Third—Disputes of any kind arising between any of the affiliated unions of the Iron Trades Council and a member of the California Metal Trades Association, an accredited representative of each organization shall proceed to the shop where dispute exists and endeavor mutually to settle the same, and any dispute which cannot be settled in this manner must be referred to conference, and should this conference of itself be unable to settle any questions which may come before it, it shall provide some method of adjusting the same, and pending a decision, there shall be no lockout on the part of the employers, nor strike on the part of the employees.

"Fourth—Eight hours shall constitute a day's work until November 9th, 1911. On September 9th, 1911, a conference shall be called to decide as provided in Section three (3) of this Agreement, what hours shall be in effect from November 9th, 1911, until November 9th, 1913. This conference shall be called for the purpose of equalizing hours in force at that time among men working within the states of Washington, Oregon and California, and their decision shall become operative on November 9th, 1911, and shall be in effect until November 9th, 1913."

The history of the formation of this agreement is interesting as showing the use of an English method of settling labor disputes in America. The California Metal Trades Association, entered into an agreement with the Iron Trades Council, in the Spring of 1907, for a period of three years, gradually reducing the hours of labor from nine hours per day to eight hours per day, on June 1, 1910. This agreement was generally conceded by all of the Iron Trades in this city to be necessary on account of the conditions following the fire of 1906. Previous to June 1, 1910, both parties to this agreement met for the purpose of formulating a new agreement, and while both parties practically agreed that some form of agreement was necessary, they could not agree on terms and arrived at a deadlock in September, 1910.

Previous to this time the Commonwealth Club of San Francisco had been discussing general labor conditions; these discussions including speakers from both sides of the case and with the final result that it was decided to try the London plan of settling labor disputes as proposed and outlined by Col. Harris D. Weinstock, and which action lead to the formation of the San Francisco Industrial Conciliation Board, made up of twelve labor representatives and twelve employers representatives, the latter being selected by the San Francisco Chamber of Commerce. This board was formed about the time of the Iron Trades deadlock, and both sides agreed to submit their case to it, it being understood, however, that neither side would be bound to abide by its finding.

This San Francisco Industrial Conciliation Board appointed a committee of three labor men and three employers together with an acting chairman to handle this case, resulting in the above agreement.

The employers sub-committee consisted of Messrs. C. M. Elliott, Harris Weinstock, Joseph Martin. The Labor sub-committee consisted of Messrs. Andrew J. Gallagher, Michael Casey, and Walter MacArthur, the chairman was Capt. Wm. Matson of the Chamber of Commerce.

A member of the California Metal Trades Association in discussing the findings of this Board, outlined the situation as follows:

"We do not generally approve of the entire findings of the San Francisco Industrial Conciliation Board, particularly the recommendation accompanying the form of agreement submitted, as we think these recommendations were foreign to the subject in hand, but we do believe that the form of agreement contains several points and principles worth considering and while giving neither side all they ask for, paves the way for industrial peace for the next three years.

"Clause 3, establishes a principle for the settling of disputes which is satisfactory to both sides, prevents the possibility of a deadlock; and is the result of three years of experience with a similar clause in the old agreement. Clause 4 has been the subject of much discussion but is clearly construed as a necessary clause providing for equality of hours in the trades over the entire Pacific Coast and the wording and intent of this clause is such that at the time specified San Francisco employers will be on an hour basis which will be the prevailing hour basis in force elsewhere on the Pacific Coast.

Much criticism has been directed against San Francisco employers by other localities, but we believe that we have nothing to apologize for because we are continuing a system of handling labor disputes which has been tried for three years, and found satisfactory."

\*  
\* \* \*

## Brick Versus Frame Houses

**M**Y decision to build out of brick came out of a timely talk with a friend. This man had a house in which he had lived about five years when I went to him and told him of my plans for a home.

"Perhaps you'll be able to tell me something that will help," I suggested.

"First of all," he replied, with an emphasis that surprised me, "don't build a frame house."

"But yours is frame. You build—"

My friend smiled. "That's why my opinion of frame houses is worth something. My neighbor's house is brick; that's why my opinion is worth still more. I've seen both sides."

"But I can't afford to use brick," I objected.

"You can't afford not to."

"Well, tell me all about it." And my friend did.

"Six years ago," he said, "I made up my mind to build. Henderson, my next door neighbor here, started his home at about the same time. Our lots were just alike—in fact, their cost had been the same to the cent.

"We worked over the plans, my wife and I, the way they all do, and when we thought we had them right we laid them before a contractor whom we knew to be honest and reliable. He offered to put up the house in wood for \$7,000 brick for \$7,500.

"After paying \$2,000 for the lot, we had \$4,000 left. So we had to borrow \$3,000 or \$3,500 according as we chose wood or brick. There was no difficulty

about getting the extra \$500. Because of the better building, the local bank was only too glad to lend the larger amount, at 5 per cent.

"But somehow, the brick didn't seem worth it to me. Like thousands of other men who set out to build, I had never taken the pains to learn anything about materials. I had the notion that brick was a luxury—for people who wouldn't miss the money.

"It was different with Henderson. He chose brick. Our means were about the same, and I thought he was very extravagant.

"The first thing to make me feel his advantage occurred during construction. His brick came promptly from a neighboring brick yard. My lumber was tied up on some railroad siding a hundred miles away. If you think that was mere luck you are mistaken. With every day that passes the source of the lumber supply becomes more remote, while it is always growing easier to get brick near at hand.

"The labor for building a house of brick is available everywhere. It is a simple material to handle, and there is no community so small that competent bricklayers cannot be had. In masonry there is less chance of leaving hidden flaws than there is with carpentry.

"The appearance of a house counts heavily, not only for the satisfaction it gives the owner, but as an asset. In the first month or two I was inclined to congratulate myself that my house lacked the look of newness which seemed to stamp Henderson's. That did not last long. He trained vines over his house, and the weather began to give a pleasing tone to the walls.

"You think my house is pretty? So it is. But observe the impression of solidity, of substance, that emanates from the other.

"If I train vines on my walls, it serves to hasten the wood's decay. The weather simply washes off the paint. I've had to give the house one painting since I began living in it, and it will soon need another. Each time it costs about \$100. Henderson's brick walls don't have to be painted, and they look better every year than they did the year before.

"Every once in a while I have trouble from frozen plumbing; Henderson never does. In extremely cold weather I must have grate fires or oil stoves to help out the furnaces; he never needs them. In summer his house is 10 degrees cooler than mine. Brick is a poor conductor of heat—but I never thought of that.

"A frame house reaches its 'prime' as soon as the last carpenter and the last painter are out of the way. From then on it is inevitably on the downward path. Every year the expense of keeping it in good order becomes greater. A brick house grows more beautiful and more valuable as time passes, with comparatively little attention. In England there are brick houses that have stood three centuries. You see I know something about the subject now. It's a pity I hadn't learned it in time.

"And I built of wood to avoid borrowing \$500—about 7 per cent of the value of the frame building—which I could have had for the asking. It was one of the most expensive things I ever did. It is just what you and thousands of more like you are about to do because you won't take the trouble to make a few easy inquiries and learn something about materials before you choose."

Chastened and wiser, I rose to go.

"But you haven't heard the worst of it," said my friend.

"What is that?"

My wife stood out for brick and I overruled her. She has never said 'I told you so,' but I can't help feeling she's thought it many a time."—*Construction Record.*





*Eighty-two Foot Truss made by Pacific Rolling Mills for Native Sons' Building, San Francisco*

## Largest Steel Truss on Pacific Coast

By R. S. CHEW, C. E.\*

\*Mr. Chew designed the Engineering Features of the Native Sons' Building.

**T**HE new building for the Native Sons of the Golden West will be situated on a lot 68 feet 9 inches by 137 feet 6 inches on Mason street, near Geary street, San Francisco. The architectural design calls for an eight-story structure with brick front, the interior containing a banquet hall, free of columns, 82 x 68 feet, the height to ceiling being 33 feet, or within seven feet of the fourth floor. A balcony goes around three sides—with a large stage at the east end. The upper floors are divided into lodge rooms.

The engineering feature of the building was to frame and thoroughly brace the hall, making it capable of supporting floors and roof. Several ways of doing this were tried, but the scheme finally adopted was that of supporting a portion of the building over the hall on the truss, shown in accompanying photograph. This truss is 82 feet 9 inches long and 16 feet 8½ inches center lines deep and weighs 65 tons. It carries a load of 1200 tons. The stresses in the members due to this load are very large, the maximum being 1,620,000 in the top chord, this requires 135 square inches, or close to a square foot of steel.

The steel work was erected by the Pacific Rolling Mills of San Francisco.



Native Sons of the Golden West Building, San Francisco  
Righetti & Headman and E. H. Hildebrand, Associate Architects

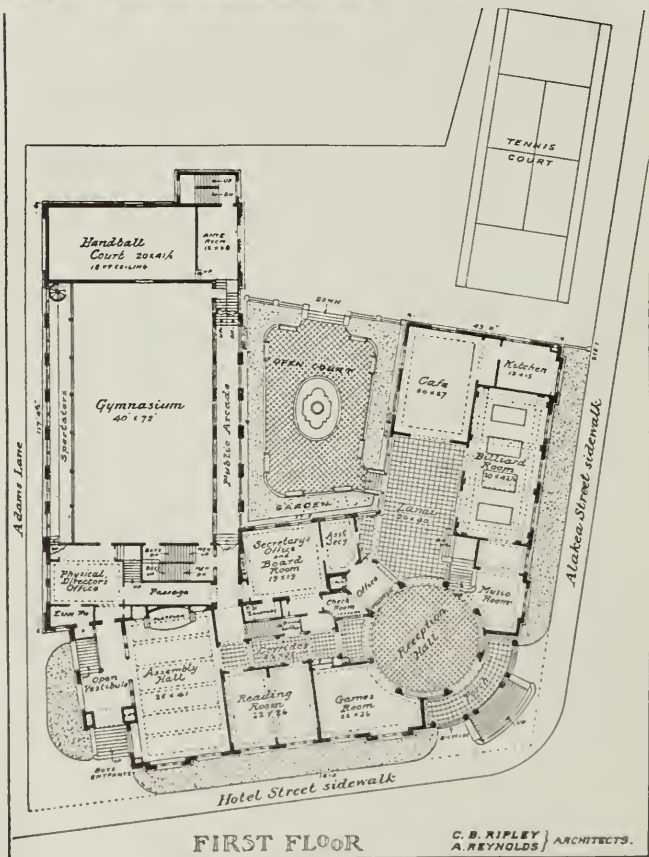
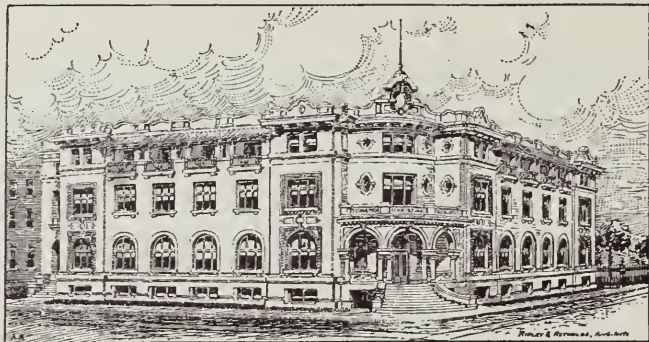

## Honolulu's New Y. M. C. A. Building

THE illustrations shown herein give a general idea of the architecture and floor arrangement of the new Y. M. C. A. building under construction in Honolulu. This building was designed by Architects Ripley and Reynolds of Oakland. Ground was broken last October and the structure is expected to be ready for occupancy next fall. The style is a combination of the California Mission and Spanish. The building is of reinforced concrete with complete steel frame and when finished will represent an outlay of \$220,000.

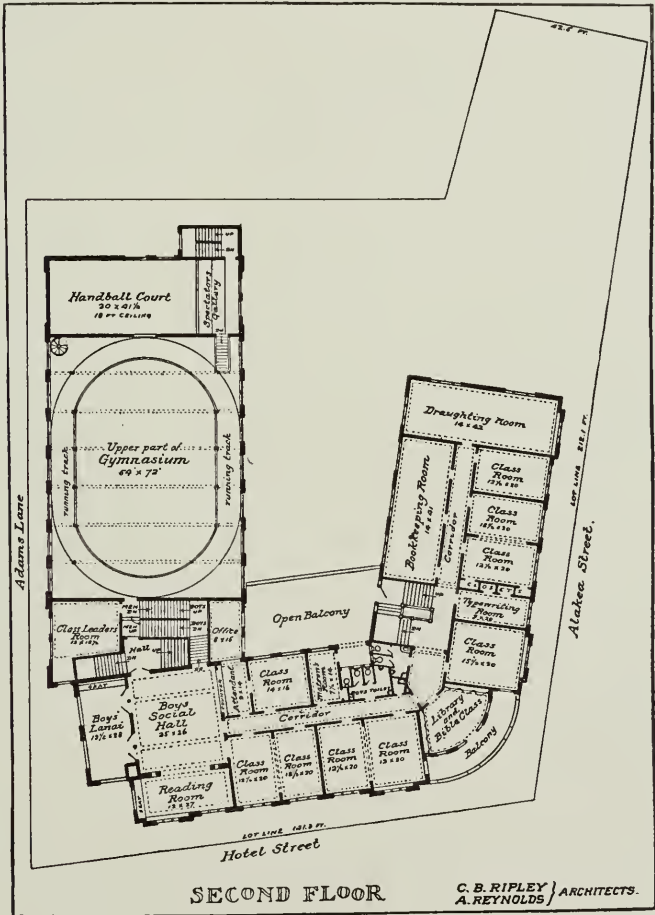

SECOND FLOOR

C. B. RIPLEY } ARCHITECTS.  
A. REYNOLDS }

Honolulu Y. M. C. A. Building

## Testing Portland Cement

By EMORY E. SMITH\*

THE necessity for cement testing, and the inspection of concrete and concrete aggregates, does not have to be argued. An examination of numerous faulty buildings, foundations, walls, sidewalks, etc., in San Francisco, and in other parts of the State, are conclusive upon this point.

Only a portion of the poor concrete work in evidence, however, is due originally to poor cement, much being chargeable to improper housing after the cement leaves the mill, and the use of inferior materials in the aggregate, such as San Francisco bank sand, rotten sandstone and shale, soft or dirty gravel, rock coated with clay, crushed brick, (uncleaned and unscreened), "slushing," (the use of an over-amount of water), improper mixing, lack of tamping, etc.

The American Society for Testing Materials recently sent out a number of letters to the Cement Testing Laboratories throughout the country, requesting a statement as to whether they were using the standard specifications of the American Society for Testing Materials, or what criticism they had to offer. The 135 replies from Testing Laboratories gave the following results:

It was found that ninety-three were using the standard specifications; twelve were using the specifications of the U. S. Army Engineers, and thirty were using their own specifications, differing somewhat from those of the American Society for Testing Materials, totaling ninety-three using the American Society's specifications, and forty-two using other specifications.

The methods used differ chiefly in the preparation of the briquettes. The A. S. for T. M. and the A. S. C. E. recommend the thumbing of the cement paste in the moulds at normal consistency, and have a graduated table for the addition of water to the 1-3 mortar.

The mechanical hammer or tamping method is used to some extent in this country, and is practiced almost exclusively in England, Germany and France. The method is much slower, and more expensive than thumbing. The briquettes produced are more homogeneous and give relatively higher results on the start off, but give an accelerated curve which enables a skilled cement chemist to more readily and quickly detect defects in the sample.

The specifications of the U. S. Army Engineers differ chiefly in the fact that an arbitrary amount of water, 20 per cent, is used in making up the neat briquettes, and 12½ per cent. in sand briquettes, and they are tamped by hand with a brass or copper rod. On our California cements it has as a rule been found necessary to use a less amount of water.

The specifications of the U. S. Navy Department differ chiefly in the fact that an arbitrary amount of water, 20 per cent to 22 per cent, is used in making up the neat briquettes, and for sand 10 per cent to 12 per cent. The briquettes are prepared with a Baume hammer. The amount of water has to be modified to suit our local cements so that the hammer can be used successfully.

Mr. Humphrey, Secretary of the Cement Testing Committee of the A. S. of T. M., stated to the writer a few weeks ago that a strong effort was being made to unify the methods of the Government Departments.

The Tensile Strength Specifications of the American Society for Testing Materials were compiled a number of years ago, and have been slow in modification, although immense strides have been made in the manufacturing of Portland Cement. It is a very poor cement indeed which will

\*Vice President and General Manager, Smith, Emery & Company, San Francisco and Los Angeles.



not at the present time pass the tensile strength tests given, and samples have to be studied with intelligent care to foretell their future value in concrete. No set of general specifications can be made which will not at times be inadequate, or do an injustice when applied to materials as variable in composition and physical properties as Portland cement.

It is also true that in cement testing any result desired can be obtained by improper manipulation of the sample. The lack of exact control in temperature of air and water and humidity of the air, gives widely variable and unreliable results.

The value of cement testing lies largely in the experience and integrity of the persons making the tests, and the completeness and control of the facilities.

## \* \* \* Life of Metal Lathing

**T**HE question is often asked: "How long will metal lathing last under ordinary conditions and in ordinary building?" This is hard to answer, inasmuch as a great deal depends upon the quality of the material that constitutes the fabric, the process of manufacture, and the method of applying the plaster.

For three-quarters of a century prior to the last decade, a wire lathing was quite extensively used in the construction of high-class structures in Europe and America, especially in the United States. These structures have been replaced since by larger and more modern buildings, and in the process of demolition it has been found that this wire meshing was in apparently as good a state after thirty or forty years, as when installed.

A couple of years ago the Fifth Avenue Hotel, on Broadway, New York, was demolished to make room for a commercial structure, and the wire lathing there was found in as good a state of preservation as when installed, fifty years previous. A year or so previous to this, the Boston Theatre, then one of the oldest buildings of its kind in the United States, was demolished, and the wire lathing there was found in excellent shape. Now, why was this lathing practically imperishable in these buildings? The reason is that the strands of the mesh were thoroughly embedded in the plaster slab. That is the solution of the whole problem: Metal lathing properly protected from rust before installation by a coat of paint, or, preferably, of zinc or galvanizing, that is thoroughly imbedded in the plaster, will outlast any building in which it is used.

This wire mesh was exclusively used in the United States until about twenty years ago, but the consumption was naturally curtailed by the comparatively excessive cost over wooden lathing, until ingenuity conceived the idea of manufacturing what appeared to be a wire mesh out of high-class sheet steel. This was the birth of expanded metals, which has revolutionized lathing and plastering in recent years, and made possible the erection of thin fireproof partitions, suspended ceilings, and a thousand and one utilities, where heretofore they had been great problems.

Great care should be exercised, however, in selecting the quality of the lathing. If circumstances will permit it, galvanized lathing should be specified in all cases, more especially in Western Canada, where wood fibres and gypsum plasters are used.

Mr. E. D. Hofeller, of Buffalo (manager of the Roebing Construction Co.), who has probably had as much experience in fireproof construction as any man in America, asserts that any metal lathing, the strands of which are less than 28 B. W. G. in thickness, is not fireproof, and this statement is worthy of consideration. If the architect and builder will keep before them the foregoing facts, they can specify metal lathing with every assurance of satisfaction and success.—Canadian Contract Record.



*A Pair of Twin American Ingot Iron Culverts, Being Installed in Kern County, Cal.*

## The Evolution of the Corrugated Iron Culvert

By PERRY VAN HORNE

IT IS probably not generally known, but it is a fact nevertheless, that corrugated metal culverts have been in use in certain localities in the United States for over a quarter of a century.

Originally they were made with cheapness paramount, hence of very light gauge galvanized steel with no pretensions other than that of temporary, or at the best uncertain longevity. Many of these culverts have long since disintegrated, the result of varying deteriorating elements of the earth in which they were imbedded; others, it is claimed, are still in a fair state of preservation.

Ten years or more ago a commendable tendency was evidenced on the part of various corrugated culvert manufacturers to consider the future. They commenced to operate in the belief that corrugated metal culverts, if made of the right thickness and of a quality of metal superior to galvanized steel, could reasonably be expected to give practical and lasting service. With this in view, the use of extreme light gauge metal which had heretofore prevailed, was discouraged, and increased gauges such as Nos. 18 and 16 for smaller sizes and No. 14 for the largest, were adopted as a fair standard.

Still later experiments were commenced and have continually progressed toward developing a metal on a commercial basis which should surpass steel and equal or excel, from the standpoint of anti-corrosive characteristics, the well-known old-time iron products. That metal meeting these requirements has been perfected is now a matter of common knowledge to the trade.

In recent years calculations based on the adoption of heavy gauges and material of this superior quality, properly galvanized, have been substantially confirmed, with the natural result that corrugated culverts have continued to grow in demand, to undergo improvement and to give satisfaction. Today there are not only recommended by metallurgical chemists and specified by engineers generally, but are also in satisfactory use by the United States government, various foreign governments and under the heaviest traffic-bearing railroads, city streets and country highways everywhere. And they are supplanting in a large degree all other kinds of culverts.

Up to about four years ago the common style of corrugated culverts was cylindrical and riveted. About that time a new and novel idea was



*"Blazing the Trail." Present Terminals of a Los Angeles Interurban Line, Which Is Preparing to Extend Its Lines, Using American Ingot Iron Culverts.*

evolved in a corrugated culvert made of upper and lower sections with lateral flanges, to be shipped knock-down and nested and set up by the use of bolts. This culvert was also characterized by the embodiment in its manufacture of still heavier gauges of metal than had ever before been used—including for the smaller diameters Nos. 16, 15, and 14 and for the larger sizes Nos. 12 and 10 gauge metal of special anti-corrosive properties, overcoming to a great extent the common criticisms regarding lightness and the effects of corrosion so common to ordinary steel. These better grades of heavier gauge culverts—both the round-riveted and the nestable, by reason of their comparative lightness and strength and their ease in handling, hauling and installing—have accomplished much toward revolutionizing permanent road improvement.

The "Engineering News," commenting editorially on Corrugated Metal Culverts, in its issue of January 20, 1910, had the following to say:

"To an engineer of the old school, accustomed to build always with an eye to permanence and solidity, the idea of putting a culvert of thin corrugated iron under an earth embankment, may seem like a crude makeshift, which ought to be condemned offhand without discussion. Very likely the first use of corrugated iron for culvert was a makeshift; but experience appears to show that under certain conditions culverts of this apparently flimsy construction have made good.



*Railroads are Using American Ingot Iron Culverts Extensively. Illustration Shows Right of Way Preparations for New Line from Los Angeles to Lankershim*

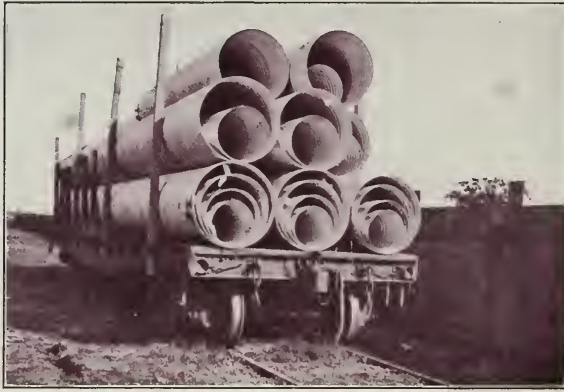

*Carload of American Ingot Iron Culverts. Ranging from 12 to 36 Inches in Diameter.*

"Such culverts are exceedingly cheap, are very light to transport and place, and have so much elasticity and 'come and go' that they will stay in place when unequal settlement occurs where a much heavier culvert would be cracked and broken. For temporary work such culverts are especially advantageous, as they are cheap to place and can be re-covered if the bank is removed.

"The rapid rusting out of sheet iron or steel exposed to the alternate wetting and drying that a culvert receives, naturally occurs as a foremost objection to corrugated iron culverts, but some of these metal culverts are said to have been in service for some fifteen years. By using a special grade of metal of high purity, the resistance to corrosion is expected to be so greatly increased that the culverts may fairly be classed as permanent construction."

A State highway engineer of a western state (Missouri) in a bulletin some time since issued on the subject of "Bridges and Culverts," had the following to say regarding corrugated metal culverts:

"Large quantities of corrugated metal for pipe-culverts and similar products are put on the markets, some of which give good satisfaction, while others do not. Some of the pipe used for culverts in this State has stood but two years, while others have been in use six times that period and are still good. . . . A good weight and quality of corrugated pipe will last fifteen or twenty years. The difficulty is to know when you are getting the good quality—and for this reason we advise great care in buying corrugated culvert pipe. Do not buy unless you feel sure of the quality—there are all kinds on the market."

The State Highway Commission of an eastern state (Pennsylvania) in a bulletin lately published on the subject of "Supervisors and Their Duties," says:

" . . . From this fact comes the corrugated metal pipe which has been on the market for several years past. If made of ordinary steel, the use of such pipe cannot be condemned too strongly, but if made of special material containing so small a percentage of impurities as to be practically pure iron, it will be found an economical investment for a township."

The sentiments expressed in the foregoing quotations have been corroborated in numerous papers and reports from time to time by the most eminent engineers and metallurgical chemists in this country, Dr. Allerton S. Cushman, formerly Assistant Director and Chemist, U. S. Department of Agriculture, Office of Public Roads, in a bulletin recently published said, among other things:

“ . . . It seems to be a fact that carefully made metal in which the ordinary impurities are cut down to mere traces and in which the heat treatment has been carefully controlled, is much more resistant to corrosion than ordinary types of metal with a comparatively high percentage of impurities. . . . The demand for this type of metal appears to be growing, and it has been largely used for the manufacture of road culverts. . . . The fact that this new metal has been largely specified by culvert manufacturers even at a somewhat added cost, is the best evidence that it is meeting a long felt want in this and allied industries.”

Thus it appears that corrugated culverts made of such recognized rust-resisting galvanized material as “No-Co-Ro” Metal, “American Ingot Iron” and “Toncan” Metal instead of ordinary steel, and of the proper gauges, properly galvanized—giving the service that they have for years past—are recognized and accepted as a very formidable and worthy suitor for practical and general adaptability in the culvert field at large.

If any one feature is likely to militate more seriously than another against the prospective future success and permanence of corrugated culverts—whether of steel or the purer metals—it is the continued detrimental exploitation of thin gauge, flimsy material. If people will persist in buying too light weight and otherwise inferior corrugated culverts for no other reason than that they are cheap, only to reap dissatisfaction as they certainly must in a comparatively short time, they should at least be fair enough to withhold judgment until they have given the better culverts a trial and not prematurely and indiscriminately condemn the various other worthy corrugated culverts, made of purer metal and heavier gauges, any of which may be bought at a reasonable price, with general satisfaction assured.

\* \* \*

## Origin of the Graceful Corinthian Column

Many years ago a young girl died in Corinth. Some time afterward her maid gathered together various trinkets and playthings which the girl had loved and brought them to the girl's grave. There she placed them in a basket near the monument and put a large square tile upon the basket to prevent the wind from overturning it. It happened that under the basket was the root of an acanthus plant. When spring came the acanthus sprouted, but its shoots were not able to pierce the basket, and accordingly they grew around it, having the basket in their midst. Such of the long leaves as grew up against the four protruding corners of the tile on the top of the basket curled round under these corners and formed pretty volutes.

Kallimachos, the sculptor, walking that way one day, saw this and immediately conceived the notion that the form of the basket with the plaque on top of it and surrounded by the leaves and stalks of acanthus would be a comely heading for columns in architecture. He from this idea formed the beautiful Corinthian style of capital. Such, at least, is the story as the architect Vitruvius told it 1,900 years ago.





*Teakwood Finish, Living Room in Residence of Mr. D. B. Gamble, Pasadena  
Greene & Greene, Architects*

## Teakwood for Interior Decoration

By C. H. WHITE.\*

AMERICAN visitors to London will recall, if they have visited any of the larger banking institutions of the British Metropolis, the massive elegance of the wainscoting and bank fixtures. These are almost invariably made of Teakwood. This wood is recognized in Great Britain as the King of all woods.

The business of getting out the Teak from the forests of India, Burmah, Siam and Java is in the hands of large and old established British and Dutch firms, some of whom have been importing Teak for several hundred years. The logging is done by elephants that handle the immense timbers with their trunks. On one large concession 6,000 elephants are employed and each elephant represents an invested capital of \$2,000. Timber is dragged sometimes over 100 miles by elephants in the primitive Burmah operations. Kipling in his "Mandalay" speaks of

"The elephants piling teak  
In the studdy, sjudgy, creek."

In fact all of the piling of Teak is done there today by elephants, who handle the large logs, often weighing from three to six tons, much better and quicker than could be done by hand. As the Teak forests of the world are very small and located some distance back from the Coast, it has always cost considerable labor to bring the wood out. These forests were for centuries badly abused and the available timber wantonly wasted. About the middle of the last century, however, when England obtained possession of India, the Government took cognizance of this situation and since that time has allowed only a certain limited number of trees to be cut each year. These trees are specifically marked by the forest inspector who also has

\*Member of the firm of White Brothers, San Francisco



Teakwood Finish in Hall of Mr. D. B. Gamble's Residence, Pasadena Greene & Greene, Architects



Teakwood Finish in Residence of Mr. R. R. Blacker, Pasadena Greene & Greene, Architects

charge of the reforestation. The Government has replanted large tracts of Teak—none of which, however, is yet old enough to cut. The trees are rarely cut when less than 100 years old and they often obtain a height of 200 to 250 feet. Like most woods, Teak has a very straight grain when grown near the water, or on low lands. It was formerly commonly believed that all Teak was straight grained. This was owing to the fact that the old Teak cut many years ago came from the river bottoms where it was easily accessible to the ever tired Oriental.

Teak has for ages been extensively used in ship building as it is the only known wood that will stand the heat of the tropics and the cold of the arctic, that can be wet on one side and dry on the other, without warp or decay. This is due to the peculiar quality of the wax or albumen in the pores of Teak. In the latter part of the eighteenth century and the first part of the nineteenth, Teak was used to the exclusion of almost all other woods in the construction of the warships of the world. Many of the old wooden battleships of Great Britain, famous in song and story, such as the vessels of Admiral Nelson's fleet at Trafalgar, have been broken up for the sole purpose of obtaining the Teakwood of which they were built. This is made into furniture and is very highly prized both on account of the beauty and richness of the wood and the sentiment attached to an article made from one of England's famous ships. The name of the vessel from which the wood in a particular piece of furniture is obtained is always carved on the piece and these articles invariably bring very high prices.

In the United States Teakwood is now being used to a very large extent in the interior finish of the finest houses. The cost of Teak, \$250 per thousand, takes it out of the reach of any but the wealthiest homes, but this high cost at the same time makes it a very exclusive wood and therefore very desirable for any one who wants the best. It is the highest class wood known as well as the most expensive, and represents the acme of elegance in hardwoods.

For centuries Teakwood has been most highly prized by the Orientals on account of its beautiful color and grain, as well as from the fact that it contains a large amount of wax—and when the wood is rubbed this wax comes to the surface and gives a high polish without the use of varnish or shellac.

We Americans have educated ourselves to believe that we must varnish all woods to obtain a finish,—from the fact that it is necessary with most of our native woods,—but the Orientals contend that Teak in particular should not be treated with anything but hand labor. In the construction of furniture they often stain it to imitate Rosewood (especially if it is for export) as it is softer, carves more easily and weighs less; but for their own use, and particularly in the trim of buildings it is left in the natural color so that it may continually throw off its delightful fragrance and grow dark and rich with age. The peculiar fragrance of Teak is lost when the wood is varnished.

When the old Palace hotel in San Francisco was being built during the later seventies, W. C. Ralston had specified a magnificent staircase of Teak which was to lead up from the grand court to the second floor. The Teak for this staircase was especially imported and the work was already completed in one of our local factories when Ralston met his untimely death. The financial panic following his death caused Wm. Sharon, the owner of the Palace, to retrench considerably and the grand staircase was cut out from the plans despite the fact that it caused quite a loss to the factory. This staircase lay for many years in a loft back of the old West Coast

Furniture Co. and was finally consumed in an unfortunate fire which destroyed that historic plant.

In Los Angeles and Pasadena a great many of the magnificent homes of the wealthy Eastern people who make their winter residence in the southern part of the State, are finished in Teakwood. Greene & Greene, the architects of Pasadena, have some very notable work in Teakwood finish. Among the best examples are the residence of Mr. R. R. Blacker at Oak Knoll, Pasadena, and the home of Mr. D. B. Gamble, No. 4 W. Moreland Place in Los Angeles. Peter Hall, the well known Southern California contractor, who did the work on these two houses, carried out the ideas and specifications of Messrs. Greene & Greene perfectly and it is safe to say that these two residences represent the last word in the architectural treatment of Teakwood. F. S. Allen, the Los Angeles architect, has Teakwood doors and window casings in the high school buildings at Perris, San Jacinto, Hemet and Holtville while Messrs. Hunt & Gray of Los Angeles, specified very ornate Teakwood windows for the million dollar residence of H. E. Huntington on his magnificent estate at Oneonta Park, Pasadena. In the San Francisco Bay region there is the residence of Mr. Wm. R. Thorson in Berkeley, a very beautiful example of Teak interior finish by Greene & Greene. In Oakland the Frank C. Havens residence has been remodeled at a cost of many thousands of dollars and the interior finish even to the flooring is of Teakwood.

\* \* \*

## Competative Work for January-February, Architectural League of the Pacific Coast

Student Work.—All mentions are credited by the Society of Beaux Arts Architects, New York. First mentions and medals must be confirmed by the New York Society before being credited by them.

### ARCHEOLOGY—"A BEAMED CEILING"

Stanley Flawn .....Mention

### PLAN PROBLEM

#### "A WINTER CIRCUS"

C. I. Harrison .....Mention  
 C. I. Warnecke ..... "  
 T. Bearwald ..... "  
 J. W. Bagley ..... " { Not counted  
 } in New York

### ORDER PROBLEM

#### "THE CENTRAL MOTIVE OF A RETAINING WALL"

Mention awarded to	Patron
Frank Bastain .....Oakland Architectural Club	W. C. Hays
Chas. K. Greene .....Portland Architectural Club	E. F. Lawrence
Barton E. Brooke ....."	"
Angelo Hewetson .....S. F. Architectural Club	Arthur Brown
H. Schroeder ....."	"
Stanley Flawn ....."	"
Albert R. Williams ....."	"
Guy L. Brown ....."	"
H. C. White ....."	"
Wm. J. Helm ....."	"
S. D. Willard ....."	"
A. G. Rouda ....."	"
H. C. McAfee ....."	G. W. Kelham
A. H. Larsen ....."	"
Phil. De Louchant.....Reno Architectural Club	Mr. Schadler

} Not registered  
 } in New York

# Among the Architects

## American Institute of Architects (ORGANIZED 1857)

Next Convention in Washington

### OFFICERS FOR 1911-12

PRESIDENT..... IRVING K. POND, Chicago  
 FIRST VICE-PRESIDENT... WALTER COOK, New York  
 SECOND VICE-PRESIDENT... F. M. WHEELWRIGHT,  
 Boston  
 SECRETARY AND TREASURER.... \*GLENN BROWN,  
 Washington, D. C.  
 AUDITORS... { JAMES G. HILL, Washington, D. C.  
 { ROBERT STEAD, Washington, D. C.

### Board of Directors for 1910-11

For Three Years—Cass Gilbert, New York;  
 Ralph Adams, Cram, Boston; John Galen Howard,  
 San Francisco.  
 For Two Years—Frank C. Baldwin, Detroit,  
 Mich.; \*S. B. P. Trowbridge, New York, N. Y.;  
 John M. Carrere, New York, N. Y.  
 For One Year—Thomas R. Kimball, Omaha,  
 Neb.; Milton B. Medary, Philadelphia; Alfred F.  
 Rosenheim, Los Angeles.  
 \*Executive Committee.

### San Francisco Chapter

PRESIDENT..... WILLIAM MOOSER  
 VICE-PRESIDENT..... G. B. McDUGALL  
 SECRETARY-TREASURER... SYLVAIN SCHNAITACHER  
 TRUSTEES..... { JAMES W. REID  
 { ALBERT PISSIS

### Southern California Chapter

PRESIDENT..... FRANK D. HUDSON  
 VICE-PRESIDENT..... R. B. YOUNG  
 TREASURER..... AUGUST WACKERBARTH  
 SECRETARY..... FERDINAND PARMENTIER

### Board of Directors

FRANK L. STIFF OCTAVIUS MORGAN  
 ARTHUR B. BENTON JOHN C. AUSTIN  
 R. B. YOUNG

## California State Board of Architecture

### NORTHERN DISTRICT.

PRESIDENT..... WILLIAM CURLETT  
 SECRETARY-TREASURER..... LIONEL DEANE  
 MEMBERS..... { WM. CURLETT  
 { JOSEPH C. NEWSOME  
 { CLARENCE R. WARD

### SOUTHERN DISTRICT.

PRESIDENT..... JOHN P. KREMPPEL  
 SECRETARY-TREASURER..... FRED H. ROEHRIG  
 MEMBERS..... { OCTAVIUS MORGAN  
 { SUMNER P. HUNT  
 { WM. S. HERRARD

## Washington State Chapter, A. I. A.

### OFFICERS FOR 1910-11

PRESIDENT..... DAVID J. MYERS  
 SECRETARY..... W. R. B. WILCOX  
 TREASURER..... C. R. ALDEN

## Architectural League of the Pacific Coast

Next Convention, Los Angeles  
 OFFICERS FOR 1910-11

PRESIDENT..... ALFRED F. ROSENHEIM  
 Los Angeles, Cal.  
 VICE-PRESIDENT..... E. F. LAWRENCE  
 Portland, Or.  
 SECRETARY..... JOHN KREMPPEL  
 Los Angeles, Cal.  
 TREASURER..... W. R. B. WILCOX  
 Seattle, Wash.

## San Francisco Architectural Club OFFICERS FOR 1911.

PRESIDENT..... ERNEST H. HILDEBRAND  
 VICE-PRESIDENT..... TOBIAS BEARWALD  
 SECRETARY..... JOHN G. DRESCHER  
 TREASURER..... ALBERT L. LAPACHET  
 DIRECTORS..... AUGUST G. HEADMAN  
 FREDERICK H. MEYER

## Los Angeles Architectural Club OFFICERS FOR 1910-11

PRESIDENT..... MYRON HUNT  
 VICE-PRESIDENT..... FRANK L. STIFF  
 SECRETARY..... H. E. BEAN  
 TREASURER..... OTTO JANSEN

## Portland Architectural Club OFFICERS FOR 1910-11

PRESIDENT..... ELLIS F. LAWRENCE  
 VICE-PRESIDENT..... DAVID L. WILLIAMS  
 SECRETARY..... FRED ALYN  
 TREASURER..... JOHN M. HATTON

## Oakland Architectural Club

PRESIDENT..... HART WOOD  
 VICE-PRESIDENT..... E. B. MEAD  
 SECRETARY-TREASURER..... W. J. KINGSTON  
*Directors*  
 JOHN G. HOWARD LOUIS C. MULLGARDT  
 OSWALD SPIER C. E. RICHARDSON

## Woman's Club Sues Architect.

The Redwood City Woman's Club has brought suit in the justice court against Architect Glenn Allen to collect a balance of \$25 due for a write-up and portrait of the architect printed in the club edition of the Democrat issued last July. The charge was \$35, on which Mr. Allen paid \$10.

## Big Sacramento Warehouse.

Plans have been prepared by Architects Cuff & Diggs, Elks' building, Sacramento, for a five-story and basement Class A warehouse to be erected at Front and R streets for the Thomson-Diggs Hardware Company of Sacramento, at an estimated cost of \$110,000. The building is to have an automatic sprinkler system, metal door and window trim, fire-proof vaults, steel tanks, steel frame, damp-proofing, etc.



**For State Institutions.**

An unusual number of bills have been introduced at this session of the California state legislature, calling for appropriations for improvements at the various state institutions. Following is the official list:

State Agricultural Society.....	\$ 310,000.00
Agnews State Hospital.....	42,500.00
Mendocino State Hospital.....	42,500.00
Napa State Hospital.....	131,302.00
Southern California State Hospital..	182,500.00
Stockton State Hospital.....	232,115.00
Sonoma State Home.....	204,000.00
Preston School of Industry.....	104,250.00
Whittier State School.....	57,000.00
Prisons and Reformatories.....	932,701.00
Veterans' Home.....	193,942.00
Chico Normal School.....	5,500.00
Los Angeles Normal School.....	165,000.00
San Diego Normal School.....	67,000.00
San Francisco Normal.....	108,000.00
San Jose Normal.....	140,000.00
Santa Barbara Normal.....	284,000.00
California Polytechnic.....	221,000.00
Home for Adult Blind.....	100,000.00
State Highways.....	285,000.00
New Schools.....	1,575,000.00
State Armories, N. G. C.....	660,000.00
Claims.....	23,055.32
Institution for Deaf and Blind.....	66,950.00
State University.....	954,791.00
University Farm at Davis.....	198,344.87
Deficiencies and claims recommended by board of examiners.....	85,766.67
Miscellaneous appropriations.....	
Over \$50,000.....	4,886,950.00
Under \$50,000.....	481,094.50
<b>Total .....</b>	<b>\$13,047,762.36</b>

**The New Lien Law**

The new amendment to the mechanics' lien law has passed the California Assembly by a vote of 66 to 8. The amendment gives mechanics and laborers a direct lien; the present law gives workmen only an indirect lien, in their claim upon the contractor.

The opponents of the bill declare it will leave owners without protection against contractors and material men in throwing upon the owners obligations incurred by the latter. It is declared, on the other hand, that the owner will have sufficient protection in being allowed to demand a bond holding the contractor to his agreement.

**A State Board of Plumbing**

George Fitzgerald of Oakland has introduced a bill in the California Assembly for the creation of a State Plumbing Board of five, to be appointed by the Governor. The board is to consist of a physician, two master plumbers and two journeymen plumbers. The members are to receive \$10 a day while actually attending to their duties. A license fee of \$5 per year is proposed for master plumbers and \$1 for journeymen.

**New Architects**

F. Garvin Hobson of Redlands, Henry C. Hollwedel of Santa Monica and Thomas B. Wiseman and Chas. H. Bigger of Bak-ersfield have been granted certificates to practice architecture.

**Ellery Loses Power.**

The handling of appropriations for the improvement of public institutions is taken away from the California state engineering department by the provisions of a bill introduced by Senator Holohan.

Under the bill the directors, trustees or commissioners in charge of public institutions will have made detailed plans and estimates for all new buildings or alterations. These plans must be submitted to the governor, state treasurer and secretary of state for approval.

There must be separate proposals for contracts for masonry, carpentry, excavation and all other branches of work.

**Plans for Convent.**

Architect J. J. Foley, formerly of Carter & Foley, and who has offices in the Monadnock building in San Francisco, has prepared plans for a convent building to be erected at Tenth and Howard streets for St. Joseph's parish. The building will be of frame construction, three stories, with exterior of cement plaster, and the design is a very attractive one. The same architect has made plans for a residence and store building to be erected at Burlingame.

**Prospects of Fair Improves Building Conditions.**

The decision to hold the world's fair in San Francisco in 1915 has already had a stimulating effect in building conditions, according to local architects and builders. Many jobs that were held up pending the decision are going ahead and the next twelve months are likely to see a veritable building boom in San Francisco, particularly in respect to hotels, apartment houses and flats.

**Oakland Auditorium and Commercial High School.**

The Oakland City Council has authorized a special bond election to secure funds with which to erect a \$500,000 auditorium and commercial high school building. Tentative plans for the former have been prepared by Architects Meyer and Reed, and for the school preliminary drawings have been prepared by Architect Lewis S. Stone of Oakland.

**Hotel for Hyman Bros.**

Architect Henry H. Meyers has prepared plans for an attractive Class C hotel to be erected on Kearny street for Hyman Bros. at an estimated cost of \$60,000. The same architect has let contracts for a five-story building, now being erected on Mission street, for E. W. Crellin, and for a \$16,000 residence in Marin county for Hugo D. Keil.

**San Jose Elks Building**

San Jose is to have a \$70,000 Elks' building and a competition will be held among the Garden City architects.

### Personal

Sullivan W. Jones, representing Messrs. Palmer & Hornbostel, architects of Oakland's \$1,000,000 city hall, has established permanent offices in the First National Bank Building, Oakland, and until the completion of the building a force of draftsmen will be regularly employed, with Mr. Jones in general charge of the office. All contracts are to be let separately, and it is understood to be the wish of the Mayor and City Council to favor local contractors and material men wherever possible.

Architect Charles C. Frye of San Francisco has associated with him E. T. Osborne, formerly with E. W. Houghton of Seattle, and attractive offices have been taken in the French Bank Building. The firm has considerable good work on the boards including an automobile factory building to be erected in Sacramento, a large warehouse for Lally & Co., of San Francisco, and a number of costly residences.

Frank T. Kegley, for some time associated with Architects Edelman & Barnett, has embarked in the practice of architecture, taking offices in the Story building, Los Angeles.

Architect T. Franklin Power, for some time chief draftsman and designer for Architect Harrison Albright, has opened an office in the Higgins building, Los Angeles.

Architect Theo. C. Kistner, a former practicing architect of Illinois, has recently opened an office in Rooms 9 and 10, Conrad block, 1047 Fifth street, San Diego.

Sidney B. Newsome has moved into his new offices on the third floor of the remodeled Commercial building, at Twelfth and Broadway, Oakland.

Architect Perseo Righetti of Righetti & Headman of San Francisco, recently enjoyed several weeks' outing in the Hawaiian Islands.

D. J. Patterson, formerly architect for the Southern Pacific Company, has opened offices in the Mechanics' Institute building, San Francisco.

### That Government Competition

(From The Builders' Guide, Philadelphia)

Participation in the recent competition for government buildings at Washington was, it may not be generally known, limited to the sixty gentlemen invited to submit sketches. Twenty-nine of these were New York architects. Three Philadelphia architects were asked to compete, three Chicagoans and three Washingtonians, and yet, New York—having submitted, out of twenty-nine sketches, the three sketches most pleasing to the jury of award—babbles noisily about "architectural primacy."

### San Francisco Architectural Club

AT the last meeting of the San Francisco Architectural Club the following committees were appointed by President Ernest H. Hildebrand to serve for the ensuing year:

House Committee—Russell Monson, chairman; S. C. Flawn, Howard Schroeder.

Class Committee—Tobias Bearwald, Carl Warnecke, Joseph Gould.

Entertainment Committee—George E. Greenwood, chairman; T. Bearwald, Herbert Brooke.

Press Committee—August Headman, J. P. Duan.

Life Class Committee—Arthur Lafranchi, Alfred Lowenthal.

Architectural History Committee—Thos. C. Bendell.

The matter of the architectural play, "Accord and Discord in a Draughting Room," written for the club by Mr. Arthur O. Johnson, was taken up and it was decided to give this play in the club rooms to members and their friends.

Mr. Greenwood of the Entertainment Committee, is preparing to put on another minstrel show in the fall. Mr. Greenwood has secured several talented singers and from the present outlook this affair will eclipse any ever given by the San Francisco Architectural Club.

The Life Class, under the direction of Mr. A. O. Johnson, was organized and will meet every Friday evening. Any member desiring to join this class should communicate with Mr. Lafranchi or Mr. Lowenthal.

Mr. J. P. Duan of the firm of Duan & Company, donated \$10.00 to the Life Class. The Duan Company was the recipient of the thanks of the club members for its substantial interest in the welfare of the class work.

The class in architectural history is conducted under the direction of August G. Headman. The lectures will be illustrated by stereopticon views from a large collection of slides in the possession of Mr. Headman. The lectures will begin with the Stone Age and then follow the development of architecture to Persian, Egyptian, Grecian, Roman, Romesque, Gothic, French and Italian Renaissance, Elizabethan Tudor, Colonial and Modern architecture.

Any person interested in architecture who wants to join the club and the above classes or the steel, or class in design, should hand their application for membership to the secretary, Mr. John Drescher, who can be seen at the club rooms, 126 Post street, every day between 12 and 1 o'clock, and he will be pleased to answer any questions or talk over any details.

**Architectural Commission for the Fair**

IN line with the suggestion of President Taft that the National Art Commission of Washington be consulted when the work of planning the actual physical structure of the Panama-Pacific international exposition begins, the San Francisco chapter of the American Institute of Architects has presented to the directors of the exposition company a comprehensive plan for the appointment of an architectural commission. The proposal of San Francisco chapter, if followed out, will make the building of the great exposition in reality a national affair.

The San Francisco architects recommend the appointment by the exposition directors of an advisory architectural board of eleven members, three to be named by the directors themselves, three to be chosen upon recommendation by the National Institute of Architecture and five to be chosen from a list furnished by the local chapter of architects.

The communication will be the subject of discussion as soon as the question of selecting a site is disposed of and the details of building come up for consideration. The letter from the San Francisco chapter follows:

The San Francisco chapter of the American Institute of Architects wishes to extend to your honored board its hearty co-operation in the labor which you have undertaken of creating the world's exposition of 1915.

The chapter realizes that the architectural scheme and the type of architecture which is chosen to express the dignity and scope of this exposition will play a decisive role in determining the success or failure of the undertaking, and urges the adoption of a scheme that shall reflect the wisdom and judgment of our people, that shall embody the traditions of our environments and shall establish a standard of architectural taste worthy of the world's admiration.

The chapter indorses the suggestion offered by the president of the United States, in which he recommends that the national art commission of Washington be asked to participate in the undertaking, and in indorsing this suggestion urges your board to create a commission of eleven architects who shall assist your board in determining the method of procedure to be followed in conducting the architectural work pertaining to the exposition.

This commission to be formed as follows:

(a) The American Institute of Architects of Washington to be asked to recommend six names of the architects, from which list your board will appoint three to serve on this commission.

(b) That your board appoint three architects to serve on this commission.

(c) That the San Francisco Chapter of Architects recommend ten names of architects, from which list your board will select five to serve on this commission.

The duties of this commission are to be advisory and formulative. They shall place before your board for approval a comprehensive and detailed solution of the many questions arising before the actual work of the individual architects begins; also the method to be followed in securing the advice and assistance of the kindred arts and professions allied to the architectural problems, including landscape artists, painters, sculptors and engineers.

Furthermore, the San Francisco chapter offers these suggestions in a spirit of co-operation and with the faith that ultimately the best solution will be adopted for conducting the preliminary

as well as final work pertaining to the architectural problems of the exposition of 1915. Respectfully submitted,

WILLIAM MOOSER, President.

**Competition for Sub-Treasury Building**

Six San Francisco architectural firms have been invited to enter a competition for plans for a \$300,000 sub-treasury building to be erected in San Francisco by the Federal government. The plans are to be submitted to the Treasury department, Washington, by May 1st.

The judges will be: D. H. Burnham, H. Van Buren Magonigle, Douglas H. Thomas, C. E. Richards, W. C. Noland and the supervising architect, ex-officio.

The following have been invited to compete:

Ward & Blohme, Alaska Commercial building, San Francisco, Cal.

Bliss & Faville, San Francisco, Cal.

Coxhead & Coxhead, 333 Grant avenue, San Francisco, Cal.

John G. Howard, 604 Mission street, San Francisco, Cal.

Bakewell & Brown, 417 oMontgomery street, San Francisco, Cal.

L. P. Hobart, 1122 Crocker building, San Francisco, Cal.

Potter & Merrill, 219 Provident building, Tacoma, Wash.

Lazarus, Whitehouse & Foulhoux, 565 Worcester block, Portland, Ore.

Wilder & Wight, Kansas City, Mo.

**John Merven Carrère, F. A. I. A.**

John M. Carrère, F. A. I. A., of the firm of Carrère & Hastings, died in the Presbyterian Hospital, New York, on March 1st as the result of a taxicab accident sustained on February 12th.

Mr. Carrère was born in Rio de Janeiro, Brazil, of American parents, on November 9, 1858. His early education was in Switzerland and Germany and it was at the Ecole des Beaux-Arts in Paris that he received his first instruction in that profession he was later to so brilliantly adorn. It was while at the Beaux-Arts that Mr. Carrère formed the acquaintance of Mr. Thomas Hastings and on their return to America, after a short period in the office of McKim, Meade & White, these two men formed the partnership of Carrère & Hastings, whose work is known and valued wherever the universal language of architecture is spoken.

Mr. Carrère's position in the field of architecture is so well known that to set down a list of the honors conferred upon him would be to repeat what is familiar to every architect. His wise counsels in the administrative bodies of the Institute, his valuable services in the educational field of his profession, his helpful and influential efforts toward placing architecture on the high plane that it holds, today are well known.

## THE Architect and Engineer OF CALIFORNIA

Member of California Periodical Publishers' Association

Published Monthly in the Interests of the  
Architects, Structural Engineers, Contractors and the Allied Trades of the  
Pacific Coast by the Architect and Engineer Company.

### OFFICES

621 Monadnock Building - San Francisco  
Telephone Douglas 1828  
Builders' Exchange, Oakland  
Room 234-223 West 2nd St., Los Angeles

### TERMS OF SUBSCRIPTION

(Including postage) to all parts of the United States \$1.50  
per annum; to Canada 50c additional; to all Foreign points  
\$1 additional.

Vol. XXIV. MARCH, 1911. No. 2

### ASSOCIATE EDITORS

MORRIS KIND, C. E.	- - - - -	Cement
WM. B. GESTER,		
JNO. B. LEONARD, C. E.	· · · · ·	Reinforced Concrete
LOREN E. HUNT, C. E.	· · · · ·	Inspection and Tests
ATHOL MCBEAN	}	Brick, Tile and Terra Cotta
W. E. DENNISON		
HOWARD FROST,		
W. W. BREITE, C. E.	· · · · ·	Structural Steel and Iron
FRANK SOULE	· · · · ·	Masonry Engineering
G. B. ASHCROFT, C. E.	· · · · ·	Artificial Stone
W. J. WATSON	· · · · ·	Roofs and Roofing
J. R. D. MACKENZIE	· · · · ·	Heating and Ventilating
F. H. BRYANT	· · · · ·	Decorative Lighting Interior Decoration
WILLIAM ADAMS,		
C. WALTER TOZER	· · · · ·	Landscape Architecture
WILBUR DAVID COOK,		
T. C. KIERULFF	· · · · ·	Legal Points
F. W. FITZPATRICK,		
PAUL C. BUTTE	· · · · ·	Fireproof Construction Electrical Construction
C. W. WHITNEY	· · · · ·	Building Construction

### ARCHITECTURAL

Fred H. Meyer	J. C. Austin
Edward T. Foulkes	F. D. Hudson
Alfred F. Rosenheim	Sumner P. Hunt
G. Albert Lansburgh	C. Sumner Greene
Jas. W. Reid	Ralph W. Hart
Clinton Day	James Seadler
Kenneth MacDonald, Jr.	Maxwell G. Bugbee
Houghton Sawyer	Clayton D. Wilson
John G. Howard	Almeric Coxhead
Arthur Brown, Jr.	Harrison Albright
M. V. Politte	John Parkinson
T. J. Welsh	W. J. Guthbertson
Chas. F. Weeks	A. W. Smith
Chas. F. Whittlesey	T. Patterson Ross
Octavius Morgan	William H. Weeks
W. A. Newman	Chas. W. Dickey
H. Alban Reeves	Henry C. Smith

### CONTRIBUTORS

Merritt Reid	Hon. Jas. D. Phelan
William Curlett	J. T. Walsh, C. E.
Albert Pissis	Chas. Havens
Edgar A. Mathews	Smith O'Brien
Julius E. Kraft	H. F. Starbuck
Geo. A. Dodge	Nathaniel Blaisdell
John C. Felton	W. T. Bliss
Herman Barth	William Mooser
Arthur O. Johnson	Geo. H. Wyman
Herbert E. Law	Robert Morgencier

E. M. C. WHITNEY      *Manager*  
FREDERICK W. JONES      *Managing Editor*

The value of punctuality in the contracting business was emphasized rather forcibly at Vancouver last month, when **A LESSON IN PUNCTUALITY** a firm of contractors lost a \$30,000 job through being two minutes behind in delivering their bid. The contractors in question submitted a bid for vitrified pipe at \$30,694, which was recommended for acceptance. One of the other tenderers, however, through his solicitor, raised the objection that the bid was not submitted by 4 p. m., as called for in the specifications. They had taken the trouble to investigate and had found that the tender was not deposited at the City Hall until past the hour. Some discussion followed, but it was moved that all tenders not complying with the advertisement be cancelled, and the motion carried. The next highest bid was accepted. The losing firm will at least have the satisfaction of watching developments closely and forming an opinion as to whether they are indebted to a special interposition of Providence or to their own unpunctuality for losing the contract. Be this as it may, the occurrence points a moral. "Better late than never" has no application in the contracting business.

A San Francisco contracting firm recently had a similar experience, its bid on some important government work arriving in Washington a few hours late. The bid is said to have been low, but Uncle Sam is noted for his punctuality, and the tardy proposal might just as well have been a donation for all the official consideration it got!

In line with our editorial on "Limiting the Height of City Buildings," which appeared in the February Architect and **MORE ANENT LOS ANGELES SKYSCRAPERS** Engineer, the following comments by the Architectural Record will be found of interest:

"One of the most interesting battles which has lately taken place in behalf of a restricted skyscraper is that which has been waged in the last few weeks at Los



Angeles. These battles are not frequent in the United States—not as frequent as perhaps they should be; and since one does not readily associate California with limitation and restriction, it is surprising to find the battle fought there.

“Los Angeles is one of the few cities in which there is an ordinance restricting the height of buildings. The limit is placed at 180 feet. The present contest arose through the petition of Hulett C. Merritt for permission to erect a building which, including its cupola, should have a height of 233 feet. Mr. Merritt, who is a prominent resident of Pasadena, proposed to erect his structure at the corner of Eighth street and Broadway. It was to be made of marble; an office building housing the Sierra Madre Club, and containing ‘the finest mining reference library in the world.’ The petition went in regular course to the Legislative Committee of the City Council. The committee unanimously recommended that it be denied, and it was reported that a majority in the council would support the recommendation of the committee. Then the interesting fight began. The business streets of Los Angeles are already congested by the traffic which goes through them. Those who opposed removing the building restriction pointed out that an increase in building height meant increase in congestion. To this Mr. Merritt replied that only the cupola of his proposed structure exceeded the present limit, and that he intended to fit out the cupola in part as an observation tower, to which the people should have access for the view, and in part as quarters for his personal use when he desired to spend the night in the city. Neither use, he claimed, would add to the crowding of the streets. It is to be observed, also, that the moment at which he presented his petition was psychological. The census report has just shown that Los Angeles had grown faster than any other community, and the city, puffed up with the sense of greatness of its present and future, was exactly in the mood to consider the removal of building limitations. The council wavered, and the matter went over for a week for consideration. During that week the conflict

was lively. Mr. Merritt threatened that if the council refused his petition he would go to the people with an initiative petition containing an amendment to the building ordinance which he desired. To show that he would not have much trouble in getting sufficient signatures, he brought before the council a petition for favorable action signed by scores of bankers, brokers, real estate firms and prominent business men. Further, he intimated very plainly that if he could not build the structure in Los Angeles in the way he wanted to build it, he would erect it in Portland. That seemed to be almost a finishing blow. Meanwhile, the other side was not entirely quiet. The Southern California Chapter of the American Institute of Architects filed with the council a protest against any increase in the building height limit. It described such an amendment as calculated only ‘to satisfy the greed of private individuals at the expense of the welfare of the community.’ Other protests were also recorded. Then came action by the directors of the Los Angeles Investment Co., an immense real estate corporation. They held a meeting and voted that if the building height limit were removed, they would increase to twenty-five stories the height of the office building which they were about to erect. And at once a lot of people began to figure how much this would mean to labor, etc., in Los Angeles. But there was another side to this action by the directors of the Los Angeles Investment Co. That was the striking proof which it gave of the increased street congestion likely to result from granting the suggested amendment. The council apparently took this view of the matter, and when the question finally came to vote, the petition was denied by a vote of eight to one. The very next morning the presidents of the Chamber of Commerce and of the Commercial Club in Portland telegraphed to Mr. Merritt to know whether he would erect the office building in Portland if permitted to do so without legal interference. His reply was to the effect that, as he believed the people of Los Angeles were by a very large majority in favor of granting the right to erect it there, he had not yet given up hope. The next day a note, printed somewhat obscurely in the newspapers, announced that the commission which is at work revising the charter, had decided to present alternative propositions concerning the height of buildings for the people to vote upon. The one amendment is to provide that the present limit be maintained; the other that it shall be removed entirely, or else that for purposes of ornamentation it may be exceeded. Thus it is not unlikely that Mr. Merritt may yet have his own way. But the fight has been well fought and with more than usual strategy.”



# HEATING AND LIGHTING

## Plumbing and Electrical Work

### What Is the Matter With Modern Heating Practice?

THE ANSWER OF AN EXPERT TO THE AGITATION AGAINST PRESENT METHODS

By KONRAD MEIER, in the Heating and Ventilating Magazine.

HERE is a widespread feeling that the efficient, are not as healthy as the open modern ways of heating, though more fireplace, the Dutch tile oven, or even the ordinary stove. Evidently, there must be some basis for this contention. We need only remember that the close, lifeless air and stuffiness too often met in buildings heated by boiler or furnace cannot always be traced to crowded occupation. Nor can it be the failure to use the windows, inasmuch as the desire to open them is rather induced, sometimes almost compelled, by these conditions. Another significant fact is that the demand for ventilation has only arisen since hot-air registers and radiators have become general. No further evidence is necessary for the general conclusion that present day methods of heating in some way spoil the air, but it is worth while to look further into cause and effect in order to find the right means of prevention.

#### THE VITIATION OF AIR BY HEATING

At first thought there seems to be no reason why a steam heating apparatus, or a hot-air furnace in good condition, should alter the quality of the room air, aside from an unavoidable drying effect, not necessarily objectionable in itself. Nevertheless, on closer investigation some distinct causes of vitation, not recordable by the ordinary methods of air testing, have been shown to exist, and found to create unwholesome conditions. We are indebted especially to two noted German hygienists, von Esmarch and Fluegge, for their investigations on this elusive subject. They have established that the stuffiness of air in heated rooms is caused by the decomposition of dust in contact with radiating surfaces at temperatures of 160 degrees F. and higher.

This process is not one of full combustion, generating carbonic acid, but a sort of dry distillation or singeing of the organic matter, which produces small quantities of the highly injurious ammonia, also traces of carbon monoxide and other gases. The presence of the former gas is explained by the quantities of animal excreta, one of the principal ingredients of ordinary street-to-house dust. It shows the little appre-

ciated fact that dust, while comparatively harmless on furniture, will become objectionable when allowed to settle and decompose on radiators.

The gases thus generated are most noticeable after a period of uninterrupted heating. Under continuous service the quantities are generally too small for detection. But, in addition to this variable pollution, a constant irritation of the mucous membrane of nose and throat is kept up through the simple drying of the dust on heating surfaces, which lightens it and causes it to be picked up freely by the warm air currents. Even the dust on adjacent objects, also in ducts and air chambers, is dried and joins the procession of irritant, disease-bearing particles induced by the common forms of modern heating.

The meaning of this is plain when we remember that the dry heat is not sufficient to kill the bacteria carried by the dust, and that we inhale them in much greater numbers owing to the currents of air created by heaters, more especially those with unsanitary surfaces. It is also the presence of fine dried dust which is often responsible for complaints from dryness. The real cause is not dryness of air, but dried dust. Pure dry air has never been shown to be harmful. It has also been established that whatever little ozone may enter a room with the outer air is quickly used up in contact with organic dust, especially when heated. A small percentage of oxygen is absorbed in the same manner, but the extent and exact bearing of this fact has not yet been determined. These last points alone would account for the lifeless quality of the air as it generally issues from a register.

When these factors are considered, it will be admitted that an open grate, carrying its own vitation up the flue, or a tile oven with clean, moderately warm surfaces, or even an iron stove kept polished, could not vitate the room air to the same extent as will a radiator with inaccessible dusty surfaces, or a register blowing hot air from a musty source beyond inspection.

All this is not meant to advocate a return to the old-fashioned ways of heating, but only to show that the newer methods are actually at fault, and should be improved along lines suggested by the recent findings of hygienists. The result eventually will be a merging of the good features of past and present methods.

## SANITARY HEATING

When planning apparatus, the first point in hygiene to be borne in mind should be to reduce contamination through dust by using the cleanest possible radiation. This means that heating surfaces should be in plain view, and accessible all around by hand, so that they will be kept clean, not by special effort, but as a matter of course in the ordinary routine of a household. Dust on concealed radiation, even if made accessible, is not seen, and, therefore, is invariably forgotten and neglected.

These facts should be sufficient, quite aside from engineering and economic reasons, to condemn all radiator screens designed for purposes of meaningless decoration. They are not the true solution of the problem and really turn direct radiation into a hot-air system without air supply. Screening is a sham, and should be vigorously opposed, not mildly tolerated. We should rather encourage neat, substantial appearance, inconspicuous finish and simplicity in arrangement of radiation. Un-sightly bulk can often be reduced by judicious disposition and selection of the most advantageous style, or by deliberate reduction of the heat requirement, such as using double glass.

When direct radiation is indicated, it is possible, even in highly ornamental and formal rooms, to satisfy the artistic sense of architects without resorting to concealment. It is mainly a matter of judgment as to style and neatness in disposition, also of having the courage of one's conviction in arguing with the client. Of course, the public must yet be educated on the sanitary points, and the engineer on the ways and means to meet the situation. The present disinclination to expose radiators is mainly due to the shabby, clumsy and tasteless treatment that now prevails.

Radiating surfaces placed overhead or tight against walls are also objectionable. They are never dusted, except by an occasional air current, and then with a decided effect on the air. Fussy, round-about pipe connections behind radiators, creating dirt corners never cleaned out, are too often seen even in the better class of buildings. They always contribute to stuffiness, as do many styles of heating surface which are designed too much with a view to saving space and give too little chance for keeping them clean.

As will be pointed out later, indirect heat should be used only with certain restrictions. The casings enclosing the stacks should never be soldered up, or provided with a hand hole only. At least one full side should be hinged or made removable to invite occasional inspection and cleaning. Air filters should be used in cities to keep out the dust as much as possible. In general, dust pockets and dirt corners must be avoided. They are objectionable anywhere, as a latent menace to health, but become at once an active agent for mischief in con-

nection with heat, which brings out the lurking germs and distributes them where they are most likely to do harm.

## TEMPERATURES OF HEATING SURFACES SHOULD BE LOWERED

The second point of importance is the lowering of the temperature of heating surfaces, both with a view to preventing dry distillation, and for reducing the intensity of air currents. Hot-water heating gives the simplest and most effective means to this end. With the piping calculated and balanced accurately to secure even circulation at any flow temperature, it gives practically a full range of general control and makes it possible to carry heat strictly to suit the weather.

This means that for the greater portion of the heating season the temperature of heating surfaces need not reach the point at which decomposition is beginning to be felt. In hospitals, schools, and in other cases the surfaces might be increased within reasonable cost to keep the highest flow temperatures down to 160 degrees F. or 170 degrees F., so that a slight formation of gas could only occur under extreme conditions.

With hot-water heat applied by clean, well distributed radiation it is, therefore, quite feasible to eliminate practically all vitiation of room air through dust.

This is the reason for the popular feeling that this form of heat does not dry the air as much as steam. With the latter it becomes all the more important to insist on the cleanest form of surfaces, and to reduce the working pressure or temperature as much as possible. At best, steam heat will always be less desirable from the hygienic point of view. Hot-air furnaces, to be tolerable at all, should be installed of very ample sizes, giving the desired heating effect without excessively hot surfaces.

When heating by warm air, whether furnace or indirect attacks, the registers should always be in vertical position, never horizontal. Floor registers, especially, are dirt catchers in the most aggravating form, throwing up the dried dust and microbes straight into one's nose.

## OVERHEATING

According to Fluegge, the proper attention to room temperature is hardly second in importance to the benefits of ventilation as generally accepted. He has demonstrated that overheating is just as injurious, if not more so, than the effect of ordinary foulness of air due to lack of renewal. He explains this through heat congestion, caused by decreased emission from the human body, with a consequent disturbance of certain functions. It may be held, at first thought, that summer heat would be equally, if not more injurious, but the conditions are distinctly different. Lighter clothing and freer air circulation usually allow of much greater heat emission by evaporation, except in the hottest and sultriest weather, which is known to be a tax

on vitality even for short periods. In crowded, overheated, though ventilated rooms, with the occupants close together, keeping each other warm by their own radiation, and wearing heavier clothing, the heat emission from the human body is very much reduced.

It is naturally difficult to determine the relative bearing of foulness and of overheating, each depending so much on the degree and also on humidity, but the fact remains that overheating has been shown to be injurious in itself and is apt to be more so when combined with foul air, humidity and with pollution through unsanitary heating apparatus. Equable, moderate temperature is, therefore, one of the primary hygienic requirements.

The logical way of meeting it is effective heat control, not only to suit the weather, but to take care of the heat from occupancy. With steam heat, which does not lend itself readily to central regulation, automatic devices for individual rooms are necessary in rooms occupied by a number of persons who are not expected to pay attention to the heating service. In other cases some form of graduated hand control of local radiation may be sufficient. Sometimes fair service can be obtained by the use of long-distance devices, facilitating better control of a plant by the engineer from a central point. With hot water heating, automatic regulation is desirable, mainly in rooms that will be crowded on occasion. On the whole, it is easiest with that system to maintain equable conditions. Still better results could be obtained by using gas for fuel in house heating boilers, as is done for bath heaters. The additional operating expense is no longer prohibitive in view of the saving in labor and other advantages. This combination of gas with hot-water heat should be the ideal domestic plant of the future. In this connection it is well to remember that the best heat regulation is

often set at naught by some extraneous heat source, such as a hot flue, or a warm floor. All such cases should be looked out for in planning and taken care of.

#### COOL AIR IS MORE WHOLESOME TO BREATHE

Aside from the desirability of avoiding excess of heat, there is still another lesson in Fluegge's findings. It is well known that a considerable portion of the heat emitted by a human body is contained in the exhaled air. Cooler air inhaled means increased emission owing to additional heat necessary to raise it to the temperature of the body. If the air is cool and sweet besides, it will be inhaled more freely and stimulate functions. Hot and dusty air makes more labor in breathing, gives less oxygen, if only for the same volume, and keeps circulation below the normal. It follows that the lowest air temperature compatible with comfort is the most rational. We all know that the indoor temperature at which one may feel comfortable varies considerably, according to the temper of the occupants, with the relative humidity and other conditions. But our sense of comfort is probably affected quite as much by the temperature of the surrounding objects, as they radiate heat or absorb it from the body. Thus we need less clothing on a sunny day than in cloudy weather, with equal air temperatures. This is so because radiant heat will pass through the air and to its destination without appreciably raising its temperature. Incidentally, it will be understood, that air is not spoiled by the heat rays, but by convection, or contact alone. For these reasons a room is apt to be most comfortable if the bulk of its walls is thoroughly warmed by continuous heating service, but the air be kept relatively cool by occasional opening of windows or by a constant inflow of sweet, uncontaminated air not heated beyond room temperature. This idea of warming the walls, or

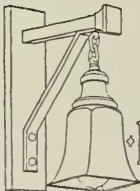

## ADAMS AND HOLLOPETER

INC

MAKERS OF

HIGH-GRADE LIGHTING FIXTURES

JOHN P. YOUNG  
WILLIAM ADAMS  
FRANK ADAMS  
W. H. HOLLOPETER

• 745 • MISSION • STREET •  
• SAN FRANCISCO • CAL •  
• TELEPHONE •  
• DOUGLAS • 1773 •

# High Grade Electrical Installation Work

**Butte Engineering & Electric Co.**

683 - 687 Howard Street  
San Francisco

PAUL C. BUTTE  
C. F. BUTTE

the structure, rather than the air within, is conducive to equable conditions, and reduces the tendency to overheating, by the heat sources, as well as by the air supply, as each can be regulated effectively, and will not interfere with the other. Warmer room air, on the other hand, produces a lower percentage of relative humidity, and naturally tends more to excessive dryness and dust pollution by heating.

For the same reasons it appears to be more advantageous to utilize the radiant heat of direct surfaces, rather than the heat emitted by convection. This would favor the selection of low, widely spaced, flat radiation, which is generally also more sanitary. (Concluded in the April Number)

## Recent Patents Relating to Building Construction.

Material for this department is compiled expressly for The Architect and Engineer by Watson & Boyden, patent and trade-mark lawyers and solicitors, 918 F street, Washington, D. C., and to them all inquiries in regard to patents, trade-marks, copyrights, etc., and litigation affecting the same should be addressed.

A complete printed copy of the specification and drawing of any United States patent in print will be sent, postpaid, to any address for ten cents.

Walter S. Mitchell, of San Francisco, California—Removable Floor-Strip.  
982,522 Patented January 24, 1911

The object of this invention is to provide a removable floor strip which can be used with concrete or other floors in order



## If You Want the Gutters to Last Use Tin and Make It Scott's Extra Coated

**HAMMERED OPEN HEARTH.** What we mean by HAMMERED is this: where the other makers stop in the ordinary Open Hearth Process, we continue by hammering under it is immense hammer (having 800 ton blows) the ingots into billets. This greatly improves the quality, giving it a greater density and increasing the ductility and toughness, which assure perfect working and wearing qualities, and then the coating of the richest quality is properly amalgamated with it.

"Tin Truth" tells the whole story. Before you specify anything investigate how the different plates are made. We are sure that after doing that you will agree with us that our Roofing Tin is made by superior methods.

**FOLLANSBEE BROS. CO., PITTSBURG, PA.**

Only American Makers Hammered Open Hearth Roofing Tin.

Pacific Coast Trade supplied through our San Francisco Branch in charge of **GEORGE S. LACY**, Marvin Building. Phone Douglas 4497.

# ELECTRIC APPLIANCE COMPANY

726-730 MISSION STREET  
SAN FRANCISCO, CAL.

## HIGH GRADE CONSTRUCTION MATERIAL

"GALVADUCT" CONDUIT (WHITE)  
"LORICATED" CONDUIT (BLACK)  
"PACKARD" INCANDESCENT LAMPS

"NEW WRINKLE" PULL AND KEY SOCKETS  
"PERKINS" PUSH BUTTON SWITCHES  
"COUCH & SEELEY" TELEPHONES

982,522.

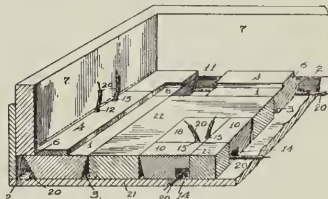

to facilitate the laying of electric wires. This strip is designated by the reference character 1, and has both its edges beveled or undercut, as shown in the illustration. A space is formed between one beveled edge and the wall for the reception of electric wires, 20, while the shape of the other edge, 3, permits the strip to be rotated about its lower outer edge in such a manner that it can be removed from its position, even though the edge of the base-board, 7, overlies it.

Charles R. Scharlandt, Alexander Scharlandt and Oscar J. Scharlandt, of San Francisco, California—Combined Sash Balance and Anti-rattler.

982,637 Patented January 24, 1911

In connection with spring sash lifters this invention provides an anti-rattling de-

vice which consists in bending the end of the spring attached to the sash so as to form a bow, 10, adapted to resiliently engage the window frame.

Arthur L. Haley, of Los Angeles, California, assignor to A. L. Haley, Architect, Incorporated, of Los Angeles, California, a corporation of California—Wall-Seat, Wall-Bed.

982,669 Patented January 24, 1911

This invention relates to that class of beds which is concealed in the wall when out of use and which provides a seat along the wall, the seat being in use when the bed is out of use.

An object of this invention is to provide a wall-bed, the frame of which is provided on its bottom with a facing and is so mounted by means of a geared rocker and rocker tracks that when the bed is upright in stored position, it will be held by gravity entirely within the recess except that the facing on the bottom of the bed is in front of, though practically flush with the face of the wall and portions of the rockers and their supports will be in front of the plane of the upright facing, and concealed by a seat-structure that will fold as the bed is lowered.

One of the principles of this invention is that the bed is carried by a quadrant-rocker that rocks on an inclined track, and is so mounted that when the bed is upright the



A. W. KENNEDY,  
BUSINESS MANAGER

CHAS. HART,  
SUPT. AND INVENTOR

## THE HART HEATER CO.

MANUFACTURERS OF

THE QUEEN GAS WATER HEATER

THE HART COMBINATION  
HOT WATER BOILER

Instantaneous — Economical — Clean.  
Copper coils insure perfect circulation.

OFFICE 406 Thirteenth St. OAKLAND, CAL. 525 Seventh Street  
PHONE OAKLAND 7821 PHONE OAKLAND 2881

When writing to Advertisers mention this Magazine.



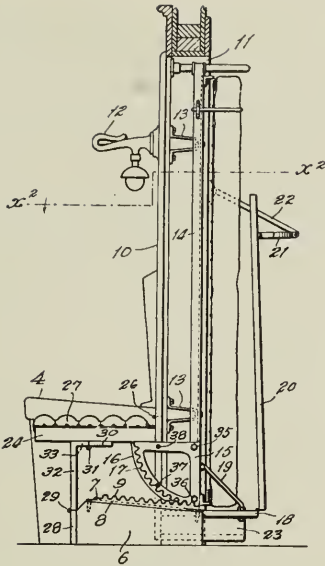

982,149

point at which the rocker rests on the track is always close to and slightly above the center of gravity of the bed.

Jesse F. Millspaugh, of Hollywood, California—Adjusting Device for Windows and Doors.

984,101 Patented February 14, 1911

This invention relates to brackets for holding swinging windows or doors in adjusted position, and its principal object is to provide means for supporting the pivoted arm by a sash without holding the sash against movement when it is desired to permit the latter to swing freely. To this end a slip connection between the arm and sash is provided, such connection comprising a trough or guide-way, 21, in which the end of the arm, 24, may rest and freely slide.

Robert H. Anderson, of San Diego, California—Recess-Bed.

984,178 Patented February 14, 1911

This invention relates to that class of devices known as wall-beds, and seeks to provide a bed of simple construction which is easily operated and which can fit into a recess of less than the ordinary height. To this end the bed is swung upon links in such a manner that the head-board rests upon the floor when the bed is in the recess, as clearly shown in full lines in the illustration.

R. J. O'BRIEN T. F. KIERNAN

# KIERNAN & O'BRIEN

## PLUMBERS

ESTIMATES FURNISHED

1754 MISSION STREET, Bet. 13th-14th  
SAN FRANCISCO, CAL.

Bullders' Association, Box 149 Phone Market 2517

Phone West 1327

# THOMAS J. FORD

## PLUMBING and HEATING

1213 Octavia Street San Francisco, Cal.

# PLUMBING and HEATING

## J. E. O'Mara

449 MINNA ST.  
Phone, Douglas 3421

H. H. FISHER, President Phone Kearny 4410  
G. H. McNISSICH, Secy.

# FISHER & WOLFE CO.

## Plumbing, Steam and Gas Fitting

TINNING AND GENERAL JOBBING

207-209 Tehama St., Near Third St., San Francisco

**we  
want  
your  
elec-  
trical  
work**

**BECAUSE**

**We know we  
can please you**

We are pleasing a good number of architects and contractors who insist on prompt service and first class work.

We get their business because our prices are fair, and they know they can depend upon us.

**CENTRAL ELECTRIC CO.**

185 STEVENSON ST.

SAN FRANCISCO

PHONE, DOUGLAS 387



An Up-to-Date Bath Room

**HEATING, PLUMBING  
AND POWER PLANTS**

Complete Systems Installed in all  
Classes of Buildings. Defective  
Systems overhauled and corrected

**GILLEY-SCHMID CO., Inc.**

198 WEST MISSION STREET

SAN FRANCISCO PHONE MARKET 966

Clarence Z. Hubbell, of Spokane, Wash-  
ton—Window.  
981,858 Patented January 17, 1911

The purpose of this invention is to provide an improved window of the class in which the sashes are pivoted to hanging stiles, so that they may both slide vertically and swing on horizontal pivots. The stiles are preferably made of folded sheet metal running in grooves in the window casing, and these stiles are provided at their bottom with specially designed L-shaped slots in which work the sash pivots, as clearly shown in the illustration.

**Law in the Building Trades**

**EMPLOYER'S DUTY TO WORKMEN RESPECTING STAGING**

If an employer undertakes to furnish complete staging and other like aids to construction for his workmen to use during the erection of a building, and fails to exercise reasonable care to make them safe, he is responsible to a workman who, while properly engaged in his work, is injured in consequence thereof, unless the workman has assumed the risk or is at fault himself. But the employer may fully discharge his duty as to staging by furnishing suitable and sufficient materials to his employes for them to use in building the stagings, if they undertake to build them for themselves. (Maine Supreme Judicial Court, Elliott vs. Sawyer, 77 Atlantic Reporter, 782.)

**EFFECT OF CONTRACT TO FURNISH BUILDING MATERIAL**

An agreement requiring plaintiff to furnish, at an agreed price, terra cotta for a building "shown on drawings and described in specifications," did not cover terra cotta lintels and sills shown on the specifications but not on the plans, where the specifications were not furnished when plaintiff made its bid. (United States Circuit Court of Appeals, Sixth Circuit, Atlantic Terra Cotta Company vs. Masons' Supply Company, 180 Federal Reporter, 333.)

**WAIVER OF STRICT PERFORMANCE OF BUILDING CONTRACT**

By accepting work done by a contractor, the owner thereby waives strict performance of the contract. (Oregon Supreme Court, Williams vs. Mt. Hood Railway & Power Company, 111 Pacific Reporter, 17.)

**NECESSITY FOR OBTAINING ARCHITECT'S CERTIFICATES—AUTHORITY OF ARCHITECTS**

After the making of a contract to erect a two-story building, which provided that the payments should be made on architect's certificates only, new agreements were made for additional work, which did not require certificates to obtain payment. Held that the original contract was so far modified as to entitle the contractor to recover on completion of the building without producing architects' certificates. An architect cannot bind an owner any farther than the owner has unmistakably agreed to be so bound. (Washington Supreme Court.

## PACIFIC BLOWER & HEATING CO.

3261 Seventeenth Street, (near Mission) San Francisco

Specialists in **HOT AIR HEATING**

Torrid Zone and Pacific Furnaces for Schools, Theaters, Residences, Etc.

## SILVER LAKE A SASH CORD

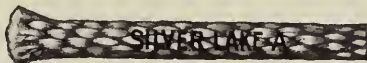

Pacific Coast Agent, SANFORD PLUMMER, 149 New Montgomery St., San Francisco, Cal.

Avoid Sash Cord Troubles among your clients by specifying SILVER LAKE A. Write for Samples and our Guarantee Certificate. It protects you.

*Our name is stamped on every foot of our cord.*  
SILVER LAKE COMPANY, BOSTON, MASS.

Phone West 7000

All Work Guaranteed

## ALEX COLEMAN

PLUMBER

706 ELLIS STREET

SAN FRANCISCO, CAL.

Phone Oakland 1753

I. A. COOKE, MANAGER

## THE J. F. KELLY COMPANY

(INCORPORATED)

MANTELS, GRATES and TILES

Fire Sets, Andirons, Fenders and Portable Baskets, Floor and Wall Tiling in Original and Artistic Effects

723-731 Seventh Street, Cor. Brush St.  
OAKLAND, CAL.

Phone Merritt 3555

Estimates Furnished

## OSCAR L. ZEIS

PLUMBING AND TINNING

♦♦♦♦ JOBBING A SPECIALTY ♦♦♦♦

456 East Sixteenth Street

Oakland, Cal.

## GEO. W. SCHMITT HEATING AND VENTILATING CO.

HOT AIR MERCHANTS

Heating of Residences and Public Buildings  
SHEET METAL WORK

1160 WEBSTER STREET  
Oakland, Cal.

HEATING

ELECTRICAL WORK

PLUMBING

VENTILATION

AUTOMATIC SPRINKLERS

SHEET METAL WORK

## JOHN G. SUTTON CO.

229 MINNA STREET

SAN FRANCISCO

Manufacturers of Abrahamson's Patent Ventilators, Galvanized Iron Cornices and Skylights. Repairing a Specialty

**Abrahamson & DeGear, Inc.**

Sheet Metal Works

Tin and Galvanized Iron Roofing, Heating and Ventilating, Registers and Ventilating Facings

655 McALLISTER ST.

Phones, Market 2898  
Home S 1857 San Francisco, Cal.

# By the Way

Some Industrial Information Worth the While

## Vacuum Cleaners.

The business, patents and equipment of the Mechanical Dust Suction Company of San Francisco, New York and Chicago, has been taken over by the American Rotary Valve Company, with offices in San Francisco (Balboa building) and Los Angeles (Los Angeles Trust building). Messrs. L. J. White, formerly selling agent for the Dust Suction Company, and S. I. Wailes, formerly sales manager for the National Air Brake Company, are active in the management of the new concern. Both young men have many friends throughout the state and their success seems assured.

The company is handling a high grade of vacuum and compressed air machinery for cleaning, sweeping and disinfecting. Complete stationary outfits are placed in hotels, office buildings, theaters, apartment houses, schools and residences. The equipment is known as the Morehead vacuum cleaning system—a system that does away with the dry and wet tanks, screens, strainers and such contrivances that make it necessary to clean the machinery in order to secure continuous maximum efficiency.

Among the important Morehead installations completed the past year were the following: Shattuck hotel, Berkeley; Boat Hall and the Library building, University of California; Hancock grammar school in San Francisco, Washington school in Alameda, Beck apartments in San Francisco, residence of George Hind in San Rafael, and four schools in San

Francisco, the installations not yet being completed.

Other buildings equipped are the Scottish Rite temple, the Mechanics' Institute building, the O'Connor & Moffatt building, the Levi Strauss building and the palatial residence of Mr. Louis Stearns.

## A Free Book on Concrete Designing.

The Northwestern Expanded Metal Company of Chicago, represented in San Francisco by the Fernald Company of 248 Tehama street, has issued some useful and valuable data in booklet size for architects and contractors engaged in reinforced concrete and metal lath and plaster construction. This company manufactures the well known Kno-Burn metal plastering lath, as well as the Fool-Proof reinforcing rods. The book is illustrated and contains a number of tables, showing compressive strength and fibre stress of different concretes, beam and column formulas and other useful data. The book will be mailed free upon application to the San Francisco branch or the home office in Chicago.

## Silver Lake Sash Cord Lasts Twenty Years

Silver Lake sash cord is finding a good market in San Francisco, and in fact throughout the coast. The cord is guaranteed for at least 20 years' unbroken service. Given pulleys of good quality it is claimed that Silver Lake A cord will average even considerably over 20 years' wear. This, of course, means im-

## *A 72-Page Building Material Catalogue in Colors*

The GOLDEN GATE BRICK CO. has just published a catalogue in colors, describing Brick, Rock, Sand, White Cements, Sewer Pipe, etc. Write

# GOLDEN GATE BRICK CO.

660 MARKET STREET, San Francisco, for a copy.

munity from trouble and expense for the owner, and the first cost will be no more than if the contractor substituted an unbraided cord.

In its advertising matter the Silver Lake company prints the following interesting information:

"The sharp bending and straightening of the closely braided cord as it runs over a pulley of small diameter calls for a material of soft, flexible fibre.

"The tensile strength of any sash cord, chain, or ribbon is amply sufficient. Where failure occurs is in the part working over the pulley—the part where the bending occurs.

"Many textile fibres have greater strength than cotton, but they are brittle in comparison and soon begin to break over the pulley.

"When the minute fibres break the cord begins to fail, first by fraying slightly, then with constantly increasing rapidity; it runs hard, catches at the pulley, and finally breaks.

"The best cord is made from the highest grade cotton yarn carefully, evenly, and solidly braided, and much depends on the man operating the braiding machine.

"For forty years we have made the best solid braided cotton cord it is within the skill of man to produce. We back that cord by our whole reputation—not by a paper label on the hank, but by our name indelibly stamped on every foot of it."

**Establish Chicago Office**

The Asbestos Protected Metal Company, which is represented in San Francisco by P. J. Knudsen of 310 California street, has recently established a branch office at 613 Fisher building, Chicago, under the management of Mr. Wilmot W. Burritt.

**Back Copies Wanted**

Elizabeth W. Champury, Perry hotel, Seattle, desires three copies of the August, 1909, number of The Architect and Engineer. She will pay 25c apiece for them, or \$1 for the three copies if sent together.

**THE ROEBLING CONSTRUCTION CO'S**



**System of FIRE PROOFING and EXPANDED METAL LATH**

**HOME INDUSTRY**  
Made in San Francisco

EXPANDED metal lath manufactured in rolls 150' long, 25' and 33' wide, or sheets if desired, plain, painted or galvanized. Crimped metal lath and wire lath for exterior plastering.

Everything in the lath line for architect, owner, plasterer and lather. Information, prices and samples cheerfully given

**OFFICES: Nos. 623-626 CROCKER BLDG. SAN FRANCISCO**

Phones—Home C-4312; Kearny 2222

**Factory and Warehouse: No. 476 Eighth St.**

**Mackenzie Roof Co.**



**425 15th St., Oakland**  
Phone Oakland 3461

**HARDWOODS**

**The Largest Stock WEST OF CHICAGO**

**WHITE BROTHERS**

**FIFTH AND BRANNAN STREETS, SAN FRANCISCO**



# SMITH, EMERY & COMPANY, Inc.

INSPECTING AND TESTING ENGINEERS  
AND CHEMISTS

651 HOWARD STREET  
SAN FRANCISCO

245 SO. LOS ANGELES STREET  
LOS ANGELES

INSPECTORS OF

## IRON, STEEL, CEMENT

REPRESENTED AT

SEATTLE  
NEW YORK

SAN DIEGO  
CHICAGO

PUEBLO  
PHILADELPHIA

BIRMINGHAM  
MONTREAL

PITTSBURG  
GLASGOW

### The Troubles of a Cement Company

The San Juan Portland Cement Company represents an investment in excess of \$1,250,000. The business is located at San Juan in San Benito county, and the property includes 2,500 acres of land, two branch railroads, a number of buildings and some very valuable machinery. J. C. Kemp Van Ee was the active organizer of the company, and when it was learned that his associates were such men of wealth as Gustave Baumann of New York, F. Sergeant of Chicago and Burrell and Ladd of Portland, it was believed that the establishing of a paying industry was assured.

Great activity was apparent around San Juan, but before the costly machinery was ready for operation there came a shut-down, and ever since that time there has been an effort to adjust financial differences which finally brought the interests to court.

One of the assets of the company is the big Chittenden ranch at Chittenden, near Watsonville.—Pajaronian.

The San Juan Portland Cement Company is the bone of contention between two factions of its owners, one of which is endeavoring to rehabilitate the plant at San Juan, and the other is trying to prevent its operation.

Nearly all of the people interested in the controversy are millionaires, and their points of difference are to be settled by law.

Strangely enough, Brown, who is president of the Palmer Oil Company, is associ-

ated with the Baumann, Ladd, Kemp Van Ee interests and is opposing the suit brought by his own company which is seeking to depose him as president. The other two members are H. P. Wilson and Victor Enginger. The company owns 12 per cent of the bonds of the Portland Cement Company, and the remainder are owned by Baumann, Ladd and associates.—Santa Cruz Sentinel.

### Reno's New High School Building.

The competition for plans for a fine high school building to cost \$150,000 and to be erected at Reno, Nevada, has resulted in the selection of the plans of Architect G. A. Ferris of Reno. The building will be Class A, steel, brick and concrete, with a large assembly hall.

### A Code of Life.

To be honest, to be kind; to earn a little and to spend less; to make on the whole one family happier by his presence; to renounce, where that shall be necessary, and not to be embittered; to keep a few friends, without capitulation; above all, on the same grim conditions to keep friends with himself; here is a task for all that a man has of fortitude and delicacy.—Robert Louis Stevenson.

### To Complete Big Reservoir

The directors of the Modesto Irrigation District are making plans to complete the big reservoir for which a special bond issue of \$50,000 was recently voted.



The "Triumph" Desk

## C. F. WEBER & CO.

Manufacturers of SEATING FOR ALL PUBLIC BUILDINGS

School Desks, Church Pews, Opera Chairs, Hall Seating, Bank Furniture, Lodge Furniture and Equipment, P. O. Cabinets. Also Venetian Blinds, Rolling Wood Partitions, School and Church Bells, Maps, Map Cases, Globes.

Manufacturers of **Kyloplate** Blackboards, in use in nearly all School Buildings.

Ask for booklet "Good Blackboards"; also "Hand Book of Seating." They are FREE to Architects.

Offices: 365-367 Market St., San Francisco. 210-212 North Main St., Los Angeles

**INVESTIGATE**

# HOLMES' Disappearing **BEDS**

**687 Monadnock Building, San Francisco, California**

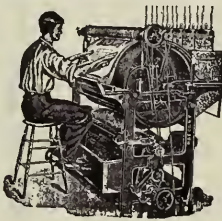

**Federal Blueprinting Machines**  
FOR PRINTING BY ELECTRIC LIGHT

A continuous printing machine. Most **economical, rapid and convenient**. Automatic tension. Variable speed, always under control. Best utilization of light. Made to print up to 30, 42, 54 inches wide. Descriptive circular on request.

MADE EXCLUSIVELY BY

**KEUFFEL & ESSER CO.**  
48-50 SECOND STREET - SAN FRANCISCO, CAL.

WE MAKE  
**BLUE PRINTS**

Make inquiry ANYWHERE as to the reputation of **BLUXOME & CO.**, 532 Monadnock Building, San Francisco, for high class workmanship and fair dealing in plain or Reinforced Concrete Construction.

Producers of Clean, Fresh-Water

## GRAVEL AND SAND

QUALITIES

- "GRADED"
- "CRUSHED"
- "ROOFING"
- "TOPPING"

CAPACITY, 3000 TONS PER DAY

Plants at Eliot, near Pleasanton and Healdsburg

# Grant Gravel Company

OFFICES  
**WILLIAMS BUILDING**  
3d and Mission Sts.

Phones } Pacific, Douglas 3078  
          } Home, J 1982

**San Francisco**

**Consider the Redwood Shingle More Fireproof than "Patent Roofing."**

The Redwood Shingle Association, in its campaign to promote the use of the redwood shingle, is endeavoring to secure certain amendments to the San Francisco building ordinance which will permit the use of redwood shingles where so-called "patent roofings" are now permissible. The following letter has been addressed to members of the Board of Supervisors:

Hon. Paul Bancroft,

San Francisco, Calif.:

Dear Sir—I desire to address you as one of the Supervisors of your city, realizing that the best interests of San Francisco and of California at large must be paramount with you, as the President of the Redwood Shingle Association, an organization of the shingle manufacturers in the redwood belt of California, whose sole purpose is to endeavor to stimulate and encourage the use of the California Redwood Shingle for building purposes.

I regret to learn that your honorable body has, by ordinance, restricted the use of this valuable California roofing material in a very large section of the residence portion of the city of San Francisco.

I assume that this has been done for the purpose of lessening the fire risk in those localities, but if a thorough investigation is made into the fire-resisting qualities of the redwood shingle the result is bound to show that this forest product has a lead over all other timber products as well as most "patent roofings" used for construction purposes.

By a system of thorough investigation the redwood shingle manufacturers have learned that the redwood shingle offers a greater resistance against fire than do many brands of "patent roofings" now used upon roofs of the buildings in your residence section.

Sparks and burning embers falling upon properly constructed redwood shingle roofs are extremely slow in igniting, and in event of ignition the flame is quickly quenched when a very small quantity of water is put upon it. This is not so with the average "patent roofing," for when once ignited the flame is very hard to quench due to some inflammable substance used in the production of this class of building material. I trust that you will give due consideration to this matter and that your honorable body can so amend your building laws that the redwood shingle can find a market in San Francisco, thereby aiding in the development of the great timber belt of Northern California, which development must necessarily mean advancement and betterment of conditions in San Francisco.

Very truly yours,

E. E. SKINNER,

President, Redwood Shingle Association

**BRIDGEPORT  
STANDARD  
WOOD FINISHES**

**SERVICE**

Good SERVICE is a broad term as applied to wood finishes.

It begins with ease of application — it ends with beauty and the lasting qualities of the wood finish.

If you want to recommend wood finishes that give the best possible SERVICE in all respects, specify the use of—

**Bridgeport Standard  
Wood Finishes**

Bridgeport Standard Wood Finishes are practical finishes—simple to use, easy to spread, great in covering capacity.

They develop the natural beauty of the wood and *never* cloud, obscure or raise the grain.

And they give an elastic, tough finish that looks good at the start and stays good with the years.

We have hundreds of letters from Architects, Property Owners, and Furniture, Piano and Car Building concerns who use Bridgeport Standard Wood Finishes which verify and emphasize this statement.

We would like to place tangible proof of the good SERVICE of Bridgeport Standard Wood Finishes in your hands.

**Write for Sample Panels**

We will be very glad to mail you on request a neat compact case of sample panels showing numerous wood finishes in new and staple effects. You will find them useful and PRACTICAL.

**Whittier-Coburn Co.,**

San Francisco and Los Angeles

Agents for the Pacific  
Coast.

**THE BRIDGEPORT CO.**  
WOOD FINISHING  
NEW MILFORD, CONN.

NEW YORK. CHICAGO. BOSTON.

ROBERT W. HUNT

JNO. J. CONE

JAS. C. HALLSTED

D. W. MCNAUGHER

**ROBERT W. HUNT & CO., Engineers****BUREAU OF INSPECTIONS, TESTS AND CONSULTATIONS**

NEW YORK LONDON CHICAGO PITTSBURG ST. LOUIS MONTREAL MEXICO CITY

418 MONTGOMERY ST., SAN FRANCISCO

Inspection of Rails and Fastenings, Cars, Locomotives, Pipes, Bridges, Buildings, Etc.

**CEMENT TESTING AND INSPECTION****Reports and Estimates on Properties and Processes****A Warning**

The following warning has been sent out by the Pacific Tank Company, manufacturers of the well known Pitcher Door Hangers and Frames:

"It has recently come to our attention that the Pitcher Patented Sliding Door Frames for 5½-inch partitions, which many architects are specifying and which have been installed in all classes of buildings in San Francisco and surrounding cities, Portland and Los Angeles, are being copied and our patents infringed upon, and that there is a very frail and poorly constructed substitute for our frames now being placed on the market and offered to contractors and builders.

"We wish to notify all architects, contractors and owners of buildings to beware of any such infringements and that we will not allow such frames to be erected without protest, and contractors and owners will put them in at their own risk.

"We wish to state to the public that we own and control letters patent covering frames which are known as the Pitcher Patented Sliding Door Frames, and that any contractors, owners or other persons who are manufacturing, or putting up, or using a substitute for this frame and infringing on our patents, will be liable to suit.

**Glidden Varnish Co. Sends Agent to South America**

The Glidden Varnish Company has sent a special representative to South America to place their concrete finishes and water-proofings among the architects and engineers. Their Mr. Tornero, a native of South America, sailed on the 25th of January to locate permanently in Buenos Aires, where he will have entire charge of the development of the concrete coating business of the Glidden Varnish Company, as pertaining to South American countries.

Demands for the Glidden products are coming from every quarter of the globe and their export business during the past year in concrete finishes are enormous. Their principal sources of outlet are India, South Africa, China and South America.

**THE STANDARD  
SUPPLY CO.****Building Materials****Agents for NEPHI  
HARDWALL PLASTER****Oakland, :: :: California****AMERICAN ROTARY VALVE CO.**

L. J. WHITE

S. I. WAILES

(Morehead Vacuum Cleaning System)

Complete Stationary Vacuum Cleaning  
Plants for Hotels, Office Buildings,  
Theaters, Apartment Houses,  
Schools and Residences

**702 BALBOA BUILDING**  
**Phone Sutter 607**  
**SAN FRANCISCO**

W. H. Henning

J. J. Burke

Phone Douglas 2298

**HENNING & BURKE****General Contractors**

Room 242 Russ Bldg.

San Francisco

When writing to Advertisers mention this Magazine.

# HARDWOOD

and **PANELS**  
**EDW. F. NIEHAUS & CO., Inc.**

548 TO 570 BRANNAN STREET  
 Between Fourth and Fifth Sts.  
 SAN FRANCISCO, CALIFORNIA

BRANCH YARDS { TRACY, CAL.  
 MAYFIELD, CAL.

PHONES { LUMBER EX. 30  
 MARKET 1485

## SANTA FE LUMBER COMPANY

DEALERS IN WHOLESALE AND RETAIL

### LUMBER

Large Timbers and Special Bills to Order      Kiln Dried Oregon Pine Finish

Main Yard on SOUTHERN PACIFIC, WESTERN PACIFIC, SANTA FE  
 17th and De Haro Streets      ::      ::      SAN FRANCISCO, CAL.

## STRABLE MANUFACTURING CO.

MANUFACTURERS OF

### HARDWOOD FLOORING AND LUMBER

"TOFCO BRAND"

Quartered and Plain Sawn White and Red Oak Flooring. Has No Equal.

OFFICE AND YARDS, FIRST ST., BET. WASHINGTON AND CLAY, OAKLAND, CAL.

# TRIANGLE MESH

Used on these Build-  
 ings is No Longer  
 an Experiment.

OLYMPIC CLUB - SATTER - CRANE CO.  
 ST. MARY'S HOSPITAL - W. P. FULLER  
 PIERS 54 & 40 - FRIEDMAN'S  
 MISSION GRAMMAR SCHOOL  
 REALTY SYNDICATE GARFIELD SCHOOL  
 SAN JOSE STATE NORMAL SCHOOL.

**THE LILLEY & THURSTON CO., 82 2nd St., San Francisco**



TELEPHONE, KEARNY 1783

# WALTER HOUGH & COMPANY

INCORPORATED

## Building Construction

503 MARKET STREET  
SAN FRANCISCO

### Notable Sale of Timber.

A dispatch from Washington states that the forest service has decided to enlarge the scope of bids to be considered for the sale of timber in Trinity National Forest and the construction of a railroad into the forest. Originally the bureau intended only to consider propositions relative to the disposal of a large tract of timber coupled with the construction of a railroad from the coast through the forest and mountains to the Sacramento valley. The proposed route of the railroad ran down Hay Fork for a considerable distance. It was expected that the Humboldt & Eastern Railroad Company would probably be the only bidder.

Recently, however, it is understood that intimations have been received by Assistant Forester Olmstead at San Francisco that certain other capitalistic interests would like a chance to bid for the Trinity forest timber and in that connection construct a railroad from the Sacramento valley into and eventually through the forest to the coast. Olmstead wrote to United States Forester Graves about the matter, asking for instructions, and the other day the forester wired him to give equal consideration to bids received from the Humboldt & Eastern proposing to build a railroad eastward into the forest, or from anybody else proposing to build westward from the Sacramento valley.

The bids are to be opened April 1 in San Francisco.

### To Design Many Bridges.

Mayberry & Parker, Pacific Electric building, have been retained as designing and consulting engineers by the board of supervisors of Ventura county

and will design eleven reinforced concrete bridges and act as consulting engineers for the erection of nine steel structures. The bridges are to be built in connection with the highway system and will be constructed across the Santa Clara river and various other streams and washes. The concrete bridges will range from one to three spans and the steel bridges will range from 100 to 1200 feet in length. The estimated cost of the work is \$232,000.



Engineers, Contractors,  
Builders and Architects

are Specifying

## BAY STATE BRICK AND CEMENT COATING

because they find it is the best to protect concrete, stucco or brick against the ravages of dampness; it does not chip, flake or peel, nor does it destroy the distinctive texture of concrete. It has been endorsed by the National Board of Fire Underwriters as a fire retarder and therefore will lessen your insurance rate. Will give concrete or wood beautiful different tints. Write at once for booklet and color card.

**WADSWORTH, HOWLAND & CO., Inc.**

PAINT AND VARNISH MAKERS  
AND LEAD CORRODERS

82-84 Washington St., Boston, Mass.

Distributing Agents:—Hiram W. Wadsworth, Chamber of Commerce Building, Pasadena, Cal.; Timms, Cress & Co., Portland, Ore.; F. T. Crowe & Co., Spokane, Seattle, Tacoma, Wash., R. N. Nason & Co., San Francisco.



Cover  
Your

## ROOF with ELATERITE

ELATERITE DRILL TOP or CLOTH TOP DECKING

MAKES AN IDEAL DECK FLOOR AND ROOF

THESE HIGH GRADE PRODUCTS MADE ONLY IN DENVER, COLO.

**THE WESTERN ELATERITE ROOFING CO.**

PACIFIC COAST AGENCY, 413 FIFTEENTH ST., OAKLAND



# WORDEN-MEEKER VARNISH CO.

Products of Uniform Quality

**PAINTS, OILS, VARNISHES, STAINS**

**EGG SHELL FINISH**

A Flat Varnish Not Requiring Rubbing

Architects will find our  
Line Unequaled

**SAN FRANCISCO .. OAKLAND**

P. P. MOORE

G. D. BOYD

## Boyd & Moore

HYDREX WATERPROOFING SYSTEM. ENAMELED BRICK. "TABOR"  
REVERSIBLE SASH FIXTURES (SEE PAGE 129). "VAN KANNEL"  
REVOLVING DOORS. "ENUPHYL" ORNAMENTAL BRONZE.  
"CROSS" HORIZONTAL FOLDING DOORS  
"CROSS" COUNTER-BALANCE FREIGHT ELEVATOR DOORS  
"ENERGY" DUMB WAITERS.  
"H. & C." METAL LOCKERS.

**356 Market Street**

**SAN FRANCISCO**

E. F. HENDERSON

W. M. WILLIAMS

CHAS. WILLIAMS

## Williams Bros. & Henderson

**BUILDING CONTRACTORS**

PHONES: KEARNY 2401  
J-2401

**351 MONADNOCK BUILDING**  
SAN FRANCISCO

## FREDERICK J. AMWEG

**CIVIL ENGINEER**  
MEM. AM SOC. C. E.

**700-705 MARSDON BLDG. SAN FRANCISCO, CAL.**

**ADVISORY ENGINEER**  
*and*  
**MANAGER OF BUILDING OPERATIONS.**

**BUILDER OF**  
KERN COUNTY COURT  
HOUSE, BAKERSFIELD,  
CALIFORNIA

## An Index to the Advertisements

	Page		Page		Page
Abrahamson & De Gear	111	Gilley-Schmid Co.	110	Pacific Fire Extinguisher Co.	125
Adams & Hollopetter	106	Glaenzler, Eugene & Co.	22	Pacific Improvement Co.	4th Cover
American Rotary Valve Co.	117	Gladding, McBean & Co.	15	Pacific Rolling Mills	29
Amweg, Frederick J.	120	Glidden Varnish Co.	20, 137	Pacific Tank Co.	126
Arenz, Richard Co.	132	Golden Gate Brick Co.	112	Palmer Shop, The	14
		Golden Gate Structural and Or-		Paraffine Paint Co.	27
		nemental Iron Works	134	Parrott & Co.	2, 3, 5
Bagge, W. H., & Son, Inc.	135	Goodyear Rubber Co.	138	Perfect Concealed and Turner	
Baker & Hamilton	33	Grand Gravel Co.	115	Bed Company	16
Bass-Hueter Paint Co.	28	Gutleben Bros.	135	Petersen, H. L.	142
Bay Development Co.	135			Peterson, Nelson Co.	128
Berger Manufacturing Co.	8	Haines, Jones & Cadbury Co.	131	Pike, C. W. Company	17
Bexhill Casement Co.	144	Hanley & McCulloch	136	Pioneer Paper Co.	142
Bill & Jacobsen	151	Hansen & Johnson	133	Puritan Brand Sash Cord	149
Blanc Stainless Cement Co.		Hart Heater Co., The	108		
		Henning & Burke	117	Ransome Concrete Co.	8
Bluxome & Co.	115	Hillard, C. J., Co.	29	Redwood Shingles, Colored Insert	
Boswall, Wallace C.	136	Hipolito Screen & Sash Co.	17	Reliance Ball-Bearing Door	
Bowser & Co., S. F.	18	Hoffman Heater Co.	18	Hanger	30
Boyd & Moore	120, 144, 151	Holbrook, Merrill & Stetson Co.	18	Rickon-Ehrhart Co.	31
Braun, J. G.	28	Holbrook, Disappearing Bed Co.	115	Rischmuller, C.	136
Braun, Williams & Russell, Inc.	133	Holmes Lime Co.	9	Roebling Construction Co.	113
Breite, W. W.	132	Hotel Victoria	22	Russell & Erwin Mfg. Co.	24
Bridgeport Wood Finishing Co.	116	Hough, Walter	119		
Brittain & Co.	27	Hoyt Bros.	132	Samson Cordage Works	135
Brode Iron Works	134	Humphrey Co.	21	San Francisco Bridge Co.	11
Brown Hoisting Machinery Co.		Hunt, Robt. W. & Co.	117	S. P. Cornice Co.	22
The	147			S. F. Metal Stamping and Cor-	
Building Material Co., The, Inc.	6	Is, John G., & Co.	133	rugating Co.	22
Butte Engineering Co.	107	Industrial Ornamental Iron &		S. F. Pioneer Varnish Works	20
		Wire Works	134	Sanborn & Corinson	134
		Ione Sandstone Company	132	Santa Cruz Portland Cement Co.	
Cabot, Samuel (Incorporated)	148	Johnson, J. A. M.	132	Santa Fe Lumber Co.	Colored Insert
California Art Glass Works	21	Johns-Hanger Mfg. Co., The	30	Sanitary Plumbing Appliance	118
California Bldg. Materials Co.	23			Co.	133
California Corrugated Culvert		K. C. T. Waterproofing Co.	145	Sartorius Co.	29
Co.	26	Kawner Manufacturing Co.	152	Scarritt & Clark	149
California Photo Engraving Co.	136	Kelly, J. F. Co.	111	Schastey & Vollmer	134
California Scagliola	150	Keuffel & Esser Co.	115	Schmitt, Geo. W.	111
California Steam and Plumbing		Keystone Boiler Works	140	Silver Sash Cord Co.	111
Supply Co.	31	Kiernan & O'Brien	109	Simmons Machinery Co.	133
Callaghan & Manetta	150	Knowles, A.	121	Smith, Emery & Co.	114
Central Electric Co.	110	Knudsen, P. J., Co.	138	Solar Heater Co.	140
Central Iron Works	114	Kompolite	142	Southern Pacific Co.	146
Clarke, D. Ross	136	Liquid Stone Paint Co.	148	Soule Reversible Window Co.	23
Clinton Fireproofing Co.	2d cover	Lilley & Thurston Co.	118	Standard Portland Cement Cor-	
Coleman, Alex.	111	Locke Foundation Co.	135	poration	Colored Insert
Columbia Lumber Co.	133	Los Angeles Pressed Brick Co.	15	Standard Supply Co.	117
Columbia Marble Co.	10	Lynch & Co., A.	128	Standard Varnish Works	129
Columbia Portland Cement Co.	30			Stanley Works	141
Cook, H. N. Belting Co.	10	Machinery and Electrical Co.		Steel Protected Concrete Co.	124
Corrugated Bar Co.				Steiger Terra Cotta & Pottery	
				Works	15
Crane Company	18-31	Mackenzie Roof Co.	113	Stoffels, Geo. H. & Co.	142
Crowe, F. T. & Co.	4	Mangrum & Otter	32	Strable Manufacturing Co.	118
Crowley, E. D. Co.	135	Marshall & Stearns Co.	123	Sutton John G., Co.	111
		Master Builders Co.	126		
		Menzer, C. & Son	150	Tay, George H.	131
		Meurer Bros.		Thieben & Co., Jos.	19
				Thomas & Schneider Art Glass	
				Company	143
Dean Reversible Window Co.	17	Mosaic Tile Co., The	139	Tomasello, S. & Co.	19
De Laval Dairy Supply Co.	17	Mortenson Construction Co.	134	Tozer Company	123
Diamond Brick Co. Colored Insert		Mott Iron Works	135	Triumph Ice Machine Co.	141
Dieckmann Hardwood Co.	32	Moulin, Gabriel	143	Trussed Concrete Steel Co.	139
Dietzgen, Eugene Co.	9, 133	Mt. Diablo Construction Co.	134	Turner Company	125
Duncan, David	136	Municipal Eng. & Con. Co.	141		
Dunlevy & Gettle	128	Murphy Mfg. Co.	132, 149	Union Metal Corner Co.	147
Dyer Bros.	140			United Glass Works	10
		Natamas Consolidated of Cal.	125		
Elam & Son, Thomas	135	Nelson, N. O. Mfg. Co.	31	Vallejo Brick and Tile Co.	16
Electric Appliance Co.	108	Nevada Gypsum Co., The		Van Emon Elevator Co.	1
Elevator Supply and Repair Co.	141				
Engstrum, P. O. Co.	142	Niehaus & Co., Edw. F.	118	Wadsworth, Howland & Co.	119
Esterly Construction Co.	136	Northern Clay Co.	15	Wagner, Ferdinand	12
				Wanted, Concrete Mixer	124
				Waterhouse & Price Co.	
					26, 143, 147
Farrell & Reed	133	O'Mara, J. E.	109	Weary & Alford Co.	32
Farrenkopf & Sons, C.	134			Weber, C. P. & Co.	114
Fee, Grant	136	Pacific Ball-bearing Door-Hanger		Wells & Spencer Machine Co.	12
Fernald Co., The	123	Co., Inside Front Cover		West, M. G. Company	12
Fess System Co.	23	Pacific Blower & Heating Co.	111	Western Building Material Co.	
Fisher & Wolfe Company	109	Pacific Portland Cement Co.,			4th cover
Follansbee Bros. Co.	107	Con., The	Colored Insert		
Foots Concrete Machinery Co.	23				
Ford & Malott	13				
Ford, Thomas J.	109				
Fox, John L.	132				
Fox, W. P. Co.	131				



*Where the Johns Door Hangers are made. Interior of the San Francisco Factory*



*New Y. M. C. A. Building, San Francisco, Warden-Meeker "Egg-Shell" Finish Used Throughout  
D. Zelinsky, Tinting and Pointing*

SOMETHING ENTIRELY NEW

# OSCILLATING PORTAL WALL BEDS

MARSHALL & STEARNS CO.

1154 PHELAN BUILDING

SAN FRANCISCO, CAL.

### Hartford's New City Hall

The final plans for the new city hall at Hartford, Conn., have been selected by a jury of prominent architects, consisting of John M. Carrere, Cass Gilbert and H. Van Buren Magonigle, and the municipal building commission. The building will be fashioned after the tentative designs submitted in competition by Davis & Brooks of Hartford, with whom will be associated the New York firm of Palmer & Hornbostel, architects for Oakland's new municipal building.

The Davis & Brooks plans are for a building of colonial style of architecture, and a distinctive feature is the "atrium scheme," allowing an open court. No vaults are required above the first floor, and galleries extend around the court on the second floor. Still less space is required for office use on the third floor, and the building will be remarkably well lighted.

### Santa Cruz Hotel

The Rickon-Ehrhart Construction Company of San Francisco is making good progress on the new Hotel Casa Del Rey at Santa Cruz, designed by Architects McDonald & Applegarth. The building is of reinforced concrete and is expected to be finished and ready for occupancy May 15th. The contractors are said to be doing a splendid piece of concrete work.

GEO. FARRELL, Burlingame  
WALTER N. REED, 239 Precita Ave.  
San Francisco  
Res. Phone Mission 2459

## FARRELL & REED

MASONS AND GENERAL CONTRACTORS

BUILDERS' EXCHANGE

Office 9th Floor, Gunst Bldg.  
Third and Mission Sts., San Francisco  
Phone Sutter 450.



Model for Orpheum Marquise

## S. TOMASELLO & CO.

ARCHITECTURAL MODELERS

METAL PATTERNS FOR CHANDELIERS  
PLASTER ORNAMENTS WAX AND PLASTER PATTERNS  
COMPOSITION AND CEMENT BRONZE TABLETS  
SCALE MODELS TELEPHONE PARK 6133  
STUDIO: 122 10TH ST., NEAR MISSION, SAN FRANCISCO

PHONE: KEARNY 263

# THE FERNALD CO.

REPRESENTING THE

NORTHWESTERN EXPANDED METAL CO., OF CHICAGO  
MANUFACTURERS OF

**KNO-BURN** DIAMOND MESH EXPANDED **METAL LATH**  
IN GALVANIZED, BLACK AND PAINTED

Our Galvanized Lath is Galvanized after  
Expanding and Cutting  
The only Galvanized Lath worthy of the name

OFFICE AND WAREHOUSE  
248 TEHAMA ST., BET. 3D & 4TH  
SAN FRANCISCO, CAL.



## ADVERTISERS' INDEX - Continued from Page 121

Western Builders' Supply Co. . . . . 25	White, S. A. . . . . 152	Woods & Huddart. . . . . 32
Western Elaterite Roofing . . . . . 119	Whittier, Coburn Co. . . . . 24, 116	Worden-Meeker Varnish Co. . . . . 120
Western Iron Works . . . . . 29	Williams Bros. & Henderson . . . . . 120	Young Machinery Co., A. L. . . . . 7
Western Lime and Cement Co. 127	Wilson, W. H. & Co. . . . . 133	
Whitaker & Ray-Wiggin Co. . . . . 13	Wittman, Lyman & Co. . . . . 125	
White Bros. . . . . 113	Wocker, A. C. . . . . 16	Zeis, Oscar L. . . . . 111

### Construction of Sacramento Court House Delayed.

The discovery by testing machines utilized by the Lindgren Company that the ground on the site of the proposed new Court House, on I, Sixth and Seventh streets, was not firm enough to support the tremendous weight of the big structure with the foundation called for in the specifications, has caused a sudden halt in the work of laying the foundations.

Architect Herold's assistant has ascertained that the ground at one point sank six inches under a given weight, made of sacks of brickbats upon a platform and used as a tester.

It will probably be necessary either to enlarge the foundation or sink piles before Contractor Lindgren can proceed further with the work.

A half dozen testers have been constructed at various parts of the site to determine the firmness of the ground. Several of these showed a pronounced sinkage, one in particular dropping a distance of six inches.

### Pioneers in the Roofing Business

Mr. George Reeves, manager of the W. H. Wilson & Co. asphaltum and composition roofing business at 40-42 Natoma street, San Francisco, is not only a coast pioneer, having arrived here in 1864, but his business house is also a pioneer in its line, and refers with much pleasure to more than 42 years of continuous, prosperous and honorable business. The work is guaranteed in every particular and architects and owners who have done business with the firm have been pleased with the way contracts have been filled. The company has on hand at the present time several large roofing contracts and is looking forward to a very successful year.

## WANTED

CONCRETE MIXER, with or without power. State size, make, age, condition, price and where can be seen.

Address Box H, Architect and Engineer.

## WAINWRIGHT GALVANIZED STEEL CORNER BAR

For Protecting Edges of Concrete Curbs, Steps, Columns, Etc.

The only effective Concrete Edge Protector offered to the contracting public

WAINWRIGHT PATENTS—March 9, 1897, November 22, 1898, May 5, 1903, March 26, 1907, August 29, 1907, August 2, 1910.

This bar has been in public use for more than ten years as the main feature of the

## WAINWRIGHT STEEL-BOUND CONCRETE CURB

THE BEST IN THE WORLD

## OVER THREE MILLION FEET

In use in more than three hundred cities in the United States

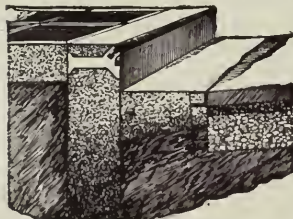

ABSOLUTELY NON-BREAKABLE  
CHEAPER THAN GRANITE

Handsome than Granite and much stronger.  
Continuous in Construction, hence Never Out of Line.  
GALVANIZED STEEL CORNER BAR Prevents Chipping or Breaking on Edges.

This Curb is Mechanically Perfect and Unequaled for Curved Corners.

THIS CURB WILL STAND HARDER USE AND LAST TEN TIMES AS LONG AS PLAIN CONCRETE CURBING.

CONTRACTORS can make money by laying this curb.

CITY ENGINEERS can save money by specifying it.

ARCHITECTS are invited to read pages 242 and 243 "Sweet's Index."

METAL PARTS FOR SALE

SEND FOR COPYRIGHTED BOOKLET NO. 16

STEEL PROTECTED CONCRETE CO.

REAL ESTATE TRUST BUILDING  
PHILADELPHIA, PA.



# PACIFIC FIRE EXTINGUISHER CO.

## ENGINEERS AND CONTRACTORS

Heating and Ventilating, Electrical Instal-  
lations, Fire Extinguishing Apparatus

### THE GRINNELL AUTOMATIC SPRINKLER

Main Office: 507 MONTGOMERY STREET, SAN FRANCISCO, CAL.

Branch Offices	{	217-218 Colman Building.....	Seattle, Wash.
		504-505 McKay Building.....	Portland, Ore.
		703 Paulsen Building.....	Spokane, Wash.

# NATOMAS ROCK

A CRUSHED ROCK that is absolutely free of sand, clay or other for-  
eign matter, very hard and very tough, without flaw or seam. Unequaled  
for concrete or macadam work. Inquiries and trial orders solicited.

## Natomas Consolidated of California,

Rock Crushing Department,

203 Hagelstein Building,

SACRAMENTO, CAL.

W. J. TURNER,  
PRESIDENT

D. TURNER,  
SECY & TREAS.

# THE TURNER COMPANY

PLUMBING, HEATING, VENTILATING  
AND ELECTRICAL CONTRACTORS

TELEPHONE SUTTER 1059

278-280 NATOMA STREET  
SAN FRANCISCO, CAL.

Phone Market 746

# WITTMAN, LYMAN & CO.

PLUMBING and GAS FITTING  
HOT WATER and STEAM HEATING

315 POLK STREET  
Bet. McAllister and Fulton Sts.

SAN FRANCISCO, CAL.

*Mr. Architect:—When you specify the*

## PITCHER SLIDING DOOR HANGER

*Insist upon its use. There is a cheap substitute on the market which some contractors would like to use. Don't be deceived for we intend to prosecute any and all infringements of the Pitcher Patents.*

### DISAPPEARING DOORS A Great Labor and Space Saving Device



**PITCHER** } Adjustable Hangers  
Patent Door Frames

Specified by nearly all leading Architects

SEND FOR CIRCULAR

**PACIFIC TANK COMPANY**

231 BERRY STREET    SAN FRANCISCO    318 MARKET STREET

## Architects!

**Y**OU have been having trouble with Dry Bonds in all Concrete Work. We can prevent this with **MASTER BUILDERS CONCRETE FILLER**. Master Builders Filler will waterproof Concrete and make a surface hard as Iron. Does not absorb oil, is used largely for floors with heavy wear; expense nominal. *Write for particulars.*

## The Master Builders Company

1054 Monadnock Bldg.  
San Francisco

25 Broad Street  
New York

### Hand Book for Cement and Concrete Users

This book by Myron H. Lewis, C. E., is a concise treatise of the principles and methods employed in the manufacture and use of cement in all classes of modern works. The author has brought together in this work all the salient matters of interest to the user of concrete and its many diversified products. The matter is presented in logical and systematic order, clearly written, fully illustrated and free from involved mathematics. Everything of value to the concrete user is given. Among the chapters contained in the book are: I. Historical Development of the Uses of Cement and Concrete. II. Glossary of Terms Employed in Cement and Concrete Work. III. Kinds of Cement Employed in Construction. IV. Limes, Ordinary and Hydraulic. V. Lime Plasters. VI. Natural Cements. VII. Portland Cements. VIII. Inspection and Testing. IX. Adulteration, or Foreign Substances in Cement. X. Sand, Gravel and Broken Stone. XI. Mortar. XII. Grout. XIII. Concrete (Plain). XIV. Concrete (Reinforced). XV. Methods and Kinds of Reinforcements. XVI. Forms for Plain and Reinforced Concrete. XVII. Concrete Blocks. XVIII. Artificial Stone. XIX. Concrete Tiles. XX. Concrete Pipes and Conduits. XXI. Concrete Piles. XXII. Concrete Buildings. XXIII. Concrete in Water Works. XXIV. Concrete in Sewer Works. XXV. Concrete in Highway Construction. XXVI. Concrete Retaining Walls. XXVII. Concrete Arches and Abutments. XXVIII. Concrete in Subway and Tunnels. XXIX. Concrete in Bridge Work. XXX. Concrete in Docks and Wharves. XXXI. Concrete Construction Under Water. XXXII. Concrete on the Farm. XXXIII. Concrete Chimneys. XXXIV. Concrete for Ornamentation. XXXV. Concrete Mausoleums and Miscellaneous Uses. XXXVI. Inspection for Concrete Work. XXXVII. Waterproofing Concrete Work. XXXVIII. Coloring and Painting Concrete Work. XXXIX. Methods of Finishing Concrete Surfaces. XL. Specifications and Estimates for Concrete Work.

This book will be mailed to any address, prepaid, upon receipt of price (\$2.50). Address F. Jones, 241 S. Whitney St., San Jose.

### The Pittsburg Bungalow Heater

Jos. Thieben & Company of San Francisco report many inquiries concerning their "Bungalow Heater," manufactured by the Pittsburg Water Heater Company. It is claimed to be one of the best automatic heaters for bungalows, cottages and apartment houses ever produced.

For small compact installations containing kitchen, bath and lavatory, you can appreciate an automatic heater such as this "Pittsburg Bungalow," and the field it is designed to cover.

Hundreds of cottages and small flats would appreciate automatic hot water service, but, until now, the price has been more or less prohibitive, but the low cost of the Pittsburg Bungalow Heater, and the economy of its operation, to say nothing of its convenience, will appeal to this class of builders.

Its main field in San Francisco will be for apartment houses where a heater installed in each apartment gives the tenant automatic hot water service and they pay their own gas bills, thus relieving the owner or lessee of this monthly inconvenience, to say nothing of the saving in installing and maintaining a central hot water plant.

### A Garbage Chute That is Sanitary.

The Bradshaw Sanitary Garbage Chute is now handled in California by Messrs. Bill and Jacobsen, 524 Pine street, San Francisco. This chute has the endorsement of leading physicians, architects and builders and seems to have solved the problem of an absolutely sanitary device for the disposal of garbage in hospitals, hotels, apartments, flats and residences. The first cost is the only cost and there is positively no expense or wear and tear for maintenance after the chute is once in operation. The chute is hermetically sealed, thus preventing all dust and odors, and shutting off any food supply for rats or domestic animals.

The chute extends from the basement to the roof, and is thoroughly ventilated and can be connected with either hot or cold water. The water and ash form a lye which cleanses the garbage and cuts all grease, making the garbage sanitary when carted to the street.

### FINISHES FOR CONCRETE SURFACES

Ordinary paints, when used on concrete, peel, crack and wear off.

Trus-Con Finishes become part of the concrete, resist wear and are waterproof.

Trus-Con Floor Enamel is dampproof, stain-proof, and prevents the formation of concrete dust on cement floors. Produces a tile-like surface which resists wear and is easily cleaned by mopping. Furnished in a variety of colors.

Trus-Con Wall Finishes make walls absolutely dampproof and allow the masonry to retain its natural texture, preserving its beautiful grain and replacing its cheerless monotony with delicate artistic tints.

Tell us condition and size of surface to be finished and we will send free trial sample. Booklet and Color Card free.

## Western Lime & Cement Co.

DISTRIBUTORS OF

CHEMICAL



PRODUCTS

268 MARKET STREET

SAN FRANCISCO, CAL.

When removing or finally disposing of the garbage, by a simple contrivance the seal is raised from the can and all doors are locked until the can is replaced, when the doors are again released. As the door is opened to receive the garbage, an automatic sprinkler thoroughly flushes the chute. The garbage can has a wire screen bottom, allowing the water to percolate through to the cesspool, where it is trapped to the sewer.

From an economical standpoint this system, through the action of the water, compresses or packs the garbage (a very material saving in disposing of same) and either eliminates entirely or minimizes the amount of janitor service now required for the disposal of any garbage.

The chute is made of heavy galvanized sheet metal and iron castings. The main pipe is 12 inches in diameter and cans are made in sizes to suit all requirements. It is installed complete for sewer and service connections and guaranteed.

Our chute can be installed at a very moderate price in old as well as new buildings and as stated before, the "first cost is the only cost."

#### Teak Wood for Doors and Windows

Teak is a wood which will not warp or twist under the most trying conditions of heat and cold, dryness and moisture. This has for centuries been recognized by the shipbuilders, who formerly used teak almost entirely in building their vessels.

At the present day the storm doors, rails, etc., on first-class vessels are invariably made of teak.

A more modern use of teak is for window sash, its excellent staying qualities making it invaluable for this purpose. A window in which the sash and casing is

constructed of teak will under no condition jam, no matter how wet the woodwork may become.

In the southern part of the State, especially around Los Angeles, a great many public buildings have teak sashes and window cases, notably the high schools at Peres, San Jacinto, Hemet and Holtville. All four buildings, the work of Architect F. S. Allen of Los Angeles, have teak doors as well as window and sash. Another fine example of the use of teak for window sash and trim is in the magnificent million-dollar house of Mr. H. E. Huntington at Ononta Park, Pasadena. This remarkable country seat is the work of Architects Hunt & Gray of Los Angeles.

Teak, while an expensive wood, is coming more and more into favor on account of its high qualities of beauty and reliability.

#### Los Angeles Engineers and Architects

The annual meeting of the Engineers and Architects Association of Southern California was held in February. The following officers were elected: William Mulholland, president; Homer Hamlin, vice-president; F. D. Hudson, second vice-president; directors—A. F. Rosenheim, E. M. Jessup, John C. Austin, Jesse O. Marsh. Twenty-two regular and four associate members were elected, as follows—regular, R. H. Ballard, Joseph G. Layne, F. J. Palomares, C. S. Walton, R. B. Young, W. E. Small, Fernand Parentier, J. C. Palmer, H. G. Miller, L. F. Mesmer, A. C. Martin, A. H. Koebig, Jr., J. H. Knapp, T. A. Jordan, W. V. Harris, F. W. Hunter, E. L. Ellingwood, C. W. Corbaley, A. L. Bush, H. E. Bean, Milton Baruch. Associates, J. D. Mackerras, H. L. Smith, J. B. Woodson, E. L. Woodruff.

E. F. GETTLE

C. E. S. DUNLEVY

## DUNLEVY & GETTLE

### SHEET METAL WORKS

Manufacturers of Dunlevy's Patent Chimneys (Pat. March 6th, 1894) Dealers in Patent Terra Cotta and Galvanized Iron Chimneys and Tops, Sewer Pipe, Flue Lining Pressed Brick Fire Brick Fire Clay, Cement, Etc.

79 City Hall Avenue Telephone Market 2165 Builders' Exchange, Box 310 San Francisco

CHAS. PETERSON, President

CHAS. H. NELSON, Vice-President

J. V. WESTERLUND, Secretary

## PETERSON, NELSON & CO., Inc.

CONCRETE CONTRACTORS

*Artificial Stone Work of all Kinds*

Phones: Douglas 1113  
Home C 1831

OFFICE: 407 PINE STREET  
Builders Association Box 327

San Francisco, Cal.

Telephone Douglas 121

Residence 291 15th Avenue. Telephone Pacific 929

## A. LYNCH & CO.

ARTIFICIAL STONE PAVEMENT  
and CONCRETE CONSTRUCTION*Estimates Given on all Kinds of Concrete Work*

Office: Builders' Exchange Building, 185 Stevenson Street

SAN FRANCISCO, CAL.



## THE ART IN ARCHITECTURE

Artistic merit in Architecture depends to a certain extent upon color. On account of the importance of this factor, too much care cannot be exercised in attaining desired tones.

To produce artistic color results in interior finishing, the preservation of the beautiful, natural figure of the wood is a vital consideration. For really artistic, modern, exclusive color effects, STANDARD VARNISH WORKS' Kleartone Stains are a constant revelation to the architect as well as his clients.

Not only does the architect have the regular up-to-date shades, but he also has our unique service in securing special, out-of-the-ordinary tones. This effective assistance makes it possible for every architect to stamp every piece of his work with his own individuality and personality.

White enamel work has a peculiar charm and richness. Our Satinette White Enamel proves its superiority wherever it is used on church, residence, office building and public institution. It does not turn yellow, it is easily cleaned and does not crack. It may be finished with a dull, flat effect or rich gloss. Satinette Undercoat should always be used for priming and undercoats for Satinette White Enamel work.



### ARCHITECTURAL FINISHES

Elastica Floor Finish for floors, Elastica No. 1 for outside work, Elastica No. 2 for inside work, Flattine Cabinet Finish for flat, dull finish, Kleartone Stains for beautiful color effects, Satinette White Enamel flat and gloss for both interior and exterior work and our other Architectural Finishes always more than meet expectations.

These Finishes give results that make high-class, artistic work possible. They make it possible for wood finishing to contribute in an unusual degree to the Art in Architecture.

## STANDARD VARNISH WORKS

NEW YORK, CHICAGO, LONDON, BERLIN, BRUSSELS, MELBOURNE

**W. P. FULLER & CO.**

DISTRIBUTORS FOR THE PACIFIC COAST AND HAWAIIAN ISLANDS

Canadian Branch: International Varnish Co., Limited, Toronto

### Reinforced Concrete, What It Is.

The Trussed Concrete Steel Company of Detroit has issued an attractive bulletin for free distribution entitled "What Reinforced Concrete Is." The paper has particular reference to the principles and advantages of the Kahn Trussed Bar which is used quite extensively throughout the United States. Here are some extracts from the paper:

"When in the late 60's, Monier, a French gardener, began making flower pots, boxes and small water tanks out of concrete and imbedded wire in the material to increase its strength and decrease its weight and bulk, he little thought that forty years later the principle he employed and upon which he was granted a patent, would be used throughout the entire world in the erection of millions upon millions of dollars worth of construction work. There has been no class of structures, no line of the building trades which has not been affected by reinforced concrete, and many of them have been revolutionized. The story of the development and growth of the use of this form of construction has filled volumes, while here it can only be touched upon briefly.

"Concrete is a rock-like substance formed by the mixture of cement, sand, stone and water. It is the result of the cementing together, through chemical action between the cement and water, of various sizes of stone so proportioned with the other material that all voids within the resulting mass are filled.

"Reinforced concrete is exactly what the name implies. It is concrete in which steel has been imbedded to give additional strength and elasticity.

"Plain concrete when used in the form of pillars and posts, is capable of carrying heavy direct loads through its great compressive strength. But when it is subjected to a direct pull, that is, to tensile strains, it is weak.

"In order to overcome this weakness, reinforcing steel is used to give proper tensile strength and elasticity. The concrete in the top of the beam takes care of the compression. A properly reinforced concrete beam has, therefore, the strength of stone in resisting compression united with the tension resisting power of steel."

### A Useful Book

"Garages and Motor Boat Houses" is the name of a useful book just published by the Wm. T. Comstock Company, 23 Warren street, New York. The volume contains drawings and photos of garages and boat houses, with floor plans and details. The book contains five divisions, as follows: Part I. Private Country and Suburban Garages. Part II. Private City Garages. Part III. Suburban and City Public Garages. Part IV. Motor Boat Garages. Part V. Garage Equipments and Accessories.

## The Murphy Concealed Wall Bed

**A**MONG the many concealed or wall beds now on the market, the attention of the Architect and Builder is called to that of the Murphy Concealed Wall Bed, as one of the latest and most up-to-date.

Taking a double bed of regulation size, and hanging it on the regular dressing room or closet door, of usual three foot width, seems impossible to the average mind; but that is what the Murphy Manufacturing Company, makers of the Murphy Concealed Wall Bed have succeeded in doing. Fastened to an ordinary paneled or mirrored door of the same finish as the rest of the room in which it is placed, the bed is concealed in every sense of the word, when not in use, while entrance to closet or dressing room is obtained through this door, with bed in either position.

Simple in construction, having done away with the usual weights and mechanism used on wall beds, it is light and easy to operate, and the absence of exterior cabinet work allows the bed to be sold at a lower figure than many now on the market. The Murphy Manufacturing Company have their temporary show rooms and office at 919 O'Farrell street, San Francisco, where working models and plans may be seen and explained. Their beds have been specified for sev-



*Showing bed when closed. Size of door, 3 ft.*

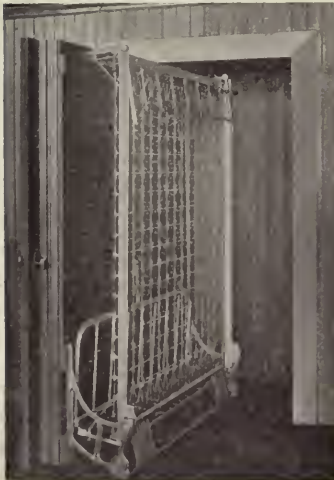

*Showing entrance to closet with bed partly open.*

eral apartment houses now in course of construction, including the "Klarenmeyer" on Taylor street which will be opened shortly.



*Showing bed ready for use with small door closed. Width of small door, 19 inches.*

# CONCRETA

*A Damp-Proof Coating for  
Surfaces of Concrete  
or Brick*

CONCRETA is a Reliable Paint Specialty prepared expressly for coating Cement, Plaster and Brick Walls. Its wearing properties are unexcelled.

It is much superior to ordinary oil paints for this special class of work.

CONCRETA works freely and covers more surface than any other Cement Coating.

Its economy, durability and sanitary properties make it an unequalled coating for use in Mills and Factories of concrete or brick construction.

WRITE AND MENTION THIS MAGAZINE TO

## W. P. FULLER & CO.

MANUFACTURERS

SAN FRANCISCO, CALIFORNIA



"Hygienic" Drinking Fountain

For other styles see samples in our show rooms  
851-859 Folsom St., San Francisco, Cal.  
Circular sent on request.

**HAINES, JONES & GADBURY CO.**

MAKERS OF PLUMBING SUPPLIES  
1130-1144 RIDGE AVENUE PHILADELPHIA

BRANCHES - SAVANNAH AND SAN FRANCISCO



HIGH GRADE

# Plumbing Fixtures

SOLD UNDER OUR

"Gold Label Guarantee"

Affords a Form of Insurance  
Equally Pleasing to Owner,  
Architect and Plumber : : :

Call at our showrooms for particulars

617 Mission Street San Francisco

**W. W. BREITE, C. E.**

*Structural Engineer*

Designs and Details of

All Classes of Metallic Structures

FOURTH FLOOR, CLUNIE BUILDING  
California and Montgomery Sts.

**SAN FRANCISCO CALIFORNIA**



(Trade Mark Reg.)  
Proven BEST by Every Test  
**JOHN L. FOX**  
TELEPHONE KEARNY 3515  
207 MONADNOCK BUILDING SAN FRANCISCO, CAL.

DR. W. J. HANNA, PRES.  
H. J. HARRISON, VICE-PRES.  
R. M. BEEBEE, SEC'Y-TREAS.

**IONE SANDSTONE CO.**

RED, WHITE AND VARIEGATED  
**BUILDING STONE**

ROOM 532 OCHSNER BUILDING  
SACRAMENTO, CAL.

TELEPHONE 9833 R

QUARRY, AMADOR COUNTY

Telephone Market 3989

**Ferdinand Wagner**

**MASON  
and  
BUILDER**

ESTIMATES FURNISHED ON ALL KINDS  
OF WORK

609 Waller Street - San Francisco

**DEWEY PATENT  
DISAPPEARING BEDS**

ALL KINDS OF WALL BEDS  
AND CABINET BEDS

MANUFACTURED BY

**THE MURPHY MANUFACTURING COMPANY**

919 O'FARRELL STREET  
SAN FRANCISCO, CAL.

**J. A. M. JOHNSON CO.**

Bank and Office  
**EQUIPMENT**

Room 519 Monadnock Bldg.  
Tel. Sutter 741 SAN FRANCISCO

**HOYT BROS.**

**CONTRACTORS**

of Northern California make a specialty of

**PUBLIC BUILDINGS**

BUILDERS: EXCHANGE  
SAN FRANCISCO

**SANTA ROSA, CAL.**

MAIN 2615

HOME F 2615

**Richard Arenz Co.**  
**Painting and Decorating**

DISTRIBUTORS  
SOUTHERN CALIFORNIA

FOR

PARKER, PRESTON & CO'S  
ART IN SHINGLE STAINS. WEATHER  
PROOF AND WATERPROOF  
COATINGS

335 EAST FOURTH STREET  
Near San Pedro Street, LOS ANGELES, CAL.



The Value of a System of  
**FLAT VERTICAL FILING**

For Drawings, Tracings  
and Blue Prints

UNTIL YOU HAVE USED IT

Write for Catalog BF

**Eugene Dietzgen Co.** 18 First St.  
San Francisco



CARSTEN HANSEN, Pres. and Mgr.

E. SCHRADER, Sec. and Treas.

**HANSEN & JOHNSON, Inc.**

**General Contractors**

OFFICE: 3 Mission St. Telephone, Kearny 278

BUILDERS EXCHANGE  
801 Jessie Street, Telephone Kearny 4700

SAN FRANCISCO

BUILDERS ASSOCIATION  
402 Kearny Street, Telephone Douglas 2525

**JOHN G. ILS & CO.**

Kitchen Equipments

and Installations

827-829 MISSION STREET SAN FRANCISCO, CAL.

OUR SPECIALTY IS FRENCH RANGES (Brick Set)

**BROWN'S GASKET**

**Sanitary Plumbing  
Appliance Co., Inc.**

A New Sanitary Plumbing Device to Prevent  
the Escape of Water and Sewer Gas.  
DEADENS NOISE OF FLUSHING  
Order from Your Jobber

412 Sheldon Bldg., First and Market Sts.  
Tel. Sutter 1476 SAN FRANCISCO, CAL.

BOILERS

ENGINES

TANKS

PUMPS

CONDENSERS

**BRAUN, WILLIAMS & RUSSELL, Inc.**

503 Market Street, San Francisco

:: Telephone DOUGLAS 5356

**MECHANICAL ENGINEERS AND CONSTRUCTORS**

Representatives

AEBERGER CONDENSER CO.

MINNEAPOLIS STEEL AND MACHINERY CO.

ROBB-MUMFORD BOILER CO.

**SIMONDS MACHINERY CO.**

**PUMPING MACHINERY**

Sole Agents KEWANEE WATER SUPPLY CO.

Phones, Kearny 1457  
Home J 3467

12 and 14 Natoma Street, Near First, San Francisco

All Orders Promptly Attended to

Old Roofs Repaired and Warranted

**W. H. WILSON & CO.**

ASPHALTUM AND COMPOSITION  
ROOFERS

42 and 44 Natoma Street, Bet. First and Second Sts.

SAN FRANCISCO

**COLUMBIA LUMBER CO.**

LUMBER OF ALL DESCRIPTIONS IN STOCK OR CUT TO ORDER

Main Office—BEACH STREET, Between Taylor and Mason, San Francisco, Calif.  
Telephones, Kearny 323 — Home C 4545

Mill—South Bend, Wash.

Yard—Block bounded by Beach, North Point, Taylor, Mason



R. J. BRODE, PROPRIETOR

TEL. KEARNY 2464

**BRODE IRON WORKS**

MANUFACTURERS OF

ORNAMENTAL  
IRON WORK**STRUCTURAL STEEL**OFFICE AND WORKS  
621-625 HOWARD STREETBET. SECOND AND THIRD STS.  
SAN FRANCISCO, CAL.

MEMBER OF TECHNICAL SOCIETY

ALL SURVEY NOTES SAVED

**SANBORN & CORINSON**

Successors to C. S. TILTON

**Surveyors and Civil Engineers**

Phone Douglas 366 Home Phone C 2741

251 KEARNY ST., Charleston Bldg., Room 406  
SAN FRANCISCO**MORTENSON CONSTRUCTION CO.**

CONTRACTORS FOR STRUCTURAL STEEL AND IRON

H. MORTENSON, PRES. CHAS. G. MORTENSON, VICE-PRES. AND MGR.

OFFICE AND SHOPS: CORNER 19TH AND INDIANA STREETS

PHONES: MISSION 5033—HOME M 3916

SAN FRANCISCO, CAL.

**INDUSTRIAL****ORNAMENTAL IRON  
and WIRE WORKS**IRON, BRASS &  
BRONZE WORK  
WIRE GUARDS  
BANK & OFFICE  
RAILINGS  
FOLDING  
GATESJOHN NORDGREN  
MANAGER552 NOE STREET  
SAN FRANCISCO, CAL.

PHONE MISSION 6237

**C. FARRENKOPF & SONS****ARCHITECTURAL IRON WORKS**Grill Work, Stair Rails, Fire Escapes, Elevator Cars, Bank and  
Office Counter and Enclosure Work, Sash Bars, Store Fronts

Phone Market 2145

623 MINNA STREET, near 7th, SAN FRANCISCO, CAL.

C. S. HOFFMAN

L. W. FLEIGNER

**GOLDEN GATE STRUCTURAL and ORNAMENTAL IRON WORKS**

Structural Works, 107-109 Eleventh Street

Ornamental Iron, Wire Works and Office, 1479 Mission Street, San Francisco  
WE CARRY A FULL STOCK OF STRUCTURAL MATERIALS

Pacific Telephone, Market 5445

Home Phone J1815

**REINFORCED CONCRETE CONSTRUCTION**Contracts Taken for Foundation Work, Fireproofing and Complete Structures,  
No Contract Too Small or Too Large. Our Motto. "One Good Job Deserves Another."**Mt. Diablo Concrete Construction Co.**

W. E. Charbonneau, President

E. Nelson, Treasurer

F. E. McCov, Secretary

Telephone, Sutter 1227

Offices, 211-213 No. 185 Stevenson St., San Francisco

**SCHASTEY & VOLLMER**

1930 Van Ness Avenue

Telephone Franklin 2729

SAN FRANCISCO, CAL.

Designers  
and

Decorators

# BAY DEVELOPMENT COMPANY GRAVEL - SAND - ROCK

Telephones, K 5313--J 3535 153 BERRY ST., SAN FRANCISCO

C. T. GUTLEBEN

DAN GUTLEBEN

## GUTLEBEN BROTHERS

CONTRACTORS ARCHITECTURAL AND  
ENGINEERING CONSTRUCTION

PHONE KEARNY 4640 927 MONADNOCK BLDG., SAN FRANCISCO

E. D. CROWLEY, PRESIDENT

S. A. JUBB, SECRETARY

## E. D. CROWLEY CO.

CONSTRUCTING ENGINEERS

EXPERTS IN REINFORCED  
CONCRETE CONSTRUCTION

PHONE DOUGLAS 982 127 MONTGOMERY STREET  
SAN FRANCISCO

THOMAS ELAM  
GROVER C. ELAM

Phone Kearny 4700

## THOMAS ELAM & SON

GENERAL CONTRACTORS

Office, Builders' Exchange, 180 Jessie Street

San Francisco, Cal.

## LOCKE FOUNDATION CO.

CONTRACTING ENGINEERS

CONCRETE AND CEMENT WORK

1107 CROCKER BUILDING

Phone Kearny 2608

SAN FRANCISCO, CAL.

## THE J. L. MOTT IRON WORKS —OF— NEW YORK

D. H. GULICK, Selling Agent for Pacific Coast

135 KEARNY ST.

Phone, West 6894

SAN FRANCISCO

## SAMSON SPOT SASH CORD

  
Guaranteed free from all imperfections of braid or finish. Can always be distinguished by our trade mark, the colored spots. Send for samples, tests, etc. SAMSON CORDAGE WORKS, BOSTON, MASS.  
Pacific Coast Agent. JOHN T. ROWNTREE, 1075 Monadnock Bldg., San Francisco and 501 Equitable Savings Bank Bldg., Los Angeles

## W. H. BAGGE & SON, INC.

BUILDING CONSTRUCTION

TELEPHONE KEARNY 4749  
ESTABLISHED 1889

3528 SACRAMENTO STREET  
SAN FRANCISCO, CAL.

No Modern Flat or Apartment House  
is Complete without—

RISCHMULLER'S IMPROVED LIQUID  
DOOR CHECK AND SPRING as well as  
RISCHMULLER'S PATENT DOOR OPENER  
and CLOSER.

HOME INDUSTRY  
Details on Application

**G. RISCHMULLER**  
BUILDERS' EXCHANGE  
San Francisco

842 37th St. - - OAKLAND

Phone Douglas 1763

## GRANT FEE

### GENERAL CONTRACTOR

Business Buildings and Heavy  
Construction a Specialty

Office:  
682 Monadnock Bldg. SAN FRANCISCO

Member of Builders' Exchange  
and Builders' Association

## D. ROSS CLARKE

### PLASTERING and CEMENT CONTRACTOR

Ornamental Plastering and Cement Plaster-  
ing or Reinforced Concrete a Specialty

EXTERIOR CEMENTING DONE  
IN WHITE OR CREAM COLOR

OFFICE:  
708 PACIFIC BUILDING

ESTABLISHED 1865

C. H. Franklin, Mgr. & Atty.

**THE FRANKFORT Marine Accident and Plate Glass  
INSURANCE COMPANY**  
OF FRANKFORT-ON-THE-MAIN, GERMANY  
INSURANCES TRANSACTED

United States Department, 100 William Street, New York

LIABILITY:—Employers, Public, Teams, General, Land-  
lords, Elevator, Vessel Owners, Contingent, Druggists and  
Physicians, Burglary, Workmen's Collective, Individual  
Accident and Health, Industrial Accident and Health.

TRUSTEES

RICHARD DELAFIELD, Pres. of National Park Bank.  
ERNST THALMANN, of Ladenburg, Thalmann & Co.  
STUYVESANT FISH, 52 Wall St., New York.

DAVID DUNCAN, General Agent, Pacific Coast Dep't.  
340 SANSOME STREET, SAN FRANCISCO, CAL.  
Agents wanted for unoccupied territory

## Esterly Construction Co.

Incorporated

CEMENT AND CONCRETE  
CONTRACTORS

2136 CENTER STREET  
BERKELEY, CAL.

PHONE PACIFIC 1822

## WALLACE C. BOSWALL

CONTRACTOR AND SUPERIN-  
TENDENT OF CONSTRUCTION  
STORE AND SALOON FITTINGS

58 BOYCE STREET  
SAN FRANCISCO

JOBGING PROMPTLY WORK OF ALL KINDS  
ATTENDED TO DONE ON PERCENTAGE

H. W. HANLEY  
P. J. McCULLOCH

Phone Douglas 2446

## HANLEY & McCULLOCH

CONTRACTING PLASTERERS



378 MONADNOCK BUILDING  
SAN FRANCISCO, CALIFORNIA

**WE HAVE MOVED**  
**to 121 SECOND ST.**  
SAN FRANCISCO, CAL.

**CALIFORNIA PHOTO**  
**ENGRAVING COMPANY**  
PHONES—SUTTER 789; HOME, J 2705

## WHAT IS OUR EXPERIENCE WORTH TO YOU?

Experience combined with research work on concrete surfaces, has taught us many lessons in general about conditions and how to meet them. However, in the field work many conditions present themselves, which were peculiar and would never have shown in the chemical laboratory or research tests—but we were fortunate in being able to combat many of those peculiar conditions by our practical experience in the field, as well as through the courtesy and assistance of many engineers, architects, contractors and owners, who, while soliciting our aid, joined with us in solving these problems—we taking up the work under and with their general supervision.

The work proved interesting and instructive mutually, with the result that we found a field of opportunity opening up for us that was beyond our expectation; then with careful and honest deliberation we advanced the idea of including with our allied lines a department of **ADVANCED FINISHES**—which are the result of many years of work.

Among the many items listed under the **ADVANCED FINISHES**, is one—**LIQUID CEMENT**—that has proved its name, to be ideal to the external conditions existing on Concrete, Stucco and Plaster veneer surfaces. It has two factors, that of Decorating and that of Damp-proofing the surface—made in many natural colors of stone and cement—with “trimmers” or “toners.”

Its action upon the surface prevents chemical or mechanical disintegration, giving true uniformity, without disturbing the original texture, only evening and filling the pores, giving a sufficient hard wearing surface, because of its physical pigment, hydrating with the waterproof vehicle—giving cleavage with substantial bonding qualities.

It has been applied to brick structures with equal success.

The line includes damp-proofing and decorative materials, (all colors), suitable to all modern building construction, both internally and externally.

The vehicles and pigments are all especially chosen for their own peculiar mission, according to the particular functions which they are called to perform.

We are now distributing our third twenty-fifth thousand edition of our booklet and specifications—which can be obtained from our local agents, **WHITTIER COBURN COMPANY, SAN FRANCISCO** and **LOS ANGELES**.

Our Mr. Robert Cathart, Technologist of the Department of Advanced Finish, is at present in California, going over the problems peculiar to this Coast and would be glad to take up with you personally any conditions that you have to meet. Address, Stewart Hotel, San Francisco, Cal.

The solution of your problems in this line is the purpose of his visit in California.

**THE GLIDDEN VARNISH COMPANY,**  
Cleveland, Ohio.

## GOODYEAR'S FIRE PROTECTION

FOR OFFICE BUILDINGS, FACTORIES AND RESIDENCES



ESTIMATES FURNISHED

All Styles Swinging Hose Reels. "Eclipse" Swinging Hose Rack, with Goodyear Special Valve. Acme Fire Extinguishers, Approved and Labeled. Always Ready for Use. Rubber Matting, Mats, Rubber Tiling, etc. Eureka's Rubber Lined Cotton Hose and Unlined Linen Hose. Specify "Eureka's Best," "20th Century" or "Worthy" for an Underwriter's Approved Linen Fire Hose.



## GOODYEAR RUBBER CO.

R. H. PEASE, President

587-589-591 Market St.  
San Francisco

61-63-65-67 Fourth St.  
Portland, Oregon



Crusher House and Ore Conveyer, Goldfield Consolidated Mines Company.

## P. J. KNUDSEN COMPANY

214 Front St., San Francisco

SOLE AGENTS FOR

ASBESTOS PROTECTED METAL COMPANY

Canton, Massachusetts



## THE CHEAPEST REINFORCEMENT AND BEST

The superiority of the Kahn Trussed Bar has never been questioned, so that we can say "cheapest" and be understood. Considered strictly from a dollars-and-cents standpoint you are losing money by buying any other bar. Remember that in the Kahn Trussed Bar the shear members are formed from the flanges of the main bar which are ordinarily wasted,—that you save all of the expense of handling a large number of loose stirrups — that you secure absolute safety and strength against fire, shock or careless workmanship, — that rigid connection makes beams 20% stronger.

**INSIST ON RIGID CONNECTION OF SHEAR MEMBERS**



## KAHN TRUSSED BARS

Other Kahn System Products include:

**Hy-Rib**, a self-centering reinforcement for Roofs, Floors, Walls, Partitions and Ceilings; **Rib Metal**, for Conduits and Slabs; **Built-up Column Hooping**; **Cup-Bars**, Straight or Bent; **Rib Lath** and **Rib Studs**, for Plaster and Stucco; **United Steel Sash** for Fireproof Windows; **Trus-Con Products**, for Waterproofing and Finishing Concrete.

Write for catalogues or call upon one of the men listed below.

### Trussed Concrete Steel Company

689 Trussed Concrete Building, Detroit, Michigan

SAN FRANCISCO, Felix Kahn,  
304 Macdonough Building.

PORTLAND, ORE., J. A. Currey,  
1009 Board of Trade Building.

LOS ANGELES, J. E. Heber,  
703 Central Building.

SEATTLE, WASHINGTON,  
Arthur T. Nelson, 836 Henry Bldg.



## THE MOSAIC TILE CO.

OF ZANESVILLE, OHIO



No 1

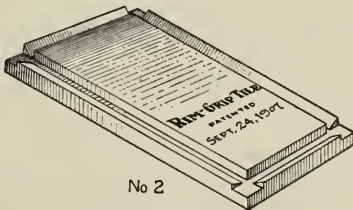

No 2

MANUFACTURERS OF

**Ceramic, Vitreous, Encaustic, Wall and Enamel Tile.**

Designs and Samples  
Furnished Architects  
Upon Application

A Large Stock is Carried at Our Pacific Coast Office and Warehouse

**230 8th STREET SAN FRANCISCO**

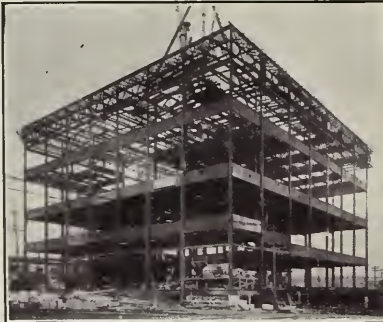

### One of our Buildings

Scottish Rite Temple, San Francisco.  
O'Brien & Werner, Architects

## STEEL

For this Building Furnished  
and Erected by

## DYER BROS.

Largest and Best Equipped  
Plant on the Pacific Coast

MAIN OFFICE AND WORKS

17th and Kansas Sts.

San Francisco, Cal.

Tel. Market 134 Home Phone M3933

**THOUSANDS IN USE IN LOS ANGELES!**

*ASK YOUR NEIGHBOR ABOUT THEM*

## IMPROVED CLIMAX SOLAR HEATER

**ABSOLUTELY RELIABLE**

WHY let the sunshine go to waste, and your money too, when at trifling expense you can put in your home an IMPROVED CLIMAX SOLAR HEATER that will furnish hot water from sunshine alone—winter and summer—for your bath, laundry, and all domestic purposes, without cost, damage or delay? It can be connected with the range, furnace or gas heater to insure hot water on rainy days, and when so connected saves the expense of a kitchen boiler. It insures a cool house during the hot season. Let us figure with you on your hot-water problem.

**SOLAR HEATER COMPANY**

342 New High St. - - - - - LOS ANGELES

## KEYSTONE BOILER WORKS

MAIN AND FOLSOM STREETS

SAN FRANCISCO, CAL.

PACIFIC COAST AGENTS FOR THE

## PARKER WATER TUBE BOILER

Self Cleaning      Absolute Safety      Greatest Economy

WRITE FOR CATALOGUE

# STANLEY'S BALL BEARING HINGES

In Wrought Bronze or Steel

Nothing else so good for Hanging Doors.

No wearing down, no creaking, no need of oiling

— For sale by —  
Hardware Dealers

Attractive Literature Free

**THE STANLEY WORKS**  
NEW BRITAIN, CONN.

# ARMSTRONG ELECTRIC SIGNALS

for Passenger and Freight Elevators

MECHANICAL FLOOR INDICATORS FOR ELEVATORS

Automatic Freight Door Operating Mechanism, Expressman Call System, Fire-proof Steel Curtains for Theatres.

## Elevator Supply and Repair Co.

GEO. A. MESICK.  
Pacific Coast Manager

BALBOA BLDG. SAN FRANCISCO

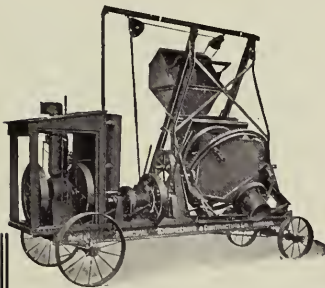

## Chicago Improved Cube Concrete Mixer

MANUFACTURED BY  
**MUNICIPAL ENGINEERING & CONTRACTING CO.**

Main Office, Railway Exchange,  
CHICAGO, ILL.

San Francisco Agents, Lansing Wheelbarrow Co., 789 Folsom St.

P. B. ENGH, 345 Pacific Electric Bldg., Los Angeles  
Special Sales Representative for Southern California

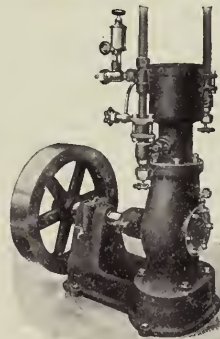

We build and install Ice Making and Refrigerating Machinery of any capacity

## Triumph Ice Machine Co.

H. F. LYON, Western Representative  
581 Monadnock Building, San Francisco.

F. O. ENGSTRUM, PRESIDENT  
F. E. ENGSTRUM, VICE-PRESIDENT

TELEPHONES :  
MAIN 3046-A-1969

H. W. BRYSON, MANAGER  
WM. MCKAY, SUPERINTENDENT

## F. O. ENGSTRUM COMPANY, Inc.

### CONTRACTORS

WHOLESALE DEALERS IN

LUMBER, BRICK, LIME, CEMENT, GLASS, SASH  
DOORS, PAINTS AND ELECTRICAL SUPPLIES

MAIN OFFICES, MILL, WAREHOUSE AND YARDS: EAST FIFTH AND SEATON STREETS, LOS ANGELES

K  
O  
M  
P  
O  
L  
I  
T  
E

## FLOORS WITHOUT FLAWS

A PERFECT FLOOR should have at least these four qualifications: It should be BEAUTIFUL and DURABLE, SANITARY and FIRE-PROOF. Those manufactured by the KOMPOLITE CO. have all these qualities, and at the same time many more which render them ideal for use in Hospitals, Churches, Factories, Steamships, Schools, Theatres, Public Buildings, Lofts, Garages, Private Houses, Etc.

TAKES AND HOLDS AN ORDINARY SCREW

FACTORIES:  
SAN FRANCISCO  
NEW YORK

OFFICES: 337 MILLS BLDG.  
SAN FRANCISCO  
132 NASSAU ST.  
NEW YORK

TELEPHONE: SUTTER 272

SANITARY  
FLOORS

## H. L. PETERSEN

### REINFORCED CONCRETE CONSTRUCTION

Artificial Stone Sidewalks, Concrete Walls,  
: : Foundations, Tanks, Reservoirs, Etc. : :

Rooms 322-24, 62 POST ST.

SAN FRANCISCO

## GEO. H. STOFFELS & CO.

### BUILDERS

830 PACIFIC BUILDING

SAN FRANCISCO, CAL.



—best by every test

THE Popularity of Pioneer Roofing is due to its wearing qualities. We want to go on record right here and now with the positive assertion that a "Pioneer Roof" will outlast two ordinary roofs. The first cost is little if any more than you would have to pay for roofing of inferior quality. And once a "Pioneer Roof" is on, there is no further cost. It requires no paint or repairs. Address Dept. 23.

**Booklet and Samples**

The Pioneer Paper Company has issued a 32 page Roofing Booklet, a copy of which, together with samples of Roofing, will be mailed upon request. Address Dept. 23.

**PIONEER PAPER COMPANY**

247-251 SO. LOS ANGELES ST., LOS ANGELES, CAL.

**GABRIEL MOULIN**

Maker of

**Photographs**

**FOR ADVERTISING AND  
COMMERCIAL PURPOSES**

**153 Kearny Street  
Wiley B. Allen Building  
San Francisco**

**Telephone Douglas 4969**



Art Glass Panel in Dunn's Cafe, San Francisco

From the Studio of

**THOMAS & SCHNEIDER  
ART GLASS CO.**

610-12 Howard Street San Francisco



Artificial Stone as Granite, Sandstone,  
Marble. Special Capitals in Classic  
and Modern Designs

**Architectural Decorating Co.**

F. J. HAHN, Manager

1255 FIRST AVENUE SOUTH,  
SEATTLE, WASHINGTON

Manufacturers of

**ARTISTIC RELIEF DECORATIONS**

For Exterior and Interior Use  
Thousands of Different Models in Stock

**Waterhouse & Price Co.**

SAN FRANCISCO  
OAKLAND LOS ANGELES SEATTLE PORTLAND



## BEXHILL WINDOWS

Used Exclusively  
in this Building

BEXHILL Patent Casement Windows are weather proof and will not rattle. No Racks, Wheels, Pulleys or Cords. Can be adjusted to any position and firmly locked.



SAUNDERS BUILDING SAN FRANCISCO

## BEXHILL CASEMENT CO.

MILLS BUILDING, SAN FRANCISCO

## DODD'S INTERLOCKING BLOCKS USED IN THIS BUILDING

*A*  
*Fire Proof*  
*Germ Proof*  
*and Inexpensive*  
*Partition*  
*Will not Warp*  
*Make an Absolutely*  
*True Surface*

INVESTIGATE

### BOYD & MOORE

SALES AGENTS

356 Market St. San Francisco



Sheldon Bldg., San Francisco. R. G. McDougall, Architect



*A. L. Haley, Architect.*

*Higgings Building, Los Angeles.*

*A. C. Martin, Engineer.*

*A. Barman, Contractor.*

# Imperial Waterproofing

Used on this Reinforced Concrete Store and Office Building

## A Strictly Chemical Solution

**“ABSOLUTELY DAMP-PROOF”**

for Brick, Concrete and Exterior Plastered Building

MANUFACTURED BY

**K. C. T. Waterproofing Co., Inc.**

**SUCCESSORS TO BAKER BROS.**

**Builders Exchange Building  
San Francisco**

**BRAUN-CHEMICAL CO.**  
906-10 E. Third St., Los Angeles

**W. O. STAMPS**  
Portland, Ore.

DOUBLE  
DAILY  
SERVICE

ON THE

SUNSET  
ROUTE

Between San Francisco, Los Angeles, New Orleans and East via the Road of a Thousand Wonders, Southern California Orange Groves and El Paso with its Mexico border scenes.

SOUTHERN  
PACIFIC

TICKET OFFICES:

Flood Building, Palace Hotel,  
Market Street Ferry Depot,  
Third & Townsend Sts. Depot,  
Broadway & 13th St., Oakland.

## METAL CORNER BEAD

THE HANNON Metal Corner Bead is acknowledged by Architects to be the **STRONGEST, MOST DURABLE** and **BEST GALVANIZED** beading on the market.

Made from one piece of metal — folded edge — naturally straight — easy to erect.

Shaped like a corner, it fits snugly to the wall — no weakening space between wall and bead.

**DOUBLY** (hot-process) **GALVANIZED** — before and after forming — **CANNOT RUST**. We originated the “**never rust**” metal corners. Others imitate — **BUT** they fail to obtain the brightness, the richness of our galvanizing. They lack the **KNOW HOW**.

**UNION METAL CORNER CO.**

MANUFACTURERS, BOSTON

**WATERHOUSE & PRICE CO.**

SAN FRANCISCO. OAKLAND  
LOS ANGELES. PORTLAND

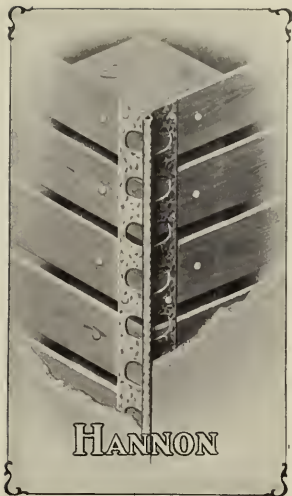

This is The BEAD To Specify

## *Ferrocinclave* The IDEAL CONSTRUCTION

For ROOFS, SIDE WALLS, ARCH and FLAT FLOORS, STAIRWAYS, PARTITIONS, TANKS, SILOS Economical, Light, Fireproof, Great Strength, Simple in Construction. Requires no Centering, Permanent



Ferrocinclave roof and floors. Power House, Great Western Power Co., California

**The BROWN HOISTING MACHINERY CO.,** Cleveland, O.  
Ferrocinclave Agent for California, CHAS. A. LEVY, 244 Balboa Building, San Francisco

When writing to Advertisers mention this Magazine.

MYRON HUNT &  
ELMER GREY  
Architects  
Los Angeles



Stained with  
Cabot's  
Shingle Stain

## CABOT'S CREOSOTE SHINGLE STAINS

THE ORIGINAL AND STANDARD STAINS

Distinguishable by their soft depth and freshness of color, richness of tone, and durability. No muddy or greasy effects, no blackening, no washing off. They have stood the test more than twenty-five years.

Cabot's Sheathing and Deafening "Quilt." Cabot's Waterproof Cement Stains. Conservo Wood Preservative. Cabot's Waterproof Brick Stains.

**Samuel Cabot, Inc., Sole Manufacturers, Boston, Mass.**

Agents { Waterhouse & Price Co., San Francisco and Oakland, Cal.  
P. H. Mathews Paint House, Los Angeles  
Timms, Cress & Co., Portland, Oregon  
S. W. R. Daily, Seattle, Tacoma and Spokane

## DAMP PROOF YOUR BRICK AND CONCRETE WALLS

**FIRE PROOF**

USE



## LIQUID STONE

It will keep walls Dry and Insure a Water Tight Structure. Liquid Stone is a Paint made from Stone and applied to the surface with an ordinary Paint Brush.

Used on the Walls of the San Francisco Y. M. C. A. Building, MacDougall Bros., Architects.

**WATER PROOF**

## THE LIQUID STONE PAINT CO., Inc.

MAIN OFFICE, 308 CHRONICLE BLDG.  
PHONE DOUGLAS 286

LAIRD & SINCLAIR AND LILLEY & THURSTON CO.  
AGENTS  
SAN FRANCISCO, CAL.



H. M. SCARRITT

W. A. CLARK

# SCARRITT & CLARK

## General Contractors

**Reinforced Concrete Construction**

Foundations, Retaining Walls, Cement Walks and Floors  
Dealers in Crushed Brick

OFFICE, YARD AND BUNKERS:

**TURK AND JONES STREETS**

**TELEPHONE FRANKLIN 1804**



### Murphy Concealed Wall Bed

Send for Circular

**MURPHY MANUFACTURING CO.**

919 O'Farrell Street      San Francisco, Cal.

## PURITAN BRAND SASH CORD



Did you ever think of the trouble you have in raising and lowering some windows? Generally defective sash cord is the answer. Insist on

## PURITAN BRAND SASH CORD

and have your windows raise and lower as if they were ball bearing.

## PURITAN CORDAGE MILLS

Incorporated

LOUISVILLE, KY.

P. J. KNUDSEN CO., Agents, 214 Front Street, S. F.

When writing to Advertisers mention this Magazine.



Interior of Banking Room, London Paris National Bank, San Francisco  
Albert Pissis Architect

Plain and Ornamental  
**PLASTER Work**

BY

**Callaghan  
& Manetta**

334 Tenth Street

**SAN FRANCISCO, CAL.**

## CALIFORNIA SCAGLIOLA CO

WE GUARANTEE  
ALL OUR HIGH  
GRADE IMPORTED  
MARBLE IMITATIONS  
TO BE PERFECT  
WITH THE VERY  
FINEST EVER-  
LASTING  
FRENCH  
POLISH.

OFFICE & YARD  
**68-70 CLARA STREET**  
BETWEEN 3<sup>RD</sup> & 4<sup>TH</sup> STREETS  
**SAN FRANCISCO, CAL.**

THE MOST  
ELEGANT  
INTERIOR  
ARTISTIC MARBLE  
DECORATIONS  
ALL COLORS  
LOWEST PRICES  
SAMPLES ESTIMATES  
CHEERFULLY  
FURNISHED

Produced in Caen Stone

Expert in the manufacture of Caen Stone and Graphite; also Fire and Waterproof Composition for the exterior of all kinds of frame buildings, etc. (Patent applied for.) Also the Menzer Interlocking Fire-proof Partition Wall Block

## C. MENZER & SON

DESIGNERS AND ARCHITECTURAL SCULPTORS
862 HOWARD ST., SAN FRANCISCO

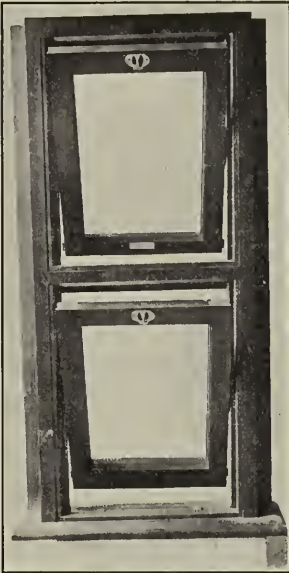

Double Hung Reversible Window,  
Style "A" Fixtures.

Manufactured by

## Tabor Sash Fixture Co.

TABOR Patent Strip and  
Fixtures for all types of  
Revolving, Reversible, Re-  
movable, Horizontal and  
Vertical Pivoted Sash, Case-  
ment Sash and Transoms.

### Boyd & Moore

Sole Agents for Northern California

356 MARKET STREET  
SAN FRANCISCO

Telephone Kearny 2386

## THE BRADSHAW SANITARY GARBAGE CHUTE PATENTED

Absolutely sanitary, odorless, germ, fly, and rat proof. Labor and Cost in disposing of garbage reduced to a minimum. Particularly designed for apartment houses, flats, hospitals, hotels and residences.

### First Cost the Only Cost

THE BRADSHAW SANITARY GARBAGE CHUTE can be applied to old as well as new buildings. It extends from basement to roof and is thoroughly ventilated. As the door is opened to receive the garbage an automatic sprinkler thoroughly flushes the chute. The

garbage can has a wire screen bottom allowing the water to percolate through to the cess-pool where it is trapped to the sewer. It is hermetically sealed, thus preventing all dust and odors and shutting off any food supply for rats or domestic animals. This system reduces to a minimum or entirely eliminates janitor service now required for the disposal of garbage. The chute is made of heavy galvanized sheet metal and iron castings. It is installed complete ready to

connect to sewer and service pipes, and is guaranteed. The mechanical arrangements are so simple as to be absolutely fool-proof and out of the reach of small children. A complete chute is in full operation at our office, 524-26 Pine St.

Our chute can be installed at a very moderate price and **THE FIRST COST IS THE ONLY COST.** No expense for maintenance or wear and tear after it is in operation.

For full particulars prices, etc., address

**BILL & JACOBSEN,**  
524-26 Pine Street,  
San Francisco, Cal.

Phones  
Kearny 1790  
Home C 6603

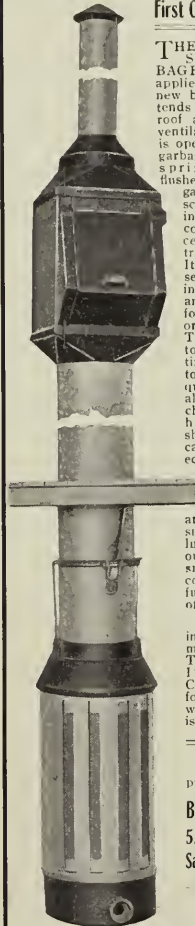

*Kawneer System*  
of Store Fronts

## Store Fronts that "Make Good"

The Kawneer System of Store Fronts is the original solid, all-metal store front construction, and from the first has met with universal approval, not only by merchants and owners of store buildings, but by technical men as well. You will approve of and use the Kawneer System if you are shown the many characteristic features that have made it so popular.

Kawneer Fronts are the faces of prosperous stores — they are good fronts and do the work intended for them.

### SIMPLE TO INSTALL

Kawneer System of Store Fronts can be found in every nook and corner of the country and in order to be a success must be simple in construction and easy to install, because we often depend upon carpenters of very ordinary ability to successfully install Kawneer Material. 2,832,940 lineal feet of Kawneer Material installed in 1910. What better proof could you want of its merits?

*Kawneer System*  
of Store Fronts

### 1911 BOOKLET No. 4 FOR YOU

We have compiled a booklet (No. 4) for technical men, and you will enjoy it. Send today and it will go forward by return mail. It contains a plain description of the Kawneer System, plenty of photographic cuts and good points of store fronts in general.

## KAWNEER MANUFACTURING CO.

Branch Offices in  
all large cities

Factory and general offices,  
NILES, MICHIGAN

*Kawneer System*  
of Store Fronts

## Architects! Contractors!

**WE** are trying to introduce **DES MOINES ELATERITE** products, using a new base for paints — which gives results that cannot be obtained with any other base. *Give it a trial.* We know we can satisfy you. If you have any special conditions to meet for Waterproofing, Acid or Alkali, Climate on *any kind* of a surface, send for us. We have special mixtures for each. Also plaster bond, marine and heat resisting paints.

**SPECIFY** Lupton Steel Sash steel and copper Skylight, and Fireproof windows, for the BEST construction. We want *inquiries* from *Contractors* for steel and Reinforcing Materials, Steel Ceiling and special paints, also for *any kind of machinery.* You will find it to your advantage to get my prices.

I have the Cheapest and Best Rock and Ore Crusher on the market, and also Oil Burning Apparatus, and the Best Bar Bender made.

**S. A. WHITE** 375 MONADNOCK BLDG.  
SAN FRANCISCO  
Phone, Sutter 1575

# THE ARCHITECT & ENGINEER

OF CALIFORNIA  
PACIFIC COAST STATES



Published by **THE ARCHITECT & ENGINEER CO.**  
25c a Copy  
\$1.50 a Year

Entered at the Post Office, San Francisco, as second class matter

621 Monadnock Bld  
San Francisco  
Vol. XXIV. No.

1006 APRIL 1911



FLOORS

NOTE CONTINUOUS BOND

ROOFS

SIDE WALKS

# CLINTON

## FIRE-PROOFING SYSTEM

FABRIC WIRE LATH

Ceilings

Partitions

CLINTON FIREPROOFING  
OF CALIFORNIA  
CONTRACTORS FOR  
FIREPROOFING

L. A. NORRIS CO.  
WESTERN SALES AGENTS  
FOR CLINTON FIRE-  
PROOFING MATERIALS

SEATTLE                      SAN FRANCISCO                      LOS ANGELES

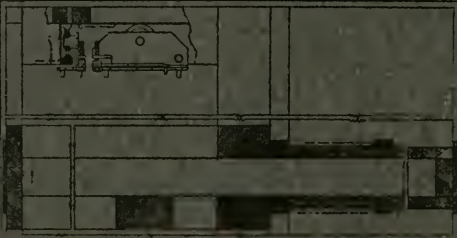

**THIS HANGER**  
CAN be put in 3 $\frac{3}{4}$ " parti-  
tion, a great saving of  
space and 50 per cent of  
labor and material.  
Specified by All Leading  
Architects.  
The new patent hanger  
with double track, upper and  
lower, which cannot bind in  
any way, with side adjust-  
ment.

## Pacific Ballbearing Door Hanger Co.

Phone Kearny 1039
959-961 Howard St., San Francisco



Metal Spanish Tile

## MEURER BROS. CO.

### METAL SPANISH TILE

TIFFANY PATTERN. A perfect and hand-  
some Roof Covering. The only tile that  
gives the effect of Lights and Shadows.  
'Tis absolutely water-tight. Used on all  
the schools in San Jose.

---

**A. H. McDONALD,**  
Office and Warehouse

PACIFIC COAST  
MANAGER

630 THIRD STREET
SAN FRANCISCO

San Francisco, April 20, 1911.

MR. READER,

Any City, Pacific Coast.

Dear Sir: — If you will take the time to visit the Foundry and Machine Shop of the VAN EMON ELEVATOR COMPANY at West Berkeley, California, you will see with your own eyes every part of the elevator machine being cast and fashioned by California workmen.

You will then be convinced that the only thing for you to do is to give your elevator contract to us, as against our competitors who assemble Eastern made apparatus.

Of course it is understood that we will guarantee the quality and efficiency of all our work.

Yours very truly,

VAN EMON ELEVATOR CO.

# CONCRETE APPLIANCES COMPANY

LICENSORS OF

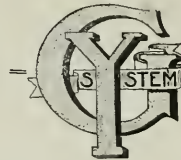

OF CONVEYING AND  
DISTRIBUTING  
CONCRETE

LOS ANGELES

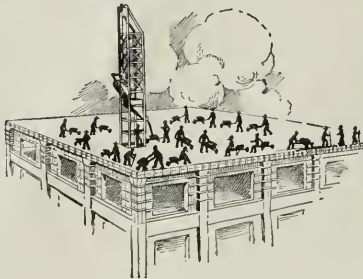

THE OLD WAY

- 1—COST TO WHEELBARROW OR CART CONCRETE, \$1 TO \$1.75 PER YARD.
- 2—SLOW AND CONGESTED, 8 TO 10 YARDS PER HOUR.
- 3—LOSS OF INITIAL SET, VARIABLE MULTILITHIC CONSTRUCTION.
- 4—CAUSES SEPARATION. AIDS LA TENGE.
- 5—DAMAGES FLOOR TILE, DISPLACES STEEL AND SPILLS CONCRETE.
- 6—EXPENSIVE SCAFFOLDING, RUNWAYS AND STAGING.
- 7—TAMPING

Some Buildings on Pacific Coast now  
being constructed by the

## Gravity System:

WILSON BUILDING, San Francisco, Cal.

FERGUSON BUILDING, Los Angeles

UNION LEAGUE BUILDING, Los Angeles

COLUMBIA HOSPITAL BUILDING,  
Los Angeles

EXPOSITION BUILDING FOR THE STATE  
AGRICULTURAL PARK, Los Angeles

SWEETWATER DAM, San Diego, Cal.

EDISON ELECTRIC CO., 3 Warehouses,  
Long Beach

SPRECKELS THEATRE AND OFFICE BLDG.,  
San Diego.

Patent Nos.

948719

948723

948746

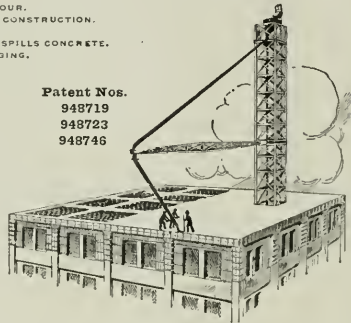

THE NEW WAY

- 1—COST FOR DELIVERING CONCRETE, 28 TO 30 CENTS PER CUBIC YARD
- 2—RAPID AND EFFICIENT, 28 TO 40 CUBIC YARDS PER HOUR.
- 3—OBTAIN INITIAL SET, HOMOGENEOUS MONOLITHIC CONSTRUCTION.
- 4—UNIFORM CONCRETE OBVIATES LA TENGE.
- 5—NO LOSS OF FLOOR TILE, DISPLACEMENT OF STEEL OR SPILLING.
- 6—SAVES SCAFFOLDING, RUNWAYS AND STAGING.
- 7—NO TAMPING.

WILLIAM B. HOUGH COMPANY

EXCLUSIVE EASTERN AGENTS

HOME OFFICES

CHICAGO, ILL.

DETROIT

MINNEAPOLIS

ST. LOUIS

DES MOINES

INDIANAPOLIS

PACIFIC COAST REPRESENTATIVES

# PARROTT & COMPANY

SAN FRANCISCO  
SEATTLE

TACOMA  
SPOKANE

PORTLAND  
LOS ANGELES



**L**AY your Terra Cotta, Bricks, Stone Facings at any story and at any height with perfect Safety. Facing can be installed in one-half the time and the important work of Cleaning down the facing can also be accomplished in one-half the usual time.

**The Patent Scaffolding Company**  
**PARROTT & CO.**

San Francisco, Seattle, Los Angeles, Tacoma, Portland, Spokane



# Building Materials

*These Three Are Permanent  
and Beautiful*

“RENO WHITE” PLASTER, a product of the Western Gypsum Co. that is beautiful, hard and lasting.

DEL MONTE WHITE SAND, to be used with Medusa and other white cement to make a beautiful white stone finish on concrete and artificial stone buildings.

“MEDUSA WHITE PORTLAND CEMENT,” a new and beautiful product adapted to ornamental artificial stone work of the highest grade.

**F.T.CROWE & Co.**  
**Jobbers and Dealers**

SEATTLE, PORTLAND, TACOMA, SPOKANE.



# WATERPROOFING WISDOM



PERMANENCY

is shown by  
the use of



ECONOMY

# CERESIT

paste. Same is simply added to the water used in mixing concrete and mortar. With the water, the CERESIT paste penetrates to all parts of the concrete and mortar and assures a permanent water- and damp-proof job.

No expert help required; no scientific and expensive mixing.

CERESIT is not an experiment, but has been used with complete success on hundreds of tanks, pits, foundations, dams and bridges. It has been employed not only by the U. S. Government, but by practically every government in the civilized world. More than 5,000,000 cubic feet of concrete and mortar have been waterproofed with CERESIT in 1909. The use of CERESIT is complete assurance against the penetration of moisture or dampness, even under high pressure, as encountered in dam work, etc.

Ask for our free book. It is money in your pocket to know about this excellent material.

## CERESIT WATERPROOFING CO.

PACIFIC COAST REPRESENTATIVES

## PARROTT & CO.

SAN FRANCISCO LOS ANGELES PORTLAND

## JULIEN A. BECKER CO.

413 BAILEY BLDG., SEATTLE, WASH.

MAIN OFFICE, 446 COMMERCIAL NATIONAL BANK BLDG., CHICAGO, ILL.

# Medusa

White Portland Cement  
Water Proof Compound



CONCRETE SWIMMING TANK. UNIVERSITY OF CALIFORNIA BERKELEY, CAL.  
WATERPROOFED WITH MEDUSA COMPOUND

HIGH-TESTING  
STAINLESS



ABSOLUTELY PERMANENT  
RESULTS

The Building Material Co. INC.  
583 MONADNOCK BLDG, SAN FRANCISCO.

# ARCHITECTS' SPECIFICATION INDEX

(For Index to Advertisements, see page 117)

- ARCHITECTURAL AND ORNAMENTAL STEEL AND IRON WORK**  
 Western Iron Works, 141-147 Beale St., S. F.  
 Pacific Rolling Mills,  
 17th and Mississippi Sts., S. F.  
 Central Iron Works, 621 Florida St., S. F.
- ARCHITECTURAL MODELERS**  
 Callaghan & Manetta.....344 10th St., S. F.  
 C. Menzer & Son.....862 Howard St., S. F.
- ARCHITECTURAL TERRA COTTA**  
 Steiger Terra Cotta and Pottery Works,  
 Mills Bldg., S. F.  
 Gladding, McBean & Company,  
 Crocker Bldg., S. F.
- ASBESTOS-PROTECTED METAL**  
 P. J. Knudsen Company, Pacific Coast Agents,  
 214 Front St., S. F.
- AUTOMATIC FREIGHT ELEVATOR DOORS**  
 Boyd & Moore.....356 Market St., S. F.
- BANK FIXTURES**  
 J. A. M. Johnson...Monadnock Bldg., S. F.  
 C. F. Weber & Co., 365 Market St., San  
 Francisco and 210 N. Main St., Los  
 Angeles, Cal.  
 Weary & Alford Co.,  
 303 Union Trust Bldg., S. F.
- BANK INTERIORS**  
 Weary & Alford Co.,  
 303 Union Trust Bldg., S. F.
- BELTING, PACKING, ETC.**  
 H. N. Cook Belting Co.,  
 317-319 Howard St., S. F.  
 Goodyear Rubber Co....587 Market St., S. F.
- BLACKBOARDS**  
 Whitaker & Ray-Wiggin Co., 776 Mission St.,  
 S. F.; 209 E. Seventh St., Los Angeles.  
 C. F. Weber & Co.....365 Market St., S. F.
- BOILERS**  
 Simonds Machinery Co., 12 Natoma St., S. F.  
 Keystone Boiler Works....Folsom St., S. F.  
 Charles C. Moore & Company,  
 First and Mission Streets, S. F.
- BRICK AND CEMENT COATING**  
 Wadsworth Howland & Co., Inc. (See Adv.  
 for Pacific Coast Agents.)
- BRICK**  
 Gladding, McBean & Company,  
 Crocker Bldg., S. F.  
 Golden Gate Brick Co..660 Market St., S. F.  
 Diamond Brick Co.....Balboa Bldg., S. F.  
 Los Angeles Pressed Brick Co.,  
 Frost Bldg., Los Angeles  
 Northern Clay Company....Auburn, Wash.  
 Steiger Terra Cotta and Pottery Works,  
 Mills Bldg., S. F.  
 Vallejo Brick & Tile Co.,  
 Monadnock Bldg., S. F.
- BRICK STAINS**  
 Samuel Cabot Mfg. Co., Boston, Mass., agencies  
 in San Francisco, Oakland, Los Angeles,  
 Portland, Tacoma and Spokane.
- BRIDGE CONTRACTORS**  
 San Francisco Bridge Co.,  
 Monadnock Bldg., S. F.
- BUILDERS' HARDWARE**  
 Reading Hardware sold by Brittain & Co.,  
 San Francisco  
 Russell & Erwin Mfg. Co.,  
 Commercial Bldg., S. F.
- BUILDERS' SUPPLIES**  
 Boyd & Moore.....356 Market St., S. F.  
 Waterhouse & Price.....59 Third St., S. F.
- CAPITALS, MOLDINGS, ETC.**  
 Western Builders' Supply Co.,  
 680 Mission St., S. F.
- CASEMENT WINDOWS**  
 The Bexhill Casement Window Co.,  
 Mills Bldg., S. F.
- CEMENT**  
 Blanc Stainless Cement Co., Allentown, Pa.  
 Standard Supply Co.,  
 First St. and Broadway, Oakland  
 Pacific Portland Cement Co....Pacific Bldg., S. F.  
 Western Building Material Co.,  
 430 California St., S. F.  
 The Building Material Co., "Medusa White  
 Portland".....587 Monadnock Bldg., S. F.  
 Boyd & Moore.....356 Market St., S. F.  
 Standard Portland Cement Co. and Santa Cruz  
 Portland Cement Co....Crocker Bldg., S. F.
- CEMENT AND PLASTER BLOCKS**  
 Dodds' Interlocking Block Company,  
 356 Market St., S. F.
- CEMENT AND PLASTER CONTRACTORS**  
 Callaghan & Manetta.....344 Tenth St., S. F.  
 D. Ross Clarke.....708 Pacific Bldg., S. F.  
 C. Menzer & Son.....862 Howard St., S. F.  
 A. Knowles.....985 Folsom St., S. F.
- CEMENT EXTERIOR WATERPROOF COATING**  
 "Blanc," manufactured by Blanc Stainless  
 Cement Company.....Allentown, Pa.  
 Protectorine, Black, White and Colorless,  
 Boyd & Moore.....356 Market St., S. F.  
 Bay State Brick and Cement Coating, made  
 by Wadsworth, Howland & Co. [See dis-  
 tributing agents on page 119.]
- CEMENT TESTS**  
 Robert W. Hunt & Co.,  
 418 Montgomery St., S. F.  
 Smith, Emery & Co....651 Howard St., S. F.
- CEMENT EXTERIOR FINISH**  
 Medusa White Portland Cement, California  
 Agents, The Building Material Co., Inc.,  
 587 Monadnock Bldg., S. F.  
 "La Farge" sold by Waterhouse & Price,  
 59 Third St., S. F.  
 Blanc Stainless Cement Co., Allentown, Pa.  
 [See color insert for Coast distributors.]  
 Bay State Brick and Cement Coating, made  
 by Wadsworth, Howland & Co. [See list  
 of distributing agents on page 119.]  
 Samuel Cabot Mfg. Co., Boston, Mass., agencies  
 in San Francisco, Oakland, Los Angeles,  
 Portland, Tacoma and Spokane.
- CEMENT FLOOR COATING**  
 Bay State Brick and Cement Coating, made  
 by Wadsworth, Howland & Co. [See list  
 of distributing agents on page 119.]
- CHEMICAL ENGINEERS**  
 Robert W. Hunt & Co.,  
 418 Montgomery St., S. F.  
 Smith, Emery & Co., 651 Howard St., S. F.

## A. L. YOUNG MACHINERY CO.

Hoisting Engines, Derricks, Concrete Mixers, Barrows and Carts,  
 Portable Saw Tables, Swing and Band Saws—in Stock

26-28 FREMONT STREET

SAN FRANCISCO, CAL.



HOME MARKET SAN FRANCISCO. CHAS. S. KAISER, ARCHITECT

## **RANSOME CONCRETE COMPANY**

### **BUILDERS**

**MECHANICS' INSTITUTE BUILDING, SAN FRANCISCO**  
**328 J STREET, SACRAMENTO**

Rust-resisting—Anti-corrosive



**Black and Galvanized Sheets**

will resist corrosion under conditions that destroy iron and steel. Durability, Ductility and Price considered it is the logical material for roofing, siding and all formed products.

*Write for Samples Prices and "Corrosion Text Book"*

CARRIED IN STOCK IN SAN FRANCISCO BY

**The Berger Manufacturing Company**  
**OF CALIFORNIA**

1120-22-24-26 Mission Street  
 San Francisco, Cal.

320 San Fernando Building  
 Los Angeles, Cal.



# WE MAKE BLUE PRINTS

DAY OR NIGHT-RAIN OR SHINE

**EUGENE DIETZGEN CO.,** 18 FIRST STREET  
SAN FRANCISCO

Architects' Supplies      Surveying Instruments

## ARCHITECTS' SPECIFICATION INDEX—Continued

### COLD STORAGE INSULATION

Neponset Waterdyke Felt and Compound, manufactured by F. W. Bird & Son, East Walpole, Mass.; sold by Parrott & Co., 320 California St., S. F.

### CONCRETE APPLIANCES

A. L. Young Machinery Co., 26 Fremont St., S. F.

### CONCRETE CONSTRUCTION

Peterson, Nelson & Co., Inc., 407 Pine St., S. F.  
A. Lynch & Co., 185 Stevenson St., S. F.  
Esterly Construction Co., Berkeley, Cal.  
Bluxome & Co., Monadnock Bldg., S. F.

### CONCRETE FOUNDATIONS

Peterson, Nelson & Company, Russ Bldg., S. F.

### CONCRETE MIXERS

Foot Concrete Mixers, Monadnock Bldg., S. F.  
Coltrin Concrete Mixers, N. J. Morehouse, Western Agent, Waterloo, Iowa; J. L. Mery Eng. Co., Monadnock Bldg., S. F.; V. W. Mason, St. Johns, Ore.  
F. T. Crowe & Co., Seattle, Tacoma, Spokane and Portland  
Chicago Improved Cube Mixer, Pacific Coast Offices, 789 Folsom St., S. F., and F. T. Crowe & Co., Portland and Seattle  
A. L. Young Machinery Company, 26 Fremont St., S. F.

### CONCRETE POURING APPARATUS

Concrete Appliances Co., Los Angeles; Parrott & Co., Coast Representatives, San Francisco, Portland, Seattle

### CONCRETE REINFORCEMENT

The Kahn System, Agents in San Francisco, Los Angeles, Portland and Seattle.  
Clinton Fireproofing System, L. A. Norris, Monadnock Bldg., S. F.  
Corrugated Bars sold by John B. Leonard, C. E. Sheldon Bldg., S. F.  
International Fabric & Cable, represented by Western Builders' Supply Co., 680 Mission St., S. F.  
Twisted Bars sold by Woods & Huddart, 356 Market St., S. F.  
Plain and Twisted Bars, sold by Baker & Hamilton, San Francisco, Los Angeles and Sacramento.

### CONCRETE SURFACING

"Concreta" sold by W. P. Fuller & Co., S. F.  
"Alkacene" Liquid Concrete—Boyd & Moore, 356 Market St., S. F.

### CONCRETE SURFACING—Continued

Concreto, Worden-Meeker Varnish Co., S. F.—Oakland  
Glidden Liquid Cement, manufactured by Glidden Varnish Company, Whittier, Coburn Co., San Francisco and Los Angeles, Pacific Coast Distributors.

### CONTRACTORS, GENERAL

E. D. Crowley Co., Monadnock Bldg., S. F.  
W. H. Bagge & Son, Inc., 3528 Sacramento St., S. F.  
Esterly Construction Co., Berkeley, Cal.  
F. O. Engstrum Co., Fifth and Seaton Sts., Los Angeles  
Hansen & Johnson, Inc., 3 Mission St., S. F.  
Henning & Burke, 242 Russ Bldg., S. F.  
Walter Hough Company, 503 Market St., S. F.  
Hoyt Bros., Builders' Exchange, S. F., and Santa Rosa Ransome Concrete Co., Mechanics Institute Bldg., S. F.  
Rickon-Ehrhart Eng. & Const. Co., 1859 Geary St., S. F.  
Scarritt & Clark, Turk and Jones Sts., S. F.  
Geo. H. Stoffels & Co., 830 Pacific Bldg., S. F.  
Williams Bros. & Henderson, 351 Monadnock Bldg., S. F.

### CONCRETE MACHINERY

Wallace Concrete Machinery Co., represented by The Lilley & Thurston Co., 82 2nd St., S. F.

### CONCRETE REINFORCEMENT

Triangle Mesh Fabric, Sales Agents, The Lilley & Thurston Co., 82 2nd St., S. F.

### CORNER BEAD

"Prescott" sold by Boyd & Moore, 356 Market St., S. F.  
Union Metal Corner Company, 206 Summer St., Boston, represented on the Pacific Coast by Waterhouse & Price.

### CRUSHED ROCK

Natomas Consolidated of California, 203 Hagelstein Bldg., Sacramento, Cal.  
Niles Rock, sold by California Building Material Company, Pacific Building, S. F.

### DAMP-PROOFING COMPOUND

John L. Fox, 207 Monadnock Bldg.  
Liquid Stone Paint Co., Inc., Laird & Sinclair and Lilley & Thurston Co., Agts., S. F.  
Boyd & Moore, 356 Market St., S. F.  
"Pabco" Damp Proofing Compound sold by Paraffine Paint Co., 38 First St., S. F.  
H. D. Samuel Co., Monadnock Bldg., S. F.  
"Protectorine" Compound, sold by Boyd & Moore, 356 Market St., S. F.  
Parrott & Co., agents for Genasco Positive Seal Damp Proof Paint.

Specify...

For Plastering

**HOLMES DIAMOND SANTA CRUZ LIME**

PHONE KEARNY 2220

Guaranteed Against Pitting or Popping

The Holmes Lime Co.,

Monadnock Bldg., San Francisco

When writing to Advertisers mention this Magazine.



## ARCHITECTS' SPECIFICATION INDEX—Continued

- DAMP PROOF PAINTS**  
John L. Fox.....207 Monadnock Bldg., S. F.
- DAMP PROOFING FOR BRICK WALLS**  
"Imperial" Waterproofing, sold by Baker Bros., San Francisco; Braun Chemical Co., Los Angeles; W. O. Stamps, Portland, and B. W. Gaisford, Seattle, Wash.  
John L. Fox.....207 Monadnock Bldg., S. F.
- DISAPPEARING BEDS**  
Holmes Disappearing Bed Company,  
687 Monadnock Bldg., S. F.
- DOOR OPENER**  
G. Rischmuller.....Builders' Ex., S. F.  
842 37th St., Oakland
- DOOR HANGERS**  
Johns Door Hanger Manufacturing Company,  
812-838 Folsom street, S. F.  
Pacific Ballbearing Door Hanger Co.,  
959 Howard St., S. F.  
Pitcher Hanger, sold by Pacific Tank Company.....231 Berry St., S. F.  
Reliance Hanger, sold by Sartorius Co., S. F.; D. F. Fryer & Co., Louis R. Bedell, Los Angeles, and Portland Wire & Iron Works.
- DOORS—FREIGHT ELEVATOR**  
"Cross" Counterbalance Automatic, Boyd & Moore, Agents.....356 Market St., S. F.
- DOORS—WAREHOUSE**  
"Cross" Horizontal Folding Doors, Boyd & Moore, Agents.....356 Market St., S. F.
- DUMB WAITERS**  
Energy Dumb Waiters, Boyd & Moore, Agents.....356 Market St., S. F.  
Wells & Spencer Machine Company,  
173 Beale St., S. F.
- ELECTRICAL CONTRACTORS**  
Electric Appliance Co., 726 Mission St., S. F.  
The Turner Co., 278 Natoma St., S. F.  
Central Electric Co., 185 Stevenson St., S. F.  
Butte Engineering Co., 683 Howard St., S. F.  
Jno. G. Sutton Co., 229 Minna St., S. F.  
Pacific Fire Extinguisher Company,  
507 Montgomery St., S. F.
- ELEVATORS**  
Van Emon Elevator Co., 54 Natoma St., S. F.  
Wells & Spencer Machine Co.,  
173 Beale St., S. F.  
Otis Elevator Company,  
Stockton and North Point, S. F.
- ELEVATOR CARS**  
Cleveland Art Metal Co., Boyd & Moore, Agents.....356 Market St., S. F.
- ELEVATORS, SIGNALS, FLASHLIGHTS AND DIAL INDICATORS**  
Elevator Supply & Repair Co.,  
593 Market St., S. F.
- ENGINEERS**  
John B. Leonard.....Seldon Bldg., S. F.  
W. W. Breite.....Clunie Bldg., S. F.  
F. J. Amweg.....700 Marston Bldg., S. F.
- EXPRESS CALL SYSTEM**  
Elevator Supply & Repair Co.,  
593 Market St., S. F.

Highest Awards Grand Medal Paris 1900  
Exclusive Designs  
Finest Workmanship

## United Glass Works

INCORPORATED

H. R. HOPPS, PRESIDENT

### Art Stained Glass

TELEPHONES

FRANKLIN 1763 HOME J 1763

115 Turk Street

San Francisco

#### FIRE EXTINGUISHERS

Goodyear Rubber Company,  
587-591 Market St., S. F.  
Pacific Fire Extinguisher Co.,  
507 Montgomery St., S. F.

#### FIREPROOF PARTITIONS

Dodds' Interlocking Block Co.,  
356 Market St., S. F.

#### FIREPROOFING

Gladding, McBean & Company,  
Crocker Bldg., S. F.  
Roebling Construction Co., Crocker Bldg., S. F.

#### FIRE PROTECTION

Goodyear Rubber Company,  
587-589 Market St., S. F.

#### FIRE PROTECTION—SPRINKLER SYSTEM

Jno. G. Sutton Co., 229 Mission St., S. F.  
Pacific Fire Extinguisher Company, 507 Montgomery St., San Francisco; Branch Offices, Portland, Seattle and Spokane.

#### FLOOR VARNISH

Bass-Hueter and S. F. Pioneer Varnish Works,  
816 Mission St., S. F.  
Standard Varnish Works,  
Chicago, New York and S. F.  
Worden-Meeker Varnish Co., S. F.—Oakland

#### FLOORS—COMPOSITION AND TILE

"Kompolite".....350 Mills Bldg., S. F.

#### FOUNDATION CONTRACTORS

Locke Foundation Company,  
1107 Crocker Bldg., S. F.

#### GARAGE EQUIPMENT

Bowser Gasoline Tanks and Outfit, S. F.  
Bowser & Co., 612 Howard St., S. F.

*Specify a  
California  
Marble...*

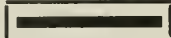

## "PORTOLA"

A DELICATE BUFF BEAUTIFULLY MARKED  
THE THING FOR BANK INTERIORS, VESTIBULES AND  
HOTEL CORRIDORS - SAMPLES ON APPLICATION

**THE COLUMBIA MARBLE CO.**

268 MARKET ST., SAN FRANCISCO

QUARRIES  
COLUMBIA, CALIFORNIA

FINISHING PLANT  
17TH & MISSOURI STS., SAN FRANCISCO

# SAN FRANCISCO BRIDGE COMPANY

INCORPORATED 1884

## ENGINEERS AND CONTRACTORS

Dredging, Pile Driving, Wharves, Piers  
Foundations, Breakwaters, Rock Work  
Concrete, Pipe Lines, Sewers, Bridges  
Steel Work

865 Monadnock Building  
San Francisco, Cal.

Agents for C. W. Hunt Company's Labor Saving Devices  
and Ambursen Hydraulic Construction Company's Dams

### ARCHITECTS' SPECIFICATION INDEX—Continued

#### GARBAGE CHUTES

Bradshaw Garbage Chute, sold by C. T. Jacobson.....524 Pine St., S. F.

#### GLASS—PRISM, ART, ETC.

Thomas & Schneider Art Glass Co.,  
610 Howard St., S. F.  
California Art Glass Works,  
768 Mission St., S. F.  
United Glass Co.....115 Turk St., S. F.

#### GRAVEL, SAND AND CRUSHED ROCK

Bay Development Co.....153 Berry St., S. F.  
California Bldg., Material Co.,  
Pacific Bldg., S. F.  
Grant Gravel Co.....87 Third St., S. F.  
Del Monte White Sand, sold by Pacific Improvement Co.....Crocker Bldg., S. F.  
Natamas Consolidated,  
Peoples' Savings Bank Bldg., Sacramento

#### HARDWOOD FLOORING

Bowl & Moore.....356 Market St., S. F.  
Dieckmann Hardwood Co.,  
244 California St., S. F.  
Parrott & Co.....320 California St., S. F.  
White Bros., Cor. Fifth and Brannan Sts., S. F.

#### HARDWOOD LUMBER

Dieckmann Hardwood Co., Welch Bldg., S. F.  
Niehaus & Co.....548 Brannan St., S. F.  
Strable Mfg. Co.,  
First St., betw. Washington & Clay, Oakland  
White Bros.,  
Cor. Fifth and Brannan Sts., S. F.  
Parrott & Co.....320 California St., S. F.

#### HARD WALL PLASTER

Standard Supply Company,  
First St. and Broadway, Oakland  
Reno Hard Wall Plaster, sold by Western  
Building Material Co.,  
430 California St., S. F.  
Empire Hard Wall Plaster Co.,  
Pacific Bldg., S. F.

#### HARDWOOD PANELS

White Bros., Cor. Fifth and Brannan Sts., S. F.  
Niehaus & Co.....548 Brannan St., S. F.

#### HEATERS—AUTOMATIC

Hart Heater Co., State Savings Bank Bldg.,  
13th and Franklin Sts., Oakland  
Hoffman Heater, sold by Holbrook, Merrill  
& Stetson, San Francisco and Los Angeles.  
Humphrey Co.,  
565 N. Rose St., Kalamazoo, Mich.  
Pittsburg Water Heater sold by Thos. Thibben  
& Co.....585 Mission St., S. F.

#### HEATING AND VENTILATING

The Turner Co.....278 Natoma St., S. F.  
Machinery and Electrical Co.,  
351-353 N. Main St., Los Angeles  
Pacific Fire Extinguisher Company,  
507 Montgomery St., S. F.  
Mangrum & Otter, Inc., 507 Mission St., S. F.  
Gilley-Schmid Co., Inc.,  
Thirteenth and Mission Sts., S. F.  
Jno. G. Sutton Co.....229 Minna St., S. F.  
Pacific Blower & Heating Co.,  
17th St., betw. Mission and Valencia, S. F.  
Geo. W. Schmitt Heating and Ventilating  
Co.....1160 Webster St., Oakland

TELEPHONE } MISSION 139  
                  } MISSION 59

HOME PHONE M 1841

A. A. DEVOTO, PRESIDENT



OFFICE AND WORKS:  
621-651 FLORIDA ST.

BETWEEN HARRISON AND BRYANT, 18TH AND 19TH  
SAN FRANCISCO, CALIF.

# WELLS AND SPENCER MACHINE CO.

F. M. SPENCER, SUCCESSOR

173-177 BEALE ST., SAN FRANCISCO

REPRESENTING

## WESTERN ELEVATOR COMPANY

REPAIRS, INSPECTIONS AND DUMB WAITERS

TELEPHONES: KEARNY 664  
HOME J 1124

### ARCHITECTS' SPECIFICATION INDEX—Continued

#### HINGES

Stanley's Ball-Bearing Hinges, Stanley Co.,  
New Britain, Conn.

#### ICE MAKING MACHINES

Triumph Ice Machine Co., H. F. Lyon, Agent,  
581 Monadnock Bldg., S. F.

#### INSPECTIONS AND TESTS

Robert W. Hunt & Co.,  
418 Montgomery St., S. F.  
Smith, Emery & Co., Inc.,  
651 Howard St., S. F.

#### INSURANCE

David Duncan ..... 340 Sansome St., S. F.

#### INTERIOR DECORATING

L. Tozer & Son Co., 228 Grant Ave., S. F.  
Sehastey & Vollmer., 1930 Van Ness Ave., S. F.  
Richard Arenz Co.,  
335 East Fourth St., Los Angeles  
A. C. Wocker.....1370 Sutter St., S. F.

#### JOIST HANGERS

Western Builders' Supply Co.,  
680 Mission St., S. F.

#### KITCHEN EQUIPMENT

John G. Iis &amp; Co.....827 Mission St., S. F.

#### LIME

Standard Supply Co.,  
First St. and Broadway, Oakland  
Holmes Lime Company,  
Mutual Savings Bank Bldg., S. F.  
Western Lime & Cement Co.,  
268 Market St., S. F.

#### LIGHTING FIXTURES

Adams & Holoopeter....745 Mission St., S. F.  
I. F. Kelly Company, 723 7th St., Oakland  
The Palmer Shop, 1345 Sutter Street S. F.

#### LOCKERS—METAL

Hart & Cooley Co., Boyd & Moore, Agents,  
356 Market St., S. F.

#### LUMBER

Columbia Lumber Co.,  
Portuguese-American Bank Bldg., S. F.  
Santa Fe Lumber Co.,  
Seventeenth and De Haro Sts., S. F.

#### MACHINERY AND MACHINERY SUPPLIES

Machinery and Electrical Co.,  
351 N. Main St., Los Angeles  
A. L. Young Machinery Company,  
26 Fremont St., S. F.

#### MANTELS

Mangram & Otter.....561 Mission St., S. F.  
The J. F. Kelly Co., 723-731 7th St., Oakland

#### MARBLE

Columbia Marble Co.....268 Market St., S. F.

#### MASONRY CONTRACTORS

Farrell & Reed.....Gunst Bldg., S. F.  
Ferdinand Wagner.....609 Waller St., S. F.

#### METAL AND STEEL LATH

Roebling Construction CoCrocker Bldg., S. F.

#### METAL CEILINGS

San Francisco Metal Stamping & Corrugating  
Co.....Treat Ave. and 19th St., S. F.  
San Francisco Cornice Co., Inc.,  
1140 Bryant St., S. F.  
Berger Manufacturing Company,  
1120 Mission St., S. F.

#### METAL DOORS AND WINDOWS

Waterhouse & Price.....59 Third St., S. F.  
San Francisco Cornice Company,  
1140 Bryant St., S. F.

#### METAL FIRE PROOF PARTITIONS

Collins Steel Partition & Lathing Co.,  
757 Monadnock Bldg., S. F.

#### METAL SHINGLES

Meurer Bros., J. A. McDonald, Pacific Coast  
Agent....Third, near Townsend St., S. F.  
San Francisco Metal Stamping & Corrugating  
Co.....Treat Ave. and 19th St., S. F.  
San Francisco Cornice Co., Inc.,  
1140 Bryant St., S. F.

#### OIL BURNING PLANTS

Fess System Company, Inc.,  
125-129 Hayes St., S. P.

#### OPERA CHAIRS

C. F. Weber & Co....365 Market St., S. F.  
Whitaker & Ray-Wiggin Co., San Francisco  
and Los Angeles.

#### ORNAMENTAL IRON AND BRONZE

Golden Gate Structural & Ornamental Iron  
Works.....1479 Mission St., S. F.  
Western Builders' Supply Co., Representing  
The L. Schreiber & Sons Co., Cincinnati  
J. G. Braun.....Chicago and New York  
Sartorius Co., Inc....16th and Utah Sts., S. F.  
Industrial Ornamental Iron and Wire Works,  
352 Noe St., S. F.  
C. J. Hillard Company, Inc.,  
211-215 Eighth St., S. F.

#### PAINT FOR CEMENT

Worden-Meeker Varnish Co., S. F.—Oakland  
Vitreolite Cold Water Paint, sold by Boyd &  
Moore.....356 Market St., S. F.  
Bay State Brick and Cement Coating—Made  
by Wadsworth, Howland & Co. (Inc.). See  
adv. in this issue for Pacific Coast agents.  
Adamant Cement, Brick and Plaster Coating.  
Made by Parker, Preston & Co., Inc.  
Samuel Cabot Mfg. Co., Boston, Mass., agen-  
cies in San Francisco, Oakland, Los Angeles,  
Portland, Tacoma and Spokane.

#### PAINT FOR STEEL STRUCTURES

Detroit Superior Graphite Paint, manufactured  
by Detroit Graphite Company. C. W. Pike  
Company, Coast Sales Agents, 22 Battery  
street, San Francisco.

#### PAINTS, OILS, ETC.

Bass-Hueter Paint Company,  
Mission, near Fourth St., S. F.  
Worden-Meeker Varnish Co., S. F.—Oakland  
Paraffine Paint Co.....38-9 First St., S. F.

## RALSTON IRON WORKS INC.

STRUCTURAL STEEL ORNAMENTAL IRON WORK

Telephone Mission 5230

Twentieth and Indiana Streets

SAN FRANCISCO, CAL.

**Opera  
Chairs**

**Buy Steel Construction every time**

**IT LASTS ALWAYS**

For Blackboard use "Olmstead Artificial Slate." Every architect wanting the best will specify this. Get our catalogues and prices

**WHITAKER & RAY-WIGGIN CO.**

776 MISSION STREET  
San Francisco

209 E. SEVENTH STREET  
Los Angeles

**School  
Desks**

**ARCHITECTS' SPECIFICATION INDEX—Continued**

**PAINTS, OILS, ETC.—Continued.**

Glidden Varnish Co., Cleveland, Ohio, represented by Whittier-Coburn Co.,

S. F. and Los Angeles  
Standard Varnish Works, represented by W. P. Fuller & Co., S. F. and Los Angeles

**PAVING BRICK**

Los Angeles Pressed Brick Co., Frost Bldg., Los Angeles  
Vallejo Brick & Tile Co., Mills Bldg., S. F.

**PHOTOGRAPHY**

Gabriel Moulin, 153 Kearny St., S. F.

**PILE DRIVING**

San Francisco Bridge Co., Monadnock Bldg., S. F.

**PIPE FOR SEWERAGE**

Gladding, McBean & Company, Crocker Bldg., S. F.

**PLASTERING CONTRACTORS**

A. Knowles, 985 Folsom St., S. F.  
D. Ross Clarke, 708 Pacific Bldg., S. F.

**PLUMBING**

The Turner Co., 278 Natoma St., S. F.  
Fisher & Wolfe Co., 207 Tehama St., S. F.  
J. E. O'Mara, 447 Minna St., S. F.  
Alex. Coleman, 706 Ellis St., S. F.  
Jno. G. Sutton Co., 229 Minna St., S. F.  
Oscar L. Zeis, 456 E. 16th St., Oakland  
Kiernan & O'Brien, 1754 Mission St., S. F.  
Thos. J. Ford, 1213 Octavia St., S. F.

**PLUMBING APPLIANCES**

Brown's Gasket, sold by Sanitary Plumbing Appliance Co., 412 Sheldon Bldg., S. F.

**PLUMBING FIXTURES**

Crane Co., Second and Brannan Sts., S. F.  
Haines, Jones & Cadbury Co., 851-859 Folsom St., S. F.

N. O. Nelson Mfg. Co., 978 Howard St., S. F.  
406 E. 4th St., Los Angeles

J. L. Mott Iron Works, D. H. Gulick, selling agent, 135 Kearny St., S. F.

**PLUMBING SUPPLIES**

California Steam & Plumbing Supply Co., Fifth and Bluxome Sts., S. F.

**POTTERY**

Steiger Terra Cotta and Pottery Works, Mills Bldg., S. F.

**PUMPS, MACHINERY, ETC.**

Simonds Machinery Co., 12 Natoma St., S. F.

**RAILROADS**

Southern Pacific Co., Flood Bldg., S. F.

**REFRIGERATING PLANTS**

Duval Dairy Supply Co., 201 Drumm St., S. F.

**ROLLING DOORS, SHUTTERS, PARTITIONS, ETC.**

C. F. Weber & Co., 365 Market St., S. F.  
Lilley & Thurston, 82 Second Street, S. F.

**ROOFING OR ROOFING MATERIALS**

J-M Asbestos Roofing, sold by H. W. Johns-Manville Co., in all the principal West Coast cities.

**ROOFING TIN**

"Scott's Extra Coated," manufactured by Folsnbee Bros. Co., Pittsburg, Pa.  
Meurer Bros. Co., A. H. McDonald, Coast Representative, 628 Third St., S. F.

**ROOFING AND ROOFING MATERIALS**

Ford & Malott, Mariposa St., at Iowa St., S. F.  
Genasco Ready Roofing, sold by Parrott & Co., 320 California St., S. F.  
"Ferroinclave," the Brown Hoisting Machinery Co., Coast Agent, Chas. A. Levy, Balboa Bldg., S. F.  
Pioneer Roll Paper Co., Los Angeles  
Mackenzie Roof Co., 425 15th St., Oakland  
Western Builders' Supply Co., 680 Mission St., S. F.

H. D. Samuel Company, 1054 Monadnock Bldg., S. F.  
W. H. Wilson & Co., 42 Natoma St., S. F.  
Meurer Bros. Co., A. H. McDonald, Coast Representative, 628 Third St., S. F.

**RUBBER TILING AND MATTING**

Goodyear Rubber Co., 587 Market St., S. F.

**SAFES**

Howe Scale Company, 333 Market St., S. F.

**SAND**

Del Monte White Sand, sold by Pacific Improvement Company, Main office, Crocker Bldg., S. F.

**SASH CORD**

Samson Cordage Works, Manufacturers of Solid Braided Cords and Cotton Twines, 88 Broad St., Boston, Mass.  
Silver Lake A Sash Cord, represented by Sanford Plummer, 149 New Montgomery St., S. F.

**SCHOOL FURNITURE AND SUPPLIES**

C. F. Weber & Co., 365 Market St., S. F.  
210 N. Main St., Los Angeles  
Whitaker & Ray-Wiggin Co., 776 Mission St., S. F.; 209 E. Seventh St., Los Angeles.

**SCAGLIOLA**

California Scagliola Co., F. Mayer, 68-70 Clara St., S. F.

**SHEATHING AND SOUND DEADENING**

Samuel Cabot Mfg. Co., Boston, Mass., agencies in San Francisco, Oakland, Los Angeles, Portland, Tacoma and Spokane.

**SHEET METAL WORK**

Berger Mfg. Co., 1120 Mission St., S. F.  
Dunlevy & Gettle, 79 City Hall Ave., S. F.

**SHINGLE STAINS**

W-M Shingle Stain, Worden-Meeker Varnish Co., S. F.—Oakland  
Cabot's Creosote Stains, sold by Waterhouse & Price, San Francisco, Los Angeles and Portland.

**SLATERS' CEMENT**

Western Builders' Supply Co., Representing Clinton Metallic Paint Co., Clinton, N. Y.

WM. H. FORD

Telephone Market 1596

W. H. MALOTT

**FORD & MALOTT**

**FELT, ASPHALT AND GRAVEL ROOFING CONTRACTORS**  
"FIBRESTONE" MAGNESITE, FLOORING ASPHALT FLOORS AND SIDEWALKS

Office and Yard: Mariposa, at Iowa St., San Francisco Members Builders' Exchange. Builders' Association

## ARCHITECTS' SPECIFICATION INDEX—Continued

- STABLE STALLS AND FIXTURES**  
Duval Dairy Supply Co., 201 Drumm St., S. F.
- STAINLESS CEMENT**  
Blanc Stainless Cement Co., Levensaler & Preston, Inc., San Francisco; Quartz Glass & Manufacturing Co., Los Angeles; John Brooke & Co., Inc., Seattle, Wash.
- STEEL AND IRON—STRUCTURAL**  
Boyd & Moore.....356 Market St., S. F.  
Woods & Huddart.....356 Market St., S. F.  
Pacific Rolling Mills,  
17th and Mississippi Sts., S. F.  
Western Iron Works.....125 Beale St., S. F.  
Brode Iron Works.....621 Howard St., S. F.  
Dyer Bros.....17th and Kansas Sts., S. F.  
Mortenson Construction Co.,  
19th and Indiana Sts., S. F.  
Central Iron Works, 621 Florida St., S. F.
- STEEL BARS FOR CONCRETE REINFORCEMENT**  
Jno. B. Leonard.....Sheldon Bldg., S. F.  
Woods & Huddart.....356 Market St., S. F.  
Baker & Hamilton, 4th and Brannon Sts., S. F.
- STEEL MOULDINGS FOR STORE FRONTS**  
I. G. Braun, 537 W. 35th St., N. Y., and  
322 S. Paulina St., Chicago
- STORE FRONTS**  
Kawneer System of Glass Setting, manufactured by Kawneer Mfg. Co., Coast agencies at San Francisco, Portland, Ore., Spokane and Seattle, Wash.
- SURVEYORS**  
Sanborn & Carinson....231 Kearny St., S. F.
- TAPESTRY AND BRONZE**  
Eugene Gaenger & Co., 705 Fifth Ave., New York
- TERRA COTTA CHIMNEY PIPE**  
Dunlevy & Gettle....79 City Hall Ave., S. F.
- TILES, MOSAICS, MANTELS, ETC.**  
Mangrum & Otter.....561 Mission St., S. F.  
Mosaic Tile Co., Zanesville, Ohio,  
228 Eighth St., S. F.  
The J. F. Kelly Co., 723-731 7th St., Oakland
- TILE FOR ROOFING**  
Gladding, McBean & Company,  
Crocker Bldg., S. F.
- TIN PLATES**  
Meurer Bros. Co., A. H. McDonald, Coast Representative.....628 Third St., S. F.
- VACUUM CLEANERS**  
J. P. Raymond, 397 Sutter St., S. F.  
American Rotary Valve Co.,  
702 Balboa Bldg., S. F.
- VALVE PACKING**  
"Palmetto Twist," sold by H. N. Cook Belting Co.....317 Howard St., S. F.
- VAULTS—FIREPROOF**  
M. G. West Company, 353 Market St., S. F.
- VENETIAN BLINDS, AWNINGS, ETC.**  
C. F. Weber & Co.....365 Market St., S. F.
- VENERS**  
Dieckmann Hardwood Co.,  
Welch Bldg., 244 California St., S. F.  
White Bros. Cor. Fifth and Brannon Sts., S. F.
- VENTILATORS AND SHEET IRON**  
Meurer Bros. Co., A. H. McDonald, Coast Representative.....628 Third St., S. F.
- VITRIFIED CLAY PIPE**  
Steiger Terra Cotta and Pottery Works,  
Mills Bldg., S. F.
- WAINSCOTING**  
"Kompolite".....350 Mills Bldg., S. F.
- WALL BEDS**  
The Turner Wall Bed Co.,  
Marshall & Stearns Co.,  
1154 Phelan Bldg., S. F.
- WATERPROOF FINISHES**  
"Trus-Con" Finish, sold by Western Lime & Cement Co.....268 Market St., S. F.
- WATERPROOFING FOR CONCRETE, ETC.**  
"Ceresit," manufactured by the Ceresit Waterproofing Co., sold by Parrott & Co., San Francisco, Los Angeles and Portland, and Julien A. Becker Co., Seattle, Wash.  
The Building Material Co., Inc.,  
587 Monadnock Bldg., S. F.  
Parrott & Co.....320 California St., S. F.  
Te-Pe-Co Waterproofing, sold by H. G. Clinton, 34 Ellis St., S. F.; Bass Ilueter Paint Co., Pacific Coast Distributors.  
Samuel Cabot Mfg. Co., Boston, Mass., agencies in San Francisco, Oakland, Los Angeles, Portland, Tacoma and Spokane.  
"Imperial" Waterproofing, sold by Baker Bros., San Francisco; Braun Chemical Co., Los Angeles; W. O. Stamps, Portland, and B. W. Gaisford, Seattle, Wash.
- WATER SUPPLY**  
Kewanee System, Simonds Machinery Co., sole agents....12 and 14 Natoma St., S. F.
- WEATHER STRIP**  
Monarch Metal Weather Strip, Boyd & Moore, Agents.....356 Market St., S. F.
- WHITE ENAMEL FINISH**  
Velvo-Tone, Worden-Meeker Varnish Co.,  
S. F.—Oakland  
"Satinette," W. P. Fuller & Co.,  
S. F. and all principal Coast cities
- WHITE PORTLAND CEMENT**  
Blanc Stainless Cement Co., Levensaler & Preston, Inc., San Francisco; Quartz Glass & Manufacturing Co., Los Angeles; John Brooke & Co., Inc., Seattle, Wash.
- WINDOWS, REVERSIBLE, ETC.**  
Dean Reversible Window Co.,  
551 Brannan St., S. F.  
Ilipolito Screen & Sash Co.,  
634 Maple Ave., Los Angeles  
Soule Reversible Window Co.,  
1061 Mission St., S. F.  
Tabor Sash Fixture Co., Blvd & Moore,  
Agents.....356 Market St., S. F.
- WOOD FINISH**  
Bridgeport Wood Finishing Co.,  
New Milford, Conn.

ARCHITECTS OWN DESIGNS CARRIED  
OUT AT MODERATE COST

DESIGNS SUITED TO EVERY STYLE  
OF ROOM

FIRE HOODS  
HOUSE HARDWARE  
SUNDIALS  
FIRE IRONS

**The Palmer Shop, INC**

MAKERS OF ARTISTIC ELECTRIC FIXTURES

1345

SUTTER STREET

PHONE  
FRANKLIN 4719



# ARCHITECTURAL FAIENCE

Faience Tiles for Exterior and Interior Decorations. Mantel Facings — Complete Mantels. Equipped to Execute Designs of Architects and Decorators. Special Designs by our own Artists

## Los Angeles Pressed Brick Co.

404-414 FROST BLDG.      SECOND AND BROADWAY      LOS ANGELES

# NORTHERN CLAY COMPANY

MANUFACTURERS OF

## ARCHITECTURAL TERRA COTTA FIRE BRICK AND CLAY PRODUCTS

MAIN OFFICE AND FACTORIES, - AUBURN, WASHINGTON

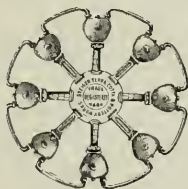

## STEIGER TERRA COTTA AND POTTERY WORKS

ARCHITECTURAL TERRA COTTA, PRESSED BRICK, SEWER PIPE  
CHIMNEY PIPE, FLUE LINING, FIRE BRICK  
MANTEL TILE, ACID WARES

FACTORY: SOUTH SAN FRANCISCO  
SAN MATEO CO.

YARD: 18TH AND DIVISION STS.  
SAN FRANCISCO

MAIN OFFICE: 729 MILLS BUILDING

TELEPHONE DOUGLAS 3010

SAN FRANCISCO, CAL.

# GLADDING, McBEAN & Co.

MANUFACTURERS CLAY PRODUCTS

## CROCKER BLDG. SAN FRANCISCO

WORKS, LINCOLN, CAL.

# PERFECT WALL BEDS HALEY SEAT BEDS

**PERFECT CONCEALED & TURNER BED CO.  
862 MISSION ST. SAN FRANCISCO, CAL.**

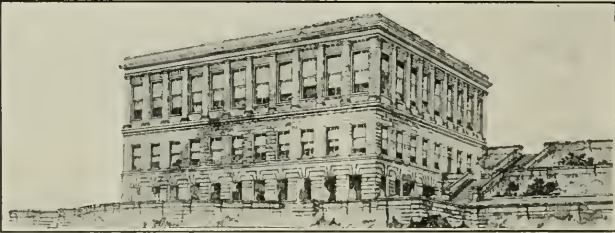

CLIFF HOUSE, San Francisco. Reid Bros., Architects. Interior Decoration by  
A. C. WOCKER, DECORATOR, 1370 Sutter Street, San Francisco



This Half Brick was subjected to over 150,000 pounds pressure, equal to 300,000 for the Whole Brick (15,000 per square inch) absorption test thirteen one-hundredth of one per cent. Test made by Engineering Department City of San Francisco.

**Monadnock Building, SAN FRANCISCO, CAL.**

TELEPHONE KEARNY 4314

## VALLEJO BRICK AND TILE COMPANY

Consolidated

MANUFACTURERS OF

## PAVING BRICK

SEWER BRICK AND  
OTHER VITRIFIED  
CLAY PRODUCTS.

WORKS AT

VALLEJO, SOLANO CO.

CALIFORNIA

TELEPHONE VALLEJO 242

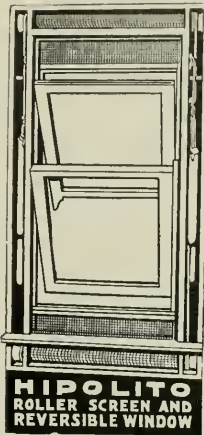

Reversible  
Window and  
Self-  
Regulating  
Roller  
Screens

**HIPOLITO SCREEN & SASH CO.**

634-38 MAPLE AVENUE  
LOS ANGELES, CAL.

DEAN REVERSIBLE WINDOW CO. INC.



SAN FRANCISCO, CAL.

Phone, Kearny 1516

OVER  
500,000  
TONS

of Structural Steel Painted with

"SUPERIOR GRAPHITE  
PAINT"

DETROIT GRAPHITE COMPANY  
PAINT MAKERS

DETROIT, MICHIGAN, U. S. A.

C. W. PIKE COMPANY

PACIFIC COAST SALES AGENTS

22 BATTERY ST.

SAN FRANCISCO, CAL.

TELEPHONE, KEARNY 4303

We are Pacific Coast Agents for

**JAMES SANITARY  
BARN EQUIPMENT**

Which is the Latest and Best in that Line

WHEN figuring plans for new Barns  
or when remodeling old ones, we  
would be glad to receive your inquiries.  
Catalogs may be had for the asking.

DE LAVAL DAIRY SUPPLY CO.

DRUMM AND SACRAMENTO STREETS  
SAN FRANCISCO, CAL.

**BOWSER**

It's Fire-proof, Leak-proof and Evaporation-proof. That means Safety, Profit and High Test Gasoline.

All Styles, Sizes and Prices—Direct Lift, Long Distance and Portable types.

Recommended by Architects, Endorsed by Owners and tested by time.

*IT'S THE PIONEER.*

**S. F. BOWSER & CO**

INCORPORATED

FORT WAYNE, IND.

Western Office, 612 HOWARD STREET  
SAN FRANCISCO, CAL.

## The Standard Gasoline Outfit for Public or Private Garages

because it fulfils every requirement. No measures—No funnels. You pump the gasoline directly into the car without exposure or possibility of explosion. **WE MAKE THE LOWEST PRICED OUTFITS AND WE MAKE THE BEST.**

Special Information for Architects. Just ask for booklet No. 107 for details.

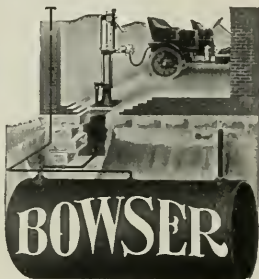

## SOMETHING NEW IN A GAS WATER HEATER

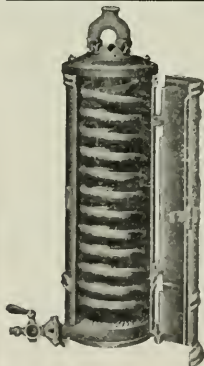

The accompanying cut is something New in a Tank Heater

**T**HIS is a double Copper Coil Heater with Union Nut Connections on each coil. This is the only double coil Tank Heater on the market with independent connections, the use of which permits the removal of either coil without interfering with the other coil.

This Heater is considered the most efficient Tank Heater on the Market. Give it a trial.

We are represented in the West by the following:  
**HOLBROOK, MERRILL & STETSON**  
San Francisco and Los Angeles, Calif.  
**CRANE COMPANY**  
Seattle and Tacoma, Wash.  
**CRANE COMPANY, Vancouver, B. C.**

**The Hoffman Heater Company.** Factory and General Offices, Lorain, Ohio, U. S. A.



**THE TOZER COMPANY**  
**Interior Decorators**  
Wall Papers and Fabrics of Character  
and Distinctiveness  
*We Design, Decorate and Furnish Interiors of all Kinds*  
The Leading Architects and Builders our References  
Correspondence and Enquiries Solicited  
228 Grant Ave. (2d floor, Next to White House)      187 Twelfth Street  
San Francisco      Oakland

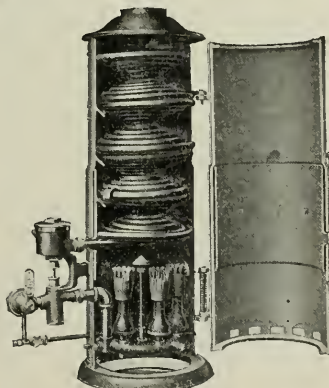

THE  
"PITTSBURG BUNGALOW"  
AUTOMATIC  
GAS WATER HEATER

Specially Designed for  
Apartments, Cottages  
Bungalows, Small Flats

Cast Iron Double Jacket, 32 Inches  
High; Copper Heating Coils; Heating  
Capacity, Two Gallons per Minute

*The usual "Pittsburg" Guarantee*

Showing Interior      Illustrated Booklet on Request

**JOS. THIEBEN & CO., Sales Agents**  
667 MISSION STREET  
Phones: Kearny 3762—Home J-3762      SAN FRANCISCO, CAL.





## THE VARNISH TO SPECIFY

# A

Thoroughly Satisfied Client is an Architect's Best Asset.

It means more Business for Him Every Time. A Well Built and Finished Interior Goes a Long Way to Impress the Owner with the Architect's Genius.

The Wood Finish, Therefore, Must Not be Neglected.

A Superior Varnish is Necessary to Insure a Satisfactory Finish

Specify **HUETER'S ARCHITECTURAL and FLOOR VARNISHES.**

Manufactured by

## S. F. PIONEER VARNISH WORKS

ESTABLISHED 1857

E. L. HUETER, Proprietor

WORKS SAN FRANCISCO, CAL.  
MAIN OFFICE, 816 MISSION ST.  
Los Angeles Office and Warehouse,  
333 to 343 East Second St.

Portland Office and Warehouse,  
191 Second Street  
Seattle Office and Warehouse,  
91 Spring Street

## GLIDDEN

WATERPROOF

## LIQUID CEMENT

GIVES TWO VALUES



**WATERPROOFS--DECORATES**

1. It gives highly efficient positive damp proof protection to concrete walls.
2. It gives a highly decorative effect to the structure both inside and out, because it obliterates the mottled effect in color tones found in all concrete buildings, and as it is made in various shades it can be used to produce various pleasing color tones to the building, without adding a cent of expense to the damp proofing process.

It is made in a variety of practical shades, including imitation of Bedford Sandstone, Colonial and Pompeian Buffs and Pure White.

Its use assures a thoroughly damp proof wall at a minimum expense and a pleasing decorative effect obtainable on concrete structures in no other way except at greatly added cost for special materials. Booklet with specifications on request.

THE GLIDDEN VARNISH CO.

FACTORIES—Cleveland, Ohio; Toronto, Ont.

BRANCHES—New Ynrk, St. Louis, Chicago

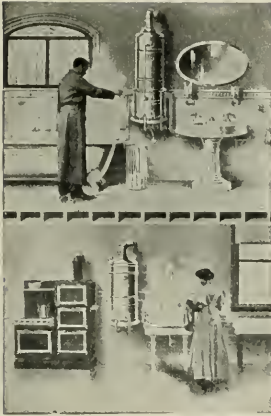

## HOT WATER SERVICE

The quickest, cheapest and most dependable is secured only from a **HUMPHREY'S INSTANTANEOUS GAS BATH WATER HEATER.**

Light the gas and out pours hot water—about as easy to secure as cold—almost as cheap: a big hot bath, **TWO CENTS.** Always ready, no repairs, makes bathing a pleasure.

Positively Guaranteed.

Sold Everywhere. Ask your Plumber. Handsome Catalog No. 11. Free on request.

**HUMPHREY CO.**

565 N. Rose St.

Kalamazoo, Mich.



Caen Stone, Entrance University Library Building, Berkeley, California, Executed by

**A. KNOWLES**

985 Folsom St., San Francisco Phone Douglas 3451



St. Patrick, Apostle of Ireland  
Installed in St. Mary's Church, San Francisco

## California Art Glass Works

WILLIAM SCHROEGER, Pres.

MEMORIAL WINDOWS A SPECIALTY

Staining Crystalizing Binding and  
Embossing Beveling Cutting

TEL. HOME J 2652

768 MISSION ST., SAN FRANCISCO

**EUGENE GLAENZER & CO.**

705 FIFTH AVENUE,  
NEW YORK



**Antique Works  
of Art**

Garden Ornaments,  
Mantels, Furniture,  
Tapestries, Bronzes,  
Paintings by Masters

PARIS, 5 RUE SCRIBE



A NATIVE SON BEAR IN SHEET METAL BY

**San Francisco Metal Stamp-  
ing and Corrugating Company**

Stamped and Spun  
Sheet Metal Ornaments

Statue Work, Mission Tile, Art Metal Ceilings

554-556 TREAT AVE., Near Nineteenth St.  
(OPPOSITE MISSION FOUNDRY)

PHONES:  
MISSION 2421  
HOME M-3428

SAN FRANCISCO,  
CALIFORNIA

**VACUUM CLEANER  
INSTALLATIONS**

Sizes and Prices to  
suit all requirements

SEND FOR INFORMATION

**J. P. RAYMOND**

397 SUTTER STREET  
SAN FRANCISCO

PHONES { KEARNY 5852  
          HOME C 5852

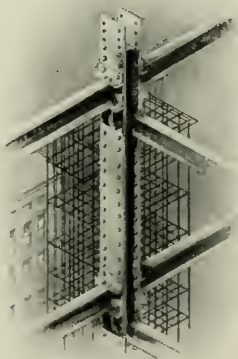

**SCHRADER IRON WORKS, INC.**

General Contractors for Structural Steel  
Work; Water Proof Trap Doors

1247-1249 HARRISON STREET

SAN FRANCISCO, CAL. TEL. MARK T 1017

## No Other Ready Roofing Can Withstand This Test

The flame of a powerful blow-torch was placed within two inches of J-M Asbestos Roofing. At the end of fifty minutes the roofing was not burned or injured, being only slightly blackened by smoke.

It is one of a number of tests which prove conclusively that the only permanently durable repaired roofing—the one that better than any other resists fire, acids, gases, rot, rust, heat, cold and wear is



## J-M Asbestos Roofing

Other ready roofings are made of wool felt, rag stock, paper, shoddy, coal tar and other highly inflammable materials which are an actual menace to a building instead of a protection.

J-M Asbestos Roofing is the "cheapest-per-year" roofing, because it requires no coating or painting to preserve it. The first cost is the only expense.

Fire, roof construction is better fire protection to a building than any amount of fire insurance. By covering buildings with J-M Asbestos Roofing it will protect them from fire at no extra cost.

Write our nearest branch to-day for Samples and Catalog 303.

### H. W. JOHNS-MANVILLE CO.

MANUFACTURERS OF ASBESTOS AND MAGNESIA PRODUCTS

**ASBESTOS**

ASBESTOS ROOFINGS, PACKINGS, ELECTRICAL SUPPLIES, ETC.

Baltimore	Chicago	Detroit	Los Angeles	New Orleans	Pittsburg
Boston	Cleveland	Kansas City	Milwaukee	New York	San Francisco
Buffalo	Dallas	London	Minneapolis	Philadelphia	Seattle
			St. Louis		1229



SHATTUCK HOTEL, BERKELEY. BEN G. MCDUGALL, ARCHITECT

NILES WASHED CONCRETE GRAVEL AND CRUSHED ROCK USED IN THE CONSTRUCTION OF BERKELEY'S BEAUTIFUL NEW HOTEL

CALIFORNIA BUILDING MATERIAL CO.

PACIFIC BUILDING,

SAN FRANCISCO



COUNTRY RESIDENCE OF MR. WILLIAM H. CROCKER, BURLINGAME, CAL.

FURNISHED THROUGHOUT WITH

## RUSSWIN HARDWARE

BY

JOOST BROS.

1274 MARKET STREET, SAN FRANCISCO

---

RUSSELL & ERWIN MFG. CO.

NEW BRITAIN, CONN.

404-411 Commercial Bldg., 833 Market St.  
San Francisco, California

Telephone Kearny 1370

NEW YORK

PHILADELPHIA

CHICAGO

LONDON, ENG.



**“QUALITY COUNTS”**

# WESTERN BUILDERS' SUPPLY CO.

ESTABLISHED 1902

**680 MISSION STREET**

**SAN FRANCISCO, CAL.**

TELEPHONE KEARNY 1991

**INTERIOR WOOD FINISH ORNAMENTS**  
(ART MOULDINGS, CARVINGS, ETC.)

**HIPOLITO EVEN TENSION SCREENS**  
(FOR GOOD HOUSES)  
CONVENIENT, DURABLE, NON-RUSTING

**STANDARD METAL CORNER BEAD**

**GOLDEN WEST VULCANITE ROOFING**

**“ENAMETILE” (METAL ENAMEL WAINSCOTING)**  
(SANITARY, INTERLOCKING)



**LANE JOIST HANGERS**  
POST CAPS AND BASES

REPRESENTING

**DECORATORS' SUPPLY CO., CHICAGO, ILL.**



**ARCHITECTURAL ORNAMENTS**

IN WOOD, COMPOSITION AND CEMENT  
EXTERIOR AND INTERIOR

**CAPITALS AND BRACKETS**

TO MATCH OAK, MAHOGANY, REDWOOD. ETC.

**Four Large Catalogs (Furnished Registered Architects)**

CAPITALS AND BRACKETS  
WOOD GRILLES

EXTERIOR COMPOSITION AND PLASTER  
COMPOSITION TO MATCH WOOD

For Information apply 680 Mission Street



## “SUN-PROOF” PAINTS

MILWAUKEE

“Pitcairn Aged Varnish”

NEWARK

**GOES FARTHEST WEARS LONGEST**

Note  
Simplicity  
and  
Effective  
Application  
of  
Fire

Sectional view of the Fess System Rotary Crude Oil Burner as applied to a Low Pressure Heating Boiler. FESS SYSTEM COMPANY, Inc., 125 Hayes Street, San Francisco.

# Will Not Stain

Limestone, Granite or Marble—  
The Best Cement for Exterior  
Stucco Construction. Also  
EXTRA WHITE LAFARGE for  
use with Light Brick, Terra  
Cotta, White Granite or Marble  
and White Stucco Exteriors

*Lafarge*

NON-STAINING CEMENT CO.  
156 FIFTH AVENUE, NEW YORK  
Sole Agents for the United States and Canada

WATERHOUSE & PRICE CO.  
SAN FRANCISCO  
SEATTLE PORTLAND OAKLAND LOS ANGELES

## BRIDGEPORT STANDARD WOOD FINISHES

### SERVICE

Good SERVICE is a broad term as applied to wood finishes. It begins with ease of application — it ends with beauty and the lasting qualities of the wood finish.

If you want to recommend wood finishes that give the best possible SERVICE in all respects, specify the use of—

### Bridgeport Standard Wood Finishes

Bridgeport Standard Wood Finishes are practical finishes—simple to use, easy to spread, great in covering capacity.

They develop the natural beauty of the wood and *never* cloud, obscure or raise the grain.

And they give an elastic, tough finish that looks good at the start and stays good with the years.

We have hundreds of letters from Architects, Property Owners, and Furniture, Piano and Car Building concerns who use Bridgeport Standard Wood Finishes which verify and emphasize this statement.

We would like to place tangible proof of the good SERVICE of Bridgeport Standard Wood Finishes in your hands.

#### Write for Sample Panels

We will be very glad to mail you on request a neat compact case of sample panels showing numerous wood finishes in new and staple effects. You will find them useful and PRACTICAL.

**Whittier-Coburn Co.,**

San Francisco and Los Angeles

Agents for the Pacific  
Coast.

THE BRIDGEPORT CO.  
WOOD FINISHING  
NEW MILFORD, CONN.  
NEW YORK. CHICAGO. BOSTON.

## Notice to Architects

We have placed on the market a new product which we have trade marked

# Amiwud

It is a stiff pulp board and made to imitate hardwood.

**Amiwud** can be nailed to studding, avoiding the necessity of lathing and plastering.

Many artistic and decorative designs for interior finishing can be made of **Amiwud** — cheaply and without difficulty — most anyone can do it.

We have demonstrated the value of **Amiwud** in our own place of business, where it is on display.

Call at our general offices and see what can be done with **Amiwud**.

## The PARAFFINE PAINT CO.

34 FIRST STREET, SAN FRANCISCO

# “TE-PE-CO”

EVERLASTING  
WATERPROOFING

**P**revents all efflorescence on scagliola, brick and cement  
**P**revents dust stains on granite and white cement  
**P**revents “burning out” of tinting and papering on lime plaster

**IS COLORLESS**

*Will Permanently Waterproof Brick and Cement and  
Asbestos Shingles*

**IS SPECIFIED BY MANY ARCHITECTS**

Used by the United States Government

Carried in Stock by the

**BASS-HUETER PAINT CO.**

San Francisco, Los Angeles,  
Portland, Seattle

ESTIMATES GIVEN BY

**H. G. CLINTON,**

34 Ellis Street,  
San Francisco

# J. G. BRAUN

537-541 W. 35TH STREET, NEW YORK  
615-621 S. PAULINA STREET, CHICAGO

CARRIES A COMPLETE STOCK OF

**Steel Mouldings for Store Fronts**

**Elevator Enclosures, Etc.**



Plain and Ornamental Sash Bars, Leaves, Rosettes  
Pickets and Ornamental Rivets, Square Root  
Angle Iron from  $\frac{3}{8}$ " x  $\frac{3}{8}$ " x 1-16" Upwards

Square Tubing for Elevators, Elevator  
Enclosures and Office Railings

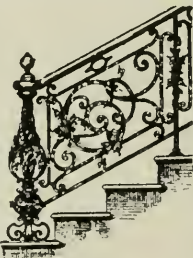

Catalog to Architects, Architectural Iron  
Works and Builders only on Application

**PATENT SHEET METAL SHEARS PUNCHING MACHINES**

All parts, including the main body, are made of forged steel, which makes these tools far superior to any made from cast steel. The Punch Machines are made from steel plates. All movable parts are steel forgings. All parts which can be are tempered. The Eccentric pillar blocks are made with independent steel rings. Some of these Machines also have Shears for cutting Angle, Tee or Flat Iron.

WRITE FOR CATALOG  
AND PRICES

**OVER 900  
MACHINES  
SOLD**



P. NOBLE, PRESIDENT H. C. BANKS, VICE-PRESIDENT THOMAS ROLPH, SECRETARY

# Pacific Rolling Mill Co.

TELEPHONE MARKET 215

SUPPLIERS OF

## STRUCTURAL STEEL

FORGINGS, BOLTS, RIVETS, FROGS, SWITCHES

## CAST IRON

GENERAL OFFICE AND WORKS  
17TH & MISSISSIPPI STS.

SAN FRANCISCO

SALES OFFICE  
908 CROCKER BUILDING



# Sartorius Company, Inc.

## Ornamental Iron & Bronze.



·ELEVATOR ENCLOSURES & CABS · METAL STORE FRONTS ·  
·STAIRS · RAILINGS · BANK ENCLOSURES & RAILINGS ·  
·BRONZE TABLETS & NAME PLATES · ANDIRONS · ETC ·  
· TELE · MARKET 1529 · SAN FRANCISCO · WORKS 15<sup>TH</sup> & VTAH STS

W. B. MORRIS, President

H. M. WRIGHT, Vice-President

L. J. GATES, Secretary

# WESTERN IRON WORKS

## STRUCTURAL IRON and STEEL CONTRACTORS

Gas Holders, Vault Linings, Jails, Fire Escapes, Beams, Channels, Angles  
and Steel Wheelbarrows Carried in Stock

Phones: Kearny 575  
J 1259

141-147 BEALE STREET  
132-148 MAIN STREET SAN FRANCISCO, CAL.

TELEPHONE, MARKET 6468

HOME PHONE, J 2376

# C. J. HILLARD CO., Inc.

MANUFACTURERS OF

## Ornamental Iron, Brass and Bronze Work

Bank and Office Railings. Elevator Enclosures and Cars.  
Cast Iron Stairs and Store Fronts. Wire Work. Fire Escapes.

211-213-215-217 8th Street  
Between Howard and Folsom

San Francisco, Cal.



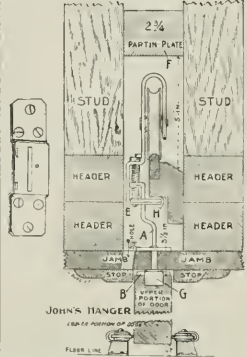

When it comes to specifying a **DOOR HANGER** you must take into consideration these essential points:

**Permanency, Smooth Action,  
Absence of Noise, Economy**

## THE JOHNS HANGER

Embodies all of these Features. Used in Hundreds of Hotels, Apartment Houses, Flats and Residences and giving Satisfaction

Strictly a California Product

### The Johns Hanger Mfg. Co.

832-838 Folsom Street, San Francisco, Cal.

## WHAT IS MORE TROUBLESOME THAN TO PACK RADIATOR VALVES

**Y**OU never seem to have the right size packing. Because there is no active rod travel through the stuffing box the packing sets and gets hard, and the valves leak more or less when opened or closed.

### PALMETTO TWIST

can be unstranded and any size valve packed from one spool. It cannot burn — its all asbestos. Does not set hard — because a perfect lubricant is forced into each strand.

Use **PALMETTO TWIST** on all the valves, and you will not have to repack so often.

We will send you a sample spool **FREE**. Just to prove this.

### H. N. COOK BELTING CO.

317-319 Howard Street

SAN FRANCISCO

CALIFORNIA



## Our 1911 Catalogue

(just out)

Contains a complete description of the many improvements, as well as the many new inventions we have added to our line of Ball Bearing Door Hangers, Elevator Door Locks and Drawer Slides, during the past year.

If you would be up-to-date, write for a copy of this new catalogue either to us direct or to our nearest agent.

### RELiance BALL BEARING DOOR HANGER CO.,

1 Madison Avenue, New York City.

PACIFIC COAST AGENTS

San Francisco: Sartorius Co., Inc., Fifteenth & Utah Sts. Seattle: D. E. Fryer & Co.  
Los Angeles: Louis R. Bedell, 1108 Storey Bldg. Portland: Portland Wire & Iron Works.

FRED J. H. RICKON, C. E.  
Member A. M. Soc. C. E.

R. EHRHART, C. E.

# RICKON-EHRHART ENGINEERING & CONSTRUCTION CO.

Civil Engineers and Contractors

Phone West 1300

1859 GEARY ST., SAN FRANCISCO

ALFRED FOWLE, President

JOS. R. WHALEN, Secretary and Treasurer

## CALIFORNIA STEAM AND PLUMBING SUPPLY CO.

SANITARY PLUMBING  
FIXTURES



WATER, STEAM AND  
GAS SUPPLIES

FIFTH AND BLUXOME STREETS

SAN FRANCISCO, CAL.

# CRANE COMPANY

Second & Brannan Sts.  
SAN FRANCISCO

High Grade . . .

## PLUMBING SUPPLIES

Steam and Hot Water Heating  
PIPE, VALVES, FITTINGS

Power Plant and Water Works Materials

STEAM SPECIALTIES

# N. O. NELSON MFG. CO.

## PLUMBING SUPPLIES



978 Howard Street  
San Francisco

406 E. 4th Street  
Los Angeles

**DIECKMANN****HARDWOOD**

HARDWOODS  
 CABINET WOODS  
 HARDWOOD FLOORING

**COMPANY**

OFFICE, 244 CALIFORNIA STREET  
 MILL AND YARD, FOOT OF TAYLOR STREET

**SAN FRANCISCO, CAL.**

**TILING  
 MANTELS  
 GRATES**



A. S. MANGRUM, PRES. & MGR. CHAS. C. HANLEY, SEC'Y. & TREAS.

**MANGRUM & OTTER**

INCORPORATED

**FURNACE AND STEAM HEATING****HOTEL AND KITCHEN OUTFITS**

Stoves, Ranges, Refrigerators, Tin and Enameled Ware

Telephone Kearny  
 3155

561-563 MISSION ST.  
 SAN FRANCISCO

**WEARY & ALFORD COMPANY****Bank Interiors and Equipment**

OF THE HIGHER CLASS

H. H. WINNER, Pacific Coast Representative

303 Union Trust Building

**SAN FRANCISCO****CONCRETE REINFORCEMENT****STEEL BARS** FLATS, ROUNDS, SQUARES & TWISTED**BANDS, HOOPS AND WIRE**

ALL SIZES IN STOCK

**WOODS & HUDDART**

356 MARKET STREET

**SAN FRANCISCO, CAL.**

# Cold TWISTED STEEL BARS

(Square, Round and Flat) for Reinforcing Concrete



OUR STOCK IS COMPLETE IN ALL SIZES

## BAKER & HAMILTON

SAN FRANCISCO

SACRAMENTO

LOS ANGELES

# The Architect and Engineer

Terms of Subscription,  
\$1.50 per Year

of California  
Pacific Coast States

Single Copies,  
25 Cents

Issued monthly in the interests of Architects, Structural Engineers, Contractors and the Allied Trades of the Pacific Coast.

## Contents for April

	PAGE
First National Bank Building, San Francisco . . . . .	<i>Frontispiece</i>
The Work of Willis Polk & Company . . . . .	35
<i>Frederick Hamilton</i>	
With more than forty illustrations of buildings designed and erected under Mr. Polk's personal supervision.	
Modern Illuminants and Their Correct Use . . . . .	74
<i>Franklin Wells Loomis, Illuminating Engineer</i>	
National Fine Arts Commission May Help Select the Fair Site . . . . .	80
A Compliment to American Architects . . . . .	80
Objection to the Narrow Building Lot . . . . .	81
Architectural Competitions . . . . .	82
<i>F. W. Fitzpatrick</i>	
San Francisco's Side of the Hetch Hetchy Controversy . . . . .	84
<i>Marsden Manson, City Engineer of San Francisco</i>	
The Passing of the Dea . . . . .	91
<i>Ann Wentworth</i>	
Culvert Construction . . . . .	95
<i>Peter Campbell</i>	
San Francisco Architectural Club . . . . .	97
Among the Architects . . . . .	98
Editorial . . . . .	102
Heating and Lighting . . . . .	104
By the Way . . . . .	114

(For Index to Advertisers see Pages 121-124)



*First National Bank Building, San Francisco*

Fronti-piece  
The Architect and Engineer  
April, 1911



THE  
Architect and Engineer

Of California  
Pacific Coast States

VOL. XXIV.

APRIL, 1911.

No. 3.



## The Work of Willis Polk & Company\*

By FREDERICK HAMILTON

**M**R. WILLIS POLK, to whose work this number of *The Architect and Engineer* is dedicated, came to San Francisco in 1889. That year marks the inauguration of what we may now properly regard as our local Renaissance; and since Mr. Polk is so identified with our advance in architectural expression, a brief review of that movement is, in a manner, but the recital of his share in it.

There was, in this community at that time and throughout the decade following, an awakening, a sudden perception of the possibilities and opportunities of our city. A sense of permanency prevailed and we realized that we had grown from a mining camp into a city.

This fresh enthusiasm was becoming articulate amongst the younger men practicing the arts, and the advent of the late A. Page-Brown and the coterie of men in his office afforded that impetus to architecture (practiced as an art) which instantly commanded the attention of the public.

The indifference of that public, during the period immediately preceding, is accountable enough. Architecturally, San Francisco had had, at

\*The First National Bank building shown on the opposite page and all other buildings illustrated in connection with Mr. Polk's work, and marked with an asterisk (\*) were designed and constructed under the supervision of Mr. Polk during his association with D. H. Burnham & Company

the beginning, by some fortunate chance a group of men trained in the European schools, who had given to our earliest buildings a character strictly architectural. We possessed, perhaps, at that early period, better architectural examples than any city in America. Surely the names of these early architects should be recovered and placed on record. Following them comes the interval between 1870 and 1890, when our architects were caught in the wave of unfeeling experiment that swept the world at that



*An Early Example of Pen and Ink Drawing by Mr. Polk*

time. It was a kind of epidemic of architectural bad taste, ending in the Titanic inebriation of the Romanesque.

A return to sanity was the only way out of this excess. However successfully Richardson had adapted a semi-barbaric style to his uses, in the hands of his followers it became an abomination, of a grossness that outraged all the intuitive predilections of the American. Early American work—the Colonial house, the American sailing ship, the American

"buggy" and the work that was distinctively our own, had a refinement that verged upon fragility; and this refinement was really the only tradition in art that we had made for ourselves. This latent tradition was perceived by McKim, Stanford White, LaFarge, St. Gaudens and others of that group, when they began their reform in the early eighties; while our small local blossoming in the nineties was of the same tree, the root was really fixed for two centuries in our national character.



*"Twelve Years Ago Mr. Polk's Reputation as a Pen and Ink Draftsman was Doubtless Greater Than His Reputation as an Architect, as Represented by These Examples of His Rendering."*

The fact of this root accounts, perhaps, for the immediate interest with which the work of A. Page-Brown, Willis Polk, Ernest Coxhead, Maybeck and others, was welcomed in San Francisco. The work had refinement, restraint, but held as well, a zest, an enterprise, an element of happy adventure, that answered to some unconscious need in the community itself.



Public Lobby, Main Banking Room and Check Desk, First National Bank Building - San Francisco

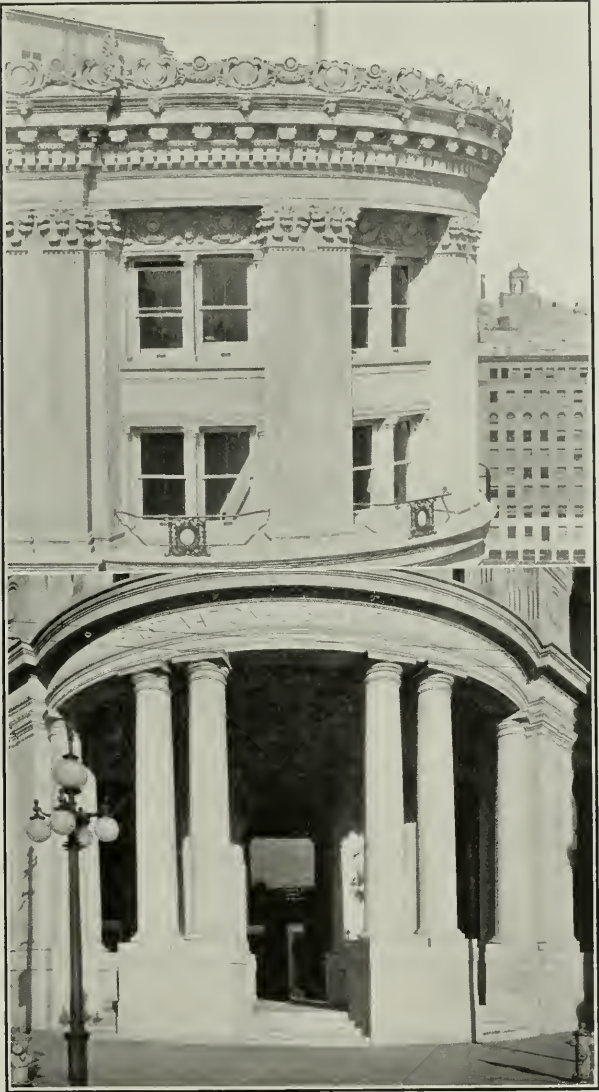

*Details of Cornice and Entrance, First National Bank Building, San Francisco*





*Water Temple at Sunol, California, for the Spring Valley Water Company\**

How good were the works produced under this stimulation, it is even now difficult to judge. There remains since the great fire in survival of all that activity, only the Crocker building, the Swedenborgian church, a house here and there; but back of the devastating curtain of flame of the year 1906, rise the tower of Grace church, the Towne and Whittell homes, St. John's church, the first Atkinson building, the previous Y. M. C. A. building—and these but accentuate the universal loss. They associate themselves in memory with the old buildings in Chinatown and on the Barbary Coast, as pleasurable things that we shall never recover and for which there can be no substitutes.

They are as utterly of our past as is that lavish publication, "The Architectural News," which Mr. Polk's enterprise launched upon an unprepared world and which died at its third issue. The "News" was an act of faith on the part of Mr. Polk, for which he dearly enough paid; but it stands as the forerunner of all subsequent ventures in special publications, and perhaps in its very imprudence, it was better than anything we have had since.

The "News" was started at the beginning of his independent career as an architect. What he has done is sufficiently set forth in the illustra-

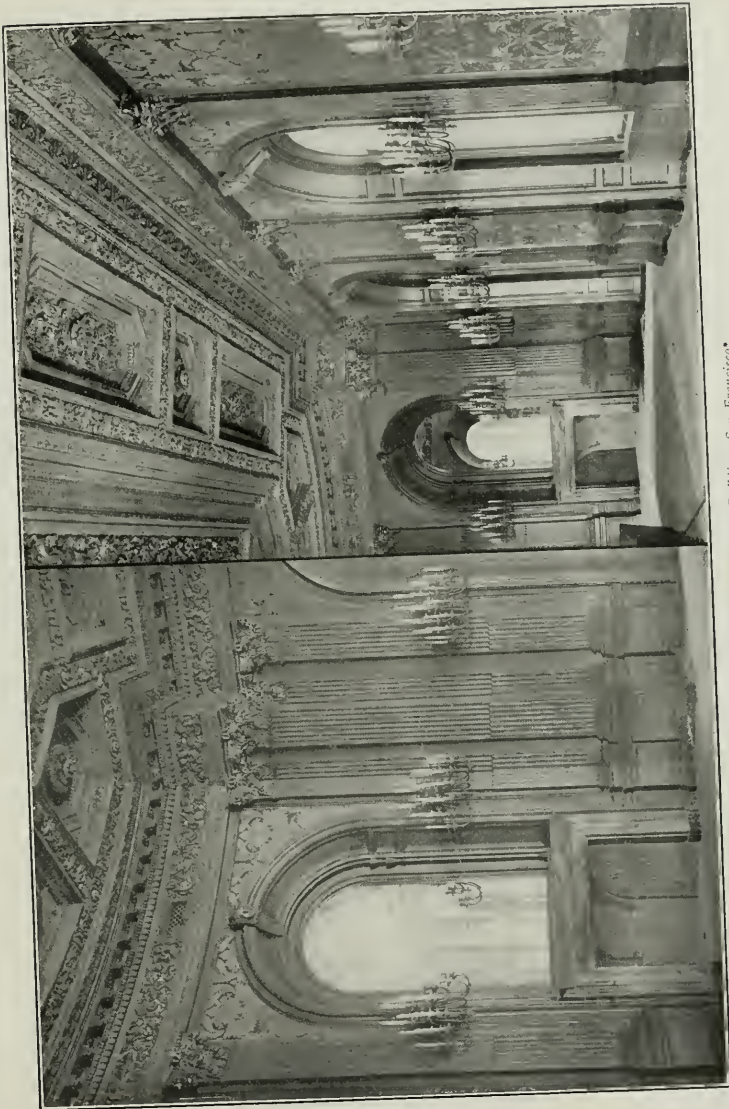

Reception Rooms, Pacific Union Club Building, San Francisco\*



*Lounging Room Ceiling, Pacific Union Club Building. Color Scheme and Decorations Executed Under the Direction of Mr. Bruce Porter.*



*Lounging Room, Pacific Union Club*

tions that follow, without written comment. But one generalization needs, perhaps, be made.

As with the majority of young architects, Mr. Polk's first opportunities were offered by the middle-cost dwelling house, and in these it is interesting to trace a logical development, which includes the latest of his buildings, public and semi-public. This development of an individual talent very closely parallels the development of architecture itself.

His small early houses in timber and shingle are, at the beginning, Gothic in their larger forms. They adapt this form very sincerely, very rightly, to a new building material, and new conditions of life, while as rightly, the interiors of these same houses (finished in wood and under the exigency of machine production) are dealt with in the flexible manner of the early English Renaissance. From this first association of styles, the exteriors are seen to change, the style expands and embraces that later period where classic motives influence the Gothic mass, in the cornice, doorways, etc., till there is a complete and agreeable union, making, for some of us, what seems to be the pleasantest solution of the problem of the wooden house and its style. It leaves the architect free within the imposed limits; it offers him his opportunity for full expression, while it protects him and his client from the perils of eccentric experiment.

This conservative quality in design has certainly not cramped Mr. Polk in his later work; the Bourn house carries the same method of reasoning into masonry, while his recent buildings of importance retain their relationship, keep their connection, with the earliest, humbler works from his hand.



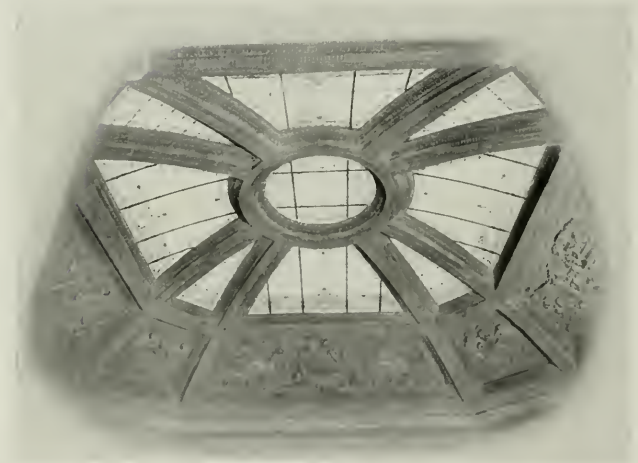
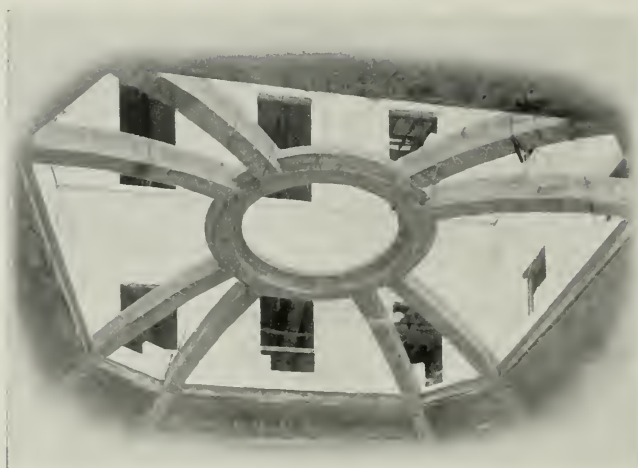

*Central Court Dome Under Construction and Completed, Pacific Union Club Building. Designed by Mr. T. Ronneberg, Structural Engineer of the Firm of Willis Polk & Company*

*Extract from Architect's report to Board of Directors of Pacific Union Club:*

"We are glad to report that we believe our judgment has been sustained in the adoption of reinforced concrete construction for your building. The contractors completed this work better in every respect than we expected and fully equal to the strictest requirements of their contract. There were a number of structural problems in this connection that to our knowledge had never before been worked out from a practical point of view and the precedent thereby established will go far toward the economical development of reinforced concrete construction as a system of building."





*Dining Room, Pacific Union Club*



*Library, Pacific Union Club*



Swimming Bath, Pacific Union Club



*Swimming Bath and Cafe, Pacific Union Club*





Card and Billiard Rooms, Pacific Union Club. The Details of This and Other Rooms in This Building Were Worked Out by Mr. H. C. Stearns, Chief Designer of Willis Polk & Company



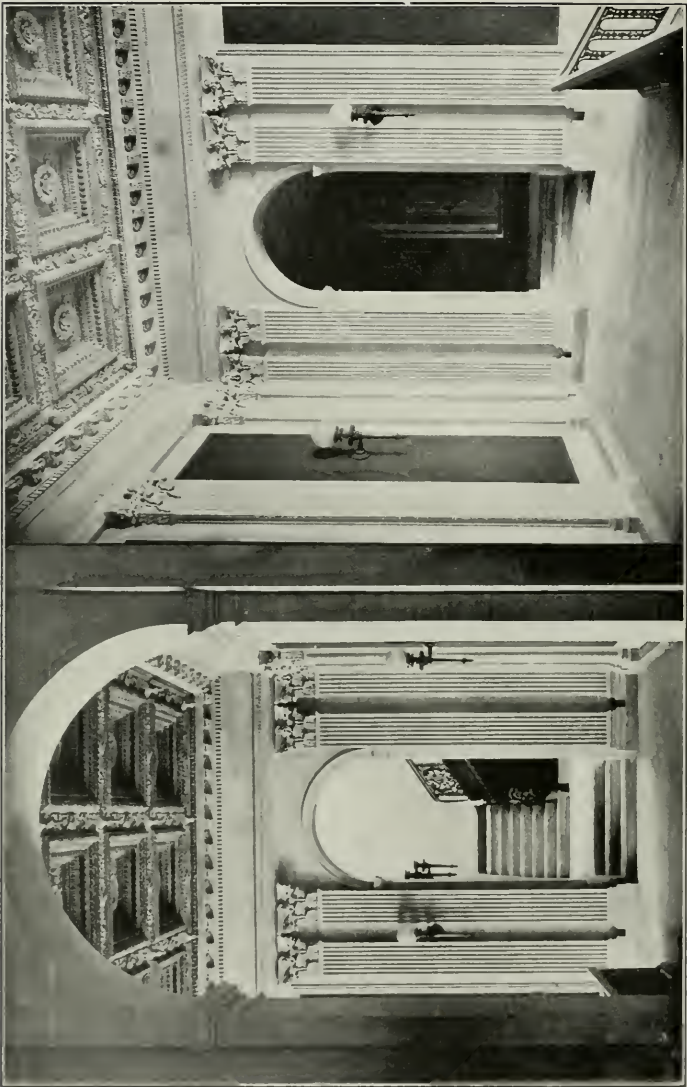

Main Staircase Hall, Pacific Union Club

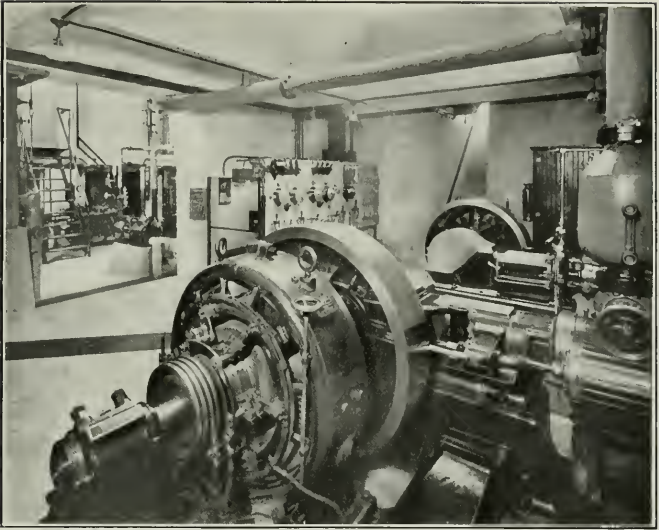

*Power Plant, Pacific Union Club Building. This and Other Mechanical Features were Designed and Installed Under the Supervision of Mr. Geo. E. Atkins, Mechanical Engineer of the Firm of Willis Polk & Company*

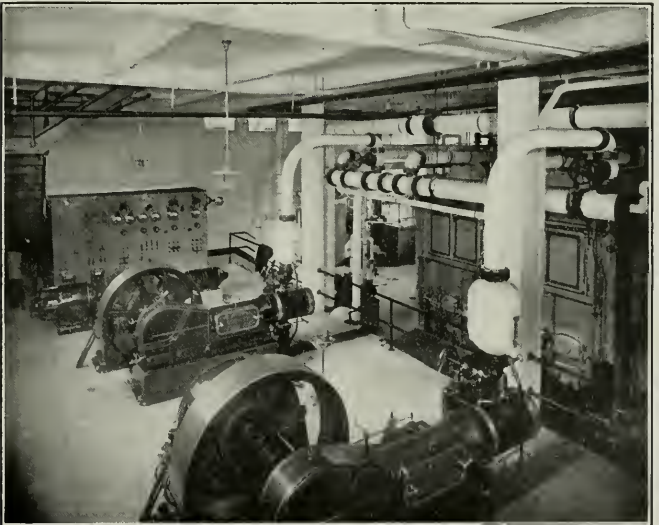

*Mechanical Plant, St. Mory's Hospital, San Francisco, California*



*Completed Section and Entrance Gates, St. Mary's Hospital, San Francisco, California.\**

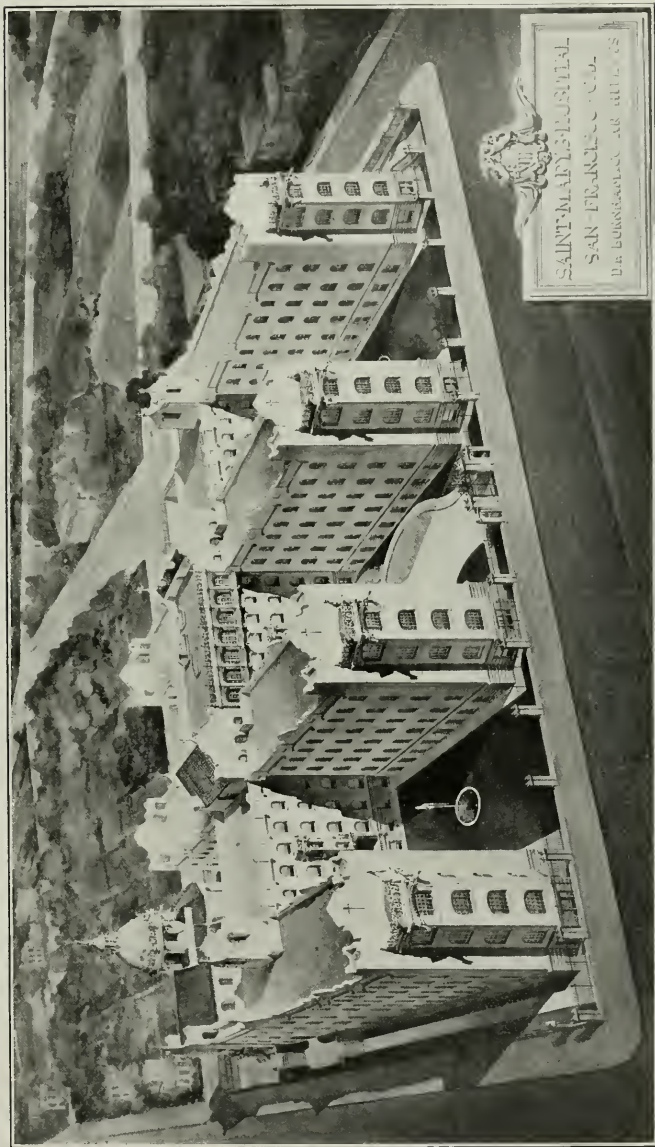

Perspective of Complete Scheme, St. Mary's Hospital, San Francisco, California



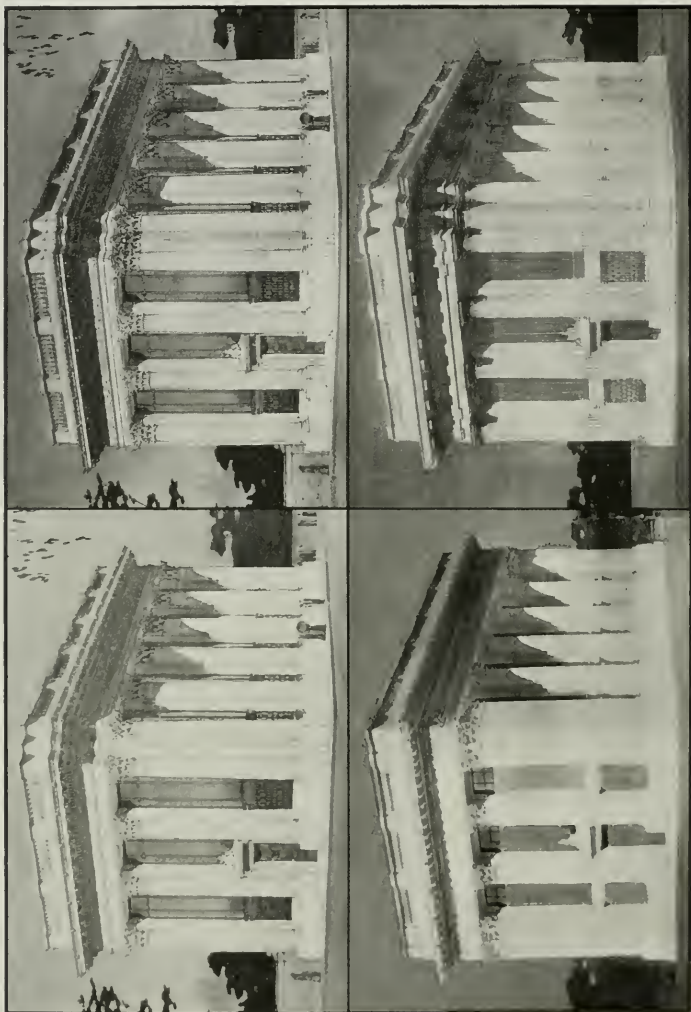

*Some of the Alternate Designs for the National Bank of D. O. Mills & Company, Sacramento, California*



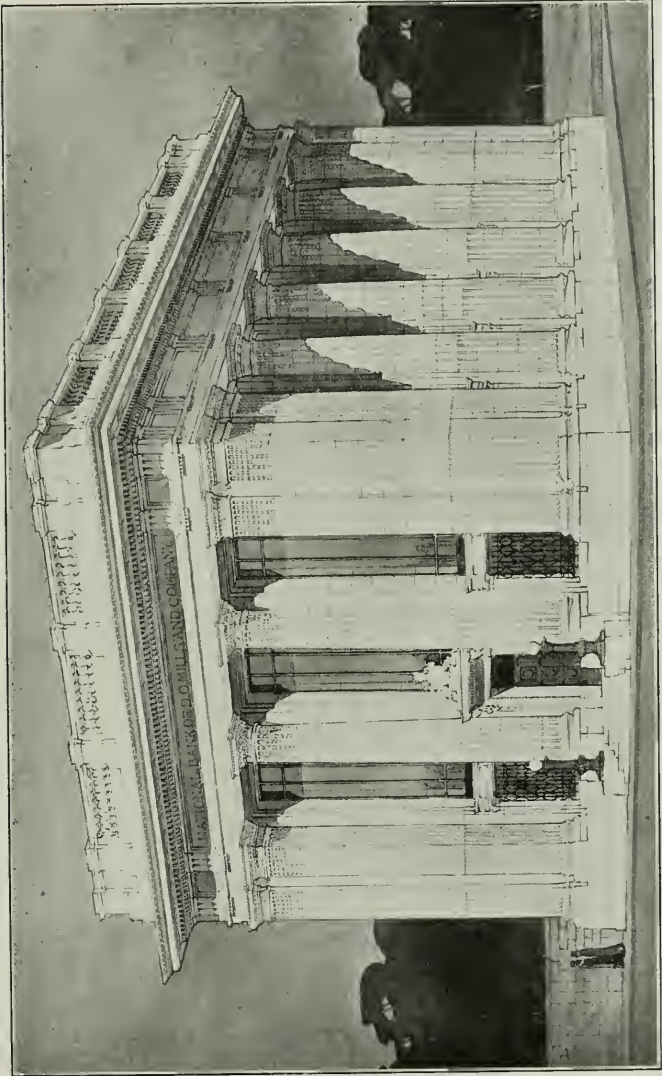

Accepted Design, National Bank of D. O. Mills & Company, Sacramento, California

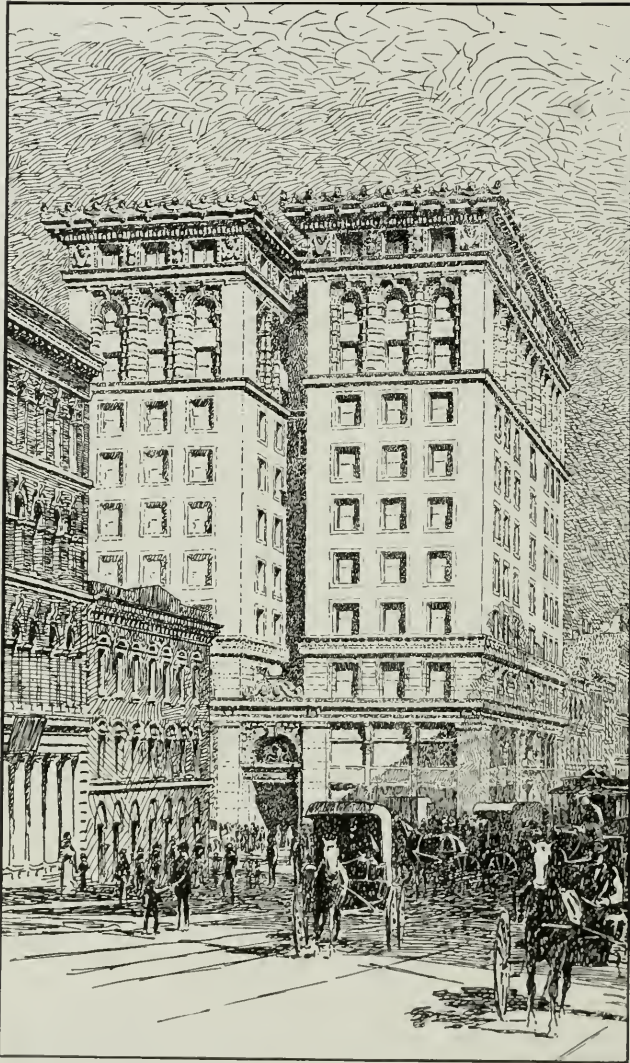

*The Kohl Building, San Francisco. Designed for Mr. Alvinza Hayward, by Percy & Polk, Architects, and Erected Under the Supervision of Mr. H. H. Meyers.*



Merchants Exchange Building, San Francisco\*

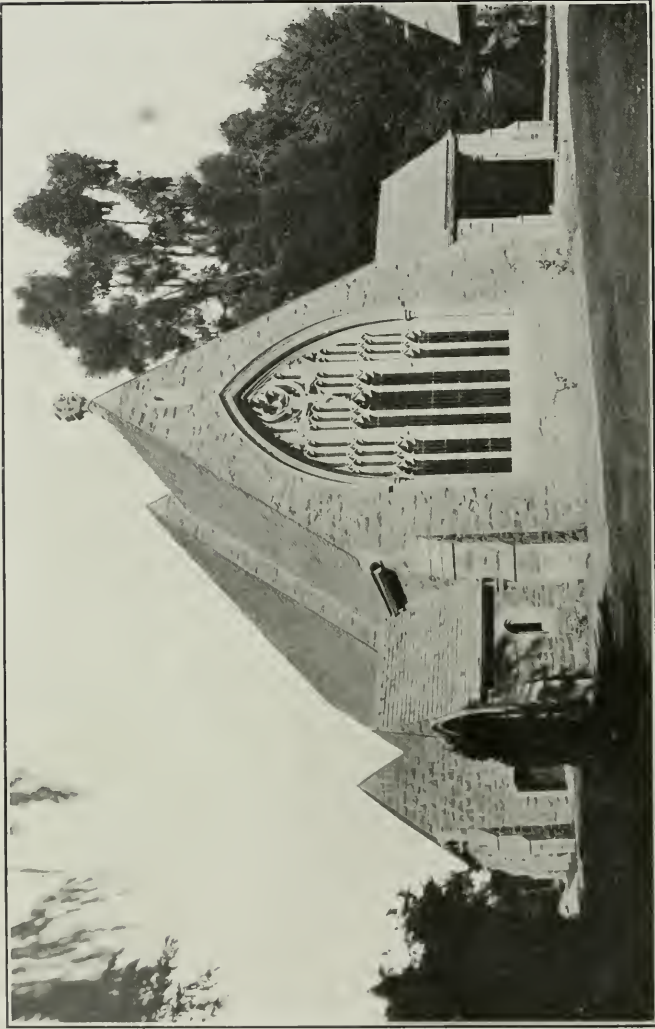

Church of St. Matthews, San Mateo.\*





*Building for the Regents of the University of California, San Francisco*





*Building for the Estate of Mr. Claus Spreckels, San Francisco, California.\**

The wisest men know that evolution, the laws of orderly growth, make the strength of an art, as of civilization; that sudden revolts, the desire for something wholly new and amazing, are but diversion and waste.

It is to the credit of Mr. Polk (with the eagerness and adventurousness of his gifts) that he has not experimented; that he has maintained a reverence for the sound traditions of architecture. It is this steadiness and respect for what has been accomplished in the past and his alert intelligence in adapting the tradition to modern usage, that give his work its value in the present and its possible challenge to the future.



*Depot at Sacramento for the Western Pacific Railroad.\**



Stations C. and G., San Francisco Gas and Electric Company, San Francisco, California.\*

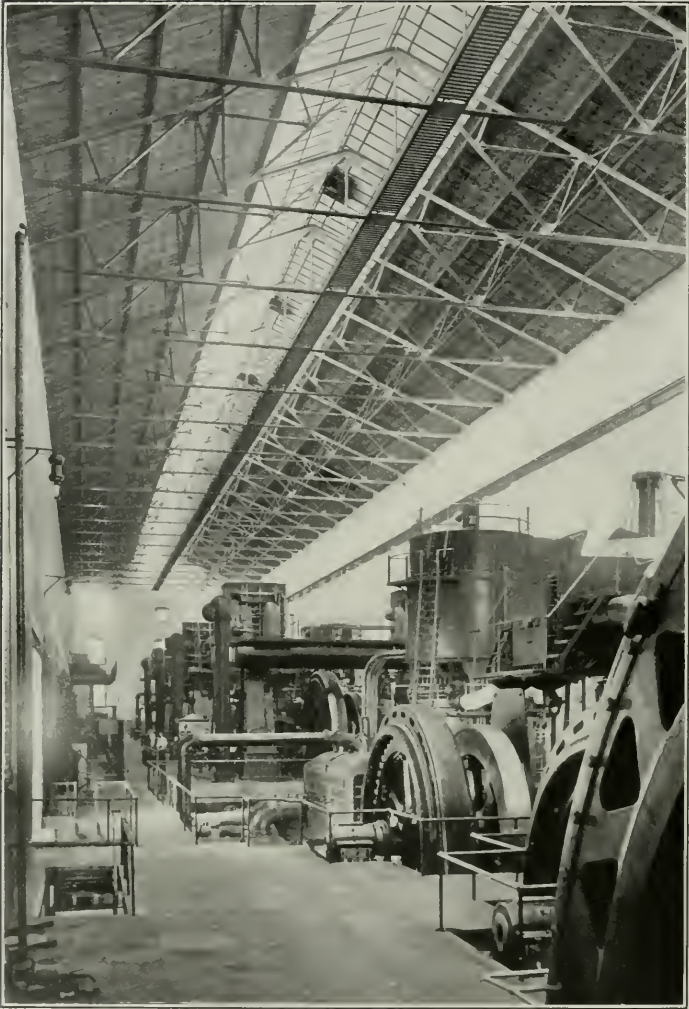

*Interior Station 1, San Francisco Gas and Electric Company, Showing Roof Construction.*

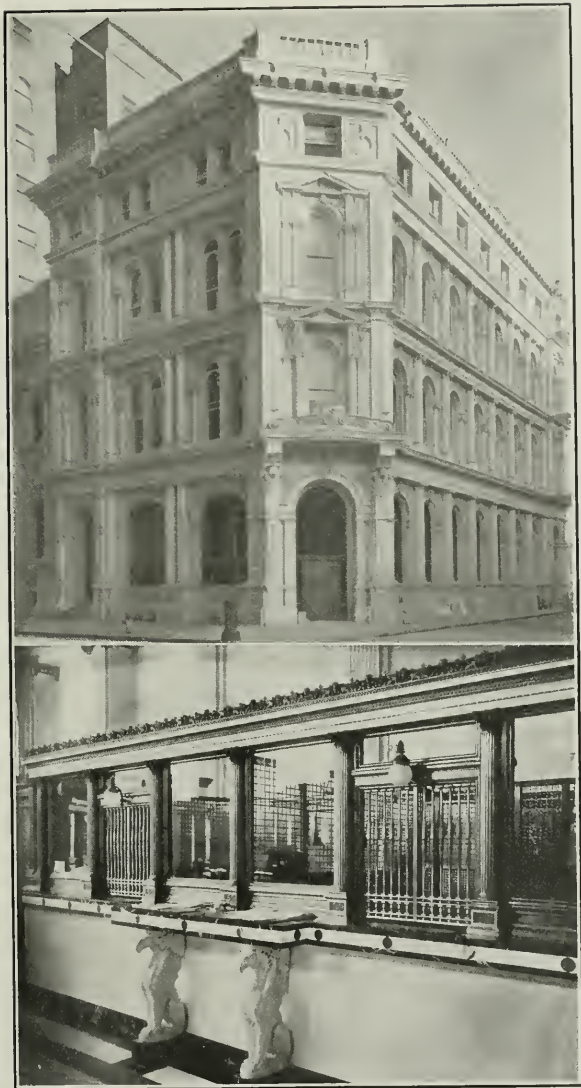

*Exterior and Bank Counter Screen, San Francisco National Bank Building.\**

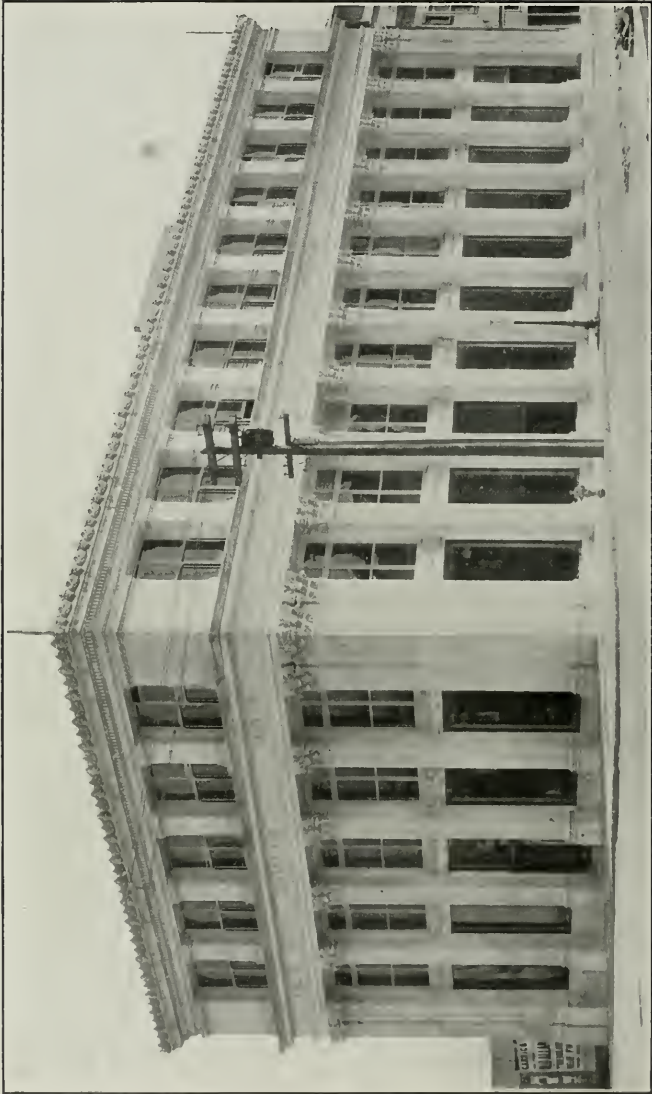

Building for Mr. Cuyler Lee, San Francisco, California.\*





*Mills Building, San Francisco, California\**



*Fredericks Building, San Francisco, California\**



*Entrance, Pacific Union Club Building*



*Drawing Room, Residence of Mr. Geo. A. Pope, San Francisco, California*



*Entrance, Residence of Mr. W. B. Bourn, San Francisco, California*



*Entrance, Residence of Mr. G. W. Gibbs, San Francisco, California*





*Veristyle at the Foot of Market Street, San Francisco. Designed by Mr. Polk as a Suggestion for Relieving Traffic Congestion and Beautifying the City's Approach*



*Mr. Polk's Private Office*



*The Sydney M. Smith Mausoleum, Cypress Lawn Cemetery*



*Chronicle Building, San Francisco, California*

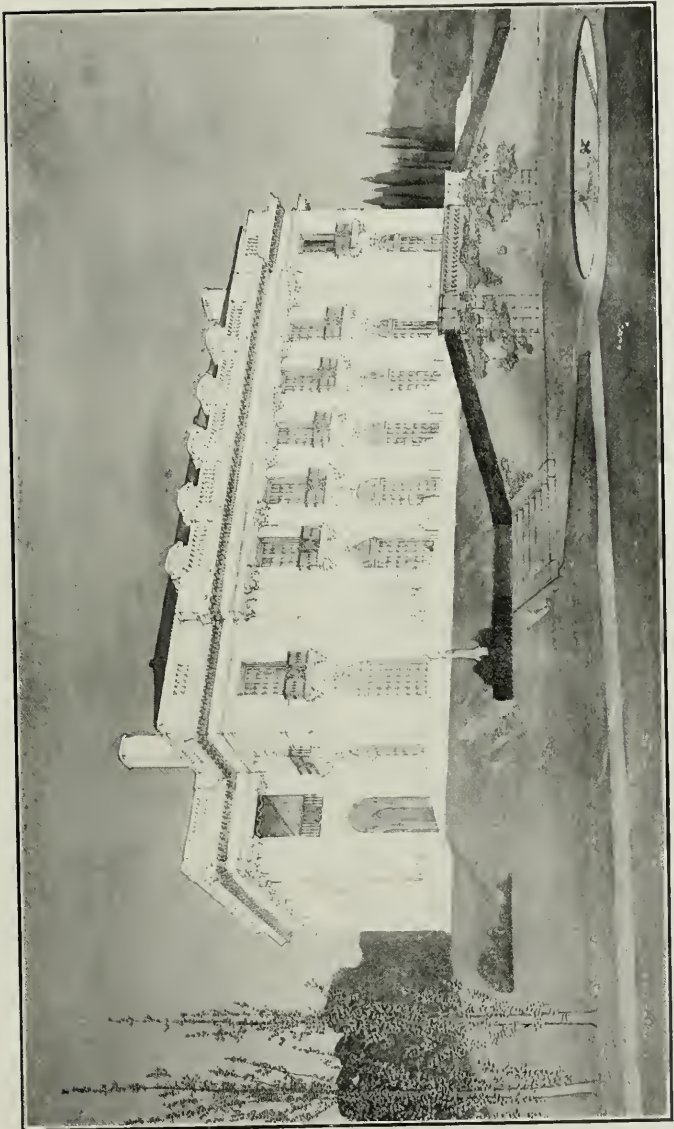

Perspective of Proposed Oakland Residence, Oakland, California

## Modern Illuminants and Their Correct Use\*

By FRANKLIN WELLS LOOMIS, Illuminating Engineer.

It is not the object of this brief paper to do other than call to your attention a few of the salient points necessary to obtain good illuminating results. The subject chosen may strike you as being rather of a misnomer as it is not the author's intention to mention all the different types of modern illuminants, but rather only the latest developments in the incandescent electric lamps.

Let us begin with the carbon lamp. In its varying forms this lamp has been on the market for something like thirty years, the filament in turn being made of paper, bamboo fiber and other materials which could be carbonized. At present cotton is the material used. This lamp has been developed from an inefficient lamp consuming ten or more watts of energy per candle; in the 16 candle power lamp, which may be called the standard, to the modern carbon lamp of today, that from 8 candle power units up, take on an average of only 3.1 watts per candle. These figures are based on the new "Top" voltage rating; the modern incandescent lamp having a three voltage rating, i. e., "Top," "Middle" and "Bottom." The candle power and the energy per candle power varying materially as the voltage. As an example of this new rating take the 50-watt carbon lamp:

Voltage Mark	Actual Watts	Mean Horiz. Candle Power	Watts per M. H. C. P.	Life
Top	50.	16.8	2.97	700
Middle	48.2	15.2	3.18	1000
Bottom	46.4	13.7	3.39	1500

This with only 2 volts variation between Top and Middle or Middle and Bottom voltage.

For 50-watt units, the Gem and Tantalum compare as follows:

	Voltage Mark	Actual Watts	Mean Horiz. Candle Power	Watts per M. H. C. P.	Life	
Gem:	Top	50.	20.	2.5	700	
	Middle	48.4	18.3	2.65	1000	
	Bottom	46.7	16.6	2.81	1500	
Tantalum:	Top	50.	27.9	1.79	800	} On direct current
	Middle	48.5	25.9	1.87	1100	
	Bottom	47.	24.1	1.95	1500	

With Mazda Tungsten we have no 50-watt unit, but the nearest size comparable in candle power is the 25-watt lamp:

Voltage Mark	Actual Watts	Mean Horiz. Candle Power	Watts per M. H. C. P.	Life
Top	25.	19.1	1.31	1000
Middle	24.2	17.7	1.37	1300
Bottom	23.4	16.4	1.43	1700

But to return to lamp developments. Some six or seven years ago a new lamp was developed that was really the first step toward the modern lamp. This new unit, the Gem, was similar to the old carbon, but showed an efficiency of 2.5-watts per candle beside emitting a slightly whiter light.

The next lamp in order of development gave a still whiter light. This, the Tantalum, consumed 2 watts per candle and is primarily a lamp best

\*Paper read before San Francisco Chapter, American Institute of Architects.



suites to direct current service, although when burned on an alternating current it now shows a reasonably good life of from 400 to 500 hours; the carbon life being approximately 600 to 700 hours of useful life.

The latest lamp to be developed is the Tungsten, also called by some of the lamp manufacturers the "Mazda." This lamp consumes but 1.25 to 1.33 watts per candle, and is the whitest of the electric incandescent lamps. Its average useful life being approximately 1000 hours; this being 300 hours better than the life of the carbon lamp. The Tungsten or "Mazda" lamps show equally well on direct or alternating current, and are much less susceptible to voltage variations than the carbon or Gem types.

Up to the present time the Tungsten filament has been extremely fragile when cold, but the drawn (Tungsten) wire filament promises to eliminate this weakness. In this newest development it is promised that we have a lamp that can be burned in any position and under any condition without a shortening of life shown in the earlier lamp of this type.

A color comparison of the Tungsten or "Mazda" lamps with the Tantalum, Gem and carbon is interesting. This, with the Mazda-Tungsten rated 100%, red, green and blue, is as follows:

	Red	Green	Blue
Mazda-Tungsten	100	100.	100.
Tantalum	100	96.8	73.6
Gem	100	93.6	72.8
Carbon	100	90.6	70.2

Now, having briefly dwelt on the different types of lamps, a few words on how to use them. There are three vital points to bear in mind, in order to obtain good illumination—quantity, quality and the correct use or control of the illuminants to the best advantage. Quantity may readily be taken care of as we range in sizes from one candle power to four hundred in individual units, while in combination any amount may be obtained. Quality is also taken care of in the wide range of color covered by the illuminants themselves. But the third factor, correct use, how many times is this neglected or at least slighted. Shades, of a light-throttling nature, are used many times when an efficient reflector or diffusing globe should be applied. The units are improperly spaced. They are hung too high or too low. The lighting is glarey, or the color of the illuminants chosen does not harmonize with the color scheme of the room and a host of other mistakes are made.

Now, to be good, illumination must please the eye. The intensity should not be too much nor too little and a balance of both light and shadow, to satisfy the eye, is imperative. No intensely bright light should be used in the field of vision as the eye is especially sensitive to glare, and thousands of cases of eye strains are due to the use of bare or glarey units.

The brilliancy of sources of light that are in the line of vision should not be higher than approximately 5 candle power per square inch luminous areas.

The following are excerpts from the table of intrinsic brilliancy of light sources.

	Candle Power per Square Inch
Frosted incandescent .....	2 to 5
Candle .....	3 to 4
Gas (open) flame.....	3 to 8
Oil flame .....	3 to 8

Gas Mantle .....	20 to 50
Bare carbon incandescent.....	375 to 480
Bare Gem incandescent.....	625
Bare Tantalum incandescent.....	750
Mazda-Tungsten incandescent .....	875 to 1000
Sun at horizon .....	2000
Sun at zenith.....	600,000

You will note that the sun at the horizon is but twice as brilliant as the Mazda-Tungsten, yet, how long can the eye stand its glare unshielded?

Where the illuminants must, of necessity, be hung low or within the range of vision, they should invariably be shaded or covered with some good diffusing medium. Flickering light sources should be carefully avoided as such are extremely trying to the eye. Examples of this effect are apparent in many building, having isolated plants, where both elevators and lights are served from the same generators.

Striations or spots in illumination are very trying to the eye, and should be avoided. These spots show with many of the polished reflecting surfaces, such as opal, silver, aluminum, and the mirror, but can be eliminated by using a frosted bulb lamp. Depolished opal and mat or brushed finished aluminum or silver should be used when the lamp is clear and these materials chosen.

Let us dwell for a few moments now on the control of our light sources. The light may be diffused or reflected and in each case a definite result may be obtained. The more commonly used diffusers are of opal or roughed (i. e., acid, ground or sand blast) glass globes. With any of these mediums the resultant distribution is approximately spherical, but they do not distribute the light widely over the horizontal plane below the light source. Also according to the density of the glass the loss of light through these materials is high, some being as great as 60%. Below is a table showing the absorption of light by such globes—also other glass globes.

	Per Cent of Light Absorbed
Clear Glass .....	5 to 12
Holophane Prismatic Glass.....	5 to 15
Light Sand Blasted Glass.....	10 to 20
Alabaster Glass .....	10 to 30
Canary Colored Glass.....	15 to 20
Opaline Glass .....	15 to 40
Ground Glass .....	20 to 30
Medium Opalescent Glass .....	20 to 40
Opal Glass .....	25 to 60
Heavy Opalescent Glass .....	30 to 60
Milky Glass .....	30 to 60

The prism, when scientifically designed for this use, is an excellent diffuser, while in the factor of absorption it heads the list running 15%, or less, of light absorbed. This figure does not apply to all prismatic globes however, as some, where the prism is not correctly designed, absorb a terrible amount of light, the factors reaching as high as 50 to 80% in some specimens.

Among the reflecting mediums polished silver heads the list with a co-efficient of reflection of 92%, followed by the prism, the mirror or silvered

surface glass, aluminum finished metal, the opal and alabaster glasses, down to the painted tin reflector.

The distribution of light obtainable on the horizontal plane below the light source varies from those extremely broad, covering 120 degrees over all, to the acme of concentration, giving the maximum intensity directly under the light source. For each problem of illumination there is a definite requirement for a light source and its controlling medium.

Compare the control of light with that of water from the ordinary garden hose. The spray stream is for sprinkling the garden or lawn, yet we have to turn the nozzle for the concentrated stream to wash off the windows, reverse the process and the dirt remains on the window while the grass on the lawn is ripped up. So, too, in lighting; use the concentrator where the spot light effect is needed and the distributor where wide areas are to be covered with even illumination.

Much, also, depends on the position of the properly designed reflector over the lamp. The length of the base of the modern lamp varies so, that to obtain the correct results, the right holder must be used. Lamps having the standard length base take the standard (Form "O")  $2\frac{1}{4}$ -inch or standard  $3\frac{1}{4}$ -inch holders, while the larger sized lamps having the long or skirted base, require the (Form "H")  $2\frac{1}{4}$ -inch or the (Form "A")  $3\frac{1}{4}$ -inch holders. Improper use of holder will throw the lamp out of focus with the reflector and many times makes a distributing type concentrate or distorts a concentrator so that it loses its value.

The amount of light necessary to illuminate a given area should be given attention as the requirements vary materially according to whether the walls and ceiling are light or dark.

Below is the result of an interesting test, using Holophane prismatic reflectors, made in New York, some time ago, that shows in a very comprehensive way the extremes of variation, due to light or dark surroundings:

Condition of Ceiling	Condition of Walls	Increase over calculated Illumination
Very dark	Very dark	none
Medium	Very dark	15%
Medium	Medium	40%
Very light	Very dark	30%
Very light	Medium	55%
Very light	Very light	80%

To solve the ordinary commercial problems of illumination is a comparatively easy proposition with the rules at hand.

A table has been compiled showing the foot candle intensities recommended for the various classes of service, while a set of constants is available covering the different illuminants depending on the condition of walls and ceiling surrounding given light source.

Where the problem is more intricate, such as period lighting, or special effects, of course, the simple rules will not apply, but time and study must be given the subject before deciding on the type of illuminant proper to use and its correct equipment.

As a science, that of illumination has now been brought up to a stage where definite results may be readily obtained, and the illuminating engineer has his own assured niche in the scheme of construction and development of the world's affairs.

## Architects and Architecture

THESE are architects and architect; there is architecture and architecture. But architecture, in a greater degree than any other among the professions and the arts, is partly a profession and partly an art. The contrast between Inigo Jones and the designer of the speculative builder's row of cottages is something like that between Mendelssohn and the cornet player on an excursion steamer. The one loved his art and lived for it above all else; the other cares principally about getting his meals regularly from day to day. The one aimed high, the other has no ambition; the one was an artist, the other is not.

Unfortunately, in architecture there are many things which tend to dull the artistic sensibilities. Most of us at the outset of our career have imagined ourselves geniuses, or, at any rate, artists to the finger-tips; and we have thought it possible to put all else aside and devote ourselves to our art and nothing else, forgetful that a time must come when a living has to be earned, and when the business side must be cultivated. Now, the realization of high ideals in architecture, writes J. H. Graham, in *Architecture*, can only be accomplished by the aid of clients, except in the rare instances of these later days, when a genius has proclaimed himself by winning competition after competition. Otherwise there is no other way of obtaining work than by seeking it, just as any other professional man has to do. In this respect an architect is an artist, handicapped in comparison with his brother artists, the painters and sculptors, who produce and exhibit their works for all to see before they expect commissions to come to them. They are first judged by their works; the architect has to be judged before he can produce his works; unless, indeed, he possesses the means and the courage to build from his own designs in his earlier days. This is so costly a procedure that it is adopted by few. The young architect who has aspired at the outset to write architecture large, who has studied with every intention of being a leading artist in his generation, finds, in the majority of cases, that he has to place architecture in the background and obtaining commissions in the front; and then it may very well follow that the "jobs" by which he makes his daily bread consist of surveys for dilapidations, technical evidence giving, and the thousand-and-one supplements to architectural practice which are very far indeed from being architecture itself. In a little time the architect within him is liable to be crushed.

Yet if the vital spark is really there, there is no doubt at all but that it will manifest itself. The trained man, who is truly an architect, cannot help producing buildings which are themselves truly architectural. But in his daily life, such a one has to compete with the purely business man, who, though calling himself an architect, has no architectural capacity whatever, and little sense of the beautiful. Yet a man like this will talk more about architecture than the other, and his works will even appeal more forcibly to the public for which he caters. We could all name "architects" of our own day whose theaters, restaurants and public houses are well appreciated, but who could not, under any circumstances, design a building in good taste. These men make money. We could all equally well point to some friend, highly sensitive, artistic to his finger-tips, a designer of beautiful things, who has occasionally carried out a building for a man of taste, and been rewarded therefore by the applause of his brother artists, but the general public neglect to employ him because his work is not showy enough, because he does not boast or push himself, and, above all, because his buildings cost a good deal of money to erect as compared with their showiness. Such a man probably may, if he is fortunate, look forward to ending his

days as a draughtsman in a Government office, if he escapes the indignity of the workhouse.

It is generally admitted that art is greater than the artist, and just as generally that the artist in a man is greater than the man himself. When architecture has been at its highest, this has been most true. Though great works have been accomplished by architects who have left names behind them, larger in the public imagination than the buildings which they have created, yet the reverse is generally the case, and the most beautiful buildings of the world, if not the most sumptuous, have been designed by architects whose names have been entirely forgotten. Perhaps Wren is the greatest example of an architect whose name is one to conjure with, yet probably, to any beside Englishmen, St. Paul's Cathedral is more significant than Wren. To them it is only otherwise because Wren's name symbolizes a type of architecture which he was strong enough to introduce, not only in the greatest church of the metropolis, but also in the minor churches, of which he built so many; while they also know that he was a man of forcible character, as was also Bramante, the great Italian who preceded him as a pioneer. In both these instances we feel that the man was great, and that the greatness of the man had something to do with the power of his architecture; yet the artist in the end predominated over the man, and we admire the buildings now at this present day more than the character of the man who made them, placing his artistic capabilities above his character. Thus the building comes first, the artist second, and the man third, when viewed from the perspective of a later generation.

\* \* \*

## The Passing of the "King of American Contractors"

JOHN B. McDONALD, the eminent engineer and contractor, who did \$18,000,000 worth of work on the San Francisco harbor, died in New York early in March. Mr. McDonald was known as the "king of American contractors." He constructed the first New York subway and the Baltimore and Ohio tunnel in Baltimore, and was one of the most noted railroad and tunnel builders in America. He took the \$35,000,000 contract for building New York's first subway, and, after furnishing a bond of \$6,000,000, went ahead and built it—a work that included digging and blasting out 3,000,000 cubic yards of earth and rocks in the streets of a crowded city.

Mr. McDonald's profits from the contract are said to have been very large. Besides the great profits ensuing from the building of the subway itself, it is said that he made \$3,000,000 from land reclaimed by means of the earth excavated. Upon completion of this great work, in 1904, Mr. McDonald's work was recognized by a banquet given by many prominent men who have been identified with New York's rapid-transit problem. In recognition of the success of the enterprise which he undertook four years before, Mr. McDonald's friends presented to him a statuette of "Winged Victory."

Besides \$18,000,000 worth of work on the harbor of San Francisco, he constructed 400 miles of the Canadian Pacific railroad; he constructed the railroad tunnel for the Baltimore and Ohio under the streets of Baltimore; he filled a half-contract for the bridge at Montreal; he helped to build the Northwestern elevated railroad in Chicago; he dug nine miles of the tunnel for the Chicago waterworks, and a double track tunnel at Hamilton, Ont. and it was he who constructed the Entrerios railroad on the west coast of South America.



## National Fine Arts Commission May Help Select the Fair Site

A GREAT deal of interest is being taken all over the country in the selection of a site for the 1915 Panama-Pacific Fair, but it is said that no choice will be made until the National Fine Arts Commission, comprising some of the most noted architects in the world, has visited San Francisco, viewed the different sites proposed and advised with the Exposition Company.

An invitation to the Fine Arts Commission to assist in choosing the site has been sent to them and while the members cannot come officially in a body (their jurisdiction being British Columbia) they may come individually and advise with the members of the Exposition Company.

The personnel of the Fine Arts Commission includes names renowned throughout America and abroad. The chairman is Daniel H. Burnham of Chicago, who some years ago drew up the "Burnham Plan" for making San Francisco more beautiful. The other members of the commission are: Frank D. Miller, New York, vice president; Frederick L. Olmsted, Jr., New York; Thomas Hastings, New York; Daniel C. French, New York; Cass Gilbert, New York and Charles Moore, Michigan.

Several members of the commission have designed buildings and assisted in laying out the grounds at other expositions.

Arthur F. Matthews, a well known artist of San Francisco, has made the suggestion that the fair be on Nob Hill, the site comprising twelve blocks and lying between Stockton and Leavenworth, Bush and Clay streets.

He estimates that the area of forty acres could be bought for about \$4,000,000 and points out that some of the most successful fairs of Paris have been held within a restricted area. Matthews elaborates his plan with a sketch in *Philopolis*, a magazine devoted to glorifying San Francisco.

\* \* \*

## A Compliment to American Architects

(From *The London Builder*)

IT has been said that one of the reasons why American builders can accomplish work at a pace which seems incredible when compared with our usual progress, is the completeness and excellence of the details furnished by the architects and the high standard of knowledge among American architects' assistants of the methods of manufacturers and practical workers in the building trades. Americans familiar with the work of drawings of English architects are apt to chaff at our details, and say that they are mere sketches, alleging also that, except in rare instances, they have to be remade by draughtsmen in the manufacturers' shops before they can be regarded as intelligible to the average workman.

One is forever reading or hearing of the "rush" in which everything is supposed to be done "on the other side," and a certain amount of credence must be attached to such persistent reports; but there must be quiet places where, free from the distracting influence of pressure and hurry, men study calmly the plans and details for the remarkable enterprises for which the United States is so well known.

That architecture in America, notwithstanding the vast shoal of cheap, speculative building amongst which it finds itself, averages very high a

compared with standards of European countries, goes without the saying. In monumental work, especially public work, the Americans, as represented by McKim, White, Burnham, Cass Gilbert, Carrere, Hornbostel, Swartwout,—to mention a few of the names we all know—may be considered the peers of the French; in the architecture of commercial buildings, what architects of any other country can be compared with their men Sullivan, McKim and Burnham? In the field of ecclesiastical work there are Maskeray, Cram, Hastings and Maginnis, who are the equals of our own best designers, and whose opportunities have been greater. As to domestic architecture, in which we have, during some years, been credited with the leading position is not that also to be fairly challenged by such artists as Charles Platt, Wilson Eyre, Frank Wright, Elmer Grey, Albro and Lindenbergh, Bragdon, Stratton and Baldwin, and a whole host of others? And in every branch of this work, whether the smallest cottage or the greatest public structures, there is evidence of the most careful, painstaking and often brilliant study of details; and no one with the least knowledge of how work is done in our American contemporaries' studios can doubt that this is due to the enthusiasm they put into it. But aside from the enthusiasm and active leadership which an architect must himself take in his work, he must have the support and assistance of better-trained and better sophisticated draughtsmen than it is our present lot to be able to obtain in England.

\* \* \*

## Objection to the Narrow Building Lot

THE narrow building lot has drawn down upon itself a long merited rebuke in a recent issue of the *Improvement Bulletin*. At the same time some suggestions are made looking toward future betterment of building, and living conditions in growing towns which we want to indorse.

It is suggested that if the various legislatures want to take up a topic which would work to the advantage of the communities they could find a line of work for their activities in passing a law to regulate the minimum widths of city and town lots which might be accepted for platting. The acceptance of plats with twenty-five and even narrower frontages for residence sections is simply a move to the encouragement of huddling houses close together; of inducing the development of slums; of increasing fire hazards, and of encouraging the things which are most objectionable in large communities.

The fire insurance companies have but recently removed the additional charge which they formerly levied upon buildings which were within a certain limit, so they now ask no more for the extra hazard of a building which is within a few feet of its adjacent neighbor than for another which is twenty or more feet separated. The wisdom of this move is very doubtful, and it would seem that in view of the heavy losses which have been sustained in the larger cities there should have been an additional charge levied rather than otherwise.

The legislatures are supposed to be seeking to make laws which work for the benefit of the communities, and this suggestion of making narrow lots in residence districts harder to acquire is one way in which better things can be accomplished. Unfortunately the damage is largely done. Plat after plat in most towns and cities have been accepted, with miserable little strips of ground, and some sections show houses huddled up nearly like sheep.

## Architectural Competitions

By F. W. FITZPATRICK

MUCH is being said and still more written about competitions. They constitute the moostest of moot questions that assail the peace of the profession. Worse than that, they are a veritable ill, and one that, like a cankerous growth, threatens to poison and perhaps destroy the entire body. Strange too, how, just like so many other ills, we seek constantly to retouch it, gloss it over, perhaps minimize it and sometimes even make frantic efforts to better it, but never seem to even dream of boldly eradicating it!

Let me suggest something. No, nothing startlingly new or original, simply something quite old but forgotten, merely a resurrection of a cobweb antique, but one that in its time worked to a charm, and is today as fit as ever if we only have gumption enough to make it do duty instead of the frapped idea of "Competition."

Architectural competition never was, is not, and never will be an ideal way of selecting an architect. Not one owner in a hundred thousand has the qualifications necessary to a discriminating judgeship as to architectural merit; his selection is either a prejudiced personal one, or he is blandished by some trick of rendering, of glibness of tongue or vain promise of extraordinary or impossible achievement. If he selects a professional advisor it is rarely a great master, or a man of noted ability and keen sense of differentiation. The judge is seldom the peer—save in name—to many of the competitors and with all the prejudices, the whims, the narrowness of the individual to which is often added an impaired digestion. The successful competitor is usually not the one who even attempts to do his best for the owner, or who honestly endeavors to solve the problem, but rather the one who best knows the judge's whims, and is shrewd enough to cater or pander to them. If there is a board of award the case is but changed in detail—not in principle: you get a compromise between half a dozen or more personal prejudices, and that's all. At best a competition is a delusion and a snare, and too often it winds up in a mess or a scandal.

Once in a while, in a free-for-all competition, a great light, a new genius is discovered, but it happens so seldom that we hardly need to sit up nights watching for the new star. I have known something of that kind to happen but twice in the past thirty years, during which period I have been more or less actively intimate with competitions. Indeed there is scant opportunity for that sort of thing these days, as in most cases the big competitions, particularly the Federal and State ones, are "restricted." The eligible competitors are naturally the most successful practitioners and the big jobs seem to be, quite by accident, of course, portioned out with arithmetical precision and rotation.

Now then, instead of all this, that rarely conduces to the best results architecturally, why not call for "collaboration" instead of the farcical so-named "competition?" If the number of competitors can be limited, then certainly an owner may with equal justice select the local or other architect—in whose integrity and ability he may have confidence—to construct his building, to let contracts and all that sort of thing and then invite and pay one, two, four or more other architects to come in and collaborate with that one, pick his design to pieces, doctor it up, lambast it generally and then hammer it into shape. They'll evolve something worth while, too; and it's

so much more sensible than the competition notion. Especially for government work. In that the government is adequately, if not admirably equipped with supervising architect and all the necessary machinery for superintendence, contract-giving and all details that are infinitely better administered generally than is the case with private work. And surely is the government architect more intimate with departmental needs than any outsider can be and in better position therefore to plan the structure to fit its purposes. So instead of going through the motions of competition, why not try and get Congress to repeal the Tarsney act and pass another authorizing the executive departments to invite and pay five or six architects to collaborate upon each new building, to discuss the design with the supervising architect, to work together to get up something useful and beautiful and that will be the result of their united energies, skill and experience?

We have at least one or had one glorious example of what could be accomplished by collaboration, an example that yielded such vastly superior results to any "competition" that had ever gone on before it that it is a marvel, indeed, that it did not take deeper root in our ways of doing things architectural. I mean the Chicago World's Fair. There a splendid corps of architects was kept together, harmonized, led, scolded by that prince of organizers and executives, Burnham, and their united work gave us a group of buildings that for beauty, unity and adaptability has never been surpassed or even equaled for modern times, nor in classic antiquity. Those buildings were a lovely dream, they lifted one above the sordid things of earth, idealized that exposition, were its chiefest charm and fascinated the buholic plainsman as well as the most cultured traveler.

COLLABORATION, that's the word. Why not try it again.

\* \* \*

## Cement Bungalows

Architects and home-builders have discovered, of late, that cement can be adapted to the construction of the bungalow with distinct success. Following this discovery, many bungalows of this kind are being erected in various parts of the country, and when skill and good taste are exercised in designing them, they present a very homelike and attractive appearance. Indeed, the indications are that cement will be one of the most common materials used in the construction of bungalows during the years to come; for the bungalow, as a type, has become firmly entrenched in the esteem of the people who desire simple and unpretentious homes, while cement has been established as one of the most valuable building materials known.—*Suburban Life.*

\* \* \*

## Concrete Coast Defenses

Recent tests at Sandy Hook of the resisting power of reinforced concrete as a defense against high-powered projectiles confirm the calculations of the penetrating power of the twelve-inch gun. A concrete well twenty feet thick, heavily reinforced with steel beams, was pierced by a twelve-inch projectile fired at high velocity. The blow delivered was sufficient to penetrate twenty-two inches of armor plate, and the reinforced concrete withstood the attacks so well that it will probably be used in the construction of the new coast defense fortifications in the Philippines. A similar attack is to be made with the fourteen-inch gun.

## San Francisco's Side of the Hetch Hetchy Controversy\*

By MARSDEN MANSON, City Engineer of San Francisco

SO much that has been misleading and erroneous has been written and stated with regard to San Francisco's application and grant for the use of the Hetch Hetchy reservoir for municipal water supply that it is necessary to lay before the public generally a clear statement of the law and the facts.

By the act of October 1, 1890 (26th Stat. at L. 651), there was established a reservation in California, on the west slope of the Sierra Nevada Mountains embracing about 1,500 square miles, and subsequently known as the "Yosemite National Park." Section 2 of the act contained the following provisions:

"That such reservation shall be under the exclusive control of the Secretary of the Interior, whose duty it shall be, as soon as practicable, to make and publish such rules and regulations as he may deem necessary or proper for the care and management of the same. Such regulations shall provide for the preservation from injury of all timber, mineral deposits, natural curiosities and wonders within said reservation, and their retention in their natural condition."

During the years 1887-88 and '89 the United States Geological Survey, in its investigations of the resources of the United States, found that within this area vast water resources originated, which are capable of being used to the benefit of the lands of the San Joaquin Valley which are deficient in natural rainfall for intensive farming; these resources could also be used for municipal and mining purposes. The Geological Survey therefore made examinations of the various reservoir sites capable of being developed and utilized as such, determined the general character of structures necessary, and made appropriate estimates of the capacities of these reservoirs, including Hetch Hetchy Reservoir. (See 21st Annual Report, U. S. Geological Survey, Part IV, Pages 450-453.)

Acting under this advice, and realizing that this and all reservoir sites must ultimately be utilized, Congress saw fit to modify the very rigid and inhibitory provisions of the law of 1890, and on February 15, 1901 (31 Stat. at L., Page 790), enacted the following law:

"That the Secretary of the Interior be and hereby is authorized and empowered, under general regulations to be fixed by him, to permit the use of rights-of-way through the public lands, forests and other reservations of the United States, and the Yosemite, Sequoia and General Grant National Parks, California, for electrical plants, poles and lines for the generation and distribution of electrical power, and for telegraph and telephone purposes, and for canals, ditches, pipes and pipe lines, flumes, tunnels or other water conduits, and for water plants, dams and reservoirs used to promote irrigation or mining or quarrying, or the manufacture or cutting of timber or lumber, or the supplying of water for domestic, public or any other beneficial uses, to the extent of the ground occupied by such canals, ditches, flumes, tunnels, reservoirs, or other water conduits or water plants. The electrical or other works permitted herein are not to exceed fifty feet on each side of the channel limits thereof, or not to exceed fifty feet on each side of the center lines of such pipes, pipe lines, electrical, telegraph and telephone lines and poles, by any citizen, association or corporation of the United States, where it is intended by such to exercise the use permitted herein for any one or more of the purposes herein named."

\* Address delivered before the Engineers and Architects' Association of Southern California, March 7, 1911.



(There then follow two provisos of no material interest to the question now being considered.)

“ . . . And provided further that any permission given by the Secretary of the Interior under the provisions of this act may be revoked by him or his successors at his discretion, and shall not be held to confer any right or easement or interest in, to or over any public land, reservation or park.”

It will be seen, therefore, that Congress, after an experience of more than ten years with the inhibitory law of October 1, 1890, above quoted, saw fit, after thorough examination and survey by its own agents of Hetch Hetchy Reservoir and other sites, to modify materially the inhibitory provisions of the law of 1890, to the extent of making possible the use of the water resources arising in the various reservations, public lands and parks named in the law. It will also be seen that this action was not taken without due consideration. Years of examination and study were devoted to the question by the trained officers of the Geological Survey, and more than a year after their report had been rendered, Congress passed the second of the laws above quoted. This latter law especially provides for the granting of rights-of-way for reservoirs.

The reservoirs were surveyed and pointed out by a scientific bureau of the government. Amongst these is the Hetch Hetchy Reservoir. On the floor of this reservoir there are meadow lands of something like eleven hundred or twelve hundred acres in extent. The title to more than six-elevenths of this area had passed from the Government to private parties prior to the act of February 1, 1890. These patented lands San Francisco purchased and holds. San Francisco also holds the right to utilize the remainder of the reservoir space, under the decision of May 11, 1908, of the Hon. James Rudolph Garfield, Secretary of the Interior, acting under the law of February 15, 1901. This latter right San Francisco holds under a law of Congress directly and distinctly passed for the purpose of pointing out to the public at large and making possible the utilization of reservoir spaces within the limits of the Yosemite National Park, as well as other parks, public lands and reservations named in the law cited.

It is to be noted that other meadow lands and other valleys have been filed upon by private individuals and by corporations within the limits of this reservation, but not one word of protest has been raised against these filings. Moreover, no protest was raised when the law opening these reservoirs to filing was proposed. Only after six-elevenths of the Hetch-Hetchy Valley are owned by San Francisco, and the remaining five-elevenths yet standing in the ownership of the Government and opened by its own acts to acquisition and utilization, and after San Francisco has been legally granted the use of this remainder, have protests been urged.

These protests come from two classes or sources: First, the Spring Valley Water Company, holding a monopoly of water supply for the City of San Francisco under the crude and ill-advised laws of the early history of the State of California, aided by those who have secured water power rights of enormous value for the development of electricity and the supply of water; secondly, a group of sentimentalists, who, in one-sided discussions amongst themselves, have decided that to “the people of the United States the Hetch Hetchy Valley has been deeded in perpetuity by Congress,” and that any utilization thereof, in accordance with the laws of Congress and in accordance with the right of the City of San Francisco to use its own holdings for the highest purposes for which they can be used, is a “desecration” of this valley.

Now, the facts are: That only to six-elevenths of the floor of the Hetch

Hetchy have any patents whatever or deeds in perpetuity been passed by the people of the United States. These are held by San Francisco. San Francisco also holds the right under the laws of this country to flood the remainder and use this and her own holdings for the highest purposes for which they can be used. The bills before Congress were not to grant San Francisco the right to use the valley, for that right that city already holds. They were to effect an exchange of lands, in order to return to the government lands to which it desires to recover title, and to remove the revocable nature of the permit already granted. It is not, however, probable, even if no exchange be effected, that, after large expenditures have been made, any Secretary of the Interior would in his discretion feel justified in considering the revocation of these permits.

But suppose these sentimentalists, backed by corporations of great power, should succeed in blocking San Francisco in this water development: Does any sane human being feel justified in considering that in the future this reservoir will not be used for the imperative needs of the human race—and possibly through the beneficent intervention of those “on whom God in His wisdom” has bestowed the right to utilize all sources of natural wealth?

It is manifest to any student of the economics of water supply and of development of electricity by water power that it is not intended by corporations who have appropriated or secured most of the sources of natural wealth that a city like San Francisco shall break into the holy circle of knowledge of how much it costs to develop, transmit and utilize hydro-electric power, or to supply the homes of a great city with that element of existence, water. It is clear that the opposition of this monopoly is selfish, and that its leading but misguided allies are the group of sentimentalists above referred to. Some few of these have actually seen the Hetch Hetchy Valley, have described the beauties of the flowers growing on the lands owned by San Francisco, have gone into ecstasies of delight over the curves and beautiful sinuosities of the Tuolumne River, flowing between green banks owned by San Francisco, have uttered their protests against cutting down oak, pine and cedar trees growing upon lands owned by San Francisco, have intimated that peaks rising one-quarter to one-half mile above the floor of the valley are to be devastated and ruined by flooding the reservoir two or three hundred feet deep, have published pictures of falls, of rapids, bluffs and magnificent scenery, big trees and precipices distant a score of miles or more from the Hetch Hetchy, and even beyond the limits of the Tuolumne watershed, which are to be “devastated” by the utilization of this reservoir. One writer in the “World’s Work” of April, 1909, published eight illustrations of scenery in and around the basin of the Tuolumne and in that of the Merced—some in the Yosemite Valley itself—only one of which will be in the least affected by the use of the lands owned by San Francisco for a water supply; the other seven are more than twenty miles distant, and six of them are not in the basin of Tuolumne River!

Another, in the May number of the “World Today,” publishes five pictures of similar features. The lower portion of the scenery in one only—namely, the Falls of the Hetch Hetchy—will be affected to a point some fifty feet below the bottom of the lower fall; the falls are above the highest proposed reservoir. The others are no more affected by this utilization of San Francisco’s lands and holdings than will be Central Park in New York or Hyde Park in London. Yet upon such articles as these public opinion is being formed upon the most erroneous and unjust basis.

Mr. John Muir describes some of these "endangered" features as follows:

"The most strikingly picturesque rock in the valley is a majestic pyramid over 2000 feet in height, which is called by the Indians 'Kolana.' It is the outermost of a group like the Cathedral Rocks of Yosemite, and occupies the same relative position on the south wall. Facing Kolana, on the north side of the valley, there is a massive sheer rock, like the Yosemite El Capitan, about 1900 feet high, and over its brow flows a stream that makes the most beautiful fall I have ever seen. The Indian name for it is Tueculala. From the brow of the cliff it is free in the air for a thousand feet, then strikes an earthquake talus and is broken up into a ragged network of cascades. It is in full bloom in June, and usually vanishes towards the end of summer. The Yosemite Bridal Veil is the only fall I know with which it may fairly be compared, but it excels even that wonderful fall in airy, swaying grace of motion and soothing repose. Looking across the valley in the spring, when the snow is melting fast, Tueculala is seen in all her glory, burning in the white sun fire in every fiber. Approaching the brink of the rock, her waters flow swiftly, and in their first arching leap into the air a little hurried eagerness appears; but this eagerness is speedily hushed in sublime repose, and their tranquil progress to the base of the cliff is like that of downy feathers in a still room. The various fabrics into which her waters are woven are brought to view with marvelous distinctness by the instreaming sunshine. They sift and float from form to form down the face of that grand gray Capitan rock in so leisurely and unconfused a manner that one may examine their texture and patterns as one would a piece of embroidery held in the hand. Near the bottom, the width of the falls is increased from about twenty-five feet to one hundred feet, and is composed of yet finer tissue, fold over fold—air, water and sunbeams woven into irised robes that spirits might wear.

"A little to the eastward, on the same side of the valley, thunders the great Wapama or Hetch Hetchy Fall. It is about 1700 feet high, and is so near Tueculala that both are in full view from the same point. Its location is similar to that of the Yosemite Fall, but its volume of water is much greater and at times of high water may be heard at a distance of five or six miles or more. These twin falls are on branches of the same stream, but they could hardly be more unlike. Tueculala, in sunshine, chanting soft and low like a summer breeze in the pine; Wapama, in gorge shadows, roaring and booming like an avalanche. Tueculala whispers that the Almighty dwells in peace; Wapama is the thunder of His chariot wheels in power.

"There are no other large falls in the valley. Here and there small streams, seldom noticed, come dancing down from crag to crag with bird-like song, doing what they can in the grand general harmony. The river falls about twenty feet into a surging trout pool at the head of the valley; and on Rancheria Creek, a large tributary that comes in from the northeast, there is a series of magnificent cascades, broad silver plumes, like those between the Vernal and Nevada Falls in Yosemite, half leaping, half sliding, down smooth, open folds of the rocks covered with crisp, clashing spray, into which the sunbeams pour with glorious effect. Others shoot edgewise, through deep, narrow gorges, chafing and surging beneath rainbows in endless variety of form and tone." (Century Magazine, August, 1908; quoted on page 38 of the Hearings of the Committee on Public Lands, U. S. House Rep., December 16, 1908.)

It may be comforting to the admirers of verbal lingerie and frills to be assured that none of these "networks," "veils," "fibers," "downy feathers," "fabrics," "textures," "patterns," "embroideries," "tissues," "plumes" nor "irised robes" are going to be interfered with in the least, now nor at any time in the future, as the features and phenomena which these millinery terms are intended to describe are far above the highest level of the proposed reservoir.

Let us for a moment forego the manifest truths, that the supply selected by San Francisco was not open in accordance with the government's own act and in harmony with the laws of Congress, and that the right to use her holdings for the highest purpose for which they can be used did not exist, and let us suppose that this magnificent supply had not been made available by Congress through the law of February, 1901. To what straits would San Francisco then be reduced?

First, it is recognized by all that this city must ultimately go to the Sierra Nevada for an adequate water supply, and that no Coast Range or nearby supply can ultimately be relied upon for this all important necessity of municipal and domestic existence. Under the munificent laws of Congress each and every one of these other Sierra sources from and including Feather River on the north to Stanislaus River on the south, has been "appropriated" by corporations and individuals who hold them at exorbitant figures; so exorbitant that one, devoid of adequate reservoirs, complicated with prior users and rights, utilized by the State for power and light, and by land owners for irrigation, polluted by hotels, summer resorts, farms, cattle ranges and other human activities, was offered for the modest sum of \$10,500,000, including works not definitely specified.

We will name over these various "possible sources."

First, there is Feather River on the north. Every adequate reservoir within this drainage basin of more than 3500 square miles is held by corporations looking to the development of or actually engaged in the development of electric power. Within this watershed are mining operations, villages, towns and farms, which contaminate the water to such an extent that if diverted at any reasonable point it would have to be filtered, conducted in closed conduits to San Francisco, and there pumped for distribution at elevations reaching from sea level to more than 700 feet above. Not one kilowatt of the power necessary for this pumping could be obtained except by the leave of some corporation which has taken up and appropriated these rights, without protest from the hundreds who protest against San Francisco doing exactly what these corporations have done for selfish ends and for their own purposes under the laws of the same Congress.

The next drainage basin south of the Feather River is its tributary, Yuba River. Every reservoir, every fork of this river is held by private corporations engaged in the supply of hydro-electric power, irrigation water, mining operations or other activities. In the entire basin of Yuba River, every one of its forks, every one of its reservoirs is owned or utilized by corporations or individuals who have appropriated and are in whole or in part utilizing its resources. It is nearly as remote as Feather River, and its waters from the upper portions, even if kept pure from contamination, would have to be transported through closed conduits over long distances through a closely inhabited, cultivated or grazed country. If permitted to flow along their natural channels to the lower reaches, to be there diverted, stored waters would become contaminated by drainage from closely occupied regions. The present users of these waters would have

to be compensated should they be diverted to other purposes, and riparian rights would have to be satisfied. These considerations and the contamination of the waters by mining debris, lead the engineers considering the various sources in 1900-1901 to abandon further consideration of Yuba River as a source of supply for municipal purposes.

The next river, the American, drains some 1800 square miles, but has no adequate storage areas within its basin. All of its low waters are fully utilized. Many of the rights are not fully established nor adjusted, so that San Francisco or any municipality utilizing these waters would have to buy out in many instances several claimants. The physical conditions known to the engineers who advised San Francisco in the beginning of these water supply examinations were such as to absolutely prohibit the use of this watershed as a possible source, and it was known that it was not necessary to make extended examinations of its manifestly inadequate possibilities.

Lake Tahoe, lying on the east side of the main crest of the Sierra Nevada mountains, has been proposed as a source. This source is impracticable for several reasons. First, it would require extensive tunneling through the Sierra Nevada mountains; second, these waters are utilized in their flow down Truckee River out upon the plains of Nevada for power, irrigation and municipal supplies. In this development, the United States government stands first in its "Truckee-Carson" project. Third, around the margins of this magnificent mountain-bound lake have grown up dozens of resorts and hundreds of summer homes, the drainage from which must ultimately pollute to a certain extent even the superbly pure waters of this grandest of mountain lakes. This source is therefore absolutely ruled out of practical consideration.

South of American River is the Mokelumne, with quite a number of small reservoir areas, all fully owned or utilized by corporations and none available except at great cost.

Next south is the Stanislaus; adequate in area, with pure waters, subject to slight contamination, but owned for many years past by corporations engaged in the development of hydro-electric power, and recently purchased from them by the United Railroads of San Francisco for the operation of their system.

Between these are one or two minor streams and lakes, Bear River and the Cosumnes, which are inadequate both in volume, storage capacity and possibility of utilization and are, moreover, lower down on the Sierra and of very inferior quality when compared with other Sierra streams.

It will be seen, therefore, that there does not exist on the west slope of the Sierra and north of the Tuolumne River a single stream which could be utilized, as has been so glibly suggested. Moreover, if these waters could be utilized, there yet remains the fact that these very corporations are allied in such a way that San Francisco would have to purchase from one or the other the power necessary to raise these waters to sufficient elevation to supply all of the five upper levels, if not the lower ones, into which the city is naturally subdivided.

It has also been alleged that in utilizing the water flowing from the basin of the Tuolumne River above Hetch Hetchy reservoir, the public must be shut out from the "people's playground." Let us study a moment the features of this "playground."

First, it constitutes 483 square miles. Through it there lies a single practicable road. Not one-tenth part of the area is accessible to any but



the hardest mountaineer, and that only during the months of June, July, August and September. Nine-tenths of it or more are mountains of extreme ruggedness, through which over narrow and dangerous trails only the hardest of mountain climbers can pass.

To speak of this as a "playground" is erroneous in the extreme. It is full of temples, placed by the hand of the Almighty in remote and inaccessible ridges and peaks rising to snowbound heights of ten to thirteen thousand feet above sea level in order that only those devotees whose worship is pure shall ever reach their gates. Shut out forever from the weak, gaping crowd who have not the energy or the soul to appreciate their grandeur, inaccessible and severe, they frown upon the weakling who would attempt to scale their sacred precincts as a "playground." From these superb heights there flows as the snows of winter melt, the purest water. During this period of melting man again can not reach the higher levels.

Only when the mountains are free of snow and the run-off practically ceased can the devotee reach these regions. During this period camp waste and impurities are exposed to the glaring sun of the clear skies of California. Later any germs which may exist in these wastes are exposed to the frosts of early autumn. It is well known that harmful bacteria can not exist under a few hours of sunshine, and but few withstand a night of frost. If the members of these mountain-climbing clubs are the polluters which their brethren represent, they should be ruled out not only from the basin of the Tuolumne, but from any mountain region from which human homes are supplied with water. If during the few months of summer and early autumn waters flowing therefrom shall be polluted by the few tourists whose energies and devotion may carry them into these regions, what must be the degree of pollution to which lower and more accessible areas, full of human climbers, are subjected?

\* \* \*

## A Good Word for Bricks

**I**N UNCOVERING the fine stone bridge over the moat at Hampton Court Palace, England, some interesting discoveries have been made.

In the wall of the north wing two large archways have been revealed, evidently designed to bring the water into the moat; and on the south side have been found some curious brick steps leading by an archway into the moat from a subterranean way. There is much which points to the waters of the moat having been utilized to flush the vast system of arterial drainage which was one of the main features of this palace. The brickwork of both the moat wall and the main building, though buried for two hundred years, has mostly been found in as satisfactory a state as the stonework of the bridge. Where it was otherwise, it has been carefully patched with the old Tudor bricks. Tens of thousands of these—unrivalled for their texture and their varied tones of rich color, extending from dark purples and crimsons to bright rose—have been collected from the debris and put aside for the restoration.

\* \* \*

**ERRATA** In the work of Willis Polk & Company an asterisk should appear under the cut of the Chronicle Building, indicating that it was designed by D. H. Burnham & Co.

On page 80 in the article headed "National Fine Arts Commission," a typographical error appears, the jurisdiction of the commission being made to read "British Columbia" instead of "District of Columbia."

## The Passing of the Den

By ANN WENTWORTH, in the House Beautiful

**F**EW blueprints now have the word "Den" fixed thereon, nor do many ground floors contain this once-popular room. It is passing away, together with "roomy" kitchens and large old-fashioned bedrooms.

In the general re-arrangement of the main rooms of the house there seems to be no longer a crying need for a place dedicated to Turkish pipes and cozy corners.

The gain in space makes possible a larger living-room; and there are other desirable features which may be attributed to its absence. Yet this much-abused room served a useful purpose and was quite a factor in bringing about several household reforms.

The first "dens" were merely means of escape from the over-feminine parlors and reception rooms. They were protests against lace curtains too easily contaminated by tobacco smoke, fragile furniture and bric-à-brac. At first they were as bare as a monk's cell. Unfortunately they did not stay that way. They were soon "decorated" and "furnished" and quite out-Heroded the reception rooms in the way of draperies and ornaments—only the ornaments were swords and daggers instead of Dresden figures and fancy matchboxes. Some of these rooms were really fine in a way and many of them were costly. One or two examples are recalled where Moorish schemes were carried out with great cleverness, but they were show places. The really comfortable every-day smoking-jacket kind of den was a terrible jumble of old and new. It was even stuffy, which was particularly unpardonable in a man's room. When the den was at its height as an exponent of Turkish schemes, the cozy corner was in the heyday of its youth. If memory serves aright, this was some time in the eighties, a darksome period in household art. Old things were passing away—new things, schemes, ideas had not arrived. It was the day of crewel work, of painted ginger jars, of decorated snow shovels and gilded rolling pins. "Artistic" was quite a new word. It meant something. "Aesthetic" was also heard a good deal. Sunflowers had a great vogue and cat-o'-nine tails were rediscovered.

Some one has described this period as a la Garfield, and perhaps it is as good a term as any. The crewel work and the painted ginger jar soon went the way of most ugly things, but the cozy corner was deeply rooted. It lasted through the nineties in a more or less vigorous form and lingered in the early years of the new century. It is not entirely obsolete now, though few people would have courage to call a corner, no matter how cozy, by such a name.

The big expositions in this country have had a marked influence on our decorative schemes. Possibly the Centennial had in an indirect way, for it came at a benighted period in our household art. Still, many hideous things in our homes can be traced to the influence of the Centennial. The British exhibit especially was at the bottom of many of the nightmares of the eighties.

But in 1893 all the foreign decorative schemes were much truer, and in 1904 they were well worth traveling many miles to see. The German and Austrian sections especially had much to offer in the treatment of libraries and studies. Nearly every suite had a man's room, and it was a convincing object lesson as to how such a place should be decorated and furnished. Sometimes the man's room was a library, but usually it was designed to

be a counterpart of the American den. But what a difference! The woodwork was the most remarkable detail about it, yet the wall treatment was invariably satisfactory and little fault could be found with the furniture. The whole effect was simple and entirely masculine.

In the first place, the woodwork was of a type then quite new in America, or at least known to few householders and little used by our architects. It was flat and so stained that the grain of the wood was plainly visible.

The stain was sometimes brown, sometimes green, and at other times a delightful gray. The color of the wall was usually like that of the trim, a little lighter or darker, and of most interesting texture. Variety was introduced in the accessories—occasionally in bands of inlaid work. The impression received was a very quiet one. It was the very opposite of our brass band schemes of mingled Oriental and North American Indian. It typified the comment of a well-known American illustrator regarding the poster work of Grasset. "It sang but never howled."

Of the many color schemes noted in the German and Austrian Buildings and in the "Rooms" shown in the Building of Varied Industries were numerous variants of the gray themes: blue-gray and green-gray and many combinations of true gray with a harmonizing color. There was little red, but a great deal of orange, used always sparingly, and there were some interesting combinations of blue, gray and green. Wall papers were little used; stains, both transparent and opaque, formed the usual wall treatment. Leather in one or two instances made an interesting wall covering, particularly in rooms where tans and light browns were the dominant notes.

The furniture in nearly every instance was good; some of it was a bit too Art Nouveau for the average house, but the color and finish of the wood and the workmanship were of the highest order. Inasmuch as these pieces were shown at a time when Mission furniture was at the height of its popularity, it was interesting to see what could be done on lines utterly different. The best of the furniture in these rooms was as simple as Mission, but without its extreme angularity. Many of our furniture shops now carry similar pieces, and today it is an easy matter to furnish a "man's room" in a manner pleasing to the owner, without falling back on any of the time-honored methods.

Mission furniture has helped in the evolution considerably. Whether we like it or not we can but realize that it made possible a simpler, saner scheme of furnishing; and in no part of the house were the results quicker than in the den. There are many rooms today where a neutral wall, Mission furniture and Navajo blankets make an exceedingly livable combination. One so-called "lounging room" is recalled where the impression in its way is as fine as any of the German schemes mentioned. On the wall is a grayish-brown stain so light and transparent as to show the grain of the plaster through. The oak trim is without finish except for a thin stain rubbed in by hand and quickly wiped off. Time will show whether this is sufficient treatment to preserve the life and beauty of the wood. At present it is very pleasing in tone and texture. After a good deal of hunting, Mission furniture was found that was not too dark for the trim, nor too heavy in design. This extremely dark mission was offered at a low figure, while the "fumed" and lighter shades were comparatively expensive. Most of the furniture was too highly polished for the dull finish of the trim; even when merely waxed it made the doors, moldings, etc., look extremely lifeless. But at last, just the right thing was found, and with the satisfaction which always attends such triumphs.

The owner of this house had a really beautiful collection of Navajo blankets picked up before aniline dyes and modern ideas of weaving were known to the Indians. Red was prominent, of course, in most of these blankets, but it was a rich deep shade, tempered by gray and black in a way known only to the older weavers. Used as rugs and couch covers, they were highly successful and, as no other figured material was seen in the furnishings, they gave a good deal of distinction. Shelves held baskets and pottery, and on the mantel was a collection of old iron implements. The Indian theme was the main one of the room, but it was not made unpleasantly prominent. A big, very plain fireplace was fitted with iron andirons. The lighting fixtures were also of iron. Before the hearth was a big black fur rug. The curtains for this room caused some perplexity. A stenciled material was tried and discarded. Cross stitching was given a trial. Finally curtains of crash, the color of the walls, were selected as suiting best the requirements. This material was made into cushions and looked very well with the gray of the Navajos.

This room was unusually good of its kind. The average Indian room is not very interesting from a decorative standpoint. It has too many things and too many colors and is a little on the brass-band order. While it would be difficult to find blankets and pottery of the type described here, still in time they could be secured, though really desirable Indian things are not cheap.

Unless the man's room is quite isolated, it fits best into the decorative scheme of the house when it conforms in woodwork and general furnishing to the other rooms of the floor. In the house mentioned the finish throughout was of flat oak, though it differed slightly in tone in the various rooms. Where white paint is used on the ground floor there are several good colonial schemes. Some of the old hunting papers with their vigorous color combinations and spirited drawing would be decidedly interesting. Occasionally it is possible to find rolls of old paper of fascinating pattern, and if one can afford them they are well worth their price, which is naturally high. The decorative quality of these sprightly scenes is considerable, and once on the wall, the other things in the room must take second place. Mahogany goes well with this background, so does simple pine furniture painted a solid color, green for instance, the tone of the trees in the paper. Rush furniture is also suitable, with frames painted an agreeable color.

A room well worth copying in an old house in New England has a curious paper which was imported from France in the early nineteenth century. There is first a fishing scene and then a hunting scene in two shades of gray—each about eighteen inches square. These are repeated over and over, covering the wall from the low wainscot to the ceiling. There is none of the decorative quality of the larger patterns where one "scene" covers merely one side of a wall and where the most brilliant colors are found. But in the gray paper of this old house there is a touch of flaming orange. It is in the form of a heavy cord of a most realistic appearance. It borders the paper near the ceiling in festoons and knots and drops in long strands with tassels at intervals of every seven feet. So real is the dangling tassel that one feels compelled to give it a vigorous pull, feeling that some invisible bell will ring in a remote kitchen and that toddy glasses for two will appear. Such things happened in the old days. The bell with a tassel is in the memory of many people who do not count themselves among the oldest inhabitants. For many years it was the regulation tavern bell for all the upper rooms.

In this room the orange cord is very attractive with the gray. On the floor is a craft rug in gray with a simple block border in orange with outer lines of green and black. The furniture is of the cottage type painted gray. At the windows are gray shades, but no curtains. There are white inside shutters that fold back into the panels, and of course, being New England, there are green blinds. Two old sofas are upholstered in green rep. The new and the old ideas do not clash. The craft rug does not quarrel with the old paper, nor does the new peasant pottery in green glaze fight with the old gray pewter. The color relation is extremely harmonious, which is always a necessity where old and new things are combined.

Probably this old paper could not be found in any shop. It was a private importation and too expensive to be very popular. But there are old papers in shades of gray and there are several good reproductions. The room in question is a man's writing room. There are guns over the old mantel and other things which give it a masculine atmosphere.

Many fitting schemes might be suggested. Dutch rooms, if well done, have the right flavor. The Grolier Club, New York City, has furnished inspiration for many such. German motifs on the Biedermier order would be well worth looking into, and coming to more familiar things, Tudor and Jacobean furnishings should not be overlooked. All of these schemes would have to be modified to fit into the average house, unless the "den" were in an attic or a detached building, where it might be as unlike the rest of the house as the owner pleased. Such a place, no matter what the scheme, should be spacious, simple, and comfortable. If it happens to be good, decoratively speaking, so much the better. If all the family prefers it to the rest of the house it may be considered a success.

If the children choose it above all other places for study and play, the daughters of the family to receive their friends, and the mistress of the house as a pleasant escape from the drawing room, it can be truly said to have all the hall-marks of an ideal "man's room."



*Apartment House, San Francisco. Bugbee & Bugbee Architects*





*American Ingot Iron Corrugated Culvert under a Placer County Road Between Alta and Emigrant Gap. Installed by Mr. Charles Geisendorfer, Supervisor, the Man in the Automobile*

## Culvert Construction\*

By PETER CAMPBELL.

IT IS necessary that the water which falls on the road and which flows upon it from adjacent lands, should be gotten rid of as soon as possible.

Culverts should be built at low points where outlets are available and existing streams should always be used for outlets. The water should never be carried in the side ditches any further than is necessary. When the volume of water is small, it may be carried across the road in small 12-inch pipe.

Large culverts and bridges should always be designed by competent civil engineers and constructed under their supervision. Indeed, very often the advice of such an engineer in regard to the smaller water ways might be sought with profit. Money is often wasted from a lack of knowledge concerning the proper sizes of culverts. When we first commenced the use of iron culverts, we made the common mistake of getting them too small in diameter and short in length, but we have since replaced some with larger ones and extended others that were short.

I am not an advocate of abutments except in rare cases, and for that reason I have always put in the culverts about four feet longer and obtained better results than by putting in abutments. My rule has been that when a 20 ft. roadway is desired, on a 5 ft. grade, that the culvert should be at least 30 ft. long, making the angle of repose 45 degrees.

We have replaced a very large number of our 12 and 16 ft. bridges with 4 and 5 ft. culverts, making a large saving in future repairs. In some cases we have placed 30 to 50 ft. bridges across dry ravines with 6 ft. culverts and made a fill of 10 to 20 ft. by cutting down hills, and making practically a level road with no future expense.

The question of culverts has always been a serious one and has been solved by some using steel, some American Ingot Iron, and others concrete. Culverts must necessarily be made either from wood, tile, steel, concrete or American Ingot Iron. So the question resolves itself into this:

\*Address delivered to the Commissioners' and Supervisors' Convention, Omaha, December 15, 1910, by Mr. Campbell, County Commissioner, Saunders County, Nebraska.

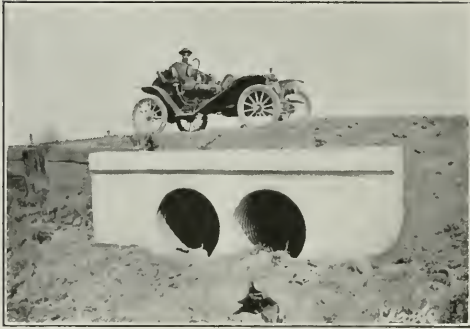

*A Wooden Bridge Has Been Replaced by Two American Ingot Iron Corrugated Culverts and Work Done by the San Joaquin County Highway Commission, Mr. R. M. Morton, Engineer, Under Bond Issue by that County of \$1,800,000*

"Who has the best and most enduring material?" So much is known of wood and tile, that any reference to them here will not be necessary, as neither should be used under any circumstances for culverts, because it is an absolute waste of money. We have used more American Ingot Iron culverts than any other county in the State, during the last six years. In the last four years, we have used more than \$8,000.00 worth per annum, and they have given entire satisfaction in every instance, except in one case, where the fault was ours and not of the culvert.

We have also used some reinforced concrete pipe, and find that some are in good shape, while others are all cracked up, and at least two are ready to collapse, due to the action of the frost.

The Montana Agricultural College issued a Bulletin No. 69 on "The Effect of Alkali on Portland Cement," in which they advise against the use of cement in alkali soils.



*An Ingot Iron Corrugated Culvert Under the Main Street of the Town of Susan. Note the High Snow Capped Peak of Mt. Shasta in the Back Ground*

I am advised that cement tile, at North Bend, used for drainage purposes, fell to pieces in eighteen months, due to alkali in the soil. Frost also has a tendency to destroy concrete pipe either by the water freezing in the pipe or by the heaving of the earth during the winter by freezing and thawing.

The amount of land to be drained should be considered when determining the diameter of a culvert, and it is always better to get it a size larger to allow for emergency. In laying culverts, they should be laid as nearly level as possible, and they are less liable to wash out than by giving them too much slope.

I have endeavored to give you my experience from conditions as they exist in Saunders County, and possibly a different treatment is required elsewhere.

\*  
\*   \*  
\*

## San Francisco Architectural Club

Mr. Arthur Brown, Jr., of Bakewell & Brown, Architects, gave an interesting lecture to the members of the San Francisco Architectural Club upon the "Life of a Student at the Ecole des Beaux Arts, at Paris." After the lecture refreshments were served.

At the last meeting of the club, Mr. Ernest Hildebrand, on behalf of the club members, presented Mr. Frank Farnkopf with a past president's badge. Mr. Farnkopf responded, expressing his sincere thanks and appreciation.

Mr. William Belk, a prominent member of the Architectural Club, at present on a leave of absence in Chicago, has won the traveling scholarship of the Chicago Architectural Club which carries with it \$600. Best of success and luck for "Billy."

At the last regular meeting of the club, Messrs. James H. Vollmar, Ernest L. Norberg, B. W. Dassow, Charles H. Pearson, J. K. Masben, W. T. O'Keefe, Roy T. Locke, W. F. Mellin, Saylor, Ralph Armitage, C. Koenig, G. Mitchell, Batchelder and Fowler Mallett were elected members of the club.

The membership committee of the club, composed of Mr. James Magee, chairman, Herbert Brooke, William Helm, H. Michelson, Frank Farnkopf, August G. Headman, Loring P. Rixford, Frederick Meyer and William Crim are sending out a letter to architects asking their co-operation in the work of the club. The educational classes are being held at a nominal cost to members, and are growing to such an extent, that the aid and advice of more of the practicing architects is requested. The Club also annually holds and finances an architectural exhibition without cost to architects.

Many of the visiting architects to the convention of the American Institute of Architects were agreeably surprised at the size and well organized Architectural Club in San Francisco, and were loud in their praises of the work which the Club is doing in setting a high standard for Architecture in San Francisco.

\*  
\*   \*  
\*

## Easily Explained

"Do you understand this building loan scheme?"

"Sure! They build you a house and you pay so much a month. By the time you are thoroughly dissatisfied with the place it's yours."—Ladies' Home Journal.

# Among the Architects

## American Institute of Architects (ORGANIZED 1857)

Next Convention in Washington

### OFFICERS FOR 1911-12

PRESIDENT.....IRVING K. POND, Chicago  
 FIRST VICE-PRESIDENT...WALTER COOK, New York  
 SECOND VICE-PRESIDENT..F. M. WHEELWRIGHT,  
 Boston  
 SECRETARY AND TREASURER....\*GLENN BROWN,  
 Washington, D. C.  
 AUDITORS... } JAMES G. HILL, Washington, D. C.  
 } ROBERT STEAD, Washington, D. C.

### Board of Directors for 1910-11

For Three Years—Cass Gilbert, New York;  
 Ralph Adams, Cram, Boston; John Galen Howard,  
 San Francisco.  
 For Two Years—Frank C. Baldwin, Detroit,  
 Mich.; \*S. B. P. Trowbridge, New York, N. Y.;  
 John M. Carrere, New York, N. Y.  
 For One Year—Thomas R. Kimball, Omaha,  
 Neb.; Milton B. Medary, Philadelphia; Alfred F.  
 Rosenheim, Los Angeles.  
 \*Executive Committee.

### San Francisco Chapter

PRESIDENT.....WILLIAM MOOSER  
 VICE-PRESIDENT.....G. B. McDUGALL  
 SECRETARY-TREASURER...SYLVAIN SCHNAITACHER  
 TRUSTEES..... } JAMES W. REID  
 } ALBERT PISSIS

### Southern California Chapter

PRESIDENT.....FRANK D. HUDSON  
 VICE-PRESIDENT.....K. B. YOUNG  
 TREASURER.....AUGUST WACKERBARTH  
 SECRETARY.....FERDINAND PARMENTIER

### Board of Directors

FRANK L. STIFF OCTAVIUS MORGAN  
 ARTHUR B. BENTON JOHN C. AUSTIN  
 R. B. YOUNG

## California State Board of Architecture

### NORTHERN DISTRICT.

PRESIDENT.....WILLIAM CURLETT  
 SECRETARY-TREASURER.....LIONEL DEANE  
 MEMBERS..... } WM. CURLETT  
 } JOSEPH C. NEWSOM  
 } CLARENCE R. WARD

### SOUTHERN DISTRICT.

PRESIDENT.....JOHN P. KREMPFEL  
 SECRETARY-TREASURER.....FRED H. ROEHRIG  
 MEMBERS..... } OCTAVIUS MORGAN  
 } SUMNER P. HUNT  
 } WM. S. HEURARD

## Washington State Chapter, A. I. A.

### OFFICERS FOR 1910-11

PRESIDENT.....DAVID J. MYERS  
 SECRETARY.....W. R. B. WILCOX  
 TREASURER.....C. R. ALDEN

## Architectural League of the Pacific Coast

Next Convention, Los Angeles  
 OFFICERS FOR 1910-11

PRESIDENT.....ALFRED F. ROSENHEIM  
 Los Angeles, Cal.  
 VICE-PRESIDENT.....E. F. LAWRENCE  
 Portland, Or.  
 SECRETARY.....JOHN KREMPFEL  
 Los Angeles, Cal.  
 TREASURER.....W. R. B. WILCOX  
 Seattle, Wash.

## San Francisco Architectural Club

### OFFICERS FOR 1911.

PRESIDENT.....ERNEST H. HILDEBRAND  
 VICE-PRESIDENT.....TORIAS BEARWALD  
 SECRETARY.....JOHN C. DRESCHT  
 TREASURER.....ALBERT L. LAPACHET  
 DIRECTORS..... } AUGUST G. HEADMAN  
 } FREDERICK H. MEYER

## Los Angeles Architectural Club

### OFFICERS FOR 1910-11

PRESIDENT.....MYRON HUNT  
 VICE-PRESIDENT.....FRANK L. STIFF  
 SECRETARY.....H. E. BEAN  
 TREASURER.....OTTO JANSSEN

## Portland Architectural Club

### OFFICERS FOR 1910-11

PRESIDENT.....ELLIS F. LAWRENCE  
 VICE-PRESIDENT.....DAVID L. WILLIAMS  
 SECRETARY.....FRED ALYN  
 TREASURER.....JOHN M. TATTON

## Oakland Architectural Club

PRESIDENT.....HART WOOD  
 VICE-PRESIDENT.....E. B. MEAD  
 SECRETARY-TREASURER.....W. J. WILKINSON

### Directors

JOHN G. HOWARD LOUIS C. MULLGARDT  
 OSWALD SPIER C. E. RICHARDSON

### Several Fine Residences

Architect Chas. E. Hodges of San Francisco, is quite busy on residence work. He has prepared plans for an English country home for Judge Fairall at Los Altos and an attractive residence to be built in the same town for Hart Keatinge. He also has plans under way for a \$10,000 residence in Piedmont and a \$30,000 apartment house.

### Mr. Brown Talks on Architecture

Architect Arthur Brown Jr., delivered an interesting but very informal talk on architecture to the members of the San Francisco Architectural Club Wednesday evening, March 22. There was a large and appreciative audience

### San Francisco Architects Are Busy

Following is some of the principal work under way in the offices of leading San Francisco architects:

Willis Polk & Company.—Building for the D. O. Mills bank of Sacramento to cost \$300,000. Working drawings about finished; residences for W. G. Henshaw and I. F. Moffitt; warehouse for the San Francisco Gas & Electric Company; reconstruction of the Byrne building in Los Angeles.

Bliss & Faville.—Plans are well along for the new Clunie theater to replace the old structure in Sacramento. Estimated cost, \$150,000; two story reinforced concrete building for the Eastman Kodak Company; residence for W. S. Oliver of Lyon & Hoag.

William Curlett & Son.—Class A store and office building, Battery and Washington streets for Mrs. R. Huddleston and seven story hotel to be erected at the foot of Market street for the Terminal Investment Company.

Reid Bros.—Ten story Class A bank and office building on the corner of Sutter and Montgomery streets; five story Class C apartment house for the Butler Street Improvement Company; department store building for Hale Bros.

Frederick H. Meyer.—Four story Class A store and office building for the Bankers Investment Company to cost \$500,000 and Class A building for the German House Association of San Francisco.

Charles Peter Weeks.—Four story and basement brick and steel apartment house for the McKinnon Company to be erected on Geary street, near Leavenworth, and five story reinforced concrete hotel for Selah Chamberlain and John Proctor; also two residences.

Smith O'Brien.—Class A fireproof building for the Mt. St. Joseph Convent to replace the building destroyed by fire; Class C priory for the Dominican Fathers; revised plans for the Knights of Columbus building.

G. Albert Lansburgh.—Class C seven story hotel at Seventh and Stevenson streets for Morris Brown; two residences for I. Strassburger to cost \$20,000 each and a large warehouse.

Cunningham & Politeo.—Hotel for A. O. Stewart on the north side of O'Farrell street, near Taylor to cost \$80,000. (Contracts let.) Crematory of reinforced concrete at Mountain View Cemetery, Oakland; theater for the Alcazar Theater Company.

William H. Weeks.—Hotel to cost \$60,000 to be erected at Concord; \$40,000

bank at Concord; \$30,000 bank building at Colusa; brick hotel at Watsonville; hospital at San Luis Obispo; school house at Gilroy; and two buildings (under construction) for the St. Francis Realty Company. The later are in San Francisco and when completed will represent a total investment of close to \$200,000.

C. W. Dickey.—The Capwell department store building in Oakland, now under construction and representing an investment of \$400,000; splendid residence for Mrs. Alexander in Oakland and apartment hotel for the Pringle Company.

Bernard Joseph.—Five story, Class C apartment house at Grove and Polk streets, 200 feet square and costing \$150,000; two story store and office building at Modesto and residence for A. Bernstein on Griffith avenue, San Francisco.

Many of the other architects are equally busy and mention of their work will be made in the May number.

### Royal Institute of Architects

Lord Aberdeen, the Lord Lieutenant, was the guest of the Royal Institute of Architects of Ireland at their annual dinner in March. In responding to the toast of his health, Lord Aberdeen referred to the overcrowding in the poorer districts of Dublin, and to the munificent action of Lord Iveagh, who had cleared and rebuilt one portion of the city. Notwithstanding all that had been done, overcrowding existed to a terrible extent. Could the municipality, it might be asked, do more to grapple with the question? In putting such a question, it was only fair to ask another, and that was: In what other city had the corporation to deal with this problem in such formidable dimensions as in Dublin? They all knew that the overcrowded tenement house was a paying concern, and he suggested that syndicates be formed, on a business basis but with a philanthropic purpose, for providing healthful dwellings.

### Mr. Thompson in New Position

Frederick Thompson, for the past three years assistant sales manager of the Pacific Portland Cement Company, with general offices in the Pacific Building, has resigned that position to become president and general manager of the North Point Company, Bay and Mason streets. This company specializes in the handling of cement products. Mr. Thompson is well known to the San Francisco building trade and his friends wish him the success he deserves.



### An Ingenious Drawing Board Light

Electric lights for drawing boards in an office where the work requires very long drawings, states the Engineering Record, are suspended from wires strung below the ceiling parallel with and directly over the boards. The connections are taken from convenient ceiling outlets, and the lamp cords are permanently tied to small white porcelain spool insulators. These insulators are strung on the wires by passing the latter through the hole. Sufficient cord hangs from the insulator to allow the lights to be dropped quite close to the boards, and enough slack is left between the insulator and outlet plug so that the lights can be moved a considerable distance along the wire and thus be placed directly over the desired point without moving the drawing. This is particularly advantageous in studying completed drawings.

### El Dorado County Court House

Bids on the bonds for the new El Dorado county court house, which will be built to take the place of the one destroyed by fire May 15, 1910, will be received at Placerville until May 2.

The plans are being drawn by Architects Cuff & Diggs of Sacramento, and they call for a building 60x100 feet with an exterior of white lone sandstone. The court room will be 36x44 feet. The floors will be tiled and all wainscoting will be of marble. The sash and doors will be of metal. The building will include courthouse, hall of records and jail.

### Personal

W. P. White, architect, lately of the Central building in Seattle, announces that he has entered into a partnership with Jesse M. Warren; the firm name to be known hereafter as White & Warren. Mr. Warren before his establishment in Seattle spent several years in San Francisco and in Eastern cities and previous to entering in partnership with Mr. White he was identified with Beezer Brothers, Thompson & Thompson, and other architectural firms in Seattle. The new company has offices at 926-7-8 Northern Bank building.

### Architect Meyer Designs Fine Building

A four story steel, concrete and brick building to cost \$500,000 will be built by the Bankers' Investment Company on the site of the old Blythe block on the north side of Market street, between Geary street and Grant avenue, San Francisco.

The plans for the building were prepared by Architect Frederick H Meyer, and they call for an attractive structure

having a sandstone front with an arcade effect. The building will contain sixteen large stores.

Two months' notice will be given the present occupants of the site to vacate. While the building will be only four stories high the foundation will be laid to support a much taller structure.

### Los Angeles Chapter Meeting

At the March meeting of the Southern California chapter, A. I. A., a resolution opposing the passage of the Kehoe bill amending the lien laws was adopted.

Mr. A. F. Rosenheim gave an interesting account of his trip East and a report of the meeting of the board of directors of the institute, which he attended at New York as a member of the board. He also reported that the committee appointed at the annual convention of the institute at San Francisco to revive the regulations for competitions had made its report and the same would soon be distributed.

Mr. J. Martyn Haenke, 314 Central Building, was elected a member of the chapter.

A committee consisting of Messrs. A. F. Rosenheim, Frank D. Hudson and Fernand Parmentier was appointed to revise the constitution and by-laws of the chapter.

Resolutions of condolence on the death of John M. Carrere, the New York architect, have been drafted by Messrs. S. Tilden Norton, Julius Krause and Fernand Parmentier and forwarded to the widow and the New York chapter, A. I. A. John M. Carrere was one of the most distinguished of American architects. His death was the result of an injury caused by being thrown from a taxicab in collision with a street car in New York City.

### Los Angeles Office Building

The Sixth Street Company, 326 Consolidated Realty Building, Los Angeles, is having plans prepared by Architects Reid Bros. of San Francisco for a steel skeleton office building to be erected on the north side of Sixth street between Broadway and Hill. The site, 42x115 feet, is now occupied by a 3-story brick building. There is a court on the west side separating the site from the First Methodist church. Sketches were prepared for a building 180 feet high with mansard roof, but under the new charter amendments the height cannot exceed 150 feet. Fred J. Ryan, an engineer, who recently came from New York, will have charge of the construction of the building. The plans provide for a banking room on the ground floor and 21 offices on each floor above, 242 in all. The exterior will be faced with glazed brick and terra cotta and the interior finish will be marble and mahogany.

### San Francisco Chapter, A. I. A.

By Sylvain Schnaittacher, Secretary

**T**HE regular monthly meeting of the San Francisco Chapter, A. I. A., was held at the St. Francis hotel on Thursday evening, March 16th. The meeting was called to order by Mr. Mooser, the members present being: William Mooser, president; Geo. B. McDougall, vice-president; Sylvain Schnaittacher, secretary and treasurer, and Messrs. Applegarth, Barth, Coxhead, Wm. Curlett, Day, Deane, Dickey, Deuel, Hatch, Jacobs, Knowles, Lichtenstein, MacDonald, E. A. Mathews, Mastropasqua, M. O'Brien, Paff, Page, Raiguel, Ratcliff, Righetti, Shea, Henry C. Smith, L. H. Smith, Vogel, Welsh and Woollett.

Mr. Mooser stated that before proceeding with the routine business of the Chapter, he would introduce Mr. Franklin Wells Loomis, an illuminating engineer of New York, who would read a paper on the subject of "Modern Illuminants and Their Correct Use." Mr. Loomis' paper is printed in full elsewhere in this number.

Mr. McDougall, secretary of the Competition Committee, stated that the committee had been in communication with various bodies regarding proposed competitions; and that the Competition Committee had been requested by the Board of Supervisors to attend a special meeting to consider the program for the proposed city hall competition. He also took occasion to request all members knowing of competitions to report the same to the committee, and likewise stated that it was not necessary that members should be notified of the disapproval or approval of competitions. If there were any doubt in the matter, members should ascertain from the committee whether a competition had been approved, and that it was essential to the success of the operation of the competition code that there should be unity of action by all members of the Chapter. The Competition Committee has been encouraged in many directions and he was also pleased to advise the members that the program for the fountain proposed by the Downtown Association had been finally modified to meet the views and approval of the Competition Committee.

In the absence of Mr. Bakewell, there was no report from the Housing Committee, and Mr. Mooser stated that the State Tenement House Law, as finally approved by the Chapter Committee, had been agreed to by the Housing Association. Senator Burnett had stated, however, that he would make the law as he saw fit, but with reference to the ground covered by the tenements on an inside lot, 75% of the lot is permitted covered as against 70% in the old law.

Mr. Mooser also took occasion to report regarding the lien law which had been amended so that the owner would not be required to pay more than the face value of the contract; also that the contractor would be required to give 50% bond instead of 25% as at present. These changes had been accomplished principally through the influence of the Southern California Chapter and the Savings Banks of Los Angeles. A law had been introduced by Senator Hare with reference to hotels and contained several obnoxious features principally with reference to the location of fire escapes.

Mr. Mooser for the Exposition Committee reported that the special committee had been granted an interview by the Executive Committee of the Exposition Company. The committee was received very kindly and the resolution adopted by the Chapter presented. There was nothing further to report except that he urged the members to use what influence they might have in seeing that the Chapter might be recognized by the Exposition Company in accordance with the resolution as adopted. He also explained that the Advisory Board recommended in the resolution was intended to be advisory only.

Mr. Emil Antonovich, having filed the necessary application for Chapter membership, and having been balloted upon, Messrs. MacDonald and Barth were appointed tellers to count the ballots. Forty-three ballots were received and counted and Mr. Antonovich was declared duly elected a Chapter member.

The following communications were received and placed on file:

From a joint meeting of various civic bodies regarding the removal of temporary buildings in the fire limits; from the American Federation of Arts, requesting the appointment of delegates to the convention to be held at Washington, May, 1911; from the Philadelphia Chapter of the American Institute of Architects, resolutions of thanks and appreciation for the entertainment provided during the convention week; from the New York Chapter of the American Institute of Architects, a telegram of thanks to the same effect.

The Chair announced that any member of the Chapter contemplating an Eastern trip in May would be appointed a delegate to the convention of the Federation of Arts.

Announcement having been made by the Chair of the regrettable demise of the late John M. Carrere, on motion of Mr. Curlett, duly seconded and carried, a committee of three, consisting of Messrs. Curlett, Day and Deane, was appointed to draw up proper resolutions to be forwarded to the family.

## THE Architect and Engineer OF CALIFORNIA

Member of California Periodical Publishers' Association

Published Monthly in the Interests of the  
Architects, Structural Engineers, Con-  
tractors and the Allied Trades of the  
Pacific Coast by the Architect and En-  
gineer Company.

### OFFICES

621 Monadnock Building - San Francisco  
Telephone Douglas 1828  
Builders' Exchange Oakland  
Room 234-223 West 2nd St., Los Angeles

### TERMS OF SUBSCRIPTION

(Including postage) to all parts of the United States \$1.50  
per annum; to Canada 50c additional; to all Foreign points  
\$1 additional

Vol. XXIV.      APRIL, 1911.      No. 3

### ASSOCIATE EDITORS

MORRIS KIND, C. E.	<i>Cement</i>
WM. B. GESTER,	
JNO. B. LEONARD, C. E.	<i>Reinforced Concrete</i>
LOREN E. HUNT, C. E.	} <i>Inspection</i> } <i>and Tests</i>
ATHOL McBEAN	} <i>Brick, Tile and Terra</i> } <i>Cotta</i>
W. E. DENNISON	
HOWARD FROST,	
W. W. BREITE, C. E.	} <i>Structural Steel and</i> } <i>Iron</i>
FRANK SOULE	<i>Masonry Engineering</i>
G. B. ASHCROFT, C. E.	<i>Artificial Stone</i>
W. J. WATSON	} <i>Roofs and Roofing</i>
J. R. D. MACKENZIE	
F. H. BRYANT	} <i>Heating and</i> } <i>Ventilating</i>
WILLIAM ADAMS,	<i>Decorative Lighting</i>
C. WALTER TOZER	<i>Interior Decoration</i>
WILBUR DAVID COOK,	<i>Landscape Architecture</i>
T. C. KIERULFF	<i>Legal Points</i>
F. W. FITZPATRICK,	<i>Fireproof Construction</i>
PAUL C. BUTTE	<i>Electrical Construction</i>
C. W. WHITNEY	<i>Building Construction</i>

### ARCHITECTURAL

Fred H. Meyer	J. C. Austin
Edward T. Foulkes	F. D. Hudson
Alfred F. Rosenheim	Sumner F. Hunt
G. Albert Lansburgh	C. Sumner Greene
Jas. W. Reid	Ralph W. Hart
Clinton Day	James Seidler
Kenneth MacDonald, Jr.	Maxwell G. Bugbee
Houghton Sawyer	Clayton D. Wilson
John G. Howard	Americ Coxhead
Arthur Brown, Jr.	Harrison Albright
M. V. Politeo	John Parkinson
T. J. Welsh	W. J. Cutbertson
Chas. P. Weeks	A. W. Smith
Chas. F. Whittlesey	T. Patterson Ross
Octavius Morgan	William H. Weeks
W. A. Newman	Chas. W. Dickey
H. Alban Reeves	Henry C. Smith

### CONTRIBUTORS

Merritt Reid	Hon. Jas. D. Phelan
William Curlett	J. T. Walsh, C. E.
Albert Pissis	Chas. Havens
Edgar A. Mathews	Smith O'Brien
Julius E. Kraft	H. F. Starbuck
Geo. A. Dodge	Nathaniel Blaisdell
John C. Pelton	W. T. Bliss
Herman Barth	William Mosser
Arthur O. Johnson	Geo. H. Wyman
Herbert F. Law	Robert Morgeneier

E. M. C. WHITNEY      *Manager*  
FREDERICK W. JONES      *Managing Editor*

Those who advocate fireproof construction point to the recent holocaust in a New York factory as one more example of the incalculable results of flimsy building. The history of the country is a repetition of just such calamities as the New York fire—all because somebody would save a few dollars and build a fire trap instead of a non-combustible building.

Not so many years ago the country was startled by reading of the terrible loss of life in the Iroquois theater which burned with its several hundred human occupants in the heart of Chicago. Then came the Collingswood disaster in Ohio and now the New York holocaust. Before the ashes had cooled the papers brought us the news of the destruction of Albany's beautiful capitol building—a structure costing millions of dollars, yet largely constructed of inflammable material. What a pity this magnificent monument could not have been fireproof! It could not have cost much more than it did even with steel, concrete, terra cotta and metal as its structural parts. These terrible examples of our criminal negligence must be exasperating to such men as Architect Fitzpatrick of Washington, whose indefatigable labors in the interests of real fireproof construction are well known. Not till we get laws that compel our property owners to build right, may we expect to eliminate frequent repetitions of the New York disaster.

\* \* \*

Here is what Fire Chief Croker says about fire traps and non-combustible buildings:

"The 'city beautiful' is less vital than the 'city safe.' Let us see first of all that our people live and work under adequate protection for their lives and persons.

"I would have fire escape landings extending all along the outside of every office, loft or factory building. I would have the balcony buildings built wide enough for two persons to pass in safety without crowding. I would have the stairways at each end, and I would have them built with hand rails, so that women and children could descend them—no ladder escapes or stairways built at acute angles.

"Let us have all inside stairways inclosed in a fireproof partition. Let us require fireproof exit doors and all doors to open outward. Never allow an exit door to be locked or blocked and make the fire escape windows open to the floor level, like a door. Protect each floor with all available automatic safety devices and sprinklers. Last, but not least, make fire drills at frequent intervals compulsory in all factories, lodging houses and institutions."

It is stated by one who knows that a fire in the financial district of New York City, could, in a small radius, wipe out all the available fire insurance capital in the entire United States.

\* \* \*

The shame and scandal of a fire-waste \$30,000,000 in excess of that of 1909, and a succession of holocausts that appall the imagination, leave us with the disconcerting impression that another decade may pass before we shall be able to reduce the size of our colossal annual ash heap. The fire losses of the United States and Canada, during the year ending with November 1910, amounted to \$232,918,000, as compared with \$198,303,000 for the preceding year, that being an increase over the next year preceding of \$34,615,000. The depreciation in burning ratio, resulting from improved building construction, growing effectiveness in inspections, testing of devices, the installation of high pressure water systems, improvements in fire departments and fire fighting appliances, and the like

are being counteracted by the steady aggregation of congested values, climatic changes due to the denudation of the forest area, and the never failing negligence with which we seem to be cursed above all other peoples.

There seem to be at times such cumulative demonstrations of our collective irresponsibility as to induce the thought that some cosmic influence occasionally precipitates a succession of horrors to reveal us to ourselves.

William S. Devery, the "best Chief of Police New York City ever had,"

has a keen insight into the workings of human nature; he is also something of a philosopher.

At the last annual dinner of the Credit Men's Association of the Building Trades in New York City, Mr. Devery was one of the "orators" and in the course of his remarks he said:

"I don't know as I'm prepared to make any remarks, but after listenin' to your speeches this evening I gather that you want all these here architects and builders and everybody who owes you money to pay up. Well, if you can't get what's owed you, take the advice of your chairman and use the big stick. It's a good thing to use to keep everybody honest, and there's nothing like honesty in this world, and men keepin' their word one to another. I used the big stick in my time, when it was necessary to get results. I gather that you wait to join in till you get nailed peekin' under a gate; then you holler and go to the association. Some of you fellows here, I bet, have scratched all of the hair off your heads trying to beat one another. My friends, you may talk all you like about fair play and a square deal, but when the long green is in sight, let me tell you, friendship ceases."

# HEATING AND LIGHTING

## Plumbing and Electrical Work

### An Unusual Heating System

THE Morse Chain Co., Ithaca, N. Y., has had installed and in operation for some time a heating system that is a radical departure from the usual methods. The system dispenses with steam coils, registers, hot-water radiators and the usual adjuncts of a heating plant, and substitutes a series of ducts in the floors. Through these ducts is led exhaust steam, hot air or waste flue gases, depending on the heating medium most available. The floors are thus heated and radiate sufficient heat to keep the rooms at a comfortable working temperature. The feet of the men are kept warm, and as the air at the higher levels is materially cooler than at the floors, their heads are cool, thus giving working conditions of maximum efficiency. The construction and working of the system were described in detail in the *American Machinist*, and the following abstract will give the reader a general idea of the plant.

At the Ithaca works, the pattern shop is heated by exhaust steam, traversing wrought iron pipes laid in the concrete floor. The main machine shop is heated by hot air, forced through a system of supply and return ducts built in as part of the concrete floor structure, and the blacksmith shop is heated by a circulation of hot flue gases through a system of tile pipes buried some little distance below the floor of the shop.

Fig. 1 shows the ground floor plan of the pattern shop, with the piping system

for heating. This building is some 80 ft. long, 22 ft. 8 in. wide and 15 ft. 6 in. high, and has a cubical content of 32,250 cu. ft. The walls are of monolithic concrete; the roof is of 3-in. plank, covered with composition roofing and the building is isolated, except for the southern end, where it joins a lumber storage and a pattern-storage building. Along the western wall is a 3-in. exhaust-steam supply main; 1-in. pipes tap from this main, run across the building, turn and run parallel with its length for a distance of about 5 ft., then turn again, cross the building again and enter a 2-in. return main that runs the length of the building on the same side as the supply main. The 3-in. supply main is at a level of about 1 ft. above the floor. The crosswise runs pass through 4-in. wrought-iron pipe buried in the concrete floor, with a covering of about  $\frac{1}{2}$  in. of floor-wearing surface. The 5-ft. runs lengthwise of the building are in an open gutter against the exterior wall; this gutter is covered with boards. Similarly the 2-in. return main is in a gutter along the opposite. The only exposed radiation in the room is the 3-in. supply main.

The total amount of radiating surface is 310 sq. ft. Of this 80 sq. ft. is in the room itself, while the balance, 230 sq. ft., is in the floor. There are approximately 104 cu. ft. of volume per sq. ft. of exterior radiating surface.

A familiar heating factor for factory



Fig. 1.—Plan of Pattern Shop



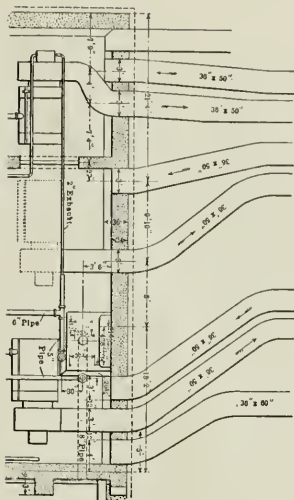

Fig. 2.—Plan of Heaters in Main Shop

buildings provides 1 sq. ft. of direct radiation surface for 75 to 100 cu. ft. of volume, with a generous addition for the sides exposed to northerly or westerly winds. The factors are for latitudes where the minimum temperature range is 10 deg. F. Accepting these factors, we see that the amount of radiation provided to heat this pattern shop through the floor is slightly less than the minimum indicated for factory buildings that are not unusually exposed to severe winds or low ranges of temperature.

The steam pressure used is about 2 lb. back pressure. The following table shows the temperature at various levels when the external temperature was zero and the prevailing wind was blowing from the northwest at a velocity of 30 miles per hr.

**PATTERN SHOP TEMPERATURES.**

(Temperature taken between heating pipes.)

	7 a. m.	10 a. m.	1 p. m.	6 p. m.
1 inch above floor	48°	52°	58°	59°
7 feet above floor	48°	52°	58°	59°
Under roof	49°	53°	58°	60°

January 4, 1910, minimum external temperature, 5 degrees below zero; maximum 11 above zero. Wind northwest, 20 to 40 miles per hour.

Temperature over pipes 1 inch above floor same day, 7 a. m., 52° to 60°.

The heating system of the main shop differs from the pattern shop in that it uses a circulation of hot air through ducts instead of a circulation of steam through pipes. Two heaters are installed with space provided for a third (see Fig.

2), where the location for the third heater is indicated by dotted lines. The provision for a third heater is made to care for the growth of the plant, as the two heaters now installed are more than ample for all the requirements of the main machine shop building.

Fig. 3 shows the basement plans of the machine shop. The point of entrance of the ducts is at the lower right-hand corner. The supply ducts connect with large chambers forming vertical flues at various points and these in turn connect with a system of 15-in. tile bell-and-spigot pipe laid with Portland cement

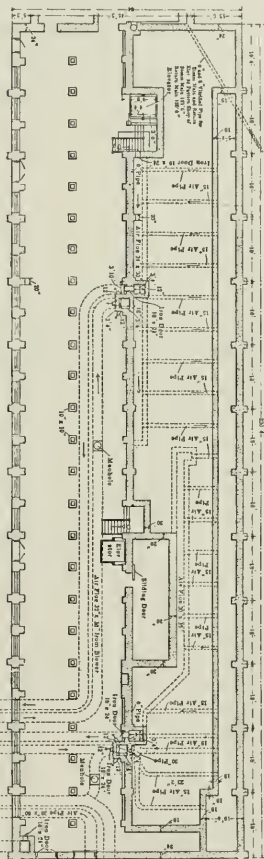

Fig. 3.—Basement Plan of Machine Shop

joints. These pipes are directly under the concrete floor and cross the building to a point some 5 ft. from the eastern wall, where they enter a large concrete duct running the full length of the building. From this duct other 15-in. tile pipes run back to the return flues and thence to the large return ducts that convey the circulating air back to the fans.

The long duct near the eastern wall also serves as a space for a long line of shafting from which the machine tools under the crane are driven through the floor by means of chains. A small amount of air finds its way through the belt or chain openings into the shop, but otherwise the circulating system is an enclosed system, provided dampers in two vertical heating stacks, to be mentioned later are closed. A system of butterfly dampers is installed in the large heating ducts, so that any duct can be changed from a supply duct to a return duct at will, as the needs of operating the system demand.

Fig. 4 is a cross-section of the machine shop, which consists of a crane floor, shown at the right, a main floor at the left, a gallery floor above the main floor, and below a basement.

Of the two heating plants one has a combined heating surface of 2,500 sq. ft.; the other has 4,840 sq. ft., a total of 7,340 sq. ft. The cubical content of the main machine shop building, including the basement, is 514,500 cu. ft., or 70 cu. ft. per square foot of indirect radiating surface.

As a matter of fact, both fans are not used in heating this building except in severe weather and between the hours of 4 and 7 a. m., at which time the two vertical galvanized iron pipes are employed and the air is re-circulated before the workmen enter at 7 a. m. At that

time the vertical stacks are cut off, the smaller heating plant is shut down and throughout the balance of the day the shop is warmed from the larger heating plant and entirely beneath the floor. Considering only the heating area of the larger plant there are 106 cu. ft. of volume per square foot of indirect heating surface. This is the factor that prevails under ordinary shop running conditions. A frequently quoted factor for the indirect radiation needed for factories in latitudes where a minimum temperature is 10 deg. F. is from 50 to 70 cu. ft. per sq. ft. of indirect radiation.

Temperatures were taken at a point 4 ft. above each of the floors on Saturday, January 8, 1910, the outside temperature at 7 a. m., being 4 deg. F., wind northwest, 6 miles per hr.

	7 a. m.	12 m.	6 p. m.
First floor .....	62°	59°	64°
Second floor .....	62°	63°	69°
Third floor .....	64°	67°	73°

In the blacksmith shop which is heated by means of flue gases, a No. 8 Sturtevant exhauster just below the level of the roof trusses sucks the flue gases from a large number of furnaces and forges and also draws a certain amount of air from the room itself through the space between the forge outlines and superimposed hoods. Under ordinary conditions this exhauster discharges directly through the roof by means of the short section of stack. In severe weather, however, a damper is closed and the heated flue gases are discharged through the pipe that follows the contour of the roof passing down to the ground. The pipe running down to the ground is 18 in. in diameter. Flush with the level of the ground is the bell of a T having one outlet on the run 18 in. diameter and the other 15 in. diameter. This T and the



## ADAMS AND HOLLOPETER INC

MAKERS OF

HIGH GRADE LIGHTING FIXTURES

•745•MISSION•STREET•  
•SAN FRANCISCO•CAL•  
•TELEPHONE•  
•DOUGLAS•1773•

JOHN P. YOUNG  
WILLIAM ADAMS  
FRANK ADAMS  
W. H. HOLLOPETER

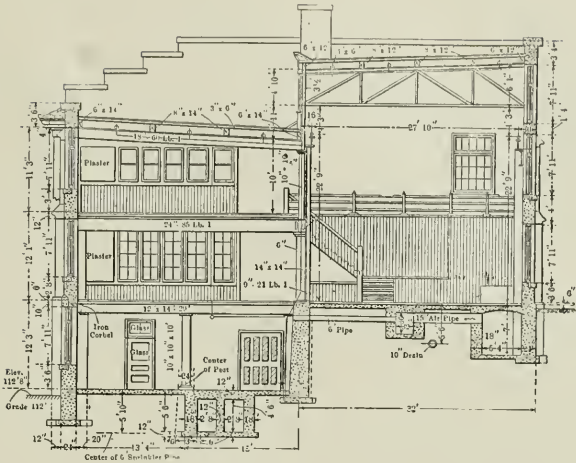

Fig. 4.—Cross-Section Through Machine Shop

connecting pipes are vitrified tile sewer pipe. Starting at this T the pipe runs in both direction around the shop near the exterior walls and discharges at one corner. Through this piping the flue gases pass during cold weather and thus thoroughly heat the floor or ground in the blacksmith and forge shops.

### What is the Matter With Modern Heating Practice?

By KONRAD MEIER, in the Heating and Ventilating Magazine.

(Continued from the March Number)

The theory of warm walls and cool air also points towards the ideal for the solution of all heating and ventilating problems, that is, to reproduce for indoor life those atmospheric conditions which we know to be most pleasant and wholesome. A direct system with continuous service, with moderately warm, well distributed, clean surfaces giving more heat by a mild radiation than by convection, combined with a tempered air supply in some sanitary form, will certainly be the nearest approach to the mild radiant heat of the sun and cool bracing air. Any apparatus using fresh air as a heat carrier will produce the opposite effect, resembling more the enervating sirocco, or warm, cloudy weather. In any event, such apparatus necessarily gives warmer air and cooler walls since it is the air that must heat the walls. Besides, the higher the incoming air must be heated, the more it will lose of its natural sweetness. Hot air heating also tends to produce strata of warmer air overhead and cooler

air near the floor, a condition which is undesirable from the hygienic as well as the economical point of view. Again, the problem of controlling the heat without either disturbing the air supply or causing other discomforts is decidedly more complex.

There are instances, of course, where heating by air may be indicated, or permissible. The indirect method, however, should be resorted to only in such cases where the heat requirement is relatively small, so that the air supply need not be warmed to an undesirable degree which will spoil it for purposes of ventilation. The same amount of heat may, of course, be obtained with smaller volumes at higher temperature as with larger volumes at lower temperatures, but the best authorities agree that it should not be brought into a room at more than 110 degrees F. Rietschel puts it at 104 degrees F. This is a severe limitation for conditions maintaining here. About 120 degrees F. would seem justified. In cases where it would still result in excessive volumes it is nearly always advisable and proper to reduce the heat requirement by extra protection.

The indirect system is often installed with the idea of securing better ventilation than is expected by direct heat alone. As a matter of fact, the air renewal in either case depends largely on the natural outward leakage afforded by the structure and the draught power of any vent flues available. The inward leakage in one case comes through the register, in the other case through walls and windows. The latter air is apt to be sweeter and purer than that from the stacks. Moreover, the

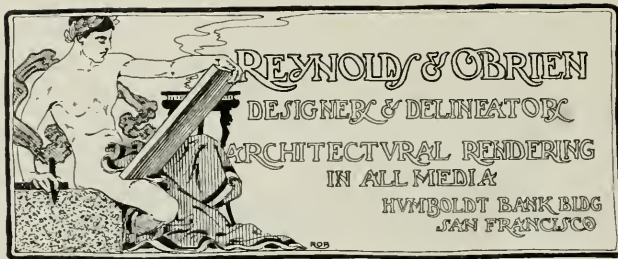

window ventilation can be increased without stopping the heat supply from radiators while the draught in a hot air flue is liable to be reversed under wind action when heat is most needed. The idea of better ventilation through hot-air heating is, therefore, nearly always a delusion.

On the whole, the use of the indirect method should be discouraged, especially where a constant air supply of a given volume is not essential. In cases where direct radiation is absolutely objected to, there are other means of meeting the situation, for those who have command of the subject. Unfortunately, it would lead beyond the scope of this article to go into the various possibilities.

Direct-indirect heating, with the air inlets back of radiators, is also adversely affected by wind and weather, giving less air when most is needed. Proper control of temperature becomes almost impossible without shutting the inlets, which is the usual fate of these devices. A more satisfactory solution in some cases may be found in the use of very small sash ventilators, admitting fresh air directly, in as many places as possible, deflecting and diffusing it, and thus keeping the room air sweeter and cooler, with comfort depending on the radiant heat provided.

In general, radiant heat is best applied by hot water radiation, which has an average temperature of only 130 degrees to 140 degrees F., and is rarely unpleasant. With steam heaters, the radiation is usually too intense and too concentrated, and should be modified by greater division of surface.

One cannot discuss hygiene in heating without touching on the same principles as applied to modern ventilating apparatus. Even though each should act independently, one may spoil the result of the other, hence they must be treated in harmony. The first point to be borne in mind when designing ventilating apparatus, more especially an air supply system, is again salubrity. This must not only be made possible, or probable, but compulsory or automatic, inasmuch as the air passages are necessarily out of sight and therefore only too apt to be neglected. In order to prevent dead spaces,

which form eddies in the current and create dust pockets, smooth clean metal or tile ducts should lead directly from outdoors to the tempering surfaces and fans, and from the same to the flues and registers. All passages should be of sizes to assure a fair velocity of the air current that will not allow of any accumulation of dust and foreign matter at any point, from intake to room. Tempering surfaces should also be spaced for a fair speed, and should be of the kind that will present a smooth surface, completely swept by the air current. The entire system in fact should be designed with the idea of sweeping itself, or making it "clean as a whistle." This is recommended not only with the idea of avoiding all possible contamination but also in order to preserve the natural sweetness of the air, which is always destroyed in contact with organic dust stirred up by the unavoidable motion. Moderate temperature of the stacks for warming higher speed in passing the surfaces, and lowest practicable temperature of the air supply will always tend to preserve its ozone and oxygen, that is, its life and wholesomeness.

These leading ideas should be carried out just the same, if the air is filtered, washed, humidified and ozonized. Cleanliness cannot hurt the treatment, but will often help it. In fact, all means should first be exhausted to secure fair results by salubrity. Artificial "air conditioning," as it is called, should be reserved for meeting severe conditions or unusual requirements, that is, when it is desired to improve upon the outer air for special reasons. This refers especially to moistening, which is rarely needed, if the air supply is pure and cool.

Ozone should not be regarded as a substitute for ventilation, as it does not supply all the elements required. It should be used only to help in relieving extreme, intense vitiation that would call for excessive air volumes.

Preventive medicine should be used in ventilating work not only in applying hygiene, since poor engineering may offset the effort at sanitation. It is only necessary to point out that there are frequent chances

# High Grade Electrical Installation Work

**Butte Engineering & Electric Co.**

683-687 Howard Street  
San Francisco

PAUL C. BUTTE  
C. F. BUTTE

tor pollution of room air from outside sources not under control, which may spoil the results, unless taken care of. Lack of provision, for instance, for effective removal of odors from kitchens, toilets, wardrobes, in other parts of the same building, almost inevitably make themselves felt. It would lead too far to go into all these probabilities, but in general it is necessary to realize that highest efficiency depends on good engineering as well as on sanitation.

The mere capacity of an apparatus to heat, and to affect a certain renewal of air, should no longer be the only criterion of performance. The sanitary requirements must receive equal consideration, if the best results are to be obtained. It will be

conceded that the average practice in the planning and installation of apparatus is still deficient in these respects. Indeed, probably the best chances for improvement in this field at the present time may be found in the application of hygiene. In any event, due attention to this subject is more likely than anything else to prevent such extremes as the establishment of open-air schools. It will also tend to overcome the frequent opposition to modern ways of heating and to artificial ventilation on the part of the medical profession, which has no doubt its basis of justification. As a general conclusion it may be stated that the preventive sanitary measures advocated can only increase the efficiency and usefulness of modern installations.

## HAMMERED! Open Hearth Roofing Tin



This picture shows how the greatest improvement is made in the manufacture of Roofing Tin. Open Hearth material is noted for its purity. Note the Distinction.

**HAMMERED**—We hammer every ingot into billets under the repeated 800 ton blows of this immense hammer. It gives the base plates the desired working and wearing quality. No other American maker does this work.

**SPECIFY**

### SCOTT'S EXTRA COATED

**HAMMERED OPEN HEARTH**

**Follansbee Brothers Co., Pittsburgh, Pa.**

**MAKERS**

**PACIFIC COAST BRANCH,**

**GEO. S. LACY, Manager**

Marvin Building, Phone Douglas 4497,  
**SAN FRANCISCO, CAL.**



# ELECTRIC APPLIANCE COMPANY

726-730 MISSION STREET  
SAN FRANCISCO, CAL.

## HIGH GRADE CONSTRUCTION MATERIAL

" GALVADUCT " CONDUIT (WHITE)  
" LORICATED " CONDUIT (BLACK)  
" PACKARD " INCANDESCENT LAMPS

" NEW WRINKLE " PULL AND KEY SOCKETS  
" PERKINS " PUSH BUTTON SWITCHES  
" COUCH & SEELEY " TELEPHONES

### Recent Patents Relating to Building Construction

Material for this department is compiled expressly for The Architect and Engineer by Watson & Boyden, patent and trade-mark lawyers and solicitors, 918 F street, Washington, D. C., and to them all inquiries in regard to patents, trade-marks, copyrights, etc., and litigation affecting the same should be addressed.

A complete printed copy of the specification and drawing of any United States patent in print will be sent, postpaid, to any address for ten cents.

William Ashley Snyder, of Los Angeles, Cal.—Furniture. Patented Feb. 28, 1911. 985,371.

This invention provides a bed or similar article of furniture which is adapted to normally fit in a recess when not in

use and which, when pulled out of the recess, may be swung around a vertical axis to a position at right angles to the recess. The illustration shows a bed (12) which has been pulled out of the recess adjacent the wall (5) and swung to a position near the window. This permits another article of furniture such as a table (25) to occupy a position adjacent the mouth of the recess.

George Roeth and Byron W. Haskell, of Oakland, Cal.—Pier Construction. 985,371. Patented Feb. 28, 1911.

This improved pier is supported on floating caissons and is connected to the

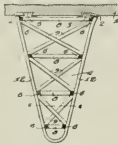

985,371

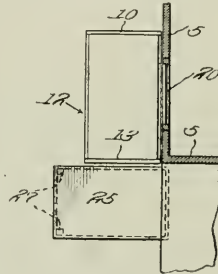
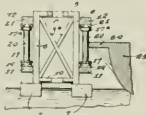

985,219



A. W. KENNEDY,  
BUSINESS MANAGER

CHAS. HART,  
SUPT. AND INVENTOR

## THE HART HEATER CO.

MANUFACTURERS OF

THE QUEEN GAS WATER HEATER

THE HART COMBINATION HOT WATER BOILER

Instantaneous — Economical — Clean.  
Copper coils insure perfect circulation.

OFFICE 406 Thirteenth St. OAKLAND, CAL. FACTORY 525 Seventh Street  
PHONE OAKLAND 7921 PHONE OAKLAND 2891

When writing to Advertisers mention this Magazine.

abutments by means of a sliding tongue and groove joint so that it may rise and fall with the tide. A plurality of rollers (20) are provided in each side to engage the edges of a boly so as to prevent excessive wear.

Charles A Foster, of Portland, Ore.—  
Sheet-Metal Culvert.  
985,738. Patented Feb. 28, 1911.

This improved culvert is formed from sheet metal preferably corrugated and comprises a flat bottom having upturned

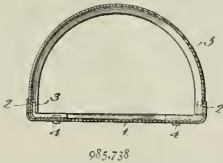

flanges (2) and an arch-shaped top (5). The edges of this top fit between the flanges (2) and L-shaped fastening members (3) bolted to the bottom plate.

Frederick L. Wissman, of San Francisco, Cal.—Sash-Lock.  
986,337. Patented Mar. 7, 1911.

This is an improved sash-lock which consists of a curved locking bolt mounted in a casing and having a knob by means of which it may be operated. A

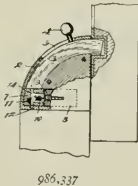

locking block (7) is urged by a spring (9) so as to hold the bolt (3) in the position shown in the illustration. The block (7) may be withdrawn by means of a key and the bolt (3) thus permitted to drop.

#### Collapse of a Bridge

A newspaper dispatch from Jackson, Amador County, states that "The Middle Bar bridge over the Mokelumne River, between Amador and Calaveras Counties, collapsed causing the death of nineteen of twenty-nine cattle passing over the structure at the time.

R. J. O'BRIEN T. F. KIERNAN  
**KIERNAN & O'BRIEN**  
**PLUMBERS**  
ESTIMATES FURNISHED  
1754 MISSION STREET, Bet. 13th-14th  
SAN FRANCISCO, CAL.  
Builders' Association, Box 149 Phone Market 2517

Phone West 1327  
**THOMAS J. FORD**  
PLUMBING  
and HEATING  
1213 Octavia Street San Francisco, Cal.

**PLUMBING**  
and **HEATING**  
**J. E. O'Mara**  
449 MINNA ST.  
Phone, Douglas 3421

H. H. FISHER, President Phone Kearny 4410  
G. H. McKEISSICK, Secy.  
**FISHER & WOLFE CO.**  
Plumbing, Steam and Gas Fitting  
FINING AND GENERAL JOBBING  
207-209 Tehama St., Near Third St., San Francisco

**we  
want  
your  
elec-  
trical  
work**

**BECAUSE**

**We know we  
can please you**

We are pleasing a good number of architects and contractors who insist on prompt service and first class work.

We get their business because our prices are fair, and they know they can depend upon us.

**CENTRAL ELECTRIC CO.**

185 STEVENSON ST.

SAN FRANCISCO

PHONE, DOUGLAS 387

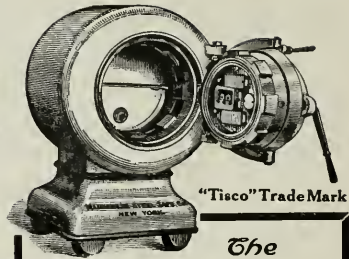

"Tisco" Trade Mark

*The*  
**Real Manganese Safe**

New York Manganese  
Steel Safe Company

**HOWE SCALE COMPANY**

EXCLUSIVE AGENTS

333 TO 339 MARKET ST.  
SAN FRANCISCO, CAL.



An Up-to-Date Bath Room

**HEATING, PLUMBING  
AND POWER PLANTS**

Complete Systems Installed in all  
Classes of Buildings. Defective  
Systems overhauled and corrected

**GILLEY-SCHMID CO., Inc.**

198 WEST MISSION STREET

SAN FRANCISCO PHONE MARKET 965

*You will like*  
**TACOMA**  
WASHINGTON

and the

**CARLTON HOTEL**

A New Fireproof Hotel  
Modern in Every Detail

Cafes of Acknowledged Excel-  
lence. Overlooking the Sound  
and beautiful Mt. Tacoma. One  
block from Union Depot.

Rates \$1.00 upwards

JONES & SHAFER, PROPRIETORS.

**PACIFIC BLOWER & HEATING CO.**

3261 Seventeenth Street, (near Mission) San Francisco

Specialists in **HOT AIR HEATING**

Torrid Zone and Pacific Furnaces for Schools, Theaters, Residences, Etc.

**SILVER LAKE A SASH CORD**



Pacific Coast Agent, SANFORD PLUMMER, 149 New Montgomery St., San Francisco, Cal.

Avoid Sash Cord Troubles among your clients by specifying SILVER LAKE A. Write for Samples and our Guarantee Certificate. It protects you.

*Our name is stamped on every foot of our cord*  
SILVER LAKE COMPANY, BOSTON, MASS.

Phone West 7000

All Work Guaranteed

**ALEX COLEMAN**

PLUMBER

706 ELLIS STREET

SAN FRANCISCO, CAL.

Phone Oakland 1753

I. A. COOKE, MANAGER

**THE J. F. KELLY COMPANY**

(INCORPORATED)

MANTELS, GRATES and TILES

Fire Sets, Andirons, Fenders and Portable Baskets, Floor and Wall Tiling in Original and Artistic Effects

723-731 Seventh Street, Cor. Brush St. OAKLAND, CAL.

Phone Merritt 3555

Estimates Furnished

**OSCAR L. ZEIS  
PLUMBING AND TINNING**

♦♦♦♦ JOBBING A SPECIALTY ♦♦♦♦

456 East Sixteenth Street

Oakland, Cal.

**GEO. W. SCHMITT HEATING AND VENTILATING CO.  
HOT AIR MERCHANTS**

Heating of Residences and Public Buildings  
SHEET METAL WORK

1160 WEBSTER STREET  
Oakland, Cal.

HEATING

ELECTRICAL WORK  
AUTOMATIC SPRINKLERS

PLUMBING

VENTILATION

SHEET METAL WORK

**JOHN G. SUTTON CO.**

229 MINNA STREET

SAN FRANCISCO

Manufacturers of Abrahamson's Patent Ventilators, Galvanized Iron Cornices and Skylights. Repairing a Specialty

**Abrahamson & DeGear, Inc.**  
Sheet Metal Works

Tin and Galvanized Iron Roofing, Heating and Ventilating, Registers and Ventilating Facings

655 McALLISTER ST.

Phones, Market 2898  
Home 5 1857 San Francisco, Cal.

# By the Way

Some Industrial Information Worth the While

## A Superior Oil Burner

Mr. M. A. Fesler, of the Fess System Company, left recently on the Steamer President for Seattle to superintend the installation of some of their new rotary crude oil burning plants.

This new system of burning crude oil is going to the front by leaps and bounds, judging from the long list of recent installations, over thirty orders having been filled in the past ninety days.

Consulting engineers and architects who have visited the plants installed and examined the mechanical construction of the burners, are specifying and recommending them for apartment houses, hospitals, churches, and hotels on account of their being noiseless and simple of operation.

Judging from letters from some of the owners who have had plants working since last fall, they are getting wonderful results, cutting coal bills from 50 to 70 per cent and distillate bills 40 per cent, heating and furnishing hot water in hotels for about 50c per room per month.

## The Hyloplate Blackboard

The C. F. Weber Company of San Francisco and Los Angeles, reports a steady increase of sales of its Hyloplate blackboard. School superintendents who have used it speak highly of it. Hyloplate is made in both black and green

color. Many school principals prefer green on account of its soft tone. Architects who plan school houses will doubtless be interested in the following facts about Hyloplate blackboards, this information being furnished by the manufacturers.

"Hyloplate is the favorite everywhere of school house architects, school board officials and principals, teachers and pupils. It is the universal blackboard, and is in use in practically every civilized country in the world.

"It is produced from wood pulp, paper and cement by the same process as the indestructible car wheel. It is made in slabs of even thickness, 3, 3½, and 4 feet wide, and in lengths up to 12 feet. The slating is then applied by machinery and the matchless writing surface is brought out by special method of treatment. The back is coated with a solution which makes it waterproof and prevents warping.

Hyloplate has a certain elasticity and a velvety surface which makes it a pleasure to use. It takes chalk readily and erases easily. It is the superiority of its writing surface that has made Hyloplate famous. It is also practically noiseless.

"It can be glued to a wood backing, thus making it a permanent part of the building, or it can be nailed to the wall over plaster, lath, brick, ceiling or on bare studding. It can be put up anywhere by any one and can be taken down and moved without injury.

## *A 72-Page Building Material Catalogue in Colors*

The GOLDEN GATE BRICK CO. has just published a *catalogue in colors*, describing Brick, Rock, Sand, White Cements, Sewer Pipe, etc. Write

**GOLDEN GATE BRICK CO.**

660 MARKET STREET, San Francisco, for a copy.



"Hyloplate will, with proper care and usage, last as long as the school house. It does not warp, crack or split, and cannot break in handling or in shipment. It is light and easy to handle."

**A New and Artistic Treatment for Interior Finish**

Beaver Board, now being so extensively advertised all over the country, is a pure wood fibre product, pressed into panels of uniform thickness with a pebbled mat surface. Beaver Board should not be confused with the flood of composition or plaster boards which have appeared on the market from time to time. Beaver Board will neither chip, crack nor deteriorate with age; it retards fire; is a superior sound deadener; is uninjured by dampness or shock, and keeps rooms warmer in winter and cooler in summer. Supplied in a variety of sizes, the most artistic arrangement of paneling is possible for wainscoting, walls, or ceilings, and as it is nailed directly to the wall studding or ceiled joists, or to the walls of old rooms without removing lath and plaster, the work is very inexpensive and not attended with the usual dirt and disorder.

Any one handy with tools can do the work; but very little cutting or fitting is necessary, and the seams are covered with decorative strips of wood, which give most artistic paneled effects.

The soft-toned pebbled surface of Beaver Board offers a new and wonderfully artistic effect for tinted or painted walls and ceilings, varying from a soft flat tint to an enamel gloss and producing a harmony in decorative schemes that has never before been realized.

The Lilley & Thurston Company of 82 Second street, San Francisco as Coast distributors, will be glad to co-operate with any one toward beautifying club houses, residences, offices, stores, or show windows with Beaver Board.

**THE ROEBLING CONSTRUCTION CO.'S**

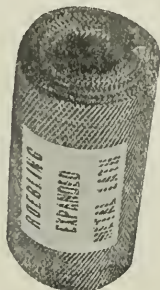

System of FIRE PROOFING and EXPANDED METAL LATH

HOME INDUSTRY  
Made in San Francisco

EXPANDED metal lath manufactured in rolls 150' long, 25" and 33" wide, or sheets if desired, plain, painted or galvanized. Crimped metal lath and wire lath for exterior plastering.

Everything in the lath line for architect, owner, plasterer and lather. Information, prices and samples cheerfully given.

OFFICES: Nos. 623-626 CROCKER BLDG.  
SAN FRANCISCO  
Phones—Home C-4312; Kearny 2222

**Mackenzie Roof Co.**



425 15th St., Oakland  
Phone Oakland 3461

**HARDWOODS**

The Largest Stock WEST OF CHICAGO

**WHITE BROTHERS**

FIFTH AND BRANNAN STREETS, SAN FRANCISCO

# SMITH, EMERY & COMPANY, Inc.

INSPECTING AND TESTING ENGINEERS  
AND CHEMISTS

651 HOWARD STREET  
SAN FRANCISCO

245 SO. LOS ANGELES STREET  
LOS ANGELES

INSPECTORS OF

## IRON, STEEL, CEMENT

REPRESENTED AT

SEATTLE  
NEW YORK

SAN DIEGO  
CHICAGO

PUEBLO  
PHILADELPHIA

BIRMINGHAM  
MONTREAL

PITTSBURG  
GLASGOW

### J.-M. Asbestos Roofing

Johns-Manville asbestos roofing was submitted to a test recently out of which few ready roofings would have emerged unscathed. The flame of a powerful blow torch was held within two inches of J.-M. asbestos roofing for the space of fifty minutes. At the expiration of this time the roofing was taken down and examined. Beyond a slight blackening due to the smoke the asbestos was uninjured. There is no shoddy, wool rags, paper stock or coal tar in J.-M. roofing. It is what it purports to be, a genuine fireproof roof covering. The H. W. Johns-Manville Company, which makes J.-M. roofing, will send samples and catalog 303 to persons who write, mentioning the Architect and Engineer.

### Safety in Metal Doors.

Following the New York factory disaster the destruction of the capitol at Albany accentuates the need of real fireproof protection. The spread of these fires, it is stated on the authority of the officials of the fire departments, was greatly accelerated by inflammable doors. In this connection John A. Westman, general manager of the Dahlstrom Metallic Door Co., furnishes some interesting facts regarding the safety element of metallic doors, door trim, window sashings and trim.

"It has been proven in a fire such as the one which occurred in the Singer Building last September," he says, "that the fire remained isolated, owing to the building being equipped with metallic doors, partitions and windows. The flames could not spread from the room in which the fire originated. The question of making a building fireproof resolves itself into determining whether windows, doors, transoms or partitions are to be fireproof or not, for, like a chain, the weakest point in a building is its measure of safety. The committee on retardance of the National Board of Underwriters is considering the making of a special rate on buildings that are made all steel-proof, which means that the windows and doors and transoms are steel construction, instead of wood, or wood covered with some thin coating of metal.

"This system has been adopted by the Pennsylvania Railroad for its all-steel car construction equipment. It is available for steamships, and can be installed in buildings that are not otherwise fireproof, thereby greatly reducing their fire risk. In New York such buildings as the United Express Co., the Barclay Building, the Singer Building, and the new Bankers' Trust Co. building, now in course of construction, have the Dahlstrom system. A number of large apart-



The "Triumph" Desk

## C. F. WEBER & CO.

Manufacturers of SEATING FOR ALL PUBLIC BUILDINGS

School Desks, Church Pews, Opera Chairs, Hall Seating, Bank Furniture, Lodge Furniture and Equipment, P. O. Cabinets. Also Venetian Blinds, Rolling Wood Partitions, School and Church Bells, Maps, Map Cases, Globes.

Manufacturers of the Celebrated **Hylaplate** Blackboards, in use nearly all School Buildings.

Ask for booklet "Good Blackboards"; also "Hand Book of Seating." They are FREE to Architects.

Offices: 365-367 Market St., San Francisco. 210-212 North Main St., Los Angeles

ROBERT W. HUNT

JNO. J. CONE

JAS. C. HALLSTED

D. W. MCNAUGHER

**ROBERT W. HUNT & CO., Engineers****BUREAU OF INSPECTIONS, TESTS AND CONSULTATIONS**

NEW YORK LONDON CHICAGO PITTSBURG ST. LOUIS MONTREAL MEXICO CITY

418 MONTGOMERY ST., SAN FRANCISCO

Inspection of Rails and Fastenings, Cars, Locomotives, Pipes, Bridges, Buildings, Etc.

**CEMENT TESTING AND INSPECTION****Reports and Estimates on Properties and Processes**

ment houses of the type of the Hendrik-Hudson, also have adopted the metallic door, and because of the fact that the metal can be finished in imitation of the grain of any wood, so as to practically defy detection, it makes it available without defeating the decorative scheme of a room or hall."

**What About Decoration?**

Much depends upon how this question is settled, therefore it deserves careful consideration from all who are concerned in decorative work—the client who pays, the architect who plans and the decorator who produces.

This article deals solely with one kind of decorative finish—White Enamel, and its purpose is to show the advantages of using this material on any job.

Whether it be a block of flats, a country cottage, a city house, a palatial hotel, a large mansion, a yacht or a steamship, White Enamel appeals on purely artistic grounds and is economical.

The discriminating buyer does not decide upon price per gallon. So-called cheap enamels give cheap effects; they are not durable and do not cover as far as the higher grade enamels, such as Satinette and others of equal grade. The main expense of decorating is labor which costs the same whether a good or indifferent material is used. It is poor economy to waste labor and then spoil a job by using cheap enamel. A high grade enamel always looks well and wears well.

In homes of every degree, where elegance and refinement are part of the atmosphere, the pure whiteness and soft lustre will be appreciated and is nothing more or less than perfect taste. Where elegant surroundings are necessary to attract people of fashion and taste, such as some of our present day hotels, White Enamel is an essential feature of decoration—its whiteness is not glaring—simply a soft true color that imparts much dignity to an apartment.

*(Continued on page 119)***THE STANDARD  
SUPPLY CO.****Building Materials****Agents for NEPHI  
HARDWALL PLASTER****Oakland, :: :: California****AMERICAN ROTARY VALVE CO.**

L. J. WHITE

S. I. WAILES

*(Morehead Vacuum Cleaning System)*

Complete Stationary Vacuum Cleaning  
Plants for Hotels, Office Buildings,  
Theaters, Apartment Houses,  
Schools and Residences

**702 BALBOA BUILDING  
Phone Sutter 607  
SAN FRANCISCO**

W. H. Henning

J. J. Burke

Phone Douglas 2298

**HENNING & BURKE****General Contractors**

Room 242 Russ Bldg.

San Francisco

# HARDWOOD

and **PANELS**  
**EDW. F. NIEHAUS & CO., Inc.**

548 TO 570 BRANNAN STREET  
 Between Fourth and Fifth Sts.  
 SAN FRANCISCO, CALIFORNIA

BRANCH YARDS { TRACY, CAL.  
 { MAYFIELD, CAL.

PHONES { LUMBER EX. 30  
 { MARKET 1485

## SANTA FE LUMBER COMPANY

DEALERS IN WHOLESALE AND RETAIL

### LUMBER

Large Timbers and Special Bills to Order      Kiln Dried Oregon Pine Finish

Main Yard on SOUTHERN PACIFIC, WESTERN PACIFIC, SANTA FE

17th and De Haro Streets      ::      ::      SAN FRANCISCO, CAL.

## STRABLE MANUFACTURING CO.

MANUFACTURERS OF

### HARDWOOD FLOORING AND LUMBER

#### "TOFCO BRAND"

Quartered and Plain Sawn White and Red Oak Flooring. Has No Equal.

OFFICE AND YARDS, FIRST ST., BET. WASHINGTON AND CLAY, OAKLAND, CAL.

# TRIANGLE MESH

Used on these Build-  
 ings is No Longer  
 an Experiment.

OLYMPIC CLUB   SATTER - CRANE CO.  
 ST. MARY'S HOSPITAL - W. P. FULLER  
 PIERS 54 & 40 - FRIEDMAN'S  
 MISSION GRAMMAR SCHOOL  
 REALTY SYNDICATE GARFIELD SCHOOL  
 SAN JOSE STATE NORMAL SCHOOL.

**THE LILLEY & THURSTON CO., 82 2nd St., San Francisco**

TELEPHONE, KEARNY 1783

**WALTER HOUGH & COMPANY**

INCORPORATED

**Building Construction**503 MARKET STREET  
SAN FRANCISCO*(Continued from page 117)*

**Durability**—Perhaps the most convincing test of durability is its general and constant use by most of the large steamship companies—numerous boats, including many which run through the tropics, have their deck houses painted with white enamel as well as the cabins. These external structures get the force of all the weathers—heat, cold, rain, wind, snow and fog, but still the enamel stands up—a wash-down after a long run sees the enameling as spick and span as ever, a fact vouched for by the companies themselves as well as those who have traveled in the boats.

Many large ship and yacht builders employ White Enamel regularly and many of the great railways. Hotels throughout the country are so decorated, besides numerous public buildings, baths, offices and private residences.

A few hints as to the manner of finishing might not be out of place. If the woodwork is new and inclined to be "pitchy," it should be covered with some preparation to stop the pitch, then three coats of pure white lead thinned with turpentine, then one coat of some special undercoating, a non-oily preparation that sets hard, it will hold up and display the final coat of enamel to best advantage. Enamel work will sink away and lose its lustre by suction if the immediate undercoat is porous such as white lead or by amalgamating with oil if the undercoat is too oily. Mixing enamel with the last coat of lead would obviate this trouble.

The final coats should be two coats of a high grade white enamel, allowing sufficient time between coats to become thoroughly hard. If a semi-gloss finish is desired the final coat may be rubbed with pumice stone and water.

**Kawneer Company Now Maintains Its Own San Francisco Office**

The Kawneer Manufacturing Company, makers of the well known metal store fronts, has established an office in San Francisco, Room 301 Williams Building, in charge of Robert C. Oliphant, formerly with the Lilley & Thurston Company. The demand for the Kawneer goods in California in the last year or two has been phenomenal. Many of the leading architects are specifying the system exclusively.

THE ORIGINAL

**BAY STATE BRICK AND CEMENT COATING**

is a perfect coating for concrete, stucco or brick. It will protect concrete, brick or stucco against disintegration or hair cracking from moisture, give it any shade desired, can be used as a finishing coat instead of plaster on concrete walls, is applicable also to interior woodwork and for interior decoration, has been endorsed by the National Board of Fire Underwriters as a fire retarder and will therefore lessen your insurance rate. It does not destroy the distinctive texture of concrete. Will not drop off when applied above delicate machinery.

**WADSWORTH HOWLAND & CO., Inc.**Paint and Varnish Makers and Lead Corrodors  
82-83 WASHINGTON STREET, BOSTON, MASS.

DISTRIBUTING AGENTS: HIRAM W. WADSWORTH, Chamber of Commerce Building, Pasadena, Cal.; TIMMS, CRESS &amp; Co., Portland, Ore.; F. T. CROWE &amp; Co., Spokane, Seattle, Tacoma, Wash.; R. N. Nason &amp; Co., San Francisco, Cal.

Cover  
Your**ROOF with ELATERITE**

ELATERITE DRILL TOP or CLOTH TOP DECKING

MAKES AN IDEAL DECK FLOOR AND ROOF

THESE HIGH GRADE PRODUCTS MADE ONLY IN DENVER, COLO.

**THE WESTERN ELATERITE ROOFING CO.**

PACIFIC COAST AGENCY, 413 FIFTEENTH ST., OAKLAND





# WORDEN-MEEKER VARNISH CO.

Products of Uniform Quality



**PAINTS, OILS, VARNISHES, STAINS**

**EGG SHELL FINISH**

A Flat Varnish Not Requiring Rubbing

Architects will find our  
Line Unequaled

**SAN FRANCISCO .. OAKLAND**

P. P. MOORE

G. D. BOYD

## Boyd & Moore

HYDREX WATERPROOFING SYSTEM. ENAMELED BRICK. "TABOR"  
REVERSIBLE SASH FIXTURES (SEE PAGE 129). "VAN KANNEL"  
REVOLVING DOORS. "ENUPHYL" ORNAMENTAL BRONZE.  
"CROSS" HORIZONTAL FOLDING DOORS  
"CROSS" COUNTER-BALANCE FREIGHT ELEVATOR DOORS  
"ENERGY" DUMB WAITERS.  
"H. & C." METAL LOCKERS.

**356 Market Street**

**SAN FRANCISCO**

E. F. HENDERSON

W. M. WILLIAMS

CHAS. WILLIAMS

## Williams Bros. & Henderson

**BUILDING CONTRACTORS**

PHONES: KEARNY 2401  
J-2401

**351 MONADNOCK BUILDING**  
SAN FRANCISCO

## FREDERICK J. AMWEG

**CIVIL ENGINEER**  
MEM. AM. SOC. C. E.

**700-705 MARSDON BLDG. SAN FRANCISCO, CAL.**

**ADVISORY ENGINEER**  
*and*  
**MANAGER OF BUILD-  
ING OPERATIONS.**

**BUILDER OF**  
KERN COUNTY COURT  
HOUSE, BAKERSFIELD,  
CALIFORNIA

## An Index to the Advertisements

	Page		Page		Page
Abramhamson & De Gear.....	113	Glænzer, Eugene & Co.....	22	Pacific Fire Extinguisher Co.....	158
Adams & Holloper.....	106	Gladding, McBean & Co.....	15	Pacific Improvement Co. 4th Cover	
American Bridge Co.....	157	Glidden Varnish Co.....	20	Pacific Rolling Mills.....	29
American Rotary Valve Co.....	117	Golden Gate Brick Co.....	114	Pacific Tank Co.....	126
Amweg, Frederick J.....	120	Golden Gate Structural and Or-		Palmer Shop, The.....	14
Arnez, Richard Co.....	132	namental Iron Works.....	134	Paraffine Paint Co.....	27
		Goodyear Rubber Co.....	138	Parrott & Co.....	2, 3, 5
Bagge, W. H., & Son, Inc.....	135	Grant Gravel Co.....	122	Perfect Concealed and Turner	
Baker & Hamilton.....	33			Bed Company.....	16
Bass-Hueter Paint Co.....	28	Haines, Jones & Cadbury Co.....	131	Petersen, H. L.....	142
Bay Development Co.....	135	Hanley & McCulloch.....	136	Peterson, Nelson Co.....	134
Berger Manufacturing Co.....	8	Hansen & Johnson.....	133	Pike, C. W. Company.....	17
Bexhill Casement Co.....	144	Hart Heater Co., The.....	110	Pioneer Paper Co.....	143
Bill & Jacobsen.....	151	Henning & Burke.....	117		
Blanc Stainless Cement Co.....		Hillard, C. J. Co.....	29	Ralston Iron Works, Inc.....	12
		Hipolito Screen & Sash Co.....	17	Ransome Concrete Co.....	8
		Hoffman Heater Co.....	18	Raymond, J. P.....	22
Bluxome & Co.....	122	Holbrook, Merrill & Stetson Co. 18		Redwood Shingles, Colored Insert	
Boswall, Wallace C.....	136	Holmes Disappearing Bed Co.....	122	Reynolds & O'Brien.....	108
Bowser & Co., S. F.....	18	Holmes Lime Co.....	9	Reliance Ball-Bearing Door	
Boyd & Moore.....	120, 144, 151	Holm Victoria.....	131	Hanger.....	30
Braendlein, George & Son.....	153	Hough, Walter.....	119	Rickon-Ehrhart Co.....	31
Braun, J. G.....	28	Howe Scale Co.....	112	Rischmuller, J. P.....	136
Breite, W. W.....	132	Hoyt Bros.....	132	Roebing Construction Co.....	115
Bridgeport Wood Finishing Co.....	27	Humphrey Co.....	21	Rulofson Metal Window Works.....	154
Brittain & Co.....	156	Hunt, Robt. W. & Co.....	117	Russell & Erwin Mfg. Co.....	24
Brockhage, Foley & Green.....	155				
Brode Iron Works.....	134	Iis, John G., & Co.....	133	Samson Cordage Works.....	135
Brown Hoisting Machinery Co.....		Industrial Ornamental Iron &		San Francisco Bridge Co.....	11
The.....	147	Wire Works.....	134	S. F. Metal Stamping and Cor-	
Building Material Co., The, Inc. 6		Ingerson & Glaser Company.....	155	rugating Co.....	22
Butte Engineering Co.....	109	Ione Sandstone Company.....	132	S. F. Pioneer Varnish Works.....	20
				Sanborn & Corinson.....	134
Cabot, Samuel (Incorporated) 248		Johnson, J. A. M.....	132	Santa Cruz Portland Cement Co.....	31
California Art Glass Works.....	21	Johns-Hanger Mfg. Co., The.....	30	Colored Insert	
California Bldg. Materials Co.....	23	Johns-Manville Co., H. W.....	23	Santa Fe Lumber Co.....	118
California Corrugated Calvert				Sanitary Plumbing Appliance	
Co.....	140	K. C. T. Waterproofing Co.....	145	Co.....	133
California Electrical Con. Co.....	157	Kawner Manufacturing Co.....	152	Sartorius Co.....	29
California Photo Engraving Co.....	136	Kelly, J. F. Co.....	113	Scarritt & Clark.....	139
California Scagliola.....	150	Keuffel & Esser Co.....	122	Shastey & Vollmer.....	134
California Steam and Plumbing		Keystone Boiler Works.....	160	Schmitt, Geo. W.....	113
Supply Co.....	31	Kiernan & O'Brien.....	111	Schrader Iron Works, Inc.....	22
Callaghan & Manetta.....	150	Knowles, A.....	21	Selden-Breck Construction Co.....	142
Carleton Hotel.....	112	Knudsen, P. J., Co.....	138	Silver Lake Sash Cord Co.....	113
Central Electric Co.....	112	Kompolite.....	Colored Insert	Simonds Machinery Co.....	133
Central Iron Works.....	11			Smith, Emery & Co.....	116
Clarke, D. Ross.....	136	Liquid Stone Paint Co.....	148	Snook, William & Son.....	157
Clinton Fireproofing Co.....	2d cover	Lilley & Thurston Co.....	118	Southern Pacific Co.....	146
Coleman, Alex.....	113	Locke Foundation Co.....	135	Soule Reversible Window Co.....	131
Collins Steel Partition & Lath-		Los Angeles Pressed Brick Co.....	15	Standard Construction Co.....	137
ing Co.....	159	Lyden, Martin.....	153	Standard Portland Cement Cor-	
Columbia Lumber Co.....	133	Lynch & Co., A.....	133	poration.....	Colored Insert
Columbia Marble Co.....	10			Standard Supply Co.....	117
Cook, H. N., Belting Co.....	30	Machinery and Electrical Co.....	130	Standard Supply and Equipment	
Corrugated Bar Co.....		Mackenzie Roof Co.....	115	Co.....	123
.....	Inside Back Cover	Mangrum & Otter.....	32	Standard Varnish Works.....	129
Crane Co.....	31	Marshall & Stearns Co.....	123	Stanley Works.....	141
Crowe, F. T. & Co.....	4	Master Builders Co.....	126	Steel Protected Concrete Co.....	124
Crowley, E. D. Co.....	135	Menzer, C. & Son.....	150	Steiger Terra Cotta & Pottery	
		Mercer-Fraser Company.....	155	Works.....	15
Dean Reversible Window Co.....	17	Meurer Bros.....	Inside Front Cover	Stoffels, Geo. H. & Co.....	142
De Laval Dairy Supply Co.....	17	.....	Inside Front Cover	Strable Manufacturing Co.....	118
Diamond Brick Co. Colored Insert		Miliken Bros.....	149	Sutton John G., Co.....	113
Dieckmann Hardwood Co.....	32	Mosaic Tile Co., The.....	135		
Dietzgen, Eugene Co.....	9, 133	Moore, Charles C. & Co.....	160	Thieben & Co., Jos.....	19
Duncan, David.....	136	Mortenson Construction Co.....	134	Thomas & Schneider Art Glass	
Dunlevy & Gettle.....	135	Mott Iron Works.....	135	Company.....	143
		Moulin, Gabriel.....	143	Tozer Company.....	19
Elam & Son, Thomas.....	135	Mt. Diablo Construction Co.....	134	Triumph Ice Machine Co.....	141
Electric Appliance Co.....	110	Municipal Eng. & Con. Co.....	141	Trussed Concrete Steel Co.....	139
Elevator Supply and Repair Co.....	141	Murphy Mfg. Co.....	132, 143	Turner Company.....	125
Engstrum, F. O. Co.....	142				
Esterly Construction Co.....	136	Natomas Consolidated of Cal.....	125	Union Metal Corner Co.....	147
		Nelson, N. O., Mfg. Co.....	31	United Glass Works.....	10
Farrell & Reed.....	123	Nevada Gypsum Co., The.....	15	United Materials Company.....	155
Fee, Grant.....	136	Colored Insert			
Fernald Co., The.....	123	Niehau & Co., Edw. F.....	118	Vallejo Brick and Tile Co.....	16
Fess System Co.....	26	Northern Clay Co.....	15	Van Emon Elevator Co.....	1
Fisher & Wolfe Company.....	111				
Pollansbee Bros. Co.....	109	O'Mara, J. E.....	111	Wadsworth, Howland & Co.....	119
Footo Concrete Machinery Co.....	125	Otis Elevator Co.....	Back Cover	Wagner, Ferdinand.....	132
Ford & Malott.....	13			Walter, D. N. & Co.....	152
Ford, Thomas J.....	111	Pacific Ball-bearing Door-Han-		Waterhouse & Price Co.....	26
Fox, John L.....	132	ger Co.....	Inside Front Cover	Weary & Alford Co.....	32
Fuller, W. P. Co.....	131	Pacific Blower & Heating Co.....	113	Weber, C. F. & Co.....	116
		Pacific Portland Cement Co.,		Wells & Spencer Machine Co.....	12
Gilley-Schmid Co.....	112	Con., The.....	Colored Insert		

INVESTIGATE  
**HOLMES' Disappearing BEDS**

687 Monadnock Building, San Francisco, California

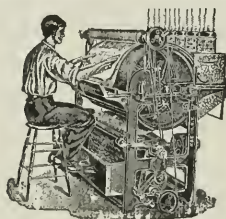

**Federal Blueprinting Machines**

FOR PRINTING BY ELECTRIC LIGHT

A continuous printing machine. Most economical, rapid and convenient. Automatic tension. Variable speed, always under control. Best utilization of light. Made to print up to 30, 42, 54 inches wide. Descriptive circular on request.

MADE EXCLUSIVELY BY

**KEUFFEL & ESSER CO.**

48-50 SECOND STREET - SAN FRANCISCO, CAL.

WE MAKE

**BLUE PRINTS**

Make inquiry ANYWHERE as to the reputation of **BLUXOME & CO.**, 532 Monadnock Building, San Francisco, for high class workmanship and fair dealing in plain or Reinforced Concrete Construction.

Producers of Clean, Fresh-Water

**GRAVEL  
 AND SAND**

QUALITIES

"GRADED"  
 "CRUSHED"  
 "ROOFING"  
 "TOPPING"

CAPACITY, 3000 TONS PER DAY

Plants at Eliot, near Pleasanton  
 and Healdsburg

**Grant Gravel  
 Company**

OFFICES  
**WILLIAMS BUILDING**  
 3d and Mission Sts.

Phones Pacific, Douglas 3078  
 Home, J 1982

**San Francisco**

SOMETHING ENTIRELY NEW

# OSCILLATING PORTAL WALL BEDS

MARSHALL & STEARNS CO.

1154 PHELAN BUILDING

SAN FRANCISCO, CAL.

### Rivals Vermont Marble

A press dispatch from Cincinnati reads: "Attorney Richard T. Durrell and Civil Engineer Charles Cornelius of Cincinnati, accompanied by T. Swain, a marble expert of Vermont, left this city today for Los Angeles, en route to Lower California to inspect a marble quarry there, which is said to be worth at least \$1,000,000.

"This journey will be made for the Pacific Italian Marble Company, which is capitalized under the laws of Ohio for \$800,000."

At a recent meeting of the Home Industry League, the Vermont Marble Company was elected a member. Next!

### The Trus-Con Slotted Insert

The Trussed Concrete Steel Company, makers of a great many meritorious articles for use in reinforced concrete construction, has recently placed on the market the Trus-Con Pressed Steel Slotted Insert, which is installed in concrete construction at the time that the concrete is being poured for the purpose of attaching shaft hangers, sprinkler systems, fixtures, etc. The Trus-Con Pressed Steel Slotted Insert is made of one piece of metal, and is so arranged as to allow a wide variation for adjustment in the location of shaft hangers, etc.

GEO. FARRELL, Burlingame  
WALTER N. REED, 239 Precita Ave.  
San Francisco  
Res. Phone Mission 2459

## FARRELL & REED

MASONS AND GENERAL  
CONTRACTORS

BUILDERS' EXCHANGE

Office 9th Floor, Gunst Bldg.  
Third and Mission Sts., San Francisco  
Phone Sutter 450.

W. McCLENAHAN, Mgr. SUTTER 1939

## STANDARD SUPPLY and EQUIPMENT CO.

CONTRACTORS AND BUILDERS  
SUPPLIES—EQUIPMENT

Give us your plans or material schedules.  
We do your figuring, act as purchasing  
agents and will show you where and how  
much money we can save you.

407-9 Lick Bldg. San Francisco

PHONE: KEARNY 263

# THE FERNALD CO.

REPRESENTING THE

NORTHWESTERN EXPANDED METAL CO., OF CHICAGO

MANUFACTURERS OF

**KNO-BURN** DIAMOND MESH METAL LATH  
EXPANDED  
IN GALVANIZED, BLACK AND PAINTED

Our Galvanized Lath is Galvanized after  
Expanding and Cutting  
The only Galvanized Lath worthy of the name

OFFICE AND WAREHOUSE:  
248 TEHAMA ST., BET. 3D & 4TH  
SAN FRANCISCO, CAL.

## ADVERTISERS' INDEX—Continued from Page 121

Western Building Material Co. 128	White Bros ..... 115	Woods & Huddart..... 32
Western Builders' Supply Co. . . 25	Whittier, Coburn Co. .... 27	Worden-Meeker Varnish Co. . . 120
Western Elaterite Roofing . . . 119	Williams Bros. & Henderson. . 120	Young Machinery Co., A. L. . . . 7
Western Iron Works. .... 29	Wilson, W. H. & Co. .... 133	Zeis, Oscar L. .... 113
Western Lime and Cement Co. 127	Wittman, Lyman & Co. .... 125	Zelinsky, D. .... 149
Whitaker & Ray-Wiggin Co. . . 13	Wocker, A. C. .... 16	

**The Bungalow Heater**

The following facts about the Pittsburg Bungalow Heater are contributed by the San Francisco agents, Thos. Thieben & Co., 667 Mission Street:

"The 'Pittsburg Bungalow' gas water heater has made hot water a necessity, instead of a luxury, in every cottage, bungalow, apartment or office.

"Why?"

"Because with it hot water costs less than with coal fuel.

"No home is so humble as to be unable to afford it.

"The only gas that burns when hot water is not needed is at the pilot light which costs only 20 cents per month.

"Its construction is such that the cost of upkeep is not greater than that of an ordinary range.

"Its coils are designed with especial reference to avoidance of clogging by sediment, no matter what the character of the water.

"Its valves are of the non-stickable kind—that means you cannot fail to get hot water through failure of the heater to operate.

"The gas is turned on and off when the hot water faucet is opened and closed—no gas to light or turn down, no danger of waste of gas through failure to turn it out.

"With artificial gas at \$1.00 per thousand the 'Pittsburg Bungalow' will supply 10 gallons of hot water for one cent's worth of gas—a steaming hot bath (20 gallons) for 2 cents."

**Plumber**

Mulligan, the contractor, put up a church building. Dunn was building inspector then, and when he saw the church he said, "Pat, it isn't plumb."

That made Mr. Mulligan pretty mad. He climbed right up and began to take measurements. Having squinted down the plumb line in a dozen different places, he was ready to report. There was a ring of triumph in his voice.

"Mr. Dunn," he said, "come and look at it v'rself. Plumb, eh? By th' piper that played before Moses, it's more than plumb!"—Cleveland Plain Dealer.

**WAINWRIGHT GALVANIZED STEEL CORNER BAR**

For Protecting Edges of Concrete Curbs, Steps, Columns, Etc.

The only effective **Concrete Edge Protector** offered to the contracting public

WAINWRIGHT PATENTS—March 9, 1907, November 22, 1908, May 5, 1903, March 26, 1907, August 29, 1907, August 2, 1910.

This bar has been in public use for more than ten years as the main feature of the

**WAINWRIGHT STEEL-BOUND CONCRETE CURB**

THE BEST IN THE WORLD

**OVER THREE MILLION FEET**

In use in more than three hundred cities in the United States

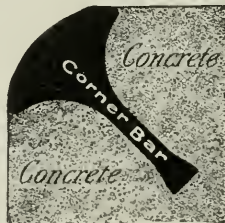
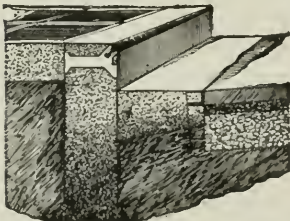

ABSOLUTELY NON-BREAKABLE  
CHEAPER THAN GRANITE

Handsome than Granite and much stronger.  
Continuous in Construction, hence Never Out of Line.  
**GALVANIZED STEEL CORNER BAR** Prevents Chipping or Breaking on Edges.

This Curb is Mechanically Perfect and Unequaled for Curved Corners.

**THIS CURB WILL STAND HARDER USE AND LAST TEN TIMES AS LONG AS PLAIN CONCRETE CURBING.**

**CONTRACTORS** can make money by laying this curb.

**CITY ENGINEERS** can save money by specifying it

**ARCHITECTS** are invited to read pages 242 and 243 Sweet's Index."

METAL PARTS FOR SALE

SEND FOR COPYRIGHTED BOOKLET No. 16

**STEEL PROTECTED CONCRETE CO.**

REAL ESTATE TRUST BUILDING  
PHILADELPHIA, PA.



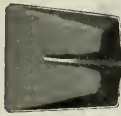

## Cut Down Shovel Expense!

Use "CONNEAUT SPECIAL" SHOVELS  
"Mikkola Patent"

Order NOW from

### FOOTE CONCRETE MACHINERY CO.

CONCRETE MIXERS — CONTRACTORS EQUIPMENT

Telephone: Douglas 1380

999 Monadnock Bldg., San Francisco

NATOMAS CONSOLIDATED OF CALIFORNIA

ANNOUNCES THAT THE

ROCK CRUSHING DEPARTMENT

NOW OCCUPIES THE SEVENTH FLOOR OF THE

PEOPLES SAVINGS BANK BUILDING

SACRAMENTO, CALIFORNIA

W. J. TURNER,  
PRESIDENT

D. TURNER,  
SEC'Y & TREAS.

## THE TURNER COMPANY

PLUMBING, HEATING, VENTILATING  
AND ELECTRICAL CONTRACTORS

TELEPHONE SUTTER 1059

278-280 NATOMA STREET  
SAN FRANCISCO, CAL.

Phone Market 746

## WITTMAN, LYMAN & CO.

PLUMBING and GAS FITTING  
HOT WATER and STEAM HEATING

315 POLK STREET  
Bet. McAllister and Fulton Sts.

SAN FRANCISCO, CAL.

*Mr. Architect:—When you specify the*

## PITCHER SLIDING DOOR HANGER

*Insist upon its use. There is a cheap substitute on the market which some contractors would like to use. Don't be deceived for we intend to prosecute any and all infringements of the Pitcher Patents.*

### DISAPPEARING DOORS A Great Labor and Space Saving Device



TOTAL THICKNESS OF WALL 5½ INCHES

**PITCHER** } Adjustable Hangers  
Patent Door Frames

Specified by nearly all leading Architects

SEND FOR CIRCULAR

**PACIFIC TANK & PIPE CO.**

231 BERRY STREET SAN FRANCISCO 318 MARKET STREET

## Architects!

**Y**OU have been having trouble with Dry Bonds in all Concrete Work. We can prevent this with **MASTER BUILDERS CONCRETE FILLER**. Master Builders Filler will waterproof Concrete and make a surface hard as Iron. Does not absorb oil, is used largely for floors with heavy wear; expense nominal. *Write for particulars.*

### The Master Builders Company

1054 Monadnock Bldg.  
San Francisco

25 Broad Street  
New York

### Sound Damp-Proofing

As the name would indicate, the primary object of damp-proofing is to keep out dampness, not only in concrete construction but in masonry work. Cracks and crevices are the easiest for the water to leak through and water will settle upon and penetrate a rough and uneven surface more easily than a smooth one. Foundations and basement walls in their natural roughness are most susceptible to dampness. It is often found practicable to fill cracks and crevices with a compound that insures water tightness. The material must have sufficient body to fill up the cracks and adhere firmly to concrete, plaster or brick. To apply this treatment satisfactorily a pump can be used with excellent results. The spray gives better results than the brush, for the pressure from the nozzle sends the materials into the weakest spots, the latter often-times inaccessible by any other methods.

It is well known that asphaltum is one of the best water-proofing materials on the market today. The California asphaltum, by reason of its high percentage of bitumen and freedom from vegetable and mineral matter, is particularly valuable for water-proofing purposes. It is more viscous than European or South American asphaltum and considerably more penetrating. By reason of its plasticity, it will give and contract with the building, and on account of its purity, or absence of foreign matter, it will not stain the plaster.

Maltho Damp-Proof Paint has as its principal ingredient Maltha asphaltum, the purest asphaltum with the highest penetration on the market. This paint is used almost exclusively, by John L. Fox, who has offices in the Monadnock Building, San Francisco.

Mr. Fox has during the last four years, damp proofed with this material not only the most prominent buildings in San Francisco, but all over the state. In every competition entered, Maltho

Damp-Proof Paint came out with first honors, and Mr. Fox guarantees every building damp-proofed by him with Maltho Damp-Proof Paint.

### Wants Authority to Inspect Federal Plans

The Secretary of the Treasury at Washington has not answered State Mineralogist Aubury's request for due authorization to inspect the plans and specifications relating to the public buildings that have been planned for California by the supervising architect of the Treasury and Aubury wonders why. He has sent a second dispatch to the Secretary of the Treasury in which he explains why he made his request. The custodian of the building plans and specifications in San Francisco refused two representatives of the California State Mining Bureau permission to inspect the papers. These representatives were instructed to make extracts from the plans and specifications to show, on the testimony furnished by the Supervising Architect's department, that many discriminations had been made against California's structural materials. The State Mineralogist desires to cover the facts relating to each and every one of the public buildings planned for California in a series of years. He has the facts concerning half a dozen buildings, but he wishes to make a showing that will be conclusive in regard to all. He does not yet despair of getting the authorization from the Secretary of the Treasury and therefore has made his second appeal to that official for an opportunity to inspect the official papers in each case.

### Taking Care of the Pennies

How many contractors who give their personal attention to the purchase of a new piece of machinery, such as a hoisting engine or concrete mixer, ever consider that there may be improvement in such an ordinary implement as a shovel by which five men can perform the work

#### FINISHES FOR CONCRETE SURFACES

Ordinary paints, when used on concrete, peel, crack and wear off.

Trus-Con Finishes become part of the concrete, resist wear and are waterproof.

**Trus-Con Floor Enamel** is dampproof, stain-proof, and prevents the formation of concrete dust on cement floors. Produces a tile-like surface which resists wear and is easily cleaned by mopping. Furnished in a variety of colors.

**Trus-Con Wall Finishes** make walls absolutely dampproof and allow the masonry to retain its natural texture, preserving its beautiful grain and replacing its cheerless monotony with delicate artistic tints.

Tell us condition and size of surface to be finished and we will send free trial sample. Booklet and Color Card free.

## Western Lime & Cement Co.

DISTRIBUTORS OF

CHEMICAL



PRODUCTS

268 MARKET STREET

SAN FRANCISCO, CAL.

ordinarily done by six with even less exertion?

There is now a shovel, manufactured under the "Mikkola patent," which is of such shape that the edge is self-sharpening, the blade enters the material without obstructing sides, and the bowl will hold more than any other shovel of similar size. Also, it is possible to make these shovels one pound lighter than other shovels of similar size, and on account of the steel used and process of manufacture they are guaranteed to outwear all other makes of shovels.

Will it not pay the progressive contractor or builder, the one who "looks after the pennies," to give even such a seemingly small matter as the purchase of his shovels his attention? If using a gross of shovels in a season, will it not pay to buy shovels which will necessitate the purchase of but half a gross to do the same amount of work, and more than pay for the additional cost over common shovels by the increased efficiency of the men using them?

The "Mikkola Patent" shovels are manufactured by the Conneaut Shovel Co., and are carried in stock by the Foote Concrete Machinery Co., 999 Monadnock Building, San Francisco.

**Bryan Having His Troubles**

A. J. Bryan, a Chico architect, is endeavoring to secure for himself the supervision of the new municipal building, which work he would seem justly entitled to.

Mr. Bryan sent the following letter to Lionel Dean, Secretary of the State Board of Architects:

Dear Sir: Our good people here have on hand at the present time two freak cases relating to the erection of public buildings, and in each case the resolutions of local boards have made it necessary for their attorneys to prepare "special" contracts for the building contractors to sign in order to permit the boards to employ carpenters to interpret the plans and specifications of the architects, and to decide all matters pertaining to the business of an architect during the construction of these public buildings. I am interested only in one of these buildings, and the attorney for the board having that work on hand told me that he had written in the contract "the terms architect and superintendent shall be considered synony-

mous," and I have since been told by Mr. E. D. Sharp, the contractor for the erection of this particular building, that the contract which has been finally made up for him to sign, now reads "that anything in the plans or specifications which are in conflict with this contract shall be considered null and void." Being only a layman, I may be wrong in thinking that this is making law to fit the case. The specifications were carefully read and approved by the same attorney, before notice was published inviting building contractors to make estimates and proposals for the construction of the building.

The board set out the full allowance of six per cent for the making of plans and specifications and the supervision of the construction, and in their publications of notice to architects asking for competing plans they divided the six per cent (against protest) into two parts, three and one-half per cent for plans, etc., and two and one-half per cent for supervision, and now they have decided that it is good business—or politics—to pay two and one-half per cent to a carpenter to take the architect's place and take charge of all architectural supervision and the issuance of architect's certificates of completion and acceptance, etc. And, finally, the attorney dug up the antiquated law of 1871, requiring me to go out and buy a surety bond amounting to twenty per cent of the entire cost of the building, and to obligate myself to furnish other bonds amounting to 100 per cent of the whole cost in case some one or more building contractors failed to bid lower than the amount the board decided should be invested in the structure. As to these bonds, I know it is considered wrong to submit to such impositions—and that it is also wrong to allow a carpenter to assume the duties of an architect and stand around a building and "look wise" when he can have no authority to either accept or reject any materials or work.

But as against local boards and their attorney we can have little to say, as they assume the right to settle matters in regard to architecture without any regard to your California Board of Architecture, or your attorneys; therefore, we will simply refer the matter to your board to take such action as seems to be your duty.

Sincerely yours,

A. J. BRYAN.

**Cold Rolled Steel a Cheap and Effective Fireproofing**

Steel is rapidly growing in favor as a material for interior fireproofing on the Pacific Coast, and especially in San Francisco.

According to an exchange, in a recent test before the National Board of Underwriters at Chicago, cold rolled steel and hard wall plaster as a material for fireproofing in partitions and furring, withstood the shock of the extreme heat followed by water, to a greater degree of satisfaction than terra cotta tile. Steel

**WESTERN BUILDING MATERIAL CO**

- 430 California Street - - - - - San Francisco
- First and Market Streets - - - - - Oakland
- 816 Lewis Building - - - - - Portland
- 426 Central Building - - - - - Seattle

Nanaimo, B. C.

## THE ART IN ARCHITECTURE

Artistic merit in Architecture depends to a certain extent upon color. On account of the importance of this factor, too much care cannot be exercised in attaining desired tones.

To produce artistic color results in interior finishing, the preservation of the beautiful, natural figure of the wood is a vital consideration. For really artistic, modern, exclusive color effects, STANDARD VARNISH WORKS' Kleartone Stains are a constant revelation to the architect as well as his clients.

Not only does the architect have the regular up-to-date shades, but he also has our unique service in securing special, out-of-the-ordinary tones. This effective assistance makes it possible for every architect to stamp every piece of his work with his own individuality and personality.

White enamel work has a peculiar charm and richness. Our Satinette White Enamel proves its superiority wherever it is used on church, residence, office building and public institution. It does not turn yellow, it is easily cleaned and does not crack. It may be finished with a dull, flat effect or rich gloss. Satinette Undercoat should always be used for priming and undercoats for Satinette White Enamel work.



### ARCHITECTURAL FINISHES

Elastica Floor Finish for floors, Elastica No. 1 for outside work, Elastica No. 2 for inside work, Flatline Cabinet Finish for flat, dull finish, Kleartone Stains for beautiful color effects, Satinette White Enamel flat and gloss for both interior and exterior work and our other Architectural Finishes always more than meet expectations.

These Finishes give results that make high-class, artistic work possible. They make it possible for wood finishing to contribute in an unusual degree to the Art in Architecture.

## STANDARD VARNISH WORKS

NEW YORK, CHICAGO, LONDON, BERLIN, BRUSSELS, MELBOURNE

**W. P. FULLER & CO.**

DISTRIBUTORS FOR THE PACIFIC COAST AND HAWAIIAN ISLANDS

Canadian Branch: International Varnish Co., Limited, Toronto.

and plaster partitions were therefore placed on a par with the best fireproofing materials for the interior of buildings.

It is of interest to know that San Francisco and the West is decidedly in advance of the East, in regard to the fireproofing of the interiors of Class "A" buildings with light steel channels and wire lath and plaster. It has been mainly through the efforts of Mr. Cornelius Collins, a pioneer lather, who for the last fifteen years has experimented, invented, and contracted in steel studding and furring, that this material has achieved such high standing throughout the country. His cold rolled steel studding is at present well known here and in the East where it has become a factor in fireproofing. During the last month and since the granting of the Exposition to San Francisco Mr. Collins has organized a new concern, the Collins Steel Partition & Lathing Company, with offices in the Monadnock Building and a factory at Brannan & Dore streets, San Francisco.

The firm is at present manufacturing a new perfected studding, which is designated as the "Interlocking Steel Studding" on account of the peculiar construction of the material, the joints of which are a sort of dovetailed interlocking structure which allows the use of a light steel channel and yet forms a perfectly taut and strong wall at a minimum cost.

### Pasadena High School

The citizens of Pasadena have voted a bond issue in the sum of \$550,000 for the purpose of purchasing a site and erecting a new polytechnic high school. Tentative plans prepared by Architect Norman F. Marsh, 212 Broadway Central Building, Los Angeles, have been adopted.

The group plan will be followed and five buildings will be erected. The style of architecture will be classic. The administration building will be a two-story structure, 180x170 feet, with two two-story wings, each 75x150 feet, for the classical and commercial departments. The home economics building will be two stories and basement, 70x120 feet; the science hall, 70x120 feet, two stories and basement; mechanics' building, 200x100 feet, one story and mezzanine floor, and physical training building

### Bids for Oakland's City Hall

All bids are to be in for work on Oakland's new million dollar city hall by May 11. Bids are expected from all parts of the country. The entire specifications have been printed in book form. The construction of the building will consume at least a year's time.



# MACHINERY & ELECTRICAL COMPANY

## ENGINEERS



**H**AVE installed Heating and Ventilating Plants in School Buildings, Theatres and other Public Buildings in California and Arizona, exceeding two hundred and fifty in number.

Vacuum Cleaners  
Power Plants

Machinery & Electrical  
Company

351 - 353 N. MAIN STREET  
LOS ANGELES, CAL.

# CONCRETA

*A Damp-Proof Coating for Surfaces of Concrete or Brick*

CONCRETA is a Reliable Paint Specialty prepared expressly for coating Cement, Plaster and Brick Walls. Its wearing properties are unexcelled.

It is much superior to ordinary oil paints for this special class of work.

CONCRETA works freely and covers more surface than any other Cement Coating.

Its economy, durability and sanitary properties make it an unequalled coating for use in Mills and Factories of concrete or brick construction.

WRITE AND MENTION THIS MAGAZINE TO

**W. P. FULLER & CO.**

MANUFACTURERS

SAN FRANCISCO, CALIFORNIA



"Hygienic" Drinking Fountain

For other styles see samples in our show rooms  
851-859 Folsom St., San Francisco, Cal.  
Circular sent on request.

**HAINES, JONES & CADBURY Co.**

DEALERS OF PLUMBING SUPPLIES

1130-1144 RIDGE AVENUE PHILADELPHIA

BRANCHES - SAVANNAH AND SAN FRANCISCO

## Architects and Owners

We have Something Better in Reversible Sash Single Casement, French Sash, Single Pivot Sash, Double-hung Reversible Sash :: Call and be convinced of their absolute Simplicity and Perfect Mechanism :: :: :: :: :: :: :: :: Absolutely Water Tight :: :: :: :: Write for Attractive Booklet with Full Particulars :: :: :: :: :: :: ::

**SOULE REVERSIBLE WINDOW COMPANY**

OFFICE AND DISPLAY ROOM

1061 MISSION STREET SAN FRANCISCO, CAL.

## HOTEL VICTORIA Chicago

In the Heart of  
wholesale, retail  
and theatrical  
district.

Fireproof Construction

\$1.00 AND UP PER DAY

Remodeled and refurbished at an expense of over \$150,000.

OPPOSITE LA SALLE  
DEPOT

Cor. Clark and Van Buren Sts.

ELMER C. PUFFER,  
Managing Director.

**W. W. BREITE, C. E.****Structural Engineer**

Designs and Details of

All Classes of Metallic Structures

FOURTH FLOOR, CLUNIE BUILDING  
California and Montgomery Sts.**SAN FRANCISCO CALIFORNIA**

(Trade Mark Reg.)  
Proven BEST by Every Test  
**JOHN L. FOX**  
TELEPHONE KEARNY 3515  
207 MONADNOCK BUILDING SAN FRANCISCO, CAL.

DR. W. J. HANNA, PRES.  
H. J. HARRISON, VICE-PRES.  
R. M. BEEBEE, SEC'Y-TREAS.**IONE SANDSTONE CO.**RED, WHITE AND VARIEGATED  
**BUILDING STONE**ROOM 532 OCHSNER BUILDING  
SACRAMENTO, CAL.

TELEPHONE 9833 R

QUARRY, AMADOR COUNTY

Telephone Market 3989

**Ferdinand Wagner****MASON  
and  
BUILDER**ESTIMATES FURNISHED ON ALL KINDS  
OF WORK

609 Waller Street - San Francisco

**DEWEY PATENT  
DISAPPEARING BEDS**ALL KINDS OF WALL BEDS  
AND CABINET BEDS

MANUFACTURED BY

**THE MURPHY MANUFACTURING COMPANY**919 O'FARRELL STREET  
SAN FRANCISCO, CAL.**J. A. M. JOHNSON CO.**Bank and Office  
**EQUIPMENT**Room 519 Monadnock Bldg.  
Tel. Sutter 741 SAN FRANCISCO**HOYT BROS.****CONTRACTORS**

of Northern California make a specialty of

**PUBLIC BUILDINGS**575 MONADNOCK BLDG.  
SAN FRANCISCO

SANTA ROSA, CAL.

MAIN 2815

HOME F 2815

**Richard Arenz Co.**  
**Painting and Decorating**DISTRIBUTORS  
SOUTHERN CALIFORNIA

FOR

PARKER, PRESTON & CO'S  
ART IN SHINGLE STAINS. WEATHER  
PROOF AND WATERPROOF  
COATINGS335 EAST FOURTH STREET  
Near San Pedro Street, LOS ANGELES, CAL.



The Value of a System of  
**FLAT VERTICAL FILING**

For Drawings, Tracings  
and Blue Prints

UNTIL YOU HAVE USED

Write for Catalog BF

**Eugene Dietzgen Co.** 18 First St.,  
San Francisco



CARSTEN HANSEN Pres. and Mgr.

E. SCHRADER, Sec. and Treas

**HANSEN & JOHNSON, Inc.**

General Contractors

OFFICE: 3 Mission St. Telephone, Kearny 278

BUILDERS EXCHANGE  
801 Jessie Street, Telephone Kearny 4700

SAN FRANCISCO

BUILDERS ASSOCIATION  
402 Kearny Street, Telephone Douglas 2525

**JOHN G. ILS & CO.**

Kitchen Equipments

and Installations

827-829 MISSION STREET SAN FRANCISCO, CAL.

OUR SPECIALTY IS FRENCH RANGES (Brick Set)

**BROWN'S GASKET**

A New Sanitary Plumbing Device to Pre-  
vent the Escape of Water and Sewer Gas.  
DEADENS NOISE OF FLUSHING  
Order from Your Jobber

**Sanitary Plumbing  
Appliance Co., Inc.**

412 Sheldon Bldg., First and Market Sts.  
Tel. Sutter 1476 SAN FRANCISCO, CAL.

Telephone Douglas 121

Residence 291 15th Avenue. Telephone Pacific 929

**A. LYNCH & CO.**

ARTIFICIAL STONE PAVEMENT  
and CONCRETE CONSTRUCTION

Estimates Given on all kinds of Concrete Work

Office: Builders' Exchange Building, 185 Stevenson Street

SAN FRANCISCO, CAL.

**SIMONDS MACHINERY CO.**

**PUMPING MACHINERY**

Sole Agents KEWANEE WATER SUPPLY CO.

Phones, Kearny 1457  
Home J 3467

12 and 14 Natoma Street, Near First, San Francisco

All Orders Promptly Attended to

Old Roofs Repaired and Warranted

**W. H. WILSON & CO.**

ASPHALTUM AND COMPOSITION  
ROOFERS

42 and 44 Natoma Street, Bet. First and Second Sts.

SAN FRANCISCO

**COLUMBIA LUMBER CO.**

LUMBER OF ALL DESCRIPTIONS IN STOCK OR CUT TO ORDER  
Main Office—BEACH STREET, Between Taylor and Mason, San Francisco, Calif.  
Telephones, Kearny 323 — Home C 4545

Mill—South Bend, Wash.

Yard—Block bounded by Beach, North Point, Taylor, Mason

R. J. BRODE, PROPRIETOR

TEL. KEARNY 2464

**BRODE IRON WORKS**

MANUFACTURERS OF

**STRUCTURAL STEEL**ORNAMENTAL  
IRON WORKOFFICE AND WORKS  
621-625 HOWARD STREETBET. SECOND AND THIRD STS.  
SAN FRANCISCO, CAL.

MEMBER OF TECHNICAL SOCIETY

ALL SURVEY NOTES SAVED

**SANBORN & CORINSON**

Successors to C. S. TILTON

**Surveyors and Civil Engineers**

Phone Douglas 366 Home Phone C 2741

251 KEARNY ST., Charleston Bldg., Room 406  
SAN FRANCISCO**MORTENSON CONSTRUCTION CO.**

CONTRACTORS FOR STRUCTURAL STEEL AND IRON

H. MORTENSON, PRES. CHAS. G. MORTENSON, VICE-PRES. AND MGR.

OFFICE AND SHOPS: CORNER 19TH AND INDIANA STREETS

PHONES: MISSION 5033—HOME M 3916

SAN FRANCISCO, CAL.

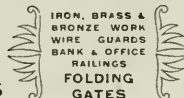
**INDUSTRIAL  
ORNAMENTAL IRON  
and WIRE WORKS**JOHN NORDGREN  
MANAGER552 NOE STREET  
SAN FRANCISCO, CAL.

PHONE MISSION 6237

CHAS. PETERSON, President

CHAS. H. NELSON, Vice-President

J. V. WESTERLUND, Secretary

**PETERSON, NELSON & CO., Inc.**

CONCRETE CONTRACTORS

*Artificial Stone Work of all Kinds*Phones: Douglas 1113  
Home C 1831OFFICE: 407 PINE STREET  
Builders Association Box 327

San Francisco, Cal.

C. S. HOFFMAN

L. W. FLEIGNER

**GOLDEN GATE STRUCTURAL and ORNAMENTAL IRON WORKS**

Structural Works, 107-109 Eleventh Street

Ornamental Iron, Wire Works and Office, 147<sup>9</sup> Mission Street, San Francisco

WE CARRY A FULL STOCK OF STRUCTURAL MATERIALS

Pacific Telephone, Market 5445

Home Phone J 1815

**REINFORCED CONCRETE CONSTRUCTION**Contracts Taken for Foundation Work, Fireproofing and Complete Structures.  
No Contract Too Small or Too Large. Our Motto: "One Good Job Deserves Another."**Mt. Diablo Concrete Construction Co.**W. E. Charbonneau, President  
Telephone, Sutter 1227

E. Nelson, Treasurer

F. E. McCoy, Secretary

Offices, 211-213 No. 185 Stevenson St., San Francisco

**SCHASTEY & VOLLMER**

1930 Van Ness Avenue

Telephone Franklin 2729

SAN FRANCISCO, CAL.

Designers

and

Decorators



# BAY DEVELOPMENT COMPANY GRAVEL - SAND - ROCK

Telephones, K 5313--J 3535 153 BERRY ST., SAN FRANCISCO

E. F. GETTLE

C. E. S. DUNLEVY

## DUNLEVY & GETTLE SHEET METAL WORKS

Manufacturers of Dunlevy's Patent Chimneys (Pat. March 6th, 1894) Dealers in Patent, Terra Cotta and Galvanized Iron Chimneys and Tops, Sewer Pipe, Flue Lining Pressed Brick Fire Brick Fire Clay, Cement Etc.

79 City Hall Avenue Telephone Market 2165 Builders' Exchange, Box 310 San Francisco

E. D. CROWLEY, PRESIDENT

S. A. JUBB, SECRETARY

## E. D. CROWLEY CO.

CONSTRUCTING ENGINEERS

EXPERTS IN REINFORCED  
CONCRETE CONSTRUCTION

PHONE DOUGLAS 982

127 MONTGOMERY STREET  
SAN FRANCISCO

THOMAS ELAM  
GROVER C. ELAM

Phone Kearny 4700

## THOMAS ELAM & SON

GENERAL CONTRACTORS

Office, Builders' Exchange, 180 Jessie Street

San Francisco, Cal.

## LOCKE FOUNDATION CO.

CONTRACTING ENGINEERS

CONCRETE AND CEMENT WORK

1107 CROCKER BUILDING

Phone Kearny 2608

SAN FRANCISCO, CAL.

## THE J. L. MOTT IRON WORKS —OF— NEW YORK

D. H. GULICK, Selling Agent for Pacific Coast

135 KEARNY ST.

Phone, West 6894

SAN FRANCISCO

## SAMSON SPOT SASH CORD

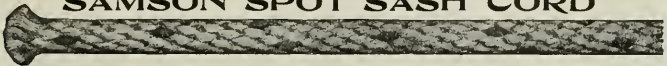

Guaranteed free from all imperfections of braid or finish. Can always be distinguished by our trade mark, the colored spots. Send for samples, tests, etc. SAMSON CORDAGE WORKS, BOSTON, MASS. Pacific Coast Agent, JOHN T. ROWNTREE, 1075 Monadnock Bldg., San Francisco and 501 Equitable Savings Bank Bldg., Los Angeles

## W. H. BAGGE & SON, INC.

BUILDING CONSTRUCTION

TELEPHONE KEARNY 4749  
ESTABLISHED 1889

3528 SACRAMENTO STREET  
SAN FRANCISCO, CAL.

No Modern Flat or Apartment House  
is Complete without—

RISCHMULLER'S IMPROVED LIQUID  
DOOR CHECK AND SPRING as well as  
RISCHMULLER'S PATENT DOOR OPENER  
and CLOSER.

HOME INDUSTRY  
Details on Application

**G. RISCHMULLER**  
BUILDERS' EXCHANGE  
San Francisco  
842 37th St. - - OAKLAND

Phone Douglas 1763

## GRANT FEE GENERAL CONTRACTOR

Business Buildings and Heavy  
Construction a Specialty

Office:  
682 Monadnock Bldg. SAN FRANCISCO

Member of Builders' Exchange  
and Builders' Association

## D. ROSS CLARKE

PLASTERING and CEMENT CONTRACTOR

Ornamental Plastering and Cement Plastering  
or Reinforced Concrete a Specialty

EXTERIOR CEMENTING DONE  
IN WHITE OR CREAM COLOR

OFFICE:  
708 PACIFIC BUILDING

ESTABLISHED 1865

C. H. Franklin, Mgr. & Atty.

THE FRANKFORT Marine Accident and Plate Glass  
INSURANCE COMPANY  
OF FRANKFORT-ON-THE-MAIN, GERMANY  
INSURANCES TRANSACTED

United States Department, 100 William Street, New York  
LIABILITY:—Employers, Public, Teams, General, Land-  
lords, Elevator, Vessel Owners, Coagents, Druggists and  
Physicians. Burglary. Workmen's Collective. Individual  
Accident and Health. Industrial Accident and Health.

TRUSTEES

RICHARD DELAFIELD, Pres. of National Park Bank,  
ERNEST THALMANN, of Ladenburg, Thalmann & Co.  
STUYVESANT FISH, 52 Wall St, New York.

DAVID DUNCAN, General Agent, Pacific Coast Dep't.  
340 SANSOME STREET, SAN FRANCISCO, CAL.  
Agents wanted for unoccupied territory

## Esterly Construction Co.

Incorporated

CEMENT AND CONCRETE  
CONTRACTORS

2136 CENTER STREET  
BERKELEY, CAL.

PHONE PACIFIC 1822

## WALLACE C. BOSWALL

CONTRACTOR AND SUPERIN-  
TENDENT OF CONSTRUCTION  
STORE AND SALOON FITTINGS

58 BOYCE STREET  
SAN FRANCISCO

JOBGING PROMPTLY WORK OF ALL KINDS  
ATTENDED TO DONE ON PERCENTAGE

H. W. HANLEY  
P. J. McCULLOCH

Phone Douglas 2446

## HANLEY & McCULLOCH

CONTRACTING PLASTERERS



378 MONADNOCK BUILDING  
SAN FRANCISCO, CALIFORNIA

**WE HAVE MOVED**  
**to 121 SECOND ST.**  
SAN FRANCISCO, CAL.

**CALIFORNIA PHOTO**  
**ENGRAVING COMPANY**  
PHONES—SUTTER 789; HOME, J 2705



FREDERICKS BUILDING, SAN FRANCISCO  
Willis Polk & Company, Architects

# STANDARD CONSTRUCTION CO.

FRED O. FARRALL, Manager

## BUILDERS

Hooker & Lent Building, San Francisco

Other buildings designed by Willis Polk & Company and erected by the **STANDARD CONSTRUCTION COMPANY** are:  
SAN FRANCISCO GAS & ELECTRIC COMPANY'S STATION G.  
BUILDING FOR THE REGENTS OF THE UNIVERSITY OF CALIFORNIA, FIRST ST., SAN FRANCISCO.  
WAREHOUSE FOR MRS. ELEANOR MARTIN.  
PACIFIC UNION CLUB BUILDING, SAN FRANCISCO.

# GOODYEAR'S FIRE PROTECTION

FOR OFFICE BUILDINGS, FACTORIES AND RESIDENCES

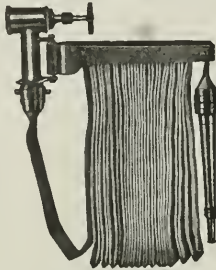

ESTIMATES FURNISHED

All Styles Swinging Hose Reels. "Eclipse" Swinging Hose Rack, with Goodyear Special Valve. Acme Fire Extinguishers, Approved and Labeled. Always Ready for Use. Rubber Matting, Mats, Rubber Tiling, etc. Eureka's Rubber Lined Cotton Hose and Unlined Linen Hose. Specify "Eureka's Best," "20th Century" or "Worthy" for an Underwriter's Approved Linen Fire Hose.

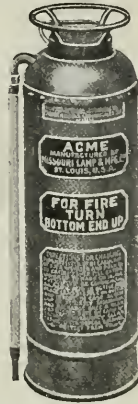

## GOODYEAR RUBBER CO.

R. H. PEASE, President

587-589-591 Market St.  
San Francisco

61-63-65-67 Fourth St.  
Portland, Oregon



Crusher House and Ore Conveyer, Goldfield Consolidated Mines Company.

## P. J. KNUDSEN COMPANY

214 Front St., San Francisco

SOLE AGENTS FOR

ASBESTOS PROTECTED METAL COMPANY

Canton, Massachusetts

**THE CHEAPEST REINFORCEMENT—AND BEST**

The superiority of the Kahn Trussed Bar has never been questioned, so that we can say "cheapest" and be understood. Considered strictly from a dollars-and-cents standpoint you are losing money by buying any other bar. Remember that in the Kahn Trussed Bar the shear members are formed from the flanges of the main bar which are ordinarily wasted,—that you save all of the expense of handling a large number of loose stirrups — that you secure absolute safety and strength against fire, shock or careless workmanship, — that rigid connection makes beams 20% stronger.

**INSIST ON RIGID CONNECTION OF SHEAR MEMBERS**



**KAHN TRUSSED BARS**

Other Kahn System Products include:

**Hy-Rib**, a self-centering reinforcement for Roofs, Floors, Walls, Partitions and Ceilings; **Rib Metal**, for Conduits and Slabs; **Built-up Column Hooping**; **Cup-Bars**, Straight or Bent; **Rib Lath and Rib Studs**, for Plaster and Stucco; **United Steel Sash** for Fireproof Windows; **Trus-Con Products**, for Waterproofing and Finishing Concrete.

Write for catalogues or call upon one of the men listed below.

**Trussed Concrete Steel Company**

689 Trussed Concrete Building, Detroit, Michigan

SAN FRANCISCO, Felix Kahn,  
304 Macdonough Building.

LOS ANGELES, J. E. Heber,  
703 Central Building.

PORTLAND, ORE., J. A. Currey,  
1009 Board of Trade Building.

SEATTLE, WASHINGTON,  
Arthur T. Nelson, 836 Henry Bldg.



H. M. SCARRITT

W. A. CLARK

**SCARRITT & CLARK**

**General Contractors**

**Reinforced Concrete Construction**

Foundations. Retaining Walls, Cement Walks and Floors  
Dealers in Crushed Brick

OFFICE, YARD AND BUNKERS:

TURK AND JONES STREETS

TELEPHONE FRANKLIN 1804





☞ The wonderful intelligence of the elephant is no more clearly shown than his careful selection of a secure footing. He will not trust his great weight on weak structures.

## American Ingot Iron Culverts

have the strength to carry the greatest loads.

The corrugations make them 29 times as strong as plain pipe of the same weight material.  
*They are the lightest and most easily handled.  
 They will last a lifetime because*

They are made of American Ingot Iron 99.94% Pure

"The purer the iron, the greater its resistance to corrosion."

Let Us Demonstrate These Facts to You

**CALIFORNIA CORRUGATED CULVERT CO.**

Los Angeles, Cal.

West Berkeley, Cal.

# STANLEY'S BALL BEARING HINGES

In Wrought Bronze or Steel

Nothing else so good for Hanging Doors.

No wearing down, no creaking, no need of oiling

— For sale by — Hardware Dealers

Attractive Literature Free

**THE STANLEY WORKS**  
NEW BRITAIN, CONN.

# ARMSTRONG ELECTRIC SIGNALS

for Passenger and Freight Elevators

MECHANICAL FLOOR INDICATORS FOR ELEVATORS

Automatic Freight Door Operating Mechanism, Expressman Call System, Fire-proof Steel Curtains for Theatres.

## Elevator Supply and Repair Co.

GEO. A. MESICK.  
Pacific Coast Manager

BALBOA BLDG. SAN FRANCISCO

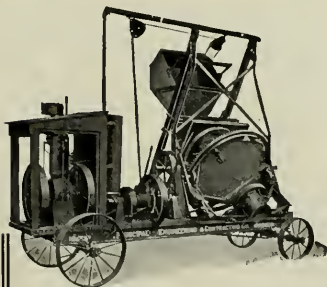

## Chicago Improved Cube Concrete Mixer

MANUFACTURED BY  
**MUNICIPAL ENGINEERING & CONTRACTING CO.**

Main Office, Railway Exchange,  
CHICAGO, ILL.

San Francisco Agents, Lansing Wheelbarrow Co., 789 Folsom St.

P. B. ENGR. 345 Pacific Electric Bldg., Los Angeles  
Special Sales Representative for Southern California

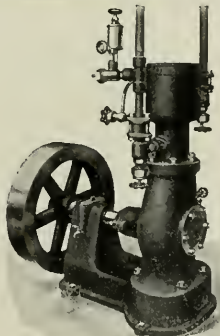

We build and install Ice Making and Refrigerating Machinery of any capacity

## Triumph Ice Machine Co.

H. F. LYON, Western Representative  
581 Monadnock Building, San Francisco.

F. O. ENGSTRUM, PRESIDENT  
F. E. ENGSTRUM, VICE-PRESIDENT

TELEPHONES  
MAIN 3045-A-1969

H. W. BOYDOR, MANAGER  
W. W. MCKAY, SUPERINTENDENT

## **F. O. ENGSTRUM COMPANY, Inc.**

### **CONTRACTORS**

WHOLESALE DEALERS IN

LUMBER, BRICK, LIME, CEMENT, GLASS, SASH  
DOORS, PAINTS AND ELECTRICAL SUPPLIES

MAIN OFFICES, MILL, WAREHOUSE AND YARDS: EAST FIFTH AND SELTON STREETS, LOS ANGELES

ST. LOUIS  
Fullerton Bldg.

LOUISVILLE  
Lincoln Savings Bank Bldg.

ST. JOSEPH, MO.  
Corry-Furpot Bldg.

SAN ANTONIO  
237 East Houston St.

## **J. H. JACOBS**

REPRESENTING

### **Selden-Breck Construction Co.**

Herman W. Hellman Bldg.

Phone A3998

Los Angeles, Cal.

## **H. L. PETERSEN**

### **REINFORCED CONCRETE CONSTRUCTION**

Artificial Stone Sidewalks, Concrete Walls,  
: : Foundations, Tanks, Reservoirs, Etc. : :

Rooms 322-24, 62 POST ST.

SAN FRANCISCO

## **GEO. H. STOFFELS & CO.**

### **BUILDERS**

630 PACIFIC BUILDING

SAN FRANCISCO, CAL.



— best by every test

**T**HE Popularity of Pioneer Roofing is due to its wearing qualities. We want to go on record right here and now with the positive assertion that a "Pioneer Roof" will outlast two ordinary roofs. The first cost is little if any more than you would have to pay for roofing of inferior quality. And once a "Pioneer Roof" is on, there is no further cost. It requires no paint or repairs. Address Dept. 23.

**Booklet and Samples**

The Pioneer Paper Company has issued a 32 page Roofing Booklet, a copy of which, together with samples of Roofing, will be mailed upon request. Address Dept. 23.

**PIONEER PAPER COMPANY**

247-251 SO. LOS ANGELES ST., LOS ANGELES, CAL.

**GABRIEL MOULIN**

*Maker of*

**Photographs**

**FOR ADVERTISING AND  
COMMERCIAL PURPOSES**

**153 Kearny Street  
Wiley B. Allen Building  
San Francisco**

**Telephone Douglas 4969**



Art Glass Panel in Dunn's Cafe, San Francisco

From the Studio of

**THOMAS & SCHNEIDER  
ART GLASS CO.**

610-12 Howard Street San Francisco



**Murphy Concealed Wall Bed**

Send for Circular

**MURPHY MANUFACTURING CO.**

919 O'Farrell Street

:::

San Francisco, Cal.

## BEXHILL WINDOWS

Used Exclusively  
in this Building

BEXHILL Patent Casement Windows are weather proof and will not rattle. No Racks, Wheels, Pulleys or Cords. Can be adjusted to any position and firmly locked



SAUNDERS BUILDING SAN FRANCISCO

## BEXHILL CASEMENT CO.

MILLS BUILDING, SAN FRANCISCO

## DODD'S INTERLOCKING BLOCKS

USED IN THIS BUILDING

*A*  
*Fire Proof*  
*Germ Proof*  
*and Inexpensive*  
*Partition*  
*Will not Warp*  
*Make an Absolutely*  
*True Surface*

INVESTIGATE

### BOYD & MOORE

SALES AGENTS

356 Market St. San Francisco



Sheldon Bldg. San Francisco. B. G. McDougall, Architect





*Higgins Building, Los Angeles.*  
*A. I. Haley, Architect. A. C. Martin, Engineer. A. Barman, Contractor.*

# Imperial Waterproofing

Used on this Reinforced Concrete Store and Office Building

## A Strictly Chemical Solution

**“ABSOLUTELY DAMP-PROOF”**

for Brick, Concrete and Exterior Plastered Buildings

MANUFACTURED BY

### K. C. T. Waterproofing Co., Inc.

**IMPERIAL COMPANY**  
Builders Exchange Building  
San Francisco

**BRAUN-CHEMICAL CO.**  
906-10 E. Third St., Los Angeles

**W. O. STAMPS**  
Portland, Ore.

## Couple Rest with Pleasure

BY INCLUDING THE

# New Orleans-New York Steamship Line

Between *New Orleans* and *New York* in the routing of your ticket East. Costs less than an all rail route and affords an interesting and delightful diversion on your trip.

### RATES

First class rail to New Orleans and	}	-	\$ 77.75	
First Cabin steamer to New York				
Round Trip	-	-	-	145.50
One way rail, one way steamer be-	}	-	70.00	
tween New Orleans and New York				
Second class rail and second cabin	}	-	-	65.75
New Orleans to New York				

Rates include meals and berth while on steamer

Write or ask any agent for details

# SOUTHERN PACIFIC

### TICKET OFFICES :

Flood Building, Palace Hotel, No. 32  
Powell St., Market St. Ferry Depot,  
Third and Townsend Sts. Depot,  
Broadway and 13th St., Oakland.

**Hannon "OUTERSITE" Metal Picture Moulding (patented)**  
**Hannon ORNAMENTAL Metal Picture Moulding (patented)**

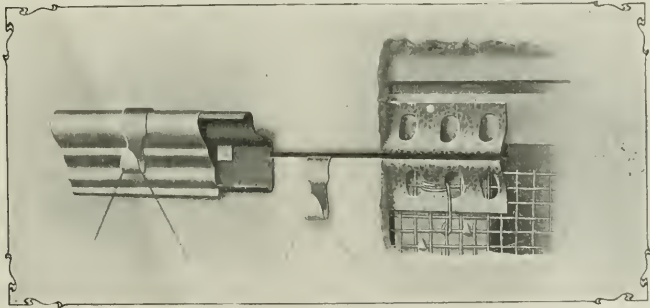

**Hannon Ornamental  
Metal Picture Moulding**

Showing Bracket Inserted into "OUTERSITE" and HANNON METAL PICTURE MOULDING attached thereto.

**"Outersite"  
Plastered**

Showing Hook Inserted

[Hook can be placed wherever desired.]

**Hannon "Outersite"  
Metal Picture Moulding**  
[An invisible moulding]

Above section shows "Outersite" applied to wood lath (upper half) and to wire (lower half). Can be used on any kind of fire proof construction. "Outersite" is doubly hot-galvanized. Made in one length only—10 ft.

**UNION METAL CORNER CO.**  
MANUFACTURERS, BOSTON, MASS.

OR

**WATERHOUSE & PRICE CO.**  
SAN FRANCISCO PORTLAND  
LOS ANGELES OAKLAND

**Ferrocinclave** The IDEAL CONSTRUCTION

- FOR --
- ROOFS
- SIDE-WALLS
- ARCH & FLAT FLOORS
- BINS
- STAIRWAYS
- PARTITIONS
- TANKS
- SILOS

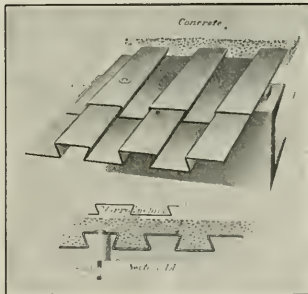

- ECONOMICAL
- LIGHT IN WEIGHT
- GREAT STRENGTH
- FIRE-PROOF
- SIMPLE IN CONSTRUCTION
- REQUIRES NO CENTERING

Because of the Patent INVERSE TAPER of the Corrugations the end laps are tight and rigid, the dove-tail is not destroyed and there are no voids or air spaces which allow the steel to rust out and destroy the PERMANENCY of the construction.

**The BROWN HOISTING MACHINERY CO.**  
Cleveland, Ohio.

Ferrocinclave Agent for California, CHAS. A. LEVY, 502 Hooker & Lent Bldg., San Francisco

MYRON HUNT &  
ELMER GREY  
Architects  
Los Angeles



Stained with  
Cabot's  
Shingle Stain

**CABOT'S CREOSOTE SHINGLE STAINS**  
THE ORIGINAL AND STANDARD STAINS

Distinguishable by their soft depth and freshness of color, richness of tone, and durability. No muddy or greasy effects, no blackening, no washing off. They have stood the test more than twenty-five years.

Cabot's Sheathing and Deafening "Quilt." Cabot's Waterproof Cement Stains. Conserve Wood Preservative. Cabot's Waterproof Brick Stains.

**Samuel Cabot, Inc., Sole Manufacturers, Boston, Mass.**

Agents { Waterhouse & Price Co., San Francisco and Oakland, Cal.  
P. H. Mathews Paint House, Los Angeles  
Timms, Cress & Co., Portland, Oregon  
S. W. R. Dally, Seattle, Tacoma and Spokane

**DAMP PROOF YOUR BRICK  
AND CONCRETE WALLS**

**FIRE PROOF**

USE



**LIQUID STONE**

It will keep walls Dry and Insure a Water Tight Structure. Liquid Stone is a Paint made from Stone and applied to the surface with an ordinary Paint Brush.

Used on the Walls of the San Francisco Y. M. C. A. Building, MacDougall Bros., Architects.

**WATER PROOF**

**THE LIQUID STONE PAINT CO., Inc.**

MAIN OFFICE, 306 CHRONICLE BLDG.  
PHONE DOUGLAS 258

LAIRD & SINCLAIR AND LILLEY & THURSTON CO.  
AGENTS  
SAN FRANCISCO, CAL

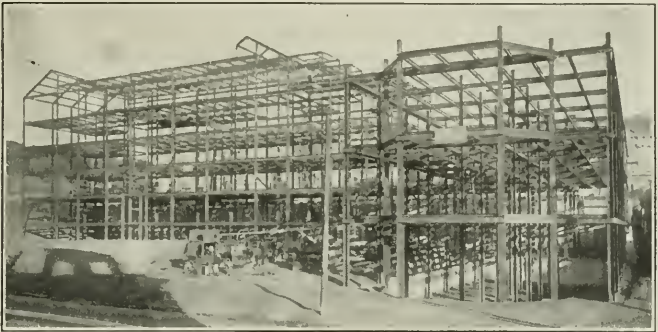

STEEL FRAME, ST. MARY'S HOSPITAL. WILLIS POLK & CO., Architects

FURNISHED AND ERECTED BY

**MILLIKEN BROS., Inc.**  
ENGINEERS AND CONTRACTORS

Humboldt Bank Building

San Francisco, Cal.

PHONE, FRANKLIN 2318

**D. ZELINSKY**  
PAINTER and DECORATOR

564-566 EDDY ST., SAN FRANCISCO

ON THE FOLLOWING BUILDINGS:

WHITE INVESTMENT BUILDING	STOCKTON HOTEL
SHELDON BUILDING	HOTEL GRANADA
MECHANICS INSTITUTE BLDG.	MECHANICS BANK BUILDING
PACIFIC UNION CLUB	CHILDREN'S HOSPITAL
UNION LEAGUE CLUB	NEWHALL RESIDENCE
REGENTS BUILDING—1st St.	FIRST NATIONAL BANK — San Jose
OLYMPIC CLUB	NICOLAUS JOB—Sacramento
COMMERCIAL BUILDING	CLUNIE THEATRE—Sacramento
ELKAN GUNST BUILDING	AND OTHERS
Y. M. C. A. BUILDING	



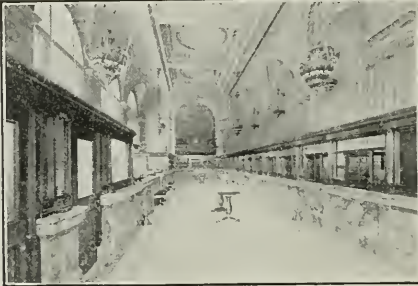

Interior of Banking Room, London Paris National Bank, San Francisco  
Albert Pissis Architect

Plain and Ornamental  
**PLASTER Work**

BY

**Callaghan  
& Manetta**



334 Tenth Street

SAN FRANCISCO, CAL.

**CALIFORNIA SCAGLIOLA CO**

WE GUARANTEE  
ALL OUR HIGH  
GRADE IMPORTED  
MARBLE IMITATIONS  
TO BE PERFECT  
WITH THE VERY  
FINEST EVER-  
LASTING  
FRENCH  
POLISH,

THE MOST  
ELEGANT  
INTERIOR  
ARTISTIC MARBLE  
DECORATIONS  
IN ALL COLORS  
LOWEST PRICES  
SAMPLES ESTIMATES  
CHEERFULLY  
FURNISHED

OFFICE & YARD  
68-70 CLARA STREET  
BETWEEN 3<sup>RD</sup> & 4<sup>TH</sup> STREETS  
SAN FRANCISCO, CAL.



Produced in Caen Stone

Expert in the manufacture of Caen Stone and Graphito; also Fire and Waterproof Composition for the exterior of all kinds of frame buildings, etc. (Patent applied for.) Also the Menzer Interlocking Fire-proof Partition Wall Block

**C. MENZER & SON**

DESIGNERS & ARCHITECTURAL SCULPTORS

882 HOWARD ST., SAN FRANCISCO

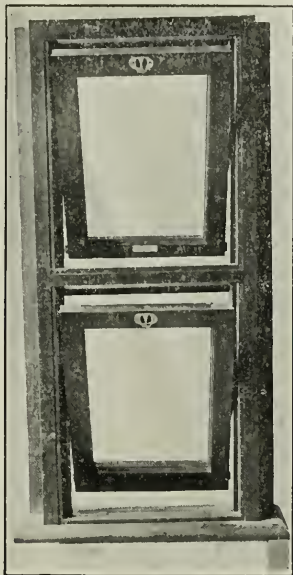

Double Hung Reversible Window,  
Style "A" Fixtures.

Manufactured by

## Tabor Sash Fixture Co.

**T**ABOR Patent Strip and  
Fixtures for all types of  
Revolving, Reversible, Remov-  
able, Horizontal and  
Vertical Pivoted Sash, Case-  
ment Sash and Transoms.

## Boyd & Moore

*Sole Agents for Northern California*

356 MARKET STREET  
SAN FRANCISCO

Telephone Kearny 2386

## THE BRADSHAW SANITARY GARBAGE CHUTE PATENTED

Absolutely sanitary, odorless, germ, fly, and rat proof. Labor and Cost in disposing of garbage reduced to a minimum. Particularly designed for apartment houses, flats, hospitals, hotels and residences.

### First Cost the Only Cost

**T**HE BRADSHAW SANITARY GARBAGE CHUTE can be applied to old as well as new buildings. It extends from basement to roof and is thoroughly ventilated. As the door is opened to receive the garbage an automatic sprinkler thoroughly flushes the chute. The garbage can has a wire screen bottom allowing the water to percolate through to the cess-pool where it is trapped to the sewer. It is hermetically sealed, thus preventing all dust and odors and shutting off any food supply for rats or domestic animals. This system reduces to a minimum or entirely eliminates janitor service now required for the disposal of garbage. The chute is made of heavy galvanized sheet metal and iron castings. It is installed complete ready to

connect to sewer and service pipes, and is guaranteed. The mechanical arrangements are so simple as to be absolutely fool-proof and out of the reach of small children. A complete chute is in full operation at our office, 524-26 Pine St.

Our chute can be installed at a very moderate price and **THE FIRST COST IS THE ONLY COST.** No expense for maintenance or wear and tear after it is in operation.

For full particulars prices, etc., address

**BILL & JACOBSEN,**  
524-26 Pine Street,  
San Francisco, Cal.

Phones  
Kearny 1790  
Home C 6603

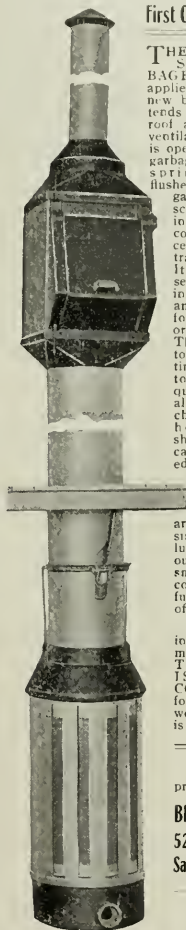

# Store Fronts

that can be  
Installed Successfully

Unless the Kawneer System of Store Fronts were simple of construction and easily installed, do you suppose architects and contractors would use it, and continue its use? To prove to you the universal approval of the Kawneer System, we simply state that in 1910, 2,832,940 lineal feet of Kawneer Material was installed in every State in the Union.

We would be flooded with "kicks" unless the Kawneer System were practical, because carpenters, in a great many



cases of very ordinary ability, are installing it in every nook and corner of the country, with no previous experience in this line. The Kawneer System is the only construction on the market that enables you to regulate the ventilation and drainage of show windows. Simply a V-shaped slide built in the gutter of the sash that opens and closes the vent holes. Ventilation in Winter and dust-tight in Summer. **BOOKLET No. 4 FOR YOU.**—It plainly describes the Kawneer System and gives you general information on store fronts that will be most interesting to you.

## KAWNEER MANUFACTURING CO.

Branch Offices in  
all large cities

Send today for  
Booklet No. 4

Factory and general offices,  
NILES, MICHIGAN

# D. N. & E. Walter & Co.

**W**ERE awarded the contracts for all of the draperies and wall hangings of the Pacific Union Club Building, and also furnished all of the floor coverings for the main floors, which included high grade carpets of special weaves, fine Oriental rugs, and the enormous hand tufted rug in the lounging room, which is the largest one piece rug in America.

**100 Stockton Street, San Francisco**



View of Dining Room, Pacific Union Club

**Interior Finish** of Lounging Room, Dining Room, Card Room, Billiard Room, Cafe and Basement Hall of Pacific Union Club, also alterations of Geo. A. Pope Residence made by

## **GEO. BRAENDLEIN & SON**

**Interior Woodwork and Office Fittings**

3155 Eighteenth Street

San Francisco, Cal.

**BUILDERS' EXCHANGE:**

180 Jessie Street  
Tel. Kearny 4700

**RESIDENCE:**

430 Eureka Street  
Tel. Mission 593

# **MARTIN LYDEN**

## **Cement Plastering Contractor**

**Ornamental Plastering and Cement  
Plastering a Specialty**

**CEMENTING DONE IN WHITE OR CREAM COLOR**

Contractor for Plastering in CUYLER LEE GARAGE, FREDERICKS BUILDING,  
and OTHER STRUCTURES shown in this issue.

# RULOFSON METAL WINDOW WORKS

MANUFACTURERS OF

## Hollow Frame Metal Windows

Tested and Approved by the National Board of Fire Underwriters

Installed in the Best Buildings in San Francisco



S  
K  
Y  
L  
I  
G  
H  
T  
S

•  
C  
O  
R  
N  
I  
C  
E  
S  
•

### SPECIALTIES

Metal Windows

Fire Doors

Hollow Metal Doors and Trim

Kalamein Doors and Trim

Art Metal Furniture

Metal Library Equipment

G. H. THOMAS, Vice-Pres. and Gen'l Manager

— FACTORY —

8th and Brannan Sts., San Francisco



J. L. CHADDOCK, PRESIDENT

W. S. HOYT, SECRETARY  
S. W. SMITH, TREASURER

## UNITED MATERIALS COMPANY

FACE, FIRE, ENAMEL,  
HOLLOW, SAND LIME,  
COMMON and KLINKER

**BRICK**

LIME, CEMENT

HOLLOW PARTITION TILING, SAND  
AND SEWER PIPE, ROOF TILE

FACTORS FOR

LOS ANGELES PRESSED BRICK CO.  
CALIFORNIA BRICK AND CLAY MFG. CO.  
FORT COSTA BRICK WORKS  
MONTEREY BRICK CO.  
LAKE MAJELLA SAND

**604 BALBOA BUILDING**  
SAN FRANCISCO, CAL. PHONE KE-ERNY 1426

JAS. D. FRASER, President

C. M. MERCER, Vice-President

H. A. GRAHAM, Secretary

## MERCER-FRASER COMPANY

GENERAL CONTRACTORS & ENGINEERS

Warehouse, Wharf and Bridge Building, Pile Foundations

OFFICES: 16 California St., SAN FRANCISCO—109 G St., EUREKA, CAL.  
PHONEs: Sutter 372—C 3764

LEADED ART GLASS WINDOWS AND DOMES IN FIGURE, LANDSCAPE AND  
CONVENTIONAL DESIGN

## Ingerson & Glaser Company

**Specialists in Stained Glass**

DESIGNERS :: ARTISTS :: CRAFTSMEN

1739 SACRAMENTO STREET TELEPHONE FRANKLIN 5096  
SAN FRANCISCO, CALIFORNIA

Art Glass Dome and all other leaded glass in Pacific Union Club and St. Mary's Hospital  
shown in this issue, furnished by us.

## Brockhage, Foley & Green

BUILDING CONTRACTORS

Telephone Market 5665

F. A. BROCKHAGE, Manager  
1326 NATOMA STREET

SAN FRANCISCO



St. Mary's Hospital, San Francisco

D. H. Burnham &amp; Co., Architects

**BOTH BUILDINGS FINISHED THROUGHOUT WITH****READING HARDWARE**

REPRESENTED BY

MARKET AND MASON STS.  
SAN FRANCISCOPhones: Pacific, Douglas 2949  
Home, C-2949 and C-2060
***Brittain & Co.***  
 INCORPORATED
908 BROADWAY  
OAKLANDPhones: Oakland 1185  
Home A-3395

Pacific Union Club Building, San Francisco

Willis Polk &amp; Company, Architects

# The Structural Steel

for all the large office buildings  
shown in this issue was furnished

BY

## American Bridge Company of New York

General Offices Hudson Terminal Building, New York

**SAN FRANCISCO OFFICE**  
**906 Crocker Building**

Annual Capacity 750,000 Tons

PHONE KEARNY 1545

HOME PHONE J1545.

### CALIFORNIA ELECTRICAL CONSTRUCTION CO.

EVERYTHING ELECTRICAL

680 MISSION STREET

SAN FRANCISCO

WM. S. SNOOK, President

F. W. SNOOK, Vice-President

### WM. S. SNOOK & SON

PLUMBERS

594-596 CLAY STREET

SAN FRANCISCO, CAL.



ST. MARY'S HOSPITAL, SAN FRANCISCO  
D. H. Burnham & Co. (Willis Polk, Manager) Architects

ELECTRICAL EQUIPMENT INSTALLED  
BY

# PACIFIC FIRE EXTINGUISHER CO.

**507 Montgomery Street  
San Francisco**

Other Buildings Designed by Willis Polk & Company and of which we were the contractors include:

Lincoln Realty Building, Automatic Sprinklers.

San Francisco National Bank, Electrical Work.

First National Bank, Electrical Work.

University of California Building (First St.), Electrical Work, Automatic Sprinklers, Heating, Ventilating and Sheet Metal Work.

Martin Warehouse, Electrical Work.

MAXIMUM EFFICIENCY

MINIMUM COST

# INTERLOCKING STEEL STUDDING and FURRING

## For Hollow and Solid Partitions, Wall and Ceiling Furring



SOLID PARTITION

Economy of Space  
Perfect Rigidity  
and  
Alignment

Spaced for 12, 14 and  
16 inch Centers  
Any width of  
Partition



HOLLOW PARTITION



Arrow indicates flat clips pressed in place



## Collins Steel Partition & Lathing Co., Inc.

Manufacturing Specialists of Cold Rolled Channels, Clips, Sliding Shoes,  
Hangers and everything in conjunction with Metal Partitions,  
Wall Furring and Suspended Ceilings

FACTORY: BRANNAN & DORE STS.  
OFFICE: 757 MONADNOCK BLDG.,  
PHONE SUTTER 1976

San Francisco, California



# CHAS. C. MOORE & CO. ENGINEERS

HOME OFFICE, 99 FIRST ST., SAN FRANCISCO

## HIGH GRADE MACHINERY

Contractors for Complete Plants

POWER

PUMPING

LIGHTING

MINING

INDUSTRIAL

Information and Catalogues at

SAN FRANCISCO  
LOS ANGELES

SEATTLE  
PORTLAND

SALT LAKE  
NEW YORK

## THIS SPACE IS RESERVED

for the

## PARKER WATER TUBE BOILER

Each month you will find here an important  
feature concerning boilers in general.

*Next month we talk about the important subject of*

**CIRCULATION**

### Keystone Boiler Works

Pacific Coast Agents.

201 Folsom Street

San Francisco.



