

technol
A

Vol. CXVIII
July-December
1920

Special Index Issue

THE AMERICAN ARCHITECT

243 West 39th Street
NEW YORK

Founded 1876
Published Weekly
in New York
Ten Dollars
Yearly

This index covers six months—twenty-six weekly issues. During that period there were presented more than 875 pages of text and above 300 full page plates, illustrating the latest and best of new construction in the Architectural and Engineering fields.

There were also included in this volume more than 400 text cuts of large suggestive value as supplementing the various topics to which they refer.

There were more than 200 pages of technical information on Architectural Engineering and a like number on the Economic Aspects of Building.

During the six months covered by this volume there were presented as Current News more than 150 pages of happenings in the field of Architecture and its allied arts.

Twenty-six frontispieces of the highest artistic and suggestive value are included, as are also twenty-six full page plates reproduced from original drawings of early American Architecture by Otto R. Eggers.

All of this in six months of issues at a cost of but \$5.00 to the annual subscriber.

EDITORIAL COMMENT

Figures refer to text pages

- A-**
Advertising the Architect, 322.
American Specification Institute, 643.
Architect and Engineer, 789.
Architect's Function? 286.
Architectural Competitions, 644.
Architectural Quicksands, 113.
Art, Cultivating a National, 252.
"Artist," Again the, 790.
- B-**
Bomb Explosion, 444.
Building Industry, Reputable and Disreputable Practices in, 823.
Building Industry, What is the Matter With, 671.
Building Trades Inquiry, 605.
By-Product, Utilizing a, 443.
- C-**
A Case in Point, 411.
Casa Gilbert Visits England, 213.
Color in the City Street, 146.
Condition and its Cure, 354.
Car Shortage, Facts About, 76.
- D-**
Draftsmen, A New Effort to Unionize, 789.
- E-**
Early American Architecture, Notable Examples Drawn by O. R. Eggers, 145.
Education in the Fine Arts, 285.
Eggers' Sketches, 11.
Europe's Debt to Us, When She Pays, 382.
- F-**
Farm, Exodus from the, 577.
Fifteen to Thirty Per Cent., 535.
- G-**
Graft, High Cost of, 577.
Guild System, 824.
- H-**
Housing for Health, 502.
Housing Question, 285.
- I-**
Illinois Architects Co-operate with Calder Committee, 672.
- K-**
Knack and Efficiency, Regaining, 75.
- L-**
Labor Over-Turn, 43.
Lincoln Memorial, 501.
Lockwood Building Committee Investigation in New York, 672.
Look Ahead, A, 861.
- M-**
Middle West Has the Right Idea, 444.
Misapplied Maxims, 536.
Model Making at Columbia University 113.
Models, Scale, at Architectural Exhibitions, 473.
Morals and Architecture, 705.
Mortgage Tax Exemptions as Impetus to Building, 381.
Motion Pictures, Architect and, 12.
- N-**
National Construction Congress, 353.
The Newly Poor, 412.
New York's Hotels, Old and New, 43.
Not What I Have but What I Do Is My Kingdom, 11.
- O-**
Office Accounting, 145.
"On With the Dance, Let Joy Be Unconfined," 411.
Opportunities, Wasting, 177.
- P-**
Postal Arrangements, Pressing Need for, 251.
- R-**
Railway Labor Board Award, 145.
Registration Boards, Conference of, 474.
Registration, Question of Joint, 705.
- S-**
Sculpture to Architecture, Relation of, 737.
See America First, 578.
Sleepy Hollow, A Legend of, 473.
Slum Areas, Planning in, 321.
State Society, An Efficient, 177.
- T-**
Theatre vs. Home, 213.
Transportation, More, 353.
- W-**
War Memorial in New York, 178.
War Memorial Building in Washington, 474.
Waste Spaces, 738.
Wasting Our Water Power, 213.
"What is Art?" 501, 606.
Will History Repeat Itself? 737.
Wrecking of Old Buildings, 535.

TEXT ACCORDING TO SUBJECT

Figures refer to text pages

- A-**
Alma-Tadema, The House of a Great Artist, 409.
Alteration Movement in New York, 691.
American Lumber Industry, 212.
Americanizing from the Start, 601.
- Anecdotes of English Architects, 703.
Apartment House Plan, New, Has Good Results, 379.
Apartments, Group Ownership of, 378.
Apartments Necessary, Are? 78.
Arcades, Builders', 695.
Architect, What is An, 6.
- Architect's Relation to his Professional Organization. By Frank E. Davidson, 42.
Architectural Acoustics. By Paul E. Sabine, 102.
Architectural Quicksands. By Clinton H. Blake, Jr., 97, 137, 174, 316, 373, 433, 506, 569, 743, 821.

1
227 940

107 679
15/11/20

TEXT ACCORDING TO SUBJECT

(Continued)

Architecture, Relation of Painting to. By George Bellows, 847.
 Architecture, Relation of Sculpture to. By A. Stirling Calder, 723, 775.
 Art and Architectural Artifice. By Jerome Lachenbruch, 563.

—B—

Back Yard, Making the Most of the, 575.
 Battle of Atlanta, 210.
 Beaux Arts Institute of Design, 109, 149, 243, 281, 319, 348.
 Billboard Ordinances, Reasonable. By A. L. H. Street, 573.
 Bombay Plans 50,000 Tenements, 470.
 Brownstone Front Loses Distinction, 750.
 Building Industry, What is the Matter with, 659.
 Building Industry, Present Situation in, 248.
 Building Prospects, 406.
 Building Situation in Chicago, 666.
 Buxton Hall, Williamstown, Mass. Country House of Alvah K. Lowrie, James Purdon, Architect, 397.

—C—

Cenotaph and the Abbey, 855.
 Client, The Suspicions, 574.
 Community Center Developments, North Shore Suburbs of Chicago, 272.
 Converting Private Houses Into Small Apartments, 597.
 Co-operative Art Building, 77.
 Crosses and Lych Gates, 100.

—D—

Dickens' Haunts to be Pulled Down, 603.
 Dynamic Symmetry and the Greek Vase, 669.

—E—

Ecclesiastical Metal Work of Ireland. By W. H. McGinty, 437.
 Emory University, Atlanta, Ga., 429.
 Employers' Housing Project, 315.
 Engineers and Architects in Artistic Collaboration Shaft Houses at Ishpeming, Mich. By Arthur T. North, 783.
 England Has 10,000 Housing Schemes, 471.
 English Housing and Town Planning Legislation, 290.

—G—

Gas, Early History of, in New York, 436.

—H—

Hartford Times Building. Donn Barber, Architect, 140.
 Holabird & Roche, Work of, 165.
 Hotel Ambassador, Atlantic City, N. J. Warren & Wetmore, Architects, 314.
 House of Albert G. Milbank, John Mead Howells, Architect, 351.
 Housing Boards, Need for Permanent, 698.
 Housing Committee Report, N. Y. State Association of Architects, 733.
 Housing Legislation in the United States, 408.
 Housing Plan Suggested by Labor Party, 376.
 Housing Problem, Series of Interviews on, 627.
 Housing Relief in New York, Proposed for; Plan Suggested by Labor Party; Relief as Proposed by Mayor's Committee, 16.

—I—

Industry, Trinity of, 735.

—K—

Kitchen Model, Competition for. Herbert Foltz, Professional Adviser, 745.

—L—

Lincoln Memorial in Washington, D. C. Henry Bacon, Architect. By Glenn Brown, 489, 523.
 Lumber Sizes Standardized, 544.

—M—

Madrid's Scheme of City Planning, 173.
 Mayflower, Finding of the, 595.
 Memorial Bridge Proposed for New York, 250.
 Men and Business, 471.
 Milwaukee County General Hospital Competition, 630.
 Mission Inn at Riverside, Cal. By Dwight James Baum, 201.
 Model Making by Architects, 749.
 Motion Picture Production, Architectural Problems in. By James Hood MacFarland, 65.
 Motion Picture Settings, Architecture of, 1.

—N—

Nebraska State Capitol Competition, 79.
 New England Farm House, Seventeenth Century, 320.
 Notes from London, 14, 208, 369, 595, 819.

—O—

Office Sketches to Promote Business. By Alfred Hopkins, 33.

Organization, Management and an Accounting System for an Architect's Office. By H. P. Van Arsdall, 129, 179.

—P—

Pan-American Congress of Architects' Resolutions, 602.
 Playgrounds, 463.
 Post War Housing, 809.
 Prague, The Palace-Fortress of Hradcany. By Selwyn Brinton, 269, 739.
 Pyramids, Theories on Construction of, 751.

—R—

Radium, 700.
 Reconstruction of Northern France. By Ralph Fanning, 71, 345, 401, 540.
 Rural Problem, Solution for, 539.

—S—

Safety, State Campaigning for, 735.
 Salvage from Old Buildings on New Plane, 440.
 Schoolhouse Design and Construction. By Frank Irving Cooper, 9.
 Scottish Rite Hospital for Crippled Children, Atlanta, Ga. Hentz, Reid & Adler, Architects, 341.
 Small-Town Architect and His Problems. By Ralph Bryan, 852.
 Spain to Have Skyscraper, 856.
 Spanish Scaport a Colorful Old City, 543.
 Specification Clauses. By Francis W. Grant, 279.
 State Departments of Architecture. By E. T. Huddleston, 287.
 Surface, Saving, With Paint and Varnish, 147.

—T—

Tenement Block, Architectural Competition for, 305.
 Theatre Regulations in Pennsylvania, 284.
 Town-Planning, Early, in New England. By Oliver H. Howe, 464.
 Tree Planting for Beautification, 539.

—W—

Waste Spaces in New York. Interview with Thomas Hastings, 771.
 What is Art? 568.

—Z—

Zoning Regulation in New York. By Thomas Hastings, 461.

CURRENT NEWS

Figures refer to text pages

—A—
 Adobe, Denver to Build Houses of, 392.
 Advertising Literature of Interest, 300.
 Air Route to Alaska, Ten Hours, 556.
 Alaska Gets First Concrete Building, 152.
 Alaska Has Museum, 422.
 Albany Builders Organize, 363.
 A. I. A. Co-operates with Thrift Week, 873.
 Amazon Valley Riches Undeveloped, 556.
 American Reconstruction Unit Leaves for France, 225.
 American Wooden Houses in France, 85.
 Annexations and City Planning, 228.
 Apartment for Babies, 685.
 Apartment in New York, 590.
 Arc de Triomphe Scoured, 19.
 Architects in Vienna, 393.
 Architectural Course Mass. Inst. Tech., 838.
 Architectural League Spring Meeting, 872.
 Architecture, the Art, 454.
 Architecture (in Judge), 226.
 Architecture, International Exhibit of, 762.
 Are You a Leader in Your Town? 763.
 Army Houses to be Sold, 22.
 Army and Navy Club's Memorial Building, 53.
 Art, American, 453.
 Art and Commerce, Brotherhood of, 265.
 Art, Increasing Interest in, 484.
 Art, London's Indifference to, 453.
 Art Restoration Planned, 85.
 Artificial Stone, New Kind of, 85.
 Asbestos Cement, 872.
 Automatic Fire Escape Approved, 621.
 Aztec Shrine Reveals Fine Workmanship, 392.

—B—

Band Stand for Philadelphia, 622.

Bank Built of Rocks from Near-by Fields, 557.
 Bath, Glass, in New "Luxury" House, 153.
 Bath Truck for Travelers, 874.
 Beaux Arts Prize Winner, 115.
 Belgium Organizes for Cheap Homes, 715.
 Berlin's Populace Discontented with Housing Conditions, 335.
 Bermuda Offers Tourist Accommodations, 686.
 Billboards, How One Artist Cleared Away, 49.
 Billboards, Victory Over, 300.
 Black Beetle Destroys Forests, 685.
 Book by John Nolen, 85.
 Book Notes—Blue Print Reading, Personnel Administration, Hellenic Architecture, 542.
 Analysis of Paint Vehicles, Japans, etc., 377.
 Boston Society Exhibition, 517.
 Breck, George W., Dead, 841.
 Brick by Parcel Post, 555.
 Bricklaying, Facts on, 871.
 Bridge Builders, Opportunity for, 421.
 Bridge Into Juneau Park, Milwaukee, 365.
 Bridges Surround New Construction to Protect Public, 364.
 Buenos Aires, Houses Scare in, 423.
 Builders Advocate Lower Structures, 84.
 Builders' Exchange Hold Exhibit, 555.
 Builders Use Camp Dix Materials to Reduce Costs, 337.
 Building Associations Grow, 263.
 Building Blocks Interlock with Herringbone Grooves, 556.
 Building Costs Less than Other Commodities, 336.
 Building Decreases in Brooklyn, 301.
 Building Figures, 483.
 Building Industries Ask Recognition in Car Service, 17.

Building Loan Associations, 301.
 Building Problem Discussed, 335.
 Building Program, Gigantic, Planned, 264.
 Building Stone, Valuable, Found, 49.
 Building Trades Represented by D. K. Boyd, 189.
 Buildings, Low, Pay More Than Skyscrapers, 301.
 Business Men's Art Club, 623.
 Business Men's Art Club for Boston, 684.
 Business, Who Owns a, 470.

—C—

Canadian Highway, Five Million Dollars for, 337.
 Canada to Replant Forests, 555.
 Canal Blasted to Increase Fish Supply, 621.
 Cedars of Lebanon Almost Extinct, 393.
 Cement Construction, Theory and Practice in, 454.
 Cement from Dead Sea, 716.
 Cement Lawn Painted, Has Advantages, 423.
 Cement Mortar, Contraction of, 423.
 Cement, Open Carload, Protected by Own Crust, 556.
 Cheap Houses, 619.
 Chicago Architectural Exhibit, Further Details, 683.
 Chicago's \$5,000,000 Dwelling Fund Grows, 589.
 Chicago to Have Huge Post Office Terminal, 683.
 Chicago Improves South Water Street, 116.
 Chicago to Rebuild Fort Dearborn, 422.
 Chimney Two Miles Long, 590.
 Chimneys Not Needed, 364.
 China, Construction in, 152.
 China Wants Industrial Information, 653.
 Chinese City Becomes Modern, 556.

CURRENT NEWS

(Continued)

Chinese Manufacturing Town Develops Large Industries, 50.
 Church 125 Years Old, 684.
 Church for Children, 83.
 Civil Service Examination, U. S., 338.
 Cliff Dwellings Found in Colorado, 782.
 Color in the Hospital, 226.
 Color Screens for Show-Window Lights, 838.
 Communal Forests Solve Up-State Tax Problems, 21.
 Community Centers for Indianapolis, 337.
 Community Systems, Our Outworn, 19.
 Concrete Brine Troughs Protect Railway Bridges, 841.
 Concrete Building Seventeen Stories, 839.
 Concrete Cascades Protect Railroad Right of Way, 717.
 Concrete Slab Bridge Not Reinforced, Fails, 621.
 Concrete Window Weight Replaces Cast Iron, 717.
 Confederate White House to Be Moved, 872.
 Conservation of Material Studied, 363.
 Construction Division, Decentralizing, 300.
 Consumer's Dollar, Dividing, 300.
 Convention Hall Had Unusual Equipment, 590.
 Cornerstone, Ceremony of, 871.
 Credit Rates, 81.
 Cypress Durability, 765.
 Cylindrical House, 424.

-D-

Dallas Architects Organize, 188.
 Death Announcement, False, 761.
 Decorations in the Business Office, 685.
 Decoration, Moneybag, 84.
 Defective Flues, 483.
 Desks, Eight, Combined in One, 623.
 Disciples Build 113 Churches in United States, 716.
 Distinguish Mahogany and Walnut From Imitations, 51.
 Doorway Without a Door, 364.
 Doors of History, Famous, 558.
 Double Deck Subway Planned, 619.
 Dust, An Industrial Criminal, 685.

-E-

Electric Homes Go Up in the West, 335.
 Electric Wiring, For Adequate, 336.
 Electrical Houseboat to Educate Chinese, 620.
 Electricity by Wind Power, 718.
 Ellis Island Asks for More Buildings, 687.
 Elms, To Save Fifth Avenue, 589.
 Employment for Builders, All-Weather, 189.
 Engineer, The Limer, 421.
 Engineering Council Formed, 875.
 England, Construction in, 265.
 English Impressions of New York Architecture, 765.
 English Names for English Streets, 151.
 Eperanto Gains Recognition, 425.
 European Hotels to be Built in China and Japan, 622.
 Exchange Council Formed in East, 555.

-F-

Farmers' Cooperative Association in New Zealand, 116.
 Fenner on the Witness Stand Before Lockwood Commission, 803.
 Fifth Avenue Association Awards, 715.
 Fine Arts, Report of National Commission, 188.
 Fires, Percentage of, 116.
 Fire Prevention in Public Schools, 20.
 Fire Resistant Wood Made So by Paint, 50.
 Fire Waste and the Business Men, 558, 621.
 Foundation Method, Novel, 117.
 Forest Under Water, 872.
 Freight Situation Halts Building, 48.
 French Coal Plants, Electrifying, to Save Coal, 454.
 French Dwellings, State Aid for Cheap, 18.
 French Property Damaged by War, 440.
 Fuel Saving by Electrifying Railroads, 152.
 Fuel-Saving Plan Announced, 619.
 Furniture, Revival of Hand Painted, 683.
 Furniture Situation Acute, 393.

-G-

Gasoline Baby, 455.
 Gateway Built of Hay, 620.
 Ghosts No Drawback, 838.
 Glacier Park Highway Will Cross Divide, 622.
 Gorgas Memorial Contemplated, 392.
 Government-Built Workmen's Houses in New Zealand, 82.

Grand Union Hotel Site Used by Bowery Savings Bank, 840.
 Grant Memorial to be Unveiled, 803.
 Growing Homes, 716.

-H-

Hair as a Building Material, 655.
 Hall of Fame Slow to Admit Artists, 763.
 Hancock House Still Stands, 622.
 Hancock House, 761.
 Haunted House Demolished, 424.
 Health Center for Chicago, 435.
 Health Officials Meet, 871.
 Hearthstone Fire, 654.
 Herculeum May Resume Excavations, 557.
 High Bridge, Effort to Save, 301.
 High Bridge, Protest Again Razing, 716.
 Hilton Gets Its Brick, 590.
 Historic Brick Building, 484.
 Hobo Hotel Rates Soar, 872.
 Hollow Bricks in England, 336.
 House Built Like Refrigerator, 50.
 Housing Brevities—Housing Plans for Railroad Employees; Revised Edition of "Model Housing Law"; More Hotels for New York; Dividing Old Houses, 86.
 Housing Brevities Overcrowding; Houseboat on Land; New York's Rent Laws Ineffective, 154.
 Housing Brevities, 265.
 Housing in New Zealand, 485.
 Housing in Philadelphia, 363.
 Housing Plans for Cities, 227.
 Housing, a Railroad Problem, 393.
 Housing Relief in New York, Proposals for; Plan Suggested by Labor Party; Relief Proposed by Mayor's Committee, 16.
 Housing Situation, Sociological Effect of, 456.
 Housing Trouble, Urge Relief for, 51.
 Housing Women, 871.

-I-

Holder is Manager, Civic Development Department, 765.
 Illinois Society Monthly Meetings, 517.
 India Builds Dam to Avert Famine, 838.
 India to Exploit Its Forests, 364.
 Industrial Reconstruction in Northern France, 365.
 Iowa Chapter Discusses Housing Problems, 588.
 Isle of Artists, Lake Como, 242.

-J-

Japanese Architecture Gives Way to Modern Styles, 839.
 Jefferson's Home for National Memorial, 48.
 Judgment Deferred in N. Y. Tenement Competition, 225.
 Junk Pile, Robbing the, 455.
 Jurisdictional Awards, Board of, Meets, 300.

-K-

Kaiser's Home Used, 422.
 Keys Not Needed in Russia, 589.

-L-

Labor Party Proposed Housing Relief, 16.
 Labor, Skilled, Lacking to Build Houses, 655.
 Landscape Architects Meet, 81.
 Landscape Painting, History of, 453.
 Laws for Housing Crisis, Suggest New, 226.
 Lehigh Valley Architects Affiliate with A. I. A., 588.
 Library Serves Its Public, How One, 84.
 Liege Defence Memorial, 557.
 Lightning Rods and Buildings, 151.
 Limit Chimney Area to Reduce Fuel Consumption, 485.
 Limousine Fitted for Touring, 874.
 Lincoln Highway Association Issues History of Work, 117.
 Living in the South, 112.
 Loan Plan, New, to Encourage Building of Houses, 112.
 London Astor House to be Sold, 716.
 London Hotel for Infants Only, 557.
 Louvre Extends Appeal to Art Lovers, 20.
 Lumber in America, Use of, 654.
 Lumber in Building, Use of, 227.
 Lumber Company Closes Plant, 762.
 Lumber Supply Threatened, 152.
 Lumber Tragedy of the United States, 17.

-M-

Manila, National Theatre In, 424.
 Master's Rooms Cost More, 457.
 Mayor's Committee Proposes Housing Relief, 16.

Memorial, Design, Competition for, 421.
 Memorial, A Sacred, 117.
 Memorial Where Washington Crossed Delaware, 392.
 Memorial to Grant Unveiled, 873.
 Mexico Has Building Boom, 555.
 Mexico Retains Its Strength, 837.
 Militarism Disappears, 655.
 Moorish Walls, Paving With, 761.
 Motion Picture Field, Designer Enters, 49.
 Motor Convoy Sent by War Department Cross Country, 18.
 Motor Trucks for Street Cleaning, 622.
 Municipal House Building Considered, 424.
 Municipal Loan Association, 116.
 Museum Uncarths Old Glass, 422.
 Museum for War Relics, 590.
 Museum Will Be Wrecked, 153.

-N-

National Academy Elects Officers, 115.
 National Housing Conference, 763.
 Nature Models in Clay, 715.
 Neater City, Mayor's Plea for, 52.
 New England, Old-Time, 336.
 New York Society of Architects, 82.
 New York Society of Architects, 457.
 N. Y. State Association of Architects, 588.
 New Zealand Will Develop Water Power, 299.
 New Zealand Gets Homes, How, 19.
 Noiseless Chamber at University of Utrecht, 686.
 Northern and Southern Estates Change Hands, 352.
 Norway, Housing in, 393.

-O-

Oak Lasts for Centuries, 804.
 Odd Construction Preserves Old Utah Fort, 620.
 Omaha Architects to Reduce Building Cost, 151.
 Omaha Tenants Form Corporation, 299.
 Open Fires, 518.
 Oregon Chapter A. I. A., 263.

-P-

Palace of Colored Stone, Work of One Mao, 654.
 Palestine is Transformed, 556.
 Palm Leaves Replace Canvas in Tent Walls, 838.
 Papyrus, Store of, Found, 653.
 Paris Again a Glitter of Lights, 623.
 Paris to Build Mohammedan Mosque, 484.
 Paris, House Shortage in, 422.
 Park, Olean, N. Y., Builds, 337.
 Park Preservation Assured, 423.
 Payment for Estimating, 116.
 Peru Spends Thirty Million for Building, 422.
 Philadelphians Appoint Committee on Town Planning and Housing, 761.
 Pictures, New Method of Producing, 423.
 Picture Sells at \$15,000, 153.
 Pioneer, Halt of the, 52.
 Plans Filed in Manhattan During July, 299.
 Playground Built in Tiers, 264.
 Plymouth Rock, to Reset, 405, 874.
 Poe Cottage, Funds to Preserve, 589.
 Poland's Landlords Gouging, 762.
 Post Office Buildings in New York, 335.
 Postal Savings Funds to Aid Home Builders? 589.
 Powder Depot on Sandy Hook Hidden by Camouflage, 621.
 Priority for Building Materials Urged, 365.
 Prison Bar, Novel, Designed, 685.
 Prize Offered to Architects, 188.
 Prizes for Fifth Avenue Buildings, 115.
 Progress, Good New Work the Milestone of, 189.

-R-

Race Suicide and the Housing Shortage, 653.
 Rat Proof Houses Demanded by Building Codes, 365.
 Rebuilding Ruined Areas, 684.
 Recreation Suggestions, 189.
 Registration Board, National, to Meet in St. Louis, 456.
 Registration Boards Hold Formal Meeting, 518.
 Rent Increases in the Fall, 264.
 Replanning Field Columbian Museum in Chicago, 620.
 Rhems Foundation, Older Church Found Under, 424.
 Rio Janeiro Has Shortage of Houses, 484.
 Room Without Columns, Largest, 555.
 Rayton Hall, a Home of the Byrons, 654.
 Russia, Hunger and Want, but Order in, says Wells, 718.

CURRENT NEWS

(Continued)

—S—

Safety Congress in Syracuse, 715.
 Safety Engineers to Meet, 762.
 Salisbury Cathedral, 225.
 School Betterment, National Conference Pledges, 152.
 School Buildings, Temporary, 226.
 Scientists Will Explore Amazon, 621.
 Senate Resolution, 189, 350.
 Shingle Production in Washington State, 227.
 Sidewalks in Buildings Make Streets Wider, 557.
 Sign Posts Elaborately Carved, 623.
 Skyscraper, New York, to be Largest, 425.
 Small House Service Bureau for Illinois, 555.
 Smoke Evil an Architectural Problem, 263.
 Snow Sheds to be Used as Motor Path, Railroad, 838.
 Soundproof and Sightproof, 18.
 Sportsman's Stable Becomes Restaurant, 589.
 Stained Glass, Progress Made in Art of, 337.
 Stamps and Housing, 686.
 State Federation of Architects and Engineers, Minnesota Proposes, 115.
 Stonehenge, Restoring, 653.
 Store on Wheels, 763.
 St. Louis, Comprehensive Plan for East, 151.
 St. Louis' Problem, 335.
 Strikes, A Record Year for, 228.
 Subway Needs, New York's, 839.
 Sunny Cells in Joliet, 299.
 Sweden Suffers From Money Shortage, 684.

—T—

Temple in the Jungle, Sixth Century, 837.
 Theatre Built Instead of Houses, 264.
 Timber Cut From Live and Dead Trees, Comparative Value of, 51.
 Timber in New England, 22.
 Thames River to Have New Bridge, 589.
 Timber From Dead Trees, 623.
 Timber, Northwest Situation, 454.
 Timbers, Longer Life For Mine, 839.
 Town Burned to be Rid of Rats, 422.
 Town Planning a Necessity, 555.
 Transportation of Building Materials, to Relieve, 394.
 Tunnel, Largest World, 838.
 Turkish Buildings Seldom Painted, 558.

—U—

United States Sells Housing Land, 21.
 Utah Architects to Design War Monument, 588.

—V—

Vanderbilt Home to be Bank, 874.
 Vanderlip Preserves "Beautiful Pieces of Architecture," 717.
 Veneer Waste as Paper Source, 839.
 Vienna's Art in Vienna, to Keep, 365.

—W—

Wall Papers, Old, Sought, 655.
 War Memorial, Pittsburgh Plans High Building as, 17.
 War Memorials, Projected, 361.

War Memorial in Ten Years, 83.
 Warren, Whitney, to Restore Louvain, 841.
 Washington, D. C., Still Feels Building Pinch, 518.
 Warsaw Limits Every Family to Three Rooms, 683.
 Waste Heat to Reduce Fuel Costs, 558.
 Waterpower Bill, Federal, 264.
 Way of Roses Proposed to Cross New York State, 717.
 Westminster Abbey in Need of Repair, 83.
 Wet and Dry Sand for Concrete, 804.
 "White Coal" in Canada, 839.
 White House for Tokio, 484.
 White Mouse Modeled After Palace, 557.
 Women Engineers and Architects Organize, 392.
 Wood Construction in Shamrock IV, 82.
 Wood That Does Not Rot, 839.
 Wooden Houses for Northern France, 336.
 Woods—How to Distinguish, 764.
 Woolworth Building, Cass Gilbert Explains, 299.
 Worcester Architect, 686.
 World War Museum, 263.
 Workers Idle, Many, 484.

—Y—

Yellow Light Best, 19.

—Z—

Zone System for Camden, 518.

TEXT ACCORDING TO AUTHORS

Figures refer to text pages

—B—

Barber, Donn:—
 Hartford Times Building, 140.
 Baum, Dwight James:—201.
 Bellows, George:—
 Relation of Painting to Architecture, 847.
 Blake, Clinton H., Jr.:—
 Architectural Quicksands, 97, 137, 174, 316, 373, 433, 506, 569, 743, 821.
 Boughton, W. H.:—
 Southern California Earthquake, 157.
 Bourne, Frank A.:—
 Architect a Necessary Factor in Bridge Building, 217.
 Brinton, Selwyn:—
 Prague, The Palace-Fortress of Hradcany, 269, 739.
 Brown, Glenn:—
 Lincoln Memorial in Washington, D. C.
 Henry Bacon, Architect, 483, 523.
 Ryan, Ralph:—
 Small Town Architect and His Problems, 852.

—C—

Calder, A. Stirling:—
 Relation of Sculpture to Architecture, 723, 775.
 Cooper, Frank Irving:—
 Schoolhouse Design and Construction, 9.
 Cowles, Louis:—
 Improved Contract Forms, 419.

—D—

Davidson, Frank E.:—
 Architect's Relation to Professional Organization, 42.

—E—

Edwards-Ficken, H.:—
 Other Side of Billboards, 147.

Eisen, Gustav:—
 Dynamic Symmetry, 701.

—F—

Fallows, Ernest:—
 Modern Textile Mills, 675.
 Fanning, Ralph:—
 Reconstruction in Northern France, 71, 345, 401, 540.

—G—

Gardner, Henry A.:—445.
 Grant, Francis W.:—
 Specification Clauses, 279.

—H—

Hastings, Thomas:—
 Zoning Regulations in New York, 461.
 Hentz, Reid & Adler:—
 Scottish Rite Hospital for Crippled Children, 341.
 Helmle & Corbett:—
 The Bush Addition, 509.
 Hopkins, Alfred:—
 Office Sketches to Promote Business, 33.
 Howe, Oliver H.:—
 Early Town Planning in New England, 464.
 Howells, John Mead:—
 House of Albert G. Milbank, 351.
 Hubbard, Charles L.:—
 Heating and Ventilating Industrial Buildings, 545, 707.
 Huddleston, E. T.:—
 State Departments of Architecture, 287.
 Hunt, George M.:—
 Forest Products Laboratory and Engineering, 25.

—L—

Lachenbruch, Jerome:—
 Art and Architectural Artifice, 563.

—M—

MacFarland, James Hood:—
 Architectural Problems in Motion Picture Production, 65.
 McGinty, W. H.:—
 Ecclesiastical Metal Work of Ireland, 437.

—P—

Perrot, Emile G.:—
 Office of an Architect and Engineer, 121.

—S—

Sabine, Paul E.:—
 Architectural Acoustics, 102.
 Smith Howard Dwight:—
 Stadia in Various Universities, 94, 124, 160, 221, 260.
 Street, A. L. H.:—
 Reasonable Billboard Ordinances, 573.
 Swales, Frances S.:—
 Competitions, 45.

—T—

Tucker, Wm. C.:—
 Safeguarding Water Supply for Isolated House, 383.

—V—

Van Arsdall, H. P.:—
 Organization, Management and an Accounting System for an Architect's Office, 129, 179.

—W—

Warren & Wetmore:—
 Hotel Ambassador, Atlantic City, N. J., 314.
 Whiting, R. S.:—
 Some Phases of Lumber Manufacture, 28.

CRITICISM AND COMMENT

Figures refer to text pages

American Specification Institute. Communications from Architects, 792, 825.
 Billboards. By H. Edwards-Ficken, 147.

Competitions. By Frances S. Swales, 48.
 Dynamic Symmetry and Its Reviewer. By Gustavus Eisen, 701.

Jurisdictional Awards. By Robert D. Kohn, 391.
 Knack and Efficiency, 249.

DEPARTMENT OF ARCHITECTURAL ENGINEERING

Figures refer to text pages

- American Society for Testing Materials, Annual Meeting, 57.
 Arc Welded Building in Course of Erection, 297.
 Architect a Necessary Factor in Bridge Building. By Frank A. Bourne, 217.
 Architects and Engineers Co-operate, 618.
 Book Notes—Earthwork and Its Cost, 757; Modern Brickmaking, 802.
 Building Code for Pennsylvania, 681.
 Bush Addition, Features of Interest in. Helmle & Corbett, Architects, 509.
 Calculations, Short Cuts to Accurate, 416.
 Calculation, Short Cuts to Accurate, 450.
 Capper Resolution, 298.
 Chimney Construction, Data on, 123.
 Contract Forms, Improved. By Louis Cowles, 419.
 Corrosion Tests, National Lime Assn., 385.
 Cost Plus Fixed Fee, 867.
 Creosote Oils in Wood Preservation, 64.
 Drain Tile and Sewer Pipe Under Different Conditions, 27.
 Earthquake, Observations on Southern California. By W. H. Boughton, 157.
 Engineer and Architect, Historical Notes on, 334.
 Engineers Discuss Transit Development, 800.
 Fire Protection and the Lumber Industry, 30.
 Forest Products Laboratory and Engineering. By George M. Hunt, 25.
 Foundation and Roof Construction, Building for Stromberg Motor Device Co. N. Max Dunning, Architect, 291.
 Foundations, Their Selection, Design and Construction, 386, 579, 795.
 Foundation Work, Novel Method in, 513.
 Glass, New Type, Resists Shock, 415.
 Government Bulletins Issued, 332.
 Heating and Ventilating Industrial Buildings. By Charles L. Hubbard, 545, 707.
 Hoover President of Engineering Federation, 758.
 Idiosyncrasies of Building Materials, Lime, 615.
 Illumination Design, Fundamental Principles, 475.
 Insulating Values of Various Coverings for Hot Air Pipes, 648.
 Jurisdictional Awards, 360.
 Linoleum as a Safety Stair Tread, 31.
 Lumber Manufacture, Some Phases of. By R. S. Whiting, 28.
 Material, New, Used in Manufacturing Building, Newark, Porete Mfg. Co., 255.
 Modern Textile Mill. By Ernest Fallows, 675.
 Motion Picture Theatres, Artificial Illumination of, 645, 678, 801.
 National Lime Association Holds Annual Meeting, 64.
 National Public Works Progress Report, 332.
 Office of an Architect and Engineer. By Emile Perrot, 121.
 Ohio Stadium, 617.
 Paint Exposure Tests. By Henry A. Gardner, 445.
 Port Development at Portland, Ore, 863.
 Precast Pile, Method of Driving, 295.
 Quantity Survey, Action of A. I. A. on, 334.
 Schoolhouse Entrance Doors, 389.
 Quantity Survey System Receives Further Endorsement, 127.
 Reinforced Concrete Flat Slab Design, 89.
 Reinforced Concrete Tanks for Storage of Fuel Oil, 753.
 Revolving Door, 327, 355.
 Rigidity Tests on Various Types of Wall Construction Made by Omaha Building Department, 199.
 Safeguard Water Supply for Isolated House. By Wm. C. Tucker, 383.
 Senate Committee to Consider Crises, 128.
 Sheepshead Bay Race Track Demolished, 60.
 Stadia in Various Universities. By Howard Dwight Smith, 94, 124, 160, 221, 260.
 Stadia Design, Shall Architect or Engineer Predominate, 333.
 Structural Slate, Data on, 262.
 Stucco, Successful Building in, 61.
 Thermal Conductivities of Insulating and Building Materials, 682.
 Tile and Concrete Floor Shows to Advantage, 193.
 Transportation, Engineers Discuss, 647.
 Ventilation of Public Comfort Stations, 611.
 Wall Construction, Distortion Tests on Types of, 413.
 Zoning Ordinance Modified, 713.

ILLUSTRATIONS ACCORDING TO AUTHORS

Figures refer to the number of the issue, not to the text pages

- Barnett, T. P.:—
 House of George S. Johns, St. Louis, Mo., 2349.
 Barber, Donn:—
 Hartford Times Building, Hartford, Conn., 2328.
 Benedict, J. B.:—
 House of George E. Cranmenr, Denver, Colo., 2344.
 Benjamin, Charles H.:—
 House of Robert J. Edwards,
 House of James Warburton, Jr.,
 House of James J. Zisette,
 House of John J. Fisher, Paterson, N. J., 2341.
 Carrere & Hastings and R. H. Shreve:—
 Fisk Building, New York, 2338.
 Liggett-Winchester-Ley Building, New York, 2338.
 Comes, John T.:—
 St. Columba's Church, Johnstown, Pa., 2335.
 Cram, Ralph Adams:—
 Chapel at Nahant, Mass., 2330.
 Eggers, O. R.:—
 Drawings of Early American Architecture: St. Paul's Chapel, New York, 2328.
 Portico, St. John's Chapel, New York, 2329.
 Doorway, Washington Square, New York, 2330.
 Patchin Place, New York, 2331.
 No. 7 State Street, New York, 2332.
 City Hall, New York, 2333.
 Eastern Portico, St. Paul's Chapel, N. Y., 2334.
 House, Washington Square, New York, 2335.
 Old Town Hall, Hartford, Conn., 2336.
 St. George's Church, Hempstead L. I. 2337.
 St. Mark's Church New York 2338.
 St. George's Church Yard Hempstead L. I., 2339.
 Dyckman House New York 2340.
 Street Bridge, Hartford, Conn., 2341.
 House in Litchfield, Conn., 2342.
 Doorway, Old Town Hall, Hartford, Conn., 2343.
 Daniel Lake House, Staten Island, N. Y., 2344.
 On the Green, Plymouth, Conn., 2345.
 Mount Vernon, Va., Home of Washington, 2346.
 Detail of a House in Litchfield, Conn., 2347.
 Gateway to Thomas Cowoes House, Farmington, Conn., 2349.
 Graham, Anderson, Probst & White:—
 Kimball Hall, Chicago, Ill., 2332.
 Haas, Robert:—
 Motion Picture Sets, 2324.
 Hentz, Reid & Adler:—
 Scottish Rite Hospital for Crippled Children, Atlanta, Ga., 2334.
 Holabird & Roche:—
 Miscellaneous Works, 2329, 2331, 2339.
 Holabird & Roche, Architects:—
 Nursery and Orphan Asylum, Chicago, Ill. Commonwealth Edison Co., Chicago, Ill. Margaret Mackin Hall, Chicago, Ill. Franklin Exchange, Chicago, Ill. Kildare Exchange, Chicago, Ill. McKinley Exchange, Chicago, Ill. John Crerar Library, Chicago, Ill., McCormick Building, Chicago, Ill., Mandel Bros.' Store, Chicago, Ill., La Salle Garage, Chicago, Ill. Hotel Deshler, Columbus Ohio, Garrett Biblical Institute, Evanston, Ill., 2329, 2331.
 Second Artillery Armory, Chicago, Children's Memorial Hospital, Chicago, Geological Building, Chicago University, 2339.
 Garrett Biblical Institute, Evanston, Ill., 2339.
 Century Building, Chicago, Ill., 2339.
 Hopkins, Alfred:—
 Office Sketches to Promote Business, 2325.
 Hornbostel, H.:—
 Emory University, Atlanta, Ga., 2337.
 Howells, John Mead:—
 Corona Building, New York, 2334.
 Memorial for City of Beloit, Wis., 2334.
 House of A. G. Milbank, Huntington, L. I., 2334.
 Jackson, John F.:—
 House of Wm H. Carey, Passaic, N. J., 2325.
 House of Charles I. Denison, Passaic, N. J., 2335.
 House of Judge W. W. Watson, Passaic, N. J., 2335.
 House of B. D. Benson, Passaic, N. J., 2342.
 Keele, Charles S.:—
 Store Building, Hudson New York, 2335.
 Housing at Kingston, N. Y., 2335.
 Mayer, Gordon E.:—
 House of Mrs. Helen S. Pearson, Miami, Fla., 2348.
 House of Miss Caroline J. Brownell, Miami, Fla., 2348.
 McIlvain & Roberts:—
 House of Lawrence D. Beggs, Harford, Pa., 2338.
 Otto, Olaf:—
 House of G. I. Taggart, Savannah, Ga., 2347.
 Pardon, James:—
 Ruxton Hall Williamstown, Mass., 2336.
 Houses at Williamstown, Mass., 2347.
 Schmidt, Garden & Martin:—
 Milwaukee County General Hospital, 2343.
 Study, Guy:—
 House of Guido Doering, St. Louis, Mo., 2345.
 Study & Farrar:—
 Church of Our Lady of Lourdes, St. Louis, Mo., 2345.
 Sutton & Whitney:—
 Garage Building, Portland, Oregon, 2332.
 Thomson, R. B.:—
 House of Mrs. C. B. Adams, Dallas, Texas, 2349.
 Van Leyen, Schilling & Keogh:—
 Public Comfort Stations, Detroit, Mich., 2342.
 Warren & Wetmore:—
 Hotel Ambassador, Atlantic City, N. J., 2333.
 York & Sawyer:—
 United States Assay Office, New York, 2337.

ILLUSTRATIONS ACCORDING TO SUBJECT

Figures refer to the number of the issue, not to the text pages

- Administrative and Governmental
 Children's Memorial Hospital, Chicago. Holabird & Roche, Architects, 2339.
 Horace White Memorial for City of Beloit, Wis. John Mead Howells, Architect, 2334.
 Milwaukee County General Hospital. Richard E. Schmidt, Garden & Martin, Architects, 2343.
 Nebraska State Capitol Competition: Goodhue, Pope, McKim, Tracy & Swartwout, Cret and Zantziger, Borie & Medary, 2326.
 Magonigle, Bliss & Faville, Ellery Davis, McDonald, 2327.

ILLUSTRATIONS ACCORDING TO SUBJECT

(Continued)

- Public Comfort Station, Detroit, Mich. Van Leyen, Schilling & Keogh, Architects, 2342.
 Scottish Rite Hospital for Crippled Children, Atlanta, Ga. Hentz, Reid & Adler, Architects, 2334.
 Second Artillery Armory, Chicago, Holabird & Roche, Architects, 2339.
 United States Assay Office, New York. York & Sawyer, Architects, 2337.
- Ecclesiastical**
 Chapel at Nahant, Mass. Ralph Adams Cram, Architect, 2330.
 Church of Our Lady of Lourdes, St. Louis, Mo. Study & Farrar, Architects, 2345.
 St. Columba's Church, Johnstown, Pa. John T. Comes, Architect, 2335.
- Educational**
 Emory University, Atlanta, Ga. H. Hornboistel, Architect, 2337.
 Garrett Biblical Institute, Evanston, Ill. Holabird & Roche, Architects, 2339.
 Geological Building, Chicago University. Holabird & Roche, Architects, 2339.
- Frontispieces**
 Vestibule of St. Mark's, Venice, 2324.
 Detail, Palace of the Doges, Venice, 2325.
 Detail, Church of St. Mark's, Venice, 2326.
 Gallery in St. Mark's, Venice, 2327.
 Doorway, Church of S. Maria Maggiore, Bologna, 2328.
 Old Buildings, Salamanca, Spain, 2329.
 City Hall, Elche, Alicante, 2330.
 Detail, Alhambra, Granada, 2331.
 Cathedral of St. Vitus, Hradecany, 2332.
 Detail, the Alhambra, Granada, 2333.
 Gateway, the Alcazar, Avila, 2334.
 Old Convent, Tarragona, 2335.
 The Alcazar, Segovia, 2336.
 Detail of Cathedral, Murcia, 2337.
 Church of St. Maclou, Rouen, 2338.
 Lincoln Memorial, Washington, D. C., 2339.
 Lincoln Memorial, Washington, D. C., 2340.
 Old Tower in Salamanca, 2341.
 Old Houses on the Plaza, Segovia, 2342.
 Doorway, Palace on Rio Bella Fava, Venice, 2343.
 Detail of an Old Palace, Toledo, 2344.
 Renaissance Doorway, Hotel De Vogue, Dijon, 2345.
 Detail, Washington Arch, New York, 2346.
 Old City Walls, Tarragona, Spain, 2347.
 Facade, Church of S. Zaccaria, Alinari, Italy, 2348.
 Chateau de Chaumont sur Loire, 2349.
- Industrial**
 Century Building, Chicago. Holabird & Roche, Architects, 2339.
 Corona Building, New York. John Mead Howells, Architect, 2334.
 Fisk Building, New York City. Carrere & Hastings and R. H. Shreve, Architects, 2338.
 Garage Building, Portland, Oregon. Sutton & Whitney, Architects, 2332.
 Hartford Times Building, Hartford, Conn. Donn Barber, Architect, 2328.
 Kimball Hall, Chicago, Ill. Graham Anderson, Probst & White, Architects, 2332.
 La Salle Garage, Chicago, Ill. Holabird & Roche, Architects, 2331.
 Liggett-Winchester-Ley Corp. Bldg., New York City. Carrere & Hastings and R. H. Shreve, Architects, 2338.
 McCormick Building and Mandel Bros.' Store, Chicago. Holabird & Roche, Architects, 2329.
 Store Building, Hudson, New York. Charles S. Keefe, Architect, 2335.
 Telephone Exchanges, Chicago. Holabird & Roche, Architects, 2329.
- Residences**
 House of Mrs. C. P. Adams, Dallas, Texas. H. B. Thomson, Architect, 2349.
 House of Lawrence D. Beggs, Harford, Pa. McIlvain & Roberts, Architects, 2338.
 House of B. D. Benson, Passaic, N. J. John F. Jackson, Architect, 2342.
 House of Miss Caroline J. Brownell, Miami, Fla. Gordon E. Mayer, Architect, 2348.
 Buxton Hall, Williamstown, Mass. James Purdon, Architect, 2336.
 House of Wm. H. Carey, Passaic, N. J. John F. Jackson, Architect, 2325.
 House of George E. Cranmer, Denver, Colo. J. B. Benedict, Architect, 2344.
 House of Charles L. Denison, Passaic, N. J. John F. Jackson, Architect, 2335.
 House of Guido Doering, St. Louis, Mo. Guy Study, Architect, 2345.
 House of Robert J. Edwards, Paterson, N. J., House of James Warburton, Jr., Paterson, N. J., House of James J. Zisette, Paterson, N. J., House of John J. Fisher, Paterson, N. J., Charles H. Benjamin, Architect, 2341.
 House of A. G. Milbank, Huntington, L. I. John Mead Howells, Architect, 2334.
 House of George S. Johns, St. Louis, Mo. T. B. Barnett, Architect, 2349.
 House of Mrs. Helen S. Pearson, Miami, Fla. Gordon E. Mayer, Architect, 2348.
 House of G. I. Taggart, Savannah, Ga. Olaf Otto, Architect, 2347.
 Houses at Williamstown, Mass. James Purdon, Architect, 2347.
 House of Judge W. W. Watson, Passaic, N. J. John F. Jackson, Architect, 2335.
 Housing at Kingston, N. Y. Charles S. Keefe, Architect, 2335.
 Office Sketches to Promote Business. Alfred Hopkins, Architect, 2325.
- Miscellaneous**
 Cyclorama Building, Atlanta, Ga. Competitive Designs, 2330.
 Motion Picture Sets. Work of Robert Haas, Architect, 2324.
- Hotels**
 Hotel Ambassador, Atlantic City, N. J. Warren & Wetmore, Architects, 2333.
 Hotel Deshler, Columbus, Ohio. Holabird & Roche, Architects, 2329.

ILLUSTRATIONS ACCORDING TO LOCATION

Figures refer to the number of the issue, not to the text pages

- Colorado—**
 Denver:—
 House of George E. Cranmer. J. B. Benedict, Architect, 2344.
- Connecticut—**
 Hartford:—
 Hartford Times Building. Donn Barber, Architect, 2328.
- Florida—**
 Miami:—
 House of Mrs. Helen S. Pearson. Gordon E. Mayer, Architect, 2348.
 House of Miss Caroline J. Brownell. Gordon E. Mayer, Architect, 2348.
- Georgia—**
 Atlanta:—
 Cyclorama Building. Competitive Designs, 2330.
 Scottish Rite Hospital for Crippled Children. Hentz, Reids & Adler, Architects, 2334.
 Emory University. H. Hornboistel, Architect, 2337.
 Savannah:—
 House of G. I. Taggart. Olaf Otto, Architect, 2347.
- Illinois—**
 Chicago:—
 Kimball Hall. Graham Anderson, Probst & White, Architects, 2332.
 Works of Holabird & Roche, 2329, 2331, 2339.
 Second Artillery Armory, Children's Memorial Hospital, Geological Building. Holabird & Roche, Architects, 2339.
 Evanston:—
 Garrett Biblical Institute, Holabird & Roche, Architects, 2339.
 Century Building, Holabird & Roche, Architects, 2339.
- Massachusetts—**
 Nahant:—
 Chapel, Ralph Adams Cram, Architect, 2330.
 Williamstown:—
 Buxton Hall, James Purdon Architect, 2336.
 Houses by James Purdon, 2347.
- Michigan—**
 Detroit:—
 Public Comfort Stations. Van Leyen, Schilling & Keogh, Architects, 2342.
- Missouri—**
 St. Louis:—
 Church of Our Lady of Lourdes. Study & Farrar, Architects, 2345.
 House of Guido Doering. Guy Study, Architect, 2345.
 House of George L. Johns. T. B. Barnett, Architect, 2349.
- New Jersey—**
 Atlantic City:—
 Hotel Ambassador. Warren & Wetmore, Architects, 2333.
 Passaic:—
 House of Judge W. W. Watson. John F. Jackson, Architect, 2335.
 House of Charles L. Denison. John F. Jackson, Architect, 2335.
 House of Wm. H. Carey. John F. Jackson, Architect, 2325.
 House of B. D. Benson. John F. Jackson, Architect, 2342.
 Paterson:—
 House of Robert J. Edwards, House of James Warburton, Jr., House of James J. Zisette, House of John J. Fisher. Charles H. Benjamin, Architect, 2341.
- New York—**
 Hudson:—
 Store Building. Charles S. Keefe, Architect, 2335.
 Huntington, L. I.:—
 House of A. G. Milbank. John Mead Howells, Architect, 2334.
 Kingston:—
 Housing at Kingston. Charles S. Keefe, Architect, 2335.
 New York:—
 United States Assay Office. York & Sawyer, Architects, 2337.
 Liggett-Winchester-Ley Building. Carrere & Hastings and R. H. Shreve, Architects, 2338.
 Corona Building. John Mead Howells, Architect, 2334.
 Fisk Building. Carrere & Hastings and R. H. Shreve, Architects, 2338.
- Ohio—**
 Columbus:—
 Hotel Deshler. Holabird & Roche, Architects, 2331.
- Oregon—**
 Portland:—
 Garage Building. Sutton & Whitney, Architects, 2332.
- Pennsylvania—**
 Harford:—
 House of Lawrence D. Beggs. McIlvain & Roberts, Architects, 2338.
 Johnstown:—
 St. Columba's Church. John T. Comes, Architect, 2335.
- Texas—**
 Dallas:—
 House of Mrs. C. P. Adams. H. B. Thomson, Architect, 2349.
- Wisconsin—**
 Beloit:—
 Horace White Memorial. John Mead Howells, Architect, 2334.
 Milwaukee:—
 County General Hospital. Schmidt, Garden & Martin Architects, 2343.

269

for paper + the ...

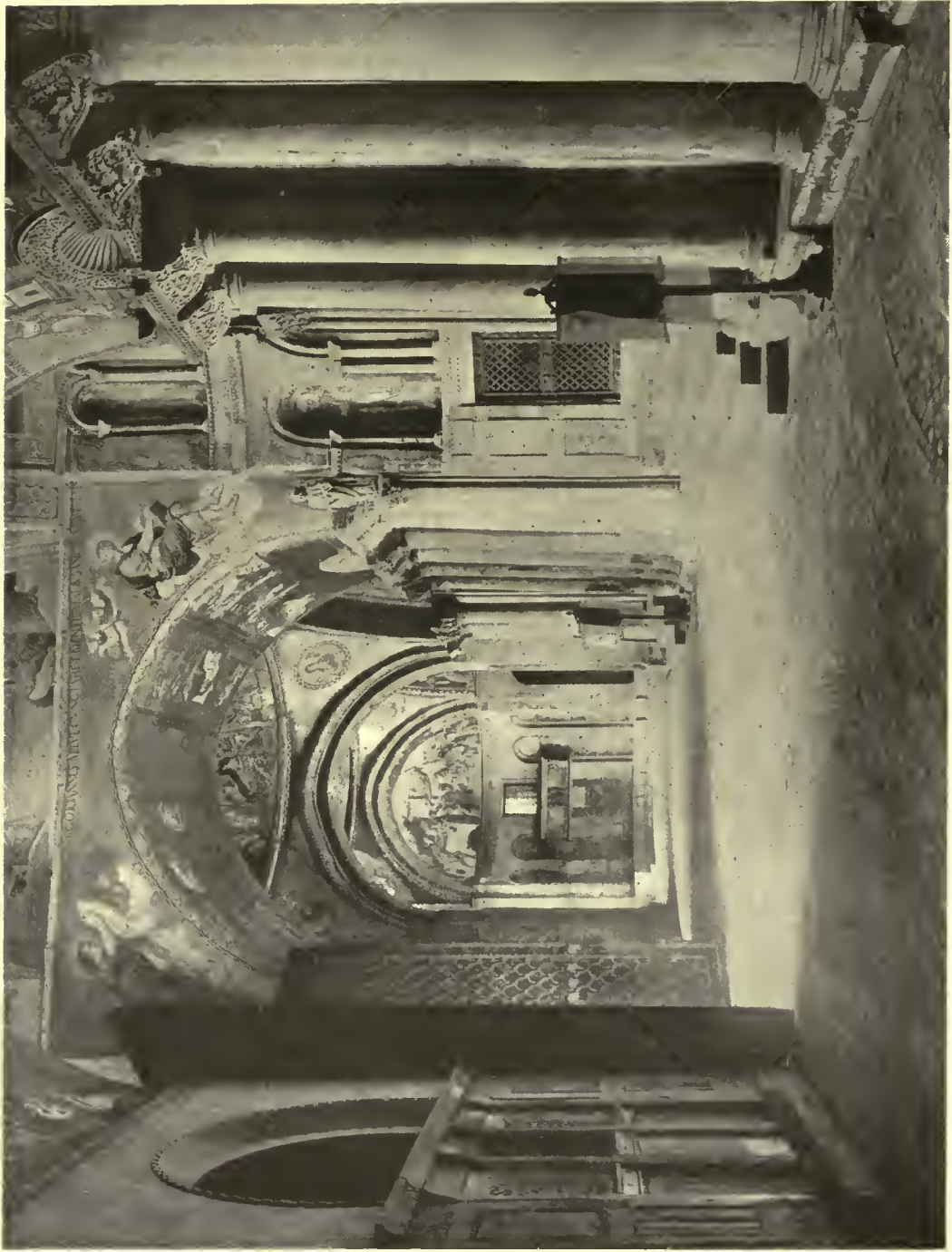

VESTIBULE OF ST. MARK'S, VENICE

THE AMERICAN ARCHITECT

VOL. CXVIII

WEDNESDAY, JULY 7, 1920

NUMBER 2324



A MOTION PICTURE SET, DESIGNED AND EXECUTED UNDER THE DIRECTION OF ROBERT HAAS, ARCHITECT

This is a representation of a patio in an American house. It is a garden scene as constructed on the studio floor. The pool and fountain are substantially constructed to use actual water. The floral decorations are living plants. The steps and platform were built with sufficient strength to support the players during a part of the action.

The Architecture of Motion Picture Settings

Illustrated by Examples of the Work of Robert Haas, Architect, for Famous Players-Lasky Corporation

MORE than two years ago THE AMERICAN ARCHITECT, in commenting on the development of motion pictures, ventured the opinion that as the cinema settings were not problems of color but chiefly of correct and pleasing adaptation of forms to spaces, it would be logical to expect them to be solved by the architectural profession.

At the earliest stages of the cinema, it was an art strongly influenced by the theatre and the scenery was such as had been supplied by scenic painters for the stage. Subsequently, well-known painters and decorators were engaged for the work. But

now, within the past year, the larger and more successful producers have been engaging architects to plan and superintend the building of their "sets." The results are so satisfying that the differentiation between stage and cinema design now seems to be clear—the former is one of the decorative and the latter of the structural arts.

It is a fertile field for architects. With the results of invention so quickly materialized, with freedom from the whims of clients and from the practical exigencies of contractors, and with the subsequent possibility of aesthetic experiments of a most pronounced character—it is a rare opportunity for

THE AMERICAN ARCHITECT



A MOTION PICTURE SET, DESIGNED AND EXECUTED UNDER THE DIRECTION OF
ROBERT HAAS, ARCHITECT

a richly creative talent. And it is a work, too, which is potentially one of our most powerful educational forces. The people, through this pastime, may be made familiar with that which is beautiful; they may see what good architecture and well-arranged interiors look like. Fortunate it is that the times are past when, if they went to the "movies," they must deprave their taste with everything that was bad.

The settings are now coming within the influence of trained architectural skill. We may, for this reason, safely expect interesting and perhaps even an inspiring architectural development in the newest of the arts.

IT seems almost banal to indicate the educative power of the motion picture. As a factor of instruction the screen has been recognized by commerce, by moral propagandists and even by the governments. During the Great War it was the means of suggesting the aims and showing the methods of armies. It attracted recruits as posters and as speeches never could and it aroused patriotism with its presentation of the magnificent panoply of war. These results were achieved not solely by the pictures issued by the governments obviously for such a purpose, but indirectly and powerfully by those scenarios sketched against a romantic background

of war. In these fictional presentations the educative influence has been far more insidious. The audience opened its mind to the plot and the background made its certain impression—unsought, but effective. The motion picture should be taken seriously.

When the motion picture was nothing more nor less than a mechanical toy, plots were unfolded by characters who moved about in rooms such as never were inhabited by man. There were flat stairways painted quite out of the perspective of normal eyes, there were immovable palms of one dimension. The drawing rooms of English nobility were stuffed with onyx tables, with furniture of an unknown period, and with bric-a-brac such as even a parvenu would not be guilty of possessing. And when the exteriors were then shown, the beholder was astonished that they could contain the spacious halls and the palm trees, and so much furniture.

The development came rapidly. Producers realized they must do better than that. They began to take themselves and their productions seriously. There was a reaching for verities. Actual houses were sometimes temporarily rented for "properties" and finally the stage of growth has been reached where the entire background is conceived and built to fit the plot.

THE AMERICAN ARCHITECT



A MOTION PICTURE SET, DESIGNED AND EXECUTED UNDER THE DIRECTION OF
ROBERT HAAS, ARCHITECT

This illustration, with the one on the opposite page, represent two periods in the life of an Illinois town, as constructed for the production of "The Copperhead." The land where the town stands was barren fields overgrown with underbrush, somewhere on Long Island, N. Y. The representation of the town as it appeared during the Civil War (shown on the opposite page) was finished after four weeks' work by the carpenters. All of the houses were actually constructed and roofed, and sufficiently well built to be used as living quarters. Note the comparison of the two scenes. The church and town hall are retained in the picture above and several other buildings are clumsily remodeled. There is a new postoffice. The brick gutters and concrete walks are replaced by asphalt. The kerosene street lamps are replaced by electric.

An architect who is engaged in this work says that he first reads the story and gets acquainted with the character who is to live in the scene which he must build. That character, fictitious, but of clearly defined tastes and habits, becomes his client. A house is to be built and rooms are to be decorated to suit such a personality. Perhaps it is a man who has lived for many years in the Far East or it may be an English gentleman living in Constantinople; in such cases the blend of two cultures must be evident. It may be a man shown at ten year intervals but living always in the same town—as in "The Copperhead." Here there must be no anachronism in showing the progress of the years and the individual taste of the character in his surroundings must be preserved. If an Italian inn is required, a Connecticut farmhouse will not do; the audience is too intelligent. Any one might

wonder in what sort of a house Dr. Jekyll would have lived, or Adam Bede, or Robespierre—but it is a clearly defined problem for an architect to decide.

In his attempt to attain the proper effects, the architect draws his plans. And from his blue prints the carpenters build in actual materials, which are in some cases cleverly disguised as brick, or stone, or plaster. The house is very much as any house except that the ceilings may be missing, or the roof; a stairway may lead to a second floor which does not exist. It may be a house of thirty rooms, of which four only are to be used—the other twenty-six therefore are not drawn or built but are present only in the architect's mind and in the imagination of the audience.

Such an architect is not troubled with problems of durability or of plumbing. In three or four

THE AMERICAN ARCHITECT

days' time he directs the construction and interior decoration of the living rooms of an English manor, and its façade with spacious doorway. It stands for a day peopled by gentry meeting the climax of their lives. For one day the clocks tick on the mantels and the butler stands in the hall. For one day there is an illumination of glaring blue light and then the walls are torn down. A town house appears—pavement, steps, wrought iron railings and so forth. The Adam decorations of the interior have been discarded that l'art nouveau may appear.

And though such scenes may occupy but a few minutes upon the screen at the theatre yet thousands of dollars are spent in their construction. For it is held fundamentally important that they shall be, with good taste, a reflection of the character of the mannikins who move before them. If fiction and drama record and develop the social aspirations of civilization, do not these backgrounds or "sets" record the surroundings in which the civilization lives and have they not the same potentiality for developing taste?

THROUGHOUT the winter months in the large cities there are held architectural exhibits which are prompted with a view of promoting good architecture and bringing to the general public a realization of what is being done and of what good architecture is. As a vehicle for achieving a similar purpose the moving picture should be taken seriously. It would not be contended that the finest development of architectural forms are shown on the screen, but it may be stated with assurance that the educative influence is there. The architects who do this work have the responsibility of widest influence in the molding of public taste. Wherever the film goes their influence extends. *THE AMERICAN ARCHITECT*, therefore, believes it does a valuable service to reproduce examples which show the trend in this field and to express the serious purpose which dignifies the work being done by one member of the architectural profession.

There may be in some minds a question whether the men who create two or three sided, roofless and impermanent buildings are architects—but this would seem to others a matter of overfine distinction and a splitting of hairs which ends in separation where there should be co-operation. It is in the same sense that there may be men who refuse to recognize Bakst as a serious artist; yet, without doubt, Bakst has made a profound impression upon the present generation's sense of color. In the long run it is the result that counts. It is the influence which the work of a creative imagination has upon the culture of its time and upon some specific expression of that culture. Just how much influence

upon architecture the designer of buildings used for motion picture settings might have, clearly depends upon the distinction of his individual talent.

Impermanence of structure was never used as an argument against the serious purpose of a designer of buildings for an exposition. That a building is seen by the few and has made its influence vitally felt through means of the camera would never be held against the Parthenon. One fundamental fact which always remains is that an architect is at all times responsible, when he undertakes the creation of a building which shall serve the life of some individual or group of individuals, that he shall make that building a simple and beautiful expression of their needs. If the occupants don't need a roof he shouldn't build one, if they demand a Georgian façade but no rear elevation whatsoever, he fills their needs and nothing more. That is the architect, is it not? His work satisfies the requirements of his clients—be they imaginary or real, or he is no longer retained. And insofar as he transcends these requirements and envelops them with beauty, thus far does he serve his profession and his generation. That is an aesthetic ideal, is it not?

IT has been contended, and with much insistence by men in the profession of architecture, that motion picture work as carried on after the methods shown in these illustrations was unethical and had a tendency toward commercialization. Further, it has been contended that ethically an architect could only render service in motion picture work as in a consulting capacity and that when he confined his work to a single client, he had in a sense taken himself out of the professional rank.

The inconsistency of such an attitude at once becomes apparent when we consider that large group of extremely competent men who are today engaged on architectural work for cities, states and the national government. When a man devotes his entire time to a municipality as superintendent of design and construction of its school buildings, he works for a single client at a salary. Or, when he competently acts as a State Architect, reforming the design and construction of its buildings, and acts as consultant on all the many vital matters that the well-trained architect is so competent to advise, and all for a salary—is he unethical? Probably if there were enough of these important and dignified offices to go around, we should find the public clamoring for architectural assistance and the only aid available would be that small group who shout ethics on every occasion, and who were sulking because they had been taken at their word and overlooked.

Like many another sweeping statement, this one of unethical commercialization of architecture in

THE AMERICAN ARCHITECT



A MOTION PICTURE SET, DESIGNED AND EXECUTED
UNDER THE DIRECTION OF ROBERT HAAS,
ARCHITECT

The two illustrations on this page show two views of an old street in London in the period 1850-60 as it was reproduced and used as a setting for the John Barrymore production of "Dr. Jekyll and Mr. Hyde." It was constructed on the studio floor of wood and plaster.

motion picture work is based on lack of knowledge of the actual and surrounding conditions. It would seem to be inconsistent for those men in the profession of architecture who insistently claim that architecture is entirely an art and resent with uplifted hand and arched eye-brows the very suggestion that it is in any way a business to declare unethical the work of an architect when competently directed toward the improvement of motion picture production. In work of this character the more sordid elements of construction are escaped and the aesthetic elements are raised to their highest position. The architect may witness the growth in a few days of a structure designed as a setting for an important gathering of people—that, if it were an everyday construction, he might wait for months for completion and perhaps with less satisfaction as to the results attained.

As was stated at the outset of this article, it

is now a matter of years since this magazine first contended that there was a valuable field for architects in connection with the higher type of motion picture work, and it is believed that the thoughtful reader who will carefully examine the various illustrations reproduced with this series will be compelled to admit that there can be no more dignified, more valuable or more instructive work in architectural practice than is shown by the architect who has permitted us to avail ourselves of these examples of his work.

In a succeeding issue—probably that of July 21st—there will appear another article—from the standpoint of the producer—which takes up the matter of constructing motion picture "sets" and which gives some of the problems presented and tells how they are met.

This makes entertaining reading and presents for the first time informing facts of that half-way ground between reality and romance, which is the evening playground of so many of us.



A MOTION PICTURE SET, DESIGNED AND EXECUTED
UNDER THE DIRECTION OF ROBERT HAAS,
ARCHITECT

What Is an Architect?

Extracts from the Inaugural Address of John W. Simpson, President, R. I. B. A.

IN all the world's history, there has been never an epoch like that to which we are come. Four years of energy and skill have been devoted by the nations to the work of mutual destruction; and now they see, revealed by the light of peace, the precipice of ruin to which their struggles have brought them. Aghast at the imminent danger, they turn—still faint and bruised with fighting—to mend the neglected structure of their prosperity, to renew the arrested progress of their social welfare.

In these tremendous circumstances, I invite your attention to the functions of the architect. Plan—born of the fertile union of reflection, analyzing the conditions of the problem, with imagination, quick to perceive its true solution; construction, daughter of caution, testing the soundness of each audacious artifice. Such faculties, at once quickened and chastened by severe technical training, conduce—as I shall submit—to a type of intellect in the designer of buildings which is a national asset; an instrument to be employed to its very limit at this present time.

* * *

What is an architect?

There can be no better definition than that given by the dictionary of the Académie Française: "The artist who composes buildings, determines their proportions, distributions and decorations, directs their execution, and controls the expenditure upon them."

First then, foremost, and above all, he is an artist. And by the term artist, I understand no more a painter, or a draughtsman, than I do an actor, or—for that matter, a hairdresser—but that which all who honestly practice those professions would wish to be: delighting in their work for its own sake, yet discontented with it because of perpetual endeavor to reach a higher perfection. Not that fitful dilettante who justifies himself his idle hours with empty phrases—"a lack of inspiration," or the like—but a man with a life's work before him, and the time desperately inadequate in which to do it. A man of remorseless severity in the standard of his own attainment, insomuch that he shall grudge no expenditure of time and pains to achieve the smallest improvement in his work. One in whose mouth the words "it will do," and "near enough," are not found; nor will he tolerate them in the mouths of those who work with him.

With such a temperament, imagination, an eye

trained to the appreciation of form and color, and the rare creative faculty, endowed with all attributes of the artist—he is yet but an imperfect architect. For to the artist must be added the technician, to make the architect. Of what avail is his gift of creation, if he have not constructive science that alone shall enable the offspring of his vision to reach maturity?

And, what a very mountain range of obstacles now appears between our eager artist and the promised land of his desire. Not seldom, indeed, his heart fails at the steep ascent, and either he turns aside into by-paths which he conceives easier or more direct—or, he becomes fascinated with the very ruggedness of his toil, and remains contentedly constructing, with never a regret for what lies beyond his vision.

The artist, then, must train his unaccustomed feet to tread firmly the slippery planes of geometry; for he is to be able, you must remember, to delineate things, not merely as they exist, but as they are to be. Geometer and—that he may calculate—mathematician, he must still surmount and master the rocky intricacies of the trades. Mason and brick-layer shall he become, and carpenter to boot. The workers in metal must yield to him the secrets of their crafts, nor shall he rest till he has explored the whole mystery of material—rocks and trees, and sand which is by the seashore.

Something of an engineer he will find himself nowadays, being called upon to deal with steel as a familiar friend; recognizing its great possibilities, and—its limitations. He is but a poor designer who shall set aside materials as "inartistic"; rather should he recognize it as his duty, by masterful handling, to imbue them with beauty.

The study of hygiene is within his province; for he must be nicely studious in arranging all sanitary matters, and that not merely as to their general disposal. Judging no detail of pipe, trap, joint or fitting unworthy of attention, he must narrowly supervise each with the authority which is born of knowledge. Upon climate, aspect, rain-fall, sub-soils, and all matters pertaining to the public health, he will be required to advise; and to plan aright the defences against those insidious, persistent foes of humanity, sickness and disease.

Armed, then, with this panoply of attainments, and the vigorous constitution proper for their exercise, yet another gift is needed for his full equip-

THE AMERICAN ARCHITECT

ment. The very weight of his intellectual armor may be his disadvantage and undoing, if it be not supported by that solid sense of proportion—those powers of inductive and deductive reasoning—which go to make what is commonly called "business ability."

And here we come upon our architect in an aspect quite different from any in which we have hitherto viewed him. An aspect, too, which perhaps most of all differentiates him from his brethren who take the arts for their trade.

For, consider his position who is entrusted with an important work of architecture, and how his conditions vary from those of the painter or the sculptor. These last produce their work, agree terms of its purchase, and there's an end to the transaction! A mere matter of interchange, so far as finance is concerned.

But the architect, from the moment the building contract is signed, is invested with the discretion of an almost unfettered trustee. Vast sums of money are at his disposition, and are disbursed by his direction. None can tell, till such time as the work is completed and the cost reckoned, whether or no he has wisely and honestly acquitted himself of his stewardship, and obtained full value for the moneys entrusted to him.

A trustee, did I say? Nay, more; a very judge. As the employer lays down his gold, so the builder bestows freely his work at the word of the architect, neither doubting but that justice shall be done them. When I think of the unlimited trust and confidence which are placed in us day by day, year by year, by men of opposing interests, strangers moreover for the most part, who know us not at all in private life; when I think, too, that among both small and great, high and low, that trust and that confidence are justified—I profess I am proud of my calling. Mistakes are made, no doubt, "to err is human"; I have known cases of unpardonable oversight—but (I speak of those who rightly bear the title) who ever heard of a dishonest architect?

To prolong the list would weary you. I could speak of the necessary knowledge of accounts; of some familiarity with the law, as it affects the drawing of contracts, the rights of dominant and servient owners of easements, the complexities of building acts and such like mysteries; of the need that he should be able to express his views with clarity and terseness, whether in writing or in speech; of the architect as the "polite letter writer," dealing daily with the correspondence of a bishop.

You will say—I fear—that my sketch of the "complete architect" is but a fancy portrait, that so many accomplishments cannot crowd into the few years of a working life. My picture, it may be, is exactly

true of none of us, as we are—I freely disclaim its likeness to the author—but it may stand for all of us—as we would be.

* * *

Be this of the workman as it may be. What of the work?

It will not have escaped you that, although the quality of artist stands foremost in the making of an architect, I have described in greater detail his faculties of construction and administration. It is with intention that I have chosen for my discourse these less familiar aspects of our art. To cultured minds, the aesthetics of architecture are a perennial interest, and, since buildings make appeal to the sense of beauty, the emotions they inspire must form the measure for their criticism. Yet it is seldom realized how much of the greatness of the art of architecture is due to the severely practical nature of its medium, to the necessity of expressing the artist's ideal in terms of cubic reality. When the enthusiast speaks of it as "frozen music," he is apt to forget that the freezing inspired, and is the very essence of, the music. For architecture is, above all, building; the calculated, right disposition of proportioned solids and voids—in other words, plan and construction; not the cornices, moldings and carvings which define the masses, add desired emphasis to light and shadow. To create it, no dexterous suggestive sketch suffices; no magic wand, nor lamp, nor potent incantation will raise it from the ground. Patient complex diagrams of geometrical projection, sown with myriad notes and figures, must show how bricks are placed in unseen foundations, and how joints of cunning fashion couple the roof beams.

But, for all that I have dwelt upon the material, I would not be thought unmindful of the spiritual aspect of our calling. "Morality, in fact, is architectural; and goodness, for human nature, is the queen over truth and beauty." I quote from Addington Symonds. "Experience leads me," he adds, "to think that there are numerous human beings in each nation who receive powerful and permanent tone from the impressions communicated to them by architecture." Very great, therefore, is the importance of a prevailing standard of good design, of logical, comely compliance with our domestic and commercial needs.

I am not now thinking of great monuments. Placed in the hands of competent designers, the government housing scheme may effect ethical results of more value to the nation than the satisfaction of its physical demands. The clerk and the artisan, on their way to the morning train, pass by rows of dwelling places, ill planned within, monotonously vulgar without. "One of these days," thinks

THE AMERICAN ARCHITECT

our friend, "I will have a house of my own," and in his mind the house of his desire shapes itself, like to those he daily sees. What an ideal! Yet how should it be otherwise? The only effective education of the public in architecture is the object lesson of good design.

All creative art must have a motive. Gaudet, in his wonderful "Cours d'Architecture," reveals the basic influence which governs our art, in an illuminating phrase. "The great architect of a period," says he, "is its social condition; the technician realizes, but does not create, the aspirations of his time." Yet, while it remains true that architecture reflects, and writes in stone, the history of its time, the legend is no mere transcript, but a conception whereby the fertilizing suggestion is transmuted, vitalized and perfected. Versailles owed its existence to the autocratic splendor of Louis XIV, but the minds that created it were those of Mansard, of Le Nôtre, and Le Brun.*

The pageant of Versailles has passed into the shades; there breathes no wind of life among the phantoms of that splendid court; alone, the artists' work remains, immortal. To us—as it did to them—inspiration must come from the living world, from them that are next to us, from the resistless, limitless future. For good or ill, the old order is well nigh gone; the short retrospect of our own lives tells of a mighty social change, and in the fruition of the new state, architecture must fulfil its glorious part. "Did you, O friend," said Whitman, "suppose democracy was only for elections, for politics, or for a party name?" and, "To the men and women of a country, its aesthetics furnish materials and suggestions of personality, and enforce them in a thousand effective ways."

To those impatient for results, let me say that economy in building is effected, not by the omission of ornamental details—and, indeed, it is but a poor design which needs them—but, by minute study of the plan and construction, upon whose importance I have already insisted. "Plan" means far more than the arrangement of rooms; it comprises the scrutiny of every foot of ground, its contours and subsoil, whereby foundation work is saved; it covers the economical disposition and grading of roads, the aspect of each house site, the water supply, lighting, drainage, and—in many cases—reasoned investigation of the general and local social problems incident to the formation of a township. "Construction," too, may be but a small thing, in—for example—a cottage roof; but to perfect it, so that wood, slate, lead and labor may be reduced in each

*"On ne peut pas, Sire, employer trop d'étude pour concevoir quelque dessein qui réponde à la grandeur de vos actions. Comme elles ont surpassé tout ce qui s'est fait dans les autres temps, il faudroit que leurs monumens fussent aussi au-dessus de tous ceux de l'antiquité."—François Blondel

of several hundred cottages, will perhaps need days of work and experiment. And the time lost in preliminary study is regained many fold in the end. To produce in bulk such comparatively simple things as shells needed months of preparation, but, when organization was complete, they poured forth like water from a pierced dam. So, houses, far more complex constructions than shells, will presently arise as by enchantment; the process has already begun.

Like religion, architecture, if it is to profit a nation, must be part of its daily life. It is in plan that lies the true economy—prevention of waste. Waste of time and energy, wandering about the tortuous passages of tube stations, where lifts are planned remote from trains, and fatuous stairs intervene between them and the platforms. Waste of property in the squalid hinder parts of main line stations, untidy sprawling areas dotted with lamentable sheds, and linked by bridges whose building has darkened and desolated streets of houses; waste which defiles and depresses whole communities. I mention "backs," because architecture is matter not only, as is sometimes thought, for fronts, but equally for backs and sides; for all, in short, that connotes orderly, cleanly life, and the beauty of efficiency.

* * *

War, like architecture, is an art, and is practised "according to plan." Its principles demand the same insistence on a leading motive, the same subordination of the part of the whole; and there is the hazard variant from which skill may make, or folly mar, success. The commander, like the architect, must work within the limitations of his budget, though his expenditure is counted not, alas, in terms of his employer's money, but of his men's lives! Marshall Foch, indeed, pushes the parallel still closer. "The development of the art of war is like that of the art of architecture. The materials you use for your buildings may change; they may be wood, stone, steel. But the static principles on which you house must be built are permanent."

Those who know me will not misunderstand; will not think me less enthusiastic for art, that I have dwelt almost wholly tonight upon plan and construction. Assuredly, I yield to none in my reverence for the sublime qualities of painting, music, sculpture. But, among the fine arts, architecture is unique in that it alone subserves utility. By reason of its very limitations—the intimacy of its relation to the needs of humanity, its incessant conformation with cosmic fact, and the rigorous severity of its principles—its votaries are compelled to understand widely, to see quickly and well, to be eclectic and tolerant while holding unsullied their own artistic faith. It is more particularly upon these

grounds that I have ventured to assert the value of our profession to the state.

It is not among those callings which bestows great wealth on those who practise it. Few architects retire upon their earnings; fewer still leave riches at their death. Yet no art bestows greater fortune

of pleasure upon those who give themselves wholly to its service; and what can money give besides?

To us, architects, the immortal words which Carlyle puts in the mouth of Teufelsdröckh yield their fullest meaning. "Not what I have," said he, "but what I do is my kingdom."

Standard Test for Schoolhouse Design and Construction

BY FRANK IRVING COOPER, *Architect*

Chairman of The National Education Association Committee on Standardization of Schoolhouse Planning

POSSIBLY one of the most remarkable omissions in the literature on school building is the absence of any work upon the economical utilization of floor space in a modern departmental school building.

The subject is of great importance, in these times of high prices of materials and labor of all kinds. It is of importance, not only to the taxpayer, who must foot the bills, but to the artificers, who must gain their daily bread by work upon new structures. The artificers suffer when the high cost of school building prevents the carrying out of new undertakings.

The investigation undertaken by the Committee on Standardization of Schoolhouse Planning and Construction, of the National Education Association, purposed to determine—if such an ambition may be permitted—without speculations as to what might be ideal planning, what part of the modern school building could reasonably be declared as being used for the purpose of instruction, the object for which the building was erected.

For a historian, the story of the committee's tabulations, its comparison of data, and its experiments to discover the use of floor space in school buildings, will prove interesting reading. It reveals a condition of lack of interest and study on the part of those responsible for the school plan that passes belief.

Spaces in the school plans were marked as being used for purposes for which they were totally unsuitable. Spaces were marked for activities which, if carried on in the areas assigned to them, defied all sense of proportion in curriculum and class unit.

What our tabulators thought about these things is their own affair. The architects are safe because the tabulations were known only by numbers and

complexity of findings meant little to the draughtsman and measurer of plans.

It is another story, however, when plans of new school buildings are seen, appearing in current magazines, plans based on old formulas apparently still serving architects as if they were beginners, instead of designers living in an age when all is motion. A schoolhouse plan should be luminous from its purposeful energy to serve the spirit of modern education.

Previous to the year 1920 there was progress, but the progress was, year by year, hardly measurable. The awakening and development of school life, since the tragedy of America's unpreparedness in 1916, has served to hasten the slow moving steps of progress in the science of school planning.

The building of school houses ceased during the war and now comes the reaction. Progress comes into her own. Natural law affirms that progress, which well nigh ceased, shall take on new energy and the educational and architectural world look to the committee of the National Educational Association for an accounting of its time, during the period of seeming inactivity.

The president of this society has very kindly intimated that this accounting shall be termed "The Next Step," and this indicates that steps have been already taken by which the committee has arrived at its present position; and because there have been previous steps, it may not be amiss to acquaint the reader with the standards adopted by the committee and already generally accepted.

The most important of these standards is called the Candle of Efficiency. This was determined upon after some two hundred school buildings had been tabulated, to discover how the floor area of each had been used. Step by step the statistical facts

THE AMERICAN ARCHITECT

were obtained and averages taken; then these averages were assembled, tabulated and studied.

This Candle of Efficiency, with its six main divisions, is now being used in checking school plans in some of our most important architects' offices and the rules for measuring the floor spaces are here given, that an understanding may be had of the practical every day use of this measure.

- C. Compute each floor and mezzanine separately.
- D. The area of light wells, courts, air shafts, etc., are not to be included in floor areas.
- E. In rooms and auditoriums which extend through more than one story the area of such space shall be deducted from the floor or floors through which it extends.
- F. In the case of an Assembly Hall or Gym-

		CHART FOR COMPUTATION FOR THE NUMBER OF ROOMS NEEDED FOR INSTRUCTION PURPOSES IN A SCHOOL BUILDING BASED ON ONE WEEKS PROGRAM																											
		FIRST YEAR					SECOND YEAR					THIRD YEAR					FOURTH YEAR					TOTALS							
FORMULA →		A	B	C	D	E	F	G	H	I	J	K	L	M	N	O	P	Q	R	S	T	U	V	W	X	Y			
SUBJECT	DUPLICATE USE	STUDENTS	MAXIMUM SIZE OF CLASSES	CLASSES REQUIRED	ALLOTMENT PERIODS	PERIODS	STUDENTS	MAXIMUM SIZE OF CLASSES	CLASSES REQUIRED	ALLOTMENT PERIODS	PERIODS	STUDENTS	MAXIMUM SIZE OF CLASSES	CLASSES REQUIRED	ALLOTMENT PERIODS	PERIODS	STUDENTS	MAXIMUM SIZE OF CLASSES	CLASSES REQUIRED	ALLOTMENT PERIODS	PERIODS	STUDENTS	MAXIMUM SIZE OF CLASSES	CLASSES REQUIRED	ALLOTMENT PERIODS	PERIODS	USABLE ROOMS	USABLE SPARE PERIODS	ACTUAL ROOMS REQUIRED
				<i>SPECIAL ROOMS</i>					<i>ROOMS</i>																				
Home Economics Gen Voc	Recitation	45	30	2	4	8	35	30	2	4	8	15	30	1	4	4	15	30	1	4	4	24	30	1	4	4	+6	1	2 Double
Woodworking		25	15	2	4	8	15	15	1	8	8	10	15	1	8	8	10	15	1	8	8	24	30	1	4	4	+6	1	4 "
Printing Machine							20	15	2	4	8											8	30	1	4	4	+22	1	2 "
Mech Drawing		40	30	2	2	4	25	30	1	4	4	15	30	1	4	4	10	30	1	4	4	16	30	1	4	4	+14	1	5 "
Free Music		100	30	4	2	8	50	30	2	2	4	30	30	1	2	2	20	30	1	2	2	16	30	1	4	4			
Phys Training Boys		130					90					70					60												Auditorium
" Girls		60	60	1	4	4	40	60	1	4	4	30	60	1	4	4	28	60	1	4	4	16	30						Gymnasium
		60	60	1	4	4	50	60	1	4	4	40	60	1	4	4	32	60	1	4	4	16	30						
		<i>LABORATORIES</i>																											
General Science	Biology - Recitation	70	30	3	5	15	50	30	2	5	10											25	30	1	4	4	+5	1	
	Chemistry											20	15	2	6	12						12	30	1	4	4	+18	1	
	Physics																15	15	1	6	6	6	30	1	4	4	+24	1	
		<i>COMMERCIAL ROOMS</i>																											
Business	Book keeping	40	30	2	5	10						21	30	1	6	6	20	30	1	6	6	22	30	1	4	4	+8	1	
Comm Geography	Stenography											30	30	1	5	5	25	30	1	5	5	15	30	1	4	4	+15	1	
	Typewriting						30	15	2	5	10	30	15	2	5	10	20	15	2	5	10	30	30	1	4	4			1
		<i>STANDARD CLASS ROOMS</i>																											
English		130	30	5	5	25	90	30	3	5	15	70	30	3	5	15	80	30	2	5	10	65	30	2	4	4	-5		
History & Civics		90	30	3	4	12	20	30	1	4	4	25	30	1	4	4	60	30	2	4	8	28	30	1	4	4	+2		
Mathematics	All rooms may be used in duplicate	100	30	4	5	20	60	30	2	5	10	20	30	1	5	5	15	30	1	5	5	40	30	1	4	4	-10		
Latin		40	30	2	5	10	30	30	1	5	5	15	30	1	5	5	10	30	1	5	5	25	30	1	4	4	+5		
Spanish												30	30	1	5	5	15	30	1	5	5	10	30	1	4	4	+20		
French		40	30	2	5	10	35	30	2	5	10	20	30	1	5	5	20	30	1	5	5	30	30	1	4	4			

NOTE: THIS CHART IS BASED ON AN ACTUAL PROGRAM IN A SMALL HIGH SCHOOL.

SPECIAL ROOMS, LABORATORIES AND COMMERCIAL ROOMS HAVE 164 SPARE PERIODS AND WOULD HAVE SUPPORTED MORE PUPILS BUT THE GYMNASIUM AND TYPEWRITING ROOM ARE IN USE DURING THE ENTIRE SCHOOL WEEK

Rules for measurement and tabulation of school buildings as formulated by the Committee on Standardization of Schoolhouse Planning and Construction of the National Education Association.

RULE 1. COMPUTING AREAS.

A. Line of measurement for area of all floors is to be taken at the outside face of exterior walls. Deduct all recesses which are the full story height.

B. The area of basement floor is to be measured from same line as outside wall of first floor.

nasium which has a balcony, the area of such balcony shall be taken separately.

G. In figuring wall or partition areas, no door or window openings shall be deducted but the wall shall be figured solid as though no openings occurred.

H. Exterior walls and interior partitions are to be figured the finished thickness including any lath and plastering.

(Continued on page 13)

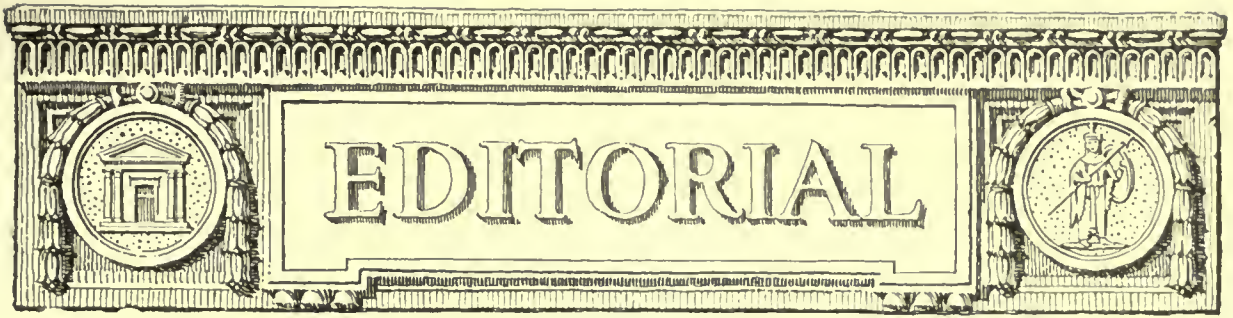

Mr. Eggers' Sketches

IT was the announced purpose to commence in this issue the presentation of a series of sketches, specially made for THE AMERICAN ARCHITECT, by Mr. Otto Eggers, of old types of architecture in the United States.

Owing to the shortage of high grade print paper, on which it was proposed to present these drawings, it has been found impossible to print these plates in time for this issue, nor does it seem likely that they can first appear earlier than our issue of August 4.

Not What I Have, but What I Do is My Kingdom

ATTENTION of the reader is directed to an extract from the inaugural address of Mr. John Simpson, president of the Royal Institute of British Architects, printed in this issue.

Mr. Simpson asks, "What is an Architect?" and proceeds to give his conception of the attributes of a many sided professional man. It is both satisfactory and interesting to note that in stating the exact field in which the architect is in these days expected to function, Mr. Simpson is entirely in accord with the opinion so long urged by THE AMERICAN ARCHITECT. First and foremost contends Mr. Simpson, the architect is an artist. A man "delighting in his work for its own sake, yet discontented because of a perpetual endeavor to reach a higher perfection." This exactly analyzes the true mental attitude of the artist architect toward his profession. The perpetual endeavor toward a higher perfection is the straining for every last bit of knowledge that a man may acquire toward his work as an architect.

And in making this endeavor, the thoughtful man, early in his career, learns that he shall have to group with his inclination as an artist, many attributes that in his early or student days he firmly believed

were incompatible with the artist's attitude toward his work. Just what all these things are Mr. Simpson has stated with profound knowledge. The poseur who aims to practice the fine arts generally is of a mentally lazy disposition, and it is his habit to create an impression among his listeners that all the practical elements that accompany his work are sordid and non-essential. Behind such a plea he shows an ignorance that is profound. It is the cultivation of such an attitude by architects that has led to certain well defined opinions of the general public that architects are impractical men. Thus, they have seen their once proud positions as Master Builders gradually declining and have been lazily willing to allow others outside of their profession to assume responsibilities which they, through inaction and consequent loss of ability, are not qualified to perform.

AS Mr. Simpson correctly puts it, the architect from the moment the building contract is signed is invested with the discretion of an almost unfettered trustee, a very judge. It is, therefore, necessary that an architect should be qualified to accept so great a responsibility. To dodge it on the plea that he is an artist and not also a business man is to shirk a responsibility.

More and more every day is this correct idea of the true meaning of the practice of architecture becoming accepted. Its general acceptance will result in more complete and modern forms of architectural education. Education is undoubtedly the cause of the present misguided views as to the true meaning of an architect's attitude toward his work. It will be by a deviation of educational methods by the practical men of the profession that we shall become set upon the right road.

The education of the architectural student is not confined to that curriculum of study that he will for a certain course pursue at the architectural school. It is largely influenced by the attitude or expressed opinion of men in his profession to

THE AMERICAN ARCHITECT

whose spoken and written words he will lend a listening ear. It, therefore, becomes necessary that the man in practice should by careful consideration of this important question so bring his ideas up to the conditions of modern practice that he will not mislead his younger brethren, but by sound precept and good example show them that, while they are embarking on the oldest and greatest of all the arts, they are at the same time to become immersed in all the complex problems that attend every business venture.

The Architect and the Motion Picture

HERE appears in this issue the first of two articles, very fully illustrated, on the relation of architects to motion picture production.

As a means of educating the masses, and more particularly the large number of people in this country not yet fully Americanized, the motion picture is considered as of the highest value. Also the audiences have become extremely cultured, and to an extent that all producers know that to slight them by presenting "sets" not accurate in every detail is the worst possible business policy.

How was the public to become assured that the architecture shown on the screen was good, or simply florid, sensational or grossly inaccurate? This problem of placing the stamp of correctness on the architecture of "sets" was at once solved by a large picture corporation when they included in the "le-

gend" that was shown prefatory to the running of the reels, the statement that the architectural and decorative effects were produced under the direction of a certain architect whose name was prominently displayed.

It was this unusual attribution of authorship, and commendably proper regard for the architectural verities that led to an investigation which resulted in the careful preparation of this series of articles.

It is erroneous to assume that the "sets" used by the larger motion picture producers are not in the truest sense structural. Visiting a large studio in New York City, there was found a carpenter shop of vast area, equipped with the most modern woodworking machinery and in which more than fifty skilled men were engaged in construction work. On the main floor of this studio, an equally large group were building in the most solid manner and decorating and furnishing the most substantial interior and exterior "sets."

Every detail was constantly under the direct supervision of the architect or one of his trained assistants. The basis from which this work was constructed were sets of plans and specifications as carefully drawn as if for absolutely permanent construction.

Motion picture sets constructed in this manner are sure to be as correct in their interpretation of architecture as any could be. The value of the architect's work in their production is proven beyond question.



PATIO OF THE LIONS—THE ALHAMBRA



A MOTION PICTURE SET, REPRESENTING A FARMHOUSE, DESIGNED AND EXECUTED UNDER THE DIRECTION OF ROBERT HAAS, ARCHITECT

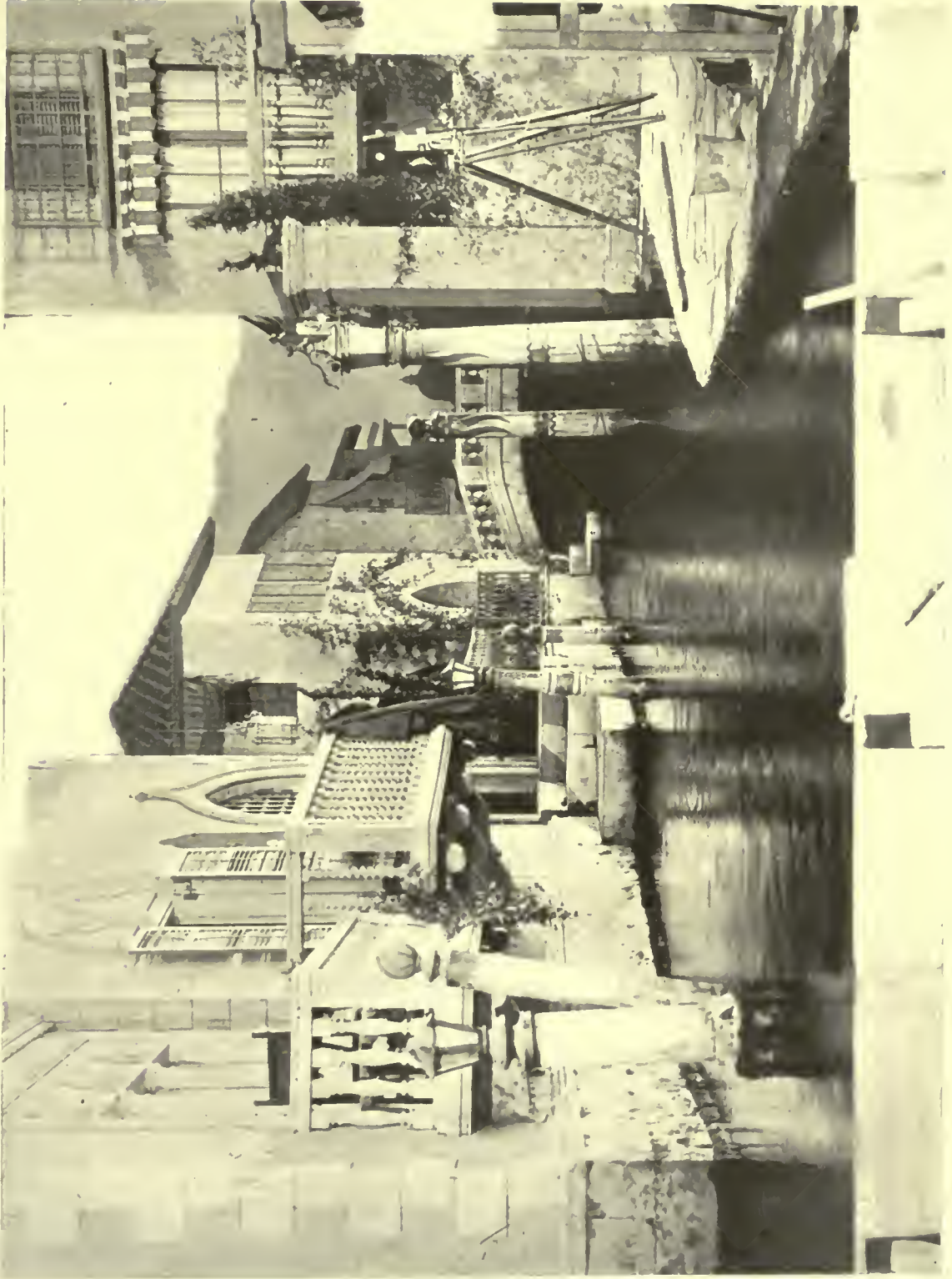

A MOTION PICTURE SET, DESIGNED AND EXECUTED UNDER THE DIRECTION OF ROBERT HAAS, ARCHITECT

As is apparent, this represents a canal in Venice which was constructed on the studio floor. The tank is about 120 feet long and was built deep and wide enough to permit the passage of two gondolas required in the plot for use in the production of "A Society Exile."



A MOTION PICTURE SET, DESIGNED AND EXECUTED UNDER THE DIRECTION OF ROBERT HAAS, ARCHITECT

This room represents the library of a wealthy and dignified New Yorker. As he was a self-made man and fond of splendor, the Empire style was thought to be the most suitable. The cumbersome desk in the left background was placed for a central spot of plot and action. Note the base of the pilaster and the caps which are so excellently brought out in the photograph. Three other rooms of this imaginary gentleman's house were built actually adjoining.



FOR THE REPRESENTATION OF AN AMERICAN COUNTRY HOME.



MOTION PICTURE SETS, DESIGNED AND EXECUTED UNDER THE DIRECTION OF ROBERT HAAS, ARCHITECT

A scene for use in "The Avalanche" to represent a Spanish inn. The building was not as a copy but a composite. All the walls are of real plaster and the stairs and platform are solidly built for use by the actors. There are entrances from the platform to three rooms in which subsequent action was carried on.

124



A MOTION PICTURE SET, DESIGNED AND EXECUTED UNDER THE DIRECTION OF ROBERT HAYS, ARCHITECT
Representation of an American country house of a style adapted from an Italian villa, used for the photoplay, "Erstwhile Susan," constructed out of doors, of wood and plaster. The rooms of this house, as used for the interior action, were built on the studio floor

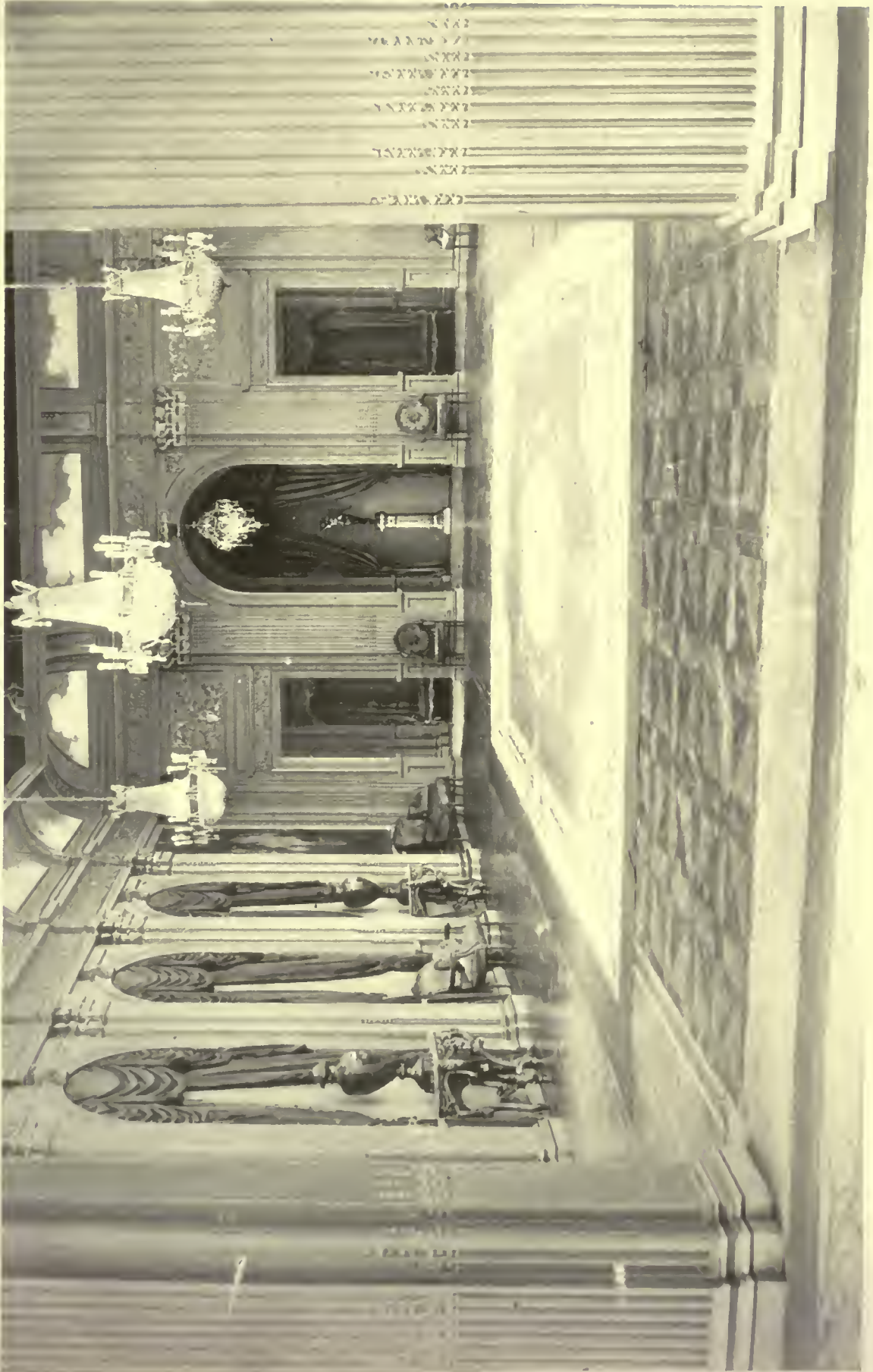

A MOTION PICTURE SET, DESIGNED AND EXECUTED UNDER THE DIRECTION OF ROBERT HAAS, ARCHITECT
A salon of the Elysee Palace, Paris, reproduced on the studio floor. This room occupies a space 80 by 120 feet. The walls are of wood ornamented with plaster.
Note the presence of the ceiling cove and absence of a ceiling proper.



A MOTION PICTURE SET, DESIGNED AND EXECUTED UNDER THE DIRECTION OF ROBERT HAAS, ARCHITECT
A representation of a doorway in an American city, built on the studio floor. It is intended to suggest a house in an old and aristocratic quarter—such as Washington Square, New York. The door opens into a hallway, but the other rooms of the house were built separately.

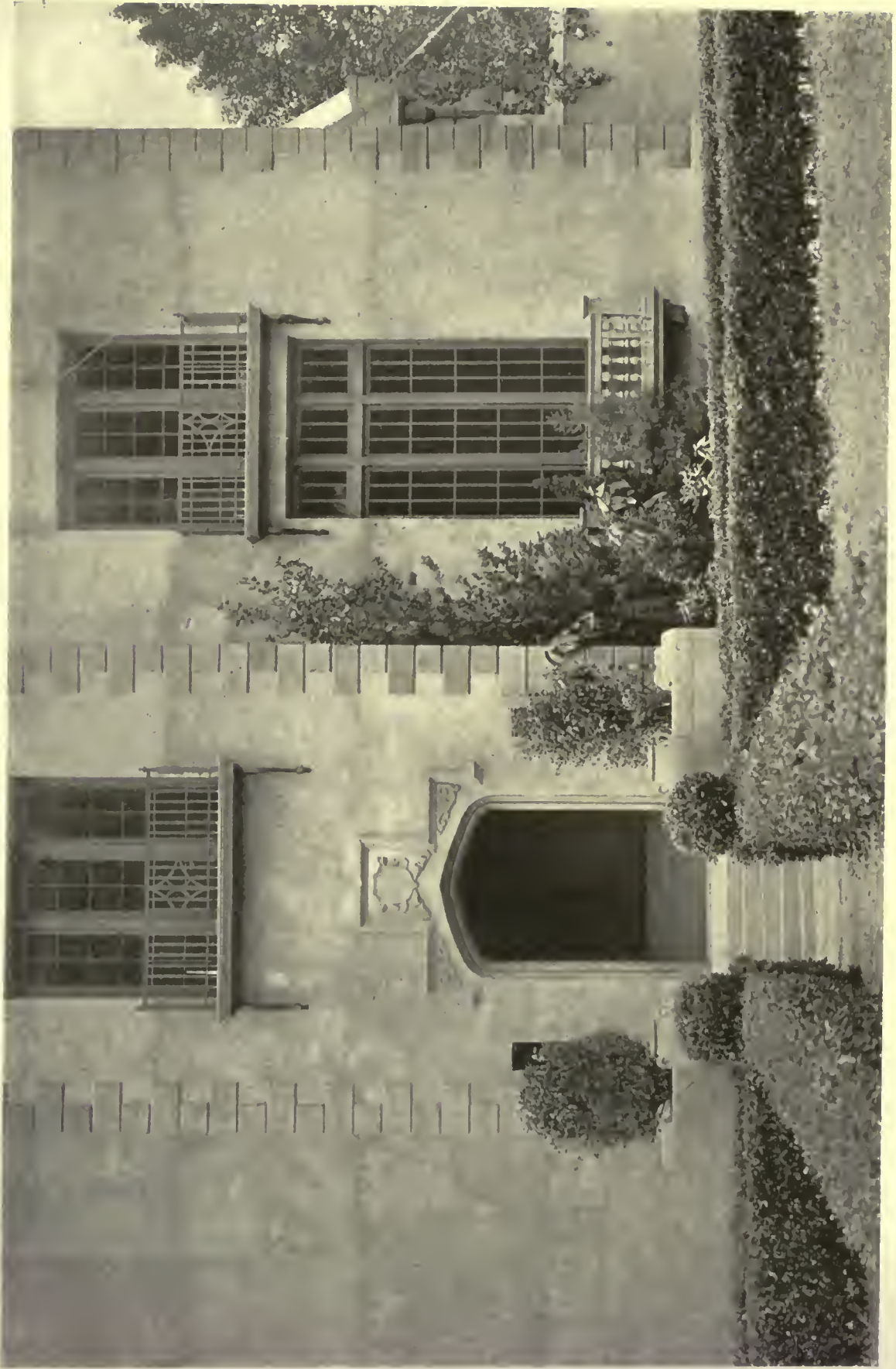

A MOTION PICTURE SET, DESIGNED AND EXECUTED UNDER THE DIRECTION OF ROBERT HAAS, ARCHITECT
Façade of an American country house built of wood and plaster without interior rooms. Constructed out of doors.

22

Standard Test for Schoolhouse Design and Construction

(Continued from page 10)

I. Flues are to be figured to include all surrounding walls and partitions except interior walls and partitions figured under H.

J. Where closets or bookcases or dead spaces occur in a bank of flues, same are to be figured in as flue area.

K. Stairs extending a full story in height are to be taken as stair area. Steps not a full story in height are to be taken as part of the floor area of the room or corridor in which they occur.

L. Large piers occurring in rooms are to be deducted from floor areas and added to wall areas.

M. Chimneys are to be figured in as flue areas.

N. Area of each individual space is to be taken separately in accordance with schedule.

O. Areas of arcades, open porches, uncovered corridors, pergolas and open air theatres or auditoriums, are to be figured separately.

RULE 2. COMPUTING CUBICAL CONTENTS.

A. Ascertain the cubical contents of the building by multiplying the area of the first floor computed by Rule 1, by the height of the building from the underside of basement floor to the mean of the roof.

B. In buildings whose basements are not entirely excavated, multiply the area of the first floor computed by Rule A (areas) by the height of the building from the underside of the first floor to the mean of the roof. To this content add the cubical content of any space between the underside of the first floor and the surface of the excavation, and in addition add the cubical contents of any partial basement which may be found in the building.

C. When portions of the building are built to different heights, each portion is to be taken as an individual unit.

D. Projecting entrance porches are not to be included.

E. Porches, covered verandas, used for school activities and open air rooms and auditoriums are to be included.

The percentages of the Candle of Efficiency have given standards by which architects reach a better understanding as to whether their plans are well designed for economy of floor space.

The study of school building plans, taken the country over, revealed a startling variation between them. Even when the buildings were designed to house practically the same number of pupils, engaged upon similar lines of work, there was often no similarity between the details of the plans. It

would appear that building programs are prepared and working plans made without comprehension of the fundamental facts covering the conditions of the work to be later performed by the teachers and pupils in the every day order of school exercises.

If the probable future program is laid out for a definite number of pupils and the type and number of rooms to fit this program is determined, a foundation of fact is laid, upon which to plan the lay out of the proposed new school building.

The success of the school in the use of a new building is largely determined before a line is drawn in the architect's office, by the care with which this future program is studied.

Once the foundation of fact above referred to is laid, the architect can make every dollar expended upon the new building carry a peak load, by spending at least fifty cents of every dollar for those parts of the building to be devoted to purposes of instruction.

A study of the fundamental facts and a determination of what is required, in the way of a building program to meet those facts, will enable the superintendent to face the financial world and demand, with every assurance of success, the appropriations required properly to carry on the educational program needed for the proper development of his town.

Our next step, therefore, is the development of a method, or rule, by which the general size of the new school building may be determined.

If we can do this, by the application of a method that will work the greater number of times it is tried, the planning of school buildings will no longer be a matter of opinions and guesses. The new building will be founded on a basis of fact. No argument is needed to prove that such a method is desirable provided it is confined to translating the superintendent's data, on the maximum number of proposed pupil occupants, and the course of study into the number and the size of rooms and their floor area required to accommodate a definite number of pupils, when engaged upon their school work.

The rule should solve this problem and should in no way hamper or interfere with the creative impulse of the skilled architect. Such a rule used with the per cents of the Candle of Efficiency will be the means of ending the confusion and waste now so apparent in the planning of school buildings. It will result in the same form of economy that now comes from the use of the budget system in financial undertakings. With such a rule, guess work, uncertainty, worry and loss of time in laying out the requirements of the floor plan are eliminated and the designer, given his problem, may at once

THE AMERICAN ARCHITECT

proceed on a sure footing, for he will know from the start the exact requirements which he will be called upon to meet.

A six months' study of this problem and the trial and elimination of numerous methods in the practical work of the architect's office, gradually produced a certainty that facts obtained by the following rule were the basis upon which to plan.

SUGGESTED METHOD OF COMPUTATION FOR SIZE OF SCHOOL BUILDINGS.

Compute the probable maximum number of pupils in each grade for which the building is to be planned. Each study and special activity for each grade, with their period allotment per week, is to be worked out by the superintendent. Determine the maximum number of pupils that would probably take each study and special activity. The maximum number of pupils taking a subject is

multiplied by the number of periods per week allotted to that subject. This product is divided by the average number of pupils in a group or class in that subject. This is divided by the number of periods in which a room can be used in a week.

In the last computation any fraction is counted as a whole number.

The result is then charted for use of rooms. First is shown each room with its distinctive purpose, then any supplementary or duplicate use that might be made of the room, then the home room pupil accommodation, and then the teacher use of the room.

Charting the school, first by special activities and studies and then by rooms and their possible multiple use, shows what margin for flexibility will be required in determining the final number of class and study rooms.

Notes from London

By Special Correspondent of THE AMERICAN ARCHITECT

THE conclusions recently arrived at by the City of London Churches Commission, and expressed in their report, recommending the removal of nineteen churches and the sale of their sites have aroused a storm of indignant protest in this country. Even in signing the report Lord Hugh Cecil added a note, in which he said, "I must add that I think the removal of a church and the desecration of its site a great evil"; and the offer in the report itself that "wherever the tower is worth keeping we have recommended that it should be kept" does not by any means satisfy public opinion.

The Lord Mayor has stated that he is not in favor of demolition of some of the nineteen churches on the list for destruction, and mentioned particularly St. Mary Woolnoth as one which should be spared, adding the wise suggestion that a special committee of archaeologists and experts should be appointed to inspect the churches, and report before the matter were definitely decided and Sir Banister Fletcher F. R. I. B. A., the well-known architectural historian, said that the city churches form an architectural heirloom of which any city might be proud, and any attempt such as was being now tried to destroy or remove them should be resisted to the utmost. Mr. Frederick Hiorns, writing yesterday in "The Observer," says: "Such contemplated vandalism is almost past belief . . . Of the original fifty churches which

Wren built eighteen have already suffered destruction, making it the more desirable to retain the thirty-two that remain. Yet we are to understand that thirteen more of Wren's structures are now threatened, and they include examples of such beauty and interest as St. Vedast, St. Magnus, All Hallows-Lombard street, St. Anne and St. Agnes, and St. Mary-at-Hill (the last two with most original and beautiful interiors), while of the churches of Wren's successors we are warned that a work of the exceptional merit of Hawksmoor's St. Mary Woolnoth may, after long hesitation, be swept away . . . The financial needs of the Church, even when supported by demonstration of the "superfluity" of this or that of its buildings, cannot here be the final word; and there is here a strong case for considering primarily the spiritual as opposed to the financial and materialistic aspect of buildings which embody fine architecture."

Another suggestion offered is that these churches should be "carefully taken down and re-erected complete in suburbs that needs churches." Among the notable Wren churches which are now threatened are those of St. Anne and St. Agnes, with its garden upon Gresham St., St. Nicholas Cole Abbey, which has been called "a jewel like example of Wren's conception of a preaching-house," and St. Vedast, whose walls withstood the great fire and are partly recased, and which possesses a notable steeple enclosing a clock whose mechanism is com-

plete, but which has no dial face. One humorist remarks of the commissioners, "How such valuable sites as those occupied by the Abbey at Westminster and the Cathedrals of St. Paul and St. Saviour came to escape their attention it is remarkable, indeed, to conceive."

Architecture at the Royal Academy

ON the whole this may be considered a very successful Royal Academy as far as architecture is concerned. There are noticeably few photographs of executed work, which is to be regretted, for in the case of some buildings these are most valuable; but their absence may be accounted for by the new regulation that photographs, which must not exceed half-plate size, are only admissible when exhibited in connection with working drawings and in the same frame.

Apart from this the work seemed to me good throughout, and the drawings in many cases excellent. This remark applies to Mr. Robert Atkinson's two well-handled drawings of "Entrance Hall to Theatre, Brighton" and "Proposed Theatre and Winter Garden at Liverpool"; to Mr. Raffles Davison's work "Stornoway Town Improvement" and elsewhere which is always good throughout, using pencil, brown ink and watercolor to get the effect needed; and to that fine water-color artist William Walcot's masterly drawing for Sir Edwin Lutyens' "Jaipur Column," which has, skillfully combined with Renaissance elements just the note of the East which is needed for the soil of India.

I imagine we may trace the same artist's hand in the drawing of the Imperial Ballroom (interior) at Delhi from Sir E. Lutyens' design; and coming to domestic architecture we can have nothing but praise for Mr. Ernest Newton's "Flint House, Goring" (entrance front and garden front) and "House at Kingswood. Garden Front," which are typical

of this architect in house design. I admired also his "Memorial Shrine for Uppingham School." The group of buildings at Whiteley Village, Burrell, Surrey by Sir Aston Webb, P. R. A. and Mr. Maurice Webb are to be noted; and I liked particularly, for general composition and detail of work the "Elevation of the London County Westminster and Parr's Bank, Antwerp Branch," exhibited by Messrs Mewes and Davis. To be compared with this is Mr. Curtis Green's "Reconstruction of Nos. 258-260, Piccadilly," in Renaissance composition. But yet more important, in London street architecture, is the "Model of East Pavilion: south side of the Quadrant," in which Sir Aston Webb, Sir Reginald Blomfield and Mr. Ernst Newton have collaborated, the problem being, as I imagine, to combine harmony with existing buildings on this important West End centre with the legitimate requirements as to frontage of shop-holders.

War Memorials are, of course, still well to the front in this academy; and I should select for notice the "Harrow School War Memorial" by Herbert Baker F. R. I. B. A., the "Proposed War Memorial Hall at Lambeth" by H. Austen Hall, though I do not care so much for Frederick Wilson's "Memorial Church." Very noticeable among memorial schemes is the perspective view of the Egyptian Expeditionary Force Memorial at Jerusalem by W. Palmer Jones, shown also here in a large-scale model, in which Greek and Egyptian elements have been blended into the design, which is boldly conceived but somewhat overweighted by the towering centre-piece. A very pleasing design for domestic architecture is Mr. H. S. Goodhart-Rendel's "Cottages and Village Shop on an Estate in Hertfordshire"; and with these last may be compared the "Group of Cottages at Turner's Hill Sussex, exhibited by Sir Aston Webb, P. R. A. and Mr. Maurice Webb.

(From The Architectural Journal)

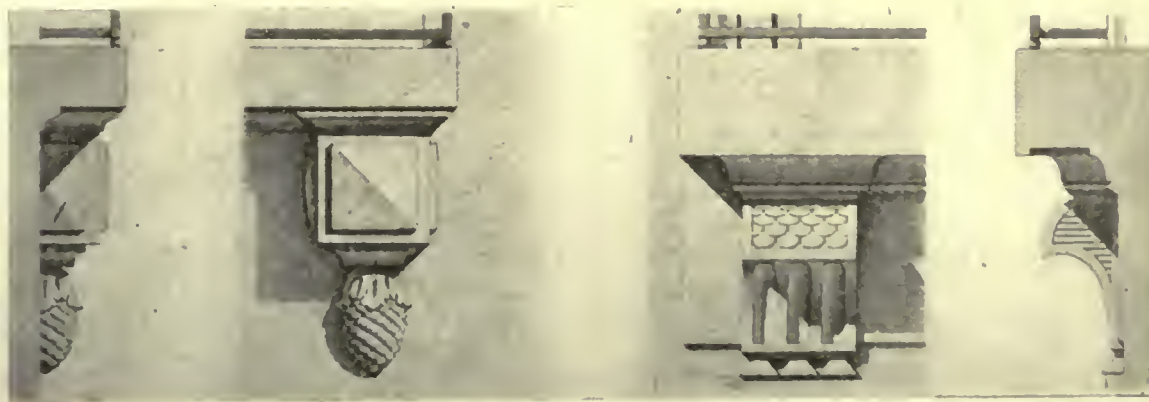

SMALL CONSOLES FROM A PARIS BUILDING (LOUIS XVI)

Proposals for Housing Relief in New York

Plan Suggested by Labor Party

Labor must be given a responsible part in any successful housing programme, states Frank E. Hill in the *New York Globe*.

Participation by labor becomes possible with the extension of state loans for housing and the creation of state housing boards.

These boards should contain definite labor representation, and should encourage the formation of non-profit-making societies of architects, builders and workers which could employ state funds for furnishing houses to the laboring classes.

These are the conclusions of certain labor specialists, architects and workmen. They have just been adopted at Schenectady by the American Labor Party. They are believed by Ordway Tead of the Bureau of Industrial Research, a member of the committee of experts which drafted a plan at the request of the American Labor Party, to offer remarkable promise for a solution of labor difficulties in connection with present day construction. According to many who meet labor in a practical way in the building field, such a plan has a promise of success.

It is generally admitted that the present labor situation is unsatisfactory. Wages are high. In many cases the men insist on a ten-hour day with two hours paid at overtime rates. Labor of all kinds is scarce, and skilled labor is scarest of all. It has gone into the factories and into transportation service where brawn can command high rates at loading and unloading. That disagreements and strikes frequently interrupt building operations is the general testimony of both speculative builders and architects, and even when work is done it is often not as efficient work as was performed ten years ago.

The plan of the American Labor Party, in Mr. Tead's opinion, will strike at all of these evils.

"One of the great difficulties," he declared, "is as usual a psychological difficulty."

Relief as Proposed by Mayor's Committee

The Mayor's Committee on Housing is working valiantly to stimulate the building of apartments and it is accomplishing a partial relief. It is, for instance, securing pledges of loans on second mortgages; it has secured the promise of a thousand building lots on terms by which the first mortgage shall cover the cost of the ground and no initial pay-

ment shall be required from home builders who purchase them, and it is trying to induce employers to join a building association which shall co-operate with various loaning organizations so that their employes may be able to build homes for themselves on the credit of their characters and their jobs.

All these are excellent steps so far as they go and are especially excellent in that they stimulate men to own their own homes and to pay for them out of their savings. But if all the reliable and permanent workers who could be induced to make this home building venture were to be housed upon suburban lots under conditions of long and easy credit, the pressure for apartments in the more central sections would be reduced but little. New York is so far behind in its building program that nothing but a very large investment—the committee figures it at \$560,000,000—will meet the need.

Banks and insurance companies are lending less money on building mortgages than they would do if they could get the same returns for their capital as they can in other lines. Building mortgages yield small returns because of the Federal and State income taxes, and this results in building congestion, not only in New York but quite generally throughout the country. To remove that obstacle the committee urges that the income from such mortgages be exempted by Congress from the payment of income taxes.

The representatives of several insurance companies said that their companies were lending on building in preference to more profitable forms of security because the housing situation here is so grave as to require emergency relief, but, of course, such a course cannot be depended upon. Unless building loans can compete with other forms of investment, building will be squeezed down to the lowest limits. The exemption of such loans from the Federal income tax is the obvious means of making them attractive. The Government can better afford to lose the income derived from that source than it can to encourage housing conditions which congest population to the danger of health and which prevent the revival of business activity in building materials.

A Correction

We are in receipt of a letter from Mr. T. MacLaren, of Colorado Spring, in which he states:

"In your issue of April 21, 1920, appear illustrations of Durango High School, Colorado, credited in error to Charles E. Thomas, architect, instead of the former firm of MacLaren and Thomas."

Current News

Happenings and Comments in the Field of Architecture and the Allied Arts

Pittsburgh Plans High Building as War Memorial

The world's tallest building is being planned by Pittsburgh citizens as a memorial for Pennsylvanians in the war, according to an announcement by the bureau of memorial buildings of the War Camp Community Service. The tower is expected to reach an altitude of 2,100 feet, high above the smoke screen of the city, and will be almost three times the height of the Woolworth Building and seven times as high as the Flatiron Building.

On the 2,000-foot level an observation tower will give a view of 40 miles radius, and vari-colored electric searchlights will radiate in various points of the compass. An assembly hall to accommodate 15,000 persons will occupy the second story, which will exceed by 5,000 the proposed capacity of Victory Hall in Pershing Square, New York. A restaurant will occupy the floor at the 1,000-foot level, which will offer a wide view of the city. A memorial room, situated 500 feet above this, will be large enough to house any instrument used by the army in the war.

Lumber Tragedy of the United States

1. The New England states are no longer self-supporting in a lumber way.

2. The Lake States, once our greatest producers of lumber, are now importing lumber to keep alive the many wood using industries in that section.

3. The center of the lumber industry is fast moving to the Pacific Coast, which means long hauls and high freight rates.

4. The lumber people of the Southern States admit they are through in fifteen or twenty years, as far as yellow pine is concerned.

5. The forest fire loss in this country is about \$28,000,000 every year, and the area burned over is ten times greater every year than the devastated areas of France we have heard so much about. This must stop:—U. S. Agricultural Department.

Building Industries Ask Recognition in Car Service

Following the petition of the carriers to the Interstate Commerce Commission to invoke its executive powers to relieve the nation-wide freight congestion, the National Federation of Construction Industries has addressed a request to the commission asking that recognition be given the various branches of the construction industry in such orders for car service as might be issued by the commission. The closing paragraph of the builders' petition follow:

"The railroads are dependent upon the construction industry for the material wherewith to maintain their roadbeds. Highways, bridges, agricultural, industrial and other structures are products of this industry. Approximately fifty per cent. of the cement produced in this country, and large quantities of hollow tile, brick, lumber, lime, crushed stone, sand and gravel and other materials supplied by the industry are consumed by the farmers of the United States, mainly in the improvement and enlargement of their productive units.

"The attention of the commission is respectfully called to the fact that the uses to which construction materials are usually put are essential to the welfare of the general public; and that the degree of essentiality of any material in an emergency such as is now reported to exist should be determined by the consideration of the purpose to which it is put.

"Wherefore, having called the earnest attention of the commission to the essential character of the construction industry, and having set forth all the matters hereinbefore mentioned, and now assuring the commission of its willingness to furnish to the commission upon request any additional facts which it may have in its possession or may be able to obtain, your petitioner prays that in the effective exercise of the powers and duties cast upon the commission by law in emergencies such as are reported now to exist, the commission will recognize the essential character of the service being rendered by the construction industry and save the same harmless in this emergency.

Sound-proof and Sight-proof

A western paper looks into the future and states that with the invention of the geophone the world will have to be made sound-proof.

The device enables the human voice to be heard through fifty feet of solid coal and the voice has been detected one hundred and fifty feet away through less solid substances. It would seem that the dictagraph will be supplanted. Anybody can place a geophone and no one be the wiser. This paper says in part, "A law may have to be devised to forbid its use because it can be turned to any number of improper and even very embarrassing employments. Applied to the walls of a room it would give facility to hear anything said in an adjoining room. Fancy the United States Senate in secret session, regarding which it is very sensitive. It would be easy to apply the instrument and listen to all the learned senators might have to say. One would not be dependent upon some senator who took notes on his cuffs for translation outside.

"It would seem that conferences involving secrecy might be compelled to devise new means of conduct. Such conferences may have to employ writing for communication between the individuals."

It is today permitted to observe as far as the eye can see. Why not leave unrestricted the hearing facility. If people conduct themselves as they should, there need be no embarrassment. Character has been defined as "what you are in the dark." If we need the lights turned on to keep at the level of our best moments, why, let us have the geophone to help us.

War Department to Send Motor Convoy from Washington to Los Angeles

Plans have been completed whereby the War Department will send a motor convoy from Washington to Los Angeles over the Bankhead National Highway on or about June 15, due to arrive at Los Angeles September 1.

The purpose of this and other overland trips will be to study the handicaps which surround the transportation needs of the army on account of the lack of dependable and definite systems of highways; to secure data relative to the use of various types of motor vehicles; to secure relative data on solid and pneumatic tires; to train officers and men en extended field operations, and to recruit personnel for the various branches of the army.

The Federal Highway Council feels that such study by the Motor Transport Corps will be of great value to the entire country, because it will thor-

oughly establish the necessity of the Federal Government undertaking the construction and maintenance of a definite system of national highways.

The convoy will be under the supervision of the Motor Transport Corps and will consist of a motor transport unit complete, at war strength, one service park unit, at war strength, detachment from Engineers Corps, and detachment from Medical Corps. All motor trucks will be one and one-half tons capacity equipped with pneumatic tires.

The tour will start from Washington passing through the following states: Virginia, North and South Carolina, Georgia, Alabama, Mississippi, Tennessee, Arkansas, Texas, New Mexico, Arizona and California, ending at Los Angeles.

State Aid for Cheap French Dwellings

The French law of April 12, 1906, amended Dec. 23, 1912, relative to state loans to enterprises engaged in the building of cheap dwellings has been further amended so as to provide for multiple dwellings, or apartment houses. The principal provisions of the amendment according to a recent issue of the Monthly Labor Review issued by the Bureau of Labor Statistics, U. S. Department of Labor, allow certain state aid on multiple dwellings when the annual rent of each apartment does not exceed at the time of construction a maximum of 300 francs per year for three rooms and toilet containing a total floor area of from 376.7 to 484.4 sq. ft., for communes having a population of 5,000 and under; to 720 francs per year for the city of Paris for the same number of rooms, with the same approximate floor area. For more than 484.4 sq. ft. of floor space the maximum annual rental is fixed at 325 francs for communes of 5,000 population and under to 760 francs to the city of Paris and the Province of the Seine. The law also applies to construction of apartments containing two rooms with kitchen and toilet; one room with kitchen, and one isolated sleeping room.

The annual rental of individual dwellings is fixed at 4 per cent. of the actual cost. The state may advance through the mortgage bank not more than 200,000,000 francs and the Bank of Deposit and Consignation (under government supervision) is authorized to advance not more than 300,000,000 francs for such enterprises.

Loans are to draw 2 per cent. interest annually if used in the acquisition or construction of individual cheap dwellings, or in the acquisition of small properties, under the provisions of the law of April 12, 1906, that of April 10, 1908, and subsequent laws. If used for the acquisition or construction of cheap dwellings or small properties for

rent only, the rate of interest is $2\frac{1}{2}$ per cent. Provision is made for loans for completing dwellings now under construction.

Arc de Triomphe Scoured

The world famous Arc de Triomphe, which is perhaps the dominating symbol of the French capital in the minds of many foreigners, became the subject of a heated controversy between a Paris newspaper, the *Intransigeant*, and the local government authorities. According to the report in the Philadelphia *Ledger*, it appears that the French peace loan posters, which were issued in innumerable variety, had been plastered through the length and breadth of the capital, but only were stuck on government buildings, banks and such places as permission was not necessary to ask. The bill poster men did a thorough job. They plastered the walls of the Louvre, the colonnades of the Rue de Rivoli, church walls, palaces and monuments, and the handsome arch was literally covered with posters over the ones already stuck up.

The arch was a cubist-futurist delight in a dazzling array of colors. Its camouflaging was so complete that long after the loan passed the posters remained ragged, dog-eared, torn and weather beaten. The newspaper protested with photographic eloquence and editorial invective, the public, too, felt the shock to their æsthetic sense, but the government remained impassive. After due warning, the newspaper hired a wagon and a gang of laborers, armed them with ladders, sponges, scrappers, hot water and soap and, while puzzled gendarmes looked on, the premiere toilette of the arch was performed. A load of rubbish was scraped off and the monument emerged from its chrysalis of rags and tatters with all the architectural beauty and dignity that its name suggests.

How New Zealand is Getting Homes

Most of the other countries affected like the United States, by a shortage of houses, have established some system of governmental aid for those who want to own their own homes. One of the most interesting arrangements is that of New Zealand.

The housing act passed last year provides a national board, in charge of a fund for helping anyone who meets the conditions set down. The measure is intended to help only those of comparatively small incomes. No citizen whose income exceeds \$1,525 a year is eligible, and the limit is lower for small families. The price of the house, too, is limited; a wooden house may not cost more than

\$3,750, and a brick or stone house not more than \$4,250.

The dwellings are built by the government, and the buyer obtains possession by paying only \$50 down and guaranteeing to pay the rest in installments over a period of $25\frac{1}{2}$ years to $36\frac{1}{2}$ years. With each installment he pays the interest, at $5\frac{1}{2}$ per cent., due on the balance outstanding at the time. He may pay off at any time as much of the principal as he pleases, and in case of defaulted payments he receives back whatever he has paid, less a stated allowance for depreciation of the property during his occupation. He also pays the insurance charges.

Some extremely conservative folk might term this "socialism." It is at least an extreme form of national "paternalism." Nevertheless such a plan does not look half so radical as it would have looked before the war. Some of the conditions would obviously not be suitable for the United States; the price limits, for example, are too low, and perhaps the time allowed for payment is unnecessarily long. These, however, are more or less accidental details. The point is that here is a definite plan whereby the entire community is helping its homeless members to obtain homes, on terms fair to both parties, and that it is considered in almost every civilized country a legitimate and commendable public enterprise.

It matters little whether the enterprise be conducted by the nation or state or city, so long as it is in responsible hands. A writer in the Lansing, Mich., daily press believes that Americans might profitably follow the example.

Yellow Light Best

Illuminating engineers some months ago made a series of tests with incandescent electric lamps, gas, gas mantles graded for color, and oil lamps, the candlepower being the same in each case. The larger the number of yellow rays in the light, it was found, the greater the optical efficiency. Blue rays were found to be conducive to earlier fatigue of the eyes. Thus, it appears, that the general preference for light of a yellowish cast is not the result of mere whim or habit, but of the eyes' recognition of the fact that such a light is less tiring.

Our Outworn Community Systems

The world is coming to realize that our whole theory of community building will be made over. Old communities are struggling in the throes of congestion of all kinds and yet there are not enough houses or recreation places or schools or buildings of all types in these centers.

THE AMERICAN ARCHITECT

What will be the streets of the future? Will street level sidewalks disappear in our cities? What is to become of pedestrians? Where shall we park the comming 50,000,000 automobiles by day? Where will they be stored by night? Where will the hundreds of airplanes land. And for the countryside, what of our national highways.

What is the answer? The *Seattle Daily Journal* justly states that it is science. Science which is the business of knowing what to do. The whole civilized world wants to know what to do with its outworn community systems. It is groping for the answer and only groping. London is planning a new city of a quarter million to take care of its human overflow. A new paved highway 100 feet wide it to be built between Edinburgh and London. England would seem to be feeling the urge for the new order of things first and is groping—but only groping.

The restless fever of men, in all callings, will no longer be abated by the old prescriptions. Men are seeking more of a chance to live—for themselves and their families.

But living involves communities, giving comfort and convenience and full of life, variety and color in a broader sense.

We used to think that people lived in houses. It was our great mistake in building communities. People dwell in houses but living is another matter. It involves life, contacts with other lives, the spirit of play, recreation and work, of festival and pageant, of music, decoration, schools, theatres, gardens, woods, streams—and grass that does not warn us to keep off.

Fire Prevention in Public Schools

The study of fire prevention has been added to the curriculum of the New York public schools by the Board of Education. The board has adopted as a basis for regular study the school manual entitled "Safeguarding the Home Against Fire" prepared for the United States Bureau of Education by the National Board of Fire Underwriters.

Emphasis will be laid in the instruction upon the fact that a fire occurs in New York City on an average of every twenty-one minutes, day and night, with "most of these due to carelessness, according to engineering experts." Many of the fires occur in homes and so many are attended by injury or loss of life that it has been estimated that about 100 persons are burned to death in Greater New York each year and many more seriously injured.

Making this study compulsory is following the example of many other communities. Kentucky has had a statute for some time making the study of

fire prevention compulsory and the last New Jersey legislature passed a law providing for this study in September. In Minnesota it is also planned that pupils and teachers should study the subject before the close of the school year.

Louvre Extends Appeal to Art Lovers

Artists and the art lovers of Paris, as well as the American tourists, are much interested in the opening of the Grand Gallery of the Louvre Museum, which, with the Chauchard and the Schlichting collections, comprise the most admirable offerings found in any national museum. The square salons have been entirely remodelled, while the new arrangement of the gallery is said to effect a greater range of lighting interpretation than ever was before possible.

The parts to be reopened offer principally the works of Rembrandt and Rubens and those of their schools, with Dutch and Flemish subjects. In the Rubens salon nothing has been changed. Rembrandt's grandeur and profound expression are found expression are found especially in the series containing "La Bethsabée," "Saint Luke," the "Good Samaritan," the "Two Philosophers," the "Disciples of Emmaus" and several portraits.

M. Arsene Alexandre, the leading French art critic, considers this the most wonderful collection in the world and he only regrets that Paris has not yet obtained "The Syndics and the Ronde de Jour" from Amsterdam, which would give fuller scope to the realization of what the Rembrandt school intended to convey.

The smaller salons are being redecorated, maintaining throughout the high sense of artisticity which always characterized the Louvre arrangements, especially as far as the art section is concerned. These salons later will be used to house the Chauchard and Schlichting collections which have been lost in comparative darkness, in the drearier corners of the Salle Lacaze.

But while the Louvre makes a constant appeal to the trained art lover, it is now intended to inaugurate a series of lectures, commencing next November for the benefit of the academic pupils. Twelve sections are being formed, each one to be guided by an authority who is familiar with the artistic and historical relics of his particular section. In the past, teachers of art frequently have conducted brief courses of study in the Louvre, but this is the first time that an effort is made to employ the national institution for public instruction, similar to the practice prevailing in the American museums of art and natural history.

It may be that some complaint will be made that

the chattering of the young students will disturb the serious reflections of the older visitors to the galleries, but in official circles praise is given to the author of the innovation, which, it is asserted, will have a widespread effect on the future welfare of the French nation in the sense that even the ordinary individuals will begin to appreciate what a wealth of art remains for their admiration.

Communal Forests Planned to Solve Up-State Tax Problems

The Northern New York Development League, a regional Chamber of Commerce, including all the varied interests of the northern third of the state, has decided to actively undertake and sponsor a reforestation program whereby it is hoped that it will impress upon the public not only the value of the forests in industrial lines, but in the deriving of revenues from the forest which has proved successful in the reducing of taxation in many parts of Europe.

The fundamental principle of the league's campaign is the communal or public forest, which does not mean that it will be less active for private or corporation reforestation. It stands first for the public idea because the private idea will thereby be given encouragement and private effort will then have a constant example of public accomplishment along the same lines.

One of the best known examples of a communal forest, cited by the *New York Times*, is that of Zurich, Switzerland, which city controls 2,840 acres of land, of which the city uses the forest mainly for fuel wood which furnishes 64 per cent. of the income from the forest. Lumber, ties and miscellaneous materials make up the balance of the revenue. There is one technical man in charge of the forest, which has netted the municipality an average income of nearly \$20,000 annually.

The state laws now provide full authority for communal forests. Chapter 74 of the Laws of New York, General Municipality, which became effective on March 26, 1912, allows the governing board of a county, town or village to acquire by purchase, gift, lease or condemnation and hold as the property of such municipality, such tracts of land, and may appropriate therefor the necessary moneys of the county, town or village for which lands are acquired. The procedure is by resolution of such board, after having published notice two weeks in the newspapers prior to such action. The lands acquired for public forests may be located outside of the municipality and may be located in separate parcels of land, if desired. Part or all the municipal forest may be

located around the water supply of the municipality to protect and to perpetuate the future supply of water.

Many communities have already started small forests for this purpose, but the real communal forest is one that provides public revenues. These forests by law can be cut off along the lines of scientific forest management and the timber sold in the interest of public revenues. Not only do they offer a perpetual income to the taxpayers of the community, but also the advantage of forest cover which means the protection from floods, snow slides, earth slides, the regulation and the preservation of the water of streams, shelter from winds, protection of birds, fish and game, and healthful playgrounds for the young and old.

Little or nothing has been done under this law and it is proposed to have the North Country take the leading place in this kind of work and set an example to the rest of the nation. Northern New York has had a leading place in private reforestation and some of the best individual and corporation planting programs have been carried out here.

Many of our large interests are practising scientific forestry by cutting down only certain sizes and varieties of trees and are contributing their share in the reforestation movement. A very large fraction of the land in Northern New York is not suited to farming purposes but is excellent for reforestation. These lands are well adapted to become communal forests, which will substantially decrease taxes and thereby keep up the roads and contribute generally to public improvements.

The State Conservation Commission offers effective assistance in furnishing trees of many varieties at low cost. The league has been working on the proposed free-tree law and there is every expectation of success in the near future. Whether we have this law or not the present cost of trees is so reasonable that any one can afford to reforest to some extent. The College of Forestry is co-operating in this work and offers practical assistance to the municipalities and to the northern section in mapping out local programs and in superintending the setting out of trees.

United States To Sell Housing Land

The United States housing corporation tract of 376 acres in East Bethlehem, known as Pembroke village, which cost the government about \$2,800,000 before the armistice, which amount included \$376,000 paid by the corporation to the Bethlehem Steel Co., former owner, will be sold through the housing corporation of Bethlehem.

Army Houses To Be Sold

Washington, District of Columbia.—Sale of public auction of 690 buildings at Camp Dodge, Iowa, has been authorized by the War Department as a means of relieving the housing situation at Des Moines, Iowa. These buildings were put up to house army squads of eight men each, and are said to be available for family use. It is expected that they will help materially to improve conditions in Des Moines.

Timber in New England

The output of lumber in the next decade in Maine, Vermont and New Hampshire will be greatly reduced because of the heavy inroads on the timber made by the pulp and paper industry. The paper manufacturers are making an effort to get all available pulp stock before it is necessary to abandon their plants. The result is that much of the timber that would otherwise be cut into lumber has been made into wood pulp. If it were not for the pulp and paper interests, the New England states, say a recent investigator of timber conditions, could keep up their present rate of lumber production for a long period. It is estimated that the production in Maine will shrink a quarter of a billion feet in the next ten years, although it has been said that Maine would hold her own from now on. The same situation prevails in a proportionate degree in Vermont and New Hampshire.

The Forest Service has been investigating production, timber stand, etc., in these New England states this spring in preparation for the report required by the Senate under the Capper Resolution.

Personal

George W. Maher announces the removal of his office from 208 South LaSalle St., Chicago, to his building, 157 East Erie St., Chicago.

Stork & Knappe, school architects, have moved from Palisade, N. J., to King St., Ardsley, N. Y.

A. Kingsley Porter, known to readers of this paper as an authority on mediaeval architecture, and author of numerous articles on that topic published in *The American Architect*, has resigned as assistant professor of the history of art at Yale to accept an appointment as professor of fine arts at Harvard.

Frank A. Spangenberg, architect, and Earl Martin, associate, have moved from 160 Franklin street, to 1322 Prudential Bldg., Buffalo, N. Y.

Joseph Impellitier, architect, formerly of 280 Prospect avenue, announces removal of his offices to 156 Elmwood avenue, Buffalo, N. Y.

Nathaniel Koenigsberg and Louis I. Simon announce their association as architects and engineers at 8 South Dearborn street, Chicago.

Westinghouse, Church & Kerr have moved their offices from 37 Wall street, to Grand Central Palace, New York City.

Sanford O. Lacey and Gerald G. Schenck announce that George Bain Cummings, formerly of New York, has been admitted to partnership. The new firm will continue architectural practice at 514-6 Phelps Building, Binghamton, N. Y.

George R. Morris and the Apartment Corporation have moved to the Morris Building, Charles and Saratoga streets, Baltimore, Md.

Wm. T. Braun has formed a partnership with Edward A. Nitsche and will continue the practice of architecture at Steinway Hall, 64 East Van Buren street, Chicago.

Warren W. Day has formed a partnership with Clark Wesley Bullard of Champaign, Ill. A general practice of architecture will be conducted under the name of Day & Bullard at 527 Main street, Peoria, Ill.

A partnership for the practice of architecture and engineering has been formed between Clarence H. Larsen and John Glenn Mason, both of Lincoln, Neb., with offices at 408 Terminal Building.

George M. Hopkinson and Wellington J. Schaefer have formed a partnership with offices at 5716 Euclid avenue, Cleveland, O. Samples and catalogues are desired.

H. H. Whiteley, Los Angeles, Cal., formerly at 429 Story Building, is opening new offices at "La Cabana Azul" 520 South Western avenue. He desires samples and catalogues.

George S. McCrea, architect in the Pacific Building, Oakland, has moved to Capitola, Cal.

Charles W. Deusner and Miss Helen Dupuy Deusner announce that they have resumed the practice of landscape architecture in Southern California, under the firm name of C. W. and H. D. Deusner, with an office at 15 North Euclid avenue, Pasadena, Cal.

Edgar W. Maybury, of Pomona, Cal., has established offices at 125 West Monroe street, Phoenix, Ariz., as representative of Messrs. Reginald D. Johnson, architect, and Gordon B. Kaufman, associate, of Pasadena. He desires catalogues and building samples from the trade.

Weekly Review of Construction Field

With Reports of Special Correspondents in Prominent Regional Centers

"Firm Minus Pint of Oil or Foot of Land Sold \$20,000,000 Stock." So it goes according to a headline in a New York daily.

We don't know where this \$20,000,000 came from but it is safe to suppose it is cheerfully offered by the dear public.

We don't know why people prefer to put up their money for the perpetuation of a get-rich dream rather than for something they need, but we hazard a guess that they rather spend their thoughts and money for the imagination of a vain thing—than for a house and lot.

It seems fair to suppose that this money came into New York—not from those who have both town and country houses, but from those who want to have them. There is a continual multiplication of the type which imagines an ambush against work and looks for quickly made money to build such a bulwark.

What folly it is to discuss means of relieving the financial stringency which has been brought about by goods held in transit, by low returns on mortgages and other building investments, by general unsettlement and uncertainty as to the future—when the people of this country are so gullible as to listen to the claptrap of promoters; or rather, not to listen to it but to interrupt a fantastic story by coughing up \$20,000,000 into their faces.

So many little communities there are, where the worn out farms are now called upon to gush forth wealth upon the inhabitants. The hopeful owners sit before their weather-beaten doorways and expectorate. So many brokers' offices all over the country are handling the surplus of wages of the common every-day people whose minds have newly evolved the old hope of acquiring, without work, money, leisure, and everything their heart desires.

Idealistic America: probably it will always be that. But idealism sometimes goes wrong. When it aims at a new heaven upon earth which shall be a place without work and cheered perhaps by twanging harps and jazz bands; the entrance fees to be paid by stock exchange profits or by the edict of some new social system: then do we succeed in perverting our noblest quality.

On the day this item appeared on the front page, the same paper's financial column announced that capital before giving permission for its money to be used in safe and legitimate enterprises was demanding interest of eight per cent., that during the afternoon its demand increased to fourteen per cent.

And the people give it away.

(By Special Correspondence to *The American Architect.*)

Chicago.—Strikes, higher wages, lack of transportation, higher building costs, increased money rates, checked construction! When will the situation change for the better? When will common sense return, production rise to normal and profiteering and extravagance cease? Well, anyway—

Overtures made recently to the employers by representatives of the Chicago building crafts, urging resumption of normal building activities, and promising increased output as a part solution of the high building costs, indicate that labor is beginning partly to realize its responsibility in the decline of construction work here which has amounted to approximately \$100,000,000 since the first of the year.

Though many of the craft lay the slump in individual production to the cost-plus system, with its opportunities to pile on labor costs and thus increase the percentage to the contractor, the average man on the job is willing to acknowledge he has about "killed the goose that lays the golden egg." Following restricted output come high wages and less work—and the fact is driven home.

Carpenters, bricklayers, plumbers and the rest of the trades are facing a slack season, unless something happens. This is accounted for in the slackening in building activities and the influx of workmen from other points attracted by the higher wage scale. Competition for work has stimulated the output. Builders report the attitude of labor has changed within the last month and an increase of from 15 to 20 per cent. in man hour output is noted. It is apparent that the men realize they will have to speed up if they want to keep their jobs.

There also has been a change in the building material market, to some extent. Where formerly it was the builder who was frantically bidding for supplies, now it is the brickyards, the cement works and the manufacturerers who are anxiously inquiring why orders are not coming in in larger volume. While transportation conditions are a little better and building supplies somewhat easier to get in some lines, owing to restrictions placed on less essential industries, prices on building materials are still abnormally high. Builders do not look for any big increase in construction activities until there is a decided drop in building costs. Building permits this week totalled 36, valued at \$2,148,000 as compared with 125 permits and \$3,603,300 for the corresponding week last year.

THE AMERICAN ARCHITECT

(By Special Correspondence to *The American Architect*.)

San Francisco.—There seems little doubt that San Francisco is on the verge of greatly increased building activity, and local architects are busy with plans for new structures which will undoubtedly be undertaken in the very near future. Speaking on this conditions, R. W. Kline, head of the construction department of Willis Polk & Co., says:

"Housing conditions have become acute, apartments are overcrowded and the same applies to office buildings. With office and business structures occupied 100 per cent.—plus, there is a general demand among business firms for room to expand, and none is now available. New rental standards have been generally adopted showing an increase of 30 to 40 per cent. While the costs of building have gone up these new standards permit construction on a profitable basis. This means that in the very near future building will become heavy. At the present time we are about three years behind in our building program; there has been much emergency work, and there is much to be done; but a great wave of new building is now due, and the industry will, almost before we know it, be one of the most important activities in the city."

A local banker of prominence gave the following advice this week to a prospective home builder: "When you build a home you should locate in a district where the homes surrounding yours are as good or better than your own. Such conditions make your property more valuable and more readily saleable if you ever have to dispose of the place. You should chose a lot that has some particular individuality not to be found in any other lot in San Francisco and then plan your home to conform to the lot."

(By Special Correspondence to *The American Architect*)

Seattle.—North Coast jobbers are able to report an improvement in the delivery of steel building products from the East and although three cars of nails to one house in a week is under normal conditions but a circumstance, it so far overshadows what has been the course of deliveries during the past ninety days that the trade is greatly encouraged. In addition, sheet metal is being released to a marked degree. There is no improvement in the condition of delivery of steel pipe, especially the smaller sizes necessary in plumbing and heating. The markets on all steel products are steady.

The car shortage and its train of evils in the disturbance of business credits and profits may be

relieved through the Jones bill before the United States Senate which would permit the Steel Corporation to operate coastwise ships from the Atlantic seaboard through the Panama Canal under the name of the Isthmian Steamship Company. This line has notified jobbers that it expects to make the trip in 26 days and will undertake to guarantee to cover the distance between New York and Puget Sound in 30 days. Sailings are to be spaced ten days apart. But this new transportation is not expected to aid the delivery of the smaller pipe and essentials to any marked degree owing to the fact that the mills are not turning the material out. It would, however, closely approach a miracle in the delivery of structural steel and sheet metal stock. All the North Coast jobbing interests favored the Jones bill.

Building projects have eased off, and the outlook today is that work under way will be completed at as early a date as possible, but there will be no new large commitments this summer. Jobbers of pipe, fabricated steel, brick, cement, roofing and lumber are almost a unit in the expression that they have no hope for a beneficial improvement during future months.

Jobbers this week picked up the first lot of channel iron that has been seen here for 90 days.

The demand in Alaska for minor building essentials is very brisk, and this trade is helping materially to keep Seattle architects at work on the smaller jobs and it also makes for the movement of brick, cement, lumber and roofing into the North.

Fir lumber held steady for the week after the slump a week ago of \$3 to \$5, and it is almost universally felt, in unprejudiced sources that builders will not be able to buy fir lumber any cheaper this year. Common dimension is selling at \$1.50 under the bare cost of the logs. The mills are closing down for the annual overhauling, and the duration of the suspension may reach sixty days. Logging camps are to be shut down on account of the fire hazard, and production will fall rapidly during July. The mills are not expecting to make any further price concessions, but reports from eastern builders indicate a dull Summer and a limited fir lumber movement eastward.

The paint and oil market is steady. Carload prices of lead f. o. b. Seattle have declined slightly. The weakness in the raw lead market in New York during the week was not reflected here. Paint jobbers predict a higher market for oils in the Autumn.

A diminution of the movement of paints corroborates the report from lumber and building material jobbers of an impending lull in the demand.

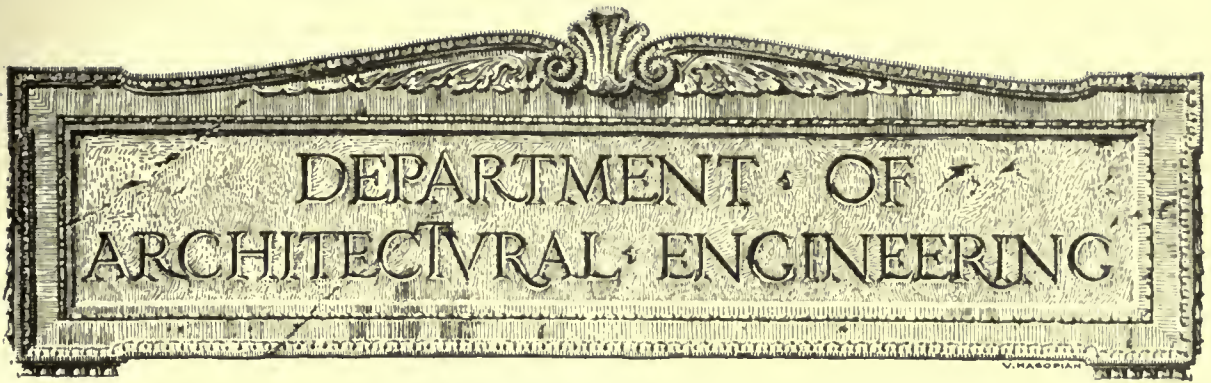

The Relation of the Work of the Forest Products Laboratory to Engineering*

By GEORGE M. HUNT

In Charge, Section of Wood Preservation, Forest Products Laboratory, Madison, Wisconsin.

IT is my intention to present something about the laboratory, what it is, and what it has that might interest you, so that when faced with a problem concerning the use of wood, the Forest Products Laboratory and its equipment will be at the disposal of the technical profession.

The Forest Products Laboratory is a branch of the United States Forest Service, which is a branch of the Department of Agriculture. The Forest Service has for its principal work the administration of the public forests, protecting them from fire, re-foresting burned over areas, protecting them from timber thieves, and regulating the grazing. The grazing feature alone on the National Forests for cattle, horses, sheep and hogs is a big business. It amounted to over two and one-half million dollars last year in grazing fees. The Forest Service also has, of course, the disposal of the timber that grows on the forest. When the timber is ready to be cut and when a market is available then obviously the thing to do is to sell it. If left standing, it deteriorates, and after a while there remains a forest which is half full of dead and decaying trees.

It would not be right to sell to the public this timber, letting them make what use of it they can, without giving them as much information as possible about what timber is and what are its peculiar properties, how different species vary from each other, and how wood may be most efficiently used in the various lines of work where it finds application. The need for technical data about wood was recognized a good many years before the laboratory was established, and efforts were made to collect infor-

mation of this kind. For many years people have been interested in the study of wood. There has never been a concerted effort on an extensive scale to gather the technical data that is needed.

The field of forest products is a very broad one when studied carefully. It does not consist merely of strength tests on timber or of studying the chemical products that can be made from wood. There are unlimited fields for study and in order to attack the problem in the best possible way, the organization of the laboratory was grouped into a number of sections. We have the director and the assistant director in general charge of the work, then five technical sections.

The section of timber physics includes kiln drying. The importance of artificially seasoning timber became evident during the war when a stock of air dried timber was needed for making vehicles and artillery trucks, automobile trucks, propellers, airplanes, and the various other implements of war—and of peace also—where wood was required. Seasoned timber was not available. There was only one thing to do, and that was to cut down green trees and season them.

There had always been a prejudice against kiln dried timber. It has been said that when timber is kiln dried the strength is reduced, it breaks easy, and that it will spoil in a dozen other ways. They were correct in part. Unless the timber is properly dried it is injured, but the tests that have been going on for the last ten years, and especially those during the last two and a half years, have shown conclusively that timber can be kiln dried without injury. In fact, if the drying is properly done, the

*Abstract of an address before the Western Society of Engineers.

timber is likely to be a little bit better than it would be if air dried.

The time required by kiln drying, of course, will depend upon the size of the timber. If it is inch boards it can be dried much more quickly than four by four or six by six wagon stock; but whatever the size of the timber, it can be dried much more quickly in a kiln than by air seasoning.

Kiln drying work is being continued, because the demand for timber is, if anything, greater now than it was during the war, because of the demand of the furniture industry and various other industries which were partly closed down during the war, but are working full force now.

In the section of timber physics they also study the microscopic structure of timber. The microscope is a valuable instrument in the study of forest products and tells a great deal about timber that cannot be learned in any other way. It tells why it is easy to force wood preservative through a red oak stick when it cannot possibly be forced through a white oak stick. It tells the difference between a piece of pine and a piece of fir or a piece of spruce. By means of the microscope species of wood can be identified that cannot very well be identified in any other way; and since the properties of wood depend very largely upon the species, identification is often very important.

As an illustration of the practical use of the microscope I can cite one instance. A few years ago a railroad company was buying several carloads of oak ties. They ordered white oak. When the ties arrived the railroad men claimed they were red oak, while the tie contractor claimed they were white oak. Both parties secured samples of the ties in question and brought them to Madison. They were examined under the microscope and it was found that the shipment contained both white oak and red oak.

PERHAPS the section which would be most interesting to the bridge and structural section of this society is the section of timber mechanics. This is a section which studies the mechanical properties of timber, which attempts to find out why one timber is strong and another one is weak, which attempts to find the average strength of various species of timber.

One thing included in the study of mechanical properties is the relation of the strength of timber to its density. It has been conclusively shown that the strength of a stick of timber, other things being equal, is very largely dependent upon its specific gravity, its density, which means, to be exact, the amount of wood substance there. Wood is composed of woody material and air and the more

woody material there is in a cubic foot of wood, the greater its density and the greater its strength. That is a general rule. There are exceptions to it, and slight variations from it. Ordinarily, a person is likely to think that the strength of oak is so much; the strength of pine is so much—that is the general impression. As a matter of fact, one can get pieces of oak that are much weaker than pieces of pine, and pieces of pine that are much weaker than other pieces of oak. It is easy to get pieces of pine which will have less than one-third of the strength of other pieces of the same species, and to the man uninformed, it is hard to tell the difference.

The need for some means of telling the difference has resulted in density grading rules for structural timbers. By means of these grading rules it is possible for a man with relatively little study to select the wood which has the required strength and thus eliminate the weak timbers. The relation of density to strength, of course, assumes that all other factors are equal, but of two sticks of equal density one may be spiral grained and the other straight grained. The spiral grained stick will be weaker.

A NEW development in timber construction which is receiving increased attention is the use of laminated members instead of solid members. As timber becomes more expensive and the larger pieces are harder to get, it is of greater advantage to be able to use smaller lumber and build it up into the sizes and shapes desired in structural members. In doing that, it is necessary to know the effect of various methods of fastening these laminations together; one must know the effect of defects. Can we put five 2-inch planks together to make a beam, allow defects in three of those and get sufficient strength? If we can allow defects, in what part of the member can they be permitted? Does the strongest plank of the five break first or does it break last? Those and numerous other questions can be asked, but some of them cannot very well be answered until a great deal more work is done.

In the section of wood preservation we formerly confined ourselves to the study of the preservative treatment of wood, the durability of wood and the fire-proofing of wood. But because we were called on for so many other things during the war, we had to include also the study of glues and glueing, the study of the manufacture of airplane propellers and methods of coating wood to prevent the entrance of moisture. An airplane propeller is a rather delicate instrument. If it is not properly balanced it is likely to tear the engine from its bearings when it gets to going 1,500 or 1,800 revolutions per minute. If it warps a little bit more one side than it

does on the other, it is apt to be inefficient, or to damage the machine. It has been found that changing moisture content causes the warping and shrinking of wood. When water leaves wood it shrinks. When water is absorbed by wood, the wood swells. If wood is to "stay put"—to remain at the size desired—the moisture must be kept from changing back and forth.

Airplane propellers are used out in the open and cannot be protected like a piece of furniture. They needed, then, a method of keeping out moisture which was better than anything we knew of. It is commonly considered that varnish will prevent the absorption of moisture. As a matter of fact, varnish merely retards the absorption. Ultimately, if the varnished piece of wood is kept under constant conditions, the moisture will come to practically the same point that it would if there were no varnish present.

Various methods of preventing moisture changes were studied. Finally, by accident, as much as anything else, a method which is nearly one hundred per cent. efficient was discovered. This is done by first sizing the wood, then coating it with varnish, then, while the varnish is still "tacky," laying very thin aluminum leaf on it and afterwards varnishing again. That gives a thin metal coating around the wood. Its weight is negligible. It takes less than half a gram of aluminum leaf to coat an eight-foot propeller. The aluminum leaf is so thin that it takes about 15,000 sheets to make an inch. The cost of it is practically nothing. So we have for airplane propellers a means of keeping out moisture that is entirely practical. The process also has possibilities for other purposes that have not yet been worked out.

WE have a big subject in the study of glues. You may not realize that glue is really a structural material. It permits the manufacture of ply-wood and out of ply-wood airplanes are made. If we had this ideal glue our whole system of forestry might be altered. By means of glue small pieces of wood can be joined together to make large pieces. Waste wood can be used in that way to a greater extent than available means now permit. We would not have to wait for trees to grow so large as they do now to get large timbers. Until we find that perfect glue, however, we will have to continue along many lines very much as we have in the past. We must take advantage of each progressive step and use it to its fullest measure, and hope that some day, somebody will find the perfect glue.

In wood preservation we have studied methods of injecting preservatives into woods; how different

woods take preservative treatment; and methods of protecting piling against decay and marine borers. How can the damage created by marine borers be prevented? A great deal, of course, is already known. The use of creosotes is fairly well, but not well enough, understood. We do not know what is the best creosote to use against marine borers. We do not know how to get the best penetration; how to get the oil in uniformly and deeply enough. It will take a long time to find the preservative which will prevent marine borers from attacking timber throughout its useful life. The same is true, to a certain extent, of preventing decay in land structures.

The structural engineer and architect can find information on safe working stresses for structural timbers, the effect of defects on strength, the effect of seasoning on strength, density grading rules, the durability of various species of wood, the efficiency of joints and fastenings, and the strength of built-up or laminated structural members.

More and more people are learning what the laboratory is and what it has, by writing in for information on technical problems. Sometimes they get what they want. Sometimes they must be disappointed because the information is not available. We give them the best we can.

Supporting Strength of Drain Tile and Sewer Pipe Under Different Pipe-Laying Conditions

Under the above title, the Iowa State College of Agriculture and Mechanic Arts of Ames, Iowa, has issued bulletin 57, prepared by W. J. Schlick, drainage engineer.

The purpose of the tests was to obtain reliable data for the use of those engaged in the design and construction of such work. The engineers charged with the design of pipe drains and sewers have been compelled, until within comparatively recent years, to depend wholly upon rule-of-thumb methods to determine whether or not the pipe to be used in each drain or sewer would have the supporting strength required safely to support the loads due to, or transmitted through, the ditch filling materials. This practice has resulted necessarily in the construction of many drains and sewers which later cracked and often collapsed because of insufficient supporting strength.

Copies of this bulletin may be obtained through a request addressed to the Engineering Experiment Station, Ames, Iowa.

Some Phases of Lumber Manufacture

I.—Shingles in the Making

By R. S. WHITING, *Architectural Engineer*

OF the materials in most common use and particularly those constantly before us we give perhaps less thought than to those which are not so common but which have been more recently brought to our notice, because of the new properties they may possess, or because of a supposed need they may seem to fill.

Shingles, for example, are one of the oldest of

factured from slabs and other waste from the log, these reproductions, showing the process of manufacture from the log to the finished material, have been made. The views illustrating this article were taken in a typical shingle mill in the Northwest where most of our shingles are manufactured and are intended to show as nearly as possible the complete process of their manufacture.

Of the eleven hundred shingle mills operating in the United States, the majority of them are located on some body of water where the logs may be conveniently floated into the "pond" adjoining the mill. From this they may be easily carried to the second floor by means of a conveyor. After they have been washed by a spray of water, the conveyor further brings them to the teeth of the first saw where they are cut into "bolts" sixteen, eighteen or twenty inches thick, depending on the length of shingles required.

These "bolts" are then passed along to the second saw where each of them is "quartered," and thence to a third where they are trimmed and the defects cut out. The quartering of the bolts not only works them down to a more practical size to be handled in the process of manufacture but also is the initial operation by which an edge grain shingle is made.

An edge grain shingle, because of the natural grain of the wood, will not warp or curl when in place on the roof or wall of a building, because of atmosphere conditions, and is, therefore, much preferable to flat grain shingle for exterior coverings for buildings. The flat grain shingles will cup and curl when subjected to the hot rays of the sun,



FIG. 1. SELECTING STANDING TIMBER SUITABLE FOR FELLING

our building materials, having been in constant use in this country for nearly three hundred years. Because of the great demand for them the old methods of manufacture have long since been done away with and have been replaced by the use of the most modern machinery. Shingles were first rived from the solid wood and later split in order to obtain a straight and more even grain. Now they are manufactured in a most scientific and economical manner.

To correct the impression that shingles are manu-



FIG. 2. THE LOG BEING CUT INTO "BOLTS"



FIG. 3. QUARTERING

often to such an extent that the surface over which they are placed will become leaky.

The bolts, after being quartered and trimmed, are passed on to the "shingle machine" where they are run through two more saws completing the process of manufacture. Each quarter bolt is gripped in the machine which moves forward and backward on the fourth saw automatically feeding out the bolts as the saw cuts off the shingles. The shingles then drop to the left of the machine operator who squares up the edges by means of a fifth and last saw.

As the machine operator completes his part of the work, the finished shingles are passed down a chute to the "packer" on the floor below, where they are gathered in bundles of a standard size, banded and placed on conveyors which carry them to freight cars to be packed for shipment.

When shingles are to be dried they are either



FIG. 5. THE SHINGLE MACHINE

The quarter sections are gripped by machine at left, which moves forward and backward on saw. Machine operator squares up edges

piled on trucks and run into the kiln for the required length of time or stacked out of doors for nature to do the drying. In either case, after being dried, it is necessary to reband the bundles since in the process of drying there is some shrinkage which loosens the shingles in the bundle.

Shingles are packed so that there are a sufficient number in each four bundles to cover an area of 100 square feet, commonly known as a "square," when laid on a roof or wall surface. The average exposure to the weather when laid on a roof is four and one-half inches and on walls five inches. When laid four and one-half inches to the weather



FIG. 4. QUARTER SECTIONS BEING TRIMMED

It is in this part of the process that any defects appearing in the lumber are cut out

there are about 863 shingles to the square, and when laid five inches to the weather about 782 shingles, using the unit shingle which has a width of four inches. As a matter of fact, however, there are on the average 460 actual shingle pieces in one square of 16-inch shingles.

The number of shingles reported produced in the United States during the year 1918 was 5,690,182,000, three-fourths of which number were manufactured in the state of Washington. These shingles, if laid four and one half inches to the weather, would cover an area of equal to 647,761,500 square feet or 23 square miles.

THE AMERICAN ARCHITECT

The terms 5 to 2 and 6 to 2 refer to the standard thickness and mean that five shingles will measure 2 inches in thickness at the butts or six shingles will measure 2 inches in thickness at the butts. That is, the fewer the number of shingles measuring 2 inches at the butts, the thicker the shingles.

Four bundles of 5 to 2—16-inch shingles (enough to cover a square of roof or wall surface) will weight about 160 pounds and the same number of bundles of 6 to 2—16-inch shingles will weight about 140 pounds, while four bundles of 5 to 2—18-inch shingles will weigh about 150 pounds.

It will thus be seen that the production of the shingle forms an important branch of the lumber industry. For suburban structures, and especially



FIG. 6. THE SHINGLES ARE BUNDLED AND CONVEYED TO FREIGHT CARS

dwellings, wood shingles have been and still are used extensively. In congested sections, the build-laws usually require the roof surface to be of incombustible material. When properly painted the fire hazard of the shingle roof is materially reduced. Special fire-retardent paints are made for shingles containing asbestine and other mineral pigments not reducible to metals. These are ground in linseed oil with thinner and drier. The preservative qualities of shingle *stains* are well known. They are usually prepared of a high grade of creosote mixed with various colors and ground in oil. Attractive finishes in many colors are thus to be had.

Fire Protection and the Lumber Industry.

IN an address before the Southern Pine Association, Mr. Wharton Clay, Commissioner of the Associated Metal Lath Manufacturers, chose the above title as his topic. Copies of this address,

reprinted from the American Lumberman, have been widely distributed by the National Fire Protection Association.

The combustibility of the frame structure has



FIG. 7. ENTERING THE FREIGHT CAR READY FOR USE

always been a talking point in favor of other types of buildings. We have not yet developed a type of construction totally unaffected by fire, and, therefore, the fireproof building is yet an ideal to strive after and not an accomplished fact. What we have done is to develop types of construction that are fire resisting to varying degrees. The timber structure is not necessarily the one which will be the most greatly damaged by fire. Some of the old log cabins could well resist the effects of this destructive agent. One of the safest types of structure from the fire hazard standpoint, known as "mill construction," employs the use of heavy timbers. But wood will burn, and the common type of frame building is undoubtedly a fire hazard in built-up sections. However, as Mr. Clay points out, timber can be protected and frame structures thus rendered more fire resisting. In his address he stated:

"Your industry has done splendid work in cooperation with various insurance and fire prevention agencies on mill construction and placed this type of a building in high public esteem. There is no reason why the neglected construction, consisting of joists and studs, which affects such a large percentage of the lives of the common people, should not be equally studied from a scientific standpoint and made equally as safe from fire. Single handed, the Associated Metal Lath Manufacturers have established the 1-hour rating for exterior stud walls, and every indication points to a 1-hour rating for interior bearing partitions, and I am asked to announce at this meeting that the National Lumber

Manufacturers' Association and ours will jointly apply to the Underwriters' Laboratories for a test and rating on the other principal structural element in this type of building; namely, floors with wood joists protected by metal lath."

It would seem that, in line with other conserva-

tion measures, the lumber industry could do real public service by co-operating to the fullest extent with all other agencies who have for their object a reduction of the fire loss. More important than ever before is the need of conserving the homes now being built, for they are doubly needed.

The Use of Linoleum as a Safety Stair Tread

A Further Discussion of Accident Prevention on Stairways

THE necessity for correctly designing stairways is being realized to an increasing extent. The figures given in the article entitled, "Safety Engineering," published in the June 16 issue, furnish opportunity for thought. A great many accidents are caused by slipping in public places, such as stairs, corridors, etc. Several types of safety treads were discussed in a paper by G. L. H. Arnold, entitled, "Factory Stairs and Stairways," published in two parts (see THE AMERICAN ARCHITECT, issues of January 28 and February 4, 1920), the types of treads discussed therein being by no means restricted to factory use. Additional materials for special uses are available.

In public and semi-public buildings where quietness, non-slipperiness and durability are essential to the staircase, stair treads surfaced with linoleum have been found to give satisfactory service. This material can be readily applied either to new or existing stairs, whether of wood, metal or concrete.

The heaviest grade of plain linoleum, one-quarter inch thick and known as Battleship, is best suited for heavy traffic conditions. For a wood stair, a pad of linoleum should be cut the exact size of the tread and cemented firmly to its upper surface with a high grade waterproof linoleum cement. A shellac cement is recommended. The cheaper cements usually contain sodium silicate (water-glass) which, in the presence of water, becomes injurious to all linoleum.

As a nosing to protect the forward edge of the surface from breaking or being torn loose by the traffic, a brass strip may be attached to the edge of the step, brought flush with the surface. This provides satisfactory protection, with a minimum of metal on the tread proper, and at the same time gives a neat and finished appearance to the stair.

In installing linoleum on a metal tread the same method of cementing as employed over wood will serve. That a good adhesive will hold to iron is proved by the United States Government's experience in cementing thousands of yards of linoleum to the steel decks of battleships every year.

Care must be taken, where the nosing forms a part of the metal riser or tread, to cut the linoleum to fit snugly against the nosing as well as against the other edges of the step. In case the metal stair has no built-on nosing, such a strip of brass or other metal may be employed as with wood.

For a concrete stair, linoleum may be used to serve both as tread and as riser, if desired. The concrete must be given a smooth and even finish, as any inequalities will also appear on the linoleum surface. The concrete must also be thoroughly dry, as any moisture remaining in it will tend to lessen the adhesive powers of the cement. Two or three months, depending on weather conditions, should be given the concrete for seasoning before the surfacing material is applied. A metal nosing, anchored in the concrete when it is laid, is most satisfactory. The nosing should be set a quarter inch above the surface of the concrete, so as to finish flush with the linoleum when the latter is cemented down. In case linoleum is to cover the riser, similar precaution should be taken to make the forward edge of nosing cover the upper edge of the linoleum riser. Separate pieces of linoleum should be cut to fit exactly the tread surface and the riser surface and cemented in place.

It is often found advisable to install linoleum on the treads over a layer of building felt paper. In the case of concrete, felt paper helps take up any irregularities there may be in the surface, while with wood stairs it absorbs any expansion or contraction that may take place, thereby lessening the strain on the linoleum. When it is desired to use the felt layer, this material, cut to proper size, is first cemented to the step, after which the linoleum is cemented down firmly on top of the felt.

A linoleum stair offers the same ease of cleaning that has made this material invaluable as a household floor. Its non-slip qualities, due to the large percentage of cork used in its manufacture, are well known. The resiliency of the cork, which enables the foot to gain a firm grip on the step, also renders the linoleum stair a quiet stair, especially

THE AMERICAN ARCHITECT

suitable for hospitals and sanitariums where silence is a necessity. The material withstands severe abrasion tests, and stairs covered with it have stood up

under hard usage for many years.

Figures 1 to 4 illustrate the methods here described.

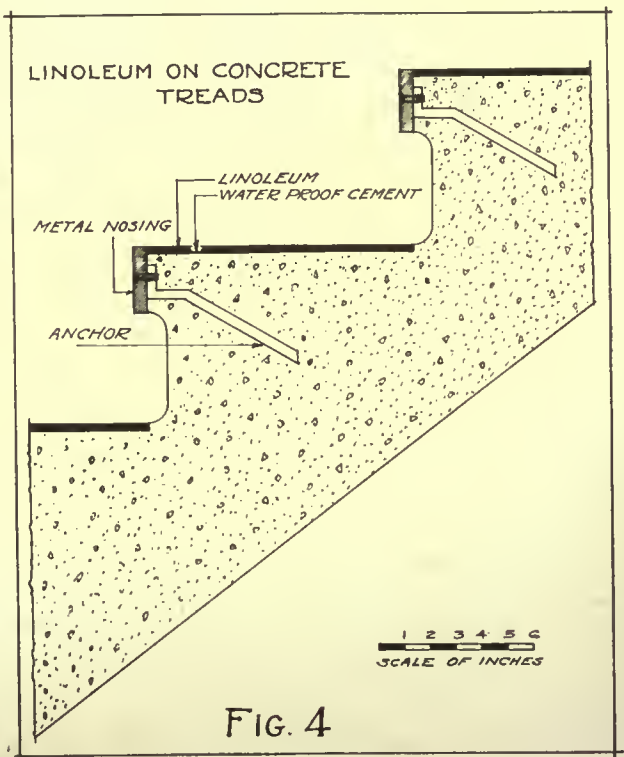
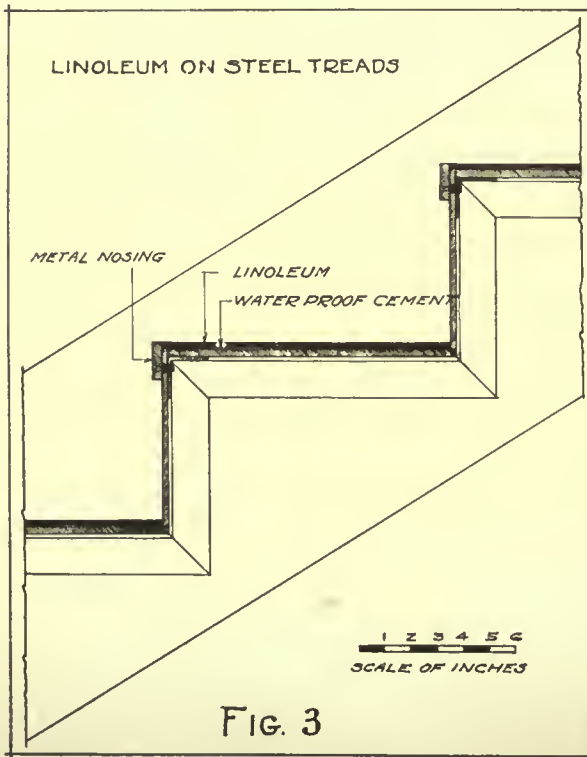
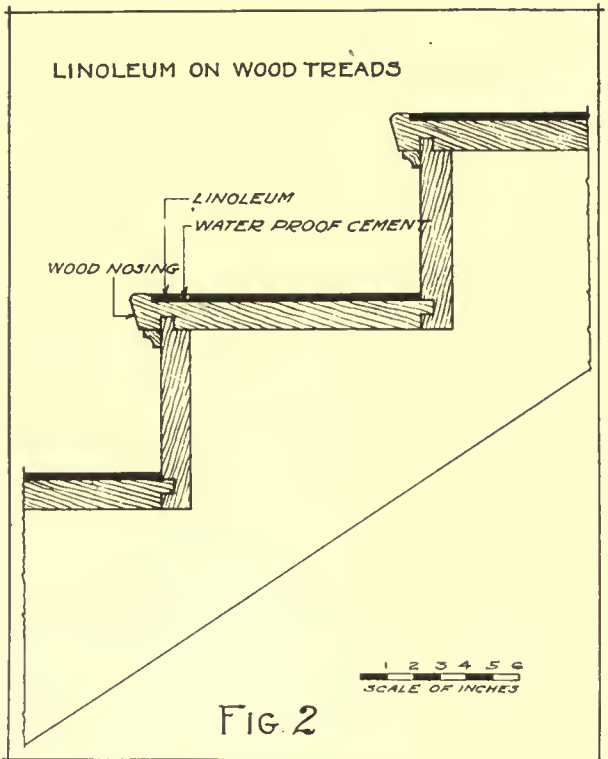
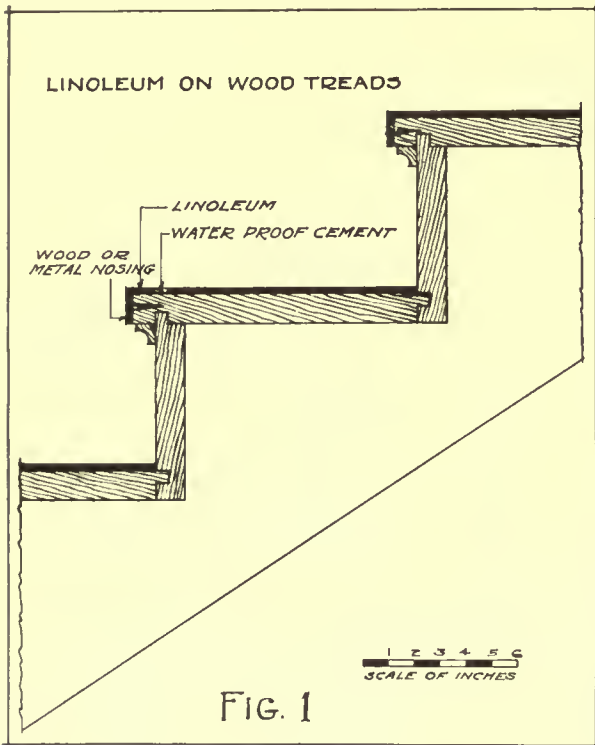

CONSTRUCTION DETAILS FOR THE LINOLEUM STAIR TREAD



CAPITAL OF THE LOWER PORTICO, PALACE OF THE DOGES, VENICE

THE AMERICAN ARCHITECT

THE AMERICAN ARCHITECT

VOL. CXVIII

WEDNESDAY, JULY 14, 1920

NUMBER 2325



PROPOSED HOUSE FOR JAMES H. PERKINS, GREENWICH, CONN.

Office Sketches to Promote Business

Illustrated by Sketches by ALFRED HOPKINS, Architect

UNTIL comparatively recently, the ethics of architectural practice arbitrarily forbade that architects advertise or take any of those methods of publicity that in commercial fields and some professional ones are considered as legitimate and proper means of earning a livelihood. It has been commented on that so small a proportion of architects have paid income tax as to make the number insignificant. The average of income in the profession of architecture certainly does not favorably compare with other professions, yet architects must live and they must present a "front" compatible with that of other professional men, and in keeping with the very high ideals that must govern their work.

The same amount of diplomacy that has enabled architects to pursue the evasive client and secure the commission and not infringe upon the ethics of his profession as put forth by men who have arrived and seem to have forgotten their own early struggles, would if placed at the disposal of our Department of State, very greatly raise the efficiency of our consular and diplomatic service. It is now conceded by thoughtful men that architecture, at

all times the greatest of the arts, has to-day become in the most pronounced way, a business.

Any business conducted along lines of artistic organization stands small chance in the open competitive field of to-day. Architects must therefore, if they are to get a proper remuneration for their work or get sufficient work to be moderately satisfactory in remuneration, regard in a practical way the business-securing things that lead toward commissions.

Every architect knows that in the field of domestic architecture the prospective client must be stimulated to a point of interest that will arouse a somewhat lethargic intention to build "some day" into a very acute activity that will urge him to build now. A prospective client having been located, his probable location discovered and the extent of his spending power determined, the architect sets about the preparation of a tentative design and plan, made to suit the client's purse and family. Some of the happiest things that architects have done, have had their origin in these tentative sketches or colored drawings.

There is the essence of good salesmanship in such

Copyright, 1920, The Architectural & Building Press (Inc.)



A HOUSEHOLD FOR J. WATSON ARMOUR

ALFRED HOPKINS, ARCHITECT

OFFICE SKETCH TO PROMOTE BUSINESS
ALFRED HOPKINS, ARCHITECT

THE AMERICAN ARCHITECT



PROPOSED HOUSE FOR JAMES H. PERKINS, GREENWICH, CONN.

work. First discovering an inclination, then providing a tantalizing suggestion to be followed by a closing of a deal that will make both the architect and his new client happy. Undoubtedly the suggestiveness of these designs, their elaboration of detail, their suggestion of planting and garden surroundings will represent an aggregate of cost larger than the present client can consider. But he has before him what would be the desired culmination of a long indulged "day dream," a castle perhaps not in Spain, but nearly as visionary. There is at once secured an ideal, something to work for, something to practice self-denial and for which to exercise correct habits of thrift. In this very considerable education of people, the profession of architecture plays a most important part.

To illustrate in a certain sense the idea we have been attempting to express, we are fortunate in having secured from Mr. Alfred Hopkins, architect, a series of office sketches, and while these drawings were not made to "promote" a project we would like to point out how effective they might be for such a use. It is correct to state that while none of these sketches have proceeded further than

the office stage, it was only by reason of the deterring conditions set up by the war that they have not been.

At the request of the editors, the architect has dictated a series of notes that describe briefly the more important of these sketches. They are in the largest sense educational, particularly to younger men in the profession, and we believe will be read with considerable interest.

Notes by the architect on a series of his office sketches:

The proposed house for William T. Hyde at Cooperstown was drawn during the war period and is to be built in the near future. It will be constructed of native stone which breaks out in small flat pieces which are admirably suited to the Tudor type of architecture. This type is particularly adapted to American conditions, requires little detail in the way of stone moldings and carvings and when judiciously used gives an unusual architectural expression to the country home.

The principal things to bear in mind in designing



ENTRANCE FRONT
HOUSE FOR GEORGE P. GREENHALGH, TOLEDO, OHIO



FARM BUILDINGS OF GEORGE S. V. BREWSTER, BROOKVILLE, L. I.
ALFRED HOPKINS, ARCHITECT



ELEVATION TOWARDS RIVER
HOUSE FOR GEORGE P. GREENHALGH, TOLEDO, OHIO

this style, and in fact any other for country building, is the outline of the roof. With an agreeable roof silhouette the rest of the work should be easy. Nothing therefore could be simpler or more natural than the roofing of the Hyde house, which will be of rough slate, with the slate laid but three or four inches to the weather. This laying of slate is an important matter to bear in mind, as many of the old Tudor slates were small, thus giving a more artistic appearance to the roof. The edges of the slate being rough—the more edges that are seen the better the roof will look.

Architectural ornaments have been reduced in this house to the minimum and the effect has been obtained by breaking the building up into various parts. Advantage has been taken of the beautiful bay windows of this style not only for exterior but interior ornament. Nothing can be finer in effect than the lighting which these windows afford to a big room. One feature of the house is the two liv-

ing porches at each end of the living-room. The owner has four children and one living porch is being especially set apart for them and their friends.

The dining-room will be a spacious room extending through two stories while the living-room will gain in height by being below the floor level of the rest of the house. The house has a fine setting, overlooking a beautiful lake.

The house of James H. Perkins at Greenwich is carried out in the same style as the Hyde house, but in a much smaller building. One of the great advantages of this style is—that it is just as suitable to the small structure as the large. This house also had the advantage of a picturesque site. The thought was to place it at the very edge of a deep gully and near the large oak tree which is indicated in the sketch.

In this plan it was desirable to take advantage of the artistic effect to be gained by not having all

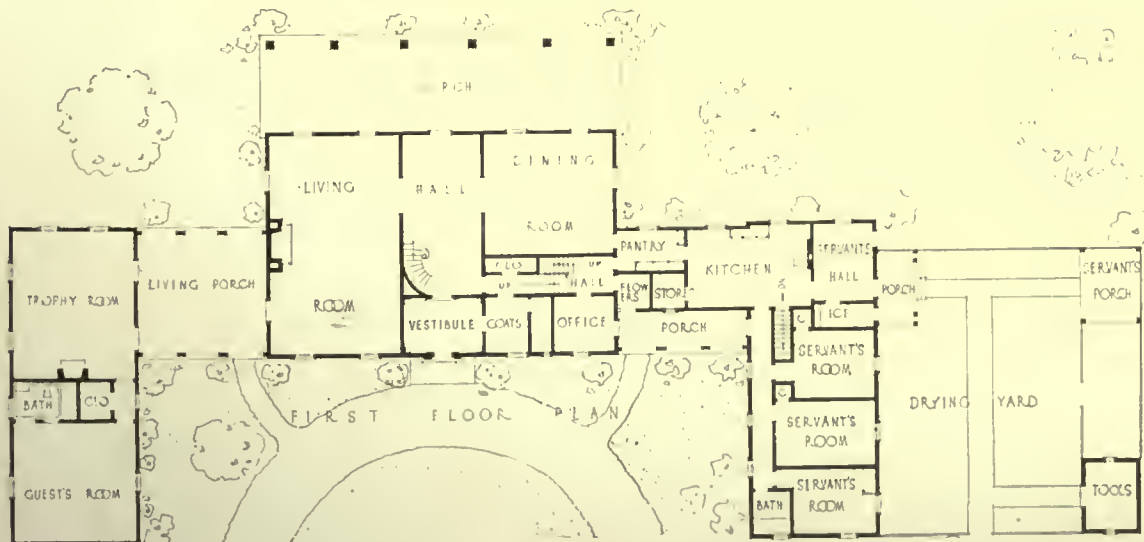

PROPOSED HOUSE FOR GEORGE P. GREENHALGH, TOLEDO, OHIO



SKETCH OF FARM BUILDINGS FOR HOWARD BROKAW, BROOKVILLE, L. I.
ALFRED HOPKINS, ARCHITECT

THE AMERICAN ARCHITECT

the angles right angles. The Tudor style is very much enhanced in its effect by this sort of treatment. Any change in straight lines is an advantage. The T square and triangle methods of design are not suited to the Tudor.

An interesting feature of the Perkins plan is the

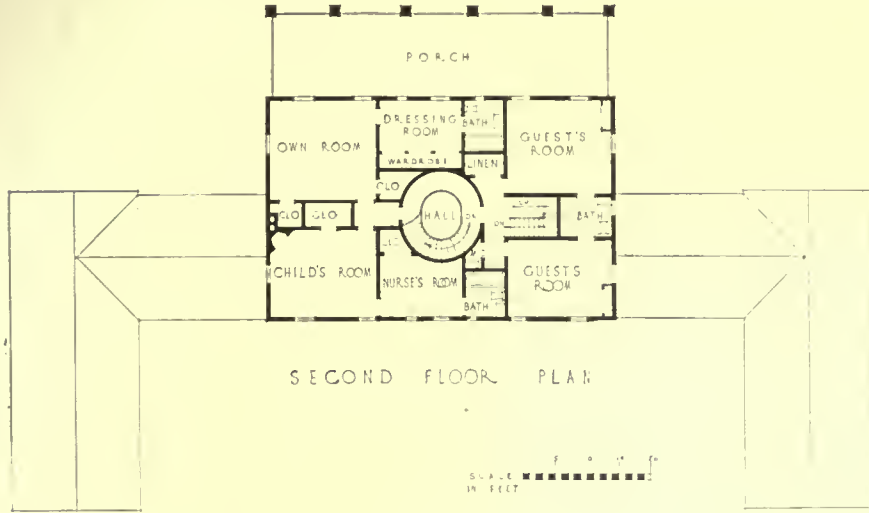

PROPOSED HOUSE FOR GEORGE P. GREENHALGH, TOLEDO, OHIO

location of the great rooms by themselves entered from the living porch. The guest rooms have a pleasant outlook on the garden. This is an always attractive feature and is a useful way to dispose of the guest rooms. Our modern requirements as a rule demand more room on the second floor than on the first. For some time it has been usual to make the first floor larger than is required or desired simply to give space above for additional bedrooms. By putting these rooms in a one-story wing greatly adds to the effectiveness of the building and makes particularly agreeable guest rooms. The owner was anxious to see an alternative sketch for a Colonial house for the same location, so such a scheme was made which is more conventional and less attractive.

The residence for Geo. B. Greenhalgh at Perrysville, Ohio, is a project in the same style, but a somewhat different plan. The central hallway was introduced so as to get the advantage of all outside rooms. This house has a pleasing location overlooking the Maumee River. The colonnade on the front provides a porch on the second story as well as on the first. Advantage has been taken here of the one-story building in order to throw out and make prominent the central mass. A trophy room and an extra guest room occupies one wing, with the servant's room in the other wing. The owner stipulated that he wanted the drying yard where the wash would not be on view when hung to dry, so that this yard has been made of unusual size with a tool house in one corner and a servant's porch at the other. In all these plans it will be noted

that the servants have been as much as possible segregated from the family for the comfort and satisfaction of all.

The plan of the large house at Guinea Chase Farm is also to be proceeded with when building conditions become more stable. The special features of this house are the grouping of some bachelor rooms around the swimming pool and the small winter cottage to the right, with its own garden. In the summer time this is to be used as a guest cottage. A very delightful arrangement. Otherwise the plan follows out a usual scheme except, perhaps, as to location, the natural contours of the site allowing for a large sunken garden some twelve or fifteen

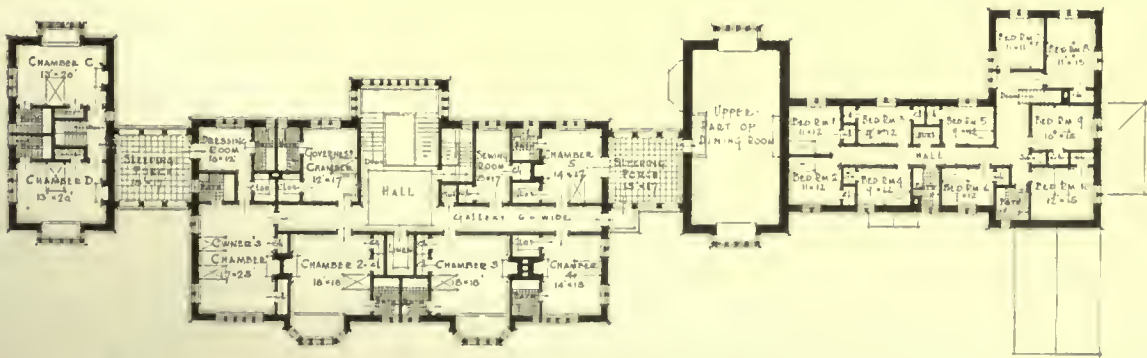

PROPOSED HOUSE FOR W. T. HYDE, COOPERSTOWN, N. Y.



NORTH · ELEVATION ·



· WEST · ELEVATION ·



· SOUTH · ELEVATION ·

· PROPOSED · RESIDENCE · FOR · JAMES · H · PERKINS · ESQ ·
GREENWICH · CONN ·

· ALFRED HOPKINS · ARCHITECT ·

OFFICE SKETCHES TO PROMOTE BUSINESS
ALFRED HOPKINS, ARCHITECT

THE AMERICAN ARCHITECT

feet below the main terrace. The building is to be built of brick and limestone along the simple lines indicated.

The owner, however, thinking this may prove too expensive, wanted to see a design carried out in wood, so the alternative sketches showing a Colonial house with shingle walls and wood trim were made.

The Labor Party on Housing

HERE has always been a shortage in the supply of suitable houses for workingmen, says a report of the special problems committee of the New York State Labor party. Therefore relief measures must not only go beyond such feeble attempts to curb rent profiteering as were made by the New York Legislature in its recent session—they must go beyond the present emergency entirely. The fundamental difficulty, according to the report, is that investments in wage-earners' houses have never been as profitable as investments in expensive apartment houses and office buildings. Remedies designed to touch this central difficulty are proposed in a housing platform which has been adopted by the Labor party. Some of the suggestions may be summarized as follows:

State credit should be extended on a large scale to aid in the construction of moderate priced houses through the sale of state housing bonds carrying a low interest charge. These bonds could be bought by banks and insurance companies as legal investments. Thus the savings of working class people, accumulated by savings banks and insurance companies, would be applied to working class housing, instead of being used as they are now for more profitable building ventures which do not benefit the workers.

The granting of state credit should be administered by a state housing board and local boards in cities. On these boards there should be representatives of the organized workers, both in general and in the building trades, and actual working class tenants.

The state, cities and towns should be enabled to go into the business of building, owning and renting houses. This competition would break the "extortionate hold" of manufacturers of building materials on the market.

Cities should take by right of eminent domain outlying land in the line of probable housing development, so that the unearned increment would go to the community.

Non-profit making corporations of actual building workers, including architects, construction engineers and manual workers, should be organized to carry on building operations as a public service, under the direction of the housing boards.

The program has the merit of flexibility; it holds out the possibility of different plans being worked out in different places and at different times. The final suggestion, which evidently has its inspiration in the Manchester building guild, seems to be the ultimate development which is hoped for. "This type of autonomous industrial development is to be preferred," it is stated, "because in this way, with the motive of public service, the actual hand and brain workers can be brought to a maximum co-operation and effectiveness in producing units."

House Shortage in Marseille

The housing problem in Marseille is becoming more serious every day. Although there has been during the war an increase of at least 200,000 in the population of the city, which has now 800,000 inhabitants, only a few new buildings were erected during the last six years. Rents have also been increased by 300 to 400 per cent., and in many cases the percentage of increase is much higher.

A colonial exhibition is to be held in Marseille in the summer of 1922, which will probably aggravate the housing crisis, unless steps are soon taken to provide lodging accommodations for the visitors. There is an abundance of available building sites in the central section of the city, which could be purchased at fairly reasonable prices. The erection of wooden structures on the American pattern, with American materials, was considered, but owing to the exchange situation this idea appears to have been abandoned.

The matter is one which deserves the attention of American architects, builders and financiers. But it will be impossible to achieve any result without personal contact with the local architects and investors. The extension of long-term credits would also be required and provisions made for payment when the rate of exchange is about normal. Unless adequate financial cooperation is assured it will be useless to approach the local contractors and dealers. Definite proposals along these lines should also be submitted. This consulate general would be glad to extend all possible assistance in this connection, but it should be noted that little, if anything, could be achieved through correspondence in this case.

The Architect's True Relation to His Professional Organization

An Address by F. E. DAVIDSON, President-Elect Illinois Society of Architects

A GOOD architect is one who is ever willing to give of his time, experience and worldly goods to the advancement of his profession, and who is so interested in the work of his professional society that he is not only a regular attendant at its meetings, but has thrown away his hammer and bought a horn.

In this age of organizations we will not secure very much recognition, nor will we amount to very much to society if the light of our organization is hidden under the bushel of indifference. Our problem is not so much what the Society can do for our individual members, but, what can our members do for the Society, and through the Society, for the profession as a whole, and for society in general.

Dr. Ebersoll, at the recent convention of the American Institute of Architects, at Washington, wrote the following specification of what a profession should stand for:

First—Service to Society. Second—Service to the individual client. Third—Service to the professional society; and, Fourth—Adequate remuneration to the individual supplying that service.

As members of the Illinois Society of Architects, how nearly do we comply with this specification?

Committees of the Society have placed their services at the disposal of our state and municipal authorities, and these services have been gratefully accepted. The influence of our Society has been felt in the legislative halls of our state, as well as in the council assembly room of many of our cities. During the past year, the Society has broadened the scope of its activities and resulting influences. More, however, needs to be done.

Why should not the Society become active in the political life of our state and its cities? We must play the game of life with the cards we hold, not those in the discard. If the Illinois Society would agree as a body, to support men and measures, friendly to the profession, and would devote to the accomplishment of that object, the same thought, system and energy we all display in handling any of our clients' problems, the influence we would then have, with the aid of contractors, supply dealers, and others requesting favors at our offices, would be at once recognized as one to be reckoned with. If there is any one thing that those in political life recognize, it is the power of organization.

I am also convinced that the Illinois Society of

Architects should be the important factor in adjusting differences between contractors and labor organizations. I believe that a federation of all the construction interests of the state should be at once formed. Such a federation, if properly organized and managed, could be all-powerful in the field of construction. The following interests should compose this federation:

First—Architectural societies. Second—Banking interests. Third—Real estate interests. Fourth—Contracting associations. Fifth—The labor organizations themselves.

It is only by the cooperation of all interests that the right solution of the many problems of our business, the business of constructing buildings, may be rightly solved. I believe that the officers of the societies of every interest I have mentioned will welcome such cooperation, and that now is the time to perfect such an organization.

THE recent futile and lamentably ineffective attempt made by the Building Construction Employers' Association of Chicago to prevent the twenty-five or more per cent. increase in the rate of wages paid to building mechanics, as well as their attempt to keep peace in the building trades, is proof of this statement. Here is a powerful organization, that finds itself utterly helpless because it has not and cannot secure the support of all interests having to do with buildings. The bankers are absent, the real estate men do nothing, and the committee appointed to represent the architectural profession is mostly conspicuous by its absence. The result:—Organized labor gets everything it asks for and new building construction has practically ceased. But little new work is in sight, a result largely brought about by a most ludicrous lack of cooperative effort.

Notwithstanding the new agreements made with organized labor, as we all know, there have been more strikes and interruptions to work than ever before. At present, there appears to be no method of preventing these unnecessary and ever costly delays to our work—delays that benefit no one except the business agent who is successful in forcing the owner or contractor to "come across."

The next duty of the architect is to his individual client. Our Society, in cooperation with the Illinois Chapter, has recommended to the American Insti-

(Continued on page 46)



Labor Over-turn

THE Todd Shipyard Corporation, it is stated in the daily press, have begun the distribution to faithful employees of bonus stock of the company. This distribution is in fulfillment of a promise made in 1916 when all those employed by this company were informed that every one loyal for a period of four years and who faithfully worked to help the company make good on its contracts would be suitably rewarded. In all \$1,000,000 of shares, now worth \$165 each have been distributed among 727 employees.

Commenting on this *The Sun and New York Herald* pertinently comments: "This is fine, but there is another side to the picture," and directs attention to the fact that of an approximate total of 15,000 employees but 727 are entitled to the bonus.

Here is an accurate illustration of the extravagant labor over-turn which characterizes our American industries. Further quoting from *The Sun and New York Herald*, we read: "Investigation would unquestionably reveal the fact that a high proportion of the persons who quit the Todd corporation in four years did so for no adequate reason. Some of these went out for adventure, some of them looked for that ideal shop which is always in the next town, some of them quit through sheer inability to stay long on any job. Many of them were not conscious slackers, though everybody knows it takes time and money to train a man for a job. Altogether the expense and delays to be charged to this class of labor are tremendous."

This corporation has renewed its offer for a further period of four years. Will labor learn a wholesome lesson from this actual illustration of the good results that accrue from "sticking to the job," or will it continue the scramble for higher wages and supposedly better conditions that really are never in the end found to be so satisfactory as patient and persistent effort at a single well-paid job.

New York's Hotels, Old and New

WHAT boots it, now that we have the eighteenth amendment and are debarred from even the mention of varied and sundry seductive concec-

tions known as cocktails, now prohibited—what boots it to mourn the passing of the hotel where the famous "Manhattan" originated. That which was once a daily habit has long since become a memory. Nor can we make a pilgrimage to the shrine where the man with a gift for invention which found recognition around the world, first developed "the Manhattan."

The passing of our landmarks no longer seriously affects us. We can even read in the daily paper, as we have just done, that the famous Manhattan Hotel on 42d Street and Madison Avenue will soon be replaced by a towering office building. At the same time it is stated that the Commodore Hotel, but only recently completed, is to be doubled in its number of rooms by an addition to be built along Lexington Avenue. Further, the historic old Murray Hill Hotel, a short two blocks from the Commodore, is to be razed and rebuilt to a great height. On its completion there will have been formed the largest hotel group development in the world, with a total of 10,000 rooms.

There are traditions hovering about the early hotels of New York, full of interesting reminiscence to the old New Yorker. The Grand Union, long a popular resort, was directly across the street from where the Commodore now rears its height. Here was housed the famous collection of pictures gathered by Samuel Shaw, part owner and proprietor, and one of New York's foremost art collectors. The walls of the public rooms of this old hostelry were hung with masterpieces of modern art and in each sleeping room, in place of the hideous chromo or duplicated etching that many larger and more popular hotels are wont to inflict on guests, there hung equally important examples of good American art. And there was Simeon Ford, Shaw's partner. No public function was complete without the presence of that brilliant after-dinner speaker. His wit was keen and honest; his stories clean and to the point.

HERE were the "links" of the famous "Forty-second Street Country Club." Here, during the days before the Volstead act, the golfers would "drive off" from the bar at the Grand Union to the

THE AMERICAN ARCHITECT

"nine hole course" that took in the Belmont, Park Avenue, Murray Hill, Knickerbocker, Wallicks, Astor, Ritz-Carlton and Vanderbilt—"holeing out" as a sort of "nineteenth" hole at the Manhattan. And these things are now tradition. The Grand Union is but a memory; the Knickerbocker has closed its doors. The Murray Hill and Manhattan are soon to pass, and this famous and well played course is now no more.

With the completion of the Viaduct continuing Park Avenue to and around the Grand Central Station, and with the many important buildings comprising the Grand Central Group, that section of New York has risen from a somewhat commonplace neighborhood to one of importance and dignity. The construction of the three large buildings now projected will give to this section of the city a very decided interest. The addition of more than 5,000 rooms to New York's hotel capacity will merely fill a present need and not, as it might appear, provide for future growth.

These things would seem to indicate more strongly than ever that the Manhattanite will, in the future, become a hotel dweller, and that the stately private house or many-roomed and very expensive apartment have had their day. To finance these large operations will take vast sums of money and the tendency, therefore, towards the erection of the apartment house with five to eight rooms or more would seem to be lessened. Just where the middle class man of moderate income will be able to find a home on Manhattan Island is not apparent. Real estate agents report that they could rent four times as many of the medium sized apartments as they have available. Meanwhile, owners of houses everywhere in the city are converting them into "race suicide flats," the small two and three room apartments where kitchens or even kitchenettes are unknown and where gas is not introduced so that tenants are prevented from preparing even the simplest of meals, except on the most primitive of electric "griddles."

THE atmosphere of domesticity is changing in New York. We may soon look in vain, south of 110th Street, for a sign of those places which, even though they were apartment houses, contained what were in the truest sense homes. The jaded New Yorker, tired of all the bustle of our commercial activity, sighing for the change that comes with association of wooded areas and country roadsides, may, if he knows his New York, find all these restful places without leaving the limits of Manhattan Island. Most New Yorkers do not know that leav-

ing the West Side subway at 215th Street there is a neighborhood absolutely untouched that stands today just as it did when Hendrik Hudson and his crew rested beneath the famous tulip tree near Spuyten Duyvil creek—now so carefully preserved from vandalism. The searcher for this neighborhood has only to scale the easy heights of Isham Park and wend his way through tree embowered roads along the southern edge of Spuyten Duyvil, finally to emerge through trees of forest growth to the sunlit waters of the Hudson. Not yet has the speculative builder invaded this wondrously beautiful neighborhood. Here the man or woman in search of rest from the nervous activities of the city's daily life, may walk and view from the heights the vast expanse of Van Cortland Park and the Bronx stretching away to the Eastward. It is less than forty minutes from the bustling location of the Hotel Commodore.

One may, on these brilliant summer days visit this section in a matter of two or three hours. He can then vividly compare the New York of today with that of even a hundred years ago. The experience is a novel one and one does not need a motor car to avail of it.

PERHAPS no other city can present as many radical changes in its growth as can that part of Greater New York, located on Manhattan Island. Our early Dutch settlers could not in their wildest visions have foreseen the changes that have occurred in two centuries. The contour of Manhattan Island has caused these things. The extreme length of about twelve miles and width at no place to exceed three miles, with the early location of its business centers at the southern extremity has caused an ebb and flow of daily traffic. This has seriously complicated traffic problems, many of them yet unsolved.

The congregation of specific lines of business exclusively in certain areas and their rapid expansion is a further interesting phase of the growth on Manhattan Island. And now, so rapidly are all these changes occurring that in place of being things that one generation may describe to another, they are matters of less than a year's development. Witness the case with which we first set out to write these lines, the building up of the Grand Central district. From any tall building at 42d Street and Broadway, looking south toward the Pennsylvania Station, note the many skeleton frames soon to become buildings that will house the clothing trade. Here are radical changes that will have matured within but a few months.

Criticism and Comment

The Editors, THE AMERICAN ARCHITECT:

Your Editorial, "A Matter of Competitions," appearing in your issue of June 16th should receive the attention and start some action on the part of architects who enter competitions, the officers of architectural associations and especially upon the part of advisers who prepare programs and conditions of competition.

The instance of an invited competition given in your article, in which the cost to each competitor amounted to double the amount paid "to defray the cost of the competition drawings" indicates that in that particular case the client was unusually generous. So very few people, including professional advisers, realize the amount of unnecessary expense, frequently exceeding a thousand dollars, in stupid mechanical labor, required by conditions calling for drawings at a scale too large for convenient study; for the drawings to be in "India ink and no other color"—when pencil and wash would be much more expressive of the designer's ideas and intentions; for drawings to be made upon sheets which are either unusual sizes for hand made paper or do not allow for trimming after stretching on the boards; for showing the dimensions and areas of rooms in figures on the plans and demanding "the walls and solid supports to be blacked in solid," and the useless requirement, which still occasionally crops up, of "a perspective," which is at its worst when required to be "in line only." Surely all of the above requirements should be eliminated as being of no assistance whatever to any competent judge of architectural design, and as demands for sheer waste of the architects' time and money. In these times, when well-informed draftsmen are not available for temporary assistance, when space for temporary expansion of the architects' offices—in New York at least—is out of the question; and even material, such as good sheets of paper of the larger sizes, suitable for fine renderings, cannot be readily obtained, some thought should be given by advisers to avoid waste labor, and inconvenience in the preparation of the merely tentative drawings which is all that competitive drawings can, or should attempt, to be.

I think that at least the following points should be observed in the preparation of programs:

1. All drawings should be at a uniform scale, except in the case of large sites the block plan might be at a smaller scale.

It would be a convenience if the survey or diagram of the site were provided on white paper at the scale required for the block plan, so that it might

be drawn directly on the sheet supplied. In cases when the adviser deems it necessary to define the type of lettering to be used, such sheet should be printed to serve as a model of the type and size of lettering desired.

2. Drawings should be as few in number, and as small in scale as possible to adequately show the general working out of the *parti* adopted, and no more.

Plans and elevations of buildings having a greatest dimension of 200 feet, should be at not more than one-sixteenth inch scale; those of 400 feet, not more than one-thirty-second inch scale, and those of 800 feet at one-sixty-fourth inch scale. A drawing of some feature at one-sixteenth scale in the case of very large buildings would ordinarily be sufficient to show the character of the architecture and quality of detail which the designer proposes.

3. No inked-in drawings should be required, but should not be prohibited. The kind of drawing (the medium) should be left to the competitor, and should be that in which he can best express his ideas.

I contend that the man who can draw should not be held down to the level of the one who cannot, especially as in these times every good designer is a good draughtsman.

4. Lettering, figuring, dimensions and areas, except of the more important rooms, close computations of cubic dimensions and diagrams to show how the cube is arrived at should not be required—in any event not upon the drawings. Rooms could be numbered on the plans and the areas, etc. given in a typewritten schedule in the report.

Such detail does not bear any weight with a judge or jury until all but two or three designs have been eliminated. Therefore it is preposterous to require sometimes as many as one hundred competitors to put in lettering and figuring of unimportant details demanding in each case the time of an expensive draughtsman during a week or more, when the judge can find out for himself in a few minutes by scaling, all that he wishes to know regarding the two or three designs remaining for final consideration. It should be observed that in the working drawings the dimensions of rooms are almost invariably changed from those required in the competition programs.

5. Perspectives should be prohibited.

They are of no assistance to a good judge of design. The architect of such little experience, knowledge or imagination who requires the help of a per-

(Continued on page 48)

The Architect's True Relation

(Continued from page 42)

tute of Architects, an amendment to its code of practice, making it the duty of architects to furnish complete services and all for one fee. In order to compete with the builders, and the so-called professional interests who are unable to qualify under the law as architects, yet who have by the weight of organized numbers, been able to secure legislation that legally qualifies them to plan buildings, and who are now competing with our profession for work; architects must give, not only complete service, but a quality of service that can be given by no one else. Our training and experience has qualified us to give that quality of service; and when architects as a profession, give to their clients this super-service, owners will soon learn that it always pays to employ an architect. An architect has something to give as well as something to sell, not possessed by any one else.

Regarding the third paragraph of Dr. Ebersoll's specification—Service to the professional Society—For some reasons our members have not supported the Society as loyally as I believe they should. There has been evidenced on the part of some a general feeling of indifference.

The Illinois Society of Architects is not a kindergarten. It is not conducting a soup kitchen. It is organized to perform a definite service to society and to its members, and any man unwilling to do his share should not remain a member. We want with us every architect who is willing to do his bit, but there is no room in our ranks for the parasite, the mere hanger-on, who only joins for what he may secure in prestige. Every member of the Society should and must evidence the utmost loyalty to the Society and show as commendable a willingness to work for the common good as that shown by your officers and directors. It is not enough that you elect some of your members to office. Your officers must have the loyal cooperation of our members. You are or should be just as much interested in the Society as they are. If you are willing to work as a member of any committee, advise your president of your desires. If you think of some way to extend the Society's influence, and thus increase your own standing as an individual, let your officers know about it. Make the Society your own society. You can do it and we will all be benefitted.

IF we may rightly read the signs of the times, you will for some time have plenty of opportunity to think and study professional and society matters. As Mr. Dunning so ably stated in the report of the Post-War Committee on Architec-

tural Practice to the 53rd Annual Convention of the American Institute of Architects, "The Committee is regrettably led to the conclusion that architects do not actively interest themselves in the problems concerning their profession, except in times of depression. Then they turn to the organization for help and suggestions with which they may meet the problems incident to depression, only to find that they themselves have neglected to help their own organization in the task of preparing for just such emergencies."

The next paragraph of Dr. Ebersoll's specification demands adequate remuneration for individual service. Perhaps no profession is less adequately paid for services rendered than architects. No profession assumes a greater responsibility or renders a greater service to society or the individual client. It has been estimated that the net average income of the architects of Illinois is less than the average net income of members of the Chicago Building Trades Council, and this, notwithstanding the many years of study required for the necessary education and training in order to qualify as an architect. The financial return even to the most successful in the profession is not commensurate with the time spent in preparing for the profession and for the service rendered. The same preparation, the same concentration of purpose, the same consecration of every energy of mind and heart in commercial fields of endeavor would make millionaires of us all.

A change in the system of payment for architectural service is now being considered seriously by the profession as a whole, and we may predict that at the next Annual Convention of the Institute, definite recommendations will be made which will at least increase the recognized minimum fee for architectural service, if said fee is to be based on a percentage of the cost of work.

I would add a fifth paragraph to the specification for a profession. I would add, Service to the Individual member by the Professional Society.

If we will compare the service rendered to the individual by the society in the learned professions, we will find I am sure, that as architects, we do not compare very favorably with the professions of law or medicine. Who ever heard of a doctor testifying on the witness stand in a Court of Record, against the charge of a brother physician, yet how often we observe architects using their testimony to defeat the righteous cause of a brother architect. Who ever heard of a doctor belittling the skill and professionalism of a brother physician? In the mad scramble for jobs that now seems the rule, is this primary and fundamental rule of conduct always observed by us? Let any of my hearers who has not sinned, raise his voice in protest. Remember that your clients and the public will never

THE AMERICAN ARCHITECT

place a higher valuation on your own services than you yourselves do, and will judge you as much by what you say as by what you do.

One of the first things I propose to do as your president, if you and our board of directors will approve, is to appoint a strong committee on "legal service." The specific duty of this committee will be to advise any of our members who may wish assistance, as to the proper procedure to be followed in collecting their just fees. The most experienced of us may find that he has a crook for a client and quite frequently, the younger practitioner finds that either he failed to secure a legal contract for services, or finds that he can only secure payment for services rendered by a suit at law, and is confronted with the problem as to how to proceed. Our committee will be able to suggest proper procedure and may even with propriety, suggest the names of legal counsellors that they know to be all that an attorney should be.

The second duty of this committee will be to investigate and report to the board of directors for action on those cases where architects appear as expert witnesses against another architect.

I shall also insist that the membership committee I shall appoint endeavors to secure the application for membership of the younger men—all those just entering practice. It is to these we may look with certainty as the coming men who shall take up the work we shall ultimately be compelled to relinquish. We should take them in and inspire them to give our work the spirit of loyal devotion that animates most of us.

Since the beginning of the Great War there have been many changes as affecting the practice of architecture. It was an Art, or a Business. I believe it was, and is, both an Art and a Business, that

while we are at all times artists, we are at the same time, Master Builders, whose duties, as the result of modern commercial methods, bring us so intimately into association with every commercial detail, that to conserve the best interests of our clients, we must needs be equipped with more business acumen than is necessary in any of the arts allied to ours. Any architect who fails to recognize this rapidly growing condition, will find scant recognition for ability when he comes in contact with that hard-fisted client who, while perhaps willing to give a grudging assent to the introduction of certain features of our art in his building, is more anxious to learn its true rental return.

The success of our Society, devoting its activities largely to the business problems of the profession, is proof of the importance of the business aspect of the profession.

IN conclusion, let me say a word about our Society as a National influence. It is a source of satisfaction to me, as I know it must be to you, to know that wherever and whenever state societies are discussed, the Illinois Society of Architects is held up as the best example of an efficient working organization. We have it, therefore, as a duty, to maintain this reputation and secure for our membership the largest proportion of eligible men it is possible to obtain. In this effort, I am hopeful of your earnest and loyal cooperation. We may not set a limit on our activities, but I hope we may so organize our activities that they will draw to us a membership that will make the Illinois Society of Architects so powerful a factor in organized architecture that it will be something to reckon with—a power in itself.

Criticism and Comment

(Continued from page 45)

spective in order to judge of the appearance of the design, is unfit to be a judge, or to act as adviser of a competition.

6. The size of sheet should be an ordinary Whatman paper size, less two inches in each dimension to permit stretching, cutting from the board and trimming. Borders to sheets should be left to the judgment of competitors.

While the above points are but a few of many improvements that might be made to the sort of program that is approved by—or gets by—the American Institute of Architects' censors, they represent fifty per cent of the cost of the ordinary set of competition drawings to each competitor. Observance of those points would allow more time the designer for the important thing—the study. It would result in more and better designs being submitted in competitions by the older men to whom time is the matter of importance, and afford the usually intended opportunity to the younger individual, who believes in his own talent, to try his skill without being obliged to require assistance beyond his means.

FRANCIS S. SWALES.

New York.

Freight Situation Continues to Halt Building

In an effort to break the embargo on building materials, Senator William M. Calder of New York, chairman of the Senate Special Committee on Reconstruction and Production, sent the following telegram recently to the Interstate Commerce Commission:

"There is now before your body an application filed by the sand and gravel interests requesting permission for the building industry to appear before your Commission and present facts concerning the serious conditions now confronting the building industry of the country as a result of recent car service orders, which amount to an embargo on the transportation of building materials. As chairman of the Senate Special Committee on Reconstruction and Production, I respectfully request that all branches of the building industry be given an opportunity to present to your Commission facts as to the inevitable results of a continuance in operation

of the recent car service orders. Preliminary investigation made by experts of Senate committee is developing the fact that the country is in a critical condition because of lack of housing and general construction."

Senator Calder has also conferred with several of the leading railroad executives, drawing their attention to the importance of immediate transportation of building materials to New York City, where construction must be started during the next two or three months if relief is to be expected this year.

Senator Calder pointed out that the building shortage is so acute in New York City that the movement of building materials should take precedence over all shipments, excepting food and fuel.

Senator Calder explained that at a meeting of the leading building material manufacturers of the country last Friday evening at the Engineers' Club it was developed that there is in existence today at the several plants sufficient building materials to meet all present requirements of the industry, but that the need of additional cars to move those materials to the places of consumption had cut down the shipments about 66 2-3 per cent.

Jefferson's Home for National Memorial

Monticello, the home of Thomas Jefferson, at Charlottesville, Va., which has been sought as a national memorial by public-spirited citizens organized to purchase the historic property from its owner, Jefferson M. Levy, may be bought soon by the Thomas Jefferson Memorial, of which James W. Gerard, former Ambassador to Germany, is president, according to Charles W. Swan, secretary of the organization.

The estate, comprising nearly 700 acres, has been offered by Mr. Levy for \$1,000,000, on condition that it be converted into a national memorial.

The restoration of Thomas Jefferson's home has been completed in the smallest detail by the present owner, whose family came into possession of it in 1820. The house has been described as one of the most perfect pieces of Colonial architecture in America. The estate has been open to the public, and thousands of persons daily make pilgrimage to the home of the signer of the Declaration of Independence and former President.



HOUSE OF WILLIAM H. CAREY, PASSAIC, N. J.
JOHN F. JACKSON, ARCHITECT

48'



DETAIL OF MAIN ENTRANCE
HOUSE OF WILLIAM H. CAREY, PASSAIC, N. J.
JOHN F. JACKSON, ARCHITECT

982

THE AMERICAN ARCHITECT

JULY 14, 1920

VOL. CXVIII, No. 2425

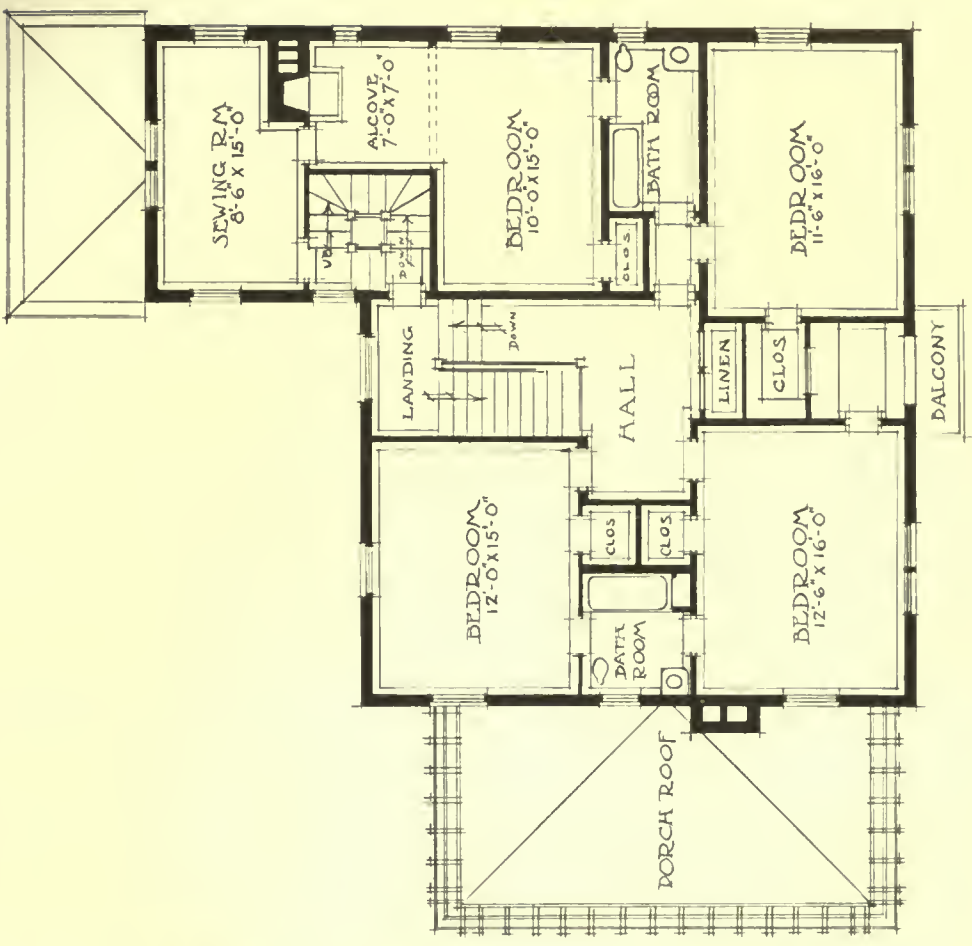

HOUSE OF WILLIAM H. CAREY, PASSAIC, N. J.
JOHN F. JACKSON, ARCHITECT

483

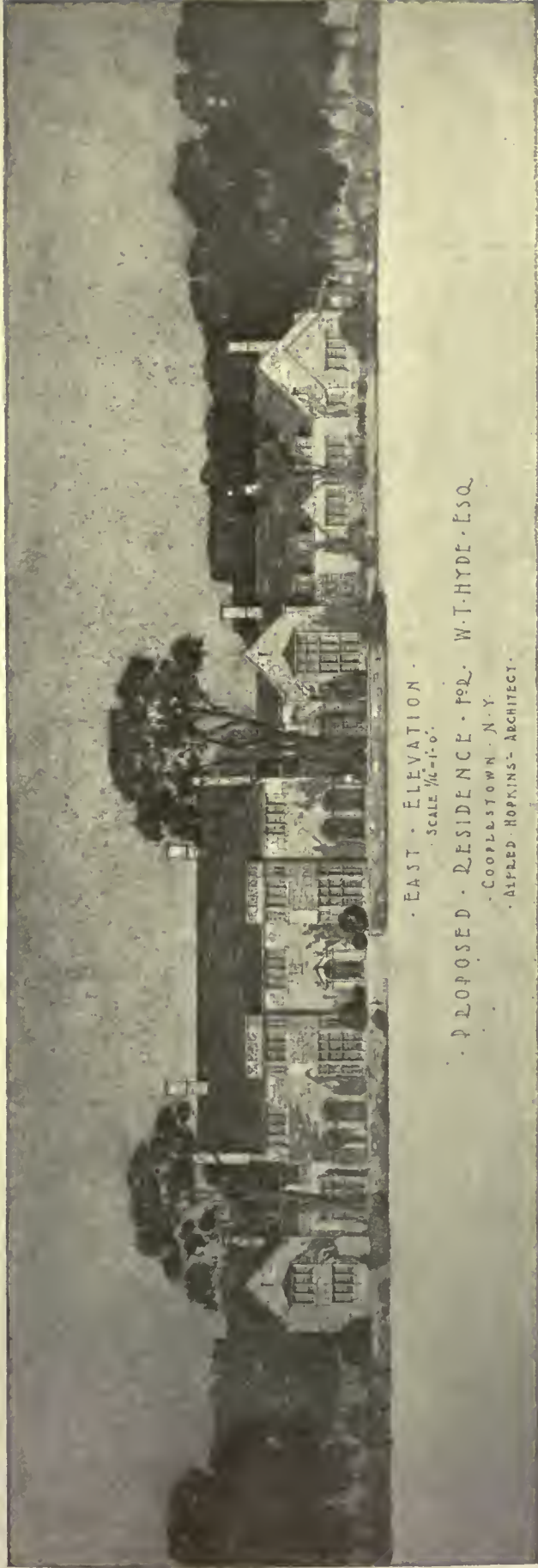

EAST ELEVATION
SCALE 1/16" = 1'-0"

PROPOSED RESIDENCE FOR W.T. HYDE, ESQ.
COOPERSTOWN, N. Y.
ALFRED HOPKINS - ARCHITECT

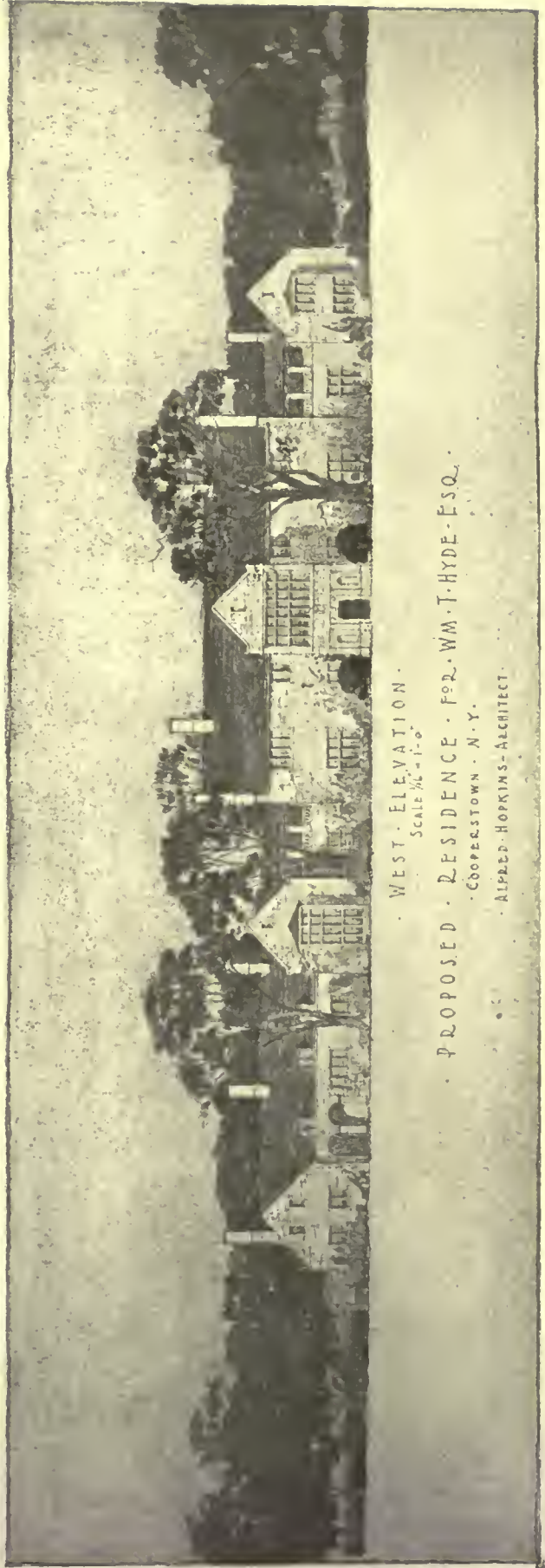

WEST ELEVATION
SCALE 1/16" = 1'-0"

PROPOSED RESIDENCE FOR W.T. HYDE, ESQ.
COOPERSTOWN, N. Y.
ALFRED HOPKINS - ARCHITECT

THE AMERICAN ARCHITECT

JULY 14, 1920

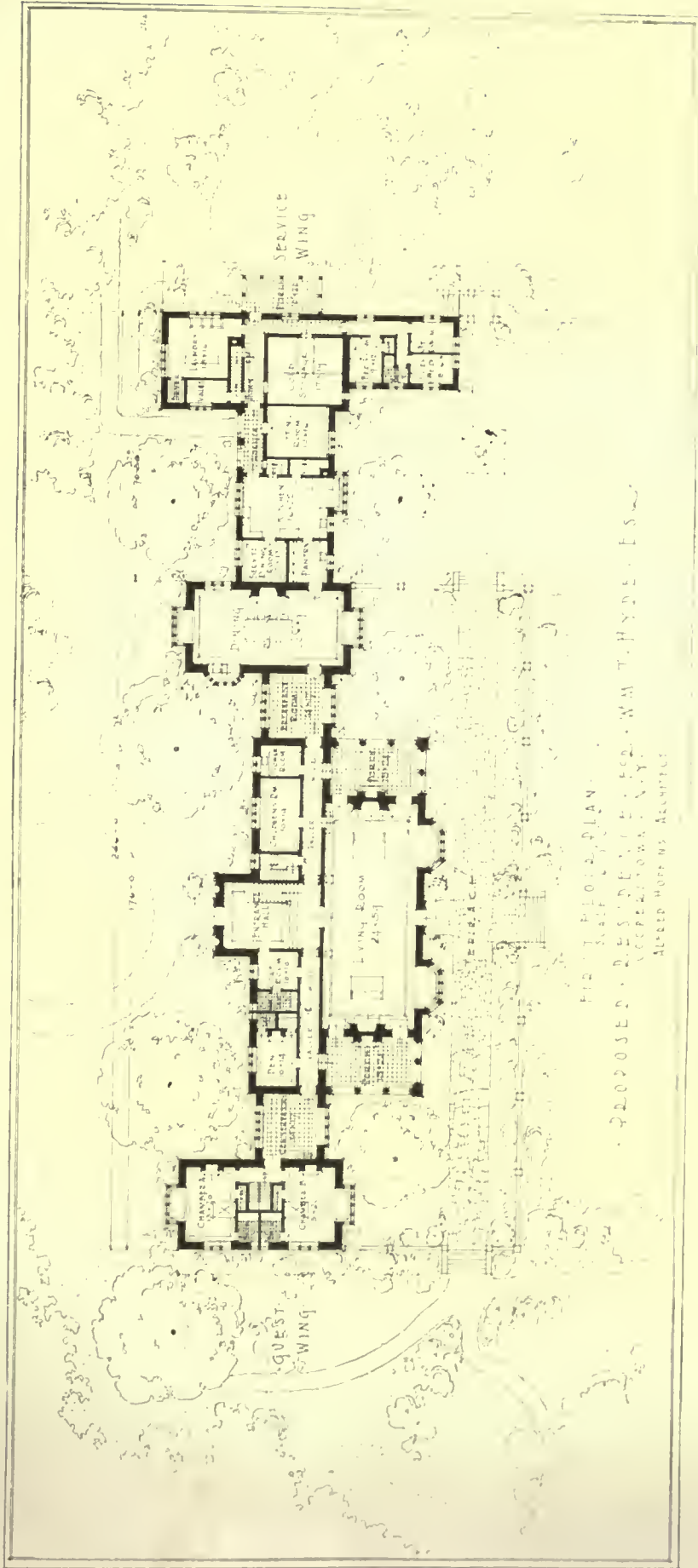

FIRST FLOOR PLAN
 PROPOSED RESIDENCE FOR WM. T. HYDE, ESQ.
 ALGERIA, N. Y.
 ALFRED HOPKINS, ARCHITECT

OFFICE SKETCH TO PROMOTE BUSINESS
 ALFRED HOPKINS, ARCHITECT

483



ENTRANCE FRONT
PROPOSED RESIDENCE AT WESTBURY, L. I.



GARDEN FRONT
PROPOSED RESIDENCE AT WESTBURY, L. I.
ALFRED HOPKINS, ARCHITECT

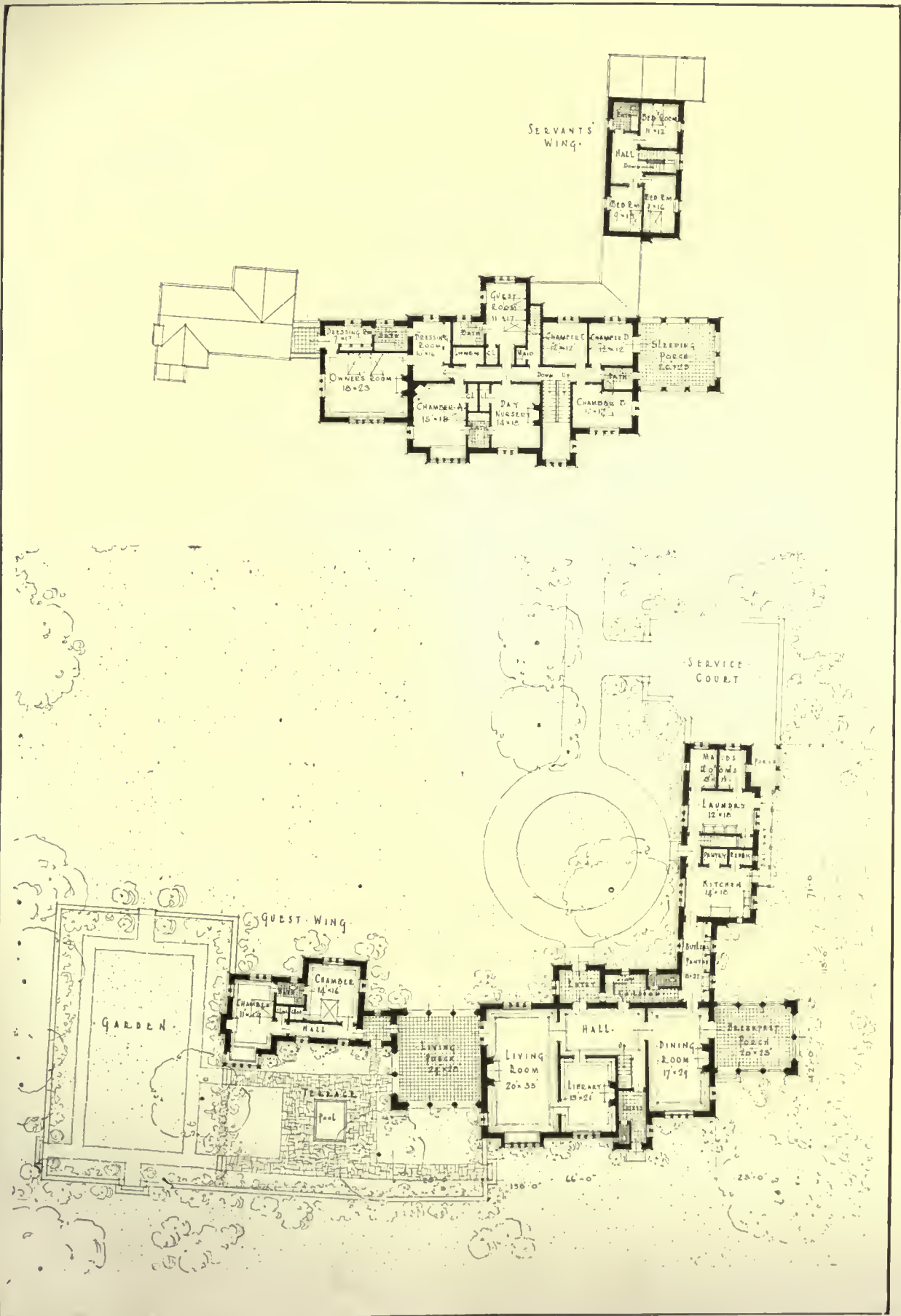

PROPOSED HOUSE FOR JAMES H. PERKINS, GREENWICH, CONN.
 ALFRED HOPKINS, ARCHITECT
 (See page 40 for exterior views)



SECOND-FLOOR PLAN
SCALE 1/16" = 1'-0"

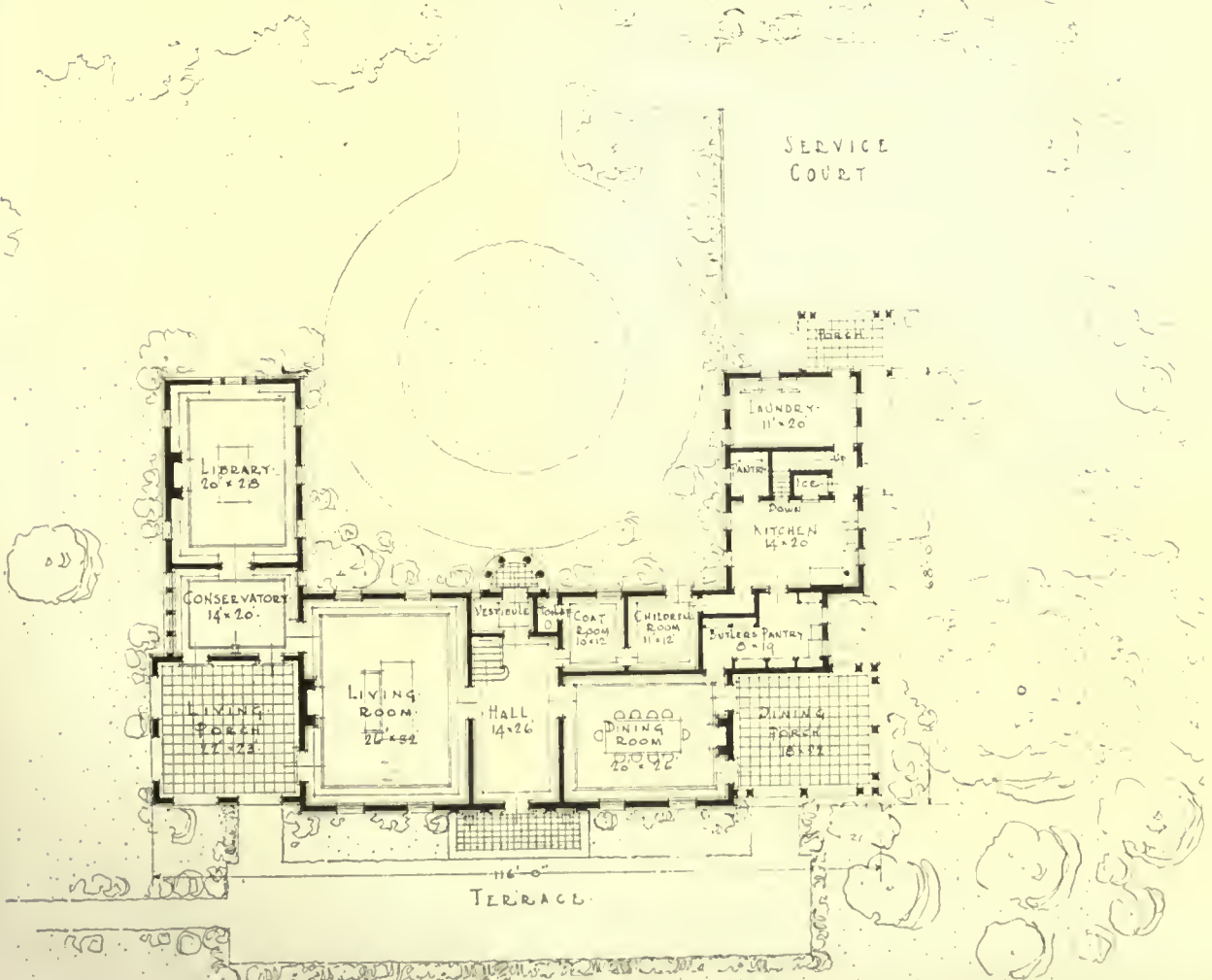

FIRST-FLOOR PLAN
SCALE 1/16" = 1'-0"

PROPOSED RESIDENCE FOR JAMES H. PERKINS, ESQ.
 GREENWICH, CONN.
 MOVIOUS & ROTCH
 ALFRED HOPKINS - ARCH
 101 PARK AVE. - NEW YORK

Current News

Happenings and Comments in the Field of Architecture and the Allied Arts

Designer Enters the Motion Picture Field

The decorations of New York City for the return of the troops from France and the planning of other smaller fetes may be recalled as the work of Mr. Paul Chaffin. We now learn from the newspapers that he is going to California to assist Cecil DeMille in the production of motion pictures. Mr. Chaffin studied art in New York, subsequently at the École des Beaux Arts in Paris and at the Amsterdam Academy in Rome.

With men who are trained in the arts turning their talents to the motion picture field, we may expect to find some worthwhile and carefully planned effects coming along with the evening's amusement.

How One Artist Cleared Away Billboards

The following story was recounted by W. A. Rogers in the *New York Times*, as a word of encouragement to Mr. Pennell. This happened in 1879 in Colorado, at the time of the great Leadville boom:

Tom Parrish of Colorado Springs was in 1879 an etcher, and a very good one. He was also interested in mining properties. Both these lines of endeavor took him about in the mountains and he was greatly distressed when he saw advertising signs, with letters ten and twenty feet high, painted on the great cliffs which formed the mountain sides of that wonderful region.

Tom Parrish was a mining man by stress of circumstances, but he was an artist by nature.

Artists, public opinion to the contrary notwithstanding, are practical people. They deal with the visible world, and the visible world in Colorado was being ruined by a lot of vandals.

Tom Parrish was a popular man in Colorado Springs. He got himself nominated for state senator and won the election.

Then he prepared a bill making it an offence punishable by a fine of \$1,000 or one year in jail to deface the scenery in the state of Colorado. This bill also provided that offenders should at their own expense obliterate all signs hitherto painted on the

rocks. When his bill was presented and read before the legislature a howl of derision greeted it.

"We are practical men," said the other members of the legislature, "not a lot of fool dreamers. We want business, and advertising makes business. You'd better go back to making pictures and not laws, Parrish."

"All right," said Parrish, "I'll make you a picture right now that maybe you can see. You want business; so do I. What has Colorado got to sell? Silver and scenery! Just those two products—silver to the mints, scenery to the tourists. You haven't another thing today to offer. And the best and surest product you've got you are willing to let a lot of rustlers destroy. There's my picture: what are you going to do about it?"

An old miner got up and banged his fist down on his desk. "Parrish is right. He's got more business in his head than all of us put together. Let's pass his bill!"

They did, the governor signed it and it became the law of the state.

Valuable Building Stone Found

What geologists and experienced quarrymen pronounce to be the most valuable building stone ever found in the United States has been discovered ninety miles south of Memphis, in North Mississippi, along Big Bear Creek. It is said to be the finest Silica stone in America and the only specimen of its kind is found near Edinburgh, Scotland, where most public buildings have been erected of it.

Practically all of the stone lies in a deep gorge, through which flows Big Bear Creek. Acres of it is on top of the ground, formed in such a way that it can be gotten in slabs or blocks of most any size. There is little overburden to any of it.

Dr. L. C. Glenn, geologist at Vanderbilt University, Nashville, who went to the locality and made a report of his findings, said the vein averaged 25 and 30 feet deep and that its bedding is usually remarkably uniform and parallel, so that when split along the bedding planes the blocks have almost perfectly even surfaces.

When the stone is exposed to air it readily hardens, according to Dr. Glenn. It will resist weather indefinitely without crumbling or disintegrating. The natural color of the stone is white

and free from the influence of surface percolating waters.

Experts say the stone can be marketed in Memphis fifty per cent. cheaper than any other class of white building stone, and considerably cheaper than cement or brick. The Illinois Central Railroad has a track extending through the property.

In order to market the stone, C. C. and Thos. J. Wellford of Memphis and W. F. Dunbar of Atlanta have secured an option on 1,100 acres of land through which the vein of rock has been traced. They are now organizing a \$1,000,000 company to market the stone.

Chinese Manufacturing Town Developing Large Industries

Seventeen hundred years ago, the Chinese potters began work in Kingtecheng, for the town, now one of the four largest towns in the country, dates from the Han dynasty, when, according to the records, porcelain was first made in China, although vessels of earthenware were probably produced some centuries earlier.

A large and picturesque town of potters it still is, to judge by Frank B. Lenz's description in *Millard's Review*, and modernly interesting because its product, hitherto largely confined to China, will no doubt enter more and more into world trade with the present development of international commerce. They call it a "town" in China, because, although some 300,000 people live in it, it has no wall; practically it is a great manufacturing city, where warehouses, shops, furnaces, and the homes of the people are all jumbled together, as they have come into being during the centuries, and where, century by century, the great mounds of chipped and defective pottery have grown steadily higher along the banks of the river.

One reaches the town by launch or houseboat from Nanchang, and is likely to meet the small flat-bottomed boats loaded with soft white bricks, that bring the clay to the potteries from the various deposits around Poyang Lake, that so long ago led the earliest potters to establish themselves in Kingtecheng. Nowadays there are at least 200 firms engaged in the occupation. 120 pottery kilns, 1,500 art shops, and more than 2,000 form factories; and of the 300,000 inhabitants, about 200,000 live by the manufacture and sale of porcelain and pottery. And although Kintecheng is not governed by unions, and the worker is paid by the piece, there is a simple custom in force which takes the place of the eight-hour day elsewhere. If a workman works too long, the other workmen beat him.

House Built Like Refrigerator

Built on the principle of a refrigerator, with its walls insulated to keep the cold out, a new idea in construction of residences is according to the *Improvement Bulletin* being tested in the cold country in Canada. The residence has been used for a year, being occupied by the designer and his family. It was tested severely during the last winter when temperature ran to forty below zero, but it stood the test and was heated throughout with electrical heat during the hardest weather. The walls were designed to keep the cold out and appear to have done so.

The walls are hollow, the outer walls being cement plaster on metal lath with a top coat of stucco. Back plaster is placed between the metal lath and the studding. The outer wall is a sheet of concrete one and one-half inches thick. The inner wall is of two layers of asphalt paper with wood lath and plaster on top. The airtight space in the walls filled with insulating material, granulated cork with a mixture of planer shavings. The theory on which it is built is to prevent the movement of warmed air toward a cold surface.

The cost of construction was given as 10 per cent. above ordinary methods. The purpose of the test in construction was to learn how greatly heat conservation might be developed. On the cold prairies of Saskatoon the conservation of heat and fuel in winter is an important item. The test house has attracted much attention from construction and heating engineers.

Making Wood Fire Resistant With Paint

Fire retardent paints are the most practical means so far discovered by the Forest Products Laboratory by which small amounts of wood can economically be made fire resistant. The only other known methods of decreasing the inflammability of wood are to keep it wet, or to inject into it certain chemicals under pressure. These methods, though more effective than painting, are usually either impracticable or too expensive to be considered.

Ordinary calcimine or whitewash has proved in tests to be as fire resistant as any paint covering dried. It is cheap and convenient to use. Although it will not prevent the burning of wood exposed continuously to a high heat, a good coat of calcimine on wood will decrease the danger of a blaze spreading from burning cigarettes, sparks, matches and similar small sources of fire. Calcimine is, of course, more effective for inside than for outside use.

For exterior use numerous patented fire retardent

THE AMERICAN ARCHITECT

paints are available. An effective outdoor paint which has been developed at the Forest Products Laboratory consists of linseed oil, zinc borate and chrome green. This paint has maintained its fire resisting properties through more than three years of exposure to the weather.

How To Distinguish Mahogany and Walnut From Red Gum

In the manufacture of furniture and cabinets a great deal of red gum is used as an imitation of mahogany or Circassian walnut. When red gum is properly finished it can be made to look so much like either of these woods that only by very careful observation can the true be distinguished from the substitute. There is a very distinct difference, however, between red gum and mahogany or walnut. This difference lies in the size of the pores.

In mahogany, Circassian walnut and black walnut the pores are so large that they can be seen very distinctly on a smoothly-cut surface of the end grain, where they appear as minute openings smaller than pin holes but visible without magnification. On surfaced faces the pores appear as fine grooves, running parallel with the grain. They are even visible through the varnish, appearing as dark lines.

In red gum the pores are much smaller and can be seen only with a magnifying glass.

Comparative Value of Timber Cut From Live and Dead Trees

Prejudice exists in certain quarters against the use of timber cut from dead trees, and some purchase specifications insist that only timber cut from live trees will be acceptable. As a matter of fact when sound dead trees are sawed into lumber, and the weathered or charred outside is cut away, there is no method known to the Forest Products Laboratory by which the lumber can be distinguished from that cut from live trees, except that the lumber from dead trees may be partly seasoned when sawed.

All the information available at the laboratory indicates that timber cut from insect or fire killed trees is just as good for any structural purpose as that cut from live trees of similar quality, providing the wood has not been subsequently injured by decay or further insect attack. If a tree stands on the stump too long after it is killed, the sapwood is likely to become decayed or badly infested by wood-boring insects; and in time the heart-wood also will be similarly affected. The same thing is true of logs cut from live trees and not properly cared for. Until the wood becomes affected by

these destructive agents, dead tree wood should be just as strong and just as durable as sound live tree wood.

In considering the subject it may be useful to remember that the heartwood of a living tree is entirely dead, and in the sapwood only a comparatively few cells are living. Most of the wood cut from trees is dead, therefore, regardless of whether the tree itself is living or not. Such being the case, purchase specifications, instead of providing that material must not be from dead trees, should state that material showing evidence of decay or insect infestation exceeding a specified limit will not be accepted.

Urge Relief for Housing Trouble

Tenement House Commissioner Frank Mann, at the next meeting of the Mayor's Housing Conference Committee, in New York, will submit the draft of a bill to be introduced at the next session of the Legislature exempting real estate mortgages from the income tax law. Congress will be asked to adopt a similar amendment to the Federal income tax law.

The necessity for such action, if the housing situation is to be relieved, was dwelt upon by Walter J. Stabler of the Metropolitan Life Insurance Company, at a meeting of the committee held in the City Hall yesterday, over which Mr. Stabler presided.

"I feel certain," he said, "that if Congress does not do something to help the situation, a crisis is not far off. Investors in mortgages are withdrawing on account of the income tax. They are taxed so heavily that there is very little left. There should be a total exemption in both the Federal and State income tax for real estate mortgages."

According to C. H. Kelsey of the Title Guarantee and Trust Company, there appears to be a disposition on the part of lenders to call in their loans. "But," he said, "my company, since January 1, has taken \$27,000,000 in loans and sold \$25,000,000."

Charles Froeb, president of the Lincoln Savings Bank of Brooklyn, reported to the committee that his bank had lent \$1,000,000 on new construction since the first of the year. A resolution offered by Mr. Froeb that the Board of Estimate be requested not to demolish houses to make room for public improvements until the housing situation has been to some extent relieved was adopted.

The Guarantee Life Insurance Company informed the committee that in its loans thus far this year, amounting to \$4,500,000, it had given preference to the construction of new houses. The Franklin Savings Bank reported loans of \$1,000,000 a month for the last year.

The Prudential Savings Bank of Brooklyn reported that it had lent from 50 to 60 per cent. of its deposits on new buildings, and a representative of the Long Island City Savings Bank stated that his institution had lent more than \$7,000,000 to aid the construction of 1,286 buildings and expected to lend \$1,000,000 more for that purpose before the end of the year. The spokesman for S. W. Straus & Co. reported that his firm had lent about \$70,000,000 in the last year, two-thirds of that amount being for the construction of apartment houses.

Edward P. Doyle, secretary of the Mayor's Conference Committee, said today that about half a billion of capital would be required for the construction of enough apartment houses to thoroughly relieve the housing situation.

Mayor's Plea for Neater City

Every man who owns or rents a house or holds title to vacant lots ought to give serious attention to Mayor Hylan's plea for a neater city. New York is comparatively free from nuisances that imperil public health. She is notoriously careless about the little things that make for the effect of neatness and beauty. Lots filled with unsightly weeds that scatter their seeds on all well-kept lawns and front-yard flower gardens in the vicinage, piles of ashes, or rubbish, tin cans, broken bottles, discarded shoes, offend the eye. The issue is not trivial, not negligible.

We do not know how far the Mayor's menace of prosecution for some offenders may be backed by existing statutes and ordinances. Unauthorized billboards on private property, or on city property, should be torn down. We think there is no ordinance to compel a man to keep vacant lots clear of weeds. New Orleans has such an ordinance, and it is a good one.

One phase of what the Mayor protests against is largely the fault of his Street Cleaning Department. Carelessness in emptying ashes, and in letting loose papers fly into the street is noticeable for any one who cares to keep his eyes open. An ounce of prevention is worth a pound of cure. Citizens who have done all they could to meet complex orders of the department can hardly be expected to clean up after Mayor Hylan's cleaners. His Commissioner should insist on care, and get rid of the men who leave trails of unsightliness. But quibbles over technical responsibility are to be avoided. The best rule for department employees or for the citizen is to brush up where brushing up is needed. Duties are of more importance than rights to the thinking American, and the city itself should exhibit the pride it wants instilled in its citizens.

The Halt of the Pioneer

HOWEVER incomplete up to the time of writing, the census figures of 1920 show a decided check to the westward march of the population. Another fact already established is a decline in the rate of increase of population for the country as a whole, urban as well as rural. Not only has immigration shut off during the war, but there has been a further decline in the size of the family. Some very remarkable changes have taken place in the population increase of individual cities: Listed in the *Survey*, two small towns in Michigan, both of them suburbs of Detroit, Hamtrank and Highland Park, have in the last decade increased by over 1,000 per cent. Flint and Pontiac, of the same state, have an increase of 136 and 138 per cent., respectively. Akron, Ohio, is the only large city so far returned with an increase of over 200 per cent. Toledo's growth was 44 per cent., that of Dayton only 31 per cent., and that of Cincinnati only 10 per cent. Louisville, Kentucky, comes very low in the scale with an increase of less than 5 per cent., while Spokane, Wash., has remained quite stationary. There are no outstanding examples of new boom towns in the mine and lumber region of the West; most of the large increases are east of the Mississippi. Nevertheless, grouping them by states and regions, the cities and towns of the West still increase faster than those of the Atlantic coast and of the center.

Patriotic Englishmen recognize with sorrow that in their geographies they will probably have to erase London and substitute New York as the largest city. As in the case of the figures just quoted for two of Detroit's suburbs, however, such comparisons are very misleading. London simply is twenty years ahead of New York in the movement of decentralization, which has extended beyond the so-called "outer ring" of Greater London; and a far greater proportion of its industries and residences are situated in pleasant satellite towns. An editorial in *Community Leadership*, the organ of the American City Bureau, aptly expresses a sentiment in this respect which has on various occasions been voiced in these columns:

In America we have grown so accustomed to thinking in terms of size and numbers that we seldom pause to ask ourselves whether an increase in population is an asset or a liability. Too often we have deluded ourselves with the belief that size itself was a virtue, but the war has taught us anew that it is not the biggest man or the biggest implement that best withstands the crucial test, but that one in which all the parts are best coordinated. Accordingly, as the census figures are announced, it is an opportune time to ask ourselves whether

THE AMERICAN ARCHITECT

the measure of our cities should be numbers of inhabitants or quality of citizenship. Each newcomer adds to the city's responsibilities.

Army and Navy Club's Memorial Building

As a permanent memorial to the more than 3,000 American officers who died in the world war the Army and Navy Club of America, of 18 Gramercy Park, will establish in New York City a \$3,000,000 service club house, where, among other memorial features, the military record of every officer will be preserved for future generations.

In making the announcement Rear Admiral Bradley A. Fiske, U. S. N., retired, president of the club, said that it is proposed not only to make the new building a memorial of national significance, on the order of Grant's Tomb on the Hudson, but also to establish a great center for general patriotic activities and an auditorium for large public assemblages.

With 2,500 members already in the club and approximately 195,000 others, in all branches of the service, to draw from the club in time should become, even without civilian memberships, by far the largest in the world, Admiral Fiske said.

It is the intention of the club, however, he said to make the memorial feature predominant.

The record of all officers, with personal data and souvenirs contributed by their families, will be preserved in the new building in a special memorial court or hall, which will be built from plans drawn in competition by leading architects of the country. The memorial in this respect would be unique, nothing like it ever before having been attempted.

It is planned, by appealing to the adjutant generals, to the Red Cross and other organizations, to make the final list of those who died in service the most complete and authentic in the country.

"It is planned to make the new building not only a monument to the heroic dead, but a home for the living, where the best traditions of the service will be maintained," Admiral Fiske said.

"Officers in all branches of the service coming to New York can find at this club accommodations at prices commensurate with their incomes. Our present quarters are entirely inadequate, and something must be done to provide for the hundreds of officers who are passing through New York at all times and for many of whom satisfactory hotel accommodations are a serious problem.

"Dues and house charges, accordingly, will be exceedingly moderate. There will be a large number of bedrooms, but in addition, the plans include a dormitory furnished with cots, where army officers may always be sure of a place to sleep. The new building will also have, besides the meeting rooms

for patriotic societies, a special dining room with private entrance for ladies, and others attractions appealing to patriotic men and women.

"It is hoped that the building will become a center of patriotism, where the histories of the officers of the United States Army and Navy may be kept and where coming generations may find inspiration. This will serve also in keeping before the public the importance of officer service.

"Civilians will be eligible to associate membership, it being the desire to establish a place where officers and men of affairs can get closer together to their mutual advantage.

"We want the new club, in fact, to be a national institution for the preservation of American ideals and the propagation of American principles."

News Notes from Various Sources

Frederick Rasmussen, Pennsylvania State Secretary of Agriculture, says there are from 4,000 to 6,000 idle farms in Pennsylvania today, many of them among the most fertile in the State.

* * *

Trustees of General Educational Board and of Rockefeller Foundation announced appropriations totaling \$20,261,900 for various purposes of general education and medical schools.

* * *

Dwelling house fires in 1919 numbered 210,000, and represented over 22 per cent. of the total value of the fire loss of the country, according to the annual report of the statistical bureau of the National Board of Fire Underwriters.

* * *

Plans for organization of a National Chamber of Agriculture along lines of Chamber of Commerce of United States were made at opening at Washington June 17 of first annual convention of American Association of Agricultural Editors.

* * *

Chicago has adopted daylight saving, and has set the clock forward for one hour, following the example of New York City. The municipal, State and Federal departments have agreed to adopt the new time, but it does not affect railway trains.

* * *

Construction Division, one of the emergency creations of the war, is about to pass out of existence as a separate institution. Plans for its merger with the Quartermaster General's Department, from which it was made at beginning of war, are now in hands of Quartermaster General.

* * *

A conference of representatives of various wood-using industries is to be held in Madison, Wis., on the afternoon of July 23, 1920, and the question

THE AMERICAN ARCHITECT

of a national forest policy will be discussed. It will be an open meeting, and the discussions should be of wide general interest.

* * *

At the Commencement of the University of Illinois on June 16, 1920, and at various times during the year, 162 B. S. degrees were granted to students of the College of Engineering. Of these 18 were for architecture and 24 for architectural engineering.

Personals

Jerauld Dahler, architect, is now located at 320 Fifth Ave., New York City.

J. L. Vannucci, architect, has gone into business at 1024 Main street, Bridgeport, Conn.

John D. Boyd, architect, has opened an office at 105 West Fortieth street, New York City.

Steinler and Kritz, architects, formerly of 103 Park Ave., New York City, have gone out of business.

Frank Newman and Norman McGlashen have opened an office for architectural practice at 120 East Fortieth street, New York City.

An architectural office has been opened by John V. Van Pelt at 126 East Fifty-ninth street, New York City.

The firm of Ford, Buck and Sheldon, 60 Prospect street, Hartford, Conn., is now known as Buck & Sheldon, Inc., architects and engineers.

Howard Major, architect, has recently become associated with Walter D. Blair, with offices at 154 East 61st street, New York.

Lockwood, Green & Co., engineers, 101 Park avenue, have established an office in Philadelphia under the management of Charles P. Wood.

Bly & Hamann, architects, announce the removal of their offices from 833 St. Johns place to 551 Nostrand avenue, Brooklyn, New York.

G. C. Freeman has removed his office from 1111 North 11th Street to the Reading Liberty Bank Building, Reading, Pa.

Rudolph Kruger and Nathan Siegler announce that they have opened offices at 207 Market St., Newark, N. J., for the practice of architecture and engineering. Catalogues are desired.

Theodore A. Meyer has moved from 114 East 28th St., New York, to 150 E. 41st street, New York, and desires manufacturers' catalogues.

John C. Black, landscape architect and engineer, Tacoma, has gone to Chicago to take an editorial position on "Engineering and Contracting."

Earl A. Roberts, architect, now located in the American Bank Building, Seattle, is to take up quarters at 1056 Empire Building.

Harry Bryant, architect, formerly at 291 Hinsdale street, has moved his offices to 367 Fulton street, Brooklyn, New York, Room 512.

Hays & Hoadley, architects, formerly at Broadway and 68th street, are now located at 204 Amsterdam avenue, New York.

Marohak & Hickey, architects, Strand Bldg., Providence, R. I., have dissolved partnership and the firm is now under the name of Joseph A. Hickey.

Milton P. Pettebone has opened an office for the practice of architecture at 71 Broadway, Detroit, Mich. Mr. Pettebone was formerly with McKee, Williams and Pettebone, Newport News, Va.

Announcement has been made that Stork & Knappe, architects, formerly of Palisades, N. J., have removed to Ardsley, N. Y., where they are located on King street.

Removal notice has been issued by J. Floto, architect, whose offices were formerly at 139 North Clark street. He is now at 189 West Madison street.

H. H. Whiteley of Los Angeles, California, formerly 429 Story Building, has opened new offices at 520 South Western avenue, Los Angeles, for the practice of architecture. He wishes samples and catalogues.

John H. Holler, Jr., and John G. Kleinhenz, architects, have formed a partnership for the general practice of their profession, with offices at 1012 Gates avenue, Brooklyn, New York. Mr. Holler was formerly a member of the architectural firm of Froling & Holler, 150 Nassau street, Manhattan, which was dissolved some time ago.

Samuel L. Malkind, architect, formerly located at 1270 54th street, has moved his office to 16 Canal street, Brooklyn.

Mann & MacNeille, architects and engineers, with offices at 70 East Forty-fifth street, New York, have been compelled by their steadily growing practice to open a permanent Western branch office, which is located in the Book Building, Detroit, Mich. This firm specializes in town planning and civic development.

Weekly Review of the Construction Field

With Reports of Special Correspondents in Prominent Regional Centers

FROM Glasgow, Scotland, comes the news of a just, common-sense view of restrictions and limitations laid upon the building program.

There is so generally current a theory of the exclusive importance of dwelling house construction and such an easy-going acceptance of such a pronouncement that it is a relief to see the carefully stated decision of the Appeal Tribunal at Glasgow, published in *The Architect*, London. The Corporation had prohibited the erection of nine motion picture theaters; but on the judgment of Tribunal this prohibition has been annulled. The judgment is such a simple, straightforward statement of facts that we quote:

"This tribunal is fully alive to the importance and the need of building dwelling houses in Glasgow. But this statutory tribunal has been set up to protect the interests not only of the building trade generally but of the community as a whole, and they have a great deal more to consider than the needs of the contractors who have been selected by the respondents to do their dwelling-house work. The purpose of the creation of this tribunal is to safeguard the interests of others than those carrying out the housing schemes of local authorities. The duty of this tribunal is to interpret and administer this Act of Parliament; not merely to register their assent to orders made by a local authority, unless the local authority has discharged the onus resting upon them of showing that the making of such orders was an absolute necessity of the circumstances. A statute conferring powers of restricting trade or industry is to be strictly construed against those operating such restrictions.

"It does not appear to the tribunal that there need necessarily be competition for men or material between the buildings prohibited and the housing schemes of the respondents. It has not been established that material or labor would become available to respondents' housing contractors by the appellants' buildings being prohibited.

"In the opinion of the tribunal, the extent of the responsibility laid upon local authority under the statute is very much more extensive than merely to contrast the relative importance of dwelling-houses and cinema houses after they have been built. If this had been intended to be the limit of a local authority's outlook, there was no need for an Act of Parliament at all, for everybody realizes, and none more so than the members of this tribunal, that dwelling accommodation is the pressing national necessity. But the duty laid upon a local authority is to have regard to the relative public importance of all building operations, and it is not the intention of this statute that the interests of many sections of the building trade should by prohibition be sacrificed to the interests of one section, unless there is no other way, after every effort has been made to find it, of accomplishing the house building."

We are having our fill of dwelling-house propaganda, whether it comes from political, or journalistic, or some other source. We all know that small dwelling-houses are needed, but whether they are to be constructed to the extinction of all other forms of construction, is another matter. Probably there will be no such entanglement with restrictions of officialdom in this country as in England and the buildings put up will be those so urgently needed that the effort brought to bear will overcome all difficulties and competition.

It is difficult to decide just which type of building is most important and which of a secondary nature: whether factories, apartments, or workers' cottages. But such economic problems have a way of working their own solution and we need not fear under present conditions that an appreciable amount of building which is without great economic value will manage to get itself done.

(By Special Correspondence to *The American Architect*.)

Chicago.—The construction industry of Chicago seems to be playing a waiting game. Apparently the builders are willing to wait to allow the material men to fight the battles with building labor.

The building supply men, particularly the lumber interests, have been roused by the falling off in the demand for their products. And they blame the present high prices and consequent decrease in building on labor and its "Unreasonable wage demands." They believe that many contractors and builders have been antagonized by the attitude of labor and hampered by the constantly recurring jurisdictional strikes until they have ceased all building operations rather than submit to wage demands which in many instances have exceeded reason.

It is expected by both building and lumber interests that this stand on the part of the employers will eventually bring prices and wages down. Much unemployment in the trades is said to exist and expert building craftsmen are reported to be now seeking employment in shops—offering to work at any job or any wage.

While high prices of labor and materials lead in reasons for light construction, a third cause for the present stagnation is found in the shortage of cars. The heads of building material companies say that the present assignment of all open-top cars for coal and of tight box cars for grain has left the building material interests absolutely without cars. A dele-

THE AMERICAN ARCHITECT

gation from Chicago has appeared before the Interstate Commerce Commission urging that body to apportion cars to their industries.

(By *Special Correspondence to The American Architect.*)

Seattle.—There has been some relief in the movement of small pipe into this territory from eastern mills, but three-quarter inch stock is still short. There have been no price fluctuations in these materials. Nails are still being rationed although tentatively jobbers are getting more of a supply.

The car shortage is sharing honors with the lack of skilled workmanship in the eastern mills in keeping the supply at a heavy percentage under the demand. In all products where skill is requisite, there seems to be a woeful lack of arrivals. Jobbers who have examined recent receipts of shingle nails have discovered that the small blued nails do not even attempt to conform to equality in size, and here can be found the proof of the claims of manufacturers of their inability to get experienced men.

There has been a fair increase in the stocks of black pipe, which has carried the bulk of the demand so far during the building season. There is more half-inch pipe on hand. The demand has fallen. All the big jobs in this territory so far known to be going through have been taken care of on sub-contract, and due to the presidential election year with its disturbance of business jobbers of building materials predict that the North Coast territory is in for a dull period.

Fire brick advanced to \$75 per thousand this week. During the past four months, while shipyards that had been on the speeding-up war basis of war time have been dismantling, 200,000 low heat fire brick have been offered which upset the market for high standard materials. The last of this lot has been cleaned up, and instant strengthening of the market followed. Some of these yards have catapulted a bearish tone into the steel market by throwing 2,000 tons of steel materials at the buyers. The bulk of this is steel bars. Until the lot is cleaned up un-settlement is expected.

Eastern steel mills claim to be sold up on all small sizes and complain of the difficulty of turning out materials that run heavily into tonnage. On this account they are firming orders for the third quarter with the reservation that they make delivery in the fourth quarter.

The reduction in the rates on steel from Colorado mill points to Puget Sound this week is taken to mean that this district is to be permitted to enter

into closer competition with Pittsburgh against the forthcoming resumption of coast-to-coast water service through the Panama Canal. Pittsburgh has a rate of 99 cents by combination of rail to the Atlantic and water to Puget Sound against an all-rail rate of \$1.25. The new rate from Pueblo, Colo., will be 86½ cents per cwt. on iron and steel, a reduction from 94 cents. The bulk of nails for this territory is coming from Colorado.

Lath is down to \$7.50 delivered on the job. More roofing, plaster board, cement and brick is being offered than the jobbers can move.

Lumber is steady. Wholesalers state they can get plenty of new business if they will cut the market, but this they are refusing to do on the ground that the market is near a rally. They are hedging by accumulating a lot of orders on the "short" basis. The firm mills are 6,500 carloads behind on their eastern rail business, or 50 per cent of the accumulations during the high midwinter market. The car shortage is getting more serious.

The red cedar shingle market broke again to \$3.75 for clears and \$3.25 for stars, f.o.b. mill.

(*From our New England Correspondent*)

BOSTON.—This week started off with a marked improvement in the tangled railroad situation and with bright prospects for an early increase in coal shipments to relieve the acute need in New England. Although many industrial plants are running on three or four day schedules, the coal shortage is so serious that these plants must close down entirely unless some increase is shown in the shipments this coming week. It is also reported that two of the railroad systems have only a sufficient quantity of coal on hand to carry them through the next thirty-six hours.

The now "outlaw" strike on the part of certain of the railroad employees is hampering the return of cars to the mines for fresh loadings and slackening the flow of goods to and from New England. By holding up the transport of goods, this strike is also retarding the liquidation in commodities and the reduction of loans, which the banks are so anxious to bring about in the interests of national business safety.

That 400 new one and two-family houses and one big apartment block will be available in Springfield, Mass., in the fall was the estimate made this week by the president of the Tenants' Protective Association. One of the men sent out to investigate building operations reported about 200 houses going up on a two-mile stretch in one of the suburbs.

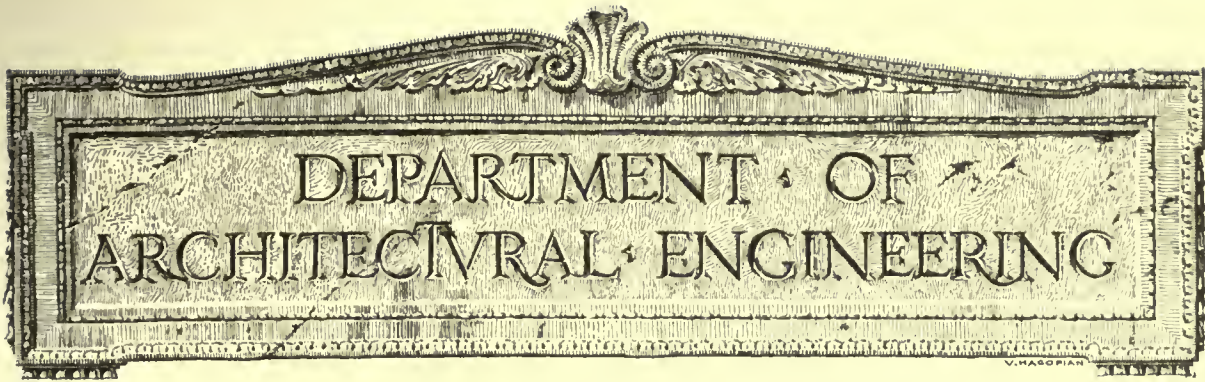

Annual Meeting of American Society for Testing Materials

Asbury Park, N. J., June 22-25

THE twenty-third annual meeting of the American Society for Testing materials was held at the New Monterey Hotel, Asbury Park, N. J., June 22 to 25, 1920. The total registration was 550 members, 108 non-members and 143 ladies, a total of 801 persons.

Many reports and papers were presented, covering a wide range of subjects. Only those of particular interest to the architectural profession will be here mentioned.

In the annual address, J. A. Capp, retiring president, said in part:

In the charter of the American Society for Testing Materials it is stated that "the corporation is formed for the promotion of knowledge of the materials of engineering, and the standardization of specifications and the methods of testing." Our founders appear to have divided the field which they selected rather sharply into two sections or divisions. That the two sections are closely interrelated is evident; in fact, one may say that successful cultivation of one section may not be expected until after the reaping of crops from the other. Standardization of specifications for materials before a reasonable knowledge of those materials has been obtained is patently absurd and this knowledge may only have been acquired through development and application of methods of testing which, in turn, must have been so commonly used that investigators may understand the recorded results of others and compare them with their own. Yet our founders had good reason to define two sections in the field of our society's work. While all standardization is founded upon knowledge of materials it does not follow that all the knowledge of materials which we may acquire leads necessarily to the formulation of specifications, nor even to standardization of methods of testing. * * * * *

No time need be spent in arguing for or against the desirability of establishing standards. Last year,

President Clamer ably discussed this subject, and the perilous times through which we have recently passed have taught us the great value of standardizing. There is, in fact, a great wave of effort to unite in standardizing work passing over not only this country but practically over the civilized world. The American Engineering Standards Committee has gotten into its stride and rapid progress is being made both in organizing for work on proper lines of co-operation among the bodies in this country which have heretofore carried on their efforts more or less independently, and for concurrent work with other countries. Whatever may be the opinion of some who pessimistically believe that standardization will retard progress, we must recognize that fact that the day of standardization is here. We need have no fear of stopping progress. So long as human beings are richly endowed with curiosity and with a desire to learn and excel, progress will be made in all fields of human endeavor. No amount of fixing of rules will stop man trying the effect of breaking rules or of making new ones to cover new conditions. No standards can continue to hold in the face of newly developed qualities or materials which can be shown to be improvements upon those previously fixed. * * * * *

The making of specifications presupposes a knowledge of the materials covered. None who have had the privilege of participating in committee activities will ever have any other impression than that of a wide knowledge of materials among the committee members. In fact, that is why they are members. It is a safe statement that the issue of each set of specifications marks a distinct and definite step forward in our knowledge of materials. * * * * *

The real user of engineering materials is the designing engineer who must make a definite selection of the material to be used in the fabrication of each part of his design. He must base this selection upon facts which may be listed under three headings—cost, availability and suitability. Market conditions supply the matter to be placed under cost and availability, while under suitability must be included all of the knowledge of the materials which he can gather together. He

THE AMERICAN ARCHITECT

must have not only the control properties commonly specified, but also data on such questions as reliability and duplication and on the special qualifications which must be possessed in order that the part in question may render the service demanded of it. The development of modern engineering practice has made necessary a much more intimate knowledge of the general and special properties of materials than was formerly required and there has grown into existence among engineers a class of specialists on materials. * * * * *

The designer presents a concrete problem, he wants to know what material he should use in a certain part and why. The listing of properties as determined by tests, even including many sorts of tests not usually made in routine inspection, is not a sufficient answer, because it is not usually possible to say in any quantitative sense what influence any given property has upon the useful life of the material in a specific application. The questions asked by the designer must be answered and in most cases, the answer is possible only by long explanations and discussions which lead to a decision based upon inferences drawn from experience and backed up by judgment. This process has sometimes been called "educated guessing," and that so much of engineering is based upon inference and judgment is simply because the demand for knowledge has grown so much more rapidly than the supply.

The demand was recognized when, twenty-three years ago, our society was organized. The first problem to be attacked was obviously that of standardizing the commonly available materials and the methods of testing them. To that problem our committees have addressed themselves and the results have been of inestimable value. The work will never be completed because new materials are constantly being developed and old materials improved as methods of manufacture are bettered. There will never come a time when there need no longer be committees whose main business is the formulation of specifications. * * * * *

We know the conditions to be met in service by any structural part and we know many of the useful properties of materials. Must we not now address ourselves to the solution of the problem "on what properties does the suitability of a material for particular applications depend and how may these properties be used to measure suitability"?

There is no more profitable field for committee work and it is one obviously within the boundaries set and described by our founders in their application for a charter. If we do not actively cultivate this field through committee work and every other sort of society activity, are we doing all we should do for "the promotion of knowledge of engineering Materials"?

Steel Pipe.—The report of Committee A-1 on steel includes proposed revised standard specifications for welded steel pipe. Contained therein are tables of weights, dimensions and test pressures for standard and extra strong welded pipe of diameters from $\frac{1}{8}$ to 12 inches, the latter size being the present limit for commercial sizes.

Timber.—Committee D-7 included in its report proposed revised tentative specifications for structural Douglas fir. The previous specifications were based largely on a visual method for determining density, as was the case for southern pine, but be-

cause of the difference in the size and the characteristics of growth of Douglas fir and southern pine, it was found after considerable experience that many serviceable pieces of Douglas fir timber were rejected under the clauses of the tentative specifications. Since the original publication of the specifications, a good many tests have been conducted by the U. S. Forest Service and others, as a result of which much information has been developed that is of importance in connection with the revised specifications submitted with this report. It is of particular interest to summarize briefly the significance of density and structural grading rules:

Tests at the Forest Products Laboratory of the U. S. Forest Service and elsewhere have shown that the production of timbers wherein uniformity of strength properties, durability and resistance to wear and abrasion are required is dependent chiefly upon two factors: (1) The density or dry weight per cubic foot of the wood; and (2) the character, size, number and location of defects. Strength is closely proportional to the density of the clear wood and is limited by the defects present. Density is a factor in durability and in resistance to abrasion.

Heartwood and sapwood are not factors in strength, exhaustive tests having shown them to be of practically equal strength; but they are important factors in durability, heartwood being far more durable than sapwood. Heartwood requirement is not, therefore, a part of a structural grading rule except as a special requirement in timbers which will be subject to decay-producing conditions.

The production of good structural material of any species, therefore, depends upon enforcing a specification which provides: (1) That the density, or dry weight of the wood, shall not be below a certain minimum; and (2) that the defects shall not exceed certain definite limitations.

Brick.—The report of Committee C-3 on brick, which was adopted, recommends that a revision be made in the specifications so as to change the proposed standard size for building brick from $2\frac{1}{4}$ by $3\frac{7}{8}$ by 8 inches to $2\frac{1}{4}$ by $3\frac{3}{4}$ by 8 inches. This change was made for the purpose of conforming to the standard sizes adopted by the Common Brick Manufacturers' Association and other organizations. The tentative specifications for building brick, as thus revised will be referred to letter ballot of the society for adoption as standard.

Sand.—The importance of sand is not generally recognized. At the last annual meeting Committee C-7 on lime, of which D. K. Boyd, F.A.I.A., is chairman, requested that as nearly all of the "Group C" committees of the society are interested in and have to deal with the question of sand as an admixture with the material over which each committee has jurisdiction, the Executive Committee be requested to instruct all standing committees inter-

THE AMERICAN ARCHITECT

ested in sand to elect sub-committees on this material; and that the Executive Committee be requested to create a standing committee on sand to be composed of one delegate from each of the above mentioned sub-committees.

The Executive Committee subsequently went on record as follows:

"That it is undesirable to create a separate standing committee on sand as suggested by Committee C-7, and that if any committees of the society concerned with specifications for sand desire, the present machinery of the society provides a satisfactory means of discussing matters of common interest through the formation of a conference committee on which each standing committee concerned would be represented."

During the annual meeting a conference on sand, as suggested by the Executive Committee, was held.

Structural Lime.—Sub-Committee H of Committee C-7 on structural lime reported that it has been unable to obtain a satisfactory standard sand for use in laboratory tests of lime; also that the desired co-operation with Committees C-1, C-9 and C-11 has not yet been perfected in detail.

After a general review of its previous work the sub-committee finds that there are some fifteen properties which should be included in specifications for different kinds of structural lime. It is now prepared to write the requirements for most of these properties. Information is required concerning a few properties, and the year has been spent in the development of the necessary test data. The items of particular interest are plasticity and soundness.

Gypsum.—The report of Committee C-11 on gypsum includes proposed tentative specifications for gypsum, calcined gypsum and gypsum plasters, as well as for tests of gypsum and gypsum products.

Cement.—Committee C-1 on cement reported that its activities during the past year have been largely centralized in the endeavor to secure one generally accepted "Specifications and Tests for Portland Cement."

The present specifications of the American Society for Testing Materials for Portland cement became effective on January 1, 1917. There was an opinion among some, however, that the specification for the "fineness" should be different and for this reason the U. S. Government Departmental Committee concluded to specify a fineness with a permissible 2 per cent. less residue on the No. 200 sieve than that permitted by the American Society for Testing Materials specifications. Their specification was finally made by the Government Departmental Committee to become effective January 1, 1920.

A conference between committees appointed by the Government Departmental Committee and the

Executive Committee of the society was held on May 10 at the Bureau of Standards, Washington, D. C. This conference entered fully into the effect of fineness on the strength of cement and concrete and also into the cost of producing additional percentages of fineness. The results of the conference were most satisfactory.

As a result, Committee C-1 requested the society to withdraw from the standard specifications and tests for Portland cement section 36 on permissible variation in fineness. This request was acted on favorably at the annual meeting.

Reinforced Concrete.—Committee C-2 on reinforced concrete is co-operating with the Joint Committee. It will probably be some time, however, before the work of the Joint Committee has progressed to a point where tentative specifications can be published.

At its meeting on May 12-1920, Committee C-2, after careful consideration of the situation, decided it would be unwise to undertake any work until the Joint Committee had made sufficient progress in its work as would indicate along what lines Committee C-2 could assist in the work of preparing specifications for concrete and reinforced concrete.

Concrete.—The report of Committee C-9 on concrete aggregates was devoted largely to the results of investigations of various methods to determine the method and apparatus by which the most satisfactory results may be obtained in the determination of the unit weight of aggregates by different operators under different conditions.

The method found most satisfactory is specified as the rod method. Its application is described as follows:

Fill the measure one-third full, level off top surface with the fingers, tamp with pointed rod 25 times. Fill measure two-thirds full and tamp 25 times. Fill measure to overflowing, tamp 25 times. Strike off surplus aggregate, using rod as straight edge and weigh.

Accompanying the report of this committee were two appendices as follows: Appendix I. Recommended Practice for Making Compression Tests of Concrete; Appendix II. Effect of Tannic Acid on the Strength of Concrete, by Professor Duff A. Abrams. The latter gave results which sand containing varying degrees of impurities—organic matter—might be expected to have on the strength of concrete. The results thus obtained will be printed in a later issue.

The annual golf tournament was held on the afternoon of June 25, and a goodly number tried their skill.

Considerable merriment as well as some embarrassment to Mr. E. D. Boyer, chairman of the Entertainment Committee, was caused at the evening

session when the time came to present the two cups and three medals awarded by the society to the winners. This was due to the mysterious disappearance of two of the medals. Mr. Boyer placed the blame on some jealous golfer. However, the missing medals were later located, and all ended well.

Other Papers.—At the closing session among

other interesting papers presented was one on the "Effect of Hydrated Lime and Other Powdered Admixtures in Concrete," by Professor Duff A. Abrams, and the "Effect of Rodding Concrete," by Professor F. E. Giesecke. The important points brought out in these papers will be summarized in a later issue. The effect of hydrated lime on concrete has been a subject of interest for several years.

Sheepshead Bay Race Track Demolished

Former Structures Will Probably Be Replaced with Dwellings

IN 1915 one of the finest automobile race tracks in the East was completed at Sheepshead Bay, N. Y., at a cost of several millions of dollars. The track, which was timber surfaced over a structural steel framework, was of oval shape, two miles to

the necessity of bending them against the webs to a specified curvature in order to produce the saucer-shaped track. These are now of very little commercial value due to this very feature which added so materially to their original cost.

The primary reason given for the demolition is the consequent reduction of taxes. Since this property is adjacent to a well developed residential section, and forms a very valuable site for such further development, it is quite possible that the removal of the track is but the preliminary step to an extensive residence building program on the site. Such buildings are greatly needed, and undoubtedly



THE GRANDSTAND, WHICH PROVIDED SEATING ACCOMMODATIONS FOR 35,000 PERSONS, IN COURSE OF DEMOLITION

the lap, one-half mile on each straightaway and one-half mile at the turns. The grandstand provided seating accommodations for 3,500 persons, and 3,000 persons could be seated in the "bleachers." The entire area occupied by the track and accessory structures included an area of 430 acres. Apparently the venture proved disappointing from a financial standpoint, and a decision was recently arrived at by the owners to demolish the entire structure.

The illustrations show the track and grandstand in process of removal. The steel, timber, etc., is being sold for what it will bring, but it is doubtful if any material balance will remain after the demolition costs have been deducted.

The steel track beams were very costly due to



A VIEW OF THE TWO-MILE TRACK, WITH TIMBER SURFACE REMOVED

would prove more successful financially than the structures now taken down.

Koehler, Spyer & Farrington were the architects and engineers of the structure, the construction work of which was completed within five months.

The fabricated structural steel amounted to approximately 4,500 tons and some seven million feet B.M. of yellow pine were employed in the construction.

Successful Building in Stucco

VIII—The Reinforced Concrete Frame Building

THE preceding articles of this series dealing with proper methods of building in stucco, lend additional interest to a recently developed system of concrete frame and stucco construction that has successfully withstood the preliminary tests of actual building operations.

girders, lintels and ledger boards, all forming a complete frame-work with which is cast as a monolith the 1½ in. reinforced concrete outer shell. The character of the final structure was not the only consideration but the details of this system were developed with the view of also simplifying methods of construction, which may be described as follows:

After the cellar has been excavated, the stone or concrete foundation wall is built, the first floor wood joists are set in place on the foundation walls. On this a frame, consisting of studs, joists and rafters, is erected, following the usual method of building the skeleton of a timber frame house with these slight modifications to adapt it to this system: (1) Every fourth stud is doubled, allowing a 3 in. x 4 in. space between, which, when filled with concrete, will form a concrete stud. (2) At the second floor and roof levels ledger boards, with bottoms attached, are placed over the studs and so arranged that when filled with concrete they form beams, which, in connection with the vertical concrete studs make a complete homogeneous concrete frame. The concrete studs when filled form continuous posts from foundation to roof, and the main beams form continuous bands entirely around the building.

The wood framework of the building is erected and the roof is completed, as well as the door and window frames, before the placing of the concrete or stucco. If necessary, either because of delay or for economy of construction this wood framework can stand for some time, as it is amply self-supporting.

The next operation is the nailing of heavy waterproof paper on the outside of the exterior wall studs, leaving open the space between the double studs and the spaces made in front of the lintels and ledger boards to receive the concrete. Over the waterproof paper, expanded metal or other form of reinforcement is stretched, care being taken to place sheet metal chairs under the reinforcing so that it is held ½ in. away from the surface of the paper.

The concrete work can now be started. The 1½ in. thick concrete coating can be applied to the exter-

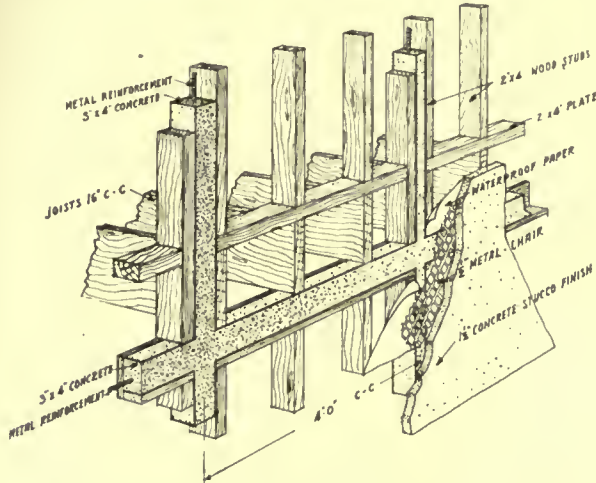

FIG. 1. GENERAL ARRANGEMENT OF THE FRAMEWORK

In this new system, here described and illustrated, no sheeting nor back-plastering is employed. It produces a house with 1½ in. reinforced concrete outer wall with stucco finish, cast as a monolith and supported by a reinforced concrete framework. The originator of the system, having had experience with various forms of construction,—brick, hollow tile, stucco and combinations,—became convinced that the solution of the problem required some new and permanent form of masonry construction, sufficiently low in cost to be within the purchasing power of a man of ordinary means, yet of a type which should provide a permanent structure with low upkeep cost.

In solving the problem the general ideas of reinforced concrete factory construction have been largely followed. Where, in the factory, there are main columns, lintels and girders as a frame, and openings in the outer wall filled with spandrels of brick, windows, etc., in dwellings there are 3 in. x 4 in. reinforced concrete studs, not over four feet on centers and reinforced concrete

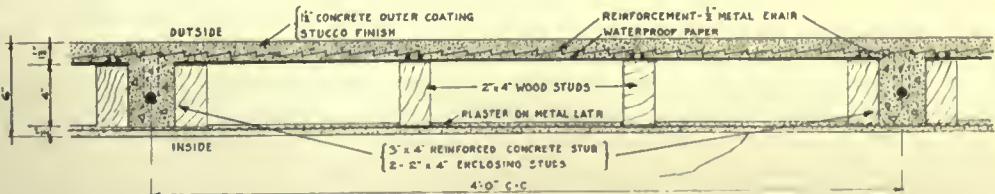

FIG. 2. TYPICAL CROSS-SECTION OF THE OUTSIDE WALL



FIG. 3. INSIDE VIEW OF WALL, SHOWING CONCRETE STUDS, ALSO SPECIAL LINTEL OVER TRIPLE WINDOW

ior either by hand plastering, cement gun or stucco machine. If applied by hand, the concrete studs, beams and ledger boards are generally poured in advance and a reinforcement of rather fine mesh is used. This reinforcement covers the openings left in the waterproof paper and thus becomes the front form for the studs and beams. The concrete, when poured, flows only partially through the fine mesh, leaving a rough face which later on forms a good bond with the 1½ in. outer coating. The general arrangement is illustrated in Figure 1. When the exterior coating is applied by a cement gun or stucco machine, the reinforcing is of a larger mesh and the concrete studs and beams are filled at the same time that the outer coating is applied, the concrete material passing readily through the large mesh of the reinforcement.

The addition of mortar stain to the concrete while it is being mixed, makes possible any desired color effects. Any of the well-known, successful types of stucco finish can be used. Moreover, in place of the 1½ in. concrete slab, a 4 in. brick wall can be substituted, the brick being anchored securely to the concrete studs. Pleasing variety can be obtained by having a brick first

floor and a stucco second floor, or by having stucco throughout with brick trim, or by a number of other equally attractive combinations.

The exterior wall work being completed, metal lath is applied to the inside of the wooden studs, and the interior of the building is plastered. This completely encloses the wooden studs and gives that highly desirable dead-air space. The wood studs act in a dual capacity, as a temporary support for the stucco and concrete frame while it is being placed, and later on as furring strips in the finished building.

As soon as the concrete and stucco work has set up, the entire weight of the building, including roof and floor loads, is carried on this concrete frame. The general wall cross section shown in Figure 2 shows the complete absence of sheeting, and illustrates how the

reinforcing is held ½ in. away from the waterproof paper. It also shows that when the 1½ in. outer coating is put on and forced in place against the paper the concrete is folded back on itself and completely and thoroughly encloses the metal reinforcement, and no back plastering is necessary.



FIG. 4. EXTERIOR VIEW SHOWING PAPER AND REINFORCEMENT IN PLACE. Concrete studs and beams have just been cast.

THE AMERICAN ARCHITECT

No attempt has been made to make the entire house fireproof, as for commercial and financial reasons, it was deemed sufficient to have the exterior and party walls, as well as the roof of fire-resisting construction, it being a well established fact that in group houses with party walls made of fire-resisting materials there is little danger of fire spreading to other houses, each house in itself being an independent unit when the spread of fire is considered. The roof covering most generally used with this type of construction has been slate or asbestos shingles or some similar material.

This wooden floor construction, however, has merely been a matter of economy. If desired, the floors can be constructed of thin concrete slabs supported on concrete beams. In fact, because of the scientific design of the walls as compared with a



FIG. 6. OUTSIDE REINFORCEMENT ENTIRELY IN PLACE

Pouring of all beams and studs completed, ready to receive the outside coating

and supported by rigid reinforced concrete studs and beams.

The stucco has been made up of Portland Cement Mortar and treated with waterproof materials. The waterproof treatment prevents rusting of the reinforcing metal as well as stops the passage of moisture through the $1\frac{1}{2}$ in. slab.

The advantage of this system over the older forms of stucco construction may be summarized as follows: It possesses in large measure virtues and advantages common to masonry construction, while retaining the economies of wood. It permits the erection of a reinforced concrete masonry house by ordinary members of the building trades, without requiring of them any additional skill or knowledge other than what they already possess. It re-



FIG. 5. TIMBER FRAMEWORK COMPLETE

Waterproof paper partly in place showing openings left for studs

solid 6 in. or thicker concrete wall, there is enough saving to supply all the material necessary for these floors. Also, in the design of the framework, the system is extremely flexible, and especially designed beams or lintels can be placed over long window openings and similar places if desired, as shown in Figures 3 and 4. This type of construction being purely an engineering design, openings can be left at any place and members reinforced to take care of any loads coming down, thus giving great latitude in design.

This new type of construction should not be confused with the ordinary type of stucco on wood or metal lath over standard wooden frame where trouble is more likely to occur from cracks due to shrinkage or settlement. It is something radically different from this older form of construction.

The fundamental causes of cracking and crazing are eliminated since the outer coating is backed up



FIG. 7. OUTSIDE STUCCO WORK IN PLACE. BUILDING COMPLETED.

THE AMERICAN ARCHITECT

quires no special forms for erection and, therefore, dispenses with any costly form rentals. It offers a limitless variety of outline or architectural treatment—a variety in fact limited only by the desires of the owner or scope of the architect. It does not require that a large number of houses be erected in order to attain a fair degree of economy, but retains economy with even a single house. It imparts all the benefits accruing from a dead-air space with the walls, thus eliminating condensation and dampness, and providing a house which will be cool in summer and easy to heat in winter. While the wooden frame house is slightly cheaper in first cost, its maintenance will be quite likely to increase the ultimate cost to a higher figure than a house built by the concrete frame system. The accompanying photographs show a typical twin house in various stages of construction built by the new system.

Because of its recent appearance, the building code of the average city has not yet recognized this form of fire resisting construction. Thus under present building requirements, in many places, it has not, as yet, been permitted within the fire limits. However, this is a matter which will undoubtedly be corrected in time and the recent tests made by the Fire Underwriters' Laboratories at Chicago, of typical sections of wall 10 ft. x 11 ft. were so successful that there should be no trouble overcoming this difficulty.

The original investigations and later development of the system, (patented) were carried out by Mr. Emile G. Perrot, of the firm of Ballinger & Perrot, Architects and Engineers, Philadelphia, Pa. It has already found considerable favor and a large number of dwellings have been constructed by this method.

National Lime Association Holds Annual Meeting

The second annual meeting of the National Lime Association was held June 16-18 at the Hotel Astor, New York City.

The first day's session was devoted to the meeting of the Board of Directors.

At the second session, on June 17, various topics were discussed, including a review of the year's work of the National Lime Association and its aims and ideals; reports of Standing Committees on uniform cost accounting, trade practices and accident prevention and insurance; statistics of the lime industry and their place in business development; the new electrolytic lime treatment of sewage, and the use of lime in construction: the needs, problems and methods.

The discussion of the latter subject by Mr. T. B.

Shertzer, engineer, Eastern bureau of the association, was particularly interesting. Mr. Shertzer had recently returned from a 10,000-mile trip and gave his impressions, gathered therefrom, especially with reference to the use of lime in building construction. Because of the lateness of the hour, it was agreed to carry over the discussion of this topic until the following day.

Due to illness, President Charles Warner was unable to attend several of the sessions, but was sufficiently recovered to take the chair on June 18.

The subject relating to the regional bureau as an agency for effective association work was discussed June 18, as well as the matter of the advantage to the industry of well planned field work in the regional bureau, and several other topics.

The excellent attendance and interest of the members present indicate that the National Lime Association is a live and "going" concern.

Creosote Oils in Wood Preservation

LIGHT creosote oils properly injected into wood apparently will prevent decay until the wood wears out or until it checks so badly that the untreated portions are exposed. Such is the indication of service records collected by the Forest Products Laboratory on railway ties and telegraph poles preserved with low boiling creosotes. The ties so treated lasted from 15 to 20 years, and failure was traceable in most cases to mechanical wear, such as rail cutting and spike killing. In no case was failure found to be the fault of the preservative.

Of 1,558 telegraph poles in the Montgomery-New Orleans line, which were pressure treated with a light creosote oil, 1,049 poles were still sound after 16 years. In 91 per cent. of the cases of decay, the fungi had entered the wood through checks and shakes. Representative sections in the Norfolk-Washington line showed that after 17 years' service, of the 1,614 poles inspected, 1,469 were sound, 92 decayed at the top and 105 decayed at the ground line. The decay at the top was caused chiefly by cutting off the poles. In those decayed at the ground line, the causes of failure, as determined in 88 per cent. of the cases, were checks or shakes. Here again as in the ties, the preservative outlasted the mechanical life of the wood.

Unless some other factor than protection from decay is considered important, therefore, there is apparently no need to specify high boiling oils. The important point is that any coal tar creosote which is not extremely low boiling or extremely high boiling will satisfactorily prevent decay, and in the selection of an oil, factors, such as price, penetrability and convenience in handling, should receive greater consideration than moderate differences in volatility.

Frontispiece to No. 2378

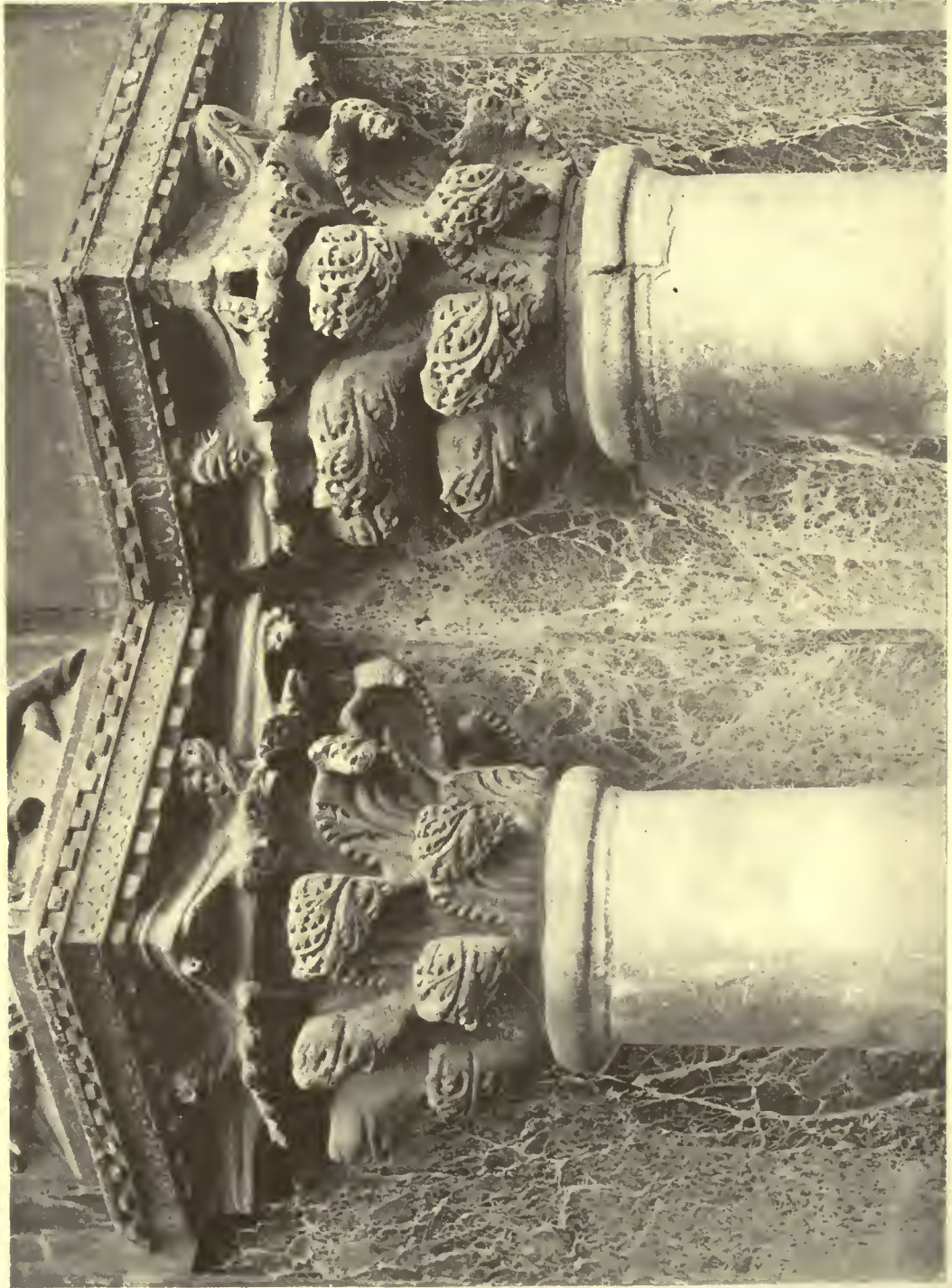

CAPITALS OF MAIN DOOR OF THE CHURCH OF ST. MARKS, VENICE

THE AMERICAN ARCHITECT

VOL. CXVIII

WEDNESDAY, JULY 21, 1920

NUMBER 2326



A MOTION PICTURE SET, DESIGNED AND EXECUTED UNDER THE DIRECTION OF
ROBERT HAAS, ARCHITECT

This building and gateway represents the yard of a Spanish convent for the production of "The Avalanche." It was constructed out of doors with plaster walls, Spanish tile and real stone pavements.

Architectural Problems in Motion Picture Production

By JAMES HOOD MACFARLAND

Illustrated by Examples of the Work of Robert Haas, Architect for
Famous Players-Lasky Corporation

A NOVEL having a sale of twenty-five thousand copies is a successful and popular novel. A newspaper having a circulation of one hundred thousand copies is a successful paper of great influence. A magazine of one million copies in each issue cannot be overlooked. But let us consider the motion picture production.

Statistics have told us that ten million people see motion pictures each day. The average at-

tendance at one of New York's motion picture theatres is eight thousand daily. The picture runs for seven days and fifty-six thousand people view it. If at the same time the picture is being shown—as is usual—in twenty-seven other cities for a week's run, our estimate is that a million five hundred thousand people over the country view the same picture the first week it is run. That is the beginning of the picture's life and influence.

Copyright, 1920, The Architectural & Building Press (Inc.)

THE AMERICAN ARCHITECT

Six years ago, at the time when the first feature picture made its appearance, not much attention was given to the building and construction of interior and exterior "sets," the attention being particularly directed to the action of the scene. The backgrounds upon which a plot was enacted were borrowed from the stage, which was, of course, the natural thing to do. Settings were used which now appear to be ludicrous: a painted drop, for example, giving the impression of trees but with a branch from a real tree secured through it to impart realism. The branch was latched with a string



A MOTION PICTURE SET, DESIGNED AND EXECUTED UNDER THE DIRECTION OF ROBERT HAAS, ARCHITECT

This room in L'Art Nouveau was constructed for "On with the Dance," a George Fitzmaurice production. It was imagined for the occupancy of a woman of the demi-monde. Particular interest attaches to the room because it is one of the few times that a ceiling has been built to be shown in a motion picture interior

and it swayed realistically when a stage hand yanked it. Or again there were rooms made of canvas and painted, rooms which shook and swayed and threatened to fall as the characters opened and closed the doors.

Throughout the six years time in which the motion picture has risen from a cheap form of entertainment to the fifth largest industry in the country,

more and more attention has been paid to the selection, designing, building and decorating of the backgrounds, or "sets" as they are called in the technical language of the motion picture studio.

LONG before the public had a chance to demand it, the producers—always with a finger on the pulse of the public—realized that if motion pictures were to hold their increasing popularity more effort must be devoted to the selection and building of suitable backgrounds upon which to tell the story and it was then that suggestion as it is used upon the stage became substituted by realism.

Architects and decorators were attracted to this new industry and now there is hardly a company which does not employ the skill of experienced architects, many of whom gave up excellent practices for the opportunity of assisting to place before the public correct architecture and decoration. An attempt has been made to show, at the beginning of this article, the tremendous public witnessing the work of these men—and now we may ask ourselves—Does the public appreciate this work?

And the answer is—Yes, not only does the public appreciate it but the architectural profession as well. For the producers have received unsolicited letters of commendation from architects, letters which were inspired by nothing other than the beauty and correctness of the architecture as represented in the pictures. As for educating the public to appreciate the beautiful, there is no doubt but that the efforts are successful, possibly in most cases only in a subconscious way, but it is everywhere apparent the general demand is always that more attention be paid to the correctness of the surroundings in which the action takes place.

One thing must be borne in mind when considering from an artistic standpoint the educational value of motion pictures. In planning "sets" every effort is made to place the characters in the surroundings which they would choose in real life rather than to make each "set" an example of some form of absolute artistic achievement. Take for example the character of a newly made millionaire who comes to New York for a splurge. He would surround himself with gaudy, flashy appointments, with the idea of exhibiting his newly acquired wealth. By placing him in surroundings such as he would himself choose, his character may be forcibly and quickly pictured—"put over," so to speak, without encroaching on the field of literature with long and tiresome explanatory titles. An establishment set up by a titled Englishwoman who brings her daughter to this country in an effort to arrange an advantageous match would be perfect in the taste of all its appointments. Therefore, when criticising

THE AMERICAN ARCHITECT

the "sets" it will be seen that it is necessary to also consider the character.

Reproductions of internationally known buildings, places of interest and objects of art are being made faithful to detail through the use of reference

of Long Island, picking up driftwood and galvanized iron until enough building material was accumulated to construct several shacks and from this debris the architects made careful choice.



A MOTION PICTURE SET, DESIGNED AND EXECUTED UNDER THE DIRECTION OF ROBERT HAAS, ARCHITECT

This house is intended to be characteristic of the hard lines so common in the early work of the Middle West. The people who are supposed to have lived in this house were hard-fisted and without taste. Probably they were economical on architect's fees

libraries which are kept constantly up-to-date. Scenes depicting the Casino at Monte Carlo are constructed in the studio; they would be passed without criticism by any one familiar with that famous gambling resort.

Once at a New York theatre when the program included as a feature film, "The Society Exile," which opens in Venice upon a canal built with all elaboration in the studio; the theatre management developed its program in this way. It gave first a travel picture of a trip about Venice which closed with a long shot of the Grand Canal. Then, without intermission, came a long shot of the studio-built canal; actual water, mooring posts and moving gondolas. It was a trying comparison, a stiff test, yet the audience never thought but that they were still watching pictures which were taken in Venice.

The public is demanding that the pictures be accurate in every little detail and the lengths to which the producers will go to reproduce scenes with absolute realism are interesting. In building a shack to represent a structure on the South Sea Islands, three trucks were dispatched from the studio to scour the beaches

WHEN the interiors are constructed upon the studio floor, they are built by the carpenters from carefully prepared blue-prints made in the Art and Decoration department. No tricks of perspective are used in the construction of these "sets," which seems to be contrary to the general belief; the rooms and houses are built (though with certain eliminations) exactly as they would be if intended for actual use. The men who design the "sets" are constantly striving for the better effect of actuality.

One of the recent developments has been the construction of rooms in a proper and harmonious group rather than the building of one room at a time. It is not an unusual thing to see an entire lower floor representing the interior of a spacious home built upon the stage at one time. Entering through a doorway one walks into the reception hallway and on the left finds the reception room, he sees a library and to the right a living room and dining room. Somewhere in the group is a stairway leading upstairs and through some distant door may be seen a sunny porch or conservatory. This adds more realism and permits the artistic camera shots through vistas which



A MOTION PICTURE SET, DESIGNED AND EXECUTED UNDER THE DIRECTION OF ROBERT HAAS, ARCHITECT

A reproduction of an old English inn. The fireplace shows the Italian influence brought to England with the sculptors imported by Queen Elizabeth



A MOTION PICTURE SET, DESIGNED AND EXECUTED UNDER THE DIRECTION OF ROBERT HAAS, ARCHITECT

This set used in a George Fitzmaurice production called "The Right to Love," represents the upper hall of a house presumed to have been built in Turkey by an English architect for the occupancy by an English gentleman. Real plaster walls have been built with actual tiles inserted for decoration.

could not be obtained if a single room were constructed at a time. For instance, when the camera follows a guest who approaches the entrance door, the guest is not left standing there, but is admitted by the butler. As the door swings open we may follow him through the reception hallway and have glimpses of other rooms just as we would in real life; and when, in the further development of the plot, these rooms are shown more completely, we recall them and the memory serves as another means of knitting up the unity of impressions.

When planning the locations for the George Fitzmaurice production, "The Right to Love," it was decided, in representing a palace on the Bosphorous, to use an estate occupying one of the islands off the coast of Florida. After permission was obtained a cameraman was dispatched to make photographs of the estate from every angle. He returned with nearly seventy-five pictures, including close-ups of doors and windows. The department

of Art and Decoration, using these photographs to guide them, went ahead on plans for the interiors. In this manner it was possible to match up the interiors and exteriors perfectly although they were separated by many miles. As an example of the attention to detail, the director of the picture stopped all work until the proper kind of handle for the door was procured.

One who is not familiar with the mechanical side of the production of motion pictures would naturally inquire what was the reason for not taking the interiors while the company was there on the location; why, in this film were not the interiors also taken upon the estate off the coast of Florida, thus avoiding all the work of building the sets in the studio? This could have been done if it was practical to transport the necessary lights. There are sunlight arcs of three thousand candle power strong (exposure to this light for half an hour will produce a sunburn quite as good as a day spent on

THE AMERICAN ARCHITECT



A MOTION PICTURE SET, DESIGNED AND EXECUTED UNDER THE DIRECTION OF
ROBERT HAAS, ARCHITECT

Representation of an American colonial hallway. A complete room adjoins at the left and the stairway leads out of the picture to a platform. The house had no second floor. Note the stair carpet, which gives the required touch of modernity. The cable of the studio lighting device had not been put in place and hangs over the mahogany hall table.

the beach); there are Cooper-Hewitt banks, spots and Kleigs—all necessary to secure the illumination of interior views but bulky and difficult to handle in the restricted spaces of normal rooms, even if it were possible to obtain the current necessary to operate these batteries of lights. Special cables supply the studio. Another reason for constructing the interiors in the studio brings up an old story about a motion picture carpenter not being trusted with the building of a house, for he might leave off the roof or a side. It is exceptional to see the ceiling of a room in a motion picture. The ceiling is left off, for in its place there must be enormous flood lights to eliminate all shadows.

The detail involved in a production such as "The Copperhead" which was recently produced by the Famous Players-Lasky Corporation is tremendous. Two months before the production was begun, the Art and Decoration department began their research work. After many vain attempts

to find the documents they required to reconstruct a town of the period 1846, the information was finally located in the Newark Public Library. From the information secured a town was built at Elmhurst, L. I., in addition to the court house and church it contained ten houses lining the main street. One interesting fact in the construction of this town was that contrary to usual, the houses were built up on all four sides, making it possible to photograph from any angle. The houses were used by the workmen while building the town and by the thousand people employed to lend atmosphere when photographing. This same town went through three periods: first, 1846, after which it was remodeled for 1861 and after that—1904. The changes were marked and were worked out with a careful attention to detail; a flag (as one instance) was made which bore but twenty-nine stars, although at no time was the flag close enough to the camera to register plainly.

THE AMERICAN ARCHITECT

In the tremendous audience of a motion picture there are bound to be those who are familiar with some one particular thing and only too willing to show their knowledge in criticism. These are the ones who appreciate the attention to detail, such as has herein been in part described, and it is for the most critical audience that motion pictures are now made.

Museums Urge Fine and Industrial Art Combinations

Museums and the influence they should exert on the communities in which they are established were among topics discussed at the recent annual convention of the American Federation of Arts in the Metropolitan Museum of Arts, in New York.

The future museum, Richard F. Bach, of the Metropolitan, said in his address, will be a combination of the fine art and industrial art institutions under a single governing body with separate directors. Such a museum, he declared, would maintain close relations with the industries of the town or city in which it was established and work with them to raise the

artistic standard of American productions of all sorts.

Charles L. Hutchinson, President of the Chicago Art Institute, led the discussion on the best methods of extending the influence of the federation. He announced that a clearing house for art information had been established and was proving effective in fostering interest in Western and mid-Western States.

George W. Stevens, director of the Toledo, Ohio, Art Museum, spoke on "How to Establish an Art Museum," saying that his city had not waited for "some woman to die" in order to obtain funds for the establishment of such an institution, but had plunged boldly in and to-day had on hand assets of \$3,000,000.

George W. Eggers, director of the Chicago Art Institute, discussed "Museums as Community Centers." Francis G. Jones, Allen Eaton and Joseph Pennel presented a petition signed by more than 500 artists here and abroad urging that reforms in the copyright law be accomplished to make it conform to the British law.

George S. Booth, of Detroit, and H. K. Bush-Brown, of Washington, also spoke.



A MOTION PICTURE SET, DESIGNED AND EXECUTED UNDER THE DIRECTION OF ROBERT HAAS, ARCHITECT

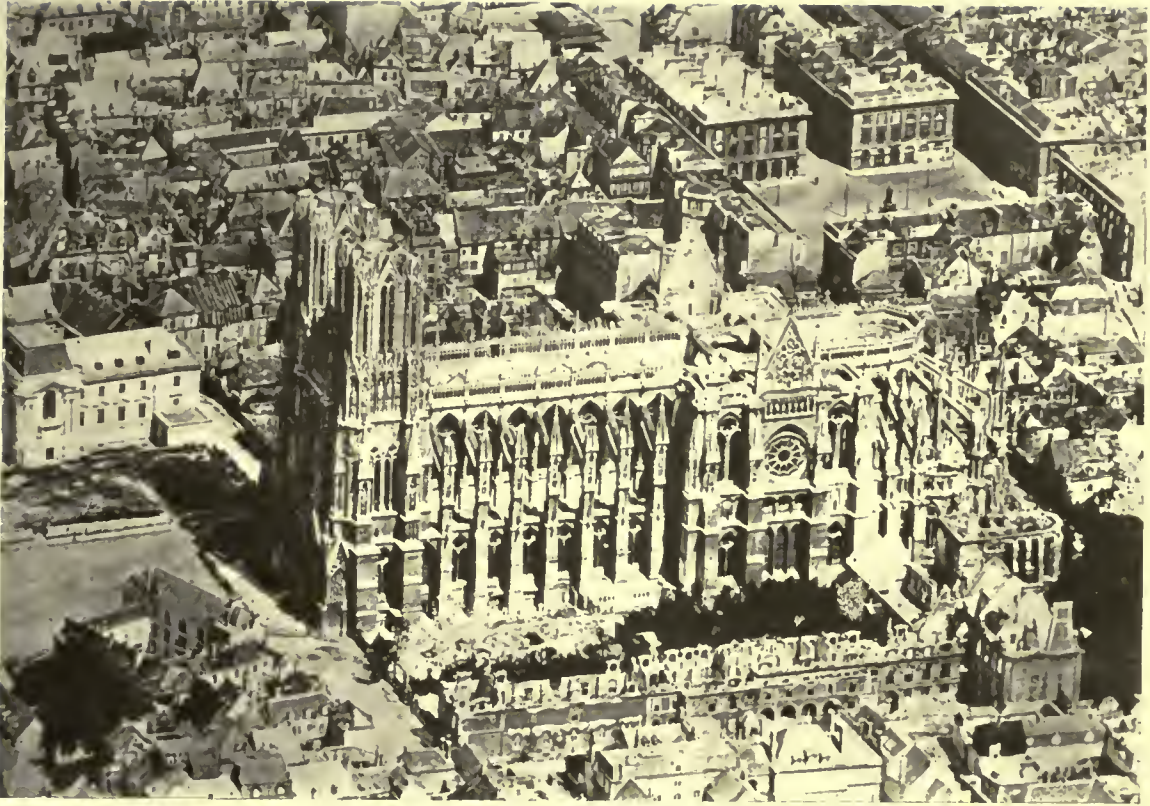

RHEIMS, FROM THE AIR

Reconstruction of Northern France—Part II

By RALPH FANNING, *M. A., B. Arch.*

The Northern French Village Before The War

THE present day tourist, bent upon obtaining "de luxe" all the war thrills that a well organized Cook's can crowd into a trip of several days, is hurried from the Somme through the departments of the Aisne, the Ardennes and the Meuse. If he registers impressions well, he is rather certain to return with crowded reels of battlefields, trenches, desolate landscapes and destroyed towns, recorded on his mental films. After being deeply impressed by the great waste areas of the old battle lines, awed by the vast destruction outside of Verdun, and thrilled by battered Rheims with its great cathedral, more majestic than ever, towering above the ruins with an immortal beauty, he has, perhaps, little energy left for the contemplation of reconstruction problems for these tragic scenes. Yet there is a feeling among most who have witnessed these scenes that all expediency should be used in erasing and obliterating the scars of war, as one would try to

conceal the blots upon the records of a boasted civilization. Nature has already done much to heal the wounds. Man, shackled with all the fetters of complicated political and economic modernism, must strive to do his part.

In approaching the problems of reconstruction in Northern France, it may be well for one to carry a mental picture of the pre-war village of these districts, so few of which have not been sadly changed. There is the immediate need of recreating the villages, churches and farms, that are now but crumbling masses of ruin, to facilitate the continuation of a course of life that centuries of civilization had developed. Americans, for the past fifty years, have been accustomed to seeing cities spring up in a marvelously short space of time with the rapid growth of virile industries. The West has frequent instances of this mushroom growth in its municipal life, but it is invariably upon virgin fields nourished by undrained resources.

THE AMERICAN ARCHITECT

Such are not the problems of Northern France. Here is a country exhausted of much of its natural and artificial wealth, but already refilled with a loyal, pathetically home-loving people bound by certain very strict traditions of life and building. To understand this and approach the problem in a just manner, one must try to recall the little French village in its pre-war days—the little village because these harbor much that is real and true and worthy of preservation in French national life.

Let one close one's eyes for a moment on the debris and barbed-wire, on the acres of crosses



A VILLAGE STREET

and the fragments of churches and try to recall the picture of another day. Let it be a picture on a day in spring or early summer in 1912 or 13. A turn on a hard white road revealed a cluster of warm red-tiled roofs huddled about some towering gray spire in the midst of many colored fields running over the slightly rolling hills like a grandmother's crazy-patch-work quilt over a soft feather-bed. Fresh greens and yellows and madders with strips of dark woodland and gray willow banks enframed the village: smoke blue horizon and distant hills melting into freshly washed sky-blue made a background. It was a picture to entice one to turn from the dust growing road and stop by the blue smocked old stone-breaker, leisurely pounding in the shade of the wayside fruit trees, to ask

the name of the "petite ville" and inquire as to which of its cafés would serve the best supper. The name of the village might have been "Villers en Argonne" or "Dun sur Meuse" or numerous variations of "Clermont" or "Brabant," of "Beauchamps" or "Chaufontaine." One was sure to find the recommended Café de la Madeleine or Café du Singe Verte or Hôtel de Paix, with its genial, bemoustached host and politely shrewd Madame to give one welcome and cater to one's desire for "café au lait" or "vin rouge ordinaire."

There would usually be one long main street on either side of which the century old houses clustered, leaning on one another in relaxed familiarity. Soft yellow and gray stone might be varied by plaster and half-timber, while a more vivid brick might add a warmer note to harmonize in the moss-grown tile roofs and terra cotta chimney-pots. Gentle freedom, but no license, was the key-note of the village street. A graceful curve was in its course and to its line the houses conformed. Here, the street might invite domestic intimacy and even familiarity as it gave place for farm carts around a drinking trough, or for the games of a crowd of black-aproned garçons. Beyond, realizing its public importance, it would widen out into pronounced formality to announce the mairie by an introduction of trimmed planes or rarer clipped yews. It might even develop into a proper village square with a fountain and promenades for public functions or space for an out-door market-place. Then, relaxing from the dignity demanded by municipal life, the friendly road would take an easy curve down over an old stone bridge, even giving way to such wanton abandon as to dip into the flowing stream where old housewives on their knees in boxes of straw, with back-aching industry, paddled the linen white in the frothy waters.

IN many villages, the dusty highway would have a rival for its locomotive interest in the canal with its shady cow-paths, its locks and bridges, inviting prolonged interest. An old stone cross by the roadside, a niche sheltered Virgin enshrined on a bridge, proclaimed devout progenitors. If such did not call forth the obeisance of the passing marketman, a deserted stone "octroi" might well make him give thanks for the better day when an eighth of his produce did not have to be surrendered as toll or tax to stronger though worldier powers.

Over road and bridge from field or barge, the peasants would come driving their tandem teams before loaded two-wheeled carts, or with village flock or herd with barking dogs and squalling geese to arouse the village from its afternoon quiet. The doors of the old houses would open to admit

THE AMERICAN ARCHITECT

the homecomers and emit the savory odors of cooking suppers. The wider street doors with stone arches or great oaken lintels supporting the wall above, admitted the teams and cattle into the rear courtyards where, in compact quarters, were the seats of household activities, be they agriculture, commerce or craft. Passing from the courtyard into the house, which also opened directly from the street either as shop or dwelling, one found a simple arrangement. The main room was the living room in fact, with cooking range or great fireplace with its shining array of copper and pewter; the table laid with colored linen and figured plates and bowls; flowers blooming in the small windows and cat and canary to welcome one into the family. Perhaps a spiral stairway in the corner led to sleeping rooms above with their great feather beds covered with red satin "duvets" reflected in the much belabored parquet floors. Great ceiling beams would tell of the age of the house built in the days of rough hewn but solid construction.

Hospitality was the law of the land, the inn simply being a home where it could be dispensed with greater ease. It would be built and furnished like the other homes, but naturally on a somewhat grander scale, and with a more conspicuous frontage for the public gaze. Exteriorly, nearly all presented the same appearance of soft stone walls with pleasing variations of wood and plaster, small panes in casement windows behind wooden shutters, moderately pitched roofs with dormers symmetrically placed, but saved from any monotony by varying levels and varieties of hipped gables and unexpected chimneys.

Mingling in the common conversation of the inn, it would be strange if one did not hear some refer-

the saintliness or villainy of its occupants, seem ever to have been an important factor in village life, and the building the object to be pointed out with pride to all visitors. There was something invariably characteristic, invariably charming about the French country-seat, although the last century had witnessed the building of many that did not add



THE CHATEAU-WALLY—MEUSE

to the credit of architectural taste. In most cases might be found a graceful setting, a studied formality and a pretentious design. These, of any class of buildings in the invaded regions, seem more often to have escaped damage except by occupation.

Dominating over all the village architecturally as well as socially, would be the church. Volumes could be written about the part the church has played in French life, and nothing could be of more interest than these structures which greatly antedated any other building in the village. Often reaching back almost to Roman times, they were built with a solidity that, until the great war, had defied most of the destructive agencies of time. The rest of the village might change, burn or decay, but the church remained the main motif of the village picture. Simple, basilican types, these churches would often show excellent stone vaulting over the nave and side aisles with massive supports of columns and thick walls. The small windows would be filled with well executed stone tracery and bits of early glass were not rare, although in the poorer districts, much of the glass was painted. A Ro-



FARM CHATEAU IN THE MIDST OF THE ARGONNE—BEAUCHAMPS

ence to the chateau. This might be only an isolated little mansion apart from the village, or, on the other hand, a grand affair set in a wide park with elaborate gardens. In any case, the chateau, with

THE AMERICAN ARCHITECT

manesque tower of sturdy proportions seemed often to antedate and oddly join a later Gothic structure, but in most cases this formed the dominating feature regardless of the more recent additions of copper plated turrets, ogive openings or Rococo



BRIZEAU—MEUSE

doorways which different periods imposed upon the chief architectural structure of the village.

IN such a setting, one can picture the pre-war village of the now devastated regions of Northern France. Of course, the villages and towns were not all the same. In fact, one of the most typical things about French villages at large was their individuality, each with its prided feature of ancient tower or historical shrine or, perhaps, only its reputation for the output of a special brand of "confiture." Another typical characteristic was their isolation and contentment with such, for many were the old dames who had seldom if ever traveled beyond a ten kilometer radius. Yet, village life had much that was common to every other village.

France, the land of democracy, had in its local government all the merits of an autocracy, not to mention any of the defects. As the character of the prefect, so were the affairs of the department; as the character of the mayor, so was the rule of the village. Once the mayor had his affairs of State safely in hand, his powers were immense, being disputed only by the curé and the schoolmaster with their more limited temporal potentiality. With the houses of a village all grouped together, there was little of the isolation of English and American family life where a man's house is his castle. The Frenchman's home was the property of his neighbors. They were about as "au courant" with what went on within its walls as he himself—more so if he worked long hours in his fields and they kept shop next door. Hence the feuds and many tasks for the mayor and curé who must needs have a share in all. This communal and congested life was no doubt a product of early feudal days when

men of necessity lived close together for protection and defense. Thus the Frenchman inherited, together with his towny little village, a dread of living alone and a love of village life and his neighbor's affairs.

The village life was also promoted by the land system which made each man owner of his own strip of land. Thus if a man with thirty hectares of land had six sons, each son automatically became heir to five hectares, which on their death would again be subdivided. Endless subdivision continued until the whole countryside was divided into small strips which, planted in different crops according to individual desires, made the landscape look like a futurist painting. One cultivator might own a dozen or more separate patches scattered around the village, necessitating his spending his time in hand labor and in going from one patch to another. The system tended to make the transfer of land difficult and any one such "terrain morcele" too small to accommodate anything like proper farm buildings. Thus the farmyard, huddled and insanitary, was apt to be in the village. With all the disadvantages of this old system, it probably helped to give the French peasant that independence and stability of character that proved so great a strength to the nation in her days of stress.

Nor were the tradesmen and craftsmen less in-



A VERANDA—CHAUMONT

dependent and sturdy. Crafts and trades were often inherited, passing from father to son. Particularly in the building trades, did one find prevalent a love of well executed work, a pride of craftsmanship and a personal interest in handicraft as opposed to the machine made. A man might win a lifelong repute and live under a halo of local re-

(Continued on page 77)

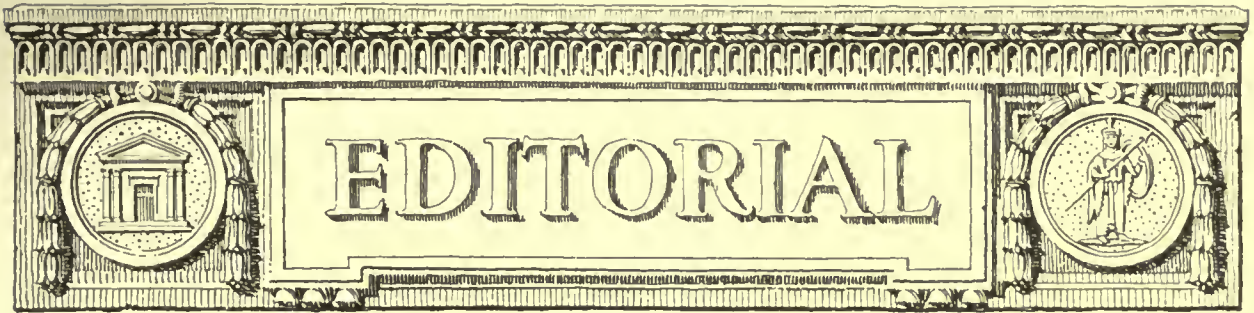

Regaining Knack and Efficiency

FEW men who took part in the late war, either on land or on the sea, either as soldier or sailor, followed in even a limited degree the same class of work they had been engaged in when they took up arms. The question arises whether cessation from a certain type of work, in many cases the result of special training, causes impairment of ability when resumption is attempted, or whether the enforced change from a previous occupation has been in a sense rest, effecting increased vigor and a largely augmented power for performance.

One of the errors in both naval and military administration during the world conflict was that the governments failed to assign men by special selection to a line of duty for which they might be assumed to be well fitted by previous education. Take architects and engineers for example. It is well known that men of unquestioned ability in these two professions were assigned to duties very far removed from work for which they had previously been thoroughly trained. It was not until almost the very close of the war that this error was realized. And after the armistice, in the way of preparation for peace, schools of instruction were started in France and conducted under men specially selected for their ability. The good results have been widely acknowledged. But of that large class of men who were compelled so radically to change their daily activities as completely to disassociate them from former work—what has been the result? Have they resumed their civilian activities better equipped than before, or have they suffered a lack of enthusiasm? It would be interesting to learn the opinion of readers of this journal who have seen service.

THE ARCHITECTS' JOURNAL of London, editorially discussing the matter of "regaining knack and efficiency," states the opinion that it has been the experience of most men that knack and knowledge were more easily lost than acquired. Continuing, it is stated: "In five years or more of dis-

use, the mechanic lost much of his skill of hand—his 'touch,' his 'knack,' his habit of concentration. In most instances the old mechanical dexterity will be restored through renewal of steady application to the old work. In this comparatively simple matter of handicraft there is no other way, although the craftsman anxious to recover his old form will be less disdainful than it is said that he used to be of the aid of technical manuals. To these he will now turn more eagerly than ever before in the hope that they will show him a short cut to the recovery of his old skill and efficiency. More difficult and more painful is the effort of the professional man to 'come back to his old form.' Not only has much of his laboriously acquired knowledge completely evaporated, but some of that which has remained with him he finds, to his dismay, is incomplete and out of date. He cannot apply it easily to the new conditions that have sprung up during his absence."

Considering the case of the professional man, just how far may the statement that it is a difficult and painful effort for the professionally trained man to "come back to form" be correct? The first impression is that the case is over stated, this impression being formed by association with men who have come back to "form" and in many cases much better form.

Some professional men, it is true, used and developed their knowledge (often in a sea of detail), but these were chiefly in the sciences. Some artists developed out of the material at hand both their technique and their vision. But the architect, an amphibious animal, what of him? So far as the creative side is concerned, he may well be compared with the artists. It is a well recognized fact among painters and sculptors that a complete rest for long periods from application to their art makes for increased efficiency. Even though a painter may lay down his palette and never touch a brush for many months he will be unconsciously studying and analyzing form and color wherever he finds it. Meantime he has opportunity to digest what he already knows, docket it in his subconscious mind, and when

THE AMERICAN ARCHITECT

he resumes his work he finds that he has made progress and has increased ability.

It would seem that every professional man would find the same results through a period of abstention from professional effort, and that no matter what a man's work may have been before he took service under the colors, he would be better fitted to take up that work on his return. Is this reasoning correct?

The Facts About the Car Shortage

WASHINGTON is filled, it is said, with representatives of all classes of shippers who are there to make application for cars. Invariably they are being turned down—hundreds every day—and are compelled to leave the city without obtaining any satisfaction or encouragement. The two committees which have authority over the disposition of all railroad stock, that is to say, the Car Service Bureau of the Interstate Commerce Commission and the Commission on Car Service of the American Railroad Association, find themselves unable to promise anything like immediate relief from the car shortage.

During the war not more than 100,000 cars were constructed, an amount far less than the number of cars retired. And now it is stated that a large number of cars still in service must soon be discarded. Never in the history of America has our transportation system been so nearly broken down.

Just before the closing of its late session, the United States Senate appointed a Committee on Reconstruction and Production. One of the chief duties of this committee is to investigate the causes for the existing car shortage, and for this purpose hearings are to be held in various parts of the country. But most important among the measures for relief already active is that the Interstate Commerce Commission has recommended a loan of \$125,000,000 out of the revolving fund authorized by Congress. In order to avail themselves of this assistance the carriers must organize separate corporations which shall advance an amount equal to that loaned by the Government. This they are preparing to do, but it will mean at least a year before the equipment authorized can be made available.

ANOTHER development which seems significant is the purchase of rolling stock by the industrial companies. For, although this amounts to but a few thousand cars, which is but slight relief,

still it promises a more immediate effect and gives the car shops which have been operating at about 10 per cent. of their capacity a chance to increase their production.

The situation just at the present time is complicated to the utmost degree. Statistics of many of the roads show that with the limited rolling stock which is available they are handling a greater volume of tonnage than for many years. But there seems to be trouble not only with the shortage of cars, but with the congestion of the terminals as well. Several thousand cars loaded with coal are now at the Atlantic seaboard awaiting export. This tie-up will not be increased, as an order has now been issued prohibiting further exportation of coal; but such an order cannot be prolonged indefinitely, because the Government is committed to the shipment of a large amount of coal to Italy. The Gulf ports, it is said, are encumbered with large numbers of cars of miscellaneous material which await the arrival of steamers before they can be unloaded. Efforts are being made to find storage space in order to relieve these cars.

The condition of the terminals was made worse by the strikes of the switchmen, those so-called "outlaw" strikes which were carried on either as a protest against the delay of the Labor Wage Board or else in the interest of the Plumb plan.

EXTREME efforts have been made to locate equipment in which to handle the crop, and adverse criticism was aroused when for this purpose many cars were sent empty from the East to the grain belt. It was explained that if these cars were loaded for Western destination there would be no certainty that they would not be diverted and become unavailable for the shipment of grain.

The rule prohibiting the use of open cars for anything but the transportation of coal has also created loud protest. It was shown, however, that unless the coal was moved now and stored there would be severe suffering in the coming winter.

On the whole it seems a tangle of almost unsurmountable difficulties. The solution calls for that aptitude in administration and organization which is assumed to be typically American. The public was warned six months back that it must have patience with the railroads during a period of restoration. The public has patience under its inconvenience—lots of it. But the public is impatient to see attack vigorously applied to some vulnerable point of this tangle.

THE AMERICAN ARCHITECT

Reconstruction of France

(Continued from page 74)

nown because he, Monsieur le Charpentier, had made the wooden cock, the vane that turned on the village church spire. Rather much of a solo performer, the French craftsman liked to do his job in his own way, and what better way could there be since it was the way his father and grandfather

that went its leisurely course under the slowly warping roof tiles and down their quiet village streets. Whether they are pictures to be restored or not, only time can tell, but certain it is that the world of beauty will be the loser if the picturesque charm produced by their simple building be unheeded and discarded.



HONEST STONE WORK OF THE MEUSE

and, no doubt, great and greater grandfathers had done before him? Trade unions with rules and hours might flourish in larger towns, but they did not greatly concern Monsieur le Maçon in his little village. Yet among him and his companions there seemed to exist more of that spirit of the old craft guilds that made mediaeval France productive of some of the most beautiful of buildings.

Such are but a few ill-illuminated pictures of the pre-war village of Northern France and of the life

Co-operative Art Building

At a meeting of representatives of seven art organizations, the American Institute of Graphic Arts, the Art Alliance of America, Louis C. Tiffany foundation, National Society of Craftsmen, Pictorial Photographers of America, Society of Illustrators and Society of Jewelry Designers, held recently, the plans of a proposed Co-operative Art Building, to house, with offices and exhibition rooms, the Societies above noted, and to afford a much-needed assembly place for all Metropolitan art organizations were discussed.

The purpose of the co-operative building is briefly as follows: To avoid duplication of effort, obtain a common meeting place and exhibition galleries, each society to have its own quarters with a central office and staff. The unity of these organizations will reflect on public taste, inspire a keener appreciation and elevate the standards and usefulness of the crafts, the graphic and the industrial arts to the benefit of the artist, artisan, producer and consumer.

There are now more than 100 separate art organizations in New York City with more or less common aims, the majority of which have no permanent headquarters, because there is now no central clearing house for the co-ordination of their interests and efforts, and because there is no permanent exhibition and sales galleries for general promotion of their interests.

There are more workers in the various crafts in New York City than in all the rest of the United States and infinitely greater demand for the production and sale of their work. In spite of that, other cities with smaller population, less wealth and demand have large, flourishing and profitable headquarters.

Such a unity of effort will inspire higher standards of art and their application to trade, because such a unity of effort will increase the efficiency of each organization and strengthen the individual aims.

The organization plans to purchase two or three houses in an accessible and central location, to remodel them with exhibition galleries, auditorium, individual organization rooms, central office staff, salesrooms and restaurant.

Are Apartments Necessary?

An Important Test as to the Legality of Zoning Regulations. Judge Kramer Rules Against Establishment of Apartment Houses in Resident Sections

THE legality of regulation for different types of residence district was tested recently in an interesting case in East Cleveland, a suburb of Cleveland, with a population of about 30,000 administered under the commission form of government. The case arose from the refusal of the building inspector to issue a permit for the erection of eight apartments in a zone restricted to one or two-family dwellings. After a decision adverse to them, according to a report in the *Survey*, the plaintiffs secured a rehearing at which, in addition to the city manager, such authorities as Haven Emerson, former health commissioner of New York city; Robert H. Whitten, adviser of the Cleveland City Plan Commission, and Paul Feiss, chairman of the housing committee of the Cleveland Chamber of Commerce, gave evidence. In sustaining the earlier judgment, Judge Kramer said:

It would seem that there could be no two opinions upon the proposition that the apartment house, or tenement, in a section of private residences, is a nuisance to those in its immediate vicinity. Under the evidence, and as a matter of common knowledge, of which the court may take judicial notice (16 Cyc. 582), it shuts off the light and air from its neighbors, it invades their privacy, it spreads smoke and soot throughout the neighborhood. The noise of constant deliveries is almost continuous. The fire hazard is recognized to be increased. The number of people passing in and out render immoral practices therein more difficult of detection and suppression. The light, air and ventilation are necessarily limited, from the nature of its construction. The danger of the spread of infectious disease is undoubtedly increased, however little, where a number of families use a common hallway, and common front and rear stairways.

The erection of one apartment house in a district of private homes would seriously affect only those persons living in the immediate vicinity thereof, but the common experience is that the erection of one apartment drives out the single residences adjacent thereto, to make way for more apartments. The result is that, in time, and not a very great time, when one apartment is erected, the

whole street is given over largely to apartment houses.

With the growth of its population, it appears to be practically certain that unless restricted, the greater part of East Cleveland will be built up with apartments, and the home owners must choose either to adopt apartment life or abandon their depreciated property, and move out of the city or into its more remote parts.

If the claim of the relator here is sound, a city of private homes, grass plots, trees and open spaces, with the civic pride and quality of citizenship which is usually found in such circumstances, is powerless to protect itself against the obliteration of its private residence districts, by apartments, which shut out the sun and sky from its streets, and one another, and are generally owned by those whose greatest interest is in the revenue that the building will produce. If such is the law, it must be conceded that it is unfortunate.

The apartment house is, for many, a desirable convenience and, for some, a necessity. They are a recognized necessity in cities of any size. Their erection should not be prohibited and, under this ordinance, are not prohibited. Private residences, with yards for play spaces, with grass, trees and flowers, are necessities for people with children, and as much a convenience to the people without children who take an old-fashioned pride in owning their homes, as is the apartment to those who are willing to accept its restrictions for its compensatory freedom from responsibilities. It is at least equally important to preserve the private home for this class as it is to provide the apartment for the first. Under this zoning ordinance, both the private home is preserved and the apartment house is provided.

It seems eminently fair to restrict the apartment builder to a limited area, where his use of his property will do the least damage to others and to the community. The necessities or convenience of those who live in them will be served thus with the least sacrifice of the necessities and conveniences of others. Whatever of the burden arising from apartments there is, will be borne by those whose purposes they serve, and not shifted to the other property owners of the city, to make their property unfit for use as a home.



FINAL STAGE, NEBRASKA STATE CAPITOL COMPETITION
WINNING DESIGN
BERTRAM G. GOODHUE, ARCHITECT

78'

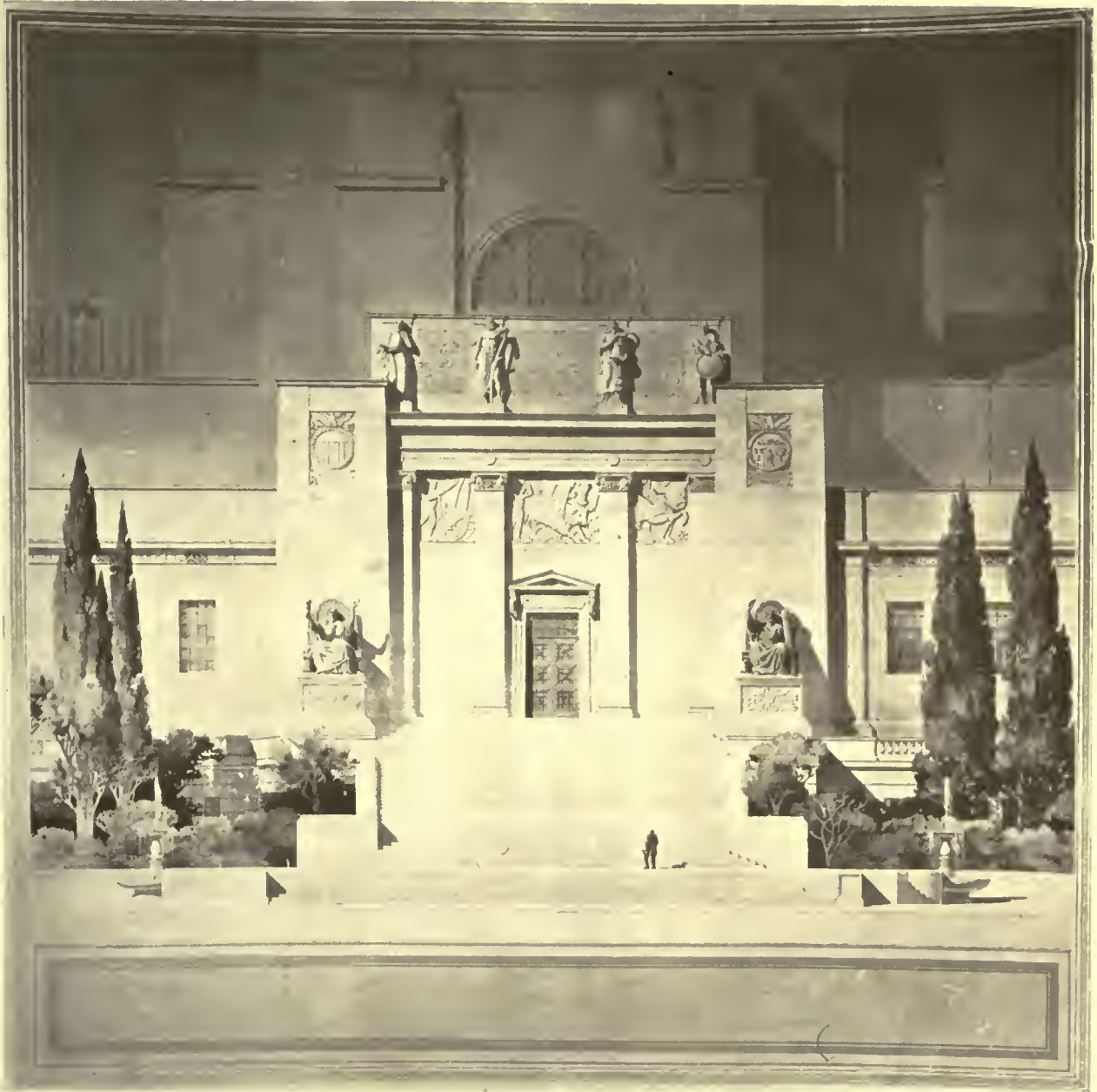

FINAL STAGE, NEBRASKA STATE CAPITOL COMPETITION

WINNING DESIGN

BERTRAM G. GOODHUE, ARCHITECT

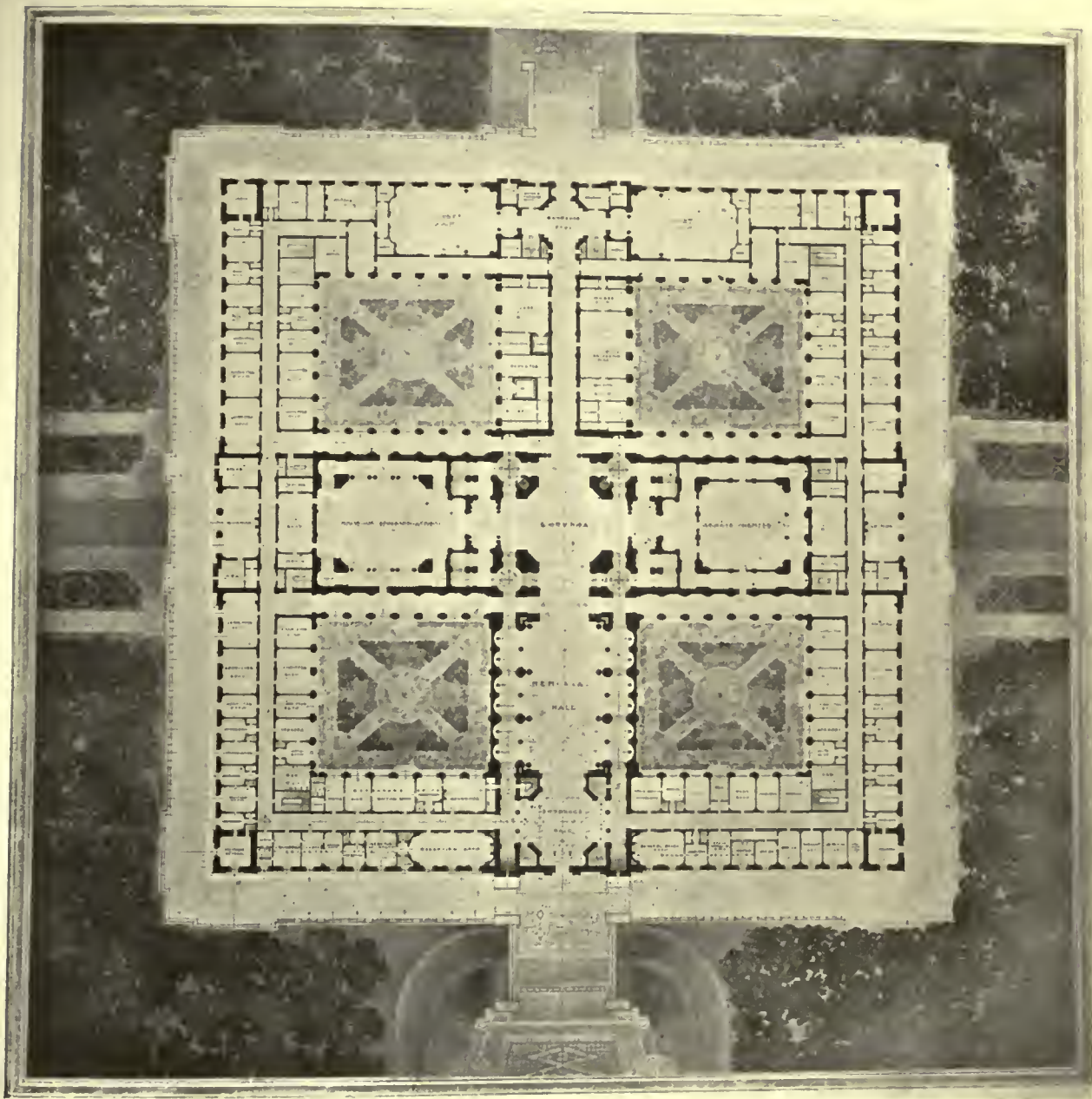

FINAL STAGE, NEBRASKA STATE CAPITOL COMPETITION
WINNING DESIGN
BERTRAM G. GOODHUE, ARCHITECT

72³





FINAL STAGE, NEBRASKA STATE CAPITOL COMPETITION

DESIGN SUBMITTED BY

JOHN RUSSELL POPE, ARCHITECT

284

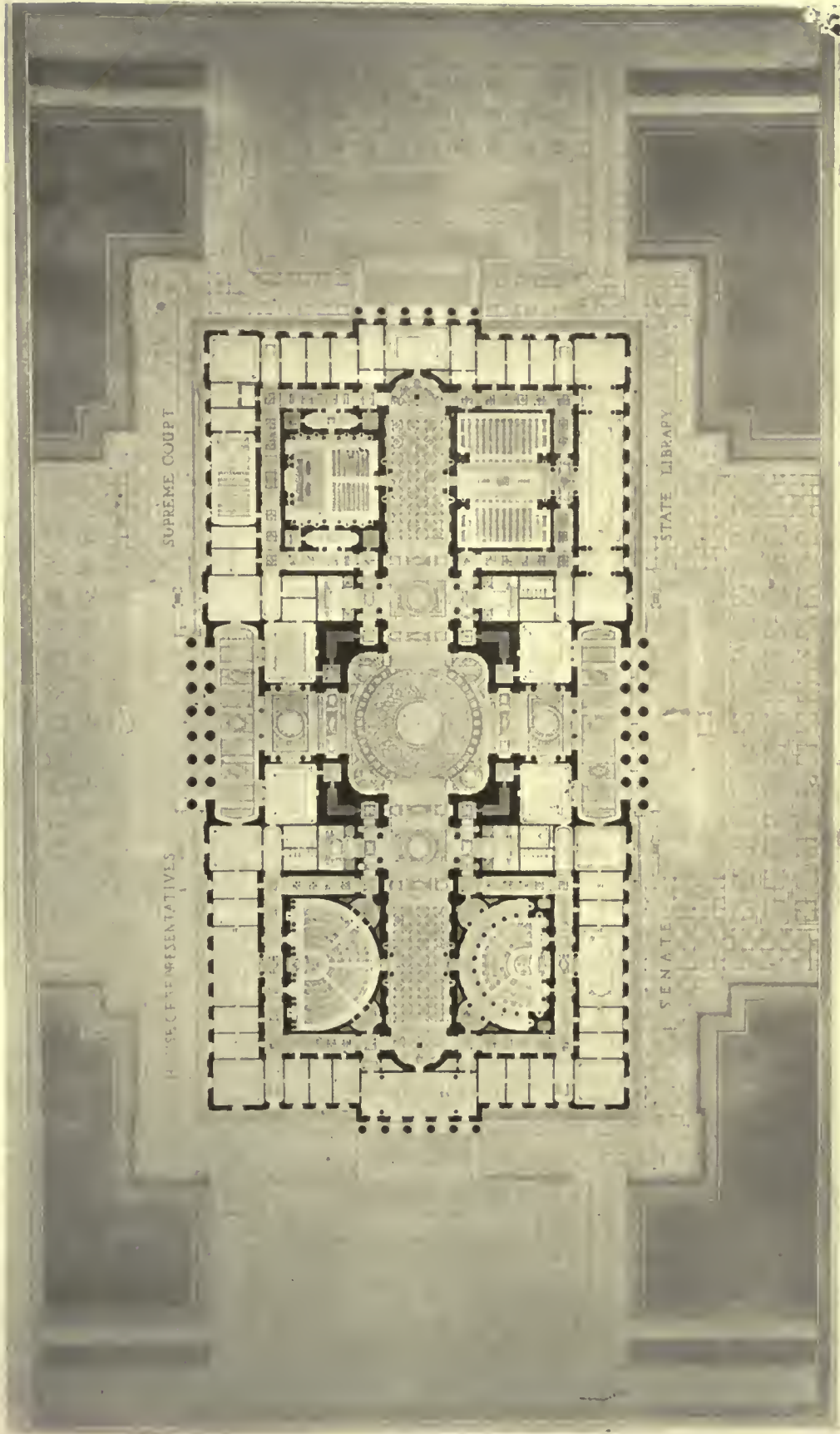

FINAL STAGE, NEBRASKA STATE CAPITOL COMPETITION

DESIGN SUBMITTED BY

JOHN RUSSELL POPE, ARCHITECT

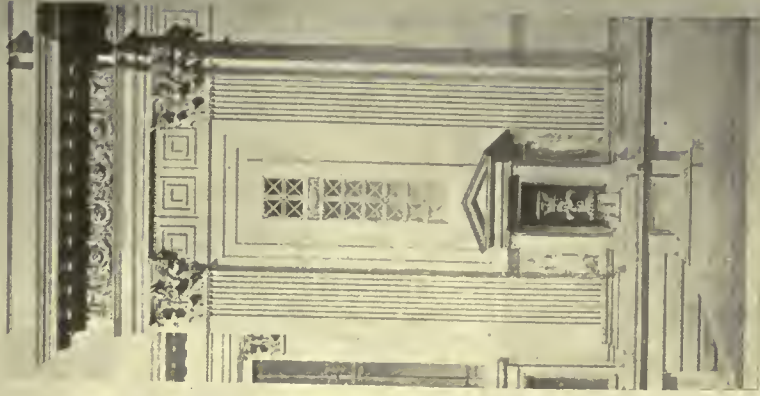

FINAL STAGE, NEBRASKA STATE CAPITOL COMPETITION

DESIGN SUBMITTED BY

JOHN RUSSELL POPE, ARCHITECT



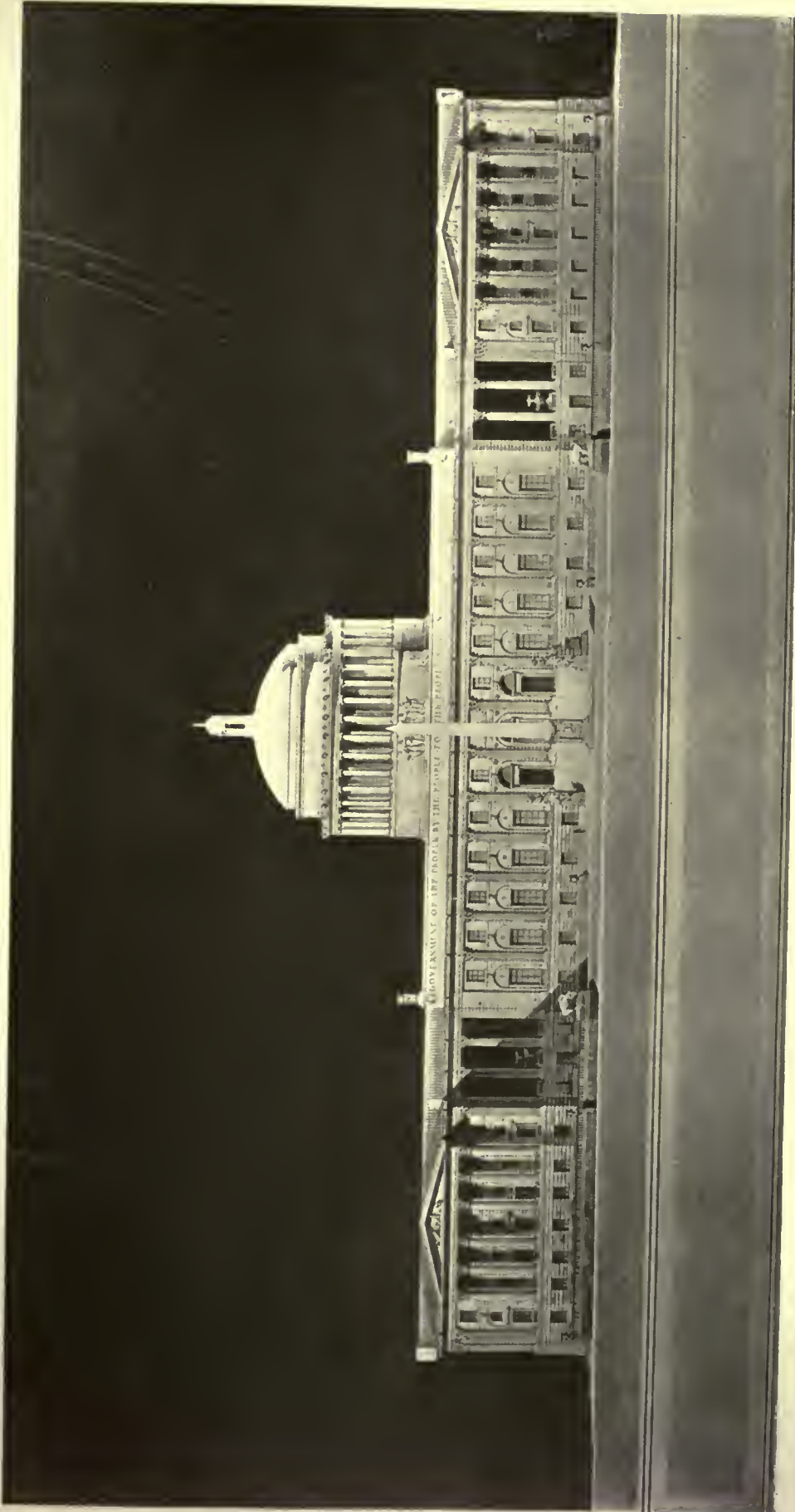

FINAL STAGE, NEBRASKA STATE CAPITOL COMPETITION

DESIGN SUBMITTED BY

McKIM, MEAD & WHITE, ARCHITECTS

787



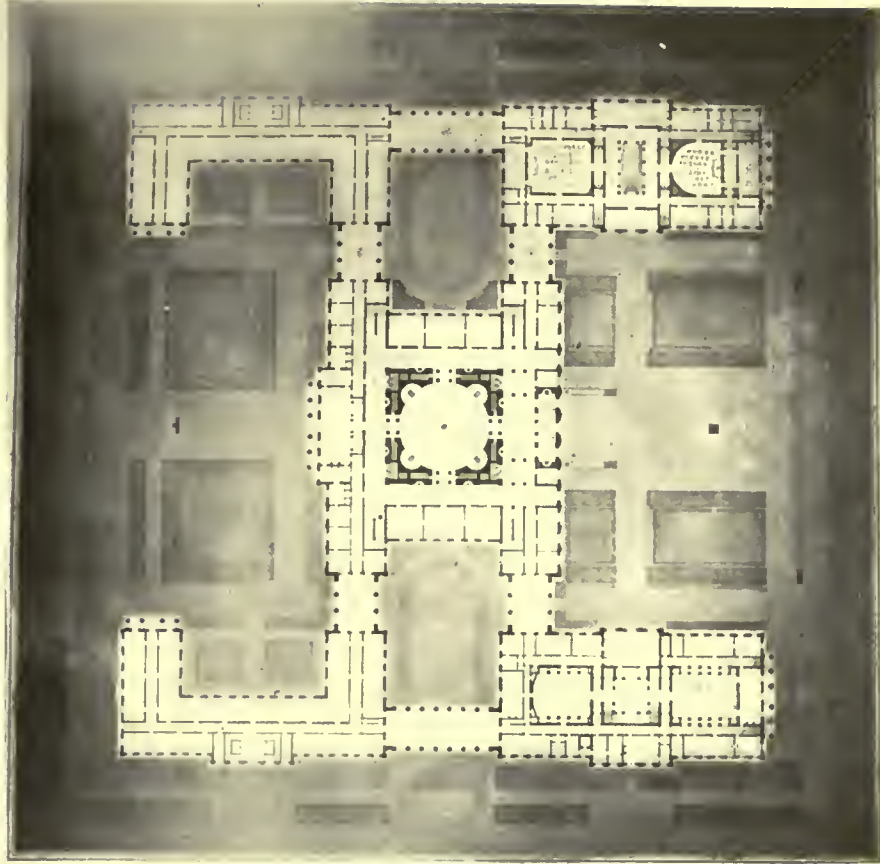
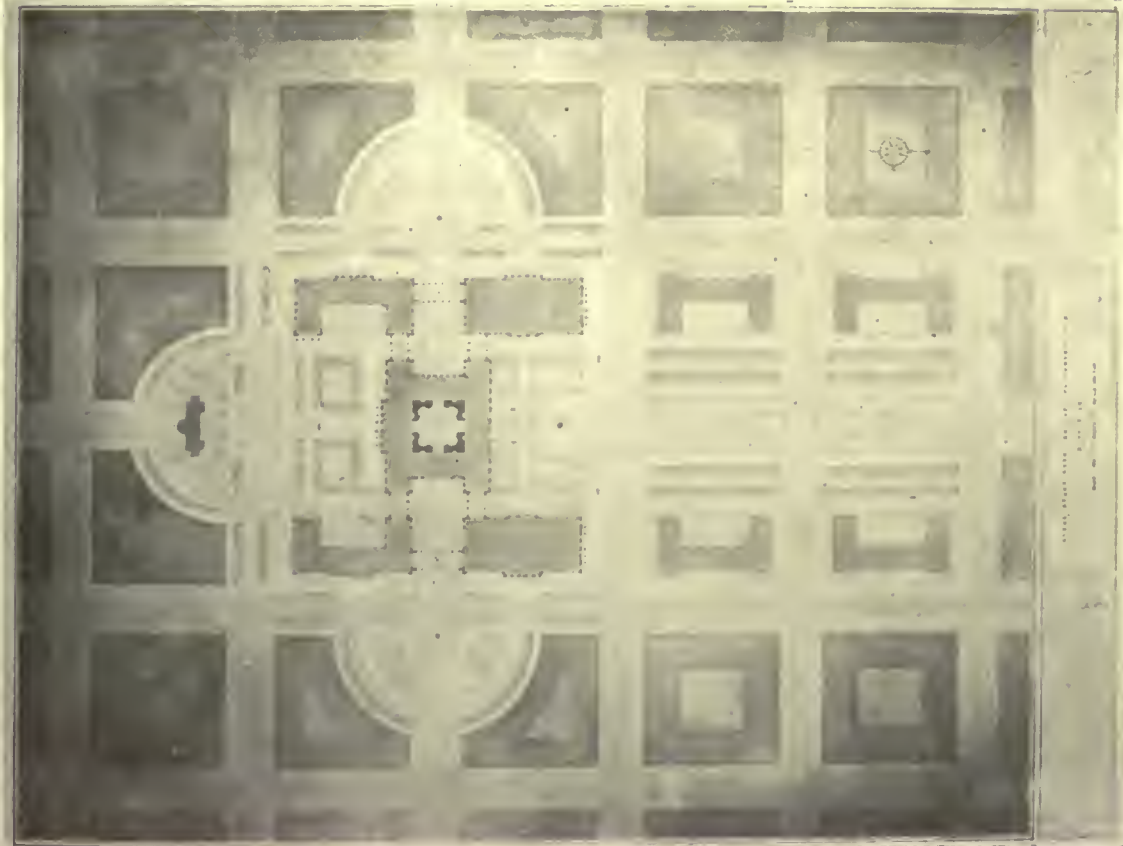

FINAL STAGE, NEBRASKA STATE CAPITOL COMPETITION

DESIGN SUBMITTED BY

MORIM, MEAD & WHITE, ARCHITECTS





A PROPOSED CAPITOL FOR THE STATE OF NEBRASKA IN THE CITY OF LINCOLN

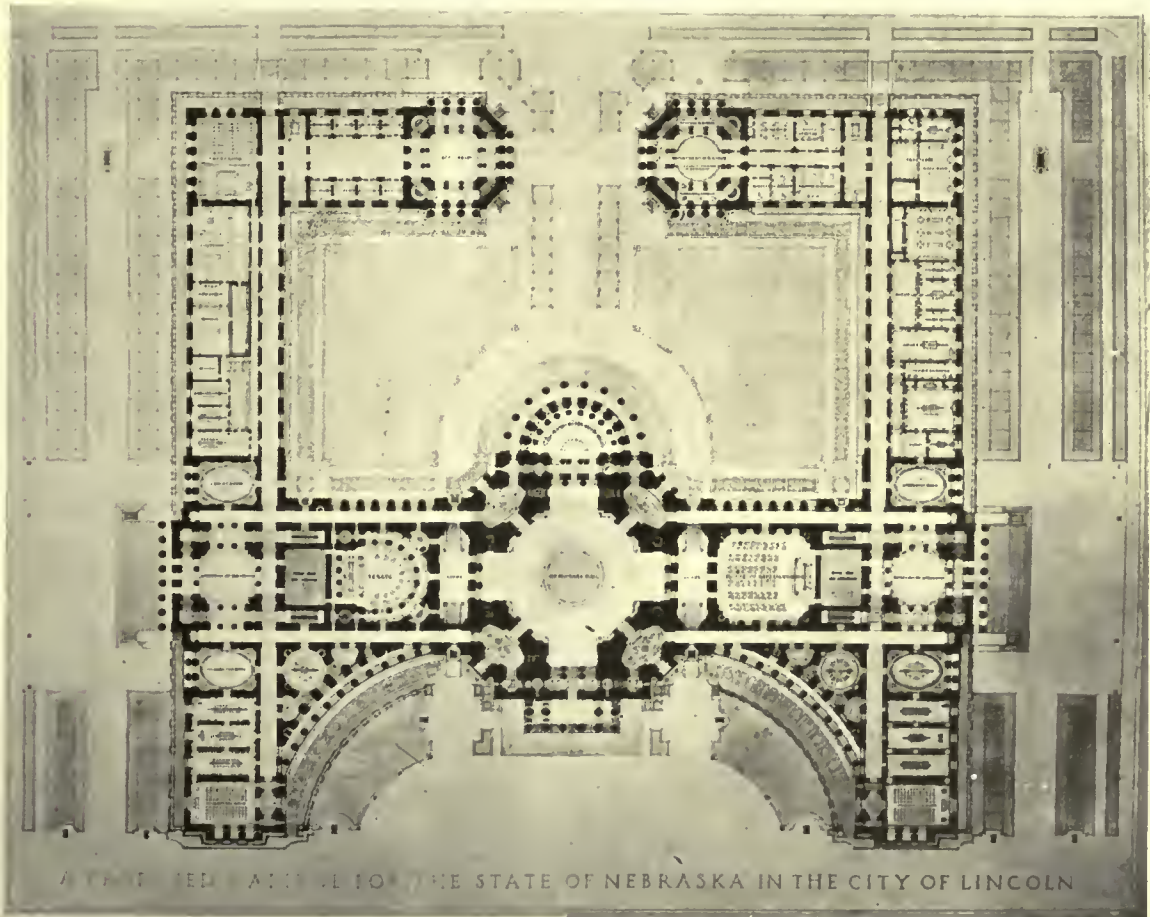

A PROPOSED CAPITOL FOR THE STATE OF NEBRASKA IN THE CITY OF LINCOLN

FINAL STAGE, NEBRASKA STATE CAPITOL COMPETITION

DESIGN SUBMITTED BY
TRACY & SWARTWOUT, ARCHITECTS

78⁹



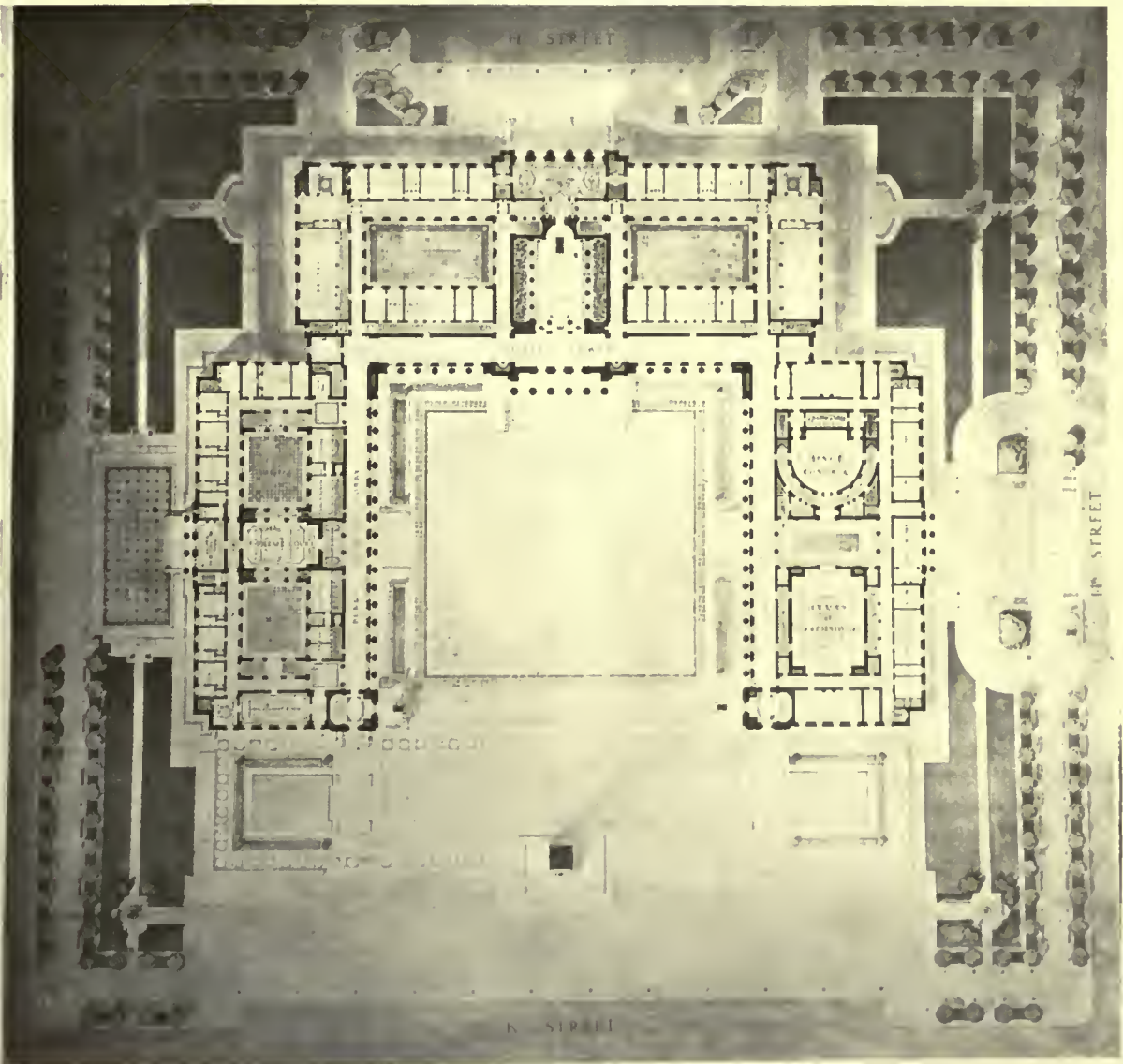

FINAL STAGE, NEBRASKA STATE CAPITOL COMPETITION
DESIGN SUBMITTED BY
PAUL P. CRET AND ZANTZINGER, BORIE & MEDARY, Architects

78¹⁰

Nebraska State Capitol Competition

Statement by the Capitol Commission

AS RECITED in the program for the preliminary stage of this competition, the ultimate object of the Commission is to secure to the citizens of Nebraska the best Capitol that is obtainable under present conditions. In adopting a competition as the best means of selecting an architect, the Commission is following what it believes to be the best custom, and in detail is being guided by the usage of the American Institute of Architects, and in accord therewith has appointed Thomas R. Kimball, Architect, of Omaha, Nebraska, its Professional Adviser, and has conducted the preliminary stage of this competition under his guidance.

As to plan, scope, style, type or material, the capitol commission will offer no suggestion. Even in the matter of tradition it is clearly the desire of the commission that each competitor shall feel free to express what is in his heart, unmindful of what has been inherited in this regard, willing even that the legacies of the masters should guide and restrain rather than fetter.

While the commission is very anxious not to handicap the competitors, or to limit the possibilities, it is nevertheless quite clear on much that it seeks to realize in the final result, and is certain to be disappointed should the capitol finally erected not prove to be:

AIMS SUMMARIZED

First—A practical working home for the governmental machinery of the state; adequate not only for present needs, but with provision made or anticipated for development and growth for a century to come.

Second—An inspiring monument worthy of the state for which it stands; a thing of beauty, so conceived and fashioned as to properly record and exploit our civilization, aspirations and patriotism, past, present and future; intelligently designed, durably and conscientiously built, and of worthy materials; and all beautifully and fittingly set, surrounded, embellished and adequately furnished.

Third—The whole accomplished without friction, scandal, extravagance, or waste—a work calculated to inspire pride in every Nebraskan.

The commission believes that the following memorandum (New Capitol Requirements) quite accurately represents the requirements of the offices and departments for which provision is to be made, and offers it and the accompanying observations as representing its latest opinion. In studying these

suggestions competitors are referred to the accompanying pamphlet by Governor S. R. McKelvie, entitled "A Responsible Form of Government," and marked Exhibit "D," which includes the scheme of governmental machinery now being tried in Nebraska.

OBSERVATIONS ON ARRANGEMENT

Should a separate housing be suggested for some of the large and growing, though less conspicuous

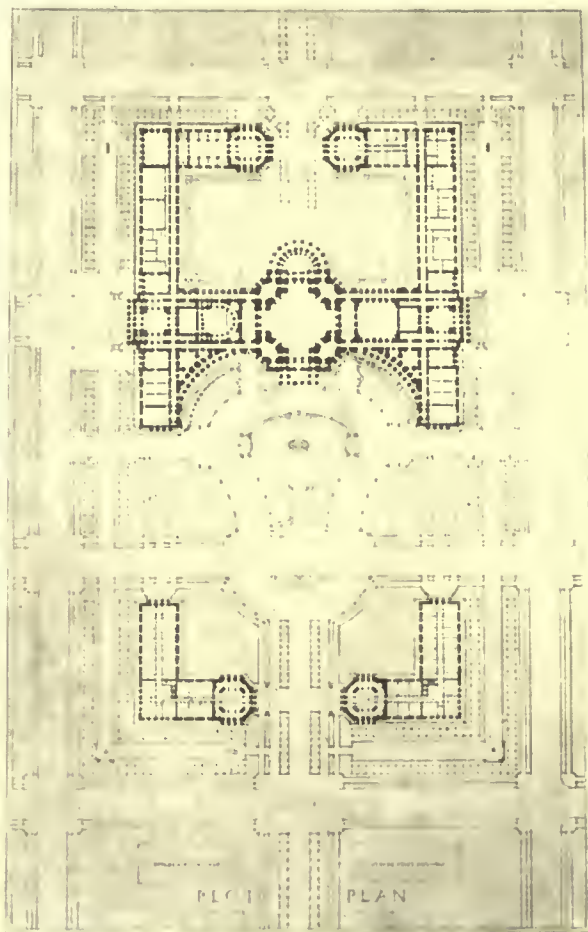

PLOT PLAN

TRACY & SWARTWOUT, ARCHITECTS

departments, it is pointed out that the monumental or more distinguished group or groups, should still include in addition to the legislative halls, supreme court and library, the offices and quarters for all the elective officials of the state and a war memorial room. However, the supreme court, state library

THE AMERICAN ARCHITECT

and attorney general's office might function perfectly as an independent unit. It is desired that each competitor charge himself with sufficient study of the requirements of state governments in general and of Nebraska in particular to enable him to offer a solution based on his original research and understanding of the whole problem: particularly is this desirable in the groupings of important departments with relation to each other, and of accessory elements with relation to the important units with which they are intended to function.

PURPOSES OF COMPETITION

Here, however, competitors are again reminded that in their solutions they are not asked to make working drawings or even sketches for any purpose other than *to aid in the selection of an architect*, and that the study of the broad problem is far more important at this time than striving for exact disposition of minor details.

NEW CAPITOL REQUIREMENTS.

SENATE CHAMBER (*thirty-three senators*).

For the senate there should be provided about twelve committee rooms with proper dependencies, and reasonable space for visitors.

HOUSE OF REPRESENTATIVES (*one hundred members*).

For the house of representatives there should be provided about twelve committee rooms with proper dependencies, and reasonable space for visitors.

LEGISLATIVE REFERENCES.

For this bureau, which functions only while the legislature is in session, there should be provided at least three rooms—reading room, reference library and stenographer's room.

SUPREME COURT (*seven judges and three commissioners*).

For the supreme court there should be provided two court rooms, two consultation rooms, ten judge's rooms, with stenographer's rooms attached, one lawyer's retiring room, all with proper dependencies.

One clerk's room to function with main court room and to accommodate clerk, deputy clerk, journal clerk, opinion clerk and stenographer.

An adjoining bookkeeper's room, and receiving and storing room for briefs, blanks, etc. A connecting vault and two reporter's room adjacent to state library.

STATE LIBRARY (*in same building with supreme court*).

A law library of 80,000 volumes, increasing at

the rate of 2,000 per year (400 feet of shelving added per year).

The state library should have an adequate reading room with separate rooms for receiving and forwarding, cataloguing, preparation for binding, and correspondence, with five or six small private rooms for dictation and a stack room with adequate ultimate shelving capacity.

ADDITIONAL REQUIREMENTS.

In addition to the above requirements, about eighty thousand square feet of floor space seem to be advisable.

THE OLD CAPITOL.

The present capitol is a four-story and basement building, of local limestone, in a very bad state of repair; it was erected in 1886, and is today wholly outgrown and inadequate. Its total length is three hundred twenty feet; the central portion measures one hundred by a depth of one hundred and eighty feet; the wings are ninety-five feet deep by one hundred long.

The site is practically level (sloping slightly from the building in all directions), and is generously covered with well-grown trees.

Prevailing winds are from the south in summer, and northwest in winter. The climate ranges between extremes, and the west exposure is hot, dry and glaring in summer. Manifestly the power plant should not be located on the building site proper; suitable locations on trackage and within practical distances are available and need not be given much consideration at this time.

It is estimated that about three-quarters of the traffic approaches from the northwest at present, with the major part of that coming from the west; also that fully one-half of those entering the old building do so by the west door, and about one-quarter by the east door, a distribution likely to continue indefinitely.

Present property lines, topography, neighboring traffic arteries, with car-lines and other public service contracts, will be shown on the Survey (Exhibit "C" herein) and the location in the city is shown on the map of Lincoln (Exhibit "F" herewith).

Attention is directed to French's bronze statue of Lincoln at present on the site. Solutions should consider this monument and suggest for it a proper part in the ensemble, preferably but not imperatively on the building site proper.

Nebraska produces practically no coal, and only minor lines of building material, thus relieving the problem of home-production complications and handicaps.

Current News

Happenings and Comments in the Field of Architecture and the Allied Arts

Landscape Architects Meet

A number of leading authorities on landscape architecture were present at the national conference on professional instruction, recently held in Cambridge. The architects met on the invitation of Professor James S. Pray of the Harvard School of Landscape Architecture, and represented thirteen institutions over the country. Among the delegates were Frank A. Waugh of Massachusetts Agricultural College, who is in the employ of the Federal Forest Service in connection with recreation areas; Professor E. Gorton Davis, in charge of landscape architecture at Cornell, and Professor Frederic N. Evans, occupying a similar position at the University of Illinois.

The conference continued through three days and included an exhibition of drawings and plans by students from the schools represented. One session was for the purpose of appointing committees on instruction, landscape extension, town-planning and publicity. It was decided to make the conference an annual affair, at which the American Society of Landscape Architects would be represented by the standing committee, and by delegates from the schools throughout the country.

After the business session the architects adjourned to the Cambridge School of Domestic Architecture and the party went by automobile to the Arnold Arboretum. Gorham P. Stevens, director of the American Academy at Rome, spoke on the work of the American Academy, and Charles N. Lowrie, chairman of the standing committee of the American Society of Landscape Architects, discussed the professional needs for education in landscape architecture, at the dinner at the St. Botolph Club.

The conference was motored the next day through the Boston Park system. At the final session formal action was taken upon the recommendations of the committees previously appointed. The following-named institutions sent representatives to the meetings in Cambridge: Cambridge School of Domestic Architecture and Landscape Architecture for Women, Cornell University, Lowthorpe School of Landscape Architecture for Women; Massachusetts Agricultural College, Michigan Agricultural College, New York State College of Forestry, Ohio State University, Pennsylvania State College, Uni-

versity of California, University of Illinois, University of Missouri, Missouri Botanical Garden, Harvard University.

Chicago Banker Talks About Credit Rates

At the convention of the Illinois State Bankers, Mr. Arthur Reynolds of the Continental & Commercial National Bank said, in expressing his view of the present conditions:

"There is a reported shortage of commodities all over the world, and holders have the comfortable feeling that as fast as produce, raw materials and manufactured goods can be moved to market, they can be converted into cash with which to pay indebtedness. But we must not make the mistake of thinking that because we have the federal reserve banks we can go on expanding without limitation. The object in creating those institutions was to assist legitimate business, not to foster undue expansion or speculations; in fact they were designed partly as a steadying factor; it was the intention that they should call a halt when necessary to correct a situation that might be getting unhealthy; and they were also intended as a resource to which the individual banks could apply for help in meeting the seasonal ebb and flow of industry as a whole.

"Up to now, in our orgy of general expansion and extravagance, the thought seems to have been common that credit was limitless, like air; that all the producer of raw materials had to do was to find a purchaser who would promise to pay almost any price and then ship the materials, that the manufacturer could do the same, and that the retailer could follow their example. The opinion seemed to be that the banks could supply the credit without any limitation whatever as to amount.

"But the cheap credit policy as a means of stimulating production and lowering the price level has been a complete failure. Fifteen months after the armistice, the loans of the reserve banks were \$800,000,000 more than in the preceding year and upon the basis of these enlarged reserves the commercial banks had expanded their credits to several times that amount. The treasury continued to place certificates at low rates for more than a year and the

ease with which money was obtainable contributed to fundamental extravagance and all the machinery of war, except troops, was maintained. The railroads continued to be run at a loss. The cry for a bonus to soldiers was raised and production was not increased.

"Suddenly we find that cheap credit is an illusion and we proceed to make credit dear. The reserve bank's rates are increased and then increased again, and they may be increased again. Sliding scales are adopted in some cases to penalize heavy borrowers. The treasury rate on its new issues of notes is advanced to 5 per cent. and then to 6 per cent."

Government-Built Workmen's Homes in New Zealand

The Prime Minister of New Zealand has announced that good progress is being made in carrying out the law, passed at the last session of the legislature, which provides for the erection of workmen's homes in the different centers of the Dominion. One hundred and eighty-three houses are now in course of erection and 122 additional under consideration, with several other centers to be canvassed, including the city of Auckland. Of these dwellings, 113 have been or are being erected at Wellington and suburbs. These homes are being built by the Government and sold to workmen at cost, with the privilege of paying in monthly installments.

The Prime Minister stated that he is satisfied there are more buildings in course of construction in New Zealand at this time than ever before in the history of the country; and it would seem that this is but a beginning of the general move for the development, not only of the business and industrial centers of the Dominion, but for the smaller cities and towns, as well as rural districts.

The cost of building is so high in New Zealand that private capital is not attracted to the erection of homes, so the Government is assuming the responsibility. Five years ago Oregon pine sold here at \$3.53 per 100 feet, while now it sells at \$14.60. Redwood has advanced at about the same ratio, and Australian lumber is expensive and hard to get at any price. A good grade of English corrugated iron sells at \$404 per ton of 2,240 pounds, and nails at \$263 per ton. It is stated that a home that would have cost \$3,000 to build before the war would now cost more than \$5,000.

To improve Grand Central Station ten stories will be added to Grand Central Station, New York, for office space, according to Whitney Warren, of Warren & Wetmore, architects.

Wood Construction in "Shamrock IV"

The wonderful strength of carefully selected, well-seasoned and properly disposed wood is emphasized by the designers of Sir Thomas Lipton's challenging yacht, "Shamrock IV," as quoted in an article in a recent "Scientific American" which gives the leading characteristics of this craft. The international yacht races held July 15 have arrested widespread attention, as in former years.

Although "Shamrock IV" is of practically the same displacement as the cup defender "Resolute," it carries 25 per cent. more canvas or 10,800 square feet as against 8,650 square feet for "Resolute." "Shamrock IV" is a boat of great initial stability, capable of carrying a huge spread of canvas—its spread of sail reaching 170 feet above the deck—and this ability is due, according to its designer, to the "wonderful strength" of the wood. The hull is sheathed with three layers of mahogany, two layers inch thick, placed diagonally in opposite directions at 40 degrees to the vertical, and an outer layer 5-8 of an inch thick, placed longitudinally, the whole being very thoroughly fastened together with the joints evenly distributed. The deck is of birch veneer, 5-8 of an inch thick and the hull is stiffened against distortion by running birch veneer bulkheads at each web frame from the bilge to the deck along each side of the hull. The hull is also stiffened longitudinally by a series of wood longitudinals, about 2½ inches square in section.

The mast, two feet in diameter, is of wood and hollow, as are the other spars. The topmast truck is 145 feet and the top of the clubtop sail 170 feet above the deck. This means that if Shamrock were afloat on Broadway the topmost point of her clubtop sail would be level with the cornice of a 14-story building, and this, on a waterline of 75 feet.

New York Society of Architects

About three dozen members of the above-named society had a most enjoyable outing on June 30 to Bayville, L. I.

Leaving the Society's headquarters, West 39th Street, at 10 a. m., the party proceeded by motor bus via Queensborough Bridge, Jamaica, Hollis and Oyster Bay—a three hours' ride through some of the most picturesque scenery in this section of the country. The weather was propitious and the season of the year at its best.

After a refreshing dip in the clear and cooling waters of the Sound—so far as the somewhat limited supply of bathing suits would allow of it—full justice was done by members to a liberal and varied

THE AMERICAN ARCHITECT

repast. This was followed by a game of baseball, and the skill and agility displayed by some of the older men, who it is safe to say had not handled a bat for 20 years or more, was as remarkable as it was gratifying to behold.

Genial humor and good fellowship were the order of the day, and it was felt on the whole that the time could not have been better spent than it was; the hope being expressed that a recurrence of the occasion might take place in the near future.

Church for Children

CZECHOSLOVAKS of New York City have established a church solely for children, with a children's choir and orchestra and child ushers. Its doors are open only to those under 15 years, with the exception of the pastor and organist.

Look in on the Bohemian colony over on the upper east side of New York any Sunday morning and you will see scores of little girls in stiffly starched white dresses and as many small boys with their hair slicked back and shoes carefully polished making their way toward the attractive little stone church at 374 East Seventy-fourth street. They don't have the doleful, "wish-it-were-Monday" appearance customary with youngsters being dragged unwillingly to church by their parents. They look as though they expected a good time.

When 300 children go to church regularly every Sunday in the year, one can be sure there is something unusual about the service. The pastor, the Rev. Albert J. Murphy, boasts that it has all the elements of a regular Presbyterian church service from invocation to benediction, but he has skilfully adapted it so that it will be attractive to the young mind.

The church—Jan Hus Church, it is called—is the kind of a place any one feels more cheerful for being in, especially the light-hearted Bohemians, whose mother country has endowed them with a love of the gay and vivid. The panels of the walls are decorated in Czechoslovak fashion, with brilliantly colored designs. The painting was done by one of the neighborhood men, by trade an ordinary artisan, but with the unerring skill and feeling for color of the true artist. His work has made of the church a place full of life and beauty. No wonder it is the mecca for all Bohemians who live in the eastern part of the country.

To come to the children's service—at nine-thirty on Sunday morning when the little ushers in their stiff Buster Brown collars have finished their task of seating the congregation, the boys' choir, thirty strong, enters marching in processional. It is one of the finest boys' choirs in the city, having as its

director Francis Pangrac, a Metropolitan baritone.

The stringed orchestra, which supplements the choir, is the product of the Jan Hus Neighborhood House, which is conducted in connection with the church. This is one of the United Neighborhood Houses of New York, a federation of forty-seven settlements. It is the community centre of the 30,000 Bohemians who live in the district, the place where the young people come for athletics, dancing, lessons in cooking, arts and crafts and music; the older generation, to learn English, to dance the folk dances of their beloved Bohemia, or just to enjoy one another's society in the comfortable clubrooms.

To return to the children's service—what of the sermon? There are no dry, doctrinal harangues in the children's church. Mr. Murphy has solved the problem of retaining the sermon and yet keeping his youthful congregation interested.

"Preaching and moralizing are horrible," he says. "It is much better to let the children draw their own lesson from some interesting tale."

So he tells them stories, sometimes old Bohemian folktales translated into English, sometimes a Bible story, and sometimes a modern story.

Westminster Abbey in Need of Repair

But little attention was paid to the needs for repair in Westminster Abbey during the war and it is now estimated by the Dean that it will be necessary to spend as much as \$500,000 to put the structure in a condition worthy of so dignified and revered a monument. The sum fixed for maintenance of the Abbey some fifty years ago is quite inadequate and the Dean, in his appeal for funds for repair, has asked for £150,000 in addition to be used for the establishment of a fund which shall keep the building in a constant state of efficiency.

It may be the vibration from the continual and constantly increasing traffic, or it may be the natural result of age which makes constant attention and renovation necessary. At any rate, great masses of decaying stonework are badly in need of reconstruction and the authorities are without funds. Although the abbey was started so long ago as when there was a King Sebert of Essex, and that was in 616, it isn't so old that it should be permitted to fall apart—not yet. The King has headed a subscription list with a donation of £1,000.

War Memorial in Ten Years

After discussing details as to the most recent of several ineffective conferences held in New York by the Mayor's War Memorial Committee, the New

THE AMERICAN ARCHITECT

York *Times* recommends that the example of Paris be carefully noted.

That city is perhaps the most spacious, orderly and harmonious in the modern world. The French have in full measure the instinct and the skill for monumental works of art. Yet they have lately decided not to begin the planning and construction of their War Memorial until after the lapse of ten years. As the Jury of Artists well says: "Only time can develop the full strength of the artistic talent and imagination of the community." To settle the fate of so momentous a project forever at a meeting held at the end of July would be, all too literally, midsummer madness.

Moneybag Decoration

The statement of the president of the Incorporated Institute of British Decorators that the Institute desired to direct decorative art into a thoroughly English channel and to restrain it, because there is a danger that decoration may be carried out under the orders of war millionaires, whose money may be in excess of their taste, opens a subject of speculative interest in these transitional times, states the *Glasgow Herald*. What exactly is meant by directing decorative art into a thoroughly English channel we confess we cannot understand. Heaven help the art, or the people fated to live with it, which is "thoroughly English." But we presume it to be the intention of this body to encourage the development of English tendencies in art and to permeate whatever of "foreign" art as may be introduced, with the traditional spirit of the environment and setting to which it may be adapted. The point of interest, however, will be to watch the conflict which is sure to come in the artistic world between those whose work has been strengthened and tightened and steeled by the fact of war and the artists whose works will be produced to meet the demands of a new public, largely an uneducated public so far as art is concerned, and a public with moneybags.

History shows that the transference of wealth which follows all great national struggles and upheavals, and the consequent change of patrons of the arts, has reacted on art in a manner which has in the long run proved beneficial to the progress of much that is best in art, including the decorative branches of it. Be that as it may, we nevertheless sympathize with such members of the Incorporated Institute of British Decorators who come into actual contact with the war millionaire who dreams of possessing a succession of glittering and gaudy salons in the rococo style, and is ushered in by his decorator to quiet rooms panelled in the tones of Morris. It would almost be as dangerous as condemning the

furs of his wife in favor of a Greenaway cloak. That is, of course, taking the war millionaire at the Decorators' estimate. Nevertheless it is a scheme on the right lines and one that could well be applied to more than the newly rich. But the greatest influence which will counteract extravagance in affairs of art lies in the war-tempered school to which we have referred.

Builders Advocate Lower Structures

Building skyscrapers on their sides, instead of one end in the air in order to save the tremendous cost of foundation and enormous elevator equipment, also to spread business districts of cities over a wide area, was discussed at the recent annual convention of the National Association of Building Owners and Managers in the Twin Cities.

Low buildings in the business district was the theme of a paper on "Analysis of the comparative investment value of office buildings of various height," was read in Minneapolis by Edwin S. Jewell of Omaha.

Jewell advocated the building of low buildings in place of the sky-scraper thereby spreading the business section of a city over wide territory.

Pointing out that land values come from the size of population in a section and not from the buildings put on it, he declared that low building on large lots were more profitable than a structure towering in the air.

Other papers of the afternoon were read by Adrien W. Vollmer of Philadelphia on "The ethics of office building ownership and management," and by Colonel Gordon Strong of Chicago on the "Fundamentals of the office building business for profit."

How One Library Serves Its Public

It's a dull day in Newark, New Jersey, editorially comments *The Sun and New York Herald*, on which John Cotton Dana does not find a new way to make the public library more useful. One of his recent exploits is a scheme to "Get Wise Quick," which is "addressed to young people; but men and women will find it useful if they wish to begin again to learn." To get wise quick, of course, the ambitious youngster or adult is to make intelligent use of the public library, of which the bulletin issued on this subject says:

"In your library are 240,000 books. In these books lie the sum and substance of all the wisdom getting, memory improving and salary raising ideas that anybody has ever had since the world began.

"And in your library are persons who jump at the chance to pick out just the books and parts of books that will best help you to just exactly what you want to learn.

"Their work is paid for already."

Mr. Dana would like to have the potential stu-

THE AMERICAN ARCHITECT

dent come to the library, but for those who cannot manage to do this he has prepared a card to be filled in and mailed by the would-be student. On this card the librarian says:

"Mail this card in an envelope if you so prefer. Why not write a letter telling what you have studied, and what trade you have worked at? This is all confidential, of course."

The library encourages those to whom it appeals by telling them that it has "learned, what thousands of self-taught citizens have proved, that every man or boy or girl is his own best teacher." There is no attempt to mystify or to awe the prospective delver after knowledge; he is not approached as if he were a suitable object for charitable treatment; there is no hint of patronizing in this circular advertisement of "the biggest academy in New Jersey, with the best staff of teachers in the world (the writers of the 240,000 books and with the finest student body you can find—yourself.

If Newark's population does not attain intellectual supremacy over all the other people in the United States its failure cannot fairly be laid at the door of the public library.

New Kind of Artificial Stone

Consul General Yeo J. Keena reports from Zurich, Switzerland, that the Gyr-Guyer Bank for Financing (Gyr-Guyer Banque pour Financements) of Zurich states that they are holders of a Swiss patent for the manufacture of a kind of artificial stone which can be made at one-third the cost of ordinary artificial stone. A description of this stone and a report of an examination of it made by the Examining Board of the Federal Laboratory for Material Analysis, at Zurich, may be inspected at the Bureau of Foreign and Domestic Commerce on referring to file No. 8492.

A Recent Book By John Nolen

A new book by John Nolen is always a matter of interest in the town planning world. His latest book, "New Ideals in the Planning of Cities, Towns and Villages," is really a primer of town planning, written as it was for use in the Army Educational Course with the boys "over there." The book has the great advantage of being attractive in form, being small and something that one can slip into a coat pocket and yet being very comprehensive and

attractive in appearance. It is pointed out that the book is not a dissertation on "City Beautiful" vagaries that look well on blue prints, but which never get themselves adopted, but is a thoroughly practical book that coordinates industrial and business needs with the best thought on beautification. It reflects not only a faithful history of the city planning movement, but is as well a text-book for methods of procedure. In it Mr. Nolen discusses such topics as Specific Needs of the Smaller Cities, City Planning Misconceptions, How to Replan a City, Controlling purposes of a City Plan, How to Get a City Plan into Action, Does City Planning Pay, and a number of similar important phases of the city planning movement.

The book is published by the American City Magazine, Tribune Building, Nassau Street, N. Y. City.

American Wooden Houses in France

Five hundred from an order of 1,000 wooden houses for the devastated regions of northern France have been delivered by a New York firm this spring. These houses are 7 meters or about 23 feet square and have three rooms and a shed. They are delivered in sections and complete, according to the Review of the American Chamber of Commerce in France, including windows, doors, glass, paint, nails, bolts, all ready for erection. Their erection is under the direction of one of the French building departments. About a hundred of these houses are being erected in the Arras and Lens districts.

Art Restoration Planned

Arrangements are under way to restore the 150 portraits of the signers of the Declaration of Independence, members of the Continental Congress and other celebrities of Revolutionary days, which are now stored in one of the upper rooms of Independence Hall.

"These paintings," said Joseph C. Wagner, acting Director of Public Works, "are valued at over \$500,000, and for the sum of \$10,000 they can be restored. We have \$1,000 available for the purpose and I propose to ask City Council to appropriate additional money for the purpose."

The work will be done by Prof. Pasquale F. . . .

Housing Brevities

Housing Plans for Railroad Employees

Plans for building homes for employees are being considered by the Pennsylvania Railroad. Their plan provides for the construction of houses, either singly or in groups at division points and terminals. The houses would be rented to the employees or sold to them at the cost of construction. Railroads have difficulty in getting labor, frequently because the men cannot secure living accommodations.

The laws of some states, however, do not allow the railroad corporations to engage in the real estate business. The lawyers say, however, that if the houses are used exclusively for Pennsylvania employees on a cost basis, the legal barrier might be overcome.

The Pullman Company built the town of Pullman and rented houses to employees. The state attacked the plan and the courts ruled that the company could not engage in the real estate business and accordingly the company sold the houses.

Revised Edition of "Model Housing Law"

When Lawrence Veiller's book, "A Model Housing Law," was published five years ago it was to a large extent a pioneer effort; for, at that time there were no housing laws in the country, but only tenement house laws, most of which had been modeled upon the New York Tenement House Law.

Since then, through the activities of the National Housing Association, housing laws have become firmly established in many states and the country has accepted such legislation and no one outside of New York City thinks any longer in terms of tenement laws.

The experience of the past five years in adapting the Model Housing Law to the varying conditions existing in different communities has developed many important and new features in housing legislation.

The result of this experience has been embodied by Mr. Veiller in a Revised Edition of this book which has just been published.

The Revised Edition is almost a new book, for many changes have been made in the law.

To those who are not interested in legislation but who seek information as to what should be the housing standards that should prevail in their community this book should prove of value. The law itself

serves as a set of standards and the copious notes and explanations with the reasons for the adoption throw much light upon the reasons for the adoption of a particular standard.

In addition the author has included in the Revised Edition a new chapter on "Housing Standards" and has included there the verbatim text of the "Housing Standards" adopted by the Federal Government of which Mr. Veiller was the chief author.

He has also included in the book a new chapter on "Zoning" and has accompanied it with a Model Zoning Enabling Act to be adopted in large cities before zoning is attempted.

The book can be obtained from the publishers, the Russell Sage Foundation, 130 East 22d Street, New York City—380 pages.

More Hotels for New York

Plans for doubling the size of the Hotel Commodore here to 4,000 rooms, making it the largest hotel in the world, were announced by John McE. Bowman, proprietor. Mr. Bowman, who owns several hotels here, also announced that a new 3,000-room hotel would be built on the site of the Murray Hill Hotel. Mr. Bowman recently sold the Manhattan Hotel to the National City Company, which will convert it into an office structure.

Dividing Old Houses

IT IS a significant and gratifying fact to notice, among the permits for building granted in the last few months a large number of "remodeling and alteration" permits, where old homes are being made up-to-date or changed into apartments, housing two or three families where one was housed before, and tending to do away with the much-mooted question as to why so many large dwelling houses stood idle and dusty while the clamor increased for homes. This fact was recorded by E. E. Hollenback, President of the Master Builders' Exchange in Philadelphia.

In a time when building materials are subject to so much delay in transportation and prices fluctuate almost with the temperature, it is a wise move to make habitable houses already built, make two homes grow where but one was before, and help to house the working force of this country, who cannot, of necessity, produce more unless comfortably sheltered.

Weekly Review of the Construction Field

With Reports of Special Correspondents in Prominent Regional Centers

Slight changes are evident during the past week in the construction industry, if indeed there be any change. The general trend in regard to labor seems to be toward a more free supply which was to be expected as a result of the shortages in material and the impossibility of pressing forward work now on the way or already started.

The chief interest of the builders at the present time is to get their materials. Prices have been so erratic that practically all work is done on a cost-plus basis and speculation as to whether prices will come down or go higher is beside the mark, the question is whether or not the building materials can be obtained. This is dependent on the transportation problem and hardship is felt as it has been felt for months. Several cars just arrived at Toronto have been twelve weeks on the way from Pittsburgh, so it is told. Every contractor has similar stories to tell, and only too frequently the difference in his story is that the cars haven't arrived yet.

Now a question seems to be coming to the fore as to whether the manufacturers will be able to accumulate enough coal to keep running. Opinions as to the facts seem varied by the expression of one coal operator that there was no shortage of coal. Possibly not and it is comforting to suppose that General Order No. 7 which restricts the use of open top cars to the carrying of coal has had something to do with achieving this consummation. There is being held in Washington, at this writing, a conference between the coal operators and the railway executives.

There is but one certain solution to the car shortage and that is to build more cars; it is quite as simple as the solution to the building shortage. Which is very easy to say and to put on paper. But quite apart from the realm of gentle criticism is the announcement of straight fact that the manufacturers of lime have closed down for lack of coal. And that there is talk among the steel mills of suspending operations to permit a clearing away of the congestion. Iron Age estimates stocks of finished material awaiting shipment in the Pittsburgh, Youngstown and Shenango districts to aggregate 1,000,000 tons.

(By Special Correspondence to The American Architect.)

San Francisco.—With the National Democratic Convention in full swing throughout the week, the minds of San Francisco people have been more on

politics than upon pushing plans for new structures. The most important development of the week has been the letting of contracts for the steel and some other parts of the twelve story and basement Class "A" building to be erected by the Standard Oil Co. at Bush and Sansome streets on the plans prepared by George William Kelham. The building will cost approximately \$4,000,000 and an interesting feature in connection with the project is the leasing of the ground floor for a term of fifty years to the Anglo and London-Paris National Bank for a total rental of \$2,000,000. This bank is now located at Sansom and Sutter streets and it has acquired the property between its present site and the new Standard Oil building upon which to erect a building connecting its present quarters with the Standard Oil building.

Buildings constructed of adobe are coming into some popularity in the southern part of the State. W. H. Austin, a Long Beach architect, says of this material: "The adobe house lends itself to attractive architecture. It is a material which is most artistic. The architect can use ideas which would not work out so well in a frame construction. It seems to me that adobe houses would do much to relieve the present difficulties and at the same time would have such a variety of architectural expression as to be a distinctly beauty asset."

(By Special Correspondence to The American Architect.)

Seattle.—Rationing of steel building products, including nails and small pipe, must continue in the North Coast jobbing territory until the eastern mills are able to secure competent production. This is the opinion of jobbers as expressed this week. Hope for relief in that direction seems remote, as several of the larger mills have wired that, due to incompetent labor, they are expecting to close down.

Prices, however, are holding steady, and the talk is not for lower quotations, but none feel that they will advance due to the liberal offerings in comparison with the demand. Building seems to be at a standstill, and no new jobs of moment have come out of the hands of architects during the past thirty days.

There is a keen shortage of three-quarter inch pipe. Black pipe of an inch and two inches seems to be plentiful, if a dull demand can balance against a light supply. Sizes of 1½ and 2-inch pipe are

THE AMERICAN ARCHITECT

short and lots badly broken. North Coast jobbers are of the opinion that the threatened close down by the mills for 60 days because of shortage of labor is more than of a commercial nature.

Shortage of materials seems to be caused more through light production than the car shortage, although both are serious enough.

Screws are plentiful, but small nails are being rationed out through the entire territory, particularly in staple sizes. Jobbers say there would be more buying if the material was here.

Because of the high cost of tile, builders are making enquiry and experiments with hard plaster for bath rooms. Results are being watched with much interest.

Moulding plaster, with Kansas as the shipping source, is scarce. White cement is just coming through from York, Penna. Fire brick is slow. Plenty of patent roofing is now being offered.

Real estate is dull and there is an increasing number of houses for sale, but not for rent.

Fir lumber is steady. A new price list issued by one of the largest mills with its own selling agency carries quotations of \$26.50 for No. 1 common dimension, \$77 for No. 2 vertical grain flooring, \$54 for No. 2 and better slash grain, \$51 for drop siding, \$29.50 for boards and shiplap and \$7 for lath, all as a basis to the eastern trade at the mill. This, however, is practically what wholesalers have been quoting for ten days. The mills and logging camps have closed for the early July period, and declare they will not resume until the railroads can definitely promise relief in the car emergency.

(By Special Correspondence to The American Architect.)

Boston.—Construction work continues hampered by lack of money, material and transportation, while industrial plants are confronted with the possibility of shut down due to shortage of coal and cars for the bringing in of raw materials and the transportation of finished products.

Various housing projects, though, are under way: one in Worcester with a contemplated expenditure of \$1,500,000 and averaging around \$6,000 per dwelling was started this week.

The delay in bringing the much-needed coal into New England can be laid at the door of the Interstate Commerce Commission which under a recent act was directly charged with the responsibility of meeting transportation emergencies. Although they have issued a so-called priority order, up to the present writing they have taken no practical steps to ward off the approaching coal crisis.

With a return to more normal transportation conditions brought about by an increased supply of coal and cars, building construction should gain a decided impetus. Reports show that there is an ample labor supply: meaning competition for jobs and a more nearly normal production.

The restrictions in business circles are beginning to make themselves felt in decreases in the volume of clearings at the various clearing house centers throughout the country. Until a few weeks ago, it was customary for clearings to show a substantial increase week after week as compared with the previous week. That was partly because of more active business and partly because check transactions passing through the banks were swollen by the rising commodity prices. In New England, in the first five months of this year, clearings were 24.9 per cent. greater than in the corresponding time of a year ago. In the month of May alone, bank clearings throughout the country showed a total increase of 10.5 per cent. over the same month last year and New England showed an increase of 17.1 per cent.

But in June, when business retrenchment became popular, gains have been very much smaller and in many cases actual losses are shown. In the week ending June 5 New England showed a decrease of 5.4 per cent. In the week ending June 12 it showed a decrease of 0.8 per cent. And so the tide of business contraction which was forced by the contraction of credits throughout the country is being written into reduced volumes of commercial transactions. This situation can be explained also, in part, by the fact that the business world usually experiences some let-up in activity around the mid-year period. It is the between seasons in many lines and the beginning of the holiday months.

(By Special Correspondence to The American Architect.)

Birmingham. — With a population just reported by the Government to be in excess of 178,000, Birmingham stands well toward the front in its urgent need for more dwellings and apartments in which to house its population. This condition, while not specially different from that prevailing throughout the country, is becoming more serious as the Federal Reserve Bank's effort at deflation strikes a note of discouragement for those who have been contemplating building on borrowed money. The local result of this has been the abandonment of quite a number of prospective efforts at construction which could not be carried forward without the aid of reasonable loans.

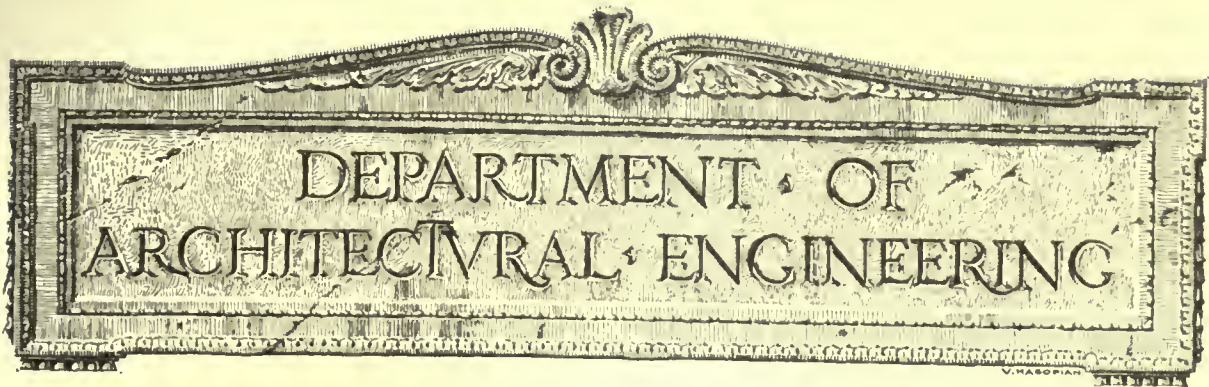

New York City Adopts Rules Governing Reinforced Concrete Flat Slab Design and Construction

Uniform Regulations Advocated by THE AMERICAN ARCHITECT Become Effective August 2, 1920

ON July 8, 1920, the Board of Standards and Appeals of New York City adopted regulations governing the design and construction of the flat slab type of reinforced concrete building. This marks a notable step in advance, and these regulations can be profitably studied by other cities.

New York City consists of five separate boroughs—Manhattan, Bronx, Kings, Queens and Richmond, each of which possesses an autonomous form of government, headed by a Borough President under whose jurisdiction comes the Building Bureau of that borough. Thus while the provisions of one building code govern throughout the city, there may be five different interpretations of a single section or clause. Prior to the creation of the Board of Standards and Appeals in 1916, the Superintendent of Buildings of each borough had the authority to adopt rules governing various phases of building construction, such as ele-

vators, plumbing, reinforced concrete, etc., provided such rules were not in conflict with any specific provisions of the building code. All such rules remained in force until amended or superseded by new

rules adopted by the Board of Standards and Appeals after public notice and hearing. Since these old rules varied in the different boroughs, the Board of Standards and Appeals has done much meritorious work in promulgating and adopting uniform rules superseding the older ones.

However, where rules existed, even though in need of revision, they at least furnished a guide to the designer. Where no rules existed and the matter was left entirely to the discretion of the superintendent of buildings of each borough added difficulties arose. This was exactly the situation with respect to the "flat

slab" type of reinforced concrete construction. The reinforced concrete regulations of the building code made no provision for it, and each borough ap-

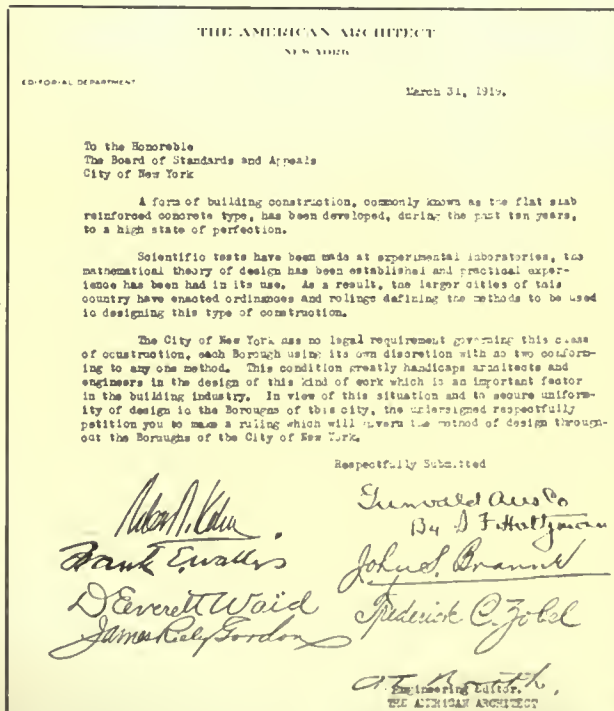

THE AMERICAN ARCHITECT

parently had different ideas as to how this form of design should be treated. Accordingly a building erected in Queens and approved by the Building Bureau there might be declared weak in Manhattan, and similarly for other boroughs. Such a condition was not so embarrassing to the architect when but comparatively few structures of this type were being built, but as their number increased, so did a most difficult situation, as the designer had no definite guide. Clearly some remedy was necessary.

This condition was brought to the attention of THE AMERICAN ARCHITECT early in 1919, by some of the leading architects and engineers of the city, and after an investigation made by Mr. Arthur T. North then Engineering (now Western) Editor, it was found that the only solution lay with the Board of Standards and Appeals, in whom was vested the power to adopt uniform rules governing such construction. Accordingly a petition to this effect was presented March 31, 1919, a reproduction of which is shown on page 89.

The matter was referred to a committee of the board and seemed to lay dormant for some time. In the meantime, realizing that the drafting of satisfactory rules was a most difficult task, and did not consist of simply duplicating those already in use in other cities, THE AMERICAN ARCHITECT at once set about to get the necessary machinery in motion for accomplishing this purpose, so that it could be of the greatest assistance to the City Board.

After a conference of those who signed the petition it was realized that each was exceedingly busy attending to his own business, and could not give the time needed to this highly specialized work. The situation was very aptly stated by Mr. Robert D. Kohn as follows:

"I have so many public obligations outside of my professional work that I cannot possibly assume an additional one (drafting flat slab rules). What is more to the point perhaps is that I am not at all qualified to be of assistance in such a matter."

The consensus of opinion was that a consulting engineer who could devote adequate time to the task was necessary, and no one seemed better qualified for the work than Mr. Rudolph P. Miller, who later agreed to take over this task. Shortly after retaining the services of Mr. Miller, Mr. George E. Strehan (who had just returned from overseas military service) and Mr. Miller became associated as consulting engineers, and as Mr. Strehan's previous experience was most valuable in this work, both cooperated in the preparation of the flat slab rules. Many drafts were prepared and numerous conferences held with those intimately connected with this type of construction. Members of the board were freely consulted, and a conference held with the several superintendents of buildings. It

was an arduous task, however, and on the first of January, 1920, the acceptance of appointment as superintendent of buildings, Borough of Manhattan made necessary the relinquishment of this work by Mr. Miller, Mr. Strehan, continuing as consulting engineer. Months were consumed, but finally what seemed to be a satisfactory draft was prepared and 1,000 copies of it printed by THE AMERICAN ARCHITECT and mailed to leading architects and engineers throughout the country for criticism and comment. The replies received were on minor items. All criticism was carefully analyzed and several slight changes made, and the revised draft submitted to the Board of Standards and Appeals early in June, 1920. After consideration by a committee of the board, the rules were reported for public hearing, and on July 8 the revised rules printed below were adopted.

TABLE I. COMPARISON OF MOMENT FACTORS, REINFORCED CONCRETE FLAT SLAB DESIGN.						
W = Total Load on Panel = wL^2 L = Length of Square Panel. Dimension of Capital Assumed as 0.225L; of Drop, as 0.33L.						
AUTHORITY	MOMENT SECTIONS				TOTAL MOMENT	REMARKS
	Z-COL HEAD	MID	INNER	Z-OUTER		
NEW YORK CITY Rules Adopted 7-8-20	$\frac{1}{32}$ WL	$-\frac{1}{133}$ WL	$+\frac{1}{53}$ WL	$+\frac{1}{80}$ WL	$\frac{1}{17}$ WL	
CHICAGO CINCINNATI INDIANAPOLIS MINNEAPOLIS	$-\frac{1}{30}$ WL	$-\frac{1}{120}$ WL	$+\frac{1}{120}$ WL	$+\frac{1}{60}$ WL	$\frac{1}{15}$ WL	Allow Steel Stress of 18,000 lbs. sq. in. factors marked † are based on Steel Stress of 16,000 lbs. sq. in.
PHILADELPHIA BALTIMORE	$-\frac{1}{37}$ WL	$-\frac{1}{128}$ WL	$+\frac{1}{128}$ WL	$+\frac{1}{80}$ WL	$\frac{1}{16.9}$ WL	
PITTSBURGH	$-\frac{1}{29.6}$ WL	NOT SPECIFIED	$+\frac{1}{128}$ WL	$+\frac{1}{63}$ WL	$\frac{1}{15.4}$ WL	W = Total Positive Moment on Circular Section thru Panel Ctr.
DETROIT	$-\frac{1}{31}$ WL	$-\frac{1}{116}$ WL	$+\frac{1}{116}$ WL	$+\frac{1}{62}$ WL	$\frac{1}{15.3}$ WL	
ST. LOUIS	$-\frac{1}{33}$ WL	$-\frac{1}{133}$ WL	$+\frac{1}{133}$ WL	$+\frac{1}{67}$ WL	$\frac{1}{16.6}$ WL	
NEW YORK CITY BOP OF MANHATTAN (SUPERSEDES RULES)	$-\frac{1}{24}$ WL	$-\frac{1}{140}$ WL	$+\frac{1}{140}$ WL	$+\frac{1}{48}$ WL	$\frac{1}{13}$ WL	
TAYLOR & THOMPSON	$-\frac{1}{27.7}$ WL	$-\frac{1}{157}$ WL	$+\frac{1}{104}$ WL	$+\frac{1}{69.3}$ WL	$\frac{1}{15.1}$ WL	
MENSCH	$-\frac{1}{30.6}$ WL	$-\frac{1}{76.8}$ WL	$+\frac{1}{123}$ WL	$+\frac{1}{57.7}$ WL	$\frac{1}{13.7}$ WL	
S. M. I.	$-\frac{1}{36}$ WL	$-\frac{1}{172}$ WL	$+\frac{1}{104}$ WL	$+\frac{1}{92}$ WL	$\frac{1}{18.5}$ WL	
NICHOLS					$\frac{1}{17.2}$ WL	Distribution not Specified
JOINT COMMITTEE WASHINGTON BOSTON	$-\frac{1}{26}$ WL	$-\frac{1}{104}$ WL	$+\frac{1}{138}$ WL	$+\frac{1}{78}$ WL	$\frac{1}{13}$ WL	Pos. Mom. = 37 1/2% Total. Neg. Mom. = 62 1/2% Total. Minimum Specified Values Given for Each Section.
AM. CONCRETE INSTITUTE	$-\frac{1}{30.8}$ WL	$-\frac{1}{154}$ WL	$+\frac{1}{128}$ WL	$+\frac{1}{65}$ WL	$\frac{1}{15.4}$ WL	Pos. Mom. = 35 1/2% Total. Neg. Mom. = 64 1/2% Total. Min. Spec. Values for Each Sec.
FORMULAE Derived Analytically	$-\frac{1}{32}$ WL	$-\frac{1}{78}$ WL	$+\frac{1}{118}$ WL	$+\frac{1}{77.5}$ WL	$\frac{1}{15.1}$ WL	Pos. Mom. = 35% Total. Neg. Mom. = 65% Total. Min. Spec. Values for Each Sec.
* With and Without Drops. NOTE: Third Value of Joint Committee Moment on Outer Section Used to Determine Slab Thickness Only						

In the preparation of the rules the data obtained from the many extensometer tests made both on actual structures and at recognized experimental laboratories on test structures, was carefully analyzed and considered. It has been stated that the fundamental principles of applied mechanics determine the design of flat slabs as they do of all other structures. Yet designing engineers and mathematicians differ radically in the application of those fundamental principles to this type of structure because there exist factors which have not yet been satisfactorily analyzed and reduced to a basis of practical design.

A table showing how the moment coefficients contained in these rules compare with those specified by other authorities is here included, as well as diagrams (Plates I and II) which will more clearly illustrate the terms used.

Several articles have appeared in THE AMERICAN ARCHITECT dealing with the waste of materials of-

ten required by too conservative building codes. THE AMERICAN ARCHITECT took the action it did because it believed that sufficient tests had been made to demonstrate the possibility of a more economical design than that which had existed in several of the boroughs, as well as with a view to simplifying the work of the designing engineer, and providing for him a guide by which to work. At the present time this is more necessary than at the time the original petition was presented, in order that not a single pound of steel or yard of concrete above that required, be placed in the building.

The economy thus made possible is clearly demonstrated by the following incident: A large reinforced concrete building for which McKenzie, Voorhees & Gmelin are architects will shortly be

constructed in the lower part of Manhattan Island. The design worked out under the rules just adopted will permit a saving of approximately \$35,000, compared with a design based on the requirements previously in force in the Borough of Manhattan.

Mr. John P. Leo, chairman of the Board of Standards and Appeals, himself an architect, is to be commended on his attitude of support and co-operation on this matter, which is in line with his previous stand on other matters which have come before the Board, where economy of construction was possible without sacrificing safety.

Mr. Leo has just been reappointed by Mayor Hylan for a further term of three years. New York City is fortunate in having so able and conscientious a man serving at the head of this important Board.

Rules Governing the Design of Reinforced Concrete Flat Slabs in New York City

Adopted by the Board of Standards and Appeals July 8, 1920. Effective August 2, 1920

Rule 1. Application. The rules governing the design of reinforced concrete flat slabs shall apply to such floors and roofs, consisting of three or more rows of slabs, without beams or girders, supported on columns, the construction being continuous over the columns and forming with them a monolithic structure.

Rule 2. Compliance with Building Code. In the design of reinforced concrete flat slabs, the provisions of article 16 of the building code shall govern with respect to such matters as are specified therein.

Rule 3. Assumptions. In calculations for the strength of reinforced concrete flat slabs, the following assumptions shall be made:

- (a) A plane section before bending remains plane after bending;
- (b) The modulus of elasticity of concrete in compression within the allowable working stresses is constant;
- (c) The adhesion between concrete and reinforcement is perfect;
- (d) The tensile strength of concrete is nil;
- (e) Initial stress in the reinforcement due to contraction or expansion in the concrete is negligible.

Rule 4. Stresses. (a) The allowable unit shear in reinforced concrete flat slabs on *bd* section around the perimeter of the column capital shall not exceed one hundred twenty (120) pounds per square inch; and the allowable unit shearing stress on the *bjd* section around the perimeter of the drop shall not exceed sixty (60) pounds per square inch, provided that the reinforcement is so arranged or anchored that the stress may be fully developed for both positive and negative moments.

(b) The extreme fibre stress to be used in concrete in compression at the column head section shall not exceed seven hundred fifty (750) pounds per square inch.

Rule 5. Columns. For columns supporting reinforced concrete flat slabs, the least dimension of any column shall be not less than one-fifteenth (1/15) of the average span of any slabs supported by the columns; but in no case shall

such least dimension of any interior column supporting a floor or roof be less than sixteen (16) inches when round nor fourteen (14) inches when square; nor shall the least dimension of any exterior column be less than fourteen (14) inches.

Rule 6. Column Capital. Every reinforced concrete column supporting a flat slab shall be provided with a capital whose diameter is not less than 0.225 of the average span of any slabs supported by it. Such diameter shall be measured where the vertical thickness of the capital is at least one and one-half (1½) inches, and shall be the diameter of the inscribed circle in that horizontal plane. The slope of the capital considered effective below the point where its diameter is measured shall nowhere make an angle with the vertical of more than forty-five (45) degrees. In case a cap of less dimensions than hereinafter described as a drop, is placed above the column capital, the part of this cap enclosed within the lines of the column capital extended upward to the bottom of the slab or drop at the slope of forty-five (45) degrees may be considered as part of the column capital in determining the diameter for design purposes.

Rule 7. Drop. When a reinforced concrete flat slab is thicker in that portion adjacent to or surrounding the column, the thickened portion shall be known as a drop. The width of such drop when used, shall be determined by the shearing stress in the slab around the perimeter of the drop, but in no case shall the width be less than 0.33 of the average span of any slabs of which it forms a part. In computing the thickness of drop required by the negative moment on the column head section, the width of the drop only shall be considered as effective in resisting the compressive stress, but in no case shall the thickness of such drops be less than 0.33 of the thickness of the slab. Where drops are used over interior columns, corresponding drops shall be employed over exterior columns and shall extend to the sixth (1/6) point of the panel from the center of the column.

THE AMERICAN ARCHITECT

Rule 8. Slab Thickness. The thickness of a reinforced concrete flat slab shall be not less than that derived by the formulae $t = 0.024 L \sqrt{w + 1\frac{1}{2}}$ for slabs without drops, and $t = 0.02 L \sqrt{w + 1}$ for slabs with drops, in which t is the thickness of the slab in inches, L is the average span of the slab in feet, and w is the total live

the distance, center to center, of columns, rectangularly and diagonally, from center of columns for panels, without drops, and three-tenths (3/10) of such distance for panels with drops.

Rule 11. Moment Sections. For the purpose of design of reinforced concrete flat slabs, that portion of the section across a panel, along a line midway between columns, which lies within the middle two quarters of the width of the panel shall be known as the inner section, and those portions of the section in the two outer quarters of the width of the panel shall be known as the outer sections. Of the section which follows a panel edge from column to column and which includes the quarter perimeters of the edges of the column capitals, that portion within the middle two quarters of the panel width shall be known as the mid section and the two remaining portions, each having a projected width equal to one-quarter of the panel width, shall be known as the column head sections.

Rule 12. Bending Moments. In the design of reinforced concrete flat slabs the following provisions with respect to bending moments shall be observed. In the moment expressions used:

W is the total dead and live load on the panel under consideration, including the weight of drop whether a square, rectangle or parallelogram;

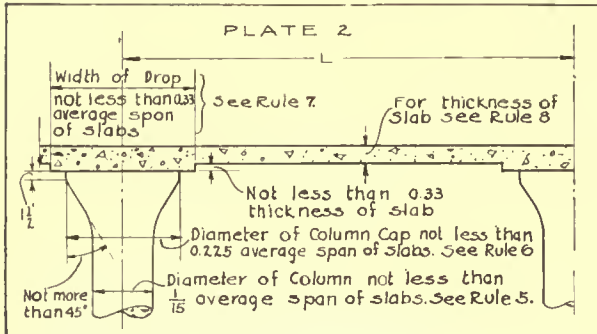

and dead load in pounds per square foot; but in no case shall this thickness be less than one-thirty-second (1/32) of the average span of the slab for floors, nor less than one-fortieth (1/40) of the average span of the slab for roofs, nor less than six (6) inches for floors nor less than five (5) inches for roofs.

Rule 9. Reinforcement. (a) In the calculation of moments at any section, all the reinforcing bars which cross that section may be used, provided that such bars extend far enough on each side of such section to develop the full amount of the stress at that section. The effective area of the reinforcement at any moment section shall be the sectional area of the bars crossing such section multiplied by the sine of the angle of such bars with the plane of the section. The distribution of the reinforcement of the several bands shall be arranged to fully provide for the intermediate moments at any sections.

(b) Splices in bars may be made wherever convenient but preferably at points of minimum stress. The length of any splice shall be not less than eighty (80) bar diameters and in no case less than two (2) feet. The splicing of adjacent bars shall be avoided as far as possible. Slab bars which are lapped over the column, the sectional area of both being included in the calculation for negative moment, shall extend to the lines of inflection beyond the column center.

(c) When the reinforcement is arranged in bands, at least fifty (50) per cent. of the bars in any band shall be of a length not less than the distance center to center of columns measured rectangularly and diagonally; no bars used as positive reinforcement shall be of a length less than half (1/2) the panel length plus forty (40) bar diameters for cross bands, or less than seven-tenths (7/10) of the panel length plus forty (40) bar diameters for diagonal bands and no bars used as negative reinforcement shall be of a length less than half (1/2) the panel length. All reinforcement framing perpendicular to the wall in exterior panels shall extend to the outer edge of the panel and shall be hooked or otherwise anchored.

(d) Adequate means shall be provided for properly maintaining all slab reinforcement in the position assumed by the computations.

Rule 10. Line of Inflection. In the design of reinforced concrete flat slab construction, for the purpose of making calculations of the bending moments at sections other than defined in these rules, the line of inflection shall be considered as being located one-quarter (1/4)

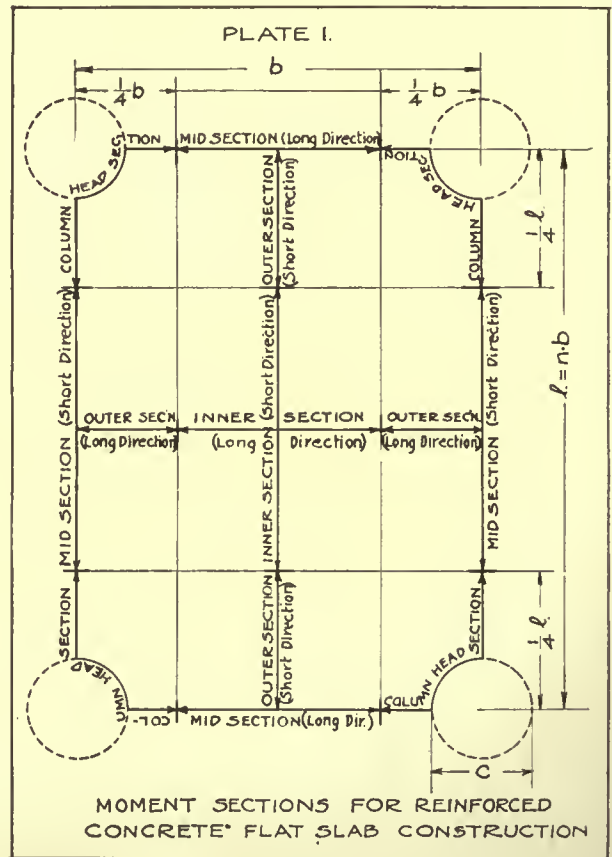

W_1 is the total live load on the panel under consideration;

L is the length of side of a square panel center to center of columns; or the average span of a rectangular panel which is the mean length of the two sides;

THE AMERICAN ARCHITECT

n is the ratio of the greater to the less dimension of the panel;

h is the unsupported length of a column in inches, measured from top of slab to base of capital;

I is the moment of inertia of the reinforced concrete column section.

A. Interior Square Panels. The numerical sum of the positive and negative moments shall be not less than $1/17 W L$. A variation of plus or minus five (5) per cent. shall be permitted in the expression for the moment on any section, but in no case shall the sum of the negative moments be less than sixty-six (66) per cent. of the total moment, nor the sum of the positive moments be less than thirty-four (34) per cent. of the total moment for slabs with drops; nor shall the sum of the negative moments be less than sixty (60) per cent. of the total moment, nor the sum of the positive moments be less than forty (40) per cent. of the total moment for slabs without drops.

1. In *two-way systems*, for slabs with drops, the negative moment resisted on two column head sections shall be $-1/32 W L$; the negative moment on the mid section shall be $-1/133 W L$; the positive moment on the two outer sections shall be $+1/80 W L$ and the positive moment on the inner section shall be $+1/133 W L$ and for slabs without drops, the negative moment resisted on two column head sections shall be $-1/36 W L$, the negative moment on the mid section shall be $-1/133 W L$, the positive moment on the two outer sections shall be $+1/63 W L$ and the positive moment on the inner section shall be $+1/133 W L$.

2. In *four-way systems*, the negative moments shall be as specified for Two-Way Systems; the positive moment on the two outer sections shall be $+1/100 W L$, and the positive moment on the inner section shall be $+1/100 W L$ for slabs with drops; and the positive moment on the two outer sections shall be $+1/74 W L$, and the positive moment on the inner section shall be $+1/100 W L$, for slabs without drops.

3. In *three-way systems*, the negative moment on the column head and mid sections and the positive moment on the two outer sections, shall be as specified for Four-Way Systems. In the expression for the bending moments on the various sections, the length L shall be assumed as the distance center to center of columns, and the load W as the load on the parallelogram panel.

B. Interior Rectangular Panels.

1. When the ratio n does not exceed 1.1, all computations shall be based on a square panel of a length equal to the average span, and the reinforcement shall be equally distributed in the short and long directions according to the bending moment coefficients specified for interior square panels.

2. When the ratio n lies between 1.1 and 1.33, the bending moment coefficients specified for interior square panels shall be applied in the following manner:

(a) In *two-way systems*, the negative moments on the two column head sections and the mid section and the positive moment on the two outer sections and the inner section at right angles to the long direction shall be determined as for a square panel of a length equal to the greater dimension of the rectangular panel; and the corresponding moments on the sections at right angles to the short direction shall be determined as for a square panel of a length equal to the lesser dimension of the rectangular panel. In no case shall the amount of reinforcement in the short direction be less than two-thirds (2/3) of that in the long direction. The load W shall

be taken as the load on the rectangular panel under consideration.

(b) In *four-way systems*, for the rectangular bands, the negative moment on the column head sections and the positive moment on the outer sections shall be determined in the same manner as indicated for *two-way systems*.

For the diagonal bands, the negative moments on the column head and mid sections and the positive moment on the inner section shall be determined as for a square panel of a length equal to the average span of the rectangle. The load W shall be taken as the load on the rectangular panel under consideration.

(c) In *three-way systems*, the negative and positive moments on the bands running parallel to the long direction shall be determined as for a square whose side is equal to the greater dimension; and the moments on the bands running parallel to the short direction shall be determined as for a square whose side is equal to the lesser dimension. The load W shall be taken as the load on the parallelogram panel under consideration.

C. Exterior Panels. The negative moments at the first interior row of columns and the positive moments at the center of the exterior panels on moment sections parallel to the wall, shall be increased twenty (20) per cent. over those specified above for interior panels. The negative moment on moment sections at the wall and parallel thereto shall be determined by the conditions of restraint, but the negative moment on the mid section shall never be considered less than fifty (50) per cent. and the negative moment on the column head section never less than eighty (80) per cent. of the corresponding moments at the first interior row of columns.

D. Interior Columns shall be designed for the bending moments developed by unequally loaded panels, eccentric loading or uneven spacing of columns. The bending moment resulting from unequally loaded panels shall be considered as $1/40 W_i L$, and shall be resisted by the columns immediately above and below the floor line under consideration in direct proportion to the values of their ratios of I/h .

E. Wall Columns shall be designed to resist bending in the same manner as interior columns, except that W shall be substituted for W_i in the formula for the moment. The moment so computed may be reduced by the counter moment of the weight of the structure which projects beyond the center line of the wall columns.

F. Roof Columns shall be designed to resist the total moment resulting from unequally loaded panels, as expressed by the formulae in paragraphs (D) and (E) of this rule.

Rule 13. Walls and Openings. In the design and construction of reinforced concrete flat slabs, additional slab thickness, girders or beams shall be provided to carry any walls or concentrated loads in addition to the specified uniform live and dead loads. Such girders or beams shall be assumed to carry twenty (20) per cent. of the total live and dead panel load in addition to the wall load. Beams shall also be provided in case openings in the floor reduce the working strength of the slab below the prescribed carrying capacity.

Rule 14. Special Panels. For structures having a width of less than three (3) rows of slabs, or in which exterior drops, capitals or columns are omitted, or in which irregular or special panels are used, and for which the rules relating to the design of reinforced flat slabs do not directly apply, the computations in the analysis of the design of such panels, shall, when so required, be filed with the superintendent of buildings.

Report on Trip to Princeton, College of City of New York, Yale and Harvard for the Purpose of Inspecting the Stadia at those Universities

Part I

By HOWARD DWIGHT SMITH

IT is a well established principle of design that in extensive new operations, the lessons of success and failure of preceding operations of similar nature be carefully studied. Progress in all lines of human endeavor is largely based upon this principle. It is particularly so in architecture and engineering.

Documents and records covering the subject of stadia have been carefully studied in connection with the design of a new Stadium at Ohio State University. The problems confronting the builders of classic times in the erection of their amphitheaters, Stadia, circuses and odeons have been studied. The work of modern engineers and architects in contemporary structures as described and discussed in current publications has also been very carefully studied. Plans, sight lines, cross sections, seating facilities, crowd control and construction methods have influenced very largely the study of the impending problem at Ohio State.

It was with a view to making the intensive study of contemporary work as effective as possible in the light of experience, that an inspection trip was authorized by the University Cabinet and the Athletic Board. This inspection trip, made from May 7 to May 14 included visits to Princeton University at Princeton, N. J., the College of the City of New York, Yale University at New Haven, Conn., and

Harvard University at Cambridge, Mass. An inspection was also made of the United States Army Supply Base, Brooklyn, N. Y., which is recognized as one of the most successful monolithic structures of the present decade.

In order best to obtain the proper benefit from an inspection the studies and observations were of two kinds. The first was a careful examination of the various structures as to their present physical condition, state of repair and the relations between original methods of construction in each case and their present condition. The second form of observation consisted in discussions with the men at the institutions who have charge of the athletic plants, men who are in a position to judge as to the effectiveness of the structures and equipment with which they work. These men unprejudiced by structural preconceptions are qualified to say wherein their stadia have been successful and wherein they might be improved.

The extent of the second phase of the inspection at Princeton was somewhat limited on account of the absence from the University of Dr. Raycroft, the Director of Athletics. The efficiency of the plan and seating arrangement, and the handling of the crowds at big games has been fairly well established in the six years of its use.

The inspection of the Stadium was made dur-



THE PALMER STADIUM, PRINCETON, N. J.

H. J. HARDENBERGH, ARCHITECT

Note openings to runways giving access to and egress from seating sections

THE AMERICAN ARCHITECT



MAIN ENTRANCE, PALMER STADIUM

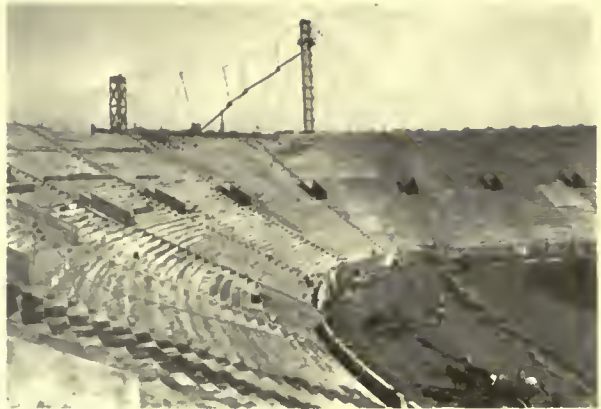

VIEW DURING CONSTRUCTION

ing a rain storm, but all parts of the structure were examined. The first general impression obtained of the structure was that it was very brown or tannish, rather than white or gray, as most of the photographs would seem to indicate. This impression was perhaps accentuated by the fact that the surface of the structure was wet. Whether this brown appearance is due to artificial coloring matter in the concrete or whether it is due to the color of the sand used was not determined.

As for architectural design, it is evident from the details that the architect is striving to make the structure look "Tudor" in style, in order that it may be somewhat in keeping with the Tudor or Collegiate Gothic buildings of the campus. This perhaps is somewhat forced, for the mass of the structure hardly lends itself to the spirit of the Tudor style without a great deal of intricate and ornamental detail. The pointed-top buttresses at each of the outside piers do not sufficiently satisfy this requirement, and the thin exterior arcade forms only a scant screen for the concrete piers, posts, girders, beams and rafters of the interior structure which are anything but Tudor in effect.

The plan of the Princeton Stadium has the shape of a letter U, in which the closed end is flattened into a three-centered curve, in the center of which is a large entrance feature consisting of a wide arch-

way flanked by two hexagonal towers. The structure is 652 feet long and 520 feet wide, seating about 42,000 people. The seats are reached by a series of 26 runways which are slightly inclined up from the exterior arcade to openings or "eyes" located about half way up the entire tier of seats. The level of the playing field is about 15 feet below the general level of the ground outside of the stadium. The topography shows a falling off from the open end so that the straightaway portion of the running track does not cut into this higher general level. The entire area surrounding the Stadium is fenced off in order to control the approach of crowds toward the structure itself. The "sight line" of the cross section is considered quite satisfactory, and the location of the track with reference to the inside wall of the Stadium is such that all spectators can see the track events. This is in contrast to the unsatisfactory condition at Harvard which will be discussed later. This inner wall is 4 feet 9 inches high, and along the two sides it is 5 feet from the edge of the running track. A curtain wall 3 feet high marks the edge of the track and serves as a suitable barrier between the first row of seats and the track itself. Experience has demonstrated that the greatest difficulty in handling crowds at track meets is that of keeping the spectators off of the field. It is desirable for pur-



EXTERIOR, PALMER STADIUM, PRINCETON, N. J.

Main entrance can be seen at extreme left

THE AMERICAN ARCHITECT

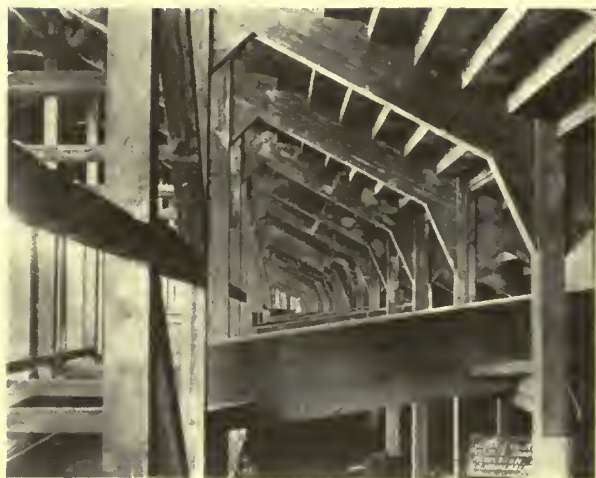

UNDERSIDE SEATING SECTIONS

poses of the convenience of great crowds leaving the Stadium after games or meets that access to the field be provided, but ample provision should be made properly to control such access. Some space under the seating structure has been used for storage of field apparatus and ground keeper's tools, but no extensive use of the space for housing has been attempted.

A careful examination of the Stadium at Princeton discloses a number of apparent defects in construction. There is evidence of deterioration in many places. This deterioration takes the form of cracks, spalls, buckling and breaking off of finish surfaces, and cracking of outside piers. In some places the surface of the seats has scaled and broken up rather extensively. In other places frost action has evidently caused some damage where small cracks have not been pointed up. In two of the exterior piers to the left of the main entrance there are rather large transverse cracks, about midway of their heights, from which there has been some extensive seepage. This seepage appears to be due to the fact that water gets into the body of the structure from above and finds its way out at these cracks.

What is written here must not be assumed to be by way of caustic criticism of the Palmer Stadium or those who have designed and built it, nor of those who are now responsible for its maintenance. It is only intended here to record some personal observations with the hope that while the good features of the Stadium, particularly as to plan arrangement may be used as inspiration in new work, the repetition of some of the less desirable features may be avoided. Articles appearing in the current technical publications upon the completion of any engineering operation of great magnitude or singular importance are usually of a highly

laudatory character, in which, quite rightly, all the distinctive features are emphasized and rightly praised. In the light of time and the experience of usage some of these features prove most admirably suited to the purpose for which they were intended. Others do not and these observations have as their object the notation of features which come in either of these two classes.

It is probably true that the absence of expansion joints in sufficient number and size is partly responsible for some of the cracking and disintegrating which is apparent in many places. Some tight or "butt" joints are noticeable but there is not sufficient space allowed for the "play" of expansion and contraction. The opinion is also hazarded that the materials and workmanship throughout the structure are not of that laboratory uniformity which is so essential to perfection in reinforced concrete construction.

Great publicity has been given to the incredible speed with which the Princeton Stadium was built. It is barely possible that the demand for speed may have had a deleterious effect upon supervision. All of these things are probably contributory factors to the condition of the Princeton Stadium to-day. While it ranks as the best in its convenience of arrangement and its facilities, it cannot be truthfully said that it compares favorably with other structures of its class in its structural qualities.

(For details of construction refer to "Engineering and Contracting" May 26, 1915, Vol. XLIII, No. 21, page 472).

(To be continued)



VIEW SHOWING SUPPORTING CONSTRUCTION

Quantities to be used.



GALLERY OVER NORTHERN AISLE IN ST. MARK'S, VENICE

THE AMERICAN ARCHITECT

VOL. CXVIII

WEDNESDAY, JULY 28, 1920

NUMBER 2327

Architectural Quicksands

By Clinton H. Blake, Jr., of the New York and Federal Bars
With an Introduction by Daniel Paul Higgins

UNDER the heading of "The Business of Architecture," articles have appeared in the September, October, November and December, 1916; January, February and March, 1918, issues of "The Architectural Review" by the writer, and continued by Professor H. D. Smith under the same heading and in the same journal in May, June, July and August, 1918, and beginning again in June, 1920, issue, as well as articles by the writer in THE AMERICAN ARCHITECT under the heading "Architect's Office Organization to Meet Post-War Conditions."

These early articles have analyzed and charted the various forms of important architect's organizations as they actually exist with many pertinent remarks and criticisms concerning same and in the final analysis have presented an ideal and practical organization based upon the conception that the most comprehensive organization can be built up with a series of units effecting special and technical training. The corollary of this proposition is that the function of the proper business administration is to maintain a balance among other units rather than to attempt the arbitrary control and administration of each unit. The trend of this administration is toward centralization, and is a system of checks and balances that centralization does not carry to the extent of devitalizing the other units such as design, engineering, supervision and decoration. The aggregation of these units will result in a unit sufficiently complete within itself for all practical purposes balancing a number of highly specialized functions to produce a homogeneous economical result.

In the previous review of the ideal organization and to complete the system of checks and balances it is pointed out that an architect with an important practice should have the legal guidance of a lawyer skilled in the law of architecture and building so that he may protect and understand the rights and obligations of himself and of his clients, thereby reaping the benefits accorded by

this law and avoiding the penalties provided for a breach of it.

An architect who exercises the duties and responsibilities of contracting for work and assumes the responsibilities for the execution of same as the owner's agent without the knowledge of the first principles of the law of contracts and in the absence of the proper legal advice and surveillance is not diligently or honestly acting for his client's best interest. Apart from his duties and obligations to his client, in this respect, self interest should induce the intelligent architect to understand his own rights and obligations.

For further amplification of the legal problem and complication which the modern architect has to face in the course of his practice and in order that he may clearly grasp the significance of the importance of attention to this part of his practice THE AMERICAN ARCHITECT has with good judgment secured the services of Mr. Clinton H. Blake, Jr., whose experience and familiarity with the law affecting Architecture and Building equip him to give an authoritative review of mistakes commonly made by architects of his acquaintance and to present essential remedies for such errors.

Mr. Blake, who is the author of the text book and writings on "The Law of Architect, Owner and Contractor" and "The Law of Architecture and Building," is a graduate of Columbia College 1904, Master of Arts, Columbia University (School of Political Science) 1905, and a graduate of Columbia Law School in the class 1906. Mr. Blake was admitted to the New York Bar in 1906 and in taking his degree of Master of Arts specialized in constitutional and administrative law. He has always taken a keen interest in architecture, and in addition to his general practice has specialized in the laws affecting Architecture and Building. He has made a special study of these laws—both the New York and Federal laws and the laws of other countries—and has won much recognition by his practical presentation of the subjects in his

writings. In practice he has shown rare ability in the application of the principles affecting the above subjects, and in his handling of cases affecting the mutual rights of architect, owner and contractor.

In 1908 Mr. Blake became a member of the firm of Strong, Blake & McAneny and has con-

tinued as a member of that firm and its successors, the firm name now being Blake, McAneny, Durham & DiMilhau. The firm has a general practice in the New York and Federal Courts with specialization in Architectural and Building Law, and in the law of estates and corporations.

DANIEL PAUL HIGGINS

The Business Side of Architecture

ARCHITECTURE has long been regarded and still is properly classified as one of the fine arts. Every element of tradition in the profession has served to confirm this classification and to emphasize in the mind of the architect the fact that the profession is primarily an art. All this is, of course, fundamentally sound, and I have no quarrel with it in any particular, except in so far as it is sought to regard the profession as an art solely and to disregard the everyday prosaic business elements entering into the practice of it. During recent years especially, it has become increasingly apparent that architecture has a business side, as well as an artistic side, and that the architect who would protect his client's interests and his own rights and avoid serious embarrassment and loss must recognize the fact that this is so.

Architects, as a class, unquestionably regard the artistic element as paramount, and it is right that they should do so. The difficulty is that very many—the great majority, I fear—persist in viewing their profession as an art alone, and seem to have a feeling that in some way directly or indirectly they are untrue to that art, if they deign to practice it on a basis of business efficiency and organization. For years I have been preaching to my architect clients the doctrine that this point of view is false, that the profession can be followed with due regard to its standing as a fine art, and without cheapening its standing as such in any way, and that at the same time, due regard may be given to the rules of business organization and conduct. In other words, I am heretical enough to believe that an architect may be a great artist in the truest sense of that term and at the same time a man possessed of sound business sense and judgment, and that he may organize his office on business principles and conduct it on a basis of business efficiency, and at the same time develop work of the highest artistic and architectural excellence. In fact, I know that this is so, because some of my very good friends and clients in the profession—men whose work is nationally recognized as deserving of the warmest praise—are also keen business men, who deliberately make use

of their business judgment and ability for the express purpose of safeguarding their own interests in the practice of their profession, and the interests of the clients whom they represent. If one consider the elements entering into the practice of architecture today, he must realize that the drafting of specifications, the securing of estimates, and the drafting and operation of the building contract, while part and parcel of the primary purpose to achieve an artistic result, have, nevertheless, each of them a purely business side. All of these phases of the work, the superintendence of the job, the arranging with the client for the payment of the fee due, and like items entering into the construction of every work undertaken and carried out, are fundamentally business propositions.

Art and business are not so diametrically and hopelessly opposed as many would have us believe. They may well go hand in hand in the conception and execution of work at once meritorious from the point of view of the most fastidious artistic critic, and at the same time satisfactory and successful, in that it has been carried forward to completion on a sound business basis and in accordance with such business principles as are necessary to protect architect, client and contractor alike. It is because I feel very strongly on this point and realize the benefit which must accrue to the architectural profession, by a more general adoption of business organization and principles by architects in their practice, that I am glad of the opportunity to contribute these articles to *THE AMERICAN ARCHITECT*; to hang up along the architectural highways, as it were, a series of danger signals, so that the architect who travels them may at least be able to sense the spots in the practice of his profession, where danger lurks, and to secure advice or perfect his judgment in time to avoid unnecessary loss and embarrassment to his client and to himself.

These danger points or "architectural quicksands," as I have called them, in the title, can be most graphically and interestingly illustrated by reference to actual cases and difficulties which have arisen in the practice of architects heretofore. I purpose

THE AMERICAN ARCHITECT

therefor to emphasize the points which I would make, by references to typical examples illustrative of the manner in which the architect may easily involve the client, the builder and himself, particularly, in difficulties and serious loss, for want of an understanding of the more important rules upon which the relationship of all the parties to the ordinary building operation are based, and for want of an observance on his part of rules which are fundamental in any successful business undertaking.

My good friend, Mr. Daniel P. Higgins, of New York, and Howard Dwight Smith, professor of architecture in the Ohio State University, and for many years a practising architect in New York, deserve the thanks of every architect for the manner in which they have, in their admirable writings in various architectural publications, emphasized the wisdom and necessity of organizing the architect's office upon a business basis and in accordance with the well-settled and recognized rules of business conduct and efficiency.

Mr. Higgins has, in his articles on the "Business of Architecture," set forth with admirable clarity and force the desirability and necessity of so organizing the office of the architect that the architect's practice will be carried on with business despatch and accuracy. He has shown that the ideal office organization, which he has so carefully and concisely outlined, is one which is at the same time entirely practicable. There is no reason why any architect can not organize his organization along the lines which Mr. Higgins has outlined, with such modifications to suit his own special conditions as may be necessary. The fundamentals are so clearly stated by Mr. Higgins and the details so nicely worked out that a careful study of his articles and the practical charts and suggestions embodied in them should convince the most skeptical that the points which he makes are well taken and the form of organization which he suggests admirable in its scope and detail.

It cannot be logically maintained that a man is any the less an artist because before undertaking his work he arrives at a clear understanding with his client as to what his compensation is to be, or as to the basis upon which he is to act. Similarly, he does not lose any of his artistic ability because he sees to it that his office is so organized that the business aspects of the contract, specifications, estimates and the like, and the engineering phases of the work, are passed upon by men trained to appreciate and check them, and that as the work progresses the sums becoming due to the contractor, the accuracy of the items embodied in the certificates, the payments to sub-contractors, and all of the other similar items entering into the usual building opera-

tion are checked by an employee with a reasonable working understanding of accountancy.

One of the most successful and artistic architects whom I know makes it his regular practice to assume a sort of guardianship over the interests of his clients in their dealings with contractors far beyond the point that the ethics of the profession require that he do this. In repeated instances he has called upon me for advice upon matters involving solely the client's interests, not coming within his province as architect as his duties are laid down in the canons of ethics or usually considered, and which he might quite conscientiously and properly have passed along to the client for attention and determination. He has done all this and has not "passed the buck," as he might have done, because he has realized that by reason of his special knowledge of the situation and facts involved and of the work done, and of the attitude of the contractor and the general psychology of the situation, he has been in a position to give valuable help to the client and to aid him in avoiding unpleasant and expensive complications. This architect has paid for such legal services from his own pocket, and yet, from personal observation, I am convinced that the practice which he has thus followed has been a very great asset to him in his relations with his clients, an element of prime importance in building up the reputation which his office enjoys, and a mighty good investment from every point of view.

The Value of Being Definite

If I were asked to sum up in one word the greatest need of the architect of today in the successful practice of his profession—aside, of course, from artistic and engineering training and ability—I should unhesitatingly answer "definiteness." More troubles brought into my office by architect clients result from a lack of definiteness than from any other dozen causes combined. The architect may be a genius. He may possess all the artistic and mechanical ability and training in the world. He may have the most charming of personalities and very unusual opportunities to make it felt. Yet, if he has not acquired the faculty of being definite, he will sooner or later, if his practice be on a really worth while and successful scale, experience a jolt which will cause him embarrassment and difficulty, and in all likelihood substantial financial loss. "Be definite" should be the watch word in the office and throughout the organization of every architect who would avoid disputes with his clients, disputes between his clients and the contractors, disputes between the contractors and his own organization, and the danger of loss and entanglement in litigation.

If one trace the course of an architect's dealings with his client in a typical case, one will find that beginning at the first interview and continuing through the selection of the site, the preparation and submissions of sketches, plans, working drawings, specifications and details, and the general superintendence of construction, not a step is taken which can be safely taken on any basis other than one of definite and complete mutual understanding. If you were to tell the ordinary business man that he should be sure that everything is understood thoroughly in putting through a business deal involving the payment of large sums of money he would in all likelihood think that you were mildly insane in thinking that he would pursue any other course. And yet, if you suggest to the ordinary architect that in his first interview with his client, or at least at the interview at which he is finally employed and told to proceed with the work proposed, the matter of the compensation to be paid him and all of the other more important elements involved in

his employment should be discussed, made clear and decided upon, the chances are about ninety-nine to one that he will tell you that he can not discuss these subjects with his client at that time, without creating a wrong impression and quite possibly losing the job in prospect. I can quite understand how the architect may feel that this is so, but as a practical matter, I am clear that the difficulty which he fears is, in the very great majority of cases, wholly imaginary, and that the client would, indeed, much prefer to start out with a full understanding of all the fundamental rights and obligations involved. I believe that he would not think less of the abilities of his architect because the latter desired to place his dealings upon a clear and business-like basis, and that his mental reaction would, on the contrary, be distinctly favorable to that architect who approached the job on such a basis of an accurate and thorough understanding.

CLINTON H. BLAKE, JR.

(To be continued)

Old Crosses and Lych Gates*

WHEN, under Constantine, the Christian religion was proclaimed to the then known world, among the efforts made firmly to establish the new faith was the obliteration, all over Europe of every existing evidence of the idolatrous religions then waning. This led to the substitution everywhere of shrines or crosses, for the mythological emblems of the supplanted faiths. These crosses and shrines, first of a crude character, were simply monolithic shafts surmounted by a stone cross. With the growth and advance of Christianity the wayside shrine and cross became important landmarks and as such were dignified by all the embellishment that a newly awakened art could provide.

The custom of erecting shrines and crosses was early taken up in Great Britain and there the roadside became in a like manner embellished. More often erected to mark a pious impulse, they also stood as memorials of historic association. In their most rudimentary form these crosses, as stated, simple monoliths of stone, a shaft tapering often to a pointed apex. In many cases the roadside crosses became rostrums from which religious services were held. A base, generally of three stone steps, formed a circular platform from the center of which the base of the cross sprang.

It is interesting to trace the artistic development of these roadside crosses from the simplest, crudest form to the architecturally designed "Eleanor Crosses" that are the delight of archaeologists and the reverent pride of possession in the communities in which they are located.

The preaching cross, or cross with steps, became later developed as the market cross, set up in towns to mark the civic centers. From the platforms of these crosses were made the announcements to the public of matters of importance, and they were often used as pulpits where were held the religious services so much affected by the people of the Middle Ages.

A careful study of these crosses develops a certain style as belonging to a certain period. They are held in veneration by the people of Great Britain, and their artistic features of design have been many times illustrated. Mr. Vallance has gathered and published in his interesting work a series of illustrations of these old crosses that constitute a valuable record and offer a wide field of suggestion in modern design.

The Lych Gate, or literally Gate of the Dead, is a picturesque feature of every English country churchyard. Through this entrance to the graveyard and pathway to the church door, the dead body was carried and here the bearers set down the corpse to rest a spell before carrying the body to the grave. As a rule these old Lych Gates were built of ma-

*Old Crosses and Lych Gates by Aymer Vallance. Full cloth, 190 pp., with many illustrations. London, B. T. Batsford, Ltd. New York, Charles Scribner's Sons.

THE AMERICAN ARCHITECT

terial the same as that used in the construction of the church structure, and also followed in design that of the church itself.

Their size and dignity varied. Early examples

are of considerable size. They have a slab on which to rest the pall, with seats on either side for the bearers. Other Lych Gates are, as their name imply, simply gates with a roof or awning. In Mr. Vallance's volume already referred to there has been made by the author an attempt to classify these gates as to their design. These he groups as porch shape, in which the roof has the same axis as the passageway, the shed like form in which the roof runs transversely to the axial line of the passage-



THE ELEANOR CROSS. NORTHAMPTON



LYCH GATE, WITH COFFIN SLAB, AT CHIDDINGFOLD, SURREY

way, and a rare variety that combines both of these features.

Much of the charm of the English countryside is due to the picturesque construction and aging of these old gates through whose portals many generations have been borne to their final resting place in the church graveyard.

Architectural Acoustics

Transmission of Sound Through Doors and Windows

By PAUL E. SABINE

THEORETICALLY and practically the transmission of sound through partitions between adjoining rooms is a complicated phenomenon. The theoretical solution of the problem of the relative sound intensities on the two sides of a simple geometrical form, is difficult, perhaps impossible. Moreover, given the solution of the problem for the ideal case, its practical application would present even greater difficulties, since the assumptions necessary for the theoretical solution, do not in any considerable degree approximate the conditions to be met in actual construction. The only method of attack, therefore, is experimental, and since the number of factors entering into any particular problem is so great, and their relative importance is unknown, the experimental conditions must approximate the actual conditions of ordinary construction as nearly as may be, if the results are to possess any practical significance for the architect or the engineer. A laboratory experiment can be devised for measuring the transmission of sound through a single unit of building material, let us say, a terra cotta tile, a gypsum block, or a concrete slab. Whether the results of such an experiment would have any significance at all, when applied to the practical problem of the sound insulating properties of walls made up of such units, is problematical, since the latter depends upon the physical properties of the entire construction considered as a whole quite as much as upon those of the materials of which it is composed. In order to meet the necessity for securing test conditions which shall approximate those in ordinary practice, a special laboratory was built which has been described in detail in an earlier number of *THE AMERICAN ARCHITECT*.^{*} It is hoped that by a thoroughly systematic study of many units and types of construction, a mass of quantitative data may be secured from which conclusions of general applicability may be drawn, as well as numerical coefficients by which the sound-insulating merits of materials and constructions may be compared.

It is important to distinguish at least two different processes by which the mechanical vibrations of a musical instrument or other source of sound

in one room may result in the aerial vibrations of sound in an adjoining room. If the vibrating source is in solid contact with the floor, then the vibrations may be conducted directly to the floor, and thence along timbers or beams to the floor of adjacent rooms, there to give rise to the aerial vibration. A large proportion of the sound from a piano, cello, or any stringed instrument, resting on the floor, as well as the hum of motors or machinery, is transmitted through buildings in this way. Thus far no attempt has been made to deal with this aspect of the problem. In the second method of transmission the alternating pressure of the sound wave in one room produces vibration of walls or partitions, which in turn communicate their motion to the air of the adjoining room. Throughout the present paper, only this latter method of transmission will be considered. In the case of previous partitions such as felts or fabrics, the motion of the air may be communicated from room to room through the pores of the materials, with perhaps little or no motion of the partition itself. This latter case will be the subject of a later paper. The present report will concern itself only with the transmission by doors and windows made of impervious materials.

The method of conducting the tests was essentially that described by Professor Wallace C. Sabine, in an article published in 1915. The passageway between two adjoining rooms is closed by the partition under test. Sound is produced in one room, the Sound Chamber, and its intensity is made to decrease by stopping the source and allowing the sound to die away at a determinable rate by successive reflections from the walls. From the time required for it to become barely audible in the test chamber, on the other side of the partition, and the known rate at which it dies away in the sound chamber, the ratio of the intensity on the two sides may be computed. For the details of the method together with the precautions taken to insure that sound shall pass between the two rooms only by way of the partition under test, the paper just referred to and that in *THE AMERICAN ARCHITECT* of July 30, 1919, may be consulted. For convenience of the reader, a plan showing the arrangement of the sound chambers and the test chambers is given in Figure 1. The very low absorption of sound by the walls of the sound chamber, makes the duration of audible sound very great, thus allowing considerable precision in the measurements.

^{*}The experimental study of the problem of Sound Transmission was begun by the late Professor Wallace C. Sabine in 1914. It was interrupted by the war. Meanwhile the new laboratory, which now bears Professor Sabine's name, was completed at Riverbank, Geneva, Illinois, by Colonel George Fabyan. A full description of the laboratory and its equipment appears in "The American Architect" of July 30, 1919. The present paper is a report on that portion which has been completed of the extensive program originally planned by Professor Sabine for this laboratory. Other researches are in progress, and will be reported from time to time.

THE AMERICAN ARCHITECT

REPRESENTATION OF RESULTS

IT is of importance that the results of any scientific investigation intended for readers who are primarily interested in the practical rather than in the theoretical aspects of the subject, be presented in a form such that they may be applied to common experience. In the present investigation what has been determined is the ratio of the intensities of sounds covering the whole range of frequencies or-

dinarily used in music and speech, i. e., 64 to 4,096 double vibrations per second, on opposite sides of doors and windows of various sorts. Thus sound of the pitch violin C (512 double vibrations) is reduced in intensity in the ratio of approximately 100 to 1, in passing through a light panelled birch door, and in the ratio of 1,000 to 1 in passing through a steel door one-quarter of an inch thick. The significance of such figures is more apparent

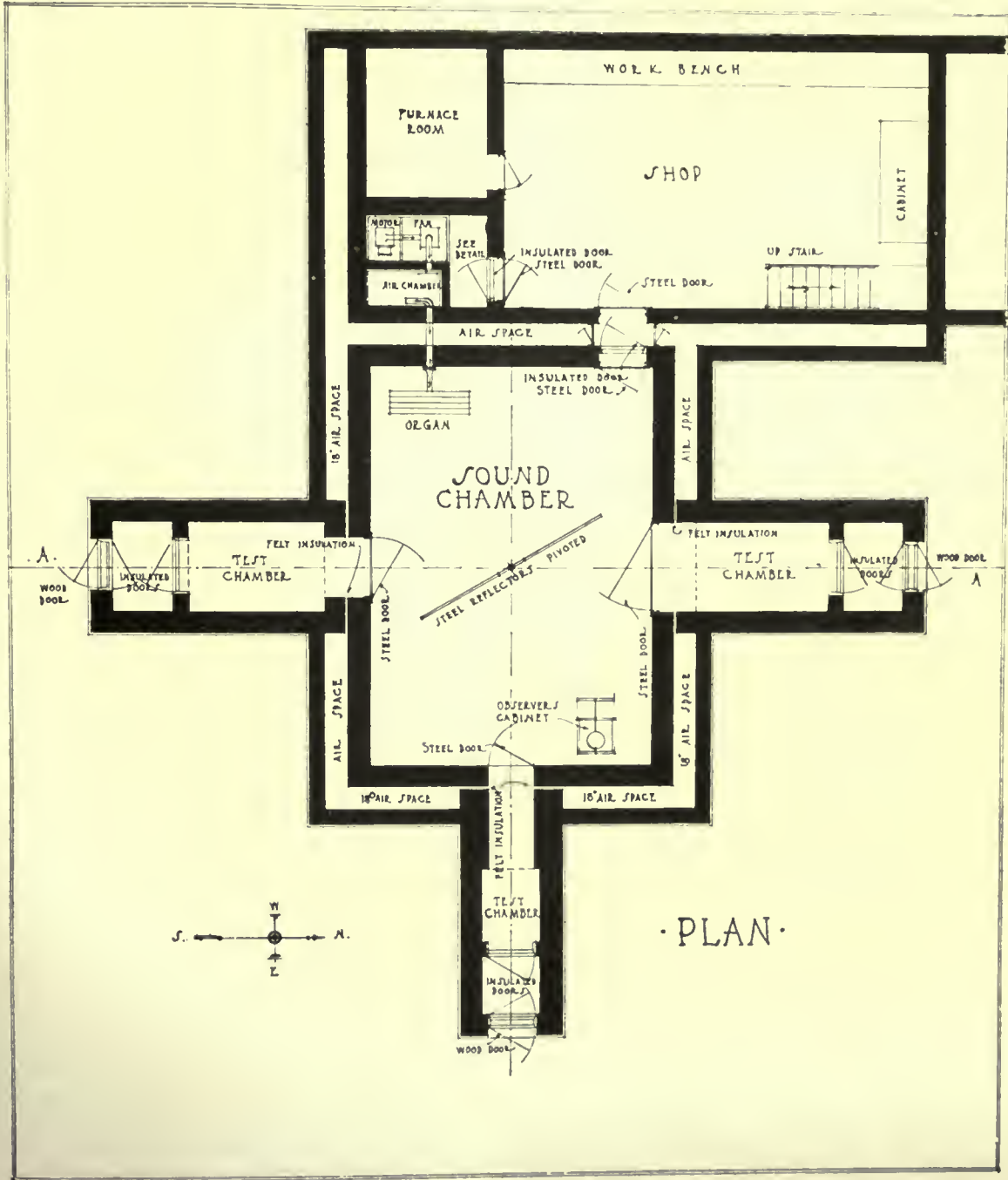

FIG. 1.

THE AMERICAN ARCHITECT

if it is recalled that in the open air at a distance from all reflecting surfaces the intensity of sound from a constant source decreases as the square of the distance increases. Thus increasing ten fold the distance between the source of sound and the observer in the open, produces the same reduction in the intensity, as is produced by the passage through the birch door. The steel door effects the same reductions as increasing the distance thirty-one fold. A further illustration: Ordinary conversation can be distinctly heard and understood through the light door mentioned above. It can be faintly heard but not understood through two such doors acoustically separated from each other. If it be assumed that the reduction in intensity in passing through the second door is equal to that in passing through the first (an assumption, which can be made only with certain important qualifications) then we have an idea of the effect upon the audibility of a sound of a reduction to one ten thousandth of its original intensity.

There are a number of ways in which the relative transmission of the various partitions studied might be represented. For example, the fraction of the sound, transmitted might be plotted as ordinate with the pitch of the tone as abscissa. The large difference between different constructions, represented in this way would, however, be misleading to one interested in the reduction of the audibility of the transmitted sound, since the sensation of loudness is proportional not to the intensity of the sound, but more nearly to the logarithm of this quantity. A very considerable difference in the measured intensity is necessary to produce a perceptible difference in the sensation produced on the ear. Thus it has been found that opening a hole three inches in diameter in the wall between two adjoining rooms in one of which was a continuous source of sound, increased the intensity of the sound transmitted to the other by about twenty per cent. Yet the change in loudness made by opening or closing a hole of this size could barely be detected. Thus it appears that while a difference of twenty per cent. in the sound insulating properties of two types of partitions is easily measurable, it is quite negligible in the problem of reducing the audibility of sound transmitted from room to room.

In the accompanying figures, the ordinates represent the logarithm of what may be called the *Reduction factor* of the partition in question. *The reduction factor for a partition is the ratio of the average intensity in the room in which the sound is produced to its average intensity on the opposite side of the partition and near it, no sound being transmitted except through the partition.* The logarithm of this ratio which is the length of the or-

dinate, measures roughly the difference in loudness on the two sides of the door or window, in question. Approximately one tenth of the unit ordinate represents a difference in loudness that is easily perceptible. This method of representation has the advantage of making the comparison between the various partitions in magnitudes that represent the audible sensations with which we are concerned.

RESONANCE PHENOMENA IN TRANSMISSION

THE question as to the process by which sound produced in one room is transmitted through a solid partition, a steel door, for example, may be briefly considered. It is conceivable that the impact of the vibrating air particles on one side, may be imparted to the molecules of the solid and in turn communicated by them to the air particles on the other side. Thus a pulse of compression in the air wave would give rise to a similar pulse in the solid, and this in turn to the air on the other side. Both theory and experiment indicate that in thin partitions, transmission by this means is vanishingly small in comparison with the actual transmission. Experiment shows, on the other hand, that there is a flexural yielding of the partition under the alternating pressure of the sound wave, and that the vibration is communicated to the air by this flexural vibration of the partition. By a delicate mechanism, which need not be here described, the actual motion has been measured and has been found to correspond very closely to the vibration of the air particles in the sound wave, thus confirming the idea that transmission occurs very largely by flexural rather than compressional waves in the partition.

Theoretical considerations show that a partition of a type approximating a rectangular uniform plate, clamped at the edges, will respond to a series of tones of definite frequencies, in a manner quite comparable to that of a stretched string. The phenomenon is complicated, however, by the fact that two dimensions are involved in the response of the plate. In the case of the string the different natural frequencies of vibration are all multiples of a single fundamental frequency, the string vibrating in segments to produce the various frequencies to which it will respond. No such simple relation holds between the natural frequencies of a plate, since both its length and breadth enter into the phenomenon. Calculation shows, for example, that with frequencies less than one thousand, a plate of one-quarter inch glass of the dimension used in the tests, has some thirty-seven different natural modes of vibration. Its response to a tone of any of these natural frequencies would theoretically be much greater than to other nearby frequencies, and its transmission of sounds of frequencies corresponding to its own natural vibrations would be corres-

pondingly great. In other words, the phenomenon of resonance may well be expected to appear prominently in transmission measurements. The experiments amply fulfill this expectation, so much so in fact, that a thorough study of the properties of a single partition should involve measurements using a large number of tones taken at very small intervals of the musical scale, and entail an amount of work that would be prohibitively great. Arbitrarily, therefore, the seven tones an octave apart from C_1 64 to C_7 4096 vibrations per second have been used, and the reduction factor for each determined. Trials with intermediate tones have shown that although the intermediate points do not lie on a smooth curve, yet the general trend of the reduction of intensity factor, considered as a function of the pitch of the sound, is represented by the curves given. Moreover, the variations from the smooth curve are, in general, slight in comparison with the relatively large differences which are necessary to give one construction a decided advantage over another as a sound insulator in actual practice.

The securing of the data given represents a year's work. A large number of detailed questions have called for experimental study, with which it is not necessary to weary the reader, but which had to be answered before one could feel any assurance of the reliability of the results of the investigation. As an illustration, one may cite the question of the effect of the acoustic properties of the room into which the sound is transmitted upon the values of the apparent transmission as determined by this method.

The average intensity of sound in a room containing a steady source of sound is inversely proportional to the product of the volume and absorption of the room. When sound is entering a room through a closed door or window, the latter may be considered as such a source, and the average intensity in the room will depend not only upon the amount of sound transmitted, but also upon the acoustic properties of the room itself. The experiments showed that an increase in either the volume or the absorbing power of the receiving chamber, did effect a decrease in the average intensity of the transmitted sound, measured at a number of different points in the room. If, however, the observations are confined to positions near the transmitting wall, the effect of changing the amount of absorbing material in the receiving room is negligible, and a large change in the volume produces only a small change in the intensity thus measured. The curves in Figure 2 illustrate this effect. Curve 1 gives the logarithms of the reduction factor for tones of the frequencies shown. Curve 2 represents similar conditions, except that the volume of the receiving chamber is increased from 104 cu. ft. to 413 cu. ft.

by the opening of a door arranged for the purpose. Further increase of volume produced no further appreciable effect. The point to be emphasized is that the apparent transmission of sound from room to room is in some degree at least a matter of the acoustic properties of the room into which the sound

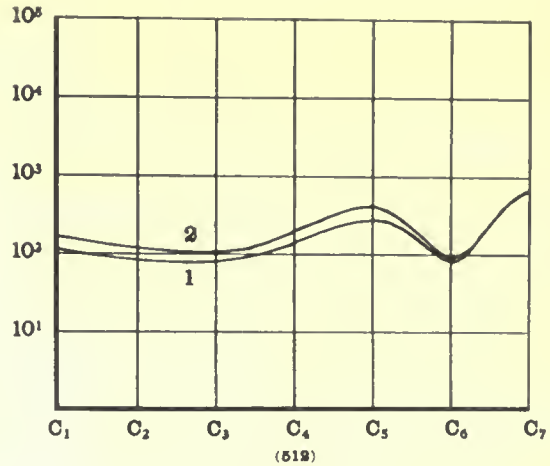

FIG. 2.

Curve 1. Reduction of intensity of sound transmitted into a small room. Curve 2. Reduction of intensity of sound transmitted into a larger room.

is transmitted, as well as of the separating walls. Experience shows that an appreciable reduction of noise in a room, transmitted from outside sources, may be secured by proper acoustical treatment of the interior of the room itself. In the results given hereafter the receiving chamber has been kept acoustically constant, with a volume of 413 cu. ft. the walls, floor and ceiling being of hard brick, cement and hard plaster.

In the later paper an attempt will be made to correlate the sound insulating properties of partitions of the type here considered with their mechanical properties of mass, viscosity and stiffness. For the present, only the results of experiment can be given. The units tested were of uniform dimensions 79 inches by 31 inches. The doors were set tight in a heavy frame of yellow pine, all cracks being carefully sealed with putty. The effective area transmitting sound was the same in all cases. Tests have been made upon some twelve different constructions. In order to save space, the numerical values of the reduction factor will not be given. They can be taken from the curves. The ordinate for any frequency as has been stated is the logarithm (base 10) of the reduction factor. The magnitude of the ordinate is a measure of the insulating property of door or window in question. The fraction of the sound transmitted is the reciprocal of the number whose logarithm is the length of the ordinate.

THE AMERICAN ARCHITECT

WINDOWS

THE transmission by a window depends upon the quality and thickness of the glass, and upon the mode of setting in the sash. In Figure 3 the latter factor is the same for all three curves. Four panes, each 15 inches by 39 inches, were set in the sash described. Curve 1 is for a specially prepared three-ply material, consisting of two sheets of 1/16 inch window glass sealed together with an intermediate sheet of celluloid, the whole forming a 3/16 inch pane of approximately the same mass as ordinary plate. Curve 2 is for 3/16 inch plate glass, and curve 3 is for 1/4 inch plate. The increase of insulating power of the heavier glass is clearly indicated. The increased reduction in substituting 1/4 inch for 3/16 inch glass in telephone booths, for example, would on the average be that secured by increasing the distance from the source of sound in the ratio of 14 to 10. The lower reduction affected by the triplex glass is of interest. It is known that under certain conditions discontinuities in stiffness and density increase the insulating power of partitions. In the present instance, however, the decrease in rigidity occasioned by introducing the celluloid, probably, more than offsets any possible advantage

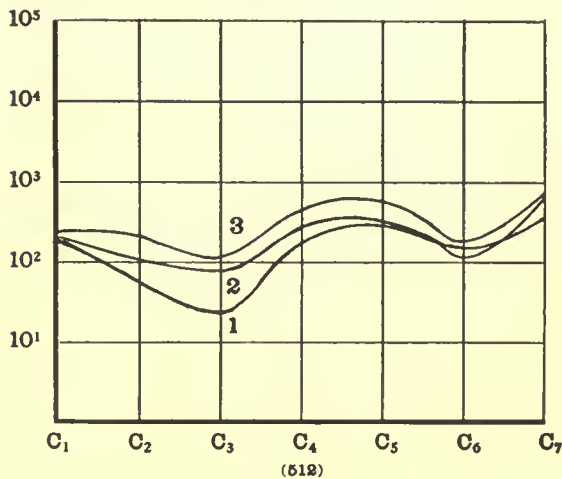

FIG. 3.
Curve 1. Reduction produced by triplex glass. Curve 2. By 3/16" plate. Curve 3. By 1/4" plate.

of the discontinuities in the physical properties, which confirms the notion that flexural vibration is the important factor in transmission of sound by thin partitions.

The five curves in Figure 4 are for decidedly different constructions, but a comparison made in connection with the type of construction in each case proves significant. Taken in order, curve 1 is for a solid steel door 1/4 inch thick filling the doorway described. Curve 2 is for the four pane window of 1/4 inch plate glass described above, curve 3 is for a single pane window of 1/4 inch plate glass 79 inches

by 31 inches. Curve 4 is for a window with diamond shaped panes 3/16 inch thick, leased in each pane having an area of 16 square inches. Curve 5 is for a twelve pane window of light construction of 1/8 inch glass, the panes being 10 inches by 19 inches. For the lower tones the reductions of intensity by the different partitions are in the same order as masses of the various partitions. That is, the more massive constructions produce the greater reduction in intensity for the lower tones. This order does not hold over the entire range of frequencies, however. For the higher tone the stiffness of the construction seems to be the more im-

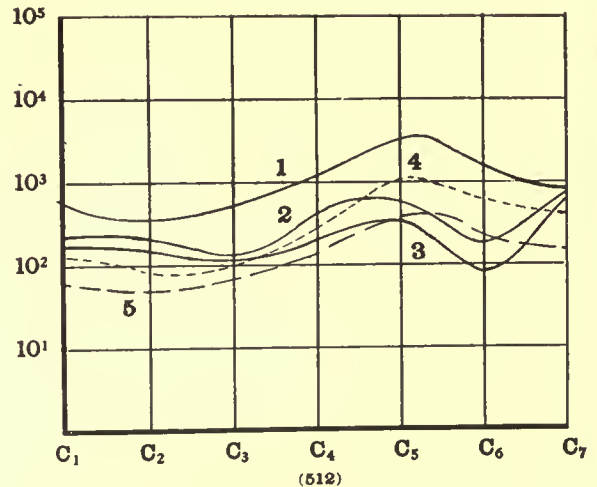

FIG. 4.

Curve 1. Reduction produced by door of 1/4" steel. Curve 2. By 1/4" plate glass with cross bracing. Curve 3. By 1/4" plate without cross bracing. Curve 4. By 3/16" small leaded panes. Curve 5. By 1/8" panes 10" x 19".

portant factor. Inspection shows that curves 1, 4 and 5 have the same shape. Apparently this is to be accounted for by the added stiffness afforded the leaded pane and the twelve paned windows by the cross bracing of the sash. It appears that the well braced lighter glass constructions of 4 and 5, may be as effective in reducing the transmitted intensity of the higher notes as is heavier material use in larger units. The transmission from the form of curve given by the more flexible single pane to that of the rigid steel is shown by curve 2 for the four paned window.

The effectiveness of a so-called "dead air space" is often mentioned in connection with sound insulation. The curves of Figure 4 illustrate well a condition that must always be met if such a space is to produce the desired results, namely, that the "dead air space" must not be bridged by any solid connection, even at the boundaries, curve 7 represents the reduction produced by a single glazed two pane window, each pane being 31 inches by 39 inches, and slightly less than 3/16 inch thick. Curve 2 is for the

same window *double glazed*, that is, with glass set "on both sides of the sash." The separation between the two panes was about 1 inch. As appears from the curves, the sound insulation afforded by the two thicknesses of glass does not at all approach what would be expected upon the assumption that the second thickness produced a reduction in intensity comparable to that produced by the first. It is apparent that the vibration of the first pane is transmitted directly to the second through the sash and that the air space is quite ineffective. Curve 3 shows the results of an attempt to insulate the two panes by setting the second one in $\frac{1}{2}$ inch saddler's felt rather than in putty. For the lower frequencies it appears that the felt is practically without effect, but that it does produce an improvement in the reduction of intensity for the higher notes. Further experiments on this point are in progress.

DOORS

A LARGE number of tests on doors of various constructions have been made, detailed account of which may be omitted from present consideration. The results of four widely different types are pre-

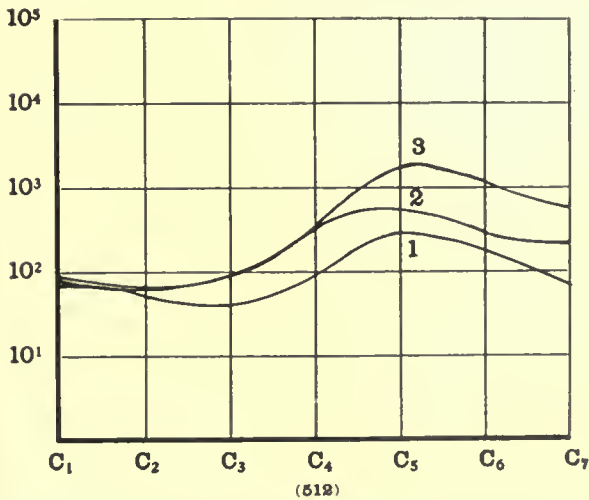

FIG. 5.

Curve 1. Reduction produced by single glazed window 3.16" plate. Curve 2. By double glazed window, with panes set in putty. Curve 3. By double glazed window, panes set in felt.

sented in Figure 5. Curve 1 is for a light, four panelled door of birch veneer. Curve 2 is for a heavy solid oak door, well seasoned, $1\frac{3}{4}$ inches thick. Curve 3 is a heavy double walled door 4 inches thick, of yellow pine sheathing, filled with heat insulating material, of the type used in refrigerating and cold storage plants; while curve 4 is for the heavy steel door referred to above. The marked superiority in insulating power of the steel over the heavy "ice-box" door was scarcely to be expected in view of the generally accepted notions of the conditions for sound insulation. It was

found that through the latter it is possible to hear easily and to understand with slight difficulty speech of conversational loudness. Through two such doors on opposite sides of a small vestibule it is possible to hear and understand very loud speech. The slight advantage of this type over the less massive solid oak door is also of interest.

How important a factor the state of seasoning of a wooden partition may be is shown by curves 2 and 3 of Figure 6. Curve 3 represents the reduc-

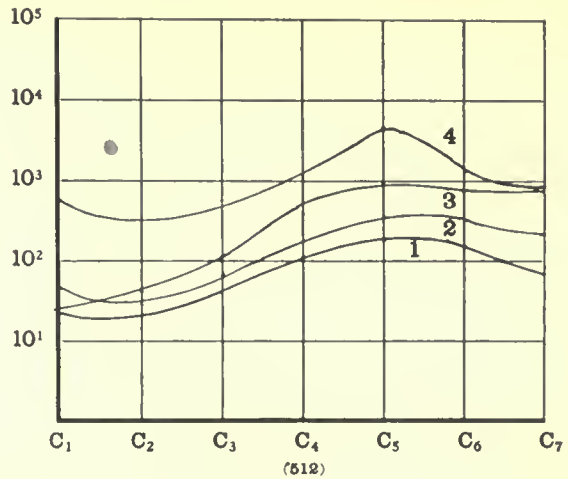

FIG. 6.

Curve 1. Reduction produced by four-panel door of light birch veneer. Curve 2. By solid oak $1\frac{3}{4}$ " thick. Curve 3. By double wall "ice box" door. Curve 4. By door of $\frac{1}{4}$ " steel.

tion produced by the oak door described, while somewhat damp from having been stored in a poorly ventilated room for several months. This was one of the first partitions tested. After having been kept in a dry room for a period of six months it was tested a second time, simply with a view to checking the earlier measurements. Curve 2 presents the results of this second test. The marked difference between the two tests placed the reliability of the method in considerable doubt, until a repetition of the early tests made on glass windows gave results in excellent agreement with those originally obtained, indicating that there had been a change in the properties of the wood through drying. The increased transmission for the extremely high and low tones of the dry, over the damp door, suggests the more nearly uniform response to the whole range of tones of the well seasoned old violin or 'cello, as compared with the "green instrument" of recent make.

In tests just described all precautions were taken to prevent the transmission of sound through cracks or openings of any kind. In practice, doors and windows are not closed air tight. The theoretical problem of the passage of sound through an opening is far from simple, and the practical problem calls

for an extensive experimental research. For the present the comparison of the reduction of intensity produced by a door sealed "air tight" into its casing, and that of the same door hung upon hinges must suffice. Curve 1 of Figure 6 is for the solid oak door, hung upon hinges and set so as to open

sion of sound through long, narrow cracks, is surprisingly large.

In the foregoing enough has been presented to indicate the limitations and advantages of ordinary door and window construction in the way of sound insulation. The aim has been not so much to develop means for preventing completely the passage of sound from room to room as to secure reliable quantitative data on the transmission through partitions of ordinary construction. Such a study serves several useful purposes. The methods for securing the greatest degree of sound insulation under the conditions of common practice become apparent. Some notion of the relative importance of the various factors that together determine the degree of sound transmission is arrived at, and consequently a clearer idea of the direction in which improvement lies. Finally, commonly accepted ideas are submitted to the test of actual experiment. Thus the frequently expressed opinion that good heat insulation and good sound insulation are concomitant conditions is scarcely supported by the investigation thus far.

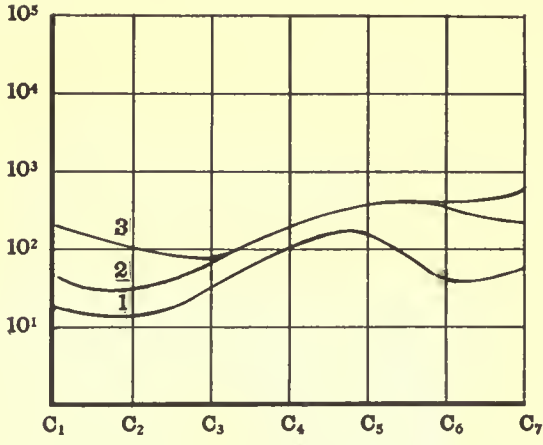

FIG. 7.

Curve 1. Reduction produced by 13 1/2" solid oak door as ordinarily hung. Curve 2. By the same door well seasoned and sealed air tight. Curve 3. By same door swollen with dampness.

and close freely. The very marked decrease in its effectiveness in shutting out sound is shown by comparison with curve 2. The experiment does not permit us to decide how much of this decreased effectiveness is due to the passage of sound through the crevices, and how much is due to the different mode of supporting the door. Other experiments on this point have shown, however, that the transmis-

Along with this study of simple partitions there is being conducted a study of the more complicated problem of wall construction, in which the method is to secure data on the transmission of walls of various types in each stage of construction. A similar investigation on the efficiency of so-called "sound deadening" materials is being pursued. It appears evident that in none but the most thoroughgoing and detailed study can results be arrived at which will be of value in the practical solution of this decidedly complex physical problem.

Beaux-Arts Institute of Design

DIRECTOR OF THE INSTITUTE, LLOYD WARREN

ARCHITECTURE, WILLIAM F. LAMB

SCULPTURE, JOHN GREGORY

INTERIOR DECORATION, ERNEST F. TYLER

MURAL PAINTING, ERNEST C. PEINOTTO

Official Notification of Awards— Judgment of March 16th, 1920

SECOND PRELIMINARY COMPETITION FOR THE
13th PARIS PRIZE
OF THE
SOCIETY OF BEAUX-ARTS ARCHITECTS
PROGRAM

The Annual Committee on the Paris Prize proposes as
subject of this Competition:

"A SAILORS' Y. M. C. A. AT MANILA"

INTRODUCTION:

The entertainment of soldiers and sailors while on leave has been, during and since the war, the subject of a great deal of study and consideration by various societies and organizations. The Y. M. C. A., in continuing this work, wishes to establish at Manila a recreation center for the sailors from the visiting warships and the naval bases located there.

The climate is sub-tropical. It is desirable, therefore, that the plan be conceived in such fashion as to provide

adequate shelter from the sun, and to allow free passage to the breeze, securing in this manner, the greatest protection and comfort to those who are pursuing the various activities provided for them.

THE PROBLEM:

The ground to be occupied by this recreation center is on the harbor, easily accessible to the ships at anchor by means of launches and other small boats, and to the naval base by a boulevard which runs parallel to the shore front. It is rectangular in shape, and its greatest dimension must not exceed 600 feet.

Provision is to be made for the following departments:

1. ATHLETICS:

Vestibule with stairways.

Physical director's room and examination rooms.

The gymnasium of not over 8,000 sq. ft. area, with running track and spectators' gallery.

A swimming pool not over 4,000 sq. ft. in area, with showers, baths, drying room, lockers, toilets and a barber shop.

Squash and hand ball courts.

There should be provided, out-of-door space for tennis, basketball and other minor sports. Baseball and football fields will be outside the grounds.

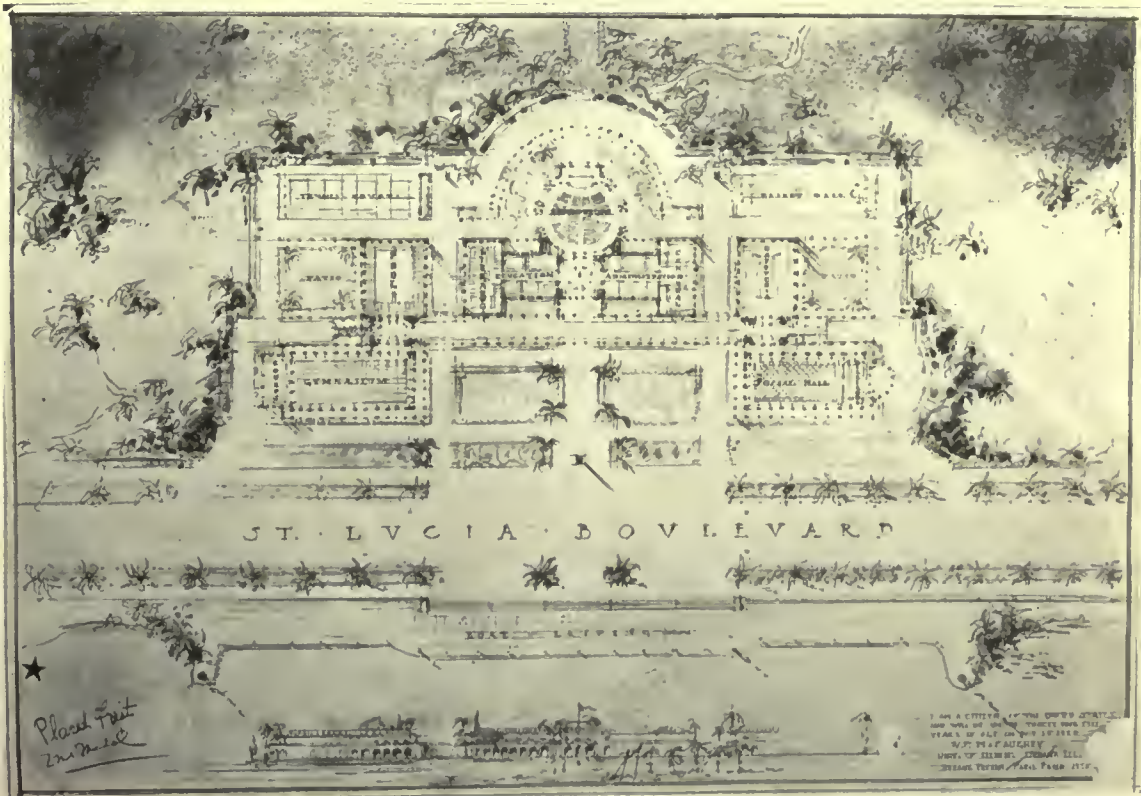

W. F. MCCAUGHEY, Jr.

PLACED FIRST

UNIVERSITY OF ILLINOIS

THE AMERICAN ARCHITECT

JULY 28, 1920

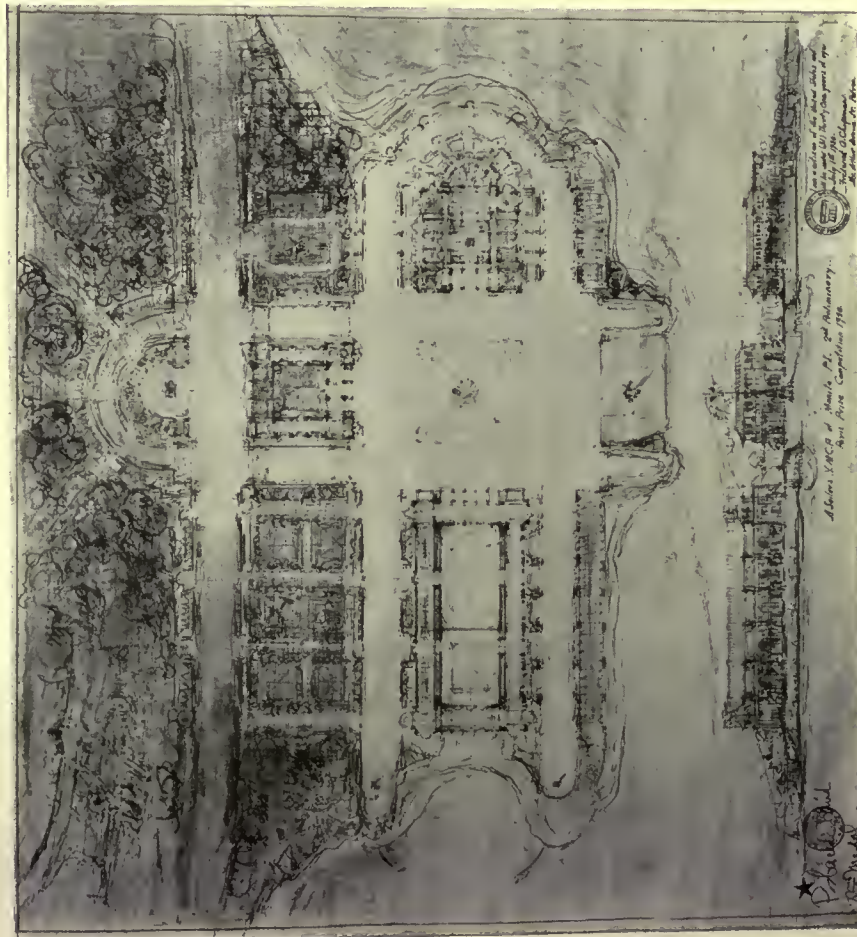

F. A. CHAPMAN

PLACED THIRD

ATELIER A. BROWN, JR.

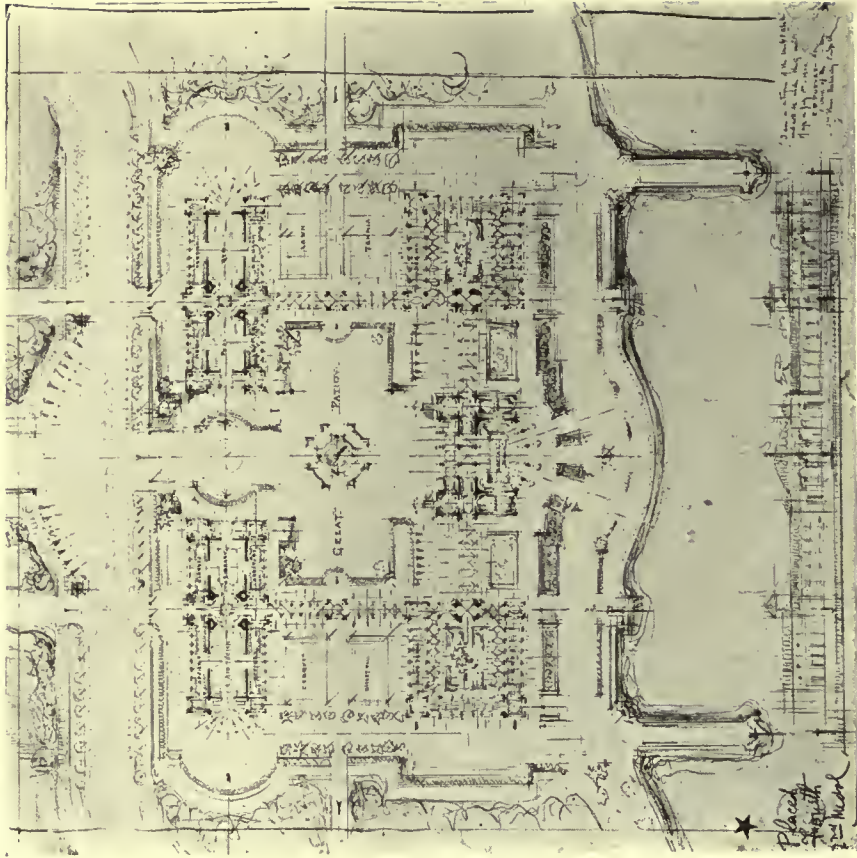

E. R. PURVES

PLACED FOURTH

UNIVERSITY OF PENNSYLVANIA

STUDENT WORK, BEAUX-ARTS INSTITUTE OF DESIGN. SECOND PRELIMINARY COMPETITION FOR THE THIRTEENTH PARIS PRIZE.

THE AMERICAN ARCHITECT

2. EDUCATION AND ADMINISTRATION:

An auditorium for lectures, concerts and moving pictures to seat 500 persons.

A library.

Four or five classrooms.

A laboratory for general scientific education.

The offices for the general administration, including the central office and several secretaries' offices.

3. SOCIAL AND RESIDENCE:

Entrance lobby.

Number of drawings submitted—13.

AWARDS:

PLACED FIRST (2nd Medal):—W. F. McCaughey, Univ. of Illinois, Urbana, Ill.

PLACED SECOND (2nd Medal):—D. McLachlan, Jr., Atelier Hirons, New York City, N. Y.

PLACED THIRD (2nd Medal):—F. A. Chapman, Atelier A. Brown, Jr., S. F. A. C., San Francisco, Cal.

PLACED FOURTH (2nd Medal):—E. R. Purves, Univ. of Pennsylvania, Philadelphia, Pa.

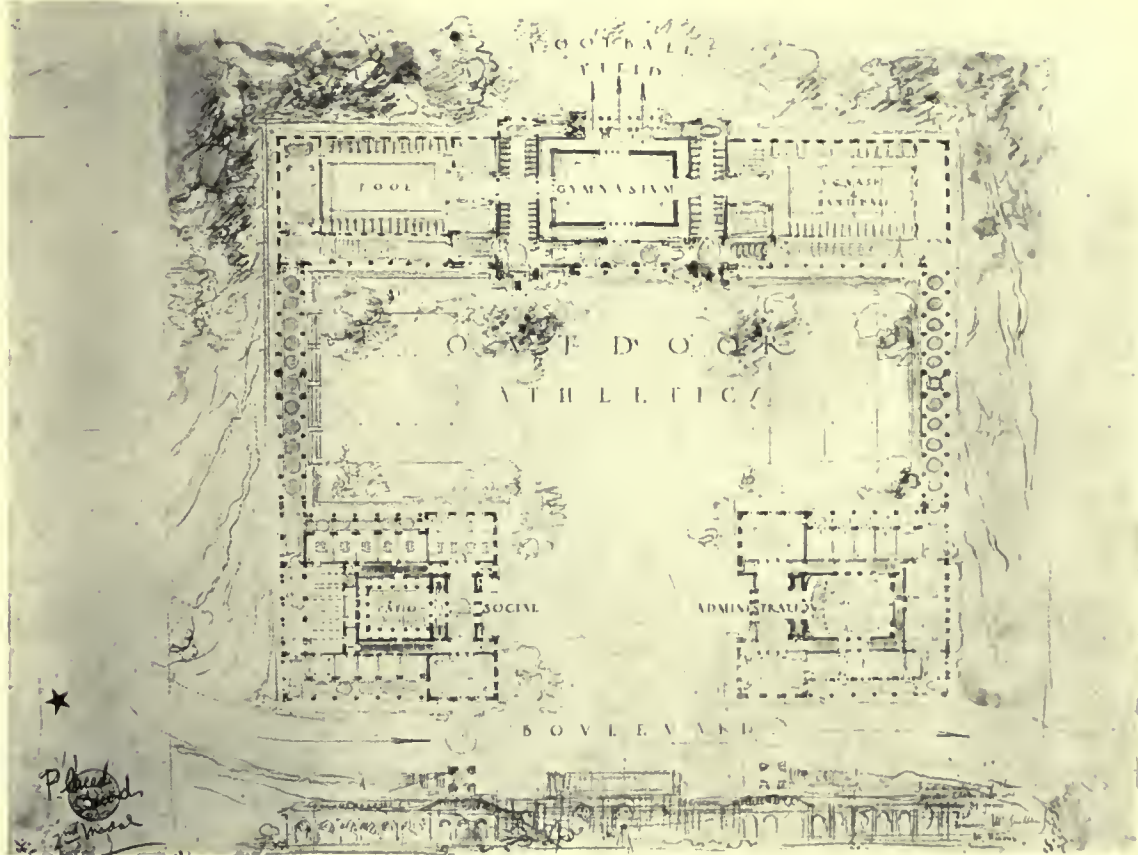

D. McLACHLAN, Jr.

PLACED SECOND

ATELIER HIRONS

Social hall.

Billiard room (8 or 10 tables).

Several small club rooms and card rooms.

Outdoor rest rooms or porches overlooking the bay.

Cafeteria for about 300, with serving pantry. (The kitchen and store rooms may be in the basement.)

Dormitories for 200 men on the floor above.

JURY OF AWARD: L. Warren, H. R. Sedgwick, W. F. Lamb, R. M. Hood, F. A. Godley, J. O. Post, W. L. Bottomley, L. Ayers, W. Van Alen, M. J. Schiavoni and R. H. Dana, Jr., chairman.

PLACED FIFTH (2nd Medal):—R. S. Simpson, Pittsburgh Archtl. Club, Pittsburgh, Pa.

PLACED SIXTH—FIRST ALTERNATE (Mention):—E. L. Howard, Cornell University, Ithaca, N. Y.

PLACED SEVENTH—SECOND ALTERNATE (Mention):—J. K. Smith, University of Pennsylvania, Philadelphia, Pa.

MENTION:—A. F. Stokes, Harvard University, Cambridge; F. J. Kuchler, University of Pennsylvania, Phila.; L. Simpson, Washington University, St. Louis; L. Fentnor, Atelier Wynkoop, N. Y. C.

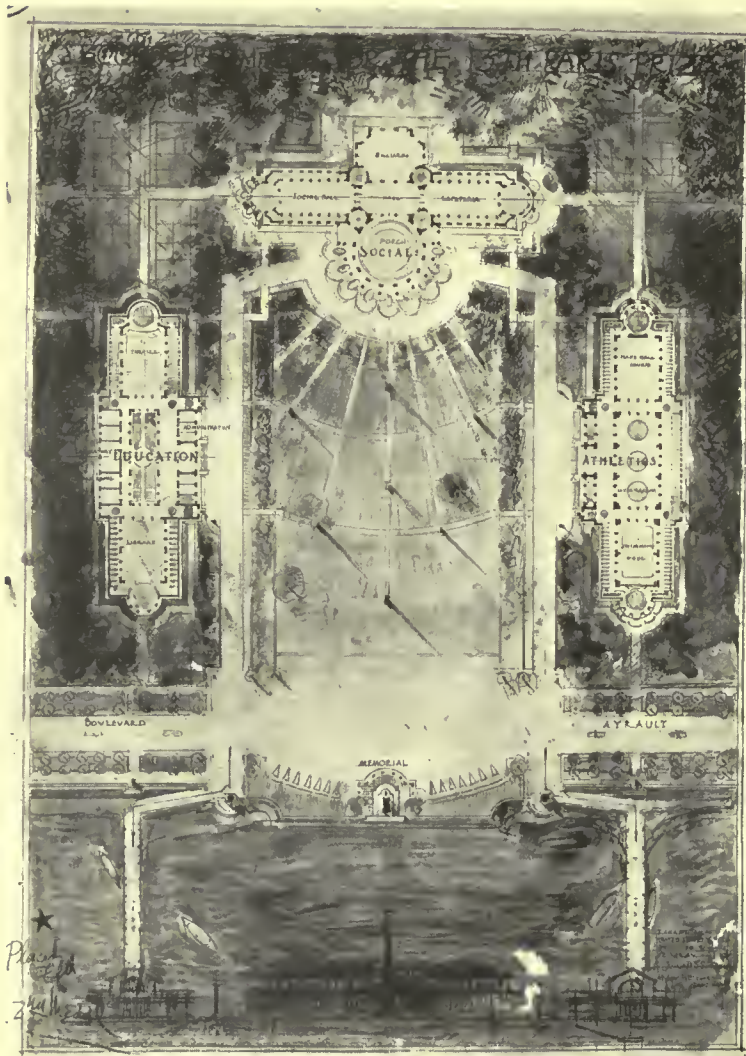

R. S. SIMPSON PLACED FIFTH PITTSBURGH ARCHITECTURAL CLUB
SECOND PRELIMINARY COMPETITION, PARIS PRIZE,
BEAUX-ARTS INSTITUTE OF DESIGN

Living in the South

As a temporary relief measure to meet the embarrassing shortage of homes in the Birmingham district, owners of vacant lots are finding it expedient to assist prospective home builders to get a roof over their heads by building on the rear of the said lots a small plain structure that can be made to serve as a dwelling for a small family, at the same time helping to combat the high cost of everything on several important counts. This emergency domicile will comfortably house a family of three or four people requiring but limited and what used to be inexpensive furnishings, and the housekeeping effort is likewise brief and inexpensive, while the interest

on the total investment is comparatively small.

The big idea here is to await the day when lower building costs will permit the main house to be constructed at a very much lower price than that for which it can now be built. If this period happens to be deferred a few years the modest manner of living forced upon the rear-enders, as they may be termed, will enable them to catch up on other things, at the same time furnishing an opportunity for practical lessons in thrift that should be helpful in years to come. When in time the larger home is built on the front of the lot the emergency bungalow can be easily converted into a combination servants' house and garage where it will continue to serve a good and valuable purpose in the general scheme of a completed home.

Some fifty or more of these propositions have been worked out with apparent satisfaction and it is believed that in this way many will find a seasonably happy escape from the restricted and congested life of the small apartment in which people are now being packed away like sardines in a box.

New Loan Plan to Encourage Building of Houses

The announcement of a new policy with regard to industrial financing has been made by S. W. Straus & Co., who state that hereafter they will

make loans in the form of first mortgage serial amortized bond issues in amounts of \$500,000 and over to reliable industrial corporations engaged in the production of essential commodities, the proceeds of the loan to be devoted to the construction of dwellings for employees.

The opinion is expressed that large institutions should develop this field of financing because of the enormous demand for housing facilities and the stabilizing influence which widespread ownership of homes by the working classes will have. It is also predicted that the next few years will be a period of very extensive home building activities as a result of this co-operation between financial houses and industrial corporations.



Architectural Quicksands

THE first of a series of articles by Clinton H. Blake, Jr., of the New York bar, with an introduction by Daniel Paul Higgins, of the office of John Russell Pope, architect, appears in this issue.

Architecture differs from all the other arts to which it is allied, as in its practical application it is an exact science. There may be no "poetical license" in architecture. There can be no exercise of artistic fervor when the architect comes to that part of his work where the client's interests are concerned, or where his own should be safeguarded. Architects may indulge in the fervor of art while designing, may take certain liberties and exercise much personality in planning. Having passed those points and set out on a sea of pure commercialism in the construction of the building there are quicksands that, if success is to attend the final result, must be avoided.

The mariner has his charts from which he may learn the location of rocks and shoals, of currents and trade winds. All these insure a safe and speedy voyage. But architects have available few of these helps and safeguards. It is to supply some of them to the profession that Mr. Blake has been invited to prepare what we are sure the readers of *THE AMERICAN ARCHITECT* will agree is a most valuable and reliable series.

Model Making at Columbia University

AMONG the innovations that it will be necessary to effect in architectural educational methods will be the elimination of one dimensional portrayal of design, and the overcoming of the malicious influence of white paper on the mind of architectural students. All great architects have been known to possess in the highest development an ability to visualize their work in its three dimensions. Men who have achieved wide reputation as designers, who, through the medium of white paper and cleverly executed designs in elevation, have been able to create wonderfully beautiful concep-

tions, are known to be simply designers and not, in the fullest sense, architects.

Of recent years there has been a pronounced tendency to avoid these studentish preliminary representations and to substitute something that would in a more tangible way present the proposed building. What was desired was a method of three dimensions. Logically the model was the thing. But, except in rare cases, or in that of the monumental structure, there was no disposition to take up and encourage the creation of good architectural design by means of the model, and the long established custom of drawings on white paper, of elevations and details, has persisted.

The tendency has been to encourage good draftsmanship at the expense of good architecture. Men but recently graduated, whose ability to create good drawings or to make fine renderings in color, have been misled in their own opinions as to their ability as architects by the steady demand for their services.

All the methods of the past have trained the student largely in an appreciation in but one dimension. He has never had opportunity to see his work in any other form, and he has gone through his college training purely along that line. It is a satisfaction to learn that the first of probably many and much needed reforms in architectural educational methods has been put into practice at the school of architecture at Columbia University in New York.

A DEPARTMENT of model making is now in operation at Columbia University, and in announcing this innovation it is stated: "It has long been appreciated that the student of architecture is trained largely in feeling for one dimensional architecture presented entirely upon paper and in the form of a plain elevation drawing. The student never has the opportunity which the practicing architect finds of observing his design completed in all three dimensions. This privilege only belongs to the architect who has secured his commission and has had his building erected at the ex-

THE AMERICAN ARCHITECT

pense of his client. Many such architects have been astonished at mistakes in their design due to the inability of drawings fully to represent the truth as it would appear in three dimensions. When the building is completed he has no opportunity of changing the form, and his mistake must stand as a glaring fault through many generations.

"The student of architecture who has designed a building or a group of buildings first on paper and then completed the same in the form of a model has all the opportunities of observing the mistakes of his design without the cost of erecting the building. Moreover, he has removed the malicious influence which pure paper design has upon his imagination.

"Many a designer who has unusual skill in drawing and rendering and who is blessed with an extremely fertile imagination is often able to mislead himself with his pictures and regard the thing he has erected on paper as beautiful architecture, while if it were constructed in three dimensions, in the form of a model, it would appear entirely absurd and ridiculous."

THIS is exactly true. There yet lingers in the minds of many teachers of architecture, and the impression has been conveyed to students, that model making is purely a mechanical process, one that may properly be turned over to some one less

artistically educated. This is certainly all wrong. Much of the time now spent in the making of pretty but useless water color drawings might better be employed in coloring the models. There is a certain fascination in model making in noting the growth of the miniature and correctly scaled structure. Mistakes never apparent in the white paper drawing are constantly to be detected in the model and can be intelligently corrected. Further, there is the stimulation of the students' ingenuity in the simulation of materials and their texture and the development of planting effects. As a recreation from the hard mental concentration of the study of architecture, model making provides a means of relaxation that is greatly to be desired.

The development of scenic art is largely due to the use of the model for preliminary study. In fact, no production of consequence is begun until all the various effects of color, of lighting, placing and construction in general have been carefully considered in the small scale model. The design and construction of motion picture "sets" has grown to its present importance as the result of an intelligent and constant use of models.

Columbia University's school of architecture is to be congratulated in being the first of our important architectural educational institutions to recognize the importance of model making in the study of architecture.



CHURCH OF S. MARIA NOVELLA, FLORENCE, ITALY.

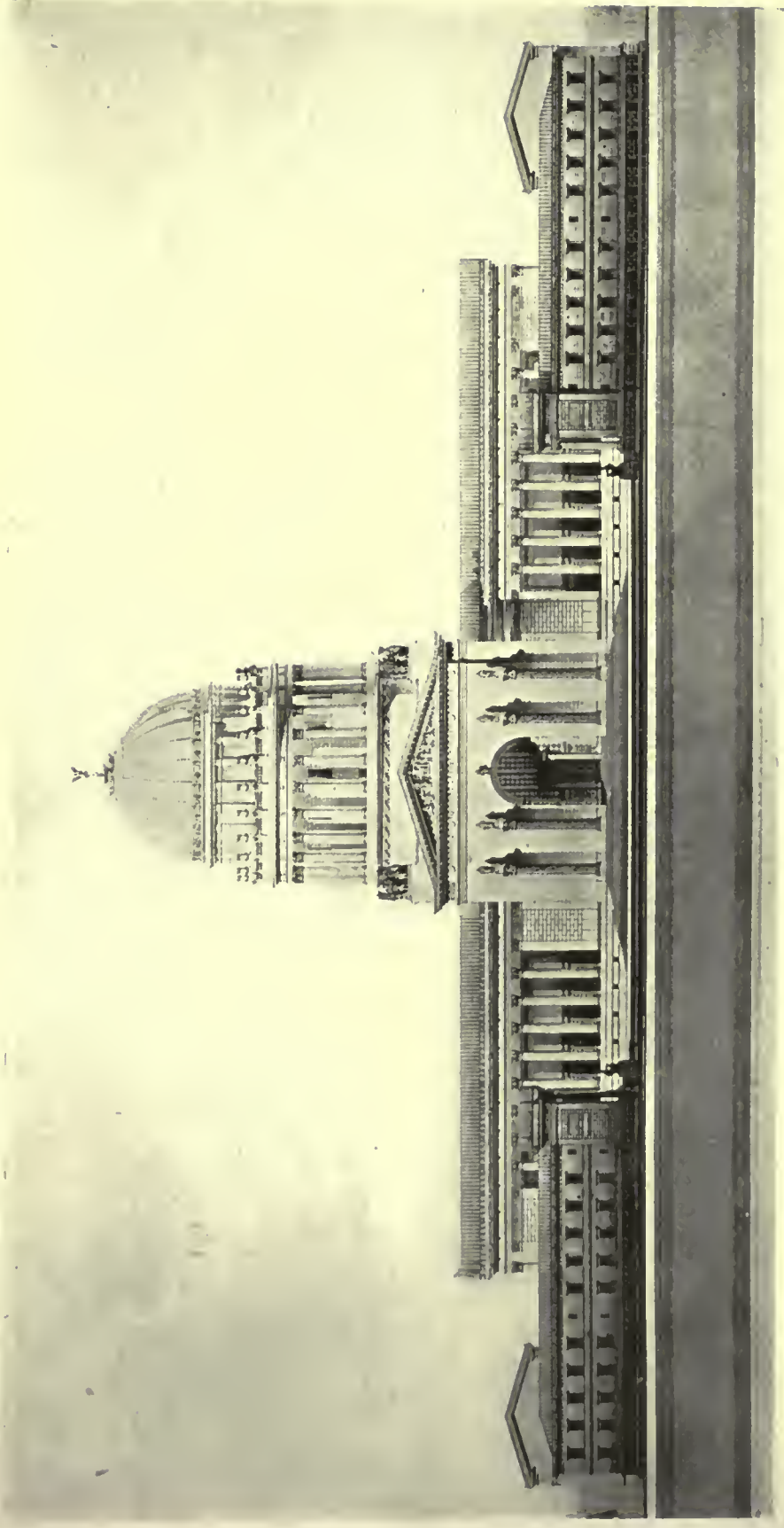

FINAL STAGE, NEBRASKA STATE CAPITOL COMPETITION
DESIGN SUBMITTED BY
H. VAN BUREN MAGONIGLE, ARCHITECT

114

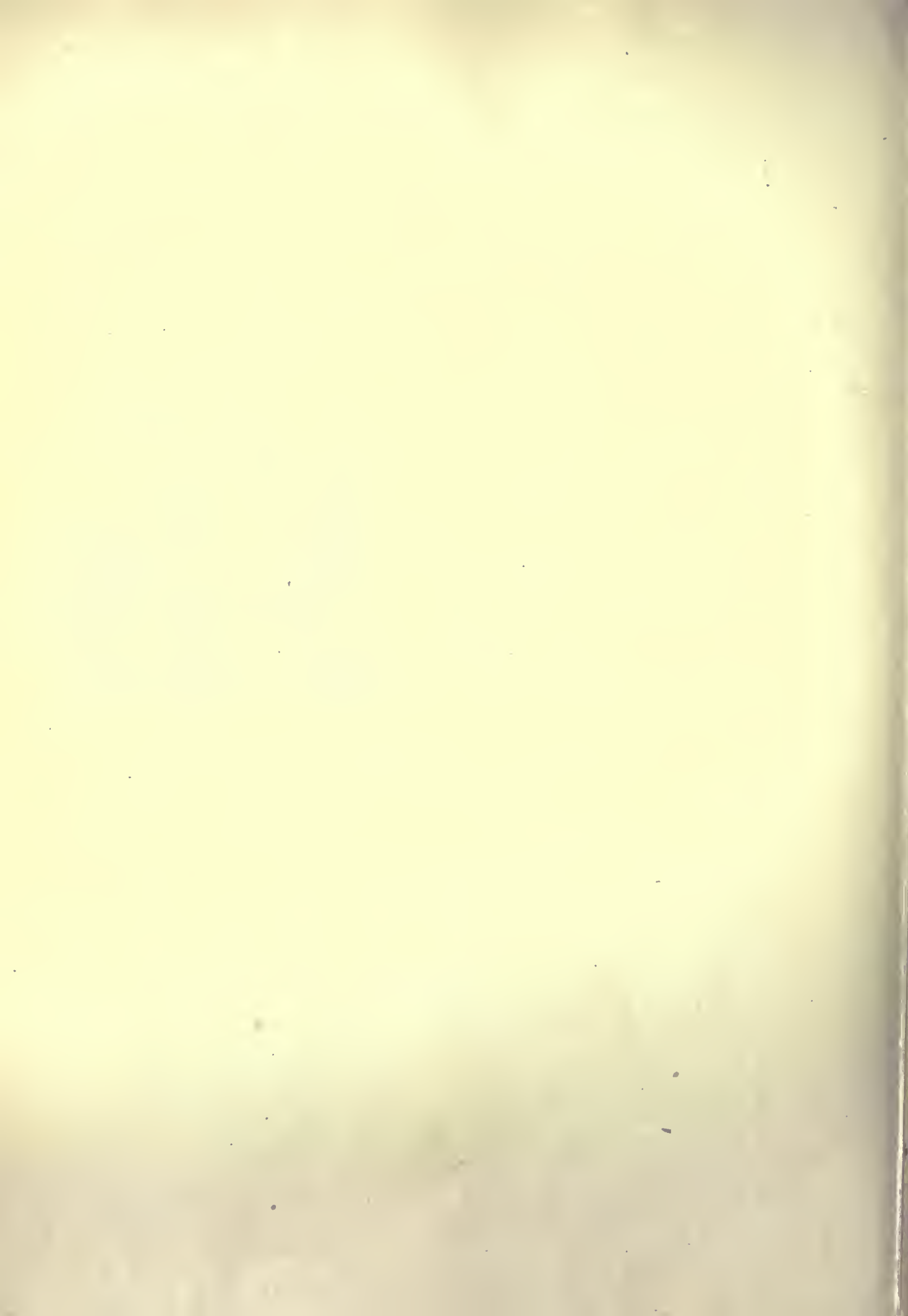

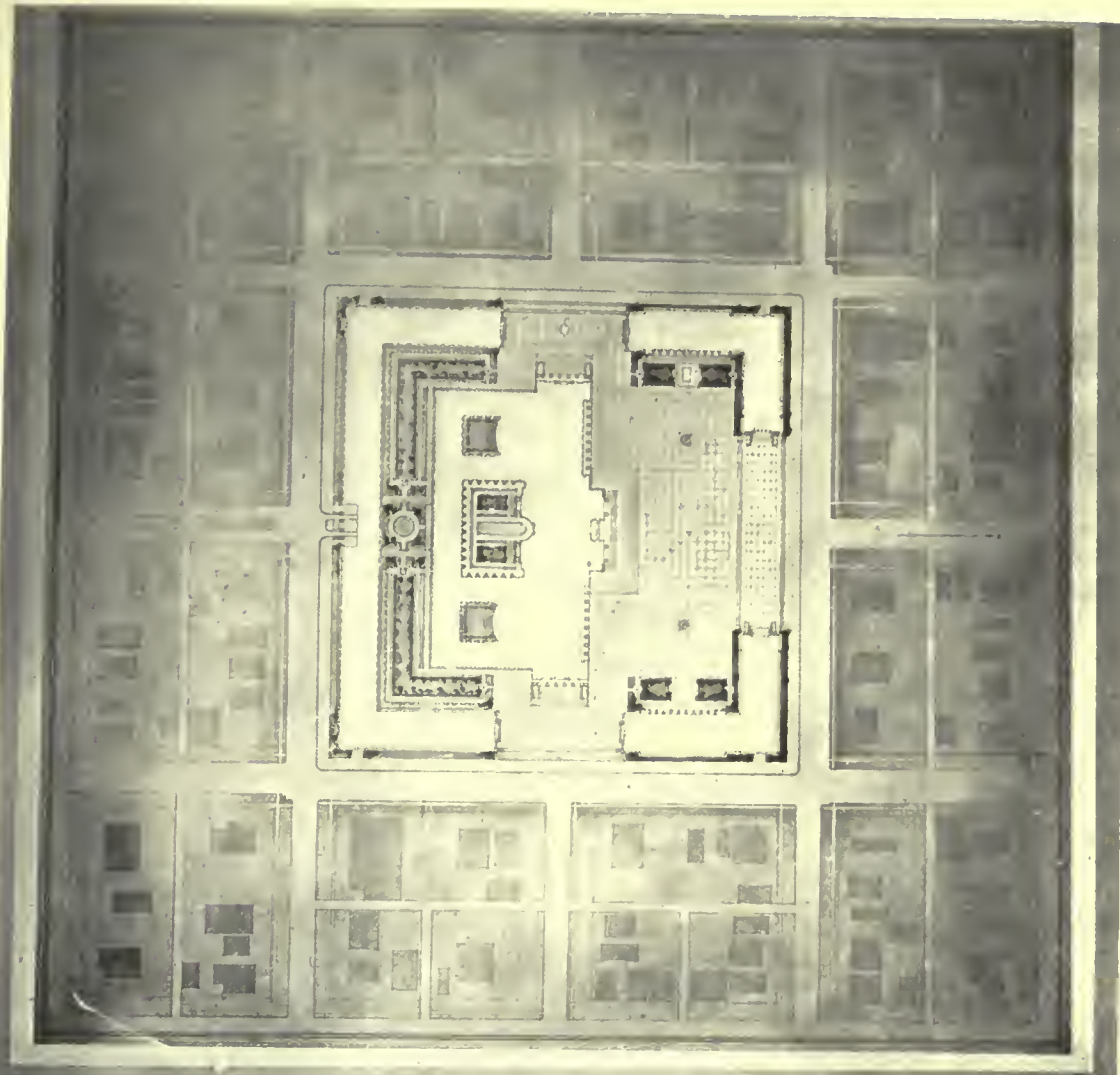
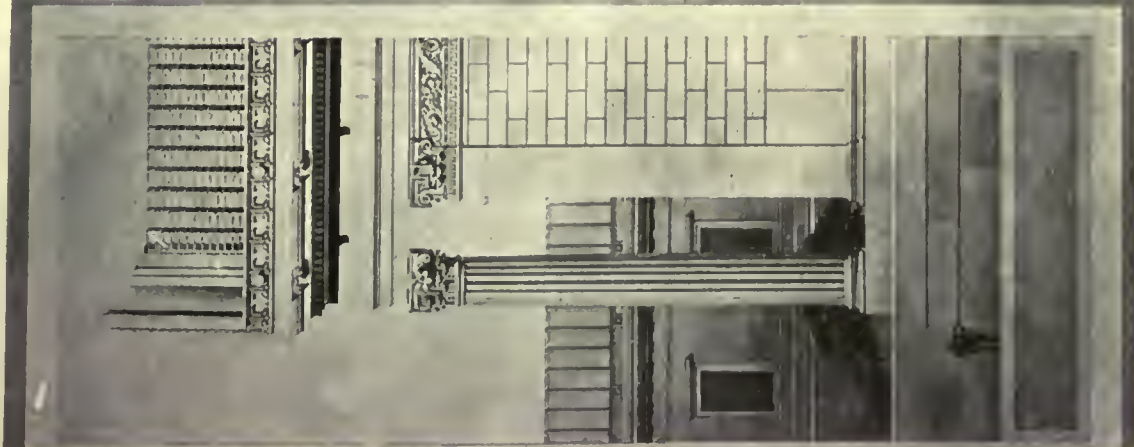

FINAL STAGE, NEBRASKA STATE CAPITOL COMPETITION
DESIGN SUBMITTED BY
H. VAN BUREN MAGONIGLE, ARCHITECT



3
14

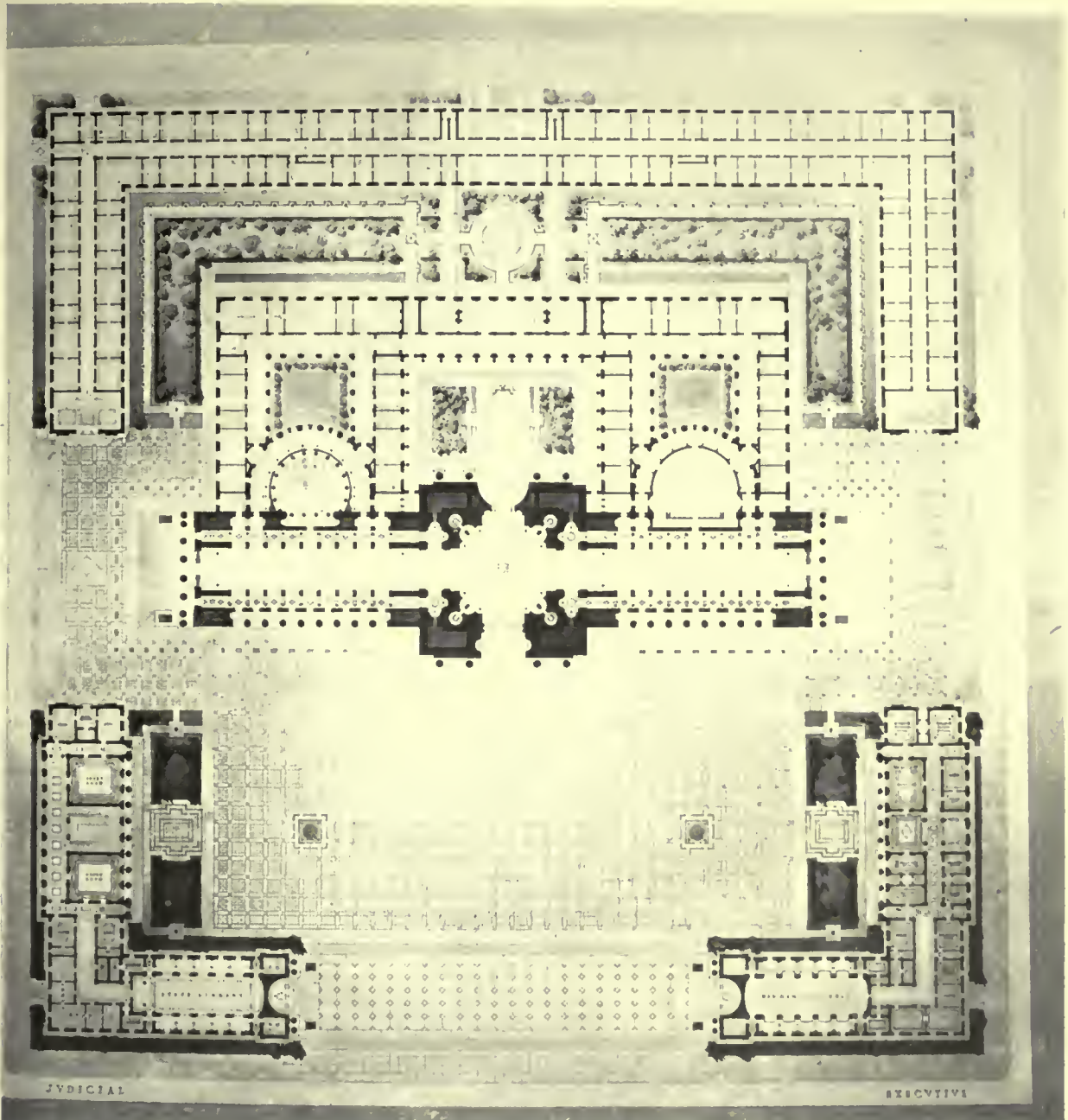

FINAL STAGE, NEBRASKA STATE CAPITOL COMPETITION
DESIGN SUBMITTED BY
H. VAN BUREN MAGONIGLE, ARCHITECT



114

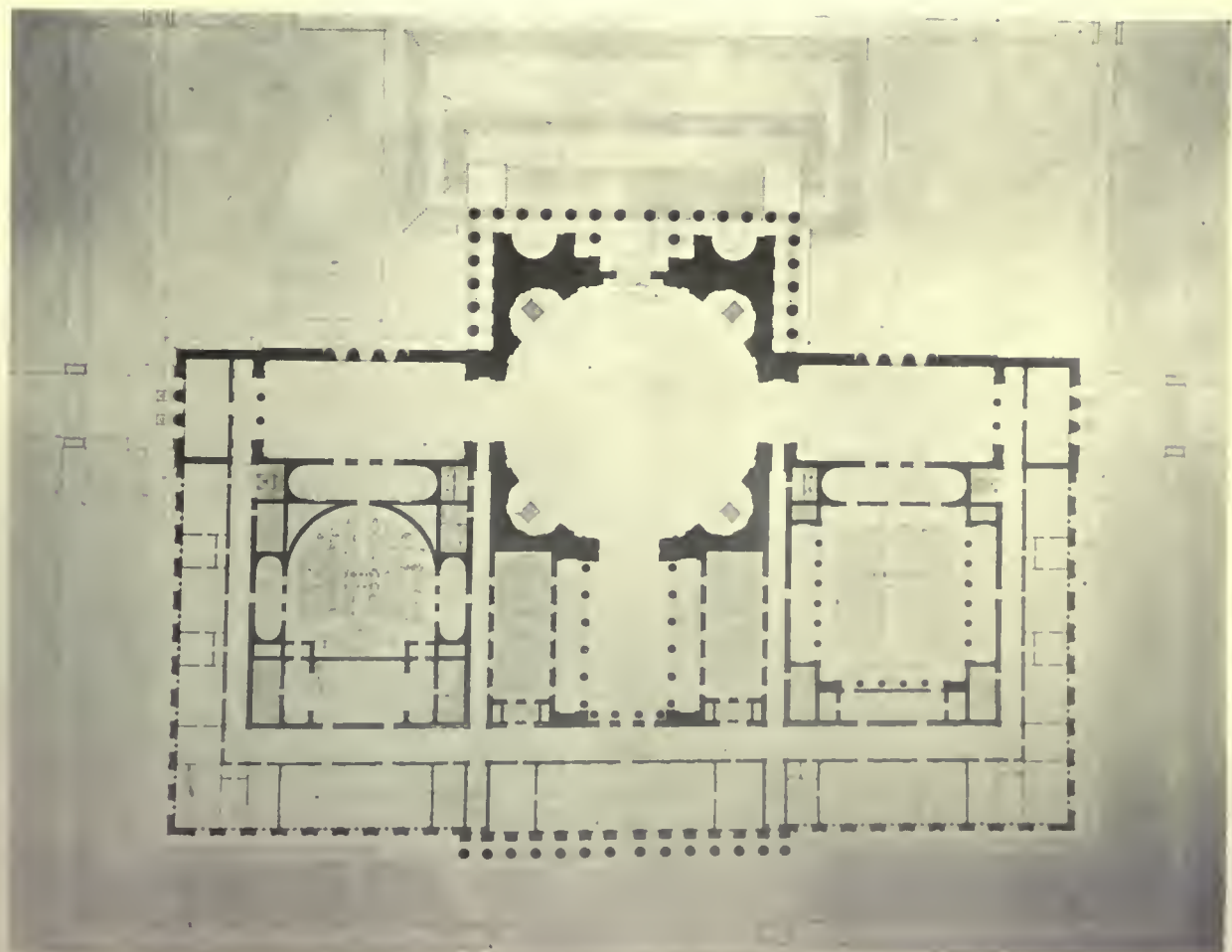
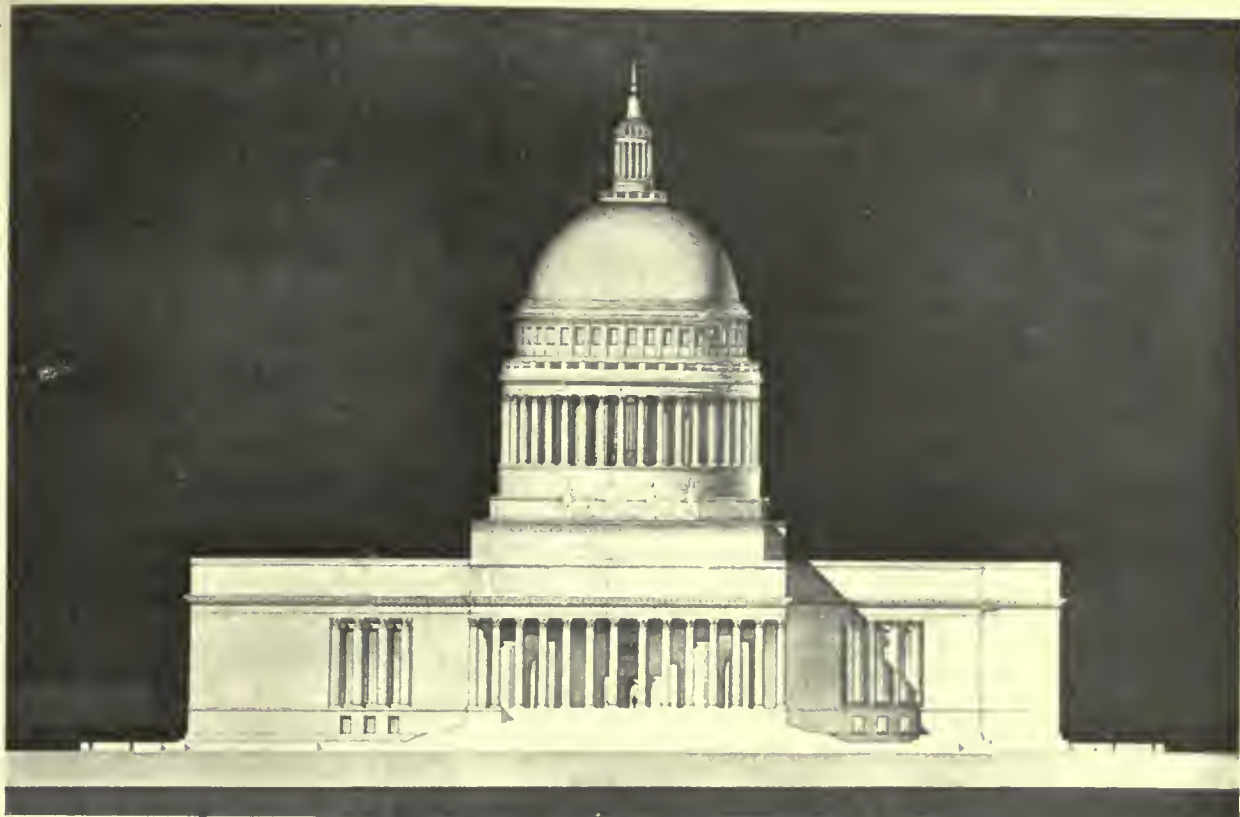

FINAL STAGE, NEBRASKA STATE CAPITOL COMPETITION
DESIGN SUBMITTED BY
BLISS & FAVILLE, ARCHITECTS



FINAL STAGE, NEBRASKA STATE CAPITOL COMPETITION

DESIGN SUBMITTED BY
ELLERY DAVIS, ARCHITECT



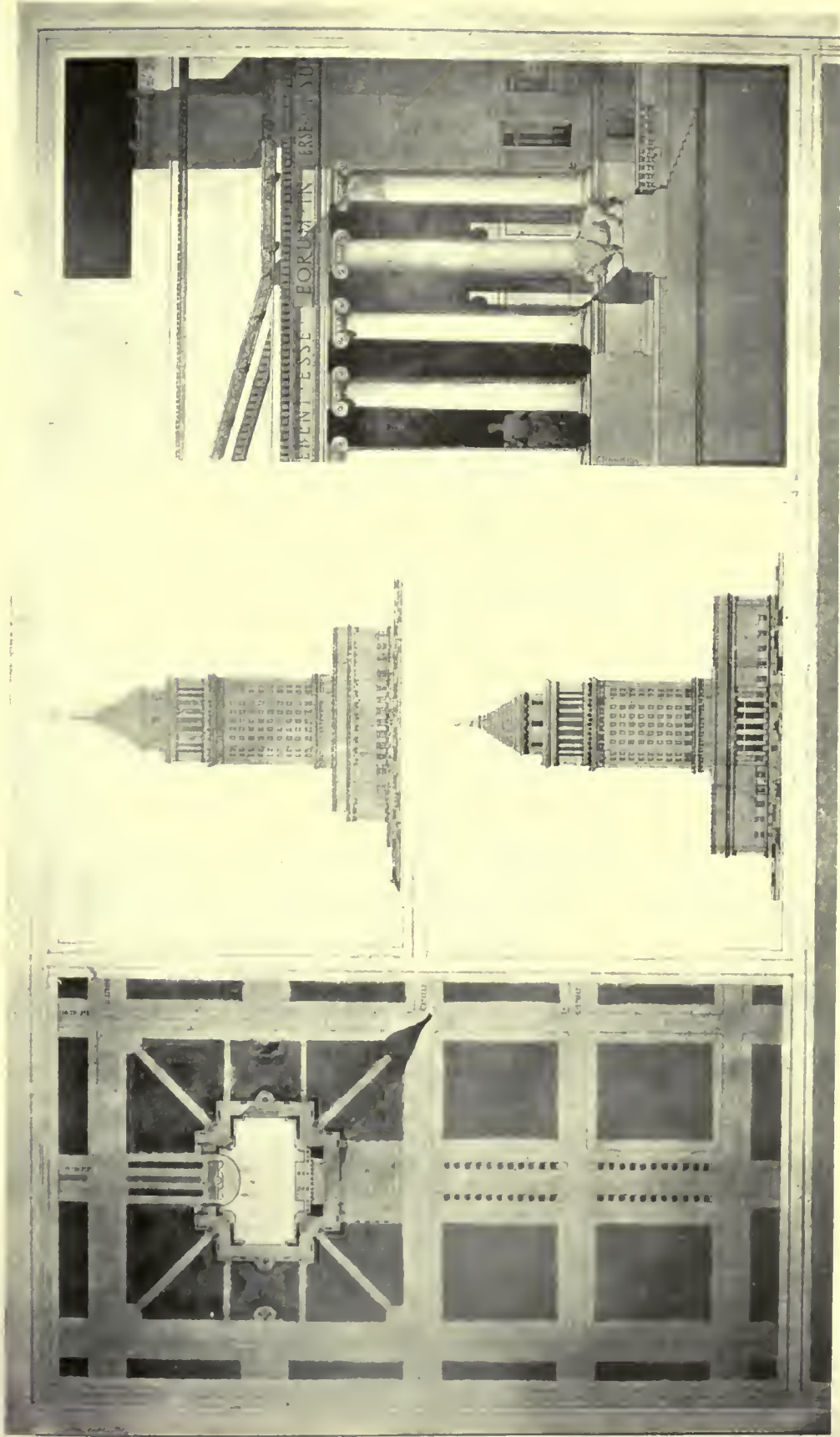

FINAL STAGE, NEBRASKA STATE CAPITOL COMPETITION

DESIGN SUBMITTED BY

ELLERY DAVIS, ARCHITECT

114



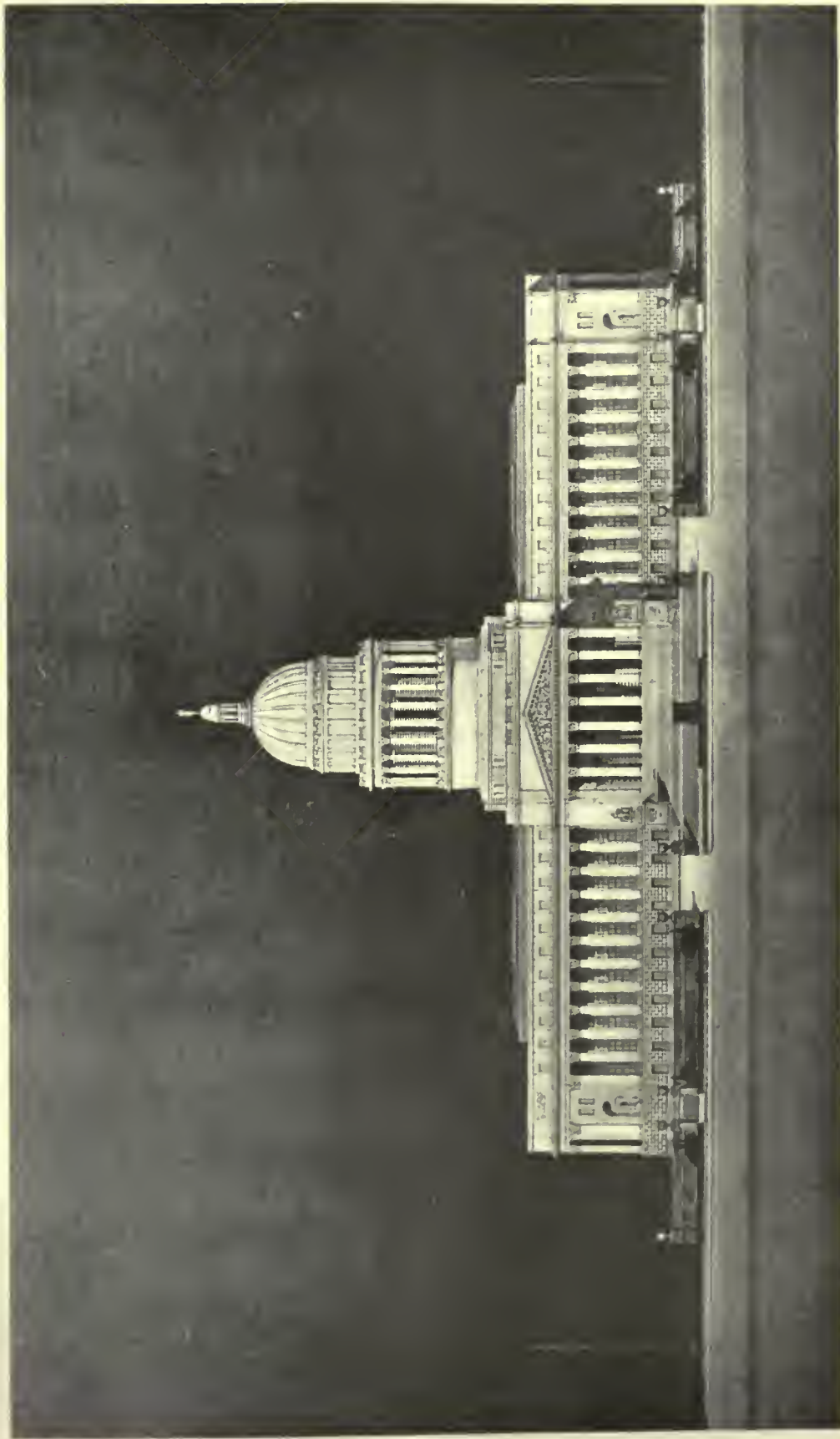

FINAL STAGE, NEBRASKA STATE CAPITOL COMPETITION

DESIGN SUBMITTED BY

JOHN McDONALD and ALAN McDONALD, ARCHITECTS

114 1



8
114

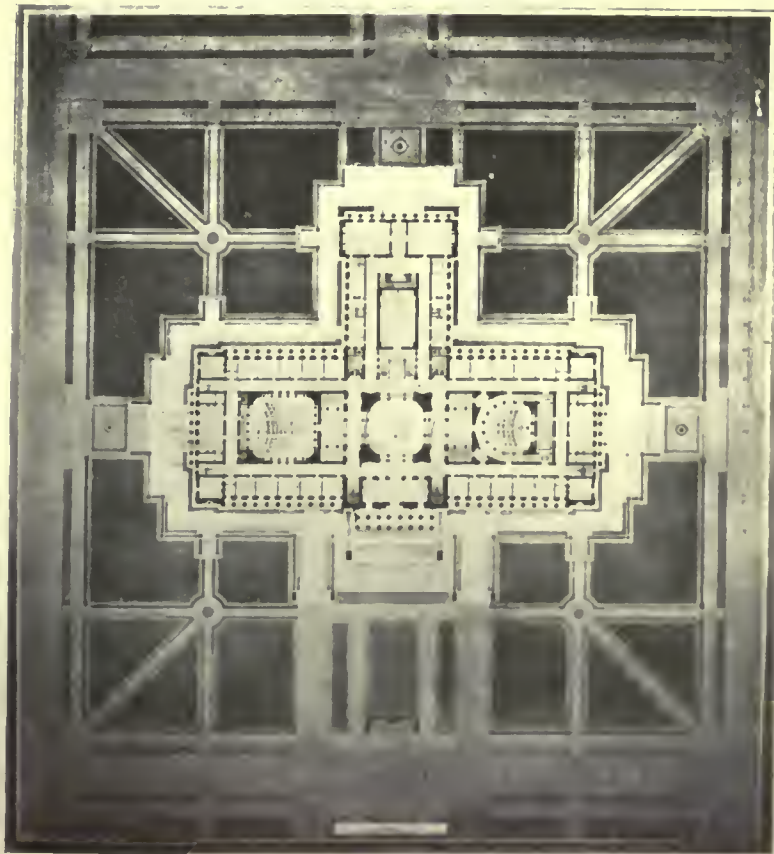
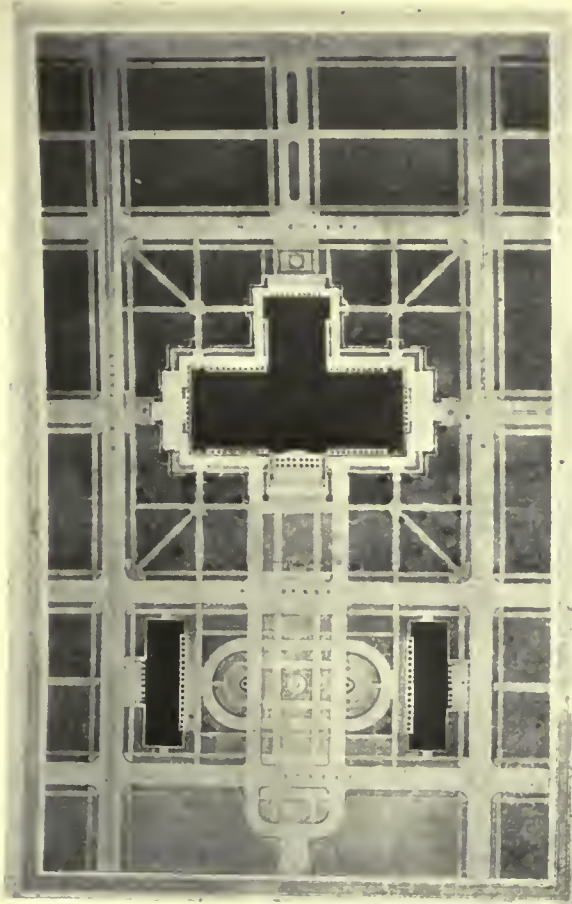

FINAL STAGE,
NEBRASKA
STATE
CAPITOL
COMPETITION

DESIGN
SUBMITTED BY
JOHN McDONALD
and
ALAN McDONALD,
ARCHITECTS



Current News

Happenings and Comments in the Field of Architecture and the Allied Arts

National Academy Elects Officers

At the annual meeting of the National Academy of Design, New York, Mr. Edwin H. Blashfield was elected president; Mr. Harry W. Watrous, vice-president; Mr. Charles C. Curren, corresponding secretary; Mr. Douglas Volk, recording secretary, and Mr. Francis C. Jones, treasurer. At the same time Mr. Max Bohm, Mr. Frank De Haven, Mr. August Franzen, Mr. Hobart Nichols, Mr. Carl Rungius, Mr. Chauncey F. Ryder and Mr. Robert Spencer were made academicians.

Minnesota Proposes State Federation of Architects and Engineers

Representative architects and engineers from all parts of Minnesota met at Duluth recently and took the first step toward the organization of a State Federation of Architects and Engineers.

The unanimous sentiment of those in attendance, as well as of other engineers and architects, who, for one reason or another, were unable to be present at the meeting, was in favor of such a federation. Only by unification into one state-wide organization will the engineers and architects of Minnesota have the power and weight of numbers behind them to force attention to matters of public concern having to do with problems of engineering and architecture, or with the regulation of affairs affecting the joint interest of these related professions.

It was pointed out by Max Toltz, chairman of the meeting, that there are about 4,800 engineers, architects and draftsmen in Minnesota. Many of these men are not identified with any existing organization. It is not the purpose of the men who are back of the proposed federation to supplant any existing organization, but it will be in fact what the name indicates, a federation of existing societies, and no man will be eligible to membership except through membership in his local organization.

Engineers scattered throughout the state in the smaller towns, having no engineering society, may join by becoming associated with the Minnesota Surveyors' and Engineers' Society, which has state-wide membership. The same is true of architects, who are eligible to membership in the Minnesota Society of the American Institute of Architects.

The engineers and architects who attended the

Duluth meeting were the guests of the Duluth Engineers' Club. The meeting was held at the Commercial Club. It was called to order by W. C. Armstrong, engineer, of St. Paul. Mr. Toltz was elected chairman of the meeting, and Professor Frederick Bass, of the University of Minnesota, was elected secretary.

Wins Beaux Arts Prize

P. McLaughlin, Jr., a student at Atelier Hiron, this city, yesterday received the annual Paris Prize of the Society of Beaux Arts Architects. The prize amounts to \$3,000 for study abroad, and by special arrangement the winner is allowed to enter the most advanced class of the Ecole des Beaux Arts in Paris, a privilege which is denied all Frenchmen.

The designs called for by the conditions of the contest were for the proposed war memorial for the city at the northern end of Manhattan Island, on the wooded knoll between Dyckman street and Spuyten Duyvil Creek. Five designs were selected for the final competition. Mr. McLaughlin's were placed first in the jury's award, and the four others were rated in the following order: R. S. Simpson, Pittsburgh; F. A. Chapman, San Francisco; E. R. Purves, University of Pennsylvania, and W. F. McCoughy, Jr., University of Illinois.

The drawings were placed on exhibition at the Beaux Arts Institute of Design, 126 East Seventy-fifth street, where they will remain until July 24. The designs have no connection with the official memorial project. The full illustrations of the prize winning and other designs will appear in our issue of July 28.

Prizes for Fifth Avenue Buildings

The Fifth Avenue Association will resume the presentation of medals for the best new buildings and alterations in the Fifth Avenue section this year. This practice was discontinued for a couple of years owing to the cessation of building. It is understood that will be made formally at the annual dinner of the association in November. The members of the Architectural Harmony Committee who make the decisions are as follows: Walter Stabler, chairman; Douglas L. Elliman, secretary; Michael Dreicer, Robert D. Kohn, C. Grant LaFarge and H. Van Buren Magonigle.

Chicago Improves South Water Street

Chicago's next big public improvement—which many experts consider as important to the city as the Michigan avenue link—converting the present narrow, congested, dirty, unsanitary, dangerous and ugly South Water street into a broad, clean, utilitarian and beautiful double decked boulevard and traffic thoroughfare, has recently received two tremendous boosts. One was the opening of the Michigan avenue bridge and the other was the more recent announcement that at last the South Water street commission merchants have signed an agreement and put up the cash to finance a magnificent new produce mart outside of the loop.

Payment for Estimating

In October, 1919, the American Institute of Architects, Engineering Council, and Associated General Contractors of America, appointed three conferees each, to discuss the matter of payment for estimating. These conferees agreed upon a report which was submitted to their respective organizations under date of February 17, 1920, and has since been under consideration by them. Engineering Council, at its meeting June 17, adopted the conclusion in a report of a special committee to which the report of the conferees had been referred, as follows:

"Whenever in the execution of work, competitive bids are asked for on detailed plans and specifications, those invited to bid should be provided with such an estimate of the quantities involved in the work as the surveys, plans and specifications permit to be made. The intent of this requirement is that a single estimate of quantities should be made by or for the engineer, architect, or other representative of the owner, so that each separate bidder will not be put to the expense of making up a separate schedule of estimates. This latter practice not only means a needless waste in the carrying on of contract work, but also discourages bidders and causes repeated handling of official plans and specifications in making up separate schedules of estimates."

Percentage of Fires

According to the National Board of Fire Underwriters, the highest percentage of the fires which occurred last year, 68.5 per cent. was registered by "sparks on roofs," which is the natural result of the prevalence of wooden-shingle roofs in so many of our cities. "Defective chimneys and flues" held second place with a ratio of 66.6 per cent. and "lightning" the third with 51.2 per cent. "Petroleum and its products" stood fifth, with 42.5 per cent.,

disclosing the great need of education that will cure the housewife of the dangerous practices of accelerating sluggish kitchen fires with kerosene and gasoline cleaning with gasoline and using improperly constructed and cared for oil lamps.

"Open lights" in dwellings caused 39.1 per cent. of the losses in this column. Under this heading comes fires resulting from unprotected gas flames, candles, torches, tapers and similar dangerous means of illumination.

Farmer's Cooperative Associations in New Zealand

The farmers' co-operative associations in New Zealand have steadily developed until they are now important factors in the business life of the Dominion, and are very rapidly gaining in strength. The Farmers' Union Trading Co. of this city is now the second farmers' trading co-operative association, in point of size, in the Dominion. It has lately taken over important interests north of the city, and now claims about 10,000 members. This company is sending a representative to open up offices in New York City through which they expect to sell New Zealand products and to purchase supplies for this Dominion. The representative will arrive in that city about the first of October.

These associations are taking up different lines of development and trade. Some of the associations have under consideration building and operating their own flour mills, establishing hydro-electric plants for the benefit of members of the association, as well as using their influence for better roads throughout the Dominion. They are also interested in fertilizer and cement plants, and, in the aggregate, control a large portion of the business of the country.

Municipal Loan Association

The municipal employes of New York City under the supervision of the Mayor's Housing Committee have formed an organization to be known as the Municipal Employes' Building Loan and Savings Association. Shares are to be sold at the rate of 50 cents a month. The par value of the shares is to be \$100. It is planned to sell 50,000 shares to the value of \$5,000,000.

The money will be used to aid municipal employes to build homes. The organization will be conducted on the lines of similar associations.

When the charter is granted a mass meeting of city employes will be called and their membership solicited. The directors for the first year, according

to Mr. Doyle, will be Frank Mann, Tenement House Commission; Frank J. Prial, Deputy Controller; L. J. O'Reilly, Colin H. Woodward, Duncan McGuinness and William J. Walsh.

Novel Foundation Method

Builders and architects throughout the country have been interested in the new idea which was introduced with the construction of the 400-room addition to the Ambassador Hotel at Atlantic City, N. J., now practically completed. Under ordinary conditions the new structure could not have been opened, it is said, prior to September 1, so that the process has shortened the construction period by fully sixty days. It is believed that the success of the experiment will revolutionize construction methods where excavation is made in sand soil. In fact, the same method is now being applied in the new Ritz-Carlton Hotel operation in Atlantic City, as well as in the cases of other buildings where the soil formation is of a character to lend itself to the innovation.

Briefly, the scheme as carried out at the Ambassador Hotel addition, consisted of punching 1½-inch holes in the sand 18 feet deep. Well-points were then introduced and the water was pumped out from a level far below the surface. Eight hundred well-points were used constantly in preparing for the Ambassador Hotel foundation. The tip of each point was covered with a 60-mesh screen so that no sand was sucked up by the pumps. The excavation work for the caissons was therefore done in dry sand and no boxing was necessary. In this way the job proceeded much more rapidly, and the Thompson-Starret Company, who did the building work, say there will be no settling. A similar process has been used heretofore in digging tunnels, sewers and excavations of that nature, but the Ambassador Hotel job is the first where the new method has ever been introduced in building work of this nature.

Lincoln Highway Association Issues History of Work

The headquarters of the Lincoln Highway Association in Detroit have just published a handsome illustrated volume entitled "A Picture of Progress on the Lincoln Way."

This 40-page volume, profusely illustrated with photographic reproductions of scenes along the Lincoln Highway between the two coasts, traces the progress of the association's inception and work from 1913 to "the beginning of the nation's real era of highway building" in 1920.

In a preface to the book, which is the most pretentious publication ever put out by the Lincoln Highway Association headquarters, its author, A. F. Bement, vice-president and secretary of the Lincoln Highway Association, says:

"As a statement of the status of the American highway situation generally, as well as a report of the accomplishments on the Lincoln Highway specifically, from men who with the best of facilities have made it their business for six years to study, investigate and endeavor to mold and lead American highway sentiment, this booklet should be of interest to every American everywhere."

A portion of the publication is devoted to a statement of the vast progress made in Lincoln Highway construction during 1919. Several pages are also devoted to picturing and describing the army convoy run over the Lincoln Highway last year, while a complete explanation of the provisions of the Townsend Highway Bill providing for a Federal Highway System is given.

Anyone interested in gaining a brief picture of the work and accomplishments of America's foremost highway promotional organization should write to the Lincoln Highway Association headquarters for a copy of this booklet.

A Sacred Memorial

The women's committee of one hundred of the Valley Forge Historical Society has completed its plans and will begin work this week in the effort to raise the money for the completion of the Washington Memorial at that historic shrine.

This is a movement which deserves the hearty support of every American, both from motives of local and of national pride. As a people, we are none too careful of our historic places, and there are few in the country or in the world which can compare in interest with Valley Forge. As one of the great turning points of the Revolution it has a sanctity perhaps felt to a higher degree by visitors from a distance than by our own people.

When the plans of the society are carried out, Valley Forge will be not only a memorial to the soldiers of the war which made our country possible, but a memorial to all of those Americans who have given their lives for freedom since the nation's birth. The Hall of Victory is to be a memorial to the soldiers of the late war, and thus the past will be linked to the present in the honoring of all those of our nation who died that freedom might live.

Surely a project like this, which has as its motive the inculcation and the perpetuation of the highest form of national idealism that any country can know, deserves the support of the country at large.

THE AMERICAN ARCHITECT

Personals

Mr. M. O. Leighton and Major C. T. Chenery, members of the American Society of Civil Engineers, and Mr. A. C. Oliphant, associate member of the American Society of Mechanical Engineers and the American Institute of Electrical Engineers, have formed a co-partnership under the name of M. O. Leighton & Company, with offices at 700 Tenth street, Washington, D. C., for the purpose of engaging in general engineering practice and industrial representation before the Federal departments. Mr. Leighton and Major Chenery will continue for the time being as chairman and secretary of the National Public Works Department Association, while Mr. Leighton and Mr. Oliphant will continue service in the Washington Office of Engineering Council pending the displacement of that body by the Federated American Engineering Societies.

W. H. Rockefeller has opened offices at 214 Market square, Sunbury, Pa., for the practice of architecture. Catalogues and samples are desired.

Frederick A. Fletcher, architect, formerly located in the Lexington Building, Baltimore, Md., may now be found at 407 North Charles street.

E. L. Rice, Jr., Co., architects, are now practicing at 17 East Seventh street, Wilmington, Del.

Reed & Brothers, general contractors, have moved to 702 Orange street, Wilmington, Del.

Edmund Herrmann, architect, has moved his office from 328 Market avenue to 134 Cleveland avenue, Canton, O.

Severance & Van Alen, architects, have moved from 111 East Fortieth street to the southwest corner of Forty-first street and Lexington avenue, New York City.

L. C. Patton, architect, has moved his place of business from 597 Fifth avenue, New York City, to 2 West Fifty-sixth street.

B. S. King & Campbell, architects, may now be found at 36 West Fortieth street, New York City.

John A. Hamilton, architect, has moved from 32 Broadway to 126 Liberty street, New York City.

John D. Boyd, architect, has recently established an office at 105 West Fortieth street.

John V. Van Pelt, architect, is now located at 126 East Fifty-ninth street.

News Notes from Various Sources

British newspapers believe the laying of 30 bricks per man per hour is not a fair output.

* * *

"Sees Worldwide Housing Shortage" is title of article in New York Times, June 27, based on views of Frank Mann, Tenement House Commissioner, New York City.

* * *

About 60 per cent. of recent immigration has been composed of women and girls.

* * *

The United States Civil Service Commission announces the postponement until August 3, 1920, of the close of receipt of applications for the open competitive non-assembled examination for senior architect; salary \$2,100 to \$2,700.

* * *

"Go to School" drive will be conducted this summer by New York State Board of Education among the 200,000 illiterates and non-English speaking persons in Manhattan and the Bronx.

* * *

The seating capacity of Madison Square Garden, New York, will be increased from 8,000 to 20,000 by Tex Rickard, prize fighter, who has a ten-year lease. The traditions of the landmark will be preserved.

* * *

According to compilation by O. P. Austin, statistician of National City Bank, New York, in current issue of The Americas, debts of world now aggregate \$265,000,000,000, compared with \$44,000,000,000 at beginning of World War.

* * *

Between three and four miles of permanent highway is being built each day by the State of Illinois. The State Director of Public Works says he hopes to finish more than 400 miles before frost.

* * *

Graphic illustration of unprecedented rise since 1914 in cost of materials and labor which enter into New York City building construction were provided by C. A. Chase, member of subcommittee on building of Mayor's Housing Conference Committee, in special report. Mr. Chase's findings cover every phase of construction cost situation. They indicate advances in prices of building material ranging from 10 per cent. to 366 2/3 per cent. Show that labor costs have gone up, but not as much as material prices. Biggest advance in wages has been granted to common laborers and to plumbers' laborers, whose rate of pay has increased 300 per cent.

Weekly Review of the Construction Field

With Reports of Special Correspondents in Prominent Regional Centers

UPON transportation conditions depends the course of the building industry. At the present time prices and supplies of materials are almost entirely a local matter. Even when manufacturers are able to procure cars to make shipment, they usually find them to be available only for short hauls. So far as New York is concerned, although prices are said to be stiffening, no precise changes of any great interest have been announced.

The present and immediate future of the building industry depending as it does upon transportation, it is but one more disappointment to learn that "Order No. 7" which has restricted the use of open-top cars to the transportation of coal, has been extended until August 22. And there is but faint hope that the complaints made by the construction industry against this order will influence the Interstate Commerce Commission to change its ruling.

Upon the eve of the announcement of the decision of the Railroad Labor Wage Board, the Pennsylvania Lines made statement that they would immediately put into effect their intention to lay off 12,000 men in order to reduce operating costs and in the interest of efficiency. The various statements that this action has been enforced by a decrease in revenue have not been authorized. The company says, however, that "some men have merely held jobs" and although the company has 18 per cent. more men than at the time the Government took over the operation of the roads, it was necessary a few months ago to send locomotives to outside shops for repairs—an unprecedented situation. This is but another example of the restricted labor output.

In connection with the labor output, it is encouraging to read the report of the Merchants Association: "Although production per man per hour has not yet reached normal, it has been gradually improving since last September." They arrive at this opinion through the reports of 49 manufacturers. Twenty-three of these stated that the efficiency of their employes has noticeably increased, 5 say that although they have observed no increase they have sensed a better spirit, 17 say that they have observed no change and 3 have noted a decrease in efficiency. These same manufacturers reported in September that their labor was not more than 70 per cent. efficient.

(By Special Correspondence to The American Architect.)

Chicago:—The recent recommendation made by the Finance Committee of the City Council in re-

gard to municipal wage boosts should make all thinking men in the building trades "stop—look and listen." The recommendation says in part: To balance union labor increases amounting to \$965,000,000 the committee recommends that enough carpenters, painters, plumbers, bricklayers, etc., be laid off to save that sum.

Incidentally, city construction and repair work would be cut 20 per cent. under the plan. In the face of this recommendation it is reported that every building tradesman employed by the city will be called out "to see that labor gets its demands." The demands being in this case \$10 a day for municipal shop work.

The union wage of \$10 a day for "outside work" and \$9 a day for "inside work" was recommended, but this was not satisfactory to the craft. While the tradesman shortsightedly insists upon a higher daily wage his working week is being steadily cut down.

The building boom which was confidently predicted would take place has failed to materialize. The man with money to build is playing a waiting game. While labor demands, contractors "pass the buck" and building costs steadily advance.

Common brick is now selling at \$16 a thousand, an advance of \$2 over a month ago. Crushed stone is now \$4 a yard as against \$2.85 and \$3.50. Sand and gravel have also advanced, while cement manufacturers are refusing contracts and builders are offering premiums for deliveries.

All hope for a lower interest rate and a loosening up of credit condition which would do much to facilitate construction work has been given up. The current talk among bankers is to the effect that money rates may be stronger in the fall—7 per cent. is a minimum charge now for collateral loans, while commercial paper ranges from 7½ to 8½ per cent.

Building permits show a decrease of 66 2/3 per cent. under the same week of a year ago. They show 31 for the week at a cost of \$582,400, as against 97 for the same week last year—valuation \$2,606,300.

(By Special Correspondence to The American Architect.)

Seattle.—Prices, finance and car shortages have been submerged in the difficulty of getting skilled labor to turn out small pipe and nails, and the labor question is paramount as the cause of irregular delivery from eastern mills to North Coast jobbers.

THE AMERICAN ARCHITECT

The pipe situation has not improved in 30 days, and while prices are stationary and no advance is expected, jobbers are passing through a critical period in taking care of not to exceed 40 per cent. of the demand.

Country buyers of builders' hardware and pipe are so thoroughly cognizant of the trouble that they are placing orders with large distributors here subject to shipment at the earliest opportunity. Jobbers are 60 days behind in filling orders, for nails and steel products excepting pipe fittings.

There seems no doubt in the minds of jobbers in this territory that the complaint as to difficulty of the eastern mills in getting skilled men who will work in the heat at the wages paid when they can secure easier environment elsewhere at as good a wage is sincere. Reduced production in consequence is anticipated for months to come. Only a small percentage of pipe needed is being delivered although building projects are not brisk. California jobbers have been reaching up into this territory with placements but jobbers have refused acceptance owing to the difficulty of taking care of their own territory. This enquiry from the south clearly indicates that stocks from the Canadian to the Mexican line are very low. Export orders also are being rationed while one length of small pipe is made to do the work of two. It is the opinion of jobbers here that normal conditions cannot return in the steel building industry in less than five years.

Colorado mills, which promised 50 per cent. of the small nail supply by July 1, have been able only to get out 40 per cent. of the requirements. Manufactured hardware which includes faucets and valves are coming this week more freely and jobbers' stocks are in fair condition. Satisfactory arrivals in fittings as against lean receipts of pipe is explained in the fact that the mills are concentrating what skilled labor they can get on turning out the materials that bring the highest profits.

Brick, plaster, plaster board, cement and patent roofing are offering two to one to the demand. Prospective construction of office buildings, which are two years behind in this city, is being deferred. Investors do not seem to care to pay present prices believing that they can save considerable money by waiting at least a year.

Red cedar shingles are stronger by 35 to 40 cents than ten days ago for clears and 75 to 80 cents higher on stars. The low points has evidently been passed. Standard clears, mill basis, are \$4.30 to \$4.50 per 1,000 and stars \$3.85 to \$3.90. A majority of the mills are down for a prolonged season of repairs. Fir lumber is firm to stronger. New price lists carrying higher quotations are believed to be impending.

(By *Special Correspondence to The American Architect.*)

San Francisco:—While no doubt much building has been postponed from time to time and is still being delayed on account of high costs of materials and labor, the first half of the year showed a big advance in construction work in and about San Francisco as compared with the first six months of 1919. Local architects, as well as contractors and building material interests consider the outlook bright for a proportionate increase during the latter part of 1920. The preparation of plans and specifications by the architects continues quite a bit ahead of the actual starting of work on many assignments, on account of the difficulty experienced in getting materials and labor to push the work along. Now a shortage of steel is one of the most serious drawbacks on large buildings in the downtown business districts. Not only is this shortage delaying the starting of certain buildings, it is halting work already in progress.

For instance, work on the California State Building on McAllister street, between Larkin and Polk streets, which is to complete the northerly frontage of the Civic Center, has been suspended owing to the delay in the arrival from the East of light sizes of structural steel required for floor beams. It is understood this contingency is confronting other contractors also.

(By *Special Correspondence to The American Architect.*)

Boston.—June building operations in New England amounted to \$32,795,000 which was somewhat less than the May figure, although greater than that of April. The total number of contracts awarded during the first half of the year was 5440 and the amount involved was \$178,854,000 as compared with 5070 contracts amounting to \$82,111,000 for the first half of 1919.

Industrial building led in this section during the first half of the current year, amounting to \$55,582,000 or 31 per cent. of the total. Other important classes of buildings were as follows: Residential \$49,035,000, or 27 per cent.; business building \$37,468,000, or 21 per cent.; public works and utilities \$15,446,000, or 9 per cent. Contemplated or projected work was reported from January 1st to July 1st as amounting to over \$340,000,000. This large figure is an indication that the rate of activity which prevailed before July 1st is likely to continue throughout the year.

Statistics of building and engineering operations in New England show that contracts awarded from January 1st to July 8, 1890 amounted to \$188,622,000 as against \$89,866,000 for a corresponding period in 1919 and \$76,328,000 in 1918.

DEPARTMENT OF ARCHITECTURAL ENGINEERING

The Office of an Architect and Engineer

By EMILE G. PERROT

IN connection with the article entitled "The Balance," which appeared in the May 19 issue of THE AMERICAN ARCHITECT, and which very ably portrayed the balance that should exist between architect and engineer, it is interesting to note that many organizations have, under the stress of necessity, solved this problem by combining the services of architect and engineer in a single organization.

The concern with which the writer is connected has been performing its work in this balanced fashion for the past twenty years. One purpose only controlled the laying out of their present offices, namely, the creation of an efficient workshop where client, architect, engineer and contractor could all labor fruitfully and satisfactorily together.

The needs of this particular office are to some extent unusual, since the firm has a clientele whose requirements embrace a wide diversity of work. Thus a portion of the activities of our organization covers institutions, churches and schools; another phase brings us in contact with business buildings

and industrial plants, while a third, related to both the above and yet different from either, directs our energies towards industrial housing and town planning. In all three fields, the architectural, the engineering and the equipment features are handled and developed *simultaneously*. This concern specializes also in mechanical work, such as process engineering, power plants, and similar developments.

Such a variety of work necessitates the establishment of a workshop or office having ample provision for efficiently handling these several lines of endeavor, and so organized that work may be carried on simultaneously and independently if desired, while permitting work of two or more branches to be correlated whenever the advantage thereof is apparent.

The offices here illustrated occupy the entire top floor of a building 90 by 150 ft. in area, receiving natural light on all four sides and in

addition a large skylight furnishes daylight over the central portion. This floor is devoted to lobby, consulting room, library, general offices, private offices,

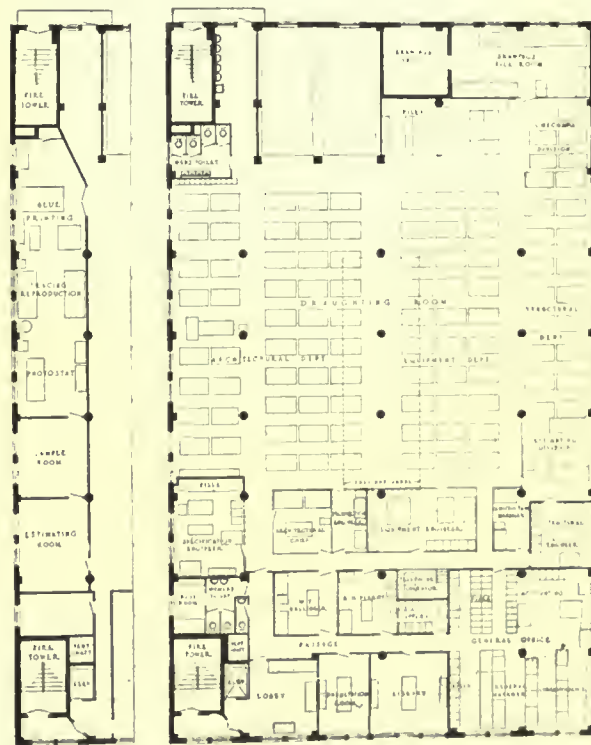

7TH FLOOR

8TH FLOOR

ARCHITECTURAL OFFICES OF BALLINGER & PERROT, PHILADELPHIA, PA.

THE AMERICAN ARCHITECT



OFFICES OF HEADS OF DEPARTMENTS IN FOREGROUND

drafting room, file room, etc. On the floor below we occupy a row of offices, extending entirely across the north side of the building. A section of this space is devoted to a reproduction plant, wherein are blueprint machines, equipment for tracing reproductions and a photostat machine. Another section embraces sample rooms and contractor's estimating room, in which contractors who have not received plans and specifications, may leisurely and quietly take off quantities, preliminary to preparing their bids.

As will be noted from the floor plan of the top floor, the lobby, or reception room, the consulting room, the library, the contract and accounting departments, with general manager's office, stretch across the front of the building. These rooms have opaque partitions and are to all intents and purposes, soundproof. Next, in a commanding position, are the private offices of the firm. These offices are enclosed in light glass partitions which are



PORTION OF DRAUGHTING ROOM

translucent to a point about five feet above the floor, providing complete seclusion to the occupants when seated, and yet, permitting them, when standing, to view almost the entire organization at a glance. In this row is also located the telephone switchboard, which is elevated to permit the operator to view the entire floor and readily locate any person wanted no matter how far he may have wandered from his individual telephone.

Next comes the row of executives, or heads of departments, with offices enclosed only by railings sufficiently low so that they do not obstruct the view from the private offices just mentioned. In this are the chief architect, production engineer, chief mechanical engineer, and construction manager with their assistants. On one end of this row, separated by a small aisle is a glass partition, housing the chief specification engineer, with his heaps of samples and manufacturers' catalogs; while situated on the other end is the chief structural



GENERAL OFFICE, CORRESPONDENCE, ETC.

engineer, with the estimating division immediately adjacent. From here, on back to the rear of the building are the drafting tables, arranged so that the forces of each department are in line with the office of their department head.

At the extreme rear an enclosed filing room is located. This consists of a large open space with wire partition, through an aperture of which drawings are handed out to those authorized to receive them. Here is also contained a fireproof vault in which are stored the record drawings of completed work.

When the work of any particular project is well under way, five or six tracing reproductions of the main outline of the particular structure are made and a complete set given each department. This not only saves time and expense, but each department has a set of drawings which are exact dupli-

THE AMERICAN ARCHITECT

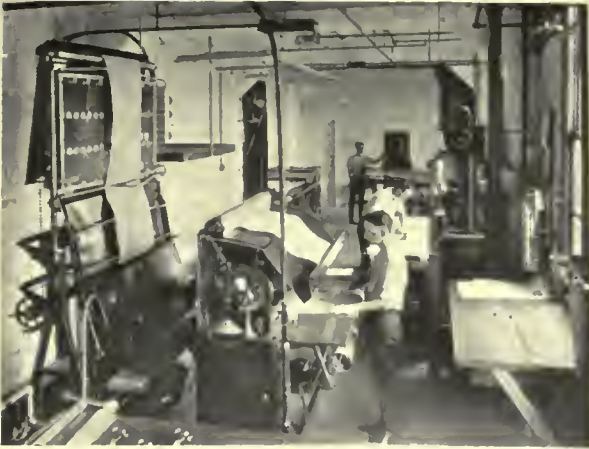

BLUE PRINTING DEPARTMENT

cates of sets given to other departments, being identical as to scale and detail. In carrying forward the work after it leaves the conference with client, there are frequent conferences between the executives of different departments, as well as between the squad bosses in command of the various groups of draftsmen.

The several features of any structure, including the architectural treatment, the engineering and equipment details, are carried forward together,

with the result that when the final drawings are made, all these various features have, as it were, been built into the drawings, producing a complete, harmonious and unified structure, a culmination not always possible where the architectural work is first completed, and then the equipment and engineering provided from sources outside the architects office, which latter method, from the very nature of things, must subordinate such features and make them mere additions to the architectural drawings.

This firm has found through long experience that its clients' interests as well as its own have been best conserved by having all branches of architecture and engineering necessary for the proper and complete designing of structures, under one roof, and also under one governing, responsible head.

The illustrations portray better than a detailed description can, the complete *balance* existing between the various departments and the ease with which the department heads can co-operate. The fact that they are all located on one floor with an unobstructed view of each other and their respective subordinates, reduces to a minimum, the time generally consumed in a useless hunt for an individual who may not be free just at the moment wanted.

Efficient business methods are as essential to the practice of architecture as in any other business.



ORGANIZATION CHART

American Wooden Houses in France

Five hundred from an order of 1,000 wooden houses for the devastated regions of northern France have been delivered by a New York firm this spring. These houses are 7 meters or about 23 feet square and have three rooms and a shed. They are delivered in sections and complete, according to the Review of the American Chamber of Commerce in France, including windows, doors, glass, paint, nails, bolts, all ready for erection. Their erection is under the director of one of the French building departments. About a hundred of these houses are being erected in the Arras and Lens districts.

Data on Chimney Construction

The National Board of Fire Underwriters has issued an illustrated 12-page pamphlet entitled "An Ordinance for Construction of Chimneys." It is so drawn as to be suitable for use in cities and towns of any size, and is also suitable for individual use as a safe guide for the construction of chimneys intended for moderate temperatures.

Due to the large number of fires whose origin can be traced to defective chimneys, it is to be hoped that the recommendations contained in this pamphlet will receive careful attention and the principles laid down be put into practice more extensively than in the past.

Report on Trip to Princeton, College of City of New York, Yale and Harvard for the Purpose of Inspecting the Stadia at those Universities

By HOWARD DWIGHT SMITH

Part II

AFTER observing the Palmer Stadium at Princeton and going immediately on to the one given to the College of the City of New York by Mr. Adolph Lewisohn one is impressed by the similarity in color. The tannish color noticed at Princeton is quite predominant at the City College. In size and in the shape of its inside curve, the City College Stadium is quite similar to the closed flattened end of the Princeton structure. It is in reality a sort of "hemi-stadium," its internal plan being half of an ellipse which has been bisected along its major axis.

Its seating capacity is 7,000, and the space which it encloses on one side is barely large enough for a football field. The running track is less than a quarter of a mile and a long straightaway is im-

possible. The structure is placed between two city streets (135th and 136th streets) and abutts on a third (Amsterdam avenue). The exterior of the structure on each of these three streets consists of a solid wall with entrances at the street intersections. On the interior the upper line of the semi-ellipse, at the top of the rows of seats, is marked by a simple Doric colonnade which terminates at each end in sturdy square towers. The placing of this colonnade gives an interesting and dignified appearance to the structure and because of the close spacing of the columns, the irregularities of the triangular spaces at each of the corner entrances are successfully masked. The great number of columns gives "scale" or an appearance of comparatively great size to the structure.



STADIUM FOR THE COLLEGE OF THE CITY OF NEW YORK
ARNOLD W. BRUNNER, ARCHITECT

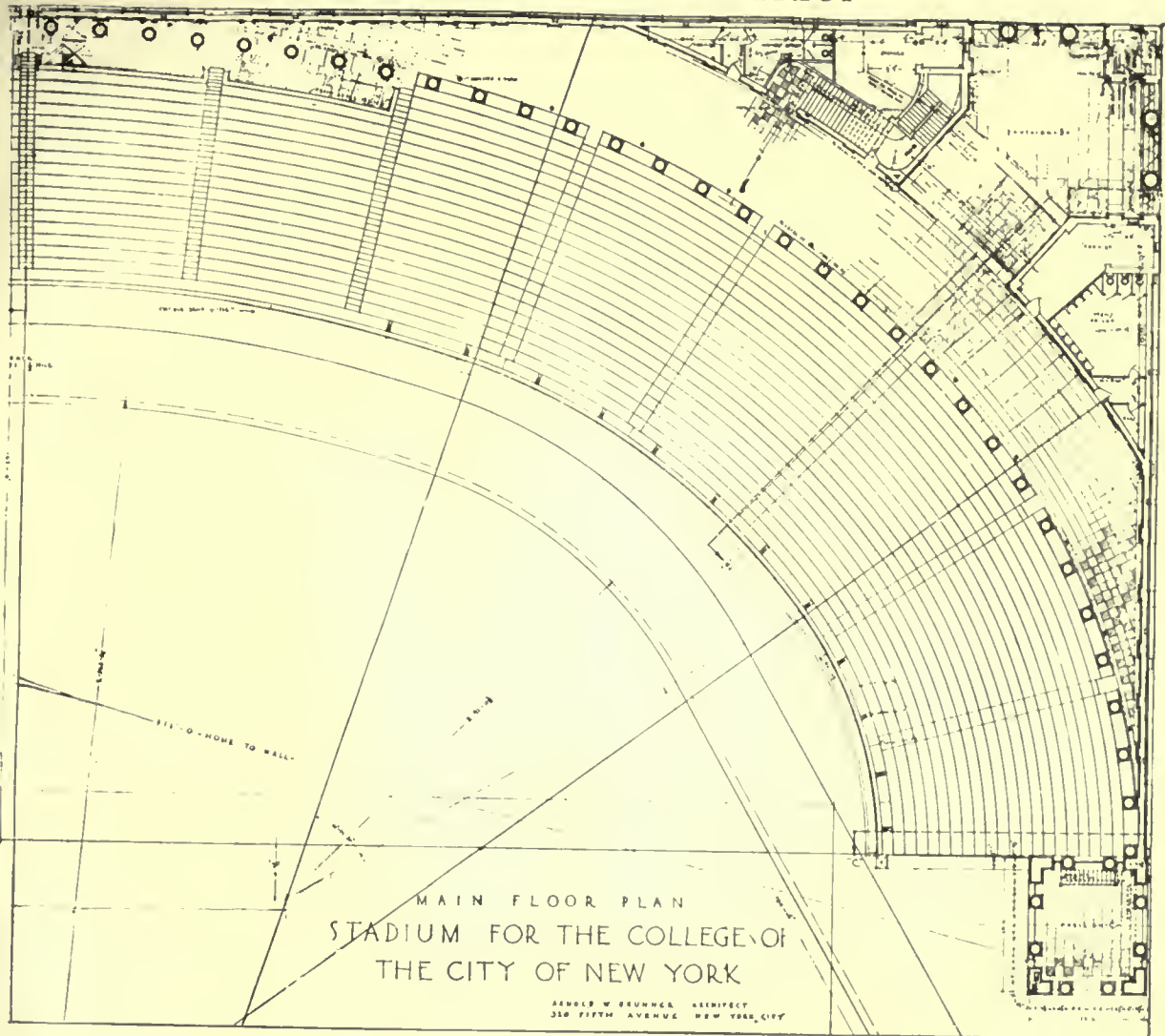

The problem of handling crowds is not great. Entrance and exit is only by way of the openings at the street corners. No provision is made for egress from the seats to the field except by small stairways in the end towers. The wall at the inner line is $7\frac{1}{2}$ feet high, the lowest aisle level being 5 feet above the playing field. All seat drainage is into this lower aisle and thence down into a cement gutter along the wall at the playing field level.

In the towers at each end of the Stadium there are showers and dressing rooms, and the stairs mentioned above. The dressing rooms and showers are quite extensively used, even though the gymnasium of the College is just across 136th street. The rise and width of the seats at City College is uniformly 16 to 28 inches which give a very satisfactory sight line.

After having been impressed with the apparent insufficiency of expansion joints at Princeton, careful observation of those at the City College stadium seemed important. It was found that the Stadium

had been built in sections with expansion joints located about 30 or 40 feet apart, around the ellipse and with a joint at the top row of seats along the flat archway or promenade at the upper entrance level. These expansion joints are of the overlapping or slip joint type in which lead plates and mastic cement have been used. The efficacy of these joints is testified to by the fact that after five years of contraction and expansion there is practically no unsightly cracking from temperature stresses or unequal settlement, except at a few points where the parapets of the four upper observation boxes overlap the expansion joints. There is a very definite lesson to be learned from this condition, and that is that extension joints should be absolutely continuous throughout the structure, that they should be designed to be a part of the architectural embellishments as well as of the structural necessities.

The expansion joints between the seat sections occur at one side of each aisle of steps. In prin-

THE AMERICAN ARCHITECT

ciple this appears to be a satisfactory solution. Inspection of the drawings and diagrams published in the *Engineering Record* of January 1, 1916 (Vol. 73, No. 1, pages 10, 12), shows that it was intended that the steps in these aisles should be so located as to have the riser of each alternate step line up with the riser of the adjoining seat. This of course would have led to difficulties with the expansion joint for the face of the joint would have been exposed for a few inches at each seat riser. This evidently has been overcome by moving the face of the step risers in order to keep the expansion covered by the overlap of the seat riser. In some cases this overlap hardly appears to be quite sufficient and some slight cracking has resulted.

The expansion joints in the floor of the promenade area at the top of the seats are covered with metal floor plates which are about 4 inches wide, secured to one section and allowed to slide over the edge of the other. This appears to be quite effective. In the vertical walls along the three adjoining streets the expansion joints have been covered by sheet copper plates. These plates not only cover the joints on the flat surfaces but have been formed to fit the profiles of the classic cornices and mouldings. The fineness of some of these mouldings has made it somewhat difficult to maintain proper contact and profiles. The lesson which is drawn from this is that (1) joints through moulded members should be plain, butt joints which should be free to open and close as necessary (with proper protection on top horizontal surfaces exposed to the weather); or, (2) that moulded courses should be designed to avoid expansion joints; or, (3) omit moulded courses, except of the most simple nature. (For structural and technical details refer to *Engineering Record* mentioned above).

For additional illustrations see *THE AMERICAN ARCHITECT*, Aug. 4, 1915.

It is realized that the problems of designing and erecting monolithic structures of reinforced concrete are not confined to stadia. Many buildings and engineering structures are being erected to-day where the problems of structural design involved are the same as or similar to those of a Stadium. Several large bridges recently built are recommended for further study.

The United States Army Supply Base at Brooklyn completed in August, 1918, consists of a group of five buildings, all built hurriedly and as a war emergency. Speed and economy of construction were prime considerations. Pretentious design is not aimed at, but the care with which the various structural members have been spaced and proportioned is sufficient indication that the fundamental principles of design can be applied to apparently so crude a material as concrete. The emphasis

of vertical lines, the suppression of the heavy horizontal lines at each floor level, the logical location of solid towers, and the frank expression of material, shown by the form marks which have in general been left untouched, mark this factory-like group of buildings as a very interesting and successful example of reinforced concrete construction.

The two large warehouses dominate this group. One is 200 feet wide, the other is 300 feet wide. Each is 980 feet long and eight stories high. To take up expansion and contraction in such large masses, each building has been divided into four parts by three continuous transverse expansion joints. The joints in the side walls are sliding



NORTHEAST PAVILION

joints filled with mastic. The joints in the floor slabs are covered with steel sliding plates. The joints in the roof are made weather proof by flexible "V" shaped copper plates. In principle all of these forms of joints just mentioned are satisfactory. However, Major H. L. Green (U. S. Q. C.) now Utilities Officer at the Supply Base, says:

"The expansion joints run all the way through the building from roof to foundation. Foundations, however, are not divided. Experience has shown that the placing of these expansion joints is not quite sufficient as there have been evidences that tend to show the area of the sections, 250 feet by 200 feet is too great and that under the changes of temperature, stresses are discovered which result in cracks."

Time alone will tell how these buildings will wear and the evidence of good workmanship and material even in spite of the roughness of surfaces due to the presence of form marks, is apparent from an inspection of the structures at the Supply Base.

Quantity Survey System Receives Further Endorsement

Engineering Council Takes Action on Report of Its Committee

IN October 1919 the American Institute of Architects, Engineering Council and the Associated General Contractors of America each appointed three conferees, which formed a joint committee to discuss the matter of payment for estimating with a view to agreeing upon certain recommendations to be submitted to their respective organizations for action. At a meeting of this joint committee, held February 16, 1920, the following resolutions were adopted:

WHEREAS, there is great economic waste in the present usual methods of individual estimating of the same quantities by several different bidders on the same project; therefore, be it

Resolved, That the following are the conclusions of this conference:

(1) That any system of duplication of effort in estimating wherein each bidder separately estimates the quantities should be condemned.

(2) That all competitive bids should be based upon a detailed schedule of quantities prepared from a survey of the plans and specifications and submitted therewith, the cost of the preparation of such survey of quantities to be borne by the owner.

(3) That while the owner should furnish a quantity survey as the basis of bids and contracts, and should submit them with the plans and specifications, and should pay for the same, the bidders should make no charge to the owner for submitting proposals, based on said plans, specifications and quantity survey.

(4) That in general, competitive bids should not be invited nor submitted on projects, the plans and specifications for which are not accompanied by a quantity survey, unless the owner agrees to pay a predetermined fee to each bidder for preparing the quantities and submitting an estimate.

On the following day, Henry K. Holsman, president of the Illinois Chapter, A. I. A., and a member of the joint committee, addressed the National Conference on Construction of the Associated General Contractors of America on the "Expense of Estimating." This address was printed in full in the April 14th issue of the *AMERICAN ARCHITECT*.

During this conference, the Associated General Contractors adopted the following resolution:

Resolved, That the progress report of the joint conference of the American Institute of Architects, Engineering Council and the Associated General Contractors,

on payment for estimating construction work as submitted to the annual meeting by the Committee on Methods, be adopted.

Engineering Council appointed a special committee to consider the report of the joint conferees, and at a meeting held June 17, Engineering Council adopted the conclusion of its committee, which follows:

Whenever in the execution of work, competitive bids are asked for on detailed plans and specifications, those invited to bid should be provided with such an estimate of the quantities involved in the work as the surveys, plans and specifications permit to be made. The intent of this requirement is that a single estimate of quantities should be made by or for the engineer, architect, or other representative of the owner, so that each separate bidder will not be put to the expense of making up a separate schedule of estimates. This latter practice not only means a needless waste in the carrying on of contract work, but also discourages bidders and causes needless repeated handling of official plans and specifications in making up separate schedules of estimates.

Eight months have passed since the nine representatives of the various organizations were appointed to the joint committee and five months since these conferees set forth their recommendations. During this period, two of the organizations represented have endorsed the findings of this joint committee. At the convention of the American Institute of Architects, held in Washington last May, no action was taken on this matter, and to date it is not known whether the report of the conferees has the approval of the Institute or not. In the meantime, it is interesting to note that the Philadelphia Chapter has gone on record as endorsing the recommendations of the joint conference, and it would seem likely that other chapters will give similar individual indorsement.

This is a matter of vital interest to the practising architect, and it is to be hoped that action will shortly be taken by the Executive Committee of the Institute removing all uncertainty, if indeed any can exist, as to the attitude of that organization toward a plan that makes for convenience, a reduction in the labor of estimating, greater accuracy, truer competition in bidding, and as an inevitable result of these attributes—economy.

Senate Committee to Consider Crises

National Federation of Construction Industries to Aid in Presenting Accurate Data

THE presidents and secretaries of the fifty odd associations affiliated with the National Federation of Construction Industries, met at the Union League Club, Philadelphia, June 17, to arrange for the preparation of statements to be submitted to the United States Senate Special Committee on Reconstruction and Production, which has recently been appointed and is particularly charged with the fostering and stimulating of construction work of all kinds.

There is a growing feeling of confidence in the work of this Senate Committee among those engaged in the construction industry, those dealing in real estate, as well as among housing and labor experts, for the reason that the chairman of the committee, Senator William M. Calder, of New York, is not only a practical builder, but has a thorough knowledge of the economic conditions surrounding the industry, as well as of the national problems with which the industry must synchronize. The personnel of the Senate Committee is as follows: Hon. William M. Calder, of New York, Chairman; Hon. William S. Kenyon, of Iowa; Hon. Walter E. Edge, of New York; Hon. Josiah O. Wolcott, of Delaware; and Hon. Edward J. Gay, of Louisiana. It is understood that the research work of the Senate Committee is being very carefully organized in advance and is in charge of Mr. Franklin T. Miller, who is a recognized authority on the economics of the construction industry.

The National Federation of Construction Industries represents, as a clearing house of information and action on the major problems of the whole industry, several hundred national and local associations engaged in the manufacture and assembly of construction materials. It is the purpose of the Federation to place before the Senate Committee exact information from each of its component associations. This information will be obtained by each of these associations from the thousands of concerns who are its own individual members and who are familiar with local conditions in every section of the country.

It is the hope of the Federation and of its affiliated bodies to thus briefly and clearly indicate to the Senate Committee the existing situation in each of the building trades, so called, to compare the potential capacity of each with the present quantity of its output, to compare the prices of the products of each with the prices of general commodities, and to draw the attention of the Senate Committee to the great influence of the factor of uncertainty

which is now so seriously affecting costs and quantity of production, as well as making for uncertainty of delivery and speculation as to future delivery.

It is believed by many that this item of uncertainty is one of the largest items entering into the cost of construction at the present time. The labor factor is hardly more uncertain than the transportation or the financial factor. The cost of the raw material used in construction is, in itself, a very small item; it is the repeated application to the raw material of overhead, labor, transportation charges together with the speculation due to uncertainty of delivery which make up the final price to the consumer.

It is very evident that the construction industry can not function at all without capital, transportation, fuel and labor. It is equally evident that the greater the supply of these necessary elements, the more speedy will be the completion and the less the costs and the lower the rentals.

The full effect of the order of June 2nd, issued by the American Railroad Association, which gave preference to the shipment of coal, has not yet been fully realized. It is believed by many that this has placed a practical embargo on the movement of building materials and will bring about speculation in materials already available.

Freight rates, which in June 1918, were increased on the average of 25 per cent on general commodities, were, it is estimated, increased 50 per cent on some important building materials and now there is a prospect of a further increase. The ultimate cost to the consumer through increased freight rates and the uncertainty of the transportation are grasped with difficulty. In Chicago, sand is now costing from \$4 to \$5 a yard, and Chicago is built on sand dunes.

A statement of the actual conditions presented in an orderly fashion by the entire construction industry, by the financial, transportation, groups and by labor and housing experts, will go far to clarify the situation and encourage individual initiative, and at least decrease one of the largest items of expense—the item of uncertainty.

It is the hope of the optimists of the construction industry that the present necessity may greatly advance the standardization of materials used in construction, so that costs may be reduced through quantity of production and speedy assembly. After all Necessity is the Mother of Invention, and the construction industry is just commencing to learn what it can accomplish through standardization.

9. uti pice & 116 22.8



DOORWAY CHURCH OF S. MARIA MAGGIORE, BOLOGNA.

THE AMERICAN ARCHITECT.

THE AMERICAN ARCHITECT

VOL. CXVIII

WEDNESDAY, AUGUST 4, 1920

NUMBER 2328

Organization, Management and An Accounting System for An Architect's Office

By H. P. VAN ARSDALL, of Samuel Hannaford & Sons, Architects, Cincinnati, Ohio

INTRODUCTION:

THE average architect, like the average doctor or lawyer, enjoys only a moderate income from his professional practice and his accumulations after the normal term of activity provide, at best, only a very modest competency.

In the writer's opinion the reason for this condition is to be found in their general indifference to the commercial side of the profession.

The practice of architecture, while very properly classed as professional in the same degree as the practice of law or medicine, is unlike others, distinctly commercial in its methods of achieving results. It is doubtless true that the creative faculty leaves little opportunity for the successful development of purely commercial functions, but since existence depends on income, there seems no valid excuse for inefficiency in management of the business end.

Architecture, as a business, has as definite an output as a factory, namely buildings, and as an intermediate process, plans and specifications.

Architects, as a rule, are liberal in their investment in literature, plates and technical information, but suggestions looking to improvement and modernization in methods of production and accounting are too frequently dismissed with little consideration for fear of reducing the office to a purely industrial level, with a consequent loss of caste—by the office force. This attitude and its correlative inefficiency is frequently a surprising revelation to clients affiliated with well organized industries and indicates an inexcusable ignorance of fundamental business principles on the part of those assuming it.

Few architects seem either to understand, or to utilize any rational system of cost accounting and, as long as they have a balance in bank, appear indifferent to the matter. In fact, very few have any adequate idea of the cost of producing a set of plans and specifications. The writer recently asked three

prominent architects, all working under practically the same conditions, as to their average rate of overhead expense. One of them replied "40 per cent. of the draftsmen time," one "56 per cent. of the draftsmen time," the third man did not know and was not interested. The head of a factory would think such ignorance imbecile, for he knows that only the Grace of God prevents bankruptcy of any concern which does not know the cost of production for the commodity sold.

It happens often that plans and specifications are prepared for a building and after bids are received the whole project is abandoned. The architect then wonders, notwithstanding the fact that the American Institute of Architects has laid down a schedule of charges, what he will get out of it or how much he should charge. Nine out of ten don't know what to charge, but make a rank guess and send out a bill. If the client objects to the amount of the bill, the architect usually has no cost records to back up his claim and under the conditions has to make the best settlement possible.

The installation of improved methods in office management and accounting cannot be accomplished in a day. It requires considerable time, labor and thought, but once installed, all friction and duplication is avoided and the organization operates like a well balanced machine.

This article was written for the sole purpose of pointing out the vital necessity of modern methods, with some suggestions looking toward improvement in a commercial sense.

ORGANIZATION:

Organization has been defined as the collecting together of individuals for the purpose of producing certain things, and the division of authority among these individuals in order that they may perform their special functions harmoniously and efficiently for the common good of all.

There are three principal forms of organization

THE AMERICAN ARCHITECT

that may be used; viz., individual proprietorship, partnership, corporate.

INDIVIDUAL PROPRIETORSHIP:

Individual ownership is the simplest form in which business can be conducted and is best suited where the amount of capital required is small and the business risk is slight. An individual may select his own time to start operating and can retire at will, providing all obligations have been met. Since all responsibility and authority is vested in one person, matters of importance that require quick decisions can be settled promptly; whereas with the other forms of organization, more time is required, as questions of vital importance are usually referred to two or more persons. This form has many disadvantages; the most conspicuous of these is limited capital, and a single mind to pass judgment on important matters. Quick action often leads to serious results. It is only in rare instances where you find a combination of keen business judgment and designing skill in one person. It has been demonstrated to the writer time and again that the strictly architectural designing mind abhors matters pertaining of finance and business. This type is eager to offer suggestions and advice, but shifts responsibility when results are bad.

This form of ownership cannot be recommended, except in the smallest of offices.

PARTNERSHIP:

A partnership may be described as an association of two or more competent persons for the purpose of combining capital, labor and skill in the prosecution of some lawful business for profit.

Our laws grant the right to any two legally responsible parties to enter into this arrangement of business organization.

Each partner is an agent of the firm, and when acting in the interest of or for the partnership can legally bind the other members to any agreement entered into.

In the case of partnership debts each firm member is liable for the full amount.

The partnership permits of a division of authority, which is very essential in any business. Usually in forming a partnership one member is of the executive type and the other man of designing ability. The executive should be familiar with good business practice and management and have a thorough knowledge of architecture; the other member or members have charge of the drafting room and the actual supervision of building construction.

This form of organization lends itself more readily to the architectural business than any other, and where harmony is secured it is the most desirable and profitable.

In the forming of a partnership the following points should be written in the articles of co-partnership: (1) The names of the contracting parties; (2) the firm name; (3) the purpose for which the partnership is formed; (4) the invested capital of each partner and the division of profits and losses; (5) the system of accounting; (6) the method of conducting business; (7) the privileges and rights of the partners; (8) the dissolution of the partnership.

CORPORATION:

Blackstone defines a corporation as "An artificial person created for preserving in perpetual succession certain rights which being conferred on natural persons only would fail in the process of time."

A corporation is a "legal entity" and has its origin under the laws of some state. Its powers are all conferred by the state under which it is organized.

It can own property in its own name, can sue and be sued; whereas a partnership can do neither. It is financed by the sale of stock or shares of equal value to individuals, and the individual's voice in the operation of the company is governed by the amount of stock held.

Since the services of an architect are strictly professional, and constitute a personal service, it can readily be seen that the removal of one of the principal units of the organization would destroy the foundation that your whole business is built upon.

It is therefore recommended that this form of organization be not considered.

MANAGEMENT:

The life of any business depends upon its management. It should therefore be organized in an orderly and systematic fashion, purposed to gain maximum production at a minimum cost. This result cannot be obtained indirectly; direct methods must be employed. Thought spent in planning your working arrangement will prove to be valuable, as it will produce harmony among your forces and at the same time increase production.

Clearly define authority and responsibility among subordinates to insure the successful co-operation of divided effort.

In many offices the old moss-eaten idea of never increasing a man's wages until he asks for it still prevails. Draftsmen and office help should not be placed in this embarrassing position. It is humiliating to ask for a "raise." An executive should quickly reward good service, as it encourages a man more than anything else. A haphazard method of increasing salaries creates dissatisfaction among employees and kills ambition.

It is a good practice (during normal times) for a firm to fix upon a just schedule of wages, and in-

THE AMERICAN ARCHITECT

form the employees that through meritorious work their wages will be increased in accordance with their efficiency records, and then go through with it.

In order to have a definite working arrangement the organization chart should be used, which clearly defines authority.

An organization chart is simple and readily understood. No one is laboring with a false idea of his position.

color drawings is done in this section. Approximate estimates of cost are also made.

2.—*Clients*: In the preparation of sketches, etc., it is necessary that consultations be had with the client. In this connection it is suggested that the head draftsman sit in these conferences and take notes of all question discussed. After the conference a letter giving in detail the results of the discussion should be sent to the client and a copy retained in the office for reference. This procedure

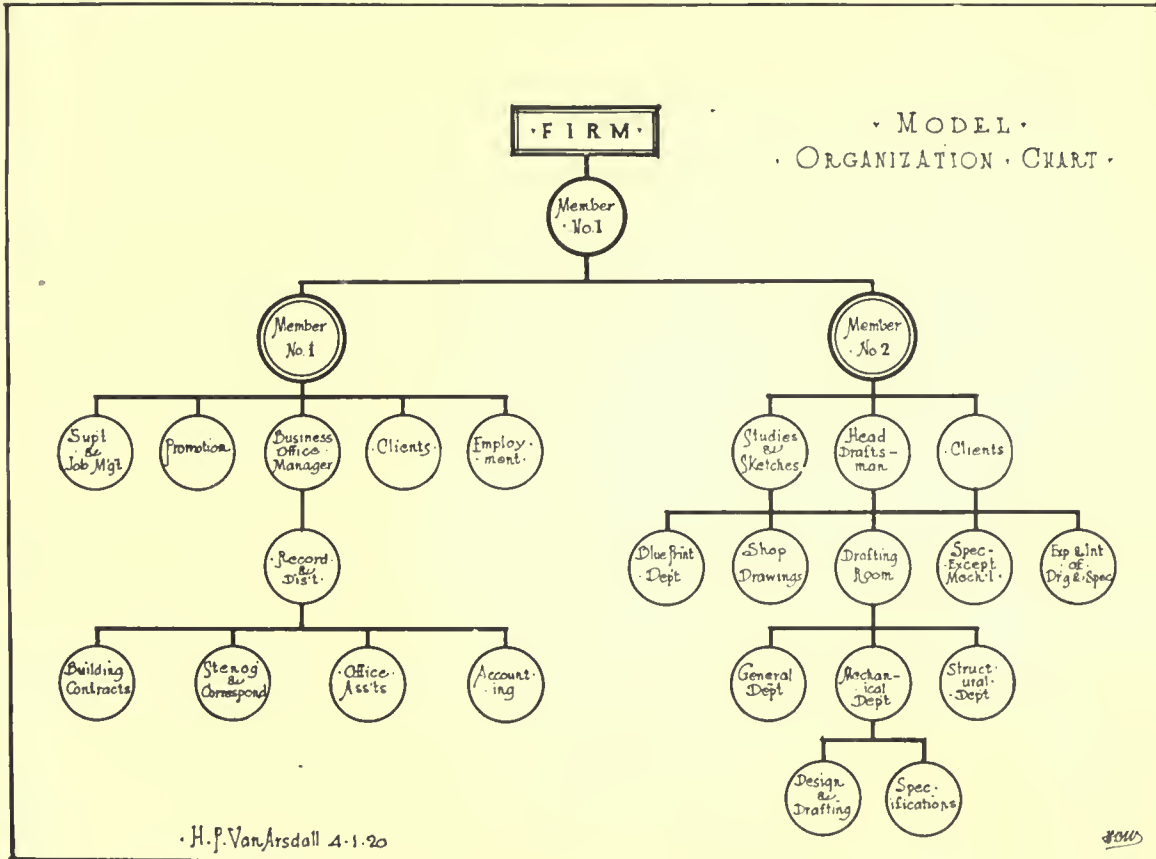

The model chart presented is a suggestive arrangement that will go far toward effecting an efficient working force.

DESCRIPTION OF CHARTS

Firm: The firm is represented by the rectangle.

Senior Member No. 1: Is the executive member of the firm who directs the business policy, solicits business, makes contracts, interviews clients, and exerts a general supervision over the entire office.

RIGHT BRANCH OF CHART:

Member No. 2: Is the firm member having charge of the production end of the business. It is customary to divide his work into three sections.

1.—*Studies, Sketches and Interior Decorations*: The preparation of all studies, sketches and water

silences all future argument as to what was agreed upon.

3.—*Head Draftsman*: The head draftsman is directly responsible to the head of this department. All instructions from the head of the department to any subordinate department must pass through the head draftsman. In this way he is in constant touch with all work in the office. All questions concerning the work in divisions below shall be brought to the head draftsman, and his decision shall be final, except where, in his judgment, the matter should be submitted to the head of the department. In the submission of matters to the head of the department a convenient and regular time should be selected.

It can be seen that this arrangement will relieve

THE AMERICAN ARCHITECT

member No. 2 of much detail and routine work and will allow him to devote his time to more pressing matters.

The head draftsman divides his work into four departments:

(a) *Shop Drawings*: On the submission of shop drawings by a contractor the head draftsman looks them over and has them checked by the regular checker or by the draftsman that is most familiar with the work. After the drawings are checked, corrected and approved he sees that they are returned and proper distribution made to the parties requiring them, together with any written instructions. A copy should be kept for the office file.

(b) *Specifications*: The writing of specifications is one of the most important branches of work and should be done by one specially fitted for it. All specifications (except those in connection with the mechanical department) are prepared in this department.

(c) *Explanation and Interpretation of Drawings and Specifications*: It is desirable and advisable that this be done by the head draftsman. It happens so often, in many offices, that a contractor, when bidding on work, asks questions regarding the meaning and intent of certain things in the drawings and specifications; usually the question is put to the first person seen, and he answers it in his own way. Then the same performance is gone through with some one else, and consequently a multitude of answers have been given, with no one responsible for them. The head draftsman should answer all questions and keep a record of questions and answers.

(d) *Drafting Room*: The drafting room is under the supervision and control of the head draftsman. Member No. 2 looks to him for its efficient and successful operation.

Every man in the drafting room should be instructed as to his duties and understand and recognize the position of other draftsmen.

In most drafting rooms considerable waste occurs through the careless handling of tracing cloth, paper and pencils. A saving in these materials can be effected by keeping them under lock and key and have one person issue supplies.

A list of standard size sheets for tracing cloth should be made, and when the office boy is not busy sheets can be cut to size and placed in a drawer ready for use.

A proper filing system for the filing of drawings, specifications, shop drawings, photographs of finished buildings, and catalogues should be worked out. There are many systems now in use. A system of filing, familiar to the writer and one that has proven fairly good, is handled in the following manner: Drawings are filed, in a vault, flat on shelves

40 by 50 inches, a space of 2 inches is left between, and a card with the name of the job is tacked on the edge of the shelf. On completion of the building, drawings, specifications, details and shop drawings are rolled up together in one bundle and filed in the store room. Specifications are filed in folders in a vertical letter file. Shop drawings are filed the same as tracings.

Photographs of finished buildings are made with linen backs, size 7 by 10 inches, with a 2-inch binder edge for inserting in a loose leaf binder. Photographs are of great value in interesting clients.

Catalogues are the most difficult to file and the greatest source of trouble in the office. A very good solution of this problem is to file them in a vertical letter file, in folders, and classify them as "electric supplies," "plumbing supplies," "tile," "roofing," etc. Heavy and large catalogues are placed on shelves.

The drafting room organization is divided into three departments: General, Structural and Mechanical.

(a) *General*: This department is charged with the production of all drawings, details, etc., and the embodying in the general drawings of all the work of other departments necessary to make same complete.

When drawings and specifications are completed, checked, numbered and signed (see Drawing Record Book page), they are delivered to the business office manager, who secures the necessary bids.

(b) *Structural*: This department does all designing and drawing for structural work, principally steel and concrete. The department is composed of a structural engineer, with assistants from the drafting room, as the work in hand requires.

(c) *Mechanical*: This department is in charge of a mechanical engineer, with such assistants as are necessary.

All work of a mechanical nature, such as heating, ventilating, power piping, plumbing, elevators and electrical work coming into the office, is handled by this department and the mechanical engineer is responsible for the production of all drawings, specifications, etc., required.

It might be well to suggest before concluding the description of this department that the drafting room should be located with the general offices in a modern, easily accessible office building. The offices should be well lighted and ventilated and properly furnished in keeping with the profession. It is depressing for a man to work in poor surroundings, all good inspirations die quickly and lack of interest is manifested. Equipment should be of the best and every man provided with proper tools. Dull tools produce a like product.

THE AMERICAN ARCHITECT

LEFT BRANCH OF CHARTS:

FIRM Member No. 1.—This member is in direct charge of the left branch of the chart, and includes the Business office, Job Management and Superintending of Construction, Promotion of Building Projects, Interviewing Clients and Employment of all help.

SUPERINTENDENT:

The Superintendent of Construction has complete charge of all building construction, management of jobs, the making of monthly estimates for the purpose of paying contractors and supervises the work of all inspectors who are actively engaged on one job.

It is the duty of the Superintendent to make regular weekly reports, stating in detail the progress of the work. For each job a report is sent to the client. These reports, on completion of the building, show a history of the entire operation, from the breaking of ground to the occupancy of the building.

WAITING ROOM:

The waiting room is in charge of a young lady. It is her duty first of all to be courteous to everyone. When a person enters the office she has him state his name and mission; if she can answer his questions satisfactorily the party is sent away without disturbing the office, if not, the proper person is called.

FILING:

The careful filing of documents, letters, etc., is highly essential.

For letters any standard vertical file case may be used, preferably metal. The drawers of these cases measure approximately 12 inches by 11 inches, are 3 feet deep and have alphabetical indexes. All correspondence relating to a building may be filed by number or name in separate folders made for this purpose. All letters of any one job are placed in a single folder, and where the job is of any magnitude the correspondence may be divided up into separate

DATE	DESCRIPTION	STATUS	ON	DRAWINGS	OWNER	GENERAL CONTRACTOR	CARPENTER
1920	Factory for The V & K Auto Company #116 Pine St. City						
4/26	1. Basement Plan	1/2	ceat	R.M.S.	4/27/20 got	5/21/20 got 5 sets	
	2. First Floor Plan	"	"	"	4/28/20 got	of 4/28/20 and	
	3. Second " "	"	"	"	pages A to G	pages A to G	
	4. Roof Plan	"	"	"	4/30/20 got		
	5. Cross Section and Longitudinal Section	"	"	"	pages H-I		
	6. Details of Front and Interior	F.S.	"	"			
7							
8							
9							
10							
11							
12							
13							
14							
15							
16							
17							
18							
19							
20							
21							
22							
23							
24							
25							
26							
27							
28							
29							
30							
31							
32							
33							
34							
35							
36							
37							
38							
39							
40							
41							
42							
43							
44							
45							
46							
47							
48							
49							
50							
51							
52							
53							
54							
55							
56							
57							
58							
59							
60							
61							
62							
63							
64							
65							
66							
67							
68							
69							
70							
71							
72							
73							
74							
75							
76							
77							
78							
79							
80							
81							
82							
83							
84							
85							
86							
87							
88							
89							
90							
91							
92							
93							
94							
95							
96							
97							
98							
99							
100							

SPECIFICATIONS							
4/26	A. General Conditions	G	Plumbing	M			
	B. Brick Construction	H	Electric Work	N			
	C. Brickwork	I	Steam Heating	O			
	D. Iron Work	J		P			
	E. Carpenter Work	K		Q			
	F. Finishing & Glazing	L		R			

BUSINESS OFFICE:

The Business Office Manager has charge of all records, documents, books, routine correspondence, securing of bids, writing contracts and bonds, issuing certificates of payment to contractors, and the handling of all financial matters. He also supervises the work of stenographers, the accounting department, office assistants, and looks after the general welfare of the office.

folders for each branch of work. Miscellaneous correspondence is filed in alphabetical order, in separate folders.

A Record Book, alphabetically arranged, should be kept, showing the cost of every building erected, together with the cost per cubic foot complete, and the cost per cubic foot without heating and mechanical equipment, furnishings, etc.

Documents such as contracts, bids, accepted prop-

THE AMERICAN ARCHITECT

ositions, etc., are filed in reversible folders and placed in standard document file cases.

Superintendent's reports are filed in separate folders in a small file case.

Six months after completion and acceptance by the owner of a building all documents, superintendent's reports and letters, are placed in the transfer case.

BUILDING CONTRACT RECORDS:

Two books are necessary. A Contract Book (see typical page, for No. 5) and a Contract Ledger (see typical page, form No. 6).

When contracts for a building are awarded the name of the owner and the location of the building are entered on the top line of a page in the Contract Book. The name and location are also written in

<p>No. <u>1</u> Cincinnati, JUN 30 1920 OFFICE OF SAMUEL HANNAFORD & SONS ARCHITECTS</p> <p>Mr. <u>The V. & K. Auto Company.</u> To <u>The W. F. Johnston Company</u> Amount of Contract <u>\$127,700.00</u></p> <table border="0"> <tr> <td>Present Estimate</td> <td>22,000.00</td> <td>less 10%</td> <td>Present Cash</td> <td>19,800.00</td> </tr> <tr> <td>Previous Estimate</td> <td>12,200.00</td> <td>less 10%</td> <td>Previous Cash</td> <td>10,980.00</td> </tr> <tr> <td>Total Estimate</td> <td>34,200.00</td> <td>less 10%</td> <td>Total Cash</td> <td>30,780.00</td> </tr> </table> <p>Received Order for <u>\$19,800.00</u> being <u>payment on account of general contract for factory.</u> <i>W. F. Johnston Co.</i></p>	Present Estimate	22,000.00	less 10%	Present Cash	19,800.00	Previous Estimate	12,200.00	less 10%	Previous Cash	10,980.00	Total Estimate	34,200.00	less 10%	Total Cash	30,780.00	<p style="text-align: center;">Form #2.</p> <p style="text-align: center;">OFFICE OF SAMUEL HANNAFORD & SONS ARCHITECTS</p> <p>No. <u>2</u> Amount of Cash <u>\$19,800.00</u> Cincinnati, JUN 30 1920 To <u>The V. & K. Auto Company.</u> We hereby certify that <u>The W. F. Johnston Company</u> is entitled to payment of <u>Nineteen thousand eight hundred</u> DOLLARS, being <u>90</u> per cent. of our estimate on <u>account of general contract for factory #116 Pine St. Cincinnati, Ohio.</u></p> <table border="0"> <tr> <td>Present Estimate</td> <td>22,000.00</td> <td>less 10%</td> <td>Present Cash</td> <td>19,800.00</td> </tr> <tr> <td>Previous Estimate</td> <td>12,200.00</td> <td>less 10%</td> <td>Previous Cash</td> <td>10,980.00</td> </tr> <tr> <td>Total Estimate</td> <td>34,200.00</td> <td>less 10%</td> <td>Total Cash</td> <td>30,780.00</td> </tr> </table> <p style="text-align: right;">(Model Filled Out) Architects</p>	Present Estimate	22,000.00	less 10%	Present Cash	19,800.00	Previous Estimate	12,200.00	less 10%	Previous Cash	10,980.00	Total Estimate	34,200.00	less 10%	Total Cash	30,780.00
Present Estimate	22,000.00	less 10%	Present Cash	19,800.00																											
Previous Estimate	12,200.00	less 10%	Previous Cash	10,980.00																											
Total Estimate	34,200.00	less 10%	Total Cash	30,780.00																											
Present Estimate	22,000.00	less 10%	Present Cash	19,800.00																											
Previous Estimate	12,200.00	less 10%	Previous Cash	10,980.00																											
Total Estimate	34,200.00	less 10%	Total Cash	30,780.00																											

Stenographer's note books, when filled, are filed away chronologically.

STANDARD FORMS:

It is desirable that every office have a complete set of Standard Forms, including large and small size Envelopes and Letterheads, Contracts, Bonds, Superintendent's Reports, Time Cards, Extra Orders, Certificates, etc. By standardizing the various forms it eliminates the necessity of working out something new every time an order is given for printing. The following forms are shown: No. 1, Drawing & Specification Record Book; No. 2, Certificate for Payment; No. 3, Superintendent's Report; No. 4, Extra Order.

ACCOUNTING SYSTEM.

This department keeps a record of all contracts for the various building operations and all firm financial books.

Samuel Hannaford & Sons
Architects
Hulbert Block, Cincinnati, Ohio

Report on The V. & K. Auto Co's. new Factory
For week ending May 22, 1920. Wm. D. Lingler
Superintendent

Excavators have been removing dirt from the premises.
Plumbers are running in drain and water lines from street.
Concrete footings have been poured and carpenters are erecting form work for the super structure.
Bricklayer is delivering brick on the premises.
Weather- Monday, Tuesday and Wednesday clear, Thursday, Friday and Saturday cold and rainy.

Respectfully,
(Signature)

Form #3.

the index, with the page number for ready reference. Just below the double line insert the following:

- Cubic contents of building.
- Cost of building complete.
- Cost of building without mechanical equipment, fixtures, etc.
- Cost per cubic foot complete.
- Cost per cubic foot without mechanical equipment, fixtures, etc.

The above figures cannot be finally determined until the building is completed.

Dropping down at least two lines we insert the contract, as follows:

Beginning on the left hand side of the page, place the date, the contract, the name of contractor, and in the ruled column the amount of contract. The second ruled column is used for the page number in the Contract Ledger. Where a contract is small and only one or two payments will likely be made before it is completed entries of payment are placed in this space. In the case of a large contract, where many payments will be made before the work is completed, it is transferred to the Contract Ledger.

The Contract Ledger page, as you will note, is constructed with the standard ruling. The name of the owner and the name of the contractor are written at the top of the page. On the credit or right side of the page is written the date, contract and amount. The left side of the page is for the purpose of entering payments. This system of keeping contract records is very simple, and at the same time efficient, no matter how large the operation.

THE AMERICAN ARCHITECT

Factory for The V. & K. Auto Company.		#116 - Pine Street - Cincinnati, Ohio.	
1920	Total Cost of Building		
	Total Cubic Contents	601520 cu. ft.	
	Cost	cts. per cubic foot complete	
	Cost	cts. " " " without equipment, etc.	
			Form #5.
Apr 28	General Contract - Including		
	{ Excavation, Concrete, Cement Brickwork Iron & Steel Work Carpenter Work Painting & Glazing	The W. F. Johnston Co.	127700 - 518
		Plumbing Cincinnati Plumbing Co.	5620 - 518
	Electric Work	Wess Electric Co.	4220 - <small>Pat. 5-30-20 #80000</small>
	Steam Heating	Jones Heating Co.	8640 -
May 12	Extra Order #1 - See below.		
	{ 50 cu. yds. conc. - 100.00 40 " " conc. - 80.00 900.00	The W. F. Johnston Co.	900 - 518

The V. & K. Auto Company and The W. F. Johnston Co.		1920	
May 30	Cash Voucher	10980 -	Apr 28 General Contract ³⁶⁰ 127700 -
June 30	" "	19800 -	May 12 Extra Order #1 900 -

The V & K. Auto Company and Cincinnati Plumbing Co.		1920	
			Apr 28 Plumbing ³⁶⁰ 5620 -

FORMS 5 AND 6, ACCOUNTING SYSTEMS FOR AN ARCHITECT'S OFFICE

THE AMERICAN ARCHITECT

SAMUEL HANNAFORD & SONS
CINCINNATI ARCHITECTS OHIO

FORM NO. 2
REV. 1920

DATE May 12th, 1920 ORDER NO. 1
OWNER The V. & K. Auto Company LOCATION 416 Pine Street
CONTRACTOR The W. F. Johnston Company

MADE FOR FOLLOWING PURPOSES BY THE BOARD FOR THE ORDER CREDIT OR NO CHARGE THEREOF TO BE NOTED
THIS ORDER SHALL IN NO WISE AFFECT THE ORIGINAL CONTRACT BE IN TIME OF COMPLETION

ITEMS	AMOUNT
SUBJECT - General Contract.	
To 50 cubic yards extra excavation @ 2.00	100 00
To 40 " " " concrete @ 20.00	800 00
TOTAL CHARGE	900 00

(These are written in triplicate)

Form
#4.

APPROVED: The W. F. Johnston Co. CONTRACTOR DATE 5/30/20
The V. & K. Auto Company OWNER DATE June 30-1920
 (Signature) ARCHITECTS

TO OWNER, IF THIS ORDER IS APPROVED PLEASE SIGN ALL COPIES. RETURN WHITE AND PINK COPIES AND RETAIN YELLOW ONE FOR YOUR FILE. IF NOT APPROVED RETURN ALL COPIES WITH INSTRUCTIONS.

Omissions and credits are entered with red ink. Entries of payments to these books are made from the certificate stubs in certificate book (see Form No. 2).

(To be Continued)

Outlook for Building

There will be no substantial relief from the housing and renting crisis from which New York suffers for at least two years yet, while the building shortage in the city cannot be fully made up until 1927, according to a booklet just issued by the New Business Department of the American Trust Company, Broadway and Cedar street.

This booklet, which was prepared by W. Burke Harmon, real estate expert, consists of a careful study of the housing situation, as indicated by past records, from 1914 to date, and as forecasted by probable developments from now until 1928.

The shortage in housing at the end of each year, measured by the gradually depreciating dollar, has been studied and conclusions reached that the present housing shortage is \$660,000,000, and that the maximum will be reached in 1923, with a deficit of \$960,000,000, whereupon the shortage will gradu-

ally begin to decrease and will continue to decrease until the normal condition is resumed in 1927.

Figured from the point of view of its purchasing power as measured by cubic feet of construction, the value of the dollar, assumed to be normal in 1914, is now reduced to 50 cents, and Mr. Harmon concludes that the dollar will begin to increase in its purchasing power in 1922, or, in other words, construction prices will begin to fall materially next year.

Building Progress in New York

The report of the Manhattan Bureau of Buildings for the six months ending June 30, as compiled by Superintendent Rudolph P. Miller, shows that plans were filed for the construction of 434 new buildings costing a total of \$67,382,458, as against 182, costing \$24,034,468 during the same period last year. Plans were filed for ten dwellings, fifteen tenements, two hotels, twenty-eight store and loft buildings, forty-eight office buildings, sixteen factories and workshops, three schoolhouses, one church, one municipal building, eleven places of amusement, six hospitals, 269 stables and garages and twenty-four other structures.

The report also shows that applications were made for alterations to 2,395 buildings, at an estimated cost of \$23,704,908, for the first six months this year, as against 1,825 alteration plans costing \$11,192,156, during the same period last year.

For the month of June the report shows that plans were filed for the construction of 104 new buildings costing \$8,447,500, as against forty-two buildings, costing \$10,700,286, for the same month in 1919.

Colossal Statue Completed

Lorado Taft's "Fountain of Time," the largest piece of sculpture in Chicago, has been completed and set up in Washington Park fronting the Midway. It is now in plaster, done at a cost of \$50,000. If it meets with approval and it is decided to give it permanent form in bronze its further cost will be around \$250,000.

Mr. Taft, who is one of the best known sculptors in the west, began working on his monumental work in 1913. He was commissioned by the B. E. Ferguson Fund, of which the Art Institute is the trustee, and which has already given several notable pieces of sculpture to the city.

The group depicts Father Time, a colossal statue, watching the procession of humanity file by.

Architectural Quicksands

Part II

By CLINTON H. BLAKE, JR., of the *New York and Federal Bars*

IT must be remembered that from the point of view of the client the building of a house is primarily a business undertaking, and his relations with the contractor and architect alike are business relations purely. He employs the architect, it is true, as an expert trained to give him both a pleasing result and a house suited to his particular requirements, but he nevertheless regards, and quite properly regards, his relations with the architect as business relations in the sense that the professional relationship involved is upon an ordinary business basis. The client does not resent, and rather welcomes, the desire of the contractor to have everything clearly understood before the work is undertaken, and there is every reason why he should welcome a similar attitude and desire on the part of his architect. If a customer desires to buy some commercial product, he will wish to know the terms upon which it will be sold; if he desires a portrait painted, he will wish to know how much the artist will charge for painting it. So, if a client desires to have plans prepared for a country home and to have the erection of the house superintended by a trained architect, there is every reason in common sense why he should prefer to know the basis upon which the architect will charge and the other terms and conditions, both as respects the rights of the architect and his own rights, upon which the work will be undertaken and carried to completion. I am glad to say that there has recently been evident an increasing and very gratifying tendency on the part of architects to appreciate the fact that this is so and to exercise a much greater degree of care in arriving at a fair and full understanding before undertaking the work.

The Contract Between Client and Architect

ONE of my clients has adopted a rather ingenious compromise, which, while not as effective as the making of a proper contract with the client, is nevertheless interesting. He has printed a small and rather informal-appearing schedule of his charges in general terms based largely upon the schedule of charges of the American Institute and of the New York Chapter, and headed, "Practice and Charges of (name of the architect)." When a client calls and asks him to undertake a new piece of work he hands him, in the course of the dis-

cussion, one of these schedules. He does not ask the client to sign any agreement or sign or initial the schedule, and does not lay any particular stress on the schedule. He says simply enough to indicate that this is the basis on which his work is done.

This procedure is frankly a compromise between the alternative on the one hand of not mentioning the matter of charges and the other terms upon which the work is undertaken and trusting to secure payment of the reasonable value of the work done in due course, and the alternative, on the other hand, of asking the client to sign a formal agreement specifying the exact terms upon which the work is undertaken, and the rights and liabilities of the architect and the client in connection therewith. The best that can be said of it is that it is a vast improvement on the custom of most architects of saying nothing, and that in the case of a dispute it enables the architect to urge, with a fair chance of success, that the client was put "on notice" as to the terms upon which the work was to be carried out.

In a number of cases which have arisen, I have brought suit for this particular architect successfully on the theory that there was a definite contract between the client and himself to the effect that the work would be done and paid for under the conditions and at the rates specified in the schedule which he handed to the client. This is on the theory that the client, in going ahead with the work, after having been given a copy of the schedule and told that it represented the charges and terms of the architect, must be deemed legally to have agreed that the work should be done and paid for accordingly. This is treading upon very treacherous ground, however, and I am never very happy in these particular cases until the court or the jury has finally determined that a contract really did exist and that the terms of the contract are the terms which are stated in the memorandum. Testimony by the client or in his behalf that the memorandum was brought to his attention in a casual way only, or that it was not made clear to him that it was to control the particular job in which he was interested, or that verbal modifications of the terms stated in it were agreed upon, might well upset the whole contract theory and rob the schedule of much, if not all, of its effect.

In such event the architect would not be able to sue upon the theory of an express contract, but

THE AMERICAN ARCHITECT

would have to depend for his recovery and for the enforcement of his rights upon the theory of what the lawyer calls a "quantum meruit." Translated into everyday English this means upon an implied agreement by the client to pay the reasonable value of the work done. When this is the case entirely new elements are introduced into the situation. The architect can not go into court and show that the client promised to pay him a definite sum and recover that sum accordingly. He must, on the contrary, bring in expert testimony—in addition to his own—to prove to the satisfaction of the court and jury the reasonable value of the services performed by the architect. The client can then introduce, on his part, testimony to show that the work was not of the value claimed, and that the experts who have testified for the architect have placed upon it too high a valuation. Thus, an entirely unnecessary issue is at once presented for the consideration of the jury, and the old condition of opposing experts testifying, some for the plaintiff and some for the defendant, is again presented. The result will probably be a compromise verdict at the best.

It needs no elaborate argument to show that a litigant who can present a definite contract signed by the man whom he sues is in a much stronger and more advantageous position than the claimant who comes into court without any such basis for his suit. Where a contract is made the defendant cannot avoid the issue by contending that the terms embodied in the agreement were not the terms upon which the work was done, because the court will not allow the terms of a written agreement to be varied or changed by an alleged verbal understanding inconsistent with them. Again, the client will not be allowed to attempt to show that the consideration to be paid the architect, as stated in the contract, is more than the work is worth, because, having agreed in writing to the specific amount, the court will hold that he is bound by the agreement which he has deliberately made. Proof of the written agreement and of the proper performance of the work contemplated by it will be enough. No expert testimony will be required as to the value of the work, and the jury, having the definite writing before it, will usually find a verdict for the full amount agreed upon.

The Danger of Any Representations or Guarantees with Respect to Cost

THE sum to be paid to the architect for his services is only one of the items which should be clearly understood and agreed upon. In many ways, it is of less importance than other points, such as the right of the architect to make necessary modifications, to authorize extras, the fact that the archi-

tect does not guarantee that the work can be done for any specified amount, the ownership of the plans and similar provisions.

If the amount due for services be the only issue, the architect may at the worst lose a portion of the gain which he anticipated would accrue to him from a particular job, and find that he has given his time for nothing or for less than he should receive for it. If, on the other hand, the client comes in with a claim against the architect based, for instance, on the allegation that the architect has represented and guaranteed that the work can be done for a definite amount, whereas in fact the cost of the work has been vastly more than the limit set by the architect, the latter is not only faced with the danger of losing his fee, but is quite likely to be called upon to pay the difference between the estimated cost and the actual cost. It is to prevent just such a claim as this, and to anticipate and make impossible misunderstandings and claims against the architect on many other points which I propose to note that the contract between the client and the architect is designed. The contract, if properly drawn, will take care of all of the danger spots in the ordinary relationship of client and architect.

For some years I have made notes of the danger points in the relations of client and architect from the point of view of the architect especially, and in getting out drafts of agreements governing the relationships of the two I have had in mind these very points. In asking me to write these articles, the editors of THE AMERICAN ARCHITECT believed that it would be of interest if I were among other things to point out the more important of these dangers and show how they can be guarded against and how a comparatively simple contract between architect and owner will remove the dangers and prevent unnecessary litigation and loss to the architect.

The matter of an alleged or impleaded guarantee by the architect, to which I have already referred, is very seldom considered by architects in their dealings with their clients, and yet among the earliest legal decisions are cases holding the architect liable on the theory of a guarantee of price on his part. This naturally comes about because one of the primary considerations with the ordinary client is that of expense and the cost of the work. This being so, at the first interview or interviews with the architect it is inevitable that such a client will ask the architect to tell him for how much the work can be done. This is the danger point. If the architect replies that he believes it can be done for a certain amount, but that he can manifestly only guess and give to the client his best judgment, and if he makes it clear that he does not in any way

THE AMERICAN ARCHITECT

guarantee that it can be done for the amount which he names the danger point is successfully passed and there will be no "come-back" against the architect. If, on the other hand, the architect, either in his natural desire to secure a lucrative or interesting piece of work, or thoughtlessly and with the best of intentions and desire to help the client and being convinced in his own mind of the accuracy of his judgment, states that the work can be done for a definite amount it is quite possible that he will so phrase his statement that the court will construe it to be a guarantee on his part that the work will be done for this amount, or, at the least, a representation by him made to induce the client to proceed with the work and binding upon him in the event that the client does so in reliance upon it. The written contract contains a clause providing specifically that any statements made by the architect regarding cost are not to be construed in any way as representations or as guarantees, but that, on the contrary, they are merely statements made by the architect and expressive of his belief; that they are made solely for the information of the client and that the architect is not to be held liable in any way on the theory of guarantee or otherwise in the event that the cost exceeds the amount estimated by him. This is a perfectly fair provision, and is so worded in the contract that no fair-minded client can well take exception to it. It effectually prevents, however, any danger of loss to the architect on this point, and at the same time is helpful to the client in that the architect being thus protected is willing to express himself with much more freedom than he would if he had in mind the necessity of making guarded estimates in the absence of such a contract provision. The client in consequence receives the benefit of estimates which the architect might ordinarily be unwilling to make.

Do Not Act as the Contractor

THERE is a somewhat similar but a less common danger in which the architect may become involved, namely, that he may, if his statements to the client regarding the cost of the building are phrased loosely, be held to have assumed himself the relationship and obligations of a contractor. This is not at all a fanciful danger, and is one which, if it come to pass, is calculated to place the architect in a distinctly unpleasant position.

It is but a few months ago that a well-known New York architect consulted me in a case where, innocently and without any intention on his part of assuming any obligations as contractor, he had become involved in this very particular. It all came about because the architect had written a few letters, the legal effect of which he did not consider, and

which he quite naturally regarded as merely routine letters incident to the work proposed. A client had come to him with some tentative plans for the alteration of an existing building. After examining them, he had advised that certain changes be made which would improve the general lay-out and scope of the work. The client, as usual, wished to know how much the work would cost. The architect promptly sat down, and, in blissful ignorance of the legal effect of his phraseology, wrote a letter by which he meant to state merely the amount which he estimated would be involved, but which, as a matter of fact, was so worded as to give some ground for a claim by the client that the architect had offered, as contractor, to do the work for the sum which he mentioned in the letter.

The plan which had really been contemplated was that the client should place the monies necessary to cover expenses in the hands of the architect from time to time as the work progressed; that the architect should attend to the employment of the contractors to do the work and should make payment to them, *for the account of the client*, from the monies so received, and for his services should receive merely a stated architect's commission. This would have been all very well if the architect had covered himself by a proper letter or contract, but the situation was aggravated by the fact that in addition to writing the client as he did he did not make clear to the contractors the fact that he was employing them in behalf of the client, but carried on his correspondence with them and requested and accepted their bids, in many instances, in his own name. The client almost from the first made changes, some minor and some radical, in the proposed plans and work, and the cost of the work naturally began to run far beyond the figure originally contemplated. The client, as is sometimes the case, did not understand why making changes in the middle of the work—taking out a staircase here and putting it in there, changing a swell-front to a square-front and vice versa and the like—should affect the cost as it did. The inevitable result was that disagreements arose between the client and the architect, and the client, seeking legal advice, was advised to hold the architect responsible as the contractor for the work on the theory that the architect had assumed this obligation, and that the contractors whom the architect had employed were really sub-contractors of the general contractor, the architect.

The situation was further aggravated by the fact that many of these same so-called sub-contractors, not receiving the amounts due them because the client refused to advance further monies, manifested a determination to hold the architect responsible as the principal with whom they had dealt. The archi-

THE AMERICAN ARCHITECT

tect, accordingly, was faced with the danger of losing his fee and of being held responsible as contractor for the performance of the work at a price far below the actual cost. All this was manifestly unfair to the architect, as he had undertaken the work in the best of faith and had suggested that he let the contracts to the contractors and attend to the payments for the purpose of saving money for the client. The client did not appreciate this, or if he did appreciate it was not inclined to "play the game," and, as a result, we had real difficulty in working out the situation in such a way as to safeguard the architect and extricate him from the position in which he had placed himself. If he had, in the first

instance, drawn up some simple contract with the client the danger would never have arisen, as it would have been made clear at once by the contract that the architect was assuming merely the ordinary obligations of an architect, and was acting as the agent of the client in arranging for the carrying out of the work by the contractors. If the architect had at that time had at his office a form of contract such as that to which I have referred he would have had no difficulty in securing the signature of the client, the work would have been completed without loss to the architect, and in all probability the client would have remained satisfied.

(To be continued)

The Hartford Times Building

DONN BARBER, *Architect*

IT has become customary nowadays to use a thing once, then throw it away; but in the older order, when there was a more profound respect for material (and perhaps more difficulty in getting it than we are even at the moment encountering) it was quite general for the treasures of demolished buildings to become reintegrated in the new.

The Madison Square Presbyterian Church was not only epoch making in its architectural design, "a protest," as Stanford White, the architect, said, "against the prevalent idea that to be church-like a building must be in mediaval style," but it was also the first instance in this country where glazed tile was used throughout the architectural members in a carefully executed color-scheme. Through a cooperation between the manufacturers and the architect this tile was especially made to harmonize with the pale green columns of polished granite in the presentation of a jewel of architecture.

It happened at the time this church was being torn down that the Hartford Times was planning a building for a conspicuous situation—to fill, in fact, a vista between the Morgan Memorial (built of pink Tennessee Marble) and the new municipal building. It was necessary that the building make some contribution to such an environment.

At first a facade was studied along restrained colonial lines, built of face brick with stone trim; the cost seemed quite out of proportion for the result achieved. It was at this state of affairs that the material to be salvaged from the Madison Square church entered in. In a most entertaining way the

story is told by Mr. Donn Barber, the architect, and published in the Hartford Daily Times, as follows:

"It was a curious and most unusual combination of circumstances that led to the use of the materials in the old Parkhurst church for the principal facade of the new Times building. In contemplating the problem presented for the facade of the new building and its important position and setting at the end of the wide short street between the Morgan Memorial and the municipal building, the matter of style, scale, color and materials became a serious and difficult consideration.

"It so happened that the proposed Times building, being a commercial building in every sense, and being a free standing building with light on all sides admitted of the principal facade being treated more or less independently of the other facades and somewhat in the nature of an architectural screen. The plan, arrangement and access to the building required merely a generous entrance into a public space on the first floor doing business with the public; access to stairways, corridors and to certain private offices. The lighting of these services was easy to arrange; therefore a wide latitude was possible in the selection of the size and character of openings. It was found that all the practical and working end of the building could be placed back of this front line of service and amply lighted through the other three surrounding walls.

"My attention having been called to the fact that the Parkhurst church, with its fine classic portico, was being demolished, I instinctively recalled to mind

THE AMERICAN ARCHITECT

the beautiful colonnades of Europe at the ends of streets and vistas; the Madeleine, Pantheon, and the Chambre des Deputes in Paris, and any number of examples in Italy and elsewhere. To refresh my memory in detail I turned to a photograph of the church and immediately seemed to see a possibility of using the six granite columns and two granite pilasters arranged as the porch motif of five bays on the church, into a colonnade motif of seven bays by bringing the wall pilasters around and out to a line in the plane of the columns; also, with many running feet of cornice and other members encircling the church, the chance of creating a long, flat composition.

"The wonderfully beautiful and picturesque precedents of the buildings of Italy, where the principal facades are treated frankly as such and backed up in many cases by buildings of an entirely different character in design, occurred to me. I went down to the church and satisfied myself that, instead of demolishing the building in the usual way, it was possible, with care, to take it down piece by piece, and number, pack and ship the pieces. I became enthusiastic and entered into negotiations with the contractor, which finally resulted in obtaining the major portion of the exterior materials of the entire church.

"In the design of the new Times facade, the original columns, pilasters and cornices are used; the steps, platforms and base courses all fitted together as they were originally, with the exception of the change in position of the pilasters. In the back wall of the arcade are used all the principal openings in the church facades. The large circular headed windows on the Twenty-fourth street facade have been used to form circular headed entrance doors, and the other windows on the Twenty-fourth street facade and the windows under the columns on the Madison avenue facade, and the two side doors, are also used in the new arrangement in this wall.

As the church was being taken down each piece of terra cotta was numbered according to an arranged scheme and although many of the pieces in the new building find themselves side by side as of old, transpositions have been made necessary in many places. For instance, there existed a certain number of definitely designed breaks and right angle turns in the cornice, so that I was limited in the new composition to these breaks that existed.

"It was also necessary to recombine the materials without any cutting, since that would have destroyed the spacing of the running ornament. It all happened very quickly after the church had been taken down, and the materials carefully packed and shipped, we were left with our numbered diagrams and numbered pieces to work with, inflexible in their sizes and their

sequence, and certain photographs especially taken of what had been existing conditions. It amounted to a cut-up puzzle of a certain picture with the possibility of creating a new picture of the pieces of the old.

"In the new composition the original Corinthian order is changed to Ionic. By the use of an Ionic cap in the order and an added plinth between the column base and pedestal we were enabled to adjust the height of the order to our established required story heights. In comparing a photograph of the old church, now destroyed, with the studies of the new Times building, it is easy to see what materials have been used and in what combinations.

"It has been an inspiration and a most interesting experience to have been able to preserve and use these gorgeous materials, most of which could in all probability not be duplicated at the present time under the conditions obtaining in the material market, and also owing to the tremendously increased cost of building materials. The facade itself having been arranged for, the other problem was that of placing the facade of the Times building in a proper relation of height to the Morgan Memorial and Municipal building.

"There is a slight crown to Atheneus street from Main to Prospect street; the Prospect street end of Atheneum is somewhat lower than the Main street end. There is quite a sudden down hill grade on Prospect street from left to right, looking from Main. I have therefore taken the water table line of the Morgan Memorial and the corresponding water table line of the Municipal building, which are practically at the same level, and carried these lines across the Prospect street front of the Times building, creating a platform or approach on which the arcade motif of the building is placed.

"Curiously enough, it was possible to carry the balustrade motif round on a level of the balustrade motif of the other two buildings. Tile roofs have been added to increase the height of the building. These, with the trees on Prospect street and around the Times building, should add tremendously to the color and framing of the picture. It seemed to me little less than a crime that all the effort, skill, study and craftsmanship of the unique and wonderful materials that went to make up the Parkhurst church should be deliberately thrown to waste.

"I have every hope now that the drawings have all been worked out and details are settled, for success in the scheme and what we are able to accomplish may lead later to the saving of the materials of other distinguished buildings, which, in their turn, may have to be destroyed for the practical and commercial development of our cities."



THE MADISON SQUARE PRESBYTERIAN CHURCH, NEW YORK
STANFORD WHITE, ARCHITECT



THE HARTFORD TIMES BUILDING, HARTFORD, CONNECTICUT
 DONN BARBER, ARCHITECT

St. Paul's Chapel, New York

McBEAN, *Architect*

(See reproduction of the original drawing by O. R. Eggers in this issue)

WHEN, in 1764, this venerable chapel of Trinity Parish was begun, it was placed to face the river whose banks at that time were many hundred feet nearer to the church than they are today. Its eastern end was close to what is now known as Broadway and owing to the pedimented portico that adorns it, is often mistakenly believed to be the front of the church.

One McBean was the architect and it is gleaned from the records of the church that, owing to slow means of transportation of material and a scarcity of competent labor, this chapel was three years under construction. It has been claimed that McBean was at one time a pupil of Gibbs of London and this claim is bolstered by the fact that this church strongly resembles St. Martin's-in-the-Field in London, which was designed by Gibbs. The fact remains that "old St. Paul's," as it is affectionately called by New Yorkers, is one of the most satisfactory examples of our extant Colonial ecclesiastical architecture. It stands in the center of its churchyard on the block bounded by Vesey, Fulton, Broadway and Church streets and is today, as for

more than a century past, a spot hallowed by every association, religious and civic, that is part of the heritage of every New Yorker. Its interior preserves all of the aspects of its English origin even to the three ostrich plumes (the crest of the Prince of Wales) that surmount the canopy over the altar. Here Washington came after his inauguration as President of the United States to attend the solemn service that formed a part of his inauguration ceremony. The pew in which he sat has been kept exactly as it was at that time.

One may judge the influence of the quiet dignity of this church if on any noonday he will visit it. Either within the dimly lighted interior, or the steps of its front or western entrance, or along the pleasant paths of the graveyard, there will be seen many office workers in the neighborhood. Here they daily seek for an all too brief spell the quietness and rest that such a sanctuary will afford.

On the wall of the eastern or Broadway end of the church there is a wall monument placed there as a record to the memory of General Richard Montgomery who lies buried in the churchyard.



BASILICA OF S. EUSTORGIO, MILAN, ITALY



ST. PAUL'S CHAPEL, NEW YORK.
THE AMERICAN ARCHITECT Series of Early American Architecture





Notable Examples of Early American Architecture

THE more nearly we approach to certain ideals in the development of architecture in this country, the more reverently and respectfully do we regard the few remaining examples of the architecture that was created in these United States between the close of the Revolution and the opening of the Civil War. In fact, it may be said that there is a pronounced tendency on the part of many of our most successful architects to hark back to the architecture of the latter years of the eighteenth and the first half of the nineteenth century.

This sentiment is now more prevalent than ever before. Men, who from the theatre of the war in Europe have viewed the awful calamity of devastated areas have seen the architectural masterpieces of the world laid in ruin, have now returned to this country imbued with an increased respect for the tangible evidence of the good in their profession and a strongly marked veneration for that which is left to us in the United States.

It is futile to hope that these may all be saved. The dollar must have its way. Its present impetus would seem to menace many structures whose quiet dignity, good architecture and venerable tradition should be—but are not, it would seem—a valid reason for their preservation. The devastating march of what is called “progress” will slowly but inevitably destroy landmarks that are to architects the very essence of their art, the things that should live forever.

To make a permanent and the best artistic record of at least parts of some of the more meritorious of these early American buildings, THE AMERICAN ARCHITECT has arranged for the presentation of a series of reproductions of drawings the first of which appears in this issue. The selection of subjects has been carefully made and, as delineated by Mr. O. R. Eggers, is of the highest architectural value. When completed these drawings will provide a collection of unusual historical and architectural value and a fund of suggestion of the largest importance.

Office Accounting

THERE is presented in this issue the first of a series on Organization and Accounting Systems for Architects' Offices.

No other artist finds it necessary to maintain an accurate system of accounts. No man engaged in any of the arts handles, as agent for another, such vast sums of money as do architects.

Obviously it is necessary that an accurate record be kept of all these transactions. In fact, success in practice hinges on a satisfactory accounting.

To support the contention that architecture is a business as well as an art, this one thing of accurate system of accounts is alone sufficiently convincing.

Mr. Van Arsdall's long association with one of the largest architectural organizations in the Middle West, qualifies him to authoritatively present his topic. The method outlined is not a theoretical discussion, but the description and various forms presented constitute part of a system that has been in actual use for a long time.

Articles of this sort have a very large practical value. Just at this time while most important building operations are suffering from the influence of the government probably meant to be paternal, but smacking largely of a “step-father” attitude, architects will have time to put their offices in order. Mr. Van Arsdall outlines a safe method of procedure.

The Railway Labor Board Award

HOW are we to find money to pay the award of the Railway Labor Board? Does it mean that further inroads are to be made upon the architect's already meagre portion?

Now comes an award of \$600,000,000 increase in wages to the railway employes of the country—an immense sum of money which must blossom forth from nowhere or be pared off of somebody's portion. Doubtless the \$600,000,000 is going to be added to freight rates and with it a few hundred million more which is necessary for the rehabilitation and development of the railways. And this increase in the cost of delivery of goods is to be

added to the bill the consumer gets, with some slight and commensurate added profit for the tradesman who collects the bill.

Payment in advance for our transportation development seems the only thing to do. There are two alternatives—pay or go without. We may even do both for a while.

The inveterate optimist cannot expect any stimulus to building programs from this one more added burden. And the particularly unfortunate position of the architectural profession is this: That an income already too picayune to be taxed must be further reduced by the retardance of building construction that has long been contemplated and by the abandonment of schemes even less well defined.

It does seem, however, that we are now getting so deep in the mud that we must soon strike rock. More fundamental than the matters of profits and high wages is an actual need for buildings and with it the basic fact that buildings to be built for efficiency must be planned by one who knows his business.

The tone of the newspapers in regard to these matters of wage awards and taxes, is that "the American public which foots all the bills, isn't going to be bled white forever." Most of this bleeding seems to be but a transfusion—a trick to which the professions have not yet caught on. But if they are of this "public which foots all the bills," well, there is just so much blood in a turnip and no more.

Color in the City Streets

IN letters to the editors published in the London architectural press there arises a plaint against innovations that originate mainly in this country. The bulk of this tale of woe seems to consist of objections to tall buildings as destructive of traditions long cherished and which many ultra-conservative men are loath to relinquish. Just now there are published letters both for and against color in street architecture. One man rails at the tendency to introduce multi-colored terra cotta in areas that for centuries have been gloomy through dinginess. Another will loudly acclaim the merits of color that is shown in the smoke and fog stained surface of stone or granite. Still a third holds the stucco facade that has been stained in lighter shades as anathema. "Who shall decide when doctors disagree?"

It would not seem necessary to advance many arguments as to the desirability of color in our city streets, and particularly in a city whose atmospheric conditions are like our own Pittsburgh. The very monotony of brick and stone and mortar in their natural colors breeds morbidity and makes one yearn for the country roadside and the open places. There are no good reasons why all this question of color should not more seriously receive the attention of architects both here and in England. "How use doth breed a habit in a man." How we do go on year after year following in the rut and dead level of monotony.

Here and there in all the cities of this country are to be found men of sufficient originality to attempt an introduction of color in the facade of buildings. The results, while often not satisfactory from an accurate color standpoint, are none the less encouraging indications of a desire to get away from the commonplace. The trouble with the introduction of color is exactly similar to the selection of motives of design in any particular locality. Each architect and his client works independently of his neighbor and the result while taken independently is commendable, is not when grouped as satisfactory.

DOWN in Greenwich Village, in this city, where the conversion of substantial dwellings into two and three room apartments is being carried forward on a large scale, it has been desired to preserve the artistic aspect of this old neighborhood. As a means to such an end, the brick fronts are being covered with colored stucco and the window and door frames given a contrasting color. It is interesting to note how this innovation is alluring tenants and how eagerly these converted structures are sought out and rented at good prices and for long terms. Whole blocks have been transformed from a dreary monotony of red brick, duplicated structures, to broken lines of color that present a pleasing contrast.

In more pretentious buildings of the loft and office types, there has been a tendency towards the introduction of color, but mainly in low tones that do not impress their excellence of effect and which with weathering become uninteresting.

The selection of color of sufficient brilliancy should be easy, and with its more general introduction it is safe to predict the popular verdict will be a strong support of every architect who will essay a venture in the direction of applied color to the exteriors of his buildings.

Criticism and Comment

The Other Side of Billboards

The Editors, THE AMERICAN ARCHITECT:

In connection with the "Other Side" of Billboards appearing in your June 30th number I would suggest to Mr. Oakley, whose presentation of the Other Side you quote, that he discovers all the spots in nature where she is absolutely hideous and by him supposed capable of artistic improvement by spellbinding masterpieces, "the fairy dream-like inspirations of artist's messages" and there erect them that all who run may read how God's works are infinitely inferior.

A further suggestion would be to cover the "frightful piles of stone and iron slung together by contractors" and the "thousands upon thousands of repellent rows of houses" with the powerful ap-

peals of Mr. Oakley's enthusiastic imagination that all their ugliness he alleges may be obliterated in chromatic posters in their "commanding dignity," "force and grandeur."

We have seen the city made hideous with posters—and designed by "master-painters"—and the runner did not stop to read, but fled. It is sad to realize that the impressionist sometimes seems to really believe in his impressions from some erratic or contradicting bent of mentality; hence our asylums for their care.

The influence of the billboard for "better art" and "better life" is to heartily curse the cause that gave it birth as Mr. Pennell does so eloquently.

It is possible Mr. Oakley is a humorist, in which case I apologize for taking him seriously.

New York.

H. EDWARDS-FICKEN

Saving the Surface with Paint and Varnish

The decay of structural materials is rapid. The microscope will record the initial start of such decay even after twenty-four hours' exposure of some building products, states Henry A. Gardner in *The Decorator*, and the naked eye is sufficiently strong to perceive the erosion often evidenced in a few weeks. Those materials that show relatively slow decay almost invariably present at first, or later assume, a gloomy color that is objectionable from several standpoints. It is, therefore, apparent that surface protection through paint or varnish application is quite as important as sound engineering or design.

A microscopic view of even the dressed timber that is used for interior trim in building, for musical instruments and cabinet work, for automobile or yacht construction, will show the deep channel-like grain of the wood fibre. When varnish is applied the pores are filled up and a smooth water repelling, wear-resisting surface results. The beauty of the grain and coloring of the wood is at the same time greatly enhanced.

The printed designs on some types of floor coverings wear off as the result of foot abrasion. The unsightly dark colored base may then be exposed. Occasional coats of varnish prevent this defect. Even high-grade, inlaid linoleum is improved and given greater longevity when varnished. The surfaces of all types of floors or floor coverings may

be beautified and made dirt and water resisting with floor varnishes.

BRICK AND METAL SURFACES:

Building brick may absorb from 10 to 15 per cent. of water. If a brick building should be subjected to constant rain for several days it is conceivable that many tons of water would be absorbed. Dampness might then prevail within the building, and in cold weather the tonnage of coal required to heat the interior would probably be greatly increased. The application of paint to brick fills up the pores and produces a water-resisting film. The use of white or light tinted paints improves the appearance of the structure and gives sufficient light reflection to the airways to repay for the expense of painting.

The almost universal custom of painting the interior brick walls of factories is now being extended to cover the exterior walls as well. Many gloomy appearing brick residences are also being transformed by exterior painting.

Metal surfaces may appear smooth to the naked eye, but under the microscope they often evidence a rough, porous condition. On many metals this condition is responsible for moisture retention and subsequent corrosion. Such metals as iron and steel demand immediate protection to prevent rust accumulation. The loss suffered yearly through ne-

THE AMERICAN ARCHITECT

gléct to keep metal well painted amounts to many millions of dollars.

CEMENT AND WOOD:

Cement or stucco invariably present a rough surface. Water absorption is rapid. Dust and soot accumulation is marked, especially in industrial communities. All these defects may be prevented by paint application. It is safe to state that the value of any cement building may be increased from 10 to 20 per cent. by the use of a pore-filling, water-resisting paint. Dust adherence then becomes minimized. Cement structures are almost invariably painted when appearance is a consideration.

A wood panel one-half of an inch thick, when exposed to moisture, may gain ten ounces per square yard in a week. When exposed to water it may gain 50 ounces. Moisture absorption, checking, fungus growth and fibre abrasion may take place on uncoated wood. When coated with paint, the moisture absorption is reduced to a negligible quantity and the surface is preserved from attack. Wood lasts indefinitely if kept well painted.

Wall paper is fibrous and absorbent. It may retain moisture and dust. Paints are, therefore, generally preferred for wall decoration. On existing papered walls, paints may be applied direct to the paper if desired. A smooth, washable surface of any color may thus be produced.

LIGHTING WITH PAINT:

People are just beginning to appreciate the value of paint from a lighting standpoint. For instance, the now almost universal practice of painting the interior walls and ceilings of factories in order to increase the illumination has developed within a few years. The tremendous savings in electricity or other illuminants, and the increased efficiency of the workers resulting from such practice, have given mill owners an appreciation of paint for this purpose. Discussing these matters in *The Decorator*, Mr. Henry A. Gardner believes a further and even greatly extended use of paint as an illuminant reflector will soon be observed.

In practically every old-style urban railroad terminal, he says, there are immense train sheds which present a neglected and gloomy appearance. Where paint was used a very dark color was generally selected, as paint was looked upon simply as a preservative, and black was the prevailing color of metal preservative paints. In some instances, however, no paint was applied. If such structures should now be painted so as to provide a finishing coat of white or of light tint, the amount of light inside the sheds would be tremendously increased.

Accidents would be prevented and many glaring lights might be done away with. Moreover, the arriving guest would not feel depressed or secure a wrong impression of the community.

While it is appreciated that the smoke from the locomotives would stain white paint, its surface would not become as dark as the uncoated structure. In any event, the lower parts might be washed occasionally. Similarly, in warehouses, freight sheds, wharf houses, interiors of freight cars, vessel holds, etc., the application of light paints to the present uncoated interiors would immensely improve the working conditions.

Very little has so far been done with paint or lighting machinery. For instance, many of the surfaces of the machines in large factories are uncoated. They gradually assume a dark color that gives shadows that may be responsible for many accidents. If the working surfaces of such machines should be painted white, a much greater amount of white light would be obtained. Accidents would thus be minimized and production efficiency increased.

While the use of paint for marking asphalt street for traffic regulation purposes has increased in some cities to quite an extent and has effectually aided in bringing about a more general observance of the rules of traffic, it can readily be seen how much greater should be the extension of this principle. For instance, all stone curbing on dark or poorly lighted streets might be painted white. A decrease in motor accidents would probably result. Along the open highways and boulevards, especially at dangerous corners and along embankments, marking stones and the trunks of trees at well-defined distances on either side, if painted white, would reflect the illumination afforded by headlights and make night driving much safer.

ONE WAY TO CONSERVE FORESTS:

It would be difficult to state how many million telegraph poles line the highways and railroads of America. It is not difficult, however, to show that these poles, under the climatic conditions existing in many sections, do not last indefinitely. Impregnation of the underground part is a practice that is generally adhered to in order to provide protection from underground decay. The upper part, exposed to the air, is seldom surfaced, and the ravages caused by exposure to the air soon become apparent. It is quite fair to state that overground protection, to be had through paint application, is also necessary, especially on all that are squared or otherwise dressed. Such treatment would extend the replacement period and help to conserve forests.

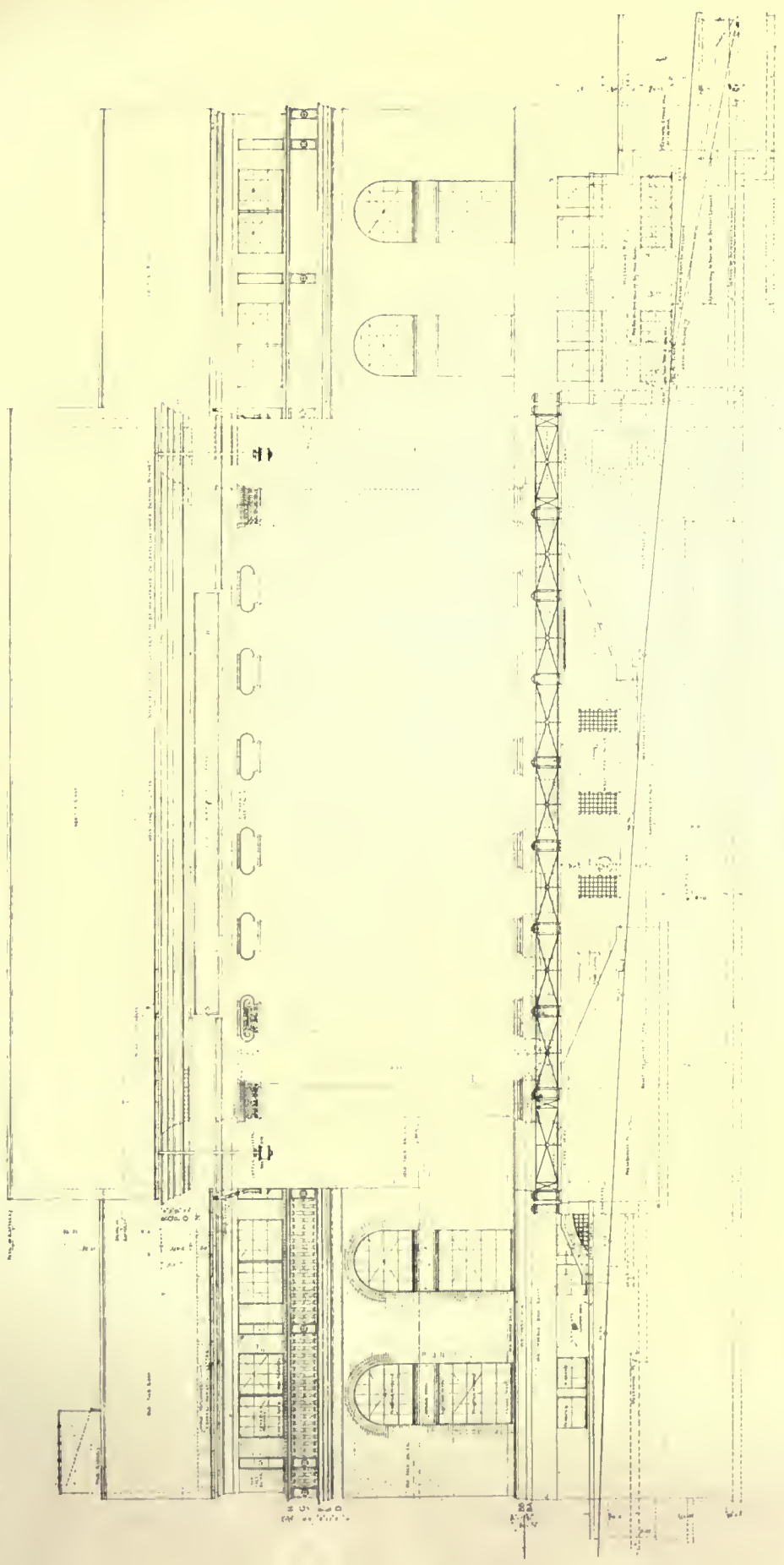

FRONT ELEVATION
THE HARTFORD TIMES BUILDING, HARTFORD, CONNECTICUT
DOXY BARBER, ARCHITECT

14 X -



1422

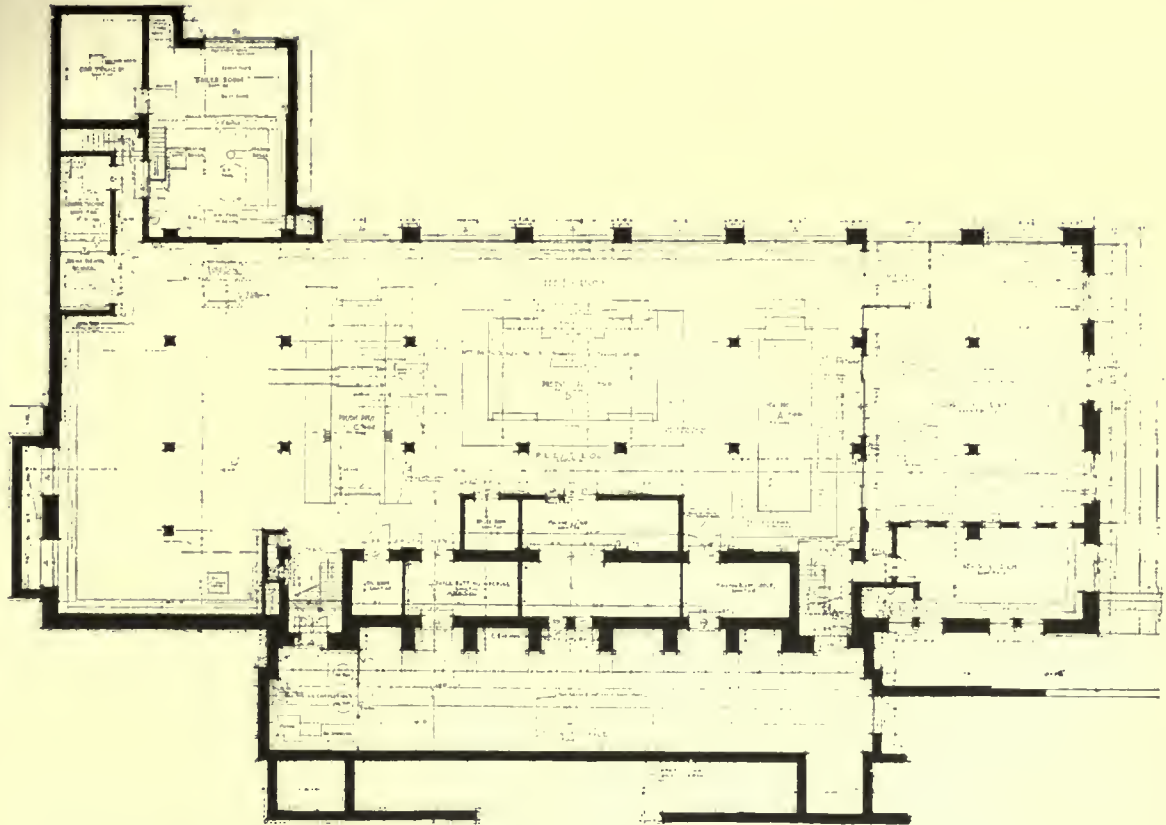

BASEMENT PLAN.

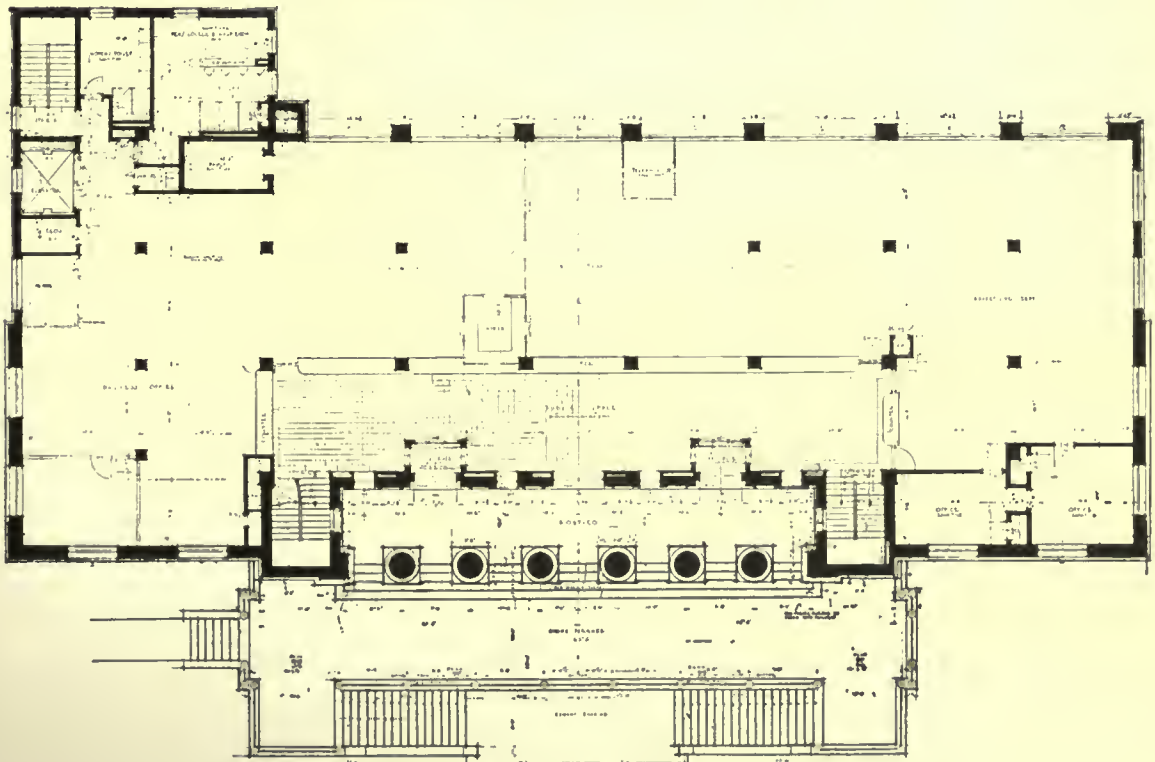

MAIN FLOOR PLAN

HARTFORD TIMES BUILDING, HARTFORD, CONNECTICUT
DONN BARBER, ARCHITECT



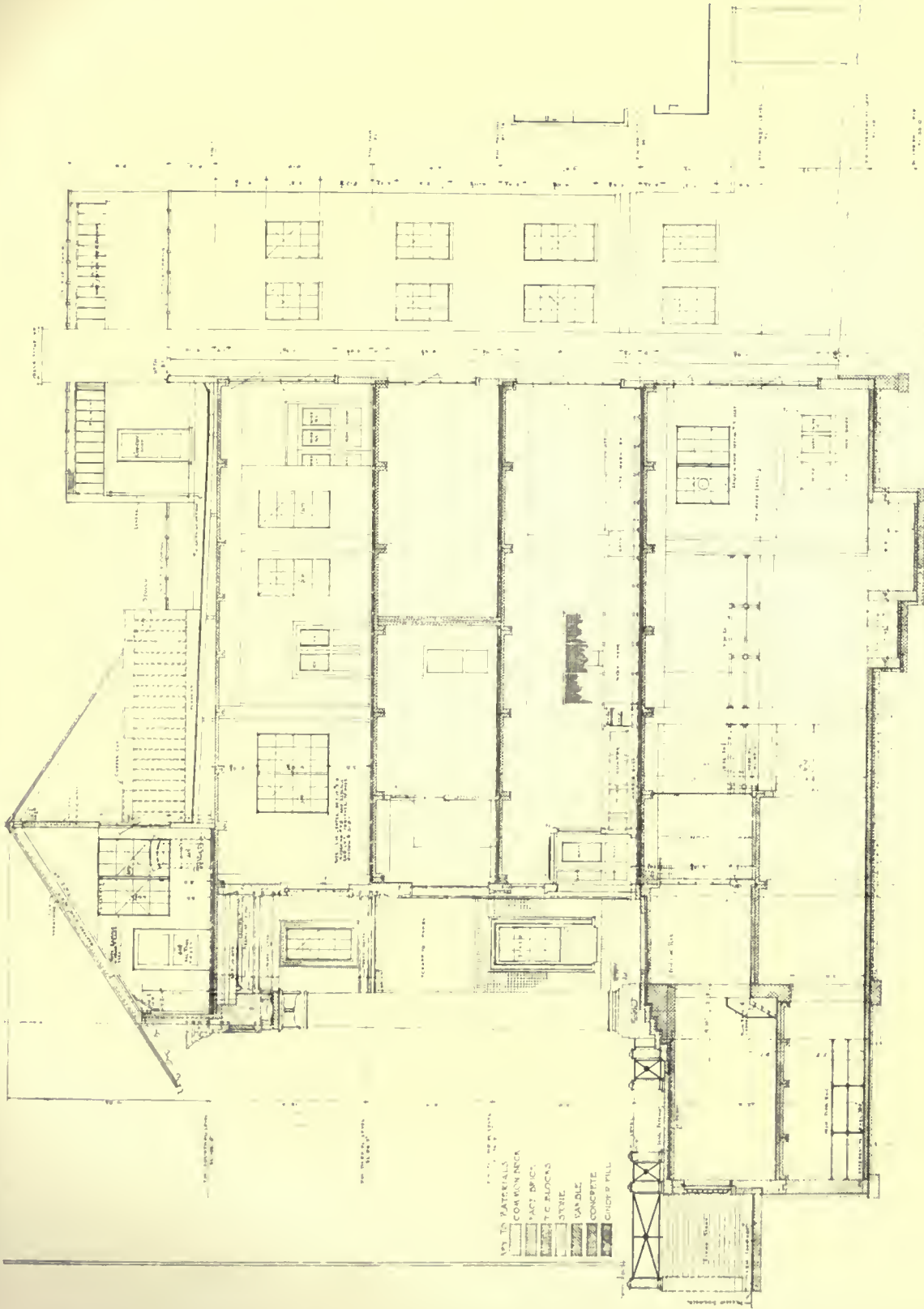

SECTION
HARTFORD TIMES BUILDING, HARTFORD, CONNECTICUT
DONN BARBER, ARCHITECT



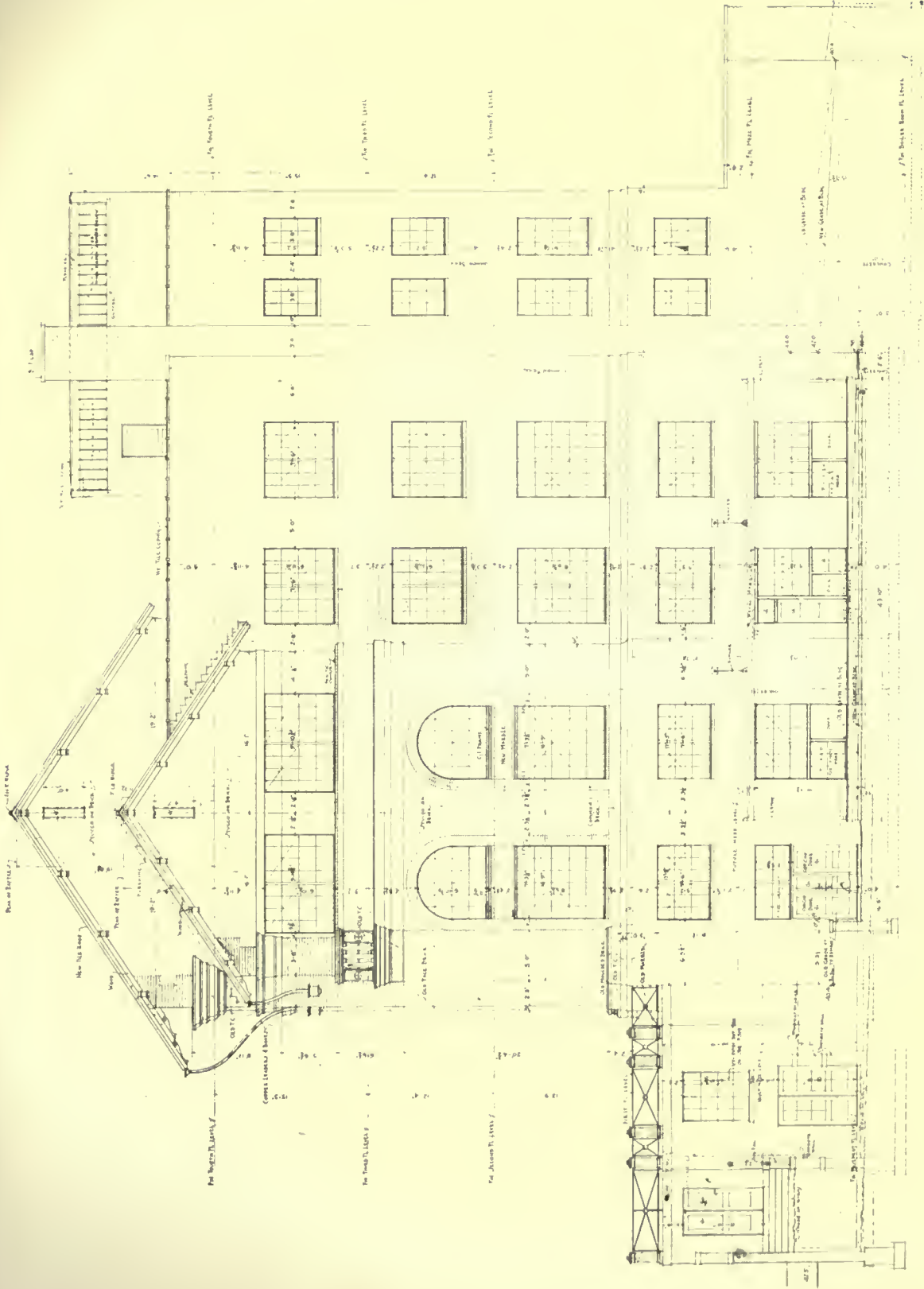

SIDE ELEVATION
 HARTFORD TIMES BUILDING, HARTFORD, CONNECTICUT
 DONN BARBER, ARCHITECT

12-1



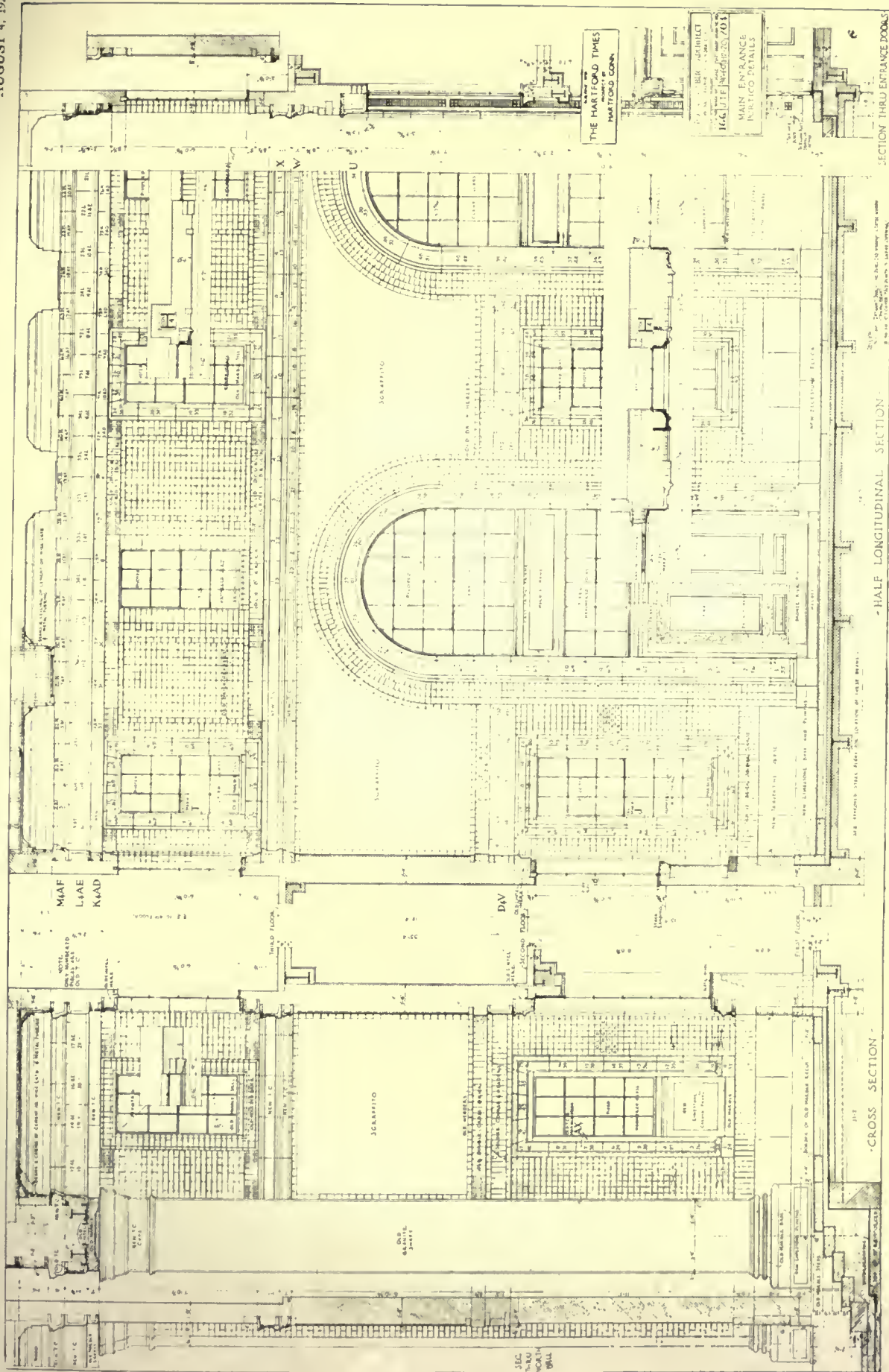

- HALF LONGITUDINAL SECTION -

- CROSS SECTION -

MAIN ENTRANCE PORTICO DETAILS
 Showing the adaptation of materials from the Madison Square Presbyterian Church
 HARTFORD TIMES BUILDING, HARTFORD, CONNECTICUT
 DONN BARBER, ARCHITECT



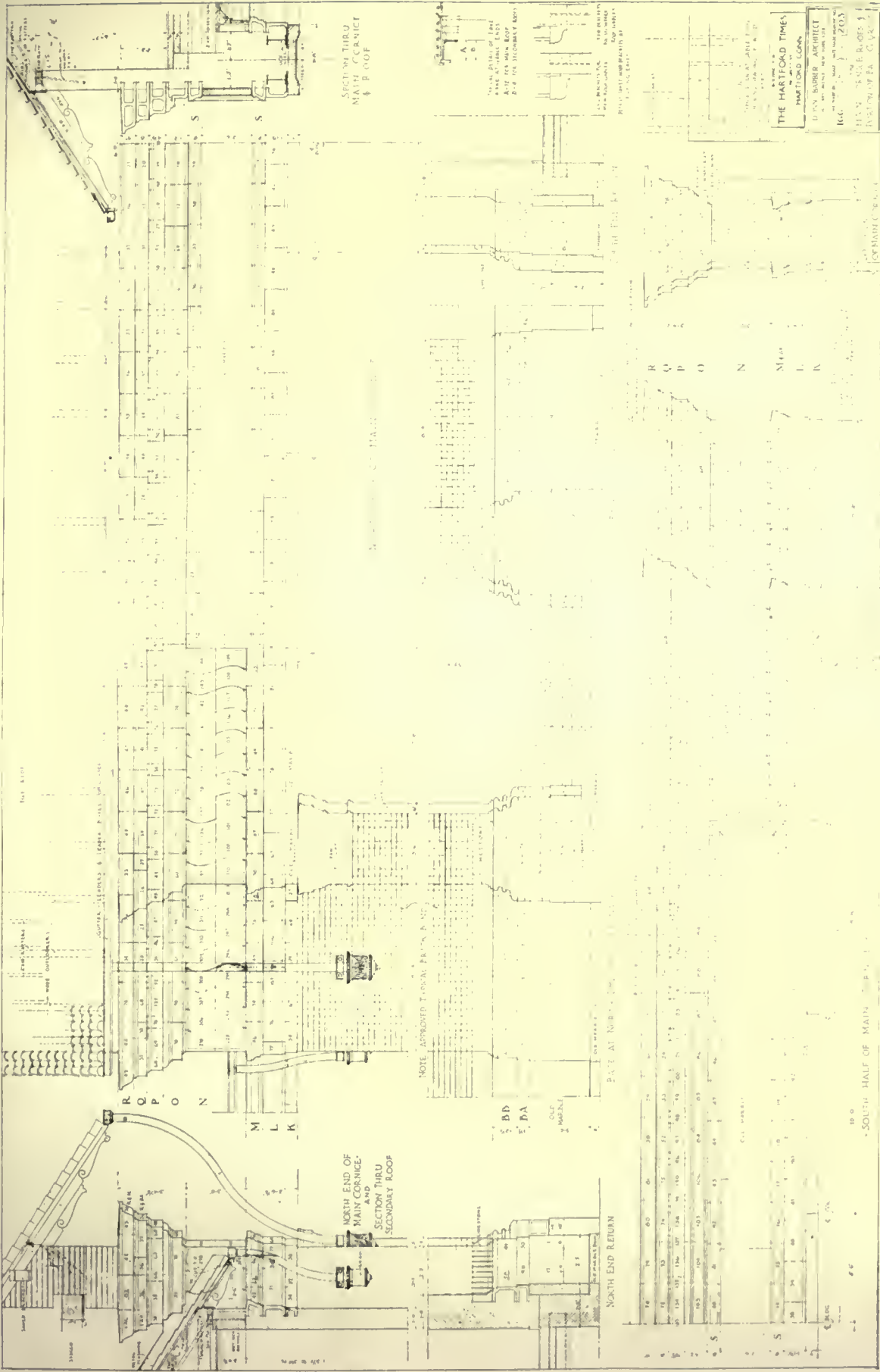

MAIN CORNICE, ROOFS AND PORTION OF BASE COURSES
 Showing adaptation of materials from the Madison Square Presbyterian Church
 HARTFORD TIMES BUILDING, HARTFORD, CONNECTICUT
 DONN BARBER, ARCHITECT

5
98 07



147



D. McLACHLAN, JR.

ATELIER IRONS

PRIZE WINNING DESIGN (1st Medal).

FINAL COMPETITION FOR THIRTEENTH PARIS PRIZE, SOCIETY OF BEAUX ARTS ARCHITECTS.



FINAL COMPETITION FOR THIRTEENTH
PARIS PRIZE, SOCIETY OF BEAUX ARTS
ARCHITECTS

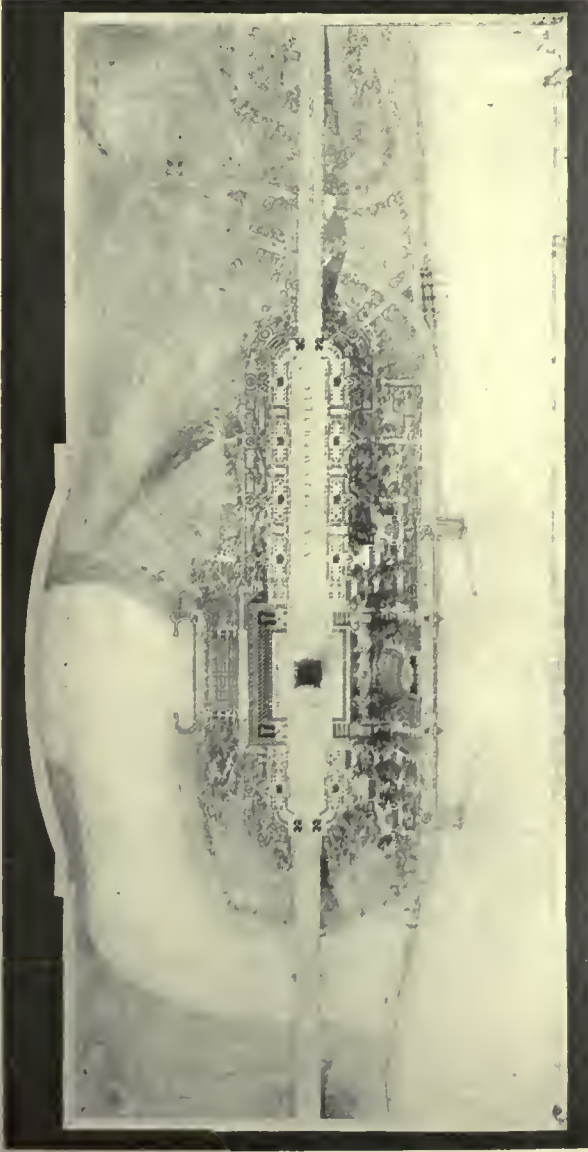

D. McLACHLAN, JR.

PRIZE WINNING DESIGN (1st Medal).

ATELIER HIRONS.

1484

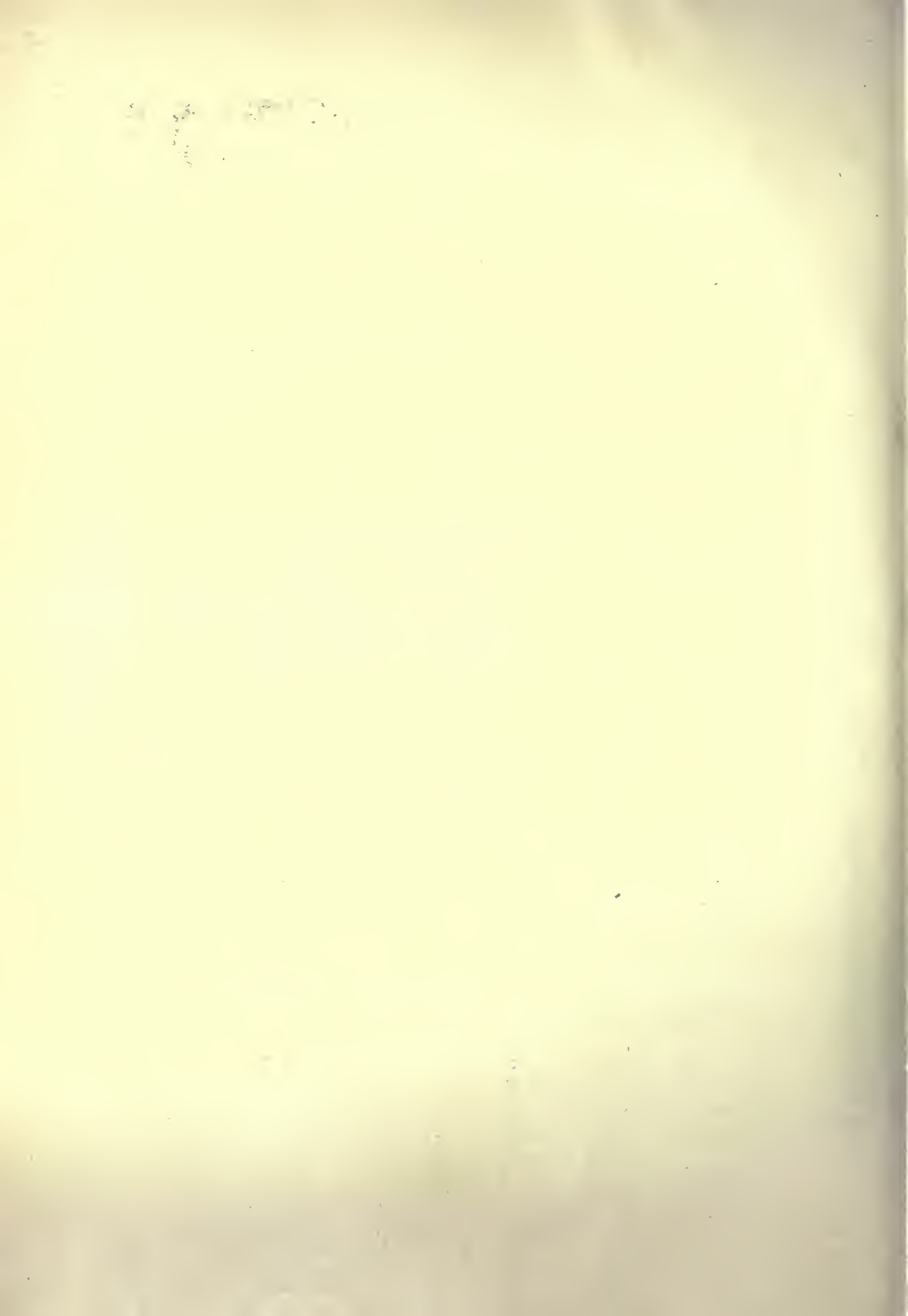

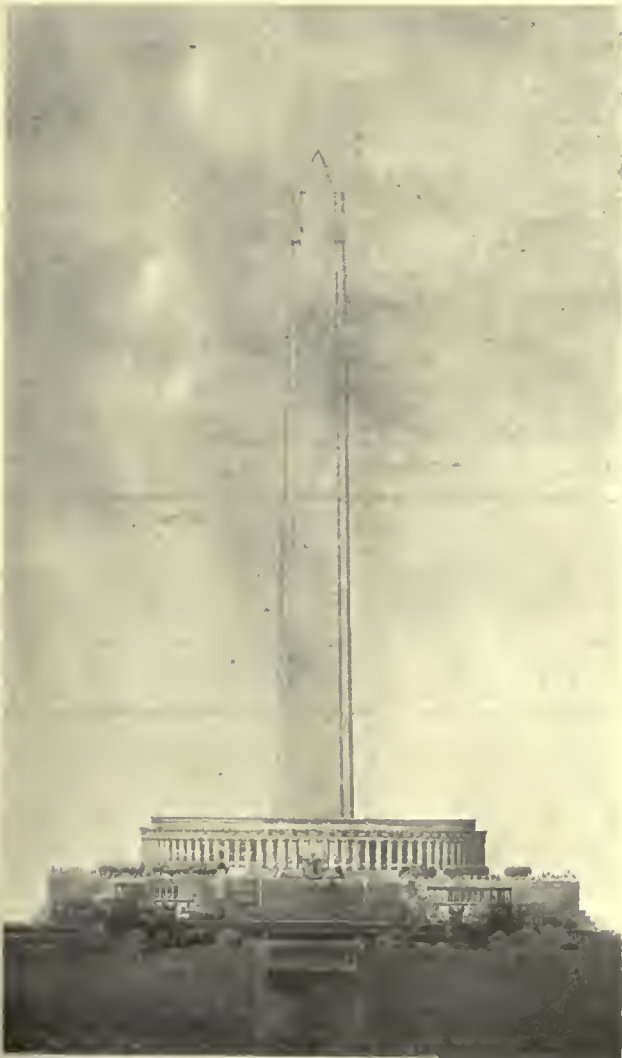

R. S. SIMPSON

CARNEGIE INSTITUTE OF TECHNOLOGY AND
PITTSBURGH ARCHITECTURAL CLUB.

PLACED SECOND (1st Medal).

FINAL COMPETITION FOR THIRTEENTH PARIS PRIZE, SOCIETY OF BEAUX ARTS ARCHITECTS.



10
u

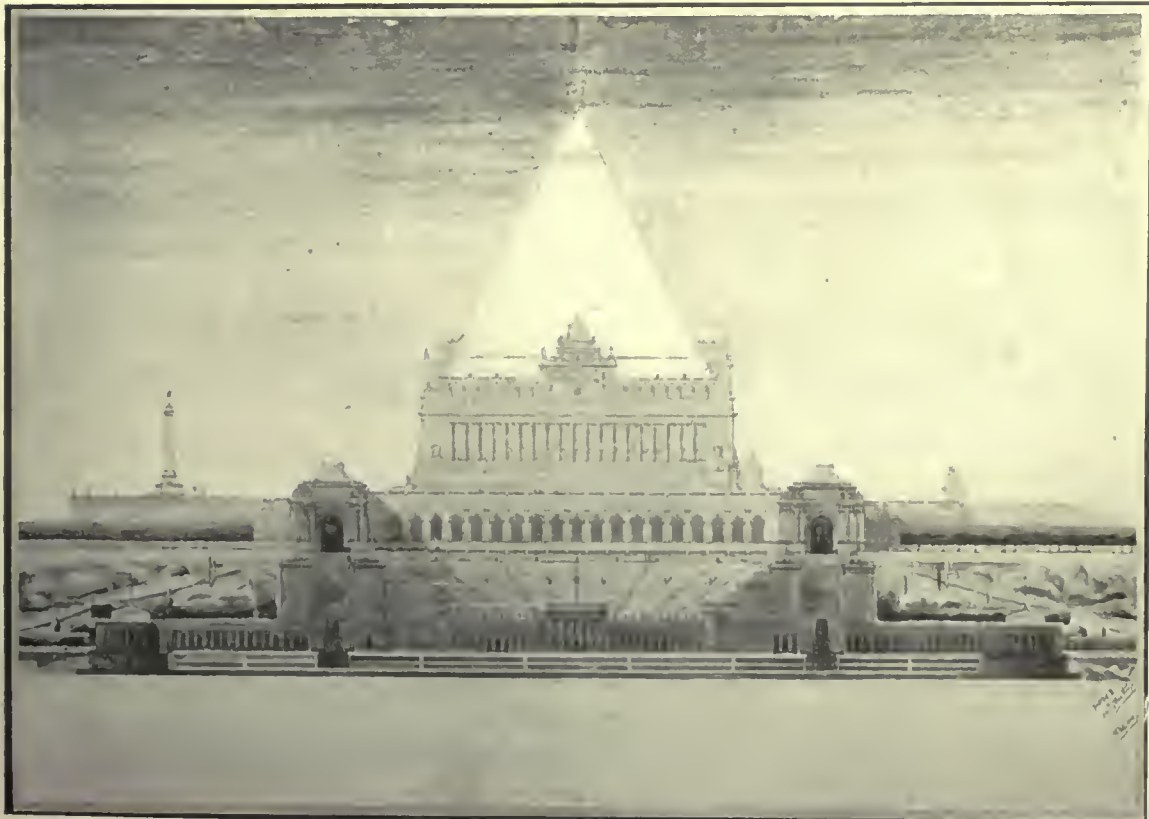
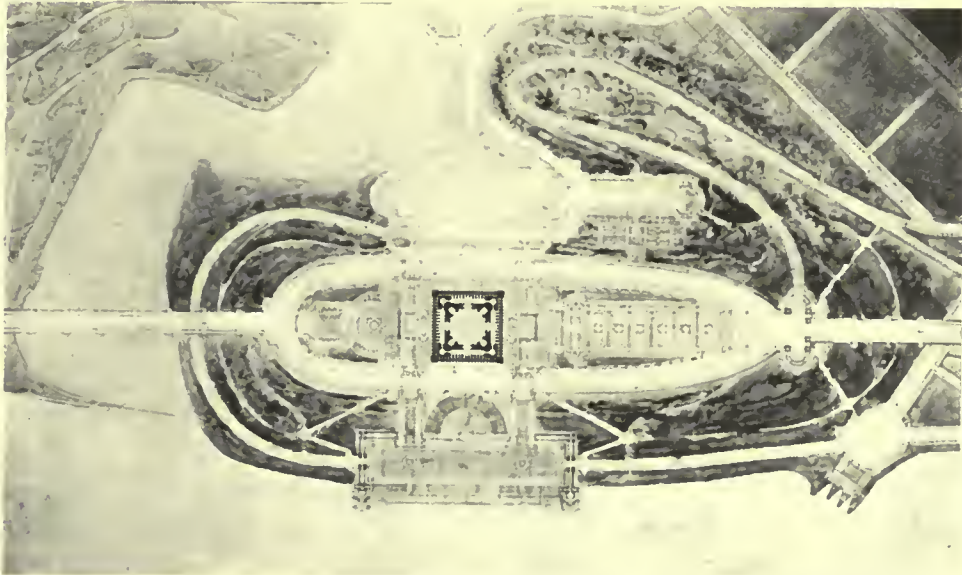
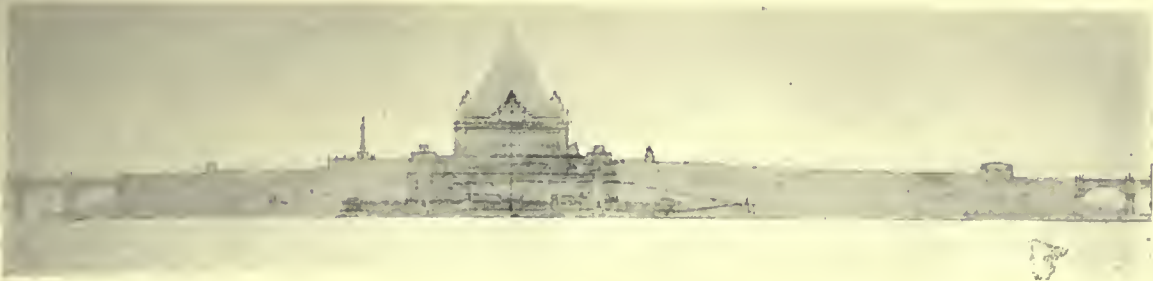

F. A. CHAPMAN

UNIVERSITY OF PENNSYLVANIA AND
SAN FRANCISCO ARCHITECTURAL CLUB.

PLACED THIRD (2d Medal).

FINAL COMPETITION FOR THIRTEENTH PARIS PRIZE, SOCIETY OF BEAUX ARTS ARCHITECTS



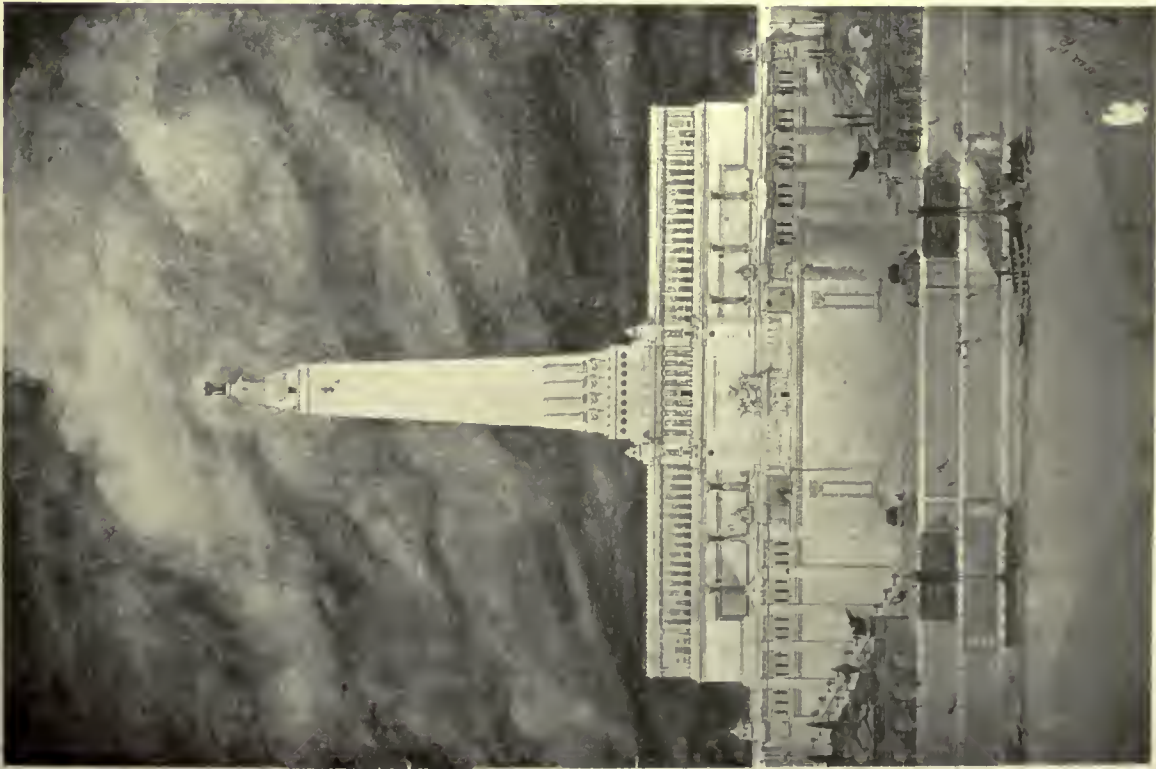

E. R. PURVES

UNIVERSITY OF PENNSYLVANIA
PLACED FOURTH (2d Medal).

FINAL COMPETITION FOR THIRTEENTH PARIS PRIZE, SOCIETY OF BEAUX ARTS ARCHITECTS.



W. F. McCAUGHEY, JR.

UNIVERSITY OF ILLINOIS

PLACED FIFTH (2d Medal).

FINAL COMPETITION FOR THIRTEENTH PARIS PRIZE, SOCIETY OF BEAUX ARTS ARCHITECTS.



Beaux-Arts Institute of Design

DIRECTOR OF THE INSTITUTE, LLOYD WARREN

ARCHITECTURE, WILLIAM F. LAMB

MURAL PAINTING, ERNEST C. PEIXOTTO

SCULPTURE, JOHN GREGORY

INTERIOR DECORATION, ERNEST F. TYLER

Official Notification of Awards— Judgment of July 13th, 1920

FINAL COMPETITION FOR THE 13th PARIS PRIZE
OF THE
SOCIETY OF BEAUX-ARTS ARCHITECTS.

PROGRAM

The Paris Prize Committee proposes as subject of this
Competition:

“THE GREAT WAR MEMORIAL FOR THE CITY OF
NEW YORK.”

FOREWORD:

The program is based on the assumption that the City of New York, Metropolis of the Greatest of Free Governments, fully appreciating its privilege and duty, has, for the purpose of creating an enduring Memorial, supreme in conception and in art, and worthy of the City and occasion, secured a commanding site of ample dimension, aspect and prospect; and has by public subscription and enactment, arranged for the necessary funds for a monumental project of the first importance.

The will of the Citizens has been made certain that as regards the Memorial they are to erect, they desire it to be for all time, an emblem, hallowed to the memory of those who were prepared to, and to those who did, make the Supreme Sacrifice in defense of their country and of

hattan Island, bounded by Dyckman street on the south, the Hudson River on the West, the Spuyten Duyvil Creek on the north and the low-lying land at the base of the cliff on the East. It is a wooded height of rock formation, rising from the river to an extreme height of 230 feet and near the summit is approximately oval. The Western, Northern and Southern sides slope steeply up from the water level, but these may at the option of the competitor be interrupted by a gently sloping shelf constructed at about two-thirds of the way up. The Eastern side, however, is nearly a vertical precipice. North and South of the high ground are valleys running in an East and West direction. Through the North valley a small river flows West into the Hudson; through the South valley Dyckman Street leads to a ferry landing. The far side of these two valleys rise steeply to the level of the shelf above or bridges, over which a Great Highway is to pass at approximately a level of 150 feet above the river.

This highway may be developed at its intersection with the easterly or transverse axis of the general plan, if there be one, into a public place arranged in proper relation to the memorial itself.

The memorial should be situated so as to dominate the site, the river and the surrounding city and country.

No restriction is placed on the treatment of the site as regards public place, ramps, stairways, landing stage on the river front, etc., nor is any one of these mandatory; if, however, any or all are introduced into the project the treatment thereof shall be dignified and in a subordinate relationship to the memorial itself. The highway and viaducts, however, are essential features of the problem.

THE MEMORIAL.

The memorial shall be of stone construction, monumental in design and suitably embellished with sculptural and color decoration used with discretion. It may take



W. F. McCaughey, Jr., University of Illinois
Placed Fifth (2nd Medal)

the rights and decencies of civilization. To this end they have determined that the Memorial shall in its essential particulars be removed as far as possible from any worldly, utilitarian or commercial nature, and that it shall in its conception, design and execution represent the highest idealism.

The site is so large that certain features of a practical nature are necessary, such as viaducts, approaches, convenience and shelter for crowds who will assemble on occasions of National importance to do honor to their dead. The solemn and dignified character of the Memorial must be clearly expressed in the development of the project and it should not be subordinated to other features of the design.

Architecture, Mistress of the Arts, has been called upon to produce the Great Design, and, as in the past, will call to her aid, her Hand Maidens, Sculpture and Painting.

SITE:

The site determined upon is the northerly end of Man-

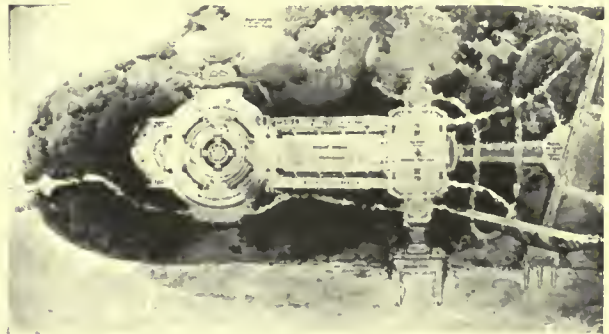

W. F. McCaughey, Jr., University of Illinois
Placed Fifth (2nd Medal)

any form desired by the competitor, such as a cenotaph (an empty tomb or sculptural monument), a memorial temple, shrine, arch, shaft, tower or other composition.

Provision shall be made for memorial ceremonies, tablets, statues and inscriptions, and the memorial shall be set in an entourage of garden or landscape treatment distinguished by dignity of character.

The site is such that the memorial may be placed so as to be visible for many miles up and down the river, and the eastern face of the cliff is visible from the main line

THE AMERICAN ARCHITECT



E. R. PURVES

UNIVERSITY OF PENNSYLVANIA

PLACED FOURTH—(2d Medal)

of the railway and the city beyond the low lying ground which is adjacent to the base of the cliff. This basin or low lying ground may be considered as the subject of a city development into a large recreation park, which, together with the site of the memorial itself, is accessible by electric transportation systems and by harbor vessels of all descriptions. A railway freight line operated electrically passes along the west front of the site about five feet above the water level. This may be diverted, tunneled or concealed behind an embankment, or rendered unobjectionable in such manner as the competitor may devise.

JURY OF AWARDS:

B. W. Morris, P. A. Cusachs, F. A. Godley, H. R. Sedgwick, R. M. Hood, G. A. Licht, L. G. White, H. Bacon, L. Ayers, and R. H. Dana, Jr., chairman.

NUMBER OF DRAWINGS SUBMITTED: Five.

AWARDS:

Paris Prize Winner (1st Medal): D. McLachlan, Jr., Atelier Hiron, New York City.

Placed Second (1st Medal): R. S. Simpson, Carnegie Inst. of Technology and Pittsburgh Archtl. Club, Pittsburgh, Pa.

Placed Third (2d Medal): F. A. Chapman, University of Pennsylvania and San Francisco Archtl. Club, San Francisco, Cal.

Placed Fourth (2d Medal): E. R. Purves, University of Pennsylvania, Philadelphia, Pa.

Placed Fifth (2d Medal): W. F. McCaughey, Jr., University of Illinois, Urbana, Ill.

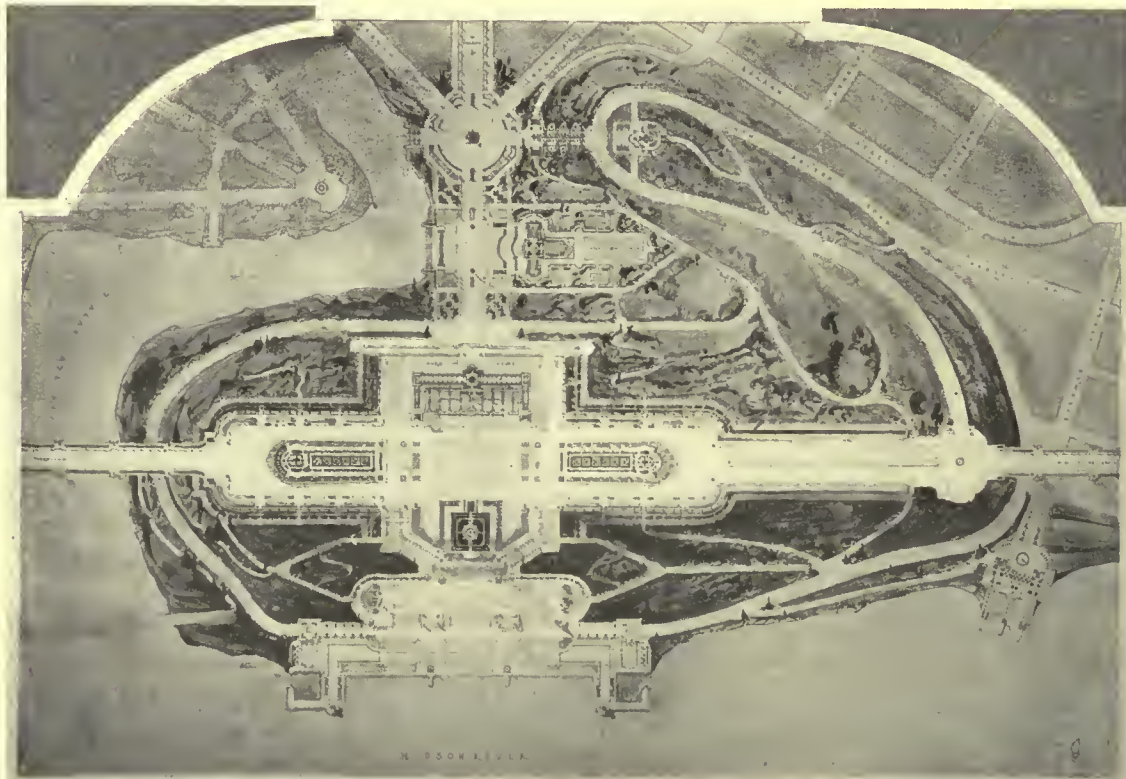

E. R. PURVES

UNIVERSITY OF PENNSYLVANIA

PLACED FOURTH—(2d Medal)

Current News

Happenings and Comments in the Field of Architecture and the Allied Arts

Comprehensive Plan for East St. Louis

An exhaustive plan for a definite scheme of development for the City of East St. Louis, Ill., has been prepared under the direction of the War Civics Committee by Harland Bartholomew, City Plan Engineer.

The features of this plan are presented in a comprehensive report of some seventy-five printed pages. The report is very completely illustrated by specially prepared plans and a large number of photographic illustrations.

East St. Louis finds, as many American cities have found, that the correction of errors due to injudicious early methods is extremely expensive. It is now proposed to take into consideration every feature of the possible growth of East St. Louis and by skillful planning, after exhaustive review and study of conditions, so direct the future growth of the city as to ultimately reach a much desired result.

This report is an extremely valuable one. It not only discusses problems that will particularly refer to the present operations, but it discusses them in a manner that makes the solution of these various problems readily adaptable to other cities where a reconstruction of the city plan is contemplated. The report will be of wide interest and not solely as referring to a specific problem.

Buildings and Lightning Rods

During the recent storms many buildings were "struck by lightning," as the popular phrase has it. Most of them, it would seem, were quite small houses, and hence arises the question whether it is justifiable to leave such buildings so entirely and so generally unprotected as they are. The efficacy of lightning rods in protecting buildings from stroke, by earthing the current received at some high point by a copper conductor, is mainly a theoretic assumption, but the comparative immunity of large buildings that are provided with lightning conductors, and the frequency with which unprotected buildings are struck, are facts that seem conclusive. The frequency and destructiveness of recent thunderstorms suggests the desirability of closer investigation of the subject for the better protection of men and beasts and buildings and trees.

Omaha Architects Plan to Reduce Building Cost

Organization of the "Architects Small House Service Bureau (Inc.) of Nebraska" has been started at a meeting of Omaha architects, realtors and home owners. A system of perfecting standard plans for modest home builders will be adopted, together with professional counsel, working, drawings, details and specifications.

English Names for English Streets

A very just comment appears in the English architectural press on the subject of the futility of expecting accurate pronunciation of foreign names as applied to English streets and other public places. In England, he says, is not Weston-super-Mare pronounced Weston-super-Mayor? And Beaulieu is called Buley. Moreover, he says, Ma-i-da Va-le is pronounced Maidenveil by twelve out of thirteen "of the proletarian class." We never heard it called that, but something just as bad; yet to pronounce it as the correspondent would seem to advocate would be to incur doubts as to one's sanity or good faith. Even a more notorious instance than any of those cited is that of Trafalgar, in which stress is never laid on the last syllable, as the pendants hold that it should be. It is not only with foreign names that we are at fault. Hundreds of English names are maltreated in the same way. Whosoever has not heard Westminster, for example, must lead a cloistered life. In the southerly suburb of Brixton, the inquirer for Robsart street would be met by a vacuous stare, with—from a really intelligent inhabitant—the counter-query whether you meant Robert street.

There would be less need to miscall the streets if they were conspicuously labeled, as, generally speaking, they certainly are not. Now that the omnibus companies are putting up sign-posts and painting the pavements to show where their vehicles stop, the local authorities may chance to regard this enterprise as a reminder of their own neglected duty. As we have said before, every street, court, and alley, in every town, should be conspicuously labeled, with the name well illuminated at night. But it would be weak to stop short at bare necessity. In each instance the name should be accompanied

by an indication of the run of the house-numbers, and the names of the branch streets right and left of the chief line. And these directions should be architecturally designed.

This point is very well taken. In the large city where there is much transient population, not only are the names of places likely to be abused, but the traveler is at a loss to know where he is. The inconvenience of having to make repeated inquiry makes a bad impression, whereas architecturally designed direction posts, as suggested, would give an air of hospitality and interest that would be appreciated.

National Conference Pledges School Betterment

At national conference on educational campaigns, Washington, June 26, called by Commissioner of Education Claxton, representatives of 31 national organizations, composed of hundreds of thousands of members, pledged themselves to promote Bureau of Education's national campaign for school betterment throughout the United States. Resolutions adopted by conference urged: (a) Assurance of adequate supply of properly prepared teachers, including greatly extended facilities for this preparation; (b) increased financial support for schools and educational agencies of all kinds; (c) readjustment of educational programs to meet demands of new era.

Enormous Consumption of Lumber Threatens Future Supply

We are consuming lumber three times as fast as we are procuring it. Experts predict our saw log lumber will be gone in fifty years. The bulk of the original supplies of yellow pine in the South will be gone in ten years and within seven years 3,000 manufacturing plants there will go out of existence. White pine in the Lake States is nearing exhaustion and these states are paying \$6,000,000 a year in freight bills to import timber. New England, self-supporting in lumber twenty years ago, now has to import one-third of the amount used. It has \$300,000,000 invested in wood and forest industries, employing over 90,000 wage earners. Fire destroys over \$20,000,000 worth of timber every year and kills the reproduction upon thousands of acres of forest lands.

Construction in China*

All lumber for building in China is bought in the log. As soon as the logs begin to arrive the contractor tackles them with the sawyers. These men are paid piece rates which average about three cash or one-tenth of a cent per square foot of surface sawed. They average a better wage than a carpenter, getting about ten cents a day, as compared with eight cents a day for the carpenter. At this rate they are cheaper than any steam sawmill that can operate in China. In fact, the only reason a sawmill can operate in China at all is because it can produce quickly and with a more even thickness than the native sawyers. The necessary doors, frames and window sashes are all made by hand.

Three Chinese carpenters at eight cents a day with their native tools can accomplish about the same work done by one American carpenter with all equipment. The work is well done if well supervised. The American carpenter has all his wood surfaced, so the Chinese carpenter is at a disadvantage. In comparison, I should say that about five Chinese carpenters at eight cents a day each are necessary to do the work of an American carpenter who receives \$6 a day and has all his wood prepared for him.

*From Face to Face With Business in Szechuan, by H. K. Richardson, in *Asia*.

Fuel Saving by Electrifying Railroads

A fuel saving of 122,500,000 tons of coal per year would be effected by the electrification of all of the railroads in the United States, according to a statement of Frank M. Kerr, Montana Power Co., Butte, Mont., in making the report of the Committee on the Electrification of Steam Railroads before the recent annual convention of the National Electric Light Association in Pasadena, Cal. "If all the steam railroads in the country were electrified with power furnished from large steam generating electric stations, the total fuel required would be equivalent to 53,500,000 tons of coal, as against the actual figure for railroad coal used during the year 1918 of 175,000,000 tons."

Alaska Gets First Concrete Building

A reinforced concrete office building will be erected in Ketchikan, Alaska. This will be the first of its kind in Alaska. The structure, for bank and post office purposes, was designed by George W. Lawton and H. Mouldenham, Seattle architects.

Old Field Museum Will Be Wrecked

The old Field Museum in Jackson Park, originally the art gallery of the World's Columbian Exposition and one of the last remaining relics of the 1893 fair, will be wrecked, it was announced by the South Park commissioners. Tennis courts will be laid out on the ground it occupies.

Although efforts have been made to save the building, considered one of the finest pieces of architecture in the country, the commissioners said it would cost several million dollars to make permanent repairs. The moving of exhibits to the new Field Museum in Grant Park has virtually been completed.

Glass Bath in New "Luxury" House

In house fixtures in London a novelty is the glass bath.

It has been introduced here by Paul Poiret, the dress designer, who is going in also for household decoration in order that his gowns might have worthy settings.

Despite many other attempts at the aesthetic bathtub, none have come up to Poiret's for beauty as well as utility.

Many folks seeking domestic luxury in their ablutions, have pounced on the idea of a marble bathtub, only to return a verdict that it was "cold and uncomfortable." Some plutocrats have even gone so far as to use a gold or silver bath, but these have been pronounced bad form, and certainly they haven't been approved very extensively by the "best people."

Poiret would seem to have solved a problem which has baffled many, for his bath is of translucent green, and the walls of its shrine decorated with fishes. A shell acts as light diffuser and there is a sea-foam frieze.

This glass bath is to be the finishing touch to what is already described as the "most colorful house in London."

One Picture Sells at \$15,000

Artists exhibiting at the Chicago Art Institute the last year have received encouragement through the museum's delegating one of its staff to stimulate sales. Several pictures sold at \$8,000, one at \$11,000 and another at \$15,000. The total ran into a substantial sum. The man working on sales has an assistant during exhibitions.

"If we don't support the artists we don't have the art," commented this official reviewing results of the last season.

Personals

John J. Donovan, Oakland, Cal., has moved his offices from the Perry Building to the fifth floor of the Pacific Building.

Beverly S. King and Shiras Campbell have removed their offices from 103 Park avenue to 36 W. 40th street, New York.

Willis Polk and R. W. Kinne, Hobart Building, San Francisco, announce that L. Gerstle Mack has become a member of the firm of Willis Polk & Co.

The architectural firm of Ashton & Huntress, 477 Essex street, Lawrence, Mass., is now Ashton, Huntress & Allen, with offices at the same address.

Stork & Knappe, architects, formerly at Palisades, N. J., have moved their office to Ardsley, N. Y.

Joseph J. Galizia, architect, formerly at 2845 West Twenty-third street, Coney Island, has moved his office to 2930 West Nineteenth street.

Kallich & Subkis, architects, formerly located at 2208 Bath avenue, have moved their offices to 7922 Twenty-first avenue, Brooklyn.

Martyn N. Weinstein, architect, formerly located at 1270 Fifty-fourth street, has recently moved his office to 16 Court street, Brooklyn.

Frank Newman and Norman McGlashan, architects, have become associated for the practice of their profession and have established offices at 120 East Fortieth street.

H. C. Meyer, architect, 357 Flatbush avenue, Brooklyn, has formed a partnership with Joseph Mathieu, under the firm name of Meyers & Mathieu, for the general practice of their profession, with offices at the old address.

Thompson & Mellema, architects and engineers, formerly at 640 Broadway, Manhattan, have dissolved partnership. Missac Thompson, of this firm, has recently established an office at 189 Montague street, Brooklyn, where he will carry on his practice as architect and engineer.

Mahan & Broadwell, of Memphis, Tenn., have opened offices in Greenwood, Miss., with H. B. Hammond associated. Catalogues requested.

A. L. Thayer, New Castle, Pa., and R. M. Johnson, formerly with Walker & Weeks, Cleveland, are associated for architectural practice. Offices at 5716 Euclid Ave., Cleveland, and New Castle, Pa.

Housing Brevities

Overcrowding

The Duluth News-Tribune recently made a survey of housing conditions in Northern Minnesota and Wisconsin towns. The result in most cases show serious overcrowding, though it must be admitted that it does not in any instance equal the serious overcrowding reported in an Eastern one-room cottage, where, rumor said, the family living in the center of the room moved out without waiting for the end of the month because the children quarreled with the children of the family living in the northeast corner of the room.

Houseboat on Land

The housing shortage in Cincinnati is presenting some unique problems to the building commissioner, George Hauser. The owner of a houseboat on the Ohio river asked permission to transfer the cabin of his boat to a foundation which he has prepared on Southside avenue. In the summer he plans to restore it to the boat, thus using the cabin as an all-year-round home. The purchaser of a number of discarded cottages built for the government nitrate plant at Ancor, near Cincinnati, has applied for a permit to bring them into the city and erect them into flat buildings by arranging them three on top of each other. He contends that this can be done with safety and convenience.

New York's Rent Laws Ineffective

The new state rent laws are ineffective and have not deterred profiteering landlords from continuing rent-gouging assaults on thousands of tenants in New York City, according to Leo Kenneth Mayer, chief counsel for the Mayor's Committee on Rent Profiteering. The landlords are adopting divers methods to circumvent the new laws, Mr. Mayer declared, and have been successful to a certain extent.

The Rent Committee, which has been in operation for fifteen months, has handled more than 80,000 cases, of which 62,000 have been settled in and out of court. Of the remaining cases 8,000 are listed as hopeless and no settlement is possible. There is a constant flood of complaints into the committee's office, which is visited by about 5,000 tenants every week.

News from Various Sources

Reclamation Service issues summary of work of December 31, 1919. Shows that projects now under way or completed embrace approximately 3,200,000 acres of irrigable land divided into about 67,500 farms of from 10 to 160 acres each. During the year water was available from Government ditches for 1,935,278 acres on 41,836 farms, and Government was under contract to supply water to approximately 1,690,000 acres. Available reservoir capacity at this time was approximately 9,432,000 acre-feet.

* * *

Galveston, Texas, has adopted a rat-proofing ordinance which is applicable to all classes of buildings in the city, on the recommendation of Dr. J. Holmes Smith, Jr., of the U. S. Public Health Service, and Dr. C. W. Goddard, State Health Officer. The complete ordinance may be read in the Galveston Tribune of July 10.

* * *

A new town is to be built at Dagenham, Essex, by the London County Council, in order to overcome the dearth of houses. Accommodation will be provided for 120,000 people on a 3,000-acre site at a cost of \$150,000,000.

* * *

Preliminary investigations by experts of Senate Committee on Reconstruction are developing that lack of transportation may postpone any relief for housing shortage during present year. The coal shortage, one of the causes of recent freight embargoes, is reported due partly to abnormal exportation of coal. Coastwise shipments are inadequate to relieve railroad congestion, it is said.

* * *

Dispatch from Pittsburgh states that conditions affecting iron and steel trade have grown worse on the whole and June, despite efforts of railroads, closed with greater accumulation of material in mill yards and with large number of plants closed. Production was maintained in excess of May and not far from rate of last March.

* * *

Henry H. Curran, President of the Borough of Manhattan, suggests that Governor Smith call a special session of the Legislature this summer to consider measures for the relief of the housing situation in New York City. Mr. Curran practically wants the Legislature to take steps to amend the State Constitution in such a way as to give the city power to utilize its own land in the construction of municipal apartment houses to be rented to families.

Weekly Review of the Construction Field

With Reports of Special Correspondents in Prominent Regional Centers

Cement has been one of the few materials which contractors felt reasonably sure of obtaining, it has accordingly felt an increasing demand and the supplies carried on hand have diminished much below normal. It is stated that in the Lehigh and Hudson districts the plants are now suffering an enforced shut-down for lack of raw materials. The price of this material has recently been advanced 30 cents a barrel in New York.

Another of the more available materials has been lumber which in the early summer fell a little in price. The market now shows evidence of stiffening. Although, however, the production of this material has been somewhat reduced, running according to some opinions 25 to 30 per cent. below normal, the bullish arguments are chiefly those of transportation.

Steel production goes on, suffering only the slight diminution which comes because of the congestion of the plants. The demand for structurals is falling off slightly but prices are well sustained as no manufacturer has as yet to go out for business. In fact, some authorities believe that indications point to still higher prices.

(By Special Correspondence to The American Architect.)

Chicago.—Chicago building and material interests, which had hoped for a modification of the open car order in their favor, as a result of the hearing before the Interstate Commerce Commission were greatly disappointed when it became known the priority order affecting coal had been extended until August 20 as the railroads requested. In the opinion of many dealers the retaining of open cars for coal only will prove disastrous to the whole construction field which is already in a chaotic state. Some go so far as to predict the cessation of all activity in every phase of the construction industry within the next sixty days. Others are looking forward with renewed hope to the hearings which the United States Senate Committee on Reconstruction and Production plans to hold in the next two or three weeks. The committee will investigate construction conditions in the central west.

In the meantime, however, materials are almost impossible to obtain, and when received prove to be of inferior grade. Sand and gravel, two of the most important basic materials used in the construction of both roads and building, are especially difficult to get. Prices continue to advance. Sand is now

costing \$4 per square yard. Dealers handling a well known brand of cement were notified the price had advanced to \$3.99 per barrel wholesale—a raise of fifty cents within a week. This same product had retailed recently at \$3.85 per barrel.

Shipments of cement to Chicago have been exceedingly low and most of the cement used recently had been hauled by truck from Indiana. Even this source may soon be cut off as it is claimed the heavy truck loads are tearing up the roads and villages and towns along the route are protesting against further use of the roads for this purpose.

(By Special Correspondence to The American Architect.)

Seattle.—Outstanding features for the steel and vitroware markets of the Pacific Coast this week was decrease in the delivery of nails with further extensions of the rationing system, firm but unchanged prices, more offerings of building paper, plaster board and patent roofing and a coming advance in fire brick of \$5 per ton. Common dimension fir lumber is \$1 higher due to the inability of the mills to get cars for loading.

Eastern mills are reporting to Pacific Coast jobbers this week that conditions are easier there as to production, but the railways are unable to carry out the feeling as to the car supply. Steel pipe used in essential building projects is scarce, with one-half and three-fourths sizes so short that rationing has been resorted to.

There has been a noticeable improvement in the loading of steel at eastern points by "outside" mills whenever jobbers expressed a willingness to pay a premium over the market. Several jobbers frankly stated that the more that is paid, the quicker the delivery. As the situation is now looked upon by the heaviest jobbing interests of the Pacific Coast there will be little improvement inside of 90 days. There is a limited acceptance by the eastern mills of business for the third quarter but the railway delivery situation promised to become more complicated in the announcement that it is proposed to move the Middle Western wheat through the North Pacific ports to Europe and reload the cars east-bound with lumber for the Central and Seaboard building trade. This would, as jobbers see it, withdraw cars from steel and merchandise service until such time as the bulk of the wheat had been moved.

Vitroware and earthenware are very scarce and none of the Pacific Coast cities have any supply

THE AMERICAN ARCHITECT

ahead. Manufacturers are able to make delivery of about 33 1/3 per cent. of requirements. Shipments ordered early in January are just now being unloaded at Pacific Coast points. To all the pleas for more, manufacturers say the railways and not themselves are defaulting. Crane & Co. received four carloads at their Seattle base this week. Manufacturers are willing to say at this time that they are rapidly catching up and may be able to promise normal delivery within sixty days if they can get cars. The demand for vitroware and earthenware is increasing.

Cast iron boilers, 48 inch, for low pressure heating plants have advanced 5 per cent. this week. There have heretofore been slight advances which the jobbers were able to absorb and to check the rise at the warehouse.

While the market has remained stationary in building paper, cement and plaster board, there are too many offerings for absorption by the jobbing trade during a period of what seems to be reaction in building as in extravagance. Jobbers have in consequence been looking for a decline. Owing to some opportune pickups, the North Coast jobbing trade has been able to get a fair supply of cement, but there is a critical scarcity all along the Coast as in the East as reflected in reports to the West Coast lumber trade from eastern lumber buyers. These buyers, who had been expecting a continued bear market in lumber, say they would buy if they could get cement—both commodities seem to be linked up in an uncommon fashion this season. Difficulty of financing cement stocks for future month delivery is preventing moderate sized jobbers from laying in a supply. Stocks of not less than \$40,000 to \$50,000 will equip a corporation in this territory to go into competition for the cement business.

San Francisco is buying fir lumber and shingles on the West Coast market. There is great delay in getting white cement from York, Pa. Orders placed in March have been shipped but the cars have been lost.

Red cedar shingles are stronger due to the car scarcity at \$4.85 for clears and \$4.20 to \$4.25 for stars—mill basis.

(By Special Correspondence to The American Architect.)

Boston.—The report that the Association of Railway Executives is attempting to increase the rate of freight car travel to thirty miles per car per day in solution of the car shortage is encouraging both to shippers and users of building materials. During the war, when the Government had at its command all the labor that it needed, had the authority

and the right of way everywhere, it got up a speed of 26.01 miles per day.

The western transcontinental lines have an enormous movement, running as high as 60 miles per day, because of their long distances. Now England, on the other hand, is virtually a terminal yard in which movement is impeded by short runs and switching and by frequent congestion. The average movement here is only in the vicinity of 18 miles per day.

A large quantity of lath is now noticed on the sidings in Maine. The mills have been handicapped because of poor shipping conditions, but are now daily receiving additional supplies of empty cars. Prices are more steady in lumber and brick, and although cement mills report plentiful supplies on hand it is still scarce at the job.

One large lumber company reports as follows: with the non-delivery of lumber, caused by the railroad strike, practically every lumber dealer in the country has been forced to extend his financial resources to the limit. It is impossible in many localities to collect for lumber until after it has reached destination, thus doubling the financial responsibility of the shipper. Within the last thirty days there has been a material reduction in lumber prices, but these will strengthen the minute we have a little reaction. A great many commodities are now being sold at less than the actual cost of production, caused largely by the indiscriminate use of the transit car privilege.

New England should spend \$365,000,000 to relieve the housing shortage so the City Planning Board reported this past week to the mayor. This report which is the result of a six weeks' survey, points out that 6,546 Boston families now have their furniture in storage, having apparently "doubled up" with their relatives or gone to lodging houses or hotels to live; and that fully 20,000 of the 39,395 industrial employes who were accounted for in the survey complained they were affected by the housing shortage. The Board received reports of conditions from 89 industrial plants employing 28,978 men and 10,357 women of whom 80 per cent. live within the city limits. Fifty-one employers stated that there were indications that many of their employes desired to purchase their homes, on a monthly payment plan. Nine of them submitted figures showing that 700 of their employes had expressed a desire to become home owners at once.

Statistics of building and engineering operations in New England show that contracts awarded from January 1 to July 15, 1920, amounted to \$193,683,000 as compared with \$97,739,000 for a corresponding period in 1919; \$78,742,000 in 1918; \$111,064,000 in 1917; \$110,141,000 in 1916; and \$93,152,000 in 1915.

DEPARTMENT OF ARCHITECTURAL ENGINEERING

Observations on the Southern California Earthquake

By W. H. BOUGHTON

WHILE earthquakes are far from welcome, they present an opportunity to study the manner in which different types of construction are affected, and from this viewpoint they present an educational advantage. Much has been learned from such catastrophes as the Baltimore fire, and the San Francisco earthquake and fire. There recently occurred in Southern California an earthquake, the effects of which, given below, are worthy of more than passing notice.

HISTORY

On June 21, 1920, at 6:47 P. M. the first shock was felt. This was rapidly followed by a longer and more severe one. The direction of the initial tremor was from approximately East to West while the second one passed from North to South. These shocks were felt as far north as Ventura and as far inland as San Bernardino down through the Imperial Valley and south to San Diego. All of the places within this circle felt the shock, more or less. In some places as many as six distinct shocks were felt, although the heaviest shocks were centralized around the town of Inglewood and Hyde Park, where the greatest damage was done.

Fronts of buildings were thrown into the street, telephone and electric power service was com-

pletely cut off, water mains were broken and all public service generally demoralized.

These shocks were followed by intermittent tremors during the night and a quite severe shock occurred about noon of the day following, June 22.

Scientists who have investigated the phenomena of earthquakes offer the opinion that the disturbances which occurred during these two days resulted from a slipping of the strata in the principal geological fault which follows the coastal range from a point 200 miles north of San Francisco to the Gulf of Lower California.

This fault reaches to a point 100 miles below San Francisco where it swerves twenty miles to the interior and reaches the Imperial Valley by traversing Los Angeles, Riverside and San Diego counties. There are at least three such geological faults in the state, two of which are in the north.

At Santa Monica the shock was severe enough to rock the walls of houses and sway trees and telephone and electric light wires. The writer was in the kitchen of his bungalow at the time, with his wife and son, and the only description that can be given is likened to a steamer which is going full speed ahead when suddenly the engines are reversed



FIRST NATIONAL BANK BUILDING, INGLEWOOD, CAL.

THE AMERICAN ARCHITECT



VIEW SHOWING SHORING OF PORTICO OF FIRST NATIONAL BANK BUILDING.

full speed astern, causing the walls and floors to heave and rock with apparent intentions of collapsing. This being our first earthquake experience, we were too astonished to do more than sit and watch things rock and, after it was over, rush out into the yard, carrying with us the things that were in our hands at the time.

RESULTS OF INVESTIGATIONS

TUESDAY morning, June 22, I started out by automobile to visit all of the places where the shocks were reported and where any damage was done, in order to find out how serious had been the damages. I finally decided to confine my efforts in and around the center of the damaged area which was the town of Inglewood. Here the damage was very severe.

The front of the Hotel Inglewood, a two-story brick and frame building with wood floor joists and plastered ceilings on wood lath, was out in the street, exposing the front bed rooms to view, while the plastered ceilings had fallen to the floor. The brick front wall in being thrown into the street, crushed a Ford car that was parked in front of the hotel. Little or no plastered work was left intact.

The Inglewood sub-station of the Southern California Edison Company, a two-story brick structure was badly wrecked, most of the front wall

having been thrown into the street. The ceilings were plastered on wood lath and large sections of the plaster had fallen.

The First National Bank Building, a comparatively new one-story structure with brick walls faced with enameled brick and terra cotta trim, was badly damaged above the cornice line and the walls cracked at the corners. The damage was considered sufficiently dangerous to warrant shoring up the walls over the main entrance. An inspection of the interior revealed that the exterior walls were furred with hollow tile on which the interior plastering was applied. These walls were cracked in many places, and much of the plaster loosened and tore away from the base. The ceiling was a suspended ceiling of metal lath and, aside from the cracks around the angles of the walls, no cracks were visible.

The main building of the grammar school, erected in 1910 at a cost \$75,000, was constructed with brick walls, stuccoed on the exterior and lined with hollow tile. The ceilings were of plaster on metal lath. The accompanying photographs will show the character of this building, also the present condition of the exterior. It was not possible to get into the interior as the walls were in danger of collapsing under the slightest additional shock. The one-story buildings or annex shown in one of the



CORNER OF THE MAIN BUILDING, INGLEWOOD GRAMMAR SCHOOL.

THE AMERICAN ARCHITECT

photographs were erected in 1915 and 1919, and are constructed with walls of wood stud, lathed on both sides with metal lath, stuccoed on the exterior and plastered with hard wall plaster inside. On the top floor, over the central section of the



HOTEL INGLEWOOD AT REAR.
Front wall entirely out.

building was located the auditorium. This portion of the structure fell clear through to the first floor, while the supporting walls were thrust sideways, leaving this section of the building a complete wreck. From present indications the main building will have to be torn down and rebuilt. The local authorities who had made an inspection of the interior reported that the plastered walls were badly cracked, even the blackboards backing up on the hollow tile being stripped clean. Floors lathed on the underside with metal lath, were reported to be in good condition, excepting where the floors



SCHOOL AT HYDE PARK, CAL.



INGLEWOOD GRAMMAR SCHOOL.
One-Story Annex in the foreground is practically undamaged.

fell through. The annexes were open for inspection and these buildings were remarkably free from cracking, either on the exterior or interior.

It was impossible to find much left in the way of chimneys in Inglewood, Hyde Park or Angeles



SOUTHERN CALIFORNIA EDISON BUILDING,
INGLEWOOD, CAL.

Mesa. At Inglewood, the fire apparatus was parked in the street, as the engine house will have to be torn down and rebuilt. This structure is a brick-stucco building, and the stucco has cracked and fallen.

The accompanying illustrations indicate, better than a written description can, the nature of the



ANOTHER VIEW OF THE HYDE PARK SCHOOL.

damage caused by this earth upheaval. In sections where such phenomena are likely to occur, the forms of construction adopted should be capable of resisting, to some extent at least, the strains thus induced, without causing the collapse of the structure or any extensive damage thereto. It is believed that a system of construction which will fulfil these requirements can be developed, and should meet with approval by the architectural profession.

In working along this line it is necessary constantly to bear in mind the fact that whatever construction is employed it should be fire-resisting, since fire is quite likely to result as an aftermath of an earthquake. By eliminating as much as possible, materials that present a fire hazard the total damage

will be kept at a minimum, which is the object sought.



A STORE AT INGLEWOOD, CAL.

Report on Trip to Princeton, College of City of New York, Yale and Harvard for the Purpose of Inspecting the Stadia at those Universities

By HOWARD DWIGHT SMITH

Part III

THERE is something distinctive about the name "Yale Bowl." The effectiveness of the structure in seating a large number of people in comparatively close proximity to a playing field justifies that distinction.

An inspection of the Yale Bowl was made on Tuesday, May 11, and certain observations noted before an interview was obtained with Dr. Al. Sharpe, Director of Athletics at the University. As the interview with Dr. Sharpe dealt more with the effectiveness of the structure in fulfilling the requirements for which it was built than it dealt with the physical condition of the work or its engineering features, it may be well to treat that part of the discussion first.

The Yale Bowl is located at the edge of the City of New Haven with the rest of the athletic plant, quite some distance from the academic and social activities of the University. This is a condition with which quite a number of large institutions have to contend, especially with the growing tendency toward participation in so-called "mass athletics." At New Haven it is necessary to go by street car or motor to reach Yale Field from the campus. Dr. Sharpe deplored this fact quite as much as he did the fact that it is quite impossible for him to have his football candidates' fall schedules so arranged that they may have no classes in the afternoon, and their morning academic work arranged so as to leave their nights for rest rather than study.

The entire athletic plant at Yale Field is quite extensive. The Bowl is only a single feature of the entire group, and while it is enormous in size, still it is perhaps the least used of the entire group. There is a separate Varsity diamond with grandstand and bleachers, several class diamonds and a running track entirely separate from the other features. There is a new armory for the artillery unit (R. O. T. C.) and a large number of tennis courts. A large new Club house, proposed in 1915 but withheld from construction during the war will add greatly to the efficiency and convenience of the athletic group.

One of the first things Dr. Sharpe mentioned in his interview was with reference to the use of such a large structure as the Yale Bowl for so few events. This, of course, is a very pertinent question and one which always comes up in a discussion of the Yale Bowl. The Bowl in its design and construction is a monument to that wonderful spirit of Yale Alumni, which has traditionally come to place more importance on the climax of fall athletics, the football game with Harvard, than upon any other single thing connected with the institution.

The spirit with which the idea was conceived and carried out by the alumni is most commendable. The whole and sole idea back of the Bowl was that a maximum number of people be accommodated at the game with Harvard, and that they be accommodated as conveniently and practically as possible, in the most economical way. This has been accom-

THE AMERICAN ARCHITECT

plished and the Bowl is a success from that point of view. Its builders and patrons are interested in one day out of 365 and are willing that a large part of their investment lie idle the other 364 days. Thus are the strong ties of Alma Mater evidenced.

It is easy to see, therefore, how the size and shape of the Bowl was determined. A gridiron was laid out and a minimum distance from the corners to the inner wall was fixed upon by the Athletic Mentors. Through four points thus determined an approxi-

Bearing in mind the ideas of the original donors of the Bowl, this is not a disadvantage. Any additional use which may be made of it may be considered as extra efficiency. Dr. Sharpe informs us that he proposes using the field for La Crosse in winter and spring when the playing surface will permit. During the last football season (fall of 1919) excessive rains and the wear of hard playing, left the turf in bad condition. Resodding of large portions of the playing field during the spring

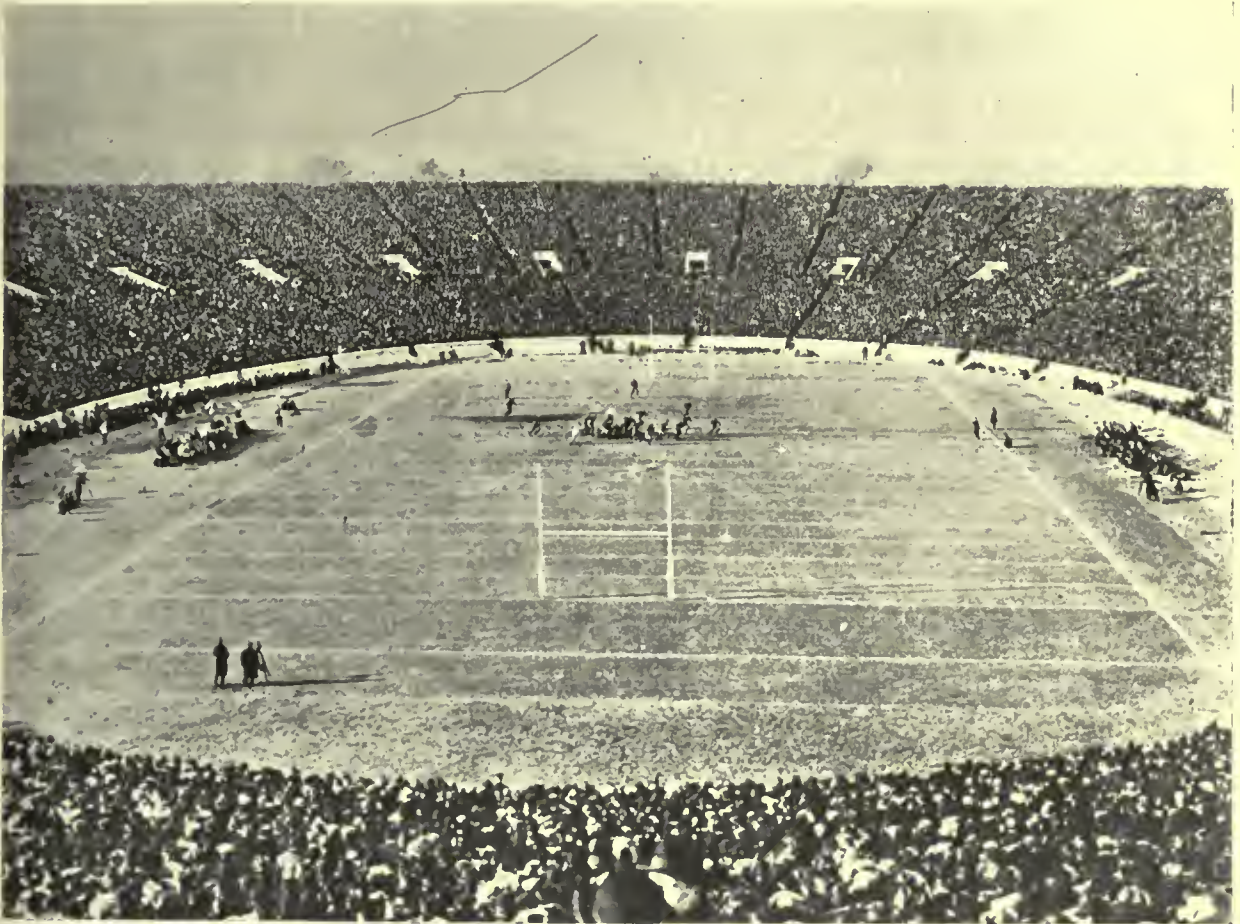

THE YALE BOWL, NEW HAVEN, CONN.

DONN BARBER, ARCHITECT.

View looking toward the narrow end of the elliptical field.

mate ellipse was described which forms the inner perimeter of the seating structure, placing the first row of spectators, as near the gridiron as possible, this being one of the prime considerations. The length of this internal perimeter is, therefore, considerably less than a quarter of a mile and the placing of a regulation running track within it became impossible, even if there had been sufficient space to pass the corners of the gridiron. Straight-away tracks also being impossible, it is evident that as far as the track team is concerned, the Yale Bowl is of little or no use.

has precluded its use for La Crosse for the current season.

The general scheme of building the Bowl has been so often described that it is hardly necessary to go into detail here. The earth was scooped from the central portions and banked up around the outside, placing the lower half of the seat section on solid ground and the upper half on excavated ground. The playing field is about 25 feet below the level of the surrounding ground and the top row of seats is about the same distance above it. This makes the top row of seats some 50

THE AMERICAN ARCHITECT

feet above the level of the playing field. The lower half of the seating section has been built permanently of concrete, but the upper half of the seating section, that which rests on the bank filled with the

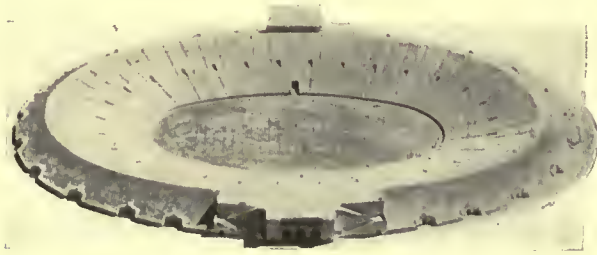

MODEL OF THE YALE BOWL.

earth excavated from the center of the bowl has only been built up temporarily of wood. Of the structural properties of these concrete seats, more will be said later, but it might be mentioned here that the greatest part of Yale's problem is ahead of it. The sandy nature of the soil has been quite an advantage for good drainage of the field itself, but as for being good for bank fill this sandy soil leaves much to be desired. It doesn't seem to settle properly and it will not "stay put." One of the greatest problems of maintenance is to keep the sand from the upper filled bank from washing down and filling up lower portions of the concrete seats and drains. Fill of this nature will be hard to build additional concrete seats on.

The ellipse of the top row of seats is about 150 feet outside of the perimeter of the inner wall. The idea has often been expressed that it might be necessary for spectators on the top seats to use

binoculars to see the game. Perhaps this feeling is due from the impression obtained from photographs. The peculiar size and shape of the Bowl make it impossible for any photograph, save an airplane view to convey the real idea. This feeling does not come to one who visits the structure when it is empty. Perhaps the vastness of the Bowl is more apparent and more impressive when it is filled to capacity, but the perimeter of the inside wall of the Bowl has been made so small that the farthest row of seats at the end of the ellipse is not more than 400 feet from the actual center of the playing field.

Entrance to the Bowl is effected through a single row of thirty-two tunnels each of which leads from the outside ground level through the upper bank fill to an eye or a portal. These portals take care of the crowd quite satisfactorily. It has been found necessary to fence off the area surrounding the bowl with a high fence in order better to control the crowds. The business manager of the Athletic Association, Mr. Woodstock, assures us that the handling of the crowds at the Bowl itself is quite satisfactory, because seats are easily found from these portals or eyes which are about midway of the seating section. The greatest difficulty seems to be to get the crowds distributed as much as possible at some distance from the structure itself, in order to avoid congestion at few points.

Casual visitors are admitted to inspect the Bowl daily from 9 to 5. One gate in the outside wire fence is left open and one of the tunnel entrances to the Bowl itself is left open. No attendants are



THE YALE BOWL AS IT APPEARED

Over 61,000 persons are comfortably seated, each possessing an unobstructed view of the field.

THE AMERICAN ARCHITECT

left in charge and all parts of the structure are open to inspection.

The top part of the exterior slope of the filled bank is covered with turf. The lower portion is held up by a retaining wall some 10 feet high, through which the tunnel entrances are cut. In these tunnel entrances it is evident that an attempt has been made to vary the color and texture of the concrete. There is quite an opportunity in using varying textures and colors in stucco, if sufficiently studied to be harmonious. In the case of these tunnel portals, the prevailing pinkish cast of the main portion of the wall does not harmonize too successfully with the dull gray tone of the rough textured portion immediately surrounding each door.

On the inside of the Bowl, the general elliptical line of the inner wall is apparent, but an appearance of crudity in execution is given by the building of the inner wall in straight chords approximately 10 feet in length. This is probably quite an economical method of construction and its use in the layout of the seating tiers is quite commendable from that point of view. The building of the inner wall in circle arcs, however, would have added much by way of an appearance of neatness and thoroughness which would have well been worth what slight additional expenditures it would have necessitated. The heavy coping over the inner wall is of rather ponderous cross section, and does not add to the refinement of line which might have been possible otherwise.

Two peculiar physical characteristics of the Yale Bowl have been noted. Dr. Sharpe points out that

in the fall the temperature within the Bowl, down on the playing field particularly, is from five to ten degrees higher than outside. This is due to the air pocket, which the Bowl itself forms within which there is little or no air circulation, and it is seldom that there is much of a breeze down near the field level. The thirty-two horizontal tunnels usually have a distinct outward draft, but they only effect the air down to their own floor levels which are some 25 feet above the playing field. This difference in the temperature is ordinarily found within all closed stadia. In those closed stadia where track work is provided for and straightaways are provided through tunnels under the seats at any one point (as at Syracuse, for instance), there is a decided draft from the inside warmer air to the outside cooler air. This draft moves in the opposite direction to the runners in the dashes and adds greatly to the inconvenience of running. Other inconveniences in running through a tunnel of this nature are sudden change of light, and a sudden change of temperature.

The other peculiar physical characteristic of the Yale Bowl which was particularly noticeable was its acoustics. From any given point at the level of the playing field even the faintest sounds made along the upper row of seats is plainly audible. During the inspection of the Bowl a party of four visitors entered through the open tunnel and portal. This party ascended to the crest of the embankment at the top seat and walked entirely around the ellipse. Every word spoken by the members of the party and even the sounds of their footsteps could be plainly heard from points along the inner



DURING A YALE-HAVARD FOOTBALL GAME.

Thirty-two tunnels give entrance to the bowl. The portals to these tunnels can be clearly seen.

wall, at the playing field level, except for a space of some 90 feet while they were passing outside the temporary press stand on the north. While the party of visitors was walking along the crest behind that stand, there were no sounds of any kind heard. Mention is made here of this phenomenon of acoustics more for its passing interest than for any conclusions or lessons to be drawn from it. The clearness and audibility of sounds when the Bowl is filled to capacity perhaps has little effect upon the crowd itself.

The engineering and structural problems involved in the construction of the Yale Bowl are somewhat different from those of most other structures. A large part of the construction consisted in moving the 175,000 cubic feet of earth from the bottom of the Bowl and placing it to form the surrounding embankment. The concrete work involved (1), the building of the lower tiers of seats, supported directly upon the inner slope of the excavation; (2) the entrance tunnels, which were built in the open and later filled by the embankment; (3) the outside retaining wall to hold the embankment; and (4) the two gate house structures, the larger one on the south, the smaller one on the north.

None of these concrete operations involved the question of vertical support which is found in most structures for the seating of a great number of people. The problems of reinforcing are largely confined to the design of the seat slabs to avoid cracking from unequal support or unequal settlement. It is quite evident that a larger structural problem will present itself to the engineers and builders when it becomes necessary to construct the upper part of the seat section on the sandy fill of the upper embankment.

Expansion and contraction in the seat section already built has been very successfully taken care of in the method of construction. The seats have been cast in position in blocks three steps high and in sections 10 to 16 feet long (depending on the distance from the inside ellipse). These blocks have been separated from each other simply by pieces of tarred felt. Three of these structural section taken together form one seating section extending from tunnel to tunnel. At one of these radial joints between tunnels there has been placed a regular street paving joint which has been filled with an elastic material. There are, therefore, in this lower part of the Bowl a total of thirty-two radial joints especially provided for temperature movement, and most of the advantages of small stone masonry construction have been obtained by the jointing of the structure into integral blocks, none of which is over 120 square feet in horizontal area. The joints about these comparatively small blocks are not designed to take up expansion and contraction, but they do permit a

certain amount of flexibility which prevents cracking and consequent disintegration. The condition of the concrete in these seats, after five and one-half years of wear, is nearly perfect. The parapet wall at the inner edge of the seats stands about 4 feet high from the field level and about 30 inches high from the first seating space. This wall is 12 inches thick, much thicker than would ordinarily be necessary, but it is just such excess mass that makes for durability and creates the impression of permanence.

One of the distinctive features of the Yale Bowl is the method of placing wood seats on the stone steps. The depth of the stone steps is not sufficient to provide comfortable seating without raising the actual seating surface. This has been accomplished by securing heavy galvanized iron standards to the front edge of each step by means of bronze U bolts. These galvanized iron standards support wooden seats and back rests built of Douglas fir. These standards are so built as to bring the wood seat always 18 inches above the foot rest of each step.

On the outside retaining wall, sliding expansion joints have been provided at the overlapping pilasters at each of the tunnel entrances. These joints have not been as effective as the plain butt joints of the seat structure. There are a number of instances of spalling off. These spalls appear to be of three kinds: (1) those caused by strains due to pressure of natural expansion or contraction; (2) those caused by frost action; (3) those caused by seepage from within the wall itself. The third kind is only slightly in evidence and may probably be considered as partly affected by the second class. Evidence of disintegration is very small as compared with the magnitude of the structure and the general appearance of the concrete is quite encouraging to those who contemplate its use in such large quantities.

Reference is made to Engineering Record, March 28, 1914, and November 21, 1914, for discussion of the technical features of the Yale Bowl.

To be continued

The Erection, Repair or Demolition of Buildings

Under the above title the New York State Industrial Commission has issued Bulletin No. 23. The rules contained in this Bulletin deal with ladders, scaffolds, runways, derricks, hoisting apparatus, etc., used in connection with the erection, altering and demolition of buildings, as well as with oxy-acetylene welding and cutting. Copies may be had on application to the Bureau of Industrial Code, 124 East Twenty-eighth street, New York City.

16⁴

frontispiece to No. 123, 9



TYPES OF OLD BUILDINGS, SALAMANCA, SPAIN

THE AMERICAN ARCHITECT

THE AMERICAN ARCHITECT

VOL. CXVIII

WEDNESDAY, AUGUST 11, 1920

NUMBER 2329

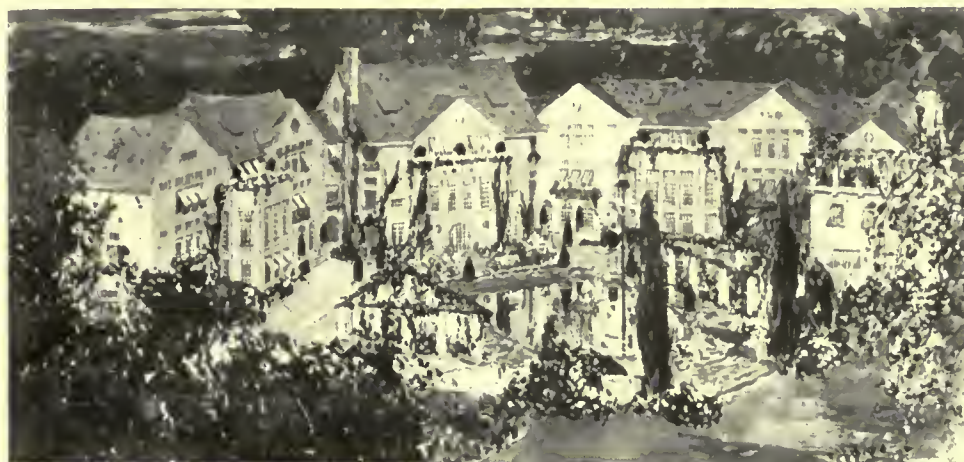

THE YARD, CHICAGO NURSERY AND HALF ORPHAN ASYLUM
HOLABIRD & ROCHE, ARCHITECTS

The Work of Holabird & Roche, Architects

WE are all more or less familiar with the monumental works of the various architectural organizations in this country as such works are usually widely published and studied. Are such works a true criterion of an organization's capabilities? Are we not too prone to base an evaluation of the organization on such works? By extreme effort an ordinary organization can be so amplified and co-ordinated that a really creditable work is produced, but the real ability of an organization is more truly indicated by the mass of production—that which makes up the daily grist. Meritorious works can only be the result of labor expended, a real effort, and when this is done consistently on minor projects through a period of years and under all conditions, it bespeaks an honesty of purpose and a real enthusiasm and love for architectural creation. In fact any successful organization must be imbued with the desire to participate in good architectural performances and anticipate the satisfaction resulting from work well done.

The object of this showing of the work of Holabird & Roche in this and succeeding issues is to illustrate some of the minor projects that have been executed by them. The examples embrace con-

structions of a diverse character, a study of which will make manifest the ability of such an organization to solve the problem at hand. Although this organization has constructed or enlarged some thirty telephone exchanges, it would rather resent the intimation that it was a specialist in such works. It is true that such structures include many features special to the operation of telephones and they are of a character that require very careful study and exact planning. Holabird & Roche contend, however, that being specialists implies a limited ability and that an architectural organization properly set up can produce a structure adequate to the demands for whatever purpose it is intended.

The larger works of this organization are well known to all students of American architecture. Of them are the County and City Building at Chicago; the Hotels La Salle and Sherman; office buildings, Otis, Lumber Exchange, Monroe, McCormick, Marquette, Monadnock and Old Colony; department stores, The Boston, Mandel Brothers' and Rothschilds'; the University Club and many others in Chicago and other cities.

To this organization belongs the credit of having planned the first all-metal frame skyscraper ever

THE AMERICAN ARCHITECT

erected, the twelve story Tacoma Building erected in 1888. It can be said that all of the developments that make possible the great structures of today, including the mechanical equipments and sanitary conveniences, have been made within the existence of this organization and to which it has made many notable contributions.

THIS firm originally consisting of William Holabird and Ossian C. Simonds, began business in 1880. In September, 1881, Martin Roche became a member of the firm under the name of Holabird, Simonds & Roche. In January, 1883, Ossian C. Simonds withdrew from the firm which

ing every feature of modern building construction, specification writers, superintendents and accountants.

THE telephone exchanges erected by the Chicago Telephone Company in outlying districts are provided with ample grounds so that light is provided on the sides and rear, allowing space for tennis courts, flower gardens and grass plots. The completed structure is to occupy only fifty per cent of the ground area. These buildings are not detrimental to the best residential districts and are constructed so as to be as fire resisting as possible.

It is necessary to plan the first unit with a view

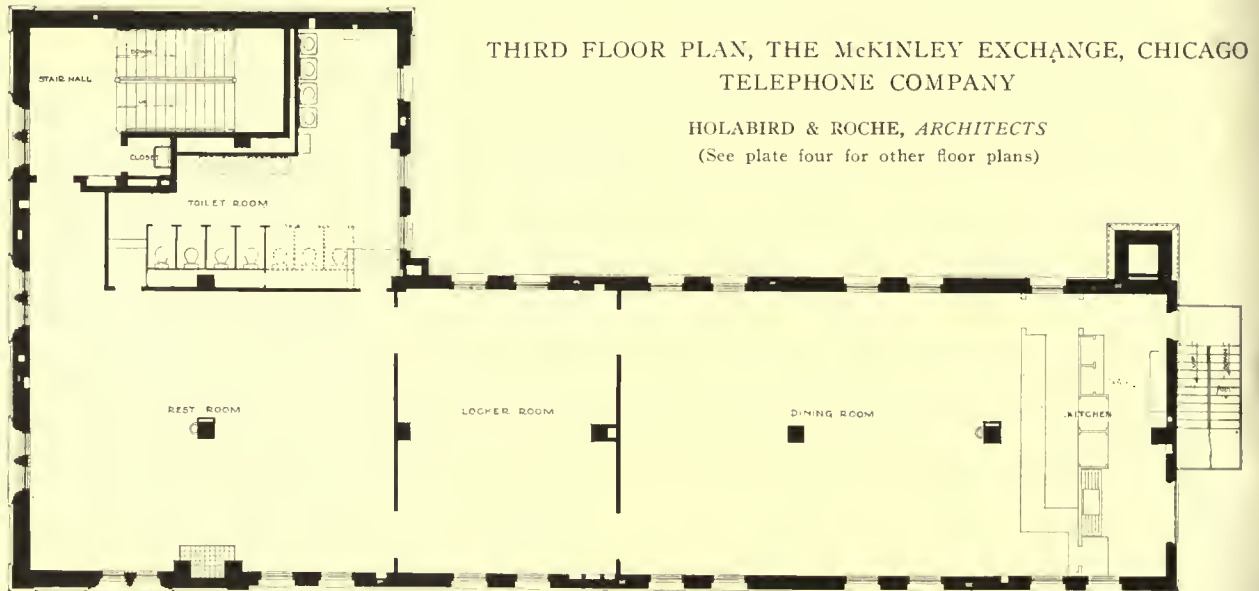

then became Holabird & Roche. In 1896, Edward A. Renwick was admitted into the partnership but no change was made in the name of the firm. These three gentlemen are still active in the affairs of the organization.

The four decades just elapsed have probably been the most important in architectural history. It is apparent that the housing of manufacturing plants, commercial enterprises, offices, governmental departments, social, educational and religious organizations; penal, eleemosynary and correctional institutions; hospitals and sanitariums; hotels, clubs and residential buildings—all have progressed more than during any four centuries of the world's history. Those who have contributed to this development will find their place in the architectural histories to be written in the future.

This organization was one of the first to be set up along modern lines. Its personnel comprises not only architects but engineers capable of design-

ing every feature of modern building construction, specification writers, superintendents and accountants. The design of the McKinley Exchange is rather typical of the style approved by the company. The Kildare Exchange is one of the deviations from this standard. The illustrations of these two exchanges show the first units to be constructed. A completed exchange is a duplication of the plan shown.

In the basement are located the cable vaults, storage-batteries, boiler room and cooling plant for drinking water. The first floor contains the apparatus room in which is placed the distributing frame, power machinery, testing apparatus, repair department and wire chief's office. The second floor is occupied by the switchboard. The third floor contains the rest room, toilet and locker rooms, dining room and kitchen. Buildings four or more

THE AMERICAN ARCHITECT

stories high are provided with a passenger elevator and the added stories devoted to switchboard operating rooms.

In the Franklin Exchange no business is conducted with the public and the design well expresses the idea of an occupancy devoted exclusively to operating purposes. The design is in the Italian Romanesque style of the Venetian type, giving a certain individuality to the building without undue cost. The sides and rear of the building

provided for. All windows are of metal frames and sash with wire glass. The windows on sides and rear have the added protection of automatic rolling steel shutters in front of the windows and which are placed back of the masonry spandrel above the windows and concealed from view. The exits consist of two enclosed stairways back of the elevators and two enclosed smoke proof stairs in the rear, which are entered from an exterior balcony.



THE KILDARE EXCHANGE, CHICAGO TELEPHONE COMPANY, CHICAGO
HOLABIRD & ROCHE, ARCHITECTS

are faced with the same brick and ornamentation as the front. The wall surfaces are of dark red vitrified paving brick, Bedford stone strimmings and the base on the street front is of granite and extends to the second floor. The court, facing south, is faced with white enamelled brick and terra cotta.

This building has a street frontage of 135 feet 5 inches and is 181 feet deep with 16 foot alleys on the west and south sides. As erected it is eleven stories high, with basement and partial sub-basement. It is so designed that five additional stories can be added. Fire resistance has been especially

Men are provided with locker and rest rooms, toilet and showers. Women operators are provided with dining, locker and rest rooms, kitchen and hospital. In addition there are provided drying rooms where rain coats and wet clothing can be properly dried. An assembly room is provided for concerts by their various choruses and bands and several committee rooms for smaller meetings.

About thirty miles west of Chicago, the Chicago Telephone Company has erected a country home where their women employes may, at nominal cost, spend their vacations make short visits or spend periods of rest during convalescence. It is not a

THE AMERICAN ARCHITECT

hospital or charitable institution. It is known as the Margaret Mackin Hall, named in honor of the "best telephone operator in the world."

The public institution, usually known as an asylum or home, is generally designed with a view of presenting an imposing appearance with domes, towers, stately classic porticoes and whatnot. The interior is planned with large rotundas and wide corridors of great length, giving an impression of

sents some problems of unusual interest and these factors were considered by the architects. The plant is a success and it is frequently visited and inspected by architects and committees from all parts of the United States and Canada. The usual depressing influence of such an institution is wanting and one scarcely realizes its purpose measured by experiences in visiting similar institutions.

The institution stands on a splendid location with

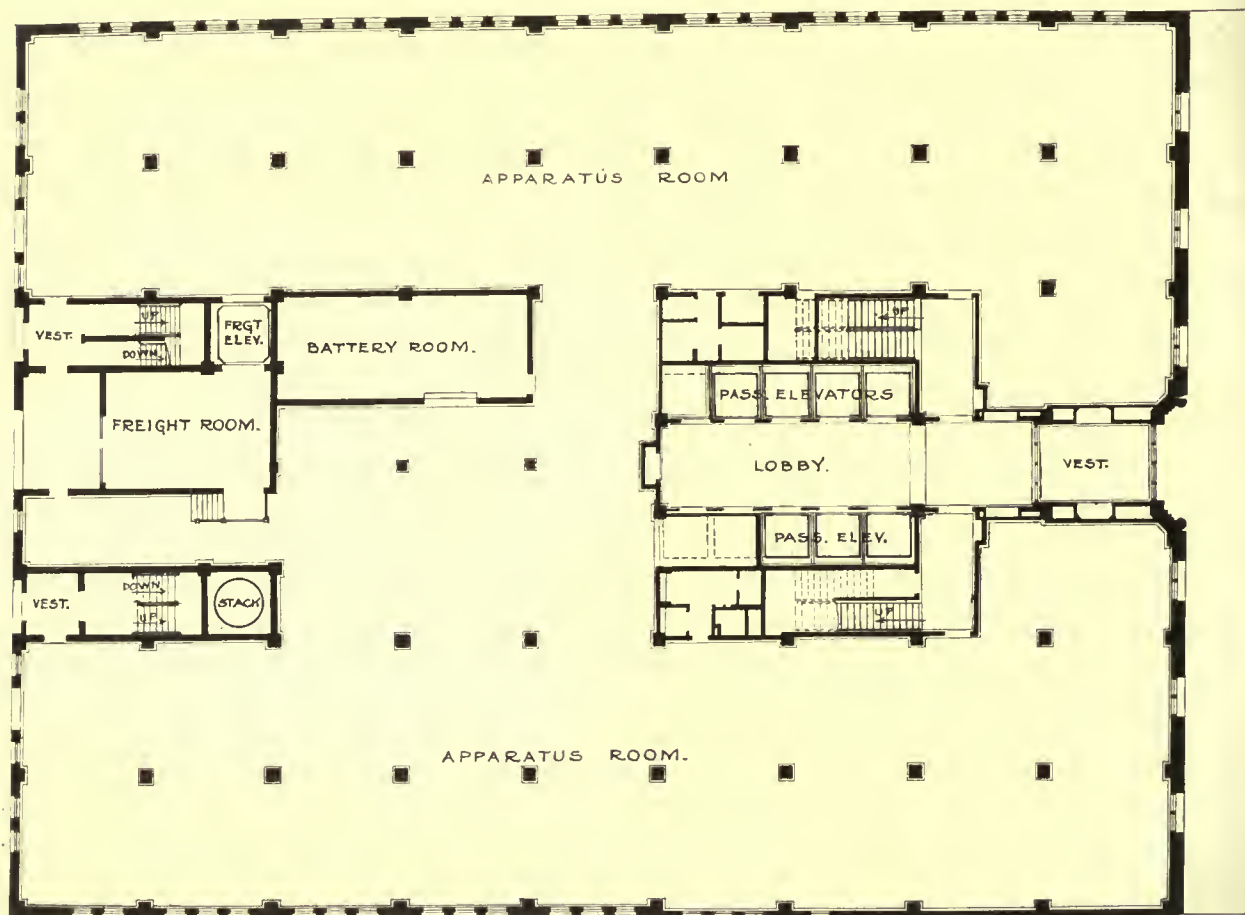

FIRST FLOOR PLAN, FRANKLIN TELEPHONE EXCHANGE, CHICAGO TELEPHONE CO., CHICAGO
HOLABIRD & ROCHE, ARCHITECTS

formality and repression which exerts a depressing effect on the normal visitor. The effect on the unfortunates housed therein must be of a greater intensity. The idea that such places should be designed as places of human habitation, homelike and congenial, seems to have been overlooked. Perhaps the influence of the word "public" is the cause of this, as communities are apt to outdo their neighbors in outward show rather than by inward workings.

In the Chicago Nursery and Half Orphan Asylum all of the traditions for such institutions have been discarded and the institution was planned along rational and humane lines. The half orphan pre-

ample grounds for all of its needs. There is nothing monumental about it. It stands unpretentious but very interesting in all of the varied and charming aspects which it presents, all made possible through its irregular plan. From all viewpoints, both front and rear, is seen the careful designing which is uniformly good in every particular. The simplicity of the designing makes this building specially expressive of its use—a home for children.

The keynote of the design is the elimination of waste space in the interests of economy and avoidance of the usual institution feeling. In plan the building is really a group of separate buildings con-

THE AMERICAN ARCHITECT

needed by stair halls, shut off by fire doors, and with an entire absence of corridors.

The buildings are three stories high with part basement, in which is located the mechanical plant, laundry, manual training, trunk and store rooms. The story heights are nine feet, six inches in the clear generally, the kindergarten is twelve feet, eight inches high and the gymnasium extends up into the pitch of the roof. The exterior is faced

has the same facilities and capacity for children three to six years of age; the third floor has the same capacity for those more than six years of age. The south wing, first floor, has a large lobby, dining rooms, toilets and pantry; the second floor is the same as the west wing with capacity for twenty-eight children three to six years old; the third floor has dormitory for fourteen children over six years old and an infirmary with twelve beds. The serv-

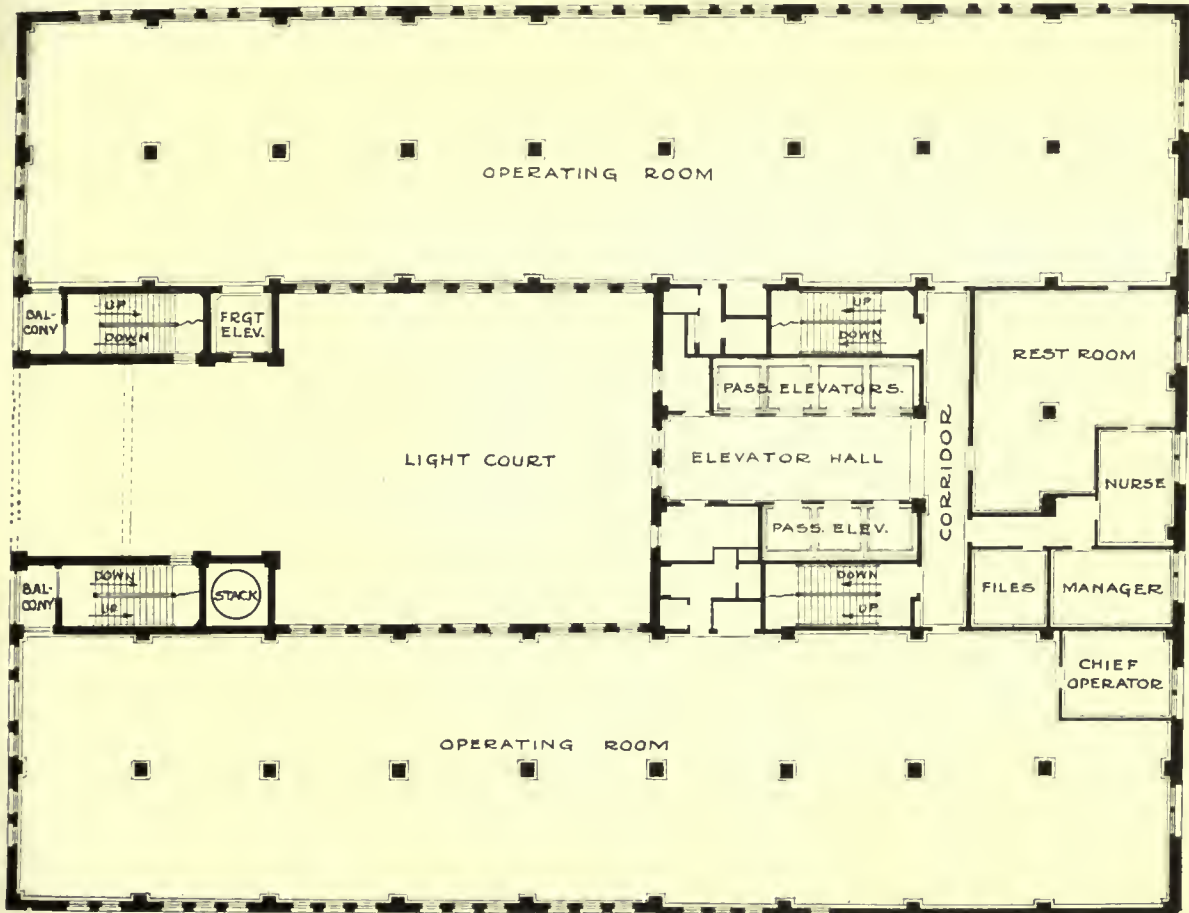

FOURTH FLOOR PLAN, FRANKLIN EXCHANGE, CHICAGO TELEPHONE CO., CHICAGO
HOLABIRD & ROCHE, ARCHITECTS

with rough finished brick of pastel shades and the roof covered with heavy graded slate. The interior finish is simple and is gray stained oak. The floors are finished cement with linoleum covering; cement base and wainscot throughout. The plumbing fixtures are of three sizes for children.

The central building contains the administrative offices, library, kindergarten and gymnasium. The west wing, first floor, contains dormitories, play-room, sun porch, lockers, toilet rooms and caretakers quarters, with a capacity for twenty-eight children under three years of age; the second floor

ice wing at the extreme south has, on the first floor the kitchen, store room, caretakers and servants dining rooms, canning room, engineers' and janitor's quarters; the second floor contains the sleeping quarters for the caretakers and servants; the third floor cares for twenty infants in two wards with changing rooms, sun porches and roof terraces.

Sleeping rooms are provided for one janitor, two engineers, one matron, one housekeeper, one seamstress, thirteen caretakers, two teachers, two nurses, twelve servants—a total of thirty-five. Accommo-

THE AMERICAN ARCHITECT.



VIEW FROM SOUTHWEST, YARD ELEVATIONS



THE ISOLATION PAVILION
CHICAGO NURSERY AND HALF ORPHAN ASYLUM, CHICAGO, ILLINOIS
HOLABIRD & ROCHE, ARCHITECTS

THE AMERICAN ARCHITECT

dations provided for one hundred and forty-six children, with an infirmary of twelve beds, making total of one hundred and fifty-eight beds.

In the group is an observation and isolation building, 57x37 feet in size, one and one-half stories high, furnishing accommodations for fifteen girls and fifteen boys, diet kitchen, pantries, quarters for doctors and caretakers, toilets and baths.

Taking the entire group in relation to the total number of children's beds, there is 3,106 cubic feet per bed at the cost of \$960 per bed.

The practice of architecture involves much

or the inspection of the plant in operation, will be of intense interest.

A POWER plant is not usually considered to be an attractive proposition from the purely architectural viewpoint. Like every other structure its design should properly express its purpose. We are all accustomed to power plants for a few hundred horse power and they are easily hidden in the structure which is largely devoted to other purposes. To house 220,000 horse power is a problem worthy of the most careful study. Its magnitude



CENTRAL PAVILION AND MAIN ENTRANCE
CHICAGO NURSERY AND HALF ORPHAN ASYLUM, CHICAGO, ILLINOIS
HOLABIRD & ROCHE, ARCHITECTS

more than the mere planning of a building for which a fee is received. There is a moral obligation included which demands that the building be suited for its purpose and render the utmost service to its occupants. When the occupants are children or those physically or mentally afflicted, the duty of the architect is greatly increased. The occupants of public institutions are not there by choice, but as a matter of necessity, or else are restrained for the public welfare. To the architect who appreciates these facts the study of this plan

demands that the treatment be dignified and worthy. While these buildings serve a mere utilitarian purpose, their immense size makes them a conspicuous object and a duty to the public and the surrounding property owners is to be considered.

The Northwest Power House of the Commonwealth-Edison Company, Chicago, is a plant of the capacity mentioned. Two buildings are required, one for the boilers and generators and one for the distributing of the electric power through the bus-board and switches. The design is severely plain



THE CARETAKER'S HOUSE, MARGARET MACKIN HALL,
CHICAGO TELEPHONE COMPANY, CHICAGO
HOLABIRD & ROCHE, ARCHITECTS

tunate that the owners and operating engineers of such plants insist on having the chimneys painted black. It is true that certain kinds of black paint are a very effective protection against the corrosion of steel stacks, but appreciation of appearances and the interest of the public should be considered. If such chimneys were painted in strong colors or light blue or pearl gray they would not be so noticeable and would really appear larger than when painted in black. The indistinctness brought about by a proper color scheme would cause this effect and the tops would be made barely visible by the light colored vapor emitted from the tops.

and treated with regard to the mass. The disposition of the ornamentation and fenestration is very carefully studied and the result is satisfactory. A very large, dark red impervious brick is used throughout the exterior except the fan, the coping and window-sills. The large panels in the distributing building and the manner of laying the brick are very effective.

Some power houses of extensive capacity have been designed in which details and motifs were adapted from classic, renaissance or gothic buildings. When we consider that the development of steam and electric power is a modern enterprise the temple or French Renaissance palace, in whole or in part, cannot express properly the modern power house. It is unfor-

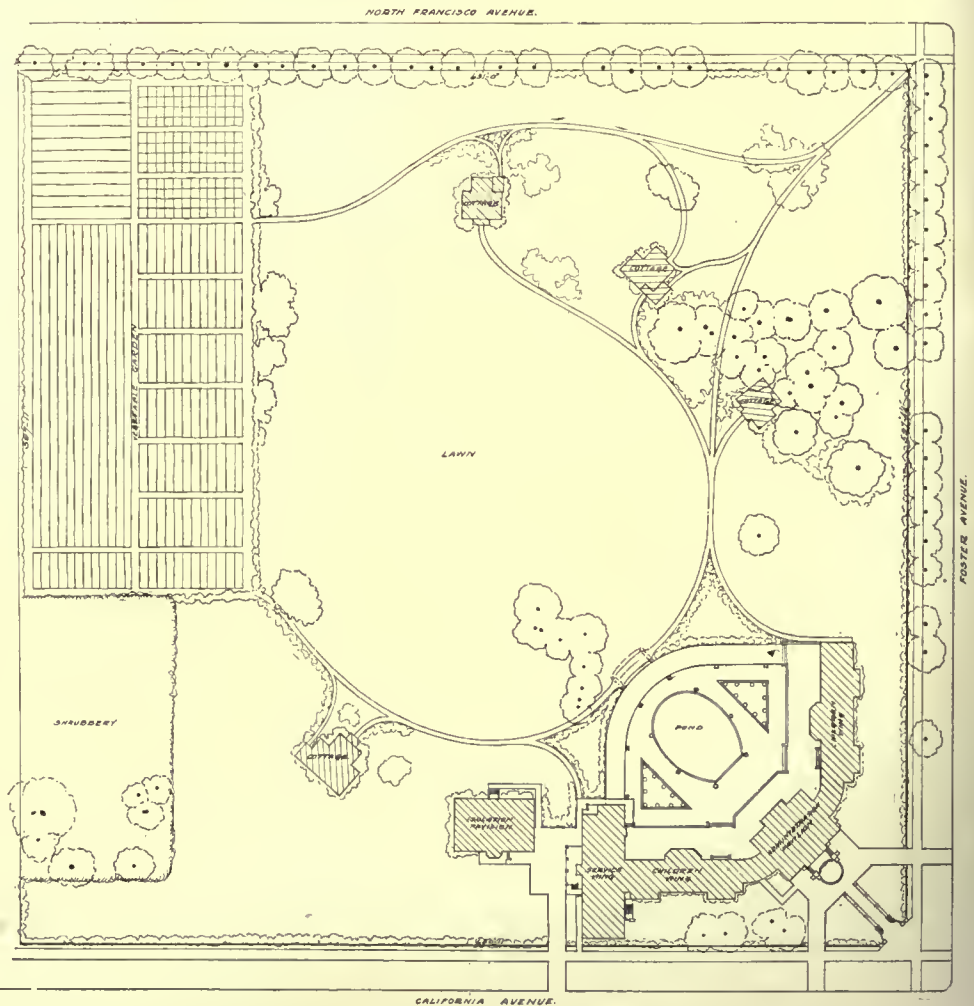

PLOT PLAN, CHICAGO NURSERY AND HALF ORPHAN ASYLUM
HOLABIRD & ROCHE, ARCHITECTS

Madrid's Scheme of City Planning

A REMARKABLE transformation is passing over the capital of Spain in the matter of its general appearance, and particularly its public, its semi-public and private buildings. The program of reconstruction has already been executed. In six or seven years the changes that have been made have been enormous and are deeply impressive. The new Casa de Correos, the many new banks—which indeed are more like palaces than banks—the new hotels, new buildings of every description, the new underground railway, and of course the Gran Via with all its new magnificent structures, including the Naval and Military Club—all these, and many more, make up a new Madrid that would puzzle somewhat those who only knew the old one.

Such a great process of transformation is unique in the history of cities; it has been necessitated by the peculiar circumstances of the history of Madrid, and the vastly changed fortunes of the country which, now rich, wishes for a better capital for itself. And while one speaks so much of Madrid, this note of transformation, improvement and beautification is repeated in many other parts of the country. It is heard clearly in Bilbao and in Vigo, and its echo rings in Barcelona.

The acknowledged chief architect of the country, who has designed and carried out a majority of the most important constructions of recent years, is Antonio Palacios, who gave an interesting interview to a representative of the daily press, at his residence in the very center of Madrid.

During an interval in the conversation, he mounted to what he playfully called his Madrilenian "azotea," one of the highest points of Madrid. From the mass of masonry the Casa de Correos and the Rio de la Plata Bank stood out prominently in one direction, and it was curious that the bank seemed to vie for prominence with all the rest, not to be beaten either. Its huge Corinthian columns rose majestically, and the "atico" which rests upon the massive square block seemed like the lid of a gigantic and beautiful box.

"That is rather interesting in a way," Mr. Palacios said, "for in the case of that bank I had a peculiar problem to solve. As you see it stands across the plaza almost opposite to the new Casa de Correos, which was built before it, and which obviously challenged comparison with any other architecture in the neighborhood, and challenged it fearlessly.

"The difficulty, however, was, that they had but a small plot of land for it, 1,000 square meters, since they desired this site in the Alcala at the corner of the Calle de Barquillo, and in the other direction along the Alcala they were absolutely stopped by the building and gardens of the War Department. The ground occupied by the Casa de Correos is twelve times as extensive as that at the disposal of the bank, but my building was to bear a certain comparison. There it is!" It certainly bears the comparison well, for it stands up strongly and boldly among all the edifices of the capital. It is in a neo-Grecian style, and it is stated that those marvelous columns cost 70,000 pesetas each.

"The problem of the architect now is difficult. There is Vigo, for instance. I am greatly interested in Vigo, which has, I think a magnificent future as the chief Atlantic port of Europe. I am interested in it professionally as well as personally. The new theatre which I planned, and which will be one of the finest in existence, is approaching completion. Vigo, as it is, has been a natural evolution like other cities, but its situation is very difficult for development, because it lies largely on a slope.

"Vigo will be different from most other cities in Spain; it is even different now. It is in constant, close, and what you might call personal contact with the English ports; it has English influences upon it, and when it wants a new thing it is inclined to look toward England, to Liverpool or London, with which it is in continual communication, for an idea.

"As to improvements and new buildings in general," Mr. Palacios continued, "the chief and really only difficulty, in the matter of a speedy fulfillment of our ambitions and intentions, is the labor one. There is the universal desire on the part of municipalities, private communities and the people to build and improve, and the money is always ready. The money is the least of all difficulties; it is, in fact, no difficulty at all."

The scene of conversation being transferred from the housetop to the studio, the architect produced the scheme of his magnum opus, the plans for the reconstruction of the whole of central Madrid, which he now exhibited for the first time. It is indeed a marvelous proposal. The plans are now being laid before the "ayuntamiento," or municipal council, for consideration.

Architectural Quicksands

By CLINTON H. BLAKE, JR., of the New York and Federal Bars

Part III

Protect Your Rights in the Plans

IN another rather interesting case an architect developed a very unique and clever plan for a certain type of semi-public building. The plan combined unusual elements both of utilitarian and artistic merit. After the architect had made the preliminary sketches, been responsible for the completion of the plan and completed the drawings, the client paid him for the work done up to that point, and then turned over the work to another firm of architects, who proceeded with it and supervised the erection of the building. I do not know whether these latter architects were aware of all the facts, and prefer to assume that they were not in view of the ethics involved. The net result unquestionably was, however, that the architect whose talent and ability was responsible for the idea received a very modest sum for the sketches and plan, and that the chief compensation was received by the architects who superintended the construction in accordance with the plans which my client had made. There was nothing which the latter could do as between himself and his client, as he had neglected to make any contract or secure any memorandum covering the relationship between the client and himself. In the absence of an agreement, the law governing the case provided that the plans belonged to the client and not to the architect, and the client, having paid for the plans, had consequently a legal right to turn over the work of superintendence to the other architects. If my client had had a contract, he would have been protected, as the contract contains a simple but sufficient provision vesting the ownership of plans in the architect and covering the contingency in question. There would consequently have been no possibility of the client taking the action which he did, and the architect would not have laid himself open to the treatment which was thus accorded him.

Alternative Forms of Contract

THIS architect has now adopted, as a regular policy of his organization the making of a contract between his clients and himself. Recognizing the fact that in many cases it is not practical to insist upon a full form of contract which may look a bit too formidable to some clients, we have prepared for him two alternative forms of contract.

The one is in a full form, providing for all contingencies which are at all likely to arise, and covers the rights and relationship of the parties in detail. This form is, of course, preferable where it can be employed, as it is the result of a study and knowledge of the difficulties which various clients have actually experienced in their practice, and provides against a repetition of them. In its printed form it is on one sheet of paper. The face of the paper, where the signatures are attached, bears only a few lines reciting the agreement of the parties, and on the reverse side, in fine type, are given the general conditions and the like embodied in the contract. This arrangement makes the contract much simpler appearing than would be the case if the conditions, were embodied in the formal agreement clause at lengths on the face of the contract.

Notwithstanding the care which has been taken to make the contract appear as simple and innocuous as possible, there are inevitably now and then clients who do not care to sign the long form of contract, or clients who might be quite willing to sign it, but to whom the architect does not care to suggest signing it. For these cases the second and so-called short form of contract has been prepared. It consists of a very few lines reciting the employment of the architect and incorporates, among its terms, simply by reference, and without setting them out as a part of it or at length, the terms and provisions of the schedules of practice and charges of the American Institute and of the New York Chapter and the canons of ethics of the American Institute. There are a number of important points which the schedules of the Institute and the New York Chapter and the canons of ethics do not cover, so that as to these, the short form contract is silent, whereas they are covered by the longer form. Nevertheless, the short form has been found to serve a most useful purpose. It is immeasurably better than no contract, and it would be a captious client indeed who would take any offense at a request that he sign it. As a matter of fact, I have in some cases incorporated in it, without sacrificing its generally brief form, provisions sufficient to meet a number of the points which are not covered by the schedules of charges and practice.

Both of these contracts are printed in moderate quantities and kept in the office of the architect ready for immediate use. Wherever circumstances are

THE AMERICAN ARCHITECT

such that the fuller form may be used it is employed. Where this is not practicable, the short form is relied upon. Since these contract forms have been in use in the office of this architect, he has not once had occasion to resort to legal proceedings as between his client and himself, in any case where the contracts have been used. The contracts have been accepted by his clients as a matter of course, and the clients have, I think, been rather favorably impressed by the business-like character of the proceeding. It is needless to say that there is nothing in either contract unfair to the client. The contracts merely give definite and concrete expression to the terms upon which the parties, in fairness to each of them, should proceed, instead of having these terms to conjecture and inference, and so inviting disputes and misunderstanding.

Payment for Plans Made But Not Used

UNDER the present extraordinary post-war conditions definiteness in the preliminary understanding with the client is of unusual importance. Building costs are such at the present time that, in repeated instances, it will happen that the client will consult the architect, request him to prepare sketches, plans and specifications, and advertise for bids, and then, when the latter are received, decide that the cost is prohibitive and abandon the purpose of letting the contract and proceeding with construction. Where this occurs, it is amazing how many clients, including men familiar with and trained in business dealings, seem to have the impression that the architect is a sort of eleemosynary institution, and that he is not entitled to any compensation for the work which he has done, inasmuch as the job has not actually been proceeded with. This is especially true in those cases where the architect has prepared preliminary sketches only and the project is then abandoned. The client assumes, apparently, that such sketches are submitted merely in the hope that they will be acceptable and that the work will then be proceeded with and that the architect is giving his time and experience to the preparation of the sketches, on the chances that by doing so he will be selected as the architect for the job when and if—especially *if*—the client decides to go ahead with it.

There is manifestly no reason why the architect should not be paid for the work which he does, irrespective of whether or not the client decides to make use of the sketches and plans and complete the building operation. No architect can afford to prepare the many sketches and layouts desired and required by optimistic clients who believe that despite prevailing building costs they will, in some way and in their particular building operations, be

able to secure moderate bids, unless he is to collect the value of the work done by him in preparing them. The law recognizes that this is so and, in the absence of a formal contract, allows him to recover in such a case on the "quantum meruit" theory the reasonable value of the work done. The architect cannot afford, however, to run the risk of the expense and loss of time and good will incident to repeated misunderstandings with clients regarding payment for such preliminary work. By exercising the slight care necessary to secure a contract with the client all this difficulty will be obviated and the client will know, in the beginning, that the architect is to be paid for whatever work he does, irrespective of whether or not the work is utilized by the client thereafter and the building erected.

The high cost of building today also emphasizes, with special clearness, the necessity of avoiding any reference to an implied guarantee of cost. A little negligence on this point, under present building conditions, may result in a claim against the architect for many thousands of dollars. At a time when builders, almost without exception, are refusing to give binding estimates or make bids for work done and are insisting upon cost plus percentage contracts, it is self-evident that the architect must exercise special care to so conduct his interviews, correspondence, and dealings with the client, that there may be no ground whatsoever for any claim by the latter that the architect has assumed any obligations with respect to the cost of the building, or made any guarantee that the cost will not exceed a certain amount, or in any way assumed liability in connection with the job, other than the ordinary obligation to perform his work in good faith and with reasonable care, skill, and intelligence.

Avoid Misunderstandings of Institute Schedules

THE architect who suffers most, by reason of a failure to arrive at a preliminary and definite understanding as to the amount of his commission, is he whose regular percentage charge is larger than the minimum charges specified in the schedules of the American Institute and of the chapters of the Institute in the states in which he practices. The rates given in the schedule of the American Institute and in the schedule of the New York Chapter are *minimum* rates, and the schedules specify that they are such. Nevertheless, even a client who has heard of the American Institute and of its schedules of charges, as most clients unquestionably have not, will often assume in perfectly good faith, in the absence of a definite agreement, that a charge by the architect in excess of the charges specified in the

THE AMERICAN ARCHITECT

Institute's schedule is an excessive charge. I had occasion but recently, in the interest of a client, to interview a business man of long training and large affairs, with reference to a claim due and unpaid to my client. The architect, in submitting his charge, had made some reference to the schedule of charges of the American Institute. The business man in question, noticing this, had carefully provided himself with a copy of the schedule of the Institute and also with a copy of the schedule of the New York Chapter. As soon as our conference opened he made the point that the charge was exorbitant, in that it was in excess of the charges specified in these schedules, that the price to be paid had never been agreed upon specifically, and that for these reasons he would not pay the bill as rendered. As a matter of fact the percentage charge was entirely reasonable, and any experienced member of the profession would have recognized it as an entirely proper charge to be made by an architect of my client's standing, for work of the character involved. No amount of argument on my part could at first convince the client that the architect was not acting improperly in charging a higher rate than that specified in the Institute schedule. The fact that the schedule specifically stated that the amounts specified therein were the minimum amounts which an

architect should charge, and the fact that my client was regularly receiving fees on a much higher percentage, affected him not at all. He would acknowledge, after considerable argument, that the schedule as worded did refer to a minimum charge, and within the next few moments would again assume, with a complete lack of logic albeit in entire good faith, that the schedule nevertheless did not contemplate the making of a higher charge. Finally, following repeated interviews and conferences, I succeeded in getting him to refer the matter to his counsel and it was then agreed that the charge as made would be allowed. The net result was that in securing the acknowledgment of the claim, many hours of my time and of my client's time had been taken up with interviews, arguments, correspondence and the like, and the client, I firmly believe, is convinced to this day that he was not dealt with in entire fairness. If an agreement had existed the question would never have arisen; the entirely proper charge as made would not have been questioned; the rates of the American Institute would not have been introduced into the matter or complicated the issue; the client would have been satisfied and not disgruntled, and the architect would have avoided the loss of his time and the expense which he incurred for legal services.

Portico of St. John's Chapel, Varick Street, New York

(See reproduction of the original drawings by O. R. Eggers in this issue)

NEW YORK'S growth is glacier-like in its movement. Slow, but irresistible. Whatever obstructs its progress is swept aside or over ridden. Dignified St. John's has shared the fate of many another of our venerable and venerated structures. The extension of Seventh avenue and the building of the subway has caused the passing of this church.

Another of the chapels of Trinity Parish (St. Paul's Chapel has been previously illustrated), and while not as old as St. Paul's, having been built about 1807, it was none the less a structure that all New Yorkers regarded with great respect and many with the attachment of actual association.

The master builders, which in those days was equivalent to being the architects, were T. C. Taylor, Henry Hedley, Daniel Domanick and Isaac McComb. The original location of this church was one of the most attractive in New York. It stood on the easterly side of St. John's Park whose em-

bowered walks were a favorite recreative spot for the well-to-do residents of the neighborhood.

In the early 70's the New York Central Railroad secured this park for a downtown freight terminal. This unfortunate occurrence not only changed the character of the residential section nearby, but the influence of so undesirable a location was felt for many blocks in every direction. What had been a neighborhood of aristocratic dwellings was reduced to a slovenly purlieu of ramshackle buildings.

St. John's was deserted, and its services became those of a strictly mission chapel. At last it ceased to exist. Those who venerate the traditions of New York could calmly watch its passing. The building was too good to have sunk to so low an estate and it was better that it should be razed. The memory of its graceful spire, its resonant bells and the shade of the portico, shown in Mr. Eggers' admirable sketch are to many, a reminiscence fraught with deep satisfaction and quiet contentment.

176^a



21

PORTICO, ST. JOHN'S CHURCH, VARICK STREET, NEW YORK
THE AMERICAN ARCHITECT Series of Early American Architecture





Wasting Opportunities

FIFTY years hence, the historian writing on the civic development of New York City will probably refer to Seventh Avenue as "a lost opportunity," just exactly as we now describe Times Square as an example of the failure properly to conserve our architectural resources.

With the erection of the Pennsylvania Station and the Hotel Pennsylvania, both by McKim, Mead & White, and the completion of Warren & Wetmore's Grand Central Station group, two exceedingly dignified architectural centers were established. There was a movement, unfortunately "dead aborning," to link these important terminals by a diagonal street that would be most advantageous in every way. The condemnations to effect this improvement were not prohibitive, but there lacked the necessary enthusiasm to carry it forward.

Seventh Avenue having been paved and redeemed as a traffic thoroughfare, it was hoped that the development between Times Square and the Pennsylvania Station would be of so fine a character as to make it one of the best in the city. Now it has apparently been taken over as the site for the new grouping of the garment making trades and there are in course of construction at least a dozen very important structures. It is not difficult to foresee that conditions that made lower Fifth Avenue so very undesirable and threatened with the same fate the shopping district between 42nd and 34th Streets will become permanent on Seventh Avenue.

Seventh Avenue between 42nd and 34th Streets was logically a hotel street, in the same way and for the same reasons as has secured for 42nd Street the location of our most important hotels. The few hotels now located on Seventh Avenue may soon find that conditions of street or sidewalk congestion will seriously impair the value of their location.

THE majority of the garment workers are colonized as to residence on the lower East side. The new location of the industry on the West side will create, if possible, an even worse

condition of crosstown surface car traffic than unfortunately now exists.

It has never been possible to get serious consideration of the project to colonize the garment industry in the suburbs. Just the number of people engaged in this business is not accurately known to us but it is very large. It is patent to even the casual observer of present conditions that the location of this industry in the suburbs would work for the very best results. The development of a community with proper housing, more healthful working surroundings would solve several important problems. It would help New York's East Side district to a less congested condition; it would swiftly advance the Americanization of a large number of people of a certain class that seem to resist any efforts to change them from old world ways which unfit them for the best duties of citizenship and correct social habits; it would conserve the dignity of Seventh Avenue, and, finally, it would lessen the force of that insidious propaganda for civic unrest that best flourishes in the purlieus of cities, the hiding places of men and women of pernicious activity.

An Efficient State Society

JUST exactly what is the value of state societies in the field of organized architecture can be learned by a careful review of the July *Monthly Bulletin*, the official publication of the Illinois State Society of Architects. Scanning the pages of this well edited publication it is found that in every phase of practice the Illinois society with watchful and efficiently directed energy is valuably functioning. In scrutinizing the examination papers for registration with a view of determining their proper value, in extending paternal and substantial aid to junior organizations, in safeguarding the ethics of practice or in taking steps to effect a pleasant and at the same time just relation between its own society and others that are allied to its field—the Illinois society is always alert. Perhaps a principal reason for this high efficiency lies in the fact that as a state society, the Illinois organization is a host unto itself.

There is no red tape of procedure in its action, no

THE AMERICAN ARCHITECT

slowing up by delay in reporting to a board of directors for permission to act. When there's something wrong this society sets it right. There is no procrastination. Its whole course is dominated by the two essentials to produce good results—action and efficient service. There's no patent or copyright on that sort of thing. It's as free as air, every state in the Union can similarly proceed. The marvel is, why they don't do it? New York has made a fine start and will with its fast increasing membership soon take its place at the front. Michigan has long been a wide-awake state in the matter of its society. There are several other states, more or less alive.

No good reason has ever been advanced for not extending organizations of state societies to every state. When that has been accomplished, organized architecture will become an important, dignified and truly representative thing. Meanwhile, there's the example of those states now thoroughly and efficiently working to set forth an argument so absolutely correct in its premise that no one may refute it.

The War Memorial In New York

NEW YORK CITY can prevent many a flagrant artistic error by so acting as not mistakenly to proceed in the matter of the proposed war memorial. One step in the right direction is the abandonment of the Grand Union Hotel site. As stated in these columns some time ago when discussing the proposed building for that site, by no stretch of imagination could such a type of building find place on that site and be a dignified memorial. Now that the city has disposed of the land, one menace at least has been removed. But there are others equally dangerous.

A certain group of the committee strenuously urge a memorial bridge: one built to carry all the varied traffic that now makes our city streets a maelstrom and a babel of discordant noises. We need a bridge across the Hudson, and we need one badly, but past experience has shown that there is no possibility of combining a respectful memorial aspect with such a structure. Imagine converting the approaches of any of the bridges across the East river into memorials for New York and Brooklyn men. The idea cannot be seriously regarded.

"Let us calm ourselves" states an editorial in the *Times*, "with a glance across the ocean. France, which has a native instinct and an educated taste in public memorials which have never been rivaled since 'the glory that was Greece and the grandeur that was Rome,' has decided to take counsel for ten

years; for fear of committing an atrocity upon her heroic dead." As everyone knows, they do these things better in France, and when they erect memorials they are such in the truest sense. They do not, as we have done in this country, proceed with ill-advised haste and create results which cause succeeding generations to feel the deepest regret.

Further, referring to the *Times* editorial, we learn that England is impetuously starting out on a path of error as great as that which now lies before us. With the Albert Memorial and the Shakespeare Memorial at Stratford as permanent "horrible examples" they are "trembling even more perilously that we are on the brink of abysmal folly." It is proposed to commemorate the great sacrifice of the British soldier by a gateway 100 feet high, with a great hall at its base and a temple on either flank, "the whole," says the *Times*, "in the style dear to Egyptian conquerors and slave drivers." And to this end, it is proposed to appropriate, and to desecrate one of the two of the finest sites in London.

What most forcibly strikes the patient, or perhaps more correctly speaking, impatient observer, is the ignoring of the existence of societies, the vary nature of whose organization absolutely qualifies them to take up, discuss and design the type of memorial we should have. We have no criticism to make as to the personnel of the present commission, as to their entire willingness to do the very best thing, but the majority is not equipped either by knowledge or training to undertake a problem of this character.

Why not give the whole thing over to the Fine-Arts Federation, receive their report and recommendations and submit it to the people for a decision? The Architectural League, the National Academy and the National Sculpture Society could bring to a discussion and determination of this important matter just the sort of ability that would insure success. Can this and similar great undertakings be spared the admixture of politics? It was by private effort that Stanford White's fine arch in Washington Square was left to mark the great work of Admiral Dewey. The great arch that the sculptors set up in Madison Square was lost in perpetuation because it became involved in a maze of local political manipulation.

France sets a good example. Better to wait a decade and do it right than, fearing the ignorant criticism of those who would rush us into some great error, take the best that is now attainable, never good, nor appropriate, and perhaps so ignorantly projected as to be absolutely disrespectful, and a constant source of regret.

Organization, Management and an Accounting System for an Architect's Office

By H. P. VAN ARSDALL, of Samuel Hannaford & Sons, Architects, Cincinnati, Ohio.

Part II

FIRM FINANCIAL RECORDS & COST SYSTEM:

This department keeps all financial records of the firm, including the cost system.

For many years the architectural profession has been endeavoring to find a system of accounting that would be applicable to their business. So far no general scheme has been devised that could be used universally. It has only been in the larger offices, where accounting systems have been installed. The writer knows from experience that the lack of an accounting system has proven very painful to certain architects. It is the common belief that the installation of an accounting system requires a large expenditure of money and the employing of additional help. This is true to a degree. The financial books, as outlined and shown in this article, cost approximately \$150, including ten thousand time cards. It is necessary, however, to spend more time on this system than on the old method of keeping books on the receipt and disbursement basis, but additional help is not required.

The financial records are designed for "double entry" and are kept on the so-called "accrual system." At the end of an accounting period (month) accrued wages, expenses, etc., are shown as liabilities, while fees earned but uncollected are shown as assets.

Deferred charges, such as prepaid insurance, are shown as assets and are extinguished by charging to an expense account the monthly proportion of the total amount. This procedure is necessary to show a true statement of affairs.

After all adjustments and entries from the journal to the ledger have been made a "trial balance" is taken from the ledger to prove the completeness of entry.

The cost system is planned so as to distribute overhead expense on the "Man-Hour Plan." Under this scheme no account is taken of the difference in rate of wages. It is assumed that every employee in a general way requires the same amount of supervision, light, heat, space, insurance, drinking water, toilet facilities, etc.

All time is divided into "Productive" and "Non-productive" hours. Productive time is spent directly producing some particular job. Non-productive time is spent on work not chargeable to any particular job.

Since overhead expense is a vital part of production costs it becomes necessary to distribute it in the proper proportion to the various jobs benefited.

To determine the amount chargeable to each job the rate (per productive hour) is found by dividing the total number of productive hours worked in the office during the month into the total overhead for the same period.

The total overhead is distributed each month.

The following model classification of accounts may be used for a small or large office. It can be extended or contracted in order to meet individual needs.

CLASSIFICATION OF ACCOUNTS.

1. *Assets.*
 11. Fixed Assets.
 111. Office Furniture and Fixtures.
 112. Books.
 - 113.
 - 114.
 - 115.
 12. Current Assets.
 121. Imprest Fund.
 122. Cash in Bank.
 123. Accounts Receivable (Controlling).
 - A
 - B
 - C
 124. Sundry Debtors (Controlling).
 - A
 - B
 - C
 125. Investment (Bonds).
 126. Materials and Supplies on hand.
 1261. Printing and Stationery Materials.
 1262. Drawing Materials.
 - 127.
 - 128.
 - 129.
 13. Prepaid Accounts.
 131. Prepaid Insurance.
 132. Advances.
 14. Working.
 141. Work in Process (Controlling).
 - 142.
 - 143.

THE AMERICAN ARCHITECT

15. Expenses.
 151. Draughting Room Salaries (To be Distributed).
 152. Engineering Expense (To be Distributed).
 153. Superintendents' Salaries (To be Distributed).
 154. Undistributed Expense (Overhead).
(Accounts 151, 152, 153 and 154 are all controlling accounts).
 1541. Non-chargeable time of principal.
 1542. Non-chargeable time of Draughtsmen.
 1543. Non-chargeable time of Engineers
 1544. Non-chargeable time of Superintendent.
 1545. Overtime allowance.
 1546. Lost time, vacations, etc.
 1547. Office Salaries (Controlling).
 - A
 - B
 - C
 1548. Rent.
 1549. Printing and Stationery.
 1550. Drawing Material.
 1551. Telephone and Telegraph.
 1552. Membership and Dues.
 1553. Donations.
 1554. Light.
 1555. Insurance.
 1556. Traveling.
 1557. Periodicals.
 1558. Legal and Accounting.
 1559. Taxes.
 1560. Depreciation of Equipment.
 1561. Bad Debts.
 1562. Miscellaneous Office.
 1563. Variations in Undistributed Expense.
2. *Liabilities.*
 21. Fixed Liabilities.
 22. Current Liabilities.
 221. Accounts Payable.
 222. Notes Payable (Loans).
 223. Salaries Payable.
 224. Sundry Creditors (Controlling).
 225. Variations in Undistributed Expense.
 226. Reserve for Depreciation.
 227. Reserve for Bad Debts.
 228. Accrued Expenses.
 229. Reserve for Lost Time, Vacations, etc.
3. *Proprietary Interest.*
 31. Capital Investment (Controlling).
 - A
 - B
 32. Surplus.
 33. Profit and Loss.

4. *Operation Profit and Loss.*
 41. Cost of Completed Work (Controlling).
 - A
 - B
 - C
 42. Fees.
5. *Incidental Profit and Loss.*
 51. Incidental Income.
 52. Incidental Expense.
 521. Interest.
 - 522.

In order to more fully explain the working of this system the writer feels that it is necessary to state the nature and purpose of all accounts under the classification.

1. *Assets.* — Assets Accounts represent values owned.

11. Fixed Assets.—Fixed Assets are properties owned that are necessary in the operation of the business. These assets, of course, are not to be sold. The subsidiary accounts under Fixed Assets are:

111. Office Furniture and Fixtures.
112. Books.

To these accounts is charged all new equipment and books that are purchased and have a life beyond one year's time. These accounts should be depreciated quarterly and the depreciation figured on a 10 per cent. annual basis. At no time should you reduce the original book value, but on the balance sheet deduct the allowance for depreciation in order that the original value will not be disturbed until it is completely wiped out.

12. Current Assets.—Current Assets represent values owned that are constantly changing in value. The following accounts come under Current Assets.

121. Imprest Fund.

At the beginning of operation this account is debited with a certain sum (say, \$25) and cash credited. This sum is placed in the cash box and is used for paying small current bills. When the fund is nearly consumed a check is drawn for the amount of bills paid during the period, restoring the fund to its original amount, and the various bills are charged to their proper accounts.

122. Cash in Bank.

Cash in Bank should represent at all times the amount of cash owned (not including Imprest Fund). All cash receipts should be deposited in the Bank intact and all disbursements made by check.

123. Accounts Receivable.

This is a controlling account and receives only the monthly totals from the Journal. The subsidiary accounts controlled by Accounts Receivable represents all moneys owing by

THE AMERICAN ARCHITECT

clients. When these accounts are debited with fees Account No. 42 should be credited.

Advances paid out for clients in the way of Building and Water permits, etc., are to be charged direct to client's account and cash credited.

124. Sundry Debtors.

This is a controlling account. The accounts that are controlled are the drawing accounts of firm members and other accounts of this nature.

125. Investments.

This account shows at all times any Bonds, Stock, etc., owned by the firm. It is credited when the Stocks, Bonds, etc., are sold.

126. Materials and Supplies on Hand.

This account is charged with all materials and supplies purchased and is credited monthly with all supplies used. The corresponding charge is made to one of the various expense accounts.

13. Prepaid Accounts.—The subsidiary accounts are such items as:

131. Prepaid Insurance.

This account is charged with all insurance premiums paid during the year and credited monthly with 1/12 of the total, and the corresponding charge is made to Account 1555.

14. Working Assets.—This account represents the work passing through the office. The subsidiary account is:

141. Work in Process.

To it is charged all Draughting Room expense, Engineering and Superintendents' time, and the total of the undisturbed (overhead) expense. This is taken from the Time Distribution Sheet and Overhead Distribution monthly. When work is completed this account is credited and cost of completed work debited.

15. Expenses.—The subsidiary accounts are:

151. Draughting Room Salaries Account.

This account is charged with all Draughting Room salaries, and at the end of the month is credited, and the amounts debited to proper jobs in Work in Process.

152. Engineering Expense.

This is treated the same as Account 151.

153. Superintendents' Salaries.

This is treated the same as Account 151.

154. Undistributed Expense.

This account controls the following subsidiary accounts:

1541. Non-chargeable Time of Principal.

All time of firm members not actually chargeable to jobs is debited to this account.

1542. Non-chargeable Time of Draughtsmen.

1543. Non-chargeable Time of Engineers.

1544. Non-chargeable Time of Superintendent.

These three accounts are treated the same as Account 1541.

1545. Overtime Allowance.

To this is charged any increased rate of pay that is paid to draughtsmen on account of overtime work. It is not just that any particular job should be burdened with this expense on account of it having been the particular job to rush through the office.

1546. Lost Time, Vacations, etc. (Draughtsmen, Engineers and Superintendents.)

This account is debited monthly with 1/12 of the annual amount set up in Reserve Account (229). A reserve account for Lost Time, Vacations, etc., will be set up, and the accrued expense shown as a credit each month and the same amount should be debited to this account.

When the actual money is paid out for the lost time, cash is credited, and the Reserve Account debited.

1547. Office Salaries.

Firm members are paid salaries the same as others in the office. The executive's salary is charged to overhead expense, and the other members are classed as draughtsmen or superintendents, as the case may be.

This account is charged with the salaries of the principal, the office business manager, stenographer and office boy.

1548. Rent.

This is paid monthly and is charged as a regular monthly expense. Credit cash and debit rent when it is paid.

1549. Printing and Stationery.

Charge this account each month with the amount of materials used and credit Account 1261.

1550. Drawing Material.

Treat same as Account 1549.

1551. Telephone and Telegraph.

Treat same as Account 1548.

1552. Membership and Dues.

This account is charged with all dues, membership fees, etc. If any one month should be overly burdened then a prepaid account should be set up and the expense distributed over the twelve months.

1553. Donations.

Treat same as Account 1548.

1554. Light.

Treat same as Account 1548.

1555. Insurance.

This account is charged monthly with 1/12 of the total annual prepaid insurance, and credit is made to Prepaid Insurance Account.

1556. Traveling.

Debit this account with all traveling expenses when it is not directly chargeable to a job.

1557. Periodicals.

Debit with all magazines, papers, etc.

THE AMERICAN ARCHITECT

1558. Legal and Accounting.
Charge with all attorney and accountant fees.

1559. Taxes.

An architect's taxes are usually small and it is not necessary to distribute the sum over the entire year. When taxes are paid, debit this account and credit cash.

1560. Depreciation of Equipment.

Debit this account monthly with 1/12 of depreciation charge and credit the Reserve Account.

1561. Bad Debts.

Handle same as Account 1560.

1562. Miscellaneous, Office.

Expenses of all other kinds are charged to this account (small).

1563. Variations in Undistributed Expense.

Where there is a balance in Account 225 it is charged out the next month and debited to this account.

2. *Liabilities*.—Liabilities are all values owed.

21. Fixed Liabilities.—Liabilities of a fixed nature only are credited to this account. Ordinarily, an architect has no fixed Liabilities, unless they have issued bonds or stocks.

22. Current Liabilities.—These are Liabilities that are alive and are constantly changing in value. This is a controlling account and has the following subsidiary accounts.

221. Accounts Payable.

All accounts due and payable are credited to this account.

222. Notes Payable.

Treat same as account 221.

223. Salaries Payable.

This account will be credited at time of closing books or when the end of the month falls in the middle of the week, with all accrued salaries up to date. When salaries are paid cash is credited and this account debited.

224. Sundry Creditors.

This account will be credited with all items not included under Accounts Payable.

225. Variations and Undistributed Expense.

Any balance at end of period remaining in Account 154 is absorbed by this Account.

226. Reserve for Depreciation.

This account is credited monthly with the regular amounts of depreciation fixed upon.

227. Reserve for Bad Debts.

This account is credited monthly with the approximate or estimated allowance for bad debts.

228. Accrued Expenses.

At the end of any accounting period any expenses not as yet paid, but accrued, are credited to this account.

229. Reserve for Lost Time, Vacations, etc.

This account is credited monthly with 1/12 of the annual estimated lost

time, etc., and the corresponding debit made to Account No. 1546.

3. *Proprietary Interest*.—This account represents the net worth of the business. The subsidiary accounts are as follows:

31. Capital Investment.—This is a controlling account and shows the original investment at start of business and represents the amounts paid in by the firm members.

32. Surplus.—All profit or loss at end of year is debited or credited to this account, as the case may be. Any dividends paid are debited to this account.

33. Profit and Loss.—All trading or operating accounts are closed into this account at the closing period, or once a year.

4. *Operation—Profit and Loss*.—Accounts Nos. 41 and 42 are closed into this account at end of accounting period.

41. Cost of Completed Work.—This account is a controlling account and controls all jobs that have been completed. These are listed in alphabetical order and on the completion of any job, Work in Process is credited and this account debited.

42. Fees.—When Accounts Receivable is debited with a fee this account is credited.

5. *Incidental Profit and Loss*.—Accounts No. 51 and No. 52 are closed into this account at the end of accounting period.

51. Incidental Income.—This account records any earnings received outside of the regular order of business, such as money paid for renting a portion of the office to an outside person.

52. Incidental Expense.—This is a controlling account and has the following subsidiary accounts:

521. Interest.

This account is debited with any interest paid out. Interest cannot be charged as an Overhead expense.

ORIGINAL ENTRIES:

In opening the books a Balance Sheet is prepared, listing in detail Assets, Liabilities and Capital. These items are then entered in the Journal, and from the Journal posted to the Ledger.

OPERATION OF SYSTEM:

The forms presented for the operation of the system are handled in the following manner:

The Daily Time Card (Form No. 7) is arranged in half-hour divisions and it is a simple matter for a draughtsman to indicate on the card just what particular work is performed during the day. A white card is used for productive work and a blue card for non-productive work. It is not necessary, but advisable, that a separate card be used for each job worked on during the day, since this permits of

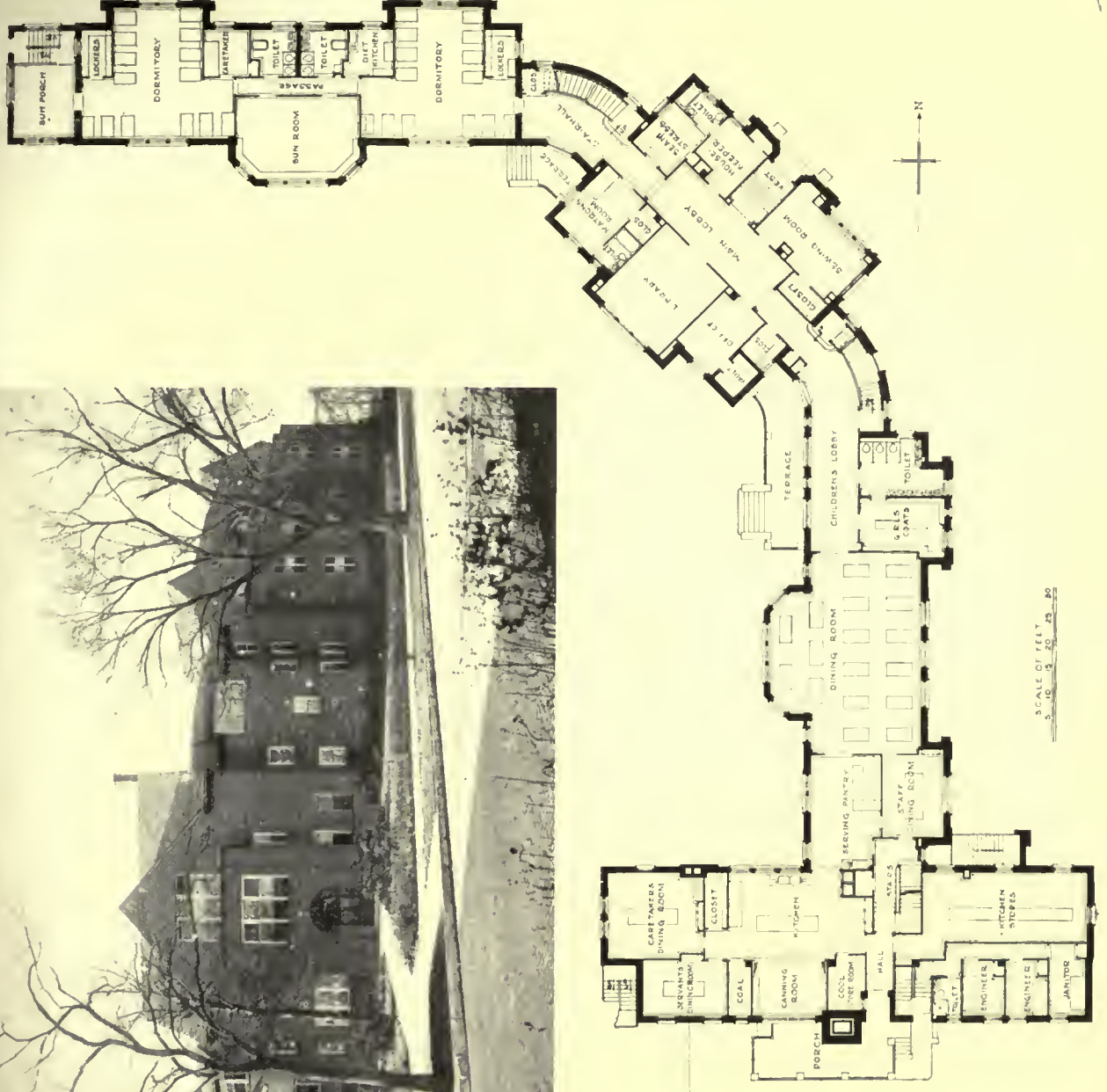

VIEW FROM NORTHEAST
AND FIRST FLOOR PLAN,
CHICAGO NURSERY
AND
HALF ORPHAN ASYLUM

HOLBIRD & ROCHE,
ARCHITECTS

1321





DETAIL OF MAIN ENTRANCE AND SECOND FLOOR PLAN

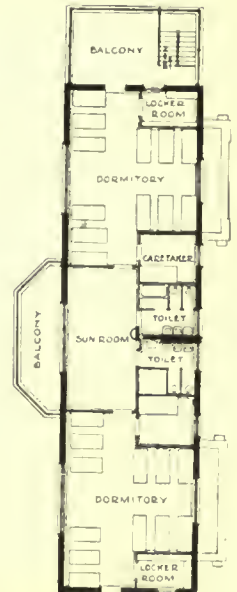

CHICAGO NURSERY AND HALF ORPHAN ASYLUM

HOLABIRD & ROCHE, ARCHITECTS

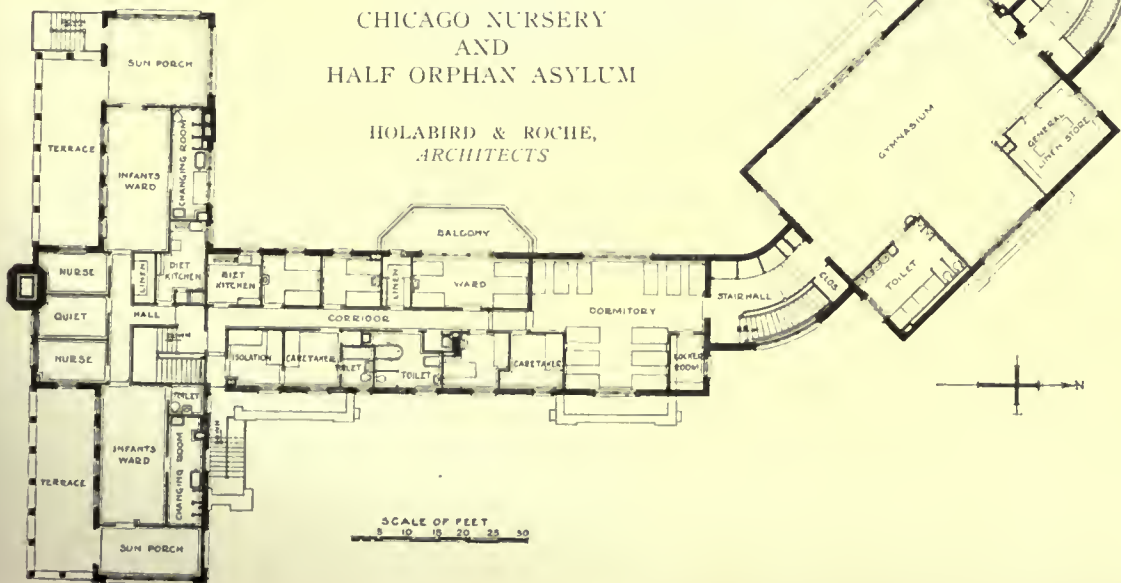

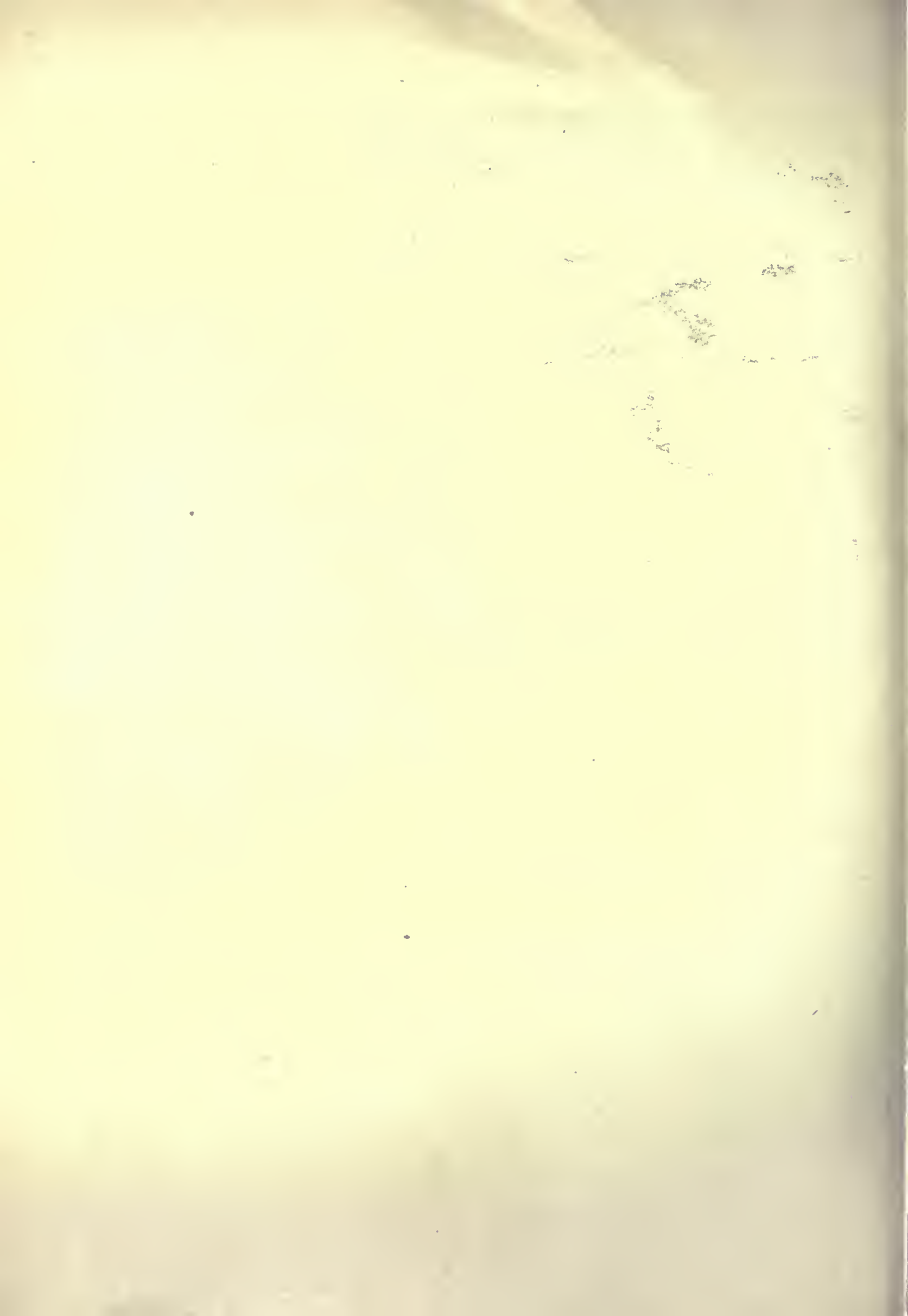

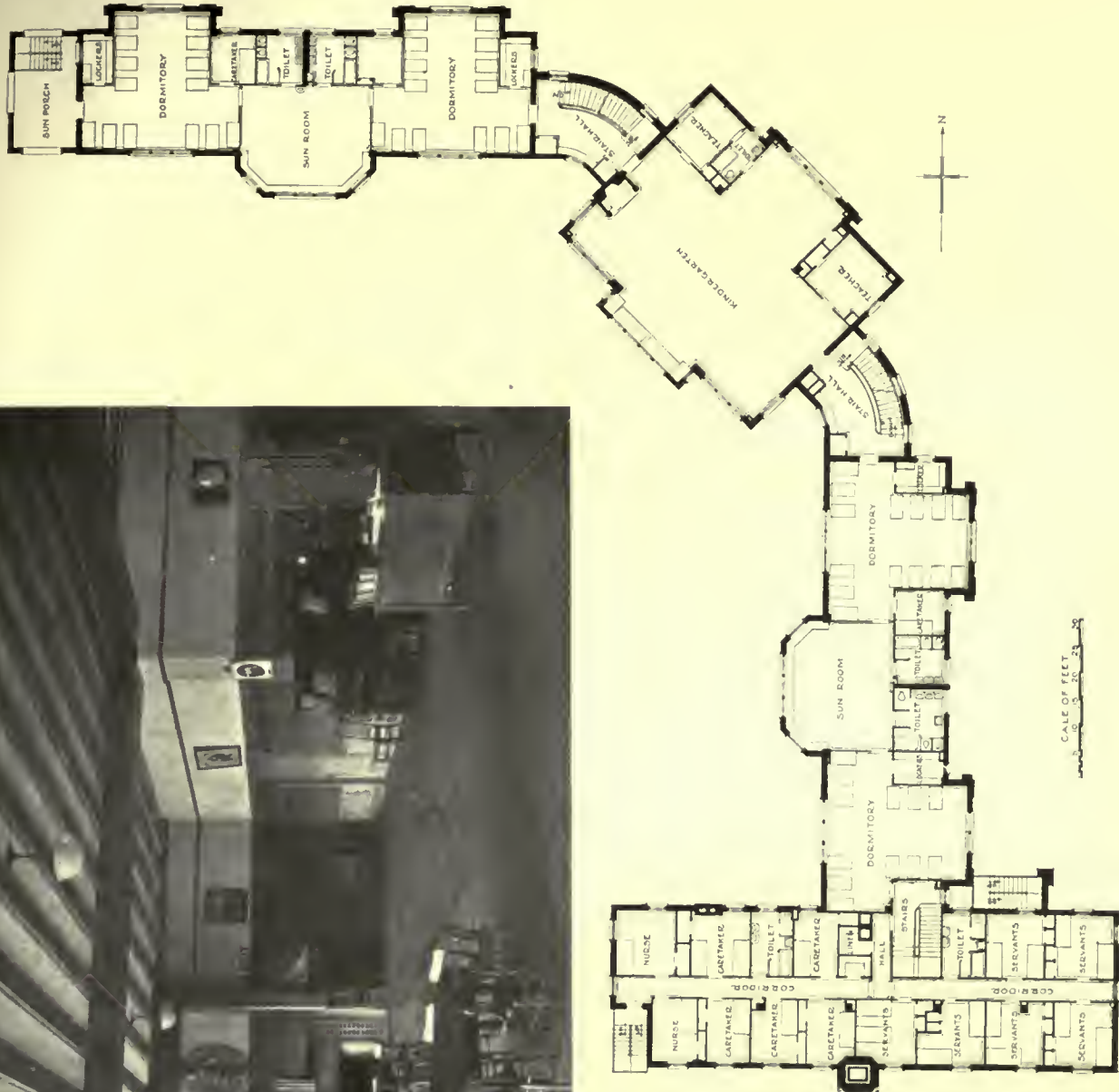

VIEW OF KINDERGARTEN AND
 THIRD FLOOR PLAN
 CHICAGO NURSERY
 AND
 HALF ORPHAN ASYLUM
 HOLABIRD & ROCHE,
 ARCHITECTS

182



182



NORTHWEST STATION, COMMONWEALTH EDISON COMPANY, CHICAGO
HOLABIRD & ROCHE, ARCHITECTS

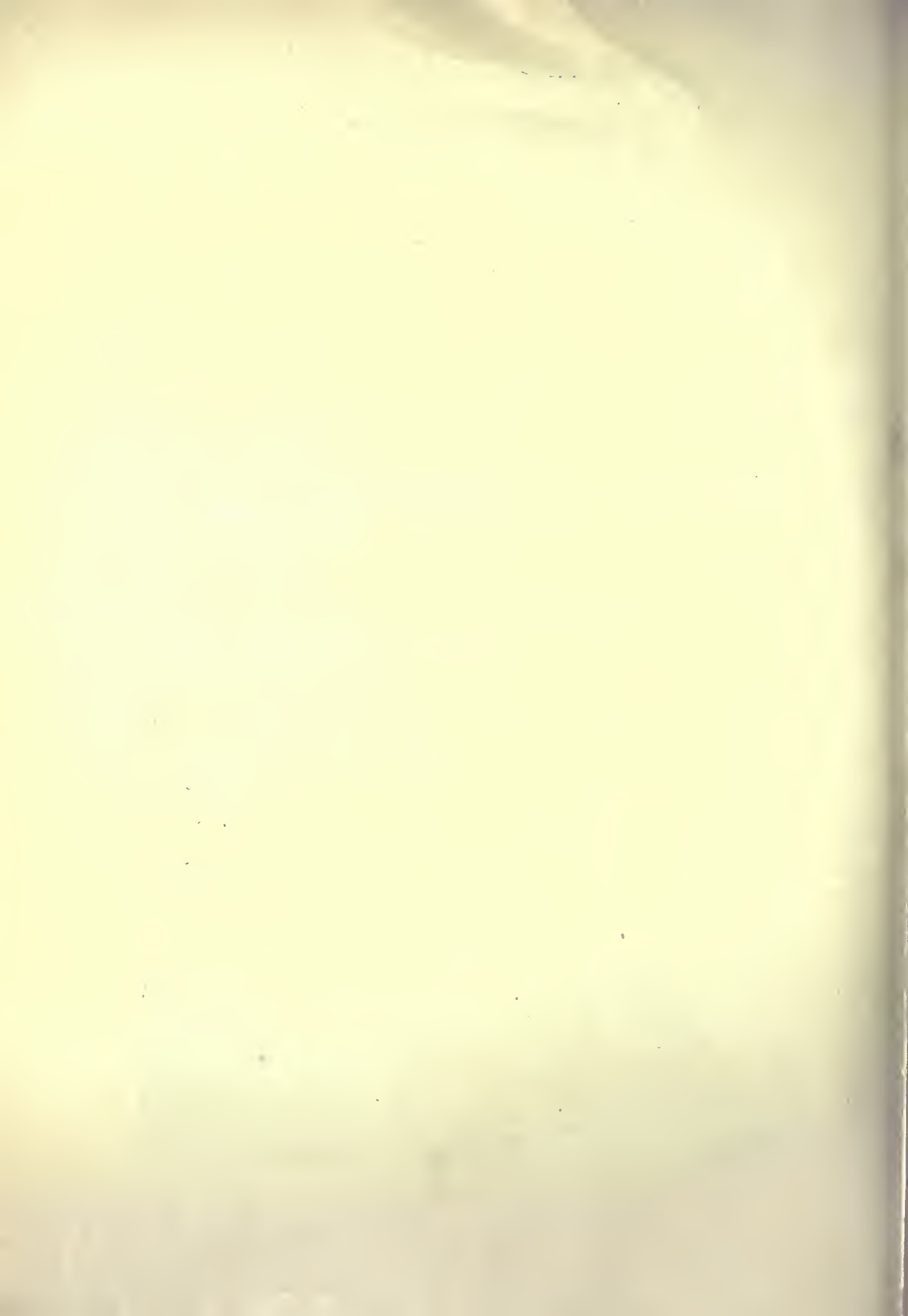



MARGARET MACKIN HALL,
CHICAGO TELEPHONE COM-
PANY, CHICAGO, ILLINOIS

(See text for other illustrations)



HOLABIRD & ROCHE,
ARCHITECTS





FRANKLIN EXCHANGE, CHICAGO TELEPHONE COMPANY
HOLABIRD & ROCHE, ARCHITECTS

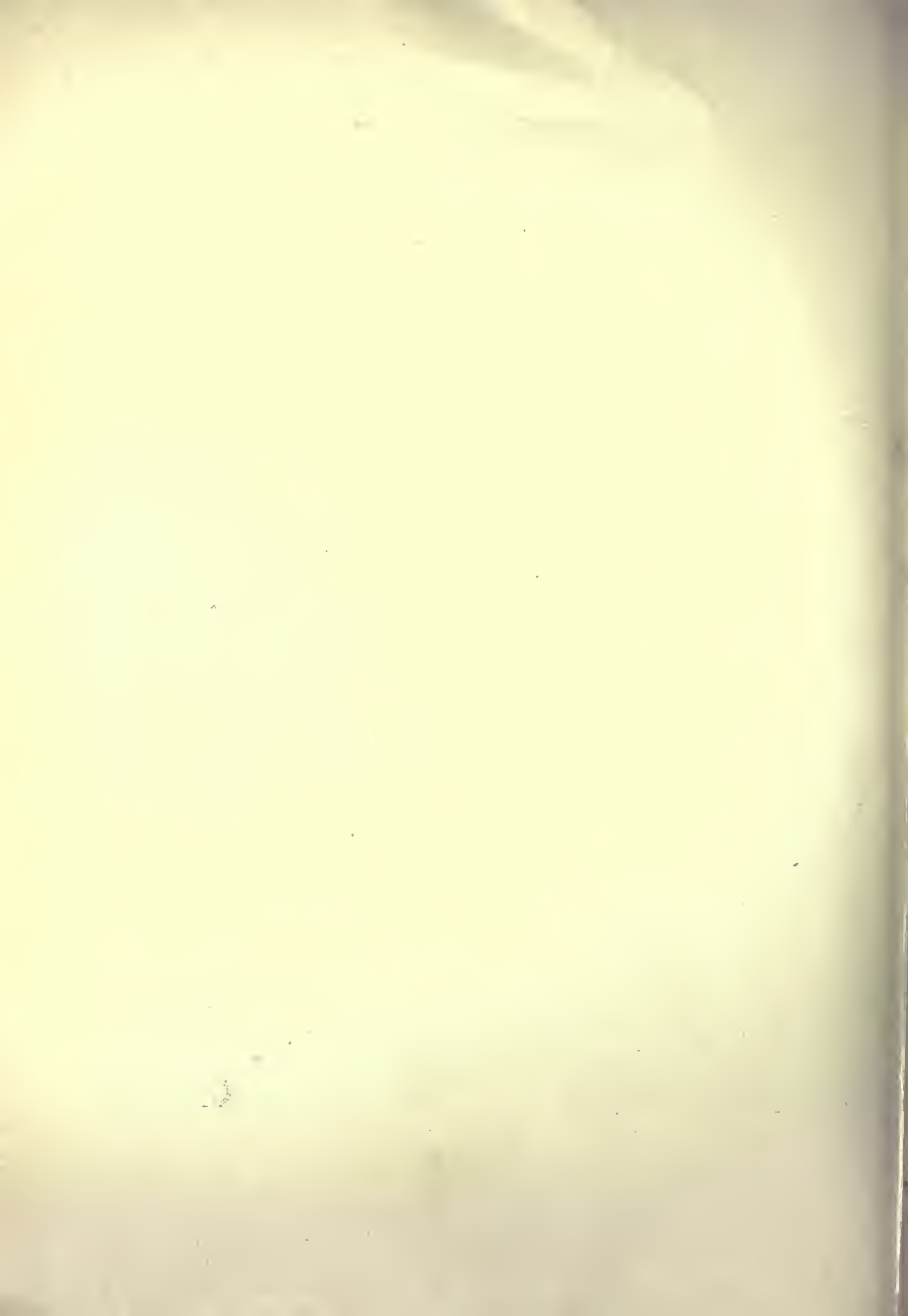

182



DETAIL OF MAIN ENTRANCE
KILDARE EXCHANGE, CHICAGO TELEPHONE COMPANY
HOLABIRD & ROCHE, ARCHITECTS
(See text for other illustration)



152

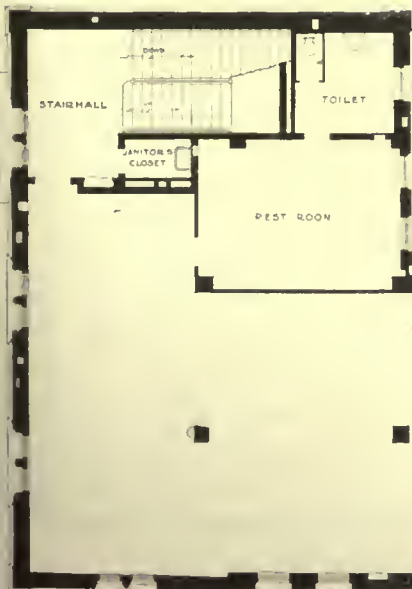

McKINLEY EXCHANGE, CHICAGO TELEPHONE COMPANY
 HOLABIRD & ROCHE, ARCHITECTS

FIRST FLOOR PLAN



u
162

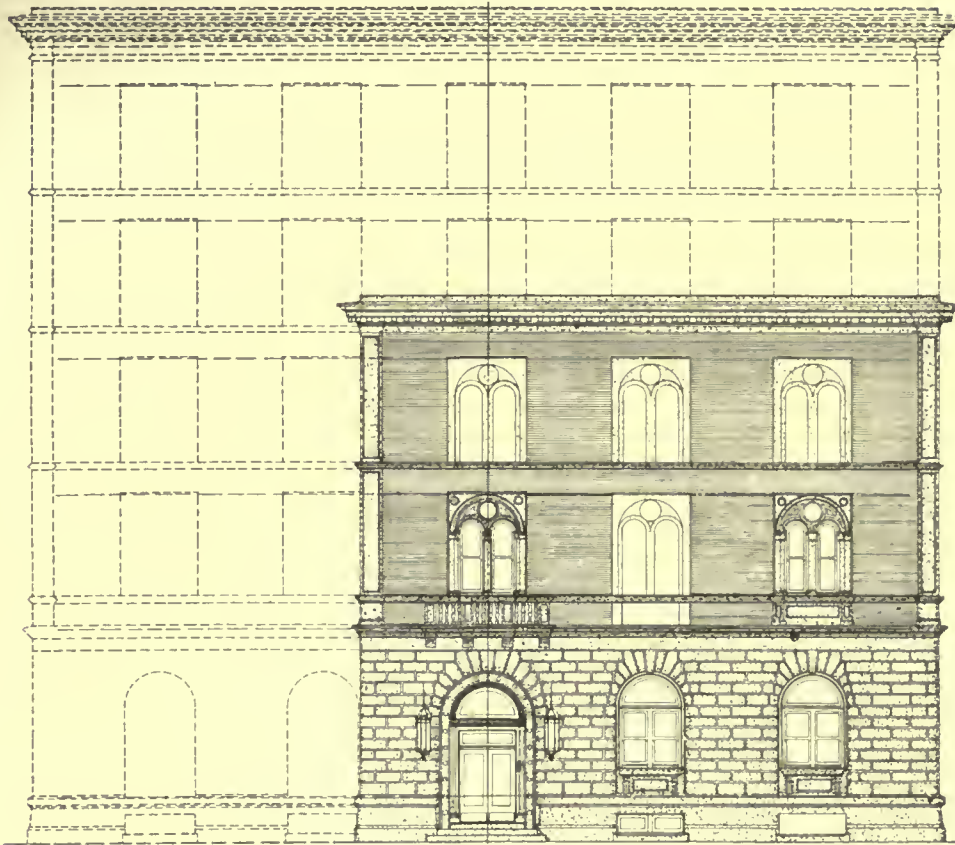

McKINLEY EXCHANGE,
CHICAGO TELEPHONE COMPANY
HOLABIRD & ROCHE, ARCHITECTS

SECOND FLOOR PLAN



THE AMERICAN ARCHITECT

the filing of all cards together that show time for one job. Cards are gathered up daily and are entered on the monthly individual time summaries (Form No. 8).

On Form No. 8 time for the various jobs that have been worked on during the month is listed in the columns indicated. Also, all the time that is non-chargeable to jobs listed, and at the end of the

time space, as provided. These totals are then debited to Work in Process and Undistributed Expense, respectively.

At the bottom of the Time Distribution sheet the totals of the individual columns under employees' names are credited to the individual salaries accounts. This is done on account of charging the regular pay roll to Salary Accounts in the ledger. It then becomes necessary to credit these accounts and place salaries in Work in Process. The reason for this is to have a record showing all salaries paid. You then enter on the journal (Form No. 10) the charges to Work in Process and charges to non-chargeable time and credit the individual salary accounts.

You are now ready to distribute the Overhead Expense (Form No. 9). Since the man-hour basis for distribution is being used we enter productive time opposite the various jobs in the columns for the various employees and carry the total horizontally over its proper space on the right-hand side of the sheet. Since we know the total productive man-hours for the month, and the overhead for the month, the rate can be found by dividing the total man-hours into the total overhead.

When the rate has been determined, this figure is used for arriving at the overhead for each particular job during the month. Entries are then made to the journal and the various jobs charged. The total of the overhead column is then credited to Undistributed Expense, which places all of the time and overhead during the month in the proper Work in Process account.

In designing the Journal it was thought best to use one book instead of having separate journals for cash receipts, cash disbursements and so on.

You will note that all accounts that are used frequently have been allotted special columns. Those that are infrequently used will be handled through the Other Accounts column and be designated by their proper numbers. The necessary columns have been provided for work in process and a single column for Cost of Completed Work.

The other forms, No. 11 and No. 12, are self-explanatory and need no discussion.

The forms shown are bound in books and filed as follows:

Form No. 7, the Daily Time Cards, are filed in medium weight envelopes, 5 by 7¼ inches. These are placed in the ordinary standard alphabetical wood file case.

Form No. 8 are kept in a loose leaf binder 9 by 11½ inches.

FORM 1 BM 1-1-20

SAMUEL HANNAFORD & SONS
ARCHITECTS
CINCINNATI, OHIO

DAILY TIME CARD

NAME P. J. Henry
DATE 4/26/20

HRS.	REMARKS
8.00	
.30	
9.00	
.30	
10.00	4 The Y & K. Auto. Co. Details
.30	
11.00	
.30	
12.00	
.30	Lunch
1.00	
.30	
2.00	4 Same Form #7.
.30	
3.00	
.30	
4.00	
.30	
5.00	
EXTRA TIME	8

DESIGNED BY H. P. VAN ARSDALL

APPROVED BY H.P.V.

month the total hours for each job is inserted in the "Total Hours" column, and the adjoining Amount Column contains the cost in dollars.

The monthly time summary for each employee is then taken and distributed on the Time Distribution sheet (Form No. 9) to the proper jobs. You will note there is a space for each employee's account number. (The account number is used instead of writing out the name), and just below it, in the corresponding column, is the total time, in dollars, for the month opposite its particular job. The horizontal extension of this time is placed in draughting, engineering and superintending, or non-chargeable

THE AMERICAN ARCHITECT

AUGUST 11, 1920

Samuel Hanesford & Sons
Architects,
Cincinnati, Ohio.

Time Distribution
Month of April 1920

Sheet No. 4
Entered in Journal
Line 27

Account Job or Name.	EMPLOYEES' NAMES (shown by ACCOUNT NUMBER IN BLOCK BELOW)												Total Credits		Total Debits		✓
	1511	1512	1513	1514	1515	1516	1517	1518	1519	1520	1521	1522	1523	1524	1525	1526	
The Van Dyke Co. #1							1280							1987			
Do #2			17728		164722		4376							20417			
The Van Dyke Co. #3			74											5846			
B of P - C. Hill School			18124		16934		29764							74769			
IR St. Charles														46117			
St. Charles														7887			
Saint Y. Church								899						498			
Washington Hospital														1817			
Franklin Hospital														933			
Kidney Dist. Co.														111			
South Bank														1955			
The Renaissance Co.														8178			
Mrs. Williams														8			
HP. Greene Lodge														2822			
The State O.S. Co. #2														1778			
Springfield Hospital														319			
Ridge Mission														744			
W. J. Jones Keefer														233			
W. J. Jones Keefer														27919			
Individual Salary Accts.														3123			
Totals														124623			

Man-Hours % Distribution of Overhead Expense.
Productive hours 151 1/2
Non-productive hours 79 1/2
Total hours → 170 1/2

Man - Hours	%	Total Overhead	Distributed
12	7%	8.64	8.64
38	22%	24.12	24.12
195	114%	122.40	122.40
1	1%	0.64	0.64
22	13%	14.08	14.08
97	57%	61.63	61.63
4	2%	2.56	2.56
43	25%	28.00	28.00
20	12%	12.80	12.80
5	3%	3.20	3.20
Total		170 1/2	170 1/2

Subtotal → **1311.42**
Credit Undistributed Account with Total Overhead **1384.84**

12-18-1919

JOURNAL ENTRIES

SHEET NO. *1*

January 1920

WORK IN PROGRESS - Amount in Dollars				OTHER ACCOUNTS				CREDIT				DEBIT			
Checked	Debit	Amount	No.	Checked	Debit	Amount	No.	Checked	Debit	Amount	No.	Checked	Debit	Amount	No.
1000	1000	1000.00	1000	1000	1000	1000.00	1000								
			111				111								
			112				112								
			113				113								
			114				114								
			115				115								
			116				116								
			117				117								
			118				118								
			119				119								
			120				120								
			121				121								
			122				122								
			123				123								
			124				124								
			125				125								
			126				126								
			127				127								
			128				128								
			129				129								
			130				130								
			131				131								
			132				132								
			133				133								
			134				134								
			135				135								
			136				136								
			137				137								
			138				138								
			139				139								
			140				140								
			141				141								
			142				142								
			143				143								
			144				144								
			145				145								
			146				146								
			147				147								
			148				148								
			149				149								
			150				150								

NAME: [Blank]

EXPLANATION: [Blank]

FORM NO. 10

THE AMERICAN ARCHITECT

SAMUEL HANNAFORD & SONS ARCHITECTS CINCINNATI, OHIO		MONTHLY TIME SUMMARY TO DISTRIBUTION SHEET		SHEET NO. <u>3</u> TO <u>3077</u> OF <u>20</u>																																
EMPLOYEE <u>P. G. Henry - Draftman</u>		ACCT NO. <u>151-3</u>		RATE <u>46 2/3¢</u> PRODUCTIVE HOURS <u>112</u> AMOUNT <u>52.27</u>																																
CHARGE TO JOB	D A Y O F M O N T H																															TOTAL HOURS	AMOUNT	✓		
	1	2	3	4	5	6	7	8	9	10	11	12	13	14	15	16	17	18	19	20	21	22	23	24	25	26	27	28	29	30	31					
<u>The V. K. Auto Co.</u>							<u>1/2</u>																										<u>1/2</u>	<u>2.24</u>	✓	
<u>The Van Dyke Co. #1</u>							<u>4 1/2</u>										<u>3</u>		<u>4 1/2</u>														<u>13</u>	<u>6.06</u>	✓	
<u>Presbyterian Hospital (ward A)</u>										<u>3</u>																							<u>17</u>	<u>7.94</u>	✓	
<u>The State Oil Co. #1</u>																<u>6 1/2</u>	<u>2</u>		<u>4 1/2</u>	<u>8 1/2</u>	<u>8 1/2</u>	<u>8 1/2</u>	<u>5</u>									<u>56 1/2</u>	<u>26.37</u>	✓		
<u>King Art Co.</u>																																	<u>18 1/2</u>	<u>8.33</u>	✓	
<u>Ridge Mission</u>																																	<u>5</u>	<u>5</u>	<u>2.33</u>	✓
Form #8.																																				
Total Chargeable to Clients																																<u>112</u>	<u>52.27</u>	✓		
(NON-CHARGEABLE TIME) Office Time	<u>8</u>	<u>8</u>	<u>5</u>	<u>8</u>	<u>8</u>	<u>7 1/2</u>	<u>3 1/2</u>	<u>8</u>	<u>5</u>	<u>5</u>	<u>8</u>	<u>2</u>																			<u>84</u>	<u>39.20</u>	✓			
Overtime Allowance																																				
Lost Time - Vacations, etc.																																				
Total Non-Chargeable Time																																<u>84</u>	<u>39.20</u>	✓		
Totals																																	<u>91.47</u>	✓		

FORM NO. 8

Form No. 9, Time Distribution Sheet, may be folded and kept in any available file, where they are safe from fire.

Form No. 11, Job Cost Sheet, and Form No. 12, Ledger Page, compose one book, and are bound in a single binder. This binder is loose leaf, size 8 by 11 1/2 inches.

Form No. 10, Journal, is a regular bound book, size 14 1/4 by 15 1/2 inches. The measurements given are the over all dimensions of the binders containing the pages.

FINANCIAL STATEMENTS:

The completion of an accounting period is signalized by the preparation of a Balance Sheet and a Profit and Loss Statement.

The Balance Sheet is a complete statement of assets, liabilities, capital and surplus at time of closing books.

The Profit and Loss Statement shows how profits were gained and losses were made. It pictures the actual operation of the business.

The following model statements in a general way show how they are prepared:

MODEL BALANCE SHEET OF DECEMBER 31, 1919.

ASSETS.	LIABILITIES.
<i>Fixed Assets:</i>	<i>Current Liabilities:</i>
Office Equipment .. \$2,100.00	Accounts Payable.. \$78.20
Books 600.00	Salaries Payable... 253.52
<i>Current Assets:</i>	<i>Sundry Creditors:</i>
Imprest Fund 25.00	Tom Jones 275.01
Cash in Bank 3,243.59	John Smith..... 2,732.78
Accounts Receivable 8,753.41	
<i>Sundry Debtors:</i>	<i>Reserves:</i>
Firm Member No.	Reserve for De-
1 1,522.94	preciation 67.53
Firm Member No.	Reserve for Bad
2 720.00	Debts 30.00
	Reserve for Lost
	Time, etc. 166.96
<i>Investments:</i>	<i>Capital:</i>
Bonds 250.00	Firm Member* No.
	1 5,000.00
<i>Deferred Assets:</i>	Firm Member No.
Prepaid Insurance . 64.60	2 5,000.00
<i>Working:</i>	<i>Surplus:</i>
Work in Process... 10,169.27	Undivided Profits .. 13,794.81
Balancing Total.. \$27,448.81	Balancing Total.. \$27,448.81

THE AMERICAN ARCHITECT.

SHEET NO. <u>1</u>		NAME <u>The V. K. Auto Company</u>					ACCOUNT NO. <u>V-141</u>	
JOB COST SHEET		ADDRESS <u>#116 Pine St. Cincinnati, Ohio.</u>						
DATE 1920	ITEM	HOURS	DRAFTING	ENGINEERING	SUPERINTENDING	OVERHEAD	TOTAL DEBIT	TOTAL CREDIT
Jan 21	From Dist. Sheet #1 To a/c #1	63	4631			6814	11445	
Feb 6	From Journal				75-		75-	11445 ✓
Feb 28	" Dist. Sheet #2	40	4152			4320	8472	
Mar 3	From Journal				75-		75-	
3	To a/c #1							
21	From Dist. Sheet #3 From Journal To a/c #1	21	4289			2276	6565	23472 ✓
Apr 20	From Journal				75-		75-	
	From Dist. Sheet #4	28	5869			2968	75-	11445 ✓
							2837	

Form #11.

MODEL STATEMENT OF PROFIT AND LOSS
JAN. 1 TO DEC. 31, 1919.

OPERATION PROFIT AND LOSS.

Fees earned during year.....	\$48,771.91
Work in process Jan. 1, 1919..	\$8,468.20
Work Put in Process During Year:	
Drafting	\$13,660.56
Superintending ..	4,553.52
Overhead	18,214.09
	36,428.17
	\$44,896.37
Less work in process Dec. 31, 1919	\$10,169.27
Cost of completed work.....	34,727.10
Operation profit	\$14,044.81

INCIDENTAL PROFIT AND LOSS.

Incidental income	\$50.00
Less incidental expense.....	300.00
	250.00
Less incidental loss.....	250.00
Net profit for year.....	\$13,794.81

The writer is deeply indebted to Samuel Hannaford & Sons, architects, Cincinnati, Ohio, for the use of the various printed forms illustrated herein. If those who have managed to wade through this dry and somewhat tedious article have found any suggestions that prove valuable in furthering the interests of their business, the writer will feel well repaid for the effort and study devoted to this subject.

SHEET NO. <u>3</u>		NAME <u>V. K. Auto Company</u>					V-123	
CREDIT LIMIT		ADDRESS <u>#116 Pine St. Cincinnati, Ohio.</u>						
RATING		BUSINESS						
DATE 1919	ITEMS	FOL.	DEBITS	CREDITS	BALANCE			
Apr 5	60% on cost for plans, specifications and superintending of factory building. (Contract)							
July 21	Permits - Building & Water	16	66-		66-			
Dec 31	Due on Contract to Date	48	182916		182916			
Jan 20	By Cash	50		1766-	12916			
Jan 23	Do	58		12916	0-			
Jan 31	Due on Contract to Date	61	5269		5269			
Feb 25	By Cash	72		5269	0-			
Mar 31	Due on Contract to Date	81	7452		7452			
Apr 17	By Cash	87		7452	0-			

Form #12.

Current News

Happenings and Comments in the Field of Architecture and the Allied Arts

Dallas Architects Organize

The Dallas Architectural Club announces its founding and organization on the second of June, 1920. The purpose of the organization is, primarily, the bringing together of individuals interested in architecture and its allied art, in and about Dallas, for the general good of the profession in the community.

The active membership is limited to architectural draftsmen. The practicing architects of Dallas have been invited into membership as "patrons of the club," while contractors, material men and others indirectly interested in the profession may obtain membership as associate members.

It is the intention of the club to maintain an atelier beginning in the fall, and, by means of exhibitions and talks on things architectural, to stimulate the public as well as the professional interest in architecture.

Club quarters have been obtained in conjunction with the Arts Club of Dallas at 108 North Poydras street, where meetings are held the first and third Mondays of each month. Communications may be addressed to Mr. J. A. Williamson, secretary, at the above address.

Chicago Artist Offers Prize to Architects and Interior Designers

At a recent meeting of the Illinois Chapter, A. I. A., Mr. Joseph Pierre Birren, a well-known Chicago artist, delegate of the Chicago Society of Artists, proposed to give a prize of fifty dollars to be awarded at the annual exhibition of architects in 1921 for the best design in color showing an interior of two walls with at least one window, one door, a mantel and appropriate spaces for the distribution of the following standard sized paintings: one 34x40, one 20x24 and one or two 16x20 framed canvases. (Sizes are exclusive of frames.)

The object of this "Birren prize" is to bring about a co-operative spirit between architect and artist painter and stimulate the architect's desire to make a more artistic appropriate use of wall spaces than has been the tendency of the past. It is Mr. Birren's contention that less expense in mouldings and plastic ornamentation and more thought given to the

painter's art in the proper handling of flat surfaces would be restful, more comfortable and pleasing to the eye.

It is also contended that framing and hanging of pictures as at present practiced is inconsistent with present interior designs and taste, and that the mouldings and ornamentation of frames is often ridiculously unrelated in style to a well designed interior and that it be made the architect's business to suggest fitting and harmonious moulding for frames and tasteful installation of the canvas on the wall, thereby working in sympathy with his client, the possible owner of cherished and appropriate pictures—working with the owner or tenant of the building and creating a co-operative harmony, rather than is so often practiced by that method of washing one's hands of a troublesome, unsolved problem and advising the exclusion of painting art, will unquestionably eventually tend toward a disorganized condition of all the arts related to building.

Mr. Birren believes that the day of temporary suspension hanging of paintings in permanent spaces is passing and that instead framed pictures should be fastened flat against the wall with a frame, which in design and pattern of moulding is related to and in keeping with other mouldings of the room and treated so that it would blend or recede to the wall and making it a part of the wall. The matter of color appropriateness of the picture comes more within the province of the painter, and co-operation would be welcomed by the client. It seem difficult to accept low-keyed paintings in our present high-keyed interiors and artists feel that they should be consulted by those who wish to have their paintings show to advantage when making color changes.

National Commission of Fine Arts Report

Containing a review of the progress made in carrying out the plan of Washington prepared in 1901 under the direction of the late Senator McMillan by the commission composed of Messrs. Burnham, McKim, Saint-Gaudens and Olmsted and outlining the work to be done in the immediate future for the development of the National Capitol. Including also material on the improvement of Army and Navy medals and insignia, a discussion of the plans for

THE AMERICAN ARCHITECT

American cemeteries in France, and advice to persons interested in erecting war memorials. There is a chapter on the memorials now being erected in Washington. 148 pp. and 70 illustrations, including a full set of pictures of the Lincoln Memorial. (Apply to the Government Printing Office).

D. R. Boyd to Represent Allied Building Trades

The Council of the Allied Building Trades, at a meeting of its executive committee in Philadelphia, has requested D. Knickerbacker Boyd, former secretary and vice president of the American Institute of Architects and a leader in local construction and city planning movements, to act as spokesman for labor in all affairs under its jurisdiction. The council represents nineteen different labor unions in the American Federation of Labor.

The delegates discussed the fact that there was very little co-operation in the building construction field. Both labor and the employers held meetings of their own, which did not tend to solve the questions causing strife between the organizations. It was finally decided, without a dissenting vote, to have Mr. Boyd act as the representative of organized labor, although he does not belong to that branch of the building industry.

Good New Work the Milestone of Progress

Willis Polk advises the architectural student as follows:

"Old stuff can't be made new; new stuff shouldn't be made old; good stuff alone may invite the toning of Time's delicate palette. First of all, make it good; second, make it new; third, antique it if there is no other way to attain results."

Moral: Good old stuff, is better than poor new stuff, but good new stuff is the milestone of progress.

All-Weather Employment for Builders

One of the features in a home building experiment in Manchester, England, as given in the last *Monthly Labor Review*, is the provision made for full week or all-weather employment by having one staff for both inside and outside work. In fine weather all the workers are concentrated on outside jobs and in wet weather they are shifted to the inside. This method will result in having many houses at different stages of completion at one time and calls for a corresponding large working capi-

tal, but Manchester stands ready to meet this difficulty.

The municipality is to provide the funds for erecting 1,000 houses in one of its suburbs, while the building guild is to furnish not only the manual labor, but also the technical and administrative workers. The city is to pay the labor cost and 10 per cent. additional and is to receive the houses when they are built. The extra 10 per cent. is to cover losses, transportation cost, etc., and the city council is to buy the building material.

Recreation Suggestions

Three pamphlets published by Community Service (Incorporated), 1 Madison Avenue, New York City, the first one in cooperation with the Playground and Recreation Association of America: "Community Recreation," December, 1919, 122 pp., containing suggestions for recreation boards, superintendents of recreation, and community recreation workers; "Comrades in Play," February, 1920, 84 pp., describing leisure-time activities which the young men and young women of America can enjoy together; "Summer Camps, Municipal and Industrial," June, 1920, 43 pp. Each one of handy size and full of practical, detailed information.

Senate Resolution 350

Whereas, The general construction of houses, manufacturing establishments and buildings necessary for the development of the nation's resources, the production of essential materials, and the amelioration of present housing conditions, was curtailed by Federal action during the war and is now seriously hampered by an unprecedented demand for consumables and luxuries which has diverted capital, labor and materials into non-productive or non-essential fields; therefore, be it

Resolved, That a committee of five Senators, consisting of three members of the majority party and two members of the minority party, appointed by the President of the Senate, is hereby authorized to inquire into the report to the Senate on or before December 1, 1920:

(a) The existing situation in relation to the general construction of houses, manufacturing establishments, and buildings, and the effect thereof upon other industries and upon the public welfare; and

(b) Such measures as it may deem necessary to stimulate and encourage such construction work, to encourage popular investment rather than spending, to foster private initiative in building, and to insure co-operation between labor and persons or corporations engaged in transportation, banking, or

other business necessary to the development of such construction.

Such committee is hereby authorized during the Sixty-sixth Congress to sit during the sessions or recesses of the Congress, at Washington or at any other place in the United States, to send for persons, books and papers, to administer oaths and to employ experts deemed necessary by such committee, a clerk and a stenographer to report such hearings as may be had in connection with any subject which may be before such committee, such stenographer's service to be rendered at a cost not exceeding \$1 per printed page, the expenses involved in carrying out the provisions of this resolution to be paid out of the contingent fund of the Senate.

The committee appointed consisted of W. M. Calder (New York), chairman; W. S. Kenyon (Iowa); W. E. Edge (New Jersey); E. J. Gay (Louisiana), and J. O. Wolcott (Delaware).

If your firm is being held up in the execution of any contracts for buildings you should communicate with the Senate Committee.

News from Various Sources

A competition for plans for the reconstructions, extension and embellishment of the city of Lille has been inaugurated. Full information on the subject can be obtained at the Renaissance des Cites, 23, rue Louis-le-Grand, Paris.

* * *

U. S. Senate Special Committee on Reconstruction and Production is holding first hearings in New York bearing upon transportation and fuel necessary for general industry and construction.

* * *

An organization calling itself the "Society of Decorators" has been formed at 9 West 47th street, New York, to place interior decorating on a professional plane, to raise the aesthetic standards, to write a code of ethics and to protect the public against the incompetent, happy-go-lucky practitioners now engaged in decorating as a business.

* * *

Dr. Royal S. Copeland, representing New York at the International Housing Conference at London and the Royal Institute Health Conference at Brussels, states that in Europe it is recognized that the housing problem has become so pressing as to demand its recognition as a public utility, to be dealt with as is any other public necessity.

It is stated by Dr. Copeland that typhus and cholera are epidemic in Europe, and that London's milk supply cannot compare with the purity and safety had in this country.

Personals

Rosell, Edward Mitchell & Co., Ltd., architects, engineers and town-planners, have moved their main office to 817 Fourteenth St., N. W., Washington, D. C., from Norfolk, Va. Manufacturers' catalogues are desired.

Bollard & Webster have moved from 303 McCagne Building, Omaha, Neb., to 521 Paxton Block, same city.

Walter B. Wills, Inc., architect and engineer, announces the removal of his offices from 1181 Myrtle Ave. to 1159 Myrtle Ave., Brooklyn.

Samuel Gardstein, architect, 1154 47th St., Brooklyn, has recently established his main office at 26 Court St. The former address will be maintained as a branch.

National Engineering Service Corporation, which maintains its headquarters in the Middle West, has recently opened an Eastern office at 30 Church St., New York City.

Severance & Van Alen, architects, have moved their offices from 111 East 40th St. to the building they recently bought and remodeled for their own use at the southwest corner of Lexington Ave. and 41st St.

McLanahan & Beneker, Bellevue Court Building, 1418 Walnut St., Philadelphia, Pa., is the name of the architectural firm which was known before July 1 as Price & McLanahan.

James A. McCarroll, architect, formerly located at 200 Montague St., Brooklyn, N. Y., may now be found at 33 Clinton St., Brooklyn.

Henry Firth, architect, is located at 8515 Bay Parkway, Brooklyn, N. Y.

G. C. Freenan, of Reading, Pa., has announced the removal of his architectural office from 111 North Eleventh St. to the Reading Liberty Bank Building.

Kallich and Subkis, architects, formerly at 2208 Bath Ave., Brooklyn, have moved to 7922 Twenty-first Ave., Brooklyn.

I. W. Eisinger, architect, announces his present address as 21-23 West Thirty-sixth St., New York City.

Morris Schwartz, architect, is located now at 1400 Broadway, New York City.

H. C. Meyer, architect, of 357 Flatbush Ave., Brooklyn, has formed a partnership with Joseph Mathieu, known as Meyer & Mathieu.

Weekly Review of the Construction Field

With Reports of Special Correspondents in Prominent Regional Centers

One hears of a summer lull. The many projects that have kept indefatigably on their way through difficulty after difficulty are not feeling any bad effect from the season of the year. And though it is true that new business is not noticeable, the opinion generally expressed is that this is more directly due to the many obstacles in the way of financing and accomplishing construction and that there is a holding off in the expectation of better times ahead.

The attempts of the Federal Reserve banks to limit the loans to requirements of essential rather than speculative enterprise have been fairly successful, but have not accomplished any decided reduction of the credits outstanding. The influence, however, is toward stability and though it directly concerns the transitory requirements—such as the matter of crop moving, for example—the investments in building and industrial activities must eventually feel its good effect.

Production seems to have developed from a byword into a fact—if the statistics of some of the more basic materials may be accepted as indicative, since March of this year, which was an exceptional Pig iron production in June was at the highest figure month, and approaches near to the average monthly production of the maximum year, i. e. 1916. Bituminous coal averaged in June ten million tons weekly production, which is two million in excess of the 1919 average. It is not expected in the face of transportation inadequacies that this rate of production can be steadily maintained, but it is encouraging and valuable to know these things as an evidence that we are hitching along.

Manufacturers generally are reporting increased difficulty in securing raw materials. But their chief difficulty is shown in a striking way by the case of the National Tube Co., which shut down on July 3 because of a congestion of finished material, but has now again begun operations. It was stated before the Interstate Commerce Commission that this company's stock on hand aggregated 100,000 tons.

(By Special Correspondence to The American Architect.)

CHICAGO.—The continued seriousness of the traffic outlook and the prospective coal shortage is causing uneasiness in Chicago's business and industrial circles. Many industrial leaders are advocating the voluntary closing of plants for thirty or sixty days in order to accumulate a coal supply, claiming that only a drastic measure of this sort will avert a severe depression later. Already hundreds of men

are out of work through the shutting down of industries because of lack of coal.

The building situation in Chicago is practically unchanged. The demand for new building continues unabated, but the industry is proceeding at such a disadvantage that it is exceedingly doubtful if the present season will accomplish any appreciable reduction in the house shortage. Building permits of this city do not show the actual situation, since many projects are abandoned after the permits were taken out.

Although, in building circles, considerable relief is expressed over the rail award, no immediate improvement is looked for in the transportation of building materials. This week's report of the railroads shows further decrease in the shipment of lumber, amounting on one road to but 38 per cent. of the movement in the same week of last year.

Housing conditions are growing worse and constitute a severe menace to the city, say housing experts. "Something must be done," is the cry. In defense, the builders claim they are helpless to remedy the situation and point out that a recognition of the importance of their industry must come from the railroads and the Government before anything can be accomplished.

In the recent hearing granted to construction and material interests by the Interstate Commerce Commission, Mr. Lemuel F. Owen, manager of the Chicago Building Materials Exchange, made an able report dealing with construction conditions in Chicago during the past five years. Mr. Owen says in part: "Upwards of 10,000 families are without homes, 40,000 people were denied admission to hospitals during the month of June because of lack of space, over 30,000 school children are housed in schools and basements which are poorly heated and unventilated." He concludes his report with this significant statement: "Under present operations these same conditions will last for an indefinite period."

The construction problems of Chicago are most serious and merit earnest consideration by the United States Senate Committee on Construction, which is expected to begin hearings in this city next week.

(By Special Correspondence to The American Architect.)

SEATTLE.—Only slight changes in the situation are needed to produce a hopeful response in the building trade on the Pacific Coast, and jobbers in

THE AMERICAN ARCHITECT

this territory were considerably heartened during the week by the improvement in the delivery of sheet metal. All manufacturers of the East seem able to promise, however, is that sometime within the next four months they hope to get production and delivery somewhere near normal. Prices are almost invariably stationary.

To complaints of poor delivery Western mills reiterate their pleas that they cannot get cars for shipping raw productions in, nor cars to ship manufactured materials out—and while it is extremely difficult to get sufficient skilled labor to turn out small pipe and nails, they believe that if the car situation could be relieved, jobbers would have little cause for complaint.

Conditions in the steel market on the Pacific Coast are identical as to prices, and all large jobbing centers have been encouraged this week by the acceptance in Eastern mills of placements for the fourth quarter. The mills specifically state that the delay in delivery on the Coast is due to congestion in the Chicago car zone.

There is no improvement in receipts of vitroware or enamel ware. Stocks all along the Pacific Coast are low, but the demand is not heavy. Manufacturers of these essentials wire that they are hopeful of an improvement by December 1. Jobbers are carefully studying the wheat movement, as it is believed cars will be marshalled by the common carriers to take care of this as a preferential over all building materials. West Coast fir lumbermen have already conceded this point, and are not hoping for better than 25 to 30 per cent. of a normal car supply until the wheat has been warehoused.

Offerings on the Coast of roofing and plaster board have been so heavy that the market has receded. Jobbers are able this week to quote plaster wall board at \$55, as against \$60 per 1,000 square feet. Cement is short in California, but in the North Coast territory jobbers have been fortunate in picking up odd lots. Scarcity of cars and of sacks is the primary reason for the cement shortage here.

Fire brick has been advanced to \$75 and \$80 delivered in the first building zone. Arrivals of materials from the East are poor in the North Coast territory, but California jobbers are more fortunate, as stocks of fire clay and which cement, there are plentiful. Seattle jobbers can get delivery in ten days by placing orders in the South as against the East. Discrimination is being hinted at.

The West Coast fir lumber mills received from the railroads a total of 1,330 cars for shipping lumber to eastern builders, 1,000 less than was demanded. The delivery this week is averaging 25 per cent. of normal. One of the larger mills got 74 cars, against an order for 400. The fir lumber market is \$3 to \$5 higher mill basis on finishing assort-

ments and \$1 to \$2 higher on dimension—due exclusively to the car shortage, as new business is light. Orders for lumber coming in now are filling out retail yard stocks in the country and not the buying for city building.

A majority of the fir lumber mills have been idle since July 4, and it is announced that they may not resume until there is an improvement in the car situation. A brisk buying movement in fir lumber is anticipated when the new transcontinental freight rate advance is announced.

A brisk and higher autumn market in paints and oils is predicted by the paint trade. Lead is arriving from Chicago and San Francisco in increasing volume. General use of light colors will be the rule.

(By Special Correspondence to The American Architect.)

WATERBURY, CONN.—During the last few days large numbers of brass workers in the Naugatuck Valley have gone back to work after an idleness of about three months. The men struck about the middle of April, and since then the Connecticut brass mills have been working only part time. As the products of these plants enter to a large amount in building construction in one form or another, a resumption of full time should be welcome news.

Large quantities of copper ordered for delivery during the second quarter were deferred in shipment. The railroad strike, which also occurred during this period, tended further to restrict the movement of raw supplies and the transportation of finished goods outward bound. In the meantime, the mills have been working up their raw copper stocks. It is expected among the producers that the buying for domestic account will be resumed in a few days.

It has been noted recently that tightness of money has developed into the chief cause for housing congestion. It is impossible to obtain anything like the amount of a loan on property such as could be secured in the past, since in some quarters there is a general fear that the real estate market is due for a decline. High prices of building materials and labor add still further to the difficulties of the situation.

The Federal Reserve Board seems to have nothing to offer in the way of remedy except to repeat its admonition to "work and save." The board can exercise supervision over commercial paper, but not investment paper, and cannot give any preferential approval to one class of borrowers over another. So long as the banks of the country are loaded up with Government bonds on which the public has not completed payments, officials point out there is little relief in sight in the money market.

DEPARTMENT OF ARCHITECTURAL ENGINEERING



TEST SLAB UNDER FINAL LOAD

Tile and Concrete Floor Shows to Advantage Under Test

Bureau of Standards Investigation Produces Valuable Design Data

WHILE new types of construction are constantly appearing, only those of proven merit should be employed in the building of any structure. Originators of such new forms of construction have complained that only with difficulty, if at all, could they persuade the architect to give serious consideration to their claims with a view to having their system specified for some structure being planned by him. The architect, though ever alert to learn of improved methods of building, by which it may be possible to execute his design more efficiently and economically, of necessity shows a conservative attitude when it comes to departing from the beaten path of precedent. His professional duty to his client compels him to be reasonably sure that he is mak-

ing a wise selection when specifying new materials, or new combinations of known materials. Of course, after any new system of construction has been employed with successful results in several structures a greater degree of confidence is naturally felt in the claims made for it, and its extended use becomes less difficult.

The characteristics of any new form of construction claiming the attention of architects should not be left to speculation, or to be discovered after the building in which they are employed has been erected, if it is possible to determine them by reliable tests. Whenever such tests are made, the results should be given the widest publicity.

The extensive series of tests recently conducted upon a type of floor construction, which appar-



REINFORCEMENT FOR TEST SLAB IN PLACE

ently possesses many meritorious features, are, therefore, of particular interest to the architectural profession. The system employs hollow tile in combination with reinforced concrete. From a cursory inspection of the photographs, it might be assumed that the construction tested does not possess any novel features, and it is true that combination systems similar to this have been used to a limited extent (See *AMERICAN ARCHITECT*, Sept. 3, 1919, page 321). Upon further study it will be noted that no concrete slab above the tile has been employed. In most of the combination tile and concrete systems hitherto employed, it has been customary to pour a 2 inch or thicker top slab over the tile, and this in connection with the concrete ribs forms a series of reinforced concrete Tee beams, the tiles being considered simply as fillers to reduce the dead load below what it would be were a solid concrete slab employed. In the design tested, the originators believed that the tiles were not mere fillers, but became an actual and integral part of the flat slab and aided the concrete in resisting both compressive and shearing stresses. That this is true, the results of the tests clearly indicate. However, it was necessary to conduct an investigation of this nature in order to lay the basis for economical design.

The purpose of the test, as stated in the report, was to obtain data which would afford a basis for the design of a concrete and hollow tile floor reinforced in two directions. The test was planned to obtain information on: (1) The effect of variation in the ratio of length to width of panels upon the bending moments in two directions at right angles to each other; (2) the relation of maximum negative moment to maximum positive moment in the same panel; (3) distribution of tensile and compressive stresses at sections of maximum negative and maximum positive moment; (4) the amount of deflection of the slab and girders under different loadings, and (5) the location of the point of zero stress in order to determine the length

of reinforcement required to give proper anchorage beyond points of support.

For the purpose of obtaining the data desired, a large floor slab consisting of 18 panels was constructed at Waynesburg, Ohio, in 1919. Measurements to determine the stress under different loads were taken on approximately 900 gage lines in the reinforcement, 500 gage lines in the concrete and 75 gage lines in the tiles of the slab. Deflections were observed in 40 places. To obtain additional information on the action of the tiles in this type of floor, two small slab specimens, termed "control slabs," were constructed upon which strain gage measurements were taken in the reinforcement, the concrete and the tiles.

The test was made for J. J. Whitacre of Waynesburg, Ohio, under the direction of Mr. W. A. Slater representing the Bureau of Standards, with the cooperation of Professor R. H. Danforth of the Case School of Applied Science, Cleveland, Ohio. The slab was constructed under the supervision of Mr. Anthes. The observations used in the report were made by Messrs. Anthes, Hagener and G. G. Scofield, all experienced observers in this line of investigation. Acknowledgment is made of the valuable assistance of R. R. Zipprodt of the Bureau of Standards during the concreting of the slab and its preparation for test and in organizing the work of testing. The report was prepared by Messrs. Slater, Hagener and Anthes.

Tests of the materials used in the slab were made at the laboratory of the Case School of Applied Science.

The average results of tests on six specimens of reinforcement used in the slab gave a yield point of 53,560 pounds per square inch and an ultimate strength of 87,220 pounds per square inch. Tests made on eleven 6 by 12 inch concrete cylinders made during the pouring of the concrete for the slab gave an average ultimate strength of 2,030 pounds per square inch at an age of 35 days, and



CONSTRUCTION OF FOOTINGS

A continuous slab of reinforced concrete and hollow tile was placed to guard against settlement

for 8 cylinders tested at an age of 115 days, the average ultimate strength was 2,980 pounds per square inch.

The tiles were furnished by the Whitacre-Greer Fireproofing Co. of Waynesburg, Ohio. They were of the six-cell type, 6 by 12 by 12 inches in size and weighed approximately 30 pounds each.

Tests on 8 specimen tiles with the load applied on the open ends gave an average ultimate strength of

were measured from the center to center of supporting columns. The panels were supported by reinforced concrete girders, the stems of which were generally 12 inches wide, making the clear spans about 12 inches less than the dimensions given above. The slab was made of 6 by 12 by 12-inch clay tiles laid in concrete and arranged in rows at right angles to each other. The rows in both directions were separated by ribs of concrete 4 inches wide and 6

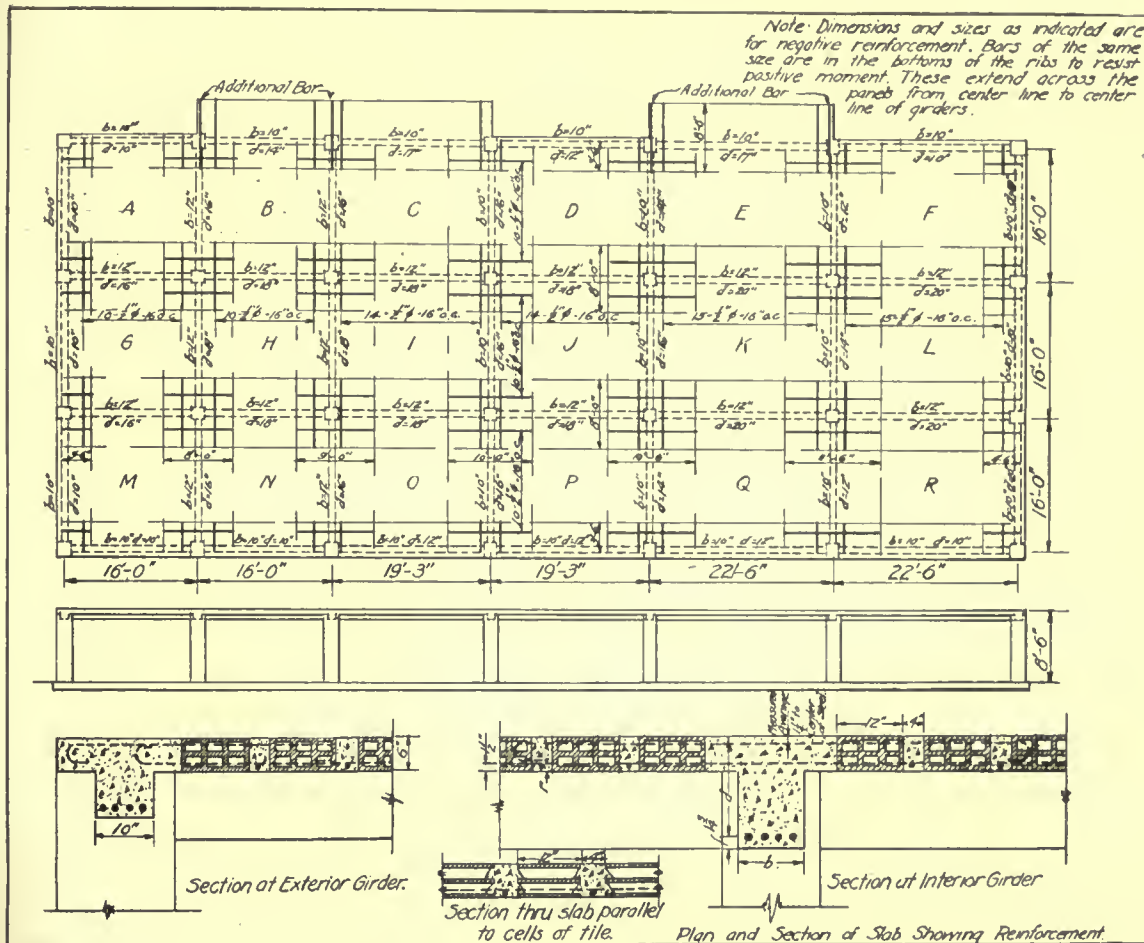

FIG. 1. PLAN OF TEST SLAB SHOWING REINFORCEMENT

Cross sections indicate method of placing tiles

4,920 pounds per square inch, and for 6 specimens in which the load was applied perpendicular to the axis of the cells, the average ultimate strength was 4,000 pounds per square inch.

The compressive strength was computed on the basis of the net area of the section through the cells parallel to the bearing surfaces.

Design and Construction of Slab. The slab was 117 feet 6 inches long by 50 feet wide, divided into 18 panels. Six of these panels were 16 feet square; six were 16 feet by 19 feet 3 inches, and six were 16 feet by 22 feet 6 inches. These panel dimensions

were measured from the center to center of supporting columns. The tiles throughout the slab were laid with the cells running in the north and south direction, that is, the short direction of the oblong panels. The ends of the tiles were left open, allowing a small amount of concrete to enter and making the tiles form an integral part of the slab.

Each concrete rib between rows of tiles was reinforced in the bottom with one 1/2-inch plain round bar extending the full length of the rib and in the top with one 1/2-inch plain round bar at each end which extended from a point one-fourth of the span length from the end of the rib and passed through



UNDER SIDE OF TEST SLAB

Holes in concrete show points at which strain gage readings were taken on reinforcement

the top of the supporting girder into the rib on the opposite side of the girder. The centers of the bottom bars were 1 inch and 1½ inches from the bottom surface of the rib for the short and long directions of the panel, respectively. The centers of the top bars were 1¼ inches below the top of the rib. The top bars were hooked at their ends to prevent slipping. Figure 1 shows the design of the slab.

In order to avoid any chance of settlement of the footings, a continuous flat slab foundation was constructed.

Work on the footings began on July 26, 1919. The columns were poured on September 25 up to the soffits of the girders, and the slab was poured between October 2 and October 10, 1919.

Radial chimney bricks were used as loading material. To prevent arching of the load and to leave all of the gage lines accessible on top of the slab, the load on each panel was divided into four stacks, as shown in Figure 2.

To avoid difficulty in stacking the bricks, due to slight irregularities in the surface of the slab, sand cushions 1½ inches thick were laid before any bricks were placed. The sand was retained in place by wooden frames which defined the size of the piles and the location of the aisles and served as screeds for leveling off the sand cushions upon which to apply the load.

Loading began on December 20, 1919, and continued at intervals up to February 5, 1920. The loaded areas and the intensities of the load on the latter date are given in Figure 2. This load is

termed the "maximum uniform load." For this total amount of load no other practicable distribution would have produced a higher negative moment.

The maximum uniform load was left in place until April 3, 1920. Shifting of the load from one part of the slab to another was then begun and continued up to April 22, 1920. The load was shifted in such a way as to maintain as nearly as possible a constant stress in the reinforcement resisting the negative moments and at the same time to increase the stress in the reinforcement resisting positive moments in typical panels. The loaded areas and the intensities of the load on April 22 are given in Figure 3. This load is termed the "final load."

The load per square foot was obtained by dividing the total load on the panel by the area of the panel within the girder lines, that is, the area represented by the product of the clear spans. This method was found by approximate analysis to give values of bending moments which did not vary by more than two or three per cent. from the moments computed from the loads as actually placed.

The deformation in the reinforcement and in the concrete under the applied loads were observed with a strain gage having a gage length of four inches and in the tiles with a strain gage having a gage length of eight inches. The multiplication ratio of each instrument was 5:1.

Considerable study was given to determining a basis for correcting the strain gage readings for changes in the length of gage lines due to changes in weather conditions. As a result of this study, it was decided that the most satisfactory basis for making corrections in the strain gage readings was to assume that the readings varied directly in proportion to the temperature changes.

Recorded deflections are given in tables 1, 2 and 3. Recovery due to partial removal of the load is shown in table 4.

TABLE 1—DEFLECTION FOR SQUARE PANELS UNDER CONSTANT LOAD.

Panel	Applied load in lb. per sq. ft.	Time under constant load in days	Deflection	
			After one day inches	Final inches
H (Interior).....	160	7	0.00	0.00
A (Exterior).....	160	7	0.08	0.10
H (Interior) ...	210	7	0.00	0.00
A (Interior).....	210	7	0.12	0.12
H (Interior).....	397	52	0.09	0.22
A (Exterior).....	372	53	0.37	0.70
H (Interior).....	730	30	0.55	0.68
A (Exterior).....	615	23	1.36	1.52

THE AMERICAN ARCHITECT

TABLE 2—DEFLECTION FOR INTERMEDIATE SIZE RECTANGULAR PANELS UNDER CONSTANT LOAD.

Panel	Applied load in lb. per sq. ft.	Time under constant load in days	Deflection	
			After one day inches	Final inches
I (Interior).....	230	11	0.10	0.11
P (Exterior).....	230	13	0.14	0.17
I (Interior).....	280	55	0.15	0.26
P (Exterior).....	280	55	0.28	0.44
I (Interior).....	605	25	0.86	1.15
P (Exterior).....	525	22	1.19	1.52

TABLE 3—DEFLECTIONS FOR LONG PANELS UNDER CONSTANT LOAD.

Panel	Applied load in lb. per sq. ft.	Time under constant load in days	Deflection	
			After one day inches	Final inches
K (Interior).....	230	69	0.11	0.11
F (Exterior).....	230	69	0.39	0.73
K (Interior).....	505	25	1.04	1.32
F (Exterior).....	370	25	1.33	1.72

TABLE 4—RECOVERY FROM DEFLECTION UPON REMOVAL OF LOAD FROM EXTERIOR PANELS.

Panel	Applied load in lb. per sq. ft.	Deflection in inches	Load Removed		Recovery		per cent. of load removed
			Lb. per sq. ft.	Per cent. of load applied	Inches deflection	Per cent. of removed	
G (Square).....	397	0.65	321	81	0.33	51	.63
O (Int.).....	280	0.52	229	82	0.29	56	.68
E (Long).....	230	0.31	148	64	0.34	110	1.71
L (Long).....	230	0.53	158	69	0.45	85	1.24

A careful study of these deflection tables is interesting. It must be remembered that the slab was but 6 inches thick and the panels varied from 16 feet square to 16 feet by 22 feet 6 inches center to center of supporting girders.

It will be noted that for panel "H" a square interior panel, no deflection was recorded under an applied load of 210 pounds per square foot after this had remained in place 7 days and only 11.16 inch under a load of 730 pounds per square foot after this increased load had remained in place for 30 days. The deflection recorded for panel "A," an exterior square panel, was greater, as was to be expected, but this could not be considered excessive. The greatest deflection recorded was 1.72 inch for "F," an exterior long panel, under a load of 370 pounds per square foot in place 25 days.

From table 4 (last column) it will be seen that the per cent. of recovery for each per cent. of load removed varied from .63 to 1.71. In the latter case no deflection existed after approximately 60 per cent. of the load had been removed. The recovery in the panels referred to in table 4 was assisted by the increase in load on the adjacent panels simultaneously with the decrease in load on panels G, O, E and L.

Auxiliary Slabs. The two slab specimens termed control

slabs already referred to, were 2 ft. 6 in. wide and 12 ft. long and of similar construction to the large slab. They were constructed in order to determine the effectiveness of the tiles in resisting compressive stresses in this type of construction. Fig. 4 is a view of one of these slabs under load. The load was applied by the reaction of two springs which had been previously rated in a testing machine, obtaining the amount of compression corresponding to a given load.

The central concrete rib in each of the control slabs was reinforced in the bottom with three 3/8-in. round bars. This gave a much higher percentage of reinforcement than was used in the large test slab. This was necessary in order to obtain large deformations in the tiles and concrete before failure.

The longitudinal axes of the cells of the tiles at mid span were parallel to the span in control slab No. 1 and perpendicular to the span in control slab No. 2. Control slab No. 1 was tested at the same time as the large slab, under loads giving stresses in the reinforcement as nearly as possible the same as the stresses in the negative reinforcement in the large slab. The test extended over a period of 84 days. Control slab No. 2 was tested to failure in one day, April 15, 1920, observations being made under different loads before failure.

Reliability of Results. Because of the unusually severe weather conditions in January and February, extreme precautions had to be taken to secure accurate strain gage readings and to protect the observation points from damage. In order to secure accuracy of readings, check readings were



CLOSE-UP VIEW OF SLAB UNDER FINAL LOAD

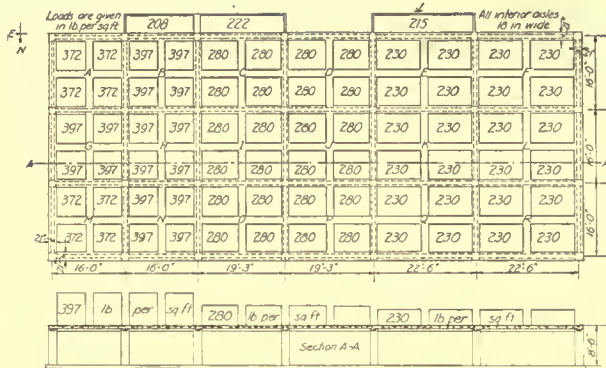

FIG. 2. DIAGRAM OF MAXIMUM UNIFORM LOAD
Showing location and intensities of load which remained in place from Feb. 5 to April 3, 1920

frequently taken. In some series readings were taken for each gage line twice, or even more if necessary to obtain satisfactory check readings. Due to the favorable weather in April, it is believed that the error in readings taken at that time was considerably less than the error in the readings taken in January and February. The total error in the corrected observations probably did not often exceed plus or minus one division of the instrument, which is equivalent to a stress of 1,500 lb. per sq. in. in the reinforcement.

The complete report is most exhaustive and contains numerous tables and charts giving the entire results of all the readings. It is not possible, due to limited space, to reproduce these, but the essence of these many observations and the deductions made therefrom are contained in the following summary, taken from the report.

Summary. Deformations in the tiles were approximately 70 per cent. as great as those in the concrete. This shows that the tiles contributed a proportional share to the strength of the slab. The unit stresses in the tiles must be equal to, or greater than, the unit stresses in the concrete.

In this type of construction, it seems reasonable that the ribs of the tile in contact with the concrete

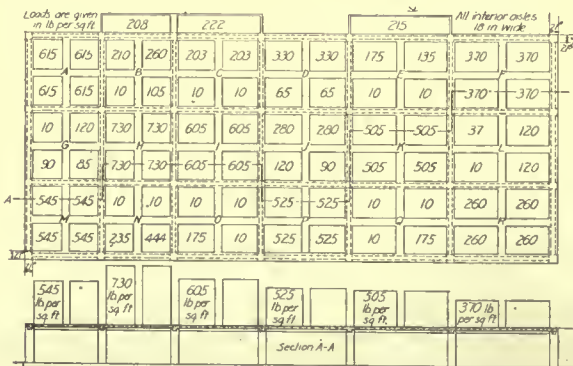

FIG. 3. DIAGRAM OF FINAL LOAD
Shifting of load commenced April 3, and was completed April 22, 1920

ribs should be considered as being effective in resisting shearing stresses equally with the concrete. The test results indicate that the ribs of the tiles were effective in resisting shearing stresses.

Average values of the negative resisting moment of the stresses in the reinforcement where the bars cross the edges of the slabs are given in table 5.

TABLE 5—NEGATIVE MOMENTS IN INTERIOR PANELS

Basis of coefficients	Direction of moment	Square panels	Intermediate sized panels	Long panels
Live load only	Short direction	.0193W ₁	.0195W ₁	.0446W ₁
	Long direction0231W ₁	.0201W ₁
Sum of live and dead loads	Short direction	.0171W ₁	.0255W ₁	.0366W ₁
	Long direction0196W ₁	.0165W ₁

In a few cases maximum values exceeded the average by as much as 33 per cent. The intensity of the measured stress from which these moments were computed was generally close to the yield point. The load on the slab was 397 lb. per sq. ft. for the square panels, 280 lb. per sq. ft. for the intermediate size panels, and 230 lb. per sq. ft. for the long panels.

At the stage of the test at which the negative moments given in table 5 were developed the stresses at the centers of the spans were resisted



FIG. 4. VIEW OF CONTROL SLAB NO. 1.

Insert shows cross section; the black marks on top surface of tiles are points at which deformation readings were taken to determine stress in tiles

so largely by the tension in the concrete that in order to obtain representative positive moments for the reinforcement it was necessary to apply more load to the slab in such a way as to increase the positive moments without affecting greatly the negative moments. For this purpose the load distribution shown in Fig. 3 was used. The positive moments for the loads in the heavily loaded panels shown in Fig. 3 averaged 49 per cent. of the negative moments given in table 5 for the loads shown in Fig. 2. The observed stresses at the time that the loads shown in Fig. 3 were in place were gen-

erally from 30,000 to 40,000 lbs. per sq. in. for the positive reinforcement in the short direction of the panel and from 16,000 to 38,000 lbs. per sq. in. for the positive reinforcement in the long direction of the panel.

The average negative bending moment for the exterior panels was 20 per cent. greater than that for interior panels of like size; in one case it was 26 per cent. greater.

By the term "Moment for the exterior panels" is meant the moment across the girder one span length from the wall.

The average positive bending moment for exterior panels was 23 per cent. greater than the positive bending moment for interior panels. This comparison was made with reinforcement extending into the wall girders.

The distance of the point of zero stress in the negative reinforcement from the edge of the supporting girder was slightly less than one-fifth of the clear span from edge to edge of the girders.

For uniform applied loads of about 175 lbs. per sq. ft. on the long panels (except corner panel R), 230 lbs. per sq. ft. on the intermediate size panels and 275 lbs. per sq. ft. on the square panels, the deflection at the center of the panels was less than 1/900 of the clear span. The deflections for the exterior panels were generally somewhat larger.

It would seem that sufficient reliable data has been made available as a result of these extensive tests, to permit of economical design of this type of floor construction, with a feeling of confidence, based not upon unsubstantiated claims, but upon as precise data as it is possible to obtain in this type of construction.

It must ever be kept in mind that expert workmanship is as essential to successful construction as accurate design, and only experienced builders

		.0128	.0173			.0296				
A	$k=0.225$ 0.173	B	.0079 .049	C	.0126 .073	D	.0164 .0102	E	.0173 .0126	F
	.0250	.0171	.0173		.0286		.0309		.0403	
	.0234	.0228	.0331		.0347		.0423		.0403	
G	$k=0.185$ 0.185	H	.0176 .091	I	.0204 .091	J	.0243 .0220	K	.0270 .0204	L
	.0192	.0228	.0347		.0347		.0423		.0423	
	.0260	.0242	.0331		.0286		.0423		.0423	
M	$k=0.217$ 0.192	N	.0199 .091	O	.0251 .091	P	.0230 .0173	Q	.0252 .0261	R

FIG. 5. DIAGRAM OF NEGATIVE BENDING MOMENT COEFFICIENTS

Values shown (based on readings taken after load had been in place 55 to 75 days) are computed from weighted maximum stresses in the reinforcement crossing the edges of the panels. These should not be confused with the average values of negative moment coefficients given in Table 5, which are the average values of all the computed values of all the panels of each type

should be permitted to carry out work of this kind.

Rigidity Tests on Various Types of Wall Construction Made by Omaha Building Department

Results Prove That Code Requirements Should Be Amended

TESTS, supervised by municipal experts, of six different types of exterior wall panels, show that forms of construction not hitherto permitted by the Omaha, Neb., building code are actually superior, from the standpoint of rigidity, to the type of frame wall construction specified by the code.

The test panels were each 4 ft. high and 8 ft. long, constructed of 2 in. by 4 in. studs, 16 in. on centers. The studs were nailed to a top and bottom sill piece with 3-20 D nails at each corner, the intermediate studs being nailed with 2-20 D nails top and bottom. These panels were covered as follows:

No. 1. Exterior: 6 in. x 7/8 in. wood sheathing, nailed with 2-10 D nails at each stud. Interior:—Wood lath nailed at each bearing by 4 D nails. No plaster or stucco.

No. 2. Exterior:—Bishopric heavy weight sheathing board nailed direct to studs with a 6 D nail through each wood strip at each bearing. Interior:—Wood lath as in No. 1. No plaster or stucco.

No. 3. Standard construction in the City of Omaha. Exterior:—6 in. x 7/8 in. wood sheathing nailed to studs as in No. 1, then covered with (a) tarred felt building paper; (b) 3/8 in. x 1 1/2 in. furring strips 16 in. o. c.; (c) wood lath nailed to furring strips with 4 D nails; and (d) one coat Portland cement stucco with dash finish. Interior:—wood lath as in No. 1.

No. 4. Exterior:—Bishopric medium weight stucco board nailed direct to studs by one 5 D nail through each strip at each bearing; one coat Portland cement stucco, dash finish. Interior:—Wood lath as in No. 1.

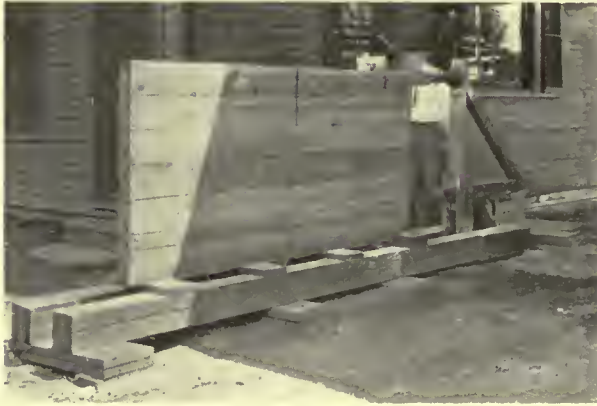

VIEW OF TEST PANEL NO. 1 BEFORE TEST



PANEL NO. 6—BACK PLASTERED METAL LATH

No. 5. Same as No. 3 except Magnesite stucco was substituted for Portland cement stucco.

No. 6. Exterior:—Back-plastered metal lath, Portland cement stucco. No interior lath.

In testing, each panel was set separately on a base of 8 in. by 8 in. timbers, 12 ft. long. The testing apparatus consisted of a screw jack for applying the load, set between the testing frame and Bell crank lever constructed of timbers and a Fairbanks platform scale. The jack acting at one of the upper corners applied increasing pressures to the frame under test, thus causing distortion. To prevent the frame under test from pulling up at the lower corner, it was secured to the base by a heavy bolt let through the frame at the corner directly below that to which the screw jack was applied.

The results of these tests are plotted on the chart (Fig. 1). They should be carefully studied. The graphs marked 4a and 6a indicate the results of a second test made on both panels No. 4 and 6.

Test panels No. 1 and 2 are comparable. The results show that considerably greater stiffness was shown by panel No. 2 covered with Bishopric sheathing board than by panel No. 1 with wood sheathing. Test panels No. 3 and 4 are also com-

parable. Here again panel No. 4, using Bishopric stucco board, showed up to better advantage than No. 3 which is the type of construction specified by the Omaha code.

It is interesting to note from Fig. 1 that the back plastered metal lath panel, the only one in which interior wood lath was dispensed with, showed the greatest rigidity of all the panels tested.

This test panel, tested to the limit of the apparatus—3,500 lbs.—showed no cracks, while both of the Bishopric board panels showed greater stiffness than the type of construction permitted by the code.

The Omaha code should be amended and modernized in this respect at least. It would seem that there is no option in the matter. The more quickly the city officials act, the more quickly will they perform a public service.

The tests were successfully carried out through the full co-operation of the following code revision committee: Harry B. Zimman, alderman; Rodney M. Brown, former building inspector; Geo. B. Prinz, architect; A. C. Arend, consulting engineer; R. E. Myers, realtor; Rex Edgecomb, present building inspector, secretary. Their recommendations should be at once forthcoming.

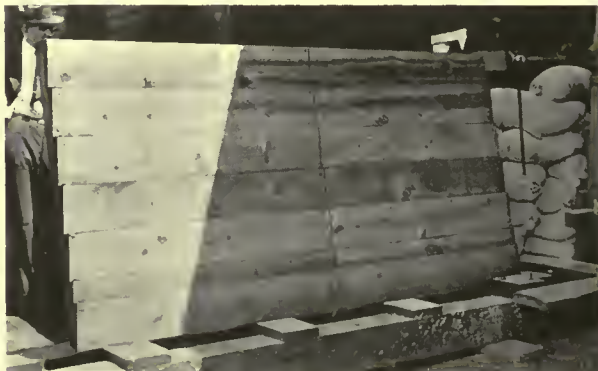

PANEL NO. 1 AFTER TEST
Distortion of 5 1/2 in. Occurred Under Load of 2,100 Lbs.

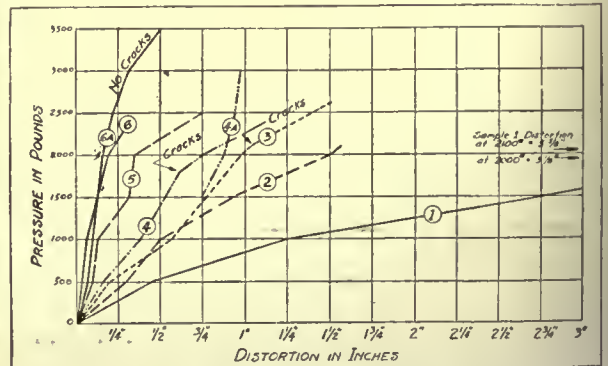

FIG. 1. DIAGRAM SHOWING DISTORTION OF PANELS UNDER TEST

200^a

fratello No 233c



THE CITY HALL—ELCHE (ALICANTE)

THE AMERICAN ARCHITECT

THE AMERICAN ARCHITECT

VOL. CXVIII

WEDNESDAY, AUGUST 18, 1920

NUMBER 2330



THE PATIO

The Mission Inn at Riverside, California

By DWIGHT JAMES BAUM, B.A., A.I.A.
Photographed Chiefly by the Writer

AN American gentleman was touring Spain just before the great war and in searching for art objects, frequented the inland towns. In one of these he met a recognized authority on Spanish art and craftsmanship. Their conversation turned to ironwork and the American, of course, praised the craftsmen of the past and the wonderful artistry shown in metals. Finally the Spaniard suggested that the American take a trip to California where there was an Inn with a collection larger than any in Spain. The comment was received with much pride by the visitor, for he

happened to be Mr. Frank Miller, Master of the Mission Inn at Riverside, California, and the owner of the collection referred to.

The writer recently spent a few weeks at this most interesting place, created all out of the mind of Mr. Miller who started this work in a small adobe which now serves as a tea room in the entrance court.

The structure with its several annexes now covers an entire square of no mean proportions, the buildings being grouped around an entrance court and a patio. The main buildings (2) were designed by Arthur Benton of Los Angeles and

this portion includes the grouping around the forecourt and the music room. The wing (3) called the cloister and the Patio was designed by Myron Hunt of Los Angeles and this includes the new art gallery. The fountain (4) in the Patio was designed by Elmer Grey of Los Angeles.



A CORNER IN THE PATIO.

The exterior elevations are designed from motifs seen on four of the missions in Southern California, the entrance front is graced by an arched arcade between the curb and sidewalks which is shaded by some wonderful live oaks and covered with ivy and the most luxuriant semi-tropical foliage.

The left side is most effective with its heavy buttresses partly covered with foliage, the balconies of iron and the window grilles, some of the fine examples of Spanish iron work referred to above.

work, it is claimed, has never been surpassed.

Probably the most interesting part of the Inn is the Patio. It is hard to imagine a more interesting place in which to spend one's time sitting on one of the various balconies. The simple lines, frank use of materials and colors introduced in tiles, canopy and striped sun shade above, present a unique architectural setting and one worth traveling a long distance to see. The fountain designed by Elmer



THE GALLERY OF SPANISH ART

MYRON HUNT, ARCHITECT



THE PATIO

MYRON HUNT & ELMER GREY, ARCHITECTS

Grey is a most effective point of interest both to color and design. The Spanish influence is again recalled combined with Indian modeling as seen in the Aztec temples.

At one end of the Patio there is a gallery called the "Court of Bells" where is assembled probably the largest collection of bells to be seen at one place. This terrace has various features that makes it interesting in itself. These include unusual wood grilles over various window, tile inserts in the walls, a wall fountain of Moorish design, low walls with arched openings and capping of hand made Spanish tiles in reds and browns.

The upper balconies are very effective framed

against the sky with striped awnings of red and yellow, tile roofs and a quaint corner treatment which has for its point of interest a large clock with carved frame and face of wood. The finest suites of rooms open from the top terrace and all have shuttered doors and screens formed by splitting small balusters in two and tacking on each side of netting making both a practical and artistic door.

Most interesting vistas can be obtained from these balconies, but probably the most effective one shows some very graceful ironwork as well as the bracketed cornice from La Granada at Seville, a fine example of carved woodwork. These brackets were worm eaten and the Spaniards did not



GLIMPSE FROM THE BALCONY, SHOWING ORIGINAL BRACKETS FROM SEVILLE

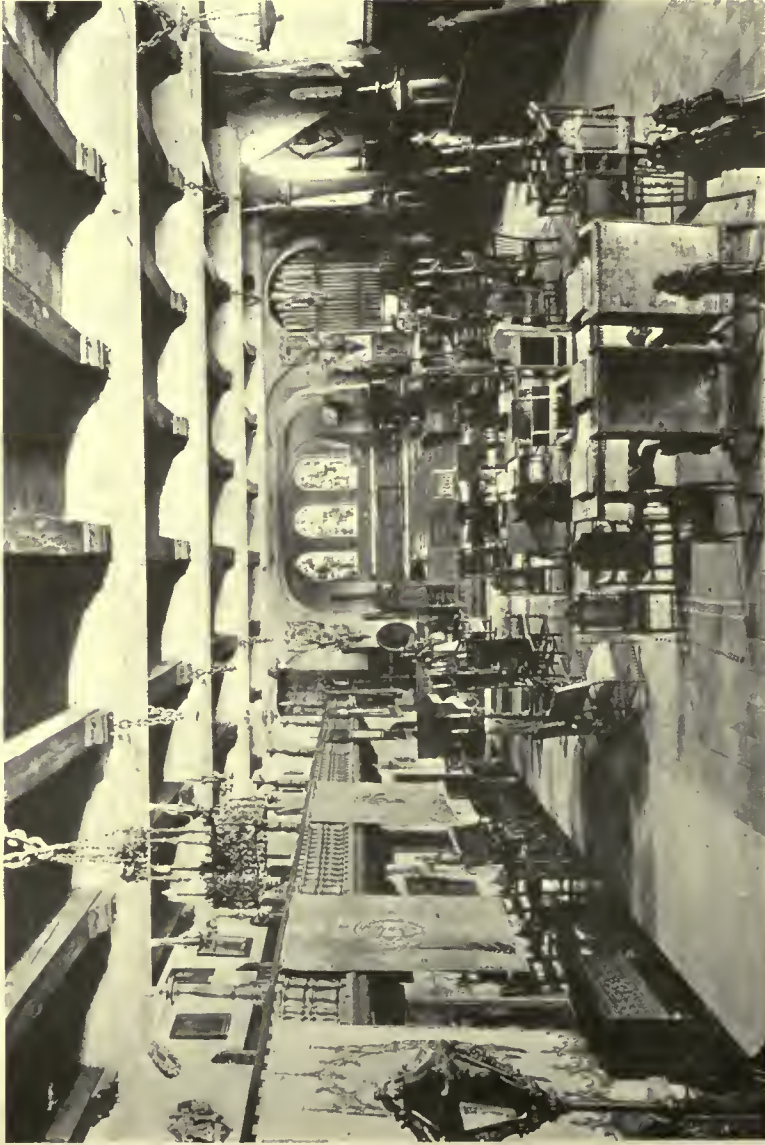

THE GREAT HALL, OR CHAPEL

ARTHUR BENTON, ARCHITECT

THE MISSION INN, RIVERSIDE, CALIFORNIA

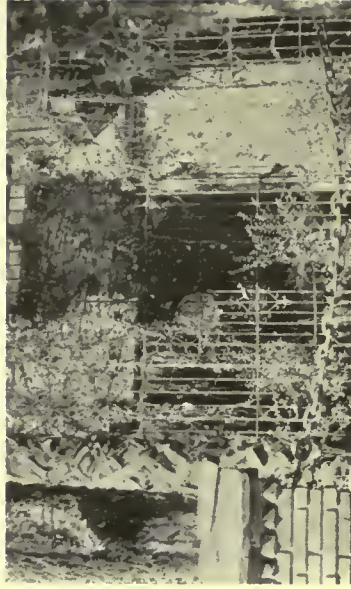

OLD SPANISH IRONWORK



SHOWING BUTTRESS TREATMENT ON SIDEWALK



ARCADE ALONG STREET FRONT
ARTHUR BENTON, ARCHITECT



DETAIL OF TERRACE WALL IN COURT OF THE BELLS

THE MISSION INN
RIVERSIDE, CALIFORNIA

THE AMERICAN ARCHITECT



IN THE COURT OF THE BELLS

know how to save them so had them replaced. Mr. Miller's representative bought them and American ingenuity saved them from being destroyed.

There are several very interesting interiors, the most unusual being the underground cloisters with their various arches and niches filled with paintings of the old monasteries, figures of monks and in some cases alcove rooms filled with interesting architectural and decorative objects.

The guest hall as designed by Mr. Arthur Benton is a room of considerable size that is used for lounging and concerts. Choir stalls on two sides and also on two balconies give plenty of seating space and serve to add to the old world appearance and attractiveness.

One of the most interesting parts of the entire structure is the Spanish art gallery designed by Mr. Myron Hunt. The most unusual proportions of the room are handled very successfully, the simple wall spaces are effectively broken up with a few features only allowing the old Spanish por-

traits to serve as integral parts of the entire scheme. The hanging ceiling of gold was partly caused by necessity. Not having an appropriation large enough to do what he originally desired, Mr. Hunt took large pieces of burlap which he held in place

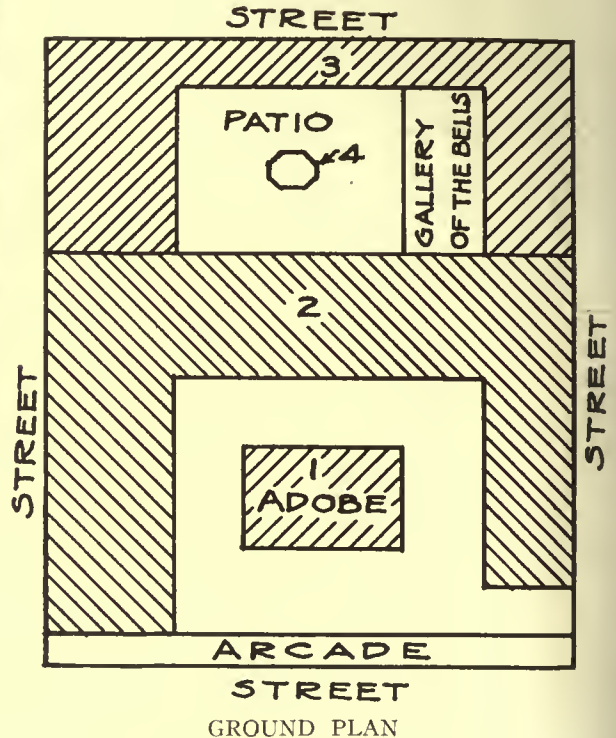

GROUND PLAN

by rope. Then an air gun was used spraying the entire surface with gold bronze. The ends of the rope were unwoven making large tassels. This different ceiling serves as well as many other features around the building to give pleasure to the many tourists from all over the world who are constantly filling this most unusual Inn.



COURT OF THE BELLS



DETAIL OF FOUNTAIN IN PATIO
MISSION INN, RIVERSIDE, CALIFORNIA
ELMER GREY, ARCHITECT

Notes from London

The Proposed Restoration of Westminster Abbey

By Special Correspondent of THE AMERICAN ARCHITECT

A STRONG appeal has been issued from the Dean of Westminster for public support toward the urgently needed repairs of that priceless heritage of our race, Westminster Abbey. During the recent war the venerable pile certainly ran very great danger: as far as possible monuments in the interior—such as Edward the Confessor's shrine, the tomb of Henry III, the great builder of this Abbey, and that richly sculptured of Henry VII, were protected by sandbags, but the grand old building itself had to take its chance of bombs from the Zeppelins with which we Londoners were then being molested. I never passed the old Abbey in those anxious days without a feeling of thankfulness that it had so far escaped, and a prayer that it might be still preserved to us uninjured.

It has escaped safely the dangers from the enemy, but is now faced with the no less serious risks of internal decay. "We are now," writes the Dean, "faced with a desperate state of things. The sum of money which more than fifty years ago was fixed for the maintenance of the fabric and services of the Abbey has become utterly inadequate for those purposes. The immense rise in the cost of materials and in the wages of the staff, together with the greatly increased standard of efficiency demanded from every branch of service to Church and nation, have brought us to the verge of bankruptcy. It has been even necessary, while fabric repairs have been unavoidably postponed, to divert to the absolutely essential duty of keeping up the services and worship of the Abbey the inadequate sum of money which had been 'earmarked' for keeping the fabric in repair. We are no longer able to pay our way."

At the same time there is urgent need for:

(1) The repair to a condition of safety of the two great western towers.



HENRY VII'S CHAPEL, WESTMINSTER ABBEY

(2) The reparation of the external stonework of Henry VII's Chapel.

(3) The renovation of a large portion of the parapet running round the roof.

(4) The repair of clerestories and flying buttresses.

There is besides a continual large outlay required by the maintenance in proper repair of much the decayed Cloisters and the ancient dwellings which, at the present scale of prices cannot be kept in suitable structural repair at the private cost of the officials who are their temporary occupants.

Bishop Ryle goes on to point out that it is impossible to meet this deficit by the funds at the disposal of the Ecclesiastical Commissioners, as those

THE AMERICAN ARCHITECT

funds are required for poor incumbents and curates, and are not permitted by Parliament to be used otherwise. "But," he continues, "the Abbey must not be allowed to suffer. The English-speaking peoples of the world glory in Westminster Abbey. They will not tolerate the thought that its structural condition should suffer from lack of adequate funds. They will expect me to take them into my confidence, as I now do. I know well after residence for over nine years in this place, I know well from the extraordinary experiences in the Abbey during the years of the Great War, how dear is this church to the people of this country, to our brothers and sisters in Canada, Australia, New Zealand, South Africa and India, and in a peculiar

degree to our brothers and sisters of the great Republic of America. I appeal to them. I ask for the sum of £250,000. Of this the sum of £100,000 is required for structural repairs in the immediate future. The remaining sum of £150,000 should constitute a fund by which the whole Abbey and any buildings of which the Dean and Chapter are custodians should in future time be kept in a constant condition of complete efficiency and repair, and be finally freed from the humiliating necessity of appeals being made now for this object and now for that."

The learned Dean has not made his appeal in vain. The Abbey is something more to us than any other Church or Cathedral. It is the shrine of our race—the epitome of England's history. Dating back to Edward the Confessor, and yet earlier to the first foundation of Sebert, it was added to and enlarged by Henry III., while it was Henry VII. who enriched it with that wonderful Chapel, a forest of fretted stone-work in which the keying of each separate part, the thrust and support of the piers is so admirably planned. In the days of the war Australians, Canadians, South Africans and Americans came streaming into the Abbey from the great military camps and felt, as we feel now, that the Abbey does not belong to the Church or to ourselves, it is the heritage for which we are trustees for our race, for all the English-speaking peoples.

Already, on Friday last, three days after the appeal had been made, more than £30,000 had been received, and the next day was expected to give £50,000 to the fund. There is good reason to hope that the amount required will be obtained, with enough over to purchase adjacent ground so that our Abbey may never be encroached upon, like St. Paul's, with crowding blocks of office structures.

At the meeting held this week at the Mansion House the question of "adoption" of devastated French towns was warmly supported by the Lord Mayor, Sir E. Cooper, the Earl of Denbigh, Viscount Burnham and other speakers. Already the lead in this movement has been taken by our Lancashire industrial centres, Manchester having adopted Mezières and Liverpool become godmother of Attigny. It is to be hoped that the City of London will assume a similar relationship to the ancient and devastated city of Rheims.

My illustrations of Westminster Abbey include the towers, which from the point of view of Gothic design are perhaps less interesting than other portions of the structure, and that wonderful Chapel of Henry VII., whose stone roof, as Mr. Russell Sturgis remarks in his "Appreciation of Architecture," was "one worthy of the shrewdest and most daring builder of the time. The stone ribs," he adds, "which spring directly from the uprights



THE TOWERS OF WESTMINSTER ABBEY

with but the slightest pretense at vaulting shafts in little round mouldings with slightly marked capitals, are really the arches which carry the whole

structure of the roof." The design marks the culmination of our beautiful English Gothic; no one can remain indifferent to its charm. S. B.



DESIGN SELECTED BY ATLANTA PARK COMMISSION
J. F. DOWNING, ARCHITECT

The Battle of Atlanta

By Special Correspondent of THE AMERICAN ARCHITECT

THE Battle of Atlanta is still being fought. On those wooded slopes and open spaces where once the uproar of battle attended the infernal destruction of war, is now a public park dedicated to peace, happiness and public welfare. In Grant Park is to be placed a great portrayal of this battle in cycloramic form, a fine representation of a beautiful southern landscape with all the details of ruthless human combat. Properly to preserve and house this important record of an historical event, the park commissioners will erect a permanent structure.

A competition was recently held among the Atlanta architects with the understanding that the award would be based on the recommendations of the Atlanta Art Commission. The design by Edwards & Sayward was recommended by the art com-

mission; the park commissioners, however, selected the design of J. F. Downing. These, with the designs by Burge, Stevens & Conklin, and A. Ten Eyck Brown, are now illustrated and described.

In addition to housing the painting of the battle, the building is intended to include a war museum, two famous war-time locomotives used in historical raids, public comfort stations, restaurant, service and attendants' quarters.

Of the four designs illustrated, three clearly indicate the main function of the structure as housing a cyclorama. The selected design rather subordinates this feature and places more emphasis on the museum and service features.

The design of Edwards & Sayward, which was recommended by the Atlanta Art Commission, indicates the purpose of the building interpreted in

THE AMERICAN ARCHITECT

the most simple and direct terms. The circular superstructure befits a cyclorama according to the necessities of the interior requirements. The exterior of the wall is divided into twenty vertical panels, at the top of each is placed the coat-of-arms of the Confederate State whose name is carved in the frieze immediately above the panel. The cornice is completed in a simple and well proportioned manner, the roof is of slight pitch and inconspicuous. The base or lower story is octagonal in plan, simple in detail and monumental in character. The design is dignified and imposing in its simplicity.

The design submitted by Burge, Stevens & Conklin is octagonal in plan throughout both stories. In this plan the cyclorama feature also dominates the design and the museum and service portion is subordinate. The base might appear more substantial under the large wall space above if the fenestration were differently arranged, a detail that could be perfected by further study. The cornice is simple and effective and makes a satisfactory combination with the colored tile roof. The main feature of this design is the large paneled surfaces of the upper story. The diaper pattern in subdued colors give the necessary effect of coherence in such large areas. The body of the panel constructed with carefully selected and graded texture surfaces of brick, or possibly marbles, would have a harmonious tonal effect of color that would make this a most beautiful structure. There are great possibilities in this type of design.

The design submitted by A. Ten Eyck Brown emphasizes the cyclorama feature as prominently as the others mentioned. The museum floor is subordinated to such an extent that it is hardly noticeable in the mass of the structure. It is, however, a very effective base. The roof and cornice are more prominently featured, the sculptured frieze being a conspicuous element of the design. The walls are variously paneled by the use of pilasters and are divided horizontally by a heavy belt course near the top. Perhaps some of the effectiveness of the general design is lost through the elabo-

ratedness of the details, but it is consistently worked out withal. The plan is especially interesting and well considered.

The design submitted by J. F. Downing, selected by the park commissioners, differs materially from the others. The building is considerably lower than the others illustrated. The floor of the cyclorama section is several feet lower than the general first floor level and this portion of the building is a decagon in plan, to three sides of which is connected the museum and service portion of the building. This portion of the building is rectangular in plan, the first story of which is devoted to the refreshment and comfort service, attendants and park board quarters. The locomotives previously mentioned will be stored in a basement under this portion of the building. The second story is devoted to museum purposes. The building is low as compared with the other designs submitted, and will not, due to this fact, be as imposing in appearance. The polygonal portion of the building is severely plain in design. The main features of the exterior design are confined to the front elevation, which is enriched by the sculptured panels in lieu of the second story windows. The loggia is two stories in height with Ionic columns and pilasters. The elevation is well proportioned and consistently detailed. The cornice extends entirely around the building at a uniform level.

All of the designs will adequately serve the purpose from the utilitarian standpoint. There is ground, however, for a difference of opinion as to which type of building will present the better architectural appearance in connection with the place and surroundings. It is said that this is the only building used for this specific purpose in this country, and as such it might be worthy of a distinctive appearance which would readily proclaim its use through its design. In any event, the battle, depicted in such a masterly manner, will continue to represent the scenes of mortal combat housed in a beautiful building erected on the ground on which the historic action took place.

Doorway of a House on Washington Square North, New York

(See reproduction of the original drawings by O. R. Eggers in this issue)

ONE of the most interesting periods of the architectural development of New York City is that called by architectural writers as of the Greek Revival. Men of large means and of much culture who located their homes in the then aristocratic Washington Square section, which included lower Fifth avenue, readily availed of the suggestion that their houses be designed after these classical and refined motives. The portico illustrated is of the house standing on the northwest corner of Fifth avenue and Washington Square North and is typical of the majority of the houses in its neighborhood. Mr. Eggers has with characteristic skill retained in his sketch all the beauty of proportion and classical adaptation of this entrance detail. Of the various well known architects that lived and worked during the early thirties, Robert Mills is on good authority believed to be the man who first designed in the style now known as "the Greek Revival." The late Montgomery Schuyler, in a series of articles contributed to *The American Architect* in 1910 expressed the conviction that it was largely through the examples of Robert Mills that this dignified method of architectural expres-

sion found favor not only in the domestic architecture of all of our then large cities, but was also plainly shown in all of the important work on which Mills was engaged.

Undoubtedly good architecture is influential in setting a good example wherever it is successfully grouped. In spite of the many vicissitudes through which the Washington Square section has passed, the northern boundary of the "Square" yet presents a quiet dignity, a staid respectability, even though its neighboring boundaries on the south and east and west have long since lost all architectural coherence. The well appointed phaeton with two liveried men on the box no longer waits in front of these houses. Where once the future aristocrats played in the Square under the watchful eye of nurses and grooms, the "Villagers" congregate under the shadows of the Washington Arch or overspread the walks and lawns to listen to the music of the city band. And these stately old houses, closely shuttered, sit in all their isolation of a past splendor calmly awaiting the day when the wreckers for speculative building interests will fall upon them and raze them to the ground.

The American Lumber Industry

IT is estimated that the United States originally possessed 850,000,000 acres of timberland, of which only about 545,000,000 acres remain, says the National Bank of Commerce, in an analysis published in its monthly magazine. And yet, in spite of the methods of lumbering that have wasted so much of our original timber, the United States is still the third country of the world in respect to forest acreage, being led only by Russia and Canada. The remaining virgin stands, says this article, consist chiefly of various species of hardwoods in the central and southern hardwood regions, the yellow pine along the South Atlantic and Gulf coasts, and the Douglas fir, spruce and cedar of the far Northwest,

with smaller stands of redwood, California sugar and white pine, western yellow pine and Idaho white pine in the inland empire region, white pine in northern Minnesota and Wisconsin and spruce in Maine. Lumber production in this country reached its peak in 1906 and 1907. Since then it has steadily declined.

One hundred years ago lumbering in the United States was confined to small sawmills on the coast and river courses of the East. Except for a small export trade the markets supplied were entirely local. As the Middle West became settled and railroad transportation developed, the center of lumber manufacture shifted to the region of the Great

(Continued on page 215)

212 a



DOORWAY, WASHINGTON SQUARE NORTH, NEW YORK
THE AMERICAN ARCHITECT Series of Early American Architecture



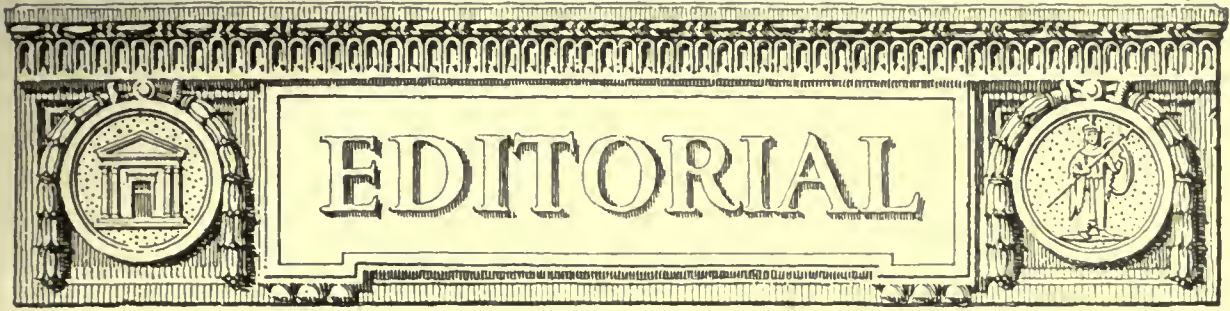

Cass Gilbert Visits England

CASS GILBERT'S sojourn in London was marked by the most delightful manifestations of good will by members of the profession in that city and a very fine appreciation of his high position among his brother architects in this country. Mr. Gilbert's fine personality would naturally attract and suggest the sort of comment that marked his visit.

It will be gratifying to architects in this country to note among the many references in the English press, that there is also included a very unselfish expression of appreciation of the work of architects in the United States.

The Architects' Journal of London writes of Mr. Gilbert and of contemporaneous and earlier American architects as follows:

"No American architect enjoys a higher reputation among us than Mr. Cass Gilbert, and the British architects who have been able to meet him personally will always consider themselves very fortunate. Very possibly it may have been the bruit of the gigantic Woolworth building that first brought his name into prominence here among the general public; but among British architects it was well known that Mr. Gilbert was capable of higher things—we mean qualitatively. It was known that he is a man of parts, a scholar who had sketched the ancient monuments of Greece and Rome, and had turned his accomplishments to fine practical account as assistant to Stanford White. Cass Gilbert is not to be classed among those superb specialists who will not, or cannot, or by an exacting public are not, allowed to forsake the class of work in which they have achieved reputation. Nor is he the all-round man, the 'general practitioner' whose deversity tends to mediocrity. He is of the rare type of those who do all things well. In this respect he is a true scion of the great house of McKim, Mead and White, whose miscellaneousness was their most astounding quality. It takes a great man to be as various as Mr. Cass Gilbert has been—his work ranging from a monumental building to a humble cottage—and, on the quality as well as on the variety of work, it is not an abuse of words to say that Cass

Gilbert is a great man, coming as near to genius as any architect that the Continent of America has yet produced, hardly excepting his great teachers, Charles Follen McKim and Stanford White. Concerning the Woolworth Building, the chief thing to take into account is not its gigantic size, but its embodiment of a very successful attempt to invest a skyscraper with architectural character."

Wasting Our Water Power

THE complication as to the mining and distribution of coal, and the prediction of experts that we are drawing perilously near the limit of production of fuel oil, makes consideration of the development and conservation of the enormous water power available in the United States a question of first importance.

The Federal Water Power bill, recently enacted into a law, makes possible the development of this power in a way that it will become a national asset and not one controlled by private enterprises.

It is claimed that there is in the United States available for development between 20,000,000 and 30,000,000 horse-power of water power that is today wasted. The use of this enormous power, when finally harnessed, will effect a corresponding saving in coal consumption. It is estimated that this saving would amount to at least one-half of the present coal consumption.

The Theatre vs. the Home

AMONG the different types of buildings projected all over the United States, it is significant that a very large number, representing a great amount of invested dollars is in theater buildings, principally of the moving picture type. It would seem to be indicated that it was more important that we Americans should be amused than properly housed. There are indications in this tendency to cater to our desire for amusement and ignore our needs for proper housing that we are becoming a frivolous and thoughtless people.

As a mass we are only the composite expression of the individual. And the individual, in spite of

THE AMERICAN ARCHITECT

the many warnings that have been given, calmly decides to relinquish next October the apartment he now occupies and lazily postpones "until the weather is cooler" the search for shelter for himself and family. Meantime, he recreates himself with the movies. And those who cater to that form of amusement sense an increasing business and decide on new playhouses.

Taking, for example, the present condition in New York City, where it is estimated there is a shortage of 60,000 homes, we learn that a survey recently made of theater construction discloses that \$25,000,000 worth of new amusement houses were underway. One may judge of the large profits that attend the amusement business, when at the present high cost of building it is considered "good business" to promote to so large an amount that type of building.

Is Building an Essential Loan •

IN the discussions as to what are the "essential" and what the "non-essential" loans referred to by the Federal Reserve Board stands the answer by Governor Harding of the Federal Reserve Board to a communication from Mr. M. Morganthau, Jr. of

New York. The letter addressed to Governor Harding contended that there was no reason why the Federal Reserve banks should not make temporary loans as required by builders during the construction which would subsequently be financed with permanent loans from savings banks or similar institutions.

The reply from the head of the Federal Reserve Board said that there was never an intention to convey the impression that essential loans were confined to those relating to the production or distribution of "clothing, food and fuel." After saying that the various war boards had experienced much difficulty in defining essential and non-essential loans, Governor Harding declared that it would be practically impossible for the Federal Reserve Board to make any general ruling or country-wide applications and urged that such discrimination might be made at the source by the member banks themselves. He added that the Board "has consistently declined to express any opinion as to the essential or non-essential character of any particular loan." The point was made also that the Federal Reserve Act permits only loans by the Federal Reserve banks to member banks direct and never to individuals direct.



CHURCH OF SS. STEPHAN AND NICOLAS, PESCIA, ITALY

THE AMERICAN ARCHITECT

The American Lumber Industry

(Continued from page 212)

Lakes. The famous white pine industry of the Lake states began about 1850 and did not decline until the end of the eighties. The industry differed from the former industry of the eastern coast in being organized and capitalized on a large scale. It catered principally to eastern and central markets.

As the white pine industry declined toward the end of the century, owing to the depletion of the virgin forest, the lumber market was diverted to pine from the southern states. In the eighties and early nineties, southern pine first extended itself beyond local consumption. Central, eastern and central markets of the United States now depend mainly on the southern forests for their lumber, but in the course of a few years the southern pine industry will return to local production on isolated bits of virgin timber and on second growth, as has already taken place in turn with the eastern forests.

The lumber industry of the Pacific Coast, which has come to be important since 1900, is the large scale American lumber industry of the future. Of the total available timber supply 54 per cent. is estimated to be in the Pacific Northwest. The territory from the Pacific Coast to the Missouri River and southward to western Kansas is now almost entirely dependent on west coast mills for its lumber supply. The tendency is to extend eastward and southward. However, for some time to come, southern yellow pine will predominate in central and eastern markets.

The United States is the largest wood-using country in the world. The great majority of dwellings and of farm buildings is made of wood. Of our total domestic consumption, more than half is accounted for by use for construction timber and lumber in the form of planing mill products. Lumber consumption in the United States, however, has of late years shown a tendency to decrease.

The organization of the lumber industry comprises five successive functions, which are carried out in great diversity of combination by industrial units. These functions are the ownership or control of standing timber, logging, manufacturing of lumber, wholesale distribution and retail distribution. The most common industrial unit combines the first three functions, and often undertakes the distribution of its own lumber to the retailer, or even the ultimate consumer. The lumber manufacturer ordinarily owns his timber. There has been a recent tendency toward the consolidation of holdings in large tracts. Owing to the unwise policy of the Government parting with its timberlands, there has been, since 1870, a vast speculative purchase of timberland far in advance of any possible use of the timber. Hence it is generally recognized that the big profit in the North-

west and also to a great degree in the South has not been in lumber manufacturing, but in the increase in the value of timberlands.

There is great diversity in the size and character of the American lumber mills. There is every variety and style of sawmill from the little stationary plant with a sash saw worked by water power to the large plant, with its main and secondary kilns. The largest mills, those having an output of 10,000,000 feet or more per year, though they constitute only about 4 per cent. of the total number of mills, now produce about 60 per cent. of the country's lumber. The proportion, both of the largest size mill and of their cut to the total, has increased during the last ten years.

But the most striking characteristic of the American lumber industry has been its lack of cohesion. This has led to a maladjustment of lumber production to the requirements of its market. Though the industry is at the present time prosperous, it contains elements of instability. It has been dominated by a strong individualism and has been backward in developing common ideas about its products. Co-ordination has been made difficult by the fact that it is not economically feasible to assemble the raw material (timber) at a few points where manufacturing may be concentrated.

The principal handicap of the lumber industry as it exists in the Pacific Northwest, and also to a great degree in the South, is the burden of timberland investments. In the last quarter of the nineteenth century lavish grants of public lands and loose, poorly defined and ill enforced land laws allowed the concentration of timberlands in private ownership. A rapid and enormous capitalization of stumpage took place, largely with borrowed funds. The result of these conditions has been that the lumber cut has tended increasingly to be governed by the financial requirements instead of demands of the market. This movement to unload stumpage while the opportunity for profit exists is the most serious cause of over-production in the West.

Violent and destructive competition exists between different regions and between different mills in the same region. The lumber industry is equipped to produce at least 50 per cent. more lumber than it has so far in any year, and probably about twice the present consumption. There has been a lack of sensitive adjustment of supply and demand. Naturally this loose and haphazard structure of the industry has operated with the speculative character of timber ownership to produce violent fluctuations in output and prices.

The value of lumber has multiplied many times since the beginning of the war. In 1914 the average price of yellow pine shipments was about \$14.50 per M. feet. In January, 1920, the price was about \$55 per M. The lumber industry of the United States

THE AMERICAN ARCHITECT

had to meet hitherto unknown conditions in 1919. The year started with stagnation and uncertainty. In the latter part of the spring the long expected building boom began to materialize and by summer there was a great demand for lumber of all sorts. Production, however, was hindered by unfavorable weather, by labor difficulties and by car shortage. It was a very prosperous year for the industry, but, on account of the handicaps mentioned, production was less than in previous years. It is now recognized that the present housing shortage will be taken care of not by a building boom but by quiet and gradual expansion of building operations. Mill stocks are low and output only fair—in some areas considerably below normal.

The annual timber growth of the country is about one-third of the annual cut. The opinion has been expressed in the lumber trade that it may be desirable ultimately to double the present acreage of the

public forests, so that they would amount to from 40 to 50 per cent. of the total forest area. State and municipal forests might also be established and some depleted and wasted cutover and burned lands should be rehabilitated. Tax accumulations, the fire menace, the fact that timber takes generations to mature, all tend to discourage reforestation by private owners, who too often take a short-sighted view of their functions.

According to Henry S. Graves, formerly chief of the United States Forest Service, if we began at the present time to protect our cut-over lands from fire and used wholly practical forestry methods to insure reproduction after logging, we could secure, in the next fifty or sixty years, an annual production of over 60,000,000,000 feet of lumber per year without lessening our forest capital. The production in 1918 was about one-half that amount and means vast needs be found for its increase.

Book Notes

There has just been published by the Chamber of Commerce of the Borough of Queens, New York, a 240-page publication of considerable interest, to architects, particularly metropolitan architects.

The book has as its object to reveal the manifold opportunities presented by this borough, for conducting vast industries and for housing great numbers of people.

To do this a history of the founding and subsequent growth of Queens Borough is included, and a very complete discussion of the assets of that section of Greater New York, as bearing upon its present remarkable development is fully set forth.

The volume is thoroughly illustrated with many pictures of the hundreds of industrial plants, and homes of various types, of new bridges and highways and other innumerable institutions that form part of a great city.

THE AMERICAN ARCHITECT has frequently had occasion to comment on the small editions of various housing publications issued by the Government during the war. All of the more important industrial housing developments have been carefully illustrated in these pages, but it has remained for a collection to be made that would adequately provide the many architects interested with descriptions and illustrations of some of the larger undertakings.

There is now off the press "The Housing Book," which contains photographic illustrations with floor plans of workingmen's homes, one and two family houses of frame, brick, stucco and concrete con-

struction, and also four, six and nine family apartment houses, showing single houses, blocks of houses, groups and developments that have been built in various parts of the United States. There are 150 illustrations and plans, 132 pages, 8½x11 inches, cloth bound. Wm. T. Comstock Co., New York, publisher.

An analysis of the present financial and economic problem of supplying homes for workers. It discusses proper rents, the advantages of home owning, the guarantee of repurchase by the employer the financing of building undertakings by Loan Associations, Mortgage Finance Corporations, and Consolidated and Individual Realty Companies, methods of selling, and co-partnership housing. Village planning, types of houses and their essentials are also touched upon. The appendix contains many forms for use by employers in selling or renting to employes. (Apply to Fred T. Ley & Co., Inc., 50 Central Park West, New York City.)

"Town Planning with Reference to Factory Development and the Distribution of Goods," by W. H. Gaunt, read at the March 5, 1920, meeting of the Town Planning Institute; "Town Planning Reports and the Graphic Representation of Statistics," by Major George B. Ford, read at the meeting of the Institute on April 6, 1920. Each with the discussion thereon. Quarto. (Published by the Town Planning Institute, 4, Arundel St., London, W. C. England.)

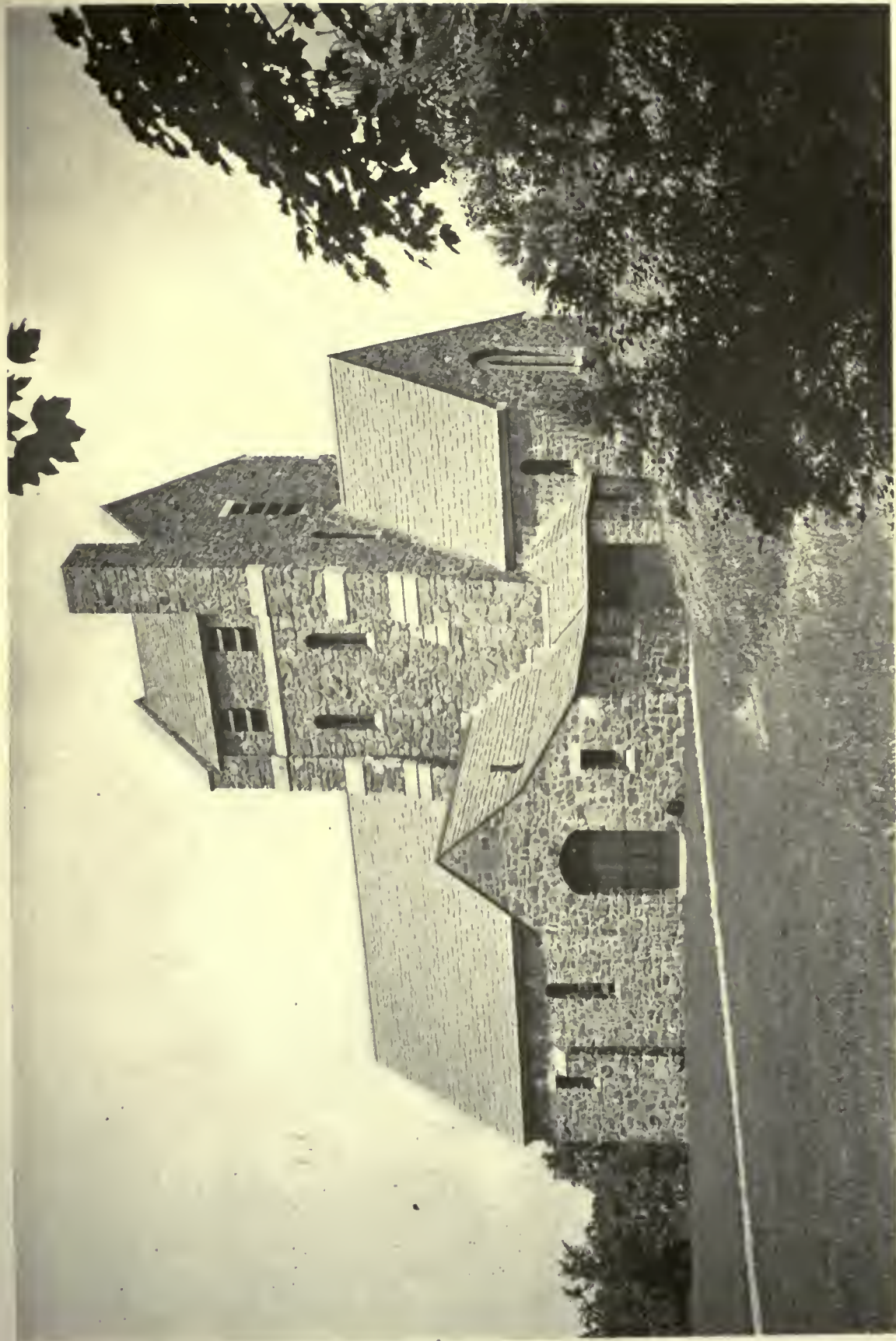

CHAPEL AT NAHANT, MASS.
RALPH ADAMS CRAW, ARCHITECT

210



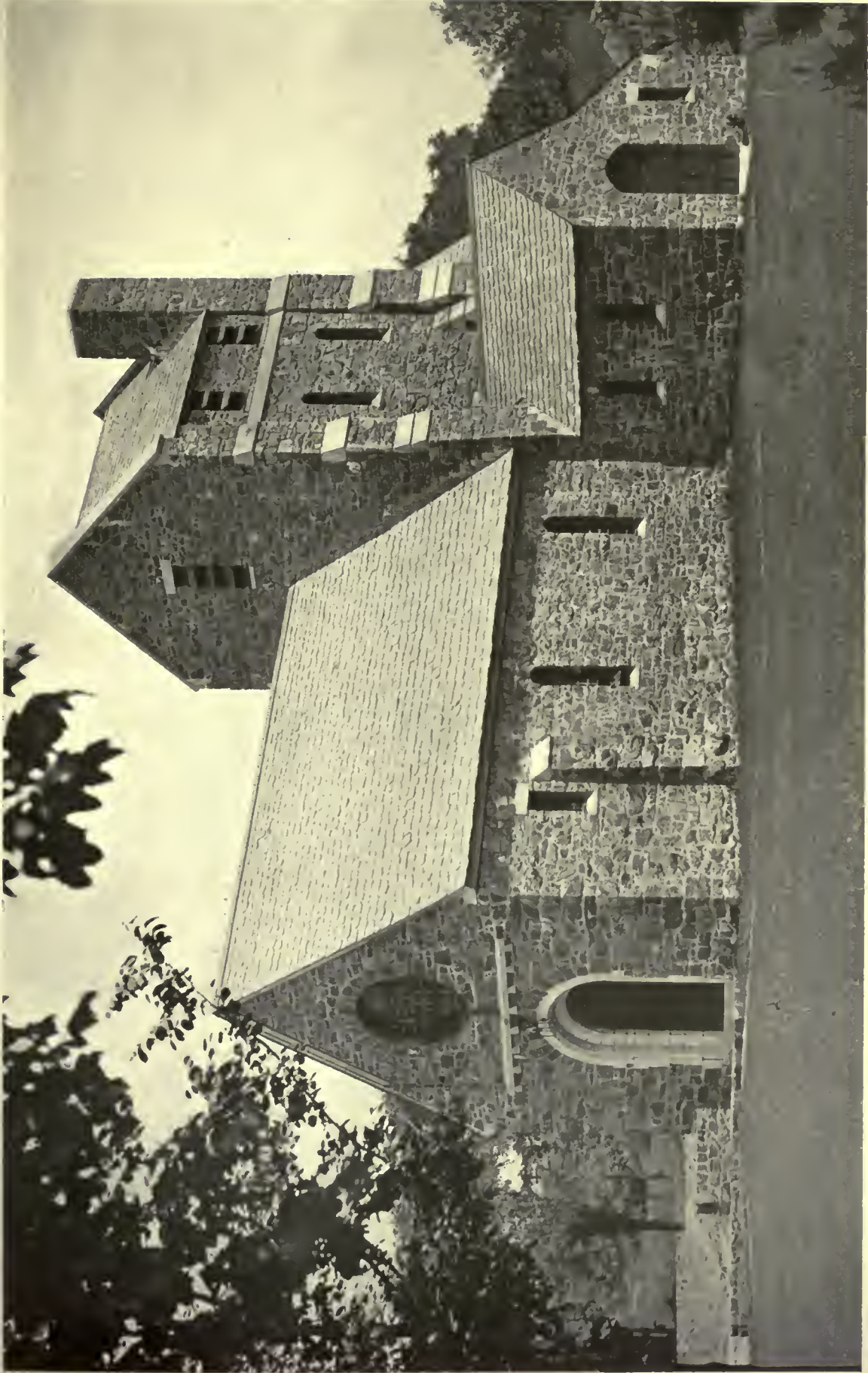

CHAPEL AT NAHANT, MASS.
RALPH ADAMS CRAW, ARCHITECT

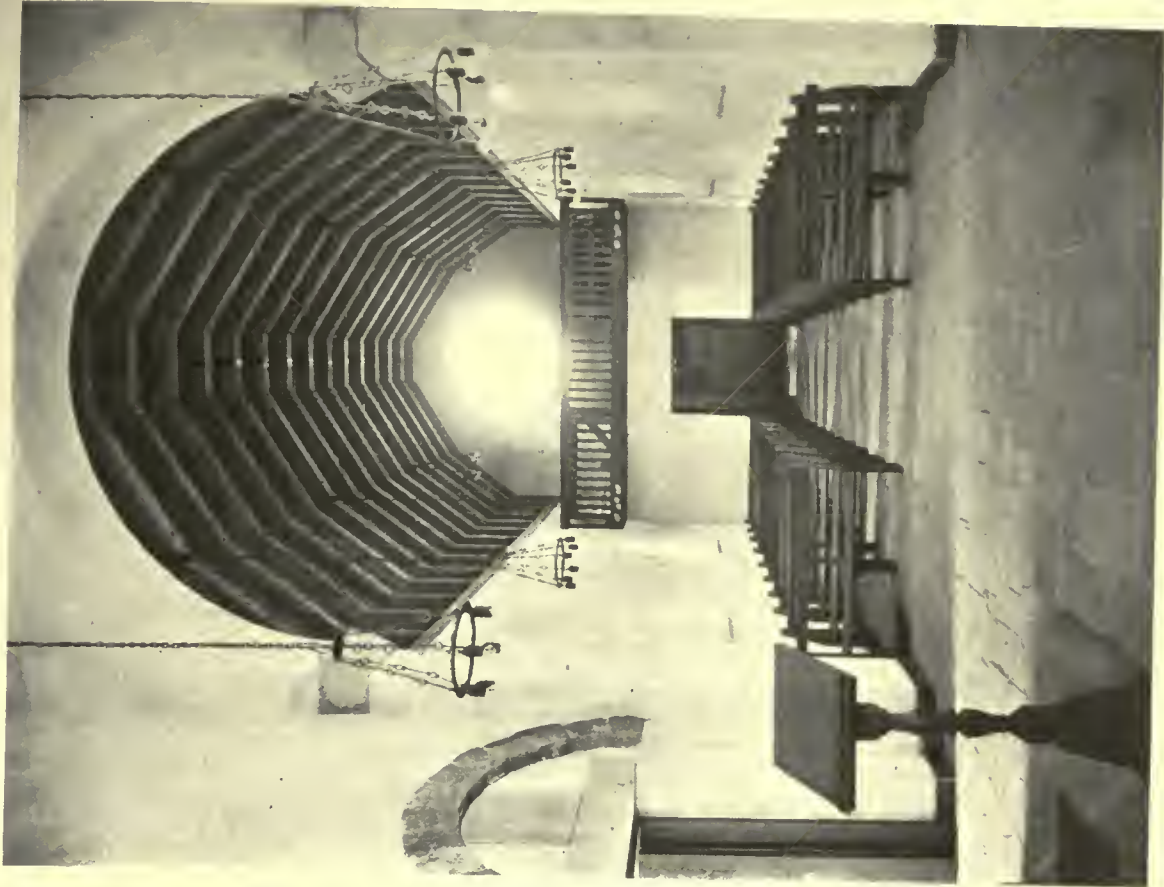
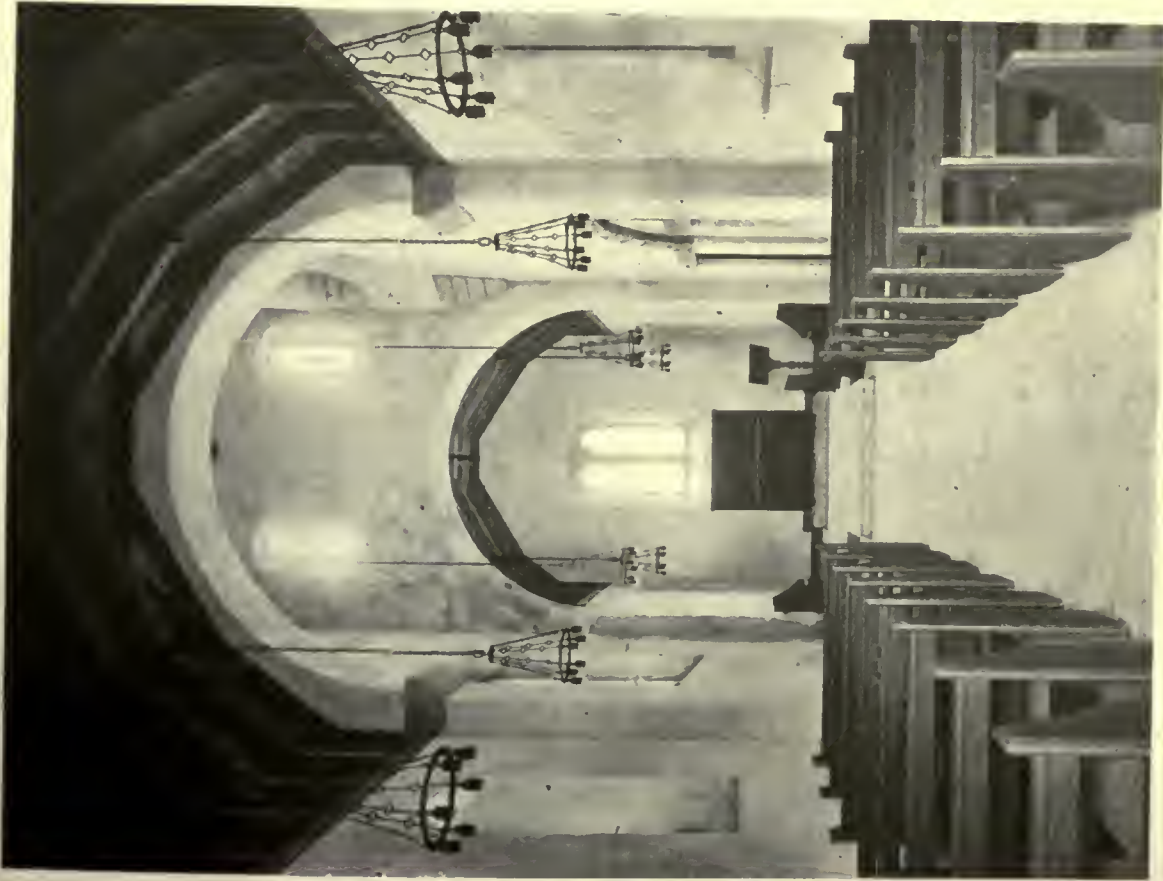

CHAPEL AT NAHANT, MASS.
RALPH ADAMS CRAW, ARCHITECT

V
153



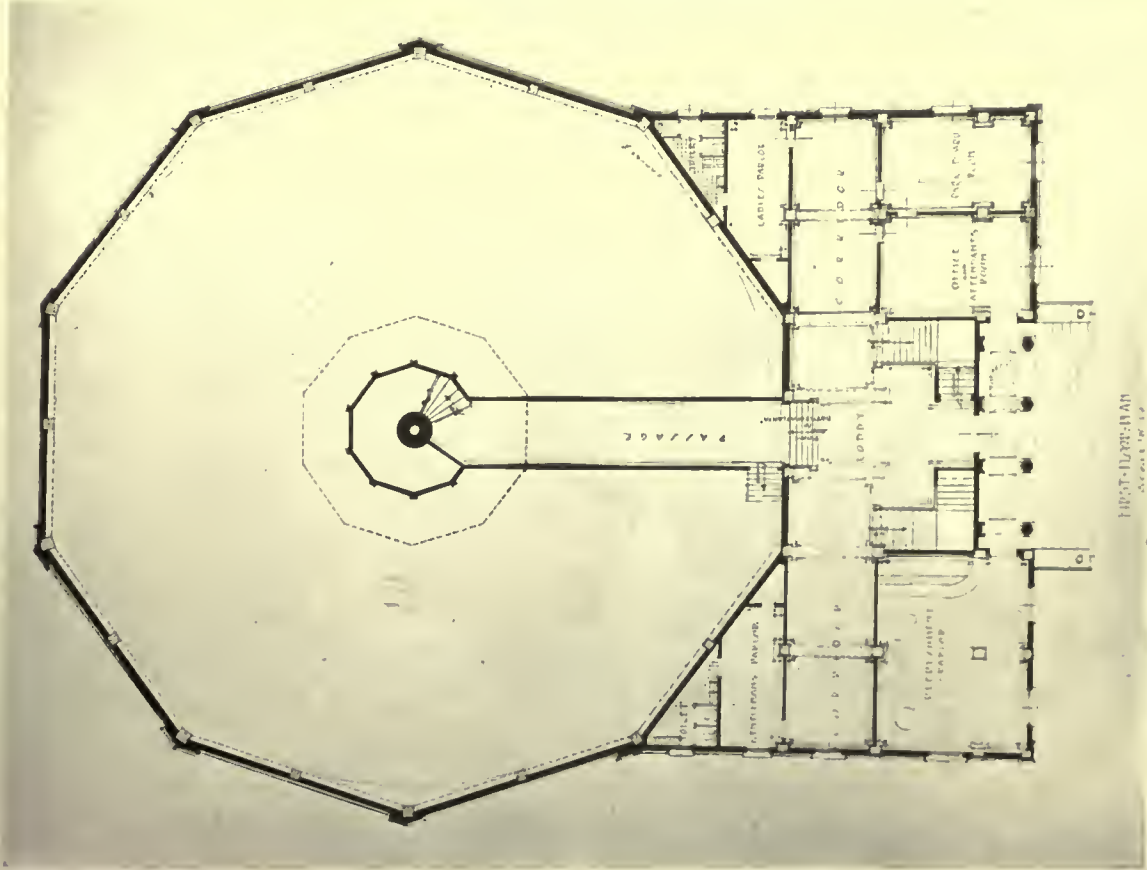

FIRST FLOOR PLAN

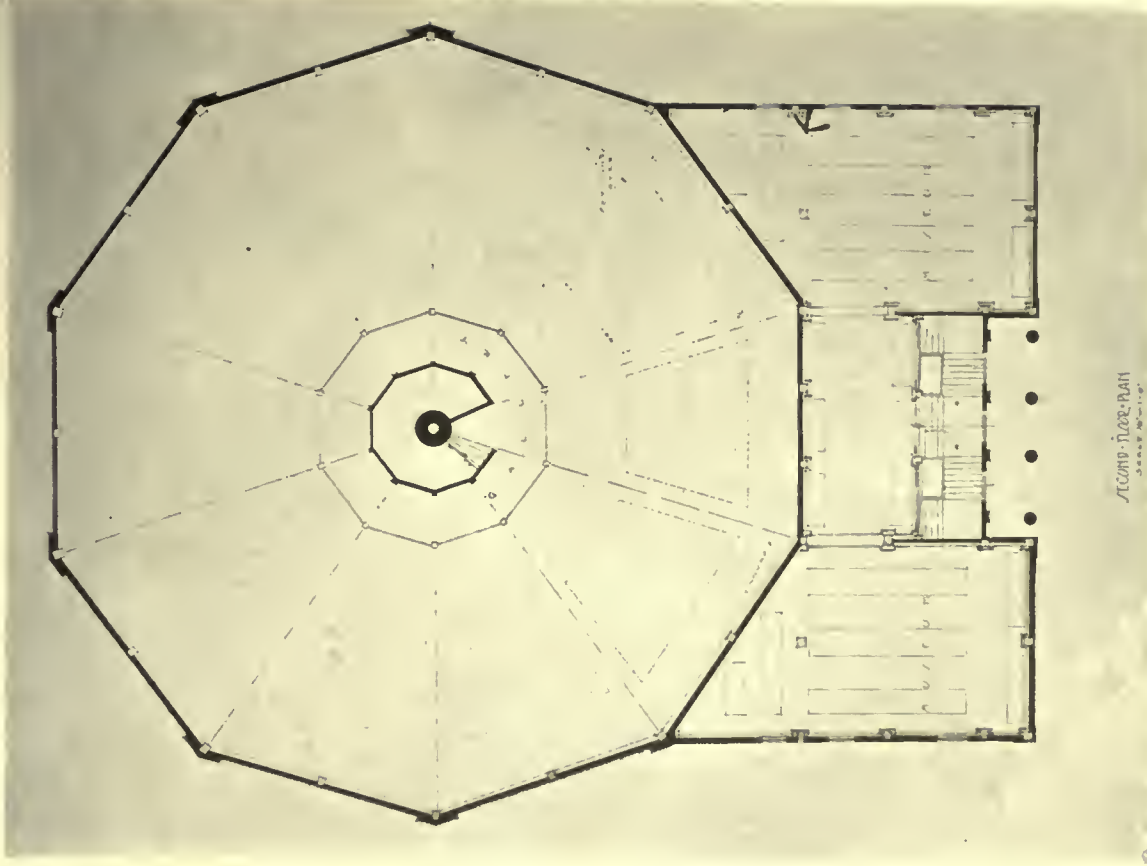

SECOND FLOOR PLAN

COMPETITION FOR A CYCLOPAMA BUILDING AT ATLANTA, GA.
 J. F. DOWNING, ARCHITECT
 (Design selected by Atlanta Park Commission)

V.C.

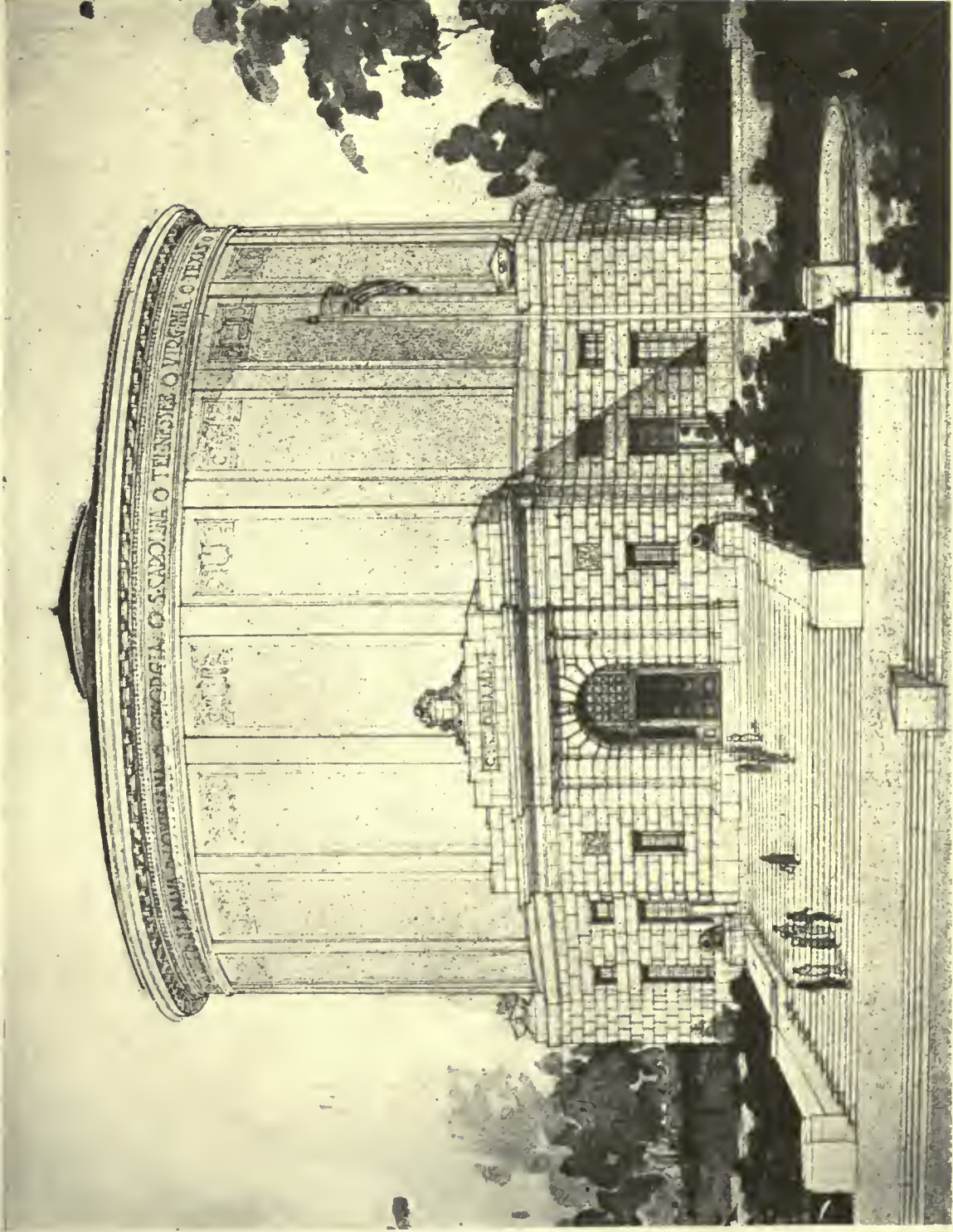

COMPETITION FOR A CYCLOPAMA BUILDING AT ATLANTA, GA.
EDWARD & SAYWARD, ARCHITECTS
(Design recommended by Atlanta Art Commission)

265

2160

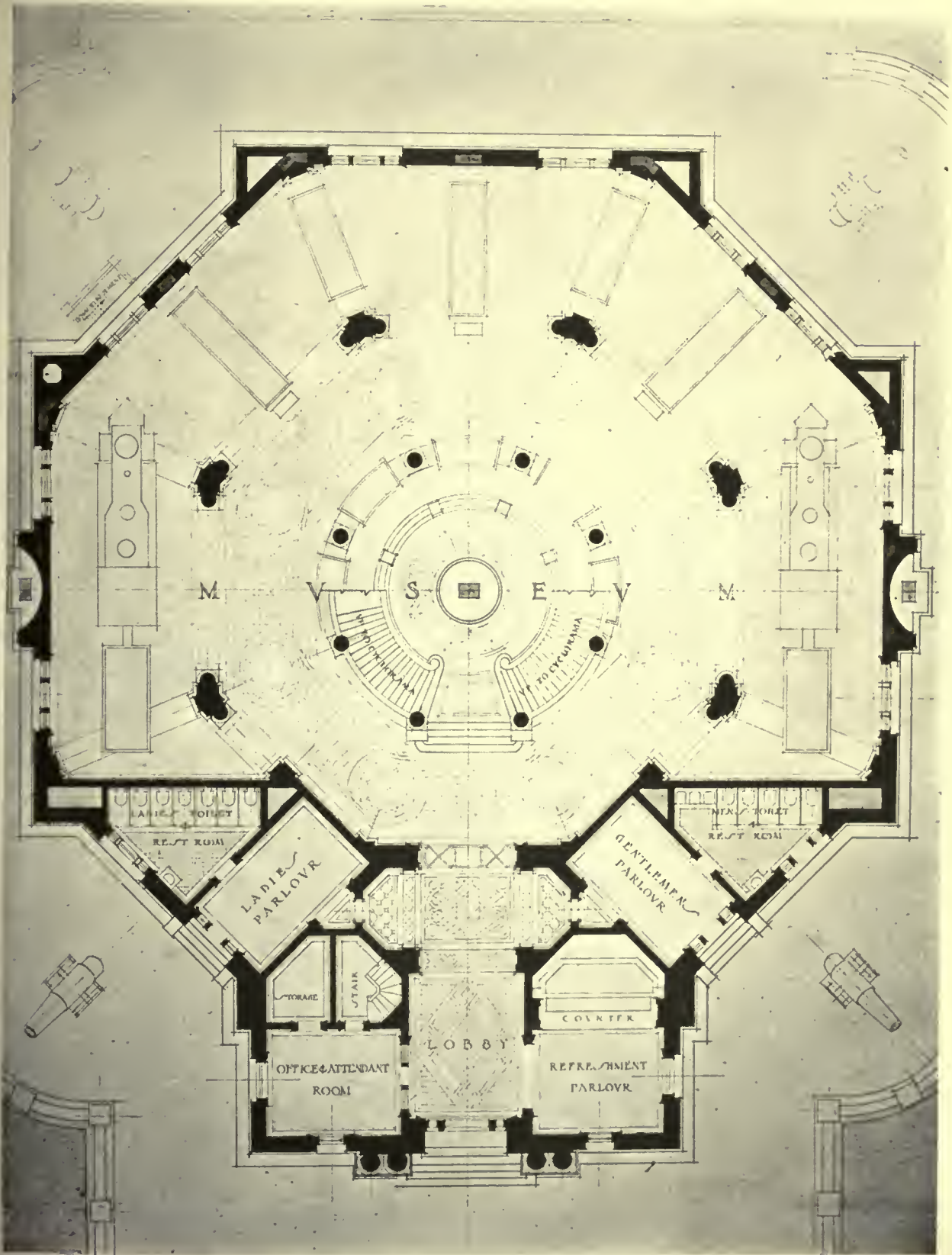

COMPETITION FOR A CYCLOPAMA BUILDING AT ATLANTA, GA.
EDWARD & SAYWARD, ARCHITECTS

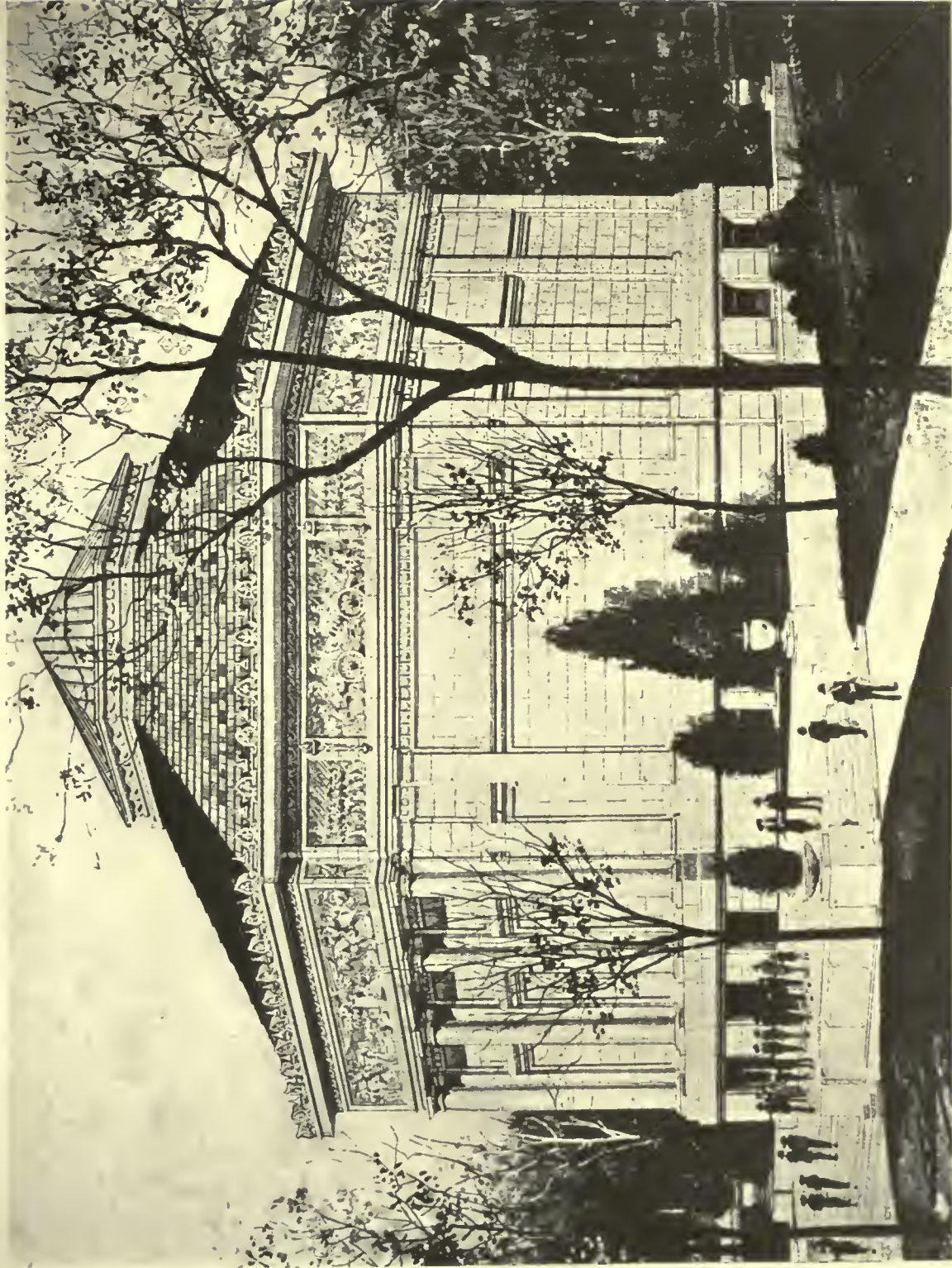

COMPETITION FOR A CYCLORAMA BUILDING AT ATLANTA, GA.
A. TEN EYCK BROWN, ARCHITECT



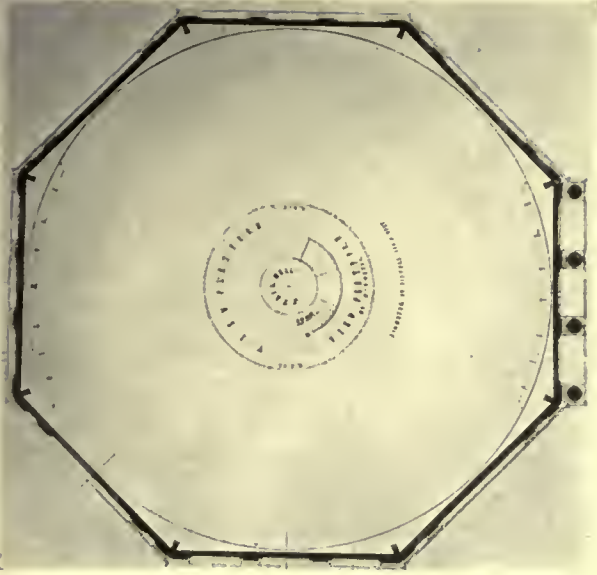
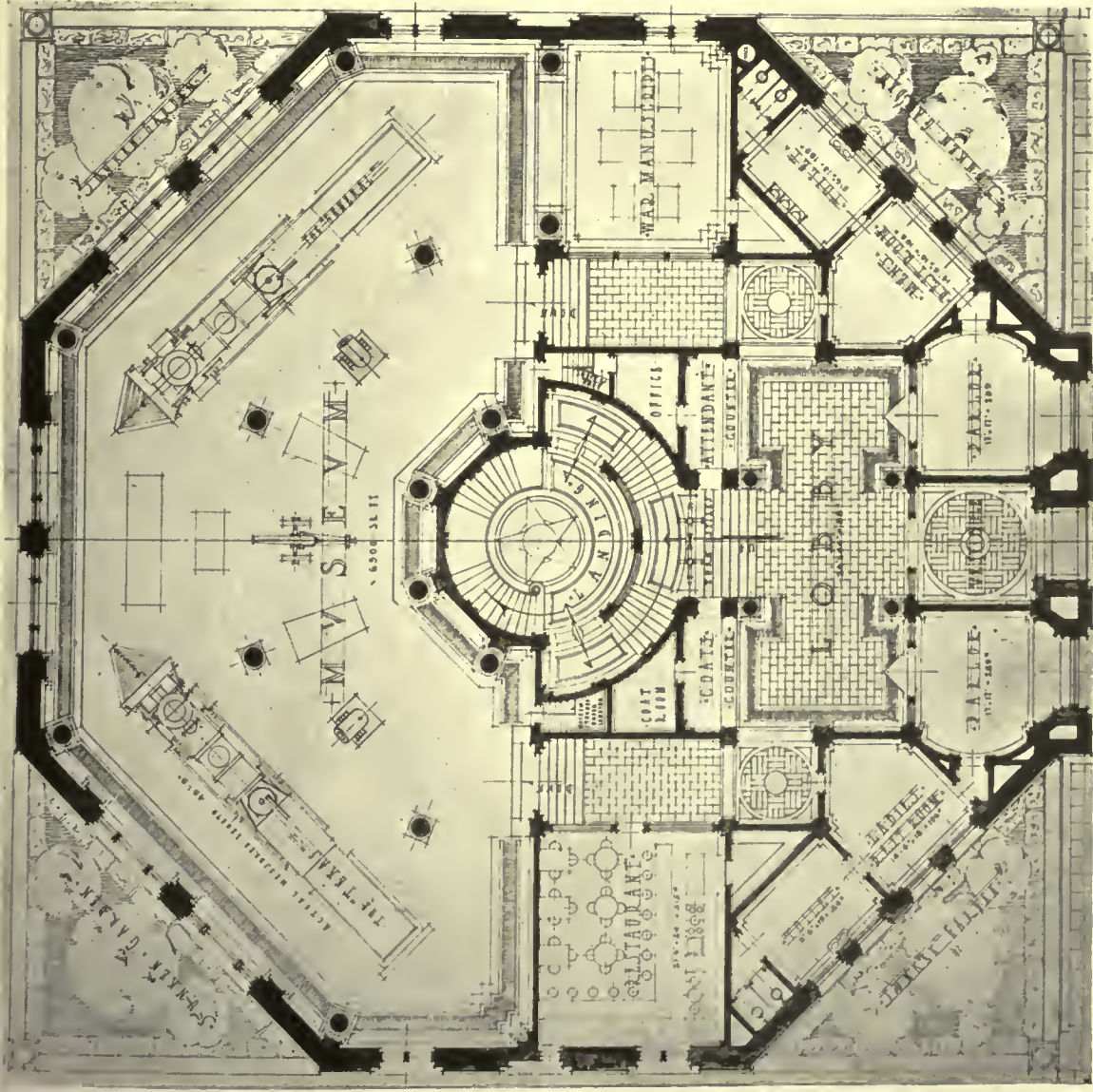

COMPETITION FOR A
CYCLORAMA BUILDING
ATLANTA, GA.
A. TEN EYCK BROWN,
ARCHITECT

216 8



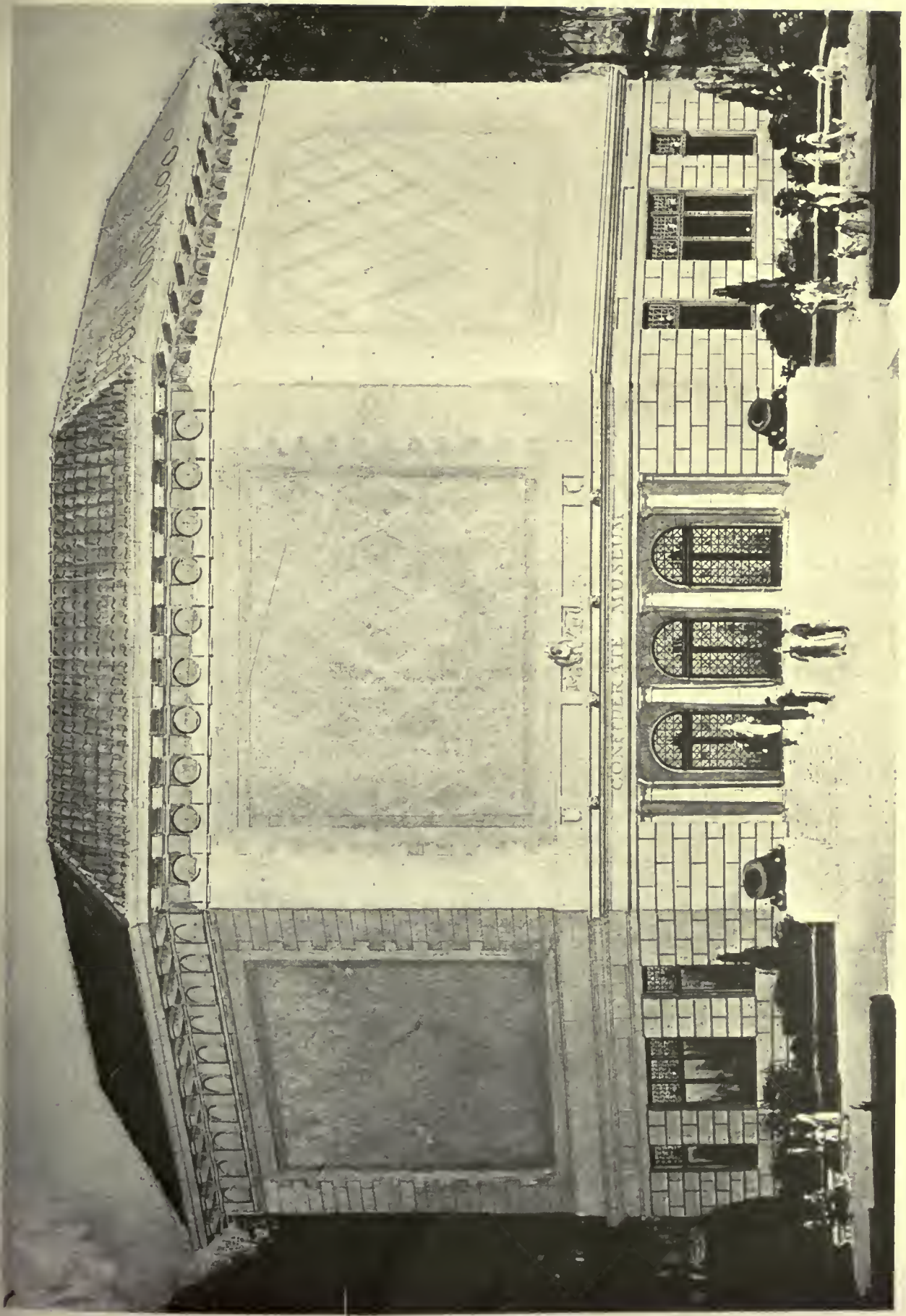

COMPETITION FOR A CYCLORAMA BUILDING AT ATLANTA, GA.
 BURGE, STEVENS & CONKLIN, ARCHITECTS



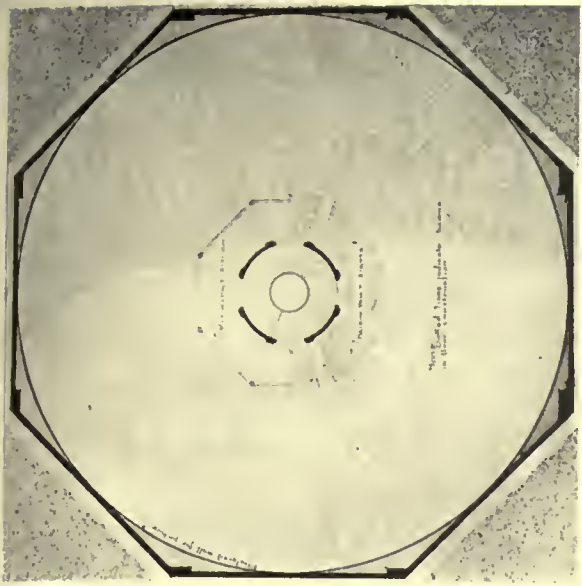
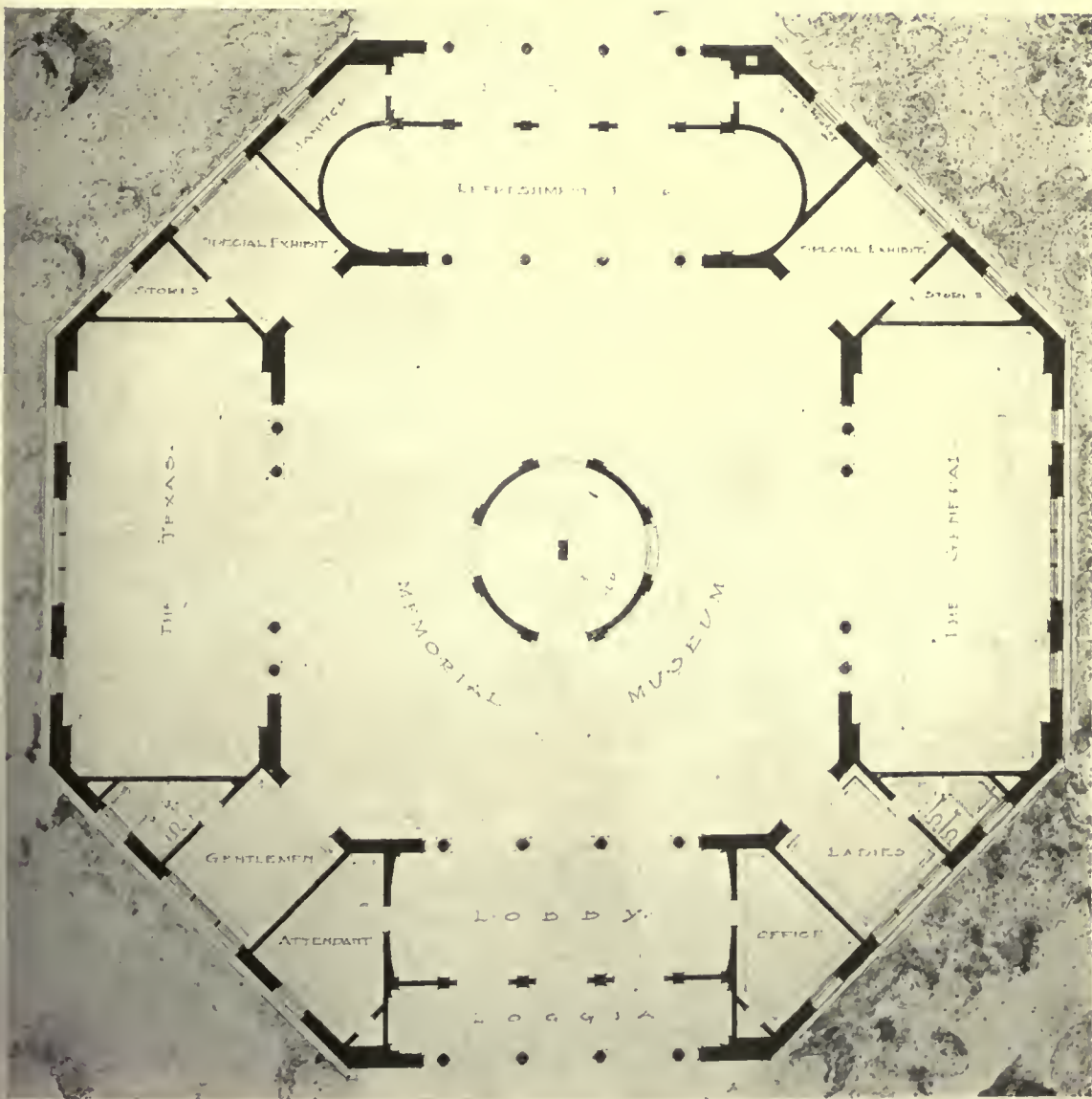

COMPETITION FOR A
CYCLOPAMA BUILDING
ATLANTA, GA.
BURGE, STEVENS & CONKLIN,
ARCHITECTS

216⁰

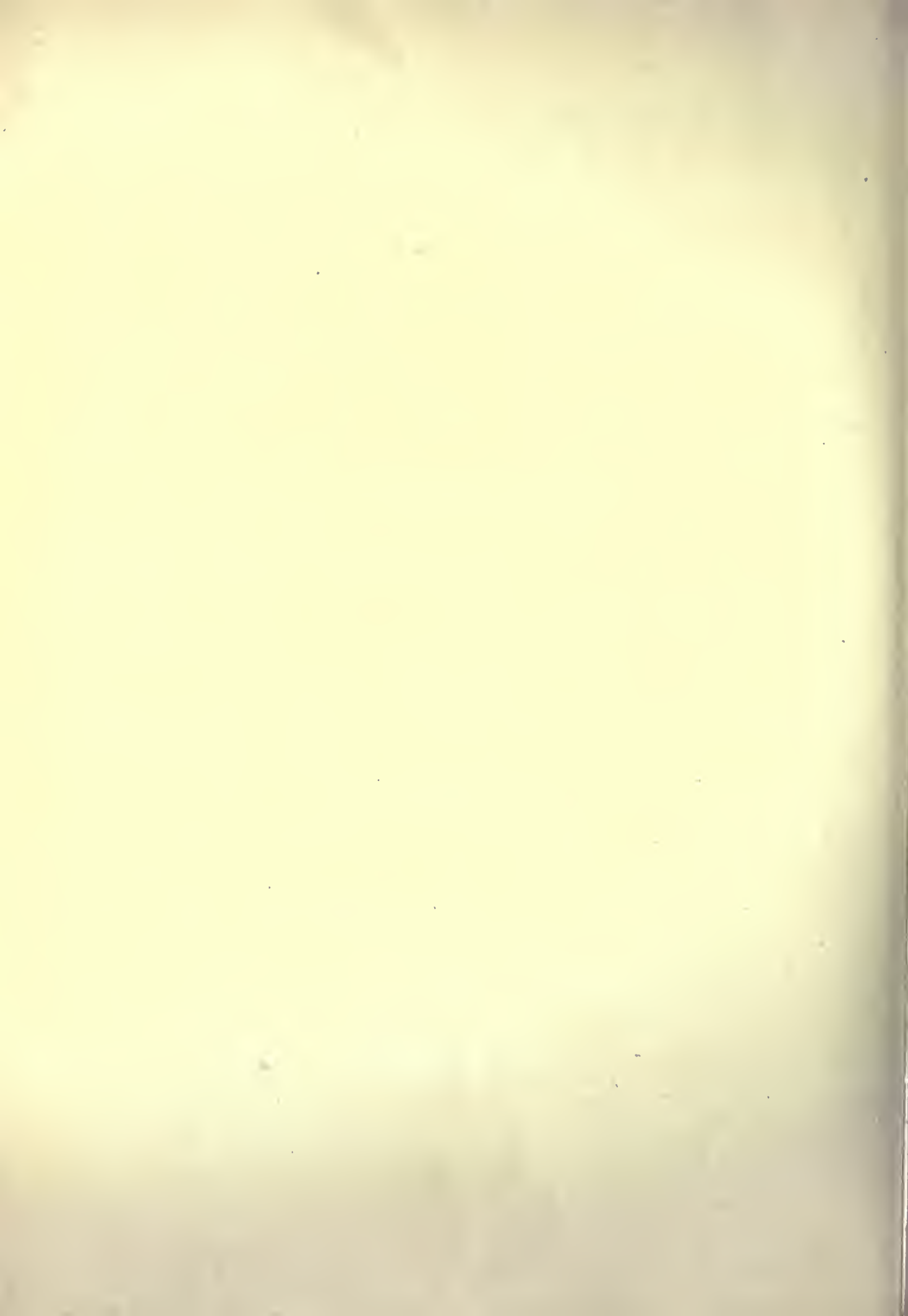

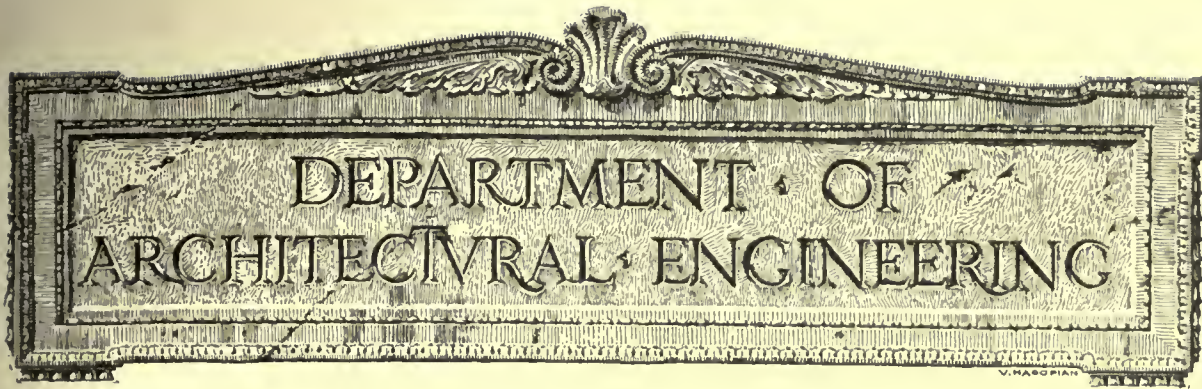

The Architect a Necessary Factor in Bridge Building

Co-operation Between Architect and Engineer Essential to Improved Bridge Design

By FRANK A. BOURNE

THERE are two points of view in bridge building. One relates to putting up a structure as inexpensively as possible to carry the traffic; the other relates to building a bridge that will be an ornament to the landscape. In Boston, as elsewhere, there are both kinds. The railroad bridges leading out from the North Station are apparently built as

—is very unpleasant, as well as disconcerting, to the observer. The smaller span is not sufficiently narrow to form a correctly proportioned alternate span, and yet not wide enough to present the appearance of continuous even spacing. The best argument in favor of a different form of construction is to compare Harvard Bridge with the West



THE WEST BOSTON BRIDGE

economically as is consistent with holding up traffic. The Harvard Bridge, illustrated on page 218, and which goes with a series of hops, skips and jumps across the Charles River, is not likely to cause a feeling of pride in the Bostonian's heart. The skip and jump construction, which is quite noticeable—i. e., one rather narrow span alternating with a wider one

Boston Bridge, an illustration of which appears above. We may, of course, criticise the towers of this latter bridge, and speculate as to the reason which led to placing the carved decoration out on the large piers at a point where no one who is not a Union Boat Club member can see it, and he only at the risk of taking a sudden

THE AMERICAN ARCHITECT

capsize. Yet the effect of the bridge on the basin is extraordinarily beautiful. Seen through the mist, it has an interesting skyline; in bright sunlight the shadows cast are very effective, while at night the reflections of the light in the water are like strands of variegated colored worsted, and the line of lights is extremely interesting against the sky.

Another interesting bridge is the Larz Anderson Bridge near Soldiers' Field. The curve of this bridge, as will be noted from the illustration, is

cost may be the amount that you will want to charge for your civic pride, or possibly if the bridge be a memorial, that difference may be what you could charge off as the cost of the memorial. The bridge will have to be built in any event, therefore, it is unfair to charge that part of it which represents stability alone to the cost of the memorial. The additional *something* which lifts such a structure above the ordinary and places it with things beautiful is the feature that will call to mind the service to be memorialized. And while it may



THE HARVARD BRIDGE

better than that of the West Boston Bridge, and the use of materials very striking.

THE point of view of the two different kinds of bridges is that of the civil engineer in contrast to the architect. It is the duty of the civil engineer to provide a stable structure with the utmost economy. He follows the most advanced "theory of structures," and stress diagrams, bending moments and mathematical formulæ are ever before him. While these are all necessary and essential to safety, the architect feels they are but a means to an end. His prime duty is to harmonize the structure with the landscape, and like any master builder building well, it is also his duty to build beautifully. Take the problem of a bridge and give it to an architect, let him develop it freely and unhampered; then give the same problem to an engineer and have it developed from the other point of view. Compare the costs and the difference in

sometimes be the case, it does not certainly follow that the architect's scheme will be more expensive than the engineer's. It may be that the beautiful line of a Melan arch will in certain localities work out as inexpensively as the crude, harsh lines of a Pratt steel truss. It may be that a perfectly simple straight line is the line that will harmonize best with the landscape, and at this point both the architect and the engineer can meet. One of the ablest civil engineers I know is very clever with his own pencil; another is an authority on French and American painters. A mechanical engineer of my acquaintance is an extremely good illustrator, and some of the sketches of "The Wonder of Work" are very alluring artistically and practically. Any of these men can outdo many architects on these particular lines. It is perfectly possible to ask what is in a name, but primarily the engineer starts with a cold mathematical, usually inelastic, analysis of the problem, while the architect starts from the

THE AMERICAN ARCHITECT

imaginary end. If the construction is to be a work of art it should be from the imagination first; then while the idea is in its plastic state, it should be moulded and carried further until perfected in every detail. When the engineer and the architect have both arrived at perfection, they will have met at the same point.

Is the bridge to be a memorial? What better can you think of? Take such a type as the Alexander Bridge in Paris, or the picturesque old bridge favorite of etchers, with all its pictures and statuary, in Prague. Notice the pride that our City Fathers take in putting tablets on bridges all over the United States.

Are you looking for interesting details? Compare the arches in this bridge construction with all other arch construction. Everything from a covert to a long steel arch can have beautiful lines. Even out of a draw-bridge you can make something interesting. The steel trusses may have aesthetic lines. There is something picturesque about the long viaduct leading to Hell Gate Bridge. The great war has taught us the military significance of bridges.

THE literature of bridge building is voluminous. United States Government in its various bureaus publishes material; the New York Rapid



CHOATE BRIDGE, IPSWICH, MASS.

Transit Commission, and many other city commissions, have illustrated reports. Bridge building has its own periodicals in the *Annales des Ponts et Chaussées*; the *Stadtbaurath* of Berlin, Germany, has something to say on the subject; the British School of Athens has published drawings of old bridges. The periodical, *The American City*, publishes a pamphlet, No 101, on the subject; the *Stadtebauliche Vortrage* has material on the subject; the International Library of Technology in its correspondence course teaches bridge building.

Bearing on the engineering and construction phase, principally in steel construction, since 1807, the following authors' and engineers' names appear: Boller, Burr, Davies, Dilworth, Fidler, Grimm, Hodge, Ketcham, Kunz, Leonard (concrete), Merriman and Jacoby, Skinner, Tedesco (concrete), Thomson, Tyrrell, Waddell, Wells, and back in the '90s George S. Morrison. Morrison's name should not be forgotten; all through the United States are found reports on his bridges. St. Louis, Bellefontaine, Bismarck, Blair Crossing and others too numerous to enumerate. Plans of all these may be found in the Peterborough house that he built. In this Peterborough house, since occupied by the late Miss Mary Morrison, so well known in Boston, a bridge engineer might find much of in-



GREEN STREET BRIDGE, IPSWICH, MASS.

terest, since here are all the drawings, drawn with the utmost care, rolled and filed in a fireproof vault, so that each could be readily located and consulted.

Page writes on Roads and Bridges for the Farmers' Practical Library; Seaton on Concrete for rural communities, containing a chapter on small highway bridges.

What more inspiring book can you find than Brangwyn's Sketches in Color of Bridges all over Europe, published by Lane in London, 1915? This is a good book for any one's table. I came across a title, *The Antietam and Its Bridges*; I have not yet seen the book, but I can imagine following some southern river up its course and taking photographs of the different old bridges. What an interesting trip it would make to follow the Connecticut in the same way! An author, Tyrrell, who generally writes on engineering subjects, has written a book, published in 1912, on *Artistic Bridge Design*. I fear that he is somewhat influenced by his engineering point of view, but the book is quite worth while. Dartin published in Paris in 1907 a book on *Old Stone Bridges previous to the 19th century*, remarkable for their decoration. Duplomb wrote a history of the bridges of Paris, published in 1911. Mehrrens gives illustrations of *A Hundred Years of German Bridge Building*. Waddell describes a system of bridges for Japan. Cresy wrote on the works of Rennie in 1839. Genneté described a wooden bridge "202 piés de longuér" in 1770. Hutton wrote on the principles of bridges in 1801. Grothe described the Tay Bridge in 1878. Peronet, the bridges of Neuilly, etc., in 1772. Leupold used the Latin title, which at first sight seemed to have something to do with a church: *Theatrum pontificiale*, Leipzig, 1726. Ware wrote on bridges in London, 1822. Welch described the Tower Bridge, 1894. The *Calcografia Camerale* published

some interesting designs for bridges by Aquaroni in Rome, 1836. Swan collected designs in architecture, to which are added *Curious Designs of Bridges*, London, 1757. Our own New England Ithiel Town, who lived from 1784 to 1844 and built many churches throughout New England, published in New Haven in 1821 a book on *Bridge Building*, republished again in New York in 1831 and 1839.

THIS shows that even in those days architects were well known as bridge builders. Even if it meant no more in many cases than the curious old covered bridges with Greek or Egyptian portals, the results achieved in most instances were certainly far better than their successors, the steel trusses, of the last twenty or thirty years. An awful example of this stood for years, and may be standing now, over the Penobscot. Originally it was a long covered bridge, with a quaint, heavy classic entrance portal. The middle span having become weak, or else damaged by a freshet, was replaced by a steel truss. The other spans of the bridge remained untouched, thus leaving a structure neither fish, flesh, fowl, nor yet good red herring. The old Choate Bridge, a photograph of which appears on page 219, has the reputation of being the earliest stone bridge in the country. It is located on the main automobile route to the north of Boston, just on entering the town square of Ipswich, and is worth more than a moment's pause. It is indeed a picturesque old stone arched bridge. The Green St. Bridge, also illustrated, is but a short distance away, in the same town. It is also most picturesque, being a two arch bridge and deserves more than passing notice. Both of these structures show that for permanence stone arches are certainly worth while. Of the materials, wood, steel, concrete and stone, the last is the one that has best



THE LARZ ANDERSON BRIDGE

THE AMERICAN ARCHITECT

stood the test of time, although its selection is not possible as a suitable material for long span bridges.

The collaboration of architect and engineer in

bridge design will bring to these structures a beauty of line not heretofore attained in the majority of American bridges.



ROADWAY, LARZ ANDERSON BRIDGE

Report on Trip to Princeton, College of City of New York, Yale and Harvard for the Purpose of Inspecting the Stadia at those Universities

By HOWARD DWIGHT SMITH

Part IV

THE information received at Harvard University both from the point of view arrangement as well as from the structural and architectural point of view is quite valuable.

Seventeen years of experience in staging athletic contests of all kinds and handling crowds of varying sizes has given the Harvard Athletic Association the opportunity to analyse their problem fairly well and to know wherein their present structure is successful and wherein it leaves something to be desired. The present Graduate Manager, Mr. Fred W. Moore, has been directly in charge for some eight years and has had considerable previous experience in the management of athletics at the Springfield Y. M. C. A. Training School.

Managing a large and extensive collegiate athletic event with a large number of spectators is not unlike managing a circus. Experience adds wonderfully to facility in handling both the exhibition and the crowds. Harvard has probably had more experience along this line than any of the large universities, and it must be said for their athletic management

that they are very generous and more than willing to be of assistance to persons who are studying their problems.

Most of the observations herein noted, particularly those which do not deal directly with architectural features, are inspired by the very interesting data furnished by Mr. Moore, Dr. Withington and the ground keeper of Soldiers' Field. Mr. Moore has said that a great deal of correspondence has come to his office containing inquiries with reference to the Harvard Stadium. These he has always tried to answer as fully as possible, but he says that seldom has any one seen fit to have a personal interview with his organization with a view to obtaining extensive information at first hand. On the occasion of this inspection, the interest shown by the Harvard men in the problem involved in the proposed Stadium at Ohio State University was as great as if the new structure were to be built for Harvard itself.

Of the many thoughts obtained at Harvard the first was this: If you have competent athletic management and experienced business management of

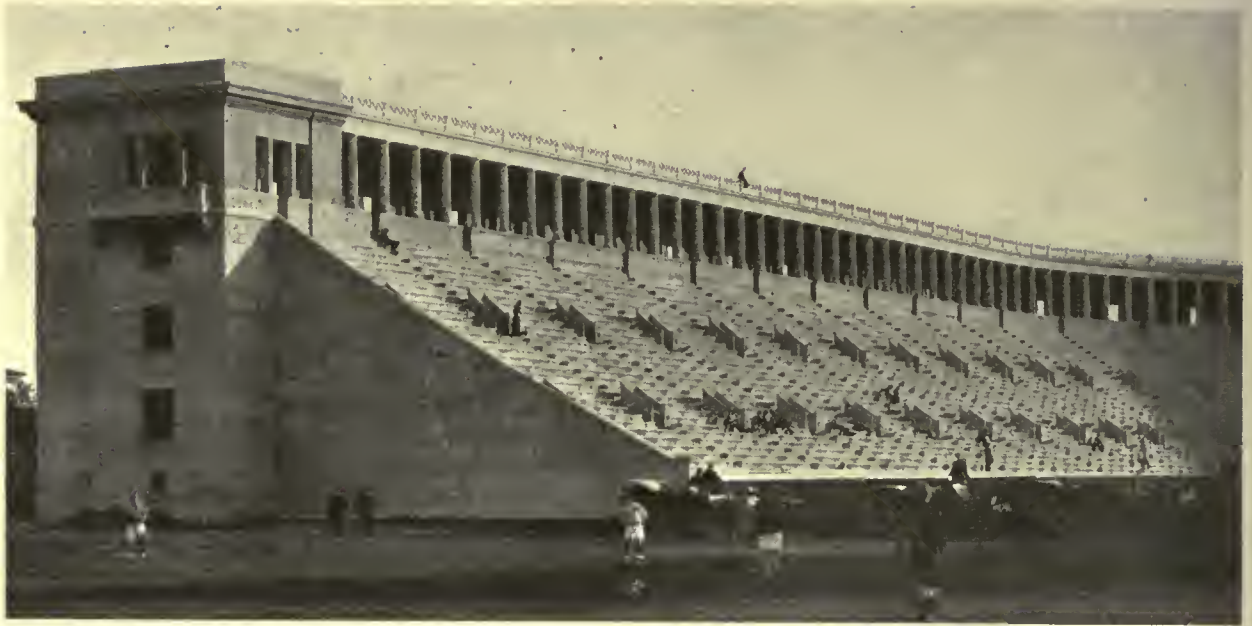

ONE OF THE STRAIGHT SIDES OF THE "U"—HARVARD STADIUM

athletic affairs, take them into your confidence, they will help make your problems practical, they know the particular peculiarities of your problems as no one else does.

Reference is made at this point to the system of handling the distribution of tickets among the alumni for the important events. Business managers of other organizations would do well to study the methods developed by years of experience, whereby applications are received and tickets distributed for events where the demand for seats always exceeds the supply. Equitable distribution, avoidance of speculation, and facility of operation are features of the system which are commendable.

The Harvard Stadium is located on Soldiers' Field, the great athletic ground of the university on the Boston side of the Charles River. It is reached from Cambridge by way of the new Larz Anderson Memorial Bridge. The proximity of the field to the college buildings, particularly the newer and larger of the dormitory groups is quite fortunate.

Although the seating capacity of the masonry portion of the structure is hardly more than a third of that of the Yale Bowl or half of that of the Palmer Stadium at Princeton, the Harvard Stadium is by great odds the most imposing. The fact that the playing field is not sunken below the level of the surrounding turf makes the structure rise actually higher from the ground than either of the others mentioned, giving it a most imposing size as viewed from the Anderson Bridge or across the river. Every advantage has been taken by the designer of its great size, which has been emphasized by crowning

the structure with a great colonnade. This colonnade is composed of so many parts as to make it look to be of enormous length. By breaking up the line of the upper seats by this architectural feature of many comparatively small parts, its developed length of some 1,350 feet appears to be considerably longer than the line of upper seats of the Yale Bowl, the developed length of which is about 2,400 feet.

The Stadium is U shaped, the closed end is built on an arc of a true circle, in contrast to the flattened curve as at Princeton, and with square towers at the end of each of the straight sides. Within this space there is the football gridiron and a quarter mile track. The track follows the circle arc curve of the closed end of the U and the opposite end of the closed track extends outside the tips of straight sides of the structure.

The inner wall of the Stadium is 9 feet high, and the space across the field from wall to wall is 230 feet. This places sides of the gridiron 35 feet from the inner wall of the stadium, but only 15 feet from the edge of the running track. Attention is directed to the fact that a hard track curb so close to the gridiron is not desirable, although under present rules there is less chance of danger to football players from this source than heretofore. The extreme height of the inner wall is of advantage in allowing the placing of twelve additional rows of seats over the running track within the entire structure, accommodating some 7,000 persons. But the great height of this wall and the closeness of the track to it make it impossible for spectators beyond the second row of seats to see any track events on the near

THE AMERICAN ARCHITECT

side. Consequently it has been found more desirable to sell seats on the side opposite the straightaway for track events. Circumstances have shown, however, that the best seats at the important meets are those around the circular end, because of the closeness to finish line of the dashes. The high seats in the circular end have proven especially desirable because of the fact that they are high enough up to allow the spectator to get a slanting view of the runners during the dashes and are close to the finish line.

Accompanying this report is a diagram of seats for the Yale-Harvard track meet, showing the prices of seats. This diagram shows that only \$1.50 seats include only two rows along the side of the straightaway up to the curved end. Practically the entire half of the curved end on the straightaway line is included in the \$1.50 section. The other half of the curved end is included in the \$1.00 section, while the entire tier of seats on the side of the U opposite the straightaway are in the 50 cent section. This circular end of the stadium will seat about 8,000 persons and is always used for class day exercises and for pageants, Greek plays, etc. The acoustics are very satisfactory and the university is considering the advisability of holding commencement exercises there.

In the stadium proper there are thirty-one tiers of seats, between the inner 9 foot wall and the colonnade at the top. The flat space behind the colonnade at the top was originally intended to be used

only as a promenade. The demand for additional seating capacity led to the placing of temporary wooden stands on the promenade back of the columns. These temporary stands accommodate 8,000 persons, and on account of the expense of taking down and putting up each season, and because the promenade was of little use as such, these seats have become a permanent feature. The great demand for seats evidently has accounted for the apparent lack of criticism of seats behind the columns.

A row of seats has also been provided on the roof of the colonnade, adding another thousand. The temporary stands placed at the open end of the stadium are arranged to seat about 12,000. The total number of seats for the Yale-Harvard game of 1919 was approximately 50,000.

The seats in the stadium proper are reached by a series of thirty-eight stairways, which rise directly from the ground beneath the seats to portals or eyes in the aisles about one-third way up. There is a second row of portals or eyes about two-thirds of the way up, which are reached from an interior promenade about 30 feet above the ground level. This promenade is reached by four large stairs, one in each of the end towers and at a point approximately where the straight sides join the circular end. These upper eyes or portals have been closed up where there have been large crowds for three reasons: (1) Those persons attempting exit by them have invariably tried to use the tower stairs, caus-



AN AIRPLANE VIEW OF THE HARVARD STADIUM
McKIM, MEAD & WHITE, ARCHITECTS

ing congestion on the upper promenade near the towers; (2) experience has shown that the lower series of portals is sufficient for all practical purposes in emptying the stadium of a capacity crowd; (3) temporary seats in these upper portals increases the seating by 550, which is an important item where the demand and the added income are considered. There are no openings through the inner 9-foot wall to allow egress to the field directly from the seats. After football games, however, when the twelve rows of temporary seats are in place, access to the field is easy. It has been found that there is some difficulty in keeping persons from scaling the 9-foot wall and getting out onto the field during a track meet. This contingency should be avoided if possible.

One of the advantages of having two rows of portals or exits from the seat tiers would seem to be the ease with which the stadium might be emptied of a capacity crowd. Experience has shown, however, that the circulation congestion does not occur at the stadium itself, but at the Anderson Bridge, which provides the only means of egress from Soldiers' Field to Cambridge. Harvard Stadium crowds have learned that haste in exit from the Stadium itself is useless on account of the "bottle-necking" of the traffic at the bridge over the Charles River. The lesson to be learned from this circumstance is that the problem of handling the large crowds is not confined to the structure alone but to the features of the surrounding territory as well.

In controlling the crowds at entrances it has been learned that they should be separated and directed to their respective sections as far away from the actual entrances as possible. Crowd psychology leads to congestion at those openings which are of easy access or prominent in appearance. All signs or placards indicating section numbers or giving directions should be large and as high as possible.

As an example of this principle it might be mentioned that in order to prevent congestion at the first few openings adjoining the southwest tower, a long rope is stretched diagonally out from the corner of the tower in order that persons may not turn the corner so close to the structure as not to be able to see the entrances farther down the long line of the Stadium.

Numerous propositions have been considered at

Harvard to increase the maximum seating capacity. It has even been suggested by one alumnus that permanent seats be built out over the track, that the sight line or slope of the existing tier of seats be lowered in the rear and that an upper deck be built over the rear third without increasing the height of the exterior wall. It is hoped that this will not be done without the advice and assistance of a designer who might study the problem with a view to retaining the present dignified architectural character. While this alteration has not yet been seriously considered, it is of interest to Ohio State University, because of the fact that the athletic authorities have presented the definite requirement of a double deck in their proposed new structure, since it gives increased seating capacity nearer the playing field than does a single tier of seats, and it also provides roof protection over a portion of the seats, which is of advantage in inclement weather as well as in extremely warm weather.

It is also interesting to note the comment of the Harvard management on the straight sided stadium, as contrasted to a structure with curved or "bowled" sides. They recognize that there is a certain psychological advantage in having the crowds so placed as to permit each person to see as much of the entire crowd as possible. This is especially noticeable with cheering sections. But an additional advantage of the "bowled" side is in the partial equalization of the desirable seats. The greatest demand for seats is, of course, along the middle of the sides. If, however, the middle sections are moved back from the edge of the playing field any appreciable distance there is less apparent difference between the value of seats in the middle section and those of the sections nearer the ends of the fields. This may be illustrated in this way: Assume a seat in the first row, opposite the middle of the playing field, and draw a line from it to the goal posts at each end of the gridiron; then assume a seat in the front row, opposite the goal posts at one end of the gridiron, and draw lines from it to the goal posts as before. The lengths of the lines from each of the seats to the goal posts in a curved side structure, show the seats in the end sections to be relatively much more desirable than in a straight-sided structure.

(To be concluded.)

Current News

Happenings and Comments in the Field of Architecture and the Allied Arts

Judgment of the Competition for Remodeling a New York City Tenement Block Is Deferred

It is announced that the final judgment of the Competition for the Remodeling of a New York City Tenement Block, which is being held under the auspices of the Joint Legislative Committee on Housing and the Reconstruction Commission of the State of New York, has been deferred until the middle of August.

A large number of very interesting solutions that promise possibilities of increased light and air have been submitted.

The competition program stated that the object of the competition was to find a plan of remodeling that would encourage such alterations by the demonstration of its economic wisdom and the value that would come from the improvements, and that the relation of costs to results obtained will be a predominating factor in determining the judgment.

So as to better judge the actual costs, it has been found necessary to procure estimates on the competing drawings. As soon as these estimates have been received, the jury will be prepared to make final judgment and an exhibition of the drawings will be held.

American Reconstruction Unit Leaves for France

One of the first officially recognized groups of American engineers and landscape architects who will engage in reconstruction work in the devastated area in France sailed from New York, July 8, under the name of the Harvard Reconstruction Unit. The organization consists of twenty members, headed by Reginald Coggeshall, Department of Government, Harvard University, who was appointed by President Lowell to take charge of the unit after it was organized by Robert Buell and Guy H. Lee of the graduate school of landscape architecture at Harvard.

The membership of the unit is made up largely of post-graduate students as follows: Harvard, fourteen; Massachusetts Institute of Technology, two; Columbia, one; Yale, one, and Princeton, one. Al-

most all of the members are former A. E. F. men. Town planning work in co-operation with the French authorities covering a period of three months has been outlined, the American unit serving without compensation, but with expenses while in France paid by the French Government and the Department of the Meuse to which it has been assigned. Its work will be carried on in the Argonne district. The temporary address of the organization is Harvard Reconstruction Unit, care Guaranty Trust Co., 1 Rue Des Italiennes, Paris.

Salisbury Cathedral

The Salisbury Cathedral was begun in 1220, and it celebrated its seventh centenary last month. Salisbury's cathedral is unique among English cathedrals as having been built practically all at one time and in one coherent style. Its most famous feature is the lofty stone spire, finished in 1258, the highest spire in England (404 feet). E. Slocombe's well-known etching of this Gothic monument is handsomely reproduced in the Illustrated London News for June 26, as a mark of the occasion. Baedeker says Salisbury Cathedral is a "splendid example of pure Early English," and that it was begun and finished within a period of forty years. Fergusson points out that there is scarcely a trace of foreign influence in the building, and that it is "one of the best proportioned and at the same time most poetic designs of the Middle Ages." Baedeker speaks of the interior as somewhat cold and bare, which is, we believe, quite true. We also remember the West Front as being quite the worst of any in England. But the cloisters are very lovely. On the whole, however, Salisbury is not by any means to be compared with Canterbury, Wells, Lincoln, York, Durham, or Ely for architectural beauty and character. It has a sort of cold correctness that some of the other English cathedrals lack, but, in spite of its "coherent style," it does not make the wonderful appeal to the heart of the beholder that the matchless mediaeval monuments above-mentioned invariably do make in their several distinctive ways. No study of England's ecclesiastical architecture would be complete without a careful reference to Salisbury.

THE AMERICAN ARCHITECT

Architecture

By ALEXANDER HARVEY, in "Judge"

Architecture is that part of a rich man's home of which he knows the least, although it cost him the most.

A great architect is one who has been dead such a long time that he can be copied with impunity.

A writer must be able to say many offensive things before he can become an authority on architecture.

A school of architecture is a collection of men with the same unintelligible idea.

Queen Anne knew nothing at all about the architecture of her period, in which respect she was no worse off than are the people who chatter about it today.

Success in architecture can be achieved only through the medium of an appropriate vocabulary.

A flourishing period of architecture in the past was fostered by the church. A flourishing period of architecture nowadays is fostered by the wives of millionaires.

If bad architecture lasts long enough it becomes good.

The most devoted lovers of the antique in architecture are the ghosts.

As to Temporary Buildings for Schools

In New Bedford, Mass., the suggestion was made at the City Property Committee meeting that the school construction program be dropped for the present and that temporary buildings be erected to house the pupils. Mayor Ashley said it was "absurd when you undertake to put up temporary buildings," he pointed out, "you have to provide heating and ventilating systems the same as you would put into permanent buildings and when you get through, you will find that you have tackled a pretty expensive proposition and it is only a make-shift after all. Taking care of 1,000 or more children in temporary buildings is a waste of money.

"We've got to go ahead with school construction; we can't stop, we must face conditions as they are. I don't know how far we can go."

Suggest New Laws for Housing Crisis

Legislation making it a crime for any individual or organization to call a strike on any building being erected for dwelling purposes, or for any individual or organization to endeavor to limit the output of workmen on similar construction, was urged by Ed-

ward P. Doyle, secretary of the Mayor's Housing Conference Committee, in a brief submitted to the Lockwood Joint Legislative Committee on Housing. The committee is gathering data to determine whether or not to recommend a special session of the Legislature to relieve the housing crisis anticipated next October.

The Doyle brief attacked the Lockwood rent relief laws passed by the last Legislature as "ill-considered and hasty legislation," in that they deprived owners of the control of their properties and placed it in the hands of Municipal Court judges. Without such legislation which discouraged builders and investors, he argued, the natural laws of supply and demand would have already operated to remedy the situation.

The Doyle brief was the only criticism of the rent laws. Municipal Court justices have been practically unanimous that the new laws have had a salutary effect and that a special session of the Legislature is not necessary.

The brief was not accepted by Chairman Lockwood, as the committee wants to cross-examine its author at the next meeting.

Witnesses heard today were Municipal Court Justices Timothy A. Leary of Manhattan and Charles J. Carroll of Brooklyn. Justice Bogenschutz of Brooklyn sent a letter stating that the rent laws were working well.

One of the weaknesses of the present laws, it was declared, was in the fact that tenants are given not more than one year's stay in holdover proceedings. It would be beneficial in some cases if the period could be made a longer one, he felt. On the other hand, such a change in the law, he admitted, might discourage builders.

Color in the Hospital

By WILLIAM O. LUDLOW, of Ludlow & Peabody, Architects.

There is a general feeling of antipathy toward the hospital, that should not and need not exist. True, it is a place of suffering, but its chief object is relief of suffering, and its most important function is convalescence.

Our feelings and sentiments of antipathy or attraction are largely influenced by the impression that the appearance of things makes on our minds, and the heretofore grim and institutional aspect of the hospital without, and its cheerless and barren appearance within, are partly responsible for the common dread of an institution whose very atmosphere should breathe a welcome to tender care and comfort.

But our thought has been so engaged in bringing about ideal negative conditions—no dirt, no noise,

THE AMERICAN ARCHITECT

no odor—that we have forgotten often the positive conditions of environment that may be more effective in bringing back bodily health than what the nurse gives from the spoon.

During the period of recovery, the mind of the one in the hospital bed is perhaps more than usually responsive to the aspect of his surroundings. The tired eye that forever roams over wall and ceiling until every crack is known by heart, craves something more positive than barren white walls; it wants objects of interest, such as pictures, stenciled patterns, hangings at the windows, and above all, the repose and warmth that only color can give.

White is negative; the convalescent needs the therapeutic reaction of the positive colors that Nature has spread so lavishly for her children. Her forest walls of white leaves! Her carpet of white grass! Her limitless ceiling of white! God forbid. Our eyes were made to find rest and contentment in soft greens, pale blues, in occasional touches of red, but above all, in the glorious golden yellow of the sunshine.

White is the winter color, dazzling and brilliant, but is somehow reminiscent of the cold and cheerlessness of that season.

Let us then cover our hospital walls with color, selecting those that give warmth and quiet, and that gentle stimulation that helps the feeble body along the road to recovery.

Housing Plans for Cities

Realizing the difficulties confronting the prospective home owner of small means and the almost complete withdrawal of the speculative builder from the present field of building activity, the Southern Pine Association has taken up the housing shortage question in what seems to it to be the only open road to that activity which alone can bring about a solution of the problem. And it may be said here that the problem now is as pressing as at any time and the troubles of the home seekers will soon reappear and possibly will be more aggravated. So the association has taken up the proposition along the line of furnishing information on how we can build now, and its first effort is a new pamphlet entitled "Housing for Cities." This publication is being distributed to boards of trade, libraries, corporations, building and loan associations, retail lumber dealers, architects, engineers and others. The booklet describes the various plans adopted by industrial corporations and other bodies to meet the situation in various cities.

The desire to build is widespread, but the great trouble is to finance the work, and the association, by making available full and reliable information of

plans now in effect, hopes to aid those who are now bending their energies to relieve the shortage through the organization of home-building companies.

Shingle Production In Washington State

Production of shingles in 1918 was three-fourths of the entire shingle output of the United States, according to official compilations just completed by the government forest service and dispatched to Seattle lumbermen Monday. During 1918 a total of 158 mills in this state cut 4,238,714,000 shingles, while the production of the entire country totaled 5,690,182,000 shingles.

In the production of lath a decrease from the previous year is shown in the 1918 forest service figures amounting to 40 per cent. This smaller output reflected the light demand and the character of construction work carried on during that year; lath production fluctuates each year with the number and class of buildings constructed. Forty-two Washington state mills cut a total of 154,668,000 laths during 1918, ranking third among the states, with Louisiana and Minnesota in the lead. In the previous year this state produced 230,194,000 laths.

The forest service also illustrates the quantity and kinds of woods cut by 455 Washington state mills in 1918 as follows:

Douglas fir, 3,578,831,000 feet; white pine, 65,865,000 feet; Western yellow pine, 220,231,000 feet; hemlock, 275,693,000 feet; spruce, 275,826,000 feet; cottonwood, 884,000 feet; ash, 47,000 feet, and 936,000 feet of minor species.

The number of shingles cut by five leading producing states in 1918 is as follows: Washington, 4,238,714,000; Oregon, 281,138,000; Louisiana, 272,866,000; Michigan, 148,565,000; California, 146,071,000; Florida, 102,725,000.

The Use of Lumber in Building

More lumber is used in the United States for general building and construction than for any other purpose, says the U. S. Forest Service report of June 1, 1920, before the Senate. In normal years probably 28 billion board feet is used in this way out of an average annual cut of 40 billion feet.

For the five years before the war, 1910-14, the average annual building bill of the country shown by building permits was approximately \$670,000,000. After dropping to \$445,549,493 in 1918, it rose in 1919 to \$1,326,736,702; but with building costs increased 100 per cent. or more, actual construction did not much, if any, exceed the pre-war average. Ap-

THE AMERICAN ARCHITECT

parently construction work throughout the United States is behind requirements. The deficit is greatest in dwelling houses.

The building permits issued in 21 cities of various sizes widely distributed over the country show that, in values, housing construction formed 36 per cent. of all building in 1913; 21 per cent. in 1918, and 27 per cent. in 1919. The amount of housing construction in 1913 was exceeded in 1918 in only two of the 21 cities, and in 1919 in only six, in spite of the "build-a-home" campaign. The falling off in house construction, continues the Forest Service report, generally appears to have been particularly marked since the latter part of 1919, when the greatest upward movement of lumber prices began.

The United States Housing Corporation states that normally 30 per cent. of the number of buildings constructed are dwellings; that in 1919 dwellings were only 15 per cent.; that 1,000,000 families in the United States desired houses even before the war; that the shortage has since increased very rapidly; that there were but 70,000 houses built in 1919, when to have met the requirements there should have been 500,000, and that in 1890 an average of 110½ families occupied 100 homes, but today 121 families occupy 100 homes.

Annexations and City Planning

Annexations of territory to cities are generally made either through a desire for increase in size or to secure public improvements in outlying districts. An added reason might well be the furtherance of comprehensive city planning comments *Engineering-News Record*. This does often enter in to some extent, but generally in a detached way and rarely if ever with a clear far reaching view of all that enters into city planning—major traffic streets from outlying districts to the center of the city, parks, transportation service and other utilities. The argument should not be carried as far as to make the extension of these facilities conditional on annexation, for a proper spirit of co-operation between cities and outlying districts will make regional planning possible without consolidation.

A Record Year for Strikes

The Bureau of Labor statistics of strikes during the year 1919, which have just been compiled, show the last year to be a high record in the number of men involved and the number of work days lost. The actual number of strikes and lockouts was more than in 1918, but less than in 1916 and 1917.

The strikes of the past year were found to include larger bodies of men. There were nine, in each of which more than 60,000 men were involved.

In 1916 there was but one of this magnitude, in 1917 there was but one in which more than 40,000 men struck.

The average duration of the strikes also reached new high figures in 1919, being 34 days for a strike and 38 days for a lockout. In 1918 the average length of the former was but 18 days, and of the latter 31 days. In 1917 the averages were 18 and 56 days respectively, and in 1916, 22 and 64 days respectively.

Personals

Chester Walcott now has offices at 8 East Huron St., Chicago.

William H. Furst, architect, has opened offices with R. G. Wolff in the Marquette Building, Chicago.

William Whitehill, architect, has moved from 32 Union Square, New York City, to 12 Elm St., that city.

Nathaniel Koeingsberg and Louis I. Simon announce their association as architects and engineers at 8 South Dearborn St., Chicago.

John A. Armstrong, architect, has moved from 11 South La Salle St. to 127 North Dearborn St., the American Bond and Mortgage Building, Chicago.

William T. Braun and Edward A. Nitsche have formed the architectural firm of Braun & Nitsche, and have offices at 64 East Van Buren St., Chicago.

Morgan D. E. Hite and Walter J. Ferguson, architects, New Orleans, La., announce the removal of their offices to Canal Bank Annex, 211 Camp Street.

The Industrial Development and Improvement Company, architects and engineers, have moved from 230 South La Salle St. to 118 North La Salle St., Chicago.

Joseph J. Galizia, whose architectural office was formerly located at 2845 West Twenty-third St., Coney Island, Brooklyn, is now located at 2930 West Nineteenth St.

Thompson & Mellema, architects, formerly of 640 Broadway, New York City, have dissolved partnership. Mr. Thompson has established an office at 189 Montague St., Brooklyn, and Mr. Mellema has gone to California.

Thompson & Binger, Inc., engineers and contractors, New York and Syracuse, have moved their New York engineering offices to 150 East 41st Street. They desire to receive catalogues of building material supplies.

Weekly Review of the Construction Field

With Reports of Special Correspondents in Prominent Regional Centers

The view of the Federal Reserve Board upon the building situation starts with the observation: "There appears to be no difference of opinion concerning the causes that are responsible for the difficulties that hamper building operations. The hindrances are summed up under the all-inclusive heads of high prices of structural materials and heavy labor costs; transportation troubles that make the securing of supplies problematical; and inability to obtain funds for financing contemplated projects, especially residential structures."

And then this report says: "It is true that although all these factors are operative, reports from certain districts are inclined to stress some one factor while minimizing the importance of others. The situation in the West and Southwest appears to be much more favorable than in other parts of the country. District No. 11 (Dallas) and No. 12 (San Francisco) both report increased activity in the month of June as compared with May. District No. 1 (Boston) emphasizes the shortage of lumber and other structural materials resulting from congested traffic conditions, and predicts that prices will remain high, probably into the spring of 1921. However, the total value of building permits in 13 principal cities outside Boston showed an increase of 4.1 per cent. in amount for the first six months of 1920, as compared with the same period in 1919, although the actual number of permits declined from 3,614 to 3,440. District No. 2 (New York) thinks that the principal deterrent to the execution of housing programs is scarcity of mortgage money, the New York situation being made worse by the fact that industrial projects have secured the limited amount of labor and materials available. District No. 4 (Cleveland), although stating that there has been some improvement in securing raw materials, especially cement, during the last few weeks, says that building operations are very low for the season and the outlook for the fall is uncertain. In District No. 5 (Richmond) no improvement is noted—a decrease in the value of permits issued as compared with May is recorded. As for building materials, it becomes increasingly difficult to secure them and a number of lumber mills have shut down because of inability to make deliveries, while cement, crushed stone, steel, brick, etc., are practically impossible of acquisition. Cessation of construction in Richmond is threatened unless the local situation is relieved. In District No. 6 (Atlanta), on the other hand, there has been an increase in the value of permits in some

of the large cities, such as Atlanta, Augusta, Savannah and Mobile. A marked drop in the total volume of building permits in New Orleans was no doubt the result of the local carpenters' strike. In District No. 8 (St. Louis) as a result of better weather and improvement in transportation, work already begun has been resumed, but new projects are few. There is no improvement in the housing situation. Labor troubles have also been experienced. Both in the Minneapolis and Kansas City districts the June reports show a reduction in building permits by number and value as compared with May. In District No. 11 (Dallas), on the other hand, improvement has occurred in June, an increase of 15 per cent. in total valuations over the month of May being noted, although the total is 16 per cent. below the record for June a year ago. For the first six months of the year the 1920 valuations exceeded those of 1919 by 147 per cent. Similarly, in the 12th District (San Francisco) building is active, permits issued in 19 cities showing valuation increases of 7.7 per cent. as compared with May, and 63.3 per cent. as compared with June a year ago. For the six month period an increase of 107.17 per cent. was recorded."

In New York as the prices of building materials advance the demand has fallen off and it is expected by many that the prices will thereby be lowered. The larger operations, however, are being carried on with premium prices frequently paid. It is observed by those interested in these larger enterprises, which are to a large extent commercial, the industry is being curtailed through the shortage of raw products at the mills, that coal is not only difficult to get but increasingly expensive and that there is no probability of a marked increase in the production of building materials for a long time to come nor of a reduction in the prices of the same.

(By Special Correspondence to *The American Architect.*)

CHICAGO.—The high rental of capital is still the menacing obstacle in the path of business and it looks like a permanent monument. The financial powers are pursuing their policy of repression and the labor supply is too small to admit of any advance enterprises. There is no general expectation that by the postponing of new building for a few months, marked savings may be realized through future declines in prices. Even should the long-desired definite recession in prices develop there is much ground for the belief that for some time yet building costs

THE AMERICAN ARCHITECT

will show at best but slight decline apart from some temporary fluctuations. It is believed by many that there will be still further advances in building costs generally. As for the influence of credit stringency upon building operations, other lines of business enterprises are also affected, but most of them show no such marked decline in activity as does the building industry.

(By Special Correspondence to The American Architect.)

SEATTLE.—More hopeful signs of a resumption of building activity on the Pacific Coast has been voiced by jobbers during the past week. The improvement as they see it is to begin after the announcement of the new freight rates. A number of the leaders in their lines frankly stated that they had every reason to expect a calming of disturbed business conditions as soon as the railway traffic officials were in position to quote rates from officially published tariffs.

The car situation, however, is showing no change that will aid the distribution of steel products from the East. All markets seem to be steady. Where there has been an occasional fractional advance jobbers have absorbed it, but it has been noted in all deliveries to the Coast from the eastern mills that the jobber who is willing to meet what might be termed a premium over the market can get delivery in two or three weeks, while he is required to wait 60 to 120 days by following the horizontal prices.

The threatened closing down of the eastern steel mills was of slightly bullish tendency, although it would require the actual fact to produce an upward swing to prices. Smaller sizes of steel pipe in halves and three-quarters are leading in scarcity and there are no stocks on the Coast. Orders for these sizes placed as long ago as last September have not yet been shipped. An occasional car, four months behind the acceptance of contents, gets through. The only improvement in transportation is shown in the delivery of sheet metals, but the small pipe required for small swellings is almost unobtainable and jobbers must continue the ration plan until there is some relief. Similar conditions prevail as to nails.

Lead advanced 10 per cent. Earthenware and enamelware is steady. Jobbers report fair delivery in staple lines, but where specialties are required they are unable to get delivery under 6 to 8 months. Brass goods and fittings are 30 to 90 days en route.

Plenty of roofing and brick is offering all along the Coast. Cement is stronger, with delivery in the first zone, Seattle, at \$4.60. Jobbers place the responsibility for the cement scarcity on the sack shortage. There is not any demand for metal lath. High rib is \$1.15, due to the fact that nothing else

is used in Class A construction in the Coast cities. Hard wall plaster as in good demand, due to the impossible prices on tile. Many small home owners and builders are using this substitute, as it is said not to chip. Labor in the tile setting is \$10 for eight hours and production is not over 60 per cent. of normal.

Lumber is again unsettled, although wholesalers who do the bulk of the buying for eastern building account report their inability to get acceptances at any easier rate or lower prices. The market has been firm and it was thought at the turn, but persistent reports, which seem to be verified in more or less degree, are that due to the congestion at the Gulf, the Middle Western grain will move to Europe through Puget Sound. In that event the lumber mills would have more cars than they could load for the return haul. The back orders of 7,200 carloads for Eastern building account would be quickly cleaned up and an irresponsible scramble for new business at cut prices would follow. Buying time for lumber does not look as opportune as a week ago.

Red cedar shingles are firm at \$5 for clears at the mill, due directly to the car shortage.

Fir lumber orders now coming in are exclusively for country account in the East; city building, as reflected through the mills of the West Coast, showing quiet in that field.

(By Special Correspondence to The American Architect.)

SAN FRANCISCO.—Notwithstanding the fact that the building situation here is being hampered by the car shortage and non-arrival of material, as well as by the contraction of credits in the banks, the architects are busy making plans for the future. The feeling is prevailing that while building may be slowed up until after the November election, the requirements in this territory are so heavy that this summer will see practically a normal amount of construction work done, and as soon as the election is out of the way a very decided increase in business will be manifested.

School construction will undoubtedly go on ahead of almost all other kinds of new buildings, and new bond elections in a number of districts are to be held during the next sixty days.

During the coming week a bond election will be held in the San Pablo Grammar School District, Contra Costa county, to vote on bonds to the amount of \$35,000 for school buildings. The Vacaville Union High School District in Solano county, will also decide on the question of issuing bonds for \$35,000 for a new gymnasium and manual training building.

Manuscript No 230,



DETAIL—THE ALHAMBRA, GRANADA

THE AMERICAN ARCHITECT

VOL. CXVIII

WEDNESDAY, AUGUST 25, 1920

NUMBER 2331



THE GARRETT BIBLICAL INSTITUTE, EVANSTON, ILLINOIS
HOLABIRD & ROCHE, ARCHITECTS

The Work of Holabird & Roche, Architects

Part II

THE combining of a library with space devoted to business purposes is a rather unusual problem, as libraries are generally housed in isolated buildings. The design of a building devoted to such uses requires that both purposes be expressed. This has been done in the John Crerar Library Building now being erected in Chicago. As this library is a reference library only, it is necessary that it be located in the business district in order

to be of easy access to the professional and business men who use it. Its location makes it possible to use a very large portion of the building for office and commercial purposes. At present the library contains 425,000 volumes and more than 150,000 pamphlets. That portion of the building now under construction provides space for housing 650,000 volumes and seats for 400 readers. The books are apportioned to various interests in the following



THE JOHN CRERAR LIBRARY, CHICAGO, ILLINOIS
HOLABIRD & ROCHE, ARCHITECTS.

THE AMERICAN ARCHITECT

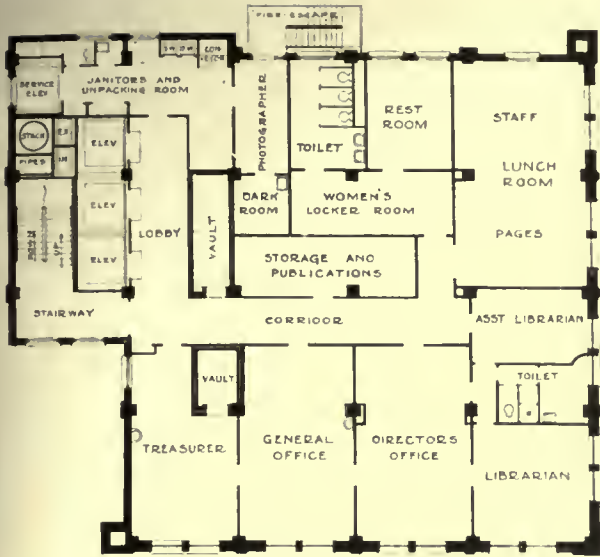

ELEVENTH FLOOR PLAN

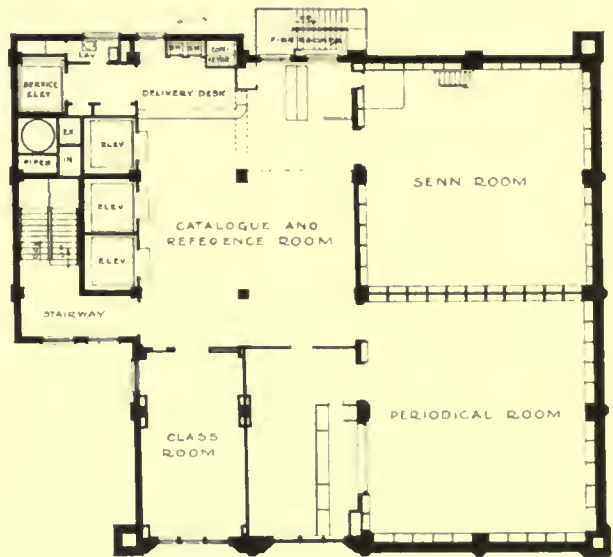

TWELFTH FLOOR PLAN



SEVENTH FLOOR PLAN

THE JOHN CRERAR LIBRARY, CHICAGO, ILLINOIS
 HOLABIRD & ROCHE, ARCHITECTS

THE AMERICAN ARCHITECT

order to physicians, engineers, chemists, teachers and business men.

When completed the building will cover an area of 127 feet by 135 feet. The portion now under construction has a frontage of 85 feet on East Ran-

tors serve the present portion of the building, the library is provided with a service elevator, two dumb-waiters and a back conveyor.

This building is in a very favorable position on the west side of Michigan Boulevard and immediately north of the lower Public Library. The John Crerar Library, with the University Club, Monroe and McCormick Buildings, are the contributions of this architectural organization to that great thoroughfare.

Transportation is one of the most important factors in office building service. A combination of a high speed elevator, with easy access thereto, is necessary to satisfactory elevator transportation. The latter element of the service is influenced by the plan. In the McCormick Building there are eleven passenger elevators so arranged that the passenger on any floor can station himself within a very short

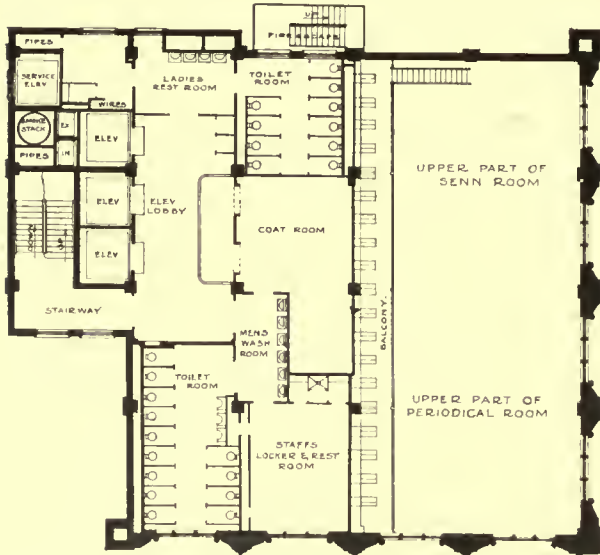

THIRTEENTH FLOOR PLAN

dolph Street and 78 feet on North Michigan Boulevard. It is fifteen stories in height, being limited to that height by the building ordinance in effect at the time construction was started. The building is faced with Bedford stone designed in a modified Romanesque style; the entrance lobby opening on Randolph Street is also finished in Bedford stone. The caisson foundations extend to rock; the frame is of steel, and floor construction of hollow tile. There is no wood used in the construction or finish of the building. Three high speed passenger eleva-

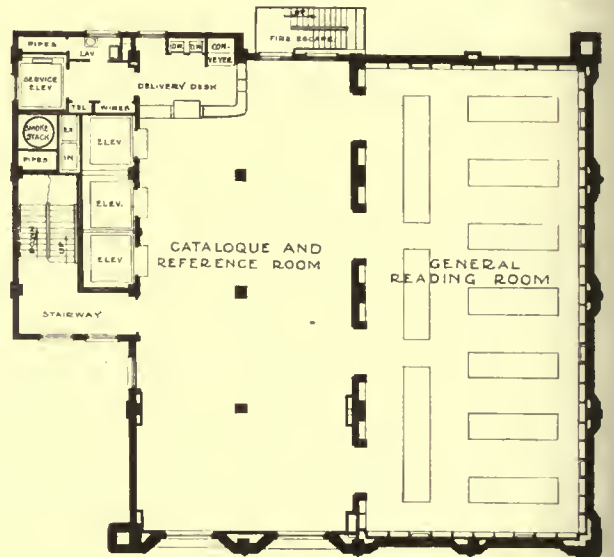

FOURTEENTH FLOOR PLAN

THE JOHN CRERAR LIBRARY, CHICAGO, ILLINOIS

HOLABIRD & ROCHE, ARCHITECTS

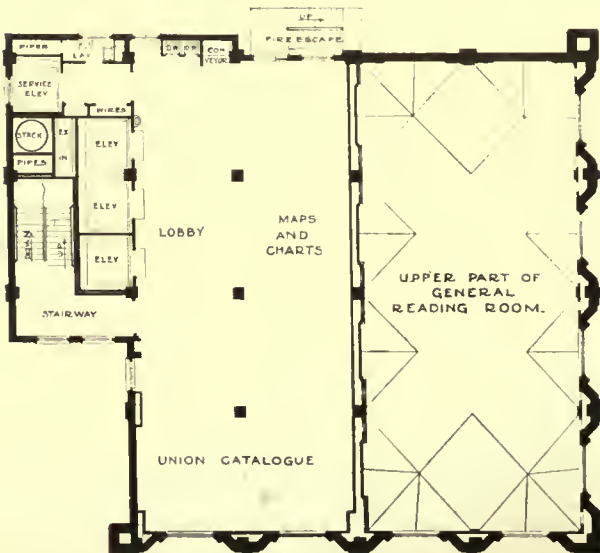

FIFTEENTH FLOOR PLAN

distance of any elevator. This materially shortens the stops at each floor where the time is generally lost. It will be seen that the best arrangement is to place the elevators about three sides of the hall, making the hall as small as possible. The service in this building is satisfactory and each elevator serves 33,500 square feet of rental office area above the first floor.

THE McCormick Building faces 183 feet on South Michigan Boulevard and extends 172 feet on East Van Buren Street to an 18-foot alley, with light on three sides. It is usual with buildings of this kind and size to use an enclosed interior



FIRST FLOOR ELEVATOR LOBBY
McCORMICK BUILDING, CHICAGO, ILLINOIS
HOLABIRD & ROCHE, ARCHITECTS

THE AMERICAN ARCHITECT

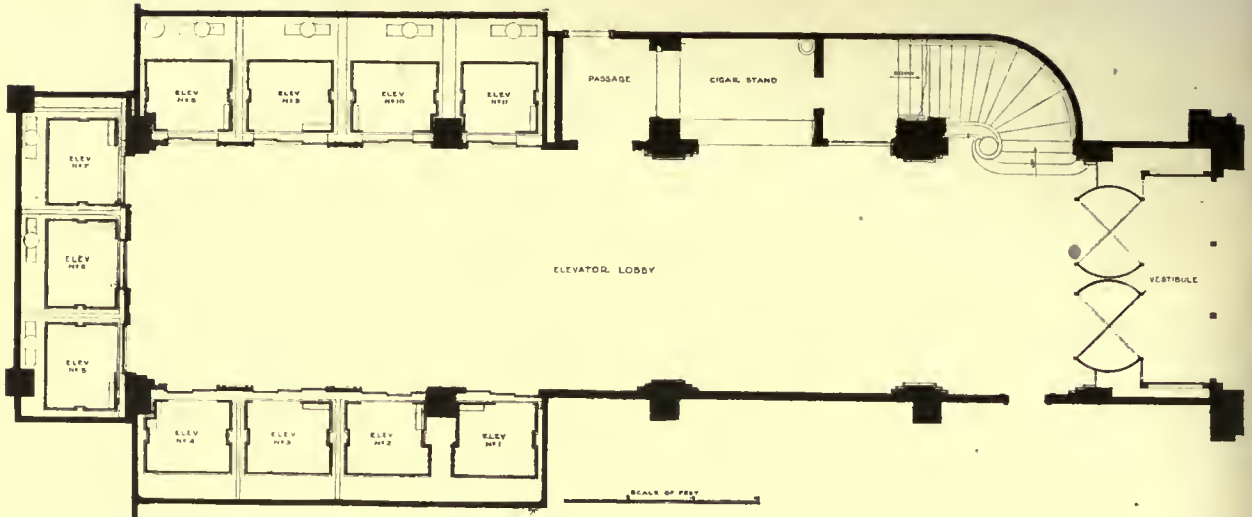

FIRST FLOOR ELEVATOR LOBBY
 McCORMICK BUILDING, CHICAGO, ILLINOIS
 HOLABIRD & ROCHE, ARCHITECTS

court with offices facing the alley. In this plan an open interior court is used and excellent light obtained in the court rooms. With no obstructions on the east side of Michigan Boulevard, the light penetrates farther into the buildings on the west side than in any other location in Chicago and the offices facing that street are made unusually deep.

The building is placed on a lot area of 31,543 square feet, of which 5,358 square feet is court area leaving 26,185 square feet of typical floor area and 19,469 square feet of typical floor renting area. In percentages the court area is 16.9 per cent. of the lot area; the typical floor building area is

61.8 per cent. of the lot area; the typical floor renting area is 74.4 per cent. of the typical floor building area. The cubic contents of the building is 8,325,282 cubic feet, and cost of construction was 36 cents per cubic foot.

THE Hotel La Salle Garage is 5 stories and basement in height, 80 feet wide and 180 feet long, facing on West Washington Street and extending through to Calhoun Place. All of the floors are used for storage of automobiles, which are driven to each floor on an inclined driveway, semi-elliptical in plan, which has a rise of 14 feet in 100-foot run. This grade has been found satisfactory for cars on second

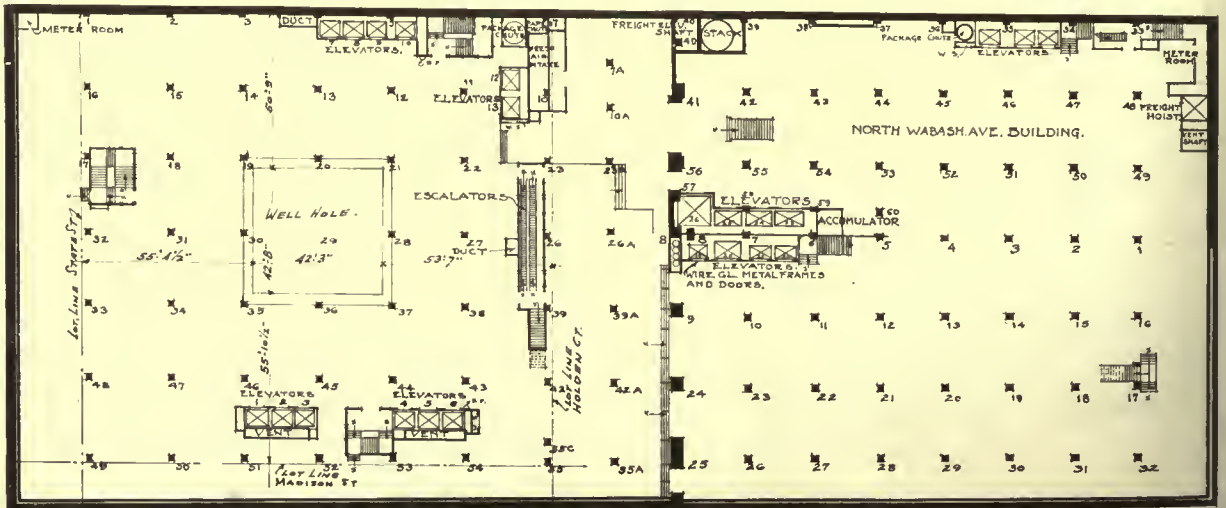

BASEMENT FLOOR PLAN
 MANDEL BROTHERS' STORE BUILDING, CHICAGO, ILLINOIS
 HOLABIRD & ROCHE, ARCHITECTS

MANDEL BROTHERS' STORE
BUILDING, CHICAGO, ILLINOIS

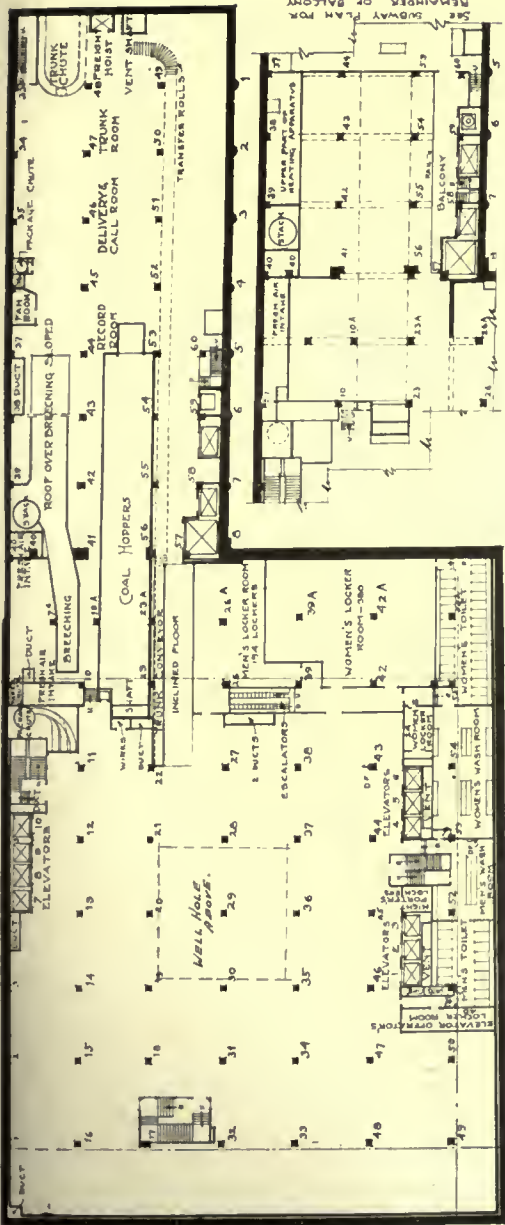

PLAN OF SUBWAY BALCONY

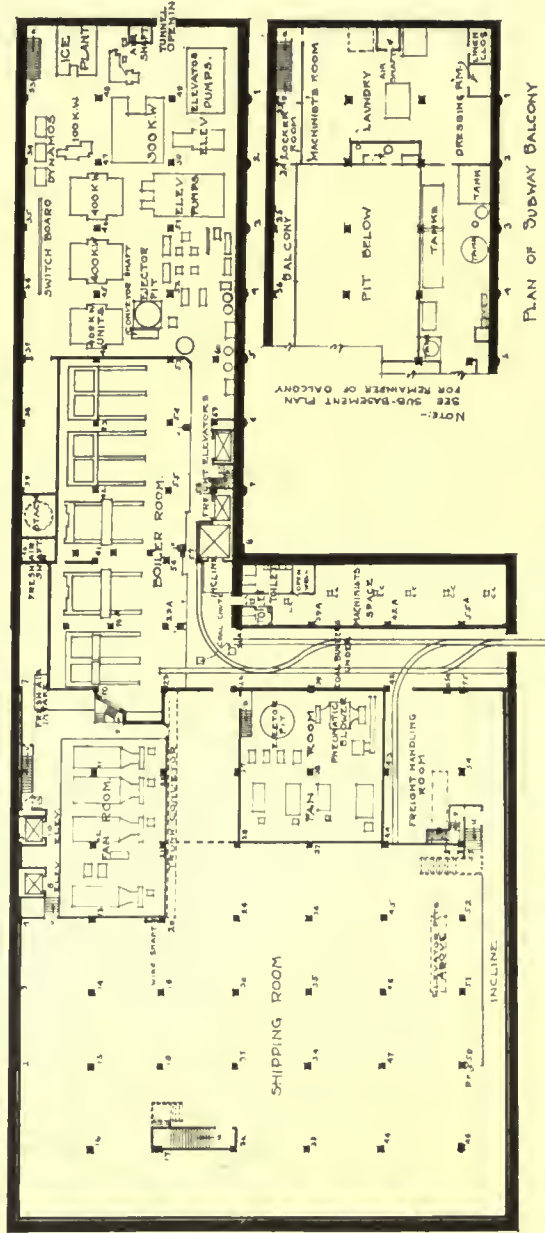

SUBWAY BASEMENT FLOOR PLAN

HOLABIRD & ROCHE, ARCHITECTS

THE AMERICAN ARCHITECT

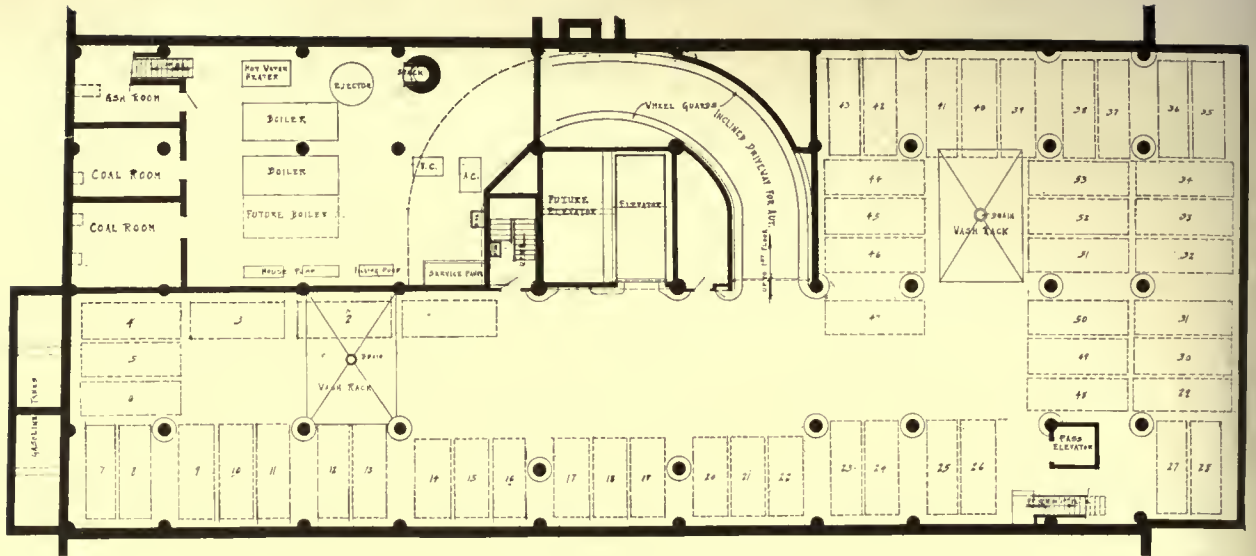

BASEMENT PLAN

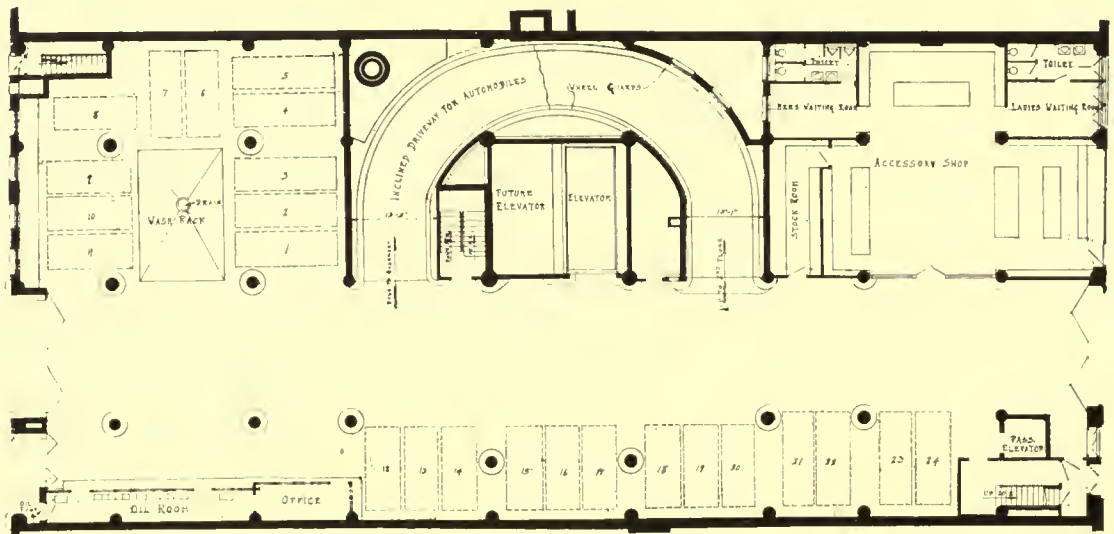

FIRST FLOOR PLAN

HOTEL LASALLE GARAGE, CHICAGO, ILLINOIS
 HOLABIRD & ROCHE, ARCHITECTS

THE AMERICAN ARCHITECT

speed. An elevator is provided for emergency use and an elevator is also provided for passengers. This is one of the first multi-story garages to be constructed and is a good example of the spiral driveway type.

THE Garrett Biblical Institute is located on the shores of Lake Michigan adjoining the Northwestern University at Evanston. It consists of dormitories and a recitation hall, arranged about three sides of a quadrangle open on the east to Lake Michigan. A street is continued through the recitation hall into the quadrangle. Between the recitation hall and Sheridan road another quadrangle will be provided about which will be grouped the library and chapel.

While the dormitories are quite severely plain in

poses, generally to a depth of 45 feet to 50 feet below the sidewalk level. This is made possible by the absence of rock until a depth of about 100 feet is attained. The freight subways of the Illinois Tunnel Company are at the depths mentioned and enter the buildings as shown in the subway basement plan of Mandel Brothers' Store Building. Coal and freight is brought to the building and ashes and refuse carried away through these tunnels. This is one reason that Chicago streets are not littered with ash cans which are hoisted to the sidewalks in some cities. Excavation for basements is also removed through the tunnels with a consequent relief from street congestion and dirt. In the subway basement is located the mechanical equipment and the shipping department. In the sub-basement is located the coal hoppers, breeching and some other parts of

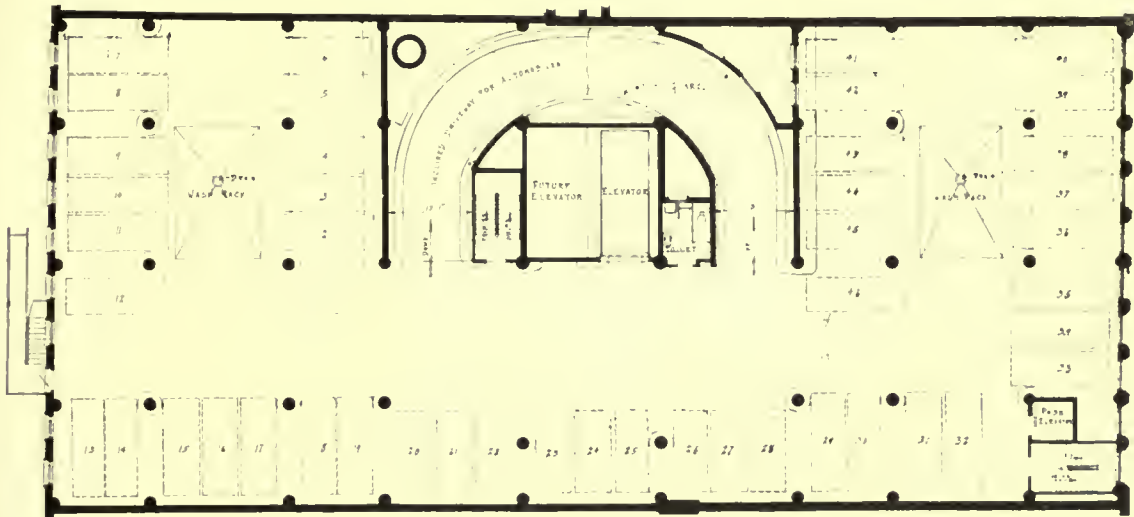

SECOND, THIRD AND FOURTH FLOOR PLANS
HOTEL LA SALLE GARAGE, CHICAGO, ILLINOIS
HOLABIRD & ROCHE, ARCHITECTS

design, they are not monotonous in appearance. Space has been economized in planning, still affording ample room for the students. Generally, each entrance serves twelve students and the study rooms have been placed on the south side of the buildings, also bath and toilet for every four students. In building D a small social hall is provided. Two-thirds of the accommodations in suites comprise bedrooms and study, one-third of the accommodations consists of single rooms. All entrances open on the quadrangle. The buildings accommodate 106 students and cost \$1,223 per student.

Building below grade is little appreciated by the ordinary observer because it is not readily seen. The great retail stores of Chicago utilize the lot area and the area under the sidewalks for business pur-

the mechanical equipment, locker and wash rooms for employes and a salesroom. The basement is used entirely for sales purposes. The high cost of real estate and the comparative cheapness of excavation justifies the construction of these deep basements. In some buildings, 20 stories high, the cost of construction below grade, including caisson foundations to rock, is from 20 to 30 per cent. of the total cost of the building. This will indicate the value of the sub-structures which are seldom seen by the public.

AMONG the later hotels designed by Holabird and Roche, is the Deshler at Columbus, Ohio, which was completed in August, 1916. This building faces on three streets, 110 feet by 200 feet in

THE AMERICAN ARCHITECT

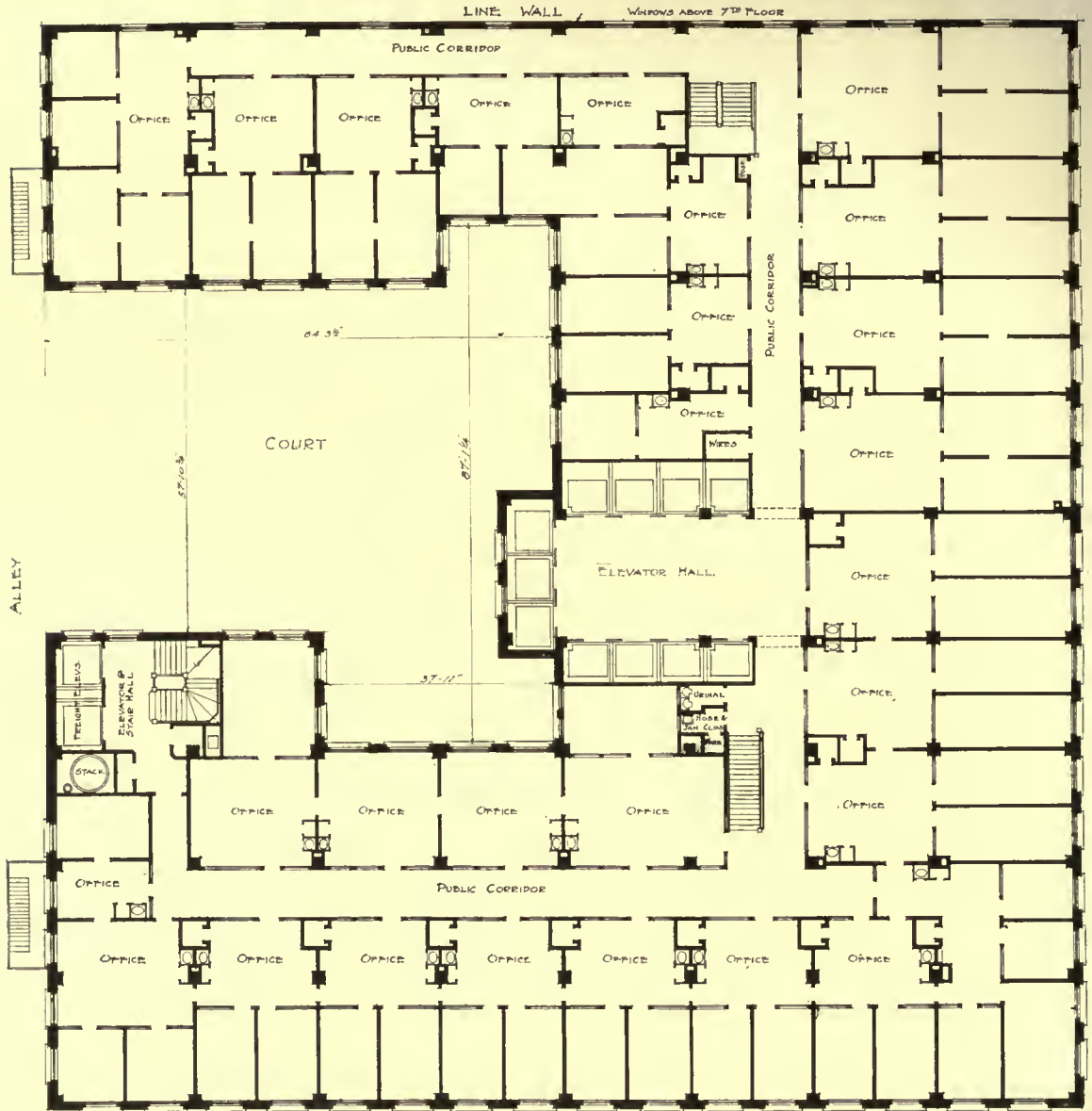

TYPICAL FLOOR PLAN

McCORMICK BUILDING, CHICAGO, ILLINOIS
 HOLABIRD & ROCHE, ARCHITECTS

THE AMERICAN ARCHITECT

size, 12 stories and basement in height. The exterior is of red brick, gray terra cotta and granite base.

Architecturally, the style of the building on the exterior and the interior, as well as the furnishings,

room are located to the west of the lobby. Five shops are located on the High Street frontage and these with the usual service, check and baggage rooms complete the first floor departments.

The second floor contains a ball room 56 feet by 80 feet, into which can be opened an assembly room 30 feet by 65 feet in size. Three large private dining rooms and a service pantry are located on this floor, the latter connected with the basement kitchen by dumb-waiters and a service stairway. Special toilet facilities are conveniently located adjoining the ball room. The balance of the floor is used for parlors and guest rooms.

In the typical floor plans the sample rooms are located in the west wing adjacent to the freight elevators. The balance of the floor is devoted to the usual guest room arrangements. An unusual feature is the extension of the corridors to the outside of the building. The service closets are grouped back of the elevators and stairs. The hotel contains 269 bed rooms and 57 sample rooms with bath, 31 rooms with toilets and 2 parlors, making in all 359 rooms.

The Broad Street vestibule has a barrel-vaulted ceiling and is lined with gray terra cotta. The main lobby is lined to a height of 12 feet with silver gray maple and the

floor is of gray Tennessee marble. The prevailing tone of the main dining room, buffet and café is gray, with the ornaments emphasized by the use of black and gold.

Located diagonally opposite to the northwest corner of the State House Square, this hotel can be seen in its entirety and its design and proportions studied with more satisfaction than is the case with the majority of city buildings. It is not the usual good fortune of the architect to be permitted to design such a structure in such an open and commanding position. The absence of the clumsy, heavy and ornate details that are common to many hotels causes the Deshler to be readily recognized as of superior design. The ornamentation is simple, refined and properly proportioned, according to its location; its relation to the entire mass is well worked out and the color effects harmonious and pleasing. This is one of the conspicuously good hotels that have been erected in recent years, either in Columbus or elsewhere.

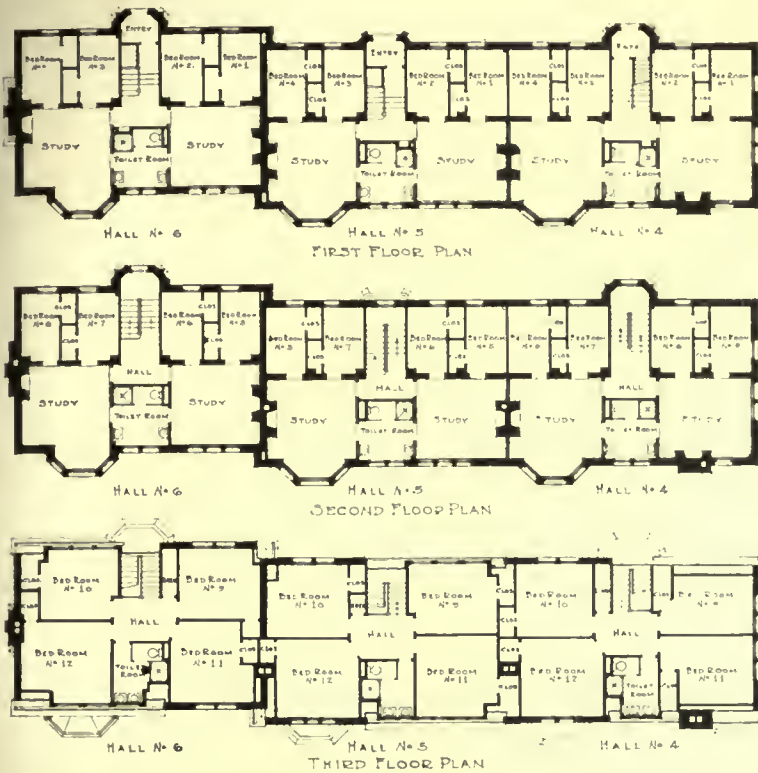

GARRETT BIBLICAL INSTITUTE, EVANSTON, ILLINOIS
BUILDING B, HALLS 4, 5 AND 6
HOLABIRD & ROCHE, ARCHITECTS

is Pompeian. This style was selected because of its flexibility and its sympathy with the Greek and Roman. Modern life as exemplified in its games, dances and costumes, may be adapted to this style by careful designing. It has a grace and liveliness which is especially pleasing in a hotel structure and does not have that flatness and insipidity which is so often seen in hotels designed in the Adam style.

The basement extends under the sidewalk to the curb line on the three streets, occupying a space 130 feet by 210 feet. The basement lobby is entered through the elevators and main stairs and is connected with the Ionian grill room, billiard room, barber shop and men's and women's toilets. The balance of the space is divided between the engine and boiler room and the main kitchen.

The first floor lobby is 65 feet by 102 feet with the street entrances, between which are located the elevators and main stairs. A section of the lobby is devoted to the use of women with retiring room connected. The main dining room and bar and grill

THE AMERICAN ARCHITECT

Our Isles of Artists

LAKE COMO TO HAVE AN ARTISTS ARCADIA

THROUGH a characteristic act of generosity and courtesy on the part of the King of Belgium, and with the co-operation of the Italian Government, says the New York Sun, editorially, there has been established in Lake Como an Isle of Artists. The island was bequeathed to King Albert by its owner and the king accepted the legacy, offering it in turn to the Italian Government on condition that it should become a place of residence for artists. Under the direction of the Italian Under-Secretary of the Fine Arts the plan for converting the island into a center for artists was put under way. It is proposed to have pavilions for exhibitions and concerts, homes for the artists and a hotel, the building scheme to be completed by next summer. With a nice touch of international courtesy one of the build-

ings is to be called Belgian House and will be reserved exclusively for King Albert's subjects.

This is a fresh illustration of the long cherished idea that workers in the arts should have refuges, if no more than temporary, from the bustle and distractions of the work-a-day world. Sometimes these are no more definite than such artists' colonies as the one from which the Barbizon school took its name in France, or our own Lyme, or Gloucester, or New Hope. The MacDowell memorial estate in New Hampshire is one American manifestation of this idea of an Isle of Artists. The Tiffany Foundation of Long Island is another. It is also illustrated locally by George Grey Barnard's Gothic museum on Washington Heights. Of this bit of the Old World set down in a teeming center of the New World's modernity Mr. Barnard has said that he hoped "young painters and sculptors and poets would come and read old books as they walked up and down in this old garden."



GARRETT BIBLICAL INSTITUTE, EVANSTON, ILLINOIS
BUILDING C, HALL 7
HOLBIRD & ROCHE, ARCHITECTS

Beaux-Arts Institute of Design

DIRECTOR OF THE INSTITUTE, LLOYD WARREN

ARCHITECTURE, WILLIAM F. LAMB

MURAL PAINTING, ERNEST C. PEIXOTTO

SCULPTURE, JOHN GREGORY

INTERIOR DECORATION, ERNEST F. TYLER

Official Notification of Awards— Judgment of February 24, 1920

THE PUPIN PRIZE.

The Gift of Prof. M. I. Pupin of Columbia University.
Offered for the ornamental treatment of some Scientific
Appliance.

FIRST PRIZE—\$50.00 SECOND PRIZE \$25.00

PROGRAM

"A DIRIGIBLE BALLOON FOR THE LEAGUE OF
NATIONS."

The transatlantic voyage lately accomplished by the British dirigible has established its practicability to transport a great number of passengers comfortably, safely, and swiftly to all parts of the globe. The use of hydrogen gas for buoyancy or lifting power is the only factor of danger, and for this reason the power plants for propulsion have been suspended in three or four well isolated units from the rigid envelope, which, in turn, contained the hydrogen gas bags. The power plants, thus suspended, complicated the entire structure, and made an efficient stream line design difficult, besides being cumbersome and easily damaged when landing. The introduction of the dead or non-explosive gas, helium, into the gas bags contained in the rigid outer hull, allows the power plants to be incorporated in the structure itself, that is to say, in the gondola or gondolas along the keel, or from the sides or ends of the rigid envelope, care naturally being taken to prevent the propeller from damaging the envelope. This fundamental



J. K. SMITH 2d PRIZE UNIV. OF PENNA.
PUPIN PRIZE COMPETITION

A DIRIGIBLE BALLOON FOR THE LEAGUE OF
NATIONS

advantage allows the stream line design of these monster structures to be greatly simplified. The center of gravity of the entire structure should be as low as possible so as to prevent overturning. The lifting, or steering planes should be well placed, the recent photographs of the English dirigibles showing these very plainly.

An observation platform on top, an entrance at the head and a platform or poop at the rear are features of special interest. The envelope itself has possibilities for mural decorations. A wireless outfit should also be considered,

and the large dirigibles should provide for an aeroplane on top with a starting and landing stage. None of these accessories should be below the gondola, as they would interfere in landing. The gondola or gondolas along the keel may be one or more stories high, and should have decks for passengers. Arrangements should also be considered for searchlights, and methods devised for illumination and decoration for gala occasions.

THE PROGRAM.

The government of the United States of America, which possesses the only supply of helium gas, has been requested

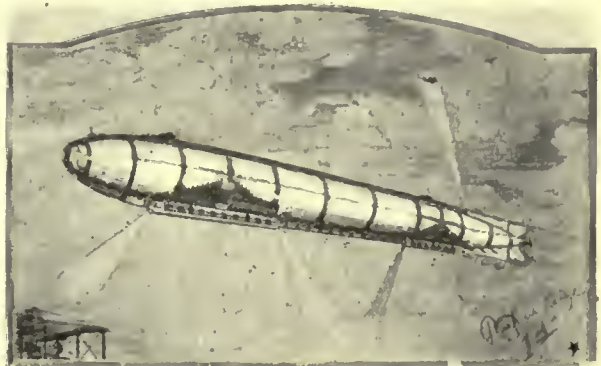

R. P. VANDERPOEL 1st PRIZE SYRACUSE UNIV.
PUPIN PRIZE COMPETITION

A DIRIGIBLE BALLOON FOR THE LEAGUE OF
NATIONS

to construct a large dirigible to transport the representatives and delegates of the different countries to and from the seat of the League of Nations. This dirigible should contain in its design all the features described above and should be 1,000 feet long.

JURY OF AWARD:

R. M. Hood, W. F. Lamb, F. A. Godley, E. S. Hewitt,
J. W. O'Connor and C. S. Peabody.

NUMBER OF DRAWINGS SUBMITTED: Thirty-three.

AWARDS:

First Prize (\$50): R. P. VanderPoel, Syracuse University, Syracuse.

Second Prize (\$25): J. K. Smith, University of Pennsylvania, Philadelphia.

Placed Third: G. M. Martin, University of Pennsylvania, Philadelphia.

Placed Fourth: R. W. Craton, Columbia University, N. Y. C.

Placed Fifth: H. Nolan, Cornell University, Ithaca.

PROGRAM.

CLASS "A"—III PROJECT.

The Committee on Architecture proposes as subject of this Competition:

"A PRINTING ESTABLISHMENT."

A company, printing and publishing books and magazines, has decided, owing to labor conditions and to secure greater economy of operation, to remove their plant to the suburbs of a large city. It has, therefore, secured a tract of land of considerable area near the main line of a

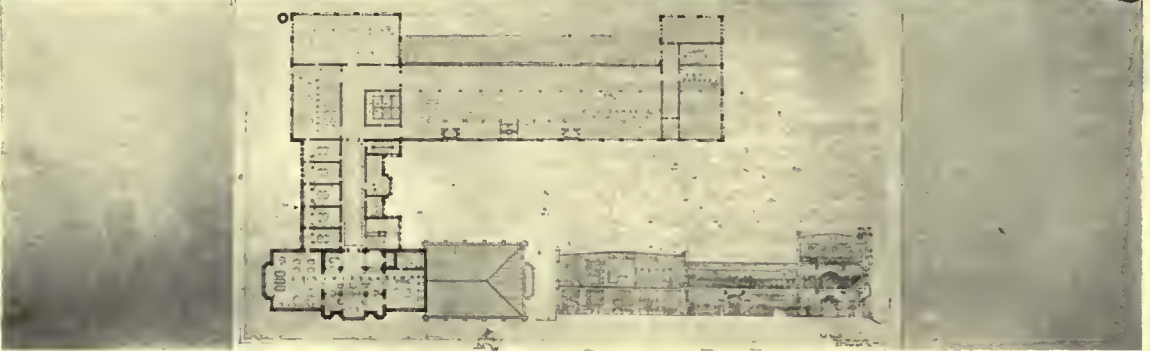

P. DOMVILLE

FIRST MEDAL

UNIVERSITY OF PENNSYLVANIA

CLASS "A" III—A PRINTING ESTABLISHMENT
STUDENT WORK, BEAUX ARTS INSTITUTE OF DESIGN

THE AMERICAN ARCHITECT

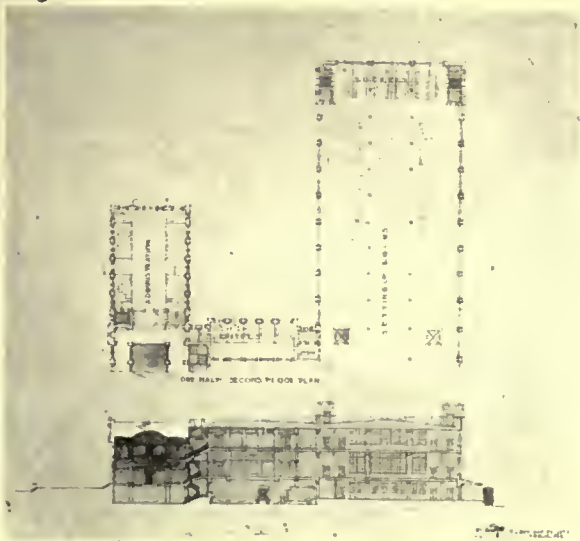

CLASS "A" III PROJET
A PRINTING ESTABLISHMENT
21 MEDAL
A. LEVY
UNIV. OF PENNSYLVANIA
STUDENT WORK
BEAUX ARTS INSTITUTE OF DESIGN

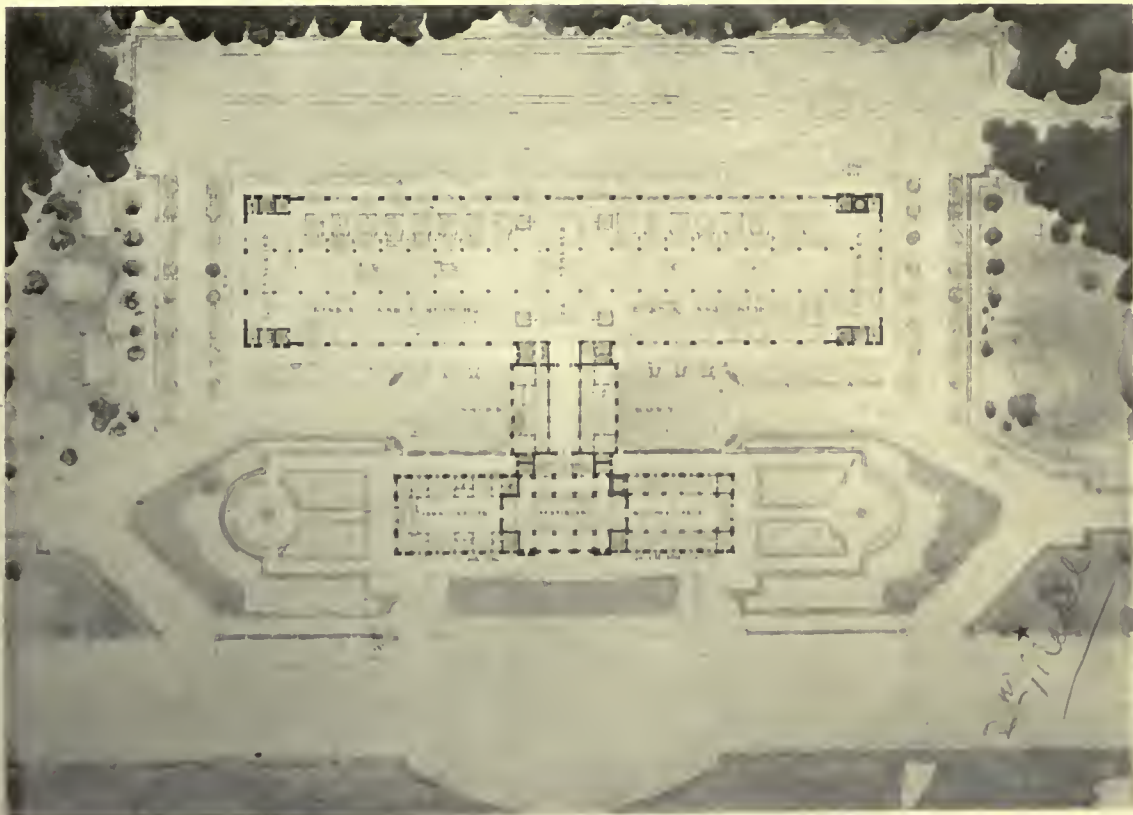

THE AMERICAN ARCHITECT

railway and facing an important thoroughfare leading to the city. Upon this site it intends to build a complete establishment, including the plant, a development for the housing of employees, and a landscape treatment that will make the scheme attractive from an artistic point of view, and will also serve as an advertisement for the company.

The problem will consist of the plant proper, excluding the housing development, but comprising the immediate

a space should be provided on the main floor for sufficient supplies for the day's work.

On the main floor there will be sixteen (16) presses, each with an overall dimension of 10 x 18 feet, a machine which collects and arranges automatically the various sheets, and three (3) or four (4) folding and binding machines.

Besides the storage in the basement for the finished product, there should also be storage and packing facilities near the shipping platform, which is accessible to the spur track or motor truck delivery.

Above the press room are to be—the Setting-up Rooms with Linotype machines which are to be in close connection with the presses by means of stairs and elevators; the Electrotyping Room, the Type Foundry where the final forms are cast; a small Rest Room and Hospital.

All these should have abundant light—in fact, the whole mechanical plant should be well lighted and ventilated.

The basement will contain, besides the storage space above mentioned, the power plant for the generation of heat and electricity for light and power.

Elevators and stairways should be provided throughout the plant to give ample communication between floors.

The land devoted to the building above must not exceed 350 x 250 feet.

JURY OF AWARD:

W. F. Lamb, B. W. Morris, P. Cret, M. Prevot, G. A. Licht, A. E. Flanagan, C. S. Peabody and J. W. O'Connor.
NUMBER OF DRAWINGS SUBMITTED: Thirty-six.



P. F. TAYLOR 3d MEDAL UNIV. OF PENNA.
CLASS "A" AND "B" ARCHAEOLOGY—II PROJÉT
THE SULTAN'S TRIBUNE IN A TURKISH MOSQUE

surroundings, and will contain, in a basement and two floors, the following:

A. A Vestibule for the reception of visitors with stairway or stairways to the other floors.

A Library or Museum for the exhibition of rare examples of the printing craft.

The Administration, consisting of offices for the various managers and superintendents and their assistants, and for members of the executive force.

The Editorial Rooms, which should be on the second floor, and in close connection with the composing room mentioned below for the convenience of copy distribution and proof correction.

B. The Mechanical Plant.

This should be so arranged that there will be the greatest economy of operation, and the various pieces of machinery should be so disposed that there is a progressive operation from the beginning to the finished product. There should be provided storage space in the basement for the paper and other raw materials which arrive by a spur from the railroad or by motor truck from the city. This storage space should be readily accessible, by means of stairs and elevators, to the point where the operation begins, and



G. B. HOUK 1st MENTION CORNELL UNIV.
CLASS "B" III—ESQUISSE-ESQUISSE
A RUSTIC BRIDGE

THE AMERICAN ARCHITECT

AWARDS:

First Medal: P. Domville, University of Pennsylvania, Philadelphia.

SECOND MEDAL: H. G. Marceau, C. Denison and J. G. Schumann, Jr., Columbia University, N. Y. C.; R. Nickel, "T" Square Club, Philadelphia; A. Levy and S. J. Laschenski, University of Pennsylvania, Philadelphia.

MENTION:

Rosamond Wolcott, A. W. Bitterman, Florence Wingate and S. Oxhandler, Columbia University, N. Y. C.; J. B. McCool, C. E. Silling, J. P. Davis, W. J. Perkins, P. Friedman and S. P. Stewart, Carnegie Institute of Technology, Pittsburgh; R. Platt, "T" Square Club, Philadelphia; G. F. Street, University of Kansas, Lawrence; W. F. McCaughey, Jr., University of Illinois, Urbana; T. B. Epps, G. K. Trautwein, E. Coscia and A. E. Westover Jr., University of Pennsylvania, Philadelphia; N. Larson, University of Minnesota, Minneapolis; T. F. Price and P. N. Jensen, Atelier Wynkoop, N. Y. C. H. C.:

of the bridge may be either wood or stone, or a combination of both, at the option of the competitor.

JURY OF AWARD:

R. M. Hood, F. A. Godley, H. R. Sedgwick, H. W. Corbett, E. S. Hewitt and M. B. Stout.

This jury also served as Jury of Award for Class "A" III Esquisse-Esquisse and Class "A" and "B" Archaeology II Project and II Measured Drawings.

NUMBER OF DRAWINGS SUBMITTED: Sixty-nine. AWARDS:

First Mention: P. F. Simpson, J. O. Cahill and K. Snow, Carnegie Institute of Technology, Pittsburgh; G. B. Houck, Cornell University, Ithaca; H. W. Gill, Columbia University, N. Y. C.; G. Chittenden, Los Angeles Architectural Club, Los Angeles.

Mention: C. B. Marks, C. A. Lake, E. A. Early, D. H. Bodin and R. Schmertz, Carnegie Institute of Technology, Pittsburgh; E. B. Mason, Cornell University, Ithaca; L. Rombotis and M. Sabransky, Los Angeles Architectural Club, Los Angeles.

PROGRAM.

CLASS "A"—III ESQUISSE-ESQUISSE.

The Committee on Architecture proposes as subject of this Competition:

"A GALLERY OVER A RIVER."

As an addition to a great country residence situated on the banks of a small river which flows through the estate, it is proposed to erect a wing or gallery, which on its main floor will contain a suite of rooms devoted to social functions, and on its second floor will house the owner's collection of antique furniture and objets d'art.

This gallery will span the river, being carried on a series of arches, and will terminate on the bank opposite to that on which the present residence stands, in a pavilion containing the entrance vestibule, stair hall, retiring rooms, etc., which serve the gallery.

The level of the main floor is 25 feet above the surface of the water, and the total length of the gallery not including the entrance pavilion, is 100 feet. The entrance pavilion is not required in this problem.

NUMBER OF DRAWINGS SUBMITTED: Seventeen. AWARDS:

Third Mention: G. W. Trofast-Gillette, Columbia University, N. Y. C.; E. R. Froese, Atelier St. Louis, St. Louis; D. M. Allison, University of Illinois, Urbana.

Mention: R. P. Vander Poel, Syracuse University, Syracuse; S. H. Brown and T. E. Ash, "T" Square Club, Philadelphia.

PROGRAM.

CLASS "A" AND "B" ARCHAEOLOGY—II PROJET.

The Committee on Architecture proposes as subject of this Competition:

"THE SULTAN'S TRIBUNE IN A TURKISH MOSQUE."

The Byzantine and the Early Christian styles of Architecture, while closely allied in many points, are separated by one basic distinction, for the domical plan is characteristic of the former while the basilian is of the latter. Also the Byzantine is largely a style of veneer. The buildings are of brick or wood, clothed with marbles, tiles or carved wood and embellished with elaborate surface detail in color and inlay. Marble columns with fantastic capitals and rich cornices of classic types are used, though the typical mouldings are flat with surface decoration. St. Sophia in Constantinople is the typical example of the style and its strong influence can be seen in St. Marks, Venice, and even in St. Front, Perigeux.

The subject of this problem is the special tribune provided for the Sultan in a Turkish mosque.

It shall be supposed to occur near one of the great corner piers supporting the central dome of the mosque, and shall be carried on piers or columns, so that its floor shall be approximately 10 feet above the floor of the



D. M. ALLISON 3d MEDAL UNIV. OF ILLS.

CLASS "A" III—ESQUISSE-ESQUISSE A GALLERY OVER A RIVER

PROGRAM.

CLASS "B"—III ESQUISSE-ESQUISSE.

The Committee on Architecture proposes, as subject of this Competition:

"A RUSTIC BRIDGE."

This bridge, which spans a small stream 15 feet wide in a picturesque and wooded part of a public park, is for pedestrians only. The banks of the stream are about 5 feet above the level of the water, and slope at an approximate angle of 45 degrees. The material used in the construction

THE AMERICAN ARCHITECT

mosque. The tribune itself, which shall not exceed 20 feet in any horizontal dimension, is to be enclosed on the sides to protect the Sultan from the view of the public by means of pierced grills of wood or marble, and shall be covered by a wooden roof or canopy. A gallery, similarly protected on the sides, shall lead from the tribune to the Sultan's private entrance. The tribune shall be rectangular or polygonal in form.

NUMBER OF DRAWINGS SUBMITTED: Three.

AWARDS:

Third Medal: R. W. Craton, Columbia University, N. Y. C.; P. F. Taylor and J. W. Brooks, University of Pennsylvania, Phila.

CLASS "A" & "B" ARCHAEOLOGY—II MEASURED DRAWINGS.

NUMBER OF DRAWINGS SUBMITTED: Three.

SUBJECT:

The Swisher Mansion, Austin, Texas.

AWARD:

Mention: K. B. Niven, University of Texas, Austin.

SUBJECT:

Old Land Office, Austin, Texas.

AWARD:

Mention: K. B. Niven, University of Texas, Austin.

SUBJECT:

The Alamo, San Antonio, Texas.

AWARD:

Mention: K. D. Beckmann, University of Texas, Austin.

Present Situation in the Building Industry

By H. H. Fox, *Vice-President of the Turner Construction Co.*

ABOUT May 1 there was a falling off in the demand for new buildings and there were some cancellations of contracts and some stoppage of work on buildings already under construction.

The probable causes of this situation seem to be as follows:

1. High estimates of the cost of new buildings.
2. Uncertainty in the minds of owners, particularly on the following points:

(a) Will the actual cost of a new building be within the estimate or will a situation prevail such as prevailed during the fall of 1919 and the winter of 1920 in which, owing to strikes, not only in the building trades but in the steel, coal and railroad industries, costs in general exceeded estimates?

(b) Will it be possible to complete a building within a reasonable length of time in view of the shortage of materials and the congestion of the railroads?

(c) Will it be possible to build a building a year or two hence for materially less than it would cost now?

(d) Will a sufficient demand for manufactured goods exist during the next few years so that a manufacturer can hope to earn a fair return on an investment made in a building at the present time?

(e) Will a sufficient supply of labor exist and will this labor work with efficiency so that a manufacturer can hope to operate a new plant to advantage?

3. High money rates.
4. Politics.

Taking up the above points in order:

1. There is no doubt whatever that the estimated costs of buildings today are higher than they have ever been. It is a fact, however, that building costs have not risen as much in the last five years as commodity prices.

(a) Will the actual cost of a new building be within the estimate or will a situation prevail such as prevailed during the fall of 1919 and the winter of 1920 in which, owing to strikes, not only in the building trades but in the steel, coal and railroad industries, costs in general exceed estimates?

The most important factor in considering this question is the railroad situation. Supplies of the principal building materials, namely, steel, cement and lumber, exist at the points of origin but on account of the car shortage which amounts to over 100,000 cars contrasted with a surplus a year ago of over 300,000) these supplies cannot be moved away as fast as they can be manufactured. With the present demand for cars for the shipment of coal, and the demand which will develop in the fall for the shipment of grain, it is difficult to see how this situation can be overcome in the immediate future. However, the increase in wages for railroad employees and the freight rate increases, which will enable the railroads to improve their equipment, should mark the beginning of a lasting improvement in this situation.

There is an actual shortage of clay products, such as brick and hollow tile as these require considerable coal for their manufacture and the requisite coal cannot be obtained. This is another result of the car shortage.

(Continued on page 253)

Criticism and Comment

The Editors THE AMERICAN ARCHITECT:

On reading the leading editorial in your issue of July 21 a trail of thought is unfolded to the writer, who is prompted to present his observations on the subject.

In noting these observations the writer is not unmindful of the fact that, though he held a diploma from one of the leading schools of architecture in the United States and had had considerable experience over the drafting board, these qualifications were not considered when he tried to enter the service. Because of a slight physical defect his application for enlistment in the Corps of Engineers was rejected, and because of his being within the age limits of the "Selective" Service Act, he was unable to secure employment with the Construction Division of the army, although his experience in connection with Industrial Housing would have rendered his services in this department peculiarly valuable. The same defect that had prevented his enlistment in the Engineers' Corps, as well as in other branches of the service, did not prevent his induction into the service when his number was reached.

Having entered the service his professional qualifications seem to have been ignored. The fact that he had had some experience as a musician was believed as of more importance, although he had had no experience whatever with a band. He was accordingly given the gracious rank of Drum Major, carrying with it the stripe of a Band Corporal. This rank he retained until discharged from the service after the armistice.

The perusal of your editorial brings up the question: Are modern industrial life and business life in general based on considerations of personal fitness and do present-day methods of education and training place sufficient importance upon the qualifications of the individual? The writer's observations lead him to the conclusion that too much importance seems to be attached to a man's affiliations, his personal and social connections, and his influence, and too little to the question of whether he is of the proper calibre for the job. This is not uttered in a spirit of indictment or resentment, but merely as an observation on a widely prevalent condition. Neither does the writer think the condition universal.

Four years attendance at a leading university brought the writer into contact with hundreds of men of all types. True, the majority were serious

and pursuing courses to which they were undoubtedly suited. On the other hand, many men's sole claim to a place on the register of the university was the fact that they (or their fathers) were able to pay the Bursar at the proper time and, by dint of cramming they were able to pass the examinations. Such men almost invariably are invited into a fraternity (and are accepted) and in the after-college years, wield considerable influence by virtue of their fraternal connections and "get away with it." Too often this influence places them in positions where they ultimately fail.

Similar conditions have too strong an influence in the U. S. Army to be beneficial. Too often has the writer seen men whose principal claim was their good fellowship or their affiliations make headway in preference to the man who had a more solid foundation.

While the broadening influence upon the mind resulting from association with men of all classes, races and creeds, such as is experienced in the wartime army, is of undoubted importance, the writer, nevertheless, cannot help but believe that its value could be greatly enhanced were more importance attached to the man's personal qualifications and less to his affiliations.

Referring specifically to the question in your editorial whether or not professional men left the service better equipped for their work, it cannot be doubted that the majority of the men gained in health and became better acquainted with the world in general. But the universal and unavoidable tendency of the rank and file of armies to pull the higher level of intellect to the plane of the average or lower intellect certainly had an unwholesome effect upon men accustomed to seeing and appreciating the finer things in life (as an example of this tendency witness the average souvenir store catering to the soldier, with its display of gaudy and silly souvenirs and trinkets). Furthermore, the total cessation of professional duties, as was the case with most professional men, and the assumption of the strenuous routine of army life could not but tend to reduce professional efficiency. Close observation since again coming in contact with professional men convinces the writer that while military service improved the physique and health it did not tend to better equip the men for the resumption of their professional duties.

New York.

EX-SERVICE.

Memorial Bridge Proposed for New York

THE War Memorial Committee of New York City looked with particular favor upon a bridge across the Hudson River. A letter to the committee from the North River Bridge Company answers some of the objections which were made to this form of memorial. As to the bridge which that company proposed to build under a perpetual Federal charter granted in 1890, it says: "Its colossal size is dictated by the needs of the city. Every foot of the two decks, each 180 feet wide, will be needed after its completion for the very pressing traffic across the river. The objections of your jury of artists to the profanation of a war memorial by the noise and clatter of railroad traffic can be readily understood and indorsed, but in this case are not well founded. The solemn monumental character of the bridge will not be impaired by railroad tracks, since they will be electrified and on the lower deck, entirely out of sight from the street level, which will be on the upper deck. They will be no more visible or noticeable than the subways are in our streets.

"The middle boulevard, eighty feet wide, will be on the upper deck, rising with an easy grade from Ninth avenue and connecting with the existing boulevard on top of the Palisades. The side avenues, with surface tracks, will be screened separate and screened from the middle boulevard by trusses. A grander concourse can hardly be conceived. The massive anchorages and the bridge towers on both sides of the river lend themselves in an extraordinary degree to monumental stone architecture of colossal proportions which decorative art can beautify to meet the most artistic taste."

Another plan for a bridge across the Hudson is now in the hands of the New York-New Jersey Port Commission, which is proposed to cross at Grand street. This bridge was designed by Alfred C. Bosson, architect, chiefly from the point of view of transportation necessities. It would provide ten tracks on its lower level which would greatly facilitate the handling of freight in and out of Manhattan Island.

Patchin Place, Tenth Street, New York City

(See reproduction of the original drawing by O. R. Eggers in this issue)

LYING in the very heart of Greenwich Village is Patchin Place. So well protected is it in its privacy and the absence of contact with the busy New York of today, that one has to search keenly for this quaint old neighborhood—almost the last record of a dignified residence location.

Patchin Place is located on that slanting direction of Tenth Street which inconsistently as it may seem crosses Ninth and Fourth Streets in its progress toward the Hudson River. Halfway of the block between Sixth and Greenwich Avenues this little group of well proportioned houses lies in a veritable cul-de-sac. Its narrow sidewalks are simple approaches for the dozen houses which, six abreast, front on an equally narrow roadway. From close to the building line there spring Acanthus trees whose tops meet in a leafy arch that embowers the street. Standing with one's back to the wall that serves as a barrier to the further extension of the place and on a moonlight night looking through a tracery of leaves toward the spires and minarets of the court building on the opposite side of Tenth

Street, it is difficult to imagine that one is exactly in the center of Greenwich Village—a bustling, ever restless part of the city. The isolation is complete. The hum and jarring noises of the city's traffic, the rumble of the nearby elevated trains, all those many discordant elements of city life are hushed to stillness in Patchin Place.

Who built this row of fine old houses we do not know, for diligent inquiry has not enabled us to discover the identity of the architect. But they arose during a period when the classically correct proportioning of solids to voids was considered the very essence of good architectural design. It seems futile to hope that this quaint location can very long withstand the progress of the city's growth, but it is reassuring to have been able to observe on the occasion of a recent visit to Patchin Place that certain necessary repairs and restorations were in progress. This gives rise to the hope that the present owners realize the artistic and historical significance of this little gem and are desirous of keeping it as it always has been.

250



PATCHIN PLACE, NEW YORK

AMERICAN ARCHITECT Series of Early American Architecture





The Pressing Need for New Postal Arrangements

THE announcement that the United States Post Office Department has taken a long term lease of a building soon to be erected on 38th Street, New York, lends encouragement to the hope that New York may eventually find relief from the poor postal service that now creates an intolerable condition. New York City transacts about one-ninth of the entire post office business of the country. Any lack of proper facilities for the easy handling and quick despatch of mail matter there accordingly affects the entire country. The proposed building on 38th Street but touches the rim of New York's necessities. Congress should at the earliest moment provide the needed authority for other similar buildings.

There should first be one in the downtown financial district. This will bring up the much discussed matter of the long delayed removal of the awful building that now spreads its disfiguring bulk along the southern end of City Hall Park. Further, Congress should provide for the extension of the Pennsylvania Terminal Post Office Building, either by enlargement or by another and new building in the immediate vicinity. There have been no new post office buildings erected in New York since 1912, in which year the Pennsylvania Branch Post Office Building was completed. No provision was made in the building for the enormous increase in the parcel post business. The rapidly growing sections in the outlying districts of the greater city will also need buildings to accommodate their imperative needs, while the Grand Central Terminal Branch Post Office has already become so congested by an enormous increase as to handicap very seriously the efficient handling of mail matter.

WHAT is true as to New York is true in an only slightly lesser degree in every large city of the United States. "The Postal Service," to quote Mr. Koons, the first assistant postmaster general, "is simply a big business of more than \$450,000,000 annually and is increasing at a rate never heretofore known."

Congress must soon tire of the game of politics it is so constantly playing and become alive to the necessity for some speedy relief in the handling of our enormous bulk of mail. When the government resumes its building operations, the needs of the Post Office Department should receive first consideration. And as these building needs are of the most commercial character, we shall have to evolve a new type of post office building, one that will serve all the necessities of the department and not become a further development of those purely ornamental civic monuments that are spread broadcast all over the United States.

The new post office buildings should be exactly for the utilitarian purposes they are intended to serve. Owing to land values, the ground areas will necessarily be restricted and it will, therefore, be necessary to carry these buildings to a height greater than buildings of this type hitherto constructed. This will be necessary not only to afford room for the large volume of business that will be conducted, but also to provide the needed light and air.

The policy of constructing post office buildings with provision for the rental by the government of space to private enterprises not connected with postal business should be discontinued. The undesirability of such a method has been demonstrated in all of our large cities, and particularly in New York. In this city there are instances where the Post Office Department has rented for its use the lower stories of buildings in busy sections. The conditions created have become intolerable, and have maintained a state that not only interfere with the public's comfort but often menace its safety.

THESE conditions of congestion and public discomfort suggest the serious consideration of some proper means of intercommunication between the various branch buildings and the railroad terminals. The logical method, because the most practical, is one of subways. This would solve the shipping problem, and prevent the blocking of sidewalks and the congestion of street traffic due to loading and unloading countless mail wagons during the entire twenty-four hours of each day.

THE AMERICAN ARCHITECT

There can be no street regulation of the postal traffic after the manner of the usual regulation of ordinary street traffic. The mails must not be delayed, hence the right of way is arbitrarily construed by employes as permission practically to completely blockade the streets and sidewalks in front of these temporary branches of the Post Office Department. The increase in business and the very radical change in its character by reason of the addition of the parcel post have created a condition that cannot be solved by precedent nor carried forward by the exercise of previous custom. It will require a new type of building, new methods and the abolishment of certain systems now antiquated and outworn. Congress should be brought to a realizing sense of the need that has developed and the present inadequacy of the methods employed to serve it. We should not wait until after election. We should get busy now.

Cultivating a National Art

WE have got to travel a long road in this country before we learn just what to us as a nation is the true value of art. Between the people and the end of the road there stands a barrier that has been many times approached and but seldom surmounted. That barrier is politics. We shall never progress unimpeded along the road to our ideals in art until we are able to show by a steadily increasing popular sentiment—a sentiment that means a preponderance of votes, that the majority demand the best expression of art in our architecture and all the arts to which architecture is allied.

We instinctively turn to France when we seek to name a country where art has really become a factor of civic government. The idea that art and the knowledge of art could ever be considered as of no importance by a civilized people or made to rank below the sordid interests that lead to money making, finds no sympathetic adherents in France. To the French, art is a necessity, not a luxury, and those in office who fail to realize this find their tenure short. In France, art and politics are indissolubly joined, but the junction is so much a part of the governmental ideals—those ideals that every man in public office must know, and knowing, further—that the union becomes one of vast importance and marks the continued progress of the French nation.

It will be the height of unwisdom first to bend every effort toward the accumulation of riches and then seek to acquire an art. You may not teach old dogs new tricks. The habit acquired by years of sordid plodding do not lead to an appreciation of art. As a nation we shall need to act along the same lines that might govern the individual. We must acquire an education in art and the refinements of life at the same time that we shall accumulate the money which will enable us to acquire good art and to appreciate what such acquisition means. Art is not a luxury, it is a necessity of our daily lives. No man is so much to be pitied as that very rich one who, having spent his life in the acquiring of money, finds that he has absolutely no ability to appreciate its advantages. These conditions may very well apply to a nation.



DECORATION, BERTINI GALLERY, MILAN

Present Situation in the Building Industry

(Continued from page 248)

One result of this situation has been to stop or slow down work on many projects and consequently throw many workmen out of work. This has created a surplus instead of a shortage of labor and should tend to increase the efficiency of labor. In several industries which we have investigated, it has had exactly this effect.

It would seem, therefore, that for the next few months labor troubles will be less frequent.

The major difficulty, therefore, is one of transportation rather than of materials or labor, and the situation is one which will affect the time of completion of a building more than the cost, although costs will be increased by increased freight rates, by the cost of expediting rail shipments, and to some extent by general inefficiency resulting from inability to have materials at the work when needed.

(b) Will it be possible to complete a building within a reasonable length of time in view of the shortage of materials and the congestion of the railroads?

Owing to the railroad situation it is impossible for a contractor at the present time to guarantee a date of completion of a large building. It is, nevertheless, a fact that many operations, both large and small, are at present under way and are being completed within a reasonable time.

(c) Will it be possible to build a building a year or two hence for materially less than it would cost now?

Consideration of this question involves two principal factors—the general price level; that is, the value of the dollar, and the demand for building construction.

Many articles have been written on the prospects of a decrease in the general price level and it is not necessary to discuss this topic at length. In view of the enormous increase of money in circulation (\$56 per capita today, against \$35 per capita in 1914); increased credit facilities due to the Federal Reserve System, making money easier to get and, therefore, easier to spend; high prices, shortage of raw materials, and inefficiency of labor in foreign countries which will prevent foreign competition which will prevent foreign competition from being a vital factor for some time, it seems unreasonable to hope for a rapid drop in the general price level.

Regarding the demand for buildings, a table was published in the Financial Chronical of February 14 giving the money value of building permits issued in the principal cities of the United States from 1906 to 1919. The figure for 1906 was about \$805,000,000 and for 1919 \$1,498,000,000.

Both 1906 and 1912 were years of good business, and according to the Chronicle's figures, the increase in building permits between those two years (disregarding the fact that several small cities are included in the 1912 table which were not in the 1906 table) was about 30 per cent. If this is considered a normal increase for a period of six years, the building permits issued in 1919 would normally have been about \$1,400,000,000. This figure, however, is based on prices prevailing between 1906 and 1912. Based on 1919 prices the normal amount of building permits in 1919 would have been about \$2,900,000,000.

If we correct the figures from 1912 to 1919 so that they are on the same cost basis and show the quantity of building done instead of the cost, we find that the building work done between 1912 and 1919 was short of normal requirements by the following amounts:

1913.....	\$50,000,000
1914.....	160,000,000
1915.....	150,000,000
1916.....	160,000,000
1917.....	730,000,000
1918.....	1,050,000,000
1919.....	600,000,000
Total.....	\$2,900,000,000

This figure is still based on the 1912 cost standard. Based on present day cost it would be over \$7,000,000,000, representing more than two years' normal building construction.

A further factor tending to increase the demand for buildings at the present time is the reduction in working hours which has taken place in many industries, necessitating a corresponding increase in working space if goods are to be produced in the same quantity.

In the face of this condition it is hard to see how there can be any material decrease in the cost of buildings for many years, excepting as these costs may be reduced by a drop in the general price level.

(d) Will a sufficient demand for manufactured goods exist during the next few years so that a manufacturer can hope to earn a fair return on an investment made in a building at the present time?

It is difficult to obtain figures on quantities of goods manufactured. Figures on basic commodities, however, are easily obtainable and it is reasonable to suppose that the amount of manufactured goods must fluctuate with the amount of basic commodities produced.

The Irving National Bank published a booklet in May, 1920, entitled "Problem of Prices," in which was shown the "Federal Reserve Bank curve of production in the United States of ten basic products."

With production in the year 1900 taken as 100 per cent., production in 1912 is shown as 160 per cent., and production in 1918 as 195 per cent. This indicates that in the years 1912 to 1918 approximately the same rate of increase was maintained as in the years 1900 to 1912. In 1919, however, the production decreased to 182 per cent. The production in 1919 was, therefore, below normal requirements, and if we take into account the fact that during the war years a large part of the basic commodities produced were used up in the war, there is undoubtedly at the present day a considerable shortage to be made up.

Contrast this condition to the one which prevailed just previous to the 1907 panic. In 1906 the production of wheat was larger than in any previous year with the exception of 1901. In 1906 the production of corn was greater than in any previous year. In 1906 the production of cotton was greater than in any previous year with the exception of 1904. In both 1906 and 1907 the production of pig iron was greater than in any previous year. In 1906 the production of copper was greater than in any previous year.

The condition as to production of commodities today is so radically different from conditions which have preceded periods of depression in the past that it is difficult to believe that any falling off in demand for goods of all kinds can continue for more than a short period.

(c) Will a sufficient supply of labor exist and will this labor work with efficiency so that a manufacturer can hope to operate a new plant to advantage?

There are already indications that the efficiency of labor is increasing. We know of specific instances in which manufacturers have laid off part of their working force without decreasing the quantity of their product. The railroad situation has caused enforced idleness in many industries so that workmen can no longer show the indifference which unfortunately has prevailed during the past year and still be sure of holding their jobs. Immigration is increasing. There are good grounds for hope that in the immediate future employers will be less troubled with shortage and inefficiency of labor than during the past year.

3. High money rates are due largely to the fact that owing to high prices, about $2\frac{1}{2}$ times as much money is required to finance a given undertaking as formerly was the case; and also to the enormous volume of new securities issued (on top of the Liberty Bond issues about \$3,700,000,000 of new securities were issued in the twelve months ending April 30, 1920, against a previous yearly maximum of \$2,300,000,000 in 1912). This situation has been intensified by the railroad situation which has kept

manufactured goods from reaching the consumer. High money rates compared with the old standards are likely to continue for several years, although there should be some relaxation after the railroad situation is straightened out and the crops are moved. Equipment bonds of first class railroads running for ten years or more have recently been sold on a 7 per cent. basis. The United States Government has announced an issue of treasury certificates maturing in one year and carrying 6 per cent. interest, a rate which has not been paid by the Government since 1867. It may be inferred that our treasury department and railroads who are in a position to secure the best financial advice would not be borrowing at these rates for such long periods if any radical decrease in money rates were in prospect.

4. *Politics:* Much as we may have been chagrined during the past year at the failure of our Legislative and Executive Departments to cooperate, and much as we may wish to see the international position of the United States clearly defined, the fact remains that it is entirely possible that no bills will be introduced in Washington during the next four years of such vital importance to the purely material interests of the country as the Federal Reserve Law and the Railroad Law which are already safely on the statute books. Individual initiative and the law of supply and demand will have a greater effect on business than will legislative activities.

Conclusion: The shortage in buildings today is so great that it cannot be corrected for many years and for this reason it is not probable that there will be any material decrease in the cost of building.

If the railroad wage award handed down by the Railroad Labor Board imbues in the railroad employees a desire to hold their jobs; and if the fact that jobs are not as easy to pick up as they have been, makes them realize that they must work a little harder in order to hold their jobs, the railroad situation should begin to straighten out. The increased freight rates agreed upon by the Interstate Commerce Commission will enable the railroads to prepare a budget and place orders for equipment. In time the car shortage will be turned into a surplus and the abnormal amount of credit now tied up on goods in transit will be released.

The prospective builder must be prepared for some delay in the completion of work ordered in the immediate future; but he can, nevertheless, in our opinion, undertake construction work without fear either that there will be a sharp drop in building costs after his work is completed, or that there will be a material falling off in the demand for his products.

254



HOTEL DESHLER, COLUMBUS, OHIO
HOLABIRD & ROCHE, ARCHITECTS

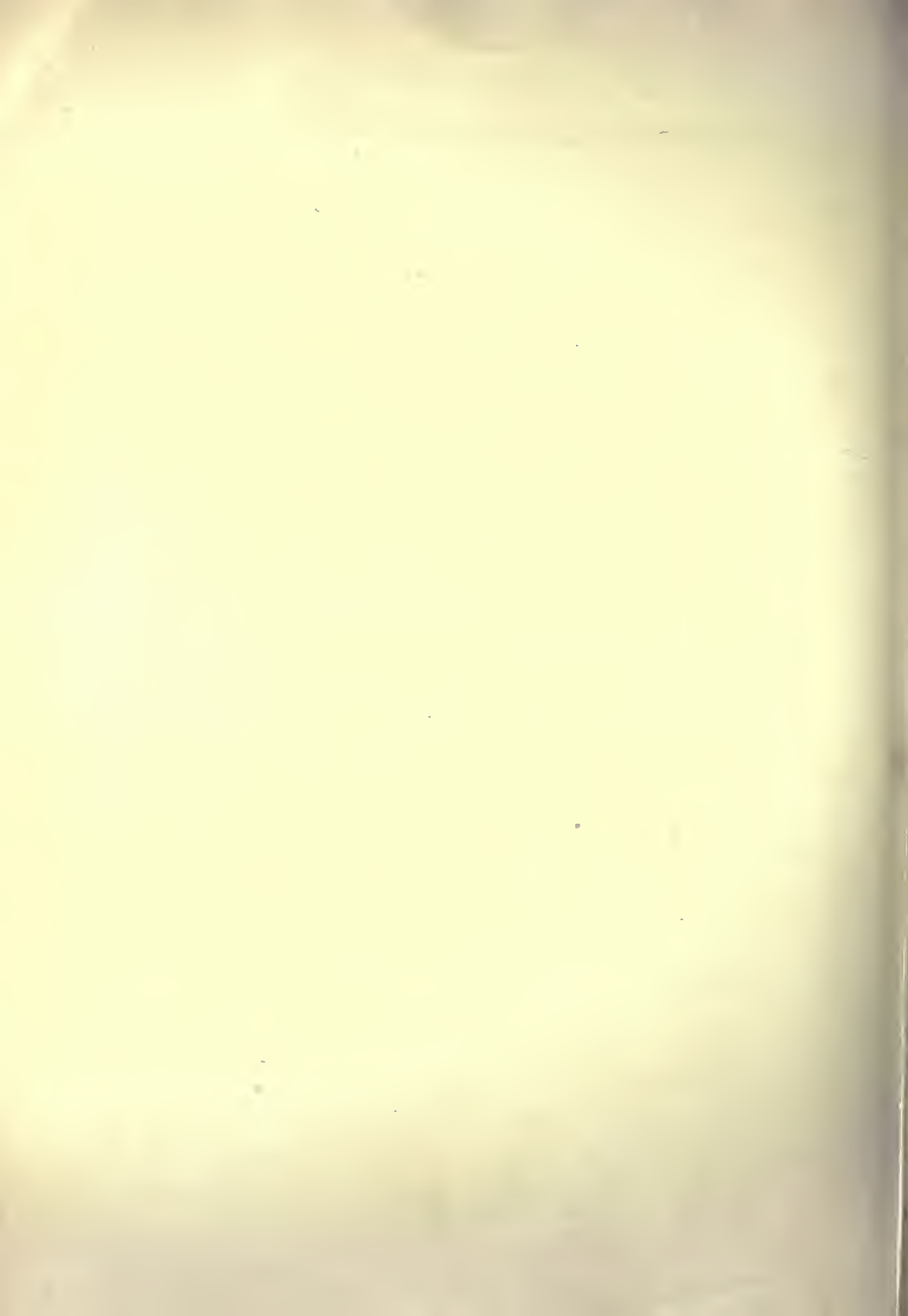

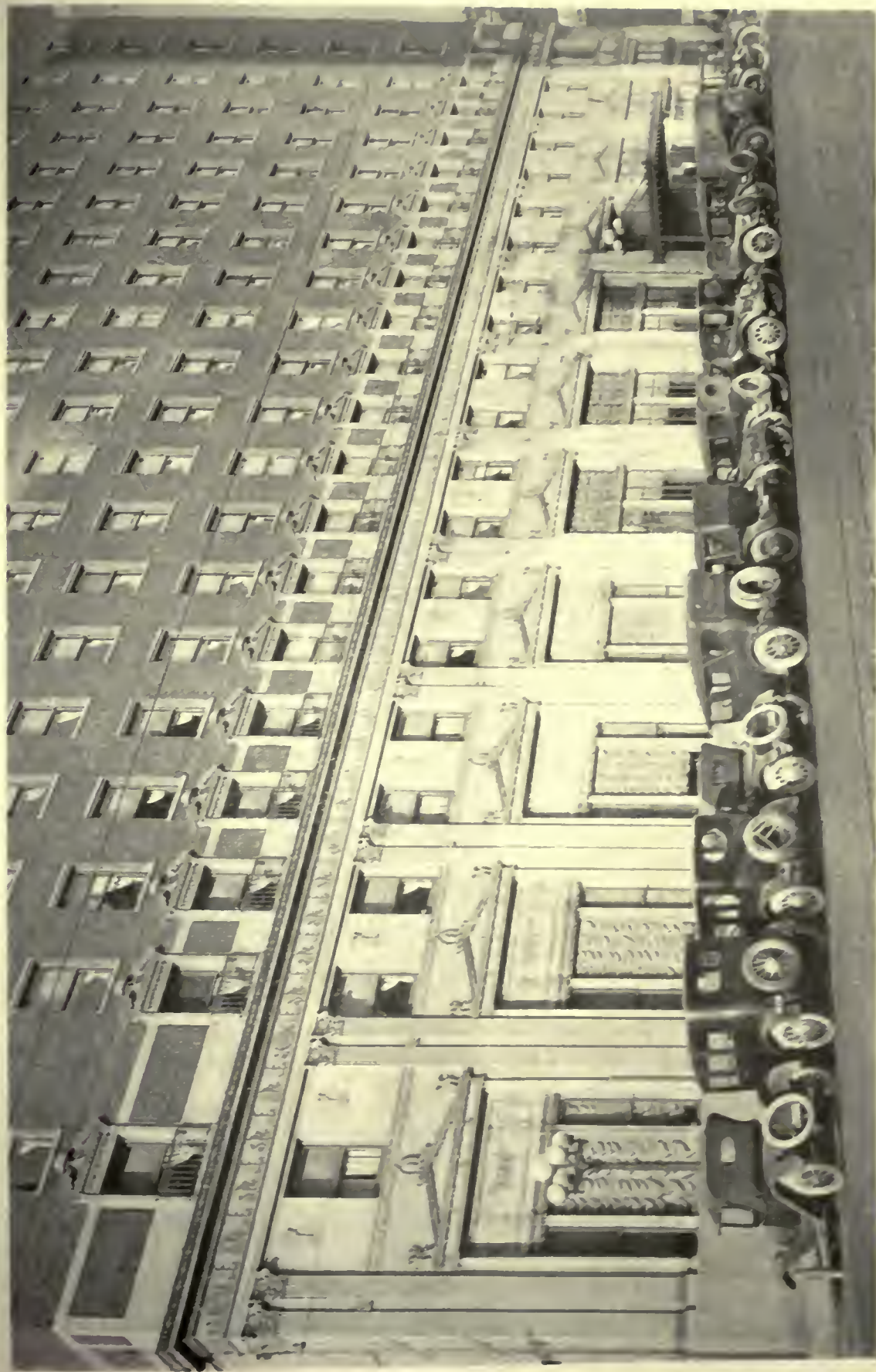

DETAIL OF LOWER STOREYS
 HOTEL DE SHELTER COLUMBUS, OHIO
 BY ARTHUR S. ROWE (ARCHITECT)

نورث

257 3



DETAIL OF CORNICE
HOTEL DESHLER, COLUMBUS, OHIO
HOLABIRD & ROCHE, ARCHITECTS



202 x



THE LADIES' PARLOR
HOTEL DESHLER, COLUMBUS, OHIO
HOLABIRD & ROCHE, ARCHITECTS



25-2-21

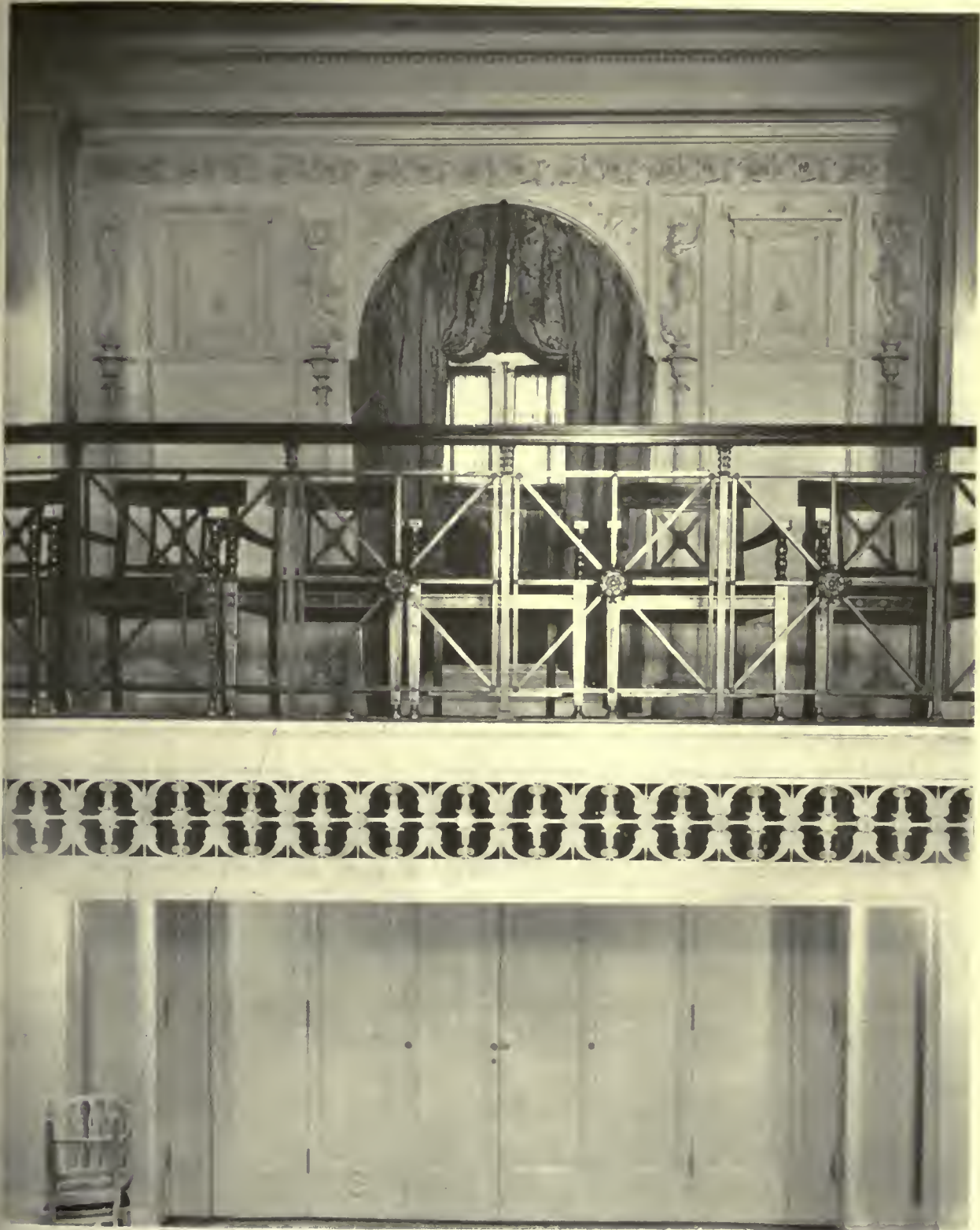

DETAIL OF BALL ROOM
HOTEL DESHLER, COLUMBUS, OHIO
HOLABIRD & ROCHE, ARCHITECTS



104



THE VESTIBULE
HOTEL DESHLER, COLUMBUS, OHIO
HOLABIRD & ROCHE, ARCHITECTS



2531



EXTERIOR DETAIL OF FIRST STORY
HOTEL DESHLER, COLUMBUS, OHIO
HOLABIRD & ROCHE, ARCHITECTS



254 8

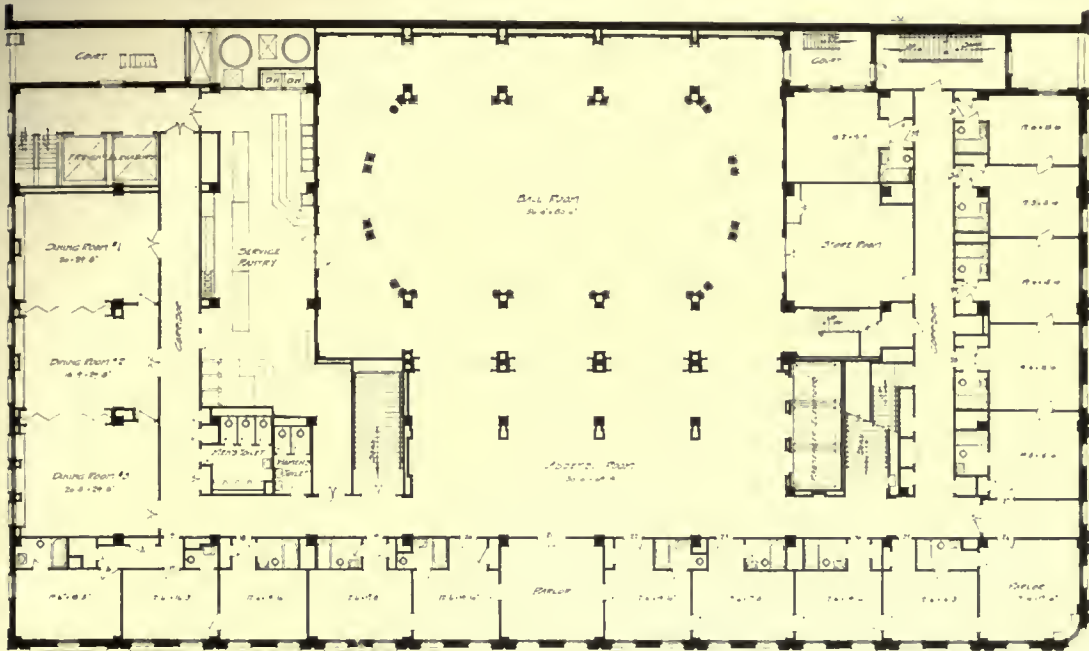

SECOND FLOOR PLAN

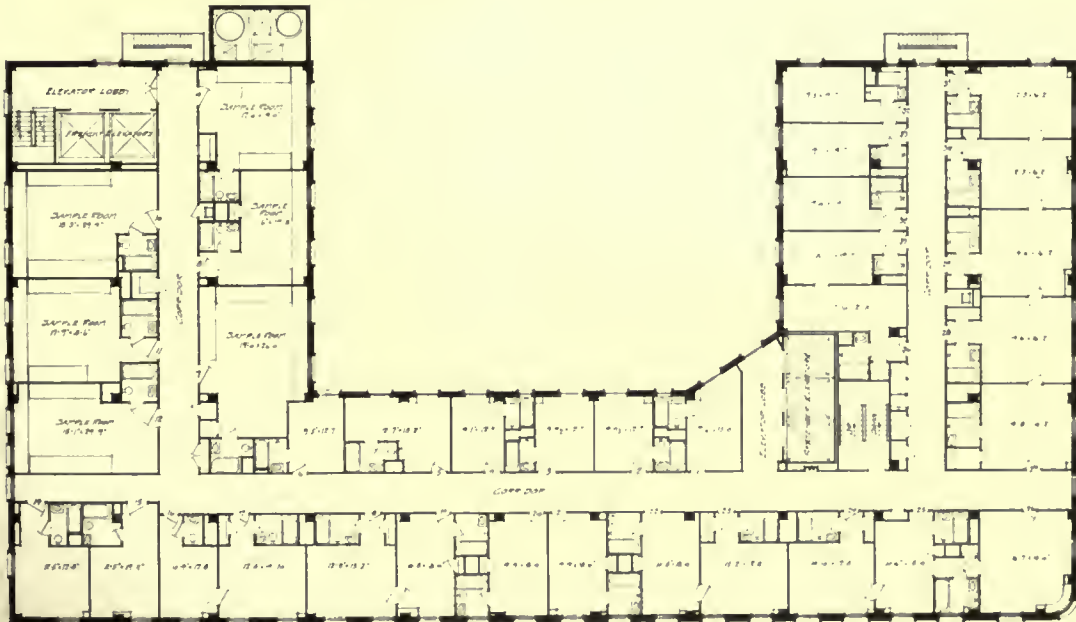

PLANS OF THE FOURTH FLOOR AND ABOVE

HOTEL DESHLER, COLUMBUS, OHIO
HOLABIRD & ROCHE, ARCHITECTS



2569

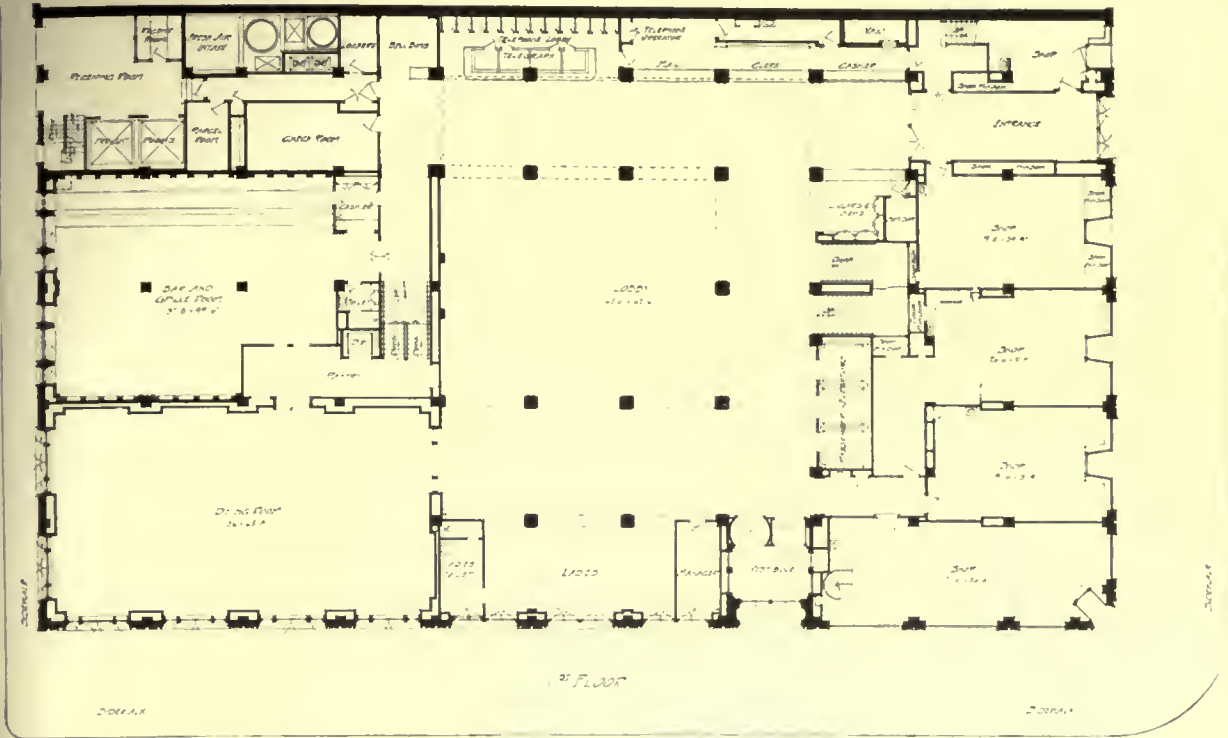

FIRST FLOOR PLAN

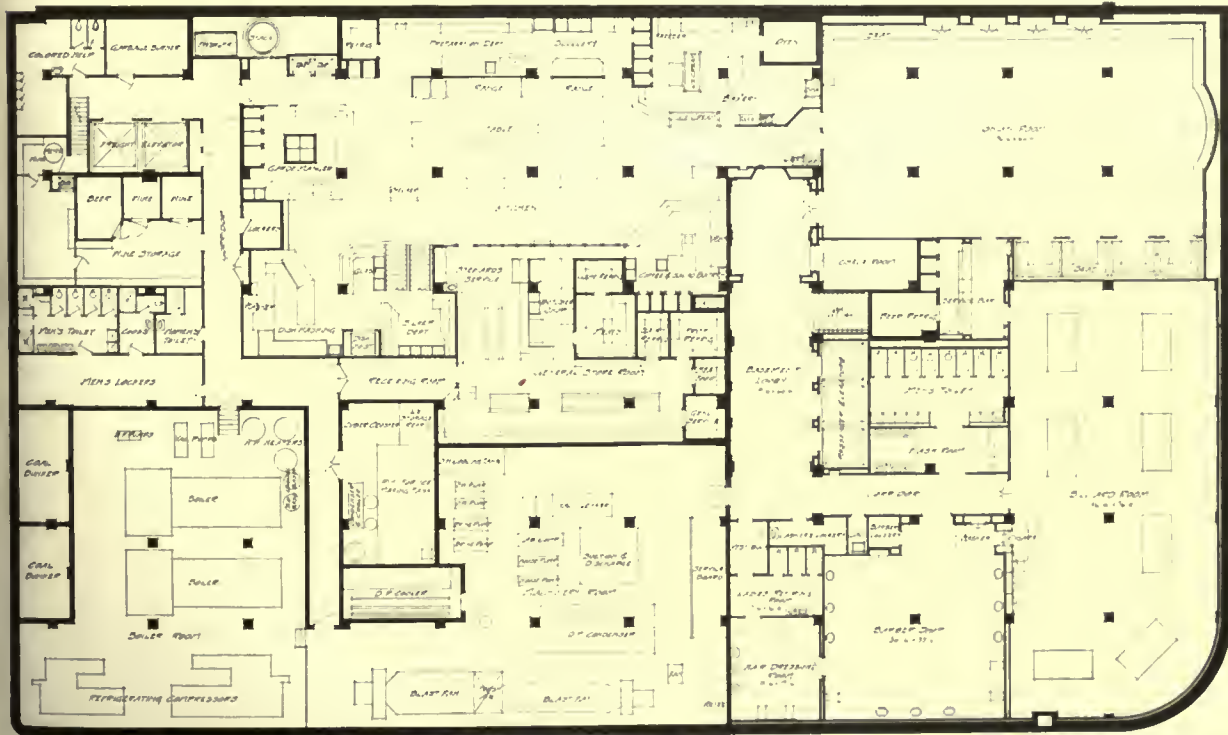

"THE DESHLER".
BASEMENT PLAN

HOTEL DESHLER, COLUMBUS, OHIO
HOLABIRD & ROCHE, ARCHITECTS



DEPARTMENT OF ARCHITECTURAL ENGINEERING

New Material Used in Manufacturing Building at Newark, N. J.

THE war was both directly and indirectly responsible for the development of many new types of building construction. The fact that certain of these are only now making their appearance is but proof of the extensive experimental work carried on during preceding years, accelerated by the hope that a practical stage of development

of reconstruction, which must be brought to a successful end before we may even enjoy the fruits of peace and victory. The building industry suffered during the war more than any other, and now that private building operations are again possible, it becomes necessary to construct with greater efficiency than ever before and to avoid all waste.



NEW BUILDING, PORETE MANUFACTURING CO., NEWARK, N. J.
E. WALTER, DESIGNING ENGINEER

could be reached prior to the termination of hostilities, that thereby aid might be rendered to one or more of the agencies conducting the Government's vast building program. But if improved materials and methods of construction were essential to the solving of our war problems, they are doubly so now, when we are face to face with the complica-

In past issues *THE AMERICAN ARCHITECT* has set forth various methods by which improved construction is possible. In this article a new material—a porous concrete—is described and methods of its application to building construction set forth and illustrated.

The laboratory research work has only recently

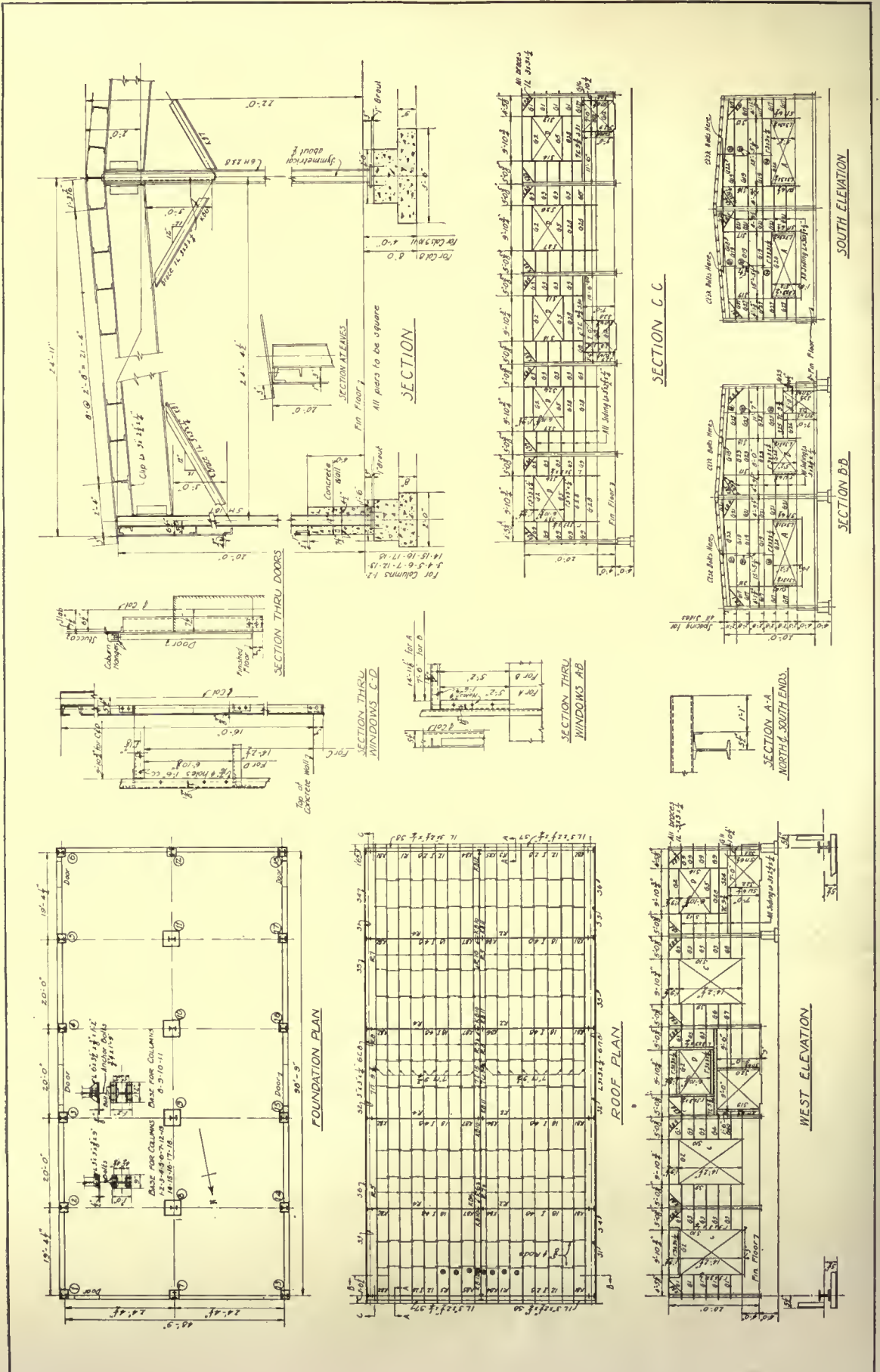

PLANS, ELEVATORS AND SECTIONS OF STRUCTURAL STEEL FRAMING, BUILDING FOR THE PORETE MANUFACTURING CO., NEWARK, N. J.

E. WALTER, DESIGNING ENGINEER

THE AMERICAN ARCHITECT

reached that point where the production of the material on a commercial basis has become possible. At present it is being produced in slabs 1 inch and $1\frac{1}{8}$ inches thick, and 24 inches by 32 inches wide. The 1 inch slabs or boards are reinforced with light 2-inch mesh poultry wire netting and are used for wall and partition construction, while the $1\frac{1}{8}$ -inch slabs are reinforced with expanded metal and are used for roof construction. The material weighs

that which has any detrimental effect on the concrete. Thus by leaching out and evaporating the material composing the pellets, the spaces formerly occupied by them become voids and the structure of the resultant concrete very much resembles that of a rubber sponge. The material forming the pellets is recuperated and used over and over again. The process as well as the product is covered by U. S. Patents. A fine Rockaway Beach sand is used



INTERIOR VIEW OF PLANT SHOWING WALL AND ROOF CONSTRUCTION

approximately 50 pounds per cubic foot, slightly more than that of the commonly used grades of lumber, and the slabs can be easily handled.

The porous character of the product is obtained by mixing with Portland cement and sand a quantity of mechanically produced pellets of a neutral wax-like material, about the size of "B B" shot. These pellets, while unaffected during the process of mixing and setting of the cement, are affected by heat, and melt or vaporize at a temperature below

in the mix. The slabs are cast in metal forms, and while the upper surface of the finished slab is rough and porous, the under surface, due to contact with the form, is smooth. After the leaching process the slabs are stacked outdoors where they remain until shipment. An examination of a number of the earlier slabs, produced about a year ago, showed the material to be in good condition, and also considerably harder, as the setting process goes on, the same as with any Portland cement concrete. These had

not been protected in any way and thus had been exposed to the elements during the past winter.

A plant for the manufacture of this product, approximately 50 feet by 100 feet in area and one story (20 feet) high has just been completed at Newark, N. J. The manufacturers have employed this material wherever possible in the construction



CONSTRUCTING AN END WALL OF POROUS CONCRETE SLABS

of this building. Thus it has been used for all side walls, roof and interior partition construction as well as for the doors. Since this plant is the first, and so far as the editors know, the only structure so constructed, it is here illustrated in considerable detail.

All footings are of normal concrete, carried 4 feet below grade. A concrete wall, 12 inches thick and extending 4 feet above grade, has been placed around the entire exterior, and this feature seems to be desirable, since it acts as a guard against damage by motor trucks, etc. The entire framework of the structure is of steel. The exterior columns are 5-inch H section and extend from 3 inches below grade to 20 feet above. The interior columns, forming a row in the center, are of 6-inch H section, and approximately 21 feet high. All columns are spaced 20 feet on centers parallel to the long axis of the building. The roof girders are 18-inch I beams set on a slight pitch, and braced to the columns by angle knee braces. The roof purlins are 7-inch channels 2 feet, 8 inches on centers, with lower flanges resting on and bolted to the girders. It would have been possible to have constructed a considerable lighter steel roof structure by using I beams instead of channels as roof beams, set farther apart and light angle iron purlins at 32-inch centers to carry the slabs. However, the owners preferred the heavier construction to simplify the structure. Horizontal angles, spaced 2 feet, 8 inches apart are connected to the outside flanges of the wall columns. All door and window openings are framed with

angles and channels. The entire steel framework is well braced. A good conception of the construction will be obtained from an inspection of the photograph of the interior.

After the erection of the steel framework, the walls were covered with the porous concrete slabs, set with the long dimension vertical. The slabs are held in place by specially constructed, heavily galvanized metal clips. Several of these clips, as well as the method of holding the wall slabs in place may be clearly seen in the illustration below. Apparently the only tools used by the workman setting these were a small hatchet and a pair of wire cutters. No scaffolding was required. The windows are of the solid steel sash type, now commonly employed in

"CLOSE UP" OF METHOD OF ATTACHING SLABS TO STEELWORK

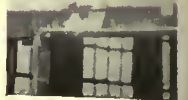

NOTE TYPE OF STEEL CLIP USED TO HOLD SLABS IN PLACE

industrial buildings, and were connected to the steel framework in the usual manner.

The roof slabs were set so as to rest on the top flanges of the channels, and metal clips used to hold them in place. These clips are formed to hook over the edge of the channel flanges and have two projection lugs, one of which extends over the slab on one side and the other one over the adjoining slab. After the roof slabs were placed, a very thin surface of cement grout about 1/16 inch thick was



ROOF CONSTRUCTION—STEEL CHANNELS AND POROUS SLABS

floated over the slabs, filling the joints and smoothing the surface. Over this a build-up tar, felt and slag roof surface was applied.

Tests made on a number of the roof slabs with the surface finish on top gave an ultimate strength of approximately 350 pounds per square foot. The expanded metal reinforcement is placed toward the underside, but not close enough to the surface to be exposed.

The walls on three sides have been given two coats of Portland cement stucco applied with a stucco machine and present a good appearance. No cracks are noticeable to date. The fourth wall has been partly covered with one coat of cement

stucco. The remaining sections are used for conducting various exposure tests.

The interior partitions around the office section, as well as two doors shown at the rear of the photograph of the interior, are also constructed of Porete slabs on a metal framework, and plastered.

These slabs can be nailed to wood studs without difficulty, the nails apparently not in any way in-



PLACING FELT, TAR AND SLAG ROOF OVER CONCRETE SLABS



CLOSE UP VIEW

Showing method of clipping roof slabs to steel channels.

juring the material. A special wire clip is used under the nail heads which acts as a washer. A panel constructed of wood studs, similar to the wall of a frame building, has been erected in the open for experimental purposes. This has been covered by the slabs and one heavy coat of stucco. So far as could be determined, one single heavy coat of stucco appears to be all that is necessary to make a satisfactory siding. A dash finish would, of course, add to the attractiveness of the appearance.

It would appear that this material has a wide field, since it combines most of the enduring qualities of Portland cement concrete with very light weight, and in addition possesses excellent insulating qualities on account of its air cell structure. Not only can it be used for the exterior of frame buildings such as dwellings, which are to be stuccoed, but also for small and large garages and industrial buildings

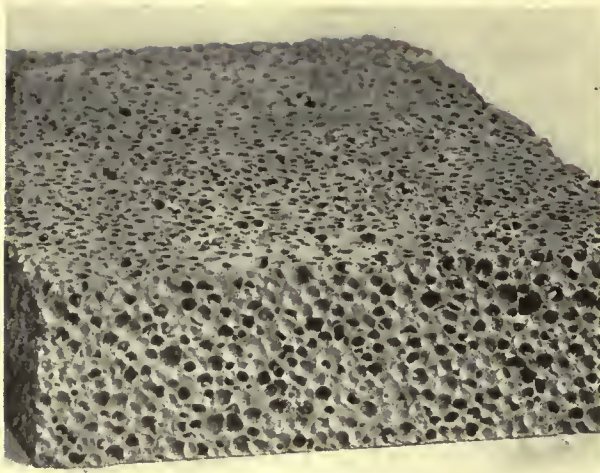

A SPECIMEN OF THE NEW PRODUCT SHOWN
FULL SIZE

where a smooth cement finish for the inside walls is obtained. For partitions, false ceilings and as a furring material for brick and concrete walls, as well as concrete roofs, it promises excellent results. As a roof-deck it combines with its fire resisting qualities, very light weight and good insulation.

The "board" idea has come into quite general use insofar as interiors for moderate sized residential buildings are concerned, and it is quite conceivable that for exterior work the same principle might, in certain classes of buildings, be found advantageous. Of course, as relating to the product here described, some type of weatherproof exterior coating is essential, since the material itself is not proof against the elements. However considerable labor on the job may be eliminated.

The construction so far as this building and similar types are concerned has received the approval of the building department of Newark, N. J.

Report on Trip to Princeton, Yale and Harvard Universities and the College of City of New York, for the Purpose of Inspecting the Stadia at Those Institutions

By HOWARD DWIGHT SMITH.

Part V

Of the architectural lessons to be learned at Harvard, the most important one, that of dignity and scale has already been mentioned. But there are some others which should be noted in passing. The Stadium has been built with three substantial steps around it, giving the effect of a platform, upon which the lower arcade rests. This avoids the stilted appearance of the supporting piers which is apparent at Princeton, for instance. The interest and character which the markings of the wood forms have given to the entire structure is perhaps a touch which the designers and builders had not fully contemplated or originally appreciated. In fact, the changing of the entire outer surface of the exterior wall by "bush hammering" or picking in order to remove all evidence of the wood forms was contemplated and actually carried out on all the piers of the lower arcade. This proved to be rather an expensive operation and it was not carried further, and it was proposed that the surface be covered over by vines. The growing of the vines has been very successful, and during the summer and fall the first two stories of the exterior wall, from tower to tower, is practically a solid mass of green.

These vines cover up the form marks on the sur-

face of the wall, even though these form marks do not necessarily mar the architectural character of the structure. In fact, the form marks still showing on the faces of the towers suggest the great possibilities in their use as a part of the design. The markings show that the form boards were for the most part placed vertically in short lengths of approximately 3 feet, each section separated by a horizontal form board eight or nine inches in width. This gives the interesting effect of alternating wide and narrow structural courses, and suggests other interesting ways in which the actual structural accessories in the use of reinforced concrete may be taken advantage of by the designer.

The structural lessons to be learned at the Harvard Stadium are quite as interesting as the architectural ones. Unlike the Yale Bowl, the Palmer Stadium at Princeton, or the Lewisohn Stadium at C. C. N. Y. the Stadium on Soldiers' Field is not entirely a reinforced concrete structure. The piers of the superimposed arcades of the exterior wall are 3 feet thick and are of sufficient cross section to carry their loads as masonry alone. The interior vertical supports and girders are of reinforced concrete, the entire seating portion is made up of seats

precast in sections approximately 8 feet long and set in place on supporting rafters of steel. The upper solid section of the exterior wall is of reinforced concrete. The double arcade portion of the exterior wall is provided with numerous joints for expansion and contraction, and it is evident from the form markings which show over the arches of both stories, that these portions of the wall have been poured in comparatively small integral sections. As in the solid seat blocks at Yale, this gives the advantages of stone masonry construction be-

colonnade. In some cases where a thin outside cement coating has been plastered over the parapet joint over this colonnade it has broken open somewhat irregularly, giving sufficient proof that even in the most insignificant places where the logical expansion joint is ignored it is detrimental to final results.

The problem of expansion and contraction in the heavy girders which support the seat structure is successfully taken care of by resting each girder separately on two supports as contrasted to a system



Photo International

OLYMPIC ATHLETES AT HARVARD STADIUM PRIOR TO THEIR DEPARTURE ABROAD

cause the expansion and contraction of each small piece is taken up mostly at the adjoining joints.

The upper wall back of the colonnade is built up with continuous expansion joints which have frankly been left uncovered throughout. They extend up through cornices and parapet, across the roof over the upper promenade and through the cornices and parapet over the colonnade itself. There is one joint to each section of seats, thirty-eight in all, which brings one over every third column of the

of the continuous girder. Each long, reinforced concrete girder rests upon two reinforced concrete posts. The supports under ends of adjoining girders are placed some four feet apart, each girder cantilevering over its support, making the actual girder joint midway between the supports. The stairs up to the lower row of "eyes" or portals go between these pairs of concrete posts.

These heavy girders support a series of steel rafters upon which there are placed clips or seat

angles, which form horizontal points of support for the seats themselves. As has been mentioned above, these seats have been precast. They were built up in forms in an area off to one side of the Stadium site much in the same way that concrete blocks are made and then transferred to the structure and set in place. Each cast seat is about 8 feet long. They have been set in place with a slight joint between each two. In general these joints are not pointed up. This allows free and independent movement in each small unit. The outstanding feature of the Harvard Stadium from a structural point of view is its structural integrity after seventeen years of use and exposure. There is no evidence of disintegration in the seat portion nor of spalling or cracking due to pressure. In the entire length of exterior wall there is one irregular crack apparent and that is in section 9, on the north side, through the haunches of arch 15 in both stories.

Aside from this there is no evidence of disintegration apparent, although the ground keeper says he has noticed some slight tendency within the past year or so to a slight thrust on the walls at the tips of the Stadium, adjoining the tower. This may be the result of cumulative expansion, because of the fact that the joints between the seats are not filled with plastic material. In cold weather, when these joints are widest open, some of them may fill with solid matter, which will make the joint ineffective during the hot weather of ensuing seasons.

The openness of the joints between each cast seat unit means, of course, that the space beneath the seats is not weatherproofed and it cannot be used to any advantage as shelter in wet weather. This could largely be overcome by some simple provision such as a series of gutters or by the use of plastic material in the joints.

The steel work used to support the cast seat units is all exposed and requires attention periodically for cleaning and painting. Attention has been directed to the fact that it has not been repainted in eight years, and for the most part it is still in fair condition. It is true, however, that just those portions which need paint protection most, that is to say the horizontal clips which hold the cast seat units, are the least accessible for repair and protection.

The "healthy" gray color of all of the concrete and cement work about the entire Stadium, bespeaks the character of the materials and workmanship used in its construction. The opinion is ventured that no small measure of the structural success of the Stadium may be due to the fact that those responsible for its erection felt they were working with a comparatively new material and that most extraordinary provisions were made and precautions taken to execute the work as nearly as possible with laboratory exactitude. Quality surely

has not been sacrificed to speed or false economy, and the results speak for themselves.

The care of the structure now is in the hands of the efficient ground keeper, who witnessed its entire erection and who knows it as well as or better than any one else. This gentleman's first interest is in maintaining well turfed playing fields and in building "fast" cinder tracks, but his keen interest in the maintenance of the structure itself, is, of course, of great value to its owners.

The inspection of the Harvard plant convinces one of the sufficiency of concrete if used intelligently and maintained properly. It makes one feel that what has been done at Cambridge can be done elsewhere if only the lessons of seventeen years can be properly heeded.

For complete discussion of structural and technical details refer to the *Journal of the Association of Engineering Societies*, June, 1904, Vol. XXXII.

More Data on Structural Slate

THE Structural Service Bureau of Philadelphia has recently issued Chapter 2 of a series on structural slate, containing a basic specification for structural slate work, as well as information on color, grading, costs and constructional data.

As stated in the announcement by the staff of the bureau, its activities are devoted to creating a greater, safer and more efficient use of building materials, equipment and devices through a better understanding of their nature, manufacture and utilization. It acts as a point of contact between the profession of architecture and industries allied with it. It embodies, to the fullest extent possible, the viewpoints of the designers of buildings and specifiers of their construction, of the producers of raw and finished structural materials, and of the ultimate consumer, the owner.

The co-operation of the architectural profession is solicited by the Structural Service Bureau in advising what the industries can do to improve their product for the architect's use, to increase its effectiveness in appearance, to eliminate unnecessary and infrequently used sizes, shapes, patterns, colors and finishes, to cut down waste in material and effort, to increase production, reduce cost, minimize calculations and details and to standardize procedure.

Incidentally, all will be playing an important part in reducing the cost of building and in preventing an enormous economic loss to the purveyors of building materials if means may be found to reduce the unwarranted amount of money expended upon that class of literature which flows through an architect's office without achieving its purpose.

Current News

Happenings and Comments in the Field of Architecture and the Allied Arts

Action of the Oregon Chapter A.I.A.

A resolution disapproving of the employment of manufacturers' engineers in designing structural steel and mechanical work, unless said engineers are employed on the same basis as independent engineers and paid for their services, has been adopted by the Oregon Chapter of the American Institute of Architects.

This chapter has also appointed a committee to meet with a committee of contractors for the purpose of discussing the recently organized association of builders, members of which are making a charge for figuring plans.

Building Associations Grow

Assets of the building and loan associations of the United States have passed the \$2,000,000,000 mark, H. F. Cellarius, of Cincinnati, secretary of the United States League of Local Building and Loan Associations announced at the twenty-eighth annual convention in Chicago.

Building and loan associations in the country total 7,788, his report showed, with a membership of 4,289,326, and assets of \$2,126,620,390. The gain during the last year was \$228,276,044, or 12 per cent.

Pennsylvania led in the increase recorded, with 110,748 new members, and \$45,797,507 addition to assets. New Jersey, Ohio and Massachusetts following in the order named.

In spite of the increase, the report says, there is a shortage of resources in most communities with the result that home building has been retarded.

World War Museum

Modern warfare as an art and a science is revealed to the most minute detail of a soldier's equipment in an exhibition at the National Museum that has just been completed in Washington. The object of the collection is "to perpetuate the part taken by the United States in the World War as a memorial and a supplement to the written history of the war. The exhibition will be of value for research work, it was pointed out, in that the military, naval and aerial activities of the Allies as well as those of the enemy will be shown. A phase of modern warfare disregarded in the past will be perpetuated in the

war posters and other "pictorial and printed matter" which carried the war into every household.

Camouflage and equipment invented during the course of the conflict to meet the impediments of trench warfare, poison gas and submarines, will form a part of the collection. A map corrected to November 11, 1918, with its accessories, as staff at Chaumont, France, and classified as a "combined order of battle used by General Pershing and his map" will form useful data for military men in their study of new rules to an old game. The war collections were gathered by special arrangement with the War and Navy Departments and their accuracy and completeness are attributed to the co-operation of Major-General Roberts, who assembled the collection of German war trophies; Colonel C. W. Weeks, Chief of the Historical Branch of the Army War College, and Captain J. J. Hittinger, of the Quartermaster Corps, who supervised installation of the gifts to the museum.

The Smoke Evil an Architectural Problem

The effect of smoke on the health, wealth and happiness of the people of Manchester, in England, has been a subject of inquiry in Manchester for eight years, and the injurious effects have been summarized in a recent report by the air pollution advisory board of the city council.

The report is no less applicable to cities everywhere that smoke is a nuisance, and is here quoted as a terse analysis of a common condition.

The introduction to the report states that "it would be difficult to cite any one cause so productive of loss, both moral, mental and material, as the smoke evil."

The report shows that not only is black smoke itself a waste, but it causes a further waste. "It levies what may be called a black smoke tax, and everybody living in Manchester pays it. It is levied on buildings, merchandise, gardens, furniture, curtains, on paint and wallpaper, on clothes, and last, but not least, on personal health, and even, we might say, on personal appearance."

It is estimated that the black smoke tax in Manchester is not less than £750,000 (\$3,750,000) a year. Architects have estimated, some that as much as

fifty per cent. and others that from fifteen to twenty per cent. would be saved on the upkeep and maintenance of buildings if the atmosphere were clean. Only house painters gain. Manchester is described as "the house painters' paradise."

Theatres Built Instead of Houses

Millions are being spent for new playhouses to insure New Yorkers ample amusement this winter, although flat builders cannot get loans for housing the masses of the metropolitan district.

This was revealed when a survey was made of the rush of theatre construction which disclosed that \$25,000,000 worth of new amusement houses were under way.

Many of the new playhouses are wiping out old flats and dwellings urgently needed for homes, social welfare investigators declare, and as a result the housing shortage is becoming more acute.

The theatre builders assert that the immense sums pouring into places of amusement are justified, as the new construction guarantees them a profitable return on the investment.

Although there are 500 running theatres in the greater city and 650 in the entire metropolitan district eight new theatres, costing more than \$12,000,000, are planned in the Long Acre-Times Square district, three in Greenwich Village, four large houses and a score of smaller theatres in the Bronx, three in Washington Heights and five in Brooklyn.

There now are 115 theatres operating in Brooklyn.

Gigantic Building Program Planned

Former Brigadier-General R. C. Marshall, Jr., since the Spanish-American War Chief of the Construction Division of the American Army and the man who had supervision over projects involving \$800,000,000 for the Government in the World War, is in Detroit, as general manager of the Associated General Contractors, for a conference with the heads of that organization on plans involving the expenditure of some \$4,000,000,000 during the ensuing year.

As Chief of the Construction Department of the American Armies, General Marshall was responsible for all building construction.

At a meeting of the national officials of the Associated General Contractors at the D. A. C. Tuesday afternoon, Mr. Marshall, as guest of honor, outlined the big program before the association for the ensuing year and the prospects of increasing responsibilities for the years to come. He declared a national issue should be made of the construction business, and a campaign instituted with both great political parties for its recognition.

The Federal Waterpower Bill

Doubtless, states *Improvement Bulletin*, the next few years will witness enormous strides in the development of the water power of the United States. This is made possible by the Federal Waterpower bill recently enacted into a law. There are commercially developable in the navigable streams of the United States from 20,000,000 to 30,000,000 horsepower of water power which has been heretofore wasting and the use of which would have saved the natural coal resources in the United States to the extent of one-half their yearly consumption.

Therefore it is that the restriction of the use of natural coal resources means conservation because it saves for the future that which has been unused, but in the case of water power resources it is different. Moreover, the non-use of water power resources is doubly and triply antagonistic to conservation, viewing conservation in its proper sense as meaning a prevention of waste. Development of a water power means saving from waste the energy which may be developed by such water power. Also, it means a diminution of the using up of coal resources. Therefore, such saving from waste is a double saving.

Playground Built in Tiers

The first municipal playground of Czecho-Slovakia, in Prague, occupies a high hill which is terraced off, supplying space at the top for tennis courts and ball grounds on a lower terrace, a pavilion, band stand and open-air theatre, on a still lower tier a running track and further down the children's grounds, with sand pile, wading pool and swings. In this latter section there are pavilions where the mothers can sit and rest or sew as they watch their children. This first playground for children is a co-operative effort of the Czech government and the American Y. M. C. A. and Y. W. C. A. which will eventually be entirely under government management. At present the city has supplied the place, the Y. M. C. A. is paying for the equipment and the Y. W. C. A. has given the leadership. Charts for smaller play places for other parts of the city are being prepared.

Rent Increases in the Fall

"The people are becoming educated to the fact that they must pay more rent," says the Chicago Daily News. "It is impossible to set an absolute and arbitrary per cent. that holders of October leases can expect to pay," this paper quotes A. W. Stanmeyer, president of the Cook County Real Estate Board. "I should say, however, that if a

man received no increase in rent in October, 1919, he would have no justifiable protest if he received a 40 per cent. increase this year. That is, if his apartment has been renting at its full value before. Much depends on the neighborhood in which the apartment is, and much on the landlord himself.

"I think the peak of prices has been reached and hope that this October will see the last of rent increases. Few complaints have reached us thus far, thanks to the campaign last spring educating the public to the reasons for increased rents."

"Fifty per cent. of the tenants who have received sixty day notices have already signed new leases," said Adolph Krammer, president of the Chicago Real Estate Board, "and the others are coming in every day. We don't get one complaint out of a hundred cases. And this despite the fact that there are fewer flats now than there were last spring."

Mr. Krammer said he could not set a per centage of increase that the tenant might expect to pay. Too many things had to be taken into consideration. Rents would remain high, he said, just as long as money was "tight" and there was an absence of building. As soon as new apartment buildings are erected, rents would start on the decline.

The Brotherhood of Art and Commerce

A Kansas City newspaper sees the Art Institute as a commercial proposition. "Simply from the business standpoint," it says, "the development of a fine art institute in this city, such as is now in prospect, is an important piece of news.

"A great art institute is not merely a school that will attract here hundreds and thousands of students. It is an organization that can and will be made to promote an interest in art throughout the city. As the school becomes more important it will attract more and more attention to the subject. It will increase the city's cultural advantages and will attract here the most desirable sort of population from the surrounding territory.

"Still, bearing in mind the business standpoint, which has to be emphasized in a case like this, the sort of families that will be drawn here will include people of means and taste. They will be an addition to the residence district in the sort of homes they will build.

"Purely as a commercial proposition there is no enterprise that should appeal more to business men as a dividend payer for the town than the Art Institute which is entering its new era of expansion and success."

Construction in England

The Government subsidy of 250 per house can be secured also for temporary wooden structures provided they cover not less than 70 square feet—it is reported by the U. S. Consul at London, England. Much English timber is being used for the housing schemes but they are not yet sufficiently advanced for heavy quantities to be required in construction.

It was stated in Parliament in the early summer by the Minister of Health that the number of disputes in the building trade had delayed construction of houses. Present rates of wages, he said, varied in different districts from the equivalent of 30 cents to 57 cents per hour—the corresponding range in 1914 being 14 to 23 cents per hour.

The general expectation is that a period of slow recovery will follow almost immediately on the present stagnation.

Housing Brevities

In the development of plans of the National Administrative Council of Uruguay for the construction of houses for laborers and government employes, the Architectural Board of the Ministry of Public Works is building houses in a suburb of Montevideo known as "La Teja." This project, on which \$206,000 will be spent is for experimental purposes.

The city building inspector announces that there is an increase in building permits for the first seven months of this year as compared with the same period of 1919 amounting to \$825,510. And that \$2,414,313 worth of building has been done this year as compared with the first seven months of 1919.

According to the report of the U. S. Forest Service, the building permits issued in 21 cities of various sizes, widely distributed over the country, show that, in values, housing construction formed 36 per cent. of all buildings in 1913, 21 per cent. in 1918 and 27 per cent. in 1919. The amount of housing construction in 1913 was exceeded in 1918 in only two of the 21 cities and in 1919 in only six, in spite of the "build-a-home" campaign. The falling off in house construction, continues the Forest Service report, generally appears to have been particularly marked since the latter part of 1919, when the greatest upward movement of lumber prices began.

The Philadelphia Housing Association has proposed to the constitutional revision commission an amendment to provide: when it is in the public interest the commonwealth or a municipality may take, improve and lease or sell land and the im-

THE AMERICAN ARCHITECT

provements thereon, subject to such limitations as the General Assembly may prescribe, and that the state may borrow and loan "for homestead purposes" an amount not in excess of \$25,000,000. This is the same amount it may borrow for forestry purposes. For highways it may borrow \$150,000,000, according to the revised constitution.

The New York Housing Corporation has secured options on land in the Laurel Hill section of Queens and proposes to build there some thousand six-family brick houses, to be rented at \$30 a month for each apartment, provided it can secure the cooperation of the Board of Estimate and the Legislature. The help it asks for is the relief of these dwellings from taxation for a term of six years.

That is in line with the plans of Senator Lockwood, who wants all building mortgages exempted from the State income tax and who has argued for a like exemption of small building investments from the Federal income tax. It is, however, suggested by the Brooklyn *Eagle* that landlords who pay heavy taxes and have advances in their rentals limited by law would not exactly welcome competition with new apartments which pay no taxes at all.

A Correction

Owing to a typographical error, the chapel at Nahant, Mass., illustrated in our issue of August 18, was incorrectly attributed to Ralph Adams Craw. As our readers have undoubtedly inferred, this chapel was designed by Mr. Ralph Adams Cram, of Boston.

Personals

David J. Varon, consulting architect, has moved his offices from 309 Broadway to 108 East 31st street, New York.

Morris & Erskine, architects, are now to be found at their new office location, 1716 Cherry street, Philadelphia, Pa

C. H. Crosby has opened offices in Halifax, P. O. Box 923, for architectural practice. Catalogues and samples desired, particularly those with reference to reinforcing and fireproofing materials.

C. Howard Crane, Elmer George Kiehler, and Cyril E. Schley have opened an office at 127 N. Dearborn St., Chicago, in charge of H. Kenneth Frangheim.

George Meisner, architect, of New London, Connecticut, has moved his office from 56 State street to 19 Grand street of that city.

News From Various Sources

The Ohio Seamless Tube Co. of Shelby, Ohio, has increased its capital stock by \$12,000,000 to provide funds for further extension.

* * *

The Ford Roofing Products Co. has moved its offices from St. Louis to Chicago and will probably, within a year, build a million dollar plant in that city, but is waiting for building conditions to improve.

* * *

Brigadier-General R. C. Marshall, Jr., formerly Chief of the Construction Division of the Army, has been appointed general manager of the Associated General Contractors.

* * *

Bayonne, New Jersey, has passed an ordinance providing a building code for that city.

* * *

Elihu Root, former American Secretary of State, has formally presented to the British people the St. Gaudens statue of Lincoln, in Canning Square, as a gift from America, and the statue has been unveiled. Premier Lloyd George abandoned pressing official business to deliver the speech of acceptance.

The presentation was made in the presence of a distinguished audience in the central hall of Westminster, with Viscount Bryce, former British Ambassador to the United States, presiding. The event was widely heralded in the British press as further cementing Anglo-American friendship.

* * *

A City Planning Commission of 51 men and women has been created by the City Council of Los Angeles.

* * *

Schonborn Palace, Prague, with its grounds, has been purchased for the American Legation. The price paid is said to have been \$50,000.

* * *

The Lighthouse Commission is willing to cooperate with the movement to continue the old Barnegat Light, providing funds can be found to build jetties on the west side where the current is eating into the foundation.

* * *

A memorial fountain and gateway has been designed for the University of Texas by Pompeo Coppini of Chicago.

* * *

It leaks out of the Tax Department of New York City that assessments on real estate will be increased by approximately two billion dollars.

Weekly Review of the Construction Field

With Reports of Special Correspondents in Prominent Regional Centers

From all sections of the country come reports of building stagnation as indicated by the building permits. In Dubuque the drop is 82 per cent as compared with the same period of last year. In Roanoke, Va., it is 60 per cent., though somewhat better showing than of the previous twelve month. In Indianapolis the drop is 30 per cent.

It should be borne in mind, however, that July of last year was the month which showed the greatest impetus of building while in 1920 the program started early in the spring; since May the permits have been falling of the necessity to catch up in the production of finished buildings.

The difficulty of securing materials is also general throughout the country. It is a situation brought about not only by the demand but also by the difficulties of transportation, and it is a hardship not only for the builders but for the manufacturers whose plants are being choked with finished product, and in many cases compelled to close; and this latter phase of the situation eats into the future supply.

There is now becoming evident a shift of sentiment.

A shift of sentiment in favor of building material tonnage on the part of the railroad executives is significant and encouraging.

The prices of building materials, in spite of this apparent slackening in building projects, are holding firm and in many cases are moving up. Cement in New York (yard base) is \$5.10, and the lately issued advances in price of coal to cement manufacturers will move it still higher. The increase in expense of fuel for manufacture falls upon almost every other item, and eventually must be felt.

So far as supply is concerned there is hardly an item that is easy to procure.

The hearings of the Senate Committee on Production and Reconstruction which opened in New York were confined during the first week to the discussion of financial expedients. Walter Stabler, comptroller of the Metropolitan Life Insurance Co., said in reply to Senator Calder's statement that Congress was adverse to tax exemptions, that the seriousness of the housing situation demanded such a remedy. Frank Mann, Tenement Commissioner of New York, urged exemption of mortgages from the income tax, financial aid to builders by the State and the use of the city's sinking fund for the construction of houses. He said that \$60,000,000 would be required in New York for the construction of sufficient apartments to alleviate the shortage. On the

day following, Otto Kahn, while objecting in theory to the placing of government moneys to such a use, agreed in theory with its present necessity.

This committee on reconstruction has placed argument with the Interstate Commerce Commission against the application of the advance in railroad rates upon building materials. The statement was simple and compelling. At the present time, it reads, the rates on sand, brick and similar construction materials are comparatively high in consequence of the increase in rates allowed to the carriers during the war, at which time we are told the rates on building materials were advanced some 50 per cent. while other commodities sustained an advance of 25 per cent. Indeed these rates established during the war were part of a system of embargoing the movement of materials not necessary for the prosecution of the war. If the rates upon basic materials are now further increased by 40 per cent. or to any very material degree, the transportation charges will inevitably seriously limit the movement of building materials and the amount of construction work which can be carried and covered by rentals sufficiently low to meet the housing problems.

One of the primary causes of the special session of the New York State Legislature is to act "in the matter of housing facilities for our people."

The opinion seems to be quite general that the reason for the hesitancy of money is that investors believe by waiting to realize some saving in building costs. And it is also said that the public's activities against "profiteering landlords" which were not always discriminating have made investments in housing less attractive. Every owner who has seen the courts knows his situation. He is faced by a woman with an inevitable baby which cries. The case is clear—the landlord is a brute. He had better have stayed away.

In these circumstances money will not naturally flow into the construction for housing and State funds is the obvious alternative.

(By Special Correspondence to *The American Architect.*)

Chicago: The situation in the building construction field in Chicago grows more discouraging because of continual delays in obtaining materials. Jurisdictional strikes are reported on the increase rather than decrease. Everybody is looking forward to the time when a favorable outlook may be reported in construction, but it is not yet here.

THE AMERICAN ARCHITECT

Of course, the financial situation has something to do with it. The banks are not advancing funds as in the past, as everyone knows. It is also generally known that the transportation situation is not normal yet. But aside from these two factors, there is a general feeling of uneasiness and nervousness reflected from events in Europe. That is psychological but everybody remembers that the world war broke out over night and the league of nations is not a reality yet.

Spending continues in the West. Retrenchments have not been along the lines as in the Eastern cities. Luxuries are still being indulged in. There is still, however, an active demand for residences and in the commercial field substantial concerns are finding it desirable to own the property they occupy. It has been a good many weeks since there have been so many transactions showing the purchase by firms of the property they occupy or of new sites for occupancy.

The real pinch in Chicago just now, however, is the continued shortage of homes and the steady increases in rents. The rent problem is far from being solved.

The money market in Chicago changes little. Ordinary loans are from $7\frac{1}{2}$ to 8 per cent.

Reports in the city on building operations here in July show a big slump, attributable to the high cost of materials and labor. Only 253 building permits, involving a cost of \$6,669,000, were issued in July, compared with 606 permits, involving \$7,714,000 for July, 1919. This is the low record for July for the last ten years as to the number of permits issued and the third lowest in capital involved. Permits issued this year since January show a decrease of 1,562, as compared with the first seven months of last year. The value of buildings proposed this year is placed at \$56,925,000.

(By *Special Correspondence to The American Architect.*)

Seattle: With prices remaining firm in most building products, supplies in many instances are becoming shorter. Considerable repair work is progressing throughout the district and this activity is moving many materials. It is the general consensus of opinion that the volume of building, while not increasing, is holding up in good shape. There is a considerable activity in residence construction.

Roofing and cement prices are firm and jobbers report that the demand for these materials has dropped off 30 per cent. There is no hard wall plaster obtainable here, a condition attributed to the car situation and labor conditions in Nevada, Montana and Utah. This is directly affecting many small structures and particularly out of town and Alaskan trade. Jobbers are making every effort to supply Alaska with plaster owing to the intermittent boat schedules.

Paint dealers declare that paint prices will remain about the same for the next six months, although turpentine has decreased 15 cents a gallon and linseed about 5 cents a gallon.

Bar steel is being received here in reasonable shipments, which average between sixty and ninety days. Conditions in sheet steel are different, as factories are giving no guarantee as to shipments. Orders are being filled as quickly as possible by factories, but allotments of this material have been toned down. Nails are also slow in shipment and arrivals are placed by jobbers at 40 per cent. of normal. Two and three kegs of a size are being handed out on orders in an attempt to keep buyers supplied.

New freight rates have had a tendency to increase the demand in many lines.

Another problem here is the supply of pipe and it is almost impossible to get this material owing to the government order reserving gondola cars for coal shipments. This order has resulted in some of the mills closing down and jobbers say the future outlook is "very uncertain." The price is firm, however, but an increase in quotations is feared if this condition continues for any length of time. Plumbing materials are also scarce.

July real estate transfers aggregated \$1,015,620, which is a decrease of about \$500,000 under July, 1919. Realty transfers for the first seven months of 1920 totaling \$14,405,213—show an increase over the first seven months of 1919 which aggregated \$12,025,758. Building permits for the first seven months of this year were \$8,788,935, as compared with \$12,025,758 for the same period of time in 1919.

Lumber prices show no change over the previous week, although the mills report a very firm market with prospects of slight price increases in the near future if inquiries for lumber stock materialize into orders.

268^u

frontispiece to Ho 2332 .



CATHEDRAL OF ST. VITUS, HRADCANY

THE AMERICAN ARCHITECT

VOL. CXVIII

WEDNESDAY, SEPTEMBER 1, 1920

NUMBER 2332



A ROOM IN THE PALACE

Prague: The Palace-Fortress of Hradcany

By SELWYN BRINTON, M. A.

(All Rights Reserved)

THE glory of old Prague, that which gives its individual charm to the old capital of Bohemia, is the old time Royal Castle, the Palace-Fortress of Hradcany, which, like the Alhambra at Granada, dominates the city, and goes back to its earliest days. It is true that Prague possesses many other palaces, churches and towers of interest—such as those grand towers which guard at either end the great bridge of Charles IV, covered like the Ponte Sant'Angelo at Rome, with groups at intervals of Baroque sculp-

ture, such as the Powder Tower, or Gate, the last survivor of the eight great gates to the city—such as the old Town Hall with its Gothic entrance, or the neighboring Tyn Church, with noble Gothic doorway, which became till 1621 the church of the Utraquists.

But from all other parts of the city our eyes wander back to this grand old castle, the Kremlin of Prague, with which, I think appropriately, I commence my account of the architecture of old Prague. For here was the seat of the Premysl and later

THE AMERICAN ARCHITECT

dynasties, and this Royal Castle still expresses the idea of the Bohemian State. Neglected during the later years of the Kaiser Francis-Joseph it is now being put thoroughly in order as the residence of the President of the new Republic. Some idea of the extent of this old palace may be given by the mere statement that it contains 711 apartments, several of which are vast halls, such as the gigantic Vladislav Hall, in which tournaments used to be held, and the still grander Spanish Hall, 48 meters long by 24 meters wide, a great state reception room, whose effect is superb.

Already in the nineteenth century the castle existed under Prince Boriskov and its fortifications were strengthened by Wenceslaus and Ottokard, but it was to the greatest ruler of Bohemia, Charles IV, that it owed its completion. Charles was the son of that romantic knight-errant monarch King John of Bohemia, who ended his career by a brave but useless charge against our English knights under the Black Prince at Crécy. Edward III of England honored the blind king's heroism, and appreciated the high qualities of his son, standing aside when this latter advanced his claim to be Emperor of the Romans; and the accession of Charles IV to the throne of Bohemia, as Count Lurzow points out, "marks the beginning of a new period in the history of the country."

It was in this monarch's reign that some of the finest monuments of mediæval architecture, which still remain at Prague came into existence. When Charles I arrived in Prague he had found the Royal Castle, the Hradcany, as he himself noted "deserted, ruined, almost levelled to the ground." He at once decided to rebuild the castle, fortifying it very strongly in the direction of Malá Strana, where the steep approach still shows evidence of his fortifications. To this great ruler was also due the magnificent bridge, still called by his name which I have mentioned, with its grand guarding towers at either end—though, of course, the statuary which adorns it belongs to a later epoch, that of the early eighteenth century. To form some idea of the extent of the Hradcany itself, I may mention that besides the vast palace the enclosure contained a cathedral, several churches, a monastery, besides the walls and great flanking tower set at the angles, which were at the same time both for tresses and prisons. I was told by the architect in charge of the restoration works, who kindly placed his services at my disposal, that there were 22 of these towers in the old time, of which 4 are still remaining: The prisons, into which their ill-fated occupants seem to have been introduced by a hole in the floor, are among the most frightful I have ever seen, not excepting those of the Castello Rosso at Ferrara and the Castel Sant'Angelo at Rome.

The oldest church upon Hradcany is that of St. George, which is Romanesque in style, and goes back to the tenth century. The cathedral, dedicated to St. Vitus, is Gothic, its foundations having been laid by King Charles IV in the middle of the fourteenth century. It is a noble structure, the lofty vaulting being especially fine, but has suffered terribly in those religious wars which were the bane of Bohemia, and one-half of the building practically ceased to exist. This is now being restored, the funds having been, as I understand, provided entirely by public subscription without aid from the Imperial Treasury. The work is now well advanced, and I was able to examine it in detail with the architect in charge, going on to the roof, from which a marvellous view of the city is obtained; when it is completed the temporary wall now existing in the center will be removed, and the full vista of this magnificent Gothic building will be unimpeded.

The existing interior in the principal nave is very rich in monuments notably in the shrine of St. John Nepomote with its silver figures of saints and angels weighing 3,700 pounds, which I shall return to when speaking later of the Baroque art of Prague; the tomb of Charles IV, with his wives and successors, and the famous chapel of St. Wenceslaus, divided from the main building by a heavy door, with a bronze lion's head which tradition relates that the saint took hold of when he was being martyred in the year 935. Incidentally, I may remark that it was a satisfaction to come back to saints one had long known by name, such as St. Vitus—whose method of martyrdom brought his name into modern medical science, as I believe—and St. Wenceslaus, whom I had hitherto associated with a delightful Christmas carol. St. George, too, seems to have been cherished in Prague, for as I have mentioned the earliest surviving church on Hradcany is dedicated to him; and his mounted figure, triumphant over the dragon, faces the entrance of the palace, while his street leads with a slight gradient to the Loebkowitz Place, which forms part of the fortified hill adjacent to the Black Tower, and which I was permitted by the kindness of the Prince to visit, and to admire his fine tapestries and wonderful library.

When we had finished sight seeing it was delightful to go out on the ramparts, as I did with the courteous administrator of the castle, and see the old city stretching at our feet, with the blue-green cupola of St. Nicholas in the foreground. This church belongs to the Baroque city, which I reserve for a special notice; as the beautiful Casino of the Belvedere, built in 1539-60 for Ferdinand I by the Italians de Spatio and Paolo della Stella does to the preceding Renaissance, of which it is one of the

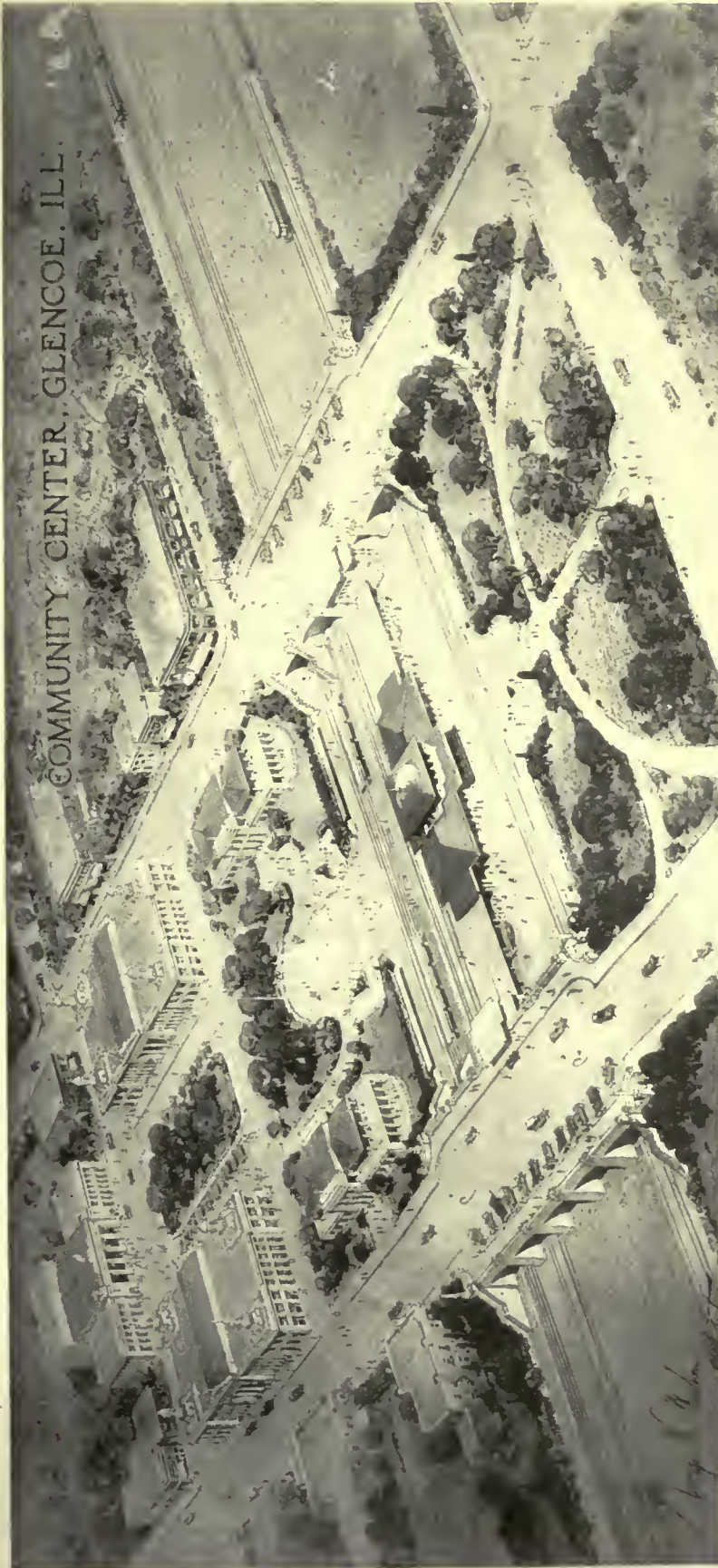

COMMUNITY CENTER, GLENCOE, ILL.

COMMUNITY CENTER, GLENCOE, ILLINOIS
GEORGE W. MAHER, ARCHITECT

purest specimens. But it is within Hradcany that the old historic life of Prague, with its racial problems and intense religious feuds, seems to center;

it is there that the old spirit comes near to us, and from this starting point I propose to approach the mediaeval city.

Community Center Developments

The North Shore Suburbs of Chicago

THE character of a suburban community is determined by three things: the lay of the land; the inhabitants, and transportation. After all it is transportation that locates the homes of the majority of the people who are so situated that they have the power of choice. Good transportation provides frequent, fast and comfortable service with conveniently located terminal facilities. The lay of the land should be such that good drainage, forestry, attractive vistas and other things that please are present. An absence of dismal, disease or pest breeding places is essential. Everything that enters into a suitable lay of the land is of nature's handiwork. To this the efforts of man add those things of beauty, adornment and convenience. The character of the inhabitants depends upon whether the community is devoted to business and manufacturing or is purely residential.

Chicago's North Shore is served by good transportation, as above defined. The Chicago and Northwestern Railroad and the Chicago, North Shore and Milwaukee Road (electric) meet every requirement of through and local service. From Winnetka north the land lies at a considerable elevation above Lake Michigan, with bluffs along the shore. Inland about two miles or more is the Skokie Valley, and about six miles from the lake is the Des Plaines River Valley. Large tracts of land in these two valleys have been and will be acquired by the Cook County Forest Reserve Commission. These tracts will be dedicated to the public use for park purposes. Every natural advantage that makes a healthy community is present.

Evanston has well developed business with no manufacturing interests. Between that city and North Chicago there is no manufacturing. North Chicago is purely a manufacturing city; Waukegan is both a manufacturing and residential city. The twenty-one miles from Evanston to North Chicago are devoted entirely to residential purposes. Some of the suburban towns in this district have taken steps to control the growth of the small business centers which such communities require. Of these,

the proposed developments of Winnetka and Glencoe are illustrated.

Winnetka is 17 miles north of the center of Chicago, has a lake frontage of $2\frac{1}{2}$ miles, 2,300 acres within its corporate limits and a population of 6,000. For the Winnetka Plan Commission Edward H. Burnett and William E. Parsons, of Chicago, developed plans for the preservation of this suburban community from unrestricted development. The combined transportation service, steam and electric, consists of 382 trains per day, with eleven grade crossings.

The noise and danger can only be eliminated by grade separation and this may be accomplished by elevation or depression. The latter is favored, as it better accomplishes the desired result, while elevation would form a dividing wall throughout the length of the town. Not only does track depression greatly reduce the noise, but it offers, where sufficient ground is available, an opportunity for sloping banks, which may be made very attractive.

The passenger station is really the heart of such suburban communities. Through it flows the current of the human tide and its surroundings should be indicative of the character of the inhabitants. It should have an attractive setting to arrive at and depart from. Recognizing this fact, the plan calls for a station spanning the depressed tracks, surrounded by adequate open spaces and roadways.

WINNETKA has quite a large business section adjoining the station which has no particular architectural merit. It is proposed to provide a Village Hall immediately west of the station, facing a small triangular track. This hall is located in the center of a business block and immediately back of it is located a field through the center of the block. The rear of the adjacent store buildings will be screened by walls, trees and trellis work. The central feature of the proposed community center is to be located in the block immediately contiguous to and part of the business section. The

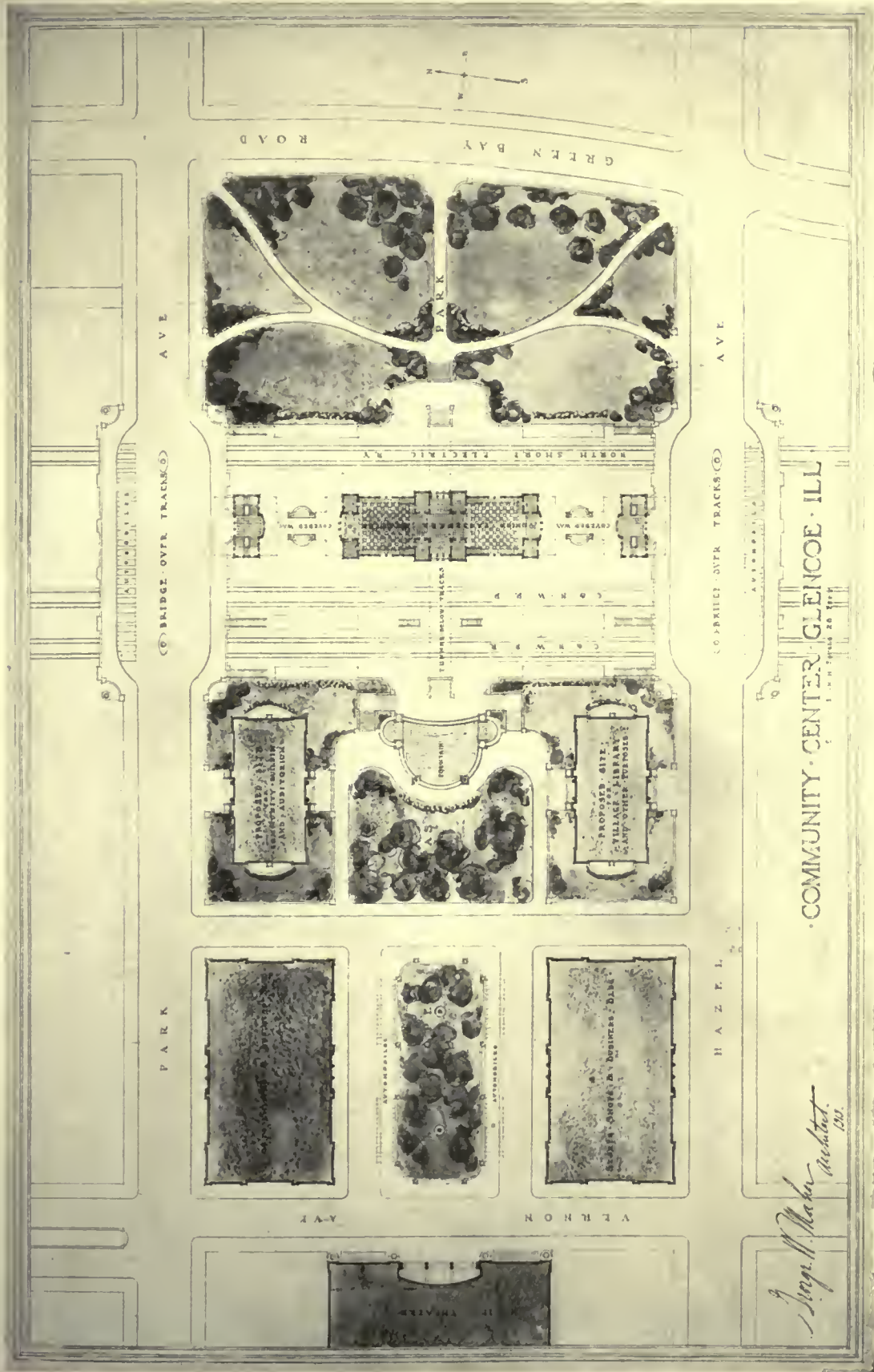

Architect
 1291
 1911

THE AMERICAN ARCHITECT

center portion of a business block containing small store buildings is invariably an unattractive place. The improvement of such spaces in the manner here suggested will transform them and probably to the financial advantage of the adjoining property. It presents a most interesting problem for the consideration of those who plan community developments.

The main road to the Lake County and Wisconsin resorts is Sheridan Road, which passes through this district. A recent count showed that 6,000 automobiles passed through one of Winnetka's residence streets in one day. This, of course, constitutes an intolerable nuisance. In order to relieve these North Shore towns from this nuisance it is proposed to construct new roads as indicated on the diagram of highways. These will originate in the northwestern part of Chicago and connect with the Sheridan Road at Wilmette. By cut-offs as indicated, the through automobile traffic will be diverted to the Telegraph and Milwaukee roads, which pass through farming communities. These highways, for the most part, exist, and with improvements, cut-offs and needed links, can be made to relieve the existing conditions.

The acquisition of grounds for parks is a part of the plan as well as the development of the waterfront by providing a harbor, lagoons and beaches. A zoning plan has been prepared and will undoubtedly be adopted as authorized by the zoning law recently enacted by the Illinois legislature. The plan segregates residence and business sections, and factories are to be excluded. Special areas adjacent to the railroad are to be devoted to the storage of coal, food supplies and building materials. Laundries, garages and greenhouses will be provided for in special areas. Residential areas will be divided into several classes; one for group house; one for single family houses, including large areas at considerable distances from the railroad station, where subdivision into small lots would be discouraged and if possible prevented. A minimum of 50 feet for each lot is proposed.

Study was also given to the subordinate stations at Indian Hill and Hubbard Woods.

GEORGE W. MAHER has prepared a plan for a community center for the village of Glencoe, which is located between Winnetka and Highland Park. In this case the railroad situation is the same, and it is proposed to depress the tracks with a joint passenger station at the track level. Broad bridges will span the tracks, with space for parking automobiles. Enclosed stairways lead from the bridges to the track level. Access to the tracks is also had through tunnels from the parks at either side of the station.

On the east side of the station, between it and Green Bay Road, a park will slope down to the track level. This park will have walks only. There will be no business buildings whatever east of the railroad. But few business buildings now exist west of the railroad and these are easily recognized in the perspective.

In making this plan, Mr. Maher was not handicapped, as in the case of Winnetka, by a considerable existing business community. He has set aside sites for stores and shops sufficient to serve the territory within the village limits. Provision is also made for community and amusement buildings. With rare skill, transportation, business, municipal government and amusements have been placed in juxtaposition with a complete harmony; over all a spell of beauty which makes it desirable and therefore valuable.

The foundations for these improvements are well under way. In 1912 the Glencoe Park District was organized, with five elected commissioners. Immediately after organization, the district began to acquire property either by purchase or donation. This was not always the procedure. The property on which the community center is to be located was acquired by the co-operation of the Chicago Title and Trust Company, by which it provided the cash for purchase. It took title in trust for the benefit of the Glencoe Library, the Park District and the village, and by the ingenious application of the statute the Glencoe Library was enabled to levy a five mill tax over a period of years for library purposes. Out of this the entire property will be paid for within a short period of time. One hundred and sixty-six public-spirited citizens signed a guarantee to the Trust Company to hold it harmless from loss by reason of the purchase of this property for the benefit of the people of Glencoe.

Property on both sides of the railroad throughout the limits of the village will be secured, a large portion of it is now in the ownership of the district. The district can then control the improvement of the property and prevent the incursion of business along the railroad, with its usual unsightly appendages.

It might be of interest to know that all of the Community Center property and a large proportion of the Park property in the village of Glencoe was bought originally without any money. When they needed a piece of property for public purposes, the fact that they had neither money nor bonding capacity did not deter them, but they would induce the owner to make a low price on the property and then get him to put a mortgage on it for the full purchase price and give a warranty deed of the equity to the Park District or Community Center, subject to the mortgage. Then, at their leisure, and when they were financially able, the public au-

THE AMERICAN ARCHITECT

WINNETKA PLAN COMMISSION *Winnetka Illinois* GENERAL PLAN OF DEVELOPMENT

E. H. BENNETT
Consulting Architect

LEGEND

- 64 FT. WIDE STREETS
- 20 FT. WIDE STREETS
- 10 FT. WIDE STREETS
- 10 FT. WIDE SIDEWALKS
- 10 FT. WIDE PARKS
- 10 FT. WIDE TRAILS

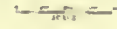

GENERAL PLAN OF DEVELOPMENT, WINNETKA, ILLINOIS
EDWARD H. BENNETT AND WILLIAM E. PARSONS, CONSULTING ARCHITECTS

WINNETKA PLAN COMMISSION
Winnetka Illinois

DIAGRAM OF NORTH SHORE
HIGHWAYS

E.H. BENNETT
Consulting Architect



LEGEND

- EXISTING HIGHWAYS
- - - PROPOSED HIGHWAYS
- GOLF CLUBS
- ▨ FOREST RESERVES
- RAILROADS



THE "NORTH SHORE" SUBURBS OF CHICAGO

THE AMERICAN ARCHITECT

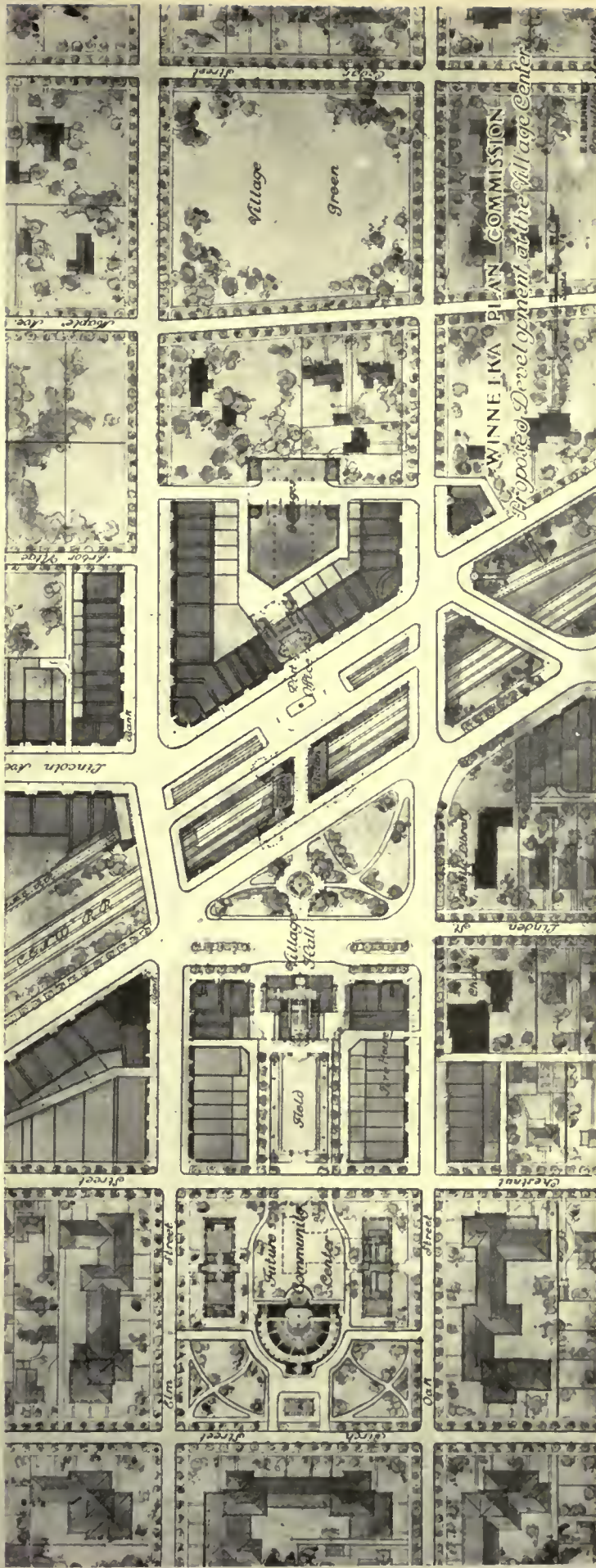

PROPOSED COMMUNITY CENTER, WINNETKA, ILLINOIS
 EDWARD H. BENNETT AND WILLIAM E. PARSONS, CONSULTING ARCHITECTS

*Proposed Village Center
Winnetka, Ill.*

E. H. Bennett, Architect.

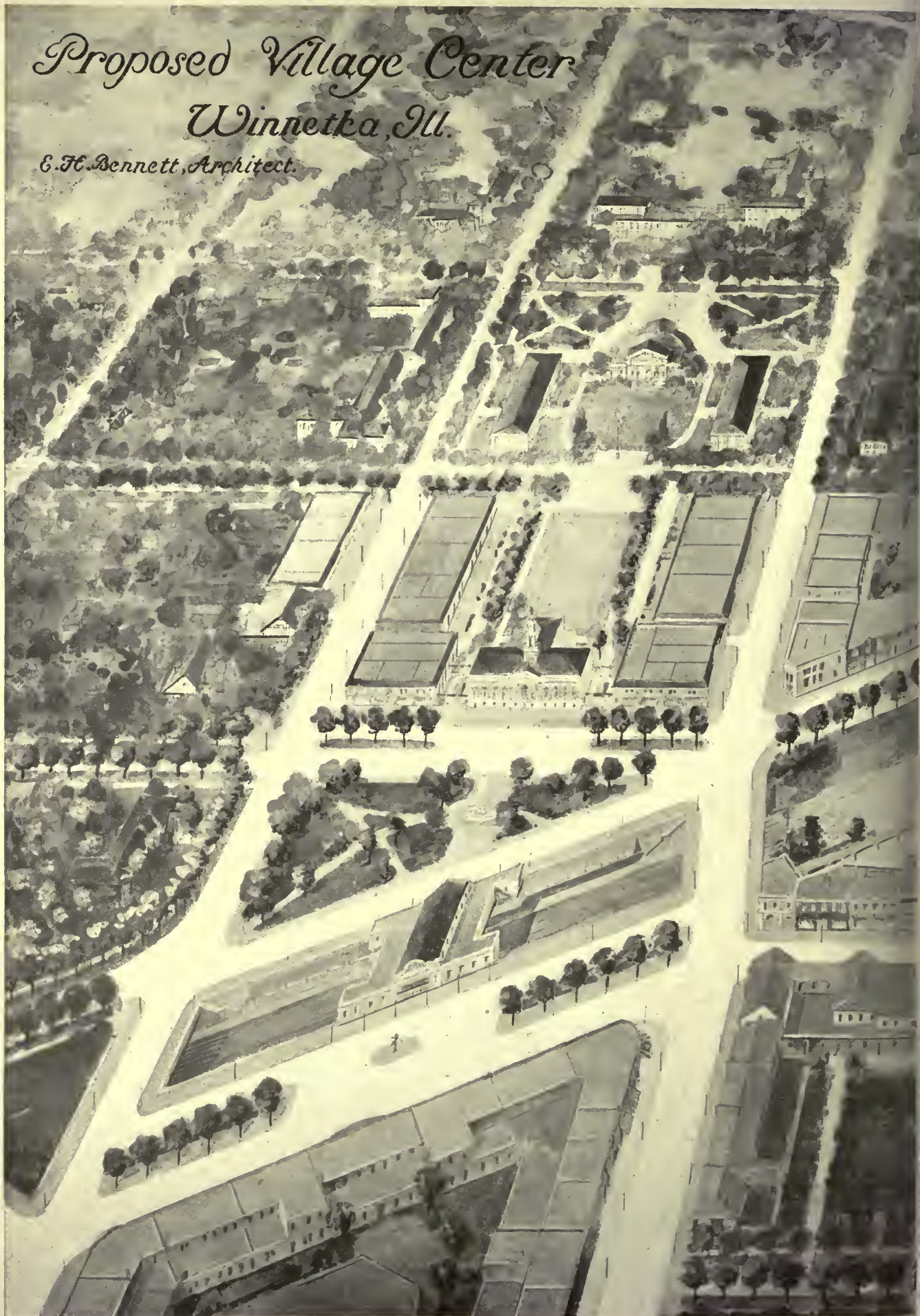

COMMUNITY CENTER, LOOKING WEST, WINNETKA, ILLINOIS
EDWARD H. BENNETT AND WILLIAM E. PARSONS, CONSULTING ARCHITECTS

THE AMERICAN ARCHITECT

thorities would pay off the mortgage, but in the meantime they had saved the property to the village and had procured the title before it was too late, and at a time when it could be obtained at ridiculously low figures. This has been the history of practically all property purchased for public purposes in Glencoe in the last eight years.

"It is a fallacy, indeed," states Mr. Maher, "to assume that man cannot create an attractive environment. The reason why our cities and towns have not generally been made more beautiful is because adequate thought has not been given to this import-

ant problem of orderly development, combining successfully nature, building, art and architecture." This is very true, but in the first instance the desire for the improvement must be engendered. This can be aided by demonstrating the ultimate probability by such legal procedure as in the case of the village of Glencoe. These things which are in the process of development along the North Shore are possible in almost any community. It is to be hoped that the interesting example of Winnetka and Glencoe will serve to stimulate such undertakings throughout the country.

Specification Clauses

By FRANCIS W. GRANT

DRAWINGS.

The extent and general scope of the work is shown on the contract drawings consisting of seventeen sheets numbered from 1 to 16 both inclusive. Larger scale drawings and full size details will be furnished from time to time as the nature of the work demands showing with greater exactness what is contemplated by the contract drawings.

All work must be executed in exact compliance with the contract drawings and with all drawings subsequently furnished in so far as these are consistent with the said contract drawings.

Figured dimensions shall be given preference to scaled dimensions and must be verified by the contractor who will be held responsible for error resulting from failure to so verify, provided, however, that no responsibility shall attach to the contractor for erroneous dimensions when these are such through error of judgment on the part of the architects.

Apparent error or discrepancy in any drawing must be promptly referred to the architects for correction and their decision obtained before the work affected is proceeded with.

WHAT shall constitute the "contract" drawings should always be plainly stated and the distinction between these and all other drawings thereafter faithfully observed. This is essential not only to ensure exact justice to the contractor but to protect the owner as well, for if there be ambiguity on this point the integrity of the whole contract is endangered.

The following quoted from specifications prepared by a well known firm of architects is an apt illustration of leaving the door wide open for trouble.

The drawings consist of a series of general drawings made at a scale of four feet to one inch, and the necessary detail drawings at a larger scale, or full size, these scales being plainly marked on each sheet.

Under such a clause bidders are asked to gamble on the unknown and will do so only when satisfied that the odds are in their favor with a considerable margin of safety.

The "contract drawings" are those only upon which the contract is founded and obviously to be such they must have been submitted to the contractor before he entered into the contract. A contract to build according to *certain* drawings would, in the absence of any evidence of the *certainly* be difficult if not impossible to enforce.

To prevent any doubt as to the exact identity of the contract drawings all references to them in invitation to bidders, bid blanks and correspondence should be in identical language and their permanent identification should be secured by the signatures of both parties to the contract affixed at the time the contract is negotiated.

Although a self-evident fact, the complaints of builders seem to justify the statement that an architect has no more right in law or equity to make detail drawings which impose obligations on the contractor exceeding, in the slightest degree, those agreed to and shown on the contract drawings than he has to pursue an opposite course at the expense of his client.

Mere carelessness on the part of draughtsmen accounts for some unlawful liberties taken in the preparation of detail drawings while in other instances these are only the cover for error in the contract drawings which the architect lacks courage to acknowledge by asking for a proposal from the contractor to cover the expense involved in rectifying.

Many times the explanation for the issuance of details not conforming with the contract drawings

THE AMERICAN ARCHITECT

lies in the honest but erroneous opinion of the architect that he should give the owner the benefit of such betterments in construction and design as the progressive workings of his mind may develop as the work proceeds. One architect of considerable note who evidently holds such views incorporates in his specifications this clause "details will be subject to minor modifications in the full size drawings." This architect apparently fails to appreciate that such "minor modifications" partake of the nature of contributions by one to the other of the contracting parties.

The practice of introducing betterments at the time details are being prepared with the expectation that the contractor will be a good fellow and make no extra charge therefore, has proved pernicious in that it encourages trading so as to secure a balance between the parties. A balance so secured will seldom stand a critical analysis for in the case of trading of this quiet nature, it may be taken as a moral certainly that the contractor will always secure advantage, for he is the only party with absolute information as to true money values, the contrary opinion of many architects notwithstanding.

All contractors do not possess a degree of familiarity with drawings and the conventions incident to architectural practice sufficient to render them competent to say what detail drawings are consistent with the true intent of the contract drawings. One of such the low bidder is pretty apt to be and the resulting controversy over alleged discrepancies in the drawings is only another item of the ills due to letting to the lowest bidders of all comers.

If, in the preparation of details, it be deemed desirable to depart from the contract drawings, even though such departure seems to involve no additional expense, it is recommended that the architect subject himself literally to the method provided in the specifications for effecting changes. A written proposal to make certain changes without cost to the owner followed by a written acceptance bars subsequent controversy and will prove very valuable at the time of final settlement.

Specifications very frequently overstep all reasonable bounds in fixing the degree of responsibility that the contractor shall assume for errors in the drawings. The clause here suggested is intended to attach responsibility to the contractor for error in dimensions of such character only as affect the general laying out of the work. Responsibility for the accuracy of dimensions involving the strength,

utility or appearance of the structure should remain absolutely with the architect who alone is reimbursed for bearing it. To show in detail the dimensions of all parts of a steel framing system and then require that the drawings shall be checked and if necessary redrawn on the basis of certain described stresses and clearances is not an uncommon practice of the profession. The architects employed by some departments of the Government shift their responsibility in this manner in all their structural drawings.

The drawings should be prepared with constant observance of what their true function is and if so prepared they will not be burdened with a profusion of notes, comments and descriptions, properly belonging in the specifications. A requirement that cannot be expressed graphically can generally be expressed with greater legal force and more appropriately in the specifications, and drawings free from such misplaced written matter will always be the better for it. On the other hand it should never be necessary to burden the specifications with bills of quantities or schedules of any kind. The dimensions of framing lumber, kinds of wood in the several rooms, quantity of radiation, capacity of light outlets, and all similar data should be obtainable from the drawings. To repeat information already given on the drawings by inclusion in the specifications is liable to result in contradiction and should never be attempted. In the case of drawings and specifications prepared by different persons omissions of serious consequence are liable to occur unless both are prepared with the understanding that neither shall attempt to repeat what the other undertakes to cover.

Ordinary justice to the client demands that the architect shall render drawings as complete as possible, reducing the necessity for shop drawings to the minimum. To this end he should endeavor to familiarize himself with modern practice and conventions of the builders of his locality or the metropolis influencing that locality and be governed by this in his work.

It is impracticable to pass a full size detail sheet along from one shop to another in the order that each completes the part of work in its line shown on the sheet and it is not good practice for the general contractor to cut up the details for distribution to the various crafts. The contractor must, however, adopt one of these methods or the more expensive one of making copies unless the architect shows regard for craft divisions and sequence of operations in the preparation of details.

Beaux-Arts Institute of Design

DIRECTOR OF THE INSTITUTE, LLOYD WARREN

ARCHITECTURE, WILLIAM F. LAMB
MURAL PAINTING, ERNEST C. PEIXOTTO

SCULPTURE, JOHN GREGORY
INTERIOR DECORATION, ERNEST F. TYLER

Official Notification of Awards— Judgment of March 16, 1920

PROGRAM.

CLASS "B"—III ANALYTIQUE.

The Committee on Architecture proposes as subject of this Competition:

"A MEMORIAL GATEWAY."

It is proposed to erect at one of the entrances to the grounds of a university, a gateway as a memorial to students who left their studies to take part in the war.

This gateway shall have piers at either side of the roadway, surmounted if desired by decorative forms. Adjoining these piers are flanking walls, pierced with openings for the footpaths bordering each side of the roadway. The space between the main piers and the openings to the footpaths may be closed with gates, if desired. One of the orders shall be used in the composition.

The width of the roadway including the footpaths shall not exceed 40 feet.

JURY OF AWARD:

W. F. Lamb, F. A. Godley, P. A. Cusachs, H. R. Sedgwick, L. Warren, A. E. Flanagan, W. Van Alen, A. L. Noel, E. V. Meeks, M. J. Schiavoni, J. O. Post, and E. Gugler.

NUMBER OF DRAWINGS SUBMITTED: Eighty-six.
AWARDS:

First Mention Placed: G. S. Beach, Atelier Parsons, Chicago Architectural Club, Chicago; A. L. Muller, 263 East 19th street, Brooklyn, N. Y.



F. J. LOGAN

PORTLAND ARCHTL. CLUB

FIRST MENTION PLACED

First Mention: G. B. Bengtson, Boston Archtl. Club, Boston; J. Truden, E. R. Coburn and J. P. Bennett, Atelier Corbett-Gugler, N. Y. C.; K. Sasagawa, Atelier Hiron, N. Y. C.; L. A. Palicki, John Huntington Poly. Institute, Cleveland; G. H. Brockow, Los Angeles Archtl. Club, Los Angeles; J. Schierhorn, Atelier Parsons-Chicago Archtl. Club, Chicago; R. R. Hibbs, University of Kansas, Lawrence; Doris Seibert and Rosalie Haas, University of Washington, Seattle.

MENTION:

H. R. Hall and W. C. McDermott, Boston Architectural Club, Boston; L. Mazurowski and C. H. Arras, Atelier Bradney, Buffalo; A. J. Bagley, P. Singer, A. R. Mohr and G. J. Hanniken, Atelier Corbett-Gugler, N. Y. C.; H. E. Rudy, C. J. Pellegrini, G. E. Tucker, F. H. Floyd, T. C. Tiffany, A. W. Chesterman and H. W. Anderson, Carnegie Institute of Technology, Pittsburgh; A. M. Taylor and

H. W. Gill, Columbia University, N. Y. C.; A. Wuchterl and S. A. Snyder, Atelier DeGelleke, Milwaukee; H. F. Hays, W. S. Robson and F. J. Brince, Atelier Hiron, N. Y. C.; J. E. Miller and E. C. Rising, John Huntington Poly. Institute, Cleveland; M. Sabransky and E. Brockow, Los Angeles Architectural Club, Los Angeles; C. E. Savage and L. E. McConville, Atelier Parsons-Chicago Architectural Club, Chicago; J. N. Maddocks and W. G. Hintz, Jr., Pennsylvania State College, State College; J. J. Welsh Swain Free School of Design, New Bedford; K. C. Albright, J. H. Geissel, W. C. Chance, J. A. Flether, H. T. Plumer, E. S. Young and E. A. Beihl, "T" Square Club, Philadelphia; W. B. Bridges and A. H. Miller, Thumb Tack Club, Detroit; Verner Carlson, W. F. Yungbauer and C. H. Hinman, University of Minnesota, Minneapolis; H. W. Watson and A. E. Evans, University of Kansas, Lawrence; G. M. Trout and K. B. Niven, University of Texas, Austin; E. G. Wendland, D. P. Thomas, A. A. Shay and M. W. Gill, University of Washington, Seattle; E. Penfield, Atelier Wynkoop, N. Y. C.

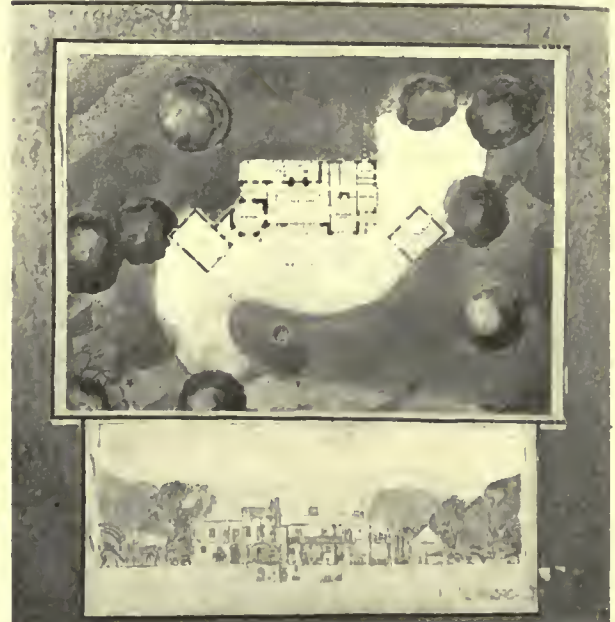

M. JAEGER, JR.

ATELIER HIRON

FIRST MENTION PLACED

CLASS "B"—III PROJET—A HUNTING LODGE



G. S. BEACH

FIRST MENTION PLACED

ATELIER PARSONS, CHICAGO ARCHTL. CLUB

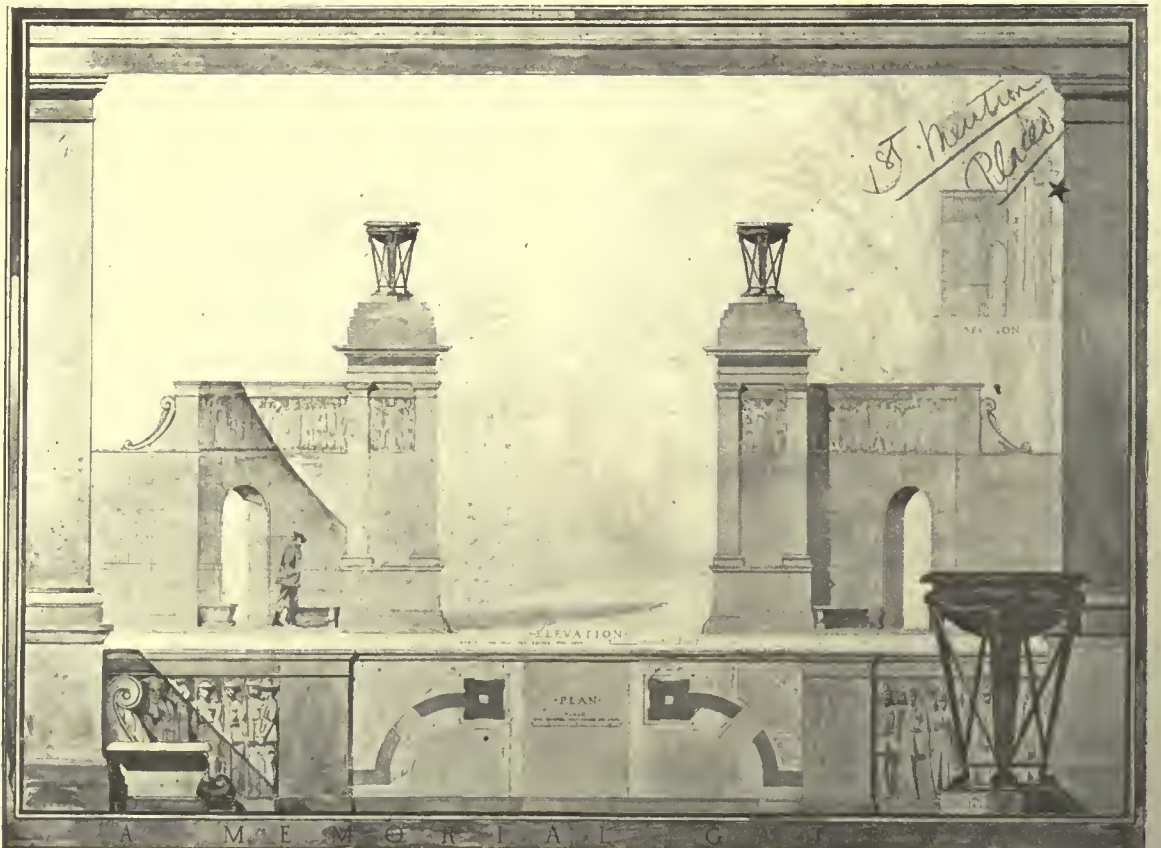

A. L. MULLER

FIRST MENTION PLACED

BROOKLYN, N. Y.

CLASS "B"—III ANALYTIQUE—A MEMORIAL GATEWAY

THE AMERICAN ARCHITECT

PROGRAM.

CLASS "B"—III PROJECT.

The Committee on Architecture proposes as subject of this Competition.

"A HUNTING LODGE."

A wealthy man desires to build a lodge on his private hunting preserve in the heart of the woods. He entertains a great deal and his guests, free from the conventions of

A great hall, a gun room, a small breakfast room, a kitchen, pantry, laundry and servants' hall, and a garage and stable for three or four cars or trucks and five or six horses. Six bed rooms with baths, a dormitory room for men guests, and six servants' bed rooms shall be provided on upper levels.

The entire plot occupied by the building or buildings shall not exceed 100 feet in any direction, and shall be considered as approximately level.

JURY OF AWARD:

R. M. Hood, B. W. Morris, F. C. Hiron, F. Hitchens, M. B. Stout, H. Davenport, O. C. Hering, C. Mackenzie, E. J. Kahn, J. Wynkoop, J. F. Harbeson and C. I. Berg.

NUMBER OF DRAWINGS SUBMITTED: One hundred and nine.

AWARDS:

First Mention Placed: L. E. Considine and F. O. Renison, Carnegie Institute of Technology, Pittsburgh; M. Jaeger, Jr., and N. P. Bevin, Atelier Hiron, N. Y. C.; O. L. Gowman, 611 West 156th Street, N. Y. C.; T. J. Logan, Portland Architectural Club, Portland, Ore.; H. R. Licht, "T" Square Club, Philadelphia.

First Mention: R. W. Schmetz, R. M. Crosby, P. F. Simpson and R. A. Fisher, Carnegie Institute of Technology, Pittsburgh; E. Olsen, R. DeGhetto and W. F. Boice, Atelier Hiron, N. Y. C.; A. Gambell, Portland Architectural Club, Portland, Ore.; A. H. Goddard, Atelier Wynkoop, N. Y. C.; A. C. Smith and L. Hamilton, Yale University School of Fine Arts, New Haven; L. F. Fuller, Los Angeles Architectural Club, Los Angeles.

Mention: R. C. Hollister, Boston Architectural Club, Boston; L. H. Rank, S. H. Jamison, E. A. Early, R. V. Murison, M. W. Pohlmeier, R. E. Dake, H. C. Brockmann, C. W. Hunt, C. L. DePfontaine, K. A. Snow and E. A. Lench, Carnegie Institute of Technology, Pittsburgh, A. K. E. Volmer, G. A. Hacker, R. H. Bickel, O. Betts, F. L. Hutchins, F. M. Libby, N. Thorsen, W. C. Yanike, H. J. R. Barrett, H. R. Kaplan and P. Simonsen, Columbia University, N. Y. C.; W. M. Dowling, Atelier Corbett-Gugler, N. Y. C.; W. A. Robinson, C. G. DeNeergaard, G. H. Gibson, W. H. Merrison and H. E. Maddox, Georgia School of Technology, Atlanta; J. Lucchesi and A. Liptak, Atelier Hiron, N. Y. C.; E. L. Babitsky, John Huntington Poly Institute, Cleveland; J. Hill, 76 Manhattan Avenue, N. Y. C.; A. G. Stanton, Portland Architectural Club, Portland, Ore.; J. W. Minick and F. S. Hobbes, Pennsylvania State College, State College; H. W. Anderson and J. B. Lindquist, Atelier Parsons-Chicago Architectural Club, Chicago; E. N. Damon, Atelier Schadler, Reno; T. R. Fahey and W. J. Rankin, "T" Square Club, Philadelphia; G. L. Dahl, Shu-Ming Lin and E. M. Loye, University of Minnesota, Minneapolis; Julia Carman, E. F. Biresak, S. W. Bihl, Jr., H. E. Machamer, G. L. Chandler and L. F. Soxman, University of Kansas, Lawrence; L. B. Wamnes, Atelier Wynkoop, N. Y. C.; D. W. Murphy and R. B. Thomas, Yale University School of Fine Arts, New Haven; L. Rombotis, Los Angeles Architectural Club, Los Angeles.

H. C.: C. A. Lake, T. G. Todd and A. A. Lewis, Carnegie Institute of Technology, Pittsburgh; G. W. Green, Atelier Corbett-Gugler, N. Y. C.; J. Y. Arnold, Georgia School of Technology, Atlanta; P. Goodman, Atelier Licht, N. Y. C.; D. K. Frohwerk and J. L. Fleming, University of Kansas, Lawrence.



T. J. LOGAN

PORTLAND ARCHTL. CLUB

FIRST MENTION PLACED

the city and without any formality of dress, tramp the woods and ride through the country, coming and going at all hours as they please. Only at dinner, or about a great log fire in the evening, do they all gather together to entertain one another and to relax after the fatigue of a long day in the open air.

So, though the lodge need not be luxurious, it should be commodious in its arrangements and suitable, in character for the simple and unaffected life of the woods. The following requirements are to be grouped into two or three detached units or in a single building, arranged about a closed or open court or courts.

Early Home of Colonel Van Vredenburg No. 7 State Street, New York

(See reproduction of the original drawing by O. R. Eggers in this issue)

THIS fine example of architecture in New York was erected about the year 1800. It was then considered one of the best mansions of that locality, fronting on Bowling Green. It stands today as it did then, an example of the quiet dignity of well considered design. And, while the rapid march of time has served entirely to change the character of the buildings which surround it, there are yet unspoiled those elements of architectural excellence that are so well accented by Mr. Eggers' pencil.

Today the house stands well back from the Battery wall, as between it and the bay lies the broad expanse of Battery Park, and to the westward, the Bowling Green. At the time of its erection, this house stood almost at the water's edge. Shackleton,

in the "Book of New York," relates: "When Colonel VanVredenburg, who had served in the Revolution, moved away in 1804, he loaded his furniture into a boat at his front door, and then he and his family started on their journey up the Hudson to a new home in the Mohawk Valley." This is interesting as showing the very radical changes of a century in the topography of lower Manhattan Island.

No record has been discovered as to the name of the architect.

At present the building is occupied by the Mission of Our Lady of the Rosary. This occupancy is perhaps the reason that has saved this building until today from a fate similar to other fine structures that at one time graced the neighborhood.

Issues Regulations for Theatre Buildings in Pennsylvania

SPECIFICATIONS to architects and builders regarding the construction, alteration or repairing of buildings in which public entertainments are given have been issued by the Commissioner of Labor and Industry, says the Philadelphia *Public Ledger*. It is provided that the location must be suitable and that no steps will be allowed at the entrance or exits other than one of eight inches rise. All other differences in levels must be overcome by means of inclines which cannot exceed one foot rise in ten feet. If side and rear courts are necessary, they must be not less than five feet wide in the clear and they must lead to a street or alley. All doors opening into the courts must be made to swing flush within the wall.

Exits cannot be less than five feet in width or more than six feet wide in the clear. They must have outswinging, double doors, equipped with approved panic locks. The colored illuminated "exit" sign must be placed at each door. All aisles having seats on both sides must be not less than four feet wide in the clear and wall aisles must be at least three feet, six inches wide. Cross aisles must be five feet wide. It is provided that there shall not be more than six seats between any one seat and an

aisle and not more than fourteen seats between any two aisles. Seats must be eighteen inches between the arms and thirty inches from back to back of rows. They must be fastened securely to the floor and the front rows cannot be closer than twelve feet to the screen, and the rear seats five feet from the foyer wall.

The specifications provide that picture booths be constructed to conform with the motion-picture act of 1919, and that wiring must be done in accordance with the electrical code and rules of the Underwriters' Association, while the stage must conform with the fire and panic act of 1909. Galleries must be constructed according to general requirements, and in buildings hereafter erected means of egress must be within the walls of the building. Plans for these buildings must be submitted in duplicate to the Department of Labor and Industry for approval.

Theatres seating fewer than 251 persons shall, in addition to these requirements, have two five-foot exits in front and two of the same size in the rear. Houses seating fewer than 501 and more than 250 shall have three five-foot exits in front and two six-foot exits in the rear. Theatres seating fewer than 1,001 and more than 500 shall have three five-foot exits in front and twenty inches additional for each 100 or fraction of 100 persons over 500, two six-foot exits in the rear and two five-foot exits, placed one on each side of the theatre.

254



HOUSE No. 7 STATE STREET, NEW YORK



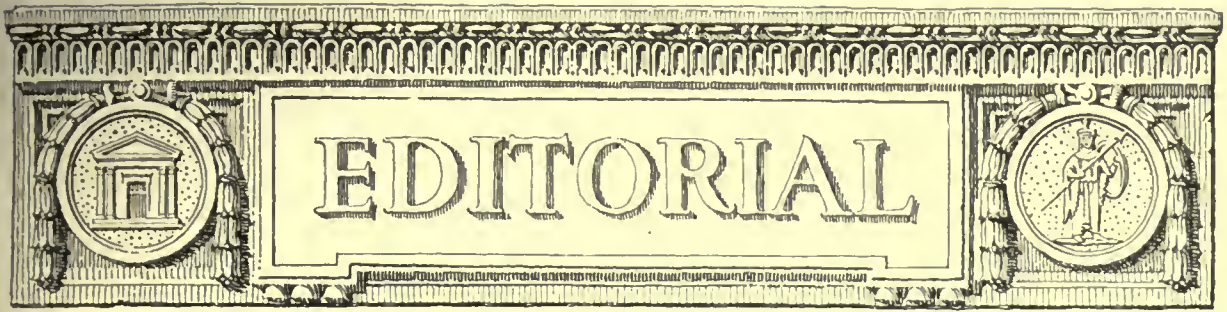

Education in the Fine Arts

PERHAPS the chief cause for our failure in this country more rapidly to approach a better appreciation of the fine arts is due to the tendency on the part of our colleges to instruct more largely in the liberal arts. A most excellent authority is George C. Nimmons, of Chicago. Speaking before the recent convention of the Institute, and with special reference to the report of the Institute Committee on Public Appreciation of the Fine Arts, Mr. Nimmons stated:

"Our college students" (meaning all colleges and not specifically colleges of architecture), "outside of a few of the leading large colleges, are turned out every year without one word of instruction or information on this great subject of the Fine Arts. The educated American is deficient in that great subject which European scholars give proper importance to and which we to our discredit have so much neglected."

The great trouble with our educational methods is that curricula are largely controlled by an impractical element which from year to year continues in a rut of repetition and does not or will not realize the necessity for meeting new and much changed conditions.

This journal has in and out of season urged that it was the duty of the men in practice to concern themselves more seriously with matters of educational methods. No one can better judge of the shortcomings of present methods than men in practice. To them, fresh from our architectural colleges go the students, with all the ideals and points of view their school training has given them. No better opportunity could be afforded to study just how well these students are equipped to start correctly and successfully continue their chosen profession.

This matter of education, whether in the fine arts or specifically as confined to architecture, is one that needs much revision. So much was practically conceded by every man who spoke on this topic when the report of the Committee on Education was at some length debated at Washington during the last Institute Convention. The report was a splendid

one. In fact it was along the lines of similar reports during past years that have been presented by the Committees on Education. But what of it? What do all the patient research, the careful study and the wise recommendations amount to without the machinery of the Institute behind them to give an impetus and practically to put in force the things that are so wisely set forth.

Nine-tenths of the troubles which the profession of architecture has experienced during recent years can be directly traced to faulty educational methods. As this appears to be generally conceded, as the attitude of the Institute is thoroughly in accord with the wise recommendations of their Committee on Education, why not take action and get something done.

No organizations of technically trained men have ever produced more valuable reports than those annually presented at conventions of the Institute. And of these, none are of greater merit than the reports of the various Committees on Education. Aside from the very practical value of the work done and the method endorsed, these reports have a literary value that makes them desirable to read as models of good style.

The Institute's attitude toward its reports and its failure to carry forward even a small proportion of their recommendations reminds one of the busy housewife who declared she had so much to do that she believed she would take a nap. More and more do these conditions indicate the necessity for the extension of the duties and the authority of the Executive Secretary. Under such a well conducted office as would naturally become evolved, the Institute could carry forward at least a part of the important tasks it sets itself when it adopts at its conventions these splendidly prepared reports.

The Housing Question

THE theorist is, as usual abroad in the land. In the quiet seclusion of many a "study" from which in the past so many unfulfilled prophecies have emanated, we are seriously told just how the shortage of houses may be remedied. A little matter of

conflict with the constitution does not deter these sapient ones from insisting on the wonderful cure-all features of their schemes.

Meanwhile practical men are disheartened and wonder what the cold days of this autumn will bring forth when a frenzied lot of people without house or home clamor for relief. The real trouble with the housing situation is practically created by the large amount of non-essential building now going forward. Every city in this country is contributing in that way to the present complication. Meanwhile the rent profiteer goes on his way, creating despair in the heart of the homeseeker.

Governor Lowden of Illinois sounded a timely word of warning when he recently told a committee of Chicago real estate men that if they did not take steps to relieve the present situation to stop the excessive advance in rents, real property might be impressed in Chicago as a public utility. Under our present constitution profiteering in rents cannot be legally curbed.

The landlords point to the published percentage of advance in all the various departments of merchandising and accent the fact that the average rate of advance is lower than on anything else. Percentages up to more than 200 are cited, and the fact that the percentage of rent advance is but about 65 per cent. is the basis of the arguments advanced by landlords that they should not be classed with profiteers.

Building interests since the very outset of the war have suffered more than perhaps any other. With an almost entire cessation during a period of two years, it was confidently hoped that with the signing of the armistice, an industry that is in this country second in volume only to agriculture might resume its former activities. Complications as to financing loans, labor strikes and now the very serious problems of transportation all combine to hamper the resumption of building except in certain directions.

And, unfortunately, these directions are not toward the greatest good for the greatest number. Housing, the vital part of building today, languishes, and it would seem that it will only be through some such action as Governor Lowden has suggested can we hope to find relief.

Where Does the Architect Function in this Case

WHO shall decide when trade unions disagree? Evidently not the masterbuilder, or the architect, as he is now called. If ever there was a case where the tail wagged the dog, it is to be found in a recent jurisdictional dispute carried on in Chicago between the plumbers and the bricklayers.

The plumbers arbitrarily announce that no member of their union will be permitted to work on any building where the entire drainage system from the building line is not laid with iron pipe.

The bricklayers virtuously declare that this action is but another of the schemes to increase the cost of building. They further state that from both a sanitary and economic standpoint tile pipe drains should be installed wherever the grade will permit.

So then, if neither union recedes from its present position, construction may very likely stop as one will not work if the other does. Meanwhile the architect will remain a very much interested but a quite unimportant onlooker.

Reminds one of the oft told story of "Father" Taylor, a well known pastor of Boston's celebrated Bethel Church. Accosting a sailor one Sunday morning, he urged him to come along with him to church. The sailor answered, "I'm damned if I will," to which Father Taylor replied, "You'll be damned if you don't."

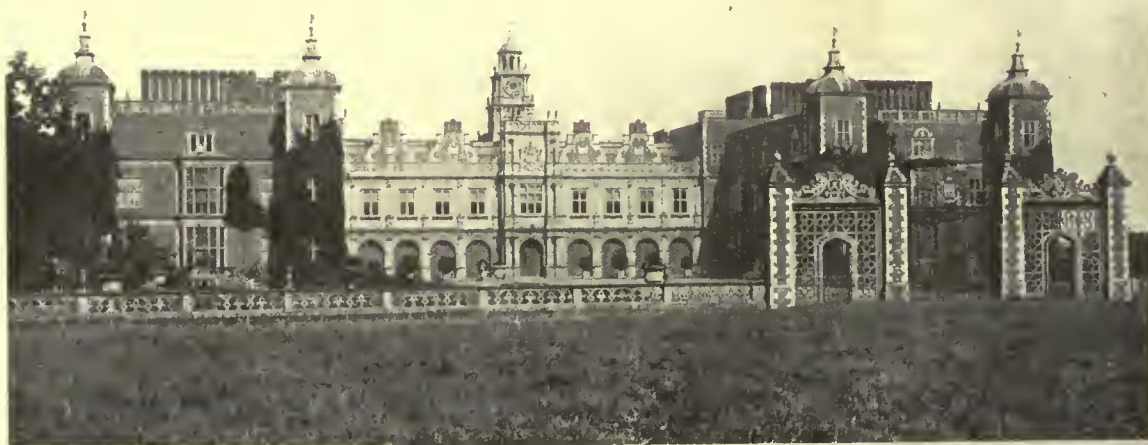

SOUTH FRONT, HALFIELD HOUSE, HERTS, ENGLAND

286



KIMBALL HALL BUILDING, CHICAGO, ILL.
GRAHAM, ANDERSON, PROBST & WHITE, ARCHITECTS

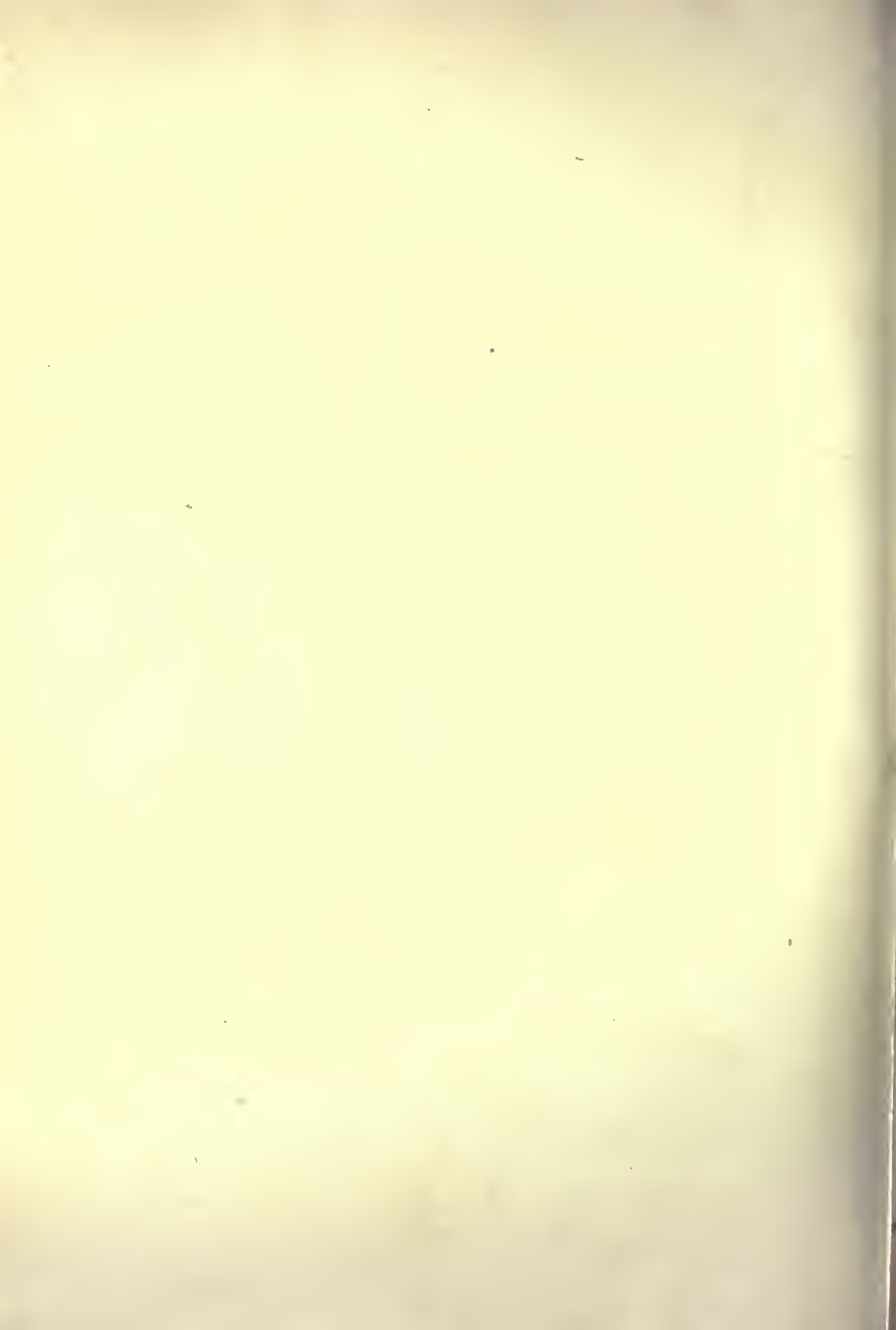

286 ✓

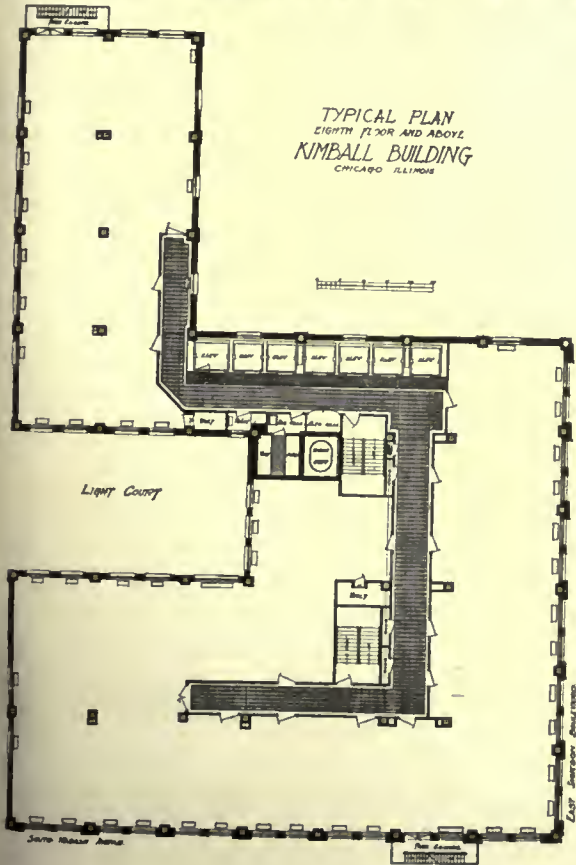
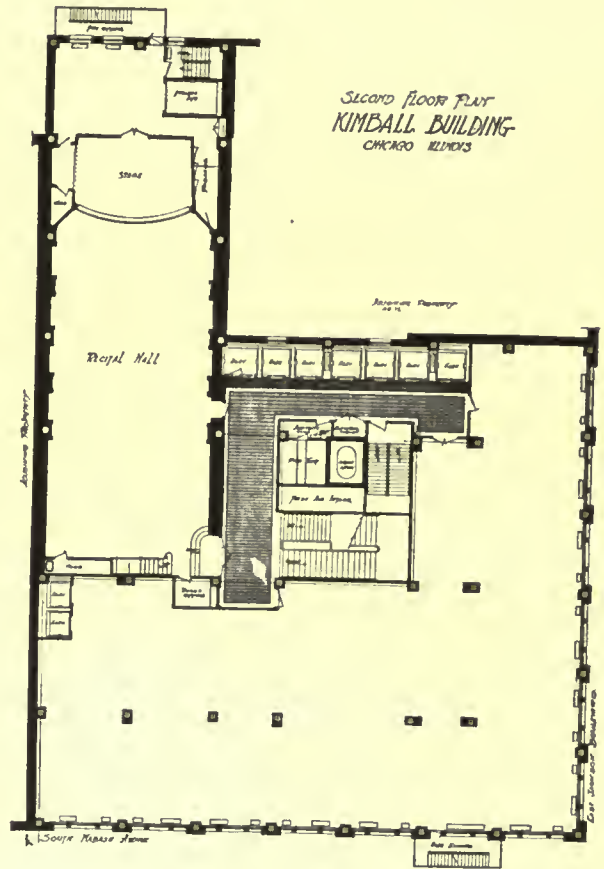
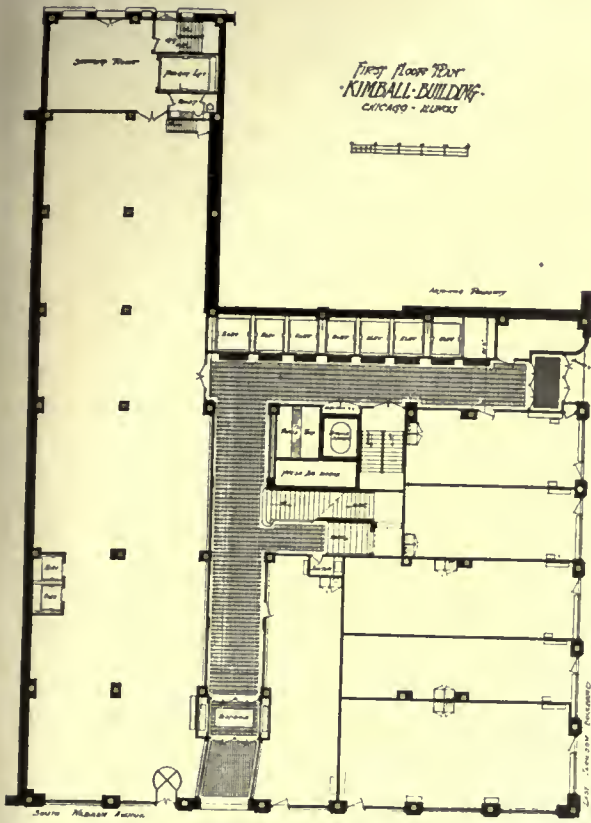

KIMBALL HALL BUILDING,
CHICAGO, ILL.

GRAHAM, ANDERSON, PROBST & WHITE, ARCHITECTS



286



DETAIL OF LOWER STORES
KIMBALL HALL BUILDING, CHICAGO, ILL.
GRAHAM, ANDERSON, PROBST & WHITE, ARCHITECTS





DETAIL IN LOBBY



MAIN STAIRWAYS

KIMEALL HALL BUILDING, CHICAGO, ILL.
GRAHAM, ANDERSON, PROBST & WHITE, ARCHITECTS

1-82-2



286 5



THE RECITAL HALL
KIMBALL HALL BUILDING, CHICAGO, ILL.
GRAHAM, ANDERSON, PROBST & WHITE, ARCHITECTS





GARAGE BUILDING, PORTLAND, OREGON
 SUTTON & WHITNEY, ARCHITECTS

This building is of heavy mill construction, 100 by 100 feet, and cost about \$50,000. The columns were cast in two operations, the structural column first and the outside fluted shell being cast afterward.

2866

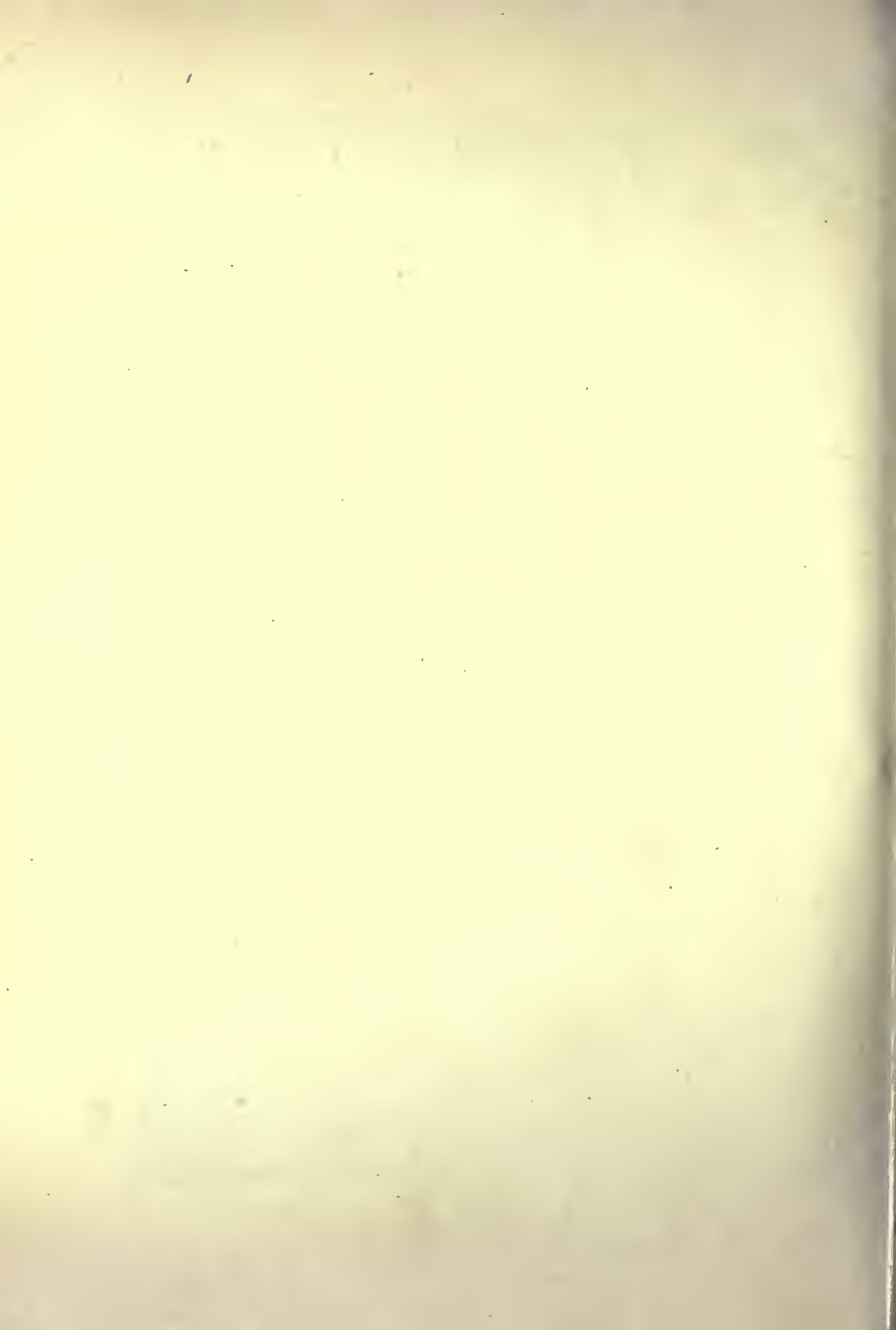

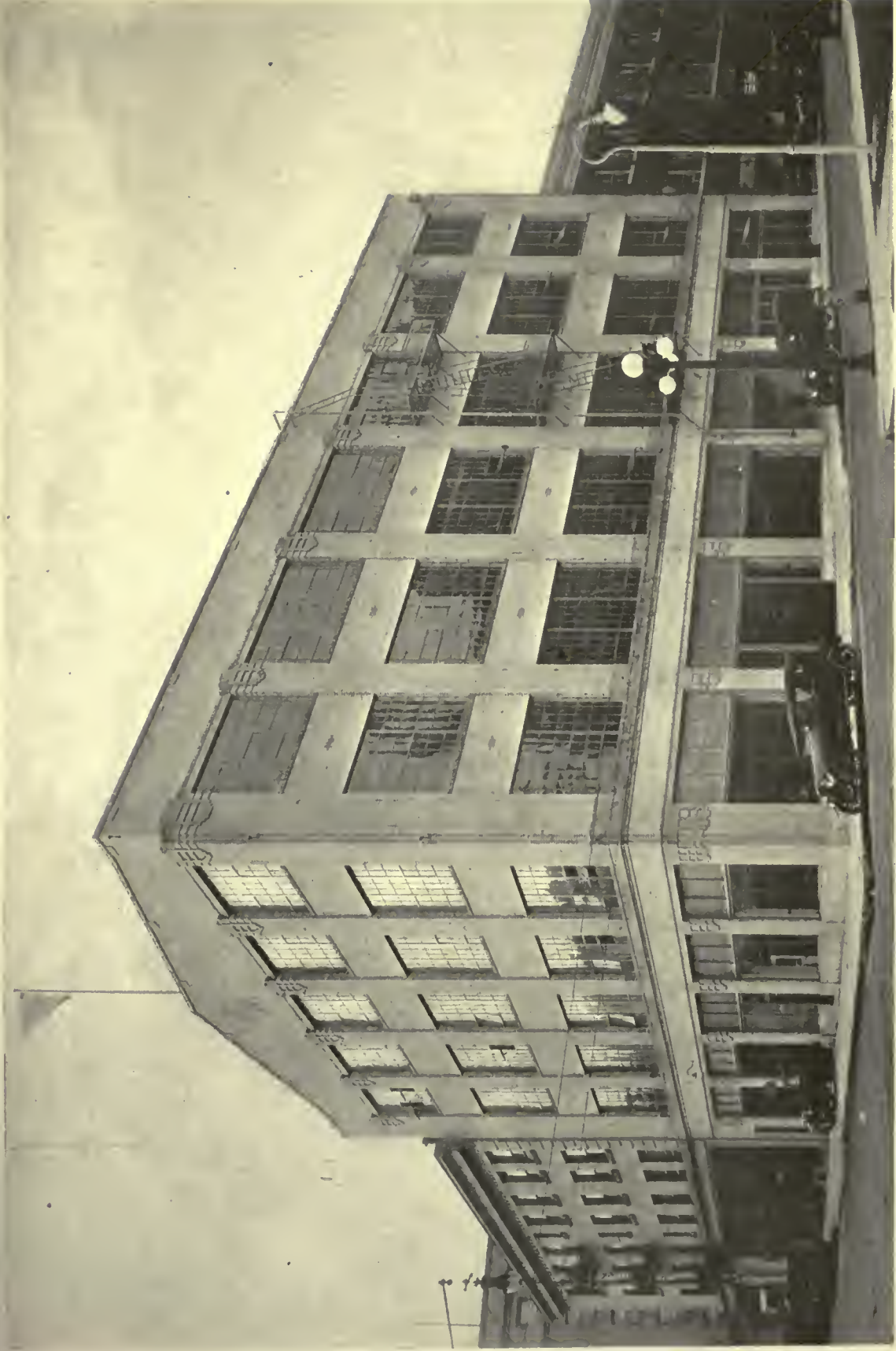

GARAGE BUILDING, PORTLAND, OREGON.
SUTTON & WHITNEY, ARCHITECTS

The building is 75 by 112 feet, and is of heavy mill construction with a floor finish of concrete.

2867



State Departments of Architecture

A Solution for a More Professional Type of Architectural Training

By E. T. HUDDLESTON

MUCH has been said and written about the shortcomings of the past and present day methods of architectural education, but as yet there seems to have been no decided action taken by any particular body of architects or group of educators in changing those methods as set forth in the existing curricula of the architectural schools. True, a few courses of study have been dropped or substitutions made that may have strengthened the course but as yet no concrete plan, to the writer's knowledge, has been accepted as meeting the criticism directed against the architectural schools.

Granted, that the present methods of education for young men who intend entering the profession as architects is wrong or deficient in principle or subject matter taught, whatever the real reason may be for the acknowledged failure to produce men qualified to carry on the work of the architect. Can there not be found among the whole profession one man or a group of men who can crystalize this elusive element and inject it by reason of his or their standing and with the backing of such a body as the A. I. A. into the consciousness of those who have the direction of architectural curricula in the schools of the country and bring order and assurance out of the uncertainty that now exists?

The writer offers a few suggestions he trusts will lead to a more thorough discussion of this subject by those individuals who are in time to lead us out of the wilderness, and after all is said and done, I believe we will find that a large part of our present uncertainty and difficulty with this problem has been due to a difference in point of view of the whole matter. Are we not visualizing the path of the aspiring student of architecture from the "finish" instead of traveling that path with him from the very start? And, after the student has finished the prescribed course and offered himself to the profession, is he not judged wholly from the level of the successful architect and not from that of the beginner who is equipped to take on responsibility and, with proper direction, assume more and more the duties of the architect as he grows in experience?

Assuming the student has finished his course in one of our colleges of architecture and, without having had much experience in an architect's office, he offers himself to the profession. What service can he render and, in so doing, how is he fitting himself for independent practice if that is his ambition? Has

that not been largely the state of affairs the architect has had to face in recruiting his office force and, in the failure of the novice to fit into any niche which the present-day office has open to him, is not that the reason for the cry of failure on the part of the educational institutions?

It may be the schools have fallen short in providing their students with the proper foundation on which to build a successful career. I feel that the greater mistake has been and is being made in the manner in which the students are received by the profession and their abilities put to use.

Let any successful architect think back to that point of time in his career comparable to that of the student leaving college and seeking his first job in an office and he will remember that the immediate future held for him a maze of diverging paths with very few sign boards to direct or assist him. Contrary to his expectations of an assured place in the profession as engendered by the spirit of his work and his associations in the school, he finds himself placed at the very bottom of the ladder and told in no uncertain terms that he is not a practical man and that he can be of no real value until he throws overboard all his theories and learns the duties of the office-boy and apprentice draftsman. In just about one week, such a beginner has had most of his ideals of a career destroyed and his outlook upon the profession is narrowed down to an eight-hour day of monotonous toil as a tracer alongside the apprentice draftsman with no college education who may be making full size details.

Your answer to this is right. The beginner should have worked in offices during summer vacations and been ready to assume greater and more responsible tasks when he had graduated from his college course. I believe here is where we shall find the right solution in giving our new men a better equipment to earn their places in the profession.

The schools are doing and will do their part to give all the academic work that the men need, but they cannot do it all. The architect must cooperate to the extent of recognizing the limitations of the schools and make places for the men in their offices during their preparatory years of study, treating them not as wage earners alone, but as students who are in time to carry on the work of the profession.

So I repeat, is it not a difference in point of view between the educators and the employers or archi-

THE AMERICAN ARCHITECT

jects that is causing the difficulty and not in what the schools are teaching? Are not the schools attempting to produce architects and, contrary to popular belief, are not the architects confining their consideration of the students' qualifications too closely to the field of drafting? And if that is at all true, can any one expect the student to develop himself with his academic training as his stock in trade by the process of absorption and what contact with those in the offices can do to give him his insight into the larger field of effort that the architect is supposed to control?

This same question has been discussed and is no doubt still under consideration by the Post-War Committee on Education but, unless I am very much misled, they have made no definite program other than a recommendation to the architectural schools to change or enlarge their courses that certain subject matter may be introduced into the curriculum which, if done, will not meet the situation or alter the standing of the student when he has completed the course and applied for admission to the profession.

The school, as a school alone, cannot give the student the training he requires to fit into the organization of an architect's office and render a service other than that of what I might term as the office-boy-draftsman type. It cannot, with its present form of instruction, accomplish anywhere near the results accomplished by the "University of Beaume" of the A. E. F. which largely confined its curriculum to the study of executed work. There we have the two extremes in method of instruction and surely a happy medium, containing the good points of both methods, should produce results with less faults than are now obtained.

I hesitate in offering any direct solution. Others who have studied the problem have no doubt felt the same way about it. It is a question that cannot be settled in a moment or by the stroke of the pen, but there can be no doubt in our minds that some radical steps must be taken soon if we are to get out of the present ruts of precedence and tradition. I do not claim to have a solution to this problem but, by reason of having been such a student as above portrayed, a graduate from a college of architecture with no previous office experience, several years spent in different offices acquiring that experience we now acknowledge as represent the weak point in our school training, several years more as a teacher, developing a course in architectural construction in a State College, and now head of such a department in which the institutional buildings are designed and their construction supervised, I feel that what I do offer in the way of a suggestion for a course of training is not so visionary in character but what

some point may be found worthy of consideration by others and lead to a better understanding of the problem that must be solved soon if we are to fill the ranks in the profession with men capable of becoming leaders.

In the January, 14, 1920, issue of THE AMERICAN ARCHITECT the New York State Department of Architecture was featured and "Architectural Education" was the main topic in the editorial section, and I assume that the subject matter contained in those articles is familiar to all who are keeping in touch with matters architectural.

A few of the larger states have established State Departments of Architecture for serving the architectural interests of the state efficiently and economically and it is only a question of a few years when all states will have done the same. These departments should by all means cooperate as suggested in the above mentioned article to produce that harmony and uniformity in institutional architecture that will lead to economy in not only the work in the department, but also in the construction under its supervision.

In order, however, to make such a department an economical investment for the state, sufficient work must be required of it that otherwise would go to outside agencies at a greater cost, or additional functions must be incorporated that are income bearing in order to reduce the maintenance costs.

State Colleges are recognized as paying investments, although they cost the state money to maintain. Every State College already has certain state departments doing work for the state and also serving as educational media in the college. Whether or not all state departments should be located at the state college as already advocated, is a question beyond the point at issue, but I do believe there can be found no better location for such departments whose functions are such as will readily coordinate with the educational departments of the college and thereby eliminate the wasted effort in maintenance and personnel of two separate departments and also deprive each other of the benefits of cooperative research, use of equipment, and the stimulus that would come from the greater demand for its product due to the larger interests it would serve.

Such a location is proper and practical for a state department of architecture and if so located, the advantages are very apparent as shown by the organization chart and explanation following.

Disregarding the make-up of the curriculum which is a matter now receiving very earnest study by those who are best fitted to solve its problem, we start our students in their course and hold them to their academic work for at least two years, possibly three, with such supplementary study during their

THE AMERICAN ARCHITECT

summer vacations as conditions will permit, sketching, measuring details and studying executed work. From that time on, the student should then be introduced into the state department and given such duties as would ordinarily fall to the apprentice, at the same time carrying on his academic work.

A proper co-ordination of these two activities is possible whereby the student can very rapidly grasp the routine of an architectural office, understand the different processes that go to make the finished product and at the end of the fourth year, he should have completed his normal academic work and be in a position to render a real service in the department office.

I suggest that the course should be of six years

operation with the college department in utilizing the same men as teachers who will have charge of the actual work in the state department.

This economy holds true all the way down from the head, who can well be the state architect in charge of the two departments, to the stenographer and where, in the present schools of architecture, the effort expended on design and drafting is wasted as a commercial product, by proper coordination of work in class room and department office and supervision of advanced student over those of less experience, much of that effort that has for its primary object the training of the student as a draftsman and architect can be turned into an asset that will show a credit for the state work.

DEPARTMENT OF ARCHITECTURE

State Architect as
Head of College Dep't.

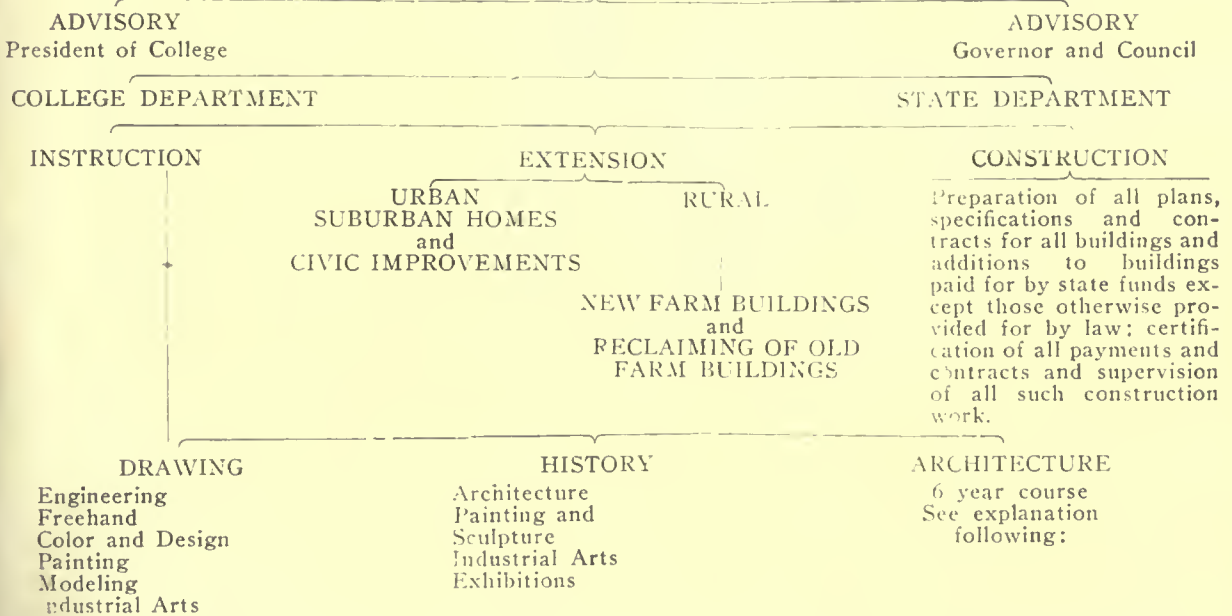

rather than of four in that there seems to be no doubt but what heretofore students have been rushed through their school training at too rapid a rate and dumped into the profession in a rather bewildered state of mind. The fifth and sixth year spent in the department office on state work, supplemented with advanced study in design, engineering, or whatever phase of the work he is best suited to follow, will give him an equipment that will go far toward meeting the criticism that is now directed against the school graduates.

On the other hand, the state is receiving the assistance of these men for two and three years. The overhead expense of doing this state work is partially absorbed by this assistance and by the co-

The profession in general will be greatly benefited by such a program in that the instruction given to the students who are afterwards to carry on the work of the architect will be given by practical men who are in touch with the progress that is being constantly made in methods and materials and thoroughly acquainted in all details pertaining to the practice of architecture as a profession.

The school will be benefited by the closer relations that would prevail between it and the building interests of the state which now have very little to attract them to the state college, while both the school and state will receive the benefit of the saving that such a department can make in the institutional construction work and in the increased efficiency

in the training that can be offered to the men and women of the state in not only architecture as a profession, but also architecture as a cultural study which now is being denied to the larger proportion of college students.

Recent English Housing and Town Planning Legislation

ENGLAND in her housing and town planning legislation is becoming more and more mandatory and socialistic. To prove this, F. B. Williams, in the *American City*, shows that in the recent amendments of her "Housing, Town Planning, etc., Act, 1909," "Housing, Town Planning, etc., Act, 1919," and "Housing (Additional Powers) Act, 1919," she supersedes the clause in the older law empowering local authorities to do necessary housing and town planning, by clauses compelling them to do so, incidentally enlarging their already considerable powers to that end, and also agrees to pay, with State funds, a portion of any loss they may suffer in so doing; and grants individuals a subsidy on houses built. This is written in no spirit of criticism. The failure of local authorities to undertake essential housing, and the apparent impossibility of obtaining anything like sufficient private funds for the purpose, in this crisis, seem in England to have left no other course open.

The housing provisions in this recent legislation make it the duty of the local authority to prepare within three months a scheme adequate to the local needs for the housing of the "working classes," which has been held to mean, in this connection, those of limited means and for slum clearance schemes when necessary. These schemes, when approved by the national authorities, the locality must carry out within a reasonable time. If the local authority fails to perform either of these duties the national authorities are given the power to act in its stead and at its expense. Any loss to be suffered by the locality the nation repays in full, less the proceeds of a tax to be levied by the locality, or a penny (two cents) in the pound; or, in the case of housing by the county of its employes, the nation pays 50 per cent. of the annual loan charges until April 1, 1927, and 50 per cent. thereafter. Powers are conferred upon localities and their previous powers increased to borrow, to acquire, sell, lease and develop

land, providing for incidental industries and the amenities, and to lend to individuals, to assist limited dividend corporations for low-price housing and garden city developments, etc.

The Minister of Health is empowered to make grants not to exceed in the aggregate £15,000,000 to persons constructing suitable low-priced houses within twelve months. Building operations which interfere with the provision of new dwellings, and the demolition of existing dwellings, may be forbidden.

Grave as the crisis is, England has not forgotten the lesson taught by the war, that dwellings and their surroundings must be pleasing in appearance. The law requires that schemes for housing shall take into account, and so far as possible preserve, existing erections of architectural, historical or artistic interest, and shall have regard to the natural amenities of the locality. The State may also require for the work the selection of an architect from a panel of the Royal Institute of Architects.

In the provision for compensation for slum areas and buildings condemned, England has adopted the principle, which, startling in its novelty and radicalism as it seems to us, has long been a part of one or two housing laws of continental Europe, that improvements, so called, which are so unsanitary as to be unfit for use, according to existing standards, should not be paid for. The amount to be given the owners of land and buildings condemned in such cases "shall be the value at the time the valuation is made of the land as a site cleared of buildings and available for development in accordance with the requirements of the building by-laws for the time being in force in the district;

"Provided that if in the opinion of the Local Government Board it is necessary that provision should be made by the scheme for the rehousing of persons of the working classes on the land or part thereof, when cleared, or that the land or a part thereof when cleared should be laid out as an open space, the compensation . . . shall be reduced" in accordance with certain provisions of the act.

In town planning, as in housing, the recent legislation changes optional provisions into mandatory ones, and local authorities with a population of over 20,000 are now required to prepare planning schemes within three years, submit them to the national authorities and carry them out, on pain of having the nation act for them at their expense.

DEPARTMENT OF ARCHITECTURAL ENGINEERING

Interesting Features in Foundation and Roof Construction

Building for Stromberg Motor Device Company

N. MAX DUNNING, *Architect*. LIEBERMAN, KEIN & HEIN, *Engineers*

THE building recently erected for the Stromberg Motor Device Company, Chicago, presents some interesting features. These are in the two extreme parts—the foundation and the roof.

The development and improvement of building foundations is but little appreciated by those who cannot recollect the old time foundation piers and

walls made of great flat stones, or stepped up brick work. These foundations were so cumbersome that valuable space was occupied and the modern basement was unknown. With the introduction of columns in the exterior walls, the earlier type of continuous foundation wall was displaced by isolated footings.

The introduction of concrete, made possible com-



UNUSUAL ROOF CONSTRUCTION—NOTE REINFORCED CONCRETE HIP GIRDERS
N. MAX DUNNING, ARCHITECT. LIEBERMAN, KLEIN & HEIN, ENGINEERS

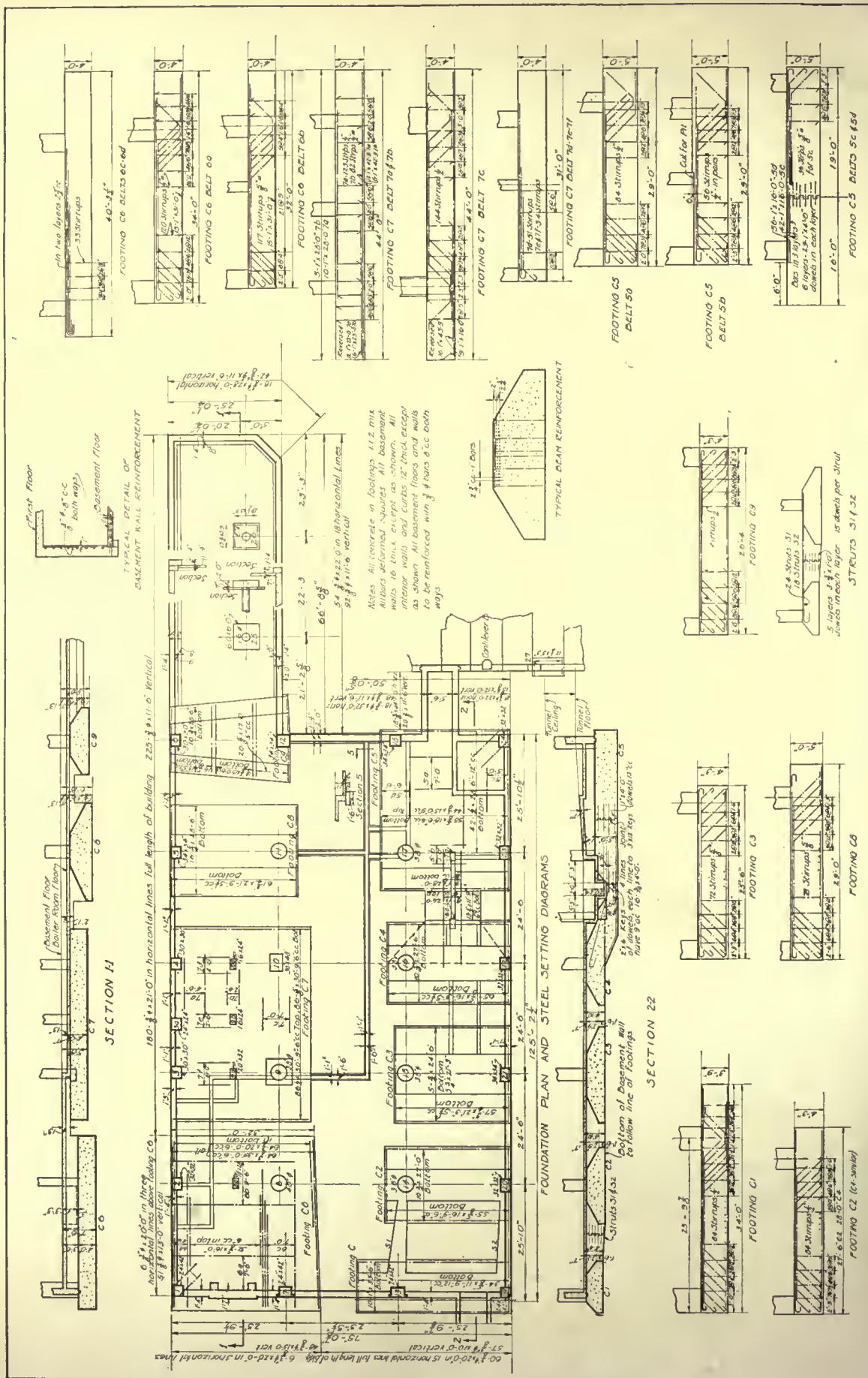

FOUNDATION PLAN AND DETAILS OF REINFORCING, STROMBERG MOTOR DEVICE COMPANY BUILDING, CHICAGO
 N. MAX DUNNING, ARCHITECT. LIEBERMAN, KLEIN & HEIN, ENGINEERS

footings at different levels can be connected is well exemplified in the case of Footings C4 and C5. (See foundation plan and section 2-2). This is a good example of the ease with which the almost insurmountable problems of former times are solved by the use of reinforced concrete.

THE top story of this building is used as a brass foundry. It was found desirable to make the roof in the form of pyramids with an opening at the apex for the escape of the fumes and gases. In order to preserve an unbroken surface in the ceiling, that is a smooth inner surface, the supporting ribs were placed above the roof line. The roof slabs are of the combination tile and concrete joist type. They are supported by the hip girders and the horizontal girders. The horizontal component of the hip and slab thrust is resisted by reinforcing placed in the horizontal girders. The ring at the opening at the apex, which has an inside diameter of 5 feet, is reinforced, as indicated for the stresses developed. In this case the combination slab between the reinforced concrete ribs and girders acts in the capacity of a roof slab only, having no induced secondary stresses to resist. Each pyramid contains a skylight, 6 feet by 28 feet 9 inches on one side to provide additional natural illumination for the central portion of the top story.

The roof over the furnaces is constructed of inclined solid concrete slabs, and in the ridge four circular openings, each 4 feet 6 inches in diameter, are provided for the escape of the fumes. In this case the slabs act in a manner similar to the compression members of a truss, as well as roof slabs. The method of forming and handling the concrete is shown in the illustrations.

An Improved Method of Driving a Precast Pile

IN order to demonstrate the merits of an improved method of pile driving used in connection with the Giant precast concrete pile, several test piles were recently driven at Long Island City, N. Y., before a number of engineers and others interested in this phase of building construction.

The piles used in this demonstration were cast last winter during freezing weather, the temperature averaging 27 deg. F., maximum being 33 deg. and minimum 20 deg. All piles showed frost marks upon the surface, and the concrete, where fractured, showed little cleavage through the stone aggregate, the adhesion of cement to aggregate generally having failed. Such fractures were made for the purpose of examining the condition of the interior of the piles.

The composition of concrete mix by volume was Portland Cement, 1 part; sand, 2 parts; $\frac{3}{4}$ in. to $\frac{1}{4}$ in. crushed trap rock, 4 parts.

The mix was made sufficiently wet to flow into place. The time of setting was greatly retarded by low temperature, and, for this reason, forms were kept in place for six days.

The piles are made with a cast iron point, 21 in. square, containing interior webs around which webs the reinforcing bars are looped. These loops are 2 ft. in length. The reinforcement, consisting of four bars $\frac{7}{8}$ in. square, cold twisted, extended the entire length of each pile and projected 2 ft. from

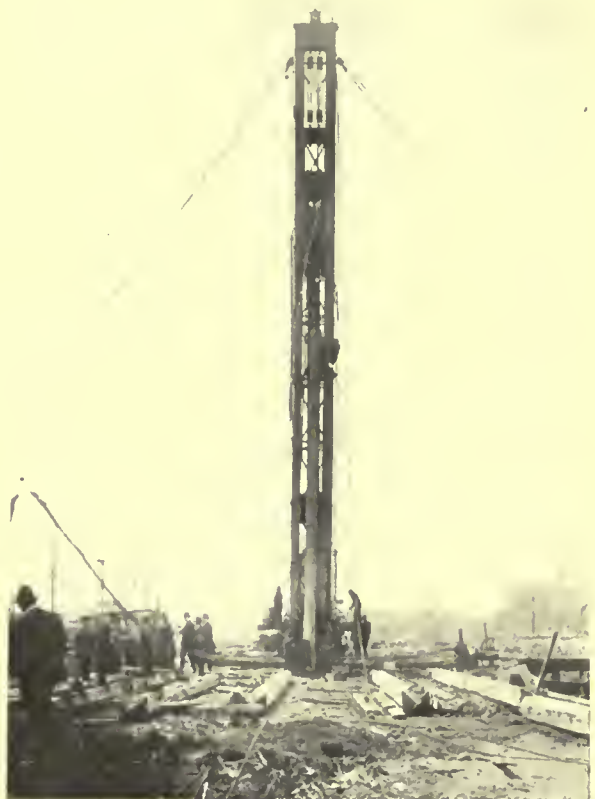

PRECAST CONCRETE PILE BEING DRIVEN

the pile head. Four additional bars of the same size, and likeness looped around the point webs, extended up 6 ft. above the point. No spiral or other horizontal reinforcement was employed.

Each pile was 16 in. square with corners chamfered 4 in., and 44 ft. long from tip of point to head. They were handled with a single line attached to a chain looped around the pile approximately 12 ft. from the head.

Borings made prior to the driving showed the subsurface strata to be of the following nature:

Fill, 13.5 ft.; stiff blue clay, 10 ft.; silt, 3 ft.; com-

THE AMERICAN ARCHITECT

mercially by the production of American Portland cements, displaced the old time foundation stones and later the huge piers. The concrete, however, was used in combination with a steel grillage. When wrought iron, and later steel, was scarce and expensive, the use of second-hand railroad rails for grillage purposes was common. These sections were not economical from an engineering standpoint, owing to the disproportion of weight and depth, but I beam sections at that time were manufactured in

extended beyond street and alley lines and when placed along party lines, expensive cantilever construction was often necessary.

During more recent times the introduction of reinforced concrete has changed the whole character of foundation design and construction. The value of concrete in compression is now utilized. The steel reinforcement is disposed of in almost every conceivable manner, without disproportionate expense, and in connection with the initial semi-fluid

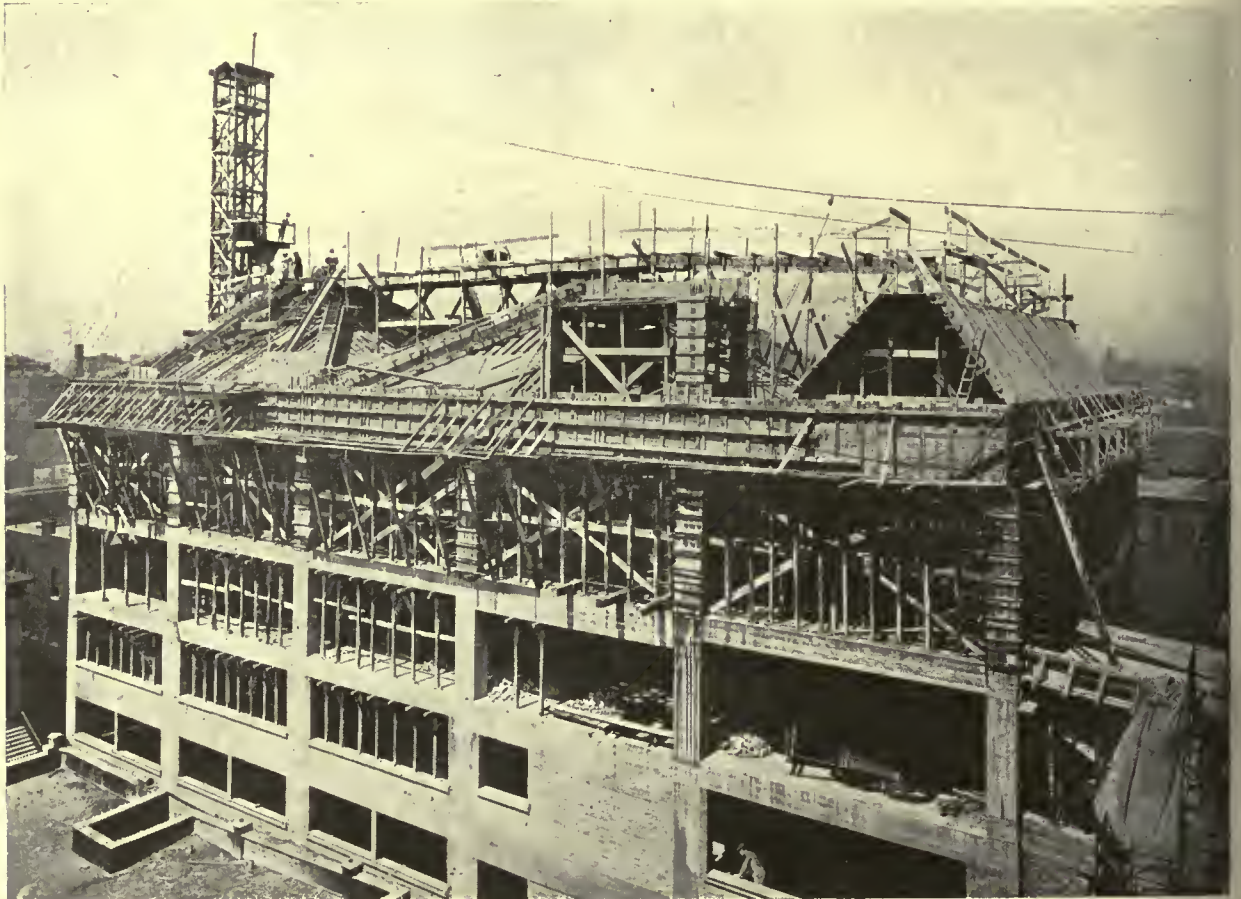

VIEW OF BUILDING IN COURSE OF ERECTION

Special roof construction required, due to occupancy of top story as a brass foundry

limited quantities and were very expensive. Thus the use of old rails continued for some time.

In the later '80's the production of steel structural shapes caused the universal use of I beam sections for the foundation grillage. The use of materials in such was not the most economical, since the steel sections were depended upon to resist the stresses of both tension and compression, the enveloping concrete being considered merely as a filler and as protection to the encased steel. The value of concrete in compression was neglected. Foundations

condition of the concrete almost any desired shape is possible.

In the building here illustrated, the foundations are entirely within the property lines, except a small projection along the street front. The individual foundation slabs each support two or more columns and in one case these are connected by struts. (See footings C1 and C2). It will be noted that the footings so connected were not poured in one operation, but that the joint in the struts was made secure by the use of steel dowels. The simplicity with which

footings at different levels can be connected is well exemplified in the case of Footings C4 and C5. (See foundation plan and section 2-2). This is a good example of the ease with which the almost insurmountable problems of former times are solved by the use of reinforced concrete.

THE top story of this building is used as a brass foundry. It was found desirable to make the roof in the form of pyramids with an opening at the apex for the escape of the fumes and gases. In order to preserve an unbroken surface in the ceiling, that is a smooth inner surface, the supporting ribs were placed above the roof line. The roof slabs are of the combination tile and concrete joist type. They are supported by the hip girders and the horizontal girders. The horizontal component of the hip and slab thrust is resisted by reinforcing placed in the horizontal girders. The ring at the opening at the apex, which has an inside diameter of 5 feet, is reinforced, as indicated for the stresses developed. In this case the combination slab between the reinforced concrete ribs and girders acts in the capacity of a roof slab only, having no induced secondary stresses to resist. Each pyramid contains a skylight, 6 feet by 28 feet 9 inches on one side to provide additional natural illumination for the central portion of the top story.

The roof over the furnaces is constructed of inclined solid concrete slabs, and in the ridge four circular openings, each 4 feet 6 inches in diameter, are provided for the escape of the fumes. In this case the slabs act in a manner similar to the compression members of a truss, as well as roof slabs. The method of forming and handling the concrete is shown in the illustrations.

An Improved Method of Driving a Precast Pile

IN order to demonstrate the merits of an improved method of pile driving used in connection with the Giant precast concrete pile, several test piles were recently driven at Long Island City, N. Y., before a number of engineers and others interested in this phase of building construction.

The piles used in this demonstration were cast last winter during freezing weather, the temperature averaging 27 deg. F., maximum being 33 deg. and minimum 20 deg. All piles showed frost marks upon the surface, and the concrete, where fractured, showed little cleavage through the stone aggregate, the adhesion of cement to aggregate generally having failed. Such fractures were made for the purpose of examining the condition of the interior of the piles.

The composition of concrete mix by volume was Portland Cement, 1 part; sand, 2 parts; $\frac{3}{4}$ in. to $\frac{1}{4}$ in. crushed trap rock, 4 parts.

The mix was made sufficiently wet to flow into place. The time of setting was greatly retarded by low temperature, and, for this reason, forms were kept in place for six days.

The piles are made with a cast iron point, 21 in. square, containing interior webs around which webs the reinforcing bars are looped. These loops are 2 ft. in length. The reinforcement, consisting of four bars $\frac{7}{8}$ in. square, cold twisted, extended the entire length of each pile and projected 2 ft. from

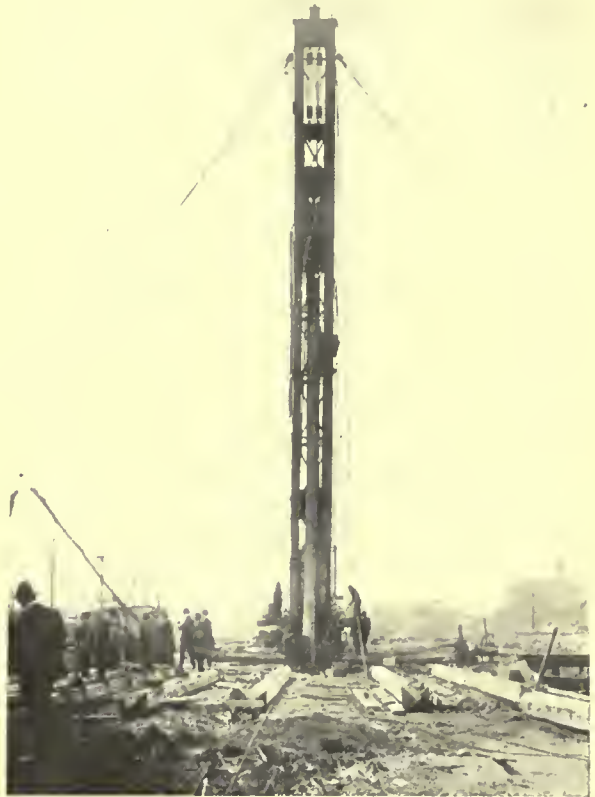

PRECAST CONCRETE PILE BEING DRIVEN

the pile head. Four additional bars of the same size, and likeness looped around the point webs, extended up 6 ft. above the point. No spiral or other horizontal reinforcement was employed.

Each pile was 16 in. square with corners chamfered 4 in., and 44 ft. long from tip of point to head. They were handled with a single line attached to a chain looped around the pile approximately 12 ft. from the head.

Borings made prior to the driving showed the subsurface strata to be of the following nature:

Fill, 13.5 ft.; stiff blue clay, 10 ft.; silt, 3 ft.; com-

THE AMERICAN ARCHITECT

compact fine blue sand, 8 ft.; hard clay, 6 ft.; sand and clay, 1 ft.; rock.

The hammer used was a double acting steam ram, total weight 12,000 lbs., giving a striking force of 15,600 ft. pounds per blow. It was operated at a pressure of 100 lbs. from a 60 H. P. boiler, giv-

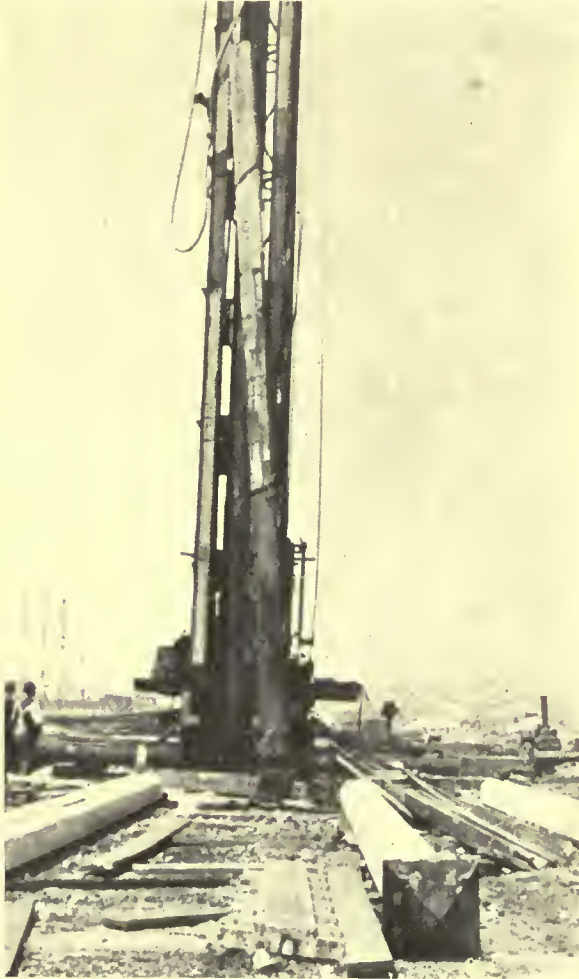

WITHDRAWING ONE OF THE TEST PILES

ing at final penetration 110 strokes per minute, or approximately 1,660,000 ft. pounds per minute. The unique feature of the driving is that the hammer force is transmitted direct to the cast iron point by exterior driving members on two opposite sides of the pile, causing the pile to be pulled into the ground without reception of the driving force upon the concrete portion of the pile. Thus the driving produces no damaging effect to the concrete. During the process of driving, the pile bears a superimposed load of approximately 26 tons.

A penetration of 26.5 ft. to sand was obtained in approximately four minutes in the case of each of three piles driven, very few hammer blows be-

ing required due to the heavy superimposed loading.

Upon reaching the sand stratum, approximate refusal was indicated. The first pile was driven into this sand to a depth of 6.5 ft. making the total penetration of this pile 33 ft. Final penetration was 565 blows per inch, the driving being continued for about one-half hour after refusal was indicated, during which time the penetration decreased from 30 blows per inch to that given.

The second pile was driven to a depth of 4.5 ft. into the sand stratum, total penetration being about the same as with pile No. 1.

Pile No. 3 was driven with hammer assisted by a water jet delivering 350 gals. per minute at 200 lbs. pressure. No advantage could be noted from the use of the jet. Driving was stopped at 60 blows per inch of penetration.



CLOSE UP VIEW, SHOWING CONDITION OF C. I. DRIVING POINT AND CONCRETE

An effort was then made to withdraw these piles for examination. Twelve parts of $\frac{3}{4}$ in. steel cable were used with a 60 H. P. engine. Pile No. 1 could not be moved and fractured in several places above ground from the applied strain. A heavy water jet was used to loosen the earth about pile No.

2 to a depth approximately down to the sand stratum which refused to yield to the water pressure. The same pulling tackle was then applied. After repeated efforts, the pile was moved slowly upward for a distance of 12 ft. when a crack developed at the point of contact of the chain, followed by failure of the lifting tackle and settlement of the pile back into place. The pulling stress being again applied, the pile was lifted out, two additional



ALL METAL PILE DRIVER AND 60-H.P. ENGINE.

chains being looped around the pile and all three engine drums being utilized. The pile was found to be intact, except where the chains were attached, at which point it was spalled and partially cracked through.

Efforts to withdraw the third pile resulted in its destruction. A heavy water jet was used in combination with 14 parts of steel cable attached to the engine. The pile was finally pulled apart before it could be entirely withdrawn.

Close inspection of the points of these piles and the concrete immediately above the point showed both the points and the concrete to be uninjured.

The accompanying illustrations show both the driving and drawing processes. The pile driver used is constructed entirely of steel.

Arc Welded Building in Course of Erection in England

A FACTORY building is being erected at Brixton, England, by the electric arc welding process, according to the *Engineer*, London, England. The factory which, when completed, will cover an area of 22,000 sq. ft., is to be one story high enclosed with brick walls. The roof will be a welded roof of saw-tooth construction. A total of 93 trusses of the type shown in the accompanying illustration will be used.

Vertical H-shaped steel columns are arranged in lines at about 22 ft. centers and support 5 by 12-in. steel joists. Some of the trusses are fixed immediately over the columns, while the others are carried by the joists, being fixed to the lower flanges of the latter midway between the posts.

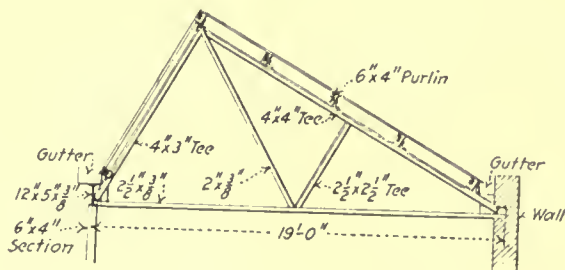

ARC WELDED ROOF TRUSS FOR SAWTOOTH CONSTRUCTION

Where the walls come, of course, the ends which are not supported by columns or joists rest on the brickwork.

The method of procedure employed is, first of all, to weld to the ends of each column a cap and a baseplate. They are then erected in line on concrete foundations, the concrete being carried up for some distance above the base-plate. When the concrete is firmly set the H-joists are hoisted upon the column cap plates, where they are held in position by special clamps, which insure their correct placement. They are then welded. The trusses are welded separately at ground level, and when completed are lifted into position and welded to their supports. In the case of those trusses which come midway between columns, angle iron cleats are used to form the junctions between the trusses and the joists. One cleat is welded to each joist before the joists are hoisted into position, so that it is quite simple to make the trusses assume their correct position and to clamp them there while the welding proceeds. Similar cleats are welded to the ends of the trusses while the latter are being constructed, so that when placed in position there is a cleat on each side of each end of the trusses and all the

cleats are welded to the trusses and to the joists, thus making a good strong job.

The various parts which go to make up a complete truss are assembled in a horizontal position in simple but effective jigs made on the site and the various joints are arc-welded on the A.W.P.—Alloy Welding Process, limited system, alternating current being used. Fillet welds are employed for the most part, though in some portions butt welds are required. No scarfing or bevelling is resorted to and no pains are taken specially to clean the parts which are to be welded. Where all the necessary joints on one face of a truss are welded the truss itself is turned over so that welding may be continued on the joints on its other face. For the latter operation a jig is not required, since the welds on the other face keep the various parts accurately in position. When completed each joist weighs about 3 cwt.

It is stated that one welder and one laborer having the materials cut to length, can assemble and weld complete one truss in an average total time of 1½ hr., and attain an average output of over five complete trusses in one 8-hr. day.

The current comes on the site at 6,000 volts and is stepped down to 200 and then again to 70 for the welding circuit, in which a reactance coil is inserted. The electrodes which are employed are of mild steel, flux coated.

Answer to Capper Resolution

REPORT OF FOREST SERVICE STATES THAT HIGH PRICES GENERALLY WERE BROUGHT ABOUT BY ECONOMIC CONDITIONS.

FINDINGS of the United States Forest Service in its investigation of the lumber industry and prevailing prices, conducted in accordance with the Senate resolution, were submitted to the Senate recently. From this it would appear that high prices generally were brought about by economic conditions. The official report exploded the charges of Senator Capper, of Kansas, author of the resolution, that a group of men controlled the lumber market and artificially enhanced prices. Warning was sounded, however, of the probability of a natural monopoly in high-grade softwood lumber. The investigators were of the opinion that the car shortage and timber depletion have been chiefly responsible for the advance in lumber prices.

The report was submitted to the Senate by Secretary of Agriculture Meredith, together with his recommendations as requested in the Senate resolution. The Secretary urged legislation designed to carry out the forestry program long advocated by the Forest Service. It is to be hoped that legislation to this effect will be enacted.

Some outstanding facts reported by the Forest Service are:

1. That three-fifths of the original timber of the United States is gone and that we are using timber four times as fast as we are growing it. The forests remaining are so localized as greatly to reduce their national utility. The bulk of the population and manufacturing industries of the United States are dependent upon distant supplies of timber as the result of the depletion of the principal forest areas east of the Great Plains.

2. That the depletion of timber is not the sole cause of the recent high prices of forest products, but is an important contributing cause whose effects will increase steadily as depletion continues.

3. That the fundamental problem is to increase the production of timber by stopping forest devastation.

The two striking effects of timber depletion already apparent are:

1. The injury to large groups of wood users and to many communities resulting from the exhaustion of the nearby forest regions from which they were formerly supplied; and

2. The shortage of timber products of high quality.

* * *

INITIATING NEW PRICE LEVELS.

In the Middle West, the building grades of white pine lumber cut in Michigan, Wisconsin and Minnesota, retailed at \$15 to \$20 per thousand feet prior to 1900. As lumber from the Lake States became exhausted and Southern pine took over this market, the retail prices rose to a level of \$25 to \$35 per thousand feet. The replacement of Southern pine by West Coast timbers now in progress is initiating a new price level of about \$80 to \$85 per thousand feet. The increased cost of transportation is but one factor in these new price levels, but it is an important one. The freight bill on the average thousand feet of lumber used in the United States is steadily increasing.

Sand and Gravel in 1919

Approximately 60,196,000 short tons of sand and gravel of all grades was sold in the United States in 1919, according to preliminary estimates made by L. M. Beach, of the United States Geological Survey, Department of the Interior. This quantity represents a decrease below that sold in 1918 of about 1,628,000 tons. The value in 1919, however, was \$37,819,000, as compared with \$37,927,079 in 1918, which shows that the average price had increased. Demand was heavy, but production curtailed.

Current News

Happenings and Comments in the Field of Architecture and the Allied Arts

Mr. Gilbert Explains the Woolworth Building

"The dinner held in honor of Mr. Cass Gilbert," says *The Architect* (London), was a very pleasant function, and the president welcomed Mr. and Mrs. Cass Gilbert in a most felicitous little speech. Mr. Cass Gilbert, *The Architect* goes on to lay, like most men who have made a deserved reputation, preferred to say little about himself and a great deal about an object which all good Americans have very near their hearts—the real union of feeling and aims which override the superficial differences between the English-speaking nations, whose effective cooperation with that of France can more than anything else secure the future peace and happiness of two hemispheres. Mr. Cass Gilbert, who had been fairly cornered by indiscreet disclosures, was prevailed upon to show and explain a very interesting series of slides illustrating the Woolworth Building and other of his works. It should be difficult to say how the governing conditions of the problem could have been altered, and Mr. Gilbert's confreres must feel that it does not do to condemn what is a simple and natural outcome of overwhelming economic and local conditions, but to consider how, given those conditions, a problem has been solved. We agree with the architect in holding that the choice of a Gothic meter for a building whose lines are so predominantly vertical was a natural and happy one, and much of the detail which is based on the secular mediaeval buildings of Bourges is distinctly characteristic, and good in form and scale.

Plans Filed in Manhattan During July

The report of building operations as given out by the superintendent of the Manhattan Bureau of Buildings shows a decided increase for July of this year, as compared with the same month of 1919. Plans were filed last month for 575 new structures, involving an estimated outlay of \$73,652,258, against 219 buildings costing \$28,053,061 last year. The tendency of building on Manhattan Island is shown in a striking way by the fact that among the plans filed there was but one apartment house to cost \$2,500,000 and one dwelling to cost \$120,000. The rest

of the program is three loft structures, five theatres, and one hundred and fifteen garages.

Applications for alterations to 2,759 buildings were filed, estimated to cost \$26,993,893. For the same month last year there were 2,189, costing a total of \$14,200,361.

Omaha Tenants Form Corporation

The Omaha Tenants Protective League plans to form a corporation for the ownership of apartment houses, the capital to be furnished by the tenants. The proposition as it now stands is that each member of the league will subscribe for a certain amount of stock, paying for his subscription at the rate of \$10 a month. The capital invested would pay a 6 per cent. dividend and the apartments would be rented on a basis of this dividend, making allowance for depreciation and expense.

Sunny Cells in Joliet

Sunlight for every cell and individual washbowls with hot and cold water are conveniences to be found within the new cylindrical State prison at Statesville, Ill., says the *Boston Transcript*.

The prison house, first of its kind in the world—says this paper—gives one the impression upon entrance of being in an aviary. Every cell has been provided with ninety minutes of sunlight through a skylight, which has been accomplished by a slight curve in the skylight planned by Forest R. Moulton, professor of astronomy at the University of Chicago.

There are 248 cells, all alike, built of concrete, with cork insulation in the walls. In the center of the prison is a tower, from which the guards can watch the movements of all prisoners. The building is surrounded with a circular wall of concrete 33½ feet high.

New Zealand Will Develop Water Power

Among the hydroelectric developments undertaken on a national scale are those of the New Zealand Government, which plans the expenditure in the immediate future of about \$24,000,000 for the development of a large station south of Auckland. Here

it is expected to produce about 160,000 horsepower. The erection of the dam will form a lake 18 miles in length. Its construction will cover a period of three years. The dam will be 160 feet high, 48 feet at the base and 16 feet at the top; the requirements for cement are estimated at 65,000 tons.

This Government has recently taken over the hydroelectric plant at Cambridge and will expend about \$7,750,000 in its development.

In the south of the island a new electric power plant is planned, which will require an expenditure of nearly \$5,000,000. An appropriation has been made for the purchase of additional machinery to develop the capacity of the plant near Christchurch, amounting to \$1,125,000.

Meeting of Board of Jurisdictional Awards

At the meeting of the Board of Jurisdictional Awards held in Atlantic City early this month, Mr. Robert E. Kohn, of New York, is reported as saying:

"The situation in New York with respect to materials is serious. Materials simply cannot be obtained at any price. If an attempt were made to carry out the building program now contemplated in New York, a snag would be found at every turn.

"Building now is being generally discouraged and I don't know where it is all going to end. If the material were available we couldn't get the money. They talk about the shortage of houses and the housing problem. How can we supply houses? We can't supply them. Money is now so valuable it is not going into houses."

Dividing the Consumer's Dollar

A significant tabulation of costs to the consumer has been presented at the World's Advertising Convention at Indianapolis by the Ingersoll Company. The purpose is to establish a conclusion as to the evolution of costs of manufactured articles from the original cost to the cost to the consumer. The table is said to be the most extensive study of costs and prices in all lines ever arrived at, and was submitted to the convention as "the most authoritative subdivision of the consumer's dollar which has yet been made."

For each average one hundred dollars expended for finished products by the consumer, the following proportions were arrived at:

Manufacturer's cost to produce, \$37; manufacturer's cost to sell, \$12; manufacturer's profit, \$4; wholesaler's expense of doing business, \$10; whole-

saler's profit \$3; retailer's expense of doing business, \$28; retailer's profit, \$6.

That is to say, when the consumer purchases goods which cost \$37 to manufacture he pays \$50 for the transmission of the goods, and also a profit of \$4 to the manufacturer and a profit of \$9 for the use of this expensive machinery of transmission.

A Victory Over Billboards

The Bronx Parkway Commission, New York, is to be given credit for its accomplishment in the Bronx River Valley—first, by reclamation of the land for a parkway, and second, in the successful elimination of long rows of ugly billboards.

As to the suppression of these billboards, The American Magazine of Art quotes Mr. W. W. Niles, vice-president of the commission, as follows: "The Bronx Parkway Commission secured title to the property by purchase and immediately thereafter demolished the billboards. The commission was not able to accomplish anything by way of public sentiment except with regard to certain billboards which were maintained by and were upon the property of the New York Central Railroad Company. Upon the demolition of the adjoining billboards upon the lands of the commission, we presented the matter to the railroad company and, yielding to our urgent demands, they caused the billboards upon their own premises to be removed."

Decentralizing the Construction Division

The word of the Construction Division, Quartermaster's Corps, has been decentralized and will in the future be carried on from district offices located at San Francisco, San Antonio and Washington, D. Co. The sub-divisions will continue under Major C. L. Corbin, administrative officer; Lieut.-Col. L. L. Calver, in charge of Building Division; Lieut.-Col. F. B. Wheaton, Engineering Division; Major R. H. Case, Contract Division, and Major Carl F. von dem Bussche, Real Estate Division.

Advertising Literature of Interest

A series of windows admirably suited to memorial use have recently been completed by the Pittsburgh Art Glass Company, Pittsburgh, Pa. These windows, designed to serve as honor rolls, typify The Crusader, Peace and Victory. In each instance the symbolism has been worked out with artistic skill, the coloring is exactly correct and the purpose of a memorial skilfully carried forward. A more than

usually artistic folder, in color, simply illustrating these windows has been prepared. Architects may have a copy by applying to the Catalog Department of The American Architect, or directly to the Pittsburgh Art Glass Company.

Building Loan Associations

There was no diminishing in the development of building and loan associations during July. In the state of Pennsylvania alone more than twenty-five were chartered, some with \$5,000,000 authorized capital stock and others with \$2,000,000 or \$3,000,000. And a number of old associations filed notices of increase in stock.

It was announced at the annual meeting of the League of Building and Loan Associations, held in Cincinnati, that the assets of such associations in the United States have passed the two billion mark. There are 7,788 associations in this country with a total membership of 4,289,326. The gain in their assets during the past year was \$228,000,000—or 12 per cent.

Effort to Save High Bridge, Over Harlem River

The New York Chapter of the American Association of Engineers is opposed to the plan to remove High Bridge in order to improve the navigation of the Harlem River and has petitioned the Board of Estimate, through the chapter's president, R. H. Jacobs, to save the structure. "The American Association of Engineers," says the letter, "believes that High Bridge is a structure of architectural and aesthetic merit and an important monument marking the progress and advancement of the City of New York."

Projected War Memorials

A building to be used as an auditorium and gymnasium which will cost about \$225,000 will stand as a Soldiers' and Sailors' Memorial Hall on the campus of the Mount Union College (Ohio). About \$75,000 has been already raised.

The 1st Division plans the erection of a monument at Washington to commemorate the men they lost in the war. The survivors have decided upon a monument that will cost \$250,000. Practically all of them have donated to the fund and about \$60,000 has been pledged. This division, it will be remembered, organized a circus in Germany. Since returning to America the circus has been enlarged and is

touring the country to earn money for the memorial.

The Indiana State Legislature has accepted the joint committee report on the State War Memorial Bill. The state will therefore build a \$2,000,000 memorial on the grounds now occupied by St. Clark Park and the Indiana Institute for the Blind. The original proposal that the city of Indianapolis and Marion County were to contribute \$5,000,000 in cooperation with the state has been eliminated.

Decrease of Building in Borough of Brooklyn

As Brooklyn has come to be one of the chief residential sections of New York, it is significant to find that only 1,508 plans were filed in the month of July. In July, 1919, 1,502 plans were filed. As the cost this year was \$4,829,898, against \$10,855,955 it shows a great falling off in construction work for this year.

The total of the first seven months of this year was \$55,412,000, while for the corresponding months of 1919 it was \$74,000,000—a reduction of 25 per cent. This is attributed to the shortage of material, the high cost of labor and scarcity of money for building loans.

Low Buildings Pay More Than Skyscrapers

Low buildings erected on expansive lots are more profitable than skyscrapers towering into the air in the opinion of various members of the National Association of Building Owners and Managers expressed at their annual convention in Minneapolis. This is contradictory to the generally accepted theory of realty men.

Reading a paper at one of the sessions on "Analysis of the Comparative Investment Value of Office Buildings of Various Heights," Edwin S. Jewell, of Omaha, an advocate of the low building theory, said that since land values are enhanced by the increase in population in a section and not by the size of buildings on it, structures under 10 stories in height were more profitable in that a saving would be made on the tremendous cost of foundation and enormous elevator equipment.

"If a builder erects a six to eight story building in a part of the city that is the business section," Mr. Jewell said, "and if that business section shifts in a decade or two, the structure can readily be used for a factory, still a marketable building. The same is true of a warehouse, easily used for other purposes. It is not true of the skyscraper.

"When builders begin to erect low building foundations and sub-basements the tremendous amount of money now being used for buildings in our cities can be put into other buildings. The money put into elevators, heavy framework and other incidentals necessary to the erection of a skyscraper would pay for a good, practical office building four to six stories high covering the same piece of ground."

Mr. Jewell, who is chairman of the operating experience committee of the Building Owners' and Managers' Association, also asserted that the low office building plan would spread the business districts of cities over wider areas and raise land values, enabling cities to raise more revenue for schools and other public improvements.

"The low building plan," he said, "would prevent congestion, promote safety and good health and by forcing the spreading of the business district over a wider area, provide more stores, which would result in greater competition and lower prices to the buying public."

News Notes from Various Sources

It is reported that building contracts awarded in states east of Missouri and north to Ohio rivers during the week ending July 30 amounted to \$50,420,400. This compares with \$39,937,900 for week ended July 23.

* * *

It is announced that the Chamber of Commerce of the United States, by vote July 30, approved of "open shop" in industry, members holding that strikes in public utility operation should be forbidden by law, and that tribunals should be set up with power to fix wages and working conditions for employes of utilities.

* * *

Approximately 15,000 cars were made available for carrying steel under an order from the Interstate Commerce Commission, which declared the priority orders covering coal cars shall not include flat bottom cars with sides less than 38 inches high.

* * *

Dr. Charles Mayo stated on his arrival from Europe that an American hospital to cost several million dollars will be erected in London.

* * *

One-fourth of the estate of Arthur Jerome Eddy is bequeathed to the Art Institute of Chicago with which to encourage by prizes and purchases the production of painting and sculpture, especially decorative and architectural, in America, by native Americans working and residing in this country. The estate is valued at \$600,000.

Prof. R. Tait McKenzie, of the University of Pennsylvania, whose exhibition of sculpture has created great interest in London, has been asked to design the war memorial for Cambridge University.

* * *

Seven five-story tenements in the lower East Side of New York have been sold by the Marquis Charles Pierre de Bausset Roquefort. The buildings were the property of the family of the marquis for eighty years.

* * *

A national organization of engineers, civil, mechanical, electrical and mining, is being formed which perpetuates the war time engineering council.

* * *

The Executive Council of the A. F. of L. has ordered that the right of assembly and free speech for union labor organizers and sympathizers in the steel making territories of Pennsylvania, Ohio and Indiana be made a political issue the coming fall in every congressional district where steel workers vote.

* * *

The West Coast Lumbermen's Association states the balance of unshipped orders for transcontinental delivery amounts to 6,973 cars.

* * *

The War Department has granted authority for an aeroplane flight from the Panama Canal Zone to Washington, D. C. The attempt will be made by First Lieutenant C. B. Austin.

* * *

Unfilled orders of the U. S. Steel Corporation for the month ending July 31 were 11,118,468 tons. This is an increase of 139,651 over the previous month and is the highest figure since July, 1917.

* * *

French Section of Department of Foreign Information, Bankers' Trust Company, New York, issued statement on France's progress in reconstruction. Gives statistics on various phases of situation.

* * *

Mr. Leroy K. Sherman, member American Society of Civil Engineers, president American Association of Engineers, has resigned as president of the U. S. Housing Corporation to resume private work in Chicago.

* * *

Philadelphia building permits for July amount to \$4,726,420—a decrease of \$2,016,595 compared with the previous month, and a decrease of \$1,897,365 as compared with July of last year.

* * *

Total imports for June, 1920, were \$552,875,088 as compared with \$292,915,000 for June, 1919. Total exports for the month were \$631,082,648.

Weekly Review of the Construction Field

With Reports of Special Correspondents in Prominent Regional Centers

IT is stated in the steel industry that transportation conditions have so far improved that there is now a balance between production and shipment. Stocks of manufactured materials are no longer increasing at the mills and it is expected that in a short time they will begin to show reduction. Not long since many factories were so embarrassed with the accumulation of their production that an enforced closure was imminent, in a few cases necessary.

Great encouragement is felt in the evidence that transportation is beginning to meet its problem. All those who have been held up in their work while waiting for materials are glad to find ground for belief that the worst is over.

This is a change which is felt all up and down the line. The coal mines report a more free supply of cars. The steel mills show not only a balance between production and shipment but a substantially improved production.

Although prices hold about the same, with some expectation that there soon will be further advances, the chief interest of the buyers is for a dependable supply which will allow them to complete jobs without expensive and annoying delays. To this end, improvement in the freight system offers encouragement. It is expected too that the increased earnings of the railroads will enable them to rehabilitate their equipment. They are, in fact, placing orders. And so, very gradually, this difficult tangle is getting straightened out.

Of more immediate interest to those interested in building construction is the proposal before the Senate Committee on Reconstruction and Production made by Daniel Willard of the Baltimore & Ohio, which plans a co-operation between the builders and the railroads. The practical workings of the plan proposed are as follows:

Committees representing the construction industry have been appointed in various districts. In cases brought to their attention, where building material is being delayed, the construction committee will pass upon the necessity for the building and upon the construction committee's recommendation—a committee of railroad officials will see that the material arrives. W. H. Truesdale, president of the Delaware, Lackawanna & Western R. R., will be in charge of all the railroad committees.

APPEARING before the Senate Committee on Reconstruction, Mr. Otto Kahn said that although he did not consider it sound economics he favored the lending of money by the city or the state to relieve the housing situation. He opposed the plan sponsored by Mr. Stabler, comptroller of the Metropolitan Life Insurance Co., that certain mortgage investments should be exempted from taxation in order to stimulate building.

Mr. Kahn spoke most authoritatively upon the subject of taxation which he thought to be a chief cause of the country's halting production. He remarked that men prominent in finance were reluctant about discussing the present system of taxation because their criticism might be thought nothing but the squeal of a rich man against heavy taxes. While as a matter of fact all they have to do is to convert their capital into tax-free securities.

In the way of constructive suggestions, Mr. Kahn said that the excess profit tax should be abolished or essentially modified and some other method devised to tax corporate profits. The extreme scale of surtaxes actually defeats its own purpose and should be revised downward; they must not be so extreme that they cripple production, discourage or prevent normal enterprise, and preclude that accumulation of business and investment funds which is an indispensable prerequisite for material progress and prosperity.

Careful investigation should be made of the question whether means should not and could not be found to prevent further issues of tax-exempt securities, or at least to limit such exemptions, for instance, to normal Federal and State taxes.

(By Special Correspondence to The American Architect)

Seattle.—Building materials will be increased thirty-three and one-third per cent. in price on the Seattle market when freight increases go into effect late this month.

Nails and wire products advanced twenty cents per 100 pounds at the mills for Seattle and other Pacific Coast points last week, but some of the local wholesalers are not raising on their retail prices on these products, and no advances in quotations of any building material is anticipated until the freight raise goes into effect.

Seattle jobbers reported favorable conditions and a brisk demand for materials last week and the only thing holding back a more general movement of materials for new construction is the transportation

THE AMERICAN ARCHITECT

situation. Deliveries, however, show an improvement over the previous week, particularly in sheets and nails. The pipe supply is also better, although heavy shipments of this product are held back by the freight congestion in the East. Several cars of sheet iron and steel have been delivered in the last few days.

Local dealers estimated that the freight increase would mean an advance of approximately fifty cents per 100 pounds in hardware and other material lines. Conditions in roofing, cement and plaster are unchanged, with deliveries still tight. Several shipments of plumbing supplies are also held up by embargoes in the East while en route to this section.

It is reported here that pipe and boiler tubes are much scarcer and that some of the mills are closing down because of the scarcity of cars. There is a tendency here to hold down prices as much as possible as a means of encouraging building construction.

With the volume of business higher than production, district lumber mills were besieged with orders during the week and this activity was attributed to the effort of buyers to have their lumber requirements shipped before the freight increase becomes effective. Many of the orders specified that shipment must be guaranteed before the freight raise, but owing to the scarcity of cars, many of these orders had to be turned down. The flurry of orders received by mills during the week was from eastern lumber yards which wanted general yard stocks. Shingles show a price slump of about \$8 per thousand, while fir vertical grain flooring is \$2 and \$3 lower. Drop siding, flat grain ceiling, boards and shiplap also show price declines.

Linseed oil dropped fourteen cents a gallon in price here this week.

(By Special Correspondence to The American Architect)

Chicago, Ill.—Business and residential demands are absorbing vacant lands in every direction around Chicago at present and plans are still in the making for expansion of many industries. Apparently, prices are not coming down with much of a rush in the very near future, although merchants are proceeding with caution, based on financial conditions. Money rates in Chicago continue very firm. Commercial paper is selling at a shade under 8 per cent.

Lest we forget, some interesting figures have just been published showing the increased cost of living in Chicago since 1914. From December, 1914, to June, 1920, costs of food have increased 120 per cent.; clothing, 205 per cent.; housing, 35 per cent.; fuel and light, 62 per cent.; furniture and furnishings, 215 per cent., and miscellaneous, 87 per cent. Which might indicate that the "rent profiteers" are still somewhat behind the more ambitious in other lines, despite the public outcry that has been made here and elsewhere about increased rents.

Ernest R. Graham, of Graham, Anderson, Probst & White, architects, who has returned from a seven weeks' trip abroad, reports big crops in Europe, but says that housing conditions are in many cases bad, especially in England where the demand for living accommodations exceeds the supply by far. The city of London, he says, is giving bonuses to householders to build.

As to building conditions in Chicago, Mr. Graham says he is uncertain but hopeful that the entire aspect here will change before long. "It is always darkest just before the dawn" was his optimistic remark. No definite word has yet been given as to when the actual construction of the new Federal Reserve Bank building will begin nor the Illinois-Merchants and Corn Exchange National bank be started. The razing of the old structures on the site of the Federal Reserve bank building is about completed.

304 ✓

Handwritten text, possibly a signature or date, appearing as "v. n. h. p. e. t. h. e. 1833".



DETAIL—THE ALHAMBRA, GRANADA

THE AMERICAN ARCHITECT

VOL. CXVIII

WEDNESDAY, SEPTEMBER 8, 1920

NUMBER 2333

Notes on an Architectural Competition for Remodeling of a Tenement Block

Held Under Auspices of Reconstruction Commission, State of New York, and Joint Legislative Committee on Housing

THE problem as set forth in the program was "the remodeling of a characteristic old tenement block in the City of New York so as to make it a decent place to live in. The object of the competition was two-fold: First, to find the best method of improving living conditions in the old law tenements without entirely destroying the buildings; second to find a plan of remodeling that will encourage such alterations by the demonstration of its economic wisdom. The relation of costs to results obtained was a predominating factor in determining the judgment.

For the purpose of this study the block bounded by Rutgers, Madison, Jefferson and Monroe Streets on the lower East side of the Borough of Manhattan was chosen. This block contains examples of various types of old tenements. There are on Rutgers Street old private houses, that have been converted into apartments. These have dark rooms in the center of the building. On Madison Street are examples of the so-called railroad type of apartment with no means of ventilation in the center of the building excepting from small shafts two to four feet in width. There are in certain cases a series of three to four rooms borrowing light one from the other with only the first having windows directly opening on the street or yard. On Jefferson and Monroe Streets are the later type of so-called dumb-bell apartments. In these, the inner court, the greater part of which is no more than five feet in

width, is entirely enclosed on all sides, so that fresh air, if it enters at all, must enter from the top.

Each competitor was supplied with complete plans of the ground floor and a characteristic floor and elevations of the street fronts of all the buildings of the block. They showed the present actual conditions. They were required to submit two plans showing similar floors after the proposed alterations had been made and a description.

The jury based its judgment on three considerations in the order given:

1. The improvement of living conditions.
2. Economy in cost of alteration.
3. The number of persons and families that could be decently housed.

In its consideration of decent living conditions, the jury accepted as primary factors:

1. Direct light and air in every room; the elimination as far as possible of shafts and closed in courts, receiving air only from the top and the

concentration of space devoted to courts in large areas.

2. Proper sanitary facilities including a bath tub and individual toilets for each apartment.
3. Compact plan without wasteful corridors and with privacy in individual rooms.
4. Direct and easy access to apartments from well-lighted stairs conveniently located. The elimination of useless and dark corridors. An important consideration was the means of reaching the stairs from the street.



SCENE IN A REAR ALLEY

THE AMERICAN ARCHITECT

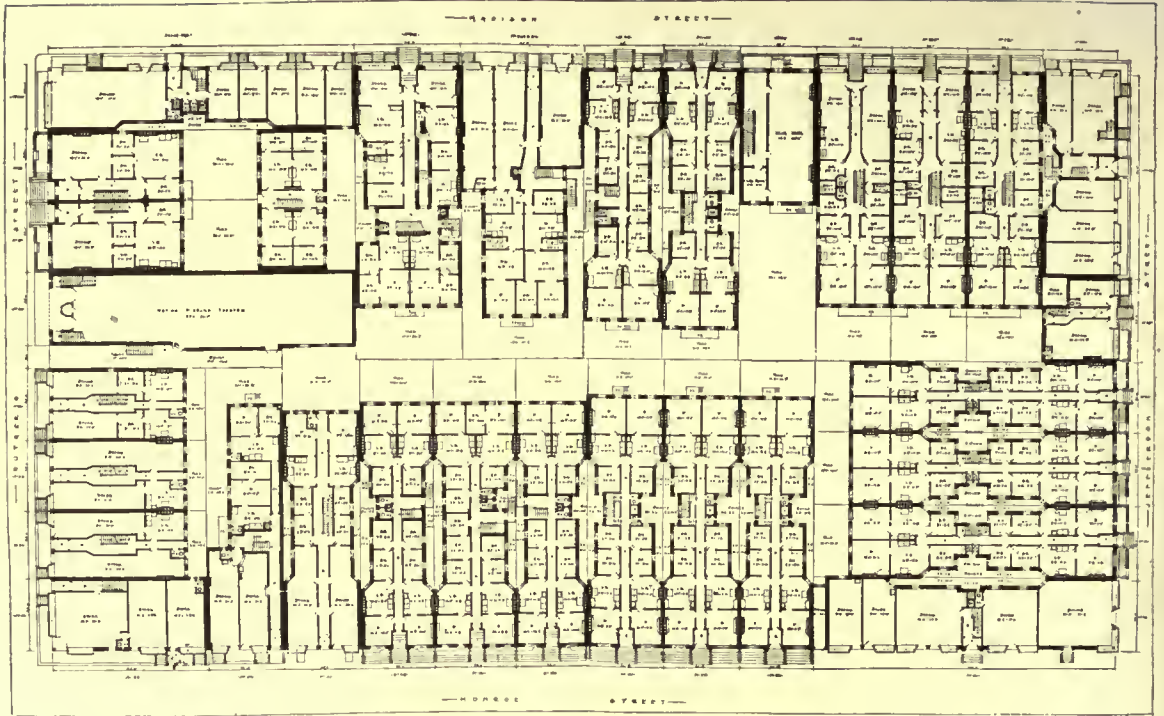

CHARACTERISTIC PLAN

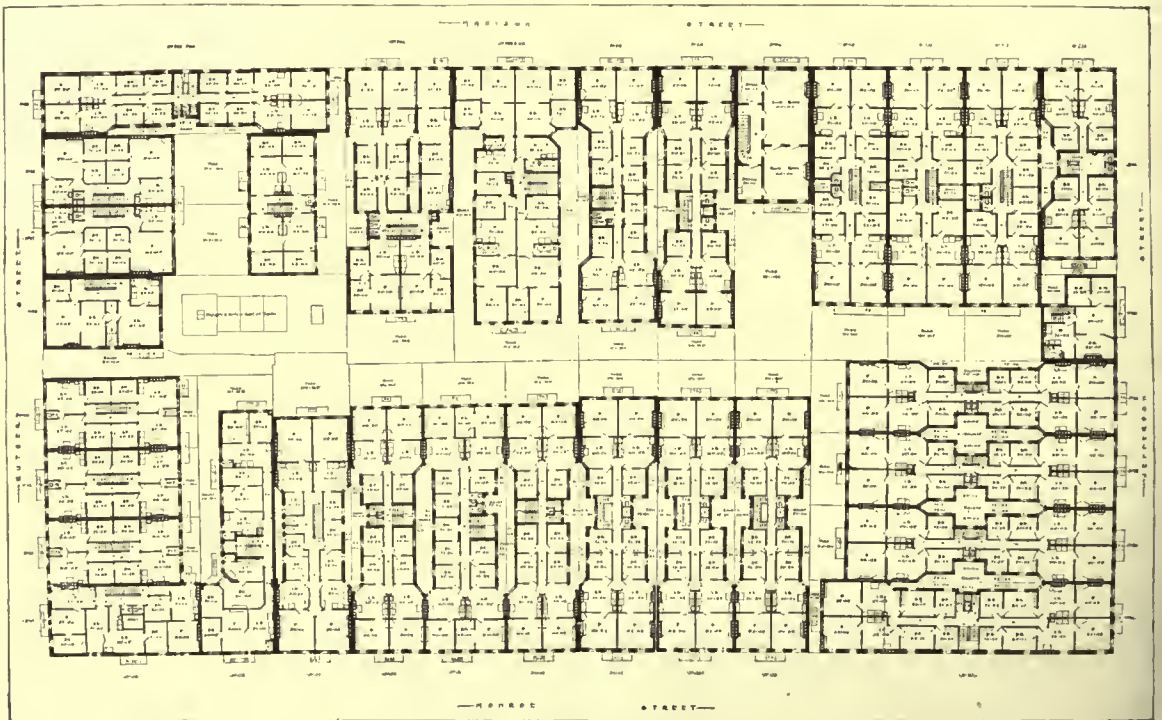

GROUND FLOOR PLAN

Floor plans of block bounded by Rutgers, Madison, Jefferson and Monroe Streets, New York, furnished to competitors as basis for remodeling

THE AMERICAN ARCHITECT

5. Space for play and recreation, either in yards, courts or on roofs.

6. Laundry facilities and place for drying clothes.

7. Conveniences essential to modern living such as dumb-waiters, sinks, wash tubs, etc.

The second consideration was the cost of alteration. Many plans were submitted which had great merit as plans of new tenements but the expense of carrying out these plans would be equal if not greater than that of completely rebuilding the block.

The Jury was assisted by estimates on certain of the proposed schemes of alteration. These were

the number of rooms now existing has been but slightly decreased though every room has been given direct light and air on the street or on large courts or yards.

After due consideration of each proposed alteration on the basis of the two main points of good housing and practicability from an economic stand-



VIEW IN A COURT WHICH IS A CHILDREN'S PLAYGROUND



CHILDREN FLEEING APPROACH OF THE PHOTOGRAPHER. NOTE THE ACCUMULATED RUBBISH

point, the Jury concluded that although there were good solutions of each, no solution was found that combined both. The Jury felt that no complete solution was offered in any one plan that would give a combination of good housing and a low alteration cost. Though this is true of the block as a whole, it is very likely that experiments with parts of blocks will prove that there are practical means of approximating the suggestions offered in the plans submitted in this competition. Many of the plans suggest desirable alterations of groups of houses that appear



A TYPICAL "PLAYGROUND"

prepared by Myrich & Ward, Inc., and J. Odell Whitenack, two contractors who have had much practical experience in alterations of this type.

The economic wisdom of a solution as a business proposition must be based not only on the cost of the remodeling but also on the comparison of the present rentals with those that could be expected as a result of the changes proposed. The Jury's next consideration was therefore the number of families decently housed. In many of the schemes

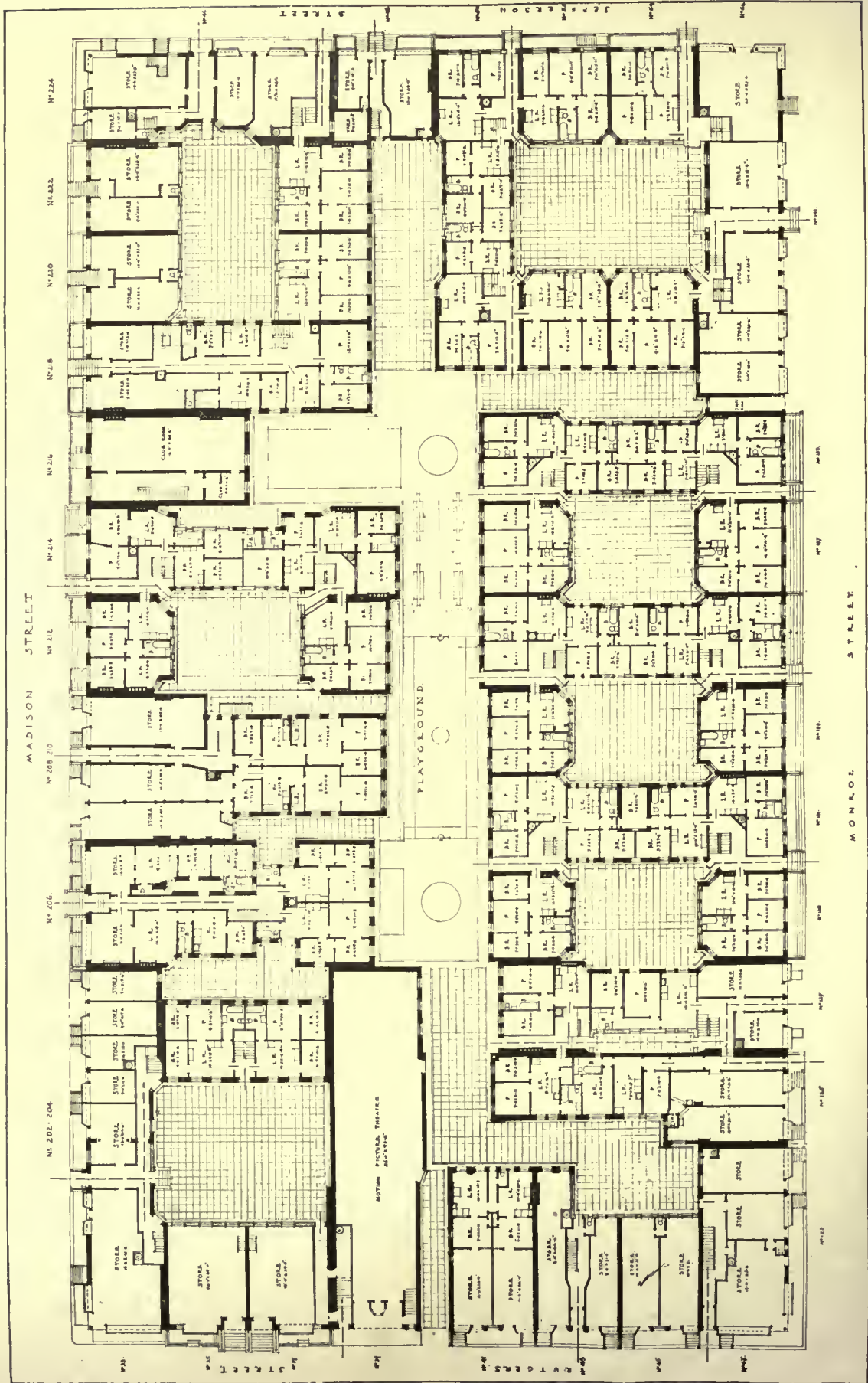

GROUND FLOOR PLAN
SIBLEY & FETHERSTON, ARCHITECTS
AWARDED FIRST PRIZE OF \$1,000

THE AMERICAN ARCHITECT

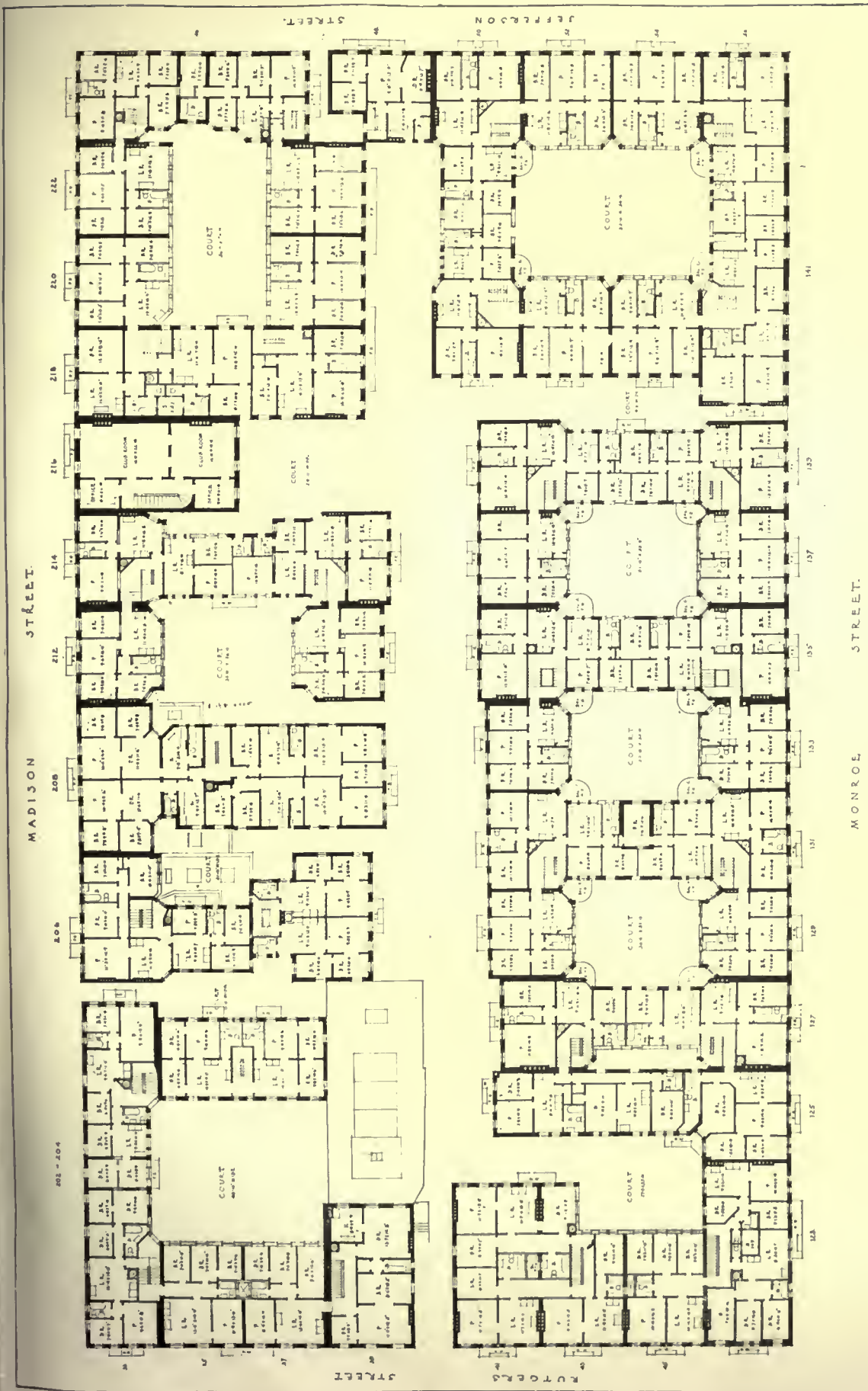

TYPICAL FLOOR PLAN
 SIBLEY & FETHERSTON, ARCHITECTS
 AWARDED FIRST PRIZE OF \$1,000

THE AMERICAN ARCHITECT

to be simple enough so that they would pay as a purely commercial venture. However the Jury was able to choose no one solution offered as a combination both of entirely satisfactory housing and a reasonable cost.

The two plans to which the largest awards were made offered each a different phase of the solution. That of Messrs. Sibley & Fetherston illustrated the maximum of good housing without entire reconstruction of the buildings themselves. However, in economy of cost that of Robert Gilbert Ecob affords lower costs and therefore would make possible

they succeeded in doing by eliminating most of the space devoted in the present buildings to lengthy corridors. Stairways are arranged so that entrances from street halls to apartments is direct and apartments are arranged in such a way as to almost entirely eliminate private corridors. Most all the principal rooms are placed in such a manner as to have cross draft. Estimates for this series of plans were received, amounting to over \$900,000. It is very probable that with slight changes the scheme could be simplified in such a manner as to cut down this price considerably, without loss of the essential

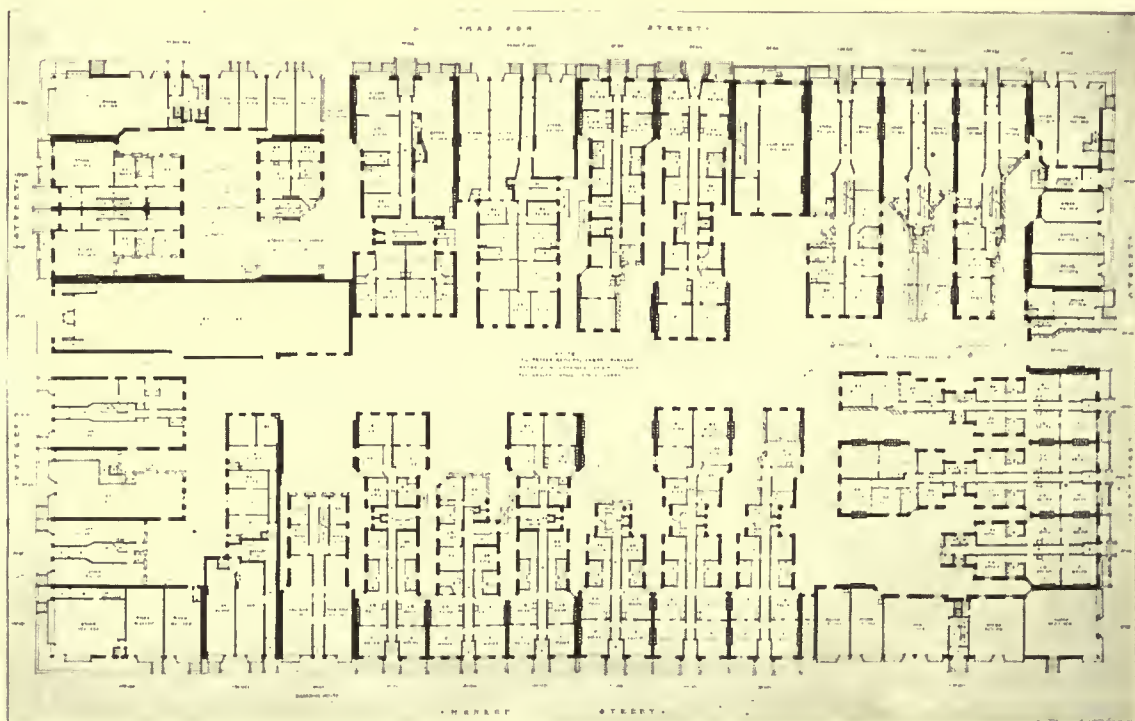

GROUND FLOOR PLAN
ROBERT GILBERT ECOB, ARCHITECT
AWARDED PRIZE OF \$1,000

lower rentals on a commercial basis, although less desirable living conditions are produced.

The plans of Messrs. Sibley & Fetherston secure ample air and light for all apartments by destroying the central portion of certain of the buildings. In the case of the dumb-bell type, they do away with a portion of each second building so as to leave courts approximately 30 and 35 ft. wide instead of the former courts five feet wide. In place of the 1,587 rooms in the existing plan, they preserve 1,481 rooms. In other words, they closely approximate the number of existing rooms although they greatly decrease the area covered by the buildings. This

features of the plan. It is proposed by the authors of this plan that courts be used as playgrounds and that roofs be used for the drying of clothes. The plan of Mr. Ecob is very much less ambitious but very much more economical. Instead of destroying large units of buildings, Mr. Ecob opens up the ends of the long courts so that air can enter freely from the ends of these courts. This would not give the most desirable type of light and ventilation but would be a vast improvement on the existing conditions. The cost of this alteration would probably be less than half that of the scheme of Sibley & Fetherston.

THE AMERICAN ARCHITECT

Various other prize winners show different schemes of altering by the destruction of the central portions of certain of the buildings in such a way as to open up large courts, which are used as playgrounds for the children or as small green parks. Many ingenious schemes of planning far superior to those in existing apartments of more expensive type were intelligently shown in these plans.

The manner of carrying out the proposed

schemes was various. A number of the competitors suggested the formation of a company of the present tenants for the purpose of carrying on all the constructional work. Others favor the assistance of the State or municipal committees of commissions and the use of State credit for the purpose of carrying out the alterations.

On the question of management most of the



APPROACH TO UPPER COURT FROM MONROE STREET. NOTE THE BLOCKED FIRE PASSAGE

authors agreed in suggesting some form of cooperative management with a single heating plant and lighting plant and efficient management by a central office. It was pointed out by many of the competitors that both the construction and management could be carried out in a practical manner in small units.

Messrs. D. Everett Waid, Allan Robinson, Alfred E. Marling, Edgar A. Levy, Clarence S. Stein, Andrew J. Thomas, Burt Fenner,

Robert D. Kohn, Alexander M. Bing, Hon. Frank Mann, Tenement House Commissioner; Senators Charles C. Lockwood and John J. Dunnigan; Mrs. Henry Moskowitz, and Miss Lillian D. Wald made up the Jury. Their study of the plans has continued for a period of almost two months with the results as herein set forth.

Basing its consideration on two main points,

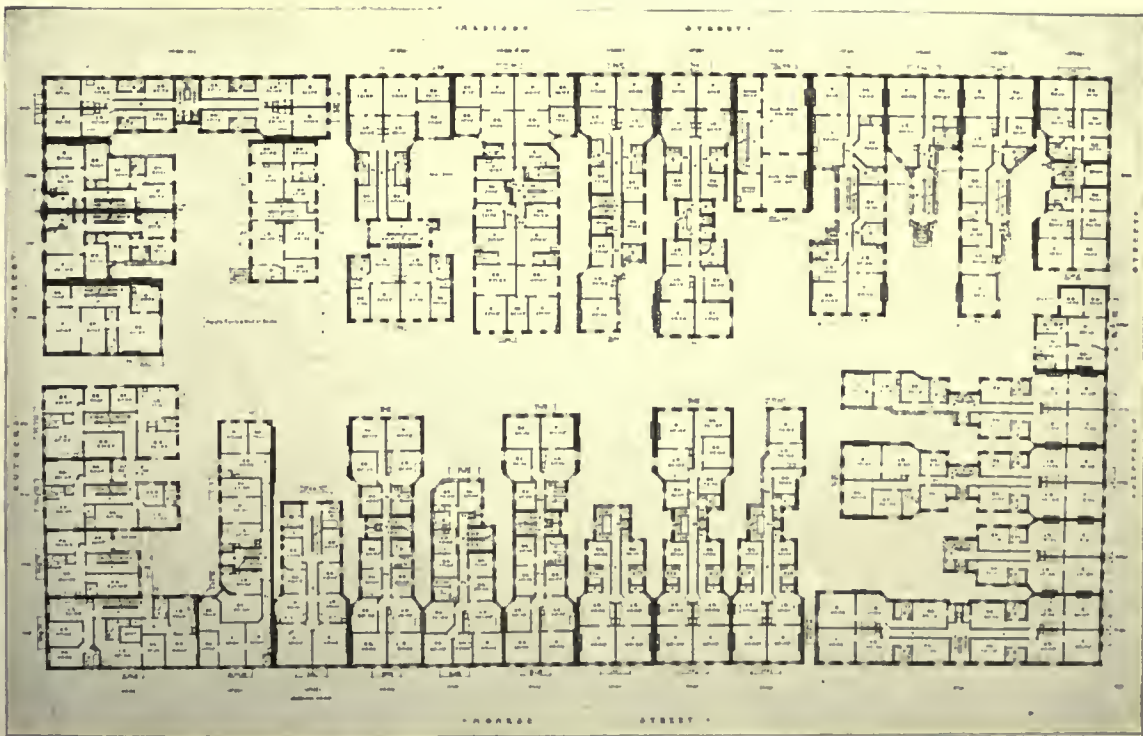

CHARACTERISTIC FLOOR PLAN
ROBERT GILBERT ECOB, ARCHITECT
AWARDED PRIZE OF \$1,000

THE AMERICAN ARCHITECT

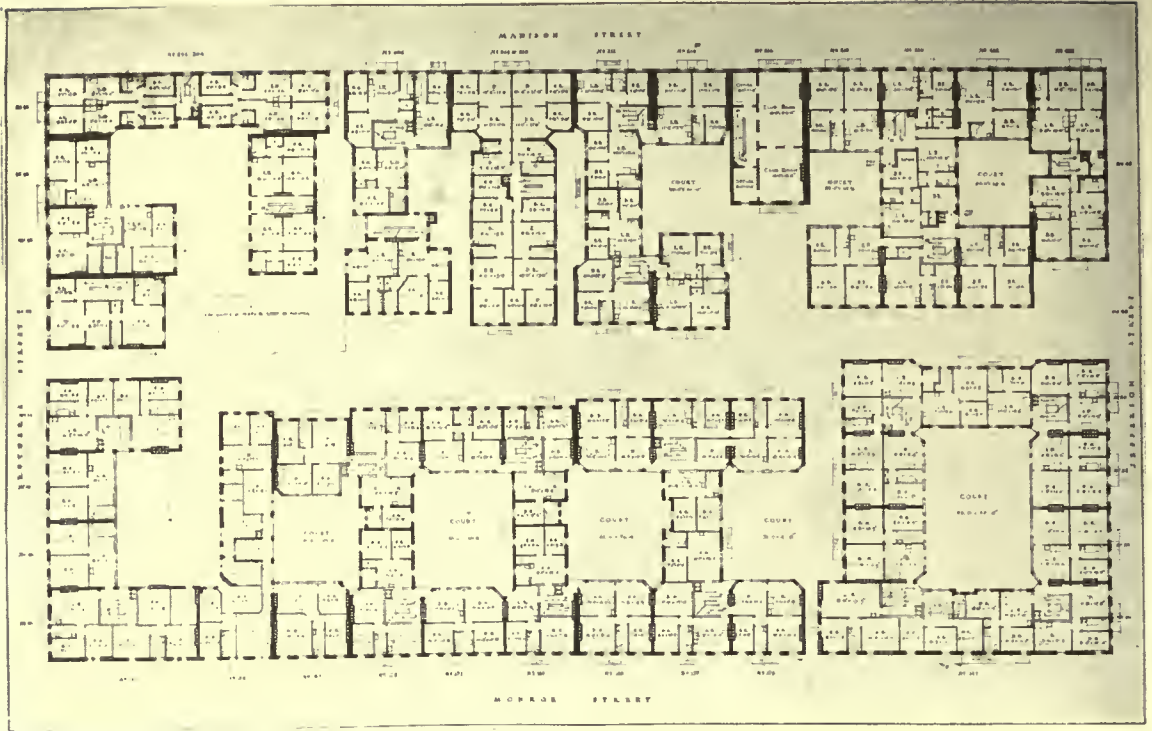

CHARACTERISTIC FLOOR PLAN

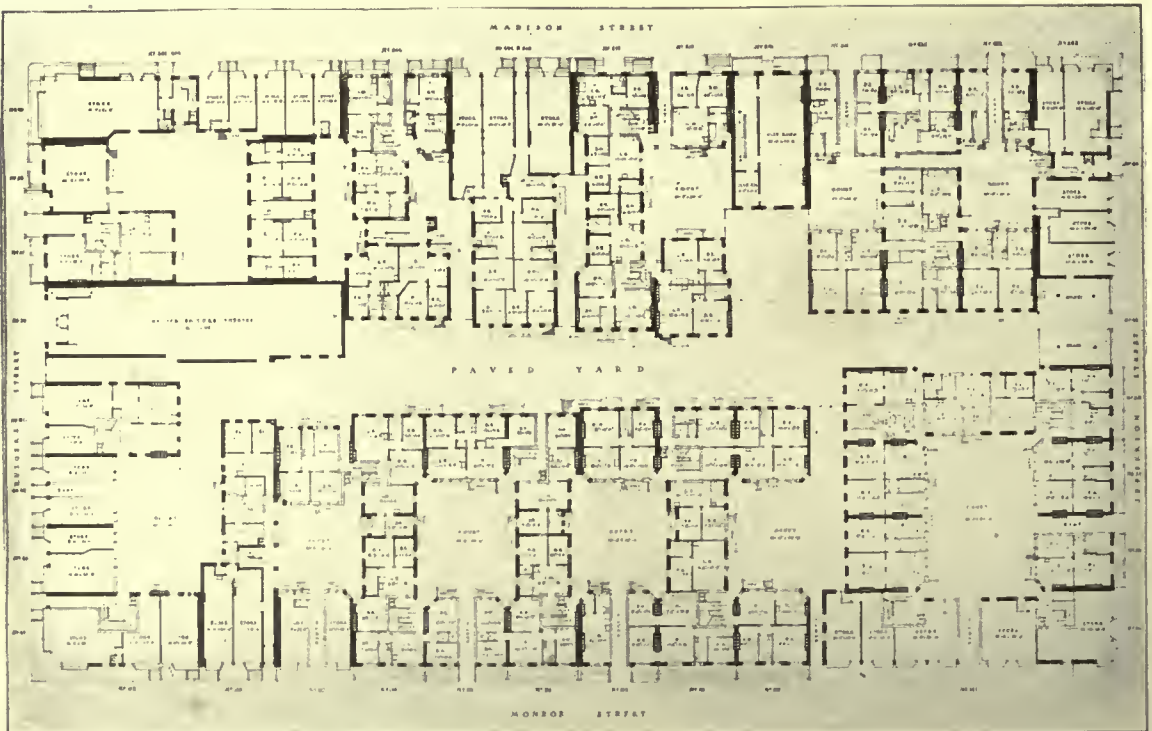

GROUND FLOOR PLAN
MURPHY & DANA, ARCHITECTS
AWARDED PRIZE OF \$500

THE AMERICAN ARCHITECT

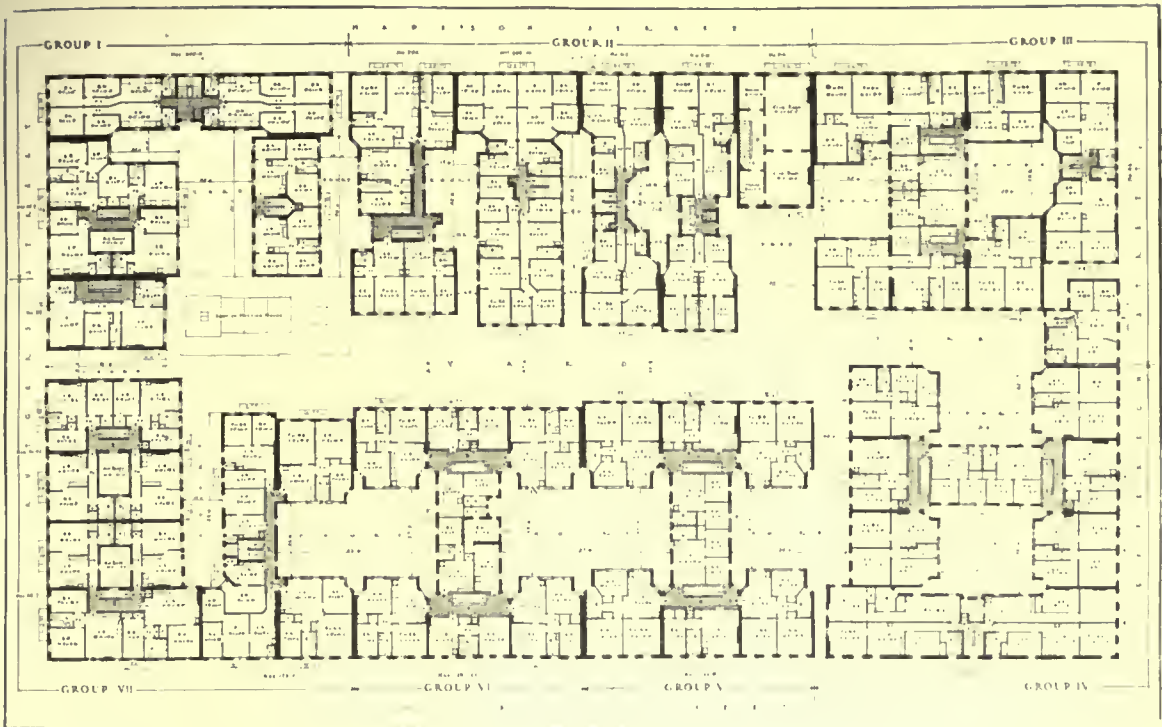

CHARACTERISTIC FLOOR PLAN

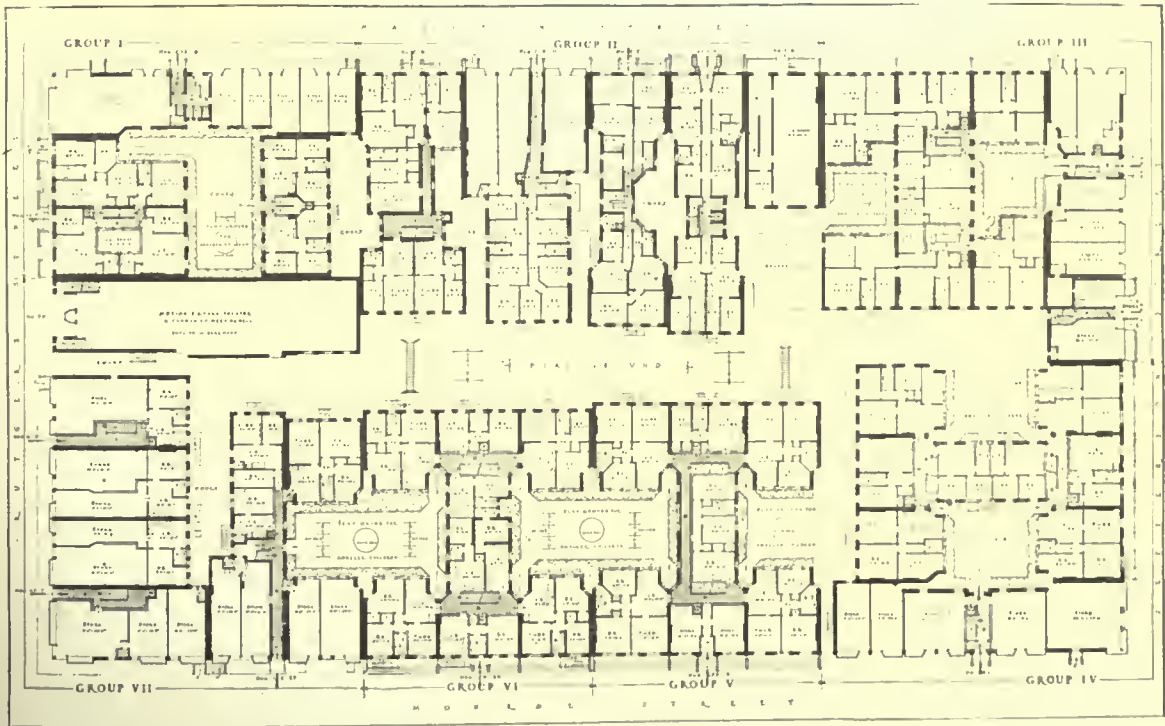

GROUND FLOOR PLAN
E. H. KLABER & E. F. WASHBURN, ARCHITECTS
AWARDED PRIZE OF \$500

that of good housing and practicability from an economic standpoint, the Jury made the following awards:
 Sibley & Fetherston..... \$1,000
 Robert Gilbert Ecob..... 1,000

Murphy & Dana..... 500
 Sibley & Fetherston..... 500
 Eugene Henry Klaber and F. Washburn.... 500
 Schenck & Mead..... 250
 Ford Butler & Oliver..... 250.

Addition to the Hotel Ambassador, Atlantic City, N. J.

MESSRS. WARREN & WETMORE, *Architects*

THE Hotel Ambassador at Atlantic City was opened to the public in the summer of 1919 as a link in the chain of hotels operated by the Ambassador Hotels System, extending from Los Angeles to New York.

Designed by Messrs. Warren & Wetmore, of New

York City, it embodied the very latest achievements in the design, equipment and furnishing of the modern hotel at that time. Its 390 guests rooms, together with its lounging and dining rooms, made it one of the largest of the numerous hotels at this seaside resort.



LOGGIA—BRIGHTON AVENUE SIDE

THE AMERICAN ARCHITECT

The demand for hotel accommodations at Atlantic City became so great, due to the city's popularity as an all-year-round health and pleasure resort and its selection by many deliberative bodies for a convention city, that it exceeded the available supply. As a result of this demand an extension has been built to the Hotel Ambassador, which more than doubles its original size and extends it to the limits of the full city block bounded by Brighton avenue, the Boardwalk, Stanton place and Pacific avenue. The extension is 125 x 228 ft. and was designed by the architects for the original building.

Improvements in hotel design, developed since the construction of the original hotel, have been incorporated, making the new building even more complete than the original.

Like the older building, the addition is twelve stories high, finished in buff rough textured brick.

It contains 450 guest rooms. It is joined to the old building on the first floor only. Above the first floor the extension is L-shaped and is separate and distinct from the original hotel. A colonnade loggia runs along the Brighton avenue and Pacific avenue sides. The first story is occupied by a large entrance foyer, European and American plan dining rooms and kitchens. The European or Renaissance dining room is designed to be used for large functions, as a ball room.

The dining rooms in the extension serve the entire hotel, the original dining room being utilized as a lounge.

Some novel features in foundation design and construction were developed in the construction of the extension. This subject will be treated in the Engineering Department of this journal in a succeeding issue.

Employers' Housing Project

IN an interesting interview in the *New York Times*, Mr. Wm. E. Harmon of the Housing Conference Committee described certain pros and cons of housing by employers. A common error is, he says, to build houses of a kind foreign to the make up of the individuals who will either buy or rent them. The man in the machine shops and his wife do not, for instance, want their walls papered in tans and grays. They want gayly-colored flowers. The architect that the employer retains cannot conceive of lending himself to a housing scheme where every law of art and decoration is defied.

He fails to recognize the fact that, even as his sense of artistic conventions is being shocked, he is overturning the sense of color and beauty which these people have made their own. It is true that his ideal of beauty may be the truer one as far as consensus of artists is concerned, but it is the fool-hardy man who attempts to superimpose ideas of any sort upon a group of people before the groundwork to support them has been dug.

Mr. Harmon suggests that employers contemplating a housing project should first have a committee on which the employes have a commanding vote to assure the characteristics they deem necessary.

This done, the next step is to hire a builder, not an architect, who can give the employe the kind of

house he wants. For this special problem Mr. Harmon thinks the insignificant builder on the street is more valuable than the exclusive architect with offices in an expensive building. The first knows the people whose houses he is building; his tastes are their tastes, his needs are their needs, his ideas and ideals of beauty are theirs.

"If I were building an industrial housing centre for employes who were of Irish extraction," he says, "I should choose a builder of Irish extraction or one who was familiar with their domestic idiosyncrasies; if I were building a centre for Italians, I should attempt to get a man of their own nationality to plan the details of the houses; if I were building homes for Jewish men, it would be the Jewish builder with whom I would confer. What the employer is primarily interested in is the happiness of his employes, which, in turn, insures him the prosperity of his business. He must learn to put himself in their place. He must understand that green wallpaper with pink flowers is all right even if it is an eyesore to him. He must appreciate the truth that, in planning for things outside of the factory for his employes, the less authority he exerts the less mistakes he will make in matters of which he has no knowledge. Once he understands that, the matter of perpetuating their stay with him will take care of itself."

Architectural Quicksands

Changes in Plans

By CLINTON H. BLAKE, JR.

PROBABLY the phases of the architect's work which proves in many ways most exasperating is the making of the many changes in the sketches and plans demanded by the client. It is natural that the first sketches and floor plans submitted should not absolutely meet the ideas and approval of the client. The architect knows only too well how many suggestions for changes the ordinary client will make and what a large proportion of them will probably be entirely impractical and impossible of adoption. Usually these very ones are those upon which the client has particularly set his heart, and it takes a considerable degree of both patience and tact on the part of the architect to convince him that they should not be forthwith incorporated in the plans. For some reason, the ordinary client is not able to "read" a plan or visualize an interior from the plan with any degree of accuracy. The inevitable result is that in almost every case, after sketches and plans have been prepared and tentatively agreed upon, the client will direct that certain changes in elevation and lay-out be made. As a result, the plans must be redrafted and specifications changed. Clients, even those who are trained business men, seem to realize very little of the amount of time and labor, and expense—as well—which enter into the preparation of sketches and plans. They realize even less the real expense in the time of the architect and his draftsmen and organization which the making of changes in the plans and specifications entails.

The architect, in the absence of any agreement on the point, is entitled to recover the reasonable value of the services and time given. Nevertheless, as a practical matter, unless the point has been specifically covered and unless the client understands fully the basis on which the work is done, it will be found that he will object strenuously to any substantial charge for changes and alterations, and that the fact that the changes and alterations are due to his own desires and directions will not alter his feelings in this respect. To prevent complications with respect to alterations it is essential that the architect should, in the first place, be sure that under the agreement with the client he has not obligated himself in any way to make changes without additional charge, and in the second place, see that some affirmative agreement on the part of the client is entered into, whereby the architect is insured payment for the extra work done.

Recently I was consulted on a case coming under the first of these possibilities. The client had written a letter to the architect at the beginning of their relationship, outlining in a general way his understanding of the terms upon which the work was to be done. The letter was received by a subordinate in the architect's office and accepted by him without the knowledge of the architect. The job in question involved the erection of an elaborate country home. From the beginning, the client required repeated changes in the elevation, and in the plans and specifications, as well, with the result that, by the time the work was completed, the architect had given to the job about three times the time and attention which would have been required had the work been proceeded with along the lines of the plans and specifications, as originally drawn and prepared. When the architect submitted his bill for the additional time which he had given to the changes the client produced the letter which he had written and which the office of the architect had acknowledged and accepted and claimed that under the wording of the letter the architect could make no charge for any of the changes and the extra work represented by it.

When the highly indignant architect submitted the facts to me, I was forced to advise him that, in view of the letter which had been written and the acceptance of it by the architect's office, the client was within his legal rights in taking the position which he did, however unethical and morally indefensible that position might be. If the letter from the client had been properly considered and its legal effect appreciated, the architect could, in the beginning, have told the client that he would not proceed on the basis outlined and could undoubtedly at that time have secured the assent of the client to stipulation that the architect should be paid for any changes asked for by the client. The architect has needed no second lesson, and ever since the foregoing occurrence has made it a rule in his office to secure a definite contract, the provisions and effect of which he fully understands, and to embody in this contract, as one of its terms, the provision that he shall be paid the reasonable value of all work made necessary by changes in sketches, plans or specifications required by the client.

It is self-evident that a provision of this sort is entirely proper. Of course, any changes which the architect may be required to make to correct inac-

THE AMERICAN ARCHITECT

curacies in his preliminary work cannot properly be the subject of a charge. Where the client himself insists on changes, however, and thus is the direct cause of the extra work done, it is both just and proper that he should pay for the work, and no client, if the matter be properly broached in the beginning, can well refuse to agree to such a condition. On this point, as on all the other points covered by the contract between architect and client, the many terms which will be readily agreed to at the first interview or before the work has actually gotten under way, may, as the job develops, be exceedingly difficult to arrange. One cannot look ahead sufficiently to anticipate what complications may arise, what the mental re-actions of the client may be, or how the attitude and feeling with which he at first undertook the work may be affected by unexpected increases in cost, changes in his own financial situation, possible friction between the architect and himself, or by any one of a score of like possible causes.

The philosophy of "doitfust," so pleasantly set forth by David Harum, applies to the dealings of the architect with his client, just as emphatically and pertinently as it does to any other business dealings. Get your agreement clear in the first place and do not trust to everything working out without complications or to fortune favoring you in case complications do arise!

SPECIAL WORK.

A phase of the ordinary high-class job, which is analagous to the extra work proposition, is that having to do with work of a special and extraordinary character. The architect's commission is based on the assumption that the job is to be of the ordinary kind and that no special work, requiring an unusual degree of care in design or execution, is to be incorporated in it. In repeated cases, however, this is exactly what is done, and in any very high-class and extensive piece of construction, especially in the cases of country homes, special work will be called for in the design and installation of panelling, cabinet work, *torchères* or other similar items. This work requires, naturally, a special degree of thought and a special degree of skill, and it is fair that the architect should be paid on a higher percentage basis for items of this character than for the ordinary design and construction. I have in mind, among other two rather interesting examples of how the architect may, unless he take proper precautions, suffer loss in this way. Each of these cases had to do with a country home, costing a large amount of money, and recognized as an extraordinarily effective and high-class piece of work.

In the one case the item on which the controversy arose was a specially designed door and doorway. The client desired a very particular and unusual ef-

fect, and the architect, at the expense of a great deal of time and personal study and attention on his part, had worked out and incorporated in the plans a design of unusual attractiveness and excellence. After the architect's work had been done, the client, for some reason, decided that he would not pay more than the ordinary commission for this special work, and the architect, as matters stood between them, was unable to force him to do so. The architect's office had been foolish enough, in this case also, to allow correspondence to stand on the record, which precluded any extra charge for the work done.

The second example which I have in mind arose in the course of the construction of the home of a man widely known and of high standing in his community. When the work was under discussion in the first place, the client, calling at the architect's office and noticing a rather choice old Chippendale cabinet, stated to the architect that he would like to have the woodwork in his house finished in a similar manner. What he had in mind and what the architect naturally understood was that he wanted to have the wood-work made to appear as nearly as possible similar to the antique. The architect did remember the client's request and gave special attention to the wood-work and achieved what he considered an unusually successful result in the finish. The client, after a critical inspection, decided that the new wood-work was not entirely comparable with the hand work of Chippendale, and, absurd as it may seem, insisted that the architect had not fulfilled his agreement and that he was entitled to exactly the same tone and the same "patina" on the woodwork in his house as that which the mellowing of age had given to the original piece. The result was that the client sincerely, but absolutely without cause, conceived a violent prejudice against the architect and refused to make payment of the many thousands of dollars which were still due the latter.

It was at this stage of the proceedings that I was brought into the matter. I spent many days listening first to the curses of the architect directed against the client, and then to the curses of the client directed against the architect, and finally was able to induce the client to make payment of the amount in full. This was not accomplished, however, until the architect, as a result of the misunderstanding, had lost a perfectly good and valuable client, and until he himself had given, and I had given, to the matter, attention and time representing a considerable amount of money. All of the difficulty in these cases might have been avoided quite easily, and the good-will of the client retained, if the architect had had a contract with the client properly drawn and executed, and had been more definite in his conversation and dealings with him. The case of the doorway and similar

THE AMERICAN ARCHITECT

cases emphasize anew, also, the importance of developing a system of open organization and conduct which shall avoid as nearly as may be, the danger of some employee innocently committing the firm, by letter or otherwise, on points of importance, involving loss to the architect and calculated to breed misunderstanding and ill feeling between the latter and his client.

DELIVERY AND ACCEPTANCE OF PLANS.

In any discussion relative to the right of the architect to recover for plans which he has prepared it must be understood that, to enable him to recover, he must have made a proper delivery of the plans to the owner. Of course, if the owner waives such a delivery, or by some action on his own part, prevents the delivery and makes it impossible, this rule would not bar the architect from recovering the amount due him. Unless, however, the owner waives or prevents delivery, or unless there be some contract between the owner and the architect, under the terms of which delivery need not be made, the plans must be delivered by the architect to the owner, in order to enable the former to recover for their preparation. The phrase "delivery to the owner" is used in a relatively broad sense, and if the owner directs that they be delivered to someone else, as, for instance, to his contractor, the delivery of them, in accordance with this direction, would be considered as a delivery to him.

The main point to remember, however, is that the mere preparation of the plans in the office of the architect is not sufficient. The point is important, because it often happens, that, after the plans have been prepared, the architect, either has some dispute with the client or perhaps becomes doubtful of the client's financial stability, and conceives the idea that he will demand payment for the plans, before delivering them. This is putting the cart before the horse, and might result seriously for the architect, in that the client could well refuse to make payment for the plans, on the ground that they had not been delivered and that payment had been demanded before delivery, and might even conceivably claim a definite breach of the whole agreement on the part of the architect, and so terminate the contract and relation between them, if the architect were to persist in his attitude.

In Massachusetts some years ago an owner tried to avoid liability by claiming that the plans had never been delivered to him. He had directed the architect to prepare the plans, and the architect had prepared a preliminary sketch. This he delivered to the owner, who kept it for some days, and after expressing his approval of the tentative scheme, as outlined, told the architect to proceed with the plans. He then had his builder call on the architect and take the completed plans and submit an estimate, based upon them. While the owner, in person, never received the plans, the Court quite properly decided that a proper delivery of them had been made and that the owner could not, under such circumstances, successfully claim non-delivery.

I have, in other writings, drawn attention to the distinction between the delivery and the acceptance of the plans, and a word or two more here on this point may, perhaps, not be amiss. The layman might ordinarily confuse delivery with acceptance. In fact, they are quite distinct. The architect may deliver the plans and the same may be received by the owner, and yet the latter may not necessarily accept them. If the architect has lived up to his obligations and agreement and on the work which he was employed to do, the owner, after the plans have been delivered to him, can not avoid his liability to pay for them by an arbitrary refusal to accept them, or by that claim that, because he does not accept them, they can not be considered as having been legally delivered. The architect, in such a case, can proceed with a clear conscience to collect the amount due him, and the Court will back him up and will not allow the owner to hide behind any such flimsy technicality. On the other hand, there are cases, not infrequently, where the distinction between delivery and acceptance becomes of prime importance, and where a failure to accept may well prevent the collection by the architect of the fee upon which he has counted. A typical case of this sort is that of the ordinary competition, where plans are prepared and delivered, with the understanding that the architect who has prepared the successful plans is to be chosen. In such a case, acceptance of the plans is necessary to enable the architect to recover for their preparation, except insofar as the competition may provide for some specific remuneration to unsuccessful contestants.

Beaux-Arts Institute of Design

DIRECTOR OF THE INSTITUTE, LLOYD WARREN

ARCHITECTURE, WILLIAM F. LAMB

SCULPTURE, JOHN GREGORY

MURAL PAINTING, ERNEST C. PEIXOTTO

INTERIOR DECORATION, ERNEST F. TYLER

Official Notification of Awards— Judgment of April 13, 1920

PROGRAM.

THE MUNICIPAL ART SOCIETY PRIZE.

Through the generosity of the Municipal Art Society of New York City this prize will be awarded annually on the fourth Class "A" Project of the season.

First Prize—\$50.00 Second Prize—\$25.00

CLASS "A"—IV PROJET.

The Committee on Architecture proposes as subject of this Competition:

"A RAILROAD STATION PLAZA."

Modern engineering and the development of the electric

locomotive have made it possible, by means of underground tracks, to establish our railroad stations at convenient points in our cities without fear of the noise and dirt which have heretofore made them so objectionable. We are now enabled to give the proper architectural treatment to this very important type of edifice and in many cases, notably in Washington, a large plaza has been developed in



G. N. PAULY CARNEGIE INST. OF TECH.
PRIZE AND FIRST MENTION
SPIERLING PRIZE COMPETITION
CLASS "B"—IV ESQUISSE-ESQUISSE—A BAND
STAND

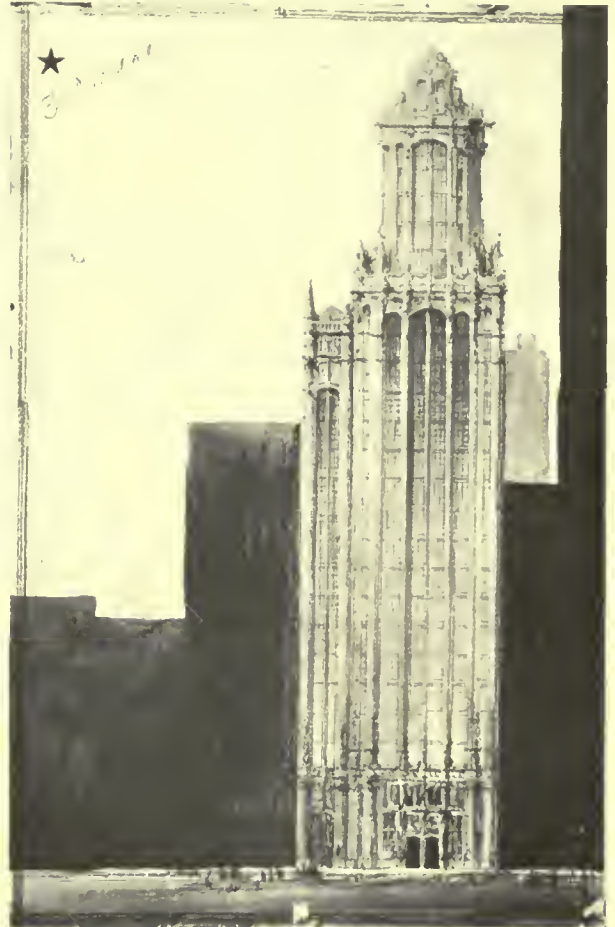

T. B. EPPS. THIRD MEDAL UNIV. OF PENNA.
CLASS "A"—IV ESQUISSE-ESQUISSE—THE
FAÇADE OF AN OFFICE BUILDING

front of it which forms, in a sense, a gateway to the city and gives a very imposing impression to those arriving in the city.

The regulation and distribution of traffic, both pedestrian and vehicular, should be recognized as of the greatest importance. This is true not only of the immediate vicinity of the station, where the greatest congestion is likely to occur, but also of the various points about the plaza where the boulevards and streets enter. It is desirable to avoid as far as possible conflicting currents of circulation and to arrange the automobile and baggage entrances and exits

(Continued on page 325)

Looking Along the Southern Facade of the City Hall in New York

JOHN MACCOMB, *Architect.*

(See reproduction of the original drawing by O. R. Eggers in this issue)

CONCEDEDLY one of the best extant examples of early architecture in America, the City Hall in New York maintains in spite of towering neighbors the distinction that has ever rightfully belonged to it. When John MacComb set about the design and erection of the City Hall he perfected a set of drawings that were then, and remain today, examples of the most excellent artistic skill. Slowly this building grew to its present proportions until finally in 1804 it was completed.

It is significant of the honesty and integrity of those days, that the Council of the City, strong in the belief that the area north of the City Hall would not become important and desiring to rid the taxpayers of an unnecessary burden, decided to make the northern facade of brownstone as a means of economy. This splendid building fortunately has been able to withstand the misdirected efforts of city governments. Many so-called improvements

have been carried forward under different administrations.

About twelve years ago there was accidentally discovered in an old chest in the rooms of the Historical Society, all of MacComb's original drawings. With these invaluable guides and due to the generosity of Mrs. Russell Sage and the city administration's concerted action, Mr. Grosvenor Atterbury has been enabled to restore the interior to its original condition. The Mayor's office, the Governor's room and the Council Chamber may now be viewed in almost exactly the same architectural state that marked the original interiors.

The exterior is practically unchanged with perhaps the exception of the cupola. This feature has been twice destroyed by fire. As at present restored by Mr. Atterbury, it is entirely fire-resisting and in design follows exactly along the major lines as shown in a series of tentative sketches made by MacComb

A Seventeenth Century New England Farm House

ONE of the best preserved houses of the earlier Colonial Period in New England is the "Parson Capen House" in Topsfield, Mass., built in 1683 by the Rev. Joseph Capen and described in the latest bulletin of the Society for the Preservation of New England Antiquities. The house is now owned by the local historical society and was carefully restored in 1913 by its secretary. This house was well built, even for its day, and it possesses architectural embellishments unknown in other existing dwellings of that period. The second story widely overhangs the first in front, the garret floor project at either end and all are supported by ornamental wooden brackets. The overhang is a form of timber construction common in old English work and seems to have been done solely for its architectural effect. Beside the front door and under the gables are brackets that help to support the overhang.

The framework of these houses was usually of oak, though sometimes of pine and made of heavy timbers mortised and tenoned together and held in place by wooden pins. Their joints were hewn with much skill by men who worked as their medieval forefathers had done. The foundation timbers rested on an underpinning of field stones, laid without mortar.

The timbers of the framing in the Parson Capen house are, of course, very old, and the original newel and turned balusters of oak are still in place. Much of the interior woodwork, however, and all of the shingles and clapboards are restored. This restoration serves to show how the houses of the early period looked when fresh from the hands of the builders. Under the northern ends of the "summer beams"—which is one of the curious features in the Parson Capen House—being girts spanning the rooms, is incised with a chisel the date, July ye 8th, 1683, so that the exact date when the "frame" was raised is known.

320^a



THE CITY HALL, NEW YORK

THE AMERICAN ARCHITECT Series of Early American Architecture





Planning in Slum Areas

EVERY large city in the United States faces the problem of replacing its old tenement districts with decent living places. Two methods are available, one razing the entire area and replacing the demolished buildings with new ones; another is so to alter and improve the existing buildings as to make them fit places to live in. Up to the time of the decision of a competition just decided in New York but little if any serious attention was given by architects to the second of these alternative methods.

The interesting competition illustrated in this issue is the first important step in a movement to reform New York's slum district. The practical value of a movement of this nature cannot be questioned.

In March, 1919, of the total 982,926 individual apartments in New York City, 587,851 were in old law tenements, that is to say they were erected before the present Tenement House Law went into effect nineteen years ago. This law fixed standards which were designed to protect the community from the most obvious dangers of fire and disease. Most of the old law tenements still fall below these standards.

The old law houses, which are detrimental to the health and well being of the community and at the same time a poor financial investment might be expected to disappear and be replaced by other buildings. The process of destruction is slow. In ten years, that is to say, between February, 1909, and March, 1919, 58,552 apartments were destroyed. At this rate, it would take 100 years for the last of these buildings to disappear.

Most of the owners of the old houses have had slight if any return from the money invested. Rentals are low. The tenants constantly move. In twenty-five old tenement house blocks in various parts of the city surveyed by the Reconstruction Commission it was found that over 20 per cent. of the inhabitants move each year. There is always a large number of vacant apartments. In March, 1916, 6½ per cent. of the old law houses were unoccupied. In March last, at the height of the housing shortage, there were 19,110 old law apartments

vacant. These were, with few exceptions, places unfit for human habitation.

Most of the defects of the old tenements are due to poor planning. Their value not only in terms of better living conditions, but also as a financial investment, would be enhanced if they were properly planned. They are below the standard fixed two decades ago. Since then great progress has been made in the planning of apartments. It has been proven within the last few years that with a use of double the amount of area required by the law for court space, apartments can be planned on the same sized lots so as to give the same rental per room, a greater return on the investment. These results have been attained by careful planning of large units.

ALL those modern features of good planning so clearly shown in the series of premiated plans presented herewith, are the result of a movement, largely given impetus by architects in this country. This very important work reached its culmination when a group of highly trained members of the profession labored in Washington throughout the war to bring to the highest state of efficiency these all-important features of low-cost housing. The value of the researches conducted by the various housing boards cannot be overestimated. The one big regret is, that owing to a shortsighted governmental policy, the various reports are not available. An edition, ridiculously short, was exhausted overnight and thousands of men to whom this report would have been of very great value must do without it. Meanwhile the government printing office is largely aiding in increasing an already serious shortage of print paper in the widespread circulation of a lot of speeches delivered in Congress, whose only value is to those members who seek to repair their crumbling "fences."

It is to give the most widespread publicity to a subject that is vital to every large city in the country that THE AMERICAN ARCHITECT has devoted the greater part of this issue to a study in practical planning in slum areas, and it is believed that the game is very much worth the candle.

THE AMERICAN ARCHITECT

Advertising the Architect

THE one time advertisement of the nude baby, reaching for a cake of soap, always accompanied by the legend "He won't be happy until he gets it," reminds one of the struggles of a certain group in the architectural profession.

This group, by its insistence for a revision of that part of the Code that forbade architects to advertise, caused ultra-conservative members of the institute to cry out in protest. However, the barriers were in part eventually let down, and architects were free to advertise. With the exception of a certain few firms, some of whose advertising methods were explained and set forth in this journal, architects who were not going to be happy until they got permission to advertise have simply contented themselves with the permission and have made very limited use of the privilege.

It would appear, however, that the true value of advertising by architects does not lie in the effort of the individual as much as it does in organized bodies of the profession. The true intent of advertising is first of all publicity, and then the wide dissemination of fact. It is undoubtedly true that the general public has a less correct comprehension as to just what are the exact functions of an architect than of any other profession. It is an old and trite saying that a man who is his own lawyer has a fool for a client. No sensible man would endeavor to supply the doctor's place in his own family. There are, as all architects know, thousands of wisecracs who dispense with an architect's services and endeavor to serve their own ends by the exercise of their own uninstructed efforts. Advertising is the exact remedy. Campaigns of publicity, statements of facts and figures. Individuals have done this to a limited extent, but it will be much more effectively carried forward if under the control of state societies or chapters. These could speak with authority and the general public would at once detect the value of such a propaganda.

WE learn from the August Bulletin of the Illinois State Society that the Ontario Association of Architects, with a membership of 150, is, through the medium of a series of well prepared advertisements appearing in the Canadian daily press, educating the public into the exact meaning and importance that attaches to the title "Registered Architect." All the requirements that an architect must meet to become a registered architect are set forth and fully described in these advertisements. The result is that the public first becomes impressed with the fact that to become legally qualified to practice architecture, a man must learn a great many obtruse things well, but they are also awakened to the fact that there may be "quackery" among architects as well as among doctors, and that it will be to their interest to be on guard against it.

It is also learned from the bulletin's comment on the action of the Canadian architects that the campaign of advertising is producing the most valuable results to the entire accredited profession.

Architects in this country have, it is feared, chased the shadows and played with the straws of things. It is possible that in searching for a basis of philosophy they have ignored a basis of practicability. It is assumed that organized bodies in the profession are created to serve the best interests of its members. The Committee on Public Information that would logically be the one to carry forward a campaign such as is successfully operated in Canada is now practically defunct. It was, considered on the basis of its organization, a most valuable factor in placing a knowledge of the architect's services intelligibly before all the people.

Why not advertise the profession more energetically, and while placing a manufactured product before a consuming public, why not educate the students so that the products will be up to the specifications set forth in the advertisement?



ORIGINAL BUILDING AND ADDITION
THE HOTEL AMBASSADOR, ATLANTIC CITY, N. J.
MESSRS. WARREN & WETMORE, ARCHITECTS

322



3222

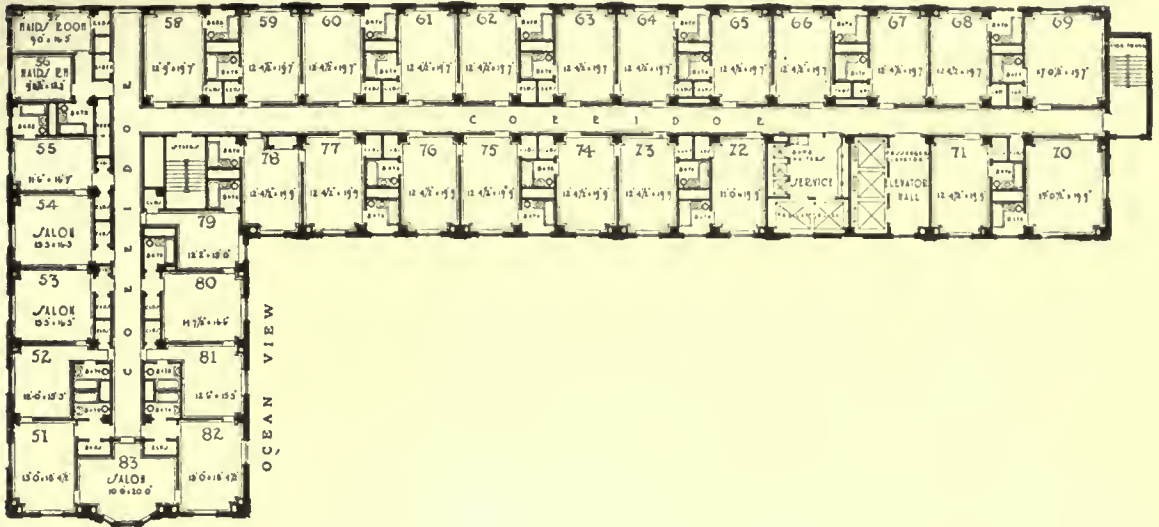

TYPICAL FLOOR PLAN

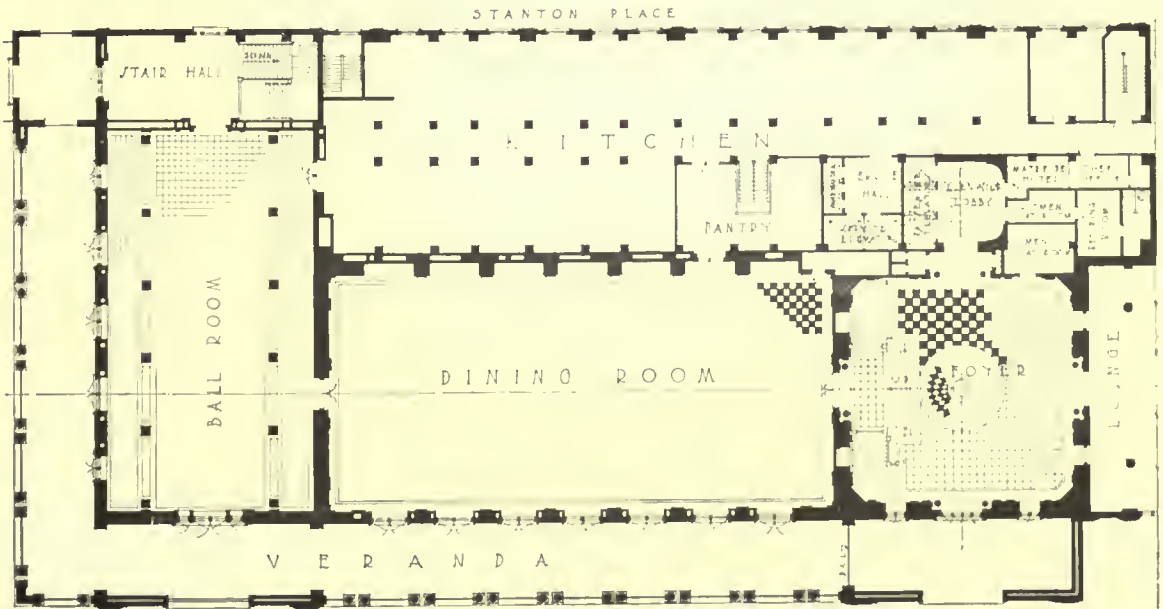

FIRST FLOOR PLAN

ADDITION TO THE HOTEL AMBASSADOR, ATLANTIC CITY, N. J.
 MESSRS. WARREN & WETMORE, ARCHITECTS





MAIN FOYER
ADDITION TO THE HOTEL AMBASSADOR, ATLANTIC CITY, N. J.
MESSRS. WARREN & WETMORE, ARCHITECTS

2223





GROUND FLOOR ENTRANCE FOYER
ADDITION TO THE HOTEL AMBASSADOR, ATLANTIC CITY, N. J.
MESSRS. WARREN & WETMORE, ARCHITECTS

1125





THE LOUNGE
ADDITION TO THE HOTEL AMBASSADOR, ATLANTIC CITY, N. J.
MESSRS. WARREN & WETMORE, ARCHITECTS





RENAISSANCE DINING ROOM



MAIN DINING ROOM

ADDITION TO THE HOTEL AMBASSADOR, ATLANTIC CITY, N. J.
MESSRS. WARREN & WETMORE, ARCHITECTS



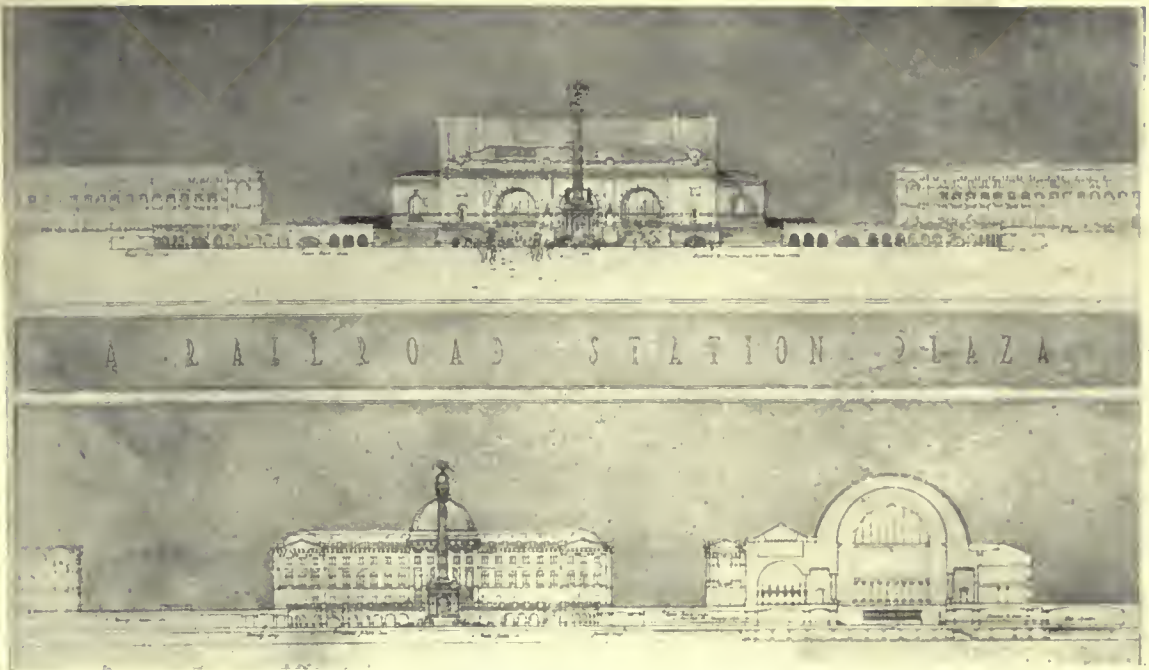

A R A I L R O A D S T A T I O N P L A Z A

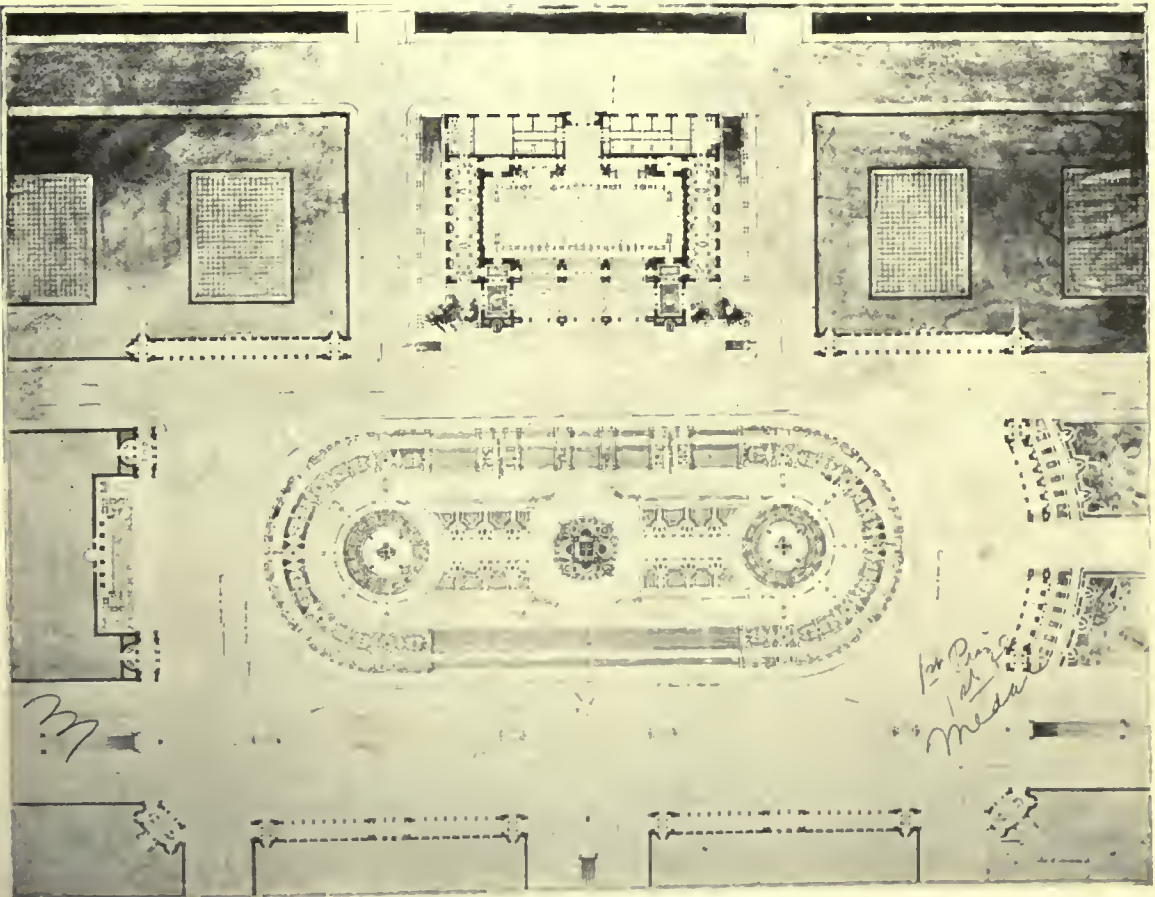

J. G. SCHUHMAN, JR.

FIRST PRIZE AND FIRST MEDAL
THE MUNICIPAL ART SOCIETY PRIZE

COLUMBIA UNIVERSITY

CLASS "A"—IV PROJET—A RAILROAD STATION PLAZA
STUDENT WORK, BEAUX ARTS INSTITUTE OF DESIGN

THE AMERICAN ARCHITECT

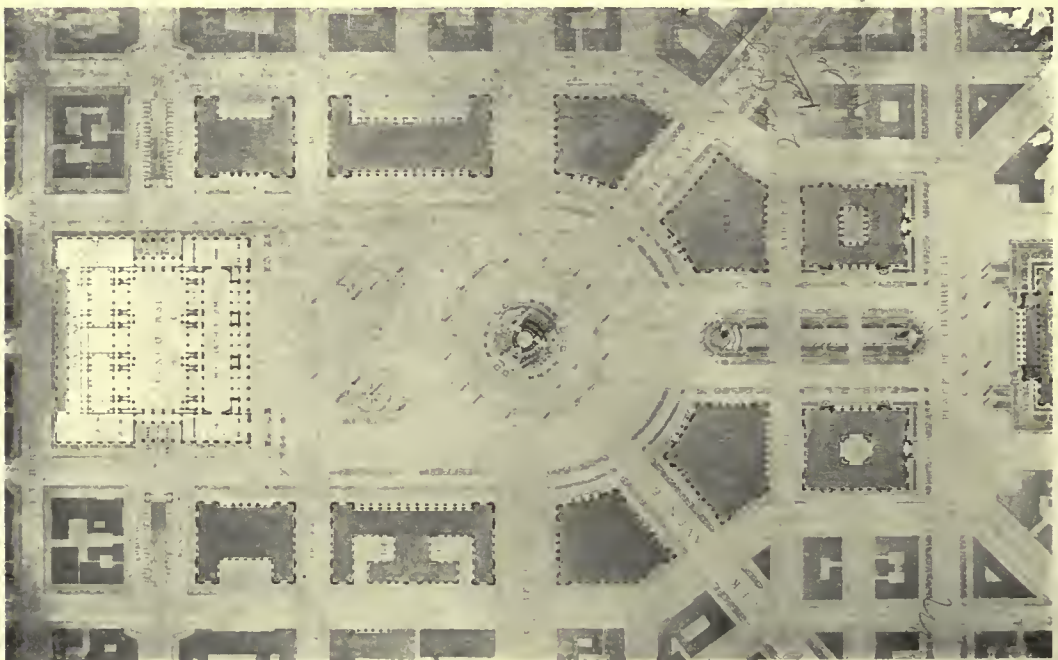

J. S. WHITMAN

SECOND PRIZE AND FIRST MEDAL
THE MUNICIPAL ART SOCIETY PRIZE

CORNELL UNIVERSITY

CLASS "A"—IV PROJET—A RAILROAD STATION PLAZA
STUDENT WORK, BEAUX ARTS INSTITUTE OF DESIGN

Beaux Arts Institute of Design

(Continued from Page 319)

to the station in such a way as to make them of the least possible danger to those on foot.

Such plazas, from their size and importance, call for a monumental treatment, frequently taking the form of a civic center, surrounded by public and semi-public buildings, such as the City Hall, the Post Office, Hotels, etc., but the



A. O. AILBERG THIRD MEDAL ATELIER, DENVER
CLASS "A" AND "B" ARCHEOLOGY—III PROJET
A BANQUET HALL IN A MEDIEVAL CASTLE

station itself should be the dominant motive. Fountains, gardens, monuments and other similar features are the natural decorative elements.

The present problem is to design such a Railroad Station Plaza. The site is approximately level, and shall not exceed 50,000 sq. ft. in area within the building line established for the surrounding buildings. These buildings are at the choice of the competitor, it being required only that the station be one of them. The width of the station shall not exceed 500 feet.

JURY OF WARD:

R. M. Hood, L. Warren, F. A. Godley, C. W. Stoughton, C. S. Pilat, L. P. Burnham, P. Cret, H. W. Corbett, D. D. Ellington, M. B. Stout, M. Prevot, J. G. Rogers, R. L. Watmough and P. Sawyer.

JURY FOR SELECTION OF PRIZE WINNING DESIGNS:

R. M. Hood, C. W. Stoughton, C. S. Pilat, J. G. Rogers, R. L. Watmough and P. Sawyer.

NUMBER OF DRAWINGS SUBMITTED: Fifty-eight.
AWARDS:

First prize, \$50: J. G. Schuhmann, Jr., Columbia, University, N. Y. C.

Second prize, \$25: J. S. Whitman, Cornell University, Ithaca.

First medal: J. G. Schuhman, Jr., Columbia University, N. Y. C.; J. S. Whitman, Cornell University, Ithaca; J. W. Brooks, University of Pennsylvania, Philadelphia.

Second medal: G. W. Trofast-Gillette and G. J. Pfost, Columbia University, N. Y. C.; S. B. Baylinson, S. K. Smith and V. B. Lee, Jr., University of Pennsylvania, Philadelphia.

Mention: J. T. Briggs, G. P. Hritz, I. Safer, F. B. Post, R. W. Craton and M. B. Loewy, Columbia University, N. Y. C.; A. L. Martsolf and M. D. Baldwin, Cornell University, Ithaca; W. R. Frampton, S. P. Stewart, G. N. Pauly, J. P. Davis, M. E. Green, N. D. Kutchukian, C. C. Pribek and A. P. Herrman, Carnegie Institute of Technology, Pittsburgh; S. F. Swales, 50 East 42d street, N. Y. C.; R. L. Walldorff, Syracuse University, Syracuse; L. A. Kruse, Atelier A. Brown, Jr., S. F. A. C., San Francisco; S. H. Brown and E. C. K. Schmidt, "T" Square Club, Phila.; H. L. Stone, J. M. Hirschman, S. J. Laschenski, C. F. Gromme, G. K. Trautwein, P. Domville, E. O. John, E. R. Purves, J. C. Jamney, A. Levy and G. M. Martin, University of Pennsylvania, Phila.; J. L. Benson, University of Kansas, Lawrence; W. F. McCaughey, Jr., and E. Pickering, University of Illinois, Urbana; T. F. Price, Atelier Wynkoop, N. Y. C.

H. C.: J. P. Morgan and R. C. Bowers, Carnegie Institute of Technology, Pittsburgh; J. W. Dawson, University of Kansas, Lawrence.

PROGRAM

SPIERING PRIZE COMPETITION.

A Prize founded in memory of Louis C. Spiering, from funds bequeathed by him to the Society of Beaux-Arts Architects and given for the best solution of the fourth Class "B" Esquisse-Esquisse of the season.

PRIZE, \$50,000.

CLASS "B"—IV ESQUISSE-ESQUISSE

The Committee on Architecture proposes as subject of this "A BAND STAND."

Competition

The importance of public concerts as a means of educating the general public has long been recognized not only in foreign countries, where regimental band concerts are given at frequent intervals, but also in America, though perhaps not here to such a large extent. It is, of course, desirable that as great a number of people as possible attend these concerts, and to this end two types of out-door bandstand have been developed, one open on all sides with the audience surrounding it and the other closed at the back so that it becomes a sounding-board which carries the music to the audience in front.

In this problem either type may be used. The stand is to be placed in a large open space in a park and is not to exceed 40'-0" in its greatest horizontal dimension. Provision should be made in the stand for the safe keeping of the large instruments.

JURY OF AWARD:

W. F. Lamb, H. R. Sedgwick, P. A. Cusachs, F. C. Hirons, H. M. Woolsey, E. V. Meeks, II, Davenport and H. I. Cobb, Jr.

This Jury also served as Jury of Award for Class "A"—IV Esquisse-Esquisse and Class "A" and "B" Archacology—III Project.

JURY FOR SELECTION OF PRIZE WINNING DESIGN:

W. F. Lamb, H. R. Sedgwick, P. A. Cusachs, H. M. Woolsey, H. Davenport and H. I. Cobb, Jr.

NUMBER OF DRAWINGS SUBMITTED: Fifty-eight.
AWARDS:

Prize, \$50: G. N. Pauly, Carnegie Institute of Technology, Pittsburgh.

First Mention: G. N. Pauly, Carnegie Institute of Technology, Pittsburgh; R. H. Bickel, Columbia University, N. Y. C.; L. F. Fuller, Los Angeles Architectural Club, Los Angeles; D. M. Campbell, Yale University, School of Fine Arts, New Haven.

THE AMERICAN ARCHITECT

Mention: R. A. Fisher, K. Snow and R. M. Crosby, Carnegie Institute of Technology, Pittsburgh; E. Babitsky, John Huntington Poly. Inst., Cleveland; E. Penfield, Atelier Wynkoop, N. Y. C.; L. Hamilton, Yale University, School of Fine Arts, New Haven.

PROGRAM

CLASS "A"—IV ESQUISSE-ESQUISSE.

The Committee on Architecture proposes as subject of this Competition.

"THE FACADE OF AN OFFICE BUILDING."

An office building occurring in the middle of a block has a frontage of 80'-0". On the ground floor is a bank which, with its mezzanines, shall not exceed 40'-0" in height, measured from the ground floor to the first office floor. An entrance for the office building and a separate entrance for the bank shall be provided from the street. Above the ground floor there shall be twenty office floors, each 12'-0" in height, floor to floor, and the necessary pent houses, water tanks, elevator machinery, etc., on the roof shall be either concealed or incorporated in the design of the building. The facade of the building is the subject of the problem.

It should be kept in mind that in the design of an office building it is a practical requirement that the offices shall be as well lighted as possible, consistent with good architectural design and expression.

NUMBER OF DRAWINGS SUBMITTED: Nineteen.

AWARDS:

Third Medal: T. B. Epps and A. Levy, University of Pennsylvania, Phila.

Mention: K. Carver, Cornell University, Ithaca; G. K. Trautwein, University of Pennsylvania, Phila.; E. Pickering, University of Illinois, Urbana.

PROGRAM

CLASS "A" AND "B" ARCHAEOLOGY—III PROJET
The Committee on Architecture proposes as subject of this Competition:

"A BANQUET HALL IN A MEDIEVAL CASTLE."

The life of the feudal lord of the 12th and 13th centuries was one of fighting and feasting, with the chase to train them for the fight and to furnish food for the feast. This was the mode of living that produced the medieval castle. Built as a refuge from marauding neighbors, its bleak exterior walls, pierced only by loop holes, were surrounded by a deep and wide moat. The castle's only entrance was across a drawbridge protected by a threatening portecullis. Within these austere walls, the rooms were grouped about a courtyard, on which opened the only windows. The main

room was the banquet or great hall, the center of the castle life. Here the lord of the castle feasted on the dais, and his retainers ate and slept in the hall below.

On the banquet halls the castle builders lavished all their art. The rooms were entered through a screened entry at one end, while at the other was placed the raised dais of the lord. The fire in the older castles was built in the center of the hall, and the smoke let out through a hole in the roof. Later, massive fireplaces were placed against the walls. A musician's gallery was provided, either over the entry or at the side. The floors of earth or of stone were strewn with rushes, and the cold masonry walls were hung with tapestries and embroideries. The ceiling was either vaulted in stone, trussed in wood, or spanned by massive beams decorated with carving and color. This roofing problem necessitated a narrow room, but did not limit the height.

The subject of this problem is the design and decoration of such a room of about 2,000 square feet floor area.

NUMBER OF DRAWINGS SUBMITTED: Eleven.

AWARDS:

Third Medal: H. B. Pierce and F. K. Draz, Carnegie Institute of Tech., Pittsburgh; A. O. Ahlberg, Atelier Denver, Denver; R. W. Bauhan, Princeton University, Graduate College, Princeton; G. M. Martin, University of Pennsylvania, Phila.

Mention: P. Simpson, Carnegie Institute of Tech., Pittsburgh; G. McCormick, Princeton University, Graduate College, Princeton; S. M. Palm, Pennsylvania State College, State College; S. B. Baylison and H. L. Stone, University of Pennsylvania, Phila.

SUPPLEMENTARY JUDGMENT OF MARCH 16, 1920

CLASS "B"—III ANALYTIQUE.

"A MEMORIAL GATEWAY."

NUMBER OF DRAWINGS SUBMITTED: One.

AWARD:

Mention: C. A. Smith, Jr., George Washington University, Wash., D. C.

CLASS "B"—III PROJET.

"A HUNTING LODGE."

NUMBER OF DRAWINGS SUBMITTED: 20.

AWARDS:

First Mention: H. T. Aspinwall and H. B. Dierks, Carnegie Inst. of Tech., Pittsburgh.

Mention: H. W. Stone and D. H. Bodin, Carnegie Inst. of Tech, Pittsburgh; T. R. Edwards and H. Bradley, Geo. Washington University, Wash., D. C.; Elizabeth Ayer, J. L. Skoog, P. E. French, F. V. Lockman and J. P. Jones, University of Washington, Seattle.

H. C.: D. H. Oertel, M. C. Drebin, L. J. Rockwell and L. L. Nasbaum, Carnegie Inst. of Tech., Pittsburgh; E. W. Grandstrand, University of Washington, Seattle.

NOTE: These drawings were delayed in transit.

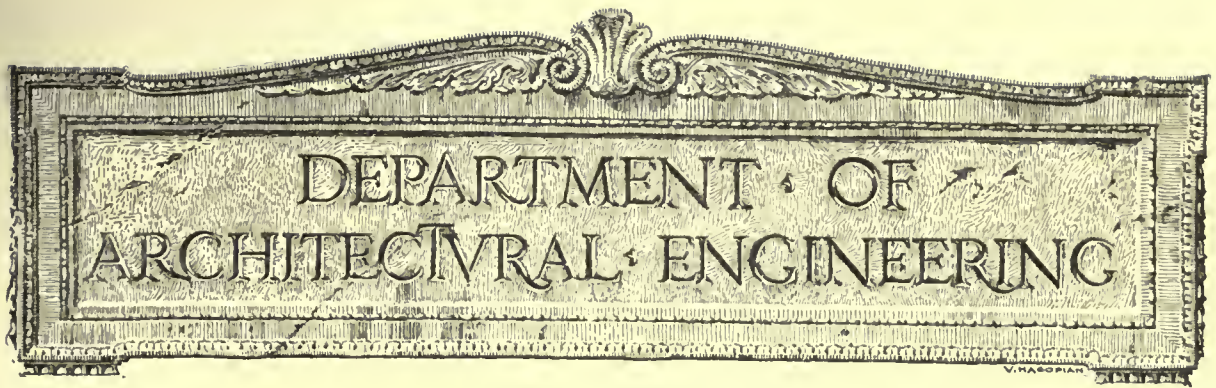

The Revolving Door, Its Characteristics, Design and Installation

Part I

THE fact that a considerable number of revolving doors are annually manufactured, and that these are installed in many buildings, would indicate that such a type of door possesses, under certain conditions at least, a distinct advantage over the usual swinging door.

It is the purpose of these articles to describe the conditions under which the use of the revolving door is advisable, and to point out certain practical considerations in connection with their design, selection and installation.

During the late war many conservation measures were advocated by various governmental bureaus, prominent among which were those of the U. S. Fuel Administration. A considerable saving in the use of coal was accomplished by alterations to existing heating systems, so as to utilize exhaust steam wherever the mechanical equipment of the building made this feature feasible. In some structures, such as department stores, hotels, etc., it was found that the wide entrances permitted the admission of so large a volume of cold air that it was difficult to provide adequate heat during very cold weather by the use of exhaust steam. A study of this condition led to the belief that by installing revolving doors at these entrances, this difficulty would be overcome. In instances where this was done, the results obtained justified the change. Thus from one standpoint, that of conservation of fuel, the revolving door possesses an advantage in buildings where the exits are fairly wide and persons are constantly entering and leaving. In a structure with but one average size entrance, used infrequently, no great advantage would be gained in this direction by installing a

revolving door, although other considerations might make this type of door desirable.

In many ground floor occupancies draughts form a serious problem. Cold weather, often accompanied by high winds, is common throughout a large part of the United States for six months during the year. The frequent opening of doors during such weather in buildings occupied as restaurants, department and other stores, banks, etc., not only tends to cause a general lowering of the inside temperature, but also permits draughts to blow across the open floor area, thus endangering the health of the occupants, scattering papers, etc. The complaint on the part of sales girls compelled to work near doorways in department stores, has been emphatic, and records show that such employees are frequently ill as a result of this exposure. In restaurants, even when the doors are arranged on the vestibule plan, draughts are not uncommon and are most objectionable. Therefore, from both the standpoint of fuel conservation and health, there are certain occupancies wherein the revolving door will prove of advantage. There are other instances where the use of this type of door seems essential and these will be discussed later. It might here be added, however, that revolving doors have also been used for the purpose of keeping out the heat in summer as well as the cold in winter.

In viewing any subject, we must not alone consider the advantages, but also the objections raised, and this applies with equal force to the subject at issue.

While revolving doors have been used in many buildings, their use has sometimes been restricted to

THE AMERICAN ARCHITECT

secondary exits, or to certain classes of buildings where the occupancies were not large. In several cities, their use is prohibited for such structures as theatres, dance halls and other places of public assembly, where large crowds may use the exits under emergency conditions. In other occupancies auxiliary swinging doors are sometimes required.

They are termed (a) panic-proof or automatic collapsible, and (b) rigid brace or manually collapsible. In the former the wings are designed to collapse when subjected to undue pressure through the releasing of the braces, after which they either fold together or function as double-acting doors. It is assumed that in the event of a panic, a large stream of persons forced against a panic-proof type of revolving door would exert sufficient pressure on the wings to automatically effect their collapse, after which such a door would offer no greater impediment to exit than an ordinary swinging door. For this reason, it was claimed by the manufacturers and those desiring to install this type of door, that it was amply safe and should be permitted under all circumstances, except possibly in theatres.

In the second type of revolving door, the braces which hold the leaves or wings in position must be



WEST ELEVATION, MUNICIPAL BUILDING,
NEW YORK CITY

Prior to the installation of revolving doors, exits on this side could not be used during winter months, due to the excessive external pressure.

Plainly the reason back of such limitation in use was the belief on the part of public officials, that under panic conditions in buildings containing large occupancies the revolving door would not function properly; in other words, that as an emergency exit, it could not be considered on a par with the ordinary door, swinging in the direction of exit travel. This has resulted in the construction of revolving doors with special self-releasing braces, and at present revolving doors of two general types are manu-

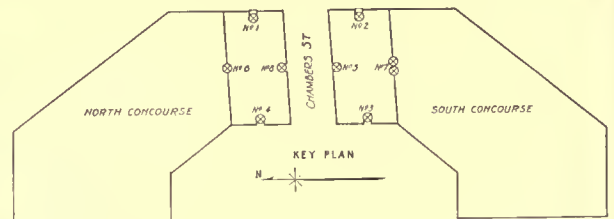

DIAGRAM OF GROUND FLOOR PLAN, MUNICIPAL BUILDING, SHOWING EXITS.

dislocated manually, as they remain rigid and in place irrespective of the intensity of pressure on the wings. Due to the seriousness of the situation, there has resulted a careful study of the various conditions relating to this type of exit door. In New York City a series of tests was made to determine the necessity and safety of revolving doors, with a view towards revising the rules governing their installation. Such a revision followed these tests.

TWO of the most interesting buildings studied in this respect were the Municipal and Equitable Buildings, Manhattan, diagrammatic ground floor plans of which are shown. It will be noted that in both these structures the exits face the four points of the compass. No revolving doors were originally installed in the former building and during preceding winters the swinging doors on the western exposure proved so difficult to open that they were usually kept locked and signs to this effect posted. This, of course, reduced the exit facilities considerably, and was inadvisable. The expedient of locking these doors was not resorted to until a number of accidents to persons using them had occurred. In cold weather the draught throughout the build-

THE AMERICAN ARCHITECT

ing was uncomfortable. Strong draughts came into the entrance halls and were carried up the stair and elevator shafts each time entrance doors were opened. This unsatisfactory condition during winter weather led to the installation of panic-proof revolving doors at all entrances several years after the building had been completed and occupied. However, after installation, the revolving doors which were located on the westerly side were continually collapsed—apparently due to the high wind pressure—and the tension in the brace adjustment of such doors was subsequently increased to prevent this happening.

The tests made on this building, which is 26 stories in height, exclusive of the tower, showed that the pressure necessary to revolve these doors varied from five to ten pounds applied three feet two inches from the center, and the average pressure to collapse two opposite wings, with the exception of the doors at the westerly entrance, where the tension had been increased, was 69 pounds. While no actual count was made of the traffic capacity of these doors, it was observed that practically no congestion occurred

exits it will be noted that there are swinging doors adjacent to some of the revolving doors. It required on the average a pressure of 27 pounds to open these. The pressure required to open one of the swinging doors leading to Chambers Street was 51 pounds. This door has since been replaced by a revolving door. In the Equitable Building the entrances are equipped throughout with the panic-proof type of revolving door. A photograph of the Broadway entrance is shown. While no tests were made to determine the pressure necessary to collapse these doors, the actual external pressure on them was de-

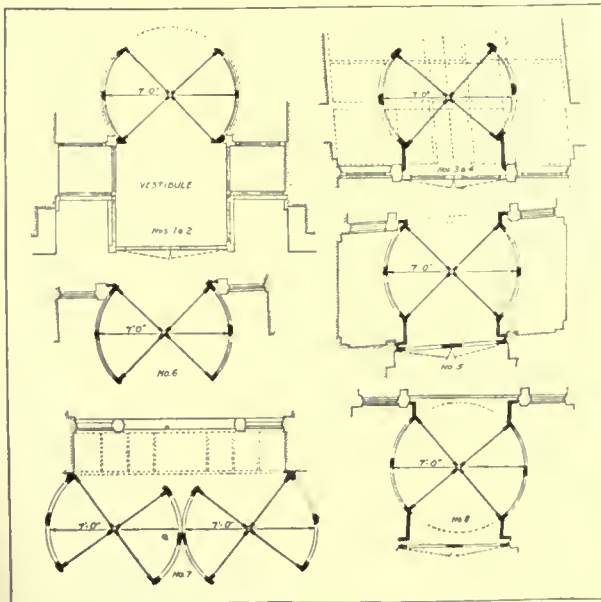

ARRANGEMENT OF REVOLVING DOORS,
MUNICIPAL BUILDING

For location see key plan on preceding page

during peak traffic loads, i. e., 9 A. M., noon, and 5 P. M., so that apparently the revolving doors were able to accommodate as many persons as the replaced swinging doors. In a test made at another building by the Public Service Commission it was clearly demonstrated that the revolving doors were able to accommodate as many persons in a given period of time as were swinging doors.

From the diagrams of the Municipal Building



REVOLVING DOOR AT EXIT NO. 6, MUNICIPAL
BUILDING

terminated by releasing one of the braces and recording the pressure necessary to prevent the wing from being forced *inward*. This pressure was not due to any wind blowing at the time, but is apparently due rather to suction described later. By releasing the wire ties between two wings of one revolving door and holding the dynamometer against its outside edge, a pressure of 72 pounds was recorded. It, therefore, follows that a pressure of over 72 pounds would be necessary to collapse the door, otherwise the ordinary external pressure would be constantly causing collapse.

In high buildings (20 to 30 stories) equipped with swing doors arranged on the vestibule plan, it was found that about 30 pounds pressure was

THE AMERICAN ARCHITECT

required to open a door, during outside temperatures of approximately 15 degrees, with but slight wind blowing. To overcome this pressure, a considerable effort would be required on the part of a girl of slight stature.

The most remarkable feature of the tests was the

in amount with the height of the building, the difference in temperature between the inside and the outside air, also, apparently with the number of elevators. It decreases with the efficiency with which vertical shafts such as stairways and elevators are cut off from the entrance hallway.

Since several indeterminate factors enter, it is not possible to calculate this pressure with any degree of mathematical precision. While in the Equitable Building, 72 pounds applied at the outer edge of a released wing of a revolving door was required to balance the external pressure, in the Woolworth Building, a considerably higher structure, but 30 pounds, or less than half this force, was required to accomplish the same purpose, under very similar weather conditions. In the Municipal Building, revolving doors on the westerly side, designed to collapse at a pressure of 70 pounds applied at the outside edge, were constantly collapsing from external pressure.

Eliminating elevator suction, and assuming a tall building to be a vertical flue or chimney, the pressure exerted at the base, calculated on a theoretical basis for a structure five hundred feet high, such as the Equitable Building, with an outside temperature of zero F. (at which temperature 11.583 cubic feet of air weigh one pound) and an inside temperature of 70 degrees F. (at which temperature 13.342 cubic feet of air weigh one pound) would be 5.6 pounds per square foot. The total pressure on each leaf of the average size revolving door would be 146 pounds, resisted in part by the central shaft and in part by the connecting brace. Were the brace released, a force of 73 pounds would have to be exerted at the outer edge to hold the leaf or wing from being forced inward by the external pressure. To open a swinging door of the same area, a slightly greater force would have to be exerted. To

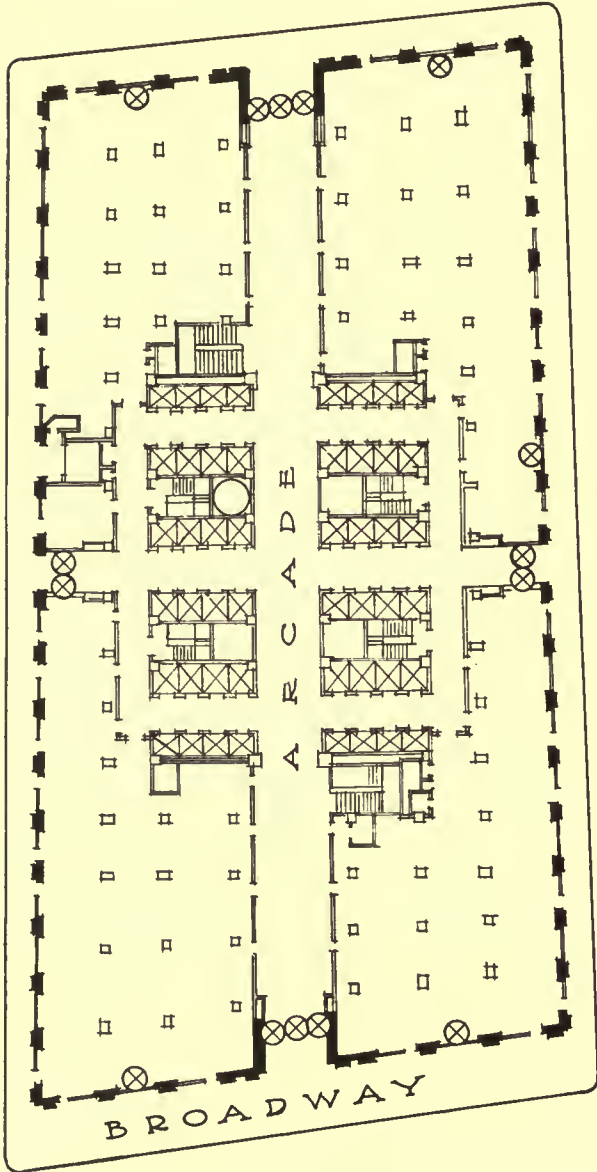

GROUND FLOOR PLAN, EQUITABLE BUILDING, NEW YORK CITY

discovery that so long as the outside temperature is lower than that inside, it requires a pressure in excess of that necessary to overcome inertia and friction to open an outwardly swinging door. The external pressure which must be overcome is entirely apart from and in addition to the wind pressure; the action causing it is somewhat analogous to draft action in a chimney. The external pressure increases

Standard Table Showing Velocity and Force of Winds

Description	Miles per Hour	Feet per Minute	Feet per Second	Force in lbs. per Sq. Ft.
Perceptible	1	88	1.47	.005
Just Perceptible ...	2	176	2.93	.020
Gentle Breeze	3	264	4.4	.044
	4	352	5.87	.079
Pleasant Breeze ...	5	440	7.33	.123
	10	880	14.67	.492
Brisk Wind	15	1,320	22.0	1.107
	20	1,760	29.3	1.968
High Wind	25	2,200	36.6	3.075
	30	2,640	44.0	4.428
Very High Wind...	35	3,080	51.3	6.027
	40	3,520	58.6	7.872
Storm	45	3,960	66.0	9.963
	50	4,400	73.3	12.300
Great Storm	60	5,280	88.0	17.712
	70	6,160	102.7	24.108
Hurricane	80	7,040	117.3	31.488
	100	8,800	146.6	49.200

THE AMERICAN ARCHITECT

operate a revolving door, the exterior pressure may be neglected since the pressures on opposite wings neutralize each other. Since the revolving door is hung from a ball bearing carriage and the wings are weatherstripped, oscillations are prevented.

Irrespective of the height of building or the outside or inside temperatures, a pressure is exerted at all times when the air is in motion, due to the force of the wind itself. According to tests by the Weather Bureau, the wind may exert a pressure as high as 30 pounds per square foot of vertical surface in most localities. A table of velocities and corresponding wind pressures is given on the preceding page.

accidental collapsing of the revolving door, and, further, it would still permit the quick and automatic collapse of these doors by a crowd in case of fire or emergency. Of course, it is not desirable to have such doors adjusted to pressures higher than necessary, but only sufficient to avoid their accidental collapsing from external pressure. That this is serious in very tall buildings is vouched for by the managers of such structures. In one instance, while no trouble occurred during the summer, yet after cold weather came, several accidents were caused by accidental collapsing and the accompanying shattering of the glass panels. This led to the

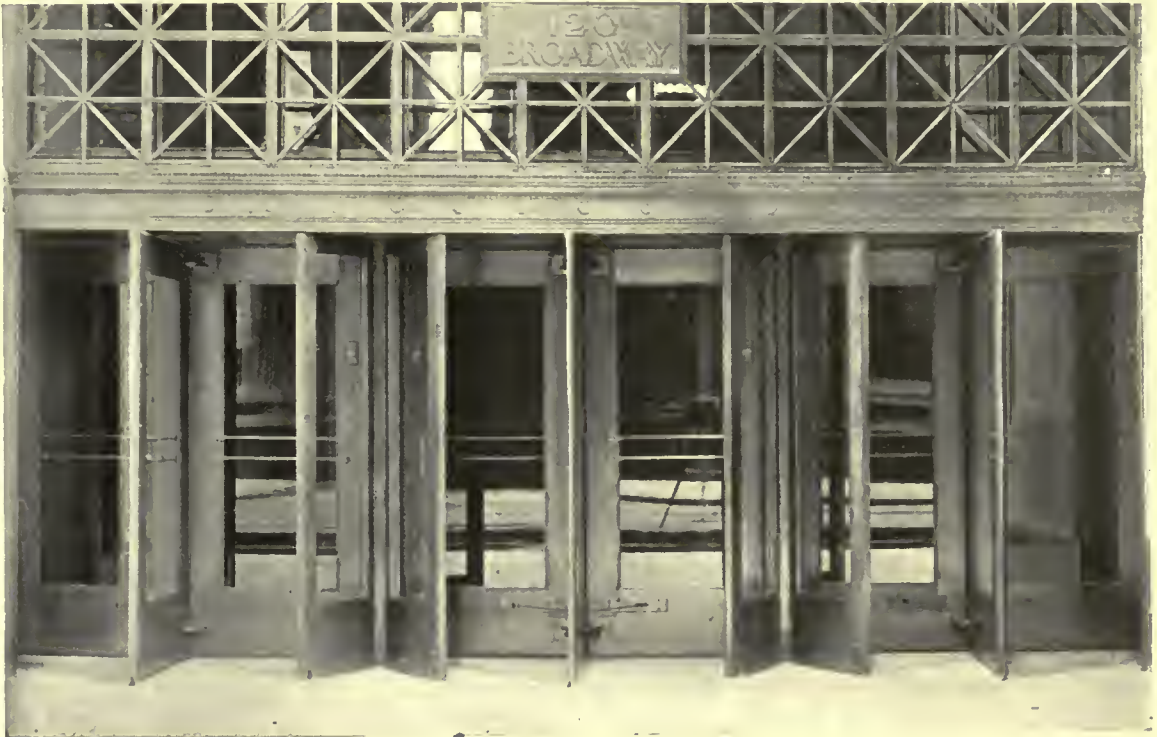

BATTERY OF THREE REVOLVING DOORS AT BROADWAY ENTRANCE OF EQUITABLE BUILDING
More persons pass through these daily than through the entrance of any other building in the United States

Through actual observation, it appears that the wind pressure exerted on the outside of a high building is usually much greater than that on the outside of a low building. This is undoubtedly due to the vertical wall of the building acting as a dam against the action of the wind and deflecting downward.

In view of the foregoing factors of wind and such other pressures as might be exerted against the revolving door, it seems advisable when installing doors of the automatically collapsible type in high buildings to require them to be adjusted so that they will collapse at a pressure ranging from 100 to 150 pounds, exerted at the outer edge of the wings. This would seem to insure against any

use of wire glass for all the revolving doors in this building, as well as a readjusting of the tension.

Where vestibules are provided, it is difficult, under unfavorable weather conditions, for the average individual to open the swinging street doors, which are usually required by local ordinances to open out, or *against* the pressure. While a pressure of five pounds gives passage through a revolving door, often one of thirty pounds is required to open a swinging door similarly located.

In high buildings and especially those located in windy districts, the revolving door appears to offer a solution to three very serious problems, since it effects more economical heating, eliminates draughts, and provides easily operated, yet safe, exit doors.

Progress Report of National Public Works Department Association

By M. O. LEIGHTON, *Chairman*

THE technical men who started the public works movement ought to know the accomplishments to date so that they may plan wisely for the future. This is a period of recess in legislative matters and we are given an opportunity to derive lessons from the events of the past.

Like all other movements of this kind, there are stages in which there is much visible progress and others in which development can be discerned only by those in intimate touch. We are now in one of the latter stages in which the principal effort is the preparation for achievement at the fall session of Congress.

We have won decisively in the first phase of this campaign, which is the establishment of the underlying principle. The leaders of Congress are in agreement on the principle and some of them are working on its details during the present legislative recess. The candidates for president and vice-president in both great parties have signified their approval and in this they are in step with the great leaders of thought and action the country over.

The second phase of the campaign, which consists of securing the right kind of a department of public works, will be more laborious than the first. It involves the minute consideration of details, the sifting of evidence and the presentation of the results in convincing form. The supporters of this movement should not make the mistake of believing that the campaign is over merely because the principle has been accepted. It is obvious that the wrong kind of a Department of Public Works will be as bad if not worse than the present organization of governmental functions.

THE most troublesome as well as the most inexcusable setback has been the failure of the movement in the referendum of the Chamber of Commerce, U. S. A. This was plainly due first

to the lack of adequate publicity, and second, to the inaction of the local technical bodies which were depended upon to take care of the issue in their own local commercial organizations. Our finances would not permit us to handle the first, but we had every good reason to expect diligence on the part of "our own crowd" in the second. Evidence is constantly being accumulated that the important commercial bodies which voted adversely on that referendum did so in ignorance of the character, intent and purport of the movement. Reports received from certain important places in which local chambers of commerce voted adversely are to the effect that the adverse action was the direct result of the influence of certain members of the Corps of Engineers, U. S. Army. If such be the case, our only comment is that these engineer officers acted within their rights and in accordance with their convictions. The incident substantiates the previous announcements of this Association that the Corps of Engineers is a powerful body and the effects of its opposition to a measure of this kind must not be minimized.

From the present until the convening of Congress on the first Tuesday of December next, the architects, engineers and technical men of other branches throughout the country have a rare opportunity to further this movement because Congress is in recess and the representatives are at home. If each man who is convinced of the necessity for this reform would embrace this opportunity to instruct his representative in Congress and to enlist his active cooperation in the furtherance of this legislation, progress at the next session of Congress would be rapid and certain. For the present, members of Congress are almost out of reach of the Association's officers. The field of intensive effort has shifted "back home" where the technical men of the country may render first aid.

Governmental Bulletins Issued

The Department of Commerce, Bureau of Standards, Washington, D. C., of which S. W. Stratton is the director, announces that it has just issued the following circulars:

No. 39. Household Weights and Measures.

No. 89. Recommended Specifications for White Paint and Tinted Paints Made on a White Base—Semipaste and Ready Mixed.

No. 90. Recommended Specifications for Red Lead, Dry and Paste.

No. 91. Recommended Specification for Ocher, Dry and Paste.

No. 93. Recommended Specification for Iron-Oxide and Iron-Hydroxide Paints.

No. 94. Recommended Specification for Black Paint, Semipaste and Ready-Mixed.

No. 152. Investigation of the Compressive Strength of Rectangular Spruce Struts.

Shall Architect or Engineer Predominate in Stadia Design

Architect Answers Resolutions Passed By Council of Associated Engineering Societies of Seattle, Wash.

Charles H. Bebb,* well known Seattle architect, in a letter to Pacific Builder and Engineer, takes exception to certain resolutions passed by the Council of the Associated Engineering Societies of Seattle and addressed to the Board of Regents of the University of Washington, wherein it was sought to have the Washington Field Stadium built under the direct supervision of engineers rather than architects. This communication to the Board of Regents was published in Pacific Builder and Engineer under date of May 28. Portions of Mr. Bebb's letter, taking exception to the views therein expressed follow:

Seattle, Wash., June 21, 1920.

Pacific Builder & Engineer,
602 Pacific Block.

The communication appearing in last month's issue of your publication addressed by the Council of the Associated Engineering Societies of Seattle to the Board of Regents, University of Washington in regard to the Washington Field Stadium now being constructed on the campus of the State University brings up again the perennial question of the relationship between the architect and the engineer.

Purely from the altruistic standpoint if we correctly construe the set of resolutions as submitted to their final analysis the Associated Engineering Societies of Seattle in the fear that the stadium may be built under the direct supervision of architects and upon the theory that such a building should be primarily the work of the engineer while admitting the necessity of collaboration with the architect, somebody to throw in here and there a veneer to cover up the hard bones of the skeleton frame as it were, feel constrained to point out to the Board of Regents and public officials charged with the responsibility of public works their duty to properly distinguish between what works should be assigned to the architect and what to the engineer.

The logical basis of reasoning from the engineer's standpoint can only be that the physical properties of the building are more vitally the prime factors than the purposes and conception of the building as a whole. That the expert knowledge of the bearing values of the soil, the properties of re-enforced concrete, the strength of columns, girders and joists, etc., are the primary points to be considered and that the planning and design are secondary considerations requiring reluctantly the collaboration of the architect. This argument would hold good were it a fact, for every kind and class of building erected by human hands from the mighty Woolworth building in New York to the

simplest structure erected in space for in none can we neglect at least a modicum of engineering knowledge.

It is possible of course, the Associated Engineering Societies might admit in the matter of buildings that the position of the architect should predominate. But when it comes to a stadium the resolution sets forth "Whereas a structure of the type and for the purposes here contemplated is essentially and predominantly an engineering structure and its architectural features a secondary consideration," and upon this hypothesis the Associated Engineering Societies consider the architect is only a mere adjunct. In other words in the thought of HOW the structure should be built all consideration of WHY is lost sight of.

Considering the building from the standpoint of its individual requirements, while we may be wrong, it being human to err, we believe the architect by reason of training and experience is more competent to successfully plan it than the engineer, that having in view the purposes of the building he will give better consideration to the seating and sight lines, circulation and methods of ingress and egress, drainage and comfort stations and all other desiderata pertinent to the structure.

It is in the question of design, we presume, that the Associated Engineering Societies admit the necessity of collaboration between architect and engineer, and we admit it also. But which shall predominate and which subordinate? In the completed building we shall look for unity, symmetry, proportion, the harmonic relation of parts to the whole and these are thoughts not consonant with the education and training of the engineer and again we doubt the hypothesis upon which the Associated Engineering Societies have based their resolutions, namely, that a stadium "is essentially and predominantly an engineering structure and its architectural features a secondary consideration."

If we look for precedent and seek the authors, or creators of other stadiums that have arisen in this country in the past years we find that the Harvard Stadium is credited to the architectural firm of Messrs. McKim, Mead & White; the Princeton Stadium to Mr. H. J. Hardenberg; the Chicago Stadium to Messrs. Holabird & Roche, the University of Chicago Stadium to Messrs. Coolidge & Hodgson, all of them architects.

The final paragraph of the resolutions offered by the Associated Engineering Societies disclaims that anything of a personal nature is intended. This is, of course, as it should be. In an undertaking so important as the building of this stadium personalities are as inconsequential as the drops of the last pattering of rain on Puget Sound. It is somewhat extraordinary, however, that in all the publicity that has been given this matter, the repeated publication of the plans and bird's-eye view of the proposed building, the Council of the Associated Engineering Societies has failed to observe that the name of a well known engineer has always been associated with the names of the architects.

CHARLES H. BEBB, F. A. I. A.

*Mr. Charles H. Bebb, F.A.I.A., and Mr. Carl F. Gould, A.A.I.A., are architects for the new Seattle stadium for the University of Washington, described in the June 23d issue of The American Architect. The names of the architects were inadvertently omitted in that issue.

THE AMERICAN ARCHITECT

Historical Notes on Engineer and Architect

THE following historical notes are from a somewhat voluminous paper entitled "A Study of Definitions of Professional Engineer and Engineering" by Alfred D. Flinn, with the collaboration of Alfred W. Kiddle and Harrison W. Craver, recently issued by Engineering Council.

Historically the builders of fortifications, the military engineer, and the builder of dwellings and temples, the architect, were earliest on the ground. The distinction was then between soldier and architect, not between engineer and architect. All of us who have translated him, remember that Julius Caesar built a bridge—and we know of the military Roman roads of England.

The very considerable Avignon bridge across the Rhone River (about 1200 A.D.), with eighteen clear arch spans of from sixty-five to eighty feet each, in a swift-flowing river subject to ice jams, was regarded as a work of architecture. The term Architect of Bridges is authentic. Michael Angelo (1475-1564) was not only the Architect of St. Peter's, but he designed the fortifications of Rome.

Leonardo da Vinci (1452-1519) not only made plans for Milan Cathedral, and painted the "Last Supper" and "Mona Lisa," but he was a Chief Military Engineer, and a Hydraulic Engineer dealing with irrigation, river control and harbor works, and designed a flight of six vessel-locks. He styled himself engineer as well as architect.

The term Architect in its etymology means "Master Builder."

In the evolution of construction, two classes of builders have by some vagary of word-growth been verbally torn apart and their kinship sometimes questioned. It is odd that in this juggling of old terms and the emergence of new terms, one class of engineers—and a class whose work is of the highly-specialized, technical kind which deals with the direction of great mechanical forces,—has kept the old family name, the Naval Architects. An accident of name-evolution has tended to segregate one class of master builders from the other classes of master builders. It may be thought that initiative and imagination are the qualities of Architects, while Engineers deal with the prose of construction. Analysis will, however, reveal the fact that eighty per cent. of the architectural structures of our cities are commonplace, with no peculiar beauty or originality. Now and again a Woolworth building springs sky-

ward, worthy of the phrase "frozen music," and we recognize again the master builder of the sixteenth century. But the same quality of mind went into the wireless telegraph, the airplane, the Panama canal and hydroelectric developments and transmission at Niagara. Engineers without creative imagination are as mediocre as Architects without this same vital and indispensable attribute of the master builder. Architects must recognize that scientific imagination is on the same high plane as their own best creative thought; and Engineers must concede the esthetic contribution of Architects in adding to the durable satisfaction of life. Both are creative workers.

Action of the American Institute of Architects on the Quantity Survey System

IN our July 28th issue in commenting on the action of Engineering Council in endorsing the use of the Quantity Survey system, it was erroneously stated that no action had been taken on this matter by the Institute.

A recent communication from D. Everett Waid, Treasurer of the American Institute of Architects, states in part:

"The Institute went on record at its May Convention as favoring in principle the use of the quantity survey system by architects, preparatory to receiving bids on construction work.

"I believe I am correct in saying that it is the conviction of the Board of Directors that it will be a matter of gradual education of the profession and of builders generally before we can expect to see the present American system of each contractor taking off his own quantities displaced by a radically different method, which, if developed on right lines, should ultimately result in an economic saving. The change will be necessarily so revolutionary that it can be accomplished, I believe, only in a gradual manner. The attitude of the Executive Committee is one which will encourage the introduction of the system as means for its experimental trial become available. At present there is machinery for such trials in only two or three large cities."

The official stamp of approval by The American Institute of Architects, the Associated General Contractors of America and Engineering Council should do much to facilitate the extended use of this commendable system by architects in general.

Current News

Happenings and Comments in the Field of Architecture and the Allied Arts

Building Problem Discussed

Architects, builders, engineers, labor men and others met at Atlantic City recently to consider a plan to overcome present conditions in the building trade. The meeting was presided over by E. J. Russell of the American Institute of Architects, New York. The principal address of the evening was delivered by Robert E. Kohn.

The conference was held under the auspices of the National Board of Jurisdictional Awards in the building trades industry. Several remedies were suggested and a committee appointed to try to have them generally adopted.

Post Office Buildings in New York

Not since 1912, when the post office was built at the Pennsylvania Terminal, has there been any new building. This was before the establishment of the parcels post and the increased volume of mail has been housed in rented buildings quite ill adapted for that use.

It is now announced that the Post Office Department has leased a three-story structure which is soon to be built on West 38th street, between Seventh and Eighth avenues, at a rental of \$3,500,000 for a twenty-year period. The new building will have a floor area of 57,000 square feet.

St. Louis' Problem

St. Louis, Mo., has issued a City Plan Commission Report urging that the city be given more control in the development of land. A shortage of 10,122 dwellings in 1921 has been estimated. It is regarded as unreasonable that the solution of this problem should be left to chance or to the whim of an individual landowner.

The desirable results of wider municipal control are as follows:

Old property, already having all-city improvements, will be built up; new property, when opened, will be more promptly utilized, greatly reducing the charges, which result in no additional profit to the first owners, but add greatly to the cost to the purchaser. The city department of public service will be enabled to make a comprehensive and efficient plan for the extension of public utilities and other public conveniences.

Such a control of land development should eliminate to a large degree unscrupulous speculations in real estate, resulting in lower first cost for home sites and in a reduction of delay in securing street and utility improvements. There will also be a decrease in rent profiteering, overcrowding with its attendant unwholesomenesses of increased disease and crime and unstable development of city growth.

Berlin's Populace Discontented With Housing Conditions

A mass meeting was recently held in Berlin in the Schlossplatz between the Imperial Palace on Unter den Linden and the Kaiser's stables. It was attended by 4,000 people who are discontented with the efforts of the various housing commissions. "We demand," said one of the speakers, hanging from a piece of statuary, "that the 800 rooms of the palace be placed at the disposal of the homeless Berlin families. We demand that the empty barracks which formerly housed more than 24 regiments be converted into dwellings until the housing privation has passed." The resolutions were adopted but the new tenants have not yet taken possession.

More Electric Homes Go Up in the West

The San Francisco *Chronicle* points with pride to the recognition given to the popularity of the Electric Home in St. Francis Wood, which has stimulated the erection of a number of similar buildings.

These homes will be electrical homes in every sense and it is proposed to make St. Francis Wood a community of electrical homes.

One of the big obstacles that the "own your home" has had to overcome was that offered by the servant problem. Electricity has made a complete demonstration over this stumbling block.

The new homes in St. Francis Wood are being provided with double wiring circuits for illumination purposes and power appliances. The power circuit reduces to less than half the cost of operation of electrical appliances. The popularity of this modern way of operating the home is demonstrated by the fact that more than 18,000 visitors passed through the Electrical Home during its short exhibition.

Wooden Houses for Northern France

The Review of the American Chamber of Commerce in France says that McArthur Brothers, of New York (8, rue St. Florentin, Paris), have delivered 500 of an order of 1,000 wooden houses for the devastated regions of northern France. These houses are 7 metres square and have three rooms and a shed. They are delivered in sections and complete, including windows, doors, glass, paint, nails, bolts, all ready for the erection, which is being done under the direction of the Department of the Ponts-et-Chaussées. About a hundred of these houses are being erected in the Arras and Lens districts.

Hollow Bricks in England

A new brick that has recently been introduced in England is nearly five times as large as an ordinary brick, but in comparison is much less heavy and is easily handled, states the *Scientific American*. The lighter weight results from the hollowing out of the brick to provide air layers. By the shaping of the ends the existence of joints running all the way through the wall is avoided. The brick is, as a rule, made of one part of cement and four parts sand by simple hand machinery. Three men can make enough bricks in a day to build 400 to 500 square feet of wall. A further economy is effected by the manner of laying the walls, inasmuch as the ends and bottoms of the bricks need only be dipped in a thin lime mortar mixed with a small amount of cement. If laid in the usual way the air channels in the bricks would become filled.

Increased Costs of Building Less Than of Commodities Costs

There is much talk of the high cost of building and in this connection it is satisfying to see the computations made by the Aberthaw Construction Co. which were published in the Boston News Bureau.

Taking 1914 as a standard, it is said that commodity prices had risen 20 per cent., and building prices 17 per cent.. By the end of 1917 general commodities had advanced 89 per cent., and building but 39 per cent. Building costs through 1919 were 90 per cent. above the 1914 level, whereas general commodities were up 138 per cent. The latest computation which this company has made show building costs to be 135 per cent. above the 1914 level, while general commodity prices are 142 per cent. above that level.

Old-Time New England

One of the results of the celebration of the three hundredth anniversary of the landing of the Pilgrims at Plymouth is to increase public interest in things bearing upon the antiquities of New England.

It is, therefore, fitting to call attention to the Society for the Preservation of New England Antiquities, which has headquarters in Boston.

Beginning with the July, 1920, issue, the bulletin of this society will now be published quarterly under the more comprehensive title of "Old Time New England." The magazine will, as heretofore, be devoted to antiquarian research and to the preservation of old buildings and landmarks. But it is proposed to increase the scope of activities. The current issue is devoted not only to ancient buildings, but to household furnishings, domestic arts and crafts, manners and customs, and other matters of interest. Copious illustrations will afford to architects and their clients a comprehensive picture of these by-gone days. Interesting buildings will be described, and much space will be given to the artists and craftsmen of the early days. The society contemplates some important restorations, and will also develop a valuable museum.

For Adequate Electric Wiring

Much difficulty is experienced in urging architects to wire their buildings sufficiently for the proper use of electric appliances. A Pacific Coast electrical society states that they are obstructing the wider use of home labor saving devices by America's overworked housewives. Says this society very graphically:

"Thousands of women still bend over the wash-tub, hundreds of thousands are still condemned to uncounted hours of dishpan drudgery, millions still sweat and suffer at the ironing board, because designers and builders of dwellings fail or refuse to provide the wiring connections which would permit these menial tasks being done by electrical machinery."

A further retardant in this simplification is the fact that in the case of washing, ironing and dishwashing machines, space has not been provided in kitchen or laundry where they might properly be located.

The buyer then faces the expense of alterations and additional wiring out of all proportion to what the cost would have been had the house been equipped originally, and frequently goes without things that are really desired, because of someone else's oversight in the adequate wiring and outlets for electric appliances.

Builders Use Camp Dix Materials to Reduce Costs

Lumber and other building materials and equipment formerly used at Camp Mills, Mineola, Long Island, are being used by small house builders in the surrounding towns to add appreciably to the supply of residential properties. In Mineola, Hempstead, Baldwin, Freeport and neighboring communities the materials formerly part of dormitory, hospital, kitchen, store houses, and other cantonment buildings, which formed the now rapidly disappearing camp are being reconstructed into small and substantial one-family houses that will materially relieve the dwelling shortage. Many of the houses have been sold from the plans, so keen is the demand for properties of this type.

Five Million Dollars for Canadian Highways

Five million dollars will be spent this year in making better the main highways of Canada through Federal and provincial grants. Of this amount the Dominion Government will contribute \$2,000,000 and the provincial governments \$3,000,000. This is the first year in which the road money has been available, and in view of the time taken in preparing plans the initial year's outlays will not be so heavy as in some succeeding years.

The improvement scheme, however, is general. Before the Dominion Government makes any grant for the purpose the provinces have to file general plans, and every one of them, from coast to coast, has done so already. The detailed plans also need approval by the Dominion Government, and this has been done in several instances and work is under way. While the provinces may improve whatever roads they choose to, the Dominion grant of 40 per cent. of the cost is restricted to main or trunk highways.

Community Centers for Indianapolis

The report of the Park Commissioners of Indianapolis plans the establishment in various parts of the city of neighborhood centers which, it states, shall embody the following: the neighborhood park, the playground, the swimming pool, the bathhouse facilities, and the community building, which is in reality "the workshop" in which all type of wholesome legitimate activities may be carried on. These buildings will have such facilities as a main auditorium with a stage and scenery, a main assembly room, a lounging room, gamerooms, reading rooms, committee rooms together with the ordinary comfort

station facilities and in some cases locker rooms. Such a building should become a little town-hall in the community and in it will be grouped all types of community activities and all types of organized work—such as athletic clubs, women's clubs, Boy Scouts, forums, parent-teacher organizations.

Thirteen playground swimming pools and two park pools for adults are expected to be ready for use next summer.

Progress Made in the Art of Stained Glass

All the valuable stained glass windows were removed from the large churches in Paris in order to protect them against air raids and destruction by long range gunfire during the war. The windows were stored in safe places and remained unharmed. They are now to be carefully retouched and then to be reinserted. These windows, we learn from the *Scientific American*, total approximately 470,000 square yards of stained glass, and their renovating will take a long time and will be of considerable expense.

A wide and remunerative scope of work has thus been opened to the Paris Association of Glass Stainers, some members of which are noted artists. Although this association and some other guilds of glass stainers work entirely in a mediaeval craft, it would be wrong to conclude that their methods are behind the times. Fifty years ago the old secret of staining glass, which was lost with the decline of art in the seventeenth and eighteenth centuries, was rediscovered and, with the aid of chemistry, has made remarkable progress. This is shown by the fact that today the glass stainer disposes of over five thousand different pigments, while in the twelfth century, the golden age of glass staining, only twelve colors were known.

Olean (N. Y.) Builds a Park

Five years ago there was a public dump caused by a big levee project for the prevention of annual inundations at the time of the spring floods. The city determined to convert the dump into a park and the State College of Forestry at Syracuse was asked to help in the development.

Plans were laid which included not only the extensive planting of trees and nearly 3,000 flowering shrubs, but walks and the few necessary buildings. One of the methods by which the work was pushed ahead was the planting of about 150 trees by school children who raised funds for the trees by solicitation. A small concrete marker was placed at the base of the tree with the names of the young planters on it.

THE AMERICAN ARCHITECT

News from Various Sources

An entire quarter of the city of Florence, Italy, was shattered by the explosions in the powder magazine at San Gervasio.

* * *

Quincy, Massachusetts, favors as its war memorial a building which shall be entirely separate in style and location from all other municipal buildings.

* * *

Contracts for construction in Lima, Peru, of dwellings, churches and office buildings have been let to a New York firm. The work is being financed by the Roman Catholic Church.

* * *

A meeting of the Board of Directors of the Northwest Master Builders' Assn., held in Aberdeen, Wash., endorses the proposed Federal Public Works Department.

* * *

Of the 1,206 new students who have submitted their records to Northwestern University, not more than half can be admitted on account of lack of boarding places.

* * *

West Coast lumber interests have decided upon the formation of the West Coast Forest Products' Bureau, whose principal function is to be the education of Eastern consumers.

* * *

A worker in a house near Derby Academy, Hingham, found a piece of paper in a mouse nest which proved to be a receipted bill for the construction of the house and was dated 200 years ago.

* * *

On August 10, H. L. Kerwin, Director of Conciliation, Department of Labor, reported that there were before the department 19 strikes and 37 controversies which had not reached the strike stage.

* * *

The city planning committee of the Association of Commerce will ask the public land commission to change the proposed ordinance, limiting the height of buildings in Milwaukee to 125 feet, to permit erection of buildings 175 feet or approximately sixteen stories.

* * *

The Art Students' League of 215 West 57th St., New York, has issued its catalogue for the season of 1920-1921. The pamphlet, profusely illustrated with cuts of the work of the students in the different classes, gives a history of the League, its object and management, as well as a complete list of the classes and instructors.

* * *

Plans for only one apartment house and one dwelling were filed in Manhattan in July, compared

with plans for five theatres, 115 garages and three loft structures, indicating that despite agitation for construction of dwelling building trend was reflecting little interest in housing situation. According to Tenement House Commissioner Mann, normal construction in New York is about 28,000 apartments a year, in addition to two-family houses and hotel apartments, but during past four years average construction has dwindled to about 4,000 a year.

Personals

A. Frank Wickes, architect, formerly located at 506 Gary Theatre Bldg., has moved to larger quarters in suite 206 Harries Bldg., Gary, Indiana.

E. C. Hemmings & Jens C. Petersen, architects, and Leo D. Hudnutt, engineer, formerly the Sacramento Elementary School Commission, have opened offices in City Library Bldg., where they desire samples and catalogues.

George P. Fernald, formerly connected with the offices of Little & Brown, of Boston, died in Taormina, Sicily, where he had gone in search of health. Mr. Fernald was about fifty years old. His work has been mostly in the way of interior wall decorations for large private residences. He was a member of the Boston Society of Architects and the Boston Architectural Society.

Henry T. Barnham and Charles L. Hofmann have formed a partnership for architectural practice under the firm name of Barnham & Hofmann, with offices in the Chamber of Commerce Bldg., Richmond, Va.

United States Civil Service Examination

DRAFTSMAN, ARCHITECTURAL AND STRUCTURAL STEEL

September 14, 1920

The United States Civil Service Commission announces an open competitive examination for draftsman, architectural and structural steel. Two vacancies in the Lighthouse Service, Milwaukee, Wis., at \$1,560 to \$1,800 a year, and vacancies in positions requiring similar qualifications throughout the United States, at these or higher or lower salaries, will be filled from this examination, unless it is found in the interest of the service to fill any vacancy by reinstatements, transfer, or promotion.

For circular setting forth the full particulars, write Civil Service Commission, Washington, D. C.

Weekly Review of the Construction Field

With Reports of Special Correspondents in Prominent Regional Centers

WITH the approach of October 1 the housing shortage is assuming a most acute aspect, and there is an uneasy feeling that unless municipal, state and national governments take decisive steps a condition already extremely grave may become something that will work a very great amount of suffering.

In almost every important city throughout the United States there are being made efforts, more or less practical, to relieve the situation. But these matters move too slowly to be of present and practical use.

In Minnesota the Department of Agriculture is seeking some concrete plan to submit to the Legislature at its next session which will encourage capital to build homes. Large corporations that have built and expected to begin operations are confronted with an almost certain suspension owing to the shortage of houses.

A review of the housing situation in New York State discloses many angles. It is contended that the shortage of houses and the activity that is going on in other departments of building is due to the action of the Legislature in placing a limit on rentals and in other ways restricting the owner's use of his property. While very few plans for tenements or apartment houses are being filed, there is apparently no lack of money for building garages and theatres, and there appears to be no difficulty in finding labor and materials for that sort of building which is now booming. The Legislature by a somewhat unwise action has contributed to this shortage, and it must likewise remedy the results of its own error. Just how that may be accomplished is the problem now engaging close attention.

A scheme that has perhaps met less adverse criticism than any other is one proposed by Senator Lockwood of the New York Legislature. He would exempt mortgages on buildings from the State income tax. This would afford but a moderate inducement to investment, as there is no present hope of the exemption from the much heavier Federal income tax. Senator Lockwood, it is stated, has also under consideration a bill to exempt all building improvements for dwelling purposes from taxation for a period of ten years. Just how far such exemptions would stimulate investment in buildings intended for housing is, of course, problematical. The condition is with us; the remedy lies in the dim distance of legislative action.

In New Jersey there is already apparent a strong disposition to criticize the tardy action of the Legislature in coming to the relief of the people of the State in the matter of housing. The question of congestion due to lack of housing is one that is causing much concern to health officials, who see in its continuance a very pronounced danger to the public health. In fact, it is probably through just such an effect that a nation-wide movement will be inaugurated to find a remedy for a condition that has now spread to every State and will undoubtedly become a menace to public health.

St. Louis, Mo., boasts that it is one of the few cities which has devised and successfully put into operation a practical scheme for relieving the housing shortage. A \$2,000,000 corporation, supported by the Chamber of Commerce and the city commercial clubs, has been organized and, it is stated, is successfully providing the men of moderate income with homes. In fact, St. Louis claims that through the operation of this and similar organizations there is practically no very serious housing shortage there.

One of the most interesting features of this housing enterprise is the scheme of payment. This calls for 10 per cent. cash on the price of the house and the balance in ten or twelve years. On the ten-year plan the purchaser pays \$11.35 per year on every thousand of the selling price after the 10 per cent. cash payment has been deducted. On the twelve-year plan he pays \$9.95 per thousand of debt. The association will not permit a man to invest more than 27 per cent. of his monthly income in one of their houses—a feature of the transaction which is clearly specified in the deed.

In Boston a most unusual remedy is suggested. Mr. R. P. Delano, of the Dorchester Board of Trade, has suggested to Mayor Peters of Boston that approximately \$10,000,000 originally contributed by the public to aid in great emergencies, such as the funds for San Francisco, Armenia, Halifax and India, and also those created by some of the many "drives" during the war, and which lie unexpended in Boston banks, might be used in helping to solve the housing problem. Probably similar funds exist in other cities. Their use as loaning capital would not impair their integrity.

In Delaware, and particularly in Wilmington, where large corporations are located, the housing question is assuming such large proportions as seriously to menace the uninterrupted progress of manufacturing.

THE AMERICAN ARCHITECT

(Special Correspondence to The American Architect)

Seattle.—Careful canvass among architects of the North Pacific Coast territory shows that high prices of building essentials, excepting lumber, is holding off fall building projects, and this part of the season, which on the Pacific Coast is frequently the most active of the year, due to climatic conditions which permit of outdoor operations, will be very quiet unless there is some radical change in the outlook.

Heavy sheet metal is coming through from the East more readily than thirty to sixty days, but small pipe, specifically in sizes of an inch down to three-quarters and one-half are continually scarce. To Pacific Coast jobbers the eastern mills are insisting that higher prices and a more acute shortage are coming. Probably the only normal pipe supply on the Pacific Coast today is in cast iron soil pipe. The shortage from the British Columbia to the Mexican line varies only in degree, and this was checked forcibly last week when the Crane company at Seattle shipped a carload of a half to two inch black and galvanized pipe to Los Angeles to supply an acute shortage there.

Enamelware advanced 10 per cent., and delivery of staple assortments is six to eight weeks behind. Special sizes will not be accepted by the mills for delivery in less than 90 to 120 days, and bathtubs are not placed in less than six months. Special wall tubs, eastern mills report, cannot be accepted for delivery under six to nine months. Conditions as to vitroware are very similar.

North Coast architects report only two minor contracts for the week, \$12,000 and \$20,000, respectively, and almost without exception it is reported that there are no large jobs in sight. The high price wave is cutting severely into the smaller jobs. Investors say they will wait, preferring to save the artificial expense which obviously would have to come out of the property and caused continued unhealthy rentals.

Plaster is scarce, with the responsibility on the carriers. A little is arriving at Seattle from Utah, but the bulk is being drawn from California. The largest cement plants on the Pacific Coast are clustered within a radius of 125 miles of Seattle, but due to the condition of the car supply a Seattle jobber can get fire brick and plaster from the East as quickly as he can spot a car of cement from his own territory.

Fire brick is \$5 higher at \$75 warehouse basis and common brick is \$16 and \$17 at the yard. Clay products this week jumped 200 per cent., the first change in quotations in several months. Sewer pipe is about 20 per cent. higher.

Fir lumber is unsettled. The advance in freight rates did not produce the effect of a buying rush from eastern builders that has always heretofore

stiffened prices, and inasmuch as eastern buyers have not sought placements ahead of the advance, mills and wholesalers fear that they will not buy at all this season. The fir mills hold unfilled orders for 8,163 carloads, 30,000 feet to the car, of fir lumber for eastern building account, but in view of the rate advance which became effective August 26 many cancellations are expected. New orders from the East are practically an offset to the car supply of 30 per cent. of normal. The new freight rates are heavily discriminatory against West Coast fir woods in favor of southern pine, the differential running from 44 cents to \$13.37 per 1,000 feet. The mills declare officially that the average cost of producing fir lumber today is \$32 per 1,000 feet.

(Special Correspondence to The American Architect)

Chicago, Ill., Aug. 24.—Again official announcement comes that the high cost of material and labor will bring building construction to a standstill within the next sixty days, except for a few theatres, hotels and apartment houses. E. M. Craig, secretary of the Building Construction Employers' Association, sizes the situation up in this manner. He estimates that about \$15,000,000 worth of work is now held up by prohibitive costs, which is \$50,000,000 above what it was estimated in January it would be at this time.

In the case of building of houses and flats, it is estimated that only about one-tenth the needs is under way. Chicago today stands about 60,000 houses short of its absolute necessity in dwellings. Residents are therefore forced to "double up" in many apartments and houses in order to get a roof over their heads. Inasmuch as prospective home builders see little chance of ever getting back their investment, their plans for building have been shelved. In the meantime rents continue to advance.

The let-down in building activities has removed the labor shortage which some time ago caused some embarrassment among contractors. Plasterers, however, are still hard to get, although carpenters and bricklayers are plentiful. Labor is drifting to Chicago now from Pittsburgh, Detroit and other points where there has been a sag.

Local street car companies report plenty of applications for work and, while employment is not slack, many industries report men applying for jobs.

President Adolph F. Kramer of the Chicago Real Estate Board is active in a plan to reduce the cost of constructing apartment buildings. He has called a conference of leading building material, building labor, real estate and mortgage banking men for the latter part of this week to discuss the apartment and high rent situation, with the hope of arriving at some remedy for relief.

front piece of Th. 2334



GATEWAY—THE ALCAZAR, AVILA.

THE AMERICAN ARCHITECT

VOL. CXVIII

WEDNESDAY, SEPTEMBER 15, 1920

NUMBER 2334



GENERAL VIEW, FROM ARCHITECT'S DRAWING

The Scottish Rite Hospital for Crippled Children, Atlanta, Ga.*

MESSRS. HENTZ, REID & ADLER, *Architects*

THE Scottish Rite Hospital for Crippled Children, in Atlanta, is a splendid example of successful designing for a special use. The plan is well worth careful study as it can be adapted to uses other than in this case. Climatic conditions might make some changes desirable but these would be in minor details. It would be difficult to improve the general scheme.

The hospital is built in the northeastern section of Atlanta. It faces south, is on a main thoroughfare and convenient to street car transportation. The group at present consists of an administration building and two ward buildings. A nurses' residence is immediately adjoining the East Ward. Future extensions will consist of ward buildings 60 feet in the rear of the north of the present ward buildings and connected therewith by corridors. An out-patient building will be constructed adjoining the West Ward building and connected by an extension of the present corridor. This building will be convenient to the street cars.

The administration building is two stories high with basement under the rear portion to accommodate the heating plant, storage and laundry. The first floor contains the offices, reception room, store room, elevator and receiving room where the incoming patients are held in quarantine. In the rear are the nurses' and servants' dining rooms, kitchen, pantry and store rooms. In the second floor front are the superintendent's and interns' quarters, laboratory, anaesthesia and recovery rooms. In the rear are the X-ray, plaster, sterilizing, operating, surgeons' wash and nurses' work rooms.

The ward buildings are one story in height, except for a basement under a portion of the West Ward intended for a gymnasium and storage. The gymnasium is temporarily used as an out-patient department. Each ward building contains two wards with a nurses' station between, from which the nurse can see all patients of the building. On the south front is a porch opening into the wards. Two observation rooms are provided and each has a portion of the porch which can be separated from the ad-

*For additional illustrations see plate section.

THE AMERICAN ARCHITECT

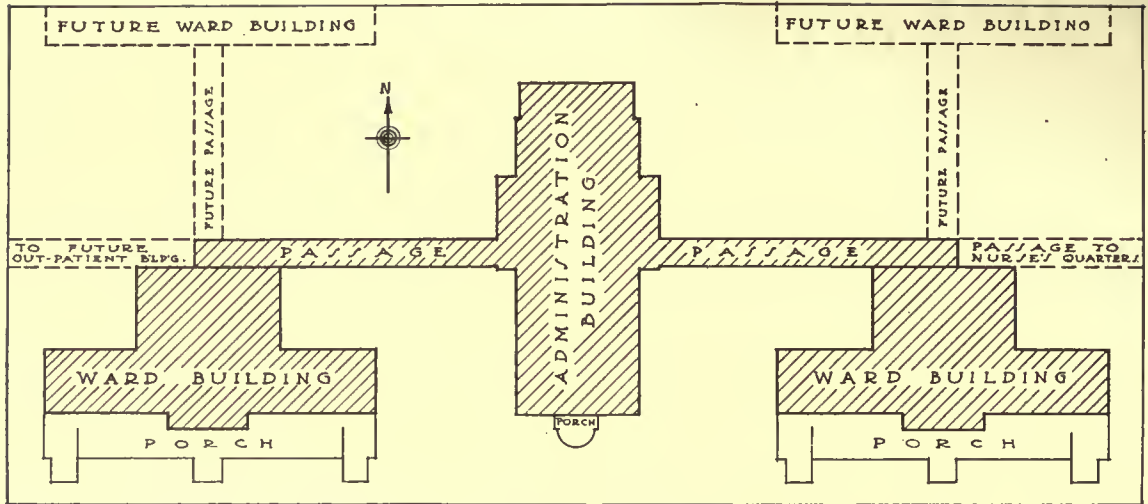

PLOT PLAN

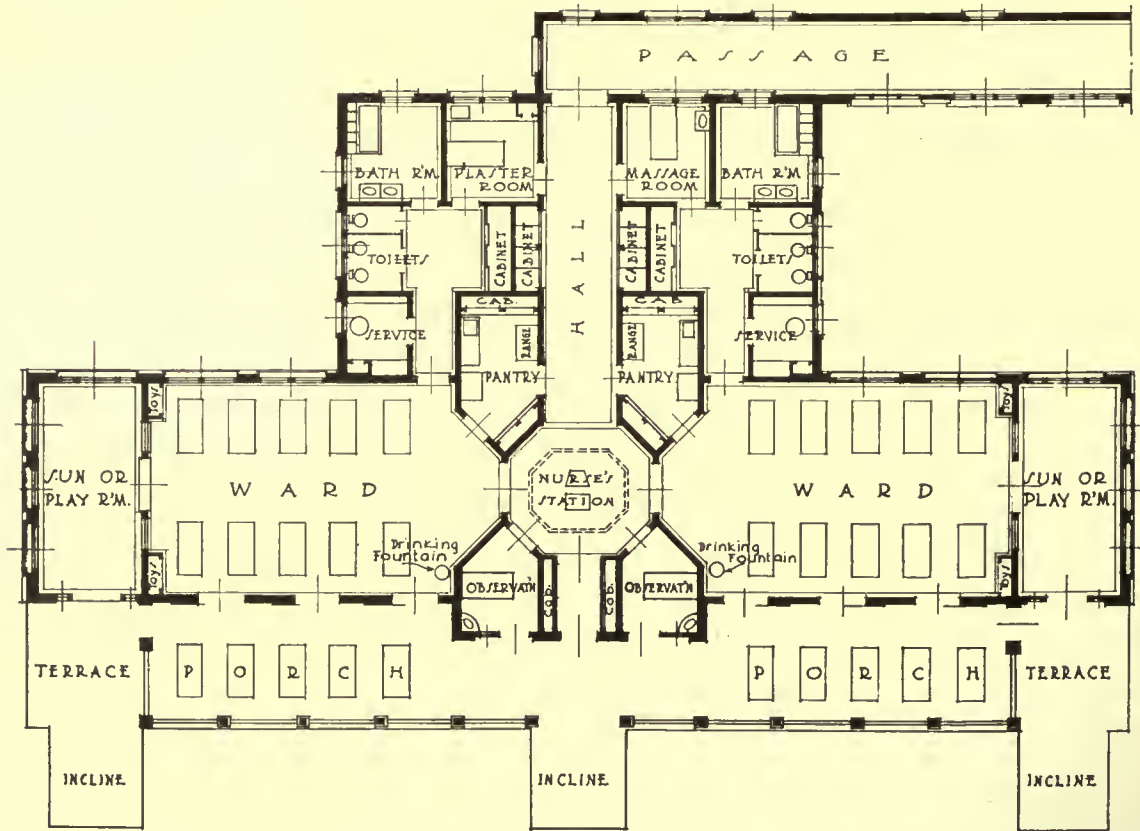

TYPICAL WARD PLAN

SCOTTISH RITE HOSPITAL FOR CRIPPLED CHILDREN, ATLANTA, GA.
 MESSRS. HENTZ, REID & ADLER, ARCHITECTS

THE AMERICAN ARCHITECT

joining porch by folding, glazed, accordion doors. At each end of this building is a sun or play room. These are furnished with toys, games, books, pianos or Victrolas. Over the wards is a monitor construction which, with the windows and doors on the north and south sides of the wards, furnish ample

weather this corridor is used as a place for exercising by patients who can walk. These long corridors are not only necessary for this purpose, but they permit of sufficient space between the buildings to make possible perfect ventilation in hot weather.

All entrances to the ward buildings and corridors

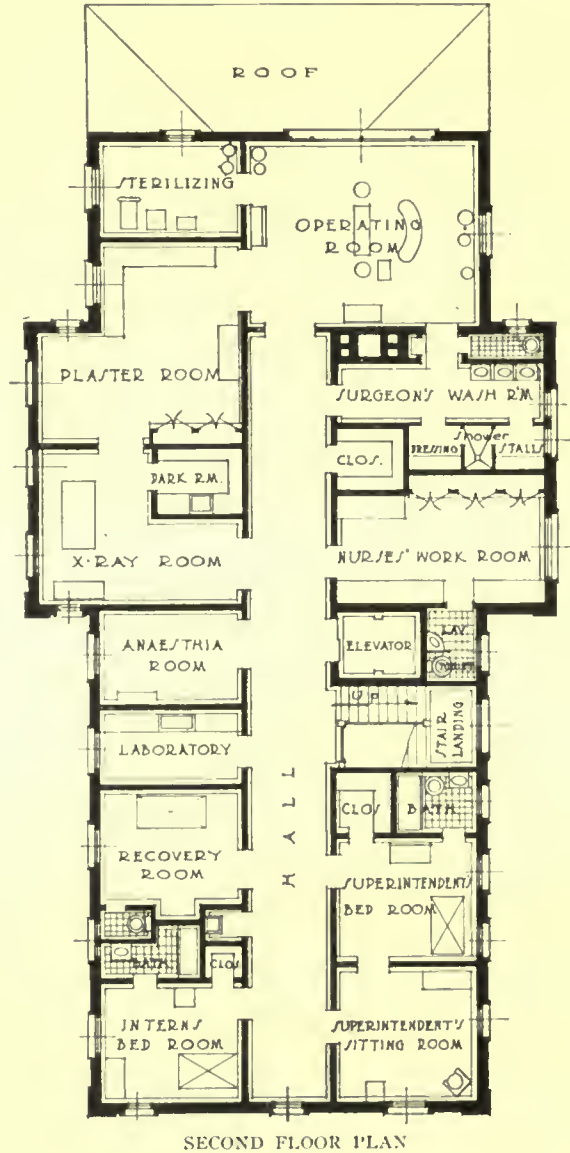
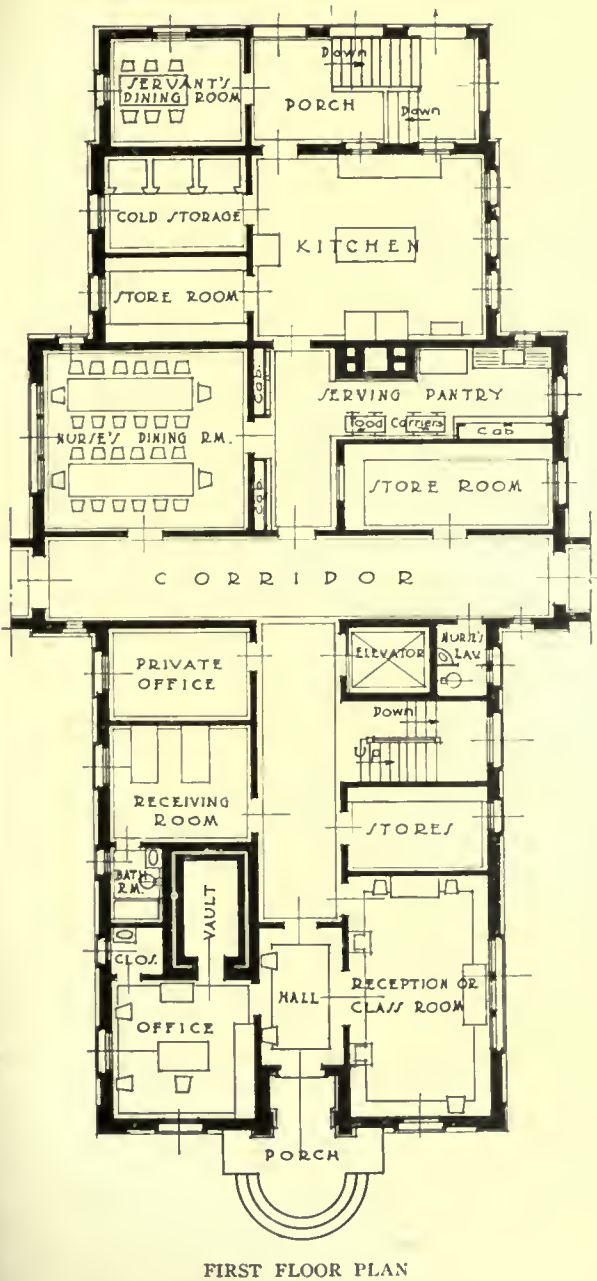

light and ventilation. In the rear are pantries, wash, toilet and bath rooms. There is also a plaster and massage room.

The connecting corridor has a total length of about 235 feet, including that portion included in the administration building. In cold or stormy

are made by easy sloped inclines for the accommodation of the patients who are learning to walk or those in wheeled chairs. The only exterior steps are at the main entrance to the administration building and at the kitchen entrance.

The youngest children are housed in the West Wards, the older children in the East Wards. The toilet fixtures, lockers and other accessories are installed with regard to the age and size of the users. Sixty patients can be accommodated.

THE AMERICAN ARCHITECT

This hospital was built, is maintained and operated by the Scottish Rite Consistory of Atlanta. The medical staff, consisting of surgeons, medical practitioners, dentists, oculists and other specialists, serve without pay and are selected for ability and willingness to serve. They are selected without reference to religion, political or fraternal associations. The patients are crippled children whose parents are unable to pay for treatment and they are accepted without reference to nationality, religious, political or fraternal affiliations. They are a remarkably joyous group of children, being well fed, clothed and cared for. They are the subjects of the kind and careful attention of many visitors and others who are interested in their welfare and above all, they have an abiding faith that they will soon stand erect and be whole human beings as it was intended they should.

The remarkable success of this first or parent institution has instigated the undertaking of similar hospitals by other consistories of the Scottish Rite. It was also the prime-mover of an action by the Imperial Council of the Shrine, composed of delegates from the United States and Canada, at Portland, Oregon, in the summer of 1920. The Council set aside \$800,000 which is now available, the income from which will annually provide whatever sum may be necessary for the construction, maintenance and operation of hospitals for crippled children. A committee of seven is empowered to procure sites, plans and specifications, execute contracts for construction and do everything needful and desirable to put in operation the things specified in the resolution.

The Atlanta hospital may well be accepted as a model, both in plan and operation, for these future hospitals.

Preliminary Notice—LeBrun Traveling Scholarship Competition

PRELIMINARY NOTICE—LEBRUN TRAVELING SCHOLARSHIP COMPETITION

The Executive Committee of the New York Chapter of the American Institute of Architects, as trustees of the traveling scholarship, founded by

Pierre L. LeBrun, announces a competition for the selection of a beneficiary, the programme of which will be issued about November 1, 1920, calling for drawings to be delivered about January 15, 1921.

The following excerpts from the deed of gift explain the award and conditions:

Fourteen hundred dollars—is to be rewarded—to some deserving and meritorious architect or architectural draftsman, resident anywhere in the United States, to aid him in paying the expenses of an European trip, lasting not less than six months.

The selection of the beneficiary of the Scholarship is to be by means of a competition—and the drawings called for—are to be submitted for examination and judgment to a jury consisting of at least three practicing architects, no one of whom is to be connected with any school or atelier for the teaching of architecture. In making the award the jury are to give a full and careful consideration to the records of qualification filed by the competitors as well as to the comparative excellence of the drawings submitted.

Any architect or architectural draftsman, a citizen and resident of the United States, not under twenty-three or over thirty years of age, who shall, for at least three years, have been either engaged in active practice, or employed as an architectural draftsman and who is not and has not been the beneficiary of any other traveling scholarship, shall be eligible to compete.

Every competitor must be nominated by a member of the American Institute of Architects who shall certify in writing that the above conditions are fulfilled, and that in his opinion the competitor is deserving of the scholarship. No member of the Institute shall nominate more than one (1) candidate.

Every competitor must engage to remain, if successful, at least six months abroad and to devote well and truly that length of time to travel and the study of architecture otherwise than by entering any school or atelier or attending lectures, it being intended that the benefit derived from this traveling scholarship shall supplement school or office experience.

The successful competitor shall write from time to time, but not less than once every two months, to the New York Chapter of the American Institute of Architects, giving an account of the employment of his time.

It is requested that those wishing to enter the competition arrange at once for their nomination by a member of the American Institute of Architects, according to the conditions outlined above, which nomination should be sent with his application so that it may be received before November 1, 1920, to Louis Ayres, 50 East 41st Street, New York City, Chairman LeBrun, Scholarship Committee.

The Reconstruction of Northern France

The Northern French Village After the War

By RALPH FANNING

EVEN before the armistice was signed in November, 1918, the French refugees, driven from their old homes by the advance of the enemy, were pushing north and literally staying on the very edges of the battle fields in order to get to their former abodes at the first possible moment. In the Somme they were back with aid to rebuild their destroyed villages in some places when the last big German drive again forced them to flee, losing their little all for a second time. In the Marne there was less disturbance after the first tremendous drive and retreat. Here the inhabitants were able to come back to take up a new life among the still smoking ruins while the big guns were still sounding not far distant, and become well settled in new conditions before hostilities ceased. In much of the Meuse and parts of the Anise and Ardennes there was little opportunity even to ascertain what the homecoming would be while the armies still held complete occupation. So the long-enduring

refugees waited and saved and hoped for the glad day when they could leave the none too welcoming towns of their adoption and start back to prepare the old homes for still mobilized sons and husbands and long separated wives and children.

Long before the government would grant permission or advise it the people were coming back driving and pushing their goods and chattels, carrying treasured household or personal objects which, like ancient Lares and Penates, had accompanied them in their hurried exile. Many a third-class coach on the adventurous though uncertain little "chemin de fer" would deposit its load of old men

and black-veiled women with little children and bags and bundles innumerable at some partially wrecked station or at a heap of crumbling stone and tile with only a signboard to mark the site of a pre-war post of some pompous chef de gare. With much scrambling and many a plaintive "Oh, la-la!" the family would at last be "descended" and the little train would hesitatingly venture on its dubious way.

The returning refugees would set out through the debris to find what would await them in some little hamlet reached only by a muddy road, a secluded place which in pre-war days had borne for them that all significant name of Home. Even more heartbreaking than the exciting evacuation in the path of the enemy, a scene more tragic and productive of emotion could hardly be imagined than the return of some brave old grandmere with her grandchildren clinging to her mourning weeds. Back she would come to the place where she and her fathers before her had toiled and played through peace-

ful lives, where her thoughts had ever been turning during the long, cruel years of war, and where her one hope had been to return before she died. Fortunate were those who upon their return fell into the helping hands of some relative who had arrived back first to prepare a welcome, or who came in contact with some busy relief worker first on the spot with supplies and good cheer. To all the homecoming was sad enough, although with all there was the strange joy of being again on home soil even in the dire state in which it was apt to be found.

What a homecoming the devastated regions had



AN INNER GATE AT VERDUN

THE AMERICAN ARCHITECT

and still have to offer! Able pens have written stirring descriptions of destroyed villages, but only first hand inspection can really give due impressions of what a country may suffer in modern warfare. At first sight one ruined village may seem exactly like every other ruined village, and often they are much the same. In each there is likely to be the same heap after heap of powdered and crumbling stone, of dusty and muddy refuse, of grotesquely wrought fragments of former metal work, the shattered trees and traces of pre-war gardens still trying to offer their bits of color and fragrance. A rusty remains of a broken sewing machine, a battered birdcage, a bit of Louis XV. gilt mirror, add touches of dismal realism. But as one gets to know a village better and to study its possibilities of rehabilitation, many a bit of individuality

Eprenay or Chalons that can show the effects of aeroplane bombs and more or less damage done by shell fire; more contested strongholds like Rheims or Verdun which were systematically shelled or fiercely fought over until hardly a house escaped.



HOTEL DE VILLE, RHEIMS



RHEIMS

SIDE VIEW OF CATHEDRAL TOWER

asserts itself. Here a dubious wall seems indecisive whether to stand or fall. There a well built chimney leans threateningly against the sky. Here a solitary archway stands in the midst of dirt and rubble. There an antique stone stairway climbs ridiculously into space. Here a broken row of trimmed trees marks a former public place. There a floorless room shows a pink wall and marble mantelpiece in whose bottomless grate no hearth fire will ever more burn.

All the villages were not destroyed or molested in the same manner or to an equal degree. As reconstruction problems they offer many different studies. There are well known towns like Amiens,

There are towns like Montfaucon in the Meuse or Attigny in the Ardennes to mention as examples among the hundreds that were about as cleanly shot off the face of the earth as human force could do it. As extreme cases, there are such places as Voquois par Varennes where the site of the former village, situated on a hill, now shows nothing but a deep crater many meters across. Oftentimes it was only a case of damaged roofs, broken windows and fallen plaster that needed to be cleaned up before the home was again fit for habitation. Sometimes by propping walls or tar-papering roofs and filling in holes, temporary living quarters could be made.



THE VISIT OF A BOMB REVEALS OLD METHOD OF CONSTRUCTION

Very often in villages swept by fire, the only places in which the returning owners could live were the cellars and caves, excellent for safety if bombs were still falling, but not ideal for a habitation for any animals much higher than rabbits. In other villages still more devastated, the barracks and dugouts left

THE AMERICAN ARCHITECT

by the military, were the only shelter to protect the returners.

The evacuated villages within the lines that awaited the refugees' return unmolested by actual battle fire shared none too easy a fate of neglect and foreign occupation. This was also true of the French village far back of the lines where troops were thickly quartered and the owners and craftsmen whose

often make careful tenants for the upkeep of house and garden and village improvement, especially soldiers of another color and continent. So it could hardly be expected that the little French village of the North could retain much of its pre-war attractiveness, even when it escaped the more disastrous reign of shell and fire.

Naturally the home was the first thing to occupy the thoughts of the returned villager. Unless one had known the refugees in their exile and experienced a few of the trials under which they had to live during the years of war, it is difficult to appreciate what could induce, not to say attract, them back to some of the old homes that they had left, so disheartening were the tasks of reconstruction that awaited them. Streets would have to be cleaned and made passable before the homes could be reached. In this work the military did efficient ser-



THE INTERIOR OF THE CATHEDRAL AT RHEIMS



RHEIMS

care it had been to attend to their upkeep killed or still with the army. Building materials were exorbitant in price or impossible to obtain, and complicated red tape must be unwound to obtain permission to make any extensive repairs. Labor was not available, and had there been, there was not much incentive to putting on a new roof perhaps for an enemy to sleep under or to drop bombs upon. Even the best of soldiers quartered in a village did not

vice, but they usually heaped the debris in great piles by the roadway, and through these the owner had to burrow to reach his house site. If shelter and even crude habitation were left him, there were many handicaps in livelihood that had to be overcome. Some source of food supply had to be assured before stores and markets were started. Wells had to be cleaned or re-excavated. Chickens, rabbits and all live stock had practically all disappeared from the country. The fields and garden sites had to be cleared of barbed wire entanglements and all manner of refuse before an attempt could be made to reclaim them from the four years' growth of weeds and wildflowers that had run riot between the battle fields. Property lines and landmarks had often disappeared, their owners lost or in a distant town, yet very apt to appear with a claim should another party start renovations upon a property where rights of ownership were uncertain. All of

this made for delay and discouragements, as did the tardy distribution of the "dommage de guerre," the money which the French victim ever expected to obtain from his government for war damages. Until such a claim was settled, a cautious man would hesitate about making any reparation for fear of not being able to collect his just dues.

In spite of all the seemingly terrific drawbacks, the people returned as soon as the guns ceased their destructive work—returned to beat their swords into pruning hooks. They continue to return, for to paraphrase John Howard Payne, "be it ever so shattered, there's no place like home."

Beaux-Arts Institute of Design

DIRECTOR OF THE INSTITUTE, LLOYD WARREN.

ARCHITECTURE, WILLIAM F. LAMB
MURAL PAINTING, ERNEST C. PEIXOTTO

SCULPTURE, JOHN GREGORY
INTERIOR DECORATION, ERNEST F. TYLER

Official Notification of Awards— Judgment of April 27, 1920

PROGRAM.

CLASS "B"—IV ANALYTIQUE.

The Committee on Architecture proposes as subject of this Competition:

"A PROBLEM IN SUPERPOSED ORDERS."

In the design of the facade of a two-storied private library the use of superposed orders is required, i. e., each of the two stories shall be expressed in facade by the use of an order, the order of the second story being thus placed above that of the story beneath.

Well known examples of superposition are the Coliseum in Rome, the Library of St. Mark and the Palazzo Grimani, both in Venice, the Palazzo Porto Barbarano in Vicenza, the entrance pavilion of the Luxembourg Palace in Paris, Tiffany's Store in New York City, and the Pittsburgh Athletic Club in Pittsburgh.

The facade called for is the end facade on a side street, the main entrance and entrance being on an avenue running at right angles to the street. It shall have not more than three bays, nor be more than 60 feet in width. The heights of the stories and the choice of the orders to be used are discretionary.

JURY OF AWARD:

R. M. Hood, F. A. Godley, E. V. Meeks, H. O. Milliken, L. S. Butler, D. J. Baum, A. E. Flanagan and A. L. Guptill.
NUMBER OF DRAWINGS SUBMITTED: 116

AWARDS:::

First Mention Placed: S. Grillo, Atelier Corbett-Gugler, N. Y. C.; S. M. Clement and M. L. Colean, Columbia Univ., N. Y. C.; V. M. Reynal and W. Douglas, Yale Univ.-Sch. of Fine Arts, New Haven.

First Mention: A. L. Muller, 263 East 19th street, Brooklyn, N. Y.; A. B. Butts, Pratt Institute, Brooklyn, N. Y.; J. H. Geissel, "T" Square Club, Phila.; R. E. Tatum, Univ. of Kansas, Lawrence; D. M. Campbell, H. S. Kelly, A. G. Clay and S. Georges, Yale Univ.-Sch. of Fine Arts, New Haven.

Mention: H. H. Price, G. L. Newman, R. W. Arnold and M. E. Witmer, Boston Archtl. Club, Boston; J. Truden and T. Koch, Atelier Corbett-Gugler, N. Y. C.; M. Grisez, A. H. Gilman, G. Trinin, A. Perrella and A. M. Taylor, Columbia Univ., N. Y. C.; M. Mut, J. D. Mawhinney, F. H. Floyd, G. E. Tucker, H. E. Rudy, E. Hughes, H. W. Anderson, G. O. Schoonover, R. A. McKee, F. K. Wets and R. Berkey, Carnegie Inst. of Technology, Pittsburgh; H. Van Der Lyn and K. Sassagawa, Atelier Hiron, N. Y. C.; W. A. Schabel, K. Steinbach, J. B. Watterson, N. O. Matson, J. E. Miller and L. A. Balicki, John Huntington Poly. Inst., Cleveland; H. Sabransky and W. W. Mezger, Los Angeles Archtl. Club, Los Angeles; R. Gum Lee, R. L. Hedlander, A. O. Angilly, J. M. Rosales, H. L. Coggins,

D. W. Lockard, A. Kaplan, J. J. Murphy, G. S. Vibberts and D. Markowitz, Pratt Institute, Brooklyn, N. Y.; C. E. Maule, Pennsylvania State College, State College; L. E. McConville and C. K. Kruchten, Atelier Parsons-Chicago Archtl. Club, Chicago; E. S. Young, L. V. Navitsky, J. A. Fletcher and W. C. Chance, "T" Square Club, Phila.; R. B. Bloomgarten and A. E. Evans, Univ. of Kansas, Lawrence; A. A. Shay, E. G. Wendland, Doris Seibert and Rosalie Haas, Univ. of Washington, Seattle; Essie Lipscomb, G. L. Walling, B. H. O'Connor, R. Alsup and H. C. Heath, Univ. of Texas, Austin; C. H. Hinman, Verner



S. M. CLEMENT COLUMBIA UNIVERSITY
FIRST MENTION PLACED

CLASS "B"—IV ANALYTIQUE—A PROBLEM IN
SUPERPOSED ORDERS

THE AMERICAN ARCHITECT

Carlson, A. D. Harrington and S. Selway, Univ. of Minnesota, Minneapolis; L. G. Adams, P. E. Isbell, C. B. Lewis and D. Weinstein, Yale Univ.-Sch. of Fine Arts, New Haven; F. Harvey, Atelier Schadler, Reno; A. Wuchterl, Atelier DeGelleke, Milwaukee; E. W. Klawuhn, A. H. Miller and E. Giberson, Thumb Tack Club, Detroit; T. S. Browne, George Washington Univ., Wash., D. C.; J. H. Geering, San Francisco Archtl. Club, San Francisco.

H. C.: R. W. Watson, Univ. of Kansas, Lawrence.

PROGRAM.

CLASS "B"—IV PROJET.

The Committee on Architecture proposes as subject of this Competition:

"A CLOCK TOWER ON A COLLEGE CAMPUS."

A clock tower is to stand on the edge of a college campus, telling time to the students and to the people in the adjoining town, for whom it will form a land-mark. It may if desired contain a chime of bells.

Prof. Ludlow, H. W. Corbett, F. C. Hiron, J. F. Harbeson, D. Candler and M. B. Stout

NUMBER OF DRAWINGS SUBMITTED: Ninety-six
AWARDS:

First Mentioned Placed: R. B. Schell, L. H. Rank and A. W. Chesterman, Carnegie Inst. of Technology, Pittsburgh; H. W. Gill and Helen M. Gail, Columbia Univ., N. Y. C.; R. DeGhetto, Atelier Hiron, N. Y. C.

First Mention: J. E. Linnett and O. P. Morton, Boston Archtl. Club, Boston; R. M. Crosby, H. T. Aspinwall, B. Dierks, D. H. Bodin, D. H. Oertell, L. E. Considine, M. C. Drebin and R. D. Devney, Carnegie Inst. of Technology, Pittsburgh; W. A. Strong, K. Matsunoi, F. W. Brown and R. S. Buck, Jr., Columbia Univ., N. Y. C.; G. W. Green, Atelier Corbett-Gugler, N. Y. C.; J. W. Walker, Jr.,



S. GRILLO ATELIER CORBET GUGLER
FIRST MENTION PLACED

CLASS "B"—IV ANALYTIQUE—A PROBLEM IN SUPERPOSED ORDERS

To be visible above the trees, the clock-dials are to be centered at least 150 feet above the ground. At the foot of the tower, or forming its base, is an open-air loggia, so disposed with relation to the campus as to form the nucleus and gathering place for student activities, open-air meetings and celebrations of victories on the athletic field. If the loggia is so arranged as to admit of the placing of statues, busts, plaques and inscriptions, it will in time be complete as a memorial to the student life of the college.

This composition, exclusive of terraces, is not to exceed 125 feet in its greatest horizontal dimension.

JURY OF AWARD:

B. W. Morris, W. Warren, J. Oakman, H. A. Boehm,

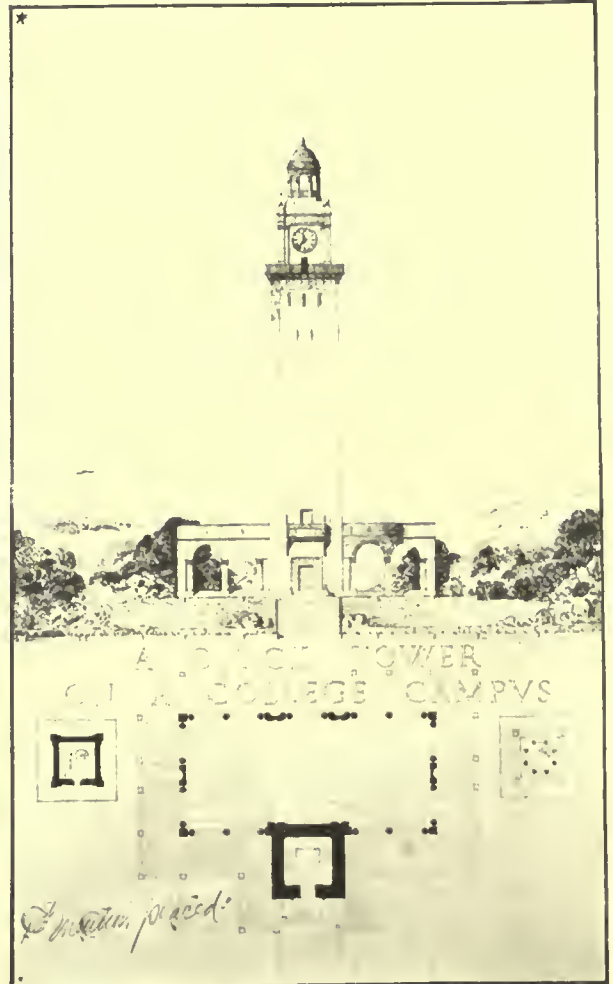

HELEN M. GAIL COLUMBIA UNIVERSITY
FIRST MENTION PLACED

CLASS "B"—IV PROJET

Georgia School of Technology, Atlanta; W. S. Boice, Atelier Hiron, N. Y. C.; C. Steck, Patron-R. M. Hood, N. Y. C.; H. H. Weeks, San Francisco Archtl. Club, San Francisco; W. J. Rankin and R. L. Goldberg, "T" Square Club, Phila.

Mention: C. F. Wright, Boston Archtl. Club, Boston; G. H. Jamison, H. W. Stone, L. L. Nusbaum, J. H. Todd,

(Concluded on page 363)

THE AMERICAN ARCHITECT

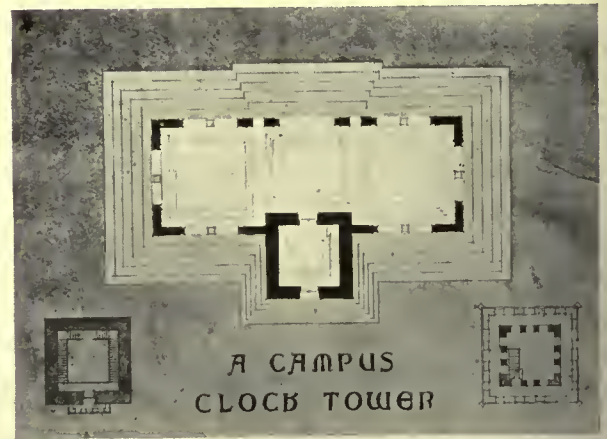

R. B. SCHELL CARNEGIE INSTITUTE OF TECHNOLOGY
FIRST MENTION PLACED

H. W. GILL COLUMBIA UNIVERSITY
FIRST MENTION PLACED

CLASS "B"—IV PROJET
STUDENT WORK. BEAUX-ART INSTITUTE OF DESIGN



House of Albert G. Milbank, Esq.

HUNTINGTON, LONG ISLAND, NEW YORK

MR. JOHN MEAD HOWELLS, *Architect*

MOST American country houses are so very new in all their elements that they are generally not fit to be photographed until they are so old as to be no longer regarded as a desirable novelty by architectural publications. The Albert G. Milbank Estate at Lloyd's Harbor, Huntington, L. I., although lately finished has already taken a certain aspect of maturity from the remarkably large tree and especially large vine planting by Mr. Milbank's head gardener. The disposition of the land where this house was to be placed showed a sharp bluff to the water of Lloyd's Harbor. Along the top of this bluff was a heavily wooded strip about 100 feet wide, and against these woods the house was set. This left the approach to the house through a straight level field; a driveway between turf bands and hedges. The driveway ends in a circle with 150 foot sweep in front of the house. In the centre of the circle is a carp pool 80 feet in diameter, and facing the house on the opposite side of the circle are two walled gardens; the walls follow the sweep of

the circular drive and are built of the same material as the house.

The house itself is very heavily constructed of brick, with a stucco surface and fireproof floors. Many of the building materials were made for this house, as for instance, the flat English roofing tile and various surfaces of purple and green. The house is an old English type, more like the simple houses of the Cotswold district than the imposing cut stone Tudor type. The approach to the house is through the rather distant wood and by a pond, but the entrance to the home land proper passes between gate houses and semi-circular entrance grills. Just inside of this, as you pass down the drive, you find yourself inside a sort of service court about 300 feet wide. At the extreme right of this you see the stable group and at the extreme left the garage group which are similarly arranged. This arrangement of entrance and disposition of service buildings is more like that used in the later French chateaux, and was the natural solution of conditions.

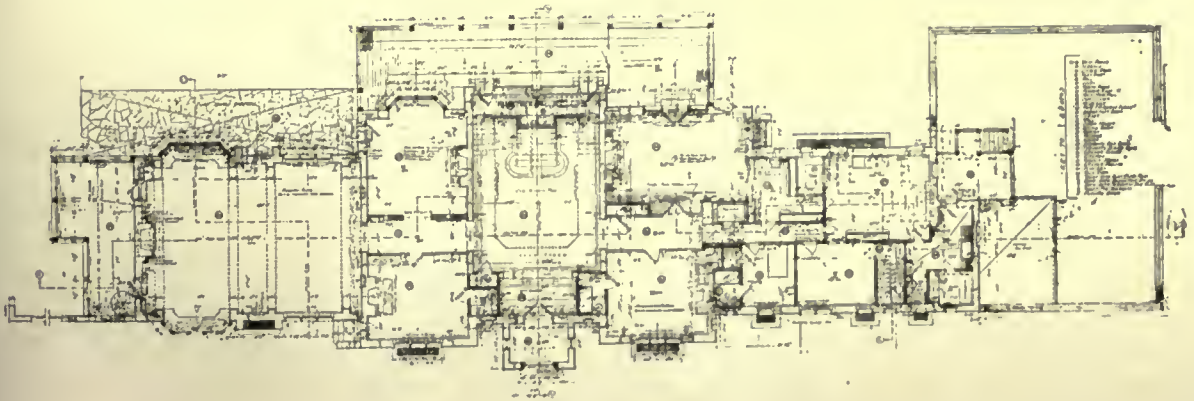

Eastern Portico, St. Paul's Chapel, New York

McBEAN, *Architect*

(See reproduction of the original drawing by O. R. Eggers in
this issue)

A MORE general view of St. Paul's and a brief account has been published in a preceding issue. The view that Mr. Eggers here presents is one looking north along Broadway from a point where Fulton Street crosses.

The fine architectural expression of this church may here be studied more in detail. The columns of this portico stand as will be seen, at the very edge of the sidewalk line. Here six days in every week hundreds of thousands of people pass, but neither the roar of traffic nor the restlessness of the city's populace can destroy the calm of this enclosure.

On every Sunday, as for a century past, the religious services call to this chapel people whose families for generations have worshipped at its altar and whose ancestors lie buried in its churchyard, while daily, in its interior, hallowed by many momentous observances devout workers of the neighborhood find a restful spot for quiet meditation.

Northern and Southern Estates Change Hands

There is a sort of hands over the land pleasantry going on between New England and Virginia, the Old Dominion. Wealthy New England people are acquiring the great estates in Virginia that have been abandoned virtually for many years through the inability of the "first families," so called, to maintain them. The civil war made the owners poor. These great estates have been discovered lately by the wealthy of the North and are being bought right and left and restored to their former grandeur. The Weld family, of Boston, has acquired the great estate called Temple Gwathmeys, near Warrenton, and Larz Anderson, also of Boston, has recently acquired a great estate in Virginia despite his beautiful possessions in Brookline. The estates may be made exceedingly productive if cultivated, and many is the Westerner who knows farm conditions, who has wondered that the

Virginians were not making their properties bloom like gardens and flourish otherwise, contributing to the wealth of the owners and that of the nation.

But the Virginians seem to have lost energy in this direction or were perhaps too proud to stoop to the hard work necessary to give impetus to a restoration of the estates. They have preferred in the main to wander and let the old houses fall into decay. The first instance of the discovery of old estates in Virginia was by a wealthy man from Chicago, who found Gunston Hall an attractive spot, overlooking the Potomac, not far away from Mount Vernon. It appeared a ruin, but he restored it to its original grandeur, discovering old treasures in wall decorations under the many layers of wall paper that had been put over the original. He showed what could be done with an old estate and the original home of the Masons of Virginia is as grand as ever it was. The Welds are to spend three millions in improving the estate they purchased. A part of Monticello, the Jefferson estate, has also been acquired by a wealthy man and is to be improved. These things are set down in a recent issue of the *New Bedford Times*.

In a sense the restoration and revamping of the estates so that they live again and are fruitful is to be regretted. There is a charm in abandoned estates. Ruins appeal to the romantic side of many people. And there has been much romance connected with old Virginia estates, with their slaves and aristocratic pretensions, their hunts, politics and duels.

The war laid waste their estates and exhausted their progeny. The glamour of it all is one reason why the estates are being sought. The flavor of old times is left in Virginia, the grand manner and style of the "Old First Families." While esteeming themselves as of old, they are not averse to welcoming the strangers from the North, gold laden though they be rather than surcharged with blue blood. So in this year of 1920, the three hundredth anniversary of the landing of the Pilgrims, finds some New England families moving to the country of the men who established Jamestown in 1607. It is, of course, not to be understood that the New Englanders are to be permanent settlers in old Virginia. They seek there, literally, happy hunting grounds, just as the people of the South formerly came to New England to spend the warm period.

352



EASTERN PORTICO, ST. PAUL'S CHAPEL, NEW YORK
THE AMERICAN ARCHITECT Series of Early American Architecture



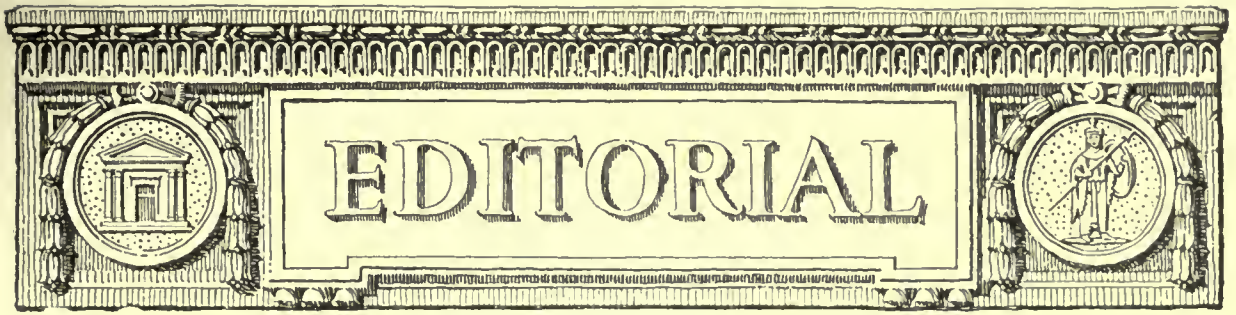

A National Construction Congress

UNDOUBTEDLY one of the most important things to be accomplished at this time in the building construction fields is a better and more intimate arrangement between the employing and working elements. It is therefore of interest to learn that the newly organized National Congress, based somewhat along the lines of the Parliament of the Building Trades in England, has taken steps to form a permanent establishment of a building and construction congress to give continuity to these nationally beneficial objects.

An organization committee has been formed to take up this important question. It is to meet in Chicago on September 27. The representatives are from all of the many elements of the building and construction industries and its efforts, as outlined in a preliminary notice, would seem to be along the most practical line and one that would insure some tangible results.

There can be no doubt that the history of civilization in all countries is closely linked with the periods of prosperity where the greatest building activity has been shown. One, if not the principal, cause of the present chaotic condition in the industry that is now being watched is that the general stagnation is very seriously retarding our national growth. If this is true, then the vital thing would be to devise such methods as will give the proper impetus to construction all over this country and remove those retarding influences that are now seriously impeding the normal growth of building.

THE committee, in its report, has stated that it is its belief that acceleration cannot be solved from the standpoint of any single element or by attention to local problems unless there is concurrence generally over the country as to the good purpose of such action. This committee, therefore, will very wisely take up and carefully study the relations of the various elements of building interests which enter into building and construction activities, and in this way arrive at a solution that will not specifically accelerate activity in any one location, but will have

a nation-wide influence in correcting the evils that so seriously hamper our building progress.

It is gratifying to note that in the organization of this committee an architect is at its head and that the representation of the practical elements in every other field of building, engineering, construction, contracting, large manufacturers of material and, in fact, all of the various complex factors that contribute to the building industry are very completely represented. Mr. Robert D. Kohn, architect, of New York, is chairman pro tem, and Mr. Wm. Couper, secretary.

THE AMERICAN ARCHITECT has, from time to time, referred to the inactivity of members of the profession in vital matters of this character and it is therefore a great pleasure to be able to record that in this important committee, which will undoubtedly go a long way in solving our construction problems, there is a satisfactory proportion of architects and engineers among its members.

More Transportation

NOW that the railroads are back again in the hands of their owners and they have been able to take account of stock of the deterioration that occurred during Government control, it is natural to expect that the Advisory Committee of the Association of Railway Executives would be able after a thorough examination of conditions, to suggest a means that would promptly increase the transportation mileage, based on such facilities as are available and that they would not wait that interminable period until they could build a sufficient quantity of cars to accomplish that purpose.

As referred to in the economic section of this issue, it is proposed to increase the loading of available cars to a maximum carrying capacity and by this means increase the tonnage to a very considerable degree. The Advisory Committee have now announced that the efforts in this increase are seriously handicapped by the very large proportion of bad order cars and that steps will be at once taken to put these cars in such condition that they will

THE AMERICAN ARCHITECT

be able to carry a full load and stand the wear of almost constant use.

When federal control began there were in use about 2,260,000 freight cars, of which not quite 6 per cent. were reported in bad order. At the end of federal control the number of cars had been increased about 100,000, of which not quite 8 per cent. were in bad order.

The cure of this situation is one of the first and most important problems in transportation. Naturally this cure is an expensive one on account of the present high prices of material, but there is assurance that it can be done and it is believed that within a reasonable length of time the cars available for transportation of all material will be so largely increased as to afford a very measurable relief. This will be cheering news to everyone in the building industries, as will, also, the word that comes from the railroad companies that they are speeding up these repairs to the greatest possible degree and that each succeeding month will mark a more satisfactory condition.

A Condition and Its Cure

FEW people aside from those who are directly interested realize the serious and helpless condition in which the building situation is today. Millions of dollars' worth of building material, contracted for in the belief that it could be used in building operations (which everyone felt sure would by this time be actively going forward) now lies in the mills and yards of dealers, the orders for it having been cancelled.

It is exasperating to read the theoretical reasoning of many writers in the daily and technical press. We learn from these that the real cause of delay is lack of transportation, labor unrest, shortage of material or injudicious meddling of state legislatures. These

are none of them major causes, although all of them tend to complicate the situation. It is the unwillingness of banks to make loans that is the real cause.

It may be well to make some examination into the underlying reasons for this unwillingness, and having arrived at a definite conclusion endeavor to prescribe a remedy.

It was not because of any of the factors of transportation, labor troubles or material shortage that the banks have stopped making loans. It was because they could not dispose of these real estate mortgages to their customers. This condition is largely due to the Federal Income Tax which with the heavy surtax on the larger incomes makes mortgage buying at 6 per cent. absolutely impossible.

It therefore becomes the privilege as it is also the duty of every one connected with the building industry who understands the situation and whose livelihood depends on building activity, to urge to the full extent of his power such legislation as will release vast sums of money for home building. Tax exemption for real estate mortgages is the one big thing that will hasten a cure. Every architect should work early and late to secure passage of an exemption law. He should write to his Congressman and to his Senator setting forth the need of haste in action.

It is going to take a large and well directed propaganda to put the urgency of the present building situation before our National legislators. Few of them realize how helpless is the present situation. Make it plain that prompt action is desired and if it is withheld that political support will be transferred to a more intelligent representation and the battle will be won.

We shall more fully discuss this situation in the building field in a later issue. Facts and figures will be set down that will be valuable in the propaganda that is urged and in which every architect should take a prominent and active part.



HOUSE OF A. G. MILBANK, HUNTINGTON, LONG ISLAND
JOHN MEAD HOWELLS, ARCHITECT





HOUSE OF A. G. MILBANK, HUNTINGTON, LONG ISLAND
JOHN MEAD HOWELLS, ARCHITECT

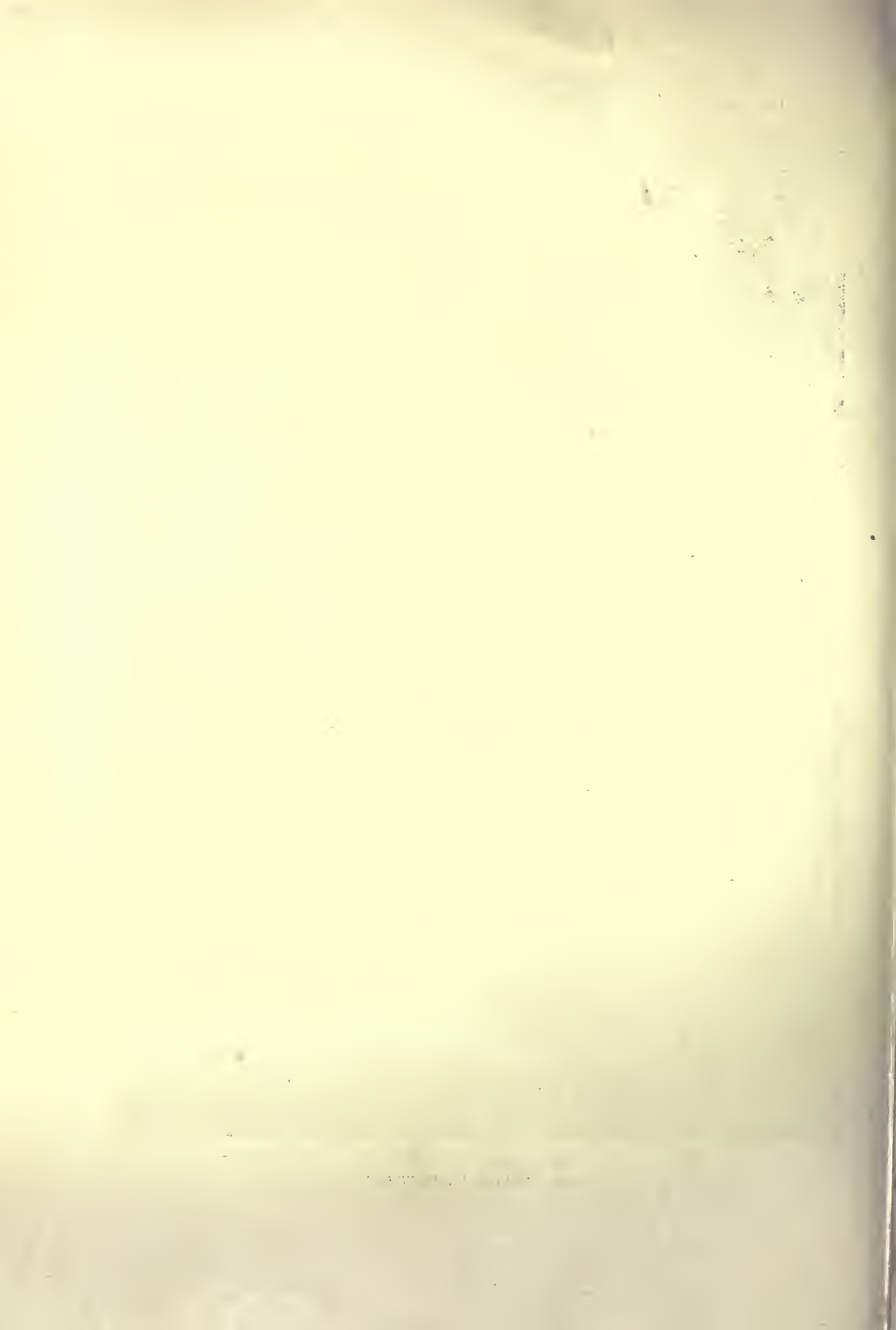

35*



HOUSE OF A. G. MILBANK, HUNTINGTON, LONG ISLAND
JOHN MEAD HOWELLS, ARCHITECT

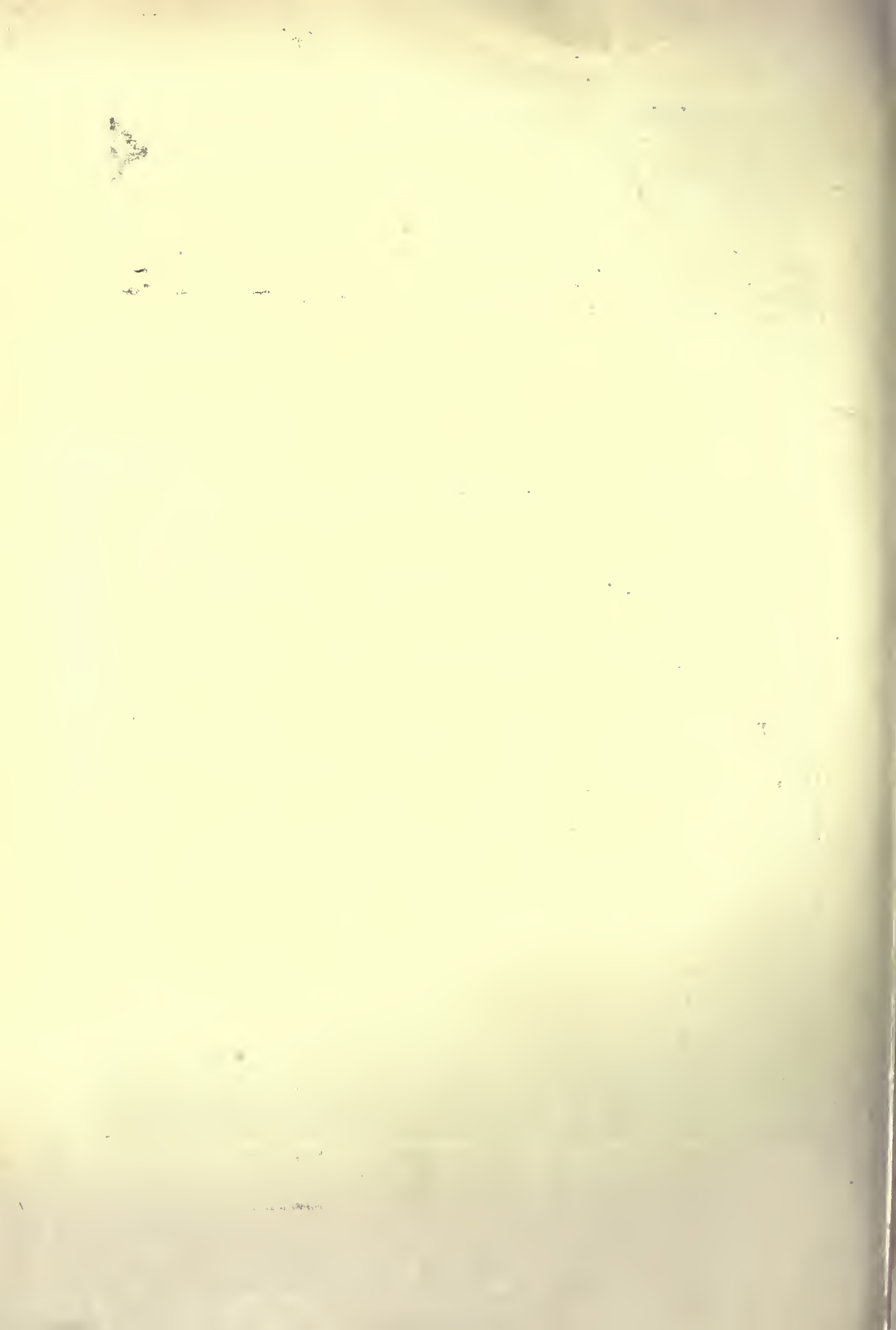



LIVING ROOM
HOUSE OF A. G. MILBANK, HUNTINGTON, LONG ISLAND
JOHN MEAD HOWELLS, ARCHITECT





STAIRCASE

HOUSE OF A. G. MILBANK, HUNTINGTON, LONG ISLAND
JOHN MEAD HOWELLS, ARCHITECT



HALL

354 5





HORACE WHITE MEMORIAL FOR THE CITY OF БЕЛОИТ, WIS.
JOHN MEAD HOWELLS, ARCHITECT. F. M. L. TONNETTI, SCULPTOR



1
354



CORONA BUILDING, 42D STREET, NEW YORK
JOHN MEAD HOWELLS, ARCHITECT



354



SCOTTISH RITE HOSPITAL FOR CRIPPLED CHILDREN, ATLANTA, GA.

HENTZ, REID & ADLER, ARCHITECTS

(For descriptive article, see text)



4
25



GENERAL VIEW



EAST WARD BUILDING

SCOTTISH RITE HOSPITAL FOR CRIPPLED CHILDREN, ATLANTA, GA.
HENTZ, REID & ADLER, ARCHITECTS



D
352



ADMINISTRATION BUILDING



VIEW IN WARD, LOOKING TOWARD NURSES' STATION, OPENINGS TO PORCH ON THE RIGHT
HENTZ, REID & ADLER, ARCHITECTS



DEPARTMENT OF ARCHITECTURAL ENGINEERING

The Revolving Door, Its Characteristics, Design and Installation

Part II

IN this article certain practical considerations in the design, selection and installation of the revolving door will be treated.

Since the revolving door will constitute both entrance and exit for the building, it is necessary, in order to determine the number of such doors required, that the probable traffic shall first be estimated. As a rule this can be done with a reasonable degree of accuracy. Buildings may be roughly divided into two classes for the purpose of traffic regulations—those in which peak conditions occur at definite, stated periods, when the occupants of the building regularly enter and leave, such as office buildings, schools, etc., and those in which there is a constant traffic of transients or visitors throughout the entire day, as, for instance, in hotels, banks and libraries.

In the former an estimate can be made of the probable number of occupants on a "floor area" basis, using some reasonable ratio. The New York Building code provides as follows:

When the number of persons to be accommodated by the exits is not stated in the application for a per-

mit to construct, such number of persons within any floor area shall be taken, according to the use of such floor area, as one person:

a—for every ten square feet in dance halls, lodge rooms and places of assembly;

b—for every fifteen square feet in court rooms, restaurants and classrooms in schools and colleges;

c—for every twenty-five square feet in stores, markets and lodging houses and reading rooms;

d—for every thirty-two square feet in workrooms;

e—for every fifty square feet in offices and show rooms.

f—for every one hundred square feet in hospitals, hotels and lodging houses and other residence buildings.

Let us assume a 12-story office building, with 5,000 square feet floor area per story, the ground story to be occupied as stores with direct independent egress to the street. Then the number of persons to be accommodated by the street entrance, on the basis of the New York Code would be 100 persons per story or 1,100 persons above the ground floor. While peak conditions may vary in different

localities, it is safe to assume that in a large city 60 per cent. of the occupants would enter the building within a fifteen minute period in the morning, as, for



REVOLVING DOOR USED IN LARGE OPENING
Space on Each Side and Above Revolving Door Filled With Glass Panels. Note the Heavy Exterior Doors Which Are Closed and Locked after Banking Hours.

THE AMERICAN ARCHITECT

instance, from 9 a. m. to 9:15 a. m. In other words, the entrance for the building under consideration must accommodate 660 persons in 15 minutes, or 44 persons per minute.

In some cases it might be found that 90 per cent. of the occupants would leave the building in a similar period at the close of the working day. For such a condition the exit would have to take care of a traffic of 990 persons in 15 minutes, or 66 persons per minute.

In a public building it should be possible to make a close estimate of the number of persons which would enter and leave during a given period, and then provide exits slightly in excess of this number.

Much valuable data can be obtained by making actual counts of those entering and leaving buildings of similar character to one which may be planned, and properly analyzing the results.

Below is given a tabulation of counts made in six New York City buildings of varying character of occupancy.

Number of Persons Passing Through Revolving Doors

Name of Building and Entrance	Start Finish		In Out		Maximum persons in one direction per minute
	M.	P.M.	In	Out	
<i>Lunch hour traffic</i>					
World building, main entrance	12	12:15	130	199	13
" " " "	12	12:30	227	308	
" " " "	12	12:45	355	444	
" " " "	12	1:00	496	629	
Boreel building.....	12	12:15	82	100	7
" "	12	12:30	163	197	
" "	12	12:45	231	274	
" "	12	1:00	337	363	
" "	12	1:15	406	448	
" "	12	1:30	476	524	
<i>Transient traffic due to general business transactions</i>					
	P.M.	P.M.			
Manhattan Life building.....	3	3:15	164	128	11
" " "	3	3:30	311	238	
" " "	3	3:45	453	251	
" " "	3	4:00	559	432	
American Tract Society Bldg.	2	2:15	160	172	11
" " "	2	2:30	311	310	
" " "	2	2:45	416	421	
" " "	2	3:00	533	516	
Commercial Cable building, Broad street entrance.....	2	2:15	276	291	10
" " "	2	2:30	551	545	
" " "	2	2:45	737	777	
" " "	2	3:00	1018	1034	
" " "	2	3:15	1253	1304	
" " "	2	3:30	1520	1521	
Bank of Commerce building..	2	2:15	298	200	20
" " "	2	2:30	502	345	
" " "	2	2:45	748	533	
" " "	2	3:00	961	679	

It will be noted that the maximum traffic shown is 20 persons per minute. Some of these buildings have several entrances, and in laying out the entrances in such a case, an assumption must be made as to the probable distribution of traffic among the several entrances. For instance, the Equitable Building has exits leading to four streets, yet the greater number of persons entering and leaving the building use the Broadway entrance. This was to be expected, since Broadway is the main street on which the structure fronts.

REVOLVING doors are manufactured in varying sizes and styles, ranging from a three and four wing 6-foot diameter door to a six wing, power driven, 8-foot diameter door. The most practical, and by far the best door to install under most conditions

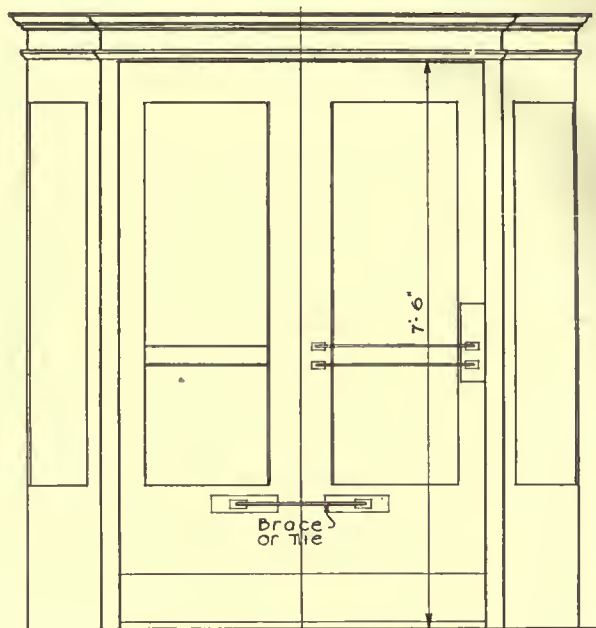

ELEVATION

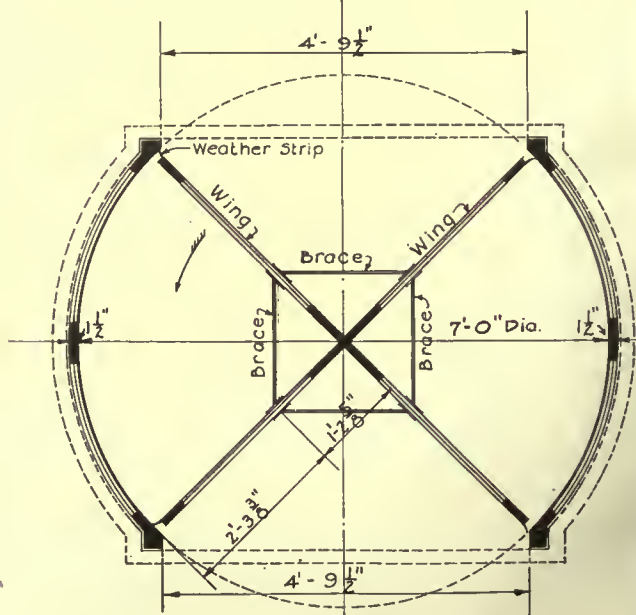

PLAN

FIG. 1. STANDARD 7 FT. DIA. REVOLVING DOOR

is a four wing, 7-foot diameter door, the dimensions of which are given in Fig. 1. Such a door will take care of a traffic of 40 persons per minute, which is

THE AMERICAN ARCHITECT

ample for all average conditions. Preferably a panic proof or automatically collapsible type should be selected. Where the traffic is small it may be felt that a 6-foot diameter door would prove adequate. This smaller size door will only accommodate approximately 50 per cent. of the traffic of the larger door. This is mainly due to the cramped position that those using it assume when passing through, and the consequent reduced velocity. It should be noted, that while each wing of a 6-foot diameter door has a width of 3 feet, yet the unobstructed space from brace to outer edge is only 1 foot 10 inches, whereas in the 7-foot door this is over 2 feet, 3 inches, permitting much freer movement on the part of those using the door.

A revolving door may be placed either within or without the entrance doorway, or centered in the opening. Various arrangements are shown in Fig. 2. In most cases the first floor is slightly above the street level, necessitating the use of steps. The first riser should not be less than 14 inches distant from the path of the revolving wings; 18 inches is prefer-

provide a weather proof roof, this increasing the cost. However, this is not a serious item.

Where space permits, it is always advisable to place an auxiliary swinging door in close proximity to the revolving door. This need not be more than



AN APARTMENT HOUSE INSTALLATION

This Building Is So Located as to Be Exposed to Very Severe Winds

able. When steps are again encountered after entering the building, the first riser should be kept at least 24 inches from the door. See Fig. 2.

It must be remembered that where the revolving door projects outside the doorway it is necessary to



MAIN ENTRANCE TO A BANK BUILDING

3 feet wide. For department stores, and other classes of buildings, where it is possible that children accompanied by adults or persons unfamiliar with the operation of revolving doors may enter, auxiliary swinging doors, adjacent to the revolving door, should always be provided. This gives a choice to any who may prefer using the swinging door. In this respect, the New York City regulations now provide:

Department Stores. Type A (panic-proof) revolving doors hereafter installed shall be accepted in exit doorways from department stores provided doorways aggregating at least fifty per cent. of the legal required width, equipped with swinging doors, are installed, and one or more such outwardly swinging doors are located immediately adjacent to each revolving door. Such swinging doors need not be equipped with handles on the outside, and shall have a minimum clear width of three feet.

New Revolving Doors. In buildings other than assembly halls, asylums, auditoriums, churches, dance halls, department stores, hospitals, motion picture theatres, schools and theatres, coming under the exit provisions of the building code, doorways serving as required exits may hereafter be equipped with Type A revolving doors, or with Type B (rigid-brace) revolving

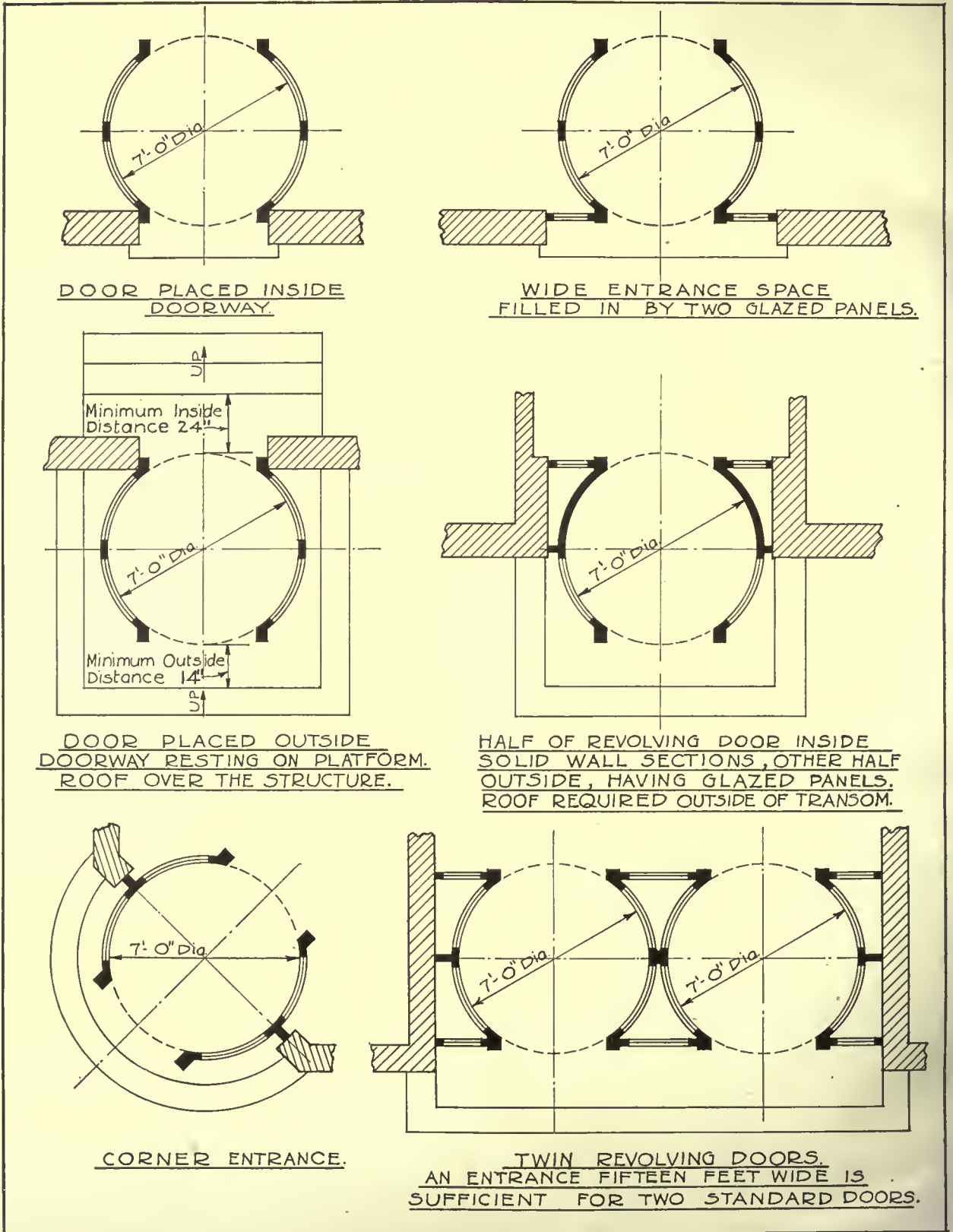

DOOR PLACED INSIDE DOORWAY.

WIDE ENTRANCE SPACE FILLED IN BY TWO GLAZED PANELS.

DOOR PLACED OUTSIDE DOORWAY RESTING ON PLATFORM. ROOF OVER THE STRUCTURE.

HALF OF REVOLVING DOOR INSIDE SOLID WALL SECTIONS, OTHER HALF OUTSIDE, HAVING GLAZED PANELS. ROOF REQUIRED OUTSIDE OF TRANSOM.

CORNER ENTRANCE.

TWIN REVOLVING DOORS. AN ENTRANCE FIFTEEN FEET WIDE IS SUFFICIENT FOR TWO STANDARD DOORS.

FIG. 2. VARIOUS ENTRANCE ARRANGEMENTS FOR REVOLVING DOOR INSTALLATIONS

doors, provided such revolving doors, not exceeding three in a unit, shall have an outwardly swinging door at least three feet wide located immediately adjacent thereto.

The accompanying illustrations show revolving doors installed in several types of buildings.

Investigation has shown that the revolving door is particularly popular for bank buildings. Since many bank robberies have occurred in which the lone teller and sometimes his assistants working after hours have been forced to throw up their hands, while the thieves gathered and made off with their booty, a special electrically controlled revolving door locking device has been developed, which can be operated by either hand or foot switch from any desired location. It is customary to have the control made possible from several locations. With such a device installed, a bank teller forced to throw up his hands can automatically lock the revolving door by pressing a foot switch, and at the same time cause the burglar

device is illustrated in Figs. 3 and 4. The lock proper consists essentially of a solenoid. Throwing the operating switch raises the metal core, thus releasing the catch, which engages the nearest wing of the revolving door, when exit is attempted by revolving it.

When a panic-proof type of door is installed four

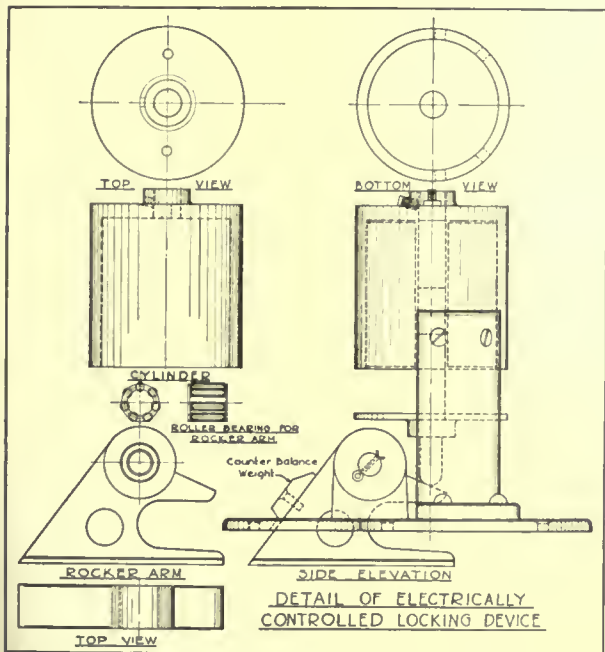
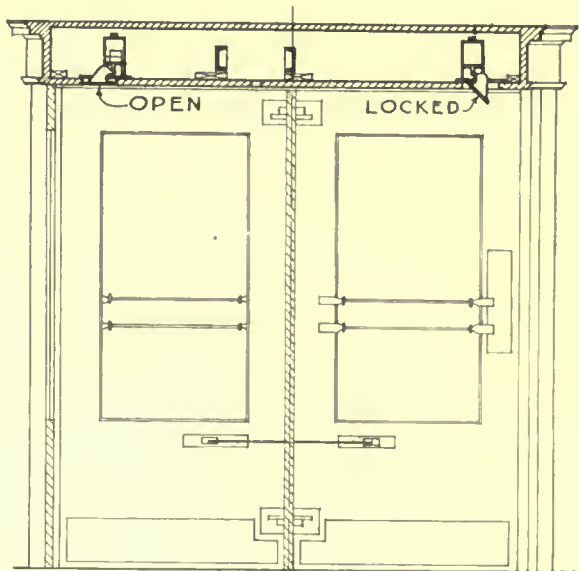

FIG. 3

alarm to operate. The thieves, having completed their "clean up" and unaware of what has secretly taken place, will find their usual egress blocked, and before being able to break plate glass windows and effect an escape, would probably be captured. Recently the operation of such a device installed in a New York City bank prevented the escape of burglars. Since this episode received much notice in the public press it has led to much inquiry on the part of other banks relative to this electrically controlled lock.

Doors provided with this device should have the panels in the wings glazed with wired glass. Such a



SECTION A-A

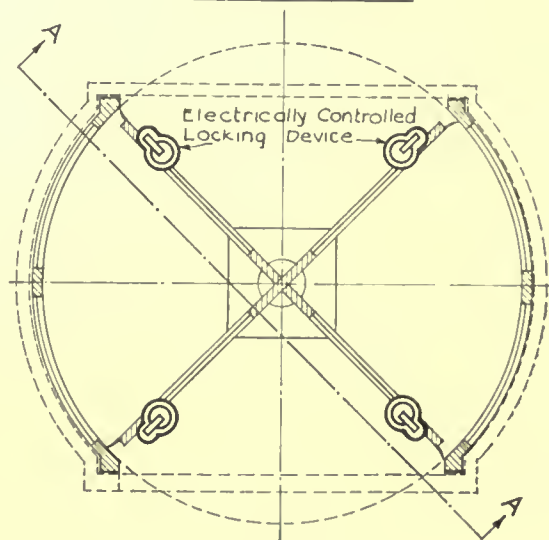

PLAN

FIG. 4. ARRANGEMENT OF ELECTRICALLY CONTROLLED LOCKING DEVICE FOR PANIC-PROOF DOOR

such locks are necessary—one for each wing—since the stopping of a single wing would still permit exit by collapsing the remaining wings.

It is hoped that the data presented in this and the preceding article will prove of value to architects designing buildings for which the revolving door is adapted.

Decisions Rendered by the National Board for Jurisdictional Awards in the Building Industry*

AIR COOLERS, AIR WASHERS AND BLOWERS, CONSISTING OF THE ASSEMBLING OF SHEET METAL AND PIPE FITTING

[Subject of dispute between Amalgamated Sheet Metal Workers' International Alliance and the United Association of Plumbers and Steamfitters.]

The following agreement between the Amalgamated Sheet Metal Workers' International Alliance and the United Association of Plumbers and Steamfitters was confirmed:

September 9, 1918.

The undersigned committee, appointed by the general presidents of their respective international organizations, name, the United Association of Plumbers, Steamfitters and Steamfitters' Helpers, and the Amalgamated Sheet Metal Workers International Alliance, held joint conferences in the City of New York, beginning September 5, 1918, in an endeavor to arrive at an agreement concerning air washers, fans, blowers, the housing of same, and the pipe fitting on same.

After lengthy meetings participated by all of the undersigned, representing the Joint Conference Committee of both international unions, the following has been agreed to:

Section 1. That all sheet metal work of No. 10 gauge, or lighter, when used on air washers, fans, blowers, or on the housing of same, shall be recognized as being the work of the members of the Amalgamated Sheet Metal Workers' International Alliance.

Section 2. That all pipe fitting in connection with the above first section shall be recognized as being the work of the steamfitters, members of the United Association of Journeymen Plumbers, Steamfitters and Steamfitters' Helpers.

Section 3. It being thoroughly understood by all of the undersigned that all the assembling and erecting of the work as defined in Section One, shall be the work of the members of the Sheet Metal Workers' International Alliance, excepting pipe fitting of all kinds, which shall be the work of the steamfitters and steamfitters' helpers of the United Association.

Section 4. This agreement shall become effective and in full operation for all parties concerned beginning November 1, 1918.

Signed for Sheet Metal Workers this 9th day of September, 1918:

JAMES LENNON, <i>Gen. Org.</i>	WM. H. LYONS
R. PATTISON, <i>Chm.</i>	THOS. WALSH
W. M. O'BRIEN, <i>Secy.</i>	EDW. P. O'NEIL

Signed for United Association:

E. W. LEONARD, <i>Gen. Org.</i>	RICHARD P. WALSH
CHARLES M. RAU	A. P. JOHNSON
LEO A. MURPHY	

LOW PRESSURE HEAT

[Subject of dispute between the United Association of Plumbers and Steamfitters and the International Union of Steam Engineers in the matter of maintaining temporary heat while structure is in course of construction.]

*Decisions rendered at the meeting on April 26, 1920, were published in the June 9 issue of THE AMERICAN ARCHITECT, and are not here included.

DECISION—In the matter of the controversy between the engineer and steamfitter on the question of low pressure heat during completion of the heating system, jurisdiction shall rest with the steamfitters until the initial test is completed, immediately after which time, whenever necessary to maintain heat, a stationary engineer shall be employed either by the contractor or the owner.

PIPE RAILING OR GUARDS FOR ENCLOSURES, STAIRWAYS, HATCHES, ETC.

[Subject of dispute between the Bridge and Structural Iron Workers' International Association and the United Association of Plumbers and Steamfitters. Claimed by the Iron Workers entirely except when not used as a conduit for fluids or vapors; claimed by Plumbers and Steamfitters when of standard sized cut and threaded pipe.]

DECISION—Pipe railing, consisting of standard-sized cut and threaded pipe, not used in connection with structural or ornamental iron work, is awarded to the United Association of Plumbers and Steamfitters.

RE-ENFORCED CONCRETE, CEMENT AND FLOOR CONSTRUCTION

[Subject of dispute between the Bridge and Structural Iron Workers' International Association and the Wood, Wire and Metal Lathers' International Union.]

DECISION—In the matter of the controversy between the Iron Workers and Lathers over re-enforced concrete construction, it is decided that all iron and steel used for re-enforcement in re-enforced concrete, cement and floor construction be awarded to the Iron Workers.

In such cities or localities as are covered by existing agreements with employers awarding Lathers control over re-enforced concrete construction, these agreements are to be maintained inviolate until the date of their expiration, after which this decision shall prevail.

ELECTRICAL WORK ON ELEVATORS

[Subject of dispute between the International Brotherhood of Electrical Workers and the Elevator Constructors' International Union.]

DECISION—In the matter of the dispute between the Elevator Constructors and the Electrical Workers on the question of all electrical work on elevators, it is agreed that the electric work on flashlights, electrical annunciators and lamps and feed wires to the controller is awarded to the Electrical Workers. All other electrical work is awarded to the Elevator Constructors in accordance with the conditions under which the charter was issued to the Elevator Constructors' International Union by the American Federation of Labor. Constructors and the Electrical Workers on the question of all electrical work on elevators, it is agreed that the electric work on flashlights, electrical annunciators and lamps and feed wires to the controller is awarded to the Electrical Workers. All other electrical work is awarded to the Elevator Constructors in accordance with the conditions under which the charter was issued to the Elevator Constructors' International Union by the American Federation of Labor.

VITROLITE AND OTHER OPAQUE GLASS

[Subject of dispute between the Bricklayers, Masons and Plasterers' International Union and the Brotherhood of Painters, Decorators and Paperhangers.]

DECISION—That in the matter of the controversy between

THE AMERICAN ARCHITECT

the Painters and Bricklayers on the subject herewith referred to, jurisdiction over the setting of vitrolite and similar opaque glass is awarded to the Bricklayers, Masons and Plasterers' International Union.

CUTTING CHASES OR CHANNELS IN BRICK, TILE, MASONRY, ETC.

[Subject of dispute between the Bricklayers, Masons and Plasterers' International Union and the International Brotherhood of Electrical Workers.]

DECISION—That in the matter of the controversy between the Bricklayers and Electrical Workers concerning the question of cutting grooves, channels, chases, etc., the Bricklayers are awarded jurisdiction over the work, except when channels do not exceed two inches by two inches in size or require labor not to exceed eight hours continuous time, in which case the award is in favor of the Electrical Workers.

NOTE: This decision does not contemplate the channeling or cutting of granite or hard stone.

LIGHT IRON FURRING, BRACKETS, CLIPS, HANGERS, CORNER GUARDS, BEADS AND METALLIC LATH

[Subject of dispute between the International Union of Wood, Wire and Metal Lathers and the International Association of Bridge and Structural Iron Workers.]

[Award of the Denver Convention, Building Trades Department, A. F. of L., adopted November, 1908. See printed proceedings, pages 69 to 71, inclusive.]

DECISION—In the matter of dispute between the International Union of Wood, Wire and Metal Lathers and the International Association of Bridge and Structural Iron Workers referred to in the foregoing title the following award is concurred in:

After going into an extended hearing of the jurisdiction claims of both organizations, your committee recommends that the erection and installation of all light iron work, such as light iron furring, brackets, clips, hangers, steel corner guards or beads,* and metallic lathing of all descriptions, belongs solely to the lather.

This does not give the right, however, to the lathers to install or erect any other iron work than as herein specified and outlined.

This decision is based in conformity with the agreement entered into by the national officers of both organizations and endorsed by the Kansas City Convention of Structural Iron Workers and concurred in by the American Federation of Labor.

In supplement of the foregoing decision the Rochester Convention of the Building Trades Department, November 29, 1912, awarded jurisdiction over Hyrib lath to the Wood, Wire and Metal Lathers' International Union.

*Note following decision:

METALLIC CORNER BEADS WHEN SET IN PLASTIC MATERIAL

[Subject of dispute between the Operative Plasterers and Cement Finishers' International Association and the Wood, Wire and Metal Lathers' International Union.]

DECISION—In the matter of the controversy between the Plasterers and Lathers on the question of the adherence of corner beads by plastic material, it is the opinion of the board that deserved consideration was not given the subject when the previous decision was reached. It is, therefore, agreed that the plasterers are awarded jurisdiction over sticking with plastic material metallic corner beads.

ACETYLENE AND ELECTRIC WELDING

[Subject of dispute between the trades named in the following memorandum.]

DECISION—In the matter of the dispute referred to in the foregoing title, as approved by the Philadelphia Con-

vention of the Building Trades Department, A. F. of L., November, 1914 (see printed proceedings, page 99), the following agreement is concurred in:

Representatives of the Electrical Workers, Sheet Metal Workers, Iron Workers, Plumbers and Steam Fitters, and Machinists mutually agreed to the following decision:

Each trade to have jurisdiction over all acetylene and electric welding when such process is used to perform the work of their respective trades.

BRONZING AND PAINTING OF RADIATORS AND PIPE CONNECTIONS

[Subject of dispute between the Brotherhood of Painters, Decorators and Paperhangers and the United Association of Plumbers and Steam Fitters.]

[Award of Rochester Convention, Building Trades Department, A. F. of L., adopted November 29, 1912. See page 141, printed proceedings.]

DECISION—In the matter of the subject referred to in the foregoing title, the following award is concurred in:

Resolved, That the United Association of Plumbers and Steam Fitters be and is instructed to require that its affiliated unions desist from further trespass upon the jurisdiction of the Brotherhood of Painters, Decorators and Paperhangers of America, and when and where necessary to notify their employers that neither journeymen nor helpers will be permitted to do this work.

CORK TILING, LAYING OR SETTING OF

[Subject of dispute between the United Brotherhood of Carpenters and Joiners and the Bricklayers, Masons and Plasterers' International Union.]

DECISION—In the matter of the dispute referred to in the foregoing title, the following agreement is concurred in:

Agreement entered into this 14th day of October, 1913, by and between representatives of the United Brotherhood of Carpenters and Joiners, and representatives of Bricklayers, Masons and Plasterers' International Union.

Jurisdiction is hereby conceded the Bricklayers, Masons and Plasterers' International Union to the laying or setting of all cork tiling when laid or set in any composition of sand and Portland cement.

Jurisdiction is hereby conceded the United Brotherhood of Carpenters and Joiners to the laying or setting of all cork tiling when laid or set in any composition of glue or when nails or brads are used in laying above referred to cork tiling.

APPLICATION OF DAMP-RESISTING PREPARATIONS AND WATERPROOFING

[Subject of dispute between United State, Tile and Composition Roofers, Damp and Waterproof Workers' Association, and the Brotherhood of Painters, Decorators and Paperhangers.]

DECISION—In the matter of dispute referred to in the foregoing title under the following agreement is concurred in:

Agreement entered into by and between the Brotherhood of Painters, Decorators and Paperhangers of America and the United Slate, Tile and Composition Roofers, Damp and Waterproof Workers' Association.

First. That the painters do not claim the right to apply any of the material claimed by the United State, Tile and Composition Roofers, Damp and Waterproof Workers' Association except such material as is applied by a brush that is ordinarily used by the painters in applying the materials covered in their jurisdiction.

Second. That the United Slate, Tile and Composition Roofers, Damp and Waterproof Workers' Association does not claim the right to apply any of the material in dispute except when applied by or with a three-knot, long-handled brush, mop or swab, and spray system employed therein.

THE AMERICAN ARCHITECT

MARBLE AND SLATE PARTITIONS, BACKS AND FLOOR SLABS FOR URINAL STALLS, CLOSETS AND SHOWERS, SETTING OF

[Subject of dispute between the Bricklayers, Masons and Plasterers' International Union and the United Association of Plumbers and Steam Fitters.]

[Award of Rochester Convention, Building Trades Department, A. F. of L., adopted November 28, 1912. See page 132, printed proceedings. Award of Buffalo Convention, November 9, 1917. See page 92, printed proceedings.]

DECISION—In the matter of the subject referred to in the foregoing title, the following award is concurred in:

Resolved, That the setting of floor slabs, backs, partitions of urinal stalls, closets and shower baths, properly belong to the Bricklayers, Masons and Plasterers' International Union.

The foregoing decision does not concede to the Bricklayers the right to install marble work that is connected with the water supply or sewer or watertight work regularly catalogued as plumbing fixtures.

MUSLIN AND CANVAS FOR DECORATIVE PURPOSES, TACKING OF

[Subject of dispute between the Brotherhood of Painters, Decorators and Paperhangers and the I. A. Heat and Frost Insulators and Asbestos Workers.]

[Award of Buffalo Convention, Building Trades Department, A. F. of L., adopted November 10, 1917. See page 108, printed proceedings.]

DECISION—In the matter of the subject referred to in the foregoing title, the following award is concurred in:

Resolved, That this convention notify and instruct the officers of the Asbestos Workers' International Union that the tacking of all muslin and canvas for decorative purposes is the jurisdiction of the Brotherhood of Painters and that they instruct their members to refrain from doing any of this work.

PILE DRIVING MACHINERY AND ENGINES, OPERATION OF

[Award of Buffalo Convention, Building Trades Department, A. F. of L., adopted November, 1917. See pages 59 and 105, printed proceedings.]

DECISION—In the matter of the subject referred to in the foregoing title the following award is concurred in:

Such workmen as are employed in the operation of engines or machinery in connection with a pile driver come under the jurisdiction of the International Union of Steam Engineers.

SHEET METAL GLAZING FOR SASH, FRAMES, DOORS, SKYLIGHTS, ETC.

[Subject of dispute between the Brotherhood of Painters, Decorators and Paperhangers and Amalgamated Sheet Metal Workers' International Alliance.]

DECISION—In the matter of dispute referred to in the foregoing title the following agreement is concurred in:

Agreement entered into by and between the General Executive Board of the Brotherhood of Painters, Decorators and Paperhangers of America, and the Amalgamated Sheet Metal Workers' International Alliance, shall take effect December 1, 1910, and remain in force until amended, revised or changed, at a meeting between the representatives of both organizations called for this purpose.

Section 1. It is agreed by both parties to this agreement that all glass set in sheet metal sash, frames, doors, or skylights shall be set by members of the Brotherhood of Painters, Decorators and Paperhangers of America, according to their claim of jurisdiction granted by the convention of the Building Trades Department, A. F. of L., at St. Louis, December, 1910; and that all sheet metal work on sheet metal sash, frames, doors, or skylights shall be done by the members of the Amalgamated Sheet Metal Workers' International Alliance.

Section 2. In localities where differences now exist or may arise in the future, such differences shall be adjusted

by a committee appointed by and representing the district councils or local unions of both organizations in that locality. Should this committee be unable to agree, a representative of the General Executive Board of each organization shall be called in to assist in the adjustment.

Section 3. It is also agreed that the national officers of both organizations where local unions fail to agree shall insist that this agreement be carried out by affiliated unions.

SLATE TREADS WHEN SET ON IRON STAIR CASE

[Subject of dispute between Bricklayers, Masons and Plasterers' International Union, and the International Association of Bridge and Structural Iron Workers.]

DECISION—In the matter of dispute referred to in the foregoing title the following award is concurred in:

Slate treads on iron stairs having provoked a dispute in jurisdiction between the organizations above named was submitted to the Executive Council November 29, 1909. The action taken follows:

The Executive Council of the Building Trades Department, on being called upon for a decision, awarded the work in question (slate treads) to the Bricklayers, Masons and Plasterers' International Union.

LOADING AND UNLOADING MATERIALS FOR REINFORCED CONCRETE CONSTRUCTION.

[Subject of dispute between the International Hod Carriers, Building and Common Laborers' Union and the International Association of Bridge and Structural Iron Workers with special reference to the loading and unloading of material as applied to reinforced concrete construction.]

Decision—In the matter of the dispute between the Laborers and Iron Workers:

It is the decision of the Board that the loading, unloading, carrying and handling of all rods and material for use in reinforced concrete construction shall be done by the laborers under the supervision of such person as the employer may designate. The hoisting of rods, except when a derrick or outrigger is used, shall be done by laborers, this decision to apply only to the character of work stipulated herein. In such localities where existing agreements provide otherwise, this decision is to become effective at the expiration thereof.

RETOUCHING CONCRETE WORK.

[Subject of dispute between the International Hod Carriers, Building and Common Laborers' Union and the Operative Plasterers and Cement Finishers International Association relative to Defects in Concrete Caused by Leakage, Bulging, Sagging, etc., through Defective Or Shifting Forms.]

Decision—In the matter of the dispute between the Laborers and Plasterers and Cement Finishers:

It was decided that where finishing tools are not used or required the work shall be done by the laborer. The filling of voids or other work requiring patching where finishing tools are required shall be done by the cement finisher.

The next meeting of the Board will be held at Washington, D. C., on November 29, 1920.

Patent Decision on Flat Slab Design

A recent patent decision of interest is that of the Examiner in Chief on Appeals which allows the claims in full of the application for a patent for the improvement in building construction filed July 18, 1911. This patent covers the broad use of the combination of "two way" and "four way" flat slab reinforcing consisting of running the bottom slab bars both directly and diagonally between the columns while the steel in the top of the slab, over the column head, extends in two directions only. This top steel may consist either of fabricated units, loose bar units or of the bent up ends of the bottom slab steel belts extending directly between columns.

The patents are owned by the Barton Spider-Web System, Inc., of Chicago.

THE AMERICAN ARCHITECT

(Continued from page 350)

H. Pohlmeier, N. P. Rice, J. P. Kefalos, T. A. Lynch, C. W. Hunt and C. L. DePrefontaine, Carnegie Inst. of Technology, Pittsburgh; O. T. Obel, H. R. Kaplan, A. I. Berkow, B. H. Bickel, A. E. Egeressy, C. Contreras, F. L. Hutchins and S. Dresser, Columbia Univ., N. Y. C.; C. G. deNeergaard, G. H. Gibson, H. E. Maddox, Jr., W. A. Robison, W. H. Merriam, R. P. Bell and J. Y. Arnold, Georgia Sch. of Technology, Atlanta; F. J. Brince and E. Olsen, Atelier Hiron, N. Y. C.; E. Babitsky and E. C. Rising, John Huntington Poly. Inst., Cleveland; L. Rombotis, Los Angeles Archtl. Club, Los Angeles; D. Earle, Patron-R. M. Hood, N. Y. C.; A. Gambell, Portland Archtl. Club, Portland, Ore.; M. Sillani, Atelier Parsons-Chicago Archtl. Club, Chicago; W. R. Fisher, E. A. Beihl and K. C. Albright, "T" Square Club, Phila.; E. M. McGinnis, Thumb Tack Club, Detroit; P. E. French, Jr., and Elizabeth Ayer, Univ. of Washington, Seattle; H. F. Neville, R. R. Hibbs, L. F. Soxman and H. E. Machamer, Univ. of Kansas, Lawrence; B. F. Miller, Univ. of Minnesota, Minneapolis; G. M. Trout, Univ. of Texas, Austin; W. L. Siebel and G. A. Daidy, George Washington Univ., Wash., D. C.; E. Penfield, Atelier Wynkoop, N. Y. C.

H. C.: C. J. Pellegrini, R. V. Murison, J. O. Cahill and K. Snow, Carnegie Inst. of Tech., Pittsburgh; W. M. Dowling, Atelier Corbett-Gugler, N. Y. C.; D. W. Murphy and L. Hamilton, Yale Univ.-Sch. of Fine Arts, New Haven; P. Goodman, Atelier Licht, N. Y. C.

SUPPLEMENTARY JUDGMENT OF APRIL 13, 1920.

CLASS "A"—IV PROJET.

"A RAILROAD STATION PLAZA."

NUMBER OF DRAWINGS SUBMITTED: Three.

AWARDS:

Second Medal: G. S. Underwood, Yale Univ.-Sch. of Fine Arts, New Haven.

Mention: O. Wilkins and R. B. Thomas, Yale Univ.-Sch. of Fine Arts, New Haven.

CLASS "A" AND "B" ARCHAEOLOGY—III PROJET.

"A BANQUET HALL IN A MEDIEVAL CASTLE."

NUMBER OF DRAWINGS SUBMITTED: One.

AWARD:

Mention: A. C. Smith, Yale Univ.-Sch. of Fine Arts, New Haven.

Note: These drawings were delayed in transit.

Current News

Happenings and Comments in the Field of Architecture and the Allied Arts

Albany Builders Organize

A meeting of the builders of Albany, Troy and Schenectady formed an organization to be known as the Tri-City Builders' Exchange Council with the object of protecting and promoting the building business. The council expressed itself as particularly anxious to secure harmonious relations between the builders and their employes and between the builders and the architects.

Conservation of Material Studied

A technical committee of the National Federation of Construction Industries finds that archaic building codes demand large quantities of superfluous materials because of too stringent rulings in the cause of safety, thus unnecessarily increasing the cost of construction.

To expose this situation and aid in leveling the building codes to a safe and sane position, the Technical Committee of the Staff Council of the National Federation of Construction Industries is inaugurating an important study of the situation throughout the country. The executive committee are preparing this study and will shortly issue a tabulation showing the stresses allowed by the Bureau of Stand-

ards and other authorities. Against this will be shown the building ordinance requirements of the various cities.

One feature of the work that is developing already is the more sane requirements adopted by the lately framed building codes, indicating that a full understanding of the technique of use of various materials is rapidly being appreciated and no extra useless material is being required by the more modern codes.

It is not the plan of the committee to determine the proper stresses, but to compile them so that building and government officials may have a bird's-eye view of the situation and the building industry in the various cities may realize how much valuable material is being required for extra and unnecessary strength. Waste of this kind must stop and this committee will soon place the facts before the public.

Housing in Philadelphia

"The indications are that this year will not be as bad as last," says John Ihlder, secretary of the Philadelphia Housing Association, in his statement to the councilmen who are studying the housing question. "Families are moving away," he said, "because

they cannot find places in which to live. But for all that, Philadelphia is very much underbuilt and unless constructive measures are taken soon we shall have a great and permanent increase of insanitary, unfit and overcrowded housing.

"Philadelphia's housing situation is frequently compared to New York's. But there are important differences. We had a larger proportionate increase of population during the war than did New York, yet we absorbed it more successfully for two reasons. First, most of our people live in single family houses and had a room or two more than they absolutely required. So they were able to take in relatives or roomers. Second, during and since the war the federal government erected several thousand houses in and around Philadelphia which have somewhat relieved the pressure.

"In Pennsylvania it is held that neither the state nor municipality has constitutional power to buy land for housing purposes or to erect dwellings. Experience makes it doubtful whether the government should itself build and manage houses, but seems to show that there is possibility of relief if the government can take land at a proper value and make loans to limited dividend house-building companies under definite restrictions."

India to Exploit Its Forests

India is a little less than half the size of the United States. It possesses untold timber wealth. In only one section, the Province of Burma, has there been in operation any mills sawing lumber. In every other portion of the country all lumber has been whipsawed by hand out of the tree. Teak is at the present time the wood mostly used in producing lumber because teak is the only wood that will resist the attacks of the white ants of India. This timber grows along the coast lines, and in the Province of Burma alone there remain untouched nearly thirty million acres of timber land.

Starting on the sides of the hills, at an altitude of from 580 to about 3,000 feet is found the hardwood and this will be the first species of timber to be exploited, owing to its accessibility. The logs will be brought down the hills to the waterways. From about 5,000 feet altitude to 11,000 feet are found the coniferous woods with the snow line of the mountains about 14,000. Owing to their great distance to tidewater these forests will not be used as yet.

The timber of India will be operated upon a gigantic system of conservation. None but the large timber will be cut at any time and the methods of logging will be so developed as to insure the least damage to the smaller trees. This is possible in that country as it has never been possible in America,

owing to the title to the timber lands being vested in the state and the operations, therefore, conducted by the state on one national system.

No Chimneys Needed

In describing the Minidoka project in the state of Idaho, Franklin K. Lane writes in the *Geographic Magazine*: "Here I saw a town where there never has been a fire lighted and some houses without fireplaces and without chimneys. No fires were necessary because at the dam above the town the water had been stored to irrigate the land and at the dam electricity was generated for use as heat, light and for cooking. The women churned with electricity and the sewing machines were run with electricity."

Bridges Surround New Construction Jobs to Protect Public

Thousands of dollars are spent today by the better New York construction companies to build bridges in front of their building jobs to protect the public from accident and annoyance.

Until very recently the erection of a big building, even on a plot 50 by 100 feet, entailed no end of annoyance and danger to not only pedestrians but vehicular traffic.

The sidewalks were almost impassable, while the street was littered with sand barrels, timber and steel.

Today, however, every possible consideration is given to the welfare and comfort of the public, with the result that buildings appear and are up several stories before the public is aware that the job is well under way.

The excavation is marked by a high fence, and those who are obliged to pass the spot are protected from dust and dirt by a carefully constructed covered bridge extending from building line to curb.

These bridges, which are constructed of heavy timbers, are faced with painted boards. They are lighted with electricity, and the sidewalks under them are constantly swept and kept free of debris by men assigned to this work alone.

Doorway Without a Door

"Doorless doors," that make flyscreens unnecessary and keep out rain and snow without other agency than that of a properly directed air current are described by H. S. Knowlton in *Electrical Merchandising* (New York). They are the invention, he says, of a Boston mechanical engineer, Henry H. Cummings, who is also the inventor of the ship log

which was generally installed on vessels of the United States Navy during the war. We read:

"The 'doorless door' consists of a motor-driven fan installed below or behind a grill in the entrance of a store or other building and arranged to draw air downward from the upper portion of the doorway, whence it is carried by a duct to a hood at the top of the entrance and then discharged downward, completing the cycle. A quarter-horse-power motor driving a 16-inch fan and connected with a 9-to-12-inch diameter duct provides a current of air under about 3-inch water pressure, which is unnoticed by persons standing in the doorway, but which is most effective in keeping out insects, snow and cold air. The use of the equipment enables close regulation to be made with ease, of the interior temperature of the room, and the absence of a closed door, winter and summer, in a trial installation, actually increased trade by one-third. The cost of operation is about two cents per hour."

Industrial Reconstruction in Northern France

Of the manufacturing establishments employing at least twenty persons in the war area of France 74.8 per cent. had resumed business on May 1, according to the Statist (London). Few of these are as yet able to transact business on the pre-war scale. The difficulties surrounding the rebuilding of factories, and the engagement of suitable staffs have been overcome, however, with skill and expedition. But it is not surprising to find that, although three-quarters of the establishments have resumed business, the labor employed in this district is but 40 per cent. of the pre-war figure. The personnel engaged in these plants in 1914 was 679,188; in May it was 257,874. There are engaged in restoration work in these districts 82,128. The clothing industry is in the best condition and the mines and quarries are in the worst.

Railway Executive Urges Priority for Building Materials

Daniel Willard, president of the Baltimore and Ohio Railroad, testifying before the Senate Committee on Reconstruction and Production here today, suggested that all large cities appoint committees to determine what building materials should be given priority in the use of transportation facilities and to advise with the Interstate Commerce Commission and the carriers to put needed priorities into effect.

Mr. Willard, who is chairman of the advisory council of the Association of Railway Executives,

said the roads would like to co-operate with the big and congested communities where attempts are being made to meet critical housing situations.

Bridge Into Juneau Park, Milwaukee

In the spring construction will be begun on the bridge across the tracks of the Northwestern R. R. at Milwaukee, designed by A. C. Clas, architect. This bridge will connect Mason and Wisconsin street with the reclaimed portion of Juneau Park. The structure will be of reinforced concrete faced with red granite, one long span of 120 feet and two short spans to support the approaches. It will support a boulevard 85 feet wide.

Building Codes to Demand Rat Proof Houses

Standard plans for rat-proofing business buildings, dwellings and wharves are being drawn up by the public health service as part of its campaign to stamp bubonic plague out of the country. The plans are to be furnished to states and cities for incorporation in building codes.

"While bubonic plague is under control in this country, there will always be scattered infection until the rat can be exterminated," said Surgeon General Cumming.

"According to authoritative estimates, there is one rat for every one person in the United States. To maintain this huge number of rats costs the people of this country approximately one cent per person every day for rat food, an intolerable and unnecessary burden for the people to carry."

To Keep Vienna's Art in Vienna

There has been much talk since the armistice of the probable forced disposal of Austria's art treasures, many of them the finest works of art in existence, which before the war were housed in Vienna's public and private galleries. Some of them have already actually changed hands, and many have been the attempts of dealers everywhere to benefit by Austria's need for money and food, to procure her works of art.

Many proposals have been made for preventing this forced sale and dispersal, and one which seems to meet with both British and Austrian approval, according to the *London Post*, is Earl Curzon's suggestion in the House of Lords that Vienna's works of art should be pledged as security for food from England. This magnanimous offer was warmly welcomed by Herr Enderes, under secretary of State

and Chief of the Commission for Utilization of Works of Art, and it is understood that Earl Curzon's scheme has been or is about to be carried out.

A commission of British art experts was recently sent to Vienna to value the collections in order that a basis for the arrangement might be decided upon. Their report has not yet been made public.

News From Various Sources

In Karachi, India, the Karachi Building & Development Co., Ltd., has been capitalized at about \$3,250,000. It plans to include in its management: architectural, engineering and constructional experts; and in its equipment steam and electric plants.

J. P. Morgan & Co. have acquired the Mills

Building which adjoins their bank on the corner of Wall Street, New York, and plan its rebuilding when building conditions become more stabilized. Trowbridge & Livingston are the architects.

Thomas M. James, architect of Boston, Mass., announces that his office is now incorporated under the name of Thomas M. James Co., with offices at 3 Park street, Boston, Mass.; American Trust Building, Cleveland, and Fuller Building, Springfield, Mass.

The partnership is announced of Marzillier & Chromaster, architects and engineers, with offices at 211 Reporter Building, Milwaukee, the members being C. O. Chromaster and Paul Marzillier. (Manufacturers' catalogues are requested.)

Weekly Review of the Construction Field

With Reports of Special Correspondents in Prominent Regional Centers

IN a voluminous report issued by the Committee on Statistics and Standards of the Chamber of Commerce of the United States, it is stated that in the opinion of the committee there is wide-spread feeling that business will probably continue good for the remainder of the year.

Tight money, labor unrest and the high cost of necessities are at present disturbing business factors, but there is no need, states the report, to become panicky over these matters.

While the opinion of an authoritative body lends stability to the trend of public feeling, it must be acknowledged that surface indications are not altogether reassuring. The unwillingness of banks to finance the smaller housing operations accents the already acute situation, the outlook in the anthracite fields does not encourage an altogether placid view of cold days of the coming winter, while in all our large cities labor is uneasy and in some instances as, for example, the present traction strike in Brooklyn, is ignoring their contract with employers and by strikes and unwise methods adding to the general uneasiness.

Amid all the cross currents and eddies of the industrial situation a definite trend seems to be slowly developing toward a gradually increasing gain of supply upon demand and a somewhat lower level of prices. In textiles and in some manufacturers of

leather there has been a decrease in production and lower prices.

Here and there mills have shut down. Here and there they are running on reduced time. It is a scattered and local matter rather than a general proposition. What will happen next is exciting much interest and many prophecies on both sides of the question.

Construction and building have slowed down, because of many things—such as high prices and scarcity of both labor and materials—practical withdrawal of credit accommodations on new constructions. Some essential materials of building are very scarce. Cement and wire nails for instance. Lumber can be had, but cars for transportation of it cannot.

From every state and every section comes the complaint of the lack of cars as greatest of all handicaps to the transaction of business, and one of the moving causes of the continuance of high prices.

The railroads are endeavoring to bring order out of the chaos of conditions they confronted when the Government turned back the lines to their owners. It is agreed that the most practical and quickest solution of the transportation problem is to give the maximum of service from existing facilities.

An average daily minimum movement of freight cars of not less than thirty miles per day is the aim first stated in the program of the railroads for more

THE AMERICAN ARCHITECT

transportation. To increase the average loading of cars to thirty tons per car is the second aim of this program.

Statistics show that the average car loading on all railroads in the United States is only about 70 per cent. of the carrying capacity of the car. Furthermore, about 32 per cent. of the total freight-car mileage is made with empty cars. An average increase of only one ton per each loaded car would be equivalent to the addition of 80,000 new cars to the available supply.

The average loading per loaded freight car in 1919 was 27.8 tons. If this average were raised to 30 ton, it is estimated that the total ton mileage would be increased from 395,000,000,000 to 426,000,000,000. This great increase would be accomplished without any other change in handling of cars than is involved in the increased load.

The combined effect of increased daily mileage to 30 miles and of loading each car to 30 tons, would be to increase the capacity of the railroads to 553,000,000,000 ton miles.

In many current discussions of the probable course of the deflation which appears to have begun it is quite commonly said that wages and prices must come down together, some writers even going so far as to assert that wages must come down before commodities can decline. It may be helpful in considering this question to study the actual experience of two war periods concerning which reasonably accurate statistics are available; namely: the Napoleonic war period in England and the Civil War period in this country.

After the Napoleonic war prices in England declined, at first rapidly, and then steadily over a long period of years, while wages receded not only more gradually but much less. During the thirteen years following the Civil War prices in currency dropped rapidly, while for seven years wages actually rose.

While unquestionably in the years following the European war the law of supply and demand will operate with respect to labor as well as to commodities, in labor the law operates less promptly and freely. It is, of course, impossible to predict the future, but two things should be remembered at this time; that labor is now much better organized to resist wage reductions than it was in either 1815, 1865, and that since 1914 the United States has received about 3,000,000 less immigrants than would normally have entered the country.

The monthly statement of the Federal Reserve Board, issued on September 1, says that the situation in lumber and building materials is variable. The expectation that heavy buying would develop in anticipation of higher freight rates has been disappointed. Stocks are small in numerous quarters. Near Atlanta the lumber market is dominated by the

transportation situation. The curtailment of production is becoming more general, but apart from a continuous scarcity of cars the immediate outlook is satisfactory. In the Middle West high costs of lumber, mill work and other materials have seriously retarded building. In Kansas City the lumber and material markets have been inactive, with lowered demand, due to unsatisfactory distribution. In New England dwelling house construction is still backward, partly due to the increased cost of material and labor. On the Pacific Coast car shortage has restricted lumbering operations, and 20 per cent. of the mills are closed, while those that are running are operating at only 75 per cent. capacity. Building, however, is active. From Minneapolis it is reported that the lumber cut and shipped by producers increased about 50 per cent. during the month. The labor situation is reported generally favorable.

(By Special Correspondence to The American Architect)

SEATTLE.—The new freight rates caused a horizontal advance in all steel building materials on the Pacific Coast of 50 cents per hundred pounds and there was a slight mill advance on nails and pipe which has not yet reached the jobbing trade. The new freight rate is also back of this. Jobbers estimate that the advance at the mill will approximate 25 per cent. Protection to themselves is the reason given by the jobbing trade for the new quotations.

The new continental freight rates have brought other distributive problems to the jobbers in the building trades for immediate solution. The railroads have proposed to raise the distributive rate for building materials 100 to 125 per cent., in addition to the Interstate Commerce advance, and claiming that such a burden would be "spotted" in its effect and not only ruinous to the jobbing interests, but would effectually stop all building projects, jobbers have secured a halt in the application of the rule. In the meantime, the local distributive rate has advanced 25 per cent., to which jobbers have made no objection. Jobbers in building materials insist upon competitive rates and conditions.

Aside from the advance in freight rates there has been no lift in quotations warehouse basis for steel building materials. Small nails are so scarce in the Pacific Coast territory that fruit shippers have been compelled to use finishing nails to build crates. Colorado mills seem to be in much better condition for delivering than the East. New prices will be \$1.50 per cwt. for three-penny nails, against the former price of 75 cents, and four-penny nails will be 80 cents, against 50 cents as before. The mills reiterate that this rise is due to industrial conditions and the difficulty of getting and keeping skilled labor on the job. It is predicted by the jobbing trade of the Pacific Coast that while metal prices may not soon

THE AMERICAN ARCHITECT

(By Special Correspondence to The American Architect)

advance the possibility of recessions is remote.

There is but a slight inquiry for bars and channel iron, but department heads, who pass upon these inquiries, say the stock is for manufactured products rather than building.

Brick, fire, common and face, is stationary, with no great demand. Wall plaster board declined \$10 to \$15 per thousand feet warehouse basis, due to freedom of offerings and a none too brisk demand. Plaster is very scarce and jobbers have practically been compelled to fight for possession. The bulk of the orders from the Coast are being filled in Nevada and Utah. Manufacturers assert that labor troubles, strikes and unrest are crippling production over and above the delays caused by inadequate car supply. Loadings at shipping points do not arrive under 30 days. Shortage of retarder is also holding back delivery.

Metal lath is steady, with light inquiry. Demand is now exclusively for built-for-sale buildings of two stories and less. Fir lath is steady at \$7.50, but the jobbing trade reports a higher grade of the product. Arrivals of cement are slow, and the orders are far in excess of the supply.

Eastern mills now explain that delay in delivery of small sizes of steel pipe on the Coast is due to shortage of fuel, made necessary by the inadequate car supply in hauling raw products to the mills. Jobbing houses on the coast have refused to affirm any more orders for pipe on the carload basis.

Enamelware has advanced 10 per cent. Pipe stocks are light all along the Coast. Elger's earthenware is 10 per cent. higher.

The fir lumber market in the West Coast producing territory is barely steady. The new freight rate advance in the eastern and middle western territory is held to be discriminatory in favor of southern pine and wholly a shut-out and a barricade against the fir mills. Until the carriers themselves make a fight to restore equality and competitive conditions the mills will absorb the freight advance. There have been many cancellations of back orders for fir to move into the eastern building territory and more are expected, although the fir mills still hold orders for 8,479 cars, 30,000 feet to the car, for eastern building account.

Probably the most weakening future factor in the fir lumber trade is that stocks at the mills are 45 per cent. over normal. The bulk of these storages consist of dry dimension, well suited to underweights, that must be loaded and shipped before the rainy season of the North Pacific territory sets in.

CHICAGO.—The Chicago committee recently appointed by the United States Senate Committee on Construction to co-operate with the railroads in this city in an attempt to hasten the movement of building materials finds itself with nothing to do. According to Mr. C. F. Perkins, of the Illinois Brick Co., who represents the brick interests on the committee "the act came too late."

Only four complaints have been brought to the attention of the committee, and these were from the same company. No complaints of delay in delivery have been registered by builders of house or apartments and no architect has appeared before the committee so far.

"On the surface this would indicate that the grievances of the construction industry against the roads had been exaggerated, but the real reason in the lack of work for the committee is plain: Building, outside of streets and a few public buildings, has practically ceased in Chicago, and it is my opinion that within the next sixty days the work will come to a complete standstill.

"The only thing that can save the industry now is money and, more than that, easier and cheaper money. The apparent apathy of builders and contractors with regard to new housing needs and new construction is explained when their inability to get credit is considered, or in the event of getting a loan, the enormous rate of interest demanded."

Mr. Perkins, with others of the industry, think it is "up to" the banks now. Labor is plentiful, transportation conditions have improved, individual output has increased to almost that of the pre-war basis, so that, even with the handicap of increased freight rates the building industry would take on new life if money was easier to obtain.

With \$150,000,000 in building projects in Chicago tied up and scores of building plans tucked away on the shelf, the time for talking is past.

Mr. Adolph F. Kramer, president of the Chicago Real Estate Board, believes that concessions by all building interests would result in a boom of apartment and house building. To that end he recently called a meeting of the leading building materials, building labor, real estate and mortgage banking men of Chicago in an attempt to cut building costs.

It is time that real estate, building, labor and financial interests realize that some of the profits must be eliminated and the cost of construction lowered before the necessary home building can be accomplished.

368

Contes p. 16. 2335-



OLD CONVENT, TARRAGONA

THE AMERICAN ARCHITECT

VOL. CXVIII

WEDNESDAY, SEPTEMBER 22, 1920

NUMBER 2335



SULGRAVE MANOR
THE ENGLISH HOME OF THE WASHINGTONS
FROM THE PAINTING BY STEPHEN REID

Notes from London

Sulgrave Manor, the Home of the Washingtons, and the Threatened London Churches

By Special Correspondence to The American Architect

THE Sulgrave Institution came into existence when, early in 1914, the Washington Manor House at Sulgrave, Northamptonshire, was purchased by the British-American Peace Centenary Committee, in commemoration of the completion of

one hundred years of peace between Great Britain and the United States. This institution was organized and incorporated as "an international fellowship for fostering friendship and preventing misunderstanding between the American and British peoples, and

THE AMERICAN ARCHITECT

for the promotion of peaceful intercourse among the nations; and its purpose is to maintain Sulgrave Manor in the future and for all time as a place of pilgrimage for all Americans visiting England, and an active center of work for the furtherance of Anglo-American friendship, the building being equipped as a museum and depository of documentary, pictorial and other records of Anglo-American relations.

The building of Sulgrave Manor—of which, through the kindness of the Secretary of the Anglo-American Society, I am able to offer an excellent illustration—stands on the ground of a pre-Reformation Priory of the monks of St. Andrew, and was purchased in 1539 from King Henry VIII, who had dissolved the monasteries through England, by Lawrence Washington, Mayor of Northampton. Lawrence was a prosperous woolstapler, and built the Manor House, which became the home of the Washingtons. Over the main doorway are the Washington Arms of three stars and two cross bars, or in more exact heraldic language "Argent, Two Bars Gules, in Chief Three Mulletts of the Second"; which are reputed to be the origin of the national flag of the States, the Stars and Stripes, and are so described by the poet Tupper:

"For on the spur when we must choose a flag
Symboling independent unity,
We, and not he—all was unknown to him—

Took up his coat of arms and multiplied
And magnified it every way to this
Our glorious national banner."

Unfortunately this interesting coat of arms has suffered from the weather conditions; but in the gable window the letters E. R. with the Tudor Rose and Fleur de Lys of France seem to date from the "spacious times of great Elizabeth." As a matter of fact, not much of the Tudor building remains, but there has survived some interesting Jacobean work, including a good staircase. The house, a gabled limestone building of two stories, with dormer windows, is made up of two blocks at right angles, the south south-east part consisting of a porch and gable, hall and bedroom, all forming part of the original work, while the main entrance was through the porch and doorway above mentioned.

The grave of Lawrence Washington and his wife Amee is in the churchyard of Sulgrave and is marked by the brass inscription which records "Here lyeth ye bodys of Lawrence Washington Gent & Amee his wyfe"; and the great George Washington seems to have been connected with another Lawrence Washington, who married Mary Jones, and with one John, who received a grant of land in Virginia in September, 1667, and from whom, the first emigrant of the family, he was directly descended.

The Threatened London City Churches

THE question of the threatened city churches is still before the public, and in this connection *The Daily Telegraph* is giving an interesting and well informed series of articles on the subject, beginning with the fine church of St. Mary Woolnoth, which is on our right as we stand facing the Royal Exchange and Bank of England. St. Mary Woolnoth is not actually a Christopher Wren church, being designed and built by Nicholas Hawksmoor, his "clerk" and assistant in many of his churches.

One excellent practice in the most of these city churches is that they are to be found open for three hours in the middle of the day, organ recitals being sometimes arranged. I visited three of them, including St. Mary Woolnoth, all within an easy walk of St. Paul's yesterday, between midday and the lunch hour, and found them so interesting that I propose to renew the experience with others. St. Mary Woolnoth, at the corner of Lombard Street and King William Street, and close to the Mansion House, has a fine frontage, and does justice to its position. The tower is especially remarkable. Over a severely grand and massive rusticated lower story Hawks-

moor set his pedestal for the support of four composite columns against a plain surface, with the belfry window placed in the center. Above this again he put two turrets, connected with a balustrade, avoiding thus any spire, such as we find hard by at St. Stephen's, he gave us a tower which is original and striking, while we must go round the corner into Lombard Street to see the man's inventive fancy, which has filled an ugly blank wall with an attractive design.

Within the building is a square in length, width and height, the total width equalling the height to the ceiling panel, and the whole effect of the building is singularly pleasing. At the angles of this atrium lofty fluted Corinthian columns are placed in groups of three in the angles of the square, supporting a rich entablature, above which rises a clerestory whose sides provides the lighting with four semi-circular windows. The whole building, like St. Stephen's Walbrook, is flooded with light, and this, together with the fine proportions, is part of its attraction. The wood-carving is frequently excellent in these churches of the Wren period in London, but

here the side galleries have been removed—regretably, for they formed an integral part of the design—and placed against the walls at the side only the small gallery, containing the organ, and decorated with the banners of the Goldsmith's Company, have been left *in situ*. It is fortunate that the side gal-

was given to Nicholas Hawksmoor to create the fine church still existing. Its site is so precious that it has had more than one narrow escape, having been priced for sale in 1863, and saved by the energetic resistance of Lord Mayor Rose, a parishioner of this church, and its vestry. The post office set covetous



ST. MARTINS IN THE FIELDS



ST. CLEMENT DANES, STRAND

leries, with their bold carving, were not destroyed. As it is they survive, but in a meaningless and useless position as wall covering.

St. Mary Woolnoth is a very ancient city building, its records going back to 1274, and even earlier. The gift of its living belonged to the nuns of St. Helen's Priory, Bishopsgate, but when Henry VII destroyed and robbed the monasteries of England he gave this living to a rich goldsmith, Sir Martyn Bowes. After the Great Fire of London Wren was called in to patch up the shaky walls, but the building was so unsound that, as Wren himself was by that time too old to undertake further practice, it

eyes upon it, and the City and South London Tube successfully annexed its old crypt, placing the church upon steel girders.

The same railway company are responsible for defiling the lower portion of the building beside the west door with tasteless and hideous advertisements. These ought to be removed—and would be if Londoners took any proper pride in the aesthetic aspect of their old city—and the church itself preserved as an integral monument of bygone faith and high architectural merit.

We need turn back only a few paces, beside Dance's classic front of the Mansion House, to find

one of Wren's masterpieces, the church of St. Stephen's, Walbrook. The attraction here within is the central dome, set on Corinthian columns, and flooding the building with light. The whole effect is wonderfully graceful and harmonious in its design. An old print on the walls gives the interior as designed, and is dedicated to the master as "one of the Noble Proofs of Superior Genius."

Here the square tower, with a spire, is not equal to the interior, but that of St. Martin's Ludgate forms a grateful addition to the beautiful view of St. Paul's, looking up from Ludgate Circus. I can imagine no more delightful morning for any lover of architectural beauty than that which could be filled in going round a selection of these city churches, with perhaps St. Paul's itself as a finale; and with these should be included at some time or other those lying more west—St. Clement Danes, St. Mary le Strand, St. Martin's in the Fields, St. George's Bloomsbury and St. George's Hanover Square.

An interesting discovery, especially in connection with the recent celebrations of the sailing of the Pilgrim Fathers, held last month at Southampton, is that the hull of the famous "Mayflower" may have been built into the walls of a barn at Gerrard's Cross. Dr. Rendel Harris, who claims to have made this discovery, has recently addressed a group of interested listeners from the Celebration Committee at Old Jordan's Hostel, near Gerrard's Cross, within a stone's throw of the burial place of William Penn, The farmstead is now made into a Quaker hostel, and near this is the barn, some 60 ft. by 30 ft., which Dr. Harris claims to contain the timbers of the "Mayflower." He bases his argument on expert evidence and dates, the "Mayflower" having been, as he states, broken up in 1624, and the barn built in 1625, the appraisement having been made in 1624 by



ST. MARY, WOOLNOTH

three out of the four owners of the pilgrim vessel. Dr. Rendel Harris informs me today that he is this month publishing with Messrs. Longmanns, of London, the results of his researches, under the title of "The Finding of the Mayflower," so that I reserve any further discussion of this interesting suggestion, as I may have something further to communicate at a later date. If, in the course of examination of the building in question, some detail, definitely connecting itself with the vessel which carried the Pilgrims, could be discovered, this would obviously strengthen the claim very considerably, but we have yet to learn that this is the case.

Architectural Quicksands

By CLINTON H. BLAKE, JR.

SUPERINTENDENCE.

THE average architect would probably be astounded if he were told that in many ways his profession is similar to the legal profession. His natural off-hand impression is that the two professions are so wide apart as to have no substantial similarity to one another. As a matter of fact the architect, in placing himself before the public as a practicing member of his profession, assumes exactly the same responsibility, for reasonable skill and care in the practice of his profession, as that which rests upon a lawyer, or for that matter upon a physician. Like the lawyer the architect is acting in a position of trust and confidence; like the lawyer he is the authorized agent and representative of his client, within the scope of his employment; like the lawyer he is assumed to possess by reason of his calling, special skill and ability in the practice of his profession; like the lawyer he is under definite obligations to the public, to practice his profession with proper care and diligence, and in all work relating to the construction of public buildings, used generally by the public or by special classes thereof, to conduct himself with the reasonable skill which, as an architect, he is assumed to possess. It is not necessary that he be possessed of extraordinary skill, but he must at least be possessed of sufficient ability and training so that he will be generally considered by other architects as possessing a reasonable degree of professional knowledge and skill. He must, also, as a lawyer must do, gauge his skill and services by the necessities of the case which he is called upon to handle. If he undertakes any work, his undertaking of it is, in itself, an implied representation that he is capable of carrying it out and of securing the result desired, with reasonable and proper skill.

In designing country houses certain elements of skill will be demanded which will not be called for in ordinary city residence or commercial work. On the other hand, the city practitioner is expected to give attention to city ordinances, building regulations and the like, to a much greater extent than does the architect practicing in the country. In defining reasonable skill and attention, as applied to the particular job involved, it is natural that the superintendence side of the work should be the one which, more than any other, creates situations as a result of which the architect is subjected to a claim by the client that the architect's work has been negligently performed. Many clients have a totally erroneous idea of the connotation of the word "superintendence," as applied to the duties of the architect. A

surprising number seem to feel that the agreement of the architect, to superintend the work, is tantamount to a covenant on his part to personally overlook the placing of every stone and every detail of construction generally.

A litigious client helped to establish the law on this point a great many years ago. The front parlor windows in the building which was being constructed by him were so constructed that they were between two and three inches higher than indicated on the plans, and the same distance higher from the floor than the rear parlor windows. The reason for the difference was that the masons had not properly followed the plans and specifications. It appeared that the architect had been diligent in his attendance at the job, and that no fault lay with the drawings and specifications. The client claimed, in effect, that the mere existence of the difficulty was proof of the negligence of the architect and that the failure of the latter to detect the difficulty constituted a negligent supervision by him of the work, to such an extent as to render him liable to the client for damages. The case was finally carried to the Court of Appeals of New York, argued at length, and decided in a rather detailed opinion in favor of the architect. So much expense and controversy may a matter of two inches cause!

The Court went to the root of the matter, when it said that the architect was not under any obligation to measure the lumber and make actual measurements on the ground, in the erection of the building; that the contract with the mason provided that the latter should "lay out" his work, and that the difference was not such that the knowledge and skill of a good architect should at once have detected it. In another, very similar, case, it was claimed that the architect was negligent, in that certain of the flues were not sufficiently large. The client tried to defeat all recovery of compensation on the part of the architect, on the ground that, if the architect had furnished proper plans and superintendence, the flues would not have been defective, and that the contract was what is known as an "entire" contract, and that a breach of any part of it must be considered therefore as a breach of the whole. The Court, as was proper, allowed the client compensation for the faulty flues, but it refused to countenance his attempt to escape his obligation to make payment for the balance of the work. It quite properly pointed out that an architect is not bound to spend all of his time at a building which is being erected under his care, that he is not in any sense an insurer of the perfection of the plumbing

THE AMERICAN ARCHITECT

or carpentry or masonry work, and that he is not expected to watch the turning of every screw and the driving of every nail.

The above reference to the driving of a nail brings to mind a recent case in which I represented an architect in a claim against a man rather well-known in business and public life. The architect had built a really beautiful home for the client, but the latter was dissatisfied. About a year after the house had been completed and paid for, his bill remaining unpaid, the architect pressed the client for payment, and the latter submitted a long list of grievances. Prominent among these was a harrowing history of how the bathroom pipes had leaked, and how the local plumber had been unable to stop the leak, with a resultant damage to ceilings and hangings. The architect very decently sent down one of his head associates to look into the complaint, and it then developed that the whole trouble came from a leak in a leaden pipe, due to the fact that a nail, in the course of construction, had been driven through it.

When the case came into my hands, the client, in a number of successive interviews, was most vehemently and sincerely outraged at what he termed the incompetence and the neglect of the architect, in allowing such a situation to arise. He failed utterly to grasp the fact that no architect, under the most stringent rule, could be regarded as under an obligation to see that every nail driven reached its proper mark and that none was so deflected as to cause damage. He insisted that he had employed the architect to superintend the work and to see that it was done properly, that no mischance of this sort should occur, and that each detail, important and unimportant alike, should be carried out, literally and absolutely, in accordance with the specifications and plans and without a hairsbreadth deviation therefrom. Finally, the client became sufficiently reasonable, so that he made payment of the architect's account. He is still convinced, however, I am sure, that the architect was grossly negligent in failing to see that particular nail driven in the first place, and if not, then that he was certainly negligent in failing to investigate and to check up the driving of the nail, after it had been driven, and before the floor had been laid. An instance of this sort appears, of course, laughable and in many ways a triviality. As a matter of fact, it may mean, as the case cited meant, a loss of a considerable amount to the architect in time and expense, and a much more serious loss, perhaps, in the dissatisfaction of the client.

A somewhat similar incident came to my attention about a year ago. The architect, in designing a country house, had provided outside blinds equipped with a standard form of hinge and lock, in use

generally throughout the locality in which the house was erected. About six months after the house had been completed, the blinds were torn from their hinges by the force of the wind, and it was then found that, to prevent any possibility of a recurrence, it would be necessary to substitute a heavier form of hinge and catch. The architect gladly had this done, giving considerable time, both himself and through his organization, to this and other similar details, in an effort to give the utmost service to the client. The latter was not to be appeased, however, and held up the payment of the architect's bill in toto, claiming that the architect should have known, in the first place, that the hardware used was not sufficiently strong, and that in the second place, if he had given proper supervision to the work, he would have gauged more accurately the force of the local storms in the locality, and seen that hinges sufficiently strong to resist them were employed. If the much abused law was as unreasonable as are some clients the practice of architecture would, indeed, be an uncertain and hazardous undertaking.

PERSONAL SUPERVISION BY ARCHITECT.

Another thought all too generally held by clients is that supervision by the architect necessarily means supervision by him, personally, at all times. The employment of the architect, is, of course, a personal employment and the architect can not delegate his authority to others, as it is upon his skill and character that the client relies, just as a client similarly relies upon the abilities and standing of his lawyer or his physician. Nevertheless, it is evident, that no architect with a large practice and busy office can himself in person superintend every job during all of its stages. Unless the client specifies specifically that the architect himself is to attend to the supervision work, therefore, superintendence by the architect through competent subordinates and associates in his office and organization, of details which he can not personally supervise, will be sufficient, and will be legally considered as supervision by the architect himself. As a practical matter this very often displeases the client, however, and I imagine that every architect has encountered that peculiarly aggravating case of the client who thinks that the architect has nothing to attend to, other than the particular job in which the client is interested. This is a situation in which I can truly sympathize with the architect, as a fellow professional man, and at the same time it is one which can not be disregarded, but must be so handled that the client may be at once satisfied and his interests properly taken care of.

About six months ago a particularly aggravating case came to my attention. A client of mine in New York was architect for a very large and beautiful

THE AMERICAN ARCHITECT

private home in the South. The client, a man of considerable wealth and standing, was, nevertheless, arbitrary and unreasonable to an unusual degree. The architect had, I suppose, in this particular case given fifty per cent. more personal time and attention to the sketches, design, specifications, drawings and superintendence than he would be called upon to give in any ordinary case. He made trips to the South and personally looked over the building on a number of occasions, and he had had exceedingly competent men from his organization assigned to the job and giving strict superintendence service in connection with it. Unfortunately, the client and the architect, through some misunderstanding or for some other reason, failed to meet on one or two of the occasions when the architect inspected the work. The client became unreasonably annoyed, or claimed to be so, and refused to make payment of the architect's fee, claiming that he was entitled to the personal supervision of the architect, that the latter had merely sent a few "clerks" to look over the job, and that he would not make payment of the amount due. The result has been that we have been forced to bring suit for the substantial fee which is due.

It is difficult to avoid a situation of this sort. Of the ultimate result I have little doubt, as the architect will, I think, have no trouble in establishing his claim and securing judgment. On the other hand, it is a great unfairness to him that he should be forced to go into court in the matter. Here again, "definiteness" seems to be the most available remedy. If the client and architect have a definite understanding in the form of a contract and if it be understood that "superintendence" is not to be construed to mean superintendence necessarily by the architect personally, but merely superintendence by his office, through a competent representative or, if desired and so specified, by a "clerk of the works," then the client will necessarily realize that he can not sustain any such claim as that made in the case to which I refer, and will make payment of his just debt to the architect, accordingly.

In general, the question of whether the architect has been negligent and whether he has shown reasonable skill and diligence in the performance of his duties, is a question of fact, rather than a question of law. As such, in case of legal procedure, it is to be determined by the jury in the last analysis upon all of the facts presented.

I have already referred, in a prior article and in another connection to the important bearing which the agency of the architect bears to the relations between him and the client. The architect, as the agent of the owner, is probably more concerned with the matter of superintendence than with any other phase of his agency relationship. As the super-

intendent of the work he will, in all probability, be called upon more frequently than in any other capacity, to act for the owner and as his representative in matters involving large sums of money, to construe the extent and scope of the agency which has been granted him, and to pass upon questions of vital interest to the owner and to himself. I suppose that every architect, in the course of his practice, is confronted frequently with a situation where he believes a change in the specifications or plans is advisable. No matter how clear he may be in his mind that it is in the interests of the client that the change be made, let him beware of assuming that his authority, as supervising architect, carries with it any right to alter or change the conditions of the building contract. The architect, as happened in a case which I have before me, may tell the contractor "to go ahead and do the work" as the architect directs, and that the contractor will "be paid for it." If the owner does not back up the architect no amount of statements of this character, no matter how definite, will enable the contractor to collect the amount due from the owner, if the contract provides, as is usual, that any additions to or deviations from the plans or specifications shall be approved in writing by the owner. The result may well be the possibility of suit by the contractor against the architect and general misunderstanding and difficulty.

Back in 1894, in New York State, a building was being erected under specifications which provided that a certain cement should be used, mixed with equal parts of good sharp and dry sand. There was also the provision, similar to the provision so commonly used at the present time, that all disputes regarding the true construction of the specifications should be decided by the architect, and that the latter's decision should be final and conclusive. The contractor, in the course of the work, changed the cement mixture, as specified in the agreement. The unfortunate builder, who had apparently acted in good faith, submitted proof that he had been told by the superintendent of the job to mix the cement as he had mixed it, and that the architect had directed him in writing to follow the instructions of the superintendent in every particular. The Court of Appeals held that no change in the mixture could be authorized, without the consent of the owner. To have allowed this to be done would have, in effect, allowed the architect to make a new contract for the owner, and it is well settled that the employment of an architect, to superintend the erection of a building and to see that the contractor properly performs his contract, does not vest in the architect any authority to make any new contract, in the stead of the old.

Housing Plan Suggested by Labor Party

LABOR must be given a responsible part in any successful housing programme, states Frank E. Hill in the *New York Globe*.

Participation by labor becomes possible with the extension of state loans for housing and the creation of state housing boards.

These boards should contain definite labor representation, and should encourage the formation of non-profit-making societies of architects, builders and workers which could employ state funds for furnishing houses to the laboring classes.

These are the conclusions of certain labor specialists, architects and workmen. They have just been adopted at Schenectady by the American Labor Party. They are believed by Ordway Tead of the Bureau of Industrial Research, a member of the committee of experts which drafted a plan at the request of the American Labor Party, to offer remarkable promise for a solution of labor difficulties in connection with present day construction. According to many who meet labor in a practical way in the building field, such a plan has a promise of success.

It is generally admitted that the present labor situation is unsatisfactory. Wages are high. In many cases the men insist on a ten-hour day with two hours paid at overtime rates. Labor of all kinds is scarce, and skilled labor is scarcest of all. It has gone into the factories and into transportation service where brawn can command high rates at loading and unloading. That disagreements and strikes frequently interrupt building operations is the general testimony of both speculative builders and architects, and even when work is done it is often not as efficient work as was performed ten years ago.

The plan of the American Labor Party, in Mr. Tead's opinion, will strike at all of these evils.

"One of the great difficulties," he declared, "is as usual a psychological difficulty.

"The plan which our committee worked out for the Labor Party seeks to change the entire viewpoint of the worker.

"He will have representation on the state board and the local boards handling the state financing of housing which it is proposed to initiate.

"He will become a member of the non-profit-making organization, which can in many instances handle the housing problem under state direction. He will thus assume responsibility. Building will be his job as well as that of the man who happens to be directing building. It will furthermore in many cases be construction for those of his own class.

"Part of our programme also provides that the workman will be given opportunity to study building as a whole—an opportunity which has been taken up by workmen when, as in the case of the bricklayers of Philadelphia, it has been offered.

"With a definite representation on the part of labor in building activity, it will also become possible to guarantee steady employment.

"If this can be effected, it will remove the cause of much existing difficulty. Unquestionably workmen are in many instances not giving full measure. They are afraid their jobs will not last. Remove uncertainty about the job and you remove the willingness to give rapid and efficient service. Of course we know that with the present 50,000 house shortage in New York, and lack of housing in proportion in our other cities there is no danger of work running short for years to come. The time is ripe for the state to create an organization which can encourage group effort, which will in turn organize workers and builders for cooperative effort. Such organization will guarantee our keeping unemployment at the minimum in any future time of a scarcity of work."

The committee of which Mr. Tead was a member was not a committee of members of the American Labor Party. On the contrary, although it contained one party member, it was composed for the most part of men chosen for their expert knowledge alone. It included John Russell Pope and Clarence S. Stein, both well-known architects, and the latter secretary of the governor's housing committee. John A. Fitch, Alexander A. Bing and J. M. Budish were besides Mr. Tead the remaining members.

The basis of the machinery for bringing labor into the housing problem is the establishment of the state and city right to furnish building credits.

This, will require a constitutional amendment, and the amendment, in order to be effective as soon as possible, will require a special session of the legislature.

When the state and the municipalities have the power to lend money, this power will be exercised through housing boards such as the Housing Committee of the State Reconstruction Commission has advocated. The members of these boards, if the American Labor Party had its way, would be composed of representatives of those interested in building—tenants, workers and architects. These would be chosen by the governor or mayor, according as to whether the board was state or local, from panels furnished by those to be represented.

The state and municipal credit would be made

THE AMERICAN ARCHITECT

available by state and city bonds, which could be floated at a lower rate of interest than bonds of private companies. Through these bonds housing boards would be able to influence building activity. Unquestionably one result of such influence could be the building of working-class housing.

The programme which Mr. Tead supports would also have a provision for the control of building materials. If necessary the state and its municipalities could go into the extraction of their materials and their preparation for use.

Non-profit-making organizations are to be encouraged "as soon as the brain and hand workers see the advantage" of forming them. These are expected to eliminate all but legitimate profit, and are preferred to state or municipal activity as giving greater spontaneity of effort.

This is the plan of the American Labor Party in so far as it affects labor itself.

It is an interesting plan because it is the only one recently advanced here which considers the worker as of sufficient importance to give him a place in the working machinery by which housing is to be secured.

I do not pretend to say how practicable this plan would be. Certainly it agrees with unbiased authority on the housing problem in so far as state direction and encouragement of building is pronounced necessary by it. It agrees with much that I have heard in the course of several months of observation and study of construction in New York with regard to the psychology of labor.

"Labor," said one of the most prominent architects in the city to me, "has made its mistakes and has its vicious practices. At the same time it must be remembered that capital sets it a bad example. If you ask a man to play fair you must play fair yourself. Labor is asked by capital to give steady, hard work at a fair price. But labor sees capital erecting an apartment house which it at first will rent at \$9 per room, then at \$15, then at \$25, and which before construction is finished it will refuse to rent at all, but will sell at a fabulous profit. Labor sees hotel and office buildings going up which it knows will bring capital tremendous returns. Why shouldn't the idea come to labor that it might get in on the game itself? It strikes for more wages, and more. There may not be a justification for the strike, but there is an explanation."

"Let labor know that the job is clean," said another man connected with the building industry, "and I believe you can depend upon it to be square."

Now the plan I have sketched above at least has the merit of providing for a machinery of encouraging housing which would gain the laborer's confidence. It will represent his class officially, and it will be calculated to furnish what we are not at present getting—houses for people of moderate means. If his co-operation is worth having, there may be something in the housing plank of the American Labor Party which New York ought to have.

Book Note

Analysis of Paint Vehicles, Japans and Varnishes. Full cloth, 200 pp., 5¼ x 8 inches, New York, John Wiley & Sons, Inc. London, Chapman & Hall, S. W.

PAINTS, enamels and varnishes used as protective coatings for such surfaces where they may be properly applied, are the armour that resist attacks and wards off the insidious influence of changing temperatures, the action of the elements and the disintegration that accompanies the hazards of constant use. It is to groups of men like the author of this extremely technical and at the same time very practical volume, to whom we are indebted for the realization of the urgency for systematic methods of analysis, and who have labored experimentally in the direction of discovering the possibility of the utilization of many vehicles hitherto ignored.

This book is one of twenty chapters, each treating very thoroughly of a certain medium, its use and availability. The result of this painstaking laboratory work will be the better compounding of paints.

Most pigments in their crude state are permanent and reliable. It is when the "medium," the fluid to make them applicable to surfaces, is introduced that deterioration sets in and the purpose for which the protective paint is used becomes useless.

It is this careful method of analysis of mediums employed that insures the durable and efficient quality of paints, enamels and varnishes, and it can therefore be readily understood that the careful attention to the valuable suggestions and formulae set forth in this book gives the paint user a basis of absolutely certainty.

Group Ownership of Apartments

A Method Being Tried Out in Many Cities in the United States
With a Varying Degree of Success

THE shortage of apartments in our large cities and the abuses perpetrated by profiteering landlords and speculators in apartment houses have brought about the widespread development of group ownership of apartments. *The National Real Estate Journal* (Chicago) can not say whether this species of ownership is a temporary phase of the existing scarcity or whether it will prove a permanent form of residence-property ownership, but, at any rate, "it is being tried out in a number of cities and is attracting considerable attention." This organ of the real-estate business proceeds to explain the workings of the new plan to its readers by quoting this article on the subject from the *Washington Times*:

The co-operative housing plan as applied to multi-family houses is the sale of the building to the tenants or to a group of people who become tenants of it. This plan, while worked out independently, has many points of similarity with the so-called co-partnership housing schemes abroad. Several such enterprises have been started in which the co-partners rent their homes from a corporation in which they are stockholders. In this way, if they are compelled to move by reason of a change of employment or otherwise, they can surrender their homes and move in a new locality, at the same time holding their stock interest in the corporation if they choose, which pays them a dividend.

The co-operative housing plant, as adopted in other cities, is to meet the needs of people whose incomes range from \$3,000 to \$5,000, and who seek the comforts of living in apartment-homes and wish to protect themselves against excessive increases in rent.

There are a number of co-operatively owned apartments in New York, but these have usually been confined to buildings owned by people of large means, who take perpetual leases upon their apartments, and when not occupying them either sublet or pay the rent themselves. This scheme is not applicable to people of moderate means, who frequently are compelled to move because of change of employment and other reasons and cannot afford to assume the responsibility of possibly paying rent in two places.

To meet this situation and at the same time prevent a possible deterioration in the tenancy of the building the lease of the apartment and the ownership of the building have been kept separate in the co-operative-ownership plan, except that in the first

instance the tenant and the owner are the same person. Literally, each tenant is his own landlord. The equity in any building above the mortgage, usually a savings bank or insurance company mortgage of long term, is capitalized by the formation of a corporation to take title to the building. The tenant-owners each subscribe for an amount of stock in proportion to the size of the apartment which they occupy.

The tenant-owner at the same time that he purchases the stock leases an apartment at the current rent, renewable from year to year indefinitely at the will of the tenant, but with the option that, upon notice before July 1 in any year, he may surrender his lease the following October 1.

The corporation of tenant-owners, of which each tenant is a director, makes a contract for the management of the building with some competent real estate agent.

The agent collects the rent, makes all the disbursements on account of the operation of the building, and what is left comes back to the stockholders as a dividend upon their investment. It will thus be seen that the tenant-owners have no burden in connection with the management of the building, and are only required to meet once or twice a year as directors of the corporation, of which they are stockholders, to declare a dividend.

The by-laws of the corporation are framed in such a way that at all times the market rent of the building shall be the rent charged. Of course, as regards the original tenant-owners, as long as they occupy the building they are protected by their leases, but the purpose of the provision to require the market rent at all times is to protect the tenant-owner who ceases to be a tenant and remains interested in the building from an investment standpoint.

The question is often asked, "Why not sell a man an apartment instead of a stock interest in the building?" There are two reasons.—One of them has been referred to—namely, the tenant who moves away is not held responsible, if he owned his apartment, to find a tenant or pay the rent himself.

The second reason, of more importance to the tenant-owners, is to protect them in a possible deterioration in the tenancy of the building, which might arise if one of the original owners through some reverse of fortune might sell his stock at a low price to an undesirable person. If the stock

carried a right to the apartment this person could demand the occupancy of the apartment and thereby cause annoyance to other occupants of the building reducing the value of the investment.

Under the co-operative-ownership plan there is,

of course, no restriction upon any tenant-owner to sell his stock and a situation might arise where the stock would be sold to some undesirable person, but such purchase of stock would not carry the right to occupy an apartment.

New Apartment House Plan Has Developed Good Results

AMONG the architects who are trying to afford relief in the housing situation in New York may be mentioned the firm of Warren & Wetmore. This firm is reported to have prepared plans, the execution of which will not only greatly reduce present rents and minimize housework, but will also very much increase the return to landlord or owner.

Buildings are already being erected on this basis.

It is no longer possible, according to Mr. Julian Holland, of Warren & Wetmore, for owners of property to continue the development of apartment houses with the old scheme of extensive floor plan and construction without tremendously increasing rentals, and the housing problem will never be solved in the increasing expansion and congestion of New York. The available land is almost all taken—the zoning laws which prohibit building above certain restricted heights in various parts of the city have automatically made lateral or longitudinal extension impossible.

Accordingly, says Mr. Holland, the inevitable development must be in restricting the size of apartments, in such a way as will meet all sanitary and fire laws, satisfy the tenant and afford general satisfaction and real hominess to the suites.

In the first application of these principles, the designing of a California type of apartment house on West End avenue, between Eighty-eighth and Eighty-ninth streets, the architects have attempted to solve the problem of aiding both tenants and landlord. The system, adapted to New York needs and restrictions after several months of intensive study, is simplicity itself. It applies to the dwellings of the congested tenement districts as well as to the west side.

On a plot of ground 60 by 100 feet they have been able to get a maximum of 70 per cent. of building usage—affording courts on either side of the thoroughfare frontage and a rear areaway on the plot in perfect accordance with the tenement house regulations.

The unique feature is that instead of three five-room apartments on a floor of 4,800 square feet net, two front and one rear apartment facing only brick walls—the maximum obtainable under the present general custom, there are four apartments on each floor, all of which have a view of the thoroughfare, West End avenue. This arrangement secures cross ventilation and sunlight in the rooms of every apartment, with good drafts of fresh, clear air during the hot weather.

The system of floor planning simply reduces the arrangement to a twenty-four-hour usage of every room in the California type of apartment. By day the living room and the dining room are used by the family and guests without the slightest suggestion of bedrooms. The drawer beds of a newly designed type pass through oblong spaces in the walls, without being attached to the building and without folding up. They are complete beds and their only evidence in the living and dining rooms is in the form of the lower drawers of escritoirs and china closets, respectively, while the bodies of the beds are extended, fully made up with pillows and headboards, into two dressing rooms behind the larger rooms, where windows opening to the outer air—not air shafts—give complete ventilation while not in use.

At night these beds are drawn out into the two larger rooms, and consequently there is no loss of living space in the commodious apartment.

At present in New York apartments the bedrooms are a sheer waste of space for at least fourteen hours a day, while for the remainder of the time the living and dining rooms are wasted through non-usage. The New York type of apartment contains, for five rooms of approximately the same proportion, about 1,600 square feet; the California type not more than 1,200 square feet. This means a saving of twenty-five per cent. on the floor space per apartment, and consequently a greater rental receipt for the landlord, a reduction in the price of rent to individual tenants and better living conditions.

Detail of House on Washington Square North, New York

(See reproduction of the original drawing by O. R. Eggers in this issue)

THIS interesting detail of a house on Washington Square North, in New York, is pendant to a view of the portico of the same building illustrated and described in a previous issue. This Ionic detail is the porch at the rear with a glimpse of the house and iron balcony and fence. The view is looking north along Fifth avenue. The trellis is evidently of later placing but having been well designed adds to the generally good effect.

The house, standing at the southmost edge of Greenwich Village, shows an example of the hand wrought iron that was so extensively used in that section in the early part of the nineteenth century. Every well considered element of good design was lavished on the railings, porch rails and balconies of these houses. Unfortunately much of this good iron work has disappeared, but there are yet extant, if one seeks them out, many examples to prove how carefully the architects of those days designed every detail that formed a part of their buildings.

Neighborhoods in the early thirties were more nearly communities than they will ever be again. Here on summer evenings either seated on the balconies or on the "stoops" there was much visiting to and fro. It was for this reason that these places became as much a location of social activities as did the drawing rooms of the interiors during the winter. The same pride of well designed surroundings was ever present.

The yard at the rear of this house abuts on the easterly end of Macdougall Alley, widely known as

the place where numerous artists of fame, wealth and social position have created a picturesque locality, the mecca of every rural visitor to New York.

It is pathetic to men born and residing in New York for more than sixty years to mark the changes that have occurred in the Washington Square district. In the early 70's, North Washington Square, on which is located the subject of this sketch, was occupied by the stately houses of those among whom the late Ward McAllister counted the "400" as constituting the very cream of New York society. These one-time prominent people have with few exceptions moved from the neighborhood. The aristocratic seclusion that was once maintained became no longer possible. The towering apartment house, the church settlement, on the south, and the gradual encroachment of an undesirable lot of citizens have robbed the neighborhood of its semi-isolation.

Yet, today, there may be seen a solitary but well appointed carriage with two well groomed horses; on the box a portly coachman and by his side a slender footman, both in the most correct livery. There they await the coming of the mistress of the house who in spite of the dangers of the swiftly moving motor car, proceeds to ride as she has done for many years past, up Fifth Avenue and into the park for the daily airing.

But the march of progress is irresistible. It will not be long before this, last of an old order, will have passed, and we shall only know customs as recent as a quarter of a century as traditions.

Noise in the City Streets

Is noise inseparable from progress? asks the *New York Commercial*. We are accustomed to speak of the "roar of a great city" as if it were something unescapable. Perhaps it is, but not all of the clatter and bang is essential, nor need be tolerated. The racing through the streets of heavy motor trucks has increased tremendously since the war, seemingly driven by daredevils who obtained their schooling in France, driving army trucks.

The worst part of their offense, short of killing and maiming people, is the deafening noise of their motor horns. These, for the most part, are vicious affairs attached to the exhausts, screeching when the button is pressed, with every throb of the engine,

and with a degree of noise in proportion to the horsepower. For some strange reason this character of warning has been made a feature of motor truck construction, as though the heavier the truck the louder must need be the noise. A small truck can kill or maim just as efficiently as a large one, and so can a passenger car for that matter.

The horns on these cars are bad enough and are quite as capable of warning possible victims as the ear-splitting contrivances of the trucks. It is within the power of the city authorities to abate this nuisance by forcing truck owners to provide milder methods of warning. These exhaust horns should be abolished, for trucks are not permitted to travel at so great a speed that they need to be heard blocks away.

380 a



DETAIL OF A HOUSE, WASHINGTON SQUARE NORTH, NEW YORK
THE AMERICAN ARCHITECT Series of Early American Architecture





Mortgage Tax Exemptions as an Impetus to House Building

THE City Club of New York, in a memorandum on the housing crisis, prepared for the special session of the New York legislature, very thoroughly analyzes the factors that have created the present grave condition and discusses forcefully the remedies that are proposed to ameliorate it.

We learn that ever since 1916 the demand for dwellings in New York City has greatly exceeded the supply. The situation is growing steadily worse. The number of tenement or apartment houses built in the city in 1914 and since was as follows:

Year	No. of tenement houses	No. of apartments
1914	1,242	20,577
1915	1,368	32,617
1916	1,207	21,359
1917	760	14,241
1918	130	2,706
1919	89	1,481

Year by year, continues the memorandum, the city has been growing and the demand for dwellings becoming more urgent. This is indicated by the steadily diminishing percentage of vacancies. A certain number of vacant apartments is essential for a number of reasons, such as to permit the inevitable movement of population, the making of repairs, and the discarding of worn out tenements no longer fit for occupancy. A margin of vacancies is absolutely necessary in order to afford that possibility of change without which the landlord has the tenant absolutely in his power.

Any relief that would lessen the gravity of the present situation is nowhere in sight.

AFTER reviewing the more important of the many schemes that have been brought to the attention of the State Commission on Housing, the City Club regards as most important the suggestion of a proposed tax exemption. Weakness of the mortgage market is one, if not the leading factor now operating to check the building of houses by

private enterprise. The exemption of mortgages from the income tax laws would have a tendency toward easing the present situation, but the difficulties would be considerable. Continuing, the report states:

The state income tax rates are so low that without a corresponding Federal amendment State exemption would mean little. But official legal opinion is to the effect that statutory provision for a State exemption cannot be directly dependent in its operation upon the enactment of a similar amendment to the Federal law. Those in touch with the situation at Washington, on the other hand, assert that the only hope of securing a Federal exemption is through initial action by the New York Legislature.

A much worse difficulty is the insistence by advocates of the measure that it must affect mortgages on new and existing buildings alike and must apply to commercial and industrial mortgages as well as to loans on individual and multi-family houses. This point of view is to regard the general mortgage market as a whole and to give it a measure of general relief in the hope of an incidental benefit to new housing projects.

Obviously the plan would involve the cutting off of a large source of national revenue, which would have to be made up elsewhere.

Holders of existing bonds secured by mortgages on public utilities and on commercial and industrial plants would be given a substantial appreciation in the value of their securities.

The volume of tax revenue waived from mortgage interest on new single and multiple houses—the end really aimed at—would be comparatively small. The revenue waived from mortgage interest on buildings erected at pre-war prices, and therefore already favorably situated, would be immensely greater.

The current argument is that any discrimination as to use or period of construction would result in extensive calling of existing mortgages. There may be some force in this point. Existing mortgages are already being called for the purpose of reinvesting the proceeds in securities of an entirely different character. This process would be greatly accelerated by any statute which should exempt all future mort-

gages from income taxes. It might even be somewhat accelerated by an exemption applying only to mortgages on new dwellings. The degree of such influence would be dependent largely upon the extent of new house building operations.

To the foregoing the City Club's committee adds that the club is not prepared to give support.

EXEMPTION of taxes on new dwellings is regarded as more direct and much more patent in its effects. Such a plan would not cut off any public revenues from the land on which new buildings stand, but would only waive for a limited period the tax on the value of the new house or tenement erected.

By this plan the present excessive cost of home building could be measurably overcome. Present builders would be put more nearly on a basis of equity with those who built at pre-war costs. The new building would have an actually increased market value and more mortgage money could be safely loaned upon it. The relief would go exactly where it is socially needed, for every student of the problem agrees that there can be no genuine relief without the resumption of house building.

The proposed exemption would not differ greatly in principle from the existing exemption of shipbuilding from the operation of the Federal excess profits tax. If the power to tax is the power to destroy, an emergency exemption may represent the power to keep alive. The sovereign power of taxation is so broad, and our State constitution so open, that there is little doubt this measure can be effected immediately by statute. As repeatedly interpreted by the United States Supreme Court, there is nothing in the fourteenth amendment to the Federal Constitution to interfere with any sane exercise of state discretion in choosing or classifying the subjects of local taxation.

When Europe Pays Her Debt to Us

WHAT will happen in this country when Europe settles down to payment of the debt she owes us? Today that debt amounts to some ten bil-

lions of dollars. There is not so much money and Europe must, therefore, pay in commodities.

Just what, then, will be the effect of so vast a stream of commodities, cheap in price, when they are rushed to our markets? Undoubtedly it will mean a precarious situation to manufacturers of competing commodities in this country. It will not be wise to ignore this danger for the reason that this influx has not yet begun. Every wisely thinking man knows that eventually it will occur.

R. H. W. Ross, president of the National Marine League of the United States, in an address before the Engineering Society of Philadelphia, very ably discussed the probable effects of this large dumping of foreign goods in this market. He contends that there are three outstanding issues far more important than any others in the American political economy of today. These issues are vital to the profession of architecture, as they are closely related to our economic welfare and would at the very outset affect building construction. We have learned the necessity for a closer consideration of these economic principles, and the fact that building is today in such a precarious state is largely due to a failure to sense the true relation of the many factors only now realized as dominating ones. The three issues referred to by Mr. Ross are:

1. The necessity for the continued operation of American ships, in order that the transportation of American products to both new and old markets may be absolutely under our own control.

2. The establishment of free ports in the United States, so that most of the products of other countries that we shall have to accept in payment of foreign indebtedness to us "may be conveniently received, worked over, blended, repacked, relabeled, transshipped, re-exported, and finally marketed in other countries, all this being done without seriously disrupting the course of our own domestic trade as it now exists under policies that have prevailed for sixty years."

3. The entrance by America into some form of international league, "if for no other reason than to have ready and friendly access to our debtors and their affairs."

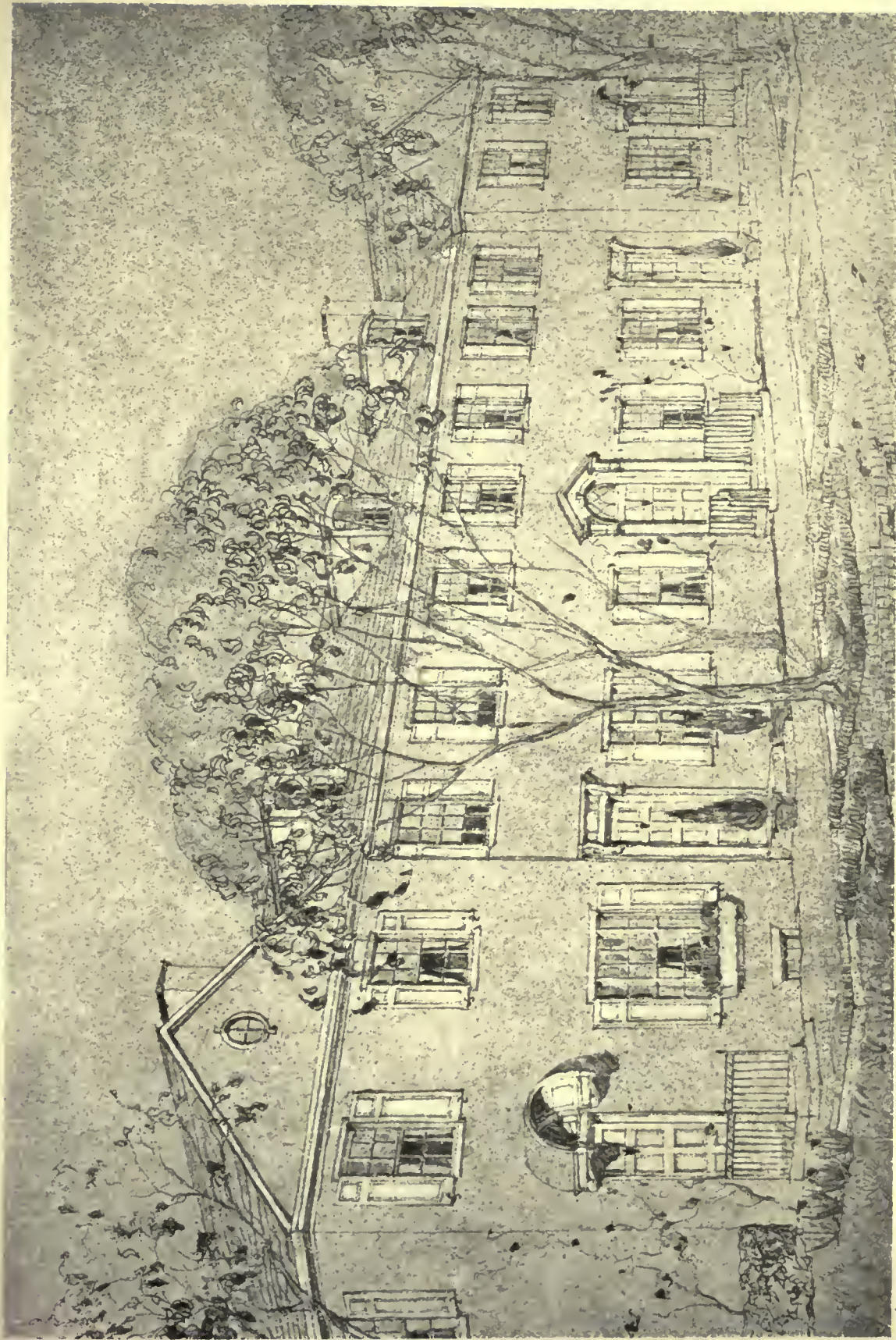

HOUSING AT KINGSTON, NEW YORK
CHARLES S. KEEFE, ARCHITECT

9-2



These buildings were designed to be sold in separate units. As shown on the plan Nos. 1, 3 and 5 are arranged for single families. Nos. 2 and 4 are arranged for two families. This last layout gives a small apartment on each floor.

The center house, No. 3, could in any case be arranged for a single family, but any of the others could be made for one or two families, as desired, by substituting the proper plan.

Where the plan is made for two families it is supposed that the owner will occupy the lower apartment, renting the upper one and supplying heat for both. The plan can be extended to any length desirable, each building occupying a width of 20 feet.

If built as an apartment house heat could be furnished from one source.

382

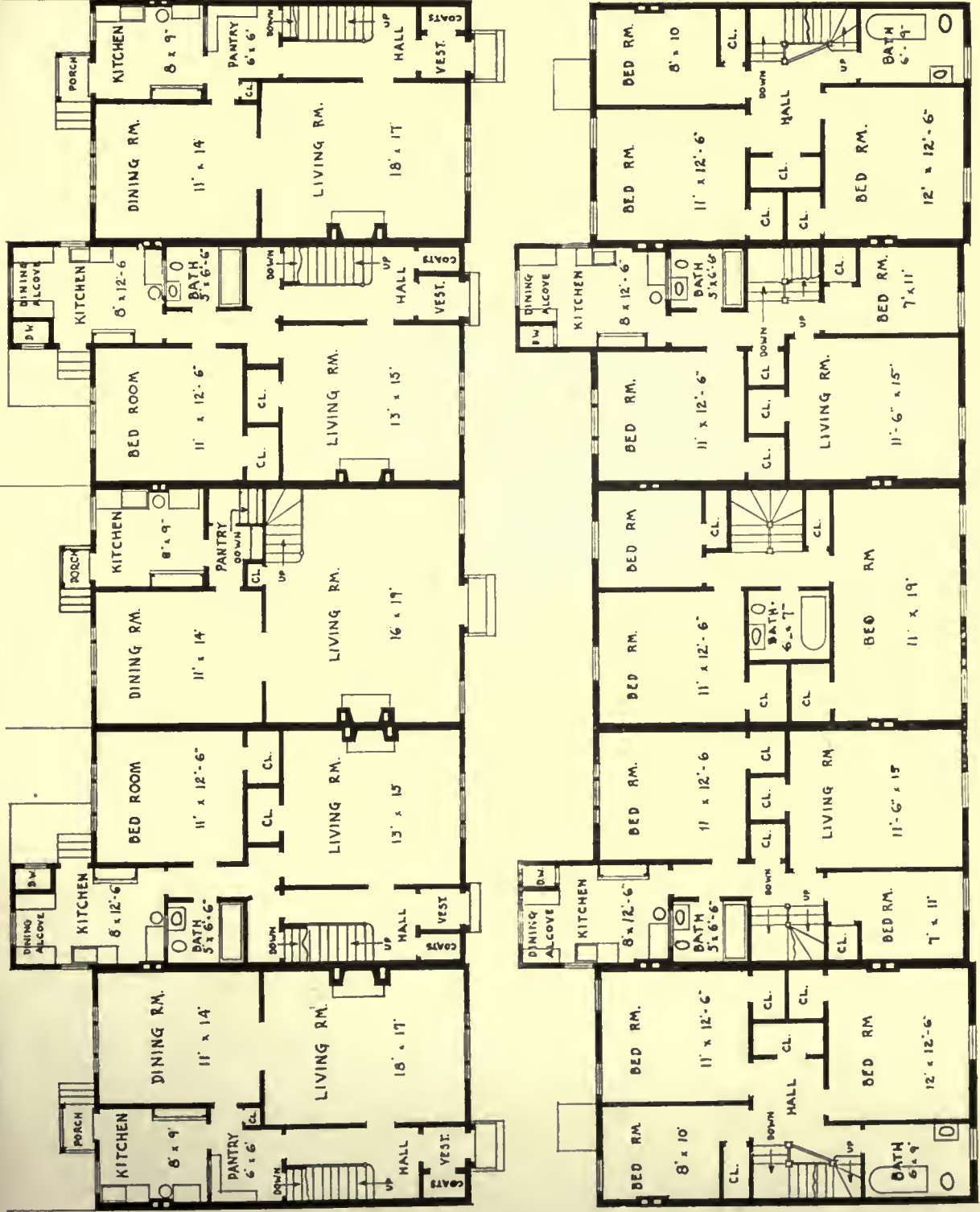

HOUSING AT KINGSTON, NEW YORK
CHARLES S. KEEFE, ARCHITECT



THE AMERICAN ARCHITECT

SEPTEMBER 22, 1920

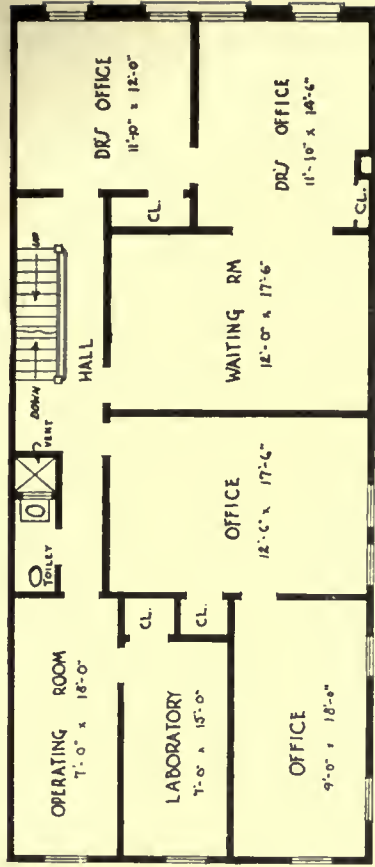

SECOND · STORY · PLAN ·

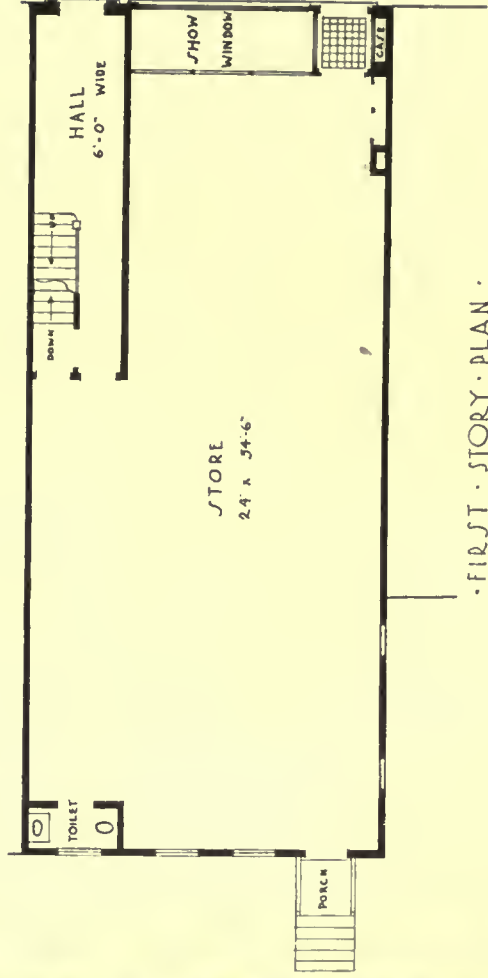

FIRST · STORY · PLAN ·

STORE BUILDING, HUDSON, N. Y.
CHARLES S. KEEFE, ARCHITECT

3-23





HOUSE OF CHARLES L. DENISON, PASSAIC, N. J.
JOHN F. JACKSON, ARCHITECT

3824



382



MAIN ENTRANCE DETAIL
HOUSE OF CHARLES L. DENISON, PASSAIC, N. J.
JOHN F. JACKSON, ARCHITECT

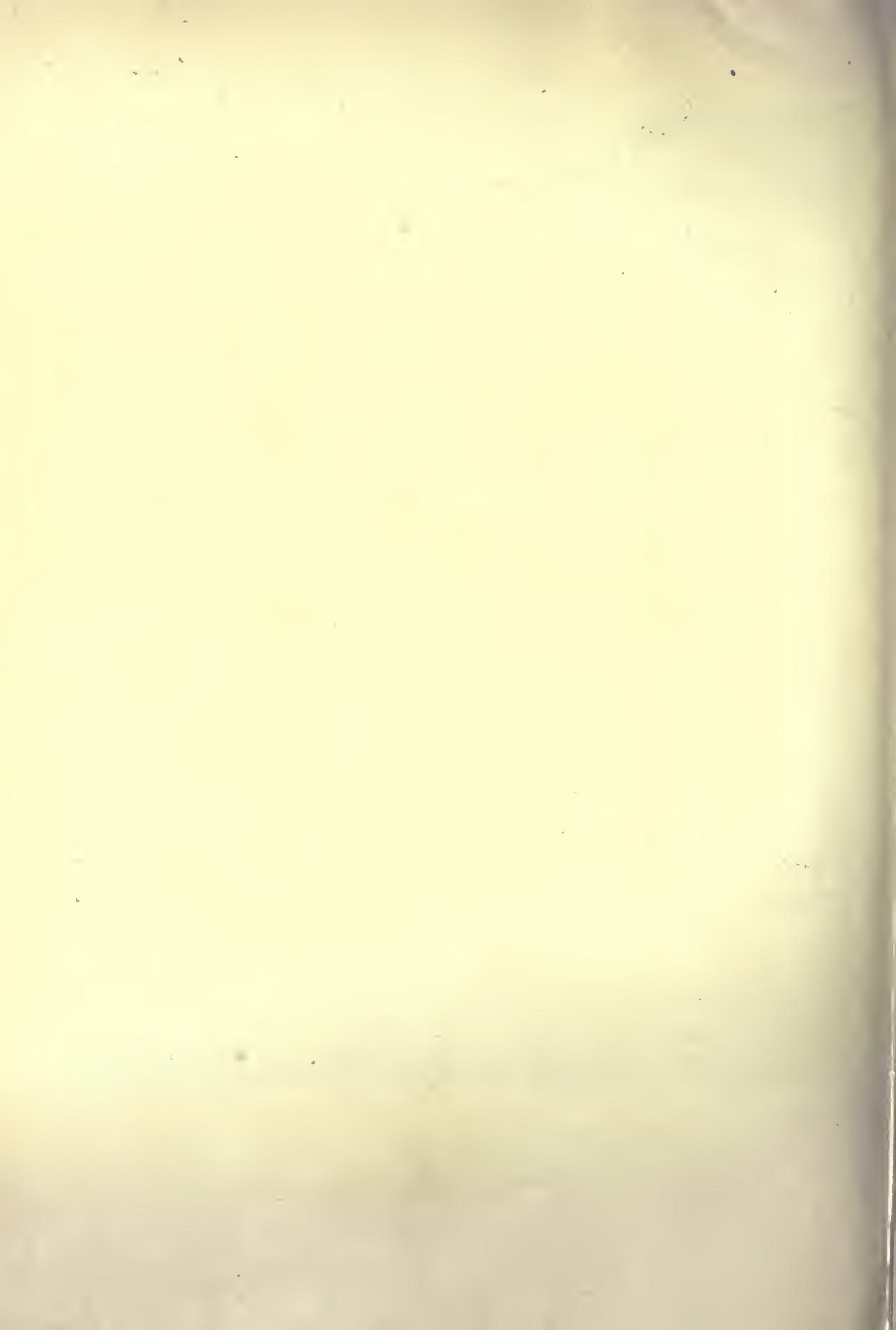

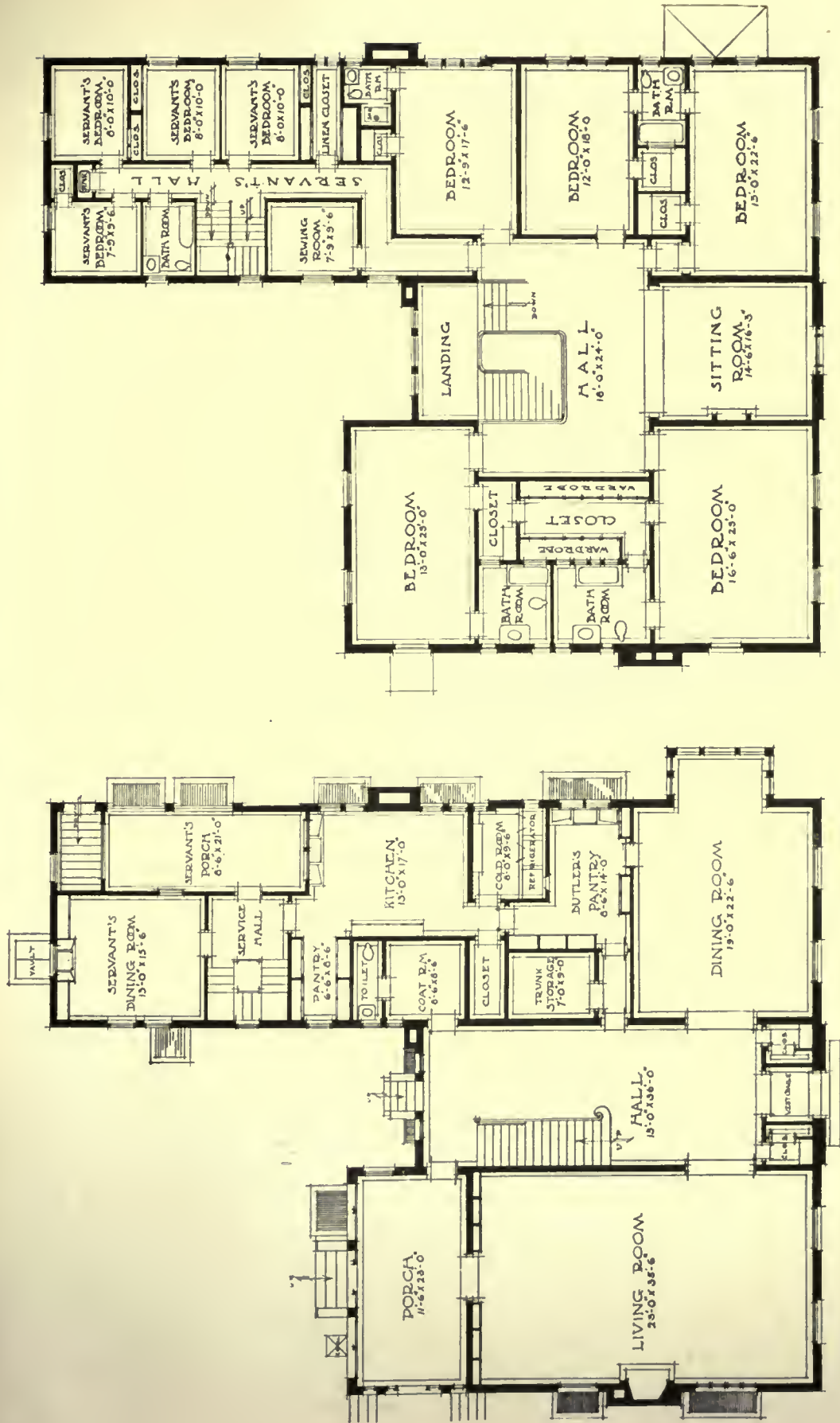

HOUSE OF CHARLES L. DENISON, PASSAIC, N. J.
JOHN F. JACKSON, ARCHITECT

3825





HOUSE OF JUDGE W. W. WATSON, PASSAIC, N. J.

JOHN F. JACKSON, ARCHITECT

382 7

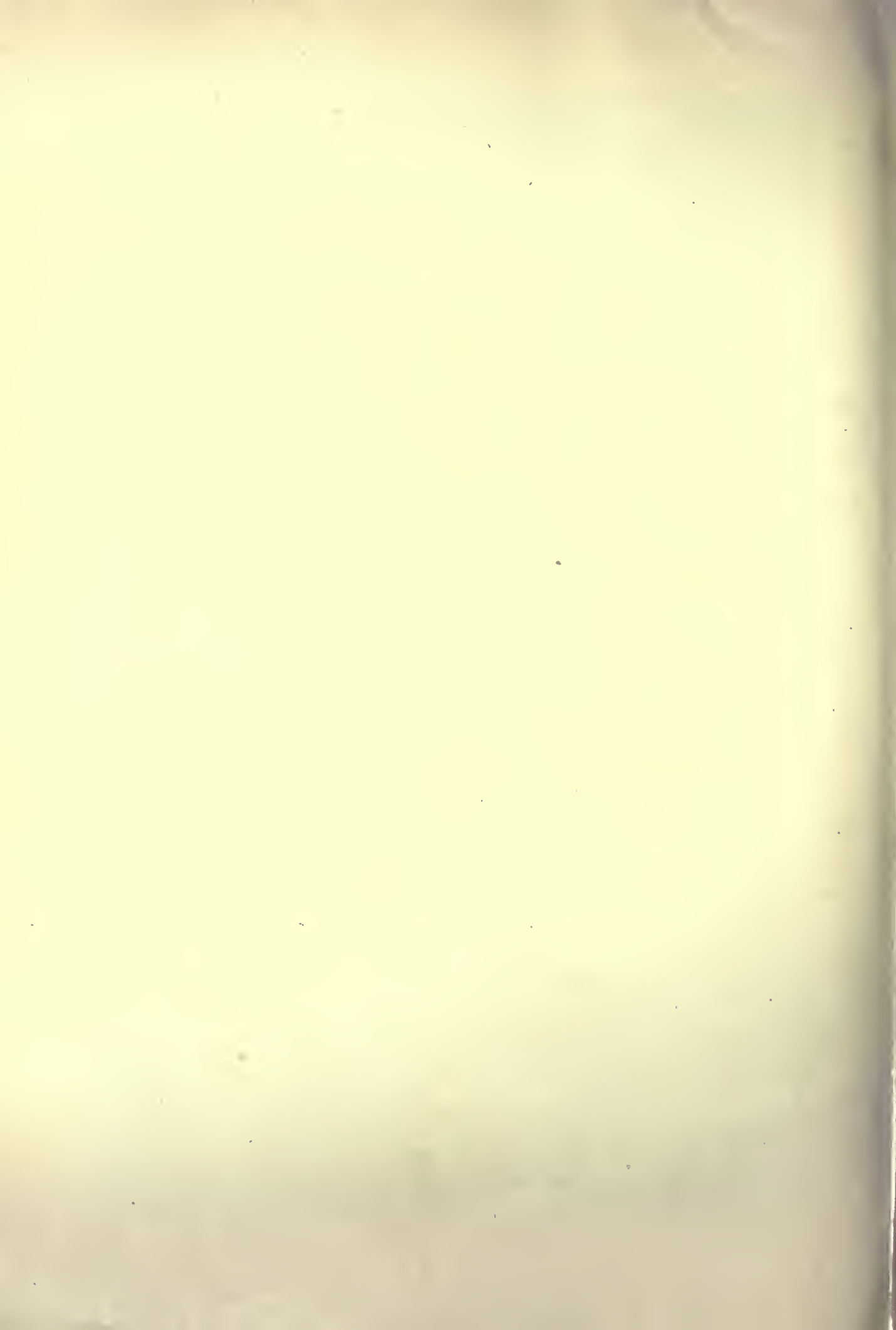

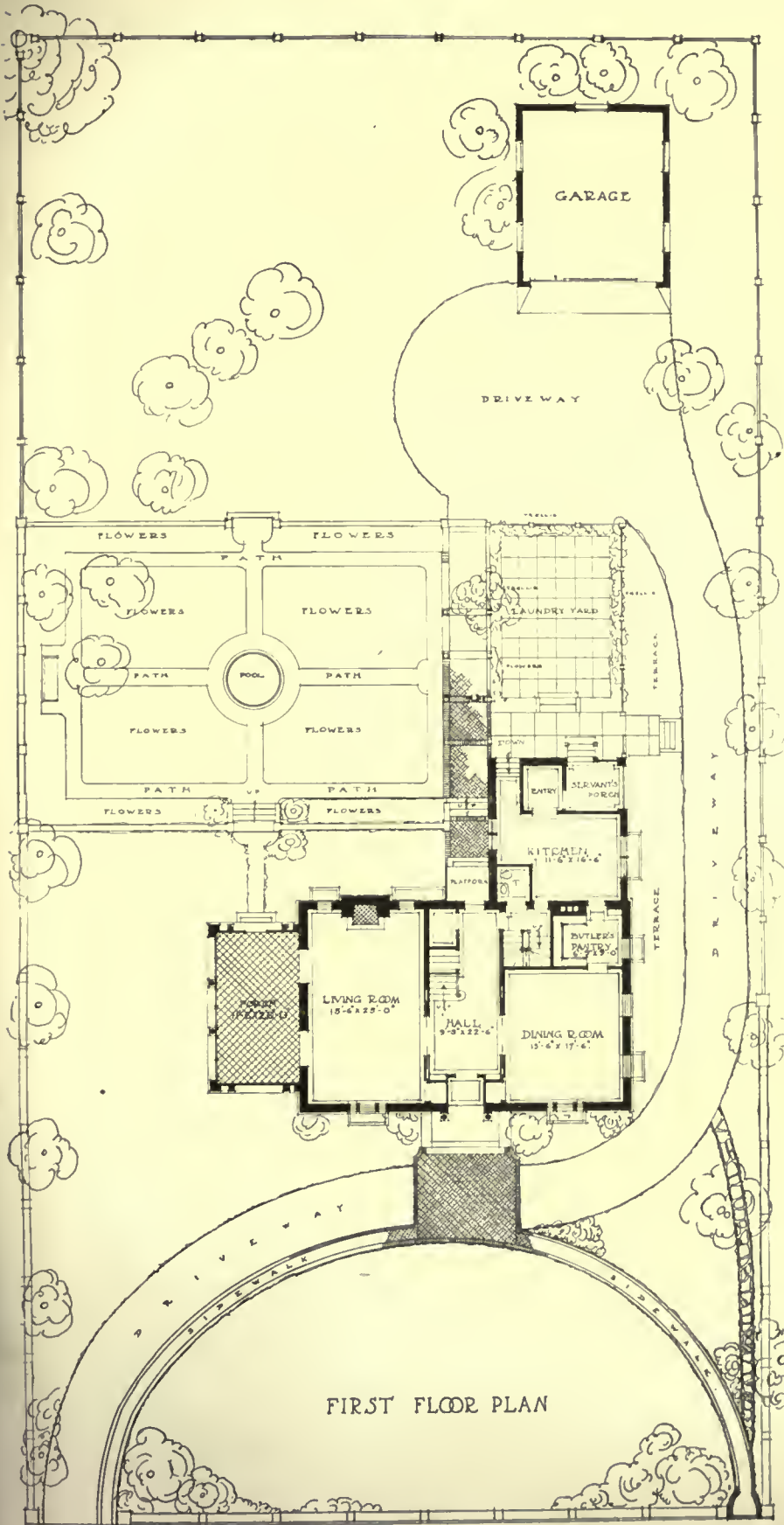

HOUSE OF
JUDGE W. W. WATSON,
PASSAIC, N. J.

JOHN F. JACKON,
ARCHITECT



3829

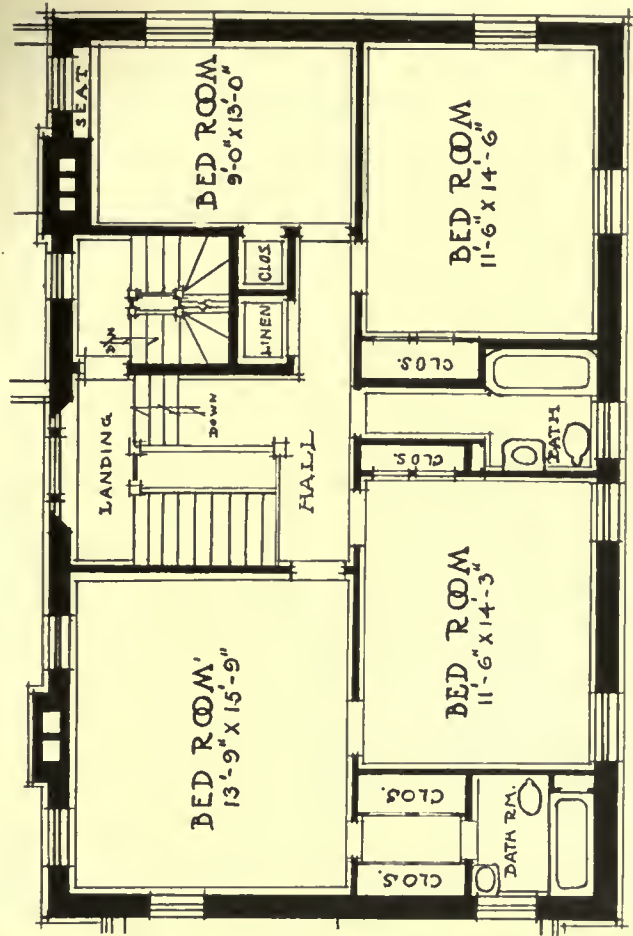

SECOND FLOOR PLAN

HOUSE OF JUDGE W. W. WATSON, PASSAIC, N. J.
JOHN F. JACKSON, ARCHITECT

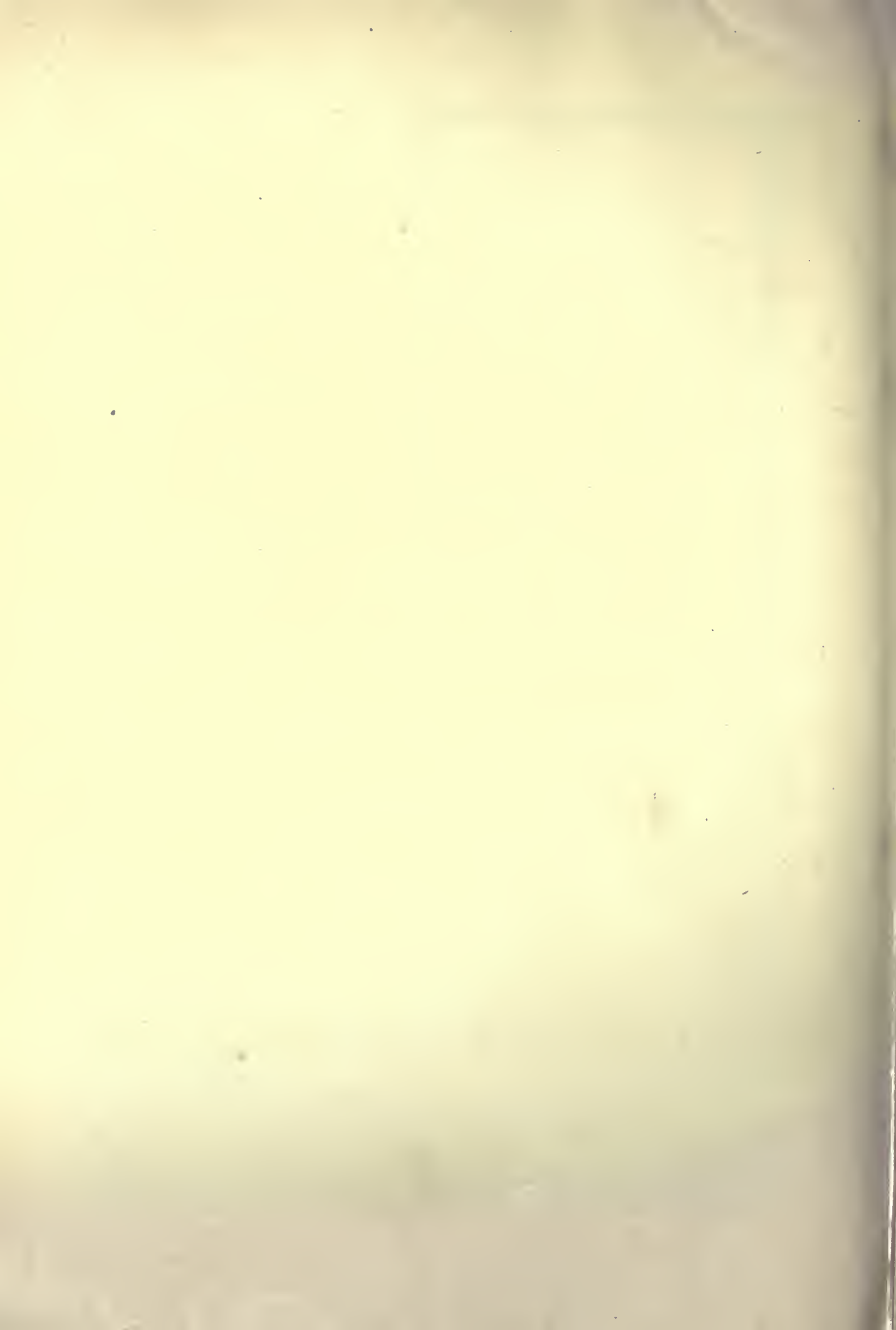



THE SANCTUARY

ST. COLUMBA'S CHURCH, JOHNSTOWN, PA.

JOHN T. COMES, ARCHITECT

The Altar and Screen are executed in lime, as are also the Statues on either side of the Sanctuary
The mural painting and the decorations on the Tympanum are by F. B. Lieftuchter



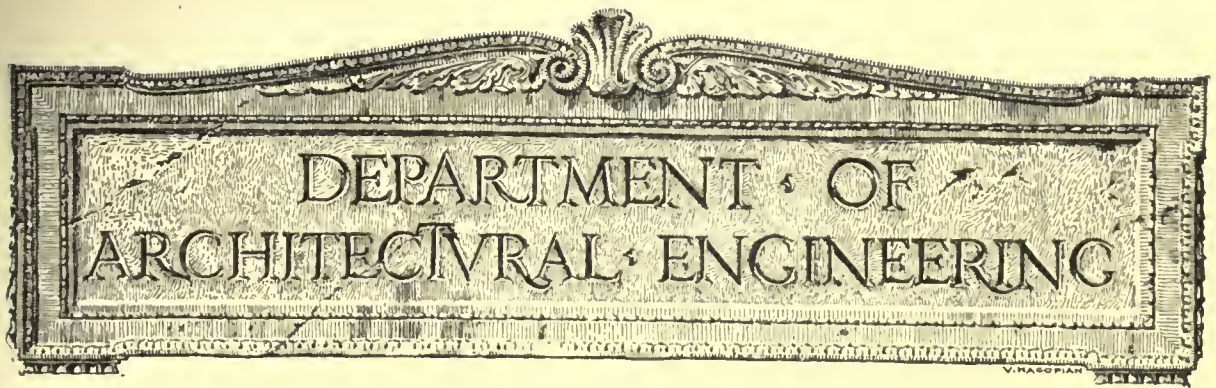

Safeguarding the Water Supply for the Isolated Country House

Some Important Notes on Its Selection and Installation

By WILLIAM C. TUCKER, *Sanitary Engineer.*

THE introduction of a water supply system for the isolated country house, which shall be permanently safe, of reliable quantity, and of low cost, is a problem which demands scientific and business acumen.

SURVEY OF PROPERTY:

The owner of a country estate should not enter upon the development of his property, be it small or large, in an impulsive or haphazard manner but with careful forethought. To accomplish this and to aid him in his study, a topographical map should be accurately prepared.

Immediately upon obtaining possession of the property, a casual examination should be made for a permanent water supply, during which it is well to note carefully the location of that on the neighboring land, and the method of pumping. This will eliminate much perplexity and save the loss of valuable time, leaving the more promising features for a thorough and scientific investigation. Every possible source must be marked for observation,—springs, brooks, water shed, seepy ground, and points of vantage for the location of an artesian or driven well, should all else fail.

SOURCE OF WATER SUPPLY:

A careful examination of the environment of the source of a proposed water system should always be made. The slope of the ground, the drainage area, the character of tillage of adjoining land, with the thought in mind of the possibility of direct or indirect contamination. The writer has in mind a flowing well in a section of New Jersey, given to the beautiful homes of New York men of means, which

upon analysis by the State Board of Health gave indications of insecurity, never satisfactorily explained. It was discovered that excessive amounts of fertilizer had been applied to the poor land of an estate three miles distant, under control of a wealthy and impatient owner who wished to produce glowing results over night, but whether this suspicion was tenable or not is problematical.

The permanent source of the water supply with its tributaries must, if possible, lie wholly within the confines of the property, to insure absolute control and freedom from contamination. Its rate of delivery must be accurately known from a series of careful intermittent gaugings, taken at different periods, some of which must be in the fall of the year, when the flow is at its lowest. It must be at a safe distance from the house, barn, and farm activities, and other points from which there may be fear of the slightest possible future contamination, but with which it must coordinate as closely as possible. This demand is often most perplexing, and may lead to an undesirable solution.

EXAMINATION OF THE WATER.

WHEN the permanent source of supply has been selected, after careful investigation, a sample should then be sent to the State Board of Health for a chemical and biological examination, with accompanying reports. This examination is free of all charge, except that for the container, to and from the laboratory. A number of examinations, within reason, will be cheerfully made. The report will clearly indicate the chemical constituents which the sample may contain and their percentage. The biological

examination will show the pathological germs discovered if any, and the count. Such a report also contains a most comprehensive and concise statement of the deductions as indicated in the analysis, which is most valuable, is always conservative, and must be conscientiously followed, often necessitating the abandonment of a beautiful and what may appear healthy source of water supply, and the renewal of investigation for a substitute source. The enthusiastic owner is so often deceived by the appearance of the limpid and sparkling water from a running spring; and analysis should be made once a year or at such time as there may be cause for the slightest apprehension. This is well illustrated by an incident which occurred to the writer in the course of his professional duties. The young members of a family and their mother, living in a beautiful home in the country, surrounded with every luxury and comfort, from some cause became listless and lacking in animation; their food was wholesome, the air invigorating, and they had ample rest and recreation. The writer made diligent investigation and suggested that an analysis of the potable water be obtained. This was ridiculed as being unnecessary, as "the spring has been running ever since grandfather was a boy." The water was analyzed and the report came back indicating contamination, which was then easily traced. Another incident most similar occurred in connection with a well on the property of a large, fashionable and most exclusive young ladies' school on the Hudson River not far from New York. This well was most popular and had been in use many years, and "I drank from this well when I was a boy," said the old gardener, who was well over sixty. This water, too, was analyzed with similar results. Thus time may change conditions.

There is an erroneous impression along the country side, particularly amongst those of untutored mind, and tenacity of opinion, that any impurity contained in flowing water will in time be removed. This is true of any impurity held in suspension which can be removed by sedimentation in quiescence, but this does not hold, should the impurity be of a pathological nature. It is possible, of course, to remove pathological impregnation, but the method is most delicate, of the highest scientific attainment, requires unceasing scrutiny, and is most costly. Boiling will absolutely purge the most contaminated of waters; this has often been demonstrated by intrepid explorers in tropical climates. It may be accepted as an axiom, that should the water under consideration show any evidence of contamination, that source must be abandoned, and search continued for a pure, wholesome, healthy supply. It is doubtful if most persons fully realize the importance of pure water.

AN IDEAL SOURCE.

THE ideal source is the isolated, never failing, cool and refreshing bubbling spring. Such a source is to be highly treasured. It must be thoroughly explored, its tributaries traced and its complete history learned. The intermingled earth should be removed, and the spring surrounded with a water-tight masonry wall to exclude ground water, which must be extended well above surrounding surface with curb to provide against surface drainage. Bottom of spring must be left absolutely free. It is most essential in this connection that all the branches be gathered together, so that the greatest possible amount of water may always be available for which there will always be found use. Excess supply may be used in the creamery or a swimming pool. The spring must be provided with suitable housing for protection against the intrusion of superficial material and to insure its exclusive use for potable purposes.

OTHER SOURCES.

The use of the brook meandering through the property with its foreign source, it not to be received with unalloyed complacency. That portion within the boundary is, of course, under control as to safety and conservation, but that beyond is not. There is always the fear of pollution and interference with its entire delivery.

The development of seepy ground as a source of water supply is not to be encouraged: There is always the fear of unreliability of purity and quantity.

The reversion to the artesian or driven wells as a source of permanent supply is only to be entertained, to the writer's mind, as a last resource, when all other methods are found wanting; the initial cost is never definitely known until water of desired quality and quantity has been obtained; the permanency of rate of delivery is not certain; the quality is generally hard and not as beneficial as that from the spring, and it is generally unpopular for use in the laundry.

RESERVE SUPPLY.

PUMPING directly from the water source is inefficient, and lacking in engineering ability; a reservoir or reserve supply should always be maintained. The rate of flow of the spring may not be great, but it probably is constant, and the total yield per day will usually be found sufficient to meet all demands. The reservoir may be located at any point which may be found appropriate, in relative proximity to the farm activities and well below the spring so that the overflow may be quickly delivered, thus obviating freezing. It should be well constructed of masonry, carefully laid in Portland cement with brush smooth inner surface, and of strength to with-

stand the earth pressure from without when empty and the water pressure from within. The wall should extend well above ground with curbing. The reservoir should be so located that it may be drained for cleaning and repairs, the drain should be at centre of bottom, from the four walls so that in making repairs should leak occur, only small section of flooring would be flooded.

It will be found advisable to provide a small silt or grit chamber, with removable wire screen, at end of basin of which it forms an integral part, to intercept the grit, sand any foreign material which the overflow might bring into the basin. The reservoir should be of ample capacity to carry a week's supply, should the purse allow, so that emergency of drought or other causes may be readily met. The dimensions which will meet the demands for the average country property cannot be accurately determined, but a basin 12 ft. x 8 ft. with 4 ft. 6 in. depth of water, or 3,250 gals. capacity, will not be found excessive of cost. It will cost less to provide area than depth and the length can easily be extended should this be found necessary. The reservoir should be carefully housed and protected in similar manner and for the same cause, as the spring, and should be extended so as to provide shelter for pumping equipment.

PRESSURE SYSTEM:

Any point demanding water service which may be situated below the level of the reservoir may be supplied by gravity flow, but in many instances this will not be found possible, in which case an elevated tank, or the pneumatic pressure system will have to be employed. The latter consists of a cylindrical steel tank automatically kept filled and under pressure by a small pump and motor on the same bed-plate, controlled by pressure in the tank.

ELEVATED TANK

The elevated tank will require pumping equipment which may vary according to the duty demanded, and cost available.

WINDMILL:

The use of the windmill will be found most economical but most unreliable, and for this reason the common form of pumping equipment will be found much more satisfactory.

HYDRAULIC RAM:

The hydraulic ram has given excellent service; it requires little or no attention, is self contained and of little or no operating expense. It should be housed for protection and safety. This form of pumping, however, can only be employed where there may be an abundance of water, as under ordinary circumstances, only one tenth of the water passing through the ram can be raised to a height ten times that of the fall from the source.

The successful solution of the problem of providing a wholesome and copious water supply system for the country estate, and one which will be found efficient, and may be operated at low cost, will be found to depend upon a close study of existing conditions upon the property, and the most economical means of producing results which shall meet all demands.

Results of Corrosion Tests Conducted by the National Lime Association

THE final report on the corrosion tests conducted by the National Lime Association has been issued, and from this it would appear that the addition of from five to fifteen per cent. of hydrated lime to a gypsum mix will greatly retard corrosion of imbedded steel. The extent of the tests, i. e., three months, and the number of specimens tested does not seem sufficient to prove beyond doubt, the theory that the National Lime Association seeks to establish, and it would appear that this might be a fertile field for such an organization as the Bureau of Standards to investigate more fully. The report follows:

A series of ten slabs of each of 14 different materials were made up, each slab having embedded in it two polished steel rods and each series being divided into two sub-series of 4 slabs each. One sub-series was stored in air only, while the slabs of the duplicate sub-series were immersed in water for five-minute periods once a week during the conduct of the test. Slabs from each sub-series were broken and the extent to which corrosion of the steel rods had proceeded was noted at the following periods: one week, two weeks, one month, two months, and three months.

None of the concrete or lime mixtures showed any corrosion in either the air or water-treated slabs, but in series 7 to 10 inclusive, consisting of gypsum and hydrated lime—ranging from 100 per cent. gypsum to 85 per cent. gypsum and 15 per cent. hydrated lime—some interesting results were obtained.

One hundred per cent. gypsum, air-cured, showed a visible corrosion at the end of one week, which apparently reached a maximum in about one month due to the protective coating of iron oxide formed.

One hundred per cent. gypsum, water-dipped, showed a greater corrosion than the air-cured slab, and this kept increasing throughout the time of the experiment.

Ninety-five per cent. gypsum and 5 per cent. hydrated lime, air-cured, showed no corrosion at the end of three months, while the water-dipped slab showed noticeable corrosion at the end of two months and visibly increased corrosion at the end of three months.

Ninety per cent. gypsum and 10 per cent. hydrated lime, air-cured, showed no corrosion, and the water-dipped sample showed none at the end of two months, but very evident corrosion in three months.

Eighty-five per cent. gypsum and 15 per cent. hydrated lime showed no corrosion in either the air-cured or water-dipped slabs at the expiration of the three-months' test.

Foundation, Their Selection, Design and Construction

Part III

As pointed out in previous articles, it is necessary before an intelligent study of a foundation problem can be made, to determine two governing factors, i. e., the load to be supported, and the nature of the sub-soil. The former is determined entirely by the size, type of construction and character of proposed occupancy of the building, while the latter can only be judged from a preliminary investigation sub-soil conditions.

The weight to be supported may vary from less

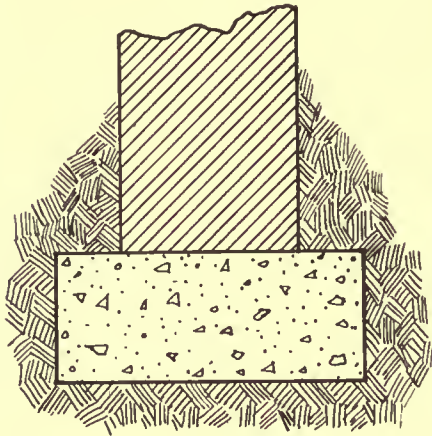

FIG. 1.

than a ton per running foot of wall for a small structure to over 1,000 tons per column for a skyscraper, while the soil may vary from a soft wet clay with a bearing capacity of only one-half ton per square foot to good hard rock capable of supporting a safe load of forty tons per square foot. For the majority of commercial structures the values of these factors will lie well within the extremes stated.

It is the purpose of this and succeeding articles to describe the various conditions under which different types of foundations are suitable, commencing with simple illustrations and working up later on to more intricate problems.

THE SPREAD FOOTING.

The most common, as well as the simplest type of foundation is known as the "spread footing." In this type the footing is placed just below the basement level, or if there is no basement then below the frost line, and constructed with a spread sufficient to cover a ground area capable of resisting the in-

posed load. Spread footings are used in all classes of construction. Perhaps its simplest application is under a wall where an equal projection of footing on each side is possible, as shown in Fig. 1. Its most extended use is when developed into a continuous mat of reinforced concrete covering the entire ground area of the lot, with both walls and columns resting thereon. Where the soil is capable of supporting in excess of two and one-half tons per square foot its use will usually prove economical, except where very heavy concentrated loads occur. Even for bearing values under this figure it can be used to advantage in buildings of moderate size. Let us take as an example a twelve-story office building with columns spaced 20 feet each way. The total load on each column footing would be in the neighborhood of 400 tons, which for a four-ton soil would require a spread of 100 sq. ft. A footing 10 ft. square would therefore be adequate. By using a reinforced concrete mat of this area, a comparatively shallow footing could be designed, thus keeping the

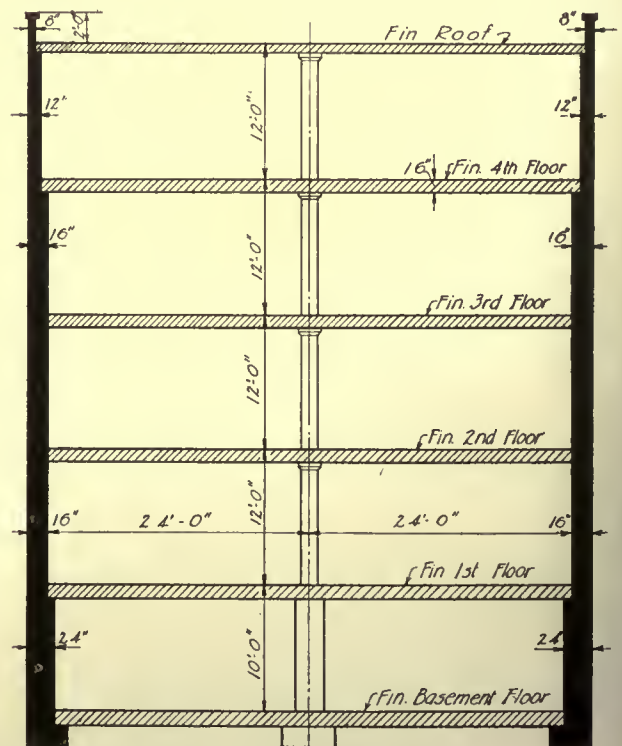

FIG. 2. CROSS SECTION

excavation to a minimum. Were a medium rock encountered, capable of carrying 20 tons per square foot, all that would be necessary would be to excavate pockets 5 ft. square at the column locations and about 2 ft. below the basement floor, level the rock, and use C. I. bases 4 ft. 6 ins. square, grouted in place.

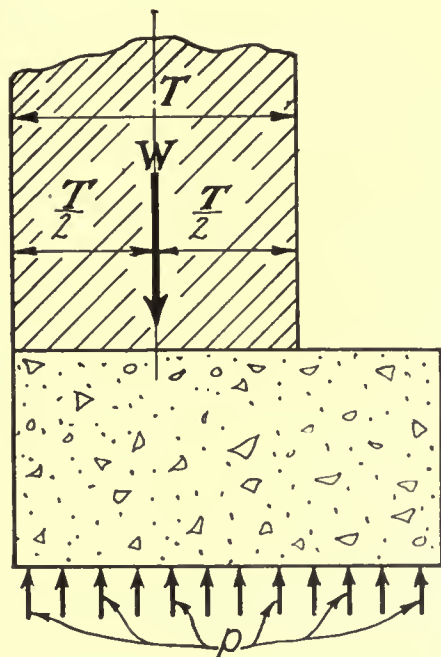

FIG. 3.

THE ECCENTRIC WALL FOOTING.

For buildings of moderate height, where bearing walls are used, the design of the wall footings for walls located on a lot line often requires careful study. In such locations it is necessary to use eccentric footings, that is with a spread of one side only. A common practice is to make the footing anywhere from 6 ins. to 2 ft. wider than the basement wall, and assume that all the requirements for a safe footing have been complied with. If settlement occurs, it is easy to place the responsibility on the builder, rather than acknowledge a faulty design.

Consideration will be given to a problem involving this type of spread footing.

Let us assume a 4-story factory with bearing walls and wood floor joists having a clear span of 24 ft. Assume that the live load is 120 pounds and the dead load 20 pounds per sq. ft. For the roof a live load of 40 pounds and dead load of 15 pounds per sq. ft. will be assumed. The wall thickness and story heights are taken as indicated on the sketch. (See Fig. 2.) The total load coming on the soil at the footing level will be 9.1 tons per linear foot of wall computed as follows:

	Width	Length	Load per sq. ft.	Total Load
Floor and Roof Load	1	12	(40 + 15)	660 lbs.
Roof	1	12	40	480 lbs.
Floors	4	1	15	600 lbs.
Total				6,720 lbs.

	Thickness	Length	Height	Wt. per cu. ft.	Total
Wall Load					
Parapet	2/3	1	12	120	160 lbs.
Fourth story	1	1	36	120	1,440 lbs.
Three lower stories	1.33	1	36	120	5,760 lbs.
Basement	2	1	10	150	3,000 lbs.
Total					17,740
Assume weight of footings					460
Total load on soil					18,200
					Or 9.1 tons per linear foot of wall.

For a wall two feet thick, the maximum footing projection permitted by good practice for an eccentric footing is one foot. It might here be well to correct an erroneous impression as to the effectiveness in distributing load produced by extending the footing projection on one side only.

Let W, Fig 3, be the total load of the wall, floor, etc., which for analysis may be assumed to act through the center of gravity of the wall section. To determine the actual center of gravity for the problem under consideration would be a lengthy calculation, but an inspection would indicate that it is near the center of the basement wall, and it will be so assumed. This force must be resisted by the upward pressure of the soil, and this pressure per unit area will be designated as p. Now if the footing were extended a considerable distance, and it were possible to obtain a distribution of load over the entire spread, it will be seen that this upward pressure would cause an unbalanced overturning moment on

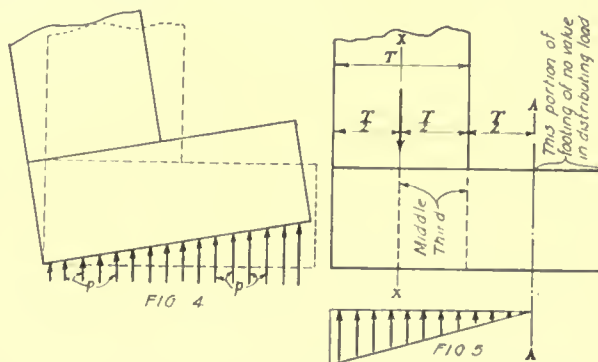

the wall producing rotation, as shown in Fig. 4. This condition, however, is not possible, and what actually occurs is a decrease in the intensity of pressure until zero is reached, as shown in Fig. 5. It will thus be seen that any projection placed beyond the line A-A is worthless and a waste of material; further than that, it is positively detrimental since it tends to produce rotation when settlement occurs. When the center of gravity of the load comes at the center

of the wall the maximum projection can only be equal to one-half the width of the wall. Under these conditions the line of resultant pressure XX does not fall outside the middle third of the footing. Whenever this resultant force falls without the middle third, tension occurs at the extension of the footing.

Thus for the problem under consideration the

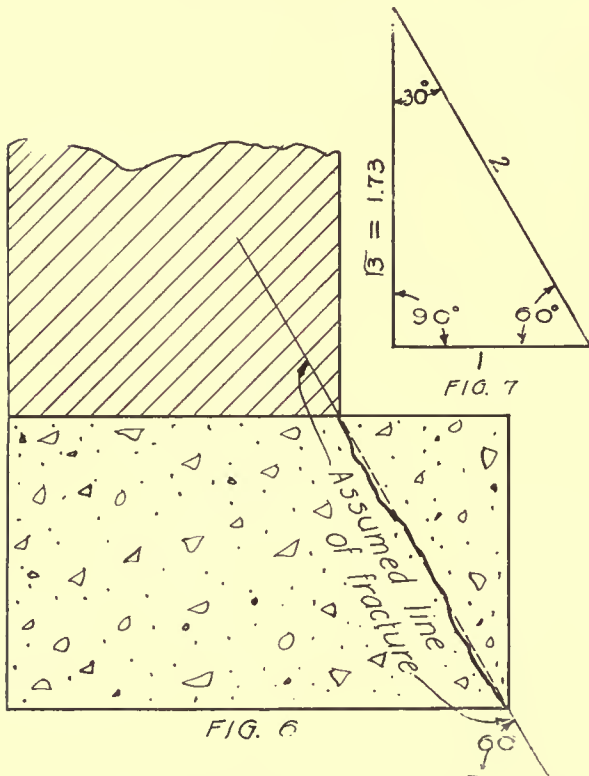

For economy the footing should be stepped up as shown in Fig. 8.

In case the soil were of such nature as to be unable to support a loading of over three tons per square foot, it would then be necessary to either excavate to a firmer strata or drive piles. If ground water were encountered at the footing level, wood

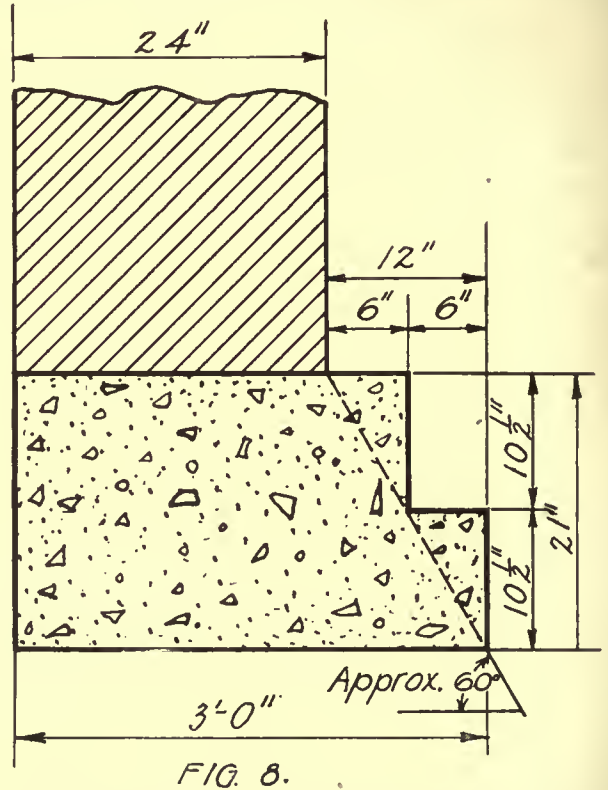

maximum projection will be 1/2 of 2 feet or 12 inches and the total width of footing will be 3 feet. Since the load to be carried is 9.1 tons per linear foot, the average load on the soil will be $9.1 \div 3 = 3.03$ tons per sq. foot. From Fig. 5 it will be noted that this intensity of pressure is not uniformly distributed over the soil under these conditions, although if the soil is considered as capable of supporting a uniform load in excess of 3 tons per sq. foot this foundation can be considered as safe to use.

Unless reinforcing steel is used, the thickness of the footing is determined by the rule that the line of fracture of the material will make an angle of approximately 60° with the horizontal, as shown in Fig. 6. The sides of a 30° and 60° right triangle are in the ratio of 1 : $\sqrt{3}$: 2 as shown in Fig. 7. It will be noted that the vertical leg is 1.73 times the horizontal one. Since the former represents the thickness and the latter the projection, the thickness should be made approximately 1 3/4 times the projection. For this problem as the offset is 12 inches the thickness should be $1\frac{3}{4} \times 12$ or 21 inches.

piles should, under most conditions, prove the most economical, otherwise the choice would lie between concrete piles and deeper excavation, unless it were possible to offset the wall so as to make the construction of a concentric footing possible. It is usually the case that the value of the lost floor space due to offsetting the wall is greater than the increased cost of pile or other footings.

Jack Pine

Under the above title, the United States Department of Agriculture has issued Bulletin 820, prepared by William Dent Sterrett, Forest Examiner. This bulletin goes thoroughly into the subject of this tree, describing its distinguishing characteristics, range, geology, the various uses to which it can be applied to advantage, etc., and is replete with illustrations and tables. Copies may be obtained from the Superintendent of Documents, Government Printing Office, Washington, D. C., at twenty-five cents per copy.

An Efficient Arrangement of Schoolhouse Entrance Doors

METROPOLITAN railroad stations have very generally adopted a type of entrance which experience has shown to be well suited to the varying conditions of traffic. The ingress and egress requirements in such buildings are hardly more severe than those which obtain in the large city school buildings, through the doors of which a large number of persons have to pass in a very short space of time. These doors must also afford ready passage to solitary individuals, be designed to present a barrier to draughts and should be equipped with fixtures which while permitting egress at all times may be locked against incomers at specified periods. The type of entrance now in general use in schools, with double doors opening out, alone or with single doors at the side, might, it would seem, be replaced to advantage by the row of single doors which the railroad stations employ and which are shown in the accompanying illustration. In the design of new schools it would seem well to adopt this arrangement.

This type presents a number of advantages. In the first place, where there are double doors, one of them is inactive except upon special occasions and is fastened against entrance, but the presence of the usual knob or handle on the outside frequently leads the incomer to endeavor to use the locked door, particularly since it is the one nearest his right hand. This is especially true of children who have no knowledge of structural details and with habits not yet fixed by usage.

Again, with the idle leaf fastened, the space available for passage is only that of the single door both for exit and entrance, causing inconvenience to persons who meet at the door. With exit fixtures such as panic bolts, the idle leaf can be opened from the inside, but the person seeking to pass out through it passes to the left, where incomers will be encountered. If both doors open at will, swing to a common center in closing, there is liability of people being struck by the closing doors. With single doors, all hung alike, passers in either direction instinctively keep to the right, finding ready passage without interruption and with only the amount of opening required by the occasion. Individuals passing in are not disturbed by files of pupils passing out. Several doors may be used for exit at the same time permitting several columns to pass out simultaneously without confusing, or for files to pass in opposite directions.

There is less open space with the row of single doors—a fact worthy of attention in times of low temperature or strong winds. They are easier to move by children than the larger doors in pairs and close more surely and with a closer fit.

Again, the arrangement recommended makes any door as available as any other. Each of the doors is a unit of the same value for use as the others,

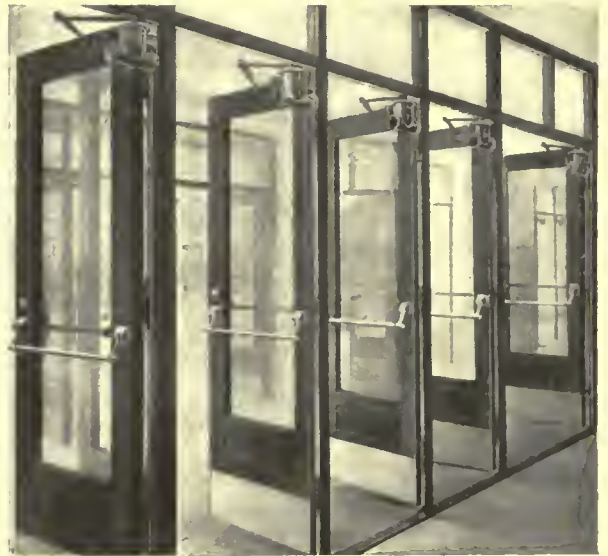

THIS ARRANGEMENT OF ENTRANCE DOORS HAS BEEN FOUND TO GIVE EXCELLENT SERVICE

distributing the traffic and reducing the chance of congestion.

There is a certain advantage to the user in having all doors alike in their action. Pupils soon learn the movements required in opening and closing of the doors—which are the same as with the doors in their homes—and learn to keep to the right. In time of fire or panic the value of this familiarity is most apparent, but it has a constant advantage in the ease with which the doors are manipulated without conscious thought.

In addition to the advantages to the inmates there are others which appeal to the builders and the caretakers. The effect of shrinkage in a pair of double doors is twice as great as in a single door, and often interferes with the security of locks or the proper connection between the latch bolt in one door with the lock strike in the other. It also makes it difficult to provide a weather-tight entrance, par-

THE AMERICAN ARCHITECT

ticularly when the doors open independently of each other, as this type of entrance does not permit the use of an astragal.

The illustration shows a typical entrance with the arrangement of doors as proposed, viewed from the hall or corridor side. The automatic exit bars or panic bolts are such as have been made obligatory by some State enactments and the ordinances in most of the principal cities. Such fittings permit instant egress at all times but the locks can be made to prevent entrance when so desired. Door checks should be provided to keep the doors closed except when they are fastened open by hold-back attachments to the door checks or by door holders affixed to the bottoms of the doors. The entire trim is so planned that the doors cannot be locked against exit, but intruders can be kept out; the doors are normally in a closed position, are weather-tight and have the least possible shrinkage-interference with the lock action; and they can be readily provided with standard hardware from any of the principal manufacturers.

In conclusion, such a series of single doors, all in similar and active operation, affords the full and free use of each opening at all times, permits similar application to all the doors, ensures the familiarity of the pupils with the operation of each door, affords weather protection and is found more desirable in operation, viewed from any angle.

U. S. Civil Service Examinations

ENGINEER EXAMINER, CLASS A, \$3,900 TO \$4,800 A YEAR. ENGINEER EXAMINER, CLASS B, \$2,220 TO \$3,600 A YEAR. CIVIL, ELECTRICAL, MECHANICAL, SIGNAL, STRUCTURAL, TELEGRAPH AND TELEPHONE. INTERSTATE COMMERCE COMMISSION. OCTOBER 1, 1920.

The duties of these positions involve (a) the analysis of applications for certificates of public convenience and necessity under the Interstate Commerce Act, in the matter of the construction of new lines, the extension of existing lines and the abandonment of all or part of lines, the undertaking or abandonment of the operation, and the consolidation of lines; (b) field work to determine from actual conditions the correctness of claims in these applications; (c) in connection with the issuance or assumption of securities, the analysis of applications, the determination of the reasonableness of the proposals therein, that the work is properly chargeable to capital account, that the

amounts named are reasonably required for the purposes set forth, and that the proceeds derived from the sale of securities are applied to the purposes originally proposed; (d) in connection with excess and guaranteed earnings, the study and analysis of expenditures for maintenance of way, structures and equipment, and the determination of the reasonableness of such expenditures.

Competitors will not be required to report for examination at any place, but will be rated upon for sworn statements in their applications.

For further information, address the United States Civil Service Commission, Washington, D. C.

American Society of Civil Engineers to Vote on Joining Federated American Engineering Societies

VARIOUS organizations of engineers have already signified their intention of becoming charter members of the Federated American Engineering Societies.

The annual convention of the American Society of Civil Engineers, held in Portland, Oregon, August 10, 1920, adopted resolutions which provided "that the Board of Direction of the American Society of Civil Engineers be directed to submit at once the question of the American Society of Civil Engineers becoming a charter member of the Federated American Engineering Societies to referendum vote to the Corporate Membership of the American Society of Civil Engineers as recommended by the Joint Conference Committee, said ballot to be accompanied by a copy of the Constitution and By-Laws of said Federation" and "that the Board of Direction of the American Society of Civil Engineers be further instructed in event of a favorable vote on said referendum to proceed at once to take such steps as may be necessary for the American Society of Civil Engineers to become affiliated with said Federation."

There seems to be no doubt that applications for membership in increasing numbers will continue to reach the Joint Conference Committee. This new Federation of engineering societies, if recruited to its fullest possible strength, will undoubtedly become a strong power, both for the good of the individual engineer and of the public. It may be that the form of organization approved at the organizing conference held last June is not perfect, and that amendments may later be found advisable, but a start in the right direction has been made, and the new organization deserves the heartiest support.

Criticism and Comment

The Editors, THE AMERICAN ARCHITECT:

In your issue of September 1, on page 300, I have just noticed a quotation possibly from a newspaper report of remarks which it would appear I made at a meeting of the Board of Jurisdictional Awards held in Atlantic City early in August.

The quotations published in the daily press were quite incomplete and hence somewhat misleading. To begin with the meeting was not one of the Board of Jurisdictional Awards, but followed the sessions of that Board. It was a special meeting called at the invitation of the American Institute of Architects and attended by an invited group of representatives of various branches of the building industry.

The particular part of my opening address, from which the quotation was taken in its complete form was about as follows:

"The situation, for instance, in New York with regard to materials is serious. We cannot get materials except at prohibitive prices. The general impression is that even if it were not for that problem of price the necessary building program could not be carried out. Contractors say there would not be enough brick, for instance, if everybody attempted to go ahead. At every point (labor and materials, etc.), the game is tied up. On every side there seem to be fences that block the way and building is being discouraged. We are not proposing our plan because we are interested in our own hide. We have in our charge a great industry—the building industry. The country has certain needs at the present time, for instance, housing. How can we supply them? As things are now, we cannot do so. Only this morning I attended a meeting of the Senate Committee on Housing. It was brought out that houses could not be built,

for one thing, owing to the serious financial problem involved. Money is not going into houses. As against 20,000 apartments usually erected per year in New York the net increase of houses built over houses destroyed is something like 212 buildings. Our building industry cannot get over the financial problem when money can produce so much larger a return in other fields."

It is to be noted that the matters mentioned in this paragraph were only a few of the many subjects brought up at this meeting. The discussion also included reference to the current accusations being brought up by each branch of the building industry against some other branch; each charging that some one else in every case was responsible for the difficulties. The material men were being very generally accused of artificially raising the price of materials; contractors were being accused of collusion in bidding; labor was being accused of soldiering on the job; the bankers were being accused of withholding money necessary for the housing situation; and doubtless architects and engineers were accused with not knowing anything about their respective professions.

After a discussion of the whole building situation by men from almost every part of the country, it was agreed that a committee of thirty-three should be appointed to organize a movement in which every branch of the building industry should be asked to co-operate in an investigation of present conditions, and the means for bringing about change and betterment. It includes six representatives of each of the fields of contracting, engineering, architecture, labor, materials and three members at large.

ROBERT D. KOHN.



THE CRYSTAL PALACE FOUNTAINS

Current News

Happenings and Comments in the Field of Architecture and the Allied Arts

Women Engineers and Architects Organize

That the general advancement of women in engineering and architecture may be served, the American Society of Women Engineers and Architects has been organized with the following officers: President, Lou Alta Melton, Boulder, Col.; vice-president, Hilda Counts, Pittsburgh, Pa.; secretary and treasurer, Hazel I. Quick, Detroit, Mich.

Ancient Aztec Shrine Reveals Fine Workmanship

Another discovery, in the form of a sealed room, has just been made at the Pueblo ruin in Aztec, New Mexico, which is being excavated by the American Museum of Natural History of New York City.

Dr. Clark Wissler, curator of the museum's department of anthropology, has reported by letter to his associates in New York:

"The room is in perfect condition. The interior is plastered and painted in a brilliant white with dull red side borders and a running series of triangular designs. No room approaching this in beauty and perfection has ever been discovered in America. There are several adjoining rooms that seem to have some relation to this, but it will be some time before they can be dug out.

"What we have is obviously the holiest sanctum or shrine of these prehistoric people. There is not much in it, all the sacred objects having been removed from the altar. But a sacred serpent is carved in wood over the ceiling. It is 2½ feet long and of the finest workmanship. Nothing like it has ever been found to my knowledge. On the ceiling-beams are imprints of hands made by rubbing white paint on the palms and fingers and then pressing down upon the beams. Several strands of beautifully made rope hang from the ceiling, presumably for the support of hanging objects. On the floor were a large number of nicely-cut stone slabs, one of which was 2½ by 1½ feet and 1¼ inches thick."

Denver to Build Houses of Adobe

Adobe houses may soon be seen in Denver. House shortage and the high cost of building material recently resulted in a change of the city regulation

permitting adobe construction. Several requests for permits have already been filed.

"Houses of adobe can be made durable and attractive," F. M. Ladd, city building inspector, declared in commenting on the changes. "If they are constructed properly we will not oppose their construction."

Three conditions were named in the issuance permits. They will be permitted only in frame residence districts, advice of the city building inspectors as to making adobe bricks and construction must be followed and the buildings, when completed, must be given coats of stucco.

Gorgas Memorial Contemplated

Establishment in Panama of an International Institute for the Research of Tropical Diseases is proposed as a memorial to the late Major General William C. Gorgas, who died recently in London, and whose most noteworthy health work was carried on in the Canal Zone.

The Panamanian Government, according to advices to Senor Don J. E. Lefevre, Charge d'Affairs of Panama at Washington, would be willing to donate the \$1,000,000 St. Thomas' Hospital for the proposed institute. Mr. Lefevre made it known that he plans to take the matter up with the Rockefeller Foundation.

Memorial Where Washington Crossed the Delaware

The old ferryhouse and tavern at Washington Crossing, Pa., is being restored and adapted as a central building for park purposes.

All the properties on the Delaware River bank east of the River road as far as the upper end of the island, behind which boats were secreted ready for the embarkation of George Washington's troops for the attack on Trenton, have been bought by the Washington Crossing Park Commission.

This covers a river frontage of more than 1,500 feet and includes the point of embarkation and the Old Ferry road leading to it. The commission also has purchased the island and about sixty acres to the west of River road which includes the ridge behind which the Continental troops were massed and

drilled that eventful Christmas day before the battle of Trenton.

The commission has laid out a general scheme covering the territory in which Washington's troops were quartered after having been driven across New Jersey and over the Delaware River on December 8, at Morrisville. This includes the base of supplies and New Hope ferry, the uppermost ferry guarded to keep the British from crossing.

It covers the headquarters houses of Washington and eleven of his generals. At the graves of the soldiers who died it is proposed to erect monuments. Eventually the national government will be asked to build a memorial bridge over the Delaware at the point where Washington made his never-to-be-forgotten journey across the swollen river amid ice floes and dangers from an unseen foe.

Brother Architects in Vienna

It is learned from a letter addressed to the American Institute of Architects, that the profession in Vienna is at a standstill for want of work and is literally starving and dying from weakness and ill-health. An appeal has been submitted in their behalf to relieve their tragic straits, and it is hoped that all who can will send funds to them through the Treasurer of the Institute, The Octagon House, Washington, who has the matter in charge.

Housing in Norway

"An Example of Town Planning in Norway: Notes on the Development of Trondhjem," by Sverre Pedersen, town architect, Trondhjem. A 12-page illustrated reprint from the March, 1920, issue of the Garden Cities and Town Planning Magazine, giving an interesting account of the local housing history and present conditions, and the plans for the expansion of the town. The municipal factory for the manufacture of wooden houses is a feature of this work. Also reprinted from the same issue, "Housing in Norway," by Christian Gerloff, secretary-general of the Norwegian Housing and Town Planning Association; 8 pp., illustrated, outlining the prevailing plan of municipal house building and the endeavor to form public utility societies—or "building-municipalities"—for the sole purpose of building and letting houses; containing a view and description of a row of experimental houses in Trondhjem, built of different materials, with a view to testing the qualities of each. (Apply to The International Garden Cities and Town Planning Association, 3, Gray's Inn Place, Gray's Inn, London, W. C. 1.)

Cedars of Lebanon Almost Extinct

The famous cedars of Lebanon were almost wholly destroyed during the world war, according to a writer in a San Francisco periodical. The trees date back to the earliest times. They were historic during the wars of Sennacherib, 608 years before Christ, as described in the psalms of David. Pliny, the Roman historian, claimed their wood to be everlastingly durable, and the Arabs believed the trees to exist for all time. Timbers unearthed in the ruins of ancient Assyria have been found practically unchanged after 2,000 years and more. In olden times the oil from the trees was used as a cure for leprosy, and it was used by the Romans to preserve their manuscripts. Individual trees were often 42 feet in circumference and 90 feet in height, with a wonderfully beautiful spread of branches.

During the late war the Turks cut them down for fuel for locomotives and then the opposing forces continued their destruction for fuel and other military purposes.

Furniture Situation Is Acute

The American home without its conglomeration of furniture is a difficult picture to imagine, but the furniture situation indicates that we may yet see a reversion to the Japanese style, which considers a few mats and a tea table adequate equipment for housekeeping. The present high cost of labor, the decrease in lumber production, are so affecting manufacturers as to tend toward simplification and even standardization.

There has been a lull in the vogue of Chippendale chairs with their complicated legs, and in the other elaborate kinds of period furniture. In their stead makers favor such patterns as the Queen Anne style, which is simple and still has the desirable period effect.

Housing a Railroad Problem

Relief from the nation-wide housing shortage depends largely upon rehabilitation of the railroads so that building materials can be transported in large quantities, according to reports to officials in Washington.

"Building has been almost completely halted all over the country because materials cannot be obtained," said Chief Engineer Chase of the United States Housing Corporation.

"The shortage of houses now is more acute than it was at the time of the armistice, when building had been suspended for nearly three years. Little improvement can be expected until spring.

"The priority orders issued by the Interstate Commerce Commission favoring the movement of grain and coal made it practically impossible to get materials. In only a few cities of the middle West has any considerable building been undertaken.

"Builders in practically all big cities now are making elaborate plans to begin work on a big scale next spring. This, however, is contingent on their being able to get large supplies of brick, sand, gravel and hardware."

The country now is short five million buildings, according to estimates prepared by Mr. Chase.

To Relieve Transportation of Building Materials

At the suggestion of Mr. Daniel H. Willard, Chairman of the Advisory Council of the Association of Railway Executives, made to Hon. William N. Calder, Chairman of the Special Senate Committee on Reconstruction and Production, during his testimony, a Committee of Representatives of

the Construction Industry in Greater New York has been organized for the purpose of acting directly with the Association of Railway Executives in securing the prompt movement of construction material essential to the public interest.

It is believed the work of this committee will go far toward relieving the acute housing shortage in Greater New York.

The committee is prepared to receive applications for assistance in expediting the movement of construction materials from point of origin to destination, in cases where the ordinary routine methods have failed, and where the public interest is at stake.

The committee especially requests that applications be made to it only after the usual methods have failed to produce desired result. The suggestion of the organization of this committee by Mr. Willard indicates the determination on the part of the carriers to use the present facilities of the railroads as far as possible to relieve cases where the emergency is greatest.

Its headquarters will be at room 1605, 29 West 39th Street, New York.

Weekly Review of the Construction Field

With Reports of Special Correspondents in Prominent Regional Centers

THE movement to exempt mortgage investments from the income tax has received impetus from an analysis published by Mr. Wharton Clay, of the Associated Metal Lath Manufacturers. Railroad conditions and coal are only incidental, he says, but the minute the banks were unwilling to float loans, construction activities stopped.

The banks were obliged to stop construction loans, says Mr. Clay, not because of prices of materials but because they could not dispose of the real estate mortgages to their customers. This was largely due to the Federal Income Tax which, with its heavy Surtax on the larger incomes, makes mortgage buying at 6 per cent. absolutely impossible. Exactly how this works against the larger incomes—the sources of most of the investment money—is seen below. Continuing Mr. Clay states:

"The present agitation to make mortgages on homes exempt from Federal Tax should, therefore, be thoroughly understood by those who are in the building business, and who are now powerless to aid in the housing shortage, because loans are not available.

"No one factor is as vital to the safety of the whole country as the building of homes, and it is, therefore, the privilege as well as the duty of everyone connected with the building industry who understands this situation and whose very livelihood depends upon construction activity, to advocate legislation which will release cast sums for home-building.

"The Government—that means the people—have within their reach a very powerful force to attract sufficient capital to the construction of homes if it is only called into play. To encourage American manufacture, a Tariff was imposed, and to increase farm loans and municipal improvements, exemption from Federal Income Tax was inaugurated.

"No one can blame the man with an annual income of \$50,000 for refusing to make investments that will yield but \$412 on \$10,000 when he can get \$600. It is good business for rich man or poor, to make the investment that looks most profitable, so a unified appeal to every member in Congress for the tax exemption is now the only logical solution.

"The bulk of new money for mortgages must come from estates and individuals having such ex-

THE AMERICAN ARCHITECT

cess funds as are not available until incomes of \$20,000 or over are reached. As an example, an income of \$30,000 is subject to a Federal, Normal and Surtax totaling 21 per cent. in addition to the income taxes levied by several of the States. This income tax must be deducted from the gross return on the mortgage before the net return to the investor is found.

"To compete with the 6 per cent. Municipal Bond which is exempt from income tax, the banks cannot offer a \$30,000 investor anything less than 7.6 per cent. on a taxable mortgage, or to the \$50,000 investor anything less than 8.7 per cent. and have him come out even. With mortgages tax exempt, however, they could readily be sold at a 5 per cent. and 6 per cent. basis.

"Already the State of New York has removed the State Income Tax from mortgages up to \$40,000. It is up to Congress to remove the Federal Income Tax. All people must understand the situation, because Congress responds only to popular demand.

"The building industry is at a stalemate. If new money is not provided by investors, Mr. Clay concludes, the housing shortage will continue at its alarming rate and in less than five years there will be 130 families to every 100 houses in the United States. What conditions will be under those circumstances can be best pictured by the Health Departments of the large cities that are already worrying over the rapidly spreading slum districts where the number of families obliged to live in one house is spreading disease and dissatisfaction throughout the community."

There is no doubt, as has been said many times in these pages, but that mortgage moneys must be relieved of their present disadvantage, and this will not be done until there is a public understanding of the situation.

(By Special Correspondence to The American Architect.)

CHICAGO.—Committees on construction co-operating with the railroads report slightly improved transportation conditions in Chicago, but continued slackening in building operations. Every effort is being made by the committee to hasten the shipment of material for jobs still unfinished, and in most cases satisfactory results have been obtained. When these jobs are completed the committee anticipates an enforced vacation, as very little if any new work has been started.

The rise in freight rates has made itself felt this week. Most building material has taken a decidedly upward trend. In many cases the increased rate has been added to the cost of the product. In

some instances the ultimate consumer is caught "going and coming." He has to pay the increased rate to the manufacturer as well as on the finished product. Some dealers rather than add to the already heavy burdens of the consumer are shipping by truck and themselves absorbing the difference in costs. The differences in rates, however, has not created the stir expected in building circles. Predictions of heavy buying in anticipation of the increased rates did not materialize here, and reports indicate a similar attitude on the part of buyers in other cities of the middle west.

The lethargy of buyers reflects the whole construction situation. Though builders and material men welcome the prospect of improved transportation even at the cost of additional freight charge, they realize the improved transportation (though they concede the breakdown of transportation was the dominating factor in the demoralization of the industry) cannot, alone, set the industry on its feet. But they assert confidently, in the face of the bleakest outlook the construction field has faced in years, that given the co-operation of finance and labor as well as improved rail facilities, spring will see the greatest boom in construction ever known, for the demand exceeds anything in construction history.

(By Special Correspondence to The American Architect.)

SEATTLE.—Automatically adding the new emergency freight rate, the jobbing trade has advanced the cost of all steel products without affecting the intrinsic price to the point of curtailing an already limited Pacific Coast demand. Jobbers state, however, in explanation that builders have become so reconciled to price advances that they are making little comment.

Stocks are very low along the Coast in steel pipe, with three-quarter inch galvanized as a conspicuous figure in that regard. The movement of pipe is principally for residences, with little in the way of large jobs that has not been taken care of. Heavy steel building stocks are fair, due to the fact that the Eastern mills hurried delivery before the freight advance, and the Pacific Coast is in a good position. Reactionary tendencies are expected to follow, however, and reduction in the volume moved is among the prospects for the next ninety days. The mills are accepting orders for the last quarter, but jobbers will be satisfied if they can get delivery on steel accepted in the second and third quarter. Generally little improvement in arrivals is expected for the balance of the year.

Enamelware advanced ten per cent. outside the emergency freight rate. The mills say they will make no promises as to delivery on cast iron and

THE AMERICAN ARCHITECT

malleable plumbing fittings. The mills explain failure in production in the statement that it is difficult to get cars for moving the raw products to the mills. Stocks are so badly broken that jobbing houses are borrowing from each other and from one Pacific Coast branch to another to fill urgent orders. Two of the larger Eastern mills have closed and jobbers who had placed orders for the Pacific Coast territory have been compelled to cancel with consumers. One of the dominant reasons for a slow filling up on the larger sizes of pipe was the decline in the demand from Japan, which because of its financial panic quit buying everything that was offered. There is an impression on the Coast that with the new high revenues, the carriers will make the cars work harder and will reduce the strings on the bad order tracks that the transportation problem may be simplified for the building trade within the next sixty days.

Small angle and channel irons are very slow in arrival. The nail situation is brighter. The mills are now said to be taking a profit on the last advance, and the export demand through Pacific ports has decreased. Japan has been a heavy nail buyer.

Plaster is scarce. Cement stock is light and all orders are taken subject to delay in delivery. North Coast jobbers have absorbed the freight advance on fire clay. Hydrated lime has advanced 18 cents per barrel and cement \$1.50 per ton by reason of the new freight rates. There is plenty of wall board at \$55 per 1,000 square feet, warehouse basis. The Government has asked for bids for 25,000 square feet of wall board for work in Alaska. Galvanized wire is scarce but metal lath is plentiful. The brick market is steady, with ample supplies and a steady price list.

West Coast fir mills are absorbing the new freight differential, and to the Eastern buyer the market is steady. New business will remain at a low point until the railways secure competitive rate against Southern pine. Only 922 carloads of Eastern business was placed during the week, or 1,300 cars under normal, 30,000 feet to the car. This business was for non-competitive territory. Stocks of

dry lumber at the West Coast mills were 45 per cent. over normal, and these stocks must be loaded and moved East before the rainy season, due now at any time, sets in and soaks them. Activity in getting these stocks on the rails is likely to weaken the market. Red cedar shingles are weak at \$3.75 to \$3.80 for standard stars and \$4.50 to \$4.55 for clears—basis to the trade.

(By Special Correspondence to *The American Architect*.)

BOSTON.—The readjustment of business which has been going on for several weeks continues. In some lines of business there is evidence that the process is about completed. There is a distinct note of returning confidence. Curtailed buying in both wholesale and retail is a feature of the situation, though there is a very fair distribution of goods going on all the time. The most impressive obstacle in the way of immediate improvement in New England is the lack of coal. The priority order which promised to relieve the situation was rescinded.

An officer of one of the largest construction companies reported that new industrial buildings were being held up due to the acute coal situation. In many instances the mills have not enough to go through the next forty days.

The report of the Public Employment Office for August shows a decided improvement in the labor situation from July and from August, 1919. There has been very little demand for help in the building trades, but a fair demand for carpenters and painters for renovation work, which has been easily filled. The demand for factory workers is good, but the supply is exceedingly limited.

Reports of building and engineering operations in New England show that contracts awarded between January 1 and September 1, 1920, amounted to \$233,453,000, as against \$135,925,000 for the corresponding period in 1919; \$113,859,000 for 1918; \$138,994,900 for 1917; \$139,065,000 for 1916; \$117,539,000 for 1915; and \$119,384,000 for 1914.

Yonkers June 16, 1830



THE ALCAZAR, SEGOVIA

THE AMERICAN ARCHITECT

VOL. CXVIII

WEDNESDAY, SEPTEMBER 29, 1920

NUMBER 2336



Buxton Hall, Williamstown, Mass.— Country House of Alvah K. Lowrie

JAMES PURDON, *Architect*

THANKS to the insistence on the part of architects in this country, we may not be held up in ridicule to all the world for the bad taste of our domestic architecture. With each succeeding year there reach completeness examples of the very best expression of the pretentious country house. No longer does blatancy rule nor assertiveness coupled with poor design offend the artistically trained eye. There is a well sustained harmony, indoors and out. Probably we may never again follow the custom so common during the time of the Georges in England when the architect was summoned to a conference with my Lord and his Lady to suggest and supervise every detail of a stately occasion. Then the architect suggested or designed the decorations,

the placing of each set piece, and, odd as it may seem to-day, went into a very serious conference with the ladies of the family as to the cut and color of their gowns, and the "patches" they should wear. Certainly if such a custom were revived to-day, architects would need to become more versatile than now, and probably there is no profession to-day that demands more varied accomplishments than the successful practice of architecture. But excepting those features of fashion and social form it is very plain to be seen that clients who are spending large sums of money on palatial country houses are more and more lending a listening ear to the counsel of their architects. The result is shown in our country houses and Buxton Hall at Williamstown, Mass., the country home of Alvah K. Lowrie, is a very fine example.

NEW ENGLAND is perhaps more intimately associated with English tradition than any other of our colonial states, not even excepting Virginia. Architects throughout the New England states have by the adaptation of the very best English architectural types, modified to suit our own conditions, kept this local type always in evidence. It was natural, therefore, that Mr. Purdon should have designed along the best features of the stately English manor house. In fact, no other type could so fittingly be set down among such surroundings that in a large measure suggest the English country landscape. The general view of this house, taken looking across the greensward far away to the mist-enveloped, low lying hills will suggest just such a type of house as here so fittingly supplements its surroundings. All the viewpoints from which photographs of the exterior have been made are interesting; all will repay careful study and analysis of their dominating features. Supplementing the work of the architect there has become a very in-



HALL, FROM LIVING ROOM

only to suggest the work of nature, there is the best expression of landscape architecture. It largely helps to create that true feeling of domesticity, of a well conducted home life that it is necessary to maintain among such restful surroundings lest all be lost in a general feeling of inconsistency and an aspect of incongruity.



VESTIBULE

French caenstone, limestone columns and Tennessee marble floor

imate co-operation with the landscape architect, a profession that is steadily assuming a very great and desirable importance. When the landscape is treated with the reverence it should receive, when the hand of man has been so cleverly concealed as



ENTRANCE HALL

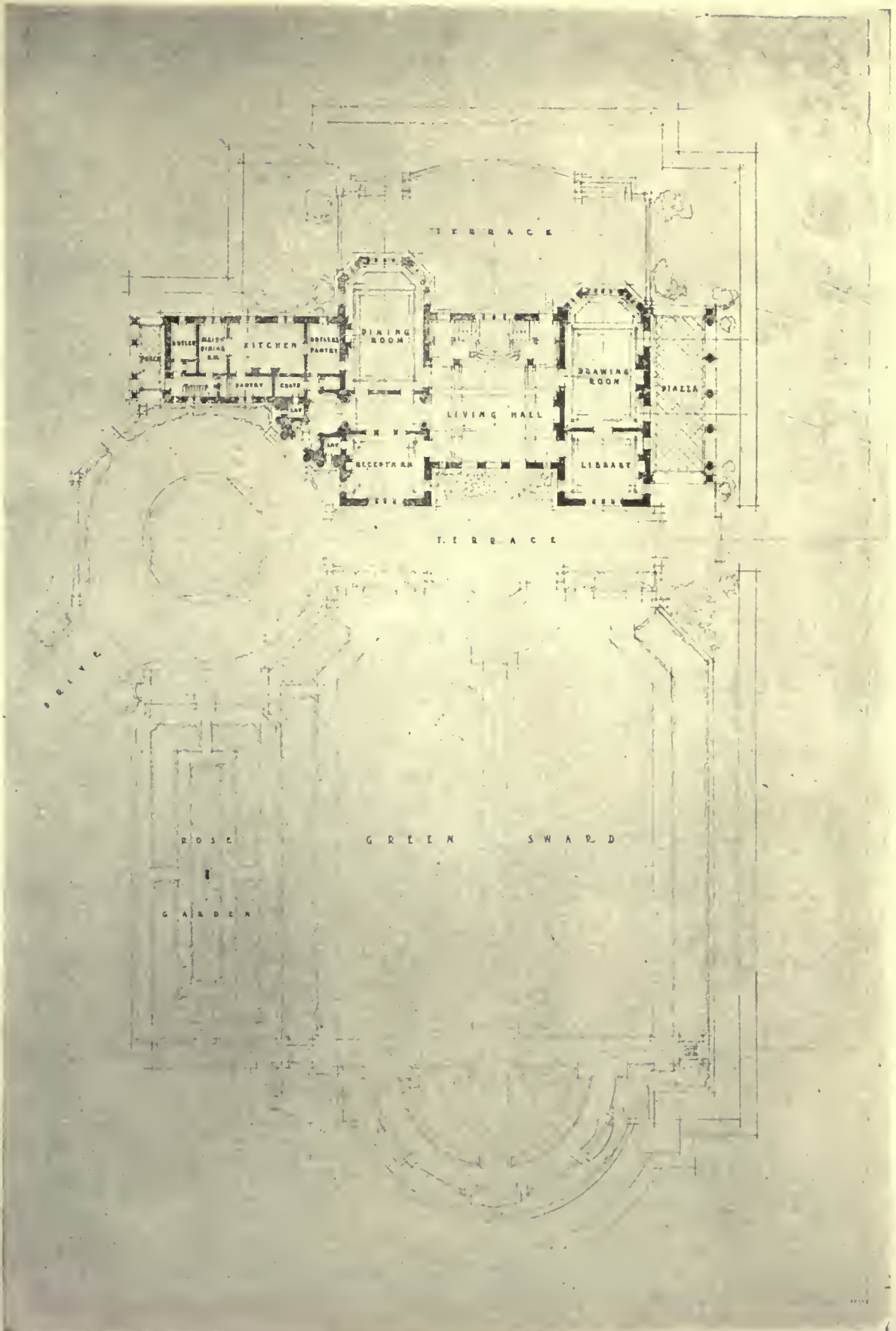

PLOT PLAN
BUXTON HALL, WILLIAMSTOWN, MASS., COUNTRY HOUSE OF ALVAH K. LOWRIE
JAMES PURDON, ARCHITECT

THE AMERICAN ARCHITECT

The plan of Buxton Hall is about as simple as could be devised to serve the needs of so large a house. Like its prototypes abroad, the main element is the large living hall, to-day, as in baronial times, the central point of the domestic life of the household as it is also the chamber wherein are held the more stately social functions.

The disposition and placement of the remaining rooms on the ground floor follow the best expression of our methods of country life. Convenience of circulation, the grouping of rooms of ceremony together and the accessibility of rooms of daily use and those that serve them. Planning in this country has become a very fine thing.



RECEPTION ROOM



HARRIAN TYPE BARRACK WITH AN UNEXPECTED VISITOR

Reconstruction of Northern France

The First Building Problem in the Devastated Regions

By RALPH FANNING

THE word "Reconstruction" has, for the architect, as for all the world, a pleasant sound. It suggests the righting of wrongs, the re-establishing of old order out of chaos and the making of shattered buildings into their former unity and beauty. The architect is apt to associate with the word that of "restoration" with all the interest and studious research that such a word has usually implied. The first tasks that awaited the reconstructive builder in Northern France were more prosaic. To the first builders in the devastated areas, reconstruction came more often to mean dead horses and putrid debris, broken stones and crumbling mortar, scrap iron and unexploded shells rather than architectural studies or garden cities. Problems of sanitation, of social adjustment or even of bare existence for the workers and returning people had to be faced before very much could be attempted in the matter of rebuilding. However, no one factor seemed to play a greater part in the big problem of the renewal of any satisfactory life in a stricken village than the establishment of new homes, be they only one roomed abodes, one of which a long suffering family could claim as its own. With his own roof-tree once more,

the French peasant could face the tasks of the new regime with some confidence and courage.

The immediate building work of the "region liberee" was largely relief work and as such could usually be divided into two parts for the work of rehabilitation in any village, briefly that of repair work and of barrack erection. As in nearly every village to which the inhabitants were able to return, houses could be found in many stages of decay or destruction, from that of being merely dust filled to being themselves mere heaps of dust, repair work could take numerous forms according to the amount of labor and materials available. Barrack building, that is the erection of portable, wooden sectional houses, was resorted to where the houses were beyond repair or where a cleared site was selected for the new home groups.

A first difficulty in repair work was offered by a dearth of building materials which are still scarce and proportionately expensive in most parts of Europe. The emergencies of war used up most of the available lumber supply of France, although the forest protection laws did not sanction the wholesale slaughter of growing timber as has so frequently



A STREET CORNER IN THE NEW PART OF SERMAIZE-MARNE

been the case in this country. Many saw-mills in the North were demolished and robbed of their machinery, while many in the other parts of the country were not able to furnish near their regular output, due to lack of man power and raw materials. What was true of building lumber was true of many other materials, especially cement, plaster, glass, nails and all metal work. The American Red Cross brought in generous supplies for the rehousing work, and after the armistice, the engineering divisions of the armies were able to liquidate for reconstruction purposes large supplies of tools and materials that had been collected near the front for future drives. Where these materials were thus available, there was that ever difficult problem of getting the supply to the demand, of overcoming transport difficulties and of guarding against local and individual profiteering.

The debris and fallen plaster removed, safety from dangerous walls and unexploded shells assured and the general conditions made somewhat sanitary, the problem of repairs needed to be quickly tackled. A solid roof to protect against the plentiful rainfall was a first consideration. Minor holes and leaks could be temporarily patched with tar paper. More satisfactory roof repairs could usually be attempted by replacing or reinforcing any damaged girders or rafters and, from the removed tile, selecting the unbroken ones that would cover well one necessarily small slope or section to insure at least one room fit for dry habitation. Most houses of Northern France were covered with century old, half cylindrical interlocking tiles which, covered with moss and assuming gently sloping lines with the years, gave the roof a texture and color that must have charmed many an artist eye. The French

tuilleries have not been manufacturing this shaped tile for a considerable number of years past, due to their far greater consumption of material than the less picturesque, though more efficient, modern interlocking shingle tile. This alone made the restoration of many of the delightful old, but partially porous, roofs impossible, although attempts were made to collect the ancient tile from some abandoned roof for patchwork upon others specially worthy of preservation.

WINDOW glass was an almost universally minus quantity nor could much be safely installed during the summer following the cessation of hostilities without a risk of its being shattered by explosions of waste ammunition which was being destroyed in great heaps at numerous places. Oiled paper and prepared cloth of various kinds were used to keep out wind and rain and afford some light, but the advent of new glass was a great factor in bringing sunlight and cheer and sanitation into the gloomy homes. French windows were usually designed to hold comparatively large panes of glass of little uniformity of size or shape, which added another difficulty to that of a broken, warped and worm-



"THE TOWN PUMP" CITÉ AT SERMAIZE LES BAINS, ERECTED BY THE ENGLISH FRIENDS

eaten sash requiring kilos of putty and brads for the proper installation of new glass. At a so-listed "undestroyed" hospital at Clermont en Argonne, the reglazing alone cost the hard and continuous labor of three men nine weeks time and the material expenditure of several thousand francs.

With plaster and cement much repair work could

THE AMERICAN ARCHITECT

be done with the crushed and broken stones always at hand. This, however, required skilled labor for efficient work and native masons were hard to find during or after the war. A liberal distribution of whitewash, with glue and brushes for the same, was



A RECONSTRUCTED CITÉ IN THE MARNE, BUILT BEFORE THE ARMISTICE BY THE SOCIÉTÉ DES AMIS. BRICKS WERE AVAILABLE FOR THIS SCHEME

a great asset toward the health and cheerfulness of the homes, while in some cases great pleasure and renewed hope could be furnished by bright wall paper, so great is the physiological effect of environment upon the French or any other family. Broken door hinges, shutters and locks were the minor details that the problem of rehabilitation had to offer, but which were often as distressing to a wearied Madame as trembling walls and tottering chimneys, once the filth and debris had been removed from within her walls.

In spite of this enumeration of difficulties, there was, to the architect or reconstructual builder, a fascination about even the most prosaic of repair work besides the inspiration that came from rendering aid and encouragement to a tired and disheartened people. The devastation revealed many interesting bits of ancient construction; the technique of massive masonry; giant post and lintels that, embed-



A COMPLETED BARRACK, HOME CITÉ DE LA SOCIÉTÉ DES AMIS, MEUSE

ed in the masonry, might have been the forerunner of our modern steel skeleton work; great wooden trusses of curious triangulation, probably untried by any student of graphics, but built according to traditional rule of thumb; odd mixtures of mud and timbers; coverings of slate or metal over forms unique and surprising. In some cases explosions would remove the sides of houses so as to reveal the vaults, floor and roof construction as plainly as a draftsman's section. The backing or bind of some unusual arch, the course of some curious chimney, the



THE BEGINNING OF A BARRACK, CHALONS

core of some puzzling wall could be studied at first hand dissection. With all the pitifulness of shattered houses, there was this fascination for an architect learning as it were the anatomy of the structure as he strove to render first aid in binding up and dressing its wounds.

The erection of a barrack was a simple matter provided the site could be determined and, what



ELEPHANT IRON STORAGE HUTS

was a more serious problem, the sections for it deposited near the desired place. Demountable or sectional wooden houses were manufactured after various types and patterns by interned French soldiers and refugees in Switzerland and other places where lumber could be obtained during the war. With a supply of these ready on hand, the minute hostilities



A SWISS CUT TIMBER 5-ROOM HOUSE

or military orders would permit, the barracks might be rushed to the needy district and the returning populace quickly and comfortably housed, thus lessening the period of direst suffering for a totally destroyed village.

EVERY refugee family returning to the villages of the Meuse sector west of Verdun were enabled to obtain a needed home barrack from the Societe des Amis, an Anglo-American organization for the relief of war victims, that had worked in France during the Franco-Prussian war of 1870, and with the outbreak of the European war in 1915 were early on the field to help the suffering civilian population. This organization had established saw-mills and section and window factories at Dole and Ornans in the Jura. By a special government grant, lumber was obtained from Switzerland, from which a specially durable, yet easily mounted, type of barrack was made. From the required number of typi-



READY FOR THE ROOF—SECTION BARRACKS FOR REHOUSING IN THE "REGION LIBEREE"

cal sections, three sizes of houses could be erected, two, three or four roomed with or without "hangars" or sheds. With floor joists and roof girders cut to proper length and the floors and ceilings as well as supporting walls in madeup sections, the houses

could be rapidly erected even by unskilled labor, two men being able to handle any section. The section walls which supported the roof timbers were of double thickness, with dead air space between, the interior boarding being smooth, ready for white-washing or papering, as the occupant desired, while



ROOF SECTIONS, NEARLY READY TO THROW UP THE TILE

the outer boards were connected by cover strips and usually creosoted a rich brown.

Other types of barracks were used by other emergency builders, some for more temporary housing, as the Blockus type, others like the Hadrian type used for the foyer des soldats, capable of being extended to any desired length by continuing the sections. A patent sectional barrack of concrete was advocated in some regions, but offered difficulties of transport and manufacture in regions where suitable sand for concrete could not be found. Small houses of brick were built with success in the Marne districts, where the foundries were able to continue their output of clay products. Among the types of ready made houses were several different patterns, differing chiefly in their ease, and thus efficiency, of erection. From one part of the Vaud canton of Switzerland was produced timbers cut to sizes ready to be made into very substantial frame dwellings, something on the order of the ready made houses put out in America by several well-known companies. These required more skill and time for erection as well as costly nails, and so were not as popular for the preliminary housing as the simpler sectional baraquements. For storage and form buildings the military semi-cylindrical "elephant huts," iron sections forming a twenty foot tunnel, were used after the armies had discarded them, while excellent concrete balloon-anchors and artillery bases made solid foundation material. In spite of the compactness of the pre-war French village and the congested conditions of refugee life, the idea of several families oc-

cupying one large barrack never seemed to work out successfully. In fact, it has lead to rather wretched social conditions wherever it has been tried, for mankind at large seems to be too far from the savage or perhaps not yet highly enough developed to make communal life at such close quarters a success.

WHERE only parts of a village has been destroyed, it was usually beyond the question of emergency housing to do much toward re-planning or changing any of the village arrangement, a thing ever difficult to do hastily among the numerous petty property owners. The barrack had usually to be placed where Monsieur or Madame had a cleared space among the ruins for it, in order that some sort of family life might be established as soon as possible. In other instances, especially where the former village would be for the greater part or totally demolished, yet with enough returning citizens to justify it a new site would be chosen for a site on communal property. In some cases, opportunity was given for more model village planning, with some attention to draining, sanitation, convenience and unity in design. Examples of such cites may be seen at Sermaizes les Bains and Paragny in the Marne, fully established by the English Friends two years before the signing of the armistice or at Neuville or Aubreville in the Meuse. Opportunities for studied planning were rare in the first emergency relief work, but occasional improvement could be made in location and sanitary arrangement. Farmsteads were re-established on the separate farms rather than huddled together in congested centers, now that the fires had swept away village traditions. The first thing was to give shelter to the returners and make for them as comfortable and encouraging a substitute for home as was possible in a short time, so that the long suffering people could pick up the broken threads of the torn fabric of their existence. With the fabric intact, even in small or

sadly stained pieces, some design and embellishment may be considered for the future.

To Reset Plymouth Rock

PLANS for resetting Plymouth Rock and for improving the waterfront at Plymouth have been approved by the Federal Pilgrim Tercentenary Commission, which voted to released \$300,000, the Federal Government appropriation for the work proposed.

Under the plan Plymouth Rock will be set again in the water and will be covered by a canopy of stone to be erected by the Society of Colonial Dames. Improvements of the shore are being delayed by excessive demands by owners of property involved, according to the report of the local committee.

The Federal commission decided to withhold the \$100,000 appropriated for Provincetown until it presented a definite plan.

At the meeting Congressman Joseph Walsh showed proofs of the Pilgrim Tercentenary stamps to be issued by the Post Office Department. They will be of one, two and five cent denominations.

The 1-cent stamp will be green, with a picture of the Mayflower in the centre. On one side will be the hawthorne, the May flower of England, and the other the arbutus, the May flower of New England. At the top will be the words "Pilgrim Tercentenary."

The 2-cent stamp will be similar in general design, with a picture of the landing of the Pilgrims, and will be red.

The 5-cent stamp will have as its centrepiece the Signing of the Compact and will be blue.

The celebration is to begin on Dec. 21 of this year with formal exercises at Plymouth, and it is planned to have the day observed nationally as Forefathers' Day. The principal celebration, however, will come next Summer.

Building Prospects

A Well Considered Editorial Review of the Building Situation in the Middle West

THE only change since our last issue in the building situation, states the September issue of the *Bulletin of the Illinois Society of Architects*, is the further postponement of many large projects, a continued increase in the cost of practically all materials entering into any structure and a further advance in bankers commission charges for building loans.

Many owners who have had complete plans and specifications for important work prepared are ready to proceed notwithstanding the present high building costs if they could secure any assistance from the banking interests in financing; but with U. S. bonds selling in the open market at prices netting the investor over 6 per cent., with foreign government bonds selling at prices netting better than 8 per cent., with securities of firstclass industries realizing from 9 per cent. to 12 per cent., there is practically no money available for building operations.

Perhaps one way to temporarily stimulate the construction of buildings of all classes would be to amend the present Income Tax law and exempt from taxation for a period of say five years all moneys invested in new buildings. This exemption, if granted, would make first mortgage securities more attractive to investors and would undoubtedly result in large sums being immediately placed at the disposal of builders.

It is a peculiar circumstance that, notwithstanding the great falling off in the amount of work contracted for in Chicago and vicinity that the cost of almost all building materials are continually advancing.

The editor recently addressed a letter to a representative contractor in each of the various building trades doing work in Chicago, this letter being as follows:

"The writer, as editor of the Bulletin, is collecting data as a basis for a short article on 'building costs.'

"Will you do me the courtesy of replying at once and advising me of the percentage or amount of increases or decreases that have occurred since August 1 in the cost of building materials used by you, and oblige."

A tabulation of the replies received follows:

Material.	Increase per cent.	Decrease, per cent.
Cement	16¾
Torpedo Sand	6¼
Bank Sand	6¼
Stone or Gravel	6¼
Lime	8
Carney's Cement	15

Flue lining	30
Tile Coping	30
Plaster Board	14
Fire Brick	25
Hydrated Lime	5
Pyrobar	8
Waterproofing Cement	20
Partition Tile	2½
Reinforcing Steel	12
Structural Timber	10
Form Lumber	5½
Structural Steel & Iron	3
Cut Stone	17½c per cu. ft.
Plastering Materials	10
Ornamental Iron	11
Boiled Oil	20
Turpentine	24
Soil Pipe	8
Pumps	10
Magnesia pipe covering ..	5
Asbestos cement	10
Vitri. Asbestos Fibre Blks.	25
Cast-iron water pipe	5
Cast-iron pipe fittings	8
Sewer pipe	10
Castings for heating and power boilers	10
Plumbing enamel ware	10
Plumbing brass goods	5 to 38½
Black and Galvanized Malleable fittings	9 to 52
Plumbers' shop tools	5½
Assembled plumbing fixtures	16 2-3
Cast-iron basins, etc.	12
Lead pipe per hundred.55 per lb

Where no increases or decreases are noted we are advised that prices quoted today are the same as those of August 1. (In this connection it might be noted that the present selling price of wrought iron pipe is only 6 2/3 per cent. greater than it was three years ago, while the cost of plumbers earthenware has increased over 300 per cent. during the same period of time.)

Owners contemplating building are advised that there are practically no available stocks of most building supplies, and that delays in any building project are bound to occur, due to the impossibility of contractors securing materials as they will be required for any building operation to proceed in an orderly manner.

Owners are further advised that under present circumstances that they are confronted with the certainty of there being further delays in construction, due to the jurisdictional claims of the Chicago union labor trades. As a matter of history, there have been more strikes reported during the past sixty days than ever before in a like period in the history of Chicago. Responsibility for this condition should be placed where it belongs, which is with the Contractors' As-

THE AMERICAN ARCHITECT

sociations of Chicago. For some reason the carpenters' and masons' associations have refused to affiliate with the Building Construction Employers' Association, and the Building Construction Employers' Association has refused to affiliate with the carpenters and masons. Thus the two big associations are not working together and are apparently unable or unwilling to unite and agree upon a plan of action which could and would control the labor situation in a short time. The situation complained of has been corrected in other cities by the united efforts of all the interests interested in building, and it will never be corrected in Chicago until all employers associations are united under one management, with a strong guiding hand, an autocrat if you will, who must be given the power to act.

At present building operations which could be consummated in a period of say four months now require eight or ten months to complete, notwithstanding all the efforts of the architect and contractors for the improvement.

Owners contemplating building are advised that it is the editor's opinion that building material costs will continue to be enhanced for many months and that there is no prospect of any immediate lowering of building costs. In fact, building costs will probably increase for at least two years more.

Union labor has agreements which do not expire for many months, so that it is utterly hopeless to expect any reduction in labor costs before this time, and as labor in the ultimate represents by far the largest item in the cost of any building project, building costs cannot and will not be reduced until the wage scales have been revised. Not only the wage scales of the building mechanics, but the wage scales of the laborers and mechanics producing and creating all of the various items of building materials.

This is the condition confronting owners and architects today and there is no use of camouflaging the situation or of kidding our clients or ourselves into believing that building costs are going to be reduced for many months.



ENTRANCE STAIRWAY, COMPTON HILL RESERVOIR, ST. LOUIS, MO.
STUDY & FARRAR, ARCHITECTS

Housing Legislation in the United States

Enabling Acts Passed in Various States, Enabling Functioning in Activities Hitherto Regarded as Private Business

A LETTER has been addressed by Louis L. Suskyn, of the New York Bar, to the daily press, in which enabling acts passed in other States are discussed.

The State of North Dakota, he writes, passed laws which set a new mark in authorizing the State to function in activities that have been considered private business. Under these laws a State commission is authorized to establish a State bank, to loan money on farm land, to build homes and to establish a State warehouse, elevator and flour mill system. The commission is given sweeping powers to manufacture and sell at prices set by it, all kinds of raw and manufactured food products and by-products and to operate markets and agencies anywhere in America or in foreign countries. The commission is empowered to buy all necessary property or seize it by right of eminent domain. The program outlined is to be financed by the State through taxation.

These laws were passed by the Non-Partisan League Legislature of North Dakota. Citizens of that State contended these laws violated the spirit of the Fourteenth Amendment. The United States Supreme Court was called upon to decide the constitutionality of these laws. The court rendered a decision and, in upholding these laws, it distinguished between a tax for private purpose and public purpose. The court reaffirmed former refusals to define the term "due process of law," as contained in the Fourteenth Amendment, and insisted that definitions must be based on each individual case. The North Dakota legislation, said the court, "was adopted under the broad power of the State to enact laws raising by taxation such sums as are deemed necessary to promote purposes essential to the general welfare of the people. With the wisdom of such legislation, and the soundness of the economic policy involved, we are not concerned. Whether it will result in ultimate good or harm it is not within our province to inquire.

In many years and in several instances, continued the court, States and municipalities have in late

years seen fit to enter upon projects to promote the public welfare which in the past have been considered entirely within the domain of private enterprise.

The Maine Legislature had given cities and towns the right to establish fuel yards for the purpose of selling wood, coal and fuel at cost to inhabitants. The act defined the term at cost as meaning "without financial profit." The Maine Supreme Court upheld the act and the decision was upheld upon appeal. The ground of said appeal was that the establishment of a fuel yard is not a public purpose and that taxation to maintain one would be taking property without due process of law, which is a violation of the Fourteenth Amendment to the Federal Constitution. It will be noted that the same contention was made by the citizens of North Dakota, who appealed the Non-Partisan League laws to the United States Supreme Court. In upholding the municipal fuel yard laws the United States Supreme Court ruled that there is no difference, of vital magnitude, in a city maintaining a central heating plant that furnished heat through pipes to homes and delivering coal direct to the user's home.

"It seems illogical," said the court, "to hold that a municipality may relieve its citizens from the rigor of cold if it can reach them by pipes or wires placed under or above the highways, but not if it can reach them by teams traveling along the identical highways. It will be something of a task to convince the ordinary intelligent citizen that an act of the Legislature authorizing the former is constitutional, but one authorizing the latter is unconstitutional beyond all rational doubt."

From the above it may be concluded that the New York Legislature in its special session to be held next month may feel itself safe in passing such acts to enable immediate and near-future relief in the housing situation. To allow the use of State funds for building houses for the people will in all likelihood be within the spirit of the Fourteenth Amendment of the Federal Constitution, as decided by the United States Supreme Court.

The House of a Great Artist

THE late Sir Laurence Alma-Tadema's residence in St. John's Wood—which is now offered for sale—may be said to have been the record of his life, "written in great syllables of color and form," states *The Architects' Journal* of London.

At a cost of over £70,000, he filled the house with tapestries, marbles, metals and precious woods, and just saved the whole from becoming a mere museum by the greatness of his artistic individuality. But of the force of that individuality the individual himself seems to have been least confident, for the initials of his name are burnt in on every tile, woven into every piece of stuff, empanelled on door, floor, and ceiling, as if he had been a little fearful lest it might be overlooked. Never; when one is surrounded, as here, by things he must have worked and waited for, with a place standing vacant for each treasure, which, when secured, was put so confidently in its place, one realizes that the place has become his very self.

Though it is the house of a great artist, there are not many pictures—the panels and the woven tapestries, the fine vistas, the goodly proportions, are themselves the picture.

The great domed studio—over twenty feet high—is said to be the finest in the world. In any case, it is "absolutely unique." The big north-light window gives full upon a Byzantine apse, hung with

Tunisian embroideries in rose velvet, and roofed with shining aluminum. The cold light of day is goldened by passing through windows of thin onyx, and gleams softly upon walls panelled in green marble. If one may descend to what would seem the least detail of this temple, the egg-and-tongue moulding worked upon the back of a semi-circular seat in the apse is said to have taken two years to complete.

The front door of the house is set in bronze "cast from the door frame of a house in Pompeii," the entrance hall is floored with Persian tiles, and white marble steps lead to an inner hall where over the



DOORWAY AND BRASS STAIRCASE IN HOUSE OF THE LATE SIR LAURENCE ALMA-TADEMA

huge open fireplace are inscribed: "I count myself in nothing else so happy, as a soul remembering my good friends." And the friends he had! The very floor of this inner hall is tiled from a friend's design, the walls are finely decorated by their brushes, and can one ever forget those gatherings where were assembled all the men whose names were first in literature, music, and the arts?

The private library and writing-room is built like the Atrium of an old Roman house, with Pompeian



THE LATE SIR LAURENCE ALMA-TADEMA'S STUDIO

ceilings and walls of alabaster, and from it ascends a staircase leading up to a gallery overlooking the grand studio, impluvium, and palm house.

There is a second studio, used by Lady Alma-Tadema, for she also was an artist, and had her own workshop, and there is even a third studio—in the garden, and only telephonically attached to the house.

"If a man's talk is of oxen, he will dream of oxen," says De Quincey. In Sir Alma-Tadema's best bedroom—white and fine old gold and costly Japanese paper—one will not dream of oxen, however the day has been spent, but will out-dream the opium-eater himself.

It was no ordinary soul who thought out the details of such a home. The very doors are different from other doors, and are constructed so that the two faces are of wood matching the two rooms. Nor did their fitting satisfy this fastidious mind, but they had to be made with a special flange overlapping the jamb, and special hinges fixed accordingly to give the necessary clearance for opening. Is there a golden staircase up to the studio? Then such must be appropriately lighted, and a perfect "harvest moon," a full orb of onyx laden with fire, shines upon it clear by reflected light.

It was hoped by all that this memorial of so great an artist might pass into the keeping of the people, but already one sees poised the auctioneer's hammer, and hears that warning and infinitely disturbing "Going—going—?"

The Freest Country

CHINA, says one enthusiastic traveler, is "the freest country in the world." A writer in the *Central China Post* admits it, and gives some illustrations that dull somewhat the edge of appreciation.

Liberty of speech and press is so complete, he explains, that it permits blackmail without redress.

The use of public highways is so free and unrestricted that it is not unusual to find a public road dug up and planted in vegetables, or obstructed by a house built on it.

Choice of occupation is so free that anybody who can live by begging is allowed to do so, and beggars take possession of public buildings in bad weather, and camp, unhindered by the authorities, at the door of any merchant who refuses them alms.

There is freedom in sickness. Any citizen is freely permitted to catch any kind of disease, and when a man falls sick of smallpox, typhus or other infectious ailment, his friends and neighbors are at liberty to crowd into the patient's room by day and night, and so, thus helping to spread the infection.

A similar freedom is found even in death. When a man dies who has no near relatives, whoever happens to be burdened with the corpse can put it in a box and deposit, without any formality, by the roadside. It stays there until the box falls to pieces or some Good Samaritan volunteers to bury the body.

Liberty is a glorious thing, but there seems to be such a thing as having too much liberty.

Old Town Hall, Hartford, Conn.

(See reproduction of the original drawing by O. R. Eggers in this issue)

IN 1639, the freemen of Newtown, Conn., now called Hartford, met and adopted the famous Fundamental Order of Connecticut, the first written constitution adopted by a people that ever organized a government. For this reason, historians are wont to declare Hartford "The Birthplace of American Democracy."

The sentiment of independence thus early displayed and which grew to such successful proportions more than a hundred years later, found Hartford ever the center of the political activity that led to the Revolutionary War and the independence of the Colonies.

It is fortunate that the spirit of patriotism should so warmly be espoused by the people of Hartford from so early a period. It is for this reason that we have had preserved to us so many splendid examples of our Colonial building. The old town hall at Hartford was built as a state house in 1796. Its classic

lines and correct proportions are the pride of the citizens of Hartford and the delight of those who have been so fortunate as to visit this city.

So carefully have all the various details of this fine old building been preserved, so reverentially have its restorers proceeded with their work, that the building may today be viewed almost exactly as it stood 125 years ago.

Who designed this fine old building we do not know but it is known, for there is much tangible evidence all over New England, that the master builders of our colonial period, founded everything they created on the most classically correct principles of good architecture. The longer they remain as evidences of good, honest and well considered structures, the stronger is their appeal. One is led to wonder why with such excellent examples close at hand there should be erected buildings that suffer so badly by comparison.



OLD TOWN HALL, HARTFORD, CONN.
THE AMERICAN ARCHITECT Series of Early American Architecture



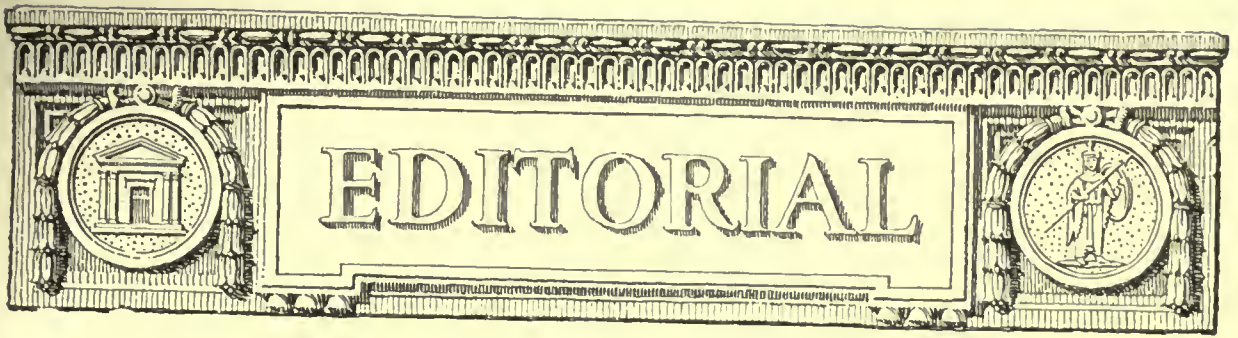

“On With the Dance, Let Joy Be Unconfined”

IN the September issue of the Journal of the A. I. A. under the head of Shadows and Straws, which is the standing title for the editorial utterances of this representative journal, there appears the following:

“Another has written an appreciation of the etchings of Troy Kinney which are published in this issue. I have not yet read what he has to say, but I have no doubt that it will be well said and well worth the saying. Of what I have to say, I have not the same confidence. I think of dancing as the handmaiden of architecture, not because of the direct connection of line and form, which is the essence of design, but because I feel that people who know how to dance beautifully will know how to build likewise. For dancing is the universal sense of rhythm, out of which architecture was born. * * * 'Tis sadly true that the day of Grecian maidens dancing on the flower-strewn banks of rivers has long since passed, yet I have an idea that we are not likely to get much that is real or important in the field of art until the custom is resumed.”

Richard III criticized those about him for “capering nimbly in a ladies’ chamber to the lascivious pleasing of a lute.” Have we not had enough Bunthornes in architecture? Shall we not need, if we are to get anywhere as a profession, emphatically to discourage such a composite figure of the incentives to professional excellence as this whole editorial suggests?

Will the architectural student of the future need to include among the essentials of his daily attendance at college a well polished pair of dancing “pumps”? Or will it become necessary that the reception room of the architect of the future be enlarged so that it may have a wide expanse of polished floor on which his drafting force and his stenographers may gracefully interpret some symbolic dance while the “chief” sits in a fine frenzy and becomes in a properly receptive mood to evolve some wonderful elements of design.

A Case in Point

WRECKED by fire some years ago, Grace Church in Chicago is now being reconstructed. Designed by Bertram G. Goodhue and acknowledged to be among the most notable examples of ecclesiastical architecture in the middle west, it was logical to assume that its rehabilitation would be at least placed in the hands of competent architects, if not given over to the man who was responsible for the excellence of its design.

What has happened is the entrusting of this important work to a firm of structural engineers whose record is exactly along the lines of their professional announcement and who have not, so far as known, heretofore assumed responsibility for any original work of this character.

Engineering organizations have quite recently passed radical resolutions as to just what were and were not engineering problems and have emphatically sought to lay down a certain law for the edification of the general public and as a rule and guide for the architectural profession. It has been stated in these resolutions that the profession of engineering would regard as a “menace to the public health and safety and the adequacy of a structure purely engineering” if the architects were permitted to dominate the construction of bridges. If such action is consistent, and many architects will dispute that it is, would it not be equally consistent for architects to specifically claim that any phase of ecclesiastical architecture was completely within their field and that the undertaking by engineers of such work as the present example would jeopardize the artistic aspect of the church and very probably its adequacy—we must thank the engineers for that word, adequacy.

JUST how it happened that a commission so purely architectural should be entrusted to structural engineers is not known to us, but we do know something of the strange actions of church building committees. In this case the action of this Grace Church committee would seem to be unmoral. They have

THE AMERICAN ARCHITECT

ignored the just claims of the profession of architecture to work exactly in their line, and have set a very bad example.

We are not criticizing in any way the probable outcome of this action, or seeking to prove that those who have undertaken this reconstruction will not satisfactorily—to their clients—complete the operation, but we are emphatically and adversely referring to the inconsistency of engineers in accepting work that, according to the resolutions of their representative societies, is entirely outside the field of their professional practice.

What would have happened in New York when St. Thomas' in Fifth Avenue was destroyed by fire, if its reconstruction had been placed in the hands of engineers? The present structure, as created by Mr. Goodhue, is one of the architectural beauties of New York.

Inasmuch as the American Institute of Consulting Engineers and the American Society of Civil Engineers have thought it necessary to define work which they regard as predominantly engineering, such as bridges for example, would it not be well for the American Institute of Architects to take similar action with reference to the case at issue?

The Newly Poor

IN his essay on Compensation, Emerson explained certain laws of nature that have been variously called balance, polarity, etc., and by which it was made evident that any situation implied its opposite. An object, for instance, could not be good except insofar as it was not bad. It could not be beautiful unless it had escaped being ugly.

It is doubtless true, that of a given sum of wealth in the world, certain people cannot have too much without certain other people having too little. The "nouveaux riches" have long been a source of amusement, with their suddenly acquired wealth. At the other end of the vista, is automatically produced that opposite class of people whom we might call the "nouveaux pauvres" whom present conditions have knocked off their dignified perch into a social order which they in the past had scorned.

There is an internal revolution bubbling up in the hearts of people whose incomes have not kept pace with rising rents. Those among them who have been unable to buy a house are, many of them, driven to quarters where a much lower standard of living prevails than that to which they have through many years been accustomed. It will not be possible for these individual families perceptibly to influence the poorer neighborhoods of which they

thus become a part. Whatever value their presence in that neighborhood develops, it will be a slow process, and one fraught with much sacrifice and difficulty, and growing constantly more so as the effects of their new environment are more insistently felt.

The intermingling of classes would be desirable if the elements of each class were good. But investigation will no doubt show that for some reason, not the better traits, but the less desirable frequently dominate any mixture, as for instance the border peoples between any two countries. Thus we regard with a certain discomfiture the present necessity of the middle classes to be thrown into unfamiliar surroundings among people whose point of view it is difficult for them to appreciate and whose standards of refinements are so radically different from their own.

NO zoning law has distinguished between the types of residents that shall dwell in residential communities. The natural tendency is for each class to herd by itself. In New York there is Little Italy, and Chinatown, and the Ghetto, the Irish section, the German and Greek neighborhoods, each and all going their own way much as they did in their native countries. In some instances, private landlords, without authorization, have excluded negroes, or Chinese, or babies or Jews, or any other group against which they had for some reason a prejudice. All of which results in delayed Americanizing.

The result will probably be that with a continuation of the razing of old houses and the substitution of offices and places of business, Manhattan Island will soon cease to be a residential community. Instead of placing factories in the suburbs where their employees might live close by, the factories are going up on Manhattan Island, and people of old New York who have lived here for generations are buffeted about and driven away, and all that will be left will be developed into what may be called a "clearing house" for incoming foreigners, where they will have to be satisfied with what everyone else has despised until they can fight their way out.

While these things are in process of evolution, the architect can do his part to make the standard of living so good everywhere, that there will be no chagrin on the part of any class to transfer to another social plane.

In the present acute shortage, it would seem only decent that those with any spare room at all should make it available to those less fortunate, for it is the helping through emergencies that is the true test of strength.



TERRACE FRONT

BUXTON HALL, WILLIAMSTOWN, MASS., COUNTRY HOUSE OF ALVAH K. LOWRIE

JAMES PURDON, ARCHITECT

Exterior materials. Germantown stone. Indiana limestone trimmings.

412





GARDEN FRONT

BUXTON HALL, WILLIAMSTOWN, MASS., COUNTRY HOUSE OF ALVAH K. LOWRIE
JAMES PURDON, ARCHITECT

f 2 2





TERRACE FRONT

BUXTON HALL, WILLIAMSTOWN, MASS., COUNTRY HOUSE OF ALVAH K. LOWRIE
JAMES PURDON, ARCHITECT

4123





DETAIL OF APPROACH, GARDEN FRONT

BUXTON HALL, WILLIAMSTOWN, MASS., COUNTRY HOUSE OF ALVAH K LOWRIE
JAMES PURDON, ARCHITECT

4125



5
412



THE GARDENS



PERGOLA AND POOL IN GARDEN
Note the well arranged planting

BUXTON HALL, WILLIAMSTOWN, MASS., COUNTRY HOUSE OF ALVAH K. LOWRIE
JAMES PURDON, ARCHITECT

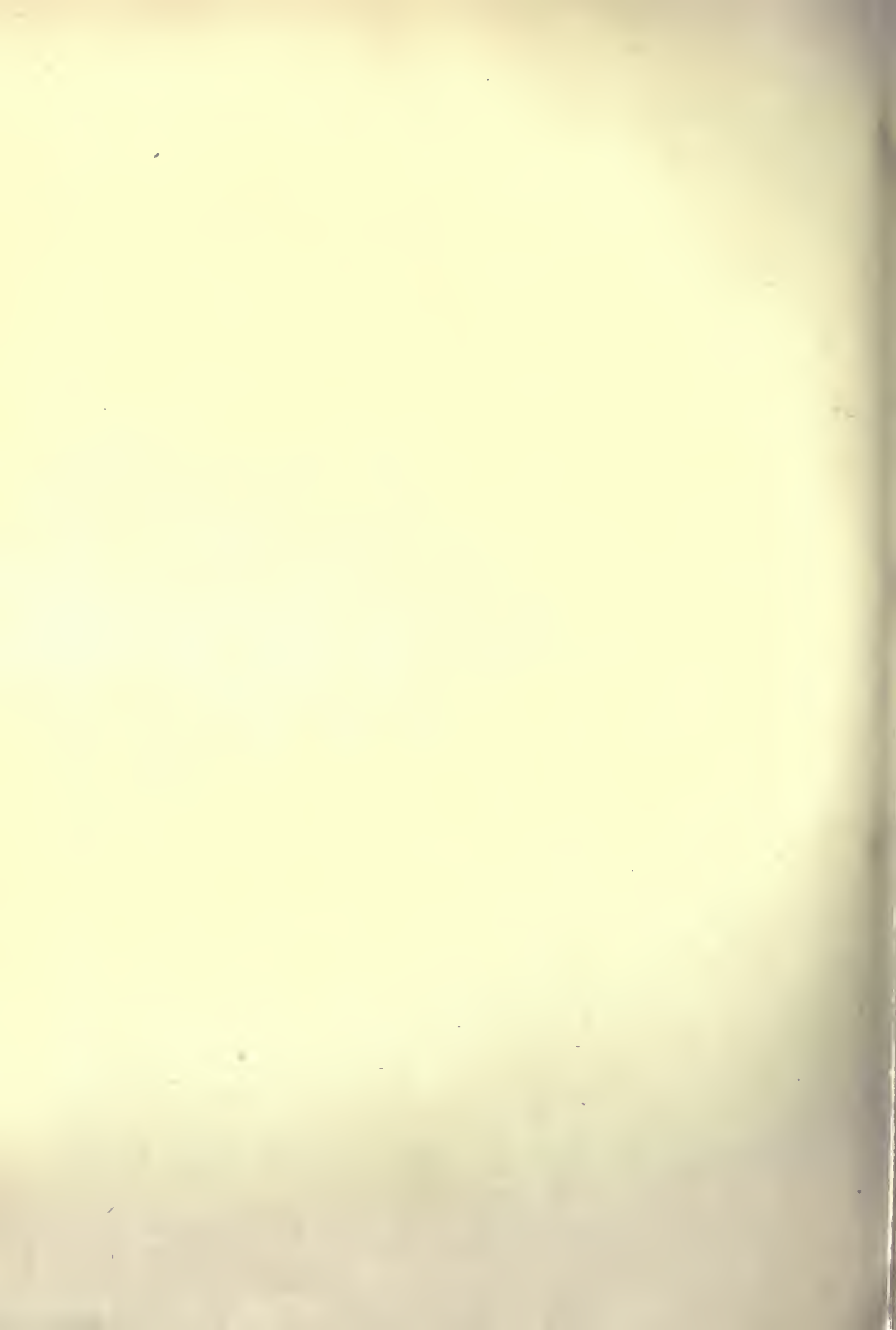

5126



VERANDA



VIEW FROM THE GARDEN

BUXTON HALL, WILLIAMSTOWN, MASS., COUNTRY HOUSE OF ALVAH K. LOWRIE
JAMES PURDON, ARCHITECT



4127



DINING ROOM



DINING ROOM

Paneled whitewood. Has a pearl grey Sienna marble fireplace. Fixtures and andirons are of silver. Grey velour hangings and floor covering

BUXTON HALL, WILLIAMSTOWN, MASS., COUNTRY HOUSE OF ALVAH K. LOWRIE
JAMES PURDON, ARCHITECT



412



LIVING HALL

Paneled oak walls with old English oak ceiling. The mantle is of carved limestone.



FIREPLACE IN LIVING ROOM

BUXTON HALL, WILLIAMSTOWN, MASS., COUNTRY HOUSE OF ALVAH K. LOWRIE
JAMES PURDON, ARCHITECT



DEPARTMENT OF ARCHITECTURAL ENGINEERING

Results of Additional Distortion Tests on Various Types of Wall Construction.

THE report of the testing engineer, Armour Institute of Technology, giving the results of distortion tests conducted in that Institute's laboratory on four different types of exterior wall construction, closely following as it does the report of the tests conducted by the Omaha, Neb., Building Department (published in the August 11 issue) is of particular interest at this time. Some of the wall panels tested were of a construction quite similar to that of the panels in the Omaha tests, and it will be noted that in both series of tests, back plastered construction on metal lath offered the greatest resistance to distortion. Such construction was fully described and illustrated in an article entitled "Successful Building in Stucco" published in the December 17, 1919, issue of THE AMERICAN ARCHITECT.

The report of the tests, conducted by J. F. Peebles, testing engineer, under the direction of Prof. G. F. Gebhard follows:

Purpose of Tests.—The purpose of these tests was to secure data in regard to the behavior of the different wall sections when under load,

and the strength shown by each to resist such loading. Particularly it was desired to observe the behavior of the inside plastered surface, to note such cracking, crushing or falling away of the plaster as might occur under the load. Similar observations were also made on the stucco in the samples using this type of construction.

Construction of Panels.—The samples tested conform in detail to the following descriptions:

1. Back-plastered stucco on Metal Lath
 Back-plaster on metal lath furred out by 3/16 in. pencil rods on 2 x 4 in. wood studding with 1 1/16 in. Portland cement stucco on outside, back plastered with 1 1/16 in. Gypsum plaster, making 1 3/4 in. from outside surface of back-plaster to outside surface of stucco. On the inside 1 1/4 in. Gypsum plaster. Each wood stud toe-nailed to sill at top and bottom with two 10 penny nails.
2. Siding and Sheathing.
 Ordinary wood construction, metal lath and Gypsum



CORNER OF TESTING LABORATORY, SHOWING MACHINE USED, ARMOUR INSTITUTE OF TECHNOLOGY

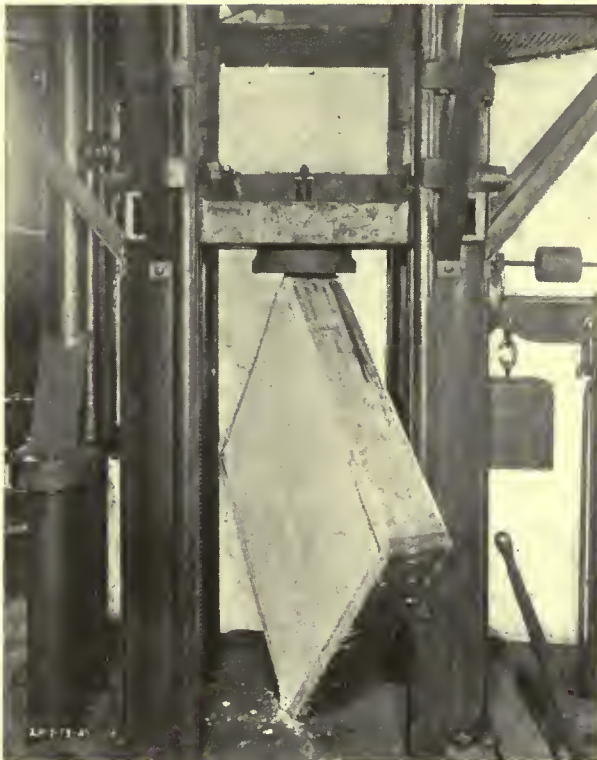

WALL PANEL UNDER TEST

plaster $1\frac{1}{4}$ in. thick on inside, and sheathing and drop siding $1\frac{3}{4}$ in. thick on outside. Each stud toe-nailed to sill at top and bottom with two 10 penny nails. Each piece of sheathing nailed to each stud with two 10 penny nails, and each piece of drop siding nailed with one 4 penny nail.

3. Stucco on Metal Lath over Sheathing.
Same as ordinary wood construction except that in place of the drop siding $1\frac{1}{8}$ in. Portland cement stucco on metal lath was used, furred out with $\frac{3}{16}$ in. pencil rods laid on ordinary building paper stretched over the siding.
4. Stucco over 6-inch Hollow Clay Tile.
Six-inch hollow clay tile covered on outside with $\frac{7}{8}$ in. Portland cement stucco and on inside with $\frac{7}{8}$ in. Gypsum plaster.

Size of Panels. All the samples used in these tests measured 42 x 42 in. outside dimensions. The thicknesses, of course varied, depending upon the character of construction, and were as follows:

Panel No.	Construction.	Thickness, inches.
1	Back-plastered Stucco on Metal Lath.	$.6\frac{5}{16}$
2	Siding and Sheathing.	$.6\frac{3}{4}$
3	Stucco on Metal Lath over Sheathing.	$.7\frac{15}{16}$
4	Stucco over six-inch Hollow Clay Tile.	$.7\frac{3}{4}$

Method of Testing.—In making these tests the

sample was placed in an upright position on the bed of the testing machine resting on one of its short edges. The load was then applied vertically downward on the diagonally opposite edge. This is clearly shown in the illustrations. It will be noted that with the sample in this position the studs are not vertical but at an angle of about 45 degrees with the vertical. Thus the studs are not loaded like a long column in compression, but the load is rather a combination of compression, cross bending, and shear. Unless the plastered surface is exceedingly rigid such a stress should produce cracks which would cause the plaster to fall away.

RESULTS OF TESTS.

No. 1—Back-Plastered Stucco on Metal Lath.—No effect was noted until the load reached 10,000 pounds, at which loading cracks appeared in both plaster and stucco near top and bottom corners of the sample. At a load of 14,200 pounds the sample was destroyed by the failure of the interior framework of 2 x 4 in. timbers. The metal lath was torn from the studs, due to the failure of the latter, but the greater part of the plaster remained unbroken except for cracking and crushing around the edges.

No. 2—Siding and Sheathing.—Plaster slightly crushed at top and bottom corners and a crack produced about 12 in. long near the top corner at a



FAILURE OF WALL PANEL

Note practically undamaged slab of plaster on metal lath

load of 5,460 pounds. Sample destroyed by failure of interior framework at a load of 8,800 pounds.

No. 3—*Stucco on Metal Lath over Sheathing.*—Small cracks appeared in both plaster and stucco near top and bottom at a load of 9,100 pounds. Sample destroyed by failure of interior framework at a load of 10,800 pounds.

No. 4—*Stucco over 6-inch Hollow Clay Tile.*—Tile, plaster and stucco crushed at top and bottom corners, and a crack about 15 in. long produced in plaster just above center of sample at a load of 8,000 pounds. Sample crushed so that tiles fell apart at a load of 9,600 pounds.

One point of importance to be noted from these tests is the manner in which the plaster held together, even when the supporting framework was

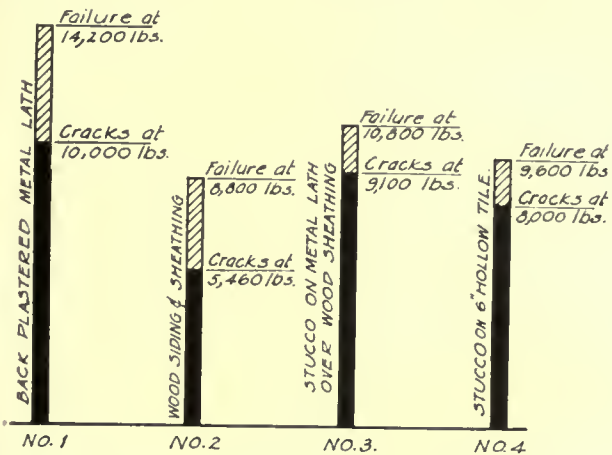

DIAGRAM SHOWING RESULTS OF TEST

completely destroyed. This was noticeable in all the samples tested, and is doubtless due to the monolithic character of the metal lath and plaster construction.

These tests show further that the strength of a wall to resist such load does not depend entirely upon the character of the framework, but is affected to a considerable extent by the nature of the wall surface materials. Note that the only structural difference between sample No. 3 and sample No. 2 of this report lies in the substitution of Portland cement stucco on metal lath in place of the drop siding. A reference to the above results shows that sample No. 3 is considerably stronger than sample No. 2, thus indicating that stucco on metal lath has greater structural strength than the siding.

Further, the back-plastered construction comprising back-plastered stucco having a total thickness of 1¾ in. on the outside of the wall and Gypsum plaster 1¼ in. thick on the inside, shows greater strength than any of the others, although the interior framework is the same as that for samples Nos. 2 and 3. This increase in strength is due to the monolithic

character of the stucco and plaster and to the absence of wood in the wall surface.

(Signed) J. C. PEBBLES, *Testing Engineer.*

The results of both this and the Omaha series of tests demonstrate the superiority of back-plastered metal lath construction to metal lath over wood sheathing. There seems to be no logical reason, where stucco on metal lath is to be used, for sticking to the older (metal lath over wood sheathing) but less satisfactory type. The tests conducted by the U. S. Bureau of Standards show the back-plastered type to be the best from a weathering standpoint, and it is equally if not more fire resisting. As to the question of thermal conductivity, tests so far made indicate excellent insulation if a layer of good weather proof paper is used or two layers of common builders' paper. As compared with the usual type of frame wall construction, it has many points of advantage both from the constructional and fire resisting standpoint.

While a hollow tile panel was included in this test, and such construction is not directly comparable with that using a timber framework, yet it is interesting to note that this masonry construction, loaded on the diagonal, resisted a load 50% greater than the frame wall type before showing cracks.

New Type of Glass Shows Remarkable Resistance to Shock

IN view of the great extent of broken glass resulting from the recent bomb outrage in Wall Street, renewed interest is being manifested in "shock proof" glass. Wire glass is quite familiar to us all, but has been found unsuitable in many locations where clear plate glass is customarily used. While due to its extra cost, it is not likely that any of the types of unbreakable glass so far developed will find extended use throughout a building, but there are certain locations where the extra cost would be warranted. This applies particularly to banking houses, show windows of jewelry stores, etc.

Recently some tests conducted by the New York City Police Department on a bullet proof glass have shown very satisfactory results. In response to a request for information relative to these tests, Joseph A. Fautot, Third Deputy Police Commissioner, writes us as follows:

"I would state that this product has been demonstrated to me in a shooting gallery, where four 45-calibre steel jacket bullets were fired point blank at a slab of Bullet Proof Glass from an army automatic pistol. The bullet failed to penetrate the glass and rebounded. As a result of this test, I can unhesitatingly say that this glass is absolutely proof against any revolver or pistol shot that may be fired at it."

Short Cuts to Accurate Calculations

Timber Beams and Steel Girders

By E. I. FREESE

WHILE, with the aid of handbooks, it is possible to determine the size of beams and girders without going through intricate mathematical calculations, yet the time consumed in hunting up the data, reading over the explanations for use of tables, formulae, etc., is often as great as that required to make the necessary calculations. In order to provide, in concise form, the data necessary for all usual calculations, four tables are here presented. Their correct use in solving problems commonly confronting the architect will be demonstrated in the solution of several problems.

CONDITIONS OF LOADING.—The types of beam and girder loadings encountered in building construction are termed either concentrated or uniform. Any load applied at one particular point is said to be concentrated, such as that transmitted from a header to a trimmer beam. The uniformly distributed load is the one assumed to occur in most cases. Floor beams are considered as supporting a uniform load. Under certain conditions a beam or girder may be subject to both kinds of loads. The weight of the beam itself must always be considered as a uniform load.

BENDING MOMENT.—The application of a load to a beam produces a bending moment, which is a measure of the bending tendency produced by the load. Eight conditions of loading are shown diagrammatically in Table 2 and the corresponding formulae for computing the value of the bending moment produced thereby, given. The bending moment is resisted by the beam, the total resistance which it can offer being the product of the section modulus and the ultimate strength per square inch of the material against rupture from bending.

ALLOWABLE SAFE WORKING STRESS.—All loaded beams are subject to stress, and, when the material of the beam becomes stressed beyond its endurance, the beam fails. The stress at time of failure is termed the breaking or ultimate stress, which, divided by a "factor of safety," gives the allowable safe working stress of the material. This working stress is always given in pounds per square inch, and its amount is represented by the letter *F*. Table 1 gives the safe working stresses for steel and all kinds of structural timber, based on a factor of safety varying from 4 to 6, which is in accord with good engineering practice. For instance, if the beam be of steel, $F = 16,000$ pounds per sq. inch; the safe stress. Or, if the beam is to be of Oregon pine, $F = 1,200$ pounds per sq. inch; the safe stress.

Most building codes specify the safe stresses to be used for all structural materials. Where no building code is in effect, the value as given in Table 1 should be used.

SECTION MODULUS.—The section modulus of a beam is a purely geometrical quantity that determines the shape and size of the beam. It is represented by the letter *S*, and its required value can readily be found by dividing the bending moment of the beam (*M*) by the safe working stress of the material (*F*). Hence, the section modulus (*S*) is given by the following easily remembered formula:

$$S = \frac{M}{F} \quad (1)$$

Two practical examples will now be worked out so as to render clear the process of application. It is to be remembered that the following method of procedure is the same in all cases, whether for timber or for steel, and whether for concentrated loads or for distributed loads, or both.

EXAMPLE No. 1.—A timber girder 16 feet long is required to span across a basement room. It must support the floor joists which rest upon it as well as a first-story non-bearing partition. The joists are 2 in. x 10 in., 16 in. on centers. The floor is double; and the basement ceiling is to be plastered. The floor area to be supported by the girder is 200 sq. feet. The live load is to be taken at 40 pounds per sq. foot. The partition to be supported is the full length of the girder, 8 ft. high, of 2 in. x 4 in. studs, plastered on both sides. What size girder will be required if the timber is long leaf yellow pine?

SOLUTION.—*First*, calculate the total load which, in this case, is uniformly distributed. The floor area, carried by the girder is 200 sq. feet. The dead load will be taken at 20 lbs. per sq. foot, which added to the live load gives a floor load of 60 lbs. per sq. foot. Thus the total floor load will be $60 \times 200 = 12,000$ pounds.

The partition is 8 feet high, so that the partition area carried by the girder is $8 \times 16 = 128$ sq. feet. Taking 22 pounds per sq. foot as the weight of the partition, the total partition load will amount to $22 \times 128 = 2,816$ pounds.

The entire load on the girder will then equal the sum of the above two loads, or $12,000 + 2,816 = 14,816 = W$, the total uniformly distributed load (in pounds) to be supported by the girder.





Second, from Table 2 find which case of loading the girder comes under. It is found to be Case 6,

TABLE 1. GIVING THE ALLOWABLE SAFE WORKING STRESS, F , IN LBS. PER SQ. IN., FOR STEEL & TIMBER BEAMS.

Steel.....	16000
Long Leaf Yellow Pine.....	1500
Oregon Pine.....	1200
Oak.....	1200
Spruce.....	1200
Fir.....	1200
Short Leaf Yellow Pine.....	1000
White Pine.....	1000
Hemlock.....	900
Redwood.....	800

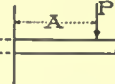
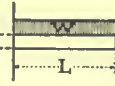
NOTE: This table shows the value of F to use in the calculations of Table #2 for finding the Required Section Modulus, S , for a beam of the given material. If a local bldg. ordinance is in effect, then the allowable safe working stress, F , as therein specified for the given material, must be used in place of the value for same given in this table.

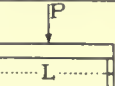
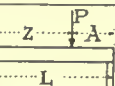
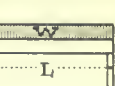
TABLE 2. SHOWING HOW TO CALCULATE THE REQUIRED SECTION MODULUS, S , FOR ANY BEAM UNDER ANY GIVEN CASE OF LOADING.

<p>CASE 1. Overhanging beam carrying only a load, P, concentrated at any given point.</p> 	$M = P \times A$ $S = \frac{M}{F}$
<p>CASE 2. Overhanging beam carrying only a load, W, uniformly distributed.</p> 	$M = \frac{W \times L}{2}$ $S = \frac{M}{F}$
<p>CASE 3. Overhanging beam carrying both a load, W, uniformly distributed, & a load, P, concentrated at any given point.</p> 	$M = P \times A + \frac{W \times L}{2}$ $S = \frac{M}{F}$
<p>CASE 4. Beam supported at each end & carrying only a load, P, concentrated at the center.</p> 	$M = \frac{P \times L}{4}$ $S = \frac{M}{F}$
<p>CASE 5. Beam supported at each end and carrying only a load, P, concentrated at any given point.</p> 	$M = \frac{P \times A \times Z}{L}$ $S = \frac{M}{F}$
<p>CASE 6. Beam supported at each end & carrying only a load, W, uniformly distributed.</p> 	$M = \frac{W \times L}{8}$ $S = \frac{M}{F}$
<p>CASE 7. Beam supported at each end & carrying both a load, W, uniformly distributed, & a load, P, concentrated at the center.</p> 	$M = \frac{P \times L}{4} + \frac{W \times L}{8}$ $S = \frac{M}{F}$
<p>CASE 8. Beam supported at each end & carrying both a load, W, uniformly distributed, & a load, P, concentrated at any given point.</p> 	<p>Use the GREATER of the following two values of M, for finding S:</p> $M = \frac{W \times A \times Z}{2 \times L} + \frac{P \times A \times Z}{L}$ $M = \frac{A \times A \times P \times P}{2 \times W \times L} + \frac{A \times P}{2} + \frac{W \times L}{8}$

NOTE: In above formulas, the letters stand for the following values: - P = the total concentrated load in POUNDS. W = the total uniformly distributed load in POUNDS. L = the total length of beam, in INCHES. A & Z = distances in INCHES. M = the maximum bending moment, in INCH-POUNDS. F = the allowable safe working stress, in POUNDS PER SQ. INCH, either as given in Table #1 or as fixed by local building ordinance. S = the REQUIRED Section Modulus of the beam, found by dividing M by F . The size of beam is then found by looking in Table #3 or #4 for a beam that has a GIVEN Section Modulus equal to or greater than the REQUIRED Section Modulus. Use Table #3 for TIMBER beams, & Table #4 for STEEL BEAMS.

SHORT CUTS TO ACCURATE CALCULATIONS

Tables for use in determining size of timber beams and steel girders for various conditions of loading

SECTION MODULUS, S	3.0	4.5	5.3	6.0	10.4	12.0	18.0	21.3	24.0
SIZE OF BEAM $b \times d$	2x3	3x3	2x4	3x4	4x4	2x6	3x6	2x8	4x6

TABLE 3.

GIVING THE SECTION MODULUS, S , OF ALL TIMBER BEAMS FROM 2x3 UP TO 20x24

Size of beam in inches

b = the breadth, d = the depth

EXAMPLE:

Suppose a beam requires a section modulus of 165. Look along the rows marked S and skip when 165, or the next higher value, is reached. In this case, the stopping point is 166. Then, the size of beam given for 166, or any other size beyond this, can safely be used - either the 10x10, 4x16, 8x12, 6x14 etc. In this case, the 4x16 should be used, if conditions permit, because it contains the least lumber, & has the greatest depth. The 4x16 will therefore be the most economical, as well as the stiffest, to carry the given load.

S	32.0	33.3	36.0	42.6	48.0	50.0	64.0	65.3	66.6
$b \times d$	3x8	2x10	6x6	4x8	2x12	3x10	6x8	2x14	4x10
S	72.0	85.3	96.0	108.0	100.	108.	128.	130.	
$b \times d$	3x12	8x8 or 2x16	4x12	3x14	6x10	2x18	3x16	4x14	
S	133.	144.	162.	166.	170.	192.	196.	200.	216.
$b \times d$	8x10	6x12	3x18	10x10	4x16	8x12	6x14	3x20	4x18
S	240.	256.	261.	266.	288.	322.	324.	326.	341.
$b \times d$	10x12	6x16	8x14	4x20	12x12	4x22	6x18	10x14	8x16
S	392.	400.	426.	432.	457.	484.	512.	533.	540.
$b \times d$	12x14	6x20	10x16	8x18	14x14	6x22	12x16	8x20	10x18
S	576.	597.	645.	648.	666.	682.	756.	768.	800.
$b \times d$	6x24	14x16	8x22	12x18	10x20	16x16	14x18	8x24	12x20
S	806.	864.	933.	960.	968.	972.	1066.	1129.	1152.
$b \times d$	10x22	16x18	14x20	10x24	12x22	18x18	16x20	14x22	12x24
S	1200.	1290.	1333.	1344.	1452.	1536.	1613.	1728.	1920.
$b \times d$	18x20	16x22	20x20	14x24	18x22	16x24	20x22	18x24	20x24

TABLE 4. GIVING THE SECTION MODULUS, S , OF STANDARD STEEL I-BEAMS.

SECTION MODULUS S	DEPTH d	WEIGHT PER FOOT
3.0	4"	7½#
4.8	5"	9¾#
7.3	6"	12¼#
10.4	7"	15*
14.2	8"	18*
18.9	9"	21*
24.4	10"	25*
36.0	12"	31½#
58.9	15"	42*
88.4	18"	55*
117.0	20"	65*
173.9	24"	80*

THE AMERICAN ARCHITECT

which indicates a "beam supported at each end and carrying only a load, W, uniformly distributed."

Third, calculate the bending moment, M, by solving the formula for same. $M = \frac{WL}{8}$ given with this case of loading.

As already determined, $W = 14,816$ lbs.

$L = 16 \times 12 = 192$ inches, the total length or span of the girder.

By substituting these values in the above formula, and solving, we get

$$M \text{ (the bending moment)} = \frac{14,816 \times 192}{8} = 355,584$$

inch-pounds.

Fourth, from Table 1 find the safe allowable working stress of the material. In this case, the girder

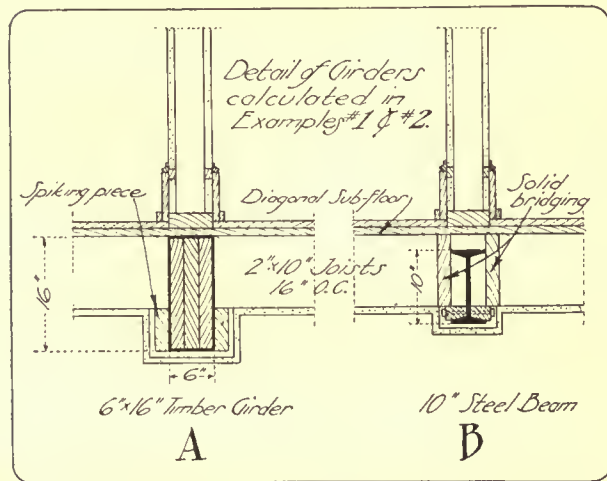

CONSTRUCTION DETAILS, ILLUSTRATING PROBLEMS 1 AND 2

der is to be of long leaf yellow pine. Hence, from Table 1, $F = 1,500$ pounds per sq. inch.

Fifth, calculate the required section modulus, S, by solving formula (1).

Since $M = 355,584$ inch-pounds, and $F = 1,500$ pounds per sq. inch, by substituting these values, we get

$$S = \frac{355,584}{1,500} = 237$$

the required section modulus for a timber beam.

Sixth, consult Table 3, of timber beams, and select one having a section modulus equal to or greater than 237. It is found that a 10 in. x 12 in. timber is the first one in the table to meet the re-

quirement. Hence, either this one; or any other one that has a section modulus greater than 237, can safely be used as far as *strength* is concerned. However, in this case, *deflection* must also be taken into account, for the girder is to carry a plastered ceiling. Moreover, the deeper a girder is to carry a given load, the less lumber will it contain, and consequently greater economy is attained. Hence, the choice should always be given to the girder that has the least number of sq. inches in its cross section, provided that its section modulus is at least equal to that required. Again consulting Table 3, it is found that, of all the beams therein having a given section modulus greater than 237, the 4 in. x 20 in. beam has the least cross sectional area. If this cannot be obtained, since it is a rather odd size, then the 6 in. x 16 in. or the 8 in. x 14 in. should be given preference over the 10 in. x 12 in., since all three of the deeper beams contain less lumber, and have a greater section modulus, than the 12-inch beam, and, therefore, would be more economical, stiffer and stronger, than the latter. Of course, the matter of head room must also be given consideration. The 6 in. x 16 in. girder will be assumed to have been decided upon, and a detail of same is given at "A" in the accompanying sketch.

EXAMPLE 2.—What size steel beam would be required to take the place of the timber girder in the first example?

SOLUTION.—The bending moment will be the same as found above, because the load is the same. Hence, it is only necessary to find the required section modulus for steel.

Looking in Table 1, it is seen that the safe allowable working stress for steel is 16,000 pounds per sq. inch. Hence, in this case, $F = 16,000$, and $M = 355,584$. By formula (1) the required section modulus S is:

$$S = \frac{355,584}{16,000} = 22.2$$

Consulting Table 4, it is seen that there is no standard steel beam having a section modulus of 22.2, so that the next *higher* value of 24.4 must be used, which calls for a 10-inch, 25-pound I-beam. This steel beam could be used in place of the 6 in. x 16 in. timber girder of example 1. A detail of the steel beam is also given at "B" in the accompanying sketch.

By adhering to the above method of design, one will have no difficulty in calculating the size of any timber beam or steel girder, for any condition of loading given in Table 2.

A Further Discussion of Improved Contract Forms*

By LOUIS COWLES

At present there are at least five quite different forms of contract in use for building work, commonly termed the "Lump Sum Contract," the "Percentage Contract," the "Cost Plus a Fixed-Sum Contract," the "Emergency Contract" and the "Cost Plus Fixed Sum With Bonus or Penalty contract."

After years of experience, much inquiry among builders and careful study of each of these forms, we believe the last named is by far the best for use, at least during the period of uncertainty in which we now find ourselves. Various advantages and objections will be later pointed out, but it is first necessary to have a clear conception of the Cost Plus Fixed Sum With Bonus or Penalty Contract.

First, fully complete plans and specifications must be worked out to provide accurate information to all bidders as to the kinds, qualities and amounts of the work to be done. Then, by the best practice, a full "Bill of Quantities" is made out, so that all bidders shall work on the same basis, simply adding their prices in detail and footing up the totals. This practice removes the main source of the common omissions, mistakes and other variations in bids, which in the past have differed surprisingly, even up to 100 per cent on the same building.

By this plan, bids received will show less variation and other very important matters can be more fairly judged, such as the character, ability and other qualities of the contractor to be chosen.

In order that all bidders shall know from the start, what the form of contract is to be, the following clause is incorporated in the specifications

Every bid shall state a fixed sum (aside from net costs) for which the contractor will execute the work complete (as indicated by plans and specifications); this sum to be his sole compensation for his part in

*[Editors' Note:—In an article entitled "Formulating Improved Contract Forms" which appeared in the June 9 issue of THE AMERICAN ARCHITECT, an extract from a contract form used by the office of Louis Cowles was quoted, as well as resolutions adopted by the National Association of Building Trades Employers. In a subsequent communication to the Editors, Mr. Cowles stated: "In thinking over the resolutions adopted by the National Association of Building Trades Employers, it occurs to me that their effect would be to put upon the owner alone all the risks and burden of any rise in prices, leaving the contractor in a don't care attitude. Would it not be much better on the whole for them to share this burden between them especially considering that the contractor is usually far better trained, qualified and situated for watching market conditions, changes and prospects, and buying to advantage? This is a very important part of a contractor's service to an owner. The owner cannot afford to dispense with it, neither can the contractor in the long run, afford to relinquish this service to the owner. It is vital to the principle and the spirit of co-operation in such an enterprise." His reasons for advocating the form of contract known as the Cost Plus a Fixed Fee with Penalty or Bonus clause are set forth in the article by him, published herewith. It is believed that a discussion on the important subject of contract forms will prove of mutual benefit and the views and experiences of other architects are solicited by the Editors.]

the work and the use of his organization and equipment, not to be augmented by commission, discount, rebate or other profit, hidden or known.

Every bid shall also include a careful estimate of the net cost of the work to the contractor (aside from his organization and equipment). This estimate and bid shall consist of (or be accompanied with) complete bills of quantities with prices of materials and labor attached, to be used for reference by contractor and owner or architect, to facilitate part payments and settlements, or any changes, and to help keep account of actual costs.

Then it is provided that if the actual cost of the work is *less* than the estimate, the difference saved shall be divided between the owner and contractor, in the proportion of one-third to the contractor and two-thirds to the owner. Also, if the actual cost is *greater* than the estimate, the excess shall be borne by owner and contractor in like proportions, the contractor's share being deducted from his fixed sum compensation mentioned above.

This feature applies to each separate general contract. It also applies to each sub-contract as between the sub-contractor and his general contractor.

If any contractor with his men or any of them, choose to organize a co-operative plan under the same rules, for doing any of his contract work, it is very likely to be approved and encouraged by the management. The main purpose of this arrangement is to bring about actual friendly co-operation in mutual confidence and helpfulness, in place of opposition of individual interests.

It is provided that if the costs be increased by fault of contractor or his men, such as neglect, carelessness, known willful act, continuous loafing or correction of faulty work, he shall bear the loss due to such fault without the owner sharing it.

It is also provided that if the cost is increased by fault or act of the owner, such as failure to pay installments as due which were agreed upon, or changes after work affected is under way, or unreasonable delay in deciding what to do, the loss due to this condition shall be borne by the owner without the contractor sharing it.

Daily or frequent reports of work done, with its cost, made to owner or his agent, are required as a check on any trouble liable to arise, before details and circumstances are forgotten.

FORMS of contract for building work are now under intensive study and discussion all over this country and in Europe, in architectural and building magazines, in societies and gatherings of

THE AMERICAN ARCHITECT

representative building men, in the newspapers and between persons interested.

The old form of "Lump Sum" contract, although for fifty years a bar to worse evils, has been the instrument of an immeasurable amount of damage, sometimes resulting in ruin to good builders, to owners, to sub-contractors and to material men. Its evils, under certain unfavorable circumstances, became so notorious, that with no guarantee as to prices of labor and material, many good men quit the building business in despair while many owners and officials regarded the business with aversion.

During and subsequent to the War, the old lump sum contract passed—or more correctly speaking, is very generally passing out of use all over the country, as well as overseas, while other forms of contracts have come into use. These all claim to have special merits and various degrees of improvement over the older form, but it is believed by the author that the best is the form described herewith. It seems to include the merits of all others, while being free from their objections, and its adoption makes possible the important advantages of co-operation. Under it the purposes and interests of owner and contractor are the same, namely, to carry out the plans in the most efficient manner possible. There is nothing to be gained by scheming or "buck-ing" each other.

Under the lump sum contract large amounts of time and effort are required by the owner and architect on one side in watching, striving and often fighting to get the contractor to perform the work as planned, while he on the other side was scheming and squirming and camouflaging to squeeze out a profit or at best a poor living. Under such conditions the best work is impossible of realization.

The following quotation is from Mr. W. H. Hall of San Francisco, commenting on the form of contract advocated:

The best system does not tend to make gamblers of contractors, nor conduce to 'skinning' of work, as the lump sum system does. It does not conduce to under-estimating, or to running up the cost of work, as the percentage system does. It does not conduce to neglect of the work, as the percentage and cost plus fixed sum systems do. It does not conduce to antagonism between owner and contractor or architect and contractor, as all the other systems do.

This system puts a premium on good faith, energy and special ability in the contractor, for the owner's benefit as well as the contractor's profit, and it puts a penalty on bad faith, neglect and incompetency in the contractor, for the owner's protection. But it does not penalize the contractor for what he cannot reasonably fore-see, nor beyond the limit of his profit in any ordinary case.

The principle of this system of contract agreement is distinctly right, in the honest interest of all concerned.

All that can be said against it is that its application may be inconvenient in some cases and under some business conditions.

It may call for more work in accounts, by owner or some one representing him. It gives opportunity

for as much interest and watchful care as the proper officials choose to give to the work as it goes along. Improvements can be made or items eliminated without impairing the contract or exciting antagonism. This is especially the case when all "quantities" are carefully estimated beforehand, with detailed prices attached.

THE resultant benefits need not necessarily stop with owners and contractors. When workmen begin to see and realize these improved conditions, and feel even a little of the stimulating good spirit of helpful co-operation which this plan is adapted to call out, there should be some degree of relief from the feelings of resentment from being driven, exploited, impoverished and suppressed, or discharged on a triviality. Seeing the opportunity to share in more and better work, they will feel encouraged to do so and derive the benefits as well as to help guard against losses which they will share if they fail to do their best.

We should see some speeding up, now so sorely needed, more interest and more pride in quality of results, more sense of responsibility and a growing unity of feeling and effort for the welfare of all, and a reduction in the causes of strikes.

Opinions may differ on the fairest proportion to use in sharing of savings or losses. Half and half is often specified and seems proper for small contracts. If, however, excess costs come to 20 per cent. of the estimated cost, the contractor would lose his 10 per cent. compensation.

On the other hand, in a recent article appearing in an eastern magazine, it was urged that whatever percentage the saving or loss is of the whole estimated cost be used; that is, if contractor saves (or loses) say 10 per cent. of estimated cost, then he gains (or loses) 10 per cent. of that saving (or loss), the other 90 per cent. going to the owner. On a school estimated at \$100,000, for a saving of \$100, which is one-tenth of 1 per cent. on \$100,000, he would have ten cents for his extra care—too trivial for a second thought. So this rule clearly is inadequate for small amounts.

Somewhere between these extremes the best proportion should lie. Since the owner bears the greater burden of cost and also receives the greater benefit in the finished building, he should have the greater proportion of saving or loss.

In view of all these factors, it would seem most fair and equitable to provide a sharing of two to one, i. e., two-thirds for owner and one-third for contractor, the latter gaining one-third of all savings or losing one-third of all extra costs. This should prove an effective incentive for him to do his best in either case, and it eliminates excessive gambling risks.

Current News

Happenings and Comments in the Field of Architecture and the Allied Arts

The Liner Engineer

Under the above title, the *Western Architect* for September, publishes the following well merited appreciation of a most efficient officer of the Institute. The editors of THE AMERICAN ARCHITECT, having also with much pleasure observed the efficient activities of Mr. Kemper, take pleasure in giving further publicity to this article:

The *Western Architect* states:

The convention reports that have of late occupied a measure of attention in the architectural press reminds one of the central figure, the liner engineer in that superb and technical poem of Kipling's, in which the passenger after reaching port thanks the officers on deck from captain to cabin boy for contributing to a successful voyage, and forgets the engineer, without whose constant watchful care the ship would have lain "a log upon the sea." As it is too common for the architect to receive the owner's praise and his "clerk-of-works-superintendent, draftsmen, et al, overlooked, so it is not strange that the understanding, constant and faithful activity of the executive secretary should be passed unnoticed. Yet it is not too much to say after close observation, that the smoothness with which the business of the convention was carried through was owing, not to the captain-secretary and his deck-crew, but to the silent, assiduous and most capable engineer below decks at the Octagon. His work, most noticeable at the end of the voyage when the convention-dock is made, is most effective during the long year passage when his "purring dynamos" are most active in carrying out the details of Directory and Committee, directions that center at headquarters. Mr. Kemper this year received the thanks of the convention. He has earned the approval of all who have noted the order and capability in general that has distinguished his prompt and efficient executive service at the Octagon.

Competition for Memorial Design

Gen. William J. Nicholson, vice-president of the Army and Navy Club of America, has announced the names of the committee of architects who will select the design for the three million dollar memorial clubhouse to be erected in New York City as a tribute to the officers who died in the war. The committee, to which the leading architects of the

country will be asked to submit competitive drawings, is composed of Charles Dana Gibson and Edwin Howland Blashfield, artists; Henry Bacon and Benjamin W. Morris, architects, with Admiral Bradley A. Fiske, president of the club, as chairman. A meeting of the committee will be called soon to go over the tentative plans for the contest and formulate a statement on specifications.

The memorial club building will be centrally located and will serve as a monument to the military leaders who died, and as a home for living officers, active or retired, in all branches of the service. Leaders in civilian life are eligible for associate membership.

"It is probable that the memorial feature will take the form of a central court, with bronze paneled walls, where the names of those who made the supreme sacrifice will be engraved," Gen. Nicholson said.

"For practical clubhouse purposes many interesting features are under consideration," he continued. "Thousands of officers annually pass through New York City and for their accommodation the building will contain at least 400 bedrooms. There also will be a large assembly hall and smaller rooms for meetings of patriotic societies as well as other usual conveniences found in a modern clubhouse. A ladies' dining room and reception room will be provided for the relatives of members or relatives of the dead who come to this city to see the memorial."

The club recently broadened its scope so as to include in its membership all officers, ex-officers and all commissioned men in the Allied armies during the war, numbering approximately 200,000.

Opportunity for Bridge Builders

Owing to the general destruction of bridges during the war there is an exceptional opportunity in Roumania for American bridge builders. A bridge over the Danube to connect Roumania with Serbia is being considered by the Roumanian government. There are eighteen important bridges in other parts of Roumania awaiting reconstruction. In addition, the great bridge over the Danube at Cernavoda, in many respects the greatest structure in Europe, must be reconstructed. This bridge, known as the King Carol Bridge, is 1,260 feet long and 11.4 feet above high water.

Kaiser's Home Used

In the Berlin Schloss, the former Emperor William's town residence, on the banks of the Spree, is now installed the Psychological Institute of the University of Berlin. Scaffolding is still up, and workmen are leisurely repairing the front, which was badly scarred in parts by machine-gun fire at the time of the revolution.

Chicago to Rebuild Fort Dearborn

Plans are being made in Chicago to reconstruct historic Fort Dearborn at Eighteenth street and Lake Michigan as a permanent educational exhibit.

In addition to the stockade, it is proposed that the homes of the earliest settlers of Chicago, or "Fort Dearborn," shall be rebuilt. The work will be done under the direction of Chicago's First Families.

Alaska Has Museum

Alaska's first museum is being completed in Juneau to house several thousand articles from all parts of the territory. One big exhibit to be brought to the museum from Washington, D. C., was on display at the St. Louis World's Fair. Another exhibit, to be loaned to the museum by Dr. Daniel S. Neuman, is considered the most complete collection of Eskimo curios in existence. The territorial government is building the museum.

Peru Spends \$30,000,000 This Year for Building

Contracts for construction in Lima, Peru, of dwellings, churches, office and other buildings costing nearly 30 million dollars, have been let to the New York contracting firm that built Camp Devens, Ayer, Mass. The firm announced today that contracts already signed amounted to more than one million dollars. The Peruvian work, which a member of the firm described as "a sort of housing and reconstruction project," is being financed by the Roman Catholic Church of Peru. It is to be finished within a year and to assure its completion within the allotted time a force of engineers and workmen is being sent to South America.

Town Burned to Be Rid of Rats

Tens of thousands of rats which infest the town of Paita, Peru, caused the Peruvian Government to order the town destroyed and rebuilt in a ratproof manner, according to William Moss, who recently returned from South America.

Yellow fever is raging in some districts of Peru, Mr. Moss reported. The town of Paita, with 5,000 population, has been particularly hard hit, scarcely a family escaping the ravages of the disease. The advent of swarms of rats caused fear that bubonic plague also would develop and the government ordered the town evacuated, the people going to the outskirts and living in tents.

All the buildings will be burned, the rats exterminated and new sanitary homes constructed, he said.

House Shortage in Paris

Following a law passed during the recent session of Parliament, the city of Paris has ceded 7,000 square metres of land in its suburbs to the Government for the construction of a total of 346 apartments to relieve the housing problem which still is very serious. The bill provided for an expenditure of 25,000,000 francs for building. The lodgings will be let at popular prices.

According to official figures the population of Paris has increased 6,000,000 since 1914, of which number approximately 400,000 were refugees. There has been practically no construction of houses since the beginning of the war. Landlords seem to raise rents to a staggering height. The courts are continually occupied with cases of rent profiteering. While awaiting the construction of the new buildings the public office of housing will erect temporary structures in the suburbs to care for immediate needs.

Museum Unearths Old Glass

After digging in a field near Alloway, N. J., three members of the staff of the Pennsylvania Museum have obtained a thousand specimens of the glass that was the first to be manufactured successfully in this country. The field in which they dug was once the site of the old Wistar Glass Works, founded nearly 200 years ago by Caspar Wistar, who was of Austrian extraction and titled. At present there is not a trace of the industry or the buildings.

The specimens found were for the most part fragments of bottle and window glass, of which there have not been many specimens until now. The museum is now making a study of the types of glass that were produced in the early days of Pennsylvania and New Jersey. The first glass to be manufactured in this country was that of a Virginia company located at Jamestown, but the first produced successfully was that of Alloway, then known as Wistarburg.

Advantages of a Cement Lawn, Painted

A lawn that is not a lawn, but looks like a lawn and is said by its owner to be better than a lawn—a waterless, mowerless, weedless, lawn—in short, a cement “lawn,” painted grass green, has made its appearance in front of a Los Angeles bungalow.

Mrs. A. C. Woodward, inventor and owner, says it saves time, money and worry. She never has to water it; she never has to weed it; she never has to cut it; it is always dry enough to sit on—and it needs painting only once a year.

She has circular holes cut through the lawn and in them and along the edges she has flowers planted.

She invented the cement lawn because of difficulty experienced in getting some one to take care of her old grass lawn. It cost only \$65.

Houses Scarce in Buenos Aires

Startling living conditions as the result of high rents in Buenos Aires are disclosed in a report by Alejandro Bunge, director general of national statistics.

Eighty of each hundred families occupy only one room, he says. Of this 80 per cent., “nineteen families consist of four persons, twenty of five, eleven of six, four of eight, two of nine and one of seven persons, all living in one room in each case.”

Comparing the respective positions of a workman in the United States and in Argentina, he cites the case of a bricklayer who in the United States with the wages earned in “600 working days could have built a house in 1919 which here would have taken the wages earned in 3,500 days.”

However, he finds that the cost of necessities in the United States other than rent is about 60 per cent. higher than in this country.

Contraction of Cement Mortar

The Technical News Bulletin No. 39, issued July 13 by the Bureau of Standards, Department of Commerce, Washington, D. C., states that an attempt has been made to effect a combination of cement mortar by using a local mix that would not show unfavorable volumetric changes when cast in a dry absorptive form. Such a combination seems to have been obtained by using one part of this local mix with 6 parts of gravel screenings. The difference between this and other combinations is that the present one results in a harsh mix rather than a salvy or sticky one since 1:1 or 1:2 mortars, which are salvy or sticky, are inclined to show unfavorable volumetric

changes. Results suggest that a harsh, initially in-adhesive mix is more likely to be susceptible to influences for reducing volumetric change than any other type of mixture.

New Method of Producing Pictures

It is not often that an entirely new method of producing pictures is discovered, and an Oregon artist is attracting considerable attention with a process as pleasing as it is original. Instead of using fluid pigments of any kind, bits of colored cloth, painstakingly cut to particular shape and size of each detail of the work, are pasted upon the canvas background, which is stretched over thin board. Some of the almost infinitesimal particles of fabric are shredded out to mere threads to get the desired effect, while the bulkier objects of the scene are built up in relief, says *Popular Mechanics Magazine*. A sharp-pointed stick serves as a brush for this curious art. The finished pictures exemplify the remarkable results attained when patience and the artistic sense are coordinated.

Park Preservation Assured

By a decision of the Appellate Court of New York, a long-fought battle to retain Central Park purely for purposes of recreation and pleasure has been won. The opposition in the fight was not attempting to turn the park over for apartment house sites or anything of that kind, but was fostering a movement to place in the park various buildings for housing educational exhibits and the like. The court held that “a park is a pleasure ground, set apart for the recreation of the public and to promote its health and enjoyment,” and that filling it up with buildings intended for more serious purposes was a mistake.

Whether it be New York or some smaller community, no city has breathing spaces enough, outdoor play spots enough, or sufficient area where its people may learn and enjoy the beauties of nature. There are in every city places more suitable for the erection of public buildings than its parks.

The world is wiser in such matters than it used to be. The park as an asset, promoting public health and cheerfulness and even improving real estate values, is better understood. And this is a good thing.

It is to be hoped that New York's example will be followed generally, and that every city will guard the playgrounds of the living and the sleeping places of the dead as she guards her Central Park and the sacred ground of old Trinity Church yard.

The Cylindrical House

The house can be no wider than its lot, but it may be wider than its foundation, and roomier by several feet than the dimensions of its side would betoken. In proof of this a Kansas City man has built a 22-foot house on a 25-foot lot, and has seven feet of yard left—three and a half feet on each side. He accomplished this remarkable feat by making his house cylindrical. Far from sacrificing any element of beauty to the unusual design, the appearance of this novel dwelling is entirely pleasing, outside and in, says the *Western Contractor*. The foundation measures 18 feet wide by 36 feet long, with its walls vertical up to the swell of the cylinder. The basement windows are round port holes giving a nautical effect, and perched in the centre of the room, like a turret, is a little sleeping porch. The roof itself is a segment of a cylinder, extending over the front porch. Inside are four good-sized rooms and a large hall, which serves as a spare room by virtue of a built-in-bed, occupying the curve of the wall.

A Haunted House Demolished

Sherard House, in the High Street of Eltham, Kent, is being demolished to make room for business buildings, according to the *Architects' Journal* of London. It is of the seventeenth century, and one will be sorry to lose it; but the tramways are being extended through Eltham, which, from being a pleasant and quiet village, will soon become a noisy town. In anticipation and furtherance of this unhappy transformation, the beautiful old houses are disappearing, among them Sherard House, which was reputedly haunted by the ghost of a beautiful woman, whose murdered body, so the story goes, was taken through an underground passage and thrown into Eltham moat. There were sturdy old oak beams in the house, and it is stated that the oak panelling, staircasing, and other interior treasures have been bought by an enterprising American. It is not recorded whether he has bought the ghost as well. "Alas, poor ghost!"

National Theatre in Manila

Fifty prominent business men co-operating with the Philippine Government, propose to erect the "most beautiful and best equipped theatre in the far east, at an initial cost of one million dollars.

The National Theatre is to be of reinforced concrete, five stories in height. A roof garden will top the structure. A large grill and buffet will be operated on the ground floor; the chairs in the theatre will be specially constructed for the tropics, broad-seated and wide-armed, so that each person may sit comfortably and without crowding. Cold, filtered

air will be piped through the entire building. The stage will be especially large for the accommodation of opera companies, Filipinos being enthusiastic patrons of grand opera.

Shower baths and lounging rooms will supplement the comforts of well-appointed dressing rooms and every modern stage equipment and apparatus for lighting effects will be installed. Private dining rooms on the second floor will copy the interiors of famous places in other cities; for example, the "London" room will be a miniature replica of the Ritz-Carlton grill, the "Tokyo" room will breathe the atmosphere of Japan, the "Peking," "Paris," "Rome" and "Washington" rooms will carry out similar schemes.

Municipal House-Building Considered

Governor Smith, of New York, before the joint legislative housing commission here, has declared himself an unqualified advocate of a proposal to empower New York City and other municipalities to meet their housing problems through municipal construction of dwellings.

Both Governor Smith and F. H. La Guardia, President of the Board of Aldermen, declared in favor of passing municipal legislation at the special legislative session called for September 20.

The chief opponent of the plan was Edward P. Doyle, secretary of Mayor Hylan's housing committee. He said it would cost the city \$600,000,000 to go into the housing business, quoting figures to show that the cost of building materials and labor had increased 250 per cent. since 1914.

"The cost is not the question," answered Governor Smith. "Are you opposed to cities of the State acting in such an emergency as we have at this time?"

Mr. Doyle admitted he did oppose such action.

Mr. La Guardia outlined a plan which he submitted for the consideration of the commission.

"I would take the cost of construction," he said, "the same as we do with our piers, and I would fix the rental on the basis of a 7½ per cent. on the cost of construction. In thirty years it would amortize itself, even considering the cost of material and labor, we still could rent at far less than the artificially-created rentals of today."

Older Church Found Under Rheims Foundation

A treasure trove, dating from the beginning of the fifth century, has been found beneath the foun-

dations of the Rheims Cathedral, according to a special cable to the *New York Times*.

A few days ago workmen engaged on the restoration of the cathedral found traces of a far earlier building beneath it which the monkish records declare was a basilica founded in honor of the Virgin by Sant Nicaise in the year 401. The nave of the primitive building was disclosed supported by three Roman arches in good condition.

An archeologist summoned made a careful investigation of the sandy floor of the ancient edifice and found buried in a corner sacred images of ivory strangely and beautifully carved among the mouldering debris. Evidently the priests of the period had buried their most precious treasures to save them from the barbarian invader 1,500 years before the German cannon thundered against the masterpiece of Gothic architecture that had replaced their primitive church.

New York Sky Scrapper to Be the Largest

The \$40,000,000 Park-Madison Building, which will occupy three city blocks, over the railroad tracks north of Grand Central terminal, between Park and Madison avenues, from 45th to 47th streets, will be the largest office structure in New York City and in the world.

This announcement was made recently by the Weaver-Crawford Corporation, 420 Park avenue, following receipt of a report from Warren & Wetmore, the architects, that the building will contain more than 1,600,000 square feet of floor space.

For a few years after its completion, the Woolworth Building, with its 50 stories, was the largest office building in the world. Then the Equitable Building rose a few blocks farther down Broadway to claim this distinction.

Now the prestige acquired by the greatest of skyscrapers is to move to the new financial and business district, around Grand Central terminal.

Plans for the Park-Madison Building have been amended so that a subway under 46th street will connect the two sections on Madison avenue, to be surmounted by twin towers 31 stories high. The section 17 stories high, fronting on Park avenue will be united with the main structure by a connecting wing over Vanderbilt avenue extension. Including the lease of the site from the New York Central railroad, the Park-Madison Building involves an expenditure of \$40,000,000. It will be erected on a plan of co-operative ownership.

Esperanto Gains Recognition

Some months ago the Soviet Government of Russia submitted the whole question of international auxiliary language to an official commission. According to the *Nation's Business* after a thorough examination of various proposals the commission approved Esperanto as the best and it has been decided to use it in all the schools of the Russian Republic. Obligatory courses of study have already begun in Moscow, Petrograd, Tver, Orel and Smolensk.

For some time past the Republic of Brazil has favored Esperanto in its telegraphic and cable service by placing it on the same basis of charges as Portuguese, and is also introducing it in its courses of study in secondary schools.

For the first time in history the soldiers of Europe are forming international associations for education against war. A congress was recently held in Geneva and it was decided that, after October 1 of this year, Esperanto shall be the official and obligatory language of the correspondence and meetings of the federation.

The Chamber of Commerce of the State of New York, at its recent commercial examinations, gave the same value to Esperanto as to other languages, and a number of candidates passed the examination with success.

Personals

Samuel Prescott Hall and Col. H. M. Bush have entered into partnership under the name of Hall & Bush, with offices at 16 South Third Street, Columbus, Ohio.

C. Howard Crane, Elmer George Kiehler and Cyril E. Schley announce the opening of a Chicago office at 127 North Dearborn Street, to be in charge of H. Kenneth Franzheim.

Borden B. Harris, consulting engineer, has opened an office at 132 Nassau Street, New York.

Peacock & Frank announce the opening of offices at 520 Colby-Abbot Bldg., Milwaukee, Wis., for architectural practice.

Harland Bartholomew announces the opening of new offices in the Compton Bldg., St. Louis, Mo., for professional practice in city planning and allied subjects.

Philip S. Avery has moved his office from 95 Milk St. to 99 Chauncy St., Boston.

Weekly Review of the Construction Field

With Reports of Special Correspondents in Prominent Regional Centers

WHILE undoubtedly the building industry will have to pass through a further period of readjustment as to price conditions, it is also equally true that the country is steadily moving forward to a normal basis of operation. The real attainment of such a desirable condition may be so long delayed as to cause the impatient ones to chafe, but it is only logical to assume that after so long a period of unsettled conditions, they cannot be brought to a satisfactory outcome except by the most careful and serious plodding to reach a final normality. In many sections and branches of the building industry this process of improvement is making distinct progress especially where better employment conditions exist. At the present writing the coal situation is probably the least encouraging spot in the general industrial field. The miners in the anthracite district are still on "vacation" in what it is expected will be a vain attempt to force the reopening of the wage award rendered by the coal commission and to which they had promised to abide.

"There is no general expectation that by postponing new building for a few months, marked savings may be realized through future declines in prices," reports the Guaranty Trust Co. "Even should the long-desired definite recession in prices develop it is believed that for some time yet building costs will show at best but slight decline and many think there will be further advances in building costs generally.

"The raw materials for building are available in abundance, sufficient to support the most ambitious building program and in the lumber industry it is estimated that there is an excess plant capacity of 50 per cent. The supply of materials may therefore in many cases promptly be enlarged whenever demand calls for it. Other lines of business enterprises are affected by credit stringency, but most of them show no such marked decline in activity as does the building industry. It appears that the transportation tangle is the primary source of the decline in building operations."

Statistics as to building operations during the month of August indicate that there was a slight increase in the total over July. In the northeastern quarter of the country, comprising twenty-five states, August operations amounted to approximately \$206,000,000, as against \$204,000,000 for July. There is nothing in this increase to indicate an upward trend in building activity, but other elements as referring

to these figures would seem to indicate that the slump had reached its nadir.

The latest reports received on wage and labor conditions indicate that the situation is improving rapidly. There is a notable improvement in the supply of laborers, carpenters, masons and other building trade mechanics, with the possible exception of New York City.

There is little if any change in the general transportation conditions as affecting the supply of building material. The railroad management of transportation is concededly becoming more efficient and this efficiency will undoubtedly make itself felt in the building material market as fast as the necessities of transportation of the enormous grain crops have been taken care of. Naturally the general scale of prices of building materials has felt the effect of the increased freight rates, which in some commodities have created prices that to the ultimate consumers have seemed too high and have caused them to proceed cautiously in building operations.

A summary of building operations for the first six months of 1920 shows a total of approximately 31,000 building contracts let during that period, with a total value of about \$1,500,000,000. Slightly more than one-half of this construction represents residential work at a total cost of \$350,000,000, or less than one-quarter of the total valuation. The average for each residential project ranges from about \$14,000 in the Northwest to more than \$30,000 in the Middle Atlantic states, or a mean average for the entire country of about \$22,000. This would indicate that most of the residential undertakings are multi-family buildings rather than individual houses.

Normal requirements for residential construction are calculated on two broad bases—to provide for increases in population and to replace wastage resulting from various causes. Despite the almost total cessation of residential construction during the war period and the slow return to normal conditions, the demands of the increased population have not lessened; nor have the forces of wastage, such as fire, deterioration and conversion to business purposes, diminished. The remodeling of residential buildings for commercial use or their total demolition to make way for purely commercial structures, has been notably increased, particularly in the larger cities. The natural result of this situation is a condition of congestion that is felt acutely throughout the country and particularly in the large centers of population.

THE AMERICAN ARCHITECT

Among the principal causes of the disproportionately low amount of residential construction is the financial problem faced by the average home builder. The difficulty in securing a loan and the high rates demanded, together with the high cost of labor and materials, render it almost impossible for the average home builder to proceed with building operations. The man who erects his own home must consider its cost and maintenance as an expenditure. On the other hand, the excessive cost of construction of a commercial building is usually reflected in the increased rentals demanded and an increase in business profits.

The New England correspondent of THE AMERICAN ARCHITECT writes that although there seems to be a growing note of confidence in business circles in the New England states, there is evidence of timidity among dealers in taking options at the prices now ruling in a ragged building material market. Price cuts in materials have so far proved insufficient to start active buying. No one wants to be caught in a falling market with high cost materials on hand. Brick, North Carolina roofers, wood lath and oak flooring are examples of price reductions, but dealers report that no greater volume of business was noted after these price changes went into effect.

The prospective buyer believes that if prices have dropped at all they will continue to go lower. Manufacturers, on the other hand, report that the weakness in quotations is based upon factors removed from the immediate conditions affecting building construction. Many of the latter believe that the entire building material supply situation is unsettled because of the impending great building movement, signs of which are actually appearing. They say that price reductions merely indicate the effort to secure an inside position for this promised new business—a scramble for early orders.

Dealers claim that fear of the rule of radical factions in the labor market is a damper on new building construction.

Events are occurring that suggest the building world is to see better things in the not distant future. The action of the American Woolen Co. this week in making a bid for a tremendous business this fall and winter is an example. The company named its new spring prices, and even with wages maintained at the highest rate in the history of the industry, it named prices on the average of 20 to 25 per cent. less than those prevailing in the fall of 1920. The response from buyers makes the officials of the company believe that orders will be obtained to keep the mills in full operation throughout the winter.

In explanation of the action of the company in thus slashing prices, President Wood said, "we are going after orders to fill our mills. It is time busi-

ness started up. The way to start the market is to slash prices. No one can ask for lower prices than we have named. These are attractive and so far as we can foresee, no lower ones can be made. We have got to have prices such that our distributors can do business with confidence."

Whether this will be the beginning of a general naming of a new price basis throughout the industrial world which would command public confidence is a question. Many believe that such an attitude on the part of industrial leaders in general in going after new business will bring a full-fledged business boom after election.

The following facts and figures were taken from the files at the Boston Real Estate Exchange relative to transfers of all kinds.

Number of transfers for the week ending Sept. 4 was 441 and the number of mortgages was 208, with values amounting to \$902,221. For the corresponding week in 1919 the transfers amounted to 351, mortgages 177 and amounting to \$1,180,450. For the corresponding week in 1918 the transfers numbered 243 and mortgages 96, amounting to \$436,812.

(By Special Correspondence to The American Architect.)

SEATTLE.—Due to the prostrated condition of the fir lumber market following the enactment of the emergency freight rates which have shut out fir from the short-haul eastern territory in favor of southern pine, more cars are being received by the mills than they can load, the shortage is at an end and cars spotted on mill tracks for loading have repeatedly been turned back to the carriers empty. Manufacturers who have been absorbing the freight differential in order to keep their organizations intact for better days announce with emphasis that they will not maintain the practice much longer, and that they will close down before they will quote less.

No. 2 vertical grain flooring is selling at the mills at \$67.50 to \$69, No. 2 and better slash grain, sizes 1x4, at \$52.50; boards and shiplap are \$27.50 to \$30.50. Shingles are weak and a bottom is believed to be here in clears.

The shortage of reeds in 6 and 8 common, finishing and shingle is so acute all along the coast that jobbers of California, Nevada and Montana are wiring into Seattle distributors for a supply. Similar conditions prevail as to small sizes of galvanized pipe, with halves, eights and three-quarters heading the list of shortages. Seattle jobbers during the week hold wires from these three states pleading for any sort of delivery, with small lots acceptable and no questions pressed as to the cost. Mixed car-loads arriving with 10,000 to 15,000 feet are melted

THE AMERICAN ARCHITECT

away into the trade on arrival before unloading. It is the feeling among coast jobbers that the pipe situation will not improve this year. Plumbing supply houses tell jobbers that they will accept any small lots that may be grabbed out of the turmoil and will pay any price asked.

Eastern mills are refusing even to sketch the future as regards delivery of earthenware and enamelware. There are no price advances, as it seems to be the feeling that this would not cure the trouble. There are no warehouse stocks on the coast. While there are no big jobs behind the demand, the retail trade will buy wherever stock is offered and pay the price without complaint. Delivery by rail from the East is irregular and disheartening.

Delivery of cement is very slow, although there is a group of heavy producing mills within 125 miles of Seattle. The demand has been ahead of delivery for six months. A little cement from British Columbia has been arriving by barge as an accommodation, as these plants are not offering on the open market.

There are no plaster stocks in Seattle, and none of the Pacific coast consuming markets are able to report any more satisfactory conditions. Mill conditions are believed by coast jobbers to be responsible. Salt Lake plants are doing best work in maintaining the coast supply.

Fire clay is arriving spasmodically, with California as the largest shipper into North Coast markets. The bulk of the brick is moving coastwise by water.

Jobbers of steel products, as nails and pipe, are endeavoring to meet a critical situation by invoking the aid of the ration plan. New accounts are offering freely, but despite the financial strength of these buyers all are being declined as diplomatically as possible under stress of emergency.

(By Special Correspondence to The American Architect.)

CHICAGO.—The problem of the building industry in Chicago has become one of financing rather than increased cost of material. The question of obtaining labor is no longer a thing for contractors to worry about. In fact, labor is hunting up the contractor, instead of the contractor bidding for labor. This condition is pretty general throughout the Middle West and has been for some time.

Some weeks ago, from some rather mysterious

source, there came over the financial field a firm belief that it was not good business for the bankers to make further loans on real estate and building projects. Whether this belief was based on the feeling that such loans could no longer be considered as safe investments was not explained. Nevertheless, the belief apparently was unanimous among the bankers. And as the purse strings tightened building gradually declined until today, in Chicago and vicinity, construction work has been confined to the more pretentious hotels, apartment houses and larger commercial structures.

While the general public has suffered for the need of ample housing, the situation has not been an un-mixed evil. It has tended to squeeze out some of the autocratic poison that has been afflicting labor. Mechanics are beginning, finally, to realize that the slogan, "fewer hours and more pay," eventually, when applied generally, will drive them to the line of subsistence just as surely as will long hours and less pay, for decreased production means economic ruin for all.

The settlement of the "outlaw" switchmen's strike is looked upon as one of the hopeful events of the past week. This ends the last of the more serious labor troubles that have been springing up from time to time during the summer. The defeat of this group of hectic labor enthusiasts has demonstrated that transportation can be maintained even without switchmen, and has emphasized to labor that industry requires both capital and labor if all are to prosper. On the other hand, railroad managers have been taught the much needed lesson of waste elimination in transportation service through an increase in freight car loading and mileage.

Lumber prices in this section, due largely to the decrease in demand, have dropped from twelve to twenty per cent. Prices of cement, stone and other of the heavier building materials, however, have advanced, due to their increased use in both buildings and highways. Expressions are heard that steel may become a little more plentiful because of the slacking up in the automobile industry, which has been "overplayed" recently.

An interesting meeting of the Real Estate Association of the state of Illinois will be held at Rockford, Ill., beginning Sept. 30, at which prominent bankers of the Middle West will discuss real estate and building financing. Some valuable suggestions are expected to come at this meeting.

428

Quintessence of 1/6 2337



DETAIL OF THE CATHEDRAL, MURCIA

THE AMERICAN ARCHITECT

VOL. CXVIII

WEDNESDAY, OCTOBER 6, 1920

NUMBER 2337

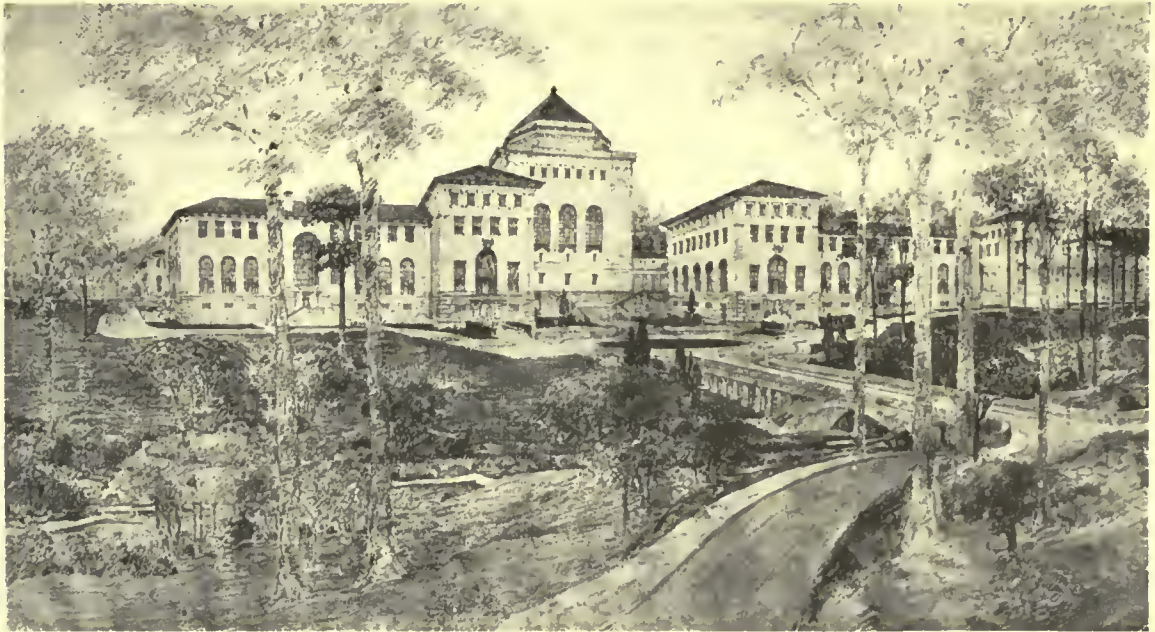

EAST ELEVATION ACADEMIC BUILDINGS
Approach is by concrete bridge over the ravine.

Emory University, Atlanta, Georgia.

H. HORNBOSTEL, *Architect*

By ARTHUR T. NORTH

IN a clearing, atop a range of low, thickly-wooded hills traversed by deep ravines, is located the remarkable group of buildings which are the commencement of a great university. These buildings are notable in several particulars; the use of a well-known material in a new manner, an unusual color scheme, an honest designing which is the true basis of architectural expression. These simple, exquisitely colored buildings along the borders of the forest begirt clearing, are as iridescent opals deep in a green jewel casket.

With limited means at his disposal, Mr. Hornbostel sought every opportunity to render the maximum service and to accomplish this he made a study of the local materials that were available. Georgia Marble, as marbles are ordinarily used, is relatively an expensive structural material. Visiting the large quarries near Atlanta he noted the large amount of

offal, the first sawing of the rough blocks. This material had one plane face, the back being uneven and the thickness varying from less than one inch to several inches. To use this waste material was the problem.

These slabs were roughly cut into square or rectangular shapes of whatever size the piece best afforded. The face was polished and the joints made square and true by grinding on carborundum wheels. The colors embraced almost every shade of gray, pink and brown confined to one piece—or several colors common to one piece. The majority of the pieces, however, have a dominant color. The pieces were placed in the wall in random range without reference to size or color with exceptions as later explained.

The exterior walls of the building are made of concrete faced with marble. Against the outer form

THE AMERICAN ARCHITECT

the pieces of marble were placed in position and the joints merely closed with the least possible amount of plaster of Paris. The mortar in these joints is not apparent. With wire anchors, as in marble wainscoting, the pieces are attached to the concrete which was poured into the forms after the marble facing was in position.

The marble work obviously indicates its purpose as a veneer or facing and not as having structural functions. The impression is gained by the absence

or size. As the jointing was not laid out on the drawings but made as the circumstances determined during construction, it is this unordered arrangement in size and color that gives the great beauty and charm to these buildings. A band of ornamental glazed terra cotta is in the center of the jambs and soffit of the great arched entrances. This band is pierced on each side at the spring of the arch by a window opening into the second floor toilet rooms. The ornamentation is subdued and harmonious with



THE LAW BUILDING

of the usual mortar joints. The window and door jambs consist of slabs showing an even edge of perhaps two inches. These are made of long slabs while the soffits of the arches are formed of narrow slabs.

In the academic buildings, Law and Theology, and the Dodds Dormitory, the corners are finished with a pilaster effect made of large slabs. These slabs are placed with vertical grain, with a slight projection beyond the face of the wall and finished with a simple moulded cap and base. They are selected for a fairly uniform color of dark reddish shade. A heavily moulded base with plinth is placed immediately above the panelled concrete basement walls. Above this base is a panelled course with slightly projected narrow stiles and rails selected for color. The frieze, immediately above the second story windows consists of large plain slabs selected for a fairly uniform dark color corresponding with the corner pilasters. The field of the wall is laid up of square and rectangular pieces without regard to color

the cotton flower and leaf and boll as the motif. The windows are made with metal frames, sash and muntins and the division of the glass varies with the different buildings.

The chapel in the Theology Building has a wooden wainscoting, ceiling and trusses made of California Red Wood unfinished. These trusses are especially beautiful in design and when the ultimate scheme of bright spots of color is applied they will tend to lighten up the ceiling and present an appearance of richness and subdued brilliance. The walls above the wainscoting are faced with marble in a manner similar to the exterior walls. The electric lights are placed on chased bronze brackets in front of which are very thin slabs of marble in bronze frames and with bronze ornaments applied to the face. This provides a very attractive and effective indirect artificial lighting. The organ loft is treated with a very graceful and effective colonnade in plaster. Contrary to the usual custom, the chapel windows

THE AMERICAN ARCHITECT

are glazed with plate glass. No ornamental glass in colors can excel the exquisite beauty of the pine trees to be seen outside—as effective as a Japanese landscape. The beauty of these buildings is increased by the reflection of the surrounding forest and the vistas seen through and beyond the plate glass windows.

The dissimilarity of the fenestration on the principal elevations will not be apparent when the covered colonnade is constructed as shown in the drawing. The transverse colonnade in front of the central library building will house in its attic the bookstacks and be accessible to the main library building and the adjoining buildings at either end.

The Physiology and Anatomy Buildings of the medical group are treated in a different manner. The walls are constructed similar to those already described except that the corners are finished with large quoin slabs instead of pilasters. These quoins are irregular in size and selected for fairly uniform color and shade. There is no moulded base

course as in the academic group but instead a plain projecting belt course with the courses of uniform height below and between it and the panelled concrete basement walls. The ends are treated with very low relief pilasters, with cap, base and frieze. Between these is placed a name panel ornamented with inscriptions. These buildings are exceedingly simple in design and inexpensive but withal presenting an attractive and satisfactory appearance.

The main buildings of the Dobbs Dormitory are connected by an arched passage behind which is a large, light and attractive common lounge room. Back of the building and at a lower level are tennis courts.

The broadly projecting cornices are built with great simplicity and are exceedingly effective in appearance. In the Academic Group the cornice is supported on a framework of structural steel. Supported on the ends of the steel lookouts or brackets is an angle iron carried entirely around the building, with the upstanding leg exposed. To the steel lookouts are suspended cream colored terra cotta brackets having a broad soffit and with but slight projection below the main soffit of the cornice. At the intersec-

tion of the dark colored marble frieze and the soffit of the cornice there is a cream colored terra cotta bed mould, into which the end of the terra cotta brackets member. In what might be termed this terra cotta frame is placed a large slab of marble, which forms the panel of the soffit. It is selected for color and in combination with the beautifully moulded, light colored terra cotta, the rich marble frieze, the dark colored angle at the eaves, the red tile roof and delicately colored and skillfully arranged marbles of the walls, the effect is so entirely



A WINDOW DETAIL

good and satisfactory as to be beyond criticism.

The cornices of the Medical Group are constructed with broad concrete lookouts having a slight drop below the plane of the cornice soffit. Between the lookouts are placed large panels of marble, as in the Academic Group. This design is much more simple and almost devoid of ornament, but in keeping with the buildings. The concrete lookouts are constructed as cantilevers from the exterior walls of the building. The construction of a cornice of this type is comparatively inexpensive and very effective.

The columns supporting the ceiling and second floor over the library rooms in the Law and Theolo-

THE AMERICAN ARCHITECT

gy buildings are placed well toward the corners of the room, as shown in the illustration of the library. This column arrangement permits of a large unobstructed space in the center of the room. There are diagonal girders from the columns to the corners of the room and similar girders at right angles to these connecting columns. The soffits of the girders are arched and the effect is that of a slightly groined ceiling on a flat plane surface. Between these arched girders and enclosing the large central area are concrete girders of rectangular sections. This is a very good construction from a structural viewpoint. The peculiar column arrangement and the design and disposition of the girders give a spacious appearance to this room that could not be secured by any other means.

The roofs are covered with red burned-clay shingle tile not selected for shade. They are very effective in combination with the marble walls and the surrounding forest.

The complete plant will consist of the academic group in the front center of the bird's eye view, the theology and law buildings are already constructed at the left and right front respectively; the physics building at the left of the central library building is also constructed as well as the basement of the chemistry building. To the left center is the dormitory group with athletic field and gymnasium adjoining. The rear center and left constitute the medical college and hospital groups. To the right center is the domestic service group. The power house is located in the center of the plant. Roadways are constructed with concrete bridges over the ravines and ornamental concrete balustrades along the edges of the ravines—as shown in the rear of the law building.

Great credit is due to that master mind and skilled hand which has found a use for a waste product—a use that has resulted in buildings of incompar-



INTERIOR OF LAW LIBRARY

able beauty. It requires a certain measure of bravery on the part of the architect to make such a radical departure from the traditional methods and designs applied to such an important project. Happily, success attended the effort and there stands a group of buildings well worthy of the attention of all students of American architecture.



ACADEMIC BUILDINGS

Theology Buildings at left, Law at right, Library in center. Book stacks are located over the transverse colonnade and accessible from buildings at each end.

Architectural Quicksands

The Checking of Estimates

By CLINTON H. BLAKE, JR.

WHILE treating of this subject of superintendence I should say a word of the extreme importance of another phase of the architect's duties as the representative of the owner in building operation. In a sense, it is not a part of his duty as supervising architect, and still, in a broader and perhaps truer sense, it is. I refer to the proper checking of certificates and statements of materials used and work done. Manifestly, there is no phase of the whole building operation which more directly and vitally affects the pocketbook of the owner, and yet it is, I am afraid, often true that, in many instances, the architect gives inadequate thought and attention to this phase of his work. Many an architect will be inclined to treat it as a purely routine matter, and to accept the statements submitted by the contractor, prepare his certificates on the basis thereof, and issue them, without adequate auditing or appreciation of the importance of the step taken. There has recently been a very refreshing change in this respect, and a much more general appreciation of the importance of a more business-like administration of this part of the architect's duties. Mr. Higgins, in the articles to which I have already referred, has treated the subject admirably and driven home the importance of the point which I have in mind.

It has recently been impressed upon me anew, by a case in which I have represented the architect, and in which, if it had not been for the vigilance of the latter, the business-like organization of his office and his insistence upon having all details as to materials and work checked and in proper form, before authorizing payments to the contractor, the owner would have suffered a loss of a very large amount. In the case which I have in mind the architect had endeavored to guard against all contingencies, and yet, much of the trouble, to which he was put to defeat the unjust claims which the contractor in that case made, could have been avoided if the contract had been in a slightly different form. The contract set forth estimates of the various component parts of the work and provided payments to the contractor of specified sums for each component part, such as excavation, masonry, and the like. This left it open to the contractor to lump his largest charges on the earlier items, viz.: the

items for which the early payments were to be made. In fact, we found that he apparently had done this very thing, and that he had added practically all of his prospective profit on the job to the earlier items. The result was that if these items had been paid in full on the basis of the estimate as originally submitted, the contractor would have received in the early payments all of the profit which he expected on the entire job, and would have had little interest in the balance of the work. The architect, fortunately, realized the troublesome possibilities in the situation, and took care to analyze the estimates submitted. He insisted on the submission by the contractor of statements of quantities and prices covering each component part of the construction, as the work progressed. He checked these quantities and verified the market prices in connection with the items on which the quantities were submitted. He soon found that the contractor was about to secure all of his profit and overhead on the first few items for which he had submitted statements. He immediately took up the matter with such good effect that he was able to hold out a sufficient sum to safeguard the owner, and to compel the contractor to complete the work, eventually, without loss to the client. It is evident that if the contractor sees that he can secure all of his profits and overhead on the component parts on the earlier items, due to the fact that these are in excess of the true valuation of the work which they represent, his interest in the remaining items involved in the work is small. In fact, in the case to which I have just referred, the contractor, when the job was substantially completed, went into bankruptcy. If the architect had not acted as promptly and as vigorously as he did, the owner would have been left with a half-finished work on his hands, all of the contractor's profits would have been paid to him, and the owner would have been faced with the necessity of completing the work with less money in hand for this purpose than would suffice to pay the subcontractors and materialmen, and finish the details left uncompleted by the main contractor.

When, following the selection of the architect and contractor, the latter is asked by the architect to submit an estimate of the cost of construction of the component parts of the building, such as excavation, masonry, timber work, trim and the like, the contractor, in submitting this estimate, will almost

THE AMERICAN ARCHITECT

invariably be found to submit it in lump sum items, without giving quantities and prices. If one stops to think, and analyzes the legal and practical effect of handling the matter in this way and of accepting estimates so submitted, without additional safeguards on details, the danger of such a proceeding will be obvious. To eliminate the element of uncertainty and risk, the architect should insist on the submission of quantities and prices on each item and component part. He should then take the quantities and investigate and verify the current market prices on each of the items on which the respective quantity estimates are submitted. He should then make sure that a proper agreement is made with the contractor under which the latter will be called upon to submit each month, with his application for payment, a similar list of quantities and prices. The matter of extras must, of course, be considered and the agreement should provide for additional quantities made necessary by extra work, on the basis of the quantities and prices originally approved and accepted. Payments are then made on the basis of the agreed quantities and prices, as installed in the building and approved by the architect. As a phase of operation, a more detailed explanation of the approval would come from the general superintendent, and, if a clerk of the works be employed, his report and approval would be secured in the first instance. By following this plan the contractor will be paid for the true value of the work done, the reasonableness and accuracy of the quantities and prices will be duly checked and known, and the danger of the contractor securing all of his profit and overhead on the earlier items will be eliminated.

DANGER OF ALLOWING OWNER TO AUTHORIZE EXTRAS DIRECT.

It seems self-evident that if the architect be entrusted with the duty of supervising the construction of the building, all orders to the contractor, involving additions to or modifications of the contract, should be submitted through the architect. I have already touched upon the danger of the architect authorizing any extras or changes without the definite and clear approval of the owner. It is very nearly as important that where the owner desires changes made he should communicate his wish to the architect and not direct to the builder. Where the latter course is followed confusion must invariably result.

I have had before me, during the last few months, a case in which a very unpleasant situation was created, and a great deal of misunderstanding caused, by the owner giving orders to the contractor direct. He did not do this because of any conscious desire to slight the architect, but because he did not realize probably the effect of handling the

job in this way. Impatient to secure quick results, changing every few days in his decision as to details of construction and the like, and meeting the builder at the job, in the absence of the architect, he would issue instructions to the former for changes in construction, plumbing, decorating and similar items, without troubling to communicate them through the architect, or even to advise the architect promptly of the instructions so given. The inevitable result ensued. The owner, in changing some item, which he regarded as a minor matter involving small expense, and without the prior knowledge of the architect, would make necessary other changes, the aggregate expense of which would be considerable. In directing that an electric outlet be changed from one side of the room to another, he would not consider that, in order to do this, the floor or ceiling work might have to be changed, or that in cutting out an alcove or doorway, steel or timber construction would be required to bear the weight which the alcove partition or doorway had formerly supported. The builder was somewhat at fault, in that he did not, apparently, make as clear to the owner as he should have the effect and cause of the various changes. Be that as it may, the result was that, after the owner had proceeded thus for a number of months, he received a bill from the builder which showed a tremendous increase in the original estimated cost. He at once refused to make payment of the bill, and descended upon the architect, with an evident intention and desire to hold him responsible for the adjustment of the situation. The architect had sensed the danger of the situation some time before, when he learned of the course which the owner was following, and had unsuccessfully tried to point out to the latter the foolishness of the method which he had adopted, and the result which must surely follow. He had pointed out, also, that it was not fair to him that the work should be handled as it was being handled; that changes might be made which would result in architectural work which he would not care to have pointed out as the work of his office; and that his responsibility as supervising architect should not extend to work which he did not authorize, or to changes made and work done without his knowledge or approval.

This particular case was aggravated by the fact that the architect had agreed with the owner on a definite charge for his services. When he agreed to this he of course expected that the work would proceed, as originally planned, and did not count upon the repeated modifications, additions and extras decided upon by the owner. The owner, to cap the climax, took the position that, while he would not pay the architect a cent more than the amount originally agreed upon, or allow him any commission

THE AMERICAN ARCHITECT

on the added cost of the work, made necessary by the orders given by the owner to the contractor, yet he would hold him responsible as supervising architect for the proper construction of the entire job, including both the work originally laid out by the architect and the items authorized by the owner during the progress of the construction.

As a legal proposition, the owner could probably not sustain any such inconsistent claim as this position would involve. As a practical matter, however, the architect was faced with the alternative of retiring from the job, to avoid possible responsibility for work which he did not approve, or of continuing with the work, making the best of a bad situation and endeavoring to make the owner see reason. It was also clear that if he did not continue the contractor would probably not receive payment for the work done. While this might be just retribution for the failure for the contractor to insist that orders should be given to him through the architect, and for his failure to report to the archi-

tect the orders given to him direct, yet the architect did not feel that he could withdraw without an effort to secure an adjustment which should be reasonably fair to the contractor. He accordingly chose to continue on the job and succeeded in arranging a proper settlement between the owner and the contractor. The owner refused, however, to pay him any commission beyond the amount originally specified and the final result was that the amount which he received was about one-third of the value of the services which he rendered. If it had been more clearly and definitely agreed that the owner should not follow the course which he did, and if the architect, when the tendency of the owner to handle things direct had become manifest, had insisted either that the practice be discontinued, or that he be allowed to withdraw, the difficulty would have been avoided, the architect would have saved many hours of time for which he never received remuneration, and much of the unpleasantness which developed between him and the client would never have arisen.

Chicago to Build Big "Health Center"

An institution which in the last thirty-four years has ministered to more than a million patients among the city's poor and whose laboratories and clinics have been of untold value to the medical profession of Chicago and the world at large is the Chicago Polyclinic and Hospital, which on November 8 will inaugurate a drive for \$1,000,000 to enable its supporters to erect a modern hospital and "health center." The original buildings, long since inadequate for the service of the rapidly growing city, were erected and supported by a group of leading physicians and surgeons who felt the need of such a clinic and such a hospital. The public has never before been asked to contribute to this praiseworthy effort but its importance in the community is vital and far-reaching.

The "health center," with its popular lectures on sanitation, nutrition and other important health topics is unique in civic annals and it is the purpose of the polyclinic to make it a model for other cities of the United States. Not only will the public be taught how to keep well, but a dispensary or "out patients' department," a diagnostic clinic, where

leading specialists will examine and recommend, laboratory tests and examinations, and other allied activities among the features. All branches of medicine will be represented and clinics will be open daily and available to all.

The care and reconstruction of men injured in industries will be also considered in the new polyclinic. Special effort has been made to design a building which will be sanitary and comfortable for the patients and staff. Noise has been practically eliminated by isolating the birth rooms, pantries, kitchens, laundries, power plants and other places where there might be commotion to annoy the patients. All signals are to be the silent light type. There will be solariums and roof gardens with special play rooms for children and gymnasiums for corrective exercises. Closed stair cases and elevators opening into noise-proof vestibules will add to the general quiet as well as preventing hospital odors from circulating from floor to floor.

In the group contemplated will be the out department, an educational department, a complete hospital, a training school and home for nurses and a social service department.

The drive is directed by Mrs. Mary F. Korn, and headquarters in the LaSalle Hotel, Chicago.

The Early History of Gas in New York

ON the northeast corner of Elizabeth and Hester Streets it was that one of the original offices of a gas company in New York City was located, the headquarters of the New York Gas Light Company, writes Robert E. Livingston, in the *New York Evening Post*. The brick building that has been used all these years as a gas office was originally, and for forty-one years of the last century, New York's leading Quaker church.

This building, it is expected, will soon be demolished, and the site will be used for a substantial building that will afford better accommodations for the immense business that is done in that office by the Consolidated Gas Company. The site is a valuable corner and the buildings that now stand have always been kept in excellent condition. The plot covers 100 feet on Hester Street and 150 feet on Elizabeth Street. This gas office is the headquarters for all gas consumers below Fourteenth Street. With the exception of a new front on Hester Street, the quaint, low, red brick building, with its peaked roof, exists to-day almost exactly as it did when it was the sanctuary of the Society of Friends. It still preserves much of the atmosphere of peace and quiet that hovered about it in its early youth, notwithstanding it is one of the busiest gas offices in the world.

Just how it came about that the old New York Gas Light Company succeeded the Society of Friends in the occupancy of the old church edifice when the Society members moved uptown is not altogether clear. It is thought probable that William Fox, a prominent Quaker, who in the sixties was president of the New York Gas Light Company, and other prominent Quakers who were active in the affairs of the gas company, had much to do with the transfer.

The church was built in 1819. The old high stone steps up which the Quakers climbed to attend meetings are still in use. The original cobblestone court is still in the rear of the building where one of the gas company's emergency crews is housed, and ready for call day or night. The interior of the building still reminds one of the old-time Quaker "meeting-house" and there is still there a curious narrow iron railing gallery running completely around three sides of the large open room, the ceiling of which is the roof of the building. Remove the decks and a partition or two and one would have restored the original appearance of the place.

The small brick building in the rear facing on the court, now occupied by the handsome red emergency automobile and its crew of five men, was

originally occupied by the Quaker school. Just in the rear of the church there was for many years an old Quaker burial ground. When the Society of Friends moved up to Stuyvesant Square the bodies of the departed Quakers were reburied in a new cemetery in Brooklyn.

It is ninety-six years ago that the first gas company in this city received its charter. It was the New York Gas Light Company and it was established "for the purpose of better lighting the said city and the buildings, manufactories and houses therein." This pioneer gas corporation was given the right "to manufacture, make and sell gas, to be made of coal, oil, tar, peat, pitch or turpentine or other materials."

The romance of the introduction of this commodity with which we are now so accustomed to do lighting, heating and cooking, and which now has such a tremendous use for industrial purposes, is set forth as follows:

There were 17,000 houses in the city in 1822 when a group of men put their heads together and decided that gas could be made and sold. In those days New York lived down around Battery Park and in Franklin Square. The first gas works were built in Centre Street, not far from the Tombs. The city's population was 150,000. Samuel Leggett, a Quaker, was the first president. He lived at No. 7 Cherry Street, his house with others giving way for the building of the Manhattan pier of the Brooklyn Bridge. John Hancock lived at No. 5 Cherry Street, and at No. 1 Cherry Street George Washington had lived as President of the United States. Samuel Leggett was only forty-one years old when he decided to set an example to the citizens of his country at large by illuminating his private residence with the new illuminant—gas.

The press account read:

"The exhibition of gas lights last evening at 286 Water Street attracted a great number of ladies and gentlemen, notwithstanding the unfavorable state of the weather; it will be repeated again *this evening*. Six new burners have been added, which rendered the display considerably more brilliant than that of the preceding occasion. It has been suggested that it would be more gratifying to our citizens to have the apparatus removed to a more central situation than where it is at present. We think either the City Hall, or Washington Hall, would be more eligible."

It was from the small beginning, as sketched here, that this enormous organization as it exists to-day came into existence. To-day there are 1800 miles of gas mains under the streets of Manhattan

THE AMERICAN ARCHITECT

and the Bronx and thousands of miles of service pipes connecting the mains with the buildings in our avenues and streets. More than 900,000 gas meters are in use in those two boroughs. At the works of the Astoria Light, Heat and Power Company, Astoria, L. I., stands a gas holder with a

capacity of 15,000,000 cubic feet of gas, the largest in the world. Gas mains connecting with the Bronx are six feet in diameter, also the largest in the world. The plants of the Consolidated Gas Company have provided the world record daily output of gas—160,327,000 cubic feet.

Ecclesiastical Metal Work of Ireland

By W. H. McGINTY, *Architect*

IN their metal work as in the high crosses, manuscripts and other designs of the ancient Irish artisans there is found a well developed and perfected Irish style.

Writing of the Irish churches and oratories, Ferguson in his History of Architecture states that the style is as interesting, in itself, as that of any local minor style found in any part of the world. In addition he makes the flat statement "That without the

specimens of work in bells, croziers, processional crosses, bell shrines, book shrines, brooches and pins.

One great peculiarity of this ornamental metal work is the slight intrinsic value of the materials entering into its manufacture, copper and bronze and other inexpensive materials composing these precious relics. Their great value, however, is attained by the wonderful skilled workmanship displayed in their creation. It is generally accepted as a fact that intrinsic value of materials enter into a work only when artistic talent is at a low ebb. As in the making of a fine violin the cost of wood is not considered, so in the works of art in Ireland at this period when designing the beautiful chalices and



THE ARDAGH CHALICE

intervention of the Celt we should not have possessed a picture or statue that we could look at without shame." And again "The Celt makes the best of colorists and where his influence was strongest there architecture was the most perfect; as his influence faded or as the Aryan prevailed the arts first languished and then died." It is safe to assert that where no Celtic blood exists there no real art is found."

In metal work of this period of ancient Irish art there now are in the museums of Ireland and Scotland and in the British Museum in London the finest



THE DEVONSHIRE CROZIER

croziers, they were enriched by the skill of the most patient and careful workmanship, and not made of materials valuable because of their scarcity.

It seems quite safe to assert that the art which

culminated in such a design as the Ardagh Chalice must have been practiced many years in order to reach such a high degree of perfection. That these intricate and interesting articles were designed and manufactured in Ireland from fourth to the eleventh centuries of the Christian era is well established. Whether or not the art originated in Christian Ireland or in Pagan times, as some writers state, is needless to discuss here.

THE ARDAGH CHALICE

This artistic and wonderful design is only nine and one-half inches high and seven and one-half in diameter. It is, however, made up of more than three hundred and fifty different parts. Like other metal work of the time it was made of gold, silver, lead enamel, glass, amber and mica.

This chalice belongs to a well recognized class of early metal work in use in the Irish church before the tenth century. It is made principally of an alloy stated as three parts silver to one of copper. The ornamentation cut into the bowl, consists of an inscription, interlaced patterns terminating in dog's heads and at the bottom of the bowl a circular band of a

Greek pattern. The ornamentation seems to have been made with a chisel and hammer. The band encircling the cup is composed of two semi-cylindrical rings of silver ornamented with small punched dots. Between the rings the space is filled by twelve plaques of gold repousee ground work and is ornamented by fine wire filigree wrought on the front of the repousee ground work. This is of the interlace pattern always found in Irish art.

An analysis of the enameling of this work discovers that there are three distinct kinds, each difficult and interesting. Color enters largely into the beauty of the design as it does into all similar work in Ireland.

Engraved on the exterior of the chalice are the names of the twelve Apostles in which the form of the letters conforms with those in the Book of Kells.

This chalice is a masterpiece of the artistic metal work of Ireland at its best period. Designers of any age or period in any part of the world have not been able to surpass its high standard.



THE CROSS OF CONG—
BRONZE, SILVER AND GOLD, JEWELLED

THE CROSS OF CONG

With the exception of one discovered at Monaghan a few years ago, the Cross of Cong is the only processional cross of the Celtic style now in existence. It was originally made for the church at Tuam and was intended to enshrine a portion of the True Cross as stated in the "Annals" of Innisfail A. D. 1123.

The core of the cross is of oak, covered with copper plates, on which is the decoration of richly designed tracery interwoven. Concealed at the time of the Reformation, it was found early in the nineteenth century by the parish priest of Cong.

In height it is two and one-half feet and a trifle more than one and one-half feet across the arms. The outer margin is formed by a roll moulding and in-

side the moulding the space is divided into panels decorated by enameling in relief. There are eight panels surrounding a center of rock crystal at the crossing of the arms. Thirty-eight other panels in the arms and shaft are all decorated in gold filigree work.

The entire design is remarkable in its beauty, showing a very high artistic development.

THE MONAGHAN CROSS

There was recently discovered at Belfast, Ireland, another example of ancient Irish art in the shape of a bronze processional crucifix dating from the eleventh century and almost perfect. This cross

which is twelve inches high has at the head and arms enlarged terminals each of which was jewelled and ornamented in the ancient Irish way with silver and precious stones. The sacred figure while much worn, is perfectly modeled.

A most unusual feature is the addition of large beads on each arm and at the base, skillfully fastened through the cross with bronze pins after the style of the Cross of Cong. A large bulb terminating in a serpent's head forms the base. This bulb

design of the Ardagh chalice. It bears in simple Gaelic a suitable inscription.

St. Patrick's Bell is an example of the early Irish work in metal, and is known as the oldest authentic Irish Christian relic in that material in the Royal

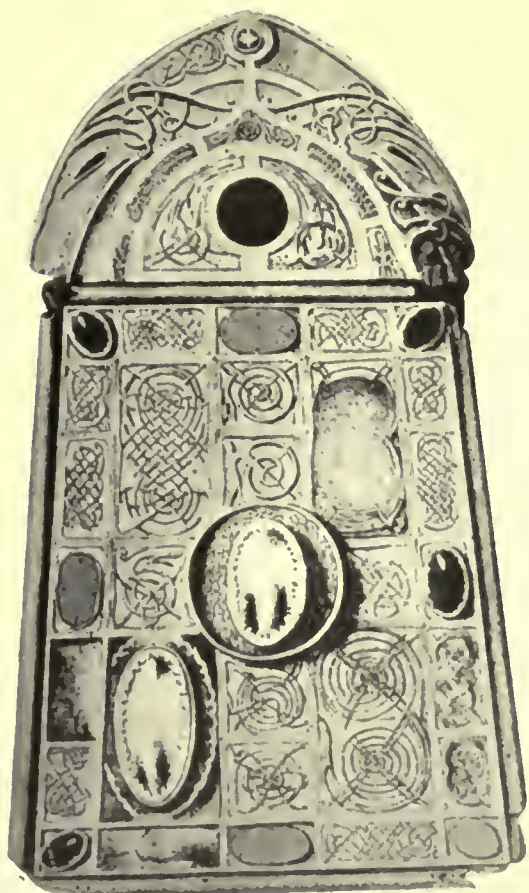

THE SHRINE OF ST. PATRICK'S BELL—
SILVER, JEWELLED

is elaborately interlaced, the four intersecting crosses having specimens of the marbles of the four provinces of Ireland. The center of the staff has a raised bronze band with Celtic ornaments from the

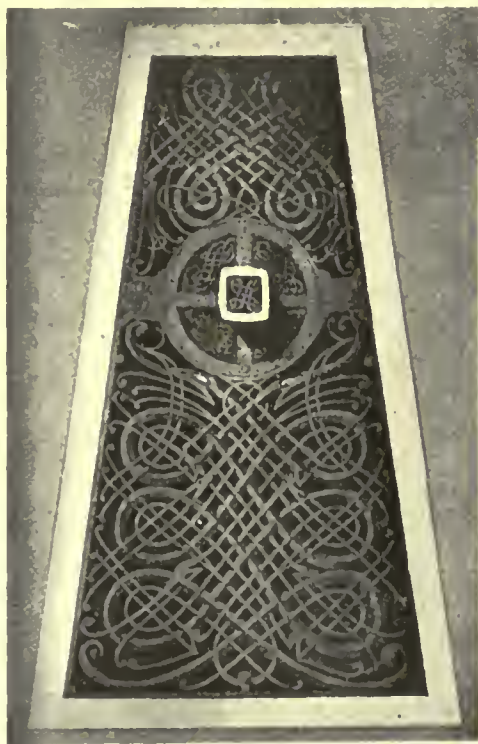

ST. PATRICK'S BELL SHRINE

Irish Academy. It is a square iron bell lined with bronze, and is formed of two sheets of metal, one bent over to meet the other and riveted together.

It is about six inches high, four and three-quarters by one and one-half in width at top and four by five inches at mouth. The outer case, eleven inches high is an exceedingly rich example of art work. On a ground of brass fine filigree of gold and silver applied in curves, interlacings and knots.

On the back of the case or shrine is an inscription in most decorative lettering. This shrine is of copper and originally was covered with gold and silver. In many interlacings, especially on the side there are many intricate patterns of serpents. The beauty of the entire design is of the highest order.

Salvage from Old Buildings on New Plane

With building materials continuing at a high level, and the demand for houses greater than ever before in history, calls for material are constantly being made upon the wreckers of old buildings, and instead of yards being piled high with goods, as was once the case, old brick, second-hand lumber and other materials that enter into home-building are eagerly sought.

There are many peculiar angles to the wrecking and salvage of materials in old homes and other buildings, and contrary to the common belief that handsomely finished buildings with fine interiors are the best for the wrecker, they would rather have plain buildings of ordinary structure to wreck.

"There is always a sale for old material of any nature," said the manager of a large Cincinnati wrecking company. "If you have a place to store it somebody will come along and buy it for some purpose. The only thing is in the waiting.

"Times have changed in the wrecking and salvage of materials," he said. "Some of the things that had a ready sale a quarter of a century ago now are the hardest to get rid of. Take the fine marble mantels that we get out of some of the old homes that have outlived their usefulness. A person would think that they would find a ready sale, but there is no call for them. People today want wood mantels. Unless they are perfect it is hardly worth the trouble to attempt to sell them. Iron mantels that were the rage twenty-five years ago find no market, and are worth almost as much as junk as they are offered for private sale.

"There is a constant demand for brick and lumber, doors and door frames, windows and window frames, and these we sell as fast as we get them. All that is needed is a little care in taking them out of a building and they can be used over again. Iron pipe also finds a ready market, but we junk most of the lead pipe, as plumbers are reluctant to use second-hand lead pipe. It is worth almost as much as junk, so little is lost on it.

"Finely finished interiors have little attraction for the wrecker. Unless extreme care is used the woodwork will be marred and it does not find a ready sale. Some people ask, as a matter of sentiment, that some particular part of a home be saved when we take over a house, but this is infrequent.

"Where does the majority of the salvaged goods go? Well, the best answer to that is 'to the four winds.' The brick and lumber is used largely here in Cincinnati, being bought by contractors. Then the country people come in and ask for certain things they would like to obtain. I would say that we send

things to points within a radius of fifty miles of the city, but it would not pay to ship it any further than that."

Many interesting things are to be seen in the storerooms of the World's Fair Wrecking Company at Gest street and Mill Creek. Chandeliers, from the massive size that once graced Cincinnati's finest homes to the two-burner size, can be found and an occasional seeker after chandeliers of a certain type helps to keep the supply limited.

Fancy tile and roofing slate are also things that find an occasional buyer, but unless they are in good condition these materials are not as a rule saved.

French Property Damaged by War

The completion of the estimates of losses caused by the war now makes it possible to state the number of little villages, farms, and real estate holdings which were partly or wholly destroyed in France. These final estimates, prepared for the use of minister delegates to forthcoming allied conferences, show that 1,659 towns and villages were totally wiped out by war's ravages.

Some of the more interesting returns of these official figures, which have been obtained by the French Section of the Foreign Information Service of the Bankers Trust Company, are as follows:

Number of towns and villages injured:	
In the six departments which were invaded	4,022
In the department of Seine, Seine-et-Oise, Seine-et-Marne, Seine-Inférieure	173
Number of towns and villages in which destruction reached	
100 per cent	1,659
50 to 100 per cent	707
Less than 50 per cent	1,656
Number of real estate holdings	
Entirely destroyed	290,300
Partially destroyed	269,870
Number of private wells damaged or destroyed	62,900
Number of cubic meters of earth to be moved to restore property	42,100,000

As an indication of the progress made in restoring these losses, the official figures show that nearly all the injured towns and villages (4,006) have been re-established and 134,000,000 cubic meters of trenches have been filled up.

THE AMERICAN ARCHITECT



VIEW SHOWING THE RESULT OF BOMB EXPLOSION

YORK & SAWYER, ARCHITECTS

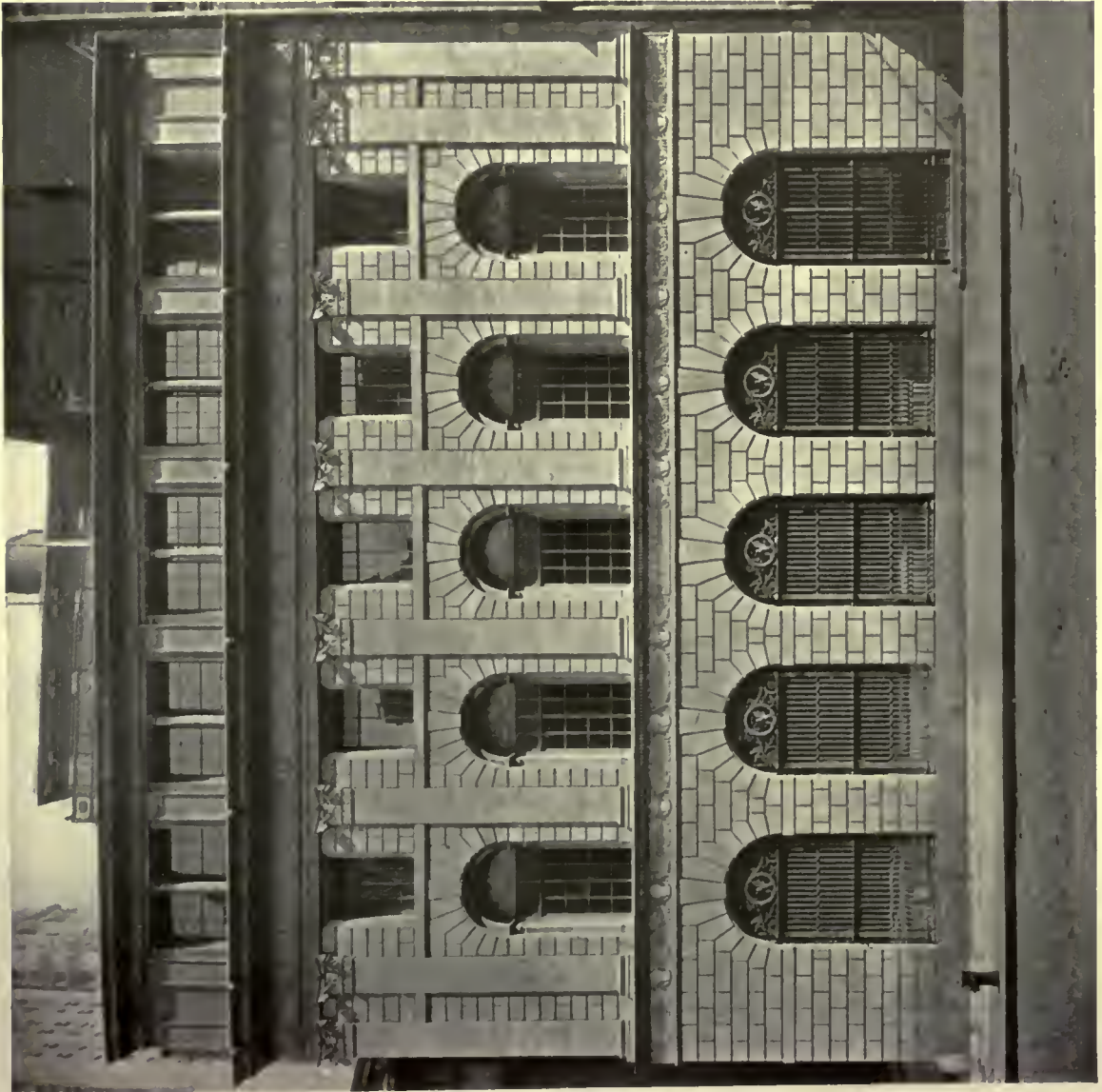

UNITED STATES ASSAY OFFICE, WALL STREET, NEW YORK

St. George's Church, Hempstead, Long Island, New York

(See reproduction of the original drawing by O. R. Eggers in this issue)

WHO designed and built this church is not of record. It is one of the few remaining two-story meeting houses that stand a relic of that past when our forefathers either had or took the time formally to express the religion that so dominated their daily lives.

Like the old church at Lyme, designed originally, it is claimed, by Sir Christopher Wren, and made famous by the brush of Childe Hassam, this Long Island church stands as a solemn reminder of a day when the church was interwoven into not only the religious but the social activities of communities. Its quaint churchyard, where "each in his narrow bed forever laid, the rude forefathers of the hamlet sleep," forms a sacred enclosure in which there has been reared this church.

Its square tower and clock with the latticed windowed cupola suggests those types erected when the dweller on the shore of Long Island Sound and our New England coast was either seafaring or intimately connected with our then important shipping industry. From these cupolas or the balconies that often surrounded them, anxious eyes peered out to sea to mark, if they might, the familiar sail of some long overdue ship.

The intimate relation of these country meeting houses, the fact that they not only served as places of worship but also as community centers, caused them to be regarded with deep reverence and enabled them to receive all the affectionate care that it was possible to give to their design, planning and maintenance. For the small community we might with profit more often look back to this earlier type.

442^a

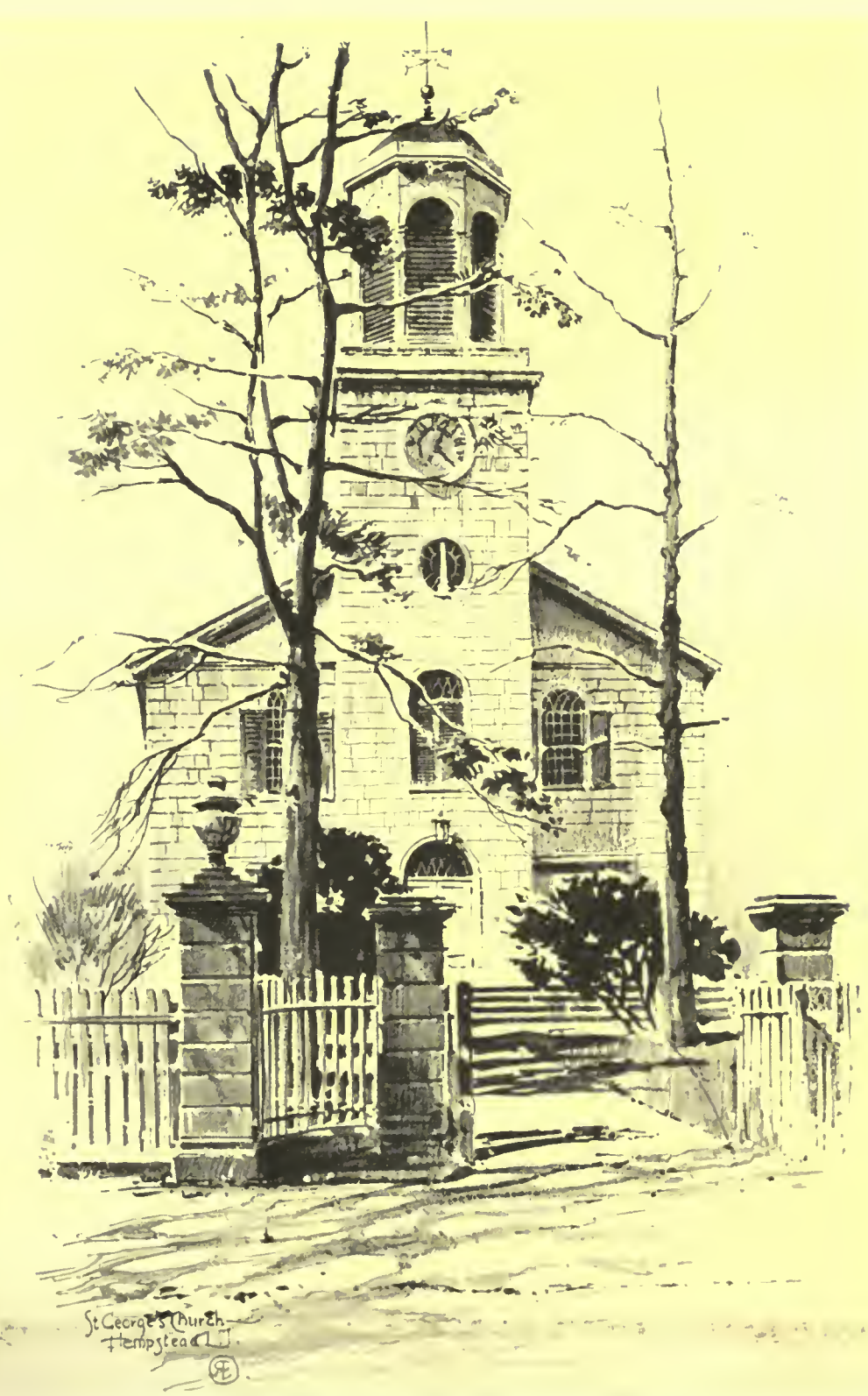

ST. GEORGE'S CHURCH, HEMPSTEAD, L. I.
THE AMERICAN ARCHITECT Series of Early American Architecture





Utilizing a By-Product

IT is a tradition among architects that the present development of textured brick was the result of a resort to the "cull pile" at a brick yard to find enough additional brick to tide over an urgent need. When these had been set into the wall the result was so very satisfactory, so very artistic, that a new idea in brick was evolved. The up-to-that-time standard "Philadelphia pressed brick" at once lost its prominent position and brick makers, active with architects, set about the production of textured brick. The result has been most successful and much of the color present in the architecture of our city streets is due to this simple incident where the "cull pile" was made the source of an artistic result.

It is unfortunate that we are unable to reproduce in color the wonderful tones of the buildings of the Emory University, illustrated in this issue. Mr. Hornbostel has by the use of what was practically a rejected material obtained a result which, like all really good artistic things, does not entirely depend upon the costliness of material used to produce a good effect. Those who are familiar with the rare colored marbles quarried from the hills of Georgia, will recall the dazzling white, the cerulean blue and the richly tinted pink and red hued effects. On a huge pile, the accumulation of years, Mr. Hornbostel found the first sawing of the originally quarried blocks. Much of this rejected material possessed the qualities of rich color and fine effects of weathering that would attract the eye of an architect keenly alive to its artistic possibilities and as keenly alive to the economic value of the material. From this heterogeneous lot of rejected material, Mr. Hornbostel has constructed this important group of buildings. The result may not be adequately described. It must be seen to appreciate the most wonderful effect that has been secured.

IT is "a far cry" from the state of Georgia to the roadside of England, but it is not possible to refrain from a comparison that proves a certain con-

tenion. And that contention is, that the beauty of the rural domestic architecture of England is due to the fact that it is created almost entirely from materials that are taken from the very soil itself. The stones used, the timbers and the thatch, are all from the nearby fields. The result is that the whole effect simply "belongs," it is as if the very houses had grown from the soil itself.

Now, in the case of Mr. Hornbostel's fine group, we have an almost identical result. These "culls" of marble slabs are from the very heart of Georgia, and they find a very appropriate lodgment in a group of buildings that are intended to foster the mental growth of the rising generations of that state.

We shall get nowhere in the evolution of a national type, nor even a regional one, as long as we go so far afield for main structural material, or adhere so strictly to academically expressed motives of design. It was noted in these columns in the issues devoted to the recent convention of the Institute that so similar was the designing and detailing of buildings that were illustrated in the National Collection and exhibition of architectural work that in ignoring the "legends" of locality, no one could even make a remote guess as to the regional location of the buildings. Every state, all regions, have their flora and fauna that provide motives of design that would be a fine encouragement to a regional pride. But with one or two exceptions these were ignored, and in their place we find that same familiar acanthus, the "egg and dart" and the "reed and bead." In like manner the material employed seemed to have flowed from a common source. Mr. Hornbostel's group takes no part in this monotony. These Georgia buildings are built of a Georgia product and the very building seems to take a pride in its right to "belong," for the large surfaces of its windows reflect the graceful forms of the Georgia pines and other arboreal surroundings. We might to great advantage have more of this sort of thing, and when we have we shall be well started toward a freely developed regional type and have escaped the dead level of monotony that now seems to obsess us.

The Middle West has the Right Idea

IN sharp and most satisfactory contrast is the action of the National Building and Construction Congress in the matter of stimulation of building and particularly with reference to the housing situation, as compared with that of the New York State Legislature. On the one hand we have a group of highly trained and specialized men who know their work; on the other a political body who, as the daily papers state, have reached their conclusions and based their final action solely on party lines.

At the Contractors' Congress, opened in Chicago on Sept. 27th, the most energetic element fortunately was in the majority. An effort to postpone definite action until June 1st, when another congress would be convened, was strenuously and successfully opposed. The majority, with characteristic Western energy, demanded immediate action and fortunately for building interests in the Middle West, they got it. The result is that every possible stimulant to building activity that can be applied will be at once organized and set afoot.

E. M. Craig, secretary of the Building Construction Employers' Association of Chicago, was a most strenuous advocate of immediate action.

"Why delay eight months?" said Mr. Craig. "June is a long way off. Meanwhile the people need more houses. Let's start something. Let us stimulate building before spring building starts. We know what's the matter. Factors have been thoroughly discussed.

"The National Board of Awards is now functioning in jurisdictional disputes, which means fewer chances of structures being tied up by such disputes. We ought to tell the public this and start something that will restore public confidence. We ought to have a meeting in January instead of June to stimulate building in the spring."

It is now decided to adopt this policy of prompt action and to further this purpose local committees are to be formed in each community. All of this will tend to bring together in co-operation every element contributing to a resumption of building activity. By these methods there will result, and speedily, a promotion of efficiency and an improvement in quality in the service rendered to the building trades. But what will be of prime importance is that this efficient method, based on the necessities that confront us will early develop an understanding of interdependence within the building industry, so that each part will smoothly work with the other. The result will be the rehabilitation of the building industry, the co-ordination of all of its complex factors and a better all around understanding.

The Western builders have set a fine example to the entire country. The way to resume building is

to resume. The energetic men in the West have shown that apathy at this time borders on a crime. Why not let this enthusiastic and practical spirit spread all over the country? When it does there will be no trouble in securing the right sort of legislation to smooth matters to a speedy and safe conclusion.

The Bomb Explosion

NEVER before in this country has it been possible to learn by practical demonstration just exactly what would be the result of the explosion by hostile act, in time of war, of a bomb in the crowded sections of any of our large cities.

The setting off of a bomb, supposed to have been filled with TNT and a large quantity of metal slugs, in the most congested spot of the financial district in New York on September 16 affords an opportunity to draw certain conclusions based on an actual experience. Undoubtedly the most important element in any attack by a bombing force is the purely psychological aspect, the destroying of the public morale, the lowering of the power of well organized resistance to an attack that cannot with any certainty be foreseen. The material destruction that would be involved bears so small a proportion to a city's area as to be hardly worth consideration.

Careful investigation of the results of the recent explosion in Wall Street would seem to justify the contention that the letting off of even so large a quantity of high explosive, merely subjects the adjoining property to slight surface damage but in no way destroys the stability of the structure. Even in the case of a bomb let off from a plane which finds its point of impact on the top of a building, it is highly improbable that the damage would extend far beyond the building attacked, and in the case of one of our more modern buildings it is reasonable to assume that damage would fall far short of demolition.

It would take many hundreds of bombs to create a condition that would seriously affect the entire city's buildings. The main result would be more largely nerve wracking and morale impairing. Close investigations by trained observers have failed to disclose damage that in the slightest degree impaired the safety of any of the structures within the affected area of the explosion. A large breakage of window glass, estimated to entail a cost of \$250,000 in replacement and the scarring of buildings by flying missiles, seems to have been the sum total of the damage to the Wall Street district.

In technically reviewing this explosion, at no time is the deplorable fact of the large loss of life ignored. When, if ever, we shall trace the perpetrators of this outrage and bring them to the bar of justice, an outraged people will know how speedily to mete out punishment.



H. HORNBOSTEL, ARCHITECT

444

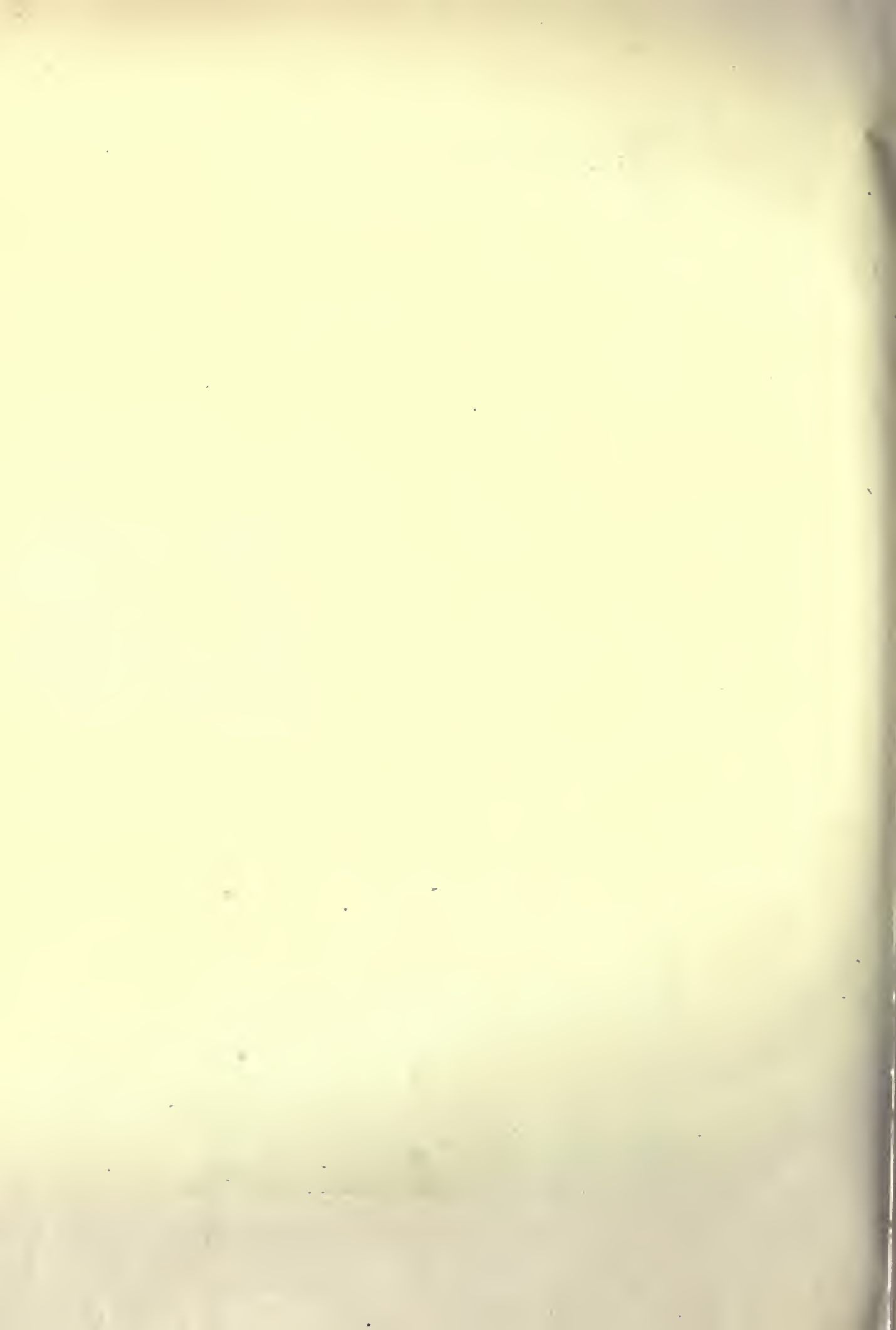



DORMITORY BUILDINGS
EMORY UNIVERSITY, ATLANTA, GA.

H. HOBBS

EMORY UNIVERSITY

ATLANTA, GA.





THEOLOGY BUILDING

EMORY UNIVERSITY, ATLANTA, GA.

H. HORNPOSTEL, ARCHITECT





ANATOMY BUILDING

EMORY UNIVERSITY, ATLANTA, GA.

H. HORNBOSTEL, ARCHITECT



PHYSIOLOGY BUILDING

442



444



MAIN ENTRANCE, THEOLOGY BUILDING
EMORY UNIVERSITY, ATLANTA, GA.
H. HORNPOSTEL, ARCHITECT





LIBRARY WINDOW, THEOLOGY BUILDING

EMORY UNIVERSITY, ATLANTA, GA.
H. HORNOSTEL, ARCHITECT

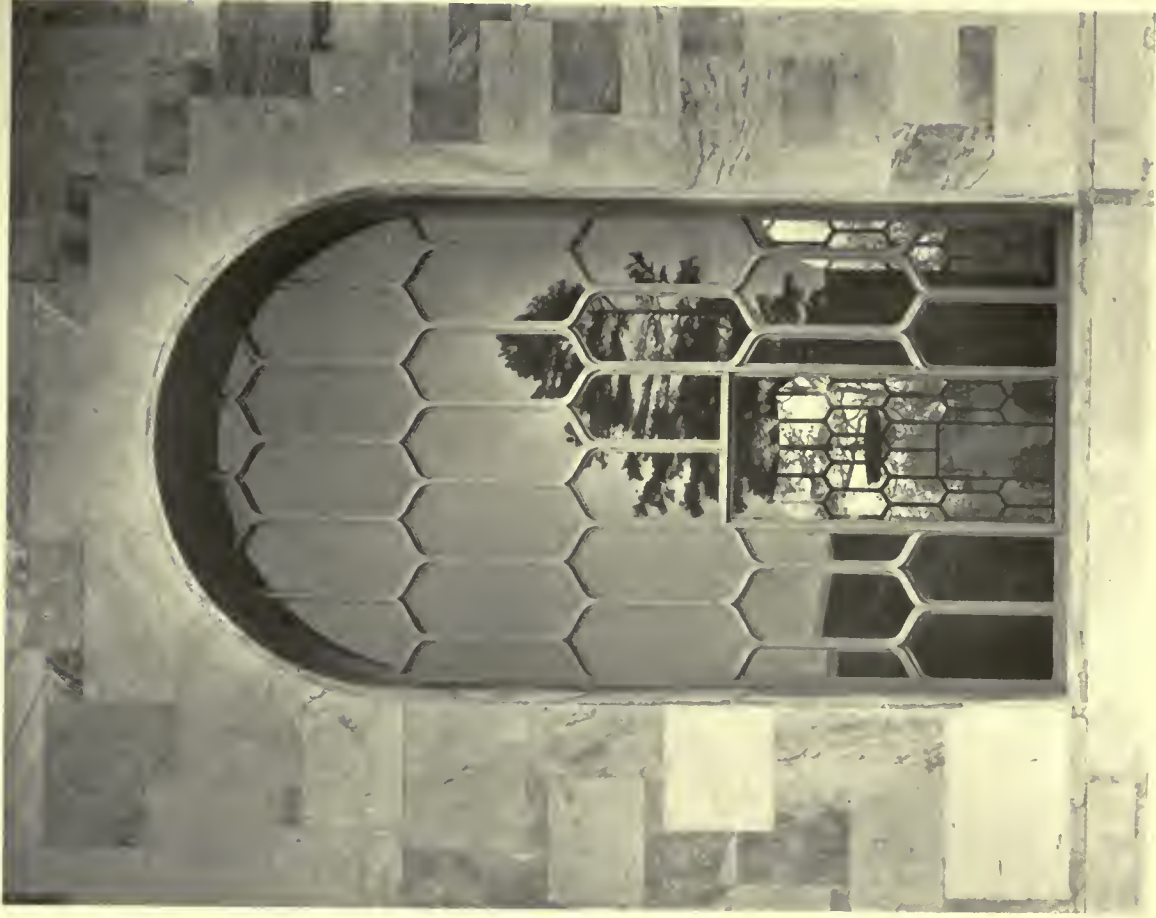

LIBRARY WINDOW, LAW BUILDING

444 b



444 7



MAIN STAIRWAY, LAW BUILDING
EMORY UNIVERSITY, ATLANTA, GA.
H. HORNPOSTEL, ARCHITECT





INTERIOR OF CHAPEL
EMORY UNIVERSITY, ATLANTA, GA.
H. HORNPOSTEL, ARCHITECT



DEPARTMENT OF ARCHITECTURAL ENGINEERING

Report on Paint Exposure Tests at Atlantic City, New Jersey

By HENRY A. GARDNER.

THE paint exposure test panels consisting of wood and metal, both bare and coated with various types of paint and varnish, exposed on Young's Million Dollar Pier at Atlantic City, N. J., and described in the August 27, 1919, issue of THE AMERICAN ARCHITECT, were examined after a period of exposure of one year. Since the composition of the various paints was given in the previous article, this information will not be here repeated. Some very interesting developments have taken place during that time. After the inspection the panels were rearranged for further exposure. The results of the inspection are presented below.

SERIES I—TIN PLATE.

One-half of the back surface of each panel from No. 1 to No. 6 was originally given one coat of spar varnish. Being protected from direct sunlight, the varnish has stood up in most excellent condition, preserving the underlying surface of the panels from corrosion. The uncoated

portion of the under surface shows even greater corrosion than the upper sides, which were exposed to sunlight. This is probably due to the constant presence of moisture on the unexposed surfaces. The moisture had, however, but little effect upon the spar varnish in the absence of direct sunlight,

although only one coat was used as contrasted with three coats on the surfaces exposed to the sun. These tests indicate that sunlight is probably the most destructive factor in the decay of varnish films. They also indicate the great value of varnish in preserving tin plate or other metals from corrosion. Even the heaviest coated tin plate requires surface protection. Table I gives the details relative to this series.

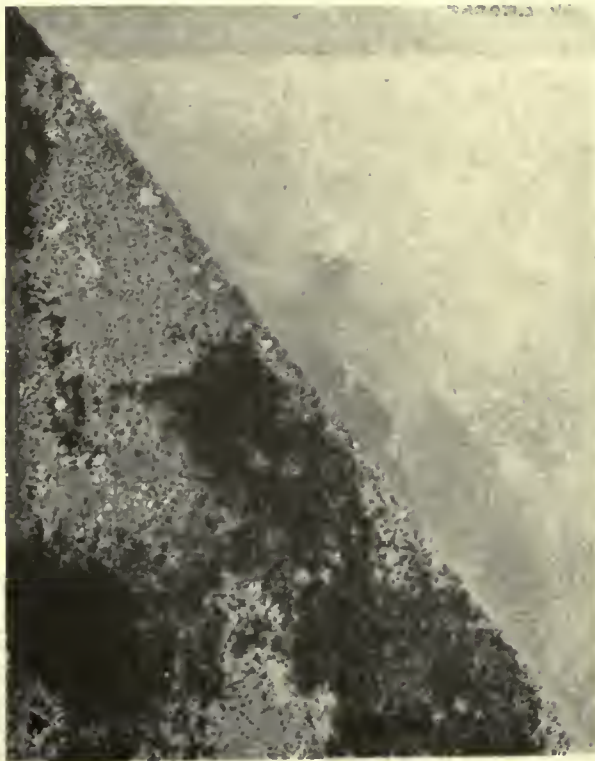

BACK OF PANEL No. 6—SERIES I
Upper portion coated with varnish and in good condition.
Lower portion, left unprotected, is badly corroded.

SERIES II—BLACK SHEET IRON PANELS.

The tests on this series indicate that aluminum powder and zinc powder are both valuable metal protectives, but it is apparent that spar varnish or

THE AMERICAN ARCHITECT

TABLE I.
SERIES I—BARE AND PAINTED TIN PLATE.

No. Panel.	Description of Panel.	Section of Panel.	Treatment.	Condition After Exposure for 1 Year.
1	E-X (Tin Coated)	Upper	Vermilion Paint, 3 coats	O. K.
		Lower	Bare	Very rusty.
2	E-X (Tin Coated)	Upper	Spar Varnish	Slight rust spot at center.
		Lower	Bare	Very rusty.
3	E-X (Tin Coated)	Upper	Collodian Dope D, 1 coat	Film scaled off. Some rust.
		Lower	Bare	Very rusty.
4	A-P 40 lb. (Heavy Tin Coated)	Upper	Vermilion Paint, 3 coats	O. K.
		Lower	Bare	Few small pin-hole rust spots.
5	A-P 40 lb. (Heavy Tin Coated)	Upper	Spar Varnish, 3 coats	O. K.
		Lower	Bare	Film scaled off, but no rust.
6	A-P 40 lb. (Heavy Tin Coated)	Upper	Collodian Dope N, 1 coat	Film scaled off, but no rust.
		Lower	Bare	Few small pin-hole rust spots.

linseed oil are better liquids for exterior exposure than collodion dope, especially in the case of the zinc powder. The very much greater durability of collodion dope containing aluminum powder as compared to clear collodion dope on panel No. 3 or No. 6 should be given attention. The aluminum powder present in the dope has a direct effect in reflecting the sun's rays and thus protecting the dope film from decay. The present condition of these panels is indicated in the last column of Table II.

SERIES III—BLACK AND GALVANIZED SHEET IRON AND STEEL PLATES.

In this series of tests the value of a paint coating in protecting metal from corrosion is clearly demonstrated. It is apparent that even the highest grades of carefully made black sheets cannot be exposed for even a short period without surface protection. Test panels No. 11 and 12 show that linseed oil has a

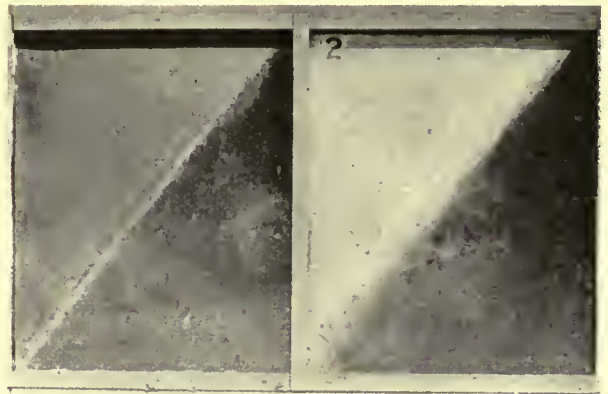

PANELS 1 AND 2 OF SERIES I

This test illustrates the desirability of painted or varnished tin plate. The lower portions, showing rust, were unprotected.

longer life than spar varnish, although the varnish is initially more water-resisting. Table III gives the data in detail relative to this series.

SERIES IV—WAR PAINTS ON SHEET METAL.

This series indicates the value of several of the paints made use of by the United States Government during its extensive war work. Except for test panel No. 20 these paints showed to good advantage. Test panel No. 23 indicates the value of grinding pigments in spar varnish to increase the durability of the coating. The light reflecting value of the pigment accomplishes the purpose of protecting the varnish film from decay. The effects of exposure on this series are given in Table IV.

ADDITIONAL TEST PANELS.

The results of the tests, insofar as they relate to the wood panels are given in tables V to VIII, inclusive.

The wood panels, consisting of white and yellow pine, cypress and redwood, show very

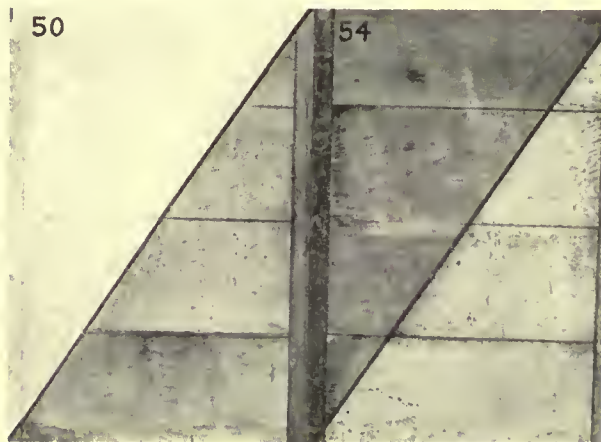

TWO WOOD PANELS OF SERIES V

Upper sections in excellent condition. Lower sections already show decay.

TABLE II.
SERIES II—BLACK IRON PANELS, BARE AND COATED WITH METAL POWDER COMPOSITIONS.

Panel No.	Description of Panel.	Section of Panel.	Treatment.	Condition After Exposure for 1 Year.
7	Open Hearth Steel (Black Sheet)	Upper	Aluminum powder in Spar Var., 2 coats.	O. K.
		Lower	Aluminum powder in Lins'd Oil, 2 coats.	A few pin-hole rust spots.
8	Open Hearth Steel (Black Sheet)	Upper	Aluminum powder in Collodion Dope D, 2 coats.	A few slight rust spots.
		Lower	Bare	Very rusty.
9	Open Hearth Steel (Black Sheet)	Upper	Zinc powder in Spar Varnish, 2 coats.	O. K.
		Lower	Zinc powder in Linseed Oil, 2 coats.	A few slight rust spots.
10	Open Hearth Steel (Black Sheet)	Upper	Zinc powder in Collodion Dope D, 2 coats.	Sealed off in many spots.
		Lower	Bare	Very rusty.

THE AMERICAN ARCHITECT

TABLE III.

SERIES III—BLACK AND GALVANIZED SHEET IRON AND STEEL PLATES.

Panel No.	Description of Panel.	Section of Panel.	Treatment.	Condition After Exposure for 1 Year.
11	Open Hearth Steel (Galvanized)	Upper	Spar Varnish, 3 coats	Protective film nearly gone.
		Lower	Bare	O. K.
12	Open Hearth Steel (Galvanized)	Upper	Linseed Oil, 3 coats	O. K.
		Lower	Bare	O. K.
13	Open Hearth Steel (Galvanized)	Upper	Copper brushed, then vermilion paint, 3 coats	Film showing slight scaling.
		Lower	Bare	O. K.
14	Open Hearth Steel (Black Sheet)	Upper	Vermilion paint, 3 coats	O. K.
		Lower	Bare	Very rusty.
15	Copperized Steel (Galvanized)	Upper	Copper brushed, then vermilion paint, 3 coats	Film showing slight scaling.
		Lower	Bare	O. K.
16	Copperized Steel (Black Sheet)	Upper	Vermilion paint, 3 coats	O. K.
		Lower	Bare	Very rusty.
17	R-R Iron (Galvanized)	Upper	Copper brushed, then vermilion paint, 3 coats	O. K.
		Lower	Bare	O. K.
18	R-R Iron (Black Sheet)	Upper	Vermilion paint, 3 coats	O. K.
		Lower	Bare	Very rusty.
19	R-R Iron (Heavy Tin Coating)	Upper	Vermilion paint, 3 coats	O. K.
		Lower	Bare	Badly spotted with rust.

clearly the need of surface protection by timber.

An inspection of the "close-up" of one of the panels of Series V, reproduced on page 448, shows the extent to which the weather etching has progressed during a period of only twelve months, whereas the surfaces protected by paint or varnish are in excellent condition. The value of lead and zinc paints was brought out during the war, and the behavior of the prepared lead and zinc paint used on panels 50 to 53 of Series V is of interest.

Although the manufacture of paint dates back many years, it is true that we yet have much to learn about this product. When the materials and labor which entered into the manufacture of paint, as well as the labor necessary for its application, were less costly than today there was perhaps greater excuse for a lack of definite knowledge as to the service which combinations of various pigments and vehicles would give. But when we consider the cost of application alone, it is distinct economy to use the paint or varnish which will give the greatest protection for the longest period. It therefore becomes necessary for the architect, as far as possible, to acquaint himself with the service records of different compositions in order to know the merits of these

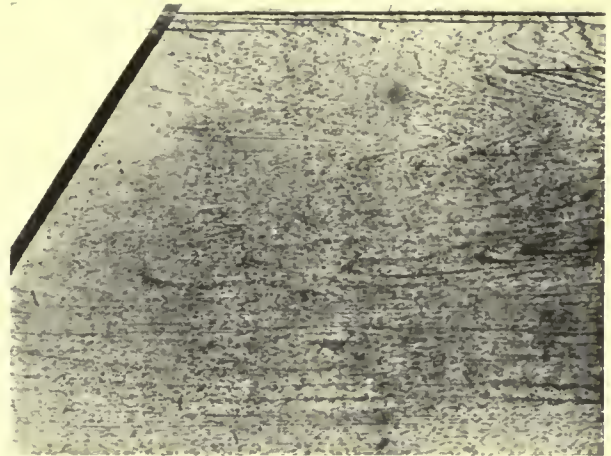

DETAIL VIEW OF UNPROTECTED WOOD PANEL IN SERIES V

Note the spots and excessive pitting.

protecting coatings. The Educational Bureau, Scientific Section of the Paint Manufacturers' Association of the United States, with which the National Varnish Manufacturers' Association is co-operating, and of which the author is director, has been conducting investigations which are making available such data.

TABLE IV.

SERIES IV—WAR PAINTS ON SHEET METAL.

Panel No.	Description of Panel.	Section of Panel.	Treatment.	Condition After Exposure for 1 Year.
20	Open Hearth Steel (Black Sheet)	Upper	Spar Varnish (W. D. 6), 3 coats	Film disintegrated and rust developed.
		Lower	Bare	Very rusty.
21	Open Hearth Steel (Black Sheet)	Upper	Spar Varnish, 3 coats	Film disintegrated and rust developed.
		Lower	Linseed Oil, 3 coats	Rusty below oil film but film is in good condition
22	Open Hearth Steel (Black Sheet)	Upper	Camouflage O. R. 333, 3 coats	O. K.
		Lower	Camouflage N. O. R. 334, 3 coats	O. K.
23	Open Hearth Steel (Black Sheet)	Upper	Yellow W. D. 37 and Olive Green W. D. 33 Projectile Paints, 3 coats	These four paints show very dull surface
		Lower	Blue W. D. 34 and Black W. D. 38 Only a very few slight rust spots discernible.	
24	Open Hearth Steel (Black Sheet)	Upper	Brown Enamel Primer W. D. 13, 1 coat	
		Lower	Red Oxide W. D. 11, 2 coats	O. K.
25	Open Hearth Steel (Black Sheet)	Upper	Reinforced Red Lead Ready Mixed W. D. 40, 3 coats	O. K., but slightly dull.
		Lower	Red Lead Hand Mixed, 3 coats	O. K.
26	Open Hearth Steel (Black Sheet)	Upper	Helmet Paint, 3 coats	Heavy checking.
		Lower	Navy Camouflage, Gray, 3 coats	O. K.
27	Open Hearth Steel (Black Sheet)	Upper	Standard Olive Drab, W. D. 28, 3 coats	O. K.
		Lower	Quick Drying Olive Drab W. D. 29, 3 coats	Few slight pin-hole rust spots.

THE AMERICAN ARCHITECT

TABLE V.
SERIES V.—WOOD PANEL TESTS.

Panel No.	Description of Panel.	Section of Panel.	Treatment.	Condition After Exposure for 1 Year.
50	White Pine	Upper... Bare	White Paint, 3 coats	Painted or varnished wood surfaces are in generally excellent condition. Uncoated wood surfaces are rough, pitted, weather-etched, and covered with spots of black fungua growth.
		Lower... Bare		
51	Yellow Pine	Upper... Bare	White Paint, 3 coats	
		Lower... Bare		
52	Cypress	Upper... Bare	White Paint, 3 coats	
		Lower... Bare		
53	Red Wood	Upper... Bare	White Paint, 3 coats	
		Lower... Bare		
54	White Pine	Upper... Bare	Spar Varnish, 3 coats	
		Lower... Bare		
55	Yellow Pine	Upper... Bare	Spar Varnish, 3 coats	
		Lower... Bare		
56	Cypress	Upper... Bare	Spar Varnish, 3 coats	
		Lower... Bare		
57	Red Wood	Upper... Bare	Spar Varnish, 3 coats	
		Lower... Bare		

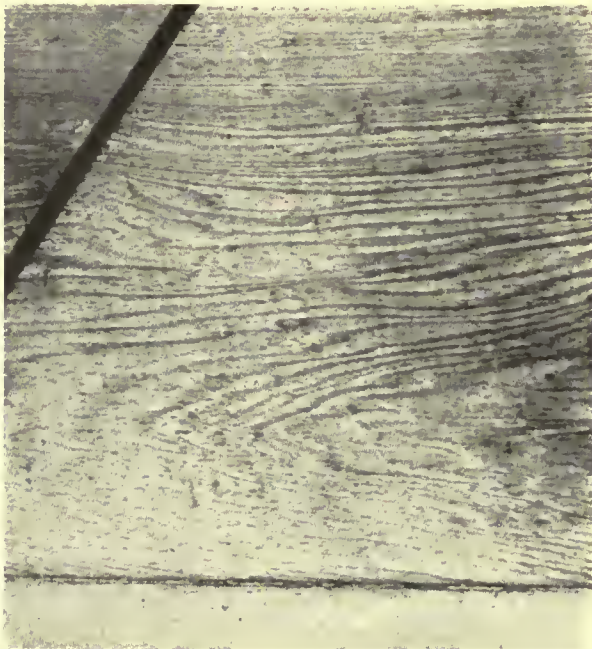

ABOVE—CLOSE-UP VIEW OF UNPROTECTED WOOD PANEL OF SERIES V

Note weather etching, pitting, etc.

AT RIGHT—PANELS 57 AND 53 OF SERIES V

Upper portion of panel 57 coated with spar varnish; of 53 with white paint. Both are in excellent condition. Lower portions of both panels left bare. These are rough, weather etched, etc.

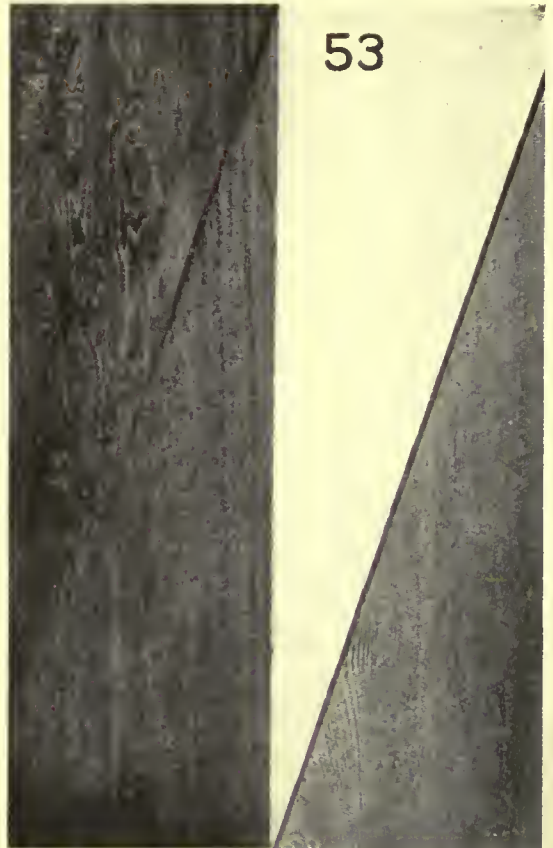

TABLE VI.
SERIES VI.—WAR PAINTS ON WOOD.

Panel No.	Description of Panel.	Section of Panel.	Treatment.	Condition After Exposure for 1 Year.
58	Cypress	Entire Panel	Primed with Red Lead, then: Upper... Exterior Paint, Pearl Gray W. D. 50, 3 coats Lower... Exterior Fire Resisting Paint, Gray Green W. D. 21, 3 coats	O. K. Moderate chalking only.
59	Cypress	Entire Panel	Primed with Red Lead, then: Upper Board 1. Anti-Actinic Wing Enamel Army Olive Drab, 3 coats Upper Board 2. Anti-Actinic Wing Enamel Light Gray, 3 coats Lower Boards. Anti-Actinic Wing Enamel Semi-Flat 1 and 2 Navy Dept. Aero. Spec. C. & R. No. 3, 3 coats	O. K., except where bird shot have penetrated 2 upper boards. Moderate chalking developed.

THE AMERICAN ARCHITECT

TABLE VII.

SERIES VII.—SPECIAL PRIMER TESTS ON WOOD.

Panel No.	Description of Panel.	Section of Panel.	Treatment.	Condition After Exposure for 1 Year.
60	Yellow Pine	Upper 2 Boards	Vermillion Paint, 1 coat	White paint checking over black and red. Panel removed for Laboratory study.
		Lower 2 Boards	Lampblack, 1 coat	
		Right half of panel	Then coated with White Paint, 3 coats	
		Left half of panel	Coated with Spar Varnish, 3 coats	
61	Cypreas	Upper 2 Boards	Vermillion Paint, 1 coat	O. K.
		Lower 2 Boards	Lampblack, 1 coat	
		Right half of panel	Then coated with White Paint, 3 coats	
		Left half of panel	Coated with Spar Varnish, 3 coats	
62	White Pine	Upper 2 Boards	Lampblack, 1 coat; then White Paint, 3 coats	Heavy checking noted over lampblack. Panel removed for Laboratory study.
		Lower 2 Boards	Bare, then White Paint, 3 coats	

TABLE VIII.

SERIES VIII.—SPECIAL TESTS.

Panel No.	Description of Panel.	Section of Panel.	Treatment.	Condition After Exposure for 1 Year.
63	White Pine	1st Board	Red Paint, 3 coats	Panel removed for Laboratory study of thermal properties.
		2d Board	Green Paint, 3 coats	
		3d Board	Yellow Paint, 3 coats	
		4th Board	Black Paint, 3 coats	
64	White Pine	Upper 2 Boards	Red Oxide Machine Ground, 3 coats	O. K.
		Lower 2 Boards	Rex Oxide Hand Mixed, 3 coats	
65	White Pine	Upper 2 Boards	White Paint Pure Oil, 3 coats	Good condition except where birdshot have penetrated 2 upper boards. Panel removed for Laboratory study.
		Lower 2 Boards	White Paint Foots Oil, 3 coats	
66	White Pine	1st Board	White Paint B-T-X	Very slight checking and moderate chalking. Few slight scale spots at joints.
		2d Board	Yellow Paint B-T-X	
		3d Board	Gray Paint B-T-X	
		4th Board	Blue Paint B-T-X	
67	White Pine	1st Board	White Paint L-Z-X	Very slight checking and moderate chalking. Few slight scale spots at joints.
		2d Board	Yellow Paint L-Z-X	
		3d Board	Gray Paint L-Z-X	
		4th Board	Blue Paint L-Z-X	
68	White Pine	Upper	Spar Varnish, 5 coats	Disappeared from fence.
		Lower	Linseed Oil, 5 coats	

Many Problems Confront Construction Industry

The recent action of the Federal Reserve Board in the curtailments of credit is being interpreted by many member banks as a further curtailment of loans on construction, but the usury laws already prevent bidding by the construction industry of interest rates in competition with the consumables and luxuries of commerce. On the other hand, rent regulating laws make housing less and less attractive to capital, and as money goes where it makes friends, the housing shortage is accumulating.

Relief can only come through the cooperation of the transportation, financial and labor groups, and there are those who now venture to state that it cannot be realized unless new construction is exempted from taxation for a period of years.

The curtailment of construction during the war, the successive freight embargoes, the discrimination against long term loans, labor troubles, difficulty of obtaining fuel, together with the uncertainty of returns from rentals, occurring successively during the past five years, have hardly left the construction industry without some element of change or restriction for a month at a time.

To those engaged in the construction industry who believe that the very basis of credit is earning power, whether it be the earning power of the individual, the firm or a community, it is very evident that the earning power of the nation is decreasing through the continued dilapidation of its plant, and it is equally evident to them that the practical way to increase production is to increase the means of production and distribution—the tools of industry, and that the deferring of the rehabilitation of construction will not decrease the ultimate cost of the structures but will result in a continued loss to those who need to use the transportation systems, the highways and housing.

With the uncertainty of freight, fuel and labor on the one hand and the uncertainty of returns through rent regulations on the other hand, those engaged in the construction industries, are in the position of the unfortunate billiard player who was condemned to play "on a cloth untrue, with a twisted cue and elliptical billiard balls."

It is believed, however, that the Senate Committee will carefully weigh the presentation of the various phases of the matters which influence the construction of the nation, that it does not favor a housing subsidy or a national housing program

Short Cuts to Accurate Calculations

Computing Steam Radiation,

WHILE it may often be necessary to make extended calculations in the design of a heating system, yet many cases will present themselves in which it will be possible to arrive at a solution by the use of either the accompanying table or chart with but a small amount of multiplication. Both are presented, and it will be found that very close results are obtainable by the use of either. It is quite possible that the table will appeal to some, while the chart will seem more simple of application

air change in the room, which is assumed at one or more complete changes per hour, depending on the tightness of the construction. The radiator must supply sufficient heat to make up the deficit caused by these two factors. The area of exposed wall and glass surface must be computed and multiplied by the proper factors, and also the air change per hour in cubic feet. If this is but one per hour, it will, of course, equal the cubical contents of the room. For roofs and floors over unheated spaces, heat loss

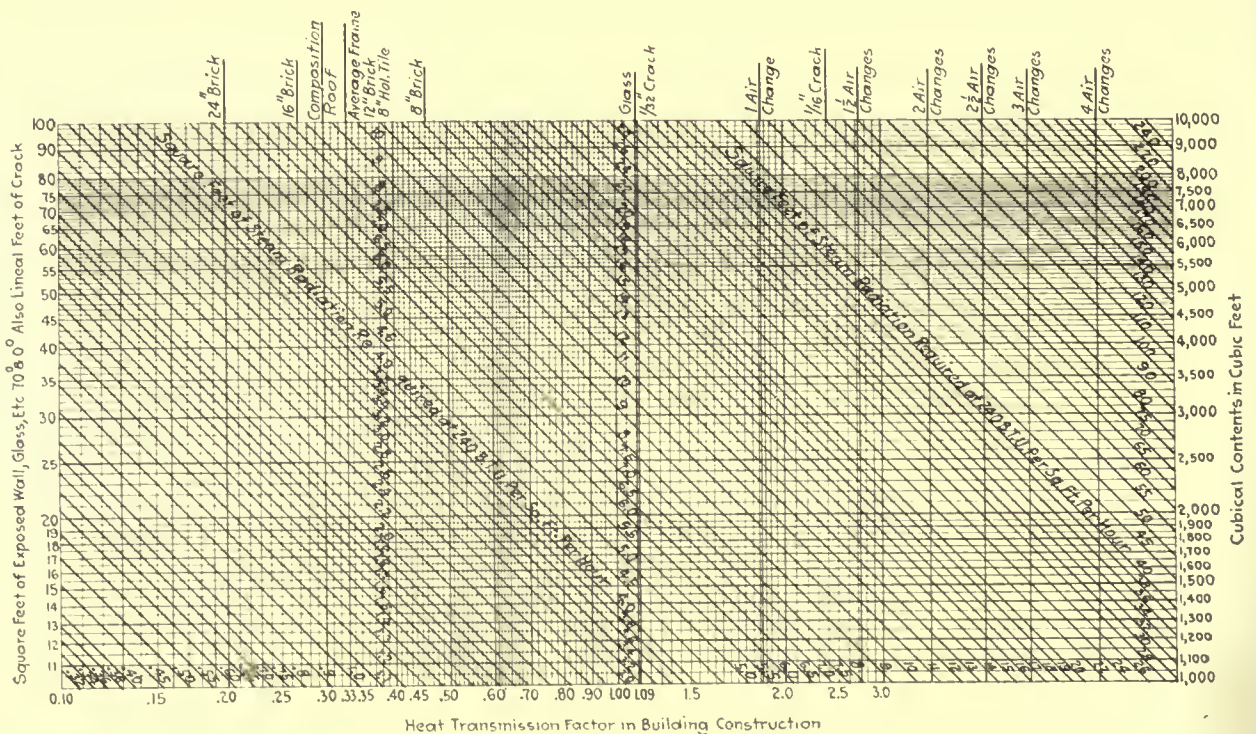

CHART FOR COMPUTING STEAM RADIATION

to others. By the use of the latter, less calculation is required.

In order to demonstrate the use of these time saving helps, several examples will be worked out. It might be well, however, first to outline the method of procedure in computing the heat loss of any enclosed space.

First, heat is lost through the walls, windows, floors, ceilings, etc., the quantity depending on the nature of the construction and difference between inside and outside temperature; secondly, heat is lost by leakage at doors and windows. Unless forced ventilation is used this leakage is responsible for the

through such construction must also be taken into consideration.

Problem No. 1.—To determine the number of square feet of steam radiation required to maintain an inside temperature of 70 deg. F. with an outside temperature of zero, for a room 20 x 30 ft. and 10 ft. high, exposed on the 30 ft. side only, this wall containing five windows 5 x 5 ft. each. One air change per hour. Exterior wall constructed of brick, 12 in. thick.

Solution.—Total exposed wall surface (30 x 10 less area of windows) = 200 sq. ft.

Total area of windows = 4 x 5 x 5 = 100 sq. ft.

THE AMERICAN ARCHITECT

Air change per hour (cubical contents of room) = 20 x 30 x 10 = 6000 cu. ft.

By reference to the table, we have under the column headed "70 deg." and opposite "12 in. brick wall" a factor of .0868 which must be multiplied by the wall area, giving 200 x .0868 = 17.36.

Similarly, the area of single window surface (in sq. ft.) multiplied by the value opposite "Single win-

To solve this problem by use of the chart proceed as follows:

Run along left hand vertical line marked "Square Feet of Exposed Wall, Glass, Etc." until a figure corresponding to the wall area is encountered. Since this only gives values up to 100, for larger areas it is necessary to take values of one-tenth and multiply the results obtained by ten. In this case the ex-

TABLE FOR COMPUTING STEAM RADIATION

MATERIAL	Heat Loss per sq. ft.	Difference Between Inside and Outside Temperatures																						
		10°	10°	15°	20°	25°	30°	35°	40°	45°	50°	55°	60°	65°	70°	75°	80°	85°	90°	95°	100°	105°	110°	
One air change per hour per cu. ft. contents		.00008	.0008	.0012	.0016	.002	.0024	.0028	.0032	.0036	.004	.0044	.0048	.0052	.0056	.006	.0064	.0068	.0072	.0076	.008	.0084	.0088	
Single Window	1.03	.00412	.0412	.0618	.0824	.103	.1236	.1442	.1648	.1854	.206	.2266	.2472	.2678	.2884	.309	.3296	.3502	.3708	.3914	.412	.4326	.4532	
Double Window	5.18	.02207	.0207	.0305	.0414	.0515	.0621	.0725	.0828	.09315	.1035	.11385	.1242	.13455	.1449	.15525	.1656	.17595	.1863	.19665	.207	.21735	.2277	
Single Skylight	1.118	.00447	.0447	.06705	.0894	.11175	.1341	.15645	.1788	.20115	.2235	.24585	.2682	.29055	.3129	.33525	.3576	.37995	.4023	.42465	.447	.46935	.4917	
Double Skylight	.621	.00248	.0248	.0372	.0496	.062	.0744	.0868	.0992	.1116	.124	.1364	.1488	.1612	.1736	.186	.1984	.2108	.2232	.2356	.248	.2604	.2728	
Brick Wall	4"	.68	.00212	.0212	.0408	.0544	.068	.0816	.0952	.1088	.1224	.136	.1496	.1632	.1768	.1904	.204	.2176	.2312	.2448	.2584	.272	.2856	.2992
" "	8"	.46	.00184	.0184	.0276	.0368	.046	.0552	.0644	.0736	.0828	.092	.1012	.1104	.1196	.1288	.138	.1472	.1564	.1656	.1748	.184	.1932	.2024
" "	12"	.31	.00124	.0124	.0186	.0248	.031	.0372	.0434	.0496	.0558	.062	.0682	.0744	.0806	.0868	.093	.0992	.1054	.1116	.1178	.124	.1302	.1364
" "	16"	.26	.00104	.0104	.0156	.0208	.026	.0312	.0364	.0416	.0468	.052	.0572	.0624	.0676	.0728	.078	.0832	.0884	.0936	.0998	.104	.1092	.1144
" "	20"	.23	.00092	.0092	.0138	.0184	.023	.0276	.0322	.0368	.0414	.046	.0506	.0552	.0598	.0644	.069	.0736	.0782	.0828	.0874	.092	.0966	.1012
" "	24"	.20	.0008	.008	.012	.016	.02	.024	.028	.032	.036	.04	.044	.048	.052	.056	.06	.064	.068	.072	.076	.08	.084	.088
" "	28"	.174	.0007	.007	.0105	.014	.0175	.021	.0245	.028	.0315	.035	.0385	.042	.0455	.049	.0525	.056	.0595	.063	.0665	.07	.0735	.077
" "	32"	.15	.0006	.006	.009	.012	.015	.018	.021	.024	.027	.03	.033	.036	.039	.042	.045	.048	.051	.054	.057	.06	.063	.066
" "	36"	.13	.00052	.0052	.0078	.0104	.013	.0156	.0182	.0208	.0234	.026	.0286	.0312	.0338	.0364	.039	.0416	.0442	.0468	.0494	.052	.0546	.0572
" "	40"	.115	.00046	.0046	.0069	.0092	.0115	.0138	.0161	.0184	.0207	.023	.0253	.0276	.0299	.0322	.0345	.0368	.0391	.0414	.0437	.046	.0483	.0506
Stone Wall	4"	.91	.00364	.0364	.0546	.0728	.091	.1092	.1274	.1456	.1638	.182	.2002	.2184	.2366	.2548	.273	.2912	.3094	.3276	.3458	.364	.3822	.4004
" "	8"	.61	.00244	.0244	.0366	.0488	.061	.0732	.0854	.0976	.1098	.122	.1342	.1464	.1586	.1708	.183	.1952	.2074	.2196	.2318	.244	.2562	.2684
" "	12"	.41	.00164	.0164	.0246	.0328	.041	.0492	.0574	.0656	.0738	.082	.0902	.0984	.1066	.1148	.123	.1312	.1394	.1476	.1558	.164	.1722	.1804
" "	16"	.35	.0014	.014	.021	.026	.035	.042	.049	.056	.063	.07	.077	.084	.091	.098	.105	.112	.119	.126	.133	.14	.147	.154
" "	20"	.31	.00124	.0124	.0186	.0248	.031	.0372	.0434	.0496	.0558	.062	.0682	.0744	.0806	.0868	.093	.0992	.1054	.1116	.1178	.124	.1302	.1364
" "	24"	.27	.00108	.0108	.0162	.0216	.027	.0324	.0376	.0432	.0486	.054	.0594	.0648	.0702	.0756	.081	.0864	.0918	.0972	.1026	.108	.1134	.1188
" "	28"	.23	.00092	.0092	.0138	.0184	.023	.0276	.0322	.0368	.0414	.046	.0506	.0552	.0598	.0644	.069	.0736	.0782	.0828	.0874	.092	.0966	.1012
" "	32"	.20	.0008	.008	.012	.016	.02	.024	.028	.032	.036	.04	.044	.048	.052	.056	.06	.064	.068	.072	.076	.08	.084	.088
" "	36"	.17	.00068	.0068	.0102	.0136	.017	.0204	.0238	.0272	.0306	.034	.0374	.0408	.0442	.0476	.051	.0544	.0578	.0612	.0646	.068	.0714	.0748
" "	40"	.15	.0006	.006	.009	.012	.015	.018	.021	.024	.027	.03	.033	.036	.039	.042	.045	.048	.051	.054	.057	.06	.063	.066
Concrete Wall	4"	.82	.00328	.0328	.0492	.0656	.082	.0984	.1148	.1312	.1476	.164	.1804	.1968	.2132	.2296	.246	.2624	.2788	.2952	.3116	.328	.3444	.3608
" "	8"	.55	.0022	.022	.033	.044	.055	.066	.077	.088	.099	.11	.121	.132	.143	.154	.165	.176	.187	.198	.209	.22	.231	.242
" "	12"	.37	.00149	.0149	.0222	.0296	.037	.0444	.0518	.0592	.0666	.074	.0814	.0888	.0962	.1036	.111	.1184	.1258	.1332	.1406	.148	.1554	.1628
" "	16"	.31	.00124	.0124	.0186	.0248	.031	.0372	.0434	.0496	.0558	.062	.0682	.0744	.0806	.0868	.093	.0992	.1054	.1116	.1178	.124	.1302	.1364
" "	20"	.28	.00112	.0112	.0168	.0224	.028	.0336	.0392	.0448	.0504	.056	.0616	.0672	.0728	.0784	.084	.0896	.0952	.1008	.1064	.112	.1176	.1232
" "	24"	.24	.00096	.0096	.0144	.0192	.024	.0288	.0336	.0384	.0432	.048	.0528	.0576	.0624	.0672	.072	.0768	.0816	.0864	.0912	.096	.1008	.1056
" "	28"	.21	.00084	.0084	.0126	.0168	.021	.0252	.0294	.0336	.0378	.042	.0462	.0504	.0546	.0588	.063	.0672	.0714	.0756	.0798	.084	.0882	.0924
" "	32"	.18	.00072	.0072	.0108	.0144	.018	.0216	.0252	.0288	.0324	.036	.0396	.0432	.0468	.0504	.054	.0576	.0612	.0648	.0684	.072	.0756	.0792
" "	36"	.16	.00064	.0064	.0096	.0128	.016	.0192	.0224	.0256	.0288	.032	.0352	.0384	.0416	.0448	.048	.0512	.0544	.0576	.0608	.064	.0672	.0704
" "	40"	.14	.00056	.0056	.0084	.0112	.014	.0168	.0196	.0224	.0252	.028	.0308	.0336	.0364	.0392	.042	.0448	.0476	.0504	.0532	.056	.0588	.0616
Hollow Tile Wall	4"	.51	.00204	.0204	.0306	.0408	.051	.0612	.0714	.0816	.0918	.102	.1122	.1224	.1326	.1428	.153	.1632	.1734	.1836	.1938	.204	.2142	.2244
" "	8"	.345	.00138	.0138	.0207	.0276	.0345	.0414	.0483	.0552	.0621	.069	.0759	.0828	.0897	.0966	.1035	.1104	.1173	.1242	.1311	.138	.1449	.1518
" "	12"	.23	.00092	.0092	.0138	.0184	.023	.0276	.0322	.0368	.0414	.046	.0506	.0552	.0598	.0644	.069	.0736	.0782	.0828	.0874	.092	.0966	.1012
" "	16"	.195	.00078	.0078	.0117	.0156	.0195	.0234	.0273	.0312	.0351	.039	.0429	.0468	.0507	.0546	.0585	.0624	.0663	.0702	.0741	.078	.0819	.0858
" "	20"	.17	.00068	.0068	.0102	.0136	.017	.0204	.0238	.0272	.0306	.034	.0374	.0408	.0442	.0476	.051	.0544	.0578	.0612	.0646	.068	.0714	.0748
" "	24"	.15	.0006	.006	.009	.012	.015	.018	.021	.024	.027	.03	.033	.036	.039	.042	.045	.048	.051	.054	.057	.06	.063	.066
Studs with Clap Boards	.44	.00176	.0176	.0264	.0352	.044	.0528	.0616	.0704	.0792	.088	.0968	.1056	.1144	.1232	.132	.1408	.1496	.1584	.1672	.176	.1848	.1936	
Studs with Clap Boards a Blg. Paper	.31	.00124	.0124	.0186	.0248	.031	.0372	.0434	.0496	.0558	.062	.0682	.0744	.0806	.0868	.093	.0992	.1054	.1116	.1178	.124	.1302	.1364	
" " " " Paper & Sheath.	.23	.00092	.0092	.0138	.0184	.023	.0276	.0322	.0368	.0414	.046	.0506	.0552	.0598	.0644	.069	.0736	.0782	.0828	.0874	.092	.0966	.1012	
" " " " " Sheathing	.28	.00112	.0112	.0168	.0224	.028	.0336	.0392	.0448	.0504	.056	.0616	.0672	.0728	.0784	.084	.0896	.0952	.1008	.1064	.112	.1176	.1232	
Roof - Slate Exposed	.80	.0032	.032	.048	.064	.08	.096	.112	.128	.144	.16	.176	.192	.208	.224	.24	.256	.272	.288	.304	.32	.336	.352	
Roof - Slate Over Wood	.30	.0012	.012	.018	.024	.03	.036	.042	.048	.054	.06	.066	.072	.078	.084	.09	.096	.102	.108	.114	.12	.126	.132	
Roof - Iron Exposed	1.32	.00528	.0528	.0792	.1056	.132	.1584	.1848	.2112	.2376	.264	.2904	.3168	.3432	.3696	.396	.4224	.4488	.4752	.5016	.528	.5544	.5808	
Roof - Iron Over Wood	.17	.00068	.0068	.0102	.0136	.017	.0204	.0238	.0272	.0306	.034	.0374	.0408	.0442	.0476	.051	.0544	.0578	.0612	.0646	.068	.0714	.0748	
Roof - Composition Over Wood	.30	.0012	.012	.018	.024	.03	.036	.042	.048	.054	.06	.066	.072	.078	.084	.09	.096	.102	.108	.114	.12	.126	.132	
Roof - 1/8" Tile - 1" Thick	.80	.0032	.032	.048	.064	.08	.096	.112	.128	.144	.16	.176	.192	.208	.224	.24	.256	.272	.288	.304	.32	.336	.352	

dow" and in the column with caption of "70 deg." gives 100 x .2884 = 28.84.

To provide for leakage, multiply the cubical contents of the room by the factor opposite "One air change per hour" in the column with caption of "70 deg." This gives 6000 x .0056 = 33.60.

Adding these we have—Total radiation required = 17.36 + 28.84 + 33.60 = 79.80 sq. ft.

posed wall area is 200, so we take a value of 20. Trace this line across horizontally to the right until it intersects the vertical line marked "Average frame and 12 in. brick." Find value of diagonal line passing through point of intersection, in this case 1.9, which multiplied by 10 gives 1

100 sq. ft. and the vertical line marked "Glass" are on the diagonal line marked 32.

For leakage, run along the vertical line at the extreme right marked "Cubical Contents in Cubic Feet" until the horizontal line representing 6,000 is reached. Trace this to the left until it intersects the vertical line marked "1 air change." The diagonal line passing through this intersection is marked 32. Adding these three values we have $19 + 32 + 32 = 83$ cu. ft. radiation, about 4 per cent. more than previously determined by the table.

Problem No. 2.—Determine the steam radiation required for a one story building, 50 ft. 8 in. by 100 ft. 8 in. in area, 18 ft. high, with 16 in. brick walls and exposed on all sides. There are 10 windows, each 15 ft. wide by 7 ft. high, and 5 windows 10 x 7 ft., also a door 10 x 10 ft. Composition roof on wood sheathing. One air change per hour. System must provide inside temperature of 70 ° F. when outside temperature is zero.

Solution.—Inside dimensions are 48 x 98, making total inside perimeter 292 ft., and a total wall area

Roof area = $48 \times 98 = 4704$ sq. ft.
 Window and door area = $(10 \times 15 \times 7) + (5 \times 10 \times 7) + (10 \times 10) = 1500$ sq. ft.
 Area brick wall = $(5256 - 1500) = 3756$ sq. ft.
 Room area = $48 \times 98 = 4704$ sq. ft.
 Cubical contents = $48 \times 98 \times 18 = 84,672$ cu. ft.
 From the table we have:

For 16 in. brick wall... $3756 \times .0728 = 274$
 Single windows..... $1500 \times .2884 = 433$
 Composition roof..... $4704 \times .084 = 395$
 Leakage $84672 \times .0055 = 475$

Total 1577 sq. ft.

Solving by the chart we have:

16 in. brick wall..... 290
 Windows 470
 Roof 410
 Leakage 450

Total 1620 cu. ft.

Here the difference amounts to but $2\frac{3}{8}$ per cent. which is very slight.

Some difference of opinion exists as to the proper values of the constants used for different types of building construction, but the differences are so slight as to be negligible.

In selecting the sizes of radiators, if the exact area of radiation cannot be obtained in the style of radiator selected, use the size which will give the least excess radiation. Do not use less radiation than computed. For bad exposures (north or west) it is

good practice to add from 5 to 10 per cent. to the computed radiation placed on that side to take care of this condition.

Illuminating Engineers to Hold Convention

THE date for the next annual convention of the Illuminating Engineering Society, to be held in Cleveland, originally set for September 27-30, has been changed to October 4-7. The change was made to avoid conflict with the American Legion Convention to be held in Cleveland the last week in September, it being felt that the gathering together, in one city and at the same time, of the two organizations, would cause visitors to suffer inconveniences.

It is the aim of the committee to make this convention carry a popular appeal not only to technical men, but to all those in any way interested in illumination. Attendance of men, such as architects, contractors and educators, as well as jobbers and dealers—men who can put the better lighting idea before the public has been solicited.

Classification and Compensation for Engineers

IT is doubtless known that engineers in all branches of the profession have suffered serious hardship during the past three years from the great decrease in buying power of the dollar. In few cases has their pay been increased sufficiently to offset any large proportion of the increased cost of living.

Engineering Council, which represents over 45,000 engineers in all parts of the United States, has had this matter under investigation for over a year. The standard classification of grading for engineering service, with a tentative schedule of standard rates of compensation in each of the proposed grades as contained in the report of the Council's special Committee on the Classification and Compensation of Engineers follows:

Adopted Grades	Compensation Schedule (Tentative)
Junior Aid	\$1,080 to \$1,560
Aid	1,680 to 2,400
Senior Aid	2,520 to 3,240
Junior Assistant Engineer....	1,620 to 2,580
Assistant Engineer	2,700 to 4,140
Senior Assistant Engineer....	4,320 to 5,760
Engineer	5,940 and upwards
Chief Engineer	8,100 and upwards

Engineering Council has approved this classification, and it is believed to be applicable to all branches of engineering service.

Current News

Happenings and Comments in the Field of Architecture and the Allied Arts

American Art

The progress of art in the United States is too little appreciated abroad, according to a Danish authority who stands high in the artistic world. He is sailing back to Europe after a visit in this country, with the avowed intention of enlightening the old world on the amazing status of painting and sculpture in the new.

Not only did the professor find American collections, public and private, of the old masters noteworthy; he was also deeply impressed with the strength, beauty and vigor of the work of contemporary American artists.

It is to be hoped that the stamp of European approval upon American art will lead to better appreciation of it by Americans, and that those who have money to spend for this sort of thing will spend a fairer share of it among their own countrymen.

History of Landscape Painting

We are accustomed to seeing nature so widely represented in art that we take for granted that this must have been contemporary with the birth of art.

But the art of painting had been appreciated and patronized for centuries before the landscape came into its own. A good account of its rise to recognition appeared in a recent issue of the *Houston Chronicle*. Here it was stated that during the middle ages when painting was thriving in Italy the subject that engrossed all minds was religion. Everything was done from the viewpoint of the church and with its objective the advancement of the church, and painting was recognized as a good medium to spread the story and the doctrine of the church. Therefore, as a study of the pictures of the old masters will show, most painting then was either historical or religious.

With the great reawakening of the Renaissance men began to appreciate the beauties of nature which they had so long taken for granted. They became conscious that nature was good to look upon, therefore good to portray. And the same spirit that caused Petrarch to defy the laughter of his contemporaries by climbing a mountain simply for the sake of the view from its summit caused painters gradually to introduce landscape into their art.

First, it was used incidentally in the religious pictures, sometimes merely as a decorative device and

at others significantly, to place the scene out of doors. Its early treatment was not very intensive, a straight line topped off with a flat leaf often representing a tree, the other factors of the landscape, if indeed any others were introduced, receiving similar attention.

But landscape was represented more and more until finally it came to be used independently and then came the fuller development of this important branch of the art.

London's Indifference to Art

A strong word of protest is uttered against the manner in which the Imperial War Museum pictures are displayed at the Crystal Palace, London, by the *Architects' Journal* of that city. During a recent visit it was noticed that there is no guard-rail of any kind in front of the canvases, the great majority of which are unglazed. Hence there is nothing whatsoever to protect them from damage. If the public were properly regardful of national art possessions this would not matter very greatly; but unfortunately a becoming respect for art is not one of the distinguishing traits of the British public, who, consequently, must be protected against themselves. It fills one with a sense of utter despair to see, as seen recently, these great canvases, mostly by highly distinguished artists, laid open to mutilation by the thoughtless crowd. In one instance might be observed a burly member of the proletariat in the act of reclining gracefully against a fine canvas, which bulged in perilously towards the wall, the while his offspring amused himself by scratching off as much paint as he could with his finger nails. Surely, reflects the editor, in no other country but England would such a thing be possible. No other nation (looking at the matter from the material point of view alone), would be content to see the things which it has bought at great cost deliberately placed in such a position as to invite, even to provoke, destruction. But beyond that there is the art aspect of the matter. The criminally careless manner in which most of these pictures is displayed is a national disgrace and an affront to the artists themselves. It is only hoped that prompt action will be taken to protect and preserve these art records of the Great War before they become irreparably mutilated.

Electrifying French Plants to Save Coal

The present coal shortage and the realization that great economy will be necessary to avoid an even greater shortage of fuel has caused considerable activity in the work of electrifying industrial districts. In the Upper Marne, the vicinity of Wassy is to be electrified to within a short distance of Nogent and in the Loire district, where manufacturing is almost at a standstill, there is great activity in the installation of electric units. Work of electrifying industrial districts in the Meurthe and Moselle is progressing rapidly.

Much of the electric power will be state owned and operated. The power plants at Mohon, Sedan and Stenay are to generate 120,000 volts and will connect with stations in the Briey Basin. Later, it is planned to connect them with the hydro-electric plants of the Rhine Valley. A line is now projected from Sedan-Bazeilles to Montlibert, which will utilize power generated by old German canals, estimated at 40,000 volts.

Northwest Timber Situation

The amount of timber cut each year from the forests of the United States is about three times the annual growth, it is declared by the National Bank of Commerce in New York in a review of the American lumber industry published in the August number of its magazine, *Commerce Monthly*. Lack of an adequate national forestry policy, together with speculation in privately owned timber lands and the absence of co-operation within the industry itself, have all combined rapidly to reduce the country's timber resources. Provisions for reforestation up to the present have been entirely inadequate and the oncoming growth is ordinarily of inferior species and grade.

"It is estimated that the United States originally possessed 850,000,000 acres of timberland, of which only about 545,000,000 acres remain," *Commerce Monthly* says. "The original forest acreage contained approximately 5,200 billion board feet of merchantable timber. The latest estimate of timber remaining is 2,826 billion feet. Of this difference about one-third has been lumbered, one-third destroyed by forest fires and one-third wasted."

Theory and Practice in Cement Construction

Practically half the strength of concrete as a structural material is lost in the ordinary job because of mistakes made in laying it, according to

Lieutenant H. C. Boyden, who lectured on the subject before the Engineer's Club, Seattle.

The greatest common mistake in the laying of concrete is the use of too much water in the mixture, said Colonel Boyden. It has been proved by countless tests that the strength of concrete falls off very quickly with the addition of too much water. We have come to the conclusion that the smallest amount of water should be used which will give a workable mix. Theoretically, you can have too little water, but practically it is almost impossible. Fifty to 60 per cent. of the strength of ordinary cement has been wasted by the addition of too much water in the original mixture.

However, after the materials are in place, concrete cannot have too much water. Unless setting concrete is kept constantly moist it will lose about half its potential strength. The time of mixing is also an important factor. Concrete increases in crushing strength rapidly as it is mixed up to 60 seconds and more slowly after that, but no batch should ever be laid which has had less than a minute mixing.

Experience has shown that pressure on the concrete before it has set also has a good effect on the amount of load it can stand up under. However, we believe that this is due almost entirely to the amount of water squeezed out, and is proportional to it. Warmth and water will increase the crushing strength of the concrete and consequently the amount of wear it will stand, if applied during the time of setting. This period should never be shorter than 14 days, and if possible should be made three weeks. The temperature of the mixing water, however, has little to do with the strength of the resulting material.

A convenient test for the cleanness of the sand used in cement, is made by shaking the sand up in a bottle containing a strong solution of caustic-soda, said the speaker. If the liquid becomes black, the sand is unfit for use, and the contractor is throwing away much of the wearing qualities of his material.

We have come to the conclusion, he continued, that a contractor should begin a job by designing the strength of the concrete he will use, and then adhere to that type. As, for instance, there will be times when he will wish to sacrifice strength in order to have a material which is plastic. And at the same time we feel that the contractor at present is not getting more than 60 per cent. of the strength from his concrete which it would produce if he were to take the above facts into account.

The Art, Architecture

As painting is art in manual expression, poetry and music art in language and sound so architecture is art in building. And it is not a question of what,

but how. A bungalow might be an excellent example of architecture, while a very large building might have no more relation to architecture than the wail of an infant to a Brahms's Symphony.

It is a good indication to note that the daily press is emphasizing the importance of good architecture. Take this example from the *Houston Chronicle* as an instance.

Architecture is an outgrowth, a development of the early crude caves and huts of man. Like the other arts it started with the application of aesthetic interest to natural needs. Every spire, every dome, practically every element of the various styles reverts back to some natural shape or form, something in the early shelters. But the art begins where man, thinking not only of the practical need for shelter branched into the decorative, pursued beauty and strove for interpretation in the construction of his home. And the very earliest attempts at architecture show the desire to make pictures, stone pictures out of that which was being constructed. These were pictures not primarily decorative, but representative, significant above all else. For instance, pillars carved out of the stone wall would illustrate the support of the ceiling, satisfying the eye and pleasing the senses.

And though this is at best a hint, it is the key to architecture as an art—representation without of that which is within. And in so far as a building expresses in its construction its purpose, and by indentations, windows, pillars and projections indicates its inner divisions into floors and rooms, in so far as its construction is representative and symbolic as well as pleasing to the eye, it may be ranked a work of art.

The Gasoline Baby

There is righteous indignation printed in the *Public Ledger* on the substitution of motor cars for babies and garages for nurseries now noted throughout the country.

When flats came in children went out, it declares. More and more individual houses, too, are being built on child exclusion principles; the nursery distinctly minus, but the garage very much plus. People must have a car; the car must have a home, and there you are.

Sometimes the builder tucks it away under the kitchen floor, where it greatly reduces the domain of our ancient autocrat, the furnace, although outshining the same by reason of a more polished color scheme and a full blooming double doorway. Or it may be separated from the house proper by a cemented open space. That space, formerly a fenced-in backyard with something of privacy and indi-

viduality, now becomes merely an approach to engine snorts, and gasoline odors.

Does the average home today afford a playroom where the rocking horse may snort and roar, the doll's house enjoy its daily refurnishing and the lead soldiers perish in platoons all gloriously? It does not—but it has a garage. Isn't there somewhere a room, or at least an attic, happily possessed of a shabby atmosphere and a tattered welkin with a cracked and overworked ring? There is not; but there is a place to keep the car. No single spot where on rainy days the gang may hold forth. Not one. The tiny table and tiny dishes—all past and done. Nurseries don't obtain any more. The busy little folk are turned out on the streets.

Apparently the occupants of these modern dwellings are expected to run to cylinders instead of to children. Possibly house builders have become followers of the Sanger cult! If so, they will defeat their own ends, for lacking a coming generation, a rising crop, so to speak, who will buy their houses?

Robbing the Junk Pile

Few persons realize the amount of material scrapped on the average construction job that could be salvaged if a little thought and study were exercised, which in these days of high prices and scarcity of material is worthy of consideration, writes V. H. Wilkes, in *Successful Methods*.

The writer, who has charge of the construction plant and storage yard for one of the largest engineering corporations in the East, was endeavoring to clean up the congested condition of its yard and discovered under some tarpaulins a number of kegs of nails which had been shipped into the yard upon completion of work and return of equipment, which were the accumulation of a number of jobs.

Upon investigation it was found that practically all were badly rusted and not fit for use in this condition. During the further investigation of the equipment an old 10 cu. ft. concrete mixer with gasoline engine was noticed which was in such condition that it would not mix concrete or pay to repair. After issuing orders to retire this mixer to the scrap heap it was decided that the outfit might possibly be put to some use as a rattler or tumbler for the purpose of cleaning the rusted nails. Without cutting out any of the mixing blades or changing the drum in any manner about three kegs of nails, a quantity of iron borings and rough dry sand were put through the mixer with a result that approximately 3,500 pounds of nails were salvaged and have since been used on construction work. The machine was operated exactly as a mixer except when discharging a sieve was placed under the discharge

chute which separated the nails from the iron borings and sand.

This plan proved so successful in cleaning the rusted nails that a considerable quantity of cast iron inserts, universal form clamps, bolts and numerous items have been cleaned and rescued from the junk pile.

If it is necessary after cleaning any material by the above method to store until such time as it can be used it is a good plan to put it through the machine the second time, using instead of iron fillings and sand a quantity of sawdust saturated with a cheap form of oil which will oil up the articles cheaper and better than when applied by hand.

The Sociological Effects of the Present Housing Situation

The rent raises in Manhattan are reported to be much greater among the rich than among the poor, because the rich won't go to court to fight advances greater than the 25 per cent. which the law allows. In some of the well-to-do neighborhoods rents are quoted at \$1,000 a year per room, and men on \$5,000 salaries are said to be moving to the country or to Brooklyn.

One result of this is that the charitable organizations are getting their subscriptions cut in halves or quarters, if not cut off altogether. And the demands on the charitable societies are heavier than ever before because they are now asked to help pay rents, where heretofore the semi-dependent have only asked for help on food, medicines and occasionally for clothes on which workers might be able to hold their jobs. The people who don't ask for help meet their rents by taking in lodgers or boarders in such numbers that not merely the health but the morals of the families are endangered. The charity workers report two families each with children in three-room apartments and others in which the halls are utilized at night for cots for lodgers.

The enlightened people of New York have spent years in fighting dark-room tenements and in seeing that the requirements for sanitary plumbing and for decent family privacy were enforced. In that way the fight against "the white plague" has been waged and the death rate has been cut down. Now in the housing congestion these advances of ten years are to be swept away in one year, unless the quick building of some thousands of tenements can be brought about. When the standards of health and morals have been broken down the building of new tenements will not restore them automatically. There must follow another long campaign of education to see that the promiscuous living arrange-

ments brought about by congestion are not continued and in the meantime the death rate will go up and the recruiting for vice and crime will go on.

The building of new houses is in part an economic problem, but only in part. It is a social problem as well and in it are involved the standards of civilization of a city which has brought itself to the front rank among world cities by long and persistent effort.

National Registration Board to Meet in St. Louis in November

The first formal meeting of the National Council of Architectural Registration Boards will be held in St. Louis, Missouri, on November 18 and 19, 1920.

All architectural, registration or licensing departments, boards or committees throughout the United States are invited and urgently requested to send representatives to this meeting in St. Louis.

While membership in the Council is restricted to the legally appointed representatives of the registration or licensing authorities of states having registration or license laws, the Council would be glad to welcome the attendants at the Council meeting of committees of architects from states having no registration or licensing laws.

Legislative Committees from states having laws pending will find the proceedings of the Council very helpful and instructive. Among the papers to be presented will be a report of a committee appointed at the Washington Conference to make a careful, analytical, comparative study of the various registration laws now in force in the various states. Efforts will be made to harmonize these various requirements so as to make easy reciprocal transfer of registration from state to state and thereby facilitate interstate practice.

A desirable outgrowth of the Conference will be the formation of some sort of clearing house of information with reference to the records of architects asking extension of registration from one state to another. It is hoped that the Council may be able to recommend a uniform law, which may be adopted by the various states.

Committees and Registration Officials are urged to make arrangements for representation at the earliest possible date and notify the Secretary of the Council, furnishing the names and credentials of their official representatives. Emil Lorch, chairman, 718 Church St., Ann Arbor, Michigan. E. S. Hall, secretary, 1107-64 E. Van Buren St., Chicago, Illinois.

Calling Them Master's Rooms
Makes It Cost Much More

A snappy account of his personal experience of the renting situation is set down in The New York Tribune by Heywood Broun. He states in part:

Once upon a time you got a month rent free and the man would ask you if he should paper the parlor in pink or blue. In those days the advertisement read "Seven rooms and bath, \$65 a month," and if you spoke sharply to him he would take less. Today the same apartment is listed "EXCEPTIONAL OPPORTUNITY—Polonius Terrace, nine beautiful rooms and exclusive bath in select residential neighborhood. Three masters' bedrooms and two maids' rooms. Everything up to date. Free use of the elevator before noon. Might rent to refined people of the highest standing for \$450. Must be small, blonde, adult family with wedding certificate. Weight not to exceed 192 pounds net. No children, dogs or Ford automobiles. Business, social and medical references absolutely essential. No Unitarians. Apartment to be seen, by appointment only, from 3 to 3:30 on alternate Thursdays in June."

The rent crisis is to a large extent a matter of morale. In some way or other not only the landlords but all of their agents have acquired what is known on the stage as authority.

When we went to Polonius Court we might possibly have confounded the young earl by remarking that the two maids' rooms looked remarkably like clothes closets. We lacked courage. In fact, we were unnerved from the very moment he pointed to the small cubicle off the airshaft and said, "You see, this master's bedroom opens on the court." Our only excuse is that we had never seen a master's bedroom before. We have always set our heart upon being masterful, but we can't afford one of the bedrooms.

And yet, for all our envy, it seems to us that the development of the master's bedroom is a sinister movement in American life. Before the days of the suffrage amendment nobody would even have considered the possibility of there being more than one master's bedroom in any house or apartment. Now we sometimes see advertisements which offer three, four and even five masters' bedrooms. All we can say is go on your luxurious way and enjoy your steam heat and your three baths and your exclusive neighborhood and your five masters' bedrooms while you can, but remember that a house divided against itself must fall. Still, even if it did, we don't suppose the rent would follow. If Newton had thrown a lease into the air instead of an apple he never would have discovered gravity and it would still be something one had to learn by experience, which would

be a mighty hard school for the tenants in the Woolworth Tower.

French Art Losses Due to the War

One of the most interesting items in the latest inventory of the losses of France through the war is that which tells of the extent of the damage to her art treasures and historic monuments. The official estimate for this loss, which has been obtained by the Paris information service of the Bankers Trust Company, is placed at over \$125,000,000.

This figure, which has been recently calculated for the information of French minister delegates to forthcoming international conferences, has been arrived at after an exhaustive examination of the ruins of historic monuments, statues, churches, museums and their contents. The irreplaceable nature of these losses is indicated by the sum of 600 million francs which is set against "moral injury."

"This sum of 600 millions," explains the official text, "is an approximation of the loss the French people have sustained by having lost forever works of peculiar value because of their beauty and historic associations."

In order that a fair statement of values might be made the art commission sets forth the losses in terms of both pre-war and post-war currency, as follows:

	1914 value, francs	1920 value, francs
Historic buildings (750 in all) ..	300,000,000	1,200,000,000
Historic monuments	25,000,000	50,000,000
Museums	15,000,000	30,000,000
Moral injury	300,000,000	600,000,000
Total	640,000,000	1,880,000,000

The 640,000,000 francs of losses, on the basis of pre-war values, are equal at normal exchange, which then prevailed, to about \$128,000,000.

An estimate of the loss in stolen or damaged jewelry and precious stones is placed at 1,119,000,000 francs, present values.

The loss in personal property and objects of art owned by private individuals has been placed at 4,500,000,000 gold marks.

New York Society of Architects

This society held its first meeting after vacation on Tuesday evening, September 21, at the organization's headquarters, the United Engineering Societies Building, West 39th street, Manhattan, President James Riely Gordon in the chair. There was a goodly number of members present.

Extended discussion took place on the continued depression in the domain of building and architecture, this being attributed mainly to prevailing un-

rest and luxurious tastes among mechanics and to profiteering on the part of material men.

The over-shadowing and practical extinction in large part of the architectural profession by engineers and construction companies, which has been in evidence for some time past, was commented upon at length; and Secretary Zobel urged upon the meeting, as a measure of self-defence, the wisdom of advertising—a practice now sanctioned by the American Institute of Architects and the profession generally. The feeling was that more attention should be paid than has hitherto been done to giving publicity to the work both of individual architects and to that of the body as a whole.

Vice-President Fisher called attention to the proposal to appoint a City Architect, and on the speaker's motion it was resolved that the Society dis-

approves of the proposed appointment, on the ground that the interests of the public will be best served by the employment, in each case as it arises, of individual architects of recognized standing and ability.

The proposal, now before the Legislature, to relieve the present lack of housing accommodation by adding one story to existing tenement houses throughout the city was discussed at length; and the general opinion was expressed that while in itself desirable the proposition is impracticable, owing to the excessive cost of giving effect to it.

Five applicants were voted to membership, and several additional names reserved for further consideration.

The October meeting of the Society will be preceded by a dinner and fall rally of members.

Weekly Review of the Construction Field

With Reports of Special Correspondents in Prominent Regional Centers

THE credit situation has continued, during the period ending September 15, to evidence in a substantial measure the improvement which had become apparent a month ago. There has not, it is true, been any easing of credit. Banking loans as reported by the National Bank of Commerce in New York have increased in response to seasonal needs; there has been no relaxation in commercial money rates; and little change in this situation can be expected until the major requirements of the crop-moving season has been met. Nevertheless, substantial progress has been made in overcoming the difficulties in the credit situation.

While loans are now expanding in response to seasonal needs, as these seasonal requirements are liquidated a considerable reduction in the volume of outstanding credit may be anticipated. Meanwhile, through the shifting of credits and through the facilities of the Federal reserve system, pressure on the banking facilities of particular sections is being distributed throughout the banking system and the strength of the credit structure as a whole is absolutely sound and unimpaired.

A number of factors have facilitated the improvement in the credit outlook. As the continued improvement in transportation permits more normal movements of commodities, the mobility of credits is gradually being restored. Progress is being made in the liquidation of commodity stocks and of loans

against them. While the downward trend of prices involves current difficulties, it is a movement toward greater rather than less stability in both the credit and the general business situation, since it tends to reduce the pressure on banking facilities and at the same time to stimulate the large potential demand for goods which increasingly high prices had impaired. In contrast with the movement in progress a year ago, therefore, the general trend of business conditions within the United States is in the direction of increasing soundness and stability.

In many important groups of raw products there has been a steady downward trend in prices. In some lines this reduction has passed on to the finished product.

Unless untoward social and political developments should take place, it now seems likely that in the case of most commodities the period of rapid price adjustment has passed, and that fluctuations from now on will be through a gradually narrowing margin. Present price movements, however, must be interpreted with the greatest care. Cases in point are those commodities the prices of which appear superficially stable, but in which, as a matter of fact, almost no business is being done. In such cases, actual values cannot be known until trading operations are resumed.

While price changes were so radical, curtailment of manufacture and the unrestricted course of mer-

THE AMERICAN ARCHITECT

chandizing was inevitable. While slowly receding prices will tend toward the ultimate attainment of normal conditions, it will be just as necessary that business be carried on thoughtfully and conservatively.

The United States is in a more favorable position than any other country in the world. If a mutual basis for transactions is found in the immediate future, labor will be kept reasonably well employed, and manufacturing, commercial and financial operations will be maintained at a healthy level. Delay in finding such a mutual basis is not only unwise but it might well result in entirely unnecessary industrial, financial and social disorganization.

August building statistics reported from the larger cities of the country show, according to the *American Contractor*, that while there has been no perceptible gain over the preceding month's activity, the mere fact that there has been no further recession is encouraging because during August the unfavorable influences hampering building have been intensified. During the month the advanced freight rates resulted in additions to the high prices of materials. The fact that building permits show no recession coupled with the fact that a better condition in transportation can reasonably be expected to take place, leads to the conclusion that the last four months of 1920 may see augmented plans for much needed building.

The housing shortage has become an issue of national importance. The unwillingness of banks to loan on real estate mortgages for housing and the rapacity of owners of available housing of all kinds have combined to create conditions that menace public health and safety. State legislatures are discussing these problems from points of view both practical and impractical, and in sheer despair of finding an early and complete solution, are preparing to put the whole matter up to Congress. Meantime, those who have more closely studied the situation, not locally, but broadly, all over the country, are firm in the belief that the basis of a complete remedy lies in tax exemption and in legislation that will prevent landlords from continuing the present orgy of rent boosting.

The shortage of apartments in New York City is variously estimated from 40,000 to 160,000. One hundred garages and five theatres to one apartment and one dwelling house is the proportion in which building plans were recently filed in Manhattan, states the mid-September Bulletin of the National Lumber Manufacturers' Association. To the intelligent reader this statement will need no amplification. It clearly shows that it will ultimately become necessary to enact legislation that will prevent what at this time is such a large proportion of non-essential building.

In the material market in New York there are in-

dications that materials are available from their sources and are moving more freely. The demand, however, is still light. A reason for this is seen in the high wage scale which along with other conditions already referred to deters the prospective builder. There seems to be a slight tendency toward lowering of the prices of brick, particularly in the Hudson River district.

The New England correspondent of *THE AMERICAN ARCHITECT* in the usual weekly review of that section reports:

In view of the seriousness of the housing situation, representatives of the building trades' council of Greater Boston and elsewhere have pledged themselves to assist Mr. John F. Walsh, the newly elected chairman of the National Association of Builders' Exchanges, which has been combined for the sole purpose of devising ways and means to bring pressure to bear to relieve a condition in transportation that is now causing general apprehension.

In discussing his election, Mr. Walsh said: "Now that the winter season is approaching, contractors feel some little consideration is due them by the Interstate Commerce Commission in order that large operations may not be compelled to shut down entirely for want of necessary materials to keep men employed."

Shortly after the election, Mr. Walsh got in communication with representatives of the United Building Trades' Council of Greater Boston and the State Council of the building trades. They heartily offered their co-operation in the matter.

That money has definitely turned easier would seem to be indicated by the difficulty note brokers find in obtaining the best grades of commercial paper. With the appearance of time money on stock exchange collateral for the first time in a year, it would seem that at least high interest rates have satiated the demand for credit. Call money, another index to money conditions, is easy. In Boston it stands at the usual 8 per cent. which has prevailed for months, whereas in New York it opened at 7 per cent. and yielded to 6 per cent.

Statistics of building and engineering operations in New England show that contracts awarded from January 1 to September 15, 1920, amounted to \$242,058,000, as compared to \$147,850,000 for a corresponding period in 1919; \$125,236,000 for 1918; \$151,681,000 for 1917; \$146,636,000 for 1916, and \$124,502,000 for 1915.

(By Special Correspondent of the *American Architect*.)

SEATTLE.—Until the Presidential elections are over the building trade of the Pacific coast may show no symptoms of activity. Among the lumber

THE AMERICAN ARCHITECT

mills, the architects, jobbers of cement, steel, brick and plaster the feeling is the same, that business conditions will warrant no new commitments until the unsettlement that precedes and follows a Presidential year has been definitely put out of the way. After this there will come the annual stock taking, and it is regarded as highly probable that the year may elapse without any improvement in the outlook.

The most serious handicap on the Pacific coast to prosecution of needed building projects is the halting and uncertain delivery of essentials in materials. The scarcity of small sizes of steel pipe, now in the third month of an abnormal and dislocated basis, is preventing home and apartment house projects from closing. In this field the half and three-quarter-inch galvanized pipe supplies 90 per cent. of the home and apartment needs, but unfortunately these are the sizes that are most difficult to get. Advices from the mills in response to pleas of jobbers are to the effect that no promises will be made henceforth to the end of the year as to the approximate date of acceptance of orders for steel pipe.

Jobbers have been compelled to buy from each other and to move the pipe from one city to another in widely separated points in the attempt only to partially meet the demand. Many houses are awaiting pipe to complete before winter sets in.

The situation as to nails is easier, as forecasted in these columns when the mills tacked on a higher price. The claim of the mills was that there was no profit in the 6 and 8 common, shingle and finishing nails at the old price and that the heavier tonnage yielded profit. The shortage is less keen, but the demand has also fallen off.

There are no cement or plaster stocks, and cement and steel pipe on the coast are about on a parity of shortage. More plaster board and patent roofing is

offering than is required and the market is unsettled. Fire clay and brick is plentiful.

Prices are steady in vitroware and enamelware and the demand slack, indicating a lessening of new building projects over the territory. There are no stocks on the coast. One ship of the Isthmian fleet is due within a week with steel pipe from the Pittsburgh district, but jobbers hold so many back orders that the shipment will be swallowed up and still leave the market short.

The fir lumber market is undergoing one of the dullest periods in 25 years. The eastern building demand, on which the industry depends as an avenue for the bulk of its output, reports that southern pine mills are cutting under prices of Douglas fir. The new emergency rail rates have effectually shut out fir from its former eastern outlets in favor of southern pine, and while conferences between the manufacturers and the carriers in regard to petitioning the Interstate Commerce Commission for a rate revision and the restoration of competitive conditions have been arranged, the process is expected to be a long one and there seems to be no hope that the subject can be reached this year.

Average costs of standard building sizes at the mill this week are as follows: One by four No. 2 vertical grain ceiling, \$61.50 to \$69; No. 3, \$48; 1x4 No. 2 and better slash grain flooring, \$43 to \$55; stepping No. 2 and better, \$75 to \$80; No. 2 and better finish 1x8-10 ft, \$64 to \$71. Ceiling, 5-8 by 4 No. 2 and better is \$51; No. 3, \$37.50. Drop siding, 1x6 No. 2 and better is \$45 to \$56, and boards and shiplap No. 1, 1x8-10 ft., \$24.50 to \$31. No. 1 dimension, 2x4 12-14, surfaced and edged runs from \$22.50 to \$26.50. Plank and small timbers 4x4 12-16 surfaced four sides is \$26.50 to \$30.50, with 3x12's at \$26 to \$31.



SOUTH FRONT, HALFIELD HOUSE, HERTS, ENGLAND

✓
460

Printed piece to no 2338,



DOORWAY—CHURCH OF ST. MACLOU, ROUEN

THE AMERICAN ARCHITECT

VOL. CXVIII

WEDNESDAY, OCTOBER 13, 1920

NUMBER 2338

The Zoning Regulations in New York

By THOMAS HASTINGS, F.A.I.A.

THE lower part of Manhattan Island has been built up on that good old plan of "he may take who hath the power and he may keep who can." In the rush of building to enormous heights not only has adjoining property been shut out from light and air, but there have also been created in the financial district canyons whose depth as represented by the sidewalk receives sunshine and light but a very limited portion of the day. There are in this country no ancient rights of light and air such as have been regulated by statute in England since the time of William IV. The result has been to create conditions the danger of which has been many times referred to by architects and those interested in the progress of building in this country.

The conditions of the shutting off of light and air and the menace to health of those who are employed in these buildings were perhaps the first that caused the thoughtful observer to set about to find some means whereby there might be secured better methods of building that would more equitably serve the owner of property and protect the lives and health of people. In addition to this menace, the rapid shifting of business centers on Manhattan Island, due to a phenomenal building activity coupled with the greed of investors in real estate produced a condition that marred the architectural growth of the city, infringed on the rights of adjacent property owners and was altogether a state of affairs that would eventually transform the architectural aspect of Manhattan Island into a conglomerate and inartistic mass. The placing of an apartment house in residence districts, the encroachment of places of business in similar localities, the injudicious erection of high buildings that threatened to repeat the conditions in lower Manhattan at once demanded some efficient and speedy method of correction.

It was only after the most well-organized opposition had been overcome that the city was enabled to enact a zoning law that would restrict indiscriminate building not only as to character of occupancy, but also as to height and area of the structure. While it is now less than two years since this zoning law has actually been in operation the good effects are

461
already apparent and a type of building as unusual as it has proved to be desirable is being erected in many locations. It will not take the eye of the trained observer to appreciate the advantages that have already accrued from the adoption and the careful enforcement of these new zoning regulations. They have not only saved dignified locations, those that would naturally be restricted to their present class of occupancy, from the danger of further encroachment, but they have also prevented what might be termed the deprivation of adjoining property owners from the rights of light and air.

The so-called stepped back building, while yet in its very infancy as to its design, has already developed some very interesting phases of its architectural treatment and these influences will undoubtedly create new forms of architectural design that will add a very desirable aspect to the skyline of New York and create a pleasant outlook from the upper windows of our tall buildings. As it is today, the men of aesthetic training find their sensibilities disturbed when they view the expanse of Manhattan's roofs and consider the economic waste of space that has taken place ever since this was a city.

REGARDING the restriction of the height of buildings, it is to my mind primarily a question of sanitation and a question of law. The aesthetic consideration should not enter into the case. What is reasonable can under all conditions be made to look well. If certain main arteries, streets or avenues have increased in value because of an increased demand, this demand becoming more than the supply within a given reasonable height, then, instead of allowing property owners to build without restraint in height, those property owners right and left of such an avenue should benefit by the increased demand by way of legally so restricting the height within reason as to force spreading out instead of towering up into the air. Only incidentally do rational restrictions produce harmony and uniformity and other aesthetic results. To appeal to the public and the legislature for the direct consideration of the aesthetic side of such questions only ex-

cites opposition and does more harm than good. The real issues are those of light and air, justice to neighboring property owners and the overcrowding of the streets caused by super-imposing buildings on each other. It would be interesting to look into the situation in some of the great cities in Europe. Our city is not a peculiar case different from all others as some have argued because of the shape of the island, as though this has had something to do with the outcome, allowing tall buildings on an island of so great a length and so narrow. It is almost a proof of this that some one has calculated the average height of all buildings including unimproved property lying between Battery Park and 59th Street and they have found this average height to be only about three stories or approximately 35 feet. This would seem to indicate possibilities for building out instead of up. Mr. Carrere at one time made a very interesting suggestion which might seem most just and practical. Inasmuch as so much license has been allowed in the past, so much unreasonable height having been allowed far beyond the possible building laws, he believed that any man who had been allowed in the past to build, for example, twice as high as reasonable on a certain site should be taxed twice on the value of his land, inasmuch as the two rent producing buildings, as it were, had been built one on top of the other on one site. His idea was to apply this principle proportionately to any excess height over and above the fixed limit of height. These property owners should pay proportionately more taxes and so reduce the tax upon those who will build in the future and be restricted to a reasonable height within the present law. To cite the laws of European cities restricting the height of buildings would take us outside of the confines of this article, but to give a general case illustrating the laws similar in all cities of Europe we might refer to an individual case of the city of Paris—there is every variety of street widths and the law varies in accordance with the width. For example, in a street 18 meters wide or under, one is allowed to build as high as the width of the street plus 18 meters for the front wall. This height once so determined, one is obliged to keep all roof lines within a half circle whose radius is equal to the width of the street drawn tangent to the highest point of the front wall. All dormers, chimneys, etc., must be so designed as to keep within a straight line drawn tangent to this circle and at 45 degrees. In case any building is on a street incline, this formula must be applied over again at every 50 feet in the width of the frontage. One can readily realize a certain regularity and uniformity of line and height and scale which would obtain under these laws, especially when we realize that further than this, there is a minimum restriction of ceiling heights which

must be adhered to in buildings built for commercial purpose, the limit of whose total height is so obtained. I believe this law provides that no one shall be allowed to build the ground floor less than 4 meters high and all the other floors not less than 3 meters each. As belt courses and cornices generally indicate floor levels, this produces oft-times continuity in horizontal lines for long distances at a time. It is said that these laws are responsible for the mansard roof, a form of roof which gives the maximum amount of room within the arc of the circle referred to. Further uniformity even obtains because of the tax on windows, which tax has a tendency to diminish the number of windows and increase the fenestration and wall surfaces and enlarge the scale of the openings. All these considerations, however, are established without thought of the aesthetic question, excepting in certain individual cases monumental in character or of historic interest, as for example, on the rue de Rivoli, or on important squares and similar streets throughout the city. These streets and public squares of such historic interest are controlled by the city in every detail of design, and while the property may be sold at any time, the owner is not permitted to change the exterior design of his building, not even in any minor detail. It is said that in the case of the Place Vendome the front walls of the building surrounding the square were built a generation before the buildings themselves were built behind them and that these walls stood all this time without even window sashes in the window openings until each building was built in turn behind the walls. When we consider our new zoning laws, one can readily see how different the outcome will be from the enforcement of the European laws. Naturally it would have been unfair to owners of unimproved property in our case to restrict their buildings to the European laws because of the fact that their neighbors had been allowed to build without restriction before these laws were enacted. That such building license as has been permitted in the last 30 years in this city, in the absence of laws, is the greatest physical calamity which could have possibly befallen a municipality; worse than an earthquake, which it can live down, or a pestilence, which can be cured. The success of our new laws is most promising, but in my opinion it is too soon to judge of the results, more especially from the artistic viewpoint. Houses on top of houses and houses on top of these make a very difficult condition and present new problems for solution, the outcome of which is an unknown quantity. We little know what the effect will be when these will have been repeated many times all over the city. In Europe, with their forms of restrictions, the natural expression or outcome of the enforcement of their laws is generally a series of

THE AMERICAN ARCHITECT

continuous roofs varying in form and design with considerable regularity, but always normal in character, not reminding one of restricting laws as our buildings are always sure to do. One considerable

such spaces for advertising purposes. There should be, in my opinion, a revision of the laws governing this atrocious habit of advertising. It would seem inexcusable, for example, that whoever leases the

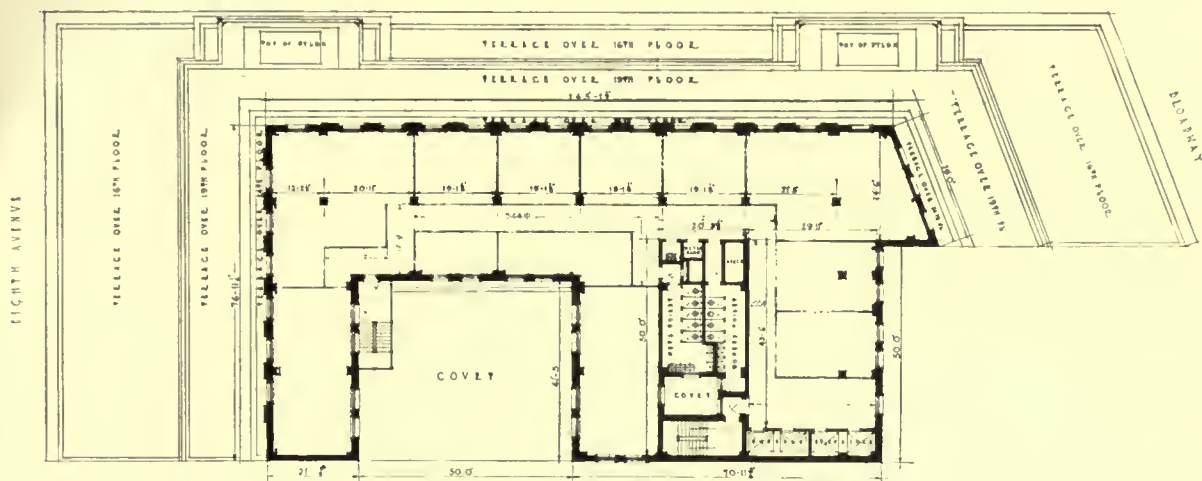

PLAN OF 25th FLOOR
FISK BUILDING, NEW YORK CITY

advantage we may foresee in the outcome of the new zoning laws for New York applied to our high buildings, is the fact that there will be fewer wide expanses of side brick walls without windows, ugly in themselves and ugliest when the owners will sell out

northwest corner of Fifth Avenue, opposite the New York Public Library, should be allowed to build an advertising sign nearly fifty feet high and the length of his building. The proper laws should be enacted to curb further examples of this lack of civic pride.

Playgrounds

Like the poor, the question of keeping children off the streets is always with us. That this is a community responsibility is made clear in suggested standards for children's play published in "Standards of Child Welfare" by the Children's Bureau of the U. S. Department of Labor. These standards cover in detail the subject of organized recreation for city children only, but it is hoped that in the near future similar standards will be worked out for rural children, whose need for wholesome recreation under intelligent leadership is as great as the need of city children.

The standards given declare that at least two hours of organized play every day throughout the year are necessary for every child. To insure this, there should be a playground within a quarter of a mile of every child under 6 years of age, one within half a mile of every child over 6, and a baseball field not more than a mile distant from every boy old enough to play on a team. One acre to serve 500 children is advised as a minimum amount of space. This general playground should not be used for

games requiring a great deal of space. Baseball, football, tennis and similar games should be provided for by an athletic field containing about 6 acres.

Where lack of funds makes it necessary to limit equipment, the standards point out that game supplies such as basket balls, baseballs, bean bags, etc., are more important than fixed apparatus, though swings and a sandbox are essentials for little children.

Leadership is declared to be of fundamental importance and should never be sacrificed to elaborate equipment. Experience has shown that splendidly equipped playgrounds are little used when they lack the inspiration of real leadership, while nearby alleys and streets are crowded with children. The interesting suggestion is made that children be formed into groups of from 8 to 12 members "with a gang leader self-selected and self-propagating as in the old neighborhood type of gang."

In New York, it is interesting to note that certain blocks are denied traffic, and are set apart by the mayor's committee on recreation and playgrounds for the use of children not otherwise provided for.



CENTRAL PART OF CONCORD, MASS.

The above is a northern view in the central part of Concord village. Part of the Court House is seen on the left. Burying Ground Hill (a post of observation to the British officers in the invasion of 1775) is seen a short distance beyond. The Unitarian Church and Middlesex Hotel are seen on the right.

Early Town Planning in New England

By OLIVER H. HOWE, M.D.

MOST towns and cities, when first settled, were laid out according to some rudimentary plan. As later growth took place little attention was given to planning and new streets were laid out without much thought or purpose other than to develop real estate. Although many picturesque situations have come about without designs, as a rule, towns that have grown up entirely in a haphazard way show the fact plainly and lack dignity and charm. On the other hand, the taste and judgment of careful planning usually leads to attractive and satisfactory results. Again, however carefully the original scheme may have been prepared, it will usually require, at some time, readjustment or replanning to accommodate itself to growth and new conditions. The transformation of a small settlement into a city requires a great expansion and rearrangement of its plan, together with almost entire replacement of its original buildings.

A brief study of town planning in New England may be of interest in this connection. Some of the earliest settlements were made at harbors at the point of landing. A certain number of others were located on rivers up which the immigrants had

sailed, as at Watertown and Haverhill, Mass. The tendency in most early settlements in the interior was to place the church upon a high hill and gather the settlement about it. Whether this was from a desire to exalt the sacred edifice and a possible survival of the placing of ancient temples on lofty hills would be an interesting matter for speculation, but doubtless more practical reasons existed in the matter of defense against the Indians. The early church at Plymouth was so placed and had port-holes in its sides. It was thus an ark of safety in more than one sense, being a fort as well as a church. The practice at any rate became very general throughout New England, and we have many hill towns, each showing the white spire upon the hilltop, visible for many miles. The arrangement of the village remains perhaps as a single street passing over the hilltop as at Rutland, Mass., or a four corners as at Scituate Center, or sometimes a meeting of three roads in a triangular common. There are at least sixty hill towns in Massachusetts. Typical examples are Rutland, Shrewsbury, Sharon, Goshen, Princeton, Grafton and Leicester.

Before long a rival center of interest appeared in the case of every hill town. The farmers' corn

THE AMERICAN ARCHITECT

had to be ground in a mill, and it must be taken down into the valley to a mill turned by the water power of some stream. As the men went to the mill and waited for their grists to be ground, they met and exchanged ideas, and the earliest stores were doubtless started near the mills and dwellings naturally followed. The fact of these centers has served to multiply villages in our Massachusetts towns, the hill being the center of dignity and social life, while the valley village gained a certain amount of business importance. The hills held their own pretty well until the advent of the railroad. The

and no importance. Peru, also a Berkshire town, is at the top of a lofty hill two thousand feet above sea level. The spacious meeting house, which in the good old times was crowded to the doors, is now almost deserted. With the little schoolhouse and about four dwellings in sight it occupies the top of this great hill with the unique distinction that the rain falling on one side of its roof goes eastward in the Connecticut River, while that falling on the other side flows westward into the Housatonic River. Those of us who have driven over Hoosac Mountain by the Mohawk Trail will re-



BIRD'S-EYE VIEW OF SOUTH DEERFIELD, MASS.
Sunderland and Connecticut River from Mt. Sugar Loaf.

iron horse must needs follow the lower levels and be a companion to streams, ponds and swamps. From then on, although the hills might hold their stately traditions, the valley settlements developed business and manufacturing and advanced by rapid growth, attracting the homes of the people as well. Then it became obvious that the hill location had been a disadvantage from the start. The steep hill must always be climbed to reach the town, all heavy loads must be drawn up the weary slope and it was exposed to the violence of every wind.

Sandisfield, a hill town in Berkshire County, which had for many years been one of the leading towns in that part of the State, soon lost its prestige when the railroad reached Pittsfield. Sandisfield remains stranded twenty miles from a railroad, a mere name on the map with dwindling population

member seeing at the summit a little weather beaten church and about two houses. This is the center of the town of Florida, the most woe-begone hill town I know. A little group of such buildings upon a wind-swept hill top suggests empty seed pods waving in the wind. Where has the seed taken root? In Pittsfield, in Holyoke, in Springfield, and perhaps in Boston. In most cases, however, there is in the same town a valley settlement which has absorbed a portion of the original strength. A few of these towns like Hopkinton, Gardner and Spencer have reached marked industrial development in their hill location. In a few towns the hill top location has been abandoned, leaving only an ancient cemetery and church cellar as relics. As a rule the advantageous sites for growth and prosperity consist of good harbors, navigable rivers, or unnavi-

gable rivers with good water power and locations on railroads or main highways.

Having giving this brief consideration to the town site, the next most important element consists in its lines of communication. These should stretch out in several directions in the form of good roads of easy grade; not necessarily straight, but with easy curves. The main roads radiate from Boston

turned after the spider's web, with main streets converging to the center and minor connecting streets for residential occupation. It is an interesting fact that the city of Washington, laid out in 1790 by Major L'Enfant, shows the ingenious combination of the gridiron and the spider web plans in a very satisfactory way. Crossing the arrangement of streets in squares is another system of wider avenues, radiating from the capitol, the White House and from several other centers. Wherever these avenues cross there is a little park in the form of a square or circle. These latter furnish admirable sites for civic monuments, the acute angles make prominent situations for buildings or architectural merit, while the avenues themselves yield fine vistas, each terminating in some notable building, monument or fountain. Washington has



TOWN HALL, ATHOL, MASS.

like the spokes of a wheel, each one subdividing in various ways to reach the surrounding country. Main roads should be of greater width than the ordinary residential streets. Their intersections should be plain and plainly marked, for unnecessary stopping of vehicles to inquire the way obstructs traffic and is likely to cause accidents.

Upon these radiating main roads as a basis is usually built the street plan of the town. Villages are spread out in various shapes; oval, triangular or other more irregular shapes according to the sites. In the instances where main roads cross each other at right angles the temptation is strong to lay out the whole village in squares. Many cities, following the example of Philadelphia, have this layout with streets numbered in one direction and named in the other. Advocates of this system claim facility in finding their way about, but it has the disadvantage that one has to traverse two sides of a square to get anywhere, and that the main streets do not converge to the civic center. A further drawback is that it renders the city monotonous. One has always the same view of straight converging street lines, and important buildings are not well displayed. Boston with all its faults has a picturesqueness and surprise about it that is very interesting.

A somewhat more advantageous plan is pat-



CONGREGATIONAL CHURCH FROM CITY PARK, BATH, MAINE.

the finest city plan from an artistic standpoint. More than half its area consists in streets, avenues and open spaces, but a capital city can afford to be a little prodigal of space in order to assert its dignity and fulfil its public functions.

There may be some excuse for a rectangular plan of streets in a town situated on a level plain or prairie, but where natural features exist, such as hills, rocky eminences, the curving bank of a stream

THE AMERICAN ARCHITECT

or lake or an irregular ocean shore, the streets can be so disposed as to enhance the beauty of these natural features. The expense of pushing streets in undeviating lines through a rocky or hilly tract must be far greater than if they are allowed to follow the lay of the land. The abutting property, also, becomes less valuable when it is left at the top of precipices or high retaining walls. Think of the beauty of the Grand Canal of Venice and consider how much is due to the graceful curve of its shores. Many streets are beautiful for the reason that they unroll their treasures in such a way as to be seen



COUNTY COURT HOUSE AND REGISTRY,
PLYMOUTH, MASS.

to the best advantage. This doctrine does not need to be preached so loudly in seashore towns, for there many of the roads follow the graceful curves of the shore, giving a constant change of view. As they sweep round bold ledges of rock or follow natural valleys, one gets the idea that the roads grew there. They certainly belong there and are placed in the most advantageous positions possible.

The very worst result is produced when a rectangular gridiron plan is inflicted on a hilly site as at Wollaston, Mass. Steep and dangerous roads are thus established in such a way that no replanning can change them. The treatment of a similar locality, Aspinwall Hill in Brookline, shows wise planning and no unpleasant grades.

THE impression of a town is greatly enhanced if one's first view of it is pleasing. A hill town is conspicuous at a distance. In other situations one often has a sudden and pleasing view of it from some hilltop. Such a view one gets of Bridgewater, Mass., as he reaches the top of Sprague's Hill and still more strikingly of North Adams, Mass., from the summit of the Mohawk Trail. The first glimpse of approach from a railroad unfortunately is rarely pleasing. Two reasons

exist for this blemish—first, lack of planning, and second, sheer neglect and indifference. A far too common arrangement is to have the railroad tracks bordered on either side by the outbuildings of dwell-



THE COMMON, COHASSET, MASS.

ings that back up against the line. Occasionally we see a town in which the dwellings face the railroad on either side. This is good planning. It keeps the homes freer from noise, cinders and danger of fire, and is pleasing in every way. This disposition is common through the West and Canada. Often a broad strip of lawn or park extends beside the railroad, then comes the street and the further side of the latter is lined with stores or dwellings all facing the railroad. Lumber and coal yards and factories must needs be close to the railroad, but there is a vast difference in the way such establishments are kept. Creditable examples, although perhaps few in number, go to prove that ugly and disorderly arrangements are not inevitably required in those trades. A seaport town is fortunate in having a real front door, and the harbor approach to Portland or Boothbay Harbor, Maine, or to Cohasset or Plymouth, Mass., is very attractive.



A TYPICAL NEW ENGLAND COMMON

THE AMERICAN ARCHITECT

Country villages should wear a country aspect. A few places in the business portion should have cement sidewalks and curbing, but in the main, sidewalks of fine crushed stone edged with grass borders are more pleasant and suitable. In the old days with the somewhat loose gravel road, trees could be successfully grown in the narrow grass border. With the present Tarvia roads and more impervious sidewalks there is danger that such trees will be starved. The Washington Elm in Cambridge has been gradually starving to death, being in a small island of natural soil, surrounded by large areas of pavement. The proper treatment of village trees within the street consists of a broad planting strip from six to ten feet wide between the sidewalk and roadway. This is sometimes expanded to twenty feet wide or more in such beautiful villages as Stockbridge and South Hingham, Mass. These attractive strips of green add much to the beauty and charm of a town and also provide abundant nourishment and moisture for the roots of the trees and shrubs. Adequate planting strips are usually provided in layouts of new towns, but are sadly deficient as a general thing in old communities.

I have been much interested in studying the careful planning that has been embodied in the construction of Biltmore, N. C., Garden City, N. Y., and in the newer parts of Lakewood, N. J. The two former were carefully planned in their entirety before building began. The sidewalks, the planting strips, the curbing, the street signs, the lamp fixtures and the tree planting were all carefully designed and made harmonious. In Biltmore the railroad station, the post office, block of stores, and the church were all part of the scheme and were built by the owner, Mr. Vanderbilt. The street plan was attractive, including a radiation from the center connected by some curved streets. The dwellings varied somewhat in size and plan, but were all harmonious in architecture. The railroad freight yard was carefully screened by shrubbery and every part of the village showed careful thought and displayed attractive vistas. These ideal conditions can rarely be secured, yet recurring changes in all towns furnish opportunities to make decided improvements and oftentimes a small amount of replanning will yield material results. The most characteristic feature of a town is the civic center. It is the element by which we usually judge of the character and spirit of the community. By civic center we mean the group of public buildings to be found near the center of the population. Some towns have no such group and the stranger will drive clear through the town without ever knowing when he gets there. Such a center should have the advantage of some favorable site. It should be placed on a slight eminence if there be one rather than in a hollow.

The first Parish Church in Cohasset has a favorable setting in the green and amid the foliage. The elevation above Little Harbor adds to the effectiveness when approached from the north and it forms the center of a very attractive village group. St. Stephen's Church upon a rocky eminence has a novel and commanding location which greatly enhances the dignity and beauty of its architecture. Both of these churches are more effective because of the open space about them, a feature which is also appreciated in Church Green, New Haven.

A civic center is poorly placed if all the buildings are upon one side of a main street. Their architecture cannot be sufficiently appreciated and their presence is not well enough emphasized. On the other hand, if a little square or park exists and the buildings are grouped around it or on two sides of it, they enhance each other and multiply the impression of their importance. If, for instance, one comes upon a fine church and after admiring its architecture and location, glancing across the street sees a fine library or town hall and perhaps a court house or academy the buildings reinforce each other and the impression of dignity and importance is increased. A fine example of this arrangement is seen at Lancaster, Mass., which is an ideal town in many respects.

The buildings of such a group are concentrated first for convenience so that persons coming to the center from various converging roads may be able to gain whatever privileges of public nature and transact whatever business they desire. The business center should be a little to one side from the true civic center, although near by. As example of interesting civic centers I will mention the following, all Massachusetts towns. At South Weymouth the dignified Fogg Building containing opera house, post office, bank and store in a structure of which any town might be proud. The beautiful public library and three churches complete the group, while between and at the intersection of important roads is a small park with shrubbery. Needham and Braintree have fine modern town halls, the latter having grounds of some distinction. Milton has a fine civic group; two churches, town hall, high school, fire and police station, with the public library across the street. The group in Milton also crowns the hill in a rather effective way. The court house group in Dedham with the village green and two churches is very attractive, although the county buildings are more monumental than would be found in ordinary towns. Springfield and Quincy have both developed new civic centers within recent years, the former notable for its beauty and dignity. In cities and in large towns public buildings need not be confined to one civic center. One group may be about the town hall and post office and another about the

public library or high school, or separate school centers or church centers may be developed. The important thing, however, is that each center be complete in itself, contain buildings that are harmonious in architecture and purpose and that each group have a distinct meaning.

Fine trees add greatly to such a center; and a lawn with or without shrubbery serves to make it more attractive. Natural features, ledges of rock, a forest background, or a small pond like that at Cohasset, if they are available, should be made to contribute to the scene.

tains proper relations and grouping of its buildings, so that they will support and reinforce each other. Civic art at first thought might be something involving great expense, but in true definition it is merely the doing and making of useful things in the best possible way. The aim should be to have the civic center express the spirit of the town; to show that it is striving for the best things, that it cares both for its traditions and its progress, that it makes use of its natural advantages, that it has not only respect and dignity, but also a high regard for the welfare of its people.



VIEW OF GLOUCESTER, MASS., AND HARBOR

A town with sound ideas of beauty and fitness can replan and improve its center from time to time. New buildings will occasionally be required. Trees and laws can be made more beautiful. The prime requisites are the seeing eye, good taste, and the progressive spirit.

The small town with few public buildings can attain considerable results at little expense if it main-

Such a town will exalt its best things. It will refuse to see its beauty defaced and degraded. It will maintain such an aspect that the stranger can easily read its character and its worth. It must not consider itself perfect and therefore remain stationary but must be alive to new conditions and replan when necessary; always bearing in mind the fitness of things and the best way of attaining its ideals.

Who Owns a Business?

HERE is a man, for example, who owns and operates a large farm. He bought it with his own hard-earned money; on it he works ten to fourteen hours a day.

Giving his whole time and strength to the work, he finds it necessary to employ three farm laborers to assist him in getting the maximum production. He agrees with them for wages and pays what they are willing to work for.

But, according to modern thinking, this system is all wrong.

These three men ought to control the farm, decide how much in money and produce should go to the theoretical owner, and keep all the rest themselves. These men are giving their lives for the work. "If you deny them control of what they give their lives for, you deny them justice." The owner is also giving his life for the farm, but of course that is different; he is a capitalist and exploiter of labor.

Does labor in and by itself give the right to control the profits? If men work on a railroad, does the fact of that labor itself give the workers the right to control the profits? Surely not, unless the labor itself furnishes a title to ownership. Is this true?

* * *

If you own a valuable gold watch and take it to a skilled watchmaker to be repaired, whose watch is it after he has repaired it? Does it still belong to you, or does it now belong to the man who worked on it, by virtue of his labor?

To whom does the control of the watch belong? Does the man who worked upon it, by that labor gain the right to decide whether he will hand it back when you have paid his bill, or sell it and divide the proceeds with you?

* * *

The laborer surely has a right to a fair even a generous, return for his labor. He has a right to reasonable hours and good working conditions. But certainly his labor gives him no right to control the industry since it gives him no title to ownership.

We are losing sight today of elementary economics.

We live under democracy, and it may be possible to nationalize the railroads by legislation. We might then nationalize the mines and all other industries, finally nationalizing our farms and giving all the profits to the hired farm laborers.

But let us be honest.

Let us not call it "industrial democracy," for "industrial democracy" is concerned with the welfare of all classes.

It is not even true Socialism. It is really turning over the control and profits of industry to a single

class in industry for the sake of that one class alone. We would call it American Bolshevism were it not that those whose doctrine it is to have their feelings hurt when called Bolshevists.—*Boston Transcript*.

Bombay Plans 50,000 Tenements As Thousands Protest High Rents

CORRESPONDENCE reveals that the problem of rents and housing has become as acute in India's great industrial cities as anywhere in the world. Calcutta, since the armistice was signed, has absorbed nearly 2,000 ex-British officers into its industrial system. American concerns are directing their attention to India's trade and opening branches here. The Japanese are ubiquitous where formerly they were never seen. Yet hardly a new dwelling has gone up since 1916. The price of all building materials is prohibitive and new buildings can be constructed only at a price which demands a rent that appears preposterous gauged by the old standard of salaries and incomes.

In response to popular clamor—it would be almost accurate to write popular "fury"—a rents limitation act was passed last May. In the court set up by the act 1,000 appeals against extortionate rents were heard the past month. If there were six courts probably 6,000 cases would have been presented. How the problem will be solved no one knows.

Companies representing some 3,000,000 or 4,000,000 sterling have recently been started to exploit the almost limitless riches of the area adjacent to Calcutta.

Apart from one electric tramway the communications of the city are almost nil. The suburbs need opening out by means of electric omnibuses and the electrification of the suburban railway system. The inner railway system, it is generally recognized, needs developing by the circle plan adopted in so many European cities, including London and Paris. Whether the peculiar nature of Calcutta's subsoil—the city is really built on a gigantic raft of floating silt—rules out the underground railway proposition is still uncertain. That there is a field for the work of the imaginative pioneer in the construction of new communications is certain.

In Bombay matters are worse. The rapidly growing city with its great cotton mills and railway works, carried on within the limited space of a single island has become a byword for epidemics and infantile mortality. The never-ending series of strikes which from time to time paralyze the life of the place are in large measure a product of its wretched housing. The government has at last taken up the problem in hand and a great scheme recently announced provides for the immediate initiation of

a plan for the erection of 50,000 tenements at an estimated cost of 5,500,000 sterling and a further capital expenditure of 6,000,000 sterling on the rapid improvement of municipal amenities.

So urgent has the problem become that Bombay improvement is to be made a species of government department with a special development director. Doubtless Sir Lawless Hepper, the first director, will have an open ear for any reasonable suggestion put forward as the outcome of American experience in rapid city development.

England Has 10,000 Housing Schemes

ATTEMPTS to solve Great Britain's housing problem have already brought forward upwards of 10,000 schemes involving an annual capital expenditure of \$600,000,000, according to a report by a representative of the Foreign Trade Bureau of the Guaranty Trust Company of New York. After giving details as to various plans and the number of houses to be built in each of more than thirty cities visited, the report says:

"The program of the Ministry of Health—complete rehousing in three years—is about one year behind, and is costing more than double the original estimates.

"The Ministry of Health works in conjunction with the Office of Works. Where a local authority defaults, the business is then entrusted to the Office of Works.

"What is keeping back housing at the present time is the fact that there are not enough skilled men to do even a quarter of the work wanted. The Trades Unions will now allow the number to be increased from the outside. The government is using a sort of indirect compulsion by prohibiting 'luxury and unessential building,' so that if a man will not build cottages he is not allowed to build anything else. There are various suggestions for speeding up the work, including a guarantee to the Trades Unions of employment for a term of years to men employed on housing work, to ensure them against loss of time in bad weather by a minimum wage 'wet or dry.' In return the Trades Unions will be asked to consent to dilution and the employment of unskilled and semi-skilled labor, to give up their apprenticeship rules, and abandon all opposition to the employment of ex-service men, trained or untrained. There are 'luxury building' tribunals to hear appeals against decisions prohibiting buildings regarded as non-essential.

"There are housing bond campaigns all over the country. In London subscriptions to the 6 per cent. bonds are coming in at the rate of about £100,000 a day. While the local governments are issuing 6 per cent. bonds, the British Government charges 7 per cent. Borrowing in the ordinary way for housing schemes not financed by bonds is usually 7 per cent.

"On the 21st of July the total number of housing schemes in England and Wales numbered 10,673, covering in all land for 800,000 houses. Of these 7,120 have been approved with an area for 550,000 houses. In Scotland 103,000 houses have been authorized, the bids averaging about £1,000 per house. This is roughly about £100-£150 more than it costs per house in England."

Men and Business

IN the editorial columns of the *Philadelphia Public Ledger*, Richard Spillane from time to time gives many interesting sidelights on matters of national importance. Recently he said:

Three cities—New York, Chicago and Philadelphia—have an aggregate population of 10,145,521, or nearly one-tenth of that of the United States. That is unhealthy in many ways. More than one-quarter of all the people in the republic live in the sixty-eight cities that have a population in excess of 100,000.

There is going to be a change. Big corporations have been conducted with the idea that it was good business to create big plants in or near great cities. The bigger the plant, the greater the economy was the belief. Industrial chiefs are discovering they were wrong in their reasoning. There is an old saw that it is bad to put all your eggs in one basket. It is bad, too, to put all your eggs in a few baskets. A high official of a great corporation employing approximately 80,000 persons is authority for the statement that never again will his concern establish a plant employing more than 1,000 workers.

"Many units instead of a few units will be the rule with us hereafter," he says. "We have found, and I have no doubt others have discovered, that labor troubles are many where labor is assembled in one establishment in huge numbers. A strike in one department is likely to tie up or cripple all of them, either by spreading to the others or because the trouble is in one branch of the works that has an important bearing on all. Our aim is to make all of our plants self-contained or to get as near to that ideal as is possible. No more big plants for us."

St. Mark's in the Bouverie

(See reproduction of the original drawing by O. R. Eggers in this issue)

P*PETER STUYVESANT, that famous old Dutch Governor of New York, within the sound of the bell that hung in the low belfry of the chapel that once stood on the site of the church, founded the community of St. Mark's in the Bouverie about 1760. In 1795 the present edifice was built.*

With perhaps the exception of the erection of a few stately mansions surrounded by wide parks or grounds, this quaint old neighborhood saw few important changes up to the outbreak of the Civil War. The Bouverie was a winding, dusty roadway that led from the city northward. It was a favorite walk and place for summer outings. The land sloped by gentle undulations to the East River.

St. Mark's, while not of first importance from an architectural viewpoint, is of moment as being the second oldest church structure on Manhattan Island. Over zealous restorers have from time to time somewhat marred the classic correctness of its original lines. But even such vandal hands cannot rob this venerable structure or the neighborhood which it has dominated for so many years of the interest which surrounds it.

A more detailed description of St. Mark's will be found in an earlier issue in which was shown the portico of this church. Fortunately St. Mark's has escaped the fate which has overtaken St. John's Church on the west side, and it will probably stand for many years as it has stood in the past, the symbol of a God-fearing citizenry who clung to the traditions of their ancestors and with the utmost solicitude preserved an edifice so closely woven with the religious and social life of old New York.

472



St. Mark's Church - New York







A Legend of Sleepy Hollow

IS there a Scenic Preservation Society in existence today, and if so, what is it doing? The writer hereof recently visited the Washington Irving country, that part on the east bank of the Hudson River lying north from Yonkers and extending to Sleepy Hollow just beyond Tarrytown. The road which skirts the undulating country close to the river's banks presents many splendid opportunities for long vistas up and down the river. These are among the most picturesque localities in suburban New York.

It is more than annoying to find that there is a high barricade of advertising signboards placed at every vantage point. The river, with its magnificent views, has been absolutely shut out. Is it futile to protest against this vandalism? Is there no relief? Why could not an indignant public protest against this sort of thing in a manner that would work a speedy reform? If every motorist would notify the advertisers that positively would they refuse to purchase any of the wares thus advertised, these atrocious billboards would quickly disappear. Probably in most cases advertisers do not know just how these boards are located. The work is done under contract and the enthusiasm of the signboard builders absolutely clouds their feeling for the fitness of things.

The crowning indignity is to be found in Sleepy Hollow. In this picturesque locality Washington Irving set the scene for one of the best known legends of the Hudson River district. There the luckless and witless schoolmaster, Ichabod Crane, raced with the headless horseman. It is a locality annually visited by thousands of tourists, a literary mecca.

Just a few paces from the stone bridge where Ichabod is said to have been tumbled from his nag, there has been placed a most enormous advertisement for a certain tire. The blatancy, the vulgarity of the thing cannot be adequately described. A patriotic man will experience indignation that the traditions of his country should be so ignored as to permit a thing of this sort. A man of artistic impulse will become irritated at the marring of so beautiful a

feature of the landscape, and everyone with even a limited sense of the fitness of things will question the justice of such acts as these. Have the people no rights which these vandals will respect?

Scale Models at Architectural Exhibitions

IT will not be long before the opening of the first of the season's architectural exhibitions will be announced. Based on the progressiveness of past years, the forthcoming exhibition will undoubtedly be of the most educational value. The real educational value of these annual shows is to the laity, and to make this education more easy of acquirement, to permit the visitor to combine pleasure and instruction, it will be necessary largely to present the material in a manner that the layman can easily understand.

Architects are able to visualize a subject in its three dimensions of length, breadth and thickness from an inspection of the usual drawings. The average layman cannot do this. But, with a scale model, the non-technical visitor may see the thing as it will ultimately become, and it therefore seems desirable that there should be more scale models shown than has heretofore been the custom.

Comment has been made in these pages as to the proposed action of the Architectural School of Columbia University, in promoting model making. It would be well for other schools at our universities to follow this example. If there could be assembled at the first of our larger architectural exhibitions a comprehensive display of scale models, to be sent out on a circuit of other exhibitions, the same large educational result would be achieved as has been secured by the National Sculpture Society in its peripatetic collection of small bronzes.

The fire that destroyed the exhibition of the Architectural League of New York on the very eve of its opening was calamitous, as it deprived the profession of an opportunity to see and to study many innovations in architectural exhibitions. Among these were a large number of scale models. They

were admirably placed and lighted, and there is no doubt that they would have formed central points for a large number of interested visitors.

A War Memorial Building in Washington

THE collection of relics of the great war which is being assembled in Washington by the War Department has reached such proportions that it is proposed to ask Congress to provide the funds necessary for a building adequately to house them. This will afford a good opportunity to provide a dignified structure that will combine the aspects of a museum and a national memorial of the war.

Already is the National Museum, completed but a few years ago, and in which this accumulation of valuable historic relics is stored, taxed to capacity. If Congress will provide sufficient funds for an adequate structure there will be presented to architects an opportunity to design a building which will be a credit to the nation and a fitting memorial to the men who laid down their lives in the great conflict.

An appropriate building, or better yet, a group of buildings, would assume large proportions. There should be sections that would represent all the states and colonies and the various branches of the Government. Just what could be accomplished in the erection of such a group it is wonderful to contemplate. It would fittingly carry forward the idea that is inspired by the magnificent Lincoln Memorial, beautiful in its simplicity, and typify our progress as a nation from the close of the Civil War to the end of the great struggle in Europe.

Of course, the whole idea is more or less embryonic at this time, but it is one that in development may become a stupendous undertaking. It will be well to give it consideration and early to proceed in the preparation of a scheme that will be fitting and architecturally good.

The Conference of Registration Boards

THE first formal meeting of the National Council of Architectural Registration, which will be held in St. Louis on November 18, affords opportunity to accomplish a much to be desired reform in the drafting of future state registration laws. At one time and another THE AMERICAN ARCHITECT has urged that action be taken so to codify the registration laws already enacted in some eighteen states, as to harmonize their requirements and to make easy reciprocal transfer from state to state.

The wisdom of such a course would not seem to require much argument to secure proper action. It is therefore most encouraging to note in the published announcement of this meeting that these important matters are set down for serious consideration. Let us hope that the time is not far distant when every state will have enacted laws licensing the practice of architecture.

When that time has arrived, it will become necessary nationally to control the boards of registration in the various states. A national body would logically be called upon to pass on the records of applicants seeking transfers and the reasons for such requests. With a uniform law and a centrally controlling body, the practice of architecture in the United States would become safeguarded from the incursion of irresponsible and incompetent men. Every architectural organization is directly concerned in the outcome of this important meeting.

It is now a good time to continue the discussion of a further formation of state societies. If there were such organizations in all the states, a meeting such as is proposed would take on a very comprehensive character and the results achieved through well organized co-operation would be of the utmost value.

279



FISK BUILDING, NEW YORK CITY
CARRERE & HASTINGS AND R. H. SHREVE, ARCHITECTS

CARRERE AND HASTINGS N. Y. 1912
R. H. SHREVE N. Y. 1912



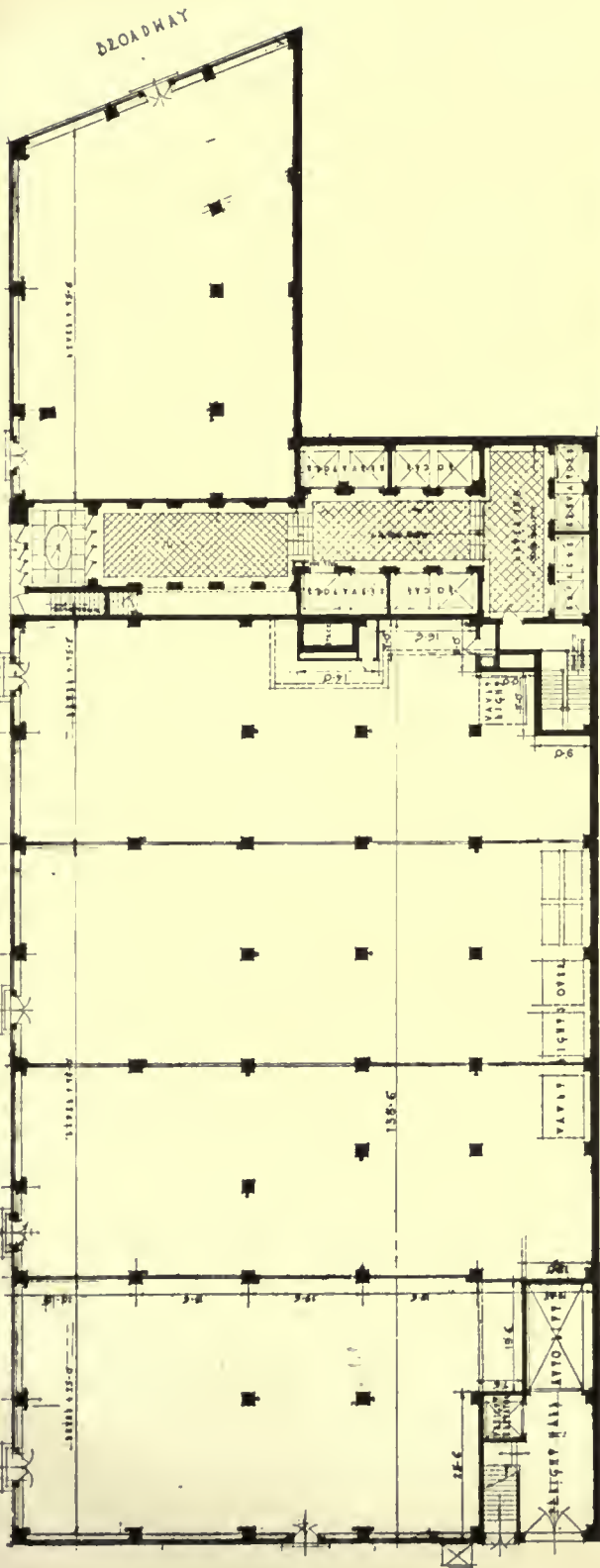

FIRST FLOOR PLAN.

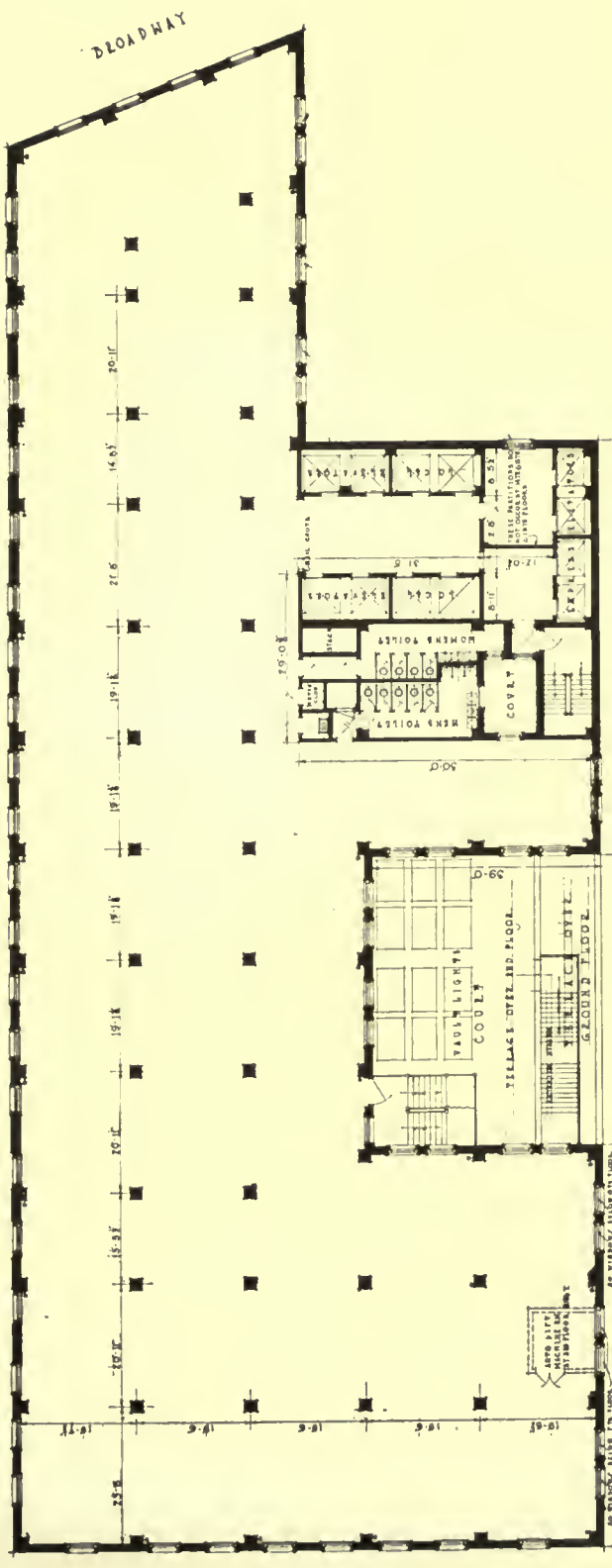

TYPICAL FLOOR PLAN



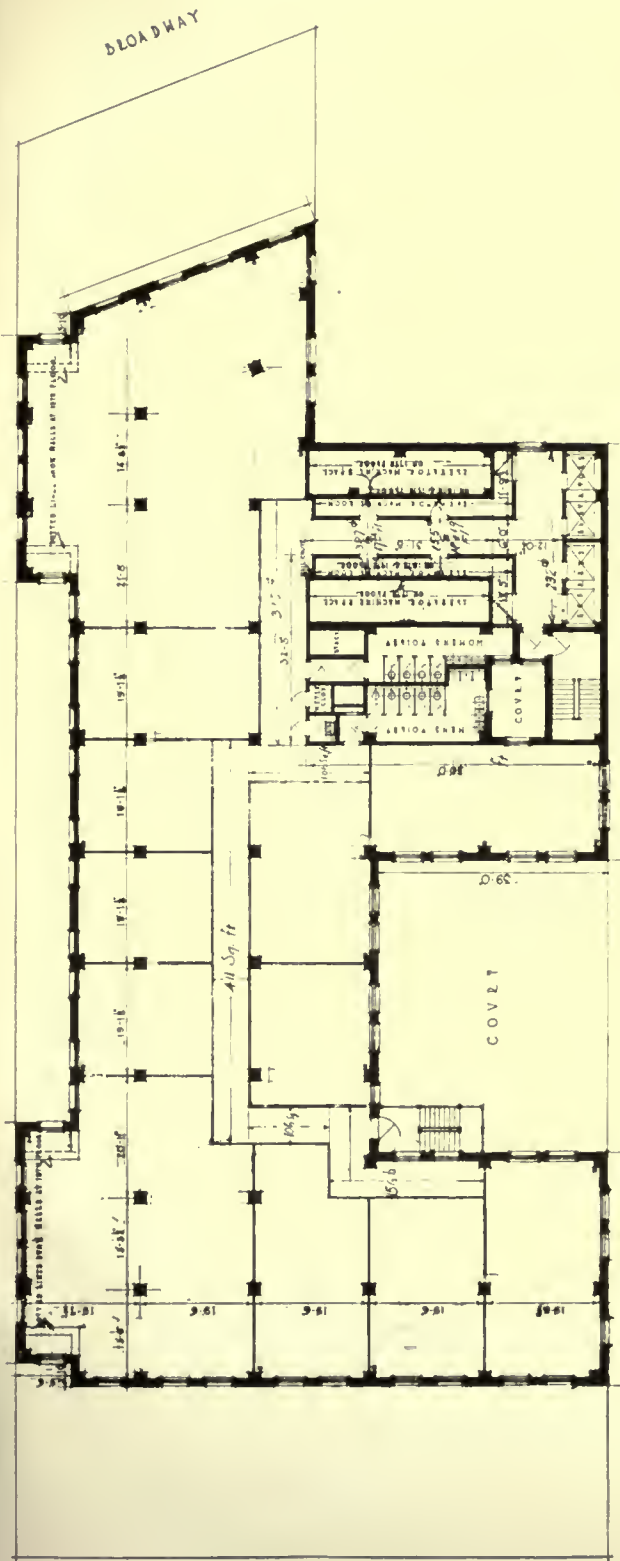

PLAN OF 17th, 18th AND 19th FLOORS.

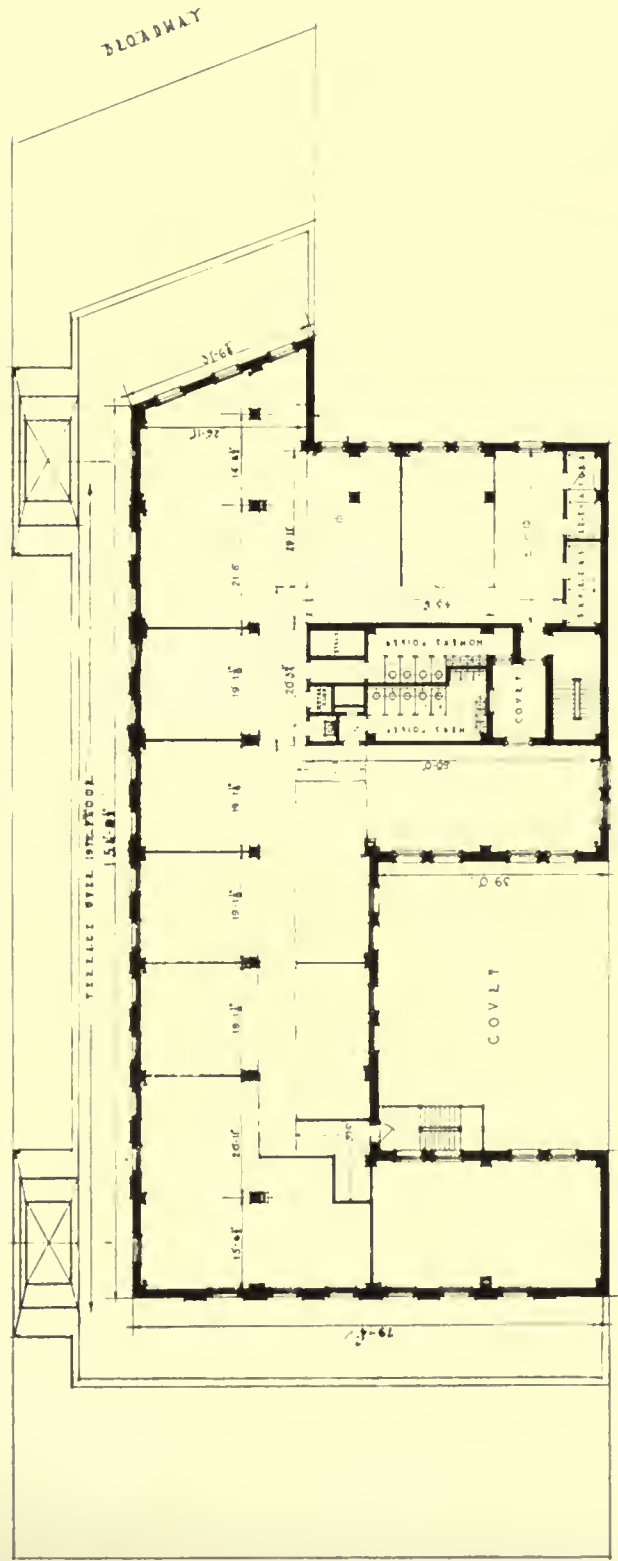

PLAN OF 20th TO 24th FLOORS.

FISK BUILDING, NEW YORK CITY

4763





LIGGETT-WINCHESTER-LEY CORPORATION BUILDING, NEW YORK CITY
CARRERE & HASTINGS AND R. H. SHREVE, ARCHITECTS



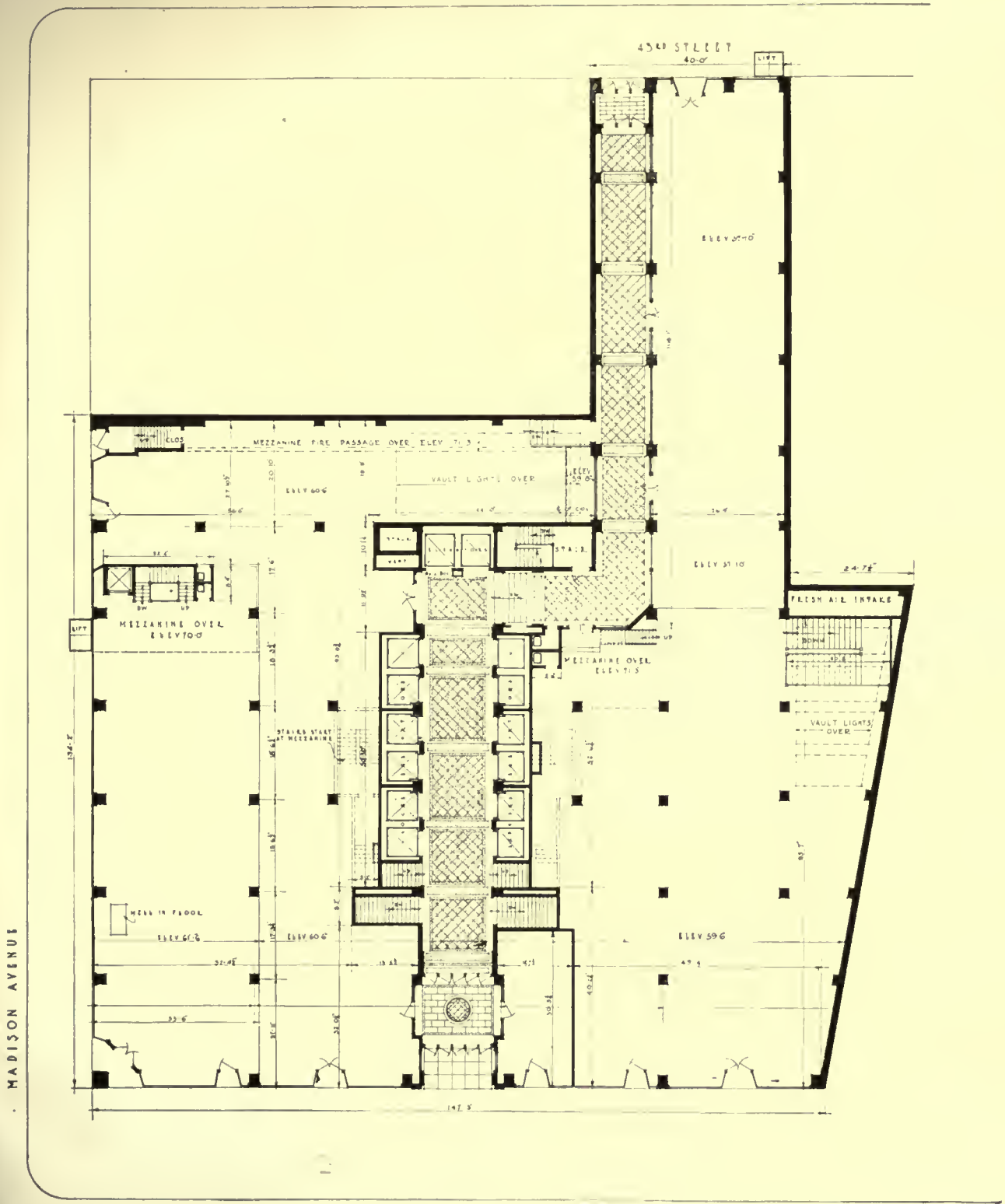

42ND STREET

FIRST FLOOR PLAN
 LIGGETT-WINCHESTER-LEY CORPORATION BUILDING, NEW YORK CITY
 CARRERE & HASTINGS AND R. H. SHREVE, ARCHITECTS

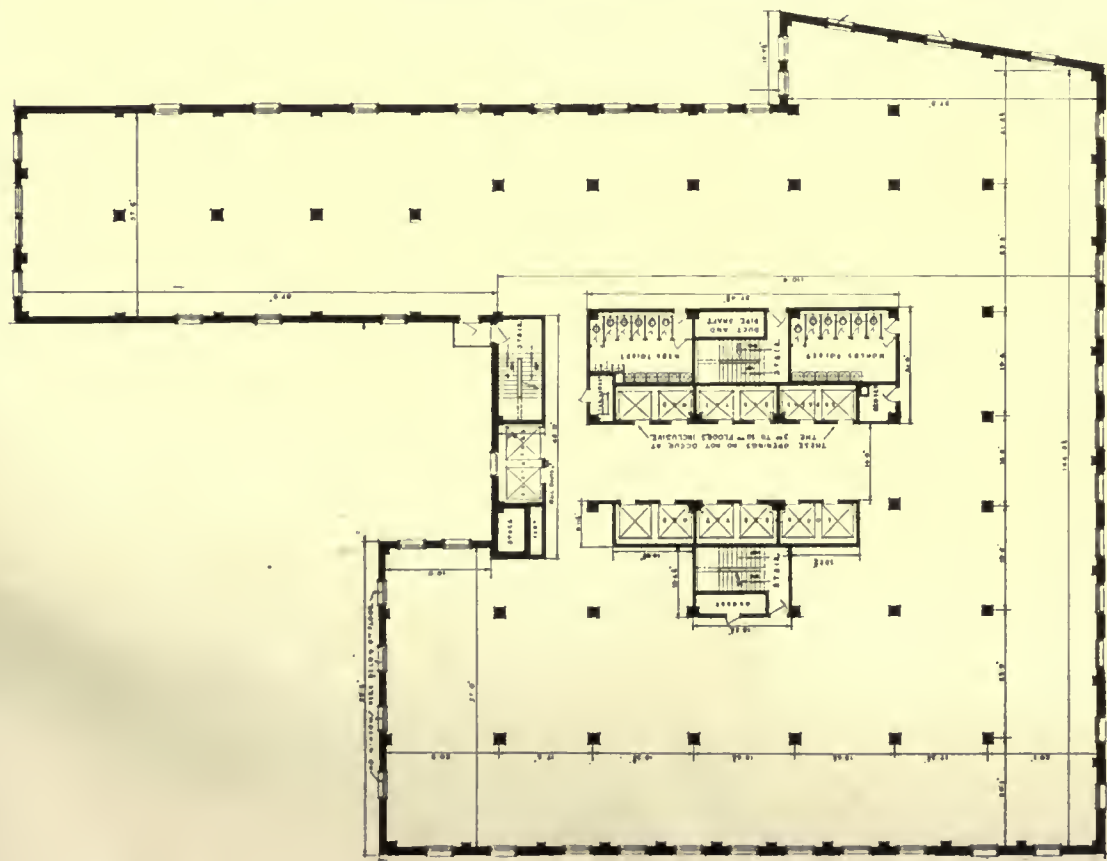

TYPICAL FLOOR PLAN

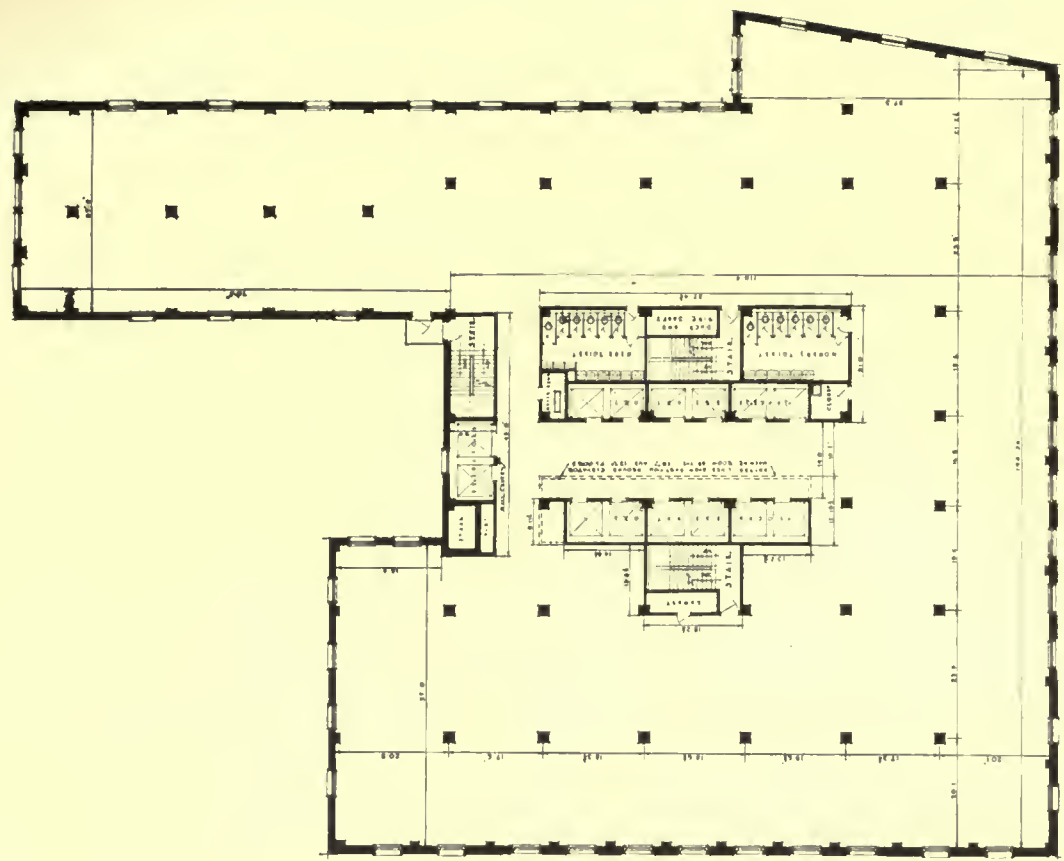

PLAN OF 13th, 14th AND 15th FLOORS

LIGGETT-WINCHESTER-LEY CORPORATION BUILDING, NEW YORK CITY
 CARRERE & HASTINGS AND R. H. SHREVE, ARCHITECTS



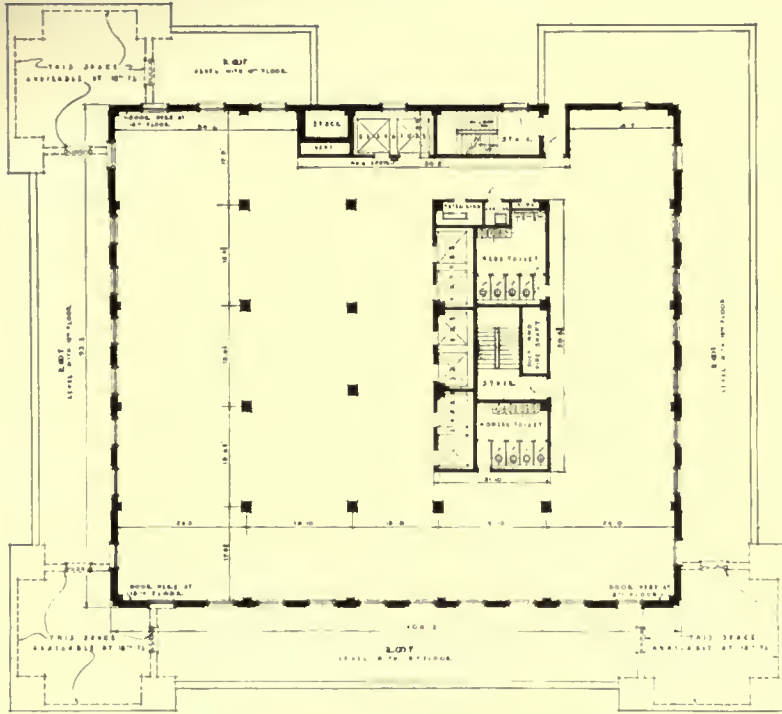

CARRERE & HASTINGS AND
R. H. SHREVE, ARCHITECTS

PLAN OF 18th TO 22d FLOORS

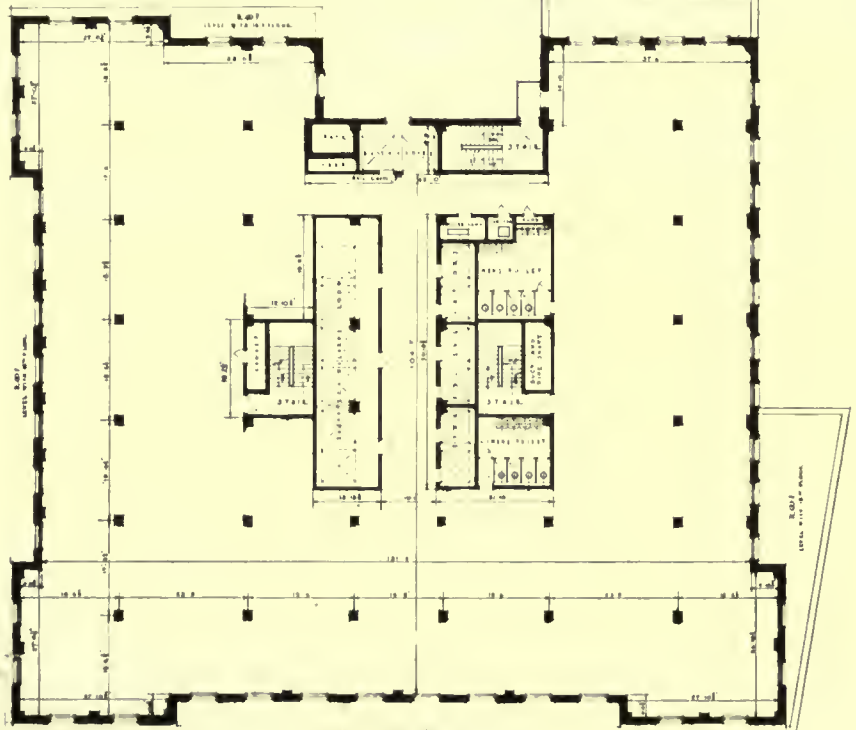

PLAN OF 16th FLOOR

LIGGETT-WINCHESTER-LEY CORPORATION BUILDING, NEW YORK CITY



ENTRANCE FRONT
HOUSE OF LAWRENCE D. BEGGS, HARTFORD, PA.
McILVAIN & ROBERTS, ARCHITECTS





TERRACE FRONT
HOUSE OF LAWRENCE D. BEGGS, HARTFORD, P.A.
McILVAIN & ROBERTS, ARCHITECTS



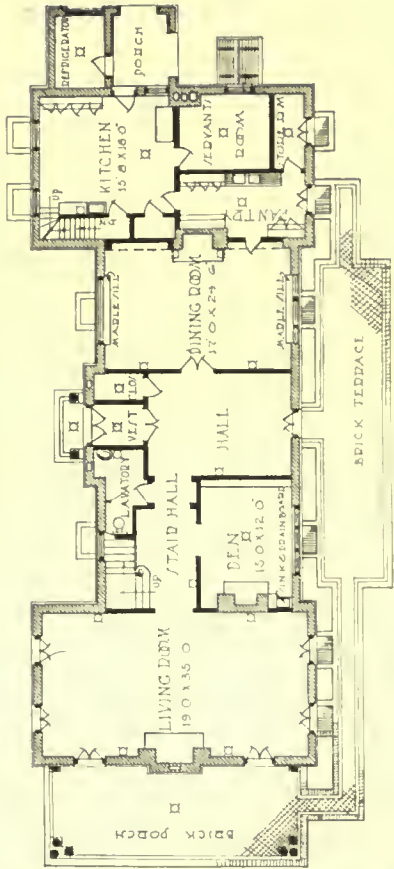
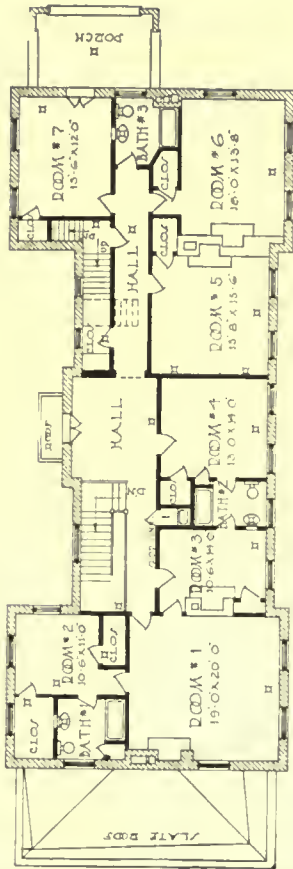
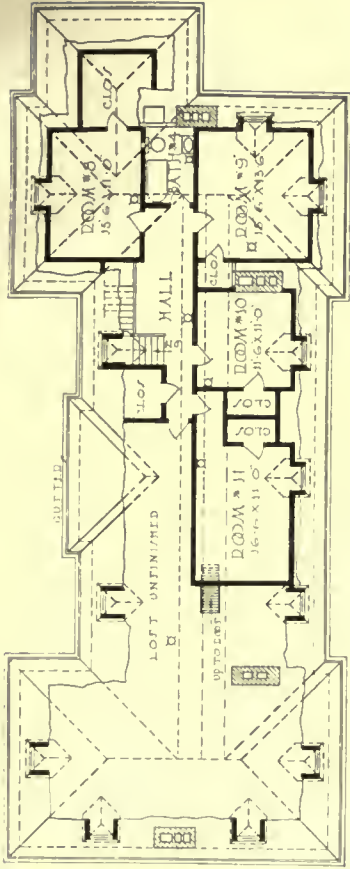

HOUSE OF LAWRENCE D. BEGGS, HARFORD, PA.
McILVAIN & ROBERTS, ARCHITECTS

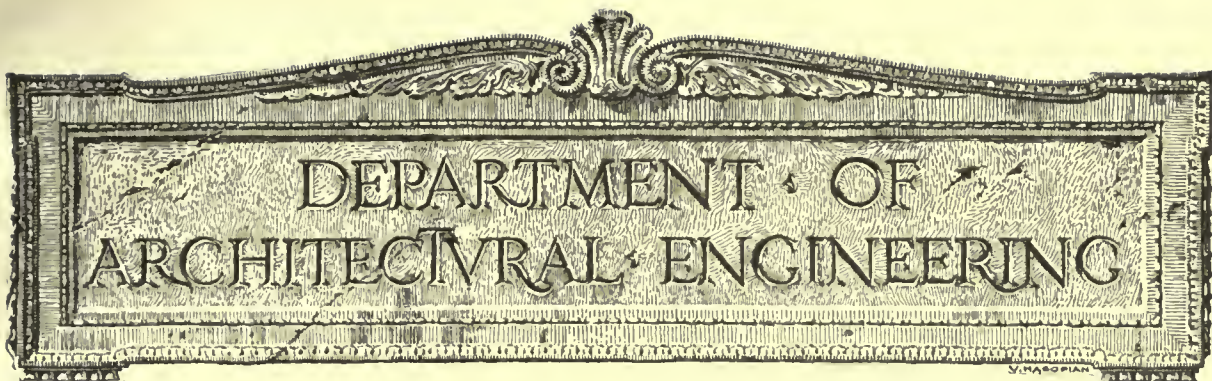

The Fundamental Principles of Illumination Design

IV - Calculation and Design

IN the design of any system of lighting the determination of the *intensity* of illumination necessary to produce satisfactory results is of prime importance. After this value has been fixed the method of procedure is substantially as follows: (1) Selection of the general scheme of lighting and type of lighting units; (2) Calculations to determine the quantity of light flux required to produce the desired intensity of light; and (3) Fixing location and size of lighting units.

Most of the problems confronting the architect are those in which a certain average general illumination is required. The fixing of such an average presupposes that the minimum in any part of the working area shall not fall too far below that average. In modern practice, this minimum is usually not less than 25 per cent. below the specified average. The spacing of units too far apart will tend to produce a considerable variation over a given area, and should be avoided. Uniformity of illumination should be aimed at.

The selection of the general scheme of lighting and type of lighting units requires an intimate knowledge of the systems available, their merits, objections and adaptability to any particular type of occupancy. The various systems of illumination were described in the preceding article (issue of June 30) and a careful study of the data presented therein, coupled with the architect's own experience and observations should aid materially in selecting the proper type.

There are several methods of determining the quantity of light flux required, most of them cumbersome and requiring somewhat complex calculations. These will not be described. The simplest

and for all general purposes the most satisfactory method is to use the following formula:

$$L = \frac{i a d}{e} \text{ in which}$$

L = total light flux, in lumens, which lamps must furnish to provide required intensity on working plane.

i = average intensity of illumination, in foot candles, required on working plane.

a = area of working plane in square feet. For all general lighting schemes this will be the room area.

d = depreciation factor (this is sometimes disregarded).

e = coefficient of utilization.

The factor "*ia*" represents the total lumens effective on the working plane, and the difference between this value and L is the quantity of light flux absorbed or otherwise lost in transit from the source to the working plane, modified by the probable depreciation of the lamp itself.

The value of "*i*" will vary from 0.25 in corridors, toilets, etc., to 20 in drafting rooms or factories in which extremely fine work is done. For show window illumination even higher intensities are used. This value will either be fixed by a state code, or else will be selected on the basis of experience, when no codes govern.

Table I shows the intensity of illumination considered desirable by a number of authorities for various classes of interior lighting.

The question of proper illumination for reading has been investigated much more thoroughly than that for other purposes. Tests show considerable



AN EXCELLENT EXAMPLE OF MODERN INDUSTRIAL LIGHTING.

In this armature winding room the average intensity of illumination is 17 ft. candles. The fixtures are R. L. M. standard dome, with 300-Watt Mazda C bowl-enameled lamps, mounted 11 ft. above the floor and 8 ft. above the working plane, spaced 10 ft. x 12½ ft. The cost of light is negligible compared with the increased returns, due to maximum production made possible under such conditions.

difference between individuals, although the same individuals show consistent repetition of the quantities considered sufficient.

TABLE I—ILLUMINATION FOR VARIOUS PURPOSES IN FOOT-CANDLES.

	Min.	Max.	Notes
Reading: U. S. Gov. Postal Car Minimum requirements	2.8		See a
Clerical and other work.....	3	8	
General drafting	5	10	
Drafting, tracing on blueprints or faint pencil drawings.....	10	20	See b
Factory work, coarse.....	1.25	2.5	See c
Factory work, fine.....	3.5	10	See c
Corridors	0.25	1	
Stores, ordinary practice.....	3	7	
Stores, first floors, large cities...	5	10	See d
Audience rooms	1	3	
Show windows	5	40	See d

Notes.—(a) Some individuals are satisfied with half this while others, especially the aged and those not properly fitted with glasses and those whose eyes are subnormal for any reason, may be satisfied only with values considerably higher than this; perhaps 5 to 10

foot-candles. When such individuals are to be satisfied this fact must be remembered in the design.

(b) Illumination from below is preferable, using a translucent table.

(c) Depends also on color.

(d) Depends on surrounding competition.

As a result of extensive tests of postal clerks and others on the light required for reading under postal car lighting conditions, the United States Government now specifies a minimum illumination of 2.8 foot-candles at points where reading of letter addresses is to be done by postal clerks.

There is no conclusive evidence at present that there is any marked hygienic advantage in color of one artificial illuminant over another. This statement refers to purely physiological results rather than to aesthetic effects. An exception to this which should be noted, however, is that there is good evidence that the chromatic aberration of the eye causes a certain lack of clearness with most natural and artificial illuminants so that for seeing fine de-

THE AMERICAN ARCHITECT

tails a light which is nearly nonchromatic like the mercury-vapor light is preferable.

The following is taken from the New York State Industrial Code:

DESIRABLE ILLUMINATION.

	Foot-candles at floor level—modern practice	
1. Roadways and yard thoroughfares...	0.05 to	0.25
2. Storage spaces	0.50 to	1.00
3. Stairs, stairways, halls, hallways, passageways, aisles, exits, elevator entrances and elevator cars	1.00 to	2.00
	Foot-candles at the work—modern practice	
4. Work not requiring discrimination of detail.....	1.00 to	2.00
5. Rough manufacturing requiring discrimination of detail.....	2.00 to	4.00
6. Rough manufacturing requiring closer discrimination of detail..	3.00 to	6.00
7. Fine manufacturing	4.00 to	8.00
8. Special cases of fine work.....	7.00 to	15.00

In the preceding table the upper portion of the range of modern practice intensities is preferable to the lower in most cases. Sometimes even higher intensities than those cited are desirable; for example, in very fine manufacturing operations, such as special engraving and dark colored lace work, an intensity exceeding 20 foot-candles is not uncommon in modern practice.

In addition this code contains a table giving various classifications of work in detail, and the minimum intensities permitted.

The value of "d" will vary from 1.1 to 2, depending on the occupancy, probability of dust collection, lack of cleaning, etc. In most cases a value of 1.25 will be found satisfactory.

The co-efficient of utilization can be selected from Table III. The most important part in the application of the formula given is the selection of the proper value for "c."

Having determined L, the total lumens required, representing the output of the lamps, there remains



GOOD LIGHT IN THE OFFICE IS ESSENTIAL TO GOOD WORK

Here dense opal, semi-indirect fixtures containing 200-Watt clear Mazda C lamps are used, mounted 3½ ft. below the ceiling and 11½ ft. above the floor. The spacing is 10½ x 11½ ft. and the average illumination is 8 ft. candles.

THE AMERICAN ARCHITECT

TABLE II—ROOM INDEX



















For finding coefficient of utilization from Table III.

D	ROOM LENGTH	ROOM WIDTH—FEET																
		8	10	12	14	16	18	20	24	30	35	40	50	60	70	80	100	120
For Direct Lighting Sources Located 5 Ft. Above Working Plane and for Semi and Indirect Lighting Where Ceiling is 7½ Ft. Above Working Plane	10	0.8	1.0	1.0	1.0	1.25	1.25	1.25	1.5	1.5	1.5	1.5	1.5	1.5	1.5	1.5	1.5	1.5
	12	0.8	1.0	1.25	1.25	1.25	1.25	1.5	1.5	1.5	1.5	2.0	2.0	2.0	2.0	2.0	2.0	2.0
	14	1.0	1.0	1.25	1.5	1.5	1.5	1.5	2.0	2.0	2.0	2.0	2.0	2.0	2.0	2.0	2.0	2.0
	16	1.0	1.25	1.25	1.5	1.5	1.5	2.0	2.0	2.0	2.0	2.0	2.0	2.0	2.0	2.0	2.0	2.0
	18	1.0	1.25	1.25	1.5	1.5	2.0	2.0	2.0	2.0	2.5	2.5	2.5	2.5	2.5	2.5	2.5	2.5
	20	1.0	1.25	1.5	1.5	1.5	2.0	2.0	2.0	2.5	2.5	2.5	2.5	2.5	2.5	2.5	2.5	2.5
	24	1.25	1.25	1.5	1.5	2.0	2.0	2.5	2.5	2.5	3.0	3.0	3.0	3.0	3.0	3.0	3.0	3.0
	30	1.25	1.5	1.5	2.0	2.0	2.0	2.5	2.5	3.0	3.0	3.0	3.0	3.0	3.0	3.0	3.0	3.0
	35	1.25	1.5	1.5	2.0	2.0	2.5	2.5	2.5	3.0	3.0	4.0	4.0	4.0	4.0	4.0	4.0	4.0
	40	1.5	1.5	2.0	2.0	2.0	2.5	2.5	3.0	3.0	4.0	4.0	4.0	4.0	4.0	4.0	4.0	4.0
	50	1.5	1.5	2.0	2.0	2.0	2.5	2.5	3.0	3.0	4.0	4.0	5.0	5.0	5.0	5.0	5.0	5.0
	60	1.5	1.5	2.0	2.0	2.0	2.5	2.5	3.0	3.0	4.0	4.0	5.0	5.0	5.0	5.0	5.0	5.0
	70	1.5	1.5	2.0	2.0	2.0	2.5	2.5	3.0	3.0	4.0	4.0	5.0	5.0	5.0	5.0	5.0	5.0
	80	1.5	1.5	2.0	2.0	2.0	2.5	2.5	3.0	3.0	4.0	4.0	5.0	5.0	5.0	5.0	5.0	5.0
	100	1.5	1.5	2.0	2.0	2.0	2.5	2.5	3.0	3.0	4.0	4.0	5.0	5.0	5.0	5.0	5.0	5.0
	120	1.5	1.5	2.0	2.0	2.0	2.5	2.5	3.0	3.0	4.0	4.0	5.0	5.0	5.0	5.0	5.0	5.0
	140	1.5	1.5	2.0	2.0	2.0	2.5	2.5	3.0	3.0	4.0	4.0	5.0	5.0	5.0	5.0	5.0	5.0
	170	1.5	1.5	2.0	2.0	2.0	2.5	2.5	3.0	3.0	4.0	4.0	5.0	5.0	5.0	5.0	5.0	5.0
200	1.5	1.5	2.0	2.0	2.0	2.5	2.5	3.0	3.0	4.0	4.0	5.0	5.0	5.0	5.0	5.0	5.0	
For Direct Lighting Sources Located 6 Ft. Above Working Plane and for Semi and Indirect Lighting Where Ceiling is 9 Ft. Above Working Plane	10	0.8	0.8	0.8	1.0	1.0	1.0	1.0	1.0	1.25	1.25	1.25	1.25	1.5	1.5	1.5	1.5	1.5
	12	0.8	0.8	1.0	1.0	1.0	1.25	1.25	1.25	1.5	1.5	1.5	1.5	1.5	1.5	1.5	1.5	1.5
	14	0.8	1.0	1.0	1.25	1.25	1.25	1.5	1.5	1.5	1.5	1.5	1.5	1.5	2.0	2.0	2.0	2.0
	16	0.8	1.0	1.0	1.25	1.25	1.25	1.5	1.5	1.5	1.5	1.5	1.5	1.5	2.0	2.0	2.0	2.0
	18	0.8	1.0	1.25	1.25	1.25	1.5	1.5	1.5	1.5	1.5	2.0	2.0	2.0	2.0	2.0	2.0	2.0
	20	1.0	1.0	1.25	1.25	1.5	1.5	1.5	1.5	1.5	1.5	2.0	2.0	2.0	2.0	2.5	2.5	2.5
	24	1.0	1.25	1.25	1.5	1.5	1.5	1.5	2.0	2.0	2.0	2.5	2.5	2.5	2.5	2.5	2.5	2.5
	30	1.0	1.25	1.5	1.5	1.5	1.5	2.0	2.0	2.5	2.5	2.5	2.5	2.5	3.0	3.0	3.0	3.0
	35	1.25	1.25	1.5	1.5	1.5	2.0	2.0	2.0	2.5	3.0	3.0	3.0	3.0	3.0	3.0	3.0	3.0
	40	1.25	1.5	1.5	1.5	2.0	2.0	2.0	2.5	2.5	3.0	3.0	3.0	4.0	4.0	4.0	4.0	4.0
	50	1.25	1.5	1.5	2.0	2.0	2.0	2.0	2.5	3.0	3.0	4.0	4.0	4.0	4.0	4.0	4.0	4.0
	60	1.25	1.5	1.5	2.0	2.0	2.0	2.5	2.5	3.0	3.0	4.0	4.0	4.0	5.0	5.0	5.0	5.0
	70	1.25	1.5	1.5	2.0	2.0	2.0	2.5	2.5	3.0	3.0	4.0	4.0	5.0	5.0	5.0	5.0	5.0
	80	1.25	1.5	1.5	2.0	2.0	2.0	2.5	2.5	3.0	3.0	4.0	4.0	5.0	5.0	5.0	5.0	5.0
	100	1.25	1.5	1.5	2.0	2.0	2.0	2.5	2.5	3.0	3.0	4.0	4.0	5.0	5.0	5.0	5.0	5.0
	120	1.25	1.5	1.5	2.0	2.0	2.0	2.5	2.5	3.0	3.0	4.0	4.0	5.0	5.0	5.0	5.0	5.0
	140	1.25	1.5	1.5	2.0	2.0	2.0	2.5	2.5	3.0	3.0	4.0	4.0	5.0	5.0	5.0	5.0	5.0
	170	1.25	1.5	1.5	2.0	2.0	2.0	2.5	2.5	3.0	3.0	4.0	4.0	5.0	5.0	5.0	5.0	5.0
200	1.25	1.5	1.5	2.0	2.0	2.0	2.5	2.5	3.0	3.0	4.0	4.0	5.0	5.0	5.0	5.0	5.0	
For Direct Lighting Sources Located 7 Ft. Above Working Plane and for Semi and Indirect Lighting Where Ceiling is 10½ Ft. Above Working Plane	10	0.6	0.6	0.8	0.8	0.8	0.8	1.0	1.0	1.0	1.0	1.25	1.25	1.25	1.25	1.25	1.25	1.25
	12	0.6	0.6	0.8	0.8	0.8	1.0	1.0	1.0	1.25	1.25	1.25	1.5	1.5	1.5	1.5	1.5	1.5
	14	0.6	0.6	0.8	1.0	1.0	1.0	1.0	1.25	1.25	1.5	1.5	1.5	1.5	1.5	1.5	1.5	1.5
	16	0.6	0.6	0.8	1.0	1.25	1.25	1.25	1.5	1.5	1.5	1.5	1.5	2.0	2.0	2.0	2.0	2.0
	18	0.6	0.8	0.8	1.0	1.0	1.25	1.25	1.25	1.5	1.5	1.5	1.5	2.0	2.0	2.0	2.0	2.0
	20	0.6	0.8	1.0	1.0	1.25	1.25	1.5	1.5	1.5	1.5	2.0	2.0	2.0	2.0	2.0	2.0	2.0
	24	0.8	1.0	1.0	1.25	1.25	1.5	1.5	1.5	2.0	2.0	2.0	2.5	2.5	2.5	2.5	2.5	2.5
	30	0.8	1.0	1.25	1.25	1.5	1.5	1.5	2.0	2.0	2.0	2.5	2.5	2.5	3.0	3.0	3.0	3.0
	35	1.0	1.0	1.25	1.5	1.5	1.5	1.5	2.0	2.0	2.5	2.5	3.0	3.0	3.0	3.0	3.0	3.0
	40	1.0	1.25	1.25	1.5	1.5	1.5	2.0	2.0	2.5	2.5	3.0	3.0	3.0	3.0	3.0	3.0	3.0
	50	1.0	1.25	1.5	1.5	1.5	2.0	2.0	2.0	2.5	3.0	3.0	4.0	4.0	4.0	4.0	4.0	4.0
	60	1.0	1.25	1.5	1.5	2.0	2.0	2.0	2.5	2.5	3.0	3.0	4.0	4.0	5.0	5.0	5.0	5.0
	70	1.0	1.25	1.5	1.5	2.0	2.0	2.0	2.5	3.0	3.0	3.0	4.0	5.0	5.0	5.0	5.0	5.0
	80	1.0	1.25	1.5	1.5	2.0	2.0	2.0	2.5	3.0	3.0	3.0	4.0	5.0	5.0	5.0	5.0	5.0
	100	1.0	1.25	1.5	1.5	2.0	2.0	2.0	2.5	3.0	3.0	3.0	4.0	5.0	5.0	5.0	5.0	5.0
	120	1.0	1.25	1.5	1.5	2.0	2.0	2.0	2.5	3.0	3.0	3.0	4.0	5.0	5.0	5.0	5.0	5.0
	140	1.0	1.25	1.5	1.5	2.0	2.0	2.0	2.5	3.0	3.0	3.0	4.0	5.0	5.0	5.0	5.0	5.0
	170	1.0	1.25	1.5	1.5	2.0	2.0	2.0	2.5	3.0	3.0	3.0	4.0	5.0	5.0	5.0	5.0	5.0
200	1.0	1.25	1.5	1.5	2.0	2.0	2.0	2.5	3.0	3.0	3.0	4.0	5.0	5.0	5.0	5.0	5.0	
For Direct Lighting Sources Located 8 Ft. Above Working Plane and for Semi and Indirect Lighting Where Ceiling is 12 Ft. Above Working Plane	10	0.6	0.6	0.6	0.6	0.6	0.8	0.8	0.8	0.8	1.0	1.0	1.0	1.0	1.0	1.25	1.25	1.25
	12	0.6	0.6	0.8	0.8	0.8	0.8	1.0	1.0	1.0	1.0	1.25	1.25	1.25	1.5	1.5	1.5	1.5
	14	0.6	0.6	0.8	0.8	1.0	1.0	1.0	1.0	1.0	1.0	1.25	1.25	1.25	1.5	1.5	1.5	1.5
	16	0.6	0.6	0.8	1.0	1.0	1.0	1.0	1.0	1.0	1.25	1.25	1.5	1.5	1.5	2.0	2.0	2.0
	18	0.6	0.8	0.8	1.0	1.0	1.0	1.25	1.25	1.25	1.5	1.5	1.5	1.5	1.5	2.0	2.0	2.0
	20	0.6	0.8	0.8	1.0	1.0	1.25	1.25	1.25	1.5	1.5	1.5	1.5	1.5	2.0	2.0	2.0	2.0
	24	0.6	0.8	1.0	1.0	1.25	1.25	1.25	1.5	1.5	1.5	1.5	1.5	2.0	2.0	2.0	2.0	2.0
	30	0.8	0.8	1.0	1.0	1.25	1.25	1.5	1.5	2.0	2.0	2.0	2.5	2.5	2.5	2.5	2.5	2.5
	35	0.8	1.0	1.0	1.25	1.25	1.5	1.5	1.5	2.0	2.0	2.5	2.5	2.5	3.0	3.0	3.0	3.0
	40	0.8	1.0	1.25	1.25	1.5	1.5	1.5	1.5	2.0	2.5	2.5	2.5	2.5	3.0	3.0	3.0	3.0
	50	1.0	1.0	1.25	1.25	1.5	1.5	1.5	2.0	2.0	2.5	2.5	2.5	3.0	3.0	3.0	3.0	3.0
	60	1.0	1.0	1.25	1.5	1.5	1.5	2.0	2.0	2.5	2.5	3.0	3.0	4.0	4.0	4.0	4.0	4.0
	70	1.0	1.25	1.25	1.5	1.5	2.0	2.0	2.0	2.5	3.0	3.0	3.0	4.0	4.0	5.0	5.0	5.0
	80	1.0	1.25	1.5	1.5	2.0	2.0	2.0	2.0	2.5	3.0	3.0	3.0	4.0	5.0	5.0	5.0	5.0
	100	1.0	1.25	1.5	1.5	2.0	2.0	2.0	2.5	3.0	3.0	3.0	4.0	5.0	5.0	5.0	5.0	5.0
	120	1.0	1.25	1.5	1.5	2.0	2.0	2.0	2.5	3.0	3.0	3.0	4.0	5.0	5.0	5.0	5.0	5.0
	140	1.0	1.25	1.5	1.5	2.0	2.0	2.0	2.5	3.0	3.0	3.0	4.0	5.0	5.0	5.0	5.0	5.0
	170	1.0	1.25	1.5	1.5	2.0	2.0	2.0	2.5	3.0	3.0	3.0	4.0	5.0	5.0	5.0	5.0	5.0
200	1.0	1.25	1.5	1.5	2.0	2.0	2.0	2.5	3.0	3.0	3.0	4.0	5.0	5.0	5.0	5.0	5.0	

THE AMERICAN ARCHITECT

TABLE III—COEFFICIENT OF UTILIZATION

Find room index from Table II. Check wall and ceiling reflection factors with Table VI.

COLOR REFLECTION FACTOR	CEILING	VERY LIGHT (70%)			FAIRLY LIGHT (50%)			FAIRLY DARK (30%)			COLOR REFLECTION FACTOR	CEILING	VERY LIGHT (70%)			FAIRLY LIGHT (50%)			FAIRLY DARK (30%)											
		FAIRLY LIGHT (50%)	FAIRLY DARK (30%)	VERY DARK (10%)	FAIRLY LIGHT (50%)	FAIRLY DARK (30%)	VERY DARK (10%)	FAIRLY LIGHT (50%)	FAIRLY DARK (30%)	VERY DARK (10%)			FAIRLY LIGHT (50%)	FAIRLY DARK (30%)	VERY DARK (10%)	FAIRLY LIGHT (50%)	FAIRLY DARK (30%)	VERY DARK (10%)	FAIRLY LIGHT (50%)	FAIRLY DARK (30%)	VERY DARK (10%)									
REFLECTOR TYPE	ROOM INDEX	COEFFICIENT OF UTILIZATION									REFLECTOR TYPE	ROOM INDEX	COEFFICIENT OF UTILIZATION																	
 R.L.M. DOME Clear Lamp	.6	.34	.23	.24	.34	.29	.24	.28	.24	.24	 DIFFUSING GLOBE Light Opal	.6	.18	.13	.10	.16	.12	.10	.10	.09	 SEMI-ENCLOSING Opal Bowl	.6	.22	.17	.13	.21	.16	.13	.13	.11
	.8	.42	.38	.34	.42	.37	.33	.37	.33	.33		.8	.28	.22	.19	.26	.20	.17	.17	.14										
	1.0	.46	.43	.39	.45	.42	.39	.42	.39	.39		1.0	.36	.31	.28	.35	.31	.28	.28	.25										
	1.25	.50	.47	.43	.49	.46	.43	.46	.43	.43		1.25	.39	.34	.31	.38	.34	.31	.31	.29										
	1.5	.53	.50	.46	.52	.49	.46	.48	.45	.45		1.5	.42	.37	.33	.40	.36	.33	.33	.31										
	2.0	.58	.55	.51	.57	.54	.51	.53	.51	.51		2.0	.47	.42	.38	.45	.41	.38	.38	.35										
	2.5	.62	.59	.55	.61	.58	.55	.56	.55	.55		2.5	.50	.45	.41	.48	.44	.41	.41	.38										
	3.0	.64	.61	.58	.63	.60	.57	.58	.57	.57		3.0	.53	.48	.44	.51	.47	.44	.44	.41										
	4.0	.67	.65	.63	.66	.64	.62	.63	.61	.61		4.0	.54	.49	.45	.52	.48	.45	.45	.42										
5.0	.69	.67	.65	.67	.66	.64	.65	.63	.63	5.0	.54	.49	.45	.52	.48	.45	.45	.42												
 R.L.M. DOME Bowl Enameled Lamp	.6	.32	.28	.25	.32	.28	.25	.27	.25	 SEMI-ENCLOSING LARGE REFLECTOR Opal Bowl	.6	.22	.17	.13	.21	.16	.13	.13	.11											
	.8	.40	.35	.32	.39	.35	.32	.35	.32		.8	.30	.24	.21	.28	.24	.21	.21	.18											
	1.0	.43	.39	.37	.42	.39	.37	.39	.37		1.0	.31	.26	.23	.30	.26	.23	.23	.21											
	1.25	.46	.43	.41	.45	.43	.41	.43	.41		1.25	.35	.30	.27	.34	.30	.27	.27	.24											
	1.5	.48	.45	.43	.47	.45	.43	.45	.43		1.5	.38	.33	.29	.36	.32	.29	.29	.26											
	2.0	.52	.50	.48	.51	.49	.47	.49	.47		2.0	.41	.36	.32	.40	.36	.33	.33	.30											
	2.5	.56	.54	.52	.55	.53	.51	.53	.51		2.5	.44	.39	.35	.43	.39	.36	.36	.33											
	3.0	.57	.55	.53	.56	.54	.52	.54	.52		3.0	.45	.40	.36	.45	.41	.38	.38	.35											
	4.0	.60	.58	.56	.59	.57	.55	.57	.55		4.0	.46	.41	.37	.46	.42	.39	.39	.36											
5.0	.61	.59	.57	.60	.58	.57	.58	.56	5.0	.46	.41	.37	.46	.42	.39	.39	.36													
 GLASS TOP DOME Bowl Enameled Lamp	.6	.31	.27	.24	.31	.27	.24	.26	.24	 ONE-PIECE UNIT Reflector and Bowl	.6	.21	.17	.15	.20	.16	.14	.14	.12											
	.8	.34	.31	.29	.33	.30	.28	.30	.28		.8	.27	.23	.20	.26	.22	.19	.19	.17											
	1.0	.38	.35	.33	.36	.34	.32	.33	.32		1.0	.30	.26	.23	.29	.25	.22	.22	.20											
	1.25	.41	.38	.36	.39	.37	.35	.36	.35		1.25	.34	.30	.27	.32	.28	.25	.25	.23											
	1.5	.43	.40	.38	.41	.39	.37	.38	.37		1.5	.37	.33	.29	.34	.30	.27	.27	.24											
	2.0	.47	.44	.42	.45	.43	.41	.43	.41		2.0	.41	.37	.33	.38	.34	.31	.31	.28											
	2.5	.50	.47	.45	.48	.46	.44	.46	.44		2.5	.44	.40	.36	.41	.37	.34	.34	.31											
	3.0	.51	.49	.47	.49	.47	.45	.47	.45		3.0	.47	.43	.39	.43	.39	.36	.36	.33											
	4.0	.53	.51	.50	.51	.49	.48	.48	.47		4.0	.51	.47	.43	.47	.43	.41	.41	.39											
5.0	.55	.53	.52	.53	.52	.50	.49	.49	5.0	.53	.49	.45	.48	.45	.42	.42	.40													
 ENAMELED BOWL Clear Lamp	.6	.30	.26	.23	.30	.26	.23	.25	.23	 SEMI-INDIRECT Light Opal Clear Lamp	.6	.18	.14	.11	.16	.12	.10	.10	.07											
	.8	.35	.31	.28	.32	.28	.25	.27	.25		.8	.22	.18	.15	.19	.15	.12	.12	.10											
	1.0	.38	.34	.31	.34	.31	.28	.29	.28		1.0	.24	.20	.18	.22	.18	.15	.15	.12											
	1.25	.41	.37	.34	.37	.34	.31	.32	.31		1.25	.26	.22	.20	.24	.20	.18	.18	.14											
	1.5	.43	.41	.39	.41	.39	.37	.38	.37		1.5	.28	.24	.21	.26	.22	.20	.20	.16											
	2.0	.47	.44	.42	.44	.42	.40	.41	.40		2.0	.30	.26	.23	.27	.23	.21	.21	.17											
	2.5	.50	.47	.45	.46	.44	.42	.43	.42		2.5	.33	.29	.26	.30	.26	.24	.24	.19											
	3.0	.51	.49	.47	.48	.46	.44	.45	.44		3.0	.34	.30	.27	.31	.27	.25	.25	.20											
	4.0	.53	.51	.50	.51	.49	.48	.47	.47		4.0	.34	.30	.27	.31	.27	.25	.25	.20											
5.0	.55	.53	.52	.53	.52	.50	.49	.49	5.0	.35	.31	.28	.32	.28	.26	.26	.21													
 ENAMELED BOWL Bowl Enameled Lamp	.6	.29	.25	.22	.29	.25	.22	.23	.22	 SEMI-INDIRECT Light Opal Bowl Enameled Lamp	.6	.18	.14	.11	.16	.12	.10	.10	.07											
	.8	.35	.31	.28	.32	.28	.25	.27	.25		.8	.22	.18	.15	.19	.15	.12	.12	.10											
	1.0	.38	.34	.31	.34	.31	.28	.29	.28		1.0	.24	.20	.18	.22	.18	.15	.15	.12											
	1.25	.41	.37	.34	.37	.34	.31	.32	.31		1.25	.26	.22	.20	.24	.20	.18	.18	.14											
	1.5	.43	.41	.39	.41	.39	.37	.38	.37		1.5	.28	.24	.21	.26	.22	.20	.20	.16											
	2.0	.47	.44	.42	.44	.42	.40	.41	.40		2.0	.30	.26	.23	.27	.23	.21	.21	.17											
	2.5	.50	.47	.45	.46	.44	.42	.43	.42		2.5	.33	.29	.26	.30	.26	.24	.24	.19											
	3.0	.51	.49	.47	.48	.46	.44	.45	.44		3.0	.34	.30	.27	.31	.27	.25	.25	.20											
	4.0	.53	.51	.50	.51	.49	.48	.47	.47		4.0	.34	.30	.27	.31	.27	.25	.25	.20											
5.0	.55	.53	.52	.53	.52	.50	.49	.49	5.0	.35	.31	.28	.32	.28	.26	.26	.21													
 METAL-CAP DIFFUSER Silver Cap	.6	.28	.24	.21	.28	.24	.21	.22	.21	 SEMI-INDIRECT Dense Opal Clear Lamp	.6	.16	.13	.11	.14	.10	.08	.08	.06											
	.8	.32	.29	.26	.31	.28	.25	.26	.26		.8	.20	.17	.15	.18	.14	.11	.11	.09											
	1.0	.35	.32	.30	.33	.30	.28	.29	.28		1.0	.22	.19	.17	.20	.16	.13	.13	.10											
	1.25	.38	.35	.33	.37	.34	.31	.32	.31		1.25	.24	.20	.18	.21	.17	.14	.14	.11											
	1.5	.40	.37	.35	.39	.37	.35	.36	.35		1.5	.27	.23	.20	.24	.19	.16	.16	.13											
	2.0	.43	.41	.39	.42	.40	.38	.39	.38		2.0	.30	.26	.23	.26	.22	.19	.19	.15											
	2.5	.46	.44	.42	.44	.42	.40	.41	.40		2.5	.33	.29	.26	.29	.25	.22	.22	.17											
	3.0	.47	.46	.44	.45	.44	.42	.43	.42		3.0	.34	.30	.27	.30	.26	.23	.23	.18											
	4.0	.49	.48	.46	.47	.46	.44	.45	.44		4.0	.34	.30	.27	.30	.26	.23	.23	.18											
5.0	.50	.49	.47	.48	.47	.45	.46	.45	5.0	.34	.30	.27	.30	.26	.23	.23	.18													
 FLAT CONE Clear Lamp	.6	.26	.20	.16	.26	.19	.16	.19	.16	 ENAMELED INVERTED Diffusing Glass Plate Bottom Clear Lamp	.6	.16	.13	.11	.14	.10	.08	.08	.06											
	.8	.32	.26	.22	.32	.25	.22	.24	.22		.8	.20	.17	.15	.18	.14	.11	.11	.09											
	1.0	.36	.30	.26	.36	.29	.26	.28	.26		1.0	.22	.19	.17	.20	.16	.13	.13	.10											
	1.25	.41	.35	.30	.41	.34	.30	.33	.30		1.25	.25	.21	.18	.22	.18	.15	.15	.11											
	1.5	.44	.38	.33	.43	.37	.33	.36	.33		1.5	.27	.23	.20	.24	.19	.16	.16	.12											
	2.0	.50	.44	.38	.48	.42	.38	.42	.38		2.0	.33	.29	.26	.29	.25	.22	.22	.17											
	2.5	.54	.48	.42	.52	.46	.42	.46	.42		2.5	.36	.32	.29	.32	.28	.25	.25	.19											
	3.0	.57	.51	.46	.55	.50	.46	.50	.46		3.0	.39	.35	.32	.34	.30	.27	.27	.21											
	4.0	.62	.56	.51	.60	.54	.50	.53	.50		4.0	.43	.39	.36	.37	.33	.30	.30	.24											
5.0	.65	.60	.56	.62	.56	.52	.55	.52	5.0	.44	.40	.36	.39	.34	.31	.31	.25													
 FLAT CONE Shielding Band Bowl Enameled Lamp	.6	.25	.21	.18	.25	.19	.16	.19	.16	 ENAMELED INVERTED Diffusing Glass Plate Bottom Bowl Enameled Lamp	.6	.16	.13	.11	.14	.10	.08	.08	.06											
	.8	.31	.28	.26	.31	.27	.25	.27	.25		.8	.20	.17	.15	.18	.14	.11	.11	.09											
	1.0	.34	.31	.29	.34	.31	.29	.31	.29		1.0	.22	.19	.17	.20	.16	.13	.13	.10											
	1.25	.37	.34	.32	.36	.34	.32	.33	.32		1.25	.24	.21	.19	.22	.18	.15	.15	.11											
	1.5	.39	.36	.34	.38	.36	.34	.35	.34		1.5	.26	.23	.21	.24	.20	.17	.17	.13											
	2.0	.43	.40	.38	.43	.41	.39	.41	.39		2.0	.31	.28	.25	.28	.24	.21	.21	.16											
	2.5	.46	.43	.41	.45	.43	.41	.43	.41		2.5	.34	.31	.28	.30	.26	.23	.23	.17											
	3.0	.49	.47	.45	.48	.46	.44	.45	.44		3.0	.36	.33	.31	.32	.28	.25	.25	.19											
	4.0	.52	.49	.47	.50	.48	.46	.47	.46		4.0	.37	.34	.32	.33	.29	.26	.26	.20											
5.0	.54	.52	.50	.52	.50	.48	.49	.48	5.0	.38	.35	.33	.34	.30	.27	.27	.21													
 MIRRORED GLASS Bowl Enameled Lamp	.6	.26	.22	.19	.26	.19	.16	.19	.16	 INDIRECT Clear Lamp	.6	.15	.12	.10	.11	.09	.07	.07												

THE AMERICAN ARCHITECT

the determination and decision as to how this total flux is to be divided, or in other words, the sizes of lamps and their locations.

In most cases there are certain natural divisions of the rooms by ceiling panels or other architectural features so that it is necessary in the interest of good appearance to make the lighting outlets symmetrical with reference to these panels. The ideal condition to be sought after is to divide the ceiling into a number of squares with an outlet at the center of each

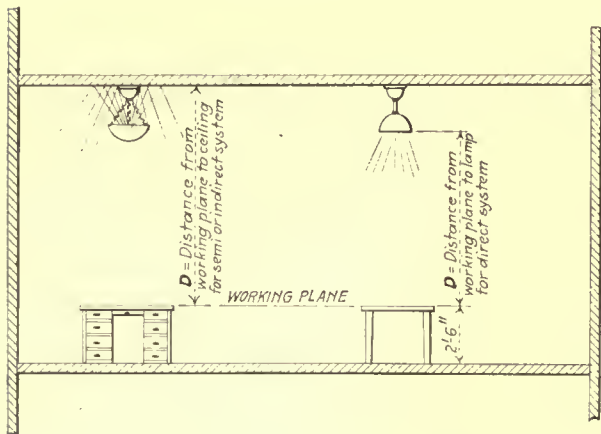

FIG. 3.

TABLE IV.—SPACING AND MOUNTING HEIGHT OF FIXTURES.

D*	Max. dist. bet. outlets, Ft.	Max. distance between outlets and sidewalls.	
		For general Lighting, Ft.	In offices Ft.
6	9	4½	3
7	10½	5	3½
8	12	6	4
9	13½	6½	4½
10	15	7½	5
11	16½	8	5½
12	18	9	6
13	19½	9½	6½
14	21	10½	7
15	22½	11	7½
16	24	12	8
18	27	13½	9
20	30	15	10
22	33	16½	11
24	36	18	12
27	40½	20	13½
30	45	22½	15
35	52½	26	17½
40	60	30	20

*See Fig. 3. For semi and indirect fixtures D is the distance from plane of work to ceiling, while for direct fixtures it is the distance from plane of work to lamp.
For most occupancies the plane of work is assumed as 2½ ft. above the floor, so that to find D for semi and indirect systems, deduct 2½ from the clear story height.

square. Frequently it is not possible to do this, but it is well to maintain the divisions as nearly squares as possible. In other words, if an oblong division is necessary, long and narrow rectangles should be avoided.

HEIGHT.—To secure proper uniformity either with semi and indirect or with direct lighting fixtures, the height of the source of light above the working plane should in general be not less than two-thirds their distance apart, taking the height of the sources of light as the height of the ceiling in the case of semi and indirect lighting and as that of the lamp in the case of direct lighting. Spacing at shorter intervals than the maximum permissible is desirable in order to secure greater uniformity, freedom from annoying shadows, and a reduction in the amount of specular reflection or veiling glare from papers and polished metals. Closer spacing is necessary if concentrating direct reflectors are used. Table IV gives proper mounting height and spacing of fixtures under various conditions.

When the spacing has been determined in a way which will fit in symmetrically with the architecture and at the same time conform to the uniformity requirements, the number of outlets is ascertained and this number divided into the total lumens to be generated by the lamps gives the the lumens per lamp. From the proper up-to-date manufacturers' information the lamp size most nearly answering the requirements can be selected. Table V will be referred to in this connection.

TABLE V.—OUTPUT OF MAZDA LAMPS IN LUMENS.*

Size of lamp in watts.	110-125 volt Standard Lighting Service		
	Mazda C	Mazda B	Daylight Mazda
10	75
15	125
25	226
40	372
50	450†	480
60	575
75	865	600
100	1,260	875
150	2,040	1,400
200	3,100	2,000
300	4,840	3,360
500	8,750	5,600
750	13,900
1,000	19,300

*Corrected to April 1, 1920.
†White Mazda.

THE AMERICAN ARCHITECT

In order to clearly demonstrate the application of the method described, the following problems and their solutions are given:

Problem No. 1.—To design a lighting system for a general office occupancy, floor plan of which is shown in Fig. 1. Ceiling height 15 feet.

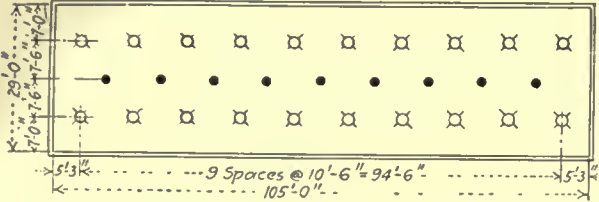

FIG. 1. FLOOR PLAN OF OFFICE.

Solution.—Since the fixtures can be placed quite high it would be possible to use either a direct, semi-indirect or indirect system. Giving due consideration to all factors, it appears that a semi-indirect system will prove most satisfactory in this case. In order to provide a high standard of illumination, an intensity of 7-foot candles will be selected. It will be assumed that both walls and ceiling will be painted a light color. A depreciation factor of 1.25 will be used. Before determining the co-efficient of utilization it is first necessary to obtain the correct "room index" from Table II. In this problem the room is 29 x 105 x 15 feet high. The working plane for an office occupancy is taken as 2½ ft. above the floor level, so that the distance "D" for a semi-indirect system (see Fig. 3) is 12 ft. 6 in. It will not always be possible to find in Table II a room corresponding exactly to every problem, but as the room index does not vary greatly within narrow limits, that given for the size of room coming closest the case in point will be sufficiently accurate.

We will therefore take the room index for a dimension of 30 x 100 feet, with a value of D of 12 ft. (for semi-indirect lighting) which is given as 2.5. Consulting Table III to obtain the value of "e", we find that for a semi-indirect system employing light opal glassware and clear lamps, for a room having "very light" ceiling and "fairly light" walls, the coefficient of illumination corresponding to a room index of 2.5 is 0.41.

We now have the following values for use in the

$$\text{formula } L = \frac{i a d}{e}$$

$i = 7 \text{ ft. candles, } a = 29 \times 105 = 3,045 \text{ sq. ft., } d = 1.25, e = 0.41.$ Substituting

$$7 \times 3,045 \times 1.25$$

$$\text{we have } L = \frac{\quad}{0.41} = 65,000 \text{ lumens,}$$

which is the total output to be furnished by all the lamps.

These lamps should be hung 3½ ft. below the ceiling, thus giving a mounting height of 11½ ft. Two rows of lights 15 ft. apart and 7 ft. from the side walls will be within the maximum spacing limit and will provide satisfactory illumination. These should not be spaced further apart longitudinally than the distance center to center of columns. Such spacing will require two rows of 10 lamps each. The

$$\frac{65,000}{20} = 3,250 \text{ lumens.}$$

A 200-watt Mazda C (gas filled) lamp has an output of 3,100 lumens and may be used, since this is quite close. A greater degree of uniformity of illumination would be obtained by using 3 rows of 10 lamps each instead of two, thus providing closer spacing, and the area served by each lamp would be more nearly a square.

Problem No. 2 required a system of illumination for a drafting room, the floor plan of which is shown in Fig. 2. Ceiling height is 14 ft. 6 in. There are no interior columns.

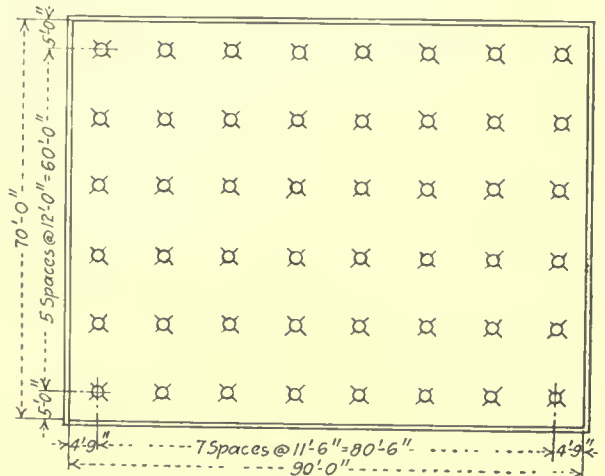

FIG. 2. FLOOR PLAN OF DRAFTING ROOM.

Solution.—An indirect system will be selected, this providing well diffused light and absence of glare. It will be assumed that walls and ceilings will be of light color.

By reference to Table I it will be noted that an illuminating intensity of 10-foot candles is considered adequate for practically all drafting room requirements. A depreciation factor of 1.33 will be used, since, as the fixtures are mounted high, they may not be cleaned as often as desirable.

From Table II the room index is found to be 5, and for the conditions stated "e" is given as 0.42 in Table III.

The area of the room is 70 x 90 = 6,300 sq. ft.

THE AMERICAN ARCHITECT

Substituting these values in the formula, we have

$$L = \frac{10 \times 6,300 \times 1.33}{.42} = 200,000 \text{ lumens.}$$

To obtain uniform illumination, a fairly close spacing will be used, i. e., 11 ft. 6 in. x 12 ft. 0 in. This gives six rows of 8 lamps each, or 48 lamps.

The output of each lamp must be $\frac{200,000}{48} = 4,167$

lumens. Reference to Table V shows that a 200-watt Mazda C lamp (3,100 lumens) is inadequate. The next size is a 300-watt gas-filled lamp having an output of 4,840 lumens. This will be used. While this size lamp will provide a slightly higher intensity than assumed, this is by no means undesirable.

Additional problems might be worked out, but it is believed that the foregoing are sufficient to dem-

onstrate the method of procedure and the use of the tables.

It is considered good practice to locate the first row of lamps from a wall somewhat less than one-half the distance center to center of rows. See Table IV.

Occasionally, due to changes in some of the factors used in calculations, it becomes necessary to check back to find the intensity which will result from a changed set of conditions. Sometimes an owner or tenant will desire a different type of fixture, or the walls and ceilings may be painted a darker color,

etc. For this purpose the formula $i = \frac{e n l}{a d}$ may be

used, in which "n" represents the number of outlets and "l" the lumens per outlet, the other factors being as before specified.

For example, let us assume that in Problem II the
(Continued on page 486)



A WELL ILLUMINATED DRAFTING ROOM.

These indirect lighting units contain 300-Watt clear Mazda C lamps, and are mounted 3 ft. below ceiling and 9 ft. above floor. They are spaced 10 ft. apart each way, and produce an intensity of illumination of 10 ft. candles. The architect can fully appreciate the advantages of good lighting in the drafting room.

Current News

Happenings and Comments in the Field of Architecture and the Allied Arts

A Correction

The Editors, THE AMERICAN ARCHITECT:

Referring to an article published in your issue of June 23, 1920, we beg to call your attention to certain errors in the capacity and cost of the stadium for the South Park Board of the City of Chicago quoted therein.

The stadium for the South Park Board, for which we are now completing the working drawings, and work on which will shortly be undertaken, will have a capacity of 100,000 seats, and will cost \$2,500,000 at the minimum. Of this capacity, 25,000 seats are to be erected on wooden frames on permanent concrete embankments. The width of the arena is 320 feet and its length 1,000 feet.

Chicago.

HOLABIRD & ROCHE.

Building Figures

Figures showing real estate sales, building permits and mortgages filed during the years 1914-1919 have been compiled by the United States Mortgage & Trust Company of New York, covering the following cities in which it is represented: Atlanta, Ga.; Birmingham, Ala.; Cincinnati, O.; Dallas, Tex.; Denver, Colo.; Des Moines, Ia.; Houston, Tex.; Jacksonville, Fla.; Kansas City, Mo.; Memphis, Tenn.; Mobile, Ala.; Omaha, Neb.; Portland, Ore.; Richmond, Va.; St. Paul, Minn.; Salt Lake City, Utah; San Antonio, Tex.; San Diego, Cal.; Savannah, Ga.; Seattle, Wash.; Sioux City, Iowa; Spokane, Wash.; Toledo, O.; Topeka, Kan.; Wichita, Kan.

Comparisons for the years 1914 and 1919 are shown by the following tabulation:

	Real estate sales	Building permits	Mortgages filed
1914...	\$201,987,000	\$100,122,000	\$222,628,000
1919...	390,073,231	141,863,445	310,226,658

The totals are based on daily published reports in the cities covered, but on account of the large number of transfers made at nominal considerations and the custom of understating building costs in connection with applications for permits, they are doubtless far below the actual figures.

Practically without exception substantial gains were made in real estate sales and building permits in 1919 as against 1914, noteworthy increases being

shown by Cincinnati, Dallas, Des Moines, Fort Worth, Omaha, Seattle, Sioux City, Topeka, Wichita and Oklahoma City.

In commenting on the general situation Mr. Frank J. Parsons, vice-president of the United States Mortgage & Trust Company, says:

"It is clear that construction costs and labor difficulties have made it almost impossible for new building to keep pace with real estate sales and the real demand for homes and business structures. This has resulted in increased borrowing and to a certain extent makes the real estate situation insecure and calls for careful watching. In the long run it may prove, however, that these factors are blessings in disguise, as they have prevented excesses in building construction and real estate speculation at a time when the mass of the people were little inclined to put any restraint upon their spending or the enterprises in which they were engaged."

Defective Flues

Defective flues are caused by some obstruction in the flue, or some defect in their construction that permits the smoke to issue from openings or crevices in the chimney wall. This generally occurs between the floors and ceilings of a building where chimney wall has been left unplastered, or where the mortar between the bricks has become loose or where wooden floor or roof beams have been permitted in violation of law to enter the chimney walls. Sometimes the ends of these beams will become charred from heat if the flue takes fire, and the same will spread across the floor between the beam. The ceilings in such cases generally become blackened around the end of the beams and is a warning that a defect exists. When a defect allows smoke to issue from between the bricks for lack of mortar or for want of terra cotta lining, and there is doubt as to which chimney flue is defective, a piece of cardboard or tin placed across the top of the suspected flue and a piece of paper burned in the stove connected to the same will show where the defect is, as the smoke finding no outlet above will issue from the defect in flue. A defective flue should always be reported and immediately remedied, as it may cause loss of life and property by fire breaking out any time.—*Official Bulletin*, Tennessee State Fire Prevention Department.

Increasing Interest in Art

The Art Institute of Chicago is becoming each month a more popular center of civic interest. In July of this year 108,762 persons visited the institute, and in August 105,875, as compared with 62,762 persons in July, 1919, and 77,805 in August, 1919.

The winter season of exhibitions opened on September 22 with an exhibit by Carl Krafft and an exhibition of advertising art assembled by the art directors of the studios of advertising concerns. The annual exhibition of American oil paintings and sculpture will open November 4.

Many Workers Idle

Approximately 150,000 carpenters, plasterers, bricklayers and other employees of building contractors are idle in Chicago, according to a dispatch from the National Financial News Service. The building situation is very serious, it is said.

The unemployed in all branches of the building trade in that city are spending their time at amusement resorts and in motion picture houses, the communication states.

The efficiency of labor is noticeable among relatively few men who are engaged in building construction, it being estimated by an expert that bricklayers who three months ago were laying 3,000 brick daily are now laying 1,500.

Shortage of Houses Felt in Rio De Janeiro

Both federal and municipal governments are about to take action to relieve the shortage of houses in Rio de Janeiro.

In the Chamber of Deputies a bill has been introduced providing for a special bond issue of \$50,000,000 for the construction of houses for working families. In the Municipal Council a measure was presented providing that all workers' houses built in the next two years be free from the usual municipal taxes.

The federal bill proposes the construction, under the municipal administration, of 20,000 houses in various districts of the capital wherever nationally or municipally owned ground is available. It is intended that the houses shall be sold to heads of working families, payment being spread over a period of 20 years. In addition, the bill provides for the construction of two huge apartment houses, for families and for bachelors, respectively, with common kitchens and other communal installations, the rent being placed at a very low figure.

White House for Tokio

An exact copy of the White House as an American embassy in Tokio is the plan of Stephen G. Porter of Pennsylvania, chairman of the House Foreign Affairs Committee. After inspecting the grounds with a representative of the *Public Ledger*, Mr. Porter said:

"The present embassy is a disgrace to Americans and a mark of disrespect to the Japanese. The grounds form an ideal background for an embassy of the White House model. The present buildings are an eyesore. They are so located as to completely hide the natural beauties of the grounds. I believe the relationship between the two countries is of such importance as to warrant a creditable building, and I intend that it shall be characteristically American. My idea is to construct embassies modeled after the White House in all the capitals of the world."

Historic Brick Building

A Builders Supply & Brick Co., Cleveland, Ohio, issues a house publication called "Material Facts," in which of late they have been making a feature of historic brick buildings. For example, there was illustrated on the front cover in June the Wadsworth-Longfellow house, built in Portland, Me., in 1785, one of the historic brick homes of the country, which is still in an excellent state of preservation. In the July issue there is a front cover illustration and a brief historical sketch of our great Independence Hall at Philadelphia, the construction of which was started in 1729. These historic sketches are not only interesting within themselves, but the compiling of them should put in good reference form some excellent historic data of prominent brick buildings that will prove of inestimable value in the future.

Paris to Build Great Mohammedan Mosque

France, as one of the big Mussulman protectorate powers of the world, is soon to erect at Paris not only a Mohammedan Mosque but a university of Isamic studies.

In precisely the same way that the Sorbonne for centuries past has attracted to Paris the young students of the entire Christian world, France hopes her new Mussulman university will draw to Paris students from the entire Mohammedan world. In the future, therefore, Paris not only expects to welcome white-turbaned students who will come here to study the Koran, but the Parisian themselves and American tourists, too, will be able to hear daily the

melodious cry of the sheik as he mounts to the little balcony at the summit of the mosque's minaret, and facing Mecca, calls the faithful to prayer.

As the first step toward the erection of the Mohammedan mosque and university, the French government has just appropriated half a million francs.

The project has the full backing of the society of the Habous of the Holy Places of Islam, one of the most powerful organizations of the entire Mohammedan world. This society has among its members all of the leading dignitaries of the French Mussulman colonies of Algeria, Morocco and Tunis. This society organizes every year pilgrimages to Mecca and the other sacred places of Islam.

Limit Chimney Area to Reduce Fuel Consumption

It has been seriously suggested that to economize in heating a house the chimney area, where open fires are used, should be restricted. It is claimed that with a large open chimney five to ten changes of air per hour may occur. Smoking chimneys are recognized as a source of great discomfort and damage from contamination of the air. Frequently it is said that there is a great loss of fuel due to the carbonaceous smoky particles, but one writer says that smokeless chimneys may indicate waste also if they are kept smokeless by the introduction of a great excess of air. Smoke, it is claimed by the same writer, only indicates one or two per cent waste of fuel, a smokeless chimney may indicate much more. The open-hearth fire, however, is coming to its own, as some recent experiments by the English Fuel Research Board show that 60 to 70 per cent. of the heat in an open fire is usefully employed in warming the room itself and the general fabric of the building. Of the total heat of the coal no less than 20 to 25 per cent. goes out into the room as radiant energy and with coke as much as 35 per cent. may be so radiant.

Housing in New Zealand

The 1916 census revealed the fact that the population of New Zealand was crowded into 32,000 dwellings. Since that time comparatively few new homes have been built and the population of the country has increased materially. The Board of Estimate in 1918 stated that there was a demand for at least 20,000 additional dwellings of four and five rooms each. The New Zealand Government has interested itself in the erection of homes for workers, and already the government has 155 homes under construction, and provision has been made for the erection of 700 more. Besides this the different municipalities are attempting to aid in the mat-

ter of more and better homes for the wage earner, with the result that the New Zealand Government, the municipal authorities of the Dominion, and private enterprises are expected to supply 5,000 homes within the next year or 18 months. There will be no trouble in finding occupants for these homes at good rentals.

News from Various Sources

Washington Post, September 19, publishes latest official estimate of Louis Dubois, president of Reparations Commission, Paris, on restoration of France. States that France may be able to rebuild entirely her devastated regions in 6 years.

* * *

Foreign Information Section of Bankers Trust Co., New York, issues comprehensive statement today on losses caused by the war in France. States that estimates show that 1,659 towns and villages were totally wiped out by war's ravages.

Personals

The address of L. W. Eisinger is 241 West 36th street, New York and not 21 West 36th street as previously recorded.

Henry T. Hey has opened offices in the Thiesen Building, Room 306, Pensacola, Fla., for architectural practice. Catalogues and samples desired.

Fundamental Principles of Illumination Design

(Concluded from page 482)

color of ceiling and walls, instead of being "light" are so painted that they should be rated as "fairly light" and "very dark," respectively; also that a semi-indirect (dense opal) instead of an indirect system is to be used. What intensity will the 300-watt lamps give?

In this case $e = 0.30$; $n = 48$; $l = 4,840$; $a = 6,300$, and $d = 1.33$.

Substituting in the formula we have

$$i = \frac{0.30 \times 48 \times 4,840}{6,300 \times 1.33} = 8.3 \text{ foot candles, which is } 17$$

per cent. less than the intensity originally selected. In such a case the size lamps originally selected would prove inadequate and a larger size would be required.

In order to comprehend what the terms "very light 70 per cent.," "fairly light 50 per cent.," "fairly dark 30 per cent.," and "very dark 10 per cent." in Table III indicate, Table VI, giving the proportions of light reflected by walls and ceilings of various colors, termed their "reflection factor," should be consulted.

THE AMERICAN ARCHITECT

TABLE VI.—COLOR REFLECTION FACTORS.

Color	Reflection Factor	Classification
White	81 per cent	Very light
Ivory White	76	"
Very light gray	73	"
Caen stone	72	"
Ivory yellow	72	"
Lichen gray	70	"
Pearl gray	70	"
Primrose	67	"
Satin green	67	"
Buff	59	Fairly light
Ivory tan	58	"
Shell pink	57	"
Pink	51	"

Medium gray	46 per cent	Fairly light
Bright sage	43	"
Tan	37	Fairly dark
Pale azure	36	"
Sky blue	31	"
Cardinal red	27	"
Dark gray	18	Very dark
Olive Green	14	"

Acknowledgment is made of the help contributed in the preparation of this article by the engineering staff of the National Lamp Works, Nela Park, Cleveland, Ohio. The data contained in several of the tables here included is from a concise and valuable publication entitled "Illumination Design Data" just issued by that company and prepared by its engineering department. Copies of this bulletin may be obtained on application.

Weekly Review of the Construction Field

With Reports of Special Correspondents in Prominent Regional Centers

REPORTS that practically cover the entire United States conclusively show that building operations are constantly on the increase, with perhaps the exception of the west, north, central and mountain states. In these sections the reasons are purely financial ones and building lacks the proper impetus that a good investment would be more likely to encourage. There is apparently no shortage of labor in spite of many assertions to the contrary, but it is increasingly evident that labor, after receiving today's peak of high wages, is not increasing in productivity.

The general feeling throughout the country among those classes of business men who are most likely to be able to foresee with reasonable accuracy just what the future might bring forth, is one of optimism. Reports from manufacturing plants indicate they are filled with orders. In fact, the prospects for a good manufacturing business, especially in building material lines, is so strong that many very important buildings are contemplated for erection as soon as the financial market sufficiently stabilizes so as to permit these ventures to go forward with a reasonable degree of security as to the outcome.

General transportation conditions appear to be everywhere improving and it is confidently expected that as soon as the season demands in the movement of crops have been cared for, the railroad companies will be in position to give better service in the transportation of materials than has been the case since the beginning of the war.

One feature of building that has become an impor-

tant one is that of co-operative enterprises and the reports received indicate that this new form of housing is being more and more considered and resulting in favorable action. The only locality in which there appears to be some doubt as to the value of such investment in a home is in the Middle West.

There is a general tendency toward a lowering of prices for raw material and basic commodities, but with few exceptions the effect has not yet been felt to an appreciable degree in the articles as sold to the ultimate consumer. It will probably require a very strong public sentiment backed by legislative authority to curb the profiteer and bring him to reason, but the general tendency is undoubtedly toward prices based more reasonably on the cost of production, and the retailer will be compelled to either give substantial reason for maintaining high prices or make a very considerable cut.

SIGNIFICANT of the tendency toward a reduction in prices is the cut announced by the Ford Motor Co. in the prices of their automobiles. This example has been followed by other manufacturers and the result will be a very marked decrease in prices of this year's models. There can be no doubt that this example will be followed by manufacturers in other lines and in fact the American Woolen Co.'s action in the announcement of new prices, which will result in a very radical readjustment in the woolen industry came before that of the Ford Co. Shrewd manufacturers of material all over the country are doubtless very keenly aware of a certain public sentiment which now has reached a point

THE AMERICAN ARCHITECT

where it irritably shows its disinclination to submit to what has been clearly shown to be extortion and we may undoubtedly look in the near future to a general stabilization of costs, particularly in building materials in every section of the United States.

The attitude of the Federal Reserve Board toward building credits is very clearly shown in a letter recently addressed by Governor Harding of the Board to a large lumber company. He states:

The Federal Reserve Board does not feel that it can be justly charged with responsibility for any restrictions of credit to the building industry. The rediscount transactions of the Federal Reserve Banks are limited by section 13 of the Federal Reserve Act and reserve banks are not permitted to make direct loans to borrowers; they can only discount for member banks upon their indorsement "notes, drafts, and bills of exchange arising out of actual commercial transactions: that is, notes, drafts, and bills of exchange issued or drawn for agricultural, industrial, or commercial purposes, or the proceeds of which have been used, or are to be used, for such purposes, the Federal Reserve Board to have the right to determine or define the character of the paper thus eligible for discount within the meaning of this act." "Notes, drafts, and bills admitted to discount under the terms of this paragraph must have a maturity at the time of discount of not more than 90 days, exclusive of days of grace." The Federal Reserve Banks, therefore, clearly have no power to finance building operations in the sense that a savings bank or insurance company can finance such operations by taking a mortgage extending over a term of years, but when a building operation is properly financed in advance by contract with some responsible individual, firm, or corporation to furnish money at various stages of the construction, a reputable owner or contractor ought to have no difficulty in getting short-time accommodations at his bank for pay-roll purposes or for current purchases of material. Notes given under these conditions maturing within 90 days and otherwise conforming to the provisions of the Federal Reserve Act are eligible for discount at a Federal Reserve Bank when offered by a member bank with its indorsement.

Much uneasiness has been felt in manufacturing circles as to the probable availability of a sufficient coal supply during the coming winter. It is therefore reassuring to learn from a recent statement over the signature of Mr. James A. Broderick, vice-president of the National Bank of Commerce in New York, that although there is an apparent coal shortage which menaces the world, only the United States and Great Britain are assured of sufficient fuel to sustain their industries at capacity.

The article indicates that at the present rate of monthly receipts, not a single importing country in Europe or South America is receiving a supply which is even approximately adequate. France is now receiving coal at about two-thirds the rate which would be necessary to assure operation of French industries at capacity; Italian receipts are about three-fifths of the estimated necessary amount;

Netherlands is receiving only one-third the amount of coal required by its industries, and Norway is receiving approximately one-half. The situation is no better in the case of the other chief European and South American buyers in the international market.

In order to attain a security as to supply in the United States, a definite limit has been placed upon British coal available for export, and in the United States exports have been automatically held in check to secure domestic supply.

THE New England correspondent of THE AMERICAN ARCHITECT reports that growing realization that more and more of the business leaders are now facing the bed rock facts of the current situation; that the days of rapidly rising commodity prices are past, that lower prices are inevitable is the outstanding feature of business in New England as well as in other parts of the country during the past week.

This has been reflected in the slashing of prices by the largest cotton manufacturer in the United States, the Amoskeag Manufacturing Company of Manchester, N. H., in the cut in the prices of automobiles by the largest single unit in that industry as well as in other lines of business. It is the opinion here that many of the manufacturers who are at present protesting that they cannot and will not reduce the prices of their products because costs are so high, will have to swallow good sized losses along with the wool and hide, the leather, the silk and the rubber people. Then they will have to get their costs down.

The week saw a big slump in the demand for steel both for building and automobile purposes. Amesbury, Mass., the center of the automobile body industry, received a jolt out of a clear sky with telegraphic orders to suspend the making of bodies for some of the best known automobile manufacturers.

Lower wage scales seem inevitable because the public is in a mood at which it balks as much at paying current labor prices as it did at paying recent merchandising and manufacturing costs or profits. For, after all, the cost of anything is the cost of the labor that goes into it.

The sooner the business men and labor adjust themselves to this situation the sooner the country can be back on an even business keel.

(Special Correspondence to THE AMERICAN ARCHITECT)

CHICAGO.—Retail lumber dealers are setting the pace in a price cutting campaign, which is expected to force reductions in the price of other building

THE AMERICAN ARCHITECT

materials and pave the way for a building boom for the coming year.

The new schedule of prices shows a reduction ranging from 16 to 35 per cent. on the price of all finished timber. The biggest cut is in the hardwoods, which is about 35 per cent.

Clear quarter sawed oak flooring selling last February at \$330 per thousand feet has been reduced to \$265. Common maple flooring, formerly selling at \$185, is now \$175 per M; yellow pine boards (2x4) were reduced from \$61 to \$58 per thousand feet, while an average reduction of three dollars per thousand feet was noted on all other sizes. Framing lumber used in rafters and joist work has dropped from \$73 to \$55. For lumber used in concrete construction work, formerly retailing at \$72, is now \$52.

The reduction in the cost of form lumber should materially reduce the cost of concrete work, as heretofore contractors have maintained the high cost of building forms made concrete so expensive.

No change has been noted in the price of brick, glass roofing material, cement, tile, plaster stucco, stucco, sheathing or wall board.

(By Special Correspondence to THE AMERICAN ARCHITECT)

SEATTLE.—Scarcity of steel pipe on the Pacific Coast has reached the point where jobbers are rationing what few feet there is available, and it can be definitely stated at this time that there is not 100 feet of three-quarter or half inch galvanized pipe in Seattle, with little more in San Francisco. Expected relief on the steel corporation steamer which arrived in port this week was not forthcoming, as the vessel carried no small pipe. The significance of this is that many small homes will be delayed farther in completion, and the fortunate thing is that the climate will not be cold enough to cause any distress anywhere along the coast.

The nail situation has again become more aggravated. In a car of nails that reached here this week there were only twenty kegs of 3-penny fine blued nails, and 200 kegs of 8-common were exhausted within a matter of hours. Six-penny common nails have been out of the market for six months.

Shortage of plaster in this territory has stimulated the general use of plaster board as a substitute. Cement is a little easier but the restricted

supply is due to transportation conditions in part.

North Coast jobbers are endeavoring to secure a ship charter for the purpose of importing a cargo of Scotch fire brick and clay. Higher temperatures are desired, and the American and Canadian product do not seem to attain the heat values desired. Prior to the war Scotch brick was commonly quoted on the Pacific Coast, but the demoralization of shipping conditions drove it out, and jobbers are endeavoring to build up the trade. Ships are scarce and the project may not succeed at this time. Experiments and tests here show that the Scotch fire brick will stand 3,000 degrees Fahrenheit, with Claybourne (B. C.), brick at 2,800 and the American 2,000 degrees.

Plenty of plaster board is offering due to competition among manufacturers for the business. It is being used freely in small buildings where plaster is unobtainable. Reinforcing wire is practically out of the market.

Fir lumber prices have softened considerably. Accumulated stocks are heavy and the Eastern building orders are at the lowest volume in years. The mills have been selling 2 x 4, 1214 No. 1 dimension surfaced and edged at \$20.50 to \$26.50, and 1 x 4 No. 2 vertical grain flooring at \$69 and the same size in slash grain No. 2 and better at \$44. Finishing lumber No. 2 and better 1 x 8 x 10 inches is \$66 and five-eighths by four No. 2 and better is selling at \$37 to \$53. Drop siding is \$52 in 1 x 6 No. 2 and better.

Red cedar shingles are weak at \$3.60 to \$3.65 for stars and \$3.80 to \$3.85 for clears.

A number of the representative fir mills that have no timber and must buy their logs on the commercial market have closed down and others will do so. It seems clear that fir lumber of all grades is actually selling below the cost of production. Many in the trade believe that fir lumber has touched bottom, and that the Eastern building trade would find it advantageous at this time to accumulate spring stocks.

Rate conferences between West Coast lumbermen and transcontinental traffic officials relative to restoring competitive conditions with Southern pine were held this week, and the manufacturers feel that the emergency rate which has shut them out of Eastern territory will early be equalized. This course, it is thought, would stimulate the Eastern demand.

Yucca x 110 2339.



VIEW DURING CONSTRUCTION
THE LINCOLN MEMORIAL, WASHINGTON, D. C.
HENRY BACON, ARCHITECT

THE AMERICAN ARCHITECT

VOL. CXVIII

WEDNESDAY, OCTOBER 20, 1920

NUMBER 2339



BIRD'S-EYE VIEW

The Lincoln Memorial in Washington, D. C.

PART I THE SITE

By GLENN BROWN, F.A.I.A.

With a Foreword by HENRY BACON, Architect

FOREWORD

*B*ELIEVING that there should be a limitation to conclusions about contemporary works of art, for the reason that the value of an effort in art is best determined when the perspective of it is greater than is possible in the day of its exercise, at which time the author and his friends are prejudiced in its favor and the prejudice of others may lean too far in the opposite direction, I have nevertheless consented to write this foreword to the article on the Lincoln Memorial for the purpose of paying tribute to the sincerity and good faith which attended its design and construction, not only on the part of the authorities who had the project in charge, but also of those who executed the work.

I have never undertaken any construction in which all engaged in it have been imbued with so high a spirit of excelling in their various branches of responsibility and workmanship, and this was of course due to the reverence we all hold for the memory of Abraham Lincoln.

HENRY BACON.

ALTHOUGH Lincoln died in 1865, no definite step was taken to raise a memorial to him in the National Capital for nearly fifty years. This is strange, as all recognized him as next to George Washington, the greatest man the country had produced.

It was in 1902 that the Park Commission in studying the development of Washington City, fixed a site and suggested a form for a Lincoln Memorial. In the L'Enfant scheme for the treatment of the

Mall the Washington Monument, located on what was then the bank of the Potomac, completed the west end of the composition. In a little over a century after the L'Enfant plan was presented, the Potomac west of the Washington Monument had become marsh land. When it became necessary to dredge the river channel it was most economical to dispose of the mud by pumping it from the river to this marsh land. This pumping continued for a number of years, and before the people realized the fact



BIRD'S-EYE VIEW, SHOWING RELATION OF LINCOLN MEMORIAL SITE TO PARK SCHEME AND SURROUNDING COUNTRY

between six and seven hundred acres of reclaimed land was connected with the Mall and the Washington Monument stood about the center of a tract between the Capital on the east and a bend in the Potomac on the west.

When the Park Commission was called in by the Senate to study the future Washington, this reclaimed land was in an undeveloped condition. They selected as a site for the Lincoln Memorial an important vacant point in the new park development, the

west end on the Potomac, second only to the Washington Monument. A line running from the Capitol through the Washington Monument to the Lincoln Memorial, made it an important terminal in the composition. The great vista proposed by George Washington and Peter Charles L'Enfant from the Capitol to the Washington Monument was continued over the newly made ground to the Lincoln Memorial, some three-fourths of a mile from the Washington Monument*. While the vista from the Capitol



VIEW SHOWING RELATION OF LINCOLN MEMORIAL SITE TO THE POTOMAC RIVER.

THE AMERICAN ARCHITECT

to the Washington Monument was to be between the graceful drooping branches of dignified American elms over a broad green sward, the vista from the Washington Monument to the Lincoln Memorial was to be over a lagoon 200 feet wide, bounded on either side by stately upright English elms, eventually, as at Hampton Court, England, forming a magnificent hedge bounding the view and leading up to a simple, dignified, classic, marble structure on the Potomac; the prime object of the important site.

The fact that a memorial to Lincoln was suggested, in this broadly circulated and widely republished report, aroused both patriotism and cupidity. Many

This latter scheme was supported by three classes—those who desired to beautify and emphasize the railway station; those who desired to increase real estate values in this section, and the pride many representatives had in Capitol Hill. These interests, combined with the desire of many Representatives to destroy the integrity of the Park Commission plans, formed a strong and influential body whose efforts culminated in the bill of Representative Samuel W. McCall, May 18, 1908.

While D. H. Burnham advocated a semi-circular peristyle around the station plaza, for which his firm made studies as to the proper treatment to com-



THE GRANT MONUMENT AND PLAZA

conscientiously thought the Memorial on the low, marshy, new made ground, as they recollected it, filled in but bare and unimproved, was a most unfortunate selection. Others wished it located where they thought it would enhance the value of property or act as an attraction to their locality. Then there was strong opposition from one branch of Congress, apparently because the Park Commission Plan was a Senate measure.

Many thought Sixteenth Street Hill was the most suitable site, and a triumphal arch the best form for such a memorial. This site, while talked of and approved by a large number, was never officially brought to Congressional attention. The move to place the memorial in connection with the Union Station was the first to jeopardize the suggested site.

plete the Union Station, he did not advocate it as a memorial to Lincoln. While the discussion was at its height Burnham informed me that he had the studies for sites on Capitol Hill prepared to demonstrate the impropriety of using them for the purpose of commemorating Lincoln. After the McCall bill was introduced the American Institute of Architects, who fathered and protected the Park Commission plans, began an active propaganda in favor of the site on the Potomac.

While the McCall bill did not call for a definite site or design, the semicircular peristyle was very favorably considered and presented a concrete object for Institute opposition. The Institute flooded the country with literature showing that the Memorial would be a part, an insignificant part, of the

THE AMERICAN ARCHITECT

station; a mere vestibule guiding to the railway station, a background for a proposed Christopher Columbus fountain.

This, all acknowledged, would form an admirable embellishment for the station, but it was easy to prove that such a site and surroundings destroyed the individuality and distinction necessary to commemorate a great American. W. S. Eames, president A. I. A., deserves great credit for his business-like management of this campaign.

Those in favor of the McCall bill had two other plans under consideration—a colonnade on Maryland Avenue leading to the station, and a memorial arch between the Capitol and the station. Neither of the proposals received serious consideration. The first lacked the distinction of the peristyle and became an approach to the focal point of the Columbus Fountain; the second reminded the people too forcibly of triumphal processions, commemorating great field battles, warriors with their captives chained to their chariots, pomp and ceremony in no way typifying our simple American.

It was clearly shown that the station site was neither of sufficient size nor proper form for imposing landscapes; that it lacked the repose necessary to commemorate one of our great men. The opposition to the station site and advocacy of the site on the Potomac culminated in the introduction of a Senate bill by Senator Francis G. Newlands, Jan. 28, 1909. This bill called for the character of design and site recommended by the Park Commission, which had notable arguments in its favor. The men who formulated the plan—Charles F. McKim, Architect, sensitive, refined, honored in this country and Europe for capacity in design; Augustus Saint Gaudens, Sculptor, one of the world's great artists, who loved the memory of Lincoln and depicted I feel as only he could, Lincoln's character and nobility in two great, enduring statues; D. H. Burnham, noted for broad views in design and execution, known as head of the Columbian Exposition, and Frederick Law Olmsted, whose firm gave the landscape treatment to the greatest parkways of the country. No stronger appeal could be made to the common sense of the people than the character of the Commission, who had thoroughly studied and recommended the site on the Potomac. W. H. Taft, as Secretary of War, wrote across a proposed change: "When capable experts have studied a scheme and made a recommendation their recommendations should be followed."

The opposition to a site on Capitol Hill became so effective that McCall introduced, Feb. 10, 1909, a joint resolution for a commission to recommend a site for the memorial. Although the commission named had Charles F. McKim and D. H. Burnham among its members, the majority was so evidently in favor of the Capitol Hill site that the commission

was strongly opposed. This commission was to select a plan and approve a site. McKim at that time was stopping in Washington. Frank D. Millet and myself went to see him and told him of the resolution. He was indignant and immediately drafted a letter declining to serve on such a commission, saying in effect that he had thoroughly studied the question as a member of the Park Commission, and that further consideration of the scheme for seven years had confirmed his opinion that the site selected was the only site for a Lincoln Memorial in Washington. In connection with this McCall cabled Burnham, who was in Europe at the time. Burnham's answer by cable was used in the House as an indorsement of the peristyle scheme. In this cable Burnham intended to emphasize his desire to adequately complete the station, but was not advocating it as a memorial to Lincoln. When McKim and others cabled him of the use being made of his message Burnham cabled that the Potomac Park site was the only place for a Lincoln Memorial.

In the meantime art societies, municipal associations and patriotic organizations throughout the country began taking an active and intelligent interest in the subject, and expressed their opinion in favor of the site selected by the Park Commission. One of the most notable indorsements of this kind was that of the National Institute of Arts and Letters, composed of 250 noted, selected men in arts and letters. It was their first and I believe their only indorsement as a society of any project.

Their indorsement, Feb. 5, 1909, was as follows:

"Resolved, That the National Institute of Arts and Letters heartily approve of the plan for a Lincoln Memorial in Washington as provided in the plan of the Park Commission, and in the bill of Senator Newlands, now pending in Congress, and the Institute records its earnest conviction that historically as well as artistically it would be a mistake to locate the memorial between the railway and the Capitol."

Theodore Roosevelt, in appointing his Fine Arts Council, Jan. 11, 1909, said: "I shall request the Council to immediately report and give their opinion (see Article on Theodore Roosevelt and Fine Arts, in *THE AMERICAN ARCHITECT*—2) on the location of the Lincoln Memorial."

The first question considered by the new Fine Arts Council was the location of this memorial. They brought out in their report the bad effect of placing a memorial at the foot of a down grade, other buildings like the Capitol and station dominating the structure; its non-relation to the composition as a whole; the want of space for adequate landscape treatment, and the lack of dignity in connection with a railway station, and indorsed the site and landscape treatment on the Potomac. This report of the Fine Arts Council, which was composed of thirty picked



DESIGN SUBMITTED BY JOHN RUSSELL POPE FOR A LINCOLN MEMORIAL
CIRCULAR IN PLAN

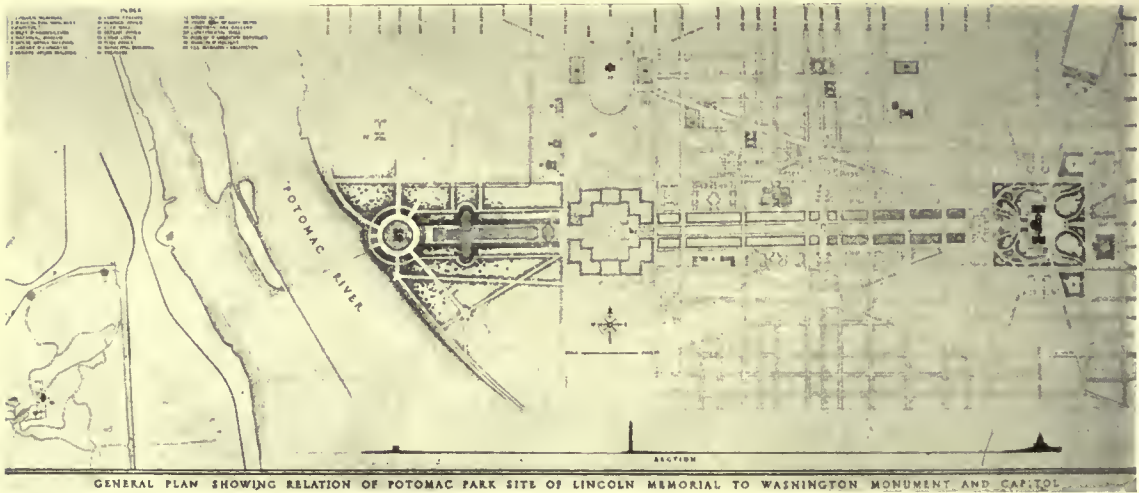

GENERAL PLAN, SHOWING RELATION OF POTOMAC PARK SITE OF THE LINCOLN MEMORIAL TO THE WASHINGTON MONUMENT AND CAPITOL

architects, painters, sculptors and landscape architects, representing the most enlightened artistic opinion of the country, backed by Theodore Roosevelt, defeated the effort to get the memorial between the Capitol and the railroad station.

Not long after the McCall bill was introduced Representative Lafean introduced a bill (Dec. 7, 1908-Jan. 10, 1909) for a highway two hundred feet wide from Washington to Gettysburg, to be known as the Lincoln Memorial Highway. No one objected to a highway, but there was positive objection to a highway taking the place of a real memorial. Those who appreciated the fact that combinations of idealism and utility usually lost their identity as a

memorial in their use as a utility. Those in favor of the Park Commission plan had no fear of the roadway scheme. They did not appreciate the strength of the landed interests advantaged, of the joy riders thrilled, or of motor factories' increased sales.

There is little further to record until Congress provided for a memorial to Abraham Lincoln in the act approved Feb. 9, 1911, appointing the following commission: W. H. Taft, Senators S. M. Cullom, George P. Wetmore, H. D. Money, Representatives J. G. Cannon, S. W. McCall and Champ Clark.

The commission was given full power to select a site, architect and design. The cost was fixed at \$2,000,000 for a memorial in the City of Washing-



THE WASHINGTON MONUMENT AND TERRACE
Showing park, 900 feet wide, as urged by Charles Follen McKim and ordered by President Roosevelt.

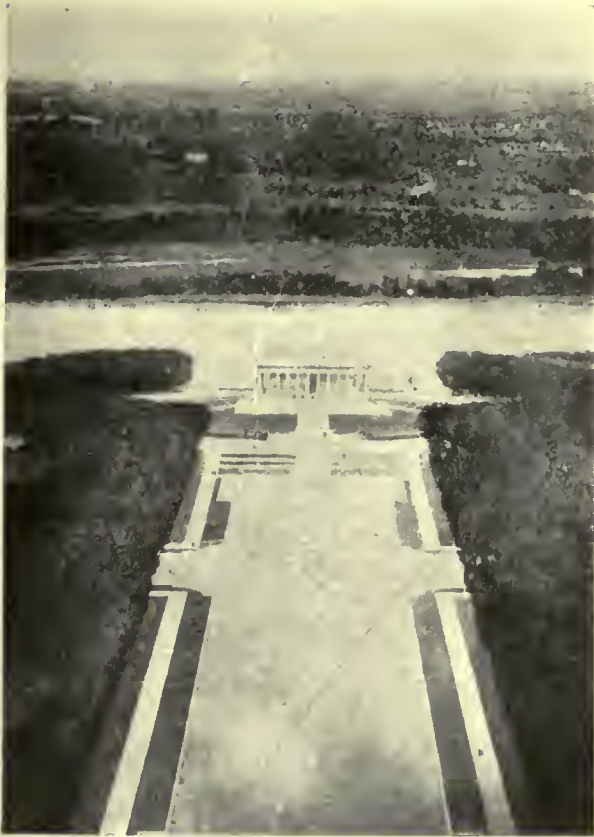

THE LINCOLN MEMORIAL
Showing relation of site to Virginia Hills.

ton. The composition of this commission was interesting. Taft and Wetmore had expressed their approval of the Potomac site; McCall was known to be favorable to the Capitol Hill site; Cannon was strongly opposed to the Park Commission site; Money was indifferent, with no convictions; Clark was in favor of a roadway; Cullom, a friend of Lincoln, very old, was most anxious to see the work started on his friend's memorial, gave mild approval to the Potomac site, but was willing to accept any site if he could see the work in progress.

With a commission of this composition it took some time to arrive at a conclusion.

The first step was a wise one. They submitted questions in dispute to the Commission of Fine Arts for a report on a site and a method of selecting designs.

The Fine Arts Commission were asked for advice on the following locations: The axis of Delaware Avenue, or the site between the Capitol and the railroad station; the site proposed on the avenue near the Peace Monument; on newly acquired land between the Capitol and station, and on the Potomac Park site. The Fine Arts Commission, July 17, 1911, after four months' study, made a unanimous

report in favor of the Potomac Park site. Although their report covered the ground passed upon by other experts, it may be well to give a brief outline of their conclusions.

These were, briefly:

On sites near the Capitol:

"It would not only mar the new structure, but destroy the orderly plan and impair the beauty of

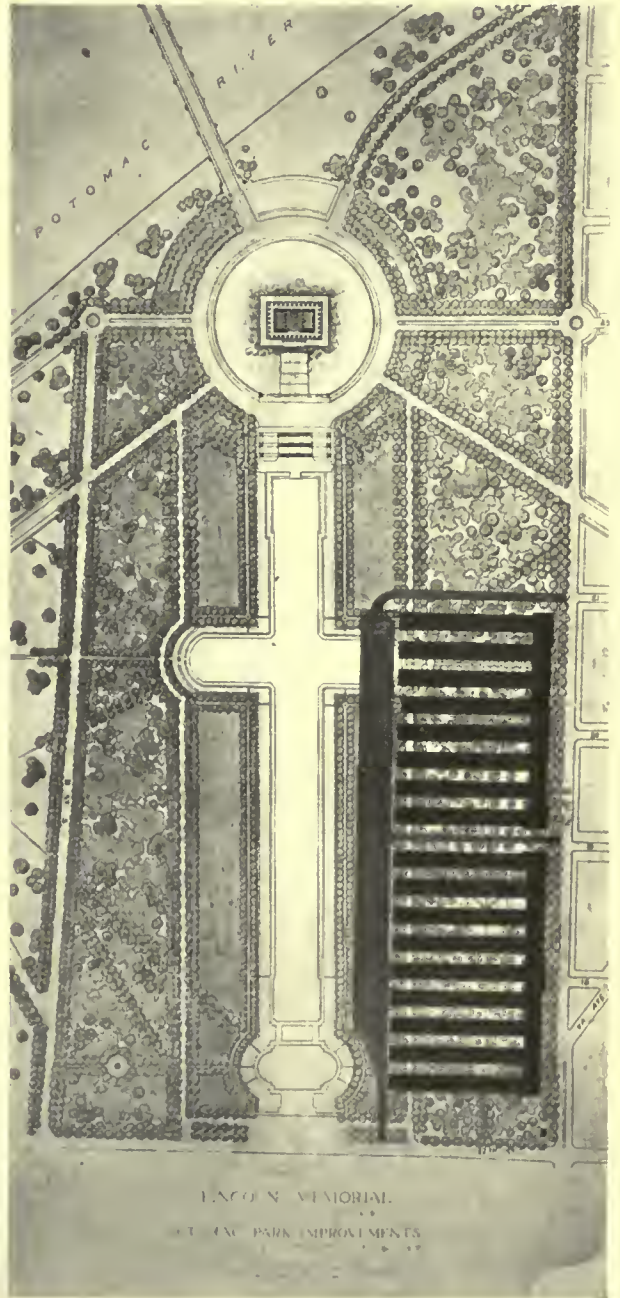

LANDSCAPE TREATMENT OF LINCOLN MEMORIAL SITE

The black gridiron shows destructive effect of war-work buildings, which should be removed.

THE AMERICAN ARCHITECT

present buildings by introducing a new and non-relating element."

On the axis of Delaware Avenue:

"Any structure on this axis would destroy the effect of the Capitol dome to visitors entering the city, a vista which should never be obstructed by a large object."

On the proposed avenue to Peace Monument:

"It would be impossible to locate a dignified structure on this axis without a peculiarly ugly, angular relation to the Capitol and the Union Station."

The same reasons governed in their consideration of the land for enlarging the Capitol grounds and the territory east, south and west of the Capitol. Any structures of importance would be marred and mar the effectiveness of important, historical buildings already in place.

They noted that a colonnade around the plaza would be more a part of the station than a memorial to Lincoln, and that an arch on either of the axes mentioned would seriously detract from the dome of the Capitol. Minor structures on these axes would not be large enough to give them dignity. They called attention to the fact that the least desirable location for an exhibit is near an entrance, and placed near the station the memorial would teach but a feeble lesson. After considering more than a hundred studies made during a series of years for a memorial near the Capitol, they "prove conclusively that any location near the Capitol presents obstacles that are insurmountable, if the manifest desire of Congress for a great memorial is carried out."

The proposed arch on Meridian Hill:

"That it was surrounded by incongruous structures, not sufficiently isolated, and the monument would occupy a position of distinctly inferior rank."

Fort Stevens, on Seventh Street, was not a radial avenue, and a site on it would not co-ordinate with any of the chief monuments of the Capitol.

Against a memorial bridge across the Potomac, the commission states the form a memorial should take:

"Some abstract form of art typifying the endeavors and character of the man. Because of traffic a bridge would not in itself alone impress one as a memorial.

A road to Gettysburg was dismissed with the statement:

"Although they considered it, it was precluded as the act called for a memorial in the City of Washington, but there are reasons which appear conclusive why a road to some distant point could not be made a suitable memorial to Lincoln."

Why did they agree on the Potomac Park site?

The isolation; nothing for it to clash with or to mar its beauty.

Independent area, with a possibility of treating the landscape to enhance the structure.

The undisputed domination of a large area.

While isolated, it is readily accessible and prominently in view from the river, park and amphitheatres of hills in the District of Columbia and Virginia.

Its forming a part of the great art composition. The Lincoln Memorial would be most prominent, ending the axis running from the Capitol through the Grant Memorial and the Washington Monument.

Secretary John Hay expressed clearly the sentiment and reasons for the park site.

"The place of honor is on the main axis of the plan. Lincoln, of all Americans next to Washington, deserves this place of honor, he was of the immortals. You must not approach too close to the immortals. His monument should stand alone, remote from the common habitations of man, apart from the business and turmoil of the city, isolated, distinguished, serene."

After the approval of the Park Commission, the Fine Arts Council, of Roosevelt, and the careful review and approval of the site by the National Fine Arts Commission, we thought the question finally settled.

The Memorial Commission before approving the site selected Mr. Henry Bacon to prepare designs for the Potomac Park site, acting upon the advice of the Commission of Fine Arts. Members of the Memorial Commission antagonistic to the Park plans were sufficiently strong to demand drawings for other sites. A few weeks after Mr. Bacon's appointment Mr. John Russel Pope was directed to prepare plans for a memorial in the Soldiers' Home grounds on the axis of North Capitol Street, and on Sixteenth Street Hill. The designs of Mr. Bacon and Mr. Pope, beautifully rendered and lavishly presented, with carefully made models of the memorial and landscape, were put on exhibition in one of the halls of the New National Museum.

Here the Memorial Commission gave them careful study, and on Feb. 3, 1912, by majority vote, adopted the site on the Potomac River, according to the Park Commission plan.

Those interested in the development of Washington and in satisfactorily commemorating Lincoln, who had been striving for ten years toward this end, felt that their labors were over. They did not take into account that the site selected served no interest except the best development of the city and the most distinguished memorial to Lincoln.

The desire to use the two million dollars appropriated where it would increase property values, widen motor sales and foster traffic and pleasure



INTERIOR VIEW
DESIGN SUBMITTED BY JOHN RUSSELL POPE FOR A LINCOLN MEMORIAL ON
SIXTEENTH STREET SITE

THE AMERICAN ARCHITECT

riding, appealed to a large, aggressive and influential body of our citizens. With two millions as a stimulant, little consideration was given to the proper development of the city or the memory of Lincoln. We came near losing after being assured of our victory. The Lafean bill for a roadway to Gettysburg was revived by Representative W. P. Borland, of Missouri, in the form of an amendment to the act creat-

mobile Associations, and to highway and touring clubs.

The Lincoln Memorial Road Association, Mr. James T. McCleary, former Representative, president, his son, Leslie T. McCleary, ex-secretary, and Charles J. Glidden (of Glidden's Tours), secretary, was the organization representing those interested in the roadway.

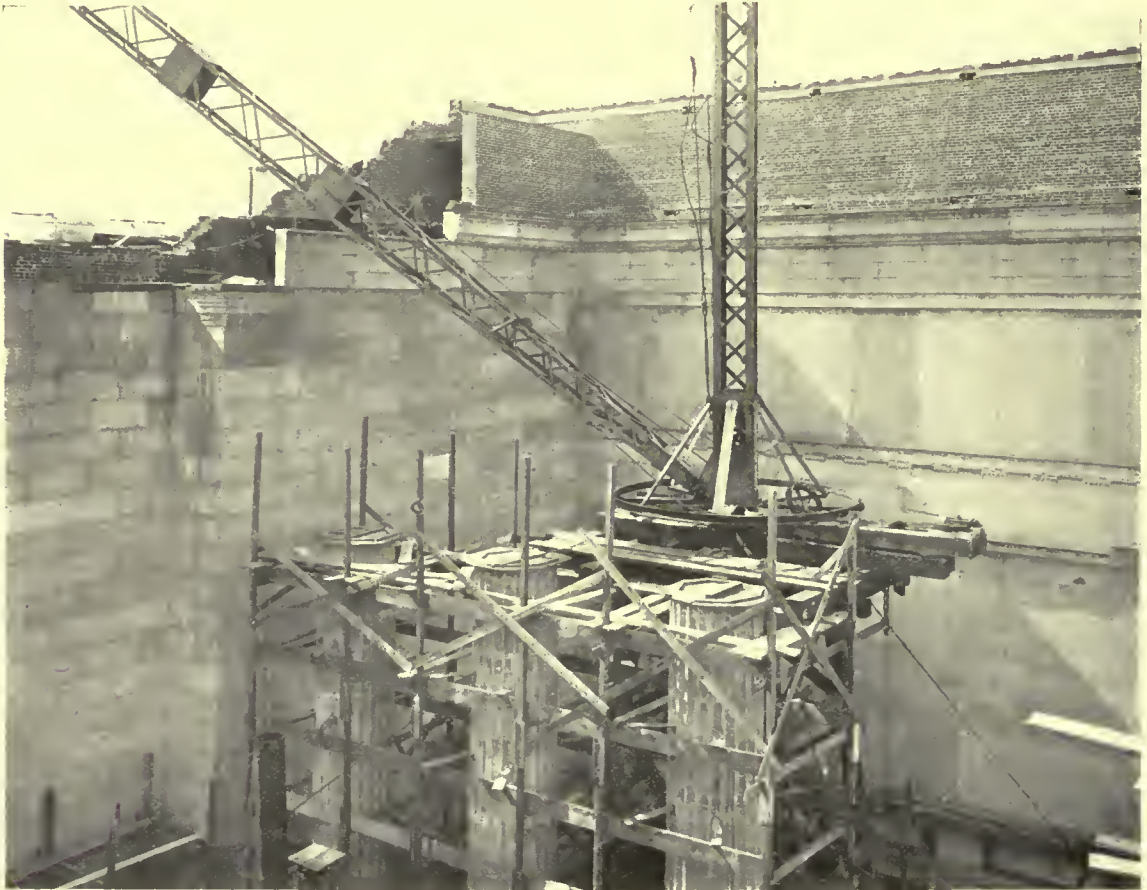

VIEW OF INTERIOR DURING CONSTRUCTION
THE LINCOLN MEMORIAL, WASHINGTON, D. C.
HENRY BACON, ARCHITECT

ing the Lincoln Memorial Commission to secure plans and designs for a memorial to Abraham Lincoln. His proposed amendment struck out the paragraph "in the City of Washington, District of Columbia," leaving it within the power of the commission to use the money for a roadway.

Representative Borland supported his amendment by a speech in the House of Representatives, July 28, 1911. This speech he circulated extensively, sending it to posts of the Grand Army of the Republic, the camps of the Loyal Legion, the branches of the Federation of Labor, to the State Grangers of Pennsylvania and Maryland, the American Auto-

Mr. Borland circulated his documents so as to get the support of organizations mentioned, in February, 1912, and gained the active support of many of them for the hearing before the Library Committee of the House of Representatives, James L. Slayden, of Texas, chairman, held March 5 and 6, 1912. The hearing was on the amendment to the act creating the Lincoln Memorial Commission.

At this hearing were marshalled the forces in favor of the roadway, commanded by Representative Borland and ex-Representative McCleary. Those in favor of the Potomac Park site were acting under the auspices of the American Institute of Architects.

THE AMERICAN ARCHITECT

The conduct of the case for the Potomac site side before the committee was placed in the hands of Mr. A. S. Worthington, one of our ablest lawyers, who gave his services *pro bono publico*. Representative Lynden Evans, member of the Library Committee of the House, who led the opposition to the Borland amendment, was indefatigable in collecting data and information on the subject, and

licity to get the wishes of the people before Congress. As a part of the campaign it is very important to send a personal letter. To put these enclosures in the mail costs about \$45 per thousand, or a total of \$12,375.

"Having in mind the far reaching importance of this matter one of the good roads committees connected with the Automobile Industry has subscribed



PLACING THE COLONNADE
THE LINCOLN MEMORIAL, WASHINGTON, D. C.
HENRY BACON, ARCHITECT

showed his knowledge in questioning the various presentations of the roadway advocates. He was particularly curious as to the kind of Lincoln Highway they proposed to build for twenty thousand dollars a mile, and brought out clearly that it was an ordinary country road, in no sense the proposed Appian way, as advocated, and a poor tribute to Lincoln. He presented a letter sent by the Executive Secretary of the Lincoln Memorial Road Association showing some of the interests most anxious for this road. I quote a part of this letter.

"We are conducting a National Campaign of Pub-

\$2,500 to aid our publicity campaign. Many of the automobile clubs and individual manufacturers have subscribed varying amounts. You may have subscribed directly or indirectly. But even if that is the case it is vital to the success of the movement that you subscribe a substantial amount in addition, as more money is urgently needed and a popular subscription could not be raised in time to be available.

"Over one hundred members of the House of Representatives, including the Speaker of the House and many of the leading Senators of both parties

(Continued on page 503)

St. George's Church Yard, Hempstead, Long Island, New York

(See reproduction of the original drawing by O. R. Eggers in this issue)

THE casual observer, untrained in an appreciation of good art and its correct architectural expression, would perhaps pass with but indifferent glance this "bit" that has arrested Mr. Eggers in his tramp about Hempstead and caused him to set down with his usual facility and happiness of expression a most interesting and worth while motive.

In a previous issue the front of this church was illustrated. The present illustration shows the conscientious manner in which the colonial master builder set about his work. This Doric pillared porch with its well proportioned cornice might serve as a correct interpretation of one of the orders. If it shall serve as a suggestive motive to our readers, the purpose of its illustration will have been effected.

Hempstead has an interesting colonial history, and has been the theatre of many important incidents during the struggle for American Independence. Hempstead was settled by a group of New Englanders in 1643. The Presbyterian church, organized in the following year, claims to be the oldest Presbyterian society in the country.

St. George's, while of later erection, dates back to the early history of the town. It owns a communion service said to have been presented by Queen Anne.

550 a



St. George's Churchyard
+ Hempstead, L. I.





The Lincoln Memorial

OF the many memorials that have been erected to Abraham Lincoln, none is so stately, none more beautifully conceived and none more brilliantly executed than the imposing pile that now graces its site in Washington. The many factors that have led to this most satisfactory conclusion are studiously set forth in the first of a series of articles by Glenn Brown, which appears in this issue.

At the outset of his article Mr. Brown states that it was not until a lapse of fifty years that any steps were taken to raise a monument to Lincoln in the National Capitol. Will this lapse of half a century and the success that has surrounded the undertaking be sufficient to prove conclusively that there is un-wisdom in speed in the matter of our war memorials? That we shall show a greater respect for the historic dead of our last war, by waiting until we are sure there has been developed an opportunity and a scheme that will fittingly represent a nation's gratitude and respect? In France it has been agreed to defer for at least a decade the construction of a national monument to her martyred dead. This example we of the United States may with good judgment follow. The Lincoln Memorial of Washington affords a most wonderful example of the wisdom of the policy of study and preparation.

It should be a source of the most profound satisfaction to every architect in this country to learn as he reads these articles how thoroughly the American Institute of Architects safeguarded every step in the selection of the present site and the formulation of its dignified design. Without such efficient guardianship there is no doubt that this monument would have become the plaything of real estate speculators and the object of bungling efforts on the part of politicians and others with sordid interests to serve. These things are facts and are set down with absolute accuracy by Mr. Brown, either in the present series or in that on Roosevelt and the Fine Arts, recently presented in *THE AMERICAN ARCHITECT*.

IT will be unjust too harshly to criticize the erection of the war emergency buildings at a place that just now seriously destroys a view which, when all

the landscape features are developed, will be one of very great beauty. War's necessities must first be served and now, having been served, it is reasonable to suppose that these unsightly structures will soon be removed. As to these features and any others similarly discordant, there can be no doubt that a people who have, after the lapse of half a century found their judgment of the great Lincoln to be well founded, will not permit the slightest act that will in any way mar the integrity of the monument that has been erected to his memory.

Parties rotate in power, men may prominently stand in the spotlight of temporary importance. It is the truly great that live in the hearts of a nation. Lincoln needed no monument to make sure that his memory would, as does Washington's, live forever in the hearts of a grateful posterity. If some tangible manifestation of that gratitude and respect were needed, it is a deep sense of satisfaction to have one so very dignified and appropriate in all of its phases as this memorial to Lincoln that stands in classic beauty on the banks of the Potomac at Washington.

"What Is Art?"

IN its issue of September 16, *Engineering News-Record* illustrates the Bensalem Avenue Bridge in Philadelphia and prints a thoughtfully prepared descriptive article in which this fine bridge is called "an essay in ornamentation." Architects will find little if anything to criticize in the tenor of this article.

But the fact that the editors have been willing to concede to architects their just recognition for the part they have played in the designing of this bridge does not appear to justify them in giving space to the letters of correspondents that have been printed in subsequent issues. As a striking example of a most incorrect inter-professional attitude, these letters are of interest. But just what purpose the editors of *Engineering News-Record* hope to serve by presenting, even as the opinion of others, a series of statements that are unjust, misleading and in a certain sense pernicious it is difficult to discern.

The inter-relation of the professions of architec-

THE AMERICAN ARCHITECT

ture and engineering is today closer than ever before. Men in these professions find themselves working side by side on every important structure. The success of this joint effort absolutely depends on the most harmonious relations. There is no room for these petty jealousies, this insistence on a point of view. In fact, architects and engineers, as super-educated men should be above such jealousies and spiteful allusion. To indulge in such practices is to lower the dignities of these professions and it becomes the duty of the representative men and the representative journals in these fields sharply to rebuke these displays of querulous squabbling.

In the *Engineering News-Record* of September 20, Mr. John C. Trautwine, Jr., an engineer, vigorously takes exception to the attitude of the editors for their views on "What is Art?" If Mr. Trautwine's premise was correct, it would serve no good purpose to give such views publicity. But as he rushes into print adversely to criticize a closely related profession, and absolutely fails in truth or justice, we are disposed to wonder why *Engineering News-Record* gives space to this sort of thing. It only accents a condition that every soberminded man is trying all he can to ameliorate.

Housing for Health

IN view of the fact that Europe is over-run with contagious diseases which "are knocking at our doors," coupled with the danger to health in the United States arising from the housing shortage, Health Commissioner Royal S. Copeland, of New York, has decided to go before the special session of the Legislature this month with recommendations which he believes will obviate the danger. The Commissioner has just returned from Europe, where he studied the housing situation.

Chief among the suggestions will be the appointment of a Central Housing Commission, with power to handle all rent problems, to determine what is essential construction, to pass on all plans for build-

ing operations, to determine zones for dwelling construction, to seize houses withheld from occupancy because of exorbitant rent demanded and rent them at reasonable prices to the homeless.

"The commission would also have the authority to erect buildings for the laboring classes and to determine the conditions under which they should be rented or sold," he said. "It should have the authority to offer bonuses to private individuals who care to erect homes. The Legislature should further grant the city power to issue bonds for building purposes."

America should profit by the experience of European countries and not repeat their costly mistakes. The problem of housing is a matter of grave public health concern. The desired results would be more readily achieved if action were taken on additional suggestions as follows:

The state and city should be authorized by the Legislature to engage in the purchase of land and the construction and rental of dwellings.

The renovation of existing insanitary tenements as contemplated by the State Reconstruction Committee and the Joint Legislative Housing Committee.

The modification of existing interest and taxation statutes, so that private capital may be made available for housing.

Immediate steps to be taken to obtain the cooperation of labor and of those in control of all materials used in building. But action is the keynote. Without it, discussion is useless.

Unnecessary and selfish building must be prohibited. This is no time for construction not essential to the public good. Public health is at the basis of all other activities and is the point of departure from which all our future welfare starts. The bearing of housing on health, and of health on housing are closely inter-related and are at the foundation of national progress. Will these suggestions end in more talk?



BURNHAM'S SCHEME FOR TREATMENT OF STATION PLAZA

(Continued from page 499)

have already expressed themselves in favor of the Memorial Road. We would like to make it as nearly unanimous as possible. * * *

"In addition to making a substantial subscription now, I hope each of your executive officers will write a personal letter to his Congressman and his two State Senators urging them to favor the plan for the Lincoln Memorial, which includes the road to Gettysburg, and you will arrange to have each of your representatives and agents throughout the country to do the same."

Representative Evans brought forcibly to the attention of the committee the necessity of a broad right of way to protect the dignity of the roadway from objectionable buildings. He showed clearly how ridiculous was the assertion what the roadway at \$20,000 a mile would be when compared with the Appian Way, uprooting one of the favorite assertions of the claimants. They were also quizzed on the subject of maintenance, character and cost. On May 6 Messrs. Walter Cook, R. Clipston Sturgis, Irving K. Pond, M. B. Medary, architects, brought to the attention of the committee the importance of artistic landscape, dignified bridges and architectural

structures to give the roadway the character necessary for a national memorial.

Mr. A. S. Worthington summed up the points against the roadway and in favor of the Potomac Park site. Mr. Worthington, through a letter of Col. J. A. Watrous, proved the claimed action of the Grand Army in favor of the road was uncertain, that Mrs. Moore who represented several hundred women advocating the road was untrue. He presented a letter from her approving the Potomac Park site and stating she represented 800,000 women. He called attention to the three expert commissions who had approved the Park site. He called attention to the fallacy of confusing a memorial to Lincoln with anything simply utilitarian. Then he brought out the personal interest of the advocates for the roadway and explained the legal complications arising from the United States owning a string of land cutting Maryland into two parts. Major W. V. Judson, engineer-commissioner, who brought with him probably the only estimate made for a memorial road in this country, a document carefully prepared by the Engineer Corps of the Army. It constituted the simplest form of construction and planting for a memorial road and was estimated to cost \$120,000



TREATMENT OF THE PLAZA AS PROPOSED BY D. H. BURNHAM

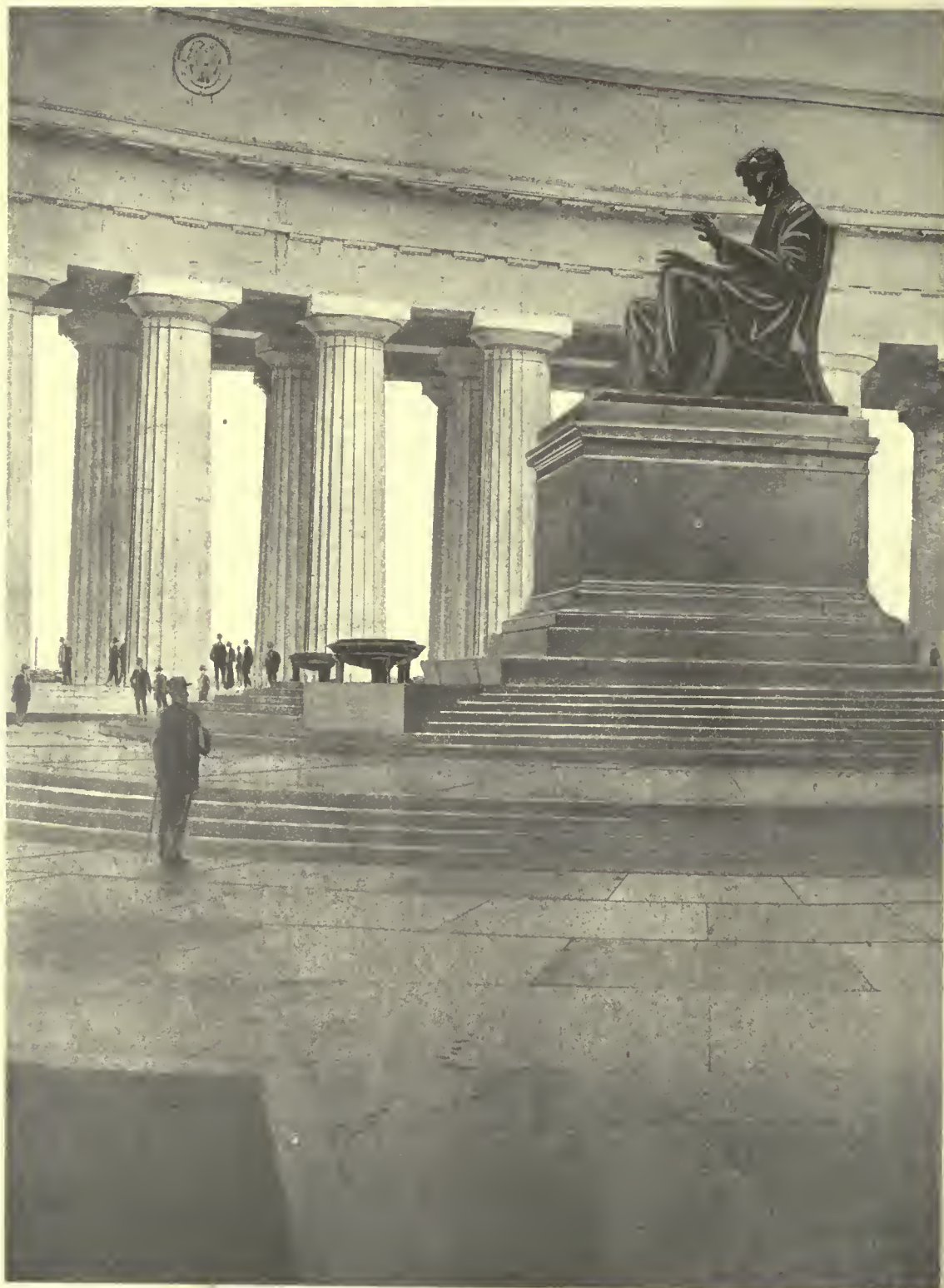

INTERIOR DETAIL
DESIGN SUBMITTED BY JOHN RUSSELL POPE FOR A LINCOLN MEMORIAL OF A
CIRCULAR MOTIVE FOR THE PARK SITE



GENERAL VIEW

DESIGN SUBMITTED BY JOHN RUSSELL POPE FOR A LINCOLN MEMORIAL.
CIRCULAR IN PLAN

per mile instead of \$20,000. Major Judson said on the basis of conditions at the time of his testimony, a highway of the character mentioned would cost \$20,000,000, without ornamental features of any kind, even trees.

Major Judson stated that 10 cents per square yard per annum was a fair estimate for maintenance, which would make such a road cost between \$600,000 and \$700,000 per annum, and if fences and parking were included the maintenance would amount to \$1,000,000 per annum.

On the strength of these hearings the Library Committee approved the recommendation of the site made by the Fine Arts Commission.

Rep. Lynden Evans presented the report, bringing

out clearly the reasons as mentioned throughout this article for their decision.

In the meantime the advocates of the Borland amendment were active and aggressive in proselyting representative and in securing strong support in the House.

A short time before the measure came up for action in the House of Representatives, Senator Elihu Root made a telling speech before a popular audience on the advantages of the Park site and the futility of the Roadway, stating that the roadway was fostered by real estate interests along the proposed route.

This speech was given great publicity in the press



MERIDIAN HILL SITE. VIEW FROM THE SOUTH

and as we had first hand evidence of the activities of real estate speculators, it was effective. Congress began to take notice; although two weeks before it was presented for final action, Representative Slayden and Senator Root thought we would lose.

When the amendment was brought up, due to Representative Evans' clear telling report and statements as to the cost and maintenance of a memorial

road, the personal interests of those advocating a roadway, aided by the effect of Senator Root's speech, opposition to the park site vanished and the Borland amendment was defeated by a large majority.

After more than ten years of anxiety and labor, the site called for in the Park Commission's plan was fixed.

Architectural Quicksands

By CLINTON H. BLAKE, JR.

Negligence in Issuance of Certificates

THERE is another reason, and one more directly affecting the personal interests of the architect, why he should exercise adequate care in checking the estimates and requisitions of the builder and the work done, before issuing certificates. The saving to the client, and the protection afforded the interests of the client, by careful attention to his side of the architect's duties as superintendent, has been already referred to. This is, naturally, important and part and parcel of the obligation which an architect owes to his client. Every conscientious architect will appreciate this fact and realize that, as the trusted agent of the owner, it is incumbent upon him to overlook no reasonable means of protecting the latter, in supervising the work done and in checking the payments which the owner makes to the builder, in reliance upon the certificates of the architect. Aside from this, however, the architect may, if he fails to give proper care to this matter of certificates, incur a direct personal responsibility. If the architect gives certificates to the builder, exceeding the sums which should be certified under the contract, it is quite possible that he will be called upon to make good to the owner the loss occasioned the latter by such neglect on the part of his representative.

In pointing out the necessity of a careful survey and checking of materials and of all of the component parts of the building operation, I have already referred to a case where the contractor endeavored to secure all of his profit by including the major part of profit and overhead in the earlier items included in his estimates. This contractor, as stated in a prior article, finally became insolvent, and if it had not been for the careful checking by the architect, of the estimates and his discovery of the fact that the contractor had included his profits and over-head on the earlier items, the owner would have been left with an uncompleted building on his hands and with a reserve fund insufficient to complete it, without

serious loss. It is in just such a case that the architect might easily incur personal liability and a substantial loss. If the architect, by lack of reasonable precaution or thought, certifies amounts larger than those which he should certify, and the builder then becomes insolvent or goes into bankruptcy, the owner may be entitled to recover from the architect the amount of the loss which he has suffered by reason of the over-certification.

There would seem to be no reason why the same rule should not apply where the neglect of the architect consists, not so much in over-certification, as in a failure to perceive the fact that the estimates originally accepted are improper and unfair to the owner, in that the items of cost are not distributed properly with respect to the various component parts of the building, but are so arranged, as to give to the contractor the major part of his profit on the earlier items of construction. It is possible that the architect might defeat recovery by the owner in such a case, by the plea that the architect was acting in the quasi-judicial capacity of arbitrator, and that he was, therefore, entitled to the certain immunity from damages, based on errors of judgment or even neglect, which is referred to under the heading following.

THE ARCHITECT AS ARBITRATOR

I have already pointed out the fact that the relationship between the architect and the owner is very similar to the relationship between the lawyer and his client. This similarity between the two professions may be properly carried a step farther and the ordinary architect will no doubt be especially astonished to know that, in his capacity as supervising architect, he is constantly acting in a judicial or quasi-judicial capacity.

Every architect is, of course, familiar with those clauses of the construction contract now so generally used, which designate the architect as arbitrator, to determine matters in dispute, and to pass upon ques-

THE AMERICAN ARCHITECT

tions involving the construction of the plans and specifications and the work done thereunder. The architect, when acting under such a clause of the construction contract, acts in a quasi-judicial capacity. This is true, even though the contract be so worded that he is not appointed arbitrator in the fullest sense of that term, or in the sense that he is to determine an amount in dispute between the parties and render an exact decision thereon, accordingly. If he is called upon, under the contract, to act generally in the capacity of an arbitrator, or if, under the operation of the contract, it comes about that the parties to it are placed in a position where their rights are to be determined by the decision of the architect, he is acting as arbitrator sufficiently to bring him within the classification of a quasi-judicial officer. In his capacity as such it is manifest that the rights of the builder are dependent upon his determination, fully as much as are the rights of the client. While the architect is employed, in the first instance, by the client, when he is placed in this judicial position, he should and must carefully observe the rights of the builder as well as the rights of the contractor and hold the scales as evenly as may be between them. The builder, in becoming a party to the building contract, with its provision that the decision of the architect, in matters of dispute and the like, is to control, has deliberately placed his interests as to any such questions in the hands of the architect. This necessarily implies his trust in the fairness and good faith of the decision which the architect may be called upon to render.

The Courts will be diligent to protect the builder in the trust and confidence which he so places in the architect, just as they are diligent to protect the owner in his reliance upon the ability and fairness of the architect. The latter, while acting in this judicial capacity, is accorded, to a certain extent at least, the immunity which is ordinarily enjoyed by judges or those acting in a judicial capacity. Certain courts have held, accordingly, that an action for want of proper skill or care, or an action based upon negligence, will not lie against an architect, when the neglect, or oversight complained of, related to the acts of the architect in his judicial capacity. It has even been argued that, as an arbitrator, he would not be liable for misconduct. I should not advise any architect to rely upon his position as an arbitrator or as a quasi-judicial officer, to afford him immunity in the latter case. I mention it merely to emphasize the extent to which the courts have gone in their logical application to the architect, when acting judicially, of the same rules which they apply to any other judicial officer.

It is, of course, evident that, in whatever capacity he may be acting, the architect must not be guilty of any fraud or collusion with either of the parties

to the building contract. For infringement of this rule, for any concealed interest in the building operation or any improper collusion with either of the parties thereto, inconsistent with the duties which he owes to them as architect under the contract, the architect will be liable to the injured party. It is unnecessary to discuss this phase of the matter at length, as it is the purpose of the present articles to treat of the "Quicksands" which await the negligent, thoughtless, or unwary architect, rather than to consider the case of an architect who is acting deliberately with any degree of bad faith. Undoubtedly the safer plan, in any event, will be for the architect to proceed on the assumption that no immunity will attach to him, and to so conduct his work that he will have no need to rely upon any such defense.

BEARING OF ARCHITECT'S CERTIFICATE ON RECOVERY BY CONTRACTOR

The architect is familiar also with the usual contract provision, whereby the payments to the contractor are made dependent upon the issuance of certificates by the architect. Construed literally, the provisions on this point, as often drawn, might be construed to mean that in no case could the contractor recover, without showing the issuance of the certificate due him. It is quite possible, that if the contract clause is so drastically worded, as to provide that the determination of the architect, as to the issuance or non-issuance of certificates, may not be questioned or impeached in any way, either on the ground of fraud or collusion or bad faith or otherwise, the courts would hold the issuance of the certificate to be an absolute condition precedent to any recovery by the contractor. Such a provision has, in fact, been employed and countenanced by the courts. It is obvious that an agreement of this sort is, in the ordinary case, inequitable and unfair and that it should not be employed, except in exceptional circumstances. Such is a case where there is good reason to suspect the intentions and character of the contractor, or where, for some other special reason, it is necessary to vest the architect with absolute discretionary powers.

In order to do justice to both parties and to apply common sense, in construing the terms of the contract, the courts have generally determined that the failure to produce the architect's certificate will not, in certain cases, be fatal to a recovery by the contractor, even if the contract provide in general terms that no recovery can be had by the latter, until the certificate be produced. The courts will, accordingly, excuse the failure to produce the certificate, and relieve the contractor of the necessity of so doing, where they find the existence of fraud, or collusion, or bad faith, or negligence so gross as to amount to bad faith. They will protect the contractor, simi-

THE AMERICAN ARCHITECT

larly, where circumstances, or an accident beyond his control, or the passing of time (not including delay for which he is responsible), have made the performance of the contract impossible. They will intervene, also, where the owner prevents the contractor from securing the certificate, or where it appears that the architect has any concealed interest in the contract, or where the failure to secure the certificate is due to the refusal of the architect to act and to perform the duties which, under the contract, he is called upon to perform.

A reading of the above may, perhaps, give an impression that the rule requiring the production of a certificate is more honored in its breach than in its observance. This is not the case. An analysis of the instances where the court will intervene, to prevent an injustice being done to the contractor, will show that they are exceptional cases, where the contractor is not in any way at fault, but where his failure to produce the certificate is the fault of the owner, or of the architect who represents him. In an ordinary case, where the usual good faith is observed on all sides, where there is no collusion between owner and architect, and where the latter is acting to the best of his ability and good faith in arriving at his determination, the failure by the contractor to produce the certificate called for by the contract will, in all likelihood, be fatal to his recovery, where the contract makes the production of the certificate a condition precedent to payment.

I recently represented an owner in a case of this kind. The architect, in his discretion, and in ac-

cordance with what he believed to be just to both parties, had refused to issue a certificate for the work done. The sub-contractor decided that he would secure this payment, whether the certificate were issued or not, and accordingly brought suit against the general contractor and demanded a jury trial. It was well nigh impossible, in the court where the suit was brought, to secure a jury which would not naturally favor the subcontractor in a controversy of this kind. Despite everything which one could do in selecting the jurors, and despite all the challenges allowed under the law, the jury as finally constituted, contained a number of men, themselves engaged in trades akin to the business carried on by the sub-contractor, and naturally predisposed to view the controversy in a light favorable to him. The subcontractor's case was presented to the jury and it was quite evident that, no matter how many nor how impressive witnesses the defendant might introduce, to negative the allegations of the sub-contractor that his work had been properly done and completed, the jury would render a substantial verdict for the latter. The owner's one chance was to prevent the case from going to the jury, and the one ground on which it was possible for him to do this was the fact that the architect had not issued the certificate called for by the contract. At the close of plaintiff's case, I presented this objection, accordingly, and moved for a dismissal. The result was that the case never went to the jury, and that the contractor and owner finally arrived at a valuation adjustment which was fair and satisfactory to each of them.



DECORATION, CHURCH OF THE CARMINI, VENICE

508



THE CENTURY BUILDING, CHICAGO
HOLABIRD & ROCHE, ARCHITECTS



THE CENTURY BUILDING,
CHICAGO

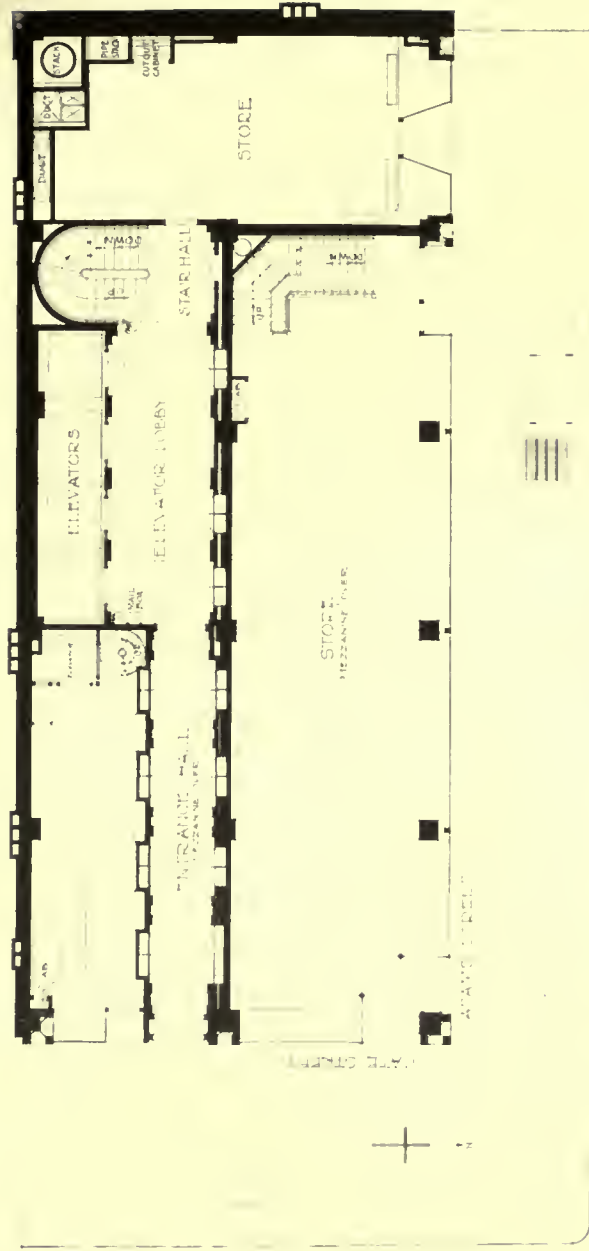

FIRST FLOOR PLAN

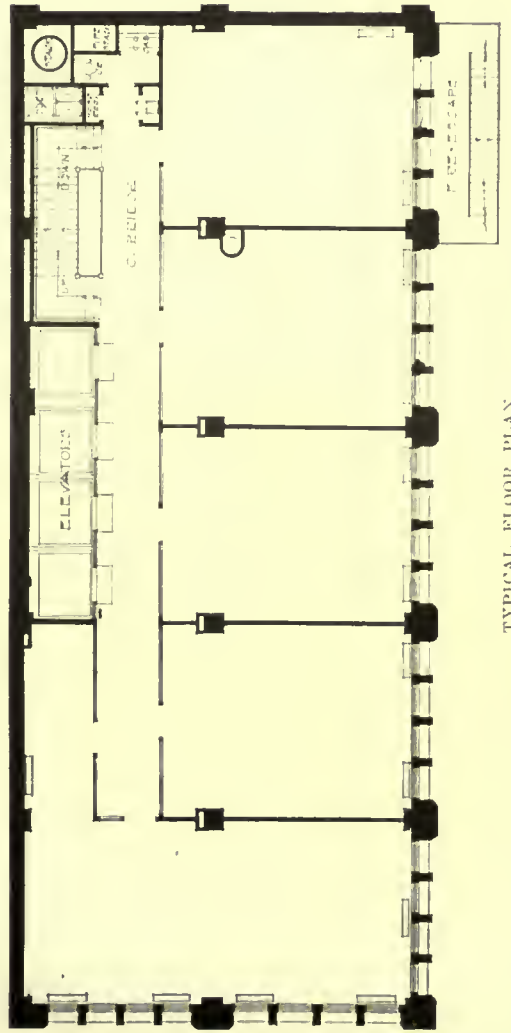

TYPICAL FLOOR PLAN

HOLABIRD & ROCHE, ARCHITECTS

b7



GARRETT BIBLICAL INSTITUTE, EVANSTON, ILLINOIS

BUILDING C; HALL 7

HOLABIRD & ROCHE, ARCHITECTS

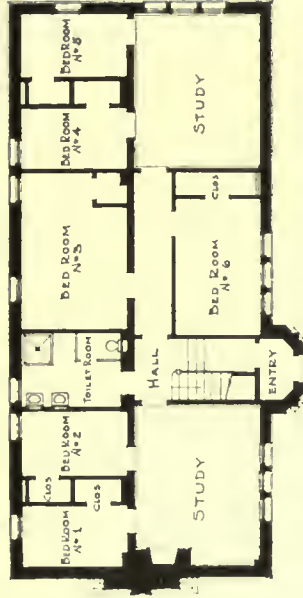

HALL No 7
FIRST FLOOR PLAN

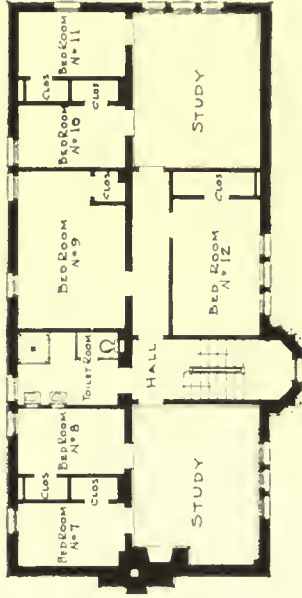

HALL No 7
SECOND FLOOR PLAN

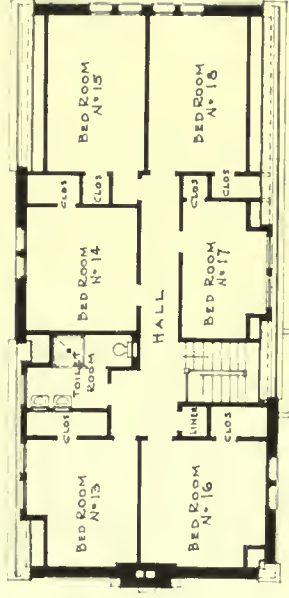

HALL No 7
THIRD FLOOR PLAN

52

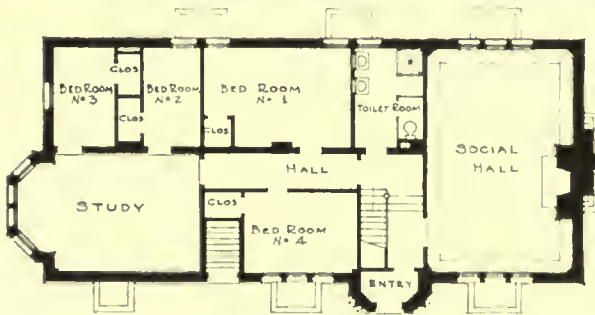

HALL N° 8
FIRST FLOOR PLAN

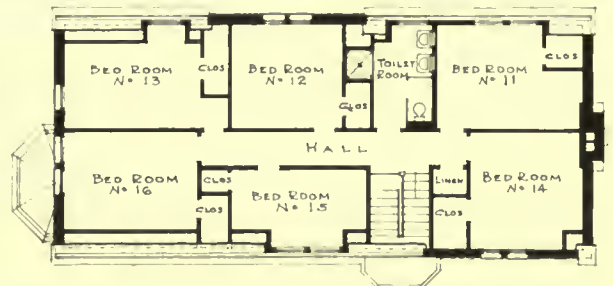

HALL N° 8
THIRD FLOOR PLAN

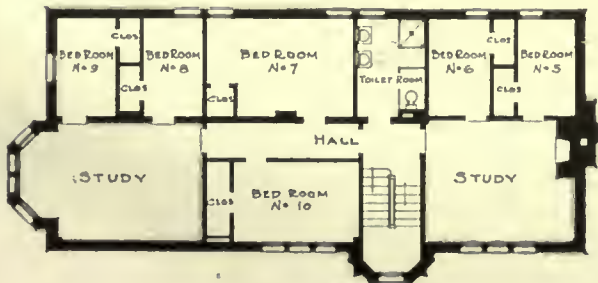

HALL N° 8
SECOND FLOOR PLAN

GARRETT BIBLICAL INSTITUTE,
EVANSTON, ILLINOIS
BUILDING D; HALL 8

HOLABIRD & ROCHE, ARCHITECTS



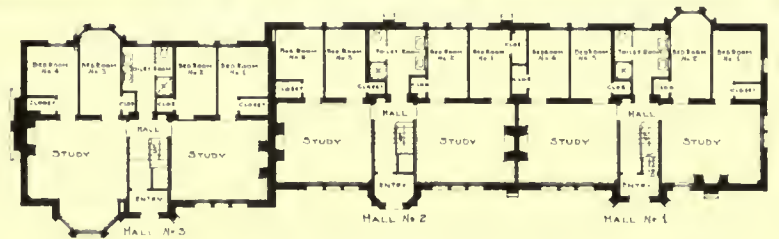

FIRST FLOOR PLAN



SECOND FLOOR PLAN

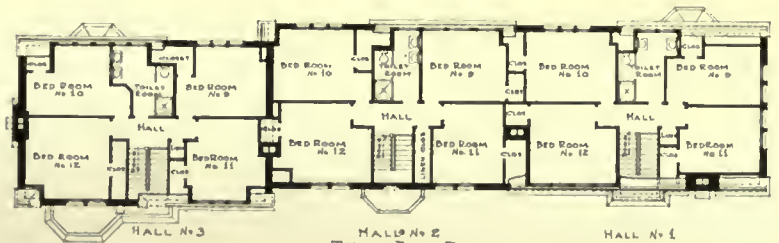

THIRD FLOOR PLAN

GARRETT BIBLICAL INSTITUTE,
EVANSTON, ILLINOIS
BUILDING A; HALLS 1, 2 AND 3

HOLABIRD & ROCHE, ARCHITECTS



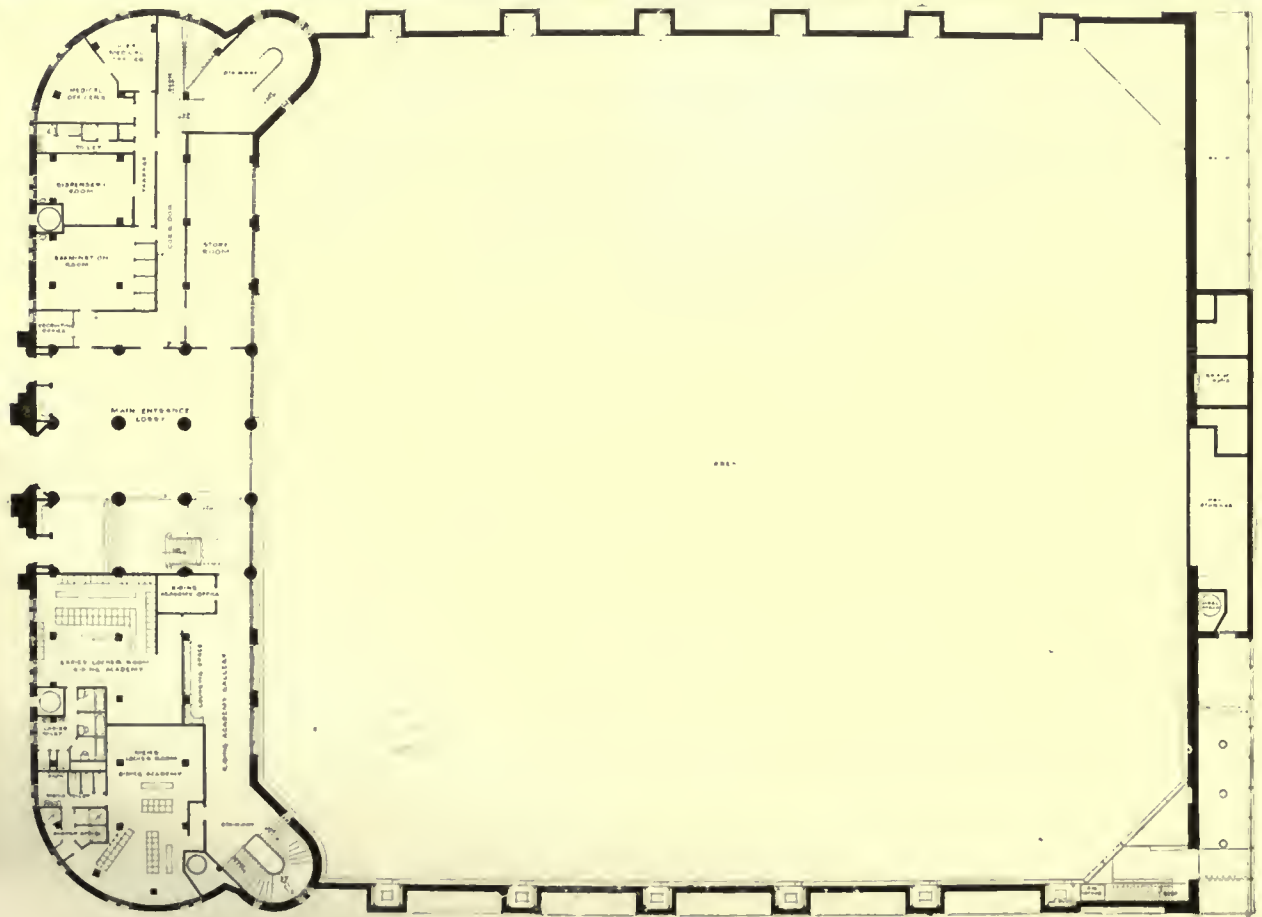

SECOND ARTILLERY ARMORY, CHICAGO
 HOLABIRD & ROCHE, ARCHITECTS





CHILDREN'S MEMORIAL HOSPITAL, CHICAGO
HOLABIRD & ROCHE, ARCHITECTS

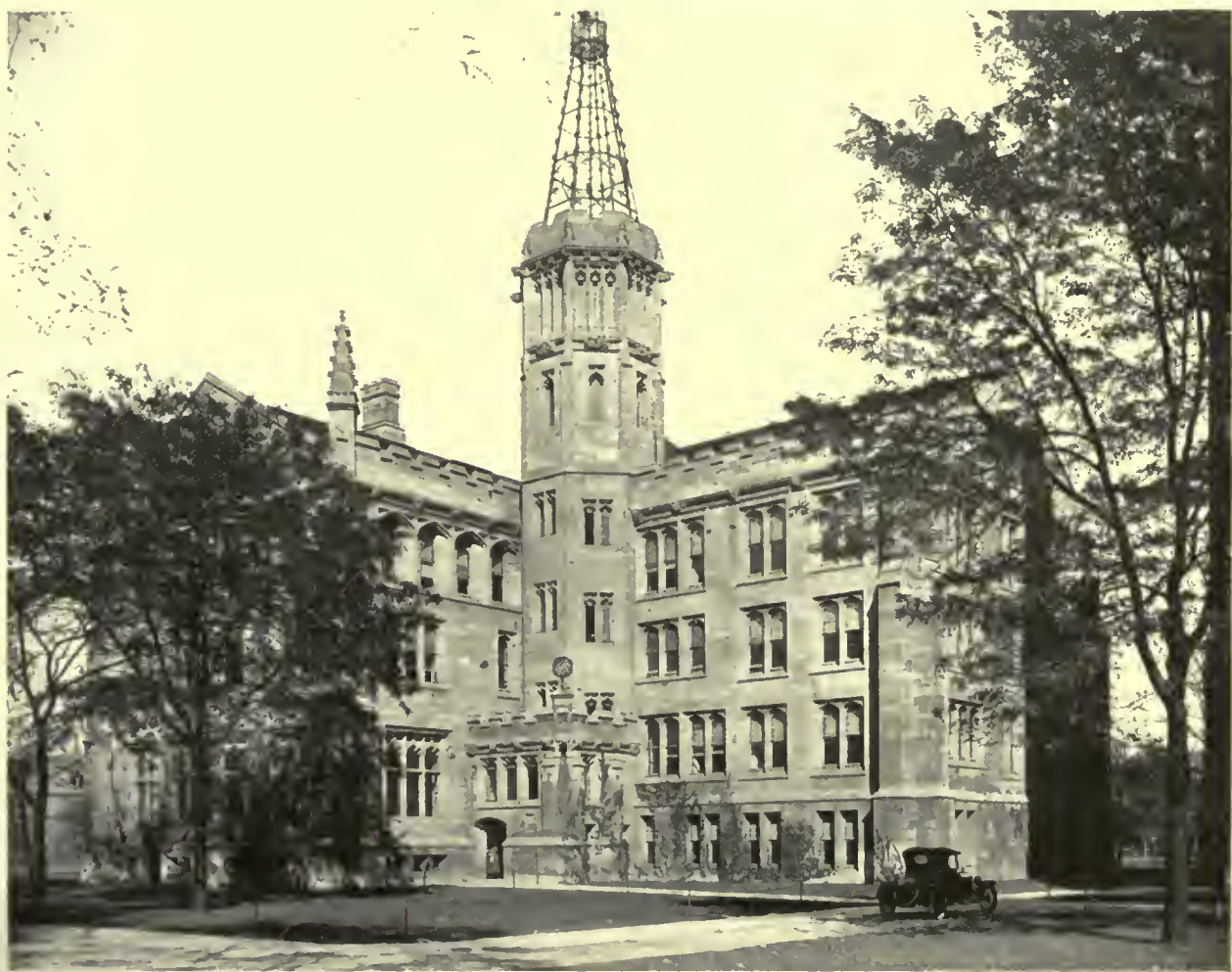

GEOLOGICAL BUILDING, CHICAGO UNIVERSITY
HOLABIRD & ROCHE, ARCHITECTS



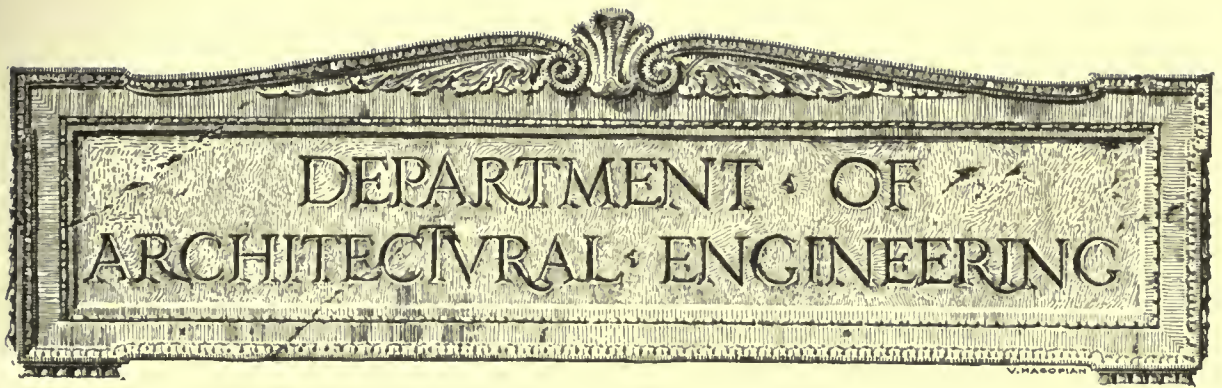

Features of Interest in the Bush Addition

HELMLE AND CORBETT, *Architects*

THE towering thirty-two-story Bush Terminal Sales Building, New York City, completed in 1917, holds the same high place of architectural eminence in the Forty-second Street district as does the Woolworth Building in lower Manhattan. Many of the interesting features of the design and construction of the Bush Terminal Sales Building were presented after its completion. (See *THE AMERICAN ARCHITECT*, Oct. 17, 1917.) The addition, now under construction, while not so tall as the original building, presents in its design several features of interest.

It might be well to mention at the outset that at the time the Bush Terminal Sales Building, which fronts on West Forty-second Street, was erected, a ten-story section extending through to Forty-first Street was also built. The frontage of this building, shown in one of the accompanying illustrations, is slightly over fifty feet. The present addition, also fronting on Forty-first Street, adjoins the older extension to the west. The front façade of the new building is designed to conform with that of the older extension. Practically the only variation in exterior design occurs in the two lower stories, and this is due to the centrally located entrance. After completion of the addition, these two buildings will in reality comprise a single structure with a 100 ft. frontage on Forty-first street.

In the first floor of the Bush Addition, which occupies a ground area of approximately 50 by 100 feet, there will be located an auditorium having a clear height of 24 feet. To either side and just within the central entrance from the street are stairs leading to a balcony. This balcony projects some 25 feet from the inside face of the front wall, and is supported by cantilever brackets connected to steel beams framed between the side walls

and two intermediate steel columns, on a line parallel with the front wall and 10 feet inside. These beams and columns are on line with a cross partition below the balcony which separates the balcony stairs from the auditorium proper. At the rear of the auditorium there will be a raised platform, but this has not been designed for the handling of scenery and can hardly be classed as a stage. A permanent fireproof motion picture booth is provided at the rear of the balcony.

No interior columns extend below into the auditorium. The method of supporting the floors above the auditorium and also the interior columns is as follows:

At the fourth floor level four double cross plate girders A, B, C and D span from wall to wall, framing between wall columns 5 and 8, 9 and 12, 13 and 16, and 17 and 20, as shown on the fourth floor framing plan. Each of these cross girders supports two intermediate columns, which terminate at this level. On center with the intermediate interior columns 6, 7, 10, 11, 14, 15, 18 and 19, and connected to the underside of the cross girders, hangers extend below at these points and support the third floor framing, which is directly over the auditorium.

Cross girders B, C and D are six feet deep, each consisting of two 72 in. x $\frac{5}{8}$ in. web plates, eight 6 in. x 6 in. x $\frac{3}{4}$ in. angles, and twelve 14 in. x $\frac{3}{4}$ in. cover plates. Girder A at the rear, which has less load to support, is 5 ft. deep and of lighter section. The story height in the third story is 16 ft. 9 in., thus giving a clear height from finished floor to soffit of girder of approximately 10 ft. The girders are completely encased in concrete, for purposes of fireproofing. The construction described is clearly indicated in the longitudinal section through the auditorium as well as by the framing plan of the

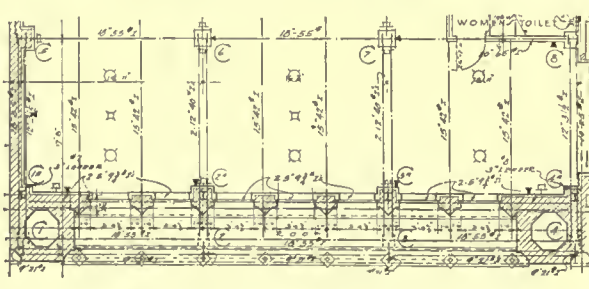
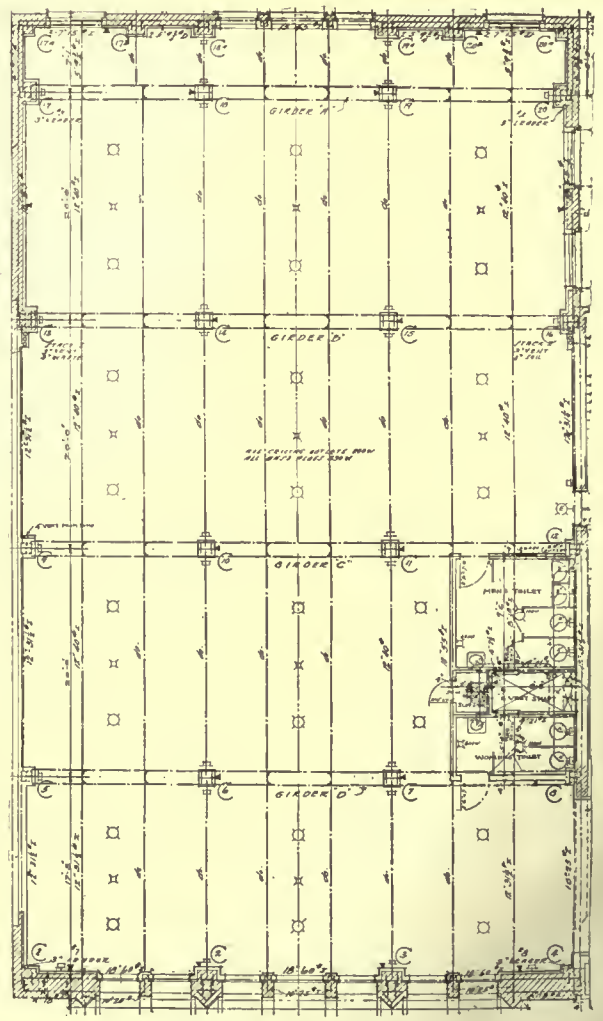
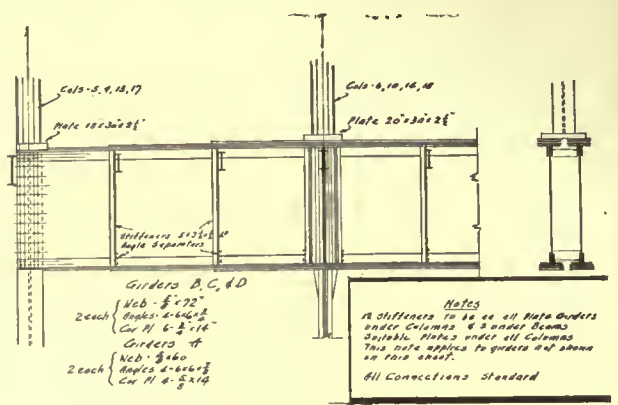
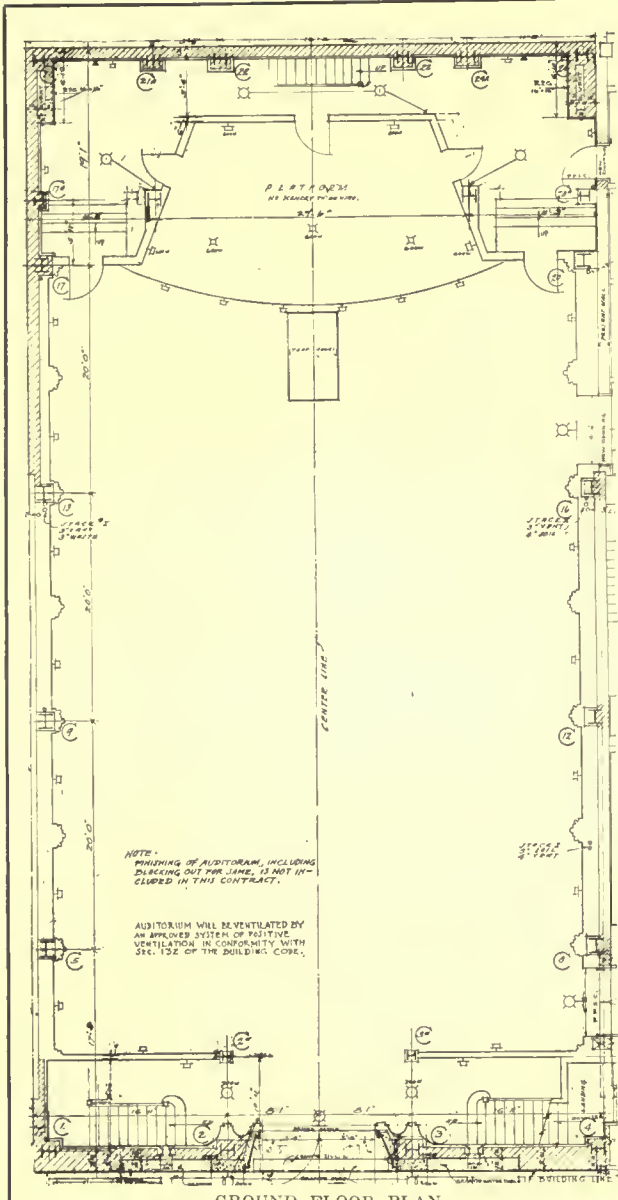

THE BUSH ADDITION, NEW YORK CITY
HELMLE & CORBETT, ARCHITECTS

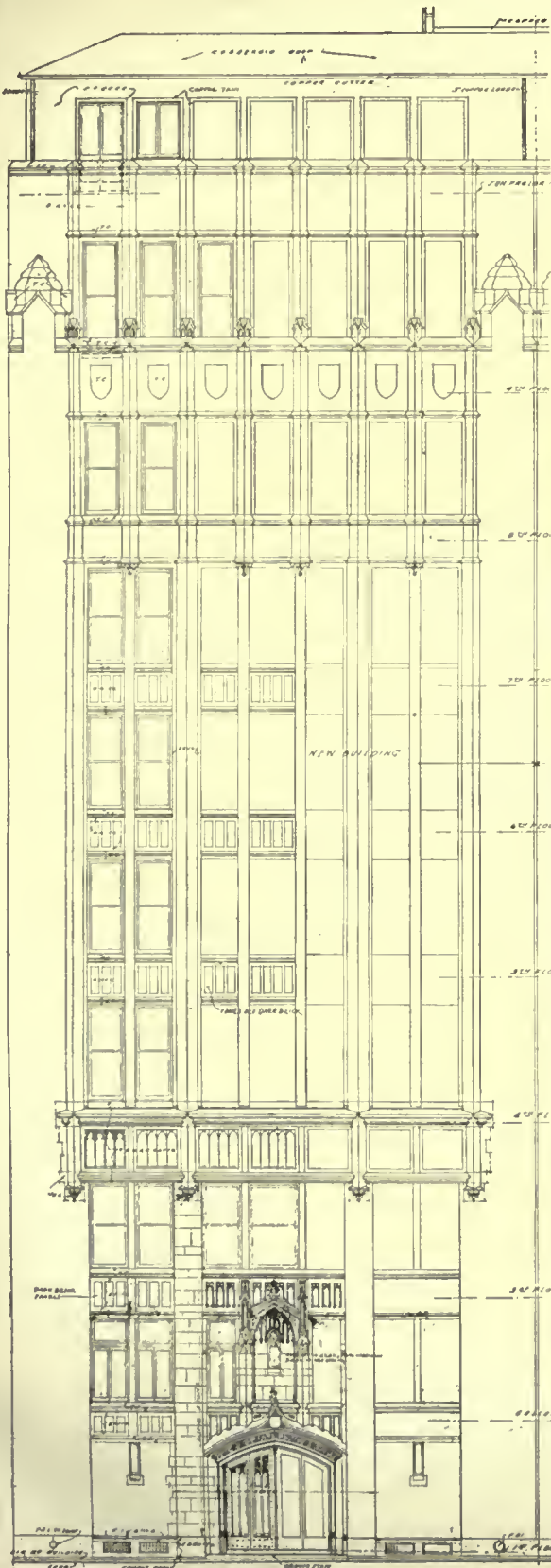

FRONT ELEVATION

Above the fourth floor level the design is identical with adjoining building.

THE BUSH ADDITION, NEW YORK CITY
HELMLE & CORBETT, ARCHITECTS

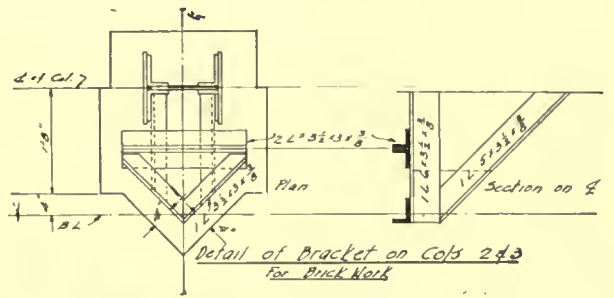

These brackets can be clearly seen in the photograph below.

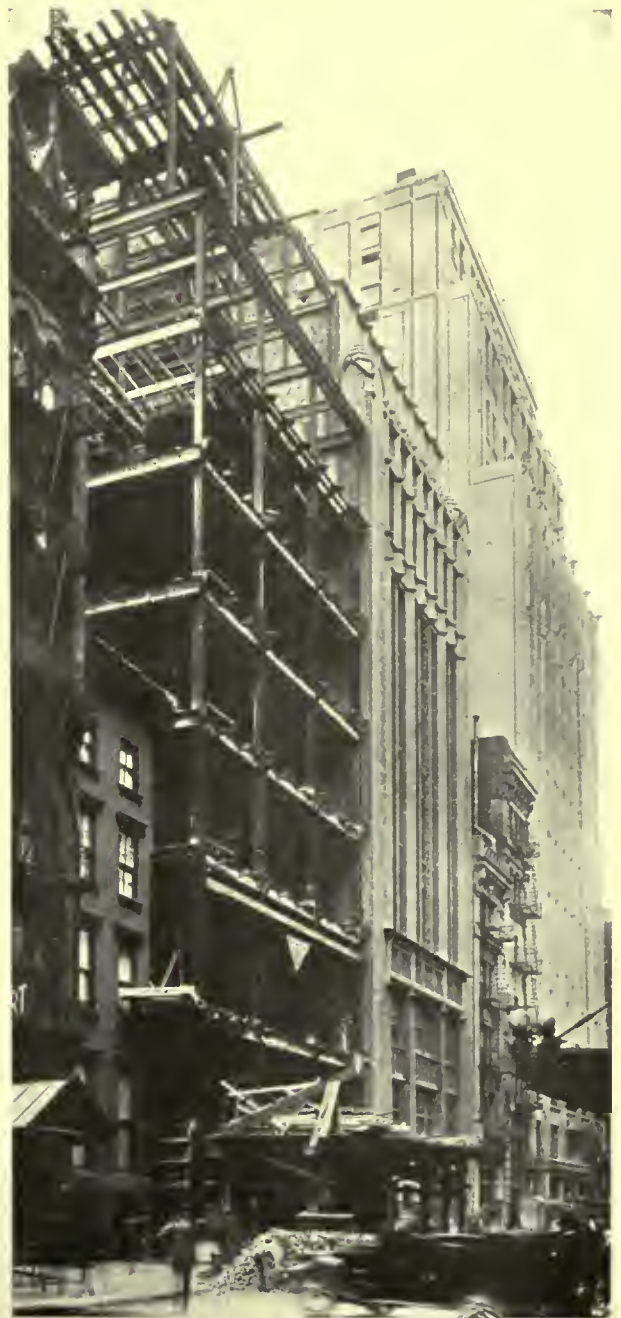

PROGRESS VIEW, OCTOBER 1, 1920

Note conformity in outline with original extension.

fourth floor and the detail of the cross girders. It will be noted that by using the arrangement shown there are no deep projecting girders below the auditorium ceiling.

Another point of interest is the arrangement of the steel framing for carrying the front wall. This wall is carried at each floor, and due to the V shape (in plan) of the masonry encasing front wall columns 2 and 3, above the fourth floor level, special construction was necessary properly to support the brickwork. A detail drawing of this construction is shown, which can also be seen in the photograph of the completed steelwork.

At each story a double bracket consisting of steel

columns 2A and 3A which extend two stories above this level. This framing is shown in the portion of the ninth floor framing plan reproduced.

No stairways or elevator shafts are being provided in the addition, a connection being made with the adjoining building in each story, so that the stairs and elevators of that building will provide service for both structures. A vent shaft 3 ft. 8 in. by 8 ft. 8 in. extends from the third floor to the roof and ventilates the toilets on each floor.

The Bush Terminal Sales Building, of which the new addition, when completed, will form a part, is unique in New York City. It is a Mecca for buyers of merchandise, both domestic and foreign. Here

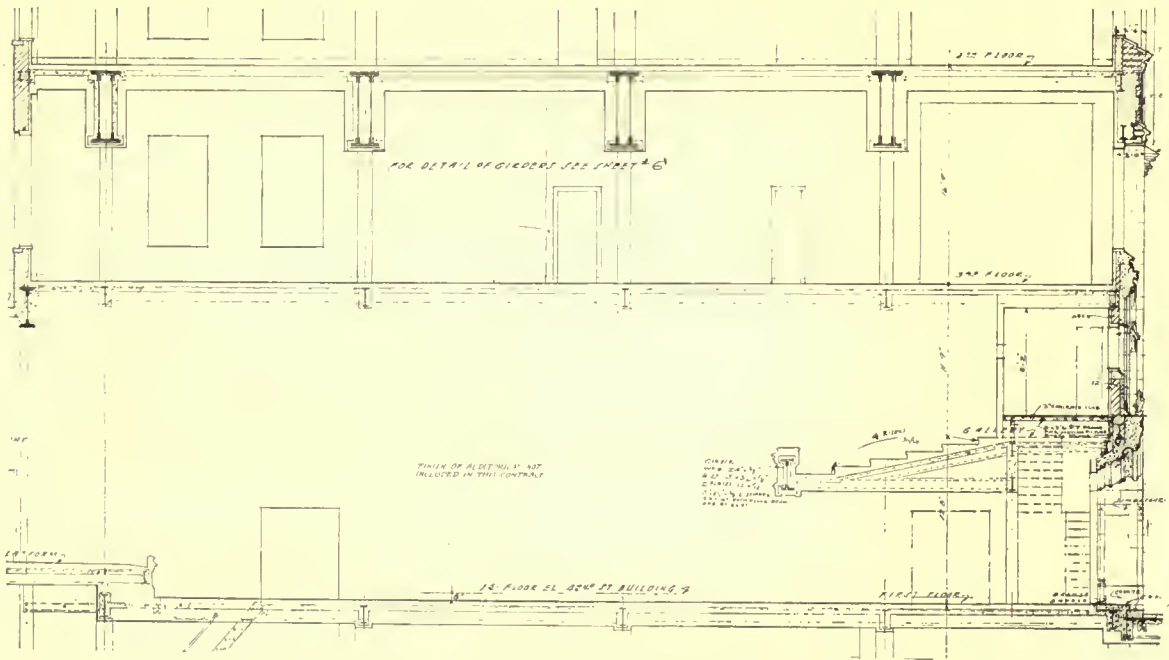

LONGITUDINAL SECTION THROUGH AUDITORIUM

Note location of double plate girders at fourth floor. Hangers from these girders support framing directly over Auditorium.

angles is connected to the column, supporting a triangular framework of angles on which the brickwork is built.

On line with the front wall columns centers heavy I-beams are framed, supporting the floor beams and wall. In each of the three front wall bays, and on line with the floor beams, short pieces of 10 in. I-beams connected as cantilevers, project beyond the cross girder and support the small brick piers between the windows.

Above the ninth floor the front wall sets back, conforming with the existing extension. At this level two 12 in. 40 lb. I-beams, frame between columns 2 and 6, and 3 and 7, supporting the offset

almost a thousand firms manufacturing various lines of goods have their sales rooms and displays. Thus by congregating the various displays, the buyers, instead of wasting much time traveling from place to place, may inspect in one building samples of the many lines in which they may be interested. Buyers from the far corners of the earth meet in this building as a central point to transact business totaling many millions of dollars annually.

The building includes a library of books relating to manufactured products, as well as a clubroom and restaurant. It is, in fact a building for permanent exhibitions on public display and a headquarters for visiting buyers. Merchants or their representa-

tives may view with critical comparison the samples displayed by many manufacturers whose plants are widely separated as to location.

The new addition will bring added facilities to

this sales institution, as will also its auditorium.

The addition was designed by Helmle and Corbett, architects for the original structure. It is being built by the Thompson-Starrett Company.

Novel Method in Foundation Work Proves Economical

Excavation Carried Below Water Level for Ambassador Hotel Annex, Atlantic City, N. J., Without Use of Compressed Air

IN the issue of Sept. 8, the Annex to the Ambassador Hotel, Atlantic City, N. J., designed by Warren and Wetmore, architects, was described and illustrated. In the present article, the unique method adopted in constructing the foundations and carrying on of the excavation will be set forth.

Those familiar with building at seaside resorts will appreciate the difficulty encountered in such foundation work when heavy loads are to be carried. The construction of deep basements is made extremely costly, and in some cases becomes prac-

tically impossible. These conditions have led to their general elimination under such conditions.

Up to certain limits of load, wood piles can be used for the foundations, but as for permanence these should be constantly wet, their tops must be kept but little above the low water level. This means excavation below high water level involving additional and costly excavation. Concrete piles have been used to advantage and may carry considerably heavier loads than wood piles when driven to practical refusal.



EXCAVATION IN PROGRESS, AMBASSADOR HOTEL ANNEX, ATLANTIC CITY, N. J.
This photograph was taken December 15, 1919. The tops of the well points and connecting pipe line used to drain the excavation are plainly visible.



GENERAL VIEW OF THE SITE DURING CONSTRUCTION OF FOUNDATIONS

This photograph was taken one month after that shown on the preceding page. Note the excellent progress.



WALL FOOTINGS IN PLACE. SETTING FORMS FOR CONCRETE BASEMENT WALLS

The system of sub-surface drainage was kept in operation until after the installation of the basement floor.

AMBASSADOR HOTEL ANNEX, ATLANTIC CITY, N. J.

WARREN & WETMORE, ARCHITECTS

THE AMERICAN ARCHITECT

Atlantic City, N. J., the most famous of our Atlantic seaside resorts, rests upon a bed of fine, compact, white sand, only a few feet above high water. This sand is subject to erosion from the action of the waves. Basements, therefore, when built, are shallow, and it is necessary to protect the beach end of all foundations with a relatively deep structure. Piles jettied into place have been used almost entirely to meet the latter condition.

It is, therefore, of interest to learn that a novel and more economical method was successfully adopted in the construction of the Annex to the Ambassador Hotel at Atlantic City. It is quite possible

“Part of the basement of the Annex extended about 12 feet below the mean high water, and the footings extended 4 feet beyond this depth, making it necessary to adopt some other way of taking care of the water than by open pumping.

“Messrs. James Ferry & Son of Atlantic City, suggested to us that they could take care of these conditions by a method they had used some time previously in constructing a deep sewer and the contract was let to them for the foundation work. Briefly, this method consisted of driving well points about 2 or 3 feet apart all around the lot and connecting the tops with a horizontal run of pipe which



ONE MONTH LATER—FOUNDATIONS COMPLETED AND STEEL WORK WELL UNDER WAY

that this method may find extended use where similar conditions exist. Mr. George Simpson, Chief Engineer of the Thompson-Starrett Company, builders of this structure, in describing the method of procedure, said:

“The Annex to the Ambassador Hotel is back from the beach about 300 feet and is protected from erosion by the old building. For this reason it was thought safe to use spread footings, and tests were made which showed that the sand in its natural bed would stand six tons per square foot without dangerous settlement. Three tons were used as the safe working load in the design of the footings.

in turn was attached to a pump. The well points were made of 1½ inch pipe with a strainer at the bottom to prevent the sand from entering them, and were driven 2 or 3 inches below the level of the proposed excavation.

“The sand is so fine and compact that water does not run through it freely and the water in the soil was soon lowered by the pump to the desired level, and all excavation was done in dry firm sand that stood up straight without any sheet piling. Even during a bad storm and extremely high tide which occurred while excavation was in progress, there was no difficulty in taking care of the water. Pumping

was continued during the installation of the foundations and basement floor.

"We believe that the foundations as built will be less subject to a settlement than a pile foundation would be, because it is on firm, undisturbed ground. If piles had been used they would have had to be jetted in, thereby disturbing the ground upon which they depend for support."

The accompanying illustrations clearly show the arrangement of these drainage pipes and the construction of the foundations. The foundation walls are of concrete; the forms were placed as soon as the excavation had reached the required level, and the concrete poured.

Slate Industry Improved in 1919

The value of the slate sold in the United States in 1919, according to a statement made public by the United States Geological Survey, Department of the Interior, was \$5,065,000. This value represents an increase of 26 per cent. over the value for 1918 but does not equal the value for 1917, which was \$5,749,966.

ROOFING SLATE.

The output of roofing slate, which represents more than half the total value, was 475,000 squares, valued at \$3,040,000 an increase of 25 per cent. in quantity and of 30 per cent. in value over that in 1918, which was 379,817 squares, valued at \$2,219,131. The average price per square increased 56 cents—from \$5.84 in 1918 to \$6.40 in 1919—although several firms reported an increase of \$1 a square or more. The demand for roofing slate, which was poor during the first six months of the year, increased later, and notwithstanding the difficulty of obtaining labor the output of nearly all the quarries showed an increase. The roofing-slate quarries in Pennsylvania, which furnish most of the slate sold for roofing, showed an increase of about 30 per cent. in quantity and 40 per cent. in value. Virginia and Maryland also showed a considerable increase in 1919. The reports from Vermont were less favorable, indicating a gain of not more than 10 per cent.

Work of the National Lime Association

Announcement is made by the National Lime Association, Washington, D. C., that it has just issued a new pamphlet entitled "Who We Are—What We Do," its purpose being to acquaint the

public with the scope, functions and aims of the association.

The association has also made a final report on the corrosion tests which it is conducting to determine whether or not the presence of lime in mortars and other building materials prevents the corrosion of metal lath used as reinforcement. Slabs were made of various materials employed in building operations both without lime and with varying quantities of lime in which polished steel rods were imbedded. In one series of tests, these slabs were cured for different periods in air only, while in duplicate series they were dipped at regular periods in water for five-minute intervals. Some of the results of these tests are given.

Both the pamphlet and the final report are obtainable, upon request, from the National Lime Association, Washington, D. C.

Construction Materials and Machinery in Brazil

Under the above title the Department of Commerce has issued a 96-page booklet, extensively illustrated, which clearly outlines the conditions of the building materials markets in Brazil. It treats fully of the general topography of the country, its economic aspects, labor conditions, fuel and water power, architecture and construction and many other points of interest and value. The particular building materials and equipment used in Brazil are given, supplemented with data telling under what conditions and in what sections of the country they are employed. Apparently this information is included to show the possibilities of the construction materials markets.

Because of its immense resources and vast amount of undeveloped territory, Brazil offers a splendid market for all kinds of building materials and machinery not only in the immediate future, but for an indefinite time to come. Prior to the Great War, Europe supplied Brazil, to a large extent, with this class of goods. However, after the outbreak of the war, the United States superseded Europe in this respect, and sent materials to Brazil as well as other South American countries. Very soon, however, importations on all classes of goods showed a decided slump, domestic manufacture in many lines being the cause of this condition.

Copies of this booklet may be obtained upon request from the Superintendent of Documents, Government Printing Office, Washington, D. C., the price being 15 cents.

Current News

Happenings and Comments in the Field of Architecture and the Allied Arts

The Editor, THE AMERICAN ARCHITECT:

In a very admirable editorial in *THE AMERICAN ARCHITECT* for September 29, entitled "A Case in Point," after condemning very properly and adequately the reported action of the parish authorities of Grace Church, Chicago, in employing a firm of structural engineers as their architects, you make a reference to St. Thomas' Church, which must be corrected in the interest of professional and historical accuracy. You say, in speaking of St. Thomas Church, "the present structure as created by Mr. Goodhue, is one of the architectural beauties of New York."

St. Thomas' Church was not "created by Mr. Goodhue." It was the work of the firm of Cram, Goodhue & Ferguson. It has always been known as the work of the firm, and always must be known in this sense. There have been many cases during the lifetime of the firm in which one building or another would be designed by either Mr. Cram or Mr. Goodhue, acting more or less independently. St. Thomas Church does not come in this category. While the firm maintained offices both in Boston and in New York, certain buildings were published as the work of "Cram, Goodhue & Ferguson (Boston Office)," or "Cram, Goodhue & Ferguson (New York Office)." Neither St. Thomas' Church nor the work at West Point was ever so known, and it must not be so known in the future. St. Thomas' Church was par excellence the building where Mr. Cram, Mr. Goodhue and Mr. Ferguson worked together most intimately. It represents the united efforts of the three members of the firm, and any attribution of the building to one member or another is false in fact and unjust in principle.

Boston, Mass.

CRAM & FERGUSON.

Boston Society Exhibition

The next joint exhibition of the Boston Society of Architects will be held during January, 1921.

It must be a creditable exhibition and one which will accomplish its purpose; namely the stimulation of public interest in architecture.

To be the exhibition it is desired to be, it must contain the best work of the architects and designers, properly presented in an interesting way.

This year's committee desires and urges the members of the society to bear this exhibition in mind dur-

ing the next three months and to endeavor to prepare interesting exhibition drawings in connection with their regular work.

The public is attracted by sketches, models, well presented photographs, proposed architectural schemes of a public nature, but insists upon good presentation.

The committee hopes that it will be possible to group the exhibits in a definite, satisfactory way and urges the architects to consider their selection of drawings with this in view. Further information is obtainable from William G. Perry.

Illinois Society Has Planned Interesting Subjects for Monthly Meetings

The Illinois Society of Architects has completed its calendar of meetings for the remainder of 1920 and for the first six months of 1921. They are to be held on the fourth Tuesday of each month at 6 o'clock in the Art Institute, Chicago, Ill. Dinner is served at 6:30 o'clock on the evenings of the meetings. They are scheduled as follows:

October 26, 1920: "Horrible Examples and New Stunts." Ten minute talks by a number of well-known architects with illustrations of common mistakes in detailing—and advice in reference to new ideas in construction. General discussion.

November 23, 1920: "Legal Mistakes Common to Architects." A thirty minute talk by a well-known attorney, covering information and advice on legal matters of interest to architects—followed by a general discussion of the subject.

January 25, 1921: "Shall the Illinois License Law Be Revised to Provide Five Years' Actual Experience in Addition to Present Requirements as a Prerequisite to Filing an Application for Examination for Registration?" Thirty minute talk by a well-known architect. General discussion.

February 22, 1921: "Methods of Estimating Cost of Buildings." Area—How figured? Cubic or square foot basis?

Short talks by a number of well-known architects, with cost data from their practice—and general discussion.

March 22, 1921: "Office Practice and Business Methods." A discussion of means and methods by which an architect can run his office and carry on his business in such a way as to give an owner efficient

service and win the respect of clients who are pre-eminently business men.

Ten minute talks by a number of prominent architects and general discussion.

April 26, 1921: Ladies' Night. Program to be determined later.

May 24, 1921: "Mechanical and Structural Engineering as Applied to the Average Architect's Practice."

Methods of handling:

- (a) Through contractors.
- (b) By consulting engineers.
- (c) Advisability of organizing a service bureau to provide such service to architects.

Ten minute talks by three well-known architects. General discussion.

The general business of the society will be transacted at each meeting in addition to the matters listed above. The committee in charge of the entertainment includes: Robert C. Ostergrenn, chairman; John A. Armstrong, Albert P. Dippold, Ralph W. Ermeling and H. L. Palmer.

Registration Boards Hold Formal Meeting

The first formal meeting of the National Council of Architectural Registration Boards will be held in St. Louis, Mo., Nov. 18 and 19. All architectural or licensing departments, boards or committees throughout the country are invited and urgently requested to send representatives to this meeting.

While membership in the council is restricted to the legally appointed representatives of the registration or licensing authorities of states having registration or licensing laws, the Council would be glad to welcome the attendants at the council meeting of architects from states having no registration or licensing laws.

Legislative committees from states having laws pending will find the proceedings of the council very helpful and instructive. Among the papers to be presented will be a report of a committee appointed at the Washington conference to make a careful, analytical, comparative study of the various registration laws now in force in the various states. Efforts will be made to harmonize these requirements so as to make easy reciprocal transfer from state to state and thereby facilitate interstate practice.

A desirable out-growth of the conference will be the formation of some sort of clearing house of information with reference to the records of architects asking extension of registration from one state to another. It is hoped that the council may be able to recommend a uniform law, which may be adopted by the various states.

Committees and registration officials are urged to make arrangements for representation at the earliest possible date and notify the secretary of the council, furnishing the names and credentials of their official representatives.

Open Fires

Experiments conducted by Dr. Margaret Fishenden for the Manchester Corporation Air Pollution Advisory Board, England, with the assistance of grants from the Department of Scientific and Industrial Research, are said to prove that open fires are neither as wasteful nor inefficient as has been generally supposed, because the extent to which neighboring rooms are warmed by a fire placed in an internal wall has been generally overlooked. As a result of experiment it was found that the supposed difference in radiant efficiency between different kinds of grates was practically non-existent. The loss of heat occasioned by placing fireplaces on an outside wall is stated to be as high as 25 per cent. in many cases, and as a result of investigation it is considered that the greatest amount of heat-saving is to be sought in the proper regulation of the draught, as radiant efficiency is independent of the amount and character of the draught.

Plan Zone System for Camden

Preliminary steps will soon be taken toward building a zoning plan system for the city of Camden, N. J. George B. Ford has been recommended for this work by the New York Real Estate Board.

In brief, Mr. Ford's plan is that the city should be distributed into sections; i. e., one for residential purposes exclusively, one for factories exclusively, and one for business districts exclusively. Under the plan no other use could be put to the particular district mapped out. It is the same plan which is already effective in New York City.

Washington, D. C., Still Feels Building Pinch

According to reports from Washington, D. C., that city never was in a worse way for homes. There is a widespread effort to get apartments and homes. Never were there so many tenants put to the discomfort of moving and seeking new locations at one time.

Real estate men want to go ahead with building operations, but the stringency in money during the past few months has prevented much of the construction work.

News From Various Sources

The largest base-ball park in the world is proposed for New York City. Three sites near the center of the city are being considered. Tentative plans call for grandstands and bleachers capable of seating from 50,000 to 60,000 persons. No further details available.

* * *

On the roof of the Fairmount Hotel in San Francisco, a school has been established so that it is not necessary for the children to leave the hotel at any time and subject themselves to the danger of passing traffic in the street.

* * *

The Federal Reserve Board in its latest reports states that there is "an important downward tendency" in prices of all commodities, excepting food, in all parts of the country. The Board also said there had been a "pronounced checking" of speculation.

Personals

Frank V. Prather has moved from 38 South Dearborn St., Chicago, to 714 South Wabash Ave., where he will practice on his own account.

S. L. Hyman has moved from the Crocker Bldg. to the Foxcroft Bldg., San Francisco.

C. C. Rittenhouse is now located in Room 317, Wilcox Bldg., Los Angeles.

G. Tandy Smith, Jr., has recently opened an office at 201 True Heart Bldg., Paducah, Ky.

A firm has been incorporated under the name of Maritz, Henderson & Young, with offices in the Chemical Bldg., St. Louis, Mo.

Jos. Stasny, Jr., has opened an office for architectural practice at 432 West Main St., Pittsburgh, Pa., care of Ried & Kunkle Co.

Ford Witt, architect, formerly located at 569 Fifth Ave., New York City, is now with R. J. Rucker and P. J. Murray, 6 East Forty-sixth St., that city.

W. J. Fletron, architect, formerly of 24 Stone St., New York City, has gone out of business.

S. N. Polis, architect, formerly with Deutsch & Polis, is now practicing alone at 81 Broad St., New York City.

Huse T. Blanchard, architect, formerly located at 597 Fifth Ave., New York, has gone out of business.

Thomas J. Herron, architect, formerly in the Publication Bldg., Pittsburgh, Pa., is now located at 1012 Fordham St., that city.

Franklin M. Small, architect, is now practicing at 407 Broadway, New York City. He was formerly located at 265 Broadway.

N. I. Crandall, architect, 55 Hansom Pl., Brooklyn, N. Y., has recently moved from 507 Fifth Ave., New York City.

Sternier & Wolffe, architects, have moved from 569 Fifth Ave., New York City, to 9 East Forty-eighth St., that city.

Zink & Sparklin, Inc., and Alexander Deserty, associated architects, with offices in the Munsey Building, Washington, D. C., have recently established a branch office at 110 West Twenty-fourth street, New York City. This firm specializes in the design of theatrical projects.

Warren & Wetmore, architects of New York City, have purchased the entire thirty-first floor and more than half of the thirtieth floor, approximately 15,000 square feet, in the thirty-one story Park-Madison Building in New York.

Clare C. Hosmer, architect, formerly of 53 W. Jackson boulevard, Chicago, will move his offices to 133 W. Washington St. in the near future.

Harold Holmes, architect, is now located in his new studio building, 151 East Chicago Ave., Chicago.

Bontempo & Howard, architects and structural engineers, have moved their offices to 382 Franklin avenue, Woodlawn, Pa. The firm was formerly operated under the name of Jos. F. Bontempo.

Amos W. Barns, architect, 1507 Arch street, Philadelphia, Pa., announces the removal of his office to 10 S. Eighteenth street, that city.

George S. Hughes, architect, has opened an office at 223 West Franklin street, Baltimore, Md.

Joseph J. Breitman has opened an office at 1777 Broadway, New York. He also has an office at 16 Speedway avenue, Newark, N. J.

Harry M. Pedrick and Mr. Creighton of Darby, Pa., have consolidated under the name of Pedrick & Creighton and have offices in the Post Office Building, Darby, Pa.

Weekly Review of the Construction Field

With Reports of Special Correspondents in Prominent Regional Centers

THE sharp public demand has undoubtedly caused manufacturers of building material to abandon their position as to the maintaining of high prices, and commodities are now marked down to price levels to stimulate a demand and to enable the manufacturer of building material to keep up production and to insure the distribution of goods so produced. The effect of this overtaking of demand by supply, states the Monthly Review of the Federal Reserve Bank, has been to re-establish competition in one industry after another, that is, competition between sellers, which during the war had given way to competition between buyers without the inevitable increase in prices and credit volume implied in such a condition.

Natural forces are now again asserting themselves and prices in future will develop from natural causes rather than as an accompaniment of the constant creation of new purchasing power set in motion by the necessity of conducting the war on a basis more extensive than current saving could finance. Competition, when it is once more generally re-established, will determine the level at which prices will finally become stabilized, and the return of competition will assure our gradual but eventual return to more healthy business conditions and living costs.

As whatever goes up must ultimately come down, as credit and prices went up together they logically should come down together.

On the one hand increasing inventories which result from slowly moving stocks, and on the other cancelled orders and poor collections produce a demand for credit not unlike that of last spring when the railway and ocean freight movements were temporarily congested. Such a period calls for a credit policy on the part of the banks looking to conservation of sound business. Such additional credits as are required are not for further expansion but are for the protection of industry. They are to enable business men to undertake in an orderly manner the reduction of inventories and the descent to lower price levels.

The bulk of new building going on in September in New York City, according to statements received from three of the largest builders is on contracts executed last spring or late in the winter. Some projects, contemplated from the time the war started, are now being put into contract form, but they are comparatively limited. It appears that building at prevailing prices has reached or already passed its peak. Brick delivered at docks in New York City

very recently declined from \$25 to \$17 a thousand, but are still about three times pre-war cost. There has also been a slight decline in structural steel, which is attributable to a fall not in prices at the mills but in the prices charged by fabricators and erectors.

According to the figures recently compiled for August, 1,025 contracts for buildings of all classes were awarded in New York State and northern New Jersey, the valuation of which was \$38,500,000. Comparable figures for July were 880 contracts amounting to \$36,000,000. The number of contracts awarded for residence buildings in this district increased from 425 in July to 496 in August, and their value from \$8,320,400 to \$12,800,300.

Commenting on the efficiency of labor, the National Reserve Bank's Monthly Review for September states:

A change for the better appears to have taken place in the efficiency of labor, as shown by answers to an inquiry made by this bank from thirty-one of the largest corporations in the country. In all cases except nine improvement is reported. None of the concerns reported any decrease in efficiency; five reported that there was no change one way or the other and four were unable to draw conclusions from any data at hand. In some cases where comparisons are made with pre-war standards the efficiency is said to be lower, but in three instances individual efficiency is said to be higher than ever before.

In certain industries where a great number of operations go to make up a single finished product, and particularly when the finished product of a corporation is widely diversified, it is difficult to secure an exact statement in figures of the percentage of increase in efficiency. But it is felt that sufficient figures have been received to confirm the opinions expressed in the other answers. In a number of industries improved methods and more highly developed labor-saving machinery have tended to increase the individual efficiency of workers without necessarily implying increased willingness to work or increased individual performance. In fact figures rarely convey without explanation an intelligible idea of any change in labor efficiency. At one plant of a large chemical corporation, for instance, the cost of common labor per ton decreased from 95 cents an hour in January to 45 cents an hour in July. At another plant of the same corporation the corresponding figures rose in about the same proportion, the explanation being that at the latter plant re-

handling was necessary because of difficulty in securing railroad cars at that time.

General expressions reflect more faithfully the change in labor efficiency. A plant of one of the large steel corporations reports that its product has increased 6 per cent., with substantially the same payroll. Two clothing factories at Rochester report that individual efficiency has increased 7 or 8 per cent., which nearly offsets a decrease in the working week from 48 to 44 hours—a result ascribed to the installation of scientific management. Other large concerns report variously that there has been an increase in efficiency varying from 10 to 17 per cent. over a year ago.

This change is attributed to various causes. Among them is an increase in the number of men looking for work over previous months this year. In a number of industries the turnover among the employees has decidedly lessened. One plant reports a decrease of 40 per cent., others 17 to 10 per cent., with the inference that men are tending to remain at their work long enough to become accustomed to it. A majority of the answers indicated an improved morale on the part of the workers.

In the matter of railroad transportation there is a gradual and very marked improvement in conditions and it is believed that now that the roads are back in the hands of their owners, this betterment will continue to a point where normality will again be reached. Beginning with the first of June the amount of tonnage handled by the various railroad companies has created a record. Modifications of the various embargoes that have permitted an accelerated flow of cars into the terminals and switching points and this has resulted in relieving a congestion which during midsummer proved a very serious obstruction to the free movement of building material. Railroad managers report that there has been a gain in efficiency on the part of workers and while there is still some interference from striking employees the general transportation situation may be said to be coming along more satisfactorily every day.

The question of mortgage money and its availability for new construction will not down. In some quarters the majority of our present ills are based on this question and in a statement made by Frank J. Parson, vice-president of the United States Mortgage and Trust Co., he says:

"No adequate amount of building can be looked for until it is recognized that mortgage money is entitled to a higher rate of interest than borrowers are now willing to pay."

Continuing, Mr. Parson says: "Viewing the situation throughout the country as a whole, the shortage of money for mortgage purposes is more apparent than real. The fact is that mortgage money, by reason of taxation and other factors, is entitled to

a higher rate than previously, and in part, it is the slowness of borrowers to appreciate this fact, which is causing much of the difficulty. Money is a commodity and is bound to seek the highest return consistent with safety. No artificial means, either legislative or otherwise, can permanently, or to any large extent, circumvent this law.

"Whenever investments in mortgages are discouraged by unsatisfactory yield or restrictive laws, it is quite idle, so far as any large practical results are concerned, to attempt to force into that channel the funds of the people as represented by life insurance moneys, building and loan association investments, savings bank deposits, etc.

"The difficulties as to housing have been increased the past year, as the bulk of new construction has consisted of factories, warehouses and garages, together with theatres, clubs and other special improvements which not only give no help in the matter of housing, but actually increase the shortage by making possible a further concentration of population.

The mortgage situation as an essential part of building construction must improve. The most hopeful sign is that the construction of workmen's cottages and homes of the smaller type is on the increase. At the present time, speaking generally, there is no substantial shortage of labor, nor of raw material used in building construction. It is mainly a question of confidence and an adequate return to capital."

The New England correspondent of THE AMERICAN ARCHITECT in discussing the present conditions in his territory states:

Mr. Frederic H. Curtiss, chairman of the directors of the Federal Reserve Bank says that he finds manufacturers, wholesalers and retailers in New England cautious and inclined to safeguard themselves against overstocking. The demand for luxuries has dropped noticeably. Attached is Mr. Curtiss' business review in more detail.

Statistics of building and engineering operations in New England show that contracts awarded from Jan. 1 to Sept. 30, 1920, amounted to \$256,129,000 and compared to \$155,361,000 for a corresponding period in 1919; \$127,185,000 in 1918; \$155,992,000 in 1917; \$155,177,000 in 1916 and \$132,418,000 in 1915.

The Massachusetts list of new corporations chartered during the past week comprises twenty-seven, including one with a capitalization of \$5,000,000, another of \$600,000 and a third of \$500,000.

Reports indicate that although building operations as a whole continue upon a restricted basis, industrial building has not decreased and the construction of small homes is increasing. This, coming as it does, from the smaller communities, as a rule, has not

begun to show in state reports or in building permit statistics. Real estate transfers during the last days of September were unusually brisk.

SEATTLE.—Architects, jobbers and contractors in the North Pacific Coast territory are looking hopefully and confidently to the spring for a return to normal conditions in building as a result of increased enquiry among architects for plans for jobs for the new year, many of which will be of large proportions. The decline in prices of many other commodities seems to have been the vitalizing factor required to rouse investors, for architects report that they have started more new projects than at any time in approximately a year. In this statement architects are borne out further in reports of jobbers who daily make the rounds of the architects offices. The story seems to be uniformly that courage has returned and investors do not longer feel that scarcity of materials or price recessions will render building ventures hazardous.

New projects to the end of the year are expected to be held to the minimum. In all sources the report is similar that there are no big jobs under contemplation in the territory. It is felt that little relief can be expected in the supply of plumbing supplies and nails, and that the winter lull in building will give manufacturers an opportunity to "catch up" and accumulate desirable sizes in readiness for spring delivery.

The light supply of small galvanized pipe is discouraging investors who are trying to complete before winter sets in. In order to circle the slow rail delivery Pacific Coast jobbers are using the coastwise water route from Pittsburg to Puget Sound on a rate of \$1.49 combination rail and water against \$1.69 all-rail. This highway is being used extensively in pipe, sheets and plates, and delivery is made from the date of sailing in 60 days. Pacific coast enamelware and earthenware plants of California have been taking care of the coast demand, production having been increased to fair proportions.

The nail situation is easier, with more delivery, although 6 and 8 penny common and 3-penny fine blued shingle nails are practically off the market.

The cement supply is steadily decreasing. Warehouses of the coast are empty. Scarcity is attributed both to low production and inadequate car supply. Prices are \$4.13 warehouse basis in straight cars. \$4.70 in l. c. 1. Scarcity of plaster is similar to that of cement. Metal lath is plentiful but wire is almost unobtainable. Wood lath prices are steady at \$7.50, but the quality has heightened sharply during the past 30 days. There is plenty of fire, common and face brick.

North Coast jobbing houses who have been endeavoring to place a ship charter for importing a cargo of Scotch fire brick have temporarily abandoned the plan on representations of manufacturers at Troy, Idaho, from which the bulk of the coast demand is being supplied. These companies are conducting experiments in the mix whereby they will use one standard for heat and another for abrasion, and hope to be able to produce a brick that will stand the heat required in a cupola smelter. The Northern Pacific railway system is using the Troy brick for linings for its locomotive fire boxes, which indicates to jobbers that it will suffice for commercial purposes in building. Some doubt is expressed whether Troy can put it on the market at a workable price for completing.

It is evident to architects and builders, although not yet clearly indicated, that the Stone-Webster interests known here as the Metropolitan Building Co. and the Puget Sound Light and Power Co. plans to utilize more of the ground leased from the state in the heart of the city next year for construction of office buildings. The officials of the Metropolitan Co. have stated that Seattle is two to three years behind in its office building equipment, and have indicated that if they can be assured of \$3 per square foot per annum as rentals they would be willing to bring this shortage to normal. This time seems to have arrived. The heavy bond issue of the Power and Light company sold through newspaper advertising carried 8 per cent. interest, and the bonds were sold within a few days after the first offer.

The fir lumber market has fallen perceptibly during the week. Common dimension, which makes up the bulk of production, is now selling freely at the mills in sizes of 2x4, 12-14, at \$20.50 to \$24.50, and wholesalers are able to buy at \$18.50 to \$19.50. Flooring in 1x4, No. 2 vertical grain is \$56, which in May sold at \$74. Ceiling, five-eighths by four No. 2 and better is \$40, which moved at \$58 in May. Drop siding, 1x6, No. 2 and better is at 41, against \$61 in May.

Stocks of fir at the mills are very heavy. Operating costs are stationary, and it is claimed that the cost of producing lumber on an average is \$32 per 1,000 feet. Unsettlement to the end of the year is predicted.

For the first time in many months, red cedar shingles are selling at the same prices, clears and stars at \$3 and \$3.10 per square respectively. Only 65 per cent. of the mills are in operation due to lack of business. West Coast fir mills hold unshipped orders for 5,205 cars for the eastern construction trade. The railroads this week bought 29,000,000 feet for new maintenance and construction.

522

front piece 7 16.23



SEATED STATUE OF LINCOLN BY DANIEL CHESTER FRENCH, SCULPTOR,
IN CENTRAL HALL, LINCOLN MEMORIAL

HENRY BACON, ARCHITECT

(Photograph from model)

THE AMERICAN ARCHITECT

VOL. CXVIII

WEDNESDAY, OCTOBER 27, 1920

NUMBER 2340



LINCOLN MEMORIAL AS IT NOW APPEARS

HENRY BACON, ARCHITECT

The Lincoln Memorial in Washington, D. C.

PART II—THE DESIGN

By GLENN BROWN, F.A.I.A.

THE site selected for the Lincoln Memorial terminating a vista, called for a design of magnitude dominating its immediate surroundings. The quiet river which it overlooked required repose and dignity. Its distant connection with the vertical Washington Monument called for a horizontal treatment in design. The peaceful hills of Virginia in the background, varying from the green of summer to the brown and red of autumn and the gray and white of winter, made most fitting a structure light in tone.

The Memorial must present to the imagination an ideal object that would typify the simplicity, dignity and noble life of Lincoln.

The Park Commission, through Charles F. McKim, suggested in their plans an oblong, open portico with its simple and dignified classic columns and entablature. In the view from the east the hills across the river would have been visible through the columns, thus adding to its charm.

Looking from the Capitol on the axis the Memorial forms an interesting exhedra to the Washington Monument, strongly recalling Robert Mills' design for the Washington Monument with its Pantheon. When seen from the axis line in passing along the eastern roadway to Arlington it appears as an appropriate colonnade at the base of the Washington Monument.

One of the most interesting features of the Mall composition is that it will be seen as a whole from such viewpoints as Arlington and the Anacostia Heights, and probably from Mount Hamilton, where we hope to have an adequate Botanical Garden. To obtain and retain these views is important. To achieve this object the best distant views of the Mall, including the Lincoln Memorial, should be sought and opened up where necessary and never allowed to be destroyed by an overgrowth of trees or careless planting. New structures interfering with such views should not be tolerated, as such vistas are the asset to future generations which we should leave unimpaired. Let this generation develop, cherish and leave them intact for the benefit of those to come after us.

One of the most charming views of the Lincoln Memorial has been most seriously marred by the steel truss railway and highway bridges crossing the Potomac. There would be no more effective view of this structure than the one seen by the thousands who get a first view of it coming into Washington by way of the Potomac. Now these bridges cut across and destroy this most important view. These bridges are not only obnoxious because of the effect on the Lincoln Memorial, but because they nullify one of the most important reasons for placing the White House on its present site, which was the



THE PARK COMMISSION DESIGN FOR A LINCOLN MEMORIAL

FIRST SUGGESTION OF A MEMORIAL ON THE PRESENT SITE BY A COMMITTEE COMPOSED OF CHARLES FOLLEN McKIM, DANIEL H. BURNHAM,
AUGUST SAINT GAUDENS AND FREDERICK LAW OLDMSTED

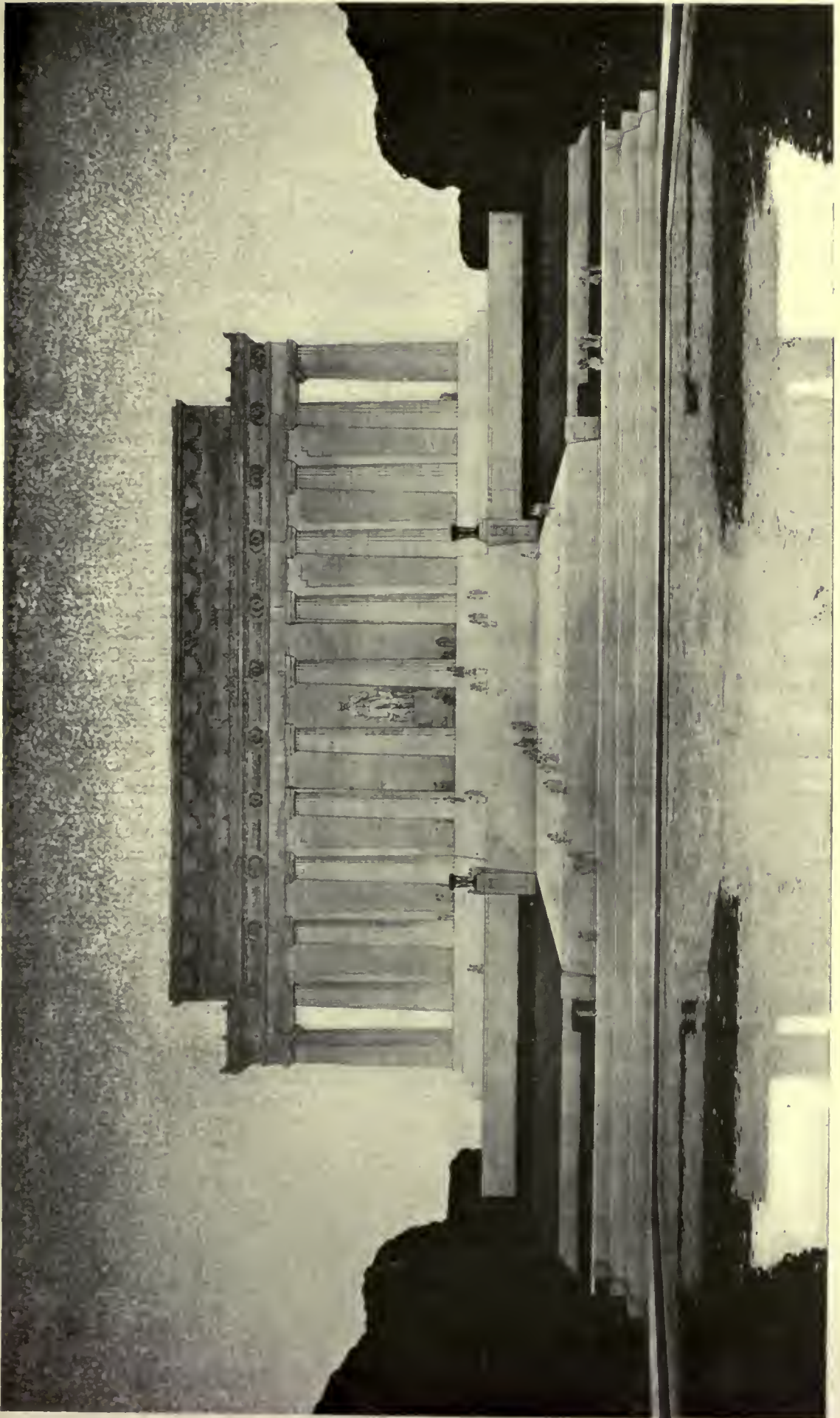

THE LINCOLN MEMORIAL
PRELIMINARY DRAWING FOR THE PRESENT STRUCTURE
HENRY BACON, ARCHITECT

charming view from the south down the Potomac River.

As Secretary of the Institute it had been my custom in showing foreign architects and artists around the Federal City to call their attention to this satisfying view as one of the reasons for the location of the White House.

These bridges were erected quickly. We had no Fine Arts Commission then. I had not been to the White House during their progress. After their completion I had occasion to take a distinguished Japanese architect to the White House. After describing to him what a beautiful view bound it up with the location of the President's residence, I meant to show it to him. I took him out to the south portico; imagine my chagrin when the stiff, long, ugly steel bridges loomed up as the dominant element, destroying what had for a hundred years given pleasure to thousands. I could only apologize for his and my disappointment. It is fortunate that these bridges are steel and will before many years be replaced by concrete or stone. When this happens, let us hope those in authority, officials and the Fine Arts Commission will have vision enough to build them low; a stone or concrete structure would give a good base line to the Memorial when seen from the river. In this connection the planting and growth of planting on the Potomac Park needs great care. Open views of the important elements of the Mall should be carefully preserved in planting and protection from the overgrowth of planting. Unfortunately several of the important views, one from the White House over the bridges is being finally obliterated by the rapid growth of trees along the railway embankment. The same planting is shutting off views from the river of the Lincoln Memorial. In this connection let us get rid of the temporary structures and semi-temporary structures which mar so disastrously the Memorials to Washington and Lincoln and destroy their beauty of design. Let us hope that the power plant with four huge smokestacks

which the authorities proposed to erect almost in the center of the park scheme, permanently destroying its beauty, has been finally if not officially dropped.

Let us not only hope, but keep a perpetual guardianship over these important views from far and near, so that future generations may enjoy the beauties of the design which perpetuates the memory of Lincoln.

In the first article I described the selection of the architect which went with the final selection of the site. Mr. John Russel Pope's design for the site showed a circular portico, forming a massive, simple, open Doric Colonnade which guards but does not conceal a quiet central area and the figure of Lincoln. The colonnade was designed to be sixty feet in height on a raised platform, 40 feet above the Potomac, 320 feet in diameter. Mr. Pope adopted the circular form, as he felt it best fitted in the plan of the Park Commission for a great round point from which various roads and approaches lead. While the Park Commission drawings show the radial character of the site, the most important element in the landscape composition is the rectangular area between the Washington Monument and the Lincoln Memorial. The great Lagoon, 200 feet wide and 1,200 feet long, is bounded by English elms on the north and south and by the future terraces of the Washington Monument on the east and the formal steps of the Lincoln Memorial on the west. McKim evidently felt the need of a structure at right angles to this area as forming its most fitting terminal in making the design for the Park Commission.

The feeling of many that the site called for a circular Memorial shows more strongly on the drawings than it will to any one on the ground. I feel that the view from the Washington Monument, or from any point in

this area, requires a rectangular structure, dominant and at right angles to the principal axis. The memorial with its formal steps will be beautifully reflected in the Lagoon in the varying conditions of sunlight and shadow.



WASHINGTON MONUMENT
AND CAPITOL DOME SEEN
THROUGH NORTH
COLONNADE



WASHINGTON MONUMENT AND LINCOLN MEMORIAL FROM CAPITOL

A charming view marred by war work chimney stacks which should be removed from the Mall

The principal axis, down Twenty-third street, is most fittingly ended by a rectangular memorial.

The radial drive over the future Memorial Bridge to Arlington is the only view in which the diagonal view is unhappy, as the roadway leading to Rock Creek is in no sense a radial but a curved, winding drive. The other smaller radials are tree concealed walks or drives.

The architectural features and the planting in the Mall scheme suggest in all their main lines a rectangular treatment and it is fitting that this one of the principal architectural features should conform to the dominant lines of the composition, rather than to the minor lines shown in the radial one to Arlington and the curved one to Rock Creek Valley.

The Park Commission while probably appreciating this fitness in the landscape of the general form suggested by McKim, in making their decision in favor of the Bacon design, do not mention it in their report of March 23, 1912, but rest their case upon the excessive cost of the Pope design. In this final competition as we may call it, Mr. Bacon submitted

three designs, one for two large terraces supporting a Doric colonnade representing the United States, a great exhedra, surrounding on three sides a colossal bronze figure of Lincoln facing the Capitol. At the ends of the great colonnade were placed tablets on which were inscribed the two great speeches of Lincoln. This design contemplated a colonnade of 100 feet by 200 feet, with 40-foot columns, two great terraces, the total height from the river being 117 feet. The second design showed a succession of terraces on which was placed a Doric peristyle four columns deep, representing the states. In front of this peristyle and facing the Capitol was placed a colossal bronze statue of Lincoln, and inside the peristyle at the ends, between two of the inner columns, were located tablets with quotations from Lincoln's speeches. This design called for a colonnade 50 feet wide and 240 feet long, columns of 40 feet high and a statue 22 feet high. The total height of the structure from the river was shown as 110 feet.

Of the third design, which was accepted, Mr. Bacon says:

"On the great axis, planned over a century ago, we have at one end the Capitol, which is the monu-



VIEW FROM ROAD TO ARLINGTON

Suggests Robert Mills' design for the Washington Monument.

ment of the Government, and to the west, over a mile distant from the Capitol, is the Monument to Washington, one of the founders of the Government. If the Lincoln Memorial is built on this same axis still farther to the west, by the shore of the Potomac, we will there have the monument of the man who saved the Government, thus completing an

Memorial, will make the Potomac Park site readily accessible, as it should be, to all classes.

"The design submitted of the Lincoln Memorial is a development of the designs already submitted by me. The structure has been enlarged, the design of the approaches, terraces and steps has been revised and the front of the Memorial has been made

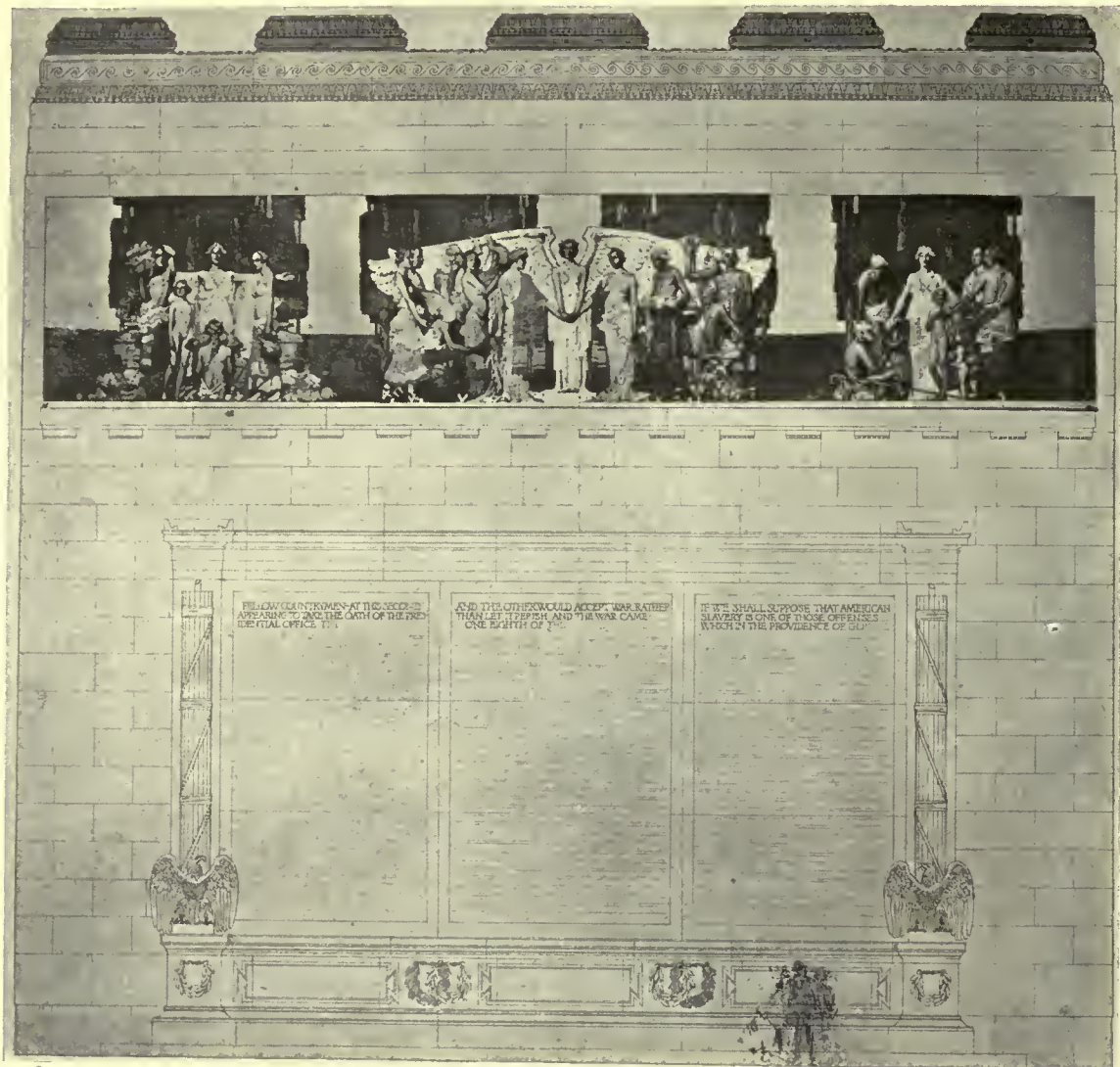

END OF HALL, WITH INSCRIPTION OF SECOND INAUGURAL ADDRESS
DECORATIONS BY JULES GUERIN

unparalleled composition which can not fail to impart to each of its monuments a value in addition to that which each standing alone would possess.

"An extension of the street car lines down Eighteenth Street and across B Street into the park, thence turning westward and running about 40 feet south of B Street to the Twenty-third Street entrance of the park, opposite the site of the Lincoln

more open. From the beginning of my study I believed that this Memorial of Abraham Lincoln should be composed of four features—a statue of the man, a memorial of his Gettysburg speech, a memorial of his second inaugural address and a symbol of the Union of the United States, which, he stated, it was his paramount object to save, and which he did save. Each feature should be related to the others by

THE AMERICAN ARCHITECT

means of its design and position, and each should be so arranged that it becomes an integral part of the whole, in order to attain a unity and simplicity in the appearance of the monument. Each feature should impress the beholder with its greatest force, and by means of isolation this can be accomplished, though this isolation should not be planned to the

occupied by any other object that would detract from its effectiveness, and the visitor will be alone with it.

"The smaller halls at each side of the central space would each contain a memorial—one of the second inaugural and the other of the Gettysburg address. These speeches would be shown by bronze letters arranged on a monumental tablet, and adjacent low

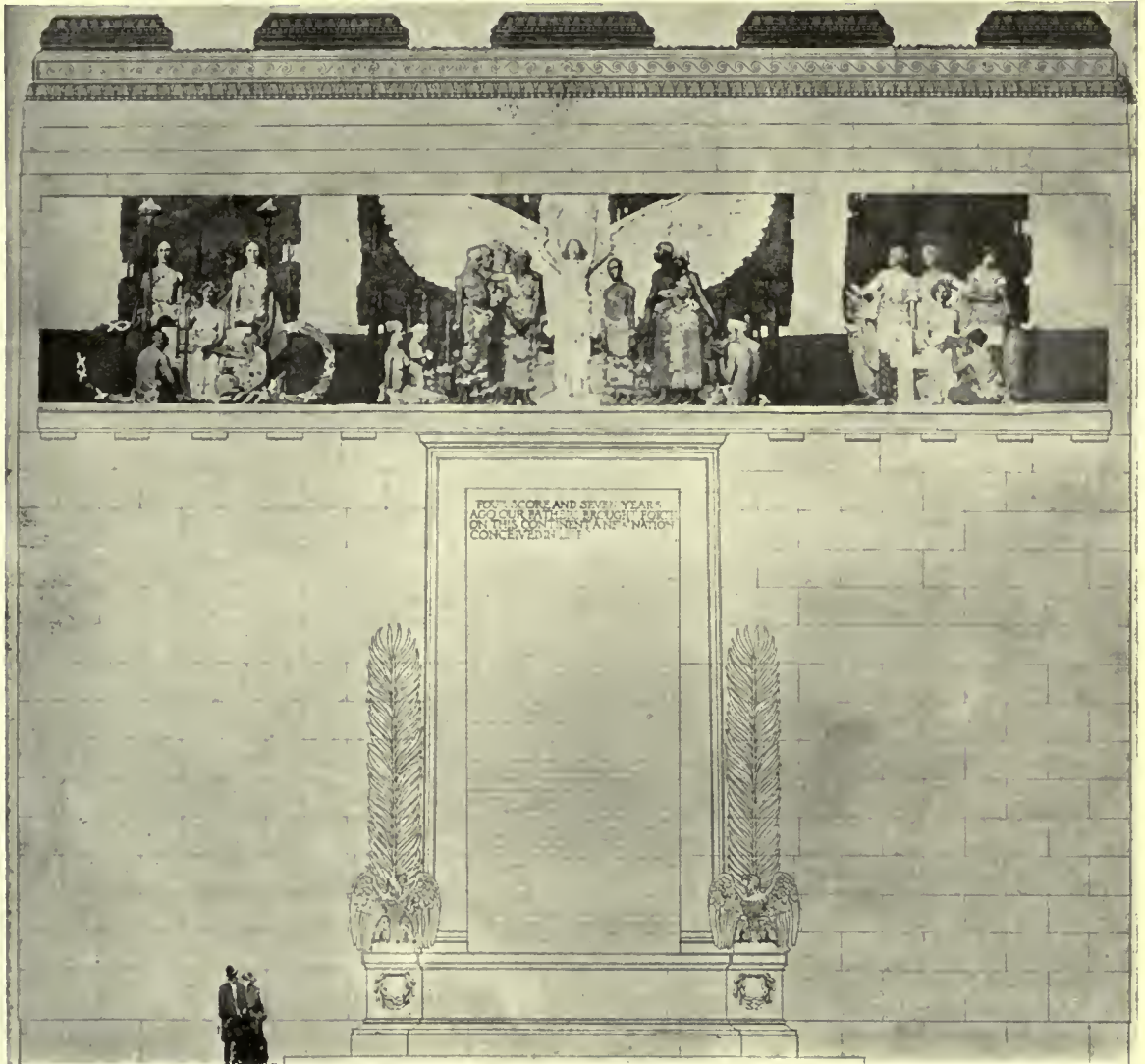

END OF HALL, WITH INSCRIPTION OF LINCOLN'S GETTYSBURG ADDRESS
DECORATIONS BY JULES GUERIN

extent of impairing the relation of each feature to the others.

"The most important object is the statue of Lincoln, which is placed in the center of the Memorial, and by virtue of its imposing position in the place of honor, the gentleness, power and intelligence of the man, expressed as far as possible by the sculptor's art, will predominate. This portion of the Memorial where the statue is placed would be un-

reliefs or decoration would relate in allegory Lincoln's great qualities evident in those speeches. While these memorials can be seen from any part of the hall, they are partially screened from the central portion where the statue is placed by means of a row of Ionic columns, giving a certain isolation to the space they occupy and augmenting thereby their importance. I believe these two great speeches made by Lincoln will always have a far greater

THE AMERICAN ARCHITECT

meaning to the citizens of the United States and visitors from other countries than a portrayal of periods of events by means of decoration. I think, however, some reliefs and decoration designed in conjunction with these memorials and representing

of the man is planned a colonnade forming a symbol of the Union, each column representing a State—36 in all—for each State existing at the time of Lincoln's death, and on the walls appearing above the colonnade and supported at intervals by eagles, are



THE WASHINGTON MONUMENT AS SEEN LOOKING OVER THE LAGOON FROM
CENTRAL HALL OF LINCOLN MEMORIAL

HENRY BACON, ARCHITECT

in allegory Lincoln's qualities, such as charity, patience, intelligence, patriotism, devotion to high ideals and humaneness, will emphasize the effect of the speeches.

"Surrounding the walls inclosing these memorials

48 memorial festoons, one for each State existing at the present time.

"I believe this symbol, representing the Union, surrounding the memorials of the man who saved the Union, will give to them a great significance that

THE AMERICAN ARCHITECT

will strengthen in the hearts of beholders the feelings of reverence and honor for the memory of Abraham Lincoln.

TECHNICAL DESCRIPTION.

"By means of terraces the ground at the site of the Lincoln Memorial will be raised until the floor of the Memorial itself will be 45 feet higher than the

wall 14 feet high, 256 feet long and 186 feet wide. On this rectangular terrace rises the marble Memorial. All the foundations of the steps, terraces and Memorial will be built on concrete piling which extends down to the solid rock.

"Three steps 8 feet high form a platform under the columns. This platform at its base is 204 feet long and 134 feet wide.



FIRST INAUGURAL ALCOVE
THE LINCOLN MEMORIAL
HENRY BACON, ARCHITECT

- present grade. First, a circular terrace 1,000 feet in diameter is raised 11 feet above the present grade, and on its outer edge will be planted four concentric rows of trees, leaving a plateau in the center 755 feet in diameter, which is greater than the length of the Capitol. In the center of this plateau, surrounded by a wide roadway and walks, will rise an eminence supporting a rectangular stone terrace

"The colonnade is 188 feet long and 118 feet wide, the columns being 44 feet high and 7 feet 5 inches in diameter at their base.

"The total height of the structure above the finished grade at the base of the terrace is 99 feet. The finished grade at the base of the terrace being 23 feet above the present grade, the total height of

(Continued on page 537)

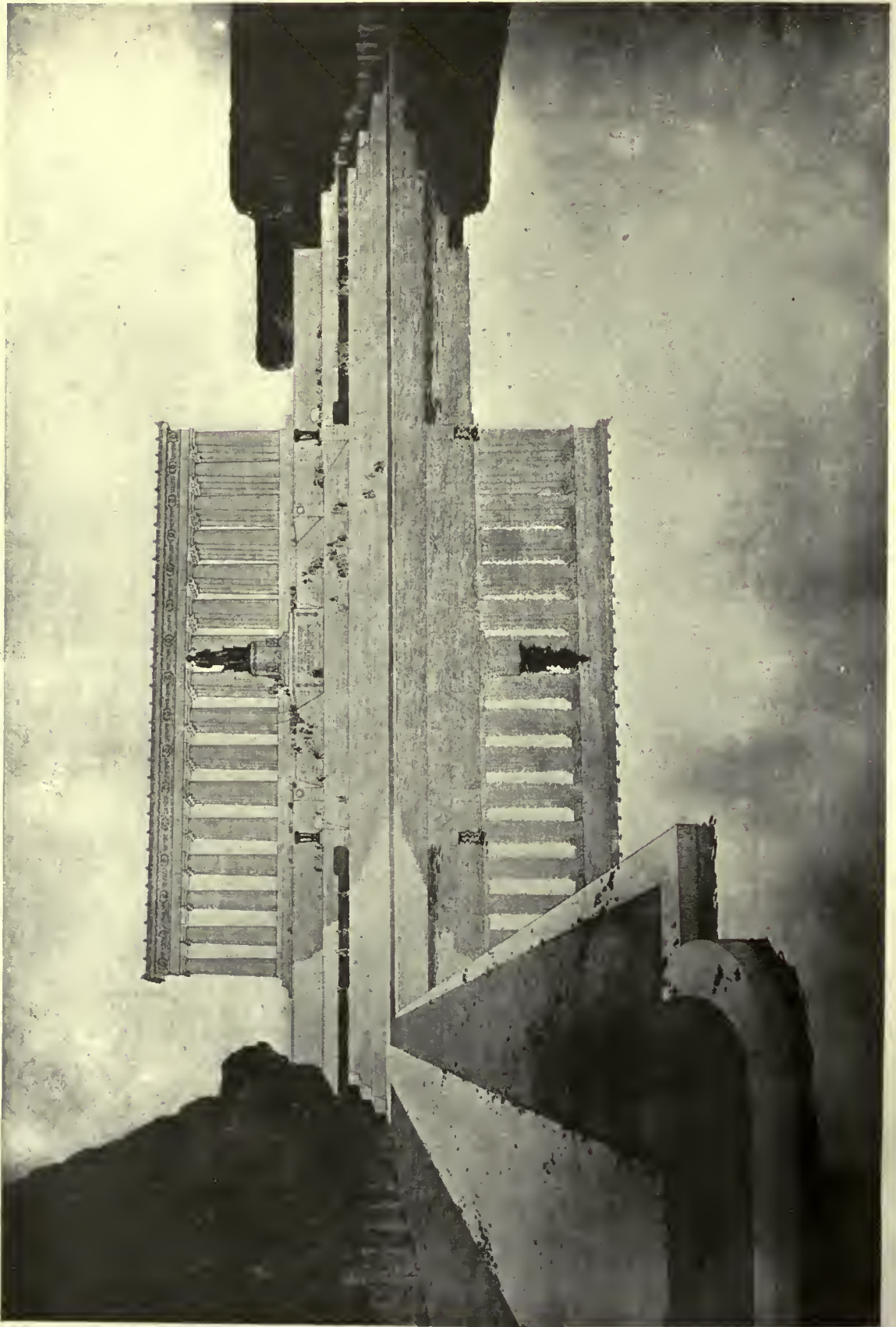

THE LINCOLN MEMORIAL, WASHINGTON, D. C.
DESIGN SUBMITTED FOR AN OPEN COLONNADE AS PREPARED BY
HENRY BACON, ARCHITECT

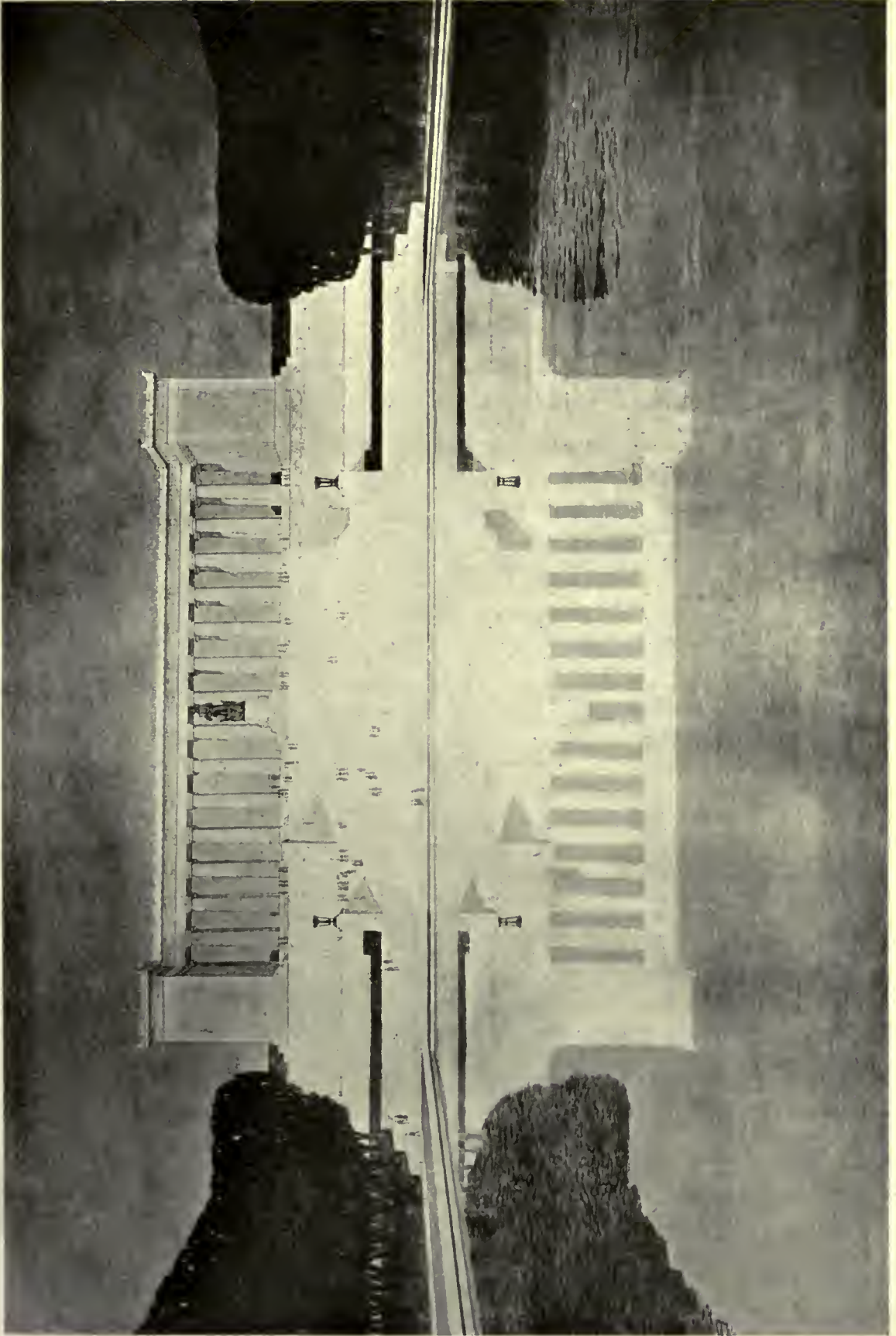

THE LINCOLN MEMORIAL, WASHINGTON, D. C.
DESIGN FOR AN OPEN COLONNADE WITH SOLID RETURNS
HENRY BACON, ARCHITECT

Dyckman Farm House, Broadway and 200th Street, New York

(See reproduction of the original drawing by O. R. Eggers in this issue)

THE *New Yorker*, whose boyhood recollections go back half a century, will recall that having ventured through those dark tree-embowered lanes which parallel the Hudson, or along the seldom frequented continuation of what we now call Broadway or the Boston Post Road, he came finally to the Dyckman Farm, whose rolling meadows reached down to the Hudson River.

There he found a low gambrel roofed farm house which even then showed all the weather marks of old age. There were Dyckmans living there then, and there they continued to live until about 1871, when the phenomenal progress of the city northward had surrounded the farm with a well developed suburban community.

The Dyckman house is a good example of the type of house that the early Dutch settler on Manhattan Island and across the Hudson in New Jersey so much affected. Long and low, these houses, correctly proportioned at the outset, received equally well considered additions as the needs of the increasing family demanded. In the present instance the "wing" of this house is of earlier date than the main building, which was built in 1783.

Owing to the generosity of Dyckman descendants, this old farm house has been restored as far as possible to its former condition, and with the ground about it presented to the City of New York as a historical museum and park.

534^u



Dyckman House
N.Y.

(E)

DYCKMAN HOUSE, NEW YORK
THE AMERICAN ARCHITECT Series of Early American Architecture



Wrecking of Old Buildings

JUST now wreckers of old buildings are reaping a harvest. Old brick, second-hand lumber and all the salvage from old buildings are now eagerly sought and at offered prices that have made the dealers in second-hand materials extremely happy. If it is true that everything comes to him who waits, then those dealers who have kept stored in heterogeneous piles the vast accumulation of years are at last coming into their own. The Golden Dustman of Dickens had no more valuable store in his heaps of refuse, nor Quilp in his dingy yard by the river, than have those dealers who have stored away for years all that was left of many a one-time important structure.

There's always a certain romance in an old building when it comes under the wrecker's hands as there is a pathetic aspect to a one-time noble ship, when careened on its bilges on some muddy flat where it awaits demolition and the salvage of its copper and oaken planks. We tear down, alter or enlarge so much in this country that buildings seldom reach a ripe old age and are comparatively young when demolished. But in the widespread operations of converting one-time stately New York residences, built often in the '50s and '60s, into modern apartment buildings, there is much salvage that has not only an intrinsic value but also a considerable artistic importance. Collectors of such things are constantly alert, and wreckers have become keenly alive to the fact that many things that through ignorance they regarded as so much rubbish have been eagerly sought for and purchased at good prices. Particularly is this true in the Greenwich and Chelsea Village sections of New York. Fine old iron work, entire entrance doorways, and solid mahogany interior doors are examples. In some cases fine paneling has suddenly been transferred from these old houses to stately suburban places. Architects, always keenly alive to the possibilities that have attended such demolition, have been watchfully awaiting every opportunity.

BUT the value, to-day, of the purely structural material must not be overlooked. There is constant demand for brick and lumber, door frames,

windows and window frames, and these are sold as fast as they can be taken out of the old buildings. A comparison of the value of certain of this second-hand material as compared with its salvage value twenty years ago is interesting. Times have changed and the fashions of architecture and decoration widely altered. Fine, hand-carved black and white marble mantels such as carried considerable pride of possession a quarter of a century ago are now of little value. Unless they possess some out of the ordinary artistic merit there is no sale for them, and even those which a collector may regard with a longing eye may be had for a most reasonable price.

Many are the lessons we have learned since the world was set topsy-turvy by the Great War, and perhaps the most valuable is that of economy and thrift. The man who recklessly cast aside things but partly worn and bought anew, now sets about effecting their rehabilitation. Less goes to waste now than over before, and the old house that at one time would have gone to the scrap heap and burned as refuse, now lives again in part in many an important building. "Thrift," said Theodore Roosevelt, "is judicious spending." The best expression of our newly developed ideas of thrift is shown by the careful conservation of many things that once, in a spirit of reckless extravagance, were discarded, and the judicious purchase of many a thing which in the days of comparative opulence we despised.

Fifteen to Thirty Per Cent.

JOHAN SKELTON WILLIAMS, Comptroller of the Currency, in a statement given wide publicity by the daily press, asserted that unjustifiable interest rates have been charged on demand loans in New York. In order that the public might be fully informed and know the exact facts in regard to the money situation in New York, the national banks in New York City were requested by the Comptroller of the Currency to furnish, under oath, a report of the number and amount of all demand loans made during a certain period. These sworn reports disclose that during the period from October 1, 1919, to August 1, 1920, there were made by the national banks in New York City more than four thousand

loans at rates of 15 per cent., 20 per cent., 25 per cent. and 30 per cent. per annum, and that the amount of these loans, including only a portion of those made during this period at the above rates in three of the largest banks, aggregated \$600,000,000.

Mr. Williams also pointed out in his statement that the banks which had been charging their customers these excessive rates have themselves at the same time been liberally accommodated with millions of dollars by the Federal Reserve Bank at average rates of considerably less than 6 per cent.

With such conditions as these, the truth of which cannot be questioned, is it not pertinent to inquire what chance will a man have who wants to build him a house and expects to get the money at a legal 6 per cent. rate? In spite of high prices of material and labor, in spite of all the irregularities of railroad transportation, and in spite of all these adverse conditions that surround the housing situation today, the American man is acknowledgedly a good sport and would take a chance on his house if the banks would let him have the money to build it with. With money selling, as Mr. Williams shows, from 15 to 30 per cent. the contention that has been made in these columns and on the part of others quoted therein, that the real retardance to housing was due more to the attitude of capital than to any other factor, would seem to be justified.

Misapplied Maxims

THE voice of the theorist is heard in the land. Under the subdued light of "study" tables there are penned and sent forth ponderous views on every vital question. For example, during the past months, when the housing shortage has been so acute that sober-minded, rational people have been at their wits'

ends in the matter, forth come these studious gentlemen with some space-filling thesis whose clear cut use of English, whose polished style is in directly opposite proportion to the practicality of their schemes.

Metaphors are their delight, old folk lore sayings their stock in trade. They smugly tell the world that "it's an ill wind that blows no good," and then continue by a fine argument set forth in correct English to prove to the man who is vainly seeking a shelter for himself and family that there are really some fine compensations in the present conditions and that the poor wretch should be glad that he is alive. "How often does the current of intelligence get itself clogged by a metaphor and there it stick," says a writer in *The New Republic*, "and," he continues, "a conspicuous obstruction at the moment is that half a loaf is better than no bread."

"Now, half a loaf is better than no bread at all. But the cool assumption that half of anything at all is better than none of it is one of the curiosities of the human reason. For, while there is a good deal to be said for half a loaf, there is little to be said for half of an automobile, half of a railroad engine, half of a bridge, half of a steel girder, half of a safe deposit vault, half of a glass jar, half of a pair of trousers, half of a deck of cards, or, as King Solomon demonstrated, half of a baby. When the thing you are talking about depends for its usefulness on structure and organization, the metaphor about half being better than none seems not to be of universal scope. For these cases proverbial wisdom provides another metaphor: it says that a miss is as good as a mile."

"A little learning is a dangerous thing" but not more so than too much learning illogically set forth to account for present conditions.



THE CRYSTAL PALACE FOUNTAINS, LONDON

The Lincoln Memorial

(Continued from page 531)

the building above the present grade is 122 feet.

"The outside of the Memorial Hall is 84 feet wide and 156 feet long.

"The colonnaded entrance to the Memorial Hall, which is 45 feet wide and 44 feet high, is equipped with sliding bronze grilles, filled with plate glass. These grilles during the day will be rolled back into the space provided in the walls, and will be closed at night for the protection of the Memorial. As they are mostly glass, they can also be kept closed during the day in cold weather without obstructing the entrance of light through the entrance, and a temporary bronze and glass vestibule can be provided in the lower portion of the grilles, which are subdivided at the bottom for this purpose.

"The central hall, where the statue stands, is 60 feet wide, 70 feet long and 60 feet high.

"The halls where the memorials of the speeches are placed are 37 feet wide, 57 feet long and 60 feet high.

"The interior columns are of the Ionic order and are 50 feet high.

"The cost of erecting this Memorial, according to estimates received from a contractor of the highest standing in monumental work, the quantities being carefully computed, is \$1,775,000. This estimate does not include the steps at the head of the Lagoon, the statue of Lincoln, the memorials of his two speeches, or the architect's commission. With the exception of the steps at the head of the Lagoon, which are properly a part of the landscape gardening around the Memorial, the design I have submitted, including the statue, the memorials and the

architect's commission, can be built for the sum authorized by Congress."

This design fits into the landscape composition, in its classic lines; it typifies the culture to which Lincoln attained. The simple dignity of the Doric best represents his straightforward life and the dignity his services to the country justified. Its isolation, unhampered by other structures, surrounded by a landscape accentuating its prominence, illustrates the eminent and isolated position Lincoln occupies in our history. The interior is lighted through translucent marble panels. In the central hall Daniel C. French has sculptured a colossal seated statue of Lincoln. The propriety of Lincoln in the clothes of his period, fitting into the classical period of the architecture has been questioned. The suggestion was made by Paul Wayland Bartlett for an altar on which a bust of Lincoln should be the focal point of interest as requiring no time fixing clothes. This, supported by ideal figures of say patience and patriotism, would fit into the architectural scheme possibly better than the figure in modern clothes. Such sculpture would have been just as effective in commemorating Lincoln as it would have appealed to the imagination of the observer rather than to his craving for realism.

Jules Guerin's decorations in the north and south halls are effective in giving necessary color to the interior and emphasizing the tablets on which are inscribed the speeches and typify the qualities of Lincoln's character.

Congress this year appropriated the money for the water basin between the Washington Monument and the Lincoln Memorial which is destined and necessary in the completion of the landscape compo-



MOST PROMINENT VIEW FROM THE LINCOLN MEMORIAL, SHOWING THE UNFORTUNATE LOCATION OF THE WAR WORK BUILDINGS AND THE DESTRUCTION OF THE ELMS, WHICH CONSTITUTE SO IMPORTANT A FEATURE OF THE COMPOSITION OF THE LANDSCAPE



ALCOVE FROM CENTRAL HALL
THE LINCOLN MEMORIAL, WASHINGTON, D. C.
HENRY BACON, ARCHITECT

sition, and in giving the Memorial its most dignified effect. When the planting and grading are complete there is only one thing that will be an eyesore and mar the effect of the design. That one thing is the Army and Navy concrete building, whose numerous gridiron prongs project out into the park far beyond the building line fixed by the Senate some years ago, obliterating trees very important in the design. It is crude and ugly in itself and on the park and affects unpleasantly the repose and beauty of the Memorial.

Let us hope that the friends of beauty and those who revere the name Lincoln will take steps to have these marring elements removed. (The end.)

Tree Planting for Beautification

Plans for a state-wide tree planting survey, to be undertaken in the near future for the beautification of the California road system, were announced in Sacramento by George C. Mansfield, a member of the State Highway Commission. The State Board of Forestry is to be asked to assist in the work.

Mr. Mansfield said the object of the survey is to eliminate the haphazard, hit-and-miss methods now employed in tree planting, and to place the Commission in possession of the data needed to enable the Commission to act wisely and intelligently upon applications in the future. He said it is planned to begin the survey just as soon as funds are available.

"The Purpose of the proposed survey," declared Mr. Mansfield, "is not to work out a uniform scheme of tree planting, which would be impracticable and quite undesirable in a State as large as California, but to secure the technical knowledge needed in the adoption of a comprehensive plan of beautification.

"While one species of tree might be well suited for the needs of a certain locality, it is possible that it would be entirely out of place in another. That is the principal object of the survey—to find out the different varieties of shade and ornamental trees best adapted to climatic and soil conditions in various localities.

"Not only trees will be studied, but it is the plan of the commission to look into the desirability of planting shrubs in certain localities."

With such a fund of information, the Commission then will be in a position to advise civic bodies or other organizations seeking permits, the variety or varieties of trees which will be acceptable to the Commission.

Tree and soil experts will be entrusted with carrying out the main part of the survey, although the employment of landscape artists in some communities, it was indicated, is not an impossibility.

Along certain sections of the highway, he pointed out, it may be desirable to plant a variety of tree that grows tall to hide some blemish in the landscape, while on the other hand, scenic beauties may be best

brought out by low-growing shrubs or by leaving the highway frames in the natural scenery of the country.

It also is the aim of Mr. Mansfield to have most of the trees needed for carrying out the scheme of beautification propagated at the proposed State nursery, a project for which provision was made by the Legislature several years ago, but which has been hanging fire due to the inadequacy of the appropriation and difficulty experienced by the Board of Forestry locating a suitable tract of land.

Solution for the Rural Problem

The great, almost startling exodus from the country to the city of young people, and many who are not young, is shown by the census figures recently published—the facts showing that during the past ten years the cities grew seven and one-half times as fast as country districts. What is the reason of this? Young men are not leaving the farms only to enjoy libraries, lecture courses or museums, or even for the sake of pleasure. The greatest lure of the city has been due to the high wages and superior conveniences.

The Albany *Knickerbocker Press* has stated a possible solution of this rural problem when it says:

"There is a remedy, however. It was suggested by Judge Howard, of Troy, several years ago; it is in operation in Australia and in California; it has just been proposed again, in substance, by Asher Hobson, professor of economic agriculture in Columbia University. It is to provide funds or credit with which any family which desires to take up farming may establish itself in some well developed and convenient farm area. This is getting down to first principles. It takes several thousand dollars to buy any sort of a farm worth having; to stock and equip it will cost, at the lowest, a thousand or two additional. Among the surplus population of the cities there are hundreds of thousands of worthy, industrious people who would welcome the chance to turn to farming if they had the means to get started. They are natural farmers, if they could only get on the land. But they can scarcely raise the next month's rent.

"Here is the state's opportunity. The expenditure by the state of a small fraction of the hundreds of millions it has spent on waterways and highways would subtract many thousands of families from the ranks of the consumers and turn them into producers. They would fill up the unoccupied homesteads; they would bring new life into the countryside; they would help solve the rural labor problem; they would have their own homes, cut their own fuel, raise their own milk, butter, eggs and meat, and they would add hugely to the surplus from which city consumers must live. By adding to this measure appropriate legislation fostering the interests of the small farmer, New York could settle its rural problem within five years."

The Reconstruction of Northern France

The Fate of the Village Churches

By RALPH FANNING

MORE to be lamented from an architectural standpoint than the homes, as picturesque and charming as they so often were, was the destruction of the churches of Northern France. More revered and adorned than any other edifice of a village, they naturally occupied a most prominent and conspicuous site. Landmarks in the landscape, their towers rising above the low-roofed cottages, they were the first objects to attract the attention of friendly advance or enemy assault. Evidence has been given from both sides that these towers were used for signal places and so, from a military standpoint, had to be destroyed. Instances are known where machine guns were advantage-

fire and bombs dropped from swift aeroplanes are not religiously discriminating.

Fortified by a cold philosophy and attempted suppression of sentiment, it is yet difficult to pass by these slaughtered churches without a feeling of horror as for wanton desecration and barbaric assault. Even a non-conformist to churchly traditions, untrained by generations of reverence to symbolism,



SOUTH AISLE OF CHURCH AT
DUN-SUR-MEAUSE



THE CHURCH AT CLERMONT
EN ARGONNE

ously placed in churches, and, with the modern technique of war, if one sanctions it at all, one cannot consistently appear to be too greatly shocked by the destruction of churches. Long range cannon

cannot help but be shocked by the heedless fall of the image of some smiling saint, a wrecked crucifix, or the vulgar misuse of a consecrated altar. The world has shuddered over the mutilation of the cathedral of Rheims or the ruin of Soissons, and much has been told of the sad fate of the many more famous sanctuaries; but of the little village churches, modest and unrenowned, much, quite as touching, could be related. Statistics show that over eight hundred village churches in the departments of the Nord, Somme, Aise, Ardennes, Meuse and Marne have been destroyed beyond repair. This does not include the cathedrals and great town churches, but the church of the rural parish, where the country people for many generations had gathered for prayer and worship.

THE AMERICAN ARCHITECT

Gone with the churches are many a quaint architectural feature, the results of centuries of builders' skill and love inspired handiwork, for one's best was ever given to the church as beautiful evidence of Catholic faith and piety. The silhouette of a belfry tower, its oddly arched openings, the niche for a painted saint, unique mouldings varying between the Gothic and neo-Classic, the stone tracery and gaudy glass, crude art in painted canvas or ecclesiastical objects; all these are too often now but powdered fragments or dingy debris. Gone are



BRIZEAU, UNDESTROYED, BUT MARRED BY THE PASSING OF MANY ARMIES

many of the homely objects, homely only in the sense of being familiar and intimate, altars, confessionals, pulpits and founts, modeled after some more famous prototype in the nearest cathedral, but village-made and bearing the tool marks of painstaking village handicraft. Gone, too, are the records of birth, baptism, marriage and death, that these churches had guarded for so many generations.



NEUVILLY-MEUSE. THE CHURCH BEYOND REPAIR

From some village churches in the stricken areas the Angelus still sounds, calling to the laborer as he toils at the discouraging tasks of reconstruction, but it must ring as a sad reminder, as to toll for

happier days and for sons and friends who will never again join them in the simple services led by the old priest. Monsieur, le Curé, who has made such a heroic record during the war years, proving himself a real father to his village family with untold courage and devotion, also must strive to keep in hiding the sad recollections. He sees his church, if not already in ruin, falling into decay, his flock scattered and lost during their banishment, and he feels the difficulty of reestablishing the former influence of the Church over Her people. One hears rumors of the lost power of the church over the people, who have had forced upon them a broader viewpoint than their old village life ever afforded, and who have come back to see their trusted sanctuaries in defilement. More often, however, among the first rumors that reach one, is of the requests of a returning populace for the materials to repair the church or for a barrack in which to continue



AT DOMBASLE THE CHURCH TOWER STILL STANDS ABOVE THE FALLEN VILLAGE, THOUGH ITS WALLS ARE UNSAFE

worship if the church were too badly damaged even for partial repair.

In many cases any sort of architecturally authentic restoration of the village churches is going to be impractical. Disintegration follows very rapidly once some shell holes and broken windows have allowed the frequent rains and rapid growing vegetation to enter unrestrained. Century-old vaulting is hard to repair once its vital voussoirs become loosened or displaced. Tottering or unstable walls are often a greater hindrance than help in the re-making of a ruined church. As appealing as is the call to save the crumbling church structures before further decay completely obliterates its form, little time or materials can be spent upon places of worship while hospitals need to be restored and women

and children are without proper shelter. Oftentimes the new village will be erected on a new site, so great will be the difficulty of clearing and reclaiming the old. In such cases the old church site, with its sacred ground, will probably have to be abandoned for a more convenient location. Thus even if

the new and more costly edifices could be built to replace the old religious houses, nothing can replace the old structures with their associations, their atmosphere, their very being which is so intimately a part of the vigorous France of the North, the France that has suffered as none other.

Book Notes

Blue Print Reading, Interpreting Working Drawings, by E. M. Wyatt. Full cloth, 85 pp. text and working drawings, 9 x 6 inches. Milwaukee, The Bruce Publishing Co.

THIS book is practically a course in blue print reading and the making of mechanical and architectural drawings. It has been prepared by a man who has taught these subjects to classes and used the material contained in the book for his text. The course has been prepared, as the author asserts in his introduction, to provide a working knowledge of the fundamental or underlying principles of mechanical drawing, a knowledge of drafting conventions, practice in the interpretation of drawings and some practice in expressing individual ideas by "shop sketches."

The volume consists of a series of chapters or "lessons," each accompanied by one or more well drawn plates of working drawings illustrating the matters dealt with in the text. Appended to each chapter is a series of questions for the purpose of supplementing a thorough study of the drawings.

The illustrations consist of both machine and architectural drawings, ranging from simple sketches, showing various methods of representation to drawings of a completed machine and of house plans.

Included in the "lessons" are such topics as The Theory of Orthographic Projection; Foreshortened Lines, Inclined Surfaces, Auxiliary Projections; Bolts, Screw Threads, Machining or Finish; Architectural Conventions, and others of equal importance to those interested in the subject of reading and understanding of mechanical and architectural drawings.

Personnel Administration, Its Principles and Practices. By Ordway Tead and Henry C. Metcalf, Ph.D. Full cloth, 540 pages, 6½ x 8 inches, New York, McGraw-Hill Book Company, Inc.

THE purpose of this book is to set forth the principles and the best prevailing practice in the field of administration of human relations in industry. This field includes all those efforts usually included in personnel management; employment,

health and safety, training, personnel research, service features and joint relations. The book is addressed to employers, personnel executives and employment managers, and to students of personnel administration. The subject is of vital importance to the architect, just as is any topic dealing with industrial relations. The authors' aim is to make this volume a helpful manual and they tend to create the proper point of view rather than to indicate specific next steps.

The book is divided into nine chapters and an appendix, each dealing with a different phase of the subject. After the first introductory chapter the personnel department and methods of employment are taken up. The subjects of health and safety, and education are next discussed with considerable detail. Industrial research and the very important matter of the correlation and co-operation of the executive departments and the various shop departments of the plant are considered in two well-written chapters. Joint relations, dealing with such topics as shop committees, employees' associations, collective bargaining and other similar topics is considered in the last chapter which is followed by the appendix containing a topical outline for the use of students in visiting plants.

This volume should prove of considerable value to those interested in the subject of industrial relations and particularly with employment and personnel management.

Hellenic Architecture, Its Genesis and Growth. By Edward Bell, M.A., F.S.A. Full cloth, 185 pp., 5 x 7½ inches, London, G. Bell & Sons, Ltd.

THIS book is one of a series dealing with the origins of architecture. It may suggest that it is somewhat uncalled for in view of the number of standard works that already deal exhaustively with the subject of Greek architecture. The archeological discoveries and disclosures of the past few years, the result of research expeditions undertaken since the publication of these standard books, give ample material for further literature dealing with the sources of Hellenic art. The author,

through careful original research and with the aid of data gathered by various archeological bodies which have conducted expeditions, has prepared a volume of unusual interest on a topic, the discussions of which supplement many extant works that deal with the subject.

The origins of Greek architecture are painstakingly traced from the prehistoric era, through the early periods of the Mycenaean and Doric builders, to its culmination in the Ionic and Corinthian styles. The thirteen chapters treat in detail the various influences which were at work in developing the Grecian style to its perfection.

The book is illustrated with numerous plans and photographs of buildings, existing and restored, and a map of the ancient Eastern Mediterranean area.

Spanish Seaport a Colorful Old City

LEAVE Fuenterrabia for San Sebastian and you will pass within less than one hour from the Spain of other days—proud, indolent, and down at heel—into the energetic, opulent and business-like Spain of today, a writer in the *London Times* reports.

I had not seen her for ten years or so. What a change! In those days you plunged straight into wild country—uncultivated fens, bumpy roads, furrowed deep with ruts, wretched hovels, passengers afoot clothed in dust-ridden rags. Today the train runs between rows of gleaming fields, where the young crops rise thick and sturdy. Motor cars, numberless as in France, glide along the greyish-blue high roads that are smooth like ice. Everywhere are factories with reeking chimneys; villages, roofed with new tiles, cast their crude-tinted girdle about bell-fries harmoniously tempered by sun and air. The peasants in Basque bonnets and well cut suits, exude health and ease. But the pang at my heart is not all regret for the vanished picturesque; happy are the people whom the war has left untouched.

At San Sebastian the impression of opulence grows stronger; the streets, ruled straight and cutting each other at right angles in the American fashion, are broad, airy and admirably kept; the houses—shrines somewhat perhaps too lavish of the deplorable art moderne imported direct from Munich—look solid and respectable beneath the stucco proportions and gilded vermicelli with which they are tricked out. Squares and spaces open out everywhere, and their brilliant, bushy gardens frame themselves about statues that are quite devoid of genius, but copiously bespread with marble and gold. All this, to be sure, is not beautiful, in the purely esthetic sense, but it is rich, and the whole town throbs with the vigorous, buoyant and daring impulse of youth.

On the Paseo, fringed with tamarisk, which runs all along the shore, the Casino squares itself proudly;

its theatre and gaming tables remain open all the year. People come from long distances in France and Spain in order to play here, and the sums won, or more often lost, mount up to considerable figures.

Although it is only 11 o'clock in the morning on a bandstand soldiers in bright red caps and trousers are playing dance airs that seem punctuated with the cheerful clatter of castanets. A laughing, chattering, many-colored crowd surges all around—workmen in butcher-blue; diminutive warriors, completely lost in uniforms too ample, but predominantly scarlet; pale green gendarmes in canary-yellow strappings, with shiny eyes under a leather cocked hat. Their pealing merriment drowns at times the sonorous brasses of the band.

But there is something odd about this crowd; what can it be? Ah—now I have it! The crowd is a crowd of men—in Spain women do not go out at all of a morning)—in the full strength of their manhood. In France and in England, alas! this is something that we know of no more.

Immediately behind the Casino you stumble all of a sudden upon the old harbor, tucked away at one of the far ends of the bay, under the lee of lofty dilapidated houses gaily festooned with multi-colored raiment drying on pointed wooden balconies. Along the quays fisherman unfurl their vast brown nets; workmen are unloading coal; and fisher-girl trips lightly on bare feet, with a roll of the hips, and looking like caryatids as they grasp the round baskets poised upon heads nobly erect. And slender boats, with wings red or white folded back along the masts, slumber amicably shoulder to shoulder, on the dead-level of the water, in a powerful stench of sardines, brine and tar.

Here starts the winding path that beneath the kindly shade of the beeches climbs to the summit of one of the two scraped rocks which, crowned with the imposing mass of their ramparted red bastioned forts, stand sentinel on either side of the extended bay.

No line could be purer than the rounded, perfect curve of this Bay of San Sebastian, so happily named La Concha, whose luminous blue waters seem encased in a threefold circle—a circle of sand, polished in grain, and with a glint of gold; a circle of houses and hotels, gleaming softly in the distant sunshine like marble palaces; and a circle of mountains whose severe outline is mitigated by a light mist. In the distance the sparkling, empty sea meets the boundless sky. A prospect of harmonious, restful majesty which man has been powerless to disturb.

The races at San Sebastian are not run in an environment so grandiose, but a few miles outside the town, in an agreeable hilgirt arena which spring adorns with delicate tints. No crowd, but a good humored public equally ready to cheer the horses,

with their fine drawn shapes; or the British jockeys; or the reines des marches of Paris and Metz, who figured in the after-war Mi-Careme festival in Paris, young swallow harbingers of peace, whose first return San Sebastian has desired to celebrate.

Arrayed in democratic "tailor-made" costumes, pink and smiling under their light hats, the little majesties pluck daisies in the grass, seemingly more sensitive to the charm of spring than to that of the races and of the betting. For spring, indeed, is the winner of the day. Between the events the patrons of the Pelouse—young women, modish but hatless, their heads geared only with their hair built up into a cunning tower from which here and there a kissing curl escapes; young men in cap or soft hat, with a rose in their button hole—just stretch themselves upon the velvety-soft grass, and, with their arms beneath their heads and with a violet twixt their teeth, they contemplate the purple sky through half closed lids . . .

A group of men in tight blue jerseys and in the soft shoes of the country are conspicuous by their boisterous gaiety. They are French fishermen. The Bidassoa's neutral stream belongs by local usage for alternate twenty-four hours now to the Spanish fishermen, now to the French fishermen. At this season the river is full of salmon, and these Frenchmen have taken seventeen fish, each weighing some sixteen to twenty pounds.

"We came to San Sebastian to sell them," they cheerfully explained. "At 3.50 pesetas a pound, prices are lower than in France; but reckoning the exchange this will make a tidy sum; near on 2,000 francs!"

"Well, it's an ill wind," they say . . .

"But," as somebody remarked, "the Spaniards will eat the salmon!"

Standardized Lumber Sizes

The need of standard sizes for all the different lumber products has been felt for some time, due to the exceedingly numerous and constantly changing sizes, and the action of prominent lumbermen in promoting standardization presages another progressive step in the lumber industry. The United States Forest Products Industrial Research Laboratory at Madison, Wis., has been co-operating during the past

year with the National Lumber Manufacturers' Association in working out an equitable basis for standardizing softwood lumber sizes. Some of the benefits to be derived from standardization follow:

1. It makes possible a common language for all. The consumer can substitute one species for another with assurance of getting material of the same size. Similarly, if a contractor starts to build several house and orders his millwork, sash, doors, etc., based on certain lumber sizes as to stock around which the casing fits, the kind of wood can be varied as he desires.

2. Architects and purchasers can order more rapidly with one set of sizes—looking for sizes scattered throughout different grading rule books is eliminated.

3. Material of standard sizes is more salable and by increasing the consumer's good-will creates and adds value to the products.

4. Building design is simplified, since fewer sizes can be used.

5. Uniformity in construction results, regardless of the grading rules under which the material is purchased. Manufacturers now cannot standardize millwork, etc., because it is dependent upon the sizes of the lumber used in building.

6. Remanufacture of larger sizes to match smaller sizes will be reduced and greater utilization with less labor and expense result. The architect frequently designs a building in accordance with the minimum sizes of lumber which may be furnished rather than on a species that can be procured in larger sizes.

7. Standardization of sizes eliminates local legislation on lumber sizes which confuse manufacture and distribution. Such legislation has already been suggested.

8. Standardization makes for fewer sizes and hence greater efficiency, ease and accuracy in lumber grading.

9. It equalizes competition between manufacturers, because present differences in overrun and freight charges are important factors in determining price.

10. It makes possible uniform practice and sizes in resawing.

11. It makes possible a fewer number of drying schedules in the kiln drying of lumber. At present the actual thicknesses of lumber of the same and different kinds cut under the rules of different associations often varies several per cent.

DEPARTMENT OF ARCHITECTURAL ENGINEERING



FACTORY OF PHILADELPHIA TEXTILE MACHINERY COMPANY, PHILADELPHIA, PA.
Wall radiators used effectively along skylights

Heating and Ventilating Industrial Buildings Part—I

By CHARLES L. HUBBARD, *Heating Engineer*

THERE are three general methods of heating industrial buildings, these being classed under "direct steam," "direct hot water" and "hot blast." Each of these systems has two or more sub-divisions, and various combinations may often be used to advantage in special cases. The requirements of industrial buildings vary

widely, depending upon the character of the goods manufactured and the special processes carried on in different departments. Certain buildings, like woodworking and machine shops, having a large cubic content per occupant, require very little, if any, outside air supply, other than that furnished by natural leakage, and may be heated in a per-

fectly satisfactory manner by direct radiation, which may be supplied either with steam or hot water. In shoe shops, textile mills, etc., where the space is more crowded, and where the air contains more or less dust, lint, odors, etc., fresh air is needed in greater quantities and the hot blast system in some form is necessary. If these conditions exist only in certain rooms or departments, direct heating, combined with exhaust ventilation, may often be used to advantage. While forge shops and foundries may be satisfactorily warmed by direct radiation, the excessive amount of smoke and vapor makes it necessary to employ some special means of ventilation, and it is usually best to combine this with the heating in the form of a hot blast system.

In laundries, dye-houses, etc., the removal of

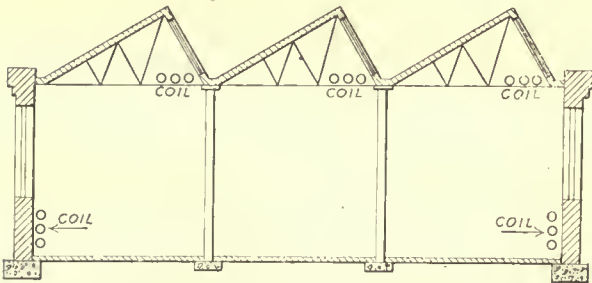

FIG. 3. OVERHEAD HEATING COILS

water vapor is an important factor, and this should be studied in connection with the problem of heating, as will be shown later. The modern factory building differs from the older type in its greater proportion of glass surface and the thinner wall construction, which is usually of steel and concrete, with a brick facing in some cases.

While the greater proportion of glass exposure adds to the heat loss by transmission, the general use of metal sash reduces the loss by leakage, due to the greater tightness of construction.

But this, however, reduces the natural ventilation and makes it all the more necessary to provide artificial means for the outward passage of the exhausted or overheated air. With the older type of construction, having wooden sash and other means of leakage, it was usually sufficient simply to supply fresh air and let it leak out as best it might under the slight pressure produced by the fan. With concrete walls and iron sash the same general fan arrangement may be used, but special means must be provided for exhausting the air.

HEAT LOSS.

In giving data for the heat loss from industrial buildings, two types of construction will be considered, designated as Class A and Class B.

Class A. Buildings of this type are usually constructed with walls of solid brick or concrete, without insulating finish or any kind on the inside walls,

except in special rooms, such as offices, drafting rooms, etc.

The figures in the last column of Table I give the heat loss by transmission in thermal units per square foot of outside wall and roof surfaces per hour for an inside temperature of 70 degrees when it is zero outside.

TABLE I—HEAT LOSSES IN B.T.U. PER SQ. FT. OF SURFACE PER HOUR.

For Inside Temperature 70 deg. F. Outside Temperature Zero.*

	Construction	Heat Loss
WALL	Brick 4 in. thick	38
	" 8 in. "	28
	" 12 in. "	22
	" 16 in. "	18
	Concrete 4 in. thick	50
	" 8 in. "	37
ROOF	" 12 in. "	30
	" 16 in. "	24
	Slate on matched boards	21
	Iron on matched boards	12
	8-in. hollow tile, 1-in. concrete, tar and gravel	28
	6-in. concrete, cinder fill, tar and gravel	38
GLASS	Patent roof (tar and gravel)	18
	Unlined Metal	78
	Single sash windows	84
	Double sash "	42
	Single skylight	90
	Double "	45
	Tile and concrete on earth	6

*For other differences multiply by factor given in Table II.

TABLE II.—CORRECTION FACTOR FOR VARIOUS TEMPERATURE DIFFERENCES.

50 degrees	Multiply by
60 "	0.71
70 "	0.86
80 "	1.00
90 "	1.14
	1.30

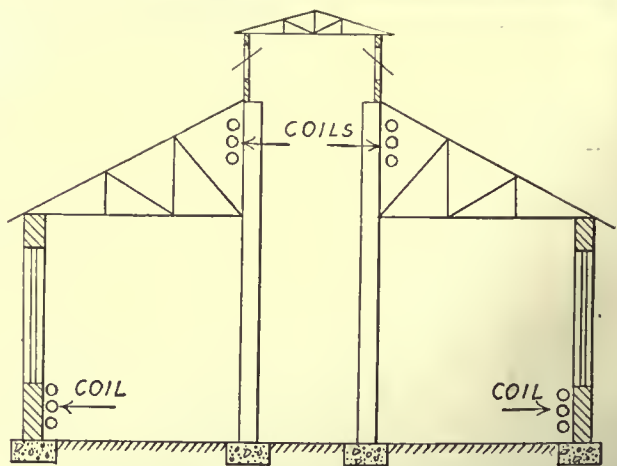

FIG. 2. ARRANGEMENT OF HEATING COILS FOR MONITOR ROOF CONSTRUCTION



WALL RADIATORS INSTALLED IN RECESSES BETWEEN PILASTERS

In addition to the heat loss by transmission, there is also a certain amount due to leakage around doors and windows, and to a slight extent through the walls and roof construction. With average exposure to winds, this may be taken as 1.5 for wooden sashes and 1.25 for iron. That is the loss previously found by use of Table I is multiplied by these factors.

To find the total heat loss per hour from a given building, multiply the exposed outside wall, roof and glass surfaces in square feet, by the proper factors from Table I. Add the results and multiply the sum by 1.5 for wooden sash, or by 1.25 for iron sash. If there is a tile or concrete floor, multiply the floor surface by 6 and add to the general loss by transmission before making the correction for leakage.

Class B. Buildings of this type are confined chiefly to foundries, boiler shops, forge shops, etc., where the normal inside temperature may be comparatively low, as from 50 to 60 degrees in zero weather.



AN OBJECTIONABLE INSTALLATION

When the heating surface required is such that a single pipe coil would extend above the window sill, either a double coil or a compact bank of wall radiators should be used

Tests show that the transmission losses through unlined corrugated metal are very nearly the same as for a single window, and for all practical purposes no distinction need be made between the walls, roof or windows of a building of this kind. After taking into account transmission losses and leakage, a heat loss of 100 B. T. U. per hour per square foot of gross wall and roof area (counting windows as wall) will safely cover all ordinary conditions where the outside temperature does not fall much below zero.

DIRECT STEAM HEATING.

IN the case of industrial buildings the direct heating surface is usually installed in the form of circulation coils made up of 1¼ inch or 1½ inch pipe. Wall radiators are also used to a considerable extent.

In special instances it may be necessary to use pipe of other sizes to get the required amount of surface into the given space for pipe coils.

Under ordinary conditions circulation coils are best hung along the outer walls beneath the windows, as this is where the heat is most needed.

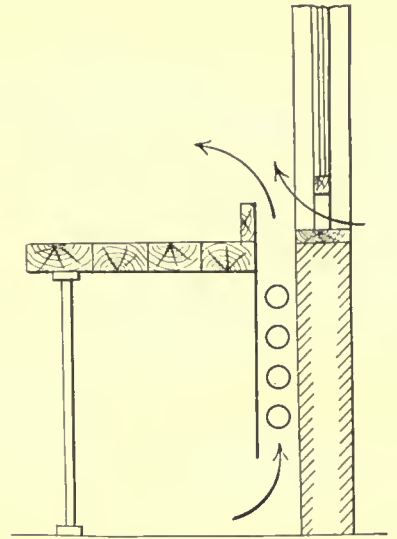

FIG. 1. A SUGGESTED ARRANGEMENT

A good arrangement for a shop is illustrated in Fig. 1, in which case the bench is set out about 4 inches and an apron of galvanized iron carried down on the rear supports to a point slightly below the lower pipe. With this plan the warm air is not thrown into the workman's face, as with the usual method, but passes upward in front of the window. By properly proportioning the height of bench and window, and raising the sash slightly, a good supply of fresh air may be obtained without objectionable drafts.

In small buildings, and in large ones also when divided into stories 10 to 14 feet in height, very good results may be obtained by this general arrangement.

Direct heating is especially adapted to cases where the plant is made up of a group of small or medium size buildings instead of one or two large ones, as the duplication, in this case, of fan and heater outfits would prove quite expensive. Again,

direct radiation is convenient for heating special rooms or departments requiring different temperatures from the main shop, such as offices, drafting rooms, shipping rooms, paint shops, etc.

The principal disadvantage of direct heating, aside from the lack of ventilation, is that in buildings with an extended glass exposure, such an amount of heating surface is required as to make it



FACTORY BUILDING—THOMAS A. EDISON, INC.,
ORANGE, N. J.
Wall radiators used throughout

uncomfortably warm for those working near the coils. This is especially true in that type of modern building construction having considerable height, with galleries and monitor roofs. In this case the warm air rises rapidly to the upper part of the building, greatly overheating it, and increasing the rate of transmission through the roof. At the same time the zone near the floor, occupied by the workmen, remains too cold for comfort except in the immediate vicinity of the coils.

A typical arrangement for direct heating surface in a one-story building with monitor roof is illustrated in Figure 2. In this case part of the radiation surface is placed at an elevation so that it warms the monitor space and prevents cold down-drafts, while the lower walls and windows are cared for by coils near the floor.

One-story buildings, with saw-tooth roof construction, are satisfactorily heated by direct steam or water coils placed as shown in Figure 3. The illustration on page 545 shows an installation of wall radiators located along the saw-tooth roof construction.

Overhead coils should only be used in low rooms, and in cases where the pipes would interfere with

machinery or other fixtures if carried on the walls. If the room is over 9 or 10 feet in height the amount of such surface should be increased from 10 to 20 per cent. above that when placed near the floor, in order to force more of the heat downward to the level occupied by the workmen. In some cases the building construction is such that recesses are formed between the pilasters, as shown in Figure 4. These are often utilized for the radiating surface by using double coils of the "return-bend" or "trombone" form, if of sufficient length and height to just fill the spaces and allow room for making the supply and return connections. The ordinary sectional cast iron radiator is not extensively used in work of this kind as it is desirable to extend the surface so as to get a better distribution of heat. Cast iron wall radiation is frequently used in industrial buildings when for any reason it is desired to present a better appearance, also in offices, etc. Frequently when pipe coils would obstruct the lower part of the window, cast iron wall radiators can be used to advantage. Several of the illustrations show such installations.

Amount of Radiating Surface. The square feet of radiating surface for a given room or building is found by dividing the "total heat loss" per hour, as found by the methods already described, by the "efficiency" of the type of radiation used.

The efficiency is the average number of heat units given off per square foot of surface per hour, and may be taken as follows for steam at 1 to 2 pounds gauge pressure.

	B. T. U. per hour
Pipe coils.....	290
Cast iron wall radiators.....	280
Common sectional radiators....	250

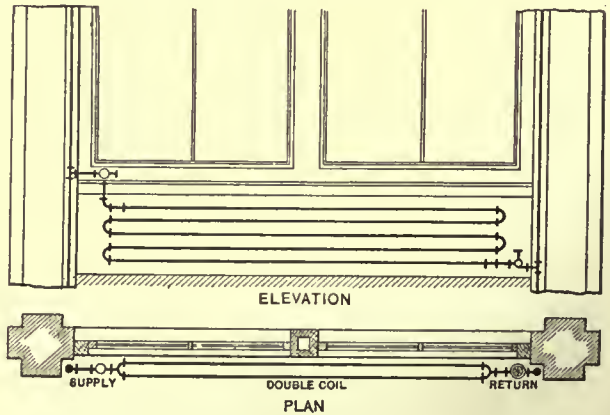

FIG. 4. HEATING COIL INSTALLED IN WALL RECESS

In distributing the radiating surface there should be from 20 to 30 per cent. more placed along the

colder and more exposed side of the building than on the other. If especially exposed to winds, the heat will tend to be driven with the air currents to the leeward side of the building and it may be necessary, in some cases, to place a still greater proportion of the heating surface on the windward side to offset this effect.

Piping Arrangements. All steam coils, and cast iron wall radiators in most cases, are connected up on the "two-pipe" system. The general arrangement will, of course, depend largely upon the type and use of the building, number of stories, etc. Usually the first floor or basement is utilized the same as the others, so it is not desirable to mass the supply and return piping at the ceiling of this room as is frequently done in other types of buildings where the basement is largely given up to piping and mechanical equipment of different kinds. In general, the supply and return branches should be distributed as much as possible over the entire building, and this is frequently simplified by using the overhead distribution, shown in diagram in Fig. 5. In this case a single supply riser is carried to the top of the building, with branches to the different drops just below the roof. With this plan the supply system is at the top of the building and the return in the basement. Another advantage is that the mains and branches close to the roof serve as radiating surface for warming this part of the building.

Another point in favor of the overhead system for work of this kind is the matter of drainage. In the case of industrial buildings the ground area is often large compared with the height, thus spreading out the supply and return systems and calling for long runs of horizontal piping.

With the general arrangement shown in Fig. 5 it is easy to provide a continuous downward pitch from the top of the main riser back to the receiving tank or boilers as indicated by the arrows, and furthermore, the flow of condensation and steam is in the same direction, which is a matter of much importance in securing good drainage.

SYSTEMS OF HEATING.

The systems of direct steam heating employed for this class of work are known as the "gravity return" and "return line vacuum" systems. In the first of these the condensation flows back to the boiler or receiving tank by gravity, the entire system of supply and return pipe being under the same pressure. With the vacuum system the usual return valve on the coil or radiator is replaced by an automatic valve which allows the passage of air and water but closes in the presence of steam. A vacuum pump is attached to the main return pipe, drawing out both air and water, which are dis-

charged into a separating or receiving tank. From here the air passes to the atmosphere and the water is returned to the boilers in the usual manner by a separate feed pump.

In a tall building, or wherever the horizontal runs of piping are short and can be given a good pitch so as to secure proper drainage, there should be no difficulty in securing satisfactory results with a gravity return system. On the other hand, where the plant is more or less spread out, and especially if made up of a number of buildings so as to necessitate long runs of horizontal piping, a return line vacuum system is advisable. This is especially

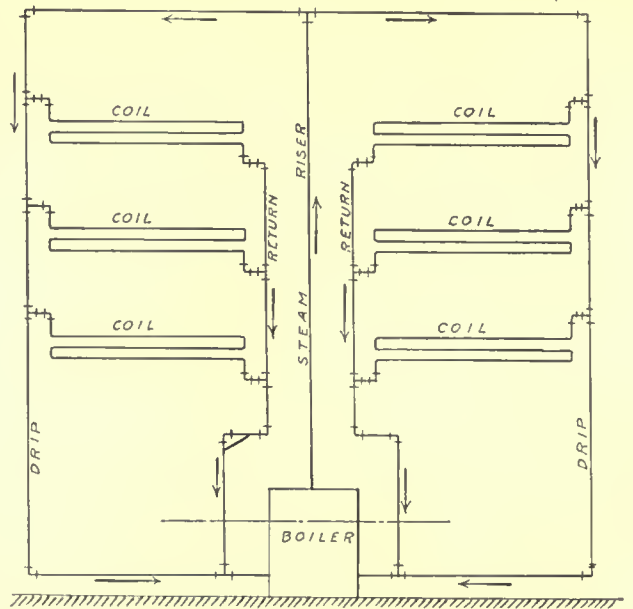

FIG. 5. PIPING ARRANGEMENT FOR OVERHEAD DISTRIBUTION

adapted to cases where new buildings or extensions have been added from time to time so that the original mains have become overloaded, and perhaps also out of line so as to form pockets for the accumulation of condensation.

Connecting a suction to the main return reduces the required pitch and prevents water hammer, which is likely to occur in plants of this kind operated on a gravity return. Steam may be circulated at or slightly below atmosphere, thus relieving instead of adding to the back pressure on the engines in case exhaust steam is used in the heating system. As a majority of industrial plants generate their own power and utilize the exhaust steam for heating purposes, this is an important item. In addition to this, a plant equipped with a vacuum system may be warmed up quickly in the morning, and when the coils and radiators are provided with graduated valves at the steam inlets, is capable of a fair degree of hand regulation.

In any case, only enough vacuum should be carried to insure a prompt removal of air and water from the coils and to lower the initial steam pressure on the heating system to approximately that of the atmosphere. A high vacuum tends to produce a leakage of steam through the automatic valves into the return main, which is undesirable.

Ordinarily a vacuum of about 2 inches is carried at the most distant coil or radiator, which will usually call for a vacuum of 3 to 10 inches at the pump, depending upon the lift and length of run.

Pipe Sizes. The sizes of the steam or supply

pipes may be made the same for both the gravity and vacuum systems, and for average conditions may be taken from Table III, these figures being based on a drop in pressure of 1/4 pound in each 200 feet length of run.

TABLE IV.—PIPE SIZES.
For return line vacuum systems.

Dia. of return.	Square feet of radiation drained.		
	200 foot run.	400 foot run.	600 foot run.
3/4 inch	250	200	160
1 "	800	600	500
1 1/4 "	2,000	1,500	1,200
1 1/2 "	4,500	3,500	3,000
2 "	9,000	7,000	6,000
2 1/2 "	15,000	12,000	10,000
3 "	25,000	20,000	16,000
3 1/2 "	38,000	32,000	26,000

Vacuum Pumps. Both direct-acting steam pumps of the single cylinder type, and motor or turbine driven rotary pumps are used in connection with vacuum heating.

While the former is wasteful in the use of steam, it is easily regulated to maintain any desired vacuum and is extensively used for this purpose. When there is an abundance of exhaust steam from the main engines for all heating purposes it is usually more economical to employ a motor-driven pump in plants of large size. Table V gives sizes of vacuum pumps for different quantities of direct radiation.

TABLE V.—SIZES OF SINGLE CYLINDER VACUUM PUMPS.

Square feet of radiation	Size of pump*
2,000	3-in. x 4-in. x 4-in.
4,000	4-in. x 5-in. x 5-in.
6,000	4-in. x 6-in. x 5-in.
8,000	5-in. x 6-in. x 6-in.
10,000	5 1/2-in. x 6-in. x 7-in.
12,000	5 1/2-in. x 7-in. x 7-in.
15,000	6-in. x 7-in. x 8-in.
20,000	6-in. x 8-in. x 8-in.

*In reading the pump dimensions the first figure indicates the diameter of steam cylinder; the second the water cylinder, and the third the length of stroke, all in inches.

Different makes of pumps will vary somewhat in their dimensions for the same capacity, but the above, rated on a steam pressure of 100 pounds, will serve as a guide in making a selection. When the pump suction is larger than the corresponding return, it should be bushed down to the same size. Vacuum pumps, like all other special equipment of a similar kind, should always be furnished in duplicate in order to guard against accident.

Boiler Room Piping. The simplest arrangement of boiler room piping is that shown in Fig. 6, which illustrates a battery of four low-pressure heating boilers with a gravity return of condensation from

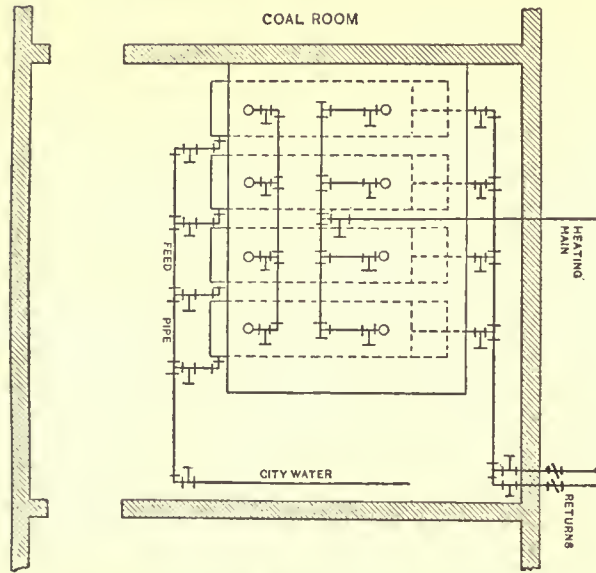

FIG. 6. ARRANGEMENT OF BOILER ROOM PIPING

TABLE III.—PIPE SIZES.

For gravity and vacuum systems except as noted.

Diameter of steam supply pipe in inches.	Diameter of return pipe in inches.*		Square feet of direct radiation it will supply.
	(Dry)	(Sealed)	
1	1	3/4	40 to 60
1 1/4	1	1	60 " 100
1 1/2	1 1/4	1	100 " 160
2	1 1/2	1 1/4	160 " 350
2 1/2	2	1 1/2	350 " 700
3	2 1/2	2	700 " 1,100
3 1/2	2 1/2	2	1,100 " 1,600
4	3	2 1/2	1,600 " 2,300
5	3	2 1/2	2,300 " 4,000
6	3 1/2	3	4,000 " 7,000
7	3 1/2	3	7,000 " 10,000
8	4	3	10,000 " 15,000

*For gravity systems only. The return pipe for a vacuum system may be made somewhat smaller than for gravity work owing to the suction employed for drawing the water through them. Return pipe sizes for return line vacuum systems are based on the square feet of direct radiation to be drained, and vary with the length of run. Data for this work is given in Table IV.

the heating system. The steam connection from each unit leads into a cross-drum or header, from which the heating main is taken as indicated. An equalizing pipe extends across the boilers parallel with the main header, thus providing a direct connection between them through a pipe which is employed for no other purpose. While the main steam drum may serve as an equalizing pipe to some extent, the rapid flow of steam through the boiler connections tends to prevent a proper balancing of the pressure between the different units and thus causes

employed in plants purchasing electric power from a central plant, and where the boilers are simply used for heating.

The more usual arrangement is shown in Fig. 7 where power is generated on the premises and the exhaust steam from the engines or turbines utilized in the heating system.

The layout shown applies to a system operating with a gravity return of condensation to the receiving tank. Steam from the boilers is piped directly to the engines, with a branch leading to the

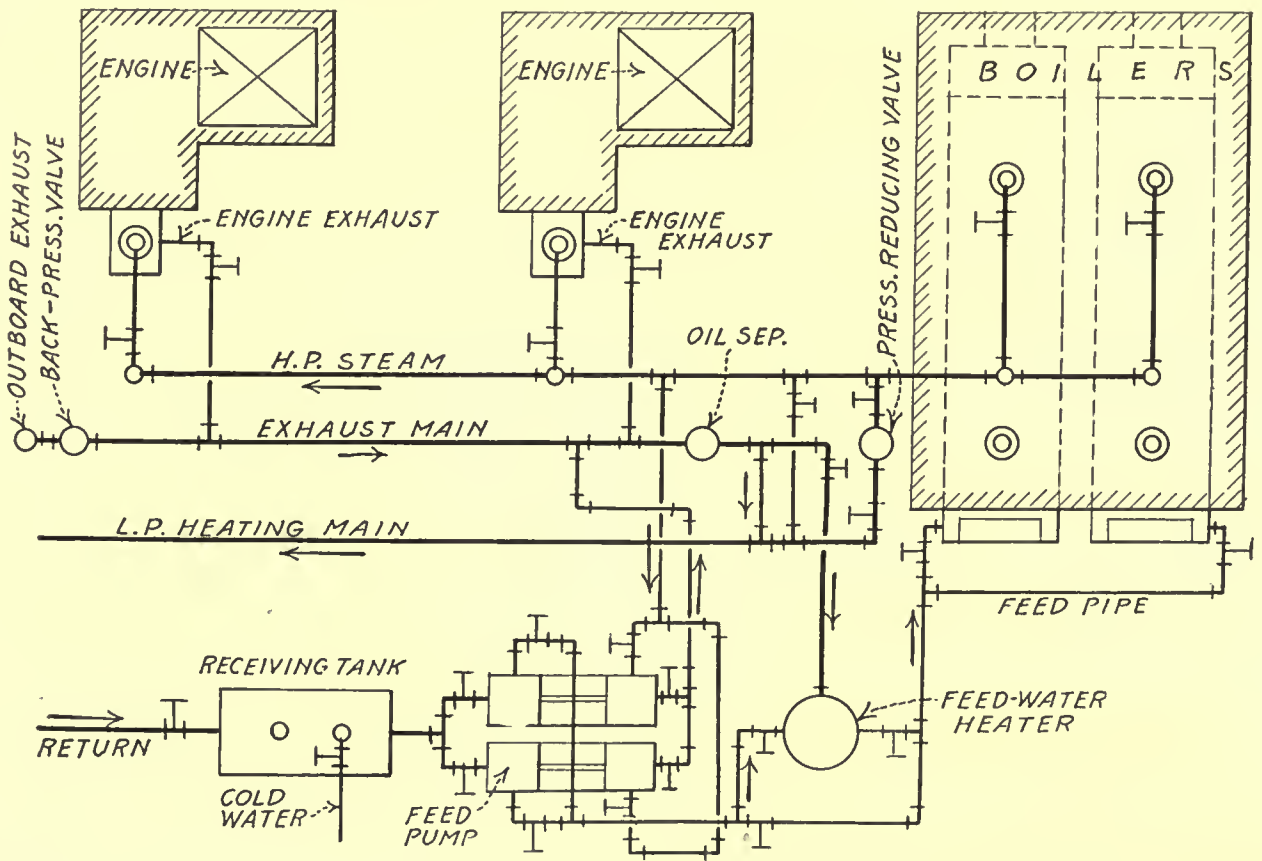

FIG. 7. PIPING LAYOUT WHERE EXHAUST STEAM IS UTILIZED FOR HEATING

the water to be lowered faster in certain boilers than in others and so produces an unstable water line throughout the battery. With the arrangement shown in the illustration, with the check valves in the main returns instead of in the individual boiler connections, the water line should stand the same in all of the boilers. A connection is made between the city pressure and each boiler for filling it independently of the others. Blow-off connections, not shown in the drawing, should be provided for purposes of drainage and cleaning, and should be so made as to enable each unit to be handled independently. Such a piping arrangement is only em-

low pressure heating main through a reducing valve. One end of the exhaust main from the engine leads outboard through a back pressure valve, while the other connects with the heating system through an oil separator. There is another branch connecting with a feed-water heater, as indicated. The main return from the heating system discharges the condensation into a receiving tank, from which it is pumped back to the boilers through the feed-water heater. When the exhaust exceeds the heating requirements, the pressure rises slightly, thus opening the back pressure valve and discharging the surplus outboard. If the exhaust is not sufficient,

then the pressure in the heating system falls slightly and the reducing valve opens and admits live steam at a reduced pressure to the heating main, the operation of both valves being entirely automatic. There are two ways of returning the condensation to the receiving tank. In the "closed system" the top of the tank is connected with the heating main or a nearby return pipe, thus maintaining the same pressure in the tank as in the heating system, so that the water flows back by gravity. In the "open tank"

The only essential difference in the boiler room piping between a vacuum system and the one illustrated in Fig. 7 is in the addition of a vacuum pump between the main return and the receiving tank. A typical layout of the return connections for a system of this kind is shown in Fig. 8. The main return pipe comes in at the right and the condensation passes through a strainer before entering the pump. A cold water jet is provided at this point for use in case there is considerable leakage of steam into the

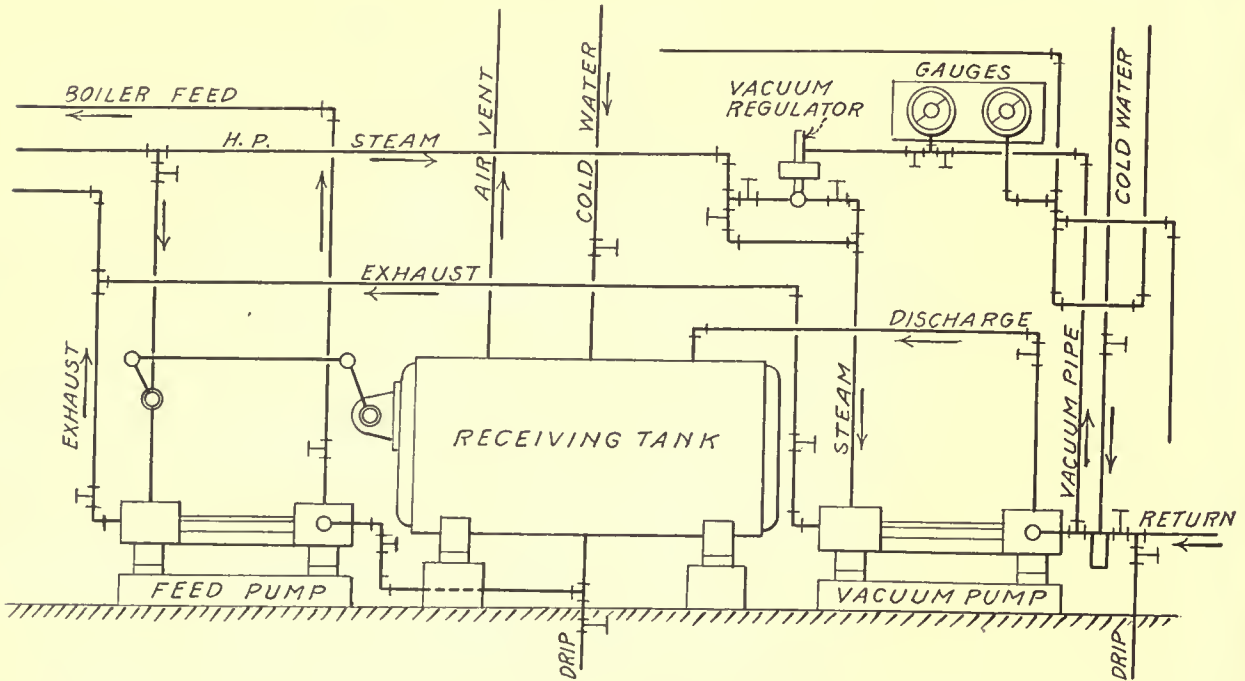

FIG. 8. ELEVATION SHOWING ARRANGEMENT OF PIPING, PUMP, ETC., FOR A VACUUM SYSTEM

system, the receiver is vented to the atmosphere and the condensation discharged into it through a steam trap. The closed system is adapted to small plants where the pressure is well equalized throughout the piping, but for extended layouts, and especially where there are two or more buildings, it is better to use an open tank and trap the condensation into it from the different sections or building. The return pumps should be in duplicate to guard against accident, and one generally operated automatically by a float in the receiving tank or by a pump governor which maintains a constant water level.

return main through defective valves. The vacuum pump is provided with an automatic regulator, which operates it at just the required speed to maintain the desired vacuum. This is shown in the steam pipe to the pump and is actuated by the pressure in the return main. Water and air from the vacuum pump are discharged into the receiving tank, where separation takes place, the air passing outboard through the vent pipe and the water being returned automatically to the boilers the same as in the gravity system previously described.

Engineering Notes of Interest

Production and Use of Magnesite

The production and use of magnesite was stimulated considerably during the war period because it enters largely into refractories in the metal industries. This is especially true of the magnesite from Montana and Washington. Quite a percentage, probably three-fourths of that produced in California, was calcined and used in the plastic trade mainly for the making of what is known as sorel cement for floor and stucco purposes.

The total output of crude magnesite in 1919, according to a Geological Survey Report, was 162,000 tons, the production being mainly in Washington, Montana, California and Texas. Most of the Washington product went to the steel mills as did also part of the California product, but the main part of the California product went into plastic industries.

The Northwest Magnesite Co., of Chewelah, Wash., is the largest producer of Magnesite, the other producers in Washington are the American Mineral Production Co., Valley, Wash. The principal producers in California are the Porterville Magnesite Co., Porterville, Cal., and the Tulare Mining Co., at Red Mountain, Cal., the White Rock Mine in Napa County and several others.

So far there has been no great resumption in the imports of magnesite and because of this fact hope is held out that 1920 should prove a very good year in magnesite development, both for refractories and for plastic uses, notwithstanding the passing of those urgent demands created by war conditions.

Forest Extension Service

"The red pine trees now being planted near Syracuse as well as in other parts of the state may be those upon which the next generation will have to depend for seed for future planting of this valuable lumber tree. The supply of seed today is extremely limited, and is far less than the demand."

This is the significant statement made by Prof. John W. Stephen, head of the silviculture department of the New York State College of Forestry at Syracuse, who has been instrumental in making several plantations of red or Norway pine in various parts of the state. He says in addition:

"Dean Toumey of the Yale Forest School, when in Syracuse in June, declared that he was able to obtain only one and a half pounds of red pine seed last fall, after a vigorous campaign of advertising widely through the region of its distribution.

"This means a really serious condition, and the greatest care must be taken lest this valuable tree

becomes practically extinct. Red pine is one of our very important timber trees, and is especially desirable for planting throughout its range, because of its immunity from disease, and insect depredations. This makes the difficulty of obtaining seed and its growing scarcity of tremendous importance.

"Because of the danger of attack on the white pine by the white pine blister rust, a fungous disease, and the white pine weevil, an insect that stunts the growth of the white pine, the red pine is replacing the white pine largely in reforestation operations. Its use is limited, however, by the scarcity of the seed. The plantations already established in the vicinity of Syracuse, therefore, will be a valuable source of seed supply for the forests of the future."

Engineering Council Bulletin

Federal Power Commission.—Applications covering 4,000,000 horse power are expected before January 1. This is more water power work than has been handled by the Government in past fifteen years. Under the old plan about \$250,000 was spent annually to care for water power work. This makes it apparent that the present appropriation of \$100,000 for the Federal Power Commission is totally inadequate. American Civic Association and National Park Association has started propaganda against Water Power Act as it effects National reservations. This action appears groundless because the Commission has announced that no applications will be accepted for projects located on National parks, and Senate committee has promised to write such provision into the Act when Congress reconvenes.

Shipping Board, Nomination of Members.—Difficulty in obtaining qualified men for the shipping board under the condition of temporary appointment and the lack of provisions for salaries of the members under the new law makes it probable that the President will wait until Congress convenes before making nominations for present vacancies.

Engineering Courses for ex-Service Men.—The Federal Board for Vocational Education has arranged with various schools of engineering in all parts of the country for engineering courses for 2,387 ex-service men in all branches of engineering. Similar arrangements are being extended as universities start courses for the current year.

Steel Basing Point.—The Federal Trade Commission has decided to hold a rehearing of the complaint recently brought before them by the Western Association of Rolled Steel Consumers against the U. S. Steel Corporation. The reargument will be-

gin November 15, in which Western steel fabricators will make another effort to do away with the use of Pittsburgh as a basing point for steel prices. The last hearing resulted in a decision in favor of the interests of the U. S. Steel Corporation.

Management Education.—A course in this subject aimed to provide sufficient number of properly trained executives for industries of the United States is to be established in majority of American colleges according to announcement by Dr. Hollis Godfrey, president of Drexel Institute and formerly member of advisory commission of Council of National Defence.

American Engineering Council to Hold First Meeting November 18

Arrangements have been made to hold the first meeting of American Engineering Council of the Federated American Engineering Societies at the New Willard Hotel, Washington, D. C., November 18 and 19. The program as announced follows:

Thursday, November 18, 1920.

Morning session: Registration of delegates.

Opening session of American Engineering Council.

Call to order by Richard L. Humphrey, Chairman, Joint Conference Committee.

Election of Temporary Chairman, Secretary and Committees on Program, Credentials, Constitution and By-Laws, Nominations, Plan and Scope, Budget and Resolutions.

Afternoon session: Address—"Engineering Council"—J. Park Channing, Chairman.

Discussion of the field of activity for the Federated American Engineering Societies.

Friday, November 19, 1920.

Morning session: Report of Committee on Nominations.

Election of Permanent Officers.

Report of Committee on Constitution and By-Laws.

Formal Ratification of Constitution and By-Laws.

Report of Committee on Plan and Scope.

Afternoon session: Report of Committee on Budget.

Report of Committee on Resolutions.

Evening session: Introductory remarks by presiding officer, the President of American Engineering Council.

Address by Herbert C. Hoover, President, American Institute of Mining and Metallurgical Engineers.

Informal reception and smoker.

Saturday, November 20, 1920.

Organization Meeting, Executive Board, American Engineering Council, of the Federated American Engineering Societies.

Engineering Board Appointed for Delaware River Bridge

According to the agreement between the Pennsylvania and New Jersey Commissions having supervision over the construction of the Delaware River bridge between Philadelphia, Pa., and Camden, N. J., one engineer was to be selected from each state and a third from a neutral state, these three to constitute the engineering board having direct charge of construction. The engineers appointed are Ralph Modjeski, of Chicago and New York, George S. Webster, Chief of the Bureau of Surveys, Philadelphia, and Lawrence A. Ball, of Orange, N. J. All are members of the American Society of Civil Engineers.

Bituminous Coal Storage Practice

The Engineering Experiment Station of the University of Illinois has just issued Bulletin No. 116 prepared by Professor H. H. Stoek, C. W. Hippard and W. D. Langtry, which bears the above title.

The authors point out the fact that fuel shortages are largely caused by the inability of existing transportation systems to handle a greatly increased winter tonnage of fuel because already overloaded by unusually heavy tonnage from other sources. As a remedy for this condition, they suggest that as large a proportion as possible of the total fuel tonnage be handled during those months of the year when traffic conditions are not so acute. If this is done, it would, of course, necessitate the storage of large quantities of fuel at or near the place of use.

Heretofore, more or less trouble has been experienced in the storage of quantities of bituminous coal, from fires, due to the spontaneous combustion of the fuel, this fact retarding to a large extent the practice of fuel storage on any considerable scale. Now that it has become so necessary to store coal, a more careful and extended study of the causes of spontaneous combustion in coal piles has been made. In this respect this bulletin contains much valuable information on the subject, devoting considerable space to actual experience with storage piles. Where fires have occurred, the causes have been carefully investigated and reports made thereon. This information should prove of great value to every prospective storer of coal. Copies of Bulletin No. 116 may be obtained without charge by addressing C. R. Richards, Director, Engineering Experiment Station, University of Illinois, Urbana, Illinois.

Current News

Happenings and Comments in the Field of Architecture and the Allied Arts

Builders' Exchange to Hold Exhibit

The Builders' Exchange of Minneapolis, Minn., will hold a building and manufacturing show in that city, during the month of February. Elaborate plans are being made to have this one of the largest shows of its kind held in that territory.

Canada to Replant Forests

The Quebec government plans to plant two pine and spruce trees for every one cut down, and has at present six hydroplanes patrolling forest areas, while at the same time it is encouraging private forest protection. Three million pine and spruce trees have been planted this year and seven associations of lumbermen organized for timber development.

A Building Boom in Mexico

A building boom has struck Mexico with the advent of the first real peace the inhabitants have experienced in many years, judging by late reports.

Practically every city of more than ten thousand people has reported much building activity.

Contractors have been asked for bids on paving, drainage systems, factories and railroad reconstruction.

Town-Planning a Necessity

The familiar rush of the people from the land to the cities, so pronounced a feature of modern times, has encouraged congestion in most communities. Recourse to town-planning has been forced by the necessities of efficient transportation and sound land values, as well as good health.

It is fashionable today to deplore the slums. Why provide new ones? Why add congestion to existing congestion, when, simply by looking ahead and taking thought, healthy growth may be assured?

Town-planning provides the city with eyes to see where it is spreading and to conform to the demands of business and comfort. A city unplanned is a blind giant, sprawling over the ground. It wastes some of its greatest assets in a building debauch.

Every city that keeps order on its streets must also keep order in its advance to greater size and influence. It must put town-planning traffic experts at important corners on its way.

Largest Room Without Columns

The largest room without columns is said to be in a solid concrete building of the mosque in Lucknow, India. It is 162 feet long, 54 feet wide and 53 feet high. The timber mold was left a year for the concrete to set, and the building, 125 years old, is still unimpaired.

Exchange Council Formed in East

An organization to be known as the Tri-City Builders' Exchange Council with the object of protecting and promoting the building business, was formed at a meeting of the builders of Albany, N. Y., Troy, N. Y., and Schenectady, N. Y. The council is particularly anxious to secure harmonious relations between the builders and their employes and between the builders and the architects.

Ship Brick by Parcel Post

When it comes to shipping brick by parcel post there is no gainsaying that transportation difficulties have hit construction a body blow. John B. Cahoon, of the Salt Lake Brick Company, states that his company shipped 15,000 face brick in that manner from Salt Lake City to Vernal, Utah. Each brick was wrapped in paper and then packed in crates of ten bricks each. The consignment cost fifty-five cents a package and the whole consignment was not shipped in one day, because to have done so would have congested the service.

Small House Service Bureau for Illinois

The Board of Directors of the Illinois Society of Architects at their September meeting appointed a special committee of the Board to incorporate the Illinois Architects' Small House Service Bureau, the incorporation to be modeled after the Architects' Small House Service Bureau, Inc., of Minnesota.

Those interested in better architecture for small houses may communicate with Charles H. Hammond, 64 East Van Buren Street, Chicago, Ill., Chairman of the Special Committee of the Board having this matter in charge.

Ten-Hour Air Route to Link United States with Alaska

Skagway, Alaska, is to be only 10 hours distant from Seattle, Wash., when, some time next summer, an aerial mail, express and passenger service is instituted. Back of the project are various chambers of commerce, and in particular, a western flying-boat corporation. This concern is now busy with the construction of the ships and with the survey of the 1,000-mile route. This course will seldom emerge from the shelter of the islands that parallel the coast.

Open Carload of Cement Is Protected by Own Crust

In filling a recent carload order of cement an Illinois concern, as an experiment, dumped the entire 208 barrels into an open coal car, sprinkled the surface with water, and started it on a 260-mile trip. The hardened surface formed a water-proof crust an inch thick, estimated to be ample for the cement underneath. But the car was started too soon, the surface cracked, and a rainstorm soon thickened the crust to 4 or 5 in., with a loss of some 50 bbl. The material below was in perfect condition, however, and the shippers believe a properly hardened crust, requiring but 6 to 8 bbl., will prove an economical and efficient packing.

Chinese City Becomes Modern

Expansion is always the order of the day in an active community; and the old city of Ningpo has given proof of her vitality by allowing her age-worn walls to be pierced by a new gate. This is situated about half way between the north and the west gates, and has been made chiefly for the convenience of workers in a grass-mat factory on the outer edge of the city foose at that point. No doubt the promoters of the factory have been the moving force in bringing in this innovation and the gate symbolizes their hopes, being named the Gate of Gain.

This mat factory was begun in a small way inside the city about two years ago. Last year it was moved to some old buildings in its present position, about thirty more of the surrounding rice fields bought in, and new buildings erected. There are now about 1,000 workers, the majority of whom are women and girls; and a wooden bridge is soon to replace the slow moving ferry between the factory and the new city gate.

The women are paid by piece work, and the skilful can earn up to 40 cents a day. Besides mats of various sizes and designs, dainty grass slippers are

turned out soled with leather. Some of the mats are made with the object of replacing in the market Japanese mats of a similar kind, the patterns on show are very attractive.

Amazon Valley Riches Are Undeveloped

The Amazon Valley is said to be the greatest undeveloped region in the world which is yet untouched. The soil is said to be extraordinarily fertile. The forests offer woods in inexhaustible variety, many of them cabinet woods of rare value. Of vegetable oil nuts, a tenth part only is known to the outside world, says the Indianapolis News. Raisins, gums, spices, medicinal plants and fibers abound in infinite variety. Kapok grows along the banks of most of the main rivers, but not a pound of it is exported to the United States, although America imported 7,000,000,000 pounds last year from far-away Java. There are mineralized areas said to contain coal, iron, gold, silver and precious metals of many kinds. They have not yet been prospected.

Building Blocks Interlock with Herringbone Grooves

Building blocks of concrete, tile, or other suitable material, are made to interlock by an ingenious formation of their top and bottom surfaces, in the design of a Wisconsin inventor. V-shaped grooves arranged in herringbone order, at a 45 degree angle, are formed in the blocks. The special unit used at corners has the axis of the herringbone design running transversely on one-half the surface, and longitudinally on the other half. Such blocks used in building a wall fit accurately together, and cannot be moved in any direction.

Palestine Is Transformed

A very interesting geological change states the *North China Herald* is taking place in Palestine. Of all countries in the world Palestine a short time ago looked the most forlorn, the least capable of achieving physical beauty. Yet she is experiencing a comely rebirth. A visitor to Palestine a few years ago would have been depressed by the vista of dull gray rock. The country seemed to be nothing but acres and acres of conglomerate rocky surface. One looked in vain for a flowering shrub or a stretch of green grass.

It has been discovered that this barren, rocky, surface, which has been hardened by exposure to the sun for years, on being covered disintegrates into a rich soil. Modern science has drilled ditches through

the flint-like substance and covered the remaining surface of the rock with clay or dead leaves. In a short space of time the rock softens and breaks up under the covering, which is then removed, and the soil, irrigated by the ditches, is planted with grain, fruits and vegetables.

After tramping over miles of rock that have not as yet received the attention of the cultivators, it is very refreshing to round a hill and find, unexpectedly, meadows of waving grain.

Liege Defence Memorial

The province and town of Liège have decided to erect a monument commemorating the defence of Belgium against the German invader. A sum of 1,000,000f. has been subscribed for the project. The design for the memorial will be decided by a competition open to architects and sculptors of Belgian nationality or subjects of the Allied Powers. The conditions of the competition may be obtained from M. Léon Maréchal, Bureau des Beaux-Arts, Hotel de Ville, Liège, Belgium. A map of the selected site will be sent on receipt of 5f.

London Has Hotel for Infants Only

Life in the city of London is becoming so complex, because of the house shortage, that many families are being forced into apartments and hotels where babies are not recognized. Two enterprising nurses have met the emergency by opening a hotel for infants only, catering to transient as well as resident business. The wall decorations of the rooms in this curious inn run largely to ducks, chickens, and similar figures, while the standard furnishings are white cots with pink curtains. A house physician and dentist are features of the establishment. The charges range from about \$13 a week for the very young, to \$21 for the older guests. Parents are permitted to call as often as they please.

Put Sidewalks in Buildings to Make Streets Wider

In undertaking the seemingly impossible task of widening the business streets of their city without moving the buildings, engineers of Nice, France, have almost succeeded in making two things occupy the same space at the same time. They have converted the old sidewalks into street space, and moved the front windows and doors of the buildings back far enough for a new sidewalk, under the overhanging second stories, to support which the original pillars are left standing. The plan is similar to that quite usual one in Southern California and other warm western states. It is quite economical, and the new

walks have the unusual advantage of protection from sun and rain for those who travel them.

White House Modeled After Palace

The White House at Washington, which after March 4 next will have a new tenant, received its name from the fact that it was built of white free stone. The site for the building was chosen by President George Washington and Major Peter L'Enfant when they laid out Washington in 1791. Its architect was James Hoban, of Dublin, who modeled the structure after the palace of the Duke of Leinster. The cornerstone of the building was laid October 13, 1792, and its first occupants were President and Mrs. John Adams, who moved in during November, 1800. After it was burned by the British in 1814 the original architect returned and supervised its restoration. The original cost was defrayed by the sale of land donated by Maryland and Virginia—Detroit News.

Bank Built of Rocks from Near-by Fields

The only bank building of its kind in the world, the owners call a structure in a town of northern South Dakota. The claim is made because the walls are built entirely of glacial bowlders collected a few years ago from the fields and prairies about the town. The work of preparing the stones occupied the better part of a year and was done by one stone-mason unassisted. He first split the bowlders with iron wedges, to reveal the original colors of pink, red, purple, brown, yellow and gray. Then they were cut to size and squared. Incorporated in the walls they have retained their striking coloring, and have imparted to the structure unusual strength and permanence. Quarried stones, and not the glacial rock, were used, of course, in building the portico.

Excavation May Be Resumed at Herculaneum

The director of museums and excavations in southern Italy, it is announced, is now agitating the resumption of work at Herculaneum, the ancient city on the western slope of Mt. Vesuvius. He desires particularly to uncover an undamaged Roman house, with all furnishings and ornaments in place. This he has never been able to do in Pompeii, but he feels that such a discovery should be made in Herculaneum. This city, it may be recalled, was not overwhelmed by a fall of stones, followed by a rain of ashes, but was simply engulfed in a flow of water, earth and small stones. While obliterative, this torrent was not, in a way, destructive.

The director has additional reason for his hope in the record of discoveries already made in the theatre, basilica, forum and villas. From these have been taken intact many marble and bronze statues, mural paintings, and one papyrus library of 1,803 volumes. Most of these antiquities were brought to light at the time of the first excavations, in the period 1738-1780. During these years tunnels were driven in all directions, though many authorities maintain that the area investigated was proportionately small. Since that time little has been done at Herculaneum because of legal, political and financial difficulties.

Business Men and the Fire Waste

The Chamber of Commerce of the United States, at its 1920 annual meeting in Atlantic City, adopted resolutions declaring strongly in favor of reduction of the preventable fire waste. The organization includes 1,300 national and local associations, having an aggregate membership of nearly 700,000 business concerns. Discussing increased production and thrift, resolutions made the following declaration on fire prevention:

"At a time when increased production is of the first importance destruction of means of production continues on a great scale. Each year approximately \$300,000,000 in property values are being destroyed in the United States through fire. A large part of this value represents waste that can be prevented. Considerations which should appeal to every individual require that, even if conditions were normal, the endeavors which are being made to stop this needless waste, with its detriment to the public interest and its private burden for all citizens, should be redoubled. At a time when economy and conservation of our resources must be paramount, in order that every effort may have its full influence toward increasing production, it becomes the immediate duty of each person, each association, and the whole nation to put an end to preventable waste through fire."

Famous Doors of History

Among the famous doors of history are the carved wooden doors of the church of Santa Sabina, Rome, depicting in relief, scenes from the Old and New Testament. These are one of the most remarkable examples of early Christian sculpture extant. In the earliest times, as in Babylon, doors swung on sockets instead of hinges. In Roman days wooden doors were decorated with bronze and inlaid, and throughout the Middle Ages richly carved doors of wood adorned the churches. In the Gothic period, wooden doors were decorated with wrought-iron hinges which were often elaborated into intricate or-

namentation covering a large part of the door. The doors of the Cathedral of Notre Dame in Paris of the thirteenth century are the finest examples of this class. During the Renaissance in Germany and France, elaborately carved doors were among the most beautiful products of wood sculpture. Some of the old English doors were formed of narrow planks placed side by side and in dwelling houses generally, in the Middle Ages the doors were small and fairly simple, meant for strictly practicable purposes and often provided with some means of defence. The doors of the Norman period were round-headed, while with the thirteenth century, came the doorway with the pointed arch and later the flattened arch. In the case of interior doors, splendid old polished mahogany doors were important features in some old English homes and there were old oak doors of wonderful beauty, especially when found in oak-panelled rooms.—National Lumber Manufacturers' Association.

Few Buildings are Painted in Turkey

Turkey is a paintless land. Most of the houses are wooden and unpainted. This is not a condition growing out of the war. The short-sighted policy of the government in imposing taxes on buildings in proportion to the sightliness of their exterior has encouraged shabbiness.

Even in Constantinople a large percentage of the residences and many of the business houses are of wood. Many of the large apartment houses and office buildings have brick or stone fronts, but wooden sides and backs. Hence the disastrous fires which have laid more than one-third of the city in ashes since the beginning of the war, and the general terror of the population when a fire alarm sounds.

Constantinople and most other Turkish cities would doubtless have been destroyed by fire long ago were it not that the shabby wooden and semi-wooden buildings have tile roofs. These roofs of bright red tile are in striking contrast to the dingy grey walls, rotted and stained by the weather.

In the past Turkish tax assessors frequently imposed twice as high a rate upon a well-painted house as that levied upon an unpainted house of exactly the same construction in a similar locality.

Waste Heat to Be Used to Reduce Fuel Costs

Utilization of heat now going to waste from the kilns of the Bath Portland Cement Co., near Bath, Pa., will save forty-eight tons of fuel a day, according to engineers who have studied the proposed plan

of the company to reduce its fuel expenditures. The kiln heat is 1500 degrees Fahrenheit, and it is estimated that 75 per cent of this wasted energy can be harnessed and put to use in producing steam for the plant. In furtherance of this plan the company has ordered boiler equipment worth \$250,000 from a Philadelphia plant, which will be installed early in 1921.

Managers of other heavy coal-using plants are watching the experiment with a great deal of interest for, if the plan were adopted throughout the Lehigh cement district, it would result in a \$4,000,000 cut in the annual fuel bill.

News from Various Sources

According to the National Industrial Conference Board, the increase in the five major items in the cost of living between July, 1914, and July, 1920, was as follows:

	Per cent
Food	119
Shelter	58
Clothing	166
Fuel, heat and light.....	66
Sundries	85
Average	104.5

* * *

A stone hewn from the bridge over the Marne at Chateau-Thierry, where American troops halted the German drive in the Summer of 1918, will be used as the cornerstone of the War Memorial Building, which will house the national headquarters of the American Legion.

* * *

In the six years from its beginning in 1914 to the present time world indebtedness grew from \$44,000,000,000 to approximately \$265,000,000,000, an actual increase in six years of over \$200,000,000,000 as against an average of a little more than \$1,000,000,000 per annum in earlier years.

* * *

A catalogue of some 600 books on architecture and the allied arts, in English, French and German may be obtained from John Tiranti & Co., 13 Maple Street, Tottenham Court Road, London, W. 1, where they are offered for sale. Telegraphic address, Tiranbosel, Ensroad, London.

* * *

Airplane mail service between the United States and Cuba is to be inaugurated this fall, according to an announcement made by Postmaster-General Burleson.

Personals

Max A. Bernhardt has enlarged and improved architectural offices at 721 Walnut St., Philadelphia, and desires new catalogues.

Lehmann & Kuehrmann announce their removal to 506 New Two-Republics Bldg., El Paso, Texas.

George Zunner, for many years in the Hartford Trust Co. Building has moved to 182 High St., Hartford, Conn.

F. L. Clepper, structural engineer, formerly with the Watson Engineering Co. of Cleveland, is now identified with the office of M. M. Konarski, architect to the Board of Education, Akron. Catalogues and samples desired.

M. M. Konarski has been appointed architect for the Akron, Ohio, Board of Education, offices in the Central High School Bldg. Samples and catalogues desired.

C. Frank Jobson is now practicing architecture under the name of Jobson & Hubbard, at 225 North Michigan Blvd., Chicago.

Clarence J. Parman has opened an office at 1521 Nicholas Bldg., Toledo, Ohio, for the practice of architecture. Manufacturers' samples and catalogues are desired.

F. T. Schneider, architect, 1314 F St. N. W., Washington, D. C., has moved to 1006 Massachusetts Ave., that city.

H. Robert Diehl and Samuel N. Vance, architects and engineers under the name of Diehl & Vance, New Monroe Bldg., Norfolk, Va., have dissolved partnership by mutual consent. The business will be continued by Mr. Diehl, with offices in the McKevitt Bldg., Norfolk, Va.

S. K. Yaukey, architect, 66 E. Main St., Waynesboro, Pa., has moved to 50 S. Potomac St., that city.

Ernest H. Schmidt, Glencoe, Minn., has associated himself with Albert Schippel in the practice of architecture at 309-11 Coughlan-Hickey Bldg., Mankato, Minn. The firm will be known as Schippel & Schmidt. They desire new catalogues and samples from material concerns.

Weekly Review of the Construction Field

With Reports of Special Correspondents in Prominent Regional Centers

THE ROAD TO RUIN

THE news columns have related and this newspaper has discussed the downward slide of crop prices with \$4,000,000,000 of price recently wrenched out of the market quotations of the three staples, wheat, corn and cotton, editorially comments the *New York Herald* in connection with a letter from a correspondent, which is also reprinted herewith. Continuing this editorial states: From a hard headed American farmer expressing himself simply but manfully on the subject we print elsewhere a letter both brimming with sound economic sense and presaging the inevitable fruits of the supreme laws of nature.

This hard headed American farmer delivers the plain warning that the producers of the nation's food and other necessities of life are not going to toil into bankruptcy while Government mismanagement squanders billions of dollars and while slackers and wasters organized to get high wages but not to earn them strip those who dig our national wealth out of the soil.

This hard headed American farmer sets forth the bald truth of the responsibility of Government inefficiency and extravagance for a large part of the high cost of living. And he declares that grossly overpaid but deliberately non-earning workers now have the choice of fitting their wage scales to the readjusted economic conditions or of losing their jobs.

It is a cold fact, as the hard headed American farmer says, that it is wanton and ruinous destruction of nature's supplies intended for the nourishment and comfort of mankind when a Government flings away its opulence like a drunken sailor. The national Government has been taking billions of dollars of the public's money, which is the public's bread and meat, the public's shelter and raiment, the public's necessities and comfort—the national Government still takes it and makes an economic bonfire of it. State governments and municipal governments take billions more of the public's money and make other bonfires of it.

And it is a cold fact, as the hard headed American farmer says, that while the producer back on the land has been laboring hard and long hours to provide the nation's food and raiment, organized individuals, organized to get a bigger and bigger share of the production but to do less and less work for it, have been raiding his granary. The hard headed American farmer says this unfair division is going to stop.

The hard headed American farmer offers no objection to lower prices for his hard earned product if other prices are similarly adjusted. He knows from his own war price experience that no matter what dollar marks are on his wheat he is better off when three bushels of it will exchange into a pair of shoes than when two bushels of it will exchange into only one shoe. He knows from his own war price experience that 100 bushels of corn exchanged into a set of harness makes a wiser bargain than 250 bushels of corn exchanged into a set of harness. He knows from his own war price experience that he is the goat, as he puts it, when a big bin full of grain is the equivalent of a little tinkering by a plumber who has his tools carried for him by an apprentice whom the farmer pays to learn his trade.

The hard-headed American farmer who has been getting for his work and his yield more dollars, but fifty cent dollars instead of fewer one hundred cent dollars, is perfectly content to go back to getting half as many sound dollars for his work and his yields. But he does not propose to go back to pre-war prices for his crops and then take plugged nickels as well for his honest wheat and corn.

So this hard headed American farmer, as all hard headed American farmers will do, sends his message to Mr. Sam Gompers or to any other labor union politician who rants and threatens that all commodity prices must come down but that the inflated wage shall not.

It will come down, as the hard-headed American farmer says, because when there is now \$9,000 of labor cost alone in what used to be a \$6,000 house rents cannot come down until those inflated labor costs come down. But nobody will build houses to give the labor engaged on them \$9,000 for a house worth all told \$6,000.

It will come down because a suit of clothes that used to cost the wearer \$30 cannot go back to \$30 when there is now \$50 of labor cost in it. And the public is not going to pay the laborer \$50 for making a \$30 suit of clothes.

It will come down because the farmer will not give fifty-six bushels of wheat for a piece of lead pipe, a couple of washers, and a plumber's stroll around the garden. He will not raise the wheat to throw away in such a swap.

It will come down because when the farmers call a halt, as the rest of the public is now calling a halt, on wages without work, whether of brains or of brawn, and on goods without value, whether of the open shop or the closed shop, the only other

THE AMERICAN ARCHITECT

choice for the man who will not do a square day's work for a square day's pay will be no job and the bread line.

Following is the letter that inspired the Herald editorial utterances as above:

To the New York Herald: In your editorial article of October 6 you state that December wheat is at \$1.90 and corn at 85 cents a bushel and cotton at 20 cents a pound. To produce either wheat or corn in the East at such figures with farm labor now demanding high war factory wages would bring a big producing loss to the farms, and instead of mortgaging his farm, which we don't propose to do, the farmer will have to let his farm land lie idle, only producing his own home wants. This will cause short production, and the public who are upholding high wage earnings, will have to pay for it.

The farm producer is certainly the goat when we have to pay 75 cents to 80 cents an hour for common farm labor. There never can be any reduction in our present high cost of living until we have a change in wage earnings and also a change in this extravagant, wasteful, reckless Administration of Mr. Wilson's, which has been the fountain head for higher prices.

I had a little plumbing work done at our farm. The bills total \$56.95; material, \$8.55; labor, \$48.40; \$1 an hour for helper, which we pay him as an apprentice to learn his trade at our expense. That's why building operations and rents have advanced. Until Mr. Samuel Gompers, our Mr. Woodrow Wilson's Assistant Secretary of Labor pro tem. (without portfolio), is made to understand that the American public will not stand his dictation, and that as food-stuffs come down wage earnings cannot increase but must decrease, the public cannot live as it is entitled to live.

WILLIAM OSBORN.

Stelton Heights, N. J., October 9.

OUR New England correspondent reports: While the housing problem is being tackled in a practical way by several New England cities, Boston presents the spectacle of tearing down good houses to make site for the new yard and inspection shops for the elevated, the demolition of houses along the entire side of one street to provide space for an office building and the trimming away of hundreds of habitable rooms by the widening of a street. This further places a minus mark against the housing facilities of a city in which 6,500 families must store their household goods and double up with friends or live in hotels or boarding houses.

Fitchburg boasts of a housing corporation composed of manufacturers which has just completed thirty new double and single houses to be paid for on easy terms, and plans to build more in the near future.

A large number of mill operatives in New England will be idle for two days next week as a result of plans announced to-day. In addition, a silk manufacturing concern announced a 15 per cent. reduction in wages, a shoe factory was closed for an indefinite period and a cotton mill was shut down until Nov. 1. Two cloth and two yarn mills will be closed all next week and many others have been placed on a four-day schedule.

As retailers do not want to buy any more goods than necessity demands until they can know the future of prices, and jobbers and wholesalers are in the same position, it reacts on the manufacturers. Hence the moves noted above. They do not care to make goods for stock at current prices for raw materials and labor on the slim chance that they can sell later at a profit, so they are curtailing operations everywhere.

(By Special Correspondence to THE AMERICAN ARCHITECT.)

Seattle.—Many manufacturers, jobbers, architects and contractors are inclined to feel that the turn of the tide in building in the Pacific northwest is near at hand. It will not be possible to deal with future contracts until prices of some essentials strike bedrock, but that this readjustment is now in full swing is also felt to be true, with lumber leading. In that single commodity, at least, there seems to be little doubt that prices can go lower and the industry survive.

Shortage of production is still a vitalizing factor in preventing development of spring building projects. The jobbing trade is able to report a slight improvement in receipts of nails and small pipe, which has led in scarcity, but the difference is not sufficiently marked to warrant too much optimism. Bettered headway may not be possible until after the end of the year, certainly not until after the presidential elections, but restored confidence in building commitments predicated on 1921 is breaking forth through statements of architects who have already been consulted severally, through the increasing enquiry for fir lumber and shingles and with contractors.

Large jobbing interests that handle plumbing supplies, radiation, vitroware and enamelware, brick and cement are agreed that no improvement can be expected before the national political contest is over. It is without political tincture rather well conceded what the result will be, but investment in new building commitments seems to prefer to have the battle over and off the Pacific coast mind before a start is made. Following that, large jobbing interests are cautious as to how they express their hopes for next year. All depends on how rapidly prices are eased

to bedrock from which point it will be regarded as safe to rebuild.

The scarcity of cement is holding back the eastern demand for fir lumber. Both commodities now seem to be interlocked. Jobbers state they are unable to place a reason, that of car shortage having been nullified by the public statements of railway officials who repeatedly assert that the shortage is now history, and "spotting" orders on industrial tracks throughout the Pacific coast bears them out. Plaster is also short, and plaster board can be used as a substitute only in a limited way. There is plenty of brick, but without cement, plaster, galvanized pipe or enamelware architects and builders cannot follow the more optimistic mental condition of buyers.

An occasional small shipment of pipe reaches Pacific coast points, but one jobber expressed the condition when he stated that 100,000 feet of halves and three quarters would vanish overnight due to the stacked up back orders held by all the distributors. Large sizes are plentiful, but these are not now in demand.

Roofing is being offered at a surplus. Seconds in fir lath are \$4, with standards at \$7.50. Hydrated lime, due to the expense of packing and securing return of sacks, is being handled in this territory in 50 pound paper bags. Jobbers who have made the experiment report satisfactory results.

Jobbers of pipe, sheet metal and wire in this territory point out that war standards of gross margins of profits were permitted to remain for the North Pacific distributing territory, and that in consequence fall of prices will not be so radical as in other portions of the country, where margins were lifted as costs advanced.

The general building situation next year, as jobbers now view it, will depend largely on what farmers get for their crops. The action of the wheat market so far has not augmented the tendency of farmers to take up deferred building projects, and predictions are being withheld temporarily.

Fir lumber prices are steady. No. 2 vertical grain flooring is \$64 at the mill, finish No. 2 and better 1x8 10 in. is \$66 to \$76, five eights by four No. 2 and better ceiling is \$40 to \$48, drop siding 1x6 No. 2 and better \$41 to \$51 and 2x4 dimension \$21.50 to \$25.75.

(By Special Correspondence to THE AMERICAN ARCHITECT.)

Chicago.—The keen attention which is being given to the immediate betterment of building is indicated by the number of conferences held in various cities during the past week.

From the reports of these conferences it appears that labor and transportation conditions have improved somewhat, but money is still unavailable for investment building, with bankers in general showing an apathy which amounts almost to complete indifference to housing needs.

According to the reports of meetings held in Chicago, no marked reduction can be looked for in the price of building materials, especially in products where labor and transportation costs constitute the entire cost of the product. Any price recessions that occur within the next sixty days will be made under pressure or in an attempt to stimulate the market.

Where a change of price is contemplated, dealers and manufacturers are urged to make the maximum reduction as quickly as possible.

Lumber interests assert that bedrock concessions have been reached in their line and any change will be in the nature of an advance. Retail lumber dealers report no great demand for lumber, and no improvement in the lath and shingle market. The price of lath has declined until it is now possible to buy lath at almost normal prices. Reported, clear red cedar shingles, Chicago base at \$5.20 per sq. \$5.60 per thousand, stars at \$4.50 per sq. and \$5 per M, No. 1 hemlock lath quoted at \$10, No. 2 at \$8.50 and No. 3 mixed at \$7.

A declining tendency is noted in Southern pine quotations; mills are now in a position to fill any orders but as the demand is very weak, are piling up stocks.

Manufacturers of sash, door and millwork in general report little activity in their line, and no prospects until building picks up. Recently there has been some demand for storm sash and doors due to the approach of cold weather.

The window glass market is rather uncertain, and it is being whispered about that increased cost of materials and higher freight rates may mean higher price for window glass in the near future.

Chicago jobbers are maintaining their prices unchanged on steel products, and report a demand still keen enough to prevent any accumulation of stocks. The demand for wire and nails has diminished to some extent, but manufacturers report demand still far exceeds the supply, in spite of the fact that production and shipments have improved greatly.

A reduction of from 10 to 25 per cent. effective Oct. 1 made by a manufacturer of plumbers brass goods, presages a further reduction in that line, if the rumor of a drop in the cost of the raw materials entering into the product is true.

562^a

Fransjeer 7 110 2341



AN OLD TOWER IN SALAMANCA

THE AMERICAN ARCHITECT

VOL. CXVIII

WEDNESDAY, NOVEMBER 3, 1920

NUMBER 2341



THE VILLAGE STREET WHERE IT BORDERS THE BROOK

Art and Architectural Artifice

By JEROME LACHENBRUCH

Illustrated by Photographs of Scenes in Goldwyn Pictures Corporation's
Reproduction of "Buntz Pulls the Strings," Under the
Art Supervision of Cedric Gibbons

WHO that has read Burns' "The Cotter's Saturday Night," or Barrie's "A Window in Thrums," has not felt a thrill of delight and made a mental resolve some day to visit the scenes that the music of the Scotchmen's poetry and prose conjured up? We feel the contentment of the old villager or see the life of the town as it unfolds through the magic of words. Yet to us in America, the pictures suggested persist as the product of our imaginations, and differ with the quality of our individual fancies.

We know that the solid homes of the Scotch villagers are a slow growth, the expression of the group

reactions of a people to their environment. And for the purposes they serve, they seem to be a complete external manifestation of a physical and a spiritual necessity. Why should their homes take the peculiar form they do? It is not that other materials cannot be obtained, or that money is lacking. With personal views of their relation to their environment, the expression of them has assumed a peculiar and original form. The result is a native art in building.

Definitions of art are more often misleading than informative. In a general way, art may be called the expression, in some form, of an emotion intensely experienced. And the great artist is he who feels in-

THE AMERICAN ARCHITECT

tensely and expresses his emotions completely. A unity, then, between the power to feel and the ability to express, results in an artistic creation. But a work of art is not necessarily the expression of one man's emotions or the fashioning of one man's hands. Emotion ranges wider fields than one man's breast. For there is the community, the shared and unified emotions of a people, which produce works of art that have a group significance. Indeed, so true have these communities been to their group expressions of themselves, that we, in a newer and more robust land, and with a different environment, still hark

imitate them. And yet, though our houses may be built of hollow tile on rock foundations, while theirs represent laborious hand work with mud and stone and thatch, there is a feeling of permanency about the Scotch cotter's hut that rarely moves one in contemplating the massive Fifth Avenue mansion of an American millionaire.

AMERICA has broken the back of nature to make her do its architectural bidding. We have levelled hills to satisfy the wishes of a successful, adopted son, or built up terraces because his



A FAITHFUL AND ARTISTIC REPRODUCTION OF A SCOTTISH MOTIVE

back to them for a suggestion of that which we feel lacking in ourselves.

Is it that we appreciate the love and the sincerity with which their homes were built, their villages grew? Are we slowly recognizing that where our homes and churches and taverns are the sudden flowerings of immediate and impatient demands, theirs is the mellow and accumulated fruit of a slow growth, a growth that has had time for reflection, introspection, questioning, for an examination of those principles in building which will best express the continuity of life and the immortality of soul that they feel?

Our appreciation of their attitude has led us to

fancy held a memory of some ancestral, Old World home. How differently his ancestor built his cot!

"Ah, there's a pretty, rolling bit of ground. I guess I'll build my house upon it."

And so, the ancestor built a stone wall following the curve of the land; and on a knoll, erected his home. Then he had a natural terrace. His was no conflict with nature. He took her as she was, worked with her and made the best of her, accommodated his necessities to her preempted rights in the soil; and the result has been a thing of beauty that we send our architects abroad to study.

We call these homes examples of native art; and in modified form, try to reproduce their lines in



SHOWING THE SKILLFUL ADAPTATION OF A LOCATION, THOUSANDS OF MILES AWAY, TO THE NECESSITIES OF A SCENARIO PRODUCED IN THIS COUNTRY



THE ATMOSPHERE OF AN "OLD WORLD" RUSTIC SCENE PRESERVED IN ALL ITS DETAILS BY THE CAREFUL STUDY OF THE DIRECTOR

THE AMERICAN ARCHITECT

some of our buildings. In some measure, America has succeeded in transplanting the artistic building ideas of the Old World to the New. But there is something heartbreaking about it. For, when a mansion, constructed on some foreign model, becomes forty or fifty years old, it is seen that the structure hasn't maintained its original correspondence with the soil in which it was planted. Its environment, which may have been made over to fit it, has changed

tectural ideas lead in direct descent to the Old World; that blood and a transplanted (and consequently, a transformed), culture would preclude the development of a distinct Americanism in architectural design.

With this in mind, it must be agreed that adaptation, rather than imitation, should be the foundation of our building art. The basis of my quarrel with American architecture is not that we have not adapted



A PICTURESQUE "LOCATION" THAT OFFERS A FINE OPPORTUNITY TO THE LANDSCAPE PAINTER

completely; and what may formerly have been an approximately accurate imitation, has become an incongruity.

As a building nation, America has not had time enough to assimilate completely its indigenous architectural ideas. We imitate too closely, and discover that the imitation does not quite fit the new, spreading surroundings. And we have been imitating, perhaps, because we have feared to take what we have and to work with that material in utter sincerity. We know that our European models are honest expressions of deep felt purposes; and in using them, we know we shall not be laughed at, for they have stood the test of time. It may be argued that all our archi-

sufficiently, but that we have not always done so with artistic intelligence. Perhaps we have not studied our models with the care and the sympathetic understanding that comes from within, an understanding that cannot be expressed in terms of linear feet and building material.

There is hope, though, that our models will be brought to us in a new way; and that instead of depending upon the visits abroad of a few chosen teachers to tell us through the medium of their particular reactions, how we should adapt Old World ideas, we may all see the originals if we have but the desire to do so. But the broad source from which we may derive a new inspiration deals very indi-



THE "AULD KIRK"

rectly with architecture and with building. I refer to the modern, carefully produced, motion picture. The most genuine contribution to art that may be laid to the motion picture lies in its architectural gifts. In this single phase of the industry, more care and ingenuity have been lavished than upon any other. Artists, architects, draughtsmen, are employed to study and to plan settings from original sources with an honest view to the maintenance of a definite verisimilitude with the locale in which a story unwinds its episodes. Many of the men directly concerned in this work have travelled far and wide; and their knowledge finds free expression in the stone and wood structures against which the celluloid tragedies and comedies are contrasted.

THE attempt to achieve on the screen a truthful representation of the original has not always succeeded. But more knowledge is continually flowing to the screen, better artists, men whose understanding is international; and consequently, we are sometimes startled to find ourselves in a little French village, or on the road that leads to the kirk in a Scotch town.

Here, in the motion picture at its best, we may find a sincerity in the spirit of the reproduction, and a verisimilitude with the original that cannot fail to stimulate our architectural interests. We may grant the artifice behind the motion picture; but this architectural artifice has, nevertheless, resulted in a close approach to art.

The accompanying photographs speak

for themselves. To obtain them, the Goldwyn Pictures Corporation built an exact replica of a Scotch village in which the photoplay, "Buntie Pulls the String," was enacted for the screen. When the Graham Moffet photoplay was made, the director, Reginald Barker, insisted that every scene be faithfully reproduced. He himself was educated in Scotland; and as a result of his feeling for the artistic proprieties, Cedric Gibbons and Julian Garnsey, construction manager, were given complete freedom in laying out a little village on a plot of ground acquired for this purpose alone. The village in which the action of the story takes place, consists of a stone church, the Robert Burns tavern, and about ten houses. A little stream runs through the town, which is about five blocks long. To add to the

fidelity of the picture, rose vines were transplanted from the hot houses of the Goldwyn studios and trained against the wall of the thatched roofed cottages. A few cows were brought to graze along the stream; a dozen ducks found a new home in it; and a stray goat edged his way into the landscape.

So successful was this architectural background for the picture, that the Goldwyn Company has leased the ground for a year, and has invited the public to visit its exhibition of the little Scotch village. The old stone kirk is solidly built; and the homes of the cotters have thatches eighteen inches thick, just as they are in Scotland. But it has not been necessary to hold the thatches down with rocks



THE MODERN MOVING PICTURE "SET" IS AS STRUCTURAL IN ITS PRODUCTION AS A PRACTICAL BUILDING

as is done in the Highlands. California winds are not so tempestuous. Yet, on the screen, the effect of the reproduction is quite as alluring as a visit to some of the villages in Scotland. And what is more, every detail of costume has been thought out so that the players appear in ancient shawls, knitted mitts and strange looking top hats.

One does not have to journey to California to see this unusual bit of Scotland. Its pictorial lesson will be shipped all over the United States on an unromantic strip of celluloid. And then, the white heat of carbon lamps in motion picture machines will once more bring to life on the screen a glorious and instructive illusion.



THE PRINCIPAL "SETTING" IN "BUNTY PULLS THE STRINGS"

What Is Art?

WE reprint with considerable satisfaction two letters addressed to the Editors of *Engineering News-Record* in further discussion of the question as to what really constitutes art in the practice of both architecture and engineering. It is certain that these well expressed and correctly stated communications more accurately outline the opinion of the large majority of engineers as to the correct interprofessional relation than did the sentiments of a former correspondent, to which allusion was made in our issue of October 20.

The letters are as follows:

Sir—It seems to the writer that your editorial "What is Art," *Engineering News-Record*, Sept. 16, 1920, p. 531, and Messrs. Trautwine's and Hering's comments thereon do scant justice to architects.

To select some examples of exceedingly poor taste in design, and to judge artists and architects as a class thereby is hardly sportsmanlike. The several horrible examples of sham and gingerbread work cited, proved merely that although a man may sign himself architect and actually practice that profession,

he is not really one unless properly trained for his work. No one would judge physicians as a class by the malpractice of some "quacks" who hold medical licenses.

Occasionally an engineer designs a bridge or other structure that has beautiful lines and proportions, as, for example, the Brooklyn Bridge, but more often we get the usual homely type of highway or railroad bridge so common everywhere. They are generally well designed and, to quote Mr. Hering, will give "The required resistance to every attacking force with the least amount of material, and in the simplest and most direct way." But they are hardly things of beauty except when judged by the rule of "handsome is as handsome does."

In France where engineers are second to none in design, an architect is always associated on important bridge work, and nowhere else in the world are these structures so beautiful as a rule. An architect of real standing was selected to assist in the design of all the large bridges built in recent years at New York. It

(Continued on page 572)

Architectural Quicksands

By CLINTON H. BLAKE, JR.

Dealings With Corporations

SO large a proportion of the business of today is carried on by corporations, that a word of caution is in order with regard to the making of contracts with business and municipal corporations or other governmental agencies. The modern business corporation is managed by its directors. The policies of the directors are put into effect and carried out by the officers but, in the last analysis, it is the directors or stockholders who must pass upon matters involving corporate obligations, if the corporation is to be bound thereby. Where a contract is to be made with the corporation, whether the other party to the agreement be the architect or the owner or the contractor, he should, if the contract involves a substantial amount, satisfy himself that the officers executing the contract in behalf of the corporation are duly authorized to do so. It is not necessarily a question of any bad faith on the part of the officers. It may be, that they will execute a contract, believing firmly that their powers are broad enough to give them the right to do so, and it may develop later that they have been erroneous in this belief and that the execution of the contract was beyond the authority vested in them.

In many instances of this kind, the party making the contract with the corporation has had the unpleasant experience of suddenly being told by the corporation that the agreement made with him was not binding upon the company, because it had not been properly authorized by the directors in the first instance, and that the company refused to recognize its liability and repudiated any obligations under the contract. To prevent such a development, if there be any doubt whatever, the corporation should be asked to deliver, at the time the contract is delivered, a copy of a resolution of its Board of Directors or, in special cases where that may be necessary its stockholders, authorizing the execution of the contract. This copy should be certified by the secretary of the corporation, and his certificate should state, in substance, that the copy so certified is a true copy of a resolution adopted at a duly held meeting of the directors or stockholders, that it is executed by the officers of the corporation, that they were officers duly acting in behalf of the corporation and under its authority at the time the certificate was issued, and that they executed it pursuant to the authority vested in them by the resolution. No elaborate resolution or certificate is necessary, provided the foregoing is covered in substance. It will be readily seen, that a resolution and certificate in this form will, in a large part,

obviate the danger of a repudiation or attempted repudiation of the contract by the corporation at a later date, and assure the other party to the contract that the corporation is bound by the agreement entered into in its name.

In the case of municipal corporations, and in dealings with state or national governments, the matter becomes of considerably more importance, and it may be safely taken as a general rule that, in all such cases, special care should be taken to see that all required formalities are complied with in the execution of the contract. During the war, for instance, various bureaus of the War Department, in purchasing materials, advertised for bids on stated materials and quantities. On receipt of bids the successful bidder was advised that his bid was accepted. Not only this, but he was sent a copy of a so-called "order," stating that the order for the materials, in accordance with his bid, was placed with him. Anyone not initiated in the intricacies of government purchases, and the operation of the machinery whereby they are made, would naturally suppose that, when a bid is called for, submitting in writing, accepted in writing, and a written order for the material placed, the transaction would amount to a contract binding upon both parties. The fact is, that, while the contractor might be bound, the government, unless it had actually received the materials covered by the order, would not in the ordinary case be bound by the order, unless, in addition to the foregoing formalities and the written order referred to, a contract had been entered into between the contractor and the government in writing "signed at the end thereof" by both parties. It is cases like this which emphasize the danger of government contracts and dealings, without adequate inquiry, care and investigation.

How easily an architect may become involved in difficulty, by a failure to take proper precautions in dealing with a corporation, was well illustrated by a case which was recently brought to me. The plans for the building were originally ordered by a client individually. It was stated, however, that a corporation was to be the owner of the property on which the building was to be erected, and that this corporation was being formed. Various letters, setting forth the agreement between the architect and the client, were exchanged. Thereafter the corporation was formed and the architect continued his dealings with the corporation, as the owner. He never secured any agreement from the corporation, recognizing definitely its obligations and the fact that it

was the party in interest, as distinguished from the original client who had first brought in the matter, and who was an officer of the corporation. Disagreements arose, and the matter developed into litigation. The situation would have been much simplified if, on the formation of the corporation, a new agreement, whether in letter form or otherwise, had been made, recognizing clearly the fact that the corporation was now substituted as the party in interest, in the place of the individual. Fortunately, in the case referred to, the subsequent dealings of the corporation with the architect were such as to remove, to a substantial extent, the doubt which might otherwise have existed on this point. The matter might easily have developed somewhat differently, however, and the failure to secure some proper evidence of the corporation's liability might well have proven the cause of serious embarrassment and loss to the architect.

A rather famous case, decided in 1880 by the Supreme Court of the United States, involved the erection of a proposed new Courthouse and City Hall in the City of Chicago. It is interesting, as showing how easily an architect may be led to believe that all necessary formalities have been complied with, when this in fact is not the case, and when an absolute legal bar to his recovery exists. The architect was represented by Mr. Melville W. Fuller, who later became Chief Justice of the United States, and it may be taken for granted, therefore, that the decision was not adverse by reason of any lack of proper legal advice or effort.

The County of Cook and the City of Chicago, situated therein, had proposed to erect certain public buildings, the portions of the buildings to be used by each to be paid for by them respectively. They jointly offered a premium for the plans. A large number of architects entered the competition and submitted designs. Building committees of the City Council and the Board of County Commissioners duly reported their award of prizes, and the plaintiff in the case referred to was awarded the third prize. The prize, which was a thousand dollars in cash, was paid to him. Later, the County Commissioners and the City Council, respectively, adopted a resolution which provided, in substance, that the plan submitted by this architect and for which the prize had been paid, as above, should be and was selected and adopted, as the plan from which the buildings should be built, subject to any changes and modifications determined upon by the City and County authorities, and provided that the estimate of the architect presenting the plan, as to the cost of building construction, should be verified.

The architect testified that he had thereafter verified the cost of construction, and produced his plans for which the prize had been given, and offered to

prove their value and the time and expense involved in their preparation. He further offered to prove a custom of architects, to the effect that the superintendence of the construction of a building belonged to the architect whose plans were adopted. He also offered to prove a custom to the effect that, where prizes for plans were offered, the plans of the successful competitor belonged to him, and that, if they were later adopted as the plans from which the building was to be erected, they should be paid for, in addition to the payment of the prize itself.

The trial court excluded all of this proposed testimony, and directed a verdict for the defense. The United States Supreme Court, in its decision on appeal, confirmed the correctness of this ruling, and pointed out that the resolutions of the County Board and City Council did not bind these bodies to make payment to the architect of the compensation which he claimed, but that they merely amounted to a selection of a particular plan and possibly, in addition, to the announcement of a purpose to erect a building in accordance with it. The court held that, if the buildings were so erected in accordance with the plans, then the claim might be well presented by the architect, but that in as much as they had not been erected, it must refuse to stretch the legal effect of the resolution adopted, to the extent of holding that it amounted to an agreement to pay for the plans, whether the work were proceeded with or not. Reading the case carefully, in the light of the court's decision, it is easy to see that the architect could not recover under the conditions which existed. On the other hand, it is not difficult to realize how the architect, in view of the resolution adopted by the governing bodies of the City and County, might easily have supposed that he had a valid agreement, that his plans had been formally selected, and that the proceedings taken had amounted, in effect, to his appointment as architect on a basis which would give to him a valid claim for the compensation which he sought, despite the fact that the work had not been proceeded with.

In a present day case, in which I represented the architect, another excellent example is furnished of the difficulty in which an architect may become involved, by reason of entering into a government contract, without proper consideration and advice. In the case which I have in mind the architect had won a competition for a memorial, to be erected under the direction of the government. The contract, which was prepared by the government and signed by the client, without any legal advice, provided a fixed compensation for the architect and further provided for a bond to be furnished by the latter. Realizing that this was a usual provision, the client signed the contract and thought nothing more of the matter, until it became apparent that the unrolling of the cus-

THE AMERICAN ARCHITECT

tomary government red tape (it was army red tape at that), would delay the completion of the memorial for many years. The memorial is not yet completed but, each year regularly, the architect receives a bill from the Surety Company which furnished the bond, requesting the payment of the annual premium due thereon. When he took up the matter with the government authorities in charge, they expressed to him their regret at the delay, but carefully set forth a number of perfectly good reasons why, under the law, the government could not make payment of the premiums, or make good the loss suffered by the architect in connection with them. The government representatives agreed with me that theoretically, on the basis on which the matter was proceeding, it might be quite possible that the total premiums paid by the architect on the bond might exceed the amount received by him for his services, if the delay of the government were to continue. They appreciated the difficulty and showed a desire to do anything which they could to help the architect, but were hampered by the laws and regulations, from proceeding as a private individual or a privately controlled corporation could have proceeded. Such a situation has in it elements of humor, which it was a bit difficult, naturally, for the architect to appreciate. We finally arrived at a solution which has straightened out the trouble, but the case remains a very good example of the restrictions which surround municipal corporations or government agencies, and which necessarily result in placing contractual and business dealings with them in a class by themselves, subject to special rules and requiring special care and consideration.

THE LIEN OF THE ARCHITECT

I venture the assertion that not more than forty per cent. of the architects, practicing today in this country, realize that the architect has been accorded protection under the lien laws and given a mechanic's lien on the building upon which his work is done. The extension of the protection of the lien law to architects is not, however, an especially recent development. The lien laws in the better jurisdictions have, for a considerable time, recognized the right of an architect to a lien for the work done. More recently, however, and especially within the last few years, the laws have been so broadened, as to give to the architect a degree of protection under the mechanics lien statutes, which he did not theretofore enjoy. In New York, for instance, prior to the Amendment of 1916, an architect was not entitled to a lien, unless he actually supervised the work done. The 1916 law so enlarged the scope of the word "improvement," however, as the latter word is used in the mechanics lien law, that the protection of the law has been now so extended, as to enable the

architect to recover for the work done in the preparation of the plans and specifications, even though he may not act as the supervising architect. This is in accordance with plain common sense and fairness. The plans and specifications certainly enter into the erection of any building, just as surely as do the bricks and mortar and timbers and plaster work. The basis of a mechanic's lien has always been the improvement of the real estate, and certainly, the plans and specifications which are responsible for the erection of a building, of beauty or utility, contribute in large part to the improvement of the property on which it is erected.

A mechanic's lien is a particularly effective way of enforcing one's rights. The ordinary architect is, of course, well acquainted with the operation of liens, from his experience with sub-contractors and materialmen. He may be pleasantly surprised to learn how efficiently the filing of a simple lien may serve to protect his own rights and enable him to secure payment of a just claim where the client is not inclined to live up to his obligations. The ordinary architect's lien applies in the case of the construction of an entire building. The lien applies, no less however, to the case of alterations, and it may be of interest to architects, practicing in larger cities especially, to realize that the lien law has been successfully applied to give relief to an architect where the services involved consisted of changes in the premises of a sub-tenant of a large building.

This point arose in my practice a number of years ago, and I derived a considerable amount of pleasure from a case which made some new law in New York on this particular point. The case was in many ways an amusing one, although the owner of the building has never been able to properly appreciate its humor. The architect whom I represented had a client who was one of the tenants occupying a portion of the space of one floor of one of the large New York City office buildings. The tenant employed the architect to plan and superintend various changes in the lay-out of the tenant's offices, the erection of new partitions and the like. The architect did the work, prepared the plans, presented them to the owner of the building, who approved them, and superintended the work called for. After the work had been done, the client, who had ordered the plans, became insolvent, and it became apparent that the only chance which the architect had to recover the fee due him lay in the enforcement of a lien against the building. We filed a lien for the amount due him accordingly. The effect on the owner was quite electrical. He was, without qualification, one of the maddest men that I have ever seen. To tell the truth, I did not blame him in the least, and I never pass the building, to this day, that I do not smile at the thought of his indignation, when he

learned that a lien had been filed against the property for alterations made by a tenant and agreed to by him as a favor to the latter. The approval of the plans by the owner, coupled with the fact that we were able to show that the partitions were not simply temporary, but were joined to the structure in a manner sufficient to bring the improvement within the scope of the statute, enabled us to sustain the lien. The owner appeared personally in court and fought

the matter to a finish, but the court awarded judgment in favor of my client, and the owner finally settled with him for the work done. The pleasant thing about the mechanics lien, from the point of view of the architect is, of course, the fact that the claim is secured, and that if judgment be recovered, you may be reasonably sure that you will be paid either from the sale of the property, or by the Bonding Company which may have bonded the lien.

What Is Art?

(Continued from page 568)

would take a hardy engineer to say that the appearance of these structures was not greatly helped thereby.

It does the engineers no good to sneer at "art" or architects, because of isolated examples of bad design. The public is coming more and more to understand that rarely does the engineer put into his design the grace and beauty that the well trained architect can give. Hence the ever growing demand that architects, landscape gardeners, sculptors, etc., be consulted on great public works.

Up to about twenty years ago, engineers or "practical builders" designed nearly all the factories and industrial plants. For that time they were very good buildings, indeed, and served their purpose most satisfactorily, but nothing has ever equalled them as a class in sheer depressing and dreary ugliness. Today, architects almost always design these buildings, very often, as subordinates to engineers. In spite of occasional examples of poor taste, these buildings are generally at least pleasing, and are often beautiful.

This difference from the old type of factory was not attained by the more common use of terra cotta, steel sash, etc. It lies in the general proportions of major and subordinate masses, the grouping of openings, the correct location of good ornamental design and a studied color scheme; all things of which the great majority of engineers have a very vague understanding.

The writer believes there is glory enough for all in large work, and that the engineer can no more enter the field of the architect than an architect can do engineering.

N. H. HOLMES,

Assistant Engineer, Charles T. Main.

Boston, Mass.

Sir—I have read with interest Mr. Trautwine's criticism of the Bensalem Ave. bridge. There is no doubt that this structure has been marred by ornamentation wrongly applied, but when a man of his standing makes the absurd statement that because the engineer's training makes him an authority on

strength it also makes him an authority upon beauty it is time to refute such a sweeping assertion.

The statement that any structure is beautiful which fulfills the purpose for which it is designed, is another half truth. Two men wear suits from the same piece of cloth. One suit has an ugly pattern and a discord of loud colors, but according to his logic, it is as beautiful as the other suit because it fulfills equally well the purpose for which it was made. Beauty is relative. A stone or concrete arch is infinitely more beautiful than any steel truss bridge can possibly be.

One of the first principles of architectural design is that ornament is not sought after itself alone. Beauty of line and proportion always come first. Ornamentation is a minor detail. If your eye is drawn to the ornamentation first, the structure has not been successfully handled.

Mr. Trautwine forgets that there are any number of bridges in this country that have been successfully treated architecturally, such treatment in no way obscuring the essential structural features. He uses this bridge as a basis for an attack upon the principles of architectural design. One might retort in kind by reminding him that the engineer's "instinct for simplicity" must have been misled when the subway layout at the Grand Central Terminal was constructed. The fearful congestion of our cities is partly due to the so-called simplicity of the "checker board" system of laying out streets. The responsibility for the lack of a definite plan of our large cities rests largely upon the engineer because it was he who had charge of laying them out in the earlier days.

It is reasonable to state that while an architect of recognized standing would hardly be so rash as to claim to be an "authority" on beauty, he is by inclination and training better fitted to be a judge of beauty than Mr. Trautwine. There are just as many mistakes and errors of judgment in the design of engineering structures as there are examples of faulty architectural design. Mr. Trautwine should endeavor to correct the errors and omissions of his own profession before attempting to pass judgment upon another.

Pittsburgh, Pa.

S. S. McKAY.

Reasonable Billboard Ordinances

Valid When in Interest of Public Health, Safety or Morals—Invalid When Based Purely on Esthetic Grounds

By A. L. H. STREET*

MAINTENANCE of billboards on private property cannot be prohibited by ordinance on the ground of offensiveness to the esthetic sense. But they may be the subject of reasonable regulations designed to promote the public health safety and morals.

It is believed that this is an accurate statement of the general rule on this subject, as determined by the weight of judicial decision.

The courts seem to have been uniform in their conclusion that enhancement of the beauty of municipal scenery is not recognized by the law as sufficient excuse for enacting billboard regulations. The judicial attitude on this phase of the subject is well illustrated by the decision of the Illinois Supreme Court in the case of *Haller Sign Works vs. Physical Culture Training School*, 249 Ill. 436, 94 N. E. 920, 34 L. R. A. (N. S.) 998, Ann. Cas. 1913D, 959. The law there under consideration provided:

"It shall be unlawful . . . to erect . . . a structure of any kind . . . within five hundred feet of any public park or boulevard within . . . any city in this state having a population of one hundred thousand or more, for the purpose of placing advertisements of any kind or character thereon, etc."

Noting that the act covered parks and boulevards only, and making other observations, the Court said:

"These suggestions lead unmistakably to the conclusion that the statute in question is an attempt to exercise the police power purely from esthetic considerations, disassociated entirely from any relation to the public health, morals, comfort, or general welfare. However desirable it may be to encourage an appreciation of the beautiful in art and to cultivate the taste of the people of the state, still it has never been the theory of our government that such matters could properly be enforced by statute when not connected with the safety, comfort, health, morals and material welfare of the people."

The highest court of the land has approved the view that esthetic considerations alone will not support an ordinance restricting the maintenance of billboards. As late as March 24, 1919, and in the case of *St. Louis Poster Advertising Co. vs. City of St. Louis*, 39 Supreme Court Reporter, 274, that tribunal said of the ordinance there under consideration:

"Possibly one or two details, especially the requirement of conformity to the building line, have esthetic

considerations in view more obviously than anything else. But as the main burdens imposed stand on other ground, we should not be prepared to deny the validity of relatively trifling requirements that did not look to the satisfaction of rudimentary wants that alone we generally recognize as necessary."

A few years ago it seems to have been quite commonly supposed that unless a billboard ordinance had some reasonable tendency to limit fire risks or to avoid blowing over of such advertising structures to the peril of person or property it could not be sustained against attack upon its validity. But this view cannot be said to reflect the law as recognized now. On this point see the further remarks of the United States Supreme Court in the case last cited, wherein the Court upheld the validity of an ordinance of the city of St. Louis containing provisions of which the following is a summary: It allows no billboard of twenty-five square feet or more to be put up without a permit and none to extend more than fourteen feet above the ground. It requires an open space of four feet to be left between the lower edge and the ground, forbids an approach of nearer than six feet to any building or the side of the lot, or nearer than two feet to any other billboard, or than fifteen feet to the street line, and without qualifications requires conformity to the building line. No billboard is to exceed four hundred square feet in area. The fee for a permit is one dollar for every lineal five feet.

In attacking the ordinance, plaintiff represented that its billboards would withstand wind of greater velocity than had ever blown in St. Louis, and that they were so covered by galvanized iron as to exclude all danger from fire. But the Supreme Court said:

"Of course, the several restrictions that have been mentioned are said to be unreasonable and unconstitutional limitations of the city in the interest of the safety, morality, health and decency of the community.' . . . It is true that, according to the bill, the plaintiff has done away with dangers from fire and wind, but apart from the question whether those dangers do not remain sufficient to justify the general rule, they are or may be the least of the objections adverted to in the case."

And the Court makes this further important declaration:

"If the city desired to discourage billboards by a high tax rate we know of nothing to hinder."

Grounds of objections to billboards mentioned by

*In *The American City* for October.

the Missouri Supreme Court in *St. Louis Gunning Advertising Company Case* included the tendency to facilitate the commission of crime and nuisances in the rear of such structures, especially where the boards are permitted to come close to the ground. And, under such circumstances, it is found that there is a natural menace to the public health. And yet the decision in this case clearly shows that billboards cannot be excluded on mere grounds of unsightliness, and that the municipal power over them ends when considerations of public safety, health, morals, and good government have been met.

Another leading decision on the point that an ordinance limiting the right to maintain billboards on private property must have some relation to the public welfare is to be found in the case of *People vs. Hastings*, 77 N. Y. Misc. 453, 137 N. Y. S. 186,

wherein it was decided by a New York court that an ordinance requiring a billboard to be constructed of metal was void as applied to a situation where a board constructed of wood could constitute no fire menace. Nevertheless the same court said that an ordinance requiring a permit for erection of boards more than five feet high was valid.

In the case of *Thomas Cusack Co. vs. City of Chicago*, 242 U. S. 526, 37 Sup. Ct. Rep. 190, it was decided by the United States Supreme Court that an ordinance of defendant city was valid which forbade erection of billboards more than twelve square feet in area in any block where one-half of the buildings on both sides of the street were used exclusively for residential purposes, unless a majority of the frontage owners consented in writing.

The Suspicious Client

MAN is born to trouble as the sparks fly upward and even architects cannot escape the ills of humanity, while we might add that of late years between the Scylla of war restrictions and the Charybdis of Government interference and labor difficulties they have had possibly an unfair share of trouble. So writes the *Architect* of London under this heading. But these or some of them we may hope to see removed—if we have the patience of Job—but there is one trouble that most of us have experienced more than once, which may be always with us, and this may be defined as the Suspicious Client. The Suspicious Client can be divided into many classes. First, we have what may be termed the lower grade of business man who, conscious of his own customs and methods of doing business, cannot conceive of the average architect's standpoint. Such a man argues that because an architect controls the expenditure of considerable sums of money some of it must stick to his fingers. He would in truth more often than not condemn an architect for stupidity if he understood that nothing of the kind took place. We have known a member of an important public body who explained at a meeting of that body that it was necessary to go through an architect's specification in order as far as possible to eliminate his opportunity of taking secret illicit commissions as he said it was well known that this was a general practice in the profession. The architect in question being present remarked that the public body were unwise if they employed any man whose honor they had reason to suspect, and privately warned the speaker that a repetition of his remarks would be

met by a demand for a written apology; but the remark was made in perfect good faith, and without the least intention of offending, and we believe the speaker afterwards thought that the architect was very thin-skinned to have objected to such an imputation. It was well known to the town we are speaking of that many years ago there was an architect, wholly unqualified and a member of no professional body, who never gave a certificate to a builder without receiving a check for his condescension first.

But these incidents happened in the bad old days, which we hope are now past and at a distance from the sacred shrine at No. 9 Conduit Street.

Another variety of the Suspicious Client is more frequently met with nearer the haunts of civilization, and may be defined as the man who makes up his mind that the architect is anxious to induce him to spend more money and to incur extras. Of such a type was a well-known provincial solicitor who built himself offices. He told his friends that when his architect came to him, as he did on several occasions, with suggestions that would improve the design, he asked him whether they would increase the cost, for if so he did not wish to hear of or discuss them. The architect filled the highly colored role of the tempter, and was at once suspected, and the solicitor advised all his friends who had to deal with the dangerous and uncertain race to follow his example.

A third variety of the Suspicious Client is the man who quickly begins to believe that architect and builder are plotting against him, and who covertly calls in other advice to see if he cannot trip up the

malefactors. Such a man will never believe that he is receiving his money's worth, and spreads a doleful story of the architect's secret machinations. He has one consolation: it is true that the world must seem to him a very interesting place, beset as it is with lurid drama, but in the process he is a little trying to the architect who endeavors to do his best.

Yet another variety of the Suspicious Client has the overmastering conviction that the architect only cares about appearances, and is ready to sacrifice all material comfort and convenience in order to carry out his artistic ideas, and such men often obtain considerable help and assistance from their wives in making out a true bill against the architect who always fails in making every room a nest of cupboards. That unhappy man may be partially consoled by the knowledge that his client does not suspect him of actual fraud, but only of criminal negligence, which is partially explained by his ignorance, but he may, nevertheless, be a terror to deal with.

The man who builds and who cannot from drawings realize fully what he is going to obtain may frequently become in the end a Suspicious Client, and his suspicion may develop on any of the lines we have described, for this reason it is always well to be extremely careful in the case of the client who is disposed to leave everything to his architect's better judgment. The client may say at the beginning that he will leave everything to the architect, but the latter is wise if he does not assume that for that

reason the client has forgone the Englishman's love of grumbling. An appearance of settled, fair weather at the commencement of a job is, in fact, more frequently than not the precursor of a stormy finish, for the client would be the last to admit that his architect had any justification for not giving him exactly what he imagines he wanted all along. The architect is, therefore, prudent if he tries to force his client to understand at the beginning, and should refuse to take the *carte blanche*, which experience should teach him is never meant. Similarly the client who affects a sort of offhand indifference to questions of cost at the beginning often quibbles about the smallest item in the end.

Our picture of the architect's burbear—the Suspicious Client—should make the rest of mankind feel how necessary it is to comfort and sustain the architect amidst his trials. To do this it is only necessary for the Ideal Client to come forward in large and increasing numbers, to remove all restrictions, and to increase the architect's rate of pay, and in short to make the practice of architecture, as it should undoubtedly be, the happiest, noblest, and most lucrative calling in the world. If this is done the occasional Suspicious Client whom we are compelled to meet and deal with will not bring us in sorrow to an early grave, though his efforts may induce the coming of silvery patches among our once raven-colored locks.

Making the Most of the Back Yard

IT is usual in the treatment of suburban properties which lie well within the corporate limits of the city proper to divide the individual lot into two main parts, the front yard and the back yard, states E. S. Stiles, landscape architect, of Charlotte, N. C. The long, narrow shape of such lots precludes any great amount of utilization of the side yard areas because the house itself occupies the greater portion of the width of the lots. Hence the usual custom is to treat these lots as a uniform development on the street or front side of the property by giving all houses a uniform setback of from twenty-five to sixty feet from the street, thereby affording a small front yard which cannot well be treated otherwise than by establishing a good lawn, planting a few shrubs around the porch steps, and sometimes adding a low hedge next to the front sidewalk.

This means that this class of suburban property owner must confine whatever development of the home grounds he undertakes to the back yard; and in the majority of cases this too often results in the

utilization of this portion of the property as a clothes drying area, a small vegetable garden, and, even worse, a general repository for odds and ends. However, if careful thought is given to the proposition and sufficient attention paid to the community spirit for the pooling of individual lawn areas, much may be done in the way of utilization of this back yard area as a place for private recreation for the owners of the properties adjacent.

This will apply equally well to two houses which back directly upon each other, a group of houses, or even a whole portion of a small block. And indeed, from a community standpoint, these last have a distinct advantage over lots of a larger area, as they are usually too small to admit of vegetable gardens of sufficient size to pay for their construction and maintenance, while the garage problem is usually solved by the owners of these properties keeping their cars in some nearby garage. The proprietor of a suburban home with a greater lawn area is usually

(Continued on page 587)

Street Bridge, Hartford, Conn.

(See reproduction of the original drawing by O. R. Eggers in this issue)

THE master builders, during and after the Colonial period, were a conscientious lot of men. Everything they did received the same careful study, the same painstaking care in the working out of every essential thing to create a proper result.

This statement finds proof in the design of the bridges they erected, and the one chosen as the subject of Mr. Eggers' sketch is a fine example.

Many of these early bridges are models of good masonry design. Their rugged surfaces after centuries of exposure have taken on a very fine patina that delights the eye of the artist. To add to the picturesque effect there is often a background of foliage that at places trails on the water's surface in the summer days or in winter gives a delicate framing of the tracery of trees and shrubs.

When carefully designed, an old bridge will have to architects the same artistic appeal as old houses. Their study, and the setting forth of their well considered outlines as a means of graphic preservation is therefore very much worth while.

576^a



STREET BRIDGE, HARTFORD, CONN.
THE AMERICAN ARCHITECT Series of Early American Architecture



The High Cost of "Graft"

THE New York State Legislature has appointed a committee to investigate the conditions which have resulted in the present high cost of building in New York City. It has been holding sessions and unearthing much evidence of illegal combinations. Samuel Untermeyer has been named as counsel for the committee, and with skill and energy, the result of long and valuable service as counsel to investigating committees, is getting valuable results. There are signs of much uneasiness and a desire on the part of many men whose skirts are not too clean to take cover under the thin cloak of the informer.

The testimony brought out is in no sense a revelation to those who are familiar with what has been going forward in New York. It is, however, a curious study in psychology to read the testimony thus far given by men whose probity is unquestioned. For example, one man commenting on the fact that a certain builder was mulcted to the amount of \$25,000 to secure the calling off of a protracted strike on a \$2,000,000 contract, made the statement that in his judgment "the graft was too high." This was said in the same serious way he might have stated that the prices paid for materials were excessive. It was a tacit acknowledgement that in figuring cost, a certain "graft" had to be added to guard against possible loss. Another feature of the testimony brought out by Mr. Untermeyer was that "graft" was necessarily higher now, as the cost of living was everywhere higher. The blunting of the moral sense appears to be at the very foundation of these irregularities.

THIS was strikingly shown by the testimony of one of the witnesses who, driven to a point of desperation by the searching questions of counsel, pathetically asked to be excused from further questioning along certain lines, stating that if he, through any admission on the witness stand was driven out of his present business, there were others, in spite of all the risks, eager and willing to succeed him and carry forward the same methods. Further, to substantiate this, he cited the case of Sam Parks

convicted of grafting and who was sent to jail some years ago and died there. The same methods, he claimed, were carried forward with more thoroughness and at greater cost to the building interests than ever before.

The point that this witness was desirous of making was that the present conditions were a necessary evil in building operations and that if those now exacting graft were eliminated, it would be but the removal of individuals and not the eradication of the methods they represented.

It would thus seem that once a man finds that it he is to continue in the business of building contracting, he must figure graft as part of his costs, he apparently loses sight of the innate wickedness of it and only condemns it when it becomes in his judgment, unreasonably high. It is well enough to state that there are laws which regulate these things, but the offender must first be caught open-handed. The ways of the grafter are shifty and he knows his risks. Besides, there is a certain freemasonry among these people which works in co-operation so subtle as to cover up all evidence and make it difficult to secure conviction. Undoubtedly "the graft is too high" today, and if we are to reduce the high cost of buildings we shall have to include in our efforts the reduction of the high cost of graft.

The Exodus from the Farm

A PRELIMINARY report issued by the Director of the Census shows that during the past ten years, cities grew seven and a half times as quickly as country districts. High wages, enlivening environment and all the many lures of city life are undoubtedly the underlying causes for this large exodus on the part of young people from the country to the city.

Just how to check this exodus, to maintain a lower average of transference of population from country districts to the city, has long been studied and no actually practical solution been evolved. Several years ago a remedy was suggested by Judge Howard, of Troy, N. Y. It is in operation in Australia and in California and has recently been again

proposed in substance by Asher Hobson, professor of economic agriculture in Columbia University.

The scheme is to provide money or credit with which any family that desires to take up farming may establish itself in some well developed and convenient farm area. Prof. Hobson is of opinion that the expenditure by the State of a small fraction of the hundreds of millions it has spent on waterways and highways would subtract many thousand families from the ranks of the consumers and turn them into producers. Possibly this might work out as it is supposed to, when put to the test of actual practice, but it would first be necessary to eliminate the political features that so largely surround our attempts at economic reconstruction as was shown when the housing and landlord and tenant bills were recently enacted in New York.

A PRACTICAL way to check this change from rural districts to the cities would be to follow the suggestions set forth in the columns of *THE AMERICAN ARCHITECT* many times in the course of the past two years. A goodly proportion of those who forsake country life for cities do so because of the sordid commonplace aspect of their surroundings. The farm is no longer the outlying inaccessible location it was a decade or more ago. With the extension of trolley systems and the development of the motor driven vehicle, farmers may find ample opportunities often to visit their market towns. Isolation, lonesomeness, is no longer the soul destroying thing that accompanied farm life in the past. But easy contact with nearby towns and villages begets knowledge of city ways of living, and the farmer is led to compare the surroundings of his own home life, its sordid, poorly designed and planned elements, with those of the people who dwell in large towns and small cities. While the responsibilities that beset him make it necessary that he stick to his farm, these responsibilities do not so insistently affect the younger members of his family. Hence the migration to cities.

When all the deterrent factors that beset the building situation in this country are removed, we shall have to give very thoughtful attention to the matter of housing. There is danger that so much thought and energy will be spent on supplying the urban dweller with a home that the needs of farming communities may be overlooked. We are not disposed adversely to criticize the scheme as proposed by Prof. Hobson, but while the legislatures are debating the means of carrying forward a scheme such as he proposes, the state departments of agriculture, already equipped to carry forward the work of improving the farmer's surroundings, may set themselves that task. The results would undoubtedly be successful

in improving the general aspect of the farmer's home surroundings and the next census, nine years hence, would undoubtedly show a lower percentage of desertion from our farming communities.

See America First

MANY of us who have travelled abroad have experienced no small sense of mortification on our inability to answer intelligently the questions that have been put to us as to important and picturesque locations in our own country. The well maintained roadways over which the tourist in Europe travels in his sight-seeing tours were until a comparatively recent period far better than any we had in similar locations in the United States. During the world war when travelling on the continent was not possible, many Americans for the first time turned their thoughts to seeing America. Those who did, found that their journeys to our national parks and other scenic locations were beset with the difficulties of poor roadways and indifferent transportation and hotel accommodations.

But these things are gradually becoming better. The Lincoln Highway is slowly but surely becoming a roadway from Coast to Coast that will eventually become one of the fitting memorials to a great man. Straight across the continental divide, the government has started to hew from the native rock of Glacier National Park, Mont., what is destined to become one of the most picturesque highways in the world. This 38-mile stretch of hard roadway will lift the motorist to an altitude of 9,000 feet at the crest of the Rockies by the most gradual rise possible. For the great part the grade will average only six per cent., though an occasional stretch will reach the eight per cent. grade to which the engineers have been restricted. The new highway is to connect with the existing 30-mile highway in the eastern part of the park, to make possible an uninterrupted tour of 68 miles over hard, smooth roads.

The war has taught the necessity for good roads as a help to transportation of materials and supplies when railroad lines were congested with government transportation, so we shall no longer have to set forth arguments for the maintaining of national highways already built and the opening up of new ones.

We may repeat the slogan, "See America First," knowing that this admonition will not rebound with a protest that it cannot be done with the same ease of travel as in Europe. And when we travel more in our own country before we attempt to cross to Europe we shall have acquired an Americanism that will result in a more cultured and better informed citizenry. The American tourist in Europe will be representatively a type which those at home need not feel ashamed to acknowledge as fellow citizens.



HOUSE OF ROBERT J. EDWARDS, PARK MANOR, PATERSON, N. J.
CHARLES H. BENJAMIN, ARCHITECT

First story exterior walls are of buff brick, with range of six colors, laid in Flemish bond with raked joints. Above first story exterior walls are constructed of 2"x4" studs sheathed and covered with heavy fibre quilt. All exterior woodwork is of cypress with stained brown finish. Half-timber work is formed with 1½"x8" rebated material. Stucco work is of light buff color with stippled finish. Roof is covered with mottled slate. Hanging gutters and leaders are of copper. Floor of porch is formed of reinforced concrete slab with red cement finish and brick border. Vestibule, den and living room are finished in chestnut. Living and dining rooms have beamed ceilings of chestnut. Floors are of white oak with border, wax finished. Floor of vestibule is of Welsh quarry tile. Walls of dining room are

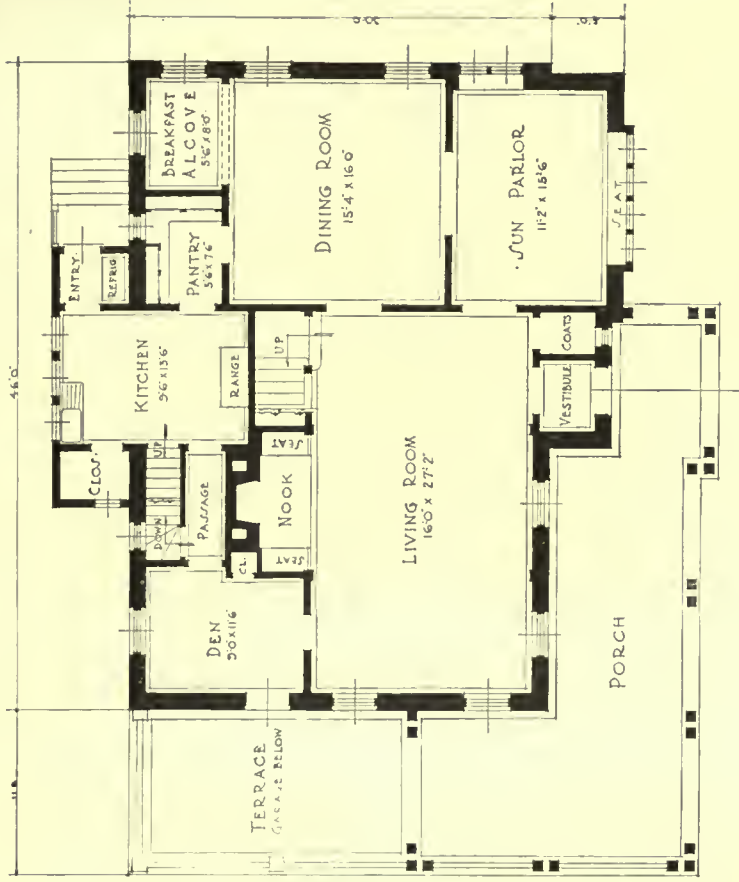

FIRST FLOOR PLAN



SECOND FLOOR PLAN

HOUSE OF ROBERT J. EDWARDS, PARK MANOR, PATERSON, N. J.

CHARLES H. BENJAMIN, ARCHITECT



HOUSE OF JAMES WARBURTON, JR., EASTSIDE TERRACE, PATERSON, N. J.
CHARLES H. BENJAMIN, ARCHITECT

Exterior walls, of 2"x4" studs, sheathed. Lower portion of walls and porch columns finished in stucco, light grey in color, stippled. Upper portion of building finished with shingles stained white. All exterior woodwork is white pine painted white excepting shutters, which are a pale green. Roof is covered with variegated slate. Gutters and leaders are galvanized iron painted white. Chimney is brick with stucco finish. Porch floor is of concrete with red cement finish and border of white cement. Living room fireplace is of red tapestry brick with Colonial wood mantel and flanked by seat on either side. Living room has beamed ceiling. Woodwork of living and dining rooms is whitewood with white enamel finish. Floors are of white oak with border, wax finished. Stairway is of Colonial design with birch treads, newels and handrails with mahogany finish. The remainder of stairway is whitewood with white enamel finish. Dining room walls are paneled 5' 6" high and finished with plate shelf. Kitchen is tiled 6' high. Second floor is finished with whitewood trim, white enameled. All walls are finished with flat paint. All doors are of birch, mahogany finished, with one panel. Bed room closet doors and door of coat closet are glazed with mirror full height. Bath rooms are tiled 4' 6" high.

5783

5-784

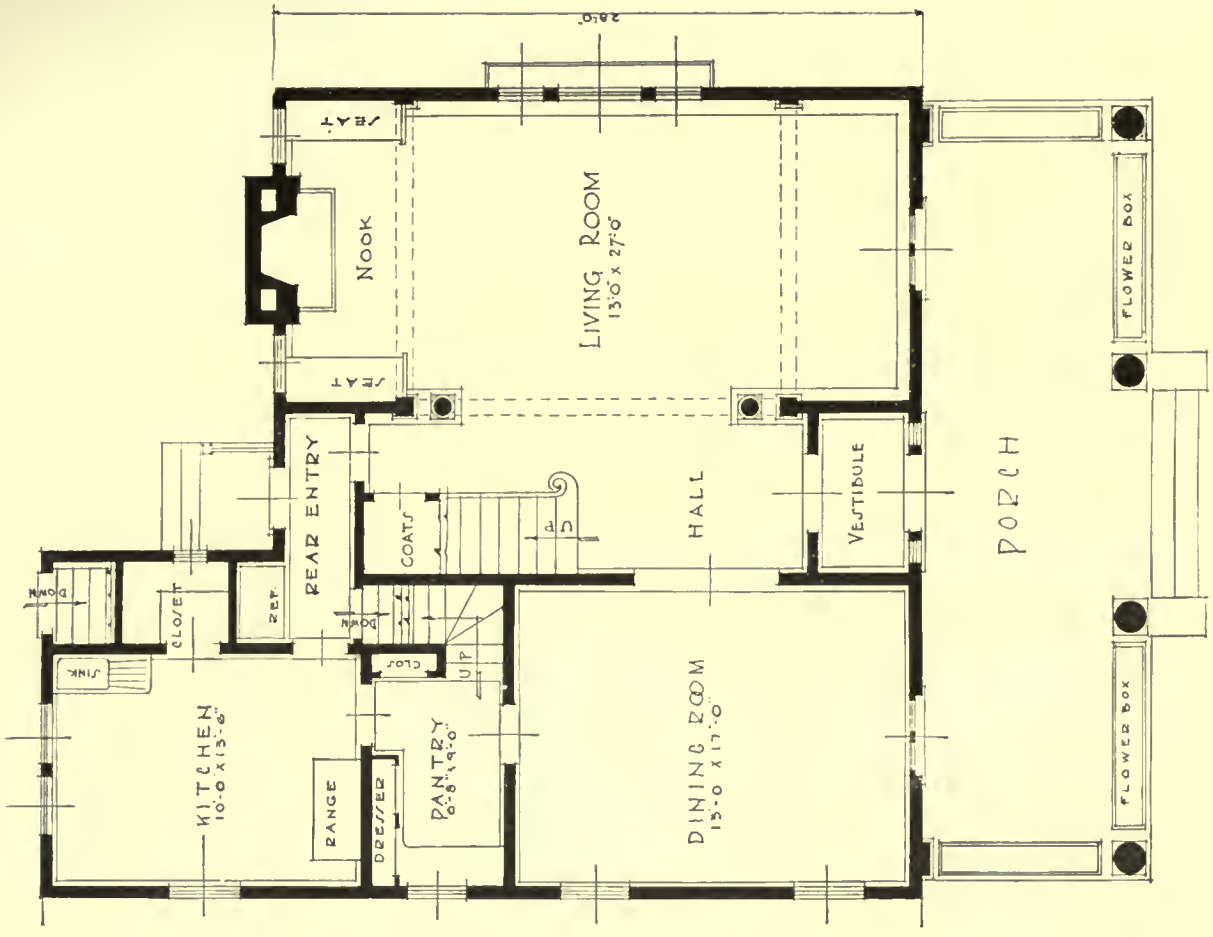

HOUSE OF JAMES WARBURTON, JR., EASTSIDE TERRACE.
 PATERSON, N. J.
 CHARLES H. BENJAMIN, ARCHITECT



HOUSE OF JAMES J. ZISETTE, EASTSIDE TERRACE, PATERSON, N. J.

CHARLES H. BENJAMIN, ARCHITECT

Exterior walls are of 2"x4" studs, sheathed and stuccoed. Stucco is light buff in color with stippled finish. All exterior woodwork is of white pine painted white. All roofs are covered with mottled slate. Gutters and leaders of galvanized iron painted white. Chimney is of brick, stuccoed and with cast stone cap. Porch floor is of concrete with red cement finish and plain cement border. Living room fireplace is of tapestry brick with Colonial mantel and built-in bookcases on either side. Living and dining rooms have beamed ceiling. All trim throughout excepting dining room and den is of whitewood with white enamel finish. First story floor of white oak with border, waxed finish. Vestibule floor is of Welsh quarry tile. Den is finished with chestnut, painted silver grey. Dining room walls are paneled 6' 0" high and finished with plate shelf. Dining room trim is of red gum, stained to imitate Circassian walnut. Kitchen is tiled 6' 0" high. All walls except as otherwise noted are finished with flat paint. All doors are of birch, mahogany finished, with one panel. Doors of bedroom closets and coat closet are glazed with mirrors full height. Bath rooms are tiled 4' 6" high.

5785

578
6

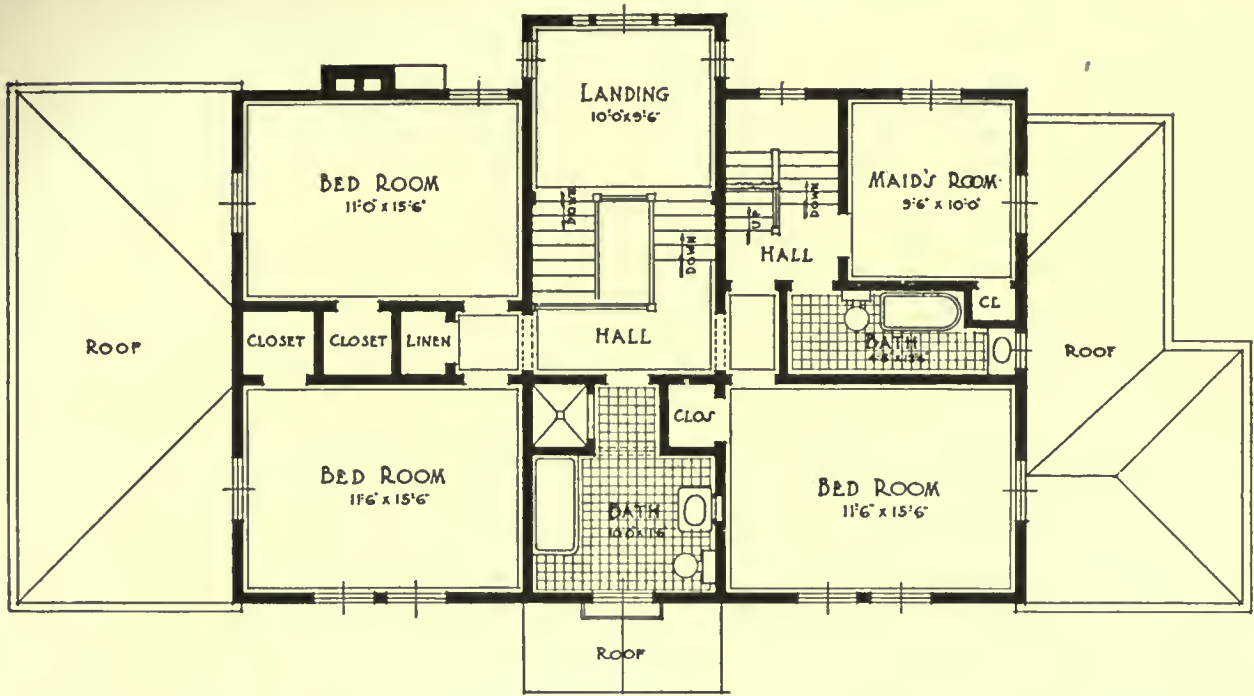

SECOND FLOOR PLAN

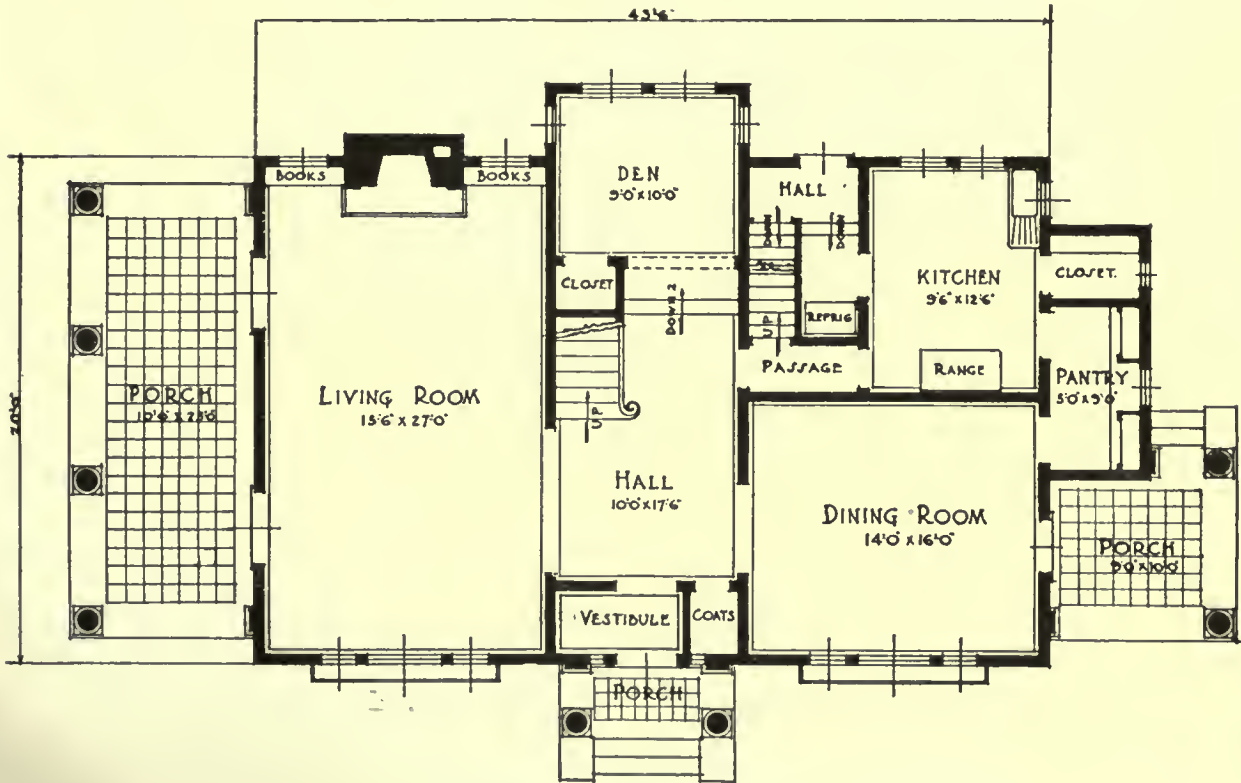

FIRST FLOOR PLAN

HOUSE OF JAMES J. ZISETTE, EASTSIDE TERRACE, PATERSON, N. J.

CHARLES H. BENJAMIN, ARCHITECT



HOUSE OF JOHN J. FISHER, PARK MANOR, PATERSON, N. J.
CHARLES H. BENJAMIN, ARCHITECT

Exterior walls are of 2"x4" studs, sheathed and finished with 1 1/4"x12" rebated white pine siding. All exterior woodwork is white pine painted white excepting shutters, which are a pale green. Roof is covered with variegated slate. Box gutters and leaders of copper. Chimney is of red tapestry brick with splayed sides, laid in white mortar. Chimney cap is of white cement. Floor of sun parlor and open terrace is reinforced concrete slab with red cement finish and tapestry brick border. Garage is located under the terrace, advantage being taken of slope in grade. Living room fireplace is of tapestry brick with Colonial wood mantel. Kitchen walls are tiled 6' high. Interior trim throughout, excepting den, is whitewood, with white enamel finish. Den has chestnut trim with silver grey finish. Living room, hall and dining room have Colonial wood cornice and dado rail. All doors are birch, mahogany finished, with one panel. Bed room closet doors and door of coat closet are glazed with mirror full height. Main staircase has birch treads, newels and railings with mahogany finish. Balusters are of whitewood. Walls of living room, hall and dining room are decorated with grass cloth. All other walls and ceilings are finished with flat paint. Bath room and lavatory are tiled 4' 6" high.

5-76

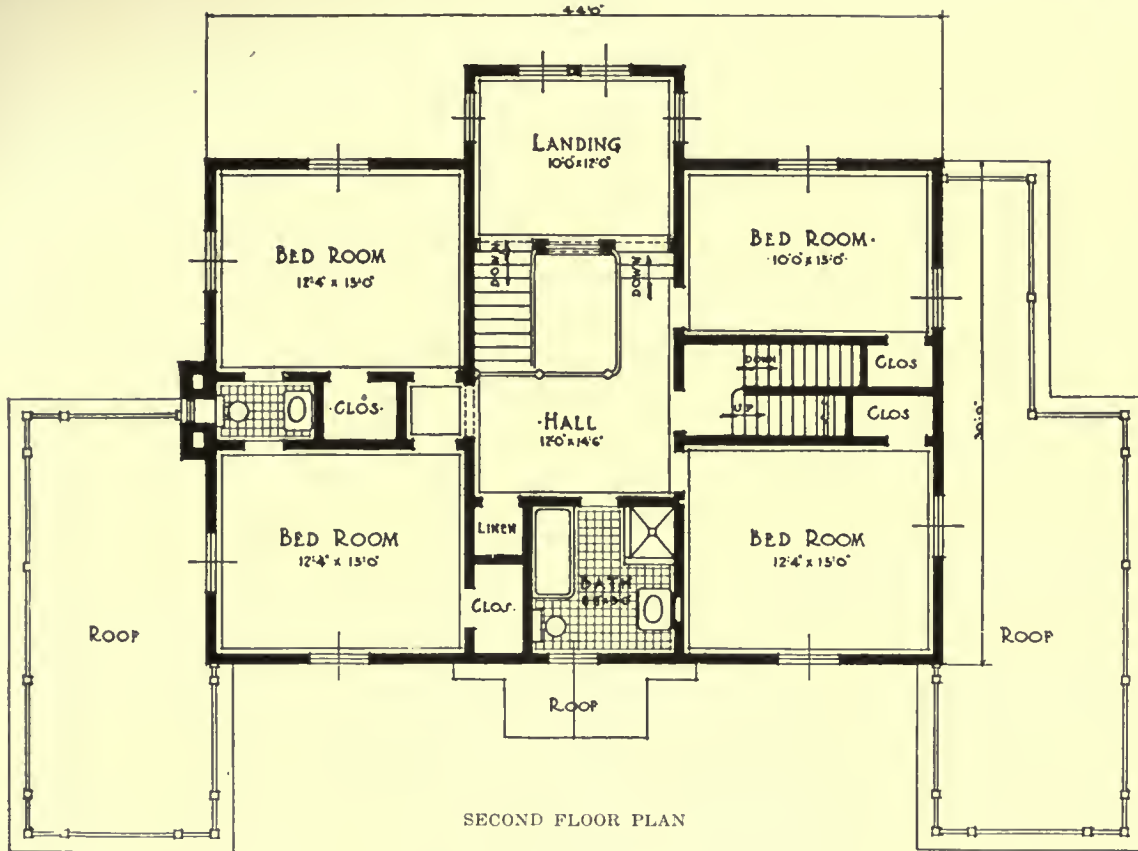

SECOND FLOOR PLAN

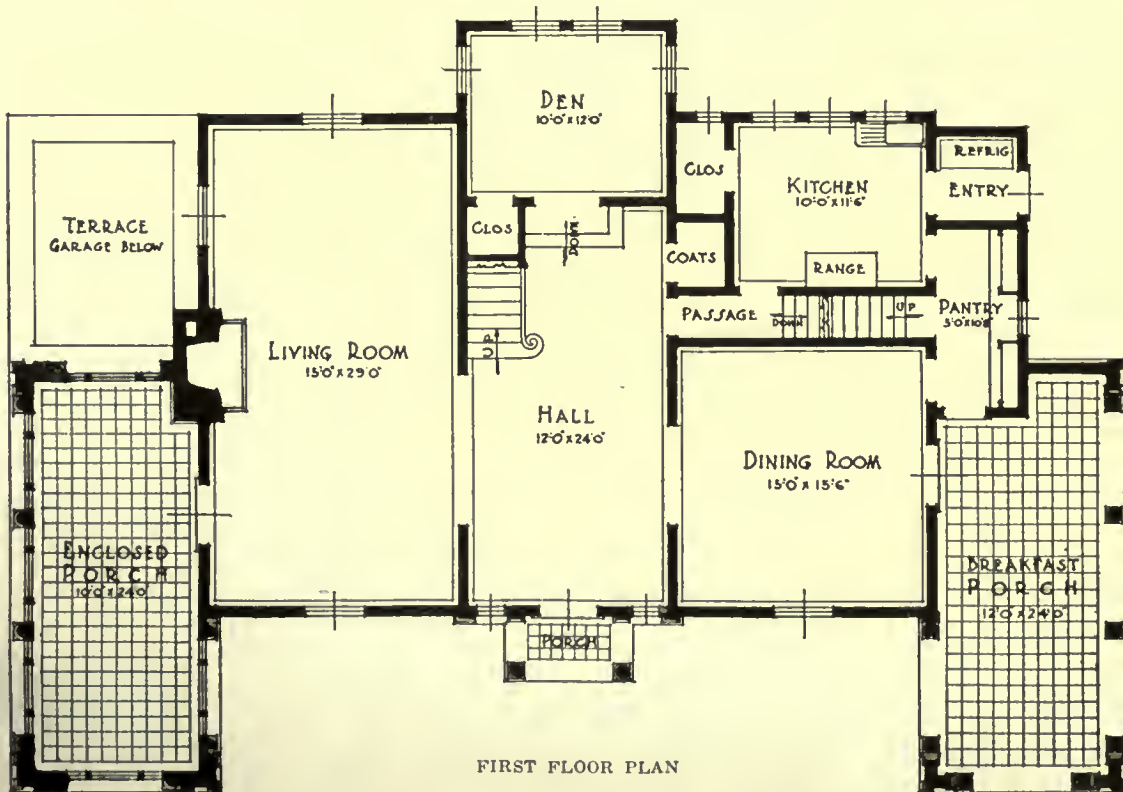

FIRST FLOOR PLAN

HOUSE OF JOHN J. FISHER, PARK MANOR, PATERSON, N. J.
CHARLES H. BENJAMIN, ARCHITECT

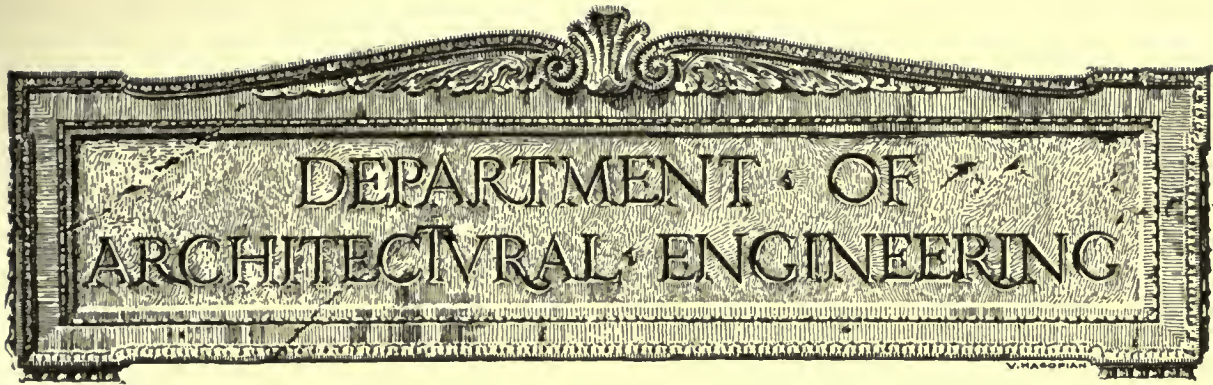

Foundations—Their Selection, Design and Construction

Part IV

IN the previous article the spread footing was described as well as eccentric wall footings. In this article we will consider another type of foundation, that embodying the use of piles.

When the nature of the soil at a depth within a few feet of the basement floor level is such that spread footings are impracticable, the superimposed load, brought down by walls, columns and piers, must be transmitted to an underlying strata of firmer material. There are three general methods of accom-

plishing this purpose: (a) piles; (b) sheet piling and open excavation; and (c) pneumatic caissons. The choice between these three methods depends on (a) magnitude of loads to be supported; (b) physical conditions at the site; (c) relative costs and, (d) time required for construction. Where the ground is dry, no difficulty will be encountered in carrying on open excavation to the desired level. All vertical banks of earth, must, of course, be properly sheet piled. In many localities, however, ground water is encountered at or below

the basement level. If the depth of firm strata, capable of supporting the weight of the super structure, is shown by borings to be not very great, and the ground water seeps in slowly, continuous pumping will permit the excavation to be carried forward in open trenches and pier holes, well sheet piled. Sometimes tongued and grooved sheet piling is used to retard water seepage. Another method is to drive interlocking steel sheet piling, which will hold back the water to a considerable extent. Some extensive work has been carried on by this method, which will



GROUP OF GIANT PRECAST CONCRETE PILES IN PROCESS OF SEASONING PRIOR TO DRIVING

plishing this purpose: (a) piles; (b) sheet piling and open excavation; and (c) pneumatic caissons.

The choice between these three methods depends on (a) magnitude of loads to be supported; (b) physical conditions at the site; (c) relative costs and, (d) time required for construction.

Where the ground is dry, no difficulty will be encountered in carrying on open excavation to the desired level. All vertical banks of earth, must, of course, be properly sheet piled. In many localities, however, ground water is encountered at or below

form the subject of a later article. The novel method employed in the excavation for the Annex to the Ambassador Hotel at Atlantic City, described in the October 20 issue, can also be used to advantage under similar conditions. Where considerable water is encountered, and a firm strata can only be reached at a very considerable depth, the pneumatic caisson offers the only solution. The foundation of the Woolworth Building is of this type, these concrete shafts, in the neighborhood of 15 feet in diameter, extending to a depth of some 130 feet below curb to

THE AMERICAN ARCHITECT

solid rock. A later article of this series will treat of the caisson foundation.

THE PILE FOUNDATION.

THE pile foundation can be used to meet a wide variety of conditions. Prior to 1896 practically all such foundations employed wood piles. Since that time concrete piles have been extensively developed and possess many advantageous features.

Wood Piles.—The wood pile may only be used in locations where water is constantly present, otherwise

$$L = \frac{2Wh}{p+1} \text{ where a drop hammer is used,}$$

$$\text{and } L = \frac{2Wh}{p+0.1} \text{ where a steam hammer is used}$$

in which L = the safe sustaining power of the pile in tons; W = the weight of the hammer in tons.

h = height of fall in feet of hammer.

p = the average penetration of the pile in inches under the last five blows.



PILE DRIVING IN PROGRESS FOR THE L. C. SMITH BUILDING, SEATTLE, WASH.

1,281 Raymond concrete piles were driven on this job, having an average length of 20.7 feet and loaded to 30 tons each

rot will set in. The tops should be cut off below the permanent water level and the piles capped with a concrete mat or ranging timbers. Wood piles, if constantly wet, will remain in excellent condition for a great length of time. Pieces of piling driven by the Romans in some of the Swiss lakes have been found in a perfect state of preservation. With respect to wharves and other water front structures located in waters infected by teredo and similar marine borers some form of effective protection must be provided.

The load which a wood pile will support is determined by the commonly accepted formula:

When driven to practical refusal, good engineering practice limits the load on a wood pile to from 20 to 25 tons. Such piles should be at least 6 in. in diameter at the point and from 10 in. to 12 in. at the butt, depending on the length. They should not be driven closer on centers than twice their diameter at the butt. It will be seen that the conditions under which wood piles may be used are somewhat limited.

The Concrete Pile.—Concrete piles may be used over a wide range of conditions. They may be designed to support heavy loads; their permanency is not dependent on either the presence or absence of



PILE DRIVING COMPLETED. CONCRETE MAT BEING INSTALLED. L. C. SMITH BUILDING

water, and since their tops are not determined by any water level, the footings may be placed at that level which will necessitate a minimum of excavation.

Concrete piles have been developed along two distinct lines, the pre-cast and the cast in place pile.

The Pre-Cast Pile.—It was but natural that the type of concrete pile first produced should follow along the lines of the wood pile. These were of the cast in place type, and were reinforced with steel. Some were made tapered and others of uniform cross-section throughout. Both longitudinal and circumferential reinforcement is generally used. Originally the driving of such a pile presented several difficulties, which have now been largely overcome.

To facilitate driving and prevent damage to the concrete a cast iron or steel driving point is provided at the lower end of the pile. Additional reinforcing is sometimes used at the head to prevent shattering. The inability of such piles successfully to withstand repeated direct heavy blows has in part been surmounted by the use of protecting devices de-

signed to resist or cushion the blows. This has a distinct disadvantage, in that considerable energy is thereby lost.

A method used advantageously in driving the pre-cast concrete pile is jetting, that is, displacing the material in front of the pile point by a water jet. This is of especial assistance where piles are being driven through sand or gravel. Many styles of pre-cast piles have been patented, the patentable features usually relating to some particular feature of the design or method of driving. For instance, the Cummings pile has a special feature in the reinforcement at the head of the pile; the Bignell pile makes use of a double jetting system in driving; the Giant pile (some tests on which were described in the September 1st issue of *THE AMERICAN ARCHITECT*) is driven by two steel channel members extending to the metal driving point, these taking the direct force of the hammer and preventing any direct blows on the concrete shaft. Precast piles are usually made square, hexagonal or octagonal in cross section.

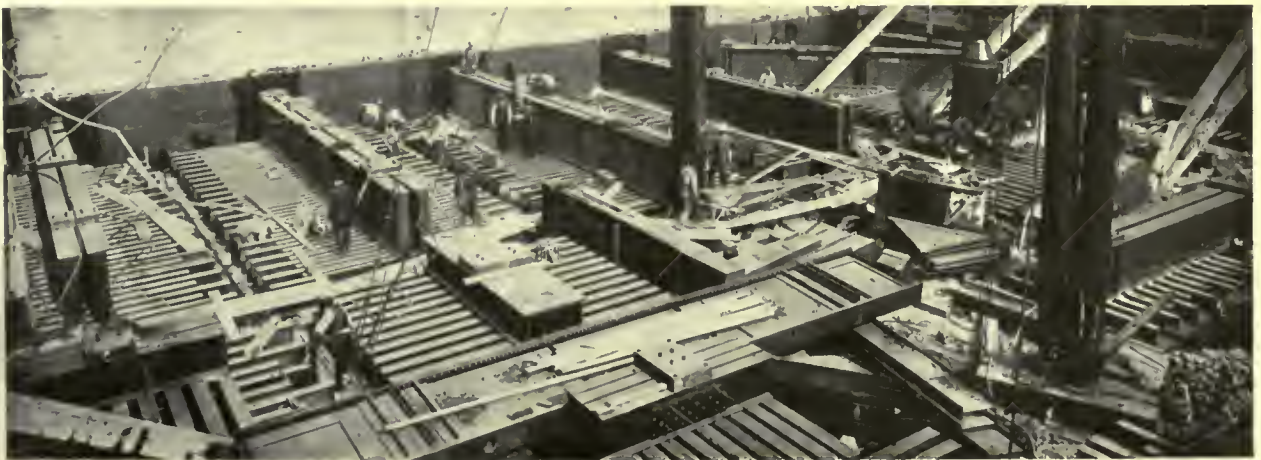

PLACING STEEL GRILLAGES—L. C. SMITH BUILDING



THE L. C. SMITH BUILDING, SEATTLE, WASH.
GAGGIN & GAGGIN, ARCHITECTS
This building, 40 stories to top of tower, is the tallest structure supported by a pile foundation

When square the corners are chamfered to avoid sharp arises. Such a pile driven to rock may be figured as a reinforced concrete column. When not driven to rock its safe load must be computed as for a friction pile.

The sizes of such piles range from 12 in. to 24 in. in diameter, and the length is usually within 40 ft., although longer piles have been driven in many instances. Loads as high as 100 tons per pile have been safely carried.

The New York Building Code provides:

Concrete piles moulded and cured before driving shall not be provided with more than 4 per cent. of longitudinal reinforcement. The diameter or lateral dimension of such a pile shall not be less than 8 inches at the foot and shall not average less than 12 inches in the length of the pile. The length shall not exceed twenty times the average diameter when the pile is driven to rock nor forty times the average diameter in any case. When driven to rock the allowable load on any such pile shall not exceed 500 lbs. per square inch on the concrete at the average cross-section and 6,000 lbs. per square inch on the longitudinal rein-

forcement. If driven to rock, the foot shall be provided with a metal shoe.

On this basis a pile 16 in. square, driven to rock could not exceed 26.7 ft. in length and the maximum load which it could safely sustain would be 89 tons, computed as follows:

Concrete 16 x 16 = 256 sq. in. less 8 sq.

in. for chamfer = 248 x 500 = 124,000 lb.

Steel 9 — 1 in. sq. rods = 9 x 6000 = 54,000

Total safe load..... 178,000

In the Halifax Terminal Pier, constructed a number of years ago, pre-cast concrete piles were used, these being 24 in. sq. and 77 ft. long. They are safely supporting a load of 100 tons each.

As previously stated, when concrete piles are not driven to rock, they must be figured as friction piles. It has been suggested that, as the pre-cast pile itself is of considerable weight, the formulae usually applied (known as the *Engineering News* formula) be modified to allow for this factor, and the following modification has been offered:

$$\text{For piles driven by drop hammer } L = \frac{2 Wh}{p \left(1 + \frac{w}{2 Wh}\right)}$$

$$\text{For piles driven by steam hammer } L = \frac{.1w}{p \left(1 + \frac{w}{.1w}\right)}$$

In which w = the weight of the pile, all other factors being as previously given.

The Cast in Place Pile.—This type of concrete pile has developed several variations. The various features of the several piles can best be illustrated by a description of some of these piles, their formation and the method of driving.



GROUP OF RAYMOND CONCRETE PILES READY FOR CONCRETE CAP

Note the spirally reinforced steel shell, which remains in the ground

The Raymond Pile employs a tapered steel shell constructed of corrugated sheet metal, 8 in. in diameter at the small end, and spirally reinforced by steel wire, the shell forming a permanent mold for the concrete. This is fitted over a collapsible steel mandrel or core, which is driven until the required penetration is reached. The pile core is then collapsed and withdrawn from the shell, which after inspection is filled with concrete. The mandrel tapers from 8 in. at the point to 20 in. at a point 30 ft. from the point. The steel shell forms a permanent mold, being left in place, and insures the pile against distor-

ing with a stream of water under pressure. When the tube has been cleaned out it is filled with 1:2:4 concrete.

Formerly interior longitudinal reinforcement was used, but in some cases this had been carried to the extreme. The writer recalls some piles of this type approximately 30 ft. long, each reinforced with 8 heavy rods. After placement these tended to interlace and prevented the complete filling of the tube by the concrete. If it is desired to use longitudinal reinforcement, four rods, not over 1 in. square, is the maximum that should be used in a 12-in. tube. This



A FOUNDATION IN WHICH HERCULES TUBULAR PILES, DRIVEN TO ROCK, WERE USED
That part of the steel tube which projects above the specified level is cut off by the use of the oxy-acetylene burner

tion while the concrete is in a semi-plastic state. This type of pile has been used extensively and has given excellent service.

The Tubular Pile.—Piles of this type are formed by driving a steel tube, usually $\frac{3}{8}$ in. thick, and from 10 in. to 16 in. in diameter. Such a tube possesses sufficient strength to resist hard driving without deformation. This type of pile is generally driven to rock, although sometimes terminating at hardpan. To obtain the full value of strength the pile must be driven to hard rock, otherwise it is not economical.

After the steel tube has been driven to a solid bearing the interior is excavated. This may be accomplished by blowing out with compressed air, which method has been found most effective, or by wash-

ing with a stream of water under pressure. When the tube has been cleaned out it is filled with 1:2:4 concrete. Formerly interior longitudinal reinforcement was used, but in some cases this had been carried to the extreme. The writer recalls some piles of this type approximately 30 ft. long, each reinforced with 8 heavy rods. After placement these tended to interlace and prevented the complete filling of the tube by the concrete. If it is desired to use longitudinal reinforcement, four rods, not over 1 in. square, is the maximum that should be used in a 12-in. tube. This

type of pile has been extensively used in New York City. The New York code, although formerly permitting interior reinforcement, now prohibits it. As bearing on the tubular pile this code states:
Concrete filled steel tubes. For piles consisting of steel tubes filled with concrete, the tubes shall have a diameter of 9 inches or more and a thickness of not less than $\frac{5}{16}$ of an inch. The ends of each tube shall be faced perpendicular to its axis. Splices shall be of an approved design and not more than one splice shall be used in the total length of the pile. The length of any such pile shall not exceed forty times the inside diameter of the tube. Such piles shall be driven to a full bearing on rock. The allowable load on any such pile shall not exceed 500 lbs. per square inch on the concrete and 7,500 lbs. per square inch on the steel, provided that in computing the effective area of the

steel the outer 1/16 inch of thickness shall be deducted from the thickness of the tube. No interior steel reinforcement shall be used.

Tubular piles will carry loads of from 60 to over 100 tons each.

In one type of pile using a heavy steel shell, a metal point is used, thus preventing the tube from filling up during driving. This feature, however, does not permit as full a bearing on the rock.

Piles Without Permanent Mold.—In this class are



DRIVING TUBULAR PILES CLOSE TO AN EXISTING WALL BY STEAM HAMMER

Wood frames and wedges are used to keep piles plumb during driving

several piles, among which might be mentioned the Simplex and the Pedestal piles.

In driving the Simplex pile a conical cast iron point is fitted loosely to the lower end of a 16-in. diameter, 3/4-in. thick, hollow, cylindrical steel tube or form, and driven to suitable bearing. When the required depth is reached the form is filled with a wet mix of concrete to the desired level by means of drop bottom buckets. The tubular steel form is then pulled out, leaving the point permanently in the ground. Due to



GROUP OF TUBULAR PILES PARTIALLY EXPOSED

the method of formation a soupy mix is made necessary to prevent the concrete arching against the sides of the tube when this is being withdrawn.

The Pedestal pile is so driven as to provide a cylindrical shaft 16 in. in diameter with a bulb or enlarged base formed at the lower end from which it takes its name. The apparatus used in driving this pile consists of a cylindrical steel casing and a core (or rammer) which fits inside the casing. This apparatus is driven into the ground to the required depth. The core is then removed and a charge of concrete dropped to the bottom of the casing. With the core as a rammer this concrete is forced out against the

CAST STEEL SLEEVE USED TO SPLICE SECTIONS OF HERCULES TUBULAR PILES





GROUP OF PEDESTAL PILES FOR THE WILLYS-OVERLAND COMPANY'S PLANT AT TOLEDO, OHIO
Earth around tops of piles excavated and forms being placed for concrete cap

soil at the bottom of the casing, and this operation of charging and ramming is continued until a bulb or pedestal of suitable size is formed. After this the casing is filled with a stiff mix concrete and pulled slowly and evenly out of the ground, the core resting on the concrete during this process, leaving in place a concrete pile of the size and shape mentioned above. Since the weight of both core and hammer (approximately 5 tons) rests on the concrete while the casing is being withdrawn, the concrete within the mold is forced against the surrounding earth as the casing is pulled out.

It has been conclusively shown that certain types of soil will transmit a pressure laterally for some distance from the point of disturbance. Due to this fact, piles not incorporating a substantial permanent mold, if driven in such soils, are subject to a lateral pressure induced in the soil during the driving of subsequent piles. Unless this fact is realized and provided against, lateral distortion may result. Certain companies driving this type of pile by developing improved methods of formation have apparently overcome previous defects, and it would seem are now able to produce good piles under various soil conditions.

Another pile, embodying some of the features of several of those previously described, is controlled by the Concrete Pile and Foundation Company. So far as the writer knows no installations have yet been made, and both its practicability and economy remain to be demonstrated. The method of driving is described by its inventor as follows:

A $7\frac{1}{8}$ -in. steel shell, 18 in. wide at the top, tapering to 8 in. at the point, split into three or more parts longitudinally, with one part acting as a "key wedge" is used. At the point is a conical driving nose, into which fits the lower end of the steel shell. At the top is placed a driving block to receive the blows of the hammer. When the driving cap and nose point are in position, and during the driving, the split sections of the shell are held tightly together. After driving a tapered pile is formed by filling the shell with concrete. When this has set sufficiently the



TWO PEDESTAL PILES, EXCAVATED FOR INSPECTION

"key wedge" is first withdrawn, after which the remaining sections are also withdrawn. It would seem that the space left by the withdrawal of the shell after the concrete had set would reduce skin friction.

It is further stated that when desirable to place arms or knobs extending around the pile, either in rows or staggered, a sheet iron shell of No. 16 gauge sheet iron, with large perforations, about 6 in. in diameter, either triangular or of some other shape, is placed outside the heavy steel shell and is driven



APPARATUS USED IN DRIVING PEDESTAL PILES

into the earth with the heavy shell. When the desired penetration has been reached, the heavy shell is withdrawn, leaving the driving nose and the perforated sheet iron shell in the earth. Concrete is then introduced and tamped, forcing the concrete out through the perforations into the surrounding earth, thereby forming knobs, as well as impacting the earth around the pile, and increasing the skin friction.

The several types of piles described in this article are shown in the accompanying illustrations.

Stimulating Building

THE Bishopric Manufacturing Company, makers of stucco board and sheathing, used extensively in home building, not long ago issued to the trade a revised price list, quoting reductions over previous prices. An accompanying letter states:

While there has been some reduction in price of the wood strips used in the manufacture of Bishopric Board, there has been a continual advance in price of other materials used in these products; further, our labor costs are still on a high level, so that conditions really do not warrant this price reduction. We are making same with the hope that it may help you to some extent in stimulating your sales.

An excellent method. No factor will so stimulate building as a reduction in costs. The architect is realizing this to an increasing degree, as estimates received on contemplated projects halt their construction until more propitious times. If every manufacturer would seek to stimulate business in this manner, a solution of the present critical building situation would automatically appear.

Mechanical Engineers Organize Materials Handling Section

FOUR hundred members of The American Society of Mechanical Engineers have organized themselves into a Professional Section on Materials Handling and will provide primarily a common channel of intercourse between all the technical and industrial organizations cooperating in the solution of engineering problems connected with the handling and distribution of materials and products.

Probably the greatest economic need of civilization today is the devising of means and a more intelligent application of proper and coordinated methods whereby materials of one kind or another may be handled more swiftly and to better advantage.

Industrial and railroad congestion has been almost intolerable and with these continued conditions have come mounting costs until better, more efficient and more adequate systems must come into being if the cost differential that is now being reflected in the soaring prices of all goods is to be modified.

The burden of this necessity made it imperative that a professional section composed of those whose interests and whose expert knowledge brings this problem close to them, should assume this work as its obligation to the technical fraternity and its contribution toward the solution of a national problem.

This section will aim to be a bureau of information—complete in its scope, specific in its knowledge of the physical and economic conditions and unbiased in its conclusions. This will be done by having special meetings on particular subjects, meetings jointly with other sections, or other organizations, by taking part in all local and national problems.

Making the Most of the Back Yard

(Continued from page 575)

obliged to build his garage upon the property itself, thereby cutting off a considerable portion of the available lot space of the back yard. The owner of the small suburban lot in a closely built up community needs to devote only a small portion of his back yard to the drying of clothes, while the remainder of the yard, not large enough for a garden and con-

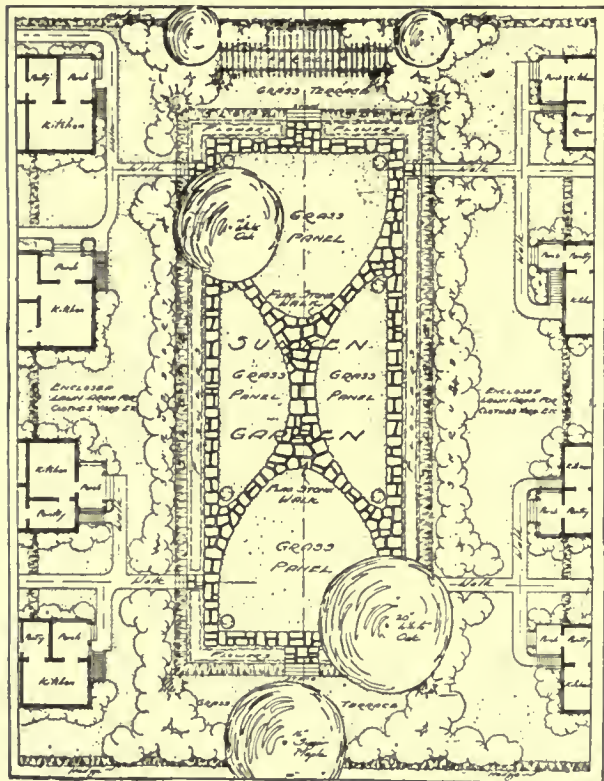

PROPOSED DEVELOPMENT OF A COMMUNITY BACK YARD GARDEN—THE INTERIOR COURT AREA OF A SUBURBAN BLOCK

sequently in reality often a waste space used as a dumping ground for miscellaneous portions of the family belongings, is frequently unsightly and generally poor in character.

The accompanying illustration in the *American City* shows one possible and entirely practical means

of community utilization of this waste area. Experiments of this character have been tried out in several of the larger and more closely built up cities of this country. Such a development affords sufficient space for the drying of laundry and other necessary back-door activities, gives perfect seclusion from the street, and at the same time privacy from the back doors of the houses themselves, by means of the shrubbery border which completely surrounds the garden area and from the fact that this area is depressed slightly below the level of the lots themselves.

A garden of this character will produce sufficient cut flowers for the tables of the neighboring families and has sufficient flowering area to afford a bright and cheerful appearance throughout the entire season. It affords a play space for the children in the morning and afternoon and a sheltered promenade for the older members of the family after work is over in the evening, or an attractive setting for the holding of outdoor afternoon card parties and little informal garden affairs in the evening. The extensive use of the stone path means dry footing even after the hardest rain and also a minimum of attention from the family lawn mower.

Such treatment is simple in character, easy of construction, and with slight modifications adapts itself well to the usual topography of city lots. The cost of flowers, shrubbery, materials for the walk, etc., will total less in the expense column than would the cost of the individual landscape treatment of each lot as a separate unit. The throwing of all waste space into one available community area makes the most out of every inch of the land involved. The plan in its entirety may not be applicable to all city blocks for which it may be used, but it is closely modeled after several developments which have actually been constructed; and in the majority of instances it can be quite closely followed by slight alterations in the shape or extent of the design.

Such utilization of the back-yard area will go a long way toward stimulating a close community interest; it will afford a place of recreation and privacy for young and old, especially in those portions of the city where a public park can be reached only by a long hot walk or a tedious ride in a crowded trolley car after the day's work.

Current News

Happenings and Comments in the Field of Architecture and the Allied Arts

Lehigh Valley Architects Affiliate With A. I. A.

At a special meeting and dinner of the Lehigh Valley Society of Architecture, held in the Hotel Allen, Allentown, Pa., the society adopted a resolution to affiliate with the architectural society of Reading and to form an Eastern Pennsylvania chapter of the A. I. A.

The business session, presided over by L. S. Jacoby, president, followed a dinner. Mr. Jacoby introduced M. I. Kast, Harrisburg, president of the Pennsylvania State A. I. A. and secretary of the State board for examining architects, as the speaker.

Iowa Chapter Discuss Housing Problems

Housing was the central theme at the eighteenth annual convention of the Iowa Chapter of the American Institute of Architects, which was held at Waterloo, October 14 and 15. The entire morning session on Friday was devoted to a discussion of this subject, with addresses as follows: "The Minnesota Small House Bureau," Edwin H. Hewitt; "Housing Development for the Government and for Cleveland, O.," Seth J. Temple; "Town Planning and Housing at Newton, Ia., and Spirit Lake, Ia.," Harold G. Sprague. There followed a discussion on the practical working of the Iowa State Housing Law.

A paper on "Architectural Photography" was read by Seth J. Temple. In the course of the convention, an address was made by Allen Holmes Kimball, chapter president; a lecture with moving pictures was conducted by the Indiana Limestone Association.

Utah Architects Asked to Submit Plans for War Monument

Utah architects are invited to submit plans for the proposed state war memorial by a resolution passed by the state memorial committee at a meeting held in the office of the county commission Thursday.

The form of the memorial and the site on which it is to be erected have not been decided upon by the committee. It was stated today that all available plans for memorials should be in the hands of the committee before the decision is made.

An auditorium, suitable as quarters for the American Legion, Spanish War Veterans, G. A. R., Mormon Battalion and similar patriotic organizations, is understood to be favored by the majority of the committee. Four sites are said to be in prospect.

O. J. Grimes, secretary, was instructed to inform architects of the state that plans should be submitted at an early date, as it is desired to get the committee's recommendations before the State Legislature at its next session.

N. Y. State Association of Architects

The New York State Association of Architects will meet in New York City on November 11th, 12th, and 13th, to discuss with representatives of the building trades, manufacturers of materials, and labor, the subject:

"What is the matter with the building industry?"

The point of view of the General Contractor, the Sub-Contractor, Building Superintendent, and Labor will be presented at the meetings on November 12th by:

Mr. Louis Comstock, of L. K. Comstock & Co.

Mr. W. G. Luce of Hegeman-Harris Company.

Mr. Hugh Frayne, Organizer for the American Federation of Labor.

Mr. Ronald Taylor, President of the Building Trades Employers' Association.

Mr. Robert Glenn of Todd, Irons & Robertson, Inc.

Mr. J. Riley Gordon, President of the New York Society of Architects and Mr. William P. Bannister representing the Brooklyn Chapter of the American Institute of Architects will discuss the subject from the point of view of the Architect.

Mr. Burt L. Fenner, President of the New York Chapter of the American Institute of Architects will lead the discussion on Housing.

Mr. Allen E. Beals of Low's Reports will speak on Building Materials, Supply and Prices.

Mr. Ordway Tead of the Bureau of Industrial Research will speak on "What is Being Done in England."

Members of the New York State Association are invited as guests of the New York Society of Architects at an informal dinner on Thursday evening, November 11th, at 7 o'clock.

Mr. Robert Glenn, Superintendent in charge of the construction of the Cunard Building, now in course of erection, has invited those who intend to be present at the meetings to visit this building on Saturday morning, November 13th.

The meetings on Friday, November 12th, will take place at the Fine Arts Building, 215 West 57th street, at 10.30 A. M. and 2.30 P. M.

Ask Funds to Preserve Poe Cottage

An appeal for funds to preserve and maintain the Edgar Allan Poe cottage in Fordham has been issued by Mrs. Charles D. Dickey, chairman of the Poe Cottage Committee of the Bronx Society of Arts and History. Mrs. Dickey said that the cottage, which is located in the little city park on Kingsbridge Road and Grand Concourse, was in need of repair and several thousand dollars must be raised at once to yield an adequate yearly income for maintenance. The Columbia Trust Company branch at Third Avenue and East 184th Street has been appointed to receive contributions.

No Use for Door Keys in Russia

Door keys are considered unnecessary in the Bolshevik scheme of life in Russia. Only privileged persons are supposed to possess them.

When the Associated Press correspondent, who recently crossed Russia, asked for a doorkey in one of the nationalized hotels at Omsk he was informed by the hotel "commissar," formerly the owner, that under the Red regime doors are not supposed to be bolted.

An appeal to the Omsk Bolshevik commandant resulted in the American correspondent obtaining an official document granting him a key and the privilege of locking the door of his room.

Wants Postal Savings Funds to Aid Home Builders

Postal savings deposits totaling \$175,000,000 would be turned into a vast building loan fund to relieve the Nation-wide housing shortage under a bill to be introduced at the next session of Congress by Representative M. Clyde Kelly, of Pennsylvania.

Kelly would have the money, and loans to be made with it, administered under the direction of a group of depositors in each community.

Kelly is one of a group of Representatives and Senators now planning to introduce bills dealing with the housing shortage at the next session of Congress.

Chicago's \$5,000,000 Dwelling Fund Grows to \$7,500,000

Under the plan being worked out by the Chicago Trust Co., to distribute in Chicago territory the \$5,000,000 offered at 6½ per cent. by the Metropolitan Life Insurance Co. for the building of homes, the fund has grown to \$7,500,000.

As explained to the Chicago Real Estate Board Housing Committee by Hiram S. Cody of the Real Estate Loan Department of the bank, the insurance company offers only to handle first mortgages up to

50 per cent. of the cost of the new dwellings. A special securities corporation is being worked out by the Chicago Trust Co. to handle second mortgages, supplementing the first, and up to an additional 25 per cent. of the cost of lot and building. The seconds will probably be at 7 per cent.

In a typical case a home hunter owns a \$2,000 lot. He wants to put up an \$8,000 house. On this he can borrow three-fourths of the total, or \$7,500, leaving him to raise \$500, plus commissions on the loans, estimated at \$375, and incidental costs of settling in his new home.

Thames River to Have New Bridge

The city of London is now resuming preparations, interrupted in 1914, for the construction of what will be known as St. Paul's Bridge. Spanning the Thames River near St. Paul's Cathedral, the bridge will relieve the present congestion of traffic by providing a new link between the north and south sections of the crowded city. Cross-country motor-truck traffic will benefit in particular, as the bridge will connect directly the Great North Road and the highway to Dover, on the Channel, 65 miles distant. The structure is to be built of stone, and in design will resemble the graceful bridges of Paris.

Sportsman's Stable Becomes Restaurant

Among the unusual sights in New York City is the restaurant, located not far from Fortieth Street and Broadway, which was once a horse stable. It was a stable of palatial sort, however, built by a world-famous sportsman to house his string of race horses. So it is in stalls marked "Hermes," "Irish Lad," and "Gold Heels" that the diner now is served. On the walls hang pictures of racing and hunting celebrities and incidents; illumination is provided by antique lamps. Altogether, the atmosphere of the strange eating place is original and quite authentic, the word "atmosphere" being used figuratively, of course.

Plan to Save Fifth Avenue Elms

Unusual methods to save Fifth Avenue's elm trees, bordering Central Park, have been taken by Park Commissioner Francis D. Gallatin, New York, under the direction of J. S. Kaplan, the department forester. Nearly one-half of the big trees have been lost within the last few years because of lack of fertilizer. The hardness of the earth about the roots and the continuous pedestrian traffic have made the fertilization of the trees a difficult problem.

The method which is now being tried is the digging of trenches at right angles to the avenue and midway between the trees. The trenches are three feet wide

and two feet deep. They are filled with commercial fertilizer, which is covered with water. After the water has soaked in the trenches are covered. The feeding roots of the trees on each side of the trench reach the fertilizer.

Trenches were tried successfully last year with the beeches, birches and maples in the park, but in an entirely different way. At that time circular trenches were dug all around the trees, a method which is impossible on Fifth Avenue.

Hilton Gets Its Brick

A shortage of buildings and of brick existed in Hilton, California. It was decided to raze an old chimney which contained eight hundred and fifty tons of brick—enough to relieve the brick shortage. A big notch was cut into the chimney's base. As the bricks were removed, supporting timbers were put in. Slowly at first, then with increased speed, the big pile of brick moved earthward. There was a great crash. When the timbers were all in place they were covered with gasoline and set on fire. The men then gathered up their tools and drew away to watch the big crash from a safe distance. As the fire burned the timbers became weakened; they groaned under the terrific weight, and—down she came!

Chimney Two Miles Long

The tallest chimney in the world is in Wales, and is over two miles in length, and has a further distinction in that it has a brook running through it. According to the *Detroit News*, it was built by a smelting company after the neighbors for miles around the plant had complained that unless something was done to alter the drift of copper smoke that destroyed vegetation and rotted the hoofs of farm animals, they would take the plant away brick by brick.

A famous engineer was called in, and after inspection of the plant began a chimney that extended from the roof of the plant up a mountain side just back of the works. The chimney, in addition to crawling the two miles up the mountain, extends 100 feet up in the air. The brook was allowed to flow almost the entire length of the chimney, as it was found the running water would condense the smoke to a great extent. Once a year the chimney is swept, and a ton of precipitated copper is reclaimed. The tip of the smoking chimney can be seen for forty or fifty miles on a clear day.

An Apartment Building in New York

In an apartment building of the most expensive type on Fifth Avenue the interior decorations are done entirely by the lessees. Under this agreement they are privileged to use any kind of woods. One of

the lessees has gone so far as to have doors and panels of an old European castle brought over to harmonize with some mediaeval period furniture.

Probably the most unusual thing about this building is that the minimum lease is for ten years. All the leases were signed before the building was completed.

Convention Hall Had Unusual Equipment

Arc lights of an unusual type illumined the Coliseum during the Republican National Convention, at Chicago, a few months ago, and by their brilliance made possible the taking of motion pictures. This had never been done at a previous convention. Each of the lights, as described in *Popular Mechanics*, was rated at 1,900,000 cp., and consisted of an arc backed by a silvered parabolic reflector. In front of each was placed a plate of ground glass to serve as a diffuser. Another item in the furnishing of the hall were the three loud-speaking telephones with rectangular amplifying horns, suspended above the rostrum to carry the speaker's voice to the remotest corners of the gallery. The receiver at the small end of each of the great wooden megaphones was vibrated by a transmitter mounted in front of the platform.

Museum for War Relics

The collection of relics of the great war which the war department is assembling has reached such proportions that Congress will probably be asked to provide funds for the erection of a new museum building when it convenes in December. The latest curio to arrive is the Order of Battle map used by Gen. Pershing in directing the movements of the American forces in France.

This map, which is 8x10 feet in size, together with the furniture, floor and walls of the room in which it hung at American headquarters at Chaumont, was transferred to the National Museum here at the request of the general. While at Chaumont the map, when not in use, was concealed by a sliding section of wall, and this has been installed in the same manner at the museum.

The map was kept right up to the minute until the signing of the armistice, and vividly depicts the exact situation of not only our own troops, but those of our allies and also the enemy. The strength and location of all divisions is shown; the correct battle lines, the names of the commanding officers and locations of headquarters and army boundaries. Detailed information is also set forth, including the percentage of fresh and tired troops in the various American sectors and the length of time various organizations have been in line or reserve.

The war collection is now crowded into the first floor of the new National Museum and some of it has overflowed into the old building. In some instances artillery pieces are out in the open waiting for a suitable protecting cover.

The airplane exhibit is especially interesting, as it includes practically all types used by the allies and the enemy and also an elaborate display of airplane motors. In addition to the world aviation section the museum contains the original Langley and Wright models.

Architects in New Nation-Wide Housing Contest

A nation-wide competition for four, five and six-room house designs, with \$15,000 in prizes, has been proposed. The winning designs will be exhibited at the Own Your Home Exposition next spring at the Coliseum in Chicago. The thirty-two prize designs will be selected by a jury of competent architects from various parts of the country and will be printed in book form and sold at a nominal price to cover cost of production.

There will be an equal number of brick, wood, stucco, and concrete block houses. Complete plans and specifications, with all necessary architectural services, will be sold for a nominal sum, not to exceed \$25. This is along the lines of the project announced recently by the Illinois Society of Architects.

Henry K. Holsman, president of the Illinois Chapter of the American Institute of Architects, has been selected by the Illinois chapter and the Illinois Society of Architects to represent the architects at the Own Your Home Exposition. He has appointed a committee of several local architects, who have passed on the design of the exposition, and who will pass on the architectural and artistic points of the several exhibits.

Personals

Messrs. Goodwin, Bullard & Woolsey, 4 East 49th st., have dissolved partnership. Messrs. Goodwin & Woolsey will continue to practice at the same address, and Mr. Bullard has opened offices for individual practice at 15 West 38th st.

Ernest H. Schmidt, of Glencoe, Minn., has associated himself with Albert Schippel in the practice of architecture at Mankato, Minn. The new firm is to be known as Schippel & Schmidt. They will be pleased to receive new catalogs and samples of materials.

New York Society Meets

The monthly meeting of the New York Society of Architects took place on Tuesday evening, the 19th ult., at Offer's Restaurant, West 38th Street, Manhattan. The meeting was preceded by a dinner attended by about fifty members of the Society. Among the guests were: Superintendent Kleinert of the Brooklyn Bureau of Buildings, Mr. Wm. Parfitt and others.

The first speaker called upon by President Gordon was Mr. Kleinert, who in the course of a brief address expressed his interest in the Society's work and the pleasure he always felt at being present at its meetings. The speaker went on to say that under present conditions no improvements in new construction of houses could be looked for. People are prone to expect more than is possible, but under the present law as interpreted property rights are taken away and capital cannot be expected to be invested until a law is passed for its protection. Mr. Kleinert advised co-operation to secure the passage of a bill of a remedial nature.

Vice-president Loth, in an interesting historical résumé, pointed out that the experience through which the country is now passing has had its parallel in former crises, in which a "slump" has been followed by a corresponding revival. As instances we had the Green-back craze, the Silver craze, and finally the great War came with all its disrupting consequences. This will surely be followed by a readjustment and revival. Such conditions are due to our imperfect civilization. Men will finally become educated to a higher conception of life and duty.

The New York State Association of Architects is to have a convention in November, which Mr. Loth said every architect in the State should attend. The State Society is putting up a fight for the registration of architects as a protective measure for the whole profession. According to Mr. Loth, the "tight wad architects" reap the fruits of the labors of the self-sacrificing practitioners.

Mr. Hugh Tallant, one of the Society's recently returned members from the war regions of France, where he has been doing duty in the A. E. F. Engineering Corps, was the next speaker. After reminding the meeting of his former lectures to the Society on the science of acoustics, Mr. Tallant remarked that the problem to be solved in this regard on the scene of his recent experience was "how not to hear," the chief requirement being a liberal supply of cotton wool for the ears. Mr. Tallant referred to several distinguishing characteristics of the French in their treatment of the American Army. First, their generosity and impressionable spirit. There never was an army treated with such indulgence. One-quarter of the regular railroad rates

was charged, and candy almost without limit provided to officers and men. Second, the interest shown in the individual soldier, extending even to his family connections at home. Also the wonderful constancy of the French. Even when under bombardment, the Big Bertha gun firing its discharges every half hour in the City of Paris, the people were free from panic, attending theatres and going about their business as usual. The French also showed a remarkable capacity for assimilation.

General Pershing, on coming to review Mr. Talant's company, met an apologetic reference to the soldier architect by the remark that they were "a d—d fine looking body of men."

The speaking program of the evening was followed by a lecture on the limestone industry by Mr. McGrath, of the Indiana Lime Stone Manufacturing Association.

The lecture was illustrated with motion pictures, showing every process, from the stripping of the rock up to the time when it is set up as a living monument to the architect. The address and exhibition met with due appreciation from all present.

The meeting, which was one of the most enjoyable in the history of the organization was brought to a close after the election of several new members and nomination of applicants for membership.

Weekly Review of the Construction Field

With Reports of Special Correspondents in Prominent Regional Centers

IN a report recently issued by the National Association of Corporation Training, it is stated that 250 industrial plants in this country have some sort of shop representation. A case in point is that of Procter & Gamble Co. which has just elected three employees, one from each of its plants, to its Board of Directors. These three directors were chosen by the workers themselves and this instance is cited in the report as the first industrial organization to have employee directors.

The steadily increasing demands on the part of employees of industrial institutions for a larger measure of authority in the management of business involves a determination of the degree of responsibility which must be accepted by these employees. Any development which tends to lessen production or deprive capital, management or employees of any of the rights which have been decreed by public opinion as just and fair must be discarded in advance. Any attempt to formulate new philosophies and new systems to be utilized in the movement more fully to democratize industry must square with the most intelligent judgment of the public.

The Secretary of the Treasury has told to the convention of bankers recently held in Washington the plain truth about our falling prices. It is equally necessary that these truths should be brought home to managers of industries and business, to those who work in these fields and in fact to the whole public. We shall only arrive at a comprehensive knowledge when all of us understand them. It seems certain that inflation in prices of abundant commodities can

not be kept from falling toward natural levels and to quote a recent editorial from the *New York Herald*, discussing this subject, "we might as well try to make the Niagara waters rush up the falls instead of down as to try to maintain war prices for prodigious stores of goods when the consuming public will not and can not pay such prices."

Assuming the premise, based on the foregoing, to be correct that there will occur a falling market in the price of building material the question might be asked what may be done to start building. In answering this question, the *Monthly Bulletin* of the Illinois Society of Architects summarizes the expressed opinion in the middle west as follows:

Considering the present shortage in construction estimated at three and one-half billion dollars in the United States, it will require the best efforts of the entire construction industry working at maximum capacity for ten years to fill this gap and get back to normal.

No material reduction in either material or labor costs may be hoped for for some time.

Building costs will be slightly lowered just as soon as the transportation systems are able to function normally, for then building materials may be secured as required and the time necessary for the completion of a structure materially shortened as compared to the time required in the immediate past. This shortening of the time of construction will reduce the amount of carrying charges. An increased output of the building mechanics which may be expected due to a scarcity of work and the consequent competi-

tion for jobs will also in a small measure reduce building costs.

Money is still, and for some years, will be the controlling factor. Money will be invested in building securities in direct ratio as the return on the sums invested bears to the return of moneys invested in bonds and other securities.

A vast amount of construction for housing is imperatively needed. Private capital will not invest until rent returns are advanced to yet higher levels, or until real estate securities are made more attractive in other ways.

There are two methods suggested to make real estate securities more attractive to investors.

a. Repeal the income tax.

b. Exempt from all taxation for a period of years, money invested in buildings.

The alternate is for the nation, state or municipality to raise money by taxation or bond issues to construct needed housing, letting the financial loss of such a proceeding be borne by the entire community.

THE conditions as affecting railroad transportation appear to be getting better and it is evident that the railroad managers are bending every energy to relieve a situation which at one time was so serious as to menace the prompt resumption of building operations even if all other contributing forces were removed.

In a recent letter addressed by the President of the Illinois Central Railroad Co. to a prominent architect in the middle west, he stated:

"For ten years prior to Federal control the revenues of the railroads were insufficient to provide cars and engines and development of the railroad plant to the extent necessary to meet the expansion of commerce. When Europe went to war, and later we were drawn in, the business of the country increased tremendously and, while the Government had charge of the lines, it failed to develop new equipment in proportion to development of business; furthermore, during the war the railroads were operated at their maximum capacity and everything was subordinated to getting the best possible use out of the cars, engines and the railroad plant. The natural consequence was greater rapidity in deterioration of equipment and plant and the result was inevitable; viz., when the railroads came back to their owners they were in worse condition than before, and the demand for transportation facilities was greater. During the time the Government had charge of the lines no new passenger cars were ordered. Consequently, there is a shortage which is severely felt by all the railroads, including the Illinois Central.

"I am hopeful that, under the new order of things, it will not be long before the income of the rail-

roads will be sufficient to take care of the essential requirements of freight traffic and permit us to increase suburban passenger train service and facilities as should reasonably satisfy the desires of all. As a first step, we have included in orders placed since the first of the year for \$27,000,000 of cars and engines one for 20 suburban cars, involving an investment of approximately \$750,000. The manufacturers expect to commence delivery in the first quarter of next year. These cars will be of steel construction and of the most modern type for that character of service, and will afford substantial relief from existing conditions, of which you complain."

President Markham's opinion probably accurately represents the point of view of railroad executives throughout the country.

THE New England correspondent of THE AMERICAN ARCHITECT finds that in reports to the Massachusetts State Board of Industries and Labor there is shown an increase in building operations in Boston from \$6,907,924 for the second quarter of the year to \$7,555,890 for the quarter ended Sept. 30. But returns tabulated from 25 cities in Massachusetts, including Boston, show a drop of 16.9 per cent.

There has been little homebuilding, although it is well known that a great demand for houses exists. Sixteen communities report "normal" conditions in building, 29 below normal and two slightly below normal. From various places came the report "many unemployed"; "building slow"; "construction slowing down"; "no new projects in sight."

Industrial returns show a declining tendency in principal lines. In textile manufacturing 12 below normal; 3 slightly better than normal. Those below normal report the percentage of capacity in operation all the way from 40 to 90. Worsted and cotton manufacturers generally report "quiet" conditions. Machinery and metal establishments are reported from 20 places as normal; 13 below normal and two above; some are working half time and others with a reduction of 10 to 15 per cent. of working hours.

In the majority of architects' offices called upon, the general feeling is that confidence is slowly returning. These organizations that are usually busy report considerable work on the boards but very few contracts being signed or projects going through to completion.

Credit and transportation conditions are rapidly improving. The last mentioned is the result of reduced traffic; more efficient management and operation of equipment and the mental stimulus given by the recent increases in freight and passenger rates.

The presidential campaign this year defers exactly in the same way as it has in preceding campaigns the adjustment of certain economic questions as

THE AMERICAN ARCHITECT

there is a tendency to await the assurance of the counted ballot and not to discount what in many minds is a certain conclusion. Our correspondent in Seattle, Washington, states that on the Pacific Coast there was until mid-October a tendency to await the result of the ballot which by the time this is read will have been accomplished and the result generally known. Our correspondent from Seattle states:

IT will be necessary at this time, in arriving at an approximate of construction and market conditions on the Pacific Coast, to digest the equation of politics as of the November elections, transportation and the attitude of bankers in whose hands the welfare of this part of the country now seems to rest.

Pacific Coast bankers are firmly of the opinion that the next 60 days will be the crucial period through which the country is passing, with the further depression and unsettlement, if it occurs, to be felt first in the east. This period will, they believe, tell the story of commercial and construction recovery, the base of commodity prices and whether and at what level it will be safe to operate. Future operations may then, they assert, be proceeded with confidence.

The carriers on the coast, particularly in the cement producing centers of the North Coast, are enforcing the "system car" rule, which prohibits loading to any point off the line. This rule is causing the cement shortage which is inextricably linked with better or worse for delayed building projects on the coast. In order to get delivery of cement without an additional and prohibitive handling charge jobbers must have their warehouses located on the same railway as the cement plants. Unfortunately only a few such harmonious conditions exist. The proposed highway law now before the voters of Washington which will mean the annual consumption of 800,000 barrels of cement for six years is causing much anxiety among builders. It has been openly asserted by those in opposition to the plan that all the cement plants of the state cannot produce so much, let alone the demands for building, and the effect must be steadily advancing prices of cement. Cement manufacturers as a rule are working for the bill which will be voted on in November.

Jobbers are not unanimous in the estimate of conditions as to the supply of small sizes in galvanized pipe. The large plants which are able to take heavy tonnage claim that the supply is ample, but admit

that they are trading one to another to maintain the supply. The smaller jobbers, who order 200 ton lots and upward, are a unit in the statement that there is an acute shortage. Light holdings over the territory are ascribed by the larger operators to the fact that tonnage has been running to larger or shipyard sizes, and that few have made preparation for the demand that is now pressing. On the other hand, one of the largest jobbers in the territory has had black pipe of small size galvanized in Seattle on an emergency order during the past week.

Rationing continues in small nails, but jobbers can report a slight improvement in arrivals. Eastern mills, especially those of Colorado, report that they expect to clean up back order files by January 1, although the improvement thereby will not be felt on the coast for several weeks later.

Arrivals of wire have been showing an improvement. Prices remain rigid. It is the impression of the largest operators here that there will be no fundamental change in the basic price of steel products to the end of the year because of present shortage, nor for that time until late in the spring because of the demand that will be come from all over the coast.

There is a plentiful supply, running to a surplus and multiplicity of offers, in face, fire and common brick, plaster board, roofing and lath, but plaster is scarce and the difficulty of obtaining even a ration is more acute.

The lumber interests share the opinion of the steel operators in the forecast that no improvement can be hoped for until the end of the year. Stock taking will follow the elections, and the coast kept in a state of unsettlement until February or later. Fir lumber, despite the feeling a week ago is slightly lower. Dimension sizes are \$1.50 under the quotations of a week ago at the mills. Flooring 1x4 No. 2 vertical grain stock is steady at \$57 to \$61.50 as compared with \$56 to \$64 a week ago. Ceiling is steady. Drop siding is lower at \$36 against \$41 a week ago.

Boards and shiplap are weak. No. 1 1x8-10 inch averaged \$22.50 to \$25.50 against \$14 to \$27.50 for the preceding week, but sizes of 1x12 inch were \$1 to \$2 higher at \$26 to \$29.50. No. 1 dimension, 2x4 12-14 surfaced and edged is \$19.50 to \$28.50 at the mill. Small timbers are lower at \$20.50 against \$24.50. Timbers 32 feet and under are stronger. Shingles are stronger. One half the mills have closed down.

594^v

front piece to No. 2242.



OLD HOUSES ON THE PLAZA, SEGOVIA

THE AMERICAN ARCHITECT

VOL. CXVIII

WEDNESDAY, NOVEMBER 10, 1920

NUMBER 2342



THE OLD BARN AT JORDANS, WHICH IT IS CLAIMED IS BUILT FROM TIMBERS OF THE MAYFLOWER

The Finding of the Mayflower

(By our Special Correspondent)

THE recent celebrations in this country at Plymouth and Norwich and at the same time across the Atlantic have brought the "Mayflower" before the public in England and America; and only last week a beautiful model in silver of the Pilgrim ship was on view at the Pilgrim's Room, in the Hotel Victoria, Northumberland Avenue, London, before it crossed the sea to be presented by a special mission to Mrs. Page, the wife of our late and much regretted American Am-

bassador. It may be mentioned here that this beautiful little model, a fine specimen of the silversmith's art, weighing 231 oz., was accurate in every detail, even to the method of tying the knots in the little silver ropes.

No better moment than the present could have been found by Dr. Rendel Harris for the publication of his work, produced by Longmans, Green & Company of London and New York, on "The Finding of the Mayflower," a work which I have already

594

THE AMERICAN ARCHITECT

mentioned incidentally in my notes for THE AMERICAN ARCHITECT and which I consider of sufficient interest to claim this special notice. This is not to assert that Dr. Rendel Harris has established an absolute claim to the discovery of the timbers of this historic ship; in fact I do not imagine that that learned gentleman would go so far as to assert this for himself. What he has done, with very considerable critical acumen and careful research, is to bring together a number of facts, which point to the possibility of the original "Mayflower" having been used in the construction of the old barn which is known as Jordans Barn at Jordans, in Buckinghamshire; let us see now what are these facts, and how far they go to prove his contention.

The spot itself is in a way sacred to memories of religious efforts in England and America, for at Jordans is the Old Quaker Graveyard, near which the Friends had their meeting-house in the seventeenth century, and use at this day the old farm as a hostel or residence. Local tradition is said to connect the Jordans Barn with the "Mayflower"; and it was this fact, which came to his notice in a direct manner while attending a Quaker funeral, which first put Dr. Harris on the clue of his present research. The "Mayflower" sailed for Virginia in 1620, under Captain Christopher Jones of Harwich, and made land in New England. Christopher Jones died in 1622; and in 1624 the ship was appraised by the Admiralty; the document for this appraisal still exists, "The appraisal or valuation of the shippe the 'Mayflower' of London and her tackle and furniture, taken and made by auctoritie of His Majestye's highe courte of Admiraltye the 26th day of May, 1624, at the instance of Robert Childe, John Moore and—Jones, relict of Christopher Jones deceased." The total price comes out at £128.8.4, which, says our author, must be the break up price, and indeed this seems certain from the Admiralty statement in the preceding Latin document, "eandem navem in ruinis esse." Mrs. Jones was, as stated, the widow of the Mayflower's captain, and Robert Child is stated to have resided near Jordans, the Childs being, as I believe, a very old Quaker family in England. Dr. Harris argues that the workmen who took her to pieces at Rotherhithe were employed at Jordans in her reconstruction; and that her "chief owner and final purchaser must have been somewhere in the Jordans area."

Here we come to a piece of evidence which is really significant and remarkable. Dr. Rendel Harris has had the Jordans Barn examined by a thoroughly qualified Thames shipbuilder and marine surveyor in April of the present year; and his evidence, very clearly stated is as follows: "The barn was built in my opinion more than two hundred years ago, and is constructed of old ships' beams and frames. These

I find in beautiful preservation. The timber uprights that support the roof are bilge timbers of a schooner: the plate on which the building rests and the sill are of the same class of timber split through. These have the original tree nails and holes through which oak pegs were driven to fasten the timbers to the bottom planking of the vessel . . . I noticed that one of the sill timbers was part of the keelson of the vessel, as it still shows the marks of the side timbers to which this part was fastened. . . . The dimensions of the schooner I estimate according to the size of the timber as being about 90 feet long, 22 feet wide and 10 feet deep, and would carry about 150 tons. In conclusion, the construction is beautiful to the nautical eye, as the building, if it were possible to turn same upside down, would resemble a timber-built ship."

I have given this evidence in some detail, because it seems to me most important in this issue. The statement of the shipbuilder, Mr. Joseph Hyams, is clear and positive that the old barn was built of ship's timbers some two hundred years old, and the reader can easily verify his last remark by turning the illustration, which I hope will accompany this notice, upside down and seeing the timber hull of the schooner in its framework for himself. What is needed is to trace further the actual delivery of the broken up ship from Rotherhithe to the barn at Old Jordans; or, failing this, some definite link, either in the persons interested or the building itself, which would practically confirm that transaction. Dr. Rendel Harris endeavors to do this at some length in his chapters IX and X, under the headings "Who brought the ship to Jordans?" and "The Owners of Jordans Farm," and lastly on "The Fourth Owner of the Mayflower" (we have seen the names of the other three), whom he finds to have been a certain Gardiner, who was a connection of one of the appraisers named Crayford; but the argument is more ingenious than convincing.

What would settle the claim, almost beyond controversy, would be any authentic and indisputable fragment of the old "Mayflower" within the barn itself; and our author evidently hoped that this was forthcoming in some lettering just traceable on a cross-beam in the south wall. But the promising discovery soon took a form which had a perilous resemblance to the antiquarian efforts of Mr. Pickwick and his friends, "My photographer, being a man of quick vision, saw at once what I was after . . . and proceeded to show that the inscription contained the following letters, R.HARRIS, and was a prophecy of my own name. This was certainly something like the introduction of Bill Stumps to his autograph." The link which failed here may yet be traced in some other form; and when this comes the result will be welcomed by many on both sides of the

water. But till this happens all we have is the certain date of the appraisal and breaking up of the vessel, coinciding approximately with that of the old Jordans Barn; the interesting fact that this barn is

shown on expert evidence to be formed of old ship's timbers, and the personal side of those concerned in the transaction, which cannot be considered conclusive.



ENTRANCE DETAIL—ALTERATION TO HOUSE ON EAST 19th STREET, NEW YORK
FREDERICK J. STERNER, ARCHITECT

Converting Private Houses into Small Apartments

TWO elements have been at work in most large cities throughout the country and perhaps in New York City to a greater extent than any other, that either promote or retard relief in the present housing shortage. One element is the converting of lower stories of apartment houses into stores and offices, thus further reducing the available housing and accentuating the already acute situation, while the other has been the converting of a great number of high class residences in the best sections of the city—houses that heretofore have housed but one family—into small apartments of two or three rooms each.

There are in New York hundreds of houses of the "brownstone" type that have either remained unoccupied for the past several years or have proved

a burden to their owners because of the excessive taxes and the low income available. The period of construction of such houses was not marked by the shortage of domestic servants that exists today. Neither was there the great number of high class apartments such as now attract the man of means. In New York during the last quarter of the 19th century it was the mark of an aristocrat to "live in a brownstone front." These houses were erected mostly in the '70s and '80s by speculators who often built block after block on both sides of a street. The poor quality of design exhibited and the inadaptability of brownstone (brown sandstone) for carving, gave an aspect of monotony that was seldom relieved by any considerable variety of facades.

These houses vary in width usually from 20 to 25

THE AMERICAN ARCHITECT

feet, although there are many as narrow as 18 feet and others as wide as 30 feet, the latter of the best type and not often built in adjacent numbers. The average house of this type consists of four stories and an "American basement," with either a high straight stoop or a box stoop. The average depth is about 60 feet with an addition, in most cases, extending about 20 feet into the yard at the rear. In the matter of planning little scope was afforded and because of their narrow width and their planning without courts, they necessarily depended for light and air solely upon the front and rear windows. The first two floors and basement usually contained two rooms, often with an alcove room on the first or par-



ROW OF REMODELED BROWNSTONE HOUSES
ON EAST 63d STREET, NEW YORK
FREDERICK J. STERNER, ARCHITECT

lor floor, and with hall rooms on the upper floors. A feature always met with on the bedroom floors is the dressing room between the front and rear bed rooms, provided with lavatory, closets and mirrors. On the top floor there were planned four or five rooms, the inner rooms lighted by a skylight from above. The bath rooms were placed in the rear extension or in the rear hall rooms.

THE replanning of these houses to contain small apartments has called for considerable skill on the part of the architects. In many cases it has been necessary to retain the existing partitions, a fact that often complicated the replanning of the interior. In some cases the remodeling has involved merely the removing or addition of a few partitions. In others the interior has been completely torn apart and an entirely new plan made. Much ingenuity has been displayed in the development of the former dressing rooms into baths, closets, and kitchenettes. In 1919 the New York State Legislature passed laws amending the Tenement House Act so that houses of this type could be remodeled into housekeeping apart-

ments. In many of these remodeling projects advantage has been taken of the provisions of this amendment and kitchen conveniences provided, usually in the form of kitchenettes. In others, of non-housekeeping types, a closet of generous proportions which has often come to be used as a kitchenette has been arranged in the plan. Such an arrangement is to be found in the Madison Avenue development and the 49th St. alteration, illustrated herewith.

A feature of these remodeling schemes is the treatment of the rear extension which usually does not extend the full height of the building. In practically every case the bath rooms and butler's pantry formerly occupying the extension, have been altered into bed rooms and, where light and air is had from two sides, rooms thus planned become most desirable.

Typical of the 20-foot house alteration is the non-housekeeping type in the row of ten houses extending from 49th to 50th St. on Madison Ave., of which Adolph Mertin was the architect. These houses were of the usual 5-story type, with high stoops. In making the alterations the stoops were removed, the first and second floors converted into stores and the upper floors divided into apartments of two or three rooms and bath. In all of the apartments the bath room has been reduced in size to a minimum and is ventilated by either a duct or a narrow shaft.

The alteration at 59 Gramercy Park, also the work of Mr. Mertin, is of the housekeeping type, some of the apartments being provided with kitchenettes of good size. This house is 72 feet deep and, with slight changes in the interior partitions, well arranged apartments were developed with large rooms and ample closets.

In the alterations on West 49th St. by Mr. Lippman, an addition in the rear and separated above the first floor from the main house by about twenty feet, gave room for two added apartments on each floor, each reached by a long hallway. This plan



HOUSES ON MACDOUGAL STREET, NEW YORK
These three houses were erected before the Civil War. They have been remodeled and the exteriors painted red, green and yellow, respectively

THE AMERICAN ARCHITECT

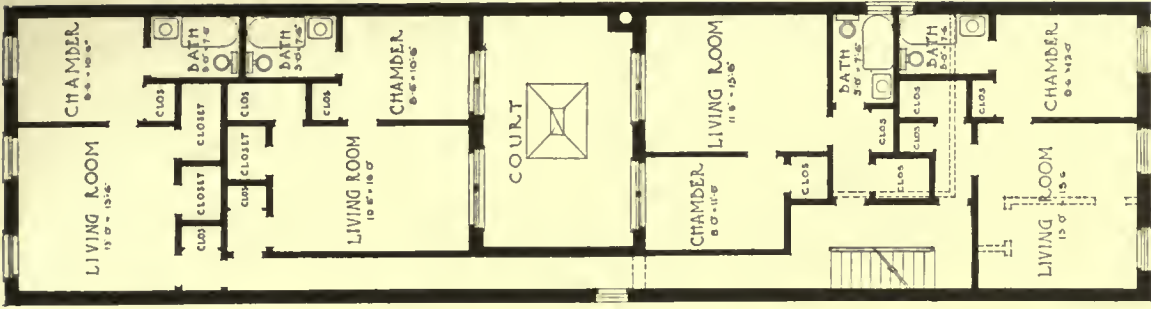

THIRD FLOOR PLAN
ALTERATION TO HOUSE, NO. 128
WEST 49th STREET,
NEW YORK
HERBERT LUTTMAN,
ARCHITECT

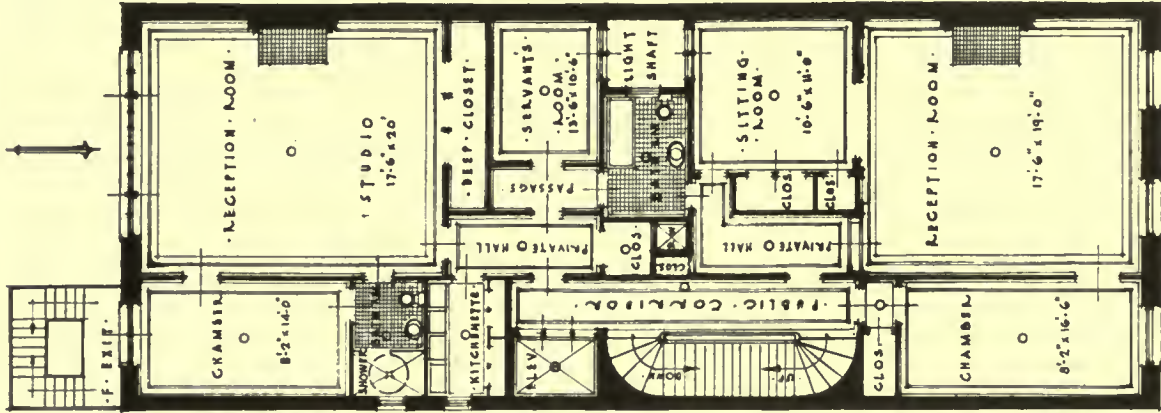

THIRD FLOOR PLAN
ALTERATION TO HOUSE, NO. 59
GRAMERCY PARK, N.,
NEW YORK
ADOLPH MERTIN, ARCHITECT

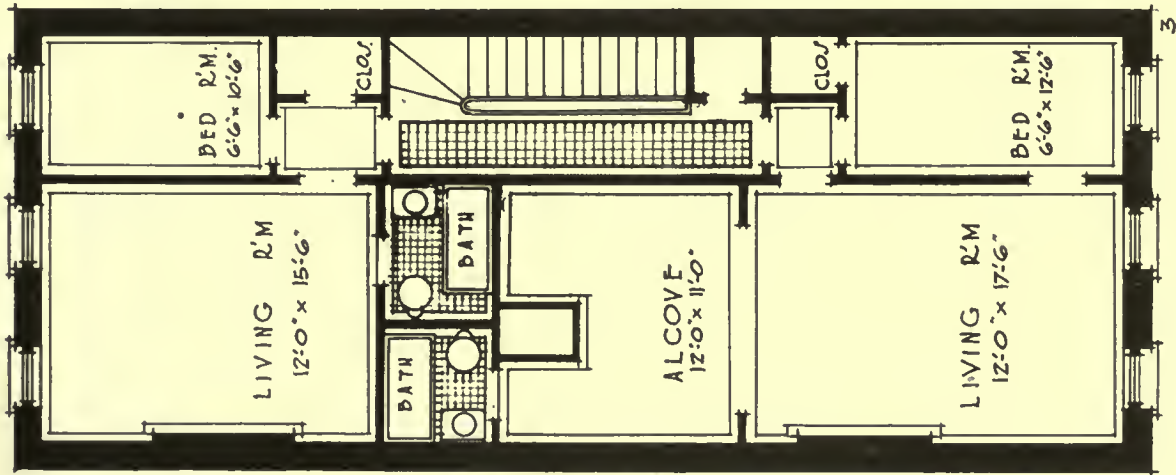

FIFTH FLOOR PLAN
ALTERATION TO HOUSE, NO. 436
MADISON AVENUE, NEW YORK
ADOLPH MERTIN, ARCHITECT

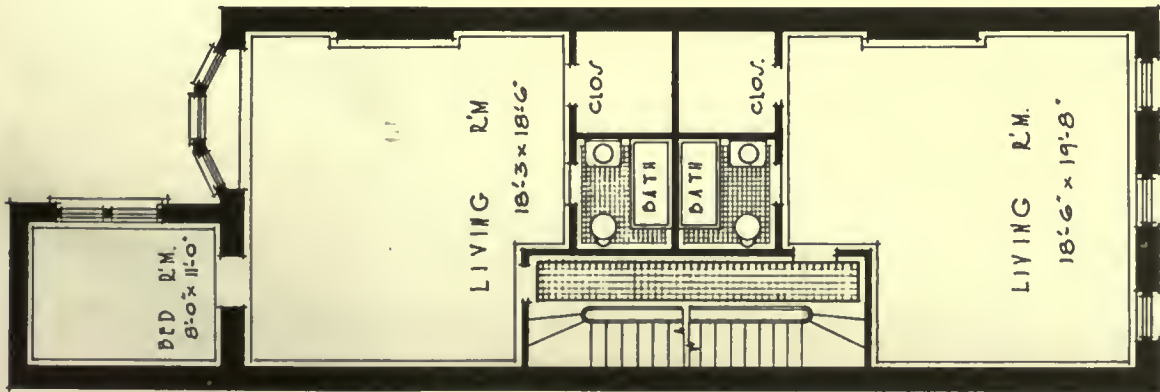

THIRD FLOOR PLAN
ALTERATION TO HOUSE,
NO. 448 MADISON AVENUE,
NEW YORK
ADOLPH MERTIN, ARCHITECT

THE AMERICAN ARCHITECT

shows an ingenious arrangement of partitions, giving a well planned layout, particularly in the compact disposition of the baths and closets.

The interior finish of these remodeled apartments has not, as a rule, been executed elaborately, and there is a tendency toward simplicity in the new trim set in place. But in some cases the accessories have taken on the most luxurious form and there are instances of houses that before the war could have been rented for from \$3,000 to \$4,000 per year that are now eagerly sought at rentals of from \$5,000 to \$5,500 an apartment. In every case the financial elements have undoubtedly proven satisfactory to the

which, with the addition of a properly selected paint for the window sash and cornice, have produced an effect that has very greatly added to the attractiveness of the architect's work out of doors. Two notable instances of such exterior treatment are seen in the 19th St. and 63d St. developments, both of which embrace a number of adjoining and adjacent houses. These were executed by Frederic Junius Sterner, architect.

A number of these remodeling projects are of the private-hotel type. In this type a suite is provided on the first (formerly the basement) floor for a housekeeper who provides restaurant facilities usual-



ROW OF REMODELED BROWNSTONE HOUSES ON EAST 19th STREET, NEW YORK
FREDERICK J. STERNER, ARCHITECT

owners because the increase of rents of reconstructed buildings has been very largely in excess of the cost of alteration figured on an ordinarily safe investment basis.

IN cases where these houses have been of the high or box stoop type, these stoops have been removed and an entrance from the sidewalk level designed to create a distinct character and redeem the houses from the monotony of the surroundings of similar facades. Many ingenious and artistic changes of the fronts of houses have been effected. These include not only the changes of window and door spaces, but in many cases brownstone fronts have been stuccoed and given various ranges of color

ly delivering meals to the tenants by means of a dumbwaiter, very often a feature of these private dwellings.

The question arises as to whether these newly made apartments are to be considered in the light of permanent improvements. They undoubtedly have many points in their favor, chiefly that they help to relieve the housing shortage. In the face of the present difficulty in securing building materials, the utilization of existing structures to increase the available supply of living quarters is highly commendable. There can be no doubt that when new construction has caught up with the demand for housing, these remodeled houses will be supplemented by new structures based on the result of these altera-

tions embodying new features of planning and equipment not possible in the alteration of the private house. Many useful lessons in planning will have been learned and while the domestic atmosphere of city life may not be best served by such types, the fact that they have helped materially to tide over a great emergency will be a valid reason for their existence. Even with a comparatively short life in

their new use, the high rental returns will probably prevent any financial loss. Looking forward to the period when new construction has once more reached its normal stage, these remodeled houses will still provide apartments for a certain class of residents who will prefer their compact "intime" atmosphere to that of the average new apartment.

Americanizing from the Start

ELLIS ISLAND was the scene recently of a ceremony new in its history. For months immigrants have been landing on Ellis at the rate of 5,000 a day. They come with dreams of a better land, a country of opportunity, peace, wealth and freedom from the war-born ills that still torture Europe. There is a whole pathetic volume of information about the conditions they leave behind them in the account of a riot that was caused by the sight of white sugar on the tables at Ellis Island.

The ecstasy with which they view for the first time the Statue of Liberty, a token of the realization of their dreams, can only be imagined by those who have known only the security and plenty of America. Then they are disembarked upon Ellis Island. Instead of the immediate freedom and generous reception they have expected, they find themselves in prison. The dingy stone buildings of the immigration bureau permit of no other description. There is confinement, examinations, the purpose of which is not understood, questionings and difficulties imposed before they are permitted to go ashore.

The rocky New England coast could not have been more forbidding to the Pilgrims. It must appear to the immigrant that the United States, far from welcoming, is setting traps to exclude him. On this occasion the situation was typical. Thousands of the new comers were locked up in the grimy buildings, wondering and anxious. Then Secretary Wilson of the Department of Labor paid a visit to

the island. The immigrants were released from their cramped quarters and given the freedom of the lawns. A band was brought over from New York, an American flag raised, and the polyglot assembly stood while the "Star Spangled Banner" was played.

Secretary Wilson delivered an address, passed on by interpreters to all of the nationalities present, in which he explained that the ceremony was a greeting to them from the United States Government. He told that he himself had landed as an immigrant 40 years ago and there was a murmur of wonder as his hearers appreciated the fact of a rise from an immigrant boy to a high position in the government of the country. He assured them that in this country they would never suffer from militarism or autocracy, and cautioned them that freedom was not to be mistaken for license and that their liberty depended upon observance of the laws of the land. When he had finished, sandwiches and coffee, cigars and candy were distributed and the immigrants sang and talked in almost hysterical joy in the new assurance that their dreams had come true.

A wonderful thing, that simple greeting to a few thousands immigrants, and the sort of thing that should mark every day's reception of newcomers to America. Inestimable good may be expected of the recent efforts to dignify ceremonies of naturalization, but vastly greater is the accomplishment to be expected should the Government make a point of creating an initial impression of this sort upon all who come. Americanization can not begin too soon.

Pan-American Congress of Architects'

Resolutions

THE first Pan-American Architectural Congress announced in these pages some months ago has now been held in Montevideo, Uruguay. Quoting in part from our previous account, it is proposed that the Congress shall be a permanent institution, which will meet every three years in the capital of some American nation. At each meeting there is to be an architectural exhibition. The aims of the organization are set forth as follows:

"To contribute to the development of architecture and to give a stimulus to the artistic and scientific studies connected with the profession; to strive toward a better understanding of all questions related to architecture, in the solving of which the nations of the Americas are interested; to promote, by all means within its power, the highest interests of architecture, and to create and maintain close relations of friendship and understanding between architectural institutions, associations and individual architects of the Americas."

The following resolutions were passed:

I.—CITY IMPROVEMENTS

1. That the Government and municipal authorities of all American countries should legislate in regard to the adoption of uniform plans for towns and cities, the present system of "squares" to be followed only in exceptional cases; the laying out of parks and gardens, and the choice of plants, shrubs, etc.; the selection of suitable sites for public buildings and monuments; and the framing of regulations complementary to the above.

2. That a special course of "city improvements" should be included in the curriculum of colleges and schools of architecture, and that free classes should be given by the architects' societies.

3. That leagues should be founded in every American city to arouse, direct, and stimulate Government initiative.

4. That a "Pan-American City League" should be founded.

II.—BUILDING MATERIALS

That the Governments of American countries should direct the attention of their institutes and state laboratories to improving the method of production and exportation of building materials peculiar to each country, and that the use of such material should be encouraged in every way. That an account of such investigations should be published by an international institute. That the architects' so-

cieties should form exhibitions of building materials and effect an interchange of such materials.

III.—PROFESSION OF ARCHITECT

That, in order to improve the aspect of towns and cities, to frame definite rules as to the conditions of dwelling houses which influence to so great an extent the people's moral and physical well-being, to insure the beauty, safety and hygiene of every kind of building, and generally to diffuse culture, the degree of architect must be recognized by the State, and the duties of the profession, which is the only one in a position to deal with the problems under discussion, established by law.

IV.—CHEAP DWELLING-HOUSES

That the Government and Municipal Authorities should be encouraged to co-operate in the construction of dwelling houses that shall be both cheap and hygienic. That the construction of detached houses in the neighborhood of industrial and manufacturing centres should be encouraged, as also the erection of tenements in densely populated centres. That, before granting permission to build, the ground on which such houses are to be erected shall be supplied with drainage system, light and pavement. That the Municipalities and Departments concerned shall be required to modify the building regulations at present in force, adapting them to the economic needs of such buildings, in order to effect a saving in the execution of the works without leaving any thing undone pertaining to the hygiene, safety, and general aspect of such buildings. That attention should be drawn to the desirability of founding in each country a "National Bank for the building of cheap houses," to which employers, capitalists, and wealthy land-owners should contribute. That night-shelters for those unable to afford a cheap and decent lodging should be built.

V.—PUBLIC CULTURE

That to educate the public appreciation of architecture, exhibitions of applied arts should be held periodically. That the authorities should form museums of casts of the works of famous sculptors and architects, and that free access to public buildings and monuments should be granted. That a yearly prize for the best conceived and executed building should be awarded, and that lectures on the subject should be given in the primary and secondary schools of each country.

THE AMERICAN ARCHITECT

VI.—PROFESSIONAL RESPONSIBILITY OF THE ARCHITECT

That the Governments of American countries should frame laws defining the responsibility of the architect, specifying clearly the responsibility of the architect and that of the contractor.

VII.—ARCHITECTURAL TRAINING

That, for any progress to be made in the architecture of American countries, special Schools or Colleges of Architecture should be founded, in which the necessary artistic, technical, and scientific training would be given.

VIII.—“PAN-AMERICAN CENTRE”

That a “Pan-American Centre” should be formed, and that an interchange of professors and students of architecture should be effected between the various schools and America, thus creating a real professional solidarity.

IX.—BUILDING ACTIVITIES

That the municipal authorities should be desired to study the modification of the system in force, with a view to increasing the tax on unoccupied sites. That all materials and machinery required for building purposes imported from abroad should be allowed to enter the country free of duty, and that the transport tariff should be revised in order to reduce freight rates. That the municipal authorities should be desired to modify the present regulations respecting the hygiene and safety of dwelling houses, with a view to transforming workmen's tenements into flats. That the public authorities should be urged to fight the trusts. That the training of competent workmen should be encouraged by the Government in their industrial schools, and that private concerns founded for the exploitation of any industry necessary to the building trade should be encouraged. That an improvement in the mortgage system should be studied, special mention being made of the system in force in the Argentine Mortgage Bank. That the laws of the country and the municipal regulations relative to building should be revised.

Dickens' Haunts to Be Pulled Down

A SEMI-CIRCULAR sweep of tall, dingy grey houses, the windows brightened in many cases with flower boxes, situated in Hampstead Road, London, and with a fine enclosed garden, boasting a magnificent avenue, comprising, in all, $4\frac{1}{4}$ acres of land, is shortly to be pulled down, and thus there will be severed another series of links with Dickens.

In one of the houses included in the area for sale,

No. 263, Hampstead Road, Cruikshank lived. Here, states H. Johnson in the *Architects' Journal* of London, he drew the illustrations for “*Oliver Twist*.” In an earlier period the same house was occupied by Clarkson Stanfield, the scenic artist, who was responsible for the scene painting connected with Dickens' few dramatic productions. Dickens frequently visited the house in the hey-day of his popularity, and in doing so touched the fringe of the twilight quarter where his boyhood had been spent, for the whole neighborhood teems with Dickens associations, and characteristic stories of his circle.

In the same block, at the corner of Granby street, stands what remains of Wellington House Academy, which Dickens attended as a day-boy for about two years, subsequent to his period in the blacking factory. The Academy is today just as the novelist described it in “*Household Words*,” in 1851, under the title of “*Our School*,” presenting itself in a green stage of stucco profilewise to the road, like a forlorn flat-iron without a handle, standing on end.”

Dickens students are practically unanimous that the Academy furnished Dickens with much of the material for Salem House in “*David Copperfield*,” though he located it at Blackheath. Indeed, there was at the Academy, at the time Dickens was there, as testified to by his schoolfellows, a master who was a lover of the flute, and was, in many other particulars, the prototype of Mr. Mell. Prior to the visit yielding the article on the Academy which appeared in “*Household Words*,” the actual schoolroom and the playground had been swallowed up by the railway. By the way, many, in trying to locate the school, have been led away by Dickens biographers to seek it in Mornington Place. Now, the portion of Hampstead Road in which both the school and Cruikshank's house are situated was known at one time as Mornington Place. There has been a bit of juggling, and Mornington Place today is a short direct cut from Mornington Crescent to Mornington Road.

If you cross the main road from the Crescent you are in the drab regions of Somers Town, where Dickens first saw London intimately. Baynham Street, his first London home, is only about five minutes' walk from the Academy, though the actual house has gone, and on its site stands the out-patients' department of a hospital. Even nearer to the school is Johnson Street, where the house in which Dickens lived as a boy is marked by a tablet stating this fact. It is one of a uniform row of squat, depressing houses in a depressed locality. Just around the corner is the Polygon, where Skimpole lived. You may not discover there, today, “poor Spanish refugees walking about in cloaks, smoking little paper cigars,” but you will probably find less picturesque aliens still hovering about the quarter.

*House in Litchfield, Conn.,
Built in 1771*

(See reproduction of the original drawing by O. R. Eggers in this issue.)

THE history of Litchfield is interwoven in the most interesting way with the early period of New England. It has been the home of many illustrious men and women and preserves today all the traditions that are so dear to the dwellers in these rural communities. Settled in 1720, it was during the Revolutionary War used as a base of supplies by the Continental Army. It was to Litchfield in 1776 that the statue of George III, which, on July 9, was thrown from its pedestal on the Bowling Green in New York, was sent. There it was cast into bullets by the women. Jurists, statesmen and writers of national fame have made their homes in this quaint New England village. All the traditions of good architecture and those elements of refinement that marked our Colonial period have been carefully preserved.

The house that Mr. Eggers has chosen as the subject of his sketch is exactly typical of many others that face the elm embowered roadways. Sitting close to the sidewalk these houses present a neighborly and a most human aspect. Their snow white walls are relieved by the green shutters while the noon-day sun casts the shadows of the branching boughs and the leaves of the trees that stand as sentinels.

Every aspect of this old house is one of refinement of the highest development of domesticity. One ceases to wonder that the New England states have from their very beginning sent to the service of the country in every important station sturdy men and women who, with sound minds in sound bodies, have labored to build up this country's greatness. Nor will any one be able successfully to disprove that long residence in a home so architecturally good will do naught but add to mental and moral development.

Such restoration as found necessary to keep this house in good repair and fit for occupancy has been skilfully and reverently conducted under the supervision of Aymar Embury II, architect.

6044



HOUSE IN LITCHFIELD, CONN., BUILT IN 1771
THE AMERICAN ARCHITECT Series of Early American Architecture





The Building Trades Inquiry

IT is unfortunate that the Lockwood Housing Committee's investigation of the building trades has given to the public an erroneous impression of the builders who have been made the "victims" of the system's illegitimate and powerfully entrenched methods of graft. A feeling of sympathy has been established in the minds of most people for the builders who have been subjected to these tactics, partly because the average reader of a newspaper fails, for one reason or another, to analyze beyond the printed word, and partly because of the manner in which the proceedings have been reported from day to day in the daily press.

It is evident that no system of graft of this sort can exist unless the victim is a party to that graft; or unless he is in collusion with the system to the point of submitting to demands made upon him. Men of the stamp who operate this system can be properly handled by due course and process of law. There is little doubt in anyone's mind that any builder who had courageously and promptly submitted these proposals to a court would have easily come off the victor in such an encounter. Such action was not taken by some "victims," however. The reasons for that are many, chief among which is the possibility of tying up a given piece of construction work until the money lost in the delay would seriously affect the builder's profits. To the builder faced with such a problem, it is more feasible and effective—so far as the continuation of operations are concerned—to submit to the extortion and proceed unmolested with the work.

But such submission acknowledges timidity, and it is upon timidity that the system depends for its operations. And that lack of willingness to fight the matter out openly before the law places the builder or the contractor somewhat on the same scale as the grafter himself, in that it makes him a party to a bribe and in that it gives the man demanding that bribe added confidence in his ability to proceed with his unlawful work. The latter statement is the most serious part of the whole business. Give a man who indulges in unlawful practices reason to believe that

he can safely carry out those practices, and he will proceed with them anew. Which, in this particular instance, meant simply that the system felt safe in approaching other prospects. It is the imposition of this handicap on builders and contractors that is the serious part of the thing, and it is this that the "newspaper public" seems to have overlooked.

THE investigation so far has been conducted by the Lockwood Committee, and Governor Smith has appointed the Attorney General as prosecutor. Now it is rumored that Washington intends to look officially into the matter. It is to be hoped that it will not become a political affair, and that it will be conducted in an unbiased manner.

The investigation has further developed the fact that the decent, conservative element of organized labor is not at all in sympathy with any system which jeopardizes its standing with the public. Evidence of this is seen, for example, in the complete repudiation of the system by the Brotherhood of Painters, Decorators and Paperhangers, in which men representing themselves to be skilled craftsmen were found to be merely common laborers holding a "privilege card" issued them by the system. This part of organized labor, as well as the public, has come to see the demoralizing influence of the system's tactics. It has lessened efficiency and daily output of highly paid workers, so that today there are a great many workmen no more efficient or productive than they were under the old wage scales. This is due to the demoralizing "protection" given incompetent workmen by the system. It has fostered an arrogant attitude on the part of "protected" members of unions, resulting in unjustifiable instances of arbitrary restrictions on a workman's daily output.

THE inquiry thus far has been valuable in bringing to the attention of both the public and the decent element of organized labor a lamentable condition. Effective continuation of the investigation on a fair and non-political basis will materially "clear the air" and reduce the possibility of a recurrence of such a condition. To conduct the inquiry effectively

there must be no hesitation on the part of those involved to testify before the committee. There must be an exhaustive search for whatever contributory element may enter into the situation, regardless of the origin of those elements. There must be the willingness on the part of the system's "victims" to furnish all the facts at their disposal and to aid the committee in revealing further malpractices. There must be, above all, an appreciation by the layman and the professional man of the seriousness of the investigation; a real interest in everything which takes place during its course, and a genuine desire to help in any way possible toward a successful and thorough elimination of the unlawful system which has caused this deplorable condition of affairs.

What Is Art?

JUST what art is to the architect and engineer is a question that has been agitating the minds of a certain group of men who are debating it in the columns of an engineering journal. Someone has truthfully stated that art is the refinement of the commonplace. That definition will serve as well as any, for the reason that for many years men have striven tersely to define art and none has really succeeded.

Fortuny, a master draftsman and colorist, painted "The Choice of the Model" and also "A Scene in an Abattoir." At one time during an exhibition of Fortuny's work in New York, these two pictures hung almost side by side—the one, a beautiful interior with all the sumptuousness of wealth and refinement, the other the loathsomeness of an abattoir of more than fifty years ago. Competent critics agree that both pictures are great works of art.

Now, if art is the creation of only that which is beautiful, wherein lay the appeal of the abattoir picture, and how was it possible to claim for it the attributes of a work of art? Was it not because it represented in the highest degree a masterly refinement of a commonplace, almost loathsome subject?

In citing this illustration it is not meant to place before the reader two extremes of art as representing

the arts of the architect and of the engineer, but to show if it may be done, that any matter to which men skilled in their professions direct all the power of their mentality, may be redeemed from the commonplace and stand created as a work of art.

A FACT that is responsible for diversity of opinion between architects and engineers as to this matter of art is that each has so closely specialized in the art of his own profession that he is not equipped fully to appreciate all the art of the other. Engineers have claimed that architects have by injudicious ornament marred the engineering beauties of their work, and architects loudly assert that engineers have built an ugly, inartistic structure. Unfortunately in many instances both contentions are correct.

The reason why these things have occurred is that in the specific cases, neither the architect nor the engineer has been sufficiently well informed as to just what art really is. If the proper proportioning and relation of solids to voids is the basis of good architecture, and a building so constructed, even if absolutely devoid of ornament, may be as worthy of approval as the most complexly designed structure, it will not be necessary to set down any instances of the work entirely done by engineers that are the masterpieces of the world. The art of the engineer is more nearly the refinement of the commonplace than is that of the architect.

As the profession of architecture slowly but surely nears the true intent of its practice, it will more certainly be able to regard with less irritation the work of engineering that its creators regard as one of art. And in like manner will the engineer become more kindly disposed toward the attempts of architects to supply to every building with which they are connected such beauty of design as will eliminate the suggestion of the commonplace. When these two professions have traveled along these two roads, they will in the future find that they have joined and that both professions will be then traveling a common path and one that will lead to the most wonderful achievement.



HOUSE OF B. D. BENSON, PASSAIC, N. J.
JOHN F. JACKSON, ARCHITECT

6061



606 2



HOUSE OF B. D. BENSON, PASSAIC, N. J.
JOHN F. JACKSON, ARCHITECT



6063



MAIN ENTRANCE DETAIL
HOUSE OF B. D. BENSON, PASSAIC, N. J.
JOHN F. JACKSON, ARCHITECT

6064



LIVING ROOM

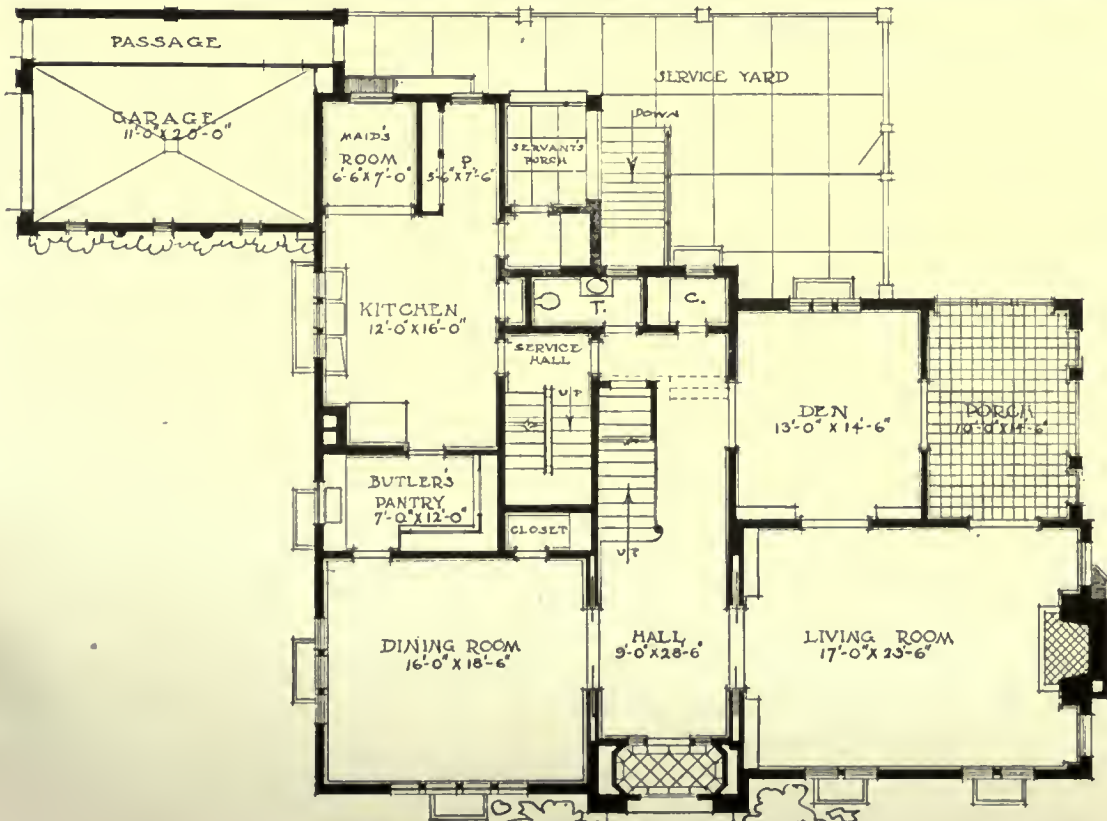

FIRST FLOOR PLAN

HOUSE OF B. D. BENSON, PASSAIC, N. J.

JOHN F. JACKSON, ARCHITECT



606 v

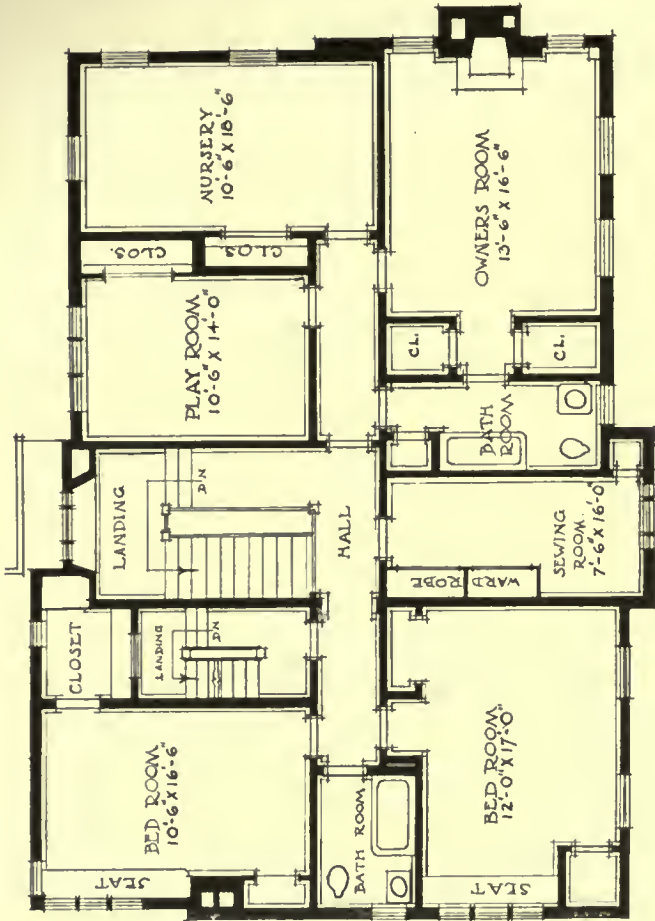

HALL AND SECOND FLOOR PLAN

HOUSE OF B. D. BENSON, PASSAIC, N. J.
JOHN F. JACKSON, ARCHITECT





6066



HOUSE OF B. D. BENSON, PASSAIC, N. J.
JOHN F. JACKSON, ARCHITECT

6067



VIEW SHOWING GARAGE



HOUSE OF B. D. BENSON, PASSAIC, N. J.
JOHN F. JACKSON, ARCHITECT



6064



PUBLIC COMFORT STATION, CAPITAL SQUARE, DETROIT, MICH.
VAN LEYEN, SCHILLING & KEOGH, ARCHITECTS

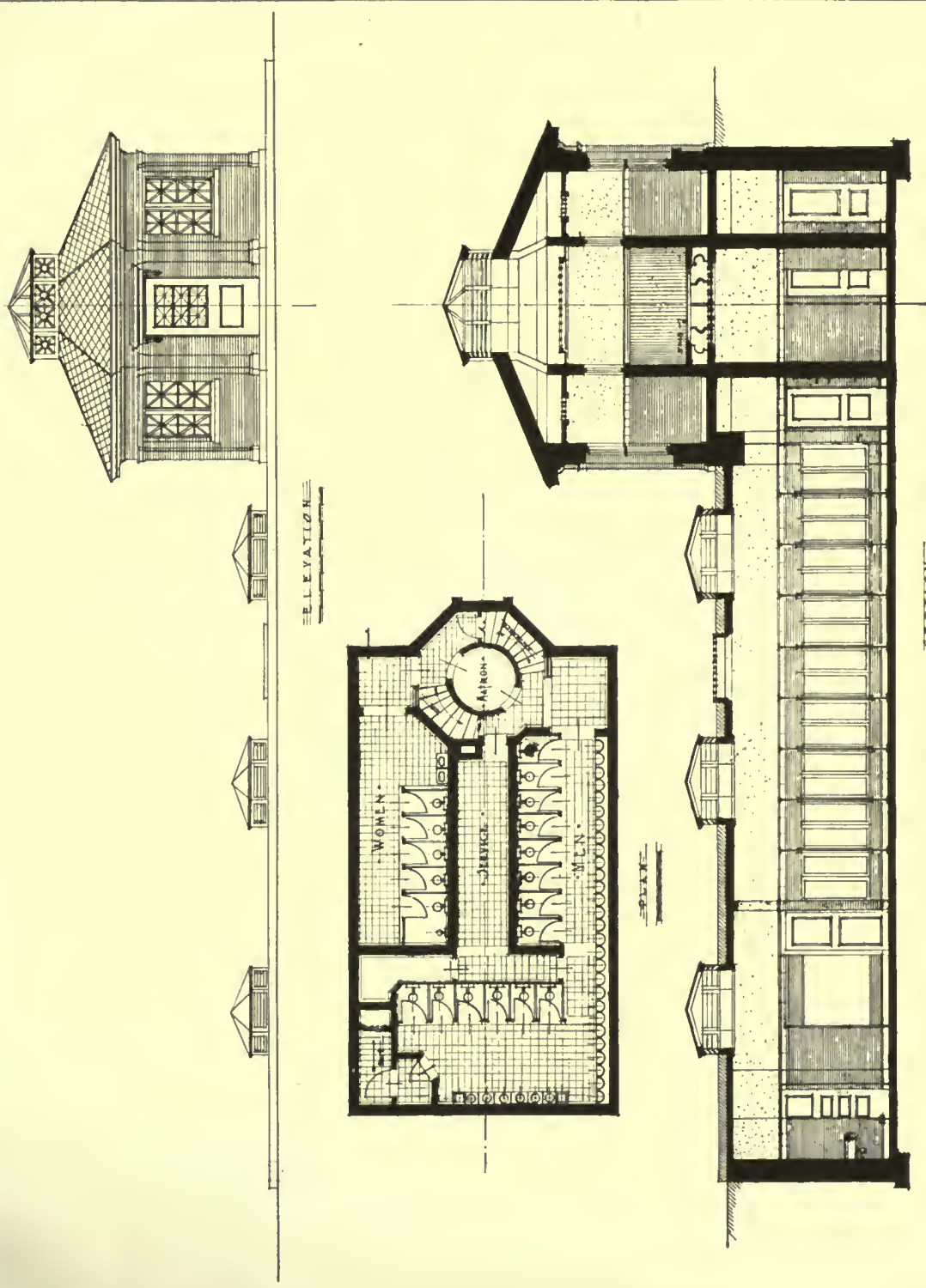

PUBLIC COMFORT STATION, CADILLAC SQUARE, DETROIT, MICH.
 VAN LEYEN, SCHILLING & KEOGH, ARCHITECTS

606 9

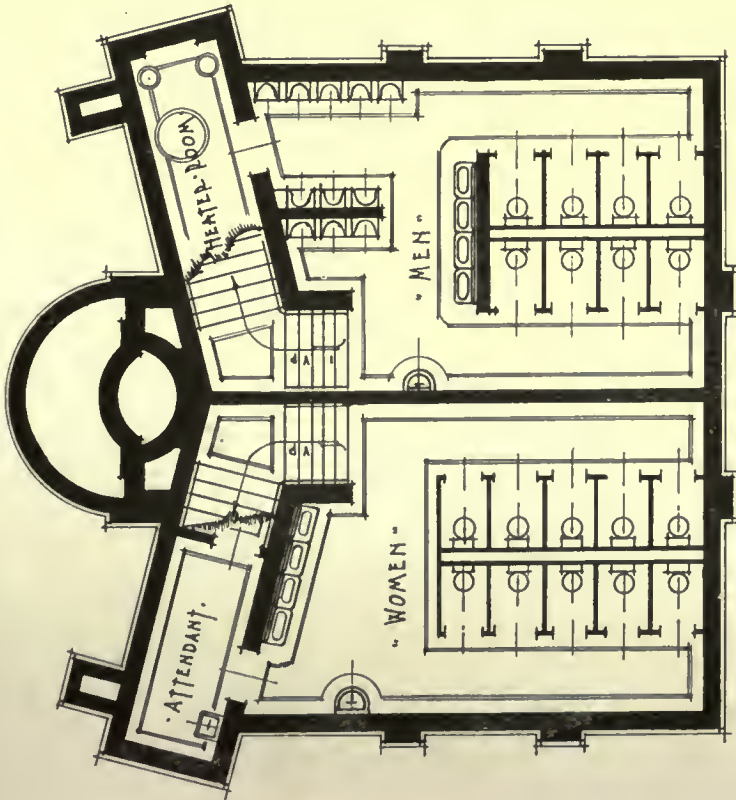
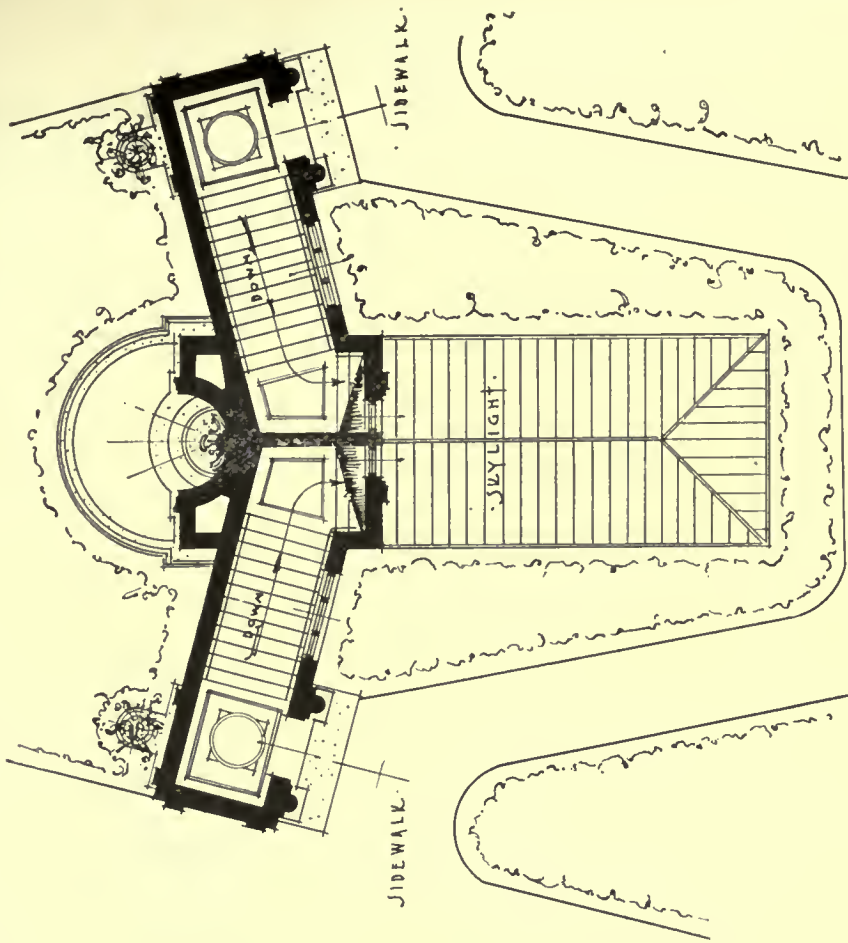

TYPICAL PLAN. SCALE 1" = 20'. PLAN AT GRADE. ENTRANCE.

PUBLIC COMFORT STATION, CAPITAL SQUARE, DETROIT, MICH.
 VAN LEYEN, SCHILLING & KEOGH, ARCHITECTS

60610



DEPARTMENT OF ARCHITECTURAL ENGINEERING

The Ventilation of Public Comfort Stations

AN efficient ventilation system is essential to the sanitary operation and maintenance of the public comfort station. The removal of objectional odors and vitiated air must not be left to chance, nor to an arrangement arrived at by guess work. In order to accomplish this purpose, it is necessary to provide a system of ducts and fans, and that these may be properly housed, the ventilation

positive exhaust and a positive supply system should be installed. However, if, due to the necessity of practising economy, but a single system is permissible, the exhaust system should be installed. The adjacent outside air will always be of a purer quality than that inside, and by providing an adequate exhaust system, thus continuously emptying the interior of its foul air, fresh air from without will find its



ENTRANCE TO COMFORT STATION, PROVIDENCE, R. I.
MARTIN & HALL, ARCHITECTS

system should be designed simultaneously with the development of the architectural layout. Due to the lack of proper provision in the original plans, some ventilating systems have been more or less of makeshift character, and therefore have rendered less efficient service than would have been the case had proper consideration to the subject been given in the first instance.

In order definitely to control the air flow both a

way in through the doors. These should then contain louvres to provide for intake when the doors are closed, since the incoming fresh air must equal in volume that displaced by the exhaust fan.

It might be thought by one unfamiliar with air conditioning that the design of such a system of ventilation is most simple, and requires but little thought—just an exhaust fan placed in a convenient place with necessary driving motor, the fresh air to find

THE AMERICAN ARCHITECT

its way in somehow. This, however, is not so. The feature which is as necessary as a proper volume of fresh air is good circulation. Those who are familiar with flying know what "air pockets" are. Air plays strange pranks. It is quite possible to pump so much fresh air into a given space per minute and

exhaust a similar volume, and yet find pockets in which the air remains unmoved, despite the fact that a considerable air change is constantly occurring. These stagnant places must be prevented by proper arrangement of ducts and registers.

At present it is considered good practice to leave

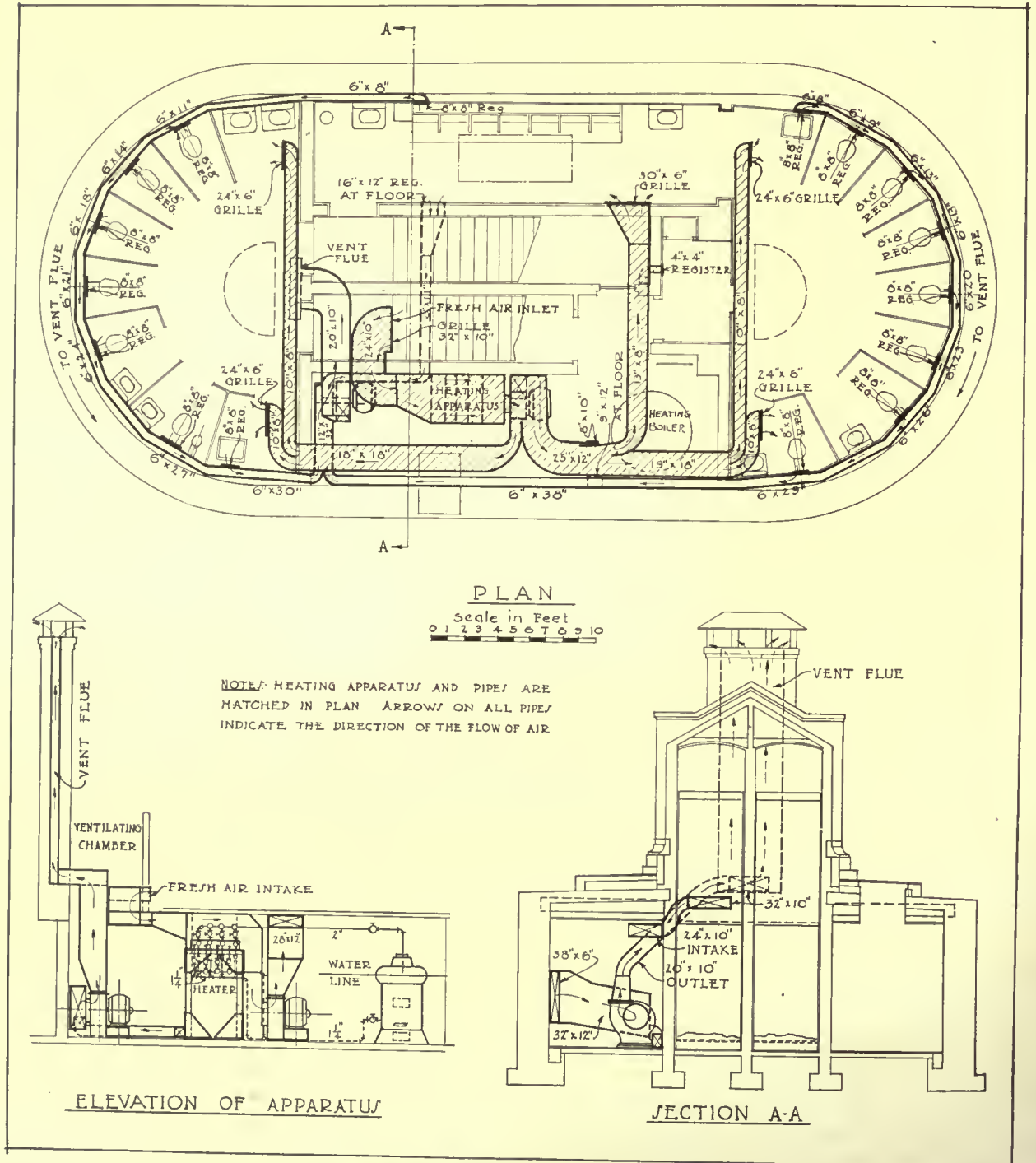

PLAN AND SECTIONS OF COMFORT STATION, PROVIDENCE, R. I.
MARTIN & HALL, ARCHITECTS

THE AMERICAN ARCHITECT

a space in back of the plumbing fixtures, thus providing for an air duct of the exhaust system.

During cold weather it is customary to furnish heat in such buildings, and the heating plant can be read-

through properly sized ducts and registers. A positive supply must, of course, be provided by an intake fan for such a combined system. Since considerable dust is liable to collect around the location

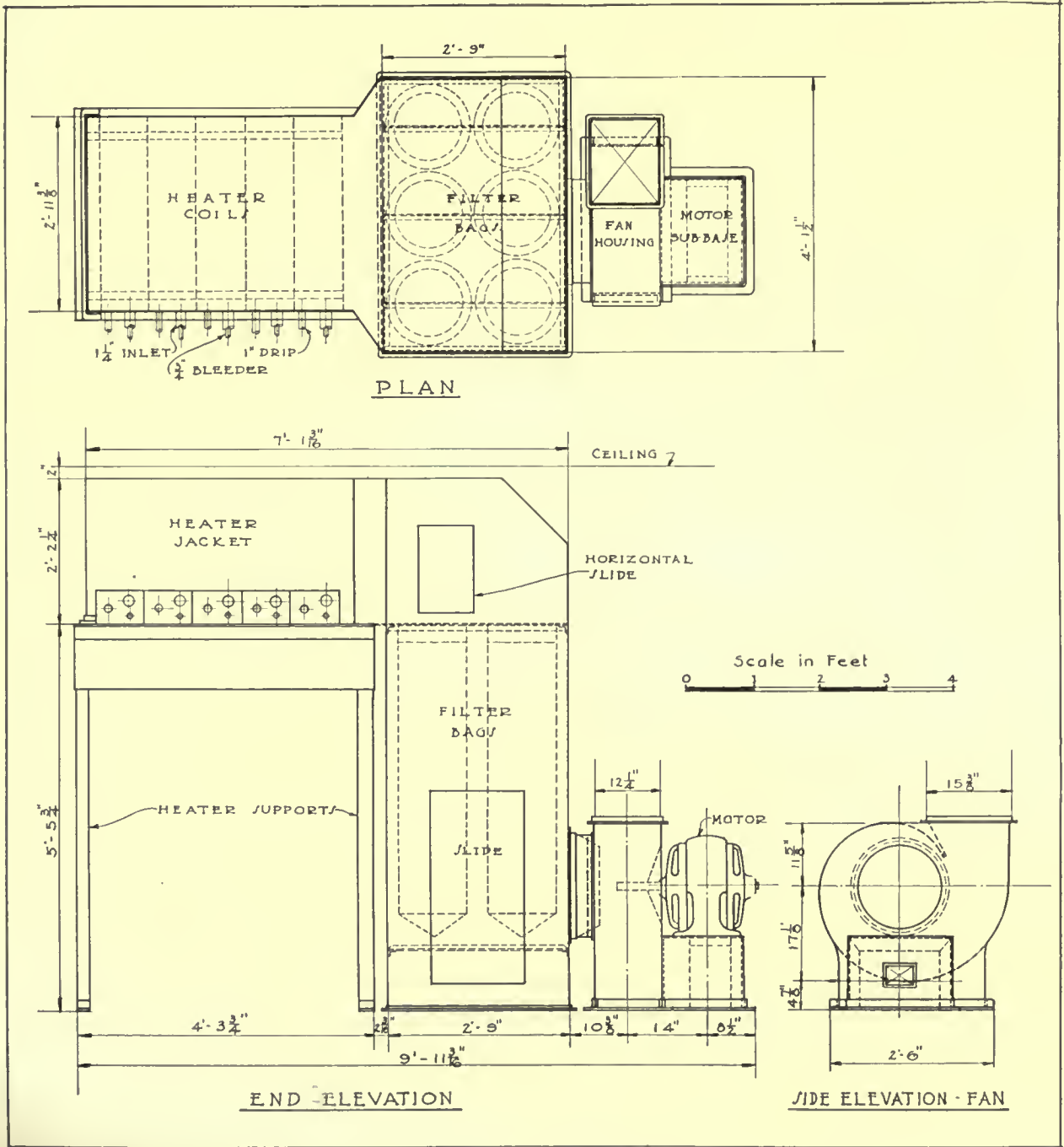

DETAIL OF HEATING AND VENTILATING APPARATUS

ily combined with the ventilation system. The fresh air may be drawn through a grillwork over the stairway and tempered by drawing it through a heating chamber containing steam coils, before it is discharged into the various rooms of the comfort station

of the intake, it is better to filter the air. This can be accomplished by the use of dust bag filters.

The foul air should be exhausted from near the floor level. The heated fresh air naturally rises, and as it cools, falls, thus reaching a lower strata, and

as it becomes vitiated is drawn through the exhaust registers. If these registers were placed near the ceiling, they would tend to draw out the fresh warm air, leaving a lower strata of stagnant foul air with no outlet.

The exhaust fans now most generally employed are of the centrifugal multivane type, and should be connected directly to the motor where this is possible. Special heating coils or radiators for hot blast heating are on the market, and are most efficient for this purpose.

The accompanying illustrations show the ventilating system installed in a comfort station at Providence, R. I., designed by Martin & Hall, architects. The ventilating equipment was furnished by B. F.



INTERIOR OF PROVIDENCE COMFORT STATION Sturtevant Company. A careful study of this arrangement will be found helpful in solving similar problems. Both positive exhaust and supply systems are installed, the latter operating in combination with the heating system. The intake grille is 32 in. by 10 in. connected to a 24 in. by 10 in. duct which leads direct to the chamber housing the steam coils, which consist of 125 sq. ft. of 1 in. pipe. The construction of this part of the apparatus is shown to a larger scale, with overall dimensions. From the heating chamber the heated air is forced by the supply fan, driven by a 1¼ h. p. motor, into a 25 in. by 12 in. duct to the right and an 18 in. by 8 in. duct to the left. The former has three branches supplying fresh air at different points in the men's compartments, while the latter has two branches supplying the women's compartment. The steam boiler is located in back of the stairs. Of course, during warm weather when the heating plant is inoperative, the supply system may operate supplying air at the normal outside temperature, or the exhaust system only may be used, in which case fresh air must find its way in through the doorways.

It will be noted that all registers for the supply system are located 7 ft. above the floor level, while those of the exhaust system are close to the floor.

Two semi-circular exhaust ducts located near the floor level, increasing from 6 in. by 8 in. to 6 in. by 30 in. in section, run in back of the water closet fixtures of both men's and women's compartments with a register in back of each fixture. These join in a 12 in. by 32 in. main duct which leads to the exhaust fan, this in turn forcing the vitiated air into a 10 in. by 20 in. horizontal duct and then up a vertical vent flue, this latter discharging to the outer air approximately 16 ft. above the street level.

It will thus be seen that a system such as that illustrated provides a very thorough air change, as well as a constant supply of fresh air.

Air ducts of circular cross-section are found to be the most efficient, but since ventilating ducts must be placed so as to occupy as little space as possible, or cut down the head room by a minimum amount, circular ducts are usually impractical, and such sizes as 6 in. by 30 in. or 10 in. by 20 in., etc., must be resorted to, to be accommodated in given spaces.

Mazout Successfully Used as Fuel

One means of solving the coal problem as applied to transportation in France has been evolved by the Orleans Railway. This company proposes in the near future to run no fewer than 400 heavy locomotives with *mazout*, a residue of petrol, the production of which is being pushed. Experiments with this fuel have been most successful and trains drawn by engines adapted to its use are made easily to attain a speed of 60 miles an hour.

The company recently inaugurated this type of locomotive with an express train from Paris to Tours, and this section is now being served regularly by means of such locomotives, drawing both passenger and freight trains. It is estimated that the 400 locomotives which the Orleans system is to employ will consume 300,000 tons of mazout annually. On the same line freight trains of 1,200 tons, drawn by powerful engines, have for some time been running regularly on mazout between Paris and Tours.

Trade Publications Wanted

Valparaiso University has recently reopened a complete course in architectural engineering. Trade publications applicable to this course will be gladly received and will become part of a file used to give the student first hand information of various materials.

Those publications giving manufacturers' specifications and methods of application will be especially welcome. Address Wilson Carleton, Professor in charge of department, Valparaiso, Indiana.

Idiosyncrasies of Building Materials—Lime

COMMERCIAL lime, used extensively in the building industry, is produced from limestone, one of our commonest rocks. In the process of manufacture the limestone is quarried, broken into sizes convenient for handling, and burned in a kiln.

Composition.—Since the composition of different deposits of limestone varies, so, also, does the resulting lime. Limestone is calcium carbonate, but is never found pure. The impurities generally present are magnesia, iron, alumina (clay) and silica.

Very pure crystallized limestone is known as calcite. As the content of magnesia increases, the stone is called magnesian limestone until the ratio of calcium carbonate to magnesium carbonate becomes 100 to 84, when the name is changed to dolomite. If the magnesia content remains low, but the other impurities increase, the rock is known as argillaceous (clayey) limestone, natural cement rock (with suitable clay content for cement manufacture), and calcareous shale.

The heat applied in the kiln breaks up the compounds of calcium and magnesium carbonates, the carbon dioxide being driven off as gas. Thus lime is merely limestone from which the carbon dioxide has been removed by heat. This, then, must constitute a definition of lime.

Classification.—The wide variation in the chemical and physical properties of limestone necessitates a similarly great difference in the kinds of lime. Therefore, some system of classification becomes necessary. That adopted by the American Society for Testing Materials is as follows.

High calcium.—Not less than 90 per cent. calcium oxide.

Calcium.—Not less than 85 per cent nor more than 90 per cent. calcium oxide.

Magnesian.—Not less than 10 per cent. nor more than 25 per cent. magnesium oxide.

High magnesian.—Not less than 25 per cent. magnesium oxide.

The total amount of impurities (exclusive of carbon dioxide) shall not be more than 5 per cent. in selected lime, or $7\frac{1}{2}$ per cent. in run-of-kiln lime.

Slaking and Setting.—When water is added to lime it slakes, that is, enters into chemical combination with the water. This reaction generates heat and is accompanied by an increase in volume. Slaked lime, when exposed to air, will set. The setting of lime is caused, first, by the evaporation of excess water, and finally by the absorption of carbon dioxide, causing

the lime to revert into calcium carbonate. Therefore, setting will take place more rapidly if the amount of carbon dioxide in the air is increased, as, for example, by the use of salamanders. Setting is always accompanied by a decrease in volume, or shrinking.

Quicklime.—Lime is put on the market as either lump or ground lime. Lump lime is shipped in bulk or in wooden barrels holding 180 or 280 pounds net. Ground lime is lump lime which has been ground and screened, generally through 60-mesh. It is shipped in air-tight iron casks.

Hydrated Lime.—Hydrated lime is prepared by adding to quicklime just sufficient water to insure complete slaking, and under such conditions that the heat generated will evaporate all the excess water, leaving the product dry. Since slaking is accompanied by an increase in volume, the lumps of lime fall into powder during the process. Any impurities in the lime will not slake, will not fall into powder, and consequently any large particles of them can be removed from the finished product by screening.

Hydrated lime is a fine, dry powder, consisting essentially of calcium hydrate and magnesium oxide, for it is generally conceded that the magnesia does not slake during the ordinary process of manufacture. The quantity of water contained varies from 24.3 per cent. for pure high-calcium hydrate to 11.3 per cent. for impure dolomitic hydrate. The proportion of impurities is generally less than that in the lime from which it was made.

In building operations hydrated lime may be used for any purpose in place of lump lime, with precisely similar results. The consumer must pay the freight on a large amount of water, but the time and labor required for slaking lime is eliminated, and there is no danger of spoiling it either by burning or by incomplete slaking.

Hydrated lime will keep better than lump lime, because the powder packs together into a dense mass, rendering the penetration of carbon dioxide very difficult. It can be stored with absolutely no danger of fire.

Hydrated lime is put on the market in paper sacks of 50 pounds each. The Urschel-Bates valve bag is used almost universally. There are many varieties of hydrated lime, depending on the fineness of the grain. It can be obtained screened through any mesh from 10 to 200.

To prepare hydrated lime for use the mere addition of water is all that is necessary. It is a rather difficult powder to wet, however, so that it is advisable to let the hydrated lime and water stand for 24 hours before using. Or it can be used immediately

*Much of the data here presented is from a recently issued circular of the Bureau of Standards entitled "Lime, Its Properties and Uses."

if the hydrated lime is added to the water, rather than water to the hydrated lime.

Mortar.—By far the greatest use of lime is as a mortar for building purposes. Whether a dolomite or a high calcium lime is best suited for this purpose has long been an important question for both lime manufacturers and builders. In considering this question the points of difference between the two limes should be noted.

A high-calcium lime slakes quickly and generates a large amount of heat, hence it is apt to burn if it is not watched carefully. A magnesian lime slakes slowly, generates comparatively little heat, and is never in danger of burning. A high-calcium lime increases in volume much more than a magnesian lime, and requires more water, both for the hydration and the formation of a paste. Magnesian mortars generally work smoothly and freely under the trowel, while high-calcium mortars are apt to be sticky and work "short." When laid in the wall, both limes set by absorbing carbon dioxide from the air. During this process a high-calcium lime shrinks noticeably, while the change of volume in a magnesian lime is much less. It must be borne in mind that the above properties are subject to radical modifications, due to different porosities of the stones or to different conditions of burning.

The usefulness of lime as a bonding agent probably depends more on the method in which it is handled than on its content of magnesium. Aside from the larger cities, where machine-mixed mortar can be had, the slaking of lime is generally left to unskilled labor. In such cases the kind of lime to be used is the kind the laborer is accustomed to handle. Thus a laborer used to high-calcium lime will probably not be able to get good results with a dolomite lime, and vice versa. Moreover, a high-calcium lime will give a much larger volume of putty than a magnesian lime, hence the laborer is deceived into adding an extra quantity of sand. However, this is not an unmixed evil, for the sand improves the spreading qualities of the mortar and lessens shrinkage. Masons generally prefer magnesian lime because it works more smoothly and sets more slowly. This latter property permits of a larger batch of mortar being made up and gives the mason plenty of time to spread it. On the other hand, the contractor prefers a quick-slaking lime, so that the job can be finished as soon as possible. The fact that a high-calcium lime gives a larger volume of putty and carries more sand is also of advantage to him.

As to the actual strength of the two mortars, recent tests conducted by the Bureau of Standards indicate that mortars made of dolomitic limes are stronger than those made of high-calcium limes.

Plastering.—Lime to be used for plastering must

work smoothly under the trowel, must not "pop" or "pit," and must not undergo too great a change of volume during setting, and, if it is to be used for the finish coat, it must have a good color.

It was noted above, when discussing the properties of the two kinds of lime, that magnesian limes work more smoothly under the trowel and shrink less on setting than high-calcium limes.

Cracking of plaster is in most cases traceable to faulty bracing of the building, settling of foundations or similar causes. Sometimes it is due to the swelling of wood lath which had not been wetted sufficiently before the plaster was applied. In the undercoats of plaster the shrinking of the lime is counteracted by diluting it with sand. In the finishing coat, calcined gypsum is mixed with the lime. This sets before the lime has begun to shrink, and thereby prevents cracking.

The cause of popping or pitting is not very well understood. In some cases it has been attributed to the impurities in the lime, such as clay, iron oxide, silicates, and pyrites. These seem to form various chemical compounds during the burning, which hydrate very slowly and expand during the process. For this reason it is generally conceded that lime to be used for plastering must be more nearly pure than that for any other purpose. Another probable cause of popping is the slow hydration of particles of calcium oxide which have been burned during the slaking. This is one more reason for the preference of magnesian lime for plastering, although extraordinary care must be taken to slake the lime properly, whichever kind is used. Recent experiments lead to the belief that impurities in the sand are frequently responsible for popping.

Magnesian limes are also to be preferred because they are generally more nearly white than high-calcium limes.

On the other hand, a given weight of high-calcium lime yields a larger volume of putty than the same weight of magnesian lime, and hence will cover a larger surface.

The time of setting is an important item, since it regulates the time required between coats. High-calcium limes set more quickly than magnesian limes, but both are rather slower than the contractor would like. It is suggested that some accelerator might be added to the lime to hasten its setting, or an atmosphere of carbon dioxide might be created for the same purpose.

For plastering hydrated lime will generally be found more economical and convenient to use than lump lime. Moreover, it has the important advantage of containing less impurities than the lime from which it was made.

Hydrated Lime and Portland Cement.—For both

building and plastering purposes, hydrated lime may be used interchangeably with quicklime and is often preferred, especially for the final coat in plastering. Hydrated lime is added to Portland cement mortars

to make them empervious in water. Quicklime will produce a similar effect, but from the nature of the substance it is obvious that hydrated lime is much more suitable.

The Ohio Stadium

In July and August the AMERICAN ARCHITECT published a report on the present condition of the stadia at four eastern colleges and a discussion of their construction and the effectiveness with which they have met the conditions for which they were built. The data contained in that report formed the basis for much of the study on the Ohio Stadium illustrated herewith.

Funds for the erection of this large structure have been generously given by the alumni, ex-students and friends of the Ohio State University, on whose grounds the structure will be built.

Expansion joints will be single continuous "butt" joints and will divide the structure into thirtyfour separate units which will have no connection with each other save their footings.

The double deck scheme is a new venture in monumental stadium design. It has been used in an attempt to provide maximum seating with minimum distance from the playing field.

The curved or bowed sides have been used because of the advantages of crowd psychology and the benefits to be derived from the possibility of each spectator being sensible of the presence of the entire crowd



STADIUM FOR OHIO STATE UNIVERSITY, COLUMBUS, OHIO

The Ohio Stadium seats 63,000 people, not counting possible temporary seating. It has three distinctive features. It will be a double deck structure, it will be a true horseshoe shape, with "bowed" sides and one open end, and the space under the lower tier of seats will be used for training quarters, team rooms, showers, lockers, exhibitions, etc.

The structure will be of reinforced concrete and of steel encased in cement. Expansion of monolithic portions will be accommodated by expansion joints every sixty feet about the entire stadium. These ex-

those on his own side of the structure as well as those opposite him.

The use of the space under the seats has been suggested as a logical and business-like proposition, making the most possible use of the capital invested in the structure.

The Ohio Stadium has been designed by an organization at the Ohio State University, composed of Joseph N. Bradford, University Architect; Howard Dwight Smith, designer, and William S. Hindman, structural engineer.

Architects and Engineers Co-operate

THE architect and engineer represent two professions whose work is daily bringing them into closer association. Jealousies that may tend to arise should be promptly squelched and should not be permitted to interfere with that friendly co-operation so necessary to the development of the highest efficiency in the art of building. In this connection it might be mentioned that the matter of state licensing laws for architects and engineers has long been held as a cause for friction. Manifestly such laws, to stand, must be fair to both architects and engineers, and any attempt to have laws placed on the statute books, which would interfere with the free exercise of duties by the members of either profession, when they are performing work of a character for which their education and experience qualify them, is indefensible and unjust to both elements.

A commendable spirit has been shown by the technical bodies representative of the two professions—the American Institute of Architects and Engineering Council—in the formation of a Joint Committee on Licensing Engineers and Architects. This committee at a recent meeting, and after an extensive discussion of the whole subject of the registration of architects and engineers, gave unanimous approval to the following resolution:

Whereas, Members of the architectural and engineering and other professions in various sections of the country are urging the enactment of state laws providing for registration or licensing;

Be It Resolved, That the Joint Committee of the American Institute of Architects and Engineering Council is of the opinion that the many points of contact between the architectural and engineering professions make it desirable for them to favor the passage of joint registration laws. In those states in which there already exists a Department of Education and Registration or other similar department, as in the cases of New York, Illinois and Idaho, it is desirable that registration laws should be administered by such state departments with the aid of professional commissions in each profession. Where such state departments do not exist, their formation should be encouraged. A joint registration law for architects and engineers should be designed to protect the title of architect or engineer and to assure the public that a person using that title is properly qualified.

Examinations for registration should in all cases be conducted only by members of the professions affected; that is, for architectural registration the examining board should be composed of architects and for engineering registration, of engineers.

Be It Further Resolved, That no registration or licensing act should deprive any person who, prior to the passage of the act, was engaged in the bona fide practice of his profession, of the right to continue, but he should not be entitled to the use of the title, "Registered Architect" or "Engineer," unless he shall have satisfied the board of his competency and received a certificate of registration; and that any person desiring to begin the practice of architecture or engineering after the act goes into effect shall be required to establish his competency before the board in order to entitle him to the use of the terms "Architect" or "Engineer."

This action, on lines that THE AMERICAN ARCHITECT has for some time advocated is a long step in the right direction. It is gratifying to note that the sober minded and best element in both professions are able to reach a common ground and certain unwise utterances have had no effect toward deferring so desirable a consummation as has been reached.

MEMBERSHIP IN AMERICAN ENGINEERING COUNCIL DISCUSSED

The matter of the American Institute of Architects joining Engineering Council or the new American Engineering Council was also discussed at the meeting previously referred to, and the following resolution was proposed, seconded and unanimously carried:

Whereas, The American Institute of Architects' Committee on Co-operation with Engineering Council recommended to the American Institute of Architects at its convention in Washington, held in May, 1920, the advisability of the institute becoming a member of the Engineering Council and that convention accepted the recommendation of its committee;

Therefore Be It Resolved, That the Joint Committee is of the opinion that the American Institute of Architects should join the American Engineering Council as soon as the institute deems it practicable to do so.

Current News

Happenings and Comments in the Field of Architecture and the Allied Arts

Cheap Houses

Referring to its own needs at the present time, a Providence paper editorially voices the statement that one of the most common of the many suggestions being advanced for the solution of the housing problem is to build cheap houses in quantity to serve the immediate need.

The shortsightedness of this policy ought to be clearly apparent, yet we read of intelligent persons advocating it and saying that public moneys should be voted for the purpose.

To build simply for the present is extravagant. It is not a cure for the housing shortage, but a kind of quack remedy. No city that wants to grow along constructive lines wants to be cluttered with cheap dwellings, which are easier to put up than to have torn down when the need of them has passed. The aim of any forward-looking community is to improve as much as possible each year the soundness and the appearance of its business structures and its homes. No city can build too well or too carefully, with an eye to beauty as well as to utility, if its aim is progress of a stable and enduring quality.

Fuel-Saving Plan Announced

A saving of 30,000,000 tons of coal and \$300,000,000 every year would be effected by a linking of the power plants of the Atlantic seaboard, declared W. S. Murray, one of the foremost electrical engineers in the country, in an address before the convention of the American Electric Railway Engineers' Association at Atlantic City.

The speaker explained the idea of the superpower system, the survey of which he has been retained to make by the Government. The zone now under investigation comprises the Atlantic seaboard from Boston to Washington to a depth of 150 miles. In this district, the engineers states that 17,000,000 of horse power were required to turn the wheels of industry and of the railroads. In the introduction of the superpower system the horse power would be cut to 5,000,000, thus saving an enormous amount of fuel and money.

According to the survey, huge steam turbine units, each with a capacity of 300,000 kilowatts, will be established at tidewater and at the mines. To these will be added hydro-electric stations on the Hudson, Delaware and Potomac rivers and other streams of

the district. The large efficiency plants in the big cities will be connected with the line. Twenty per cent. of the railroads will be electrified.

At present the stream water power is less at some seasons than at others. To keep power plants going with regularity, it is necessary at these times to use power machines and a force of laborers not required when the maximum periods of supply are available. These involve a fluctuation in labor and a rusting of unused machinery, both of which are burdens and sources of expense. The proposed method of wave motion would be a permanent service needing no such factors. It will be readily seen what a wonderful advance will have been accomplished if this new method becomes possible.

Double Deck Subway Planned

New York City will have a new double decked subway running most of the length of Manhattan Island if the plans proposed by John H. Delaney, transit construction commissioner, to provide for the increase in traffic in the next twenty-five years, are put into effect.

It will be necessary to resort to this double deck subway construction, in the opinion of the commissioner, because the congested section of Manhattan borough has only eleven north and south arteries to serve more than one hundred cross streets.

His plans call for an eight-track double-deck line on the west side of the city from the Battery to 155th street running under Eighth and Amsterdam avenues. Only four tracks would be constructed at first, but these would be so located that another four-track unit could be built under or on top of it.

Mr. Delaney also proposes the building of another north and south subway of four or six tracks under Fifth and Madison avenues, on the east side, and extending from the Battery to the Harlem River. Both these arteries would have connections extending to the Bronx, Brooklyn or Richmond.

The commissioner advocates the construction of forty-two new single track river tunnels. The present system has thirty-four such tunnels.

He says that passenger traffic on the surface of the main arteries, north or south or cross-town, soon will have to be discontinued because of the great increase of traffic, with the result that all passenger traffic on these streets would be forced into subways or on elevated lines.

Gateway to Carnival Built of Baled Hay

Hay, not marble, was the odd but entirely appropriate material used in the construction of a monumental gateway to the grounds of the farm carnival held recently by the agricultural departments of the state college at Ames, Iowa. The hay was baled, of course, and was piled to form four columns. These were then impaled with long, pointed rods of iron, and were guyed finally with wire to reinforce them against chance shocks and the buffets of the wind.

Replanning Field Columbian Museum in Chicago

The City Plan Committee, Illinois Chapter American Institute of Architects, is taking estimates on the cost of rehabilitating the Field Columbian Museum in Jackson Park, and will report to the South Park Commissioners.

The architects would employ the larger galleries in the building for a permanent exhibit of replicas of the famous architectural designs, frescoes, doorways, sculptures, etc., of Europe. There are many collections in America, but no gallery big enough to display them. A few specimens are shown in the Blackstone room at the Art Institute, but the room is too small and the lighting is poor. The nearest exhibit of the kind is in the Trocadero in Paris.

There would also be room in the museum for a permanent "Own Your Home" exhibit, showing model houses, and for indoor tennis, baseball and golf courses.

Odd Construction Preserves Old Utah Fort

Constructed in a few days, of raw adobe mud and common grain straw, the only available materials at hand in that isolated place more than 54 years ago, the walls of old Fort Deseret, in western Utah, are in a remarkable state of preservation. This is due to the Mormon pioneer builders' unique provisions for effectually weather-proofing the walls, described in a recent article by J. Cecil Alter.

Situated on the low banks of the old Sevier River bed, on a remarkably flat land, the surface of which is within a few inches of the permanent water table in the soil, the walls were rendered immune from rising water through capillarity. A foundation trench, 3 ft. wide and about 1½ ft. deep, was filled to the ground level with loose but carefully laid stones, gathered laboriously far and wide over the Pahvant plains.

Though the soil is a dark, rich adobe, the ground on the immediate site of the fort, a few miles down

the river from the town of Deseret, is laden with alkaline salts and generally waterlogged for want of drainage. Excavations, therefore, for the adobe formed moats around the fort. The walls, originally 550 ft. long and 10 ft. high, with convenient port-holes and curious bastions in the northeast and southwest corners, have no seams or joints, as they were laid in a continuous structure, though without forms. In the construction, the center of the wall was maintained higher than the edges at all times, and the straw was disposed crosswise, thus aiding in shedding rainwater from the sides and in allowing perfect drainage from the interior of the walls. The height of the wall has been reduced about one foot by settling and erosion, but the top still retains its peaked form and general contour.

The Mormon church authorities advised the construction of the fort during the Black Hawk Indian wars, in 1865, and the farmers dropped their work in mid-July, building the fort in 18 days.

Electrical Houseboat to Educate Chinese

A houseboat containing practically all of the latest electrical labor saving devices which are to be found in American homes will make a tour of the canals and rivers of China this winter. It will be used to bring home to the Oriental estate owners the possibilities of supplying their own power, light and heat by using the same type of farm light plants which have been so universally adopted in the rustic regions of the United States during the past few years.

The boat which is now being rigged out at Shanghai is scheduled to make a trip of about 5,000 miles. Its wares will be shown in a territory populated by more than a hundred million Chinese, most of whom are absolute strangers to anything electrical. It will carry a complete line of household devices, including motor driven sewing machines, vacuum cleaners, irons, washing machines and the labor saving electrical apparatus which American farmers are now using. A staff of expert demonstrators will make the trip and show how easily electricity may be introduced locally by means of the farm light plants despite the absence of electric power companies in China's farming districts.

The tour of the electrical houseboat is interesting because of the educational results which will probably follow it. With the introduction of local lighting plants one of China's greatest handicaps in the way of study and development will be relieved. It is realized that only the wealthier classes will be able to purchase the electrical apparatus, but the great number of retainers on their estates should profit indirectly.

Automatic Fire Escape Approved

An automatic fire escape was recently demonstrated at New York fire headquarters, when two men lowered themselves from an eight-story window on it. The escape is a rope with a wire running through it and running through an automatic pulley. The rope travels through the pulley at the rate of about four yards a second. It has been tested to bear 1,100 pounds.

Concrete-Slab Bridge, Not Reinforced, Fails

That mere mass is not a substitute for engineering procedure in bridge building is illustrated by the recent failure of a concrete bridge in one of the southern states. The contractor undertook to span a small stream with a structure of solid concrete slabs, supported by three piers resting on the bottom. No reinforcing was used, the slabs instead being made three times the usual thickness. The water soon undermined the piers, and the slabs, unable to support their own excessive weight, to say nothing of bearing traffic, cracked in the middle.

Business Men and the Fire Waste

The Chamber of Commerce of the United States, at its 1920 annual meeting in Atlantic City, adopted resolutions declaring strongly in favor of reduction of the preventable fire waste. The organization includes 1,300 national and local associations, having an aggregate membership of nearly 700,000 business concerns. After declaring against governmental interference with private business, and in favor of Americanism, increased production and thrift, the resolutions made the following declaration on fire prevention:

"At a time when increased production is of the first importance destruction of means of production continues on a great scale. Each year approximately \$300,000,000 in property values are being destroyed in the United States through fire. A large part of this value represents waste that can be prevented. Considerations which should appeal to every individual require that, even if conditions were normal, the endeavors which are being made to stop this needless waste, with its detriment to the public interest and its private burden for all citizens, should be redoubled. At a time when economy and conservation of our resources must be paramount, in order that every effort may have its full influence toward increasing production, it becomes the immediate duty of each person, each association, and the whole nation to put an end to preventable waste through fire."

Blast New Canal in Italy to Increase Fish Supply

Three connected lagoons that lie in the Pontine marshes of Italy, between the Roman Campagna and the Mediterranean shore, near Terracina, are remarkable for the great numbers of fish that enter them at high tide. Here they breed and fatten so rapidly that 1,000 to 4,000 pounds are removed every day for the markets, though the only inlet heretofore has been a single channel from Fogliano Lake, at one end of the chain, to the sea. An engineer of American training, noted for his war-time performance of blowing off the top of a mountain and burying hundreds of Austrian soldiers, has now blasted a new canal from the lagoon at the other end, Lake Caprolace, to the Mediterranean. The work required 50 tons of explosive and 1,200 large bombs, laid as a series of mines, or five times the quantity used in the mountain-top exploit, but it was entirely successful, and the added inlet is expected greatly to increase the available supply of food fish, besides aiding in draining those portions of the marshland that lie along its course.

Scientists Will Explore Amazon

A large party of American scientists next January will explore about 1,000 miles of almost unknown territory in the Amazon basin along eastern Ecuador and Peru, it was announced at Columbia University. Among members of the expedition, which will take an entire year, will be Henry H. Rusby, dean of Columbia school of pharmacy, who will head the party; Dr. David Starr Jordan, president of Leland Stanford University, who with Dr. Carl H. Eigenmann, dean of the University of Indiana, will study fishes and reptiles; Dr. F. E. Kremers, University of Wisconsin, an authority on Volatile oils; Prof. Gill, Boston Institute of Technology; Dr. Ruthvan, University of Michigan and many zoologists from the American Museum of Natural History.

Powder Depot on Sandy Hook Hidden by Camouflage

As they read of the wonders wrought by the camouflage along European battle fronts, few inhabitants of New York City realize that a monumental job of this kind now ornaments the sands of Sandy Hook, across the Lower Bay. Here, early in the year 1918, was established a storage depot for high explosives, consisting of numerous isolated magazines. These were strung along the coast for a mile and a half. As the big sheds were covered with white corrugated asbestos, and as all surrounding vegetation was removed to lessen fire risk, they became easily visible

for many miles at sea. This condition was allowed to exist until German submarines extended their activities to our eastern coast. Then a camoufleur was dispatched from Washington. Having learned from a voyage of inspection along the shore that cedar trees dominated the background of all the magazines, this expert ordered that each be painted in harmony. Accordingly the walls were daubed with green and yellow, the first for the trees and the second for sand. To break the rectangular outlines of the structure the painted "clumps" were extended above and to the right and left by means of cut-out metal silhouettes. As a result of this treatment the magazines are practically invisible at half a mile or so from shore.

More Motor Trucks for Street Cleaning

The city of New York ordered 212 5-ton dumping trucks for use by the Street Cleaning Department. It is the largest single order for motor equipment ever placed by a municipality. The trucks will be used for all phases of street cleaning work, including the removal of ashes, garbage and snow.

Seventy-five of the trucks will be equipped with removable bodies and may be readily converted into flushers and sprinklers by the substitution of 1,200-gallon tanks to replace the dump bodies.

The contract price for the entire order of heavy-duty trucks, including "Studebaker Model" flushing equipment for 75 of the machines, amounts to the sum of \$1,422,190.55.

New York City spends millions of dollars annually for street cleaning work, and the action of its officials in providing the Street Cleaning Department with a huge fleet of trucks, it is estimated by the city's engineers, will save the municipality large sums of money each year, and—what is of equal importance—will give the city ample protection against the blocking of thoroughfares by heavy snowfalls. The plan adopted by New York for keeping its streets clean will be watched with interest by cities throughout the country.

Band Stand to Be Erected in City's Heart

The City Hall terminus of the Parkway, which runs thence to Fairmount Park, a mile away, is soon to be the site of an improvement unique in the history of Philadelphia, Pa. This area, contiguous to the City Hall, and bounded by 15th, Arch, Broad and Filbert streets, is to be traversed by a boulevard link, or short cut, that will disentangle the daily traffic snarl at the corner of the two streets last named. Decorated then with sod, shrubs, and trees, the resulting areas will become green garden spots, with

greenness accentuated by their location in the heart of the city's business district. On the larger area, finally, will be placed a band stand and permanent benches, that the concerts formerly given in the City Hall Plaza may be enjoyed in the future by larger audiences and in greater quiet.

Famous Hancock House Still Stands

The first house of distinction to be built on Beacon Hill, in Boston, the highest of three elevations which gave to the city the name of "Tri-mountain," and which was the center of military, social and religious life, was erected by Thomas Hancock, an uncle of the Revolutionary hero. This was in 1737.

It was a beautiful mansion, built of stone, with the ground laid out in orchards and gardens, and it was here that the first tree nursery in Boston was started. Inside considerable taste was shown in the furnishings, the drawing-room containing a rare set of bird's eye maple, covered with red damask.

Hancock was a lavish host, and gave a famous breakfast to the officers of the French fleet.

While the French troops were in Boston forty or more of the officers dined at the house every day. On one occasion, however, so many unexpected guests appeared that Madam Hancock was driven to despair to know how to provide for them; so she had servants milk all the cows pastured on the common, whether this was agreeable to their owners or not. The house is yet considered a splendid piece of architecture.

Plan to Construct European Hotels in China and Japan

Announcement is made in the "North China Daily News" of the plan to establish a chain of hotels to accommodate Europeans in the Orient, starting at Shanghai with the erection of a 700-room modern building costing about \$3,000,000, to be followed by hotels in Yokohama, Peking, Hongkong, Hankow and other principal cities frequented by Europeans. Of Shanghai's population, 2,000,000 are Chinese and 30,000 Europeans, and the city is growing rapidly as trade develops.

Glacier Park Highway Will Cross Continental Divide

Straight across the continental divide, the government has started to hew from the native rock of Glacier National Park, Mont., what is destined to become one of the most picturesque highways in the world. This 38-mile stretch of hard roadway will lift the motorist to an altitude of 9,000 feet at the crest of the Rockies by the most gradual rise possible. For the greater part the grade will average only six

THE AMERICAN ARCHITECT

per cent., though an occasional stretch will reach the eight per cent. to which the engineers have been restricted. The new highway is to connect with the existing 30-mile highway in the eastern part of the park, to make possible an uninterrupted tour of 68 miles over hard, smooth roads. This journey will carry the motorist from the main gateway of the park on the east side of the continental divide to the town of Belton, on the west.

Business Men's Art Club

Chicago has a Business Men's Art Club. On two evenings a week instruction in drawing and painting is given at the Art Institute, and on Saturday and Sunday afternoons there are classes in outdoor sketching. Among the teachers are several professional artists. It is planned to hold annual exhibitions. The prospectus says: "This club is composed of business men who art studying art as an avocation or hobby. The object of the club is to encourage the study and practice of painting and kindred arts among its members and to co-operate with societies now aiming to broaden the appreciation of art in our city and elsewhere. Our club brings together men of middle age who desire to learn to paint, men who love nature and enjoy a recreation which challenges their best intellectual effort and gives them a means for self-expression." There are already about sixty members.

Paris Once More a Glitter of Lights

Once more Paris is making an attempt to look after dark like it did before the war, states a cable to the New York Times. Suddenly, one evening, 14,000 extra gas street lamps were lighted up, and the next day full sunlight electricians rehearsed with electric standards along the boulevards.

Enough German coal, it appears, has been stored in the city's yards to justify the measure, and the almost complete darkness in which the city has been wrapped at night since February is now to be ended.

At that time, rather suddenly, it was discovered that the winter stocks of coal had been prematurely exhausted, and the reduction of lighting became again almost as severe as it had been during the time of the Gotha raids. All night signs were suppressed and the number of street lamps reduced to the barest necessity.

This month, thanks to the increased output from French mines and to the delivery of coal by the Germans in accordance with the Spa agreement, stocks are nearly the normal of before the war, and the card ration to householders has been increased to a quan-

tity almost sufficient to keep every one warm throughout the winter.

Still, there is the prospect of an English coal strike looming ahead, and as this is the third time the streets have been lighted up since the armistice, Parisians are not very optimistic that it will last.

Eight Desks Combined in One by College Professor

Needing several desks to carry on his diversified work, but finding his office too small to accommodate them, a college professor in charge of an astronomical observatory on a West Indian island, devised a space-saving piece of furniture that permits him to labor at eight different desks without leaving his chair. The desks are supported by a ball-bearing pedestal, around which they revolve, and can be drawn into position with slight effort. In the center are shelves for books and supplies.

Timber from Dead Trees

The prejudice held by certain builders against the use of lumber from fire or insect-killed trees has been proved groundless by recent experiments of the forest products laboratory. Here it has been found that lumber cut from sound dead trees is in no way distinguishable from any other, except that it may be partly seasoned. If the wood has not been injured subsequently by decay or further insect attack, this "dead" lumber is the equal of "live" of the same grade for all structural purposes.

Elaborately Carved Human Interest Sign-Posts

Even in their sign-posts the Germans display their love of elaborateness. Instead of having plain wooden or metal posts with arrows pointing to the various towns, highly carved tree-stumps are used. They are fashioned to represent human beings with extended arms—the arms pointing to the various towns, and having the distances written on them.

Some of the sign-posts smile at you; others frown. Perhaps they are trying to tell you the kind of road that's ahead.

A cheerful sign-post shows a schoolboy hugging to his bosom his slate on which is written the name of the next town. He smiles at you sweetly and points toward the town, regardless of the fact that pointing is considered bad manners. The stump on which he dwells is a tall one and makes you think, at first, that the boy is wearing long dresses. These mileposts are only one of the many curious things that travelers through Europe are continually seeing.

Weekly Review of the Construction Field

With Reports of Special Correspondents in Prominent Regional Centers

THE evidence that readjustment of prices and business conditions in domestic industries are steadily continuing is everywhere apparent. In fact in some classes of goods the charges at the mills are not so very far above prewar prices. The unfortunate condition in the price question is that consumers will not probably get the benefit for a considerable length of time of these changes in prices that are being everywhere made by producers or wholesalers. Naturally such a condition tends to retard the readjustment in certain lines and also prevents consumers from absorbing goods in the market as they would most certainly do if they could receive the benefit of reductions that were properly due them. There is nothing in such conditions to stabilize business and in fact the inability of the ultimate consumer to realize any part of relief which a cut on the part of producers would ordinarily entail tends to a curtailment of buying demand with the natural reflected effects on earnings. Further thus far no very serious effects are to be noted and if the gradual restoration of normality that is predicted takes place, much of the present depression it is believed will be relieved.

The situation in the building industries shows but little relief especially in the all important question of housing. The post-war conditions that have brought about the serious retardation in our building operations and have created conditions particularly in the field of housing that are now nearing an acute stage are not confined solely to this country and in fact every belligerent in the great war is passing through an experience very similar to our own. Attempts to solve Great Britain's housing problem, it is learned from a recent bulletin of the Guaranty Trust Company of New York, have already brought forward upwards of 10,000 schemes involving an annual capital expenditure of \$600,000,000, according to a report by a representative of the Foreign Trade Bureau of that organization. After giving details as to various plans and the number of houses to be built in each of more than thirty cities visited the report says:

"The program of the Ministry of Health—complete rehousing in three years—is about one year behind, and is costing more than double the original estimates.

"The Ministry of Health works in conjunction with the Office of Works. Where a local authority defaults, the business is then entrusted to the Office of Works.

"What is keeping back housing at the present time is the fact that there are not enough skilled men to do even a quarter of the work wanted. The Trades Unions will not allow the number to be increased from the outside. The Government is using a sort of indirect compulsion by prohibiting 'luxury and unessential building,' so that if a man will not build cottages he is not allowed to build anything else. There are various suggestions for speeding up the work, including a guarantee to the Trades Unions of employment for a term of years to men employed on housing work, to ensure them against loss of time in bad weather by a minimum wage 'wet or dry.' In return the Trades Unions will be asked to consent to dilution and the employment of unskilled and semi-skilled labor, to give up their apprenticeship rules, and abandon all opposition to the employment of ex-service men, trained or untrained. There are 'luxury building' tribunals to hear appeals against decisions prohibiting buildings regarded as non-essential.

"There are housing bond campaigns all over the country. In London, subscriptions to the 6 per cent. bonds are coming in at the rate of about £100,000 a day. While the local governments are issuing 6 per cent. bonds, the British Government charges 7 per cent. Borrowing in the ordinary way for housing schemes not financed by bonds is usually 7 per cent.

The total number of housing schemes in England and Wales number 10,673, covering in all land for 800,000 houses. Of these 7,120 have been approved with an area for 550,000 houses. In Scotland 103,000 houses have been authorized, the bids averaging about £1,000 per house. This is roughly about £100-£150 more than it costs per house in England."

UNDOUBTEDLY a very serious condition is threatened in the production of coal in this country during the next six months unless some working agreement that has stability and indication of continuance can be effected. England's experience in the matter of a threatened coal strike has now become history and while the government has in a sense come to terms with the miners there are yet the mutterings of discontent and it is by no means certain that the matter may not become eventually reopened again to cause a mutiny among the manufacturers of Great Britain. While fortunately things are in better condition in this country we are nevertheless always and especially at this time of the year threatened with a menace of complications in the coal fields and it would seem a wise precaution that

THE AMERICAN ARCHITECT

we should follow the example of the British government that has begun an investigation of water resources of the United Kingdom to determine how far "white coal" may be relied on to supplement the nation's coal resources. In its weekly bulletin of foreign information the Bankers Trust Company of New York states that special committees appointed by the British Board of Trade and the Privy Council are at work on the investigation of water power.

Furthermore, an official Water Power Resources Committee has already examined and reported favorably upon nine separate schemes of water power development in the Scottish Highlands. These nine schemes, it is estimated, would yield an aggregate of 183,500 horsepower at a cost much below the present cost of generating power in Scotland by the use of coal.

The Committee has recommended the appointment of Water Commissioners under control of the Board of Trade, to insure that British water resources shall be properly conserved and that all interested parties shall be treated fairly under future development schemes. It is proposed to divide England and Wales into water power districts, according to the conformation of water shed areas, under local committees whose duty shall be to secure the best development and use of the water power resources of the individual districts.

THE proceedings of the American Bankers Convention in Washington, D. C., have attracted much attention on the part of the construction industries. Regret has been expressed in many quarters that the bankers did not more specifically outline their exact position on the subject of financing of building projects. Referring to this subject the American Contractor states:

They are not earnestly studying ways and means of meeting the construction situation as they are studying ways and means of financing foreign business, for example, or the handling of trade acceptances.

This may not be an unmixed evil, for it is inevitable, if bankers do not interest themselves in providing building finance, that methods of financing will be devised and this independent of the banks. People are going to have homes and when the pressure becomes so strong that they are forced to act they will find a way to provide the finance. Congressman Kelly of Pennsylvania, according to press reports, will introduce a bill in the next Congress proposing to divert the funds in the Federal Postal Savings Banks to building loans and it is not impossible, by any means, for home building corporations to be formed for the sale of bonds of small denomination through which popular savings can be

accumulated and the bond purchasers benefit through a rate of interest higher than is now paid by the savings banks of the country. While legislation always is a questionable palliative, when the public once is convinced that bankers do not propose to meet the building finance situation, we may expect state and national legislation that will have something to say about the investment of long-term deposits in building mortgages by savings banks. The vulnerable point in the banker's case is the fact that he does business on other people's money and when the "other people" become convinced that the banker is not doing a reasonable share in meeting national problems, other people's money will find a way to devote itself to the other people's interests.

THE Chicago correspondent of THE AMERICAN ARCHITECT reports that residential builders are being urged to build now, while the prices are comparatively low, stocks good, and labor plentiful.

While this is no doubt timely advice, buyers cannot be expected to act upon it in the face of a falling market, and no increase may be looked for in this line of building until people are convinced that prices will go no lower.

Prices in some lines have already reached rock bottom, according to the dealers, and any change will be in the nature of an advance. In other lines reductions below manufacturers costs may occur but this will be only a temporary condition and the enormous demand looked for in the spring for all kinds of construction material is likely to send prices soaring and accumulated stocks flying.

It is predicted that spring will see brick, lumber and cement in the advancing market. Just now prices on sand, stone and gravel are steady. The lumber market is dull, especially in the lath and shingle market, red cedar shingles Chi. basis for clears at \$4.81, stars \$3.97; demand for lath is very poor with No. 1 fir at \$9 Chi., bas No. 2 fir \$7.50, No. 1 spruce at \$10, No. 2 spruce \$6.50, No. 1 pine \$11.50, No. 2 at \$9.50.

(By Special Correspondence to *The American Architect*)

Boston.—The business interests in New England are steadily undergoing a process of readjustment to a lower commodity price basis with all that means in the way of financial embarrassment as one manufacturer after another abandons the rosy dreams of huge profits and reconcile themselves to the absorption of what may become substantial losses. Textile manufacturers in Lowell, Fall River, Worcester, New Bedford and other centers are facing the alternatives of closing their plants entirely, running on a part time schedule or requesting their employees to

THE AMERICAN ARCHITECT

accept reductions in wages, as the result of a situation brought about by heavy cancellation of orders and unstable market conditions. Mill owners are attempting to adopt a policy of reduction in order to keep their plants in motion and in many instances are meeting with the heartiest co-operation from the operatives. In other cases, employees state that they cannot stand a cut in wages and maintain a decent standard of living. The latter intend to fight against any suggestion of the owners that their pay be reduced. The general reason for the reduction of a complete shutdown is that the mills have few orders to fill. Sixteen new concerns were chartered in Connecticut this past week, including two for \$500,000.

(By Special Correspondence to The American Architect)

Seattle.—With every office building in the city, modern and otherwise filled and waiting lists for space in all of desirable value, the office equipment of this city is three years behind. Protests of investors, such as the Metropolitan Building Company (Stone-Webster) have for two years been against the low rental revenues, claiming that if floor space could be lifted to the San Francisco basic of \$3 per square foot per annum it would be possible to expect relief. This company still holds considerable valuable leased space in the new upper business and shopping district of the city that is suitable for the erection of Class A office structures and it is reported that some plans are now being considered for building in 1921.

Home building will be heavy. Lumber has fallen to the point where a bill for a five room bungalow, for instance, is \$300 to \$400 less than on May 1. War-standard structures, built to sell, are being offered freely, but shrewd investors are reviewing the cheap construction so well known at that time and are preferring to construct anew.

There will be no new building projects or contracts in the Pacific Coast territory, barring the summer climate districts of California this year. After election stock taking will keep off any buying until January 1, when, if agricultural products yield a living profit to farmers, one of the most gratifying construction years in a decade will be inaugurated on the Pacific Coast. Architects furnish proof of this in conditional big jobs now beyond the pencil-sketch stage. Eastern lumber buyers, who represent the building trade most closely so far as lumber is concerned, report that they will not be on the market until December. Lumber ordered in that month will

not reach Eastern buyers in time to interfere with the balancing of accounts for 1920, and already sufficient proof has accumulated in the hands of fir lumber manufacturers to warrant expectation for an unusually brisk month in December. Further evidence of expected lumber market recovery based solely on the Eastern building demand is in the fact that the larger mills are refusing to accept orders on today's market and that wholesalers are declining to sell short, fearing sharp and sudden recovery.

The pipe and nail situation, distribution and arrival standpoint has improved. Several of the larger jobbers state their ability to deliver a normal amount of small pipe, while the smaller houses deny that there are any three-quarters or halves in galvanized in the territory. The undeniable fact is that the mills are rapidly catching up on back orders, and are keenly anxious to make it clear to the Coast jobbing territory that they hope to be at normal by January 1.

The condition as to small nails, which has been abnormally acute for six months, has been greatly eased during the past week and rationing has stopped, although arrivals are quickly swallowed up into the avenues of construction. Three-penny blues are still scarce, but 6 and 8 penny common are coming quite freely, at least in so far as Colorado shipments are concerned. Increased efficiency and production at the mills as developed at this end of the line is the basis on which jobbers hope to be catapulted into normal conditions early in the spring. Water shipments of steel pipe have overcome the handicap of irregular car distribution, and 60 days to Coast points from the mill is of common occurrence. Owing to the fact that 38 vessels are now in the coastwise water trade, future delivery from Pittsburgh is assured. Jobbers announce confidently that they will be able to take care of any demand for nails after January 1.

Jobbers of fire clay and brick have stopped shipments, warehouses now carrying normal stocks. Roofing, plaster board and brick of all kinds are plentiful. More plaster is coming but the supply is under the demand. There is very little improvement in the arrivals of cement.

Shingles are stronger, with 60 per cent. of the mills closed down for lack of orders. Wholesale prices for clears are \$3.15 to \$3.25 and stars \$2.75 to \$2.80.

The fir lumber market is believed to be at bottom at \$54 to \$59 for 1 x 4 No 2 vertical grain flooring, \$37.50 to \$48 for five-eighths by four No. 2 and better ceiling and \$18.50 to \$21.50 for 2 x 4, 12-14, No. 1 stock surfaced and edged dimension, basis prices at the mill.

Journal piece to No. 2343



DOORWAY OF A PALACE ON RIO BELLA FAVA, VENICE

THE AMERICAN ARCHITECT

VOL. CXVIII

WEDNESDAY, NOVEMBER 17, 1920

NUMBER 2343

The Housing Problem

A Series of Interviews with Bankers, Builders and Real Estate Operators
by a Representative of the Editorial Department of
THE AMERICAN ARCHITECT

THERE have been a great many inquiries into the housing problem, both by individuals and committees of various sorts, but most of them have resulted in nothing tangible enough to the so-called middle class citizen to aid him effectively in getting money to build the home he desires, provided he can borrow the necessary amount of money for that purpose. The man with an unoccupied and unencumbered piece of property finds himself as badly off, so far as the possibility of building him a home is concerned, as Diogenes was in his search for an honest man. The business man can nowhere find money with which to build a home.

Such a condition must have its cause, and, since it is concerned primarily with money at its source, it seems logical to think of the banks as either a contributing factor to the situation or as having in their possession the facts of the case. It was with this object in view that two of the leading bankers of this country were approached on the subject, with a view to determining whether it might be simple money stringency, high interest rates, the situation of the call money market, or any other of the various factors which would seem to enter into the problem.

The banks, stated George E. Roberts, vice-president of the National City Bank of New York, to a representative of this journal, are in no wise to be blamed for the situation, since it has been caused by circumstances entirely beyond the control of any bank or group of banks.

"The war, high prices for commodities and for labor, and a general unsettled condition have made a real estate loan a relatively poor risk," Mr. Roberts explained. "The Liberty Loan drives made serious inroads into the capital of banks all over the country, and quite especially into that of the large banks. By serious, I mean that a goodly portion of the bank's capital was put into the bonds, thus taking just so much money from the hands of prospective borrowers. For example, a bank with ten million in capital

bought, let us say, one million in bonds. That is a high estimate, but it will serve the purpose. That million put out for bonds took exactly one million from the available money which the bank would have had for borrowers. The bank is therefore forced to operate with nine millions. First of all, it must take care of its regular customers. They have first call on any bank. Having taken care of them, it may then properly look out for the prospective buyer who is not a customer. But it lacks exactly one million dollars with which to operate, so far as outside loans are concerned. If it does make loans, it is only logical to suppose that it will make them where it can profit most by the loan."

"The call money market, for example?"

"Not necessarily. It would put out a certain amount in the call money market, but that has no relation to the real estate market. Mind you, I am giving you my opinion on this matter; for we are a national bank and are therefore prohibited from making loans on real estate. But let me emphasize that the call money market has no bearing on the loans made in real estate. They are distinctly two different affairs in the administration of the bank, and fluctuations in the one have no bearing on the other."

The banks today are going in rather heavily for both government and certain railroad bonds, according to Mr. Roberts. There has never been a time when such bonds could be bought so cheaply, and in the railroad bonds, there are a great many cheap buys in long terms—some as high as 100-year. At the present, and for some time past, the banks are naturally interested in the agricultural situation, and the crops are calling for a great deal of money. The interest rates on agricultural loans are higher than those on the small real estate loan, and it is only natural that the banks, disturbed by the war and its consequent reactions, should seek to repair their conditions by the most advantageous placing of loans.

These facts Mr. Roberts pointed to as refutation of

THE AMERICAN ARCHITECT

the statement that banks are concentrating on call loans at rates 15 to 25 and even to 30 per cent., and his opinions were shared by Francis H. Sisson, vice-president of the Guaranty Trust Company of New York.

Mr. Sisson pointed out, in an interview with the writer, that the situation may be best summed up in the fact that in 1913 the estimated building operations for the entire United States was 100 per cent. normal, and only 75 per cent. normal in 1919, with a further deficit in 1920.

"The accumulated deficit for the period from 1913 to 1920," Mr. Sisson said, "is 134 per cent. It is undoubtedly due in large part to hesitation to undertake new building at current costs and to the difficulties of financing such undertakings. There is no general expectation that by postponing new building for a few months marked savings may be realized through future declines in prices. Even should the long-desired definite recession in prices develop there is much ground for the belief that for some time yet building costs will show at best but slight decline apart from temporary fluctuations. It is believed by many that there will be still further advances in building costs generally. As for the influence of credit stringency upon building operations, other lines of business enterprises are also affected, most of which show no such marked decline in activity as does the building industry.

"In some localities there is a general dearth of available building materials. In some localities one or another material may be found in sufficient quantities for the immediate needs of the building in hand, but other equally essential materials are lacking and, in consequence, operations are as effectively suspended as if all the supplies were lacking. Brick, for example, is available where there is no cement. On the other hand, certain lumber mills are idle because they are not able to move their product."

"Then it would seem that the transportation tangle is the primary source of the decline."

"It is. It seems to me that the urgency of the need for new building would warrant a system of freight priorities which would serve to increase activity in this essential industry. The problem of priorities is, of course, a very complex one; with so many essential businesses in need of every assistance, not one of them can be favored directly by freight preference or indirectly by embargoes without, at the same time, handicapping some other enterprises. But if any claim for special treatment is warranted under the present conditions, apparently building materials are well toward the head of the list of commodities for which such claims may be rightly made."

"We made a recent survey of the situation," Mr. Sisson continued, "and based part of it upon tables

showing the number of permits issued in the first five months of the current year. Normally, the permits for the month of May are about double those for January. But in the first five months of 1920, with the exception of the Pacific and New England districts, there was a smaller volume of permits in May of this year than in January, and in the two districts where there was not a decline, the increase was relatively small. These statistics covered 105 cities, and the figures were corrected to eliminate normal seasonal variations. And investigation of the cause for such a decline invariably led, in the end, to one answer: Transportation. Everywhere that one word seemed to explain the whole situation."

THE BUILDER'S SIDE OF THE PROBLEM

THE builders differ from the bankers in their reasons for the slow improvement of the housing situation. With them there is little reference to loans or the call money market or to the financial side of the problem. They speak almost exclusively in terms of labor and of the high cost of commodities and material, and have little to say regarding the capital with which even the high prices of these things are being met today. Generally, as Frank P. McCord, of Post & McCord, of New York, explained to the writer, builders look upon the housing problem as centering around three things: Labor, materials and transportation.

"I won't speak of the financial phase of the matter," Mr. McCord said, "because I am a builder and not a banker. I am engaged principally in structural steel work, and therefore am not personally in touch with the housing situation as applied to the building of homes. But I believe that the same psychology holds true for both the small and the large builder. Both are unwilling to take the chance, at the present moment, of building. The decent element of labor is dependable and worth-while, but the radical element makes labor what the insurance men would term an extremely high risk. I do not mean by that that one has anything to fear from labor, for I would be the last man on earth to make such a statement. I have faith in labor, and know that it is sound at the bottom; but I know also that at this time there is a peculiarly restless spirit running through it as a result of the war and its aftermath, and that this spirit is, in my opinion, holding back contractors who deal in the small housing scheme or unit. Materials enter much more directly into the housing tangle than any other factor, so far as the man who is paying for the house is concerned. It is my opinion that you will find a great many men living either in apartments or hotels or boarding houses who have, at present, sufficient money with which to build themselves decent houses, even at present prices. But they are holding

THE AMERICAN ARCHITECT

off, and will continue to hold off, precisely as department stores held off buying until wholesale prices came down. The average man says to himself: 'I have seven thousand dollars. I can build a comfortable little home for that at present, but I can build a much better home for that same money when prices come down. I will live in an apartment until they *do* come down. I don't believe it will be long.' Having said that to himself, and having fully convinced himself that prices *are* coming down very shortly, he goes into an apartment and lives there. And his house is not built.

"Transportation," Mr. McCord pointed out, "is an extremely serious problem from the standpoint of the contractor, small or large. The contractor cannot depend upon delivery of materials, and since his contract price is calculated upon efficient delivery of materials, he cannot afford to take the transportation risk, as we term it, without safeguarding himself against it in the contract price. Which means more money for the house to be built, a factor which the man who is to pay for that house necessarily objects to.

"Those are the reasons for the housing situation as it stands today, in a very brief and incomplete way. There are ramifications of every reason given, and an exhaustive inquiry into all of them would turn up innumerable others. But fundamentally the whole situation is concerned only, so far as the builders are concerned, with labor, materials and transportation."

LEGISLATION, SAYS A REAL ESTATE OPERATOR

CURIOUSLY enough, one of the most prominent real estate operators in the country was most severe in his arraignment of the real estate situation as it exists today. When asked what he considered the fundamental difficulty with the housing problem, Lawrence B. Elliman, president of Pease & Elliman, stated emphatically and immediately that the recent action of the legislature in its passage of bills which make it possible to regulate real estate rentals by the judiciary and other means, was the real and fundamental cause of the present housing and real estate situation.

"Real estate operators," Mr. Elliman explained, "have no assurance, nor do they know, that the next session of the New York state legislature will not pass further laws relating to this subject. The builder of small home units especially is fearful of this possibility, because he can say quite logically, 'What is to prevent the legislature from passing a law at its next session fixing the price at which a given style or size of house will sell?' Is that not a logical possibility? Until the present rent-fixing laws, so-called, are taken off the statute books, there can be little

hope of an optimistic outlook upon the housing situation by real estate men or by builders.

"That is a local condition, of course; but if such laws are declared constitutional in this state, it will most certainly establish a precedent which any other state may take as a basis for similar laws. Such a condition, if it came to pass, would work havoc with the real estate market and therefore with housing. Real estate men cannot be expected to carry on their business under such regulations, unless they are to be considered as public utilities, such as railroads.

"An arbitrary decision as to rents—and, of course, this decision is made by men who are not expert in the proper basis for such rents—reacts always against the real estate operator. Consider the possibility of similar arbitrary decisions as to the prices of houses when completed, regardless of what they cost to build, and you have a fair idea of how much confidence builders have in the future of housing until such laws are definitely and emphatically declared unconstitutional.

"But at present," it was suggested by the writer, "the problem is in getting money to build. What is the difficulty there?"

"Simply a question of money stringency," Mr. Elliman replied. "Twenty years ago," he went on with a smile, "a banker told me that the real estate business would never amount to much unless the real estate men got together and improved their financial system. He pointed to the fact that railroads have made their success possible on long-term bonds or notes, and compared the relatively short-term mortgage to such security. I believe he was right. We need, at the present moment, such a financial revision; we need long-term mortgages as a general thing. Not five-year, but twenty or thirty year mortgages.

"Now, what has that to do with the present situation? Simply this: Investors are putting their money into tax exempt government bonds and railroad bonds, some of which are yielding them as high as 7 per cent. They are long term bonds, compared to the short term 6 per cent. real estate mortgage, which yields only about 2 per cent. when the various taxes have been paid on it, they are a logical investment. And a correct one, in my opinion. If you have \$100,000 to invest, you are not going to put it into a 6 per cent. real estate loan when you can get as high as 7 per cent. on very substantial railroad bonds. Are you?"

"Possibly not," said the writer. "It would be better yet to try the call money market."

"A thousand times better," Mr. Elliman emphasized. "I would do it myself if I had that sum to invest separately from real estate. I blame no one for putting their money into the call money market—

THE AMERICAN ARCHITECT

where undoubtedly a great deal of it is going—nor for putting it into any enterprise where it will yield him a higher rate of interest.”

“And let me say,” Mr. Elliman smiled, as the writer was leaving his office, “that I think any man a fool who would invest money in real estate when we have legislative supervision.”

JOSEPH P. DAY CRITICIZES THE BANKS

THE banks have taken a most illogical position on the housing problem, according to Joseph P. Day, one of the largest real estate operators in the country. Mr. Day stresses the fact that banks, representing a conservative and constructive force, have failed in promoting those forces by curtailing loans upon real estate, and, incidentally, pointed out that the Metropolitan Life Insurance Company is practically the only large organization of its kind which

is at present seeking to ease the housing situation by making loans to the small home builder.

“It is my contention, based upon years of experience,” Mr. Day stated, “that the man who owns property is unquestionably the better type of citizen. Sell a man a piece of land or a house and you have removed a great factor in radicalism or Bolshevism. It may work little effect in the present generation, but it is a fact that it always makes its influence felt upon the following generation, and those to follow. Property is the best check known upon radicalism, and the elimination of that dangerous factor from any nation stabilizes that nation and promotes a conservative careful mode of living.

“Now, the banks are essentially conservative. Nothing pleases them better than evidences of good citizenship, for good citizenship increases any bank’s

(Continued on page 641)

British Architects and American Architecture

WITH the coming on of autumn our thoughts turn to the meetings of the various learned societies connected with our craft, and American architecture is one subject that attracts attention at discussions of British architects, but it deserves to have even more notice taken of it; for a study of the reports of certain meetings held recently shows that the American architect has in some directions decidedly taken the lead of his European confrère. Conditions of life, says the British building press, have imposed upon him new problems, aesthetic and constructional, and in facing these, as he was bound to do, he has achieved some remarkable results on the constructional side, while as to the artistic effect of his productions, he seems to be evolving more than one new style which will be, when developed, distinctly American. Two sorts of construction in which he has gone right ahead of all European rivalry are, first, that of very tall buildings for office and residential purposes, and, next, that of huge departmental stores. As to the very tall buildings. American ingenuity has been able to provide house room or office accommodation for an enormous number of people on a relatively small space, but we do not gather that it has been equal to the problem of providing adequate lighting and ventilation for all the rooms in such a building; and if we remember that we do not always get nearly

enough light and air in buildings here on a scale very much below that of the New York skyscraper, we shall not wonder that the American architect, although favored with a brighter sky than ours, has failed in the supremely difficult task he has undertaken.

In the department stores, also, it is the case that, generally, some part of the huge floor space can only be lighted by artificial means; but there are notable exceptions to this rule, and these are to be found among the finest and largest stores. Those who have studied the planning and lay-out of American stores speak very highly of their convenience and suitability to the purpose for which they are designed, and describe the decoration and appearance of the buildings generally as magnificent. Naturally, such departmental stores do not exist in a state of splendid isolation in cities where most of the other architecture is mediocre; generally the architecture of shops, office buildings, and so on, is finer in America than here. Last year an English architect (Mr. Austen Hall), exhibiting a lantern slide of a shop front in New York, remarked that he would be happy if there were one such shop front in London; but that Fifth Avenue consisted entirely of such buildings. It was the finest shopping street in the world.

It is not, however, only in the largeness of the scale and the magnificence of the decoration of its city architecture that America has struck a new

note. Another English architect (Mr. Robert Atkinson) last year, while praising American architecture very highly indeed, complained that its decoration lacked originality. It was invariably neo-something or other; plans and constructions eminently modern in every sense were clothed in copy-book designs. But in Chicago and in the cities further west he had found a school of architecture to which this criticism did not apply. Here America was producing new designs based on modern requirements. The buildings might be ugly, but they expressed something as the architect understood it in a new spirit, and they were becoming better adapted to their requirements; they were improving every day. In Southern California also Mr. Atkinson said he had come across another and not less interesting development. Here there was a native style of architecture to be found in the mission buildings erected in the early days of Spanish conquest and settlement. The material used was baked mud, and the brown buildings set in the midst of the brown landscape had

a picturesque effect and harmonized well with their surroundings. They provided an admirable model for construction in concrete, and American architects had realized that they here got away from the classic, and were developing something which might become in time another American style.

It is only fair to the English architect to mention certain advantages which are enjoyed by his American colleague and rival. Building Acts there are less restrictive and more up to date than here, and there is an appreciation of fine architecture on the part of all classes of the population. In particular the business man does not consider his splendid building as a useless expense—at best an advertisement. He looks upon it as an investment; he takes a pride in it; he wishes it fine in every respect. This being said, the fact stands that in certain directions American architecture is the best in the world, and no young architect should consider his education complete until he has given serious attention to it.

Report of the Jury

Architectural Competition for Milwaukee County General Hospital

THE jury appointed to act for the selection of plans for the Milwaukee County General Hospital in the architectural competition, under the program prepared for that purpose by Alfred C. Clas, A. I. A., begs to make the following report:

Your committee organized itself by the election of Dr. Horace M. Brown as Chairman and Mr. Irving K. Pond as Secretary of the Jury. A due consideration of the program provided for the regulation of the action of the jury and a hasty examination of the plans led the jury to adopt the following resolution in regard to its action.

On the motion of Mr. Jensen, it was agreed that the points raised in the communication from Mr. Alfred C. Clas as to the Plans Numbers 7 and 12, be waived until further report is made.

Upon motion of Mr. Jensen it was agreed that Plans Numbers 4, 10 and 13 be considered as to the points offered by Mr. Clas before final report is made.

In regard to the points made by Mr. Clas as to Plans Numbers 5, 8 and 9, upon motion of Mr. W. L. Coffey it was agreed that Plans Numbers 5, 8 and 9 be admitted to the contest. Your board then turned its attention to the individual examination of the various plans and at 6.15 p. m. adjourned to meet at 7.30 p. m.

At 9.00 a. m., June 30, the jury met at Engleman

Hall and the entire morning was spent in examination and discussion of plans with temporary formal meetings of the jury for the discussion of an illumination of various points in the plans, as explained by the technical and medical men of the jury. The jury adjourned at 12.15 p. m. and reconvened at 2.00 p. m.

A discussion having arisen on legal points, Mr. Peabody moved that in consideration of the plans, the jury be limited to the provisions of the program and that all extraneous matters not found in the program be eliminated from the discussion of the jury.

Upon motion of Mr. Jensen it was agreed that when the jury makes its report it shall call the attention of the Board of Supervisors and the selected architect to the need that the selected architect have his attention called to the existing State, County and Municipal laws regulating hospital construction. The jury then took up a final discussion of the plans and after serious and careful consideration of all the points at issue and with full and careful discussion of all technical, medical and administrative functions, proper to be brought before the jury, by unanimous consent proceeded to ballot for the final awards.

The result of the ballot—tentative and formal ballots having been taken—resulted in the agreement of your jury to the following statement of awards:

THE AMERICAN ARCHITECT

First Prize: Van Ryn & DeGelleke, architects, Milwaukee, and Armstrong & DeGelleke, New York, associate architects.

Second Prize: Richard E. Schmidt, Garden & Martin, architects, Chicago.

Third Prize: Eric Gugler, architect, New York City.

Fourth Prize: Clare C. Hosmer, architect, Chicago, Wm. H. Furst—Rudolph G. Wolff, associated.

Fifth Prize: Robert A. Messmer & Bro., architects, Milwaukee.

Fifteen (15) sets of plans were placed in the hands of the jury. A careful examination of these plans from the standpoint of utility; function; applicability to the purpose intended; suitability for a the site; artistic design and to the neighborhood; method all classes of people in connection whether the sick methods of bringing supplies and re method of approach from street other vehicles; prob-

lems with relation to lighting, ventilation, sun supply, all questions relating to the medical, surgical and scientific purposes for which the buildings were to be used, hygienic considerations in regard to interns, nurses and administrative corps of the hospital, the needs of out-patients and their proper attention and care, and so far as was in the power of your jury, other problems relating to hospital construction and service, were duly and with great care considered, discussed and made understood to every member of the jury, and it was upon the basis of the knowledge thus applied and after a most careful consideration that the awards above specified were made.

H. M. Brown, chairman; Lewis J. Daniels, M. D.; Adelaide L. Northam, R. N.; Wm. E. McCarty; James P. Sheehan; Wm. L. Coffey; Arthur Peabody; Elmer C. Jensen; Irving K. Pond, secretary.

Council of State Registration

(St. Louis, November 18-19.)

The meeting of the Council of State Registration, to be held in St. Louis November 18 and 19, is one of more than usual importance. A full report, as far as obtainable, will be presented in an early issue.

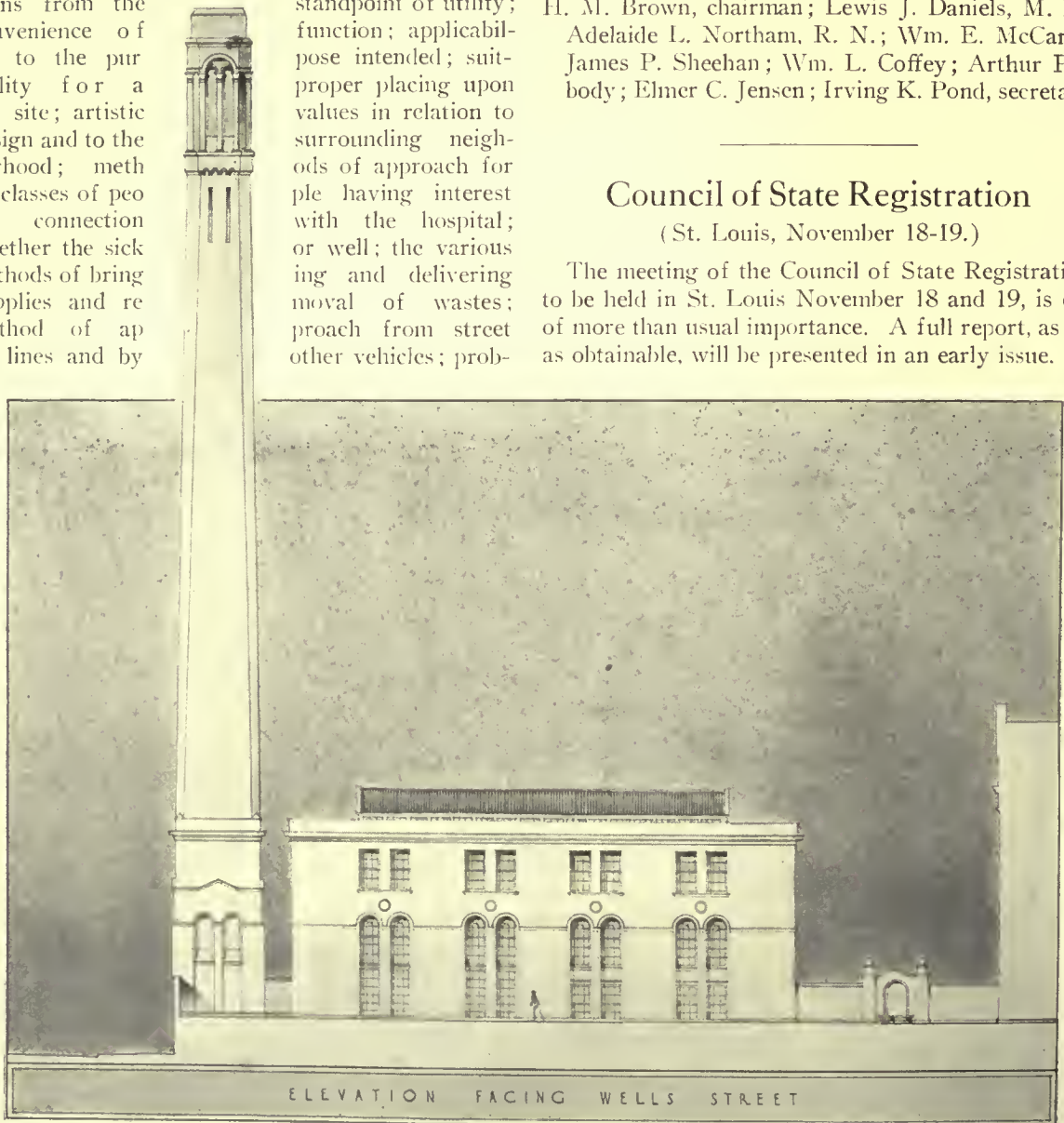

POWER HOUSE

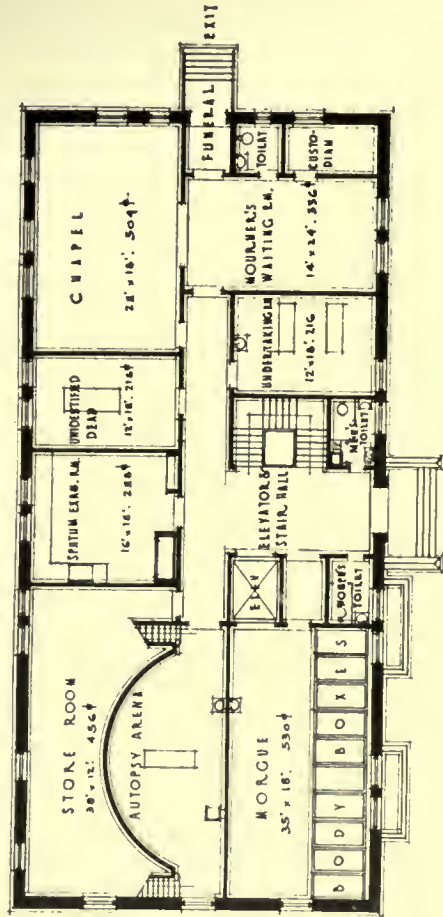

BASEMENT PLAN

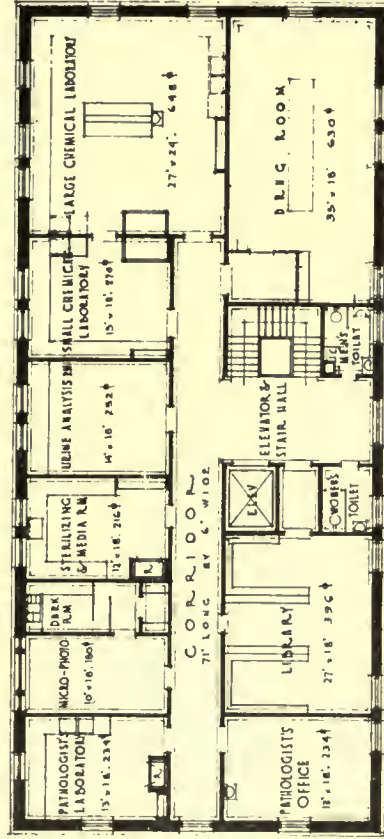

SECOND FLOOR PLAN

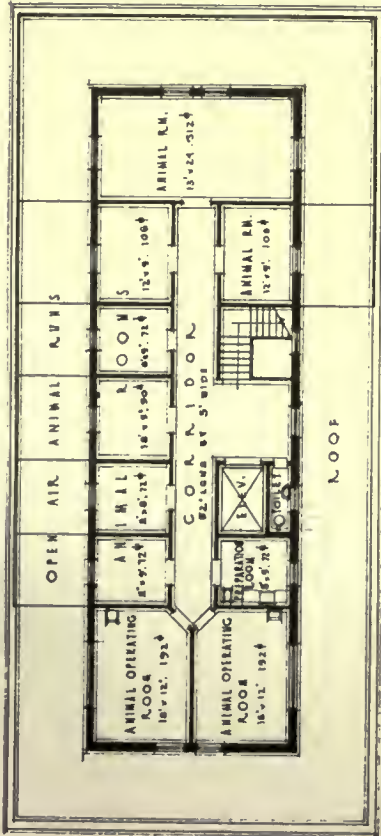

THIRD FLOOR PLAN

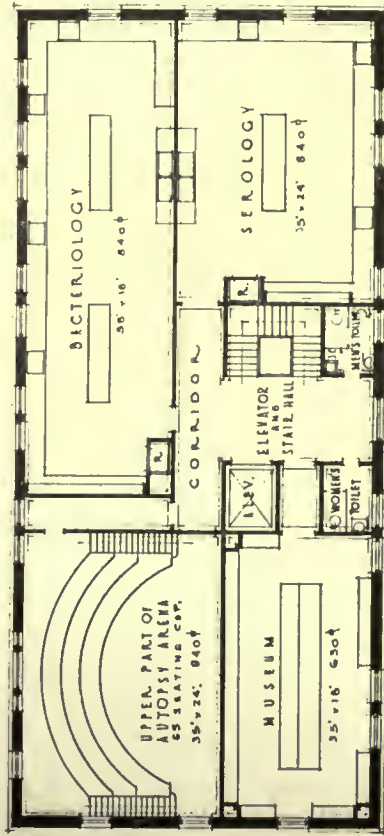

FIRST FLOOR PLAN

LABORATORY BUILDING
 AWARDED SECOND PRIZE, COMPETITION FOR MILWAUKEE COUNTY GENERAL HOSPITAL
 RICHARD E. SCHMIDT, GARDEN & MARTIN, ARCHITECTS

THE AMERICAN ARCHITECT

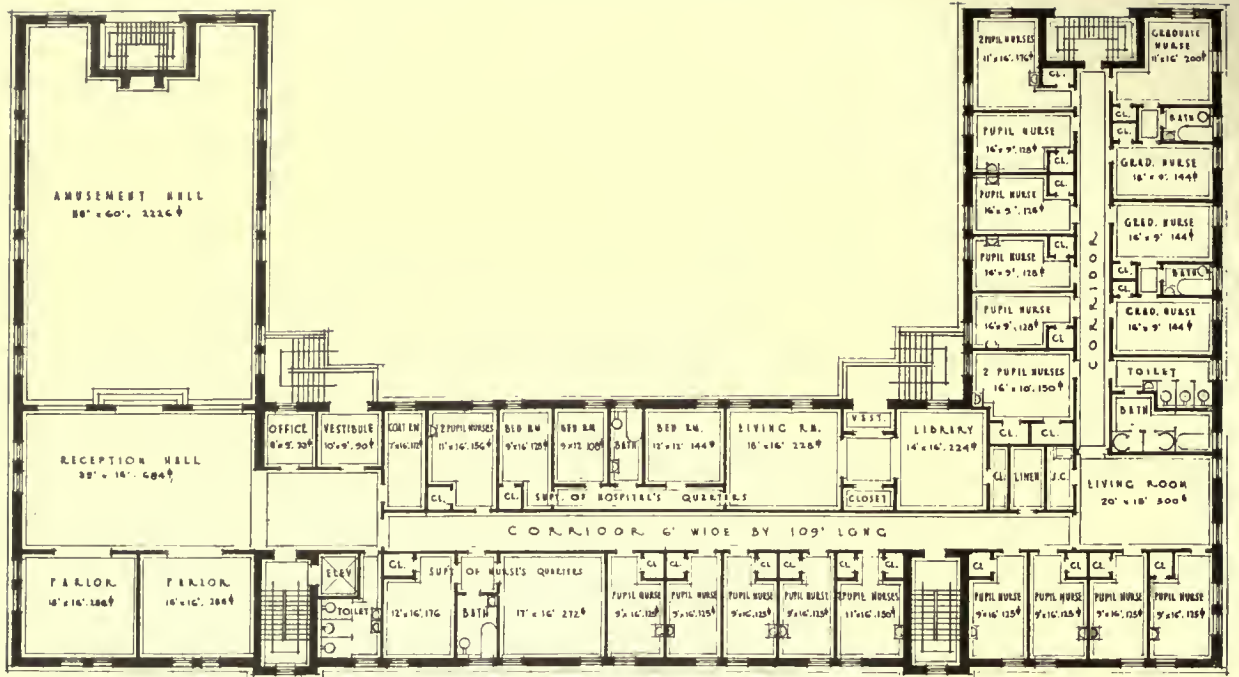

FIRST FLOOR PLAN

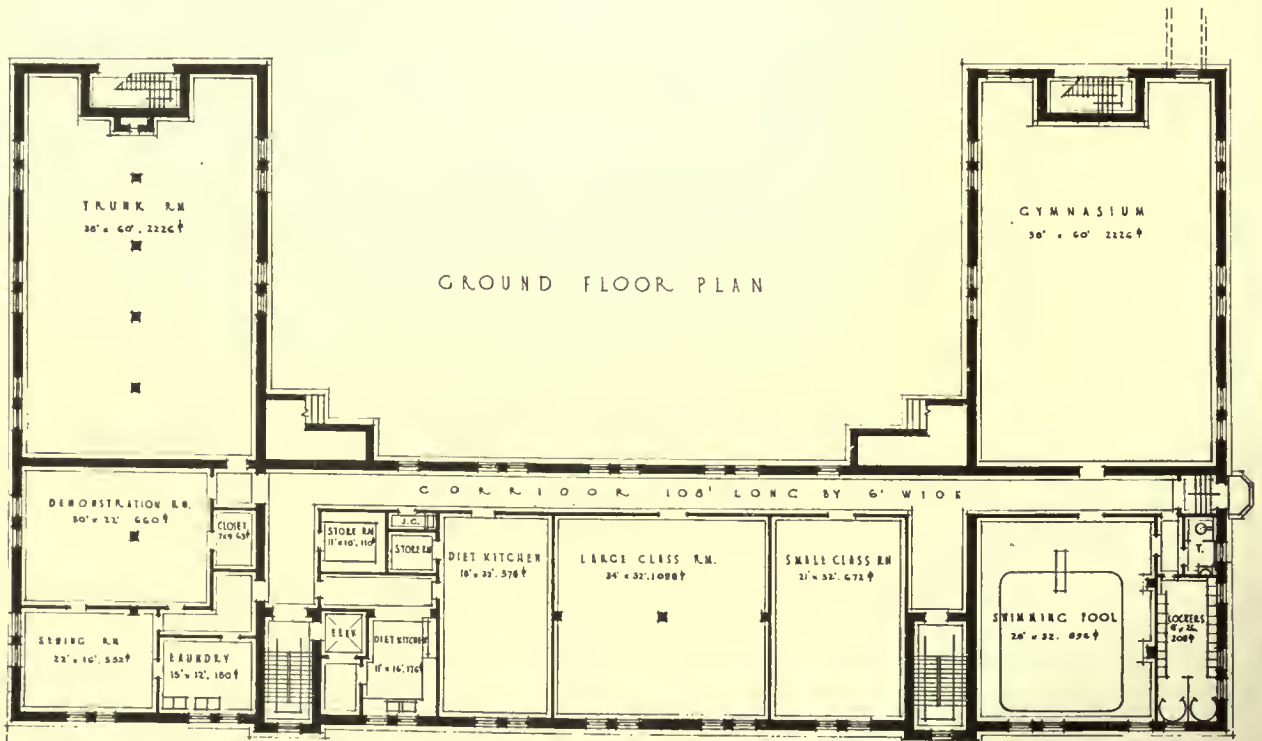

GROUND FLOOR PLAN

NURSES' HOME

AWARDED SECOND PRIZE, COMPETITION FOR MILWAUKEE COUNTY GENERAL HOSPITAL
 RICHARD E. SCHMIDT, GARDEN & MARTIN, ARCHITECTS

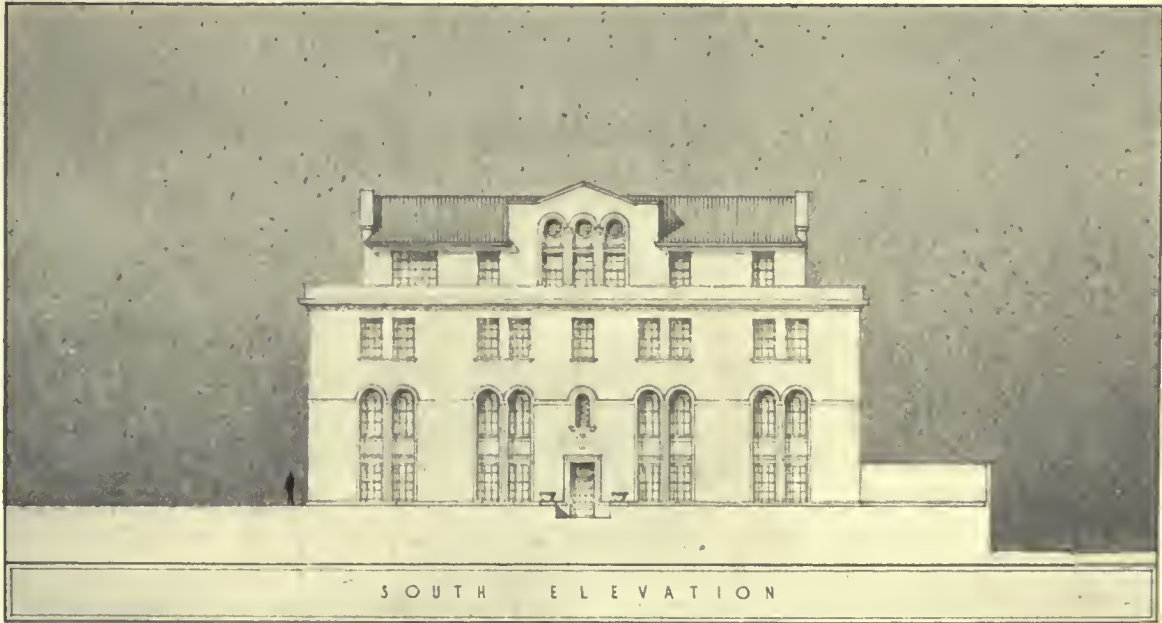

SOUTH ELEVATION, NURSES' HOME

Extracts from the Program Architectural Competition for Milwaukee County General Hospital Design

THE main provisions of the program of the architectural competition for the Milwaukee County General Hospital, as prepared by Alfred C. Clas, A. I. A., professional advisor to the County Board of Supervisors are given in the following paragraphs.

Main building is to be planned to take care of 515 beds, with a view to future extension to take care of an additional 500 beds. The following departments in this building must be planned at once so that they are of sufficient size to take care of a 1,000 bed hospital: Administration department, operating department, culinary and dining room department, and check room.

Nurses' home is to be planned to accommodate 100 pupil nurses and 36 graduate nurses, with a view to future extension to take care of double this number of pupil and graduate nurses. The large sitting room or amusement hall on first floor, toilet accommodations, gymnasium, swimming pool, private laundry and trunk room are to be planned at once to accommodate the additional nurses.

The power house and laundry are to be planned at once to take care of a 1,000 bed hospital.

The proposed building is to be erected on the site bounded by Grand Ave. and Wells St. and 24th and 25th Sts.

Cost: For the purpose of this competition the main hospital building shall not exceed 3,100,000 cubic feet. Laboratory building not to exceed 225,000 cubic feet. Nurses' home 350,000 cubic feet. Power house, laundry, garage and work shop not to exceed 300,000 cubic feet.

Cubage shall be computed so as to show exactly as possible the actual volume of the buildings calculated from the finished level or levels of the lowest floor to the highest points of the roofs and contained within the outside surfaces of the walls.

The number of beds called for in the various departments is as follows: Medical, 138 beds divided between three male wards, one female ward and separate rooms of one, three and four beds; surgical, 110 beds divided between two male wards, one female ward and twenty single rooms; maternity, 48

THE AMERICAN ARCHITECT

beds divided equally between twelve wards; pediatrics and orthopedics, 42 beds divided between one infants' ward of thirty beds and smaller rooms; eye, ear, nose and throat, 76 beds, divided between one male ward and one female ward of thirty beds each and smaller rooms; genito-urinary, 44 beds divided between one male ward and one female ward of 16 beds each and smaller rooms of one, two and three beds; psychopathic, 50 beds divided between one male ward of 28 beds and one female ward of 22 beds; nurses and doctors indisposed, 7 beds. Eighty square feet to be allowed for each bed.

In addition to the above there are to be provided the following:

ADMINISTRATION DEPARTMENT: Large reception room, cashier's office, bookkeeper's office, with vault and

room adjoining, one surgeons' room with lockers, showers and toilet (instrument room or instrument cases should be provided for), one laboratory, X-Ray department with two X-Ray rooms, one photo supply room, one dark room, one coil room, one waiting room with dressing rooms. There are to be no skylights for operating rooms; combination sky and wall windows may be used; there will be no amphitheatre, no recovery or anaesthetizing rooms.

MATERNITY DEPARTMENT: One crèche to take care of 24 infants; in connection with the crèche should be a babies' bath and dressing room, two labor rooms, two delivery rooms, one sterilizing and wash room, one laboratory, one nurses' work room, utility rooms, toilet rooms, diet kitchens, dining room, surgeons' rooms, nurses' rooms, linen closet, airing

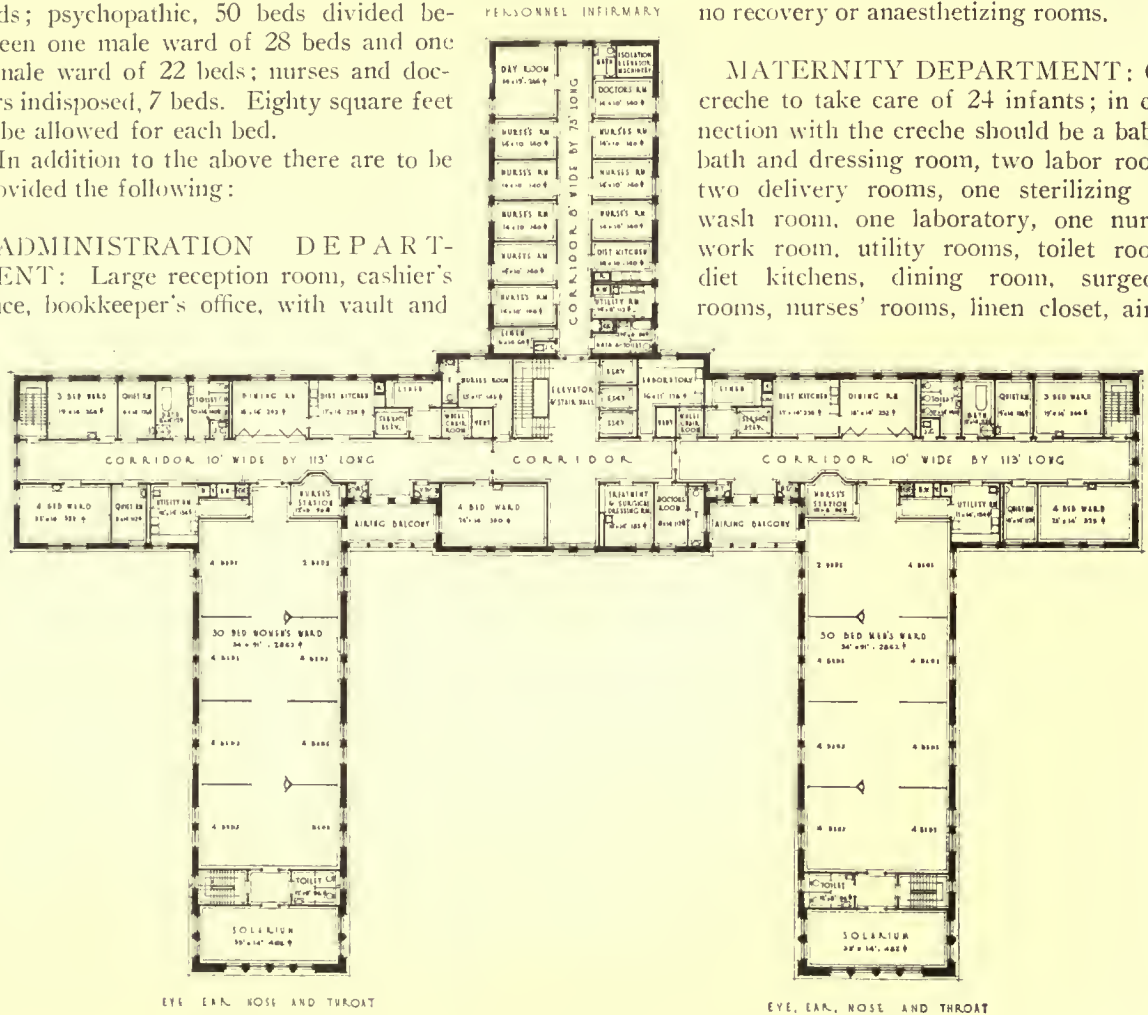

FIFTH FLOOR PLAN, MAIN HOSPITAL BUILDING

stationery storage, superintendent's general office, superintendent's private office and toilet, clerk's office, stenographer's office, record room and vault, superintendent of nurses' office, toilets for visitors and employees and toilets and lockers for doctors.

OPERATING DEPARTMENT: Two large operating rooms, four small operating rooms, two eye operating rooms, one nose and throat operating room, two orthopedic rooms, one for operating and one for plaster, one sterilizing room, one sterilizing supply room, one nurses' work room with toilet and dressing

balconies and solarium which may be used as a day or work room.

OUT-PATIENT DEPARTMENT: This department to have a separate entrance and is to be a unit on the ground floor consisting of: Waiting room, clerk's room, drug room, rooms for social service department, toilets for male and female, examination rooms at least 20 in number, for medicine, surgery, gynecology, pediatric, eye, ear, nose and throat, genito-urinary and dermatology; laboratory, nurses' room, doctors' room with toilet and lockers, record

THE AMERICAN ARCHITECT

room with with large vault, X-Ray room with one waiting room, developing room, coil room, dressing room, display room, one room not less than 14 x 20 ft. and one room not less than 12 x 16 ft.

PSYCHOPATHIC OUT-PATIENT DEPARTMENT: A unit on the ground floor with separate entrance and the following rooms: Waiting room, of-
 fice, nurses' room, doctors' room, six rooms for examination and treatment and necessary toilets.

CULINARY DEPARTMENT: A unit on ground floor, must be of sufficient size to take care of 1,000 bed hospital. Must have kitchen, diet kitchen and serving room, bakery and storage for same, scullery, butcher shop and refrigerators, steward's office, supply receiving room con-

receiving room, four single rooms with bath for male patients and three single rooms with bath for female patients and the necessary toilets.

PSYCHOPATHIC DEPARTMENT: This department is to be located on one of the upper floors and shut off from all the other departments. Provision is also required for visitors' rooms and rooms for the use of help, storage and other miscellaneous rooms in the main building.

The laboratory building is to be approximately 50 x 90 feet, with high basement. It is to contain autopsy room with provision for seats to accommodate not less than 35 people, morgue, examination rooms, laboratories, library and miscellaneous rooms connected with the laboratory department, including animal operating rooms.

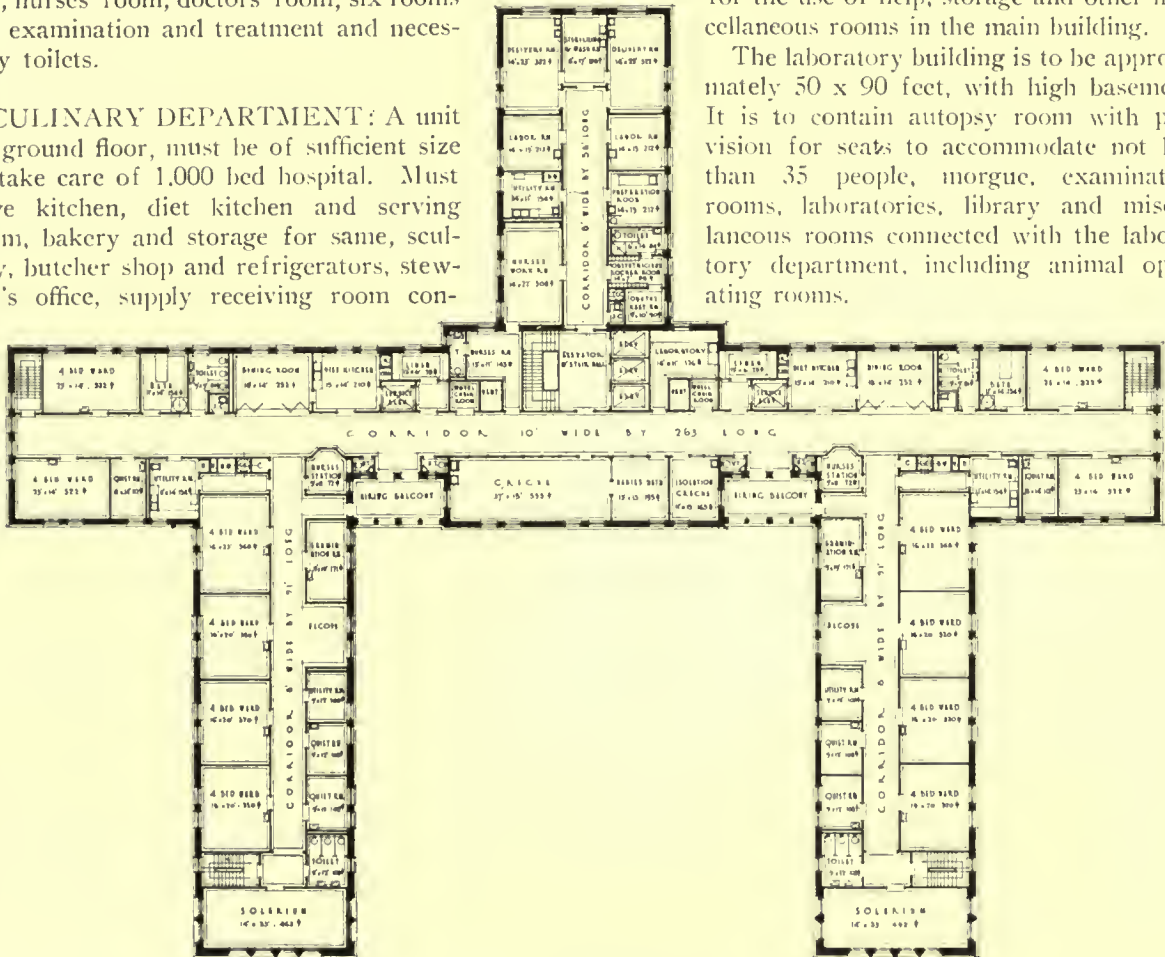

FIFTH FLOOR PLAN, MATERNITY DEPARTMENT

nected directly with large storage room. Convenient connections must be provided for all diet kitchens on upper floors.

DINING ROOM DEPARTMENT: Nurses' dining room, help's dining room, two staff dining rooms, head nurses' dining rooms, internes' dining room and serving rooms in connection with these dining rooms.

ISOLATION DEPARTMENT: This department is to be located on one of the upper floors and is to be shut off from all other departments, and is to have an independent entrance and elevator starting from the ground floor and leading to this department which will have the following rooms: One general

Nurses' home is to have single rooms for all graduate nurses, single and double rooms for pupil nurses. each room to be provided with lavatory and clothes closet. The single rooms to be approximately 8½ x 16 feet and the double rooms approximately 11 x 16 feet. Bath rooms, sitting rooms, sleeping porches, visitors' rooms and miscellaneous other rooms are to be provided.

The power house, garage, laundry and workshop are to be located in one building of sufficient size to take care of any future additions to the main hospital building.

A tunnel is to be provided of sufficient size and conveniently located to connect the main building with the laboratory building and the power house.

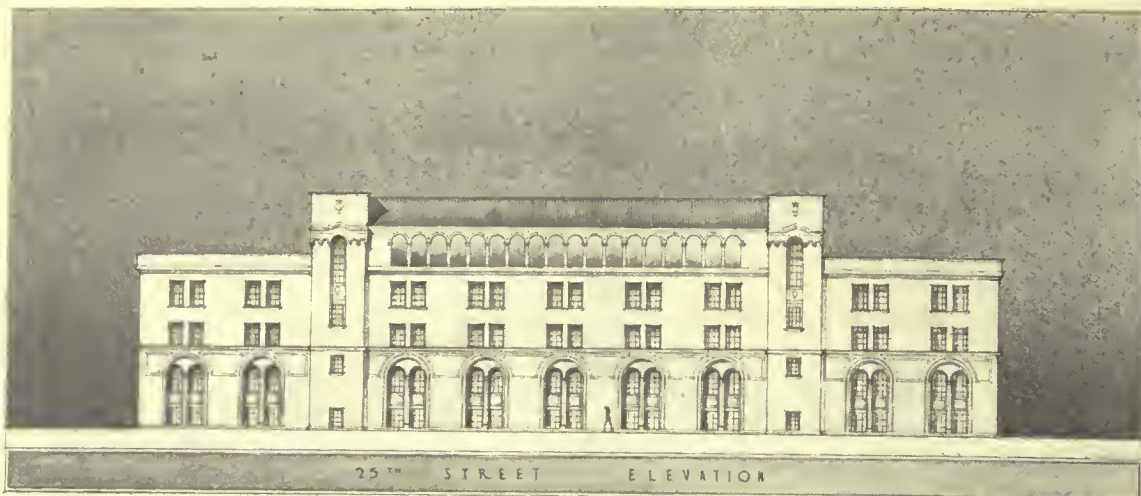

TWENTY-FIFTH STREET ELEVATION, NURSES' HOME

Statement by the Architects

Addressed to the Jury, Milwaukee County Hospital Competition, by Richard E. Schmidt, Garden & Martin

THE FUNDAMENTALS

HOSPITAL buildings must be arranged to efficiently permit the science of medicine to do the utmost in the discovery, prevention and eradication of disease. Co-ordination between divisions of the hospital must be facilitated to secure this result. Physicians' dependence on the nursing organizations, domestic and business administration and social service departments is evident. Inadequate, inconvenient or inaccessible arrangements for them would seriously interfere with their efficiency.

Outstanding medical men can be drawn to hospital service only when such arrangements exist.

Economy of operation should be aided in every possible way. As labor is the principal item in operating costs, the arrangement must conserve labor and facilitate supervision.

We have solved the basic problems without sacrificing detailed arrangement.

GROUP PLAN—SINGLE BUILDING

All patients should therefore be housed in one building to secure

- (a) medical efficiency,
- (b) economy of operation and of construction.

HOSPITALS

The Grand Avenue frontage is reserved for patients as they should have the best exposure and view.

POWER HOUSE AND LABORATORY

Power plant, laboratory and morgue are so located that they are

- (a) central and yet isolated from the patients.

NURSES' HOME

The nurses home is well separated and is so arranged that

- (a) Amusements will not disturb patients,
- (b) Visitors may reach it easily.

UNOCCUPIED AREA

Consistent with therapeutical, clinical and administrative efficiency we have the maximum percentage of open ground area.

SUNSHINE

Maximum sunshine for patients' rooms and north light for auxiliary rooms. The proportion of the wings assures sunshine to all parts of the courts.

ORIENTATION

The long axis of the wards, north and south, insures the maximum and most equitable distribution of sunlight for all beds. Any deviation from this arrangement results in gain to one side and a corresponding loss to the other.

ENTRANCES

Wells Street is obviously the street from which most visitors will arrive.

The secondary entrance on Grand Avenue is primarily for the motorist.

Service entrances are grouped around the service court, to insure proper control, supervision and the minimum of roadways.

FUTURE ADDITIONS

Additions may be made without disturbing the

THE AMERICAN ARCHITECT

operation or efficiency of the building. Basement requirements establish ground area of nurses' home. By removing the sleeping porch on the nurses' home additional stories may be added and old porch replaced.

HOSPITAL WARDS

Thirty bed wards are divided into four bed groups without obstructing complete observation by glass partitions built away from walls, above floor, and 7 feet 0 inch high. These have proven satisfactory at Rigs Hospital, Copenhagen, and at Cumberland Street Hospital, Brooklyn. Advantages are:

1. Greater classification.
2. Abundant ventilation without drafts.
3. Patients do not face light.
4. Reduces distances by shortening wards
5. Unusually large window area.
6. Greater privacy.
7. Less noise.

The typical ward data:

(a) Square feet per bed.....	95.4
(b) Clear ceiling height.....	11.6
(c) Cubic feet per patient.....	1097.1
(d) Square feet of window area.....	612
(e) Square feet of window per patient.....	20.4
(f) Percentage of window to floor area....	21.4%

WARD UNITS

The usual long dark hall leading to the ward has been avoided by making the ward unit a "T," resulting in the following important advantages:

1. Nurse from her station supervises entire unit.
2. Corridor is lighted and ventilated from three directions.
3. Distances from auxiliary rooms are shorter than possible with any other plan.

Service and accessory rooms are conveniently arranged. Toilet rooms are provided at each end of large wards. A service elevator for each unit, far more useful and convenient than dumb waiters, opens directly into the ward diet kitchen and into service hall. Each unit on floor may be isolated. Fire escapes (enclosed) as required by State Laws are provided.

OPERATING DEPARTMENT

Is adjacent to surgical and eye, ear, nose and throat ward.

MATERNITY DEPARTMENT

North wing provides the delivery department well separated from wards and yet conveniently adjacent.

PSYCHOPATHIC DEPARTMENT

The disturbed patients are well segregated.

ISOLATION DEPARTMENT

In the north wing fourth floor, convenient to pediatric wards and separated from the remainder of the hospital by an open air porch.

PERSONNEL INFIRMARY

Is entirely distinct from patients division.

ADMINISTRATION OFFICES, ETC.

1. Are of easy access to the public and doctors.
2. No one need enter the patients' quarters to reach this section.
3. The medical library and record rooms are convenient for the staff and medical personnel.

OUT-PATIENTS' DEPARTMENT

1. Most accessible and convenient to the Wells Street surface lines.
2. Adjacent to the admission department so that out-patients may be readily transferred to the "in-patient department."
3. Control is easily exercised by the clerks.
4. The drug room is a dispensing station with a stock of formulary prescriptions and connected to the main hospital pharmacy by pneumatic tube for special prescriptions.
5. The assignment into clinical departments is not shown. It is assumed that the pediatric clinic will be adjacent to the isolation department elevator so that such cases might be temporarily transferred to this department, when necessary.

MEDICAL PERSONNEL QUARTERS

Are well segregated from the hospital. May be entered without passing the patients' quarters. Each interne has a single room.

ROOF GARDENS

Though none was required we have provided these as being necessary for the convalescent and for Heliotherapy.

CULINARY DEPARTMENT

Is conveniently located for ward diet kitchens and the dining rooms. Ample space and convenient arrangements have been provided for the ultimate, 1,000-bed hospital.

BASEMENT

None is called for in the program. We believe it to be very necessary for,

1. Ground floor is used for many departments in which a large number of pipes on the ceiling would be objectionable.
2. Communication is maintained between hospital, laundry and laboratory building. Bodies, soiled linen, etc., must not be transported through departmental corridors.

CIRCULATION

The travel of patients, visitors, personnel or goods is such that they may enter and leave the hospital and their departments without passing through any other department; and, will always be under supervision.

NURSES' HOME

The plan presents these principal advantages:

- (a) One entrance, easily supervised.

THE AMERICAN ARCHITECT

(b) Entertainment room separated from sleeping quarters.

(c) Sleeping porch in the most desirable place, the roof.

(d) Hospital superintendent completely isolated.

LABORATORY

The advantages of the plan are:

(a) 400 feet of north frontage for laboratories.

(b) Concealed open air animal runways.

(c) Direct and inconspicuous underground passageways to hospital for removal of bodies.

(d) A funeral exit.

POWER HOUSE, GARAGE, WORKSHOPS AND LAUNDRY

The completed group will require three-350 H. P. boilers. Initial installation will be two.

Laundry is one large room for the best supervision and ventilation.

CONSTRUCTION

The main hospital building and the central portion of the Nurses' Home would be of skeleton frame reinforced concrete construction, other portions would be wall bearing large wards without columns, except in the exterior walls, elsewhere a row of columns in addition to the wall columns would be required.

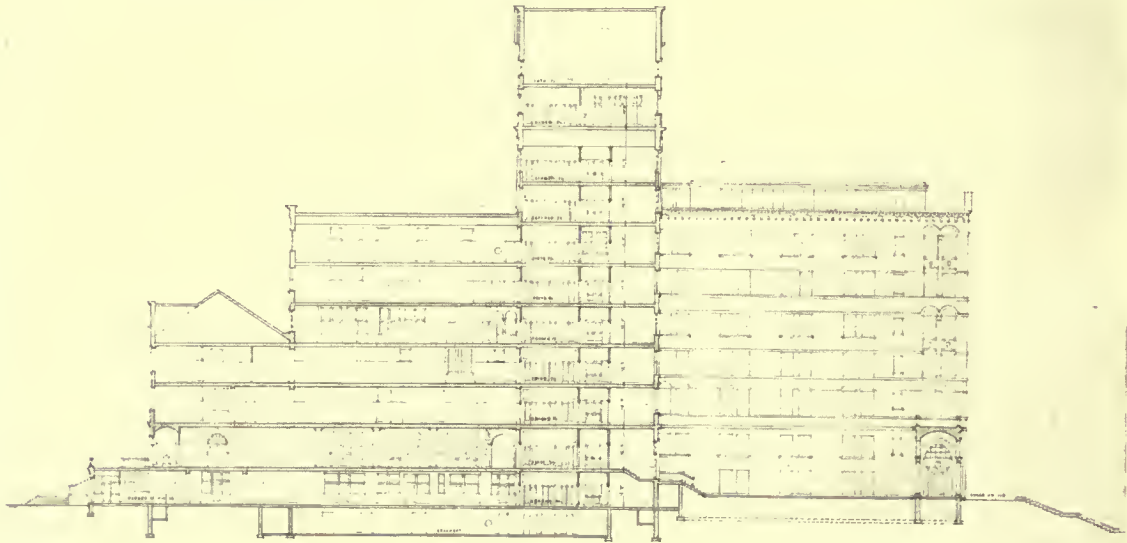

LONGITUDINAL SECTION, MAIN HOSPITAL BUILDING

The Housing Problem

(Continued from page 630)

business. Yet the banks seemed to have failed in realizing that fact, or, realizing it, they have overlooked it. They are not lending money upon real estate, or to the small home builder. They are putting that money out in call loans, or in industries where their money may be easily liquidated.

"By that they are working against themselves. They are promoting—directly or indirectly—a restless spirit among a great many persons, because the lack of a home or of a permanent residence is always productive of restlessness. It may be to the advantage of the bank at the present moment to put their money out on call loans or in other liquid loans, but it certainly will not be to their advantage ten or fifteen years from now, provided they do not alter their present viewpoint *now*, at this immediate moment. It is my firm belief that it is far better for a bank to put up with a financial loss, if necessary, rather than jeopardize the future, some ten or fifteen years from today, by neglecting to make conservative, constructive Americanization possible at the present moment. And the banks know that their very life and future depends not upon the man without a home, but on the man who owns his home. A very great percentage of investors and of bank deposits come from men who own their homes. There is no better incentive to thrift and conservatism than the ownership of one's own home."

"Are there any loan organizations which will still make loans upon real estates?" Mr. Day was asked.

"Very, very few," he said, "and among that small number is the Metropolitan Life Insurance Company. I am a director in that company, and I have faith enough in my belief in the value of the home as an instrument of Americanization to insist upon and heartily endorse that company's loans upon real estate, even at this unsettled period. One hundred \$5,000 loans were recently made by that company for 100 houses. I consider that as effective and direct a solution of the housing problem as there is."

"But does that remedy the financial situation as a whole?"

"No. For that purpose a committee of the real estate operators all over the country has proposed a law to our Federal Congress which would make mortgages on real estate tax-exempt up to \$40,000. That would be a splendid inducement, and would do a great deal toward the solution of the problem on a nation-wide scale."

"Has the lack of building any effect on land values?"

"That is precisely what has kept them down. And,

regardless of location or any of the other elements that enter into a land value, they will stay down until building is resumed. That works havoc with persons who have land and who wish to sell it. It deprives them of an effective means of raising money for legitimate business enterprises, and therefore adds to the already overstrained credit situation. The banks are forced to meet the heavy demands for credit, and the banks have, in a measure, caused that situation.

"If a just proportion of the financial resources of this country were taken from the call money market, from Government and railroad bonds, and from industries where loans are easily liquidated, and put into the hands of people who want to build, every business in the country would feel the beneficial effect of such a move, and radicalism would find itself put to in any attempt it might make to fasten itself upon any portion of our population."

IT is interesting to note that while the basic reasons for the present retardance of housing might be plainly discernible to trained observers, and there might accordingly be expected what would practically amount to a unanimity of sentiment, yet there actually exists a wide divergence of opinion.

With the intention of avoiding any attempt to discuss these many points of view and in order to permit the reader to draw his own conclusions, no analysis is attempted. Yet it may be permissible to direct attention to the fact that the present inability of those who desire to build houses to secure the necessary funds on a straight six per cent. basis, or the legal rate of interest, receives no attention from those interviewed by the representative of this journal, and it may therefore be that the "ultimate consumer" has been ignored in this investigation and that his side should be presented as well.

A careful canvas of the building field results in a firm impression that by no means will building costs be lowered in the future in larger proportion than costs of any other commodities. Further it appears to be a well grounded belief that there may not be expected for a number of years any appreciable diminution of costs even in the all important and dominating item of labor.

Further to postpone any proposed building operations would, therefore, only tend to increase the present unfortunate conditions as to housing, and invite a self denial that would bring no adequate return. This principle has been thoroughly discussed with those whose opinions as to what is retarding building are so much at variance, but who are so thoroughly agreed as to the futility of further postponing building in the hope of an early lowering of costs.

*Detail of Doorway, Old Town Hall,
Hartford, Conn.*

(See reproduction of the original drawing by O. R. Eggers in this issue.)

IN an earlier issue there was presented a general view of this fine old building. The accompanying detail is, however, so very good that Mr. Eggers has wisely considered it worthy of his pencil.

The doorways of the public buildings in New England that were erected during our Colonial period have become accepted as the most valuable precedents of correct proportion. Our readers will agree that the present example is worthy to be classed as a fine example of good proportion and correct design. It carries with it all the marks of long usage and bears the old hardware or a replica of the original, that adds a graceful simplicity to the whole effect.



DETAIL OF DOORWAY OLD TOWN HALL, HARTFORD, CONN.
THE AMERICAN ARCHITECT Series of Early American Architecture

642^a



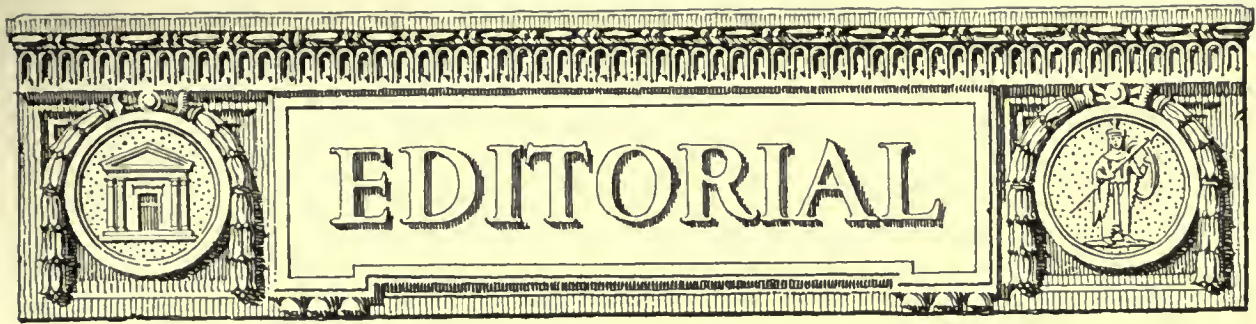

The American Specification Institute

IT is probable that few members of the profession will disagree with the statement that, considered broadly, the preparation of specifications receives less study and attention in proportion to its importance than any other phase of architectural or engineering practice. It is generally conceded that there is need for accurate, concise, yet comprehensive specifications in order to secure the best results from any set of plans. Yet to many architects and engineers the task of their preparation is onerous, and in order to produce a written document to accompany the drawings they sometimes even resort to the re-working of old specifications. It is usually discovered later that they do not accurately apply to the work in hand.

The dearth of good specification writers is also evidenced by the fact that those architects whose practice is sufficiently large to justify the employment of men to write specifications as their sole duty in the organization have experienced the greatest difficulty at times in securing men in whom they can repose entire confidence.

THE AMERICAN ARCHITECT has for years recognized the vast importance of specification writing, and has urged, editorially, improvement in this branch of architectural practice. It has advocated unceasingly the definite specification, the elimination of all ambiguous or meaningless clauses, and the qualification of the person undertaking the writing of specifications for the particular work in hand. As a further aid in this work THE AMERICAN ARCHITECT Specification Manual has been produced and distributed among architectural offices of this country to place before architects specifications covering the use of various materials and equipment, these specifications having had the approval of the manufacturers themselves.

There is, however, much more that can be done. The field is so large that what has already been accomplished is, in reality, simply a scratching of the surface. Unlike various branches of engineering, which have their text books, rules and formulæ, the art of specification writing has not been made the subject of concerted investigation. This is un-

doubtedly due, in part at least, to its very nature—that is, the necessity for treating each document as an individual problem, separate and distinct from all others. This has been the stumbling block to all attempts to produce standard specifications. Then, too, the extensive field that a specification must cover has seemed to preclude the production of anything comprehensive and appropriate under all conditions.

In our architectural schools, in the ateliers and in the various courses given, instruction in specification writing has been neglected to such an extent that those to whom the task of specification writing has fallen have usually been forced to educate themselves. As a natural sequence of this condition we find too many inaccurate and incomplete documents accompanying drawings under the guise of specifications.

It is true that the means for proper education are at the disposal of practically every architect or specification writer located in the larger cities—if he knows how and where to look for the necessary information—but the great amount of time that it has been necessary to spend in research in order to secure and properly arrange the data sought for apparently has proven too great a barrier for the majority of specification writers to surmount.

It is because of these conditions that THE AMERICAN ARCHITECT notes with the greatest satisfaction the initiation of a movement to organize *The American Specification Institute* along the lines of the National Professional Societies. As outlined to this journal, its members would be those who spend all, or a considerable portion of, their time in specification work, and its patrons would be those architects who earnestly desire the elevation of specifications to their proper place and importance in professional practice, and their general improvement in character.

It is obvious that *The American Specification Institute* should have as its fundamental purpose the education of its membership so as to assure better and more uniform specifications, the dissemination of information relating to the production of raw materials, their manufacture or fabrication into finished products, and how, when and where to use the different materials. When the specification writer has acquired a thorough understanding of the materials and equip-

THE AMERICAN ARCHITECT

ment described and called for in his specifications he will be able to write more intelligently and produce a document that will furnish protection alike to the client, the architect, the builder and the manufacturer.

THE AMERICAN ARCHITECT believes that in the formation of such a body as *The American Specification Institute* and its active support by architects who realize the utter necessity for the best specifications it is humanly possible to produce may lie the solution of the question that has been such a burden in construction work.

In order to foster the movement and provide a channel for the dissemination of news, information and reports THE AMERICAN ARCHITECT will gladly open its columns to the *Specification Institute* and devote the necessary space in each issue for the reporting of its activities.

There seems little doubt that the *Specification Institute*, if wisely formed and managed, will rapidly gain an enthusiastic membership, and it would seem that it might confidently anticipate equally enthusiastic support from the architectural and engineering professions. Now, during the formative stage, is the time for those interested in this subject to give expression to their opinions, and THE AMERICAN ARCHITECT will take pleasure in publishing comment on this subject, believing that those engaged in the formation of this new body of professional workers will welcome constructive suggestions.

Architectural Competitions

IS the method of the Institute in its conduct of competitions suited to present day practice of architecture?

On page 158 of the published proceedings of the Institute's Fifty-third Annual Convention, it is stated that one chapter reported to the Committee on Competitions that the representative of a large corporation refused to adopt the advice of the chapter's subcommittee regarding a competition which the corporation proposed to establish, and stated publicly in a meeting of engineers that "the American Institute of Architects is fifty years behind the times."

It needs no argument to prove that if competitions are to be as their name implies, a contest among architects for a specific commission, they must be conducted in an absolutely businesslike manner. In this direction the importance of the architect's business training, as shown in his representative organization, becomes at once apparent. The prime purpose of a competition is not only the evolverment of some beautiful features of design expressed in all the artistic dexterity of renderings and cleverly executed drawings of plans, but it is logically the creation of a building that will also have every element of adaptability for the purpose for which it is created.

Probably architects will need to spend more time and harder study on the latter feature, the purely utilitarian elements. And the introduction of these elements will naturally require a very thorough business attitude on the part of architects. That architects do not always present this attitude as in the case above referred to, and that the correct business approach had presumably been lacking in many other instances, undoubtedly caused the harsh criticism which was made by the manager of this large corporation.

Owners undoubtedly have rights in matters of competition, and these the present code does not always carefully consider. The proposal of the Boston Chapter to the last convention to insert in the competition circular the statement that the Institute recognize the right of an owner to employ several architects at the same time on the same problem and to pay them for their services without the use of a program and without declaring such an arrangement a competition, was warmly debated at that session. It was referred to the various chapters, who were directed to send to the Board of Directors a digest of opinion, so that the next convention might take action.

In view of the widespread dissatisfaction expressed as to some recent competitions, it would seem to be highly desirable that this digest of opinion be promptly and clearly set forth. Members of the profession who regard competitions with favor, and others who do not, should provide suggestions that would enable the Committee on Competitions to frame and present to the next convention a new competition program that would be so modern and so businesslike in all its aspects as for all time to make untruthful the assertion that the Institute's methods in conducting competitions are not progressive and up-to-date.

There has been strong opposition in the Institute to competitions for a number of years. This opposition has in a measure been overcome by the contention of those who warmly support competitions that the requirement of a comprehensive report by the Jury provided a feature of great educational value to the competitors and other architects who would study the results.

Besides presenting documentary evidence of an equitable adjudication in strict accordance with the terms of the program and giving assurance that nothing but the purely artistic aspect had been considered, the report of a Jury begets confidence and silences all the many murmurs of discontent that are the inevitable consequence when the Jury has failed in this direction. Further, it has been asked if the failure of a Jury to make such a report would not establish a basis on which to begin action to set aside its decision.

THE AMERICAN ARCHITECT

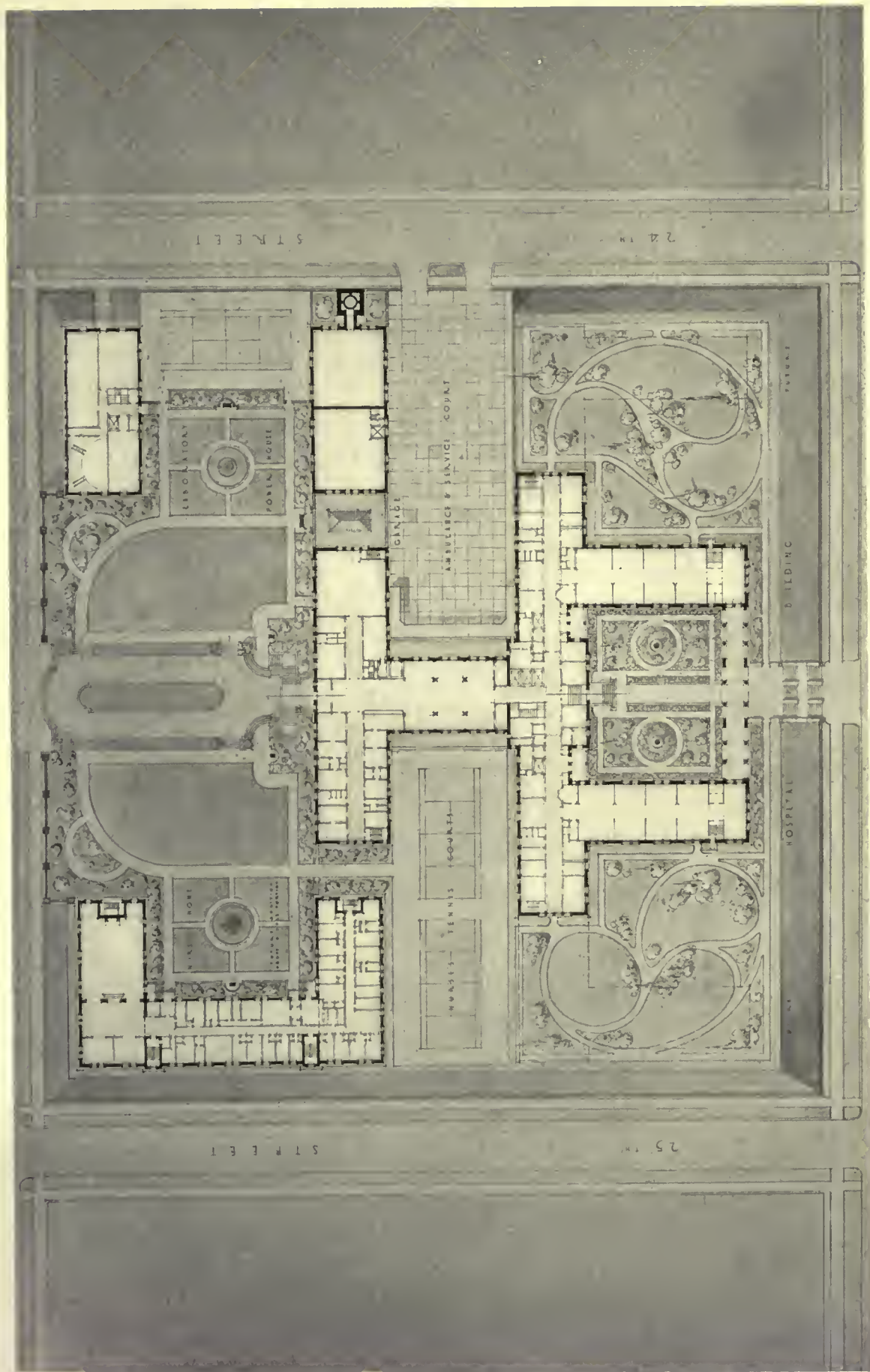

PLOT PLAN

AWARDED SECOND PRIZE, COMPETITION FOR MILWAUKEE COUNTY GENERAL HOSPITAL
 RICHARD E. SCHMIDT, GARDEN & MARTIN, ARCHITECTS

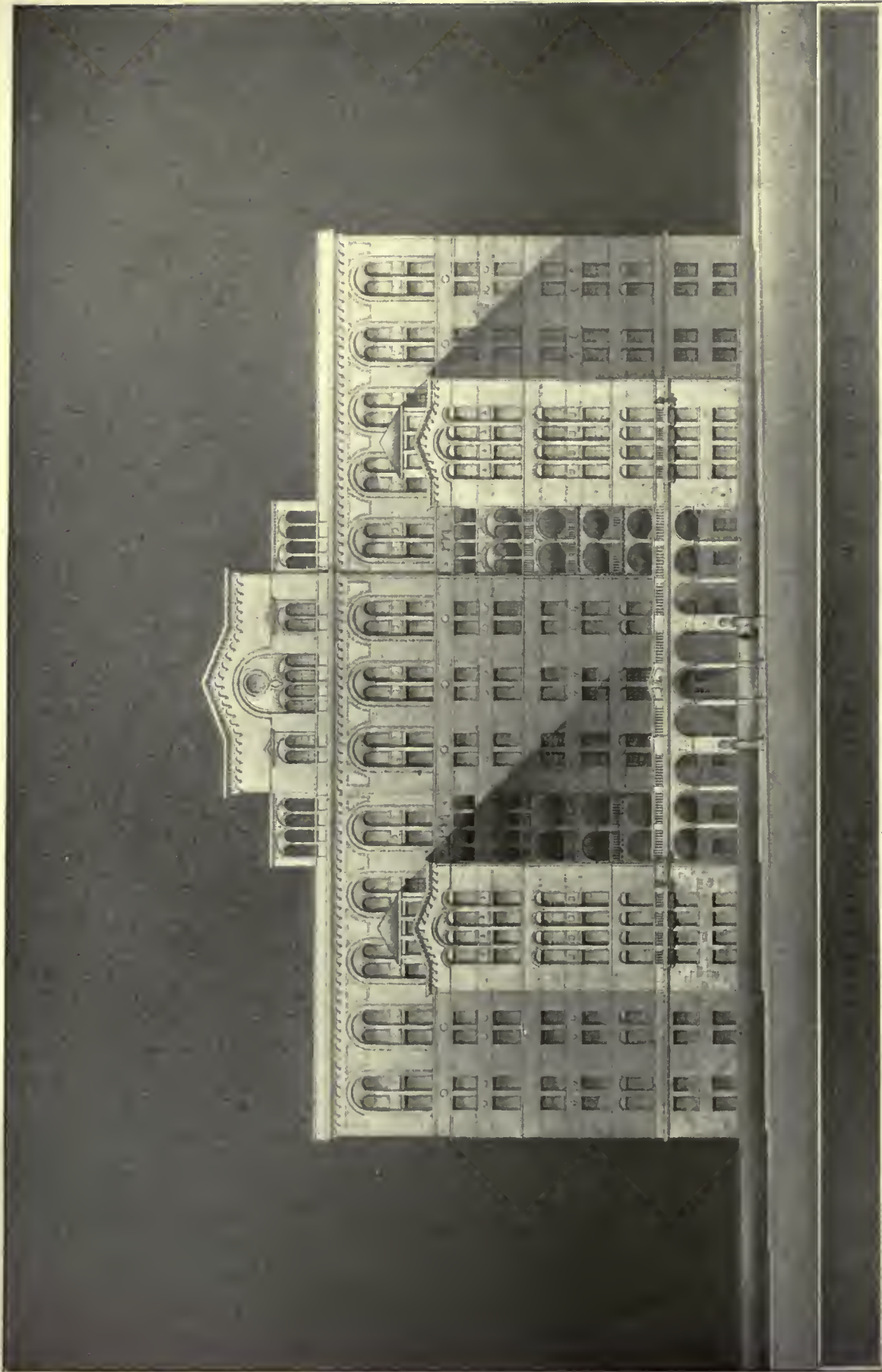

GRAND AVENUE ELEVATION, MAIN HOSPITAL BUILDING
AWARDED SECOND PRIZE, COMPETITION FOR MILWAUKEE COUNTY GENERAL HOSPITAL
RICHARD E. SCHMIDT, GARDEN & MARTIN, ARCHITECTS

6442

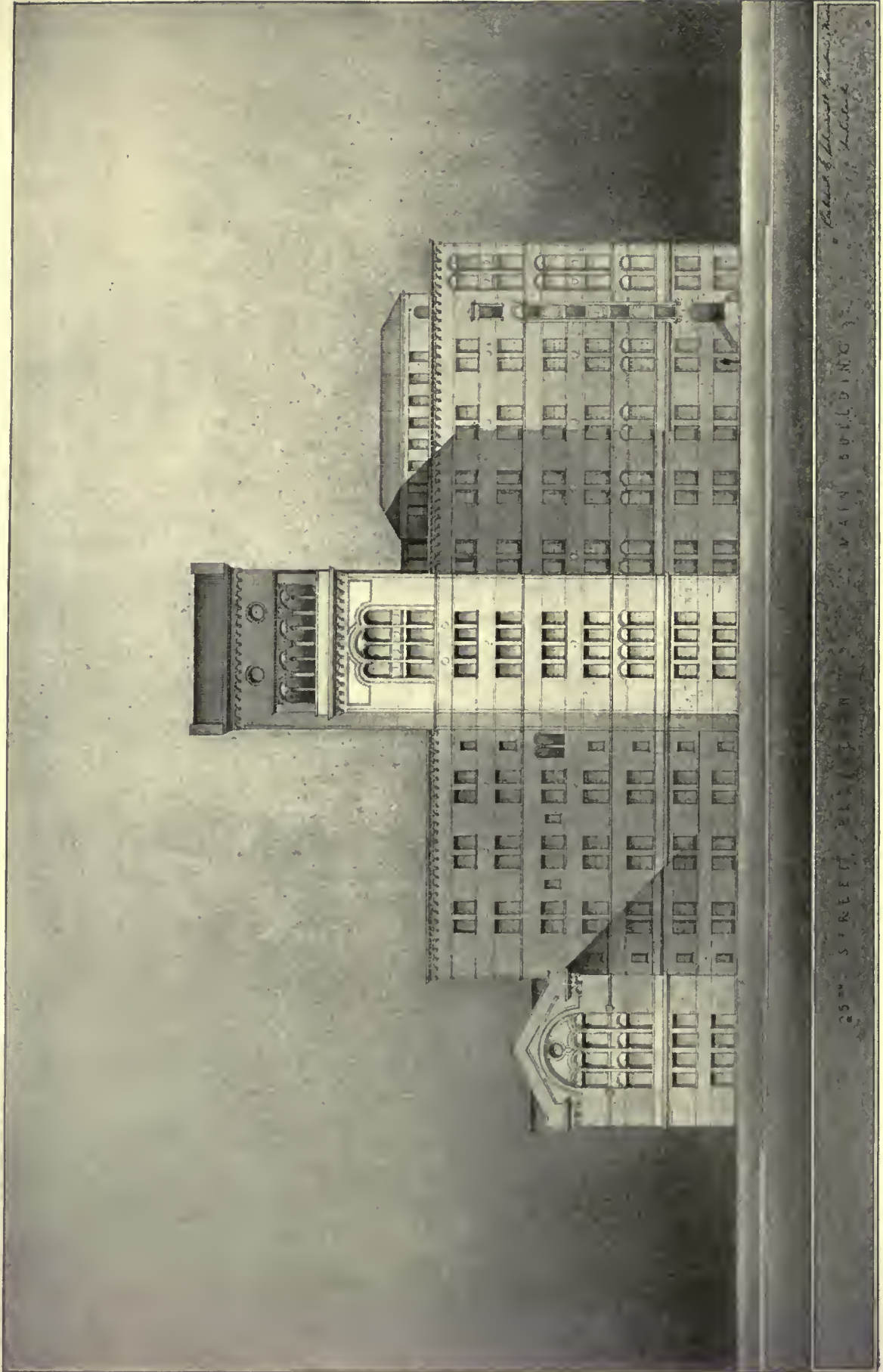

25th STREET ELEVATION MAIN BUILDING
 Robert G. Howard, Architect

TWENTY-FIFTH STREET ELEVATION, MAIN HOSPITAL BUILDING
 AWARDED SECOND PRIZE, COMPETITION FOR MILWAUKEE COUNTY GENERAL HOSPITAL
 RICHARD E. SCHMIDT, GARDEN & MARTIN, ARCHITECTS

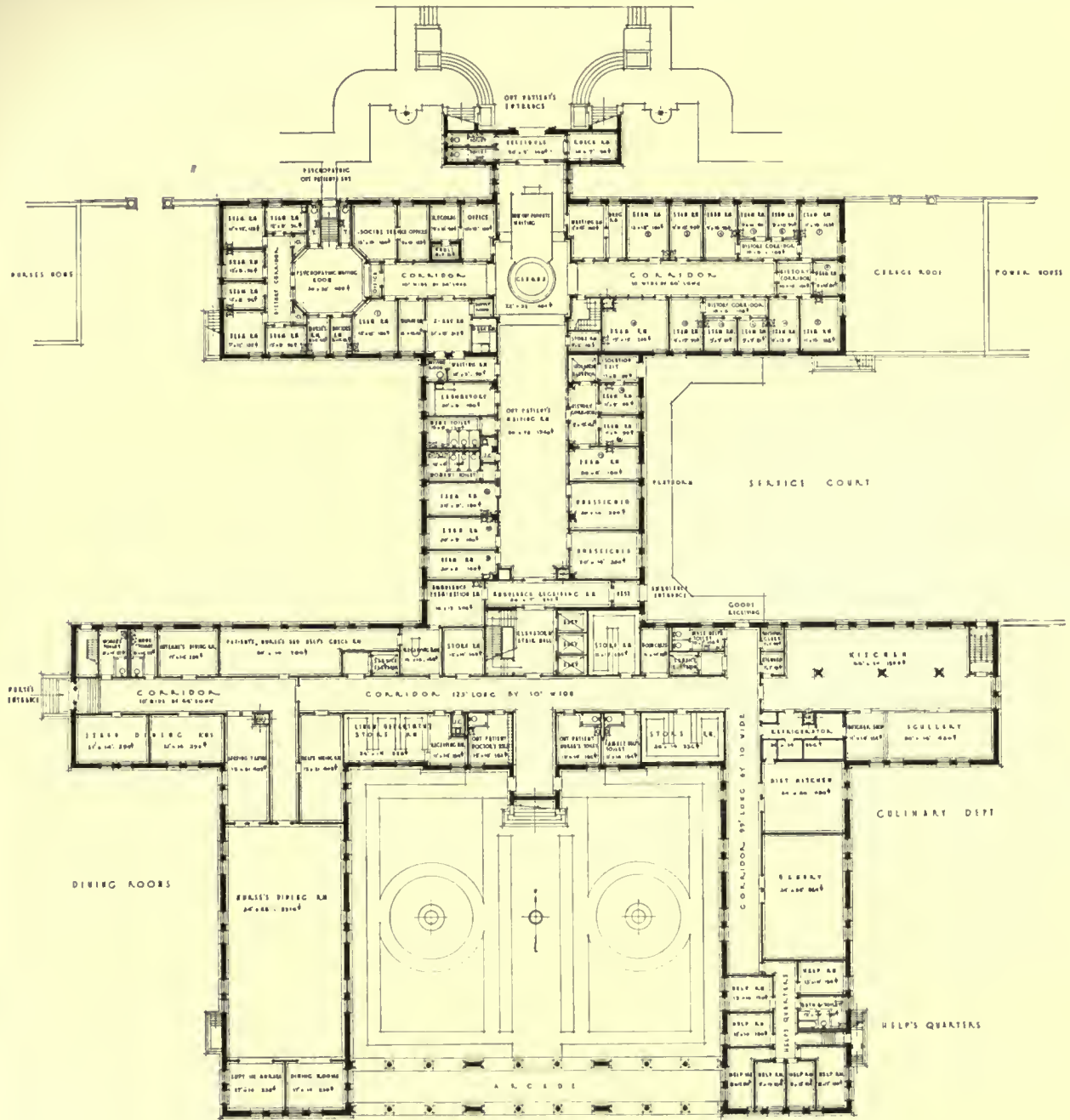

GROUND FLOOR PLAN, MAIN HOSPITAL BUILDING

AWARDED SECOND PRIZE, COMPETITION FOR MILWAUKEE COUNTY GENERAL HOSPITAL

RICHARD E. SCHMIDT, GARDEN & MARTIN, ARCHITECTS

644⁴

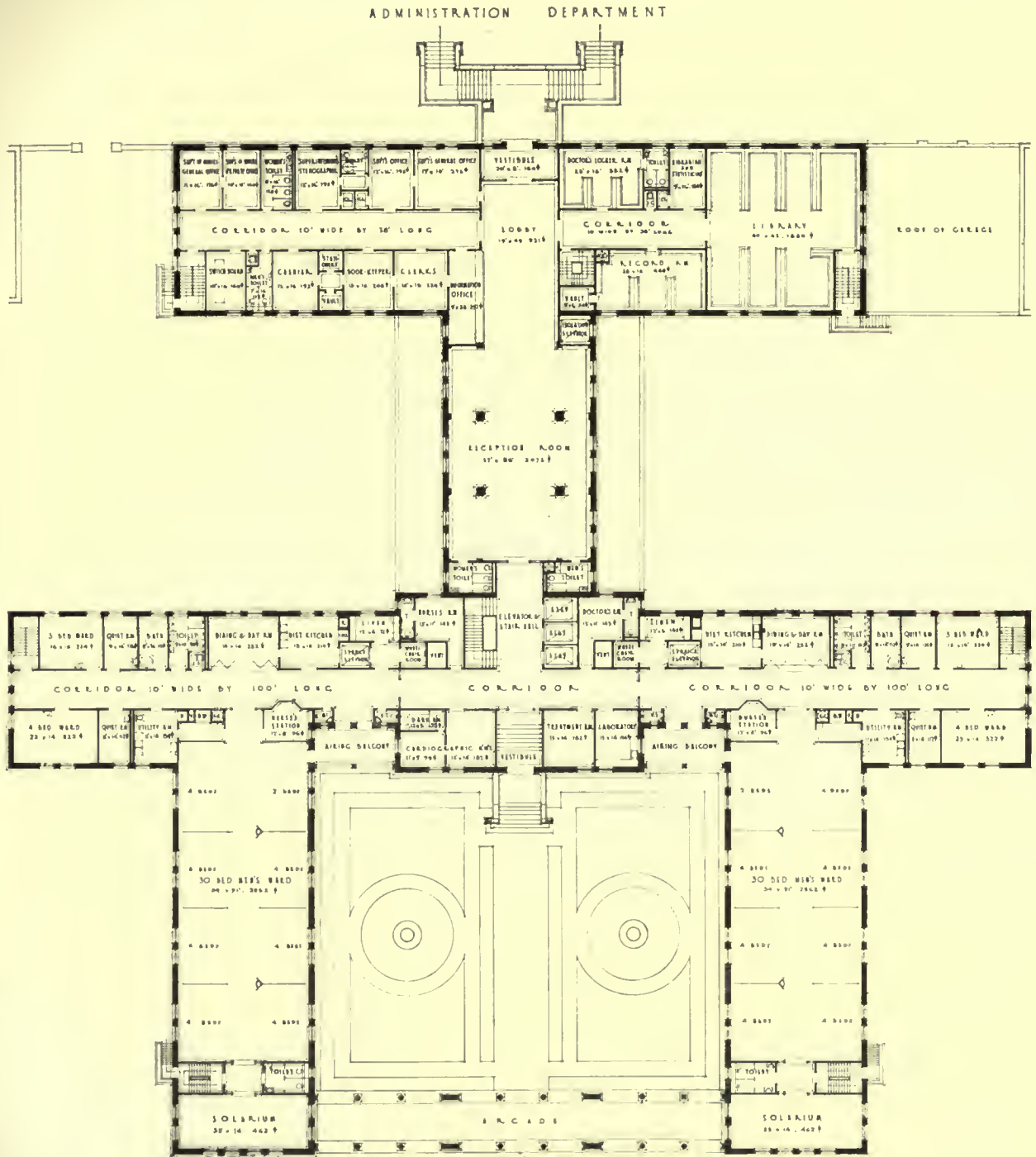

FIRST FLOOR PLAN, MAIN HOSPITAL BUILDING
 AWARDED SECOND PRIZE, COMPETITION FOR MILWAUKEE COUNTY GENERAL HOSPITAL
 RICHARD E. SCHMIDT, GARDEN & MARTIN, ARCHITECTS

644^s

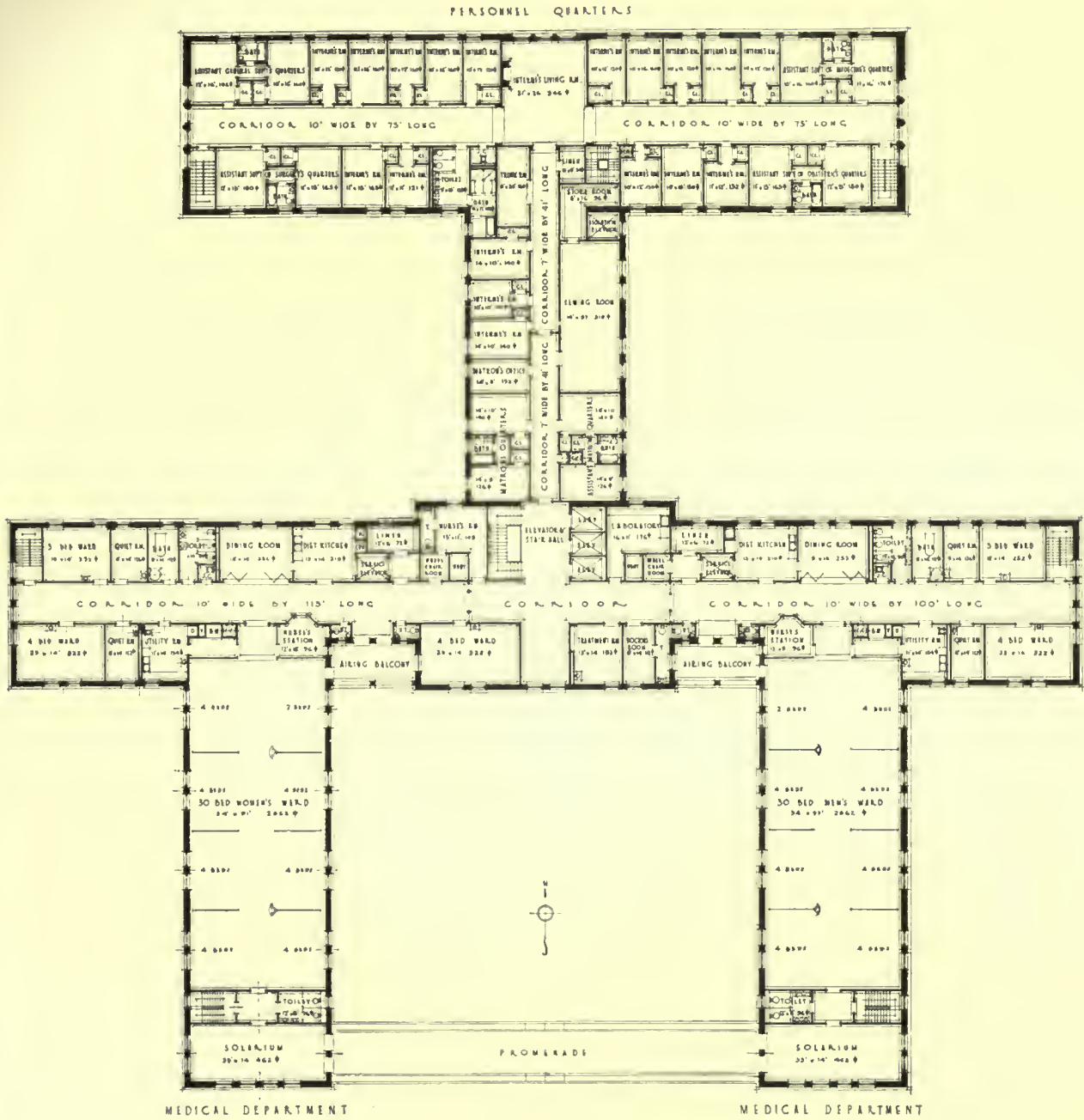

MEDICAL DEPARTMENT AND PERSONNEL QUARTERS

SECOND FLOOR PLAN, MAIN HOSPITAL BUILDING

AWARDED SECOND PRIZE, COMPETITION FOR MILWAUKEE COUNTY GENERAL HOSPITAL

RICHARD E. SCHMIDT, GARDEN & MARTIN, ARCHITECTS

644⁶

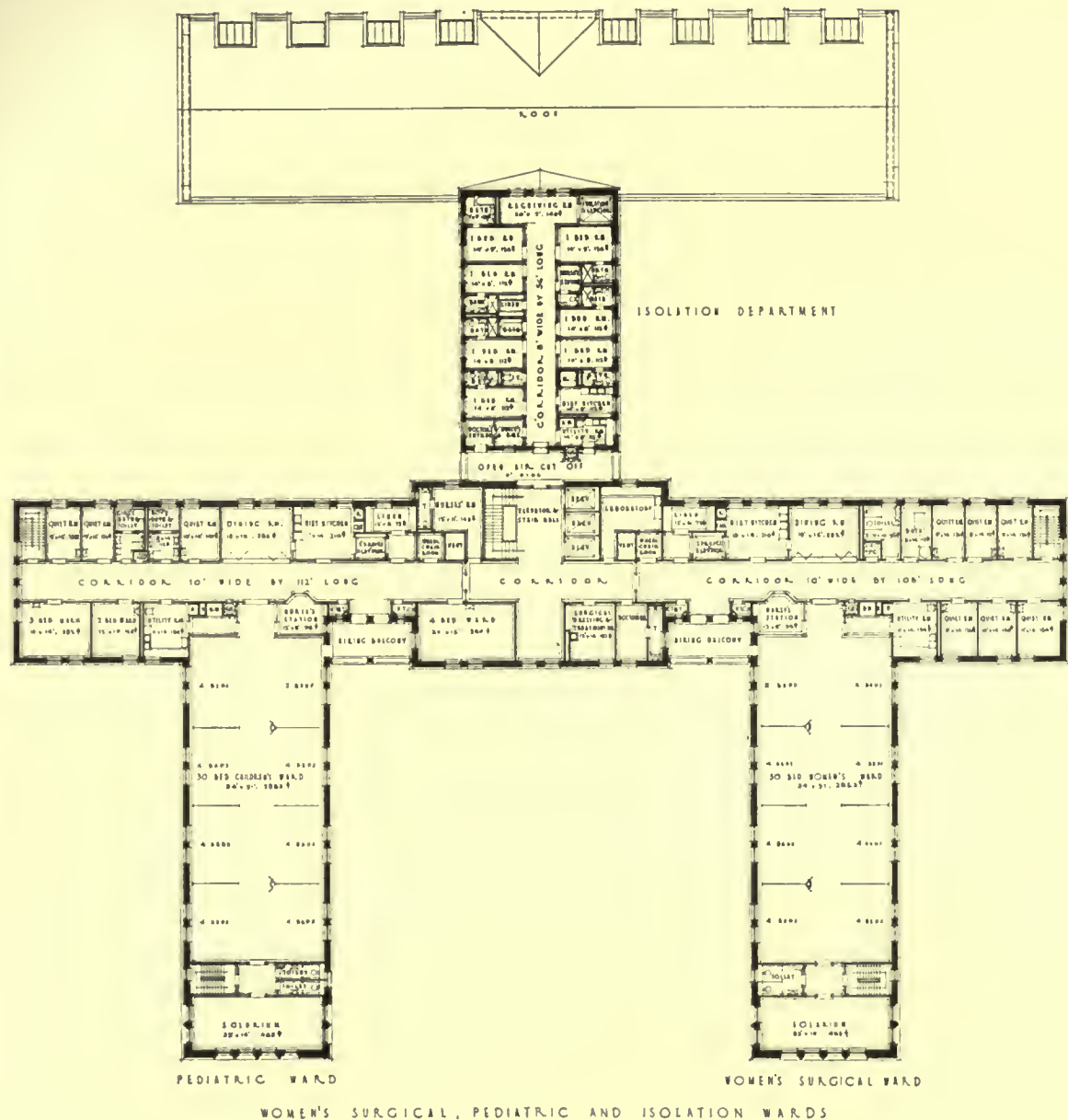

FOURTH FLOOR PLAN, MAIN HOSPITAL BUILDING
 AWARDED SECOND PRIZE, COMPETITION FOR MILWAUKEE COUNTY GENERAL HOSPITAL
 RICHARD E. SCHMIDT, GARDEN & MARTIN, ARCHITECTS

644⁸

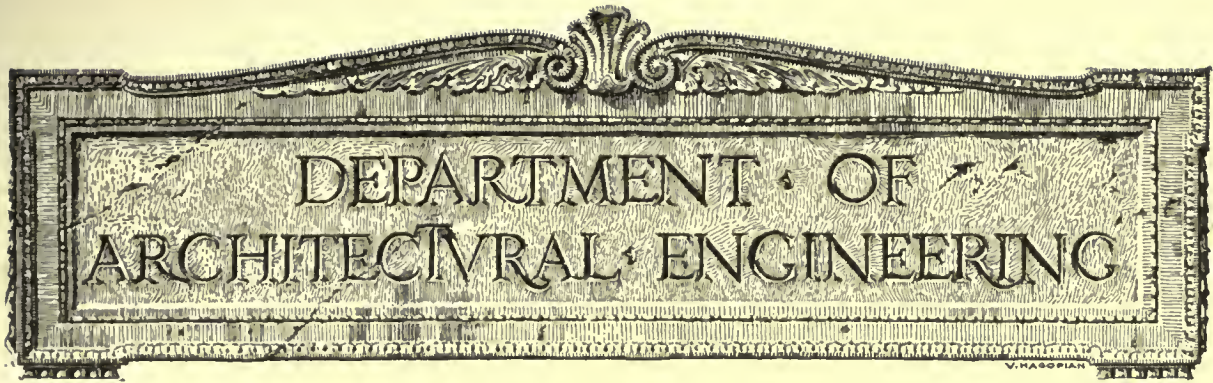

The Artificial Illumination of Motion Picture Theatres

Present Abuses and Suggested Improvements

Part I

THE growth of the motion picture industry has been phenomenal. This growth is evidenced by the continued increase of motion picture theatres. Contrasting the "movie" of ten or fifteen years ago with that of today, no one will deny that a vast improvement has been made. There is one phase, however, which it would seem still requires much improvement. This is the subject of artificial illumination. It is the purpose of this and the following article to point out some of the present defects, as well as methods whereby they may be corrected.

Perhaps no one person is more familiar with the motion picture theatre as it exists throughout the entire country than Mr. E. L. Bragdon, Technical Editor of *Motion Picture News*. In an address before the Illuminating Engineering Society, as relating to the need of improvement in the artificial illumination of motion pictures, he stated in part:

"The theatrical or exhibiting end is the phase of the film business that comes nearest to the public. If ever any part of an industry needed expert aid, it is the exhibiting end.

"There are really two fields in the theatre to be considered, that of auditorium illumination, and of projection.

"There are approximately 14,000 theatres in this country devoted to the motion picture. This number includes the 'Palace of the Cinema' in the big city as well as the once-a-week-on-Saturday-night show given in the 'Grange Hall' in some Wyoming cattle town. It is interesting to note that of the 14,000 theatres, over 65 per cent. or nearly 10,000

theatres have a seating capacity of 600 or less. This fact has been ascertained through research and records.

"Six hundred seats, mean the community house attended by the general public. It is the place where public opinion regarding motion pictures is formed and for that reason this size of theatre is a good one to keep an eye on. It is also well to give the patrons of these houses the best available insofar as possible, and that is what they are not getting as regards illumination.

"The illumination in these small theatres is, as a rule, *exceedingly poor*. Designed in most cases by a local architect, or more probably a contractor, the theatre is built and then the lighting scheme added as an accessory, much as a theatre manager goes out and buys his seats. A study of interiors of the average small theatre will often show that in one spot on the ceiling where an indirect fixture should have gone the decorator has thoughtlessly placed a beautiful figure of some dryad disporting herself. Naturally a lighting fixture must go elsewhere. According to practice, the decoration comes first. I don't know exactly why, because the patrons attend the theatres (at least after its opening night) to see the pictures and not to sit back and dream about the allegorical figures on the walls and ceilings. I do not advocate the abolishment of decorations, they have a place of their own in theatres, but I do decrie the placing of decoration before illumination for reasons which will be referred to later on.

"You may also have noticed the persistency with which candelabra brackets are placed in every panel

THE AMERICAN ARCHITECT

on the side walls. Invariably these shine directly into the faces of those in the balcony with serious effects on the vision. Why this is done, I do not know. The most plausible answer seems *imitation*.

"In general the theatres today are too well or too poorly lighted. This may sound like an aphorism but it is a fact nevertheless. It is rather strange, too, when you consider how simple it would be to travel the broad middle path of just about enough light.

"Going back into the history of the industry it appears that the first motion picture exhibition was held in a store. When the audience had been enticed

to sleep in the middle of the picture, claiming that his eyes ached. It was easy to understand why.

"To show the other side of the question the accompanying picture illustrates what happens when a motion picture theatre is built for beauty and not for motion pictures. The photograph was sent by a theatre manager who wished to show me what wonderful illumination he had in his theatre. I will let you judge for yourself.

"It is possible that an electrical contractor *might* have put in a few more fixtures but I firmly believe there must be a hidden beam or a ventilating duct in the spaces which are bare of lamps.



OVERDOING THE LIGHTING OF A MOTION PICTURE THEATRE

into the place the lights were turned out and the room made pitch dark. Then the show started.

"This method of handling the illumination of the auditorium should have disappeared early. But it did not. Only last week I happened to enter one of Broadway's leading theatres and was greeted by as dense an atmosphere as one could wish. I stumbled over a floor ornament just inside the door and finally had to be led to a seat by a torch bearing Aurora. The absence of light in that theatre was positively painful. Broadway screens are lighted to a minimum from the projection arc and the contrast between the screen surface and the surrounding areas was exceedingly vivid. My companion went

"Seriously, the lighting of theatres is a real problem. It has been overlooked in the past. As a result the optometrists or the opticians are using the motion picture as an argument for the wearing of spectacles. This should not be. Moreover, it must not be for the good of the industry.

"Without going into the preliminaries of the separate factors, the fundamentals of theatre illumination are as follows:

1. Keep as much light as possible away from the screen surface.
2. Present as little contrast as possible to eyes of the audience when viewing the picture.

THE AMERICAN ARCHITECT

3. Make the transition from afternoon sunlight or evening "white way" lighting to the viewing position as gradual as possible.

"A casual study of these broad principles will show that the perfect theatre whenever it is built, will have considerable illumination at the rear, decreasing gradually as one walks toward the front of the house. The light will be reflected chiefly from walls and ceilings with a minimum of direct illumination, and all the light must be so directed that the shadows of the screen are not veiled. This seems rather difficult, but it can be done, and will be done as soon as architects and builders realize the value of correct illumination.

"This means that the present brilliant music stand lights of the orchestra will have to be moderated. Several ways of doing away with the evil of the orchestra light have been suggested, but none is conspicuous by its practicability. One man has even suggested the printing of the music score in radium ink on black paper, but his suggestion was not considered as of much worth.

"I could go on in this manner for many minutes relating the abuses of illumination in the average theatre, but the narrative would tire you. When all the facts are sifted to their essentials it is found that the whole problem is one of co-operation between architect and illuminating engineer.

"A few words concerning the projection end of the theatre work are in order. This, of course, is also a problem of illumination. The problem is to get a steady and easily controlled, concentrated source of light, of high brilliancy, and to pass through the standard optical system as high a percentage of light as possible. To give you an idea of the troubles encountered in the projector of today consider these figures of 100 per cent. of light at the source:

25 per cent. reaches the condenser lenses,

80 per cent. of that reaches the film,

75 per cent. of that reaches the shutter,

and for good measure the shutter borrows 50 per cent. of that. Thus, only four-fifths of one per cent. of the original light reaches the screen. There are too many middlemen and each is a profiteer.

"The illuminating engineer is needed badly here but the field is a special one in optics and will demand a great deal of work before much is accomplished. What forms these improvements will take would be but a surmise.

The incandescent lamp is a wonderful possibility. I have always had faith in it and feel surer of myself at this moment than ever before. It will not supplant the arc; each has its field and they are both big fields, worth cultivating in the right way.

"In closing, I would like to emphasize the fact

that, of the whole industry, the greatest need for the illuminating engineer, his theories and his experience, lies in the field of theatre illumination. As now carried out it is unsatisfactory and something should be done at once to correct the evil. On my desk I have a card index of new theatres upon which building has begun since the first of the year. Probably there are 600 of them and it is fairly safe to say that of these 600, 550 will be lighted the same old way without thought on the part of the owner and architect. Eventually it is to be hoped that the combination of illuminating engineer and architect will solve the whole problem."

The statements made in this address by Mr. Bragdon may not be lightly waived aside. They are serious. In the early development of this class of structure, there may have been a legitimate excuse for poor lighting, but today, with information available on the subject, no architect can honestly excuse himself for being a party to the continuance of improper lighting.

In the next article the results of tests made to determine the proper light intensities in various parts of the motion picture theatre, and suggested methods of properly placing the sources of light will be presented.

Engineers Discuss Transportation

AT a meeting of the New York Section of the American Society of Civil Engineers held at the Engineering Societies Building, 29 West Thirty-ninth street, October 13, the topic, "Local Distribution of Freight and Food Products," was discussed.

The principal paper upon this subject was presented by Colonel Charles D. Hine of the old 69th Regiment, now special agent, Erie Railroad at New York. Colonel F. A. Molitor, of the 22d Engineers who holds the position of operating head of the Citizens' Transportation Committee, also presented a paper dealing with this subject.

The Merchants' Association was represented by Mr. W. H. Connell, assistant manager of the Traffic Bureau, who traced the events leading up to the appointment of the New York-New Jersey Port Terminal Commission, the efforts of the Merchants' Association to inaugurate store-door delivery, and various rules, regulations and practices adopted by the carriers in an effort to eliminate waste in transporting goods to, from and through New York.

Other men, who have devoted considerable study to this matter, discussed the subject in its several phases.

The meeting was one of the most interesting held in some time, and was well attended. The New York Section has arranged a program for the coming season, which includes a number of other local problems of equal interest.

The Insulating Value of Various Coverings for Hot Air Pipes as Determined by Tests at the University of Illinois

THE coal question, a serious one during the war, is yet with us, and as acute, if not more so, than in 1917. When we consider that only a little over one-half of the heat value contained in the coal is utilized by present methods of heating, it becomes increasingly important to stop the leaks wherever they may be found and are capable of stoppage. A great quantity of coal is annually consumed for domestic heating purposes, therefore, the more efficient such heating installations are made, the further will a ton of coal go. Conservation of coal is most desirable. Previous wasteful methods should be corrected. In this connection, therefore, it is interesting to note the results of tests as presented in a report issued by the Engineering Experiment Station, University of Illinois on the "Emissivity of Heat from Various Surfaces," this report having special reference to warm air furnace installations. The report is made by V. S. Day, research Assistant, and acknowledgment is made of the valuable assistance of Professors A. C. Willard and A. P. Kratz.

The work reported upon was done in connection with the Warm Air Furnace Investigation now in progress at the University of Illinois. This investigation has for its object the determination of the efficiencies and capacities of warm air furnaces and a study of the proper conditions of installation and operation, so that furnaces may be accurately rated and properly selected for the requirements of actual service. The work is being conducted under a co-operative agreement between the National Warm Air Heating and Ventilating Association and the Engineering Experiment Station of the University of Illinois.

TESTING EQUIPMENT.

The apparatus used in the tests, illustrated in Figs. 1 and 2, consisted of low pressure steam heated drums, five in number, surrounding a central steam header from which the drums drew their supply of steam. The drums were accurately uniform in size, ten inches in diameter by twenty inches in length and were made of sheet metal of the kind to be tested. Steam was condensed in the drums by the cooling action of the air surrounding them and was discharged through water seals connected to each drum. These seals were U-tubes made of pipe, and were long enough to contain a water head of four feet. As the steam condensed the seals became filled

with water; the condensate then dripped over into receivers as fast as it accumulated. The water in the seals cooled to room temperature before it dripped into the receivers so that evaporation was not influenced by the heat of the water in the receivers. Each receiver was mounted on a small weighing scales accurate to one one-hundredth pound.

A mercury manometer was used to obtain the pressure of the steam in the central header, and since the temperature of the steam for any known pressure may be taken directly from steam tables, it was possible to determine the temperature of the medium within the drum with great accuracy. A pressure regulator in the steam supply line held the pressure constant within a small fraction of a pound, about 0.2 pound being the variation during a test; as the temperature change for the pressure variation was negligible, the temperatures were uniform and accurate within one degree.

No thermometers were required for determining the steam temperature, but one was used in each drum at the point of outlet of the condensate to detect the presence of air in the drums. The readings of these thermometers decreased upon the formation of air pockets in the lower part of the drums or in the connected piping. Air could be blown out of small petcocks located near the thermometers in the piping. No effects on the coefficients were noticeable when steam was allowed to escape for short periods from these petcocks, which could therefore be opened during a test to discharge any small accumulation of air.

The drums were shielded from radiation from each other by blackened compo-board partitions. These partitions did not in any way interfere with the flow of natural air currents. The temperature of the air was measured by thermometers suspended at the elevation of the drums at convenient positions nearby. The thermometers were not affected by radiation from the drums.

Thus, the actual measurements involved were simple and were not liable to serious error. These measurements consisted of the weighing of the steam condensed, the reading of the pressure of the steam, and the reading of the room air temperature.

THE TESTS.

The tests, totaling forty in number, with four drums under steam in each test, were carried out at

night when the doors and windows of the large laboratory were closed. No air currents were noticeable near the apparatus. A period of ten hours was chosen for the duration of a test as that time was sufficient to permit accumulations of condensate great enough to render negligible the slight error in weighing.

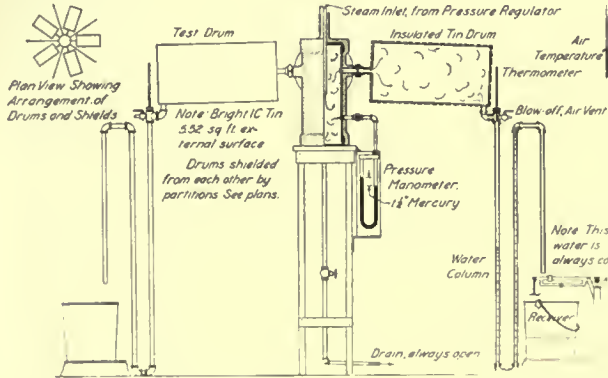

FIG. 1. SECTIONAL ELEVATION OF STEAM DRUM PLANT FOR TESTING SURFACES FOR HEAT EMISSIVITY

The drums were tested in different positions around the steam header in order to compensate for any irregularity in the flow of steam to the drums or in the currents of air about the drums. As no irregularities were noticeable in the values of the coefficients of emissivity for the various positions, the practice was abandoned after the first four drums were tested in the interchanged positions.

One drum, of bright tin not insulated, was in operation in all tests. Its performance served as an indication of any lack of uniformity in the conditions existing throughout the tests.

RESULTS OF THE TESTS.

The significance of the tests will be best understood by a study of the information presented in the diagrammatic chart, Fig. 4. The heavy black bars afford a graphic comparison of the heat emitting value of the various surfaces. Reference must be made to the descriptive list of drums in order to connect the data with particular test specimens. The relative efficiencies of the various surfaces as heat insulators are given in the next to the last column of the chart. The coefficient for bright IC tin was used as the basis for this comparison.

The first result of importance is the convincing evidence which the tests present as an argument against the use of thin layers of asbestos paper covering on bright tin pipes. The heat lost was 39 per cent. greater with one thickness of the paper than without. Such a loss is of no small degree of importance as calculations will show that it results in a waste of 5 per cent. or more of the coal consumed in the average house furnace.

The fact that the heat loss from the warm-air pipes of a furnace system is of some consequence is not appreciated generally. A considerable part of the heat of the air flowing through the pipes of the average installation is dissipated from the pipe surface to the surrounding air and nearby objects.

The significance of these preliminary tests is to bring out the fact that the heat loss from warm-air furnace pipes is a serious item. In the case of asbestos paper-covered pipes, the loss amounts to about 23 per cent. of the heat of the air at the bonnet, above inlet air temperature. If the pipe is of bright tin and not covered, this loss is reduced to about 17 per cent. of the heat available. In either case the loss is great; and with the further consideration that a warm-air furnace under average conditions of installation is, at best, only about 60 per cent. efficient, it will be understood that the actual waste of coal ascribable to poor heat pipe insulation is enough to warrant attention.

The attempt was made in the steam drum tests to determine the effect upon the heat loss of having the drum partly enclosed so that free circulation of the air about the drum would be prevented. The experiment simulated the effect of running leader pipes



FIG. 2. PHOTOGRAPH SHOWING THE PRINCIPAL OPERATIVE FEATURES OF THE STEAM DRUM PLANT

between joists. The results of these tests as shown in No. 14 and No. 14a indicated a slight decrease in the value of K for the enclosed drum.

The argument has been advanced that if bright

tin pipes were used without covering, they would soon become fouled with dirt and dust and so rendered less efficient heat carriers than asbestos paper covered pipes. The fallacy of this argument is revealed by tests No. 1a and No. 16a. In these tests fine ash dust was sifted on the test drums, one of bare bright tin and the other asbestos paper covered. The dust was more than one-sixteenth inch deep on top of the drums. The results as shown in tests No. 1a and No. 16a of the chart indicate that the bare tin suffered a loss of 11 per cent. in efficiency whereas the asbestos paper surface improved

binations Nos. 3 and 6 are excellent insulators, are easy to fit to basement leaders, are not expensive, and the latter, in particular, is not bulky.

The double wall tin pipes Nos. 10 and 12 are very efficient insulators and are easy to construct and to install. Other tests are in progress which are expected to establish still further the merits of this type.

The tests on galvanized iron specimens brought out the fact that the heat loss through this material is not greater than through bright tin of the same gage. This low heat radiating property is an argument in favor of the galvanized iron leader pipe Nos. 18 and 21 are good insulations for the exterior of furnace casings, the heat loss through the latter being almost negligible. No. 21 is very easily applied.

The tests on drum No. 11 were made to determine the effect of transparent applications on the tin surface. Bakelite lacquer was used. The result was a slight increase in the heat loss. It was thought that the use of the lacquer would be justified in practice by its rust preventing qualities, but specimens exposed to steam laden air for long periods show no advantage for the protective coating.

Tests Nos. 20 and 23 were made for the purpose of ascertaining the effect of color upon the heat radiating value of a surface. Applications of white calcimine were made on a drum which was tested; then a coat of dull black calcimine was added and the drum re-tested; a final coating of white calcimine was applied and the drum again tested. The alternate tests with white calcimine checked very closely proving that the additional thickness of the calcimine was not sufficient to have any bearing on the results. Beyond demonstrating the superior radiating value of a dark surface, the tests have little significance.

Specimens Nos. 4 and 5 demonstrated the uneconomical effect due to increased heat loss of any kind of oil paint applications on heat pipes. A comparison of Nos. 1 and 4 will show the enormous increase in heat loss caused by painting bright tin heat pipes, and a comparison of Nos. 2 and 5 will show the similar wasteful effect of painting over the asbestos paper covering. However, the use of paint on asbestos paper has in its favor the moisture-proofing effect of the paint.

Other information of value may be found in the data given in the table. To use these data for the determination of the approximate heat loss from a heat pipe, it is only necessary to multiply the value of K for the surface by the surface area of the pipe exposed and further multiply by the difference in temperature between the air inside and outside the pipe, or:

$$\text{B.t.u. loss per hour} = K \times \text{Area in sq. ft.} \times (t_1 - t_a)$$

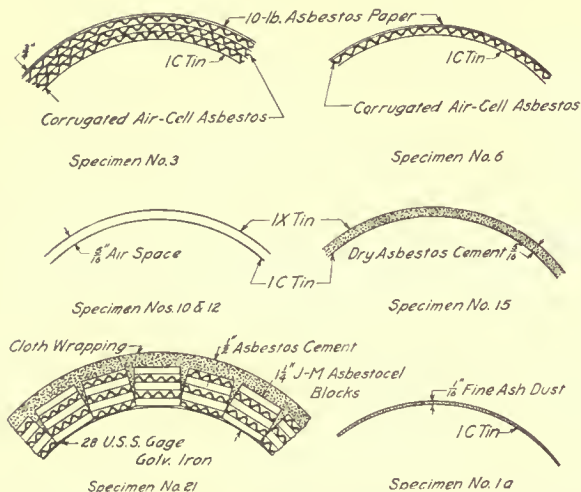

FIG. 3. SECTIONS SHOWING CONSTRUCTION OF SOME OF THE COMPLEX SURFACE COVERINGS

2.4 per cent. There still remained, however, a difference of 25 per cent. in favor of the bare tin pipe.

In order to demonstrate further the inefficacy of thin layers of asbestos paper as a heat insulator, tests were run in which the number of thicknesses of paper was increased until the heat loss became less than the loss through a bare bright tin specimen. Eight thicknesses of the twelve-pound paper were applied before the desired result was obtained. In these tests the moistened paper was wrapped tightly and shrunk on the drums so that only a small quantity of air was entrapped between the successive layers of paper. The total thickness of paper was two-tenths of an inch. The impractical features of such a method of insulating are of course evident. The use of thin layers of asbestos paper on bright tin pipes must be abandoned if the best results are to be obtained in furnace heating.

Other materials of better heat insulating value than the bare tin were tested. Numbers 3, 6, 10, 12, 15, 18 and 21 all show values which indicate that a large saving would be effected by their use. Some of them are expensive and not easy of application, but good selections may be made. The air-cell com-

THE AMERICAN ARCHITECT

Drum Number	Description of Surface	Area Exposed to Steam sq.ft.	Coefficient of Emissivity-K B.t.u. per sq.ft. per hr. per 1° F.												Relative Efficiency Per Cent	Drum Number	
			0	02	04	06	08	10	12	14	16	18	20	22			24
1	1C tin, not insulated, bright	5.53	[Bar chart showing emissivity values for drum 1]												1.280	100.0	1
1a	Same as No. 1 with ash dust sifted on 1/16" deep	5.53	[Bar chart showing emissivity values for drum 1a]												1.440	89.0	1a
2	1C tin with 1 thickness of 10-pound asbestos paper	5.52	[Bar chart showing emissivity values for drum 2]												2.080	61.5	2
3	1C tin with 3 thicknesses of air-cell asbestos and 1 thickness of 10-pound asbestos paper	5.50	[Bar chart showing emissivity values for drum 3]												0.565	226.0	3
4	1C tin with 2 applications of gray paint, (of zinc, linseed oil, and lithpone composition)	5.51	[Bar chart showing emissivity values for drum 4]												2.225	57.5	4
5	1C tin with 1 thickness of asbestos paper and 2 applications of paint, (No. 2 drum with same kind of paint as used on No. 4)	5.52	[Bar chart showing emissivity values for drum 5]												2.155	59.5	5
6	1C tin with 1 thickness of air-cell asbestos and 1 thickness of 10 pound asbestos paper, (No. 3 drum used)	5.50	[Bar chart showing emissivity values for drum 6]												0.870	147.0	6
7	1C tin nickel plated and polished	5.54	[Bar chart showing emissivity values for drum 7]												1.330	96.0	7
8	Galvanized iron, No. 28 U.S.S. gage	5.53	[Bar chart showing emissivity values for drum 8]												1.330	96.0	8
9	Black iron, No. 28 U.S.S. gage, very rusty	5.52	[Bar chart showing emissivity values for drum 9]												2.370	54.0	9
10	Surface and drum No. 3 with 1X tin casing surrounding, with 1/16" air-space and with 6 1/2" vent holes cut in the casing	5.50	[Bar chart showing emissivity values for drum 10]												0.700	183.0	10
11	1C tin (drum No. 1) coated with Bakelite lacquer	5.53	[Bar chart showing emissivity values for drum 11]												1.575	81.5	11
12	Same as No. 10 but with vents stopped	5.50	[Bar chart showing emissivity values for drum 12]												0.593	216.0	12
13	1C tin (drum No. 2) with 1 thickness of 10-pound asbestos paper and a surface of glaze finish printers' proofing paper	5.52	[Bar chart showing emissivity values for drum 13]												1.800	71.0	13
14	1C tin drum No. 4 with paint removed and a housing of campo-board construction, to represent joists, built around same. Housing 8" deep by 14" wide by 28" long	5.51	[Bar chart showing emissivity values for drum 14]												1.430	89.5	14
14a	Same as No. 14 with housing removed	5.51	[Bar chart showing emissivity values for drum 14a]												1.520	84.3	14a
15	Same as No. 10 but with the air-space packed with dry 177 asbestos cement	5.50	[Bar chart showing emissivity values for drum 15]												0.899	142.0	15
16	1C tin with 2 thicknesses of 12-pound asbestos paper	5.52	[Bar chart showing emissivity values for drum 16]												1.880	68.1	16
16a	Same as No. 16 with ash dust sifted on 1/16" deep	5.52	[Bar chart showing emissivity values for drum 16a]												1.820	70.5	16a
17	1C tin (drum No. 2) with 3 thicknesses of 12-pound asbestos paper	5.52	[Bar chart showing emissivity values for drum 17]												1.790	71.5	17
18	Galvanized iron (drum No. 8) with 3 thicknesses of air-cell asbestos and 1 of 12 pound paper	5.53	[Bar chart showing emissivity values for drum 18]												0.577	222.0	18
19	1C tin (drum No. 2) with 4 thicknesses of 12-pound asbestos paper	5.52	[Bar chart showing emissivity values for drum 19]												1.670	76.5	19
20	1C tin with 1 thickness of asbestos paper covered with a firm coating of white calcimine, (for determining the effect of light and dark surfaces)	5.51	[Bar chart showing emissivity values for drum 20]												2.050	62.5	20
21	Galvanized iron (drum No. 8) with 1 1/4" Asbestos-cel blocks covered with 3/8" of asbestos cement and a cheesecloth wrapper	5.53	[Bar chart showing emissivity values for drum 21]												0.326	392.0	21
22	1C tin (drum No. 2) with 5 thicknesses of 12-pound asbestos paper	5.52	[Bar chart showing emissivity values for drum 22]												1.435	89.0	22
23	Same as drum No. 20 with lampblack calcimine on the surface used in that test	5.51	[Bar chart showing emissivity values for drum 23]												2.120	60.5	23
24	1C tin (drum No. 2) with 6 thicknesses of 12-pound asbestos paper	5.52	[Bar chart showing emissivity values for drum 24]												1.390	92.0	24
25	1C tin (drum No. 2) with 7 thicknesses of 12-pound asbestos paper	5.52	[Bar chart showing emissivity values for drum 25]												1.320	97.0	25
26	1C tin (drum No. 2) with 8 thicknesses of 12-pound asbestos paper	5.52	[Bar chart showing emissivity values for drum 26]												1.260	101.5	26

FIG. 4. DIAGRAMMATIC TABLE OF THE RESULTS OF ONE HUNDRED SIXTY TESTS ON STEAM DRUMS

THE AMERICAN ARCHITECT

On account of the difficulty of correctly measuring the temperature of the air near the inner surface of the pipe, the method of determining the loss from a pipe as here given, is only approximate.

CONCLUSIONS.

The following significant results as applied to warm-air furnace heating are deserving of special emphasis.

(1) The use of thin sheets of asbestos paper on bright tin heat pipes results in a waste of heat. The use should be abandoned.

(2) Uncovered bright tin pipes are more efficient carriers of heated air than asbestos paper-covered bright tin pipes. See item (4).

(3) This fact is true regardless of the degree of brightness of the tin surface.

(4) No small number of applications of asbestos paper will suffice as an insulator. Several thicknesses are necessary to make a covering equal in this respect to the bare tin.

(5) The accumulation of dust and dirt on the pipes does not greatly alter the amount of the loss.

(6) The heat loss from warm-air furnace pipes covered with one layer of asbestos paper is a serious item in the cost of heating, amounting to more than 5 per cent. of the coal consumption, depending upon the number and size of the pipes used.

(7) The fact that pipes are partly protected from convection currents of air by joists and studding does not greatly affect the loss.

(8) *Unless the insulation excels the uncovered bright tin in heat insulation properties it should not be used.*

(9) Such materials are available and the tests have shown their merits.

The results of the tests have been given some publicity heretofore, but not in the complete form presented in Bulletin 117, reproduced in part in this article.

It is to be hoped that those having under their direction the specifications and installation of heating systems will put to practical application the results of these tests.

The Profession of Engineering

The following list of books and papers has been compiled by Engineering Council in response to requests, especially from parents and vocational advisers of high school boys, for information concerning the principal branches of engineering, the educa-

tion and training requisite therefore, and the possibilities for making a livelihood therein.

Those works which are followed by a code number may be consulted by the general public in Engineering Societies Library, 29 West 39th street, New York.

Engineering as a Career—Edited by F. H. Newell and C. E. Drayer. D. VanNostrand Co. 1916. 620 N. 443 E. (A collection of papers originally published in the "Cleveland Plain Dealer" and the "Scientific American" on various phases of engineering work.)

Opportunities in Engineering—Charles M Horton. Harper & Bros. 1920. 620 H 78.

Engineering as a Vocation—Ernest McCullough. David Williams Co. 1911. 620 M 139 E. (Subject matter based upon a series of addresses given before technical schools and associations of engineer assistants; published for information of parents.)

Engineering as a Career—Percival and A. A. Marshall. P. Marshall & Co., London. 1916.

Addresses to Engineering Students—Edited and published by Waddell and Harrington, Consulting Engineers, Kansas City, Mo. 2d Edition, 1912. 620 W 118 A. (Purpose of book is to give engineering students a broad conception of the profession.)

Engineering as a Profession—Milo S. Ketchum. Bulletin of University of Colorado, 1916. No. 6. General Series No. 98.

Engineering as a Profession—Dean William G. Raymond, University of Iowa. University Extension Bulletin No. 3. New Series No. 73. April 11, 1914.

New Engineering Service for Business

The Bureau of Chemistry has made arrangements to provide what they term "A New Engineering Service for Business." According to Dr. C. L. Alsberg, head of the Bureau of Chemistry, Department of Agriculture, this office will devote much time to the study and development of methods of recovering valuable products from factory wastes. The methods arrived at will be worked out in such form that they will be ready for presentation to manufacturers on a thoroughly practical basis. It is stated that the Government expects to save millions of dollars for the industries of the United States through this office.

Current News

Happenings and Comments in the Field of Architecture and the Allied Arts

Restoring Stonehenge

Now that Stonehenge, the grandest and most mysterious monument in Britain, has become the property of the nation, the government is putting it to careful and painstaking repair in order to prevent the ultimate collapse of its mighty "hanging stones." It was five years ago that Sir Edward Antrobus, a Wiltshire baronet, sold the ancient monument to E. H. E. Chubb, of Salisbury, for \$33,000, and it was two years ago when Mr. Chubb presented his purchase to the British government. The war was then still on and the office of works, to whose care it fell, had other things to think about, but now that the war is ended the office of works has speedily set about the task of preserving the great monoliths of Stonehenge.

Half a dozen men under the direction of Sir Frank Baines, of the office of works, are making the ancient circle of stones look as it did when it was completed by the sun worshippers of Salisbury plain some 8,000 years ago.

Industrial Information for China

Of interest to those who do, or desire to do, business in China is the announcement that the Government Institute of Technology at Shanghai, China, beginning with February, 1921, will open a Bureau of Information for Alumni. The above school is under Chinese government support and turns out engineers with a technical education equivalent to that of an American engineering school. There are no architectural schools, so these men serve in a double technical capacity. They are often located far from the port cities, and when they desire information regarding equipment or materials find it difficult to obtain. To meet this need the school is about to open this bureau. Manufacturers who are interested are invited to send catalogs, specifications, details, approximate cost and samples, or instruct "Sweet's" to do this. No sales will be made nor attempted. Impartial information alone will be offered. A member of the faculty is now in America on leave and he will be glad to communicate further with any who desire information regarding the China field. Address H. A. Vanderbeck, 5 Cammann Place, Somerville, N. J., until December 1, 1920, and Box 951, U. S. P. O., Shanghai, China, after that date.

Find Store of Papyri

"We have found the national wastepaper basket of ancient Egypt," was the expression used by a member of the French Academy of Historic Inscriptions to describe a recent discovery of the French Egyptologist, Lecau.

Beneath the ruins of a temple dedicated to Thoth in the holy city of Heliopolis, it was cabled to the *New York Times*, Professor Lecau found a subterranean necropolis containing tens of thousands of mummified bodies of the sacred Ibis, each neatly packed in an earthenware jar. The packing was nothing but crumpled papyri—ancient Egyptian manuscripts—which, say investigators, appear to consist of everything written, from love letters to washing bills.

There are literally hundreds of thousands to be deciphered, and it is estimated that the work of translation will take several years. When this is completed it is hoped that the whole life of the highly civilized Egyptians 4,000 years before Christ will be revealed.

"Race Suicide" and the Housing Shortage

Facing an increase in rent nearly twice as much as she used to pay, a Philadelphia mother appealed to the legal aid bureau of the department of welfare, stating that she and other tenants are "raising Americans for America, but have no place to put them."

Her petition found instant favor. It was forwarded to the Philadelphia adjustment commission for an immediate investigation. Whatever was done in behalf of this woman and her neighbors it is to be hoped that in at least one case the rapacity of landlords was checked.

The objection to children has become a national scandal. They are not wanted in apartment houses. Couples who have children and cannot afford to buy a home are at the mercy of property owners. Their opportunities to move when rents are raised to exorbitant figures are limited. A man and his wife might contrive to shift for themselves in one small room, but that is out of the question when they have several children. They must make the best of a bad situation.

There is an increasing tendency in America to keep

down the birthrate. The "race suicide" against which Theodore Roosevelt preached is revealed in the latest census figures. Children are not desired by some people because of the expense and trouble of rearing them. Others who want to "raise Americans for America" are deterred by the hostile attitude of apartment house landlords and owners of residential property.

The heartless landlord cares little for what a reduced birth rate may mean to the country, but the unpopularity of the stork is viewed with grave concern by everyone who is interested in the natural increase of population without depending on a steady influx of immigrants from the Old World, many of them of doubtful value as citizens.

Royton Hall, a Home of the Byrons

Fine oak-panelled rooms, magnificent staircases, stout rafters, choice mullioned windows—are not these elements of a sixteenth-century mansion covetable? It is said that Americans are after some of them, but it is preferable that the hall should stand intact. It is said, however, to be "in the market," and Mr. Arthur R. Scott, president of the Manchester Archaeologists' Society, is appealing to the wealthy cotton spinners at Oldham and district for funds to enable the purchase of the Hall, the idea being to make it a lecture hall. Royton, which in 1212 was held by William Fitzwilliam, and in 1301 was sold in great part to John de Byron, remained in the Byron family for 400 years. Sir John Byron rebuilt the hall about 1585. Sir J. E. Radcliffe owned the hall until last month, when he sold it to the present proprietor, Dr. Godfrey, who is offering it for sale. Members of the local architectural associations should get permission to measure and draw it before it is demolished and carried piecemeal to America. Sixteenth century houses are becoming scarce, and this one was the home of the ancestors of the poet Byron.

Fantastic Palace of Colored Stones Is Work of One Man

Ferdinand Cheval, a postman in Hauterives, France, is the builder of one of the strangest palaces in the world. As a young man, according to the *Detroit News*, he saw a series of pictures in a book of Oriental stories, and he was struck with the fantastic and picturesque qualities of the Oriental castles and palaces with their towers, minarets, highly ornamental windows, doorways and arches. He began gathering stones of various colors and types in his afterworking hours and to read books on the art of masonry. He also talked to workmen, and watched them at their tasks.

He began to build in front of his little frame house a palace of weird design. He is now 80 years old and his dream creation is complete. It has all the towers and turrets and arches and scrolls that he desired. He gathered millions of pebbles and stones, and spent 67,500 working hours on it. It is eighty-five feet long and forty-five deep. The money used came in at first from his small savings, but as the palace grew tourists visited it in hundreds, and he obtained a goodly revenue from their hands. He hoped to be buried in it and erected a monument in the main hall, but local authorities forbade his burial there for reasons of public health.

The Hearthstone Fire

When people used to come back to their old homes, after a long absence, it was often called a reunion at the family hearthstone. The fire on the hearth was a center of family life. Not merely cookery was performed there in the days before stoves, but it was a gathering place where intimate thoughts were revealed and plans for the future were made.

In these days many homes are built without any hearthstones. They seem like a body without a soul. But the crackling fire on the open hearth is still cherished by millions of people. It promotes reflection, it loosens tongues, it suggests reminiscence and conversation and adds good cheer to the family circle.

Those who put up houses without this center of warmth and life do not realize how much they detract from the value of their construction.

The Use of Lumber in America

More lumber is used in the United States for general building and construction than for any other purpose, says the U. S. Forest Service latest report. In normal years probably 28 billion board feet is used in this way out of an average annual cut of forty billion feet.

For the five years before the war, 1910-14, the average annual building bill of the country shown by building permits was approximately \$670,000,000. After dropping to \$445,549,493 in 1918, it rose in 1919 to \$1,326,736,702; but with building costs increased 100 per cent. or more, actual construction did not much, if any, exceed the pre-war average. Apparently construction work throughout the United States is behind requirements. The deficit is greatest in dwelling houses.

The building permits issued in twenty-one cities of various sizes widely distributed over the country show that, in values, housing construction formed 36 per cent. of all building in 1913; 21 per cent. in 1918, and 27 per cent. in 1919. The amount of

housing construction in 1913 was exceeded in 1918 in only two of the twenty-one cities, and in 1919 in only six, in spite of the "build-a-home" campaign. The falling off in house construction, continues the Forest Service report, generally appears to have been particularly marked since the latter part of 1919, when the greatest upward movement of lumber prices began.

The United States Housing Corporation states that normally 30 per cent. of the number of buildings constructed are dwellings; that in 1919 dwellings were only 15 per cent.; that 1,000,000 families in the United States desired houses even before the war; that the shortage has since increased very rapidly; that there were but 70,000 houses built in 1919, when to have met the requirements there should have been 500,000, and that in 1890 an average of 110½ families occupied 100 homes, but to-day 121 families occupy 100 homes.

Hair as a Building Material

At one time the Japanese made use of human hair in building churches. It was the custom for church-going people to give some of their hair as a free-will offering when a temple was being built. Such a structure at Tokio had the beams and rafters held in place by one of these human hair cables. Placed end on end, this human hair rope measured 4,528 feet long and was 7 inches in diameter, no fewer than 350,000 persons contributing before a sufficient quantity was obtained.

Old Wall Papers Sought

Wall paper, not the prosaic kind found in the ordinary band-box apartment, nor the flaring type prevalent in third-rate boarding houses, but the descriptive, illustrated variety so popular in the days of our great grandfathers, is being collected by the Pennsylvania Museum, Memorial Hall, Fairmount Park.

An appeal has been sent out to the public requesting it to preserve all available examples of early wall-papers, both imported and domestic.

The use of fancy wall-paper began shortly after the Revolution, at a time when pine paneling was much cheaper hence not so desirable. Combinations of paneling and frescoing or papering were used, and the wealthier families at the time when fantastic designs were in vogue took pride in decorating their homes with imported paper from Alsace.

Few houses are now standing with original wall-paper still in place, and the common form in which it comes down to the present generation is in fragments used to decorated the huge handboxes of the pre-Civil War days.

An amusing example has recently come to the museum, donated by Mrs. Parker Marcan, of Wiscasset, Maine, which shows an early wood-engine pulling three coaches. In the background is a landscape replete with battlements and towers of the medieval period, the whole design forming somewhat of an anachronism. It is known as the "Baltimore and Ohio paper," and is believed to have been produced in the thirties.

Skilled Labor Lacking to Build Houses

Attempts to solve Great Britain's housing problem have already brought forward upwards of 10,000 schemes involving an annual capital expenditure of \$600,000,000, according to a report by a representative of the Foreign Trade Bureau of the Guaranty Trust Company of New York. After giving details as to various plans and the number of houses to be built in each of more than thirty cities visited the report says:

"What is keeping back housing at the present time is the fact that there are not enough skilled men to do even a quarter of the work wanted. The trades unions will not allow the number to be increased from the outside. The government is using a sort of indirect compulsion by prohibiting 'luxury and unessential build,' so that if a man will not build cottages he is not allowed to build anything else. There are various suggestions for speeding up the work, including a guarantee to the trades unions of employment for a term of years to men employed on housing work, to ensure them against loss of time in bad weather by a minimum wage 'wet or dry.' In return the trades unions will be asked to consent to dilution and the employment of unskilled and semi-skilled labor, to give up their apprenticeship rules and abandon all opposition to employment of ex-service men, trained or untrained. There are 'luxury building' tribunals to hear appeals against decisions prohibiting buildings regarded as non-essential.

"There are housing bond campaigns all over the country. In London subscriptions to the 6 per cent. bonds are coming in at the rate of about 100,000 a day. While the local governments are issuing 6 per cent. bonds, the British Government charges 7. Borrowing in the ordinary way for housing schemes not financed by bonds is usually 7 per cent."

Militarism Disappears

One of the most striking physical signs of the demilitarization of Germany is in the degradation of the famous Brandenburger Thor, Germany's arch of

triumph, at the head of Unter Den Linden. Describing this in the Brooklyn *Eagle*, Guy Hickok reminds us that pre-war visitors to Berlin remember this arch as the very shrine of German militarism and kaiserliche authority.

No one but his imperial majesty was allowed to drive through the center arch. A platoon of the smartest soldiers in the German army was quartered there, ever ready to snap into the most epileptic rigidity at the approach of any high ranking officer.

Drums rolled at the arch many times a day—when ever such an officer loomed in sight—and burst into a perfect fever of thumping and stuttering when the all highest drove by. Ordinary folk had to leave the sidewalk to pass the guard at the gate.

Now every shabby cab driver, pushcart man, boy bicyclist or news vender makes it a point to go through the center arch and none other.

There is no platoon of soldiers of any sort on guard.

A thousand generals—if there were that many—might amble through without creating a stir.

There are no drums to thump.

One poor youth of the Security Police, not over well informed, sands on a block of stone, with not an atom of pomp in him.

No one in Berlin is so humble as to do him honor. No one thinks of leaving the sidewalk for him. In fact he has to have a fence in front of himself to keep from being pushed aside by civilians.

If he tried to exercise the authority of a New York policeman he would be mobbed. He assumes no control over street traffic or anything else. He merely stands.

Occasionally, but very seldom, a civilian stops to ask him the way to somewhere, and he digs out his little street directory and gives his answer meekly, embarrassed at having attracted attention.

The once proud arch itself is plastered with tattered white placards as big and as plentiful as our American wartime Liberty Loan posters. But the words and the purpose of the placards are quite different. They are there, not to increase military strength, but to reduce it. They are part of the German government's attempt to obey the disarmament conditions of the Versailles treaty and the big letters on them read:

"Deliver Up Your Weapons."

The smaller letters explain that the government must turn over to the entente the rifles that the soldiers took home with them when the army fell to pieces after the armistice and offer a premium for early surrender.

The Brandenburger Thor, used as an instrument for the weakening of German militarism, is as complete a reversal of purposes as if our own Statue

of Liberty were fitted inside with prison cells for editors who insist on a free press.

Personals

Ralph M. Weinrichten, landscape architect, has moved from the Cutler Bldg., Rochester, to 10 East 43d st., New York.

Herman D. Roller, architect, has opened an office at 64 East Van Buren street, Chicago, Ill.

S. Ben Algernon has moved his offices from 320 Fifth avenue, New York, to 122 East Seventh street, New York.

W. S. Purdy has moved from 320 Fifth avenue, New York, to 122 East Seventh street, New York.

Thomas Colesworthly has opened an office in the Courthouse, Westchester, Pa.

News Notes from Various Sources

Ohio State University has raised a fund of one million dollars for a stadium to seat 83,000. The Yale bowl seats 63,000.

* * *

Ogden, Utah, has given permission to put up rough shacks for homes at the municipal auto camping grounds. There are not nearly enough dwelling houses and the weather is getting too cold for tents.

* * *

Akron, Ohio, will have a permanent art museum in the Public Library Building on East Market street. A. V. Ritter, president of the Akron Fine Arts Club, is sponsoring the movement. Co-operating with him are the Fine Arts, Art and History and Architectural clubs, and others.

* * *

The Health Commissioner of New York has asked health officers of all cities of 200,000 population or more to attend a conference on housing problems. This conference will probably be held in Detroit, Nov. 30 and Dec. 1.

* * *

In 1919 one million weddings were celebrated in the United States, but only 70,000 new homes were erected.

* * *

Savannah, Ga., is taking steps to improve its physical aspects by better planning, and by cleaning up. Rose bushes are to be planted in numbers along roadsides and in the parks.

Weekly Review of the Construction Field

With Reports of Special Correspondents in Prominent Regional Centers

PROGRESS is being made in the improvement of railroad transportation.

Announcement on the part of the Treasury that it had extended loans to railroads in an amount close to \$290,000,000 for equipment purposes, together with a list of the railroads thus aided, shows that provision is being made under the terms of the Transportation act for the better outfitting of the carriers. Statistics compiled by the Eastern railroads also show that during a recent month an increase of about two miles a day in car mileage was effected, an increase which may be regarded as equivalent to about 100,000 freight cars. The new purchases of equipment and the increase in efficiency have resulted in a very considerable reduction of freight congestion which has had a correspondingly good effect on business in many parts of the country. Deliveries are now more regular and more satisfactory than for a good while past.

The question of employment is also vital as affecting the stabilization of labor and the prices that must be paid for it.

The Federal Government figures for July showed the first definite decline in the volume of employment in the principal manufacturing industries for the country as a whole. In the State of New York official returns for manufacturing industries have shown a slow decline in the volume of employment beginning with April, the total loss for the six months from April to October being about 7 per cent. In the earlier part of the year, the needs of the farmer and other seasonal industries absorbed the labor thus released. Agriculture is now releasing labor, and unemployment is becoming increasingly evident. Increasing unemployment is not peculiar to this country but is world-wide.

THE statistics as to building permits during the month of September have now become available and we learn from the *American Contractor* that there is a definite slump in construction in 203 cities in the United States.

These reports give a total valuation of \$101,834,-729 for 38,383 permits issued, or an average valuation of \$501,640 for September. This is considerably below the computed average monthly valuation per city for the first eight months of 1920, which is \$696,920.

September showed gains in 71 cities over August and losses in 96, Los Angeles and Detroit making

the largest gains. Chicago permits which dropped in August from July, make another drop of more than \$1,500,000 in September, and the Borough of Manhattan also shows a decided reduction. Comparison of September activity for this year and for 1919 reveals a 40 per cent. recession for 1920. August showed a 32 per cent. recession over August, 1919. When it is considered that the estimated cost of practically any class of building is from two to three times what it was in 1913 and 1914, taking into account the lower purchasing power of the dollar, the September slump of this year is all the more marked. If volume of projected work were the basis of comparison rather than monetary value, the 1920 operations would drop below the average for each month since April when building permits reached the exceptional figure of \$113,000,000.

The average value of building permits per city for months of August and September for years 1914 to 1920 follows:

Year	August	September
1920	\$626,750	\$501,640
1919	1,000,000	860,000
1918	287,000	225,000
1917	416,000	435,000
1916	624,000	627,000
1915	615,000	594,000
1914	733,000	593,000

(Special Correspondence to the *American Architect*)

BOSTON.—There is no radical improvement to report in the general business situation in New England this week. Rather does the tendency continue in the direction of further slowing up industrially and continued lack of confidence in the commercial world.

The downward readjustment of prices at wholesale is recognized as the logical development and one that must take place before business can go forward in anything like normal volume again. Many believe this condition can not be realized until labor prices fall. They are decreasing now. Employment agencies report that unemployment is increasing and it is inevitable that re-employment will be at lower wages. Local architects' offices report that more and more clients are calling for sketches of projects to be carried through either this winter or the early spring.

Large local buildings that have been held up for steel and other materials are now going up at fair speed.

Statistics of building and engineering operations

THE AMERICAN ARCHITECT

in New England show that contracts awarded from Jan. 1 to Oct. 27, 1920, amounted to \$272,954,462, as compared to \$187,388,000 for the corresponding period in 1919; \$136,200,000 in 1918; \$183,752,000 in 1917; \$172,662,000 in 1916; \$145,263,000 in 1915, and \$139,295,000 in 1914.

(Special Correspondence to the American Architect)

SEATTLE.—There is a widespread conviction that December and onward will bring a change in the outlook that has prevailed for the past six months. Confidence is returning, and preparations are being made for a stronger movement of building essentials in city and country beginning with placements that are not to be delivered until after the 1920 stock taking.

The lumber mills which have been shut out of all eastern consuming territory by reason of the high emergency freight rates are at work on a plan with the coastwise steamship companies for a \$15 rate for fir lumber to New York, Boston, Baltimore and Philadelphia. Shingle manufacturers already have secured sufficient concessions from these carriers to insure the movement of their entire output for the coming season by water at a substantial saving over the all-rail rate, and the problem of transportation is in a fair way of solution. Transportation is regarded here today as a much more serious phase of the coming construction year than finance. In accordance with the probability of equitable rates, the decline in the lumber market has been checked.

High representatives of the Pittsburgh steel mills have been in the Pacific Coast field on a survey of the prospects for 1920, and found the jobbing trade in a highly agitated state of mind. They were asked pointedly whether the mills hoped to clean up this year on back orders for small pipe, and were again reminded that orders placed with the mills in August, 1919, for galvanized pipe of three-quarters, a half and an inch had not yet been loaded. Replies were guarded, for it seems certain that if there was reliable information to the effect that the mills would be at normal on past business by that time there would be wholesale cancellations. Proportions are shown

in the fact that large jobbing houses, capable of moving heavy tonnage, have received but one car of small pipe since August last.

The nail situation is improving. In face of the very light demand the supply is nearly normal. Any sudden call, however, would dislocate the present balance.

Water shipments from Pittsburgh on pipe, wire and sheet metal are now being accomplished in forty days from the date of loading aboard ship. The transportation difficulty developed through the car shortage and the high rail rates has been satisfactorily overcome.

The shortage of cement, although plants capable of maintaining a normal supply in brisk construction seasons are located within 125 miles of Seattle, is acute. Prices have not fluctuated. The scarcity of plaster is very similar to that of cement.

There is plenty of roofing, brick, plaster wall and beaver board to meet the quiet year-ending demand.

Lumber prices show further recessions for the week end. Dimension at the mills is \$17.50 to \$21.50 against \$18.50 to \$21.50 a week ago. Flooring, 1 x 4 No. 2 and better vertical grain is \$1 lower at \$58, with the same size in slash grain \$7 off at \$34. No. 2 and better finish in 1 x 8-10" is down at \$59, and 5-8 x 4, No. 2 and better ceiling is moving at \$33 to \$40, against \$37.50 to \$48 a week ago. Boards and shiplap are stronger at \$19 to \$27.50. Shingles are steady but 60 per cent. of the mills are closed for lack of business.

General expectation of a close down of the fir and shingle industry, due to the loss on all lumber now selling has diminished through the favorable progress in the request for workable water rates into the eastern building territory which will enable the West Coast mills to compete with southern pine for the eastern and middle western business.

The overcrowded condition of office buildings in this city, the prospects for high rentals and the long waiting lists have brought investors and architects more closely together, and there is now a fair prospect for a number of big jobs in 1921.

653^a

Antipia to No 2344.



DETAIL OF AN OLD PALACE, TOLEDO

THE AMERICAN ARCHITECT

VOL. CXVIII

WEDNESDAY, NOVEMBER 24, 1920

NUMBER 2344

“What Is the Matter with The Building Industry?”

Proceedings and Impressions of the Autumn Meeting of the New York State Association of Architects, Held at the Academy Room, Fine Arts Building, in the City of New York, November 12, 1920

“In industry, those who work with their hands cooperate to produce the things which all of us need. If conflict and disunion take the place of co-operation, wealth production is hindered and everything the community requires is rendered less abundant and more costly. To secure this harmony of interest is the master problem of the modern industrial state.

“This is the definition of the meaning of the English Guild in the building industry, but it can be made to do service as a definition of that kind of co-operation which is now making its appeal to our own building industry.

“Our industry demands organization, organization demands direction, direction demands conference, conference demands compromise, compromise demands self-subordination, and self-subordination demands courage of the highest order.”

—From the Address of Mr. Louis Comstock.

THERE is no better nor more fitting summary of the spirit and essence of the fourth annual meeting of the New York State Association of Architects than the quotation given above from the address of Mr. Louis Comstock. The autumn meeting of 1920 was given particularly to a full and elaborate discussion of the question which appears at the top of this page, and addresses by men prominent in architecture and allied industries were delivered in more than usual detail; but throughout every address, and constituting the greater portion of the majority of the addresses, there was distinctly evident the thought expressed so clearly in the quotation from Mr. Comstock's admirable paper. Representatives of the general contractor, the sub-contractor, and the employer; a well known superintendent of construction; a member of the bureau of industrial research, and officials of the New York Chapter of the American Institute of Architects and the New York Society and State Association all indicated clearly, in the seven hours of discussion, that above materials, above labor, above transportation, above all physical facts which might be termed contributory causes to the present

housing situation, the matter of co-operation, on such a basis as Mr. Comstock put it, was, after all, the big and fundamental thing.

There were two sessions, one at 10.30 in the morning and the other at 2.30 in the afternoon, but, as a matter of fact, it amounted to practically one session, the total discussion lasting more than seven hours.

The morning session was devoted to the president's address, in which Mr. Waltz distinguished himself by delivering the shortest presidential address within the memory of man. Following Mr. Waltz's admirable brevity, an informal discussion on “The Housing Situation” was opened by Mr. Burt L. Fenner, president of the New York Chapter of the American Institute of Architects.

MR. FENNER prefaced his remarks by reference to those persons who had preached military preparedness for this country, and who had been frowned upon as either fanatics or visionaries, and likened them to the architects who long ago foresaw a housing shortage of the present nature and preached their doctrines of preparedness unto deaf ears.

“So that today we have commissions and committees without number,” Mr. Fenner said, “which have studied and worked over this problem with so infinitely small a result that it seems such study is now a perfectly futile affair. Yet I do not regard it exactly in that light, for it shows that the public, the great mass of laymen, of wage earners, of the middle class, if you will, is thinking today concerning problems to which it never before has given the slightest regard.

“The reasons for the situation are without number, but fundamentally I believe it to be due to transportation and finance. If you cannot move materials, and if you cannot borrow money with

which to build, it is almost futile to attempt anything constructive. . . .

"It seems as if the old machine, the old system, had broken down. It is my personal belief that ultimately we shall have to design a new machine. The old one has failed us. . . ."

"As the first steps toward immediate relief, I propose car priorities for the shipment of materials and pressure exerted on the banks to induce or force them to lend for building purposes. I hope capital will be willing to forego some of its present profits in order that money may flow into the building industry. . . ."

"Do you favor state aid for either credit or construction?" Mr. Fenner was asked by Mr. Robert D. Kohn, vice-president of the New York State Association of Architects.

"I most certainly favor state aid for credits, and I am unalterably opposed to state aid in construction," was the reply. "I hope the government will go into the matter on a regulatory basis. I trust it will study the problem thoroughly, that it will test every theory, that it will conduct both research and experiment.

"But every official or governmental bureau, commission or committee which has gone into the matter so far, with the exception of the Reconstruction Committee of this state, has failed to see the problem as a sociological problem, and has accomplished practically nothing.

"In other words, the system has fallen down. We need a new machine."

In the discussion which followed, so many opinions were voiced regarding Mr. Fenner's assertion that the "machine had broken down" that it would be almost futile to record each speaker's views. Opinion seemed rather well inclined toward the veracity and solidity of Mr. Fenner's contention regarding the failure of the present scheme of building for profit, and it was generally agreed that England's housing schemes, whereby profit has been totally or largely eliminated by the guild system, was the best sort of solution for the problem.

"It is only natural," Mr. Frederick L. Ackerman stated, "that we must ultimately come to England's solution of the matter. Credit, after all, is not so important in this problem. The vast volume of credit goes to the highest yields, and rightly so, as I see it. Any other scheme would ultimately lead to the depreciation of government securities. . . ."

"When the building industry is organized merely for profit, sabotage will exist from top to bottom. We can not expect one thing from one group and not render it ourselves. . . . So long as we are out to render ineffective any labor organization, we will find ourselves faced with failure.

"We may as well look the problem squarely in the

face and admit that the old method of profit has failed."

PRESIDENT WALTZ introduced Mr. Ordway Tead of the Bureau of Industrial Research, who was scheduled to speak on "What Is Being Done in the Building Industry in England." We regret that space forbids the reprinting of Mr. Tead's admirable address in full. Briefly, it was as follows:

"England realized that there must be very solid and fundamental causes for the housing shortage, and, after exhaustive investigation of the matter by both governmental and private agencies, the so-called Foster report was submitted, which gave as the reasons:

"1. The fear of unemployment (English workmen have been stressing reasonably full time employment at a reasonable wage).

"2. The failure of the private profit motive to interest the laborer in his work.

"3. The failure of the private profit motive to give the laborer any incentive for pride in the job as a whole.

"4. The inefficiency of the employers.

"Out of the four principal schemes evolved to meet and remedy these conditions the building trades guilds have proven most successful and efficient. Membership in these guilds consist of men who have volunteered to work upon construction work without profit, that is, without private profit. A National Builders' Guild has been formed, and it is the duty of this guild to:

"1. Standardize the purchase of materials.

"2. Regulate compensation, from the salaries of the directive heads of any building operation to the merest hod carrier.

"3. To co-operate with the Ministry of Health in its program of housing, and with local authorities in their individual problems.

"4. To unify building programs, and directly supervise them, on a non-profit basis.

"This scheme has worked wonders for England and her housing problem. There can be no doubt of its success there, and the guilds have proved to the government that they can build cheaper under their no-profit, direct-labor system than under any other existing system. So far as present records are concerned, more houses have been built in the last 6 months in England than in any other 5 previous years. Nor is this due merely to the stringency of the situation. The old private profit order of things could never have produced like results, because men will not work so well for the other fellow as they will for themselves. That is human nature, the very law of human nature, and it is

THE AMERICAN ARCHITECT

upon that law that the building guild has founded its success.

"The system has its application to our problem, because it (a) organizes to assure productivity; (b) organizes to get something out of a building program for the worker, and (c) it most certainly organizes to get something out of a building program for the public, which is constituted, in the main, of the workers themselves.

"Now, as to these contentions. Productivity is assured when workers are producing something directly for their fellow-man without any intermediary, which in our country is summed up in the architect-contractor group. It produces something for the worker because he knows absolutely that the house he is building is being put up at cost, with profit to no 'boss.' It produces something for the public in that it gives the public completed homes at a reasonable figure, with not the slightest suspicion that any portion of that figure has been eaten up by any individual or corporation in what some persons term 'useless profit.'

"I call these things to your attention in the hope that they may be of service in the stimulation of thought along the guild problem."

And "these things" did stimulate thought, as was immediately shown, at the conclusion of Mr. Tead's address, by several members who offered resolutions regarding the soundness of a "no-profit" basis for the building industry. Hearty objections were entered against any such resolution, and, as one member put it, "you can't turn the economic scheme upside down by a mere resolution. Building has always gone on under a system of profit for the builder, and it will continue to do so, or else the builder will pass quietly from the business world."

Nevertheless, there were those who distinctly favored the no-profit theory, which meant that they were willing that architects and contractors should be paid a stated compensation for their services rather than fees (for the architect) or profit (for the contractor, under the competitive bid system). Several members proposed various resolutions, but it was finally agreed that the matter was far too serious to permit of extemporaneous resolutions, and a committee was appointed by the president to draw up a suitable resolution on the matter and present it at the opening of the afternoon session.

With that the session adjourned to repair the ravages wrought by discussion and hunger.

THE AFTERNOON SESSION.

PRESIDENT WALTZ'S gavel had hardly rapped for order at the opening of the afternoon session before Mr. Kohn, as chairman of the Resolution Committee appointed in the morning

by the president, claimed the privilege of the floor for the purpose of reading the resolution which the committee had drawn up relative to the guild system as a possible solution of the housing problem in this country.

"Whereas," Mr. Kohn read slowly, while members strained to hear every word of as important and novel a resolution as this one was, "The housing situation in almost every community of the state is extremely serious and practically no new houses are being built because such building offers no profit, and

"Whereas, It is evident that the dependence of profit making as an inducement for the housing of all the community has failed,

"Therefore Be It Resolved, That we must try to find a new viewpoint leading to new methods, and that we start the essential educational process leading to such methods by encouraging the people themselves and the workers to organize their own powers in credit and work to build for themselves without profit to any intermediary."

The discussion which followed was unquestionably the most argumentative of the day. It would not be possible to put down here the names of all who spoke. Suffice it merely to state briefly the views of the two principal factions.

In favor of such a program: Absolutely sound, they maintained. Building for profit is at a standstill today. Everything is lacking. The best the architect and builder can make of the present situation is to encourage any sort of co-operative action among those who otherwise might be his client; to discourage competition. In short, anything, so long as houses actually go up. That, not profit, was the problem.

Opposed to such a program: Utterly absurd. The world, from the time of earliest barter, had depended for advancement upon competitive effort. Co-operation of that sort meant suicide for the architect. The problem was not merely one of building, but one of a continued existence for architects. Competition furnishes that existence. Profit is always the problem with architects or any business man. Profit is the basis of the economic structure. Take it away and the structure collapses.

But the meeting could not come to any agreement upon the resolution, and it was voted to postpone further discussion of it until after the invited speakers had finished with the set topic. This was done. (And at the end of the meeting, when the resolution again came up for discussion, it was tabled until the association should meet again.)

THE discussion of the afternoon's topic then began. It was first outlined in short addresses by Mr. Robert D. Kohn; Mr. J. Riley Gordon,

THE AMERICAN ARCHITECT

president of the New York Society of Architects, and Mr. William P. Bannister, representing the Brooklyn Chapter of the American Institute of Architects.

Mr. Kohn emphasized the fact that we have been wasting a great deal of time in seeking to emulate Nast's famous cartoon of Tammany Hall, and that it is absurd to be constantly blaming the other fellow for conditions which exist in the building industry rather than put some of the blame "on ourselves."

"No one thing will get to the bottom of the situation. . . . There has never been a problem in the world's history which could be held aside and dispassionately credited to one factor . . . The Brindell investigation will not get to the bottom of the building industry and its ills. That is but an incident. The real thing, the necessary thing, is to establish a system of co-operation between the architect and every allied profession strong enough, and frank enough to insure the thorough investigation by ourselves into whatever may be the matter with our own profession."

Mr. Gordon, in his short address, defended the present attitude of the insurance companies and banks toward real estate investment. No one could blame a financial institution for lending money where interest was highest. It was and is and always will be, the law of supply and demand.

"I believe firmly in the soundness of that law, and I do not believe that arbitrary measures of any sort, legislative or what not, would in the slightest fashion ease the financial stringency in which real estate finds itself today. It is the duty of finance to lend where the most can be made upon any investment, and it is the duty of bank and insurance companies toward their customers to put the money of such institutions in the highest interest channels. That is the way things have run for generation after generation, and I do not believe that we can in any way change them. Until the problem of supply and demand with regard to real estate loans is fully met and worked out by the people themselves on a gradual, soundly economic basis, I can see no hope for influencing either capital or money into the building industry."

"The building industry is suffering from faulty metabolism," Mr. Bannister said in his opening remarks. "We are not functioning as an industry. We have not gotten rid of what is evil in our ranks. We are suffering from a cancer which has been growing into the industry's vital organs for some time, and instead of diagnosing the disease, we have been content to look upon it merely as a cold, when in reality it may be compared to the more serious pneumonia. . . . The polluted air which the industry has breathed has seriously affected its lungs."

WHETHER or not the meeting agreed with these remarks was not indicated at this part of the program. President Waltz proceeded at once to the introduction of the first of the invited speakers, Mr. Allen E. Beals of Dow's report on "Building Materials, Supply and Prices."

"On the day after the armistice," Mr. Beals began, "I received a telegram from Washington which asked this question: Are you in favor of letting down the bars on non-essential building?"

"I wired back my answer, and it was no. I tried to give my reasons for such an answer. In the first place, I thought, and thought rightly, that an 'own your own home' movement would be inaugurated. That proved to be the case. Now, my organization had facts regarding the available building supplies in this country at that moment. We knew, for example, that we were short millions of barrels of cement, and that the industry could not hope to immediately swing into its old time production, plus over-production to meet the shortage. The same was true of brick and of every other building material. We knew that any 'own your own home' campaign would, with money as plentiful as it was, bring to the market a demand which could do nothing else except force prices to an abnormal level. That was inevitable, as you gentlemen can easily see.

"That is just what happened. A tremendous demand for building materials swept the country, and the demand could not begin to be met. Prices soared. Chaos began.

". . . what is the situation today? Kindly note these figures for building in the United States from 1911 to 1920.

Year	Cost of Buildings Constructed	Average Cost Per Sq. Foot	Sq. Feet Built
1911...	\$ 926,499,700	\$1.59	605,000,300
1912...	1,027,515,200	1.63	630,000,400
1913...	980,971,600	1.61	609,300,000
1914...	891,845,500	1.55	577,000,400
1915...	931,937,300	1.52	613,100,000
1916...	1,103,160,900	1.82	624,000,800
1917...	816,941,000	2.27	358,000,000
1918...	492,163,900	2.65	185,700,000
1919...	1,467,821,300	3.20	458,600,000
1920*..	1,170,000,000	3.60	325,000,000
1919*..	871,000,000	3.20	278,000,000

* First nine months.

"Now, what do the figures show? In the first three years, from 1911 to 1913, a steadily decreasing total of square feet built and higher cost per square foot. In 1914 the cost of production per

square foot was low, but production was low. In 1915 the situation was beginning to show decided improvement, but in 1916 it became worse. The square foot cost was then \$1.82, 30 cents more than 1915, and yet the increase in actual production was very small. In 1917 the square foot and total cost was way out of proportion to the production of square feet, and the following two years showed ever-increasing costs with constantly lessened production. The first nine months of this year have already totaled almost as much as 1919 in cost of building constructed, the price per square foot is higher than it has ever been, and the actual production is lower than it has ever been.

"Nothing sums the situation better than these cold figures.

"Let me give you some more of them; cement, for example. October showed the greatest production of cement ever recorded for a single month, so far as all available records show. That indicates a desire on the part of cement manufacturers to catch up with demand. Yet, in spite of that willingness to meet the deficiency, we will be 2,000,000 barrels short by March of next year. We are actually 1,600,000 barrels short at the present time, and out of an estimated yearly production of 95,000,000 barrels, 31,000,000, or just about a third, will have to go toward scheduled road improvements. That leaves you gentlemen only two-thirds of an under-production.

"Consider as common and necessary a thing as brick. There should be just about 600,000,000 brick in this market alone at this moment, but there are only 250,000,000 brick even within striking distance of the most sanguine contractor. More than half the brick supply is short. Do you believe that it can be met today, or tomorrow, or a few months after tomorrow?

"Think a moment of lumber. Is there sufficient lumber? There is not, as you know; and, what is more significant, there are no more cuts in this very necessary material.

". . . now all of you have different viewpoints. Some are hoping, I imagine, for a liquidation by labor. Let me tell you that labor will not liquidate. There is too much work to be had on the railroads, shipbuilding plants, and a thousand and one other places. Don't count on a liquidation by labor.

". . . The present position of materials men reminds me of the mules which they send down into mine shafts and bring up once every two years or so to clean. When a mule is brought to the surface, into the sunlight, they humanely attach blinders over his eyes.

"After the war the materials men were brought up to the sunlight, but there were no blinders . . .

and the total result of that is just this: Your client unless he acts shortly on any proposed building scheme will be shut off from the market. Materials are at their bottom prices now. Cancellations have stopped, and that is significant. There will be no lower levels. I say that with a very full sense of every factor which goes into building materials.

"You have your choice between the 1912 'shoe-stringer' and loose credits, and between present conditions and tight credits. The latter is the better. Tight credits are an incentive, a help, a distinct advantage. Tight credits and the realization that the present prices are the real and permanent prices are what you should think over . . . and having thought it over, you will go to your client and say this:

"If you postpone building, you are in danger of finding yourself shut off from the market'."

Mr. Beals stopped there. Looking about the room, one could see faces which expressed everything from credulity to approval, from disbelief to belief. Everywhere there were whispers, and everyone seemed to be either agreeing heartily or disagreeing much more heartily. There appeared to be no "middle ground" of opinion. Either Mr. Beals was entirely correct or absurdly wrong. Figures were all right, in a way, but what did they show? Well, if figures couldn't prove the situation or give an indication of what might be expected, what on earth could? And so on, until President Waltz introduced Mr. W. G. Luce, of Hegeman-Harris Company, as the next speaker.

MR. LUCE presented the point of view of the general contractor. In an admirable paper, he gave one of the most sincere and well put appeals for co-operation between architects and the allied profession that it has been our good fortune to have heard in a long while. Space forbids its publication here in full, and no summary could do justice to it. We will refer only to that part of Mr. Luce's address which had to do with finance, because it is our opinion that he voiced an important sentiment.

"I wish to say a few words regarding finance. We all know how hard a thing it is to get money from a bank for building purposes. We all know also that the last annual convention of the American Bankers' Association passed a resolution to assist in this building problem. Yet what have the banks actually done? The aid given, as any man here can testify, has been meagre, due to prohibitive fees and commissions. I do not agree with some of the previous speakers that it is the duty of the bank to invest where interest runs highest or where greater profit is promised from the investment. The money in the banks is the money of a vast number of middle class depositors, and it is the middle class de-

THE AMERICAN ARCHITECT

positor who wants to build at present. It is the duty of the bank, as I see it, to operate for the depositor's good, and not for the bank's good. Think that statement over, if you please, and I believe you will get my viewpoint quite fully.

"Why, we ourselves put money into banks, and yet, when we want to borrow for some operation, we find we can't get our own money out for that purpose? Is that a bank's function?"

It was overwhelmingly the sentiment of the meeting that that indeed was not a bank's function, and that the banks had unjustly and unwisely discriminated against real estate and building loans. There were two or three stout defenders of the bank's position, who, like Mr. Ackerman, believed that any other course would have brought government bonds to an even lower depreciation, but, as several of the members pointed out, why should a bank put it upon its shoulders to maintain a governmental bond at a given value when the government itself had failed to do so?

President Waltz waited patiently until the discussion should subside sufficiently to introduce Mr. Louis Comstock, of L. K. Comstock & Company, who was scheduled to present to the meeting the viewpoint of the sub-contractor on the housing situation.

It was from Mr. Comstock's splendid address that the quotations given at the beginning of this review were taken. It was on "The English Guild," and it stressed, in every line, the importance of co-operation, of self-subordination, remarking that "discussions of this sort have been exceedingly rare in the industry." One paragraph particularly appealed as typifying the spirit of the whole paper. Here it is:

"Each group in the industry must have respect for every other, not lip respect, not respect that begins and ends with words, not respect for great names or great firms, but that kind of respect evidenced by a common acceptance of a forum where all things of common interest to the member groups of the industry may be discussed with reason and understanding."

At this point Mr. Bannister was asked by the president if he would not favor the meeting with an address, and Mr. Bannister, accepting the invitation to speak, faced the meeting very squarely and determinedly and spoke as follows:

"If an architect pays \$1.00 for any service not rendered, he is doing harm to the profession as a whole. If an architect pays the contractor for anything not actually produced or delivered, he is doing harm to the profession. An architect who contributes to useless overhead does not live up to his public trust. And it is just as important that every allied profession keep close scrutiny on the other to stop at all times even a suggestion of useless over-

head. We can get together only so far as we realize that there are in the profession practices which need to be stamped out, not by investigating committees, not by the law, but by us, by the architects and by the professional men allied with us in our great work."

Mr. Ronald Taylor, president of the Building Trades Employers' Association, followed Mr. Bannister. Hugh Frayne, organizer of the American Federation of Labor, who was scheduled to speak upon labor's side of the problem, found it impossible to be there. Consequently, only the employer's side of the labor problem was heard.

Characterizing the present labor situation as a natural outcome of what he termed the "backwash of the war," Mr. Taylor told of the formation of the Builders' Trades Employers' Association in New York and the effects of that association upon labor. Applied to other cities, it appears to us that a similar association would be of benefit if organized in the same manner and conducted as effectively and with as much care to the rights of labor as this association has seen fit to grant. Every dispute in the building trades' unions in New York City is now laid before the employers' association for settlement, and the word of that association is, as Mr. Taylor pointed out, final. This has been made possible by fair dealing and by continually seeking the confidence of the men.

"I am opposed to a centralized body such as we have in this city," Mr. Taylor said emphatically, "I believe in the autonomy of the various trades. I believe complete autonomy of the trades is necessary to every city.

"... I have faith in labor, and here is one good reason for that faith. During the war, while I was in Washington, I had occasion to be at a meeting of a large number of members of the American Federation of Labor who had met to discuss the so-called Baker-Gompers agreement, the point of dispute being whether it applied only to non-union men or to both union and non-union men. The men believed, were positive, were howling that it applied only to union men. Had that been maintained, production all over this country would have been seriously cut. But it was not maintained. One of the leaders of that great federation stood up before thousands of husky, raw-boned men and said, in the deadliest tone I ever hope to hear: 'When you fellows convince me that the constitution of the American Federation of Labor is greater than the constitution of the United States, I'll see this thing your way.' And the talk on that matter was killed.

"But I feel that we have gone as far as we can in our present relations with labor," Mr. Taylor added immediately, "and in a few days it might be

THE AMERICAN ARCHITECT

right up to our association to determine our future relations. Within the week they have come to us with a demand for a dollar a day raise in pay. I can say that this will be voted down unanimously by the employers' association.

"We will then still face the proposition of whether to go to the American Federation of Labor and say: 'You have put a council in New York City, headed by men who have been proved lacking in character and honesty and we wish to know whether there is any possibility of our getting a representative body with which we can honestly deal.' If we can get that, it may be the best solution.

"Or it may be possible that after December 31, when some of the agreements expire, it may be best for us to state our rates of pay, conditions, etc., without saying anything about unionism or non-unionism, whether a man is white or black or anything about his race or religion."

Mr. Taylor said he believed in the eight-hour day and double pay for overtime. He said he believed the unions should give back autonomy to each trade. Another difficulty, he said, was a shortage of men in certain trades.

"I feel confident that the problem will be solved," he said. "I think the present trouble is a backwash of the war."

The next speaker emphasized repeatedly that he had faith in labor. He was Robert Glenn, of Todd, Irons & Robertson, Inc., who spoke of his experience as superintendent in charge of construction of the Cunard Building. While such a matter is necessarily local, and therefore of little value to the reader of this journal, it is yet true that there was one part of Mr. Glenn's address which will well bear repeating. He said:

"I am not a professional man, having gone through the ranks, from the bottom to my present position. I tell you gentlemen that you'll have to learn to mix better with your labor; to meet the hand worker on a better basis; to see his problems in his light; and to be able to call him 'Bill' occasionally, and not 'Mr. So-and-So.'

"The only way we're going to produce for the future, and for the present, is by either getting down to business with labor or by kidding labor. The first is the better way."

The meeting then adjourned, after deciding to convene next time in Albany, N. Y.

The Dinner

The previous evening witnessed a dinner tendered the State Association by the New York Society of Architects at the Hotel Astor, and the spirit of that dinner was well typified in President Gordon's opening address.

Captain John P. Leo, chairman of the New York City Board of Appeals, representing Mayor Hylan, welcomed the out of town guests to the city, referring to "our profession" as the "oldest upon the face of the earth."

Following Captain Leo, President Ornan H. Waltz, of the New York State Association of Architects, spoke briefly in appreciation of the courtesies extended by the Society. Then Mr. Robert D. Kohn, ex-president of the New York Chapter of the American Institute of Architects, spoke of the Institute, appealing to those present for better feeling and unity.

Following Mr. Kohn, there were speeches by:

Mr. D. Everett Waid, treasurer of the American Institute of Architects.

Mr. Alexander MacIntosh, ex-president of the Brooklyn Chapter of A. I. A.

Mr. Leon Stern, of Rochester, president of Central New York Chapter A. I. A.

Mr. Edward B. Green, of Buffalo, State Board of Examiners and Registration of Architects, was introduced, but Mr. Frederick L. Ackerman spoke for Mr. Green, explaining that Mr. Green was to catch a train and could not be present.

Mr. Albert E. Kleinert, Superintendent of Buildings of the Borough of Brooklyn.

Mr. Addison F. Lansing, of Watertown, was called upon to address the meeting.

Mr. Edward W. Loth, vice-president of the New York Society of Architects, of Troy.

Mr. Waid, in behalf of New York State Association of Architects, proposed a vote of thanks to the New York Society of Architects, which was unanimously carried.

The Building Situation in Chicago

A Review of the Calder Senatorial Inquiry by a Special Correspondent of The American Architect

CONCURRENT with the conference held by the New York State Association of Architects, it is interesting to note the expression of opinions of those who have appeared before the Calder Senatorial Inquiry in Chicago, as furnishing an accurate basis of comparison as to conditions on the Atlantic Seaboard and the Middle West.

Chicago's building problem shares the complexities of the building situation in other cities and has a few intricacies not found elsewhere, including a labor situation that has proven very troublesome in the past.

There are hopes, however, that by spring at the very latest there may be a decided renewal of building activity along all lines, with all the opposing elements willing to make sufficient concession as to price and pride to overcome the lethargy which has assailed the building industry in the past and which has given Chicago the onus of a very critical shortage in homes.

The Calder committee inquiry has brought out, most of all, the heavy increase in building costs over the last four years, an increase that has served to paralyze building as far as any important structures are at present concerned. Just what is to blame for the highly increased cost is a matter of varied opinion. One of the causes very frankly suggested by Henry G. Zander of Koester & Zander, important real estate operators, has to do with the elimination of competition in building materials. Mr. Zander alleged that there is very little important competition in the materials that go into building, asserting that the "Chicago list," for example prevails in practically every retail lumber yard in Chicago. This so-called "Chicago list," Mr. Zander said, has prevented any general decline in lumber retail values. His assertion, disputed rather lustily by Edward Hines, one of the leading lumber dealers in Chicago, was bolstered by the statement that building pieces which sold in 1913-1914 at \$30, sold in 1919 at \$70 and in spite of the so-called drop in lumber values are now selling at \$54. Mr. Zander also asserted that lesser materials were also largely immune from the economic force of open competition. He pointed out sand as a typical example. This material, he said sold for 90 cents to \$1.20 in 1910 and is now selling at from \$4.00 to \$5.60.

Adolph Kramer, president of the Chicago Real Estate Board, who has been active of late in efforts

to bring peace in the warring elements in the building situation suggested another cause for the increased cost of building, which he said has reached the highly aggravated point in this city. This cause, he asserted, was the fact that Chicago builders are not permitted to use materials of certain kinds which are manufactured outside of Chicago. Curtailed production in Chicago and lack of outside competition have served to heighten prices in all such materials. Mr. Kramer estimated that rentals on apartment structures in Chicago, erected under present building costs, would have to approximate \$25 per room per month in order to net the owner anything approaching a commensurate return on the invested capital. As a remedy for the situation, Mr. Kramer suggested the removal of tax exemption from all securities or the placing of building mortgages on the federal exemption list.

This idea advanced by Mr. Kramer has been given added impetus by the proposal introduced in the city council by Alderman Joseph O. Kostner to exempt from local taxation for a period of five years all improvements on real estate which may be erected during the period from January 1, 1921, to December 31, 1922. This measure, Mr. Kostner declares, will cause a building boom over the next two years that will do away with the present shortage of homes and apartments. Such a plan, he asserted in proposing the idea, has turned a building slump into a building boom in certain Ohio cities.

"Some such inducement is necessary," says Alderman Kostner, "if the people of Chicago are to have homes."

Benjamin B. Rosenthal, director of the Chicago Housing Association, estimated, for the benefit of the reconstruction committee that there is a shortage of 50,000 homes in Chicago. His solution of the problem is government aid in providing homes.

Charles O. Bostrom, Chicago city building commissioner, attributed the building slump to high interest rates on the part of bankers and mortgage brokers and unreasonable profits—ranging, as he said, as high as 100 per cent.—on the part of manufacturers of building materials.

His statistics as to the rate of building are of interest. In 1916, the last normal year of building activity in Chicago, 4,293 permits for apartments were issued. During 1918, 1919 and the first ten months of 1920, only 856 apartment permits have

been issued. Of this number, only 82 were issued in 1920, about one-fiftieth of the normal requirements for Chicago.

Frank I. Bennett, state commissioner of public works said that Illinois, as a whole, is two and a half years behind on its building program. He prescribed as a remedy for the situation, a fuller agreement between labor and the building interests, a full day's work for a full day's pay and greater moderation on the part of materials manufacturers.

The hearing was by no means entirely a matter of condemning the materials interests.

Edward Hines said that within the last seven months, building sizes of lumber have declined from 13.43 per cent. to 36.37 per cent. In spite of this, lumber sales in the Chicago district have dropped to one-third the normal rate, the slump beginning about March 1. Mr. Hines said that there is no shortage of lumber in Chicago and that the different varieties of lumber and the various competing lumber associations make it impossible for any single set of men to build up a monopoly in lumber and raise prices at will, even if the lumber interests were disposed to do such a thing.

Mr. Hines made the interesting assertion that the man who wanted to save money for himself would be rather foolish to build at this time, when by waiting six months or a year, he would be able to build at from 25 per cent. to 50 per cent. less than at present. Many mills are now selling at less than cost to get rid of their stocks, Mr. Hines assured the committee.

Just what the outcome of the Calder committee hearings will be is a matter of the future, but there is a very definite feeling among all concerned here that the building interests will get together in a way that will permit a resumption of activity on a large scale in the spring. Labor, for example, is much more productive and less defiant than even three months ago and the growing number of the unemployed in this section will have a continuing tendency to minimize labor demands.

As far as that goes, Chicago building labor has agreed to hold its demands in check. This agreement arrived at last week is a tacit pledge on the part of the building trades labor not to ask for increases in wages before May, 1922, and to refrain from strikes over jurisdictional issues in the interim. This question of striking over matters of jurisdiction has been a thorn in the side of building contractors who have been compelled to halt building activities of an important nature while factions within the labor organization fought out their petty differences. This question being subordinated and the wage issue being temporarily stabilized, contractors feel much greater assurance about going on with their plans for the future.

As far as prices are concerned, the past week has not reflected any serious change. Lumber values are still weak, though fairly stable and no immediate slump or advance is anticipated. The election did not prove a stimulus to business as had been expected by some. Retail prices are as follows for the principal lumber needs:

Yellow pine:—B. & B. 1 in., \$95 to \$130; 13-16, 3¼ flat flooring, \$85 to \$90; 2 by 4, 10 to 16 feet, No. 1 long leaf, \$51; 2 x 6, \$41 to \$49; 2 x 8, \$46 to \$50; 2 by 10, \$50 to \$52; 2 by 12, \$51 and \$54.

Northern Hardwoods, carload lots, Chicago:

Birch, four ¼ No. 1 and 2, \$155; select, \$130 to \$138; No. 1 common, \$95 to \$100; No. 2 common, \$60 to \$65; No. 3, \$35 to \$40.

Hard Maple, four ¼ No. 1-2, \$135 to \$140; select, \$115 to \$120; No. 1 common, \$95 to \$100; No. 2, \$60 to \$65; No. 3, \$32 to \$50.

Red gum four ¼ No. 1 and 2, \$148 to \$152; No. 1 common, \$88 to \$92; No. 2 \$43 to \$47.

Birch, four ¼ No. 1 and 2, \$155 to \$160; select \$130 to \$139; No. 1 common, \$95 to \$100; No. 2, \$60 to \$65; No. 3, \$35 to \$40.

Douglas fir, 12 by 12, No. 1 up to 32 feet, \$65 to \$75; 14 by 14, \$68 to \$75; 16 by 16, \$70 to \$75; 18 by 18, \$75 to \$80.

Building materials continue firm, with price advance not entirely unexpected by those in a position to know. Some of the principal retail quotations are:

Cement:—Universal, \$4 to \$4.20; Lehigh, \$4.20 to \$4.40; Portland, \$4.20 to \$4.40.

Bulk lime, \$1.70 to \$1.90; face brick, octagons, \$68 to \$75; fire brick, \$32 to \$40; 12 in. .24 to .27, 18 in. .46 to .54.

Crushed stone gravel \$3.40 to \$4.25; lake and bank sand-torpedo, \$3.40 to \$4.25.

A decline from the present price of high grade ready mixed paints is anticipated within the next fortnight. Some decline in lead is expected before the first of the year. Other values in the paint and varnish trade would seem to be holding firm.

Illinois Architects File a Brief With the Calder Committee

HENRY K. HOLSMAN, president of the Illinois Chapter, and Mr. F. E. Davidson, president of the Illinois Society of Architects, upon receipt of a formal invitation to appear before the Calder Senate Committee on Reconstruction, invited a number of the leading architects of Chicago to join in a conference to outline a brief to be presented to the Committee as a contribution of facts and a record of the opinions held by the Illinois architects. The brief was filed with the Senate Committee on

THE AMERICAN ARCHITECT

November 11 by Mr. Henry K. Holsman. It was as follows:

Twenty of the leading architects of Chicago were invited to meet and give their opinions and suggestions for submission to your honorable body. Thirteen architects met, and after discussing the matter in two sessions, the following catagorical statements respecting the existing hindrances to building and their corresponding remedies were agreed upon by the undersigned. The chief hindrances are:

1. Popular belief in the existence of monopolistic fixing of the price and the output of labor and the fear of jurisdictional and other strikes and lockouts with an attendant system of graft and frightfulness.

2. A popular belief in the existence of artificial regulation of price and output in the production and distribution of building materials with and without the connivance of organized labor, together with inadequate and manipulated transportation facilities.

3. High cost of money for building enterprises with exceedingly high commission charges for building loans.

The suggested remedies are respectively:

1. The prohibition of the use of force or coercion in strikes and lockouts for the settlement of jurisdictional or wage disputes and the restoration of the right of every citizen to enter as an apprentice or tradesman any field of endeavor he chooses without

let or hindrance from any organization except the government itself.

2. The creation of a permanent bureau or department of buildings at Washington leading to the democratization of building material associations and the prohibition of artificial fixing of prices and output and the protection of the rights of any individuals to enter production fields without let or hindrance from any association.

3. The enactment of a law making the postal savings and other savings deposits of the people available for individual home building and ownership at rates commensurate with savings deposit interest in conjunction with a national building bureau or department, operating in a manner similar to the farm loan banks system and furnishing low cost plans and desirable information relative to individual or single family home building.

We further beg to state that there is now such a volume of projects on file in the architects' offices in Chicago being held up by the prevailing unsatisfactory building conditions that if released could not probably be built within the next two years with the available supply of organized labor and building material; and further, we believe that even if money were available on easy terms the cost of building could not be materially reduced within the next few years and might be increased on account of the actually limited supply of building materials and labor.



HOUSE OF GEORGE E. CRANMER, DENVER, COLORADO

J. B. BENEDICT, ARCHITECT

Dynamic Symmetry and the Greek Vase

A Communication from Professor William H. Goodyear of the
Department of Fine Arts, Brooklyn Museum

EDITOR'S NOTE—In THE AMERICAN ARCHITECT, issue of November 12, 1919, an article by Jay Hambidge on Symmetry and Proportion in Greek Art was printed. Since that date, Mr. Hambidge's book on Dynamic Symmetry and the Greek Vase has been published. Professor William H. Goodyear, who has contributed many articles to THE AMERICAN ARCHITECT in his research as to Architectural Refinements, has addressed the following communication to the Editor of this Journal. Mr. Goodyear's views as to Mr. Hambidge's book, and as to the merit of his theory will undoubtedly be read with interest and stimulate, it is to be hoped, a more careful consideration of certain theories of design on the part of architects.

THE review in *The Nation* of a book by Mr. Jay Hambidge on Dynamic Symmetry—the Greek Vase, indicates that no important discovery is in question, but that “the familiar device . . . of creating a new vocabulary” has been employed “quite subconsciously” to cover with an air of mystery ideas with which the world of art has long been more or less familiar.

It must be immediately conceded that no reviewer is authorized to go outside the matter of the book under review in making his comments upon it, but if you will allow me to mention some facts regarding the career of Mr. Hambidge and his theory, which do not appear in the book, I shall find it a convenient way of showing that a really important discovery is in question and that this fact may be verified by the book alone. This method of procedure is suggested by the consideration that it will relieve me from debating matter, of geometry and mathematics which might be very tedious to your readers and which I am really incompetent to handle.

Let me mention first that the observations and theories of Mr. Hambidge did not begin with Greek vases. They were originally and still are, in their most important phases, architectural. They were brought to the attention of Mr. Francis Cranmer Penrose, in London, by Mr. Hambidge, personally, in 1902, and were considered by Penrose of such importance in their relations to Greek temple architecture that Mr. Hambidge was at that time invited to appear before the Society for the Promotion of Hellenic Studies, and the matter of his address was considered of such importance as to procure him an invitation, then and there, to a later appearance before the Society after his studies should have been more thoroughly developed. At this time Mr. Hambidge had applied his theory of “Dynamic Symmetry” to the design of the Ionic volute and this was of special interest to Mr. Penrose, who had at that time announced a theory of his own on this subject. During the discussion which followed Mr. Hambidge's paper Mr. Penrose took advantage of the occasion to assure the members of the Society that he was acquainted with the method of Mr. Hambidge's procedure, declared that it was scien-

tific, hoped that the matter would not be allowed to languish, and gave the method unqualified endorsement (see R. I. B. A. Journal, March 20, 1920, p. 213).

The next appearance of Mr. Hambidge before the Hellenic Society was planned for the year 1914, but this appearance was postponed on account of the war and has only recently occurred.* Following his second appearance before the Hellenic Society Mr. Hambidge was also invited to address the Royal Institute of British Architects and it was on the date of March 20, 1920, that the account of this address appeared in the R. I. B. A. Journal. By reference to this report one may learn, what is a familiar fact to many of Mr. Hambidge's friends in New York City and many architects of New York City and also to the authorities on related subjects of Harvard and Yale Universities, that Mr. Hambidge's theory of Greek design is by no means confined to Greek vases, but relates first and foremost both to Egyptian and to Greek temple architecture, and, secondly, to all phases of Greek design, of which the forms of Greek vases are certainly an important, but still only a single feature. Stated in simple language, Mr. Hambidge's theory is, that, as distinct from the proportions and ratios of linear measurement, Egyptian and Greek design were based on the relations and inter-relations and proportion of areas as determined by the procedure and methods of geometry. That this is essentially the matter of his theory may, for the minute, be attested by the remark made after the conclusion of this address before the R. I. B. A. by some of its members. Sir Cecil H. Smith, Director of the Art Division, Victoria and Albert Museum (for many years Keeper of Greek Antiquities in the British Museum), in proposing a vote of thanks said: “Judging from the evidence he had gathered from Mr. Hambidge's work and also from the results of his own researches at the British Museum, it seemed to him that Mr. Hambidge, by his theory of the *commensurability of areas*, had hit upon an *extraordinarily interesting truth* . . . Mr. Hambidge's theory deserved the fullest consideration by the

*This is the paper that was published in THE AMERICAN ARCHITECT of November 12, 1919.

(Continued on page 673)

The Old Daniel Lake House, Staten Island, New York

(See reproduction of drawing by O. R. Eggers on opposite page)

WHEN in the early part of the Seventeenth Century, the Dutch settled on Manhattan Island, they soon began the preparation for the colonization of the valley of the Hudson River. It is in this district which also includes Staten Island in New York Harbor, that there are to be found many examples of gambrel roofed houses, the present illustration being typical.

The heavy walls of these houses were constructed of stone and were usually pointed up with white mortar. The roofs were low and of moderate pitch for about ten feet both ways from the ridge. From this point the angle was sharper to near the eaves, where it curved gracefully outward, extending from four to six feet. This broad expanse of roof surface made the upper stories of the house uncomfortably hot in summer and equally uncomfortable during the rigorous winters. To overcome these undesirable conditions, hay was often placed between the rafters, which no doubt acted in a measure as a non-conductor. It is interesting to note the gradual development of the overhanging roof in the architecture of modern suburban houses, where porches are planned beneath it.

The gambrel roof as a rule is the dominating feature in correctly assigning the Dutch Colonial. In tracing the origin of the name, gambrel, we have for authority Oliver Wendell Holmes, who in his "The Autocrat of the Breakfast Table," writes:

"Know old Cambridge, Hope you do,
"Born there? Don't say so? I was, too.
"Born in a house with a gambrel roof—
"Standing still, if you must have proof.
"Gambrel? Gambrel? Let me beg
"You'll look at a horse's hinder leg.
"First great angle above the hoof—
"That's the gambrel, hence gambrel-roof."

670^r



THE OLD DANIEL LAKE HOUSE, STATEN ISLAND, N. Y.
THE AMERICAN ARCHITECT Series of Early American Architecture





What Is the Matter with the Building Industry

TWO features of timely interest presented in this issue are the conference held in this city under the auspices of the New York State Society of Architects and a very complete report of the inquiry at Chicago conducted by Senator Calder's Senate Commission.

It is extremely gratifying to be able to present these discussions on a topic that is now of first importance to every architect in the country and this gratification is further enhanced by the fact that there is clear indication that the profession of architecture is realizing its responsibility and is actively taking part in these momentous matters.

That the initiative is being taken by state societies is added proof of the desirability of similar organizations in every state.

The fundamental thing most strongly urged in the conference held by the New York State Association is the necessity for better co-operation in all the various and complex elements that combine to make the building industry. The debate was fairly representative of these various elements and it was therefore to be foreseen that there would be many diverse points of view as it was equally obvious there would be a very wide variance of opinion on each of them.

Mr. Louis Comstock, for example, believed that we should more closely apply the present workings of the English guild as furnishing the best basis for a closer and more satisfactory co-operation. Mr. Burt L. Fenner, with the conviction born of a very close co-operation with building activities during the war, believed that while there are a great many reasons for present conditions in the building industry the principal ones are finance and transportation. Stating that the whole system under which we conducted, and with fair success, building operations in this country for a long period have broken down under the strain of things as they have been since the armistice, the remedy urged by Mr. Fenner that priority in the shipment of material and pressure on the

banks to force loans on building operations would largely overcome present conditions, will not, we believe, be very largely accepted.

MR. ORDWAY TEAL strongly urged the adoption in this country of England's guild system. Such a method, it was very clearly brought out in the debate, would mean that we would need to reorganize our entire economic system and cast aside all the results of our present highly developed efficiency in the meagre hope of eventually finding a better way. Such a thing is entirely too experimental and therefore too dangerous for serious consideration at this time.

Probably a more practical discussion of the present building situation is the one that has resulted from the Calder Senate Inquiry held in Chicago. The complexities of the question, "What Is the Matter with the Building Industry?" are so many and the opinions with reference to it are so diverse that it will take some time to digest them. Meanwhile there seems to be a very pronounced sentiment that one of the most strongly deterrent factors is the scarcity of mortgage money and the high rate of interest asked for that which is available. Labor, apparently, is much more productive and less defiant today than it was six months ago. Transportation is steadily improving, and the prospect is that the prices for building materials will early become fairly stabilized. This leaves the remaining and principal factor the high cost of money. In all of the debates that have been presented this condition has been referred to and the opinion seems to be generally held that with mortgage money more easily available the building situation would become rapidly cleared of many of the impediments that now obstruct its progress.

In Chicago, as in New York, there is a plea for better co-operation among all the elements of the building trades throughout the country. The willingness, even on the part of labor, to work in that direction is so marked that it is optimistically felt that we are nearing the beginning of the end of our building troubles.

The Lockwood Building Committee Investigation in New York

THE atmosphere surrounding the investigation now being conducted in New York City into corruption in the building trades is surcharged with all sorts of threats of disclosures that in their importance will dwarf even the very unsavory conditions that have thus far been revealed. Attempt has been made to quash indictments on the plea that the life of the committee ended with the life of the State Legislature, and that any action of the present committee was therefore illegal. This attempt has been successfully combatted by Samuel Untermeyer, counsel for the commission, who plans to dig deeper than ever into the activities of the grafters in New York City and with specific reference to the city's building contracts.

Without regard to what may be further divulged, sufficient has been brought to light to show that much of the retardance of building in New York City was not altogether due to the high cost of anything more than the high cost of graft. And as these conditions have worked in certain directions almost an entire suspension of building and therefore have interfered with the business of architects, it should be the duty of architects, both as individuals and through their representative bodies to co-operate in every way possible with the Lockwood Commission and its able counsel in bringing to light every scrap of evidence that will tend to convict the grafter and as far as possible abate continuation of conditions that are unbearable.

It is encouraging to note the attitude of the contractors and their ready co-operation in securing the widest publicity in these matters.

At a meeting of the Executive Board of the Associated General Contractors of America, at Washington on November 16, resolutions were adopted unanimously endorsing the action of the Lockwood Committee, and plans were laid for securing the co-operation of the United States Chamber of Commerce and other employers' associations in urging the Lockwood Committee to pursue its investigation

without fear or favor to the end that all guilty be exposed and punished, and that justice thereby be done to those who, condemning the purchase of immunity from labor troubles by the corruption of labor officials, desire an honorable settlement of the labor problem based upon fair dealing.

Illinois Architects' Valuable Co-operation with Calder Committee

BOTH by reason of professional training and experience, no group forming part of the building industry in this country is better equipped to advise in matters pertaining to building conditions as they exist today than are architects.

It has always been urged in these columns that it was an insistent civic duty for the profession actively to co-operate in these matters, and it has been many times deplored that there was not displayed a quicker readiness so to act.

It is therefore extremely gratifying to note the present pronounced activity and to make reference to the fact that Senator Calder during his address following the luncheon tendered his Senatorial Committee by the Chicago Engineers' Club on November 11, paid special tribute to Henry K. Holsman, President of the Illinois Chapter, American Institute of Architects. Stating in substance that the suggestions presented to the committee by Mr. Holsman on behalf of the architects of Illinois were the first suggestions of a similar nature that thus far had been presented to the Senate Committee, Senator Calder added, that in his opinion there had been advanced a plan that would, if adopted by Congress, result in permanently removing the obstacles now preventing the construction of housing and impeding the building industry. He further stated that the recommendation of the architects would doubtless be concurred in by the Committee in its report to Congress.

The suggestions to which Senator Calder refers were drawn jointly by the Illinois Chapter and the State Society, and filed with the Senatorial Committee in the nature of a brief, the substance of which may be read on page 668 of this issue.

Dynamic Symmetry

(Continued from page 669)

artists of this country." "Sir Richard Paget, in seconding the vote of thanks, said that . . . the ideas which Mr. Hambidge had put forth were certainly most instructive and *opened the door to an entirely new set of ideas. The notion of measuring areas instead of lengths and breadths was fundamental and interesting.* He was sure it would have a most useful effect on all who were interested in proportion and design; they would see in it not only a basis of good design, but also of good craftsmanship, on which, ultimately, good design rests." The report of the R. I. B. A. Journal shows that Mr. Hambidge's paper was devoted specially to the Parthenon, but that it also included Greek bronzes and pottery. Remarks (not quoted here) by Sir Cecil Smith, who is an eminent authority on Greek vases, show that he considered Mr. Hambidge's theory to represent a wholly original discovery as regards the vases.

Now these facts bear on the notice of *The Nation's* reviewer in the following way, and I am preparing to explain that the theory of Mr. Hambidge represents a discovery if the theory be true, and I am not debating whether the theory is true. It so happens that Greek vases are fairly numerous in the United States, in the Museums of Boston and New York; it so happens that at quite a recent date of his observations and theories Mr. Hambidge was led to take up the subject of the Greek vases; it so happens that these vases were held by him and by the experts of the Boston and Metropolitan Museums in this department, namely, Dr. Caskey and Miss Richter, to be important and remarkable corroborations of his theory; it so happens that Mr. Hambidge was led to publish a book on this particular portion of his theory and that he very properly confined his discussions and his theory in this book to the Greek vases.

Consequently, *The Nation's* reviewer is not at all open to criticism for not knowing that the theory covers a much wider ground than that of Greek vases. But I will now proceed to debate his suggestion that no discovery is in question as regards the matter of the book, by calling attention to the fact that two leading experts on Greek vases in the United States have believed that a discovery has been made, and so much so that Dr. Caskey is, himself, writing a book on the subject of the vases. I will also remark that if a discovery is in question as regards Greek architecture, the same theory must be a discovery when applied to the vases. Now as regards the fact that the theory is a discovery as regards Greek architecture, if it be true, there can be no debate. It is attested by the interest of Mr.

Penrose and the Hellenic Society; it is attested by the reception of the theory at the time of the recent address before the Royal Institute of British Architects. Some of the gentlemen there present subsequently contested the theory, but not one denied that the theory represented a discovery if the theory were true.

My own acquaintance with the subject of Greek architecture and with the various efforts which have been made to establish a theory of ratios in the linear measurements and linear planning of Greek temples is sufficient to make me aware that Mr. Hambidge's theory represents a discovery, if it be true. A considerable number of architects and experts in New York City will support me in this opinion. Under these circumstances I venture to believe that Mr. David Eugene Smith's remarkable control of the history of geometry and mathematics has misled him to under-rate the importance of Mr. Hambidge's book. This book itself, however, shows a very considerable and intimate knowledge of the history of geometry and mathematics. In fact, the whole basis of the theory of Mr. Hambidge is that the Greek knowledge of geometry and of the proportions of areas was applied to the design of buildings and other forms of art. That the Greeks had this knowledge of geometry is known to us by history, as *The Nation's* reviewer recites and it is an essential fact in the theory of Mr. Hambidge. On the other hand, the theory that Greek design was controlled by this knowledge and that it was based on the proportions of areas and not on the proportions of lines, is, in my opinion, and according to my knowledge, undoubtedly a new one. The simple fact is of crucial importance that Mr. Hambidge has explained by his theory why all the linear measurements of the Greek temples, both in plan and in elevation, are incommensurate. This peculiarity has baffled every student, up to date, who has endeavored to determine the ratios of Greek planning by comparing the linear measurements. The fact that no scholar, up to date, has suggested any method of comparing or studying Greek temple plans except by the comparison of linear measurements is indisputable.

In 1919, Mr. Hambidge was awarded the Sachs Research Fellowship, with a very considerable income, by Harvard University, as an encouragement and support of his research. Yale University, with the same end in view, has provided the means, from a special endowment, for the publication of the book under discussion, and in the spring of this year provided funds to enable Mr. Hambidge to visit Athens and continue his research on the site of the Parthenon. Yale not only engaged Mr. Hambidge to deliver the Trowbridge lecture course last season, but

THE AMERICAN ARCHITECT

has also engaged him to appear in the same course on his return from Greece.

According to a statement made by Mr. Hambidge in his address before the Architectural League of New York about two years ago, there was in 1912 only one scholar in the United States who had favorably considered his theory. Apparently there was only one scholar who even knew of its existence. When we consider the recognitions which have recently been accorded him by Yale and Harvard, this success in the course of only seven years is without parallel in the annals of American archaeology.

For Mr. Hambidge was not educated at either of these Universities and a few years ago neither of them knew of his existence. He had made his living and achieved his first distinction as an illustrator in black and white. The most remarkable feature of his success is the fact that a considerable and constantly increasing number of artists in design are applying his theories to their own modern work and are enthusiastic supporters of his ideas, without any reference to their importance as regards archaeology and the history of art.



DETAIL OF HOUSE OF GEORGE E. CRANMER, DENVER, COLORADO
J. B. BENEDICT, ARCHITECT



HOUSE OF GEORGE E. CRANMER, DENVER, COLORADO
J. B. BENEDICT, ARCHITECT



674 ~



HOUSE OF GEORGE E. CRANMER, DENVER, COLORADO
J. B. BENEDICT, ARCHITECT

674

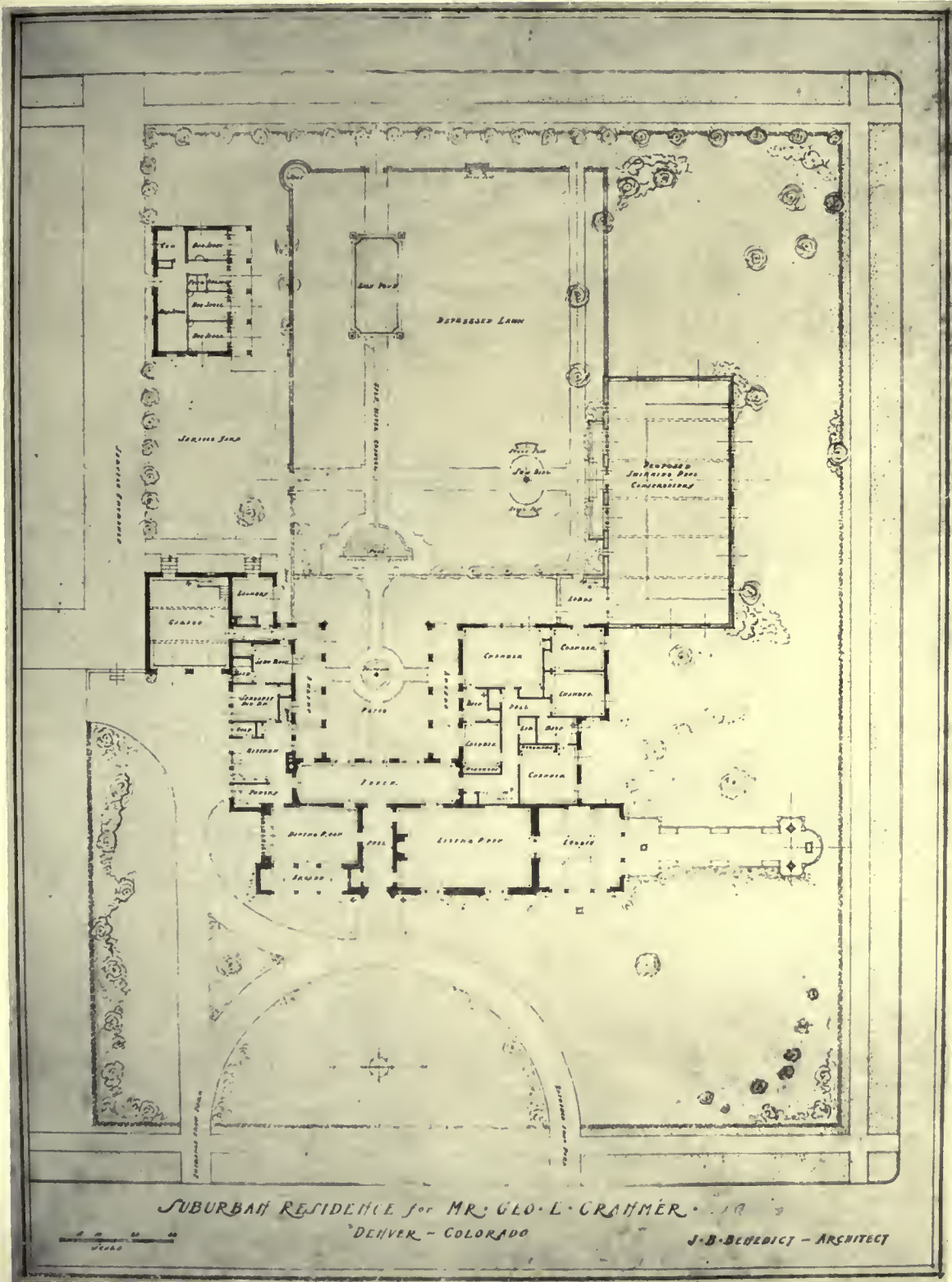

PLOT PLAN
 HOUSE OF GEORGE E. CRANMER, DENVER, COLORADO
 J. B. BENEDICT, ARCHITECT

672



DETAIL OF DOORWAY

HOUSE OF GEORGE E. CRANMER, DENVER, COLORADO

J. B. BENEDICT, ARCHITECT

Lava stone on background of salmon colored stucco—black iron and silver gray oak doors

674



ENTRANCE PORCH

HOUSE OF GEORGE E. CRANMER, DENVER, COLORADO

J. B. BENEDICT, ARCHITECT

Columns and arches are of Del Norte lava stone—fawn color—stucco walls and vaulting of salmon colored stucco, brick floor in varigated colors—basket weave pattern

674 6



THE HALL
HOUSE OF GEORGE E. CRANMER, DENVER, COLORADO
J. B. BENEDICT, ARCHITECT





LIVING ROOM

HOUSE OF GEORGE E. CRANMER, DENVER, COLORADO

J. B. BENEDICT, ARCHITECT

Walls of umbered-gilt, Gesso ornament around openings, curtains of iridescent gold and black, square pocket build in back of circular beaded openings for adjustment of curtains which may be completely concealed if desired. On left wall bookcase simulates window openings

6747



674^d



DINING ROOM
 Finished in cement plaster, stippled between ceiling beams



HOUSE OF GEORGE E. CRANMER, DENVER, COLORADO
 J. B. BENEDICT, ARCHITECT

The cast hall gives on the patio. It serves the double purpose of circulation and sun room. The openings are fitted with sash which may be opened to the full size of the masonry openings. The door in the background leads to the bedroom wing. The near end of the hall is used as a breakfast room

DEPARTMENT OF ARCHITECTURAL ENGINEERING

A Modern Textile Mill

By ERNEST FALLOWS.

THE Bay State Cotton Corporation's new 35,000 spindle combed yarn mill and storehouse, recently completed at Lowell, Mass., furnishes an excellent example of present day industrial construction.

The mill building is 394 feet long by 142 feet wide, three stories in height with a four-story tower and ample basement. The storehouse is 137 feet long by 72 feet wide, seven stories high. Both buildings are flat slab, reinforced concrete construction. Large as they are, these buildings are only the first part of a developing plan, and arranged to allow eventually, without disturbance, for a 200 per cent. addition.

Baled cotton is delivered direct from the car to the storehouse. The storage space has been carefully adjusted as to area, floor heights, windows, etc. Bales are stored on end, one bale high, with enough surplus space to give light and ventilation and room for handling of cotton. By this method of storing cotton, an accurate inventory of the various grades and marks of cotton can be readily taken.

The cotton is conveyed from the storehouse across a connecting bridge to the picker room of the spinning mill, which occupies the fourth tower floor of the building. In this mill, contrary to the usual custom in laying out picker rooms for cotton mills, the

pickers are located on the top story and there is no dust chamber. The dust from the pickers is taken care of by an exhaust system, which blows it to a specially constructed bin located in the cotton storehouse.

Finished laps are taken from the delivery end of the finisher picker and automatically conveyed in a lap carrier on belt, spiral and gravity conveyors to receiving stations at the card alleys on the floor below. The empty lap carriers are automatically returned to the picker room.

The cotton, after going through the cards located on one side of the room, passes through the combing processes, drawing and slubbers, to the other side. After the slubbing processes, the roving in boxes is just dropped through a hole in the floor, where, by the use of spiral, gravity and belt conveyors, it is carried to a receiving station on the floor below at the

intermediate frames and the empty boxes are automatically returned.

Conveyors are also employed to carry roving from the fine frames to spinning and from spinning to spoolers. This arrangement reduces to a minimum the carrying distance of material and allows for an arrangement of machinery with aisles running across the mill so that the light from the window shines down the working alley.



THE LOWELL TEXTILE MILL AND STOREHOUSE IN COURSE OF CONSTRUCTION



TEXTILE MILL AND STOREHOUSE FOR THE BAY STATE COTTON CORPORATION, LOWELL, MASS.
LOCKWOOD, GREENE & COMPANY, ARCHITECTS AND ENGINEERS

THE 'AMERICAN ARCHITECT

The windows are 25 feet wide by 13 feet high and admit an abundance of light, which, assisted by the flat slab type of construction, not only reduces the cost of artificial lighting and eye strain, but multiplies good cheer, making people happy in their work.

The columns are spaced 28 feet apart, which allows for an efficient machinery layout with good working alleys and operating floor space.

The building may be extended and additional

The welfare of the employees has been carefully considered from every angle. There is a certain amount of satisfaction and contentment that comes to the employees unawares in the knowledge that they are housed in an attractive, substantial, concrete building, safe against fire, free from constant vibration which unpleasantly affects the nervous system, and with artificial illumination that is second only to daylight.



THE SPINNING ROOM—LOWELL TEXTILE MILL

Attention is directed to the very excellent natural illumination, which will foster maximum production.

equipment added without disturbing the present machinery layout.

Heat and humidity are supplied from a central station and are all governed by automatic control to the exact requirement. There is an entire change of air containing the right amount of heat and moisture in each room at least every six minutes, and this is accomplished without draft.

Each floor is provided with clean, well-lighted and sufficient toilet facilities fitted with the best of modern fixtures. There are also locker rooms separate from the toilet room, with individual lockers for each of the employees.

The buildings themselves are splendid pieces of architectural design, and something that the employees as well as the owners cannot fail to be proud of. Mechanically perfect as present day skill and ingenuity can make it, generously endowed with the things that count for human contentment in its work, the production from the new plant cannot fail of establishing a new, high record in the industry. This is a phase of industrial development receiving ever increasing consideration on the part of manufacturers.

This plant was designed by Lockwood, Greene & Co., architects and engineers. It was built by the Aberthau Construction Company.

The Artificial Illumination of Motion Picture Theatres

Present Abuses and Suggested Improvements

Part II

IN the preceding article Mr. Bragdon set forth the present abuses which exist in the artificial illumination of the motion picture theatre, as well as indicating the steps necessary to remove them. He clearly affirmed the necessity of co-operation on the part of the architect. In an effort to determine what intensities of illumination and brightness were desirable in the motion picture theatre, a series of experiments were carried out at the Eastman laboratories at Rochester, N. Y., the results of which were presented in a paper entitled "An Improved Method for the Illumination of Motion Picture Theatres," by L. A. Jones, read before the recent convention of the Illuminating Engineering Society at Cleveland, Ohio. In this excellent paper, here presented in part, Mr. Jones briefly reviews conditions as relating to the artificial illumination of the motion picture theatre, and suggests methods, which, if adopted, would vastly improve conditions. He states:

"In the early days of the motion picture industry it was customary to present pictures in a room containing practically no illumination other than that resulting from the light reflected from the screen. This procedure may have been justified to a certain extent at the time because screen illuminations were very low, making it necessary to exclude practically all light from the room in order that the resultant picture might appear to be of satisfactory brightness. With the progress in development of projection apparatus, the screen brightness has been raised continually, until at the present time such values are relatively high. Improvements in the quality of the photographic materials have resulted in better positives for projection which also tends to give pictures of greater clearness and brilliancy. Along with this tendency to increase the screen brightness, modifications of the interior illumination of motion picture theatres have taken place. The trend has been in the direction of increased room illumination, and with the appearance of the higher class theatres, devoted exclusively to the exhibition of motion pictures, has come considerable development in the art of interior illumination of such places. The existence of higher screen brightness naturally permits of greater illumination without serious interference with the quality and brightness of the projected pictures.

"The desirability of providing sufficient illumina-

tion for the convenience and comfort of the audience, if this can be accomplished without perceptible loss of quality in the projected picture, is obvious. It is scarcely necessary to enumerate the many serious objections to the use of very dimly lighted rooms in which motion pictures are being exhibited to large audiences. The difficulty encountered by persons entering from the relatively brightly lighted exterior regions in finding their way to unoccupied seats is considerable.

"It is evident that for the satisfactory exhibition of motion pictures the general illumination in the theatre must be subdued in order that the projected picture shall be of good quality as regards its apparent brightness and contrast, and that in raising the value of the general room illumination there is a limit beyond which it is impossible to go without seriously affecting these characteristics of the picture.

"While a great deal has been done in improving the character of the illumination of such theatres, the problem seems to have been approached largely from the purely practical standpoint with the object of producing *artistic effects, and for the enhancement of the ornamental detail* of the interior rather than with the idea of producing maximum visual comfort for the audience while at the same time maintaining satisfactory photographic quality in the projected picture. It, therefore, seemed worth while to approach this problem from the standpoint of the retinal sensibilities, and to link up the conclusions drawn from such a consideration of the subject with those resulting from practical tests.

"In order to make an actual determination of the maximum general illumination permissible, an experimental lighting system was installed in the projection room in the research laboratory. In designing this system an attempt was made to obtain the maximum average illumination on the table plane (horizontal surface 30 in. above the floor) with a minimum of illumination on the projection screen, and further to distribute the light so that no area either of wall, ceiling or lighting fixture should be sufficiently bright to cause glare or appreciable increase in the adaptation level of the observer.

"In Fig. 1 is shown a side elevation of the room in which the experiments were conducted, with the locations of the various elements of interest in this prob-

lem and the dimensions of importance. In Fig. 2 is given a plan view showing the position of the stations on the table plane at which measurements of illumination were made. The ceiling of this room is painted white, while the walls are a medium tone of buff.

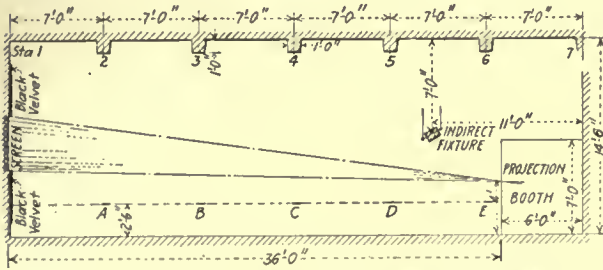

FIG. 1. LONGITUDINAL SECTION OF ROOM IN WHICH EXPERIMENTS WERE CONDUCTED

The projection screen is of the metallic type (Gau-mont), having a high reflecting power for points on and near the axis, but falling off rapidly for angles greater than 15° from the axis.

"The lighting fixture used was constructed by mounting six 10 x 12 darkroom ceiling lamps on a light wooden frame work. In order that the position of this fixture could be adjusted to give various distributions of the light, it was suspended as shown in Fig. 3.

"The vertical members *AA* carry the horizontal member *B*, which is a cylindrical metal rod about 21 feet long. One of these fixtures is mounted near each side of the room and parallel to each other.

"Upon these horizontal ways operate the sliding carriages *C*. Over small pulleys attached to this carriage the sash cords *FF* operate and suspend the light-fixture as shown. By means of these adjustments it is possible to adjust the position of the lighting fixtures to any desired distance from the ceiling, to vary its distance from the projection

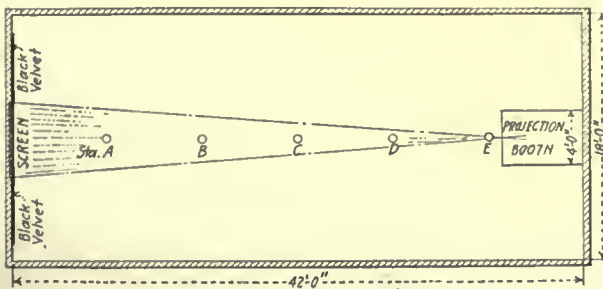

FIG. 2. PLAN OF EXPERIMENTAL ROOM

screen by a considerable amount and further to vary the inclination at which the fixture hangs, thus controlling to a great extent the distribution of the light from the fixture.

"Complete diffusion of the light from the incandescent lamps mounted in the fixture was obtained by

inserting a sheet of 10 x 12 in. opal glass in the position provided for holding the safelight. In the projection booth is situated a projection machine of the ordinary type. An arc current of 25 amperes was used throughout the tests. With this current the screen brightness as measured with the machine running, but without a picture in position was found to be approximately 20 foot-candles. This measurement was made from a point very near to the axis of projection, and, due to the character of the screen, was much higher than the brightness measurement made from points a few degrees from the axis. From measurements made previously in several of the motion picture theatres in Rochester, an average value of screen brightness under similar conditions was found to be approximately 15 foot-candles. The screen brightness used in these experiments therefore is somewhat higher than is ordinarily met with in practice.

"The lighting fixtures having been installed, the procedure followed was to determine by trial and error the maximum amount of light which it was possible to use without causing an appreciable loss of quality in the picture."

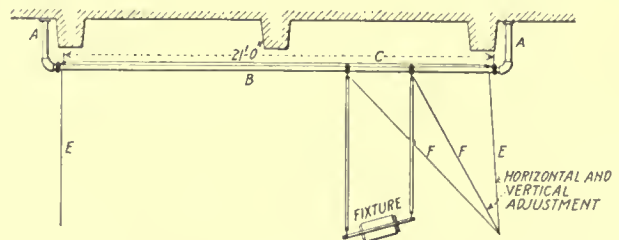

FIG. 3. METHOD OF SUSPENDING ADJUSTABLE LIGHTING FIXTURE USED IN TESTS

(The detailed account of the tests is here omitted, the conclusions following.—Ed.).

"The conclusions to be drawn from these experiments are that a relatively large amount of general illumination may exist in motion picture theatres without appreciably affecting the quality of the projected picture, provided that the illumination is properly distributed.

"In Fig. 4 is shown a possible arrangement of the lighting system which would give a highly satisfactory theatre illumination. This plan is presented as illustrative of one way of handling the problem, and undoubtedly many others may be worked out.

"The ceiling, which consists of four arches or concavely curved surfaces, is illuminated by lamps included in the fixtures as indicated, the intensity of the various lights being arranged roughly as indicated by the numbers $i = 1x$; $i = 4x$, etc. This would result in a relatively high ceiling brightness at the rear of the theatre and a relatively low value at the front. Since the lamps themselves must be placed compara-

tively close to the ceiling, it would be necessary in order to obtain an approximately uniformly graded ceiling brightness to arrange the decorative scheme applied to the ceiling so that the region marked *B* would have a relatively low reflecting power, while those marked *A*, on the other hand, would have a very high reflecting power. While the details of such decorative system have not been worked out, it is undoubtedly possible to achieve. The lighting of

only given as suggestions of what might be done in arranging an indirect system of illumination in order to conform with the conditions previously outlined. The beam structure adopted in any particular case will be influenced to a great extent by the architectural style of the theatre, and the diagrams given serve only to suggest a method of concealing the lamp within the beam structure and at the same time obtain the proper illumination of the ceiling.

"It should be mentioned also that the illumination in the lobby and in the various vestibules and extreme rear of the theatre should be so arranged that a person entering the theatre passes gradually from the illumination of the exterior to that of the body of the theatre. That is, the transition from exterior brightness level to the interior brightness level should be made in a series of gradual steps rather than in a single abrupt step.

"The general conclusions are, therefore, as follows:

"It is quite possible to use a system of lighting in a motion picture theatre which will result in illumination levels on the table plane much higher than those at present prevailing. The illumination may in fact be raised to such an extent that ordinary newspaper print can be read with ease by an observer adapted to the existing brightness levels. The presence of this increased illumination does not cause any appreciable degradation of quality in the projected picture. The accomplishment of such satisfactory results depends upon the proper distribution of the light.

"While it is impossible to outline specific instructions for particular cases without detailed knowledge of such factors as dimensions and architectural details of the room, the reflecting power of the various

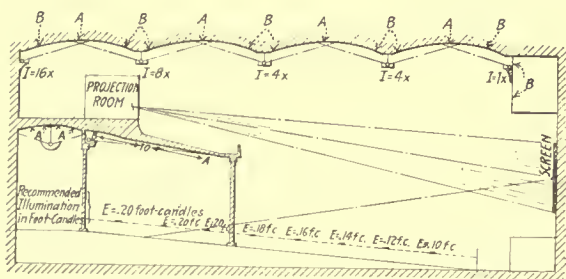

FIG. 4. LONGITUDINAL SECTION OF TYPICAL MOVING PICTURE THEATRE

Here is shown one method of providing correct illumination. The relative values of the light sources are shown. It will be noted that these increase considerably from screen to lobby. The proper light intensities on plane 30 inches above the floor are also given.

the ceiling underneath the gallery is obtained from lamps at *B*, and here again the ceiling reflecting power should vary from a low value at *B* to a high value at *A*.

"The desirability of close co-operation between the lighting engineer and the designer of the decorative scheme to be applied to the interior of the field should be emphasized. The proper adjustment of the reflecting power of various wall and ceiling elements is a powerful factor in the control of the brightness of such surfaces, and considerable judgment and skill in the adjustment of the decorative scheme to the lighting system may be necessary in order to prevent certain surfaces very close to light sources from having excessive brightness.

"From the results of the experiments in the projection room, it has been concluded that the illumination on the table plane at various points in the theatre should be approximately as indicated by the values of *E*, and the number and size of the light units used should be so adjusted as to give the indicated values. While an approximate computation could be made indicating the number and size of units necessary, it would be quite impossible without detailed information of the dimensions of the room, the reflecting power of various surfaces, and the exact position of the lamps to make a definite estimate as to the total quantity of light flux necessary.

"In Fig. 5 are shown three cross sectional diagrams illustrating the possibilities in beam design which would result in a satisfactory distribution of the light flux over the ceiling. These designs, of course, are

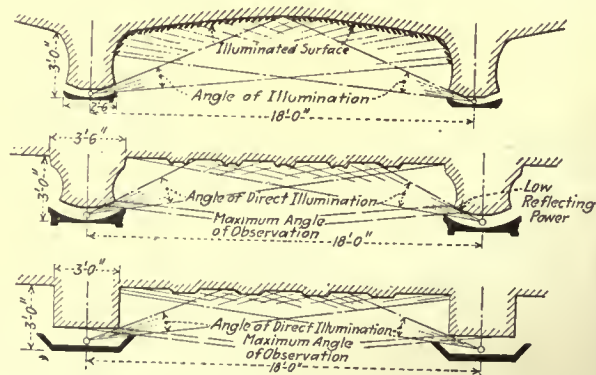

FIG. 5. THREE CROSS SECTIONS ILLUSTRATING SUGGESTED METHODS OF THEATRE ILLUMINATION

ceiling and wall surfaces, and the position of the light fixtures, the following general principles may be outlined, it being understood that the numbered values are approximate and that some variation may be allowable, depending upon the particular case.

THE AMERICAN ARCHITECT

(1) The illumination on the table plane should vary from 0.10 foot-candles at the front of the theatre to 0.20 foot-candles at the rear.

(2) No area (outside of the projected picture) visible from any seat in the theatre should have a brightness of more than 2.5 to 3.0 millilamberts.

(3) The attainment of (1) without exceeding the values mentioned in (2) requires the use of very extended effective sources such as illuminated ceiling and walls, and is best accomplished by the use of an indirect system of lighting.

(4) All light sources and fixtures, such as diffusing globes and translucent glassware having a surface brightness of more than 2.5 to 3.0 apparent foot candles should be entirely concealed from view.

(5) It should be noted that a sheet of white paper illuminated by a 25-watt lamp at a distance of 12 in. has an approximate brightness of 20 apparent foot-candles. A sheet of music, therefore, illuminated in this way, if visible, becomes a glare spot and may cause great discomfort to the audience. Arrangements should therefore be made which, while providing adequate illumination for the musicians in the orchestra, will prevent the illuminated music sheets from being visible to the audience.

(6) Considerable attention should be paid to the character and position of exit signs. While it is necessary to make such signs very conspicuous, this can be accomplished without making them so brilliant as to become disagreeable glare spots in the field of the observers' vision.

(7) The contrast between the highest light of the picture and the surrounding frame should be less than 1 to 1000, preferably less than 1 to 500. Black frames should therefore be avoided, one of neutral gray being much preferable.

(8) Lighting of lobby, vestibules, etc., should be so arranged that the transition from the brightness level of the exterior to that of the interior or vice versa is accomplished by a series of small differences rather than by a single large one. Such arrangement will to a great extent eliminate the visual shock which accompanies a sudden change in the intensity of the visual stimulus.

(9) The use of a projection screen set well back on the stage and thus shielded to a great extent from the light reflected from ceiling and walls would probably permit the use of even greater room illumination than was used in these experiments.

"In conclusion the author wishes to acknowledge his indebtedness to Dr. C. E. K. Mees for helpful suggestions throughout the course of this work, and to Mr. Milton Fillius, who ably assisted in the conduct of the investigation."

It would seem that the information obtained as a result of these tests is of a most valuable character.

The figures giving the lighting intensities which will produce the maximum of eye comfort to the audience, as well as allowing adequate contrast between the screen and its surroundings, can be at once put to practical use. The gradation of the illumination from entrance to screen seems an essential feature, and will, of course, require fixtures of varying output. By masking all sources of light, thus eliminating glare, a much softer effect is produced. It is to be hoped that a very general improvement in the artificial illumination of the motion picture theatre will soon become apparent, and the architect should use every effort to bring this about.

A Building Code for Pennsylvania

A commission designated as the State Building Code Commission has spent several years in earnest study and faithful work in attempting to formulate a building code for Pennsylvania. For various reasons it was not adopted by the legislature. That there is need for more adequate building regulations in Pennsylvania becomes more apparent each day. As a step toward securing such a code, a meeting has been called of a committee named by Clifford B. Connelley, Commissioner Industrial Board, to be held in Harrisburg, November 18, to talk over the entire situation.

The bill as presented had incorporated within it a provision, to the effect, that separate codes for the several classes of buildings be worked out as standards of the Industrial Board of the Department of Labor and Industry—a provision which, perhaps, could be developed at this particular time. The committee will probably discuss the advisability of the Industrial Board drafting a code, using as a basis the data already gathered, with the aid of a representative committee of persons interested in the building construction industry.

The building code committee consists of James C. Cronin, chairman, member of the Industrial Board, Keystone Building, Harrisburg, Pa.; Fred J. Hartman, secretary of the committee, secretary of the Industrial Board, Keystone Building, Harrisburg, Pa.; D. Knickerbacker Boyd, F. A. I. A., architectural advisor and structural standardist, Structural Service Bureau, Esty Building, 1700 Walnut St., Philadelphia, Pa.; Edwin Clark, Chief of the Bureau of Building Inspection, City of Philadelphia, Philadelphia, Pa.; S. A. Dies, superintendent, Bureau of Building Inspection, City of Pittsburgh, Pittsburgh, Pa.; Prof. C. G. Dunnells, Carnegie Institute of Technology, Pittsburgh, Pa.; C. T. Ingham, representing Pennsylvania Chamber of Commerce, Vandergrift Building, Pittsburgh, Pa.;

THE AMERICAN ARCHITECT

John Molitor, chief, Bureau of Housing, Department of Health, Harrisburg, Pa.; Bernard F. O'Rourke, Inspector of Buildings, Wilkes-Barre, Pa.; Edgar A. Weimer, consulting engineer, Leb-

anon, Pa.; E. F. Welsh, Pennsylvania Building Trades, Pittsburgh, Pa.; and G. H. Danforth, representing Pittsburgh Building Code Commission, 529 North Euclid Ave., Pittsburgh, Pa.

THERMAL CONDUCTIVITIES OF VARIOUS INSULATING AND BUILDING MATERIALS

All the figures given below, with the exception of the first two, are the results of measurements made at the Bureau of Standards, Washington, D. C., on representative samples of materials. They represent actual internal conductivities, surface effects having been eliminated. The mean temperature of the determination was about 25° C., and the temperature differences used varied from 10 to 25° C.

Material	Description	Conductivity		Density	
		K	k	D	d
Vacuum	Silvered vacuum jacket—Residual air pressure about 0.001 mm Hg.	.000002	0.1
Air	Ideal air space—If radiation or convection could be prevented	.000060	4.2	.0012	0.08
Calorox	Fluffy finely divided mineral matter	.000076	5.3	.064	4.0
Kapox	Imported vegetable fibre—loosely packed	.000082	5.7	.014	0.88
Pure wool		.000084	5.9	.11	6.9
Pure wool		.000084	5.9	.10	6.3
Hair felt		.000085	5.9	.27	17.
Pure wool		.000090	6.3	.08	5.0
Keystone hair	Hair felt confined with building paper—flexible	.000093	6.5	.30	19.
Mineral wool	Medium packed	.000095	6.6	.20	12.5
Corkboard	No artificial binder—low density	.000096	6.7	.11	6.9
Mineral wool	Felted in blocks	.000099	6.9	.29	18.
Cotton wool	Loosely packed	.000100	7.0
Pure wool		.000101	7.0	.04	2.5
Insulite	Pressed wood pulp—rigid	.000102	7.1	.19	11.9
Linofelt	Vegetable fibre confined with paper—flexible and soft	.000103	7.2	.18	11.3
Ground cork		.000102	7.1	.15	9.4
Corkboard	No artificial binder—high density	.000106	7.4	.18	11.3
Celite	Infusorial earth powder	.000106	7.4	.17	10.6
Granulated cork	About 3/16"	.000107	7.5	.13	8.1
Cabots Quilt	Eel grass enclosed in burlap	.000110	7.7	.25	16.
Flaxlinum	Felted vegetable fibres—firm and flexible	.000113	7.9	.18	11.3
Bibrofelt	Felted vegetable fibres—firm and flexible	.000113	7.9	.18	11.3
Rock cork	Mineral wool and binder—rigid	.000119	8.3	.33	21.
Balsa wood	Very light and soft—across grain	.00012	8.4	.12	7.5
Wool felt	Flexible paper stock	.000125	8.7	.33	21.
Lith board	Mineral wool, vegetable fibres and binder—rigid	.000131	9.1	.20	12.5
Planer shavings	Various	.00014	10.	.14	8.8
Pulp board	Stiff pasted board	.00015	11.
Air cell 1/2"	Corrugated asbestos paper enclosing air spaces	.00015	11.	.14	8.8
Air cell 1"	Corrugated asbestos paper enclosing air spaces	.00017	12.	.14	8.8
Asbestos paper	Asbestos and organic binder	.00017	12.	.50	31.
Infusorial earth	Natural blocks	.00020	14.	.69	43.
Fire felt sheet	Soft, flexible asbestos sheet	.00021	14.	.42	26.
Fire felt roll	Asbestos sheet coated with cement—rigid	.00022	15.	.68	43.
Cypress	Across grain	.00023	16.	.46	29.
Fullers earth	Argillaceous powder	.00024	17.	.53	33.
Asphalt roofing		.00024	17.	.88	55.
White pine	Across grain	.00027	19.	.50	32.
Asbestos mill board	Pressed asbestos—not very flexible	.00029	20.	.97	61.
Mahogany	Across grain	.00031	22.	.55	34.
Insulx	Asbestos and plaster blocks—porous	.00031	22.	.47	29.
Virginia pine	Across grain	.00033	23.	.55	34.
Oak	Across grain	.00035	24.	.61	38.
Hard maple	Across grain	.00038	27.	.71	44.
Paraffine	"Parowax," melting point 52° C.	.00055	38.	.89	56.
Gypsum plaster		.00078	54.
Asbestos wood	Asbestos and cement—very hard and rigid	.00093	65.	1.97	123.

K = Thermal conductivity in Calories per sec. per sq. cm. per deg. C. per cm. thickness.

k = Thermal conductivity in BTU per day per sq. ft. per deg. F. per inch thickness.

D = Density in grams per cu. cm.

d = Density in lbs. per cu. ft.

69700 K = k. 62.5 D = d

Current News

Happenings and Comments in the Field of Architecture and the Allied Arts

Further Details on the Chicago Architectural Exhibit

The Own Your Home Exhibition to be held in the Coliseum, Chicago, March 26 to April 2 is to be an immense affair sponsored by the Architectural League and the Federated Arts Club of New York, the Illinois Chapter of the American Institute of Architects, the Illinois Society of Architects, and the Landscape Architects of America. The exhibits will be taken by special train to New York for a second showing at the close of the exhibit here.

Model houses to be built at low cost, will be erected in the Coliseum. In and around these will be every device for comfort and economy. Every article from the latest model electric dishwasher to steam heated chicken houses will be shown in operation.

Not only will the exhibition show how to build houses, but how to get the money to build.

"The architects' committee will pass on all exhibits," said Henry K. Holsman, president of the Illinois Chapter, American Institute of Architects. "Our idea will be to make every exhibit tend to create a feeling that the visitors should own their homes.

"The architectural committee is conducting a national competition for houses of four, five and six rooms. There are four sets of prizes totaling \$15,000 for designs in lumber, brick, concrete and stucco.

"At least thirty of the designs will be published in a book to be sold at cost at the exposition and elsewhere. The leading architects of America are competing. A condition of acceptance of a prize for design is that the architect will consent to the sale of a complete set of working drawings and specifications to builders at not to exceed \$25.

"The book will give prospective builders facts on how to put up the most modern homes at the least expense.

"A special committee will be appointed to show interested visitors how to borrow building money at the lowest interest.

"The drawing of plans for small homes has been neglected because at the regular fee of 3 per cent., or 6 per cent., with personal supervision, such work does not pay a busy architect. Of course to draw plans for \$25 and a prize and then have one's name on the plans so that one will have to answer ques-

tions, will be largely philanthropic. But the architects feel that they should lead the way in making Chicago a city of homes."

The entire exposition will be laid out by the landscape architects.

Robert H. Sexton is managing director of the exposition.

Chicago to Have Huge Post Office Terminal

A post office to cost six million dollars is now being constructed in conjunction with the new Union Station in Chicago. It will be located between Harrison and Van Buren streets, just west of the river.

Postal officials believe the construction of this building will in large measure solve the chaotic conditions of Chicago's mail service. The building will be designed by Graham, Anderson, Probst & White.

Warsaw Limits Every Family to Three Rooms

All rooms in private dwellings have been commandeered by the government to meet the housing situation in Warsaw, Poland. Only three rooms will be allowed for a family with children regardless of the wealth or social position of the tenant.

Warsaw has doubled in population since the war and further complications were caused by recent arrival of thousands of Bolshevik prisoners who have not been disposed of by the peace terms.

Food distribution was largely in the hands of the American relief administration this winter as in the past. Hoover food drafts which pour into the country with every mail are saving thousands from death by starvation.

Revival of Hand-Painted Furniture

One of the large furniture companies recently located in the Long Island City section is now making an effort to engage the services of artists to decorate furniture. In sending out the announcement that it is ready to give employment to artists the firm says that an entirely new line of goods is about to be placed on the market. The decorations are to be similar to those which were used on furniture nearly a century ago and which were used most effectively

by foreign makers. Some persons who are now past middle life will remember the furniture which was to be seen in homes of thirty and forty years ago, with carefully wrought pictures upon them. This furniture, for the most part, consisted of heirlooms and it has all practically disappeared from homes of the present day. The revival has come because many people are desiring to get away from the strict lines that have existed in furniture for a number of years. It is proposed in the new furniture that is now being planned to have artistic work of real merit displayed. The cost of the furniture will be commensurate with the skill put in its manufacture.

Church 125 Years Old

The Episcopal Church, St. Mark's-in-the-Bouwerie, at Second avenue and Tenth street, New York, which was recently illustrated in *THE AMERICAN ARCHITECT* by the sketches of Mr. Otto R. Eggers, has just celebrated the 125th anniversary of its existence.

A feature of the celebration was the unveiling of three statues. Two are in the portico and one is on the lawn. Those in the portico represent "Inspiration" and "Aspiration," and they are figures of two American Indians.

The statue on the lawn is called "The Little Lady of the Dew," and is of a nude woman. The sculptor was Gutzon Borglum. There is a niche, representing the spirit of baptism, with its running water, its arbor vitae, and the girl holding forth the waters.

An address was delivered by the Rev. Dr. William T. Manning, rector of Trinity Church, on the topic, "The relations of city to Church."

Business Men's Art Club for Boston

A Business Men's Art Club, on the lines laid down in Chicago, may be formed in Boston. The article published recently in the *AMERICAN ARCHITECT*, telling of the plans and the activities of the Chicago organization, attracted the attention of Boston business men who have taken up painting as a hobby or recreation, and it is now proposed to attempt to form an organization on similar lines in this city.

"It is desired to form a Business Men's Art Club in Boston," says a communication which has been sent to *The Transcript*. "The club is to be composed of business men who are studying or would like to study art as an avocation or hobby. The object being to encourage the study and practice of painting among the members and to co-operate with societies now aiming to broaden the appreciation of art in our city.

"It is desired to bring together men of middle age, men who desire to learn to paint, but who cannot or

do not care to join day classes of young pupils, men who love nature and enjoy a recreation which challenges their best intellectual effort and would give them a means of self-expression.

"It is proposed to have classes one or two evenings a week, and on Saturday afternoons and other days, when convenient, outdoor sketching under the instruction of competent teachers."

Business men of Boston desiring to become members may communicate with Charles W. Cheney, Hotel Charlesgate, Boston.

Sweden Suffers from Money Shortage

Sweden is suffering from a scarcity of money and an abnormal economic situation. This is reflected in the report of the state bank for September.

The money shortage depresses the stock exchange, where prices of bonds and shares have touched a very low level, even the old fashioned industrial enterprises which pay dividends of 10 to 15 per cent. being quoted below par.

Causes to which Sweden's unsettled condition is attributed here include the socialist program, emanating from the present government, such as the investigation whether socialization of industry and commerce lies within the borders of possibility, heavy taxation, an increasing demand for higher wages, and the labor unrest.

Adding to this the growing debts to foreign countries through unnecessary imports, and decreased production ascribed by many to the eight-hour day, one obtains a picture of the present economic position of Sweden.

Rebuilding Ruined Areas

Throughout practically the whole of the devastated districts of France from 70 to 85 per cent. of factories and workshops employing over 20 men before the war have been rebuilt and are at work, it is stated in a cable to *The New York Times*. The latest figures, issued by the Ministry of Reconstruction, show enormous improvement even on those of the summer.

On October 1 the number of establishments again in working order was over 4,240, of which 75 per cent. have reached nearly the pre-war output. The department of Ardennes comes first in the list of those whose establishments have been put in order with 83 per cent. Meurthe et Moselle comes second with nearly the same percentage and the departments of the Nord, Pas de Calais, Marne and Vosges have all over 73 per cent. of their industries again at work. Forty-five thousand employes are back at work.

Naturally some industries have recovered quicker than others and at the head of the list is the chem-

ical industry with 54 per cent. former employes. The textile industry is employing 50 per cent. in spite of the bad season which has set in, while the metal and stone workers also number approximately 50 per cent. of those formerly engaged.

In the city of Lille, where there was not so great material damage as in other parts, 87 per cent. of factories have reopened and 64 per cent. of the former employes are again at work.

Black Beetle Destroys Forests

A little black beetle, half the size of a coffee bean, annually causes more losses to American timber than all the forest fires caused by man or nature.

Aristocrat of timber borers, called "Dendroctonus," he has been marked for extermination by the United States Forest Service, which is waging war upon him as relentlessly as upon the human firebug.

Annually he destroys almost 2 per cent. of the growing timber in the nation. More than 95 per cent. of the dead and dying trees encountered in a walk through the forests give mute testimony to his deadly operations.

"Dendroctonus" first bores in through the bark, prepares a neat little home for himself and family, and operations begin. Spreading out in all directions the family increases until the entire tree is encircled. Off the rich life tissue between the tree proper and the bark they live, cutting off the sustaining sap. This job completed by death of the tree, the whole family, this time perhaps a thousand times more numerous than before, moves on.

As many as 100 trees have been found destroyed in one section. This represents an average value of \$4,500 per section, from which it can be seen that this innocent looking little insect has cost the people of the United States hundreds of millions of dollars.

But he's a marked bug! Every tree found with signs of the Dendroctonus is cut down and burned by the forest rangers. Traps, consisting of cut-down trees, are laid for him, and then destroyed.

Dust—An Industrial Criminal

It would be difficult to imagine anything more innocent in appearance than this waste product which, in one year, killed eighty persons and destroyed \$7,000,000 worth of food and property in the United States, yet such, reports *The Nation's Business*, is the bill found by the United States Department against dust, just ordinary, commonplace dust that flies from wheels and cylinders and fans and settles all over the factory.

Grain dust, starch dust, sugar dust, leather dust and aluminum dust are all explosives, and the Department of Agriculture suspects a great many other kinds.

Grain dust is the worst enemy apparently; the damage it causes every year runs into millions. If that were the only evil result matters would not be so bad, but a more sinister item is that dust manages to kill many Americans every year.

An educational campaign is being waged by the Department of Agriculture to put an end to this industrial criminal.

Apartments for Babies

Babies are to be offered special inducements to become tenants of a row of buildings on the south side of Ninth street, from Fifth avenue to University place, which are being rebuilt by order of the trustees of Sailors' Snug Harbor.

The architects, Scott & Prescott, have been instructed to provide storerooms for perambulators near each entrance and to arrange gardens in the rear wherein baby may snatch a siesta under the shelter of a bush.

Novel Prison Bar Designed

A new type of bars designated for prisons are of hollow metal, filled with water. These pipes are all connected with a central pump, and the water is kept under high pressure. Thus, the slightest break in any bar would cause a powerful jet of water to spurt out. To continue filing the bar would be almost impossible. Also the fact that there was a leakage somewhere would be registered on a dial on the central pump, and lead to speedy investigation.

Decorations in the Business Office

Man adorns his office these days because he finds in harmonious surroundings a new power and quickened imagination, writes John Walker Harrington in *Arts & Decoration*.

Because he is in business he realizes that the man whose mind can reach out beyond four walls the greater will be his meed of success.

The idea that one might see visions of big business and develop plans and reach clear-cut decisions amid environments of beauty has come to many men by way of their homes. When they saw to it that their dwellings were appropriately decorated, they reserved at least one room where they might, on occasion, withdraw to think out their worldly affairs. Some of them had libraries, others studios, and many designated these retreats by the much abused title of den. They found that often such apartments served well for important conferences, but, above all, they answered the purpose of affording places of withdrawal from petty detail.

It came to pass, therefore, that our leaders in finance and industry said to the interior decorator: "You have done well with my home. Why can't

THE AMERICAN ARCHITECT

you do something like this for my private office?"

Why not, indeed? Hence the new movement which has resulted in making many an abode of business into a spot where dullness and banality cannot enter. Very often, owing to the lack of ground in the city, the occupant of the modern suites of offices looks out upon a narrow slit of a court or upon tier upon tier of windows piercing the steep walls of skyscrapers. If he has no view from his desk which suggests the world and the teeming city, at least he may have his working place so decorated that it will feed his fancy and quicken his mind.

The artist does his best in a studio surrounded by objects which, by color and form, give him unconscious suggestions of beauty; the author stays in his study, where, almost without his knowing it, some choice etching or a gilt title of a book may bring inspiration. The successful business man, too, although he may not be disposed always to admit it, is a seer, whose intellect is stimulated by the settings in which he is placed. The late J. Pierpont Morgan would have been fretted and harried in the presence of filing cabinets, clattering typewriting machines, and all the trappings of business efficiency. In the private office in his wonderful library he evolved great financial plans, a modern Lorenzo the Magnificent in his chamber of the palace.

A Worcester Architect

The career and works of Elias Carter, architect, of Worcester, form the topic of an interesting illustrated article by Mrs. Harriette M. Forbes in the October number of *Old-Time New England*. His designs included those for the Salisbury house, the Burt house, the Lincoln house, the Waldo house, the Dowley house and the Bullock house, all in Worcester, where he worked from 1828 to 1837. He also designed the John Wyles house in Brimfield, the Unitarian church in Kendon and the Charles Lee house in Barre.

New Tourist Accommodations for Bermuda

The project for the establishment of a new center for tourists in Bermuda having been approved, the Bermuda Development Company has begun work on what is considered the most important and pretentious undertaking the islands have ever known. A tract of 500 acres has been secured at Tuckerstown, near St. George's, for the site of the new resort. The buildings, which will include a fine hotel and a number of bungalows, are to follow the Bermuda style in exterior appearance; the

interiors, however, are to be of the most modern and comfortable type.

Noiseless Chamber Constructed for Research Work at the Famous University of Utrecht

It is said that the physiological institute of the University of Utrecht possesses what is probably the most remarkable room in the world, a chamber about seven and one-half feet square, which is claimed to be absolutely noiseless, as far as the entrance of sound from outside is concerned.

It is on the top story of a laboratory building and is an inside room, but is so arranged that it can be ventilated and inundated with sunshine. The walls, floor and ceiling each consist of half a dozen layers of different substances, with air spaces and interstices filled with sound-deadening materials.

Some persons when in the room experience a peculiar sensation in the ears. While every effort has been made to exclude sounds that are not wanted, of course the object of constructing this singular room was to experiment with phenomena connected with sound. Some of the sounds employed are made in the room itself; others are introduced from outside by means of a copper tube, which is plugged with lead when not in use.

Stamps and Housing

A practical measure to aid a practical solution of the housing problem has been adopted by the British Government. Savings Certificates issued during the war became popular immediately, and from their beginning up to the armistice produced for war expenses, \$1,015,881,075. Since the armistice and up to Sept. 1, \$725,653,210 have been sold. These certificates are popular because they cost—roughly—\$3.88 and become worth \$5 in five years and \$6.50 in ten. They are repayable at any time on short notice. The Ministry of Health has now arranged with the Government that half the money raised by the sale of the certificates in any one district should immediately become available for loans to the local authority for building houses in that district. Here is no charity, no paternal coddling by government, but an excellent chance for the people to pull themselves out of their own difficulties. Every man, woman and child can help in relieving the shortage of dwellings. If the people, really taking hold, can sell 2,000,000 certificates a week—no difficult job—\$3,875,000 is available every week for building houses.

It seems to be quite a practicable form of thrift and of community team work, with a direct bearing on a public problem.

Ellis Island Asks for More Buildings

According to plans which were prepared for and submitted to Commissioner Frederick A. Wallis, the next Congress will be asked to provide for the construction of new buildings at Ellis Island which will enlarge the present housing space of the immigration station by about 5,000,000 cubic feet. The cost is estimated at about \$5,000,000.

The entire plant on Ellis Island as it now stands cost the Government about \$7,000,000.

The heads of the immigration service and the Department of Labor at Washington have been holding conferences with a view to reaching an understanding as to the requirements of house room on Ellis Island, since the worst period of congestion ever known in the history of the plant was at its peak some three weeks ago.

Capt. A. B. Fry, U. S. N., who is chief engineer of construction for public buildings in the New York district, drew up plans and made estimates.

The improvements will include a building, or "headhouse," at the ferry slip on Ellis Island, 300 x 100. In this new building there will be a reception room, a large waiting room, headquarters for the medical director, and the general information department may learn of the status of their newly arrived relatives or friends.

There will also be two new buildings on the front lawn for quarters for fumigation rooms and executive and record divisions.

Personals

The faculty of the division of the arts of the Carnegie Institute of Technology has been strengthened this year by the appointments of three eminent figures in the world of art. They are Henry Hornbostel, Edmund M. Ashe and Joseph Bailey Ellis. Mr. Hornbostel, a member of the firm of Palmer & Hornbostel, architects, of New York, has been made professor of architectural design. He has been associated with the school since its foundation as the designer of all of the buildings on its campus and, until the spring of this year, as patron of the division of the arts. Edmund M. Ashe was the author of the famous "Lend the Way They Fight" poster that was adopted as a trademark for the Fourth Liberty Loan. He will teach illustration. John Bailey Ellis, who is professor of applied art, was formerly director of the Sawyer's Island Art School at Booth Bay, Maine.

Durham Brothers announce the removal of their offices to 1611 Sansom street, Philadelphia.

Ellert & Lahr are moving their offices from 801 World-Herald Bldg. to 1602 City National Bank Bldg., Omaha, Neb.

News from Various Sources

Douglas Volk, of New York, is painting, in Washington, a portrait of General Pershing, for the national collection to be presented to the National Gallery by a committee of public-spirited persons headed by Henry White as chairman.

* * *

The National Academy of Design announces that there will be no Winter Academy this year. The galleries in New York, which were burned last winter, are being rebuilt, but will not be ready for occupancy until about the middle of January.

* * *

Joaquin Sorolla y Bastida has postponed his journey to this country on account of ill-health. His paintings, commissioned by the Hispanic Society, New York, are not yet completed.

* * *

In the United States the loss by fire each year is about \$300,000,000—\$3 for every man, woman and child in the republic.

In Europe it is about 32 cents.

* * *

Several modern suburbs are being built about Rome. Old forts are vanishing and giving way to homes the like of which have not been seen before in that part of Italy.

* * *

In Petrograd the fare for half an hour's ride in a taxicab is 2,000 roubles, which is the equivalent of nearly \$1,000 in American money.

* * *

In order to encourage the building of beautiful residences in Paris, the authorities award three gold medals annually to the designers of the most artistic buildings.

* * *

A shortage of about 50,000 houses exists in Texas.

* * *

Schloss Fischborn, one of the most famous castles in Salzburg, Austria, has been destroyed by fire. It was a rebuilt fourteenth century building, belonging to Prince Johann Leichenstein, and contained a wealth of art and historic objects.

* * *

In Michigan, 30 firms in various sections of the state built 3,105 houses in 1919, costing \$8,955,500, for workman's dwellings. In addition 28 other firms invested \$1,500,000 in housing corporations and another firm has built a dormitory costing \$85,000 for its women employees. The General Motors Corp. has spent \$8,000,000 in Flint and Pontiac for industrial housing during the past year.

Weekly Review of the Construction Field

With Reports of Special Correspondents in Prominent Regional Centers

The general drop in prices, a recent review of credit and business conditions by the Federal Reserve Bank of New York points out, has:

proceeded with increased momentum and only a relatively small number of commodities has remained unaffected. Reports from various markets in all sections give unmistakable evidence that readjustment is in progress. Many of the basic raw products, such as hides, leather, rubber, cereals, sugar, cotton and potatoes have declined rather abruptly, and certain manufactured articles, notably textiles, automobiles and a number of other products have had substantial declines also. While quotations of iron and steel show no important changes there is an easier market, induced by such movements as the reaction in the automobile trade. The non-ferrous metals such as copper, lead and tin show substantial declines.

It is a curious and interesting fact that this drop in prices has not affected the ultimate consumer to any considerable degree. A significant example of that is shown in the clothing trade, in which thousands of persons have recently been thrown out of employment because of the shutting down of factories and mills in clothing centers in various sections of the country. This curtailment of production has been caused by the ultimate consumer himself, who has refused to buy at present prices, and who has, in reality, curtailed his buying to the point where further production by manufacturers has become little less than sheer waste. The situation, in a measure, is true of practically all industries. It is effectively illustrated in the business of department stores for October. In New York and vicinity, there was a decrease of more than 3 per cent. in sales. The increase of stocks on hand, as compared to the previous month, was about 17 per cent. for New York and vicinity and about 10 per cent. for the country at large.

THIS has had its effect on employment. There has been a reaction in that situation. Seeking the "man for the job" has now become a matter of seeking the "job for the man." In New York City the number of unemployed has been variously estimated at from 50,000 to 75,000, and it is definitely known that more than 35,000 clothing workers are at present out of work. In the country at large, the increase in unemployed over the figures of six and even three months ago is close to 15 per cent.

THIS condition has had its effect upon the financial life of the country. On November 10, the New York Stock Exchange suffered one of the worst

low level days in its history. Speaking of the stocks offered on that date, the New York Times said:

Most of them closed around the lowest of the day, and this was equally true of the railway shares, which accompanied the industrials in their early recovery and subsequent fall to a still lower level. The grain and cotton markets moved in almost exactly the same way. Wheat in particular, after rising 4 cents per bushel over Monday's closing, fell with great violence more than 11 cents, reaching the lowest price since April of 1917, the month in which the United States declared war. Cotton relapsed with wheat; its price also reached the level of the spring of 1917, and the day's New York spot price both for cotton and print cloth was marked down accordingly. Meantime the call money rate went again to 10 per cent. and, despite the recovery in European exchange, the rates on Argentina and Brazil fell to the lowest point of the present movement.

The market as a whole undoubtedly gave evidence yesterday of continued liquidation; but it is difficult to escape.

Now, the architect is little concerned, perhaps, with the technical fall and rise of wheat or spot cotton or, perhaps, with any of the stocks or commodities mentioned above, but he is concerned with any situation which shows the general downward trend so clearly as does this situation.

It applies also to lumber. There, the market is reported to remain generally dull, and several mills are preparing to cease operations. As a result, prices should come down. Perhaps they will. But, it may be asked here again, what of the ultimate consumer, the man who is building a house and who will pay for the lumber which is to go into that house? He will profit nothing, if past indications of drops in prices and prices to the ultimate consumer are any indication. Housing is as badly off at present as it has been in the past. Perhaps it is worse off. This is due, not so much to the stringency of available materials or of transportation, as the lack of money with which to build. As Joseph P. Day, the New York real estate operator, said in our last issue, "the banks are to blame." They are holding to long term bonds or loaning on call rather than investing in mortgages, Mr. Day pointed out; and, material or no material, transportation or no transportation, building cannot proceed without money.

It is interesting to note, in this connection, an address by Mr. David M. Dunning, president of the Auburn Savings Bank, at the annual meeting of the New York Savings Bank Association. Mr. Dunning takes a rather unusual position for a banker in recommending the sale of a bank's long term bonds, even if at a loss on the purchase price of the bonds, and

THE AMERICAN ARCHITECT

of investing the money thus acquired in first mortgage investments, and he gives as the reason for such a move (for the small bank) the following:

1. "They are liquid in time of trouble without serious loss. We found this feature especially desirable during the troublesome period at the outbreak of the World War in 1914.

2. "The early maturity affords opportunity for a change of interest rate, thereby enabling a bank to keep step with economic conditions, quite different from bonds, especially long time bonds.

3. "The guaranty as to principal and interest.

4. "The attention given to the insurance and taxes.

5. "The collection of interest which is invariably paid when due, is a great relief to the working conditions of our institution.

6. "At maturity the principal is available for other investment if desired. We made use of this feature during the year 1918, when we desired to invest in Liberty Bonds."

This would seem to challenge the contention of many bankers that a bank must seek investment in those industries or markets where it can draw the highest rate of interest, particularly in a call money market or in call loans. If small banks generally throughout the country adopted Mr. Dunning's attitude as the basis for loans upon real estate or building, there would be very little left of the housing problem. Building would proceed normally.

NOR would the labor element enter seriously into the matter, provided money was available for building. There has been a recent reaction in the labor situation, which is strikingly shown in the refusal, by 12,000 workers in a large manufacturing concern in Baltimore of higher wages. Labor leaders, as shown by Samuel Gompers' advice to the workers of New York City to "clean house," are realizing that high wages without consequent high efficiency, are not feasible. Labor generally seems to have realized that the wage scale must correspond to the production scale, and that inefficiency or under-production has its direct and immediate effect upon commodities, upon stock markets, and upon the finances of a nation. Production must be paid for in cash; and cash expended for a given commodity, such as labor, must be returned in full value, or suffer actual loss in its value. And the conservative element among labor leaders seem to be striving to impress labor generally with the soundness of this argument, with a consequent reduction in wages.

(Special Correspondence to The American Architect)

Boston.—As far as underlying conditions of New England business are concerned, there is as yet no evidence that the readjustment to lower commodity price levels is completed.

It is evident here in New England that confidence in the current price structure is still lacking and that there is a distinct tendency all along the line, from

manufacturer to consumer, to withhold buying until the ultimate low prices are reached. This feeling results in diminished activity in all lines of trade, curtailment of production and increased unemployment. There is hardly a day goes by but what some large New England concern, especially in textile lines, announces a reduction of working days. This, of course, has had the effect of cutting down the number of new industrial buildings for which contracts have been let.

At Plainville, and Hartford, Conn., there are housing developments well under way that will probably total ninety houses of one and two family size.

The report from the Superintendent of the Boston Public Employment office shows a big decline in business. The records show a decrease of 22 per cent. in the orders from employers, and a decrease of 26 per cent. in (compared with September) the number of people wanted by employers.

(Special Correspondence to The American Architect)

SEATTLE.—The mental attitude of investors, architects, contractors, and jobbers in building materials in this section of the country has been recently changed sufficiently to move jobs in the incipient or theoretical stage to the conclusive stage of development; but any sudden inclination in the direction of what was once known as "boom" proportions is not expected. There will be no definite improvement in the situation this year, and a majority of operators on the coast have fixed upon March 1 as the probable date of the building revival. None doubt that it will be of gigantic proportions, once prices are at bottom and confidence restored.

Inquiries from home builders and investors are visibly increased. There is a brighter aspect to finance. Change is in the air. Why this is so, no one can say, but with the shift in the mental attitude, there came spots of improvement in conditions. For some inexplicable reason the supply of cement, which has been abnormally scarce for more than 90 days was suddenly raised to the point where jobbers are able to take care of all orders. Warehouses have been slowly filling with plaster, brick of all kinds, roofing, plaster wall board, steel pipe and nails. This was due in part to the fact that steel that had been on the road was now arriving, but cement used here is manufactured within 125 miles of the city, and despite the assertions of manufacturers there has been a severe shortage. Inquiry and investigation by jobbers this week developed the fact that the two plants that closed last spring did not resume, and the 200,000 barrels on hand at the time were cleaned up, leaving two plants, one of which was exporting heavily to the Orient, to attempt to take care of the construction trade after road work had been given

THE AMERICAN ARCHITECT

priority. The export demand has suddenly ceased and the product is now arriving at warehouses along the coast.

The earliest possible date at which building projects can be revived, according to the best judgment of operators here, is March 1. The demand of investors now is for lower prices in building materials, and while there are no present symptoms of declines, jobbers are able to report that stocks are accumulating, and that if buyers refuse to trade at this level, stocks at the mills will pile up and price declines inevitably follow in time for the spring demand. The start for the new construction year is expected by Coast operators to be slow. Stock taking and the early year dull period will prevent any normal reaction until March, it is felt, but nowhere is there any doubt that once begun the shortage of homes, and Class A office buildings will be active.

The pipe situation is easier. Considerable has been arriving by water, including the small sizes of which the Coast is in great need. Within 30 days jobbers expect to see a normal supply. All orders for nails can now be comfortably absorbed.

Defeat of the Carlyon Bill, which planned 1,500 miles of road construction in the state for six years, using 800,000 barrels of cement annually, greatly eased the cement situation.

The lumber market is lower, despite the general impression a week ago that it had struck bottom. No. 2 vertical grain fir flooring, 1 x 4, at the mill, is \$54 to \$64, against \$58 a week ago, but No. 2 and better slash grain is moving from the mill at \$34 to \$36.50, against \$37 a week ago. Five eighths ceiling No. 2 and better is \$31 to \$38, against \$33 to \$40 for the week previous. Boards and shiplap are \$17.50 to \$19.50, against \$19 to \$27.50 a week ago. In dimension, the key size, the market has fallen sharply. No. 1, 2 x 4, 12-14, is now \$14 to \$14.50, against \$18.50 a week ago. Wholesalers claim to be offered No. 2 dimension at \$12.

Red cedar shingles are stronger at \$3.15 to \$3.25 for clears, and \$2.45 to \$2.50 for stars. Eighty per cent. of the entire cedar shingle mill capacity of the West Coast territory is down. Wholesalers are about to advance their quotations to the trade.



PATIO
HOUSE OF GEORGE E. CRANMER, DENVER, COLORADO
J. B. BENEDICT, ARCHITECT

090^a

Footpiece #110 2545



RENAISSANCE DOORWAY, HOTEL DE VOGUE, DIJON

THE AMERICAN ARCHITECT

VOL. CXVIII

WEDNESDAY, DECEMBER 1, 1920

NUMBER 2345

691



A GROUP OF REMODELED HOUSES ON MADISON AVENUE, NEW YORK
FREDERIC R. KING, ARCHITECT

A Notably Good Example of the Alteration Movement in New York

IF in the Seventies there was a revolt, as Mrs. Wharton says in her new novel, "The Age of Innocence," against brown stone, "of which the uniform hue coated New York like a cold chocolate sauce" we now see the fruits of revolution. The long, unbroken rows of high-stooped brownstone houses have very nearly disappeared and in many a block only an old fashioned front or two drawing back from building line between its pushing new stucco or brick neighbors remains to mark the despised period of the hated material. But, in justice to brown stone, it should be said that its unpopularity today is due far more to the architecture associated with it than to its depressing color; to ill proportioned and badly spaced openings overladen with distorted

mouldings and decoration, to cornices of rusty tin tortured into hideous brackets or modillions, to the forbidding steepness of towering stoops with their wood or cast iron sanded balusters, rather than to the stone itself. The Villard Houses on Madison Avenue and Fiftieth Street, an early work of Messrs. McKim, Mead & White, prove that brown stone is in no sense a bad medium for good design. Stucco or paint cannot, as must sometimes be thought by decorators, disguise bad proportions and ugly ornament; one must remove all the "architecture" which the original builders applied after their hurried and ill digested study of photographs (new in the 70's) of the old world and get plain surface before any real "improvement" can be made.

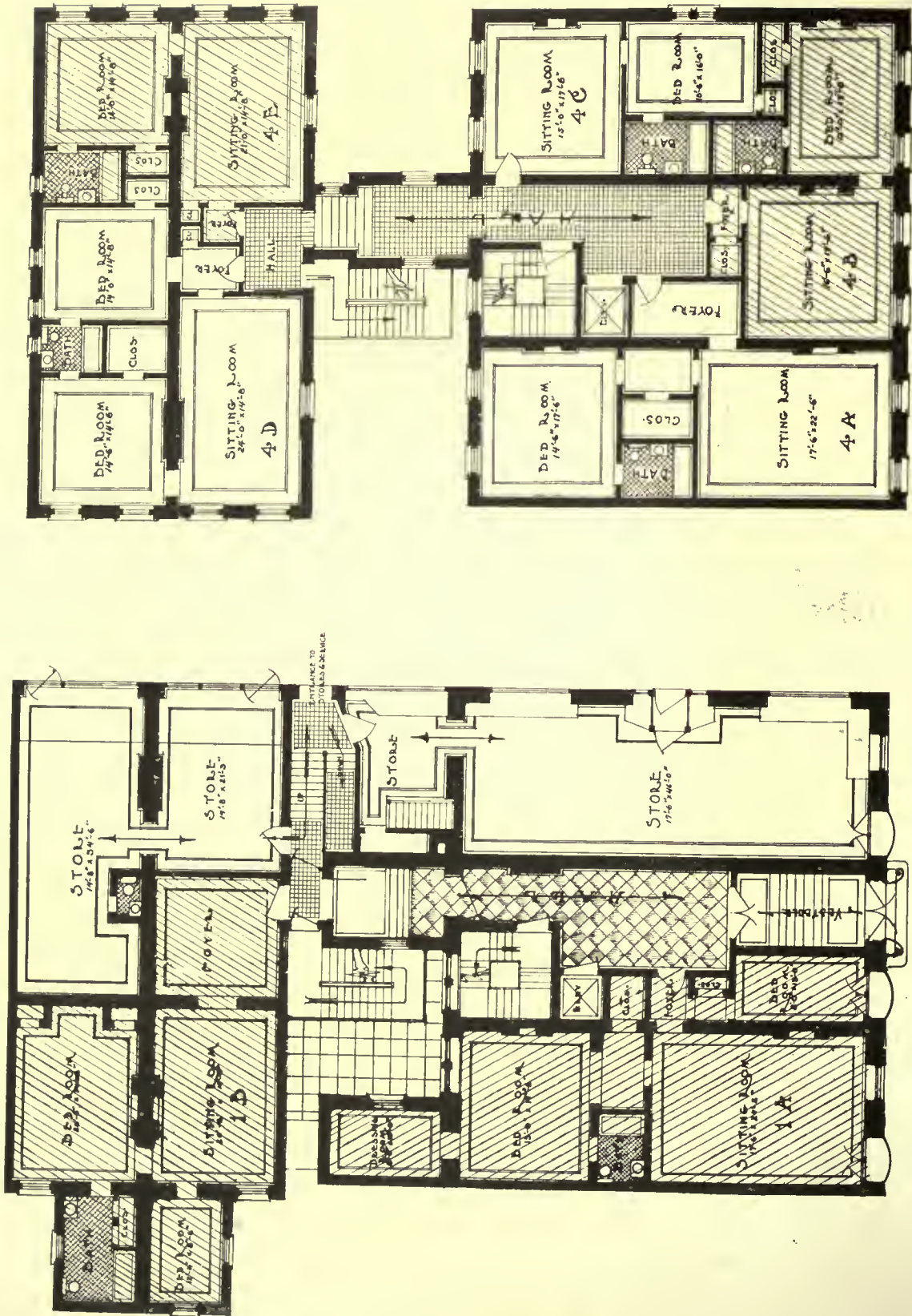

TYPICAL PLAN

FIRST FLOOR PLAN

A GROUP OF REMODELED HOUSES ON MADISON AVENUE, NEW YORK
 FREDERIC R. KING, ARCHITECT

THE AMERICAN ARCHITECT



• 3/4 INCH SCALE • DETAIL OF ENTRANCE MOTIVE •

ALTERATIONS TO 29-33 EAST 65TH ST. & 110-1122 MADISON AVE.
 FOR THE 27 EAST 65TH ST. COLD., N.Y.C.

FREDERIC R. KING, ARCHITECT

THE AMERICAN ARCHITECT

The present day high prices resulting from the war have restricted building, and the consequent housing shortage has brought about an era of high rents. Property owners, who, for years in the past, scarcely received enough rents to cover taxes, now find themselves able to get a fair return on their real estate by converting dwelling houses into offices or flats. Therefore, since the armistice we have seen in New

crisis of the day when tenants will live literally anywhere. Many people of moderate means, unable to meet doubled rents, have bought small houses in unfashionable districts and have altered them into basement entrances which show considerable ingenuity in planning and, in most cases, good taste. Communities have been developed with great success, and much can be hoped for in the future if the movement is continued with the intelligence and skill with which it has been begun.



THE HOUSES BEFORE ALTERATION

York great activity in the field of alterations to old fashioned houses, where for a comparatively small outlay large returns can be obtained. The city now fairly abounds in two-room and bath "push-button walk-ups"—brownstone houses remodeled into "light housekeeping" apartments—two to a floor—of tiny proportions, but with showy plumbing and painted or stuccoed façades; a development peculiar to the

THE alteration which is illustrated herewith presents some new and interesting features which are worthy of notice. Briefly stated, the problem consisted in converting a group of five houses, three on Eighty-third Street and two on Madison Avenue, into one building of seventeen non-housekeeping apartments served by one main entrance; stores had to be provided on the avenue frontage: differences in floor levels had to be reckoned with and economy of space carefully studied. The owners wished to make an improvement of permanent value, looking to the future rather than exclusively to the present and, therefore, insisted that all rooms should be large sized and generously supplied with windows. An elevator had to be put in and two fireproof stairways and connecting fireproof entrances built. A large dining room had to be provided where meals could be served

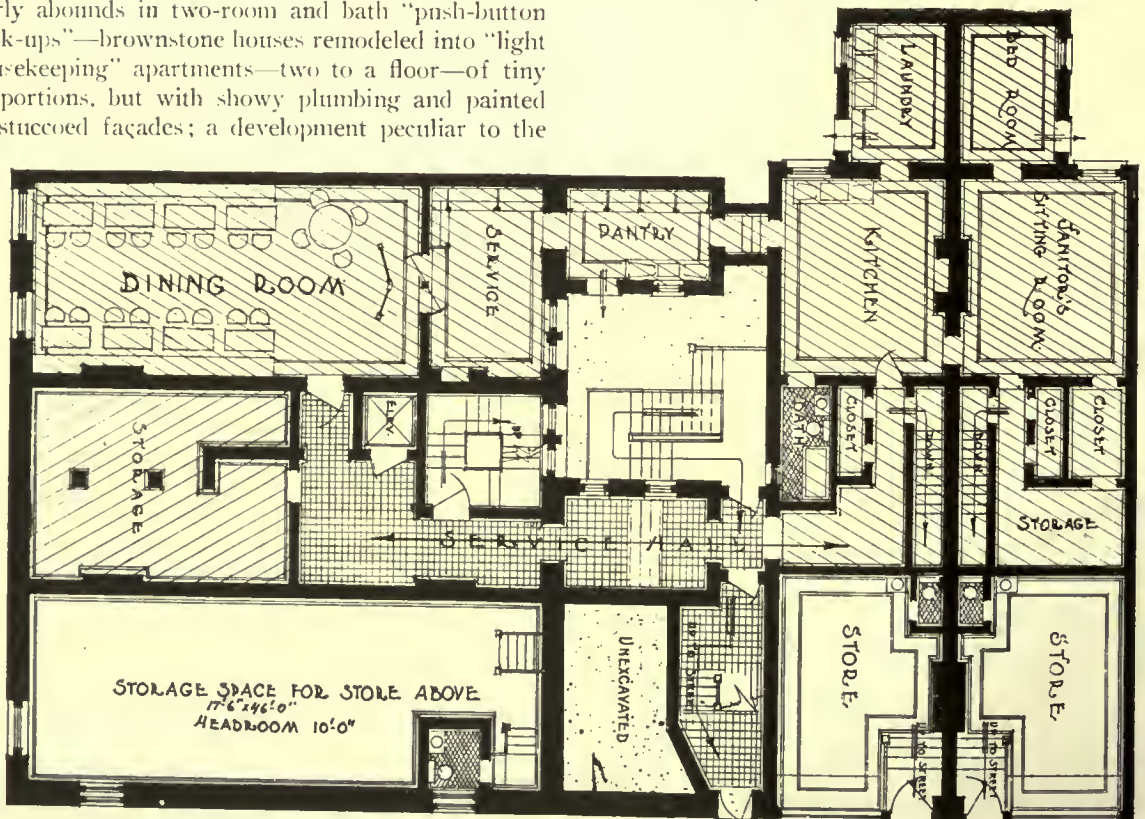

GROUND FLOOR PLAN

THE AMERICAN ARCHITECT

by the resident caterer and provision for high-class service made with a view to lessening the servant question. How the solution of this program's problems was found can be seen on the accompanying plans.

SIMPLIFICATION has been the keynote in the treatment of the exterior and by the elimination of strikingly objectionable features the unhappy restlessness of the original facade has been relieved, and continuity attained, particular study and attention being given by the architect to the ground story, which may be said to be the most important portion to consider in an expensive alteration. On Madison Avenue the store fronts were entirely remodeled with large show windows of agreeable proportions, while the side street elevation was kept strictly residential in character. Use was made of a graceful Colonial iron balcony, stretching across the front to accentuate the importance of the ground story by a heavy horizontal shadow, and thus obtaining a simple, dignified effect. The badly designed, heavily decorated, bracketed tin cornice was removed, and a flat band and a parapet of artificial stone introduced in its place as a crowning member. A new arched en-

trance, flanked by the former doorways now treated with curved balconies forms the central motive, a detail of which is given among the illustrations. In short, though no radical or extensive change has been made, a glance at the photograph of the original group of buildings and the perspective drawing will suffice to show the new character which a few simple expedients, intelligently handled, will produce.

Old-fashioned brownstone houses, it might be said in conclusion, are often adaptable to modern uses; are in general solidly constructed, and even possess in some ways advantages (such as high ceilings and a profusion of open fireplaces) over more modern buildings. They are never very high—their height is usually not quite equal to the width of an ordinary side street—and are not apt to cover a very large percentage of the lot. New York has already gained much, artistically, from the present commendable "alteration movement"; and if hitherto neglected but potentially attractive sections are improved and developed, the increasingly difficult problem of finding convenient and agreeable modern living quarters at moderate cost will be satisfactorily solved, and the city immeasurably benefited.

Builders' Arcades

THE Building Code of New York City requires that "wherever any building or part thereof within ten feet of the building line is to be erected or raised to exceed forty feet in height or wherever such a building more than forty feet in height is to be demolished, the owner or person causing such work to be done shall erect and maintain during such work a substantial shed over the sidewalk in front of the building extending as far as practicable from building line to curb." The primary object of such a shed is, of course, to protect the public from injury during the construction of the building. Contractors also use the roofs of these structures as convenient places to store materials which formerly encumbered the sidewalk and part of the roadway.

Fundamentally, the shed consists of a series of posts set at the curb line, on which rest girders braced to the posts and carrying the overhead planking. As a further means of protection against injury a parapet is often built on the three exposed sides of the shed, high enough to conceal the materials stored on the platform and to prevent material from falling on the passers below. This combination of structural elements, properly calculated for the strength required, and without further adornment, satisfactor-

ily meets the requirements of the Building Code.

It has become a general custom in erecting these sheds, to plan advertising space wherein to acquaint the public with the advantages of the building under construction, sometimes adding a list of the tenants who have contracted for space and often adding a perspective of the proposed building painted more or less faithfully. The builder usually takes advantage of the opportunity presented to display his business announcement in a conspicuous manner. To receive such advertisements the parapet is usually enlarged and treated similarly to the justly criticized billboard fence.

IN the past few years architects have brought a great many owners to the realization that these sheds, if property treated, can be made into attractive bits of design and a powerful means of focusing public attention upon the work under construction. Owners have been shown that it is as much to their interest to erect slightly temporary structures as it is to erect a well designed building and that it is their civic duty to prevent, as far as it lies within their power, the erection of even temporary structures that are offensive to the public eye. A coat of paint, a paneled parapet, lattice work, trellises and other

THE AMERICAN ARCHITECT

decorative embellishments have helped to make many of these purely utilitarian structures features of architectural interest. More properly to describe them, the term "builders' arcades" has been applied to these structures and has come to be generally accepted in designating them.

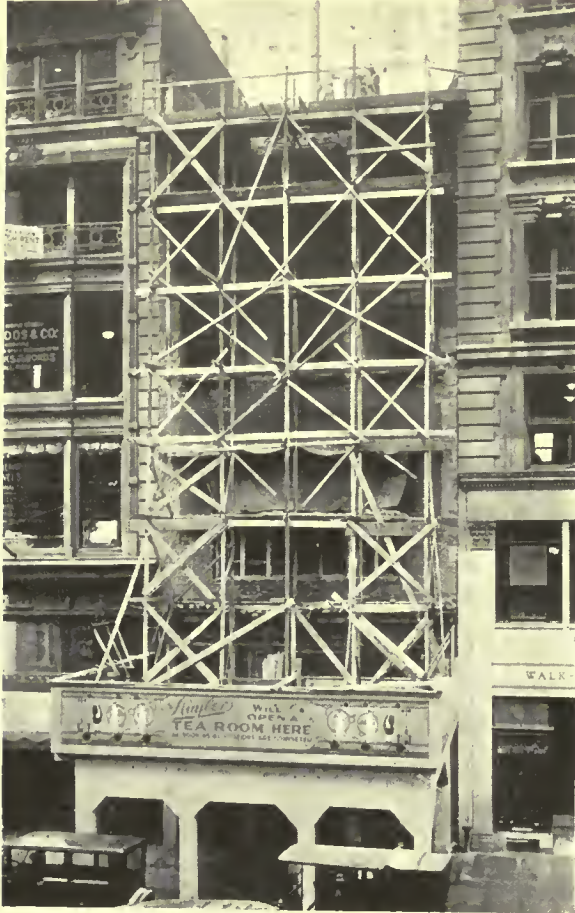

AN ARCADE POSSESSING GOOD DECORATIVE FEATURES

In designing some of the arcades seen today or that have already served their usefulness and been removed, architects have shown careful study in the grouping of the parts, the disposition of the panels, the placing of decorative motifs and in the general appropriateness of the design. Examples are occasionally met with where the decoration of the adjoining building has suggested the scheme of treatment. The arcade at No. 606 Fifth Ave., illustrated herewith, is of this type. Adjoining the structure under erection is a one time private mansion now occupied as a florist's establishment. The front of this building has been enlivened by painting the lower stories green, the upper part white and the roofs vermilion, and by placing large growing plants at all window

openings and at other points of advantage. To carry out this scheme of decoration, John H. Duncan, the architect of the new building, designed an arcade painted green in harmony with the lower stories of the florist's building, and with hanging plants placed in such positions as to give the arcade the appearance of being part of the adjoining building. A simple balustrade projecting above the foliage adds an effect of the gardener's art that is particularly pleasing. This arcade, although designed with great simplicity, is so well thought out that were it not for the contractor's house that sets on the platform, one would not suspect that a building operation is in progress at the site.

A VERY interesting example of a small but carefully executed arcade is located at No. 508 Fifth Ave., where a five-story building is being remodeled. Sibley & Fetherston, architects for the alteration, have designed an arcade that is at once practical for the use for which it is required under the Building Code, an interesting architectural work, and



BUILDERS' ARCADE AT NO. 606 FIFTH AVENUE

also a good advertising medium. Here the structural elements were covered with a fitting background provided for the unusually attractive painted sign by means of which a well known firm of confectioners

THE AMERICAN ARCHITECT

informs the public of the nature of their occupancy in the remodeled building. Surely this display with its quaint figures painted in bright colors set upon a framework which, though obviously utilitarian is nevertheless artistically attractive, cannot but drive home the message that it is intended to convey to the passersby. Furthermore, there can be no doubt that it will return with interest the money expended upon it.



ONE OF A GOOD TYPE OF ARCADE SEEN ON FIFTH AVENUE

Other examples of builders' arcades which display more or less artistic feeling are to be seen in various parts of the city. Two noteworthy examples are those at 57th St. and Madison Ave., where a building is being erected for the Bankers Trust Company, and at 34th St. and Fifth Ave., where several stories are being added to McKim, Mead & White's Columbia Trust Co. building. In both of these the disposition of the supporting posts and the paneling of the parapets show a well studied endeavor to make something worthwhile of the commonplace. In the 34th St. arcade good use is made of lattice work in working out an interesting design.

The examples mentioned above are some of the more interesting to be met with. There are others equally as interesting and still others showing a more or less successful attempt to achieve the artistic. But by far the majority of builders' arcades show that the architect has not been permitted the same degree of freedom in design that characterizes the buildings in connection with which they are constructed. In most of them the owner is apparently satisfied to comply with the letter of the law and to have the architect call for such a structure in his specifications

as will meet the requirements of the Bureau of Buildings. Nevertheless, it is gratifying to note that architects are carrying this movement forward to the point where the owner will find it distinctly to his disadvantage to erect any but a well designed builder's arcade and to note that more and more of the better types of arcades are being erected as owners become convinced that as "a thing of beauty is a joy forever," so may it also be made the best of advertisements.

CO-OPERATING with architects in New York in their efforts to improve the appearance of the city's streets, is an agency of potent influence, an almost unique organization—the Fifth Avenue Association. Fifth Avenue in New York City is concededly the finest retail merchandizing street in the world. The character of its buildings is constantly improving. Its traffic, both pedestrian and vehicular, is probably greater and also better regulated than that of any other thoroughfare. That Association has assumed the responsibility of controlling the aesthetic aspect of this important street. It seems as if it might include in its activities, influencing of every property owner to consider a slightly arcade and thus conserve, during the strenuous period of commercial building



HOW NOT TO DO IT

activities, the appearance of this important thoroughfare. As the matter stands now, the arcades, of which special mention is made in this article, are striking examples of what can be accomplished, but if architect, owner, builder and association will work more harmoniously toward this good purpose, the visitor to New York will be spared views of many unsightly spots that now disfigure Fifth Avenue from 23d St. to 59th St.

The Need for Permanent Housing Boards

THE State of New York in its struggle with its housing problem is in a situation similar to that of a community that confronts an epidemic of disease without a health department or a health officer, writes John Alan Hamilton, Chairman, Housing Committee, New York State Reconstruction Commission, in *The Survey*. In a recent address given at the City Club of New York City, Governor Smith pertinently observed that although the state furnished him with expert official advice on a multitude of subjects bearing on the state's welfare, it had neglected to provide for one of the most important of all, and that he would be at a loss where to turn to obtain authoritative information or responsible counsel on any question relating to the housing of the people of the state.

Governor Smith's reminder was exceedingly timely, directing attention as it did to an omission from the administrative machinery of the state that must be remedied before the subject of housing can receive legislative treatment adequate to its importance or to its complexity. At present New York State is without any department, board, bureau or officer whose duties comprise any study of subjects related to housing or town planning, or whose responsibilities imply the slightest competence to furnish the state with expert advice as to its housing requirements.

When the body politic is suffering from any acute discomfort, legislators, like any other laymen, are apt, in the absence of trusted professional advice, to treat the symptoms instead of the disease. This is precisely what happened at last winter's session of the New York legislature, when, confronted by a great shortage of houses and consequent rapidly rising rents, the legislature contented itself with the enactment of a series of drastic laws in regulation of rentals, which brought about some temporary relief so far as existing buildings were concerned but naturally enough failed as an incentive to build more houses.

At the special session of the legislature convened to consider the housing situation, these rent laws—their limitations having been widely recognized—have been reinforced by radical measures designed to stimulate house building. Permissive exemption from local taxation of new dwellings begun within a specified period, for a term of years, was the principal one of these measures. But neither this nor, for the matter of that, any other form of subsidy to building can be made sweeping, indiscriminating or self-executing in character without serious danger to the state. Some administrative body must be charged with the duty of determining whether each proposed dwelling is of a character to deserve the

taxpayer's special consideration—or the very success of the new legislation will be the measure of its potential harmfulness.

What the state wants is not merely more houses; it wants more houses of a certain standard of acceptability—as to sanitation, as to light and air, as to surroundings, and as to artistic merit. The state has enough houses below that standard now. The successful stimulation of a hasty, state-wide building campaign would, if the building were not controlled, bring relief from a temporary difficulty by greatly augmenting a permanent one. And outside of its largest cities, the state today imposes absolutely no regulation upon dwelling house construction.

It was with a view to all of the foregoing considerations that the State Reconstruction Commission, in its report on housing conditions, submitted to the Governor last March, placed in the forefront of its recommendations the proposal that the state establish permanent local housing boards, to be appointed in each community of ten thousand or more people, and a central state housing agency to coordinate and render effective the work of the local housing boards. It was proposed that the members of these boards be unpaid, and that their initial functions be as follows:

Aiding each locality in meeting the immediate pressing need for sufficient homes.

Collecting and distributing information relating to housing and community planning.

Assisting in the preparation of housing laws, zoning ordinances, state-wide regulatory or restrictive housing and building codes, etc.

Studying the means of lowering the cost of housing through better planning and construction of homes and through their proper location.

Development of a means for using state credits to apply to housing at low rates of interest without loss to the state; setting the standards for the use of such credits and fixing limitations upon the return of money borrowed from the state for housing purposes, so that its use shall assist in the most practical manner possible in the erection of adequate homes in wholesome environments for workers, at a rental cost dependent on the actual cost of land and building. This work to be preparatory to the final passage of a constitutional amendment permitting the extension of such state credits (which amendment formed the second of the commission's recommendations).

A bill providing for these proposed housing boards was introduced at the regular session but failed of passage. Redrawn, it was again introduced at the special session, but, although it was put forward as a part of the program of the Joint Legislative Committee on Housing and has at all times

THE AMERICAN ARCHITECT

had the hearty support of the Governor, its fortunes at this session were no happier than the last.

The bill provided for local housing boards, each consisting of not more than nine members, to be appointed by the respective mayors of the communities affected, and their appointment made mandatory. The state advisory housing board, to consist of five members, was to be appointed by the Governor, and placed in the Department of Labor.

The duties of the boards, which are prescribed in detail, follow in general the lines suggested by the Reconstruction Commission in its report, but are even broader in their scope. The functions of the local boards may be described as falling into three classes, educational, advisory and supervisory. In the first class are requirements dealing with the collection and dissemination of information as to housing and town planning, the study of local housing needs, and the rendering of reports to the state board. In the second class are the prescribed duties of assisting in the preparation of local ordinances in relation to housing, zoning, etc., and the development within a prescribed period of a plan in contemplation of the probable future growth of the city with its surrounding territory, and providing for the appropriate location of residential, industrial and business sites. In the third class is the requirement for the approval by the local board of all plans for the erection or location of any houses erected by the municipality or with the use of its money.

The duties of the state advisory housing board comprise the supervision and direction of the work of the local boards; the compilation of the data locally collected; the study in all their aspects of the problems connected with housing; the recommending of legislation; assistance and advice to municipalities, public offices, etc.; the preparation of a report on the best means of extending state credit in aid of the building of low priced houses; and finally, the approval of all houses as to both character and location, for the building of which the state shall lend its credit, or as to which it shall relieve the owner from taxes.

From the point of view of housing as a complex and permanent problem, it is not too much to say that the enactment of such a measure as that just described would be of great and lasting importance to the state. Its effects would be, in all likelihood, permanent, widespread and of controlling importance, for it furnishes a basis—a foundation—on

which can be built a consistent, far-sighted and beneficent housing policy for the state.

Diffused throughout all parts of the state as these housing boards would be, and forced as they would be to study the problem with the consciousness of responsibility, the effect of their study could not fail to be promptly and widely educational. The reaction of such wide-spread study upon future legislation would be as certain as it would be wholesome. Such a group of responsible local boards, functioning collectively under the guidance of a central state body, would not only speedily begin to mould public opinion through the mere performance of their required duties, but would in a short time be prepared to bring to bear on state and local authorities a weight of expert official advice on matters pertaining to housing and community planning that could with difficulty be disregarded. With such a governmental organization in existence, no future legislature could face the housing problem without having at least the benefit of sane, well considered counsel from its responsible official advisers.

By centering responsibility upon these boards for the administration of all state-wide measures passed in aid or regulation of housing, and of loans by municipalities, the state would go far toward assuring itself of lasting benefits from legislation that otherwise might be highly detrimental. All the good of such legislation could be preserved by enlightened administration, and the evil effects minimized or avoided. Not the least of the benefits to be looked for from this measure would be the series of town plans that would be forthcoming, covering every considerable community in the state. That would have to be done carefully and with forethought which has hitherto been done carelessly and at random, and for the first time it could be said of an entire state that it had no large community without a definite plan for its own future development. Most important of all is the consideration that these boards in the years to come would assure New York State of an authoritative source of opinion upon all matters connected with housing—a source of opinion that would make itself felt throughout the state.

Who can doubt that the result would be a more widely extended realization that since environment strongly affects character, a far-sighted commonwealth will take care that all its children shall be reared, so far as may be, among surroundings that will give them at least the opportunity to grow up physically, mentally and morally straight?

Radium

A New Element in the Safety Movement

RADIUM, the most mysterious and most powerful element known to science, which has the greatest power of all discovered sources of energy, has now been linked with the safety movement and will lend its power to the prevention of avoidable accidents. So great is its power that one gram is sufficient to raise a ton of water from the freezing point to the boiling point. If one ton of it were harnessed to a ship equipped with 1,500 H.P. engines, the ship would be propelled at the rate of 15 knots an hour for thirty years.

Radium is best known to the world through its curative properties in the treatment of cancer and through its commercial value in making radium luminous material.

Radium's role in industry as a life saver is less spectacular, but perhaps even more important than it is as a therapeutic agent. The great mass of accidents in factories, in mines and in other industrial institutions where darkness is a creator of danger, are being eliminated through the newest invention of science—radium luminous material. Radium illuminated watches are familiar articles. The same material that illuminates these is now being employed in great factories on all power line switches where fumbling might mean electrocution to the operator.

High pressure gauges, which are installed as an insurance against dangers, are deprived of a great deal of their safety value through inconstant lighting. Their dependability as indicators is increased tremendously through making them safe 24 hours a day by the application of radium luminous material, which is invariably luminous in the dark. Steam gauges and water gauges of all sorts are making use of radium to increase safety.

Electric switches are often set in places which are unlit. This includes electric lighting equipment which is usually visible only after the light it controls has been turned on. A spot of radium luminous material on the bottom of switches makes them easily located in the dark, so that in emergency they may quickly be made use of.

Likewise, a fire alarm or a fire extinguisher is deprived of a good deal of its efficiency through being invisible in the dark. Radium luminous material acts as a quick locator for them. Telephones which are often necessarily found quickly in the dark in emergencies, various emergency call bells, and revolvers are made more useful through the application of undark. Gun sights, illuminated, in-

sure accuracy of aim in the dark. The need of luminating poison bottles, so that they may stand out warningly in the dark has been demonstrated too often to need further dwelling on. An interesting safety device is the safe combination whose dial is radium luminated, so that no artificial light need be used for it.

The industrial uses of radium luminous material are many. Bolts that are necessarily attached to the dark under-portions of machines and equipment are being touched with dabs of this luminous material with a consequent great saving of bloodshed. In mines where the carrying of oil lamps or the placing of electric lighting equipment is not feasible, radium has been found to be a boon to humanity. There are dark corners in the dark underground channels which miners must traverse, corners where danger lurks—these are made safe through the unvarying luminosity of radium.

The value of radium to mariners is commencing to be recognized. Not only the compass dials, but the steering wheels, the gauges and other instruments which should be instantly and uninterruptedly visible have been touched with radium. Motorists, motor cyclists and the operators of any machinery which has indicating dials, or gauges which tell of the speed of the motor or the quantity and mixture of fuels and oils, are finding the solution of their difficulties in radium luminous material. The hazard of uncertainty has been reduced.

While radium is the most valuable element in the world—a gram of radium, which is about a thimbleful, costs \$120,000, as opposed to \$150 for an ounce of platinum—so powerful is it when mixed with other materials that even the minutest particle is effective in making material self-luminous for years. It is this quality which makes radium luminous material commercially possible.

The great value of radium is due to its scarcity, and to the great difficulty in isolating it after it has been found. Much of the radium of the world is now found in America, in carnotite fields. A great portion of this comes from the Undark Radium mines in the Paradox Valley of Colorado.

The ore is found in narrow seams in the ground. It is sorted and packed in one hundred pound sacks and transported sixty miles to the nearest railroad station on the backs of burros and mules. Thence it is shipped in carload lots 2,900 miles across the continent to an extraction plant in Orange, N. J.

Two hundred fifty tons of ore treated with an equal amount of chemicals and water yields one grain, which is about the size of a pin head.

The power of radium lies in the penetrating character of its rays, which disintegrate and travel at the rate of 3,000 miles a quarter of a second.

In addition to the use of radium luminous material on machinery in industrial plants, it is used extensively for the marking of any corner or spot which should be visible in the dark. Angles of tables and chairs, corners in rooms, numbers to indicate cubby holes or doorways on which there is no other

illumination are touched with a spot of undark. Even the valuable electric torch increases its efficiency when it has a touch of radium on it so that it can be reached instantly in an emergency in the dark.

When other lights fail, when fuses blow out, wires break down—radium will glow dependably without danger of explosion or of burning.

The employment of radium to help solve our medical and industrial problems of life safety is as yet in the first stages of its development. What the future will bring no one knows, but radium will doubtlessly become increasingly useful.

Criticism and Comment

Dynamic Symmetry and Its Reviewer

The Editors, THE AMERICAN ARCHITECT:

THE review on Jay Hambidge's epoch making book on Dynamic Symmetry and the Greek Vase, recently published in *The Nation*, is so misleading and so unsatisfactory to all who have studied this subject with care, that, in the interest of truth and justice, some further discussion of its importance is desirable. Instead of reviewing the theory of the Dynamic Symmetry, its value and application in practice, the reviewer contents himself with assailing its nomenclature and by simply asserting that the whole subject is an old one, but now presented under a new name for the purpose of confusing the reader. A greater injustice to a worthy subject which is not alone absolutely new in the sense that it was lost two thousand years ago and has been forgotten, but is really important, has not to my knowledge appeared in print for many years. The reviewer not alone condemns the nomenclature but proposes substitutes, such as "rectangles 'A and D' etc., instead of 'root rectangles' and the 'whirling square'." To the present writer and to several friends who practice the Dynamic system in their respective branches of art, these substitutes appear childish, pedantic and tiresome, and remind us of a schoolmaster with his official textbook, both intent upon making the subject they teach as unpleasant and as uninteresting to the pupils as possible. The nomenclature used by Hambidge seems not only entirely appropriate, but the very terms are stimulating and help to encourage the reader to proceed.

As regards the value and application of the re-discovered symmetry of the Greeks the reviewer says as little as possible, either for or against, leaving the reader to assume that it is as useless as the nomenclature. The fact, however, is quite different. When Mr. Hambidge began his lectures on his dis-

coveries in New York some three years ago, some of his pupils began to apply the new rules of symmetry to their own work, and a year later held exhibitions of such works so to enable the public to judge to their value. One of these exhibits was held in the rooms of the Architectural League, the other in Columbia University, both arousing much interest. The very fact that all who use the system in a practical manner agree that their work has been greatly benefited by the new theory, should prove to the reviewer that it possesses, not alone some, but really great, value. And does it not appear strange to the reviewer that Professor Caskey, of the Boston Museum of Art, should have gone to the immense trouble of measuring hundreds of Greek vases and permit Hambidge to publish these drawings, diagrams and measurements, unless he was fully satisfied that the theories of Hambidge were correct? As an archaeologist with some knowledge of art as a fundamental base for study, the present writer has found the re-discovered symmetry of the classic Greeks of the very greatest importance, and even now it is quite evident that in this system the scientific students of Art and Archaeology possess new means by which to judge the classical arts. The system not only explains satisfactorily (never done before) the cause of the superiority of the Greek art over that of the Latin, but it also gives the means by which we may determine the genuineness of many classic works of art which are now doubtful, because the Roman copyists of the older works had no knowledge of the subtle Greek symmetry and made necessarily conspicuous errors in their work when reproducing them. This we can now discover by measurements, just as we can discover if a vase is based upon the dynamic system or not. And furthermore the knowledge which this system fur-

THE AMERICAN ARCHITECT

nishes permits us to date correctly many objects which formerly could not be dated properly, because it is known that the system became lost and forgotten at the end of the first century A. D., the last objects based upon it being two altars in Pompeii. All objects based upon this system must thus be earlier than that date. A knowledge of the system permits us to restore with a greater degree of truthfulness, than it has until now been possible, many classic works of sculpture and architecture, and we may now point out with certainty the errors of older

restorers who knew nothing of the system. If to these qualities of the new system we add that it is applicable to every conceivable art—painting, sculpture, furniture making, ornamental designing, the designing of coins, the designing of monumental and minor buildings, pottery making and glass manufacturing, etc., it will be seen, or should be seen by all not prejudiced, that the newly re-discovered Greek System of Symmetry is of very great importance.

New York.

GUSTAVUS A. EISEN



LOGGIA IN HOUSE OF GEORGE E. CRANMER, DENVER, COLORADO

J. B. BÉNEDICT, ARCHITECT

For other illustrations of this house, see preceding issue

Anecdotes of English Architects

UNDER the heading of Architectural Causerie, there are presented to the *Architects' Journal* of London the following reminiscences:

In the eighteenth century it was customary to publish every telling incident connected with the lives of artists; not a little amusement was in this manner provided for a rainy day, as can be judged from a quiet perusal of the works of Walpole, Smith, Cunningham, and a host of others. We can pass over such attempts at wit as the following, "Design for a Ballroom by Dance," or "The Planning of a House by Chambers," to enjoy one or two time-honored stories of the men of genius who contributed so much interest to the reign of the Georges.

* * *

Sir William Chambers, who shared Sir Joshua Reynolds' appreciation of literature, very justly observes "that it must not be imagined that buildings, considered merely as heaping stone upon stone, can be of advantage, or reflect honor either on countries or particular persons. Materials in architecture are like words in phraseology, which, singly, have little or no power, and may be so arranged as to excite contempt; yet, when combined with art and expressed with energy, they actuate the mind with unbounded sway. A good poet can move even with homely language; and the artful disposition of an able architect will give lustre to the vilest materials, as the feeble efforts of an ignorant pretender must render the most costly enrichments despicable. The progress of other arts depends on that of architecture. When building is encouraged, painting, sculpture, gardening, and all the other decorative arts flourish as a matter of course, and these have an influence on manufactures, even on the minutest mechanic productions; for design is of universal advantage and stamps a value on the most trifling performances, the consequences of which, to a trading people, are too obvious to require illustration." The above statement, although a trifle sententious, will perhaps serve to make clear Sir Thomas Jackson's recent outburst in the public press. It is certain that never at any time like the present have the kindred arts been reduced to such impotence among the commercial assets of the country.

* * *

When Sir Christopher Wren built the Church of St. Magnus, London Bridge, there were houses on

each side of the bridge, which projected as far as the church. When these houses were pulled down the footpath came directly against the church, so that the passengers on that side were obliged to go round into the coach road. This was found very inconvenient, and a meeting of the inhabitants was held to consider if they could with safety cut a road through, which was thought too hazardous an expedient, as it was apprehended that any such interference with Wren's work might bring the church down about their ears; in consequence the scheme was shelved. A second meeting was afterwards held, when it was determined by a small majority to make the experiment. The workmen, on breaking through the wall, found a complete and perfect arch, which Sir Christopher, foreseeing with prophetic taste that the houses would at some future period be pulled down, had left in its present form. Sir Christopher, with all his sagacity, could not foresee that his Church would one day be threatened with demolition by the ecclesiastic authorities, or doubtless he would have provided against the contingency—not by leaving a single arch, but a whole court of arches.

* * *

Architects as a body are not prone to shed tears when asked to act against their better judgment. However much they feel inclined to express annoyance, it is generally held to be polite to stifle emotion and to preserve an attitude of Oriental stoicism. Sir Christopher Wren encountered many difficulties when he was engaged upon the rebuilding of St. Paul's. Charles the Second, who posed as a patron of the arts, allowed his brother, the Duke of York, afterwards James the Second, to negotiate with Wren regarding the addition of side oratories to the architect's original plan, which to Wren's mind disturbed the simplicity of his work. Sir Christopher, aware of the ultimate effect of this ill-considered project, and guessing at the Popish inclination of the Duke, could not refrain from shedding tears in speaking of the frustration of his purpose. The Duke laughed at the architect's tears, and insisted that his, the Duke's, commands should be obeyed, so poor Wren had to recast this part of the design and issue instructions anew to Master Strong.

On the Green, Plymouth, Conn.

(See reproduction of original drawing by O. R. Eggers on opposite page)

RURAL New England abounds in picturesque small towns, all laid out with orderly care. Each has its spacious common, or city park bordered on four sides by stately elms, through the dense foliage of which may be seen well designed white houses with green shutters. In these white houses, in many instances, there have lived, from the time of earliest settlement, families whose members have figured in all the town's activities. As a rule one side of the Commons was set apart as location for the meeting house, the town hall, the school and other village buildings.

Mr. Eggers has sketched with his usual fine perception of the architectural essentials, that section of the village green at Plymouth set apart for the church, with its stately colonnade and the adjacent school house. More and more each year do these fine old New England villages attract a class of people who best appreciate the quiet restfulness that residence in them affords. And it is good to know that these new residents soon imbibe the same reverential attitude towards the traditions of the place that form a religious part of the everyday life of the older inhabitants.

The commercialism of a period that until recently menaced the safety of these old towns and their locally historic buildings is now giving place to a feeling of deep respect. The evidence is to be found in the solicitous care of these old structures and a correct protective attitude toward them.

704 ~



ON THE GREEN, PLYMOUTH, CONN.
THE AMERICAN ARCHITECT Series of Early American Architecture



The Question of Joint Registration

IT is extremely fortunate that the meeting of the Board of Directors of the American Institute of Architects was timed to accord with the National Council of Architectural Registration Boards held in St. Louis, November 18 and 19. It was possible for the directors of the Institute to consider without loss of time the report of the joint committee of engineers and architects on the proposed joint registration law and emphatically and clearly to state just what was the board's attitude on this important question.

The bill, as originally formulated by the engineers for a joint "Board of Registration for Engineers, Architects and Land Surveyors," has been and is even now being actively promoted by the engineering profession. It was inconceivable that architects would concur in such a law, and so emphatically had disapproval been expressed at the recent convention that it was finally decided to redraft the proposed law.

But the redraft contains the same objectionable elements, inasmuch as it omits to remove the fundamentally objectionable features of a reservation to each profession of the complete control, not simply of examinations, but also of registration and the withdrawal of certificates.

The following telegram, sent by President Kendall of the Institute to Engineering Council, setting forth the attitude of the Board of Directors, is timely and exactly to the point:

Secretary, Engineering Council:

The American Institute of Architects in past conventions is on record cordially favoring co-operation with engineering societies but opposing joint legislation for state registration. The National Council of Architectural Registration Boards, now in session, has, by unanimous vote, expressed its opinion that joint registration boards are not desirable for the best interests of either profession. The joint registration bill just received by the Board of Directors will, however, receive the most careful consideration and action at next convention. In the meantime, where simultaneous legislation has already been initiated, Institute members will endeavor to obtain laws which will secure to each profession independent action and control of examination and issuance of registration certificates. The

Institute regrets premature publication in architectural press of joint committee report before it was received by the directors and trusts you will not assume the report of a committee is the action of the Institute.

By this prompt action the matter becomes at once clarified and set on the road to a conclusion that will be equitable and therefore satisfactory to both professions.

Morals and Architecture

THE effect of their surroundings upon people has within the last few years been more and more elaborately developed until there now exists a well defined group of people who contend that environment is a greater force in individual, and hence group culture, than those inherited instincts that form the basis of education. Whichever be the greater, it is true that surroundings produce a subtle influence for good or ill according to their worth.

Architects more than any other group, may be influential in creating surroundings that in their effect will be wholesome and salutary. While it is undoubtedly true that the client who draws the purse strings must be pleased, it is also true that wholesomeness is not dependent on large expenditures. Many clients require only the stimulation of an architect's enthusiasm for his ideals to see their justice—especially when they are not costly. In the instances where clients are obdurate, a dignified publicity is helpful. Letters to the newspapers and co-operation with the city welfare departments are welcomed. If the newspapers were given opportunity to discuss really progressive things of this sort, there would be less room for much of the useless scandal and frivolity that now finds space. Discussion, publicity, not of the architect, but of the ideal, is what is desired.

In bank architecture there is a tendency toward rectilinearity and solidity, as representing the honesty and straightforwardness of the activities within. In church architecture, the Gothic upreaching toward the nobility above our city sordidness, reveals the striving of man for something finer.

In every business, in every undertaking which re-

THE AMERICAN ARCHITECT

quires housing, there are the meaner aspects and the nobler. Architects have the opportunity insistently to accent the nobler, and make it almost impossible for any other phase to be carried on within.

On any plane of development it is possible to respond to the highest art. It has been wrongly inferred that the child and the race begin with the clumsy and imperfect, and grow gradually toward perfect art. But a simple folk song is as perfect art as a Beethoven symphony. A baby waves a goodbye with a grace and beauty of arm and hand movement which a well trained actress cannot equal. Nature does not make one kind of sunshine for children and another for adults, although their respective reactions may differ. The appreciation develops to its fullest extent, but it is there with its influence at all times.

AMONG the children of the wealthy, the neighborhood schools are usually good examples of architecture. Among children of the poor, in their crowded miserable districts, the schools reflect that sordidness. Instead they should be especially fine, to compensate for the total lack of harmony in which these children, unlike their more fortunate contemporaries, are brought up. For there is no other source for them to acquire relief from indefinable restlessness that overtakes them.

The subtle influence of good architecture is inevitable. From a proper proportioning of a building may be sensed proper proportion in other things. In the harmony and stability, the refinement and the dignity of a good building, may be learned a love for those same elements in all things.

But why do we leave these lessons to be learned by chance? The architect constantly struggles against indifference on the part of the layman. Indifference if not actual ignorance. While there is a yearning for beauty, its cultivation has no present place in the curricula of the school. A certain amount of craftsmanship, of so-called vocational training, is offered; or perhaps a meagre and thoroughly useless course in freehand drawing. But no *appreciation*, no knowledge of the history or the ideals of the arts. Even the colleges urge it not. One may have a perfectly good B.A., even M.A., and never have seen the inside of a picture gallery. As for architecture, the college professor is prone to regard it as a musty, dusty outgrowth of archeological findings, with no relation to modern building, and no bearing upon the mind in its making.

Yet with all the discussion of environment, it is time that our architectural surroundings were taking their place in the mind of the layman. Many worthwhile efforts in this direction are being made. The architectural verities as presented in moving pictures is one instance, but again an indirect and unconscious method, whose prime purpose is not to teach, but to amuse.

The matter is one for serious consideration; one in which organized architecture might assume the initiative and constructively move to insure that the layman shall be properly instructed as to what is good art, and to insure that the method of such instruction shall be along practical lines that will afford the largest measure of good result.



DECORATION, CHURCH OF THE CARMINI, VENICE

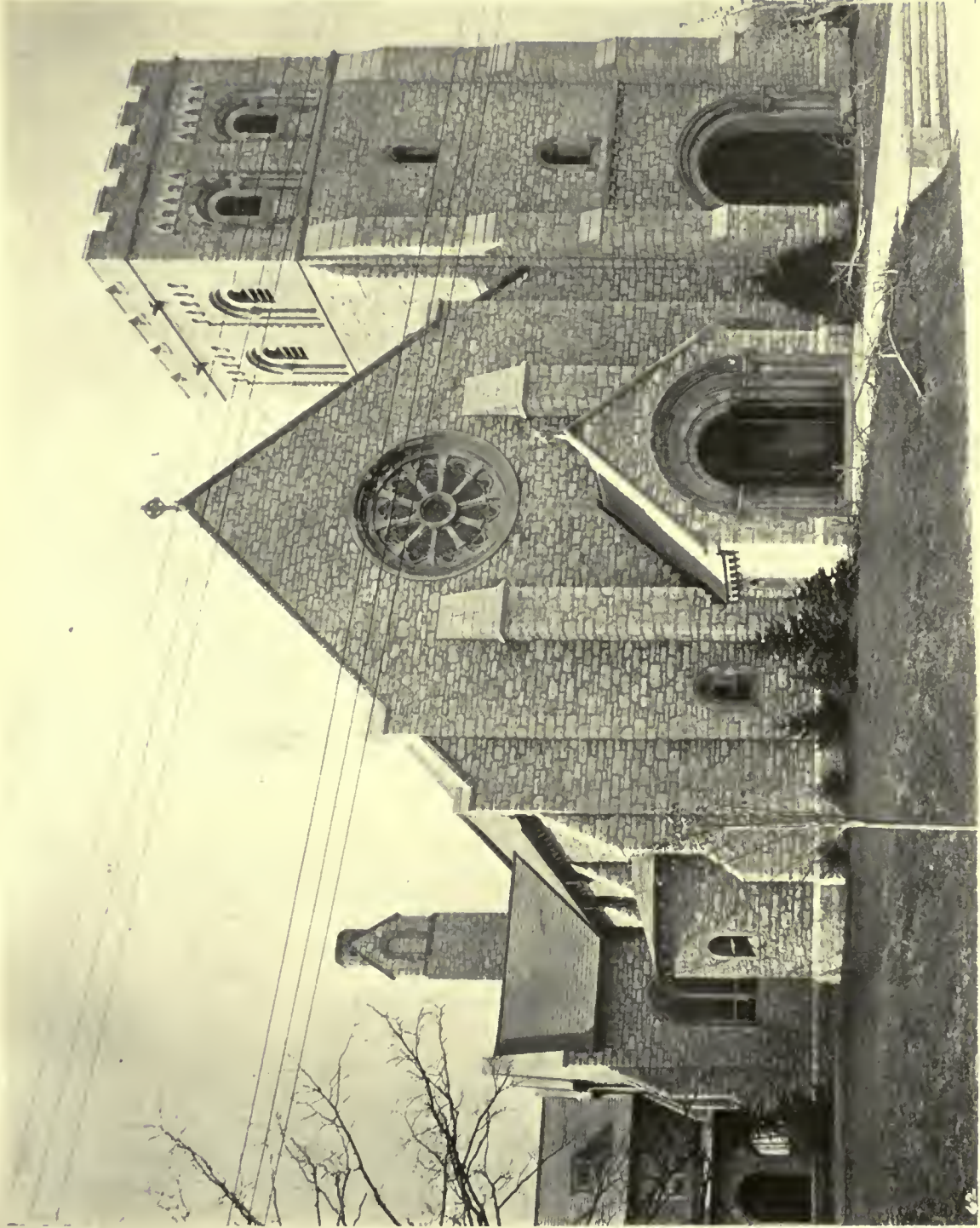

CHURCH OF OUR LADY OF LOURDES, ST. LOUIS, MO.
STUDY & FARRAR, ARCHITECTS

7061





TRANSEPT



THE PAROCHIAL RESIDENCE

CHURCH OF OUR LADY OF LOURDES, ST. LOUIS, MO.
STUDY & FARRAR, ARCHITECTS

7062



700



CHURCH OF OUR LADY OF LOURDES, ST. LOUIS, MO.
STUDY & FARRAR, ARCHITECTS



7064



CHURCH OF OUR LADY OF LOURDES, ST. LOUIS, MO.
STUDY & FARRAR, ARCHITECTS



5
706

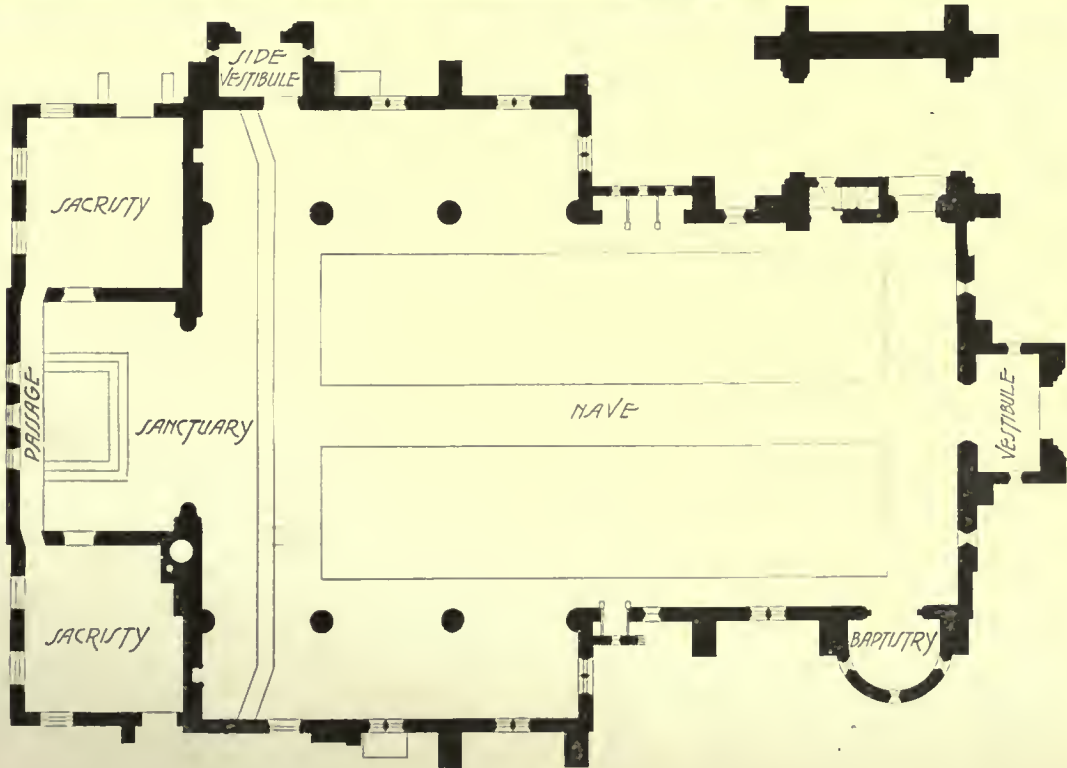

CHURCH OF OUR LADY OF LOURDES, ST. LOUIS, MO.
STUDY & FARRAR, ARCHITECTS





HOUSE OF GUIDO DOERING, ST. LOUIS, MO.
GUY STUDY, ARCHITECT

7066



HOUSE OF GUIDO DOERING, ST. LOUIS, MO.
GUY STUDY, ARCHITECT

7067



26
706



HOUSE OF GUIDO DOERING, ST. LOUIS, MO.
GUY STUDY, ARCHITECT



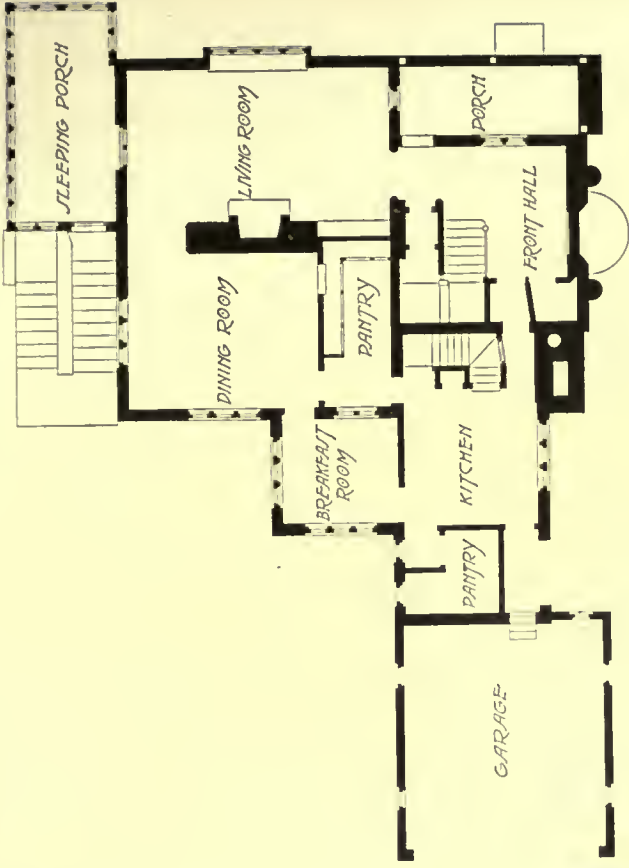

HOUSE OF GUIDO DOERING, ST. LOUIS, MO.
GUY STUDY, ARCHITECT

7069



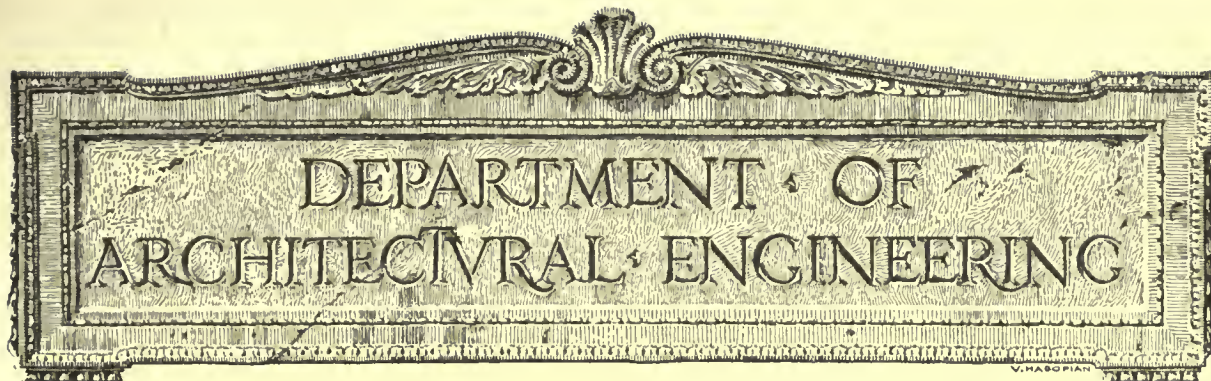

Heating and Ventilating Industrial Buildings

Part—II

Forced Hot Water Heating

By CHARLES L. HUBBARD, *Heating Engineer*

A SYSTEM of heating well adapted to shops and factories, and one that has been extensively employed for this purpose, makes use of hot water under a forced circulation. This system has two principal advantages over steam heating, the first and most important being on the score of temperature regulation, as it is possible for the engineer to vary the temperature of the water so as to supply any quantity of heat necessary to warm the buildings under varying outside weather conditions. This is of great importance, both as regards the comfort of the operatives and also in relation to economy of operation, especially where live steam is required to any extent for heating purposes.

The second advantage relates to the matter of grades, and may have considerable weight against steam, in certain cases, especially if the condensation is to be returned to the boiler or receiving tank by gravity without the use of traps.

The modern factory is usually built of brick or concrete without a basement, which brings the boiler room on the same level with the main shop. As much of the radiation must necessarily be placed beneath the windows, the boiler will be too high for a gravity return unless a portion of the boiler room is excavated to a lower depth. This not only adds to the expense, but a pitted boiler is less convenient to care for, both as regards firing and the removal of ashes. In case the boilers are run high pressure, for power purposes, and the condensation returned to a closed receiving tank, only the pump and receiver need be placed in a pit, which is not objectionable. However, with forced hot water, no

attention need be paid to grades and the return pipes may be carried at the ceiling above the coils as well as below them in many cases, which is often much more convenient where there is no basement and the floor is concrete.

The arrangement of the radiation, together with supply and return piping is practically the same as for steam so far as pipe sizes and general layout are concerned. A circulating pump takes the place of the suction pump of the vacuum system, but a special heater is required, which is an additional piece of apparatus not needed when the circulating medium is steam. The system in its simplest form is shown in diagram in Fig. I and consists essentially of a pump, heater, and distributing mains and branches for connecting these with the radiators and coils.

Pumps. The centrifugal or turbine pump, driven by a direct-connected motor, steam turbine or engine is best adapted to this work. In plants generating their own electricity the motor drive is usually more economical and is commonly employed for day service. This, however, in most cases, should be supplemented by a steam turbine or engine for night use or at such other times as electric current is not available. The head or pressure against which the pump must operate is due simply to the friction of the water as it flows through the pipes and coils, and in a properly designed system, should not exceed 40 or 50 feet "head." In case of the medium size buildings under consideration this is commonly limited to 20 or 30 feet, except in work connected with central heating where a number of

buildings are supplied through underground mains.

Table I gives working data for a standard make of centrifugal pump adapted to this particular class of work, and includes working or friction heads ranging from 6 to 50 feet.

Under ordinary conditions the efficiency of a centrifugal pump falls off considerably for heads above 30 or 35 feet, but multi-stage pumps are constructed which work with a good efficiency against 1,000 feet or more. With favorable conditions an efficiency of 60 to 70 per cent. may be obtained, but

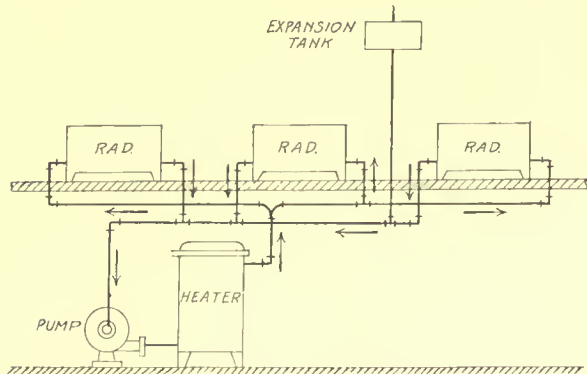

FIG. 1. A SIMPLE SYSTEM ARRANGED FOR FORCED HOT-WATER HEATING

for hot-water circulation it is more common to assume an efficiency of about 50 per cent. for the average case which is that taken in Table I.

TABLE I.

Diameter of Delivery inches	Gallons discharged per minute	Revolutions per minute for friction heads from 6 to 50 feet										Horse power per foot lift
		6	8'	12'	16'	20'	25'	30'	35'	40'	50'	
2	100	440	500	600	700	780	860	950	1020	1090	1210	0.063
3	240	420	470	570	640	710	780	850	910	970	1080	0.136
4	430	380	430	510	580	640	710	770	820	870	960	0.217
5	730	330	360	430	490	530	590	640	680	720	800	0.309
6	1050	300	330	390	400	480	530	570	610	650	720	0.446

EXAMPLE—What size and speed of pump will be required to circulate 240 gallons of water per minute against 25 feet friction head? What speed and horse power will be required?

Looking in Table I we find that a pump with a 3-inch discharge will handle this volume of water, and that for a 25 foot head the speed must be 780 R. P. M. The horse power required is 0.136 per foot lift or a total of $25 \times 0.136 = 3.4$.

If the volume of water and the head vary materially from the quantities included in the table, so that values cannot be interpolated, the following formula may be used for approximate results:

$$\text{H.P.} = \frac{H \times G}{2,000} \text{ in which}$$

H = friction head in feet; G = gallons pumped per minute; and H.P. = horse power required.

The gallons of water to be pumped in any given case may be obtained by the formula $G = \frac{R \times E}{500 \times T}$

in which

G = gallons to be pumped per minute.

R = square feet of radiation to be supplied.

E = efficiency of the radiating surface, which may be taken as 250 for direct coils under average conditions.

T = drop in temperature of the water in passing through the system, commonly taken as 20 deg.

Making a computation for 1 square foot of radiation, we have $G = \frac{1 \times 250}{500 \times 20} = 0.025$ (very

nearly) or 0.025 gallons of water must be circulated per minute for each square foot of surface in the radiating coils.

Heaters. When power is purchased from a central plant and steam is not required for manufacturing purposes the water may be heated in an ordinary boiler the same as for a system operating under gravity circulation. The usual type of cast iron water boiler is adapted to this work for plants within their capacity, and beyond this, tubular boilers, without steam space, and provided with baffle plates for equalizing the flow of water over the tubes, may be used. If more than one boiler is required, they are usually so connected that the water may be passed through them either in "series" or in "parallel" as desired. This is shown in Fig. 2. By closing valves A, A, A and opening all boiler connections wide, it is evident that all of the water will pass through each unit, one after the other. On the other hand, by simply throttling these valves (A, A,

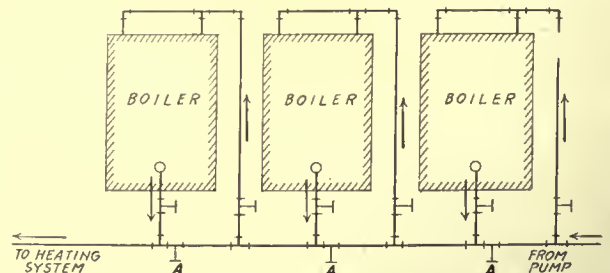

FIG. 2. BOILER CONNECTIONS

A) a portion of the water will pass through each boiler and back into the main. For the full heating capacity the water should be passed through the boilers in series, as first described, while for quick regulation of temperature, more or less of it may be by-passed by opening the valves in the main accordingly.

THE AMERICAN ARCHITECT

In most industrial plants, however, steam is required for power purposes so that it is desirable to utilize the exhaust, which is done by heating the water in tubular heaters similar to those employed for feed-water heating.

If more heating capacity is required, it is better to supplement the exhaust with live steam than to use a special water boiler. Live steam heaters are preferable to hot-water boilers for two principal reasons; first, the temperature of the water is under better control, and second, because high-pressure steam boilers are available either for power or heating purposes. Hot-water boilers, on the other hand, should be in duplicate to guard against accident, and must, in any case, be laid off during the summer, thus adding to the cost of equipment over that when steam alone is used. When there is sufficient exhaust to do the entire heating for a greater part of the time it is usually best to admit the live steam, as needed, directly to the exhaust heater through a pressure reducing valve, thus employing only one heater and making the action entirely automatic.

When the proportion of live steam is large, it is best to use a separate heater, supplied with boiler pressure, and placed in series with the exhaust heater. The condensation from this heater is usually returned to the boiler by gravity as this arrangement proves more economical in operation, owing to the tendency of water at a high temperature to break into steam when trapped to a pump receiver which is vented, thus passing off to the atmosphere as waste heat. If the pressure in an exhaust heater is always maintained above atmospheric pressure the condensation may be trapped to a hot-well or vented receiver from which it is pumped back to the boiler with the other drips and "make-up" water. If, however, the pressure is likely to fall below atmospheric a pump must be connected directly with the heater for draining it. In most plants of small and medium size, where it is desired to keep the equipment as simple as possible, it is customary to set the reducing valve on the live steam connection so as always to maintain a pressure sufficiently above the atmosphere to drain the condensation from the heater directly to the general receiving tank or hot-well.

The heaters employed for this purpose are similar to the ordinary feed-water heater, and in fact practically any standard make in which the water passage is equal to or greater than the area of the heating main, may be employed. The form in which the water is *inside* the tubes or coil is preferable owing to its greater efficiency which makes it possible to use a considerably smaller size.

The rate of heat transfer between the steam and water varies principally with the difference in temperature and the velocity of flow, and, under ordi-

nary working conditions, will range from 200 to 300 heat units per square foot of surface per hour per degree difference between the temperature of the steam and the *average* temperature of the water.

Assuming the initial and final temperatures of the water passing through the heater to be 180 and 200

$$\frac{180 + 200}{2} = 190 \text{ degrees.}$$

The temperature of steam at 2 pounds

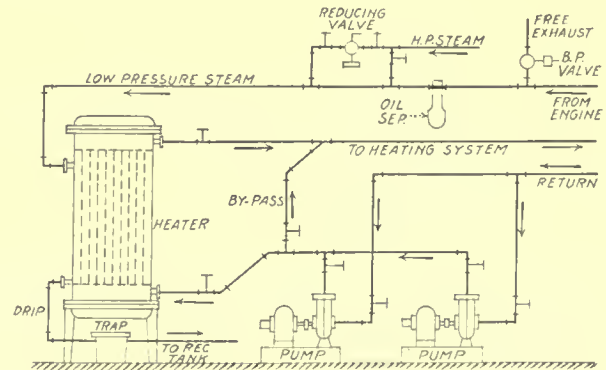

FIG. 3. PUMP AND HEATER CONNECTIONS FOR A SYSTEM USING A SINGLE HEATER

gauge is 220 degrees. Hence, the temperature difference between the steam and water will be $220 - 190 = 30$ degrees. With a transfer of 250 heat units per degree difference, this will give a total of $250 \times 30 = 7,500$ heat units per square foot of tube surface per hour. If the radiation from a direct coil is 250 heat units per hour, then 1 square foot of tube surface in the heater will supply $7,500 \div 250 = 30$ square feet of direct radiation. If a drop of 40 degrees were allowed in the temperature of the water passing through the system, then the temperature difference would be 40 degrees, and the ratio

$$\frac{40 \times 250}{250} = 40.$$

While this would

make it possible to use a smaller heater, the size of the radiators would have to be increased to make up for the lower average temperature of the water passing through them, so that the actual cost of installation would be greater than before.

In case of a live steam heater used in series with an exhaust heater, the efficiency of the tube surface will, of course, depend upon the work done by the exhaust heater and the pressure carried on the boilers.

For example, suppose there is enough exhaust steam to do one-half of the work, that is, raise the temperature of the water from 180 to 190 degrees; also by means of high-pressure steam it may be raised to a temperature of 240 degrees, which cor-

responds to a steam pressure of 10 pounds. This

$$\frac{190 + 240}{2}$$
 will give an average water temperature of

= 215 degrees. If a boiler pressure of 120 pounds is carried, the steam temperature will be 350 degrees, giving a difference of $350 - 215 = 135$ degrees between the steam and water. With this greater difference in temperature we may assume a somewhat higher rate of transmission per degree

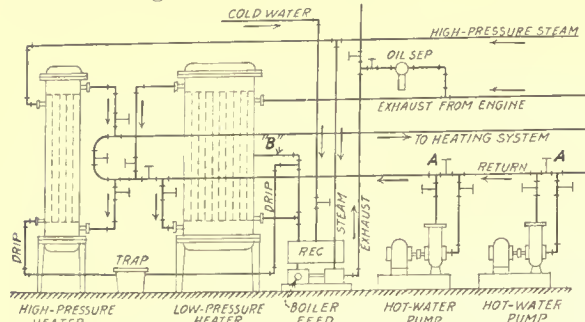

FIG. 4. SYSTEM USING LIVE AND EXHAUST STEAM HEATERS

difference, which we will take as 270 instead of 250. Hence, we have a transmission per square foot of surface per hour of $135 \times 270 = 36,450$ heat units, or nearly five times greater than before. If it is desired to do all of the work with the live steam heater in case of repairs to the exhaust heater, or for other reasons, then it should be given 1 square foot of tube surface for each $36,450 \div 250 = 146$ square feet of direct coil radiation. If it is only to be used for supplementing the exhaust heater, that is doing one-half the work. Then 1 square foot of tube surface will supply $146 \times 2 = 292$ square feet of radiation.

Pump and Heater Connections. These are best shown by simple diagrams. The simplest arrangement, employing a single heater, is shown in Fig. 3. Two pumps should always be used, each capable of doing the entire work, as the system is useless without the pump. These, in Fig. 3, are so connected that they may be used either independently or together in parallel.

The temperature of the water sent to the heating system is varied by by-passing more or less of it past the heater by use of the valve in the by-pass.

In case the water temperature is reduced in this way any surplus exhaust steam will be discharged outboard through the back-pressure valve, while the live steam supply will be shut off before this, automatically, by means of the reducing valve.

The condensation in this case is trapped to the pump receiver, the reducing valve being set so as always to maintain a pressure in the heater of 1 or 2 pounds gauge.

A system employing both live and exhaust steam heaters, is shown in Fig. 4, which also gives additional piping details. In Fig. 3 the pumps are in "parallel," that is, they may be operated together, each doing half the work, but no increase in pressure can be obtained in this way. In the arrangement shown in Fig. 4, they are in "series," and while they may be operated independently, as before, the water may be passed from one pump into the next by closing valves *A A*, thus practically doubling the pressure. This is often a convenience when it is desired to circulate the water at a high velocity for quick warming in the morning or in extremely cold weather. The heating main is so connected beyond the pumps that either heater may be operated separately or they may be run in series, the water first passing through the low-pressure unit and then through the high-pressure. The exhaust heater drains directly into a closed pump receiver, from which the condensation is pumped back to the boilers.

The drip from the high-pressure heater is *trapped* into this same receiver and any water which breaks into steam under this lower pressure flows up the pipe *B* into the low-pressure heater and is utilized instead of being wasted through a vent pipe. Cold feed or make-up water is drawn from the city mains into this same tank and pumped into the boilers with the condensation.

Another arrangement where the drip from the high-pressure heater is returned directly to the boilers by gravity is shown in Fig. 5. When the height from the water line to the bottom of the heater is

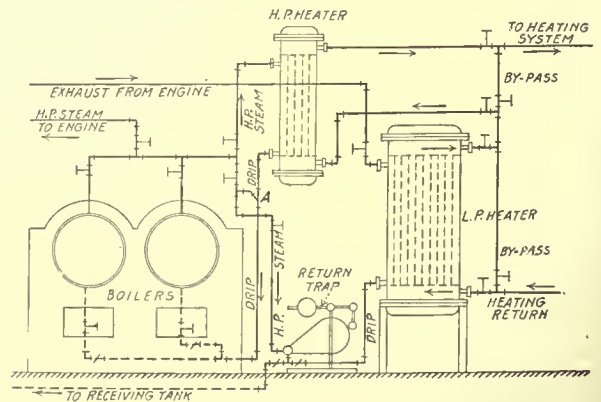

FIG. 5. ARRANGEMENT USING BOTH LOW AND HIGH PRESSURE HEATERS

less than 10 feet, a live steam connection should be made with an injector tee in the return, as shown at *A*, to overcome the drop in pressure in the heater under heavy service. Variations in water temperature are secured by throttling the steam supply to the heater, which reduces the pressure and allows the condensation to collect and partially submerge the

tubes, thus reducing their efficiency. The condensation from the low-pressure heater is discharged into the general receiving tank or hot-well by means of a *return trap*, which will work equally well whether the pressure in the heater is above or below atmosphere.

Systems of Piping. There are a number of different systems of piping employed in forced hot-water heating, and various combinations of these, according to circumstances, but only enough will be shown to give a general ideal of the principles involved. A

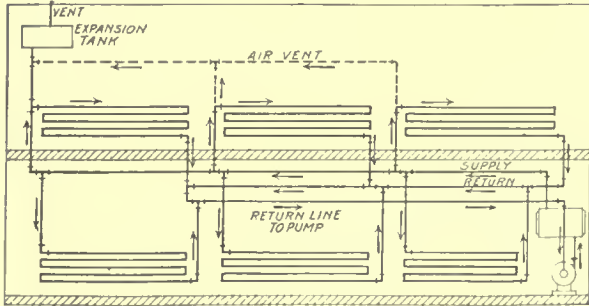

FIG. 6. DIAGRAM OF PIPING SYSTEM, SHOWING TYPICAL ARRANGEMENT FOR A TWO-STORY SHOP BUILDING WITHOUT BASEMENT

typical arrangement for a two-story shop building, without basement, is illustrated in Fig. 6. In this case the supply and return mains are carried near the ceiling of the first story, the coils on the upper floor being connected for an *upward* feed and those on the lower floor for a *downward* feed, as indicated by the arrows. In any system of hot-water heating the matter of air-venting is an important factor and must be provided for with great care.

As air is lighter than water it naturally finds its way to the highest points of the system, and these must be vented either automatically or by means of pet cocks opened at frequent intervals by hand.

In the arrangement shown the air liberated in the lower coils rises through the supply connections against the downward flow of water, passes into the supply main, then upward through the supply risers to the upper coils, from the tops of which it is taken off through small air vents (shown dotted), which, in turn, connect with a pipe line leading to the expansion tank, which is open to the atmosphere. By using this method there are no pockets in the system and the air is discharged automatically without the use of pet cocks. In following out the pipe lines it will be noticed that the supply and return mains run in the same direction and that a "return line to pump" is brought back from the extreme end of the line, without radiator connections. This arrangement is for the purpose of equalizing the flow by making the length of the circuit through each coil practically the

same. That is, starting at the pump, it will be found by inspection that the distance to any coil, through the supply and back to the pump again through the return, is very nearly the same in each case. If this were not so there would be short-circuiting through the coils nearest the pump, while the circulation through those at the end of the line would be very weak or lacking entirely. This condition is sometimes overcome by the use of throttle valves in the connections, but it is better so to design the piping as to equalize the resistance as much as possible and only resort to throttling when necessary.

Valves are usually placed in the supply and return connections of each coil for cutting it out in case of repairs, and one of these may be used for throttling if this is required in any special case.

The system shown is known as the "open system," which means that the expansion tank is placed above the highest coil and is open to atmospheric pressure. This system is commonly used where only a low-pressure heater is employed and where the maximum water temperature does not exceed the boiling point at atmospheric pressure (212 deg.). If the building were only one story in height, without a basement, the pipe connections would be identical with those shown for the first story coils. If there were a basement, the supply and return mains would probably be located there and the arrangement would be the same as though the first floor coils and their connections, in Fig. 6, were omitted.

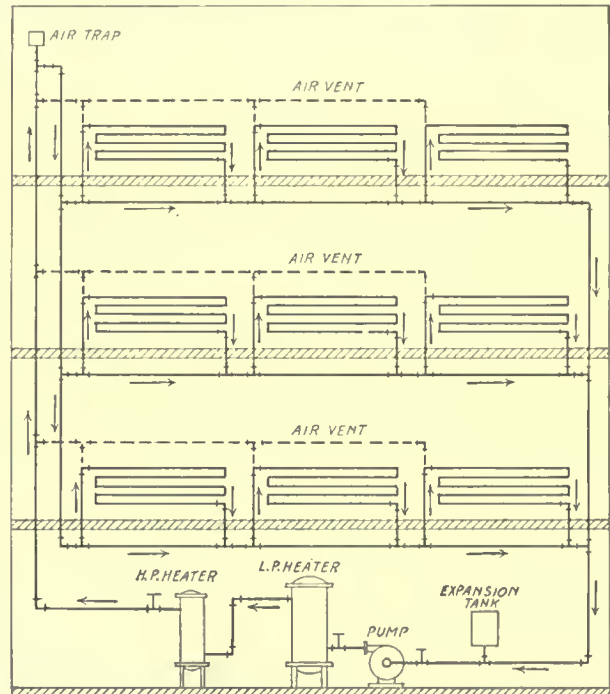

FIG. 7. RECOMMENDED ARRANGEMENT FOR A BUILDING THREE STORIES OR OVER IN HEIGHT

A good arrangement for a building, three stories or more in height, is shown in Fig. 7. In this case a high-pressure heater is used in series with the low-pressure, so that a water temperature is carried considerably above 212 degrees. Here an open expansion tank cannot be used because the water would boil if exposed to atmospheric pressure. This arrangement requires a closed tank, which will be described in detail in connection with Fig. 8. The supply main (Fig. 7) first passes directly to the top of the building, where it is provided with an automatic air vent for keeping the system clear of air. This is simply an inverted float steam trap and operates independently of pressures or temperatures. The main supply "drop" is taken from the riser near the top and is carried back to the basement, as shown. The supply for each story is taken from this and carried just below the floor, with the supply and return connections for the coils both connecting with the same pipe.

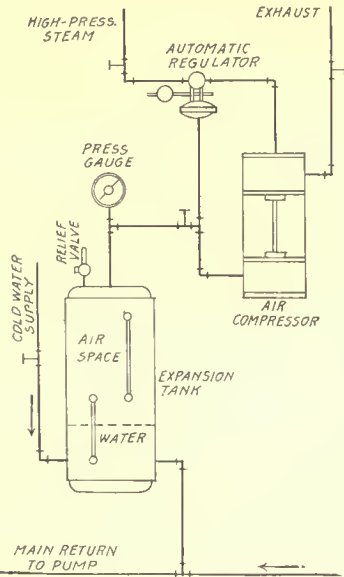

FIG. 8. TYPICAL ARRANGEMENT OF EXPANSION TANK AND AUXILIARY EQUIPMENT FOR A CLOSED SYSTEM

A typical arrangement of the expansion tank, and its auxiliary equipment for a closed system is shown in Fig. 8, in which case a constant air pressure is maintained in the upper part of the tank, above the water, by a combination of relief valve and automatic air compressor. When the water expands, due to a rise in temperature, the air in the tank is compressed and a sufficient amount escapes through the relief valve to prevent the pressure from exceeding the maximum desired. A fall in the water level reduces the air pressure, which is at once made up automatically by the compressor.

Additional water is admitted from time to time, as needed, by means of city pressure or a small pump under hand control.

Size of Mains.—The size of the supply and return mains leading from and to the circulating pump is based on the quantity of water to be handled and the length of run. The method of computing the gallons of water to be moved by the pump per minute has al-

ready been given, and Table II shows the velocity of flow in different size pipes for varying quantities of water; also the corresponding frictional resistance per 100 feet length of run, expressed in feet "head."

For ordinary work the velocity should not, in general, exceed the following figures:

TABLE II.

Sizes of hot-water mains and velocities of flow, with friction head per 100 feet:

Dia. of Pipe Velocity of flow in feet per minute	2-inch		2½-inch		3-inch		4-inch		5-inch		6-inch	
	Gallons	Friction head	Gallons	Friction head	Gallons	Friction head	Gallons	Friction head	Gallons	Friction head	Gallons	Friction head
180	29	2.0	46	1.6	66	1.4	118	1.0	184	0.8	264	0.7
240	39	3.4	61	2.7	88	2.3	157	1.7	245	1.4	352	1.1
300	49	5.1	77	4.1	110	3.4	196	2.6	306	2.1	440	1.7
360	59	7.2	92	5.7	132	4.8	236	3.6	367	2.9	528	2.4
420	69	9.5	107	7.6	154	6.4	275	4.8	428	3.8	617	3.2
480	79	12.2	122	9.8	176	8.2	314	6.1	490	4.9	706	4.1
540	88	15.2	138	12.2	198	10.1	352	7.6	551	6.1	794	5.1

TABLE III.

Dia. of Main in inches	Maximum Velocity feet per minute
2	200
2½	250
3	300
3½	350
4	400
5	450
6	500

It has also been stated that the total friction for the circuit, from the discharge outlet of the pump to the suction inlet, should not exceed 40 to 50 feet, while 20 to 30 feet is better for small plants.

The method of using these tables is best shown by working a practical example.

Example.—A factory building contains 3,000 square feet of direct radiation in the form of circulation coils. The length of the circuit is approximately 1,000 feet. What should be the diameter of the mains connecting with the pump?

Gallons of water to be circulated per minute = $0.025 \times 3,000 = 75$.

Looking in Table II we find that a 3-inch main will discharge 110 gallons per minute at a velocity of 300 feet, with a friction head of 3.4 feet. As this friction is for 100 feet length of pipe, the total head of 1000 feet will be $3.4 \times \frac{1,000}{100} = 34$ feet.

As both the velocity and friction head are within practical limits, this size pipe may be used.

The horse power for driving the pump will be 34×75

$\frac{2000}{100} = 1.28$.

2000

Modification of Zoning Ordinance

THE rapid spread of the Zoning—or more properly City Planning—idea throughout the United States, as indicated by the appointment of commissions in many cities to study conditions and present reports on which such ordinances may be based, as well as the actual adoption of zoning ordinances by quite a few cities, is an indication of the soundness of the principle involved.



THE PLAZA HOTEL, NEW YORK CITY
WARREN & WETMORE, ARCHITECTS

This photograph shows the building as it appears at present.

However, after the adoption of such a restricting ordinance, no matter how carefully worked out, many individual cases will appear in which a strict enforcement of the ordinance would seem unjust. In cases of this nature somebody capable of granting modifications must take action. The deciding of these cases is of the utmost importance, and it is essential that a careful investigation of all the facts be made, in order that the rights of adjoining property owners, as well as those of the appellant, may be properly safeguarded.

THE PLAZA HOTEL

An interesting case in which the New York Board of Appeals granted an important modification of the height regulations related to the Plaza Hotel, located at the southwesterly entrance to Central Park. From the facts brought out at the public hearing on this case, it appeared that prior to the adoption of the zoning ordinance, the Plaza Operating Com-

pany, owners of the hotel, had acquired property adjoining the hotel to the west and fronting 25 ft. on 59th street and 160 ft. on 58th street. The owners' intention in purchasing this additional land was to enlarge the hotel.

Warren and Wetmore, architects, were commissioned to prepare plans for this addition, which was done, a tower being incorporated in the design. The conditions created by the war were given as the reason why no effort had been made to proceed with the work in 1916 in accordance with this design. When plans were finally placed on file with the Building Department, approval was refused on the ground that the height proposed exceeded that permitted by the zoning ordinance, which had come into force in the interim.

In this instance part of the property is located in a one and one-half times and part in a two times height district. The existing building is 265 ft. high, or 65 in excess of the height that would be permitted for a new structure. The main portion of the proposed addition (as designed) will be 20 stories, the same height as the present hotel. Evidently due to the pleasing appearance of the existing building, and its important location, and desiring in



ROW OF FOUR-STORY AND BASEMENT HOUSES ON SOUTH SIDE OF FIFTY-EIGHTH STREET, OPPOSITE THE PLAZA HOTEL.

The house at the left is the Vanderbilt residence.

no wise to detract from the appearance of the general scheme, the Board of Appeals decided to permit the excess height.

While on the 59th street front, which faces Central Park, it would seem that no criticism of this action could be made, yet it is questionable as to how far such modifications should go on a street like 58th street, where the width (60 feet) is moderate. Of course, so long as existing conditions remain, i. e., 4-story and basement structures located



WESTERLY END OF FIFTY-EIGHTH STREET FRONTAGE OF PLAZA HOTEL, SHOWING EXISTING CONDITIONS AT SITE OF PROPOSED ADDITION

opposite, there will be ample light, air and ventilation, but should the property directly across the street be later occupied by a structure built to the height limit permitted, it would seem that the tall hotel structure would not only have less light than the law intended, but that the new building opposite would also be deprived of that light and air which the zoning ordinance sought to guarantee it in advance.

The resolution adopted in this case states in part:

"Whereas, under the plans submitted and accompanying this application it is evident that an existing nuisance, namely, the delivery of coal and hotel supplies, etc., on the 58th street sidewalk would be abated, as the appellant is creating an interior service court on his own property; and

"Whereas, there would be undue hardship in preventing applicant from completing the building in

accordance with these plans and this building being of monumental type and in a very prominent position, at the juncture of one of the main avenues and Central Park, the full spirit of the zoning resolution is better observed by carrying the proposed extension on the present lines of the building than by substituting other lines in the upper stories of the structure;

"Resolved, that the Board of Appeals does hereby make a variation in the application of the height district regulations of the building zone resolution, and that the application be, and it hereby is granted."

The elimination of the delivery entrance for coal mentioned in the resolution in itself would hardly justify a variation of the height rules. There is no doubt, however, that the action of the Board permits a better architectural treatment of the 58th street façade. The accompanying photographs and drawings illustrate the existing conditions and proposed improvement.

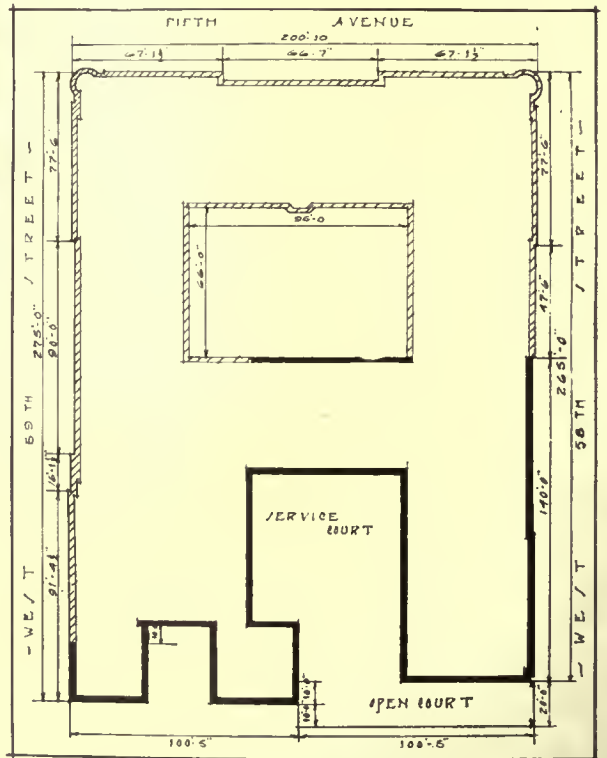

DIAGRAMMATIC FLOOR PLAN, PLAZA HOTEL

Hatched walls indicate existing structure. Solid black walls indicate proposed addition.

Current News

Happenings and Comments in the Field of Architecture and the Allied Arts

Fifth Avenue Association Makes Awards

Prizes for the best work in beautifying Fifth avenue during the year were awarded by the Fifth Avenue Association at its Twelfth Annual Dinner as follows:

Gold medal for best new building, 24 West Fifty-seventh Street Company, for their new building erected at 24 West Fifty-seventh street, Buchman & Kahn, architects.

Silver medal for second best new building, Douglas L. Elliman & Co., Inc., for their new building erected at 15 East Forty-ninth Street, Cross & Cross, architects.

Gold medal for best altered building, Guaranty Trust Company, of New York, at 522 Fifth avenue, Cross & Cross, architects.

Silver medal for second best altered building, Edward I. Farmer, at 15 East Fifty-sixth street, Trowbridge & Ackerman, architects, Lawrence Barraud, associated.

The prize winners were selected by the Committee on Architectural Harmony of the Fifth Avenue Association.

Nature Models in Clay

In the clay beds of the valley of Connecticut are found curious concretions, specimens of which, sent to England, excited the interest of the Royal Society as long ago as 1670.

These concretions appear in four principal types: disk-shaped, cylindrical, botryoidal (resembling grape-clusters), and irregularities, some of which strikingly suggest imitations of animal forms. A remarkable fact is that each claybed has a form of concretion peculiar to itself, and the principal types are never found intermingled in the same bed.

The beds are composed of stratified, river-drift clays, or "Champlain" clays.

Belgian Organization for the Construction of Cheap Homes

An intensive campaign for the construction of cheap homes has been begun in Belgium on the initiative of an organization known as La Société Nationale des Habitations et Logements à Bon Marché,

which has a capital of 100,000,000 francs and which is under supervision of the State. In Antwerp 125 of these habitations have just been completed in the populous quarter of Looibroek, due to the intervention of the communal authorities. This is regarded merely as a beginning. The city is arranging to procure the necessary space for the construction of 1,000 other houses with the aid of the Société Nationale.

About 80 local organizations already are in process of formation, and it is figured that before long much will have been accomplished toward the solution of a problem greatly aggravated by the destructions due to war. The Société Nationale is at the same time making experiments with material, apparatus, and processes of construction. It has constituted for this purpose what is termed a Comptoir National des Matériaux to facilitate the acquisition by officially recognized societies and at advantageous terms of new material and economical processes of building.

Experiment grounds are to be established in a number of regions, notably Brussels. These will permit inventors, manufacturers, architects, and contractors to come there to build habitations, develop theories of construction, or simply to carry out certain interesting ideas.

The Société Nationale will participate, if necessary, in the expense of these experiments. Certificates will be delivered participants. The organization makes an appeal to American specialists who would help in solving the living problem in submitting material and apparatus and ways of improving hygienic, economic, and esthetic conditions of popular and cheap homes. Requests for participation in the experiments should be addressed to the Director Général de la Société Nationale des Habitations et Logements à Bon Mache, 56, rue de Spa, Brussels, Belgium.

Safety Congress in Syracuse

A survey of the net results of the intensive safety campaigns conducted in New York state along the lines of promise and performance will occupy much time at the fifth Industrial Safety Congress, which will be held in Syracuse, N. Y., Dec. 6-9, under the direction of the State Industrial Commission. Safety problems will be taken up each day by men who are

charged with putting into practical operation the various plans worked out by experts to promote safety in industry.

Moving pictures, tableaux, pageants will be employed to demonstrate safe and unsafe practices.

In connection with the Congress will be held a safety exhibit, in which will be seen practical demonstrations of unsafe conditions and practices and suggested remedies.

Industrial Commissioner James M. Lynch is president of the Congress. Edward W. Buckley of New York is secretary.

London Astor House to Be Sold

The most unique office building in London, for more than a quarter of a century the business headquarters and home of the late Lord William Waldorf Astor, is to be sold. Built at a cost of more than \$1,000,000 this office-palace occupied one of the most commanding positions on the famous embankment.

Architects have called it the most original structure of its kind in the world, in that it combines many of the inspirations of the old world with all the modern devices of present-day business. It is constructed of gray stone, in Tudor style and never has any building offered such discouragement to burglars. A strong, though artistic railing surrounds the house, all the many windows have iron bars and entrance can only be obtained through a massive gateway of bronze.

Above it all is a little gilt galleon, in full sail, an exact model of the caravel in which Columbus crossed the seas, a happy reminder, as someone has pointed out "of the American-made wealth which made the splendid building possible."

When one enters the offices he is confronted by a magnificent carved staircase which occupies the greater portion of the center of the house. Oak beams, mahogany panelling, marble floors abound throughout and many of the fittings have been declared priceless by experts.

The house holds many rare treasures. Among the most important are the folio Shakespeare, the first edition of Spencer, a 16th century book of colored maps, many inlaid tables and cabinets and a ponderous fourposter bed with Gobelin hangings.

Although used as both a residence and office, several enthusiasts are urging that it be purchased by the city of London as a permanent home for the London City Museum, so well could it be adapted to public use.

The first Lord Astor spent much of his time in the building, managing his American properties from here and directing his newspaper, *The Pall Mall Gazette*. After his death, the volume of busi-

ness to be transacted became less and the present Lord Astor having no use for the building it is to be sold, but will always be a monument to the memory and personality of the late William Waldorf Astor.

Cement from Dead Sea

Ample quantities of bitumen occur in the Dead Sea region. Dead Sea bitumen was undoubtedly used in ancient times. It is evident that the walls of the temples and palaces of Babylon and Ninevah were joined with bituminous cements, and there are bitumen-lined cisterns in Syria of great antiquity which are still water-tight and fit for use.

Growing Homes

The giant edible bamboo is being introduced in some of the watery sections of the South and is expected to be of value in industry there. In Japan and the Orient this bamboo sometimes shows a growth of eight or ten inches in a single day and will reach a height of fifty feet. All by itself it can furnish food, clothing and building material. In this country it is expected to have its greatest value in furniture making, but an Oriental can build an entire home from this bamboo and live happily ever afterward. It would be practicable in Southern California, but a bamboo mansion would probably not make a hit in a New England winter.

Disciples to Build 113 Churches in the United States

Recommendations for the expenditure of \$807,750 to build 113 churches in the United States were endorsed by the international convention of the Disciples of Christ. Gifts to erect churches in New Orleans, Brooklyn, Chicago, Washington, D. C., and Vancouver, B. C., at a cost of \$325,000 were approved. Architects have not yet been appointed.

Protest Against Razing High Bridge

N. Y. Chapter, A. I. A. and N. Y. Society of Landscape Architects Among Many Protesting Associations

The removal of High Bridge, joining Manhattan and the Bronx at 168th street, which has been suggested by Grover A. Whalen, Commissioner of Plant and Structures, in a letter to the Board of Estimate, will be opposed when the matter comes before the board, by representatives of the American Institute of Consulting Engineers, the New York Chapter of the American Institute of Architects, the Parks and Playgrounds Association and the New York Chapter of the American Society of Landscape Architects.

Leading engineers, architects, landscape architects

THE AMERICAN ARCHITECT

and other persons interested in the city's landmarks have protested against the demolition of the bridge on the ground that it is "of inestimable value as an old and cherished landmark, and as a beautiful monument that celebrates the completion of a notable public work and honors the memory of a great engineer," and on utilitarian grounds as well.

It was argued that retention of High Bridge as an aqueduct was essential from the standpoint of the city's Department of Water Supply, while its destruction would lose to the city an important adjunct of the park system of Upper Manhattan and the Bronx and a possible means of vehicular connection across the Harlem River, midway between the far-separated existing crossings at 155th street and 181st street.

The New York Chapter of the American Society of Landscape Architects, in concurring in the suggestions made stated, in a letter written by Charles N. Lowrie, as chairman, to the Board of Estimate following the meeting:

"The society is of the opinion that an alteration to High Bridge, which will provide for the elimination of two river piers and the substitution of a single archway, is an admirable solution of the problem. By this process the channel way is clear of obstructing piers, head room is provided sufficient for any reasonable, conceivable navigation, a historic monument is preserved, and a traffic connection of great prospective value made possible between Manhattan and the Bronx of great scenic and practical value."

Concrete Window Weights Replace Cast Iron

With the increase in cost of iron, and the delay in obtaining it, substitutes are being adopted in many odd places. A California concern, for instance, is making and installing window-sash weights of concrete, reinforced with a wire loop. They are made large enough to occupy the whole weight run, one weight being made to serve both the upper and the lower sash by setting a pulley in the top and running the cord in a loop around it. This saves cord and labor as well as iron.

Vanderlip to Preserve "A Beautiful Piece of Architecture"

Frank A. Vanderlip, the New York financier, has bought the old Stephen Lawrence homestead in North Ossining, N. Y., to keep, as he expressed it, "a beautiful piece of architecture from going to pieces." It is a massive fourteen-room structure.

This purchase has no connection with Mr. Vanderlip's acquisition of the entire village of Sparta, at

South Ossining, where it is proposed to build homes for teachers. The Lawrence homestead, located on elevated ground on Croton avenue, was at one time the show place of the town.

It is an old Colonial mansion, finely built, and situated in the centre of a large tract of land.

Concrete Cascades Protect Railroad Right of Way

A curious sight in the rainy season, along a high bluff in Southern California, overlooking the Pacific Ocean, is a new series of 38 waterfalls of highly conventional form, provided with concrete channel and guide walls. The purpose of these standardized cascades is not esthetic, but wholly utilitarian. A railroad on the edge of the bluff was rapidly losing its right of way by erosion, and the trouble was ended only by building a long concrete retaining wall, and opening culverts to discharge the flood waters harmlessly down the spillways into the sea.

A Way of Roses Proposed to Cross New York State

Members of the leading horticultural societies and floral clubs in the state are interested in plans to plant rose bushes along the state highway from New York to Buffalo. The subject was discussed at the meeting of the State Federation of Horticultural Societies and Floral Clubs held at Syracuse. At that meeting it was decided to make a beginning by planting rose bushes along the state road from Syracuse to Auburn. This work will be undertaken by the Syracuse Rose Society, a member of the State Federation, the Auburn Rose Society and the newly organized Skaneateles Flower Club. It is hoped also to get the co-operation of the Chambers of Commerce of Syracuse and Auburn, the Finger Lakes Association, and the department of floriculture of Cornell University, the farm and home bureaus, Pomona and subordinate granges of Onondaga and Cayuga counties.

Much of the land along the state highway between the fences and the road can, it is believed, be planted with roses. In many cases the fences themselves will afford suitable support for the bushes. The riot of color which such a scheme would produce will, it is believed, make a lasting impression upon automobilists and other tourists. Should the plan work out well after a trial between Syracuse and Auburn it can easily be extended from New York to Albany, Albany to Syracuse, and Auburn to Buffalo.

Should the Syracuse-Auburn experiment prove successful the officers and special committee of the

State Federation of Horticultural Societies believe it will be an easy matter to secure the co-operation of horticultural societies, chambers of commerce, other bodies, and individuals for an extension of the plan. Dr. Earl A. Bates, Syracuse, is the chairman.

An experiment which has been conducted for many years along the New York, New Haven and Hartford Railroad between New York and New Haven gives some encouragement to those interested in the plan of the State Federation. Along the railroad are many rocks and rough places. These spots were years ago planted with rose bushes of the climbing and other kinds. Many of the residents also have planted rose bushes along their back fences. The result in the summer is a glow of color that is the wonder and delight of the travelers and commuters along the N. Y., N. H. & H.

Hunger and Want, But Order in Russia, H. G. Wells Says

Conditions in Petrograd were summarized in one phrase, "Hunger and want, but order," by H. G. Wells, in London, from a recent visit in Russia. He implied that similar conditions prevail throughout Russia.

In conversation with a representative of the Daily Mirror, of London, Mr. Wells said he had a chat with Nikolai Lenine, the Russian Bolshevik Premier, and went about freely without a guide in Petrograd and Moscow as well as other places. He said he was able to see and judge things for himself, but declined to give any general conclusions because his observations are not as yet digested. He declared he had been amused when he read of disturbances and insurrections in Russia, adding: "All that is just humbug."

Manufacturers' Catalogues Wanted

A correspondent writes us as follows:

A few days ago I received a letter from one of my former school friends in Paris, who is now a practicing architect there, and has some important work under way in connection with the rebuilding of the devastated regions. He has asked me to put him in touch with the means of acquiring catalogs of American products, and other documents that might be of use to him in this work, and it has occurred to me that a notice in your magazine, asking manufacturers to send him catalogs, might be the best means of helping one of our late allies, and at the same time developing a possible market for our products. His name is P. Perseval, Architecte D. P. L. G., 48 Rue Gassendi, Paris (XIV), France.

Electricity by Wind Power

In Sweden there is a plant which combines ancient and modern power sources in an unusual way, generating electricity by means of wind. A windmill with four 18-foot sails, making thirty revolutions a minute, produces 6.22 horse power when the wind has a velocity of 23 feet a second. The wind lifts a two-ton weight, which in its fall develops the energy to drive the dynamo. The mill produces about 4,800 kw.-hr. a year, which is used for agricultural and pumping purposes.

Personals

Hugh E. Weightman, industrial engineer and architect, has changed the firm name to Weightman & Steigeley, industrial engineers and architects. The offices are located at 21 North La Salle street, Chicago, Ill.

Joseph D. Leland, architect, is now located at 41 Mt. Vernon street, Boston, Mass. He was formerly operating at 185 Devonshire street, that city.

E. J. Ohrenstein & Hild, architects, have moved their offices from 58 West Washington street, Chicago, Ill., to 30 East Ontario street, that city.

VanLeyen, Schilling, Keogh & Reynolds, architects and engineers, are now located at 413 Genesee County Savings Bank Bldg., Flint, Mich. Their offices were formerly at 201 Walsh Bldg., that city.

A. R. Sharpe, architect, formerly located on Main street in Willimantic, Conn., is now practising at 144 Chestnut street, that city.

K. H. Sheldon, architect, formerly of Oak Park, Ill., has opened an office at 825 Harris Trust Bldg., Chicago, Ill., and desires circulars and catalogues.

Grant C. Macomber, architect and engineer, who was formerly practising at 11 Doyle Bldg., Flint, Mich., has larger and more spacious offices at 616 Genesee County Savings Bank Bldg.

Morris Whinston is now located at 116 W. 39th street, New York. Formerly practiced at 63 Park Row.

H. T. Barnham and Charles L. Hofman have formed a partnership with offices in the Chamber of Commerce Bldg., Richmond, Va.

Weekly Review of the Construction Field

With Reports of Special Correspondents in Regional Centers

SEVERE liquidation has been the order of the day in the New York Stock Exchange, and, since the Exchange can be taken as a fair gauge of the nation's money situation, it may be safely said that money is becoming less and less available throughout the nation. In the New York Herald of Nov. 16, the following appeared in the financial section.

"The 8½ per cent. renewal rate was the lowest of the month, but it was not taken as meaning that money was necessarily going to become easier in the course of the next day or two. Rather opinion was still maintained in banking circles that little ease in money will be experienced in the next month or so. As a matter of fact, no one looks for any real change until after the first of the year."

This, in the opinions of a group of financiers who met recently in New York to discuss the financial situation, is financially sound. Charles H. Sabin, president of the Guaranty Trust Company, in a statement issued at that conference, said:

"We are in the soundest financial, industrial and political condition of any important nation in the world."

As against this, it is learned that one of the largest deficits in governmental expenses in recent history will have to be met before the coming session of Congress adjourns for the Christmas holidays, according to officials of the Budget Committee who are now preparing the appropriation schedules.

All architects are aware that bankers generally blame the huge amounts of Liberty Bonds which they ascribed to as a reason for the curtailment of real estate loans, since those subscriptions removed more than \$1,000,000,000 from active circulation. Now the Government is faced with another deficit, with little hope of meeting it without extraordinary measures. Under present conditions it is difficult to understand where the money will come from to restore parity on the Liberty Bonds. Until that is done, a huge amount of money, which would be available for immediate circulation, is held up by the banks, and it is this money which should be out at present in real estate loans, for the purpose of housing. Most persons are agreed that housing is a serious problem in this country. Yet money cannot be found for putting up houses, and the Liberty Bonds in the vaults of banks all over the country will remain there until parity is restored. Which, reduced to its simplest form, means simply that millions of dollars which

should be available at the present moment for housing loans are as inaccessible as if they did not exist.

Architects can rightly question whether this is a "sound financial, industrial and political condition."

Judged from Senator Kenyon's recommendations regarding a number of things, it is not a sound condition. Mr. Kenyon was a member of the Senate committee which investigated the housing problem throughout the country, and on his return to Washington he proposed, among a number of other recommendations, the establishment of a Federal home loan bank, similar in its operations to the Federal farm loan bank, as a means of enabling the American people to have roofs over their heads. He called attention to the fact that the States of New York and New Jersey have tackled the housing problem, that Great Britain and France are taking action. He can see no reason why the Federal Government should not do the same thing.

There is no reason, the vast majority of architects are agreed, why it should not, but it is hardly necessary to establish a Federal home loan bank. All that is necessary is that the Government pass such laws as will compel banks to set aside a sufficient amount of their funds to meet the demands of those persons who wish to borrow money with which to build homes. In other words, to make it impossible for banks to *always* "seek the channels of highest return upon the investment," and to look forward a little to the future, without so much concern over the immediate present. Incidentally, one of the first things to facilitate such a move would be the passage of the law recommended by real estate operators which would tax exempt real estate mortgages up to \$40,000. That would amply provide for the *necessary* building of *homes*.

Coincident with all this, architects feel that there should be a thorough house cleaning on the part of labor. That has already begun. The Executive Committee of the American Federation of Labor recently met with Herbert Hoover in a thorough review of the labor situation. What Mr. Hoover had to say is not so important as the fact that he was invited to the committee's session by Samuel Gompers himself. This is the beginning, let us hope, of cooperation and consultation on the part of labor on the problems facing it. It may be that labor is taking account of recent developments, such as the laying-off of 2,500 workers by the Pennsylvania Railroad, 500 by the

THE AMERICAN ARCHITECT

New York Central, and wholesale cuts in the number of working hours by industrial firms all over the country. The employer is coming into his own, with an "Increase production, or get out" slogan. One of the most significant and worthwhile features of labor's program for the next year is its stand on immigration. It intends to Americanize; and, as a first step, to restrict immigration.

It has been pointed out by several architects that one of the most important comments of the week on the building situation is that of Senator W. M. Calder of New York, chairman of the Senate Committee of Reconstruction and Production. This comment is based on a mass of information gathered by the committee throughout the country.

"Wherever we have gone," Mr. Calder said, "there seems to be a fairly general opinion that prices on building materials eventually must decline. The committee so far has found a decline in only one building material—lumber, which sold for \$30 a thousand, and then advanced to \$90, has declined to \$60.

"As long as the Government's great loans are out, labor is opposed to reductions in wages, and the employer is opposed to reductions of his prices, I don't see much hope for heavy declines immediately, and it is doubtful if prices ever will attain their pre-war basis."

Transportation, however, has been bettered under private control. The car movement has gone up 23 per cent., and the freight carried during the first seven months of 1920 was billions of net tons more per mile than the corresponding period of the last three years. There are practically the same number of freight cars now in service, so the increase in haulage has come simply as an increase in the efficiency of labor. This increased efficiency has actually added the equivalent of at least 500,000 cars to the service of the shippers of the country.

(Special Correspondence to THE AMERICAN ARCHITECT.)

SEATTLE.—Stock taking will keep buyers off the building market to the end of the year and consequently there will be no incentive to discount prices as they are now being issued by jobbers. No new projects are expected until the New Year.

Fir lumber is apparently at the turning point after making recessions from the peak of from 40 to 50 per cent. and at the same time under operating costs. The key to the construction situation on the Pacific Coast as the jobbing trade views the matter is what the attitude of steel manufacturers will be. Every delegate to the convention in the east went from the Pacific Coast with the avowed determination to "smoke out" the eastern manufacturers as to what

they propose to do during early 1921 as to prices of sheet metal, pipe, nails, fittings and other essentials. On their return they had no more of a definite idea than when they left, with the exception that they feel that the mills will arbitrarily decline to yield to the downward pressure. Accumulated back orders, long held-up home, apartment and office building projects and what will undoubtedly be a heavy demand through next year will be the foundation on which the mills will lay their right to privileges of continued strong prices. In proof of this Pacific Coast jobbing interests have been making some comparisons of prices of the past five and six years with those of today, and it has been found that despite the impression that prices of steel products used in the construction industry have fallen heavily many items have been reduced only 20 per cent. The attitude of the manufacturers represented at the eastern convention was one that fell little short of defiance, according to the reports brought back by coast delegates.

The stock taking period will, in the judgment of large jobbing operators in the Coast territory, have many disclosures for the owners. It will be found that there is more stock on hand than casually surmised, and that the shrinkage in the values will set serious thought into activity. On the findings of the annual Survey will depend in large part how much new buying will be done in early 1921. More would undoubtedly have been bought when the incipient price declines set in but for the caution imposed by the federal reserve banks, for which many today are devoutly thankful.

Stocks of small pipe and nails are being brought up close to normal with the demand, with a few reserves for the new building year of 1921. Three-fourths and halves in galvanized pipe are still short, but the warehouses contain more substantial equipments than at any time in the past 90 days. There are plenty of 6 and 8 penny common nails, with the 3 penny fine blue steel showing the only shortage.

There was a little price cutting by Portland jobbers during the week in pipe, but the explanation by Seattle houses was that the declines were for stock-taking purposes.

That production at the eastern mills is increasing there is now no longer any doubt here. Estimates place the increased output at 20 to 30 per cent. The attitude of mill workers seems to be that the unemployment during the next 90 days will increase, and that the sole guarantee of holding a job is to produce. The word was passed out quietly, but firmly by the Central Labor Council, representing all the allied building trades of this city, this week, that hereafter the law will be to "work, and hold your jobs." Thus organized labor on the coast has sensed the new basis, following the conviction that a union card alone will no longer guarantee steady employment.

THE AMERICAN ARCHITECT

The Associated Industries of this city, with a membership of 2,400 against 138 in 1919, is pledged to support the "American" or so-called open shop plan, and its potency in the North Coast territory is well recognized.

Warehouses are filling rapidly with brick, plaster, cement, plaster wall board and roofing, but prices are stationary. The general plan is to wait and see what the new year brings forth. Jobbers are insisting that the public be advised and educated as to how low prices can go, and that the impression that there is no bottom should be eradicated.

Lumber seems to have touched bottom. Wholesalers are refusing to sell short on today's market for December or later delivery and the larger mills will not accept orders excepting on the market at date of loading. Vertical grain flooring is \$54, finish \$61 to \$66, drop siding \$36 and dimension is stronger at \$26.50 to \$23.50, all basis at the mill. Shingles are stronger. Practically all the mills are down.

At its annual meeting at Seattle this week the Interstate Realty Association, comprising several states and British Columbia, determined to aid the 1921 home building projects by enactment of fair and impartial tax laws. "Through our legislative committee," the resolution reads, "we are hoping to lessen the obstacles in the way of the home builder by a study of existing tax laws in the Northwestern states."

(Special Correspondence to THE AMERICAN ARCHITECT.)

CHICAGO.—The Calder senatorial committee has come and gone and the varied opinions as to the cause of the building shortage in Chicago have been aired at length, yet nothing looms up on the immediate horizon to indicate any important improvement in the local building situation. Of course, it was not expected that the mere hearing of the Calder committee would do more than provide a forum for the expression of divergent views on what the best method of procedure really is, but there has been a feeling that the various moves toward peace and prosperity in the building trades would shortly result in some appreciable improvement.

Prices continue to show evidence of further weakness, the labor problem is much less acute, and the shortage of houses and apartments would indicate a very promising field for the builder, yet nothing, somehow, seems to materialize.

The dullness in the building situation may very well be summarized in the reports of the city building departments. A typical day of this week showed only 13 permits aggregating \$241,000, as against fifty-four permits for the corresponding day in 1919, aggregating \$1,400,000. This ratio continues to hold

good for every day, as was shown in the statistics submitted to the Calder committee.

The weather has something to do with the continued dullness, but back of all this there is an elemental depression which seems to have hit all lines of Chicago industry and which is reflected in the public attitude to wait and see what is going to happen next.

The timidity of action is felt in all business and industrial lines. The average man will not buy a suit of clothes because he wants to wait to see if prices are coming down a little more, and the same feeling is manifested by the prospective builders, who want to delay a month or so to see if labor and materials won't drop another notch.

In such a frame of mind, the public declines to be interested seriously in building, and dealers in lumber and materials report that though prices are being repeatedly shaded, there is no appreciable acceleration in the buying.

Calvin Fentress, a prominent Chicago investment banker, who has recently returned from a long business tour through the lumber sections of the Pacific Coast, comes back with the expression that present mill prices for lumber place it in the bargain counter class. He predicts, however, that the hoped for pre-war level in lumber will not be reached for some time—not at any rate until labor has been reduced in price and other items which enter into the selling price of lumber materially lowered.

In spite of reports such as these Chicago lumber dealers report continued dullness in practically all lines. Even the industrial uses of lumber which kept things fairly active in spite of the building shortage have not been considerably diminished, and the volume of business being done is much below the average for the past year or so.

Activity, if it exists at all, is to be found mainly in the hardwood sections, and this activity is anticipated rather than actually enjoyed. Wholesalers and mill representatives report many requests for quotations, indicating that retail handlers are low in reserve stock. Upon these inquiries is predicated the hope that the next month will show a considerable improvement in demand.

Prices for lumber in this market are just about at the levels of a week, as will be seen from the summary below:

Yellow Pine: B. & B. 1 inch, \$95 to \$130, depending on thickness; 2 x 4, No. 1, 10 to 16 ft length, \$51 to \$53; 2 x 6, \$48; 2 x 8, \$50; 2 x 10, \$53; 2 x 12, \$55; 13-16 x 3¼ b & b flat flooring, \$85 to \$90; 1 x 6, No. 2 common, \$48 to \$90.

Douglas Fir: S & S, in sizes up to 12 x 12, in length up to 32 feet, \$65 to \$70; 14 x 14, \$68 to \$73; 16 x 16, \$72 to \$75; 18 x 18, \$75 to \$80.

THE AMERICAN ARCHITECT

Hard Maple: Four $\frac{1}{4}$ No. 1 and 2, \$135; select, \$120; No. 1 common, \$100; No. 2 common, \$65; No. 3 common, \$32.

Birch: Four $\frac{1}{4}$ No. 1 and 2, \$160; select, \$133 to \$138; No. 1 common, \$95 to \$100; No. 2, common, \$60 to \$65; No. 3 common, \$40.

Red Gum: Four $\frac{1}{4}$ No. 1 and 2, \$150; No. 1 common, \$90 to \$92; No. 2 common, \$47.

Materials have likewise held their own in this market during the week just past. No important changes are to be noted in the principal supplies, and in none of the list is business any too brisk. Dealers in materials say that charges promiscuously leveled at them during the Calder committee hearing are entirely unfair and that profiteering has not been one of the pastimes of the materials manufacturers and dealers. When labor comes down, they say, materials can also come down.

The price list for the week on a variety of items follows:

Cement: Universal, \$4 to \$4.20; Lehigh, \$4.20 to \$4.40; Portland, \$4.20 to \$4.40; Bulk lime, \$1.70 to \$1.90.

Torpedo: Lake and bank sand, \$3.40 to \$4.25; crushed stone, gravel screenings, \$3.40 to \$4.25.

Building material men are bemoaning the lack of present buying and predicting dire things for the spring, when a sudden jump in Chicago building is confidently expected. They even go so far as to say that there may be important scarcities in some of the essential materials, which will have a tendency to drive prices upward rather than lower, as most of those who have building on the mind for spring now hope.

One of the items which they say may go higher is brick. Brick business is very dull just now, practically nothing being done. There has been some curtailment of production, while the increased operating expense during this dull season will have to be added to the price of the brick when operations open up. This, according to some of the Chicago manufacturers will mean additional costs later on.

While no important new building is now being launched, considerable interest continues in the important buildings now being finished. The skyscraper office and store building which Wrigley, the chewing gum magnate, is erecting on Upper Michigan Avenue will be ready for tenants by May 1, according to present indications. The new building of the Chicago Tribune, in the same general location, is now finished and is being occupied by the various Tribune departments. This move on the part of the Tribune was brought about by high space values in the building which the newspaper has occupied for many years at Madison and Dearborn streets. The

old building, which is one of the best office buildings in Chicago, will now be devoted entirely to office and banking purposes. It has, of late, become too valuable to be devoted to newspaper activities.

The Crerar Library building at Randolph street and Upper Michigan avenue is also nearing completion and will be occupied very shortly at rental charges which are said to set new standards for Michigan avenue frontage. The opening of the Wrigley, Tribune and Crerar Library structures marks the beginning of what promises to be a new important business district of Chicago—Upper Michigan avenue, made possible by the broadening and improvement of Michigan Boulevard, north of Randolph street. Already a movement to save Upper Michigan avenue is being launched to prevent an influx of undesirable business lines in this exclusive section.

The addition of the Hamilton Club on South Dearborn street, near Madison, is also nearing completion, giving an important extension of the space of that exclusive organization.

Outlying hotels which are nearing completion are the Plaisance at the Midway and Stony Island avenue, near Jackson Park, and the hotel being erected at North State street and Goethe street by the Hotel Sherman Company. The tentative name for this hostelry has been "The Ambassador," but a suit has been filed in Chicago courts to prevent this use of the title. The bill is being instigated by the Hotel Ambassador Corporation, which insists that the Hotel Sherman Company, by using the name, "The Ambassador," in Chicago, would unfairly reap the benefit of the good-will created by the Ambassador hotels in other cities.

Interest has been created in Chicago by the efforts of the Illinois Chapter of American Architects to have the Fine Arts Building, which is all that remains of the buildings which made the Chicago World's Fair in 1893 notable from an architectural point of view.

This building, now in sad need of repair, has until recently housed the exhibits making up the Field Museum of Natural History. These exhibits have been moved to the newly built Field Museum on the Lake front at Twelfth street, leaving the old World's Fair building a "white elephant" on the hands of the South Park Commissioners, who have no money to spend on its repair and who threaten to raze it. The Illinois Chapter of Architects, having made a survey of the building, find that with a bit of remodeling and a certain amount of attention it can be made to last a number of years. They propose that a branch of the Art Institute be installed as a proper occupant for the now historic building.

722^a

Autopsies to 16,2346



WASHINGTON AS FIRST PRESIDENT OF THE UNITED STATES,
WESTERN PIER, WASHINGTON ARCH, NEW YORK

McKIM, MEAD & WHITE, ARCHITECTS

A. STIRLING CALDER, SCULPTOR

THE AMERICAN ARCHITECT

VOL. CXVIII

WEDNESDAY, DECEMBER 8, 1920

NUMBER 2346

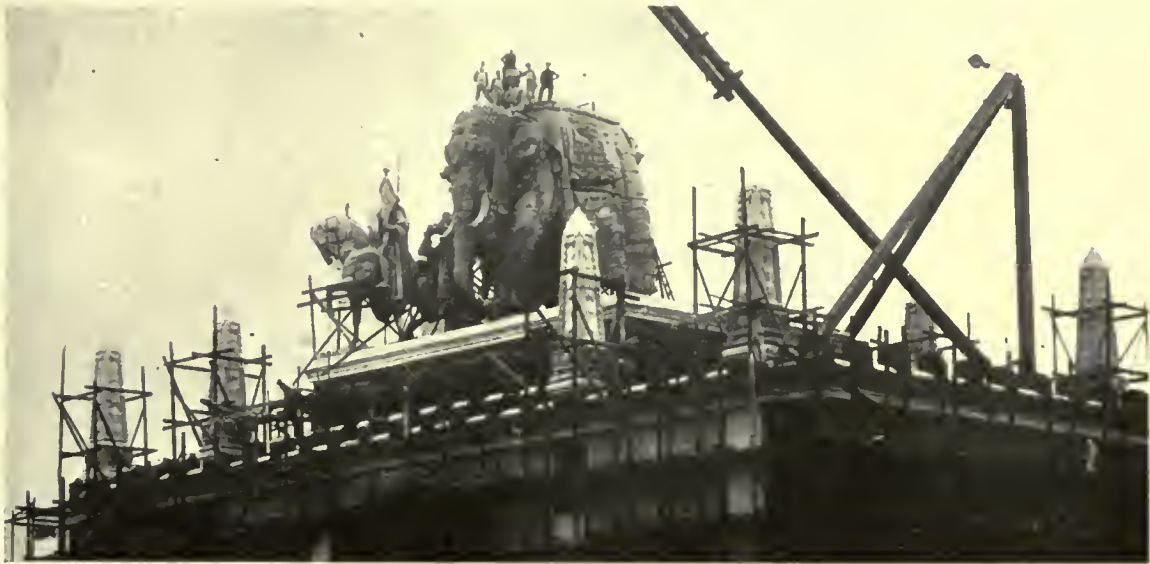

PLACING COLOSSAL SCULPTURE AT THE P. P. I. E.—THE NATIONS OF THE EAST

The Relation of Sculpture to Architecture

By A. STIRLING CALDER

Illustrated by Examples of the Work of the Author

THE development of sculpture in the United States has kept pace with the other arts. It has been a logical growth characterized by a general tendency to take its cue for production from demand rather than in obedience to profound impulse to plastic expression, and has developed along lines of refinement rather than of power. Since the days of Benjamin Rush, the Philadelphia wood carver, we have acquired more varied skill as modellers and greatly increased the number of sculptors. The technique of the great periods, and others, have been nervously noted and imitatively attempted with occasional brilliance and charm. Carefully, with calculation and thin impulse we have crept to results. The profound exaltation in form impression latent in us has not been tapped.

The great western chorus of plasticity has yet to be sung. It never can be sung until we know what we want. Until we have the simple strong frankness to draw directly from the sources of life about and within us. Little we see in nature that we dare to

make ours in art. When we can do this, when we dare to be simple, with the technical skill now at command, marvels will be accomplished. Continual exercises in the imitation and adaptation of Greek, Italian and French plastic forms, the assimilation of all former styles has been so imposed as to have occupied almost exclusively the energies of American sculptors. Only a surfeit of imitative reminiscence will eventually force the growth of a direct creative type in design. But it is due to arrive. We may be masters if we will.

Today the vivid faiths that in the past have enlisted the plastic arts in their service are dead. The Church is dead. All is polite reminiscence in Church art. There is no plasticity. Constructive national and civic pride in art that might mean so much in the evolution of living ideals is non-existent. There are private works of individuality and charm, but they are hidden and intimate, not in the grand style. We need a school of progressive, public-spirited plastic art, set up in the market places, erecting our

THE AMERICAN ARCHITECT

standards to our gods of Liberty, Power, Order, Research, Invention, Adventure, Courage — all that world of qualities in which we believe and by which we live. Our governments would do well to consider the uses of sculpture. In ancient states it played an important role in ideal building. It has celebrated the truths that could neither be spoken nor shown otherwise so purely, and sensuously it has won men's hearts through the eye, helping to prove life livable with the fellowship of pity and the love of universal beauty praised in stone and bronze. It is capable today of great conceptions, serviceable embodiments of prized qualities of men's teeming minds. The public use of sculpture is its highest field and goal. Great hope lies there for years to come, for the preservation of our reverent joy in form.

Our popular taste is more akin to the Romans than the Greeks. We love individuality. Only the service of hero worship endures as a live issue in public sculpture today in America. Portraits of soldiers and statesmen are still demanded, as much like them in body and mind as they can be made, and our best work hitherto has been in this branch of the art. But when we fill the pediments of our public buildings with sculpture, when we would see our ideals formed, we fail to express either individuality or ideal.

Sculptors forced to frame their thoughts in formal classic spaces become sterile. It must here be understood that the established character of the architectural frames or spaces provided in classic design for sculpture limits the sculptor to designs that will fill these spaces and necessarily forces a general resemblance in all such designs. This limitation of the primary outline or shape of a work of sculpture is of

the first importance. But such limitation should be dictated by structural needs that in turn have been indicated by the purpose of the work. We thus trace back to the first need of all, *purpose* in art.

Plastic thought has possibilities that have not been exhausted by the requirements of Egyptian and Greek temples or Gothic Cathedrals. These thoughts are pressing for expression and have not yet found a place, architecturally; that is the reason why so much modern sculpture finds its way prematurely to museums, permanently unplaced, a specimen, not an actor in the life of the day.

An inspired renaissance of the "Classic Spirit" in design as distinguished from the archeological spirit would do much to liberate the rigidity and enrich the practice of plastic design in connection with architecture. But no such inspiration is evident. Our practice is meticulous and unimaginative.



SON-OF-THE-EAGLE

WHAT, I am asked, about the mistaken viewpoint of the laity? The abused laity, I reply, has no viewpoint other than that of simple resemblance, and this as far as it goes is good. That the statue resembles the man, that the group breathe an idea. But they are willing to be impressed, bored only by pedantry as we all are. Life is continual readjustment; sculpture is the image of our plastic reactions to each adjustment. That is, its interest

not purely technical. Things are being done today that could never have been done before—that can never be done again.

The selection of subject matter proper to sculpture is very important. Everything is now attempted in every possible manner. Babel is again realized. All tongues clamor all conceivable theories of art.



REPEATED NICHE FIGURES, COURT OF FLOWERS, PANAMA-PACIFIC INTERNATIONAL EXPOSITION

GEORGE KELHAM, ARCHITECT

A. STIRLING CALDER, SCULPTOR

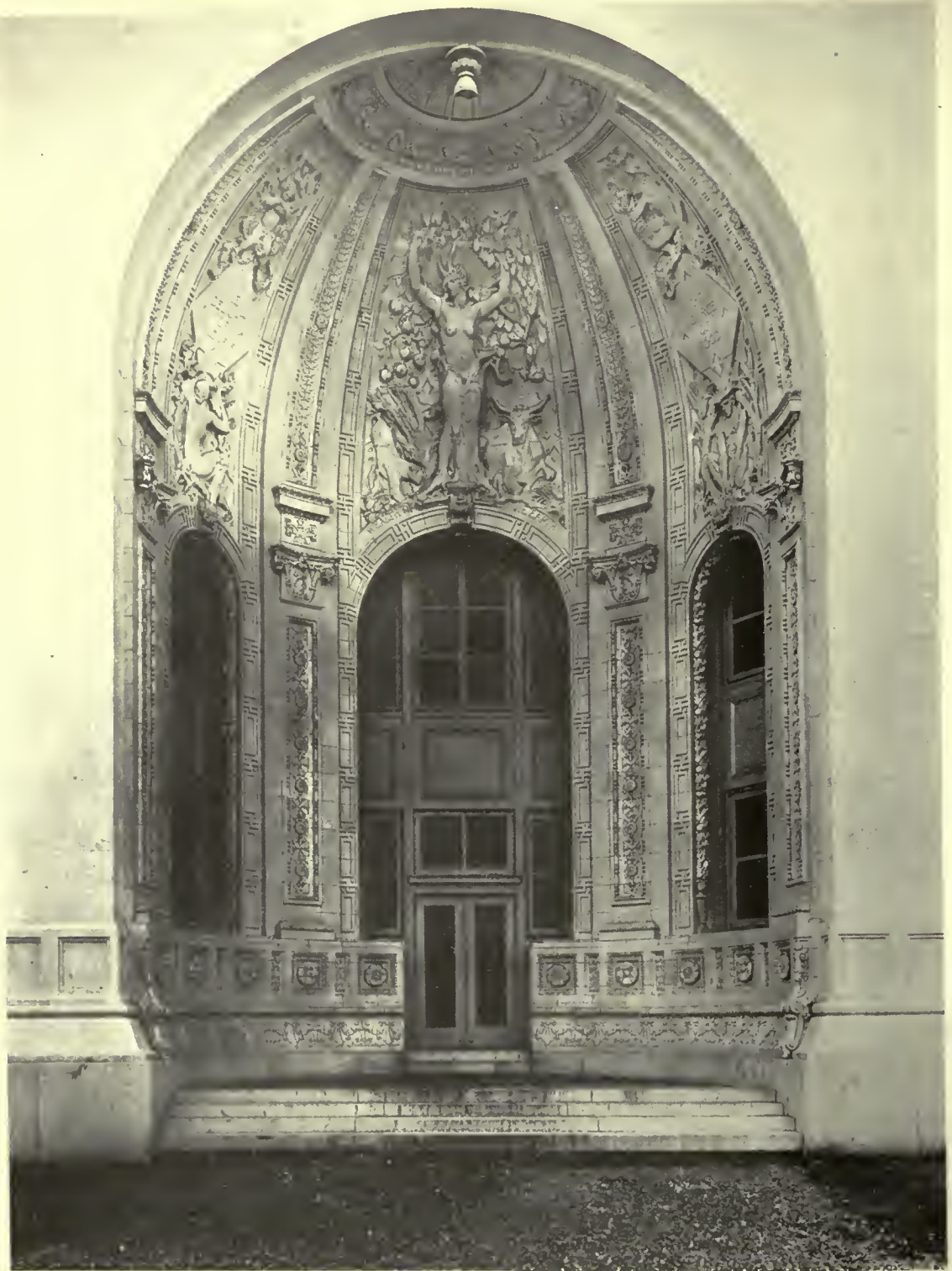

NICHE DECORATION

THE AUDITORIUM, OAKLAND, CAL.

HENRY HORNBOSEL AND JOHN J. DONOVAN, ASSOCIATE ARCHITECTS A. STIRLING CALDER, SCULPTOR

THE AMERICAN ARCHITECT

Tradition is questioned, privilege attacked, and license, if not liberty, attained as far as power will permit. This is all good because necessary. Growth is painful. Only by agonies can man find himself. Sculpture can help, and will be strongest, when limiting its choice of subject matter to those elemental truths, forces, actions and relations that must ever be kept in view. On the comprehension and acceptance of truth depends the sanity of the races.

The influence of sculpture is far-reaching. The mind that loves this art will more and more insist on order, character and beauty in visual life. The acceptance of the plastic idea begets a duty in creating and maintaining sightly order, simplicity, clarity; and will be at war with much that our suffering public endures in the varied litter of civiliza-

tion. Maeterlinck well says: "Sculpture should be the most exclusive of the arts. It should express only certain rare and irreproachably beautiful phases of life, form and mortal joy or suffering. Every plastic manifestation that fails of this is a species of lasting and inexcusable crime."

The qualities inherent in sculpture become in the



REALISTIC STUDY



ATHLETIC TROPHY FOR THE UNITED STATES NAVY

midst of our hurly-burly existence the more precious and desirable. Who that is conscious of the atmosphere of noise, motion and crowding in which we in cities live, will deny the impulse, the demand, the craving for an antidote to what we daily endure? Sculpture of all the arts is the most needed today. It embodies the spiritual fixity that anchors our emotion. Let us build again new shrines of sculptured calm that we may by daily sight of them keep the ultimate simplicity of life in view!

Sculpture is pre-eminently the outdoor art. It should be our intellectual sport, balancing those other physical sports that are so deservedly popular. As we enjoy the sight of living forms in action and contest, so may we enjoy plastic creations of those speculative, emotional or realistic sports of the mind.

Indoor sculpture will take care of itself, being easier of accomplishment, less dependent on architectural and landscape settings and the demand for it. The bleakness of our city squares and many of our important buildings because of the absence of interesting plastic manifestations is but too evident. The exterior of the Metropolitan Museum of Art is a case in point. It might be made so much more expressive of its use in its exterior appearance.

THE AMERICAN ARCHITECT

There are empty niches on Fifth Avenue and a general shut-in air to the building. Our New York City squares lack plan—are undeveloped beyond the formless open spaces of a third class city. What a chance for monumental and landscape development! Instead of spending all on donations to indoor museum art, our public spirited citizens who believe in art might well consider bequests left for the development of our city squares with a view to making them delightful places—creating monuments at the same time to themselves.



PORTRAIT BUST

THE uses of built-in sculpture in interiors is subject to the same conditions as when employed on exteriors. When it is an integral part of the interior it is limited in design to the lines laid down by the architecture. These are too often very hard lines. The time honored motifs and compositions are employed without thought of pertinence or interest except the purely technical, often dwindling into mere gestures. Let us remember that invention has made possible the history of art! When the architectural styles as now known were being invented they were not classified and laid down. They were directly expressive of artistic activities. Now they are indicative of a certain culture only. The *spirit* of their method is lost sight of in the study of their mechanics, the least important aspect of their nature. This soulless repetition of the empty shells of great plastic ideas is responsible for much of the apathy or hostility of the laity who probably vaguely imagine that these "ornaments" (sculpture as applied to architecture) are imported wholesale, or reproduced *ad libitum*, which is not far from the truth.

Now in contrast to this work which evokes only apathetic acceptance is not something more vital, less expected, more stimulating and pertinent possible? I thoroughly believe so. It only needs that we will it to begin.

In the first place the so-called "ornaments" must not be ornaments at all, in conception. They must be plastic ideas. In the creative periods of sculpture they always were plastic ideas in the first place, afterwards degenerating into mere ornaments when their significance was ignored or forgotten. But these plastic ideas cannot be built on or in buildings that are designed without ideas. The architecture that will properly give them place must be founded on ideas and in the new art deny all precedence to obsolete forms. Let the architect, knowing everything of what has been, decide only to employ the enthusiasm for design that this knowledge has engendered, and start all over again from the ground up to invent his idea-building. "Except ye be as little children ye cannot enter into the Kingdom (of Art)." Given an imaginative architect the result would be a revelation. It would be living art.

If after knowing the best of past achievement we can express nothing worthy of our own it would seem to prove that this kind of knowledge is of no use to the artist. The real use of art knowledge to the artist is as a technical foundation on which to graft his own inspiration or as a measure and spur to his own inventions. When the acquisition of knowledge results in paralysis or atrophy it had better be thrown overboard. Only recently we have witnessed the spectacle of the sterilization of design by this stubborn adherence to ancestor worship in

externals. New York cannot find the sign under which it should erect its war memorial! Design is at a loss for a symbol. Shall it be the Arch, or the Bridge, or some other form?

THE controversy and competition in ideas that has marked the efforts of the Mayor's Committee on permanent War Memorial to adopt a *form* of memorial, evidences an interest and purpose in those persons concerned in the arts that augurs well for the eventual selection of the best, most expressive and permanently satisfactory form for the memorial and for a program that will insure its execution in the best style of which American art is capable. So far we have been seeking, unconsciously, perhaps, for many of the suggestions urged are palpably inspired by group ambitions.



MARBLE SUN DIAL, FAIRMOUNT PARK, PHILADELPHIA, PA.

have been searching for a symbol, we are still searching for the expressively complete symbol under whose inspiration public sentiment will unite in necessary action for the creation of a vital and expressive design. The Arch first offered justly meets with the unanswerable criticism of being an obsolete imperial symbol of triumph in no way fitted to express the bloody sacrifice of a free people in their combat with Imperialism.

The free or nondescript type of monument might be beautiful depending on inspiration, but it lacks the initial uplifting impulse of a definite and pertinent idea in form. The War Museum Monument, the Music Player's War Memorial, both seek to impose a foreign utility as the first

consideration, making a virtue of a need. As well fill any public want and call it a war memorial. This



SKETCH MODEL FOR MEMORIAL TO WILLIAM SHAKESPEARE

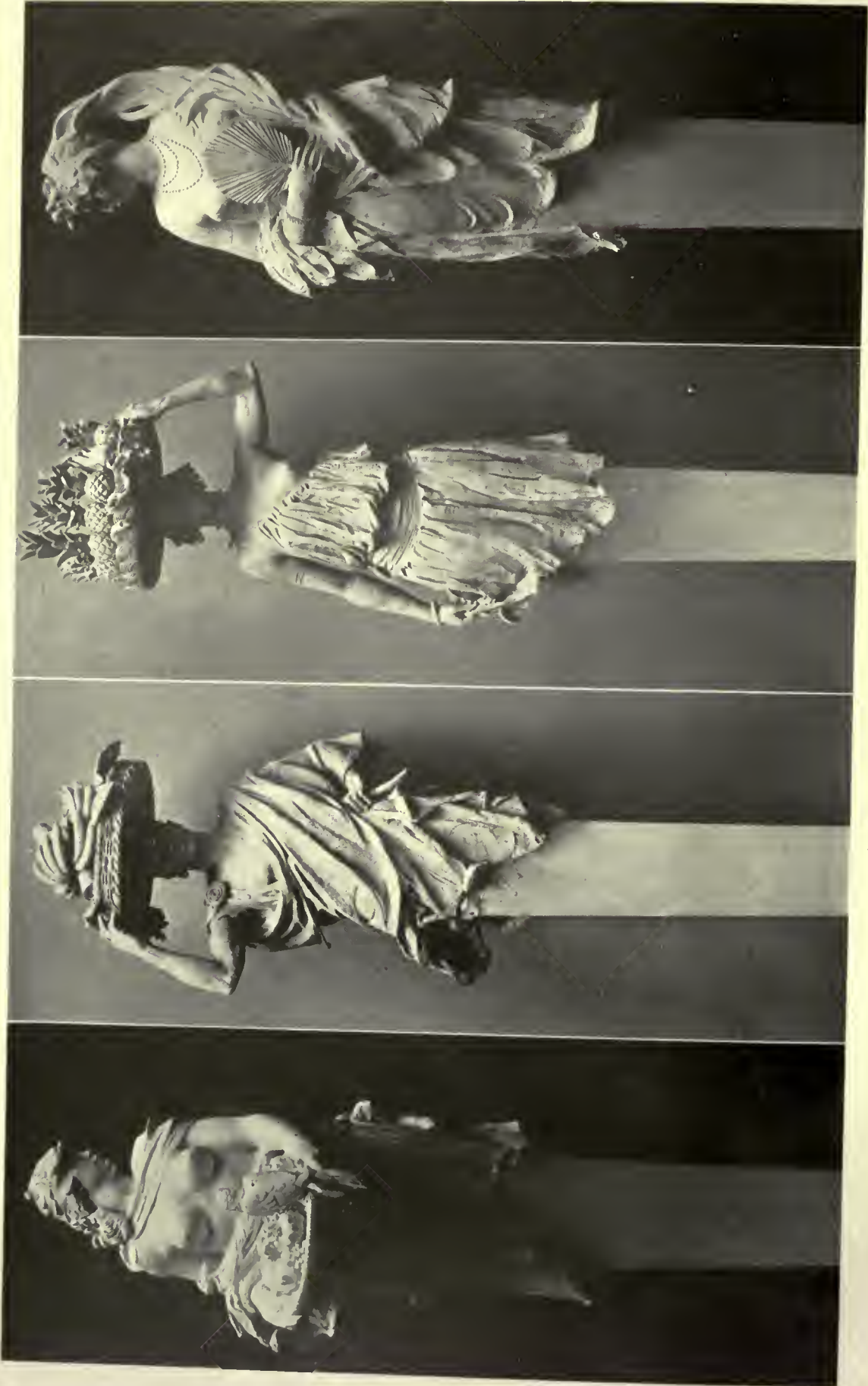

FOUR GAINES—THE ISLAND, VISCAVA
ESTATE OF JAMES DEERING, MIAMI, FLORIDA
A. STIRLING CALDER, SCULPTOR

THE AMERICAN ARCHITECT

sort of solution can never be satisfactory because the primary impulse and need for the memorial becomes a mere appendage to the gratification of other ambitions. The War Memorial Monumental Bridge is a great deal better, for there we have something approaching a symbol that is appropriate. As the arch is the time-honored symbol of imperial triumph, which has now passed forever, so the bridge, the span, is an unnamed symbol of progress, of communication. And when we consider what might be designed with a nobly sculptured tower as the central pier, whose top would be as a beacon on its commanding isolation in mid-river, the project has imaginative possibility.

But this is not yet the best. It still smacks too much of smartness and a desire to serve two ends. Our aim should be singly and solely to create under a satisfying symbol a memorial that shall inspire—The Horror of War—the Joy of Courage—the Need

of Law—the Pity of Humanity—the Obligation of Authority—the Patience of Effort—the Agony of Death, and finally the Hope for the Unity of Nations through and by the love of mankind that must assure the future.

I propose as the symbol under which our war memorial shall take form, an altar, The Altar of War. A warning against war, it should bear the character of funereal sacrifice, distinct and free from Pagan and Christian or any other creed formulae. It should be designed at great scale as a series of lofty ramps and platforms ascending to a colossal towering altar supported and enriched by sculptured figures variously applied and setting forth dramatically the thoughts above outlined. It should be built on our highest plateau, a site already suggested toward the northern end of Manhattan above the Hudson River.

(To be concluded)



SKETCH FOR A MUNICIPAL MONUMENT AND REVIEWING STAND



HENRY BACON, ARCHITECT

DEPEW MEMORIAL FOUNTAIN

A. STIRLING CALDER, SCULPTOR

Report of Housing Committee

New York State Association of Architects

THE following well considered review of housing conditions in New York State, and constructively formed recommendations for legislation, were passed at the meeting of the New York State Association of Architects, held in New York City, November 18th. The report reads:

FOR two years the citizens of New York State have known that a housing emergency existed that could only be cured by the erection of a large number of new houses. During that period in the City of New York more dwelling places have been destroyed or converted to other use than have been erected. As a result the rents of the homes of a large proportion of the citizens have been raised beyond their means; thousands of families have been crowded into dark, unsanitary, decaying dwellings; actual disease and suffering and the likelihood of epidemic have been greatly increased. Similar conditions are threatened throughout the other cities of the State.

Committees and commissions without number have investigated and reported, but no effective action has been taken that would lead to the building of more houses. The legislature has killed the incentive of speculative endeavor; it has done nothing constructive. The machinery of speculative and competitive enterprise for the production of houses has broken down. Housing is not as profitable as other forms of business. Money is being lent for other types of buildings, but not for housing; architects are planning other buildings, materials are being used by builders on other construction, but no houses are being erected. Workmen are employed on other types of building, though they need homes. It is apparent that what was our only source of supply of housing in the past—speculative and competitive enterprise—has failed us in this emergency.

The system on which we have always depended has never produced sufficient or proper housing. Private enterprise built the types of house that sold most easily, no matter how poorly they served as dwellings. In New York City and Buffalo the minimum requirements of the law was the guide of the speculative builder—that and a plan bought at a bargain. In other cities in the State he was free even of the restraint of any housing law. Most of the miles of New York City tenements as well as the cheaper houses of our smaller cities quite inadequately serve their purpose. They are built to sell, not to house.

The speculators that erected them were builders in name only—the sole skill they needed was that of borrowing money enough to pay for materials and labor.

At the present time it does not pay to build even the kind of house that the speculative builder formerly supplied the moderately well-to-do. For generations no one has built homes for wage earners. They have been herded together in insufficient, unwholesome, crowded, dark, left over dwelling places. In New York City and Buffalo the Tenement House Law offered some protection to those who could afford new homes before the war. It did practically nothing to improve the living conditions of that half of the population who live in the tenements that were built more than twenty years ago. The poorer half of our fellow New Yorkers have never received enough pay to afford even the inadequate homes that were produced. They suffered in silence. As a result of the complete breakdown of the old system of housing supply, the articulate part of the population who have been accustomed to some protection for the health, safety, morals and happiness of their families are now suffering, so we all know that there is a housing problem.

The housing problem is not a new nor a temporary problem. Rent legislation will not solve it. Offers of bounties to the speculative builders can only at best serve to resurrect an incompetent system that in a wasteful manner has given a small proportion of us quite unsatisfactory dwelling places.

We can only hope to start the machinery of house production and to make it function for the good of the community by a change in our attitude in regard to the part that must be played by credit, materials, labor, land, planning and the State.

The control of credit is mainly in the hands of a small group of men. These heads of banks and insurance companies are responsible to their stock and bond holders to get the greatest possible profit on their investments. Housing is risky. It does not pay as well as other investments. And so they will not lend money for housing. But the credit which they lend is based on the savings of workingmen and women. These same people are congested in a manner which endangers health and happiness while their money is used to build theatres and garages.

There is no solution of the housing problem until the control of credit becomes a public function. Credit for housing must be used where it is most needed and when it is most needed. This will be possible

THE AMERICAN ARCHITECT

when the State lends its money or credit for housing at a low rate of interest and for long terms or when the people finance the building of their own homes by forming credit unions for that purpose.

Material and building service, like money, are practically unattainable for housing. There has not been material or organized and trained labor enough for all purposes. Bricks have been used for loft building, not for houses; glass needed for homes has gone into automobiles. There is reason to believe that the scarcity of materials has at least in part been created by curtailment of supply for the purpose of keeping prices high enough to pay large profits. It is apparent that a stronger control by the public of the manufacturing and distribution of essential material is needed. But this alone will not suffice. All unnecessary waste and undue profit must go if we are to bring the cost of housing within the means of the more poorly paid half of the population.

Workers in the building trades are not giving their full effort. In part this is due to the disorganization that has resulted from the war. But there are more deep-seated causes. Artisans and laborers are discontented, perhaps because they feel that their efforts will not so much serve to promote their own interests as to enrich speculators and landlords who may afterwards squeeze them without mercy. If they felt that buildings were erected for the purpose of serving the need of the workers and the public in general instead of for profit, it might be more possible to get a full and enthusiastic day's work from workers.

The cost of land alone, according to the Housing Report of the Reconstruction Commission, is "generally sufficient to prevent a large part of the workers from escaping from the slums." The value of land increases with the congestion of population. However, the individuals who are crowded together in our cities get none of the increase which results from their being crowded together in insufficient quarters. The land increment is wasted in land speculation; it is ultimately added to the cost of houses. A means must be found to preserve this unearned increment for the use of the community.

Even if there were available and cheap enough credit, land, material and labor to build decent homes for all the housing problem could not be solved without a proper plan. Planning is the function of the architect. Much progress has been made during the last decade in the design of individual houses and groups of dwelling places. But the housing problem of our large cities cannot be solved by more houses. The unrestrained and unguided growth of New York

shows the waste that comes from lack of foresight in planning our communities. There is not room for the population to live comfortably, decently or healthfully near their work. Transportation cannot solve the problem. The subways are inhumanly packed. There are not streets enough to care for our traffic. New York has grown without plan to the point where it is choking its own growth. More houses—without a proper plan for their location—can only lead to more congestion and more expensive homes. All effort will be wasted if we further increase the size of our unhealthy and inefficient great cities. We should plan to decentralize our population by developing smaller, self-contained communities in which sufficient space is provided for agriculture, industry and organized social life. These should be small enough so that every family may have a garden and every worker may walk to and from his work, and large enough to allow efficient industrial organization and the social, educational and cultural activities that make city life attractive. They should be surrounded by a belt of land that should be restricted for all time to farming and recreation.

Governmental housing, though necessary as a temporary means of averting a crisis, seems dangerous and unsafe as a permanent policy. Municipalities should be given whatever power, if necessary, including that of building homes, to avert the dangers that are threatened by the present lack of sufficient houses. But the permanent function of the State in regard to housing should be that of education and of guidance of the various agencies that must need cooperate to give us sufficient, adequate homes, properly packed in relation to work, recreation and food supply. For this purpose the State and local housing agencies are badly needed.

As a first step forward in the development of such a housing program we recommend the adoption by the State of the recommendations of the Reconstruction Committee.

1. That a law be enacted requiring the appointing of local housing boards in communities having a population of over 10,000 and the appointment of a central State housing agency for co-ordinating local effort.

2. That a constitutional amendment be enacted permitting extension of State credit on a large scale and at low rates to aid in the construction of moderate priced homes.

3. That an enabling act be passed permitting cities to acquire and hold or let adjoining vacant lands, and if necessary to carry on housing.

The Trinity of Industry

GRAVE danger will menace our industrial structure, unless as a people we can be brought to realize that all industry, upon which is based our very existence as a nation, is in effect a partnership of Labor, Capital and Brains, each absolutely dependent on the other two, and none capable of separate conduct of the business. They constitute the Trinity of Industry.

Of late years, editorially states the *Seattle Journal of Commerce*, there has been a tendency to ignore the basic elements of the industrial partnership, and when that tendency has progressed to the point where one of the partners assassinates the other, as has recently occurred in Russia, the whole industrial structure collapses. So-called radical propaganda, socialistic pragmatism, and the pernicious meddling of half-baked dabblers in economics, coupled with the abysmal ignorance of the simplest laws of human relationships on the part of demagogues, has stimulated an unrest that strikes at the very roots of our national existence and welfare.

The attacks upon capital seem based on the belief that capital consists merely of money, and that those who are possessed of money can utilize it to take the place of manual labor on their part, whereas the simple fact is that capital, in reality, consists of such things as tools, credit, money, supplies for consumption, and production material. And, consequently, the history of civilization has largely been the history of capitalization. Radical argument objects to the growth of wealth, and yet every individual who possesses strength in excess of the actual needs of the moment is possessed of wealth, which can be turned to actual use to increase comfort, the standard of living, or reserve against lean periods.

Labor, Capital and Brains are natural partners, and in America we have rewarded that partnership as no other country has ever rewarded it. A mere glance at the condition of the American worker shows that he occupies a higher industrial place than the worker of any other country. His standard of living is far higher than that of any other worker in any other land, and his opportunity for advancement along industrial lines is untrammelled. Today, labor in the United States has a first lien on all products of industry, and practically dictates its own reward. There was a time in the history of American labor when the introduction of labor-saving machinery was violently opposed, but experience and a rising standard of education has shown the truly American worker that machinery has not only raised his production capacity, conserved his energy, multiplied his potential value, but increased his reward. Yet labor

alone was incapable of accomplishing such benefits for itself; they came through the co-operation of capital and labor to bring forth an industrial prosperity that is the marvel of the civilized world.

Sales Campaign for Safety

AMERICA is a gigantic suicide club, according to the facts and figures of accidents, of recklessness and general disregard of life and limb. There is no use deluding ourselves with the notion that ours is necessarily a dangerous country owing to its still relatively new development—our unavoidable grade crossings and vast network of railways in thinly populated districts. Ours is a dangerous country solely, states the *New York Tribune*, editorially, because we insist upon it being so and wantonly disregard, day in and day out, the commonest rules of safety. At any moment we could transform America into a safe country if we would make up our minds to make it so.

Fresh proof of this assertion is furnished by the safety campaign of the Long Island Railroad. This has been under way for five years now. It has utilized every available means to sell the idea of safety to the users of Long Island highways and trains. Safety advertisements were widely used, posters were put up, clergymen and school teachers were asked to urge the safety-first idea. The statistics of accidents at crossings show extraordinary results. In the last three years, for instance, the number of killed has dropped from 27 in 1918 to 10 in 1919, and 4 in the first seven months of 1920. Injuries at crossings have dropped from 209 in 1918 to 29 in 1919, and 7 in the first seven months of 1920. The number of accidents among employees has already responded to a similar campaign begun in 1918.

Unquestionably safety can be sold to all America by a similar campaign conducted upon a wide enough basis. The "safety-first" movement is an excellent beginning. The more individuals and organizations that lend their aid the quicker results will show. The reckless automobile driver should be one of the first to be reached. More stringent law enforcement is one method of curbing him. But a realization of the foolish and wanton risks of such driving, to others and to one's self, should be taught as well.

Safety means not only mechanical safety against accidents, but in building, includes those less obvious things which make for health and convenience. Their name is legion. The more responsible a man's work, the more is he depended on for honest, reliable precautions in these things—precautions which, even at increased cost, will safeguard trusting tenants and avert all possible elements of unsafety of every kind.

*Mount Vernon, Va., the Home and Burial Place
of George Washington. Detail of Entrance
and Colonnade Connecting Kitchen*

(See reproduction of original drawing by O. R. Eggers on opposite page)

ON the right bank of the Potomac, in Fairfax County, Va., fifteen miles from Washington, D. C., is Mount Vernon, the one time home and final burial place of George Washington. This stately house, with the ground that surrounds it, is typically an estate of a well-to-do gentleman of our early colonial period. The house, beautifully situated on an eminence, commands a long view of the river. It was built in 1743 by Lawrence Washington, an older brother of George, and was called Mount Vernon after Admiral Vernon, under whom Lawrence Washington served in the British Navy.

A house so well known and so reverently regarded by all patriotic Americans will need no further description.

The motive selected by Mr. Eggers for the present sketch shows the entrance front as the visitor approaches the house from the public highway. The Colonnade connects the main building with the kitchen, a detached building, a portion of which is shown on the extreme right of the sketch. Passing through the colonnade and kitchen, the visitor emerges on a short lane, bordered on either side by the many dependent buildings that were necessary in the domestic administration of so large an estate. There are coach houses, spinning houses, harness shops, a bakery and all of the many rooms and detached buildings that made housekeeping in early colonial times an earnestly studied occupation.

Further removed were grouped the cabins, in which were lodged the slaves. Every aspect of Mount Vernon suggests culture, and the architecture of the house and all the buildings that surround it is marked by the refinement of style that characterized the Georgian Period.



MT. VERNON, VA.
THE AMERICAN ARCHITECT Series of Early American Architecture



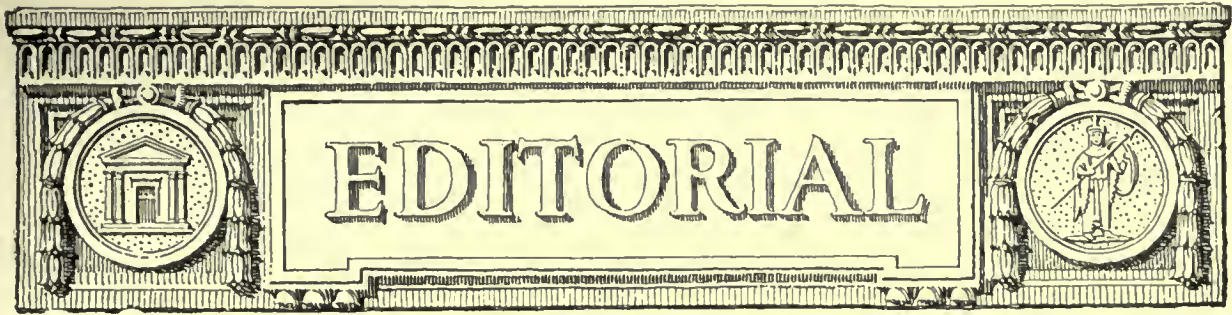

Will History Repeat Itself?

LETTERS from a number of correspondents enthusiastically refer to the recently held National Conference on Architectural Registration. The greatest measure of good, it is believed, will come as the result of this well conducted meeting. One man believes that organization within the profession of architecture will receive a very decided stimulus, and that when the plan is put into operation every architect will appreciate the importance of affiliating with his local society.

Another correspondent directs attention to the fact that the examinations for registration will include the minimum requirements for every state, and the applicant's certificate, when he has successfully complied with the examination, will permit him, on payment of state fees, to practice in any desired state.

This practically amounts to a first step in codification of registration laws, a measure that for a long time has been urged by this journal.

There can be no doubt in the mind of any architect, when he has closely examined the reports presented and read the debate at this meeting, that there are opportunities for the good of the profession fully as great as those that were in the hands of the Post War Committee when it so auspiciously started to function, now almost two years ago.

NO scheme ever evolved by the American Institute of Architects was better conceived and no committee appointed more fortunate in its personnel than the Post War Committee. It was a splendidly organized body. Its members, with a most unselfish disregard for their personal interests, gave time and hard study to the matters which they might, with large profit, consider. The results of this committee's deliberations were the very best that ever came from the Institute. They were not fanciful and impractical. There were no visionary, academic conclusions. They were red-blooded sentiments and conclusions reached by red-blooded men. The profession at large applauded, as one might do at a performance;

they were proud of the fact that they belonged to a group of such fine mentality and keen perception. Then, as, for instance, at the many public meetings of the Post War Committee, the profession went home to their offices and forgot the whole thing. Meanwhile, the Post War Committee naturally believed that it required the co-operation of the profession without regard to affiliation with the Institute to work with them constructively to build on the firm foundation that the committee had laid down. In this belief they were disheartened to observe the lukewarmness that prevailed. So, at the close of the Washington Convention, after a number of most brilliant meetings, the swan song of the Post War Committee was sung, and all the fine efforts it had made practically came to naught.

Let no one regard the practical things that the Post War Committee set out to accomplish, or the equally practical results that the National Registration Conference seeks to achieve, as among the visionary schemes that have been presented in other meetings for the reformation of architectural practice. Perhaps the Post War Committee languished and finally ceased to exist because it had too many and too complex matters to consider. But no such complexity surrounds this matter of registration. It is the one big, vital thing. Its successful handling will carry with it many of the things the Post War Committee considered.

It is not purely an Institute matter, this subject of registration, but vitally concerns any man who seeks to practice architecture. It therefore becomes the duty of all of us to forward this movement by individual co-operation. Such a co-operation should be forthcoming. If there is nothing else brought to a successful issue during 1921 than this one thing, it will be very much worth while doing.

The Relation of Sculpture to Architecture

IN this issue there is printed the first of two articles by A. Stirling Calder on the relation of sculpture to architecture.

THE AMERICAN ARCHITECT

Mr. Calder is intimately known to architects, and particularly to that group who were engaged in the development of the Panama-Pacific International Exposition, where sculpture's relation to architectural design probably reached, through Mr. Calder's fine execution of his art, its highest development.

Standardizations of material, design and types are resulting in the most unfortunate monotony in our architecture. One city is becoming so much like the other that there is a very decided lack of individuality. Mr. Calder believes that in the well considered application of sculptured ornament much of the unfortunate monotony may be overcome and a decided regional aspect be imparted.

Every state, and most cities, present in their early histories, their flora and their fauna, suggestive elements of design that would at once suggest a regional location. Not only is such a practice of design and execution desirable as an impetus to good art, but it also creates a very decided Americanism and a sense of local pride. A better, more intimate co-operation between sculpture and architecture would seem to be desirable.

The growth of the art of sculpture in this country is probably greater than in any other field of art. American sculptors have achieved results that will stand for all times as classics of plastic art. The talent is at hand, every architect may avail of it. Why not then avail of sculpture as a ready and safely artistic method of achieving well developed regional types of buildings?

Waste Spaces

A STREET can justify its existence in only two ways.

It must be either beautiful or useful. It should be both. But if beauty is lacking, usefulness must exist. The reverse is true. Complete lack of both qualities creates nothing more than a waste space.

There is a great deal of that in this country, and particularly in the City of New York. We speak of New York because it offers a splendid example of waste space to the nth degree. This is due to the gridiron scheme under which it was "planned." It is due to the fact that those who laid out this city forgot the simple rule that a street must be either useful or beautiful, and they forgot it particularly along the waterfront.

New York's waterfront presents to the trained eye a number of streets which lead to the river for no apparent reason. They are ugly streets. But they are, further, in many instances, not useful. That is, they

do not justify their existence on a commercial basis. They are waste spaces.

Careful investigation has shown that five out of six of those streets could be closed up completely without detriment to the necessary traffic which must reach the waterfront. The sixth street could bear not only its own, but the traffic of the other five. It is not necessary to quote a long series of figures to bear out this statement. Statistics prove a bore to those whose eyes are trained to observe conditions such as these waterfront streets present. The condition exists, and any architect who cared to do so could quite readily satisfy himself of its existence.

The important thing is to correct the evil.

It is a simple matter. A committee of experts could decide upon the streets to be closed. The blocks on both sides of those streets could be sold, especially those blocks where ramshackle dwelling places now exist. As an incentive toward buying such land, the city could offer the closed streets for nothing. A man, or a group of men, would thereby acquire valuable land for nothing. It would be a gift of high commercial value, a gift which would produce *complete* profits on any building scheme undertaken on such land.

What should that building scheme be? Homes.

The five-block piece as the unit would provide about 6,000 square feet of *free* land. The unit could then be designed properly by architects who understand the combination of moderate-priced housing and architectural fitness. A unit of five city blocks would give an architect sufficient space in which to create miniature communities. A definite treatment as to style, design and construction could be followed. That would insure architectural fitness all along the waterfront. It would kill the proverbial two birds with one stone, for it would both provide homes and would also tend to beautify the city's waterfront particularly and the city as a whole.

This is not the dream of a theorist. An article in an early issue of this journal, by one of the world's leading architects, will prove that conclusively. It is a practical, workable, efficient idea. Practical because it is entirely possible, from the legal or any other standpoint. Workable because it can be and has been thoroughly tested by experts who deal only in workable schemes. Efficient because it insures utilization of waste spaces, and because it offers a partial solution of the housing problem. Efficient, perhaps, because it gives to a city a definite unit system for housing which provides possibilities for some measure of beauty for the homes of the middle class, and there are few persons today who deny that environment plays a great role in efficiency.



THE OLD TOWN HALL, LOCATED ON THE CITY SQUARE, PRAGUE

Prague—The Mediaeval City—II.

By SELWYN BRINTON, M.A.

IN the last article of this series I described that wonderful Palace Fortress of Prague, which includes a cathedral, a vast palace, with separate churches and fortresses.

I come now to the mediaeval city of Prague, apart from the buildings of that period within this Palace-Fortress of Hradcany; and here we have to remember that Prague was a great mediaeval capital, that Bohemia—in the last centuries merely a province of the composite Austro-Hungarian Empire—was herself a great nation in the XIIIth and XIVth centuries, when her knights fought against the English Knights at Crécy, when her King Charles IV, Emperor of the Romans, was busied in founding the University of Prague, and making his capital one of the centers of European culture.

But these very centuries are those in which the spirit of feudal chivalry found its fullest expression, in which the marvellous Gothic architecture of

France at Rheims, Chartres, Amiens, Beauvais, Bourges and Paris, spreading into Germany and central Europe, attained its efflorescence: and we might fairly expect to find some fine examples of Gothic building in the old city of Prague. We shall not be disappointed.

Apart from Hradcany and its Cathedral in the civic architecture of the Town Hall, in the adjacent Tyn Church in spite of restorations, in the richly decorative Gothic Tower known as the Powder Gate, and those towers which guard the bridge of Charles IV we have rich examples of the Gothic style as developed in central Europe. The Town Hall itself, in the great Square of the Old Town, was commenced for communal purposes in 1338, but subsequently enlarged and extended. Thus the Oriel Chapel, beneath the great tower is XIVth century, having been consecrated in 1381, and is a good example of Gothic art at Prague in that period, while

THE AMERICAN ARCHITECT

the main entrance still Gothic in character, is some centuries later.

Very interesting here is the ancient astronomical clock, built into the wall in a very beautiful Gothic framing and canopy. Constructed in 1490 by Magister Hanns it was long considered as one of the wonders of the world, for besides the division of time for the 24 hours it has a complete calendar, including leap-years, and indicates the planets and rising and setting of the sun and moon. Above the clock itself are windows, and at these windows as the hour is being struck emerge the figures of Christ and his Apostles.

Within the old Council Chamber is of the fifteenth century, with painted ceiling and the arms of the Guilds of Prague; and in the adjoining great Assembly Hall of the Municipality, which is modern, having been rearranged in 1911, are two fine paintings by Brosik, representing the election of George of Podebrad as King of Bohemia and the reformer, John Hus, before the Council of Constance. The finely proportioned tower and the St. Lawrence Chapel belong to the old portions of the building; and the dungeons beneath are said to remain as they were when, in 1621, the Bohemian patriots were confined there before they were led out to be beheaded, on June 21 of that memorable year. In this place there now stands the monument to John Hus in the great square without.

It is, in fact, impossible to follow the art and architecture of old Prague without some knowledge of the religious differences which tore to pieces her internal harmony, and focussed in this old City Square, now dominated by that ascetic figure of the great reformer.

At the beginning of the fifteenth century the movement in favor of religious reform was steadily gaining ground; and it is an interesting fact, brought to my notice by my late friend, Mr. James Baker,

who was all his life a true friend to Bohemia, that the earliest impulse in that historic land of reform came from an Englishman. Thus from Wycliffe the sequence is direct; but it found its national leader in John Hus. Hus was a man of learning, character and great eloquence. Born about 1373-5, he studied in Prague University, became Magister in 1396, Dean of the Philosophic Faculty in 1401, Rector of the University in 1409. As Rector he became leader in the National party, and with the Wycliffian Magister Jerome, attacked the sale of indulgences. Hus, who knew his danger, was decoyed to Constance by a safe conduct, and refusing to retract his opinions was condemned as a heretic, and burnt alive on July 6 of 1415. Magister Jerome shared his fate in the year following.

But the unquenchable spirit of John Hus survived at Prague; and the Tyn Church, facing on the Great Square, was the central place of worship of his followers for two centuries, till, after the defeat of the White Mountain, the reforming party was finally crushed. Its two towers look gloomily down on the great market, where, at that time, 27 Protestant noblemen were beheaded, after having their hands cut off, their tongues cut out, and being broken on the wheel.

Itself a fine Gothic building, with a very beautiful and richly decorated entrance belonging to that period, the Tyn Church probably gained little artistically from its reforming occupants, and fared even worse when, after their suppression and the close of the Thirty Years War, it came into Catholic control. For that must have happened at the period of the triumphant invasion of Baroque into Catholic Europe; and the Tyn Church, possibly to remove the memory of its late possessors, seems to have been handed over to its worst excesses. In saying this I am not condemning, as such, the art of



ASTRONOMICAL CLOCK ON THE TOWN HALL, PRAGUE

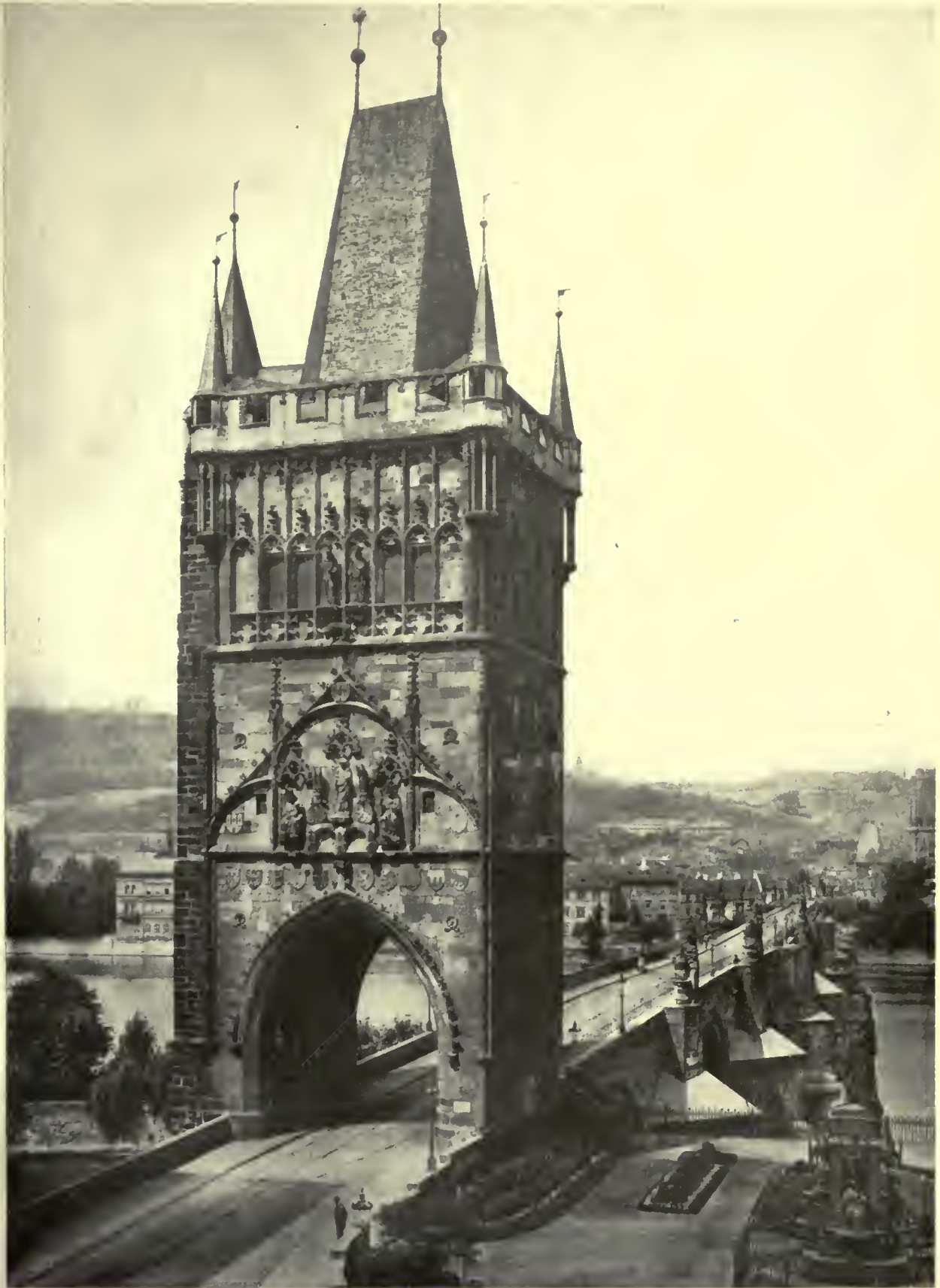

THE TOWER OF THE CHARLES IV BRIDGE, PRAGUE

THE AMERICAN ARCHITECT

the Baroque, which, as we shall see in the next article of this series produced some very interesting work at Prague in this very period; still less am I taking any part on the side either of the Catholics or the "Utraquists." But such a hash up of two entirely opposed styles, the Gothic and Baroque, as is offered by the interior of the Tyn Church is fortunately rare; the heavily gilt Baroque altarpieces are a discord to the severe and noble building which they have invaded.

Not far away from this church the Powder Gate

decorated Powder Gate is an ornament to the city.

Its design may be compared with that of the less ornate Bridge Tower of the Mala Strana, which guards the one entrance to the great bridge of Charles IV. There was a bridge here from very early times, over which, the old chronicles relate, the body of murdered King Wenceslas was miraculously conveyed, the bridge being at that date of 932, partially destroyed by flood. Two centuries later, in 1157, this old wooden bridge was carried away altogether, and replaced by that of stone which was erected by Queen



HUS MONUMENT, OLD CITY SQUARE, PRAGUE

remains to witness to the old fortifications, being a survivor from the eight fine gates which once led into the city. Its foundations were laid under King Vladislav by the builder Kamenik, though the rich external decorations were added by his successor Rejsek of Prostejov; it suffered during the Thirty Years War, was used as a powder magazine in the XVIIth century (whence its present name) and restored very successfully, in 1876-1880, by the City Council of Prague from the designs of the architect Josef Mocker. As it stands in the center of modern Prague, with its old archway restored, the richly

Judith in three years. But this Judith bridge, of which the Bohemians were so proud, also succumbed to flood in the winter of 1342; and finally the great King Charles IV came to the rescue, and put up the grand bridge which still lasts to our own days. With its mediaeval guarding towers at either end, its Baroque statues grouped along the sides, which date from the final Catholic supremacy in the first years of the XVIIIth century, and recall those by Bernini and his followers upon the Ponte Sant' Angelo of Rome, its immense stretch, and finely buttressed arches, it is a worthy monument to the great ruler who de-

signed it; and, like the Hradcany itself and the buildings grouped around the old City Square, is one of those architectural features which give to the city

its unique character and attraction, connecting, as they do, its busy modern life with an almost im-
memorial past.

Architectural Quicksands

Technicality of Lien Procedure

By CLINTON H. BLAKE, JR.
of the New York and Federal Bars

THESE is probably no branch of the law more technical than the construction and practical application of lien statutes. The Lien Law is a purely statutory creation. Unlike a large proportion of our law, as it stands today, it is not the result of a slow development based on the common law and the decisions of courts over a period of many hundreds of years. On the contrary, it is a remedy created arbitrarily by the statutes of the various jurisdictions in which it is applied, to supply the protection which, under modern conditions, it has been felt should be accorded to him who has, by his labor and services, contributed to the improvement of real property. As is well known, the doctrine has been further extended to cover mechanics in their work on articles of personal property, such as automobiles. The phase of the Lien Law with which the architect is naturally concerned, however, is the basic and important body of the law dealing with real estate improvements.

Due to the strictly statutory character of the law the statutes are necessarily technical and unless their provisions are strictly followed and observed the lienor may, as a result, lose the protection of the statute entirely. There are various requirements, for instance, which must be met in filing a lien under the laws of the different states. These laws vary in their scope and wording and the lienor, to be on the safe side, should in every case take proper advice before filing his lien. The preparation and filing of the lien is not a matter of difficulty to the lawyer but it would be dangerous for the lienor to attempt to act as his own attorney and to prepare and file his own notice of lien. The expense incident to having the lien properly prepared and filed is small and is negligible, when compared to the risk of loss incident to an attempt by the lienor to proceed alone and without proper advice.

SUPPLEMENTAL AGREEMENTS WITH CONTRACTOR.

It often happens that beside the general written contract there is a supplemental or additional agree-

ment between the owner and the contractor, covering some new developments in the work or some understanding not embraced within the terms of the general contract. Where this is the case it is of prime importance that any such additional understanding should be reduced to writing.

There is a special reason for this, aside from the general desirability, which I have emphasized, of having all understandings in written form. There is a rule of law which provides that the terms of a written document cannot be varied or changed by oral evidence. The rule is an entirely reasonable one and its purpose is to protect parties, who have entered into a written agreement, against the attempt of either one of them to evade the terms of the agreement, by testimony to the effect that the agreement does not mean what it says, and that an additional verbal agreement has been made between the parties which changes the terms of the original written instrument.

Under certain circumstances, such as the case of an agreement which is clearly collateral to the original agreement, the oral agreement will be recognized as valid, but it is never safe to depend upon this exception to the general rule. If the original agreement be in writing and any changes in that agreement are contemplated, or any new understanding between the parties relative to the work covered by the original agreement are desired, the only safe course for the parties to pursue is to reduce the new understanding, or the amplification of the original agreement or the changes therein as the case may be, to written form.

I have been discussing today, with an architect client, a case which shows how easily the failure to reduce the oral understanding to writing may result in loss and embarrassment. In the case which I have in mind the builder whom the client proposed to employ did not operate a union shop. The architect, knowing this fact, had a conference with the builder and told him that, while the client would like to employ him as the contractor on the job, he could

THE AMERICAN ARCHITECT

not do this unless he were assured that there would be no difficulties with the unions, and that the job would not suffer by reason of the fact that the contractor was a non-union man. The contractor assured him that he could do the work without precipitating any difficulties of this character and it was agreed specifically between the architect, acting for the owner, and the contractor that the contractor was awarded the contract to perform a portion of the work on the building, on the understanding and representations and guarantee by him that he could do the work, assigned to him, without any difficulty being raised by the union officials. The contract with this contractor covering the work to be done by him was reduced to writing. This contract did not make any reference, however, to the other understanding regarding the union situation and the oral agreement entered into, on this point, was not put in writing.

Hardly had the work been commenced, when the unions descended upon the owner and architect and served notice that none of the other work on the job would be attended to, so long as the non-union contractor was employed. The result was that the owner, in order to secure the erection of his house, was forced to make a new contract with a union contractor covering the work which it had been originally agreed the non-union contractor should perform. The latter promptly sued the owner, and the architect as well, for breach of the written contract.

The main defense to the action lies in the proof of the oral agreement between the parties, and in the oral guarantee and representations by the contractor that he would be able to do the work without interference by the unions, and the fact that the contract was accepted on this understanding. Fortunately this agreement can be proven and can be brought, probably, within the exceptions to the general rule excluding parole evidence which contradicts a written instrument.

The result has been, nevertheless, that the owner and the architect have both been forced into court proceedings, have had to retain counsel to defend the suit and will necessarily be put to a considerable loss of time and expense in this connection.

All of this difficulty would have been obviated had the agreement and guarantee on the part of the non-union contractor been reduced to writing. A few lines in writing signed by him, giving the substance of the oral agreement and making it clear that the written contract was entered into by the parties on the understanding stated, would have obviated the whole difficulty and would have placed the contractor in a position where the issue would have been so clear that he would not have brought the suit. It would have been better yet if there had been inserted in the original written contract itself a clause specifying that, in the event that any difficulty were raised by the unions, the obligations of the owner to continue under the contract would terminate, and that the contract might, under such circumstances, be terminated by the owner at his option, accordingly.

This is only one of a score of cases which might be cited, all emphasizing anew how many difficulties may flow from the failure to secure, in the first instance, some very simple written statement or agreement. I realize that it is quite natural that an architect, in the midst of a busy practice and with his chief attention focussed on the plans of the work proposed, should not have in mind the desirability of covering points of this character by written memoranda. If the architect will, however, realize the amount of damage which may come, both to his client and to him personally, by a failure to have all important understandings, relative to the work, reduced to writing, he will find that the acquisition of this habit is an asset of tremendous value in the practice of his profession. I can only suggest that, in handling the various jobs committed to his care, he endeavor to consider more carefully each problem of this character as it presents itself, and that, before acting, he analyze it from the point of view of whether the action which he proposes to take is sufficient to safeguard his clients' rights and his own rights as well. Where there is the slightest doubt in his mind, or where an agreement between the parties is of any substantial importance or has any possible bearing of importance on the relationships between the parties, he should take proper advice and see that the situation is covered by a definite written agreement in proper form.

Competition for Plan and Equipment of a Model Kitchen

Extract from Report of the Jury

HERBERT FOLTZ, F.A.I.A., *Professional Advisor*

THE growth and development of domestic architecture in the United States is largely due to the perfection of a plan that would meet requirements of social and domestic usage. And, having evolved a plan that adequately serves its every purpose, it is logical that the various details of that plan should receive careful attention and consideration. The following illustrations and report of a jury in a kitchen cabinet competition, while only referring to a minor detail of the domestic economy, are believed to be of sufficient interest to warrant the extended space given them. Similar study of other and equally important details of domestic planning would enable architects to render a service to clients that would be of large value.—
Editor's Note.

WE herewith hand you the report of the jury on the drawings submitted in the competition for the plan and equipment of a model kitchen conducted by the Hoosier Manufacturing Company, of Newcastle, Indiana, manufacturers of the Hoosier Kitchen Cabinet.

In making the awards, the decision of the jury hung upon its interpretation of certain general statements in the competition program, the more important of which are here recalled:

"The problem involves the design of a fully equipped kitchen for a family of four or five without a servant." * * *

"The jury will give consideration to the kitchen plan as an effective working unit; to the character of the several items of equipment and their relation each to the other; to the relation of the kitchen to other adjacent parts of a practical house plan; and to the skill and ingenuity displayed in the solution of the problem as a whole. The question of skilfulness in the execution of the drawings will not be considered, though neatness in their presentation is not to be disparaged."

Before proceeding to a judgment of the 343 drawings submitted, the jury formulated an opinion concerning what certain of the phrases of the program meant in terms of plan and arrangement.

"Family without a servant" implied that the kitchen must be self contained, complete, capable of fulfilling its function without a pantry. It implied a small kitchen in a comparatively small house. Nor should the operation of such a kitchen depend on the use of special equipment, unusual materials, or features which are not to be readily procured in the open market.

"Effective working unit" implied that there is a definite procedure which should be followed in the

use of the kitchen—the preparation, the serving, and the clearing away of a meal. In terms of plan, arrangement and items of equipment, the jury interpreted this phrase to mean a sequence in the use of equipment in preparing a meal, as follows: Refrigerator, kitchen cabinet, range, serving table, to dining room; the sequence of use following a meal, from dining room to table or counter for soiled dishes, sink, drain board, china closet, all so arranged that work goes on from right to left, leaving the dishes after drying in or adjacent to the dining room. That is to say, clearing away should proceed from and return to the dining room in a direction opposite to the movement of the hands of a clock, or "anti-clockwise." This movement of the dishes was generally disregarded by the competitors. The phrase "effective working unit" also implied the provision of ample light from sources which would also provide a cross circulation of air.

The phrase in the program "The relation of the kitchen to other adjacent parts of the house" was given a broad interpretation. To the jury this meant that the essentials of the scheme should be contained within a simple, preferably rectangular, arrangement of the walls surrounding the kitchen. Thus only could the arrangement be applied generally. As to the location of the doors connecting the kitchen with other portions of the house, the jury was satisfied on this point when a design was such as to lend itself to arrangements usually found in houses of this general category.

It was upon the foregoing summarized basis of interpretation that the work of elimination proceeded and upon which the following choice of designs was made. Because of the difficulty in reaching a decision as to the four best designs for mention out of the six last remaining drawings, suggestion was made that these six designs be mentioned, which suggestion was accepted by the Hoosier Manufacturing Company.

1st Prize, \$500. A. Thompson Thorne, Tulsa, Okla.

2nd Prize, \$200. Linden LaRue Perrine, Washington, D. C.

3rd Prize, \$100. Oscar T. Lang, Minneapolis, Minn.

4th Prize, \$50. Mary Drago, Gibsland, La.
Mentions regardless of rating, \$25 each.

— DESIGN FOR A SMALL FAMILY —
 ~ MODEL KITCHEN ~
 — AS SUBMITTED IN THE —
 HOOSIER MANUFACTURING COMPANY'S —
 COMPETITION —

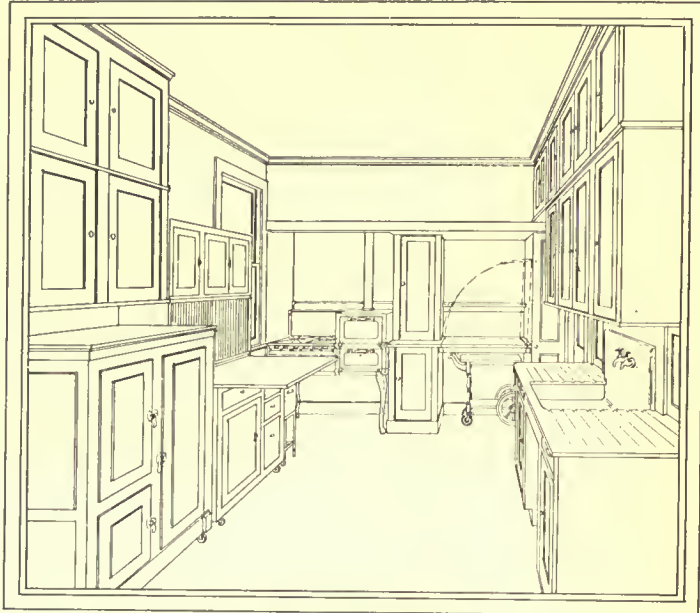

~ PERSPECTIVE VIEW ~

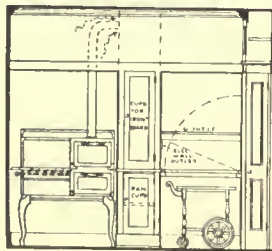
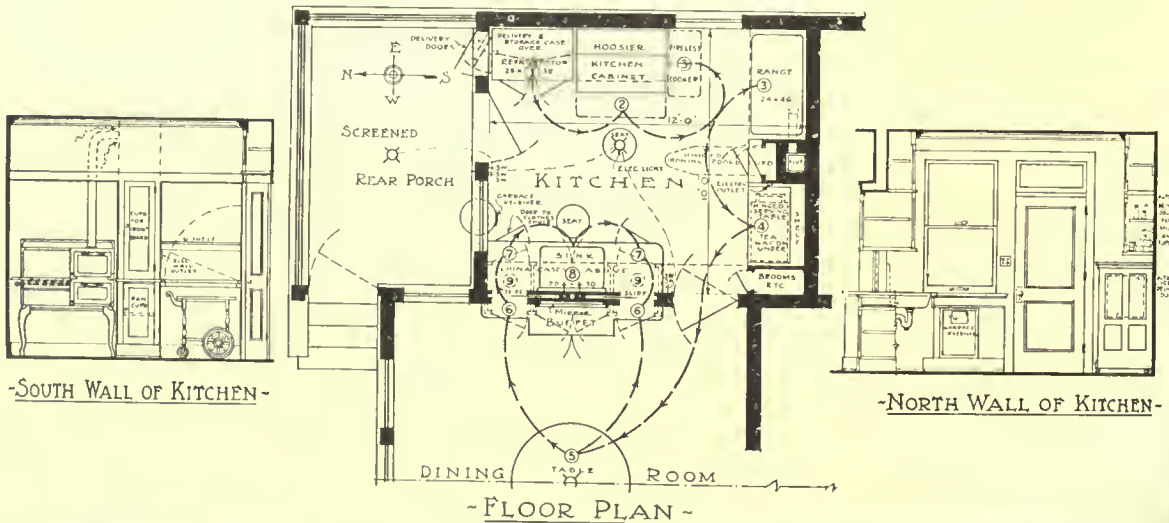

- SOUTH WALL OF KITCHEN -

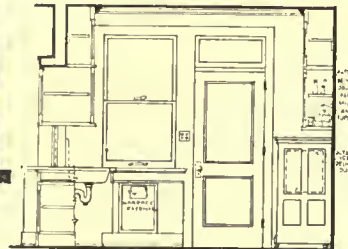

- NORTH WALL OF KITCHEN -

~ FLOOR PLAN ~

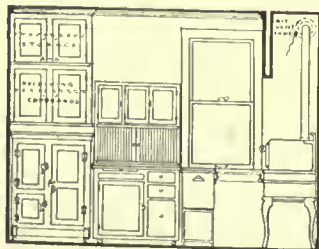

- EAST WALL OF KITCHEN -

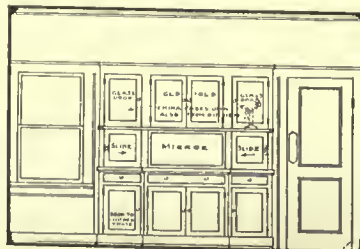

- DINING ROOM SIDE OF CASES -

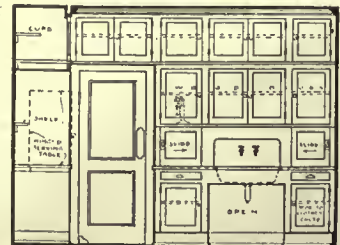

- WEST WALL OF KITCHEN -

— SCALE 1" = 4' — FEET —

FIRST PRIZE DESIGN
 A. THOMSON THORNE, Tulsa, Okla.

DESIGN FOR A SMALL-FAMILY MODEL KITCHEN AS SUBMITTED IN THE HOOSIER MANUFACTURING COMPANY'S COMPETITION

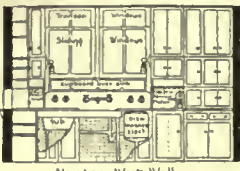

Elevation West Wall

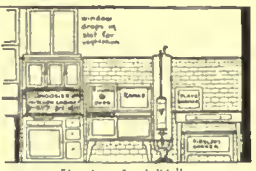

Elevation East Wall

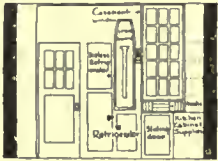

Elevation North Wall

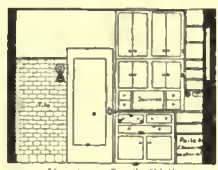

Elevation South Wall

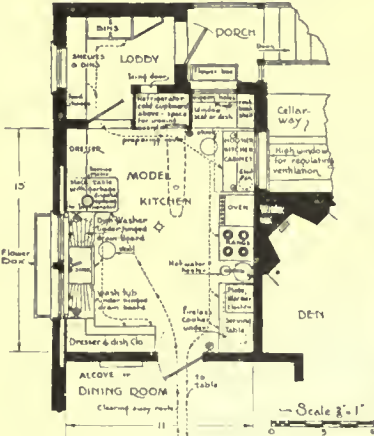

Scale 3/4" = 1'

Notation

Ceiling - Ivory - water-proof paint
Walls - Buff with apple green motif
Santas and tile Pongee curtains with apple green motif
Floor - Buff & white check
Inlaid Linoleum - Green rug - Ivory wood work



SECOND PRIZE DESIGN
LINDEN LA RUE PERRINE, Washington, D. C.

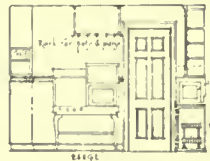

VIEW LOOKING WEST



VIEW LOOKING NORTH



VIEW LOOKING EAST

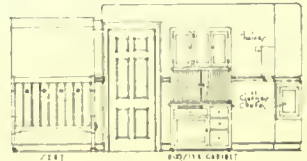

VIEW LOOKING SOUTH

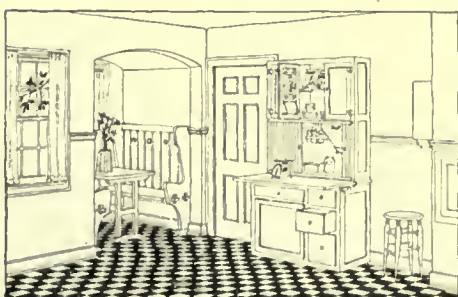

**DESIGN for a SMALL-FAMILY
MODEL KITCHEN as SUBMITTED
in THE HOOSIER MANUFACTURING
COMPANY'S COMPETITION.**

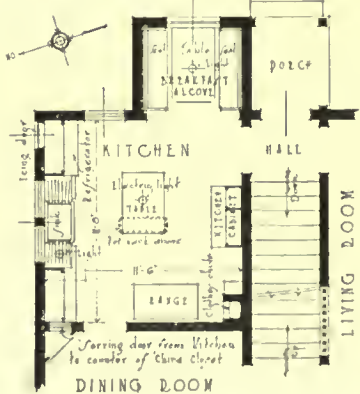

**DINING ROOM
PLAN OF KITCHEN**

THIRD PRIZE DESIGN
OSCAR T. LANG, Minneapolis, Minn.

THE AMERICAN ARCHITECT

William Berg, New York City.
 Louis Cowles, Santa Rosa, Cal.
 Mrs. William Favrao, Springfield, Mass.
 Elmer E. Nieman, Colorado Springs, Col.
 Ellis J. Potter, Detroit, Mich.
 E. D. Townsley, Ithaca, N. Y.

Concerning the award of the prizes, the jury would record that it had some difficulty in deciding between designs placed first and second. Within the kitchen proper the routing of preparation and service was equally good. The author of the design placed second got into difficulty with the arrangement of his specially designed refrigerator and his ironing board. He provided an attractive feature—a desk or seat, and bookcase—but unfortunately it was without the limit of area and could not be seriously considered. In the type of sink selected and in point of adjacent storage space, his design was considered superior. The author of the design placed first should have reduced the depth of the china closet section above the sink and provided greater window area, but when these two designs were viewed in their entirety, it was felt that in point of greater compactness (approximately 20 square feet less in area), greater economy, frank recognition of the “no servant” requirement in the small number of steps required for preparation and serving, and in the better relation of the three features, the kitchen, dining room and porch, Mr. Thorne’s design was more nearly in ac-

cord with the spirit and implication of the program.

Concerning the design placed third, this drawing was selected because of the simple way in which the author approached the problem as a whole. A usual form of a small kitchen in a usual form of a small house, well arranged as to sequence of equipment and all in recognition of the “no servant” injunction. While the dining alcove was not essential to the design, its relation to the living room constituted a point of merit. The clothes chute in its location is of doubtful value; it would have been better had the author used this space for the range so as to provide for a serving table at the end of the range and adjacent to the door leading to the dining room.

The fourth prize design shows less grasp of the problem of house design and arrangement. Its value lies in its simplicity, economy and the excellent relationship between the items of equipment. This is true in particular with respect to the location of the range, the kitchen cabinet, the refrigerator, and the relation of the sink to all of these. Additional light might have been secured from the side adjacent to the porch.

Jury {
 FREDERICK L. ACKERMAN,
 ALICE BRADLEY,
 EDWIN H. BROWN,
 IDA LANGERWISCH,
 GEORGE W. MAHER.

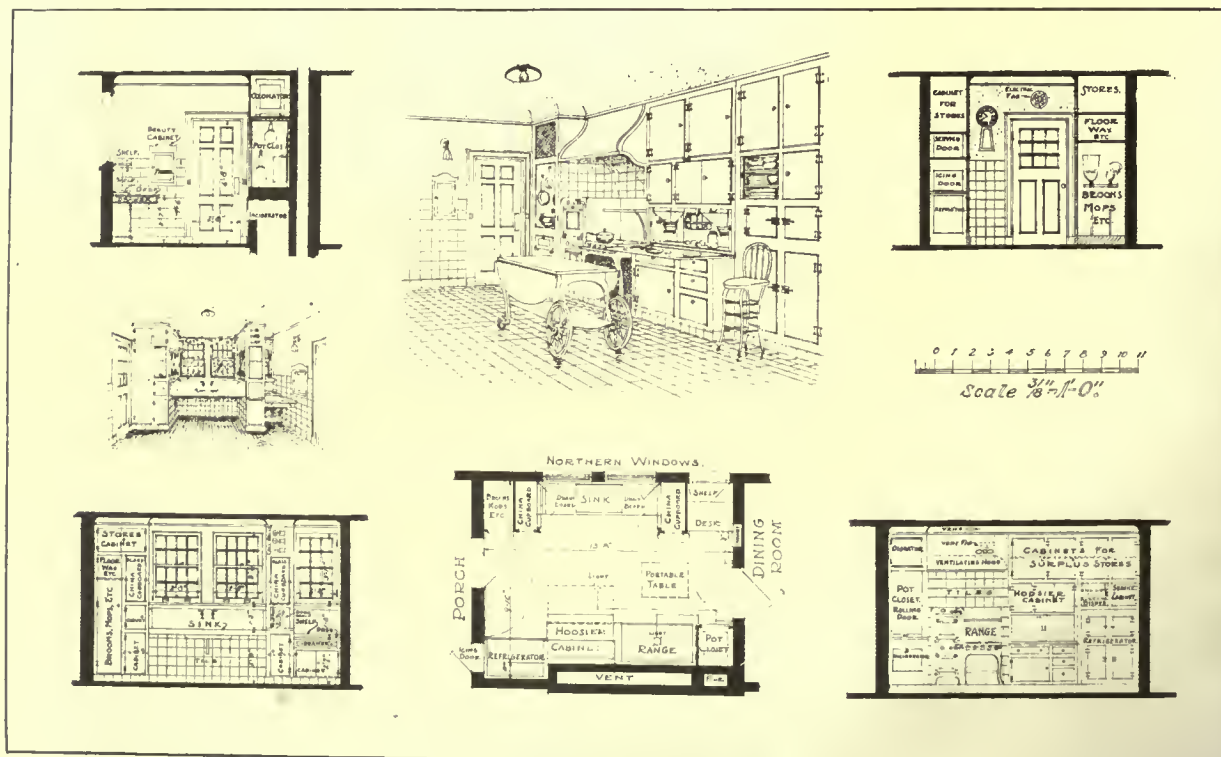

FOURTH PRIZE DESIGN
 MARY DRAGO, GIBSLAND, I.A.

Model Making by Architects

An Interesting Communication from a Reader Who Strongly Approves the Work Begun at Columbia University.

IN a communication received from Mr. Harvey L. Page, architect, San Antonio, Texas, he referred to the proposed department in the School of Architecture at Columbia University, for instruction in model making. Having during a practice extending over many years, successfully used models either of his own making or made under his personal supervision, he stated that as a means to the most thorough study of the elements of design, and the most economical development of the work, he found the architectural model indispensable in practice.

Continuing, Mr. Page stated: "In 1906 I was commissioned by the International and Great Northern Railway Co. to design and superintend their depot in this city. When I had completed the preliminary design, which included a bird's eye perspective, I

was told that they could not clearly visualize the structure, and on the spur of the moment I told them I would make an accurate model of the building. This I did personally, devising a simple method of model making and working from the ground plan up. I used mat and card board for my walls on a frame of light soft wood, rendering the exterior with plaster of Paris and glue. When the model was completed the company was perfectly satisfied and ordered me to proceed at once with working drawings. My study in making this model enabled me to effect a saving of about forty per cent. in the ultimate cost of building. The contract was let on the cost plus 10 per cent. basis, with a guaranteed limit of \$146,150. There were some twenty bidders and most of their figures ran from \$75,000 to \$100,000 higher than they who had studied the unusual simplicity of



MODEL FOR COLISEUM, SAN ANTONIO, TEXAS
HARVEY L. PAGE, ARCHITECT

the design, and the building was completed at ten thousand less than their limit, which saving was divided between Owner and Contractor. I used very much the same method in making my auditorium model and estimate that the many hours' work I devoted to it would enable me to effect a life saving in cost and betterment. It has made me so familiar with the building that I feel I know it by heart and my final plans, though following the same general lines, are some 50 per cent. better than those from which I started to build up the model.

"Model making does not require unusual talent, but does require patience and concentration. It develops the ingenuity and mechanical skill of the student and I believe in this study, not only because it enables the client to visualize the work, but best of all, it is an advantage to the architect who constructs the model and the betterment of ultimate results.

"I have no doubt but that the methods of model



INTERIOR VIEW OF MODEL FOR COLISEUM,
SAN ANTONIO, TEXAS

making at Columbia are far in advance of those I was compelled to devise, but since you ask it, I give the following notes in regard to materials I found useful: Ordinary poplar yard sticks, such as are used for advertising, are easily cut with knife and useful for structural members. Card board, mat board, safety razors, tracing linen for windows if model is to be lighted from inside, empty spools, wood buttons; lemonade straws, wheat straws or pencils for columns; pearl pins for lamps, sand, gravel, plaster of Paris, Le Page's glue, distemper colors and spring wooden clothes pins. I have sometimes used fishing line for mouldings and a sharp spring circular pen is good for cutting circles out of card board. Spherical surfaces carefully cut in zones or gores from

card board and the accuracy required in laying out all work requiring descriptive geometry are excellent practice for the student, and I am much pleased to learn of this new department at Columbia and trust other architectural schools will do likewise."

Brownstone Front Loses Distinction

ONLY a few years ago to live in a brownstone front was a badge of distinction in Manhattan. Novelists always had their rich housed in brownstone fronts. There was magic in the name a quarter of a century ago. The brownstone front was the home of the merchant prince. The material had to be mined on the western plains of New Jersey and teamed and lightered to New York at a great cost in those days. O. O. McIntyre writes there are blocks and blocks of them above Forty-second street, but of late they have fallen into decay. The advent of the luxurious apartment house put them in the shade. Now they are being torn down with ruthless abandon and the last shred of dignity has vanished.

The evolution of the brownstone front has been an interesting phenomenon of changing New York. The owner would perhaps move to the country and rent the house to a widow. She in turn would rent the second floor to a refined business man willing to make his own beds and not cook on the premises.

A hall bedroom would be let to a young man from the Middle West here in quest of a fortune. A tailor would open a "pants pressing club" in the basement, and then the front parlor would become a dentist's office. Shocked neighbors would move and the new occupant would resort to the same process.

In many streets the brownstone fronts became rows of boarding houses and the long front steps were lined with boarders after dinner. But this year trade has invaded the houses. The brownstone steps are torn out. The old basement becomes the ground floor, with a small entrance door.

The old areaway is filled in and the sidewalk brought up flush with the building, or the building comes out to meet the sidewalk. The brownstone disappears behind a thin coating of white cement or stucco.

On the ground floor a window lettering announces "Madame Marcelle, Inc." She does gowns and hats. On the next floor will be an antique shop or a tea-room, and still further above the busy hum of office life may be heard. Not a vestige of the sacred family-hearth remains. It is predicted that in five-years not a brownstone front will remain.

Theories on the Construction of the Pyramids

WE live in a mechanical age, and the aqueducts we build, the bridges we fling across ravines, the arches we hold together with tremendous keystones, awaken our wonder and admiration. We can explain how these are done, because we know we have cranes and derricks, hydraulic engines and electrical riveters, drills for rocks, stone cutters and stone smoothers. If, however states the *Kansas City Times*, we ever set about it, as the Egyptians did, and if we received a hurry call to build a pyramid, we could probably do it inside of six months. It took the ancients twenty years.

The popular idea regarding the big Pyramid of Gizeh—there are eight companions helping to keep guard with this giant on the west bank of the Nile, about ten miles from Cairo—is that it was built to satisfy the conceit of Cheops, the second king of the fourth dynasty, 3733 B. C. If the varied calculations as to the age of this pile are true, then we are confronted by the oldest structure in the world—which for size, for enormity of architectural design, has never been excelled. Its square base covers an area of thirteen acres; its vertical height is 100 feet more than St. Paul's cathedral, in London; while the Washington Monument tops it by only seventy feet.

Many have been the quandaries as to the reasons for building the pyramids—at first glance they seem to be such gigantic masses of stone, with nothing to show but their bulk, which has withstood the ravages of nearly forty-two centuries. Were they used to hold the sacred fire of old? Was grain stored within their cavernous depths? I have seen theories that Cheops, fearing a second deluge, wanted a place of safety to go to; I have seen where ancient writers have surmised that the pyramids would have a haven, should the skies ever fall. But the majority of historians have accounted for the pyramids by saying that they were ancient tombs. This latter surmise is only half correct; there was a greater reason for their erection, bound up in the Egyptians' belief in astrology—in the science of foretelling the future, of reading the past. You who would solve the riddle of the pyramids must have great knowledge as mathematicians and as astronomers, for in every turn and measurement of the pyramids—most especially the Great Pyramid of Cheops—there is hidden the philosophical and scientific knowledge of the Egyptians!

When one considers that the limestone blocks

which formed the core of this Great Pyramid of Cheops weighed from five to seven tons; and that the granite, which was the outer casing, weighed per stone from fifteen to seventeen tons, one is tempted to ask: Was there some miracle by which these sentinels of the Libyan desert were raised, or were the Chaldeans and Egyptians masons who could have put the modern worker to blush? For remember that the Cheops monument contained no less than 2,300,000 blocks of stone! What does this actually mean? It really means that were the stones to be taken from the Great Pyramid they would build a wall four feet high and one foot thick, which would extend over 4,000 miles. There was once a ruler in Egypt who actually thought of robbing the Pyramids, but he soon found that it would be far cheaper to quarry his own materials rather than deprive Cheops of his glory.

For a long while it was thought that here was a solid pile of stone, impenetrable right straight through, and, in order to prove it so, one Mamun, in 820, came to Egypt and conducted an exploration; for a long while they picked their way through the rock, and were about to abandon the enterprise, when there was heard far inside the immense structure the echo of a falling stone; this clearly convinced the workers that there was an interior to the pyramid, and future explorations revealed not only a large chamber in which the king's sarcophagus was found, but beneath it a smaller room, ostensibly for the reigning monarch's queen.

Passageways, with ventilators, were also located, and a careful study of the structure, the placing of its apertures and cavities, emphasized that the entire thing had been planned according to rigorous astronomical laws, there being a huge gallery and a passageway cut downward into tier upon tier of stone, and thence through solid rock, these channels serving in the same capacity as our huge telescopes of the present; only with this difference, that no powerful lenses were used. This astronomical foundation affords an accurate measurement of the age of the pyramid, for, as Dr. Percival Lowell has emphasized, "it is to be noticed that astronomy here furnished Egyptology with a fixed epoch from which to go forward or backward. We are not here dealing with conjectures, as to when a certain king or dynasty can be made to fit into a general chronologic scheme by the relics it has left us of itself. Calculations from known astronomic data can tell to an exactness gauged only by the size of the openings of the pas-

sage as seen from below precisely when the pyramid was built."

Only recently an engineer has come forward with a theory based on the supposition that there was an outer cement coating, smooth and hard, to the original pyramid, a conjecture formulated on the evidence of cement furnished by the second pyramid, built by Suphis II, or Cephren, which, though standing on a higher elevation, is much smaller than Cheops' tomb. He outlines his supposition in *The Calcutta Indian and Eastern Engineering Magazine*, and his thoughts run very much in this wise:

Inasmuch as the Great Pyramid was formerly covered with a smooth cement, it is not unlikely that such a surface was put on from the bottom upward, as each row of stone was put into place. With a roller on top and a number of huge ropes laid over it the stones were hauled upward, one by one. Probably the Egyptians knew the use of the block and tackle, and certainly there was manpower enough to move with these devices twenty tons at a time, 2,000 men at each hawser. There is evidence in our modern block and tackle system of hauling to show that this method could very easily have been adopted by the ancient workmen. The theorist states this as a labor-saving device, whereas former conjectures have discussed the probability of the Egyptians building huge sand ramps, which were raised for holding the stones that were thus lifted through infinite labor to the heights required.

The grand chamber in the Great Pyramid is also evidence that the Egyptians were past masters in the laws of statics and geometry. Each layer of stone was shelved inward, to overlap the last along parallel ridges, while a flat roof was preserved by continuing the process until the builder could close it over with single wide slabs of sufficient strength to support the enormous weight above.

By this guess one can see in what a chaotic state our actual knowledge is as to building methods employed by the Egyptians. When it is recalled that the soft limestone which is the core of the structure was quarried some fifty or sixty miles away, at the Mokattam Hills on the other side of the Nile valley, and that the hard granite came from the vicinity of Assouan, some 500 miles up stream, the problem is by no means simplified. It seems a waste of energy for the workmen to build embankments such as have been suggested with a twenty per cent. grade, for the sand had then to be taken back to the pits. As it is, the stone that was brought to Gizeh was not in the shape required, and the waste from this, after the stonecutters got through with their adzes, was almost one-half the bulk of the pyramid itself.

Modern investigators, among the most prominent of whom may be mentioned W. M. F. Petrie, have followed step by step every bit of evidence

furnished by the pyramids. The Egyptians had saws of bronze; there are green stains on the sides of the saw cuts to show that; and the teeth of these saws were fed with emory dust. For small chiseling, they had instruments with jeweled points, as their hieroglyphics would indicate. There are red and black markings still left in the king's and queen's chambers, which show the mason's care.

As to the labor system adopted, the following conjecture is interesting, if not wholly substantiated: Eight men could have been assigned to each block; work usually began toward the end of July, when the Nile had risen. Writes Petrie: "Not more than eight men could well work together on an average block of stone of forty cubic feet, or two and one-half tons; and the levies would probably be divided into working parties of about that number. If, then, each of these parties brought over ten average blocks of stone in their three months' labor—taking a fortnight to bring them down the causeways at the quarries, a day or two of good wind to take them across stream, six weeks to carry them up the pyramid causeway, and four weeks to raise them to the required place on the pyramid—they would easily accomplish their task in three months of high Nile. They would thus be at liberty to return to their own occupations in the beginning of November, when the land was again accessible."

A few details here of enormous proportions have to be noted in the building of the pyramid. There have been mentioned several causeways which were constructed. Figures, based on information furnished by the historian, Herodotus, who is always, by the way, to be relied on, would lead us to calculate that it took 100,000 men ten years to build a structure 3,000 feet in length, sufficiently durable to stand the strain. But search as we may the pages of this ancient recorder there is no detailed description to be had of the manner in which the Egyptians lifted the stones, tier upon tier. The other detail to be noted is that the interior of the pyramid, while in the course of building and while the mortar was still wet, had to be reinforced by wooden supports and scaffolding, which in itself must have represented a forest of no mean proportion.

The dust one finds on the rocks leading to the king's chamber is literally the dust of ages, the fine silt of a time that is swept away, except for these masses of stone. I suppose it would be an easy matter for us to build a pyramid in each city of the Union; our engineering powers are great for such work. But it is not the fashion these days to do such things. If we build for a hundred years we are satisfied. With us it is more important that a city than a concrete aqueduct in some mountain fastness than that the ages to come have evidence, in a pile of stone, of our present greatness.

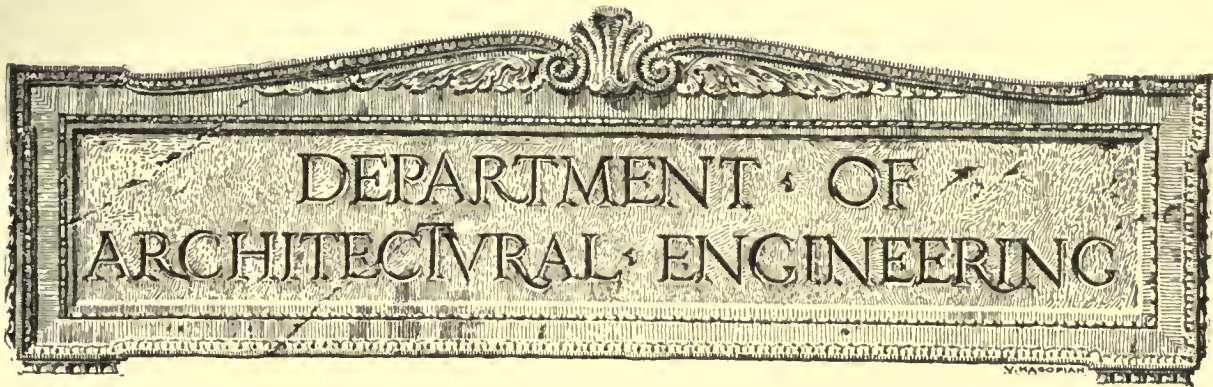

Essential Features in the Design of Reinforced Concrete Tanks for the Storage of Fuel Oil

INNOVATIONS created by necessity and adopted by manufacturers during the war have, in some cases, proven more desirable than the methods they superseded, and so have been retained after this necessity ceased.

Inability on the part of manufacturers to secure an adequate or constant coal supply during the war resulted directly in the investigation of other fuels, and in many instances fuel oil was used either to supplement or entirely to supersede coal. It is difficult to prophesy whether the benefits derived from the use of fuel oil will cause its increased use, or whether the available supply will be diminished to an extent which will result in an abnormal increase in cost, thus making its use uneconomical.

The fact remains that at present fuel oil is being used to a considerable extent in industrial plants, and during the past year many plants have thought it wise to change from coal to oil, or to make provision for oil burning equipment where new plants have been erected. This has resulted in the erection of reservoirs of sufficient capacity to store an adequate supply of fuel oil. The fire hazard in the storage of large quantities of oil has been carefully investigated and various municipalities as well as the fire underwriters have promulgated rules governing the location and construction of fuel oil reservoirs.

The National Fire Protection Association has recently adopted amended regulations for the storage and use of fuel oil, and it would be well to give these careful study before designing any storage system.

Until recent years steel tanks were extensively used, although when placed underground these were

usually surrounded with concrete. However, during the war the scarcity of steel led to the use of reinforced concrete for storage tanks of this nature. As at that time information on the adaptability of concrete for such purpose was limited, many tests have since been conducted to determine the effect of oil on concrete, the permeability of concrete to oil under pressure, the desirability of oil proof coatings, proper mixing of concrete for oil tanks, etc. A paper entitled "Tests on Concrete Tanks for Oil Storage prepared by Messrs. Pearson and Smith was presented at the 1919 annual convention of the American Concrete Institute.

The most important results of the investigation to date may be briefly summarized as follows:

1. Various mineral oils covering practically the entire range of fuel oils have been stored in concrete tanks approximately thirteen months, apparently without injuring the concrete in the slightest degree.
2. 6x12 in. concrete test cylinders have been stored in these oils during the same period and have shown no appreciable diminution in compressive strength.
3. A number of vegetable and animal oils have been stored successfully in concrete tanks for a period of thirteen months, and only two—cocoanut oil and lard oil—have appreciably attacked the concrete.
4. Quantitative losses of fuel oils have been determined in 1:3:1½ concrete tanks under pressures of 12 to 15 in. of the oils, and in a smaller number of tanks under a pressure head of 25 ft. These measurements indicate that even under the latter conditions heavy and medium weight fuel oils can be stored in concrete of this character without excessive losses. The storage of kerosenes and gasolines under these conditions will probably prove uneconomical unless some impervious coating can be found which will be durable under long exposure to the lighter oils.
5. In a single test of six months' duration spar

varnish has apparently been effective in successfully retaining a 43 deg. kerosene of 0.015 viscosity. The loss during this period has been practically negligible.

UNLESS concrete tanks are correctly designed, the concrete properly proportioned, mixed and placed, satisfactory results will not be obtained.

It will be found that there are conflicting interests tending to influence the design and location of such a storage system, and these should be harmonized so far as possible. For instance, the owner is quite likely to have determined on a site, and he may have quite fixed ideas as to the capacity and general details of construction. The site he has selected may be unsuitable. The company who is to insure the property has a vital interest in the problem, and may insist on important changes, while the municipality will re-

conformity with the regulations of the fire insurance company who is to insure the property, as well as any local ordinances bearing on the subject. Mr. Hallett, of the Hallett-Grant Construction Company, who have designed a number of fuel oil tanks, writes:

"The Fire Underwriters have different requirements relative to the placing of tanks, depending on the kind of buildings comprising the plant at which oil is to be burnt. At the Warren Cotton Mills, West Warren, Mass., it was necessary to place the tanks outside of the plant entirely and across a small river, which, of course, necessitated a very expensive piping and heating system.

"At the Boston Rubber Shoe Factory No. 1, Malden, Mass. (see illustrations) we were allowed to place these tanks in the driveway back of the boiler room and 20 feet from the boiler house wall. At the Millville plant, Woonsocket Rubber Company, the tanks were placed right alongside of the boiler house and in the coal pocket, as shown on the accompanying layout." (See page 756.)

Capacity.—In many instances, the quantity of fuel oil which it may be desired to store in order to provide against possible shutdown in the event of curtailment of delivery, will require the use of two or more tanks. Both from the constructional and fire hazard viewpoints, it is inadvisable to go beyond a certain limit. At present from 200,000 to 300,000 gallons should be the upper limit, depending on local conditions. At the 1920 convention of the American Concrete Institute, the Committee on Storage Tanks stated in its report as follows:

Concreting in tanks should be limited to three continuous operations in placing; that is, (a) the floor and footings; (b) wall and columns, if any; (c) roof.

The capacity limit under ordinary conditions—that is, for the contractor who does not handle large work—is about 200,000 gallons. If larger tanks are contemplated special care should be taken to provide constructional facilities to carry out the work as herein-after recommended. An argument in favor of tanks of moderate size is that, in case of accident or fire, a lesser amount of oil would be involved.

Shape.—Concrete tanks of various shapes have been erected, but giving due consideration to all factors, it may be stated that those of circular shape are considered best. Structures of this shape are better able to resist the induced stresses.

In many cases it will be necessary to place the tank so that there will be an earth fill of several feet above the tank roof. In such cases the roof must be flat and designed to carry the total dead load as well as any contemplated live load. If under a driveway, for instance, heavy truck loads must be allowed for. When an earth covering is not required, a dome shaped roof may prove economical, although the form work will be more expensive.

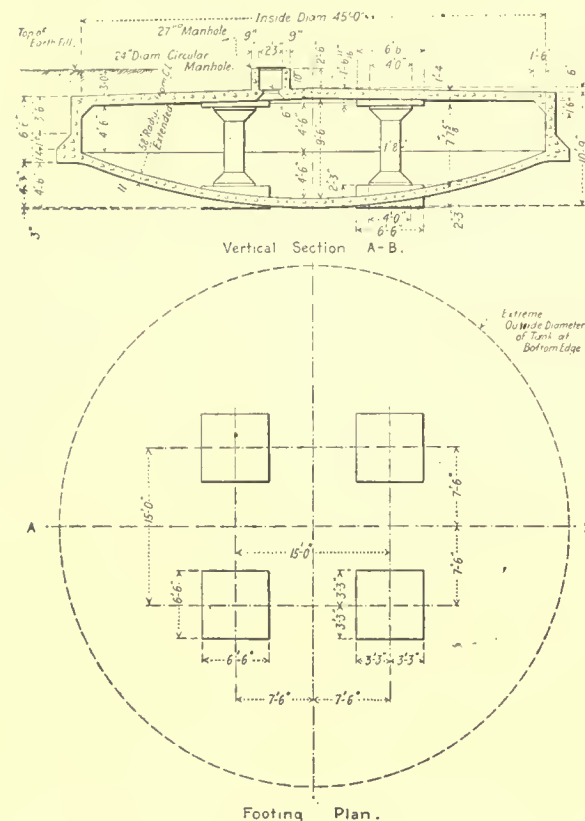

PLAN AND SECTIONS, FUEL OIL TANK, BOSTON RUBBER SHOE CO., PLANT NO. 1, MALDEN, MASS.

quire the design to be such as to minimize hazard and promote safety; the company who is to supply the oil burning equipment will probably be desirous of having the tank located as near as possible to the furnaces, and the builder may feel certain features are necessary from a constructional standpoint.

Location.—The location of fuel oil tanks, with reference to the surrounding structures, should be in

THE AMERICAN ARCHITECT

The inverted dome bottom has proven advantageous. This design gives additional storage capacity with only slight increased cost of excavation, lessens the height of wall, thus requiring less shoring of banks in loose soils, allows a better drainage of the tank than a flat floor, and is better able to resist the upward external pressure. Its use is especially desirable where excavation in wet soil is necessary. In such a case the water may be more easily pumped out, since the water will drain to a central point.

Construction.—In the design, consideration should be given to the recommendation contained in the re-

vide a continuous band on one side of the recess. Adequate lapping of reinforcing rods (not less than 40 diameters) is important and laps in adjacent rods should not come opposite.

Design.—When empty, the walls of the tank must resist the external earth pressure, and if water is present, the hydrostatic pressure as well. It would seem advisable to design the tank to resist the full hydrostatic pressure, rather than one-half the full head of water as has sometimes been done. In the report previously referred to, the following recommendation is made:



VIEW SHOWING ONE COMPLETED TANK AND ANOTHER UNDER CONSTRUCTION
BOSTON RUBBER SHOE CO., PLANT NO. 1, MALDEN, MASS.

Construction of these two tanks, each 45 ft. inside diameter, and holding 75,000 gallons apiece, was commenced November 1, 1919, and completed January 7, 1920

port previously quoted from, relative to limiting the pouring operations to three. This is an essential feature, otherwise joints between operations will prove troublesome and the completed tank may not be tight.

All form work should be most rigidly braced to prevent bulging or other distortion during the placing of concrete.

An efficient joint or dam must be formed between floor and wall. This can be constructed by providing a recess in the floor to engage the wall when poured. In this recess a galvanized iron strip about 8 inches wide, soldered and riveted, should be placed to pro-

While the hydrostatic pressure of water in oils is about 50 per cent. of the full hydrostatic pressure, it is recommended that not less than $62\frac{1}{2}$ lb. per sq. ft. for the full head of water be assumed and allow the difference as a factor of safety for unforeseen conditions.

When the tank is full the concrete forming the walls will be in tension. While these walls should be reinforced with steel, yet before the steel can take up any large proportion of the stresses, cracks must open up in the concrete. This is exactly what should be avoided, for even hair cracks will permit seepage, and prevent a tight structure. The walls should, there-

THE AMERICAN ARCHITECT

fore, be made thick enough so that the concrete alone will be able to resist the tensile stresses under a full head of oil. In other words, when the tank is full the ultimate tensile strength of the concrete should not be exceeded.

It is well to use deformed bars for reinforcing the walls in order to develop the bond strength in as short a distance as possible. These should be accurately bent and placed.

Steel in tension, whether in circumferential tension or in tension due to negative bending moments on the face of rectangular tank walls exposed to the oil to resist oil pressure should be designed for a safe working stress of 10,000 lb. per sq. in. for all work

fuel oils have a lower value than this. Mexican oil, for instance, being as low as 12 deg. Baumé.

As a rule the owner is quite likely to put a concrete oil tank into use while the concrete is still somewhat green—that is, less than six weeks old. For this reason it would be well to apply some inner coating to the concrete to protect the surface so that fuel oil will not come into direct contact with it. Many coatings have been used with more or less satisfactory results. Mr. H. B. Andrews, of Andrews, Towers & Lavelle, industrial engineers, states:

“Silicate of soda, while not a permanent coating, has been used satisfactorily for this purpose, according to the following specification for *oil-proofing*.”

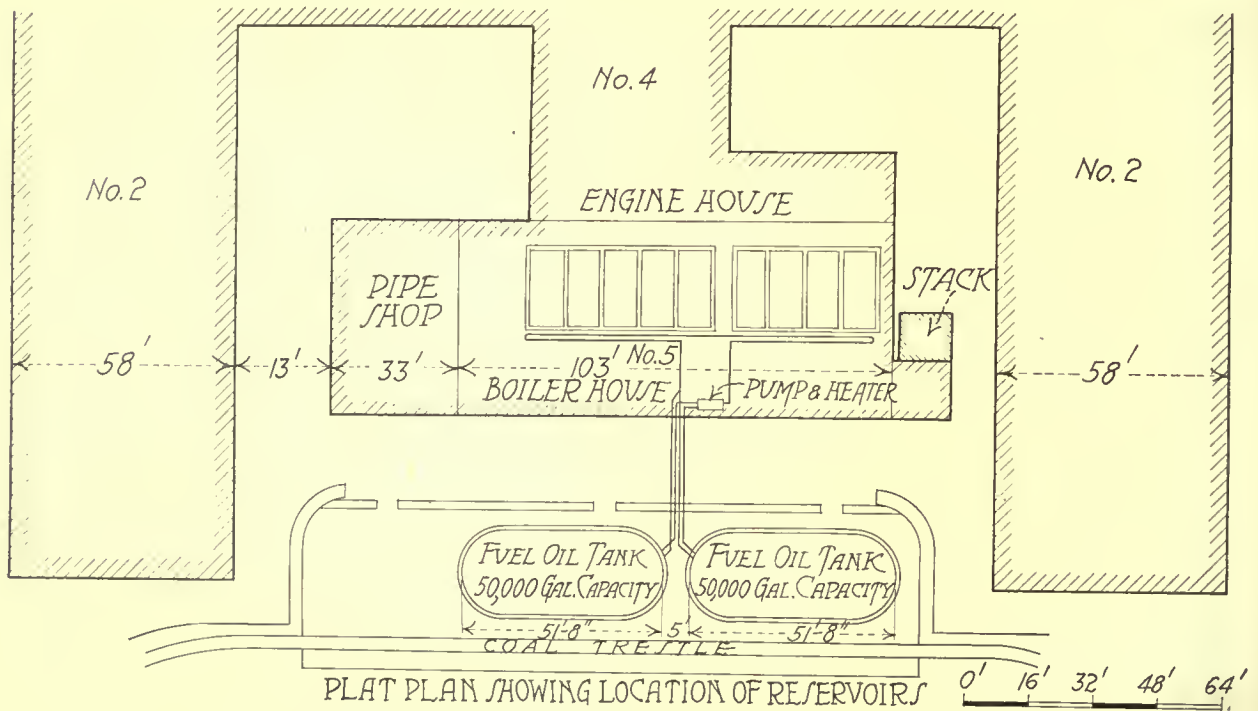

PART PLAN OF WOONSOCKET RUBBER COMPANY'S PLANT, WOONSOCKET, R. I., SHOWING LOCATION OF FUEL OIL STORAGE TANKS

above ground, and 12,000 lb. per sq. in. for underground work. In other cases the working stress in the steel may be taken at 16,000 lb. per sq. in. In circumferential walls, the thickness of the concrete should be based upon a maximum tensile strength in the concrete of 150 lb. per sq. in., but a minimum thickness of 8 in. at the top and 10 in. at the bottom is recommended for walls to give space for spading.

The concrete should not be leaner than a 1:1½:3 mix.

Treatment of Inside Surface.—When properly mixed and placed, reinforced concrete tanks are capable of retaining, with practically no seepage loss, fuel oils up to 35 deg. Baumé. The majority of

The surface of the floor and the interior surface of the wall are to be coated with silicate of soda of a consistency of 40 deg. Baumé, applied as follows:

First Coat. One part of silicate of soda and three parts water, applied with brush and all excess liquid wiped off with cloth before drying.

Second Coat. One part silicate of soda and two parts water, applied as above.

Third Coat. One part silicate of soda and one part water, applied with brush and allowed to dry.

Fourth Coat. Applied same as third.

The Construction Division of the United States Army did not require any oil-proof coating where tanks were built for heavy fuel oil, but for tanks designed to store gasoline the interior was coated as per the following specification:

THE AMERICAN ARCHITECT

When thoroughly dry the entire interior surface of the bottom, side walls and columns should be sprayed with a coat of the best "long-oil" spar varnish, thinned with 20 per cent. volatile mineral spirits and applied under a pressure of 60 lb. per sq. in. by a paint gun. After this coat has dried for a period of at least twenty-four hours it should be followed by two more coats, separated by an interval of not less than forty-eight hours, using pure, undiluted spar varnish and applied in the same manner. Each varnish coating should be put on in such a thickness that one gallon will cover approximately 200 sq. ft. The volatile mineral spirits should be a hydrocarbon distillate, water white, neutral, clear and free from water. It should have no darkening effect when mixed with basic carbonate white lead. The varnish should comply with the War Department Specification No. 6, with particular attention to the water tests.

As an alternate to the instructions of the preceding paragraph it may be deemed advisable in some cases to use one of the proprietary proofing methods on the

Such a coating should be applied as soon as possible after removal of wall forms.

Book Notes

EARTHWORK AND ITS COST. BY HALBERT P. GILLETTE. IMITATION LEATHER—4½x7—1,327 PP. MCGRAW-HILL BOOK CO., INC., NEW YORK CITY.

While this is the third edition, it has been so enlarged and revised as to be in reality a new book. Since scarcely a building operation of any nature does not involve earthwork of some kind, a handbook such as this should contain practical data for the constructor. In this work a compilation of a mass of practical data on earthwork has been made, and the cost analysis so arranged as to be useful even though labor scales vary, since by substituting new rates, changed conditions can be met. Data on excavation under widely varying conditions, and with equipment ranging from the simplest to the most elaborate, is given. There are few who have to do with construction work who will not find something of interest in this book.

MODERN BRICKMAKING. BY ALFRED B. SEARLE. 6x9½—482 PP. STIFF COVER. SCOTT, GREENWOOD & SON, LONDON, PUBLISHERS. D. VAN NOSTRAND CO., NEW YORK CITY, AMERICAN DISTRIBUTORS.

When one considers that some of the earliest of our "Colonial" buildings, still in excellent condition, had walls constructed of brick brought from England, a book on the subject of brickmaking by one as familiar with the subject as Mr. Searle, a British expert on clays and clay products, and lecturer on brickmaking, merits careful consideration. This is the second edition of this book, revised and enlarged. Although the making of bricks is as old as civilization itself, yet methods of manufacture have progressed with such rapidity during recent years, that the first edition was becoming out of date. The opening chapters deal with the nature and selection of clays, choice of process and plant. These are followed by descriptions of various processes of manufacture, types of kilns, methods of burning, machinery, etc. The book is well illustrated. Altogether this is an excellent work on the subject. At a time when the price of brick is mounting higher and higher, every manufacturer should study all methods making for efficiency with a view to modernizing his plant, otherwise it will soon become an obsolete type.

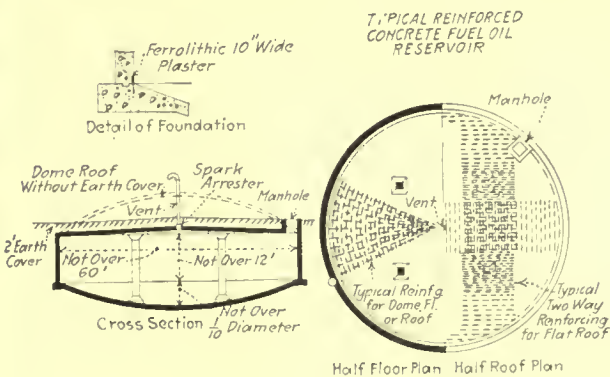

SUGGESTED DESIGN FOR CONCRETE FUEL OIL TANK

market, but only on condition that the concern awarded the contract shall furnish an acceptable surety bond guaranteeing the construction to be proof against leakage for a given period of years.

Mr. Hallett states: "We have found by experience that the only practical method of rendering oil tanks impervious is by coating on the face of the tank and not by an integral method. The integral method relies too much on labor and concrete. The method we use puts an iron coating on the inside of the tank which will not crack, which fills every pore and which is not a plaster coat; furthermore, it is guaranteed by the concern applying it."

Exterior Protection.—While not always necessary, it is sometimes advisable to give the exterior of a buried reinforced concrete tank a coating of asphalt.

Engineering Federation Elects Herbert Hoover President

First Meeting of Governing Body Held at Washington, D. C.,
November 18-20

AT an organizing conference, held last June, the foundation for a federation of existing American engineering societies was laid. The Federated American Engineering Societies resulted. At the first meeting of the governing body, American Engineering Council, held November 18-20, a well developed structure was visible, for at the present time the federation consists of twenty-one engineering and allied technical organizations, having a combined membership of close to 50,000. The new organization has not yet reached its full growth, since additional organizations now have under consideration the question of becoming members. In the case of many societies, it was not possible to submit the matter to their respective memberships prior to the first meeting of the Council, and because of this fact action was taken at the recent meeting extending the time until July 21, 1921, during which period these organizations may become charter members of the Federation. One of the organizations yet to consider the matter of membership is the American Institute of Architects. This, it is contemplated, will be taken up at the next annual convention of the Institute.

The details of perfecting the organization consumed a large part of the sessions of November 18 and 19. On the next day, November 20, the Executive Board of the Council held its first meeting.

Four addresses were made, as follows: First, by Richard L. Humphrey, chairman of the Joint Conference Committee of the Founder Societies, outlining the steps which had led to the creation of the Federated American Engineering Societies; the second, by J. Parke Channing, chairman of Engineering Council, giving a résumé of Engineering Council's work; the third, by L. W. Wallace, on factory management and labor, and the fourth, by Herbert Hoover, discussing national industrial problems.

The total number of delegates and guests attending the meeting was slightly under eighty.

Many had hoped that the American Society of Civil Engineers would make application for membership—that organization being the only one of the four founder societies represented on Engineering Council, and not represented in the new federation. Any such hopes were definitely set aside by the recent vote of the Civil Engineers, which recorded themselves as opposed to joining the new federation.

A resolution of regret that the American Society of Civil Engineers was not represented by delegates at the meeting was offered by Philip N. Moore and unanimously passed.

One of the matters which called forth a lively discussion was the choice of a permanent headquarters for American Engineering Council. The present Engineering Council has its headquarters in Washington, and by many it was felt that this was the logical choice. However, others seemed to believe that such a location would lead to the belief that the new organization was becoming over interested in "politics." Good reasons both for and against such a selection were presented, and New York City was suggested because it would offer many advantages not securable in other locations. The choice of New York, it was argued, might be looked upon by the Western societies as an attempt to control the organization by its Eastern membership. When the matter was finally put to a vote, Washington, D. C., was the choice by a large majority. Pending arrangements for permanent headquarters, the Washington office of the present Engineering Council will be utilized and material addressed to the American Engineering Council through this office will be passed on to the proper parties.

While the peculiar position occupied by Herbert Hoover in public life during the past few years was conclusive in the minds of many as fitting him peculiarly to assume the leadership of the Federation of Engineers, it was not until the nominating committee presented its report at the morning session, November 19, that all doubts were set aside. Mr. Hoover assumes the presidency of this organization with the best wishes for its success from a very large majority of engineers in this country.

The complete list of officers of the American Engineering Council, who were unanimously elected, were as follows: President, Herbert Hoover, American Institute of Mining and Metallurgical Engineers; vice-presidents, Calvert Townley, American Institute of Electrical Engineers; W. E. Rolfe, Associated Engineering Societies of St. Louis; Dexter S. Kimball, American Society of Mechanical Engineers; J. Park Channing, American Institute of Mining and Metallurgical Engineers; treasurer, L. W. Wallace, Society of Industrial Engineers.

Only minor changes were made in the constitution

THE AMERICAN ARCHITECT

and by-laws adopted by the June organizing conference. The work of the organization lies ahead of it. Just what problems it will attempt to solve remains to be seen. Among subjects suggested by L. C. Nordmeyer, chairman of the Committee on Plan and Scope, as those on which the federation might take action, are the following:

1. Serving the public interest by investigation and advice to the public and to governmental and voluntary bodies upon national problems which involve industrial and economic questions.
2. National Department of Public Works.
3. Conservation of natural resources, such as water, coal, oil, etc.
4. Maintenance of co-operative attitude toward other national organizations, both professional and commercial.
5. Technical education.
6. Transportation in its various forms, particularly highways.
7. Advice with and assistance to regional, state and local organizations upon their request.
8. National Bureau of Economic Research.
9. Public fire prevention.
10. Patents.
11. National Board of Jurisdictional Awards.
12. International affiliation of engineers.
13. State organizations of local affiliation.
14. Uniform licensing and registration laws.
15. Classification and compensation of engineers.
16. Bureau of employment.
17. Russian-American Engineering Committee.

The membership of the Federated American Engineering Societies, as of November 20, 1920, follows:

- Alabama Technical Association, Birmingham, Ala.
- American Institute of Chemical Engineers, Brooklyn, New York.
- American Institute of Electrical Engineers, New York, N. Y.
- American Institute of Mining and Metallurgical Engineers, New York, N. Y.
- American Society of Agricultural Engineers, Ames, Iowa.
- American Society of Mechanical Engineers, New York, N. Y.
- Associated Engineering Societies of St. Louis, Mo.
- Detroit Engineering Society, Detroit, Mich.
- Engineering Association of Nashville, Tenn.
- Engineering Society of Buffalo, N. Y.
- Grand Rapids Engineering Society, Grand Rapids, Michigan.
- Kansas Engineering Society, Topeka, Kan.
- Louisiana Engineering Society, New Orleans, La.
- Mohawk Valley Engineers' Club, Utica, N. Y.
- Technical Club of Dallas, Tex.
- The Cleveland Engineering Society, Cleveland, Ohio.
- The Engineers' Club of Baltimore, Md.
- The Society of Industrial Engineers, Chicago, Ill.
- Washington Society of Engineers, Washington, D. C.
- York Engineering Society, York, Pa.
- Taylor Society, New York.

WHILE space does not permit presenting the address of Mr. Hoover in full, the excerpts here given are significant, in light of the publicity given by the daily press to the recent conference of Mr. Hoover with officials of the American Federation of Labor, at the latter's request.

PROBLEMS OF INDUSTRIAL DEVELOPMENT

In addressing the meeting, Mr. Hoover said: "Some of the greatest of the problems before the country, and, in fact, before the world, are those growing out of our industrial development. The enormous industrial expansion of the last fifty years has lifted the standard of living and comfort beyond any dream of our forefathers. Our economic system under which it has been accomplished has given stimulation to invention, to enterprise, to individual improvement of the highest order, yet it presents a series of human and social difficulties to the solution of which we are groping. The congestion of population is producing subnormal conditions of life. The vast repetitive operations are dulling the human mind. The intermittency of employment due to the bad coordination of industry, the great waves of unemployment in the ebb and flow of economic tides, produce infinite wastes and great suffering. Our business enterprises have become so large and complex that the old personal relationship between employer and worker has to a great extent disappeared. The aggregation of great wealth, with its power of economic domination, presents social economic ills which we are constantly struggling to remedy. I propose to traverse only a small fraction of these matters. I do not conceive that any man or body of men is capable of drafting in advance a plan that will solve these multiple difficulties and preserve the system which makes individual initiative possible." * * *

DOMINATING GROUPS IN INDUSTRY AND THE ENGINEER'S POSITION

"We have built up our present civilization, political, social and economic, on the foundation of individualism. We have found in the course of development of large industry upon this system that individual initiative can be destroyed by allowing the concentration of industry and service, and thus an economic domination of groups over the whole. * * *

"We have the growth of great employers' associations, great farmers' associations, great merchants' associations, great bankers' associations, great labor associations—all economic groups striving by political agitation, propaganda and other measures to advance group interest. At times they come in sharp conflict with each other and often enough charge each other with crimes against public interest. And to me one question of the successful development of our economic system rests upon whether we can turn

the aspects of these great national associations toward co-ordination with each other in the solution of national economic problems, or whether they grow into groups for more violent conflict. The latter can spell breakdown to our entire national life.

"This engineers' association stands somewhat apart among these economic groups in that it has no special economic interest for its members. Its only interest in the creation of a great national association is public service, to give voice to the thought of the engineers in these questions. And if the engineers, with their training in quantitative thought, with their intimate experience in industrial life, can be of service in bringing about co-operation between these great economic groups of special interests, they will have performed an extraordinary service. The engineers should be able to take an objective and detached point of view. They do not belong to the associations of either employers or labor, of farmers, or merchants, or bankers. Their calling in life is to offer expert service in constructive solution of problems, to the individual in any of these groups. There is a wider vision of this expert service in giving the group service of engineers to group problems.

THE POSITION OF LABOR

"The American Federation of Labor has publicly stated that it desires the support of the engineering skill of the United States in the development of methods for increasing production, and I believe it is the duty of our body to undertake a constructive consideration of these problems and to give assistance not only to the Federation of Labor, but also to the other great economic organizations interested in this problem, such as the Employers' Association and the Chamber of Commerce.

"It is primary to mention the three-phase waste in production: First, from intermittent employment; second, from unemployment that arises in shifting of industrial currents, and third, from strikes and lock-outs. Beyond this elimination of waste there is another field of progress in the adoption of measures for positive increase in production. * * *

EMPLOYER AND EMPLOYEE

"There are questions in connection with this entire problem of employer and employee relationship, both in its aspects of increased production and in its aspects of wasteful unemployment, that deserve most careful study by our engineers. There lies at the heart of all these questions the great human conception that this is a community working for the benefit of its human members, not for the benefit of its

machines or to aggrandize individuals; that if we would build up character and abilities and standard of living in our people we must have regard to their leisure for citizenship, for recreation and for family life. These considerations, together with protection against strain, must be the fundamentals of determination of hours of labor. These factors being first protected the maximum production of the country should become the dominating purpose. The precise hours of labor should and will vary with the varying conditions of trades and establishments, but the proper determination of hours, based upon these factors, is an immediate field demanding attention of engineers. * * *

"I am not one of those who anticipate the solution of these things in a day. Durable human progress has not been founded on long strides. But in your position as a party of the third part to many of these conflicting economic groups, with your lifelong training in quantitative thought, with your sole mental aspect of construction, you, the engineers, should be able to make contribution of those safe steps that make for real progress."

Manual of Design and Installation of Forest Service Water Spray Dry Kiln

Under the above title the United States Department of Agriculture has issued Bulletin No. 894, prepared by L. V. Teesdale, Engineer in Forest Products, which describes in detail the "Forest Service Humidity Regulated Water Spray Kiln" designed and developed by the Forest Products Laboratory in an endeavor to produce a kiln in which the temperature, humidity, and circulation could each be regulated independently of the others. This Bulletin treats fully of the water spray kiln, kiln construction material, details of construction, heating installation, water supply, condenser coil, control instruments, and also stresses certain points that should be emphasized when writing specifications. The numerous drawings contained illustrate the principles and the typical forms of construction to be adhered to in kiln design, and may be altered to fit individual requirements and local conditions. This bulletin should prove a valuable aid to engineers who, by a careful study of the principles set forth therein, should be able to design or construct an installation of the size suited to the peculiar needs of a given plant.

Copies of this bulletin may be procured from the Superintendent of Documents, Government Printing Office, Washington, D. C., for the nominal fee of ten cents per copy.

Current News

Happenings and Comments in the Field of Architecture and the Allied Arts

The Hancock House

Mr. Henry H. Kendall, president of the American Institute of Architects, has written us the following communication:

THE AMERICAN ARCHITECT of Nov. 10, page 622, has an article entitled "Famous Hancock House Still Stands." Whether the writer intended or not to convey the impression that the house built and occupied by John Hancock in early days still exists I know not; but if he did he is laboring under a mistake.

The Hancock house was torn down many years ago and the site built over to other purposes.

Perhaps the impression was gained from an article recently published referring to a "Hancock House" in Quincy, Mass., which is still standing and to the possible purchase and remodeling of which reference was made.

Working Men and Women of Philadelphia Appoint Committees on Town Planning and Housing

As a partial result of recent educational and informative activities among the ranks of labor, three organized branches in Philadelphia have appointed Committees on Housing and Town Planning within the past week.

The chairmen of these committees are: John C. Walsh, Council Associated Building Trades; W. T. Allen, United Brotherhood of Carpenters and Joiners; Harry Weinstock, Central Labor Union.

A preliminary meeting attended by fourteen members of these combined committees was held last week in the office of John I. Bright, Otis Building, chairman of the Committee on Community Planning of the American Institute of Architects.

Arrangements are being made for a joint meeting of the members of these committees together with representatives from Union Labor College and various labor unions in Philadelphia and vicinity to consider plans for carrying forward a program of education and information, including lectures and meetings devoted to these important phases of community development.

At the recent regular meeting of the District Council of the United Brotherhood of Carpenters and Joiners, in addition to the above committee, an-

other committee was appointed of which D. Knickerbocker Boyd, architect, was elected chairman and at the same time spokesman for the Brotherhood, comprising twelve thousand members in Philadelphia and vicinity.

Mr. Boyd, who was previously made spokesman for the Associated Building Trades, representing nearly fifty thousand workers, was invited by the Industrial Relations Committee of the Chamber of Commerce of Philadelphia to attend one of the meetings with representatives of the council, and is now in communication with that committee looking toward a general conference of employers and employed, regardless of the affiliations of either.

False Death Announcement

In a recent issue of the Journal of the Royal Institute of British Architects, we find the following:

"We are glad to be able to contradict the announcement made in the last issue of the death of Mr. William Eaton, A.R.I.B.A. The contradiction is made on the authority of Mr. Eaton himself, who is holding a prominent position in the office of the Ministry of Health Housing Commissioner at Cardiff, and is in the enjoyment of the best of health."

This is reminiscent of what Mark Twain said under similar circumstances some years ago. He wrote to the paper, wherein the announcement had appeared, stating: "The report of my death has been greatly exaggerated."

Paving with Moorish Walls

Despoiling the glories of the past for the crass uses of the present has its latest example in the dynamiting of ancient Moorish walls which defended the once mighty kingdom of Granada from the onslaughts of the Spaniards. The stone of the walls is reported in the *Detroit News* as being used by some vandal in the guise of a contractor as ready-to-hand material for roadways.

Over those walls, on their battlements and in their watch towers, raged the fierce conflict of Christian against infidel. The conquering hosts of Ferdinand and Isabella swept across those barriers before the discovery of America. The storming of the fortress and citadels which formed with the walls the defense of the Moor is related by Washington Irving in his "Conquest of Granada."

Large Lumber Company Closes Plant

Announcement is authorized by officials of the John L. Roper Lumber Company, operating one of the large sawmills in the South, that their plant there would be closed down for an indefinite period, that all of the men employed therein would be laid off, that the office force would be cut down to a minimum and the logging crews laid off, making a total of more than a thousand men who would be thrown out of work.

A lack of demand of lumber and the low price that is being paid for the little that is being sold is given as the reason for the shutdown. Crews in all the logging camps in this territory will cease operations and will be allowed to seek employment elsewhere.

How long the plant will remain idle is a matter of doubt. Officials say that there is no market for their product, that the cost of operating is enormous and that there is nothing left for the company to do but to close down and remain closed until conditions are more favorable for lumber operations.

International Exhibition of Architecture

The international exhibition of architecture, building and kindred industries will be held at Ghent, Belgium, from April 16 to June 14, 1921. The exhibition will include departments for architecture in general, building construction, cheap dwelling houses, hygienic installations, lighting and heating apparatus, electricity in all its applications, the decorative arts, furniture, small tools, means of transport (motor and other vehicles). Applications for space should be addressed before January 1, 1921, to A. Decker, 40 Rue Joseph Hazard, Uccle Brussels.

Poland's Landlords Gouging

To lease a house in Poland, and neighboring countries in Europe, tenants must pay an exorbitant bonus, limited only by the greed of landlords.

Ingenuous development of a "bonus" system has sky-rocketed rents in Poland to a peak which is making decent living virtually impossible for all but the extremely rich.

This condition exists despite the fact that under legislation landlords in that country are prohibited from raising rents in excess of 20 per cent. of charges in 1914—prior to the war.

Accommodations in a fairly decent hotel in Warsaw cost about \$2 a night, according to Maurice Saeta, an attorney, who has just returned from Poland and central Europe.

"But to obtain accommodations it costs approximately \$15 a night as a gratuity or 'tip' to the hotel clerk, who is acting directly for the hotel owner," Mr. Saeta explains. Under the law the landlord cannot charge more than 20 per cent. over the pre-war rate, but there is nothing to compel him to receive guests seeking shelter at any price.

"And to be acceptable," Mr. Saeta said, "one must come across generously and withal humbly."

"Similarly, in rare instances where an apartment or dwelling is vacated, prospective tenants must convince the landlord that they are desirable.

"Proving to be desirable proves to be a most expensive business. Frequently a family seeking a small dwelling or apartment renting for \$30 a month must pay the landlord a bonus ranging from \$1,000 to \$5,000, depending on the term of the lease. And to the highest bonus-bidder goes the prize."

Circumvention of the bonus-practicing landlords by buying one's own home is so costly a proposition in Poland as to be out of the question. The bonus system is so profitable that landlords do not offer their properties at sale except at prohibitive figures to discourage home buying.

Safety Engineers to Meet Dec. 17

The American Society of Safety Engineers and the New York Chapter of the National Fire Protection Association will hold a joint meeting at 29 West 39th street, New York, at 8 p. m., Dec. 17.

This society is devoted to the development of the engineering side of accident prevention and the profession of safety engineering. It is strictly non-commercial. Its meetings are open to the public and are for the purpose of furthering interest in the broad safety movement as well as to develop engineering ways and means of accident prevention through open discussions, etc.

The program follows:

America's Challenge: Loss of Life from Fire and Safety Activities of the Past; by H. Walter Forster, vice-president, Independence Bureau, Philadelphia, Pa.

Safety to Life from Fire in Hotels; by A. T. Bell, manager Hotel Chalfonte, Atlantic City, N. J.

Safety to Life from Fire in Theatres; by Rudolph P. Miller, Superintendent of Buildings, New York City.

Safety to Life from Fire in Schools and Colleges; by Frank Irving Cooper, chairman, Committee on Standardization Schoolhouse Planning and Construction, National Education Association.

"The Menace," a two-reel photoplay produced under the auspices of the National Automatic Sprinkler Association. Introductory synopsis by Ira Gould Hoagland, secretary.

Fire Protection Features in Safeguarding Life; by Henry A. Fiske, manager Inspection and Service Department, Grinnell Company, Providence, R. I.

America's Opportunity: Conservation of Life from Fire; by T. Alfred Fleming, supervisor Conservation Dept., National Board of Fire Underwriters.

F. A. Doody is secretary.

National Housing Conference

The National Housing Association has announced that the next National Housing Conference will be held December 9-11, at Bridgeport, Conn., with headquarters at the Hotel Stratfield. The offices of the association are located at 105 East Twenty-second street, New York City.

A Store on Wheels

A traveling grocery store may now be seen on its daily rounds in Los Angeles. This consists of a large 1½ ton motor truck modified and rebuilt to meet the needs that suggest themselves. Along the sides of the interior are rows on rows of shelves and compartments. At the front end is a refrigerator of ample size for the proper preservation of butter, eggs, cheese and such things requiring a cool habitat. Backing these compartments and reached from the outside are many other cubby holes disclosed by sliding doors.

Every inch of space is conserved and an astounding number of articles can be tucked away in the limited space in an orderly array and manner readily and speedily accessible for display or sale. The traveling store has over 350 distinct articles, in fact, practically everything to be found in any grocery store, including in many instances several makes or varieties of the most generally called for articles.

This traveling store will follow a regular house to house route over as much territory as can be covered in a day. The opening of the store is a simple operation, just the swinging open of the rear doors, letting down the folding steps and sliding up of the side panels. Then the purchaser has before her all the facilities for making her selection, with the goods spread before her in compact form.

As far as groceries are concerned, it will do away with the shopping bag, the housewife's basket, car-fares and waste of time and effort ordinarily necessary to keep the family cupboard plentifully stocked with those articles so essential to its well-ordered shelves. Everything to be found in the grocery she can purchase right at her door—all the fun of shopping without the bother.

This is believed to be the first time in this country that a motor truck has ever been used for such a

purpose. It is an innovation that, if successful, will lead to a fleet of similar caravansaries conducted by the same firm and undoubtedly the innovation will spread far and wide over the streets of the land.

Are You a Leader in Your Town?

Initiative is given its word of praise in the current issue of *Forbes Magazine*. Have you, it asks, ever stopped to consider the value of being the first to do a thing in your town? Think of the free advertising John Wanamaker got, to say nothing of the tillful of cash, by being the first to boldly advertise "20 per cent. off." And did you notice that Henry Ford, by being the first to start cutting automobile prices, was given free advertising on the front page of every newspaper in the land, many of them going so far as to print in detail the old and new price of each make of Ford car? It often takes courage to blaze a new trail, to embark upon an important experiment, to dare to be a pioneer. If you have simmering in your mind an idea which you feel would make a ten-stroke with the public, but which you hesitate to bring forth until circumstances may compel you to do so, just think of the experiences of Wanamaker and Ford. The people admire a leader more than a trailer.

Hall of Fame Slow to Admit Artists

The long-awaited Hall of Fame elections have been held, and to Gilbert Stuart still belongs the honor of alone representing American artists, writes William Macbeth in *Art News*. Homer, Whistler, Inness, Martin, Fuller, Twachtman and Wyant were placed in nomination before the Senate of New York University, whose duty it was to select candidates for the later ballots.

All were approved by the Senate and their names were forwarded to the class "Authors and Editors" of the electorate, eight votes out of fourteen by this body being necessary for nomination on the final ballot. In this preliminary count, Whistler led with 13 votes, eight of them being marked M. J. F. (more justly famous), which entitled him to election if a majority instead of the usual two-thirds of the total number of electors voted for him on the final ballot. Homer was second with 12 (3 M. J. F.); and Inness followed with 11 (3 M. J. F.). Fuller, Martin, Twachtman and Wyant, without the required number of votes to put them on the final ballot, followed in the order named.

The total electorate consisted of ninety-six men and six women, giving a total of 102 votes on the final count. Whistler and Copley, whose name had been carried over from the previous election, were the only artists to receive more than ten votes.

Whistler, with 51 necessary for election, had 31, while Copley had but 12. It is interesting to note that the votes for Whistler were almost equally divided among all six classes of the electorate.

While it is disappointing that at least one more of our artists should not have been added to the list at this time, we must remember that to have any value elections to a Hall of Fame must be few and far between, and made only after the closest study, not only of merits in the light of present-day thought, but with full regard for the possible changes that tomorrow may bring in public estimate. It is a little hard to see, however, why some, at least, of the candidates did not figure to better advantage before a jury of culture and presumable art knowledge.

How to Distinguish Woods—Birch, Beech and Maple

Physical Characteristics of Birch, Beech and Maple Described

Birch, beech and maple are very similar in appearance, and have approximately the same weight. Hence it is comparatively easy to mistake one of them for another. A method which anyone can use to distinguish them is suggested by the U. S. Forest Products Laboratory. The method makes use of the relative width of the pores and medullary rays in the three woods.

If the end grain of birch, beech or maple is cut smooth with a sharp knife and examined with a hand lens, the pores will be seen as tiny holes distributed fairly evenly over the surface, and the medullary rays will appear as narrow lines of a different shade running at right angles to the growth rings.

In beech some of the rays are very distinct even without a lens. The large rays are fully twice as wide as the largest pores.

In maple the rays are less distinct, and the largest are about the same width as the largest pores.

In birch the rays are very fine, invisible without a lens. The pores are several times larger than the rays, usually being visible to the unaided eye as minute holes on the end grain and as fine grooves on dressed faces of the board. The pores in birch are considerably larger than the pores in beech or maple.

The appearance of the medullary rays on a "quartered" surface is also distinctive. Here they appear in beech as distinct "flakes," the largest being between 1-16 and 1-8 inch in height when measured along the grain of the wood. In maple they are considerably smaller, rarely attaining a height of 1-16 inch.

Personals

McElroy & Van Antwerp, Minneapolis architects, formerly located at 416 Palace Building, have moved to more spacious quarters at 901 in the same building. Their new location, which occupies the entire ninth floor, is designed especially to suit their particular needs.

Tyrie & Chapman, architects, and Jefferson M. Hamilton, associate, have moved their office to 1200 Second Avenue, South, Minneapolis, Minn.

Speiden & Speiden, architects, 1403 New York Avenue, N. W., Washington, D. C., have removed their offices to room 202, 1423 New York Avenue, N. W., that city.

Amos W. Barns, architect, has removed his office from 1507 Arch street, Philadelphia, Pa., to 10 S. Eighteenth street, that city.

Croft & Boerner, architects, of Minneapolis, Minn., have moved to new quarters, taking the entire second floor of the building at 1000-1006 Marquette avenue, where they will have exceptional accommodations for their drafting rooms.

Thomas J. Herron, architect, formerly located in the Publication Building, Pittsburgh, Pa., is now practicing at 1012 Fordham street, that city.

Harry A. Yarish, architect, has opened an office at 551 East Fourth street, Brooklyn, N. Y., for the general practice of architecture.

Seelig & Finkelstein, architects, announce that they have removed their office from 26 Court street, Brooklyn, N. Y., to Temple Bar Building, 44 Court street, that city.

The Laurelton Sales Co., architects, formerly located at Thirty-third street and Seventh avenue, New York City, are now operating at Laurelton, L. I.

S. C. MacIntire, architect, is now associated with MacKee & Williams, and the firm name will be known as the MacKee, Williams & MacIntire, architects and engineers. The offices will be located at 225 Twenty-eighth street, Newport News, Va.

Harry J. Corslan has been announced as winner of the A. Moorman prize offered to students in the college of architecture at the University of Minnesota. The prize is a three weeks' trip to leading

schools and art centers throughout the country. All expenses incidental to the trip are paid by Mr. Moorman, a St. Paul architect. The prize was awarded for meritorious work.

Hewitt & Brown, architects and engineers, formerly of 716 South Fourth avenue, Minneapolis, Minn., have moved their offices to 1200 Second avenue, that city.

Edgar H. Cline has been appointed architect for the Los Angeles Board of Education and will work in conjunction with the business department of the board under the supervision of W. E. Record, business manager. He will make his office with the business department, 1437 San Pedro street, Los Angeles, Cal.

William McKee Walton, architect, has opened an office at 136 South Fourth street, Philadelphia, Pa.

B. L. Hulsebus, architect, has moved his offices from room 1001 Jefferson Building to room 1232 Jefferson Building, Peoria, Ill.

Joseph A. Hickey, architect, formerly Grand Building, Providence, R. I., has moved his offices to 142 Atlantic avenue, that city.

Hewitt & Ash, architects, formerly located at 520 Walnut street, Philadelphia, Pa., may now be found at 1827 Arch street, that city.

Heartwood Color no Indication of Cypress Durability

Southern bald cypress is about the most variable in color of any of our native woods, and in different localities is known as red cypress, yellow cypress, white cypress and black cypress. There is a rather prevalent belief that cypress with dark colored heartwood is the most durable, but the opinion of the U. S. Forest Products Laboratory is that as far as durability is concerned the color of the wood makes very little difference. In service records obtained by the laboratory, any difference in the length of service of red cypress and yellow cypress appears to be due entirely to a difference in the amount of sapwood in the timber. Cypress trees with light colored heartwood usually have more sapwood than those with dark colored heartwood, and sapwood is not resistant to decay.

The important thing, if durability is desired, appears to be to select the heartwood of cypress regardless of its shade.

Civic Development Department of the Chamber of Commerce Appoints John Ihlder for Manager

John Ihlder, managing director of the Philadelphia Housing Association, has been chosen to be manager of the new Civic Development Department of the Chamber of Commerce of the United States. This is one of the new departments into which the activities of the National Chamber were recently divided. Three new departments—Foreign Commerce, Insurance and Fabricated Production—have been inaugurated and are performing services for the business men of the country.

Mr. Ihlder, who is a housing specialist and has had much experience along general civic lines, is taking hold of the new department at a time when the housing problem, which comes under the activities of his department, is one of the most important questions before the country. Mr. Ihlder has made a close study of the national housing situation and his practical knowledge of conditions will be helpful to the Chamber of Commerce in its efforts to assist in solving the country's housing problem.

English Impressions of New York Architecture

E. V. Lucas, of England, who has visited this country and kept "An American Notebook," has written the following extract in a recent issue of *The Outlook*:

Perhaps if I had reached New York from the sea the sky-scrapers would have struck me more violently. But I had already seen a few in San Francisco (and wondered at and admired the courage which could build so high after the earthquake of 1906), and more in Chicago, all ugly; so that when I came to New York and found that the latest architects were not only building high but imposing beauty on these mammoth structures, surprise was mingled with delight. No matter how many more millions of dollars are expended on that strange medley of ancient forms which go to make up New York's new Cathedral, where Romanesque and Gothic seem already to be ready for their divorce, the Woolworth Building will be New York's true fame. Whoever designed that graceful immensity not only gave commerce its most notable monument (to date), but removed forever the slur upon sky-scrapers. The Woolworth Building does not scrape the sky; it greets it, salutes it with a *beau geste*. And I should say something similar of the Bush Building, with its alabaster chapel in the air that becomes translucent at night; and the Madison Square tower (whose

clock-face, I notice, has the amazing diameter of three floors); and the Burroughs-Wellcome Building on Forty-first street, with its lovely perpendicular lines; and that very solid cube of masonry on Park avenue, which burst into flower, so to speak, at the top in the shape of a very beautiful loggia. But even if these adornments become, as I hope, the rule, one could not resent this structural elephantiasis a moment after realizing the physical conditions of New York. A growing city built on a narrow penin-

sula is unable to expand laterally and must therefore soar. The problem was how to make it soar with dignity, and the problem has been solved.

In the old days, when brown stone was the only builders' medium, New York must have been a drab city indeed; or so I gather from the few ancient typical residences that remain. There are a few that are new, too, but for the most part the modern house is of white stone. Gayest of all is, I suppose, that vermilion-roofed florist's on Fifth avenue.

Weekly Review of the Construction Field

With Reports of Special Correspondents in Prominent Regional Centers

CONDITIONS are improving. This is not an attempt to "coat the pill." It is merely a plain statement of fact. The press reflects the improvement, instead of forcing it, as it has done in the past. The faces of business men reflect the improvement. The tenor of business reflects it. Everything points to substantial progress.

This does not mean that conditions are satisfactory. They are far from that. But the general tone of the financial markets, of transportation, of labor, and of building activities is beginning to react to the "normalcy" period, and the reaction is based upon sound economic conditions and justifiable causes.

The building industry, for example, is pushing its head up from the turbid waters in which it has been slowly stagnating for several months—or is it years?—and breathing new air. One reason for this is undoubtedly the activities and results of the Lockwood Investigating Committee in New York City. While the investigation is in itself a local affair, it has nevertheless had a healthy effect upon building operations generally in localities other than New York. This statement is not one susceptible of proof by an imposing array of figures, but it is quite an easy matter to prove if one circulates to any marked extent throughout the "inner circle" of the building industry as a whole. There has been removed that intangible something which, for lack of a better word, we term uncertainty. And that intangible quality has, as every architect knows, the principal deterrent factor in building.

Perhaps this may have been achieved because of the fact that the Lockwood Committee stands for something more than its title would imply. It is not merely a matter of what the committee has shown or

proved that counts so much, after all; though it has secured indictments against the manipulators of the vicious system which it is seeking to uncover, as well as indictments against a very well known contractor and other persons involved in the dirty tangle. The big and the important fact of it all is that the public is showing so keen an interest in the committee's activities, as evidenced by the crowded condition of New York's City Hall during any of the hearings. It is not a morbid, speculative interest. There is too much tension in the nation's condition to permit of that. It is the interest that came primarily from a necessity born of the appalling lack of sufficient housing facilities; but it has been so intensified and so nurtured that it has become an interest in the principle of the matter itself. People are no longer asking: "Wonder what'll happen next?" Now it is: "What is the reason for the thing?" And, with a great many, there is also the desire to check its recurrence. It is not uncommon to hear newspaper readers say to one another: "We're going to put a stop to this sort of thing."

It is the "we" in that sentence that counts.

It is interesting to note that the investigation has turned to what some persons look upon as "the beginning of these things," referring specifically to the alleged control of the building materials market by one of the various "rings" which the Committee has exposed. This new phase of the Committee's activities promises other revelations, and unexpected indictments in totally new fields are expected.

The political hue and cry which this journal predicted, has been raised. An official of the city administration has been charged by the counsel for the Committee with having used the courthouse site for

THE AMERICAN ARCHITECT

a dumping ground, or rather, with having been connected with a firm which so used that site. It reminds one of the Spanish King who drove his troops up the hill and turned about and drove them right down again. Speaking seriously, however, it is to be regretted that the investigation has taken on such an intensely political aspect, and that Mr. Untermyer, the Committee's counsel, should be so hampered by petty politics. He seems to be doing well despite it.

Incidentally, it is interesting to note that Robert P. Brindell, the individual "Tsar" of the graft ring in New York's building industry, has "been forced to resign by the American Federation of Labor." The inaccuracy of this statement as given in the press emphasizes what has been already said regarding public opinion. Mr. Brindell was not forced to resign by the Federation. He would have resigned long ago if that were the truth of the matter. Mr. Brindell was forced to resign as the result of public opinion, and nothing other than public opinion. And that public is precisely the public which is to build itself nearly a million homes as soon as conditions permit. A rather significant fact.

"As soon as conditions permit." There is much in that phrase, and one of the factors is transportation. There, improvement is marked not by the intangible, but by the actual, the visible, the tangible. Figures for October show conclusively that the railroads, under private management, carried more net tons per mile per day and moved cars more miles per day per car than in any like period in the history of railroading. There has resulted a very satisfactory improvement throughout the country, and especially in those sections where building materials have been considerably held up for long periods because of coal priorities and other difficulties.

If improvement in the credit situation is looked for, it is to be found in this statement by the National Bank of Commerce in New York:

The country's credit requirements have, during the period under review, reached a maximum level. Pressure may for a time continue at this current high level but no substantial increase is anticipated in the demand for banking accommodations, either for crop financing or to meet commercial and industrial requirements. The credit position is essentially sound and the future is to be regarded with confidence.

(Special Correspondence to THE AMERICAN ARCHITECT.)

SEATTLE.—Stock taking time, unsettlement of finance and the grain and lumber markets have brought architects, jobbers and investors to the conclusion that no new building commitments should be expected for the balance of the year further than

the pencil sketch period on which some of the architects are now engaged for the spring of 1921. There seems to be no reason to expect price recessions in steel products and the jobbing trade seems firmly convinced that no such declines should be taken into the equation.

Jobbers in hardware building essentials, however, state that in place of merely taking orders that come in the trade will henceforth build on the fact of pushing the selling divisions into greater activity. The conditions that started the war-time system of withdrawing salesmen because there was no necessity for their presence have changed, and from now on the rule will be to get the business.

The shortage of three-quarters galvanized pipe is still acute, but other small sizes are arriving by water in sufficient volume to take care of the demand. The nail shortage is over, the 3-penny fine blued being the only essentials that are behind.

Collections are good because they are being forced, and credits are not being extended. Over the entire coast territory the jobbing trade is discouraging any more purchases than the needs of the hour would warrant. There is no speculative feeling even in steel, which to date has declined only 20 per cent. under quotable prices of 1915. Hardware orders placed now can with assurance be filled in 60 days, so well have eastern mills recovered on their back order files. One of the sensations of the week was the receipt of a solid carload of three-quarters galvanized pipe by a Seattle jobbing house. For months this stock has been coming in small mixed lots.

Consumers and builders over the territory are holding back on buying. Retailers' stocks are fair for the time of year. Few of the architects or builders are willing to predict that the construction revival on the coast will set in before March 1, although all agree that an extensive building program is due in 1921. Their reasons for this is that labor will be cheaper through increased production on the per capita basis, that delivery will be more in volume and with greater promptness, and that the eastern mills will be caught up on back orders before early spring.

Jobbers of roofing, brick, cement, fire clay and enamelware do not look for any fluctuations in prices. In these lines the tendency to delay buying in lieu of definite price information is general.

The lumber industry of the West Coast is practically at a standstill, with prices wavering from steady to \$2 per 1,000 lower. California, which has been a strong fall buyer, has been silenced. The building program there seems to have come to a sudden end. New schedules of prices issued by Seattle fir lumber mills this week show a reduction of 5 per

THE AMERICAN ARCHITECT

cent. on the basis of delivery on the job. Quotations are as follows: No. 2 vertical grain flooring 1 x 4 \$77; No. 2 and better slash grain 1 x 4 \$51; No. 1 common shiplap 1 x 8 \$27; No. 1 common dimension 2 x 4, 12-foot \$35; No. 1 common timbers 12 x 12, \$35; star shingles, red cedar per 1,000 \$4, and clears, \$4.75. Lath are \$7.50, which was the jobbers price for top grade stock 30 days ago.

Initial steps for revision of Seattle's building code were taken at a session of the city council this week. James F. Blackwell, superintendent of the city building department, stated before the council that the present code, adopted July 22, 1913, fails to meet present requirements, serious defects having been shown during the seven years.

West Coast fir lumber mills are now shipping lumber coastwise by water to New York through the Panama Canal in view of the prohibitive emergency freight rates. During the past 90 days the water movement to the Atlantic seaboard has been 45,434,268 feet, or practically the same as the entire movement for 1919 by rail. The railways are formulating plans for making a rate of 95 cents per hundred pounds to New York, with recessions westward between Buffalo and Chicago as a means of preventing the loss of the heavy lumber tonnage.

(Special Correspondence to THE AMERICAN ARCHITECT.)

CHICAGO.—The apathetic condition which has prevailed in Chicago building circles for several months continues unabated, but the light would seem to be breaking in the East and the optimists of the local builders' colony are freely predicting a very great building boom for the coming early spring. Activity of inquiry, real estate briskness in vacant property, declining prices in materials, a more harmonious working agreement between contractors and labor, and, most of all, a psychological expectation of a busy spring are bearing toward the single end of greatly expanded building as soon as the weather opens up next year.

Just at present all of this rosy-hued outlook is in prospect, for the same stand-still condition which has been holding the building trades in doldrums for several months is as steadily on the job as ever, and no breaking of the deadlock can be immediately expected.

One of the most encouraging indications of a building boom is news lately received by financial leaders in Chicago that the money situation is easing up considerably and that there is a fair prospect for 6 per cent. money by the first of the year. No official announcement to this effect has been made in Chicago, but there is a confident feeling in responsible quarters that the stringency is much more elastic than formerly and that the high rates will shortly be suc-

ceeded by a rate that will permit the financing of important building projects now unable to proceed because of the high interest rate. This is particularly the case with apartment buildings, which, if erected at the present money rate, would have to earn what is regarded locally as an extravagant rental in order to leave the owner with any profit above his mere operating expense at the close of the year.

At this juncture it may be interesting to point out that apartment owners and real estate managers of apartment property are determined to add nothing more to operating expense of apartment buildings. This determination was clearly brought to light this week when a demand for a wage increase on the part of the apartment building janitor's union was flatly and finally refused without discussion.

Unless lower money rates are shortly available there will be a very determined effort on the part of Chicago building interests to secure tax exemption on building mortgages. Just what avenue of relief will be sought is not made clear, but an appeal to Congress is within the realm of probabilities if state action is not sufficient to secure the desired relief.

Federal tax revision is looked to as a possible means of overcoming the heavy surtax on large incomes which makes the 6 per cent. mortgage unattractive to important investors.

At present the formerly popular 6 per cent. mortgage bond on building property is languishing. The banks are unable to dispose of the paper at this rate, and it seems impossible for builders to pay more than 6 per cent. for their money. It is lately noted that unsold 6 per cent. mortgages are being made to pay a higher net return by the simple expedient of reducing the sale price to net 7 per cent. These various expedients are not successful, however, in moving the paper and some financial relief is the biggest thing in the list of building needs just now. This particularly applies to the apartment building situation, which is the acute focus of the building shortage in Chicago.

If the building of apartments and homes cannot go forward, it is at least interesting to note that the activity in large hotel properties is not so limited.

The new Hotel Drake is now practically completed. In acknowledgment of the efforts of labor in this important project, the eight hundred employees who worked on the building were served with a pre-Thanksgiving dinner, the first dinner to be served in the building. Percy C. Drake, president of the construction company, explained to the guests that the hotel, which has 800 rooms, has been erected at a cost of \$8,500,000. The hotel was tentatively opened on Thanksgiving Day, though some slight work remains yet to be done.

THE AMERICAN ARCHITECT

The group of important hotels in the vicinity of the well-known Edgewater locality on the lake shore is to be augmented shortly by the construction of another million-dollar establishment to be known as the North Beach Hotel. It will be located at Balmoral and Kenmore avenues.

A Chicago newspaper announces that John Archibald Armstrong will be the architect for the building, which is to include 100 apartment suites of one, two, three and four rooms.

The building will be erected by the North Beach Hotel Company, and the Flat Slab Engineering Company has been awarded the principal structural contract. The date of breaking ground has not been announced, but early spring is expected to see operations under way.

Some activity is also noted in the theatrical building situation in Chicago. Two new and important moving picture palaces almost fronting each other on State street, north of Washington street, are now nearing completion. Much headway has also been made on the new Wood's theater building—as yet unnamed—which is located at Randolph and Dearborn streets. Now comes the announcement that two new theatres are to be erected here in the spring and early summer by the newly created combination of the Sam H. Harris and Selwyn theatrical interests. Tentative announcements are that one of the new theaters will be located in Dearborn street, between Randolph and Lake streets, and the other in some closely adjacent site not yet decided upon. Building plans have not been definitely made public.

This virtually sums up the new building plans of the week. Building permits continue to be practically nil as compared with normal years. Inquiry among real estate dealers reveals the fact, however, that the public interest in home building sites is showing marked improvement. Attractive north shore suburban vacant property is said to be particularly in demand at this time, indicating that the alleviation of building conditions will see many important new homes in the north shore neighborhoods.

The movement for home buying is to be given some slight impetus, it is hoped, by the Own Your Home Exposition which is to be held in Chicago some time in the early spring, probably at the Coliseum. R. D. Sexton, managing director of the exposition has been in Chicago lining up the co-operative interests, and predicts for the exposition a very successful interest on the part of the public.

The labor and materials situation in Chicago remain practically without change. There is a growing volume of unemployment in all lines, the building trades not escaping. It is estimated that there are 45,000 building craftsmen out of work, as far as their own lines are concerned. A considerable per-

centage of these, however, have gone into other employment pending a resumption of activity in building.

In this connection a special report on labor conditions compiled by one of the leading Chicago banks is of interest. An inquiry directed to building contractors, the report explains, brought the information that the labor cost in building operations at this time represents approximately 79 per cent. of the total cost of the building. The bank uses the analysis to give force to its statement that:

"Reducing rents without reducing building costs and reducing building costs without reducing labor costs are two economic impossibilities."

In lumber and materials the price changes over the last week have been isolated and unimportant.

Lumber factors report very slight activity in lumber demand, excepting certain of the soft woods, there has been a greater volume of inquiry, indicating that the spring building impulse is being reflected in the trade.

Prices range about at last week's levels, the following being the quotations on some of the principal grades:

Yellow Pine.—B & B 1-inch, according to thickness, \$95 to \$130; 13-16x3¼ B & B flay flooring, \$85 to \$90; 13-16x3¼ 1-inch common pine, \$55 to \$65; 2x4 No. 1, \$51 to \$53; 2x6 No. 1, \$48 to \$49. Other dimensions in proportion.

Douglas Fir.—All sizes to 12x12, No. 1, up to 32 ft. length, \$65 to \$70; 14x14, \$68 to \$70; 16x16, \$72; 18x18, \$78.

Birch.—Four, ¼ No. 1 and 2, \$155; select, \$137; No. 1 common, \$98; No. 2 common, \$65; No. 3 common, \$38.

Hard Maple.—Four, ¼ No. 1 and 2, \$135 to \$140; select, \$120; No. 1 common, \$98; No. 2 common, \$65; No. 3 common, \$32.

While present demand is not at all active, building supply dealers cherish the hope of others that spring business is going to be very heavy. Prices, at present, seem very stable, some of the leading quotations for the week being:

Cement.—Universal, \$4 to \$4.20; Lehigh, \$4.20 to \$4.40; Portland, \$4.20 to \$4.40; bulk line, \$1.70 to \$1.90.

Torpedo-lake and bank sand, \$3.40 to \$4.25; crushed stone, gravel, screenings, \$3.40 to \$4.25.

Face brick, octagons, \$68 to \$75; fire brick, \$32 to \$40.

"Legal Mistakes Common to Architects" was the theme of Judge George F. Rush, of the Chicago Circuit Court, who addressed the members of the Illinois Society of Architects last week. Benjamin Bills and Joseph Lawler were also speakers. New

members recently admitted to the Illinois society are J. J. Fox, W. P. Fox and C. B. Spencer.

(Special Correspondence to THE AMERICAN ARCHITECT.)

BOSTON.—The amount of building of all kinds done in Massachusetts last month showed a decrease over previous periods, according to figures contained in a report issued by the State Department of Labor and Industries today. In Boston figures ran \$914,334 for October as compared with \$2,047,385 for September. The estimated cost of new buildings and alterations for which permits were filed in thirty-seven cities during the third quarter of 1920 was \$22,857,213, a decrease of 23.5 per cent. from the aggregate of \$29,898,001 for the second quarter of 1920 and a decrease of 17.6 for the aggregate of \$27,745,911 for the third quarter of 1919. The estimated cost of alterations and repair work constituted 34.5 per cent. of the aggregate for the entire third quarter of 1920. This is a relatively high figure, the usual ratio being in the vicinity of from 20 to 25 per cent.

During October, the aggregate in thirty-six cities for new buildings and alterations was but \$4,558,701, while the aggregate for September was \$6,269,889, a decrease in October from September of 27.3 per cent. Of the October aggregate, \$1,266,786 represented repair and alteration work.

An estimate based upon reports submitted by 1,103 labor unions reporting a membership of 254,000 shows that the percentage of unemployment in Massachusetts is as follows: Building trades, 5.3 per cent.; boot and shoe, 40.9 per cent.; textiles, 26.3 per cent.; iron and steel, 9 per cent.; printing, 2.5 per cent.; all other trades, 17.1 per cent.

There has been a noticeable decrease in the number of strikes and lockouts, only eight being reported since Oct. 1.

The Splendid French Example

WITHIN two years after the signing of the armistice France has worked two veritable miracles—one of readjustment and one of reconstruction.

As a result of this miracle of readjustment, although France was the one allied country that suffered most from the war, and the one country in which the increase in the cost of living was the greatest, she is the only one of the big allied powers who today is entirely free from any strikes or social unrest of an economic nature.

Furthermore, writes Henry Wood, United Press staff correspondent, she is the only one of the big allied powers who in the same period of time has been able to free herself, and definitely, from the menace of bolshevism. The death knell of the latter was sounded a month ago when in national convention at Orleans the French Federation of Labor almost unanimously condemned the leaders who up until eight months ago ordered and supported political strikes amongst the French workmen.

Instead of waiting, as much of the rest of the world has done, for economic life to reestablish itself on the pre-war basis, France saw at once that this would never happen and immediately readjusted herself to the new economic life imposed by the war.

The official statistics of the allied countries place the increase in the cost of living in France as a result of the war at 300 per cent.

Yet, despite this astounding handicap, official figures of the French ministry of public instruction show that salaries generally throughout France have now been increased from 200 to 300 per cent.

It is this quick readjustment of the whole economic basis of French life to the new standard of living created by the war that has left France entirely free from industrial strikes for the past nine months and has wiped out completely the menace of bolshevism.

France has kept equal pace in the reconstruction of her devastated regions.

Of the 2,712,000 French citizens who were driven from their homes by the German invasion, 1,533,000 are now back on the job.

Of the 5,570 kilometers of railway destroyed during the war, 4,070 kilometers are back in operation.

Of the 5,760,000 acres of land rendered uncultivable because of the presence of unexploded shells and missiles, 5,220,000 acres have been cleaned and put back into cultivation.

Of the 3,060,000 acres of ground that were pounded into nothing by shell fire and other war activities, 2,870,000 have been restored to productivity.

Of the 11,540 factories that were destroyed by the war, 3,540 are already back in operation and another 3,842 are under reconstruction.

Of the 379,000 people who were employed in these destroyed factories before the war, 257,831 are back at work in them.

- 770⁰⁰

frontispiece to no. 2347.

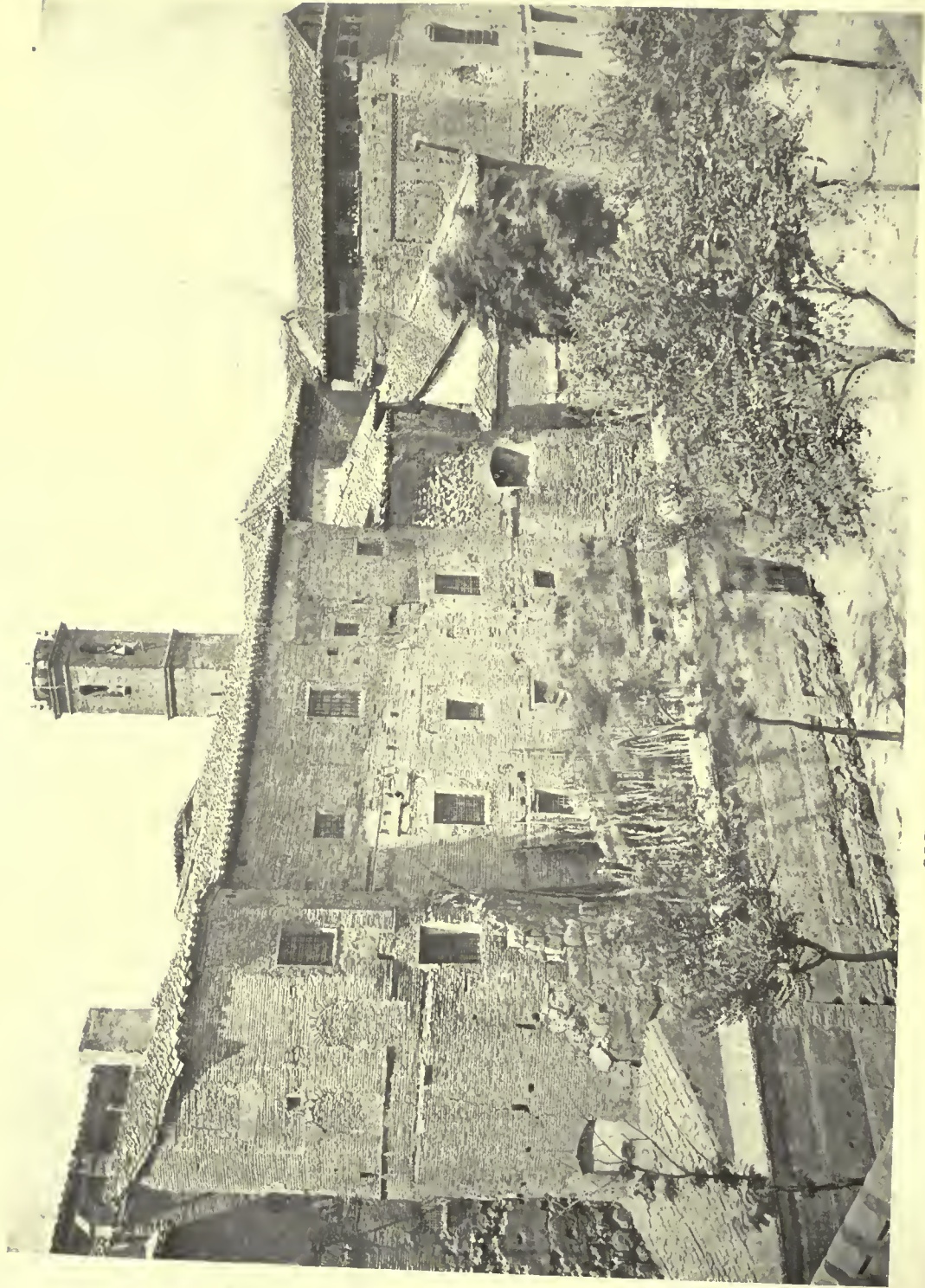

OLD CITY WALLS, TARRAGONA, SPAIN

THE AMERICAN ARCHITECT

THE AMERICAN ARCHITECT

VOL. CXVIII

WEDNESDAY, DECEMBER 15, 1920

NUMBER 2347

Waste Spaces in New York

Impressions of an Interview with Thomas Hastings, F. A. I. A. (Carrere & Hastings), in Which a Proposed Scheme for the Reformation of New York's Waterfront Was Outlined

EDITOR'S NOTE: The following article is not a verbatim report of the conversation with Mr. Hastings regarding this topic, but rather the impressions left upon the writer's mind by what Mr. Hastings said. It is the first of a series of exclusive interviews granted THE AMERICAN ARCHITECT by men prominent in the profession of architecture and the arts allied to it. The remaining interviews will appear in early numbers of this journal.

A CITY grows in two ways. Its growth is governed either by natural evolution or by deliberate design. Boston is an example of the former; Washington of the latter; New York of neither. It is of New York that I wish to speak because New York is very typical of a number of cities in this country which show lack of plan and disregard for those areas which are nothing more than waste spaces as they stand now, and which should and could be converted into architecturally correct centers or spaces.

The housing problem accentuates this. While the people of New York City are finding it difficult to get living quarters, a great amount of land lies idle—from either a commercial or architectural point of view—along the waterfront. I refer to those many streets which lead to the river and which cannot justify their existence from any standpoint. They are not beautiful. Their value as avenues for traffic is negligible, since the traffic they bear does not justify their existence from a financial standpoint. They lead simply to the river, in a great many instances to the river itself, and not to any particular building or other destination. They stand condemned as efficient streets, as beautiful streets, or as useful streets. They are waste areas.

Now, the problem of any city is to so conserve its waste areas, especially when they exist in this form, that land will produce at its maximum from a commercial, housing or recreational standpoint. Land which is being used for streets over which so little traffic moves that it may be properly looked upon as negligible is doing neither of these two things. Its only justification for existence would lie in the fact

that it was being used as streets; yet in this instance even that justification is not possible.

The fundamental cause of this is, of course, the so-called gridiron scheme of city planning, which is, as I have said, neither planning nor the result of natural evolution. . . . It is simply a disease. . . . Without regard to the usefulness or beauty of proposed streets, they have been cut here and there in a haphazard, arbitrary sort of fashion. Having been cut, they create blocks. Upon those blocks buildings of one sort or another take place. And every street of the sort of which I speak is about 1,200 square feet of wasted space; space on which houses should have originally been built. . . .

What is the obvious solution?

The elimination of such streets. Not only obvious but economically sound and architecturally correct. By eliminating those streets units would be created of fairly large dimensions, in which an architect could most certainly build more economically and with a greater regard for architectural fitness. As an arbitrary example, let us say that five out of every six streets are waste spaces. The proper thing to do would be to close the five useless streets, create a building plot of respectable dimensions, and so improve the sixth street that traffic along it would move better.

The closing of the five streets would give to those who were to build upon that area a five-block plot, plus the streets. They should be given free by the city to those who buy the blocks as an inducement for building—a very substantial inducement, by the way. The average street is approximately 60 feet wide by about 200 feet long; 1,200 square feet of free land. A builder could properly look upon that land as profit from the very start, since all houses erected on such an area would return their profit on the investment on their cost alone. What builder would not welcome a chance to put up houses on free land?

I speak here of houses because I believe that, for

the areas which I refer to, houses should be the ultimate aim. The housing problem accentuates such a statement; and regard for the architectural fitness of New York's waterfront strengthens it. Nor do I mean elaborate or costly houses. The type of house which the man of moderate means could buy would be the proper sort. Such a type could be built on five block areas (including the streets) on a very economical basis. It would amount to miniature communities, each unit being a community unto itself. Unlimited possibilities would be offered the architect for planning. A street could be cut through the center of the unit, at right angles to the closed streets, and from this the necessary walks and short streets could branch out to the houses themselves. Then, in the center of the unit, running parallel with the closed streets, a street could be cut to meet the central avenue. This would provide easy access to the unit, and would give the architect unlimited possibilities for artistic treatment of the scheme. . . .

As regards New York's waterfront particularly, it would be splendid. Moderate sized sea walls could be erected along the waterfront, all designed and built artistically. Back of this wall the units would look out upon the river, with its traffic and color. Imagine a number of such units, one after the other, along the waterfront. Each would be architecturally fit; each would contribute its individuality to the general whole; each would be beautiful. The whole would be an unbroken series of communities, one beside the other, so built and so arranged that monotony of design would be done away with. Each, being a community, could be given the fullest possible treatment for style and proportion in the plans, without an expensive building program.

As to the economy of the scheme, I think it necessary merely to point to the fact that group construction is always cheaper than the individual problem. By group construction I am not referring for a moment to the "standardized" house, but to the fact that one hundred houses, properly designed for the moderate pocketbook and possessing architectural quality, can be built cheaper, per house, than the single unit.

The houses which would be built along the waterfront would attract a splendid tenantry. What could be more delightful than living along New York's waterfront in well-designed and architecturally beautiful communities such as these would be? The man of moderate means and thorough culture would be only too glad to own a home so situated, and so surrounded by other good-looking and artistic homes. There would be no crowding; there would be land about each home, where gardens could be planted; and there would be the beauty and coherence of a well-conceived group plan, with architectural similarity stamped indelibly upon the group. . . .

To those who look upon this as some sort of dream let me say this: The waste spaces referred to exist; the laws of the city should permit of the sale of such property, and co-operative organizations without number might be quite willing to supply the money for the purchase of the property.

Allow me to become a trifle personal and say to architects: "How would you like to be given the opportunity to design such communities, and thus preserve the architectural possibilities of a waterfront as beautiful as we know New York's waterfront could be made by the right sort of planning and building?"

"Would you have the city control or regulate the architectural phase of these communities, so that they presented either a single, definite architectural scheme or so that various periods of architecture would not exist side by side, thus destroying what might be termed architectural harmony?" the writer asked Mr. Hastings.

"Architectural harmony, as you term it, is beyond the province of official control or regulation," Mr. Hastings explained. "The city should be concerned only with those phases of building which relate to the health of the community, such as ventilation, light, drainage and overcrowding. It is not the duty or business of government, large or small, to interfere in any way with the aesthetic side of a community's existence. That is a matter which regulates itself, to a certain extent; but, whether it does or does not regulate itself, it is no part of the official side of a community to interfere with it.

"I am speaking now purely in regard to architectural harmony. There is a phase of your question which I would like to speak of, however. That is in regard to the disfigurement of a city. Opposite the New York Public Library, there is a large electric sign, which is ugly and which mars the composite beauty of that portion of Fifth avenue. That sign was erected by a man whose income is sufficient without the added revenue which the sign itself may produce. There is no necessity for it. It is a blot upon the city. Looking from the Public Library, one is confronted by a glaring, ugly sign. That should not only be regulated, but *prohibited*. It has nothing to do with architectural regulation, but it *is* concerned with the community, in that it actually mars whatever beauty architects have succeeded in imparting to that community. As such, it is a disfigurement; and disfigurements of that nature should never be permitted by a city.

I should like to say something regarding the selection of sites for memorials, war memorials particularly. It seem to be the unfortunate practice in a number of cities to select such sites arbitrarily, without inquiring into the memorial itself, and what it

THE AMERICAN ARCHITECT

seeks to exemplify or preserve to posterity. A war memorial, for example, seeks to commemorate a present condition, a present achievement. It is put up in honor of an ideal, and as such it is usually erected so as to honor those who fought or worked for that ideal.

This necessarily means that everyone in this generation at all concerned with the nation and with the individuals who typified the spirit of that nation are interested in such a memorial. In other words, it should be erected to serve (if it is to be of service) or to be accessible by (if it is to be purely decorative) the greatest number of people in the community where it is erected. It is not a memorial for a limited or selected group of the community, but one for the whole community. Is it not correct, then, to so place it that it may be seen or used by the maximum number of the population of the community?

This seems a simple statement of fact, yet it is only too true that cities seem to ignore it. Memorials of various sorts are often placed in spots where a very

small part of the community's population may reach them readily, use them, or look upon them in the course of their day's activities. To place a war memorial in Battery Park in New York City illustrates this point. Or at 250th street. Neither location is in line with the heaviest circulation. Neither is readily accessible to the majority of people in Manhattan Island. Neither would afford a view of the memorial, or use of it, to the thousands who pour into the lower part of New York during the week days.

Fifth avenue, at Twenty-fifth street, offers a splendid site in this particular instance. The avenue carries the most traffic, the circulation is by far the heaviest, and it would be readily accessible to the thousands who daily earn their livelihood in lower New York. It would, in a word, possess centrality.

That is the point I wish to make. Centrality—the choosing of a site which will make the memorial of this nature most readily accessible to the greatest number of people, either directly or indirectly—should always govern the selection of such sites.



AIRPLANE VIEW—THE LINCOLN MEMORIAL, WASHINGTON, D. C.
HENRY BACON, ARCHITECT.



FOUNTAIN OF ENERGY—PANAMA-PACIFIC INTERNATIONAL EXPOSITION
A. STIRLING CALDER, SCULPTOR



MODEL FOR MARBLE FOUNTAIN—THE
LEAGUE OF NATIONS—IN GARDEN OF
JULIAN R. TINKHAM, MONTCLAIR, N. J.

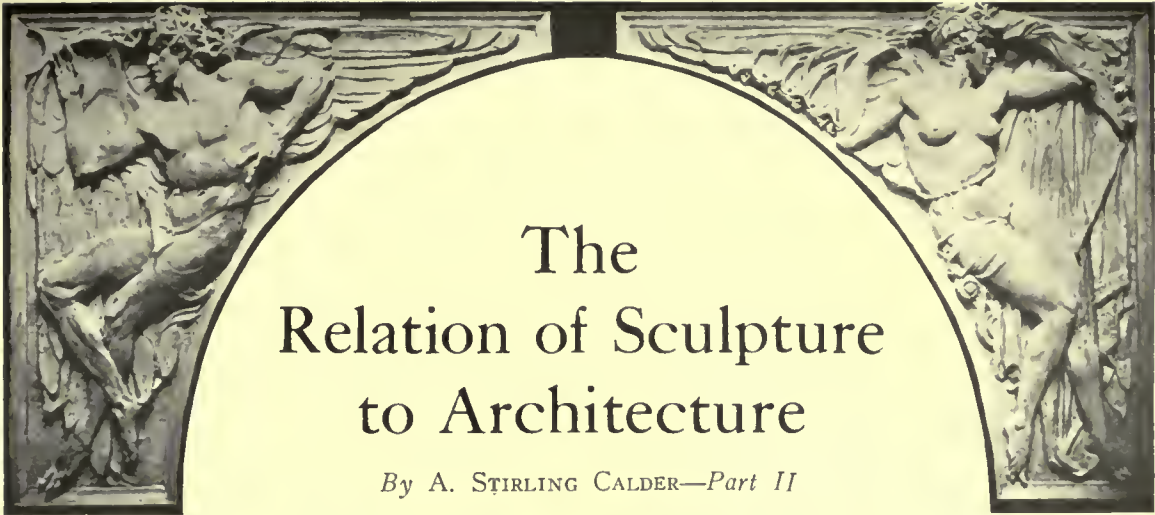

The Relation of Sculpture to Architecture

By A. STIRLING CALDER—*Part II*

Illustrated by Examples of the Work of the Author

THE elimination of all non-essentials in architectural design will make room for those plastic ideas of our time for which in classic design there is no place. By stripping construction to the bare bones of necessity, and engrafting thereon ideas, we beget our own child. It certainly is a refreshing possibility to contemplate. Let us begin our thinking in sculpture and architecture! Painting can take care of herself. But both painting and architecture would be enriched by a renewal of related vitalities. Sculpture is a ponderous matter and depends intimately on architecture for its grander uses. It is a significant fact that the most inspired sculptor of modern times found it impossible to wait for architecture.

It may be safely said that sculpture that is only ornament is not sculpture at all. What then of all the pretty details we are constantly regaled on? They had better not be done at all, except by students as training to do something else. The civilized world is familiar with neo-classic design and is fed up with it. It is not possible actually to do the real



"OUR LADY"
A STUDY IN FRENCH GOTHIC
STYLE.

classic, and our copies have no thrill because perverted. They depend for success solely on refinement and refinement persisted in is weakness. It is not to be denied that they sometimes possess beauty, but it is a weary beauty smelling of the lamp. We can go no farther on these high-ways. Another cause for the failure of so-called architectural sculpture of general appeal arises from the practice of considering sculpture as something that can be applied or dispensed with successfully at any stage of design. Built-in sculpture for exterior or interior should be considered from the first inception of the structure. Only by this early fusion of architectural and sculptural thought can the happy combination of use and beauty be achieved. Sculpture may be structural. The use gives character to the beauty. It must have a use and be beautiful in that use. Otherwise it is like a woman who is lovely to contemplate but otherwise distressing.

The only serious mistake possible to make about any art is to conclude that it is finished. A closed book of law, once learned and thereafter ever to be prac-

THE AMERICAN ARCHITECT



SOUTH PROW—THE ISLAND, VISCAAYA. FROM THE WATER-COLOR BY JOHN S. SARGENT.

PAUL CHALFIN, ARCHITECT

ticed with thought only of execution. True, all arts are governed by laws, but laws are being constantly challenged because man made and not infallible, and either approved, revised or repealed. So it is in the arts. So in sculpture. My plea for a forward looking practice of sculpture is not based on the desire for novelty or originality in the first place. It is based on the desire for pertinence and stimulation in the first place, then character and if possible beauty in its development. I place character before beauty. When a thing arrests our attention as being pertinent, well equipped for a purpose, we say it has character; and that implies satisfaction as to its right to be. If it is also pleasing to a marked degree we say it is beautiful.



MODEL FOR THE SOUTH PROW—THE ISLAND, VISCAAYA
ESTATE OF JAMES DEERING, MIAMI, FLORIDA

PAUL CHALFIN, ARCHITECT

THE AMERICAN ARCHITECT

FUTURE development in plastic art is to be expected in three ways. First by the evolution of styles in design growing out of old styles, with the consequent element of invention which must be allowed the possibility of extension to totally new types. Second, by original combinations of the materials used in sculpture made possible by such designs which would probably include certain materials not now employed. Third by distinctive, typical, pertinent and inventive technical methods in the treatment of these materials. I cannot believe that the last word ever to be said on any of these heads has

practice of "the styles" must grow more and more feeble. We sometimes hear of a copy "that is better than the original" but that is nonsense. No copy of an original that is worth copying can be so good.

Because the Greeks built very noble temples to house their sculpture of the gods is not a good reason why American architects should so persistently copy those temples to house our government department clerks, our bank clerks, our congregations for Christian worship, or our libraries. Our needs are different. May not our architecture be different also, sometimes? Based frankly on these needs, then



A SEA MOTHER

been spoken. It would be a hopeless outlook if that were true. Nor am I satisfied with the excuse commonly offered, that we are in a transitional period. All periods are transitional because they occur in change. It is disproved by the many detached individual attempts in expressive plastic design now being made. The germs of growth are alive and working. In fact these very experiments by the brave scouts of the advance are keeping alive popular interest in sculpture. Any good sculptor who is more than a technical modeller can give new interest to old forms by infusion of character. The degree of interest so infused amounts in rare cases to new style. But it is inevitable that without daring innovation, elimination and grafting of new thought the

beautiful in our own kind. All deference to the Greeks and to the Italians and all the others who have been at one time or other excellently free in plastic spirit for whom I have great admiration. I admire them and their works so much that I want to penetrate into their minds to learn the moods of life that compelled such admirable creations. If we could learn the humanity of their impulses we might also gain the confidence, the brave fervor that is now lacking to express ourselves. There is a difference between admiring antiquity, taking lessons from it, and being enslaved by it. There are other sources that point the same lesson in a more primitive way. We may well look about and sense the charm of such direct work as the wood carvings of some of our

THE AMERICAN ARCHITECT

aborigines. The totem poles and carved panels of our Alaskan Indians, some of which may be seen at the Museum of Natural History, are vigorous purposeful works of art. Skillfully simple and complete, without a trace of that forced aestheticism that is the disease of art.

The love of form is primitive, an instinct shared by all men to a degree, but reaching its highest growth in advanced civilizations that are never far removed essentially from savagery. Only scratch

in a given locality. The Puritans frowned on art and some of their influence still persists in certain hard dry conceptions and unimaginative technique.

PORTRAIT sculpture is the most popular branch of plastic art. The average person is willing to be interested in character and beauty as expressed in form individuality. The exclusiveness of plastic requirements are most manifest in portraiture. Ruskin wrote that "the portrait bust that is nothing



ARCHWAYS—THROOP INSTITUTE, PASADENA, CAL.
MYRON HUNT & ELMER GREY, ARCHITECTS

the surface, the savage is beneath. The instinct for form is part of our very physique, and the art that most purely embodies manifestations of this instinct is sculpture. Whether it was ever popular in a general sense to a greater extent than today is a question. Perhaps not. Most likely not. If it is the most exclusive of the arts in scope it probably follows that it must also be exclusive in appeal. Of course to the mass all art is taken for granted like life itself. There is no concern about it. It is merely sensed dully except by the rare spirits who live keenly. Climate has much to do with the character and amount of sculpture possible of popular acceptance

more is third-class work." And he was right in his day when classes in art were admitted. But sculptured portraits, whether statue, bust, relief or medalion that are worth anything, are also fine sculpture. The royal Egyptian portraits in granite and stone, Greek and Roman work in portraiture, Donatello's splendid busts and statues, Pisanello's medals, a wealth of later work, are all of a very high order. Sculpture should concern itself only with life, the accessories, dress or ornament must either be eliminated, simplified to extremist severity, or treated as allegory. The greatest successes of American sculpture have been in portraiture, but the application of

such work to comprehensive designs is all but unknown. The part that portraiture may be made to play in stately designs for monumental interiors, in libraries, theatres, institutions, banks, etc., is considerable. Monumental, allegorical, and realistic portrait busts and medallions lend themselves to varied and striking use architecturally. Full length portrait relief panels may be used in well lighted in-



ENTERPRISE

FINAL IN GROUP OF NATIONS OF THE WEST. P. P. I. E.

teriors and have monumental grandeur that is beyond painting. I know of no such uses yet made. Far from being exhausted the proper uses of sculpture in our day must be re-discovered.

Much remains to be done in the matter of the development of plastic design when two materials are employed. The great majority of our public statues are of bronze, practically always mounted on granite pedestals. The statues may be excellent and the pedestal excellent, each in itself, but very rarely are the two happily or interestingly combined. Rarely is any use in design made of the differences in materials, in quality of texture, color and strength. St. Gaudens and his architect saw the value of study in this respect and have left works: the Peter Cooper Memorial and the Sherman Memorial, proving its subtle value. But this was only a beginning which



THE BATHER

should be carried on; an infinity of delightful design lies beyond.

Decorative Sculpture is usually considered work of the second class. Even sculptors have accepted such classification, but it is untrue because based on differences in use, not on quality of art, which is the only true measure of excellence. There are but two kinds of sculpture whether it be large or small, ar-



A NUDE

THE AMERICAN ARCHITECT

chitectural, decorative, monumental, ideal, realistic, personal or impersonal or prefixed with any other qualifying word. It is either good sculpture or inferior sculpture. The most trivial utensils have been dignified by the beauty of their form, and the subtle art of their modelling and carving and painting by the Greeks, Italians and the rest. Vases, urns, mirrors, furniture, utensils of the table, armor, lamps. The Tanagra statuettes are little more than toys in one sense, yet many are triumphs of dignity and beauty. If one cares for beauty there is no limit to it. All must be beautiful from the cradle to the grave, inclusive. And why not? We have our lives.

Much sculpture is housed in the same way as painting, the result of taste and chance, and there are

those who suffer no shocks from the most incongruous collections provided the individual examples have merit. They are human documents, forsooth, and as such all considerations of time, race and style are insignificant in comparison. This is wise. What each art can give of beauty is the essential test, and all beauty has the same root. Better collections of many beauties related only in quality than attempts at harmonious selection that achieve only anaemic aestheticism. There is also place for the purist point of view when it can retain vigor. But that requires very great vigor indeed.

SCULPTURE drawing directly from nature and life makes new contributions to proved plastic form. These are then gradually conventionalized and absorbed into architecture.

The plastic spirit seeking for expression has invented forms beyond the realm of nature. Centaur, Minotaur, sphinx, griffin, satyr, mermaid, faun, Gods, angels, devils. The Egyptian, Greek, Hindoo and Gothic world systems of fascinating plastic imagery. Man has invented them all for his greater satisfaction and man may and will again invent more gods as needed with a following of unheard of zoomorphs to furnish forth new systems of symbols for his discoveries. The creative instinct, without which art would perish, is only thus appeased. It is the mission of some artists to blaze the trail in this pioneer kind of sculpture. Their productions may be rude and uncouth in execution but some germs of inventive insight for truth are thus added painfully and slowly to the sum total of human statement.

The grotesque is a legitimate branch of all art and has flourished side by side with beauty in most periods of notable activity. It has great value as a foil to pure beauty, in fact it is even a quality of beauty. The depth, the saturnian quality of it. When thus consciously used sculpture attains a strength and range that is dramatic. My impression is that this quality of conscious appreciation of the value of the grotesque has not been manifested in American sculpture. We have unconscious examples, the re-



MODEL FOR A MANTEL IN FAIENCE FOR SUN-ROOM OF IOWA HOUSE OF MRS. E. N. HARRIMAN, NEW YORK
GROSVENOR ATTERBURY, ARCHITECT

THE AMERICAN ARCHITECT

sult of abortive attempts at beauty, but they are distressing. There is nothing distressing about the conscious or true variety. It is an element of truth possessing humor and lusty vigor. It serves to strengthen what might tend to over sweetness in beauty. It is a tie to Earth.

Sculpture, and art generally, is not for the enjoyment of the wealthy only, but for all who understand. It is the generous Playground of the World on which poor and rich alike may pause, mingle and forget

probably necessary to insure action. However this may be there are certain men and women irresistably drawn to art as a vocation with no assurance of its bread-winning power. To the sculptor the world is a plastic mass waiting to take the impress of his thoughts. Their realization is an imperative duty. If a few of these are true, he has done well.

IT is interesting to consider the relation of artist to patron, laity, government. Imagination is constantly proposing. Authority is constantly disposing. How did these mysterious matters work out in the heyday of sculpture in Greece? Did Phidias have to talk up his conceptions for the Parthenon or was a free hand accorded him by Pericles? What were the real motives that decided the erection of the Parthenon and its sculpture? Was it an act of pure faith, devotion and piety, or a calculated effort to impress with wonder the multitude who must regard it as a miracle.

Michelangelo received certain commands from the Popes. But the real urge came from the demons within his tormented soul. Man toils when it is no longer a necessity because it is a relief. We must be about some work or play. We know not the reason any more than we know the reason of life. Art has this mysterious power of giving relief. It is beyond reason. Only he who has toiled has the right in the end to say, all is vanity.

In our sometime called melting pot for the fusion of races of the western world, education is a pressing necessity. And this must include not only that education with Americanization as its end, but also that very important education in the elemental means of communion, the arts. On the mutual good will and understanding of the races much depends. The sources of our supply of new blood from Europe includes races old in their peculiar national development of the arts. They bring much of value in return for what they receive. Assurance of confidence and unity of aim in life may be taught in art. In sculpture by plastic manifestations of our common humanity in origin and destiny.

Sculpture is part of our heritage. An art capable of the greatest grandeur only to be carried on by contributions of our own, not merely of technical excellence which is admirable, but also by things of the spirit which are more admirable. The creative impulse to plastic design exists with us but it has now no outlet. A public forum for the exhibition and judgment of sculpture is needed. American plastic art is not plastic enough! We are trifling indoors, when we should be lustily toiling for beauty in the open. There, in our open places, seen of tumultuous men in moments of impressionability and quickened



THE SIOUX, "KILL-AN-ENEMY"

the daily struggle. It is merely that those who happen to be favored by fortune have the privilege of returning joy to their less fortunate fellows by the use of wealth power. All efforts must be paid for. If the art work is had cheaply it is the artist who pays with privation and neglect. The cost of art is as nothing compared to its value. It is as necessary as the bread we eat. It is the bread of the spirit, demanding sustenance always. If not of the nobler kind, still of some kind, always. In this fair world there is plenty of everything for all, only distribution is vexing. Inequalities of wealth power are

judgment, let there be set up sculpture that is the direct reflex of this life, curbed and refined only by law and love, breathing new angles of thought on the meaning of visible life, and of that other life, the life of the spirit that haunts us all, of whatever creed, or of none but the elementally superstitious to which art also ministers. Let such images of growth be erected in temporary materials, for our deliberate consideration. Let them be so considered publicly for a considerable time. Long enough to decide their merit or demerit. Then let their ultimate execution depend on what friends and champions they can win as works desired.

Ever searching for the divine calm that life itself is denied, art seeks to set up her lovely idols of consolation. This most precious quality is far removed from practicability in its accepted sense, yet it is just this quality that is valuable to promote humanity, sympathy and understanding. Without a trace of the irrespressible optimism of art Humanity must have perish from the Earth. Life with no spark of it is an unconscious and useless thing.

Miles of Cliff Dwellings Found in Colorado Canyon

TWO new finds of prehistoric ruins in Colorado have been reported to Prof. A. Jeancon, field man of the United States Bureau of Ethnology, who is now in Colorado on important work regarding the antiquities of the State.

James Loftis, a ranchman of Youghal, a small settlement in the northwestern corner of Colorado, came recently to Denver, it is reported in the *New York Tribune*, with a detailed description of a canyon of cliff dwellings just west of the junction of the Yampa and Green rivers. These dwellings have just been discovered as a result of curiosity on the part of Loftis and two other homesteaders who have taken up land in this wild part of the western slope.

"Where the Yampa and the Green come together," said he, "there is an inaccessible canyon wall to the west. This side the wall is not so steep. Trailing cattle last summer on the near side of the river, I noticed near the top of the practically sheer wall what appeared to be a long, deep opening, resembling a great pair of lips with flat, stone-colored teeth. I asked some of the settlers in that new country what it was, but no one knew

"After my work for the summer was done I went up the Yampa and crossed a ford, gaining the other side. When I was above the place I went to inspect I lowered myself by a sort of a rope ladder. It was too short to reach the ledge, but afforded from above a view of walls of houses, caved-in roofs of what was evidently cedar, covered with tiles of baked clay, of rooms, large pieces of pottery and wicker baskets filled with what I took to be grain. Covered with dust and leaves, were skeletons in two of the rooms in which I could look.

"They apparently extended for miles, principally in the canyon of the Green River. Although the postmaster at Youghal and other settlers say they have noticed the unusual formations in the canyon, no attempts had been made to investigate because of the inaccessibility. I saw no trail or any sign of ingress."

Mr. Loftis gave Professor Jeancon and the State Historical and Natural Society a list of names of men who know of the ledge.

The other discovery is reported from the Escalante Forest, southwest of Grand Junction. Huge mounds that heretofore have been passed by as natural formations, scores of them, are said to contain evidences of houses and temples, such as have been uncovered in the Mesa Verde.

Early in November one of the mounds was opened when a ranchman started to build a dug-out for the storage of potatoes. He came across pottery of a high glaze and artistic design.

Both the finds have been reported to Washington, and will be investigated.

"This more than ever confirms the statement that Colorado is the cradle of this ancient nomadic civilization and that intelligent work will uncover ruins and relics of incalculable value to science and history," said Professor Jeancon.

Boston Architectural Club News

The Club has organized a drive to raise money to house the Robert S. Peabody library. Their leaflet tells the story in every detail, and follow-up work by members soliciting contributions is under way. This marks a very important epoch in the life of the Club. The new room will be a memorial to the club members killed in the war.

The B. A. C. Annual will deal this year with current work, and a very varied and worthy collection of drawings and photographs has been secured.



GENERAL VIEW OF SHAFT AND CRUSHER HOUSES

Engineers and Architects in Artistic Collaboration

The Shaft Houses at Ishpeming, Mich., Conclusively Proving the Satisfactory Results That Ensur in Well Conducted Team Work

By ARTHUR T. NORTH

JUST at this time, when there has been a controversy in the engineering press, somewhat acrimoniously conducted, as to the relationship between architects and engineers when these two professions combine on the one structure, it is extremely gratifying to be able to present so notable an example of just what architects and engineers can accomplish when harmoniously inter-related as in the present instance of the shaft houses at Ishpeming, designed by Condron Co., engineers, with George W. Maher, F. A. I. A., acting as consulting architect.

Through constant association certain things become accepted and approved. This applies to buildings as well as to any other activities, for building types are usually the result of well formed habits in designing. And it is through indifference born of constant association that architects are prone to give but little time to structural or engineering design, when, if they showed the proper interest and a well developed spirit of co-operation, they might, as in the present instance, aid in transforming a most commonplace structure into one of decided architectural merit.

Such a condition is inherently wrong, for every building, no matter what its purpose, has a right to some measure of beauty, and having this right, it

should undoubtedly receive it. The traveler through the mining regions of this country has undoubtedly been impressed with the sheer ugliness of the shaft houses that rear their awkward heights over fields already homely in their appearance through the litter and debris that always surrounds mining locations. The variance in the requirements of these shaft houses is so small that they assume almost identically the same characteristics of unsightliness no matter what the type of mining may be.

These structures have been designed by the structural engineers, the urgency of whose tasks has been so great that they have been erected simply to serve expediency and no effort for sightliness has been attempted. The mines of the Cleveland Cliffs Iron Co., at Ishpeming, Mich., have been in operation for more than thirty years, and from present indications they have even a longer life ahead of them. Two principal shafts occupy this area and these are 820 feet apart. The shaft house or head frames that top them are prominent and have been until recently unsightly features of the landscape. The early structures were made of framed timbers, sometimes enclosed with corrugated iron. Through the stress of hard usage and the deterioration incident to exposure to the elements the frames became loosened, decayed,

THE AMERICAN ARCHITECT

vibrating and deflecting excessively, and it was necessary at intervals to replace them.

MR. LUCIEN EATON, the engineer and superintendent of the mining company, in considering three plans for replacement, was impressed with the idea that, as in the present instance the mining operations might be looked forward to as cover-



A STRUCTURAL STEEL HEAD-FRAME

ing a long period, the shaft heads should be constructed of a more permanent material and determined that they should not be short lived structures. The three plans that Mr. Eaton considered were: first, to rebuild with wooden frames similar to those now in use; second, to erect a structural steel frame, or, third, a concrete structure. On considerations of the estimated costs it was shown that it would be uneconomical to rebuild of timbers and in the course of a few years be confronted with the same problem again. Structural steel was then considered, but as it was very costly and difficult to obtain in 1919, thereby creating a possibility of a period of delay in construction, it could not be considered. It was there-

fore finally decided to build these shaft heads of concrete. The conditions for the erection of a concrete structure were entirely favorable. Suitable gravel was available near the site, and unskilled labor plentiful, and for these reasons reinforced concrete could be used with considerable economy and the work carried forward in such a manner as would not interfere with the operation of the mines.

Sketches were accordingly prepared by Mr. Eaton for a concrete structure that would enclose the existing timber frames and support the beams and girders necessary to carry the main hoist and counterbalance sheaves. Mr. Eaton's sketches included plans, elevations and sections, but no particular study was

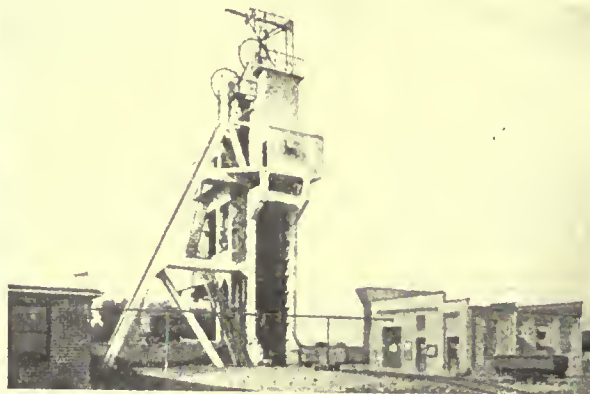

A TYPICAL CONCRETE HEAD-FRAME

made as to the general appearance of the finished concrete structure. When these plans were submitted to Condron Co., consulting structural engineers, for investigation and report as to the practicability and probable cost, and also as to the design and details of construction, this engineering corporation, with a



A—THE ORIGINAL DESIGN. C—DESIGN OF CONSTRUCTION ENGINEERS, RETAINING THE RECTANGULAR TOP. D.—THE RESTUDIED DESIGN WITH SQUARE TOP. SEE OTHER PLATES FOR FINAL DESIGNS AS COMPLETED BY THE ARCHITECT

THE AMERICAN ARCHITECT

very proper regard for the architectural aspect of their work, prepared certain tentative designs with a view to improving the appearance of the shaft heads, and these studies in perspective they submitted to Mr. Eaton.

Reference to the illustrations will show the progressive steps made in the designing. The first step was to render a perspective based on the plans submitted. Closely housing the timber frame resulted in a superstructure of the pyramidal form. The engi-

tion, retaining the form of the structure as submitted to him. It will be seen that the well trained hand of the architect added that which made the structure one that suggests all the elements of good architectural design.

THE plan adopted consists of a base 35 ft. square and 28 ft. high, from which rises a truncated pyramid 55 ft. high, 33 ft. 6 in. square at the base and 20 ft. 6 in. square at the top. This in turn is



SHAFT HOUSE A, WITH CONNECTING CAR HOUSE ON THE FRONT
SHAFT HOUSES AT CLEVELAND CLIFFS IRON CO., ISHPERING, MICH.
THE CONDRON COMPANY, CONSULTING STRUCTURAL ENGINEERS
GEORGE W. MAHER, F.A.I.A., CONSULTING ARCHITECT

neers further developed this by changing the form somewhat and arranging the windows in a symmetrical manner. The rectangular plan was found to be unsuited to a structure of this type, and a design was prepared with a base square in plan. The outlines were well studied, allowing for the limitations of enclosing an existing structure and keeping the mine in constant operation. At this stage of the development of the design, Condron Company recommended to the owner that they retain George W. Maher, F. A. I. A., as consulting architect, to study the problem from its architectural viewpoint. This was done, and Mr. Maher rearranged the fenestration and designed a simple and effective scheme of ornamenta-

surmounted by a pyramidal cap 10 ft. 9 in. high. The total height is 93 ft. 6 in.

In a paper presented at the Lake Superior meeting of the American Institute of Mining and Metallurgical Engineers in August, 1920, by J. Ellzey Hayden and Lucien Eaton, the construction of these two shaft houses is described. In the January, 1921, issue of the Journal of the Western Society of Engineers Mr. T. L. Condron, M. W. S. E., Mem. Am. Soc. C. E., will also describe these buildings.

The actual construction work was started July 21, 1919, and both structures were completed December 11, 1919. During the last three weeks of that time severe cold weather was experienced, requiring the

THE AMERICAN ARCHITECT

utmost care to prevent the freezing of the concrete. The total cost of the two structures, including the sheaves, flooring, lighting, heating, tearing down the old frames, moving tracks, chutes, supervision and engineering was \$56,543.00, or \$32.51 per cubic yard of concrete. The cost of some of the more important items, reduced to a basis per cubic yard were: Gravel, \$2.17; cement, \$3.21; forms, \$11.84; mixing and placing, \$3.20; reinforcing, \$4.79. Less than \$50 was expended for dressing the exposed surfaces of the structures. Seventeen hundred and forty cubic yards of concrete were required and the building of

urday night, when it was necessary to stop the hoisting skip while pouring beams.

The aggregate for the concrete consisted of a gravel which was irregularly stained with iron oxide. As a result, the concrete has a variegated or veined appearance with different shades of brown, pink and grey. The effect is very pleasing and gives a distinct character to the surfaces. It is due to this fact that the structures have a charm and distinction that could not be secured with a grey concrete, uniform in shade. One of the greatest objections to concrete buildings is the dreary monotony due to the somber color of



SHAFT HOUSE B. HOUSE A IN DISTANCE

the forms and placing of reinforcing was done in seventy-seven working days, and fifty-five working days were required for placing the concrete. The foundation for one house was carried down to a depth of 26 ft., while that of the other was carried only to a depth below the frost line.

The engineers of the company estimated the cost of two steel shaft houses at \$85,000, exclusive of any loss of time in operation of the mine hoists occasioned by erection of the structural steel. On the basis of this estimate, \$28,500 was saved by building of concrete. During the construction there was no interference with the hoisting operations of the mines except for a period of four hours at Shaft A one Sat-

the material. The users of this material may well profit by introducing either variously colored aggregates, as in this case, or suitable pigments. An effect can be secured, by the nature of the process, which cannot be produced by any other material. The attractive feature of these effects will be due to the fact that they cannot be accurately predetermined and hence are natural.

The suggestion of Mr. Lucien Eaton, engineer and superintendent, to construct these buildings of concrete instead of steel or wood, and the broad-minded policy of Mr. G. W. Maher and Mr. M. M. Duncan, president and vice-president, respectively, of the

(Concluded on page 791)

Detail of a House in Litchfield, Conn.

(See reproduction of drawing by O. R. Eggers on opposite page)

THE carpenter-architects of the late eighteenth and early nineteenth centuries were very often men of much refinement of mind and undoubtedly the most skilful of craftsmen. While the dominating influences which controlled their work were those gained through knowledge of earlier English examples, they, it would appear, combined with such knowledge a cleverness of adaptation that stamped a certain originality on their own work.

The present illustration is a good example in point. Mr. Eggers has sketched this most interesting "bit" with his usual keen perception of architectural significance. It is a most interesting variation of an often-seen motive of design and will repay careful study.

The sense of domestic seclusion conveyed by this sketch is perfect. It suggests the type of house affected by the upper middle class during the early part of the nineteenth century. There can be no doubt but that houses of this character stimulated better ways of living and higher ideals of citizenship. After the Civil War there was undoubtedly a decadence of our domestic types of architecture which continued for many years. But today we may take comfort in the fact that the development of the country house, by architects in the United States, is reaching the highest dignity and exerting the same influence as did those of the period represented in the present sketch.



OLD HOUSE, LITCHFIELD, CONN.
THE AMERICAN ARCHITECT Series of Early American Architecture





The Architect and the Engineer

THE line of demarcation between the professions of architecture and engineering is impossible of definition when building construction is considered. This truth is becoming better understood by leaders of both professions who are sufficiently broad-minded to be above selfishness, envy and intolerance.

Building construction as constituted today partakes largely of engineering; structural, mechanical, electrical, heating and sanitary. These elements are of such importance that they must be handled by specialists trained and qualified to do the work. Few men with but an architectural training can successfully manage these details from personal knowledge and experience. It is therefore evident that engineering is an essential element of architecture. Believing this, engineers are not satisfied to surrender the complete control of building construction to the architect and in a very large and important measure they retain control. This insistence is admittedly to the detriment of good architecture.

It must be acknowledged that when architects do not give sufficient attention to the engineering elements that are involved in some degree in every structure the results are disastrous, because poor engineering affects the monetary value of the building through faulty construction and poor mechanical equipment, always expensive to maintain. These factors affect the financial return, the true measurable value, and are fully appreciated by architects experienced in large undertakings. It is true that a building well constructed, heated, lighted, with adequate elevator and sanitary equipment is habitable and serves as a satisfactory housing for its intended purpose. Without these qualities the structure is useless and therefore valueless.

But when to this is applied an artistic design both for interior and exterior treatment, the value is doubled because the simple addition of beauty in form, color and materials compels satisfaction and enjoyment and a certain pride in that possession of the ability to see and enjoy even without actual possession of the property. It being impossible to de-

limit the function of the architect or the engineer in building construction of major proportions, it would appear that co-operation and collaboration, sincere and unselfish, is the only rational relationship. It is a most pleasing and promising development when such relationships develop and always to the advantage of architecture.

A case in point will be found in the article and illustrations of shaft houses at Ishpeming, Mich., to be found in this issue.

A New Effort to Unionize Draftsmen

ORGANIZED labor has again departed from its legitimate field and is seeking to invade the ranks of professionalism in its effort to unionize the draftsmen in the offices of architects and engineers. The demand which practically amounts to a threat was recently made on the General Contractors' Association of Newark by the Building Trades Council of Newark, N. J., that the Contractors' Association use only plans made by union draftsmen or engineers. This demand was to the effect that after November 1, 1920, union labor composing the building trades council of Newark would do no work on new buildings or other structures for which the plans were not made by union draftsmen or engineers.

When this unionization of draftsmen was first broached by the leaders of labor unions, the American Association of Engineers with its usual promptness and decisiveness pronounced the advocacy of trade union methods by any of its members as a cause for expulsion. While no similar action has been taken by the architectural profession, it would seem as if it should align itself on this principle and thus let it be clearly understood that the professions of architecture and engineering would not submit to any outside domination of its members and would continue as in the past to regulate their affairs through their duly constituted associations. When now more than a year ago the matter of unionizing the draftsmen was taken up in the middle west, it was found then as it has recently been found

in Newark, that the draftsmen almost to a man were opposed to affiliation with any form of unionism.

The General Contractors' Association of Newark have announced that they will continue to use plans made by non-union men and it will therefore be interesting to watch the result of this action as indicating to just what extent organized labor is disposed to press for the extension of its principles into fields in which it is justly believed they have no right to interfere.

Again the "Artist"

MR. JOHN W. SIMPSON, President of the Royal Institute of British Architects, in an address recently delivered before the Institute, accentuated the position of the architect as an artist, and failed, according to criticism expressed in the London architectural press, adequately to acknowledge the importance of the architect's many activities that are of the utmost practical and businesslike nature.

The Architect, referring to this address, states that it objects to this over-accentuation of the artist's side of architectural practice as likely to give rise to misconception.

The main reason for this objection is that in the too free use of the word "artist" there is likelihood of misconception. "for an artist may be described in popular parlance as one who does work which—whatever its merits may be—is not practical." *The Journal*, pursuing this line of thought, contends, and rightly, that an architect's work must be practical, and if it fails in so being it does not fulfill its primary function.

"That architecture is a great art," states *The Architect*, "is the common knowledge of those who know anything about it, but, like fundamental and self-evident truths, it is not necessary to insist on it any more than we need constantly insist upon the rotundity of the earth. Again, the greater contains the less, and the less is but a part of the greater, and the term architect is, therefore, greater than that of artist, and conveys a deeper and fuller meaning."

In the foregoing we have a clearly expressed statement of the exact position of the architect as an artist. We find that the primary function of architecture is in the art of *practical* building.

NO one may successfully refute the claims of architects to be classed as artists, but what lessens the value of such a title is the tendency of some members of the profession and some of its publications, to press the claim for the title and ignore the practical elements of the architect's work.

It is unfortunate, and true that to the average mind the word "artist" conveys no other meaning than an attitude of visionary impracticability. And, it is the hard-headed practical man who is, as a rule, the client. While he may have great respect for art, as he understands it, he generally understands that those who practice art are poor business men, and, as his money has been acquired by the most strenuous and practical effort, he may be pardoned if he hesitates to trust its expenditure to one who so insistently "plays up" the art side of his profession, and neglects with obvious intention to demonstrate his business ability.

Before the war, at the time this journal first began the discussion of this phase of architectural practice, it would have been impossible to have secured a patient listener to these arguments. Since then there has been printed in these columns letters from men high in the profession, endorsing this attitude. And now, we have from the ultra-conservative English architectural press, a criticism of the president of the Royal Institute, and the expression of a belief that is in entire concurrence.

The Architect is exactly right that it is no more necessary to state that the architect is an artist than it would be to remark that the earth is round. If architects insist upon being called "artists" they will have no one to blame but themselves if they are taken solely at their own valuation, and find themselves ultimately engaged only on the artistic aspect of building construction.

IN a certain section in New York to be largely occupied by the garment making trade there are no less than twenty major building operations now in progress or nearing completion. We are unable to find a single instance where architects have been retained, work being carried forward by the owners own temporary building organizations. These operating companies have proceeded entirely with only such architectural assistance as might be furnished by architectural employees on their pay rolls. The obvious lesson this teaches lies in the evident refusal of groups of keenly developed business men to acknowledge a like attribute in architects.

Engineers and Architects

(Concluded from page 787)

Cleveland Cliffs Iron Company, in recognizing the value of an aesthetic treatment of these designs, deserves the highest commendation. Instead of erecting the usual unsightly headframes, dominating the city of Ishpeming, there now stands two monumental structures, simple, dignified and imposing.

It is fortunate that the designers of these structures were not obsessed with a devotion to classic detail or precedents and attempt to apply them to this project. They did design in a common sense, rational and natural spirit, resulting in a most happy and successful conclusion. Unfortunately these structures are so located that they cannot be studied conveniently in the field, and it is hoped that this presentation will receive the attention it deserves.

Another instance of aesthetic design applied to an engineering structure is that of a coal unloading and storage plant on the East River, New York City. In this case, Mr. Charles Houchin Higgins, Mem. Am. Soc. C. E., developed the contractor-engineer's plans in much the same way Condron Company did. The result is worth studying from both sides of the river. Although readily accessible to a large number of architects and engineers, it has not been given the attention it so richly deserves. It is, nevertheless, gratifying to be able to call attention to these two instances of a departure from the unsightly head house and coal bunker to buildings of structural and aesthetic merit. These instances also indicate the *rapprochement* between architects and engineers, which is sure to increase because it is natural, necessary and holds great promise for future American architecture.



SHAFT HOUSE A AS SEEN FROM SHAFT B

THE CONCRETE NEW EIGHT HOISTING CABLE LEADS OUT OF AN OPENING IN THE WALL NEAR THE HIGH DOUBLE WINDOWS, AND THE MAIN HOISTING ABOUT TEN FEET ABOVE THE GROUND. BOTH CABLES RUN OVER A SUPPORTING FRAME WORK TO ELECTRIC HOISTS IN THE POWER HOUSE BETWEEN THE SHAFT HOUSES

Criticism and Comment

A Communication from Burt L. Fenner

The Editors, THE AMERICAN ARCHITECT:

On reading in your issue of November 24th, what purports to be my remarks in opening the discussion of "Housing" at the recent meeting of the New York State Association of Architects, I was first amazed, then chagrined and then amused. I take no exception to the first two paragraphs, but in the next paragraph I am made to say that "fundamentally I believe it (the present housing situation) to be due to transportation and finance," and a little further on. I am quoted as proposing "car priorities for the shipment of materials and pressure exerted on the banks to induce or force them to lend for building purposes." In almost the next sentence, I am made to say that the system of building for profit has failed, which latter proposition is a direct negation of the former.

As a matter of fact, I said none of these things. I referred to priorities in shipments of building materials as one of the many perfectly futile remedies which have been advocated by various committees and commissions. I made it quite clear that I do not favor any attempt to force the banks to loan their depositors' money on housing enterprises, which, unfortunately, are generally of a highly speculative nature.

I do believe that the old machine, which began to creak many years ago, suffered a complete breakdown under the pressure of war time conditions. I believe that ultimately we shall have to devise a

new machine through a long, evolutionary, not revolutionary, process, and I expressed the hope that, in the meantime, the old machine may be patched up in order that production may not entirely cease.

The proposition that the old machine has broken down because it was based on the system of *building for profit*, was advanced by the special committee appointed to draft the resolution. I took the floor in strenuous opposition to this theory and stated my belief that it was the *abuse* of the system by the shoe string speculator, rather than any inherent weakness in the system of conducting business for profit, which was in large measure responsible for present conditions. I stated my belief that if the system of building for profit were unsound, the same thing would be true of the mining of coal, the operation of railways and the making of shoes.

The preamble to the resolution, as offered by the committee, was a camouflaged version of the socialists' theory that what they call the "capitalistic" system is the cause of our housing troubles and of all other ills from which the world is suffering. To that theory I do not subscribe.

Architects sometimes bewail the fact that they do not enjoy the confidence of the public to the extent which they consider to be their due. Less hysteria and more horse sense might contribute to that desirable end.

My purpose in writing this letter is, not to engage in a controversy, but to ask you to correct statements wrongly attributed to me.

BURT L. FENNER.

New York.

The American Specification Institute

IN THE AMERICAN ARCHITECT, issue of Nov. 17, there was printed an editorial outlining the proposed formation of an American Specification Institute. The end it was sought to attain by such an organization appeared so very desirable that the editors of this magazine believed they would be rendering an important service by as far as possible encouraging this effort.

It is gratifying to learn through a series of letters from readers in every section of the United States, in response to this editorial and inquiries made, that a Specification Institute as proposed would perform a service of great value to the profession and the public by increasing the efficiency of practically every building operation.

Following are extracts from a few of the many letters received.

* * *

Upon thinking over the subject of discussion in the leading editorial of your issue of November 17, I am impressed that no vocation has greater claims for technical and scientific preparation than that service required in producing architectural specifications. Yet the writing of specifications is generally looked upon as a service of secondary importance and is often performed in a haphazard manner.

This vitally important instrument is prepared in most offices by the inside member of the firm or head of the draughting department by piecemeal, under the stress of directing the draughtsmen, meeting call-

THE AMERICAN ARCHITECT

ers, keeping the typist in copy, during the "march to goal"; or, in instances, an old set of specifications, selected to fit the job, is thrown into his handbag by the outside partner and he prepares the "copy" while traveling to an out-of-town engagement.

In the preparation of architectural specifications it is principally the selection of materials and the requirements upon labor that are set forth, and these writings should be done with accuracy, conciseness and simplicity so as to form a bulwark for protection of the owner and so square with the rights of the contractor that no objection could be found by him to binding himself, his heirs, executors and assigns by a contract of which such a document was a part; the general sections, the legal clauses—these, one and all, are factors, often intricate, always vital to the interests of the parties to the contract.

Now to produce such a document, worthy of binding the fortunes of owner, contractor and architect, requires a mind adapted for such intricate research, scientifically trained and judicially poised; equipment for this service should be equal to that of any other profession, and it seems clear, from this reasoning, that "The American Institute of Specifications" has come to birth at the opportune time.

CHARLES EDWARD CHOATE.

Atlanta, Ga.

* * *

We have read with much interest the editorial of November 17, and in which the subject is covered in a comprehensive way, and have also discussed the general plan with our specification writer, who is deeply interested in the project. . . .

We realize the value of comprehensive specifications. Our specification writer devotes his entire attention to that subject, and his work is thorough and has received much favorable mention. . . .

We gather from your paper that you suggest limiting the membership of the Institute to those who employ a special specification writer, hence to the larger operators whose knowledge and experience is well worth while.

This is quite in line with our ideas and we shall be glad indeed to contribute in every way to the success of such a project, while we would not be particularly interested in a project which is purely educational or academic.

We believe that much can be accomplished in this way, taking for example the general conditions of a specification which are most important, we use printed forms which we have compiled largely from those adopted by the American Institute of Architects, in which, however, we have made numerous changes, and still more changes occur to us from time to time.

We believe that a committee of experts could get together and in a short time formulate a "once for

all" set of conditions which would be complete and nearly perfect.

These general conditions are necessarily voluminous for the protection of the client, but as we frequently explain, they are intended only for wicked contractors, while those who are upright and who expect to carry out their obligations need not even bother to read them.

My view is that the general conditions should be written not particularly or solely in the interest of the architect or client, the reason being that contractors, like the "poor" are always with us, and to treat them fairly will best serve the interests of future clients.

We think also that specific branches of the work can, in a large measure, be standardized, and that trade names for materials, which convey the idea of specific preferences be, so far as possible, eliminated.

Good specification writers must be men of research. They should know of their own knowledge the things of which they write, and this research can, without a doubt, be very much shortened by the interchange of ideas and experiences which would come about in the natural process of such an institution as you have in mind.

THE WEARY AND ALFORD COMPANY.

Chicago, Ill.

* * *

I have read your editorial of November 17 and am emphatically in favor of any move which will tend to improve the quality and lessen the labor of producing architect's specifications.

I personally find the writing of a specification the most arduous and least grateful of any work in connection with our profession.

Many efforts have been made in the past and suggestions have arrived from many sources looking to the improvement of these conditions. Several chapters of the Institute have appointed specification committees, but so far nothing has "arrived."

If you, through a Specification Institute, or any other method, can supply this much needed help, you will have earned the enduring gratitude of all architects.

THOMAS L. ROSE,
Kirchhoff & Rose.

Milwaukee, Wis.

* * *

It is my opinion that the average specifications now produced is not equal in many ways to the working plans they accompany, and when it is remembered that by the terms of practically every contract in case of dispute the specifications take precedence over the working plans, it will be at once obvious that no architect can be too careful in the preparation of specifications. It is my opinion that

THE AMERICAN ARCHITECT

more disputes arise over the interpretation of specifications than over the reading of plans. I think your plan worthy of the support of the profession.

F. E. DAVIDSON.

Chicago, Ill.

* * *

Generally speaking, I am in entire sympathy with your editorial of November 17 on architects' specifications. Builders, estimators and material men have for years spoken with derision of the majority of such specifications and rightly so. I believe the practice of taking an old specification, crossing out, interlining, and then handing such a mutilated document to a stenographer, with only this much information to write the specification on a new job, is altogether too common.

To suggest a cure for this, applicable to all specifications, is not easy. I believe that the type of the building in hand must dictate the character of specification required, carrying descriptive paragraphs or not, depending upon individual instances. I do not think one form of specification that may be gotten up will be generally applicable. References to checking lists such as the one given in the back of your 1920 Specification Manual, are valuable reminders. I am not prepared to say how the "American Specification Institute" should go about its task. It will be of interest to watch the development of their problem.

ARTHUR WOLTERS DORF.

Chicago, Ill.

* * *

In our opinion, the facts generally set up in your editorial of November 17 are undoubtedly true. Specification writing is apt to be the bugbear in the architect's office, and there seems to be a great shortage of men properly trained to do this sort of work.

It is almost impossible for the principal in an office carrying on any volume of business to keep himself in a frame of mind to do this work properly, as it naturally requires concentration, which in

turn means that the specification writer should be free from disturbance of any sort.

Every office will, of course, work this problem out in a way best suited to fit the personnel of the organization, but we feel that the specification writing could undoubtedly be very much improved by the assistance that you propose in your editorial.

MILLS, RHINES, BELLMAN & NORDHOFF.

Toledo, Ohio.

* * *

I am heartily in favor of the organization of American Architects' Specification Institute. It is true that there is nothing in the architectural profession which is more lacking than a comprehensive specification, which in my opinion is due to the lack of practical experience on the part of an architect, and no doubt a Specification Institute will be a great benefit to the profession and naturally to the client.

BROWN & VON BEREN,

Per F. Von Beren.

New Haven, Conn.

* * *

Your editorial on the American Specification Institute cannot fail to interest every architect. . . . The specification is so intimate a part of the architect's work that the man who designs, the constructor and the technician must all take their share in it, and the building is the gainer in proportion as the elaboration of the specification is in the hands of men who have most to do with creating the building, rather than when it is treated as a thing as much apart from a building as some architects are inclined to treat the pure engineering. But a specification manual is something we have all been dreaming about for years but have never had the time nor the courage to undertake. If you, or the Specification Institute can evolve such a thing as that and keep it up to date by some simple process, you will earn the gratitude and thanks of every architect, and thousands of builders who now suffer by imperfect specifications will rise up and call you blessed.

C. H. BLACKALL.

Boston, Mass.

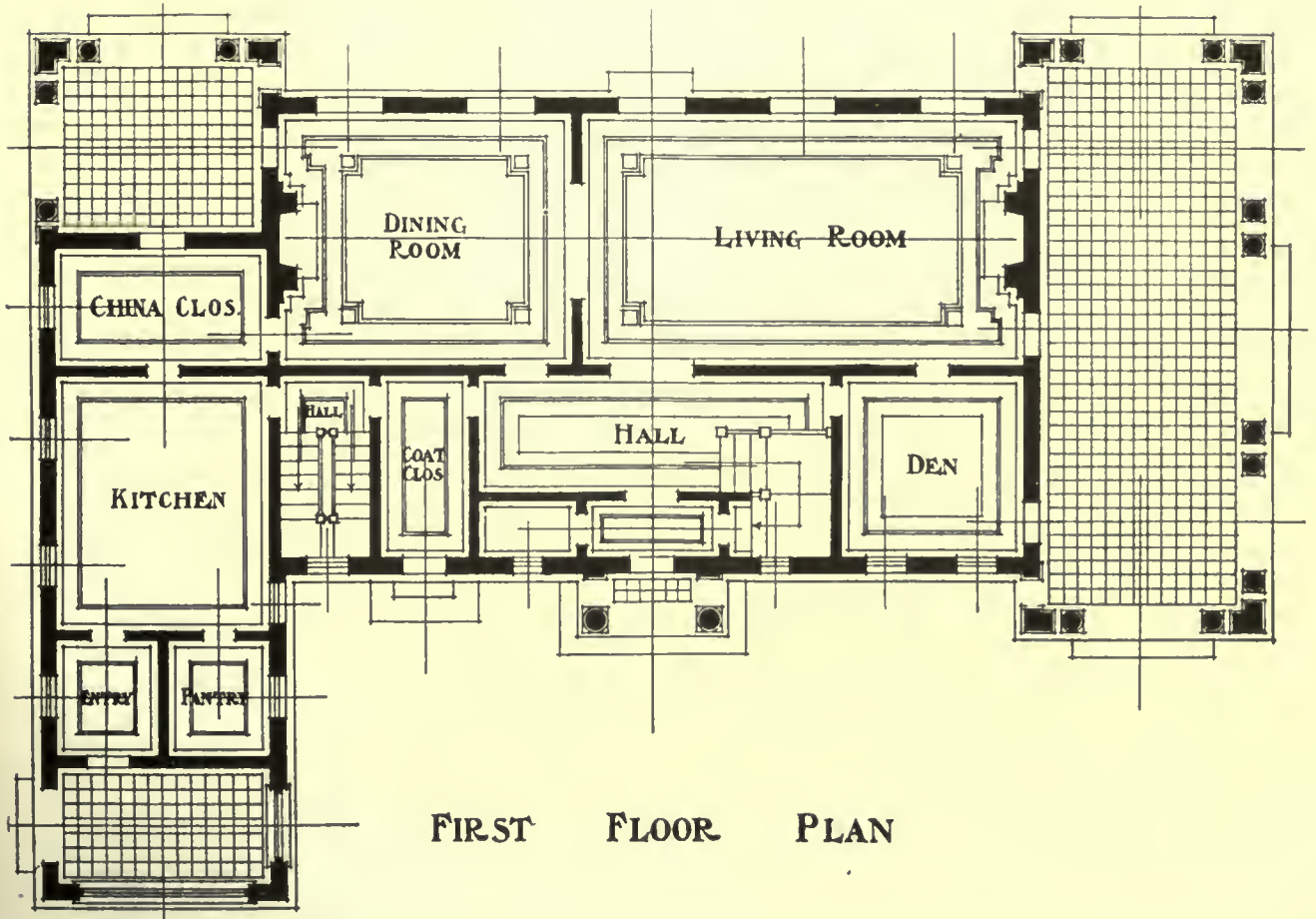

HOUSE AT WILLIAMSTOWN, MASS.
JAMES PURDON, ARCHITECT

799



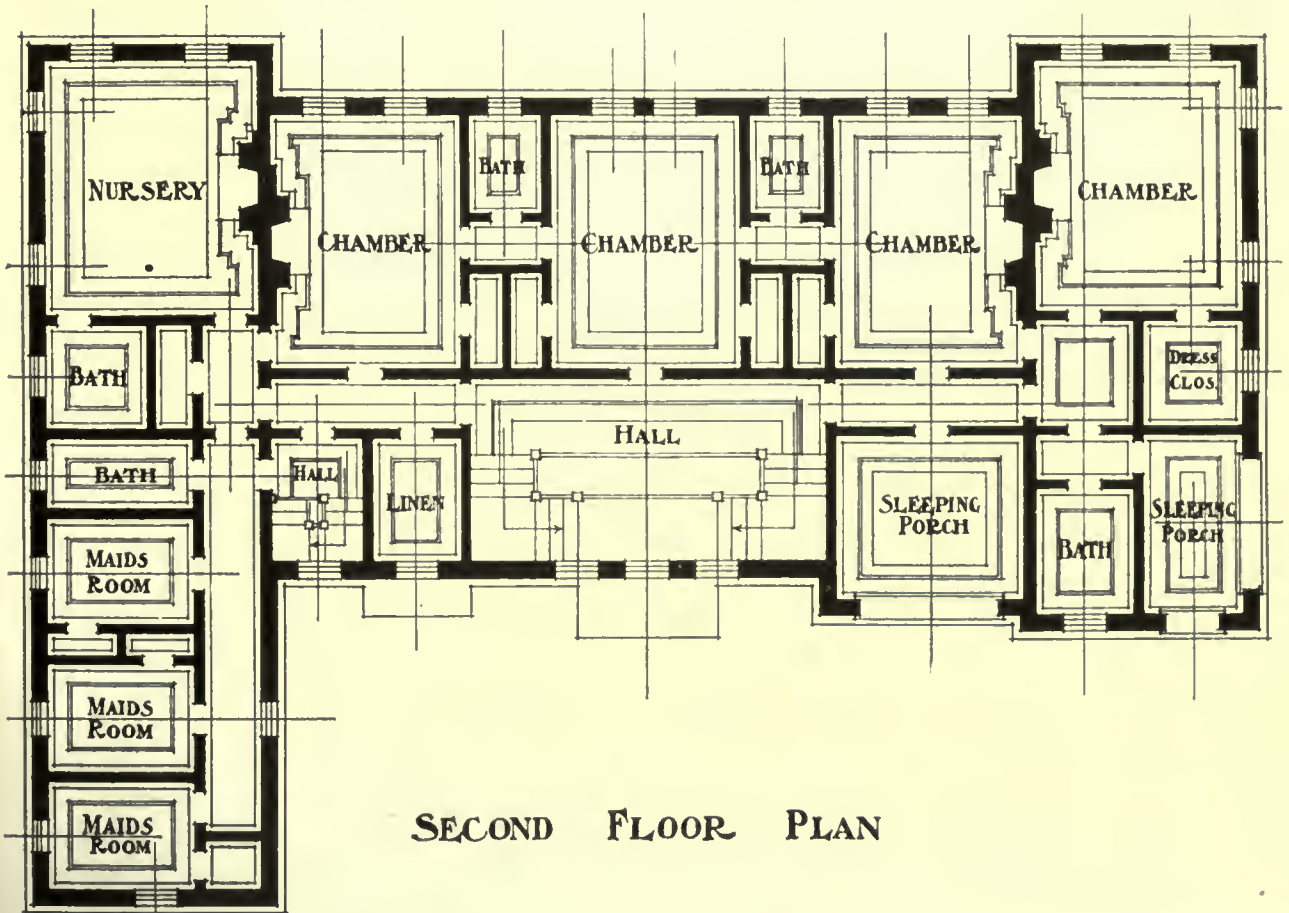

SECOND FLOOR PLAN

HOUSE AT WILLIAMSTOWN, MASS.
JAMES PURDON, ARCHITECT

794²





HOUSE AT WILLIAMSTOWN, MASS.
JAMES PURDON, ARCHITECT



794³





DINING ROOM



LIVING ROOM
HOUSE AT WILLIAMSTOWN, MASS.
JAMES PURDON. ARCHITECT

794⁹





HOUSE OF G. I. TAGGART, SAVANNAH, GA.
OLAF OTTO, ARCHITECT

794





STAIR HALL.



LIVING ROOM

HOUSE OF G. I. TAGGART, SAVANNAH, GA.

OLAF OTTO, ARCHITECT





DINING ROOM



SUN ROOM
HOUSE OF G. I. TAGGART, SAVANNAH, GA.
OLAF OTTO, ARCHITECT

7967



DEPARTMENT OF ARCHITECTURAL ENGINEERING

Foundations—Their Selection, Design and Construction

Part V—The Pneumatic Caisson Foundation

SELECTION of the pneumatic caisson foundation as the proper one for any building is usually made as a result of the existence of two conditions which, occurring together, render the use of other types of foundations extremely difficult if not impossible. These conditions are (a) extremely

restricted. Within its field, however, it is indispensable and the construction of our skyscrapers in certain sections would be impossible without resort to its use. Briefly stated then, pneumatic caisson foundations should be used for buildings in which it is desired to eliminate all possibility of settlement, no



COMMENCEMENT OF FOUNDATION WORK ON THE BARRETT BUILDING, NEW YORK CITY
 Note cutting edges with vertical reinforcement (at left) in place for circular caisson construction

heavy loads to be supported and (b) the presence of firm strata such as rock or hardpan only at a considerable depth below the ground water level. Due to the greater cost of construction and the necessity for using the pneumatic caisson foundation only under the existence of conditions unfavorable to other types, the use of such a foundation is somewhat re-

stricted. Within its field, however, it is indispensable and the construction of our skyscrapers in certain sections would be impossible without resort to its use. Briefly stated then, pneumatic caisson foundations should be used for buildings in which it is desired to eliminate all possibility of settlement, no matter how small; where the depth of rock or hardpan at the site of the proposed structure is very considerable, and the character of the overlying strata is such as to render the use of spread footings impossible; where a large quantity of ground water is present and the presence of heavy adjoining buildings requires an absolutely safe and certain method

THE AMERICAN ARCHITECT

of carrying the foundation piers to rock or hardpan.

In addition to the foregoing, there are other factors which often make the selection of the pneumatic caisson foundation desirable. With mechanical ventilation and artificial illumination, basements and even sub-basements have been found to possess a value as

four stories below grade; the U. S. Assay Office, recently damaged by the Wall Street explosion (see THE AMERICAN ARCHITECT of October 6, 1920, page 441); the Morgan bank building opposite the Assay office which has three stories below grade; the Seaboard Bank Building (see illustrations) and for

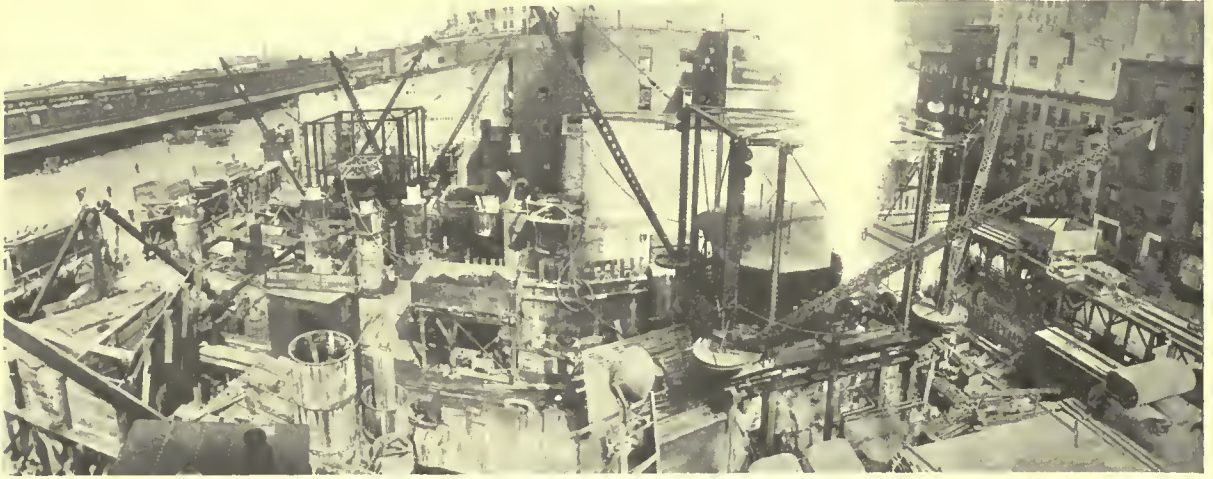

LATER VIEW, BARRETT BUILDING, SHOWING A NUMBER OF CIRCULAR CAISSONS IN PROCESS OF BEING SUNK

rentable space, whereas formerly their use was limited to the heating plant and other mechanical equipment necessary to the proper maintenance of the structure, and for storage purposes. However, if an entire basement can be rented at an attractive figure, it may prove economically advantageous to construct a sub-basement to house the mechanical equipment. The present-day use of the basements of large buildings for restaurants, barber shops, etc., is well known. In the case of large banking institutions a very considerable space below the curb level is necessary for safe deposit vaults, and even where only a small portion of a large building may be occupied by such a banking institution, the need of vault space must be met. Therefore, since in many buildings the construction of three or four stories below the surface of the ground may be necessary, thus requiring retaining walls of enormous strength to resist the exterior pressure which in such cases is liable to develop due to quicksand and water, the desired result may, in such a case, be accomplished by supporting the wall columns on comparatively long and narrow rectangular pneumatic caissons sunk very close together, end to end, and afterwards joined so as to form a continuous wall enclosing the site of the building and carried down through the water-bearing stratum to rock or hardpan.

Such construction was used in the 31-story Bankers Trust Building, New York City, in which there are three stories below the curb level; the 27-story American Telephone & Telegraph Building with

a section of the Barrett Building, illustrations of which also accompany this article.

In general, where the soil conditions are such as outlined above, the pneumatic caisson method for building foundations is also the most economical method for column loads of about 700 tons or more, and it may be often found advisable to use this

DIAGRAMMATIC PLAN OF FOUNDATIONS, BARRETT BUILDING, NEW YORK CITY

Washington Street wing enclosed by wall of rectangular caissons

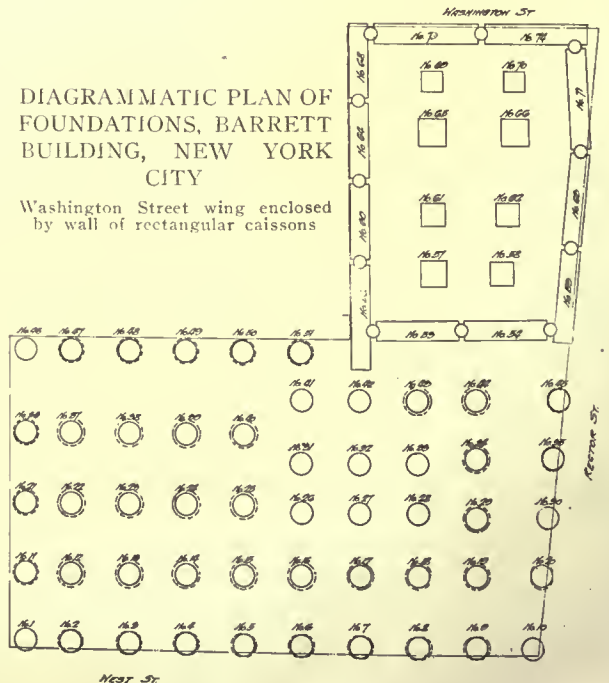

method for even smaller loads, when the cost and the importance of the building justify a greater expenditure of money for the foundations in order to insure absolute stability.

into the hardpan, and the excavation may then be carried down to rock below the cutting edge if required, as shown in Fig. 1. In this case the excavation area below the cutting edge may be increased, or in other words the caisson may be belled out to a greater bearing area in the hardpan or on the rock. Such construction is illustrated in Fig. 2.

It is in this way often possible to use a smaller caisson than would be necessary if based on the bearing capacity of the soil under the caisson in cases where this is less than the compressive strength of the concrete. The size of the caisson is then determined by the bearing area required under the grillage, allowing about 6 in. outside of this area for possible inaccuracy in sinking.

The weight of the caisson itself, although often considerable, is not included in determining the load on the bottom since the friction between caisson and soil will more than counteract the weight. In fact the caissons will have to be loaded during sinking in order to get them down to the required depth, and in sinking a small caisson the piling of this load often proves quite a problem. It is mainly for this reason that the smallest caisson which it is practical to build is about 6 ft. 6 in. in diameter.

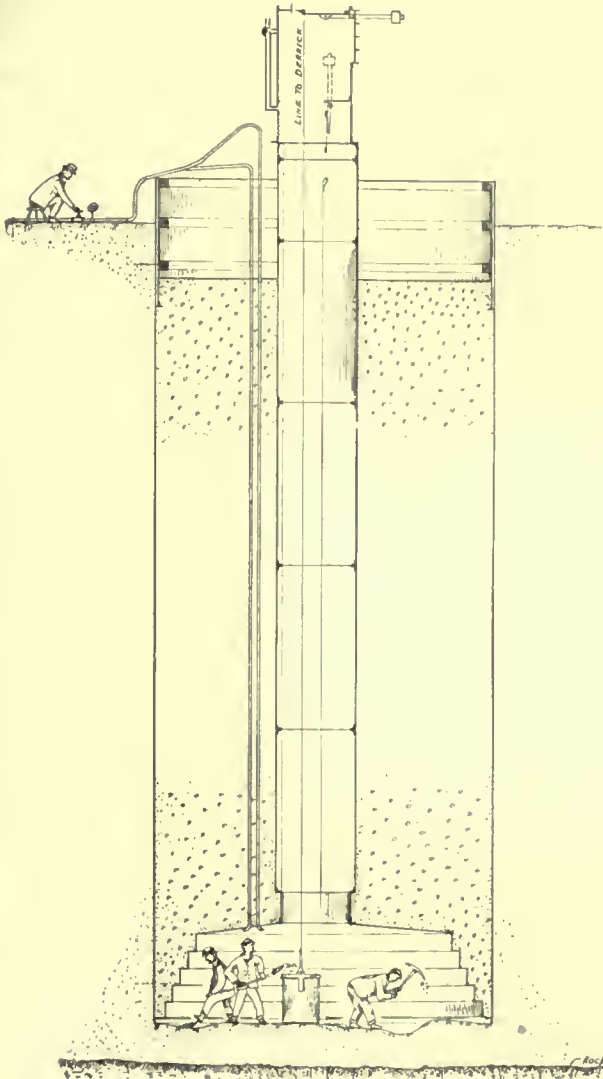

FIG. 1. TYPICAL SECTION SHOWING METHOD OF SINKING A PNEUMATIC CAISSON

The size of the caissons is generally governed by the bearing capacity of the rock or the soil underneath the caissons. The New York building code prescribes the following allowable loads per square foot:

	Tons.
Soft rock	8
Hardpan	10
Medium rock	15
Hard rock	40

Where there is hardpan overlying the rock it is generally sufficient to sink the caisson to such a depth that the cutting edge is carried from one to two feet

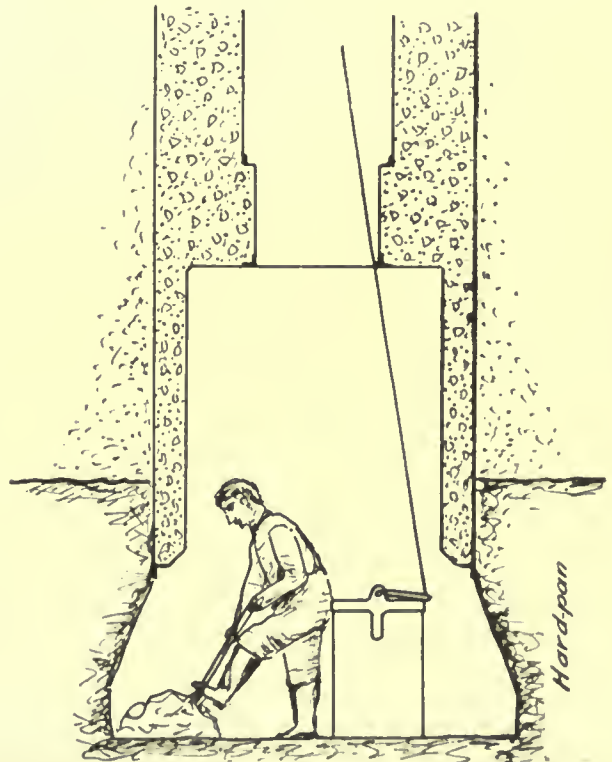

FIG. 2. WORKING CHAMBER OF PNEUMATIC CAISSON, SHOWING METHOD OF BELLING OUT AT BOTTOM AFTER CUTTING EDGE HAS PENETRATED SEVERAL FEET INTO HARDPAN

THE AMERICAN ARCHITECT

Caissons are now usually built entirely of reinforced concrete. The outside forms are either removed before sinking or they consist of a 2 in. tongued and grooved planking carried down with the caisson. The shaft-forms, through which the



EARLY STAGES OF FOUNDATION WORK, SEABOARD BANK BUILDING, NEW YORK CITY

excavated material is removed and the men enter and leave the working chamber, are made of steel and are collapsible, so they can be removed after the working chamber is filled with concrete.

In the sinking of a caisson the first step is to lay down the cutting edge. This is usually formed of steel angles and plates. The forms for the working chamber are then constructed, the necessary reinforcement placed and the concrete poured. The shaft forms and exterior forms for the next section of the caisson are then placed and this poured. The process of sinking is commenced by the men in the working chamber excavating the material uniformly within the area included by the cutting edge, and as this is removed through the inner shaft, the weight of the caisson causes it to sink. As the excavation and resultant sinking progresses, extra sections are added on top. When but a small section of the caisson has been poured, the weight not being great, must be very considerably supplemented by the piling of cast iron weights on top in order to overcome the skin friction between caisson and surrounding earth. As soon as the ground water level is encountered, further work must proceed under compressed air.

A type of air lock for work of this nature is shown in one of the drawings. The successive steps in passing through are illustrated. The air pressure increases with the depth below water level, usually being in the neighborhood of one pound (per square inch) for each two feet of depth. Since it is not possible for men to work under a higher pressure than

48 pounds, the depth to which a caisson may be sunk below the water level is limited to about 100 feet. At this pressure the men can only work for periods of 15 minutes consecutively, which, of course, makes such construction, when carried close to the limit of depth, quite expensive.

A record for rapid caisson sinking was made by the Foundation Company in 1906, when 87 caissons for the U. S. Realty Building and the Trinity Annex were sunk and sealed in sixty days, the last 57 caissons being sunk and sealed in only thirty days. These caissons extend to an average depth of 75 ft. below curb level.

Accompanying this article several photographs and a foundation plan of the Barrett Building, West and Rector streets, New York City, are presented.

This building is located on the old waterfront, North River, where the ground is filled in and a mass of old piles and timber cribs is buried to a depth, in some cases, of as much as 30 feet below street level.

The nature of the ground, more than the weight of the building, was in this case the governing factor in deciding on the type of foundation, and pneumatic caissons were selected as being the most suitable way of carrying the foundations through the buried timber construction to a safe bearing on good bottom.

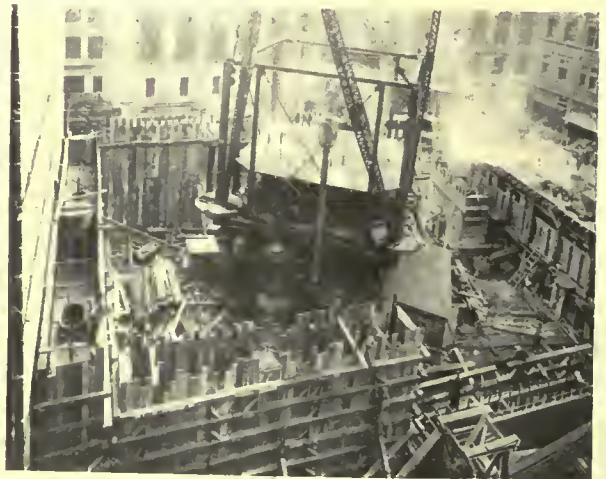

LATER VIEW, SEABOARD BANK BUILDING, ILLUSTRATING METHOD OF SINKING SERIES OF RECTANGULAR CAISSONS TO FORM ENCLOSING WALL

After caissons are sunk and sealed, entire interior is excavated to the desired level

Under the West and Rector street wing, 51 circular caissons were sunk to hardpan at an average depth of about 40 feet below street level, with some of the caissons belled out in hardpan to get sufficient area to carry the column load at 10 tons per square foot.

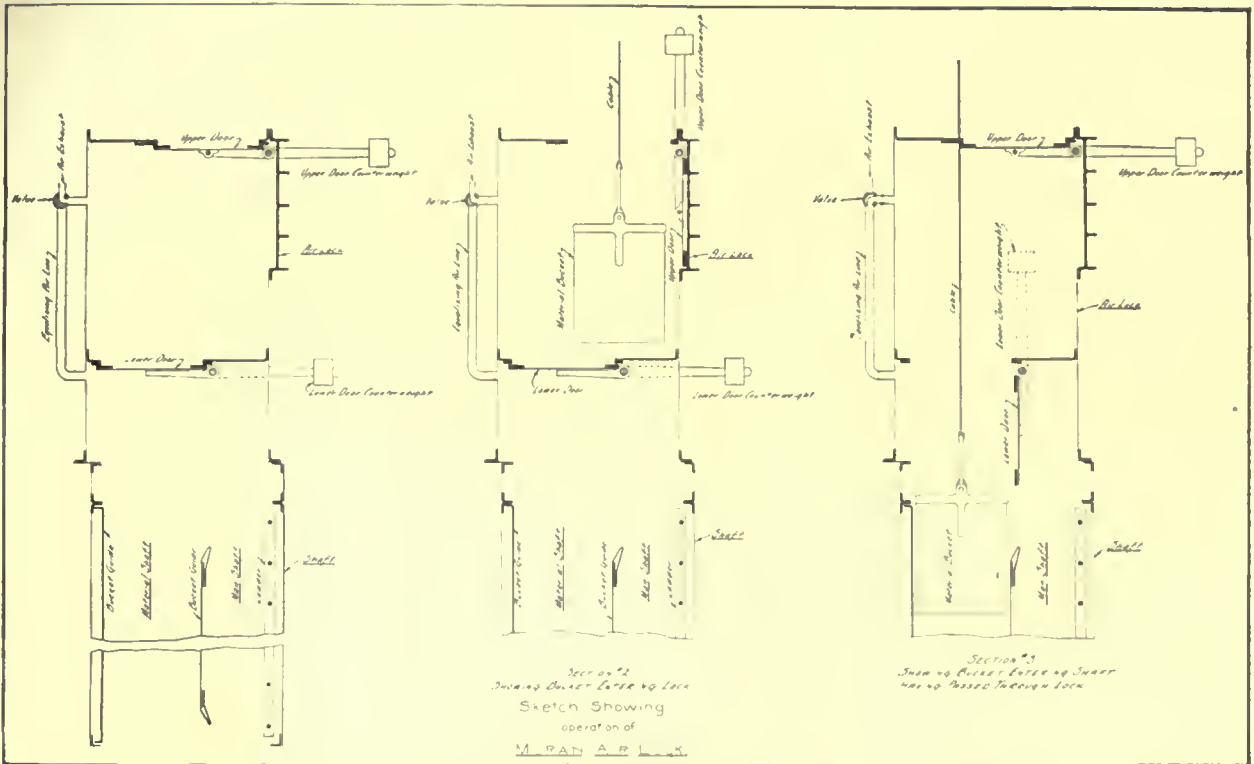

A TYPE OF AIR LOCK USED IN PNEUMATIC CAISSON WORK
 At left: Lock closed. At center: Lock open to outside, bucket entering. At right: Lock open to inside, bucket descending to working chamber

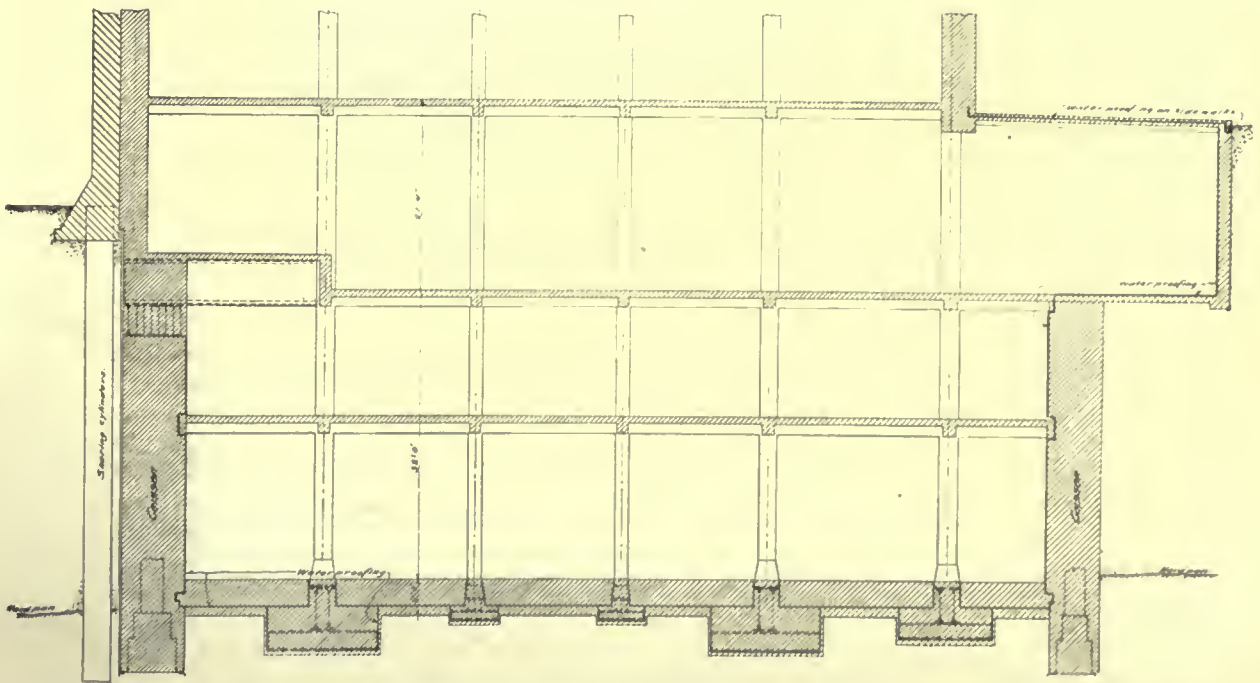

TYPICAL CROSS SECTION THROUGH SUB-GRADE STORIES OF A BUILDING, ILLUSTRATING USE OF CONTINUOUS RECTANGULAR CAISSONS JOINED TO FORM ENCLOSING WALL

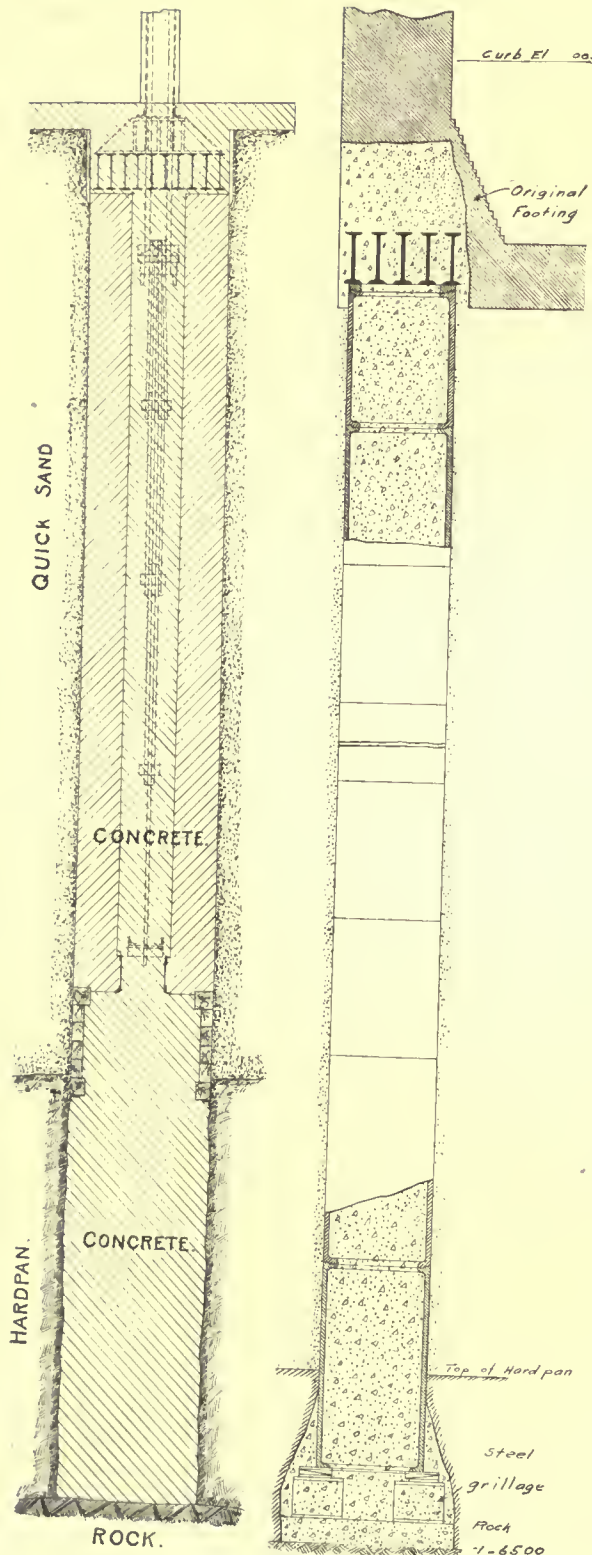

AT LEFT: METHOD USED IN ANCHORING COLUMNS TO CAISSONS, SINGER BLDG., N. Y. CITY

At right: Caisson construction used in underpinning foundations of an existing building

Under the Washington street wing, eleven pneumatic caissons were sunk. These caissons are long and narrow, joined together by the pneumatic process to form a continuous watertight cofferdam around this part of the lot, which is simplifying the excavation for the interior piers and the deep cellar required under this part of the building. The eight piers inside of this caisson cofferdam are sunk in the open in the ordinary way by using timber sheeting and bracing.

Engineers Discuss Transit Development

URBAN and Suburban Transportation for the Metropolitan District of New York formed the subject of a paper by Henry M. Brinckerhoff, associate of William Barclay Parsons, widely known for his connection with the construction of New York subways, presented at a meeting of the New York section, American Society of Civil Engineers, held November 17. This meeting was the second of a series of monthly gatherings arranged by William J. Wilgus, president of the New York section, to discuss New York City transportation and co-related problems.

The subject was treated in a most comprehensive manner by Mr. Brinckerhoff, and his talk was fully illustrated by charts showing the growth of population within the Metropolitan district during the past one hundred years, as well as the present means of transportation and the number of persons carried daily thereby. The Metropolitan district was taken as that territory included within a 20-mile radius of the Forty-second Street district of Manhattan. The Metropolitan area of New York for traction discussion may be taken as that outlined by the United States Census Bureau, inclusive of Paterson, Newark and Elizabeth on the west, Flushing and Far Rockaway on the east, and from Staten Island on the south to and including Yonkers and New Rochelle on the north. More subways, of course, are inevitable but, it was stated, these should be built as long-haul trunks and fed by the surface lines and buses. Thirty-five per cent. of the passengers in the Metropolitan district use surface electric cars today because they are the most convenient. A study of the needs of the Metropolitan district as a whole suggests the necessity for a combined system cheap enough in its outlying sections to permit of wide distribution of travel. Into lower Manhattan, i. e., below Fifty-ninth Street, or an area of ten square miles, there are daily poured over 2,000,000 people. This means almost doubling the population of the island. Judging from the fact that the resident population, as shown by the recent census, has decreased about 50,000 in the last decade,

THE AMERICAN ARCHITECT

the influx of daily non-residents is forcing the residents off the island.

The co-relation between transit development and growth of population in suburban districts was well illustrated by the charts. The difficulty of providing a well balanced system under present conditions was pointed out. Due to a large portion of the New York Metropolitan district lying within the state of New Jersey, no well co-ordinated scheme had so



SUGGESTED PLAN FOR DEVELOPING TRANSIT LINES IN METROPOLITAN DISTRICT

far been feasible. The real backbone of the transit system consisted of the elevated and subway lines, all terminating within the Greater New York City limits. The railroads take care of but a small proportion of the traffic and while the Hudson Tubes carry a considerable number of persons to and from New Jersey, this is slight when compared with the New York City subway traffic. The present New York City transportation system, supplemented by the additional lines now planned by the Public Service Commission will tend to develop further the territory east of the Hudson River, while wholly neglecting that large area on the Jersey side. Naturally it could not be expected that any system developed and financed by the City of New York would be planned to promote the growth of territory outside the city limits. This one-sided development was shown to have additional disadvantages, since practically all supplies necessary to feed, clothe and house the population on the easterly side of the Hudson River, came from the west, and had not only to be carried across the Hudson River, but also across lower Manhattan's congested streets and the East River, thus materially in-

creasing the cost to the consumer. Such transportation already forms a serious problem and by further adding to the population east of the Hudson, freight traffic conditions will become very serious indeed.

The solution proposed by Mr. Brinckerhoff would require the elimination of state lines, the constitution of the Metropolitan district into a separate political entity—a "forty-ninth state"—and a comprehensive plan providing lines of transportation to develop that territory on the westerly side of the Hudson River. The subway lines would take care of the long-haul traffic, and these in turn would be fed by the surface lines and buses. This would seem to be an ideal solution, but the changes necessary are so radical that it does not present itself for immediate relief.

Other speakers were D. L. Turner, Chief Engineer, Transit Commission; Frank Hedley, President and General Manager, Interboro Rapid Transit Company; P. H. Woodward, General Passenger Agent, Long Island Railroad; Delos F. Wilcox, Public Utilities Expert; George McAneny, formerly President of the Board of Aldermen, New York City; J. V. Davies, of Jacobs and Davies, Consulting Engineers; and Frank J. Sprague, Past-President, American Institute of Electrical Engineers.

Mr. Hedley, in discussing the paper, said in part: "Mr. Brinckerhoff has developed a very comprehensive and ambitious plan to furnish rapid transit facilities for people in the immediately surrounding districts of Manhattan Island. He suggests that we free our minds of our habitual ideas of New York as being Manhattan. That is easy enough for the purpose of Mr. Brinckerhoff's report, but it is extremely difficult to carry out in practice. Mr. Brinckerhoff's report is a study of what would be a good transportation system for the people in the vicinity of New York without reference to State lines or other physical barriers."

Mr. Woodward said the question of extending subway lines into Jersey was debatable and that many years would pass before such a plan was actually put into operation.

George McAneny asserted that a joint commission from New York and New Jersey should be appointed to study the development plan outlined by Mr. Brinckerhoff.

Engineering Data on Artificial Illumination

A SECOND set of Lighting Data Bulletins has just been issued by the Edison Lamp Works of the General Electric Company. This set consists of 9 bulletins as follows: The Lighting of Armories and Gymnasiums; The Edison Mazda Lamp for Stereop-

ticon Service; Calculation of the Lighting Installation; The Incandescent Lamp—Its History; The Manufacture of the Edison Mazda Lamp; The Lighting of Coal Mines; Medical Lighting, Including Hospitals and Dental Offices; Commercial Photometry; and The Lighting of Shoe Factories.

It is stated that additional numbers will be issued from time to time as the material is compiled.

According to the Department of Publicity of the Edison Lamp Works, a rather comprehensive program in the way of supplying engineering information on illumination has been launched by that company. Each bulletin is given an "L. D" number arranged consecutively. This indicates the order of appearance. An index number also appears, provided for ease in filing and maintaining related subjects in proximity. In brief the scheme of indexing is as follows:

The entire program is divided into five sections: Index numbers from 1 to 10 cover bulletins relating specifically to the lamps themselves. Index numbers from 11 to 30, cover general illumination questions. Index numbers from 31 to 60, cover interior, commercial and decorative lighting. Index numbers from 61 to 90, cover industrial lighting. Index numbers from 91 to 100, cover exterior and miscellaneous lighting.

As it is impossible to issue all numbers of a section simultaneously or in consecutive order, subjects which are most timely and regarding which the data is most readily available, are taken up in turn. It is anticipated that this series, when completed, will comprise a most comprehensive treatment of lighting practice. By this means of disseminating information in sections, it is possible readily to revise material which has become antedated and keep the series thoroughly up to the minute.

A container or desk file neatly finished in cloth of strong construction which is extremely handy, is available. This will be sent free of charge to anyone requesting it. For copies of these bulletins and container address Department of Publicity, Edison Lamp Works, Harrison, N. J.

Book Notes

ENGINEERING AND BUILDING FOUNDATIONS, Volume I. Ordinary Foundations, 4th Edition. Revised and Enlarged. By Charles Evan Fowler. Cloth, 6x9, 531 pp. Illustrated. John Wiley & Sons, Inc., Publishers.

In the preparation of a fourth edition of the author's treatise on Sub-Aqueous Foundations, it ap-

peared desirable to expand the work into three volumes, of which that bearing the above title forms the first. Due to the addition of much co-related and new material, including extensive data on building foundations, the title has been changed to "Engineering and Building Foundations," so as better to indicate the comprehensive scope of the data contained.

Volume I treats of the design and construction of crib cofferdams, pile driving, sheet piles, pile foundations, pier location and design, retaining walls and culverts. The author here sets forth information gained from actual experience with the class of work described. Valuable data is included on the type of machinery and contractor's plant required in the construction of piers and foundations. The various external forces acting on bridge piers are fully discussed in the chapters treating this phase, and methods of proper design of such piers given. The data on the bearing capacity of foundation beds is extensive and a valuable addition. The majority of the data in Volume I deals with bridges, it being stated in the preface that the methods used for building foundations have been covered in Volume II.

Railroad Snowsheds to Be Used As Motor Path

Ingenious plans whereby a smooth concrete auto road may be run for 33 miles through a difficult pass of the Sierra Nevada Mountains, and a great trans-continental railroad may acquire, at the same time, a system of permanent concrete snowsheds, have been completed by a western engineer. The design for the new snowsheds provides them with a continuous flat, walled roof, on which autos could run with the assurance that they would encounter no heavy grades or dangerous curves.

At the point under consideration, the track is paralleled, at an elevation of 5,000 to 7,000 ft., by the Lincoln Highway, which is blocked by deep snows for five months of the year. By transferring this link in the thoroughfare to the snowshed roofs, a little clearing work would enable autos to run practically all winter. Excessive first cost heretofore has prevented the construction of concrete snowsheds at this point, in spite of the large depreciation and fire loss on the present wooden structures. But with Federal and state aid on the highway part of the project, the burden of the railroad would be greatly reduced, and early construction encouraged. A large saving in maintenance costs would result for both.

Current News

Happenings and Comments in the Field of Architecture and the Allied Arts

Burt L. Fenner, President of the New York Chapter, American Institute of Architects, Called As a Witness in Lockwood Investigation

Resurrecting the contention advanced during a session of a Congressional committee in Washington seven years ago, that the American Institute of Architects is practically a trust, Samuel Untermyer, counsel for the Lockwood Commission, investigating housing conditions in New York, called Burt L. Fenner, president of the New York Chapter of the Institute to the witness stand on December 9th. Mr. Untermyer's attitude toward the witness and the comment in the daily papers on the testimony of Mr. Fenner, prove a deplorable lack of knowledge as to just what the Institute is and just what it stands for. The fault lies principally with the Institute itself. It has had ample time since the first imputation that the Institute was a combination of architectural practice, to clear itself and to educate the public as to the actual facts.

Mr. Untermyer's contention that the Institute is an architectural trust is based on various erroneous assumptions. First that it includes in its membership a majority of practicing architects, second—that its suggestions or advice is mandatory.

Mr. Fenner's testimony as reported in part in the New York daily press, is as follows:

Samuel Untermyer, counsel to the committee, undertook to show how the institute works to the detriment of building. He placed on the stand Burt L. Fenner, a member of the firm of McKim, Mead & White and President of the New York Chapter of the Institute. This chapter, Mr. Fenner said, comprises about 250 architects, and includes the most prominent members of the profession in the city.

It developed immediately that the institute issues a document which it calls the "Professional Practice of Architects," and which deals with the fees to be charged by all members.

SIX PER CENT. CHARGE IN THE CITY

"What is the per cent. charged for reconstruction in the City of New York?" asked Mr. Untermyer.

"Generally speaking, it is 6 per cent.," replied the witness.

"And in country work?"

"That varies all the way from 5 to 15 per cent., but these rates are not mandatory."

"We'll see about that," observed the counsel. "Let

me read you something from this Professional Practice of Architects, or code of ethics. It says, 'The architect's professional services consist of necessary conferences, preparation of preliminary studies, &c., for which, except as herein mentioned, the minimum charge, based on the total cost of work completed, is 6 per cent.' That is pretty definite, isn't it?"

"Yes," agreed Mr. Fenner. "It is what the architect believes he should receive for his services."

"And this is supplied to the members of the forty chapters throughout the country?"

"Yes."

"It also says here that it is proper to make a charge higher than 6 per cent?"

"Yes. It is necessary in order to keep out of the poorhouse."

"I don't think we will discuss the poorhouse. Now, it says that an architect is entitled to compensation for articles purchased under his direction, even though not designed by him. Is that another of the rules of the code of ethics?"

"No, I have the canons of the ethics here in a separate document."

COST INCREASED 200 PER CENT.

Mr. Untermyer read other rules and showed that the last revision had been made in 1908 when the cost of construction was much less than at present. In fact, the witness himself agreed that the increase had been all of 200 per cent.

"But the fees of architects remain the same, do they not?" asked the counsel. "That is, you have not decreased your per cent. in fees?"

"That is correct," was the response.

"But you get more money as you are paid according to the cost of the work?"

"The amount of the fee has increased in proportion."

The witness said he thought this fair, as architects' expenses have gone up with other things and building takes longer than formerly. He thought the 6 per cent. rate fair also, and he insisted that many firms cut under the percentage established as proper.

"But what chance has a young man got in your profession as against the great established firms like your own?" Mr. Untermyer asked.

"The young man, in very many cases," responded Mr. Fenner, "is paying no attention whatever to the rate which the institute feels is a fair rate."

"Don't you know as a matter of fact that architects of the city do not consider it professional for men to do work below this rate?"

"I know the opposite is true."

"I have discussed it with a great many men and I know that it is given as the reason for not reducing the rate. They say it is an unprofessional thing and it brings upon them the contempt and disfavor of their more important brethren. You yourself have said that the 6 per cent. rule is generally observed."

"I have said that this is the rate most architects charge."

Mr. Untermyer tried to get the witness to say he would aid in abrogating the rule, but he would not. He insisted it was best for the profession and that young men got along well enough under it.

Oak Lasts for Centuries

Men employed in driving a new gallery in a gold mine at Charlotte Planes, in Victoria, Australia, have made a discovery. At a depth of 300 feet below ground they have come upon pieces of timber, perfectly preserved, which have every appearance of having been sawn and shaped by the hand of man.

This timber lies in the bed of an ancient river now being worked for gold, and the timber is oak. Oak has the peculiar property of lasting for centuries when buried in water or wet sand. Oak piles have been taken out from under old wooden bridges constructed by the Romans and found as sound as when they were put there nearly 2,000 years ago.

Oak, known as bog oak, is found buried in peat bogs, and is perfectly black, intensely hard and very valuable. At present there is an absolute famine in seasoned oak wood, but if Russia could be opened up to trade that famine would soon be ended. Just before the war it was discovered that the bed of the River Moksha, for a length of over 400 miles, is full of magnificent old oak trees bedded in sand.

Small deposits are found in England. There is a pool in the River Dart, known from time immemorial as Oak Pool, in the bottom of which are masses of fine old oak. The strange thing is that there are no oak trees near the spot at present.

Wet and Dry Sand for Concrete

Wet Aggregates Require More Cement Per Cubic Yard of Concrete

During the past month several series of tests of concretes made from Potomac River sand and gravel have been carried out, using various proportions of cement to aggregate from 1:1½:3 to 1:3:6 and with the extremes of flowability used in practical concrete construction work, according to an article in *The Scientific Monthly*. The results of these tests emphasize a feature of considerable importance to the contractor. When aggregates are proportioned by volume measure, as is customary on most constructional work, it is found that the use of wet aggregates requires from ½ to 1 bag more cement per cubic yard of concrete than do dry aggregates. Sand is generally wet or at least moist when used, so that the full difference may never be apparent in field practice, yet the use of sand from a pile which has just been exposed to rain will result in the employment of more cement for a given volume of concrete than would have been the case had the work been done on a

dry day. The excess strength resulting from the increase in cement is unnecessary, providing that designed strengths were obtained with the drier materials. As above mentioned, this increased quantity of cement may be as high as one bag per cubic yard of concrete, and the increase in strength, due to the added cement in a cubic yard of concrete made with wet aggregates is roughly proportional to the increase in cement. Therefore, if there is a marked increase at any time in the moisture carried by the sand, the tendency on the job should be to use larger volumes of sand in the batch.

Marked improvement in the working qualities of the concrete will be noted under usual conditions when the relative volume of sand is increased and the gravel proportionately reduced. With well graded river sand and gravel, such as is available in the District of Columbia, the "oversanding" may be beneficial up to the point where the volume of sand in the batch is equal to the volume of the gravel. Such concrete will not segregate for maximum flowability commonly used in construction work; it will be easier working, the quantity of cement required per cubic yard will be slightly less and there will be no reduction in compressive strength.

News from Various Sources

It is announced from Geneva, Switzerland, that reports received from Freidrichshafen, Wurttemberg, state that negotiations between a newly organized American syndicate and a company composed of former Zeppelin officials have almost been completed for a transatlantic airship service and a trans-American service.

* * *

New York Times states that plans of Radio Corporation of America, which controls and operates the only high-power radio stations in United States other than those owned by Navy, for putting this country ahead of other nations, if possible, in international radio communication, include project of making New York City pivotal center of American radio communication with Europe, South America and other parts of the world, through establishment within next 8 months of most powerful radio sending station in either hemisphere.

* * *

The Cleveland School of Art, under Director Henry Turner Bailey, is paying special attention to the training of artists for the industries. Departments are maintained for architectural, printing and ceramic art and decorative and illustrative design.

Weekly Review of the Construction Field

With Reports of Special Correspondents in Regional Centers

PESSIMISM is dying. Those who orated faultlessly concerning the impossibility of any return to pre-war levels find themselves in a peculiar predicament. Their theories seemed sound enough the day after the armistice. We had been engaged in a gigantic war; the world had been practically depleted of almost every commodity; production of necessary articles for peace was years behind schedule. Or so it seemed.

It will take years to reach a pre-war level, the pessimists told us. They pointed to certain fixed facts, which seemed true enough. We were short several million brick, for example. There was no theory about that. We were short the bricks, and any possible production which could be safely guessed at failed utterly to give hope for the future.

Yet we find, despite the facts that there already is a great movement toward the pre-war level. It is much more than a movement. Prices actually are coming down in a vast number of commodities. It is useless to list them here. Mention of textiles, food products, certain sorts of steel, hardware generally, and the interest rate on call money will suffice to call the condition to mind.

What is the reason for it all?

This journal would not attempt to definitely answer a question as complex and far-reaching as that one. No one can properly answer it. But a few salient factors can be indicated, and the rest, as Henry James so often remarked, is "merely a matter of the reader's perspicacity."

Consider labor. During the war period, and immediately following it, labor assumed a nonchalant pose toward everything in general. Some five million men were taken into the service, and five million vacancies were thereby created. There resulted what is familiar to all of us. A high premium was put on the services of the individual worker, and he found himself master of the situation.

Now, this journal is of the opinion that no worker will produce at his maximum under such conditions, patriotism to the contrary. That is not saying that patriotism did not exist in the ranks of labor, but it is saying that when a man *knows* he is an absolutely indispensable cog in some machine, he is very likely to function just about as suits his will. That is true of almost any man, laborer or not, and it was true of the vast majority of the rank and file of labor when the armistice was signed.

Men do not change their attitudes or viewpoints in a day. Labor was no exception to the rule. Having been masters of the situation for nearly two years,

it was a sheer impossibility for them to realize the changed conditions in a day or a week or a month. That realization developed slowly, and as the actual result of physical facts, such as the appalling lack of houses, the inefficiency of our transportation systems, and the pitiful underproduction of the necessities of life.

But when those facts finally began to make themselves felt, labor, organized and unorganized, realized that it was being affected by them as well as that mystical "public" to which reference is too often made. Labor looked about for a solution to the dilemma. We were short of building materials, and so we could not build homes. The problem was to get more production out of the existing factories. There could not be an appreciable increase in the number of factories, but there could be, most certainly, a decided improvement in individual production.

There was the solution. Increased efficiency, which meant, after all, an honest effort on the part of the individual to produce a day's work for a day's pay. It matters not at all whether that honest effort was prompted directly by labor itself or by the "produce or get out" slogan of some industries. The fact remains that labor realized the need for increased production, and produced accordingly. This is shown in October's Portland cement record, one of the very largest in our whole history. It is also strikingly illustrated in the bettered transportation facilities, where labor's increased efficiency has speeded up car movement beyond belief and has actually given to the shippers of the country the equivalent of 500,000 cars.

SO much for one of the salient facts. Another has to do with the political situation. Not political as regards the change of party or of victory for another political faction, but political as regards the settling down of every-day business throughout to the daily routine, without consideration of eventualities. There is little if any quibbling as to policies or cabinet possibilities. A great election has passed, and in its wake has come, as Charles H. Sabin, president of the Guaranty Trust Company has remarked, an assurance "of four years of sane administration of public affairs." Whether the implied criticism of the past administration is correct or not is a matter of small moment. The nation generally is looking forward to improved conditions as a result of the election, and confidence breeds results.

Still another factor is the Lockwood Committee's investigation in New York City. This is a local mat-

THE AMERICAN ARCHITECT

(Special Correspondence to THE AMERICAN ARCHITECT)

ter, to be sure, but a great deal of control is exerted by the various systems which have been shown to be very important factors in the retardance of building in New York and surrounding territory. Since a great share of the necessary homes must go up in the East, and particularly in New York, the committee's revelations have naturally tended to stabilize conditions and to create confidence in the future of the industry. This may be looked upon as academic or purely theoretical, but it must be remembered that confidence in the soundness of any industry and faith in the economic future of it are both necessary to the continuance or development of that industry.

Such are a few of the numerous factors which the pessimists did not take into consideration. In the matter of labor it was a mistake not to take it into consideration as a very important factor. The political situation should have been considered. The Lockwood Committee could not have been foreseen.

The situation today has been bettered sufficiently to invite prophecy despite its dangers. This journal predicts now that the spring of 1921 will witness the advent of a building activity never before paralleled in the history of the country. It makes such a prediction with the full realization that it would be very unfair to architects or other professional men unless it were based upon a sincere belief in its soundness.

It is also tempted to remark upon the recently sustained rent laws of New York, which were declared constitutional by the Supreme Court of New York, and to venture a hint of prediction regarding the effect of that decision. Mr. Lawrence B. Elliman, president of Pease & Elliman, remarked in a recent interview printed in these columns: "What is to prevent other states from passing similar laws, in the case of the New York law being declared constitutional? And what is to prevent the New York legislature from fixing the prices at which houses may sell?"

Public opinion and common sense on the part of even the New York legislature will prevent such action. The rent laws for New York were passed primarily as an emergency measure (some persons hint at politics) and would not have been seriously considered except for that emergency. Other states, it is fairly certain, will not attempt either rent-fixing or price-fixing laws in relation to real estate, because such a measure is necessarily unsound economically and would work to a disadvantage in any community where an imperative emergency did not exist. And this journal again ventures to predict that the New York rent laws will cease to be laws as soon as the housing problem in New York is satisfactorily adjusted.

Legislative fixing of rents or prices exists only as part of an emergency measure and will give way to sounder economic principles.

SEATTLE.—With the exception of lumber there have been no price recessions in building materials for the week-end, but stocks of nails and pipe are accumulating and there is in fact no shortage in anything except fine blued nails and cement. Jobbers of building and construction steel state that they would be able to fill any volume of orders even over the present light demand.

To what extent prices of steel will fall next spring, if there are any fluctuations probably will depend upon how strong is the demand beginning at the expected period in March, as jobbers view the situation. Generally no recessions are hoped for. The building program on the Pacific Coast is so far behind, the necessity of providing shelter as one direct method of quieting industrial unrest and bolshevism and the evident simultaneous beginning of an extensive building program will, it is felt, justify the mills to some extent in trying to hold their balance and to prevent the demoralizing pre-war price slides of common knowledge in other products. The attitude of the mills so far, however, has not been that of inviting confidence and co-operation from the jobbing trade, as the posture has clearly been one of indifference.

From the Yakima Valley of eastern Washington, the home of rich irrigated acres and thousands of tons of merchantable apples comes the report this week that architects of Yakima are busy with plans and projects for both city and country to begin early in the spring. Always more lenient than in other parts of the Pacific northwest, banks of Yakima, it is reported here, are prepared to do the necessary financing for the building projects of eastern Washington. Money, it is stated, will be easier and interest rates low and suitable.

Odd lots of small pipe are arriving in every steamer of the Isthmian line, the fleet operated by the Steel Corporation, and stocks are now fairly liberal.

Lumber prices suffered this week by a drive of one of the larger Washington mills, spurred on by heavy accumulated dry stocks. Orders for 30,000,000 feet of fir to move east on spot delivery were taken before the price list promulgated for the purpose by mail and telegraph was withdrawn. This business was taken on a basis to the trade of \$13 for common dimension, \$29 for slash grain flooring, and \$16.50 for boards and shiplap. Much of this business went at what is known as "Rail B" list, or the list authorized by the Baruch committee during the war. The market has never before gone to this level since the list was issued, but common dimension sold at \$5 under it, and boards and shiplap at \$3 less.

Fir lumber stocks accumulated in West Coast yards will be ample for any strain that may be put upon them next spring by the eastern building trade. These stocks in many of the mills run from 20,000,-

THE AMERICAN ARCHITECT

000 to 120,000,000 feet to each mill. Their presence is of a bearish nature, as it is felt certain, if the usual course is pursued by the mills, prospective new orders would upset the market and cause a broken-dike plan of getting these orders on the books. It would be a sink-or-swim proposition.

Shingles are weak. Practically all the mills are down. The date of resumption is not known. Standard stars are \$2.50 to \$2.60 and clears \$2.90 to \$3. Clears at one time last season were \$7.60

(Special Correspondence to THE AMERICAN ARCHITECT)

CHICAGO, December 4.—The week just ending has merely lent emphasis to the monotony of dullness which prevails in the Chicago building industry. Various factors making up the industry apparently have decided that the cost of labor and materials is still too high and plans are being held in abeyance until the beginning of the new year, which is the date psychologically hit upon as the time for the resumption of general activity in all industrial lines in Chicago.

The interest in future building projects would seem to be increasing and here and there are straws in the wind that indicate the hope of enlarged activity after the first of the new year. At the present, however, the industry is becalmed in the doldrums of general industrial apathy.

Just what effect the fact will have on building does not seem certain but the fact is that there is an increasing volume of unemployment throughout industrial Chicago. Production is being shortened in many lines and many large plants, which have been running night and day almost since the opening of the war period are now reducing their production, closing less essential departments and letting off men. With one or two exceptions, the bigger industries have been as eager to retrench as the smaller lines of business. There is the ever-present feeling, however, that conditions are thoroughly stable and that no serious and long continued depression can ensue. The attitude of the industrial chief seems to be that of the man in the street which is merely that of waiting and watching to see what the future will bring forth. "After the first of the year" is getting to be the common excuse for any year-end planning in industrial and business lines.

Meanwhile the housing shortage, the high rent situation, lack of office and factory space continue to be as acute as ever. The most recent report of the Seventh Federal Reserve Bank, located in Chicago says: "It is estimated that \$150,000,000 in building projects are being held up in Chicago because of the high cost of materials and difficulty in obtaining money for construction purposes. Those engaged in building lines estimate that about 50 per cent. of the men are out of work.

While the labor situation is very much easier than a few months ago there has been no important shrinkage in the past week or so in the various building materials, so far as the local situation is concerned. Some interest is felt locally in the meeting of the dealers and manufacturers of face brick, now in session at French Lick Spring, Indiana and attended by many in the industry from Chicago. Word comes from the meeting that all hands are thoroughly optimistic as to the building prospects for 1921 but little is being said, in the public prints, at least, as to the price situation for the incoming year, although indications are that there will be a material reduction if labor and coal, the chief items of expense entering into the manufacture of face brick take the expected decline.

Even at present prices, however, brick and other materials, are reported as being lower in prices in Chicago than in other important cities. Statistics on this point, from a construction survey issued by the F. W. Dodge Company may be of interest. The comparison follows:

	N. Y.	Chl.	Det.	St. P.	St. L.
Brick, com., per M., on job	\$20.00	\$16.00	\$20.00	\$24.00	\$22.00
Cement, per brl.....	4.10	2.35	2.71	2.71	3.00
Sand, cu. yd.....	2.00	2.75	2.50	1.00	1.65
¾-inch gravel.....	3.25	2.75	2.76	2.15	1.65
1½-inch gravel.....	3.25	2.75	2.76	1.85	1.60
¾-inch crushed stone.....	2.90	2.75	2.77	2.15	2.60
1½-inch crushed stone....	2.75	2.60	2.77	1.85	2.60

New York brick prices are for truck loads delivered on job. Add \$1 to cement quotations for cloth bags, 4 to the brl. with refund of 25c for each bag returned. Add 25c for paper bags and the bulk price is 5c lower than the quotation above.

In materials, some slight reductions are noted of late. Mixed paints and varnishes are lower by forty or fifty cents per gallon than the price which has prevailed for some months. The reduction, which was reported following a recent meeting of manufacturers and dealers in New York is not sufficiently deep to satisfy the trade, in view of the lowered price of linseed oil and white lead and it is thought that a further reduction is not entirely out of question.

Price reductions have also been recently announced in asphalt shingles and prepared roofing by important manufacturers. The reduction on asphalt shingles is in the neighborhood of 33 per cent. as compared with former quotations while the cut on roll roofing ranges from 20 per cent. to 30 per cent. depending upon weight and quality.

There is the expectation, bolstered by a strong feeling of hope, that further reductions in materials will have been made before heavy building operations start in the spring. Whether lumber will share the general decline is a matter of speculation. Dealers in lumber say that the lumber industry has already absorbed the shock and has taken its losses and that any heavy buying such as is made certain by any building boom will have the tendency to drive prices upward, rather than downward.

Considerable importance is nowadays attached to

THE AMERICAN ARCHITECT

any building news in Chicago. Items of construction which formerly escaped notice in the general activity are now being heralded from the housetops as indications that the building industry is not dead, but merely lethargic for the time being.

Some of these stray bits of encouraging news are worth repeating in this review, and so they are set down in brief paragraphs thus:

Work is to start at once on a sixty apartment flat building at Clark street and Deming place. The cost, including the site, will be in the neighborhood of \$300,000. Axel V. Teisen is the architect and the matter is of special interest because it is the first large apartment building to be launched recently.

The newly completed Drake Hotel on the aristocratic northshore, in the exclusive Edgewater district, is to be formally opened December 31. Rooms and apartments in the new hotel are now being occupied.

Contracts for the steel materials to be used in the construction of the new Federal Reserve Bank Building are shortly to be awarded, it is reported. Excavation work for this building, which will be at Jackson boulevard and LaSalle street is practically complete.

A house-building boom is said to be opening in Winnetka, one of the better suburbs along the north shore above Chicago. Forty new houses of the better suburban type are said to be under construction there. The report comes from W. A. Gibbons, commissioner of public works in that suburb.

The North Central Association, which is a group of property owners along the Michigan Boulevard extension, now known locally as "Upper Michigan Avenue" has as its basic idea "Save Upper Michigan Avenue." The salvation in this instance will be accomplished by excluding undesirable lines of business from the newer section of the boulevard.

The "Own Your Home" Exposition which is being arranged in Chicago has been endorsed by the

Chicago Paint, Oil and Varnish Club, which includes in its membership, the principal manufacturers and dealers in those allied lines in Chicago.

Building permits for the week ending November 27, showed a gain over the corresponding week in 1919, both in the number of permits issued and the value of the contemplated building. Last week, there were 79 permits issued, representing a total valuation of \$4,334,800. For the same week in 1919, 57 permits were issued, the valuation being \$1,173,900.

Prices in the lumber and materials field remain around last week's level, with no particular activity in either line, although a better inquiry is reported in both. Prices are as follows:

Yellow pine:—B. & B. 1 in., \$95 to \$130; 13-16, 3¼ flat flooring, \$85 to \$90; 2 by 4, 10 to 16 feet, No. 1 long leaf, \$51; 2 x 6, \$48 to \$49; 2 x 8, \$49 to \$50; 2 by 10, \$52 to \$54; 2 by 12, \$54 and \$56.

Northern Hardwoods, carload lots, Chicago:

Birch, four ¼ No. 1 and 2, \$155; select, \$130 to \$138; No. 1 common, \$95 to \$100; No. 2 common, \$60 to \$65; No. 3, \$35 to \$40.

Hard Maple, four ¼ No. 1-2, \$135 to \$140; select, \$115 to \$120; No. 1 common, \$95 to \$100; No. 2, \$60 to \$65; No. 3, \$32 to \$50.

Red gum four ¼ No. 1 and 2, \$148 to \$152; No. 1 common, \$88 to \$92; No. 2, \$43 to \$47.

Birch, four ¼ No. 1 and 2, \$155 to \$160; select, \$130 to \$139; No. 1 common, \$95 to \$100; No. 2, \$60 to \$65; No. 3, \$35 to \$40.

Douglas fir, 12 by 12, No. 1 up to 32 feet, \$65 to \$75; 14 by 14, \$68 to \$75; 16 by 16, \$70 to \$75; 18 by 18, \$75 to \$80.

Cement:—Universal, \$3; Lehigh, \$3.50; Portland, \$3.50.

Bulk lime, \$1.70 to \$1.90; face brick, octagons, \$68 to \$75; fire brick, \$32 to \$40; 12 in. .24 to .27, 18 in. .46 to .54.

Crushed stone gravel \$3.40 to \$4; lake and bank sand-torpedo, \$3.40 to \$4.

908^a

franklin forest No. 2398



FAÇADE, CHURCH OF S. ZACCARIA, ALINARI, ITALY

THE AMERICAN ARCHITECT

VOL. CXVIII

WEDNESDAY, DECEMBER 22, 1920

NUMBER 2348



HOUSE OF ROYAL F. HAMMETT, GERMANTOWN, PA.
CARL A. ZIEGLER, ARCHITECT

Post-War Housing

POST-WAR conditions have wrought great changes in every line of business activity in this country to which even the most conservative men of affairs have had to submit or fall behind in the march of progress.

The call which these new conditions has made to the architect is no less mandatory and he who will not heed the summons cannot hope to perform his obligation to his client or to his profession. So acutely have these conditions affected the prospective home builder that our records for the past year show what is practically a cessation of home building. The shortage of proper housing facilities, which has affected all classes, has become so serious as to receive the attention of the Federal Government. The architect has not only the very considerable increase in the cost of labor and material to consider, but also

the very decided change in the attitude of the workman toward his task. It is unfortunately true that craftsmanship suffers when the craftsman is obliged to concentrate his energy on the securing of a higher wage in order to meet the increased cost of living, and once the imaginative mind of the work is turned toward the pursuit of the elusive dollar, the cunning of the hand is gone. This has ever been true of craftsmanship and therein lies the distinction between art and commercial enterprise.

To the architect these new conditions call for keener imagination, a deeper understanding of the psychology of the times, and he must not be too old or too tired to invent new methods to meet the conditions imposed upon him. How to renew the interest of the worker in his crafts is not the least of his problems, for without this sympathy his best efforts

THE AMERICAN ARCHITECT

are in vain. May it not be that in overcoming these obstacles a way may be found to eliminate many of the objectional features pertaining to so much of the pre-war designing, especially as applied to dwellings of moderate size?

Every architect has met at least once in his practice the Church Committee with a modest sum to be expended and a plan combining all the features of the cathedral. If he suggested one of the charming English parish churches as a more suitable prototype, he probably lost the commission and John Doe built the church with a galvanized iron clearstory and a skylight cover, all within the contemplated amount, and no extras. Sometimes the designing of

country as to preclude the possibility of securing for the moderate sized house any individuality other than a stilted and formal effect.

Now that we are facing new conditions in the cost of building, may we not hope for a more general use of native material, less highly finished? This would lead to an awakening of the imagination on the part of the designer and would undoubtedly result in more intimate home building.

IN certain sections of the country the profession has long been aware of the existence of just such a use of local material, which, combined with a purity and refinement of design, has led to the preservation



A HOUSE IN THE WISSAHICKON VALLEY, GERMANTOWN, PA.
CARL A. ZIEGLER, ARCHITECT

dwelling houses is surrounded by just such impossible conditions; the owner has had the matter in mind for several years and has carefully compiled a scrap book of clippings showing all the features which he wished embodied in the house. He has inspected the houses built by his friends, some of which he admits have good points, but most are failures. Now he proposes to build the "Perfect House," all the materials are of course to be of the most finished manufacture, the bricks pressed, the glass plate; add to this the fact that the house was conceived before the lot was purchased, and the result is obvious. The use of highly finished materials has set its mark so indelibly upon house building in some sections of the

of a regional type that has come down in perfectly logical order from the Colonial days, despite the fact that it has also met all the many requirements of modern life.

Perhaps no section has accomplished more in this line than the suburban section of Philadelphia. There a group of architects have so assiduously and forcefully educated the home builders to the beauty of the local ledge rocks when properly used, that there is very little demand for the stately mansion crowning the pretentious estate, which is the aspiration of so many other sections, but instead we have the intimate country house conforming to its surroundings and



GARDEN FRONT
HOUSE OF BURTON ETHERINGTON, GERMANTOWN, PA.
CARL A. ZIEGLER, ARCHITECT

THE AMERICAN ARCHITECT

expressing so quaintly in most cases the individuality of the owners.

The cost of this type of house is less than the more formal type, as the result depends more upon the ingenuity of the architect than upon the use of expensive materials.

In no other city of the first class are stone houses erected at a lower cost than in the suburban district of Philadelphia.

The houses illustrating this article are the work of Carl A. Ziegler, an architect of Philadelphia, and

the effect is very striking, especially if, as in Mr. Etherington's case, the house is surrounded by trees which cast flickering shadows across the white texture of the walls, no two portions of which are exactly alike. Walls finished in this manner cost considerably less than those laid up of face stone. The use of the dry stone wall for the terrace offers a splendid foil for the white texture walls behind.

The beauty of this house lies in the restraint exhibited in its designing, which accents the splendid proportion of the gables and chimneys. The fenestration



DINING ROOM
HOUSE OF BURTON ETHERINGTON, GERMANTOWN, PA.

were built during the readjustment period that has been so trying to all building projects. All are built of local stone, varied in treatment, and all express a well bred contempt for ostentatious ornament.

In the house of Mr. Burton Etherington the walls were built of the roughest sort of rubble work, such as would be used in the average cellar wall. The joints were then filled with a gravel mortar which is smeared on the surface of the wall, allowing a portion of the stone to show through. This gives a texture very different from the usual monotonous stucco treatment, and when coated with a special whitewash

tration on the rear is particularly interesting, as is also the drawing down of the roof line on the kitchen wing.

IF the ever mounting cost of building will force us to the use of such simple forms for our houses, students of architecture may look back upon the trials and tribulations of this period as not without its compensations.

In the other houses illustrated local stone was used for the facework. This was laid up rubble fashion by Italian masons who come mostly from Southern



ENTRANCE DETAIL
HOUSE OF BURTON ETHERINGTON, GERMANTOWN, PA.
CARL A. ZIEGLER, ARCHITECT

THE AMERICAN ARCHITECT

Italy, bringing with them little else beside an innate knowledge of stone craft which they rightly inherit from their forbears, who for generations fashioned the terraced gardens about the Gulf of Salerno and the Bay of Naples. These men may be trusted to intuitively select stones of the proper form and color to produce the best effect in the wall, and with their cheerful disposition enlivened by snatches from the operas of their beloved Verdi, they form an oasis in the desert of the present day labor difficulties.

At Princeton University it was the custom for

by the difficulties of the contracting business, may by a more imaginative use of local materials not only save his client considerable expense, but he may, at least in his country house work, develop that much to be desired regional type that means so much to us when we see it in Cotswolds of England, the Manors of Normandy, or the villages of Italy and Switzerland.

IN our early history we had such regional types, the New England type, the Dutch Colonial



STAIR HALL
HOUSE OF BURTON ETHERINGTON, GERMANTOWN, PA.

many years to import facestone from Pennsylvania at a great cost. When Holder Hall was planned the architects found a local stone which had been rejected by former builders and urged its use. After demonstrating its beauty and fitness for the purpose, the authorities consented to the change, thereby saving many thousands of dollars, and to-day Holder Hall is referred to by the profession as one of the finest specimens of stonework in the country.

The architect of today, if he has not been worn out by the multiplicity of cares imposed upon him

houses of New York, or shall we say New Amsterdam? The Pennsylvania, Maryland and Delaware farmhouse type, and the stately mansions of the Cavaliers in the South, each fittingly depicting the character of the people who conceived them.

For purely utilitarian reasons the business of house building must be readjusted to meet the new conditions, and if the architects of the country can sufficiently influence the public mind, may we not hope for some reduction in the multiplicity of ridiculous forms used in so much of our house building before

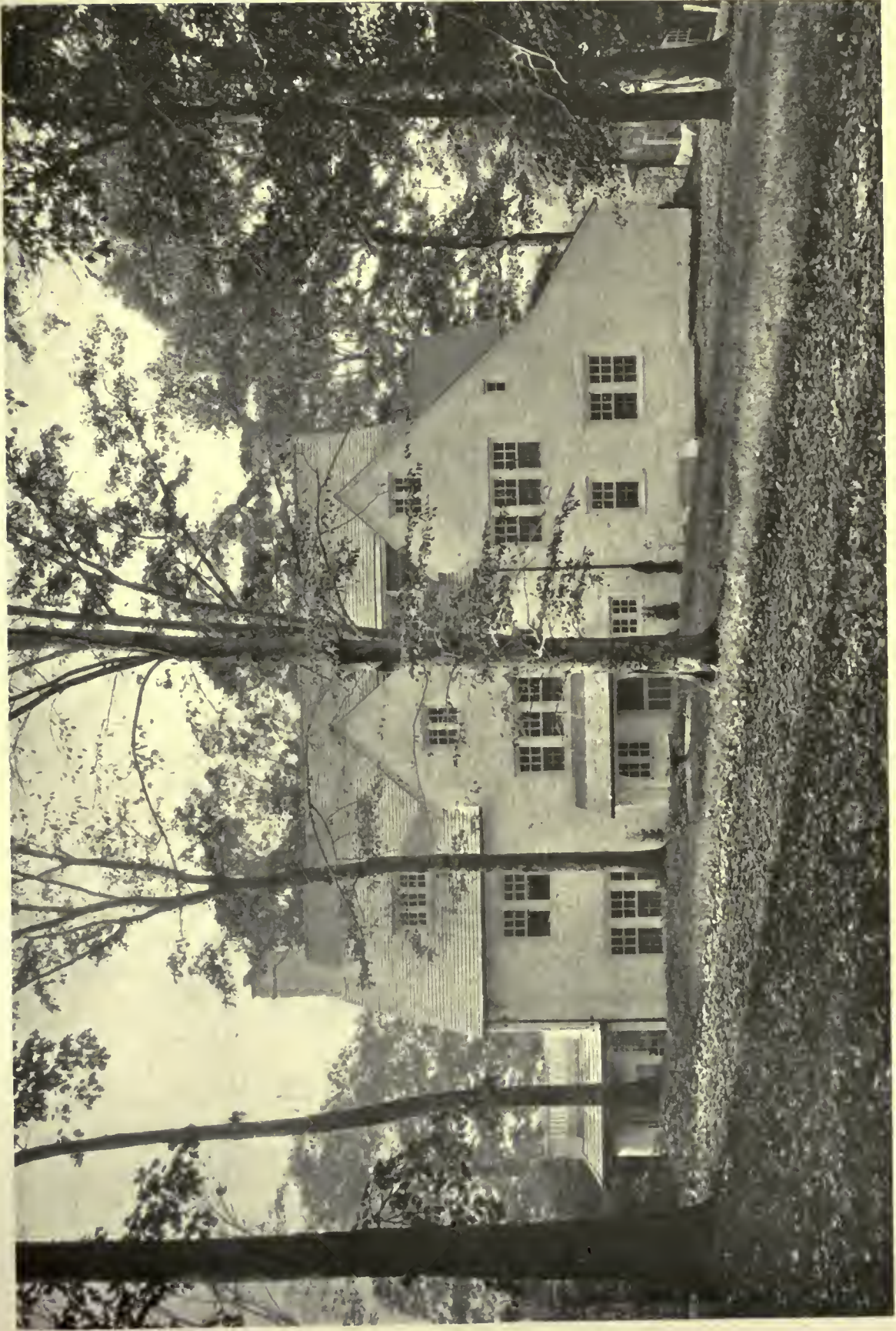

REAR VIEW
HOUSE OF BURTON ETHERINGTON, GERMANTOWN, PA.
CARL A. ZIEGLER, ARCHITECT

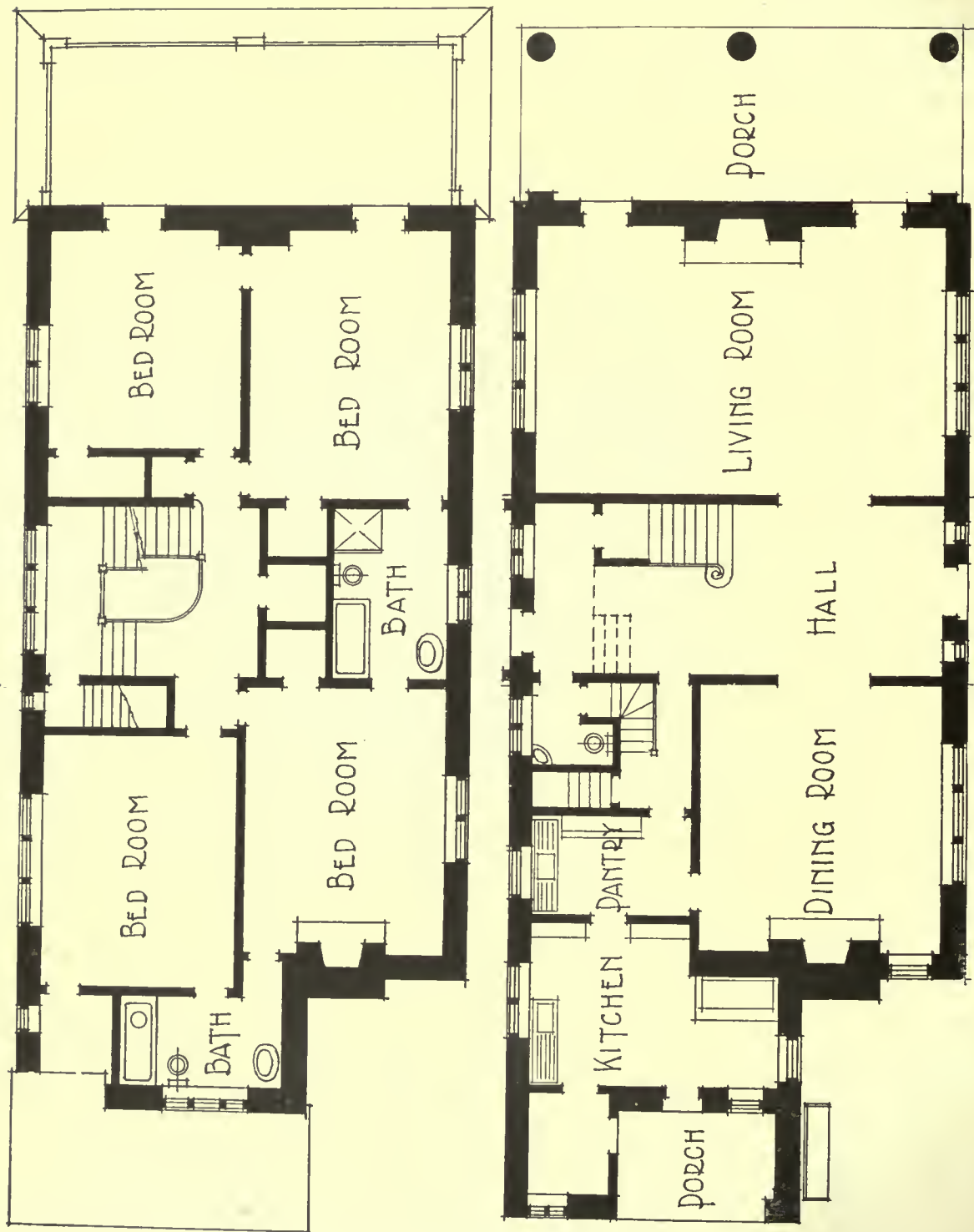

FIRST AND SECOND FLOOR PLANS
HOUSE OF BURTON ETHERINGTON, GERMANTOWN, PA.
CARL A. ZIEGLER, ARCHITECT

the war. If anything is achieved along this line, it must emanate from the architectural profession. The problem is perfectly clear and thousands of the prospective house builders are patiently waiting for the architect to demonstrate how a well designed home may be built at moderate cost.

The year 1921 holds the promise of a resumption



SERVICE WING
HOUSE OF BURTON ETHERINGTON,
GERMANTOWN, PA.

of house building on a large scale. It is true that only about 3 per cent. of all the building done in this country is designed by architects, but this small percentage is the leaven which permeates the whole, and it is to the architect that we must look for the influence that will lead the proposed home builders to an appreciation of the truly fine things that may be done in a simple way.

The Rebuilding of Regent Street, London

BIT by bit the stucco architecture of the Regency is disappearing from the west end of commercial London. Within recent years whole sections of Regent street and its neighborhood have been swept away, and, if the present rate of

demolition continues, it is prophesied in the *Architects' Journal* that within a very few more years there will be little trace of those classic but perishable façades that were the characteristic product of the Regency.

The reason for their disappearance is not far to seek. Nash built on a scale which, though perfectly adapted to the requirements of the early nineteenth century, is totally inadequate for the needs of modern commercial enterprise. Nash's elevations are seldom more than three stories in height, while the generality of modern commercial buildings in London run to more than twice that number, and height is undoubtedly still on the increase. Also, Nash "found us all brick and left us all plaster;" and while there is a natural reluctance to demolish a building constructed of good solid stone, stucco, by its very cheapness and impermanence, seems almost to invite demolition. Good as are the reasons for the destruction of so much of this work, one cannot but regret its passing: for Nash contributed a valuable and extremely interesting quota to the development of monumental architecture in this country. We was without his peer in the composition of façades of great length in infinite variety—façades, moreover, which, when placed in juxtaposition, produced a complete unity of effect. He brought the art of street-designing up to a pitch of excellence that it had never reached before, and from which it has since sadly fallen, as nearly all our modern thoroughfares make us only too painfully aware.

Regent street, it is interesting to recall, was designed and carried out between the years 1813-16; thus its term of useful service only just exceeds the century. The total cost of the entire scheme was, approximately, a million and a half sterling, which shows how economically building work could be carried out in the days of George IV. Today it would probably cost almost as much to build, in permanent materials, only one of Nash's monumental blocks.

Just recently two or three further large sections of Regent street have been demolished to make way for new buildings. One of these accommodates the new premises, still in course of erection, for Messrs. Dickins and Jones (Sir Henry Tanner, architect), while the others consist of the northwest and northeast corners of Oxford Circus, upon the latter of which palatial new buildings are to be erected for Messrs. Peter Robinson from the designs of Mr. H. Austen Hall, F.R.I.B.A. The illustrations accompanying these notes show the latter site before and after the demolition of Nash's work. The section involved, it will be seen, was typical Regency architecture, dignified and stately to the last, despite its ugly and obtrusive modern shop fronts.



HOUSE AT ST. MARTINS, PA.
CARL A. ZIEGLER, ARCHITECT

Notes from London

By Special Correspondent of THE AMERICAN ARCHITECT

AS one result of the world war London is becoming peopled with statues, and we can only pray that they may be more successful as works of art than some of those which were erected—even Cobden did not escape, but came off, if I remember right, specially badly—in the mid-Victorian era. To mention only a few of those which are now in progress there is the proposed Memorial to the Royal Naval Division, upon a site at the foot of the steps beneath the Duke of York's column in the Mall: there is the statue of the late King Edward, which is now approaching completion, and has been proposed to take the place of the existing Napier statue, for which a new place would have to be found as an alternative to its present fine position between the United Service and the Athenaeum Clubs, though it will probably still remain in the lower end of Regent street.

Even the Duke of York himself is threatened, and it has been suggested that he should descend from his airy perch, and make room for Lord Kitchener or some leader of men who had achieved more for his country than the genial Royal Duke, whose generalship seems to have been about on a level with his army patronage. Then there is the Guards Memorial, whose very appropriate site, on the west side of Horse Guards Parade, facing the archway, has been approved by the King and the joint assessors to the committee for this monument, who are a leading sculptor and architect, Sir Thomas Brock, R.A., and Sir Reginald Blomfield, R.A.

But I propose to give my attention in this notice to one monument which has a very special interest and value, in that it is the spontaneous expression of a nation's gratitude. Many among us can still remember those dark days of the winter of 1914 and yet later, when the unhappy refugees from Belgium came pouring across the Channel, often with absolutely nothing left save what they could carry in their hands. I myself knew a distinguished artist who escaped in this way, and for years could learn nothing as to his property left behind. One page in the late war to which we can look back with entire satisfaction is that of England's effort for these unfortunate people: we all did what we could, and the result, if it could not remove, did much to alleviate their sufferings.

And Belgium has not forgotten. The monument which was unveiled on Tuesday, October 12, by Princess Clementine of Belgium in the presence of M. Leon Delacroix, Prime Minister of Belgium, and many distinguished spectators, was entrusted to the

greatest living Belgian sculptor, Victor Rousseau, to hand down the memory of Belgium's gratitude to England in her day of trial. M. Rousseau has treated his subject with becoming simplicity: he has given us a group of three figures, a draped woman advancing preceded by two children, one of these a nude figure, admirably modelled, of a fully grown boy, the other a young girl. Myself an enthusiastic admirer of Victor Rousseau's genius in sculpture, and having followed his work for years, I do not hesitate to say here that the present group is not, in my judgment, one of his most successful creations. It is not so much the draped woman, who is as unattractive as the children are excellent, as the whole lines of the composition which are unsatisfactory: my reader can, however, form his own opinion on this point to some extent from the excellent reproduction which has been kindly placed at my disposal by the Anglo-Belgian Union, and will there see that these lines all run away at a slant from left to right, the only balance being in the upright figure of the boy, which is, in fact, the redeeming point of the whole group.

When, however, we come to the architectural setting, in which I understand that cultured English architect Sir Reginald Blomfield has had a large share, the impression is far more satisfying. The spacing of this screen, facing on to the Thames, is admirable, and not less so the two figures introduced of Justice and Honor—this last a male figure fully armed and with something of the inspiration of the wonderful Donatello S. George, set without Orsammichele at Florence—while the coats of arms of the Belgian provinces are as decorative as they are entirely appropriate. The week of the opening ceremony was devoted to a round of Anglo-Belgian festivities: after the unveiling followed a luncheon offered by the Lord Mayor of London in the historic Guildhall, then a Government banquet at Lancaster House in the evening, on the Thursday a luncheon by the Anglo-Belgian Union at the Hotel Victoria, and the day following a reception of the Belgian visiting members by Princess Louise at Kensington House.

What was, however, behind these official festivities, and far more important, was the sentiment here expressed of Belgium's gratitude and memory. After her terrible and scathing trial Belgium is making a marvellous and astonishing recovery, details of which I noted myself when passing through this country last spring. While we are wasting our energies in useless and costly strikes she is quietly working—working hard, preparing to take a deservedly great place in the European comity of nations.



TO
THE BRITISH NATION
FROM THE GRATEFUL
PEOPLE OF BELGIUM
1914 — 1918

BELGIAN MEMORIAL, LONDON
VICTOR ROUSSEAU, SCULPTOR

Architectural Quicksands

By CLINTON H. BLAKE, JR., of the New York and Federal Bars

Termination of Architect's Employment

THE employment of an architect, or of any similar professional man, is clearly a contract of personal employment. The client depends upon the personality and special qualifications of the adviser whom he employs. It is hardly necessary to say that a contract of this character cannot be assigned by the architect and the client thereby forced to accept, as his adviser, someone other than the person whom he chose, and to whom he has been willing to entrust the work which he desires to have done. The client is not the only one, however, who is interested in the personality of the architect and whose rights are affected thereby. The interests of the contractor are directly affected by the character of the architect that is selected. The contractor is not interested to the extent that the client is interested but he has, nevertheless, very real interest in the type of architect chosen and in his standing and ability, in the field wherein he is chosen to act.

Under the ordinary construction contract the architect is called upon to perform various duties as arbitrator and duties wherein it is necessary that he act in a more or less judicial capacity, with fairness to the client and to the builder and with obligations to each of them. This phase of his work I have already considered in another connection. If the construction contract be so drawn as to leave important details of construction, interpretation of the plans and specifications and the like, to the discretion of the architect, it is but logical that the contractor should not be forced to proceed with the work if the architect be changed without his consent and contrary to his desire, unless, of course, the contract specifically covers this point and provides that a change in architects may be made without consulting the contractor.

I was consulted recently in a case on this very point. The contract left many substantial questions open to the decision of the architect and the latter, under the terms of the contract, was necessarily called upon to act in a judicial capacity and as arbitrator, on many points, between the client and the contractor. The contractor's interests were directly involved by the decisions of the architect and the contractor entered into the agreement, in the first instance, because he knew the reputation and standing of the architect chosen and because he had faith, not only in his integrity, but also in his fairness and in his general broad-minded point of view, in dealing with questions which involved both the

rights of the owner and the rights of the contractor.

After the contract had been made the owner, for some reason, decided to employ a new architect in the place of the architect specified in the agreement. As between the client and architect, the client cannot be compelled to continue to employ an architect, longer than he desires, and he has a perfect right to employ another architect in the place of the one originally chosen, subject to any claims for damages which the architect who is displaced may legally have. A new element is brought into the situation, however, when the rights of the contractor are involved. If the contract be similar to the contract in the case to which I have above referred, the contractor may well take the position, it seems to me, that if a new architect, and one in whom he is not ready to place his confidence, is to be employed, he will not proceed under the construction contract. When the latter contract was entered into the rights of the parties became fixed thereby and, if the contractor executed the instrument in dependence upon the employment of a particular architect, it is but fair that he should not be forced to proceed with the work under the direction of an entirely different architect of the work in the first instance.

The matter, in the last analysis, is a question of contract. As such it is dependent upon the phraseology of the particular contract employed. If it is desired to give to the owner the right to change his architectural adviser, without affecting the obligations of the contractor under the agreement, the contract should be so worded as to make this point clear.

It is interesting to note that Article 9 of the General Conditions of the Standard Documents of the American Institute provide that, in the event of the termination of the employment of the architect, a capable and reputable architect may be appointed by the owner and that the status of this succeeding architect, under the contract, shall be the same as was the status of the architect whom he succeeds. Under this provision a contractor cannot object to the appointment of a new architect, provided that the new architect is "capable and reputable." This is entirely reasonable and proper and the employment of a clause, similar to the Standard clause referred to, will necessarily greatly lessen the possibility of disputes, between the owner and the contractor, in the event that a change of architects is effected, during the progress of the work or after the original contract is entered into.

*In the Kitchen Garden, Mount Vernon,
Va., the Home of George Washington*

(See reproduction of original drawing by O. R. Eggers on opposite page)

IN a preceding issue a detail of Mount Vernon, the home of George Washington, was reproduced and described. The subject of the present sketch is a view of the Gardens, which with their walks and terraces and essential buildings remain today as planned by Washington.

These lawns and gardens are on the West side of the house, where was the approach from the public highway. They comprised about twenty acres and were enclosed by brick walls. One of the two small octagon garden houses erected by Washington is shown in the sketch. These were built to store seeds and tools. They have brick bases and are boarded in imitation of stone forms, after the manner of the dwelling house.

Just what are these elements of greatness that make Washington the central figure of his age and have with each succeeding year caused his memory to be held in ever increasing respect, it would be difficult to define. Yet, the spirit of the man pervades today these historic localities. The visitor will note the absence of noisy hilariousness that usually marks the tourists to historic shrines. Perhaps it is because in a small tomb, but a few steps away rest the bones of Washington, and if the visitor fails to sense the nearness of the illustrious dead, he will have a solemn reminder in the tolling of the bell of some passing ship of war on the Potomac river, whose officers and men stand at silent salute.

From 1743 to 1859 Mount Vernon was held in possession of members of the Washington family. In 1859 it was purchased by the Mount Vernon Ladies Association. Since then the restoration of the place has been effected, much of the original furniture reclaimed and installed. Today Mount Vernon stands as nearly as it did when Washington lived there as human endeavor can make possible.



THE KITCHEN GARDEN AT MT. VERNON, VA.
THE AMERICAN ARCHITECT Series of Early American Architecture



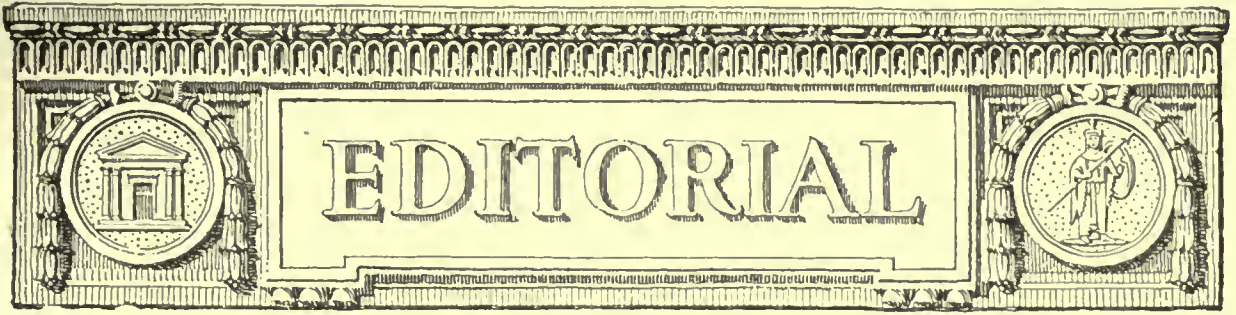

Reputable and Disreputable Practices in the Building Industry

AS an illustration of the public sentiment regarding Mr. Untermeyer's inquiry into the fee system of architects, we reprint, in full, the following editorial from *The New York Times* of Saturday, December 11. Editorial expression of as large and important a newspaper as the *Times* may be very well taken as an accurate gauge of public reaction and opinion, and it is for that reason that we reprint the editorial in full. It is as follows:

THE ARCHITECTS' CODE.

It was natural that Mr. Untermeyer as counsel for the Lockwood committee should inquire into the fee system of architects, but no impropriety of code or combination was disclosed in the testimony and none is conceivable to those familiar with the practice of the architects who compose the Institute.

The "minimum charge" of 6 per cent. "based upon the total cost of work completed" contrasts significantly with the profits of from 89 to 155 per cent. which were revealed in the investigation of manufacturers of automatic sprinklers at the same session. This charge of 6 per cent., moreover, is, as was explained by Mr. Fenner, only "what the architect believes he should receive for his services." There is no definite agreement, as in other instances which Mr. Untermeyer has brought to light, with graded penalties for the breach of it that run into the thousands and are capped by expulsion from the association. Mr. Fenner indicated clearly that architects might vary their charge upward or downward to meet exceptional conditions, and that in fact they do so.

Few things are more important to the stability and repute of a profession than a generally recognized code of ethics in all matters that are capable of an agreement. Lawyers frequently make charges far in excess of those of the American Institute of Architects. Physicians also have been known to take large fees; but they gladly practice gratis in hospitals, treat poor patients for nothing in their private practice, and renounce all patent right in professional inventions. In architecture, the need is for a gentlemen's agreement upon a definite rate that is dignified without being extortionate.

That young and untried members of the profession may sometimes find an advantage in undercutting the 6 per cent. rate is possible; indeed, Mr. Fenner admits that this actually occurs. But as soon as they feel able they ask the conventional rate and cling to it, not

merely for the monetary profit, but to maintain their professional reputation. The value of this excursion of the Lockwood committee lies in the contrast it draws between reputable and disreputable practice in the building world.

The Guild System

NO less an authority than the editor of *The Architects' Journal* of London is disposed to doubt a rapid development of Guild building in England. In fact he believes and states that the movement contains within itself the germs of dissolution. Even granting, says the *Journal*, that the Guilds possess the organizing skill of trained master builders, it is not believed they will be able to maintain the team spirit essential to success. It appears to be a case of too many masters.

During the course of the meeting held on November 12, by the New York State Association of Architects, to discuss "What is the Matter with the Building Industry?" Mr. Ordway Teal of the Bureau of Research, spoke at some length as to the merit of the Guild System in England with reference to its adoption in this country. One of the principal reasons in favor of the Guild system as stated by Mr. Teal, was the failure of the private profit motive to interest the laborer in his work. Mr. Teal apparently believes that under a Guild there would result a "team spirit" which would increase efficiency and give the laborer a more intimate interest. But those abroad who have had opportunity to study the system at close quarters do not share that view.

The London *Westminster Gazette* of November 20 printed an article advocating the Guild System. It was that article which aroused the editor of *The Architects' Journal* adversely to criticize the system. Mr. Cole, the author of the article in the *Westminster Gazette* states: "The Guild leaders are relying on the fact that the Guildsman will feel that the Guild is his own concern, as he has never been able to feel when he has been working for a private firm. He will himself be member of the Guild and will be entitled to a share in its administration."

"Quite so," comments the *Journal*, "and this is exactly how the trouble begins. 'Too many masters,'



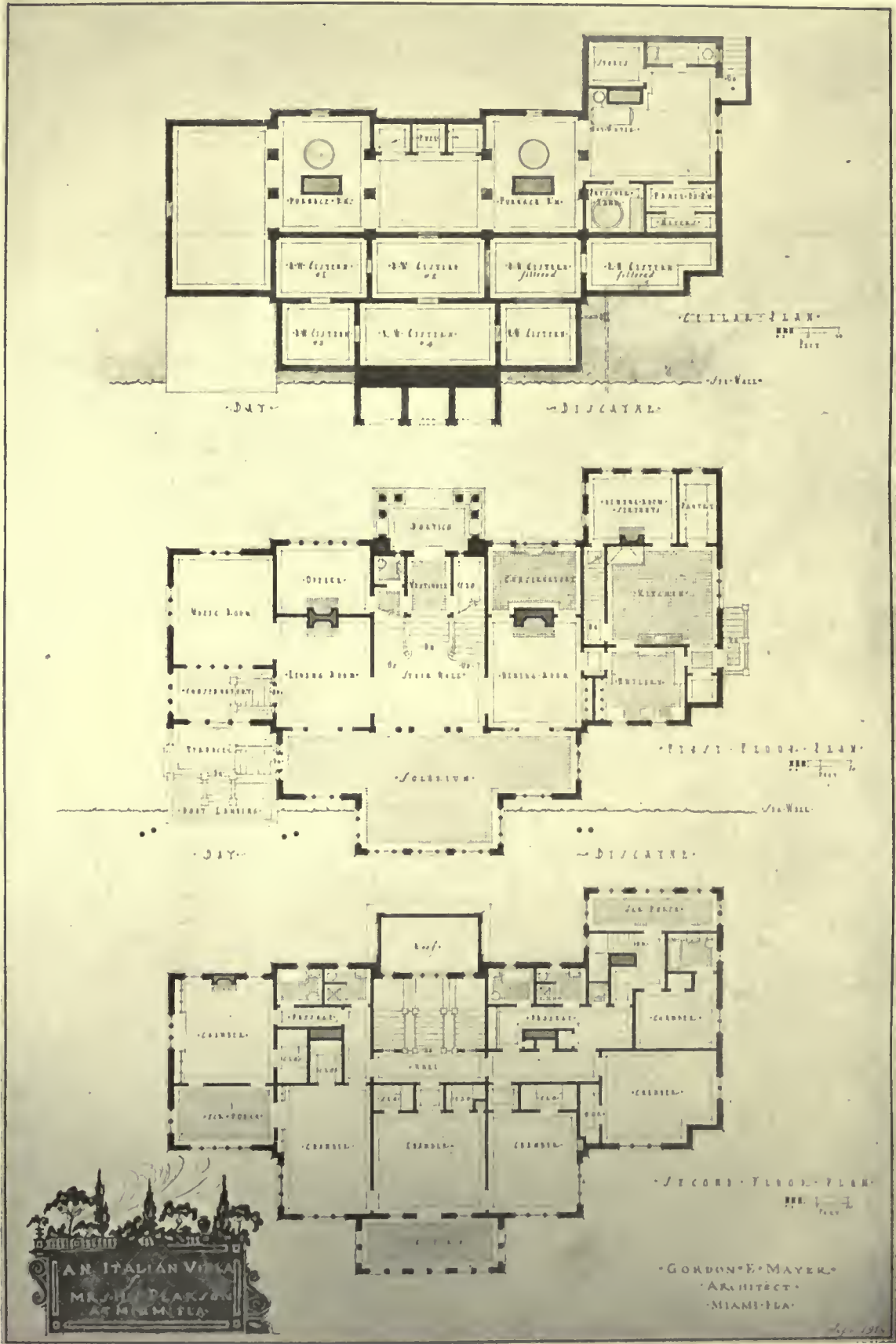

GORDON E. MAYER, ARCHITECT

824





MAIN ENTRANCE FRONT



THE FOUNTAIN, PERGOLA AND BRIDGE
HOUSE OF MRS. HELEN S. PEARSON, MIAMI, FLORIDA
GORDON E. MAYER, ARCHITECT

824³





GARAGE AND SERVANTS' QUARTERS

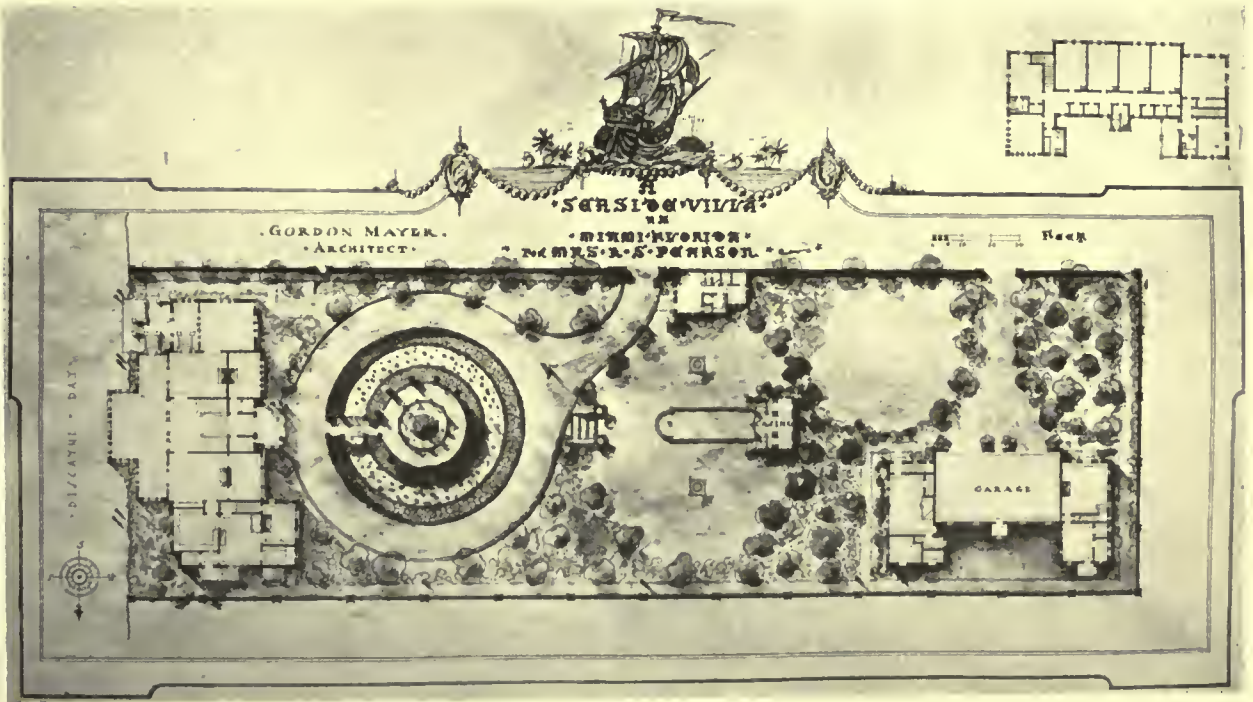

PLOT PLAN
 HOUSE OF MRS. HELEN S. PEARSON, MIAMI, FLORIDA
 GORDON E. MAYER, ARCHITECT

824⁴

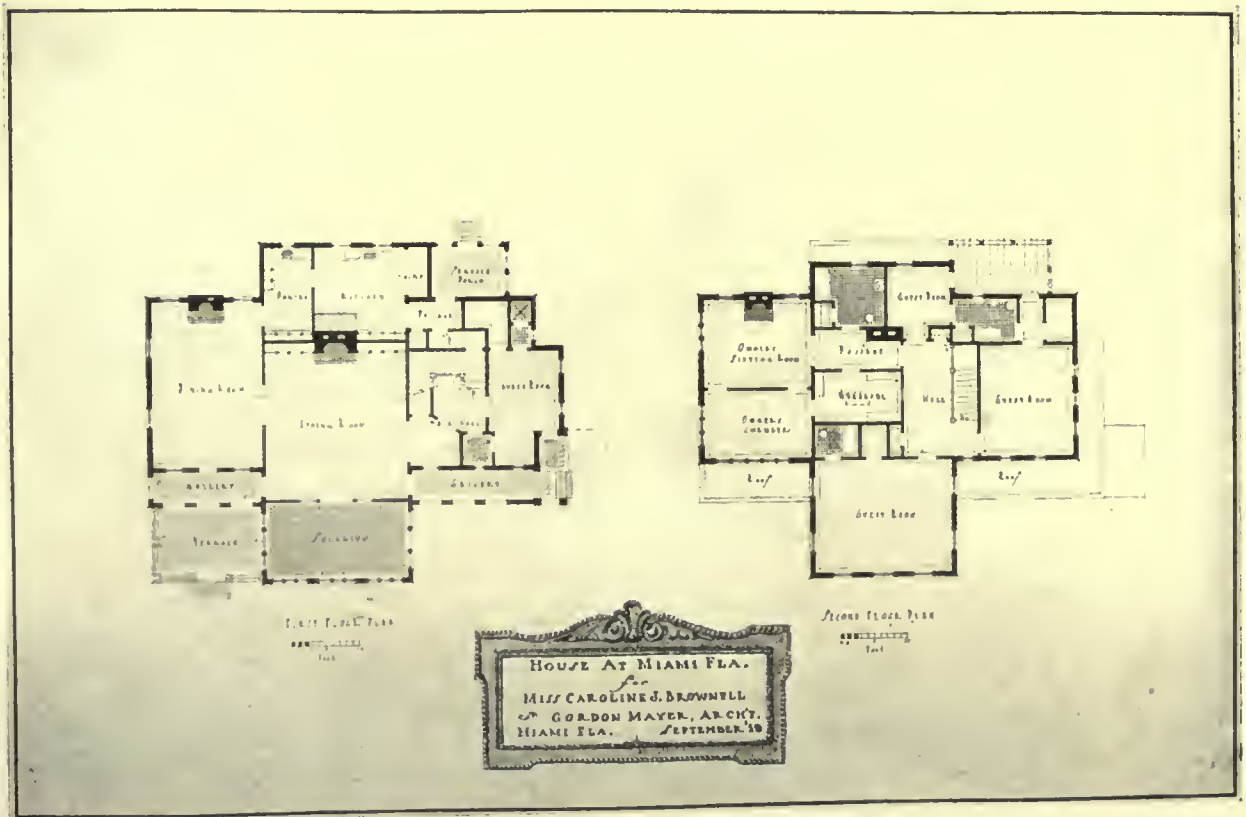

GORDON E. MAYER, ARCHITECT

824⁵¹



The American Specification Institute

IN THE AMERICAN ARCHITECT, issue of Nov. 17, there was printed an editorial outlining the proposed formation of an American Specification Institute. The end it was sought to attain by such an organization appeared so very desirable that the editors of this magazine believed they would be rendering an important service by as far as possible encouraging this effort.

It is gratifying to learn through a series of letters from readers in every section of the United States, in response to this editorial and inquiries made, that a Specification Institute as proposed would perform a service of great value to the profession and the public by increasing the efficiency of practically every building operation.

Following are extracts from a few of the many letters received.

I HAVE read with interest the editorial relative to the proposed new American Specification Institute in THE AMERICAN ARCHITECT of November 17, 1920.

It occurs to me that architects in the past have paid altogether too little attention to this important phase of their work, and too little opportunity for development has been given to those men who are engaged in specification writing. The result of this has been that often our well-conceived projects have been poorly constructed, and proper provision has too often not been made to protect various materials in the proper manner. It seems, therefore, that anything we can do to encourage men to enter the field of specification writing will in time render a very great service to the architectural profession generally.

I congratulate THE AMERICAN ARCHITECT upon being a pioneer in this movement, and assure you that we shall do everything possible to co-operate and assist in the future developments of this organization.

H. KENNETH FRANZHEIM.

Chicago, Ill.

* * *

In reply to your letter of the 24th instant, I believe the formation of a Specification Institute would be of great service to the architects, especially to the smaller offices not employing special specification writers. I agree that the specification practice of most architects offices is the least creditable part of their work, due probably to several things: First, the fact that by the time the drawings have been approved the owner wants to start work at once, and in an effort to hasten the work, old specifications for similar buildings are often rehashed

and made over with a greater or lesser degree of success, mostly less. Secondly, specifications are to the majority of architects the least interesting part of their work, the very essential to the best interests of their client. . . .

While forming the basis of the contract, I believe, we should establish a precedent for simplicity and brevity, bearing in mind the mental capacity of some of the people who have to follow the specifications, rather than follow the method of the legal profession in preparation of agreements or legal forms, which I have been told is the outcome of the days when lawyers were paid according to the number of words embodied in a contract. Most legal forms and papers would seem to substantiate this, at any rate.

Personally, I would be very glad to subscribe to such a service. It is something I have often felt the need of, and I am sure would receive support from all small progressive offices, especially those not located in the large cities, but even there it would be more convenient than the present facilities at the disposal of the architects. It would mean that for a comparatively small sum, individually, by co-operation, the small office could have the continuous services of experts in specification writing.

An old subscriber.

* * *

I have read your editorial of November 17, entitled "The American Specification Institute," and I heartily favor such a movement, having been a member of the old Building Data League, and was much distressed when they ceased operations.

The value of such an institute, as I see it, would lie principally in getting together and classifying for easy reference the different qualities of building materials, so that the specification writer can find the material that he wants without searching through a vast amount of straw.

If I can be of any service in the movement, let me know.

J. DE BRUYN KOPS.

Savannah, Ga.

* * *

I am heartily in accord with the project of establishing a Specification Institute if it is, as its name implies, for the purpose of educating specification writers.

Most specification writers receive their training at the present time solely in the school of experience, which is, of course, excellent, but does not cover the entire ground, for the reason that these men are usually the product of training of one or two offices which have their individual methods. Such

THE AMERICAN ARCHITECT

an institute, I take it, would have evening classes for the benefit of men regularly employed, as well as classes for younger men who perhaps can devote time to a more comprehensive study.

I believe, also, that an open forum both of the assembly and correspondence type, would be of great value, as perhaps in this way these men would be enabled to pull themselves out of the rut that every man is bound to get into without interchange of ideas with others doing the same kind of work.

WM. O. LUDLOW.

New York.

* * *

As the specification writer in the above office, I read with interest your editorial in the November 17 issue, referring to the initiation of a movement to form an organization termed the American Specification Institute. . . .

Specification writing is a field which is gradually receiving increased attention and research, as necessitated by the intricacies of modern architectural practice, but which is still in need of the best efforts of the entire profession.

WALKER & WEEKS,
Per Frank W. Reynolds.

Cleveland, Ohio.

* * *

Your editorial on Specification Writing is very opportune and we believe such a course of study would prove invaluable.

The average architect beginning practice to-day knows very little about this most important phase of his work.

He little knows how much stress a client will put on his knowledge of stone and concrete; the grades of lumber; the most efficient kinds of paint for various purposes; what constitutes the various grades of glass; plumbing goods; hardware and electrical work.

The architect to correctly specify must know these things intelligently and intimately so that he may not only be in a position to advise the client but to advise the builder if necessary.

To make specifications concise and intelligent is as you say another problem to be solved. A start in this has been attempted in this office by listing the items under the various headings more like a bill of materials, with all the preliminary ands and ifs and buts at the head of the page. Both for purposes of estimate and constructive purposes, this venture was successful although the specification was not as complete as we would like to make it.

We feel that architects in general would stand much higher in the estimate of the client and that the reasonableness of the fee would be conceded if we were all thorough along the lines mentioned.

Architecture is the art of building thoroughly even as much as making buildings attractive.

Philadelphia.

HEACOCK & HOKANSON.

* * *

In reply to your esteemed favor of November 24, we beg to say that we approve of any effort on the part of agencies for the advancement of our profession and accordingly approve the "American Specification Institute" provided such an agency is for the purpose of making clear the importance of specifications and of making men's minds in the profession competent and capable to take more of the idea.

We, of course, do not approve of any institution that would seek to standardize so important a document as a specification, because we believe that personality and creativeness enter as much into this branch of the architect's work as in matters of design and execution of drawings. We do not believe that you can make specification specialists because we believe the specification maker must be imbued with all the art and questions of accomplishing a building and it is a subject as intimate as the architect himself.

We do feel that greater importance should be attached to this subject and that it is a fine field for the agency you refer to offer its note of culture to the profession.

Atlanta, Ga.

EDWARDS & SAYWARD.

* * *

We have read the editorial in your issue of November 17 with considerable interest. We do not believe that, today, specifications are considered a minor part of the architect's or engineer's contract. Up to about ten years ago it was the custom of a great many architects and engineers to slight the specifications, as their importance was not recognized at that time. We believe today, however, that the most reputable architects and engineers realize that specifications play as important a part in the contract as the plans, and considerable time and thought are spent in endeavoring to write specifications that will be clear and concise.

We agree with you that it is not uncommon for a question to arise which has apparently not been taken care of in the specifications. In most cases of this kind, however, the trouble is due not to ignorance or inability to write specifications, but is rather due to lack of experience or else carelessness.

We believe a Specification Institute would prove of considerable value, if properly conducted. We would suggest that the manufacturers of various products, as well as contractors and builders, be approached, in order to obtain all the information available.

F. P. SHELDON & SON.

Providence, R. I.

DEPARTMENT OF ARCHITECTURAL ENGINEERING

The Metropolitan Annex, New York City

D. EVERETT WAID, *Architect*

THE growth of the life insurance business is nowhere more strikingly illustrated than by the example presented in the expansion of the Metropolitan Life Insurance Company's home office, New York City. In 1892 the original building on the north-east corner of Twenty-third street and Madison avenue was erected. This is eleven stories in height, with a frontage of 425 feet on Twenty-third street and 197 feet 6 inches on Madison avenue.

In the course of time more room was needed and at various periods the building was extended to Fourth avenue, the main building finally taking up the entire block frontage from Twenty-third to Twenty-fourth streets on Fourth avenue. At that time the southeast corner of Twenty-fourth street and Madison avenue was occupied by the Madison Avenue Presbyterian Church, a brownstone edifice erected many years previous. However, the growth of this life insurance company seemed so rapid that

negotiations were later entered into with the church authorities for the purchase of their property. These negotiations resulted in the transfer of the property, and the church, shortly thereafter, moved across the

street to a new edifice, built according to the design of McKim Mead & White. On the site of the former church building, the 48-story Metropolitan Tower, of which N. Le Brun & Son were architects, was soon reared. This squared out the entire block bounded by Madison and Fourth avenues, Twenty-third and Twenty-fourth streets, a ground area of 200 by 550. To furnish additional office space another building was erected on Twenty-fourth street, across the street from the main building, and adjoining the new Madison Avenue Presbyterian Church.

But the steady growth of the company continued and finally the new church followed its predecessor, and today on that site the Metropolitan Annex is now nearing completion. This building is 16



THE METROPOLITAN ANNEX, NEW YORK CITY
D. EVERETT WAID, ARCHITECT

THE AMERICAN ARCHITECT

and in part 18 stories in height, plus two stories below ground, and 75 x 225 ft. in ground area. The Metropolitan Life Insurance Company now employs over 5,000 persons in its home office, and has but recently

foundation. For the new building excavation was carried to rock, the level of which was about 25 ft. below curb. The interior columns rest on steel grillages. Below the sidewalk level, the excavation was carried out to the curb line on the two street fronts. The sub-basement level is 26 ft. 4 in. below curb. The outside 4 inches of the retaining walls are of brick, and between this and the main wall, which is of concrete between vertical steel beams, is placed a membraneous waterproofing. This waterproofing is carried through the base of the wall to connect with the sub-basement floor waterproofing. Just inside the wall line, and below the concrete floor and waterproofing, a 4 in. tile drain is laid for sub-surface drainage. This is connected to a pump whence it is pumped to the street sewer, thus preventing pressure under the waterproofed sub-basement floor.



Inner Wrapping of Metal Lath

Method of Fireproofing Columns. Space Between Metal Lath Filled with Concrete.



Outer Wrapping of Metal Lath

Diagonal "X" bracing is placed between the side wall columns and the first row of interior columns in both the sub-basement and basement stories, as shown in the wind bracing diagram.

constructed its own printing building at Long Island City, N. Y. This structure contains 9 acres of floor space.

The new Metropolitan Annex, illustrated in this article, has many features of interest.

It will be noted from one of the illustrations that the church structure was supported on a wood pile

The sub-basement and basement will be devoted chiefly to storage purposes. The main entrance to the building is at the easterly end, on Twenty-fourth street. A bank of six electrically driven elevators of the overhead 1 to 1 traction type is provided. The entire first floor, with the exception of the entrance hall, is laid out as an auditorium. The main floor has a seating capacity of 784 persons, and the balcony (second floor level) will seat 276 persons additional, a total of 1,060 seats in all. A double set of windows provides insulation against street noises, and the sub-

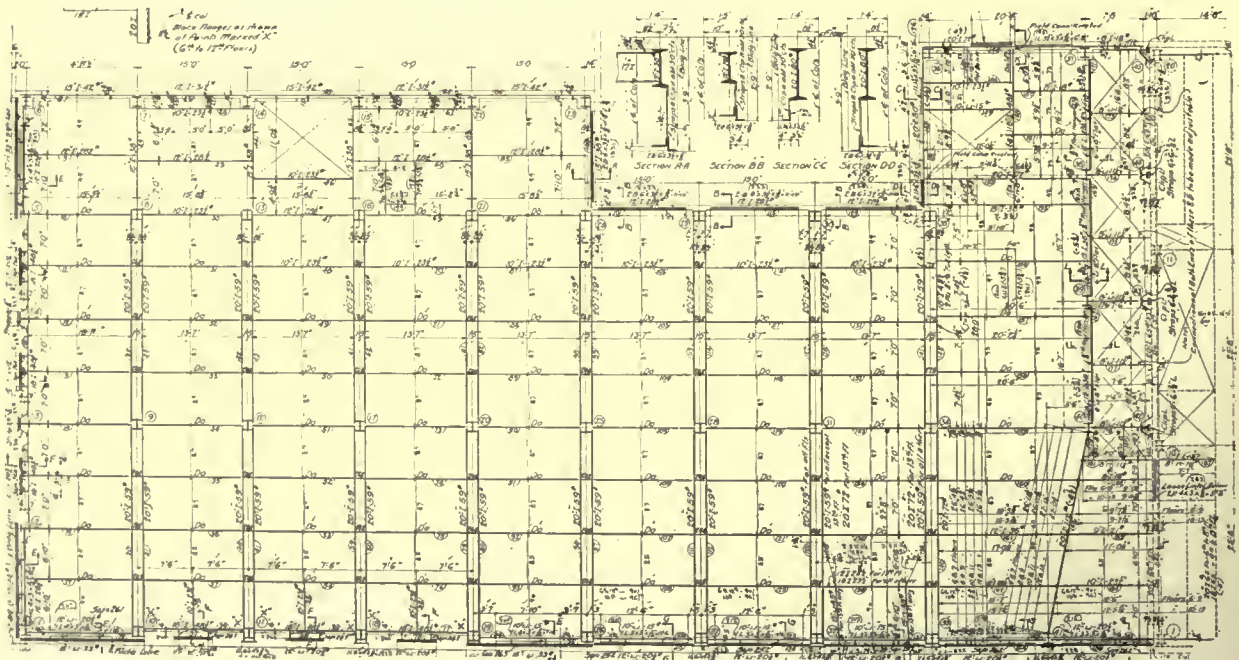

TYPICAL FRAMING PLAN FOR UPPER STORIES



SITE OF THE NEW METROPOLITAN ANNEX
Demolition of Madison Ave. Presbyterian Church in progress.



CHURCH EDIFICE ENTIRELY REMOVED
Site was excavated to rock and all old piling removed.

ject of ventilation for this auditorium has been gone into as carefully as in the case of the largest theatre. A positive supply and exhaust system has been installed. Along the basement ceiling, that is, below the auditorium floor, which is on a pitch, four longitudinal ducts, one under each of the outside blocks of seats and two under the central blocks, are

placed. Each duct distributes fresh air under the seats through slightly over 100 mushroom ventilators. These longitudinal ducts connect with a header just below, and on line with the front of the stage, which in turn is provided with fan, heating chamber and fresh air intake. During mild weather air can be circulated at the normal outside temperature, while



STEEL ERECTION IN PROGRESS
Compare adjoining structure at rear with similar view above.



PROGRESS VIEW
Street walls are faced with white marble.



PROGRESS VIEW. SLOPING STEEL WORK FOR BALCONY CAN BE SEEN AT THE LEFT

during cold weather, the air will first be heated to the proper temperature by passing through the heating chamber before reaching the distributing ducts.

Two main stairways, located at opposite ends of the building, extend from basement to roof.

A girder at front of gallery spans the width of the building, leaving the space beneath the gallery clear of columns, as shown on the balcony framing plan.

Probably the most interesting feature of the construction is the placing of trusses in the third story, to carry a central row of columns from fourth floor to roof and omitted below in the auditorium. Thirteen stories as well as a two-story pent house extend above the top of trusses. The heaviest individual column loads brought down to the trusses is approximately 600 tons, occurring at columns 28 and 31.

A detail drawing of one of the trusses is shown on page 832. The span is 56 ft. 8 in., and the height, center to center of chords, is 11 ft. 10 in. The web members are so arranged as to permit of a door at the center between the vertical members DA7 and DA8. Horizontal "X" bracing was used between each pair of trusses, as shown on the third floor framing plan. Similar bracing occurs at the fourth floor also.

The third story in which the trusses occur will be occupied as a filing room, the files being arranged in the rooms between trusses. These rooms are connected by the openings at the center.

The method of fireproofing the trusses is interesting, in that the fireproofing forms an enclosing partition as well. Metal furring bars were placed

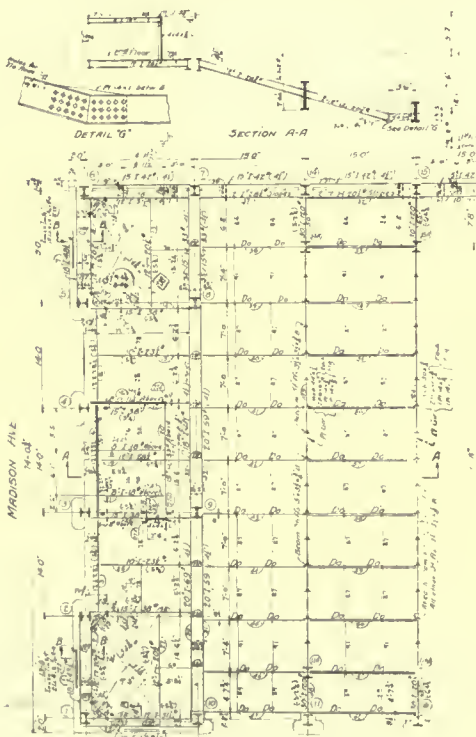

BALCONY FRAMING PLAN

on either side of each truss. Metal lath was wired on both sides of the furring bars and the space thus formed between the sheets of metal lath was poured full of cinder concrete, forming a concrete protection, when finished, 2 in. thick.

One of the offset columns, Col. 34, is supported at the third floor level by a heavy double plate girder having a span of 42 ft. This girder frames between Cols. 33 A and 35, and is 5 ft. 6½ in. deep. At the point of maximum bending moment (under Col. 34) the upper and lower flanges of each girder are composed of two 8 in. by 6 in. by 1 in. angles; 2 flange plates (vertical), 16 in. x 1 in. and four cover plates, each 16 in. x 7/8 in. The web plate is 1½ in. thick. Due to the thickness of these plates and angles all holes had to be drilled, as punching was out of the question. The detail drawing of one girder is shown on page 833. The other girder is the same, except reversed. Column 34, which the double girder carries, brings down a load of over 700 tons.

The New York building code requires wind pressure to be figured on all buildings over 150 ft. in height, and on all buildings or parts of buildings in which the height is more than four times the minimum horizontal dimension. This wind pressure is taken at 30 lbs. per sq. ft. of exposed surface, measured from the ground to the top of the structure. While wind stresses must be computed, a further paragraph provides that when the stress in any member due to wind does not exceed 50 per cent. of the stress due to live and dead loads, the working stresses prescribed may be increased by 50 per cent. in designing such members to resist the combined stresses.

In the Metropolitan Annex it was possible to take care of the wind stresses at each story by the arrangement of the double cross girders, consisting of 20 in. x 59 lb. I beams, and the special connections, details of which are shown on the sheet

with the wind bracing diagram. The floor girders did not have to be increased in section in any case to take care of the wind stresses.

The design of the steel framing on this building is worthy of careful study. It is not always possible to

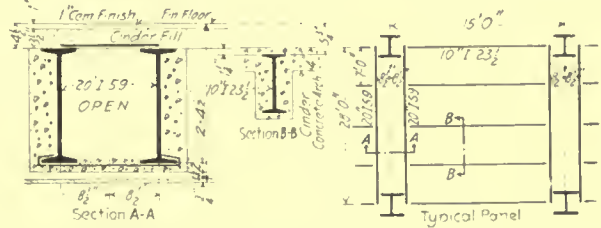

TYPICAL FLOOR CONSTRUCTION

work out an arrangement of joists and girders which, while accommodating themselves to the column layout, are at the same time fully stressed to their safe carrying capacity. In other words, the arrangement is often such that one size beam is under and the next commercial size is stronger than necessary, yet the latter must be used for safety.

The floor loads used in the computations for a typical bay of the floor framing are given in the following table. A drawing showing the typical floor construction appears above. A typical framing plan is shown on page 828.

These figures are the average value over the entire area supported by the girders, and not the actual square foot figures.

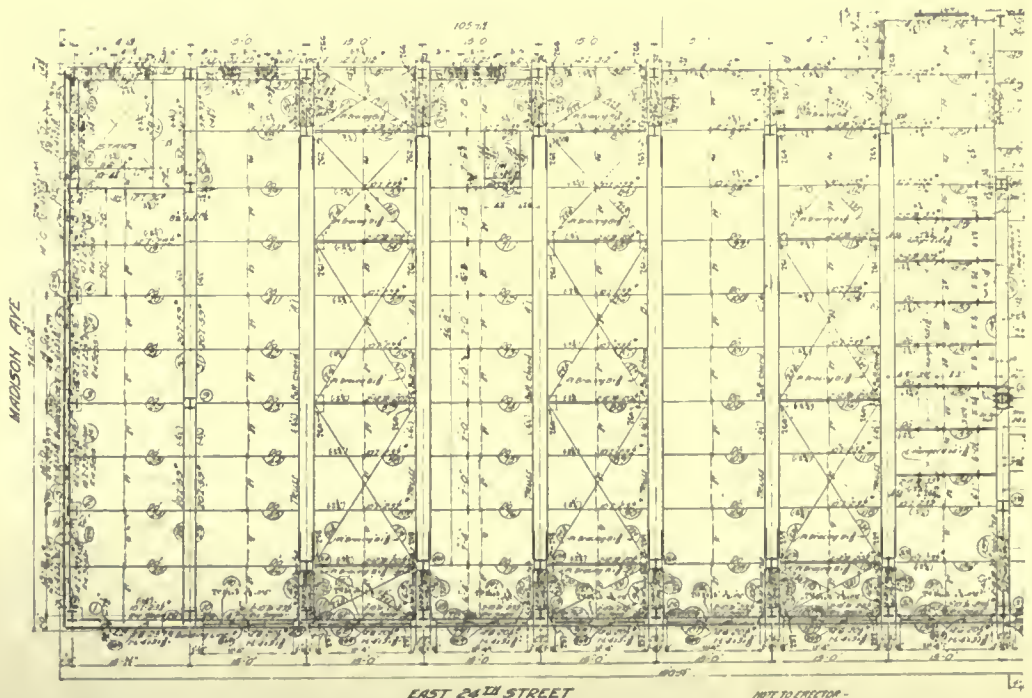

PORTION OF THIRD FLOOR FRAMING PLAN, SHOWING LOCATION OF TRUSSES AND DOUBLE-PLATE GIRDER

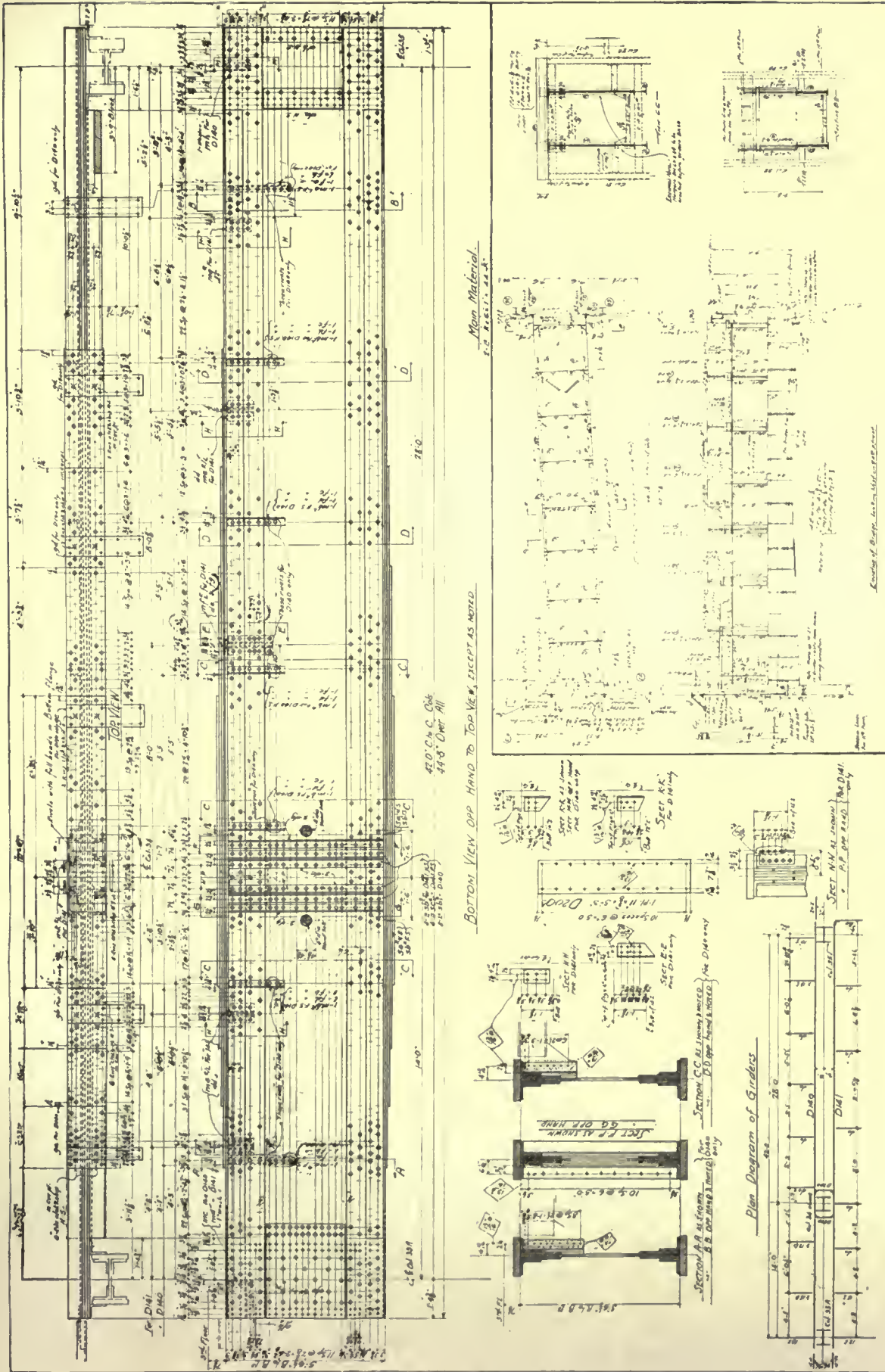

DETAIL DRAWING OF PLATE GIRDER CARRYING COL. 34 ABOVE THIRD FLOOR LEVEL.

Insert in lower right hand corner shows construction of connecting bridge at 12th story.

THE METROPOLITAN ANNEX, NEW YORK CITY
D. EVERETT WAID, ARCHITECT

THE AMERICAN ARCHITECT

THE METROPOLITAN ANNEX. Loads Used for Girder Computations.

	Lbs. per sq. ft.
1 in. Cement finish.....	12
3½ in. Cinder fill.....	17
4 in. floor arch.....	30
Beam	3
Beam haunch	7
Furred Ceiling	10
Girder	8
Girder haunch	13
<hr/>	
Dead Load	100
Live Load	120
<hr/>	
Total Load	220

For beam computations those items relating to the girders in the above list were omitted. The average sq. ft. values of some of the other items are, of course, slightly higher, resulting in a beam design total load of 206 lbs. per sq. ft.

It will be noted that by using the double girders the span of the beams is reduced 1 ft. 5 in., thus permitting a lighter 1 beam than if a single girder had been used. With a single girder framing on the column centers, knee braces or special steel "plate and

angle" knee connections would have been necessary to take up the wind stresses, whereas with the double girders, such connections were simplified. These connections, however, were specially designed to take up the secondary wind stresses, which, of course, required a greater degree of stiffness and, therefore, additional rivets above what would have been required to take the vertical reaction only. It will be noted that the girder bending moment, due to accumulated wind loads, runs as high as 323,000 ft. lbs. at the second floor level for the girder between Cols. 8 and 9. (See wind bracing diagram).

Connecting the steelwork of the new Annex to that of the adjoining easterly structure involved a large amount of field work—drilling, cutting, etc. The steel work of the older building was erected by Levering & Garrigues Company, who were awarded a similar contract for the new building. The original detail drawings of the column, girder and other connections of the older building were still in the files of this company, and by consulting these it was possible to detail accurately the new steel work which connected with the columns and girders of the existing building.

In the photograph showing the demolition of the Madison Avenue Presbyterian Church, this older building is shown in the background. It will be seen

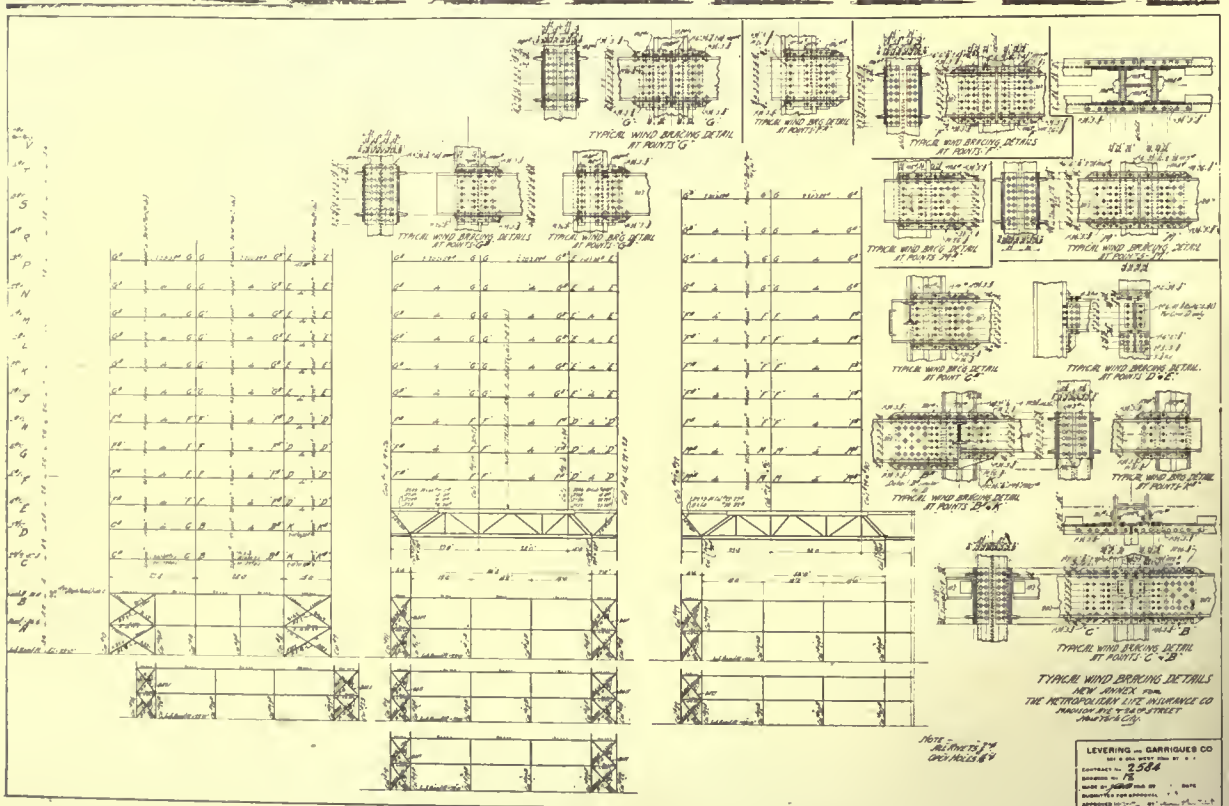

WIND BRACING DIAGRAM AND TYPICAL WIND BRACING DETAILS

that the wall toward the church site is faced with marble ashlar. After the erection of the new annex, this wall became merely a division wall, and for that reason the marble ashlar was entirely removed. This is clearly indicated in the photograph showing several tiers of steel erected. Due to the stripping of this marble facing, the old wall girders were relieved of a considerable load, thus permitting their carrying the load from floor framing of new building.

At the fourteenth floor, heavy plate girders in the wall of the existing building carrying offset columns had to be materially altered and lowered to fit in with the new arrangement, since these girders were located at a different level from the new framing.

Since the Annex is really an extension of the main building, on the opposite side of Twenty-fourth street, a connection between the two was a desirable feature. This has been accomplished by a connecting bridge over Twenty-fourth street, at the twelfth floor level. This bridge is constructed on two plate girders, carefully protected with concrete fireproofing, and covered with copper.

In order to erect such a bridge over a public highway favorable action by the Board of Estimate and Apportionment is required. The structural details of this bridge are illustrated in one of the drawings. It can also be seen in the drawing of the completed building.

Both materials and workmanship throughout are



METHOD OF FIREPROOFING STEEL TRUSSES

of the highest quality. The street walls are faced with marble.

The auditorium is designed to be an attractive con-



STEEL ERECTION IN PROGRESS ON METROPOLITAN ANNEX

Note horizontal "X" bracing in place between lower chords of auditorium trusses, also heavy plate girders. Stripping of stone ashlar on adjoining building is plainly visible.

THE AMERICAN ARCHITECT

vention and lecture hall, provided with comfortable opera chairs, 1,060 in number, and with a moving picture equipment. There are coat and toilet rooms for the public below the Madison avenue lobby, and retiring rooms for speakers near the platform.

The entrance to the upper part of the building is on Twenty-fourth street, east of the auditorium. Elevator halls are floored with Tennessee marble and wainscoted with glass. The several stories are to be used in large, undivided spaces for clerks, and lighted by means of semi-indirect chandeliers. Floors generally are terrazzo, the marble screenings being a mixture of white Italian and white Alabama marble. Toilet rooms have tile floors and white glass, W. C. stalls and wainscot.

Windows at the rear are all of rolled steel of the austral pivoted type. Street front windows are double hung copper kalamein, and all windows are glazed with wired plate glass.

The roofs are covered with red tile. Skylights and flashings are copper. The flag pole is built of several cylindrical steel tubes with a tapered effect.

The building was designed by D. Everett Waid, architect. The George A. Fuller Construction are the builders.

Decisions Rendered By the National Board for Jurisdictional Awards

November Meeting

TILE AND PORCELAIN BATHROOM ACCESSORIES

[Subject of dispute between the Tile Layers and Plumbers.]

DECISION—In the matter of the controversy between the Tile Layers and Plumbers over setting and alignment of tile and porcelain bathroom accessories, it is decided that all bath and toilet room accessories made of clay products, built in tile-faced walls, shall be the work of the tile setter.

CONCRETE COLUMNS, FOUNDATIONS, ENGINE AND MACHINERY BEDS

[Subject of dispute between Bricklayers, Hod Carriers and Plasterers.]

DECISION—In the matter of the jurisdiction over foremen on concrete columns, foundations, engine and machinery beds, as contested by the Bricklayers, Hod Carriers and Plasterers, it is the decision of the Board that the work shall be done by the laborers under the supervision of such skilled workmen as the employer may designate.

BISHOPRIC BOARD

[Subject of dispute between Lathers and Carpenters.]

DECISION—In the matter of the dispute over the installation of Bishopric Board when applied as a substitute for lath, it is the decision of the Board that the work shall be done by the Lathers; where the same is used for sheathing it shall be the work of the Carpenters.

FLAXLINUM KEYBOARD AND INSULATION

[Subject of dispute between Lathers and Carpenters.]

DECISION—In the matter of the dispute over the installation of Flaxlinum Keyboard and Insulation, it is the decision of the Board that when the same is used as a substi-

tute for lath or when any plastic material is to be applied that the work shall be done by the Lathers; when Flaxlinum is used as insulation or sheathing it shall be the work of the Carpenters.

METAL FLOOR DOMES

[Subject of dispute between the Sheet Metal Workers, Lathers and Carpenters.]

DECISION—In the matter of the controversy between the Sheet Metal Workers, Lathers and Carpenters over metal floor domes, it is decided that the placing of metal floor domes, whether temporary or permanent, whenever supported by wood props, or other wood supports and used as forms for concrete construction, come within the jurisdiction of the Carpenters.

METAL FORMS FOR CONCRETE COLUMNS

[Subject of dispute between the Sheet Metal Workers, Carpenters and Iron Workers.]

DECISION—In the matter of the controversy between the Sheet Metal Workers, Carpenters and Iron Workers over metal forms for concrete columns, it is decided that the setting of of such forms of No. 10 gauge metal or lighter is the work of the Carpenters and when heavier than No. 10 gauge it is the work of the Iron Workers.

ELECTRICAL WORK ON SIGNAL SYSTEMS, FANS, TELEPHONES, ETC.

DECISION—The electrical work involved in the installation of signal systems, fans, telephones, electric light fixtures and illuminated thresholds, and electrical interlocking devices, except on automatic elevators, and feed wires to the controller, is awarded to the Electrical Workers.

HOLLOW METAL DOORS AND TRIM

[Subject of dispute between the Sheet Metal Workers and Carpenters.]

DECISION—In the matter of the controversy between the Sheet Metal Workers and Carpenters over hollow metal doors and trim, it is decided that the hanging of such doors, except sliding doors, the installation of the door frames, the placing of the trim around door or other openings and the placing of all other metal trim, is the work of the Sheet Metal Workers whenever the metal is of No. 10 gauge or lighter.

HOLLOW SHEET METAL WINDOW FRAMES AND SASH

[Subject of dispute between the Sheet Metal Workers and Carpenters.]

DECISION—In the matter of the controversy between the Sheet Metal Workers and the Carpenters over hollow sheet metal window frames and sash, it is decided that the setting of hollow metal window frames and the hanging of hollow metal sash, when such frames and sash are made of No. 10 gauge metal or lighter, is the work of the Sheet Metal Workers.

Lime Mortars at Own-Your-Home Exposition

Lime mortars will have a prominent place at the Own-Your-Home Exposition in Chicago and New York this winter. Large centrally located spaces have been engaged in each hall, where the merits of lime in stucco, plaster, concrete and masonry mortars will be graphically depicted. Its value in waterproofing will also be shown, experimentally, as well as its soil-sweetening effect on garden produce.

Current News

Happenings and Comments in the Field of Architecture and the Allied Arts

Mexico Retains Its Strength

When redemption comes to Mexico it will not be through fire and sword, but through the soil. An American who has made a study of Mexican conditions at first hand reminds us that a great English statesman once remarked that a country whose wealth was in the soil was like a pyramid with a great base. It might suffer superficial damage through a great shock, but it could never be destroyed.

This same American tells us that conditions of revolution in Mexico with hardly a cessation since 1911 have not affected in the least the real wealth of the country. Her riches, he says, are in wheat, corn, cattle, oil, hemp, gold, silver, copper, timber, fruits, coffee, tobacco, sugar, chocolate and many other products of the soil. With a rich soil and a climate that makes harvests possible the year around she could feed a nation six times the size of her own, while her timber, oil and mineral resources are almost virgin in their luxuriance. The problem then is how to so manage these resources as to give the people that measure of sufficiency that means contentment.

It cannot be done by parcelling out the land among all the people. Madero tried this and failed ignominiously. Since the peon class constitutes nine-tenths of all the people, and since it has been in this state of peonage for centuries, it is incapacitated through ignorance and inexperience to cultivate the soil without some assistance, even if a land distribution were made. The whole class probably would starve before it raised the first crop. Some other measure is needed.

The government that is to be permanent in Mexico will be the one that hits upon the plan of helping these peons to become small land owners and then assists them in making a start as independent producers.

A Sixth Century Temple in the Jungle

In central Java there stands a temple built in the sixth century of the Christian era, which is in almost as perfect a state of preservation as when the workmen and artists laboring upon it laid down their tools. The temple is one of the architectural wonders of the world. Yet, strangely enough, little has been written of it except in great scientific volumes,

mostly in Dutch, which do not come into the hands of the American architect.

Words fail adequately to tell of this remarkable building. It was reared according to the *Boston Transcript* by Buddhist missionaries and their followers to hold a vase of ashes of Buddha. The ashes of Buddha, according to the history of the times, were divided first into eight parts and placed in tombs in certain cities in India. Later King Osaka of India, the most jealous apostle of Buddhism in the annals of that religion, had the ashes redivided into eighty-four thousand parts, which were placed in separate vases and taken by different missionaries. Some of these men went to Java and soon the country adopted their religion.

As a fitting monument in which to place the vase of ashes the temple of Boro-Budur was erected. It is particularly interesting at this time, as a syndicate of Dutch capitalists has announced the starting of an airplane service throughout the Malay archipelago. Java, with its great population and trade connections, will be one of the most important islands on the route, and its marvelous temple will be the most interesting sight.

The temple of Boro-Budur is 150 feet high, and stands on an artificial plain encased with huge lava blocks. It is made up of terraces, the galleries of which are filled with bas-reliefs. In the corner of each of the galleries, which are many-angled, sits a Buddha on his lotus leaf.

Through the parapet of the artificial plain on which the temple stands are steps which are guarded by grotesque animals of stone. On the upper flat are seventy-two bell-shaped shrines. These are of lattice work stone and within every one of them is a Buddha seated gazing toward the vast central dome. This dome is fifty-two feet in diameter, and at one time had an immense topping spire.

Following the Moslem invasion in the fifteenth century, A. D., the temple was deserted, and surrounded with jungle. It remained unknown to the world until 1814, when it was stumbled upon by Sir Stamford Raffles, then lieutenant governor of the island. He at once realized the historic value of the wonderful temple, and put hundreds of men to work to reclaim Boro-Budur from the jungle. This undertaking was continued by the Dutch when they took over the island.

Largest World Tunnels

Among the longest tunnels in the world is the Alberg tunnel under the Alps, which is six and three-quarters miles long. The Gunnison tunnel in Colorado is six miles long, and the Hoosac tunnel in Massachusetts is four and three-quarters miles long. The Mont Cenis, in Italy and France, is eight miles long.

The Croton water tunnel in New York is 33 $\frac{1}{8}$ miles long, while the tunnel which drains the Freiberg mines, in Saxony, is 31 $\frac{1}{2}$ miles long. The St. Clair tunnel, connecting Sarina, Ont., with Port Huron, Mich., is two miles long, and the Strawberry tunnel in the Wasatch Mountains is 50 miles long.

Palm Leaves Replace Canvas in Tent Cottage Walls

The tent cottage of the western summer resort is disappearing before the thatched palm house. The thatch house consists of the usual tent-cottage frame work, but instead of canvas, palm leaves are tacked on. These are quite durable and serve equally well for walls and roof. The result is a neater and more artistic appearance. The cost is also smaller as the palm thatch costs little as compared with canvas.

Massachusetts Institute of Technology Offers Architectural Courses

The Department of Architecture is offering a course in modelling in architectural ornament, under the direction of Mr. John A. Wilson, every Friday evening from half-past seven until half-past ten, and there will become available in the course of this scholastic year funds from which two scholarships will be offered, covering the amount of a year's tuition each, to special students. Details of the conditions for the latter will be announced later.

Color Screens for Show-Window Lights

Various technical obstacles have heretofore prevented the extended use of colored lighting for display windows, despite the attractive effects made possible by its application. It is learned from *Popular Mechanics* that manufacturers of a lamp reflector much used for show windows have now devised a simple metal frame which holds a removable sheet of colored gelatin over the mouth of the reflector, that material having been found eminently suited to the purpose. The gelatin, in the form of a slide,

is supported by a mesh of fine wire, and an asbestos-cord harness holds the frame on the reflector.

The slides are readily changed or combined to produce any tint desired, and by the use of a flashing switch, alternate or successive color changes may be automatically made. The effects produced are not confined to the positive colors, and the subtle shades of moonlight, dawn and other special conditions, are easily simulated.

Ghosts No Drawback

In England there are people, desperate in their search for a home, who advertise that ghosts are no drawback. Any one who happens to own a heretofore unrented house, because the word has gone around saying it is haunted, is assured that the home-hunters will accept it at the rental desired regardless of the spirits reputed to roam about the house after dark.

India Builds Enormous Masonry Dam to Avert Famine

With the object of saving crops and averting the terrible famines of the region's past history, the construction of huge storage dams in India has been proceeding for years. In the Ahmednagar district of the Deccan, east of Bombay, a masonry dam now being completed at Bhandara reaches the enormous height of 270 ft., and 85 miles of canals will be necessary to utilize the water for irrigating 75,000 acres of Ahmednagar land. At Bargha, farther south, another great dam is being built for watering 125,000 acres in the districts of Poona, Satara, and Sholapur. A still larger project is the Nira right-bank canal, now nearly ready, which cost about \$20,000,000.

Native Japanese Architecture Gives Way to Modern Styles

Modern buildings constructed after the Western manner are driving the native architecture out of the large Japanese cities, according to Dr. Y. Kataoka, consulting architect to the Osaka Municipality and member of the Osaka Municipality Laying Out Committee, who is a guest of the Hotel Pennsylvania, N. Y. Dr. Kataoka is here to study our modern office buildings and municipal building construction with a view to incorporating some of the American ideas with those at present in use in Japan.

"Our houses and shops are all built of wood after a style which dates back many centuries," said Dr. Kataoka. "It was all very well when we were isolated from Western civilization and only did our business in a small way. But with the increase of

foreign commerce and the influx of men of many nations the old method of building is absolutely out of the question. We must build to gain the most floor space and to make the most of the ground that we have, for Japan is a nation which is even more overcrowded as to population than are your large American cities, as you undoubtedly know.

"I believe that in the course of time modern office buildings and apartment houses of Western construction will entirely drive the Japanese houses out of the cities. Japan may retain her present appearance in her country districts, but the whole face of the metropolitan area will be changed. It is rather sad to see the picturesque dwellings go, but, after all, it is the trend of civilization. We are making a new and modern world and the old must yield to the new. In our architecture, locality, climate, art and even religion must be taken into account, but modern experience teaches us also the necessity of consulting expediency, comfort and efficiency."

Wood That Does Not Rot

The wood of the mangrove tree which flourishes in French Guiana, is being exploited in France as a wood which will not rot. At least it has withstood all exposure and efforts to break down its fiber in four years of experiment by the officials of the French Railway service. Every one of the many samples which were subjected to all the known processes of inducing decay, behaved faultlessly, and it would seem that the wood is rot-proof. The grain of the wood is so close as practically to exclude moisture. Its density, indeed, is placed at 110, as against 40 in fir and 70 in oak. In addition to this closeness of fiber the mangrove has an unusually large amount of tanning in its composition. This protects it from invasion by insects. It also prevents the multiplication of various germs, and is a specific against such wood maladies as mold, damp and the like.

It has other desirable qualities. For instance, tests show that while it is not brittle, it presents twice the resistance to flexion that oak does. It has about the same potency against crushing or twisting.

Plan New York Subway Needs for Next Quarter Century

Based on an expected population of 9,000,000 in New York City 25 years hence, and on a consequent traffic of 5,000,000,000 passengers a year on rapid-transit systems, engineers have recently completed plans for the subways and trackage necessary to accommodate that increase. The cost of the proposed improvements at present prices is estimated at \$350,000,000. An addition of 830 miles of single track

to the existing 616 miles is contemplated, including an eight-track, double-deck trunk line under Eighth and Amsterdam avenues, so designed that four tracks can be built any time and the other four added later. This line will connect at both ends with branch lines, four of them going into Brooklyn, and others traversing Queens, The Bronx, upper Manhattan and other tributary districts. It will make close connections with the railroad terminals and the tunnels from New Jersey. Another trunk line, under Madison Avenue, will be six-track part of its length, and four-track in other parts. Numerous extensions of existing lines are also planned. To connect The Bronx, Brooklyn, and Richmond with Manhattan, 21 new two-track tunnels will be ultimately necessary.

Concrete Building of Seventeen Stories

The first modern office building to be erected in the "Swamp," New York's historic leather district, is now in course of construction at the Southeast corner of Frankfort and Gold streets.

The Hide and Leather Building will mark a turning point in the history of concrete engineering and of architecture. It will be seventeen stories above the ground and will have the distinction of being the highest concrete structure in the world.

It is also said to be the first high-class office building to be built entirely of concrete, without a brick or stone facing.

By a method used here for the first time, the facing of the concrete for the bottom three floors is composed of pink quartz, placed at the same time as the structural concrete. Thompson & Binger, Inc., are the designers, engineers and constructors of the structure.

Veneer Waste as Paper Source

In the wood waste from veneer factories the U. S. Forest Products Laboratory sees considerable raw material suitable for the manufacture of high grades of paper. The cores of many kinds of veneer logs, now used in a large part for fuel, would make excellent pulpwood. In addition, a large part of the clippings and small veneer waste, which amount to 1-5 of the total veneer cut, probably could be turned into pulp stock with profit.

Among the veneer woods whose waste has paper-making possibilities are red gum, yellow poplar, cottonwood, birch, tupelo, basswood and beech. Many veneer factories cutting these species are already within shipping distance of pulp mills. In certain other cases, veneer factories are so grouped that they might furnish pulpwood enough to warrant the erection of

a centrally located mill. Other economic factors being favorable, such a mill could profitably operate on a daily supply of veneer waste equivalent to 50 cords of ordinary pulpwood. Of course, the construction of a mill should be undertaken only upon the advice of a competent mill engineer after a careful survey of local conditions.

"White Coal" in Canada

In view of the world's diminishing coal resources, "white coal," or developed water power, is more than ever commanding attention in various countries. Canada is now said to possess the greatest per capita water power development of any country in the world excepting Norway. According to "The Dominion of Canada," a study by the Bankers Trust Company, of New York, Canada, with 19,500,000 "white coal" horse power available, has a per capita development of .26 horse power, compared with .54 horse power for Norway, and .07 horse power for the United States. The latter country, with 30,000,000 "white coal" horse power available, leads the world in potential and developed water power resources, and Canada comes next.

Longer Life for Mine Timbers

Enormous quantities of valuable timbers are being placed in the coal and metal mines of this country without any preservative treatment against decay. That the life of these timbers might be greatly lengthened by the injection of certain chemicals has been proved by the U. S. Forest Products Laboratory in numerous service tests. In 1910 the laboratory installed in an Alabama mine untreated timbers and timbers which had been treated with coal-tar creosote. Ten years later all the untreated timbers had been removed because of decay, while 80 per cent. of the creosoted timbers were still sound, and none had decayed to a point where removal was necessary. This is only one of the many records obtained by the laboratory which should induce every mining company to install some sort of wood treating plant.

Grand Union Hotel Site Used by Bowery Savings Bank

As a site for a monumental structure for a branch bank that will be the equal of the many famous buildings in the Grand Central Terminal zone the Bowery Savings Bank has purchased the easterly portion of the old Grand Union Hotel site, Park avenue and Forty-second street.

This property, probably one of the most valuable vacant pieces of land in the world, is part of the site

chosen for the erection of Victory Hall, New York's proposed memorial to those who served America in the World War. Whether the memorial, estimated to cost about \$20,000,000, will be erected on this particular site is now a question. The Victory Hall Association will start a drive to raise the money by popular subscription soon, and if it meets with success it will be able to buy the site or, it is asserted, take it by legal action, as the Legislature on April 27, 1920, passed a bill authorizing the association to acquire, by condemnation proceedings, the property necessary for its proposed building.

Whitney Warren to Restore Louvain

Whitney Warren has been selected to restore in all its former artistic beauty the ancient University of Louvain, which was destroyed by the German army that invaded Belgium in 1914.

Mr. Warren was informed of the honor conferred upon him by a cablegram received at his studio which read:

"You were advised by letter that the committees of Louvain and Paris had both unanimously nominated you architect for the reconstruction of the University of Louvain. Today the committees met again and the president, M. Imbart de la Tour, and the vice president, M. Boutrouse, have asked me to confirm your nomination and to ask you to assume the task of reconstruction."

Mr. Warren replied:

"This is the first information I have received about my selection to restore Louvain University. It is an unusual honor and if I can possibly arrange it I shall be only too happy to take up the work. Much of the funds for this work is, I believe, to come from this country, for when Cardinal Mercier was here an American committee, co-operating with the Belgian and French committees, was formed, with Dr. Nicholas Murray Butler at its head, for the purpose of raising funds for the restoration of the library of the University of Louvain. This committee is now busying itself with the raising of a fund of \$500,000, of which \$150,000 has been pledged to date."

George W. Breck Dead

George William Breck, well known mural painter and sculptor, died at his home, 521 Broadway, Flushing, Queens, this morning of apoplexy. Mr. Breck had been a resident of Flushing for the past ten years following his work at the American Academy of Fine Arts at Rome. He was prominent in the civic work of Flushing, was a member of the Flushing United Association and also of the Artists Advisory Committee for the Flushing Soldiers and Sailors Memorial.

Mr. Breck was born in Washington, D. C., on

THE AMERICAN ARCHITECT

Sept. 1, 1863, the son of John and Annie Auer Breck. He first studied at the Art Students League in New York and was the first winner of the Lazarus Scholarship for mural painting, thereby winning the right to become a student at the American Academy of Fine Arts at Rome. He was a director of this academy from 1904 to 1909 when he returned to this country. Among his prominent works were the mural decorations of the University of Virginia, the Watertown, N. Y., Public Library, mosaics at St. Paul's Episcopal Church at Rome and the decorations in the home of the late Whitelaw Reid. He won a silver medal at the 1904 St. Louis Exposition.

Mr. Breck was a member of the Century Club, the Architectural League of New York, the Society of Mural Painters, the Municipal Art Society and served on the New York City Art Commission from 1912 to 1916.

European Streets Surpass Ours in Cleanliness

The large cities of Europe in the point of cleanliness and tidiness of streets are far ahead of New York, Chicago, Cincinnati and many cities in America, says Clyde A. Copson, manager of the anti-litter bureau of the Merchants' Association, who has just returned from a trip of observation in Europe.

"In some sections of New York," he said, "I can see more street litter in one square block than in any one city I visited abroad. Paris and London are models of cleanliness and comparatively free of street litter of any description. This is due to the fact that the people abroad are more tidy than we who live in America.

"The city of New York countenances conditions that none of the cities which I visited would tolerate for a moment."

Mr. Copson said that London has the best organized street cleaning department in Europe; Glasgow, the poorest, and Paris has the best garbage disposal system.

Referring to taxicab drivers and all chauffeurs abroad, Mr. Copson's statement said that they "seem to know their business and when in trouble, or about to run down a pedestrian, they apply the brakes instead of tooting horns. The chauffeurs in New York do just the opposite, hence the greater number of accidents and noises.

"Newsboys and venders in London," he added, "do not shout their wares, but instead carry signs

on which is printed in large letters the important news headlines. The system helps considerably in lessening the general noise. The subways, or 'tubes,' as they are called in London, are more comfortable than ours and scrupulously clean."

Concrete Brine Troughs Protect Railway Bridges

As much damage is being done to steel railway bridges as a result of brine from refrigerator cars attacking the metal, a narrow concrete trough, placed midway between the rails and designed to catch the objectionable fluid, is being installed on all steel bridges of a Michigan railroad. Concrete is unaffected by salt solutions.

Personals

W. A. Vaughn, architect, has moved his offices from 61 New York avenue N. W., Washington, D. C., to 3100 South Dakota avenue S. E., that city.

The I. T. Hatton Co., architects, 1200 U street N. W., Washington, D. C., will trade in the future under the name of I. T. Hatton, architect, and L. W. Gilles, associate architect.

Thaddens W. Parke, architect and engineer, has opened an office at 215 Foster street, Lowell, Mass.

Oscar F. Cook, architect formerly with the A. A. Honeywell Co., architects, 218 Citizens' Trust Bldg., Kokomo, Ind., has opened an office for the practice of architecture, at 217 Citizens Bank Bldg., that city.

Wm. W. Cooke has opened offices at 2308 Adams St., Gary, Ind., for the practice of architecture. He desires manufacturers' data and samples.

Jobson & Hubbard have moved from the Pullman Bldg. to 225 N. Michigan Ave., Chicago.

Hewitt & Brown have moved to 1200 Second Ave. South, Minneapolis, Minn.

Tilden & Register are in new offices at 1525 Locust St., Philadelphia.

Croft & Boerner are now at 1006 Marquette Ave., Minneapolis.

Weekly Review of the Construction Field

With Reports of Special Correspondents in Prominent Regional Centers

THE feeling of uncertainty, not only in the building industry, but in almost every other industry as well, is still with us.

This statement is substantiated by the fact that the world wide decline in commodity prices which set in last spring has shown considerable acceleration during the past month, especially in Great Britain and the United States.

The various price indices in the United States show declines of from 13 to 33 per cent., the Monthly Review of the Federal Reserve Bank of New York states in its issue of November 30:

A substantial portion of these declines has occurred in the last sixty days, and already there are signs that the lower prices for raw material and goods at wholesale are beginning in some cases to be reflected in retail prices and that thus consumers are beginning to receive the benefit of the enhanced buying power of the dollar.

WHOLESALE PRICE INDICES

Country	Per cent. decline during latest month reported	Per cent. decline from highest
United States		
Bureau of Labor	7.0	17.3
This bank's index (12 basic commodities)....	5.2	33.5
Dun's	4.3	13.7
Bradstreet's	7.3	24.9
British		
Economist	6.2	14.1
Statist	3.4	9.9
French	4.4	13.9
Italian	8*	2.1
Japanese	2.1	28.3
Canadian	2.9	11.0
Swedish	4.4	6.2
Australian	2.5	2.5
Calcutta	1.0	5.5

*Increase.

These indices include basic commodities, among which practically all the basic building commodities are listed. Yet employment decreased in the building trades some 12 per cent. during November and is now 30 per cent. below the peak reached in the spring and early summer, due, in part, to the usual seasonal declines and in part to a lack of new construction.

Perhaps this has something to do with the future rate of interest, which, it is pointed out in financial circles, will not be markedly lowered in the future. The reasons given are: First, the reported intention of the farmers to withhold their crops from the market, thus tying up an indefinite amount in loans. Second, heavy borrowings from the Federal Reserve banks. Third, the apparently unlimited demand for loans by foreign states and municipalities. Fourth, the money needs of American railroads, American industries and American cities; and finally, the funded and unfunded indebtedness of the Federal Government which will mature in the next four years. The Government requirements alone show an approximate total of eight billion dollars.

In the face of these facts it would seem that the suggestion offered by President Dunning, of the New York Savings Banks Association, that the small banks dispose of their long-term bonds, even if at a loss, for the purpose of first mortgage investment, would be seriously considered.

It certainly seems to have been seriously considered. S. W. Straus & Company has this to say regarding Mr. Dunning's proposals:

In general, his contention that the banks would do well to place a larger proportion of their assets in the highest grade mortgages has attracted widespread approval and certainly is worthy of the most serious consideration. What he says in regard to the advantage gained from disposing of long-term listed bonds, even at a loss from the purchase price, is incontrovertible and his argument in favor of high-grade securities is a very striking one which we believe merits the careful attention of bank officials, especially in those states where the legal restrictions are such that a wide choice of good mortgage investments is available to the banks.

If "what he says in regard to the advantage gained from disposing of long-term listed bonds, even if at a loss from the purchase price, is incontrovertible . . . and merits the careful attention of bank officials," why have not bank officials given it careful attention?

From all indications at the present moment it is just as difficult to obtain money for building purposes at it has been in the past. Would "careful attention" to Mr. Dunning's proposal, admittedly "incontrovertible," permit of such a condition?

As regards labor the situation is being bettered. The dismissal of two radical leaders from the national labor councils has been effected within the last

THE AMERICAN ARCHITECT

week, and the New York tangle is being slowly, but surely, straightened out.

Newark, N. J., witnessed an unusual and novel attempt by labor to unionize architectural draftsmen, but the attempt failed because of the stand both the architects and draftsmen took upon the matter. The fact that it failed is significant. It shows that labor knows its limits and will stop within them, when it meets opposition outside of those limits. There is plenty of common sense in the ranks of labor. The problem is to make it show its hand.

(Special Correspondence to THE AMERICAN ARCHITECT)

SEATTLE.—Building activity on the Pacific Coast for the coming year will depend largely on how far the retail trade is willing to go in dehydrating war-time profit margins. Wholesalers and jobbers contend that they have performed their part in acceding to the demands of the hour, but that the retail trade has made little if any change in these margins that it is felt can no longer be permitted to stand, their purpose having been served.

A rather exhaustive survey of the jobbing field which comprises all building essentials from steel and lumber to brass fittings indicates that 1921 is to be an extraordinary year on the Pacific Coast for building, but that unless all concerned in the production, jobbing and retailing of these commodities are willing to at once or immediately following stock taking bend to the demands that are familiar to all, the beginning of this wave of construction will be delayed so far into the new year that not to exceed 50 per cent. of the buildings can be got under way until cold weather again shuts off the work.

Architects have been consulted with rare frequency on the subject of building by investors, but the enquiry is never without an urge for information about prices. It seems clear that unless costs of construction materials recede signally there will be another year of "homeless" families.

The best that jobbers in steel products are able to report on the Pacific Coast is a decline of 20 per cent. in a few of the building essentials. The Jones-McLaughlin announcement of the week did not have any effect on coast steel products, as it was felt that it was provincial in its effects and not at all significant of any general reduction.

The feature of the week, however, seems to lie in the fact that in place of dodging orders or complaining of inability to load back orders the eastern steel mills are now vigorously soliciting new placements, claiming that their motive is to keep the plants in operation. There has been a slow but gradual accretion of stocks of nails and large and small pipe, which has held building in check for several months until warehouses contain a sufficient supply of these commodities to meet the demand of

the hour. Any sudden increase would obviously run jobbers short in three-quarters and half-inch galvanized pipe, but there are nails enough including the once abnormally-scarce 3-penny fine steel blues to square with an active spring building season. Jobbers are not, however, endeavoring to pile up stocks, but wish to be in position to face a busy building year should it happen to start immediately after stock taking.

It is the feeling of Pacific coast jobbers that the economic revival over the country will have its inception in building commitments, and that buying will start almost simultaneously.

Independent steel mills are recovering rapidly on back orders, as the situation is expressed to coast jobbers, and have begun to urge new business for immediate shipment. Despite this impulse in the east, jobbers are inclined to run close on stocks.

It is estimated that eastern mills are four months behind on small pipe. Cement and brick are steady, but building paper of all grades has declined 20 per cent. within the past ten days. Jobbers of building paper, wall board and cement are inclined to believe that these materials will follow closely the declines in steel.

Fir lumber prices have steadied down, but 43 large mills in the West Coast fir producing territory have closed, announcing that the market has fallen to a point where they can no longer proceed with cutting and take the losses involved. Accumulated stocks are 55 to 60 per cent. over normal and production for the last week was 30 per cent. under normal. Sales to eastern buyers were only 906 cars, against 1,077 cars for the preceding week and approximately 10,000 cars under normal for this time of the year, when eastern spring buying is usually well under way. The fir mills cut 60,100,000 feet, when their capacity is 140,000,000 feet.

Price cutting by one of the larger mills which brought eastern orders for 25,000,000 to 30,000,000 feet was not met by the mills generally. Prevailing averages at which lumber was sold this week at the mill was \$51 to \$54 for No. 2 vertical grain flooring, 1 x 4, \$31 to \$33 for No. 3, \$29 to \$31 for No. 2 and better slash grain flooring 1 x 4 and \$21 to \$31 for No. 3. No. 2 and better five-eighths ceiling sold at \$58 to \$68, with No. 3 at \$31 to \$35. Drop siding is \$31, boards and shiplap \$16.50 to \$17.50 and common dimension \$13.50 to \$15.50. Red cedar shingles are weak at \$2.40 to \$2.50 for stars and \$2.75 to \$2.85 for clears.

(Special Correspondence to THE AMERICAN ARCHITECT)

BOSTON.—While reports of further curtailment in industry, continued to fall in commodity prices and increased unemployment show still the un-

THE AMERICAN ARCHITECT

settled condition in business circles, there appears to be a more cheerful tone in several sections.

Some of the lines of business which were tardy in feeling the effects of nation-wide deflation of prices are now suffering, while those which were first to feel the drying up of public demand for goods are beginning to see relief. This applies particularly to the leather, boot and shoe industries of New England. The latter has experienced something like six months of stagnation. Readjustment has been drastic. But during the past two weeks orders have been coming in from concerns who have not been in the market for months.

There has been a decided swing to oil burning installations in Massachusetts during the past year. According to the State Fire Marshal the metropolitan area will see a cut in its coal consumption to half its present size within the next few years due to oil burners. To date there have been 122 conversions from coal to oil burning plants in Boston and 81 in the State at large. Most of the changes have been made in the past six months and many factories, stores, hotels and office buildings, it is said, are known to be planning oil burners for next winter. Five of Boston's largest hotels have installed this type of burner.

New England's remoteness from the coal mines makes substitute fuel of any kind important especially when manufactured within New England. Crude oil can be shipped here in large quantities by rail or water. Fuel oil, one of its products and manufactured at the points of greatest consumption, will obviate the possibility of fuel shortage such as New England has faced as often as labor troubles threatened mines or railroads.

(Special Correspondence to THE AMERICAN ARCHITECT)

CHICAGO.—Chicago remains locked in the unyielding clasp of its building tie-up, but there are increasing indications that something is getting ready to snap. The program of \$150,000,000 in arrested construction now seems to stand a much better show of early consummation than was the case a few weeks ago.

The recent days have brought new and interesting developments in the situation, the most important perhaps being the federal investigation, which is now said to be under way, touching the sash, door and blind problem. Heretofore only the product of union mills could be used in building construction in Chicago, and this provision automatically precluded the product of many of the outlying manufacturing centers such as Kenosha, Oshkosh, Bay City, Muskegon and other important woodworking centers where the open shop prevails. A provision in the working arrangement between the building trades unions and

the contractors and mill men insists upon union mill-work and creates, in the opinion of many, a virtual monopoly for Chicago manufacturers, although the Chicago mills cannot turn out more than 40 per cent. of the normal requirements of the city.

This situation, clouded in obscurity by the evasion of all concerned, is now being looked into by a federal grand jury upon the suggestion of United States District Attorney Charles Clyne. Mr. Clyne has made a personal investigation and believes that he has enough damaging particulars to cause the combination considerable trouble. He even hopes to break up the arrangement and permit the free inflow of outside sash and door products into Chicago. Such a removal of the restriction would undoubtedly reduce the cost of building in Chicago and would subtract, in the opinion of experts, something like \$4,000,000 from the city's rental bill.

That there will be a determined effort to offset the efforts of Mr. Clyne goes without saying, because Chicago has been for a long time a most unfavorable field for the outside producer. This was shown some months ago, when an ambitious housing plan was being discussed and when ready-cut houses from Bay City and other outside points were to be brought into Chicago to relieve the acute housing shortage. It was found that such materials could be brought here, but that union carpenters would not assist in their erection.

Anything that would tend to reduce the cost of mill work to the builder would, of course, do a great deal toward stimulating building in general, because the cost of materials is now getting to be the very eye of the building needle.

Aside from the federal entrance into the building complex, another point of interest in the evolving problem is the possibility of state supervision in some form or another. It is understood that an effort may be made shortly after the state legislature convenes next month to frame and pass a measure for the creation of a supervision body such as the Lockwood Committee in New York. This committee would be empowered to go fully into the building situation and determine the exact obstacles in the path of the \$200,000,000 program which is now being held up in Chicago and in Illinois outside of Chicago. Even a \$60,000,000 good roads plan voted by the people of Illinois in 1919 is being held back because of the high cost of materials and labor.

Even more important perhaps than the federal or state interference in the building mix-up is the drop in a considerable list of materials during the recent past. Builders contend that the slashes have not been far-reaching enough to really meet the situation, but they are thankful for any little concession that may present itself.

Cuts in cement, plaster, sand, and other items in

THE AMERICAN ARCHITECT

the materials list have suffered declines, cement being down to \$2.25 a barrel in this market at this time.

Some of the reductions made may be noted in the sub-joined list:

	Old price.	New price.	Pct. dec.
Wooden lath, per M.	\$20-\$22	\$ 9-\$12	50
Plaster, ton	22- 23	20	11
Sand, stone and gravel, cu. yd.	4.25	3.50	17.6
Hollow clay partition tile, per 1,000 sq. ft.:			
3 inch	150	110	27
4 inch	160	120	25
6 inch	220	165	25
8 inch	300	225	25
Fire clay, ton	12- 25	9- 18	27
Bricklayers' cement, brl.	3.55	3.20	10
Roll roofing, roll.	4.00	2.50	37.5
Asphalt indiv. shingles.	9.00	6.50	28
Strip shingles	7.00	5.10	28

Wall boards, per 1,000 feet—\$3 to \$5 off.

Metal lath, per square yard—Reduced 3 cents to 5 cents, a flat 10 per cent. cut.

Coping—Horizontal cut of 10 per cent.

Flue lining—Average cut of 10 per cent.

Lime—A cut of 10 per cent.

Whether these reductions are sufficient to prove of any great value in stimulating building activity remains, of course, to be seen. Important construction companies are inclined to think that the concession is the merest drop in the bucket and that further cuts must be made.

Such a condition seems to have been sensed by the manufacturers of ready mixed paints. Mixed paints were recently cut some 50 cents per gallon by the leading Chicago manufacturers, and there is the expectation on the part of those posted on such matters that further cut of perhaps the same amount will shortly be forthcoming. Whether the action of the paint manufacturers will serve as an example for other materials manufacturers is the subject of some speculation.

Incidentally the manufacturers of paint and varnish in Chicago are confidently expecting a big building boom in 1921 and in the years to follow. S. Marshall Evans, president of the National Association of Paint, Oil and Varnish Clubs, in an address

in Chicago last week, predicted a long term of very great activity in the building trades and consequent prosperity in all lines touching the building industry.

Labor costs remain stationary as far as actual figures are concerned, but the efficiency of labor in the building trades is increasing. It is estimated that individual production on building work is now 25 per cent. higher than it was during the rush period of 1918 and 1919. The specter of unemployment is beginning to be seen and feared in Chicago and this is doing much to stimulate better work and less loafing in the building trades.

Lumber costs show practically no change, although the situation in the lumber market is weak. Dealers and manufacturers alike expect a resumption of activity, however, as soon as the first of the year turns the corner.

Prices of lumber and materials at this date are as follows, in the principal items:

Yellow Pine: B. & B. 1 inch, \$95 to \$130, depending on thickness; 2 x 4, No. 1, 10 to 16 ft. length, \$51 to \$53; 2 x 6, \$48; 2 x 8, \$50; 2 x 10, \$53; 2 x 12, \$55; 13-16 x 3¼ b & b flat flooring, \$85 to \$90; 1 x 6, No. 2 common, \$48 to \$90.

Douglas Fir: S + S, in sizes up to 12 x 12, in length up to 32 feet, \$65 to \$70; 14 x 14, \$68 to \$73; 16 x 16, \$72 to \$75; 18 x 18, \$75 to \$80.

Hard Maple: Four, ¼ No. 1 and 2, \$135; select, \$120; No. 1 common, \$100; No. 2 common, \$65; No. 3 common, \$32.

Birch: Four ¼ No. 1 and 2, \$160; select, \$133 to \$138; No. 1 common, \$95 to \$100; No. 2, common, \$60 to \$65; No. 3 common, \$40.

Red Gum: Four ¼ No. 1 and 2, \$150; No. 1 common, \$90 to \$92; No. 2 common, \$47.

Building permits in November showed an increase over the preceding month. The following tabulation issued by Building Commissioner Bostrom summarizes the situation:

	Oct., 1920	Nov., 1919	Nov., 1920
Factories	109	167	121
Residences	124	527	116
Apt. bldgs.	4	38	12
Others	9	33	11
Total permits.	246	765	260
Frontage	8,510	26,363	9,839
Cost	\$3,538,150	\$17,577,000	\$3,838,150

Foreign Notes

Spanish Cities Meeting House Shortage

A gigantic effort to settle the housing problem of the Spanish capital by the inrush of thousands of country folk to the city, is in progress in the northern section adjacent to the suburb of Guatro Camios. A private concern has acquired an enormous tract of land and has begun building what for Madrid are skyscrapers of ten stories. Each of these buildings is to contain 400 flats and 40 stores. The new model suburb is to be in all respects modern. Engineers are now engaged in laying out a boulevard running through its center over half a mile long and 130 feet in width, with two carriage ways and a central promenade lined with trees.

World Competition for Cairo Hospital

We are able to announce this week an important competition, to be thrown open to architects the world over, for the design of what will be the world's largest hospital, which is to be erected by the Egyptian Government at a cost exceeding \$25,000,000. The old Qasr-el-Aini hospital is to be superseded by a new one in which provision will be made for about 1,250 beds. There will also be formed, in connection with the hospital, an important medical school (which will give special attention to the study of tropical diseases), a dental school and clinic. The medical school will be composed of 600 students; the dental students will number 120, with about sixty pharmacy students. There will also be built a large students' club and hostel, and a nurses' training school.

The site contains about fifty acres. Even so, the Egyptian Government have been strongly advised to acquire still more ground, and they have agreed to do so.

The Egyptian Government's adviser in the matter has been Mr. John W. Simpson, president of the R.I.B.A. He states that the hospital would meet all European requirements, and the site on Rohda Island, on the Nile, was probably the finest in Cairo, it being open to the cool north and north-west winds which for the most part prevail.

It has been decided to hold an international preliminary competition for the design of the hospital. Architects the world over are to be invited to com-

pete, and out of these six will be selected for the final. The Government will nominate six other architects of repute in hospital practice, so as to make in all twelve final competitors, each of which will be assured of a fee of \$2,500.

The Government have agreed to accept the R.I.B.A.'s scale of fees, to be paid in addition to the \$2,500 honorarium. Moreover, the architect placed second will receive an additional \$2,500—in all \$5,000.

The competition is one which will require a special study, owing to the difference of Egyptian from European diseases and local conditions. One important factor in the designing will be the complete separation of the sexes, to comply with the very strict Mohammedan law.

A Victim of the Bolsheviks

Bolshevism has made Petrograd a purgatory for professional men. A case in point has been brought to our notice. An architect of high attainments and considerable standing, happy and skilful in his work, and prosperous at it, has been driven into exile. "At the end of 1920," he writes in the *Architects' Journal* of London. "I escaped on foot with my family from that communistic hell" (Petrograd); "and now," he adds, with a pathetic simplicity of phrase that recalls the manner of some of the most poignant passages in Greek tragedy, "and now I am seeking for work." Was it Carlyle who said something to the effect that "the most pitiful sight on God's earth is a good man seeking work and finding none?" This exile is undoubtedly a good man in every sense of the term. A correspondent speaks of his "great natural ability, unflagging assiduity and perseverance. . . . His career at the Academy of Fine Arts at Petrograd was brilliant; his professors considered him one of their best students. His designs have been much admired, displaying practical thought, refinement and originality." He has traveled, and is master of several languages. A letter of his that we have seen is in faultless and fluent English. We are informed that he has made a close study of the housing problem. He has a young family to support. He can give excellent references. According to our information, he is of fine scholarship, high capacity, clean credentials. He should not lack opportunity for the exercise of his talents, relief from his unmerited misfortunes.

846^a

points face to No 2349.

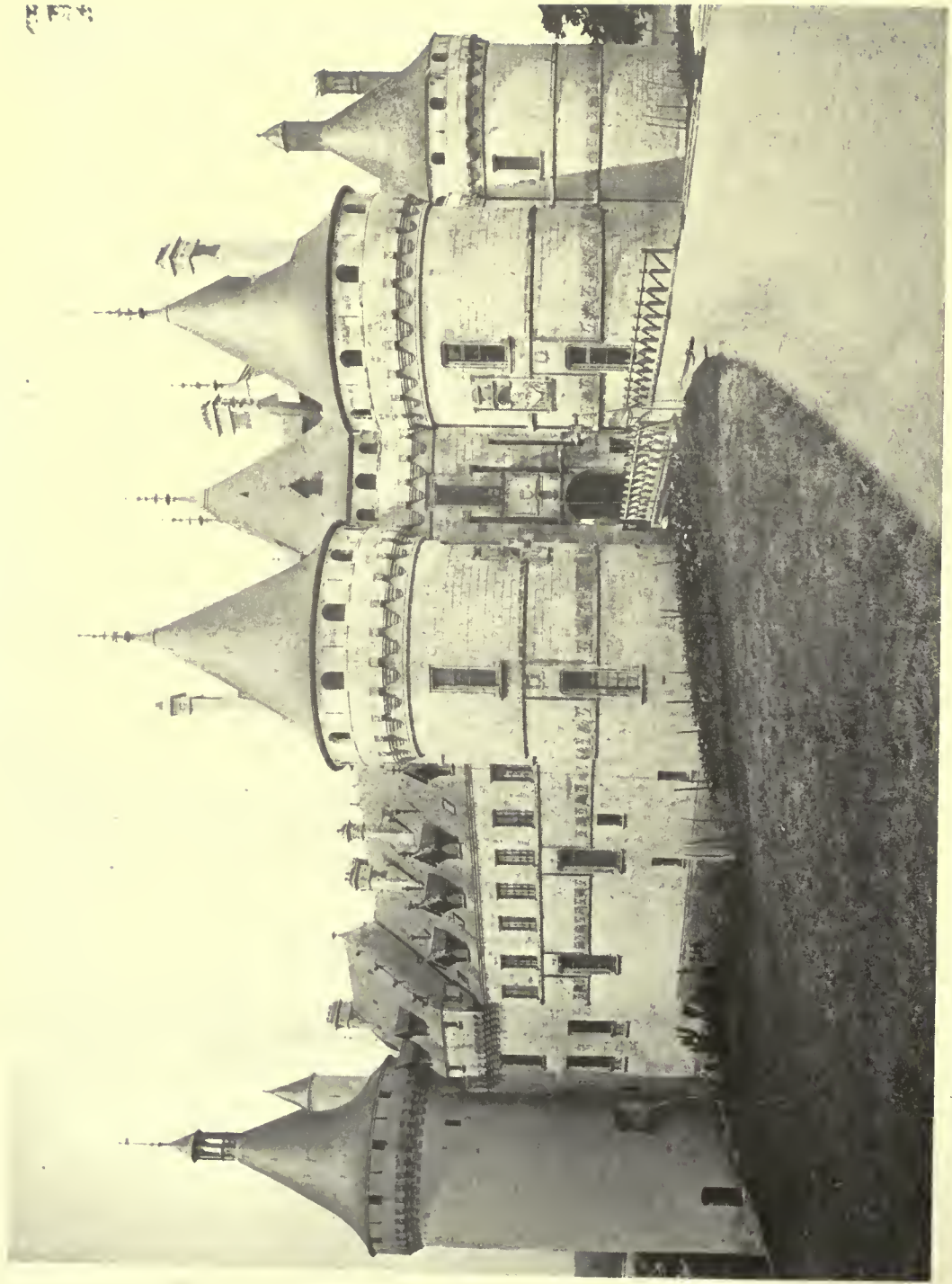

CHATEAU DE CHAUMONT, CHAUMONT SUR LOIRE, FRANCE

THE AMERICAN ARCHITECT

847

THE AMERICAN ARCHITECT

VOL. CXVIII

WEDNESDAY, DECEMBER 29, 1920

NUMBER 2349



EXCAVATION AT NIGHT
FROM THE PAINTING BY GEORGE BELLOW'S, N.A.

The Relation of Painting to Architecture

An Interview with George Bellows, N. A., in Which Certain Characteristics of the Truly Original Artist Are Shown to Have a Vital Relation to the Architect and His Profession

" . . . I am sick of American buildings like Greek temples and of rich men building Italian homes. It is tiresome and shows a lack of invention. I paint my life . . . All living art is of its own time . . . Few architects seem to grasp this. Bush Terminal Sales Building is expressive of our needs. Greek temples with glass windows are foolish."—George Bellows.

IN these words is expressed a point of departure and the essence of this interview. We sought George Bellows because we believed he represented that non-conformist attitude toward tradition which most architects unfortunately lack. We talked to him with that belief in mind. It mattered little just what the exact relation of painting, as expressed purely in pieces of canvas or in mural decoration,

THE AMERICAN ARCHITECT

might have to architecture. It mattered less to attempt any exhaustive or dispassionate inquiry into the niceties of that relation. What did matter was the fact that Mr. Bellows typifies an attitude toward art whereby he is enabled to produce really original work. How he does it is undeniably of interest to architects, and he has frankly given of himself in this interview to place before the architectural profession every helpful experience.

"There is no new thing proposed, relating to my art as a painter of easel pictures, that I will not consider," stated Mr. Bellows. "The fact that a thing is old and has stood the test of time has become too much a god to almost all men who can be termed artist. What it seems to me should interest the architect is exploration, not adaptation," he explained. "I have no desire to destroy the past, as some are wrongly inclined to believe. I am deeply moved by the great works of former times, but I refuse to be limited by them. Convention is a very shallow thing. I am perfectly willing to override it, if by so doing I am driving at the possibility of a hidden truth. It seems obvious that architects should have the same attitude toward their work."

As an example of his attitude toward the conservative acceptance of given ideas, we asked Mr. Bellows what he thought the artist should know about period styles in order more clearly to understand the work of architects. Here is the answer:

"I do not believe in period style. It seems second hand. All living art is of its own time. Few architects seem to grasp this. Period style is a reversion to past types. Originated styles of the present period would be desirable, and could vary with their locality. There would need to be no monotony. These styles, if they were devised, could be as glowing, as virile, as truly fine as any that we now worship, for they would be of our own time. We would understand them. We could do them better. They would have greater significance to the layman, for they would not be shrouded in mystery and obscure allusion." Here was our plea for regional types, set forth in all its glory by one quite outside of the architectural profession!

Then, we prompted, what would you suggest to attain that end? "The fault lies in the spirit of the times, which is reflected in the way we educate architectural students," went on Mr. Bellows. "Schools of architecture teach conventional architecture, period architecture. I do not believe in education as an end, so much as in the opportunity for men of imagination to have *opportunity*. But your schools of architecture interfere with such an opportunity. If an architect tried to create something independent of "periods" he would have a hard time to place his work. And yet all the possibilities of significant form have not been exhausted, have they?" We had

to admit they have not. "Why, then, should architects worship the 'period' as they do?" questioned Mr. Bellows. "If there are further significant forms to be originated, and every one agrees that there are, I can see no reason why we are bound to the existing forms and scorn any attempt to create the new, the original.

THERE are two rather distinct spirits in which a painting is created," continued Mr. Bellows. "One has a very decided relation to architecture, the other does not necessarily have such a relation. The mural decoration per se is essentially painted for a certain place. Other picture forms are not. In the latter case, which is the infinitely larger of the two classes, an artist may be said to be fundamentally interested in developing an arbitrary space to the profoundest condition of beauty of which he is capable. This cannot be considered, then, as essentially a decoration for a wall, but must be regarded and looked at for itself alone as a thing complete. Almost we might say in the spirit of a book, the color of whose cover is the only relation to the room in which it is placed. An oil painting in particular can only be at its best under a light which gives its exact values and therefore people to whom paintings are precious must take the greatest care to arrange for such conditions. On the other hand, the mural decoration can be created by a master without these limitations affecting his spirit. A profound understanding of space can free the painter from this one genuine limitation. The other limitations, which in our day tend to spoil and make common the mural decoration, are artificial, man-made dogmas and the limiting of the artist from the point of view of subject matter, morality, etc.

"On the other hand, a large percentage of architectural works must be limited by utility. These limitations seem to be even greater for the architect than for the painter in present day life. But these limitations need not prevent an architect from creating beautiful proportions among the utilities in space and texture and color. I feel that the architects themselves have been largely guilty for allowing the fashions of the past to become the fashions of the present. It is really a platitude to say that all living art is of its own time, expressive of the finest spiritual and even material necessities of its own people. It is not the expensive material that counts. But it is the men who sense the proper proportions and understand space itself that make great architects."

While every artist will agree that a painting may be said to have utility in a certain sense, the utility of a painting is not its essential characteristic, while the utility of a work of architecture is. Thus Mr. Bellows may say that each picture should be thought

THE AMERICAN ARCHITECT

of for itself specifically, without relation to its surroundings. People speak of pictures in the home as spots of color on the wall. That is not their primary function in Mr. Bellows's estimation. A painting



OLD LADY IN BLACK
BY GEORGE BELLOWS, N.A.

may be a decoration on the wall, but it is not necessarily so. A picture, as he understands it, is a human document of the artist, and may be as little decorative as a book; the binding may or may not be decorative, but even if it is, the decorative aspect is not the prime function. One looks at etchings frequently in portfolios, isolated from their surroundings. They are beautiful in themselves. The proper attitude, Mr. Bellows maintains, is to consider nothing but the picture, not its proposed environment. If it is right it is right. It is not valueless because one cannot find a good place for it. It is a work of art, anyway.

This, related to architecture, would mean that the architect would create something subjective as "a human document" without relation to the purposes of the structure or its environment. Just what would happen if architects were to dot the landscape with works of art that have no relation to their surroundings is something that affords interesting speculation. Is it better to put a fairly dull, trivial structure in an

unimportant locality for the sake of maintaining the present character, or should an architect take it upon himself to alter the character of the neighborhood by the construction of something very fine—too fine—like a prince among paupers. Here the proprieties war with the impulse to be free of past traditions and to express courageously one's original ideas and individuality. Should one express oneself frankly despite another's feelings? Need the architect of originality have his way, and compel the public to view his obtrusive personality as manifested in an over-assertive building? Mr. Bellows believes that the artist-architect would be creating a landscape just as a painter creates a landscape—he would do what he could to enhance its beauty. What that "what" would be is debatable.

But Mr. Bellows feels insistently that art must be original. The harking back to Greek and Roman models for today's buildings should not, he believes, be countenanced. The machine education of the present generation is so readily obtained that it leads



ANNE IN WHITE
BY GEORGE BELLOWS, N.A.

to mediocrity. It is no longer unusual to meet people who have a college degree. It is that very commonness of education that makes it mediocre. The man who is to be beyond the average must go very much further.

THE first thing a student should learn, advises Mr. Bellows, is that all education that amounts to anything is self education. Teachers, college, books—these are only the opportunity for education. They are not education per se. Mr. Bellows's own example is pertinent, and shows how well he practices what he preaches. As a college student, he cared nothing for the large train of compulsory subjects unless they appeared relevant to what he wanted to do. To him it mattered only that he learned what he wanted to learn. Some things were vitally interesting. Others had no apparent bearing on his work and were duly ignored. "I made some mistakes of judgment," confessed Mr. Bellows. "I overlooked some important things that I now realize would have been valuable. But if they are important enough I learn them now, myself, and by that self-education I have a workable, usable thing.

"Forget the routine thing, forget the college degree," he challenges. "The man of vitality is naturally self-educated. Education is largely personal. The young man with initiative will try to find a great man in his own field, will attach himself to him, will even pay to accept him as an apprentice, if possible, and will stick to him. But receiving education from a teacher has its obstacles. It presupposes that the teacher knows better than the taught, and the teacher therefore should himself do the great work, and be the great man, instead of attempting to instruct some one else how to do that which he cannot do himself.

"You do not know what you are able to do until you try," went on Mr. Bellows, now exuberantly ex-

plaining his choicest methods. "In learning a topic, whether it be painting or architecture or any other art—and the practice of that art is constant learning—try everything that can be done. Try it in every possible way. Be deliberate. Be spontaneous. Be thoughtful and painstaking. Be abandoned and impulsive. Learn your own possibilities. Have confidence in your self reliance! There is no impetus I have not followed, no method of technic I have not

tried. There is nothing I do not want to know that has to do with life or art. Any artist, any architect, can mold his ideas on the same method. One is not a good architect unless he is an artist. Otherwise he is a mechanic. Therefore, since he is an artist, why can he not very properly practice this procedure?"

Visualizing an artist working out a picture "spontaneously," we were caught by that word, and asked Mr. Bellows if spontaneity was not inconsistent with good art. He replied very forcefully that painting need not consciously conform to law. "Most so-called laws of the arts are dogmas. Rules and

regulations," he fervently declared, "are made by sapheads for the use of other sapheads! Laws may be considered judicially. Certain laws are absolute, but many others are arbitrary. The absolute laws one is naturally in harmony with and will often subconsciously adhere to in spontaneous work even better than in deliberate effort, where there is not a profound basic knowledge. The arbitrary laws do not matter. They are human, fallible and disputable points of view. The academies and art schools are full of them."



THE STUDIO
BY GEORGE BELLOW, N.A.

THE AMERICAN ARCHITECT

BY this time we were sensing the wide sweep of Mr. Bellows's thought over every possible phase and aspect of the painter's art. If, to use the vernacular, he is disposed to try anything once in the hope of finding it valuable we thought we could help him by suggesting the Hambidge theory of Dynamic Symmetry. But along with the mass of pertinent information already stored in his mind was a full knowledge of and lively interest in Mr. Hambidge's researches. "Some of the new things I have tried," said Mr. Bellows, "have naturally taught me nothing. From some of them I have acquired knowledge that has been priceless. For example, many of my painter friends have scoffed at Hambidge's law of dynamic symmetry as applied to composition. Now, I am not an authority on anything, but I must use what critical judgment I have up to my measure of understanding. Hambidge has shown me a great many things that are profoundly true, and I believe that any serious architect who will take the time to study this theory will be greatly helped.

"I see no contradictions in Mr. Hambidge's contentions, nor have I ever heard one that holds water. Ever since I met Mr. Hambidge and studied with him I have painted very few pictures without at the same time working on his theory. I believe it to be as profound as the law of the lever or the law of gravitation. No man who practices the arts, and this seems to be particularly true of architecture, can, with justice to himself, ignore the research that Hambidge has made. It has never been disproved, and the artist has but to learn and apply it in his work to know its helpfulness.

"It is the expression," continued Mr. Bellows, warming to the subject, "of the basic working of the human mind. Geometry is the picture idea of the mechanism of thinking. Not only do I regard it as

of vast importance and as expressing a fundamental natural truth, but even if it were not absolutely correct, it is anyhow useful to me."

And it is just in this way that Mr. Bellows emphasizes the openness of mind with which he attacks every problem of his art. The fact that a thing is old and has stood the test of long practice will not interest this explorer into the unknown realms of art, as much as will some new idea to which he may bring all the resources of a fertile and well balanced mind. If there ever was an iconoclast in art it is George Bellows, but he does not destroy from the wanton motive of a doubter. When he departs from convention he can supply a reason for such departure that is so sane, so logical, that argument is silenced. When an architect will have attained, through an equally well balanced mind, the same dauntless courage and independence, we shall hail him as the Moses who shall lead out of the Egypt of adaptation and precedent the whole of his profession.

At this point Mr. Bellows took from a large case a number of sketches and in the most convincing manner showed just how he had in every instance applied his knowledge of the Hambidge research. "Look," said he, "how it simplifies this certain difficulty of arrangement, how it releases me from a heretofore distracting factor, and thereby permits me to concentrate all my efforts on the infinitely more difficult aspects."

"If," continued Mr. Bellows, standing in the middle of his studio, and speaking with the earnestness that characterizes the man even when least emphatic, "a thing is made easier by technical understanding, then by so much is it true that having this particular phase made easier, your strength is conserved for those things which yet remain troublesome."

The logic of this is incontrovertible.



VIEW OF GROUP FROM ACROSS LAKE

The Small-Town Architect and His Problems

By RALPH BRYAN

THERE is no such place as an architectural Arcady. Perhaps if every architect were possessed of unlimited means of his own and his practice were confined to the designing of his own town houses and country estate, the practice of architecture would be getting close to the Arcadian borders. But even at that there would still be manufacturers' details to check.

Nevertheless, there are certain localities in this land of the free where the architectural fairway is less beset with hazards than in certain other, less fortunate localities. Such is the case in those communities which are generally looked upon as our "architectural centers." It is to these communities that the country looks for the best in architecture, and rightfully so, for amid the conditions with which the architect is surrounded there, he should naturally be capable of good things. As a matter of fact, the architect in such a community who is guilty of mediocre

work should be deserving of more criticism than his smaller brother in the more out-of-the-way district. And conversely, when a man practising away from these localities produces a creditable work, more praise should be his than his fellow's in the center of activities.

As an example of what the foregoing paragraphs intend to point out let us compare the conditions under which Mr. Brown, of New York City or Boston, we will say, practises, with those under which Mr. White, of Salt Lake City or Tulsa, works. Mr. Brown's clients come to him with a fairly clear understanding of the architect's functions and a respect for his profession. By reason of the work they daily see about them, they have a knowledge of what is good in architecture, and a reasonable idea of the cost of good work. They realize that a creditable design has a value that is more than merely aesthetic.

The contractor with whom Mr. Brown deals has a

THE AMERICAN ARCHITECT

better understanding of good work than the builder in the smaller community. If Mr. Brown has any doubts about the merits of any building material he intends to make use of he has about him in the amount of work that is going on in the big city abundant examples which will put its use beyond the experimental stage.

And, as to Mr. Brown himself, he lives in an architectural atmosphere. The ideals for which he is striving are ever kept before him through his large number of architectural associates and through the work they are doing. The country's largest architectural exhibitions and architectural libraries are close at hand. For the same reasons, his employees, from office boy up to his oldest draftsman, live their work. The number of men taking competitive work at the city's ateliers does a great deal to foster true architectural spirit.

Working amid such surroundings and under such conditions, there should be no reason why the calibre of Mr. Brown's work should not be good.

The conditions which tend to stimulate the work of the architect in the large community, by their absence in the smaller locality, make Mr. White's fight there a harder one. In regard to his clients, Mr. White must more or less take the role of a pioneer in educating them out of the commonplace. As a rule, Mr. White's clients regard an architect's services as more of a luxury than a necessity. They are still accustomed to the "architect and builder," who makes the cost of the architect's plans a useless expense.

The late Mr. Robert Sharp, F. A. I. A., of Nashville, used to relate an incident illustrating the profession of "architect and builder" as it was sometimes practised in the hill country of Tennessee. Mr. Sharp was waiting for his train at the station in a small Tennessee town when he became an accidental, though interested, eavesdropper to a conversation between two natives who proved to be an owner and his contractor. With the end of his umbrella the owner was laboriously preparing floor plans of his proposed residence in the loose sand of the station platform. The specifications followed in the form of a few remarks from the owner, dealing almost entirely with the colors he desired used in painting the exterior. At the conclusion of the preparation of the plans and specifications, he addressed his companion: "What'll that cost me, Hank?" Hank shifted his chew, scratched his head, and after a short contemplation of the plans presented his estimate. "That there'll cost you twenty-eight hundred and fifty dollars." "When kin you start?" queried the owner. "About Tuesday week, I reckon," was the answer. "All right, go ahead," the owner replied, and the contract was awarded. Thereupon, with the sole of his boot, Mr. Owner erased the plans from the sandy face of the earth.

Where the layman is not so fortunate as to be surrounded with examples of what is good in architecture, he is apt to become used to the commonplace, and is oftentimes skeptical of the architect's ideas in creating something out of the ordinary. For example, in a Texas town recently an architect prepared plans for a colonial residence. As elements in the treatment of the main facade were a series of slender pilasters. The design was in elegant taste and absolutely true to type, but at the completion of the structure the architect received considerable condemnation from the townspeople because *the pilasters were too thin*.

Fortunately the architect's reputation in the community was firmly enough established to withstand the criticism without loss of patronage. But had this architect been a younger or less known member of the profession it may have proven to be an instance of the striving after ideals resulting disastrously.

And so our Mr. White, in his class of practice, cannot always follow the true course of his ideals, but, if he intends to make his work a bread-winning profession, must consider the viewpoint of the layman of his locality and temper his design accordingly, until he has finally educated his clients to an appreciation of good architecture, or until he has established his reputation so firmly that he can be, as he should be, the absolute dictator in matters of design without harm to his prestige.

Then as to Mr. White himself; in his locality we will say that there are four or five or six architectural firms, some of which, perhaps, are just as sincere in their work as our Mr. White. But at any rate, he has not enough professional associates to create that atmosphere in his community which is so stimulating to the health of architectural ideals. When the awarding of a commission in a locality almost means taking the bread from the mouths of fellow practitioners, there is not apt to be that fraternity among the members of the profession that there is where competition is not such a personal affair. Not that competition is any less keen in the larger communities; it is simply less personal. And furthermore, where the layman is more appreciative of architectural services and their cost he is not so apt to encourage price-cutting by the letting of his commissions primarily on the basis of cost. And price-cutting among members of a profession is hardly conducive to goodfellowship within the profession.

Lacking the acknowledged stimulus of architectural fellowship, Mr. White must depend more upon himself for encouragement in his pursuing of his ideals. His practice, even if fairly successful, would hardly result in allowing him to travel extensively. He has very little source of inspiration other than whatever library he has been able to accumulate, and the architectural publications which enable him to

THE AMERICAN ARCHITECT

keep in touch with the larger field of architectural activity. And in regard to these architectural publications, let us misquote Dickens' Tiny Tim to the extent of saying "God bless them, everyone." They serve the smaller member of the profession in a way that is hardly realized by the architect in the larger community, who is able to see about him each day the originals of the works illustrated therein.

All the foregoing is not an attempt to excuse poor design or insincere work wherever it may be found, but rather an attempt at an appreciation of the efforts of the smaller architect, in the community off

the architectural highways, to follow his profession to its highest artistic ideals in spite of the restrictions which surround him.

Among the architects of the country there are perhaps a few who at times have been inclined to look tolerantly upon the work of men outside of their own chosen community. If this article is the cause of making any one of such critics put himself in the shoes of his smaller brother before rendering his comment upon his smaller brother's work, why then this article has proven itself worth while.



MAIN ENTRANCE FRONT
HOUSE OF MRS. C. P. ADAMS, DALLAS, TEXAS
H. B. THOMSON, ARCHITECT

The Burial of the Unknown—The Cenotaph and the Abbey

(Special Correspondence to THE AMERICAN ARCHITECT)

ONE of the most impressive and emotional—perhaps actually the most impressive—scene ever witnessed in London was that of November 11, and it was one whose deep impression was not only limited to the ceremonial opening of the Cenotaph, with England's king following the bier of the unknown soldier who gave his life for our cause "somewhere in France," with her greatest soldiers and seamen, Field Marshals Haig, Methuen, French and Wilson, Admirals Beatty, Jackson, Madden and Hedworth Meux, as his pall bearers, to his destination in the old shrine of Westminster; but was continued for days, and even still continues while I write these lines, as a spontaneous display of emotion of all classes, the lowest just as much as the highest, of pride in the achievement of our warriors, of sorrow, often and indeed in most cases of personal sorrow, in their loss.

That it was a great and worthy celebration on the eleventh cannot be questioned; there was something that stirred the soul in its deepest fibres when in the distance the slow beat of the drum taps came nearer and nearer, seeming to herald the approach of an invisible army, the great host of those who had fallen for England and for freedom, the comrades of him, the unknown, whom we mourned that day. At the Cenotaph the King was waiting, near him the Prince of Wales and the Ministers and ex-Ministers of the Crown—Mr. Lloyd George, Mr. Bonar Law, Mr. Asquith, the Speaker of the Commons, the Archbishop of Canterbury standing over against these last; and amid an immense and perfectly silent crowd the choir of our old Abbey sang that wonderful hymn: "O God, Our Help in Ages Past." Then, after the Lord's Prayer, read by the Archbishop, amid the chimes of Westminster, the King set his hand to the grey pillar—and the Cenotaph was unveiled.

Absolutely simple in its design Sir Edward Lutyen's monument, of which I give an illustration, triumphs by its very simplicity of design, and noble dignity of proportion; it has taken hold of the people's imagination; it has become typical and yet real to them, a part of their imaginative life, like no other monument within our time. Critically disposed friends said to me when it was unveiled, why could we not have had something better, more elaborate, more beautiful, some noble group of emblematic figures? In my humble opinion that would have been a complete mistake; the simple design, the date,

the wreath, the three words with their message of pride and suffering, "The Glorious Dead," conveyed more than any sculptured group to our people here; and it is a satisfaction to myself that as far as my own small influence could carry weight I used it to the full against the proposal, so dear to the official mind, to transfer it from the spot where it was already hallowed for all time by the popular imagination, where it had been already saluted by the soldiers and the leaders—Marshal Foch, Field Marshal Haig, General Pershing—in the "Great War."

What an extraordinary hold this symbol, the Ceno-



CENOTAPH IN LONDON
SIR EDWARD LUTYEN, ARCHITECT

taph, the Empty Tomb, the Grave of the Nameless Dead, had on our people was shown in the extraordinary scenes which followed. Day after day, even through the night and at early morning, they passed in their thousands, silent, respectful, orderly, each to lay his or her little personal offering on the tomb of "The Unknown"—yet known to them, for it was the One they had lost. They came from far away

(Concluded on page 859)

Spain to Have a Skyscraper

New York Architects Planning to Erect an Innovation in the Architecture of the City of Barcelona

SPAIN and skyscrapers! The two hardly seem congruous, for we are apt to think of that country in terms of patios, low, flat-roofed buildings, and an easy sort of philosophy which has accepted things as they have stood for century after century. A thirty-story skyscraper in the land of Don Quixote, Isabella, Columbus, and a score of other well-remembered names did not seem possible until the advent of Mr. Ramon Selles Miro and the group of Catalonians he represents.

Mr. Miro came to this country recently with his

Mead Howells and James Gamble Rogers, Associate Architects. The building will probably cover the entire irregular piece of land on the first six or eight stories. The ground floor will be devoted to the principal business houses of the city, and will be arcaded from street to street. The central part will rise to a height of thirty stories, with several batteries of elevators serving the tenants. At the level of the sixth or seventh story the principal club of the city will find a most charming home, the roofs of the lower buildings being used as roof gardens.

In the upper stories one will be able to view the

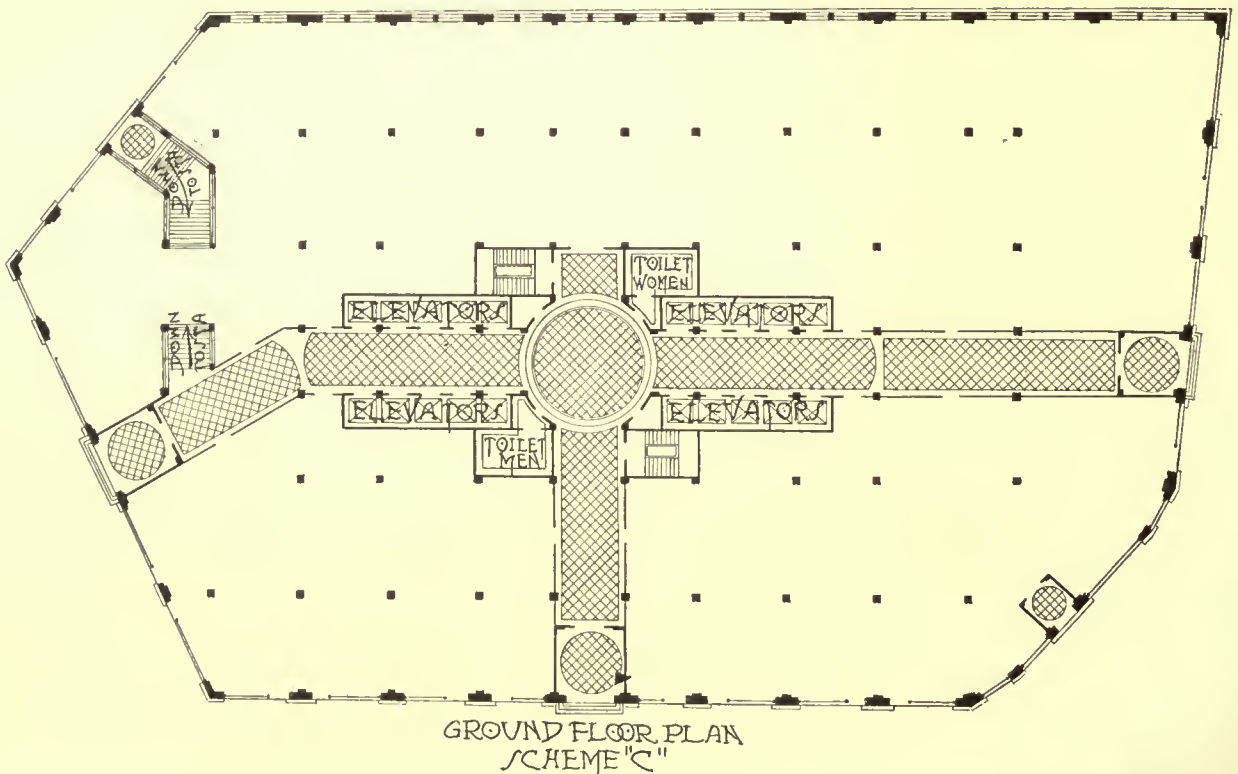

mind fully made up regarding such an undertaking. He was then, and still is, obtaining options on the real estate covering one entire side of the great Plaza Catalana, the largest and most central square in the city of Barcelona. In this part of the greatest port, and richest and most modern city in Spain, Mr. Miro and his associates will erect the building shown in our illustrations, plans for which were drawn by John

Bay and the Mediterranean on one side, and the famous hill country of Catalana on the other. What a vista for office workers! In the center of the front arch, 15 stories high, the design shows a colossal figure representing Progress.

The engineering and construction problems will probably be handled by Americans. Steel for skeleton construction will be supplied either from the



OFFICE BUILDING AND HOTEL FOR BARCELONA, SPAIN

JOHN MEAD HOWELLS } ASSOCIATED ARCHITECTS
JAMES GAMBLE ROGERS }

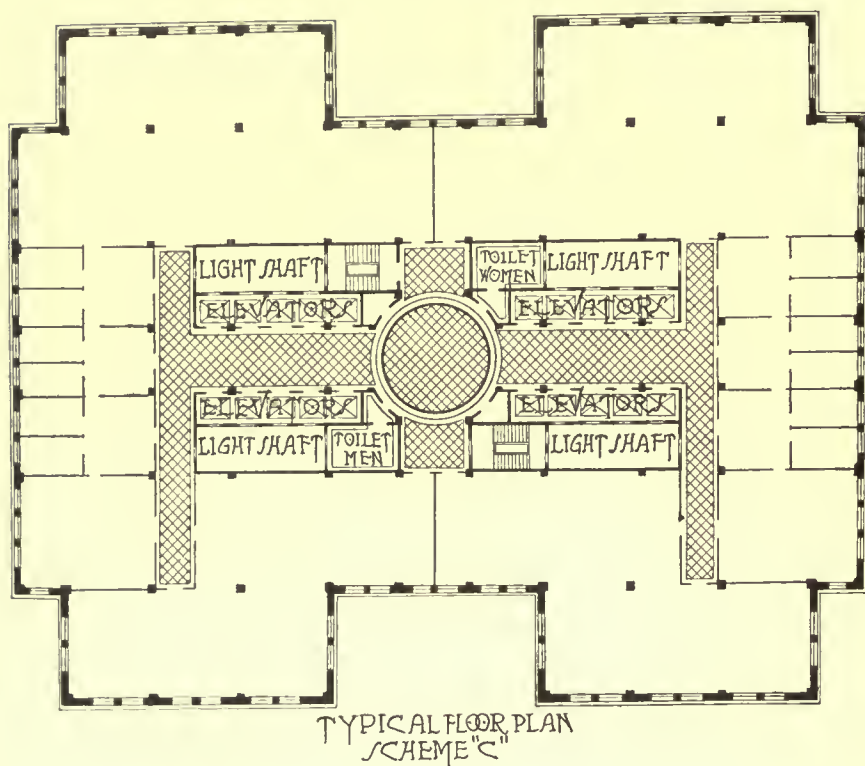

would apply. The philosopher met a man who complained that he had not been invited to a supper. "But," said Epictetus, "did you pay the price of the supper? The price of the supper was flattery; if you had flattered him you would have been invited. But console yourself; not being invited to the supper, you at least escaped the insolence of his doorkeepers."

So if they missed the advantage of the private patron, they would escape from his whims. The widening of the domain of official architecture would be due to the fact that building would depend more and more on public authorities and great trade combinations. In the past the first great patron of architecture had been the

United States or Belgium. The more difficult mechanisms, such as the elevators, will most probably be of American design and origin. As much of the material as possible will be local, and as many of the subcontractors and workmen as possible will be Spanish.

The city's railroad terminus will probably be in the basement of the building.

The financing of the scheme will be secured as much as possible in Barcelona itself. American capital, it is made plain, will be welcome.

The projects recalls this anonymous bit of verse from Acho's little book of Spanish folk-lore:

I looked upon the Bay's deep-blue

And saw reflected there a monster's

Shadow. Straight into the thinnest air it rose

As if it sought to kiss the hand of God

(A thing a good man well might do . . .)

The Future of Architecture

TAKING for his theme "Architecture in the New World," Major H. Barnes, M. P., recently delivered an interesting address before the Architectural Association at Bedford Square, London. He said that in future the profession would be followed by women as well as by men. There would be fewer private patrons, while the domain of official architecture would widen. With regard to the loss of the private patron, a story of Epictetus

priest; then came the prince, then the plutocrat. The future great patron would be the people. He (the speaker) did not shrink from the prospect; some of our labor councils were already contemplating £500,000 town halls. Two things were necessary for great architecture—one was a great idea to get the necessary wage to produce it; the other was that the patron must have somebody's else money to spend. In private life the man who spent largely on building had not earned the money, but inherited it.

Architecture's first great patron, the priest, came by his money rather easily, and the great works of Rome were built out of tribute levied on subject nations. In the future taxation would provide the fund by means of which great works would be erected, but he was not quite clear that there was any great idea to get the necessary wage. Monsieur Hebrard had collaborated with an American to produce a work, planning out a great cosmopolitan city which should be the capital city of the League of Nations.

This was an extraordinarily fine architectural conception, with tremendous possibilities, and, if realized, would produce a reflex action in every town.

Great works of architecture might be produced as the result of the new conception that the world was one, and that there should be some architectural expression of the unity.

Criticism and Comment

The Editors, THE AMERICAN ARCHITECT:

The prevailing method of charging a flat percentage commission based on the cost of the work is often grossly unfair to owners.

By way of illustration let me cite a typical case. Some years ago we were employed to make alterations to the front of an office building. The work entailed the use of fairly expensive materials, was near at hand, required not a great many drawings, and was completed in a comparatively short time. A 10 per cent. commission, therefore, held a fairly good profit.

At the same time we were building a country residence at a distance from New York, and requiring many details and long continued superintendence. The result was that the 10 per cent. commission was less than actual cost.

This sort of thing, common in the practice of all architects, simply means that the client whose job pays a good profit pays the way for the other client.

It is comparatively easy, therefore, to persuade prospective clients of the gross inequity of such an inelastic system of charges, and to suggest a plan whereby every job stands on its own bottom.

In our practice we have found the most satisfactory method is charging to the client the actual cost of the work to the architects, plus a professional fee which is from 3 per cent. to 5 per cent. of the cost of the building, according to the amount of professional service likely to be involved. A lump sum for this professional fee, as advocated by some, we have

found inadvisable, as the client usually wants to know at the outset the architect's terms; but the proposed cost of the building at that time may not be within 50 per cent. of the finally accepted cost and, therefore, an acceptable lump sum would have to be changed perhaps several times if it is to be commensurate with the services involved.

Further, the great advantage of the percentage professional fee plus the cost of services is that the reasonable variations in the fee due to variations in the cost of the building, which always entail additional professional services, are automatically taken care of, obviating the necessity of periodic application to the client for increased commissions.

If jobs could be carried through without extras and variations, the lump sum would be entirely satisfactory, but nothing disturbs the relation between client and architect more than recurring questions of fees.

I have found that this system usually meets with the hearty approval of most business men, for they see its substantial justice, and moreover, it is apparent to them that the architect is not making an exorbitant profit.

The benefit to the architect, of course, is that he no longer makes an inadequate profit or loses money on any piece of work, but of greater importance than that is the fact that he has the consciousness of treating every client with greater fairness than under the old system.

WM. O. LUDLOW.

Burial of the Unknown

(Continued from page 855)

in the country, from across the seas; they came—little children, broken old men, sobbing women, comrades of the Great War—to offer their little token, a few violets, a bunch of flowers, with their own little personal message and greeting to that dear one.

One of these messages—among the thousand such—which might seem almost droll, seemed to me on the contrary intensely, poignantly touching. "Cheerio, Cyril" were the only words on the little card. What a story those two words pictured? The boy had gone out, just a boy like the others, full of jollity, spirits, laughter, young life—never to return to that little home circle; and they sent him across the dark gulf just the message he would appreciate and understand, the message of love and remembrance, of lasting comradeship, of waiting unforgetful hope.

Compulsory Labor for Capital

The first hearing before the Kansas Court of Industrial Relations, at which employers are cited on a charge of violating the provisions of the Court act prohibiting curtailment of production in an industry essential to public welfare, "to affect prices," has taken place, at which heads of seven Topeka flour milling concerns are to appear as defendants.

According to court officials the proceedings originated with the court and were not prompted by complaints of individuals.

The *New York Times*, speaking editorially, said: "The hope may be expressed that the court will hear the flour millers on the merits of their case. In Australia mines have been ordered to stop working because they could not or would not pay the wages ordered by sympathetic authority of Government."

Gateway to Thomas Cowles House, Farmington, Conn.

(See reproduction of original drawing by O. R. Eggers on opposite page)

THE Thomas Cowles place at Farmington, Connecticut, was probably built by Judah Woodruff, who in his day was the leading builder in western Connecticut.

George Clarence Gardner, in an article in *The Georgian Period*, on "The Men Who Designed the Old Colonial Buildings," states:

"Strictly speaking, up to the beginning of the nineteenth century I know of no architects in America; but if various records and histories speak truly, fully 100 years before this time plans and elevations of buildings were prepared and drawn for the distinct purpose of either imitating or improving on English models and the men who did this may be divided into two types, the carpenter-architect and the amateur architect."

It is to the former class that Woodruff undoubtedly belonged, and that he worked with skill and built honestly is shown in his excellent works throughout the theatre of his well directed activities.

The gate to the Thomas Cowles house in Farmington, selected by Mr. Eggers as the present subject, reveals in all its features the same elements of good design as does the house to which it is the point of main approach. Fortunately, its excellence is apparent to the present owners, for it remains in a state of good repair, and serves to arrest the trained eye of the passer-by, as a silent witness of a period when our forefathers led the most cultured lives, surrounded by every attainable expression of their refinement.

860



GATEWAY TO THOMAS COWLES PLACE, FARMINGTON, CONN.
THE AMERICAN ARCHITECT Series of Early American Architecture



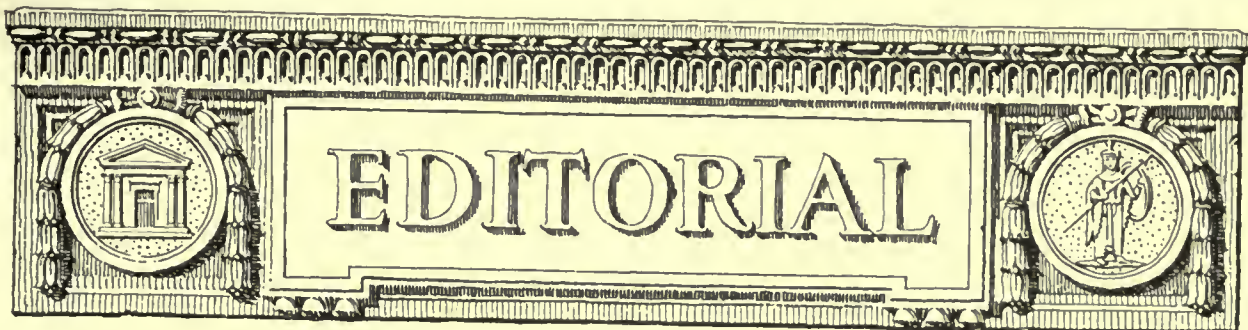

A Look Ahead

EVERY condition in the economic field of building today indicates that the outlook for the coming year may be regarded with a strong feeling of optimism. Business undertaken now will be divested of much of the uncertainty that has so strongly influenced operations during the earlier half of this year. A sounder and deflated basis is taking the place of the unsound, inflated condition that has retarded a normal program. We are returning to real values. This return, while slow, is for that reason all the more sure. There has never before been a time when greater opportunities have been presented. The accumulated work of several years of decided slackness now confronts the building industry, and it may safely be predicted that activity in the construction field will, with the advent of early spring, go forward with an impetus stronger than we have ever before known in this country.

Once the restrictions that have hindered building are removed the resumption of commerce, the up-building of the railroads and the renewed development of our natural resources will be assured. In these opportunities there are the greatest possibilities, and while we may not altogether reproach ourselves for present conditions we will in the future need to do so unless we read the portent in the skies and make ready.

We must now courageously look at the facts as they are. We must take a strict account of stock as to our possibilities in the future scheme, and we shall be recreant if we fail not alone thoroughly to realize what is in store for us if we do our whole duty, but also energetically to act. Hundreds of thousands of structures are demanded today. This demand is not born of a speculative motive, but of sheer necessity. Every type of essential building is so much in arrears that a further postponement cannot be outlived.

Bernard M. Baruch, who was head of the War Industries Board, at a recent reunion of the members of that body, gave expression to his views as to the outlook for 1921. During the course of his address he said:

"Let us look courageously at facts as they are; let us cast off the blindfold of pessimism; let us set our house in order; let us cut the Gordian knot and put the whole world back to work, realize peace in the fullest measure, face the future with American dauntlessness and look with confidence for the certain dawn of a great and enduring industrial renaissance, always bearing in mind the predominating fact that the economic, political and social elements are so interwoven that one cannot survive without the other."

That is exactly the correct point of view, and its application to the building industry will insure a future of absolute prosperity. What is past is as water that has gone over the dam. The future lies broad before us, and it is in the way we make use of its vast possibilities that we shall succeed or fail.

AS a nation we have in the past been reckless spendthrifts. The lessons in thrift we have learned during the war and the necessity for their strict application since the armistice have been a good experience. Today, by reason of this past experience, we are, individually and nationally, headed away from extravagance. Our experience has been costly, but its influence on our future will be of greater value than any can compute. No political party may seek successfully to gain the support of a majority if it shall ignore these lessons or seek to lull the people by specious arguments to cover up a failure properly to economize.

The frequent necessity for meeting a rising cost of living with a stationary income has made the voter thoughtful. He has learned in the school of actual experience that many of the things that in the past have been regarded as necessities are really luxuries or non-essentials. We have learned thrift, and the price paid is appalling; but if it shall teach us to regard not only the conduct of our own affairs, but also those of ourselves as a nation with more foresight, prudence and caution, it will have been worth while.

This application of thrift carried into our work in the future will redound to our well-being throughout our national life. Let us not forget the lessons

THE AMERICAN ARCHITECT

so dearly paid for. We are living optimistically in the hope that a new political power soon to assume control of the government will early mend conditions that are the result of all the irregularities of war. We, having ourselves learned the lesson of thrift, will insist that our government equally apply these principles. Thrift and frugality may not be regarded as habits; they are basic virtues. We had at one time forgotten this, but the necessities of the past four years have so thoroughly impressed them that we have learned a vitally necessary lesson.

Our trouble in the past has been mainly that, in a spirit of profligacy, we have failed properly to conserve our resources of every kind. We have spent lavishly, foolishly. It has been difficult to

impress upon us that the thing once wasted cannot be reclaimed, that our resources were not unlimited.

We have learned, especially in the construction industry, that there are more economical and equally good methods of building than those we one time employed. We have come to respect certain materials for their practical and economical attributes that once we refused to consider. We know the value of building space and its income-bearing possibilities. We plan better today than we ever did. All these things are but elements of thrift. What we shall need to remember in the future when the resumption of our normal activity occurs are these very essentials of thrift and not return to those habits of extravagance now fortunately checked.



AIRPLANE VIEW, LINCOLN MEMORIAL, WASHINGTON, D. C.
HENRY BACON, ARCHITECT

862



VIEW IN COURT, SHOWING TERRACE WALL AND FOUNTAIN
 HOUSE OF MRS. C. P. ADAMS, DALLAS, TEXAS
 H. B. THOMSON, ARCHITECT



VIEW IN COURT
 HOUSE OF MRS. C. P. ADAMS, DALLAS, TEXAS
 H. B. THOMSON, ARCHITECT



8622



SOLARIUM



STAIR HALL
HOUSE OF MRS. C. P. ADAMS, DALLAS, TEXAS
H. B. THOMSON, ARCHITECT



THE AMERICAN ARCHITECT

VOL. CXVIII, No. 2349

DECEMBER 29, 1920



SERVICE ENTRANCE



THE COURT
HOUSE OF MRS. C. P. ADAMS, DALLAS, TEXAS
H. B. THOMSON, ARCHITECT

8623



6624

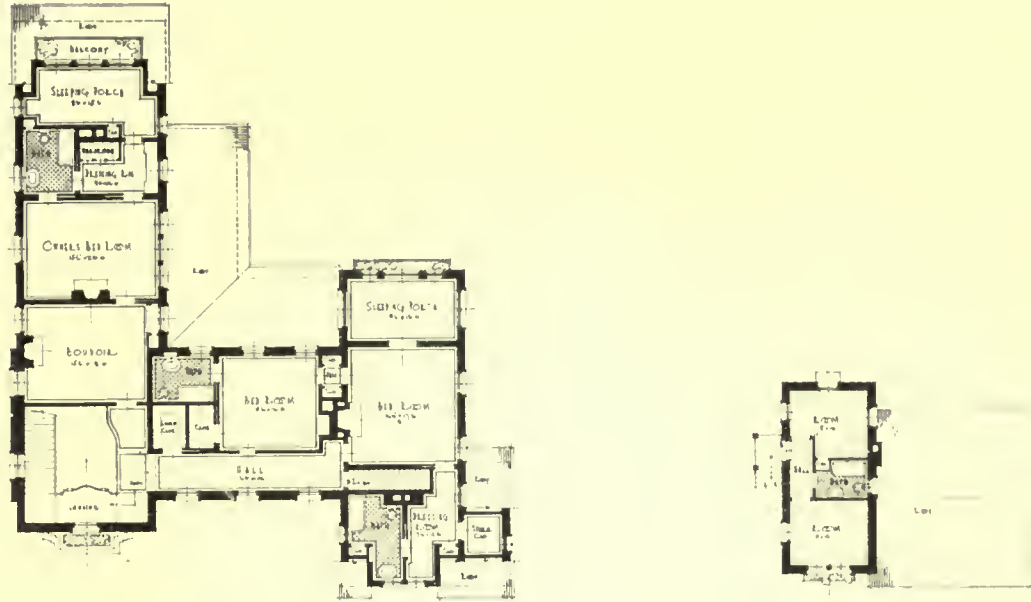

SECOND FLOOR PLAN
SCALE 1/8"=1'-0"

J. J. THORNTON ARCHT. &
BOSTON, MASS.

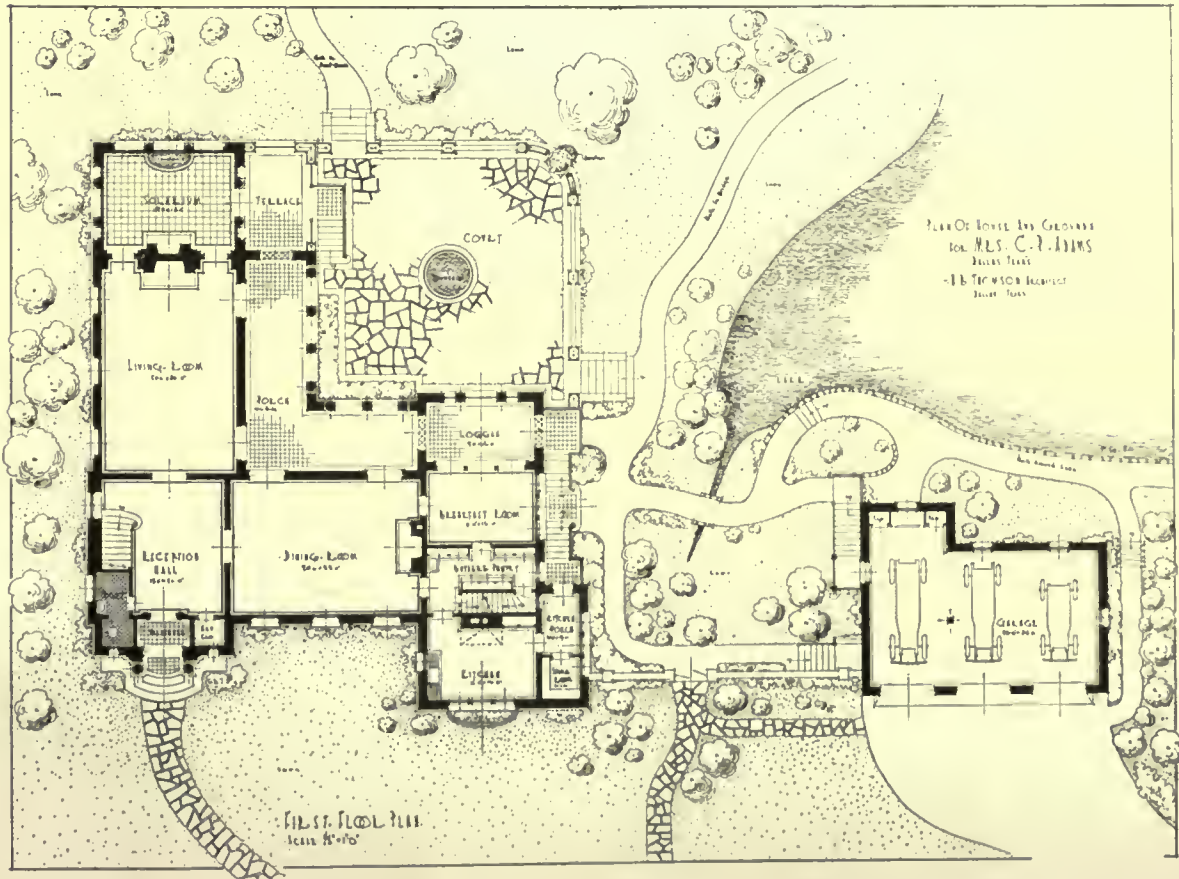

PLAN OF HOUSE BY GREENWAY
FOR MRS. C. P. ADAMS
FIRST FLOOR
-18- THORNTON ARCHT. &
BOSTON, MASS.

FIRST FLOOR PLAN
SCALE 1/8"=1'-0"





HOUSE OF GEORGE S. JOHNS, ST. LOUIS COUNTY, MO.

T. P. BARNETT CO., ARCHITECTS

The stone for this house was collected on the site of the owner and the rock quarried on the ground. The first story is constructed of heavy walls of field stone, laid in the wall as gathered from the fields, only dressed with the hammer. Joints are large and surfaces very irregular. The second story is of stucco, painted white, giving contrast to the rough stone in the first story which has a wide range of colors in grays and browns. The shutters are painted green and the shingle roof is of the natural cedar. The finish employed throughout the interior is quartered oak.

862





HOUSE OF GEORGE S. JOHNS, ST. LOUIS COUNTY, MO.
T. P. BARNETT CO., ARCHITECTS



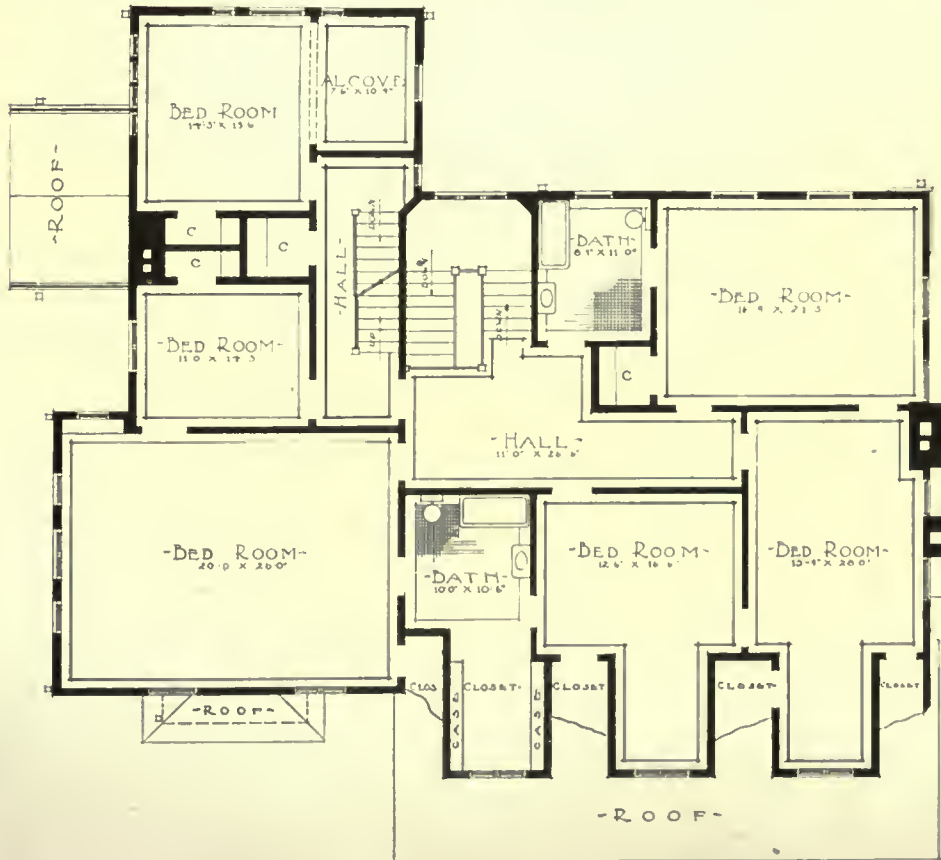
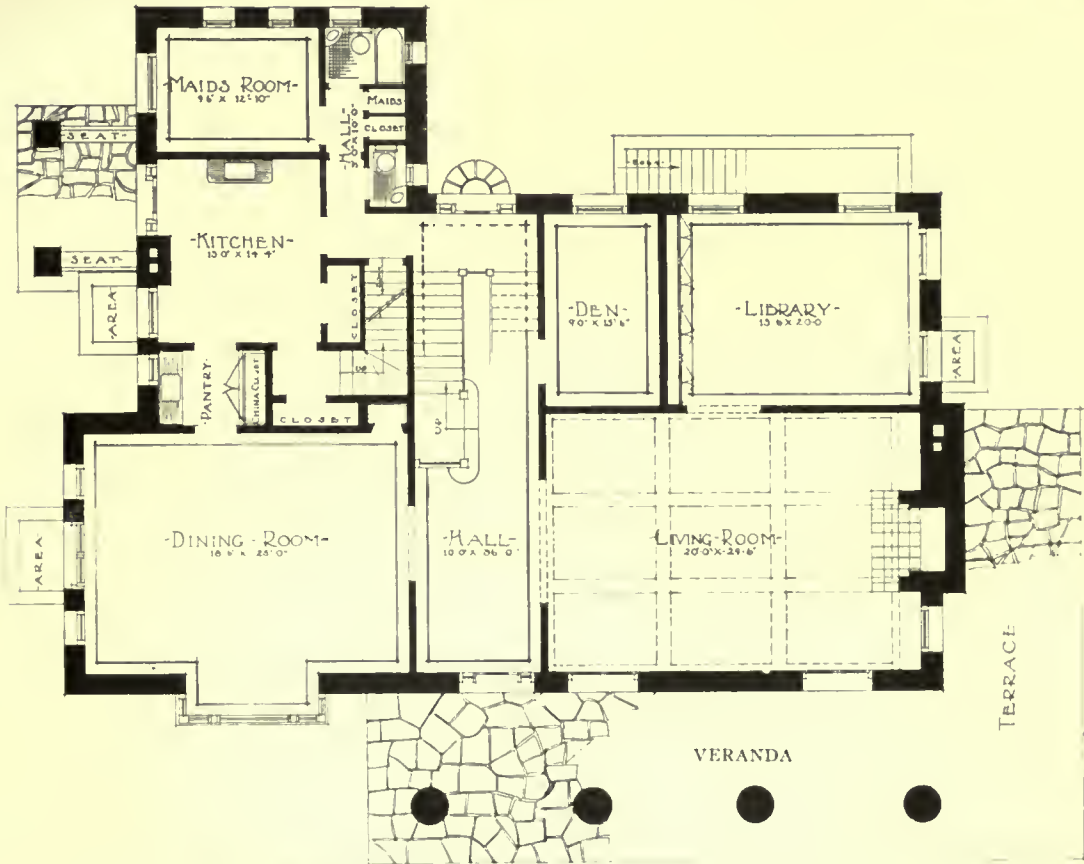

HOUSE OF GEORGE S. JOHNS, ST. LOUIS COUNTY, MO.
T. P. BARNETT CO., ARCHITECTS



DEPARTMENT OF ARCHITECTURAL ENGINEERING

The Port Development at Portland, Oregon

By G. B. HEGARDT, *Chief Engineer, the Commission of Public Docks*



7-2-20
24-12

VIEW OF MUNICIPAL TERMINAL NO. 4, SHOWING GRAIN ELEVATOR IN THE BACKGROUND AND THREE 9,500-TON VESSELS BERTHED AT PIER NO. 1

Construction work in progress on Pier No. 2, at the left

DURING the last seven or eight years the Pacific Coast has witnessed a concerted and enormous growth in port development, large sums having been expended by the major ports in the provision of modern facilities for the handling of its rapidly expanding water-borne commerce. Practically all of this terminal development work has been done by the municipalities of the various port districts, construction by private interests having been exceedingly small during this period.

It may be a surprising fact to many, however, that

Portland, Ore., previous to this time, had developed, by private interests, a harbor frontage of more than four and one-half miles in length, which was then being used by vessels ranging from the large type of ocean-going carriers to river steamers and coast-wise vessels. But Portland, in 1910, realizing the vital importance of having its port and harbor facilities brought to the highest standard and in keeping with the activities of other large ports of this coast, began to give careful and comprehensive consideration to the question of entering the field, as a muni-

THE AMERICAN ARCHITECT

cipal agency, in the reconstruction of the city's waterfront, by the construction of more modern and efficient terminals. By the creation of the Commission of Public Docks and the authorization of a \$2,500,000 bond issue, the initial start was made and actual construction gotten under way in 1912. From this appropriation three terminals were constructed in the upper harbor. These terminals were constructed solely for the handling of general cargo and have a combined berthing length of 2,505 lineal feet and cargo capacity of 35,000 tons.

In 1916, however, when it became evident that the old custom of shipping the grain crop in the port's tributary territory in sacks was soon to be

age facilities to serve the grain elevator, the piers, an industrial section and other terminal improvements. This terminal, designated as "Municipal Terminal No. 4," is served by Union Pacific, Northern Pacific, Southern Pacific and Great Northern railroads.

Municipal Terminal No. 4, being the most important of the port's improvements and one of the largest and most modern in this country, will be described somewhat in detail. There already has been spent in excess of \$4,500,000 on this terminal, and it is estimated that when fully completed its cost will approximate \$6,850,000.

Four of the piers of this terminal have a length



VIEW SHOWING HARBOR IMPROVEMENT AS IT WILL APPEAR WHEN COMPLETED

discarded and the nearly universal method of handling it in bulk instead adopted, the Dock Commission, after an extended investigation, determined to construct modern elevator facilities to meet this new condition of handling grain, and at the same time decided to concentrate at a new terminal, as far as practicable, its main facilities for the accommodation of the port's principal import and export business, and to obtain for that purpose a site of sufficient area to permit also of future expansion requirements, including space for warehouses, cold storage plant, bunkers, etc.

The site selected has an area of 160 acres and a harbor frontage of 2,730 lineal feet, with sufficient depth of property to permit of most excellent track-

of 1,500 feet, which length was adopted as furnishing the greatest flexibility and economy in operation and as being at all times ample for the accommodation of inbound and outbound cargo of two large size vessels and, in most cases, for three vessels of such type, and slips 280 feet in width, as leaving sufficient space for two vessels, in addition to lighters and fuel barges between them. This length of piers was also adopted because of the necessity of meeting the growing tendency for vessels of larger dimension in the trade of the Pacific, and for similar reasons the transit sheds were made of a width greater than is the generally accepted practice in this country—180 feet.

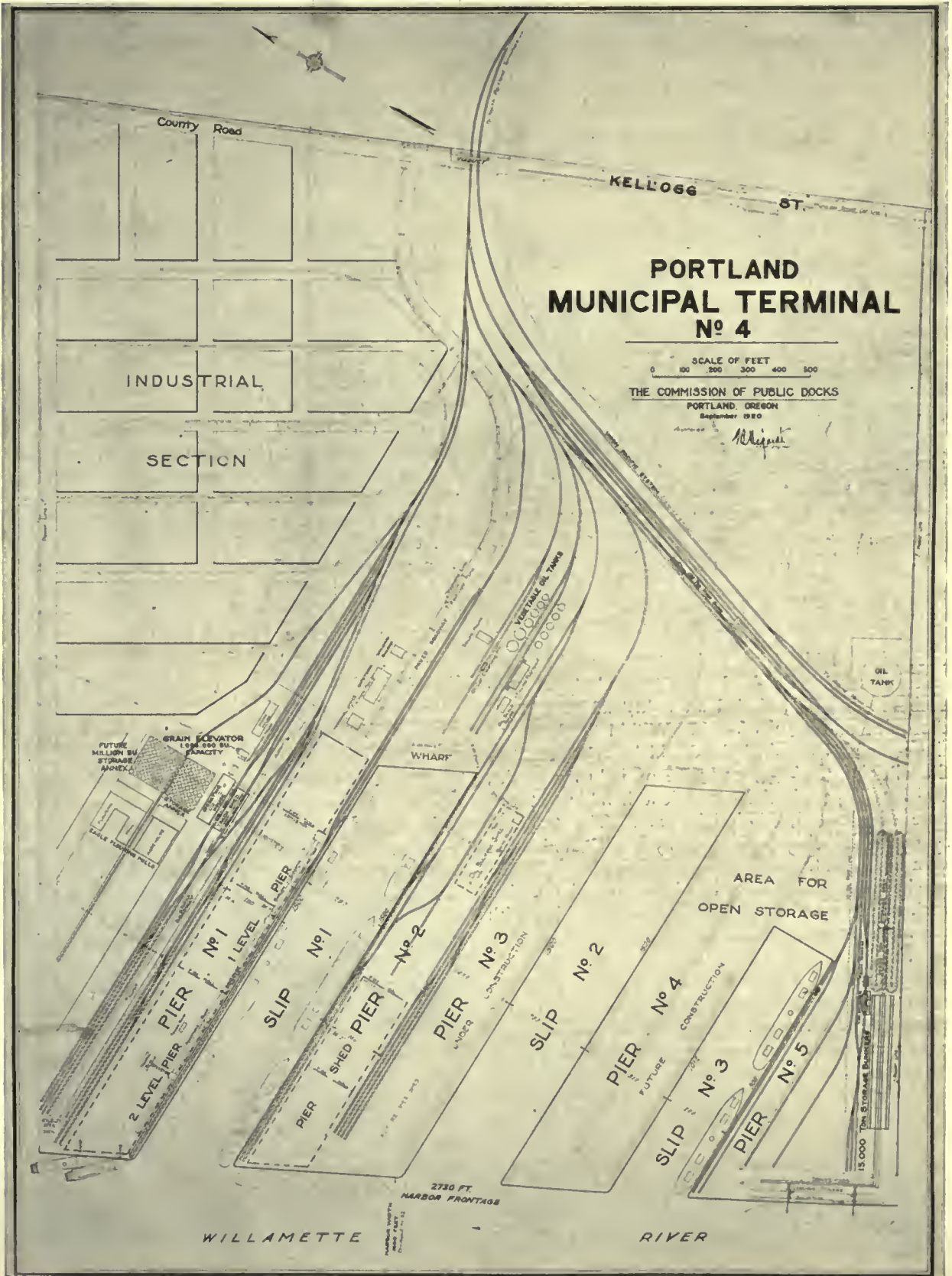

PLAN OF HARBOR IMPROVEMENT NOW NEARING COMPLETION AT PORTLAND, OREGON

THE AMERICAN ARCHITECT

The fifth pier is only 1,000 feet in length, due to property restrictions.

As will be noted in the accompanying illustrations, this terminal will, when fully completed, have berthing space for seventeen 500-foot vessels, and unusually extensive trackage facilities, which will insure the most rapid removal and replacement of both loaded and unloaded cars and greatly minimize



MAIN ENTRANCE TO TERMINAL

On Right: Welfare Building, Restaurant, Terminal Administration Building, Grain Elevator and Pier No. 1
On Left: Pier No. 2

if not entirely do away with, congestion so common to most water terminals, for one of the prime requisites of a combined rail and water terminal of considerable magnitude—and more particularly when in such terminal is included an industrial section—is the quick movement of cars. Within the limits of the completed terminal there will be approximately 20 miles of trackage, exclusive of industry tracks, which will permit the convenient handling at one time of about 1,200 freight cars. The terminal switching is being performed by the Commission's own equipment.

The industrial section has been so laid out that each industry will be served by rail connecting with the main terminal trackage.

In addition to the 1,000,000 bushel grain elevator and Piers Nos. 1, 2 and 5, now completed and in operation, the following facilities have been provided at the terminal:

(a) A large plant for the handling and storage of vegetable oils and molasses, complete with steam, air and pipe lines for pumping bulk oil, special 60-ton tank scales, tank car cleaning, bulking and barreling tables.

(b) One hundred and fifty ton standard scale for terminal weighing.

(c) Concrete bulk storage plant, constructed on Pier No. 5, of 15,000 tons storage capacity, for the handling and shipping of phosphate rock, sulphur, coal, copra and other bulk commodities, with ship

delivery of 300 to 400 tons per hour, depending on the commodity handled. A special feature in connection with this plant, for the economical and expeditious discharge of cars, is a car unloading and loading machine, which will discharge a box car in about six minutes.

(d) A large administration building, which not only houses the Commission's terminal office employees, but also those of the railroads, custom officers, state grain inspection bureau, etc.

For the accommodation of terminal employes, workmen, ships' crews and others, a restaurant seating 250 persons is in operation, serving meals at all hours, and for the benefit of workers at the terminal a welfare building has been provided, with shower baths, smoking rooms, etc.

Quite an extensive mechanical equipment is used, consisting of locomotive cranes, switching engine, with flat cars for transfer between piers and industries and dump cars for handling ballast.

On the piers there are cargo hoists, electric elevators, trucks, tractors, cranes, freight-piling machines, conveyors, etc.

At Municipal Terminal No. 4 there has, therefore, been provided a self-contained, combined rail-and-water terminal of great flexibility and expansive possibilities, where all services incidental to terminal operation are performed with economy and dispatch, where ample space is available for the accommodation of all classes of cargo, under shed or for open storage, without congestion, and where future as

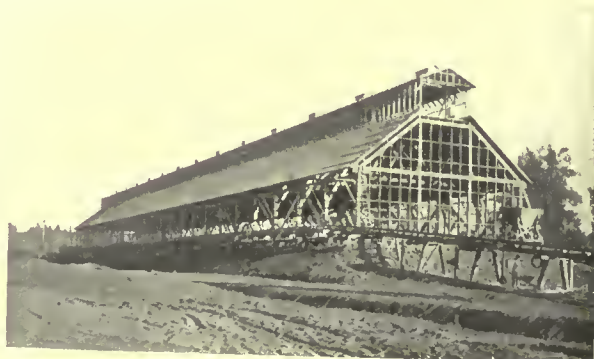

BULK STORAGE PLANT ON PIER NO. 5
NEARING COMPLETION

well as present requirements can be provided for, and where an industrial section furnishes cheap and convenient sites to such industries as more particularly require the combination of rail and water shipping facilities for the economical production and distribution of their output.

It is expected that the entire terminal development will be carried out during 1921.

THE AMERICAN ARCHITECT

The port already has a municipal floating dry dock of 10,000 tons deadweight lifting capacity, and another of 15,000 tons capacity is under construction and will be in operation about May, 1921.

The total amount voted to date for municipal



CONCRETE GRAIN ELEVATOR WITH CAPACITY OF 1,000,000 BUSHELS

water terminal facilities for the port is \$10,500,000.

While considerable space has been given to a description of the modern municipal water terminal facilities of the port, as already stated, private interests have also made large expenditures for similar improvements, and these, while not so modern as the more recently constructed municipal terminals, also play an important part in handling the port's extensive shipping.

The large sawmills have eight large wharves, with a total berthing space of 4,742 lineal feet.

Eleven grain docks, some of which at times are used for general cargo, have a berthing space of 5,415 lineal feet, with a total cargo space under shed of 1,086,750 square feet.

Five general cargo docks have a berthing space of 2,395 lineal feet, with a total cargo space under shed of 400,750 square feet.

These private grain and general cargo docks have a combined capacity for 262,450 tons at one time.

Four fuel oil docks have tankage capacity for 17,756,346 gallons of crude oil and 6,562,878 gallons of refined oil, and modern coal bunkers with 300-ton per hour ship delivery.

The commercial docks used for deep sea shipping have a least depth alongside of 30 feet at low water, thus accommodating the largest carriers.

The Cost-Plus-a-Fixed-Fee Contract

Tentative Draft Prepared by Associated General Contractors' Committee on Contracts

TEAM-WORK between contractors, architects, engineers and owners is set forth as the object of a new cost-plus contract which has been drafted by the Research Division of the Associated General Contractors under the direction of the Committee on Contracts. This type of contract is not advocated by the association to the exclusion of lump-sum agreements, but for the benefit of those not desiring to operate under the latter type. A new form of cost-plus-a-fee agreement has been drawn up. It is stated that a form of lump-sum contract is now in preparation and will be made public shortly.

Since the award of a cost-plus contract, by reason of the relation which it implies, is based upon confidence in the contractor's skill, integrity and responsibility, no attempt has been made to produce a "legally impregnable" document. The object sought in making the tentative draft was a clean cut statement of principles which shall permit the contractor to exercise freely his skill and judgment in construction work and yet give the owner quick and easy relief should the contractor fail to fulfill his trust.

Before making a final draft of the contract the Committee on Contracts desires to obtain criticism concerning any question arising from the principles expressed. All changes, omissions or additions suggested will be given careful consideration in revising the agreement. The first tentative draft follows:

COST PLUS FIXED FEE CONTRACT FORM.

THIS AGREEMENT made the _____ day of _____ in the year Nineteen Hundred and _____ by and between _____

(Name of Firm)

hereinafter called the Contractor, and _____

(Name of Owner)

hereinafter called the Owner

WITNESSETH, that in consideration of the compensation hereinafter specified, the Contractor and the Owner agree as follows:

1. SCOPE OF THE WORK.

This agreement shall provide for the construction and proper completion of _____ (Description of Project) _____

THE AMERICAN ARCHITECT

in full accordance with the existing plans and specifications of _____ (Name of Architect or Engineer) _____ and any subsequent plans and written instructions which shall be within the original intent of the existing plans and specifications.

2. OBLIGATIONS OF THE CONTRACTOR.

The Contractor shall exercise, for the Owner's benefit, his best knowledge and skill in purchasing materials, hiring labor, supplying equipment and performing all other services incident to the work. He shall cooperate fully with the Owner and the Architect or Engineer and faithfully execute the intent of this agreement.

3. OBLIGATIONS OF THE OWNER.

(a) As full payment for the services rendered by the Contractor in executing the work, the Owner shall pay the Contractor a Profit Fee as specified in Article 5.

(b) The Owner shall pay the Cost of the Work as specified in Article 6.

(c) For the use of the equipment the Owner shall pay the Contractor an Equipment Rental Charge as specified in Article 7.

(d) For the use of tools, accessories and appurtenances furnished by the Contractor, the Owner shall pay the Contractor a Tool Charge as specified in Article 8.

4. STATUS OF THE ARCHITECT OR ENGINEER.

The Architect or Engineer shall prepare all plans and specifications needed to describe properly the quality and dimensions of the work, except such working drawings as he may direct the contractor to supply. He shall cooperate fully with the contractor in executing the work and his decision on the intent of the plans and specifications shall be final. The Architect or Engineer shall inspect the work and he shall use his offices to see that the Owner shall receive full value for monies expended and to see that the Contractor shall receive full compensation for his work.

5. THE PROFIT FEE.

The Profit Fee shall be \$_____ and shall include and cover payment for the following:

- (a) The Contractor's Profit;
- (b) The professional services of the contractor, his executive officers and members of his firm;
- (c) The services of the contractor's home office employees except when executing drawings, design or re-estimation of plans required by this contract;
- (d) The expense of offices not maintained exclusively for this contract;
- (e) All general expense of maintaining the contractor's organization and doing business not directly occasioned by this contract.

6. COST OF THE WORK.

The cost of the work shall include and cover all expenditures made in good faith by the Contractor or the Owner to execute the work of this contract which are not covered by the Profit Fee, the Equipment Rental Charge, and the Tool Charge.

7. THE EQUIPMENT RENTAL CHARGE.

The Equipment Rental Charge shall include and cover payment for the service of each piece of equipment, except special equipment which the contractor may use to execute the work, providing said equipment shall be installed upon the work in good operative condition as certified by a competent inspector selected by the Owner.

The amount of the payment for any piece of equipment furnished by the contractor except special equipment, shall equal the daily rental rate herein specified for that piece of equipment, multiplied by the number of calendar days elapsing between the date of loading that piece of equipment for transit to the site and the date of reloading it for transit from the site. These dates shall be the dates certified by the bills of lading.

Any special equipment not owned by the Contractor which he may be required to purchase to execute the work shall be paid for by the Owner, and on completion of the work, all such special equipment shall be sold and the proceeds thereof credited to the Owner.

Repairs to equipment shall be paid as a Cost of the Work.

(The detailed schedule is intended to be supplied by the individual firm. Since in this contract repairs are charged as a Cost of the Work, they should therefore be omitted in determining the Equipment Rental Charge. Where desirable, the contractor may pay for repairs and cover them in the fixed rate charges. Attention is called to the Rental Schedule published elsewhere by the Associated General Contractors.)

8. THE TOOL CHARGE.

All tools shall be given a first "per cent new" value when brought upon the work. The value of new tools shall be 100 "per cent new" and the value of used tools some lower "per cent new," agreed upon by the owner and the contractor. On completion of the work all tools shall be given a second per cent new value similarly determined, and the difference between these values multiplied by the current market price shall constitute the tool charge for each tool. Lost or destroyed tools shall be paid for at the "first per cent new" value times the current market rate.

9. REBATES, REVENUE, DISCOUNTS, ETC.

The Owner shall receive the full benefit of all rebates, and refunds, and he shall receive the full bene-

THE AMERICAN ARCHITECT

fit of the discount on all sums paid directly with his capital.

The Contractor shall deliver to the Owner all revenue derived from commissary, store or other service maintained in connection with the work and all revenue derived from the sale of anything pertaining to the work except those things belonging to the Contractor.

10. FINANCING THE WORK.

The Owner shall furnish all funds for and shall provide payment for all expenditures incident to the execution of this agreement, except expenditures which the Contractor may make in fulfilling the covenants of the Profit Fee.

11. EXPENDITURES.

No expenditure or transaction involving more than \$—— shall be made in connection with this contract without the approval of the Owner, except that the Owner may authorize the Contractor in writing to make certain expenditures in accordance with the Contractor's judgment, in which case such authority shall constitute the Owner's approval of the expenditure. The Owner shall have the right to make any expenditure directly, or deal directly with any dealer.

12. PAYMENTS.

All payments shall be made by the Owner in accordance with statements issued and certified by the Contractor and approved by the Architect or Engineer, and payments may be made either directly to vendors or indirectly by reimbursing the Contractor.

Payrolls, equipment rentals, team and truck hire and other expenses which the Contractor may find it expedient to pay weekly or oftener shall be paid by the Owner within three days after receiving the Contractor's statement including such items. All other indebtedness shall be paid by the owner within 10 days after receiving the Contractor's statement covering such indebtedness.

On account of the Contractor's Profit Fee, the Owner shall pay the Contractor each month —— per cent of the cost of the work for the preceding month. This payment shall be made within seven days after receiving the Contractor's certified statement of the cost of the work. When the amount paid the Contractor on account of the Profit Fee, shall have equaled 90 per cent of the total Profit Fee no further payment shall be made on this account until the work is completed, at which time the Owner shall pay the Contractor the remaining 10 per cent.

13. AUDITING.

The Contractor shall keep accurate and detailed accounts of all disbursements, and he shall give the Owner access at any and all times to all books, accounts, documents and correspondence of the Con-

tractor which pertain to the execution of this contract.

If the Owner so desires, he shall have the right to place competent employees of his own in any position of accounting, time keeping or checking providing that such employees shall perform their respective duties in accordance with the Contractor's methods of handling the work.

14. STATEMENTS.

Statements of expenses to be paid weekly shall be accompanied by certified copies of payrolls and original invoices covering all expenditures not carried on the payrolls.

Monthly statements shall be accompanied by original bills and invoices and shall be certified by the Contractor.

On or about the fifteenth of each month the Contractor shall submit to the Owner a correct statement of the total expenditures during the preceding month and the total expenditures to date. He shall at the same time furnish the Owner with a progress report of the work.

15. SUB-CONTRACTS.

All sub-contracts shall be let by the Contractor (or the Owner) with the approval of the Owner (or the Contractor).

After the award has been made to any sub-contractor, that sub-contractor shall deal directly with the Contractor who shall have full authority over the execution of sub-contracts and shall be responsible for coordinating the work of sub-contractors with his general plan of executing the work.

16. INSURANCE.

Insurance against loss and damage to all plant owned by the Contractor shall be carried by the Contractor and the cost of that insurance shall be included and covered by the Equipment Rental Charge. The insurance on Rented Plant and Special Equipment shall be paid for by the Owner as a cost of the work.

All other insurance which the Owner or the Contractor desires to carry shall also be paid for as a Cost of the Work.

17. LAWS, PERMITS, LICENSES.

The Contractor shall abide by all legal restrictions and obligations of the locality wherein the work is located. In the event that any such legal restriction or obligation should be violated by the Contractor, or any of his employees, the Owner shall be indemnified and held harmless by the Contractor, from any legal action resulting from such violation.

The Contractor shall obtain for the Owner all permits and licenses necessary to execute the work, and the cost thereof shall be paid as a Cost of the Work.

THE AMERICAN ARCHITECT

18. LIENS.

The Contractor shall indemnify the Owner and hold him harmless from all liens and other incumbrances against the premises on account of debts or claims alleged to be due from the Contractor to any person employed by or under him.

19. TIME OF COMPLETION.

The Contractor shall commence work within _____ days after signing this contract and shall complete the work by _____. Should the Contractor be delayed in completing the work by any act or circumstances entirely beyond his control, the time of completion shall be extended until a number of days upon which weather conditions permit work, has elapsed equal to the number of such days lost by reason of any such act or circumstance.

20. OWNER'S RIGHT TO TERMINATE THE CONTRACT.

The Owner shall have the right after _____ day's written notice to terminate the contract with or without cause.

In event that the Owner shall terminate the contract, he shall have the right to take possession of the site and all materials and plant thereon and to complete, or employ any person to complete the work, providing that he shall assume all liabilities and obligations which the Contractor has assumed in good faith, and pay the following:

- (a) A per cent of the Profit Fee equal to that per cent which the total cost of the work up to the time of termination is of the estimated cost of the work.
- (b) The Cost of the Work up to the time of terminating the contract as specified in Article 6.
- (c) The Equipment Rental Charge as specified in Article 7.
- (d) The Tool Charge as specified in Article 8.

21. CONTRACTOR'S RIGHT TO TERMINATE CONTRACT.

The Contractor shall have the right to terminate the contract after ten days written notice under the following conditions:

- (a) If the work should be stopped by court order or other public authority for a period of more than _____ days through no act or fault of the Contractor.
- (b) If the Owner should fail to pay the Contractor in accordance with the terms of this contract.
- (c) If the Owner should not permit the Contractor to commence work within _____ days after signing this contract.

In event that the Contractor shall terminate the contract as provided in this article he shall have the right to remove all things from the site which belongs to him and return to the renters all things rented by him to prosecute the work, and the Owner shall pay him the sums stipulated in paragraphs *a, b, c* and *d* of Article 20, and assume all liabilities, and obligations which the Contractor has assumed in good faith.

22. TITLE.

The title of all materials for which the Owner is required to pay and of all work either completed or in the course of construction shall be in the Owner.

23. ASSIGNING THE CONTRACT.

Neither party to this contract shall assign the contract or any interest therein, without the written consent of the other party.

The contractor and the owner for themselves, their successors, executors, administrators and assigns hereby agree to the full performance of the covenants herein contained.

IN WITNESS WHEREOF, they have executed this agreement the day and year first above written,
(Firm name) _____

In the presence of _____ Contractor
By _____
as to _____ (Signature for firm)

In the presence of _____ Owner
By _____
as to _____

Cost Plus Fee with Penalty and Bonus

The following clauses should be substituted in the above form if instead of "fixed fee," a "fee with penalty and bonus" contract is desired.

5. THE PROFIT FEE.

In event of that any significant change shall be made in the plans the estimated cost shall be revised to provide for any change in quantities that may result. This adjusted cost which shall be agreed upon by the owner and the contractor shall be designated as the Revised Estimated Cost and shall be the cost of the work considered in determining the amount of a penalty or bonus.

The Profit Fee shall be \$_____, providing the actual cost of the work as specified in Article 6 is within 5 per cent. of the Revised Estimated Cost.

If the actual cost of the work is greater than the Revised Estimated cost by more than 5 per cent. the contractor shall pay the Owner _____ per cent. of the difference between the two amounts, but in no case shall the contractor pay an amount greater than _____ per cent. of the Profit Fee stipulated in this article.

If the actual cost of the work is less than the Revised Estimated Cost by more than 5 per cent. the Owner shall pay the contractor in addition to the stipulated Profit Fee _____ per cent. of the difference between the two amounts. But in no case shall the owner pay the contractor an additional amount greater than _____ per cent. of the Profit Fee stipulated in this article.

20. OWNER'S RIGHT TO TERMINATE THE CONTRACT.

- (a) A per cent. of the Profit Fee equal to that per cent. which the total cost of the work up to the time of termination is of the revised estimated Cost of the Work.

Current News

Happenings and Comments in the Field of Architecture and the Allied Arts

Housing of Women a Growing Problem

A far reaching program of housing for women, including students and business and professional women, as well as the minimum wage girl, is being launched this winter by the Y. W. C. A. as a follow up of the resolution on housing passed at the national convention in Cleveland last spring. Miss Blanche Geary, the head of building activities, has just completed a tour of the Western states, where she has helped in the organization, in several communities, of committees of social agencies which are pledged to make an immediate survey of housing conditions among employed women and then to project a program of renting or building to cover the need existing. Committees are already working in San Francisco, Los Angeles, Fresno, Sacramento, Seattle and Chicago. Fifty-five associations are at present making surveys preliminary to building, and sixty are building residences, apartments or hotels for travelers, residences for students where colleges do not furnish sufficient dormitory space, cooperative apartments for business women, residences for girls on low wages, homes for colored girls. In all the building activity of the association emphasis is being laid on simple, inextravagant building, tasteful but inexpensive furnishings and reasonable profit producing investments. There are 1,153 Y. W. C. A.'s in the United States, most of which will have taken up the housing problem in their community before next spring.

Ceremony of the Cornerstone

The custom of laying the cornerstone of a public building with ceremonies was practiced by the ancients. At the laying of the cornerstone when the capitol of Rome was rebuilt a procession of vestal virgins, robed in white, surrounded the stone and consecrated it with libations of living water. A prayer to the gods followed, and then the magistrates, priests, senators and knights laid hold of the ropes and moved the mighty stone to its proper position. In a hollow cut in the stone were placed ingots of gold, silver and other metals which had not been melted in any furnace.

With the Jews the cornerstone was considered an emblem of power and they also performed ceremon-

ies at its laying. In medieval times the rite was taken up by the order of Freemasons and has by them been brought down to modern days, the Masonic ceremony of laying a cornerstone being symbolical.

Health Officials Advocate Federal Aid to Build Homes

Public health officials from the principal cities of the East and Middle West ended their recent conference in Detroit on the housing situation with the framing of resolutions embodying conclusions reached after surveys of conditions in the centers of population.

Financial aid for home builders, provided by governmental agencies, and stricter regulation of building were among the remedies suggested for the elimination of congestion, which was held responsible for a large proportion of disease. The task was too great for individual financing, in the opinion of speakers, and should be placed in the hands of national, state or municipal governments. The recommendations of the health commissioners will be sent to the Senate housing committee, which, under the chairmanship of Senator Calder of New York, plans introduction of some remedial legislation.

Unless the Federal Government acts to relieve the housing shortage in the larger cities there is imminent danger that Socialism will prevail in the country, stated Dr. Royal S. Copeland, health commissioner of New York City, before the conference.

Declaring the slums of New York City, wiped out by Jacob Riis and Theodore Roosevelt, were being reopened, Dr. Copeland believed city officials of New York were to blame for the condition.

"We wonder why Bolshevism crops out in this country," Dr. Copeland continued. "The answer is found in the housing situation in many of our large cities."

Some Facts on Bricklaying

Speaking of Mr. Hoover's recent conference with the labor leaders, the New York *Herald* said editorially:

In a publication put out by the Associated Employers of Indiana are some statistics covering the work and the pay of bricklayers which go to the very heart of the trouble. These figures show the

THE AMERICAN ARCHITECT

different wage rates and the different production records for various years between 1909 and 1920, as follows:

Year	Rate an hour	Bricks a day
1909.....	\$0.55	1,100
1916.....	.65	900
1918.....	.80	614
1919.....	1.00	587
1920.....	1.25	541

While the bricklayer's pay, therefore, measured merely by the wage scale, has gone up from 55 cents to \$1.25 an hour, the cost to the consuming public of getting bricks laid on the eight-hour day basis has gone up from \$4.40 for 1,100 bricks to \$10 for 541 bricks. It has gone up, in other words, from \$4 a thousand to \$18.50 a thousand. While wages, therefore, apparently have gone up only one and a quarter times the actual wage cost of laying bricks has gone up more than four and a half times.

The same thing is true in a greater or less degree of the other crafts in the building trades. It is true of manufactures. It is true of coal mining. It is true of ordinary day labor. It is true of pretty nearly everything where labor enters largely into the producing and distributing costs.

Forest Long Under Water

When the government ship canal that connects Puget Sound with Lake Washington was opened, the waters of the lake were lowered 12 feet. While wire-dragging the lake, it is learned, the United States coast and geodetic survey discovered a submarine forest. The tops of the submerged trees were so close to the surface that they were a menace to navigation. Under-water logging operations to clear the lake were therefore started.

It is thought that the forest is pre-historic, a remnant of one that grew in the Lake Washington area in the days when it was dry land; or that great landslides in remote ages carried the trees into the lake.

The trees were without branches and stood vertical, or nearly so; they were semipetrified. The longest trunk removed was 121 feet 6 inches. The top, 10 inches thick, rose to within 4 feet of the surface of the lake. The butt was 5 feet 6 inches in diameter, and the roots, firmly embedded in the bottom of the lake, had a 20-foot spread. It was found 1,500 feet from the shore.

Off the south end of Mercer island, in Lake Washington, nearly a hundred trees were destroyed. The cleanup gave a count of more than a hundred trunks during the first three months of 1920, off Manitou point. The largest trunk in that area stood in 121

feet of water, 1,100 feet from shore. The tree was 111 feet long, with a 5-inch top and a 3-foot butt.

Wherever possible, the trees were pulled out by the roots. Fastenings were made to the trunks by dragging the bight of a cable through the water at the required depth. When the bight touched the trunk, one end of the cable was passed through an eye at the other end, and the loop formed was run down to the trees. When the trees were hauled up, they were cut into 4-foot sections and thrown back into the lake. Since they were water-logged, they immediately sank.

Sometimes a trunk was caught that could not be uprooted. Such trees were blasted off at the top until vessels could pass safely above them. An idea of the extent of the submerged forest and the difficulty of removing the towering ancient trees may be determined by the time—three years and six months—that it has taken the engineering corps, working steadily, to make the lake safe for navigation.

Hobo Hotel Rates Soar

Patrons of the lodging houses of New York's famous Bowery—knights of the road, hoboes, panhandlers and more prosperous individuals—were aroused with the announcement that rates have risen. The Bowery "hotels" have increased their prices from the 15 and 20 cent schedule maintained for many years to double those rates in many cases, with an average rate now of 40 cents.

In connection with the increased rate many of the proprietors have eliminated the clean towel, formerly thrown in with the night's lodging.

Asbestos Cement

LOW-GRADE ASBESTOS NOW USEFUL IN NEW PRODUCT

One of the features incidental to the shortage of many building requirements, such as tiles, timber, slates, etc., and delays in the transportation of bricks, has been the impetus received in England by newer forms of construction, notably reinforced concrete construction. Here certain limitations are felt, however, in the shortage of Portland cement and periodical difficulties in obtaining the metal reinforcement.

In this connection a new building material has come into prominence and is attracting a great deal of attention. This is asbestos cement. A rosy future is promised for this asbestos cement and for cement articles in which the binder is crude asbestos waste, according to a Trade Department bulletin:

"The British Empire produces about 70 per cent. of the world production of asbestos, the principal

sources being Canada and South Africa. This asbestos varies from high grade, from which many heat non-conducting compounds and packing are made, to low grade or waste, which, till late years, had no commercial value, owing to its lack of tensile strength.

"It was discovered, however, that the waste product, which was plentiful and cheap, mixed well with cement, to form excellent heat non-conducting and impermeable bodies, which could usefully be applied to solve the housing difficulty."

The manufacture of the asbestos cement has been taken up quite extensively in the United Kingdom, and interior and exterior slabs, slates, tiles, etc., are being produced. Decided advantages are claimed for the material for light but durable building construction, the principal ones being its adaptability, making it easily fitted to frame construction; its heat non-conducting qualities, making the building warm in winter and cool in summer; its light weight for transportation and the fact that it can be easily rendered waterproof by coating with various compounds. The fact that there is no visible shortage of poor grade asbestos, while cement is at times difficult to obtain, is brought forward as a strong argument in favor of the new material.

Architectural League's Spring Meeting

Through the courtesy of the Park Commission of the City of New York, with the cordial consent of the Trustees of the Museum, the Architectural League of New York has undertaken to hold its Annual Exhibition of Architecture and the Allied Arts in the unfinished south wing of the Metropolitan Museum of Art. The exhibition will open about March 25 and will close April 26, 1921.

A. I. A. Co-operates with Thrift Week Committee

National Thrift Week Committee, with the cooperation of the Savings Division, U. S. Treasury Department, and thirty-seven nationally known organizations, will sponsor "Own Your Home" exhibitions in all large cities throughout the country during the week of January 17 to 23, 1921, to aid in solving the acute housing problem, according to announcement just made by Adolph Lewisohn, chairman.

The American Institute of Architects has approved a national competition with prizes totaling \$15,000 for best plans of small, economically practical houses and bungalows. On Thursday, Janu-

ary 20, "Own Your Own Home Day" of the fourth National Thrift Week, a concentrated effort will be made to urge men of small means and the foreign-born to build and own homes, as a practical Americanization feature of the program.

As the two largest centers confronted with the housing problem, New York and Chicago will conduct "Own Your Home" exhibitions on a large scale, following the Thrift Week effort nationally. The Middle Western exposition will be held in the famous Coliseum at Chicago, March 26 to April 2. The two-week show is scheduled in the 22d Regiment armory at New York, April 16 to 30.

Confederate White House to Be Moved

It is proposed to start at once to move the first white house of the Confederacy to a new location near the Capitol in Montgomery, Ala. The building has passed officially into the possession of the First White House Association, having been purchased with funds appropriated by legislature last year. A site was recently acquired on which to place the building.

When the work of removal has been completed, the relics of Jefferson Davis and other persons famous in the Confederate government will be placed in the building. The relics are now with the department of archives and history and stored in vaults of local banks.

Memorial to Grant, Years in Progress, Soon to Be Unveiled

Eighteen years in the making, a memorial to General U. S. Grant is nearing completion in Washington, D. C., and probably will be unveiled before the end of the year. It is in the form of an equestrian statue of bronze, the second largest of its kind in the world, mounted on a granite pedestal and flanked on the left by a casting of a group of cavalry and on the right by a group of artillery, both groups done in bronze. Two huge lions in stone at the foot of the pedestal complete the memorial.

The memorial is located in the Botanic Gardens at the foot of the capitol and Congress has approved the removal of a section of the iron fence on the east front of the gardens to admit the statue and to provide space for spectators at the unveiling ceremonies.

Authority for the creation of the memorial was given by Congress on February 23, 1901. The competition for the statue was held in 1902 and the award was to Henry M. Shrady, of Elmsford, N. Y. The

pedestal was designed by Edward Pierce Casey, of New York, associated with Mr. Shrady and was completed and put in place in 1906.

The equestrian statue has just now been finished.

The memorial will bear no inscription. A member of the Grant Memorial commission had composed a lengthy inscription, but after careful consideration officials of the commission and of the office of public buildings and grounds deemed an inscription unnecessary.

Limousine Luxuriously Fitted for Touring

One of the most luxurious and ingenious "homes on wheels" which has yet been constructed by a motorist is that built by a Texan, states John Anson Ford, in *Popular Mechanics*. There is provided an eight-cylinder chassis with an inclosed body fitted with every imaginable household convenience, at a cost of \$10,000. With it the owner and his family have been making extended tours of the United States. This motorized home is 10 ft. long and 6 ft. wide, and is provided with seats for four. The height inside is 5 ft. 10 in. Across the back is a folding bed measuring 5 ft. 10 in. by 4 ft., equipped with spring and mattress. Above it is a clothes and parcel rack resembling that found in a railway coach. At the rear of the two front seats is a 3 by 5-ft. aisle, with window seats at either end fitted with cushions, 2 ft. wide. A table turns down in front of these seats, making a convenient eating place for four.

All the comforts of a kitchen and bath are also provided, no expense having been spared to design features that would adapt themselves to the limited space of the car's interior. These include a refrigerator, a lavatory, a cabinet equipped with thermos bottles, hot and cold water from pressure tanks, a three-burner gas stove, a two-burner oven, cupboards built against the wall, and also numerous shelves. Removal of the top of the driver's seat reveals the toilet, which can be shut off from view by curtains.

Other conveniences which bespeak the luxury in which these motorists ride are a cigar humidor within easy reach of the passengers when seated, a small cabinet containing a cuspidor, shower-bath attachment to the water tanks, electric cigar lighter, and an electric fan. Other features suggestive in part of the sea and in part of aerial transportation are a compass, an altitude meter of special value in mountainous regions, a gradometer, a thermometer, a perpetual calendar, and a ships barometer. Mirrors above the front seats give the driver an excellent view of the road at the rear through the large back window.

The body of this motor car is of steel, with the exception of the roof, which is of canvas. The car has been driven over 10,000 miles.

Bath Truck for Traveling Groups

Another recent development in motordom is a motor truck equipped for the bathing requirements of circuses, military bodies and other traveling organizations. The body contains lockers and dressing rooms and is fitted with eight shower heads. Hot water is furnished by automatically operated devices which keep two tanks of 400-gal. combined capacity constantly filled. A 2½-ton chassis is used for carrying the moving-van type of body. The dressing room is 6 by 7 ft., and is equipped with lockers and seats, so arranged as to provide ample space. The shower room is 7 by 8 ft., with the floor sloping downward from the center, and is covered with rubber matting. A telescoping trough underneath the body catches the water and carries it to the rear when the showers are in use. Translucent windows, that are suggestive of portholes, and electric lights provide ample illumination.

Plymouth Rock to Rest on Base Where It Was in 1774

The lowering of Plymouth Rock to shore level and removal of the canopy over it has now been provided for by the Pilgrim Tercentenary Commission.

The rock is to be set down in its permanent foundation, the granite base from which it was broken in 1774, when a twenty-yoke oxen team dragged it to Town Square for use as a base for a flagpole. In 1823 it was taken to Pilgrim Hall and about forty years ago it was returned to its present location on the shore of Plymouth Harbor. The foundation ledge lies about seven feet below the present level of the rock.

In the canopy are bones reputed to be those of some of the Pilgrims who died in the first year after the landing at Plymouth. They are to be taken out and returned to the original burial ground on Cole's Hill.

Vanderbilt Home to Be Bank Office

The William K. Vanderbilt mansion on the northwest corner of Fifth avenue and Fifty-seventh street which has been tentatively purchased by the Empire Trust Company will not be demolished and replaced by a skyscraper at the present time, but will be remodeled for use as banking offices.

This structure, which is one of the most costly of

the remaining Fifth avenue mansions in this region, is of gray stone in French Gothic style of architecture and was modeled after an old French chateau. Its exterior will not be altered to any great extent at the present time. Extensive alterations, however, will be made to the interior, and the grand ballroom probably will be used as the main banking room.

In the rear of the mansion, which occupies a plot fronting 100 feet on Fifth avenue, and 175 feet on the north side of Fifty-second street, an office building will be erected, connecting with the mansion.

Maryland Frame Church 238 Years Old

The durability of wood as a building material is strikingly emphasized in the old Quaker meeting house at Easton, Maryland, built in 1682-4, and probably the oldest frame building in the country without additions or alterations from the original structure. Its frame, inside woodwork and some of the weatherboarding is the same as when built in the days when William Penn, who visited the building, was laying out the city of Philadelphia. The structure is sixty feet by forty-four and is made from white oak, white pine and cypress from the Maryland forests.

The church is still a place of worship.

Inexpensive Architectural Designs Desired

If the high cost of building construction has worried the engineers and contractors in their endeavor to solve the problem for cheaper construction, it will more than worry the architect the coming year to learn cheaper design, states the Philadelphia *Ledger*. It will mean the developing of architectural ingenuity and the architects who will first become reconciled to this thought will be the first to get their buildings under contract.

The injection of architectural ingenuity into a design does not necessarily mean poor architecture; it will simply force the architects to give more thought to the costs of materials used in the construction of their buildings, at the same time making him use such materials that are available and not materials that are made expensive due to long hauls and high freight rates.

Again, the architect must display ingenuity in the use of repetition of features rather than unnecessary changing of small details which add nothing to the design with the possible exception of cost. While it is true the details materially help a design, yet it can be carried to excess by the use of specially moulded bricks, a multiplicity of variations in mouldings and in cast ornaments.

Stock designs are also something the architects must learn to at least like and forget the hatred of the past, continues the *Ledger*. While it is true the word "stock" in the past has sent a chill down the spinal column of the average architect, yet the time has come when the standardization of building materials will compel him to use stock designs, not only to keep down the cost of construction, but also to erect buildings with anything that savors of speed.

Huge Engineering Council Formed

The American Engineering Council of the Federated American Engineering Societies was recently launched in Washington, when engineers and scientists from all parts of the country held a meeting at the New Willard Hotel. It was said that organizations with a total membership of 100,000 were represented, through the delegates.

The united engineering forces of the nation will combine in a great national program of public service, it was announced. Sponsors for the council described it as a "super-engineering organization through which the efforts of the organized engineers of the nation will be enlisted in behalf of a constructive program of public service."

Among the chief features of this program are:

Conservation of the nation's resources in coal, oil, timber, water power, etc.; immediate work upon the national problem of transportation; a movement toward the solution of the relations between capital and labor in which the engineer, from his comparatively impartial point of view, is believed to be especially equipped to make recommendations; creation of a national public works bureau by means of a reorganization of the Department of the Interior, co-operation with the Drafting Bureau of Congress in its work of preparing for a national budget system, and other important legislation and guiding legislation for the licensing or registration of engineers.

Weekly Review of the Construction Field

With Reports of Special Correspondents in Regional Centers

WE are surely but definitely approaching normality.

This country will harvest this year one of the largest crops in its history. The transportation congestion is relieved. Its railroad system is for the first time in a decade on a sound financial and operating basis. Our banking system has withstood the greatest credit strain in its history. It is on a sound and workable basis. The accumulated surplus of five years of splendid prosperity is stored in many ways for our continued use. The markets of the world demand our products. A great mercantile marine is prepared to transport them. This country has not been overbuilt or overextended in any of its underlying activities. It faces no program of readjustment along those lines such as usually precipitate panic conditions.

These facts come from no less an authority than Charles H. Sabin, president of the Guaranty Trust Company of New York.

Everything bears him out at this time.

Over one billion dollars is available for road construction for next year. Much more deferred building *must* begin in the Spring. The figures compiled by the Association of American Railway Executives exhibit clearly the increasing efficiency of the roads as compared with Government ownership, and each succeeding month continues to be a record one. Labor, following the Lockwood investigation in New York City, has begun to "see the light." Even before that investigation the American Federation of Labor completely repudiated the revolutionary program of the International Federation of Trade Unions, and it has consistently rejected all European calls to aid the Soviets. Manufacturers are reducing the prices upon a great number of the basic commodities of life, and this primary reduction has run clear through the line to the ultimate consumer himself. Whether this is forced or voluntary matters little. Prices *have* come down in a great many staple commodities and the ultimate consumer is actually paying less for them. The investigations being conducted in various parts of the country into numerous activities, especially the building industry, are digging irresistibly into the facts surrounding the many "systems" which have so unfortunately retarded building since the armistice. John H. Defrees, president of the United States Chamber of Commerce, predicts relief from the industrial depression in less than six weeks, and supports his contention by solid arguments too numerous to mention here. People are looking forward hopefully to a new administra-

tion, and are expecting great things of it. Confidence is everywhere.

Under such conditions uncertainty disappears. People begin to look upon the future with faith in the permanence of their jobs. And such faith is the sort which will put money into the vitally necessary needs of the country. It will have confidence enough to build, and will be supported by a normal employment. There will be an adequate distribution of money.

And those three things—confidence, certainty of employment, and an adequate distribution of money—are the vital factors in any nation's building program.

So much for the national situation.

INTERNATIONALLY it is the same. In a pamphlet issued by the Bankers Trust Company of New York the amazing rebirth of French industry is strikingly illustrated in the fact that today 3,238, or 77 per cent., of that nation's factories are actually producing. This number, out of a total of 4,241 factories either damaged or destroyed in 1918. France's trade balance is approaching normality. Her steel industry realized greater profits for 1919-20 than in any two previous years. The fuel situation is daily becoming better. September's coal production in the Sarre bettering August's figures by more than 100,000 tons.

Great Britain is rapidly regaining her foreign trade. For the first eleven months of the present year imports exceeded exports by only 3 per cent. Houses are being built everywhere, and with incredible rapidity.

Belgium shows an almost unbelievable return to normality in every industrial phase of her national life.

Now, what bearing has the international situation upon the building industry in this country? Precisely this: The United States in general is producing goods more rapidly than we can consume them. To restrict production is recognized as fundamentally unsound. The logical thing to do is to market our surplus wherever production cannot keep pace with demand. The sounder Europe's condition becomes, the more need will it have for our raw and finished products, and, much more important, the sounder and more normal will exchange become. That assures us a market for what we have to sell. That, in turn, assures us more money in this country. But above even that, it assures employment for all, and a general prosperity.

THE AMERICAN ARCHITECT

It may be noted that our export trade is low, not so much because of the exchange situation, but because of a rather deplorable lack of an accurate knowledge of the value of foreign markets. To better and to promote this knowledge will help building in this country.

Current wholesale prices for the New York market, for the week ending December 24, follow:

LUMBER: *Yellow Pine*—B & Btr. F G Flooring, 2½" face, \$65; Long Leaf Dimension, SIS1E, No. 1 Com., 2x4", \$30; Merchantable Long Leaf Timbers, 12x12, 10 to 20 ft., \$62.

North Carolina Pine—Roofers, 12/16x6" (Air Dried), \$32.50; No. 2 & Better Flooring, 2½" face, \$66.50; Tonawanda White Pine, Fine Common, 4/4x8 and up, \$106.

Douglas Fir—No. 1 Clear Flooring, 1x4 (VG), \$77.50; Dimension, SIS1E, 2x4, 16', \$47.25.

W. Va. Spruce, 2x4", 16', \$58.50; Adirondack Spruce, 2x4", 12' to 14', \$64.

Penn Hemlock, Base Price, \$50.

Cypress, Factory Selects, 4/4, \$105; Spruce Lath, \$6.

Current retail prices (except brick) are as follows:

BASIC: *Brick*—Hudson Common, \$16-\$18; Fire Brick, Standard No. 1, per M, \$85; "Haverstraw" Hollow, \$25.

Cement—Domestic Portl. bbl., N. Y. yd., \$4.80.

Gravel—Delivered to job site, \$4.25 per cu. yd.

Grit—Delivered to job site, Cow Bay, \$3.50 per cu. yd.

Iron and Steel—Wire Rods, No. 5, Common Basic or Bessemer Rods to domestic consumer, \$57 to \$57; Chain Rods, \$57 to \$57.

Structural Steel—From N. Y. stocks, small lot quantities, cents per lb. *Bars*—Refined iron, base price, 4.70c. per lb.; Swedish bars, base price, 20c. per lb.; Soft steel bars, base price 3.37c. to 3.48c.

Beams and Channels, Angles and Tees—3"x¼" and larger, base 3.58c. per lb. to 3.80c.; under 3"x¼" and larger, 3.48c. per lb. to 3.70c.

Lime—Delivered job site, standard 300-lb. bbl., per bbl., \$5.20. Common Lime, stand. 300-lb. bbl., per bbl., \$5.20. Hydrate Fin. Lime, per ton (cloth, paper bags), \$33.85 and \$29.85. Common Hydrate Lime, per ton (cloth, paper bags), \$27 and \$23.

Sand—Per cu. yd., delivered job site, \$2.75.

Stone—Broken cu. yd., 1½x¾ broken stone, \$4.

Stone, Building—Indiana Limestone, \$1.81 to \$1.85; Ohio Sandstone, \$1.75 to \$2.35; Kentucky

Limestone, \$2.07 to \$2.07; Marble (Tenn.), \$5 to \$5; Granite, \$2 to \$3.50.

(Special Correspondence to THE AMERICAN ARCHITECT)

SEATTLE.—The attitude of the eastern steel mills has undergone so radical a change during the past few weeks that jobbers are able to report that orders are now being eagerly sought after for sheets, nails and pipe for delivery within ten to fifteen days. As a result, there are more sellers than buyers, the jobbing trade is being urged to buy beyond its willing capacity, and warehouse stocks are gradually accumulating to normal.

Representatives of the steel corporation have been on the coast this week and in conferring with them jobbers have endeavored to get a line on what their position will be as to prices. These conferences developed little, and jobbers declare that if these representatives were to "place their cards on the table" it would be to their own detriment.

It is reported on the coast that any buyer can receive recognition now. Formerly jobbers that were not known on the books of the eastern mills got scant courtesy, while so-called "pets" were being served or rationed according to the demand all through the early winter.

Sheets are \$10 lower, but nails and pipe remain stationary in price. The bulk of the steel is being moved by water, owing to a saving of \$9 per ton in the rate as compared with the rail haul.

There is a shortage in spots, however, of halves and three-quarters of galvanized pipe. Sheets for building purposes are sold practically on arrival.

Warehouses are as well stocked with cement and roofing materials as jobbers care to see. Building paper weakened slightly during the week. The number of salesmen for these commodities is multiplying, but jobbers are shoving them off on the predicate that the date of the resumption of building activities on the coast is still too remote to warrant any sort of over-buying.

The spring demand is not yet concrete enough to justify heavy contracts by jobbers. Sales of fir lumber during the week for eastern shipping account was only 673 carloads, 30,000 feet to the car, the lightest week of the year. Lumber shippers are preparing to ask the railways to create a wide parity between the freight rate on finished and common lumber, both now moving at the same rate. Seventy-five per cent. of the fir lumber shipped east is common, and the mills are objecting to paying a high freight rate on the uppers, which figure but slightly in the trade.

Eighty per cent. of the lumber mills and 90 per cent. of the logging camps and shingle mills are closed. Reduction of the wage scale of 50 cents per day has already been started, and when these plants

resume operations in February the men must be prepared to conform to the new era of prices.

When the mills closed, due to the below-cost market, they left accumulated stocks of 50 to 60 per cent. over normal, inclusive of all standard building assortments. The reduction of the wage scale may portend lower fir lumber prices next spring, but manufacturers declare they will first recover from the losses they have sustained since the emergency freight rate was put into effect.

Flooring at the mills sold this week at \$49 to \$56, ceiling at \$26 to \$35, drop siding at \$31, boards and shiplap at \$17.50 and common dimension at \$13.50 to \$15.50. Red Cedar shingles are dull at \$2.30 to \$2.40 for stars and \$2.60 to \$2.75 for clears. Perfections are \$4.50 to \$4.75, and eureka \$3.75 to \$4. All shingle prices herewith to the trade. The fourth annual shingle congress, in session here this week, decided to pack shingles hereafter entirely on the square basis, as against the per 1,000 as formerly, claiming that it is easier for a consumer to estimate what he will require in that way.

The revision of the Seattle building code was begun this week. The following organizations will participate in the work: Washington State Society of Architects, American Institute of Architects, American Society of Civil Engineers, Master Builders' Association, Board of School Directors, Real Estate Association, Building Owners' and Managers' Association, Manufacturers' Association, Municipal League, Chamber of Commerce, Building Trades Council and the medical fraternities.

(Special Correspondence to THE AMERICAN ARCHITECT)

CHICAGO.—Chicago builders, present and potential, continue to await the turn of events, with everything pointing more clearly to the long expected increase in building activity with the approach of spring. Apparently, all factors in the situation are conspiring to bring the building revival to early fruition. Materials are getting lower in price, labor is much less dictatorial and indications are not lacking that the credit situation is also improving. Considering the matter, by and large, it seems entirely safe to say that the way is pretty well cleared for progress as soon as the element of uncertain weather is eliminated.

Some of the projects now being tentatively or tangibly discussed are of sufficient importance to make certain the general acceleration of the building industry, once they get under way.

Announcement has now been definitely made that the new Union Station, for which excavation has been in progress for some months is to be sixteen stories in height, instead of three as originally

planned. The upper floors of the big building, which will cover an entire block, will be devoted to offices. Above the third floor, the dimensions of the building will not be as large as the lower floors, but the sixteen stories will provide, it is said, one of the largest office buildings in Chicago.

The opening of the new station may serve to bring about a general upbuilding of what is now the wholesale dry goods district in the territory roughly bounded by the river, Wells Street, Van Buren Street and Madison Street. Diversion of traffic from the new station may even give the district considerable retail importance, and property owners in the district thus affected are already planning important things in the way of better buildings. Generally speaking the wholesale district is lacking in high grade office or loft buildings, and improvement in this section means building from the ground up.

Perhaps the most ambitious plan which has been suggested in connection with the Union Station activity, is the proposed bridging of the railway yards leading into the station, with an enormous group of twelve story structures covering the railroad tracks. John F. Wallace, chairman of the railway terminal commission, is the proponent of such a plan, which would involve the expenditure of between \$80,000,000 and \$100,000,000.

While the Wallace plan is necessarily a bit revolutionary, it has already been portrayed to the city council on railway terminals, and the committee thought well enough of the idea at first hand to deny a terminal track permit, which might possibly have interfered with the eventual carrying out of the Wallace plan. The idea calls for the straightening of the Chicago river, the opening up of important new streets, viaducts and other municipal improvements and the final screening of railway yards with a series of buildings in the entire district bounded by Taylor, Sixteenth, Clark and Market streets and affecting principally the lines entering the Dearborn Street railway station.

More tangible and much more immediate is the plan to erect further new buildings along the aristocratic reaches of the new Upper Michigan Avenue, already the site of the new Wrigley sky-scraping office building and the new Chicago Tribune Building. Announcement is made that the Lake Shore Trust & Savings Bank is to have a new home at the corner of Ohio and Michigan Avenue. This will be a comparatively small building, but in keeping with the architectural ensemble of the new thoroughfare.

That the call of the new street is going to be heard by many lines of business is evident in the report that more than 50 per cent. of the office space in the new Wrigley Building has already been taken at \$3.50 per square foot. The eminence of the Wrigley tower is to command a rental return of \$4 per

THE AMERICAN ARCHITECT

square foot, while street level space is at a premium at \$6 a foot.

Charles E. Bostrom, Chicago building commissioner, is one who believes that the beginning of spring will witness the revival of building. By the time spring comes round, Mr. Bostrom estimates that building materials will have shown a decrease around 40 per cent., and this cut, with the increase of individual efficiency in the building trades will make building a pastime which can be indulged in on a business basis.

Activity is expected to be particularly keen in building apartments. The profit in this line of building is seen in the announcement that there is a shortage of accommodations for at least 100,000 families in Chicago.

Suburban residences are also going to be a feature of spring activity, according to best reports. Real estate in outlying sections is very active just now, and architects are receiving many inquiries for smaller residential structures. All the Chicago northshore suburbs are to share in this activity and other nearby environs such as Oak Park, Berwyn, Riverside and LaGrange. Seventy-five houses are under construction in the vicinity of Berwyn, on which work is continuing favored by the open weather which has prevailed thus far.

The financial side of building is becoming less formidable. Banks are expressing interest in building loans and the various building and loan associations are closing a very excellent year, with large funds in hand for building when spring begins.

The labor element, as previously indicated, is also less tyrannical. Carpenters, masons, plasterers and others of the building trades are picking up in individual efficiency, and the higher wages ghost seems to have been permanently interred, in view of the decline in living costs. Only the apartment house janitors have failed to sense the handwriting and they are banding together for a jump in wages beginning January 1. Owners say that if the janitors walk out they will be forthwith evicted from their basement premises as trespassers and the "no surrender" slogan is being vigorously upheld by the owners.

Lumber prices continue to hold fairly firm and dealers say that most of the slack has been taken out of the market. Naturally, the demand is quiescent just now, but the expected building boom is psychologically present in the lumber market and is doing its share in keeping the prices from any further crumbling. Prices on principal lumber items are:

Yellow Pine.—B & B 1-inch, according to thickness, \$95 to \$130; 13-16x $\frac{3}{4}$ B & B flay flooring, \$85 to \$90; 13-16x3 $\frac{1}{4}$ 1-inch common pine, \$55 to \$65; 2x4 No. 1, \$51 to \$53; 2x6 No. 1, \$48 to \$49. Other dimensions in proportion.

Douglas Fir.—All sizes to 12x12 No. 1, up to 32 ft. length, \$65 to \$70; 14x14, \$68 to \$70; 16x16, \$72; 18x18, \$78.

Birch.—Four, $\frac{1}{4}$ No. 1 and 2, \$155; select, \$137; No. 1 common, \$98; No. 2 common, \$65; No. 3 common, \$38.

Hard Maple.—Four, $\frac{1}{4}$ No. 1 and 2, \$135 to \$140 select, \$120; No. 1 common, \$98; No. 2 common, \$65; No. 3 common, \$32.

Materials are still inclined to crumble. Some of the breaks during recent days have touched such lines as wallboard, which has gone down some \$4 a thousand square feet; heating plant boilers, down 10 per cent.; plumbers' supplies, cut around 10 per cent. Other lines not yet included in the price cutting are expected to follow the lead soon, as manufacturing costs drop.

Demand for materials is slightly better than before the reductions, but is still quiet. Some of the present prices are:

Cement.—Universal, \$3; Lehigh, \$3; Portland, \$3; bulk lime, \$1.75.

Torpedo-lake and bank sand, \$3.50; crushed stone, gravel, screenings, \$3.50.

Face brick, vitrified red, \$32; smooth red, \$38; smooth, buff, grey, \$47; rough, \$45; common brick, \$16.

(Special Correspondence to THE AMERICAN ARCHITECT)

BOSTON.—A wage reduction of 22 $\frac{1}{2}$ per cent. in the textile mills in New England was forecast this past week in a statement issued after a conference of textile manufacturers. Approximately 75 per cent. of the industry in this section was represented at the conference. The industry employs 300,000 persons.

This intended reduction, according to the statement, would bring the wage schedule back approximately to the figures that existed a year ago and would leave the wage standards generally more than double those of 1915. The present stagnant condition of the textile industry made consideration of a wage reduction necessary, it was declared.

The statement said:

"The refusal of buyers to purchase goods for the past four or five months of a high basis of cost has led to a stagnation of the markets upon which the manufacturers depend, so that at the present time many of the textile mills in New England have been obliged to shut down; many more are working on short time, and unless something is done to remedy these conditions, unemployment will be increased and continue.

"If this reduction is made in the wage scale it is hoped that merchants will feel that the factor of labor as well as raw material costs have been so ad-

justed that they will feel secure in placing their orders for merchandise.

"If this turns out to be the result employment can be provided and it is hoped that the public will respond to the suggestion and that manufacturers will be able to get on with no further reduction in the wages of employees."

Building permits continue to be practically nil as compared with normal years. Real estate offices report that there is a marked improvement in the interest regarding home building sites which promises well for spring building. This, of course, is only prospective for the same conditions that have persistently held the building trades in check for four or five months are still in evidence.

Chicago Notes of Interest to Architects

The old Field Museum Building, which was the Fine Arts Building during the Chicago Columbian Exposition in 1893, is to be turned into a shooting range for the American legion posts in Chicago, according to late report. Architectural bodies in Chicago are interested in preserving and restoring the building because of its architectural beauty and history.

—:—

H. Curtis Hoffman, of the firm of Hoffman and Hotton, architects, at 64 West Washington Street, Chicago, died recently at Centerville, Michigan, where he had gone for his health. He had been ill for almost a year, having retired from his profession last April. Mr. Hoffman was 52 years old.

—:—

Edward H. Bennett, architect, gave an illustrated lecture on "City Water Fronts" at the December meeting of the Illinois Chapter of the American Institute of Architects, at the Chicago Art Institute.

Governors Discuss Housing

Governor Alfred F. Smith of New York advocates a state housing plan instead of federal legislation. At a conference of governors from all states of the Union at Harrisburg, Pa., Governor

Smith's paper was read by Edward F. Boyle, member of the New York Reconstruction Commission, the Governor being unable to attend.

Governor Sproul of Pennsylvania proposed that mortgages be exempt from taxation. Other governors were so impressed that they took up the question with representatives in Washington, it is said.

"I believe the situation would change over night if preferment were obtained for mortgages which would wholly or partly relieve them of the income tax," said Governor Sproul.

"It is time this country made adequate provision to meet the problem," was the message of the New York Governor.

"I do not believe federal legislation alone would meet the situation. The whole problem is too colossal to be solved by a single bureau at Washington. The individual states should work out systems of state credits for state purposes.

"When we can solve a national housing policy with the control centered in each state people will be in more direct and democratic control of their housing funds and their application to local conditions.

"In America our housing laws have been negative laws—restrictive laws. But in the light of the present emergency we see that the state, here and elsewhere, must offer a helping hand and must find a constructive solution if we are to have homes."

"I have not given sufficient study as yet to this means of relief, which is proposed by Governor Sproul of Pennsylvania," said Governor Coolidge, "but it seems to me that the income tax on mortgage investments, which is a comparatively small affair, is the only federal impost which would be affected by any exemption legislation. I understand that the proposal would be to place mortgages in a preferred class, somewhat on a par with state and municipal bonds as investments. In Massachusetts we have enacted legislation solely with a view to protecting the householder who pays rent. Purchasers of houses are chary about building at present prices, because none seems to know whether or not the building market is coming down, and, if it is coming down, to what extent the reduction will reach."

