



LG

Life's Good

North/Latin America
Europe/Africa
Asia/Oceania

Internal Use Only

<http://aic.lgservice.com>
<http://eic.lgservice.com>
<http://biz.lgservice.com>

LED TV

SERVICE MANUAL

CHASSIS : LA31A

MODEL : 23MA73D 23MA73D-PUP

CAUTION

BEFORE SERVICING THE CHASSIS,
READ THE SAFETY PRECAUTIONS IN THIS MANUAL.

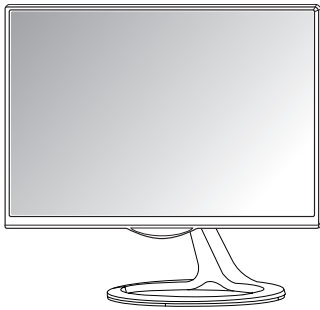

CONTENTS

CONTENTS	2
SAFETY PRECAUTIONS	3
SERVICING PRECAUTIONS.....	4
SPECIFICATION	6
ADJUSTMENT INSTRUCTION	9
TROUBLE SHOOTING	13
BLOCK DIAGRAM.....	20
EXPLODED VIEW	21
SCHEMATIC CIRCUIT DIAGRAM	

SAFETY PRECAUTIONS

IMPORTANT SAFETY NOTICE

Many electrical and mechanical parts in this chassis have special safety-related characteristics. These parts are identified by \triangle in the Schematic Diagram and Exploded View.

It is essential that these special safety parts should be replaced with the same components as recommended in this manual to prevent Shock, Fire, or other Hazards.

Do not modify the original design without permission of manufacturer.

General Guidance

An isolation Transformer should always be used during the servicing of a receiver whose chassis is not isolated from the AC power line. Use a transformer of adequate power rating as this protects the technician from accidents resulting in personal injury from electrical shocks.

It will also protect the receiver and its components from being damaged by accidental shorts of the circuitry that may be inadvertently introduced during the service operation.

If any fuse (or Fusible Resistor) in this TV receiver is blown, replace it with the specified.

When replacing a high wattage resistor (Oxide Metal Film Resistor, over 1W), keep the resistor 10mm away from PCB.

Keep wires away from high voltage or high temperature parts.

Before returning the receiver to the customer,

always perform an AC leakage current check on the exposed metallic parts of the cabinet, such as antennas, terminals, etc., to be sure the set is safe to operate without damage of electrical shock.

Leakage Current Cold Check(Antenna Cold Check)

With the instrument AC plug removed from AC source, connect an electrical jumper across the two AC plug prongs. Place the AC switch in the on position, connect one lead of ohm-meter to the AC plug prongs tied together and touch other ohm-meter lead in turn to each exposed metallic parts such as antenna terminals, phone jacks, etc.

If the exposed metallic part has a return path to the chassis, the measured resistance should be between $1M\Omega$ and $5.2M\Omega$.

When the exposed metal has no return path to the chassis the reading must be infinite.

An other abnormality exists that must be corrected before the receiver is returned to the customer.

Leakage Current Hot Check (See below Figure)

Plug the AC cord directly into the AC outlet.

Do not use a line Isolation Transformer during this check.

Connect 1.5K/10watt resistor in parallel with a 0.15 μ F capacitor between a known good earth ground (Water Pipe, Conduit, etc.) and the exposed metallic parts.

Measure the AC voltage across the resistor using AC voltmeter with 1000 ohms/volt or more sensitivity.

Reverse plug the AC cord into the AC outlet and repeat AC voltage measurements for each exposed metallic part. Any voltage measured must not exceed 0.75 volt RMS which corresponds to 0.5mA.

In case any measurement is out of the limits specified, there is possibility of shock hazard and the set must be checked and repaired before it is returned to the customer.

Leakage Current Hot Check circuit

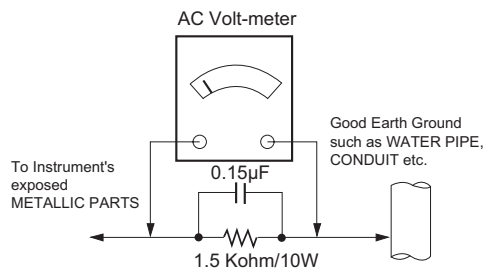

When 25A is impressed between Earth and 2nd Ground for 1 second, Resistance must be less than 0.1

*Base on Adjustment standard

SERVICING PRECAUTIONS

CAUTION: Before servicing receivers covered by this service manual and its supplements and addenda, read and follow the SAFETY PRECAUTIONS on page 3 of this publication.

NOTE: If unforeseen circumstances create conflict between the following servicing precautions and any of the safety precautions on page 3 of this publication, always follow the safety precautions. Remember: Safety First.

General Servicing Precautions

1. Always unplug the receiver AC power cord from the AC power source before;
 - a. Removing or reinstalling any component, circuit board module or any other receiver assembly.
 - b. Disconnecting or reconnecting any receiver electrical plug or other electrical connection.
 - c. Connecting a test substitute in parallel with an electrolytic capacitor in the receiver.
CAUTION: A wrong part substitution or incorrect polarity installation of electrolytic capacitors may result in an explosion hazard.

2. Test high voltage only by measuring it with an appropriate high voltage meter or other voltage measuring device (DVM, FETVOM, etc) equipped with a suitable high voltage probe. Do not test high voltage by "drawing an arc".

3. Do not spray chemicals on or near this receiver or any of its assemblies.

4. Unless specified otherwise in this service manual, clean electrical contacts only by applying the following mixture to the contacts with a pipe cleaner, cotton-tipped stick or comparable non-abrasive applicator; 10% (by volume) Acetone and 90% (by volume) isopropyl alcohol (90%-99% strength)
CAUTION: This is a flammable mixture.

Unless specified otherwise in this service manual, lubrication of contacts in not required.

5. Do not defeat any plug/socket B+ voltage interlocks with which receivers covered by this service manual might be equipped.
6. Do not apply AC power to this instrument and/or any of its electrical assemblies unless all solid-state device heat sinks are correctly installed.
7. Always connect the test receiver ground lead to the receiver chassis ground before connecting the test receiver positive lead.

Always remove the test receiver ground lead last.

8. Use with this receiver only the test fixtures specified in this service manual.
CAUTION: Do not connect the test fixture ground strap to any heat sink in this receiver.

Electrostatically Sensitive (ES) Devices

Some semiconductor (solid-state) devices can be damaged easily by static electricity. Such components commonly are called Electrostatically Sensitive (ES) Devices. Examples of typical ES devices are integrated circuits and some field-effect transistors and semiconductor "chip" components. The following techniques should be used to help reduce the incidence of component damage caused by static by static electricity.

1. Immediately before handling any semiconductor component or semiconductor-equipped assembly, drain off any electrostatic charge on your body by touching a known earth ground. Alternatively, obtain and wear a commercially available discharging wrist strap device, which should be removed to prevent potential shock reasons prior to applying power to the

unit under test.

2. After removing an electrical assembly equipped with ES devices, place the assembly on a conductive surface such as aluminum foil, to prevent electrostatic charge buildup or exposure of the assembly.
3. Use only a grounded-tip soldering iron to solder or unsolder ES devices.
4. Use only an anti-static type solder removal device. Some solder removal devices not classified as "anti-static" can generate electrical charges sufficient to damage ES devices.
5. Do not use freon-propelled chemicals. These can generate electrical charges sufficient to damage ES devices.
6. Do not remove a replacement ES device from its protective package until immediately before you are ready to install it. (Most replacement ES devices are packaged with leads electrically shorted together by conductive foam, aluminum foil or comparable conductive material).
7. Immediately before removing the protective material from the leads of a replacement ES device, touch the protective material to the chassis or circuit assembly into which the device will be installed.
CAUTION: Be sure no power is applied to the chassis or circuit, and observe all other safety precautions.
8. Minimize bodily motions when handling unpackaged replacement ES devices. (Otherwise harmless motion such as the brushing together of your clothes fabric or the lifting of your foot from a carpeted floor can generate static electricity sufficient to damage an ES device.)

General Soldering Guidelines

1. Use a grounded-tip, low-wattage soldering iron and appropriate tip size and shape that will maintain tip temperature within the range of 500 °F to 600 °F.
2. Use an appropriate gauge of RMA resin-core solder composed of 60 parts tin/40 parts lead.
3. Keep the soldering iron tip clean and well tinned.
4. Thoroughly clean the surfaces to be soldered. Use a mall wire-bristle (0.5 inch, or 1.25cm) brush with a metal handle. Do not use freon-propelled spray-on cleaners.
5. Use the following unsoldering technique
 - a. Allow the soldering iron tip to reach normal temperature. (500 °F to 600 °F)
 - b. Heat the component lead until the solder melts.
 - c. Quickly draw the melted solder with an anti-static, suction-type solder removal device or with solder braid.
CAUTION: Work quickly to avoid overheating the circuit board printed foil.
6. Use the following soldering technique.
 - a. Allow the soldering iron tip to reach a normal temperature (500 °F to 600 °F)
 - b. First, hold the soldering iron tip and solder the strand against the component lead until the solder melts.
 - c. Quickly move the soldering iron tip to the junction of the component lead and the printed circuit foil, and hold it there only until the solder flows onto and around both the component lead and the foil.
CAUTION: Work quickly to avoid overheating the circuit board printed foil.
 - d. Closely inspect the solder area and remove any excess or splashed solder with a small wire-bristle brush.

IC Remove/Replacement

Some chassis circuit boards have slotted holes (oblong) through which the IC leads are inserted and then bent flat against the circuit foil. When holes are the slotted type, the following technique should be used to remove and replace the IC. When working with boards using the familiar round hole, use the standard technique as outlined in paragraphs 5 and 6 above.

Removal

1. Desolder and straighten each IC lead in one operation by gently prying up on the lead with the soldering iron tip as the solder melts.
2. Draw away the melted solder with an anti-static suction-type solder removal device (or with solder braid) before removing the IC.

Replacement

1. Carefully insert the replacement IC in the circuit board.
2. Carefully bend each IC lead against the circuit foil pad and solder it.
3. Clean the soldered areas with a small wire-bristle brush. (It is not necessary to reapply acrylic coating to the areas).

"Small-Signal" Discrete Transistor

Removal/Replacement

1. Remove the defective transistor by clipping its leads as close as possible to the component body.
2. Bend into a "U" shape the end of each of three leads remaining on the circuit board.
3. Bend into a "U" shape the replacement transistor leads.
4. Connect the replacement transistor leads to the corresponding leads extending from the circuit board and crimp the "U" with long nose pliers to insure metal to metal contact then solder each connection.

Power Output, Transistor Device

Removal/Replacement

1. Heat and remove all solder from around the transistor leads.
2. Remove the heat sink mounting screw (if so equipped).
3. Carefully remove the transistor from the heat sink of the circuit board.
4. Insert new transistor in the circuit board.
5. Solder each transistor lead, and clip off excess lead.
6. Replace heat sink.

Diode Removal/Replacement

1. Remove defective diode by clipping its leads as close as possible to diode body.
2. Bend the two remaining leads perpendicular y to the circuit board.
3. Observing diode polarity, wrap each lead of the new diode around the corresponding lead on the circuit board.
4. Securely crimp each connection and solder it.
5. Inspect (on the circuit board copper side) the solder joints of the two "original" leads. If they are not shiny, reheat them and if necessary, apply additional solder.

Fuse and Conventional Resistor

Removal/Replacement

1. Clip each fuse or resistor lead at top of the circuit board hollow stake.
2. Securely crimp the leads of replacement component around notch at stake top.
3. Solder the connections.

CAUTION: Maintain original spacing between the replaced component and adjacent components and the circuit board to prevent excessive component temperatures.

Circuit Board Foil Repair

Excessive heat applied to the copper foil of any printed circuit board will weaken the adhesive that bonds the foil to the circuit board causing the foil to separate from or "lift-off" the board. The following guidelines and procedures should be followed whenever this condition is encountered.

At IC Connections

To repair a defective copper pattern at IC connections use the following procedure to install a jumper wire on the copper pattern side of the circuit board. (Use this technique only on IC connections).

1. Carefully remove the damaged copper pattern with a sharp knife. (Remove only as much copper as absolutely necessary).
2. Carefully scratch away the solder resist and acrylic coating (if used) from the end of the remaining copper pattern.
3. Bend a small "U" in one end of a small gauge jumper wire and carefully crimp it around the IC pin. Solder the IC connection.
4. Route the jumper wire along the path of the out-away copper pattern and let it overlap the previously scraped end of the good copper pattern. Solder the overlapped area and clip off any excess jumper wire.

At Other Connections

Use the following technique to repair the defective copper pattern at connections other than IC Pins. This technique involves the installation of a jumper wire on the component side of the circuit board.

1. Remove the defective copper pattern with a sharp knife. Remove at least 1/4 inch of copper, to ensure that a hazardous condition will not exist if the jumper wire opens.
2. Trace along the copper pattern from both sides of the pattern break and locate the nearest component that is directly connected to the affected copper pattern.
3. Connect insulated 20-gauge jumper wire from the lead of the nearest component on one side of the pattern break to the lead of the nearest component on the other side. Carefully crimp and solder the connections.
CAUTION: Be sure the insulated jumper wire is dressed so the it does not touch components or sharp edges.

SPECIFICATION

NOTE : Specifications and others are subject to change without notice for improvement.

1. Application Range

This spec sheet is applied all of the TV used LA31A chassis.

2. Specification

Each part is tested as below without special appointment

- 1) Temperature : 25 °C ± 5 °C (77 °F ± 9 °F),
CST : 40 °C ± 5 °C
- 2) Relative Humidity : 65 % ± 10 %
- 3) Power Voltage : Standard input voltage
(100 V - 240 V ~, 50 / 60 Hz)
· Standard Voltage of each products is marked by models
- 4) Specification and performance of each parts are followed each drawing and specification by part number in accordance with BOM.
- 5) The receiver must be operated for about 5 minutes prior to the adjustment.

3. Test method

- 1) Performance : LGE TV test method followed
- 2) Demanded other specification
 - Safety : CE,IEC specification
 - EMC : CE,IEC specification

4. General specification

4.1. TV

No	Item	Specification	Remarks
1	Market	AMERICA, CANADA, MEXICO	
2	Receiving system	ATSC / NTSC-M / 64 & 256 QAM	
3	Available Channel	1) VHF : 02~13 2) UHF : 14~69 3) DTV : 02-69 4) CATV : 01~135 5) CADTV : 01~135	
4	Component Input (1EA)	Y/Cb/Cr , Y/Pb/Pr	
5.	CVBS Input (1EA)	NTSC	1 System(Rear) : NTSC CVBS Video input is used by common port with Component.
6	RGB Input	RGB-PC	Analog (D-SUB 15Pin)
7	HDMI Input (2EA)	HDMI1/2	Rear / HDMI version 1.4/ support PC Support HDCP/HDMI2 : MHL Support
8	Audio Input (2EA)	RGB/DVI Audio Component & CVBS	L/R Input CVBS Audio input is used by common port with Component.
9	Earphone out (1EA)	Antenna, AV, Component, RGB, HDMI1/2	
10	Headphone out (1EA)	Antenna, AV, Component, RGB, HDMI1/2	Side 1EA
11	USB (1EA)	EMF, DivX HD, For SVC (download)	Side 1EA JPEG, MP3, DivX HD
12	Local Key (Touch)	∨ ^ - + OK SETTINGS INPUT ∅/!	

4.2. RGB(PC) Specification

No	Item	Specification			Remarks
1	Supported Sync. Type	Separate Sync., Digital			
2	Operating Frequency	Analog	Horizontal	30 ~ 83 kHz	
			Vertical	56 ~ 75 Hz	
		Digital	Horizontal	30 ~ 83 kHz	
			Vertical	56 ~ 75 Hz	
3	Resolution	Analog	Max.	1920 x 1080 @ 60 Hz	
			Recommend	1920 x 1080 @ 60 Hz	
		Digital	Max.	1920 x 1080 @ 60 Hz	
			Recommend	1920 x 1080 @ 60 Hz	
4	Operating Environment	Temp : 10 °C ~ 35 °C Humidity : 20 % ~ 80 %			
5	Storage Environment	Temp : -10 °C ~ 60 °C non condensing Humidity : 5 % ~ 90 % non condensing			

5. Timing

5.1. RGB/ HDMI (PC)

No.	Resolution	H-freq(kHz)	V-freq(Hz)	Pixel clock(MHz)	Remark
1	720*400	31.468	70.080	28.321	
2	640*480	31.469	59.940	25.175	
3	640*480	37.500	75.000	31.500	
4	800*600	37.879	60.317	40.000	
5	800*600	46.875	75.000	49.500	
6	1024*768	48.363	60.004	65.000	
7	1024*768	56.476	70.069	75.000	HDMI(PC) only
8	1024*768	60.023	75.029	78.750	
9	1152*864	67.500	75.000	108.000	
10	1280*720	45.000	60.000	74.250	
11	1280*800	49.702	59.810	83.500	
12	1280*1024	63.981	60.020	108.000	
13	1280*1024	79.976	75.025	135.000	
14	1400*1050	65.317	59.978	121.750	
15	1440*900	55.935	59.887	106.500	
16	1600*900	60.000	60.000	108.000	
17	1680*1050	64.674	59.883	119.000	
18	1680*1050	65.290	59.954	146.250	
19	1920*1080	67.500	60.000	148.500	

5.2. HDMI (DTV)

No.	Resolution	H-freq(kHz)	V-freq(Hz)	Pixel clock(MHz)	Remark
1	720* 480	31.469 / 31.5	59.94 / 60	27.00/ 27.03	SDTV 480P
2.	720*576	31.25	50.00	27.864	SDTV 576P
3.	1280*720	37.50	50.00	74.250	HDTV 720P
4	1280* 720	44.96 / 45	59.94 / 60	74.17/ 74.25	HDTV 720P
5	1920* 1080	33.72 / 33.75	59.94 / 60	74.17/ 74.25	HDTV 1080I
6	1920* 1080	28.125	50.00	74.25	HDTV 1080I
7	1920* 1080	27.00	24	74.25	HDTV 1080P
8	1920* 1080	33.75	30.00	74.25	HDTV 1080P
9	1920* 1080	56.250	50	148.5	HDTV 1080P
10	1920* 1080	67.43 / 67.5	59.94 / 60	148.35/ 148.50	HDTV 1080P

5.3. Component

No	Specification				Remark
	Resolution	H-freq(kHz)	V-freq(Hz)	Pixel clock(MHz)	
1.	720* 480	15.73	59.94	13.500	SDTV, DVD 480I(525I)
2.	720* 480	15.75	60.00	13.514	SDTV, DVD 480I(525I)
3.	720* 576	15.625	50.00	13.500	SDTV, DVD 576I(625I) 50Hz
4.	720* 480	31.47	59.94	27.000	SDTV 480P
5.	720* 480	31.50	60.00	27.027	SDTV 480P
6.	720* 576	31.25	50.00	27.000	SDTV 576P 50Hz
7.	1280* 720	44.96	59.94	74.176	HDTV 720P
8.	1280* 720	45.00	60.00	74.250	HDTV 720P
9.	1280* 720	37.50	50.00	74.25	HDTV 720P 50Hz
10.	1920* 1080	33.72	59.94	74.176	HDTV 1080I
11.	1920* 1080	33.75	60.00	74.250	HDTV 1080I
12.	1920* 1080	28.125	50.00	74.250	HDTV 1080I 50Hz
13.	1920* 1080	56.25	50	148.5	HDTV 1080P
14.	1920* 1080	67.432	59.94	148.350	HDTV 1080P
15.	1920* 1080	67.5	60.00	148.5	HDTV 1080P

ADJUSTMENT INSTRUCTION

1. Application Range

This document is applied to LA31A chassis TV which is manufactured in TV (or Monitor) Factory or is produced on the basis of this data.

2. Designation

- 1) The adjustment is according to the order which is designated and which must be followed, according to the plan which can be changed only on agreeing.
- 2) Power adjustment : Free Voltage.
- 3) Magnetic Field Condition: Nil.
- 4) Input signal Unit: Product Specification Standard.
- 5) Reserve after operation: Above 5 Minutes (Heat Run)
 - Temperature : at 25 °C ± 5 °C
 - Relative humidity : 65 % ± 10 %
 - Input voltage : 220 V, 60 Hz
- 6) Adjustment equipments : Color Analyzer (CA-210 or CA-110), DDC Adjustment Jig equipment, SVC remote controller.
- 7) Push The "IN STOP KEY" – For memory initialization

Case1 : Software version up

- 1) After downloading S/W by USB , Multi-vision set will reboot automatically
- 2) Push "In-stop" key
- 3) Push "Power on" key
- 4) Function inspection
- 5) After function inspection, Push "In-stop" key.

Case2 : Function check at the assembly line

- 1) When TV set is entering on the assembly line, Push "In-stop" key at first.
- 2) Push "Power on" key for turning it on.
→ If you push "Power on" key, TV set will recover channel information by itself.
- 3) After function inspection, Push "In-stop" key.

3. Main PCB check process

* APC - After Manual-Insult, executing APC

* Boot file Download

- 1) Execute ISP program "Mstar ISP Utility" and then click "Config" tab.
- 2) Set as below, and then click "Auto Detect" and check "OK" message. If display "Error", Check connect computer, jig, and set.
- 3) Click "Connect" tab. If display "Can't", Check connect computer, jig, and set.

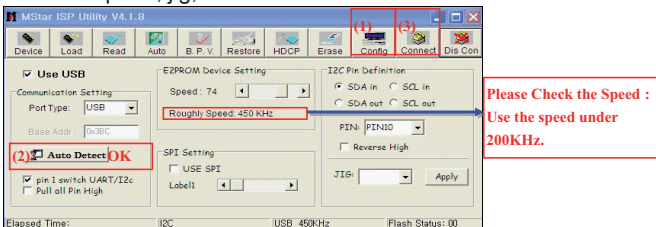

- 4) Click "Read" tab, and then load download file(XXXX.bin) by clicking "Read"

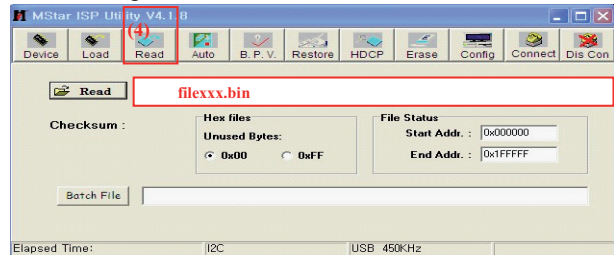

- 5) Click "Auto" tab and set as below
- 6) Click "Run".
- 7) After downloading, check "OK" message.

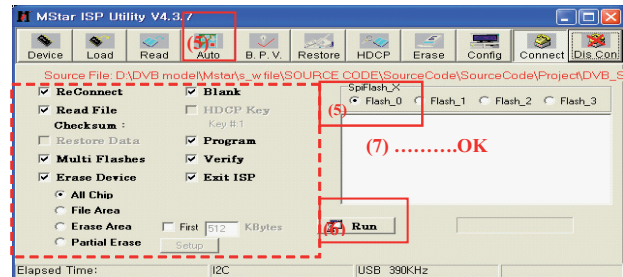

* USB DOWNLOAD(*.epk file download)

- 1) Make New folder named "LG_DTV" and put ISP file(*.epk) in the folder.
- 2) Put the USB Stick to the USB socket.
- 3) Automatically detecting update file in USB Stick
- If your downloaded program version in USB Stick is Low, it didn't work. But your downloaded version is High, USB data is automatically detecting.
- 4) Show the message "Copy the file from the Memory..."

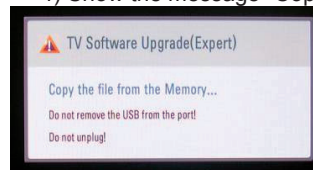

- 5) Updating is starting.

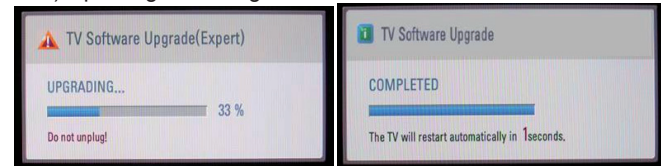

- 6) Updating Completed, The TV will restart automatically.
- 7) If your TV is turned on, check your updated version and Tool option. (explain the Tool option, next stage)

* If downloading version is more high than your TV have, TV can lost all channel data. In this case, you have to channel recover. if all channel data is cleared, you didn't have a DTV/ATV test on production line.

3.1. EDID Process

3.1.1. EDID download

- 1) Press "Power only" key of service remote control.
- 2) Press the ADJ KEY on R/C and enter EZ ADJUST
- 3) Enter EDID D/L mode by pushing "▶" key at "EDID D/L".
- 4) EDID download is executed automatically.
- 5) Press EXIT key on R/C.

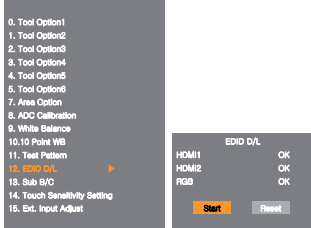

- Caution: - Never connect HDMI & D-sub Cable when download EDID.
 - Download HDMI1, HDMI2 separately because HDMI1 is different from HDMI2.

* Edid data and Model option download (USB)

NO	Item	CMD 1	CMD 2	Data 0		
Enter download MODE	Download 'Mode In'	A	A	0	0	When transfer the 'Mode In', Carry the command.
EDID data and Model option download	Download	A	E	00	10	Automatically download (The use of a internal Data)

3.1.2. RGB EDID Data

- 2D FHD (Check Sum : C1)

	0x00	0x01	0x02	0x03	0x04	0x05	0x06	0x07	0x08	0x09	0x0A	0x0B	0x0C	0x0D	0x0E	0x0F
0x00	00	FF	FF	FF	FF	FF	FF	00	1E	6D	C4	59	01	01	01	01
0x01	01	17	01	03	68	33	1D	78	EA	62	75	A3	55	4F	A0	27
0x02	12	50	54	A5	6B	80	71	4F	81	C0	81	00	81	80	95	00
0x03	90	40	A9	C0	B3	00	02	3A	80	18	71	38	2D	40	58	2C
0x04	45	00	FD	1E	11	00	00	1A	00	00	00	FD	00	38	4B	1E
0x05	53	0F	00	0A	20	20	20	20	20	20	00	00	00	FC	00	32
0x06	44	20	46	48	44	20	4C	47	20	54	56	0A	00	00	00	FC
0x07	00	0A	20	20	20	20	20	20	20	20	20	20	20	20	00	C1

*(week), *(year), *(Check sum) : Adjustable Data

3.1.3. HDMI EDID Data

1) HDMI1 (2D FHD - Check Sum: 15CE)

	0x00	0x01	0x02	0x03	0x04	0x05	0x06	0x07	0x08	0x09	0x0A	0x0B	0x0C	0x0D	0x0E	0x0F
0x00	00	FF	FF	FF	FF	FF	FF	00	1E	6D	C6	59	01	01	01	01
0x01	01	17	01	03	80	33	1D	78	EA	62	75	A3	55	4F	A0	27
0x02	12	50	54	A5	6F	00	71	4F	81	C0	81	00	81	80	95	00
0x03	90	40	A9	C0	B3	00	02	3A	80	18	71	38	2D	40	58	2C
0x04	45	00	FD	1E	11	00	00	1A	21	39	90	30	62	1A	27	40
0x05	68	B0	36	00	FD	1E	11	00	00	1C	00	00	00	FD	00	38
0x06	4B	1E	53	0F	00	0A	20	20	20	20	20	20	00	00	00	FC
0x07	00	32	44	20	46	48	44	20	4C	47	20	54	56	0A	01	15

2) HDMI2 (2D FHD - Check Sum: 15BE)

	0x00	0x01	0x02	0x03	0x04	0x05	0x06	0x07	0x08	0x09	0x0A	0x0B	0x0C	0x0D	0x0E	0x0F
0x00	00	FF	FF	FF	FF	FF	FF	00	1E	6D	C6	59	01	01	01	01
0x01	01	17	01	03	80	33	1D	78	EA	62	75	A3	55	4F	A0	27
0x02	12	50	54	A5	6F	00	71	4F	81	C0	81	00	81	80	95	00
0x03	90	40	A9	C0	B3	00	02	3A	80	18	71	38	2D	40	58	2C
0x04	45	00	FD	1E	11	00	00	1A	21	39	90	30	62	1A	27	40
0x05	68	B0	36	00	FD	1E	11	00	00	1C	00	00	00	FD	00	38
0x06	4B	1E	53	0F	00	0A	20	20	20	20	20	20	00	00	00	FC
0x07	00	32	44	20	46	48	44	20	4C	47	20	54	56	0A	01	15

3.2. Function Check

3.2.1. Check display and sound

*Check Input and Signal items. (cf. work instructions)

- 1) TV
- 2) AV
- 3) COMPONENT (480i)
- 4) RGB(PC : 1920 x 1080 @ 60 Hz)
- 5) HDMI1/2
- 6) PC Audio In

* Display and Sound check is executed by Remote controller

→ Caution : Not to push the INSTOP KEY after completion if the function inspection.

4. Total Assembly line process

4.1. Tool option & ADC Check

- 1) Press "Power on" key of service remote control.
- 2) Connect USB Port → USB to Serial Adapter (UC-232A) → RS-232C cable → PC(RS-232C port)
- 3) Check the 'Tool Option' (Refer to the BOM Comments or Adjustment spec)
- 4) Check the 'ADC' is ok.

4.2. Model name & Serial number Download

4.2.1. Model name & Serial number D/L

- 1) Press "Power on" key of service remote control.
- 2) Connect USB Port → USB to Serial Adapter (UC-232A) → RS-232C cable → PC(RS-232C port)
- 3) Write Model Name & Serial Number by use USB Port
- 4) Must check the serial number at the Diagnostics of SET UP menu. (Refer to below).

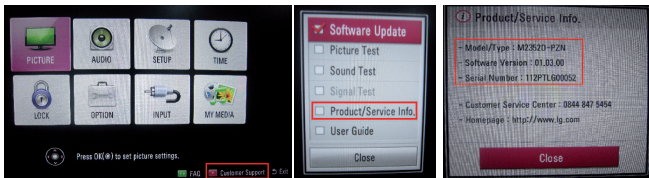

4.2.2. Method & notice

- 1) Model Name & Serial Number D/L is using of scan equipment.
- 2) Setting of scan equipment operated by Manufacturing Technology Group.
- 3) Serial number D/L must be conformed when it is produced in production line, because serial number D/L is mandatory by D-book 4.0

* Manual Download (Model Name and Serial Number)

If the TV set is downloaded By OTA or Service man, Sometimes model name or serial number is initialized.(Not always) There is impossible to download by bar code scan, so It need Manual download.

- 1) Press the 'Instart' key of ADJ remote controller.
- 2) Go to the menu 'Model Number D/L' like below photo.
- 3) Input the Factory model name(ex 27MD73D-PZP) or Serial number like photo.

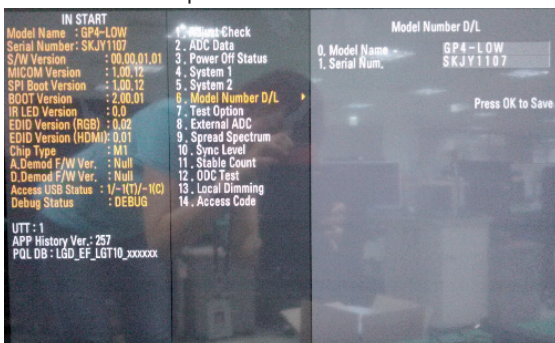

- 4) Check the model name Instart menu → Factory name displayed (ex 27MD73D-PZP)
- 5) Check the Diagnostics (DTV country only) → Buyer model displayed (ex 27MD73D-PZ)

4.3. Function Check

4.3.1. Check display and sound

*Check Input and Signal items. (cf. work instructions)

- 1) TV
- 2) AV
- 3) COMPONENT (480i)
- 4) RGB(PC : 1920 x 1080 @ 60 Hz)
- 5) HDMI1/2
- 6) PC Audio In

* Display and Sound check is executed by Remote controller

→ Caution : Not to push the INSTOP KEY after completion if the function inspection.

4.2.3. PIP Check

- 1) Press "Power on" key of service remote control.
- 2) Input RGB & TV(ATV or DTV) signal.
- 3) Set Input mode to RGB.
- 4) Press 'PIP" key of ADJ remote controller
- 5) Check TV Video & Audio signal of Sub picture.

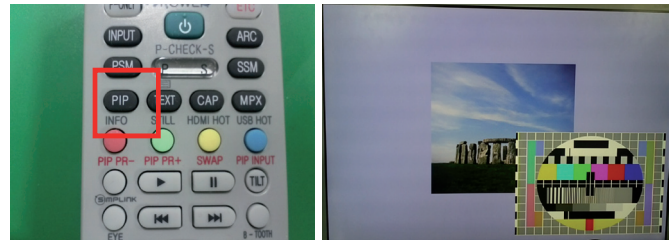

4.3.5 HDMI MHL Function Inspection.(HDMI2 Port only)

- 1) Insert HDMI cable for MHL function JIG connected to HDMI2 port of the SET.
- 2) Check that LED of JIG is green light and check that set screen is correctly worked.
- 3) If NG situation or other HDMI jack connection, LED of JIG is red light and screen is not displayed.



사진 1. MHL 검사 JIG (OK)
Picture 1. MHL Function JIG (OK)



사진 2. MHL 검사 JIG (NG)
Picture 2. MHL Function JIG (NG)

4.4. White balance adjustment

RGB Gains are fixed data for each model. Insert RS-232C Jack which is connected with PC for White Balance or equivalent device.

Color Temperature	Cool	9,300k	°K	X=0.290 (±0.03) Y=0.298 (±0.03)	<Test Signal> Inner pattern (204gray,80IRE)
	Medium	8,000k	°K	X=0.300 (±0.03) Y=0.310 (±0.03)	
	Warm	6,500k	°K	X=0.318 (±0.03) Y=0.334 (±0.03)	
Luminance (cd/m ²)	Cool	Min : 80		Typ : 110	<Test Signal> Inner pattern (204gray,80IRE)
	Medium	Min : 80		Typ : 110	
	Warm	Min : 80		Typ : 110	

* Total Assembly line should be check whether the color coordinate(x,y) data refer to below table were meet or not.
*Note : x,y coordinates are drifted about 0.007 after 30 mins heat-run. So checking color coordinate within 5-min at total assembly line, consider x,y coordinates might be up to 0.007 than x,y target of each color temperature.

*Note : Manual W/B process using adjusts Remote control.
1) After enter Service Mode by pushing "ADJ" key,
2) Enter "White Balance" by pushing "▶" key at "White Balance".

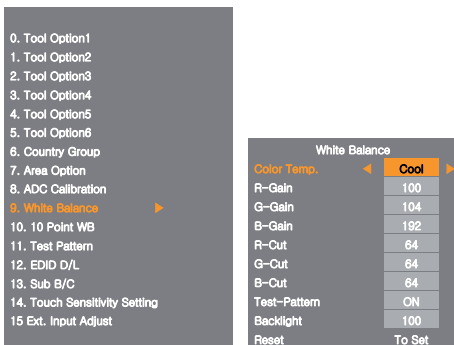

* When doing Adjustment, Please make circumstance as below.

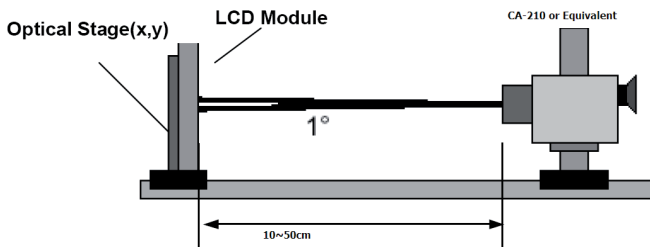

4.5. DPM Operation check

■ Measurement Condition: 100~240V@ 50/60Hz
1) Set Input to RGB-PC and connect D-sub cable to set – RGB Mode.

Set Input to HDMI1/2(with Input Label set to PC) and connect HDMI1/2 cable to set – HDMI Mode

2) Cut off H sync or V sync of signal.
3) Check DPM operation refer to the below table.

Operating Condition		Sync (H/V)	Video	LED (SET)	Wattage (W)
Power S/W On	Sleep mode - RGB,HDMI	Off/Off	Off	Amber	1

■ HDMI2 DPM Operating condition with MHL

HDMI2 Input	MHL Cable	HDMI & HDMI to DVI Cable
DPM	X	O

4.6. Model Name & SW Version & Adjust check.

* Press the 'Instart' key of ADJ remote controller

4.6.1. Model Name& SW Version Check

1) Check 'Model Name'.
2) Check 'S/W Version' (Refer to the IC Ver. in the BOM)

4.6.2. Adjust Check

1) Check 'Country Group'
2) Check 'Area Option'
3) Check 'Tool Option' (Refer to the BOM Comments)
4) Check 'Adjust ADC[Comp&RGB]' is OK.
5) Check 'EDID[RGB&HDMI1/2]' is OK.

* After check all, Press the 'EXIT' key of ADJ remote controller to go out SVC menu.



TROUBLE SHOOTING

1. No Power

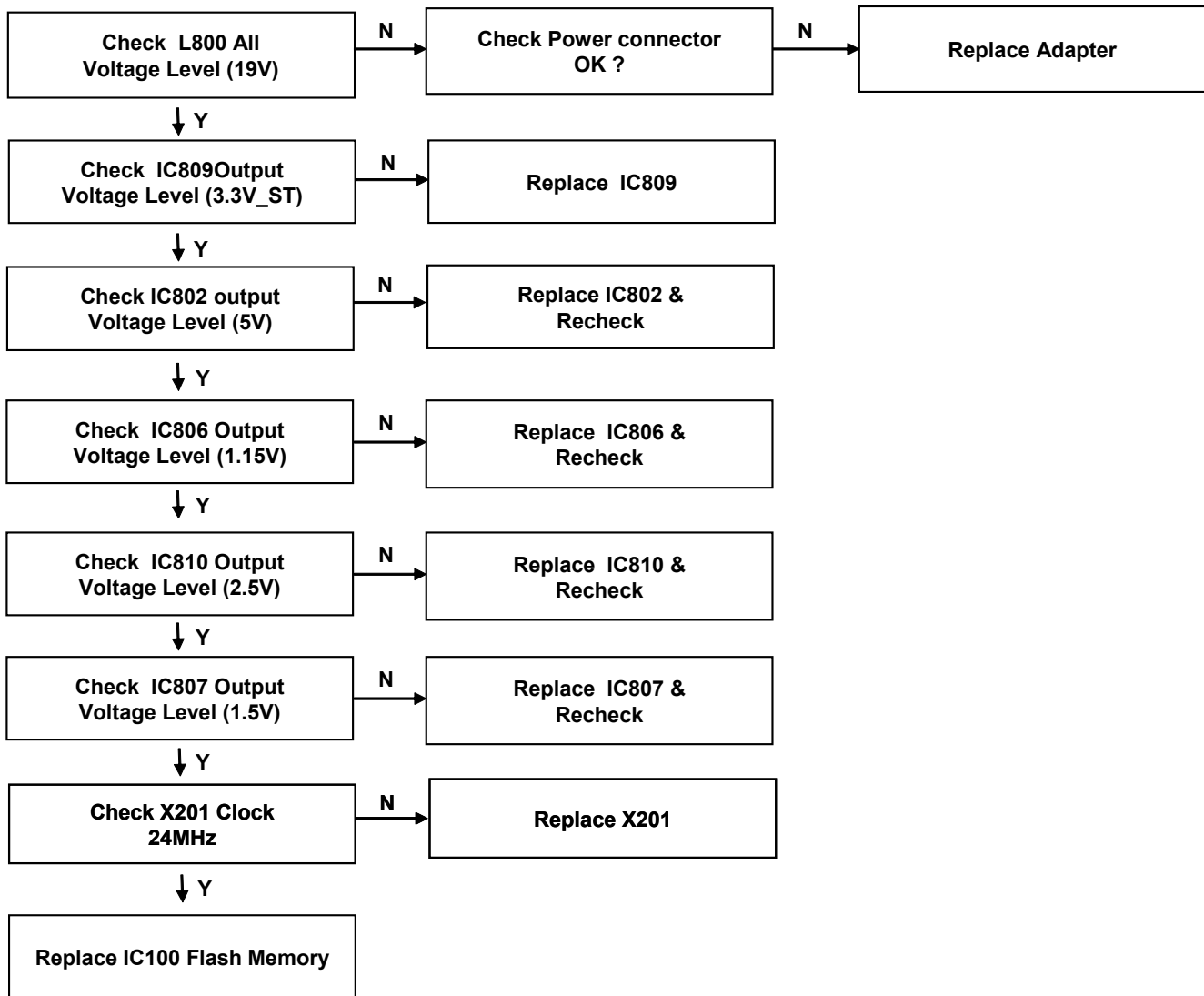

2. No Picture

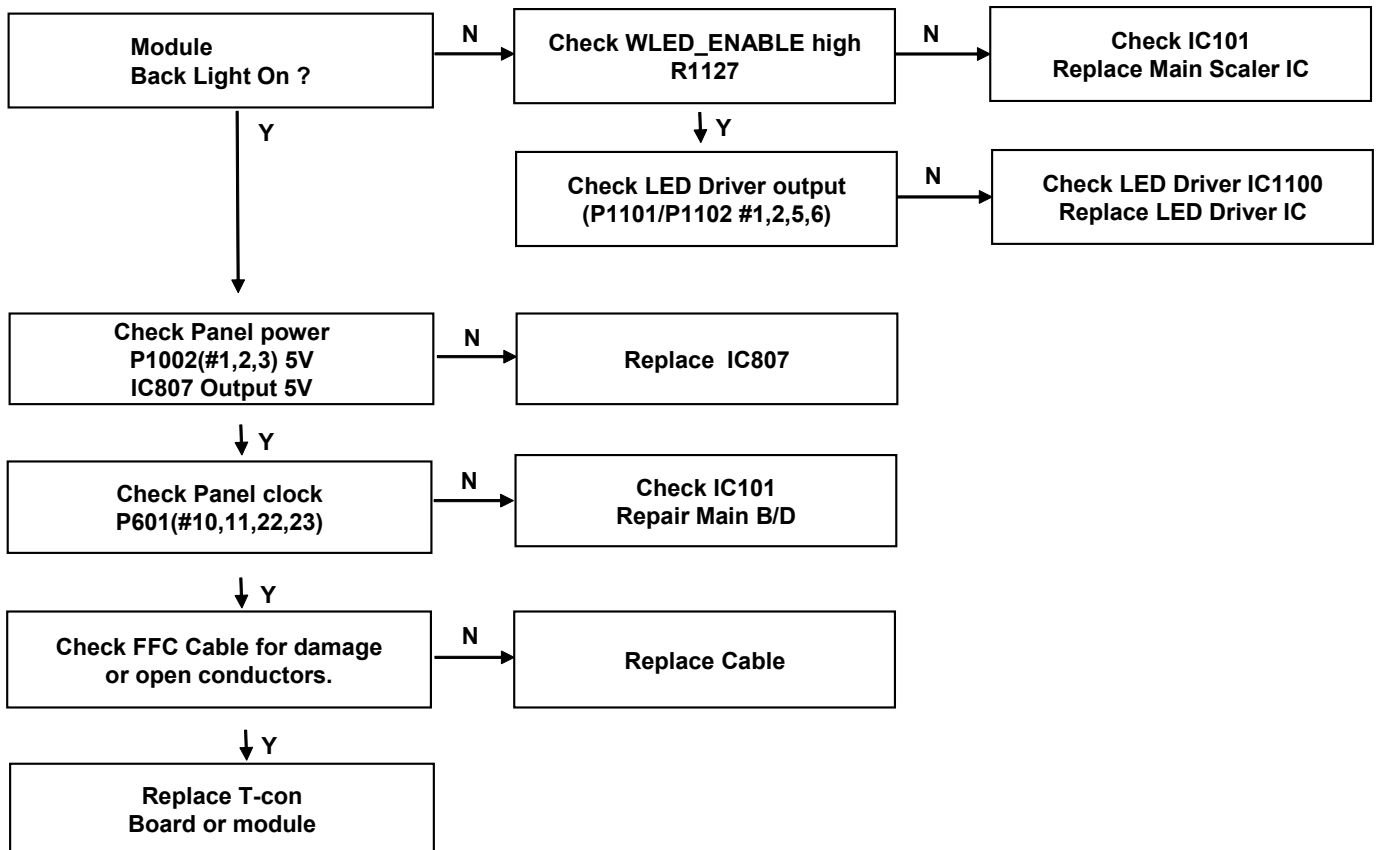

3. No Video

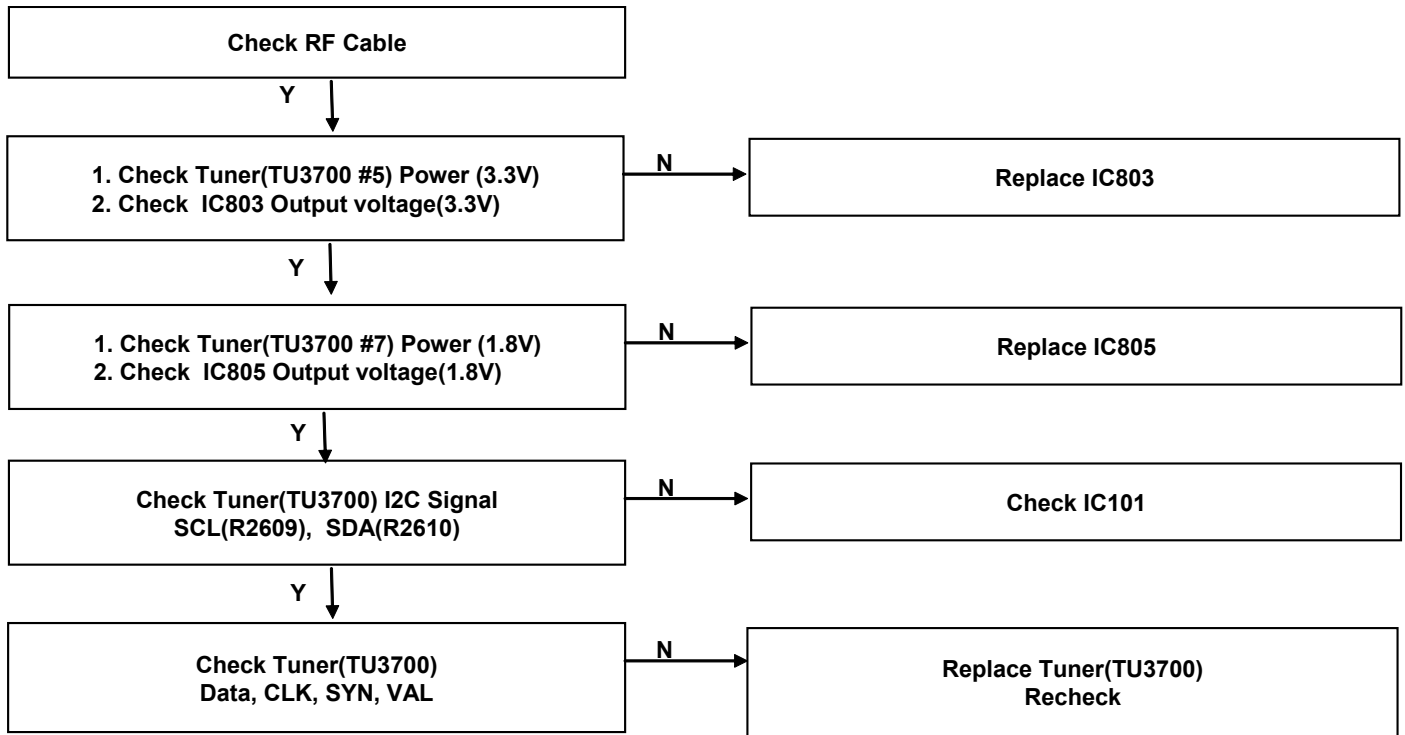

4. No Video - Component

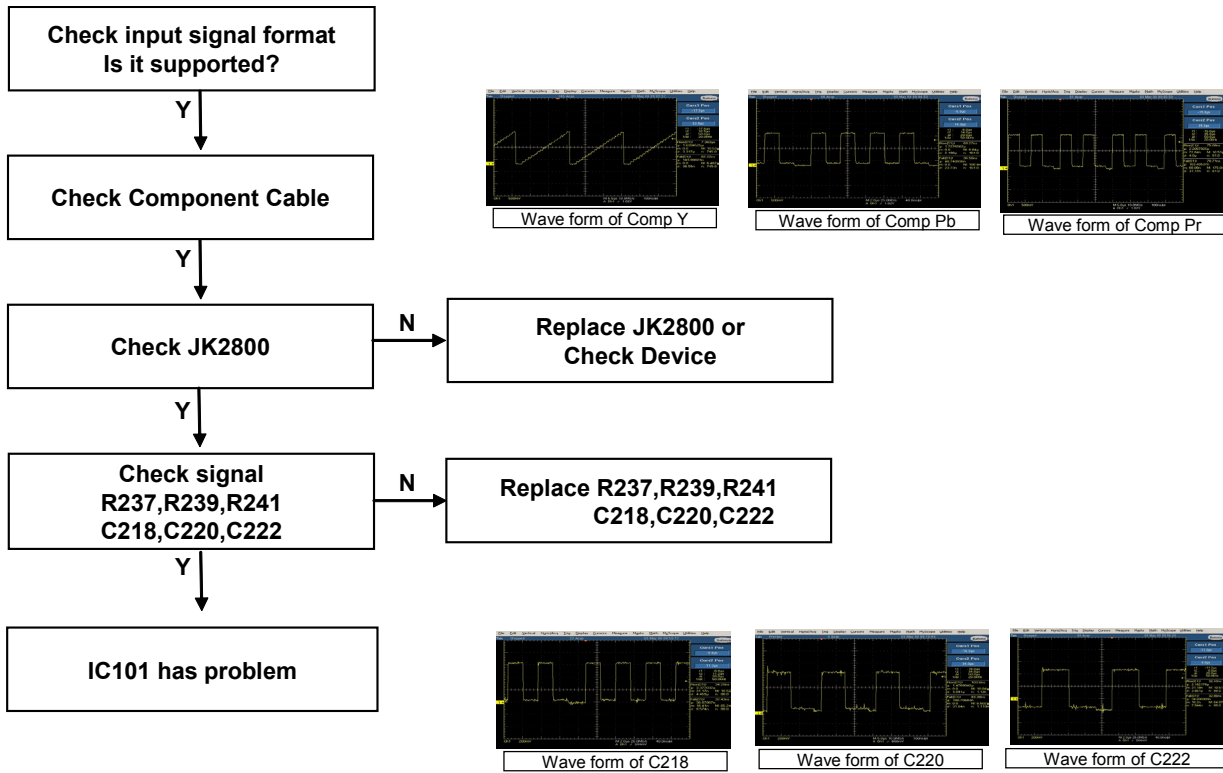

5. No Video - RGB

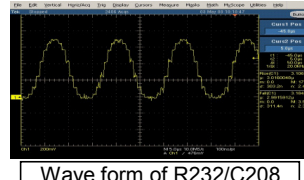
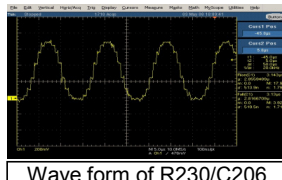
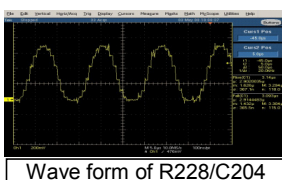
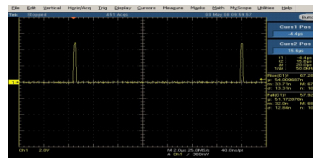
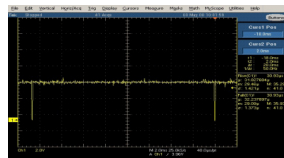
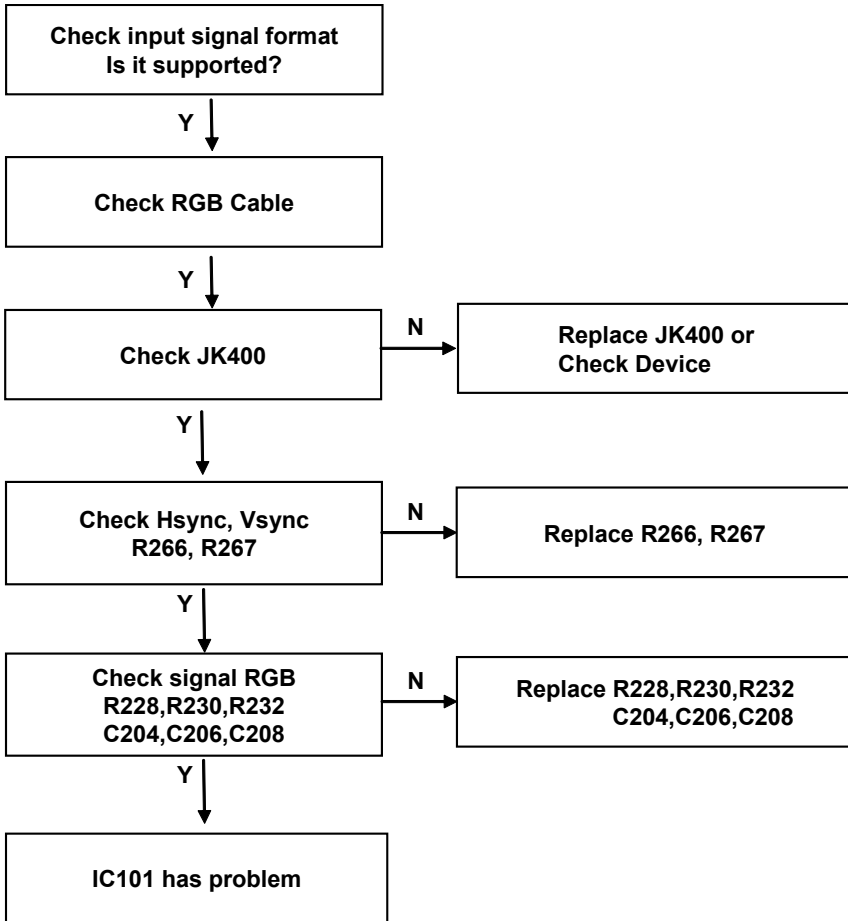

6. No Video - HDMI

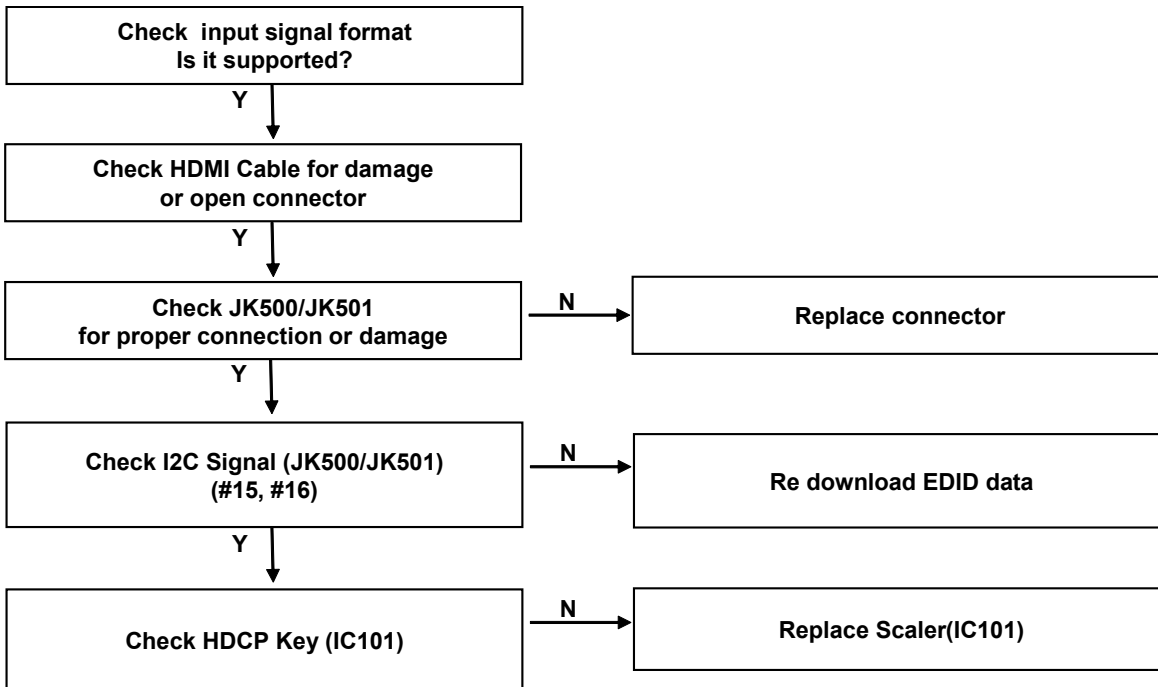

7. No Audio

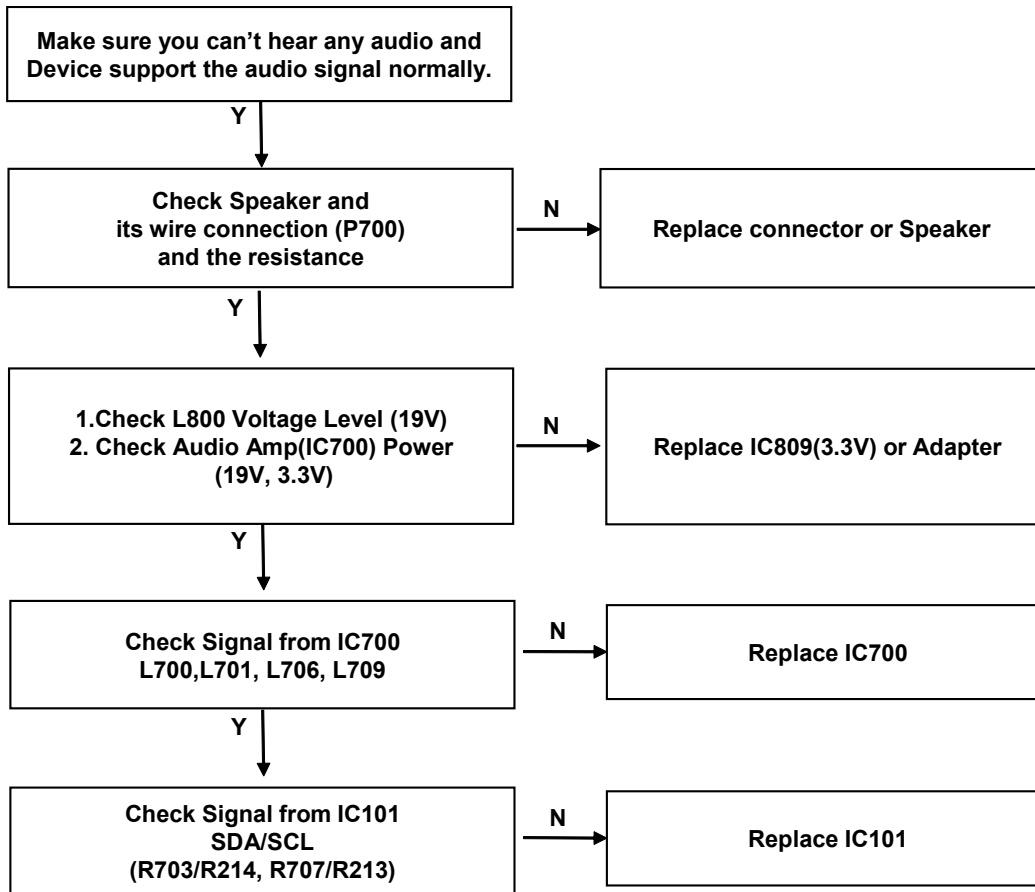

BLOCK DIAGRAM

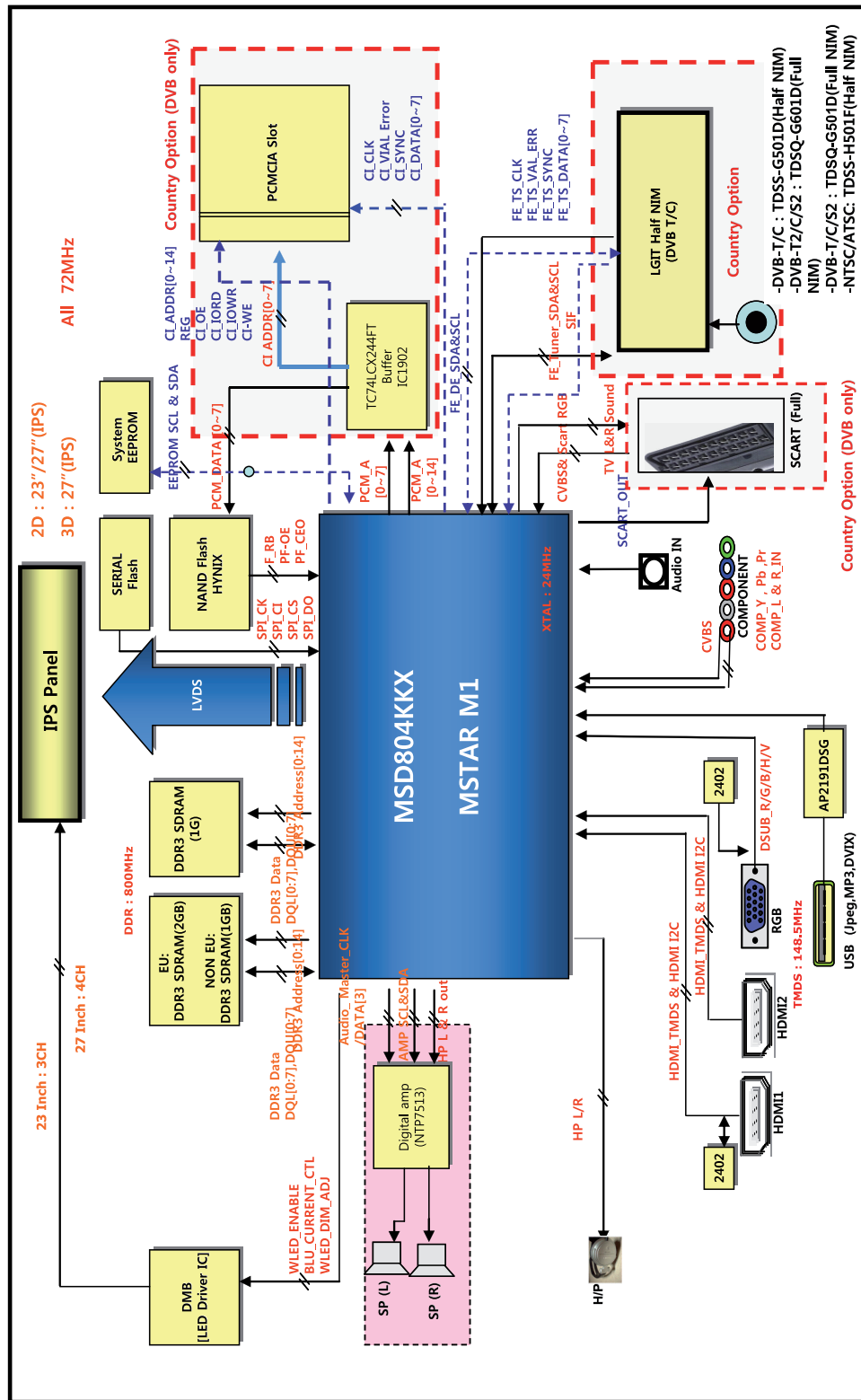

EXPLODED VIEW

IMPORTANT SAFETY NOTICE

Many electrical and mechanical parts in this chassis have special safety-related characteristics. These parts are identified by \triangle in the Schematic Diagram and EXPLODED VIEW.

It is essential that these special safety parts should be replaced with the same components as recommended in this manual to prevent X-RADIATION, Shock, Fire, or other Hazards.

Do not modify the original design without permission of manufacturer.

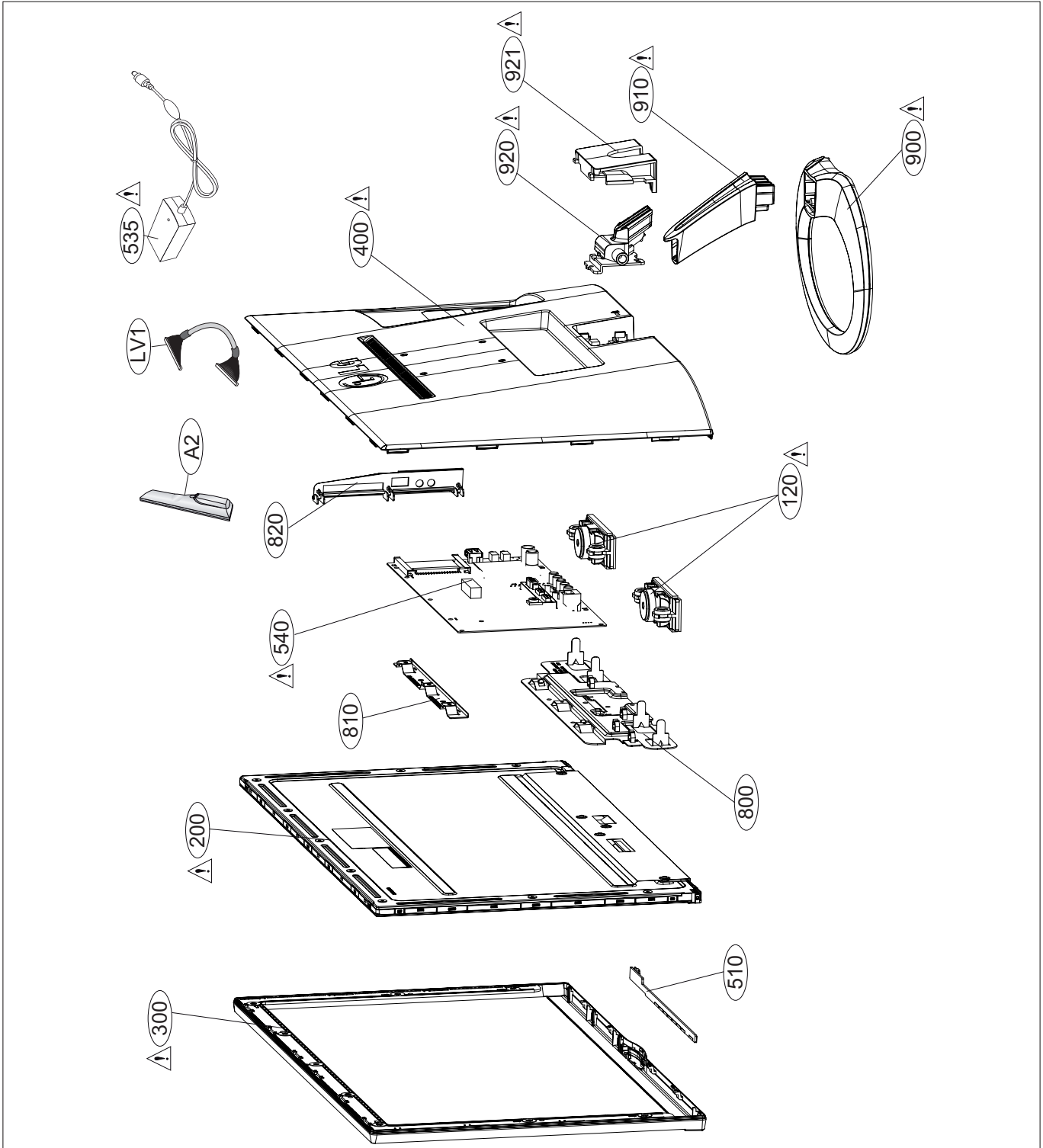

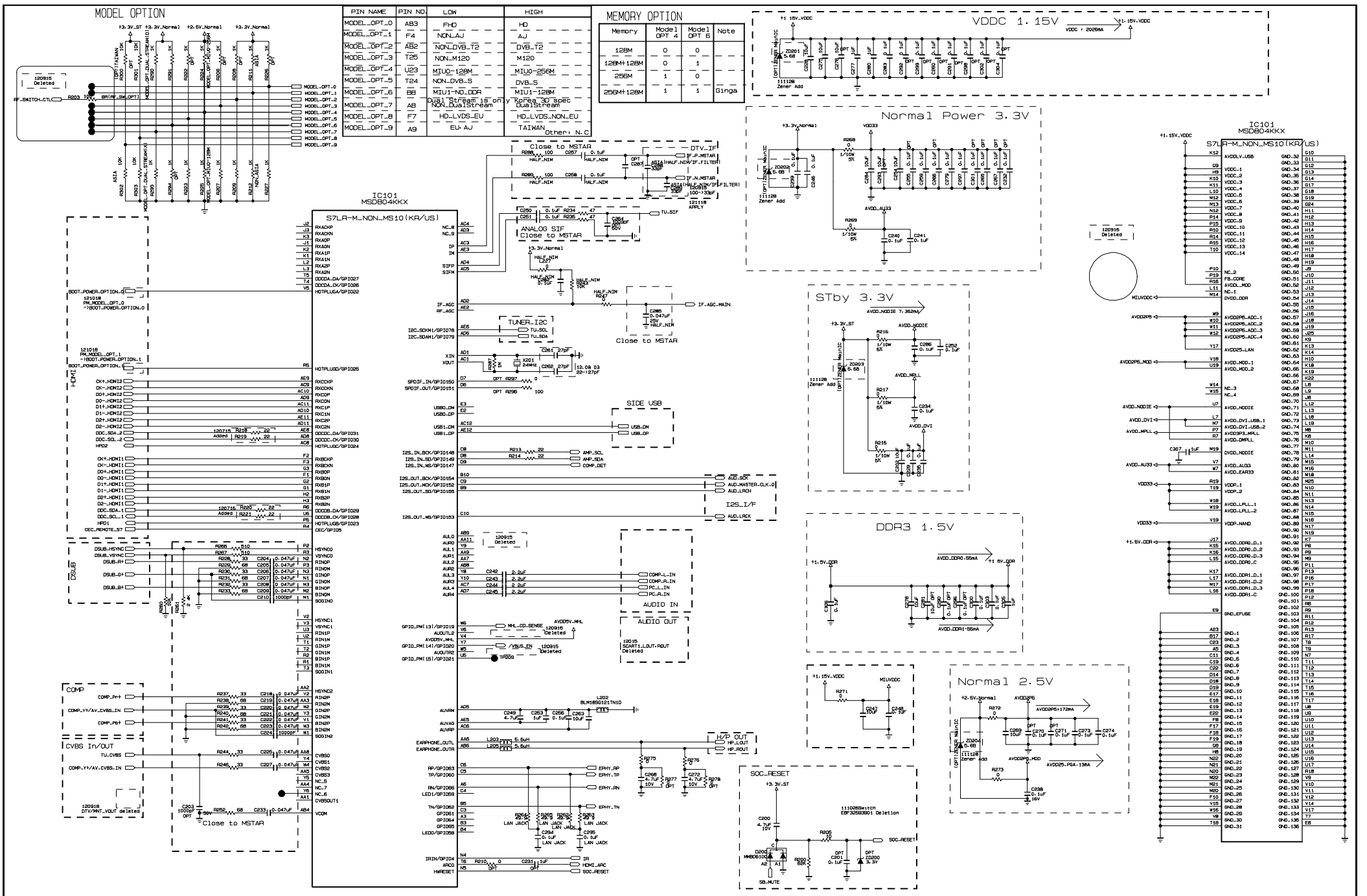

THE Δ SYMBOL MARK OF THIS SCHEMATIC DIAGRAM INCORPORATES SPECIAL FEATURES IMPORTANT FOR PROTECTION FROM X-RADIATION, FILRE AND ELECTRICAL SHOCK HAZARDS. WHEN SERVICING IF IS ESSENTIAL THAT ONLY MANUFACTURES SPECIFIED PARTS BE USED FOR THE CRITICAL COMPONENTS IN THE Δ SYMBOL MARK OF THE SCHEMATIC.

SECRET
LGElectronics



EAX65063106

MODEL	NC4_S7LRM	DATE	2013. 1. 14
BLOCK	MAIN2-NON-EU	SHEET	2 / 12

DSUB RGB

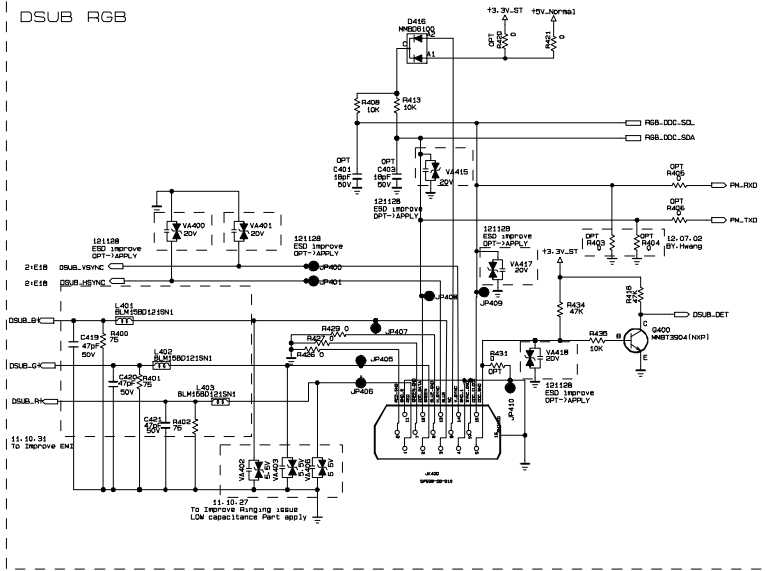

PC AUDIO (SIDE)

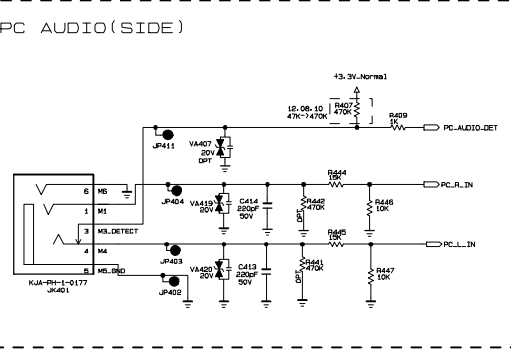

USB (SIDE)

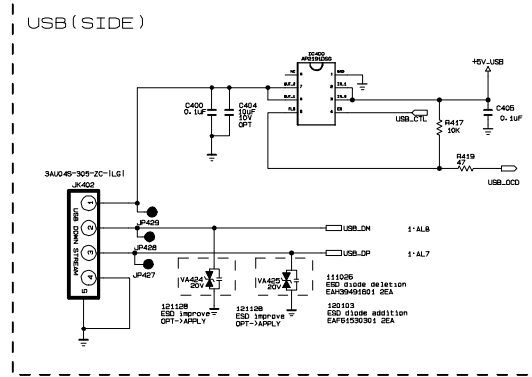

ETHERNET

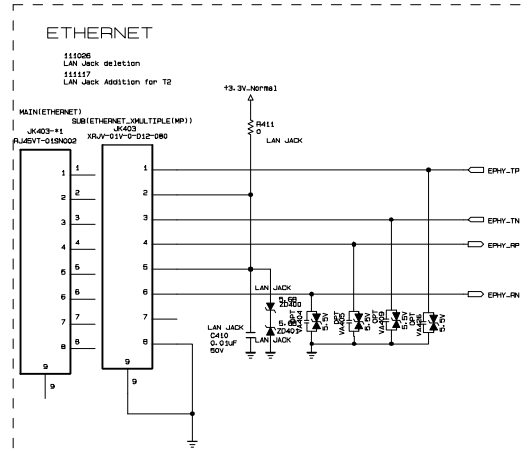

Jack Shield (HDMI1, HDMI2, RGB)

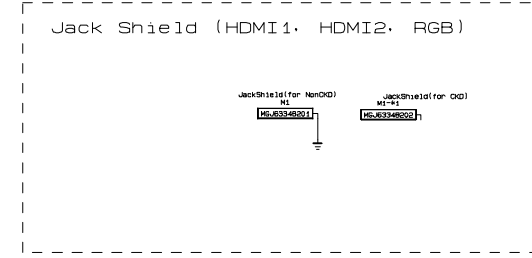

RS232C (SIDE)

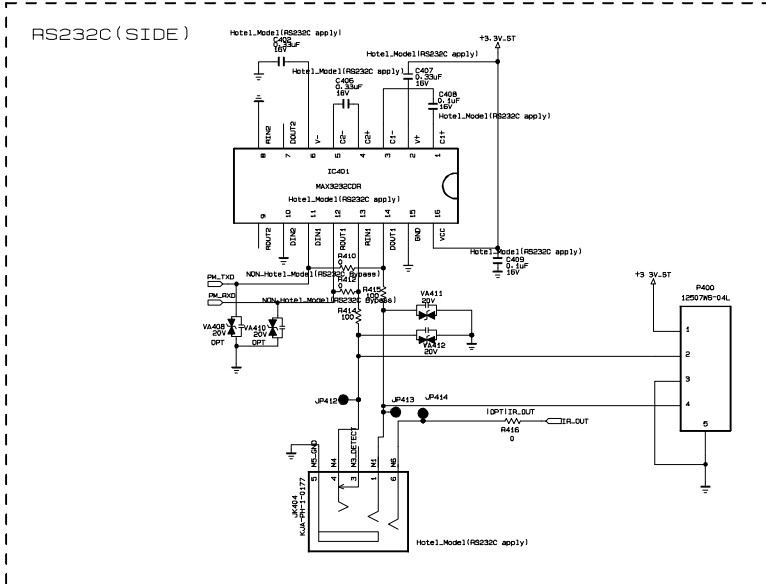

130R JIS GND Point addition

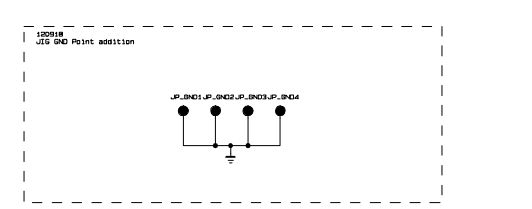

THE SYMBOL MARK OF THIS SCHEMATIC DIAGRAM INCORPORATES SPECIAL FEATURES IMPORTANT FOR PROTECTION FROM X-RADIATION, FILTR AND ELECTRICAL SHOCK HAZARDS. WHEN SERVICING IF IS ESSENTIAL THAT ONLY MANUFACTURERS SPECIFIED PARTS BE USED FOR THE CRITICAL COMPONENTS IN THE SYMBOL MARK OF THE SCHEMATIC.

SECRET
LGElectronics



EAX65063106

MODEL	NC4-S7LRM	DATE	2013.1.14
BLOCK	INTERFACE	SHEET	4 / 12

HDMI

HDMI_1

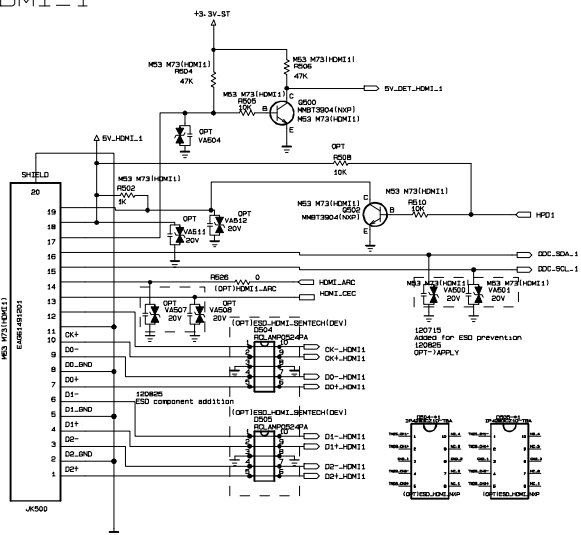

CEC

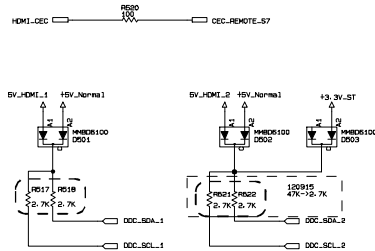

HDMI_2 With MHL

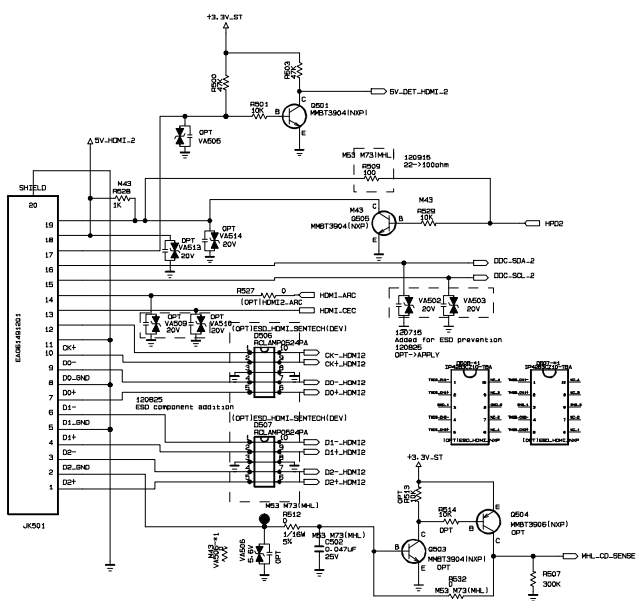

MHL OCP

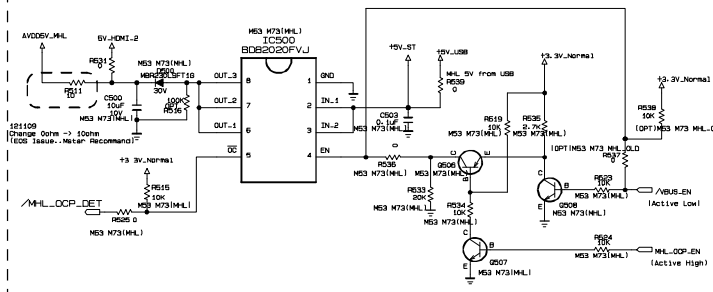

THE SYMBOL MARK OF THIS SCHEMATIC DIAGRAM INCORPORATES SPECIAL FEATURES IMPORTANT FOR PROTECTION FROM X-RADIATION, FILRE AND ELECTRICAL SHOCK HAZARDS. WHEN SERVICING IT IS ESSENTIAL THAT ONLY MANUFACTURER SPECIFIED PARTS BE USED FOR THE CRITICAL COMPONENTS IN THE SYMBOL MARK OF THE SCHEMATIC.

SECRET
LGElectronics

LG ELECTRONICS

MODEL	NC4-S7LRM	DATE	2013. 1. 14
BLOCK	HDMI	SHEET	5 / 12

EAX65063106

IR/LED and Control

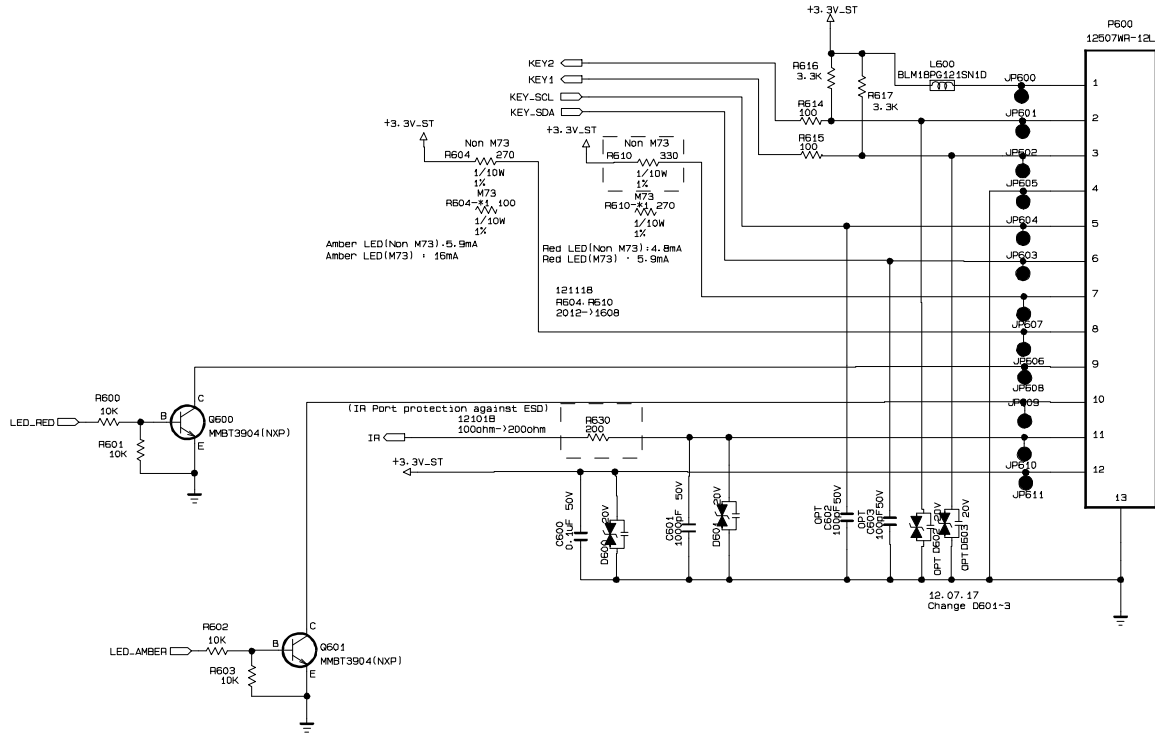

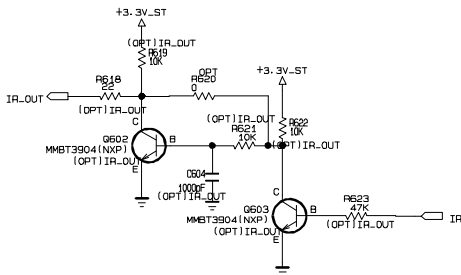

IR_OUT (Ready)

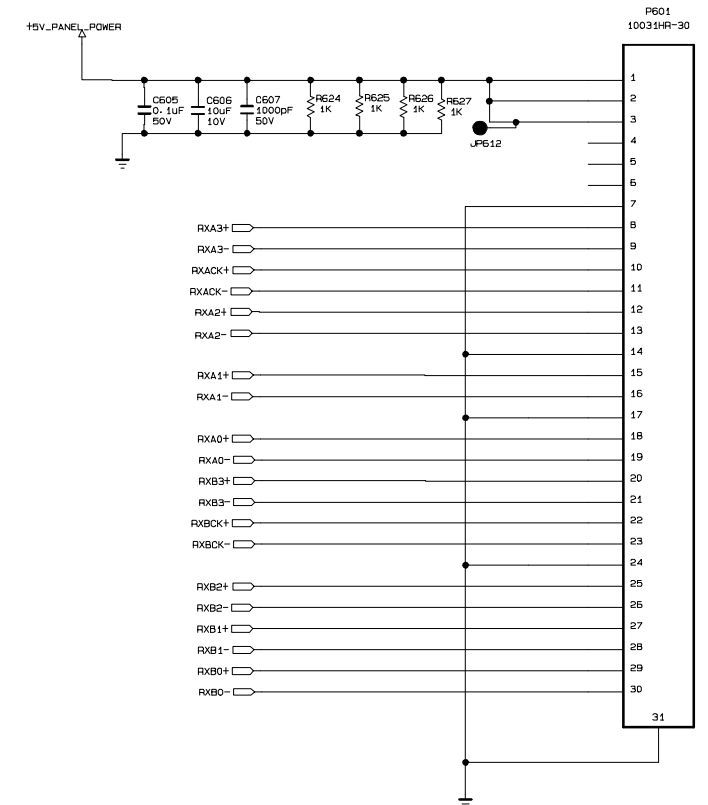

Module



THE  SYMBOL MARK OF THIS SCHEMATIC DIAGRAM INCORPORATES SPECIAL FEATURES IMPORTANT FOR PROTECTION FROM X-RADIATION, FILTRATION AND ELECTRICAL SHOCK HAZARDS; WHEN SERVICING IT IS ESSENTIAL THAT ONLY MANUFACTURERS SPECIFIED PARTS BE USED FOR THE CRITICAL COMPONENTS IN THE  SYMBOL MARK OF THE SCHEMATIC.

SECRET
LGElectronics



MODEL	NC4_S7LRM	DATE	2013. 1. 14
BLOCK	MODULE & CONTROL	SHEET	6 / 12

EAX65063106

AUDIO AMP

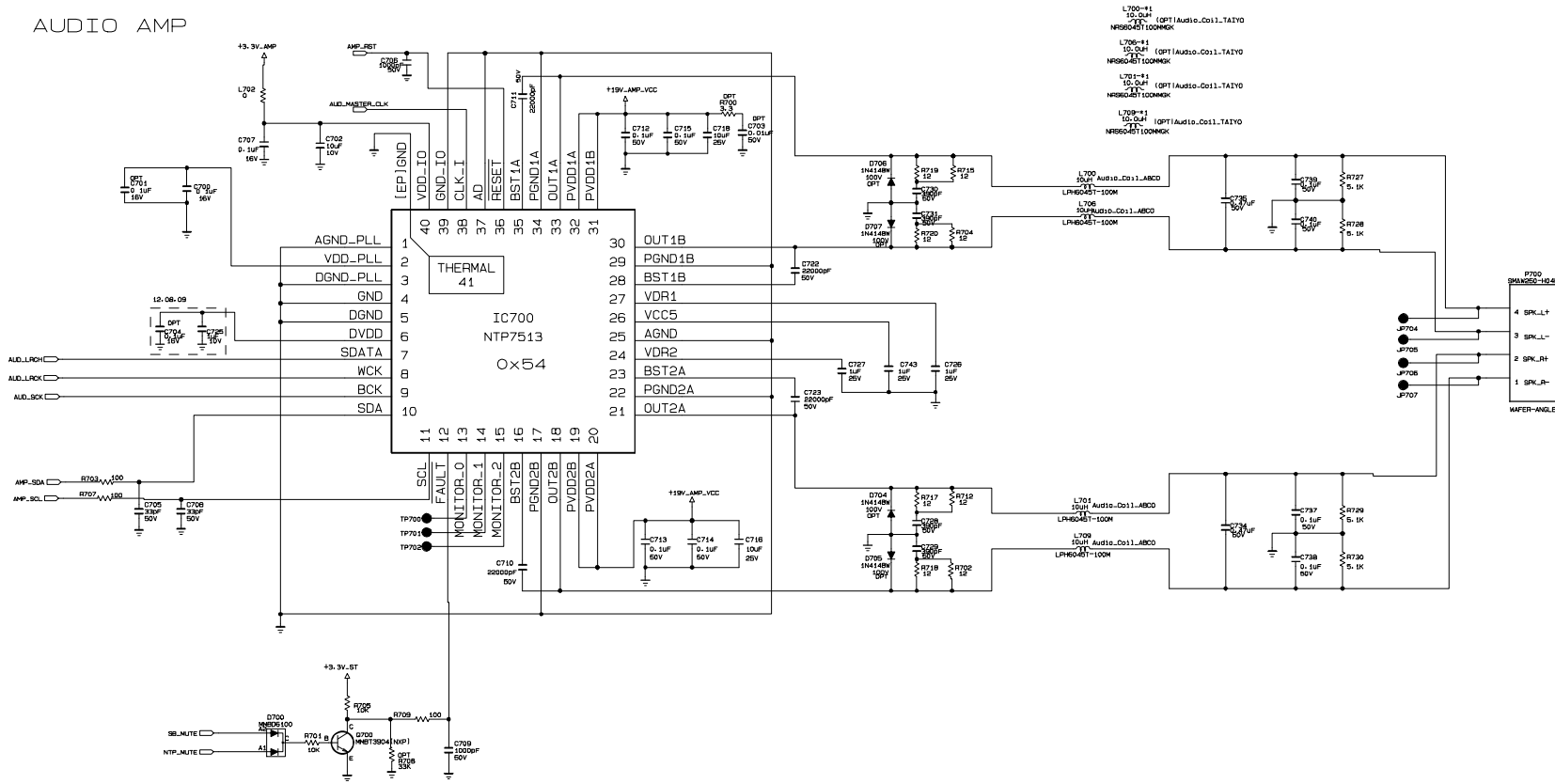

Headphone block

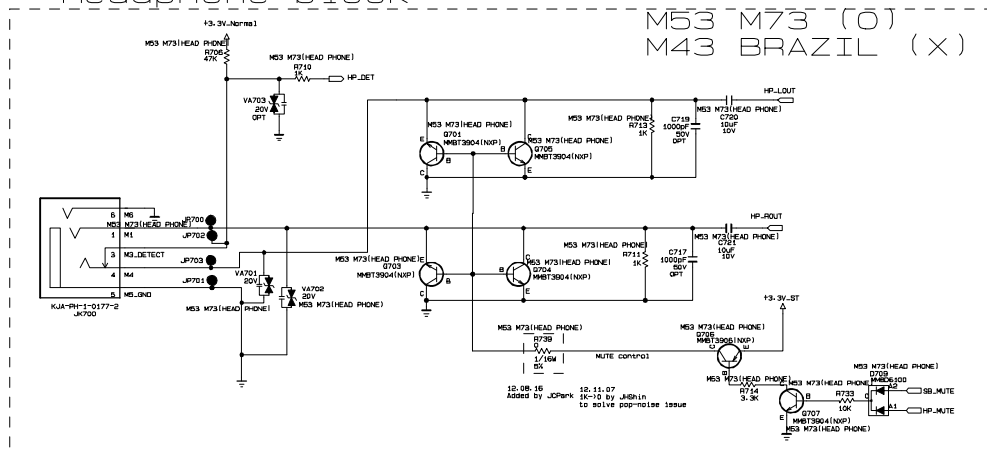

iPop-up noise killer

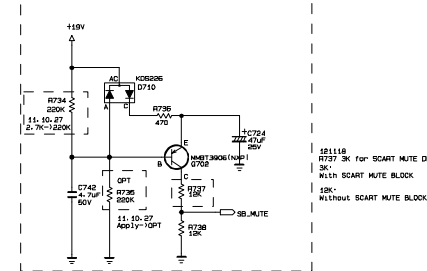

THE SYMBOL MARK OF THIS SCHEMATIC DIAGRAM INCORPORATES SPECIAL FEATURES IMPORTANT FOR PROTECTION FROM X-RADIATION, FILRE AND ELECTRICAL SHOCK HAZARDS. WHEN SERVICING IF IS ESSENTIAL THAT ONLY MANUFACTURERS SPECIFIED PARTS BE USED FOR THE CRITICAL COMPONENTS IN THE SYMBOL MARK OF THE SCHEMATIC.

SECRET
LGElectronics



EAX65063106

MODEL	NC4_S7LAM	DATE	2013. 1. 14
BLOCK	AUDIO AMP	SHEET	7 / 12

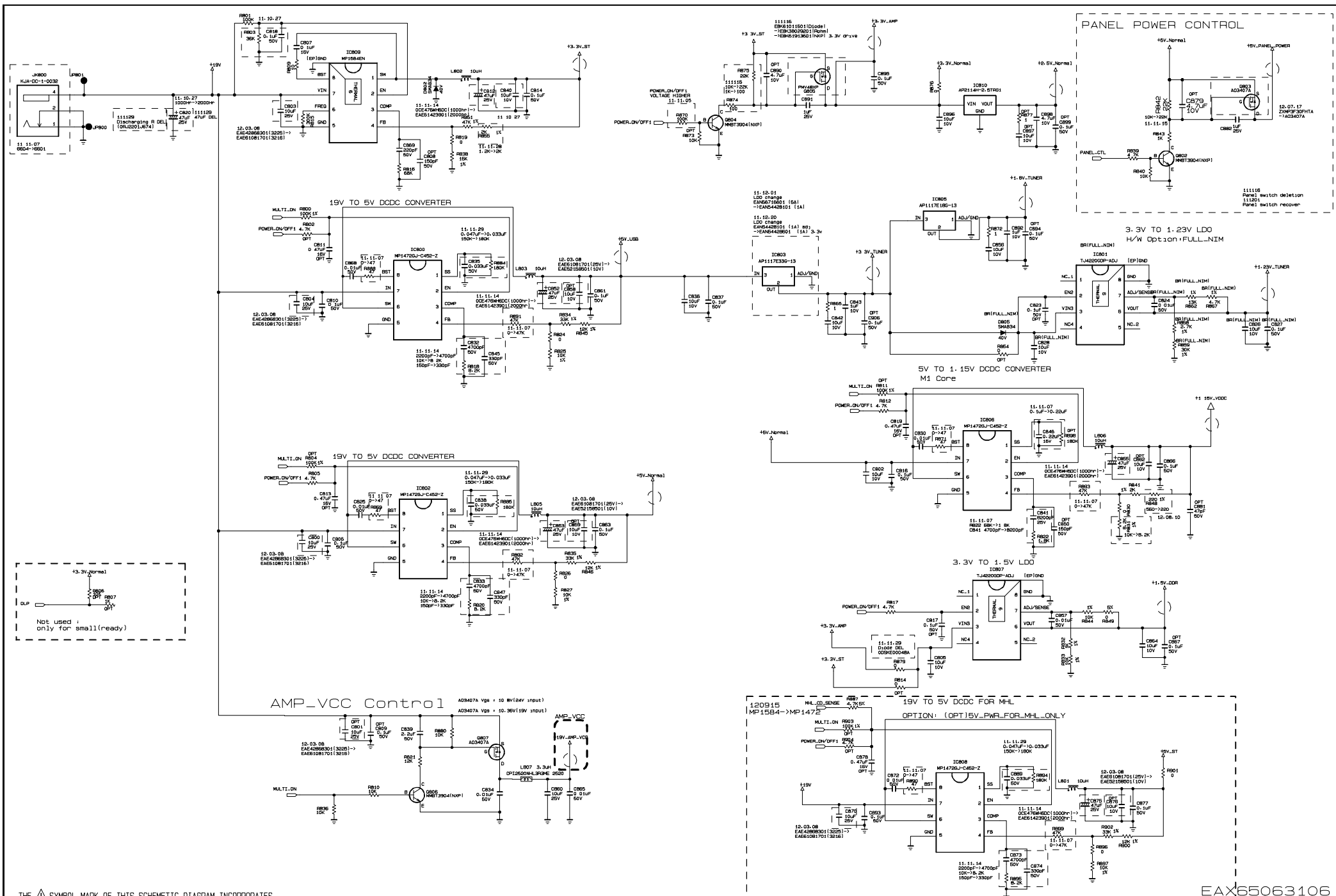

THE SYMBOL MARK OF THIS SCHEMATIC DIAGRAM INCORPORATES SPECIAL FEATURES IMPORTANT FOR PROTECTION FROM X-RADIATION, FILRE AND ELECTRICAL SHOCK HAZARDS. WHEN SERVICING IF IS ESSENTIAL THAT ONLY MANUFACTURER SPECIFIED PARTS BE USED FOR THE CRITICAL COMPONENTS IN THE SYMBOL MARK OF THE SCHEMATIC.

SECRET
LGElectronics



MODEL	NC4-S7LAM	DATE	2013. 1. 14
BLOCK	POWER	SHEET	8 / 12

LED DRIVER

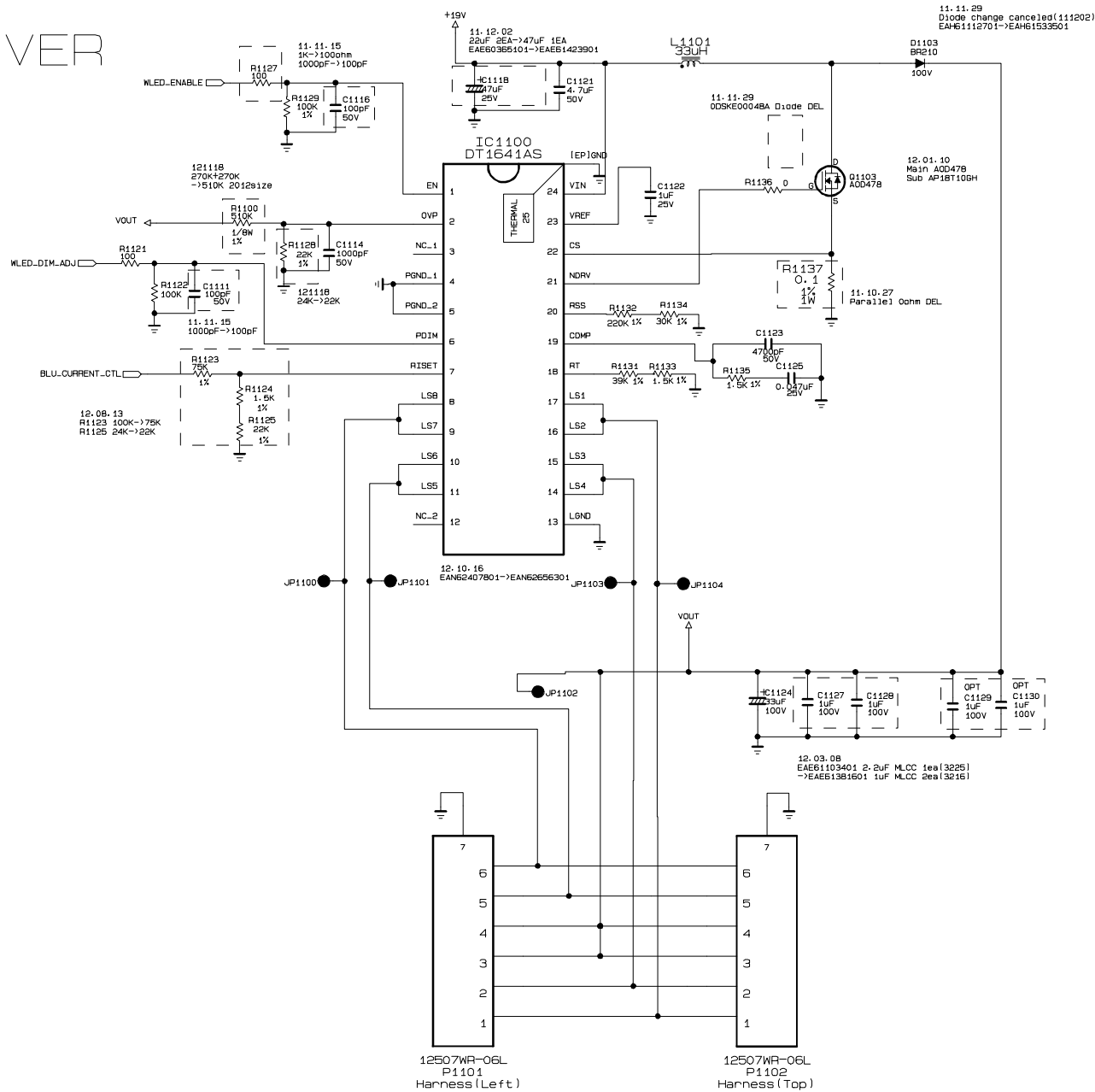

THE SYMBOL MARK OF THIS SCHEMATIC DIAGRAM INCORPORATES SPECIAL FEATURES IMPORTANT FOR PROTECTION FROM X-RADIATION, FILRE AND ELECTRICAL SHOCK HAZARDS. WHEN SERVICING IF IS ESSENTIAL THAT ONLY MANUFACTURES SPECIFIED PARTS BE USED FOR THE CRITICAL COMPONENTS IN THE SYMBOL MARK OF THE SCHEMATIC.

SECRET	
LG Electronics	

MODEL	NC4-S7LAM	DATE	2013. 1. 14
BLOCK	LED DRIVER	SHEET	11 / 12

EAX65063106

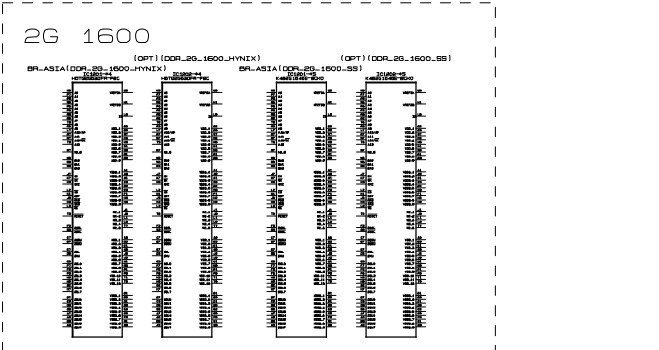
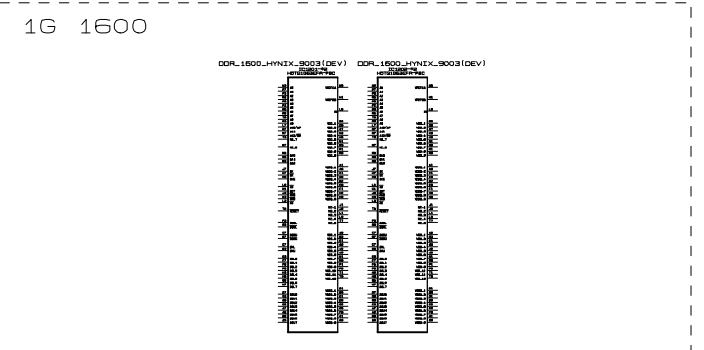
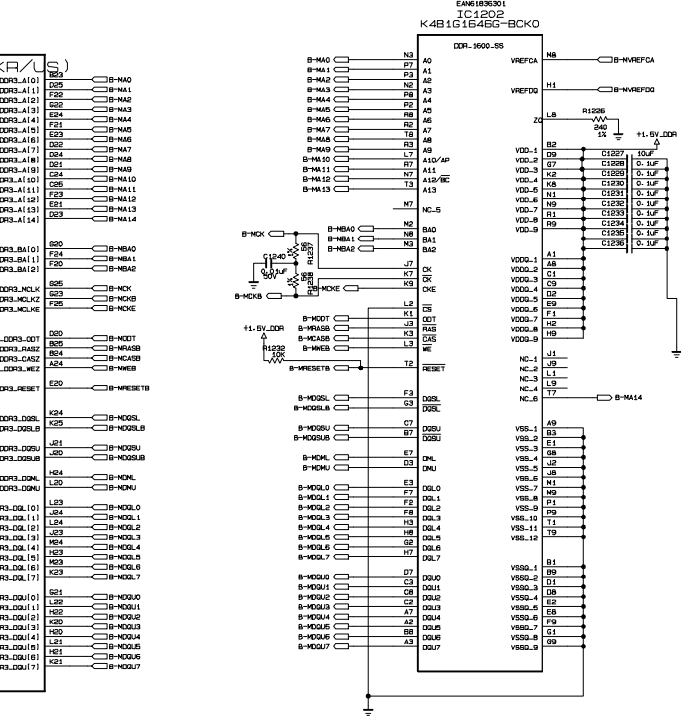
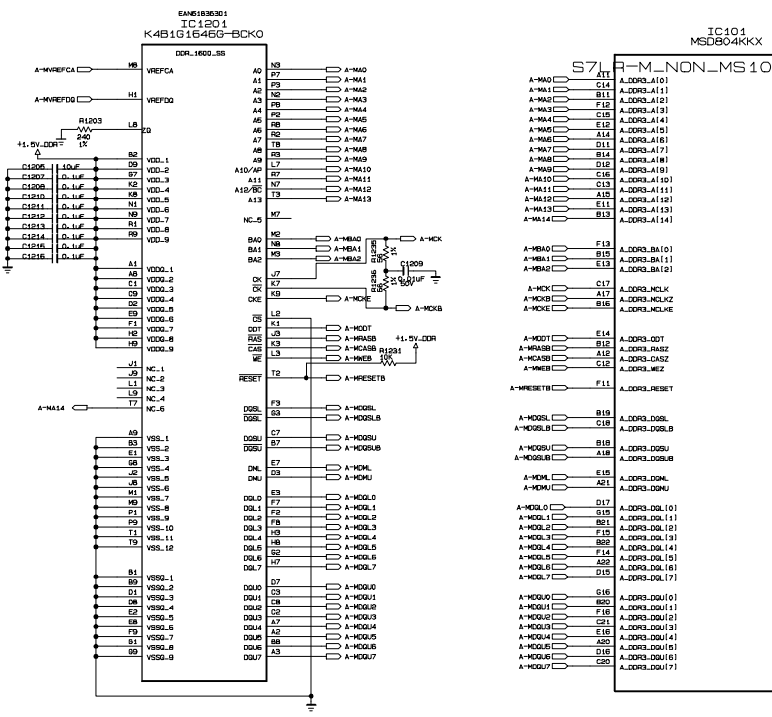
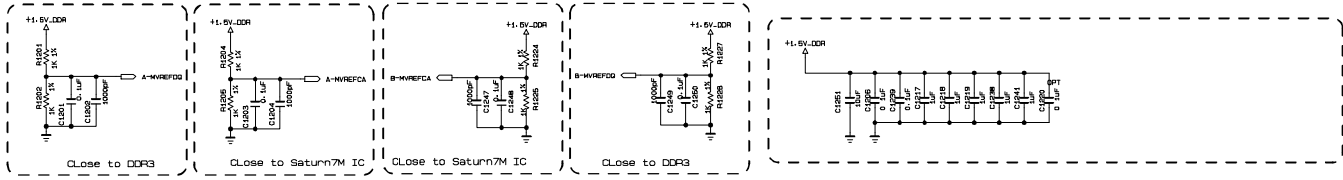

THE SYMBOL MARK OF THIS SCHEMATIC DIAGRAM INCORPORATES SPECIAL FEATURES IMPORTANT FOR PROTECTION FROM X-RADIATION, FILRE AND ELECTRICAL SHOCK HAZARDS. WHEN SERVICING IF IS ESSENTIAL THAT ONLY MANUFACTURER SPECIFIED PARTS BE USED FOR THE CRITICAL COMPONENTS IN THE SYMBOL MARK OF THE SCHEMATIC.

SECRET
LGElectronics



EAX65063106

MODEL	NC4-S7LRM	DATE	2013. 1. 14
BLOCK	DDR	SHEET	12 / 12

GLOBAL tuner block except EU and China

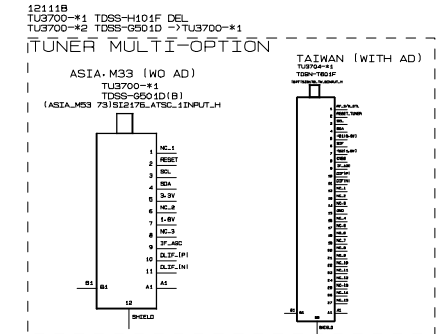
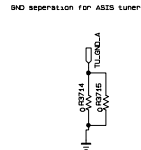
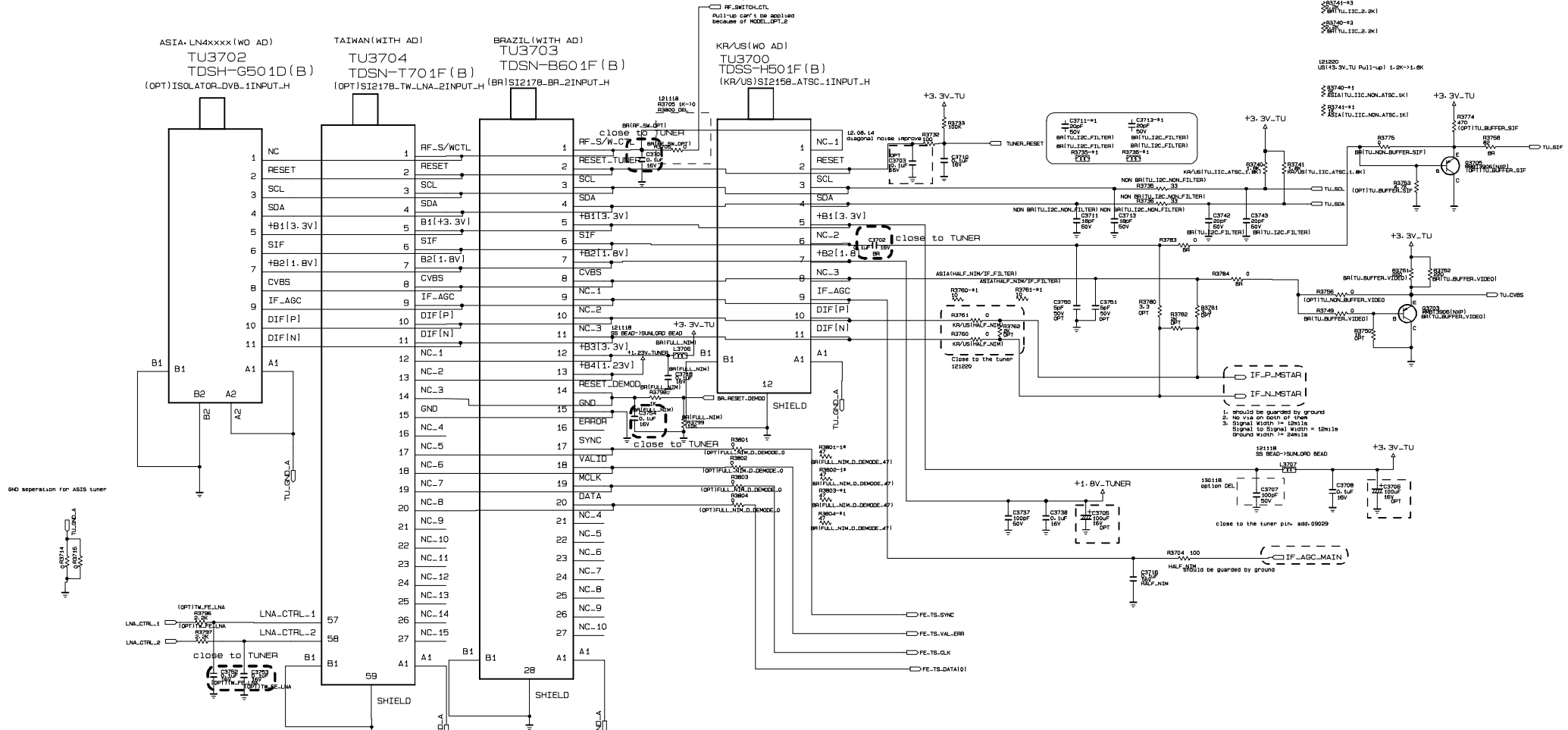

TW-FE-LNA FILTER-SETTING

Frequency	CTRL_1	CTRL_2	Filter_Type
54MHz~350MHz	1	0	LPF
350MHz~450MHz	0	0	Through
450MHz~870MHz	0	1	HFF

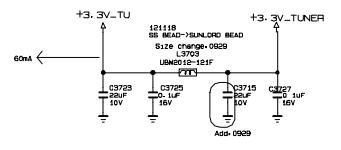

1. should be guarded by ground
2. No via on both of them
3. Signal width == 12m11s
Signal to signal width == 12m11s
Ground width == 24m11s

EAX65063106

SECRET
LGElectronics



MODEL	NC4-S7LAM	DATE	2013. 1. 14
BLOCK	TUNER_NON_EU	SHEET	26 / 12

COMPONENT & CVBS

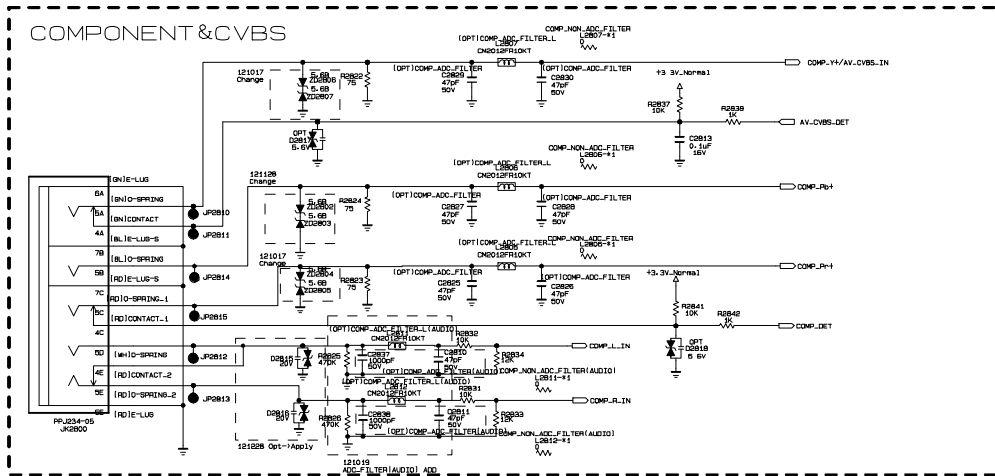

THE SYMBOL MARK OF THIS SCHEMATIC DIAGRAM INCORPORATES SPECIAL FEATURES IMPORTANT FOR PROTECTION FROM X-RADIATION, FIRE AND ELECTRICAL SHOCK HAZARDS. WHEN SERVICING IF IS ESSENTIAL THAT ONLY MANUFACTURERS SPECIFIED PARTS BE USED FOR THE CRITICAL COMPONENTS IN THE SYMBOL MARK OF THE SCHEMATIC.

SECRET
LGElectronics



EAX65063106

MODEL	NC4_S7LAM	DATE	2013. 1. 14
BLOCK	COMP	SHEET	28 / 12

