

SIEMENS

Cellular Engine Siemens M20 / M20 Terminal

Technical Description



Data
Voice
SMS
FAX
V.24

How to use this book



Table of contents



Index



How to use this book

The following navigation tools are available in addition to the Acrobat Reader toolbar or short-cut menu (right mouse key):



Click here when you see this hand.

Table of contents

- 1 Overview 11
- 2 Safety precautions for the user 12
 - 2.1 Electrical safety 12
 - 2.2 Aircraft safety 12
 - 2.3 Environments with explosive substances 12

Click here to jump to this section.

1	Feat_DCN	Called number display The dialled digits are shown on the terminal's display (AT command terminal or display, if connected) before signal transmission. <i>See "AT+CLCC List current calls of ME"</i>	GSM 02.07	5.5.1	6.5
2	Feat_CPSind	Indication of call progress signals (in accordance with GSM02.40) The call progress is signalled on the display and via audible tones after signal transmission. <i>See "AT+CLCC List current calls of ME"</i>	GSM 02.07	5.5.1	6.5.15

Click here to jump to this section.



Click here to jump to the Table of contents.



Click here to jump to the Index.

Table of contents

1 Overview	7
2 Safety precautions for the user	8
2.1 Electrical safety.....	8
2.2 Aircraft safety	8
2.3 Environments with explosive substances	8
2.4 Safety on the road.....	8
2.5 Non-ionizing radiation	8
2.6 Electronics in medical equipment	8
2.7 Precautions in the event of loss/theft of the Cellular Engine and the SIM card.....	8
3 General product description M20	9
3.1 Teleservices	10
3.2 Data services	11
3.3 Mobile station features.....	11
3.4 Supplementary mobile station features.....	14
3.5 System requirements.....	15
3.6 CE conformity.....	15
4 Hardware interfaces	16
4.1 Pin assignment of the 80-pole SMD connector	16
4.2 Power supply.....	17
4.3 Interfaces on the 80-pole SMD connector	17
4.4 Audio interface	25
4.5 Antenna interface	26
5 AT command interface	27
5.1 Syntax of the standard AT commands	27
5.2 Messages returned for normal data communication	27
5.3 Standard AT Hayes commands for controlling the M20.....	28
5.4 AT commands and responses to GSM 07.07 and GSM 07.05	54
5.5 AT Cellular commands to GSM 07.07.....	55
5.6 AT commands to GSM 07.05 for SMS	93
5.7 Siemens-defined AT commands for enhanced functions.....	111
5.8 Comparison between the MMI string commands and AT command	138
5.9 Summary of CME - CMS Errors.....	139
6 Man Machine Interface	142
6.1 Overview.....	142
6.2 Keypad address matrix.....	142
6.3 Additional display information	143
6.4 MMI features and user-defined settings	143
6.5 MMI functions	146
6.6 Power supply indicator	153
7 Peripheral devices	154
7.1 GSM antenna	154
7.2 SIM card reader	154
7.3 SIM cards	156

7.4 Handset.....	156
7.5 Sources for connectors	157
7.6 Display	157
7.7 Keypad.....	158
8 Application notes	159
8.1 General notes	159
8.2 Getting started & Installation	159
8.3 M20 diagnostics	174
8.4 Serial interface configuration.....	177
8.5 SW download (Version update)	191
8.6 EMC-relevant information for integrators of the M20	196
8.7 Getting full-type approval with the application	196
8.8 Application examples and reference circuits	198
8.9 Service information	201
9 M20 Terminal	202
9.1 General information.....	202
9.2 Electrical description and interfaces	203
9.3 Operation requirements, CE conformity, restrictions of use.....	206
9.4 Full-type approval.....	206
10 M20 Development Box	207
11 Environmental requirements for the M20	207
12 EMC and ESD requirements	207
13 Migration M1 to M20	207
13.1 SW comparison.....	207
13.2 System Parameter comparison (AT&V) on the M1 and M20.....	209
14 References	211
15 Technical data	212
15.1 Technical data of the M20	212
15.2 Design drawing of the M20.....	213
15.3 Design drawing of the M20 Terminal.....	214
16 AT commands sorted by functionality	217
16.1 Commands for Call Control.....	217
16.2 Commands for network services and status information.....	217
16.3 Commands for supplementary network services	218
16.4 Commands for SIM.....	218
16.5 Commands for interface to terminal equipment (TA – TE)	219
16.6 Commands for device control	219
16.7 Commands for device Information.....	220
16.8 Commands for SMS and CB (GSM 07.05)	220
16.9 Commands for data/fax	221
17 Appendix	221
17.1 Version History.....	221

Figures

Fig. 3-1	Design of the Siemens M20	9
Fig. 3-2	M20 interface diagram	15
Fig. 4-1	Timing of power on/off signals	18
Fig. 4-2	Write timing of display interface	19
Fig. 4-3	Read timing of display interface	19
Fig. 4-4	Timing characteristics of DAI to microcontroller	23
Fig. 4-5	Timing characteristics of DAI to codec	23
Fig. 6-1	Display structure	143
Fig. 7-1	Big SIM Card Reader (L04)	154
Fig. 7-2	Mini SIM card reader (C707-1)	155
Fig. 7-3	Mini SIM card reader (C707-3)	155
Fig. 7-4	Mini SIM card reader (holder)	155
Fig. 7-5	Mini SIM card reader (connector)	155
Fig. 7-6	SMR connector (straight)	157
Fig. 7-7	80-pole SMD connector (rigid)	157
Fig. 7-8	80-pole SMD connector (floating)	157
Fig. 8-8	Handsfree application diagram	200
Fig. 8-4	Level converter	198
Fig. 8-5	Voltage supply	198
Fig. 8-6	SIM card connection pins	199
Fig. 8-7	Handset connection	199
Fig. 9-1	Modular Cellular Engine Siemens M20 Terminal	202
Fig. 9-2	Front view of Western plug 6-6 (male)	203
Fig. 9-3	Front view of Western plug 4-4 (male)	204
Fig. 15-1	Design drawing of the M20	213
Fig. 15-2	M20 screw dimensions	214
Fig. 15-3	M20 Terminal front view	214
Fig. 15-4	M20 Terminal back view	214
Fig. 15-5	M20 Terminal top and side view	215
Fig. 15-6	M20 Terminal bottom view	216

Tables

Table 3-1	Teleservices	10
Table 3-2	Mobile station features	13
Table 3-3	Supplementary mobile station features	14
Table 4-1	Pin assignment of the 80-pole SMD connector	16
Table 4-2	2.8 V logic level specification	17
Table 4-3	Timing values of display interface	20
Table 4-4	Timing characteristics of DAI	24
Table 5-1	Standard Hayes AT commands	29
Table 5-2	AT commands according to GSM 07.07	55
Table 5-3	AT commands according to GSM 07.05	94
Table 5-4	Siemens-defined AT commands	112
Table 5-5	Summary of CMS ERRORS	140
Table 6-1	Keypad address matrix	142
Table 6-2	Description of keypad	142

Table 6-3	M20-specific MMI codes	144
Table 6-4	Languages for display text	144
Table 6-5	Value ranges	144
Table 6-6	Basic MMI codes in accordance with ETS 300-511	145
Table 6-7	Teleservices ts	145
Table 6-8	Changing the password in accordance with ETS 300-511	145
Table 6-9	Service indicator display	152

1 Overview

This document describes all the features, functions and interfaces of the Siemens M20 and M20 Terminal Cellular Engines. In addition, it states the base unit requirements which apply in connection with the operation of M20/M20 Terminal.

M20 Terminal combines the functions of the M20 unit with all peripheral devices necessary for plug-and-play usage (SIM card reader, V.24 serial Interface, Western plugs for handset and power supply) and a wide range of supply voltages. For additional information on M20 Terminal, see Chapter 9 “*M20 Terminal*” on page 202.

This document also includes the list of AT commands implemented at the serial interface and describes the MMI implemented at the display and keypad interface, the options for external M20 diagnostics, safety precautions for M20 users and M20 technical data.

In addition, this document provides service information and application notes and indicates the sources of components necessary for operation e.g. SIM reader, handset, display and keypad.

Chapters on application notes with information on getting started, diagnostics and type approval complete this document.

IMPORTANT:

This technical description applies to all M20 devices with SW Version 3.3 or higher and version number S30880-S8000-A100-1.

Users of the M20 are expressly requested to begin by reading the safety precautions in Chapter 2 “*Safety precautions for the user*” on page 8.

Information on finding out the software status is provided in Chapter 5.5 “*AT Cellular commands to GSM 07.07*” on page 55 (AT+GMR, AT+CGMR).

If you have any technical questions regarding this document or the product described, please contact your local distributor.

General information on cellular engines and a list of distributors can be found at the following Internet addresses:

- **English language:** www.siemens.de/gsm_e
- **Deutsche Sprache:** www.siemens.de/gsm

LIFE SUPPORT APPLICATIONS

These products are not designed for use in life support appliances, devices, or systems where malfunction of these products can reasonably be expected to result in personal injury. SIEMENS AG customers using or selling these products for use in such applications do so at their risk and agree to fully indemnify SIEMENS AG for any damages resulting from such improper use or sale.

DEVELOPMENT BOX (E-BOX)

Furthermore the Development box supplied by SIEMENS AG is to be used for development and test purposes only. The general terms of delivery or guarantee for the M20/M20T are not applicable for the Development box

2 Safety precautions for the user

The following notes refer to the M20/M20 Terminal Cellular Engine **AND** to applications based on M20/M20 Terminal. The manufacturer of an application based on the M20/M20 Terminal must incorporate these safety precautions in his/her instruction manual.

2.1 Electrical safety

The highest internal voltage applied to the M20 is 6 V; no special precautions are thus required to protect users against high voltages (see Chapter 4.2 “Power supply” on page 17).

2.2 Aircraft safety

Cellular engines can interfere with an aircraft’s navigation system and its cellular network. The use of M20/M20 Terminal on board aircraft is forbidden by law. Failure to comply with this prohibition may lead to temporary suspension or permanent cancellation of cellular engine services for the person who infringes this prohibition and/or to legal action against said person.

2.3 Environments with explosive substances

- a) Users are advised not to use the device in automotive service stations.
- b) Users are reminded of the necessity to comply with restrictions regarding the use of radio devices in fuel depots, chemicals plants and locations where explosives are ignited.

2.4 Safety on the road

- a) It is not permitted to signal incoming calls by sounding the vehicle’s horn or flashing the lights.
- b) Drivers are advised not to use the hand-held microphone or the telephone handset while their vehicle is in motion, except in the case of emergency. Use the handsfree facility to speak only if it does not divert your attention from the traffic.

2.5 Non-ionizing radiation

As is the case with other mobile radio transmitters, operating personnel are advised to use the device in the normal operating position only in order to ensure optimum performance and safety.

2.6 Electronics in medical equipment

Radio transmitters, including cellular engines, can interfere with the operation of inadequately protected medical devices. Please address all questions to a doctor or the manufacturer of the medical device.

2.7 Precautions in the event of loss/theft of the Cellular Engine and the SIM card

If your M20/M20 Terminal, your SIM card or both go missing, notify your network operator immediately in order to avoid misuse.

3 General product description M20

The Siemens M20 combines all the features required by developers and users. It is designed both for handling complex industrial applications such as telemetry, telematics or communication, and for integration in stationary or mobile fields all over the world.

The most important features are:

- Top quality according to "normal mobile station" requirements (−104 dBm sensitivity) instead of "small mobile station" requirements (−102 dBm sensitivity).
- Voice transmission with Enhanced Full Rate EFR and Full Rate FR
- Data transmission rate up to 9600 bit/s transparent and non-transparent
- Group 3 fax service
- SMS (text mode, PDU, MT, MO) and SMS Cell Broadcast
- Integrated echo suppression and noise reduction for handset
- Digital audio interface
- SIM Lock
- Network and service provider personalization according to GSM 02.22
- Reloadable software
- GSM900 phase II
- Compatible in terms of function and control with the GSM modules M1 and A1
- 2W power part (class 4)
- Single input voltage (6.0 V)
 - Average current: speech mode 200mA/idle mode 20mA
- Dimensions L x W x H in mm: 86.8 x 41.4 x 11.2.
- Weight: 38 g
- Temperature range: −20°C to +55°C

Note: Voltage supply: Voltage supply on connection must NOT rise faster than 3V/msec.

Additional features are listed below.

In addition to control via the serial interface, the Siemens M20 also offers the option of control by means of a connected keypad and display.

Using a board-to-board connector, the system integrator can integrate the components on the basic device's printed circuit board (e.g. hand-held devices like scanner).

All the main connections are already integrated in the Siemens M20 so that implementation can take place with only minimum development work.

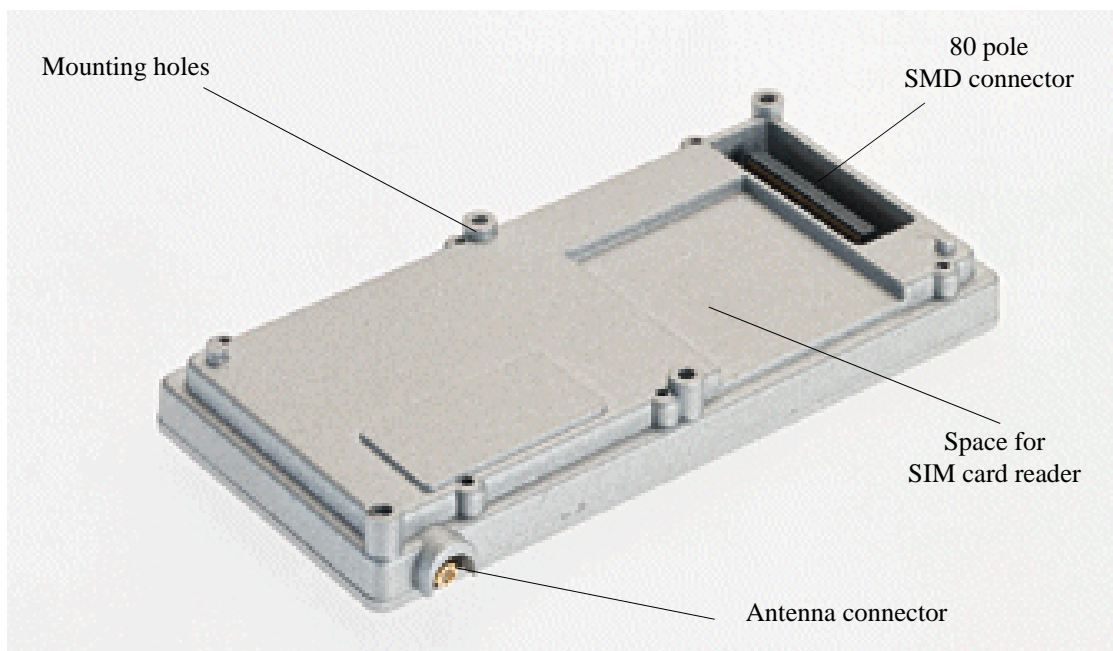

Fig. 3-1 Design of the Siemens M20

The Siemens M20 offers the following functions:

Additional Features:

- Dial tone
The SIEMENS M20 provides no dial tone at all or two permanently defined types of dial tone, as selected.
- Power management/backup routine
- DTMF
DTMF tones can be generated.
- PIN handling (protection can be activated/deactivated)
- Reload capability (software update)

Interfaces:

One serial interface (control, data transmission and software updates)

- SIM card reader interface for 3 V SIM cards.
- Analog interface for headset and microphone connection (telephone receiver)
- Digital Audio Interface (DAI)
Echo suppression for handsfree mode can be implemented by an external connection
- Ringer interface
Different ring volumes can be set
- Input port
The power supply status of the application can be signalled on the display (network operation, battery operation, battery supply jeopardized, no display)
- Display interface
Display controller for dot display can be controlled (2 lines x 13 characters).
- Connector
All interfaces with the exception of the antenna (type: SMR nano) are fed out by means of a connector on the hardware side. The connector is mechanically stable, the associated jacks can be purchased and installed worldwide by the integrators.
- Interface for a keypad with 4 x 6 keyboard matrix.
- Interface to a tuning fork contact (hookswitch)
- Power supply
- On switch

3.1 Teleservices

No	GSM standard	Teleservice	Reference	Available via AT+C	Available via MMI
1	TS11	Telephony	GSM 02.03 A.1.1	5.3	6.5
2	TS12	Emergency Call	GSM 02.03 A.1.2	5.3	6.5
3	TS21	Short Message MT/PP	GSM 02.03 A.1.3	5.6	6.5.13
4	TS22	Short Message MO/PP	GSM 02.03 A.1.3.1	5.6	–
5	TS23	SMS Cell Broadcast	GSM 02.03 A.1.3.2	5.6	6.5.13
6	TS62	Teleservice Automatic G3 fax	GSM 02.03 A.1.5	5.5	–

Table 3-1 Teleservices

3.2 Data services

Terminal adapter (TA) – terminal equipment (TE) interface:

RS232 compatible:

Baud rates: 300, 1200, 2400, 4800, 9600, 19200, 28800, 38400 and 57600.

No automatic baud rate adjustment. Default: 19200 (can be adjusted by AT+IPR). *See “AT+IPR Set fixed local rate”.*

Data stacks:

Transparent data/non-transparent data

On-air channels: TCH/9.6F, TCH/4.8F, TCH/2.4F. *See “AT+CBST Select Bearer Service Type”.*

V.42bis data compression (can be adjusted with “AT+DR V.42bis data compression reporting control” on page 47).

Transparent fax

Class 1 group 3 supported.

On-air channels: TCH/9.6F, TCH/4.8F, TCH/2.4F. *See “AT+CBST Select Bearer Service Type”.*

3.3 Mobile station features

No	Mnemonic ¹⁾	Mobile station feature ³⁾	Ref.	Available via AT+C	Available via MMI
1	Feat_DCN	Called number display The dialled digits are shown on the terminal’s display (AT command terminal or display, if connected) before signal transmission <i>See “AT+COLP Connected line identification presentation”.</i>	GSM 02.07	5.5.1	6.5
2	Feat_CPSind	Indication of call progress signals (in accordance with GSM02.40) The call progress is signalled on the display and via audible tones after signal transmission.	GSM 02.07	–	6.5.16
3	Feat_PLMNind	Country/PLMN indication The network operator is shown on the display after successful logon to the PLMN (MS idle). <i>See “AT+COPS Operator selection”.</i>	GSM 02.07	5.5.1	6.4
4	Feat_PLMNsel	Country/PLMN selection Automatic and manual network operator selection. <i>See “AT+COPS Operator selection”.</i>	GSM 02.07	5.5.1	6.3
5	Feat_Keypad	Keypad Keys are permanently assigned to their logical functionality, i.e. programmable function keys or soft keys are not implemented. <ul style="list-style-type: none"> • 0, 1, 2, 3, 4, 5, 6, 7, 8, 9, *, # keys send key • 4 abbreviated dialling keys are used in the current keypad matrix • redial/cursor up • SMS key • + (for settings) • – (for settings) 	GSM 02.07	–	6.2
6	Feat_IMEI	IMEI – International Mobile Equipment Identity An unique international identity code (IMEI) is stored in the terminal. This code is individually assigned to each terminal by the terminal manufacturer. <i>See “AT+CGSN Request product serial number identification (IMEI) identical to GSN”.</i>	GSM 02.07	5.5.1	6.4

No	Mnemonic ¹⁾	Mobile station feature ³⁾	Ref.	Available via AT+C	Available via MMI
7	Feat_SMoverflow	Short message overflow indication Messages from the Short Message telephone service are saved on the SIM. The number of messages that can be saved depends on the SIM card used. An advisory is output if there is insufficient memory available for an incoming message. <i>See “AT^SMGO Set or query SMS overflow presentation mode or query SMS overflow”.</i>	GSM 02.07	5.7.1	6.3
8	Feat_DTE_DCE	DTE /DCE interface Modem interface between data terminal equipment and data circuit terminating equipment <i>See “AT+IFC Set TE-TA local data flow control”, See “AT+IPR Set fixed local rate”, See “AT+ILRR Set TE-TA local rate reporting mode”, See “AT+ICF Set TE-TA control character framing”</i>	GSM 02.07	5.3	–
9	Feat_IntAccess	International access function The international access code to the PSTN (Public Switched Telephone Network) is dialled by holding down the <0> key until ‘+’ appears on the display (nominal time approx. 1 second). The access code, thus, does not depend on the location (international roaming). The international access code can also be dialled using the conventional country-specific prefix (e.g. 00 in Austria, Germany). <i>See “ATD Mobile originated call to dial a number and call of supplementary services”.</i>	GSM 02.07	5.5.1	6.5
10	Feat_ServInd	Service indicator The call processing status of the terminal is shown on the display when the terminal is idle. <i>See “AT+CREG Network registration”.</i>	GSM 02.07	5.5.1	6.3
11	Feat_DTMF	Dual-tone multifrequency function If you press the signal key during an existing connection, a DTMF signal is transmitted to the remote station. The digits entered between signal transmission and call pickup are rejected. DTMF digits are not saved on repertory dialling keys. <i>See “AT+VTS DTMF and tone generation (<Tone> in {0-9, *, #, A, B, C, D})”.</i>	GSM 02.07	5.5.1	6.5.12
12	Feat_SIM	Subscription identity management The IMSI (International Mobile Subscriber Identity) is used for internal signalling and is saved on the SIM (processor card). If the SIM is removed from the terminal, any existing connections are cleared down and further call setup is prevented (exception: emergency calls). <i>See “AT+CIMI Request international mobile subscriber identity”.</i>	GSM 02.07	5.5.1	6.5
13	Feat_OnOff	On/off switch²⁾ Switch off is implemented only via AT commands. <i>See “AT^SMSO Switch off mobile station turn off”.</i>	GSM 02.07	y (off)	–
14	Feat_A51	Support of encryption A5/1	GSM 02.07	5.5.1	6.5
15	Feat_A52	Support of encryption A5/2	GSM 02.07	5.5.1	6.5

No	Mnemonic ¹⁾	Mobile station feature ³⁾	Ref.	Available via AT+C	Available via MMI
16	Feat_SMS_CB_DRX	Short Message Service Cell Broadcast DRX DRX: discontinuous reception (mechanism). <i>See "AT+CSCB Select cell broadcast SMS messages".</i>	GSM 02.07	5.5.1	–
17	Feat_AD	Abbreviated dialling Abbreviated dialling keys (in MMI) or via index numbers in phone book (AT+C), to be programmed by the customer. <i>See "ATD Mobile originated call to dial a number and call of supplementary services".</i>	GSM 02.07	5.5.1	6.5.5
18	Feat_FND	Fixed number dialling Only implemented via AT command interface since the MMI has no phone book implemented. <i>See "ATDS Dial stored phone number in ME-phonebook".</i>	GSM 02.07	5.5.1	–
19	Feat_BO	Barring of outgoing calls Supported locally on the terminal (see supplementary service 'Barring of all outgoing calls'). <i>See "AT+CLCK Facility lock".</i>	GSM 02.07	5.5.1	6.5.9
20	Feat_LND	Last numbers dialled The last number dialled is displayed and an outgoing seizure is initiated when you lift the handset and press the redial key. <i>See "ATDL Redial last telephone number used".</i>	GSM 02.07	5.5.1	6.5.8
21	Feat_HumanInterface	Human interface provided <ul style="list-style-type: none"> • Display • Key-Pad • Buzzer • Audio-Tones 	GSM 02.07	5.5.1	6.1

Note:

1) "Mnemonic" defines the service name accord. to GSM standards

2) Depending on application

3) The features are defined in GSM 02.07 Version 5.1.0.: July 1996 (Annex B).

Table 3-2 Mobile station features

3.4 Supplementary mobile station features

No	Abbreviations	Feature	Reference	Available via AT+C	Available via MMI
1	CLIP	Calling Line Identification Presentation <i>See "AT+CLIP Calling line identification presentation".</i>	GSM 02.04 3.1	5.5.1	6.5
2	CLIR	Calling Line Identification Restriction <i>See "AT+CLIR Calling line identification restriction".</i>	GSM 02.04 3.1	5.5.1	6.5
3	COLP	Connected Line Identification Presentation <i>See "AT+COLP Connected line identification presentation".</i>	GSM 02.04 3.1	5.5.1	–
4	CFU	Call Forwarding Unconditional <i>See "AT+CCFC Call forwarding number and conditions control".</i>	GSM 02.04 3.1, GSM 02.07 2.1	5.5.1	6.5
5	CFB	Call Forwarding on Mobile Subscriber Busy <i>See "AT+CCFC Call forwarding number and conditions control".</i>	GSM 02.04 3.1, GSM 02.07 B 2.1	5.5.1	6.5
6	CFNRy	Call Forwarding on No Reply <i>See "AT+CCFC Call forwarding number and conditions control".</i>	GSM 02.04 3.1, GSM 02.07 B2.1	5.5.1	6.5
7	CFNRc	Call Forwarding on Mobile Subscriber Not Reachable <i>See "AT+CCFC Call forwarding number and conditions control".</i>	GSM 02.04 3.1, GSM 02.07 B2.1	5.5.1	6.5
8	CW	Call Waiting <i>See "AT+CCWA Call waiting control".</i>	GSM 02.04 3.1	5.5.1	–
9	CH	Call Hold <i>See "AT+CHLD Call hold and multiparty".</i>	GSM 02.04 3.1	5.5.1	–
10	MTPy	Multiparty Service <i>See "AT+CHLD Call hold and multiparty".</i>	GSM 02.04 3.1	5.5.1	–
11	CUG	Closed User Group <i>See "AT+CCUG Closed user group control".</i>	GSM 02.04 3.1	5.5.1	–
12	AoC	Advice of Charge (Information) <i>See "AT+CAOC Advice of Charge information".</i>	GSM 02.04 3.1	5.5.1	–
13	AoC	Advice of Charge (Charging) 1) <i>See "AT+CAOC Advice of Charge information".</i>	GSM 02.04 3.1	5.5.1	–
14	BAOC	Barring of All Outgoing Calls <i>See "AT+CLCK Facility lock".</i>	GSM 02.04 3.1, GSM 02.07 B.2.1	5.5.1	6.5
15	BOIC	Barring of Outgoing International Calls <i>See "AT+CLCK Facility lock".</i>	GSM 02.04 3.1, GSM 02.07 B.2.1	5.5.1	6.5
16	BOIC	Barring of Outgoing International Calls except those directed to the Home PLMN Country. <i>See "AT+CLCK Facility lock".</i>	GSM 02.04 3.1, GSM 02.07 B.2.1	5.5.1	6.5
17	BAIC	Barring of All Incoming Calls <i>See "AT+CLCK Facility lock".</i>	GSM 02.04 3.1, GSM 02.07 B.2.1	5.5.1	6.5
18	BAIC	Barring of Incoming Calls when Roaming Outside the Home PLMN Country <i>See "AT+CLCK Facility lock".</i>	GSM 02.04 3.1, GSM 02.07 B.2.1	5.5.1	6.5
19	USSD	Unstructured SS Data	GSM 02.30, GSM 02.07B.2.1		6.5

Note:) Prepaid SIM cards, no MMI for charge query

Table 3-3 Supplementary mobile station features

3.5 System requirements

The M20 is designed for use in a system environment comprising a GSM900 mobile radio network with one or more network operators per country. A corresponding infrastructure for a configuration level suitable for the use of terminal devices with 2 watts transmitting power is a basic requirement.

The functional environment for the M20 is constituted by a so-called base unit which supports the interfaces of the M20 (see Fig. 3-2 *M20 interface diagram*). The base unit must support at least 6 V power supply, a SIM card interface and an AT command interface via the serial interface (V.24) or Man Machine Interface (MMI). The base unit can be, for example, a GSM telephone, a ticket machine, some kind of vending machine, a hand-held device or another terminal device which uses the GSM as a medium for transmitting voice, fax/data or short messages (SMS). The precondition is that the base unit has to support the interfaces for the M20 operation as laid down in this technical description.

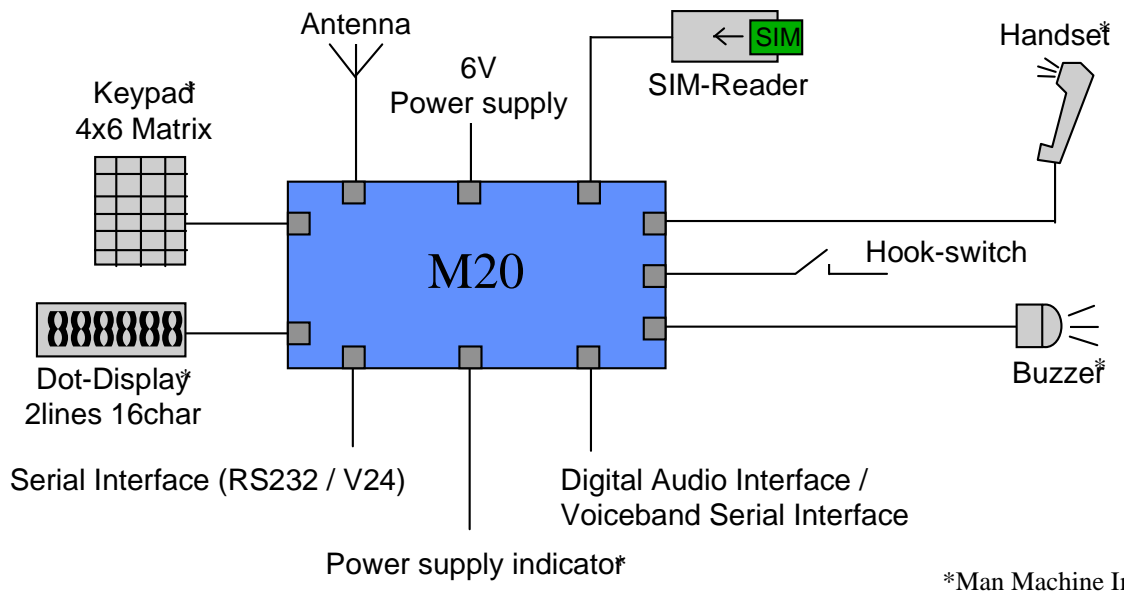

Fig. 3-2 M20 interface diagram

3.6 CE conformity

The M20 bears the CE symbol of conformity. This symbol guarantees the compliance of the design and implementation of the M20 with the currently valid versions of the following EC directives.

- 89/336/EC (EMC Directive)
- 73/23/EC (Low Voltage Directive)
- 91/263/EC (Telecommunications Terminals Directive)

Standards:

- EMC: ETS 300 342-1
- Safety: EN 60950
- GSM network: TBR 19, TBR 20

4 Hardware interfaces

4.1 Pin assignment of the 80-pole SMD connector

The location of PIN 1 is shown in “*Design drawing of the M20*”.

Site on PCB					
Parallel display data bus	Pin 1	D14	D15	Pin 80	Parallel display data bus
Parallel display data bus	Pin 2	D12	D13	Pin 79	Parallel display data bus
Parallel display data bus	Pin 3	D10	D11	Pin 78	Parallel display data bus
Parallel display data bus	Pin 4	D8	D9	Pin 77	Parallel display data bus
Parallel display data enable	Pin 5	DE	DRS	Pin 76	Parallel display address (A0)
Parallel display write	Pin 6	HWR#	DCS#	Pin 75	Parallel display chip select
Reset	Pin 7	RES#	POWER_ON	Pin 74	Power on indication
Ignition	Pin 8	IGNITION	USCRTS	Pin 73	Request to send
Clear to send	Pin 9	USCCTS	USCTX	Pin 72	Transmit data
Receive data	Pin 10	USCRX	RXDATA	Pin 71	2. serial interface receive data
Ring indication	Pin 11	USCRI	TXDATA	Pin 70	2. serial interface transmit data
USB to/from controller Synchronisation	Pin 12	VSFS_C	VSFS_V	Pin 69	USB to/from codec Synchronisation
USB to/from controller clock	Pin 13	VSCLK_C	VSCLK_V	Pin 68	USB to/from codec clock
USB to/from controller data input	Pin 14	VSDI_C	VSDO_V	Pin 67	USB to/from codec data output
USB to/from controller data output	Pin 15	VSDO_C	VSDI_V	Pin 66	USB to/from codec data input
Data terminal ready	Pin 16	DTR	GND	Pin 65	Ground
Ground	Pin 17	GND	GND	Pin 64	Ground
6 V Power supply	Pin 18	DC_IN	GND	Pin 63	Ground
6 V Power supply	Pin 19	DC_IN	DC_IN	Pin 62	6 V Power supply
6 V Power supply	Pin 20	DC_IN	DC_IN	Pin 61	6 V Power supply
6 V Power supply	Pin 21	DC_IN	DC_IN	Pin 60	6 V Power supply
6 V Power supply	Pin 22	DC_IN	DC_IN	Pin 59	6 V Power supply
Ground	Pin 23	GND	DC_IN	Pin 58	6 V Power supply
Ground	Pin 24	GND	GND	Pin 57	Ground
Ground	Pin 25	GND	GND	Pin 56	Ground
Data set ready	Pin 26	DSR	CCCLK	Pin 55	SIM card clock
SIM card reset	Pin 27	CCRST	DCD	Pin 54	Data carrier detect
SIM card data	Pin 28	CCIO	CCIN	Pin 53	SIM card inserted
Reserved pin	Pin 29	GPCS	CCVCC	Pin 52	SIM card supply
Download enable	Pin 30	BOOTCODEEN	GPIO1	Pin 51	Battery load indicator
not connected	Pin 31	NC	GPIO0	Pin 50	Supply source indicator
Keypad column 2	Pin 32	KPC2	KPC3	Pin 49	Keypad column 3
Keypad column 0	Pin 33	KPC0	KPC1	Pin 48	Keypad column 1
Keypad row 4	Pin 34	KPR4	KPR5	Pin 47	Keypad row 5
Keypad row 2	Pin 35	KPR2	KPR3	Pin 46	Keypad row 3
Keypad row 0	Pin 36	KPR0	KPR1	Pin 45	Keypad row 1
Hookswitch	Pin 37	HOOKSW	BUZZER	Pin 44	Buzzer
Ground	Pin 38	GND	GND	Pin 43	Ground
Microphone minus	Pin 39	MICN	MICP	Pin 42	Microphone plus
Speaker minus	Pin 40	SPN	SPP	Pin 41	Speaker plus

Table 4-1 Pin assignment of the 80-pole SMD connector

The interfaces are described in detail in Chapters 4.2 “Power supply” on page 17, 4.3 “Interfaces on the 80-pole SMD connector” on page 17 and 4.4 “Audio interface” on page 25.

Note: Unused pins

- In all cases in which the DAI is not used, the voiceband serial connector to/from controller has to be connected externally to the voiceband serial connector to/from codec. Connection wires should be as short as possible (10 cm maximum)
Connect VSFS_V to VSFS_C, VSCLK_V to VSCLK_C, VSDO_V to VSDI_C, VS DI_V to VS DO_C. For additional information, see also Chapter 8.8.5 “Adding echo suppression functionality” on page 200.
- RXDATA must be connected to RES#, if not used.
- The following pins (if unused) shall be:
connected to GND: CCIN
connected to a 10 kOhm - 100 kOhm pull-down (ground) resistor: BOOTCODEEN, GPIO0, GPIO1, HOOKSW
not connected: all display pins, all keypad pins, USCxxx, MICN, MICP, BUZZER, SPN, SPP, POWER_ON, RES#, DSR, DCD, TXDATA, DTR, GPCS.
- All DC_IN pins and all GND pins shall be used!
- The maximum number of push-pull cycles of the SMD connector shall not exceed 100.

4.2 Power supply

Single voltage power supply:	6V +/- 0.2 V
Current consumption:	max. 2A pulses.
Switch-in current pulse (when voltage is applied)	$I_{\max} = 15 \text{ A}$, duration: approx. 10 μs , decreasing (1/e) time constant <90 μs at $R_{\text{supply}} < 0.1 \Omega$ decreasing time to stand-by current value: < 300 μs
Stand-by state (voltage is applied, ignition not yet asserted)	$I \leq 0.2 \text{ mA}$
Idle mode	$I < 20 \text{ mA}$ average typ. 14 mA average (depends on network operator)
Call in progress	$I < 2 \text{ A}$ (pulsed $t = 577 \mu\text{s}$ at $T = 4.615 \text{ ms}$) typ. 1.5 A for performance class 5 arithmetic mean: $I < 250 \text{ mA}$

4.3 Interfaces on the 80-pole SMD connector

This chapter describes all interfaces (except power supply) on the 80-pole SMD connector.

4.3.1 Specification of 2.8 V logic level

The following diagram shows the 2.8 V logic level specification used in the M20:

Parameter	Min.	Max.
V_{O_H} output high voltage	2.3 V	2.9 V
V_{O_L} output low voltage	0 V	0.4 V
V_{I_H} input high voltage	2.1 V	3 V
V_{I_L} input low voltage	-0.3 V	0.8 V

Table 4-2 2.8 V logic level specification

4.3.2 Power on/off

Signal	Function	I/O	Level	Comments
IGNITION	Switch on	I	¹⁾	IGNITION >2.7 V for longer than 1 s switches on
POWER_ON	Power-on indicator	O	²⁾	Load current < 300 uA Note: may be unconnected if unused
RES#	Reset indicator	O	2.8V	Load current < 500 uA Note: may be unconnected if unused

Note:

¹⁾ Level range: $0 < \text{IGNITION} < 6.2 \text{ V}$, (maximum voltage: $\pm 50 \text{ V}$). For additional information see 8.8.6 “Ignition line” on page 200.

²⁾ See Fig. 4-1 Timing of power on/off signals case $\text{IGNITION} > 2.7 \text{ V}$ level = $\text{IGNITION} - 0.7 \text{ V}$.

To turn on the M20, connect IGNITION to the voltage specified in the table above. The device will then keep running even if a voltage $< 0.6 \text{ V}$ is applied to IGNITION or the device is left disconnected. To turn off the M20, use the corresponding AT command (AT^SMSO, see Chapter 5.7 “Siemens-defined AT commands for enhanced functions” on page 111).

Note: if IGNITION is connected to a fixed voltage $> 1.3 \text{ V}$, the M20 cannot be turned off with an AT command.

POWER_ON indicates that the microprocessor of M20 is supplied.

RES# level High indicates that the microprocessor of M20 is supplied and working.

Note: RES# also can be used as 2.8 V reference level for applications of the M20.

For additional information, see Fig. 4-1 Timing of power on/off signals.

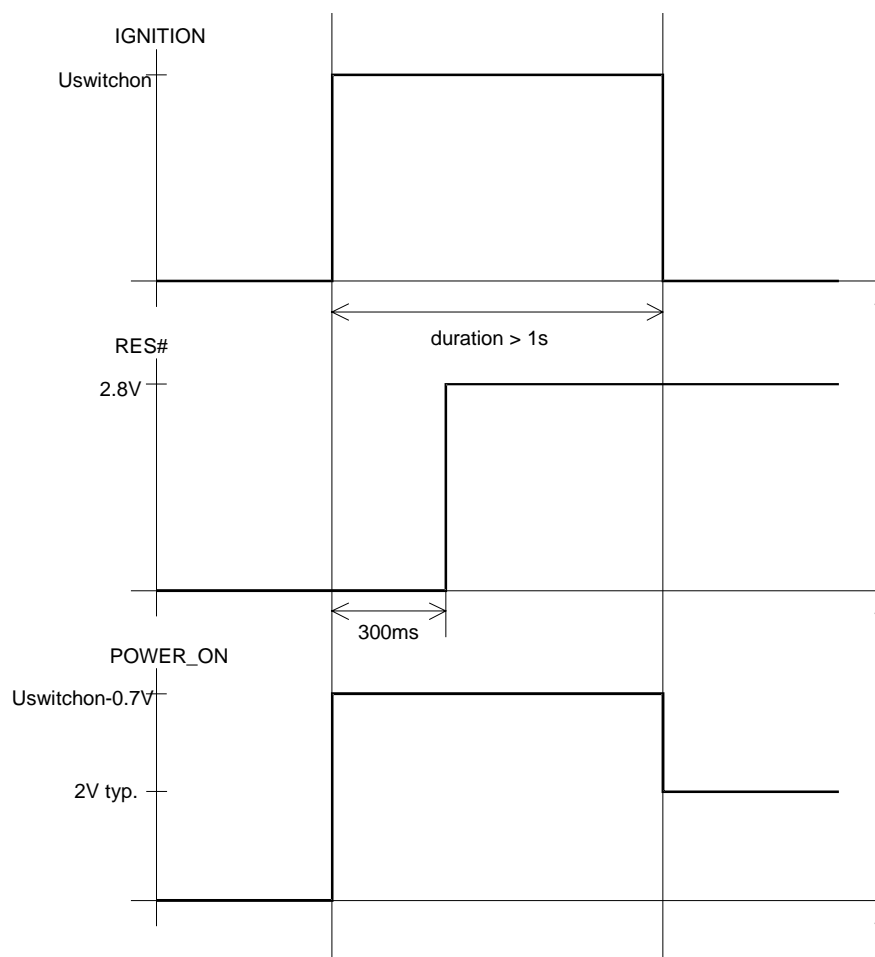

Fig. 4-1 Timing of power on/off signals

4.3.3 Display

12 Pins for connection of a dot display (2 lines x 16 columns)

Signal	Function	I/O	Level	Comments
DCS#	Chip select	O	2.8V	may be disconnected if unused
DRS	Address (A0)	O	2.8V	may be disconnected if unused
DE	Data enable	O	2.8V	may be disconnected if unused
D8...D15	Databus	I/O	2.8V	may be disconnected if unused
HWR#	Write	O	2.8V	may be disconnected if unused

For detailed information on read and write timing see *Fig. 4-2 Write timing of display interface* and *Read timing of display interface*. The corresponding timing values can be found in *Timing values of display interface*.

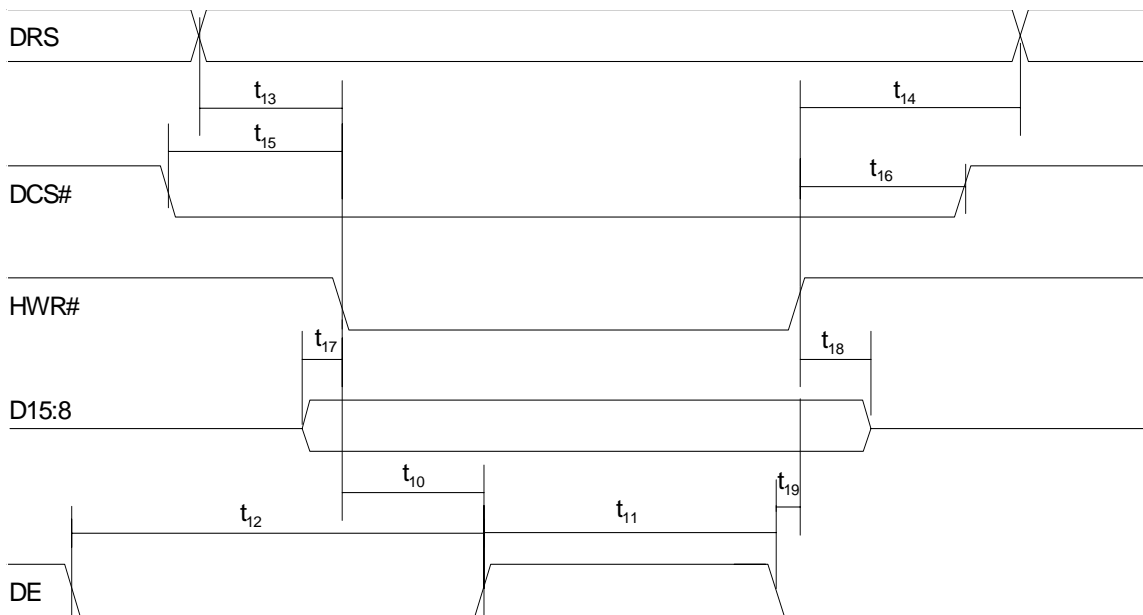

Fig. 4-2 Write timing of display interface

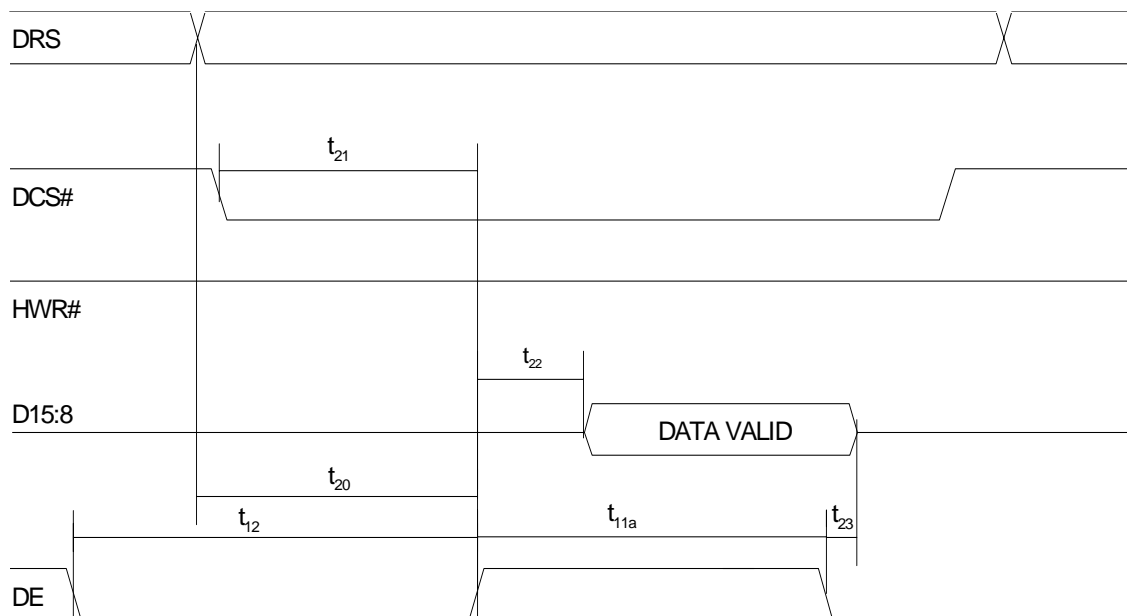

Fig. 4-3 Read timing of display interface

Parameter	Comment	Min.	Typ.	Max.	Units
t ₁₀	Write high byte to display enable high		152		ns
t ₁₁	Display enable high width	462			ns
t ₁₂	Display enable low width	462			ns
t ₁₃	Display register select setup	10			ns
t ₁₄	Display register select hold	5			ns
t ₁₅	Display chipselect setup	10			ns
t ₁₆	Display chipselect hold	5			ns
t ₁₇	Data setup	68			ns
t ₁₈	Data hold	15			ns
t _{11a}	Display enable high width read extension	538			ns
t ₁₉	Display enable low to write high	10			ns
t ₂₀	Display register select to display enable high	200			ns
t ₂₁	Display chipselect to display enable high	200			ns
t ₂₂	Display enable high to data valid			450	ns
t ₂₃	Data hold	0			ns

Table 4-3 Timing values of display interface

4.3.4 Keypad

10 Pins for 4*6 keypad matrix.

Signal	Function	I/O	Level	Comments
KPR0...5	Keypad row	I	2.8 V	may be disconnected if unused
KPC0...3	Keypad column	O	2.8 V	may be disconnected if unused

For activation of a key, connect a row signal to the appropriate column signal. The keypad address matrix implemented in the MMI software can be found in Chapter 6.2 “Keypad address matrix” on page 142.

Note: maximum input speed: 1 key per 400ms

4.3.5 Serial Interface RS323 (V.24) Connections and signals

The Serial Interface can be used for:

- AT command interface
- Software download (SW update), see 8.5 “SW download (Version update)” on page 191
- serial interface for data/fax/SMS services.

Note:

External level converter is necessary for V.24 level when using the M20.

The M20T has a direct 9 pin serial interface port.

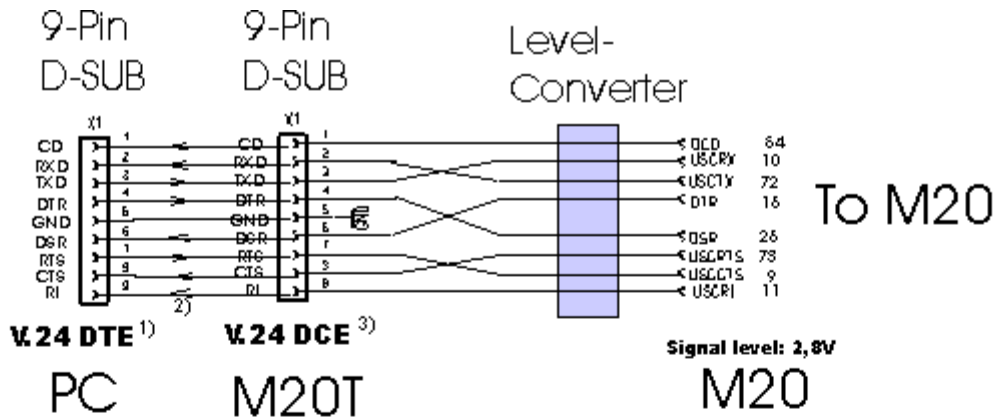

- 1) PC Serial Port, male socket
- 2) Serial cable, no crossover
- 3) Interface connector, normal DCE, female

Application example:

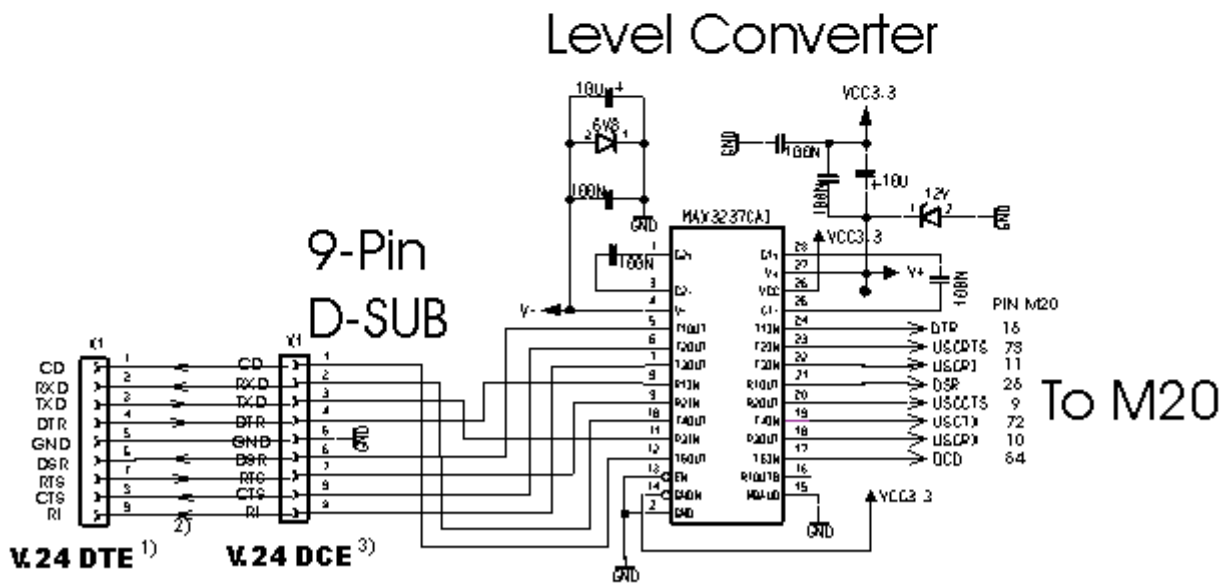

- 1) PC Serial Port, male socket
- 2) Serial cable, no crossover
- 3) Interface connector, normal DCE, female

General Note:

- 1) Signal levels on the M20T: 5-15V
- 2) Signal levels on the M20: 2,8 V
- 3) Crossing out of signal lines is done inside the M20T so that the M20T can be connected to the PC directly using a standard non-crossover serial cable.
- 4) Applications directly connecting to the M20 need to cross out the signal paths as shown in the above figure.

Note: If a Pin is not used it can stay unconnected

Signal description on the 9-pole D-sub DCE connector:

9-pole D-Sub DCE Pin No	Description	Function	CCITT V-24	EIA RS232	DIN 66020	I/O DCE to DTE
1	DCD	Data Carrier Detect	109	CF	M5	O
2	RXD	Receive Data	104	BB	D2	O
3	TXD	Transmit Data	103	BA	D1	I
4	DTR	Data Terminal Ready	108	CD	S1	I
5	GND	Ground	102	AB	E2	
6	DSR	Data set ready	107	CC	M1	O
7	RTS	Request to send	105	CA	S2	I
8	CTS	Clear to send	106	CB	M2	O
9	RI	Ring Indication	125	CE	M3	O

Signal connection 9-pole D-sub DCE to M20 80-pole SMD connector:

DCE Pin No	DCE Signal	M20 Signal	M20 Pin No
1	DCD	DCD	54
2	RXD	USCTX	72
3	TXD	USCRX	10
4	DTR	DSR	26
5	GND		
6	DSR	DTR	16
7	RTS	USCCTS	9
8	CTS	USCRTS	73
9	RI	USCRI	11

4.3.6 Additional RX/TX interface

This interface is **reserved** for Siemens development internal purposes.

Signal	Function	I/O	Level	Comments
RXDATA	Receive data	I	2.8 V	if unused, connect to signal RES#
TXDATA	Transmit data	O	2.8 V	may be disconnected if unused

4.3.7 Voiceband serial ports/digital audio interface (DAI)

To provide a digital audio interface to the user and to offer high-end echo suppression in handsfree environments as an upgrade feature, the on-board voiceband serial connector between the M20 microcontroller and codec (A/D device) is connected to the 80-pole SMD connector.

Note: the data exchanged on the interface involves 13 bit linear PCM at 8000 samples per second.

Note: in normal cases, the voiceband serial ports (to microcontroller and to codec) have to be interconnected on the PCB of the base unit.

If using the DAI, connection to the codec-oriented ports is not necessary.

For handsfree applications, see detailed information in Chapter 8.8.5 “Adding echo suppression functionality” on page 200.

Signal	Function	I/O	Level	Comments
VSFS_C	Synchronisation	I	2.8V	to microcontroller (in normal cases, to be connected to VSFS_V)
VSCLK_C	Clock	I	2.8V	to microcontroller (in normal cases, to be connected to VSCLK_V)
VSDO_C	Data output	O	2.8V	to microcontroller (in normal cases, to be connected to VS DI_V)
VSDI_C	Data Input	I	2.8V	to microcontroller (in normal cases, to be connected to VS DO_V)

VSFS_V	Synchronisation	O	2.8V	to codec
VSCLK_V	Clock	O	2.8V	to codec
VSDO_V	Data output	O	2.8V	to codec
VSDI_V	Data Input	I	2.8V	to codec

Note: data clock (VSCLK_C, VSCLK_V): 104 kHz, word length: 13 bits, synchronisation pulse rate (VSFS_C, VSFS_V): 8 kHz.

For detailed information on timing characteristics, see *Timing characteristics of DAI to microcontroller* and *Timing characteristics of DAI to codec*. The corresponding timing values can be found in *Timing characteristics of DAI*.

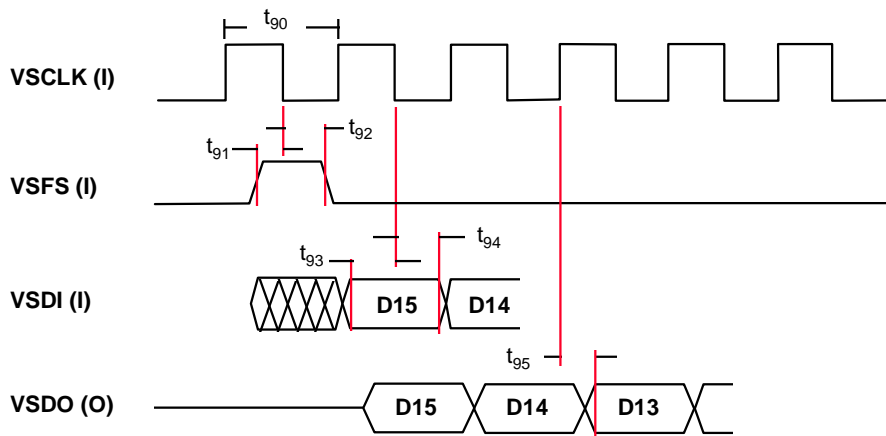

Fig. 4-4 Timing characteristics of DAI to microcontroller

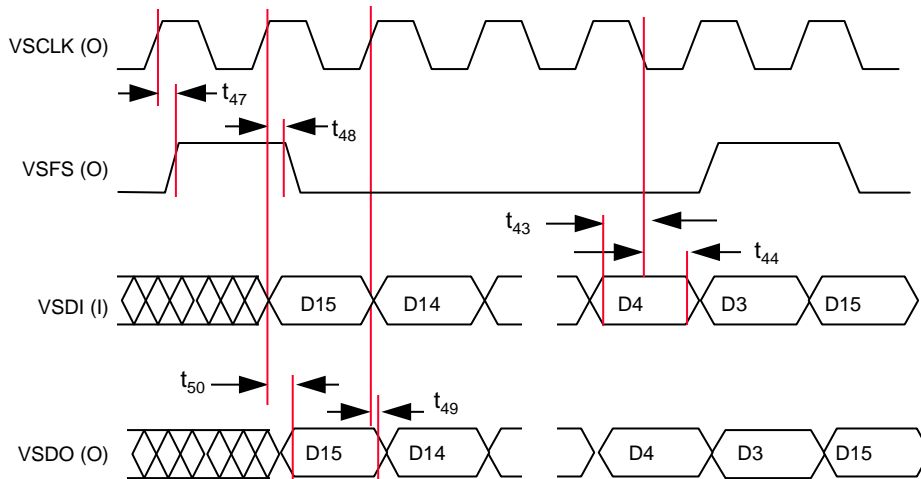

Fig. 4-5 Timing characteristics of DAI to codec

Parameter	Comment	Min.	Typ.	Max.	Units
t ₄₃	VSDI setup time before VSCLK low	25			ns
t ₄₄	VSDI hold time after VSCLK low	10			ns
t ₄₇	VSFS delay from VSCLK high			25	ns
t ₄₈	VSFS hold time after VSCLK high	-20			ns
t ₄₉	VSDO hold time after VSCLK high	-20			ns
t ₅₀	VSDO delay from VSCLK high			20	ns
t ₉₀	VSCLK period		9615		ns
t ₉₁	VSFS setup time before VSCLK low	4			ns
t ₉₂	VSFS hold time after VSCLK low	7			ns
t ₉₃	VSDI setup time before VSCLK low	4			ns

t ₉₄	VSDI hold time after VSCLK low	7			ns
t ₉₅	VSDO delay after VSCLK high	0		15	ns

Table 4-4 Timing characteristics of DAI

4.3.8 SIM card interface

In general the SIM interface is specified in GSM 11.11.

Note: the M20 supports 3V SIM cards.

Signal	Function	I/O	Level	Comments
CCVCC	SIM card power supply	O	2.8 V	Contact C1 ¹⁾
CCRST	SIM card Reset	O	2.8 V	Contact C2 ¹⁾
CCIO	SIM card data in/out	I/O	2.8 V	Contact C7 ¹⁾
CCCLK	SIM card clock	O	2.8 V	Contact C3 ¹⁾
CCIN	SIM card Inserted switch	I	2.8 V	must be connected to GND, if SIM card reader does not provide a CCIN switch. ²⁾
GND	Ground		0 V	Contact C5 ¹⁾

Notes:

¹⁾ All information provided on the SIM card interface complies with GSM 11.11 and 11.12.
Contacts C4, C6 and C8 are not provided by M20.

²⁾ When using a SIM card reader without a CCIN switch, SIM card removal must be avoided when voltage is applied to the M20. This should be avoided by the mechanical integration of the SIM card reader in the application.

4.3.9 Power supply indicator

The power supply indicator is only used by the inbuilt MMI software. This allows the M20 MMI software to indicate the actual base unit power supply status on the display.

Note: this functionality is not available when controlling the M20 via the AT command interface.

Signal	Function	I/O	Level	Comments
GPCS	GP chip select	O	2.8 V	reserved may be disconnected if unused
GPIO0	GP port pin 0	I	2.8 V	Supply source indicator (by mains or battery) if unused, connect to a 10kOhm - 100 kOhm pull-down resistor
GPIO1	GP port pin 1	I	2.8 V	Battery load indicator (full or below warning level) if unused, connect to a 10kOhm - 100 kOhm pull-down resistor

GPIO 1	GPIO 0	Description
0	0	Base unit supplied by mains, battery full (= normal state)
0	1	Base unit supplied by battery, battery full
1	0	Base unit supplied by mains, battery voltage below warning level
1	1	Base unit supplied by battery, battery voltage below warning level

4.4 Audio interface

Signal	Function	I/ O	Level	Comments
MICP	Microphone plus	I	V _{pp} (V): ¹⁾ typ.: 1.0954 / F _{scale} max.: 1.578 / F _{scale}	Differential input; must be AC-coupled; input resistance: 11–22 MΩ Note: may be disconnected if unused
MICN	Microphone minus	I	V _{pp} (V): ¹⁾ typ.: 1.0954 / F _{scale} max.: 1.578 / F _{scale}	Differential Input; internally; must be AC-coupled; in- put resistance: 11–22 MΩ Note: may be disconnected if unused
SPP	Speaker plus	O	V _{pp} (V): nom.: 2.1909 max.: 3.156	min. load resistance: 32 Ω max. load capacitance: 100 pF should be AC-coupled Note: may be disconnected if unused
SPN	Speaker minus	O	V _{pp} (V): nom.: 2.1909 max.: 3.156	min. load resistance: 32 Ω max. load capacitance: 100 pF should be AC-coupled Note: may be unconnected if unused
BUZZER	Buzzer	O	1.2 V - 1.35 V	> 2 kΩ, < 50 pF, used only with integrated MMI Note: may be disconnected if unused
HOOKSW	Hookswitch	I	2.8 V	used only with integrated MMI ON-HOOK = 0V OFF-HOOK = 2.1 - 3 V if unused, connect to a 10 kΩ - 100 kΩ pull-down resi- stor

Note:

¹⁾ $F_{scale} = 10^{((3 \cdot inBbcGain)/20)}$ (for parameter "inBbcGain", see description of command AT^SNFI in Chapter 5.7 "Siemens-defined AT commands for enhanced functions" on page 111)

The microphone should comply with the following technical data:

Sensitivity	-37 ± 2 dB (500 Hz, 0 dB = 1 V/Pa, v = 0)
Impedance	2 kΩ ± 30% (1 kHz)
Bias voltage	1.5 V DC (1–10 V DC)
Input current	≤ 300 μA
Signal-to-noise ratio	≤ 66 dB

Technical data of the speaker:

Volume	(97.0 ± 2) dB SPL
Impedance	150 ± 30 Ω
THD	≤ 4% (800 Hz, 104 dB SPL) ≤ 2% (300–3400 Hz, 94 dB SPL)

4.5 Antenna interface

The antenna must satisfy the following electrical requirements:

Frequency, TX	890-915 MHz
Frequency, RX	935-960 MHz
Impedance	50 Ω
VSWR	TX: max. 1.7:1 installed RX: max. 1.9:1 installed
Gain	> 1.5dB referenced to $\lambda/2$ dipole
3dB width of cone	vertical: 80° horizontal: 360°
Maximum power	1W (cw), 2W peak; at ambient temperature of 55°C

In principle, the GSM antenna is selected by the manufacturer of the base unit. The GSM antenna may be mounted directly or via cable, depending on the application and the RF field at the local site.

The **antenna interface connector** of the M20 unit is SMR nano (male). Hence, the connector on the GSM antenna or antenna cable has to be SMR nano (female).

Note: the maximum number of push/pull cycles shall not exceed 100.

For further information on GSM antennas and sources of connectors, see Chapters 7.1 “GSM antenna” on page 154 and 7.5 “Sources for connectors” on page 157.

5 AT command interface

The operating functions of M20 and M20 Terminal are implemented in the base unit in which the cellular engine is integrated. The corresponding functions are implemented in accordance with V.25ter, GSM 07.07 and GSM 07.05. AT+C commands conforming to GSM 07.07 and GSM 07.05 and a number of manufacturer-specific AT commands are available via the serial interface of the M20 for function implementation. These commands are described in detail below.

Command input is via the operating functions of the base unit. The base unit translates the operating functions into AT commands and the M20/M20 Terminal executes the requested action.

5.1 Syntax of the standard AT commands

The V.25ter modem guideline is applicable as regards the time sequence of interface commands. The AT standard is a line-oriented command language. Each command is made up of three elements: the prefix, the body, and the termination character.

The **prefix** consists of the letters "AT", except for the "A/" command.

The **body** is made up of individual characters as described in this chapter. The body consists of a name and, if applicable, associated values. An optional associated value is marked by square brackets ([...])

The default **termination character** is "<CR>" (= 0x0D).

Commands may be combined in the same command line. Spaces between the individual bodies are ignored. The commands can be classified as:

- basic commands (without "+" or "^")
- extended commands (with "+" or "^")

Commands are acknowledged with "OK" or "ERROR". A command currently being processed is interrupted by each subsequent incoming character. Consequently, the next command must wait until acknowledgment has been received as otherwise the current command will be cancelled. After the OK there has to be a pause of at least 100ms, until the next command is entered.

The commands supported are listed in the tables below.

General Note: The functionality of many features depends on the functionality on the network.

5.2 Messages returned for normal data communication

Response	Code	Type	Meaning
OK	0	final	Command executed, no errors
CONNECT	1	intermediate	Connection set up, if parameter setting X=0
CONNECT[<text>]		intermediate	Connection set up, if parameter setting X>0 <text>: e.g.: 'cnx 9600'. When data transfer rate is 9600 Bit/sec.
RING	2	unsolicited	Ring detected
NO CARRIER	3	final	Link not established or disconnected
ERROR	4	final	Invalid command or command line too long
NO DIAL TONE	5	final	No dial tone, dialling impossible, wrong mode
BUSY	6	final	Remote station busy
NO ANSWER	7	final	Connection completion time-out
^SBUSY	10	intermediate	Remote party busy and inband info from PLMN
^SNO CARRIER	11	intermediate	Link not established or disconnected and inband info from PLMN
^SALERTING	13	intermediate	Alerting on remote party
^SQUEUED	14	intermediate	Remote party busy with call waiting on

5.3 Standard AT Hayes commands for controlling the M20

Command	Function	
A/	Repeat previous command line	Page 29
+++pause	Switch from data mode to command mode	Page 29
ATA	Answer a call	Page 30
ATD	Mobile originated call to dial a number and call of supplementary services	Page 30
ATD<mem><n>	Originate call to phone number <n> in memory <mem>	Page 33
ATD=<n>;	Originate call to phone number <n> in current memory	Page 34
ATD<str>	Originate call to phone number in memory with corresponding alphanum. field	Page 35
ATDI<n>	Mobile originated call to dialable ISDN number <n>	Page 36
ATDL	Redial last telephone number used	Page 37
ATDS	Dial stored phone number in ME-phonebook	Page 38
ATE	Enable command echo	Page 38
ATH	Disconnect existing connection	Page 38
ATI	Display product identification information	Page 39
ATL	Set monitor speaker loudness Command ignored, command for V.25ter compatibility only	–
ATM	Set monitor speaker mode Command ignored, command for V.25ter compatibility only	–
ATO	Switch from command mode to data mode	Page 39
ATP	Select pulse dialling Command ignored, command for V.25ter compatibility only	–
ATQ	Set result code presentation mode	Page 39
ATS0	Set number of rings before automatically answering the call	Page 40
ATS2	Set Hayes ESC character	Page 40
ATS3	Set command line termination character	Page 40
ATS4	Set response formatting character	Page 41
ATS5	Set command line editing character	Page 41
ATS6	Set pause before blind dialling Command ignored, command for V.25ter compatibility only	–
ATS7	Set number of seconds to wait for connection completion	Page 41
ATS8	Set number of seconds to wait when comma dial modifier Command ignored, command for V.25ter compatibility only	Page 41
ATS10	Set disconnect delay after indicating the absence of data carrier	Page 42
ATS12	Set pause length for Hayes ESC sequence	Page 42
ATT	Select tone dialling Command ignored, command for V.25ter compatibility only	–
ATV	Set result code format mode	Page 42
ATX	Set CONNECT result code format and call monitoring	Page 43
ATZ	Set all current parameters to user defined profile	Page 43
AT&C	Set circuit Data Carrier Detect (DCD) function mode	Page 43
AT&D	Set circuit Data Terminal Ready (DTR) function mode	Page 44
AT&F	Set all current parameters to manufacturer defaults	Page 44
AT&S	Set circuit Data Set Ready (DSR) function mode	Page 44
AT&V	Display current configuration	Page 45
AT&W *)	Store current parameter to user defined profile	Page 45
AT&Z	Store telephone number in SIM fixdialling memory "FD"	Page 46

Command	Function	
AT%D	Automatic dialling phone number in mem. "ME" index "1" with DTR	Page 46
AT+DR	V.42bis data compression reporting control	Page 47
AT+DS	V.42bis data compression control	Page 48
AT+GCAP	Request complete TA capabilities list	Page 48
AT+GMI	Request manufacturer identification	Page 49
AT+GMM	Request TA model identification	Page 49
AT+GMR	Request TA revision identification	Page 49
AT+GOI	Request global object identification	Page 50
AT+GSN	Request TA serial number identification	Page 50
AT+ICF	Set TE-TA control character framing	Page 50
AT+IFC	Set TE-TA local data flow control	Page 51
AT+ILRR	Set TE-TA local rate reporting mode	Page 52
AT+IPR	Set fixed local rate	Page 53

Table 5-1 Standard Hayes AT commands

***) Note:** it is not necessary to subsequently download a stored configuration (see commands AT&Y and AT&W) since the stored configuration is automatically downloaded each time the system is started up.

5.3.1 Detailed description

A/	Repeat previous command line
Execute command A/	Response Repeat previous command line Note: it does not have to end with terminating character. Parameter
Reference V.25ter	Note

(pause)+++ (pause)	ESC from data mode to command mode
Execute command +++ (pause)	Response If TA receives pause(0,5sec) +++ pause (0,5sec), TA interrupts the data flow on the AT interface, switches to command mode. Notice: The command is available only in data mode. OK Parameter
Reference Hayes	Note +++ is a Hayes command.

ATA		Answer a call	
Execute command ATA	Response	TA causes remote station to go off- hook (i.e. answer call).	
		Note1: any additional commands on the same command line are ignored.	
		Note2: this command may be aborted generally by receiving a character during execution. This command cannot be aborted in some connection setup states, such as handshaking.	
		If successfully connected	
		CONNECT <text> Note: <text> only if parameter setting X>0	
		TA switches to data mode.	
		When TA returns to command mode after call release	
		OK	
		If no connection	
		NO CARRIER	
		Parameter	
Reference V.25ter	Note		

ATD		Mobile originated call to dial a number and call of supplementary services	
------------	--	---	--

<p>Execute command ATD<n>[:]</p>	<p>Response</p> <p>When <n> is a call string TA attempts to set up an outgoing call. If error is related to ME functionality +CME ERROR: <err></p> <p>If no dialtone and (parameter setting X=2 or X=4) NO DIALTONE</p> <p>If busy and (parameter setting X=3 or X=4) BUSY</p> <p>If a connection cannot be set up NO CARRIER</p> <p>If successfully connected and non-voice call CONNECT<text> <i>Note:</i> <text> only if parameter setting X>0 TA switches to data state. When TA returns to command mode after call release OK</p> <p>If successfully connected and voice call OK</p> <p>Parameter <n> string of dialling digits and optionally V.25ter and GSM modifier characters:</p> <p>dialling digits: 0-9 *, # only for supplementary service call + only as first character for call A, B, C they are ignored</p> <p>V.25ter modifiers: (comma), T, P,!, W, @ they are ignored</p> <p>GSM modifiers: I, #31# CLIR invocation i, *31# CLIR suppression G, g CUG info, uses set with command +CCUG</p> <p>Maximum sum of dialling digits and GSM modifiers in <n>: 20 <i>Note:</i> leading "+" is not counted as dialling digit. E.g. +...20... characters If <n> is missing: default value of <n> is last dialled number <;> voice call, return to command state</p>
--	---

	<p>When <n> is a supplementary service string: TA attempts to call the supplementary service entered in dialled string. TA returns result of invoked supplementary service AT command.</p> <p>Parameter</p> <table border="0"> <thead> <tr> <th style="text-align: left;"><n>:</th> <th style="text-align: left;">Functionality:</th> <th style="text-align: left;">Invoked supp.service:</th> </tr> </thead> <tbody> <tr> <td>*#06#</td> <td>Query IMEI:</td> <td>+CGSN</td> </tr> <tr> <td>**04[2]*oldPin*newPin[2]*newPin[2]#</td> <td>Change SIM pwd:</td> <td>+CPWD</td> </tr> <tr> <td>**05[2]*unblKey*newPin[2]*newPin[2]#</td> <td>Change/Unblocking SIM pwd:</td> <td>^SPWD</td> </tr> <tr> <td>*[*]03*[ZZ]*oldPw*newPw*newPw#</td> <td>Registration of net password:</td> <td>+CPWD</td> </tr> <tr> <td>*#30#</td> <td>Interrogation CLIP</td> <td>+CLIP</td> </tr> <tr> <td>*#31#</td> <td>Interrogation CLIR</td> <td>+CLIR</td> </tr> <tr> <td>*#76#</td> <td>Interrogation COLP</td> <td>+COLP</td> </tr> <tr> <td>(choice of *,#,*,*,*,##)21*DN*BS#</td> <td>Act/deact/int/reg/eras CFU</td> <td>+CCFC</td> </tr> <tr> <td>(choice of *,#,*,*,*,##)67*DN*BS#</td> <td>Act/deact/int/reg/eras CF busy</td> <td>+CCFC</td> </tr> <tr> <td>(choice of *,#,*,*,*,##)61*DN*BS*T#</td> <td>Act/deact/int/reg/eras CF no reply</td> <td>+CCFC</td> </tr> <tr> <td>(choice of *,#,*,*,*,##)62*DN*BS#</td> <td>Act/deact/int/reg/eras CF no reach</td> <td>+CCFC</td> </tr> <tr> <td>(choice of *,#,*,*,*,##)002*DN*BS*T#</td> <td>Act/deact/int/reg/eras CF all</td> <td>+CCFC</td> </tr> <tr> <td>(choice of *,#,*,*,*,##)004*DN*BS*T#</td> <td>Act/deact/int/reg/eras CF all cond.</td> <td>+CCFC</td> </tr> <tr> <td>(choice of *,#,*,##)43*BS#</td> <td>Activation/deactivation/int WAIT</td> <td>+CCWA</td> </tr> <tr> <td>(choice of *,#,*,##)33*Pw*BS#</td> <td>Act/deact/int BAOIC</td> <td>+CLCK</td> </tr> <tr> <td>(choice of *,#,*,##)331*Pw*BS#</td> <td>Act/deact/int BAOIC</td> <td>+CLCK</td> </tr> <tr> <td>(choice of *,#,*,##)332*Pw*BS#</td> <td>Act/deact/int BAOIC exc.home</td> <td>+CLCK</td> </tr> <tr> <td>(choice of *,#,*,##)35*Pw*BS#</td> <td>Act/deact/int. BAIC</td> <td>+CLCK</td> </tr> <tr> <td>(choice of *,#,*,##)351*Pw*BS#</td> <td>Act/deact/int BAIC roaming</td> <td>+CLCK</td> </tr> <tr> <td>#330*Pw*BS#</td> <td>Deact. All Barring Services</td> <td>+CLCK</td> </tr> <tr> <td>#333*Pw*BS#</td> <td>Deact. All Outg.Barring Services</td> <td>+CLCK</td> </tr> <tr> <td>#353*Pw*BS#</td> <td>Deactivation. All Inc.Barring Services</td> <td>+CLCK</td> </tr> <tr> <td>[C]...[C]#</td> <td>Send USSD message</td> <td>+CUSD</td> </tr> <tr> <td>C[C] in call</td> <td>Call hold and multiparty</td> <td>+CHLD</td> </tr> <tr> <td>C[C] (excluded 1[C])</td> <td>Send USSD message</td> <td>+CUSD</td> </tr> <tr> <td>where</td> <td></td> <td></td> </tr> <tr> <td>ZZ</td> <td>type of supplementary services:</td> <td>Barring services 330 All services ----</td> </tr> <tr> <td>DN</td> <td>dialling number: string of digits 0-9</td> <td></td> </tr> <tr> <td>BS</td> <td>basic service: Voice</td> <td>11</td> </tr> <tr> <td></td> <td>Sms</td> <td>16</td> </tr> <tr> <td></td> <td>Fax</td> <td>13</td> </tr> <tr> <td></td> <td>Sms+fax</td> <td>12</td> </tr> <tr> <td></td> <td>Voice+fax</td> <td>19</td> </tr> <tr> <td></td> <td>Voice+sms+fax</td> <td>10</td> </tr> <tr> <td></td> <td>Data circuit asynchron</td> <td>25</td> </tr> <tr> <td></td> <td>Data circuit synchron</td> <td>24</td> </tr> <tr> <td></td> <td>PAD</td> <td>27</td> </tr> <tr> <td></td> <td>packet</td> <td>26</td> </tr> <tr> <td></td> <td>data circuit async.+PAD</td> <td>21</td> </tr> <tr> <td></td> <td>data circuit sync.+packet</td> <td>22</td> </tr> <tr> <td></td> <td>data circ.async+sync.+PAD+packet</td> <td>20</td> </tr> <tr> <td></td> <td>all services</td> <td>----</td> </tr> <tr> <td>T</td> <td>time in seconds</td> <td></td> </tr> <tr> <td>Pw</td> <td>net password</td> <td></td> </tr> <tr> <td>C</td> <td>character of TE character set</td> <td></td> </tr> </tbody> </table>	<n>:	Functionality:	Invoked supp.service:	*#06#	Query IMEI:	+CGSN	**04[2]*oldPin*newPin[2]*newPin[2]#	Change SIM pwd:	+CPWD	**05[2]*unblKey*newPin[2]*newPin[2]#	Change/Unblocking SIM pwd:	^SPWD	*[*]03*[ZZ]*oldPw*newPw*newPw#	Registration of net password:	+CPWD	*#30#	Interrogation CLIP	+CLIP	*#31#	Interrogation CLIR	+CLIR	*#76#	Interrogation COLP	+COLP	(choice of *,#,*,*,*,##)21*DN*BS#	Act/deact/int/reg/eras CFU	+CCFC	(choice of *,#,*,*,*,##)67*DN*BS#	Act/deact/int/reg/eras CF busy	+CCFC	(choice of *,#,*,*,*,##)61*DN*BS*T#	Act/deact/int/reg/eras CF no reply	+CCFC	(choice of *,#,*,*,*,##)62*DN*BS#	Act/deact/int/reg/eras CF no reach	+CCFC	(choice of *,#,*,*,*,##)002*DN*BS*T#	Act/deact/int/reg/eras CF all	+CCFC	(choice of *,#,*,*,*,##)004*DN*BS*T#	Act/deact/int/reg/eras CF all cond.	+CCFC	(choice of *,#,*,##)43*BS#	Activation/deactivation/int WAIT	+CCWA	(choice of *,#,*,##)33*Pw*BS#	Act/deact/int BAOIC	+CLCK	(choice of *,#,*,##)331*Pw*BS#	Act/deact/int BAOIC	+CLCK	(choice of *,#,*,##)332*Pw*BS#	Act/deact/int BAOIC exc.home	+CLCK	(choice of *,#,*,##)35*Pw*BS#	Act/deact/int. BAIC	+CLCK	(choice of *,#,*,##)351*Pw*BS#	Act/deact/int BAIC roaming	+CLCK	#330*Pw*BS#	Deact. All Barring Services	+CLCK	#333*Pw*BS#	Deact. All Outg.Barring Services	+CLCK	#353*Pw*BS#	Deactivation. All Inc.Barring Services	+CLCK	[C]...[C]#	Send USSD message	+CUSD	C[C] in call	Call hold and multiparty	+CHLD	C[C] (excluded 1[C])	Send USSD message	+CUSD	where			ZZ	type of supplementary services:	Barring services 330 All services ----	DN	dialling number: string of digits 0-9		BS	basic service: Voice	11		Sms	16		Fax	13		Sms+fax	12		Voice+fax	19		Voice+sms+fax	10		Data circuit asynchron	25		Data circuit synchron	24		PAD	27		packet	26		data circuit async.+PAD	21		data circuit sync.+packet	22		data circ.async+sync.+PAD+packet	20		all services	----	T	time in seconds		Pw	net password		C	character of TE character set	
<n>:	Functionality:	Invoked supp.service:																																																																																																																																									
*#06#	Query IMEI:	+CGSN																																																																																																																																									
**04[2]*oldPin*newPin[2]*newPin[2]#	Change SIM pwd:	+CPWD																																																																																																																																									
**05[2]*unblKey*newPin[2]*newPin[2]#	Change/Unblocking SIM pwd:	^SPWD																																																																																																																																									
[]03*[ZZ]*oldPw*newPw*newPw#	Registration of net password:	+CPWD																																																																																																																																									
*#30#	Interrogation CLIP	+CLIP																																																																																																																																									
*#31#	Interrogation CLIR	+CLIR																																																																																																																																									
*#76#	Interrogation COLP	+COLP																																																																																																																																									
(choice of *,#,*,*,*,##)21*DN*BS#	Act/deact/int/reg/eras CFU	+CCFC																																																																																																																																									
(choice of *,#,*,*,*,##)67*DN*BS#	Act/deact/int/reg/eras CF busy	+CCFC																																																																																																																																									
(choice of *,#,*,*,*,##)61*DN*BS*T#	Act/deact/int/reg/eras CF no reply	+CCFC																																																																																																																																									
(choice of *,#,*,*,*,##)62*DN*BS#	Act/deact/int/reg/eras CF no reach	+CCFC																																																																																																																																									
(choice of *,#,*,*,*,##)002*DN*BS*T#	Act/deact/int/reg/eras CF all	+CCFC																																																																																																																																									
(choice of *,#,*,*,*,##)004*DN*BS*T#	Act/deact/int/reg/eras CF all cond.	+CCFC																																																																																																																																									
(choice of *,#,*,##)43*BS#	Activation/deactivation/int WAIT	+CCWA																																																																																																																																									
(choice of *,#,*,##)33*Pw*BS#	Act/deact/int BAOIC	+CLCK																																																																																																																																									
(choice of *,#,*,##)331*Pw*BS#	Act/deact/int BAOIC	+CLCK																																																																																																																																									
(choice of *,#,*,##)332*Pw*BS#	Act/deact/int BAOIC exc.home	+CLCK																																																																																																																																									
(choice of *,#,*,##)35*Pw*BS#	Act/deact/int. BAIC	+CLCK																																																																																																																																									
(choice of *,#,*,##)351*Pw*BS#	Act/deact/int BAIC roaming	+CLCK																																																																																																																																									
#330*Pw*BS#	Deact. All Barring Services	+CLCK																																																																																																																																									
#333*Pw*BS#	Deact. All Outg.Barring Services	+CLCK																																																																																																																																									
#353*Pw*BS#	Deactivation. All Inc.Barring Services	+CLCK																																																																																																																																									
[C]...[C]#	Send USSD message	+CUSD																																																																																																																																									
C[C] in call	Call hold and multiparty	+CHLD																																																																																																																																									
C[C] (excluded 1[C])	Send USSD message	+CUSD																																																																																																																																									
where																																																																																																																																											
ZZ	type of supplementary services:	Barring services 330 All services ----																																																																																																																																									
DN	dialling number: string of digits 0-9																																																																																																																																										
BS	basic service: Voice	11																																																																																																																																									
	Sms	16																																																																																																																																									
	Fax	13																																																																																																																																									
	Sms+fax	12																																																																																																																																									
	Voice+fax	19																																																																																																																																									
	Voice+sms+fax	10																																																																																																																																									
	Data circuit asynchron	25																																																																																																																																									
	Data circuit synchron	24																																																																																																																																									
	PAD	27																																																																																																																																									
	packet	26																																																																																																																																									
	data circuit async.+PAD	21																																																																																																																																									
	data circuit sync.+packet	22																																																																																																																																									
	data circ.async+sync.+PAD+packet	20																																																																																																																																									
	all services	----																																																																																																																																									
T	time in seconds																																																																																																																																										
Pw	net password																																																																																																																																										
C	character of TE character set																																																																																																																																										
<p>Reference V.25ter/ GSM 07.07/02.30</p>	<p>Note This call command or supplementary service call command may be aborted generally by receiving a character during execution. This command cannot be aborted in some connection setup states, such as handshaking.</p>																																																																																																																																										

ATD<mem><n> Originate call to phone number <n> in memory <mem>																			
Execute command ATD<mem> <n>[<I>][<G>][;]	<p>Response</p> <p>TA attempts to set up an outgoing call to stored number. e.g.: ATD>SM5; Voice call to number at position 5 on the SIM phonebook.</p> <p>Note: this command may be aborted generally by receiving a character during execution. This command cannot be aborted in some connection setup states, such as handshaking.</p> <p>If error is related to ME functionality +CME ERROR: <err></p> <p>If no dialtone and (parameter setting X=2 or X=4) NO DIALTONE</p> <p>If busy and (parameter setting X=3 or X=4) BUSY</p> <p>If a connection cannot be set up NO CARRIER</p> <p>If successfully connected and non-voice call CONNECT<text> Note: <text> only if parameter setting X>0 TA switches to data state.</p> <p>When TA returns to command mode after call release OK</p> <p>If successfully connected and voice call OK</p> <p>Parameter</p> <table> <tr> <td><mem></td> <td>phonebook:</td> </tr> <tr> <td>FD</td> <td>SIM fixdialling-phonebook</td> </tr> <tr> <td>LD</td> <td>SIM last-dialling-phonebook</td> </tr> <tr> <td>RC</td> <td>ME received calls list</td> </tr> <tr> <td>MC</td> <td>ME missed (unanswered received) calls list</td> </tr> <tr> <td>SM</td> <td>SIM phonebook</td> </tr> <tr> <td>ON</td> <td>SIM (or ME) own numbers (MSISDNs) list</td> </tr> <tr> <td>ME</td> <td>ME phonebook</td> </tr> <tr> <td>MT</td> <td>Combined ME and SIM phonebook</td> </tr> </table> <p><n> integer type memory location should be in the range of locations available in the memory used</p> <p><I> I CLIR invocation i CLIR suppression</p> <p><G> G, g CUG info, uses set with command +CCUG</p> <p><;> voice call, return to command state</p>	<mem>	phonebook:	FD	SIM fixdialling-phonebook	LD	SIM last-dialling-phonebook	RC	ME received calls list	MC	ME missed (unanswered received) calls list	SM	SIM phonebook	ON	SIM (or ME) own numbers (MSISDNs) list	ME	ME phonebook	MT	Combined ME and SIM phonebook
<mem>	phonebook:																		
FD	SIM fixdialling-phonebook																		
LD	SIM last-dialling-phonebook																		
RC	ME received calls list																		
MC	ME missed (unanswered received) calls list																		
SM	SIM phonebook																		
ON	SIM (or ME) own numbers (MSISDNs) list																		
ME	ME phonebook																		
MT	Combined ME and SIM phonebook																		
Reference V.25ter/GSM 07.07	<p>Note</p> <p>Emergency call: no SIM needed</p> <p><n> 112 worldwide number</p> <p>There is no <mem> for emergency call ("EN").</p>																		

ATD<n>	Originate call to phone number in current memory
Execute command ATD<n>[<I>] [<G>];	Response TA attempts to set up an outgoing call to stored number. The used memory is already selected with command +CPBS. <u>Note:</u> this command may be aborted generally by receiving a character during execution. This command cannot be aborted in some connection setup states, such as handshaking. If error is related to ME functionality +CME ERROR: <err> If no dialtone and (parameter setting X=2 or X=4) NO DIALTONE If busy and (parameter setting X=3 or X=4) BUSY If a connection cannot be set up NO CARRIER If successfully connected and non-voice call CONNECT<text> <u>Note:</u> <text> only if parameter setting X>0 TA switches to data state. When TA returns to command mode after call release OK If successfully connected and voice call OK Parameter <n> integer type memory location should be in the range of locations available in the memory used <I> I CLIR invocation i CLIR suppression <G> G, g CUG info, uses set with command +CCUG <;> voice call, return to command state
Reference V.25ter/GSM 07.07	Note:

ATD<str>	Originate call to phone number in memory with corresponding alphanum. field
Execute command ATD<str>[I] [G];	<p>Response</p> <p>TA attempts to set up an outgoing call to stored number. All available memories are searched for the entry <str>, except LD, MC, RC. <u>Note 1:</u> The search string has to be identical to the complete string in the phonebook. <u>Note 2:</u> This command may be aborted generally by receiving a character during execution. This command cannot be aborted in some connection setup states, such as handshaking.</p> <p>If error is related to ME functionality +CME ERROR: <err></p> <p>If no dialtone and (parameter setting X=2 or X=4) NO DIALTONE</p> <p>If busy and (parameter setting X=3 or X=4) BUSY</p> <p>If a connection cannot be set up NO CARRIER</p> <p>If successfully connected and non-voice call CONNECT<text> <u>Note:</u> <text> only if parameter setting X>0 TA switches to data state. When TA returns to command mode after call release OK</p> <p>If successfully connected and voice call OK</p> <p>Parameter</p> <p><str> string type value ("x"), which should equal an alphanumeric field in at least one phonebook entry in the searched memories</p> <p><I> I CLIR activation i CLIR suppression</p> <p><G> G, g CUG info, uses set with command +CCUG</p> <p><;> voice call, return to command state</p>
Reference V.25ter/GSM 07.07	Note

ATDI	Mobile originated call to dialable ISDN number <n>
Execute command ATDI<n>[;]	Response TA attempts to set up an outgoing call to ISDN number. <u>Note:</u> this command may be aborted generally by receiving a character during execution. This command cannot be aborted in some connection setup states, such as handshaking. If no dialtone and (parameter setting X=2 or X=4) NO DIALTONE If busy and (parameter setting X=3 or X=4) BUSY If a connection cannot be set up NO CARRIER If successfully connected and non-voice call CONNECT<text> <u>Note:</u> <text> only if parameter setting X>0 TA switches to data state. When TA returns to command mode after call release OK If successfully connected and voice call OK Parameter <n> [+]<d> phone number string with maximum length of 20 characters + international dialling format <d> ISDN number string of digits: +,0-9, A, B, C <;> voice call
Reference Siemens	Note

ATDL	Redial last telephone number used
Execute command ATDL[;]	<p>Response</p> <p>TA attempts to set up an outgoing call to stored number.</p> <p>Note: this command may be aborted generally by receiving a character during execution. This command cannot be aborted in some connection setup states, such as handshaking.</p> <p>If there is no last number or number is not valid:</p> <p>+CME ERROR</p> <p>or:</p> <p>If no dialtone and (parameter setting X=2 or X=4)</p> <p>NO DIALTONE</p> <p>If busy and (parameter setting X=3 or X=4)</p> <p>BUSY</p> <p>If a connection cannot be set up</p> <p>NO CARRIER</p> <p>If successfully connected and non-voice call</p> <p>CONNECT<text> Note: <text> only if parameter setting X>0</p> <p>TA switches to data state.</p> <p>When TA returns to command mode after call release</p> <p>OK</p> <p>If successfully connected and voice call</p> <p>OK</p> <p>Parameter <;> voice call</p>
Reference Siemens	Note

ATDS Dial stored phone number in ME-phonebook	
Execute command ATDS=<n>[;]	<p>Response</p> <p>TA attempts to set up an outgoing call to stored number. The phone number is searched in ME-phonebook "ME".</p> <p>Note: this command may be aborted generally by receiving a character during execution. This command cannot be aborted in some connection setup states, such as handshaking.</p> <p>If there is no valid number +CME ERROR: <err></p> <p>or</p> <p>If no dialtone and (parameter setting X=2 or X=4) NO DIALTONE</p> <p>If busy and (parameter setting X=3 or X=4) BUSY</p> <p>If a connection cannot be set up NO CARRIER</p> <p>If successfully connected and non-voice call CONNECT<text> Note: <text> only if parameter setting X>0 TA switches to data state. When TA returns to command mode after call release OK</p> <p>If successfully connected and voice call OK</p> <p>Parameter <n> address of stored phone number <;> voice call</p>
Reference Siemens	Note

ATE Enable command echo	
Set command ATE[<value>]	<p>Response</p> <p>This setting determines whether or not the TA echoes characters received from TE during command state.</p> <p>OK</p> <p>Parameter <value> 0 Echo mode off 1 Echo mode on</p>
Reference V.25ter	Note

ATH Disconnect existing connection	
Execute command ATH[n]	<p>Response</p> <p>Disconnect existing call by local TE from command line and terminate call</p> <p>OK</p> <p>Note: OK is issued after circuit 109 (DCD) is turned off (if it was previously on).</p> <p>Parameter <n> 0 disconnect from line and terminate call</p>
Reference V.25ter	Note

ATI Display product identification information	
Execute command ATI	Response ME issues product information text SIEMENS M20 Revision: x.yy, DD.MM.YY HH:MM OK Explanation of "Revision" parameter: Version (x) and variant (y) of software release. Date and time of software production DD: day, MM: month, YY: year, HH: hours, MM: minutes Parameter
Reference V.25ter	Note Same response for ATI1...ATI9

ATO Switch from command mode to data mode	
Execute command ATO[n]	Response TA resumes the connection and switches back from command mode to data mode. If connection is not successfully resumed NO CARRIER or TA returns to data mode from command mode CONNECT <text> <i>Note:</i> <text> only if parameter setting X>0 Parameter <n> 0 switch from command mode to data mode
Reference V.25ter	Note

ATQ Set result code presentation mode	
Set command ATQ[<n>]	Response This parameter setting determines whether or not the TA transmits any result code to the TE. Information text transmitted in response is not affected by this setting. If <n>=0: OK If <n>=1: (none) Parameter <n> 0 DCE transmits result code 1 Result codes are suppressed and not transmitted
Reference V.25ter	Note

ATS0 Set number of rings before automatically answering the call	
Read command ATS0?	Response <n> OK
Set command ATS0=<n>	Response This parameter setting determines the number of rings before automatic answering. OK Parameter <n> 0 automatic answering is disabled 1-255 enable automatic answering on the ring number specified
Reference V.25ter	Note

ATS2 Set Hayes ESC character	
Read command ATS2?	Response <n> OK
Set command ATS2=<n>	Response This parameter setting determines the characters used in Hayes ESC sequence. OK Parameter <n> 1-43-127 Hayes escape character <u>Note:</u> default 43 = +
Reference V.25ter	Note

ATS3 Set command line termination character	
Read command ATS3?	Response <n> OK
Set command ATS3=<n>	Response This parameter setting determines the character recognized by TA to terminate an incoming command line. OK Parameter <n> 0-13-127 command line termination character <u>Note:</u> default 13 = CR <u>Note:</u> Using other value than 13 may cause problems when entering commands
Reference V.25ter	Note

ATS4 Set response formatting character	
Read command ATS4?	Response <n> OK
Set command ATS4=<n>	Response This parameter setting determines the character generated by the TA for result code and information text. OK Parameter <n> 0-10-127 response formatting character <i>Note:</i> default 10 = LF
Reference V.25ter	Note

ATS5 Set command line editing character	
Read command ATS5?	Response <n> OK
Set command ATS5=<n>	Response This parameter setting determines the character recognized by TA as a request to delete the immediately preceding character from the command line. OK Parameter <n> 0-8-127 command line editing character <i>Note:</i> default 8 = backspace
Reference V.25ter	Note

ATS7 Set number of seconds to wait for connection completion	
Read command ATS7?	Response <n> OK
Set command ATS7=<n>	Response This parameter setting determines the amount of time to wait for connection completion when answering or originating a call. OK Parameter <n> 0- 60 -255 number of seconds to wait for connection completion
Reference V.25ter	Note

ATS8 Set number of seconds to wait when comma dial modifier	
Read command ATS8?	Response <n> OK
Set command ATS8=<n>	Response No effect at GSM OK Parameter <n> 0 no pause when comma encountered in dial string 2 Default value 1-255 number of seconds to wait
Reference V.25ter	Note

ATS10 Set disconnect delay after indicating the absence of data carrier	
Read command ATS10?	Response <n> OK
Set command AT10=<n>	Response This parameter setting determines the amount of time that the TA remains connected in absence of data carrier. If the data carrier is detected before disconnect, the TA remains connected. OK Parameter <n> 1- <u>15</u> -255 number of tenths of seconds of delay
Reference V.25ter	Note

ATS12 Set pause length for Hayes ESC sequence	
Read command ATS12?	Response <n> OK
Set command AT12=<n>	Response This parameter setting determines the length of pause on the start and end of Hayes escape sequence in. 0.1 sec. OK Parameter <n> 1- <u>10</u> -255 number of tenths of seconds of pause length
Reference V.25ter	Note

ATV Set result code format mode	
Set command ATV[<value>]	Response This parameter setting determines the contents of the header and trailer transmitted with result codes and information responses. When <value> =0 OK When <value> =1 OK Parameter <value> 0 Information response: <text><CR><LF> Short result code format: <numeric code><CR> 1 Information response: <CR><LF><text><CR><LF> Long result code format: <CR><LF><verbose code><CR><LF>
Reference V.25ter	Note

ATX Set CONNECT result code format and call monitoring													
Set command ATX[<value>]	<p>Response</p> <p>This parameter setting determines whether or not the TA detected the presence of dial tone and busy signal and whether or not TA transmits particular result codes</p> <p>OK</p> <p>Parameter <value></p> <table> <tr> <td>0</td> <td>CONNECT result code only returned, dial tone and busy detection are both disabled</td> </tr> <tr> <td>1</td> <td>CONNECT<text> result code only returned, dial tone and busy detection are both disabled</td> </tr> <tr> <td>2</td> <td>CONNECT<text> result code returned, dial tone detection is enabled, busy detection is disabled</td> </tr> <tr> <td>3</td> <td>CONNECT<text> result code returned, dial tone detection is disabled, busy detection is enabled</td> </tr> <tr> <td>4</td> <td>CONNECT<text> result code returned, dial tone and busy detection are both enabled</td> </tr> <tr> <td>5</td> <td>same as 4, in addition intermediate result codes ^SALERTING, ^SQUEUED, ^SBUSY and ^SNO CARRIER are sent if necessary</td> </tr> </table>	0	CONNECT result code only returned, dial tone and busy detection are both disabled	1	CONNECT<text> result code only returned, dial tone and busy detection are both disabled	2	CONNECT<text> result code returned, dial tone detection is enabled, busy detection is disabled	3	CONNECT<text> result code returned, dial tone detection is disabled, busy detection is enabled	4	CONNECT<text> result code returned, dial tone and busy detection are both enabled	5	same as 4, in addition intermediate result codes ^SALERTING, ^SQUEUED, ^SBUSY and ^SNO CARRIER are sent if necessary
0	CONNECT result code only returned, dial tone and busy detection are both disabled												
1	CONNECT<text> result code only returned, dial tone and busy detection are both disabled												
2	CONNECT<text> result code returned, dial tone detection is enabled, busy detection is disabled												
3	CONNECT<text> result code returned, dial tone detection is disabled, busy detection is enabled												
4	CONNECT<text> result code returned, dial tone and busy detection are both enabled												
5	same as 4, in addition intermediate result codes ^SALERTING, ^SQUEUED, ^SBUSY and ^SNO CARRIER are sent if necessary												
Reference V.25ter	Note												

ATZ Set all current parameters to user defined profile			
Execute command ATZ[<value>]	<p>Response</p> <p>TA sets all current parameters to the user-defined profile.</p> <p>Note 1: The user defined profile is stored in non-volatile memory.</p> <p>Note 2: If invalid, the user-profile will be reset to the factory default profile.</p> <p>Note 3: Any additional commands on the same command line are ignored.</p> <p>Note 4: A delay of 300ms is needed before next command is sent, otherwise "OK" response may be corrupted.</p> <p>OK</p> <p>Parameter <value></p> <table> <tr> <td>0</td> <td>Reset to profile number 0</td> </tr> </table>	0	Reset to profile number 0
0	Reset to profile number 0		
Reference V.25ter	Note There has to be a pause of at least 300ms after the OK, before the next command is entered.		

AT&C Set circuit Data Carrier Detect (DCD) function mode					
Set command AT&C[<value>]	<p>Response</p> <p>This parameter determines how the state of circuit 109 (DCD) relates to the detection of received line signal from the distant end.</p> <p>OK</p> <p>Parameter <value></p> <table> <tr> <td>0</td> <td>DCD line is always ON</td> </tr> <tr> <td>1</td> <td>DCD line is ON only in the presence of data carrier</td> </tr> </table>	0	DCD line is always ON	1	DCD line is ON only in the presence of data carrier
0	DCD line is always ON				
1	DCD line is ON only in the presence of data carrier				
Reference V.25ter	Note				

AT&D Set circuit Data Terminal Ready (DTR) function mode										
Set command AT&D[<value>]	<p>Response</p> <p>This parameter determines how the TA responds when circuit 108/2 (DTR) is changed from ON to OFF during data mode.</p> <p>OK</p> <p>Parameter</p> <table> <tr> <td><value></td> <td>0</td> <td>TA ignores status on DTR</td> </tr> <tr> <td></td> <td>1</td> <td>ON->OFF on DTR: change to command mode while retaining the connected call</td> </tr> <tr> <td></td> <td>2</td> <td>ON->OFF on DTR: disconnect call, change to command mode. During DTR state = OFF is auto-answer off.</td> </tr> </table>	<value>	0	TA ignores status on DTR		1	ON->OFF on DTR: change to command mode while retaining the connected call		2	ON->OFF on DTR: disconnect call, change to command mode. During DTR state = OFF is auto-answer off.
<value>	0	TA ignores status on DTR								
	1	ON->OFF on DTR: change to command mode while retaining the connected call								
	2	ON->OFF on DTR: disconnect call, change to command mode. During DTR state = OFF is auto-answer off.								
Reference V.25ter	Note M1: <value> 0-3									

AT&F Set all current parameters to manufacturer defaults				
Execute command AT&F[<value>]	<p>Response</p> <p>TA sets all current parameters to the manufacturer defined profile.</p> <p>Note: 1) When using AT&F(CR) alone a delay of 300ms needed before next command (AT...) is sent. Otherwise "OK" response may be corrupted.</p> <p>2) No restrictions of use of "&F" within a command string. (e.g.: AT&Fs0=1&W+cbst=7,0,1)</p> <p>3) A delay of 300ms is needed before next command ist sent, otherwise "OK" response may be corrupted.</p> <p>OK</p> <p>Parameter</p> <table> <tr> <td><value></td> <td>0</td> <td>set all TA parameters to manufacturer defaults</td> </tr> </table>	<value>	0	set all TA parameters to manufacturer defaults
<value>	0	set all TA parameters to manufacturer defaults		
Reference V.25ter	Note There has to be a pause of at least 300ms after the OK, before the next command is entered.			

AT&S Set circuit Data Set Ready (DSR) function mode							
Set command AT&S<value>	<p>Response</p> <p>This parameter determines how the TA sets circuit 107 (DSR) depending on the communication state of the TA interfacing TE.</p> <p>OK</p> <p>Parameter</p> <table> <tr> <td><value></td> <td>0</td> <td>DSR always on</td> </tr> <tr> <td></td> <td>1</td> <td>TA in command mode: DSR is OFF TA in data mode: DSR is ON</td> </tr> </table>	<value>	0	DSR always on		1	TA in command mode: DSR is OFF TA in data mode: DSR is ON
<value>	0	DSR always on					
	1	TA in command mode: DSR is OFF TA in data mode: DSR is ON					
Reference V.25ter, +IDSR	Note						

AT&V	Display current configuration
Execute command AT&V[<n>]	Response TA returns the current parameter setting. ACTIVE PROFILE : E1 L0 M0 Q0 V1 X4; S0:1 S2:43 S3:13 S4:10 S5:8 S6:2 S7:60 S8:2 S10:15 S12:10 S13:60 S1:0 +CBST: 7,0,1 +CRLP: 61,61,48,6,1,3 +CRC: 0 +CR: 1 +FCLASS: 0 +IFC: 2,2 +ICF: 3,3 +DR: 1 +CMGF: 0 +CSDH: 1 +CNMI: 2,1,0,0,0 +ILRR: 0 +IPR: 19200 +DS: 0,0,512,6 +CMEE: 2 ^SMGO: 0 +CSMS: 0 ^SACM: 0 ^SCKS: 0 +CREG: 2 +CCUG: 0,0,0 +CLIP: 0 +COLP: 0 +CCWA: 0 +CAOC: 1 +CLIR: 0 +COPS: 0 OK Parameter <n> 0 profile number
Reference	Note

AT&W	Store current parameter to user defined profile
Execute command AT&W[<n>]	Response TA stores the current parameter setting in the user-defined profile. <u>Note!</u> : the user defined profile is stored in non-volatile memory. OK Parameter <n> 0 profile number to store to
Reference	Note

AT&Z Store telephone number in SIM fixdialling memory "FD"	
Execute command AT&Z<n>=<x>	<p>Response</p> <p>TA stores a dial string in ME non volatile memory "ME" at memory index <n>. Only digits and the characters "i" and "+" are stored.</p> <p>OK</p> <p>If error is related to ME functionality:</p> <p>+CME ERROR: <err></p> <p>Parameter</p> <p><n> memory index</p> <p><x> [+]<d> phone number string with maximum 20 characters</p> <p>+ international dialling format</p> <p><d> ISDN number string of digits: +, 0-9, A, B, C</p>
Reference Siemens	Note A non leading + will not be stored, Letter A will be changed to + (A → +)

AT%D Automatic dialling phone number in mem. "ME" index "1" with DTR	
Execute command AT%D<n>[:;]	<p>Response</p> <p>TA attempts to set up an outgoing call to stored number.</p> <p>TA reads the phone number in "ME" memory with index "1" and calls this number.</p> <p>If no dialtone and (parameter setting X=2 or X=4)</p> <p>NO DIALTONE</p> <p>If busy and (parameter setting X=3 or X=4)</p> <p>BUSY</p> <p>If a connection cannot be set up</p> <p>NO CARRIER</p> <p>If successfully connected and non-voice call</p> <p>CONNECT<text> <i>Note:</i> <text> only if parameter setting X>0</p> <p>TA switches to data state.</p> <p>When TA returns to command mode after call release</p> <p>OK</p> <p>If successfully connected and voice call</p> <p>OK</p> <p>Parameter</p> <p><n> 0 TA ignores status on DTR</p> <p> 1 OFF->ON on DTR: TA dials telephone number in memory '1'</p>
Reference Siemens	Note

AT+DR		V.42bis data compression reporting control	
Test command AT+DR=?	Response +DR: (list of supported <value>s) OK	Parameter see set command	
Read command AT+DR?	Response +DR: <value> OK	Parameter see set command	
Set command AT+DR=<value>	Response This parameter setting determines whether or not the intermediate result code of the current data compression is reported by TA to TE after a connection setup. OK	Parameter <value> 0 reporting disabled 1 reporting enabled	
	Intermediate result code +DR: <type> <i>Note:</i> reported at call setup	Parameter <type> NONE data compression is not in use V42B Rec. V42bis is in use in both directions B42B RD Rec. V42bis is in use in receive direction only B42B TD Rec. V42bis is in use in transmit direction only	
Reference V.25ter	Note		

AT+DS V.42bis data compression control																									
Test command AT+DS=?	Response +DS: (list of supported <p0>s), (list of supported <n>s), (list of supported <p1>s), (list of supported <p2>s) OK Parameter see set command																								
Read command AT+DS?	Response +DR: <p0>,<n>,<p1>,<p2> OK Parameter see set command																								
Set command AT+DS=[<p0>[,<n>[,<p1>[,<p2>]]]]	Response This parameter setting determines the possible data compression mode by TA at the compression negotiation with the remote TA after call setup. <u>Note1:</u> only for data call <u>Note2:</u> GSM transmits the data transparent. The remote TA may support this compression. OK Parameter <u>Note:</u> see also ITU V.42bis <table border="0"> <tr> <td><p0></td> <td>0</td> <td>NONE</td> </tr> <tr> <td></td> <td>1</td> <td>transmit only</td> </tr> <tr> <td></td> <td>2</td> <td>receive only</td> </tr> <tr> <td></td> <td>3</td> <td>both directions, but allow negotiation</td> </tr> <tr> <td><n></td> <td>0</td> <td>allow negotiation of p0 down</td> </tr> <tr> <td></td> <td>1</td> <td>do not allow negotiation of p0 – disconnect on difference</td> </tr> <tr> <td><p1></td> <td>512-1024</td> <td>dictionary size</td> </tr> <tr> <td><p2></td> <td>6-64</td> <td>maximum string size</td> </tr> </table> <u>Note:</u> default determined by manufacturer	<p0>	0	NONE		1	transmit only		2	receive only		3	both directions, but allow negotiation	<n>	0	allow negotiation of p0 down		1	do not allow negotiation of p0 – disconnect on difference	<p1>	512-1024	dictionary size	<p2>	6-64	maximum string size
<p0>	0	NONE																							
	1	transmit only																							
	2	receive only																							
	3	both directions, but allow negotiation																							
<n>	0	allow negotiation of p0 down																							
	1	do not allow negotiation of p0 – disconnect on difference																							
<p1>	512-1024	dictionary size																							
<p2>	6-64	maximum string size																							
Reference V.25ter	Note Functionality depends on network																								

AT+GCAP Request complete TA capabilities list	
Test command AT+GCAP=?	Response OK Parameter
Execute command AT+GCAP	Response TA reports a list of additional capabilities. +GCAP: <name> OK Parameter <name> e.g.: +CGSM, +FCLASS, +DS, +DR
Reference V.25ter	Note

AT+GMI Request manufacturer identification	
Test command AT+GMI=?	Response OK Parameter
Execute command AT+GMI	Response TA reports one or more lines of information text which permit the user to identify the manufacturer. SIEMENS OK Parameter
Reference V.25ter	Note <i>See also "AT+CGMI Request manufacturer identification".</i>

AT+GMM Request TA model identification	
Test command AT+GMM=?	Response OK Parameter
Execute command AT+GMM	TA reports one or more lines of information text which permit the user to identify the specific model of device. M20 OK Parameter
Reference V.25ter	Note <i>See also "AT+CGMM Request model identification".</i>

AT+GMR Request TA revision identification of software status	
Test command AT+GMR=?	Response OK
Execute command AT+GMR	Response TA reports one or more lines of information text which permit the user to identify the version, revision level or data or other device information. Revision x.yy OK Parameter
Reference V.25ter	Note <i>See also "AT+CGMR Request revision identification of software status".</i>

AT+GOI Request global object identification	
Test command AT+GOI=?	Response OK
Execute command AT+GOI	Response TA reports one or more lines of information text which permit the user to identify the device, based on the ISO system for registering unique object identifiers. Cellular Engine Siemens M20 OK Parameter
Reference V.25ter	Note

AT+GSN Request TA serial number identification	
Test command AT+GSN=?	Response OK
Execute command AT+GSN	Response TA reports one or more lines of information text which permit the user to identify the individual device. <serial number id> OK Parameter <sn> IMEI of the telephone (International Mobile station Equipment Identity)
Reference V.25ter	Note The serial number (IMEI) is different for individual ME devices.

AT+ICF Set TE-TA control character framing	
Test command AT+ICF=?	Response +ICF: (list of supported <format>s), (list of supported <parity>s) OK Parameter see set command
Read command AT+ICF?	Response +ICF: <format>,<parity> OK Note: framing is applied for command state Parameter see set command
Set command AT+ICF= [<format>, [<parity>]]	Response This parameter setting determines the serial interface character framing format and parity received by TA from TE. OK Parameter Note: the parity field is ignored if the format field specifies no parity. <format> 1 8 data 0 parity 2 stop 2 8 data 1 parity 1 stop 3 8 data 0 parity 1 stop 4 7 data 0 parity 2 stop 5 7 data 1 parity 1 stop 6 7 data 0 parity 1 stop <parity> 0 odd 1 even 2 mark (1) 3 space (0) Note: if <format>=2 , the parity bit will not be transported on the radio path
Reference V.25ter	Note There has to be a pause of at least 300ms after the OK, before the next command is entered.

AT+IFC Set TE-TA local data flow control	
Test command AT+IFC=?	Response +IFC: (list of supported <dce_by_dte>s), (list of supported <dte_by_dce>s) OK Parameter see set command
Read command AT+IFC?	Response +IFC: <dce_by_dte>,<dte_by_dce> OK <i>Note:</i> This flow control is applied for data mode Parameter see set command
Set command AT+IFC=[<dce_by_dte>[,<dte_by_dce>]]	Response This parameter setting determines the data flow control on the serial interface for data mode. OK Parameter <dce_by_dte> specifies the method which will be used by TE when data is received from TA <ul style="list-style-type: none"> 0 None 1 XON/XOFF, don't pass characters on to data stack <u>2</u> line 133: ready for receiving 3 XON/XOFF, pass characters on to data stack <dte_by_dce> specifies the method which will be used by TA when data is received from TE <ul style="list-style-type: none"> 0 None 1 XON/XOFF <u>2</u> line 106: clear to send (CTS)
Reference V.25ter	Note There are no pins for line 133 at AD6426. TTP applies line 105 (RTS) for this method.

AT+ILRR Set TE-TA local rate reporting mode	
Test command AT+ILRR=?	Response +ILRR: (list of supported <value>s) OK Parameter see set command
Read command AT+ILRR?	Response +ILRR: <value> OK Parameter see set command
Set command AT+ILRR= <value>	Response This parameter setting determines whether or not an intermediate result code of local rate is reported at connection setup. The rate is applied after the final result code of the connection is transmitted to TE. OK Parameter <value> 0 Disables reporting of local port rate 1 Enables reporting of local port rate
	Intermediate result +ILRR:<rate> <i>Note:</i> It indicates port rate settings on connection. Parameter <rate> port rate setting on call connection in bauds per second 300 1200 2400 4800 9600 <u>19200</u> 28800 38400 57600
Reference V.25ter	Note

AT+IPR Set fixed local rate	
Test command AT+IPR=?	Response +IPR: (list of supported auto-detectable <rate>s), (list of supported fixed-only <rate>s) OK Parameter see set command <i>Note:</i>)1) M20 has no Autobauding, therefore only the second list is presented. 2) When using AT+IPR=x(CR) alone a delay of 300ms needed before next command (AT...) is sent. Otherwise "OK" response may be corrupted. 3) No restrictions of use of "+IPR=x" within a command string. (e.g.: AT&Fs0=1+ipr=9600&W+cbst=7,0,1)
Read command AT+IPR?	Response +IPR: <rate> OK Parameter see set command
Set command AT+IPR=<rate>	Response This parameter setting determines the data rate of the TA on the serial interface. TA must also accept the following minimum rates from TE in command mode only: 1200 bit/s and 9600 bit/s. The rate of command takes effect following the issue of any result code associated with the current command line. OK Parameter <rate> baud rate per second 300 1200 2400 4800 9600 <u>19200</u> 28800 38400 57600
Reference V.25ter	Note M20 has standard 19200 baud connection. No autobauding available. There has to be a pause of at least 300ms after the OK, before the next command is entered.

5.4 AT commands and responses to GSM 07.07 and GSM 07.05

Test command	AT+CXXX=?	The mobile equipment returns the list of parameters and value ranges set with the corresponding set command or by internal processes.
Read command	AT+CXXX?	This command returns the currently set value of the parameter or parameters
Set command	AT+CXXX=<...>	This command sets user-definable parameter values.
Execution command	AT+CXXX	The execution command reads non-variable parameters affected by internal processes in the telephone.

5.5 AT Cellular commands to GSM 07.07

5.5.1 List of commands

Commands according to GSM 07.07	Function	
AT+CACM	Accumulated call meter (ACM) reset or query	Page 56
AT+CAMM	Accumulated call meter maximum (ACMmax) set or query	Page 57
AT+CAOC	Advice of Charge information	Page 58
AT+CBC	Battery charge	Page 58
AT+CBST	Select bearer service type	Page 59
AT+CCFC	Call forwarding number and conditions control	Page 60
AT+CCUG	Closed user group control	Page 61
AT+CCWA	Call waiting control	Page 62
AT+CEER	Extended error report	Page 63
AT+CGMI	Request manufacturer identification	Page 63
AT+CGMM	Request model identification	Page 63
AT+CGMR	Request revision identification of software status	Page 63
AT+CGSN	Request product serial number identification (IMEI)	Page 64
AT+CHLD	Call hold and multiparty	Page 64
AT+CHUP	Hang up call	Page 64
AT+CIMI	Request international mobile subscriber identity	Page 65
AT+CLCC	List current calls of ME	Page 65
AT+CLCK	Facility lock	Page 66
AT+CLIP	Calling line identification presentation	Page 67
AT+CLIR	Calling line identification restriction	Page 68
AT+CMEE	Report mobile equipment error	Page 68
AT+COLP	Connected line identification presentation	Page 69
AT+COPS	Operator selection	Page 70
AT+CPAS	Mobile equipment activity status	Page 71
AT+CPBF	Find phonebook entries	Page 71
AT+CPBR	Read current phonebook entries	Page 72
AT+CPBS	Select phonebook memory storage	Page 74
AT+CPBW	Write phonebook entry	Page 76
AT+CPIN	Enter PIN	Page 77
AT+CPIN2	Enter PIN2	Page 78
AT+CPUC	Price per unit and currency table	Page 80
AT+CPWD	Change password	Page 79
AT+CR	Service reporting control	Page 83
AT+CRC	Set cellular result codes for incoming call indication	Page 82
AT+CREG	Network registration	Page 84
AT+CRLP	Select radio link protocol param. for orig. non-transparent data call	Page 87
AT+CRSM	Restricted SIM access	Page 85
AT+CSCS	Select TE character set.	Page 86
AT+CSQ	Signal quality	Page 87
AT+CUSD	Unstructured supplementary service data	Page 88
AT+FCLASS	FAX: select, read or test service class	Page 89

AT+FMI	FAX: report manufactured ID	<i>Page 89</i>
AT+FMM	FAX: report model ID	<i>Page 89</i>
AT+FMR	FAX: report revision ID	<i>Page 90</i>
AT+VGR	Receive gain selection of speaker	<i>Page 90</i>
AT+VGT	Transmit gain selection of microphone	<i>Page 91</i>
AT+VIP	Initialize voice parameters	<i>Page 91</i>
AT+VTS	DTMF and tone generation	<i>Page 92</i>

Table 5-2 AT commands according to GSM 07.07

5.5.2 Detailed description

AT+CACM Accumulated call meter (ACM) reset or query	
Test command AT+CACM=?	Response OK Parameter
Read command AT+CACM?	Response TA returns the current ACM value. +CACM: <acm> OK If error is related to ME functionality: +CME ERROR: <err> Parameter <acm> string type; three bytes of the current ACM value in hexadecimal format (e.g. "00001E" indicates decimal value 30) 000000–FFFFFF
Set command AT+CACM= [<passwd>]	Parameter <passwd> string type: SIM PIN2 Response TA resets the Advice of Charge related to the accumulated call meter (ACM) value in SIM file EF(ACM). ACM contains the total number of home units for both the current and preceding calls. OK If error is related to ME functionality: +CME ERROR: <err>
Reference GSM 07.07	Note

AT+CAMM		Accumulated call meter maximum (ACMmax) set or query	
Test command AT+CAMM=?	Response OK Parameter		
Read command AT+CAMM?	Response TA returns the current ACMmax value. +CAMM: <acmmax> OK If error is related to ME functionality: +CME ERROR: <err> Parameter see set command		
Set command AT+CAMM=[<acmmax>[,<passwd>]]	Response TA sets the Advice of Charge related to the accumulated call meter maximum value in SIM file EF (ACMmax). ACMmax contains the maximum number of home units allowed to be consumed by the subscriber. OK If error is related to ME functionality: +CME ERROR: <err> Parameter <acmmax> string type; three bytes of the max. ACM value in hexadecimal format (e.g. "00001E" indicates decimal value 30) 000000 disable ACMmax feature 000001-FFFFFF <passwd> string type SIM PIN2		
Reference GSM 07.07	Note		

AT+CAOC		Advice of Charge information	
Test command AT+CAOC=?	Response +CAOC: list of supported <mode>s OK	Parameter see execute command	
Read command AT+CAOC?	Response +CAOC: <mode> OK	Parameter see execute command	
Execute command AT+CAOC= <mode>	Response TA sets the Advice of Charge supplementary service function mode. If error is related to ME functionality: +CME ERROR: <err> If <mode>=0, TA returns the current call meter (CCM) value +CAOC: <ccm> OK If <mode>=1, TA deactivates the unsolicited reporting of CCM value OK If <mode>=2, TA activates the unsolicited reporting of CCM value OK	Parameter <mode> 0 query CCM value 1 deactivate the unsolicited reporting of CCM value 2 activate the unsolicited reporting of CCM value <ccm> string type; three bytes of the current CCM value in hexadecimal format (e.g. "00001E" indicates decimal value 30); bytes are similarly coded as ACMmax value in the SIM 000000-FFFFFF	
Action command AT+CAOC	Response TA returns the current call meter value (same as AT+CAOC=0)		
	Unsolicited result code When activated, an unsolicited result code is sent when the CCM value changes, but not more than every 10 seconds +CCCM: <ccm>	Parameter see execute command	
Reference GSM 07.07	Note		

AT+CBC		Battery charge	
Test command AT+CBC=?	Response +CBC: (list of supported <bcs>s), (list of supported <bcl>s) OK		
Execute command AT+CBC	Response TA returns battery connection status <bcs> and battery charge level <bcl>. +CBC: <bcs>,<bcl> OK	Parameter <bcs> 0 ME is powered by the battery 1 ME has a battery connected, but is not powered by it <bcl> 0 battery is exhausted. 100 battery has full capacity remaining	
Reference GSM 07.07	Note The error only occurs, if there is a voltage higher than 1,3V on both inputs GPIO0 und GPIO1 at the same time.		

AT+CBST		Select Bearer Service Type																																														
Test command AT+CBST=?	Response +CBST: (list of supported <speed>s), (list of supported <name>s), (list of supported <ce>s)	Parameter	see set command																																													
Read command AT+CBST?	Response +CBST: <speed>,<name>,<ce>	OK	Parameter see set command																																													
Set command AT+CBST= [<speed>] [<name> <ce>]]	Response TA selects the bearer service <name> with data rate <speed>, and the connection element <ce> to be used when data calls are originated. Values may also be used during mobile terminated data call setup, especially in case of single numbering scheme calls (refer +CSNS).	OK	Parameter																																													
	<table border="0"> <tr> <td><speed></td> <td>1</td> <td>300 bps(V.21)</td> </tr> <tr> <td></td> <td>2</td> <td>1200 bps(V.22)</td> </tr> <tr> <td></td> <td>3</td> <td>1200/75 bps(V.23)</td> </tr> <tr> <td></td> <td>4</td> <td>2400 bps(V.22bis)</td> </tr> <tr> <td></td> <td>5</td> <td>2400 bps(V.26ter)</td> </tr> <tr> <td></td> <td>6</td> <td>4800 bps(V.32)</td> </tr> <tr> <td></td> <td>7</td> <td>9600 bps(V.32)</td> </tr> <tr> <td></td> <td>65</td> <td>300 bps (V.110)</td> </tr> <tr> <td></td> <td>66</td> <td>1200 bps (V.110)</td> </tr> <tr> <td></td> <td>68</td> <td>2400 bps(V.110)</td> </tr> <tr> <td></td> <td>70</td> <td>4800 bps(V.110)</td> </tr> <tr> <td></td> <td>71</td> <td>9600 bps(V.110)</td> </tr> <tr> <td><name></td> <td>0</td> <td>asynchronous modem</td> </tr> <tr> <td><ce></td> <td>0</td> <td>transparent</td> </tr> <tr> <td></td> <td>1</td> <td>non-transparent</td> </tr> </table>	<speed>	1	300 bps(V.21)		2	1200 bps(V.22)		3	1200/75 bps(V.23)		4	2400 bps(V.22bis)		5	2400 bps(V.26ter)		6	4800 bps(V.32)		7	9600 bps(V.32)		65	300 bps (V.110)		66	1200 bps (V.110)		68	2400 bps(V.110)		70	4800 bps(V.110)		71	9600 bps(V.110)	<name>	0	asynchronous modem	<ce>	0	transparent		1	non-transparent		
<speed>	1	300 bps(V.21)																																														
	2	1200 bps(V.22)																																														
	3	1200/75 bps(V.23)																																														
	4	2400 bps(V.22bis)																																														
	5	2400 bps(V.26ter)																																														
	6	4800 bps(V.32)																																														
	7	9600 bps(V.32)																																														
	65	300 bps (V.110)																																														
	66	1200 bps (V.110)																																														
	68	2400 bps(V.110)																																														
	70	4800 bps(V.110)																																														
	71	9600 bps(V.110)																																														
<name>	0	asynchronous modem																																														
<ce>	0	transparent																																														
	1	non-transparent																																														
Reference GSM 07.07	Note GSM 02.02[1]: list of allowed combinations of the subparameters. The PLMN influences the second air interface (to the terminator), therefore another mode may be established from the network.																																															

AT+CCFC	Call forwarding number and conditions control
Test command AT+CCFC=?	Response +CCFC: (list of supported <reas>s) OK Parameter see execute command
Execute command AT+CCFC = <reas>, <mode> [, <number> [, <type> > [, <class> [, <subaddr> [, <satype> > [, <time>]]]]]	Response TA controls the call forwarding supplementary service. Registration, erasure, activation, deactivation, and status query are supported. When querying the status of a network service (<mode>=2) the response line for 'not active' (<status>=0) should be returned only if service is not active for any <class>. If <mode><>2 and command successful OK If <mode>=2 and command successful (only in connection with <reas> 0-3) +CCFC: <status>, <class1>[, <number>, <type> [, <time>]] [<CR><LF>+CCFC:...] OK If error is related to ME functionality: +CME ERROR: <err> Parameter <reas> 0 unconditional 1 mobile busy 2 no reply 3 not reachable 4 all call forwarding (0-3) 5 all conditional call forwarding (1-3) <mode> 0 disable 1 enable 2 query status 3 registration 4 erasure <number> string type phone number of forwarding address in format specified by <type> <type> type of address in integer format; default 145 when dialling string includes international access code character "+", otherwise 129 <subaddr> string type subaddress of format specified by <satype> <satype> type of subaddress in integer; default 128 <class> 1 voice 2 data 4 fax 7 all classes <time> time to wait before call is forwarded, rounded to a multiple of 5 sec. Default is 20. 1...20...30 (only for <reas> = no reply) <status> 0 not active 1 active
Reference GSM 07.07	Note If status is "not active", then parameter class can be ignored (0)

AT+CCUG Closed user group control																									
Test command AT+CCUG=?	Response OK Parameter																								
Read command AT+CCUG?	Response +CCUG: <n>,<index>,<info> OK If error is related to ME functionality: +CME ERROR: <err> Parameter see set command																								
Set command AT+CCUG=[<n>] [,<index>[,<info>]]	Response TA sets the closed user group supplementary service parameters as a default adjustment for all following calls. OK Parameter <table border="0"> <tr> <td><n></td> <td><u>0</u></td> <td>disable CUG</td> </tr> <tr> <td></td> <td>1</td> <td>enable CUG</td> </tr> <tr> <td><index></td> <td><u>0...9</u></td> <td>CUG index</td> </tr> <tr> <td></td> <td>10</td> <td>no index (preferred CUG taken from subscriber data)</td> </tr> <tr> <td><info></td> <td><u>0</u></td> <td>no information</td> </tr> <tr> <td></td> <td>1</td> <td>suppress OA (Outgoing Access)</td> </tr> <tr> <td></td> <td>2</td> <td>suppress preferential CUG</td> </tr> <tr> <td></td> <td>3</td> <td>suppress OA and preferential CUG</td> </tr> </table>	<n>	<u>0</u>	disable CUG		1	enable CUG	<index>	<u>0...9</u>	CUG index		10	no index (preferred CUG taken from subscriber data)	<info>	<u>0</u>	no information		1	suppress OA (Outgoing Access)		2	suppress preferential CUG		3	suppress OA and preferential CUG
<n>	<u>0</u>	disable CUG																							
	1	enable CUG																							
<index>	<u>0...9</u>	CUG index																							
	10	no index (preferred CUG taken from subscriber data)																							
<info>	<u>0</u>	no information																							
	1	suppress OA (Outgoing Access)																							
	2	suppress preferential CUG																							
	3	suppress OA and preferential CUG																							
Reference GSM 07.07	Note																								

AT+CEER Extended error report	
Test command AT+CEER=?	Response OK
Execute command AT+CEER	Response TA returns an extended report of the reason for the last call release. +CEER: <report> OK Parameter <report> Reason for last call release as number code
Reference GSM 07.07	Note

AT+CGMI Request manufacturer identification	
Test command AT+CGMI=?	Response OK
Execute command AT+CGMI	Response TA returns manufacturer identification text. SIEMENS Parameter <manufacturer>
Reference GSM 07.07	Note <i>See also "AT+GMI Request manufacturer identification".</i>

AT+CGMM Request model identification	
Test command AT+CGMM=?	Response OK
Execute command AT+CGMM	Response TA returns product model identification text. M20 OK Parameter <model>
Reference GSM 07.07	Note <i>See also "AT+GMM Request TA model identification".</i>

AT+CGMR Request revision identification of software status	
Test command AT+CGMR=?	Response OK
Execute command AT+CGMR	Response TA returns product software version identification text. <revision> x.yy OK Parameter Revision x: version, yy: variant of software
Reference GSM 07.07	Note <i>See also "AT+GMR Request TA revision identification of software status".</i>

AT+CGSN Request product serial number identification (IMEI) identical to GSN	
Test command AT+CGSN=?	Response OK
Execute command AT+CGSN	Response TA returns identification text for determination of the individual ME. <sn> OK Parameter <sn> IMEI of the telephone (International Mobile station Equipment Identity)
Reference GSM 07.07	Note <i>See also "AT+GSN Request TA serial number identification".</i>

AT+CHLD Call hold and multiparty													
Test command AT+CHLD=?	Response +CHLD: list of supported <n>s OK												
Execute command AT+CHLD=[<n>]	Response TA controls the supplementary services Call Hold, MultiParty and Explicit Call Transfer. Calls can be put on hold, recovered, released, added to conversation, and transferred. Note: the supplementary services are only applicable to teleservice 11 (Speech telephony). OK If error is related to ME functionality: +CME ERROR: <err> Parameter <n> <table border="0"> <tr> <td>0</td> <td>Terminate all held calls or UDUB (User Determined User Busy) for a waiting call</td> </tr> <tr> <td>1</td> <td>Terminate all active calls (if any) and accept the other call (waiting call or held call)</td> </tr> <tr> <td>1X</td> <td>Terminate the active call number X (X= 1-7)</td> </tr> <tr> <td>2</td> <td>Place all active calls on hold (if any) and accept the other call (waiting call or held call) as the active call</td> </tr> <tr> <td>2X</td> <td>Place all active calls except call X (X= 1-7) on hold</td> </tr> <tr> <td>3</td> <td>Add the held call to the active calls</td> </tr> </table> Note: 1) Where both are held and a waiting call exists, the above procedures shall apply to the waiting call (i.e. not to the held call) in conflicting situation. 2) The full amount of the functions described above depends on the network supplier.	0	Terminate all held calls or UDUB (User Determined User Busy) for a waiting call	1	Terminate all active calls (if any) and accept the other call (waiting call or held call)	1X	Terminate the active call number X (X= 1-7)	2	Place all active calls on hold (if any) and accept the other call (waiting call or held call) as the active call	2X	Place all active calls except call X (X= 1-7) on hold	3	Add the held call to the active calls
0	Terminate all held calls or UDUB (User Determined User Busy) for a waiting call												
1	Terminate all active calls (if any) and accept the other call (waiting call or held call)												
1X	Terminate the active call number X (X= 1-7)												
2	Place all active calls on hold (if any) and accept the other call (waiting call or held call) as the active call												
2X	Place all active calls except call X (X= 1-7) on hold												
3	Add the held call to the active calls												
Reference GSM 07.07	Note												

AT+CHUP Hang up call	
Test command AT+CHUP=?	Response OK
Execute command AT+CHUP	Response OK/ERROR All active calls and held calls are cleared down.
Reference GSM 07.07	Note

AT+CIMI Request international mobile subscriber identity	
Test command AT+CIMI=?	Response OK
Execute command AT+CIMI	Response TA returns <IMSI> for identifying the individual SIM which is attached to ME. <IMSI> OK If error is related to ME functionality: +CME ERROR: <err> Parameter <IMSI> International Mobile Subscriber Identity (string without double quotes)
Reference GSM 07.07	Note

AT+CLCC List current calls of ME	
Test command AT+CLCC=?	Response OK Parameter
Execute command AT+CLCC	Response TA returns a list of current calls of ME. Note: if command succeeds but no calls are available, no information response is sent to TE. [+CLCC: <id1>,<dir>,<stat>,<mode>,<mpty>[,<number>,<type>[,<alpha>]]][<CR><LF>+CLCC: <id2>,<dir>,<stat>,<mode>,<mpty>[,<number>,<type>[,<alpha>]]][...]] OK If error is related to ME functionality: +CME ERROR: <err> Parameter <idx> integer type; call identification number as described in GSM 02.30[19] subclause 4.5.5.1; this number can be used in +CHLD command operations <dir> 0 mobile originated (MO) call 1 mobile terminated (MT) call <stat> state of the call: 0 active 1 held 2 dialling (MO call) 3 alerting (MO call) 4 incoming (MT call) 5 waiting (MT call) <mode> bearer/teleservice: 0 voice 1 data 2 fax 9 unknown <mpty> 0 call is not one of multiparty (conference) call parties 1 call is one of multiparty (conference) call parties <number> string type phone number in format specified by <type> <type> type of address octet in integer format; 145 when dialling string includes international access code character "+", otherwise 129 <alpha> string type alphanumeric representation of <number> corresponding to the entry found in phonebook
Reference GSM 07.07	Note

AT+CLCK	Facility lock
Test command AT+CLCK=?	Response +CLCK: (list of supported <fac>s) OK Parameter see execute command
Execute command AT+CLCK = <fac>, <mode> [, <passwd> [, <class>]]	Response This command is used to lock, unlock or interrogate a ME or a network facility <fac>. Password is normally needed for such actions. When querying the status of a network service (<mode>=2) the response line for 'not active' case (<status>=0) should be returned only if service is not active for any <class>. It should be possible to abort the command when network facilities are set or interrogated. If <mode><>2 and command is successful OK If <mode>=2 and command is successful +CLCK: <status>[, <class1>[<CR><LF> +CLCK: <status>, class2....]] OK If error is related to ME functionality: +CME ERROR: <err> Parameter <fac> "PS" PH-SIM (lock PHone to SIM card) (ME requests password when other than current SIM card inserted; ME may remember certain number of previously used cards thus not requiring password when they are inserted) "SC" SIM (lock SIM cards) (SIM requests password at ME power-up and when this lock command issued) "FD" SIM fixed dialling memory feature (if PIN2 authentication has not been performed during the current session, PIN2 is required as <passwd>) "AO" BAO (Bar All Outgoing Calls) "OI" BOIC (Bar Outgoing International Calls) "OX" BOIC-exHC (Bar Outgoing International Calls except to Home Country) "AI" BAIC (Bar All Incoming Calls) "IR" BIC-Roam (Bar Incoming Calls when Roaming outside the home country) "AB" All Barring services (applicable only for <mode>=0) "AG" All outGOing barring services (applicable only for <mode>=0) "AC" All inCOMing barring services (applicable only for <mode>=0) "PN" Network Personalisation (refer GSM 02.22[33]) "PU" network sUbset Personalisation (refer GSM 02.22[33]) "PP" service Provider Personalisation (refer GSM 02.22[33]) "PC" Corporate Personalisation (refer GSM 02.22[33]) <mode> 0 unlock 1 lock 2 query status <passwd> password if <fac> = "PS" then user password if <fac> = "SC" then PIN if <fac> = "FD" then PIN2 if <fac> = "AO"... "AC" (Barring) then Network password if <fac> = "PN"... "PC" then user password <class> 1 voice 2 data 4 fax 7 voice, data and fax 8 SMS 16 Data (all sync services) <u>Note:</u> If <class> is omitted, all possible classes (depending on the network provider) are locked or unlocked. E.g. AT+CLCK="AO",1,"xxxx" <status> 0 off 1 on
Reference GSM 07.07	Note

AT+CLIP		Calling line identification presentation	
Test command AT+CLIP=?	Response +CLIP: (list of supported <n>s) OK	Parameter see set command	
Read command AT+CLIP?	Response +CLIP: <n>, <m> OK	If error is related to ME functionality: +CME ERROR: <err>	Parameter see set command
Set command AT+CLIP=<n>	Response TA enables or disables the presentation of the CLI at the TE. It has no effect on the execution of the supplementary service CLIP in the network. OK	Parameter <n> 0 suppress unsolicited result codes 1 display unsolicited result codes <m> 0 CLIP not provisioned 1 CLIP provisioned 2 unknown	
	Unsolicited result code When CLIP is enabled at the TE (and is permitted by the calling subscriber), an unsolicited result code is returned after every RING (or +CRING: <type>) at a mobile terminating call. +CLIP: <number>, <type> <i>Note:</i> 4 different cases for +CLIP: +CLIP: "number", <type> +CLIP: "number pres restricted", <type> +CLIP: "number not available", <type> (provider specific) +CLIP: "", <type> (provider specific)	Parameter <number> string type phone number of calling address in format specified by <type> <type> type of address octet in integer format; 145 when dialling string includes international access code character "+", otherwise 129.	
Reference GSM 07.07	Note		

AT+CLIR Calling line identification restriction	
Test command AT+CLIR=?	Response +CLIR: (list of supported <n>s) OK Parameter see set command
Read command AT+CLIR?	Response +CLIR: <n>, <m> OK If error is related to ME functionality: +CME ERROR: <err> Parameter see set command
Set command AT+CLIR=[<n>]	Response TA restricts or enables the presentation of the CLI to the called party when originating a call. The command overrides the CLIR subscription (default is restricted or allowed) when temporary mode is provisioned as a default adjustment for all following outgoing calls. This adjustment can be revoked by using the opposite command. OK Parameter <n> (parameter sets the adjustment for outgoing calls): 0 presentation indicator is used according to the subscription of the CLIR service 1 CLIR invocation 2 CLIR suppression <m> (parameter shows the subscriber CLIR service status in the network): 0 CLIR not provisioned 1 CLIR provisioned in permanent mode 2 unknown (e.g. no network, etc.) 3 CLIR temporary mode presentation restricted 4 CLIR temporary mode presentation allowed
Reference GSM 07.07	Note If other party sets CLIR then the M20 replies with +CLIP: number presentation restricted .

AT+CMEE Report mobile equipment error	
Test command AT+CMEE=?	Response +CMEE: (list of supported <n>s) OK Parameter see set command
Read command AT+CMEE?	Response +CMEE: <n> OK Parameter see set command
Set command AT+CMEE=<n>	Response TA disables or enables the use of result code +CME ERROR: <err> as an indication of an error relating to ME functionality. OK Parameter <n> 0 disable result code 1 enable result code and use numeric values 2 enable result code and use verbose values
Reference GSM 07.07	Note The possible error result codes are listed in chapter 5.9.2.

AT+COLP	Connected line identification presentation
Test command AT+COLP=?	Response +COLP: (list of supported <n>s) OK Parameter see set command
Read command AT+COLP?	Response +COLP: <n>,<m> OK Parameter see set command
Set command AT+COLP=[<n>]	TA enables or disables the presentation of the COL (connected line) at the TE at a mobile originating call. It has no effect on the execution of the supplementary service COLR in the network. Intermediate result code is returned from TA to TE before any +CR or V.25ter [5] responses. It is manufacturer-specific if this response is used when normal voice call is set up. OK Parameter <n> (parameter sets/shows the result code presentation status in the TA): 0 disable 1 enable <m> (parameter shows the subscriber COLP service status in the network): 0 COLP not provisioned 1 COLP provisioned 2 unknown (e.g. no network, etc.)
	Intermediate result code When enabled (and called subscriber allows), an intermediate result code is returned before any +CR or V.25ter responses: +COLP:<number>,<type>[,<subaddr>,<satype> [,<alpha>]]
	Parameter <number> string type phone number of format specified by <type> <type> type of address octet in integer format; 145 when dialling string includes international access code character "+", otherwise 129 <subaddr> string type subaddress of format specified by <satype> <satype> type of subaddress octet in integer format (refer GSM 04.08 [8] subclause 10.5.4.8) <alpha> optional string type alphanumeric representation of <number> corresponding to the entry found in phonebook
Reference GSM 07.07	Note Feature not available at some networks.

AT+COPS	Operator selection																																							
Test command AT+COPS=?	Response TA returns a list of quadruplets, each representing an operator present in the network. Any of the formats may be unavailable and should then be an empty field. The list of operators shall be in the following order: home network, networks referenced in SIM, and other networks. +COPS: [<stat>, long alphanumeric <oper>, numeric <oper>]s] [(list of supported <mode>s), (list of supported <format>s)] OK If error is related to ME functionality: +CME ERROR: <err> Parameter see set command																																							
Read command AT+COPS?	Response TA returns the current mode and the currently selected operator. If no operator is selected, <format> and <oper> are omitted. +COPS: <mode>[, <format>, <oper>] OK Parameter see set command																																							
Set command AT+COPS = <mode> [, <format>[, <oper>]]	Response TA forces an attempt to select and register the GSM network operator. If the selected operator is not available, no other operator shall be selected (except <mode>=4). The selected operator name format shall apply to further read commands (+COPS?) also. Parameters used with the set command are stored in the non-volatile memory. e.g. using AT+COPS=2 to book out of the net, causes the system to NOT automatically book in after the next power-on. AT+COPS=0/1 is needed to register into the network. OK If error is related to ME functionality: +CME ERROR: <err> Parameter <table border="0"> <tr> <td data-bbox="383 1142 478 1176"><stat></td> <td data-bbox="534 1142 558 1176"><u>0</u></td> <td data-bbox="606 1142 718 1176">unknown</td> </tr> <tr> <td></td> <td data-bbox="534 1176 558 1209">1</td> <td data-bbox="606 1176 798 1209">operator available</td> </tr> <tr> <td></td> <td data-bbox="534 1209 558 1243">2</td> <td data-bbox="606 1209 782 1243">operator current</td> </tr> <tr> <td></td> <td data-bbox="534 1243 558 1276">3</td> <td data-bbox="606 1243 813 1276">operator forbidden</td> </tr> <tr> <td data-bbox="383 1288 478 1321"><oper></td> <td></td> <td data-bbox="606 1288 989 1321">operator in format as per <format></td> </tr> <tr> <td data-bbox="383 1332 478 1366"><mode></td> <td data-bbox="534 1332 558 1366"><u>0</u></td> <td data-bbox="606 1332 1053 1366">automatic mode; <oper> field is ignored</td> </tr> <tr> <td></td> <td data-bbox="534 1366 558 1400">1</td> <td data-bbox="606 1366 1212 1400">manual operator selection; <oper> field shall be present</td> </tr> <tr> <td></td> <td data-bbox="534 1400 558 1433">2</td> <td data-bbox="606 1400 1436 1467">manual deregister from network and remain unregistered until mode 0, 1, 4 is selected</td> </tr> <tr> <td></td> <td data-bbox="534 1467 558 1500">3</td> <td data-bbox="606 1467 1133 1500">set only <format> (for read command +COPS?)</td> </tr> <tr> <td></td> <td data-bbox="534 1500 558 1534">4</td> <td data-bbox="606 1500 1436 1568">automatic, manual selected; if manual selection fails, automatic mode (<mode>=0) is entered</td> </tr> <tr> <td data-bbox="383 1579 478 1612"><format></td> <td data-bbox="534 1579 558 1612">0</td> <td data-bbox="606 1579 1324 1612">long format alphanumeric <oper>; can be up to 16 character long</td> </tr> <tr> <td></td> <td data-bbox="534 1612 558 1646">1</td> <td data-bbox="606 1612 893 1646">short format alphanumeric</td> </tr> <tr> <td></td> <td data-bbox="534 1646 558 1680">2</td> <td data-bbox="606 1646 1260 1680">numeric <oper>; GSM Location Area Identification number</td> </tr> </table>	<stat>	<u>0</u>	unknown		1	operator available		2	operator current		3	operator forbidden	<oper>		operator in format as per <format>	<mode>	<u>0</u>	automatic mode; <oper> field is ignored		1	manual operator selection; <oper> field shall be present		2	manual deregister from network and remain unregistered until mode 0, 1, 4 is selected		3	set only <format> (for read command +COPS?)		4	automatic, manual selected; if manual selection fails, automatic mode (<mode>=0) is entered	<format>	0	long format alphanumeric <oper>; can be up to 16 character long		1	short format alphanumeric		2	numeric <oper>; GSM Location Area Identification number
<stat>	<u>0</u>	unknown																																						
	1	operator available																																						
	2	operator current																																						
	3	operator forbidden																																						
<oper>		operator in format as per <format>																																						
<mode>	<u>0</u>	automatic mode; <oper> field is ignored																																						
	1	manual operator selection; <oper> field shall be present																																						
	2	manual deregister from network and remain unregistered until mode 0, 1, 4 is selected																																						
	3	set only <format> (for read command +COPS?)																																						
	4	automatic, manual selected; if manual selection fails, automatic mode (<mode>=0) is entered																																						
<format>	0	long format alphanumeric <oper>; can be up to 16 character long																																						
	1	short format alphanumeric																																						
	2	numeric <oper>; GSM Location Area Identification number																																						
Reference GSM 07.07	Note																																							

AT+CPAS Mobile equipment activity status													
Test command AT+CPAS=?	Response +CPAS: (list of supported <pas>s) OK Parameter see execute command												
Execute command AT+CPAS	Response TA returns the activity status of ME. +CPAS: <pas> OK Parameter <table border="0"> <tr> <td><pas></td> <td>0</td> <td>ready</td> </tr> <tr> <td></td> <td>2</td> <td>unknown (ME is not guaranteed to respond to instructions)</td> </tr> <tr> <td></td> <td>3</td> <td>incoming call (ringing)</td> </tr> <tr> <td></td> <td>4</td> <td>call in progress or call hold</td> </tr> </table>	<pas>	0	ready		2	unknown (ME is not guaranteed to respond to instructions)		3	incoming call (ringing)		4	call in progress or call hold
<pas>	0	ready											
	2	unknown (ME is not guaranteed to respond to instructions)											
	3	incoming call (ringing)											
	4	call in progress or call hold											
Reference GSM 07.07	Note												
AT+CPBF Find phonebook entries													
Test command AT+CPBF=?	Response +CPBF: [<nlength>], [<tlength>] OK <i>Note:</i> In case of SIM storage, the lengths may not be available. If storage does not offer format information, the format list should be empty parenthesis. Parameter see execute command												
Execute command AT+CPBF= <findtext>	Response TA returns phonebook entries (from the current phonebook memory storage selected with +CPBS) which alphanumeric fields contains <findtext>. [+CPBF: <index1>,<number>,<type>,<text>[[...] <CR><LF>+CPBF: <index2>,<number>,<type>,<text>] OK If error is related to ME functionality: +CME ERROR: <err>												
AT+CPBF=""	Response List of all phonebook entries in currently active phonebook (+CPBS).												
	Parameter <table border="0"> <tr> <td><index1>,&br/><index2></td> <td>integer type values in the range of location numbers of phonebook memory</td> </tr> <tr> <td><number></td> <td>string type phone number of format <type></td> </tr> <tr> <td><type></td> <td>type of address octet in integer format; 145 when dialling string includes international access code character "+", otherwise 129</td> </tr> <tr> <td><findtext>,&br/><text></td> <td>string type field of maximum length <tlength></td> </tr> <tr> <td><nlength></td> <td>integer type value indicating the maximum length of field <number></td> </tr> <tr> <td><tlength></td> <td>integer type value indicating the maximum length of field <text></td> </tr> </table>	<index1>,&br/><index2>	integer type values in the range of location numbers of phonebook memory	<number>	string type phone number of format <type>	<type>	type of address octet in integer format; 145 when dialling string includes international access code character "+", otherwise 129	<findtext>,&br/><text>	string type field of maximum length <tlength>	<nlength>	integer type value indicating the maximum length of field <number>	<tlength>	integer type value indicating the maximum length of field <text>
<index1>,&br/><index2>	integer type values in the range of location numbers of phonebook memory												
<number>	string type phone number of format <type>												
<type>	type of address octet in integer format; 145 when dialling string includes international access code character "+", otherwise 129												
<findtext>,&br/><text>	string type field of maximum length <tlength>												
<nlength>	integer type value indicating the maximum length of field <number>												
<tlength>	integer type value indicating the maximum length of field <text>												
Reference GSM 07.07	Note												

AT+CPBR	Read current phonebook entries
Test command AT+CPBR=?	Response TA returns location range supported by the current storage as a compound value and the maximum lengths of <number> and <text> fields. Note: In case of SIM storage, the lengths may not be available. If storage does not offer format information, the format list should be empty parenthesis. +CPBR: (list of supported <index> s), <nlength> , <tlength> OK If error is related to ME functionality: +CME ERROR: <err>
Execute command AT+CPBR = <index1> [, <index2>]	Response TA returns phonebook entries in location number range <index1>... <index2> from the current phonebook memory storage selected with +CPBS . If <index2> is left out, only location <index1> is returned. +CPBR: <index1> , <number> , <type> , <text> [<CR><LF>] +CPBR:... +CPBR: <index2> , <number> , <type> , <text>] OK If error is related to ME functionality: +CME ERROR Parameter <index> location number <index1> read from this location number <index2> read to this location number <nlength> max. length of phone number <number> phone number <text> text for phone number <tlength> max. length of text for number <type> type of number
Reference GSM 07.07	Note

AT^SPBA	Browse the phonebook alphabetically
Test command AT^SPBA=?	Response ^SPBA: <nlength>,<tlength> OK If error is related to ME functionality: +CME ERROR: <err>
Execute command AT^SPBA= <browsetext>	Response TA returns three phonebook entries in alphabetical order. ^SPBA: <index1>,<number>,<type>,<text> <CR,LF> ^SPBA: <index2>,<number>,<type>,<text> <CR,LF> ^SPBA: <index3>,<number>,<type>,<text> <CR,LF>,<CR,LF> OK If error is related to ME functionality: +CME ERROR: <err> Parameter <browsetext> searched text: "stringtext" (maximal length <tlength>) <index1> Index of the previous phonebook entry (related to <browsetext>) in alphabetical order <index2> Index of the searched phonebook entry <index3> Index of the next phonebook entry (related to <browsetext>) in alphabetical order <nlength> maximum length of phone number <tlength> maximum length of text <index> location number <number> phone number <type> type of number; e.g. 145 when dialling string includes international access code character "+", otherwise 129 <text> string type field of maximum length <tlength>
Reference	Note This command can be used for the ME, SM, MT, ON and FD phonebook. For examples refer to 8.2.7.6 "Using the AT^SPBA Browse the phonebook alphabetically and AT^SPBS Steps the selected phonebook alphabetically Command" on page 168.

AT+CPBS		Select phonebook memory storage
Test command AT+CPBS=?	Response +CPBS: (list of supported <storage>s) OK Parameter see set command	
Read command AT+CPBS?	Response TA returns currently selected memory +CPBS: <storage> OK Parameter see set command	
Set command AT+CPBS= <storage>	Response TA selects current phonebook memory storage which is used by other phonebook commands. OK Parameter <storage> "FD" SIM fixdialling-phonebook Fixed Dialling Numbers stored in the SIM may contain wild characters („B“ or „b“) and sub-address. Example: AT+CPBW=1,“1234b6“,, for „b“ any number from 0 to 9 may be used AT+CPBW=2,“011707“,, any number starting with „011707“ is accepted. "LD" SIM last-dialling-phonebook "MC" ME missed (unanswered received) call list (+CPBW can only be used for deleting) "ME" ME Phonebook (write with AT&Zn, see also AT%D) ME Phonebook storage pos.1-5 "MT" Combined ME and SIM Phonebook "ON" SIM (or ME) own numbers (MSISDNs) list "RC" ME received calls list (+CPBW can only be used for deleting) "SM" SIM phonebook <u>Note:</u> 1) LD: Last dialling phonebook: Number will automatically be written onto the last position. (+CPBW can be used for deleting only) 2) ME Phonebook data is only stored if unit is shut down using the <i>“AT^SMSO Switch off mobile station turn off”</i> command.	
Reference GSM 07.07	Note	

AT^SPBS	Steps the selected phonebook alphabetically
Test command AT^SPBS=?	Response ^SPBS: (list of supported <value>s) OK Parameter see execute command
Execute command AT^SPBS= <value>	Parameter <value> 1 to make a step downward in the alphabetically sorted phonebook 2 to make a step upward in the alphabetically sorted phonebook Response if <n>=1 TA steps down one entry. ^SPBA: <index2>,<number>,<type>,<text> <CR,LF> ^SPBA: <index3>,<number>,<type>,<text> <CR,LF> ^SPBA: <index4>,<number>,<type>,<text> <CR,LF>,<CR,LF> OK if <value>=2 (after <value>=1) TA steps up one entry. ^SPBA: <index1>,<number>,<type>,<text> <CR,LF> ^SPBA: <index2>,<number>,<type>,<text> <CR,LF> ^SPBA: <index3>,<number>,<type>,<text> <CR,LF>,<CR,LF> OK If error is related to ME functionality: +CME ERROR: <err> The parameters in the response are explained in the specification of the <i>“AT^SPBA Browse the phonebook alphabetically”</i> command.
Reference	Note This command can be used for the ME, SM, MT, ON and FD phonebook. If the command AT^SPBA=<browsetext> has not been used before using the STEP command AT^SPBS the output starts at the first alphabetical entry. For examples refer to 8.2.7.6 <i>“Using the AT^SPBA Browse the phonebook alphabetically and AT^SPBS Steps the selected phonebook alphabetically Command”</i> on page 168.

AT+CPBW	Write phonebook entry																											
Test command AT+CPBW=?	Response TA returns location range supported by the current storage, the maximum length of <number> field, supported number formats of the storage, and the maximum length of <text> field. <u>Note:</u> the lengths may not be available in case of SIM storage. If storage does not offer format information, the format list should be empty parenthesis. +CPBW: (list of supported <index>s), <nlength>, (list of supported <typ>s), <tlength> OK If error is related to ME functionality: +CME ERROR: <err> Parameter see execute command																											
Execute command AT+CPBW = [<index>], [<number>], [<type>], [<text>]]	Response TA writes phonebook entry in location number <index> in the current phonebook memory storage selected with +CPBS. Entry fields written are phone number <number> (in the format <type>) and text <text> associated with the number. If these fields are omitted, phonebook entry is deleted. If <index> is left out, but <number> is given, entry is written to the first free location in the phonebook (see note for MT phonebook). The string <number> may also contain letters, these are stored as capitals. <u>Note:</u> PIN2 is necessary for writing in FD phonebook. OK If error is related to ME functionality: +CME ERROR: <err> Parameter <nlength> max. length of phone number <tlength> max. length of text for number <index> location number <number> phone number <type> type of number; e.g. 145 when dialling string includes international access code character "+", otherwise 129 <text> text for phone number <u>Note:</u> the following characters in <text> must be entered via the escape sequence: <table border="1" data-bbox="534 1243 1029 1590"> <thead> <tr> <th>GSM char.</th> <th>Seq.</th> <th>Seq.(hex)</th> </tr> </thead> <tbody> <tr> <td>\</td> <td>\5C</td> <td>5C</td> </tr> <tr> <td>35 43</td> <td>(backslash)</td> <td></td> </tr> <tr> <td>"</td> <td>\22</td> <td>5C</td> </tr> <tr> <td>32 32</td> <td>(string delimiter)</td> <td></td> </tr> <tr> <td>BSP</td> <td>\08</td> <td>5C</td> </tr> <tr> <td>30 38</td> <td>(backspace)</td> <td></td> </tr> <tr> <td>NULL</td> <td>\00</td> <td>5C</td> </tr> <tr> <td>30 30</td> <td>(GSM null)</td> <td></td> </tr> </tbody> </table> '0' (GSM null) may cause problems on application level when using the function (strlen) and should thus be represented by an escape sequence when necessary	GSM char.	Seq.	Seq.(hex)	\	\5C	5C	35 43	(backslash)		"	\22	5C	32 32	(string delimiter)		BSP	\08	5C	30 38	(backspace)		NULL	\00	5C	30 30	(GSM null)	
GSM char.	Seq.	Seq.(hex)																										
\	\5C	5C																										
35 43	(backslash)																											
"	\22	5C																										
32 32	(string delimiter)																											
BSP	\08	5C																										
30 38	(backspace)																											
NULL	\00	5C																										
30 30	(GSM null)																											
Reference GSM 07.07	Note In case of MT phonebook this command works equal. But take care in which physical phonebook the entry is written: Unless the ME phonebook is full, the entry is written in the ME phonebook. If the ME phonebook is full, the entry is written in the SM phonebook. ME Phonebook data is only stored if unit is shut down using the "AT^SMSO Switch off mobile station turn off" command.																											

AT+CPWD	Change password
Test command AT+CPWD=?	Response TA returns a list of pairs which present the available facilities and the maximum length of their password. +CPWD: list of supported (<fac>, <pwdlength>)s OK Parameter <fac> see execute command <pwdlength> integer max. length of password
Execute command AT+CPWD = <fac>,[<oldpwd>], <newpwd>	Response TA sets a new password for the facility lock function. OK If error is related to ME functionality: +CME ERROR: <err> Parameter <fac> "SC" SIM (lock SIM card) (SIM asks password in ME power-up and when this lock command issued) "AO" BAOC (Bar All Outgoing Calls) "OI" BOIC (Bar Outgoing International Calls) "OX" BOIC-exHC (Bar Outgoing International Calls except to Home Country) "AI" BAIC (Bar All Incoming Calls) "IR" BIC-Roam (Bar Incoming Calls when Roaming outside the home country) "AB" All Barring services (applicable only for <mode>=0) "AG" All outGoing barring services (applicable only for <mode>=0) "AC" All inComing barring services (applicable only for <mode>=0) "P2" SIM PIN2 <oldpwd> password specified for the facility from the user interface or with command. If an old password has not yet been set, <oldpwd> is not to be entered. if <fac> = "SC" then PIN if <fac> = "AO"... "AC" (Barring) then network password if <fac> = "P2" then PIN2 Note: a password may already be set, depending on the provider. Please check with your provider. <newpwd> new password
Reference GSM 07.07	Note

AT+CPUC Price per unit and currency table	
Test command AT+CPUC=?	Response OK
Read command AT+CPUC?	Response Read Command returns the current parameters of PUCT. +CPUC: <currency>, <ppu> OK If error is related to ME functionality: +CME ERROR: <err> Parameter refer set command
Set command AT+CPUC=<currency>,<ppu>[,<passwd>]	Response Set command sets the parameters of Advice of Charge related price per unit and currency table. SIM PIN2 is usually required to set the parameters. If error is related to ME functionality: +CME ERROR: <err> Parameter <currency> string type; three-character currency code (e.g. "GBP", "DEM"); character set as specified by command <i>AT+CSCS Select TE character set</i> . If the currency name is longer than three characters, all characters will be cut off after the third position. Before they are written to the SIM Card, these characters are converted to the standard GSM alphabet. Any unknown characters are replaced by a space. <ppu> string type; price per unit; dot is used as a decimal separator (e.g. "2.66"). Its length is limited to 20 characters. If the string length is exceeded, the command is terminated with an error. This string may only contain digits and a dot. Leading zeros are removed from the string. The minimum and maximum value is determined by the structure of the SIM-PUCT file. The maximum price per unit value is 999 999 999.00. When successfully entered, this value is rounded off to maximum accuracy. <passwd> string type; SIM PIN2. String parameter which can contain any combination of characters. The maximum string length is limited to 8 characters. If this value is exceeded, the command terminates with an error message. If the PIN2 is incorrect, a CME error (+CME ERROR: incorrect password) is output.
Reference GSM 07.07	Note

AT+CRLP	Select radio link protocol param. for orig. non-transparent data call																		
Test command AT+CRLP=?	Response TA returns values supported by the TA as a compound value. If ME/TA supports several RLP versions <verx>, the RLP parameter value ranges for each <verx> are returned in a separate line. <u>Note:</u> versions 0 and 1 share the same parameter set. TA returns only one line for this set (where <verx> is not present). +CRLP: (list of supported <iws>s), (list of supported <mws>s), (list of supported <T1>s), (list of supported <N2>s), (list of supported <ver1>s), (list of supported <T4>s) +CRLP: (list of supported <iws>s), (list of supported <mws>s), (list of supported <T1>s), (list of supported <N2>s), (list of supported <ver2>s), (list of supported <T4>s) ... OK Parameter see set command																		
Read command AT+CRLP?	Response TA returns current settings for each supported RLP version <verx>. Only RLP parameters applicable to the corresponding <verx> are returned. <u>Note:</u> versions 0 and 1 share the same parameter set. TA returns only one line for this set (where <verx> is not present). +CRLP: <iws>,<mws>,<T1>,<N2>[,<ver1>[,<T4>]] +CRLP: <iws>,<mws>,<T1>,<N2>[,<ver2>[,<T4>]] ... OK Parameter see set command																		
Set command AT+CR- LP=[<iws>[,<mws> >[,<T1>[,<N2>[,< ver>[,<T4>]]]]]]	Response TA sets radio link protocol (RLP) parameters used when non-transparent data calls are originated. <u>Note:</u> available command subparameters depend on the RLP versions implemented by the device (e.g. <ver> may not be available if device supports only versions 0 and 1). OK Parameter <table border="0"> <tr> <td><iws></td> <td>0-<u>61</u></td> <td>Interworking window size (IWF to MS)</td> </tr> <tr> <td><mws></td> <td>0-<u>61</u></td> <td>Mobile window size (MS to IWF)</td> </tr> <tr> <td><T1></td> <td>39-<u>48</u>-255</td> <td>Acknowledgment timer T1 in 10 ms units)</td> </tr> <tr> <td><N2></td> <td>1-<u>6</u>-255</td> <td>Re-transmission attempts N2</td> </tr> <tr> <td><ver></td> <td>0-<u>2</u></td> <td>RLP version number in integer format; when version indication is not present it shall equal 0. <u>Note:</u> versions 0 and 1 share the same parameter set.</td> </tr> <tr> <td><T4></td> <td>0-<u>5</u>-255</td> <td>resequencing period in integer format, in units of 10 ms <u>Note:</u> default values and value ranges depend on RLP version; refer to GSM 04.22 [18]</td> </tr> </table>	<iws>	0- <u>61</u>	Interworking window size (IWF to MS)	<mws>	0- <u>61</u>	Mobile window size (MS to IWF)	<T1>	39- <u>48</u> -255	Acknowledgment timer T1 in 10 ms units)	<N2>	1- <u>6</u> -255	Re-transmission attempts N2	<ver>	0- <u>2</u>	RLP version number in integer format; when version indication is not present it shall equal 0. <u>Note:</u> versions 0 and 1 share the same parameter set.	<T4>	0- <u>5</u> -255	resequencing period in integer format, in units of 10 ms <u>Note:</u> default values and value ranges depend on RLP version; refer to GSM 04.22 [18]
<iws>	0- <u>61</u>	Interworking window size (IWF to MS)																	
<mws>	0- <u>61</u>	Mobile window size (MS to IWF)																	
<T1>	39- <u>48</u> -255	Acknowledgment timer T1 in 10 ms units)																	
<N2>	1- <u>6</u> -255	Re-transmission attempts N2																	
<ver>	0- <u>2</u>	RLP version number in integer format; when version indication is not present it shall equal 0. <u>Note:</u> versions 0 and 1 share the same parameter set.																	
<T4>	0- <u>5</u> -255	resequencing period in integer format, in units of 10 ms <u>Note:</u> default values and value ranges depend on RLP version; refer to GSM 04.22 [18]																	
Reference GSM 07.07	Note																		

AT+CRRC		Set Cellular Result Codes for incoming call indication	
Test command AT+CRRC=?	Response +CRRC: list of supported <mode>s OK	Parameter see set command	
Read command AT+CRRC?	Response +CRRC: <mode> OK	Parameter see set command	
Set command AT+CRRC=[<mode>]	Response TA controls whether or not the extended format of incoming call indication is used. OK	Parameters <mode> <u>0</u> disable extended format 1 enable extended format	
	Unsolicited result code When enabled, an incoming call is indicated to the TE with unsolicited result code +CRING: <type> pe> instead of the normal RING.	Parameter <type>	ASYNC asynchronous transparent SYNC synchronous transparent REL ASYNC asynchronous non-transparent REL SYNC synchronous non-transparent FAX facsimile VOICE voice
Reference GSM 07.07	Note		

AT+CR		Service reporting control	
Test command AT+CR=?	Response +CR: list of supported <mode> s OK	Parameter	see set command
Read command AT+CR?	Response +CR: <mode> OK	Parameter	see set command
Set command AT+CR=<mode>	Response TA controls whether or not intermediate result code +CR: <serv> is returned from the TA to the TE at call setup. OK	Parameter <mode>	<p>0 disable</p> <p>1 enable</p>
	Intermediate result code When enabled, an intermediate result code is transmitted at the point during connect negotiation when the TA has determined the speed and quality of service will be used, before any error control or data compression reports are transmitted, and before any final result code (e.g. CONNECT) is transmitted. +CR:<serv>	Parameter <serv>	<p>ASYNC asynchronous transparent</p> <p>SYNC synchronous transparent</p> <p>REL ASYNC asynchronous non-transparent</p> <p>REL SYNC synchronous non-transparent</p>
Reference GSM 07.07	Note The PLMN influences the second air interface (to the terminator), therefore another mode may be established from the network		

AT+CREG		Network registration	
Test command AT+CREG=?	Response +CREG: (list of supported <n>s) OK	Parameter see set command	
Read command AT+CREG?	Response TA returns the status of result code presentation and an integer <stat> which shows whether the network has currently indicated the registration of the ME. Location information elements <lac> and <ci> are returned only when <n>=2 and ME is registered in the network. +CREG: <n>,<stat>,[<lac>,<ci>] OK	Parameter see set command	
Set command AT+CREG=[<n>]	Response TA controls the presentation of an unsolicited result code +CREG: <stat> when <n>=1 and there is a change in the ME network registration status, or code +CREG: <stat>,[<lac>,<ci>] when <n>=2 and there is a change of the network cell. OK	Parameter <n> 0 0 disable network registration unsolicited result code 1 1 enable network registration unsolicited result code +CREG: <stat> 2 2 enable network registration and location information unsolicited result code +CREG:<stat>,[<lac>,<ci>] <stat> 0 0 not registered, ME is not currently searching for a new operator at which to register 1 1 registered, home network 2 2 not registered, but ME is currently searching for a new operator at which to register 3 3 registration denied 4 4 unknown 5 5 registered, roaming <lac> string type; two byte location area code in hexadecimal format (e.g. "00C3" equals 193 in decimal) <ci> string type; two byte cell ID in hexadecimal format	
	Unsolicited result code When <n>=1 and there is a change in the ME network registration status: +CREG: <stat> When <n>=2 and there is a change of the network cell: +CREG: <stat>,[<lac>,<ci>]	Parameter see set command	
Reference GSM 07.07	Note		

AT+CRSM Restricted SIM access																																																					
Test command AT+CRSM=?	Response OK																																																				
Set command AT+CRSM=<command>[,<fileid>[,<P1>,<P2>,<P3>[,<data>]]]	<p>Response</p> <p>By using this command instead of generic SIM Access TE application has easier but more limited access to the SIM database. As response to the command, ME sends the actual SIM information parameters and response data.</p> <p>+CRSM: <sw1>, <sw2> [,<response>] OK</p> <p>If error is related to ME functionality: +CME ERROR: <err></p> <p>Parameter</p> <table border="0"> <tr> <td><command></td> <td>176</td> <td>READ BINARY</td> </tr> <tr> <td></td> <td>178</td> <td>READ RECORD</td> </tr> <tr> <td></td> <td>192</td> <td>GET RESPONSE</td> </tr> <tr> <td></td> <td>214</td> <td>UPDATE BINARY</td> </tr> <tr> <td></td> <td>220</td> <td>UPDATE RECORD</td> </tr> <tr> <td></td> <td>242</td> <td>STATUS</td> </tr> </table> <p>all other values are reserved</p> <p><fileid> integer type; this is the identifier of a elementary data file on SIM. Mandatory for every command except STATUS</p> <p><P1>,<P2>,<P3> integer type; parameters passed on by the ME to the SIM</p> <table border="1" style="width: 100%; border-collapse: collapse;"> <thead> <tr> <th>COMMAND</th> <th>P1</th> <th>P2</th> <th>P3</th> </tr> </thead> <tbody> <tr> <td>STATUS</td> <td></td> <td></td> <td></td> </tr> <tr> <td>READ BINARY</td> <td>offset high</td> <td>offset low</td> <td>lgth</td> </tr> <tr> <td>UPDATE BINARY</td> <td>offset high</td> <td>offset low</td> <td></td> </tr> <tr> <td>READ RECORD</td> <td>rec No.</td> <td>mode</td> <td></td> </tr> <tr> <td>UPDATE RECORD</td> <td>rec No.</td> <td>mode</td> <td></td> </tr> <tr> <td>GET RESPONSE</td> <td></td> <td></td> <td></td> </tr> </tbody> </table> <p>Mode</p> <table border="0"> <tr> <td>02</td> <td>Next record. P1 has no significance and shall be set to '00'.</td> </tr> <tr> <td>03</td> <td>Previous record. P1 has no significance and shall be set to '00'.</td> </tr> <tr> <td>04</td> <td>Absolute mode/current mode, the record number is given in P1 with P1='00' denoting the current record.</td> </tr> </table> <p><data> information which shall be written to the SIM (hexadecimal character format)</p> <p><sw1>, <sw2> integer type; information from the SIM about the execution of the actual command. These parameters are delivered to the TE in both cases, on successful or failed execution of the command</p> <p><response> response of a successful completion of the command previously issued (hexadecimal character format)</p>	<command>	176	READ BINARY		178	READ RECORD		192	GET RESPONSE		214	UPDATE BINARY		220	UPDATE RECORD		242	STATUS	COMMAND	P1	P2	P3	STATUS				READ BINARY	offset high	offset low	lgth	UPDATE BINARY	offset high	offset low		READ RECORD	rec No.	mode		UPDATE RECORD	rec No.	mode		GET RESPONSE				02	Next record. P1 has no significance and shall be set to '00'.	03	Previous record. P1 has no significance and shall be set to '00'.	04	Absolute mode/current mode, the record number is given in P1 with P1='00' denoting the current record.
<command>	176	READ BINARY																																																			
	178	READ RECORD																																																			
	192	GET RESPONSE																																																			
	214	UPDATE BINARY																																																			
	220	UPDATE RECORD																																																			
	242	STATUS																																																			
COMMAND	P1	P2	P3																																																		
STATUS																																																					
READ BINARY	offset high	offset low	lgth																																																		
UPDATE BINARY	offset high	offset low																																																			
READ RECORD	rec No.	mode																																																			
UPDATE RECORD	rec No.	mode																																																			
GET RESPONSE																																																					
02	Next record. P1 has no significance and shall be set to '00'.																																																				
03	Previous record. P1 has no significance and shall be set to '00'.																																																				
04	Absolute mode/current mode, the record number is given in P1 with P1='00' denoting the current record.																																																				
Reference GSM 07.07	Note Parameters <command>, <fileid>, <P1>, <P2>, <P3> can also be entered in hexadecimal format. Hexadecimal characters have to start with 0x.																																																				

AT+CSCS		Select TE character set.	
Test command AT+CSCS=?	Response +CSCS: list of supported <chset>s OK Parameter see set command		
Read command AT+CSCS?	Response TA returns current setting of conversion scheme. +CSCS: <chset> OK Parameter see set command		
Set command AT+CSCS=<chset>	Response Set command informs TA which character set <chset> is used by the TE. TA is then able to convert character strings correctly between TE and ME character sets. OK Parameter <chset> conversion schemes "IRA" international reference alphabet (ITU-T T.50) "PCCP850" MS-DOS Code Page 850 - Latin 1 "PCCP852" MS-DOS Code Page 852 - Latin 2 "PCCP1252" Code Page 1252 Windows Latin 1 (ANSI) "PCCP1250" Code Page 1250 Windows Latin 2 (Central Europe) "8859-1" ISO 8859 Latin 1 character set "8859-2" ISO 8859 Latin 2 character set "TTP" GSM default alphabet (GSM 03.38 subclause 6.2.1); except the values 0 to 32 are mapped to 128. This setting does not cause problems with software flow control (XON/XOFF).		
Reference GSM 07.07	Note When TA-TE interface is set to 8-bit operation and used TE alphabet is 7-bit, the highest bit will be set to zero.		

AT+CSQ	Signal quality																		
Test command AT+CSQ=?	Response +CSQ: (list of supported <rssis>), (list of supported <ber>) OK Parameter see execute command																		
Execute command AT+CSQ	Response TA returns received signal strength indication <rssis> and channel bit error rate <ber> from the ME. +CSQ: <rssis>, <ber> OK Parameter <table data-bbox="383 470 1436 795"> <tr> <td data-bbox="383 470 590 504"><rssis></td> <td data-bbox="590 470 766 504">Receive level:</td> </tr> <tr> <td data-bbox="383 504 590 537">0</td> <td data-bbox="590 504 1436 537">-113 dBm or less</td> </tr> <tr> <td data-bbox="383 537 590 571">1</td> <td data-bbox="590 537 1436 571">-111 dBm</td> </tr> <tr> <td data-bbox="383 571 590 604">2...30</td> <td data-bbox="590 571 1436 604">-109... -53 dBm</td> </tr> <tr> <td data-bbox="383 604 590 638">31</td> <td data-bbox="590 604 1436 638">-51 dBm or greater</td> </tr> <tr> <td data-bbox="383 638 590 672">99</td> <td data-bbox="590 638 1436 672">not known</td> </tr> <tr> <td data-bbox="383 672 590 705"><ber></td> <td data-bbox="590 672 766 705">Bit error rate:</td> </tr> <tr> <td data-bbox="383 705 590 739">0...7</td> <td data-bbox="590 705 1436 739">as RXQUAL values in the table in GSM 05.08 section 8.2.4</td> </tr> <tr> <td data-bbox="383 739 590 772">99</td> <td data-bbox="590 739 1436 772">not known</td> </tr> </table>	<rssis>	Receive level:	0	-113 dBm or less	1	-111 dBm	2...30	-109... -53 dBm	31	-51 dBm or greater	99	not known	<ber>	Bit error rate:	0...7	as RXQUAL values in the table in GSM 05.08 section 8.2.4	99	not known
<rssis>	Receive level:																		
0	-113 dBm or less																		
1	-111 dBm																		
2...30	-109... -53 dBm																		
31	-51 dBm or greater																		
99	not known																		
<ber>	Bit error rate:																		
0...7	as RXQUAL values in the table in GSM 05.08 section 8.2.4																		
99	not known																		
Reference GSM 07.07	Note																		

AT+CUSD		Unstructured supplementary service data	
Test command AT+CUSD=?	Response +CUSD: (list of supported <n>s) OK Parameter see set command		
Read command AT+CUSD?	Response TA returns the parameter unsolicited result code presentation mode. +CUSD: <n>, OK Parameter see set command		
Set command AT+CUSD=[<n>[,<str>[,<dcs>]]]	Response TA controls the Unstructured Supplementary Service Data(USSD). Both network and mobile initiated operations are supported. Parameter <n> is used to disable/enable the presentation of an unsolicited result code. The value <n>=2 is used only to cancel an ongoing USSD session. When <str> is given, a mobile initiated USSD-string or a response USSD-string to a network initiated operation is sent to the network. OK If error is related to ME functionality: +CME ERROR: <err> Note: The set command should be abortable when network is interrogated. Parameters <n> 0 disable unsolicited result code presentation 1 enable unsolicited result code presentation 2 cancel ongoing USSD session <str> string type USSD-string if <dcs> indicates that GSM03.38[25] default alphabet is used: ME/TA converts GSM alphabet into current TE character set (refer command Select TE Character Set +CSCS) according to rules of GSM07.05[24] AnnexA <dcs> GSM03.38[25] Cell Broadcast Data Coding Scheme in integer format 0 GSM default alphabet is used in <str> in ME <m> 0 no further user action required (network initiated USSD-Notify, or no further information needed after mobile initiated operation) 1 further user action required (network initiated USSD-Request, or further information needed after mobile initiated operation) 2 USSD terminated by network 3 Other local client has responded 4 Operation not supported 5 network time out Unsolicited result code When the presentation of an unsolicited code is enabled, TA send USSD response from the network or network initiated operation to the TE: +CUSD: <m>[,<str>,<dcs>] Parameter see set command		
Reference GSM 07.07/V580	Note		

AT+FMR Fax: report revision ID	
Test command AT+FMR=?	Response OK
Read command AT+FMR	Response TA reports one or more lines of information text which permit the user to identify the version, revision level or data or other information of the device. <Revision Id> OK Parameters <Revision Id> according to the revision
Reference	Note

AT+VGR Receive gain selection of speaker	
Test command AT+VGR=?	Response +VGR: (list of supported <n>) OK Parameter see set command
Read command AT+VGR?	Response +VGR: <n> OK Parameter see set command
Set command AT+VGR=<n>	Response TA sets amplification of audio samples sent from the TA to the computer. OK
	Parameter <n> 0 – Automatic gain control 1(0x1)-128(0x80)-255(0xFF) gain=20*log(n/128) <i>Note:</i> default value is 64. Hex input not accepted
Reference GSM 07.07	Note Set command works only in audio mode 3.

AT+VTS DTMF and tone generation (<Tone> in {0-9, *, #, A, B, C, D})	
Test command AT+VTS=?	Response +VTS: (list of supported <dtmf>s, (list of supported <duration>s) OK <u>Note:</u> In GSM the value of tone duration is preset and cannot be altered. therefore the <duration> list is not presented. Parameter see set command
Set command 1) AT+VTS=<dtmf-string> 2) AT+VTS=[<tone1>,<tone2>,<duration>] 3) AT+VTS=<dtmf>,<duration>	Response This command allows the transmission of DTMF tones and arbitrary tones in voice mode. These tones may be used (for example) when announcing the start of a recording period. <u>Note:</u> D is used only for dialling. 1) This is interpreted as a sequence of DTMF tones whose duration is set by the +VTD command. 2) This has no function at GSM. 3) This is interpreted as a DTMF tone whose duration is determined by <duration>. OK If error is related to ME functionality: +CME ERROR: <err> <u>Note:</u> the command is write only. Parameter <dtmf> String of ASCII characters in the set 0-9,#,*,,. Maximal length of the string is 29. The string must be entered between double-quote characters (,,). Example: string is 1234, then: AT+VTS="1,2,3,4" <duration> duration of the tone in 1/10 seconds 1-255
Reference GSM 07.07	Note: 1) This command only works during active voice call. 2) In GSM the value of <duration> has no effect because the value of the tone duration is preset and cannot be altered.

5.6 AT commands to GSM 07.05 for SMS

5.6.1 List of commands

Commands according to GSM 07.05	Function	
AT+CMGD	Delete SMS message	<i>Page 93</i>
AT+CMGF	Select SMS message format	<i>Page 94</i>
AT+CMGL	List SMS messages from preferred store	<i>Page 94</i>
AT+CMGR	Read SMS message	<i>Page 97</i>
AT+CMGS	Send SMS message	<i>Page 100</i>
AT+CMGW	Write SMS message to memory	<i>Page 101</i>
AT+CMSS	Send SMS message from storage	<i>Page 102</i>
AT+CNMI	New SMS message indications	<i>Page 103</i>
AT+CPMS	Preferred SMS message storage	<i>Page 105</i>
AT+CRES	Restore SMS settings	<i>Page 105</i>
AT+CSAS	Save SMS settings	<i>Page 106</i>
AT+CSCA	SMS service centre address	<i>Page 106</i>
AT+CSCB	Select cell broadcast SMS messages	<i>Page 106</i>
AT+CSDH	Show SMS text mode parameters	<i>Page 108</i>
AT+CSMP	Set SMS text mode parameters	<i>Page 109</i>
AT+CSMS	Select message service	<i>Page 109</i>

Table 5-3 AT commands according to GSM 07.05

5.6.2 Detailed description

AT+CMGD	Delete SMS message
Test command AT+CMGD=?	Response OK Parameter
Execute command AT+CMGD= <index>	Response TA deletes message from preferred message storage <mem1> location <index>. OK If error is related to ME functionality: +CMS ERROR <err> Parameter <index> integer type; value in the range of location numbers supported by the associated memory
Reference GSM 07.05	Note

AT+CMGF Select SMS message format							
Test command AT+CMGF=?	Response +CMGF: (list of supported <mode>s) OK Parameter see set command						
Read command AT+CMGF?	Response +CMGF: <mode> OK Parameter see set command						
Set command AT+CMGF = [<mode>]	Response TA sets parameter which specifies the input and output format of messages to be used. OK Parameter <table border="0"> <tr> <td><mode></td> <td>0</td> <td>PDU mode</td> </tr> <tr> <td></td> <td>1</td> <td>text mode</td> </tr> </table>	<mode>	0	PDU mode		1	text mode
<mode>	0	PDU mode					
	1	text mode					
Reference GSM 07.05	Note						

AT+CMGL List SMS messages from preferred store																															
Test command AT+CMGL=?	Response +CMGL: list of supported <stat>s OK Parameter see execute command																														
Execute command AT+CMGL [=<stat>]	Parameter 1) If text mode: <table border="0"> <tr> <td><stat></td> <td>"REC UNREAD"</td> <td>Received unread messages (default)</td> </tr> <tr> <td></td> <td>"REC READ"</td> <td>Received read messages</td> </tr> <tr> <td></td> <td>"STO UNSENT"</td> <td>Stored unsent messages</td> </tr> <tr> <td></td> <td>"STO SENT"</td> <td>Stored sent messages</td> </tr> <tr> <td></td> <td>"ALL"</td> <td>All messages</td> </tr> </table> 2) If PDU mode: <table border="0"> <tr> <td><stat></td> <td>0</td> <td>Received unread messages (default)</td> </tr> <tr> <td></td> <td>1</td> <td>Received read messages</td> </tr> <tr> <td></td> <td>2</td> <td>Stored unsent messages</td> </tr> <tr> <td></td> <td>3</td> <td>Stored sent messages</td> </tr> <tr> <td></td> <td>4</td> <td>All messages</td> </tr> </table> Response TA returns messages with status value <stat> from message storage <mem1> to the TE. If status of the message is 'received unread', status in the storage changes to 'received read'. <u>Note:</u> if the selected <mem1> can contain different types of SMs (e.g. SMS-DELIVERs, SMS-SUBMITs, SMS-STATUS-REPORTs and SMS-COMMANDs), the response may be a mix of the responses of different SM types. TE application can recognize the response format by examining the third response parameter. (continued next page)	<stat>	"REC UNREAD"	Received unread messages (default)		"REC READ"	Received read messages		"STO UNSENT"	Stored unsent messages		"STO SENT"	Stored sent messages		"ALL"	All messages	<stat>	0	Received unread messages (default)		1	Received read messages		2	Stored unsent messages		3	Stored sent messages		4	All messages
<stat>	"REC UNREAD"	Received unread messages (default)																													
	"REC READ"	Received read messages																													
	"STO UNSENT"	Stored unsent messages																													
	"STO SENT"	Stored sent messages																													
	"ALL"	All messages																													
<stat>	0	Received unread messages (default)																													
	1	Received read messages																													
	2	Stored unsent messages																													
	3	Stored sent messages																													
	4	All messages																													

	<p>Response</p> <p>1) If text mode (+CMGF=1) and command successful: for SMS-SUBMITs and/or SMS-DELIVERs: +CMGL: <index>,<stat>,<oa/da>,[<alpha>],[<scts>],[<tooa/toda>,<length>]<CR><LF><data>[<CR><LF> +CMGL: <index>,<stat>,<da/oa>,[<alpha>],[<scts>],[<tooa/toda>,<length>]<CR><LF><data>[...]] OK</p> <p>for SMS-STATUS-REPORTs: +CMGL: <index>,<stat>,<fo>,<mr>,[<ra>],[<tora>],<scts>,<dt>,<st>[<CR><LF> +CMGL: <index>,<stat>,<fo>,<mr>,[<ra>],[<tora>],<scts>,<dt>,<st>[...]] OK</p> <p>for SMS-COMMANDs: +CMGL: <index>,<stat>,<fo>,<ct>[<CR><LF> +CMGL: <index>,<stat>,<fo>,<ct>[...]] OK</p> <p>for CBM storage: +CMGL: <index>,<stat>,<sn>,<mid>,<page>,<pages><CR><LF><data>[<CR><LF> +CMGL: <index>,<stat>,<sn>,<mid>,<page>,<pages><CR><LF><data>[...]]OK</p> <p>2) If PDU mode (+CMGF=0) and command successful: +CMGL: <index>,<stat>,[<alpha>],<length><CR><LF><pdu>[<CR><LF>+CMGL: <index>,<stat>,<length><CR><LF><pdu>[...]] OK</p> <p>3) If error is related to ME functionality: +CMS ERROR: <err></p>
	<p>Parameter</p> <p><alpha> string type alphanumeric representation of <da> or <oa> corresponding to the entry found in MT phonebook; implementation of this feature is manufacturer-specific</p> <p><ct> GSM 03.40 TP-Command-Type in integer format (default 0)</p> <p><da> GSM 03.40 TP-Destination-Address Address-Value field in string format; BCD numbers (or GSM default alphabet characters) are converted into characters; type of address given by <toda></p> <p><data> In the case of SMS: GSM 03.40 TP-User-Data in text mode responses; format: -if <dcs> indicates that GSM 03.38 default alphabet is used and <fo> indicates that GSM 03.40 TP-User-Data-Header-Indication is not set: ME/TA converts GSM alphabet into current TE character set according to rules of Annex A -if <dcs> indicates that 8-bit or UCS2 data coding scheme is used, or <fo> indicates that GSM 03.40 TP-User-Data-Header-Indication is set: ME/TA converts each 8-bit octet into hexadecimal numbers containing two IRA characters (e.g. octet with integer value 42 is presented to TE as two characters 2A (IRA 50 and 65)) In the case of CBS: GSM 03.41 CBM Content of Message in text mode responses; format:</p> <p><dt> GSM 03.40 TP-Discharge-Time in time-string format: "yy/MM/dd,hh:mm:ss±zz", where characters indicate year (two last digits), month, day, hour, minutes, seconds and time zone. For example, 6th of May 1994, 22:10:00 GMT+2 hours equals "94/05/06,22:10:00+08"</p> <p><fo> depending on the command or result code: first octet of GSM 03.40 SMS-DELIVER, SMS-SUBMIT (default 17), SMS-STATUS-REPORT, or SMS-COMMAND (default 2) in integer format</p> <p>(continued next page)</p>

	<p>Parameter</p> <p><length> integer type value indicating in the text mode (+CMGF=1) the length of the message body <data> (or <cdata>) in characters; or in PDU mode (+CMGF=0), the length of the actual TP data unit in octets (i.e. the RP layer SMSC address octets are not counted in the length)</p> <p><index> integer type; value in the range of location numbers supported by the associated memory</p> <p><mid> GSM 03.41 CBM Message Identifier in integer format</p> <p><mr> GSM 03.40 TP-Message-Reference in integer format</p> <p><oa> GSM 03.40 TP-Originating-Address Address-Value field in string format; BCD numbers (or GSM default alphabet characters) are converted into characters; type of address given by <tooa></p> <p><pages> GSM 03.41 CBM Page Parameter bits 0-3 in integer format</p> <p><pdu> In the case of SMS: GSM 04.11 SC address followed by GSM 03.40 TPDU in hexadecimal format: ME/TA converts each octet of TP data unit into hexadecimal numbers containing two IRA characters (e.g. octet with integer value 42 is presented to TE as two characters 2A (IRA 50 and 65)). In the case of CBS: GSM 03.41 TPDU in hexadecimal format.</p> <p><page> GSM 03.41 CBM Page Parameter bits 4-7 in integer format</p> <p><ra> GSM 03.40 TP-Recipient-Address Address-Value field in string format; BCD numbers (or GSM default alphabet characters) are converted into characters; type of address given by <tora></p> <p><sets> GSM 03.40 TP-Service-Centre-Time-Stamp in time-string format (refer <dt>)</p> <p><sn> GSM 03.41 CBM Serial Number in integer format</p> <p><st> GSM 03.40 TP-Status in integer format</p> <p><toda> GSM 04.11 TP-Destination-Address Type-of-Address octet in integer format (when first character of <da> is + (IRA 43) default is 145, otherwise default is 129)</p> <p><tooa> GSM 04.11 TP-Originating-Address Type-of-Address octet in integer format (default refer<toda>)</p> <p><tora> GSM 04.11 TP-Recipient-Address Type-of-Address octet in integer format (default refer<toda>)</p>
Reference GSM 07.05	Note

AT+CMGR	Read SMS message
Test command AT+CMGR=?	Response OK Parameter
Execute command AT+CMGR= <index>	<p>Parameter <index> integer type; value in the range of location numbers supported by the associated memory</p> <p>Response TA returns SMS message with location value <index> from message storage <mem1> to the TE. If status of the message is 'received unread', status in the storage changes to 'received read'. 1) If text mode (+CMGF=1) and command successful: for SMS-DELIVER: +CMGR: <stat>,<oa>,[<alpha>],<scts> [,<tooa>,<fo>,<pid>,<dcs>,<sca>,<tosca>,<length>]<CR><LF><data> for SMS-SUBMIT: +CMGR: <stat>,<da>,[<alpha>] [,<toda>,<fo>,<pid>,<dcs>],[<vp>],<sca>,<tosca>,<length>]<CR><LF><data> for SMS-STATUS-REPORT: +CMGR: <stat>,<fo>,<mr>,[<ra>],[<tora>],<scts>,<dt>,<st> for SMS-COMMAND: +CMGR: <stat>,<fo>,<ct> [,<pid>,[<mn>],[<da>],[<toda>],<length>]<CR><LF><cdata>] for CBM storage: +CMGR: <stat>,<sn>,<mid>,<dcs>,<page>,<pages><CR><LF><data> 2) If PDU mode (+CMGF=0) and command successful: +CMGR: <stat>,[<alpha>],<length><CR><LF><pdu> OK 3) If error is related to ME functionality: +CMS ERROR: <err></p> <p>Parameter <stat> integer type in PDU mode (default 0), or string type in text mode (default "REC UNREAD"); indicates the status of message in memory; defined values: 0 "REC UNREAD" received unread message (i.e. new message) 1 "REC READ" received read message 2 "STO UNSENT" stored unsent message (only applicable to SMs) 3 "STO SENT" stored sent message (only applicable to SMs) 4 "ALL" all messages (only applicable to <i>AT+CMGL List SMS messages from preferred store</i> command)</p> <p><alpha> string type alphanumeric representation of <da> or <oa> corresponding to the entry found in MT phonebook; implementation of this feature is manufacturer-specific</p> <p><ct> GSM 03.40 TP-Command-Type in integer format (default 0)</p> <p><da> GSM 03.40 TP-Destination-Address Address-Value field in string format; BCD numbers (or GSM default alphabet characters) are converted into characters; type of address given by <toda></p> <p><data> In the case of SMS: GSM 03.40 TP-User-Data in text mode responses; format: (continued next page)</p>

Parameter	
-if <dc>	indicates that GSM 03.38 default alphabet is used and <fo> indicates that GSM 03.40 TP-User-Data-Header-Indication is not set: ME/TA converts GSM alphabet into current TE character set according to rules covered in Annex A
-if <dc>	indicates that 8-bit or UCS2 data coding scheme is used, or <fo> indicates that GSM 03.40 TP-User-Data-Header-Indication is set: ME/TA converts each 8-bit octet into hexadecimal numbers containing two IRA characters (e.g. octet with integer value 42 is presented to TE as two characters 2A (IRA 50 and 65)) In the case of CBS: GSM 03.41 CBM Content of Message in text mode responses; format: - if <dc> indicates that GSM 03.38 default alphabet is used: ME/TA converts GSM alphabet into current TE character set according to rules covered in Annex A -if <dc> indicates that 8-bit or UCS2 data coding scheme is used: ME/TA converts each 8-bit octet into hexadecimal numbers containing two IRA characters
<dc>	depending on the command or result code: GSM 03.38 SMS Data Coding Scheme (default 0), or Cell Broadcast Data Coding Scheme in integer format
<cdata>	GSM 03.40 TP-Command-Data in text mode responses; ME/TA converts each 8-bit octet into two IRA character long hexadecimal number (e.g. octet with integer value 42 is presented to TE as two characters 2A (IRA 50 and 65))
<dt>	GSM 03.40 TP-Discharge-Time in time-string format: “yy/MM/dd,hh:mm:ss±zz”, where characters indicate year (two last digits), month, day, hour, minutes, seconds and time zone. For example, 6th of May 1994, 22:10:00 GMT+2 hours equals “94/05/06,22:10:00+08”
<fo>	depending on the command or result code: first octet of GSM 03.40 SMS-DELIVER, SMS-SUBMIT (default 17), SMS-STATUS-REPORT, or SMS-COMMAND (default 2) in integer format
<length>	integer type value indicating in text mode (+CMGF=1) the length of the message body <data> (or <cdata>) in characters; or in PDU mode (+CMGF=0), the length of the actual TP data unit in octets (i.e. the RP layer SMSC address octets are not counted in the length)
<index>	integer type; value in the range of location numbers supported by the associated memory
<mid>	GSM 03.41 CBM Message Identifier in integer format
<mr>	GSM 03.40 TP-Message-Reference in integer format
<oa>	GSM 03.40 TP-Originating-Address Address-Value field in string format; BCD numbers (or GSM default alphabet characters) are converted into characters; type of address given by <toa>
<page>	GSM 03.41 CBM Page Parameter bits 4-7 in integer format
<pages>	GSM 03.41 CBM Page Parameter bits 0-3 in integer format
<pdu>	In the case of SMS: GSM 04.11 SC address followed by GSM 03.40 TPDU in hexadecimal format: ME/TA converts each octet of TP data unit into hexadecimal numbers containing two IRA characters (e.g. octet with integer value 42 is presented to TE as two characters 2A (IRA 50 and 65)). In the case of CBS: <ra> GSM 03.40 TP-Recipient-Address Address-Value field in string format; BCD numbers (or GSM default alphabet characters) are converted into characters; type of address given by <tora>
	(continued next page)

	<p><pid> GSM 03.40 TP-Protocol-Identifier in integer format (default 0)</p> <p><ra> GSM 03.40 TP-Recipient-Address Address-Value field in string format; BCD numbers (or GSM default alphabet characters) are converted to characters of the currently selected TE character set (refer command <i>AT+CSCS Select TE character set.</i>); type of address given by <tora></p> <p><sca> GSM 04.11 RP SC address Address-Value field in string format; BCD numbers (or GSM default alphabet characters) are converted to characters of the currently selected TE character set (refer command <i>AT+CSCS Select TE character set.</i>); type of address given by <tosca></p> <p><scts> GSM 03.40 TP-Service-Centre-Time-Stamp in time-string format (refer <dt>)</p> <p><sn> GSM 03.41 CBM Serial Number in integer format</p> <p><st> GSM 03.40 TP-Status in integer format</p> <p><toda> GSM 04.11 TP-Destination-Address Type-of-Address octet in integer format (when first character of <da> is + (IRA 43) default is 145, otherwise default is 129)</p> <p><tooa> GSM 04.11 TP-Originating-Address Type-of-Address octet in integer format (default refer <toda>)</p> <p><tora> GSM 04.11 TP-Recipient-Address Type-of-Address octet in integer format (default refer <toda>)</p> <p><tosca> GSM 04.11 RP SC address Type-of-Address octet in integer format (default refer <toda>)</p> <p><vp> depending on SMS-SUBMIT <fo> setting: GSM 03.40 TP-Validity-Period either in integer format (default 167) or in time-string format (refer <dt>)</p>
Reference GSM 07.05	Note

AT+CMGS		Send SMS message
Test command AT+CMGS=?	Response OK	Parameter
Execute command 1) If text mode (+CMGF=1): +CMGS=<da>[,<todo>]<CR> text is entered <ctrl-Z/ESC> 2) If PDU mode (+CMGF=0): +CMGS=<length> <CR> PDU is given <ctrl-Z/ESC> ESC aborts message	Response TA transmits SMS message from a TE to the network (SMS-SUBMIT). Message reference value <mr> is returned to the TE on successful message delivery. Value can be used to identify message upon unsolicited delivery status report result code. 1) If text mode (+CMGF=1) and sending successful: +CMGS: <mr>[,<sects>] OK 2) If PDU mode (+CMGF=0) and sending successful: +CMGS: <mr>[,<ackpdu>] OK 3) If error is related to ME functionality: +CMS ERROR: <err>	Parameter <da> GSM 03.40 TP-Destination-Address Address-Value field in string format; BCD numbers (or GSM default alphabet characters) are converted into characters; type of address given by <todo> <todo> GSM 04.11 TP-Destination-Address Type-of-Address octet in integer format (when first character of <da> is + (IRA 43) default is 145, otherwise default is 129) <length> integer type value indicating in the text mode (+CMGF=1) the length of the message body <data> (or <cdata>) in characters; or in PDU mode (+CMGF=0), the length of the actual TP data unit in octets (i.e. the RP layer SMSC address octets are not counted in the length) <mr> GSM 03.40 TP-Message-Reference in integer format <sects> GSM 03.40 TP-Service-Centre-Time-Stamp in time-string format (refer <dt>) <dt> GSM 03.40 TP-Discharge-Time in time-string format: "yy/MM/dd, hh:mm:ss±zz", where characters indicate year (two last digits), month, day, hour, minutes, seconds and time zone. For example, 6th of May 1994, 22:10:00 GMT+2 hours equals "94/05/06,22:10:00+08" <ackpdu> GSM 03.40 RP-User-Data element of RP-ACK PDU; format is same as for <pdu> in case of SMS, but without GSM 04.11 SC address field and parameter shall be enclosed in double quote characters like a normal string type parameter <pdu> In the case of SMS: GSM 04.11 SC address followed by GSM 03.40 TPDU in hexadecimal format: ME/TA converts each octet of TP data unit into hexadecimal numbers containing two IRA characters (e.g. octet with integer value 42 is presented to TE as two characters 2A (IRA 50 and 65)). In the case of CBS: GSM 03.41 TPDU in hexadecimal format.
Reference GSM 07.05	Note Use CTRL-Z at the end of input to send the message and return OK. Use ESC at the end of message input to abort message send operation. NO message is sent although display returns OK! Sending e-mails via SMS: Note that some providers do not recognise @ symbol. Possible alternative "!" for "@"	

AT+CMGW Write SMS message to memory	
Test command AT+CMGW=?	Response OK Parameter
Execute command 1) If text mode (+CMGF=1): +CMGW[=<oa/da>[,<tooa/todoa>[,<stat>]]] <CR> text is entered ctrl-Z/ESC<> <ESC> quits without sending 2) If PDU mode (+CMGF=0): +CMGW=<length>[,<stat>]<CR> PDU is given <ctrl-Z/ESC>	Response TA transmits SMS message (either SMS-DELIVER or SMS-SUBMIT) from TE to memory storage <mem2>. Memory location <index> of the stored message is returned. Message status will be set to 'stored unsent' unless otherwise given in <stat>. Note: SMS-COMMANDs and SMS-STATUS-REPORTs can not be stored in text mode. If writing is successful: +CMGW: <index> OK If error is related to ME functionality: +CMS ERROR: <err> Parameter <oa> GSM 03.40 TP-Originating-Address Address-Value field in string format; BCD numbers (or GSM default alphabet characters) are converted into characters; type of address given by <tooa> <da> GSM 03.40 TP-Destination-Address Address-Value field in string format; BCD numbers (or GSM default alphabet characters) are converted into characters; type of address given by <todoa> <tooa> GSM 04.11 TP-Originating-Address Type-of-Address octet in integer format (default refer <todoa>) <todoa> GSM 04.11 TP-Destination-Address Type-of-Address octet in integer format (when first character of <da> is + (IRA 43) default is 145, otherwise default is 129) <length> integer type value indicating in the text mode (+CMGF=1) the length of the message body <data> (or <cdata>) in characters; or in PDU mode (+CMGF=0), the length of the actual TP data unit in octets (i.e. the RP layer SMSC address octets are not counted in the length) <stat> 0 "REC UNREAD" Received unread messages (default) 1 "REC READ" Received read messages 2 "STO UNSENT" Stored unsent messages 3 "STO SENT" Stored sent messages 4 "ALL" All messages <pdu> In the case of SMS: GSM 04.11 SC address followed by GSM 03.40 TPDU in hexadecimal format: ME/TA converts each octet of TP data unit into hexadecimal numbers containing two IRA characters (e.g. octet with integer value 42 is presented to TE as two characters 2A (IRA 50 and 65)). In the case of CBS: GSM 03.41 TPDU in hexadecimal format. <index> Index of message in selected storage <mem2>
Reference GSM 07.05	Note ctrl-Z sends/writes message, Returns OK ESC aborts input, message NOT sent/written. Returns OK Sending e-mails via SMS: Note that some providers do not recognise @ symbol. Possible alternative "!" for "@"

AT+CMSS		Send SMS message from storage
Test command AT+CMSS=?	Response OK	Parameter
Execute command +CMSS= <index>[,<da> [,<toda>]]	Response TA sends message with location value <index> from message storage <mem2> to the network (SMS-SUBMIT or SMS-COMMAND). If new recipient address <da> is given for SMS-SUBMIT, it shall be used instead of the one stored with the message. Reference value <mr> is returned to the TE on successful message delivery. Values can be used to identify message upon unsolicited delivery status report result code. This command should be abortable. 1) If text mode (+CMGF=1) and send successful: +CMSS: <mr>[,<scts>] OK 2) If PDU mode (+CMGF=0) and send successful: +CMSS: <mr>[,<ackpdu>] OK 3) If error is related to ME functionality: +CMS ERROR: <err>	Parameter <ackpdu> GSM 03.40 RP-User-Data element of RP-ACK PDU; format is same as for <pdu> in case of SMS, but without GSM 04.11 SC address field and parameter shall be bounded by double quote characters like a normal string type parameter. <index> integer type; value in the range of location numbers supported by the associated memory <da> GSM 03.40 TP-Destination-Address Address-Value field in string format; BCD numbers (or GSM default alphabet characters) are converted into characters; type of address given by <toda> <scts> GSM 03.40 TP-Service-Centre-Time-Stamp in time-string format. <toda> GSM 04.11 TP-Destination-Address Type-of-Address octet in integer format (when first character of <da> is + (IRA 43) default is 145, otherwise default is 129) <mr> GSM 03.40 TP-Message-Reference in integer format
Reference GSM 07.05	Note	

AT+CNMI	New SMS message indications
Test command AT+CNMI=?	Response +CNMI: (list of supported <mode>s), (list of supported <mt>s), (list of supported <bm>s), (list of supported <ds>s), (list of supported <bfr>s) OK Parameter see set command
Read command AT+CNMI?	Response +CNMI: <mode>,<mt>,<bm>,<ds>,<bfr> OK Parameter see set command
Set command AT+CNMI = [<mode> [,<mt>[,<bm> [,<ds>[,<bfr>]]]]	Response TA selects the procedure, how the receipt of new SMS messages from the network is indicated to the TE when TE is active, e.g. DTR signal is ON. If TE is inactive (e.g. DTR signal is OFF), message receiving should be done as specified in GSM 03.38. <u>Note:</u> the rules <mt>=2 and <mt>=3 for storing received SM are possible <u>only if phase 2+</u> compatibility is activated with +CSMS=1 OK If error is related to ME functionality: +CMS ERROR: <err> Parameter <mode> 0 Buffer unsolicited result codes in the TA. If TA result code buffer is full, indications can be buffered in some other place or the oldest indications may be discarded and replaced with the new received indications. 1 Discard indication and reject new received message unsolicited result codes when TA-TE link is reserved (e.g. in on-line data mode). Otherwise forward them directly to the TE. 2 Buffer unsolicited result codes in the TA when TA-TE link is reserved (e.g. in on-line data mode) and flush them to the TE after reservation. Otherwise forward them directly to the TE. 3 Forward unsolicited result codes directly to the TE. TA-TE link specific in-band technique used to embed result codes and data when TA is in on-line data mode. <mt> (the rules for storing received SMs depend on the relevant data coding method (refer to GSM 03.38 [2]), preferred memory storage (+CPMS) setting and this value <u>Note:</u> if AT command interface is acting as the only display device, the ME must support storage of class 0 messages and messages in the message waiting indication group (discard message) 0 No SMS-DELIVER indications are routed to the TE. 1 If SMS-DELIVER is stored in ME/TA, indication of the memory location is routed to the TE using unsolicited result code: +CMTI: <mem>,<index> 2 SMS-DELIVERs (except class 2 messages and messages in the message waiting indication group (store message)) are routed directly to the TE using unsolicited result code: +CMT: [<alpha>], <length><CR><LF><pdu> (PDU mode enabled) 3 Class 3 SMS-DELIVERs are routed directly to the TE using unsolicited result codes defined in <mt>=2. Messages of other data coding schemes result in indication as defined in <mt>=1. (continued next page)

	<p><bm> (the rules for storing received CBMs depend on the relevant data coding method (refer to GSM 03.38 [2]), the setting of Select CBM Types (+CSCB) and this value:</p> <p><u>0</u> No CBM indications are routed to the TE.</p> <p>1 If CBM is stored in ME/TA, indication of the memory location is routed to the TE using unsolicited result code: +CBMI: <mem>,<index></p> <p>2 New CBMs are routed directly to the TE using unsolicited result code: +CBM: <length><CR><LF><pdu> (PDU mode enabled) or +CBM: <sn>,<mid>,<dcs>,<page>,<pages><CR><LF><data> (text mode enabled) If ME supports data coding groups which define special routing also for messages other than class 3 (e.g. SIM specific messages), ME may choose not to route messages of such data coding schemes into TE (indication of a stored CBM may be given as defined in <bm>=1).</p> <p><i>Note:</i> 2 SMS-DELIVERs routed directly to TE are NOT supported</p> <p><ds> <u>0</u> No SMS-STATUS-REPORTs are routed to the TE.</p> <p><bfr> <u>0</u> TA buffer of unsolicited result codes defined within this command is flushed to the TE when <mode> 1...3 is entered (OK response shall be given before flushing the codes).</p> <p>1 TA buffer of unsolicited result codes defined within this command is cleared when <mode> 1...3 is entered.</p>
	<p>Unsolicited result code</p> <p>+CMTI: <mem>,<index> Indication that new message has been received</p> <p>+CMT: <length><CR><LF><pdu> Short message is output directly</p> <p>+CBM: <length><CR><LF><pdu> Cell broadcast message is output directly</p>
<p>Reference GSM 07.05</p>	<p>Note Parameters can only be set to provider supported values</p>

AT+CPMS Preferred SMS message storage	
Test command AT+CPMS=?	Response +CPMS: (list of supported <mem1>s),(list of supported <mem2>s),(list of supported <mem3>s) Parameter see set command
Read command AT+CPMS?	Response +CPMS: <mem1>,<used1>,<total1>,<mem2>,<used2>,<total2>,<mem3>,<used3>,<total3> OK If error is related to ME functionality: +CMS ERROR Parameter see set command
Set command AT+CPMS = <mem1> [,<mem2> [,<mem3>]]	Response TA selects memory storages <mem1>, <mem2> and <mem3> to be used for reading, writing, etc. +CPMS: <used1>,<total1>,<used2>,<total2>,<used3>,<total3> OK If error is related to ME functionality: +CMS ERROR:<err> Parameter <mem1> Messages to be read and deleted from this memory storage "SM" SIM message storage <mem2> Messages will be written and sent to this memory storage "SM" SIM message storage <mem3> Received messages will be placed in this memory storage if routing to PC is not set ("CNMI") "SM" SIM message storage <usedx> Number of messages currently in <memx> <totalx> Number of messages storable in <memx>
Reference GSM 07.05	Note

AT+CRES Restore SMS settings	
Test command AT+CRES=?	Response +CRES: (list of supported <profile>s) OK Parameter
Execute command AT+CRES[= <profile>]	Response TA restores SMS settings for +CSCA, +CSMP from SIM card. OK If error is related to ME functionality: +CMS ERROR:<err> Parameter <profile> 0 manufacturer-specific profile number where setting are to be stored
Reference GSM 07.05	Note Only one user profile supported.

AT+CSAS Save SMS settings	
Test command AT+CSAS=?	Response +CSAS: (list of supported <profile>s) OK Parameter
Execute command AT+CSAS[= <profile>]	Response TA saves current message service settings for +CSCA , +CSMP to SIM card. OK If error is related to ME functionality: +CMS ERROR:<err> Parameter <profile> 0 manufacturer-specific profile number where settings are to be stored
Reference GSM 07.05	Note Only one user profile supported. Warning: If any SMS values are changed and saved on the SIM using the AT+CSAS command, then the original values are lost and cannot be reset.

AT+CSCA SMS service centre address	
Test command AT+CSCA=?	Response OK
Read command AT+CSCA?	Response +CSCA: <sca>,<tosca> OK Parameter see set command
Set command AT+CSCA = <sca>[,<tosca>]	Response TA updates the SMSC address, through which mobile originated SMs are transmitted. In text mode, setting is used by send and write commands. In PDU mode, setting is used by the same commands, but only when the length of the SMSC address coded into <pdu> parameter equals zero. OK Parameter <sca> GSM 04.11 RP SC address Address-Value field in string format; BCD numbers (or GSM default alphabet characters) are converted into characters; type of address given by <tosca> <tosca> Service centre address format GSM 04.11 RP SC address Type-of-Address octet in integer format (default refer <todo>) Note: If Parameter field <tosca> is ignored, national/international call center numbers are recognized by the leading + in the number.
Reference GSM 07.05	Note

AT+CSCB Select cell broadcast SMS messages	
Test command AT+CSCB=?	Response Test command returns supported modes as a compound value. +CSCB: (list of supported <mode>s) OK Parameter see set command
Read command AT+CSCB?	Response +CSCB: <mode>,<mids>,<dcss> OK Parameter see set command

Reference GSM 07.05	Note The CB SMS may be output in text or PDU format. The output format is set with the command <i>“AT+CMGF Select SMS message format” on page 94.</i> Message identifiers (MI) over 999 are intended for telemetric applications. These CB SMS are not stored permanently in the module, but are sent to the TE directly - taking account of the parameter <bm> in the <i>“AT+CNMI New SMS message indications”</i> command.
------------------------	--

AT+CSDH Show SMS text mode parameters	
Test command AT+CSDH=?	Response +CSDH: (list of supported <show>s) OK Parameter see set command
Read command AT+CSDH?	Response +CSDH:<show> OK Parameter see set command
Set command AT+CSDH= <show>	Response TA sets whether or not detailed header information is shown in text mode result codes. OK Parameter <show> 0 do not show header values defined in commands +CSCA and +CSMP (<sca>, <tosca>, <fo>, <vp>, <pid> and <dc>) nor <length>, <toda> or <tooa> in +CMT, +CMGL, +CMGR result codes for SMS-DELIVERs and SMS-SUBMITs in text mode; for SMS-COMMANDs in +CMGR result code, do not show <pid>, <mn>, <da>, <toda>, <length> or <cdata> 1 show the values in result codes
Reference GSM 07.05	Note

AT+CSMP Set SMS text mode parameters	
Test command AT+CSMP=?	Response OK
Read command AT+CSMP?	Response +CSMP:<fo>,<vp>,<pid>,<dcs> OK Parameter see set command
Set command AT+CSMP=[<fo>[<vp>[,<pid>[,<dcs>]]]]	Response TA selects values for additional parameters needed when SM is sent to the network or placed in a storage when text format message mode is selected. It is possible to set the validity period starting from when the SM is received by the SMSC (<vp> is in range 0... 255) or define the absolute time of the validity period termination (<vp> is a string). Parameter <fo> depending on the command or result code: first octet of GSM 03.40 SMS-DELIVER, SMS-SUBMIT (default 17), or SMS-COMMAND (default 2) in integer format <vp> depending on SMS-SUBMIT <fo> setting: GSM 03.40 TP-Validity-Period either in integer format (default 167) <pid> Protocol-Identifier in integer format (default 0), refer GSM 03.40 <dcs> SMS Data Coding Scheme (default 0), or Cell Broadcast Data Coding Scheme in integer format depending on the command or result code: GSM 03.38
Reference GSM 07.05	Note The command writes the parameters in NON-VOLATILE memory with <i>"AT+CSAS Save SMS settings"</i> .

AT+CSMS Select Message Service	
Test command AT+CSMS=?	Response +CSMS: (list of supported <service>s) OK Parameter see set command
Read command AT+CSMS?	Response +CSMS: <service>,<mt>,<mo>,<bm> OK Parameter see set command
Set command AT+CSMS= <service>	Response +CSMS: <mt>,<mo>,<bm> OK If error is related to ME functionality: +CMS ERROR: <err> Parameter <service> 0 GSM 03.40 and 03.41 (the syntax of SMS AT commands is compatible with GSM 07.05 Phase 2 version 4.7.0; Phase 2+ features which do not require new command syntax may be supported (e.g. correct routing of messages with new Phase 2+ data coding schemes)) 1 GSM 03.40 and 03.41 (the syntax of SMS AT commands is compatible with GSM 07.05 Phase 2+ version; the requirement of <service> setting 1 is mentioned under corresponding command descriptions) Currently not available with the M20. <mt> 128 Compatibility to Phase 1 and to device type M1 (manufacturer specific) Mobile Terminated Messages: 0 Type not supported 1 Type supported <mo> Mobile Originated Messages: 0 Type not supported 1 Type supported <bm> Broadcast Type Messages: 0 Type not supported 1 Type supported

Reference	Note
GSM 07.05	

5.7 Siemens-defined AT commands for enhanced functions

Self-defined commands do not have to be implemented in accordance with the official syntax. The "+C" string can therefore be replaced by "^S" ("^" = 0x5E). If a self-defined command with the same syntax is to be included in future in the GSM recommendations, the command can be addressed with both strings.

5.7.1 List of commands

List of Siemens-defined commands	Function	
AT^SACM	Advice of Charge and query of ACM and ACMmax	Page 111
AT^SCID	Display SIM card identification number	Page 113
AT^SCKS	Set SIM conn. presentation. mode and query SIM conn. status	Page 113
AT^SCNI	List Call Number Information	Page 114
AT^SCTM	Set critical operating temp. present. mode or query temp.	Page 114
AT^SLCK	Facility lock (including Siemens-defined locks)	Page 116
AT^SMGL	List SMS messages from preferred storage without changing status to read	Page 118
AT^SMGO	Set or query SMS overflow present. mode or query SMS overflow	Page 118
AT^SMGR	Read SMS message without set to REC READ	Page 119
AT^SMSO	Switch off mobile station	Page 122
AT^SNFA	Set or query of microphone attenuation	Page 122
AT^SNFE	Set or query echo suppression parameters	Page 123
AT^SNFI	Set microphone path parameters	Page 124
AT^SNFM	Mute microphone	Page 124
AT^SNFO	Set or query audio output (= loudspeaker path) parameters	Page 125
AT^SNFS	Select audio hardware set	Page 126
AT^SNFV	Set or query loudspeaker volume	Page 126
AT^SPIC	Display PIN counter	Page 126
AT^SPLM	Read the PLMN list	Page 126
AT^SPLR	Read entry from the preferred operator list	Page 127
AT^SPLW	Write an entry to the preferred operator list	Page 128
AT^SPWD	Change password for a lock (including Siemens-defined locks)	Page 130
AT^SRTC	Select, query or test ringing tone	Page 131
AT^MONI	Monitor mode in Idle mode	Page 133
AT^MONP	Monitor neighbour cells	Page 135
AT+CXXCID	Display card ID (identical to AT^SCID)	Page 136

Table 5-4 Siemens-defined AT commands

5.7.2 Detailed description

AT^SACM	Advice of charge and query of ACM and ACMmax
Test command AT^SACM=?	Response ^SACM: (list of supported <n>s) OK Parameter see set command

<p>Read command AT^SACM</p>	<p>Response TA returns the Advice of Charge supplementary service function mode and the SIM values for accumulated call meter (ACM) and accumulated call meter maximum (ACMmax). ^SACM: <n>,<acm>,<acm_max> OK If error is related to ME functionality: +CME ERROR: <err> Parameter see set command</p>
<p>Set command AT^SACM=<n></p>	<p>Response TA sets the Advice of Charge supplementary service function mode. OK Parameter <n> 0 suppress unsolicited result code 1 display unsolicited result code <acm> ACM, string type; three bytes of the current ACM value in hexadecimal format (e.g. "00001E" indicates decimal value 30) 000000–FFFFFF <acm_max> ACMmax, string type; three bytes of the max. ACM value in hexadecimal format (e.g. "00001E" indicates decimal value 30) 000000 disable ACMmax feature 000001–FFFFFF <ccm> string type; three bytes of the current CCM value in hexadecimal format (e.g. "00001E" indicates decimal value 30); bytes are coded in the same way as ACMmax value in the SIM 000000–FFFFFF</p>
	<p>Unsolicited result code When activated, an unsolicited result code is sent when the CCM value changes, but not more that every 10 seconds +CCCM: <ccm> Parameter see set command</p>
<p>Reference GSM07.07: AT+CACM, AT+CAMM, AT+CAOC</p>	<p>Note</p>

AT^SCID		Display SIM card identification number
Test command AT^SCID=?	Response OK	Parameter
Execute command AT^SCID	Response TA returns the card identification number in SIM (SIM file EF ICCID, see GSM 11.11 Chapter 10.1.1). ^SCID: <cid> OK If error is related to ME functionality: +CME ERROR: <err>	Parameter <cid> string type: card identification number in SIM
Reference	Note	

AT^SCKS		Set SIM connection presentation mode and query SIM connection status												
Test command AT^SCKS=?	Response ^SCKS: (list of supported <n>s) OK	Parameter see set command												
Read command AT^SCKS?	Response TA returns SIM connected presentation mode and SIM connected status. ^SCKS: <n>, <m> OK	Parameter see set command												
Set command AT^SCKS=<n>	Response TA sets SIM connected presentation mode whether or not an unsolicited result code is to be sent to TE when SIM is not connected. OK	Parameter <table border="0"> <tr> <td><n></td> <td>0</td> <td>Suppress unsolicited result codes</td> </tr> <tr> <td></td> <td>1</td> <td>Output unsolicited result codes</td> </tr> <tr> <td><m></td> <td>0</td> <td>No card</td> </tr> <tr> <td></td> <td>1</td> <td>Card in card reader</td> </tr> </table>	<n>	0	Suppress unsolicited result codes		1	Output unsolicited result codes	<m>	0	No card		1	Card in card reader
<n>	0	Suppress unsolicited result codes												
	1	Output unsolicited result codes												
<m>	0	No card												
	1	Card in card reader												
	Unsolicited result code When the status SIM connected has changed, an unsolicited result code is sent to TE ^SCKS: <m>	Parameter see set command												
Reference	Note													

AT^SCNI List Call Number Information	
Test command AT^SCNI=?	Response OK
Execute command AT^SCNI	Response TA returns a list of current calls of ME. [^SCNI: <id1>[,<cs>[,<number>,<type>]]] [^SCNI: <id2>[,<cs>[,<number>,<type>]]] [...] OK If error is related to ME functionality: +CME ERROR: <err> Parameter <idx> integer type; call identification number as described in GSM 02.30[19] subclause 4.5.5.1; this number can be used in +CHLD command operations 1-7 <cs> Call status of respective call number (first parameter) 0 call hold 1 call in progress 2 Waiting call <number> string type phone number in format specified by <type> <type> type of address octet in integer format; 145 when dialling string includes international access code character "+", otherwise 129
Reference Siemens, GSM 07.07: AT+CLCC	Note

AT^SCTM Set critical operating temp. present. mode or query temp.	
Test command AT^SCTM=?	Response ^SCTM: (list of supported <n>s) OK Parameter see set command
Read command AT^SCTM?	Response TA returns setting critical operating temperature presentation mode and temperature data ^SCTM: <n>, <m> OK Parameter see set command
Set command AT^SCTM=<n>	Response TA sets critical operating temperature presentation mode OK Parameter <n> 0 Suppress unsolicited result codes 1 Output unsolicited result codes <m> 0 Below critical temperature 1 Above critical temperature (message issued when temperature of the M20-PCB is > 75°C) 2 Device switched off (this message is issued when the temperature of the M20-PCB is > 80°C), device immediately deregisters and switches off. Unsolicited result code When the temperature data has changed, an unsolicited result code is sent to TE ^SCTM: <m> Parameter see set command
Reference GSM Engine A1	Note Important: The device switches off (like AT^SMSO) even if <n> is 0 and user is not informed.

AT^SFPCS		Far party call status	
Test command AT^SFPCS=?	Response OK		
Read command AT^SFPCS?	Response ^SFPCS: <mode>	Parameter <mode>	0 or 1 representing the setting of unsolicited result code presentation.
Set command AT^SFPCS=<mode>	Response Set the presentation of unsolicited result codes or query status of current calls. ^SFPCS: <idx>, <hld>, <mpty> if <mode> = 2	Parameter <mode>	(mode of presentation) 0 Unsolicited result codes off 1 Unsolicited result codes on 2 Query status of all connections
	<idx>		Call index (value as in AT+CLCC)
	<hld>		(Call is on held by remote party): 0 no 1 yes
	<mpty>		(Call is in multiparty by remote party): 0 no 1 yes
Reference	Unsolicited result code Unsolicited result codes are sent only by state change on remote party: ^SHELD: <idx>, <hld> ^SMPTY: <idx>, <mpty>		

AT^SLCK	Facility lock (including self-defined locks)
Test command AT^SLCK=?	Response ^SLCK: (list of supported <fac>s) OK Parameter see execute command
Execute command AT^SLCK = <fac>, <mode> [,<passwd> [,<class>]]	Response This command is used to lock, unlock or interrogate a ME or a network facility <fac>. Password is normally needed for such actions. When querying the status of a network service (<mode>=2) the response line for 'not active' case (<status>=0) should be returned only if service is not active for any <class>. It should be possible to abort the command when network facilities are set or interrogated. If <mode><>2 and command is successful OK If <mode>=2 and command successful ^SLCK: <status>[,<class1>[<CR><LF> ^SLCK: <status>, class2....]] OK If error is related to ME functionality: +CME ERROR: <err> Parameter <fac> "PS" PH-SIM (lock PHone to SIM card) (ME requests password when other than current SIM card inserted; ME may remember certain number of previously used cards thus not requiring password when they are inserted) "SC" SIM (lock SIM cards) (SIM requests password at ME power-up and when this lock command issued) "FD" SIM fixed dialling memory feature (if PIN2 authentication has not been performed during the current session, PIN2 is required as <passwd>) "AO" BAO (Bar All Outgoing Calls) "OI" BOIC (Bar Outgoing International Calls) "OX" BOIC-exHC (Bar Outgoing International Calls except to Home Country) "AI" BAIC (Bar All Incoming Calls) "IR" BIC-Roam (Bar Incoming Calls when Roaming outside the home country) "AB" All Barring services (applicable only for <mode>=0) "AG" All Outgoing barring services (applicable only for <mode>=0) "AC" All inComing barring services (applicable only for <mode>=0) "PN" Network Personalisation (refer GSM 02.22[33]) "PU" Network Subset Personalisation (refer GSM 02.22[33]) "PP" Service Provider Personalisation (refer GSM 02.22[33]) "PC" Corporate Personalisation (refer GSM 02.22[33]) <mode> 0 disable lock 1 enable lock 2 query lock status <passwd> password if <fac> = "PS" then user password if <fac> = "SC" then PIN if <fac> = "FD" then PIN2 if <fac> = "AO"... "AC" (Barring) then Network password if <fac> = "PN"... "PC" then user password <class> 1 voice 2 data 4 fax 7 all classes (default) <status> 0 off 1 on

Reference GSM 07.07: AT+CLCK	Note
------------------------------------	------

AT^SMGL List SMS messages from preferred storage without changing status to read	
Test command AT^SMGL=?	Response see set command <i>“AT+CMGL List SMS messages from preferred store”</i> Parameter see command <i>“AT+CMGL List SMS messages from preferred store”</i>
Execute command AT^SMGL [=<stat>]	Response TA returns messages with status value <stat> from message storage <mem1> to the TE. The status of the messages is <u>unchanged</u> (unread remains unread). Otherwise: see command <i>“AT+CMGL List SMS messages from preferred store”</i> Parameter see command <i>“AT+CMGL List SMS messages from preferred store”</i>
Reference GSM Engine A1, GSM 07.05	Note

AT^SMGO Set or query SMS overflow presentation mode or query SMS overflow															
Test command AT^SMGO=?	Response ^SMGO: (list of supported <n>s) OK Parameter see set command														
Read command AT^SMGO?	Response TA returns overflow presentation mode and SMS overflow status ^SMGO: <n>,<mode> OK Parameter see set command														
Set command AT^SMGO=<n>	Response TA sets overflow presentation mode OK Parameter <table border="0"> <tr> <td><n></td> <td>SMS overflow presentation mode</td> </tr> <tr> <td>0</td> <td>disable (default)</td> </tr> <tr> <td>1</td> <td>enable</td> </tr> </table> <table border="0"> <tr> <td><mode></td> <td>SMS overflow status</td> </tr> <tr> <td>0</td> <td>space available</td> </tr> <tr> <td>1</td> <td>SMS buffer full (chip card)</td> </tr> <tr> <td>2</td> <td>Buffer full and new message waiting in SC for delivery to phone</td> </tr> </table>	<n>	SMS overflow presentation mode	0	disable (default)	1	enable	<mode>	SMS overflow status	0	space available	1	SMS buffer full (chip card)	2	Buffer full and new message waiting in SC for delivery to phone
<n>	SMS overflow presentation mode														
0	disable (default)														
1	enable														
<mode>	SMS overflow status														
0	space available														
1	SMS buffer full (chip card)														
2	Buffer full and new message waiting in SC for delivery to phone														
	Unsolicited result code When the status SIM overflow changes, an unsolicited result code is sent to TE ^SMGO: <mode> Parameter see set command														
Reference Siemens	Note														

AT^SMGR Read SMS message without set to REC READ	
Test command AT^SMGR	Response OK
Execute command AT^SMGR= <index>	<p>Parameter <index> integer type; value in the range of location numbers supported by the associated memory</p> <p>Response TA returns SMS message with location value <index> from message storage <mem1> to the TE.</p> <p>1) If text mode (+CMGF=1) and command successful: for SMS-DELIVER: +CMGR: <stat>,<oa>,[<alpha>],<scts> [,<tooa>,<fo>,<pid>,<dcsc>,<sca>,<tosca>,<length>]<CR><LF><data> for SMS-SUBMIT: +CMGR: <stat>,<da>,[<alpha>] [,<toda>,<fo>,<pid>,<dcsc>,[<vp>],<sca>,<tosca>,<length>]<CR><LF><data> for SMS-STATUS-REPORT: +CMGR: <stat>,<fo>,<mr>,[<ra>],[<tora>],<scts>,<dt>,<st> for SMS-COMMAND: +CMGR: <stat>,<fo>,<ct> [,<pid>],[<mn>],[<da>],[<toda>],<length>]<CR><LF><cdata>] for CBM storage: +CMGR: <stat>,<sn>,<mid>,<dcsc>,<page>,<pages><CR><LF><data></p> <p>2) If PDU mode (+CMGF=0) and command successful: +CMGR: <stat>,[<alpha>],<length><CR><LF><pdu> OK</p> <p>3) If error is related to ME functionality: +CMS ERROR: <err></p> <p>Parameter <stat> integer type in PDU mode (default 0), or string type in text mode (default "REC UNREAD"); indicates the status of message in memory; defined values: 0 "REC UNREAD" received unread message (i.e. new message) 1 "REC READ" received read message 2 "STO UNSENT" stored unsent message (only applicable to SMs) 3 "STO SENT" stored sent message (only applicable to SMs) 4 "ALL" all messages (only applicable to <i>AT+CMGL List SMS messages from preferred store</i> command)</p> <p><alpha> string type alphanumeric representation of <da> or <oa> corresponding to the entry found in MT phonebook; implementation of this feature is manufacturer-specific</p> <p><ct> GSM 03.40 TP-Command-Type in integer format (default 0)</p> <p><da> GSM 03.40 TP-Destination-Address Address-Value field in string format; BCD numbers (or GSM default alphabet characters) are converted into characters; type of address given by <toda></p> <p><data> In the case of SMS: GSM 03.40 TP-User-Data in text mode responses; format: (continued next page)</p>

Parameter	
-if <dc>	indicates that GSM 03.38 default alphabet is used and <fo> indicates that GSM 03.40 TP-User-Data-Header-Indication is not set: ME/TA converts GSM alphabet into current TE character set according to rules covered in Annex A
-if <dc>	indicates that 8-bit or UCS2 data coding scheme is used, or <fo> indicates that GSM 03.40 TP-User-Data-Header-Indication is set: ME/TA converts each 8-bit octet into hexadecimal numbers containing two IRA characters (e.g. octet with integer value 42 is presented to TE as two characters 2A (IRA 50 and 65)) In the case of CBS: GSM 03.41 CBM Content of Message in text mode responses; format: - if <dc> indicates that GSM 03.38 default alphabet is used: ME/TA converts GSM alphabet into current TE character set according to rules covered in Annex A -if <dc> indicates that 8-bit or UCS2 data coding scheme is used: ME/TA converts each 8-bit octet into hexadecimal numbers containing two IRA characters
<dc>	depending on the command or result code: GSM 03.38 SMS Data Coding Scheme (default 0), or Cell Broadcast Data Coding Scheme in integer format
<cdata>	GSM 03.40 TP-Command-Data in text mode responses; ME/TA converts each 8-bit octet into two IRA character long hexadecimal number (e.g. octet with integer value 42 is presented to TE as two characters 2A (IRA 50 and 65))
<dt>	GSM 03.40 TP-Discharge-Time in time-string format: “yy/MM/dd,hh:mm:ss±zz”, where characters indicate year (two last digits), month, day, hour, minutes, seconds and time zone. For example, 6th of May 1994, 22:10:00 GMT+2 hours equals “94/05/06,22:10:00+08”
<fo>	depending on the command or result code: first octet of GSM 03.40 SMS-DELIVER, SMS-SUBMIT (default 17), SMS-STATUS-REPORT, or SMS-COMMAND (default 2) in integer format
<length>	integer type value indicating in text mode (+CMGF=1) the length of the message body <data> (or <cdata>) in characters; or in PDU mode (+CMGF=0), the length of the actual TP data unit in octets (i.e. the RP layer SMSC address octets are not counted in the length)
<index>	integer type; value in the range of location numbers supported by the associated memory
<mid>	GSM 03.41 CBM Message Identifier in integer format
<mr>	GSM 03.40 TP-Message-Reference in integer format
<oa>	GSM 03.40 TP-Originating-Address Address-Value field in string format; BCD numbers (or GSM default alphabet characters) are converted into characters; type of address given by <toa>
<page>	GSM 03.41 CBM Page Parameter bits 4-7 in integer format
<pages>	GSM 03.41 CBM Page Parameter bits 0-3 in integer format
<pdu>	In the case of SMS: GSM 04.11 SC address followed by GSM 03.40 TPDU in hexadecimal format: ME/TA converts each octet of TP data unit into hexadecimal numbers containing two IRA characters (e.g. octet with integer value 42 is presented to TE as two characters 2A (IRA 50 and 65)). In the case of CBS: <ra> GSM 03.40 TP-Recipient-Address Address-Value field in string format; BCD numbers (or GSM default alphabet characters) are converted into characters; type of address given by <tora>
	(continued next page)

	<p><pid> GSM 03.40 TP-Protocol-Identifier in integer format (default 0)</p> <p><ra> GSM 03.40 TP-Recipient-Address Address-Value field in string format; BCD numbers (or GSM default alphabet characters) are converted to characters of the currently selected TE character set (refer command <i>AT+CSCS Select TE character set.</i>); type of address given by <tora></p> <p><sca> GSM 04.11 RP SC address Address-Value field in string format; BCD numbers (or GSM default alphabet characters) are converted to characters of the currently selected TE character set (refer command <i>AT+CSCS Select TE character set.</i>); type of address given by <tosca></p> <p><scts> GSM 03.40 TP-Service-Centre-Time-Stamp in time-string format (refer <dt>)</p> <p><sn> GSM 03.41 CBM Serial Number in integer format</p> <p><st> GSM 03.40 TP-Status in integer format</p> <p><toda> GSM 04.11 TP-Destination-Address Type-of-Address octet in integer format (when first character of <da> is + (IRA 43) default is 145, otherwise default is 129)</p> <p><tooa> GSM 04.11 TP-Originating-Address Type-of-Address octet in integer format (default refer <toda>)</p> <p><tora> GSM 04.11 TP-Recipient-Address Type-of-Address octet in integer format (default refer <toda>)</p> <p><tosca> GSM 04.11 RP SC address Type-of-Address octet in integer format (default refer <toda>)</p> <p><vp> depending on SMS-SUBMIT <fo> setting: GSM 03.40 TP-Validity-Period either in integer format (default 167) or in time-string format (refer <dt>)</p>
Reference GSM 07.05	<p>Note</p> <p>The AT^SMGR command is a specific Siemens command with the same syntax as <i>“AT+CMGR Read SMS message”</i>. The only difference is that the SMS Message, which has REC_UNREAD status, is not overwritten to REC_READ.</p>

AT^SMSO		Switch off mobile station turn off	
Test command AT^SMSO=?	Response OK		
Execute command AT^SMSO	Response Device switches off immediately (max. deactivation time 1.5 s–6 s) OK <i>Note1:</i> the IGNITION signal is checked every 100 ms. If the signal goes LOW, another two checks are performed at 100 ms intervals to ascertain whether the signal remains LOW. If it does, the shut-down sequence is initiated (for details, see “AT^SMSO”). If the two additional checks show that the signal is no longer LOW, the checks sequence restarts. <i>Note2:</i> if signal of connector 1 is set to low = device is switched off. Parameter		
Reference	Note		

AT^SNFA		Set or query of microphone attenuation	
Test command AT^SNFA=?	Response ^SNFA: (list of supported <atten>s) OK Parameter see set command		
Read command AT^SNFA?	Response TA returns the attenuation value. <i>Note:</i> if microphone is muted, TA returns value 0. ^SNFA: <atten> OK Parameter see set command		
Set command AT^SNFA= <atten>	Response TA controls the large-scale attenuation on the microphone path. <i>Note:</i> if microphone is muted, set is disabled. OK Parameter <atten> attenuation/dB = 20*log (<atten> /16384 0 (0x0) – 65535 (0xFFFF)		
Reference GSM Engine A1	Note Value 0 can be set only by AT^SNFM=0		

AT^SNFE		Set or query echo parameters	
Test command AT^SNFE=?	Response ^SNFE: (list of supported < voxGain >s), (list of supported < minMicEnergy >s), (list of supported < samplesSilencePeriod >s), (list of supported < continueSuppressPeriod >s) OK Parameter see set command		
Read command AT^SNFE?	Response ^SNFE: < voxGain >, < minMicEnergy >, < samplesSilencePeriod >, < continueSupressPeriod > OK Parameter see set command		
Set command AT^SNFE=<vox-Gain>,<minMi-cEnergy>,<sampleSilencePe-riod>,<continueSuppres-sPeriod>	Response TA sets echo parameters. Echo suppression takes place if the earpiece energy scaled by < voxGain > is greater than microphone energy, and microphone energy is greater than < minMicEnergy >. If there is silence, < sampleSilencePeriod > of frames will be transmitted before a silence frame is saved. If the echo suppression conditions are not met, echo suppression will be continued for < con-tinueSuppressPeriod > frames. OK		
	Parameter <voxGain> Scaling factor for earpiece signal in echo suppression. Scaling factor=20*log(voxGain/32768) Value range: 0(0x0)-32767(0x7FFF) <minMicEnergy> Minimum energy at the microphone before echo suppression can take place (usually set to 0) Value range: 0(0x0)-32767(0x7FFF) <sampleSilencePeriod> Number of 20-ms speech frames after the speech transcoder indicates there is silence before a 'silence' frame is saved. Used to allow speech to decay to the background (silence) level. Value range: 0(0x0)-32767(0x7FFF) <continueSuppressPeriod> Number of extra 20-ms speech frames during which echo suppression is continued after the echo suppression condition cases Value range: 0(0x0)-32767(0x7FFF)		
Reference	Note This command is only used with (AT^SNFS=3) audio mode 3.		

AT^SNFO Set or query of audio output (= loudspeaker path) parameters	
Test command AT^SNFO=?	Response ^SNFO: (list of supported <outBbcGain>), (list of supported <outCalibrate>s), (list of supported <speechVol>), (list of supported <sideTone>s) OK Parameter see set command
Read command AT^SNFO?	Response ^SNFO: <outBbcGain>, <outCalibrate>, <speechVol>, <sideTone> OK Parameter see set command
Set command AT^SNFO=<outBbcGain> <outCalibrate[0]>... <outCalibrate[7]> <speechVol> <sideTone>	Response TA sets loudspeaker path parameters OK. Parameter <outBbcGain> Setting for DAC gain amplifier attenuation (0 ≡ 6 dB, 7 ≡ 15 dB, 8 steps of 3 dB) 0(0x0)-7(0x7) <outCalibrate[0]> <outCalibrate[7]> Multiplication factor for output samples Attenuation = 20 * log (outCalibrate[n] / 32768) (0(0x0)- 65535(0xFFFF)) <speechVol> Setting of actual volume; 0(0x0)-7(0x7) <sideTone> Multiplication factor determining how much of the original microphone signal is added to the earpiece signal. Side tone gain/dB = 20 * log (sidetone/32768) 0(00x0)-65535(0xFFFF)
Reference	Note Set command only works in audio mode 3.

AT^SNFS		Select audio hardware set	
Test command AT^SNFS=?	Response ^SNFS: (list of supported <n>s) OK	Parameter see set command	
Read command AT^SNFS?	Response ^SNFS: <n> OK	Parameter see set command	
Set command AT^SNFS=<n>	Response TA activates the selected audio mode. OK	Parameter <n> 1(0x1) Audio mode 1: standard mode approved for handset, V38140-H-X33) 3(0x3) Audio mode3: customer specific mode; all audio parameters can be adjusted using AT commands	
Reference GSM Engine A1	Note The command does the same as +VIP. For more details, see relevant section.		

AT^SNFV		Set or query loudspeaker volume	
Test command AT^SNFV=?	Response ^SNFV: (list of supported <vol>s) OK	Parameter see set command	
Read command AT^SNFV?	Response ^SNFV: <vol> OK	Parameter see set command	
Set command AT^SNFV=<vol>	Response TA controls the volume of the loudspeaker. OK	Parameter <vol> Volume range (0 to 7) (0 low...7 max. volume; approx. 3 dB/stage)	
Reference	Note		

AT^SPIC		Display PIN counter	
Test command AT^SPIC=?	Response OK	Parameter	
Execute command AT^SPIC	Response TA returns the number of attempts still available for entering the required password. <i>Note</i> : command "AT+CPIN?" to check which password is currently required ^SPIC: <counter> OK If error is related to ME functionality: +CME ERROR: <err>	Parameter <counter> Number of attempts still available for entering the required password.	
Reference	Note		

AT^SPLM		Read the PLMN list	
----------------	--	---------------------------	--

Test command AT^SPLM=?	Response OK Parameter
Execute command AT^SPLM	Response TA returns the list of operator names from the ME. Each operator code <numeric> that has an alphanumeric equivalent <alphan> in the ME memory is returned. ^SPLM: numeric <numeric1>,long alphanumeric <alpha1><CR><LF> ^SPLM:.....OK Parameter <numeric> string type; operator in numeric form; GSM location area identification number <alphan> string type; operator in long alphanumeric format; can contain up to 16 characters
Reference GSM 07.07: +CO-PN, +COPS	Note

AT^SPLR Read entry from the preferred operator list	
Test command AT^SPLR=?	Response TA returns the whole index range supported by the SIM. ^SPLR (list of supported <index>s) OK If error is related to ME functionality: +CME ERROR: <err> Parameter see execute command
Execute command AT^SPLR= <index1> [,<index2>]	Response TA returns used entries from the SIM list of preferred operators with <index> between <index1> and <index2>. If <index2> is not given, only entry with <index1> is returned. ^SPLR: <index1>, numeric <oper> ^SPLR: ... ^SPLR: <index2>, numeric <oper> OK If error is related to ME functionality: +CME ERROR: <err> Parameter <index1> location number to read from <index2> location number to read to (default: <index1>) <oper> string type; operator in numeric format; GSM location area identification number <index> location number
Reference GSM 07.07, AT+CPOL	Note:

AT^SPLW Write an entry to the preferred operator list	
Test command AT^SPLW=?	<p>Response</p> <p>TA returns the whole index range supported by the SIM.</p> <p>^SPLW: (list of supported <index>s) OK</p> <p>If error is related to ME functionality:</p> <p>+CME ERROR: <err></p> <p>Parameter see execute command</p>
Execute command AT^SPLW= <index> [,<oper>]	<p>TA writes an entry to the SIM list of preferred operators (EFPLMNsel) at location number <index>. If <index> is given but <oper> is left out, the entry is deleted.</p> <p><index> location number</p> <p><oper> string type; operator in numeric format; GSM location area identification number</p> <p>Response</p> <p>OK</p> <p>If error is related to ME functionality:</p> <p>+CME ERROR: <err></p>
Reference GSM 07.07: AT+CPOL	<p>Note:</p> <p><oper> is a 5 digit number. 3 digits country code and 2 digits for the network provider</p>

AT^SPWC	List password counter
Execute command AT^SPWC	<p>Response</p> <p>TA returns the number of attempts still available for entering the required password.</p> <p>^SPWC: <code> <counter></p> <p>OK</p> <p><u>If facility locks are disabled:</u></p> <p>^SPWC: SIM PIN 3</p> <p>^SPWC: SIM PUK 10</p> <p>^SPWC: SIM PIN2 3</p> <p>^SPWC: SIM PUK2 10</p> <p>OK</p> <p><u>If facility locks are enabled:</u></p> <p>^SPWC: SIM PIN 3</p> <p>^SPWC: SIM PUK 10</p> <p>^SPWC: SIM PIN2 3</p> <p>^SPWC: SIM PUK2 10</p> <p>^SPWC: PH-SIM PIN 3</p> <p>^SPWC: PH-NET PIN 3</p> <p>^SPWC: PH-NETSUB PIN 3</p> <p>^SPWC: PH-SP PIN 3</p> <p>^SPWC: PH-CORP PIN 3</p> <p>OK</p> <p>If error is related to ME functionality:</p> <p>+CME ERROR: <err></p> <p>Parameter</p> <p><code> SIM PIN</p> <p> SIM PUK</p> <p> SIM PIN2</p> <p> SIM PUK2</p> <p> PH-SIM PIN (lock PPhone to SIM card)</p> <p> PH-NET PIN Network Personalisation (refer GSM 02.22[33])</p> <p> PH-NETSUB PIN Network Subset Personalisation (refer GSM 02.22[33])</p> <p> PH-SP PIN Service Provider Personalisation (refer GSM 02.22[33])</p> <p> PH-CORP PIN Corporate Personalisation (refer GSM 02.22[33])</p> <p><counter> Number of attempts still available for entering the required password.</p>
Reference Refer GSM 07.07	Note

AT^SPWD Change password for a lock (including Siemens-defined locks)	
Test command AT^SPWD=?	Response ^SPWD: (list of supported (<fac>, <pwdlength>)s) OK Parameter <fac> see execute command <pwdlength> integer max. length of password
Execute command AT^SPWD = <fac>, <oldpwd>, <newpwd>	Parameter <fac> "SC" SIM card (PIN) "AO" BAOC (Bar All Outgoing Calls) "OI" BOIC (Bar Outgoing International Calls) "OX" BOIC-exHC (Bar Outgoing International Calls except to Home Country) "AI" BAIC (Bar All Incoming Calls) "IR" BIC-Roam (Bar Incoming Calls when Roaming outside the home country) "AB" All Barring services "AG" All outGoing barring services "AC" All inComing barring services "P2" PIN 2 "UP" Unblocking PIN by PUK "UP2" Unblocking PIN2 by PUK2 <oldpwd> password specified for the facility from the user interface or with command. If an old password has not yet been set, <oldpwd> is not to enter. if <fac> = "SC" then PIN if <fac> = "AO"... "AC" (barring) then network password if <fac> = "P2" then PIN2 if <fac> = "UP" then PUK if <fac> = "UP2" then PUK2 <newpwd> new password Response All facility locks: AO, OI, OX, AI, IR, AB, AG, AC, have the same <password> to lock and unlock. The <password> depends on the network provider. TA sets a new password for the facility lock function. OK If error is related to ME functionality: +CME ERROR: <err>
Reference GSM 07.07: AT+CPWD	Note

AT^SRESET Software reset	
Test command AT^SRESET	Response OK Resetting module
Reference	Note A software reset is executed with this command, which takes about 4 seconds. It is necessary for a successful command execution to keep the ignition line high during this operation.

AT^SRTC		Select, query or test ringing tone	
Test command AT^SRTC=?	Response ^SRTC: (list of supported <type>s), (list of supported <vol>s) OK	Parameter	see set command
Read command AT^SRTC?	Response ^SRTC: <type>, <vol> <stat>OK	Parameter <stat>	status of test ringing 0 switch off 1 switch on
Set command AT^SRTC= [<type>][,<vol>]	Response TA sets the ringing parameters <type> and <vol>. OK	Parameter <type>	type of ringing tone 1 Sequence 1: 4 second cycle, 3 tone rise and fall <900>,<1> <0>,<3> 2 Sequence 2: 4 second cycle, single burst bitone <1425, 1625>,<1> <0>,<3> 3 Sequence 3: 4 second cycle, single burst tritone <1425, 1625, 1825>,<1> <0>,<3> 4 Sequence 4: 3.3 second cycle, double burst ('BT' style) <1700>,<0.3> <0>,<0.3> <1700>,<0.3> <0>,<2.2> 5 Sequence 5: 3.1 second cycle, rising tone on musical scale <2400>,<0.1> <2700>,<0.1> <3000>,<0.1> <3200>,<0.1> <0>,<2.7> 6 Sequence 6: 4 second cycle, 'Star Trek' alert <2400>,<0.4> <2500>,<0.24> <3000>,<0.8> <0>,<2.560>
		<vol>	volume of ringing tone 0 mute 1-7 volume varies from low to high
Execute command AT^SRTC	Response Test ringing tone sounds at audio output currently selected with "AT^SNFS". To deactivate test ringing tone use AT^SRTC again. OK Note1: the test ringing signal cannot be activated while an MTC is ringing (ERROR) Note2: if an MTC arrives while the test ringing tone is active, the test ringing will be deactivated and "normal" ringing reactivated (RING).		

Reference	Note
-----------	------

AT^MONI	Monitor idle mode and dedicated mode
Test command AT^MONI[=<period>]	Response See execute command Command is broken by any character sent to serial port Parameter <period> Display period in seconds
Execute command AT^MONI	Response Serving cell I Dedicated channel chann rs dBm PLMN LAI cell NCC BCC PWR RXlev C1 I chann TS timAdv PWR dBm Q 89 49 -61 023203 3A98 4EAF 0 4 5 -102 41 I 116 7 1 10 -60 2 OK Parameters Serving cell: chann Channel number rs RSSI value (0–63) dBm Receiving level in dBm PLMN PLMN ID code LAI Location area ID cell Cell ID NCC PLMN colour code BCC BS colour code PWR Maximal power level used on RACH channel Rxlev Minimal receiving level (in dBm) to allow registration C1 C1 coefficient for base station selection Dedicated channel: chann Channel number TS Time slot timAdv Timing advice in bits PWR Current power level dBm Receiving level in dBm Q Receiving quality (0–7) ChMod Channel coding: SIGN signalling only S FR speech full rate S EFR speech enhanced full rate D F96 data 9600 Bd D F48 data 4800 Bd D F24 data 2400 Bd
Reference	Note

AT^SSET Set some unsolicited result codes	
Test command AT^SSET=?	Response OK
Read command AT^SSET?	Response ^SSET: <SIM ready> Parameter <SIM ready> 0 or 1 representing the setting of unsolicited result code presentation.
Set command AT^SSET = [<SIM ready>],[<bbnc>]	Response Set the presentation of unsolicited result code. Parameter <SIM ready> Presentation of unsolicited result code ^SSIM READY : 0 Unsolicited result codes off 1 Unsolicited result codes on <bbnc> BREAK is sent before NO CARRIER on dropped data call: 0 BREAK not sent 1 BREAK sent Note: The current value of the parameters can be stored using the command <i>AT+W Store current parameter to user defined profile</i> . On power up or with the ATZ command the value is read from the EEPROM. The factory default value (0) is set with command <i>AT+F Set all current parameters to manufacturer defaults</i> .
Reference	Unsolicited result code Unsolicited result code sent after finish reading of SMS and phone books from SIM: ^SSIM READY

AT^MONP		Monitor neighbour cells	
Test command AT^MONP[=<period>]	Response See execute command Command is broken by any character sent to serial port	Parameter <period>Display period in seconds	
Execute command AT^MONP	Response chann rs dBm PLMN LAI NCC BCC C1 C2 46 49 -64 023102 0001 7 2 43 43 103 27 -83 023102 0001 7 3 21 21 39 22 -88 023102 0001 7 4 16 16 81 17 -93 023102 0001 7 5 11 11 104 16 -94 023102 0001 7 1 10 10 48 6 -104 023102 0001 7 7 0 0 54 3 -107 023102 0001 - - -1 -1 OK	Parameter: chann Channel number rs RSSI value (0–63) dBm Receiving level in dBm PLMN PLMN ID code LAI Location area ID NCC PLMN clour code BCC BS clour code C1 C1 coefficient for base station selection C2 C2 coefficient for base station selection	
Reference	Note		

AT^SMONC Cell Monitoring	
Test command AT^SMONC=?	Response OK If error is related to ME functionality: +CME ERROR: <err> Parameter
Execute command AT^SMONC	Response ^SMONC: 232,03,3010,4EAF,32,82,38,30,30,232,03,3010,0000,36,88,26,18,18,232,03,3010,4EC3,32,112,23,15,15,232,03,3010,4BDA,34,90,17,9,9,232,03,3010,0000,32,99,15,7,7,232,03,2010,00C0,35,113,9,1,1,232,03,3520,0000,32,85,8,0,0 OK If error is related to ME functionality: +CME ERROR: <err> Parameter The output contains 9 values from a maximum of 7 base stations. The first base station is the serving cell. Values for one base station in output order: MCC Mobile country code (3 decimal digits) e.g. 232 Value 000: Not decoded MNC Mobile network code (2 decimal digits) e.g. 03 Value 00: Not decoded LAC Location area code (4 hexadecimal digits) e.g. 3010 Value 0000: Not decoded CI Cell identity (4 hexadecimal digits) e.g. 4EAF Value 0000: Not decoded BSIC Base station identity code (2 decimal digits) e.g. 32 Value 99: Not decoded ARFCN Channel number of BCCH (decimal) e.g. 82 RSSI Receiving signal level +110 dBm (decimal) e.g. 38 C1 Coefficient for reselection (decimal) e.g. 30 Value -1: unknown C2 Coefficient for reselection (decimal) e.g. 30 Value -1: unknown Idle mode: The complete period of decoding all system information is 5 minutes. If an attempt to decode BSIC fails, the values of base station identity are reset to not decoded state. On base station with low receiving level it is possible, that some values are not decoded. Dedicated mode: On neighbor cell only values BSIC, ARFCN, RSSI are supported. On servicing cell all parameters are decoded except C1 and C2.
Reference	Note

AT+CXXCID Display card ID (identical to AT^SCID)	
Test command AT+CXXCID=?	Response OK Parameter

Execute command AT+CXXCID	Response TA returns the card identification number in SIM (SIM file EF ICCID, see GSM 11.11 Chap.10.1.1) as string type. see ^SCID Parameter see ^SCID
Reference GSM Engine A1: ^SCID	Note

5.8 Comparison between the MMI string commands and AT command

Feature	MMI	AT Command	Remark
Presentation of IMEI	*#06#	<i>"AT+CGSN Request product serial number identification (IMEI) identical to GSN"</i>	In the case of MMI, this command is called without SEND.
SIM PIN / PIN2 Change	**04*PIN*NEW_PIN*NEW_PIN# or **042*PIN2*NEW_PIN2*NEW_PIN2#	<i>"AT^SPWD Change password for a lock (including Siemens-defined locks)"</i>	In the case of MMI, this command is called without SEND. For both MMI and AT command, the command can only be used if the PIN query is activated.
Change/Unblocking SIM PIN / PIN2	**05*PUK*NEW_PIN*NEW_PIN# or **052*PUK2*NEW_PIN2*NEW_PIN2#	<i>"AT^SPWD Change password for a lock (including Siemens-defined locks)"</i>	In the case of MMI, this command is called without SEND. PIN Modification is also possible without prior blocking. The command can be used both for MMI and AT command and with the PIN query activated or deactivated.
Registering a new password	*03*ZZ*OLD_PASSWORD*NEW_PASSWORD*NEW_PASSWORD# or **03*ZZ*OLD_PASSWORD*NEW_PASSWORD*NEW_PASSWORD#	<i>"AT+CPWD Change password"</i>	For barring Services, ZZ=330. Only registration is supported.
	*03**OLD_PASSWORD*NEW_PASSWORD*NEW_PASSWORD# or **03**OLD_PASSWORD*NEW_PASSWORD*NEW_PASSWORD#		For a shared password for all usable services, excluding ZZ.
CLIP	*#30#	<i>"AT+CLIP Calling line identification presentation"</i>	Only interrogation is supported.
CLIR	*#31#	<i>"AT+CLIR Calling line identification restriction"</i>	Only interrogation is supported.
COLP	*#76#	<i>"AT+COLP Connected line identification presentation"</i>	Only interrogation is supported.
Call forwarding	*21*DN*BS*, *67*DN*BS*, *61*DN*BS*T, *62*DN*BS*, *002*DN*BS*T, *004*DN*BS*T , refer <i>"Basic MMI codes in accordance with ETS 300-511"</i>	<i>AT+CCFC Call forwarding number and conditions control</i>	
Wait	*43*BS#	<i>"AT+CCWA Call waiting control"</i>	Activation, deactivation and interrogation are supported.
Call Barring	BAOC *33*PW*BS# , BAOIC *331*PW*BS# ,... refer <i>"Basic MMI codes in accordance with ETS 300-511"</i>	<i>"AT+CLCK Facility lock"</i>	
CLIR	*31*DN or #31*DN	<i>"ATD Mobile originated call to dial a number and call of supplementary services"</i>	In the case of MMI these commands are called followed by the phone number and SEND.
Call Manipulation	0 or 1 or 1X or 2 or 2X or 3	<i>"AT+CHLD Call hold and multiparty"</i>	In the case of MMI these commands are called followed by SEND. These commands may only be used during a call. Apart from call, this entry should be interpreted as a call.

5.9 Summary of CME - CMS Errors

Final result code +**CMS ERROR:** <err> indicates an error related to mobile equipment or network. The operation is similar to **ERROR** result code. None of the following commands in the same command line is executed. Neither **ERROR** nor **OK** result code are returned.

<err> values used by common messaging commands:

5.9.1 Summary of CMS ERRORS related to V.25ter commands

Code of <err>	Meaning
0...127	GSM 04.11 Annex E-2 values, see CMS ERROR codes related GSM 07.07
128...255	GSM 03.40 subclause 9.2.3.22 values
512...	see CMS ERROR codes related to Siemens-defined commands

5.9.2 Summary of CME ERRORS related to GSM 07.07

Code of <err>	Meaning
0	phone failure
1	no connection to phone
2	phone-adapter link reserved
3	operation not allowed
4	operation not supported
5	PH-SIM PIN required
6	PH-FSIM PIN required
7	PH-FSIM PUK required
10	SIM not inserted
11	SIM PIN required
12	SIM PUK required
13	SIM failure
14	SIM busy
15	SIM wrong
16	incorrect password
17	SIM PIN2 required
18	SIM PUK2 required
20	memory full
21	invalid index
22	not found
23	memory failure
24	text string too long
25	invalid characters in text string
26	dial string too long
27	invalid characters in dial string
30	no network service
31	network timeout
32	network not allowed – emergency calls only
40	network personalization PIN required
41	network personalization PUK required
42	network subset personalization PIN required

43	network subset personalization PUK required
44	service provider personalization PIN required
45	service provider personalization PUK required
46	corporate personalization PIN required
47	corporate personalization PUK required
100	unknown

Note: all other values below 256 are reserved.

Table 5-5 Summary of CMS ERRORS

5.9.3 Summary of CMS ERRORS related to GSM 07.05

Code of <err>	Meaning
0...127	GSM 04.11 Annex E-2 values, see CMS ERROR codes related to GSM 07.07
128...255	GSM 03.40 subclause 9.2.3.22 values
300	ME failure
301	SMS service of ME reserved
302	operation not allowed
303	operation not supported
304	invalid PDU mode parameter
305	invalid text mode parameter
310	SIM not inserted
311	SIM PIN required
312	PH-SIM PIN required
313	SIM failure
314	SIM busy
315	SIM wrong
316	SIM PUK required
317	SIM PIN2 required
318	SIM PUK2 required
320	memory failure
321	invalid memory index
322	memory full
330	SMSC address unknown
331	no network service
332	network timeout
340	no +CNMA acknowledgment expected
500	unknown error
...511	all other values in range 256...511 are reserved
512	SIM not ready
513	Unread records on SIM
514	CB unknown error

5.9.4 Summary of CMS ERRORS related to Siemens-defined commands

Code of <err>	Meaning
0...127	GSM 04.11 Annex E-2 values, see CMS ERROR codes related to GSM 07.07
128...255	GSM 03.40 subclause 9.2.3.22 values
300...511	see CMS ERROR codes related to GSM 07.05
515	PHONE BUSY

6 Man Machine Interface

6.1 Overview

The Siemens M20 can be operated either via an MMI or with AT+C commands. One interface only should be used at any given time. Simultaneous operation of both interfaces has not been provided for although no algorithm preventing simultaneous operation of both interfaces exists.

Access to data services is performed with AT+C commands and is thus not supported by the MMI.

The main parts of the user interface are:

- LCD display (dot-matrix, 2 lines, 16 characters)
- 21 keys (12 keyblock, 9 function keys)
- Handset (microphone and loudspeaker)
- Hookswitch
- Buzzer

Note: the keypad driver supports 24 keys, though only 21 keys are used by the MMI software implemented.

6.2 Keypad address matrix

	KPC0	KPC1	KPC2	KPC3
KPR0	<KW3>	<KW1>	unused1	unused2
KPR1	<KW4>	<KW2>	<DIAL>	unused3
KPR2	<WW>	<1>	<2>	<3>
KPR3	<+>	<4>	<5>	<6>
KPR4	<->	<7>	<8>	<9>
KPR5	<SMS>	<*>	<0>	<#>

Table 6-1 Keypad address matrix

Keypad	Meaning
<0>, <1>, ..., <9>, <*>, <#>	Keys
<DIAL>	Dial key (OK key)
<KW1>, <KW2>...KW4>	4 short keys
<WW>	Redial/cursor up
<SMS>	Short Message
<+>	increase volume: voice/buzzer
<->	decrease volume: voice/buzzer

Table 6-2 Description of keypad

All features offered are activated or configured using function keys or codes (menu short-cuts). The codes are selected to conform to ETS 300 511. User guidance via menus is not supported. The user dialogs or input prompts are output in the following languages:

- English (factory default)
- German
- French
- Portuguese
- Spanish.

6.3 Additional display information

In addition to test messages, there are display fields on the right-hand side of the display that are shown irrespective of the operating statuses:

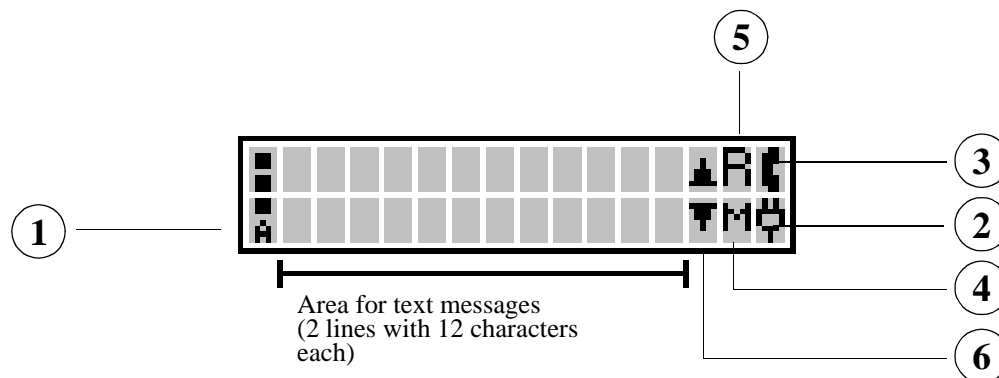

Fig. 6-1 Display structure

Field strength (RSSI) bar display in the display's left-hand margin:

- strong signal (3 segments)
- signal OK (2 segments)
- low-powered signal (1 segment)
- no signal (flashing antenna symbol)

A power supply indicator in the lower right-hand corner of the display:

- permanently lit plug symbol: powered by mains
- permanently lit full battery symbol: powered by battery (see *Fig. 6-1 Display structure*)
- flashing empty battery symbol: battery flat
- permanently lit empty battery symbol: battery loading

A connect indicator in the upper right-hand corner of the display:

- Handset symbol: call active

A message indicator:

- 'M': message saved to SIM
- flashing 'M': SMS overflow

A roaming indicator: 'R'

Character 'up/down arrow' (only in connection with SMS message): indicates that you should scroll down to read the rest of the SMS message.

6.4 MMI features and user-defined settings

The following features are activated or configured with function keys:

- Dialling with abbreviated dialling keys
- Programming abbreviated dialling keys
- Redialling
- Reading an SMS message (use the scrolling function for SMSs with more than one line)
- Deleting an SMS message
- Ringer volume setting
- Handset volume setting

The following user defined settings or queries are activated or configured with M20-specific MMI codes:

Feature	Code
Network selection list	*01763*11#
Language for display texts	*01763*12* <i>language</i> #
Timeout for automatic signal transmission	*01763*14* <i>timeout</i> #
Local call barring – off	*01763*20#
Local call barring – bar incoming on	*01763*211#
Local call barring – bar incoming off	*01763*210#
Local call barring – bar outgoing on	*01763*221#
Local call barring – bar outgoing off	*01763*220#
Setting the proceed-to-select tone	*01763*41* <i>tone</i> #
Setting the ringer tone	*01763*42* <i>ringertone</i> #
Setting the ringer volume	*01763*43* <i>ringervolume</i> #
Setting the speaker volume	*01763*44* <i>speakervolume</i> #

Table 6-3 M20-specific MMI codes

<i>Language</i>	Language
1	English
2	German
3	French
4	Portuguese
5	Spanish

Table 6-4 Languages for display text

Value	Range ¹⁾	default	Remark
timeout	5-20	5	in seconds
tone	1-2	2	different tone sequences
ringertone	0-6	1	different tone sequences
ringervolume	0-7	4	0...ringer deactivated, 1...low, 7...loud
speakervolume	0-7	4	0...low, 7...loud

Table 6-5 Value ranges

Note: ¹⁾ unspecified values are set to the default value.

The availability of user-defined settings via Basic MMI is set by the SIM card. Normally, it is not possible to activate or deactivate call forwarding or CLIR, etc., for example, with SIM cards in the lower price range.

The following user-defined settings or queries are activated or configured using Basic MMI codes (in accordance with ETS 300-511):

- Network call barring: setting the connection type
- Call forwarding
- Calling line identification restriction CLIR (on/off)

Feature	To activate	To cancel	To confirm status
CLIR	*31#<SEND>	#31#<SEND>	*#31#<SEND>
Call forwarding Unconditional	**21*phoneNo#<SEND> **21*phoneNo*ts#<SEND>	##21#<SEND> ##21*ts#<SEND>	*#21#<SEND> *#21*ts#<SEND>
Call forwarding on mobile Subscriber busy	**67*phoneNo#<SEND> **67*phoneNo*ts#<SEND>	##67#<SEND> ##67*ts#<SEND>	*#67#<SEND> *#67*ts#<SEND>
Call forwarding on no Reply	**61*phoneNo#<SEND> **61*phoneNo*ts*delay#<SEND>	##61#<SEND> ##61*ts#<SEND>	*#61#<SEND> *#61*ts#<SEND>
Call forwarding on mobile Subscriber not reachable	**62*phoneNo#<SEND> **62*phoneNo~ts#<SEND>	##62#<SEND> ##62*ts#<SEND>	*#62#<SEND> *#62*ts#<SEND>
Cancel all forwarding	##002#<SEND>		
Barring of all outgoing Calls	*33*password#<SEND> *33*password*ts#<SEND>	#33*password#<SEND> #33*password*ts#<SEND>	*#33#<SEND> *#33*ts#<SEND>
Barring of outgoing international calls	*331*password#<SEND> *331*password*ts#<SEND>	#331*password#<SEND> #331*password*ts#<SEND>	*#331#<SEND> *#331*ts#<SEND>
Barring of outgoing interna- tional calls except those di- rected to the home PLMN country	*332*password#<SEND> *332*password*ts#<SEND>	#332*password#<SEND> #332*password*ts#<SEND>	*#332#<SEND> *#332*ts#<SEND>
Barring of all incoming Calls	*35*password#<SEND> *35*password*ts#<SEND>	#35*password#<SEND> #35*password*ts#<SEND>	*#35#<SEND> *#35*ts#<SEND>
Barring of incoming calls when roaming outside the home PLMN country	*351*password#<SEND> *351*password*ts#<SEND>	#351*password#<SEND> #351*password*ts#<SEND>	*#351#<SEND> *#351*ts#<SEND>

Table 6-6 Basic MMI codes in accordance with ETS 300-511

Note: display after entry of MMI codes is context-sensitive.

ts	Teleservice
10	All teleservices
11	Language
12	Data
13	Fax
16	SMS
19	All apart from SMS

Table 6-7 Teleservices ts

"All teleservices" is automatically selected if none is specified.

Feature	Code
Change password	**03**oldpassword*newpassword*newpassword#<SEND>

Table 6-8 Changing the password in accordance with ETS 300-511

6.5 MMI functions

Logical display messages are written in square brackets:

e. g: [Network operator] appears as 'A max.', for example, on the display.

Key messages are written in angle brackets: e.g. <DIAL>.

6.5.1 Putting into service

Event	Display text: 1 st line	Remark
	Display text: 2 nd line	
SIM not inserted	Insert SIM	
SIM inserted: searching or no valid PLMN	Searching Network	Power-on, no valid PLMN signal received, SIM inserted
PIN input (dialling keys)	Enter Pin: ****	PIN entry shown as '*'
PLMN signal	[Network operator]	Idle display

6.5.2 Handset answer functions – incoming seizure

The user accepts an incoming call by off-hook (lifting the handset).

Incoming call with off-hook handset:

An incoming call is rejected in state off-hook. The calling party hears the busy tone applied by the PLMN.

Event	Display text: 1 st line	Remark
	Display text: 2 nd line	
Call	Incoming Call	
Off-hook	Call Active	

Clear down before answer

Event	Display text: 1 st line	Remark
	Display text: 2 nd line	
Call	Incoming Call	
Disconnect	Call miss	Calling party clears down the call

The calling party deactivated CLIR

Event	Display text: 1 st line	Remark
	Display text: 2 nd line	
Call	Incoming Call [Dial]	
Off-hook	Call Active [Dial]	

Clear down before answer

Event	Display text: 1 st line Display text: 2 nd line	Remark
Call	Incoming Call [Dial]	
Disconnect	Call miss [Dial]	Calling party clears down the call

6.5.3 Handset call functions – Outgoing seizure

Dialling is only possible after lifting the handset (on-hook dialling not possible). A proceed-to-signal tone is activated (on audio outputs) when the handset is lifted. The user enters the call number.

Entering the call number:

The call number can be dialled with the following keys:

- Digit keys
International access function
The international access code to the PSTN (Public Switched Telephone Network) is activated by holding down the <0> key until '+' appears on the display. The access code does not depend on the location (international roaming). International access can also be activated using the appropriate (country-specific) prefix (e.g. 00 in Austria, Germany).
- Abbreviated dialling keys
- Redial keys
The call number is shown on the display. Signal transmission occurs automatically when an abbreviated dialling key or a redial key is used. Dialling with digit keys can be started manually or automatically.

Manual signal transmission

Activated by pressing the SEND key.

Event	Display text: 1 st line Display text: 2 nd line	Remark
Off-hook		Display is deleted on first key input Proceed-to-signal tone on
Dial	[Dial]	After the first digit: proceed-to-signal tone off
<SEND>	Calling [Dial]	

Automatic signal transmission

The input of digits is monitored by a timer. Signal transmission is automatically activated after the preset timeout (default 5 sec, see Chapter 6.4 "MMI features and user-defined settings" on page 143).

Repertory and redial keys overwrite previously entered digits.

The call progress is indicated on the display and with audible tones.

If the system is unable to set up a connection, an error message is displayed and an error tone is generated.

If the party called rejects the call, the connection is cleared down by the network and an appropriate signal appears on the user's display.

Automatic signal transmission

Event	Display text: 1 st line Display text: 2 nd line	Remark
Off-hook		Display is deleted on first key input Proceed-to-signal tone on
Dial	[Dial]	After the first digit: proceed-to-signal tone off
Timeout	Calling [Dial]	The length of the timeout can be selected (5–15 sec.)

Called party free – answer:

Event	Display text: 1 st line Display text: 2 nd line	Remark
	Calling [Dial]	Signal transmission
PLMN signal	Alerting [Dial]	Calling party hears the ring tone Called party hears the ringing tone
PLMN signal	Call Active [Dial]	Called party goes off-hook, connection

Connection to called party cannot be set up

Event	Display text: 1 st line Display text: 2 nd line	Remark
	Calling [Dial]	Signal transmission
	Call failed [Error message]	Calling party hears the error tone
On-hook	[Idle display]	

Calling party clears down the call

Event	Display text: 1 st line Display text: 2 nd line	Remark
	Calling [Dial]	Signal transmission
On-hook	Ending Call Please Wait	Release procedure
PLMN signal	[Idle display]	

Event	Display text: 1 st line Display text: 2 nd line	Remark
	Alerting [Dial]	As for signal transmission
On-hook	Ending Call Please Wait	Release procedure
PLMN signal	[Idle display]	

Called party rejects call

Event	Display text: 1 st line	Remark
	Display text: 2 nd line	
	Alerting [Dial]	
PLMN signal	Call Dropped	
On-hook	[Idle display]	

Outgoing seizure:

Event	Display text: 1 st line	Remark
	Display text: 2 nd line	
Off-hook, PLMN signal	Alerting [Dial]	
Call	[Dial] Calling	

Clear down before answer

Event	Display text: 1 st line	Remark
	Display text: 2 nd line	
Call	[Dial] Calling	
Disconnect = on-hook	Ending Call [Dial]	Calling party clears down the call. Display returns to idle

6.5.4 Clearing down – idle status

The user can switch to idle from all telephone statuses by replacing the handset.

6.5.5 Dialling with abbreviated dialling keys

Signal transmission to the PLMN is started by briefly (< 300 ms) pressing an abbreviated dialling key after lifting the handset. A message appears on the display if there is no call number programmed for the abbreviated dialling key. Programming abbreviated dialling keys is described in Chapter 6.5.7 “*Programming abbreviated dialling keys*” on page 150.

Event	Display text: 1 st line	Remark
	Display text: 2 nd line	
Off-hook		Display is deleted Proceed-to-signal tone on
<KW>	Calling [Dial]	Proceed-to-signal tone off, procedure performed by manual dialling

6.5.6 Checking abbreviated dialling keys

An abbreviated dialling key can be checked in the following call processing terminal statuses:

- idle status (handset is on-hook)
- after off-hook
- when a call is in progress

The abbreviated dialling key must be held down until the saved call number appears on the display (approx. 1 second). The message "No number" is displayed if there is no call number saved. The display switches back to the original display after 30 seconds (or by going on-hook).

6.5.7 Programming abbreviated dialling keys

Abbreviated dialling keys can be overwritten (by keypad entry) while they are displayed in the checking procedure (see Chapter 6.5.6 "*Checking abbreviated dialling keys*" on page 150).

6.5.8 Redial

The last call number dialled is shown on the display and signal transmission to the PLMN is started by pressing the redial key after going off-hook. Call numbers are transferred to the redial memory during signal transmission.

Event	Display text: 1 st line Display text: 2 nd line	Remark
Off-hook		Display is deleted Proceed-to-signal tone on
<WW>	Calling [Dial]	Proceed-to-signal tone off, procedure performed by manual dialling

6.5.9 Network call barring

The PLMN offers the user the option of barring special connections. This is activated by the user with a code and password (see Chapter 6.4 "*MMI features and user-defined settings*" on page 143). The following connections can be barred:

- all outgoing connections
- all outgoing international connections
- all outgoing international connections that are not directed to the home PLMN country
- all incoming connections
- all incoming connections in the case of roaming outside the home PLMN country

6.5.10 Local call barring

As in the case of PLMN, special connections can be barred in the terminal. This is activated by the user with codes. To distinguish this feature from network call barring, no signalling information is sent to the PLMN. As a result, this feature can also be used when no connection to the PLMN can be set up.

The following connections can be barred:

- all outgoing connections
- all incoming connections

Note: local call barring features are not recognised by the network. They are locally set in the terminal.

6.5.11 Call forwarding

This is activated by the user with a code and password (see Chapter 6.4 “MMI features and user-defined settings” on page 143).

- Call forwarding, unconditional
- Call forwarding on mobile subscriber busy
- Call forwarding on no reply
- Call forwarding on mobile subscriber not reachable

6.5.12 DTMF signalling

If the signal keys (*,#,0,1,...,9) are pressed during an existing connection, they are transmitted to the PLMN as DTMF tones. DTMF tones are also audible for the user. DTMF digits are not saved on repertory keys.

Note: no DTMF tones are produced when pressing different keys from the ones specified above.

6.5.13 Reading an SMS message

Messages from the Short Message teleservice are received and saved to the SIM. The number of saved messages depends on SIM card memory (typical number: at least 10). Received messages are signalled both by a message indicator in the user’s display (“M” in the right-hand margin) and with an appropriated message text when the terminal is idle.

The individual messages can be read with the ‘SMS’ function key. The most recent message is displayed by pressing the SMS key once. The next message is displayed by pressing this key a second time, and so on. The display scrolls back to the most recent message after displaying the oldest message, (last in – first out ring memory).

A message can be read in the following statuses:

- idle status (handset is on-hook)
- after off-hook
- when a call is in progress

Event	Display text: 1 st line Display text: 2 nd line	
SMS message	[Idle display] M SMS [x], [y] new	M icon on the right-hand side of the display is visible in all call processing statuses
<SMS>	[unread message1] [unread message1]	
<SMS>	[unread message2] [unread message2]	The next unread message is displayed
<SMS>	[read message] [read message]	After reading all new messages, messages already read are displayed again

Scrolling through a multiple-line message

Event	Display text: 1 st line Display text: 2 nd line	
<SMS>	[Message/1 st line] [Message/2 nd line]>	
<WW>	[Message/2 nd line] [Message/3 rd line]>	
<WW>	[Message...] [Message end]	
<WW>	[Message/1 st line] [Message/2 nd line]	After reaching the end of the message, the display scrolls back to the start of the same message

Note: multiple-line display texts are identified by a continuation character at the end of the second line (“>”).

6.5.14 Deleting an SMS message

A displayed message is deleted by holding down the SMS key until an acoustic signal indicating the deletion is heard. The next message is displayed. If there are no more messages saved, the original display appears and the message indicator is deleted.

Deleting a message

Event	Display text: 1 st line Display text: 2 nd line	
<SMS>	[Message 1] [Message 1]	
hold down <SMS>	[Message 2] [Message 2]	Message 1 is deleted, next displayed
hold down <SMS>	[last message] [last message]	Last message deleted
	[original display]	

6.5.15 SMS message overflow

The messages indicator flashes if there is no space for an incoming message in the SIM memory. Incoming messages are temporarily stored in the PLMN.

SMS overflow

Event	Display text: 1 st line Display text: 2 nd line	
SMS message	[Idle display] M	A flashing M icon on the right-hand side of the display is visible in all call processing statuses

6.5.16 Service indicator

The call processing status M20 is shown on the display when the telephone is idle.

Event	Display - Text: 1 st line Display - Text: 2 nd line	Remark
SIM not inserted	Insert SIM	
SIM inserted: searching or no valid PLMN	Searching Network	Power-on, no valid PLMN signal received, SIM inserted
PIN input (dialling keys)	Enter Pin: ****	PIN entry shown as ‘*’
PLMN signal	[Network operator]	Idle display

Table 6-9 Service indicator display

6.5.17 Network selection

Automatic selection (default setting):

A network is automatically selected on insertion of the SIM card and when the M20 is activated.

Manual selection:

All possible network operators can be shown on the display by using the code *01763*11#. The keys <+> and <-> (or <Cursor up>) are used to scroll up and down the list. The network operator is selected with the <send> key. The user is informed via the display (error message) if he/she cannot log on to this PLMN. The call processing status M20 is displayed when the telephone is idle (service indicator).

6.5.18 SIM lock

If the SIM card is protected by a 4-digit PIN, this must be entered via the keyboard each time after inserting the card. Emergency calls can be made without the SIM card or without entering the PIN.

i.e. the user must enter the PIN at the terminal in the following situations:

- after switching on the power (i.e. when power returns after a power failure)
- after inserting a SIM card

6.5.19 RSSI

The field strength is indicated by a bar on the left-hand side of the display.

Four different levels can be shown:

- strong signal (3 segments)
- signal OK (2 segments)
- low powered signal (1 segment)
- no signal (flashing antenna symbol)

6.5.20 Ringer volume setting

The idle telephone (handset is on hook) can be switched to programming mode by holding down the <+> or <-> key. This generates a ring tone. Every time <+> or <-> is pressed, the volume is increased or decreased in stages (for the default value and value range see *Value ranges*). The setting is stored until the SIM card is reset.

6.5.21 Language volume setting

The volume can be changed by pressing <+> or <-> during a call. Every time <+> or <-> is pressed, the volume is increased or decreased in stages (for default value and value range see *Value ranges*). The setting is stored for the duration of the call.

6.6 Power supply indicator

In the event of a power failure, power supply can be switched to battery operation by means of an external hardware device.

The type of power supply and the battery status can be checked on the 'supply status' hardware indicator. See also Chapter 4.3.9 "Power supply indicator" on page 24.

7 Peripheral devices

The peripheral devices listed in this chapter are necessary for appropriate operation of the M20 or M20 Terminal. Directly connected display and keypad are not required if you are only using the M20 via an AT command interface.

7.1 GSM antenna

All major suppliers of GSM antennas can supply suitable GSM900 antennas with FME plugs to connect to M20 Terminal for a variety of applications (directional antenna, antenna with GPS, antenna with magnetic foot, antennas with screw-on foot).

To connect an antenna to the M20 module, an SMR nano plug is required. The SMR nano plug can, for example be ordered from IMS Connector Systems. For the address, please see below.

For further information on the GSM antenna, see also Chapter 4.5 *“Antenna interface” on page 26*

A **GSM antenna** with matching connector can be ordered, for example, from

IMS Connector Systems, D-79843 Löffingen (Germany),

Obere Hauptstraße 30, Postfach 1141, tel.: +49-7654/901-0, fax: +49-7654/901-199.

The max. length of the antenna cable should not exceed 2 m or an absorption of 1 dB.

7.2 SIM card reader

In general, all SIM card readers may be connected to the M20. If using a SIM card reader not listed below, please observe the information on the type approval process (see Chapter 8.7 *“Getting full-type approval with the application” on page 196*).

The M20 will be type-approved with 3 different SIM card readers, a large one and two mini SIM card readers.

Large SIM card reader

Framatome Connectors Deutschland GmbH
 Heinrich-Hertz-Strasse 1
 D-40699 Erkrath
 Tel.: +49 (0)211 9254 0
 Fax: +49 (0)211 9254 111
<http://www.fciconnect.com>
 Order no.: 7434L0423F01--

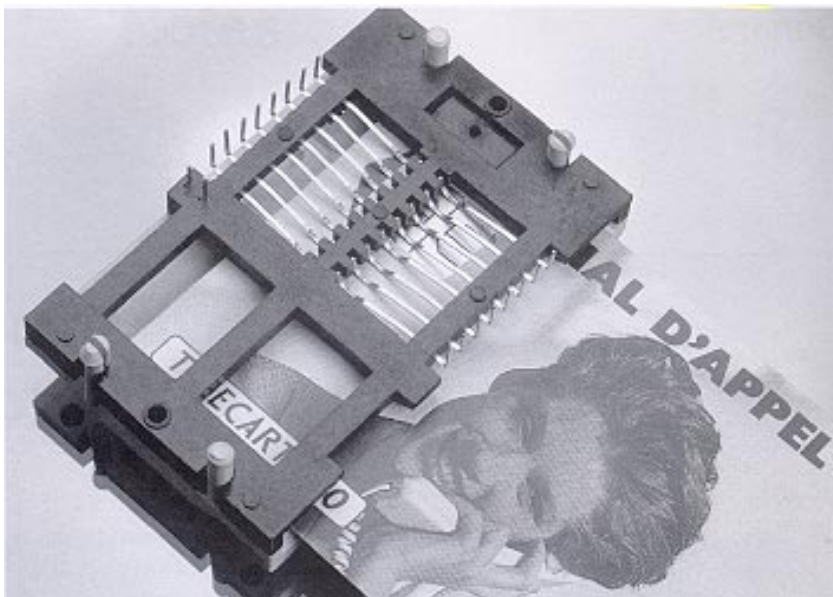

Fig. 7-1 Big SIM Card Reader (L04)

Mini SIM card reader 1

Amphenol-Tuchel Electronics GmbH

August-Häusser-Strasse 10

D-74080 Heilbronn

Tel.: +49 (0)7131 / 929 -0

Fax: +49 (0)7131 / 929 -486

– Product no.: C 707-1 (height 3.0 mm, with/without chipcard inserted – switch)

– Product no.: C 707-3 (height 2.5 mm, without chipcard inserted – switch).

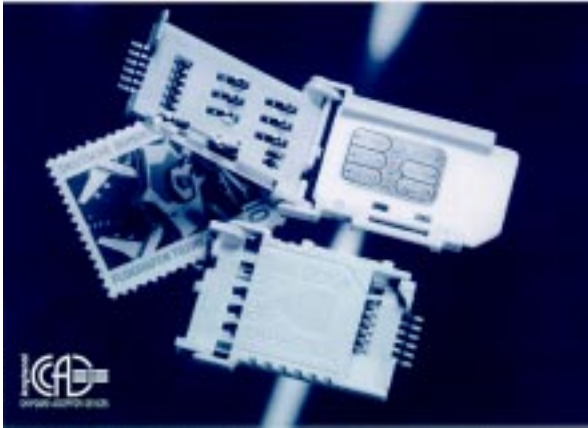

Fig. 7-2 Mini SIM card reader (C707-1)

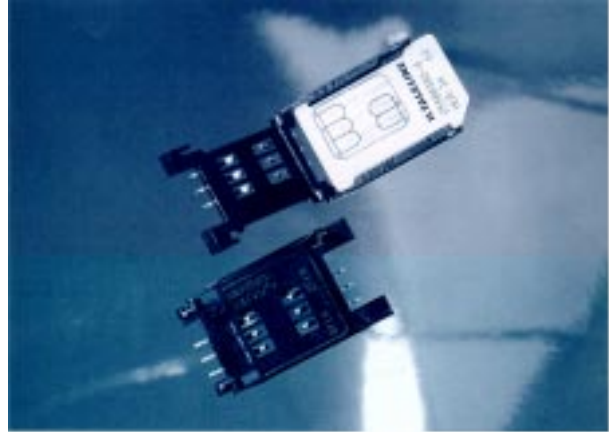

Fig. 7-3 Mini SIM card reader (C707-3)

Mini SIM card reader 2

Molex Deutschland GmbH

Felix-Wankel-Strasse 11

D-74078 Heilbronn-Biberach

Tel.: +49 7066 9555-21

FAX: +49 7066 9555-29

Order no.: card connector: 91228-0001

Order no.: card holder: 91236-0001

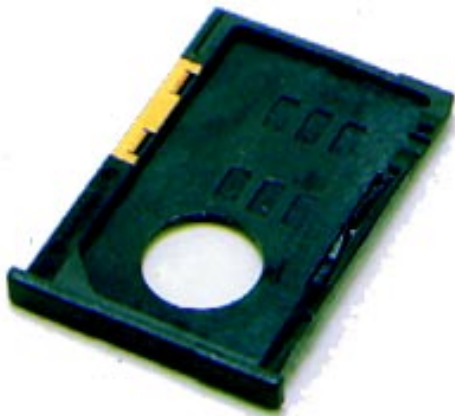

Fig. 7-4 Mini SIM card reader (holder)

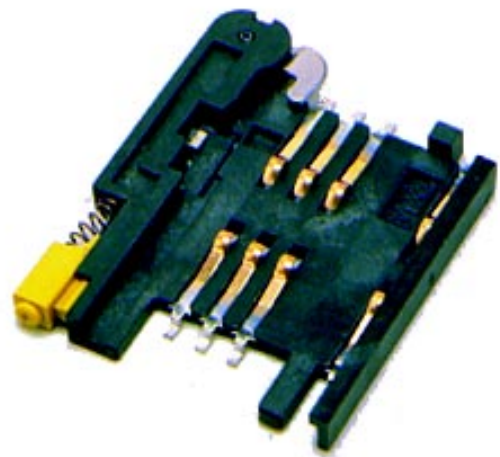

Fig. 7-5 Mini SIM card reader (connector)

7.3 SIM cards

- The following services can only be implemented if they are enabled for the subscriber (multi-numbering: each of the services has its own calling number):
 - 1) Calling number for speech and SMS
 - 2) Calling number for fax (and SMS)
 - 3) Calling number for 9600 Bit/s data transfer (and SMS)
 - 4) Calling number for 4800 Bit/s data transfer (and SMS)
 - 5) Calling number for 2400 Bit/s data transfer (and SMS)

3 V SIM cards are available from different network operators and service providers.

7.4 Handset

Depending on the type of application, handsets can be ordered from common handset manufacturers. Information is available from the M20 distributor.

If using one of the handset types listed below AND implementing the audio reference circuit for that handsets given in Chapter 8.8 *“Application examples and reference circuits” on page 198*, no additional delta type approval is necessary.

If using handsets not listed below, please observe the information regarding the type approval process (see Chapter 8.7 *“Getting full-type approval with the application” on page 196*).

Handset 1: (not shown)

Handset Siemens Gigaset

Please contact your local M20 distributor

Note: for technical data on speaker and microphone, see Chapter 4.4 *“Audio interface” on page 25*.

7.5 Sources for connectors

Note: all order numbers given in this chapter refer to matching connectors for the M20. The 80-pole SMD connector ordered using the number provided shall be mounted on the PCB of the base unit to which the M20 is connected.

7.5.1 Antenna connector

The M20 antenna connector is an SMR nano connection (male) which is a standardized type. The matching antenna connector is thus also the standardized SMR nano connector (female).

The matching antenna connector can be ordered from

IMS Connector Systems
 Obere Hauptstraße 30
 Postfach 1141
 D-79843 Löffingen (Germany)
 Tel.: +49-7654/901-0
 Fax: +49-7654/901-199
 Order no.: 31.2420.021..... 90° socket connector
 Order no.: 31.2410.021..... straight socket connector



Fig. 7-6 SMR connector (straight)

7.5.2 80-pole SMD connector

The matching connector for the 80-pole SMD connector is made by

JAE Europe Ltd.
 Coliseum Business Centre
 Riverside way, Camberley
 Surrey GU15 3YL UK
 Tel.: +44 1276 404000
 Fax: +44 1276 404010
 Order no.: WR-NF80P-VF60-A1 floating type
 Order no.: WR-80P-VF60-1 rigid type

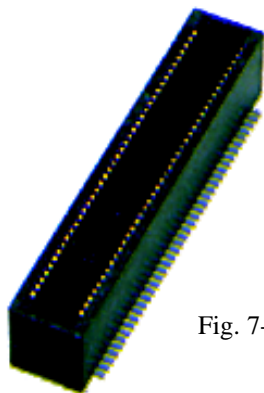

Fig. 7-7 80-pole SMD connector (rigid)

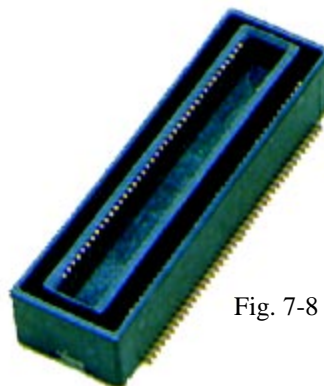

Fig. 7-8 80-pole SMD connector (floating)

7.6 Display

Any display which uses an 8-bit parallel data bus and which provides the character set in accordance with the GSM spe-

cification (GSM 0338(EPS) 300-628) can be used. In addition, the timing requirements and electrical specifications outlined in Chapter shall be respected. *See also "Display"*.

7.7 Keypad

Any keypad which fulfils the requirements outlined in Chapter 4.3.4 "Keypad" on page 20 can be used.

8 Application notes

- 1) The Cellular Engine M20 may only be used in approved configurations or with accessories (SIM card reader, handset) that have been explicitly approved. Information about approved configurations and accessories that have been approved for use with the M20 is provided in this document. This information is also available in the appendix to the EC TYPE EXAMINATION CERTIFICATE or from your local distributor.
- 2) The CE mark on the Siemens M20 with GSM-IMEI must be visible from the outside without the use of any tools, even if the M20 is integrated and/or built into an application (visibility through cooling slits is sufficient). Alternatively, an additional label can be placed on the outside of the application or if there is not enough room, it can be included in the operating manual with the wording "This application uses integrated GSM Terminal Equipment with the following registration: CE xxxx, IMEI xxxx."
- 3) An earthed wristband should be worn when handling the M20/M20 terminal components to protect against electrostatic charge. Avoid touching open contacts to prevent injury by electrostatic discharge.

8.1 General notes

- A warning symbol from TÜV (German Technical Inspectorate) should be applied to the application's identification plate, advising the user to read the instruction manual before powering up the application.
- The following services can only be implemented if they are enabled for the subscriber. Multi-numbering: each of the services has its own calling number.
 - 1) Calling number for speech and SMS
 - 2) Calling number for 4800 Bit/s data transfer (and SMS)
 - 3) Calling number for 2400 Bit/s data transfer (and SMS)
- 3 V SIM cards are available from different network operators and service providers.
- A sticker with the IMEI number is supplied with the M20 to be applied on the outside of the application. In the event of M20 module service, a new sticker with the new IMEI number will be supplied.
- Two stickers with the logo "Cellular Engines by Siemens" are supplied with each M20 (transparency/black and transparency/yellow 24 mm x 24 mm). See below in the lower left corner.
- SIM cards should only be inserted or removed when the M20 is not supplied with power.

8.2 Getting started & Installation

Using Hyperterminal or Procomm Plus for controlling the M20T:

8.2.1 Connecting the M20T

- 1) M20 Application, M20 Terminal or M20 D-Box
- 2) SIM card (activated, M20/M20 Terminal can only be activated by 3V SIM cards)
- 3) 9-pin serial cable for connection between PC and e.g. M20 Terminal
- 4) For speech transmission: Handset: speaker and microphone
- 5) Antenna cable with antenna and fitting connector for connection with M20 Terminal's FME female antenna plug.
- 6) GSM Antenna
- 7) Power supply with ignition circuit, Pin 4 of the 6 pole Western Plug can be switched to >3V for minimum 1 second (with the M20T use supply voltage for ignition).

See also following fig. "*Example circuit for IGNITION*" for details.

8.2.2 Example circuit for IGNITION

The Ignition signal is used to start the M20. Unlike the M1 the Ignition on the M20 can be activated simultaneously with the Power connection. For switching off the M20 with AT^SMSO ignition must be returned to low state!

Ignition Box

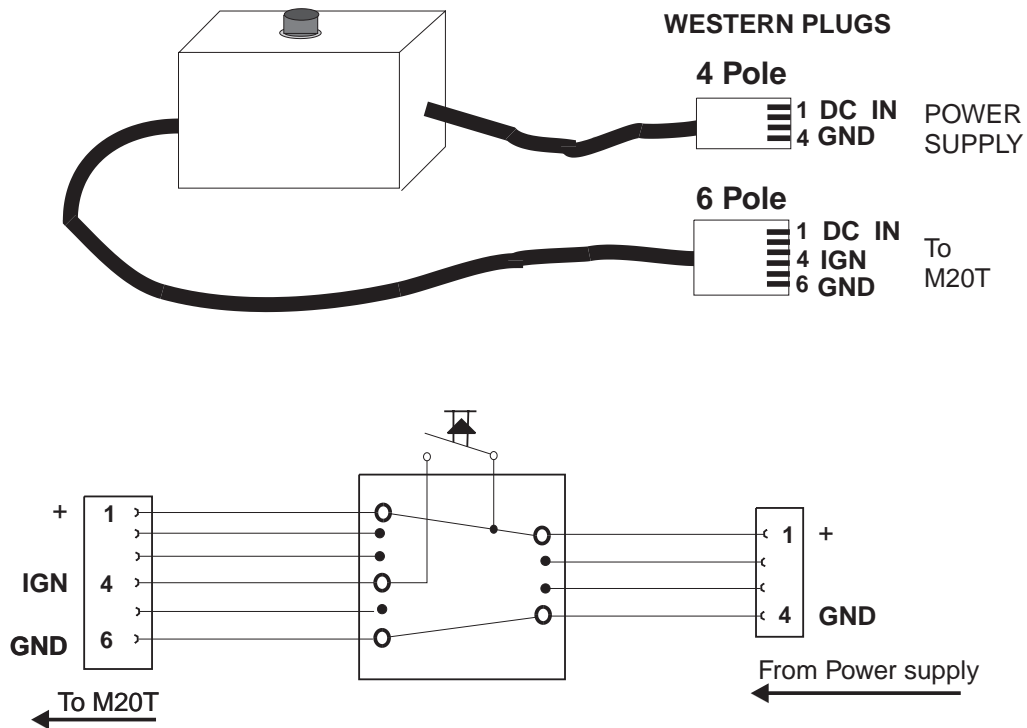

When using M20T

Implement as shown
 Power supply: 8-24V

When using M20

80 pole SMD Connector:

Power supply DC IN: 6V

Pins:

DC_IN(6V): 18-22, 58-62

IGNITION: 8

GND 17, 23-25, 38, 43, 56, 57, 63-65

8.2.3 Starting up and logging into the GSM net

- | | |
|---|--------------|
| 1) Insert the SIM card into the M20T. | LED |
| 2) Connect the serial cable between the M20 Terminal and the PC. | Off |
| 3) Connect the antenna cable and antenna to the M20 Terminal connector. | Off |
| 4) Connect the handset to the M20 (optional) | Off |
| 5) Connect the M20 Terminal to the power supply and ignition circuit, connect power supply to mains | Off |
| 6) Activate the M20 Terminal by pressing the ignition button on the ignition circuit.
for AT LEAST 1 SECOND (Ignition can be set high before, at the same time, or after power supply of the M20T) | |
| Blinking LED indicates: M20 ON, searching for Network / Waiting for PIN | Blink |

Note: Some Power supplies provided with the M20T have the Ignition signal internally connected to HIGH. In this case no extra ignition line and circuit is necessary. In this case the green LED on the M20T starts blinking when the power supply is connected.

Depending on the Terminal program used (Procomm Plus or Hyperterminal) please see the relevant chapter

7) Enter the Pin number with the command AT+CPIN="xxxx", unless AT^SFLC (facility lock for PIN code has been set. In this case the log-in to the GSM network will start automatically after the ignition phase is completed

Blink

8) Once the M20T is logged into the net the LED is on. (usually about 5 sec or longer depending on the network availability.)

Lit

8.2.4 Hyperterminal: Setup (M20.ht)

Using the Hyperterminal program: (Standard Windows application)

Copy the configuration file M20.ht (included on the CD-ROM) to the hyperterminal directory (usually: c:\ startmenu\programs\accessories\hyperterminal) up the M20T

To start:

START - programs - accessories - hyperterminal - "m20.ht"

Once the Hyperterminal window is opened and the keypresses are echoed, the M20 is ready for further commands.

To register the M20T into the net use:

Type: AT+CPIN="<four digit PIN code>"

8.2.5 Procomm Plus: Setup and activation

Getting started and basic scripts for voice and data calls and SMS (text mode).

8.2.5.1 Procomm Plus setup files:

(From the included CD-ROM copy the following files to the subdirectories of Procomm Plus on your PC)

Copy to directory:..... procomm Plus/

Connect_first.dir

Connect_first.ext

Copy to directory:.....procomm Plus/aspects

start.was	configuration information
data_ic.was	Data incoming
data_og.was	Data outgoing
sms_ic.was	SMS incoming
sms_og.was	SMS outgoing
voice_ic.was	Voice incoming
voice_og.was	Voice outgoing

8.2.5.2 Start Procomm Plus

(START - programs - Procomm - Procomm Plus)

To activate configuration file:

Activate "M20_start" by double-clicking in the data - pulldown menu.

M20T connected and ON (see chapter 3.3.1)

This automatically configures the system to connect to the M20T via **COM1**.

The script "Start" automatically is activated and a sequence of commands is executed giving information about the settings of the M20.

Enter the PIN code in the pop up window.

Once the M20T is booked into the net, -- +creg:1 - network information is displayed

M20T Ready.

NOTE: If the script is unable to process a command, there is a 15 second internal timeout after which the next command is automatically sent to the M20.

NOTE: If the script does not operate correctly it can be stopped/exited and restarted with the Button .

The Procomm Plus scripts for Data, Voice and SMS incoming and outgoing can be activated from the script window.

Using the script control button  a script can be started and stopped.

8.2.6 Setting parameters

8.2.6.1 Enter PIN1

at+cpin?	Ask which PIN is required
+CPIN: SIM PIN	SIM PIN is needed
OK	
at^spic	Display PIN counter
^SPIC: 3	3 attempts still available
OK	
at+cpin="xxxx"	Enter PIN
OK	

8.2.6.2 Enter PUK1

at+cpin?	
+CPIN: SIM PUK	SIM PUK is required
OK	
at^spic	
^SPIC: 10	10 attempts still available for SIM PUK
OK	
at+cpin="xxxxxxxx","xxxx"	Enter PUK and new PIN
OK	
at+cpin?	
+CPIN: READY	SIM is ready
OK	

8.2.6.3 Change PIN1

at+cpwd="SC","xxxx","xxxx" "SC" SIM PIN is changed
 "8418" old PIN
 "8888" new PIN

OK

8.2.6.4 Lock/unlock PIN1

at+clck="SC",2 Query PIN1 lock/unlock status
+CLCK: 1 Status is "on" (locked)

OK

at+clck="SC",0,"xxxx" Unlock PIN1

OK

at+clck="SC",2 Query status
+CLCK: 0 Status is "off" (unlocked)

OK

at+clck="SC",1,"xxxx" Lock PIN1

OK

at+clck="SC",2 Query status
+CLCK: 1 Status is "on" (locked)

OK

8.2.6.5 Signal Quality

at+csq Query signal quality
+CSQ: 23,0 Signal quality

OK

8.2.6.6 Set all current parameters to manufacturer default

at&f Set to manufacturer default

OK

8.2.6.7 Store current parameter to user defined profile

at&w Store current parameter to default profile

OK

at&w0 Store current parameter to profile no. 0

OK

8.2.6.8 Set all current parameters to user defined profile

atz Set to user default profile

OK

atz0 Set to user default profile no. 0

OK

8.2.6.9 Display current configuration

at&v	Display current configuration
ACTIVE PROFILE:	
E1 L0 M0 Q0 V1 X4;	
S0:0 S2:43 S3:13 S4:10	S0-S13 display and calling parameters
S5:8 S6:2 S7:60 S8:2	
S10:15 S12:10 S13:60	
S1:0	
+CBST: 7,0,1	<i>"AT+CBST Select Bearer Service Type"</i>
+CRLP: 61,61,48,6,2,5	<i>"AT+CRLP Select radio link protocol param. for orig. non-transparent data call"</i>
+CRC: 0	<i>"AT+CRC Set Cellular Result Codes for incoming call indication"</i>
+CR: 0	<i>"AT+CR Service reporting control"</i>
+FCLASS: 0	<i>"AT+FCLASS Fax: select, read or test service class"</i>
+IFC: 2,2	<i>"AT+IFC Set TE-TA local data flow control"</i>
+ICF: 3,3	<i>"AT+ICF Set TE-TA control character framing"</i>
+DR: 0	<i>"AT+DR V.42bis data compression reporting control"</i>
+CMGF: 1	<i>"AT+CMGF Select SMS message format"</i>
+CSDH: 0	<i>"AT+CSDH Show SMS text mode parameters"</i>
+CNMI: 2,1,0,0,0	<i>"AT+CNMI New SMS message indications"</i>
+ILRR: 0	<i>"AT+ILRR Set TE-TA local rate reporting mode"</i>
+IPR: 19200	<i>"AT+IPR Set fixed local rate"</i>
+DS: 3,0,512,6	<i>"AT+DS V.42bis data compression control"</i>
+CMEE: 0	<i>"AT+CMEE Report mobile equipment error"</i>
^SMGO: 0	<i>"AT^SMGO Set or query SMS overflow presentation mode or query SMS overflow"</i>
+CSMS: 0	<i>"AT+CSMS Select Message Service"</i>
^SACM: 0	<i>"AT^SACM Advice of charge and query of ACM and ACMmax"</i>
^SCKS: 0	<i>"AT^SCKS Set SIM connection presentation mode and query SIM connection status"</i>
+CREG: 0	<i>"AT+CREG Network registration"</i>
+CCUG: 0,0,0	<i>"AT+CCUG Closed user group control"</i>
+CLIP: 0	<i>"AT+CLIP Calling line identification presentation"</i>
+COLP: 0	<i>"AT+COLP Connected line identification presentation"</i>
+CCWA: 0	<i>"AT+CCWA Call waiting control"</i>
+CAOC: 1	<i>"AT+CAOC Advice of Charge information"</i>
+CLIR: 0	<i>"AT+CLIR Calling line identification restriction"</i>
+COPS: 0	<i>"AT+COPS Operator selection"</i>
OK	

8.2.7 Phonebook handling

8.2.7.1 Select phonebook

at+cpbs=?	Ask for a list of supported storages
+CPBS: "SM", "FD", "LD", "RC", "ON", "ME", "MC", "MT"	List of supported storages: SIM ph.b., fixdialling-phonebook, last-dialling-phonebook, own phonebook
OK	
at+cpbs="SM"	Select SIM phonebook
OK	
at+cpbs?	Ask for current selected phonebook memory
+CPBS: "SM"	Current select is "SM"

OK

8.2.7.2 Read phonebook entry

NOTE: it is useful to check which book is used before reading (see:1.4)

at+cpbr=?

+CPBR: (0-2),40,30

(ON is selected) index: 0-2;

length of no.: 40; length of name: 30

OK

NOTE: the number of phone numbers that can be stored depends on your SIM card

+CPBR: (0-125),40,30

if SM phonebook is selected

+CPBR: (0-5),40,30

...FD...

+CPBR: (0-8),40,30

...LD...

at+cpbr=number1[,number2]

reads the entries of the current phonebook entries stored between number 1 and number 2

You can only read the entry in position number 1 if you do not enter number 2

+CPBR: 61,...

The international number for Susanne is stored (SM selected) in position 62 of this memory

+CPBR: 62,

"+436642254766",145,"Susanne"

This is a national number, no name has been entered

+CPBR: 63,"01170735397",129,""

+CPBR: 64,...

OK

8.2.7.3 Select phonebook memory storage

at+cpbs=?

Ask for list of supported storages

+CPBS:

List of supported storages

("SM","FD","LD","R
C","ON","ME","MC",
"MT")

OK

at+cpbs="SM"

Select SIM phonebook

OK

at+cpbs="FD"

Select SIM fixdialling-phonebook

OK

at+cpbs="ON"

Select SIM (or ME) own numbers (MSISDNs) list

OK

at+cpbs?

Ask for current selected phonebook memory

+CPBS: "ON"

Current select is "ON"

OK

8.2.7.4 Write phonebook entry

at+cpbw=?

Ask for location range supported by the current storage

```

+CPBW: (0-3),          Index: 0-3; nlength: 40; supported type: 129 or 145; tlength: 30
40,(129,145),30
OK
at+cpbs="SM"          Select SIM phonebook
OK
at+cpbs?              Check type of phonebook selected
+CPBS: "SM"           Type is "SM" – SIM phonebook
OK
at+cpbw=?
+CPBW: (0-100),       Index: 0-100; nlength: 40; supported type: 129 or 145; tlength: 30
40,(129,145),30
OK
at+cpbw=4,"538551",   Write "John's" phonebook entry at index number 4, phone "538551", type
129,"John"            129
OK
    
```

8.2.7.5 Extending the dialling numbers to 40 digits

The dialling numbers may be up to 40 digits long. Using the internal memory (e.g. "ME" phonebook), the numbers are stored "at once". Using the phonebooks of the SIM card (e.g. "SM" phonebook) only the first 20 digits are stored. The remaining digits are stored to the SIM extension files **EF_{EXT1}** and **EF_{EXT2}**. The length of these files (EF_{EXT} and EF_{EXT2}) is defined through the configuration of the SIM card. Normally there are only few entries in these files (about 5). If the extension file is full, no more entries longer 20 digits can be written to the SIM phonebooks.

The phonebooks are using the following extension files.

Phonebook	Extension File
SM	EF _{EXT1}
FD	EF _{EXT2}
LD	EF _{EXT1}
RC	
ON	EF _{EXT1}
ME	
MC	
MT	(EF _{EXT1})

The "MT" phonebook is the combination of "SM" and "ME" phonebook. The usage of the corresponding extension file depends on the selected phonebook ("SM" or "ME").

No new commands were added to support the number extension. The AT commands for querying (AT+CPBR=?, AT+CPBW=?,...) respond in two different ways. For the phonebooks of the M20 (e.g. "ME") the result code shows the correct number of 40 digits. For the phonebooks on the SIM card the result code is 20, because there only a few entries with 40 digits. The maximum number of entries on the SIM card cannot be determined directly. The exact number can be determined with the *AT+CRSM Restricted SIM access* command.

EF_{EXT1}

AT+CRSM=0xc0,0x6f4a

+CRSM: 144,0,000000826F4A040011F4440102010D



The entries are in hexadecimal format. The record has a length of $0x0D = 13$ Bytes and the file has a length of $0x82 = 130$ bytes. Therefore the file has $130/13 = 10$ entries.

EF_{EXT2}

at+crsm=0xc0,0x6f4b

+CRSM: 144,0,000000416F4B040012F4440102010D

Therefore there are $65/13 = 5$ entries.

Individual entries can be read with the AT+CRSM command.

Entry 1 and 5 of EF_{EXT1}

at+crsm=0xb2,0x6f4a,1,4

+CRSM: 144,0,0206099078563412FFFFFFFF

at+crsm=0xb2,0x6f4a,5,4

+CRSM: 144,0,FFFFFFFFFFFFFFFFFFFFFFFF

In this case there is no entry in index 5.

Note: If there are entries in EF_{EXT1} and EF_{EXT2} without corresponding entries in the SIM phonebooks, the entries in EF_{EXT1} and EF_{EXT2} can manually be deleted with the AT+CRSM command.

Behaviour with full EF_{EXT1}

The command AT+CPBW writes numbers with less than 20 digits normally to the SIM card. If the number is longer than 20 digits, there will be an error result code "**AT+CME ERROR: SIM failure**" and the entry is not written to the phonebook. When calling a 40 digits number with ATD, there will no number be written to the "LD" phonebook. No error message is reported.

8.2.7.6 Using the *AT^SPBA Browse the phonebook alphabetically* and *AT^SPBS Steps the selected phonebook alphabetically* Command

SM-Phonebook (Precondition):

<index>	<number>	<type>	<text>
1	+4301254	145	Doris
3	00431245	129	Andi
10	+49145787	145	Paul
15	0137484535	129	AW
20	+4372323	145	AA
25	0163562365	129	aA
100	011254587	129	Emil
133	0043145874	129	Zeppelin
145	+49145711	145	Toni

CASE 1: <browsetext> exists in the telephone-list

```
AT^SPBA="Doris"
^SPBA: 15,"0137484535",129,"AW"
^SPBA: 1,"+4301254",145,"Doris"
^SPBA: 100,"011254587",129,"Emil"
```

OK

CASE 2: <browsetext> doesn't exist in the telephone-list

```
AT^SPBA="Herbert"
^SPBA: 100,"011254587",129,"Emil"
^SPBA: 10,"+49145787",145,"Paul"
^SPBA: 145,"+49145711",145,"Toni"
```

OK

Statement: If <browsetext> is not found in the phonebook the first entry in alphabetical order after <browsetext> is written on the second position.

CASE 3: <browsetext> is the last text found in the alphabetical list (wrap around)

```
AT^SPBA="Zeppelin"
^SPBA: 145,"+49145711",145,"Toni"
^SPBA: 133,"0043145874",129,"Zeppelin"
^SPBA: 20,"+4372323",145,"AA"
```

OK

```
AT^SPBS=1 (make a step downward)
^SPBS: 133,"0043145874",129,"Zeppelin"
^SPBS: 20,"+4372323",145,"AA"
^SPBS: 25,"0163562365",129,"aA"
```

OK

```
AT^SPBS=2 (make a step upward)
^SPBS: 145,"+49145711",145,"Toni"
^SPBS: 133,"0043145874",129,"Zeppelin"
^SPBS: 20,"+4372323",145,"AA"
```

OK

Statement: If <browsetext> is at the beginning or at the end of the alphabetical list the output list wraps around.

8.2.8 Phone call¹

8.2.8.1 Mobile originated call

atd015265241;	Dial the number you want to be connected with (always with dialling code)
–	You see the cursor while the called party's phone is ringing
CONNECT	Your call is answered
NO CARRIER	Your partner has hung up
ath	To end the connection before your partner
–	If your call is not answered: the cursor disappears after some time
NO CARRIER	

8.2.8.2 Redial a number

ATDL;	The phone number last called is dialled again
CONNECT	
....	

8.2.8.3 Incoming call

RING	Somebody calls you
ata	"Pick up the receiver"

8.2.8.4 Call a number stored in a phonebook

atd>3;	Rings up number 3 of your current phonebook
CONNECT	
....	
atd>"SM",3;	If you want to use a phonebook, different from the current one
CONNECT	
....	

8.2.9 Data transfer

atd015265241	Dial the number you want to be connected with (always with dialling code)
–	NOTE: do not use a semicolon at the end of the command
connect 9600	You see the cursor while the other's phone is ringing
.....	Your call is answered, the transfer rate is 9600 bit/s
+++<pause>	You exchange data
ato	Switches from transparent to command mode
	Though the phone connection is still active, characters are no longer transferred to the other modem
	Returns to transparent mode

1. If not specifically mentioned, finish your commands with ENTER.

NO CARRIER Your partner has hung up

ath To end the connection before your partner

8.2.10 SMS with M20 to SIM (in text mode)

8.2.10.1 Service centre number

The number of the SC (service center) is provider specific. "A1" and "MAX" are the 2 Austrian network providers.

at+csc? Ask for current SC number
+CSCA: "+43676021" At the moment connected with SC of Max Mobil
OK
at+csc=""+436640501" Enter SC number of SIM card (e.g. A1) used at the moment
OK

8.2.10.2 Text mode

at+cmgf? Ask whether the text (1) or PDU (0) mode is used
+CMGF:1 Text mode used
OK
 Otherwise change with:
at+cmgf=1
OK

8.2.10.3 Send SMS

at+cmgs="+436642254766" Enter phone number, afterwards: enter
> text of your SMS Text not longer than..., afterwards: CTRL Z (!)
+cmgs: 27 Counts the messages sent with the SIM card
OK
 Enter: ESC to break off the SMS anywhere in the text, without sending it
OK

8.2.10.4 Send SMS to e-mail address

e.g. with A1:
at+cmgs="+43664051" Enter number depending on the network used, afterwards: enter
>Andrea.Schmidt@siemens.at (reference) text of your SMS You have to write (...), afterwards: CTRL Z (!)
+cmgs: 28 Counts the messages sent with the SIM card
OK

NOTE: A1 will send you a SMS confirming that your SMS was forwarded to the e-mail address

8.2.10.5 Send SMS to fax address

e.g. with Max Mobil
at+cmgs="+676201170755009" 6762 (Max Mobil), 01 (Vienna), 1707 (Siemens)
> text of your SMS afterwards: CTRL Z (!)

+cmgs: 29 Counts the messages sent with the SIM card
OK

8.2.10.6 Store SMS in memory

at+cmgw="+436764910086" Except for the at – command same procedure
>text of SMS As for sending (do not forget: CTRL Z (!)
+cmgw:5 Message is stored in position number 5 of your memory
OK

8.2.10.7 List of all SMS of the memory

at+cmgl
+cmgl:2,"REC_READ","+4366422547661", "98/07/28,12:35:23+00" Stored in position number 2 is an SMS you have read, received from phone number, service centre time-stamp
text of SMS message
+cmgl:5,"STO_UNSENT","+436764910086" An SMS you stored and have not yet sent
text of SMS message
 ...

8.2.10.8 Delete SMS message

at+cmgd=2 Deletes message in position 2 of the memory
OK

Delete messages you do not need because you can only store 15 SMSs
 and cannot receive new ones if there is no space left

8.2.10.9 Send SMS stored in the memory

at+cmss=2 Enter the number of an unsent message
+cmss: 30 Counts the messages sent with the SIM card
OK

8.2.10.10 Incoming SMS message

+CMTI:"SM",14 Indicates that you have just received an SMS that is stored in position 14 of your memory

8.2.10.11 Read SMS message

at+cmgr=14 read SMS in position 14 of the memory
+CMGR:"REC_UNREAD","+436641406214", "98/07/30,15:15:30+00" The status of the SMS is received and unread, indicates the sender and when it arrived at the service centre
Text of SMS
OK

8.2.11 WinFaxPro setup

NOTE: 1) The M20 only accepts FAX Protocol T62. Some GSM providers have T61 as the standard protocol.

NOTE:2) If you are unable to receive Fax with the M20 but sending works then check with your provider if T62 fax protocol is enabled for your SIM card

Before starting WINFAX:

In this example the M20 is connected via the serial connection COM1, it works the same with COM2.

- 1) Check if Winfax controller is active (small fax icon in the bottom right-hand corner of the screen). If this is the case, click the icon with the right mouse button and close all Winfax related programs and drivers. This enables the terminal program to connect with the M20 via the serial COM port.
- 2) Open the terminal program and log the M20 into the net. Once the M20 is logged in, you must close/disconnect the Terminal program from the COM port.
- 3) Start Winfax Pro
- 4) Use the below mentioned settings for sending and receiving a fax.

WINFAXPRO settings:

pulldown menu of WinFax:

Menu - path	Function	Setting
Settings-Modem	Modem	Standard 9600
	Port	Com1
Settings-Modem-Properties-General	Communication Port	Com1
	Initialize with	19200
	Fax/Modem - Type	Class 1
Settings-Modem-Properties-Fax	Modem connection	Mobile transmission
	Transfer rate: max.	9600
	Transfer rate: min.	2400
	Initialisation seq,1)	AT&F&C1&D2S7=55
	Initialisation seq,2)	AT+ifc=2,2
	Protocol HW	ON
	Reset command	ATZ
	ECM sending	ON
	ECM receiving	ON
	2D-Compression	OFF
Settings-Call reception	Automatic Reception	ON
	Accept call after x rings	X=1

8.2.12 Provider information

(Europa_info.xls)

Comments to the expressions used:

The following information and codes are supplied by your provider:

SCSA: SMS

This is the service center address of the Provider which has to be set in the M20 when sending SMS.

Setting:

AT+CSCA="<CSCA number of provider>"

Note: The number always has to be in the international code format starting with "+" and is enclosed in quotation marks.

Facility lock code:

This code is needed when barring incoming or outgoing calls using the AT+CLCK command

The given code is the standard setting of the provider on a new card.

If the code is entered incorrectly 3 times ONLY the provider can re-activate it.

8.3 M20 diagnostics

The following AT commands can be used to query information for diagnostics:

- **AT+CSQ** Signal quality (receive level)
This command with the corresponding parameters can be used to query the reception level in dBm and the bit error rate (RXQUAL) as per GSM Rec. GSM 05.08, Section 8.2.4.
- **AT+CREG** – Network status
This command can be used to query the network status. The messages can be, for example, "not registered, currently searching for a network", "registered", "registration denied", etc. as answers to this command.
- **AT+CREG? +CREG: <n>, <stat>[,<lai>,<ci>]**
This command combination can be used to query the Location Area Identifier (lai) and the Cell ID (ci).

These AT commands are described in more detail in Section 5.1 “Syntax of the standard AT commands” on page 27.

Other diagnostics:

Sending **AT<CR>** tests the interface between the base unit and the M20. If the M20 responds with OK, the interface is basically in full working order.

Information on the status or operation of the antenna is not possible because the RF field at the local site determines the result of any function query. If there is reason to suspect that poor reception or lack of reception is due to a defective antenna, this is easily checked by connecting a reference antenna. Alternatively, the antenna could be checked separately with the aid of a voltage standing wave ratio meter (VSWR meter).

8.3.1 Basics

No	Fault	Error Message	Status	Check	SW response / comment	Action					
1	System Booting not possible		Powerconnected, Ignition high for 1 second. no system reaction to booting procedure, LED stays OFF	Power supply plugged in, Voltage available on 6 pole Western plug		Check all power connections / test for voltages.					
2				M20T fuses blown			M20: Power connected, even if Ignition is set no reaction	Ignition is set to high for at least 1 second	Check ignition key		
										Bootcode is set high. (only allowed for SW downloading)	Disconnect Bootcode from High
										M20 plugged into 80 pole wrong way round. Pin 80 with pin41.	Connect M20 other way round
3	System Booting not possible		Powerconnected, Ignition high for 1 second no system reaction to booting procedure, LED stays OFF	Power supply plugged in, Voltage available on 6 pole Western plug		Check all power connections / test for voltages.					
4				M20T fuses blown			Replace M20T fuse: SMD fuse white (marked "12"), next to 6 pole western Plug				

5	Hyperterminal responds with faulty characters		Hyperterminal, Procomm plus on, M20T on (idle)	Serial connector: Not 0-Modem cable.	Terminal program and M20T have to have the same LOCAL baud rate setting to communicate (default 19200Baud)	Hyperterminal: to set local baud rate: 1) File-settings-configure COM1-set to 19200, OK, OK 2) Main Window: Call-disconnect, Call-connect
6					Terminal echoes input keys and M20t response correctly. See also AT+IPR, AT&W	Procomm-Plus: to set local baud rate: Options-System options- Modem connection- modem connection property, set Baud rate 19200
7	Unable to book into network		SIM inserted, PIN entered, M20T LED BLINKS	AT+COPS?	ERROR	power supply: Must be able to supply 2A pulses at minimum of 8V during booking into network
8			SIM inserted, PIN entered, M20T LED BLINKS	AT+CSQ	+CSQ: value smaller 7	Reposition Antenna until Signal quality more than 11. For Data calls signal should be more than 19.
9	No response from M20 to At-commands		Application uses baud rate other than 19200; no response from M20, M20 LED ON	Set needed baud rate with AT+ipr=<rate>, store to user profile with AT&W	After power up, <rate> from user profile is active.	If the application sends a command string including AT&F then the factory setting <rate>=19200 overrides user profile settings.
10	Display requests SIM even if already inserted	AT+CPIN? +CPIN: SIM PIN		M20/M20T only accepts 3V and dual voltage SIM cards. Most 5V SIMs are not recognised		Check with provider for 3V SIM cards
11				M20: Indicator for inserted SIM (CCIN; M20 pin 53) not tied to GND		Check SIM card reader

8.3.2 Call setup

No	Fault	Error Message	Status	Check	SW response / comment	Action
1	No call setup possible	No Carrier	SIM card inserted,(3V),Antenna connected, Power On, Ignition high. M20T LED blinking	3V SIM Card?		Old SIM cards are 5V,new ones 3V. Check with Network Provider. M20 accepts only 3V SIM cards!!!!
2				AT+CSQ: Signal Quality	+csq: <value>: if less 10	rearrange Antenna position, check Antenna connections, Signal Quality for proper function needs to be larger 12.
3				AT+CPIN?: PIN Status	ERROR	No SIM-Card inserted, SIM card defective, SIM holder not inserted properly
4					+cpin: SIM PIN	Enter Pin-code: AT+CPIN="xxxx" / number in quotes
5				AT+CREG?	+CREG: 0,0	M20 not booked into Net: AT+COPS=0 (search for Network, and book in)
6					+CREG: 0,2	M20 searching for network; when LED stops blinking, booked into network
7				AT+COPS=0	(can take up to 1 minute) +cops: <provider name>	Forces M20 to search for a network
8	No call setup possible	No Carrier	M20 active, booked into net (M20 idle), number exists, M20T LED ON	AT+CLCK="AO",2	+CLCK: 0	Outgoing call possible; problem has other cause.
9					+CLCK: 1,1 / Outgoing voice call barred	AT+CLCK="AO",0,"<code>",7 /Unlock all services, <code> available from Network provider (barring services)
10					+CLCK: 1,2 / Outgoing data call barred	AT+CLCK="AO",0,"<code>",7 /Unlock all services, <code> available from Network provider (barring services)

11					+CLCK: 1,4 / Outgoing fax call barred	AT+CLCK="AO",0,"<code>",7 /Unlock all services, <code> available from Network provider (barring services)
12	No VOICE call possible	No Carrier	M20 active, booked into net (M20 idle), VOICE number exists M20T LED ON	ATD<num> ; Semicolon is last character! Otherwise DATA call	OK	Check if <num> exists, <num> has to include AREA CODE
13	No DATA call possible	No Carrier	M20 active, booked into net (M20 idle), DATA number exists M20T LED ON	SIM card must have activated DATA number		SIM card DATA number available from Network provider
14				ATD<num> NO Semicolon as last character! Otherwise VOICE call	OK	SIM card must have activated DATA number
15	No FAX call possible	No Carrier	M20 active, booked into net (M20 idle), FAX number exists M20T LED ON	SIM card must have activated FAX number		SIM card must have activated FAX number
16	Distorted or no speech from the far end during an active call		M20: microphone externally biased and not DCdecoupled from M20		Couple microphone lines to M20 with capacitors, Bias microphone balanced to GND	

8.3.3 SW download

No	Fault	Error Message	Status	Check	SW response / comment	Action
1	No SW download after power up		M20T: LED on/ blinking	Bootcode enable must be high during power up		Bootcode enable must be high together with power on and needs to remain high for at least 1 second. If initialisation correct; M20T LED stays dark after power on
2				Ignition must be set high during complete download		Ignition must be set high during complete download
3			M20T: LED Off, power is on	PCload32.exe does no download		See chapter on SW download

8.4 Serial interface configuration

The serial interface to the M20/M20 Terminal has to be initialized as follows:

19200,8,N,1 (baud rate 19200, data bits: 8, parity: no, stop bit: 1)

A serial interface configuration file for a Windows 95/98/NT Hyperterminal program (file: m20.ht) can be found on the

CD).

8.4.1 General information

The following functions are available under Windows 95. When using these functions, the user has to *include windows.h* which is available under Microsoft Visual (MSVC) or Borland C, for example.

To send an AT command within your program, use *WriteComm*, to receive the response from the mobile equipment, use the *ReadComm* function.

For further details, e.g. initializing the serial interface, see below.

8.4.2 List of functions

8.4.2.1 int BuildCommDCB(lpszDef, lpdcb)

```
LPCSTR lpszDef;          /* address of device control string */
DCB FAR* lpdcb;         /* address of device control block */
```

The BuildCommDCB function translates a device definition string into appropriate serial device control block (DCB) codes.

int BuildCommDCB(lpszDef, lpdcb)	
Parameter	Description
lpszDef	Points to a null-terminated string that specifies device control information. The string must have the same form as the parameters used in the MS-DOS mode command.
lpdcb	Indicates a DCB structure that will receive the translated string. The structure defines the control settings for the serial communications device.
Return value	0 if the function is successful. Otherwise -1.
Example	<p>The following example uses the BuildCommDCB and SetCommState functions to set up COM1 to operate at 9600 bauds, with no parity, 8 data bits, and 1 stop bit:</p> <pre> IdComDev = OpenComm("COM1", 1024, 128); if (idComDev < 0) { ShowError(idComDev, "OpenComm"); return 0; } err = BuildCommDCB("COM1:9600,n,8,1", &dcb); if (err < 0) { ShowError(err, "BuildCommDCB"); return 0; } err = SetCommState(&dcb); if (err < 0) { ShowError(err, "SetCommState"); return 0; } </pre>
Comments	<p>The BuildCommDCB function only fills the buffer. To apply the settings to a port, an application should use the SetCommState function.</p> <p>By default, BuildCommDCB specifies XON/XOFF and hardware flow control as disabled. To enable flow control, an application should set the appropriate members in the DCB structure.</p>

See also	SetCommState, DCB
-----------------	-------------------

8.4.2.2 int ClearCommBreak(idComDev)

```
int idComDev;          /* device to be restored          */
```

The ClearCommBreak function restores character transmission and places the communications device in a non-break state.

int ClearCommBreak(idComDev)	
Parameter	Description
idComDev	Identifies the communications device to be restored. The OpenComm function returns this value.
Return value	0 if the function is successful -1 if the idComDev parameter does not identify a valid device.
Example	None
Comments	This function clears the communications device break state set by the SetCommBreak function.
See also	OpenComm, SetCommBreak

8.4.2.3 int CloseComm(idComDev)

```
int idComDev;          /* device to close          */
```

The CloseComm function closes the specified communications device and frees any memory allocated for the device's transmission and receiving queues. All characters in the output queue are sent before the communications device is closed.

int CloseComm(idComDev)	
Parameter	Description
idComDev	Specifies the device to be closed. The OpenComm function returns this value.
Return value	0 if the function is successful Otherwise -1.
Example	None
Comments	None
See also	OpenComm

8.4.2.4 BOOL EnableCommNotification(idComDev, hwnd, cbWriteNotify, cbOutQueue)

```
int idComDev;          /* communications device identifier */
HWND hwnd;            /* handle of window receiving messages*/
int cbWriteNotify;    /* number of bytes written before notification*/
int cbOutQueue;       /* minimum number of bytes in output queue*/
```

The EnableCommNotification function enables or disables WM_COMMNOTIFY message posting to the given window.

BOOL EnableCommNotification(idComDev, hwnd, cbWriteNotify, cbOutQueue)	
Parameter	Description
idComDev	Specifies the communications device that is posting notification messages to the window identified by the hwnd parameter. The OpenComm function returns the value for the idComDev parameter.
hwnd	Identifies the window whose WM_COMMNOTIFY message posting will be enabled or disabled. If this parameter is NULL, EnableCommNotification disables message posting to the current window.
cbWriteNotify	Indicates the number of bytes the COM driver must write to the application's input queue before sending a notification message. The message signals the application to read information from the input queue.
cbOutQueue	Indicates the minimum number of bytes in the output queue. When the number of bytes in the output queue falls below this number, the COM driver sends the application a notification message, signalling it to write information to the output queue
Return value	0 indicates: <ul style="list-style-type: none"> - an invalid COM port identifier - a port that is not open or - a function not supported by COMM.DR ≠ 0 function is successful
Example	None

Comments	<p>If an application specifies -1 for the cbWriteNotify parameter, the WM_COMMNOTIFY message is sent to the specified window for CN_EVENT and CN_TRANSMIT notifications but not for CN_RECEIVE notifications. If -1 is specified for the cbOutQueue parameter, CN_EVENT and CN_RECEIVE notifications are sent but CN_TRANSMIT notifications are not sent.</p> <p>If a timeout occurs before as many bytes as specified by the cbWriteNotify parameter are written to the input queue, a WM_COMMNOTIFY message is sent with the CN_RECEIVE flag set. When this occurs, another message will not be sent until the number of bytes in the input queue falls below the number specified in the cbWriteNotify parameter. Similarly, a WM_COMMNOTIFY message in which the CN_RECEIVE flag is set is sent only when the output queue is larger than the number of bytes specified in the cbOutQueue parameter.</p> <p>The Windows 3.0 version of COMM.DRV does not support this function.</p>
See also	WM_COMMNOTIFY

8.4.2.5 LONG EscapeCommFunction(idComDev, nFunction)

```
int idComDev;          /* identifies communications device */
int nFunction;        /* code of extended function */
```

The EscapeCommFunction function directs the specified communications device to carry out an extended function.

LONG EscapeCommFunction(idComDev, nFunction)	
Parameter	Description
idComDev	Specifies the communications device that will carry out the extended function. The OpenComm function returns this value.
nFunction	<p>Specifies the function code of the extended function. It can be one of the following values:</p> <p>Value meaning</p> <p>CLRDRTR clears the DTR (data terminal ready) signal.</p> <p>CLRRTS clears the RTS (request to send) signal.</p> <p>GETMAXCOM returns the maximum COM port identifier supported by the system. This value ranges from 0x00 to 0x7F, such that 0x00 corresponds to COM1, 0x01 to COM2, 0x02 to COM3, and so on.</p> <p>GETMAXLPT returns the maximum LPT port identifier supported by the system. This value ranges from 0x80 to 0xFF, such that 0x80 corresponds to LPT1, 0x81 to LPT2, 0x82 to LPT3, and so on.</p> <p>RESETDEV resets the printer device if the idComDev parameter specifies an LPT port. No function is performed if idComDev specifies a COM port.</p> <p>SETDTR sends the DTR (data terminal ready) signal.</p> <p>SETRTS sends the RTS (request to send) signal</p> <p>SETXOFF causes transmission to act as if an XOFF character has been received.</p> <p>SETXON causes transmission to act as if an XON character has been received.</p>
Return value	0 if the function is successful. Otherwise < 0
Example	None
Comments	None
See also	None

8.4.2.6 int FlushComm(idComDev, fnQueue)

```
int idComDev;          /* communications-device identifier */
int fnQueue;          /* queue to flush */
```

The FlushComm function flushes all characters from the transmission or receiving queue of the specified communications device.

int FlushComm(idComDev, fnQueue)	
Parameter	Description
idComDev	Specifies the communications device to be flushed. The OpenComm function returns this value.
fnQueue	Specifies the queue to be flushed. The transmission queue is flushed if this parameter is zero. The receiving queue is flushed if the parameter is 1.
Return value	0 if the function is successful. < 0 if idComDev is not a valid device or if fnQueue is not a valid queue > 0 if there is an error for the specified device. For a list of the possible error values, see the GetCommError function.
Example	None
Comments	None
See also	GetCommError, OpenComm

8.4.2.7 int GetCommError(idComDev, lpStat)

```
int idComDev;           /* communications device identifier */
COMSTAT FAR* lpStat;  /* address of device-status buffer */
```

The GetCommError function retrieves the most recent error value and current status for the specified device. When a communications error occurs, Windows locks the communications port until GetCommError clears the error.

int GetCommError(idComDev, lpStat)	
Parameter	Description
idComDev	Specifies the communications device to be examined. The OpenComm function returns this value.
lpStat	Indicates the COMSTAT structure that is to receive the device status. If this parameter is NULL, the function only returns the error values.
Return value	<p>The return value specifies the error value for the most recent communications function call to the specified device, if GetCommError is successful.</p> <p>Errors:</p> <p>The return value can be a combination of the following values:</p> <p>Value Meaning</p> <p>CE_BREAK hardware detected a break condition.</p> <p>CE_CTSTO CTS (clear to send) timeout. While a character was being transmitted, CTS was low for the duration specified by the fCtsHold member of the COMSTAT structure.</p> <p>CE_DNS parallel device was not selected.</p> <p>CE_DSRTO DSR (data set ready) timeout. While a character was being transmitted, DSR was low for the duration specified by the fDsrHold member of COMSTAT.</p> <p>CE_FRAME hardware detected a framing error.</p> <p>CE_IOE I/O error occurred during an attempt to communicate with a parallel device.</p> <p>CE_MODE requested mode is not supported or the idComDev parameter is invalid. If set, CE_MODE is the only valid error.</p> <p>CE_OOP parallel device signalled that it is out of paper.</p> <p>CE_OVERRUN character was not read from the hardware before the next character arrived. The character was lost.</p> <p>CE_PTO timeout occurred during an attempt to communicate with a parallel device.</p> <p>CE_RLSDTO RLSD (receive line signal detect) timeout. While a character was being transmitted, RLSD was low for the duration specified by the fRlsdHold member of COMSTAT.</p> <p>CE_RXOVER receiving queue overflowed. There was either no room in the input queue or a character was received after the end-of-file character was received.</p> <p>CE_RXPARITY hardware detected a parity error.</p> <p>CE_TXFULL transmission queue was full when a function attempted to queue a character.</p>
Example	None
Comments	None
See also	OpenComm, COMSTAT

8.4.2.8 UINT GetCommEventMask(idComDev, fnEvtClear)

```
int idComDev;          /* communications device identifier */
int fnEvtClear;       /* events to clear in the event word */
```

The GetCommEventMask function retrieves and then clears the event word for a communications device.

UINT GetCommEventMask(idComDev, fnEvtClear)	
Parameter	Description
idComDev	Specifies the communications device to be examined. The OpenComm function returns this value.
fnEvtClear	Specifies which events are to be cleared in the event word. For a list of the event values, see the description of the SetCommEventMask function
Return value	The return value specifies the current event-word value for the specified communications device if the function is successful. Each bit in the event word specifies whether a given event has occurred; a bit is set (to 1) if the event has occurred.
Example	None
Comments	Before the GetCommEventMask function can record the occurrence of an event, an application must enable the event by using the SetCommEventMask function. If the communications device event is a line-status or printer error, the application should call the GetCommError function after calling GetCommEventMask.
See also	GetCommError, OpenComm, SetCommEventMask

8.4.2.9 int GetCommState(idComDev, lpdcb)

```
int idComDev;          /* communications device identifier */
DCB FAR* lpdcb;       /* address of structure for device control block */
```

The GetCommState function retrieves the device control block for the specified device.

int GetCommState(idComDev, lpdcb)	
Parameter	Description
idComDev	Specifies the device to be examined. The OpenComm function returns this value.
lpdcb	Points to the DCB structure that is to receive the current device control block. The DCB structure defines the control settings for the device.
Return value	0 if the function is successful. Otherwise < 0
Example	None
Comments	None
See also	OpenComm, SetCommState, DCB

8.4.2.10 int OpenComm(lpszDevControl, cbInQueue, cbOutQueue)

LPCSTR lpszDevControl; /* address of device-control information */

UINT cbInQueue; /* size of receiving queue */

UINT cbOutQueue; /* size of transmission queue */

The OpenComm function opens a communications device.

int OpenComm(lpszDevControl, cbInQueue, cbOutQueue)	
Parameter	Description
lpszDevControl	Points to a null-terminated string that specifies the device in the form COMn or LPTn, where n is the device number.
cbInQueue	Specifies the size, in bytes, of the receiving queue. This parameter is ignored for LPT devices.
cbOutQueue	Specifies the size, in bytes, of the transmission queue. This parameter is ignored for LPT devices.
Return value	<p>≥ 0 the return value identifies the open device if the function is successful. Otherwise < 0</p> <p><u>Errors:</u> If the function fails, it may return one of the following error values: Value Meaning IE_BADID the device identifier is invalid or unsupported. IE_BAUDRATE the device's baud rate is unsupported. IE_BYTESIZE the specified byte size is invalid. IE_DEFAULT the default parameters are in error. IE_HARDWARE the hardware is not available (is locked by another device). IE_MEMORY the function cannot allocate the queues. IE_NOPEN the device is not open. IE_OPEN the device is already open.</p> <p>If this function is called with both queue sizes set to zero, the return value is: IE_OPEN if the device is already open or IE_MEMORY if the device is not open.</p>
Example	<p>The following example uses the OpenComm function to open communications port 1:</p> <pre> idComDev = OpenComm("COM1", 1024, 128); if (idComDev < 0) { ShowError(idComDev, "OpenComm"); return 0; } err = BuildCommDCB("COM1:9600,n,8,1", &dcb); if (err < 0) { ShowError(err, "BuildCommDCB"); return 0; } err = SetCommState(&dcb); if (err < 0) { ShowError(err, "SetCommState"); return 0; } </pre>

Comments	<p>Windows allows COM ports 1 through 9 and LPT ports 1 through 3. The OpenComm function will fail if the device driver does not support a communications port number.</p> <p>The communications device is initialized to a default configuration. The SetCommState function should be used to initialize the device to alternate values.</p> <p>The receiving and transmission queues are used by interrupt-driven device drivers. LPT ports are not interrupt-driven for these ports, the cbInQueue and cbOutQueue parameters are ignored and the queue size is set to zero.</p>
See also	CloseComm, SetCommState

8.4.2.11 int ReadComm(idComDev, lpvBuf, cbRead)

```
int idComDev; /* identifier of device to read from */
void FAR* lpvBuf; /* address of buffer for read bytes */
int cbRead; /* number of bytes to read */
```

The ReadComm function reads up to a specified number of bytes from the given communications device.

int ReadComm(idComDev, lpvBuf, cbRead)	
Parameter	Description
idComDev	Specifies the communications device to be read from. The OpenComm function returns this value.
lpvBuf	Points to the buffer for the read bytes.
cbRead	Specifies the number of bytes to be read.
Return value	≥ 0 the number of bytes read, if the function is successful. 0 For parallel I/O ports, the return value is always zero. Otherwise < 0, its absolute value is the number of bytes read
Example	None
Comments	When an error occurs, the cause of the error can be determined by using the GetCommError function to retrieve the error value and status. Since errors can occur when no bytes are present (if the return value is zero), the GetCommError function should be used to ensure that no error occurred. The return value is less than the number specified by the cbRead parameter only if the number of bytes in the receiving queue is less than that specified by cbRead. If the return value is equal to cbRead, additional bytes may be queued for the device. If the return value is zero, no bytes are present.
See also	GetCommError, OpenComm

8.4.2.12 int SetCommBreak(idComDev)

```
int idComDev; /* device to suspend */
```

The SetCommBreak function suspends character transmission and places the communications device in a break state.

int SetCommBreak(idComDev)	
Parameter	Description
idComDev	Specifies the communications device to be suspended. The OpenComm function returns this value.
Return value	0 if the function is successful. Otherwise < 0
Example	None
Comments	The communications device remains suspended until the application calls the ClearCommBreak function.
See also	ClearCommBreak, OpenComm

8.4.2.13 UINT FAR* SetCommEventMask(idComDev, fuEvtMask)

```
int idComDev;          /* device to enable          */
UINT fuEvtMask;       /* events to enable          */
```

The SetCommEventMask function enables events in the event word of the specified communications device.

UINT FAR* SetCommEventMask(idComDev, fuEvtMask)	
Parameter	Description
idComDev	Specifies the communications device to be enabled. The OpenComm function returns this value.
fuEvtMask	<p>Specifies which events are to be enabled.</p> <p>This parameter can be any combination of the following values:</p> <p>Value meaning</p> <p>EV_BREAK set when a break is detected on input.</p> <p>EV_CTS set when the CTS (clear to send) signal changes state.</p> <p>EV_CTS set when the CTS (clear to send) signal changes state.</p> <p>EV_CTSS set to indicate the current state of the CTS signal.</p> <p>EV_DSR set when the DSR (data set ready) signal changes state.</p> <p>EV_ERR set when a line-status error occurs. Line-status errors are CE_FRAME, CE_OVERRUN, and CE_RXPARITY.</p> <p>EV_PERR set when a printer error is detected on a parallel device. Errors are CE_DNS, CE_IOE, CE_LOOP, and CE_PTO.</p> <p>EV_RING set to indicate the state of ring indicator during the last modem interrupt.</p> <p>EV_RLSD set when the RLSD (receive line signal detect) signal changes state.</p> <p>EV_RLSDS set to indicate the current state of the RLSD signal.</p> <p>EV_RXCHAR set when any character is received and placed in the receiving queue.</p> <p>EV_RXFLAG set when the event character is received and placed in the receiving queue. The event character is specified in the device's control block.</p> <p>EV_TXEMPTY set when the last character in the transmission queue is sent.</p>
Return value	The return value is an indication to the event-word for the specified communications device, if the function is successful. Each bit in the event word specifies whether a given event has occurred. A bit is 1 if the event has occurred.
Example	None
Comments	Only enabled events are recorded. The GetCommEventMask function retrieves and clears the event word.
See also	GetCommEventMask, OpenComm

8.4.2.14 int SetCommState(lpdcB)

```
const DCB FAR* lpdcB; /* address of device control block */
```

The SetCommState function sets a communications device to the state specified by a device control block.

int SetCommState(lpdcB)	
Parameter	Description
lpdcB	Indicates a DCB structure that contains the desired communications settings for the device. The ID member of the DCB structure must identify the device.
Return value	0 if the function is successful. Otherwise < 0
Example	<p>The following example uses the BuildCommDCB and SetCommState functions to set up COM1 at 9600 baud, no parity, 8 data bits, and 1 stop bit:</p> <pre>idComDev = OpenComm("COM1", 1024, 128); if (idComDev < 0) { ShowError(idComDev, "OpenComm"); return 0; } err = BuildCommDCB("COM1:9600,n,8,1", &dcB); if (err < 0) { ShowError(err, "BuildCommDCB"); return 0; } err = SetCommState(&dcB); if (err < 0) { ShowError(err, "SetCommState"); return 0; }</pre>
Comments	This function reinitializes all hardware and controls as defined by the DCB structure, but it does not empty transmission or receiving queues.
See also	GetCommState, DCB

8.4.2.15 int TransmitCommChar(idComDev, chTransmit)

```
int idComDev;          /* communications device      */
char chTransmit;      /* character to transmit      */
```

The TransmitCommChar function places the specified character at the head of the transmission queue for the specified device.

int TransmitCommChar(idComDev, chTransmit)	
Parameter	Description
idComDev	Specifies the communications device to transmit the character. The OpenComm function returns this value.
chTransmit	Specifies the character to be transmitted.
Return value	0 if the function is successful. < 0 if the character cannot be transmitted.
Example	<pre>The following example uses the TransmitCommChar function to send characters from the keyboard to the communications port: case WM_CHAR: ch = (char)wParam; TransmitCommChar(idComDev, ch); /* Add a linefeed for every carriage return. */ if (ch == 0x0d) TransmitCommChar(idComDev, 0x0a); break;</pre>
Comments	The TransmitCommChar function cannot be called repeatedly if the device is not transmitting. Once TransmitCommChar places a character in the transmission queue, the character must be transmitted before the function can be called again. TransmitCommChar returns an error if the previous character has not yet been sent.
See also	OpenComm, WriteComm

8.4.2.16 int UngetCommChar(idComDev, chUnget)

```
int idComDev;          /* communications device      */
char chUnget;         /* character to place in queue */
```

The UngetCommChar function places the specified character back in the receiving queue. The next read operation will return this character first.

int UngetCommChar(idComDev, chUnget)	
Parameter	Description
idComDev	Specifies the communications device that will receive the character. The OpenComm function returns this value.
chUnget	Specifies the character to be placed in the receiving queue.
Return value	0 if the function is successful. Otherwise < 0
Example	None
Comments	Consecutive calls to the UngetCommChar function are not permitted. The character placed in the queue must be read before this function can be called again.
See also	

8.4.2.17 int WriteComm(idComDev, lpvBuf, cbWrite)

```
int idComDev;          /* identifier of comm. device      */
const void FAR* lpvBuf; /* address of data buffer          */
int cbWrite;          /* number of bytes to write       */
```

The WriteComm function writes to the specified communications device.

int WriteComm(idComDev, lpvBuf, cbWrite)	
Parameter	Description
idComDev	Specifies the device to receive the bytes. The OpenComm function returns this value.
lpvBuf	Points to the buffer that contains the bytes to be written.
cbWrite	Specifies the number of bytes to be written.
Return value	The return value specifies the number of bytes written, if the function is successful. < 0 if an error occurs, making the absolute value of the return value the number of bytes written.
Example	None
Comments	To determine what caused an error, use the GetCommError function to retrieve the error value and status. For serial ports, the WriteComm function deletes data in the transmission queue if there is not enough room in the queue for the additional bytes. Before calling WriteComm, applications should check the available space in the transmission queue by using the GetCommError function. Also, applications should use the OpenComm function to set the size of the transmission queue to an amount no smaller than the size of the largest expected output string.
See also	GetCommError, OpenComm, TransmitCommChar

8.5 SW download (Version update)

The Flashloader functions under **Windows 95/98/NT** for updating and loading SW into the M20 module via the serial interface of the M20Terminal. An implementation of SW download without using the M20T module is also described.

8.5.1 M20: HW setup

For Downloading SW into the M20 without the use of the M20T, following preparations have to be made to enable M20 to communicate with the PC via the serial interface cable.

Tools and components required:

If not already installed on the application a minimum serial interface 1) between the M20 and a computer is required. (The signals RTS, CTS, DSR and DTR are not necessary for SW-update.)

M20 pins	Signal	Comments
18-22, 58-62	DC_IN	-
17, 23-25, 38, 43, 56, 57, 63-65	GND	-
8	IGNITION	Connect IGNITION to DC_IN
30	BOOTCODEEN ²⁾	Provide a switch between BOOTCODEEN and POWER_ON.
74	POWER_ON	
10	USCRX	A level shifter from 2.8 V logic to V.24/RS232 is required (must be connected to pin 3 on a computers 9-pin Sub-D serial port)
72	USCTX	A level shifter from 2.8 V logic to V.24/RS232 is required (must be connected to pin 2 on a computers 9-pin Sub-D serial port)

Note:

1) The signals RTS, CTS, DSR and DTR are not necessary for SW-update.

- 2) BOOTCODEEN is active for about 100 ms immediately after a reset. After that time, the signal is inactive
- 1) A level converter is needed to adapt the signal voltages of the M20 to those of the serial interface cable. Shows a circuit example.
- 2) For Pin numbering of the M20, 80 pole SMD plug see Fig. 0-1: Bottom view of M20 with 80 Pole SMD plug
- 3) The BOOTCODEEN pin (**PIN 30**) of the M20 must be connected to +2,8V (max +3.3V) for typ. 1.5 seconds, during the power up of the M20 to enable SW download from the PC.
- 4) Ignition line has to be set HIGH ($2,7V < \text{Ignition} < 6,2V$) (max.50V) PIN 8 on the 80-pole SMD connector during the entire SW download.
- 5) For information regarding the proper power connection of the M20 please refer to the Technical Description manual of the M20/M20T, Chapter 4.
- 6) The next steps are described in Chapter 0.4 M20T: Booting for SW loading step 2) Setting Windows95 system variable MEMIF to "1".

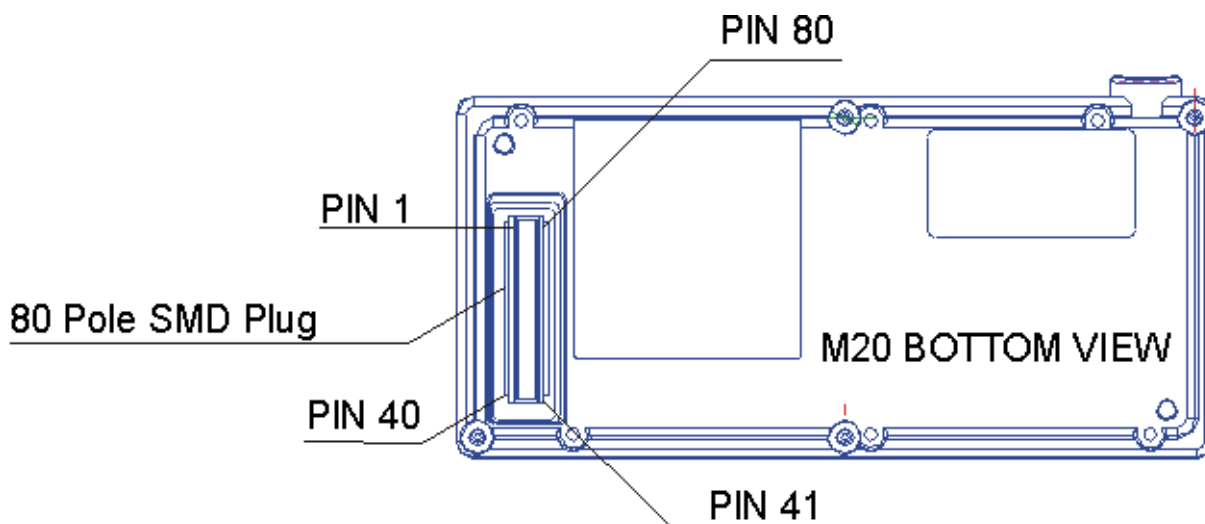

Fig. 8-1 Bottom view of M20 with 80 Pole SMD plug

8.5.2 M20Terminal

Software:

- 1) PC with **Windows 95/98/NT** operating system
- 2) Downloader: **PCload32.exe**
- 3) SW Update: **sytem.mot**

Hardware:

- 1) M20/M20T (incl. power supply)
- 2) Screwdriver or similar device to short BOOTCODEENABLE pads during power-up of M20.
- 3) Serial interface cable (M20T to PC: COM2)

8.5.3 M20T: HW Setup current HW

6-pole Western plug (female)//power supply, ignition, line-in/out

Pin	Usage
1	Power supply 8-28.8 V
2	Audio Line Ground (for pin 3/AC:in & pin 5/AC:out)
3	(This Pin must not exceed Voltages >2V to avoid power switched off!) AC: Line-in input 600 Ohm DC: Signal for power Off, power off for U (to pin6) >8V (ignition low)
4	Ignition > 5V for longer than 1 s switches on Ignition signal (see M20: 80-pole connector Pin 8) Ignition for U (to pin 6) >5V

5	(This Pin must not exceed Voltages >2V during power on procedure to avoid a change to bootmode!)	AC: Line-out 600 Ohm DC: Signal for initialisation of SW download for U(to Pin6)>8V
6		GND

Note:

(1) Ignition signal > 5V for longer than 1 s has to be set to voltage > 2.8 V, remember that this signal has to be low when switching off the M20 with AT command AT^SMSO, see Chapter 5.7 “*Siemens-defined AT commands for enhanced functions*” on page 111.

(2) SW-DOWNLOAD: To switch the M20T to bootmode use the following procedure:

Apply > 8V to Pin 5 before or together with the supply voltage. The M20T switches to bootmode. Proceed according to capt.8.5 (e.a.?) loading the SW using the RS 232-interface (9-pole SUB-D plug).

(3) POWER_OFF EXCEPTION HANDLING: In case of software hang-ups etc. the M20T can be switched off using the following procedure (exception handling): Pin 3 must be applied with a voltage > 8V AND Pin 4 must be low (0V). To switch on again, set ignition >5V (and Pin 2 <2V).

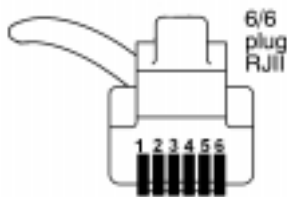

Fig. 8-2 Front view of Western plug 6-6 (male)

Follow instruction in chapter 8.5.5 “*M20T: Booting for SW loading*” on page 194.

8.5.4 M20T: HW Setup Terminal B4

- 1) Connect the M20Terminal to the PC with the serial cable.
- 2) Connect power supply of M20T to M20T; BUT do NOT connect power supply to mains!!!
- 3) Unscrew and remove top cover of M20T (Screwdriver Torx7).

8.5.5 M20T: Booting for SW loading

Please follow the given sequence exactly for successful booting and loading of M20 Software/SW updates.

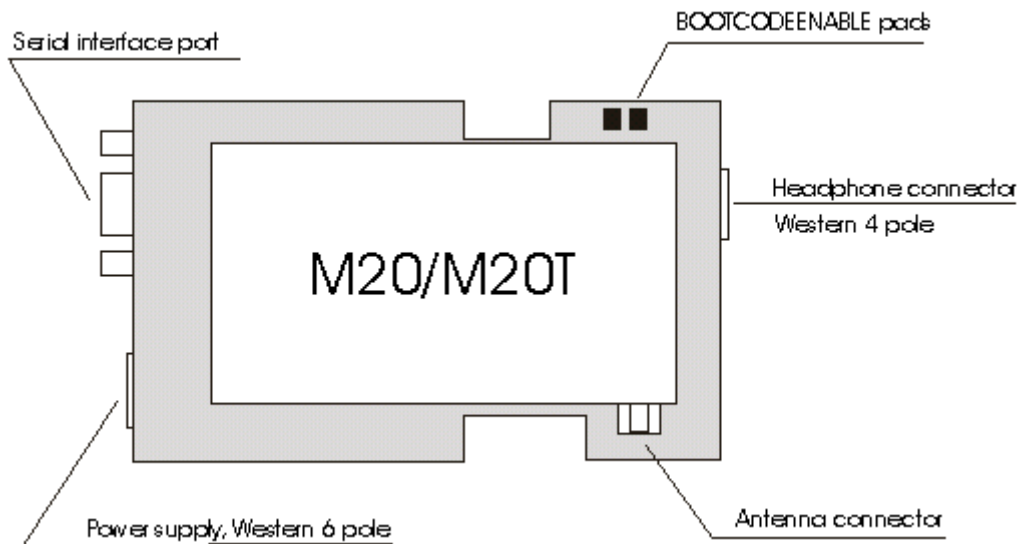

Fig. 8-3 Top view of open M20T

- 1) **To activate SW-loading mode of the M20 the BOOTCODEENABLE pads of the M20T have to be connected during the power-up of the M20/M20T. The Ignition line has to be set HIGH during the entire SW loading**
- 2) Make sure that M20T is not connected to the mains (Off)
- 3) Remove top cover of the M20T (all connections remain intact) and find 2 BOOTCODEENABLE pads (see Fig. 0-1:Top view of open M20T)
- 4) Connect the two BOOTCODEENABLE pads during connection of the M20T to the power mains.(eg. Using a screwdriver tip)
- 5) Ignition line has to be set HIGH ($2,7V < \text{Ignition} < 6,2V$) (max.50V) PIN 6 on the 6-pole Western plug of the M20T, see also Technical Description chapter: 8.8.6 Ignition line.
- 6) Once power up is achieved the connection between the pads can be removed.(about 1 sec.)

8.5.6 SW installation

- 1) Copy SW-Version **system.mot** to a local drive.
- 2) Copy the program **PCload32.exe** to a local drive.
- 3) Start **PCload32.exe** by double clicking. Note: Double-click on **system.mot** will not start the correct loading program.
- 4) Close **PCload32.exe**.

Note: This version is designed for use with Microsoft Windows95/98/NT.

8.5.7 Starting PCLoad32.exe program

1. Enter the filename of the Software to download (eg.: c:\m20\ system.mot) or find it with the “Select Download Flash File” button.



2. Set Port to COM2 (if serial cable connected to COM2)
Set Baudrate 57200
Set Modul M20

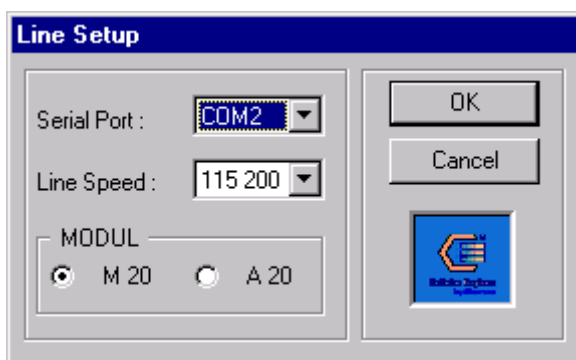

3. Click "OK"
4. Click the “Run” button.
5. Downloading time of software between 4-6 minutes.
6. The end of the download is indicated by “All done” message in "PC Flash loader" window.

8.6 EMC-relevant information for integrators of the M20

- Provide for short lines to the SIM card reader (< 150 mm).
- Provide for short lines to the display (< 100 mm) and embed well into the ground (to avoid emitted interference).
- Provide for ground feed lines to the 80-pin connector over a large area to create a screen effect.
- Connect the ground of the terminal's circuit board to a large area on a conductive-material housing, if provided.
- Keep all lines from the 80-pin connector to the peripheral units as short as possible. The maximum length for supply lines must not exceed 1 m. The maximum length for the I/O lines must not exceed 2 m. If longer lines are used, additional testing of line interference is needed. Secure the power lines against the ground with capacitors at the M20 connector, e.g. 100 nF and 25 pF.
- When laying I/O lines, remove interferences (i.e. if possible avoid parallel cabling to lines from mains supply or data) or shield I/O lines.
- Provide for large-area and low-impedance connection of M20 housing ground to ground on terminal's circuit board (screws with spring washers and solder resist release on the mother board).
- Take fine protection (varistor or transorpd diode) against overvoltage (transient and surge) into account.
- Audio:
 - Use the microphone and handset provided and provide for the suggested connection. If using other microphones, particular attention should be paid to HF resistance (no HF demodulation).
 - Embed audio lines in the ground (to avoid interference).
- Provide for fuses and reverse-connect protection of power.
- Grounded areas on the print whenever possible, prefer star-configuration and avoid circuit-configuration when contacting these areas together
- Use shielded cable for connection of the display interface pins 1-5, 75-80 when possible
- If a display is connected directly to the print avoid long paths to M20-pins
- Be careful when using #RES (pin 7), it can be influenced easily in ECD-Tests, avoid long distances
- When using the GP-Interface (GPCS/pin29, GPIO/pin50, GPII/pin51) put resistors 2k2...6k8 serial near M20-connector in the path
- Using HWR# (pin 6) affords filtering: pin 6 to ground 10pF / pin 6 to circuit 2k2
- CCRST (pin 27) to SIM-reader also needs filtering: pin 27 to SIM-Contact 1k0 / SIM-Contact to Ground 10nF
- CCVCC (pin 52) needs a capacitor 100n to Ground nearby the SIM-Reader

8.7 Getting full-type approval with the application

The Cellular Engine Siemens M20 is a GSM 900 Terminal with external peripherals and is full type approved (FTA) in two basic configurations. "Configuration" specifies the application and all GSM relevant parts of the application.

In general, new applications based on the M20 need delta-type approval. The delta-type approval process depends on the deviation between the GSM relevant parts of the new application and those of the already type-approved configurations.

Note: an updated list of already type approved configurations can be ordered from Siemens.

Type approval DeltaFTA for new applications can be carried out by Siemens.

Note: before making an application configuration (SIM card reader, handset, display, etc.) contact your distributor to send you an updated list of approved components.

8.7.1 Basic configurations with FTA

Configuration I:

- Cellular Engine Siemens M20
- Test Box
- SIM Card Reader Connector L 04, Version: 7434L0425F01, Framatome Connectors
- Handset Siemens Gigaset, Version: 1 (not for sale)
- MMI PC (AT+C Terminal) AT command terminal on PC

Configuration II:

- Cellular Engine Siemens M20
- Cellular Local Loop Phone (CLLP)

- SIM Card Reader Connector L 04, Version: 7434L0425F01, Framatome Connectors
- Handset Siemens Gigaset, Version: 1
- MMI (keypad + display integrated in the CLLP)

Configuration III

- Siemens M20 Terminal
- Handset Siemens Gigaset, Version 1
- MMI (AT+C Terminal) AT command terminal on PC

8.7.2 Delta-type approval process

The delta-type approval process can be divided into two parts: retesting and admission.

Retesting

The objects of the delta type approval process are:

- 1) Handset (handsfree device is a non-regulated accessory and is therefore not object of type approval process)
- 2) SIM card reader
- 3) MMI (e.g. keypad + display)
- 4) EMC consideration of the new application (already integrated with the M20) according to ETS 300 342-1 dated 06/97.

The objects listed above (1-3) have to be retested according to TBR 19 and TBR 20 (a list of required delta test cases according to ETS 300 607-1 is available from Siemens and can be requested by the customer). A list of subclauses of the ETS 300 342-1 dated 06/97 which are required for EMC consideration (point 4 listed above) is also available from Siemens and can be requested by the customer.

Note: only those parts which are different to the already type-approved parts have to be retested. If the new application, for example, uses the same handset as the one in the already type-approved configurations, then no retesting of the handset is required.

Admission

The following information and documents are required, for the administrative delta-type approval of a new application based on the M20:

- Test report for conformance testing of MMI, AUDIO, SIM interface
- Application (e.g. Public Phone)
Official name, photo(s), software version, hardware version, technical description with block diagram, electrical circuit (only relevant parts), software description (only for GSM part), user manual (for GSM part).
- SIM card reader
Official name, hardware version, technical specification/documentation, photo(s)
- Handset
Official name, hardware version, technical specification/documentation, photo(s)
- MMI
Official name (e.g. of the display), software version, hardware version (e.g. of the display), technical specification/documentation, photo(s)
- EMC consideration according to the ETS 300 342-1 dated 06/97.
Test report for EMC consideration (delta EMC tests) of the integrated system (Cellular Engine Siemens M20 + new application) from a "competent body".

8.8 Application examples and reference circuits

The following examples are for reference only and describe one of many possibilities to realise the shown function.

8.8.1 V.24 level converter

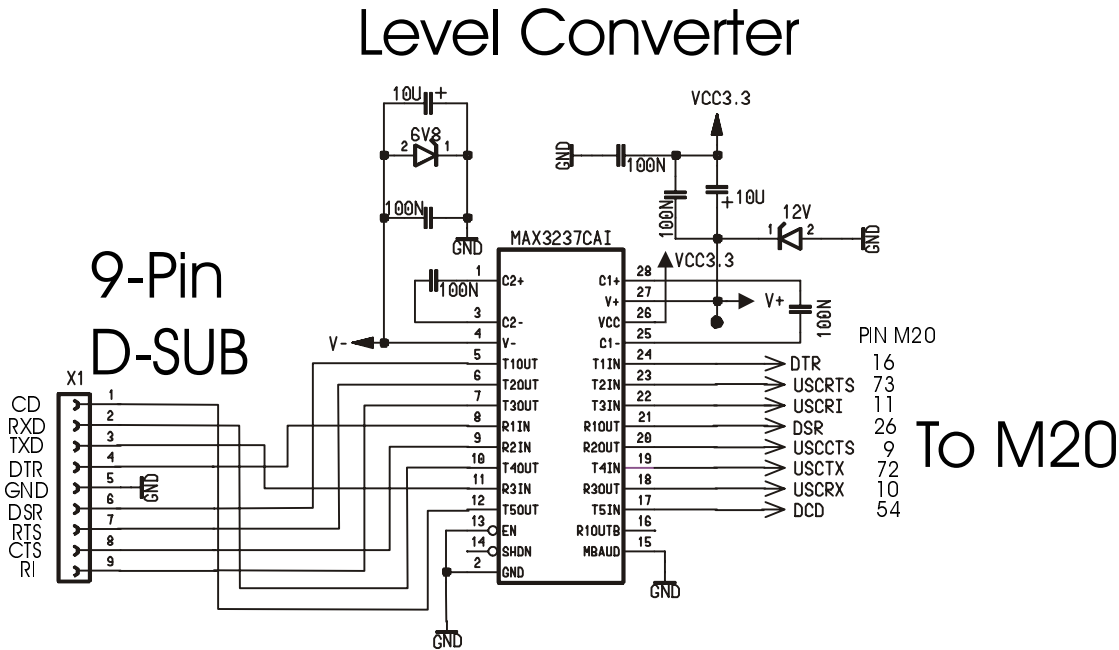

Fig. 8-4 Level converter

Application example for the conversion of M20 (2.8 V) signals to V.24 (+/-12 V) signals.

8.8.2 6 V voltage supply from 12 V source

Voltage Supply 6V

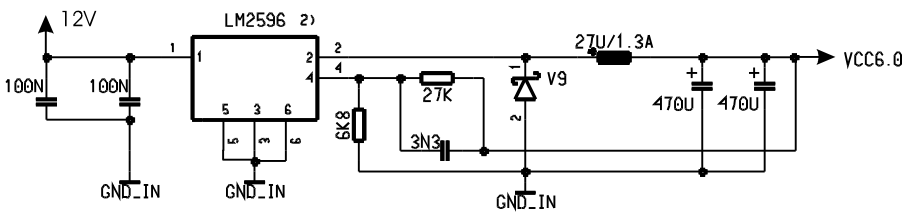

Fig. 8-5 Voltage supply

Application example for the 6 V voltage supply from a 12 V source.

Note: Voltage supply on connection must NOT rise faster than 3V/msec.

8.8.3 SIM card reader connections

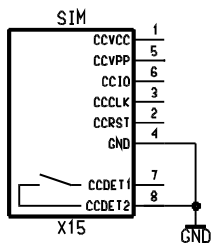

Fig. 8-6 SIM card connection pins

8.8.4 Handset connection

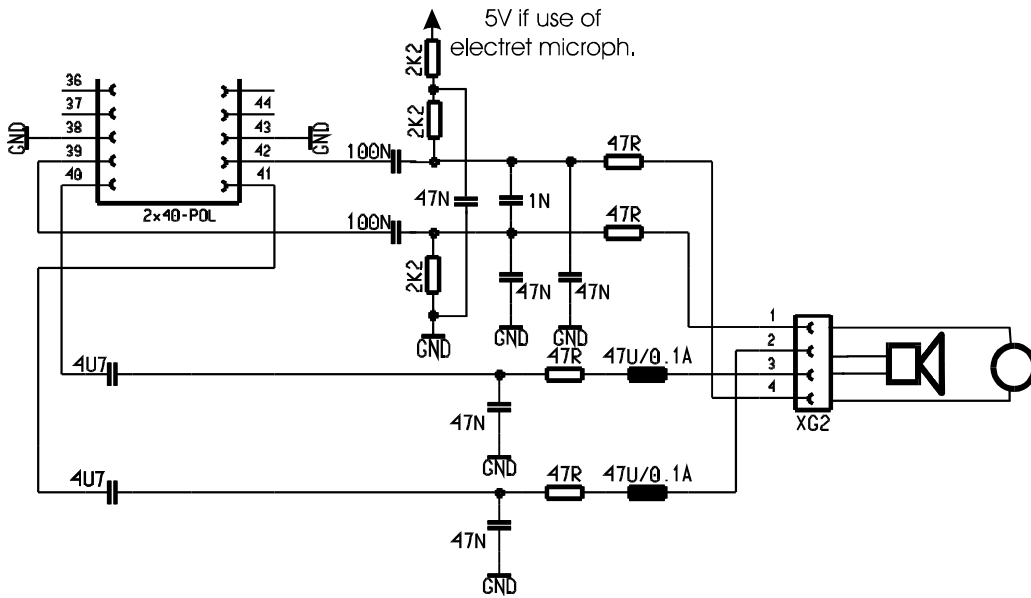

Fig. 8-7 Handset connection

8.8.5 Adding echo suppression functionality

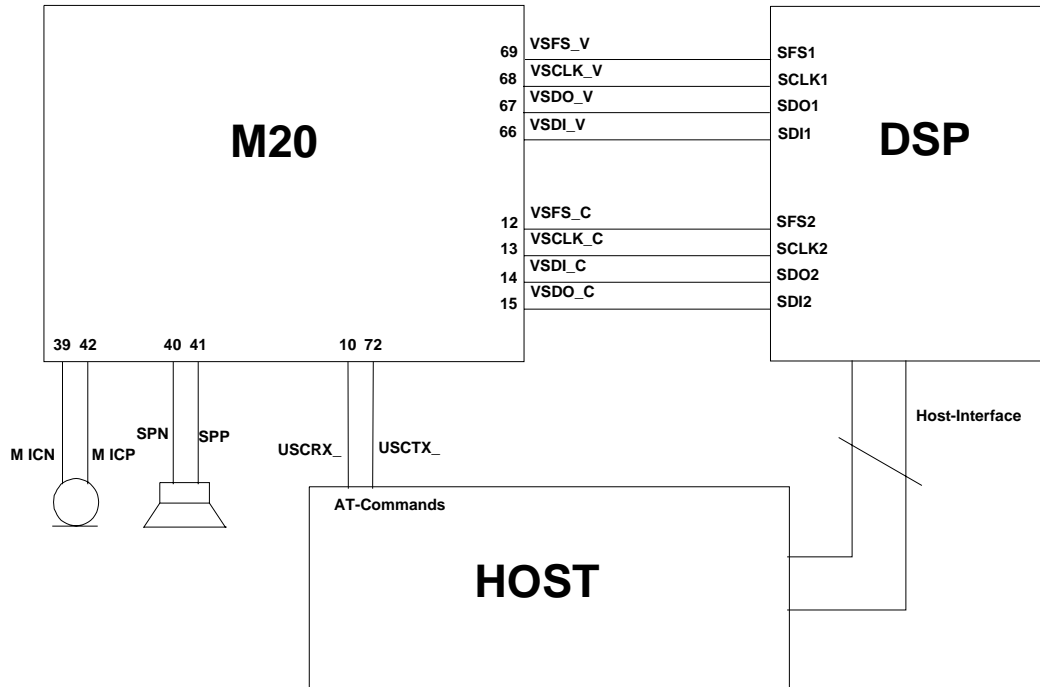

Fig. 8-8 Handsfree application diagram

The example depicted above makes use of the M20 internal voiceband codec. The M20 is controlled by the HOST via the AT commands. The HOST is also responsible for booting and controlling the handsfree DSP. If an external voiceband codec is to be used, the serial link between the DSP and the internal codec (VSFS_C, VSCLK_C, VSFI_C, VSDO_C) must be omitted and the external codec has to be linked to the DSP.

Note: External clock signalling is not possible in this configuration.

A handsfree DSP can be ordered, for example, from Analog Devices: AD2186L. For further information please contact Analog Devices (<http://www.analog.com/>).

8.8.6 Ignition line

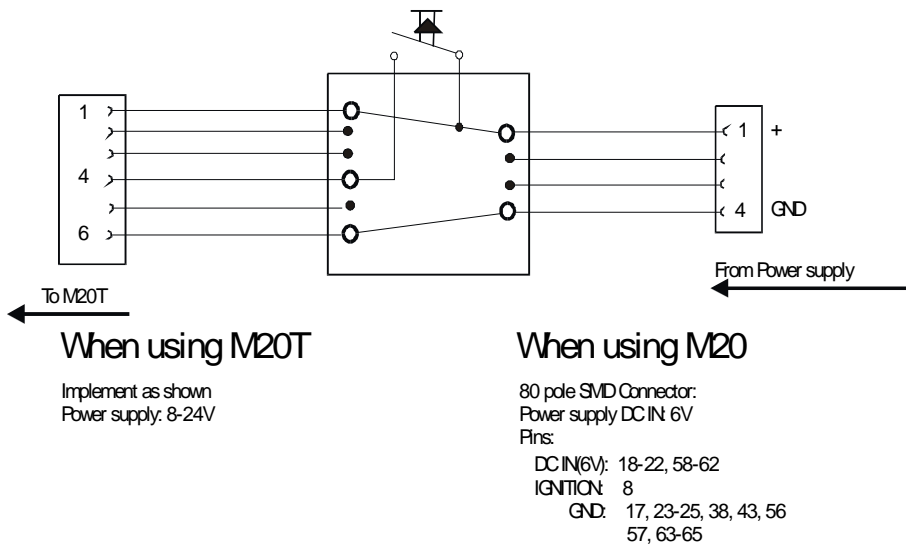

Fig. 8-9 Ignition line

8.8.7 Reset: Deadlock handling

The following sequence describes the method to reset the M20 in case there it no longer reacts to AT-commands. Cutting the power supply is not necessary.

Shutting down must be done in two steps:

IGNITION (PIN 8 on the 80pole SMD connector) must be set to TTL-low(<0.8V)

POWER_ON (PIN 74 on the 80pole SMD connector) must be set to TTL-LOW. (see Fig. For circuit example)

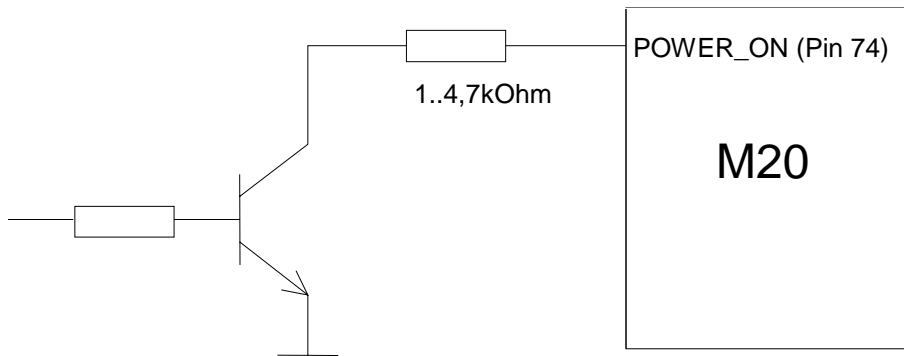

This is a sure method to power down the M20 without causing any faults or errors. Even if the IGNITION is accidentally left on HIGH, no damage is caused to the unit.

8.9 Service information

In the event of M20 malfunction, please contact your distributor. For a list of distributors, see *See "1 Overview"*.

9 M20 Terminal

9.1 General information

The Siemens M20 Terminal is a GSM900 Phase II voice, data, group 3 fax and SMS terminal device. This device is intended for universal use in various areas of application. A broad range of voltages is therefore available because common industrial interfaces have been implemented.

The terminal is compatible in most themes of function and control with the GSM modules M1 and A1. An LED in the robust plastic casing displays the operating status of the terminal.

The M20 Terminal can be mounted from above or below by means of two screws.

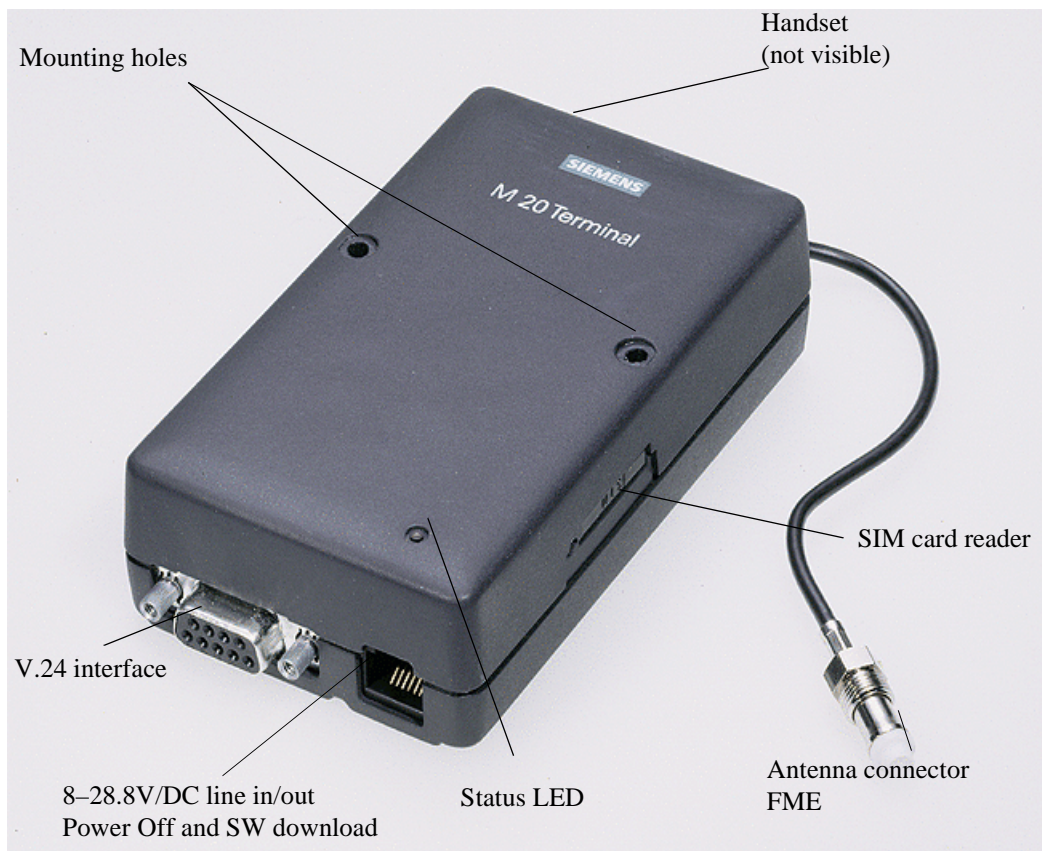

Fig. 9-1 Modular Cellular Engine Siemens M20 Terminal

9.1.1 Features

- User-friendly integration in the system environment using commercially available connection components
- Data, voice, fax and SMS services (GSM Phase II)
- Power supply/ignition line on 6-pin Western connector (8 V to 28.8 V DC, 5% ripple, surge Proof to 30V)
- Current consumption at 12V: Stand-by state (voltage is applied, ignition not yet asserted) $I \leq 0.2$ mA idle mode: $I < 60$ mA average call in progress: peak: $I < 2$ A. (pulsed $t = 577\mu\text{s}$, at $T = 4.615\text{ms}$), arithmetic mean: $I < 275$ mA
- Level on the V.24 interface corresponding to V.28
- Protected V.24/V.28 interface with 9-pin SUB-D jack (screwed)
- Mini SIM card reader with integral drawer (3V)
- FME antenna jack (female) fed out per cable (approx. 10 cm)
- Listener interface on 4-pin Western connector (listener parameters can be set with AT commands/connection of a commercially available headset)
- Mounting from bottom or top
- Resistant against supply voltage polarity reversal

9.1.2 Mechanical characteristics

Weight	145 g
Dimensions (max)	LxWxH = 107.0 x 63.5 x 31.3 mm
Temperature range	-20°C - 55 °C
Protection class	IP40 (see Notice)
Mechanical vibrations	Amplitude 7.5 mm at 5-200 Hz sinus
Max. pulse-acceleration	30g pulse with 18 ms duration time
Air humidity	5–98%

Note: the M20 Terminal shall not be used within wet environment, such as showers, bath.

9.2 Electrical description and interfaces

M20 Terminal has following plugs for power supply, interfacing and antenna:

- 6-pole Western plug (female) for power supply, ignition signal and audio-line-in/out-signal
- 4-pole Western plug (female) for connecting a handset
- 9-pole (female) SUB-D plug for V.24/V.28 serial interface
- 20 cm antenna cable with FME plug (female)

6-pole Western plug (female)//power supply, ignition, line-in/out

Pin	Usage
1	Power supply 8-28.8 V
2	Audio Line Ground (for pin 3/AC:in & pin 5/AC:out)
3 (This Pin must not exceed Voltages >2V to avoid power switched off!)	AC: Line-in input 600 Ohm DC: Signal for power Off, power off for U (to pin6) >8V (ignition low)
4 Ignition > 5V for longer than 1 s switches on	Ignition signal (see M20: 80-pole connector Pin 8) Ignition for U (to pin 6) >5V
5 (This Pin must not exceed Voltages >2V during power on procedure to avoid a change to bootmode!)	AC: Line-out 600 Ohm DC: Signal for initialisation of SW download for U(to Pin6)>8V
6	GND

Note:

(1) Ignition signal has to be set > 5V for longer than 1 s, remember that this signal has to be low when switching off the M20 with AT command AT^SMSO, see Chapter 5.7 “*Siemens-defined AT commands for enhanced functions*” on page 111.

(2) SW-DOWNLOAD: To switch the M20T to bootmode use the following procedure:

Apply > 8V to Pin 5 before or together with the supply voltage. The M20T switches to bootmode. Proceed according to capt.8.5 (e.a.?) loading the SW using the RS 232-interface (9-pole SUB-D plug).

(3) POWER_OFF EXCEPTION HANDLING: In case of software hang-ups etc. the M20T can be switched off using the following procedure (exception handling): Pin 3 must be applied with a voltage > 8V AND Pin 4 must be low (0V). To switch on again, set ignition >5V (and Pin 2 <2V).

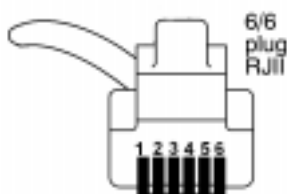

Fig. 9-2 Front view of Western plug 6-6 (male)

4-pole Western plug (female)// handset

Pin	Usage
1	Microphone (-)
2	Speaker (-)
3	Speaker (+)
4	Microphone (+), app. 5 V DC to pin 1 for supplying an electret microphone

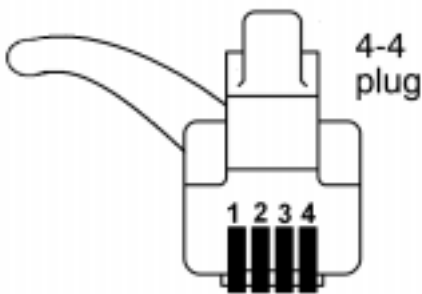

Fig. 9-3 Front view of Western plug 4-4 (male)

9-pole (female) SUB-D plug for V.24/V.28 serial interface, 1:1 cable connection (pin-to-pin) to a serial computer interface

Pin	Comp.I/O	Usage/computers point of view
1	I	DCD In Data Carrier Detect
2	I	RXD In Receive Data
3	O	TXD Out Transmit Data
4	O	DTR Out Data Terminal Ready
5	-	GND – Ground
6	I	DSR In Data Set Ready
7	O	RTS Out Request To Send
8	I	CTS In Clear To Send
9	I	RI In Ring Indicator *

Note:

The active logic level is +-5V

Detection of logic high level at $U > 1,8V$ typ. (2,4V max.)

Detection of logic low level at $U < 1,5V$ typ. (0,8V min.)

Coding of the green status LED

LED	Status	Possible Error	Checks & Actions
Dark	No power	No power supply	Check power supply Check power cable pins 6-pole Western plug pin 1: +, pin 6: GND
Blinking	Power on & Net searching	This status lasts longer than 1 minute after AT+CPIN="xxxx"	Check if SIM card is inserted Check if antenna cable is correctly connected to FME plug Check if antenna is correctly positioned Check if M20 IGNITION at Western plug has been set to logical high and Pin 3 of the 6-pole Western plug is applied with less than 4V DC
On	Power on & registered by the net	-	-

Electrical characteristics

Voltage range for correct operation	8(-0) to 28.8(+0) volts DC, +/- 5% ripple
Voltage resistance without destruction	0–30 V (resistant against supply voltage polarity reversal)
Power cable	<3m, use external "fast"-fuse 1,25 Ampere
Current consumption at 12V: Stand-by state (voltage is applied, ignition not yet asserted) I =/< 0.2 mA idle mode: I < 60 mA average call in progress: peak: I < 2 A. (pulsed t = 577ms, at T = 4.615ms), arithmetic mean: I < 275 mA	<200mA speech mode, <45mA idle mode
Mini SIM reader	For 3 V mini SIM cards <u>Note:</u> SIM cards should only be inserted and removed when the terminal is OFF
Line-in	600 Ohm (differential mode)
Line-out	600 Ohm (common mode)
V.24 interface	Double-diode protection, 150 Ohm current limiter
Max. modem cable length for correct operation	Length < 2 m
Max. handset cable length	Length < 2 m
Antenna plug	FME female, Further electrical specifications (power, sensitivity, etc.) see M20 Cellular Engine
Max. RF power	2 W at 900 MHz
Handset plug with 5V supply for electret microphone	Spark-gap protection

Note: Voltage supply: Voltage supply on connection must NOT rise faster than 3V/msec.

IMPORTANT:

To protect to device against high voltage (>32V) a 1.25A quick-break fuse on pin 1 of the 6-pole Western plug shall be used. For use with power packs and batteries observe the EN60950 guidelines. Installation and start-up may only be performed by authorized persons.

9.3 Operation requirements, CE conformity, restrictions of use

For operation requirements, see Chapter 3.5 “*System requirements*” on page 15, for CE conformity, see Chapter 3.6 “*CE conformity*” on page 15.

For safety instructions, see Chapter 2 “*Safety precautions for the user*” on page 8.

9.4 Full-type approval

In reference to the approval requirements for M20 Terminal configurations, the following points must be observed:

- 1) No further approvals are required for application when using the M20 Terminal in approved configurations. Delta-type approval is necessary if any accessories (handset, own MMI implementation supported by AT commands) other than the approved accessories are used. Information about approved configurations and accessories that have been approved for use with the M20 Terminal can be obtained in the appendix to EC TYPE EXAMINATION CERTIFICATE or from your local distributor.
- 2) Applications using the "DATA ONLY" capabilities (data, SMS, fax) of the M20 Terminal need no further delta-type approval.

10 M20 Development Box

The M20 Development Box was developed as a variant of M20 Terminal for developing and testing own applications with M20 Cellular Engine. The Development Box has almost the same functionality as the M20 Terminal with following additional features:

- On-board male pins for each relevant pin of M20 80-pole connector not used by M20 Terminal (e.g. digital audio interface, keyport interface, display interface), the connection to customers application might be with band cables.
- *Note:* Protection class IP40 can not be guaranteed for this variant.
- Male pins for application of other SIM card readers

The configuration of the additional pins is delivered with this product.

The A20 d-box is available from your local Distributor. Please note that the D-box is to be used for Development- and test purposes only, and that deviating from the general terms of delivery no responsibility or guarantee is taken over on the part of Siemens AG. Please contact your local distributor.

11 Environmental requirements for the M20

The applicable standards and internal and customer-specific supplementary requirements with regard to ambient conditions for the M20 are in accordance to IEC68.

12 EMC and ESD requirements

Standard **ETS 300 342-1** dated **06/97** applies to the M20 as regards EMC and ESD requirements.

Additional requirements with regard to EMC/ESD:

- An EMC-filtered power supply must be made available to the M20 via the base unit.
When the M20 is used in vehicles, the requirements of standard **ETS 300 342-1** dated **06/97**, Section **9.5** must be satisfied with regard to the power supply.
- When using the M20 with individual handsfree kits, the possibility of susceptibility problems exists.
- For additional EMC-relevant information (e.g. maximum length of connecting lines and shielding), see Chapter *EMC-relevant information for integrators of the M20*.

13 Migration M1 to M20

Applications using the M1 can be updated for use with the M20.

Following changes in the area of SW need to be taken into account.

13.1 SW comparison

13.1.1 SMS mode

The M1 offered only PDU SMS, on the M20 Text and PDU is available, (AT+CMGF)

Changes when creating PDU mode strings with the M20.

In the **M1** the value for the UDL (User data length) could be set to any value larger the real data length.

In the **M20** the value for UDL has to be the EXACT length of the user Data

13.1.2 AT-Commands: Functionality with new commands

M1	Description	M20	Comment
ATBn	Select GSM module operating mode	AT+CBST	No autobauding on M20
ATI1	Hardware Checksum	none	
ATI8	Display bearer services	AT+CBST=?	
ATI9	Display version	ATI	
ATS1	Ring counter	none	
ATS2	ASCII for +++	ATS2	
ATS14	Set echo, result code format, result return	ATE, ATQ,ATV	
ATS21	DTR and DCD options	AT%Dn, AT&D, AT&C	
ATS22	Reporting options	ATXn	
ATS23	local bit rate and parity	AT+IPR, AT+ICF	
AT&T	local digital test	none	
AT&Y	Load user profile on power up	none	M20 automatically loads user profile on power up
AT%Un	Autobauding between terminal and M1	AT+IPR	M20: no autobauding, 19200 bps fixed on setup; use AT+IPR to change local rate, store to config. With AT&W. Next start-up with new rate
AT\Gn	Modem port flow control XON/XOFF	AT+IFC	
AT\Nn	Requesting operating mode	AT+CBST	
AT\S	Show status package	AT&V	
AT\Vn	RLP appendix	AT+CR	AT+CR also shows sync/async
AT+CKPD	Key Simulation	none	
AT+CXXS N	Single-numbering parametrization	none	
AT+CXX- MOC	Parametrize for outgoing call	none	

13.1.3 AT-Commands: Same functionality but changes in the parameters

AT	Description	Comment
ATDS	Dial stored phone number in fixdialling phonebook	M1:0...3, M20: 1...5
ATS0	Set number of rings before automatically answering the call	M1: 1...5, M20: 1...255
ATS7	Set number of seconds to wait for connection completion	M1: 1...60 M20: 1...60...255
ATZn	Set all current parameters to user defined profile	M1:0,1 M20:0
AT&Dn	Set circuit Data Terminal Ready (DTR) function mode	M1: 0...3 M20: 0...2
AT&W	Store current parameter to user defined profile	M1: 0,1 M20: 0
AT&Z	Store telephone number in SIM fixdialling memory "FD" position"0"	M1: Stored in Registers M20: "FD" phonebook, position 1
AT+CEER	Extended error report	M20: more Parameters
AT+CPBS	Select phonebook memory storage	M20: also DC, dialed numbers list
AT+CPWD	Change password	M20: more facilities to lock
AT+CRLP	Select Radio Link Protocol parameter for orig. non-transparent data call	M20: also <verx>, <T4>

13.2 System Parameter comparison (AT&V) on the M1 and M20

ACTIVE PROFILE:

M1	Description	M20
B99	GSM speed follows Terminal speed	At+cbst=7,x,x; (9600 Baud GSM)
E1	Set Command Echo mode	E1
L2		No effect
M1		No effect
Q0	Set result code presentation mode	Q0
V1	Set result code format	V1
X4		X4
Y0		Not available
%D0	Auto FDN0 dialling	%D0
%U0	Autobauding serial Interface	Not available
&C1		&C1
&D0		&D0
&G0		+ifc=x,1
&Y0	Set user parameters	Automatically on power up
\N0	RLP on/off	F +cbst=x,0,(0 or 1)
S00:000	Number of rings before answering call	S0=x M1 (1...5) M20 (1...255)
S01:000	Ring counter	Not available
S02:043	Escape sequence Character	Automatically (+)
S03:013		S3=x
S04:010		S4=x
S05:008		S5=x

S06:002		F	Not available
S07:060			S7=x
S08:002		F	No effect at GSM
S09:006			Not available
S10:100		F	S10=x
S12:050		F	Not available
S14:2AH	Set echo result code...		ATE,ATQ,ATV
S16:00H	Function Internal use only		
S18:002	Function Internal use only		
S21:20H			AT%Dn, AT&D,AT&C
S22:46H	Reporting options		ATXn
S23:16H	Set local Bit rate and Parity		+ipr=x,x
S25:005	Function Internal use only	F	
S26:001	Function Internal use only	F	
S27:00H	Function Internal use only	F	

M1	Description	M20
Class 5 : Enabled (%C1)	Internal use only	
Messages : On (Q0)		Q0
/REL-Appendix : On (\V1)	F	+crc=x (0,1) reply is V42B...
Requested service type : Stream (\L0)	F Internal use only	
Requested operating Mode : Normal (\N0)		+cbst=x,0,(0 or 1)
BPS rate adjust : Off (\J0)	F Internal use only	
Echo : Off (\E0)	F Echo	E0
Terminal port flow control : RTS/CTS (\Q3)	F Q0 no handshake Q3 default HW handshake	+ifc=x,x
Modem port flow control : None (\G0)		+ifc=x,x
XON/XOFF pass through : Disabled (\X0)	F Internal use only	
Auto-reliable buffering : None (\C0)	F Internal use only	
Fallback character : 0 (%A0)	F Internal use only	
Maximum block size : 256 (\A3)	F Internal use only	
Break type : Queued (\K5)	F Internal use only	
Inactivity timer : 0 (\T0)	F Internal use only	
Error summary In-Coming : 0 Out-going: 0	F Internal use only	
Requested operating class : Class 2 (#C1)	F Internal use only	
Requested service level : Standard (#S1)	F Internal use only	
Maximum allowable errors : 2 (#E2)	F Internal use only	
Originator delay : 5 (#D5)	F Internal use only	
DCE speed : 9600 (#M6)	F Internal use only	
Parity generation : Disabled	F Internal use only	
Parity type : Even		AT+ipr=x,x
Word length : 8 Bits		At+ipr=x,x
Stop bits : 1		At+ipr=x,x

14 References

- [1] ETS 300 607-2: October 1996 (GSM 11.10-2 Version 4.15.0)
- [2] ETS 300 511: July 1995 (GSM 2.30 Version 4.13.0)
- [3] V.24 (ITU-T, V.24, 10/96)
- [4] V.28 (ITU-T recommendations, CD-ROM March 1998)
- [5] V.25ter (ITU-T, V.25ter, 07/97)
- [6] ETS 300 342 (ETSI – June 1997, second edition)
- [7] TBR19 (ETSI – CD-ROM A, July 1998)
- [8] TBR20 (ETSI – CD-ROM A, July 1998)

15 Technical data

15.1 Technical data of the M20

Weight:	38 g		
Output power:	2 W peak (at the RF jack of the M20)		
Sensitivity:	-108 dBm (at the RF jack of the M20)		
Dimensions (max):	LxWxH = 86.8 x 41.4 x 11.2 mm		
Volume:	31.6 cm ³		
Temperature range	Storage temperature	-40°C to +90°C	Dwell: 1 h, packaged
	Thermostable	-40°C to +80°C	Temperature cycle: 10 cycles
			Dwell: 2 h at T _u and T _o
	Operation with voltage supply	-20°C to +55°C	Fully functional and retaining data

Voltage supply: Voltage supply on connection must NOT rise faster than 3V/msec.

Single voltage supply 6.0 V ± 0.2 V, arithmetic mean: I < 250 mA
(I < 2 A, pulsed t = 577µs, at T = 4.615ms)

Interfaces

All interfaces 80-pin SMD connector

GSM standards: GSM recommendations, phase II,
Extended requirements according to class "Normal mobile station"

Environmental requirements:
According to IEC68.

MTBF value: 192 years; fit according to 595
(at 25°C, stand-by time 12 h/d and 6 d/week, including 1/6 talking time)

MMI board: Built-in MMI software, connectors for:
- DOT display (2 lines a 16 columns)
- 4 x 6 keypad matrix
- Base-unit power supply indicator

Remote control: V.24/RS232 interface
Drive via serial interface by means of standard AT Hayes and AT Cellular commands to GSM 07.07 and 07.05 and a number of the most useful Siemens-defined AT commands

SMS: SMS MT, SMS MO in text and PDU mode, SMS cell broadcast

Data services: Transparent/non-transparent data:
2.4 kbit/s, 4.8 kbit/s, 9.6 kbit/s,
V.42bis data compression

Transparent fax: class 1 group 3
2.4 kbit/s, 4.8 kbit/s, 9.6 kbit/s

15.2 Design drawing of the M20

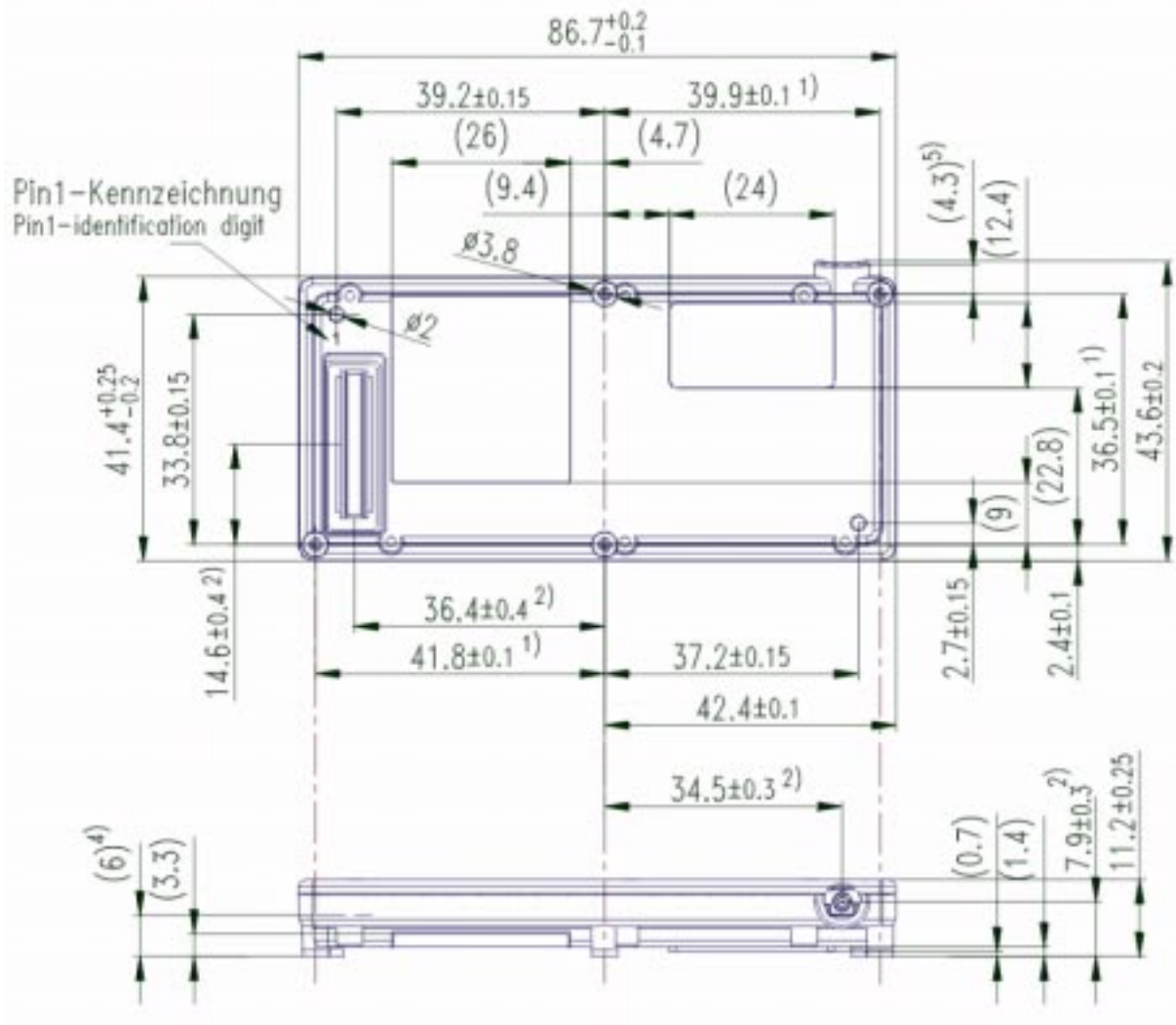
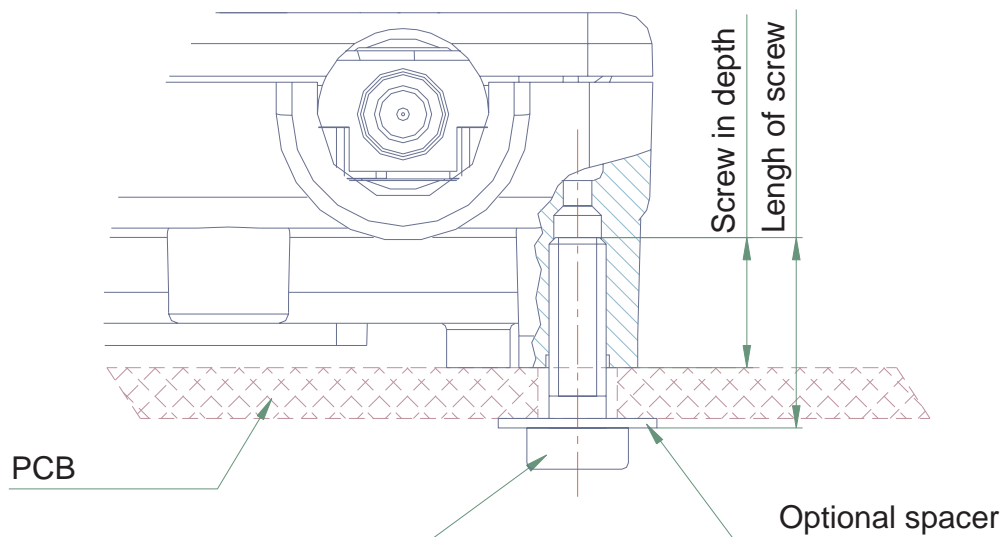

Fig. 15-1 Design drawing of the M20
All values are [mm]

15.2.1 M20 Screw Dimensions



Screw: metal thread-cutting screw, diameter 1.8mm, free of oil and grease
 Screw in depth (into housing): min 3mm, max. 4.5mm
 Tightening torque: 0.2Nm+0.05

Fig. 15-2 M20 screw dimensions

15.3 Design drawing of the M20 Terminal

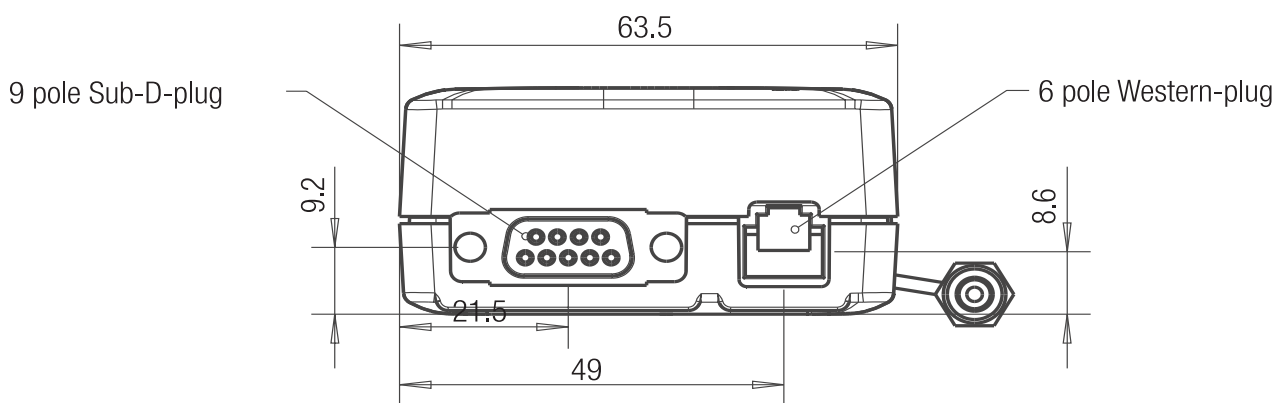

Fig. 15-3 M20 Terminal front view

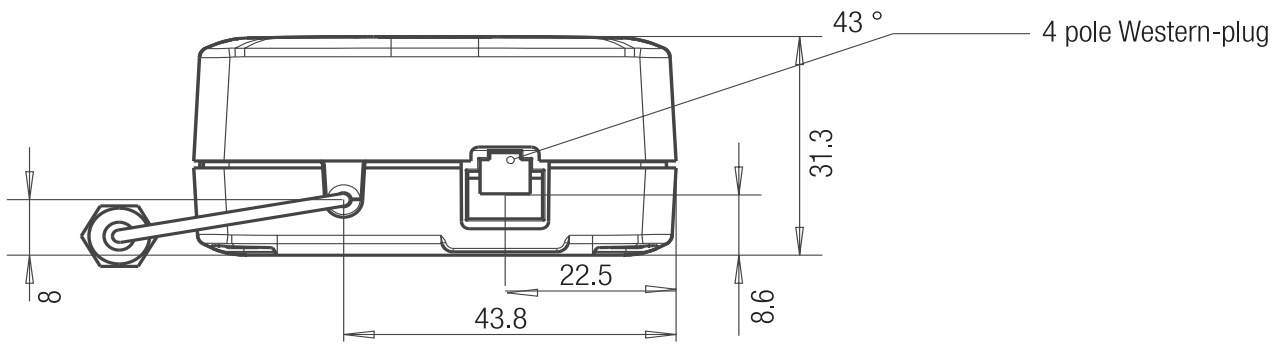

Fig. 15-4 M20 Terminal back view

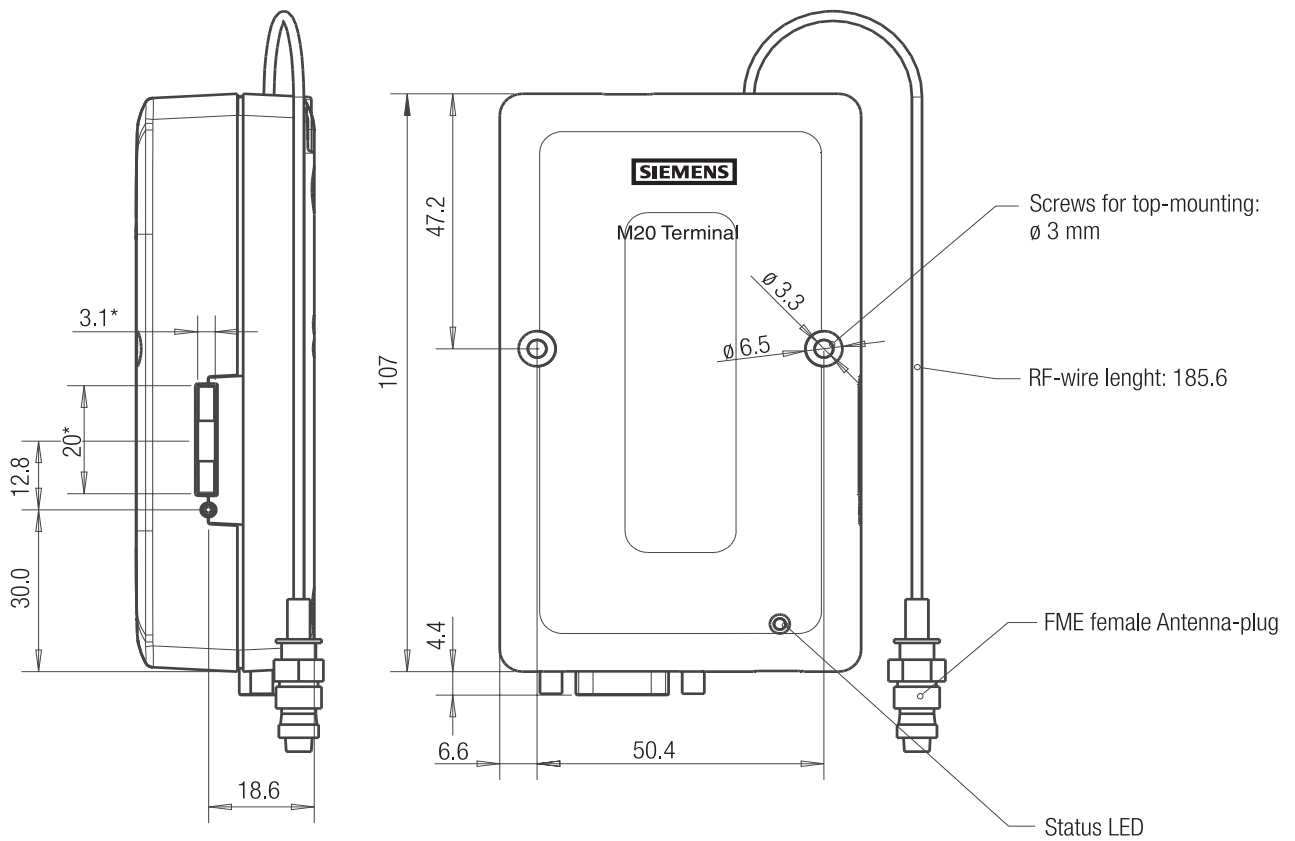

Fig. 15-5 M20 Terminal top and side view

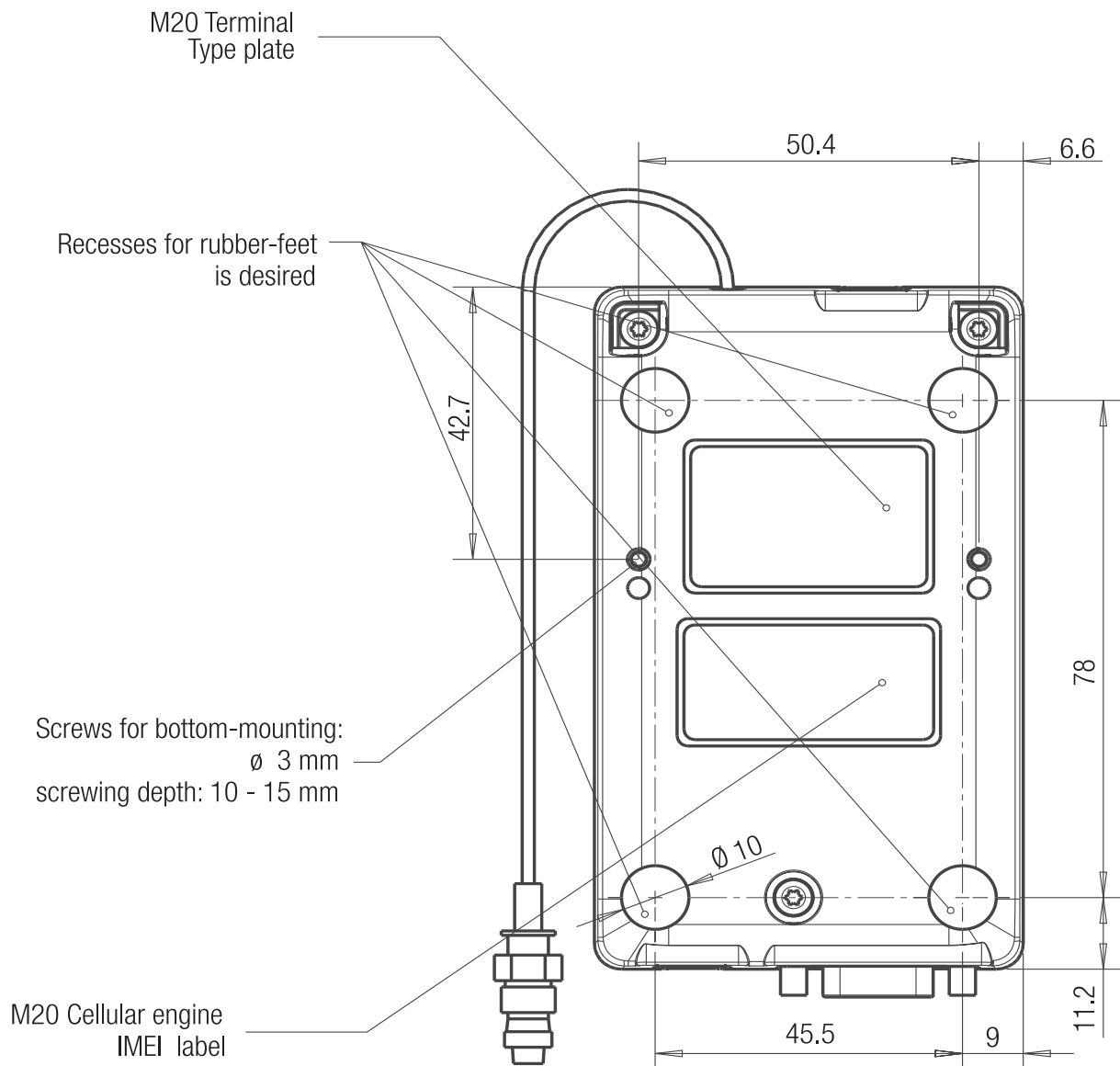

Fig. 15-6 M20 Terminal bottom view

There are two possibilities for mounting the device:

- with M3 screws (length > 35 mm) for mounting from the top
- with 3 mm diameter screws for mounting from the bottom (hole depth 15 mm)

Note: when mounting the M20 Terminal from the bottom, the holes for the screws are shielded on the inside, thus preventing particles from entering the terminal. This cover is situated 15 mm from the base. The use of longer screws will destroy this cover, resulting in a 3 mm hole if the screw is removed. In this case protection-class IP40 cannot be guaranteed!

16 AT commands sorted by functionality

16.1 Commands for Call Control

Command	Function	Page
ATA	Answer a call	Page 30
ATD	Mobile originated call to dial a number and call of supplementary services	Page 30
ATD><mem><n>	Originate call to phone number <n> in memory <mem>	Page 33
ATD><n>;	Originate call to phone number <n> in current memory	Page 34
ATD><str>	Originate call to phone number in memory with corresponding alphanumeric field	Page 35
ATDI	Mobile originated call to dialable ISDN number <n>	Page 36
ATDL	Redial last telephone number used	Page 37
ATDS	Dial stored phone number in ME-phonebook	Page 38
ATH	Disconnect existing connection	Page 38
AT+CHUP	Hang up call	Page 64
ATP	Select pulse dialling	–
ATS0	Set number of rings before automatically answering the call	Page 40
ATS6	Set pause before blind dialling	–
ATS7	Set number of seconds to wait for connection completion	Page 41
ATS8	Set number of seconds to wait when comma dial modifier	Page 41
ATT	Select tone dialling	–
AT+CRC	Set cellular result codes for incoming call indication	Page 82
AT+VTS	DTMF and tone generation	Page 92

16.2 Commands for network services and status information

Command	Function	Page
AT+CAOC	Advice of Charge information	Page 58
AT+CCWA	Call waiting control	Page 62
AT+CREG	Network registration	Page 84
AT+CLCK	Facility lock	Page 66
AT+COPS	Operator selection	Page 70
AT+CPWD	Change password	Page 79
AT+CLCC	List current calls of ME	Page 65
AT^SFPCS	Far party call status	Page 115
AT^SLCK	Facility lock (including Siemens-defined locks)	Page 116
AT^SPWD	Change password for a lock (including Siemens-defined locks)	Page 130
AT^SPLM	Read the PLMN list	Page 126
AT^SPLR	Read entry from the preferred operator list	Page 127
AT^SPLW	Write an entry to the preferred operator list	Page 128
AT+CSQ	Signal quality	Page 87
AT+CUSD	Unstructured supplementary service data	Page 88
AT^MONI	Monitor mode in Idle mode	Page 133
AT^MONP	Monitor mode: report PLMN list	Page 135
AT^SMONC	Cell Monitoring	Page 136

16.3 Commands for supplementary network services

Command	Function	Page
AT+CCFC	Call forwarding number and conditions control	<i>Page 60</i>
AT+CCUG	Closed user group control	<i>Page 61</i>
AT+CHLD	Call hold and multiparty	<i>Page 64</i>
AT+CLIP	Calling line identification presentation	<i>Page 67</i>
AT+CLIR	Calling line identification restriction	<i>Page 68</i>
AT+COLP	Connected line identification presentation	<i>Page 69</i>

16.4 Commands for SIM

Command	Function	Page
AT&Z	Store telephone number in ME memory (non volatile)	<i>Page 46</i>
AT+CACM	Accumulated call meter (ACM) reset or query	<i>Page 56</i>
AT+CAMM	Accumulated call meter maximum (ACMmax) set or query	<i>Page 57</i>
AT+CIMI	Request international mobile subscriber identity	<i>Page 65</i>
AT+CPBF	Find phonebook entries	<i>Page 71</i>
AT+CPBR	Read current phonebook entries	<i>Page 72</i>
AT+CPBS	Select phonebook memory storage	<i>Page 74</i>
AT+CPBW	Write phonebook entry	<i>Page 76</i>
AT+CPIN	Enter PIN	<i>Page 77</i>
AT+CPIN2	Enter PIN2	<i>Page 78</i>
AT+CPUC	Price per unit and currency table	<i>Page 80</i>
AT+CRSM	Restricted SIM access	<i>Page 85</i>
AT+CSCS	Select TE character set	<i>Page 86</i>
AT^SACM	Advice of Charge and query of ACM and ACMmax	<i>Page 111</i>
AT^SCID	Display SIM card identification number	<i>Page 113</i>
AT^SCKS	Set SIM conn. present. mode and query SIM conn. status	<i>Page 113</i>
AT^SPBA	Browse the phonebook alphabetically	<i>Page 73</i>
AT^SPBS	Steps the selected phonebook alphabetically	<i>Page 75</i>
AT^SPIC	Display PIN counter	<i>Page 126</i>
AT^SPWC	List password counter	<i>Page 129</i>
AT^SSET	Set some unsolicited result code	<i>Page 134</i>
AT+CXXCID	Display card ID (identical to AT^SCID)	<i>Page 136</i>

16.5 Commands for interface to terminal equipment (TA – TE)

Command	Function	Page
A/	Repeat previous command line	Page 29
ATE	Enable command echo	Page 38
ATS3	Set command line termination character	Page 40
ATS4	Set response formatting character	Page 41
ATS5	Set command line editing character	Page 41
ATQ	Set result code presentation mode	Page 39
ATV	Set result code format mode	Page 42
ATX	Set CONNECT result code format and call monitoring	Page 43
AT&C	Set circuit data carrier detect (DCD) function mode	Page 43
AT&D	Set circuit data terminal ready (DTR) function mode	Page 44
AT+ICF	Set TE-TA control character framing	Page 50
AT+IFC	Set TE-TA local data flow control	Page 51
AT+ILRR	Set TE-TA local rate reporting mode	Page 52
AT+IPR	Set fixed local rate	Page 53
AT&S	Set circuit data set ready (DSR) function mode	Page 44
ATZ	Set all current parameters to user defined profile	Page 43
AT&F	Set all current parameters to manufacturer defaults	Page 44
AT&V	Display current configuration	Page 45
AT&W	Store current parameter to user defined profile	Page 45
AT+CEER	Extended error report	Page 63
AT%D	Automatic dialling phone number in mem."ME" index"1" with DTR	Page 46

16.6 Commands for device control

Command	Function	Page
ATL	Set monitor speaker loudness, no function, only for V.25ter	–
ATM	Set monitor speaker mode, no function, only for V.25ter	–
AT+VGR	Receive gain selection of speaker	Page 90
AT+VGT	Transmit gain selection of microphone	Page 91
AT+VIP	Initialize voice parameters	Page 91
AT^SCTM	Set critical operating temp. present. mode or query temp.	Page 114
AT^SMSO	Switch off mobile station	Page 122
AT^SNFA	Set or query of microphone attenuation	Page 122
AT^SNFE	Set or query echo suppression parameters	Page 123
AT^SNFI	Set or query of audio input (= microphone path) parameters	Page 124
AT^SNFM	Mute microphone	Page 124
AT^SNFO	Set or query audio output (= loudspeaker path) parameters	Page 125
AT^SNFS	Select audio hardware set	Page 126
AT^SNFV	Set or query loudspeaker volume	Page 126
AT^SRESET	Software reset	Page 130
AT^SRTC	Select, query or test ringing tone	Page 131

16.7 Commands for device Information

Command	Function	Page
ATI	Display product identification information	<i>Page 39</i>
AT+CGMI	Request manufacturer identification	<i>Page 63</i>
AT+CGMM	Request model identification	<i>Page 63</i>
AT+CGMR	Request revision identification	<i>Page 63</i>
AT+CGSN	Request product serial number identification (IMEI)	<i>Page 64</i>
AT+CMEE	Report mobile equipment error	<i>Page 68</i>
AT+GMI	Request manufacturer identification	<i>Page 49</i>
AT+GMM	Request TA model identification	<i>Page 49</i>
AT+GMR	Request TA revision identification	<i>Page 49</i>
AT+GOI	Request global object identification	<i>Page 50</i>
AT+GSN	Request TA serial number identification	<i>Page 50</i>
AT+CBC	Battery charge	<i>Page 58</i>
AT+CPAS	Mobil equipment activity status	<i>Page 71</i>
AT+GCAP	Request complete TA capabilities list	<i>Page 48</i>
AT+FMI	Fax: report manufactured ID	<i>Page 89</i>
AT+FMM	Fax: report model ID	<i>Page 89</i>
AT+FMR	Fax: report revision ID	<i>Page 90</i>

16.8 Commands for SMS and CB (GSM 07.05)

Command	Function	Page
AT+CMGD	Delete SMS message	<i>Page 93</i>
AT+CMGF	Select SMS message format	<i>Page 94</i>
AT+CMGL	List SMS messages from preferred store	<i>Page 94</i>
AT+CMGR	Read SMS message	<i>Page 97</i>
AT+CMGS	Send SMS message	<i>Page 100</i>
AT+CMGW	Write SMS message to memory	<i>Page 101</i>
AT+CMSS	Send SMS message from storage	<i>Page 102</i>
AT+CNMI	New SMS message indications	<i>Page 103</i>
AT+CPMS	Preferred SMS message storage	<i>Page 105</i>
AT+CRES	Restore SMS settings	<i>Page 105</i>
AT+CSAS	Save SMS settings	<i>Page 106</i>
AT+CSCA	SMS service centre address	<i>Page 106</i>
AT+CSCB	Select cell broadcast SMS messages	<i>Page 106</i>
AT+CSDH	Show SMS text mode parameters	<i>Page 108</i>
AT+CSMP	Set SMS text mode parameters	<i>Page 109</i>
AT+CSMS	Select message service	<i>Page 109</i>
AT^SMGL	List SMS messages from preferred storage without changing status to read	<i>Page 118</i>
AT^SMGO	Set or query SMS overflow present. mode or query SMS overflow	<i>Page 118</i>
AT^SMGR	Read SMS message without set to REC READ	<i>Page 119</i>

16.9 Commands for data/fax

Command	Function	Page
ATO	Switch from command mode to data mode	<i>Page 39</i>
ATS2	Set Hayes ESC character	<i>Page 40</i>
ATS10	Set disconnect delay after indicating the absence of data carrier	<i>Page 42</i>
ATS12	Set pause length for Hayes ESC sequence	<i>Page 42</i>
AT+DR	V.42bis data compression reporting control	<i>Page 47</i>
AT+DS	V.42bis data compression control	<i>Page 48</i>
AT+CBST	Select bearer service type	<i>Page 59</i>
AT+CR	Service reporting control	<i>Page 83</i>
AT+CRLP	Select radio link protocol parameter for orig. non-transparent data call	<i>Page 81</i>
AT+FCLASS	Fax: select, read or test service class	<i>Page 89</i>

17 Appendix

17.1 Version History

Version 7: Author Thomas Janiczek & Alexander Pfeiffer-Widensky

Version 8: Author Thomas Janiczek & Alexander Pfeiffer-Widensky

The authors would like to thank all their working colleagues for their support.

AT command summary

(pause)+++ (pause)	ESC from data mode to command mode	29
A/	Repeat previous command line	29
AT%D	Automatic dialling phone number in mem. "ME" index "1" with DTR	46
AT&C	Set circuit Data Carrier Detect (DCD) function mode	43
AT&D	Set circuit Data Terminal Ready (DTR) function mode	44
AT&F	Set all current parameters to manufacturer defaults	44
AT&S	Set circuit Data Set Ready (DSR) function mode	44
AT&V	Display current configuration	45
AT&W	Store current parameter to user defined profile	45
AT&Z	Store telephone number in SIM fixdialling memory "FD"	46
AT+CACM	Accumulated call meter (ACM) reset or query	56
AT+CAMM	Accumulated call meter maximum (ACMmax) set or query	57
AT+CAOC	Advice of Charge information	58
AT+CBC	Battery charge	58
AT+CBST	Select Bearer Service Type	59
AT+CCFC	Call forwarding number and conditions control	60
AT+CCUG	Closed user group control	61
AT+CCWA	Call waiting control	62
AT+CEER	Extended error report	63
AT+CGMI	Request manufacturer identification	63
AT+CGMM	Request model identification	63
AT+CGMR	Request revision identification of software status	63
AT+CGSN	Request product serial number identification (IMEI) identical to GSN	64
AT+CHLD	Call hold and multiparty	64
AT+CHUP	Hang up call	64
AT+CIMI	Request international mobile subscriber identity	65
AT+CLCC	List current calls of ME	65
AT+CLCK	Facility lock	66
AT+CLIP	Calling line identification presentation	67
AT+CLIR	Calling line identification restriction	68
AT+CMEE	Report mobile equipment error	68
AT+CMGD	Delete SMS message	93
AT+CMGF	Select SMS message format	94
AT+CMGL	List SMS messages from preferred store	94
AT+CMGR	Read SMS message	97
AT+CMGS	Send SMS message	100
AT+CMGW	Write SMS message to memory	101
AT+CMSS	Send SMS message from storage	102
AT+CNMI	New SMS message indications	103
AT+COLP	Connected line identification presentation	69
AT+COPS	Operator selection	70
AT+CPAS	Mobile equipment activity status	71
AT+CPBF	Find phonebook entries	71
AT+CPBR	Read current phonebook entries	72
AT+CPBS	Select phonebook memory storage	74
AT+CPBW	Write phonebook entry	76
AT+CPIN	Enter PIN	77
AT+CPIN2	Enter PIN2	78

AT+CPMS	Preferred SMS message storage	105
AT+CPUC	Price per unit and currency table	80
AT+CPWD	Change password	79
AT+CR	Service reporting control	83
AT+CRC	Set Cellular Result Codes for incoming call indication	82
AT+CREG	Network registration	84
AT+CRES	Restore SMS settings	105
AT+CRLP	Select radio link protocol param. for orig. non-transparent data call	81
AT+CRSM	Restricted SIM access	85
AT+CSAS	Save SMS settings	106
AT+CSCA	SMS service centre address	106
AT+CSCB	Select cell broadcast SMS messages	106
AT+CSCS	Select TE character set.	86
AT+CSDH	Show SMS text mode parameters	108
AT+CSMP	Set SMS text mode parameters	109
AT+CSMS	Select Message Service	109
AT+CSQ	Signal quality	87
AT+CUSD	Unstructured supplementary service data	88
AT+CXXCID	Display card ID (identical to AT^SCID)	136
AT+DR	V.42bis data compression reporting control	47
AT+DS	V.42bis data compression control	48
AT+FCLASS	Fax: select, read or test service class	89
AT+FMI	Fax: report manufactured ID	89
AT+FMM	Fax: report model ID	89
AT+FMR	Fax: report revision ID	90
AT+GCAP	Request complete TA capabilities list	48
AT+GMI	Request manufacturer identification	49
AT+GMM	Request TA model identification	49
AT+GMR	Request TA revision identification of software status	49
AT+GOI	Request global object identification	50
AT+GSN	Request TA serial number identification	50
AT+ICF	Set TE-TA control character framing	50
AT+IFC	Set TE-TA local data flow control	51
AT+ILRR	Set TE-TA local rate reporting mode	52
AT+IPR	Set fixed local rate	53
AT+VGR	Receive gain selection of speaker	90
AT+VGT	Transmit gain selection of microphone	91
AT+VIP	Initialize voice parameters	91
AT+VTS	DTMF and tone generation (<Tone> in {0-9, *, #, A, B, C, D})	92
AT^MONI	Monitor idle mode and dedicated mode	133
AT^MONP	Monitor neighbour cells	135
AT^SACM	Advice of charge and query of ACM and ACMmax	111
AT^SCID	Display SIM card identification number	113
AT^SCKS	Set SIM connection presentation mode and query SIM connection status ..	113
AT^SCNI	List Call Number Information	114
AT^SCTM	Set critical operating temp. present. mode or query temp.	114
AT^SFPCS	Far party call status	115
AT^SLCK	Facility lock (including self-defined locks)	116
AT^SMGL	List SMS messages from preferred storage without changing status to read	118
AT^SMGO	Set or query SMS overflow presentation mode or query SMS overflow	118

AT^SMGR	Read SMS message without set to REC READ	119
AT^SMONC	Cell Monitoring	136
AT^SMSO	Switch off mobile station turn off	122
AT^SNFA	Set or query of microphone attenuation	122
AT^SNFE	Set or query echo parameters	123
AT^SNFI	Set microphone path parameters	124
AT^SNFM	Mute microphone	124
AT^SNFO	Set or query of audio output (= loudspeaker path) parameters	125
AT^SNFS	Select audio hardware set	126
AT^SNFV	Set or query loudspeaker volume	126
AT^SPBA	Browse the phonebook alphabetically	73
AT^SPBS	Steps the selected phonebook alphabetically	75
AT^SPIC	Display PIN counter	126
AT^SPLM	Read the PLMN list	126
AT^SPLR	Read entry from the preferred operator list	127
AT^SPLW	Write an entry to the preferred operator list	128
AT^SPWC	List password counter	129
AT^SPWD	Change password for a lock (including Siemens-defined locks)	130
AT^SRESET	Software reset	130
AT^SRTC	Select, query or test ringing tone	131
AT^SSET	Set some unsolicited result codes	134
ATA	Answer a call	30
ATD	Mobile originated call to dial a number and call of supplementary services	30
ATD><mem><n>	Originate call to phone number <n> in memory <mem>	33
ATD><n>	Originate call to phone number in current memory	34
ATD><str>	Originate call to phone number in memory with corresp. alphanum. field ...	35
ATDI	Mobile originated call to dialable ISDN number <n>	36
ATDL	Redial last telephone number used	37
ATDS	Dial stored phone number in ME-phonebook	38
ATE	Enable command echo	38
ATH	Disconnect existing connection	38
ATI	Display product identification information	39
ATO	Switch from command mode to data mode	39
ATQ	Set result code presentation mode	39
ATS0	Set number of rings before automatically answering the call	40
ATS10	Set disconnect delay after indicating the absence of data carrier	42
ATS12	Set pause length for Hayes ESC sequence	42
ATS2	Set Hayes ESC character	40
ATS3	Set command line termination character	40
ATS4	Set response formatting character	41
ATS5	Set command line editing character	41
ATS7	Set number of seconds to wait for connection completion	41
ATS8	Set number of seconds to wait when comma dial modifier	41
ATV	Set result code format mode	42
ATX	Set CONNECT result code format and call monitoring	43
ATZ	Set all current parameters to user defined profile	43



Abbreviations

AC	Alternate Current
ACM	Accumulated Call Meter
ADC	Analog Digital Converter
AGC	Automatic Gain Control
AoC	Advice of Charge
BAIC	Barring of All Incoming Calls
BAOC	Barring of All Outgoing Calls
BOIC	Barring of Outgoing International Calls
CBM	Cell Broadcast Message
CBS	Cell Broadcasting Service
CD	Call Deflection
CFB	Call Forwarding on Mobile Subscriber Busy
CFNRy	Call Forwarding on No Reply
CFNRc	Call Forwarding on Mobile Subscriber Not Reachable
CFU	Call Forwarding Unconditional
CH	Call Hold
CI	Cell ID
CLI	Calling Line Identification
CLIP	Calling Line Identification Presentation
CLIR	Calling Line Identification Restriction
CLLP	Closed Local Loop Phone
CME ERROR	Mobile Equipment Error
CMS ERROR	Mobile Equipment or Network Error
CODEC	Coder-Decoder
COL	Connected Line
COLP	Connected Line Identification Presentation
CTS	Clear To Send
CUG	Closed User Group
CW	Call Waiting
DAC	Digital Analog Converter
DAI	Digital Audio Interface
dB	decibel
db SPL	dB Sound Pressure Level (0dB SPL \equiv 20 μ Pa)
DAI	Digital Audio Interface
DCD	Data Carrier Detect
DCE	Data Circuit terminating Equipment
DRX	Discontinuous reception (mechanism)
DTC	Data Circuit Terminating Equipment
DTE	Data Terminal Equipment
DTMF	Dual-Tone Multifrequency
DTR	Data Terminal Ready
DSR	Data Set Ready
DTR	Data Terminal Ready
EFR	Enhanced Full Rate
EMC	Electromagnetic Conformity
ESD	Electrostatic Discharge
ETS	European Telecommunications Standard
FDN	Fixed Dialling Number
FR	Full Rate
GND	Ground
GPIO	General Purpose Interface

GSM	Global System for Mobile communication
IMEI	International Mobile Equipment Identity
IMSI	International Mobile Subscriber Identification
LAI	Location Area Identifier
ME.....	Mobile Equipment
MMI	Man Machine Interface
MO	Mobile Originated
MP	Mobile Phone
MSVC.....	Microsoft Visual C
MT	Mobile Terminated
MTBF	Mean Time Between Failure
MTPy.....	Multiparty Service
PCB	Printed Circuit Board
PDU	Protocol Data Unit
PLMN.....	Public Land Mobile Network
PP	Point-to-Point
PSTN	Public Switched Telephone Network
PtP	Print-to-Print
RF.....	Radio Frequency
RI.....	Ring Indicator
RLP.....	Radio Link Protocol
RSSI	Received Signal Strength
RTS	Request To Send
RXD	Receive Data
SIM.....	Subscriber Interface Module
SMS MO	SMS Mobile Originated
SMS MT.....	SMS Mobile Terminated
SMS	Short Message Service
TA.....	Terminal Adapter
TBR	Technical Basis for Regulation
TCH.....	Traffic Channel
TE.....	Terminal Equipment
THD.....	Total Harmonic Distortion
TÜV.....	Technischer Überwachungsverein (German Technical Inspectorate)
TXD.....	Transmit Data
USSD.....	Unstructured SS Data
VSC	Voiceband Serial Connector
VSWR	Voltage Standing Wave Ratio

Index

Numerics

4-pole Western plug **203, 204**
 80-pin connector **196**

A

Abbreviated dialling **147**
 keys – check **150**
 keys – programming **150**
 Accumulated
 call meter **56**
 call meter (ACM) **112**
 call meter maximum **57**
 ACM **56, 112**
 Activity status **71**
 Additional capabilities **48**
 Advice of Charge **56, 111**
 Advice of Charge information **55, 58**
 Alphanumeric field **35, 71**
 Answer a call **30**
 Antenna
 cable **203**
 connector **157, 202**
 gain **26**
 GSM **154**
 help **174**
 interface connector **26**
 maximum power **26**
 SMR nano connector **26**
 Application examples **198**
 Asynchronous **82, 83**
 Asynchronous modem **59**
 AT command **54**
 interface **13, 15, 20, 27, 154**
 standard **27**
 standard Hayes **29**
 syntax **27**
 to GSM **93**
 AT&F **163**
 AT&V **164**
 AT&W **163**
 AT+CLCK **163**
 AT+CPBS **164, 165**
 AT+CPBW **165, 169**
 AT+CPIN **162, 169, 170, 171**
 AT+CPWD **163, 171**
 AT+CUSD Unstructured supplementary ser-
 vice data **88**

AT^SFPCS Far party call status **115**
 AT^SMGL List SMS messages from preferred
 storage without changing status to read
 118
 AT^SMGR Read SMS message without set to
 REC READ **119**
 AT^SMONC Cell Monitoring **136**
 AT^SPIC **162, 170, 171**
 AT^SPLR Read entry from the preferred opera-
 tor list **127**
 AT^SPLW Write an entry to the preferred opera-
 tor list **128**
 AT^SPWCList all current values of SIM counters
 129
 AT^SRESET Software reset **130**
 AT^SSET Set some unsolicited result codes ...
 134
 ATS12 Set pause length for Hayes ESC sequence
 42
 ATS2 Set Hayes ESC character **40**
 ATZ **163**
 Audio **196**
 hardware **111, 126**
 interface **22, 25**
 mode **123, 124, 126**
 output **111, 125**
 Automatic
 answering **40**
 dialling **29, 46**
 Automatically answering **40**

B

BAIC **66, 79, 116, 130**
 BAOB **66, 79, 116, 130**
 Bar all incoming calls (BAIC) .. **66, 79, 116,**
 130
 Bar all outgoing calls (BAOB) .. **66, 79, 116,**
 130
 Bar incoming calls when roaming outside the
 home country (BIC-Roam) **66, 79,**
 116, 130
 Bar outgoing international calls (BOIC) .. **66,**
 79, 116, 130
 Bar outgoing international calls except to home
 country (BOIC-exHC) ... **66, 79, 116,**
 130
 Barring **145**
 Battery **24, 56, 58**
 charge **58**
 Baud rate **53**



Bauds per second	52	Command mode	29, 39
Bearer Service	59	Communications device	179
Bearer service	62	Connect indicator	143
BIC-Roam	66, 79, 116, 130	Connect line identification presentation ...	14
BOIC	14, 66, 116, 130	CONNECT result	43
BOIC-exHC	66, 79, 116, 130	Connected	69
BuildCommDCB	178	Connected line identification presentation	69
Busy		Connection completion	41
signal	43	Connection setup	27
tone	146	Control character framing	50
Buzzer	25, 142	Corporate personalization	116
C		CPBR	55
Call barring	144, 150	CPBS	55
Call forwarding	55, 60, 144, 151	CPBW	55
Call hold	55, 64	CPIN	55
Call in progress	17	CPWD	55
Call monitoring	28, 43	CREG	55
Call waiting	62	CTS	204
Calling line identification presentation ...	67	Current call meter	58
Calling line identification restriction	68, 144	Current calls	65
Card ID	136	Current consumption	17
Card identification	113, 137	Current memory	34
CCFC	55	Current power level	133
CCIN switch	24	Current pulse	17
CCM	58	D	
CE conformity	15, 206	Data call	81
Cell broadcast messages	106	Data carrier detect	204
Cell ID	133	Data carrier detect (DCD)	28, 43
Cellular result code	55, 82	Data compression	47, 48
Change password	79, 130, 145	Data mode	29, 30, 39
Channel bit error rate	87	Data rate	53
Channel number	133, 135	Data set ready (DSR)	44, 204
CHUP	55	Data terminal ready (DTR)	44, 204
CLCK	55	Data transfer	169
Clear down	146	DC_IN	17
Clear to send	51, 204	DCB	178
ClearCommBreak	179	DCB FAR	178
CLIP	55, 67	DCD	38, 43, 204
CLIR	68, 144, 146	Dedicated mode	133
Clock	22	Delta-type approval	197
Closed user group	61	Design drawing (M20)	213
CMEE	55	Destination address	96, 101
CN_EVENT	181	Development Box	207
CN_TRANSMIT	181	Device definition	178
Code presentation mode	39	Dial a number	30
Codec – A/D device	22	Dial key	142
COMM.DRV	181	Dial stored phone number	38
comma dial modifier	41	DIAL TONE	27
Command executed	27	Dial tone	43

Dialling memory	46, 66	FTA – Full-type approval	196
Digital audio interface – DAI	22	Full-type approval	196
Dimensions	203	Function mode	43, 44
Dimensions M20.....	212	Fuses.....	196
Discharge time.....	100		
Disconnect	27, 38	G	
Display	19, 39, 113, 126, 149, 157, 196	Gain	90, 123, 125
card ID	136	Gain selection	56, 90, 91
current configuration.....	28, 45	GetCommError	183
information	143	GetCommEventMask.....	184
text.....	144	GetCommState.....	184
DOT display	19, 212	Global object identification	29, 50
Download enable	16	GND – ground	24, 204
DSR	44, 204	Ground (GND).....	17, 24, 204
DTMF.....	56, 151	GSM	
DTMF generation	92	07.07	27, 212
DTR	44, 204	07.07 (list of commands)	55
		07.07 and 07.05	54
		11.11	24
		standards	212
E			
Echo		H	
mode	38	Handset	156, 196, 197, 202, 204
parameter.....	38	Handset (microphone and loudspeaker) .	142
parameters	111, 123	Handset answer functions.....	146
suppression	22, 123, 200	Handset approval.....	197
EMC consideration	197	Handset connection.....	199
Emergency call.....	33, 139, 153	Handsfree – M20.....	22
EnableCommNotification	180	Handsfree application	200
EscapeCommFunction.....	181	Hang up call.....	55, 64
Even	50	Header.....	42
Execution command.....	54	Home network.....	70, 84
Explicit call transfer	64	Hook off.....	30
Extended error report.....	55, 63	Hookswitch.....	25
F		I	
Facility lock	55, 66, 79, 111, 116	Idle mode	17, 111, 133
Fax	55, 89	IGNITION.....	18, 122, 191, 205
report manufactured identification.....	89	Ignition.....	16, 192, 203
report model identification.....	89	Ignition line	200
report revision identification	90	IMEI	64
Field strength indicator	143, 153	IMSI	65
Find phonebook entries.....	55, 71	Incoming barring services ..	66, 79, 116, 130
Fixdialling		Incoming call indication.....	82
memory	28, 46	Indicating of absence of data carrier	42
phonebook	33, 74	Indicating the absence of data carrier.....	28
Fixed local rate	29, 53	International mobile subscriber identity ..	55,
FlushComm.....	182	65	
Format mode	28, 42	Invalid command.....	27
Formatting character	28, 41		
Forwarding.....	14, 55, 60, 151		
Frequency	12, 26		

- ISDN number **36, 46**
- K**
- Keypad **11, 20, 158**
- address matrix **142**
 - column **20**
 - meaning **142**
 - redial **143**
 - row **20**
- Keypad column **20**
- Keypad row **20**
- L**
- Language volume setting **153**
- Languages **142**
- Last-dialling phonebook **33**
- LED **205**
- Line editing character **41**
- Line termination character **28, 40**
- Line-in/out **192, 202, 203**
- Link not established **27**
- Local call barring **144, 150**
- Local data flow control **29, 51**
- Local rate reporting mode **29, 52**
- Location area ID **133, 135**
- Lock phone to SIM card **66**
- Lock SIM card **66, 79**
- Logic level **17**
- Loudspeaker volume **111, 126**
- LPCSTR **178**
- M**
- M20
- design drawing **213**
 - EMC-relevant information **196**
 - service information **201**
 - Terminal **202**
- M20 diagnostics **174**
- Manufacturer
- defaults **28, 44**
 - ID **89**
 - identification **29, 49, 55, 63**
- Manufacturer-specific AT commands **27**
- ME
- phonebook **38**
- ME-phonebook **28**
- Message indicator **143**
- Messages returned **27**
- Microphone **25, 56, 123, 124, 196, 204**
- attenuation **111, 122**
 - energy **123**
 - gain selection **91**
 - impedance **25**
 - mute **111, 124**
 - sensitivity **25**
 - signal to noise ratio **25**
 - volume **25**
- Minimal receiving level **133**
- MMI
- basic codes (ETS 300-511) **145**
 - board **212**
 - codes **144**
 - features and user-defined settings **143**
 - functions **146**
- Mobile busy **60**
- Mobile equipment error **68**
- Mobile originated call **28, 30, 36**
- Model identification **29, 49, 55, 63**
- Mounting **216**
- MTBF M20 **212**
- Multi-numbering **156, 159**
- Multiparty **64**
- Mute **111**
- N**
- Neighbour cells **135**
- Network
- call barring **150**
 - facility **66, 116**
 - personalization **116**
 - registration **55, 84**
 - selection **144, 153**
 - service **60, 66, 116**
 - subset personalization **116**
- NO DIAL TONE **27**
- No reply **60, 151**
- Non-transparent **59, 81, 82, 83, 212**
- Non-voice call. **31, 33, 34, 35, 36, 37, 38, 46**
- Not reachable **60**
- Number of rings **28, 40**
- O**
- Odd **50**
- Off-hook **146**
- OpenComm **185**
- Operator selection **55, 70**
- Operators **156, 159**
- Originating address **101**
- Outgoing barring service **66, 79, 116, 130**



Outgoing call	31	Remote station busy.....	27
Outgoing seizure.....	147	Repeat previous command line	29
P		Report manufactured identification	89
Parity	50	Report model identification	89
Password.....	55, 66, 77, 79, 116, 130, 145	Report revision identification.....	90
password.....	130	Request to send	204
PCM.....	22	Reset indicator	18
PDU mode	94, 97, 100, 119	RI	204
Peripheral devices	154	Ring detection	27
PHONE CALL	169	Ring indicator	204
Phonebook	33, 71, 72, 74, 76, 95	Ringer	
Phonebook handling.....	164	tone	144
PIN.....	56, 57, 77, 153	volume.....	144, 153
check.....	162	Ringing tone	131
counter	126	RLP – Radio link protocol.....	81
enter	162	Roaming indicator	143
PIN2.....	56, 57, 77	RS323	20
PLMN ID code	133, 135	RSSI	135, 143, 153
PLMN list	126	field strength	153
Plug FME.....	154	value.....	133
Plug SMR nano.....	157	RTS	204
Plug, Western	203	RXD	204
Port rate	52	S	
Power on/off.....	18	SACM.....	111
Power supply	17, 192, 203	SCID.....	111
Power supply indicator	24, 143, 153	SCKS	111
POWER_ON.....	18, 191	SCNI.....	111
Power-on indicator.....	18	Select message service	109
Prefix.....	27	Select phonebook memory storage	74
Product identification information	39	SEND.....	147
Product serial number identification.....	64	Sending successful.....	100
Protection class.....	203, 216	Sensitivity.....	25, 212
PUK	77	Serial interface	204
Push/pull cycles	26	Serial interface configuration.....	177
Push-pull cycles SMD connector	17	Serial number identification.....	64
R		Service	
RACH channel	133	provider personalization.....	9, 116
Radio link protocol.....	81	providers	156, 159
Read command	54	reporting control	83
Read current phonebook entries.....	72	Service centre time-stamp	100
ReadComm	178, 187	Set command	54
Ready for receiving	51	SetCommBreak	187
Receive data	204	SetCommEventMask	188
Received signal strength indication.....	87	SetCommState	189
Receiving level	133, 135	Short keys.....	142
Receiving quality	133	Short message	142
Recipient address	96	Signal.....	87
Redial	37, 142, 147, 150	Signal quality	87
		Signal to noise ratio	25



SIM	
card reader	196
connected presentation	113
connected status	113
lock	153
message storage.....	105
phonebook	33, 74
PIN2.....	56, 57, 77
SIM card	8, 66, 116
clock	24
identification number	113
inserted switch	24
interface.....	24
PIN	130
power supply.....	24
reader	154, 202
reader approval.....	197
SLCK	111
SMD connector, 80-pole	157
SMGO	111
SMR connector – push/pull cycles	26
SMR nano	154, 157
SMS	
cell broadcast	104
COMMAND.....	94, 95, 97, 98, 119, 120
delete message	93
DELIVER.....	94, 97, 98, 119, 120
destination address.....	95, 97, 100, 119
discharge time	95, 98, 120
message format	94
message from preferred message storage....	93
message identifier.....	96, 98, 120
message overflow	152
messages from preferred store.....	94
new message indication.....	103
originating address.....	98, 120
overflow	118
PDU mode	94, 98, 120
preferred message storage.....	105
read message.....	97
reading a message.....	151
received read messages	94
received unread messages.....	94
recipient address.....	96, 98, 120
restore settings	105
save settings.....	106
scrolling through message	151
select cell broadcast messages.....	106
select message service.....	109
send message	100
send message from storage.....	102
service centre address	106
service centre time-stamp.....	96, 99, 121
service indicator.....	152
set text mode parameter	109
show text mode parameter.....	108
STATUS-REPORT ..	94, 95, 97, 98, 119, 120
stored sent messages.....	94
stored unsent messages	94
SUBMIT	94, 95, 98, 100, 120
switch off mobile station.....	122
text mode	94, 98, 100, 120
user data header indication.....	98, 120
with M20 to SIM (in text mode)	170
write message to memory.....	101
SMSO	111
SNFM	111
SNFS	111
SNFV	111
Software	
status	49, 63
update	191
Software download.....	191
Software library.....	177
Software release	39
Software status	49, 63
Speaker	25, 90, 204
gain selection.....	90
volume.....	144
Speaker volume.....	144
SPIC	111
SPLM.....	111
SPWD	111
SRTC	111
Standard AT Hayes commands	28
Stand-by state (power)	17
State of call.....	65
Status LED	205
Store current parameter	43, 45
Store telephone number.....	46
stored	37
Stored number.....	33, 34, 35, 37, 38, 46
Subaddress.....	60
SUB-D	204
SW	
downloading.....	191
Switch off.....	122
Switch on	18



Synchronous.....	82, 83	Volume setting.....	153
T		W	
Technical data, M20.....	212	Weight	203
Temperature range	203, 212	Weight M20.....	212
Termination character.....	27	WM_COMMNOTIFY	180
Test command	54	Write phonebook entry.....	76
Text mode 94, 95, 97, 98, 100, 119, 120, 170		WriteComm	178, 191
Text mode parameter.....	108	X	
Time slot.....	133	XON/XOFF	51
Timeout	27		
Timing advice in bits.....	133		
Timing characteristics of DAI	23		
Timing of display interface	19		
Tone generation	92		
Trailer.....	42		
Transmit data.....	22, 204		
TransmitCommChar.....	190		
Transparent	59, 83, 212		
Turn off	18, 122		
Turn on	18		
TXD	204		
U			
Unconditional.....	60		
UngetCommCha	190		
Unused pins.....	16, 17		
Update	191		
User defined profile.....	43		
Using the AT^SPBA and AT^SPBS Command	168		
V			
V.21	59		
V.22	59		
V.22bis	59		
V.23	59		
V.24	20		
V.25ter.....	27, 29, 30, 31, 69		
V.26ter.....	59		
V.28	203		
V.32	59		
V.42bis	47, 48, 212		
Vibrations	203		
Voice call.....	31		
Voice parameter.....	56, 91		
Voiceband serial ports	22		
Voltage supply.....	212		
Volume	25, 153		

