

Visual Guide to

Lock Picking

Fig. 6.

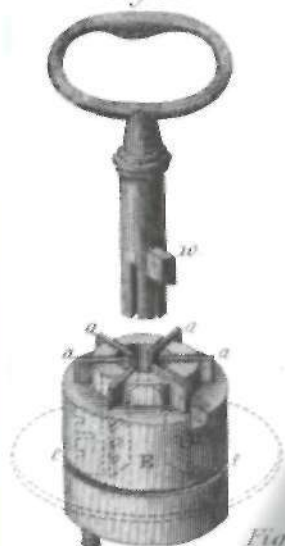
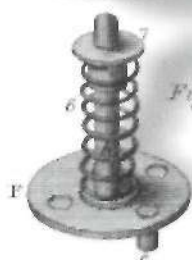

Fig. 2.



Fig. 5.



WARDED LOCKS

PIN TUMBLER LOCKS

WAFER LOCKS

EXERCISES

AND MUCH MORE

*ROXTON'S
Fig. 10.*

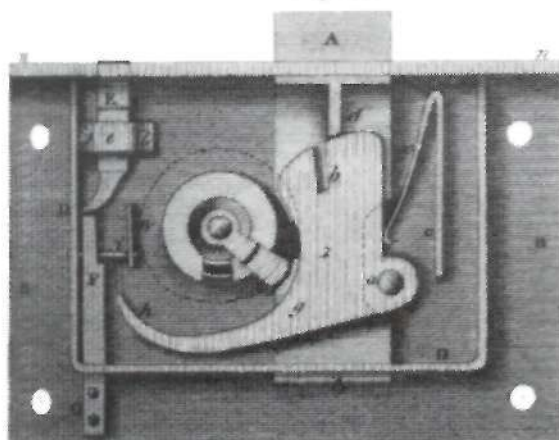

Fig. 11.



standard publications, Inc.



FIRST EDITION

1.0

Visual Guide to

Lock Picking

Mark McCloud

Illustration

Gonzalez de Santos

Editors

Lynard Richmar

Laura Neff

Standard publications, inc.



Cover design: **Mano Kime**
Layout editor: **Hori Hashimoto**
Production editor: **Rene Isaacs**
Manufacturing Producer: **Standard Publications, Inc.**

Copyright ©2001 by Standard Publications, Inc.
Standard Publications, Inc.
Urbana, Illinois 60514

All rights reserved. No part of this book may be reproduced, stored in a retrieval system, or transmitted, in any form or by any means, electronic, mechanical, photocopying, recording, or otherwise, without prior written permission from the publisher.

The author and publisher of this book make no warranty of any kind, express or implied. The author or publisher shall not be held liable in any event for incidental or consequential damages in connection with, or arising out of, the furnishing, performance, or use of this information.

The publisher offers discounts on this book when ordered in bulk quantities.

ISBN 0-9709788-0-4

Printed in the United States of America

Standard Publications, Incorporated

www.standardpublications.com

Excerpt from the 1832 edition of the Edinburgh Encyclopaedia

LOCK is a well known instrument used for securing doors, chests, &c. and preventing them from being opened without a proper key. The simple and common lock, consists of a strong bolt, which is generally fitted into a case of metal, so as to admit of a motion backwards and forwards. The bolt should be inclosed on all sides, in such a manner as to prevent any access to it, except by a small opening, through which the key is to be introduced to withdraw it ; which opening should be surrounded inside the lock, by numerous wards or pieces of metal, forming a crooked and interrupted passage, to prevent the introduction of any improper instrument or false key, to pick the lock and withdraw the bolt. ... Indeed, an ill-disposed person might provide himself with a bunch of keys, called skeleton keys, which would open almost any lock constructed upon the above principles. A skeleton key means one which is cut out, so as to leave only the extreme part of the bit entire which moves the bolt, the other part being reduced to a thin piece, of just sufficient strength to move the bolt without breaking. It will easily be seen, that such a key would not be likely to meet with any interruption from wards, as very little solid metal is left....

In order to produce a lock free from these objections, many ingenious mechanics have turned their attention to the subject of lock-making. In fact, the object of securing property from the depredations of others is so important, that few instruments have had more pains and ingenuity bestowed on them than locks.

Most of the contrivances for locks were supposed to possess some particular advantage, such as strength to resist violence, or security against being picked. Some speculators have acted upon a different principle altogether—that of attaching an alarm, a large bell, a species of fire-arms, &c. to a lock, in such a manner that an attempt, to violate the lock would set the bell a-ringing, or discharge the fire-arms ; thereby causing a great noise and confusion, that the depredator might not escape. Our limits will not permit us to enter into the details of all the schemes that have been proposed to give security to locks ; but we shall notice principally such as have come into use by their own recommendation. ...

The subject of locks is so very extensive, that it would far exceed our limits to give a description of all the different forms and arrangements that have been proposed by various persons. (J. F.)

Contents

Introduction

1	Warded Locks	10
	Identifying Warded Locks	12
	How Warded Locks Work	12
	Picking Warded Locks	14

2	Pin Tumblers	16
	Identifying Pin Tumblers	18
	How Pin Tumblers Work	18
	Parts of a Pin Tumbler	18
	Theory of Operation	20
	Standard Tools	22
	Keyless Entry	28
	Raking	30
	Picking	32
	Bypass Picking	38
	Shimming	40
	Vibration Picking	42
	Exercises	44

3	Wafer Locks	46
----------	--------------------	-----------

4	Final Rants	52
----------	--------------------	-----------

	Glossary	56
--	-----------------	-----------

	Legal Notice	63
--	---------------------	-----------

Introduction

The first thing to remember when learning to pick locks is that it is an art. You can be told exactly what to do, but you probably won't be able to just go and succeed in picking any lock right away. Like most learned skills lock picking takes practice. Lots of it. This book presents the various methods and techniques used in picking locks and the tools needed to accomplish it. It also tries to give a brief overview of how the locks work in order to better understand them. Most of the time, this is unnecessary; but there are many times when the knowledge will be invaluable. This book does not try to go into detail of the legal implications. You are responsible for determining your own local laws and regulations. Do not do anything illegal. Period. You will find there are many legitimate times when having the ability to pick locks is useful.

The actual methods of lock picking are really quite simple. You are just exploiting the design of the lock in order to open it without the key. Applying these techniques, however, can be quite difficult. As you practice you will find that, a lock that used to take you an hour to pick might now only take you ten minutes. A lock that used to take you five minutes might now only take you a few seconds. As you practice these skills you will become more efficient.

Always keep in mind why you are picking any particular lock and realize that there is often a better way. Make sure that you have a good, legitimate, and legal reason for what you are doing. There are many professional locksmiths around the country making a good living doing legitimate lock picking.



Warded Locks

Warded locks are probably one of the oldest types of lock in existence. In modern days, warded locks have been deprecated for most purposes. Used on many things, including door locks, in the early part of the twentieth century, they were common. Because they are so easy to pick, they do not provide much security. Despite this, they are still better than nothing at all. The ancient Chinese and Russians resorted to concealing the keyhole in elaborate artwork. In hopes of increasing the security of their warded locks.

Identifying Warded Locks

Today warded locks can be found on cheaper padlocks. If the *keyhole* looks something like one of these figures on the right, then it most likely is a warded lock. The keys for this type of lock will generally slide in and out with almost no friction or resistance.



Example warded keyways

How Warded Locks Work

When opening a lock, the goal is usually to rotate, move, or, in some fashion, actuate the *locking bolt*. This, in turn, frees the shackle, deadbolt, or other mechanism holding the locking bolt.

Let us begin by looking at one of the simplest types of lock. This would consist of a *keyway*, which is a hole to insert the key, and a locking bolt that the key's *bit* turns. The figures below demonstrate this type of lock.

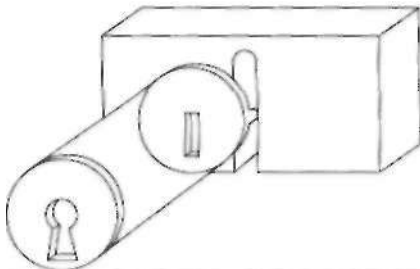

Simple lock—locked

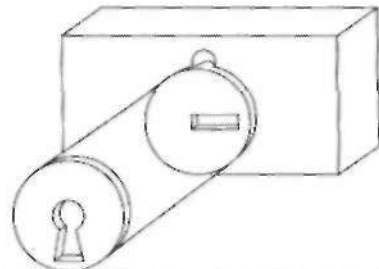

Simple lock—unlocked

Warded locks take this one step further. They simply have *wards*, which are discs of metal or other obstructions that get in the way of any key other than the designated one. This means that all keys for a particular type of warded lock have the same bit for rotating the locking bolt. The difference lies in the *notches*. The correct key will rotate, simply because it has notches that line up with the wards. Since each lock has the wards in a different location and the notches have to line up appropriately, theoretically, only the correct key will open the lock.

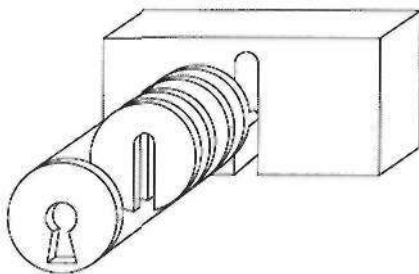
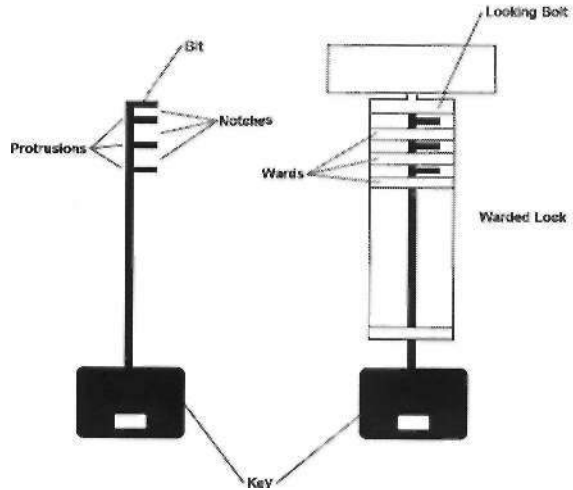

Warded lock—locked

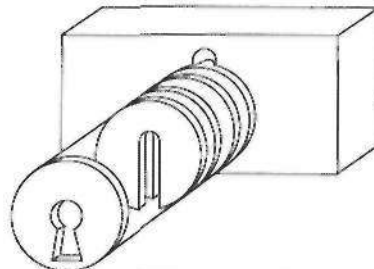

Warded lock—unlocked

Picking Warded Locks

Picking warded locks is relatively quite simple. All you need to do is rotate the locking bolt. Unfortunately, the wards will be in your way. But, if your key doesn't have any metal protrusions that get in the way of the wards, then the wards won't stop it from turning. So, let's look back at the simple lock design we described first. Let's make a key with just a *stem* and a *bit*. The bit can turn the locking bolt, and there are no obstructions on the stem to get in the way of the wards. This key would have only the bare minimum amount of metal needed to make it work. Because of this, they are called *skeleton keys*.

So, the best way to pick a warded lock is to have a collection of skeleton keys for the various types of warded locks. Try each one in your set on the lock. Insert the key as far as you can and attempt to turn it. If it doesn't work, try moving it around slightly, then move on to the next one. Making your own skeleton keys is also easy. Directions for making skeleton keys are depicted in detail in a later volume.

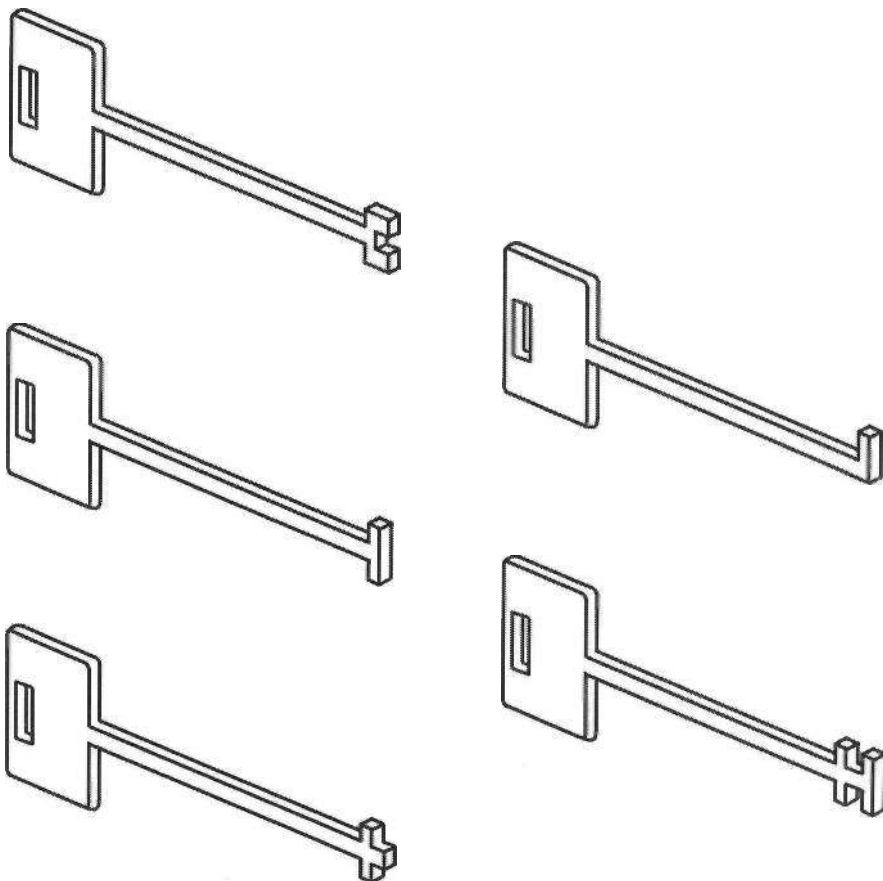

Skeleton Keys

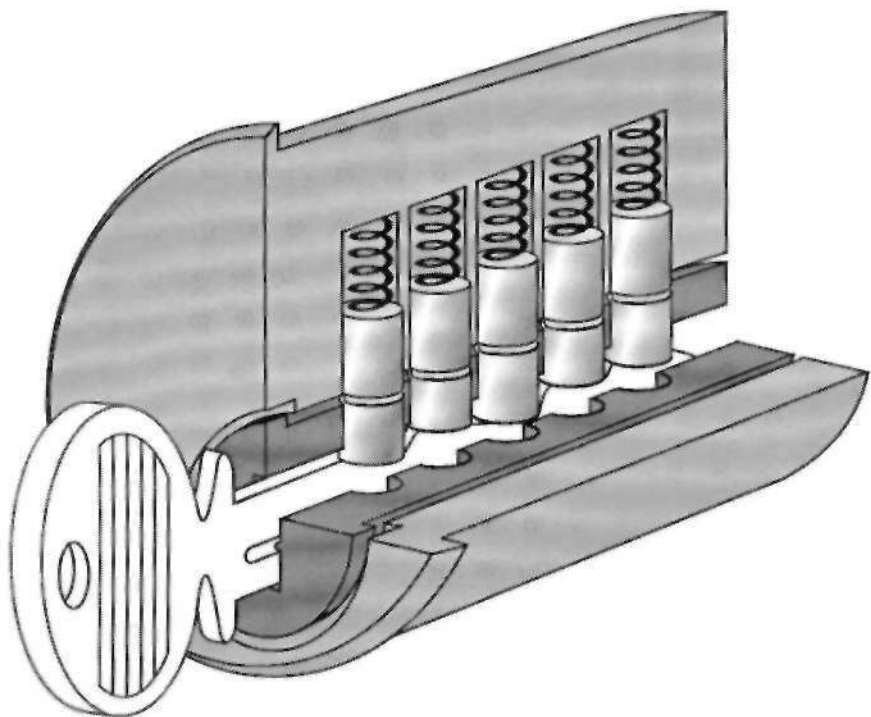



Pin Tumblers

The *pin tumbler* is the most commonly found lock in the US. It is the meat and potatoes of lock technology and is one of the oldest technologies available. A form of the pin tumbler lock was even found in ancient Egyptian pyramids. They had long wooden keys and eventually gave way to locks of iron. In fact, they are even older than the spoon and fork. Linus Yale, founder of the Yale Lock Company, implemented the modern pin tumbler in 1865.

Identifying Pin Tumblers

Pin tumblers can be found everywhere, most commonly on house dead bolts, door knobs, some cabinets, etc... They usually have *pins* that stick into the keyway. These are round and somewhat pointed. They are spring loaded, which means you can push up on them; and they will spring back down. They look somewhat similar to *wafer tumbler* locks, which will be discussed in the next chapter.

How Pin Tumblers Work

It may take some time to grasp the inner workings of the pin tumbler. So, please don't get discouraged. If you are not completely comfortable with the concept, read this section over again a few times. In addition to the diagrams here, it will help if you actually get a lock and take it apart to see how the internal parts interact with each other. Be warned, there are small parts under spring pressure that will fly all over the room if you are not careful. Perhaps try doing this with the lock inside a clear plastic bag.

Parts of a Pin Tumbler Lock

Although most pin tumbler locks have five pin columns, the number may vary depending on the quality of the lock.

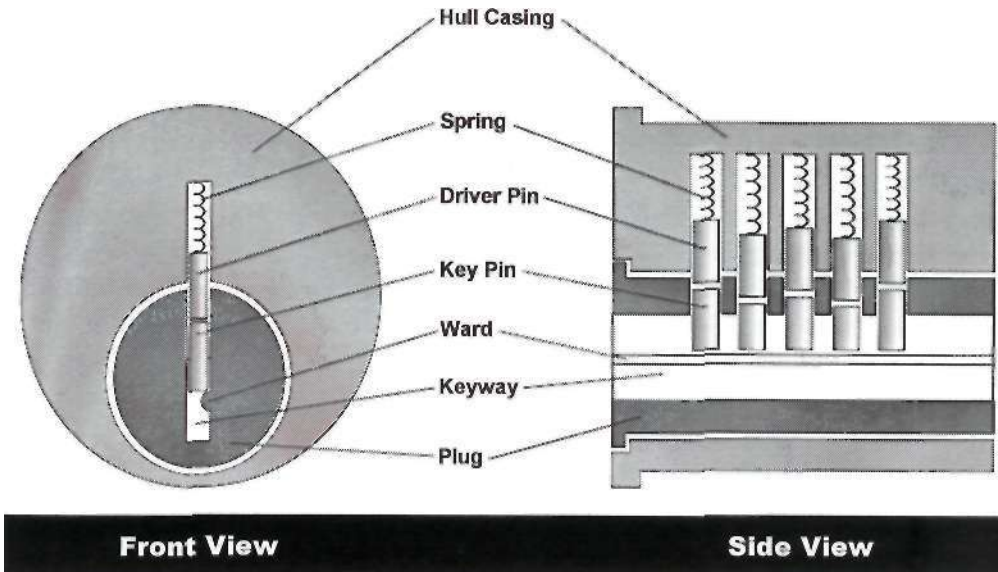

- The *keyway* is the opening into which the *key* is inserted.
- The *wards* in the pin tumbler design are lengthwise protrusions on the sides of the keyway. The wards fit into the grooves along the side of your key. They also keep the pins from coming out.
- The inner cylinder, which rotates as you turn your key, is called the *plug*.
- The *hull*, or *casing*, of the lock is the outer cylinder, which is fixed in place and does not move.
- Each set of pins has a *spring*, which pushes the pins down.
- Each pin column in the lock actually has two pins inside. One rests on top of the other, so you can only really see one with your eyes, unless you take the lock apart. The top pin is dubbed the *driver pin*. All of the driver pins are typically of the same size.
- The lower pin of each set is called the *key pin*, because it is the one that actually comes into contact with the key. When the key is not inside the keyway, the key pins often rest on the ward. The key pins vary in length and match up with the notches in the key. They usually have a somewhat pointed end that is visible.

Theory of Operation

When the correct key is inserted into the lock, the key pins rest on the notches of the key. Notice how the size of the notches complements the size of the key pins exactly. When the key notch is at the correct height, the separation between the driver pin and the key pin will be at the same height as the separation between the hull and the plug. This line of separation is called the *shear line*. When this occurs, there is no longer anything obstructing the shear line that prevents the plug from rotating. The key can now turn and will unlock the lock.

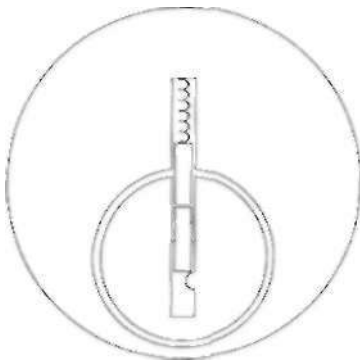

Front view



Front view—key inserted & plug rotated

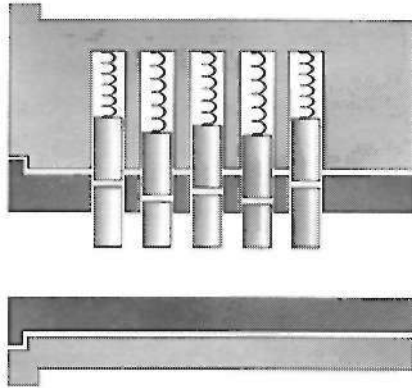

Side view cutaway

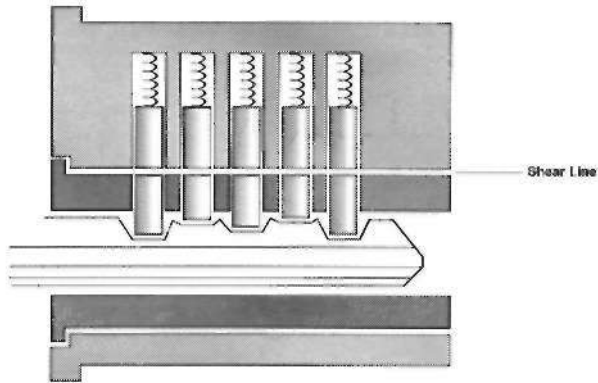

Side view cutaway—with key inserted

Standard Tools

The *handle* is that portion of the pick that you hold. Because you make actual contact with this portion, you should be especially careful to find one with which you are completely comfortable. The handles used for most of the picks will probably be the same for all of the picks and rakes in your set. The reason it is so critical to find one with a good feel is because the picks are your only form of sensory input of what is going on inside the lock.

The *tang* or *stem* of the pick is the long thin metal portion between the tip and the handle. This should be strong enough not to bend excessively; but at the same time, it should be thin enough to be maneuverable in the keyway and not obstruct the pin's movement.

The *tip* should allow for easy insertion, removal, and maneuverability in the keyway. It should also give you a good feel for the pins. This sense of feedback is very crucial to your success.

Don't get too caught up in the memorization of the various rake designs. If for some reason one doesn't work, you can just try another one. Each lock has its own personality, and through experience you will learn which picks work best in which locks.

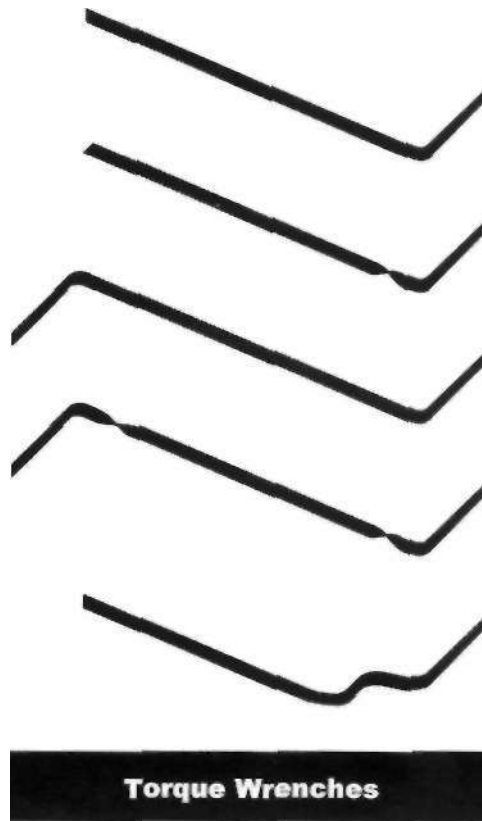

The wrench is a very important tool. Its purpose is to turn the plug. The shorter end is inserted into the keyway, and the longer end turns the plug. It is important to select the appropriate wrench for the lock you are working with. The torque wrench is used to apply a rotational force on the plug. It is important that the wrench is not too large since you have to insert it into the keyway and still have room to maneuver the pick. Also, it cannot be too small, because then it would either be too weak or not able to grip the keyway and rotate it.

**Hook picks**

These hook picks are used for standard picking of locks. With them you can feel each pin individually and lift them without disturbing the neighboring pins.

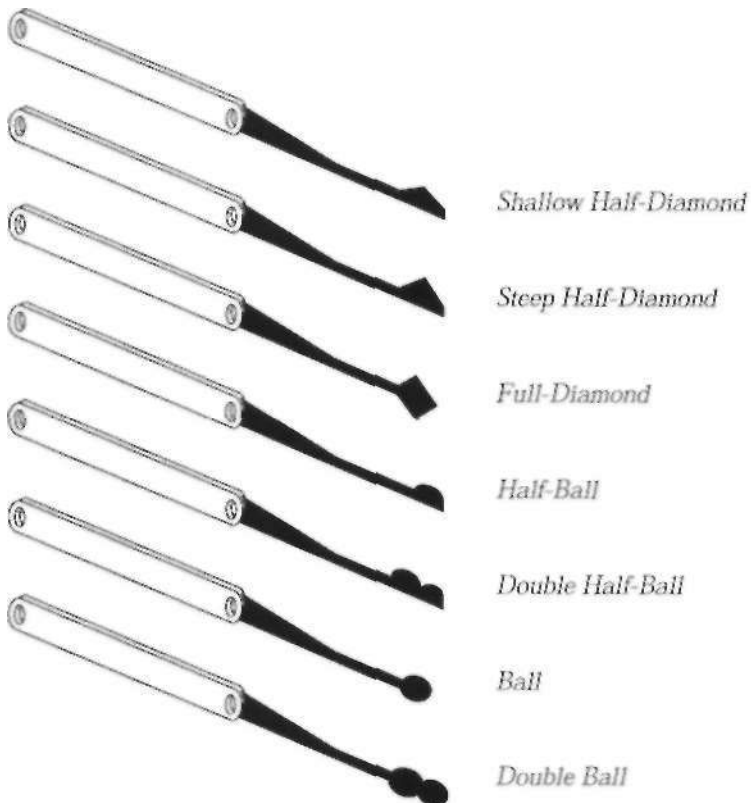
**Various lock picks / rakes**

Many of the tools listed may be used for various purposes. They may be appropriate for both raking or picking.

- *Shallow Half-Diamond.* Some advantages of this pick are that it is easy to insert, remove, and rake over the keys both forward and backward. It is good for locks where the key pins are of similar length; but if the difference is too great, the diamond won't be able to reach up high enough to one pin without lifting the one next to it too high.
- *Steep Half-Diamond.* This pick is similar to the shallow half-diamond except that it can accommodate greater differences in pin height. However, because it is steeper, it is harder to move from pin to pin. You can get half-diamond picks with a different *front angle* and *back angle*
- *Full Diamond.* Useful when the lock has pins on both sides.
- *Half-Ball.* Works well for disc tumblers.
- *Double Half-Ball.* Just like a half-ball, but with twice the tip.
- *Ball.* Useful when the lock has disks on both sides.
- *Double Ball.* Twice the fun.

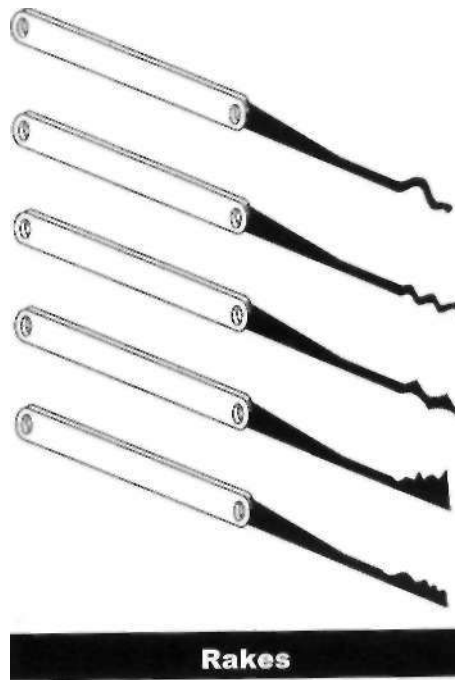

Designs for rakes differ greatly. They vary in the number and shape of bumps. Some vaguely resemble keys, while others look almost seemingly random.



As the name implies, the key extractor is used to remove broken key segments that are still stuck in the lock's keyway. They are usually hook shaped, or have one-way teeth that allow it to be inserted easily, and can grip and pull the obstructing object out.

Keyless Entry

Keep in mind that even if you read this book and fully understand the operation of a pin tumbler lock you will still probably be completely unable to pick them on your first attempt. There is no substitute for practice. Get yourself locks of varying qualities in order to experiment. You will also need a set of picks to work with. If you need to, you can even make your own. Several strategies for this are outlined in our later volumes. The easiest way, by far, is to purchase a set from a security supply company, or other distributor.

In order to successfully pick the pin tumbler, all you really need is a torque wrench and a hook pick. There are many other ways to unlock a pin tumbler, though. Picking a lock is the standard and most versatile method. Raking, however, is often a much more suitable solution than normal picking due to its ease and quickness. For more speed, you can also use an automatic picking tool or bypass the lock entirely.

You have probably seen many movies where an actor will pick a lock with some random household object, or even an authentic lock pick. But usually the actor will use only one tool: the pick. The general populace, therefore, readily believes that a lock can be opened with just one tool. This is generally not the case. Most methods of picking require a tool to turn the plug. This tool that applies a rotational force is called the *torque wrench*. It can be any object that can be inserted in the keyway and rotate it. The second tool is usually a *pick* or *rake* that is used to manipulate the pins. It would be difficult for the same tool to manipulate pins, while also turning the cylinder.

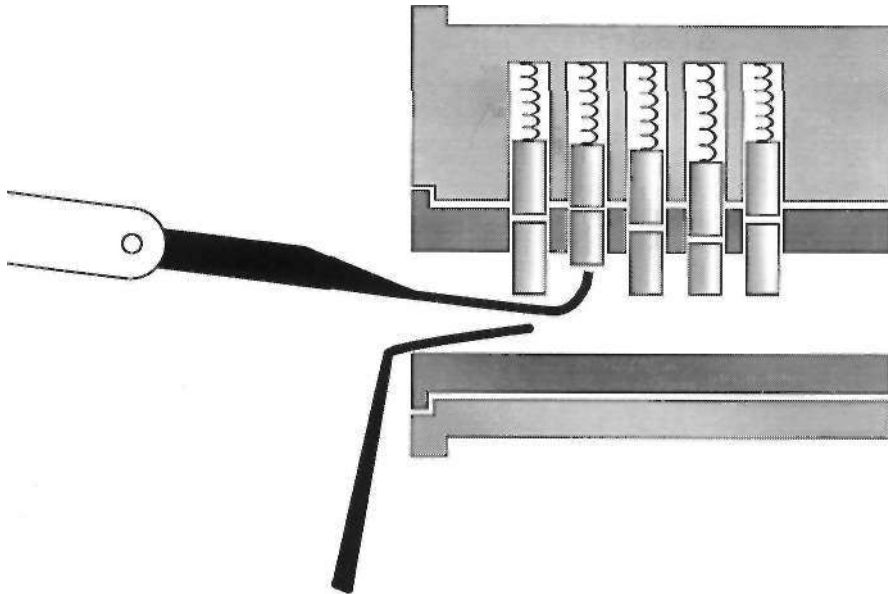

**Placement of pick and torque wrench
in lock keyway for picking**

Raking

Raking is a much easier skill to learn than picking. But while it is easy to learn, it is difficult to master. Raking requires the locksmith to have just the right "touch." This is something that can only be learned through practice, practice, and more practice. An advantage of the raking method is that it can be one of the fastest hand methods employed. It also works on both pin tumblers, as well as wafer locks, which will be covered in a later chapter.

The idea is simply to take a raking pick and repetitively pull it across all the pins in such a fashion that it unlocks the lock. While this may sound too simple, it can work if done properly.

First, place a torque wrench into the lower portion of the key way. Make sure there is plenty of room left to maneuver the pick around the pins. Now, apply a **gentle** amount of turning force on the wrench in the direction that the key would turn when unlocking the lock. It is critical that you apply an appropriate amount of force. Usually, the amount of force applied is much less than what you might imagine. The force used to push up on the pins can be much greater than that used on the wrench. Only a slight amount is needed. As frustration sets in, people have a tendency to apply too much force. This will only lead to more frustration. Take a break. Let what you learned sink in and try again when you are refreshed. Try allotting 15 minutes or so at a time. Afterward, concentrate on what you felt and compare it to what you were expecting to feel. It is important to get a good feel for the lock. Understand its personality and how it reacts to your actions. Remember, take your time and get in sync with the lock. Do not try to rush the process.

Now, while you are applying this slight force, put *the* raking pick all the way to the rear of the keyway. Apply a gentle force up and into the last pin. Now, remove the rake while continuing to apply a slight, constant force on all of the pins. Try to keep the force constant to all of the pins even though your position might have to change and the feedback from each pin will be different. Make certain you give each pin a chance; don't skip over any, especially the first pin.

It most likely will not work on the first pass, so give it a good number of passes. With each pass of the pick, slightly increase the amount of force on the torque wrench. Remember, though, you should still not rotate with too much force. After going back and forth a good number of times, you can try a different style of rake. Different styles of rake work better for different styles of lock. Experience and practice will show you which ones work better. Get a variety of locks in your collection, so that you can be comfortable with a variety of types.

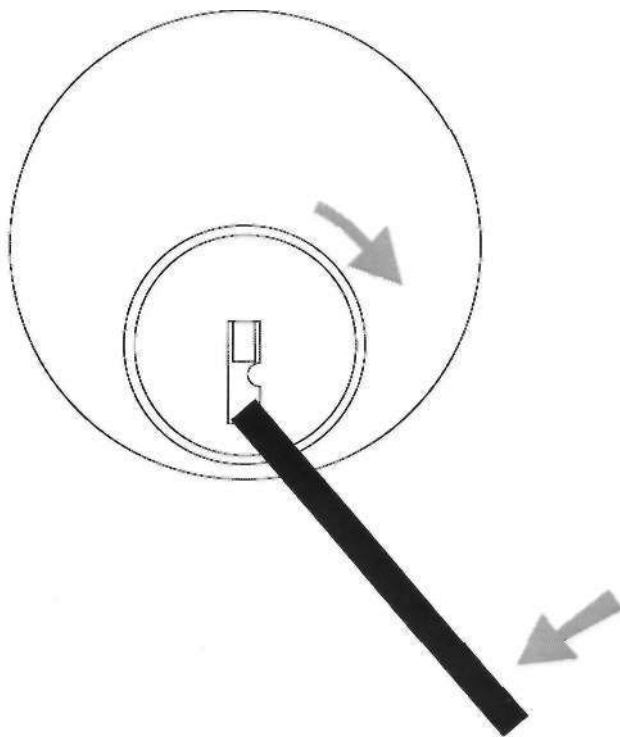

Placement of torque wrench in keyway

Picking

Picking is a technique whereby you try to "set" each of the pins individually. This method can be used on both pin tumblers and wafer tumblers. You have to know more about the inner workings of the lock to pick it, but the knowledge will greatly help when later attempting other methods. The goal when picking is to clear the shearing line and make sure that there are no pins obstructing it.

The Concept

If locks were perfectly made, than it would be impossible to pick each individual pin. But in the real world, locks have various imperfections and are built to a certain set of machining tolerances. The higher the quality of the lock, the tighter the tolerances, and the harder it is to pick. Also, remember that since the various pieces of metal have to slide, rotate, and move next to each other, there has to be slight gaps that allow for this motion. It is important to remember that this makes picking locks possible.

The first aspect we are going to look at is an important effect called *binding*. Binding is what happens when a shear force is applied to the plug when you try to rotate the cylinder with your torque wrench. The plug and the hull essentially crimp the driver pin, thus holding it in place. The hull remains fixed in place, but when you turn the plug it grabs the pin.

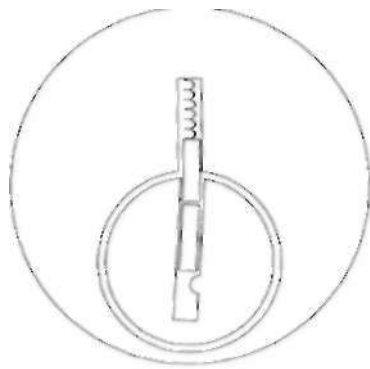

Driver pin binding

The ability to pick individual pins occurs when the locks are made with imperfections in manufacturing, sometimes as small as .0002 inches. The holes drilled for the pin columns don't lie exactly in a straight line that is exactly parallel with the axis of revolution of the plug. Because of this, when you rotate the plug only one or a few pins will bind first. The others will still be loose and able to move up and down freely. Each lock is built

slightly different and will have it's own order in which the pins set. Remember, the order in which the pins set will be reversed depending on which direction in which you attempt to turn the plug. Also, note that metal is somewhat elastic; so if you turn too hard on the torque wrench, the pins will "give" slightly, and more of them will bind. Make sure that you don't apply too much force in order to avoid this situation.

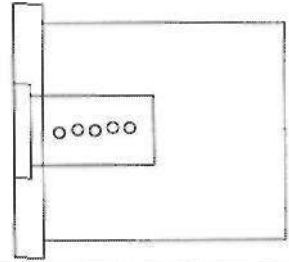

Pin column misalignment

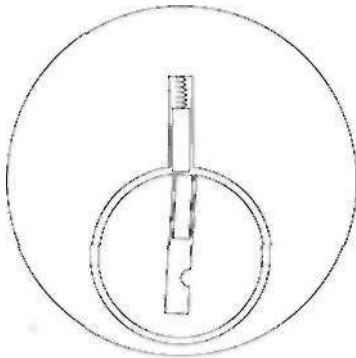

Pin has been set

You can now push up on the pin that is binding, or being held in place. As you push up on the key pin, it in turn pushes up the driver pin until you get to the point where the driver pin is completely past the shear line and up in the hull. The plug, that before was pushing on the driver pin, now has nothing in its way to keep it from rotating. Since you are still applying a light force, it will start and continue to rotate until it hits the next driver pin and stops again. Because of the extra rotation, the hole in the plug and the hole in the hull of the first pin now no longer exactly line

up. The spring can push down on the driver pin all it wants, but the pin will catch on the edge of the plug and stay completely lodged in the hull. It is now trapped. When this happens, the pin is *set*. Neither the driver nor the key pin is obstructing the shear line. This is the goal we are attempting to achieve.

When you are pushing up on the pin, you have to be finely tuned to feel the right point when this happens. Make sure to stop after the pin is set. If you continue applying an upward pressure on the key pin and keep pushing it up,

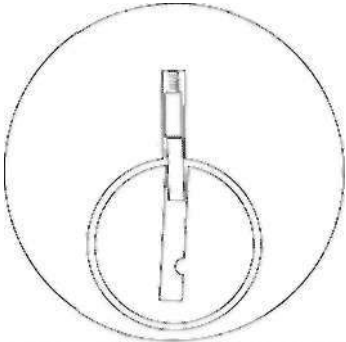

Pin pushed up too far

then you can force the key pin up into the hull as well. The rotational force on the plug will now bind the key pin instead of the driver pin, and they will both be stuck up there. You can tell when this happens when you remove the pick from the pin and the key pin stays up. This is not good because the key pin is now blocking the shear line and will prevent further pins from binding properly, as well as the lock from opening.

However, if when you remove the pick from the key pin and it free falls down without the spring pushing it down, then you have properly set the pin. At this point another pin should be binding, and the whole process can be repeated.



Key pin falls freely

Your Turn

Now it's your turn to start picking pin tumblers. First, insert a pick and torque wrench into the keyway. Now apply a **gentle** turning pressure with the turning tool. Again, the word gentle is emphasized. If too many pins bind, it will jam the lock. If the pins that do bind are too difficult to push up, then you are also turning too hard. When you become frustrated and tired, you will likely start turning harder. When this happens, take a break and recover. Well-machined locks, and those made to tighter tolerances, will require the use of more torque. Padlocks and some doorknobs also have to turn a spring-loaded locking bolt, so these require more torque. Experience will tell you how much to apply. When you pick padlocks, there is the additional skill of holding the lock in the same hand that you use to turn the wrench. With practice you will learn the method that suits you best. Try a variety of methods, and remember, this isn't a science.

While you are applying this gentle turning pressure, use the pick to feel the pins. Don't use your sight. Just feel them. By knowing how they respond in various situations, you can create an internal map in your mind of what the lock looks like and the state of all the pins. Remember to visualize. This is a critical skill to learn. Just as many athletes try to visualize before their game what they have to perform, so should you visualize the lock and what you have to do before you attempt to pick it.

Now, attempt to determine which pin is binding the most. Then position your pick directly under it and make contact with the tip of your pick and the bottom of the pin. Apply a small amount of force pushing the pin upwards in your attempt to push the driver pin completely into the upper chamber of the lock. Be sure not to disturb the neighboring pins too much during this process. There are various size hook picks that are better for different shaped locks. Also, you can use any other type of pick or rake that works well for you. Remember, the only rule is to do what works.

When the driver pin completely clears the shear line and enters the hull, you will have set the pin. This is also called *breaking* the pin. When this happens, you will hear or feel a small click. When your senses are in tune with this, it will be an earth-shattering event. You will feel the pin respond differently. Before you had to fight against the binding force and the spring pushing down. For a brief moment in the gap there will be no force resisting you. Then, there will be a large resistance as the key pin hits the edge of the hole in the hull. You must get used to how this feels. You will also feel the click in the hand that is holding the torque wrench. The wrench will give and the plug will rotate ever so slightly, and then stop. Although you can feel this, you probably won't be able to see it. Treat the tools as extensions of your body. Don't trust your eyes; use your other senses to experience the lock.

After you have broken the pin, lower your pick and make sure that the bottom key pin also free falls. If it stays up, then you have pushed the pin up too far and you will have to relieve some tension from the wrench in order to drop it, or you can start over. If the spring pushes the pin down, then you haven't set it. Perhaps this pin isn't the one binding the most, you didn't push up far enough, or you didn't apply enough force to the wrench.

The next step is to move on to the next pin. Feel the remaining pins that have not broken and try to determine which is the next one that is binding the most. This will be your next target. Repeat the steps listed above with that pin. If you set a pin and other pins fall, or if you are unable to set any more pins, you may have set one in the wrong order. Clear the lock by releasing all pressure on the wrench and start over again.

When the last pin is set, the shear line will be clear with no obstructions and the plug will be free to rotate. The lock is now unlocked! The actual mechanics behind each lock that actually unlocks, frees, or opens vary even more drastically than the actual locks themselves. Padlocks usually have to actuate a spring loaded locking bolt in order to release the shackle. This means that you need to apply a bit more torque. It also means that when they do unlock the lock, it will jump a bit. This can be a very satisfying feeling.

Since all locks are different and the holes are off axis in a different order, this means that the pins of each lock set in a different order. This is entirely due to the tolerances with which they are made. The cheaper the lock, the more the holes are off axis; and the easier the lock is to set.

Also, remember to return the lock to either a locked or unlocked position. If you leave it in an intermediate position, the key may not be able to be inserted in the keyway. This is because the pins are unable to *float*, or move up into the hull, and get out of the way of the incoming key. It's also easy to return the plug to either the locked or unlocked position; since while it is in an intermediate position, the plug is free spinning. Be sure the driver pins don't get stuck in the keyway if you turn the plug all the way upside down.

Alternative Method

There is an alternative method of picking if you want to think less and speed things up a bit. Start in the rear of the lock by trying to pick the last pin. If it doesn't set, just move on to the next pin. Go through each of the pins and try to set them all from back to front. In reality, only one or two will probably set. Just go back and start in the rear of the lock and do all of the ones that haven't set yet. With each pass over the pins one or two will set. Eventually, all of the pins will set; and the lock will open. The advantage of

this method is that you do not have to pay as much attention to each individual pin. It is a good idea to slightly increase the torque you are applying with each pass you make over the pins. This method is used for speed, but it really doesn't work too well with high security locks that have modified pins designed to false set.

Wrap Up

Also, keep in mind that the reaction of the pins will be different if the lock is "upside-down," that is, the pins are on the bottom of the key way rather than the top. The main difference is that the pins that are set will stay down instead of free falling back down in your way. Some people find this easier to deal with. Only the pins that have not set yet will be the ones sticking up in the keyway. If you are picking a padlock, then you also have to deal with holding the lock; although you can hold it any way you want. Some locks also have pins in the side of the keyway or other locations. The general picking concept is usually basically the same. You will just have to adjust for the new locations of the pins.

The knowledge you have gained by reading the material so far is more than enough to pick almost all common pin tumbler locks. There are other important aspects that are useful to know: such as locks with master keys, keys that open more than one lock, and how picking those locks are different. Plug variations, beveling, spacer pins, false sets, modified pins, angled cams, impressioning, plug spinners, and mushroom pins are all concepts that will be covered in later volumes. First, take a break and make sure that what you have learned so far sinks in. Don't try to learn everything at once. Make sure that you are comfortable picking a wide variety of locks. It is important that you have a clear understanding of what you are doing in order to be able to do it again. Later on, when you move to higher security locks, you will probably have to modify some of what you are used to doing. At the beginning it is best not to overwhelm yourself. When you are ready, move on to progressively harder and harder locks.

Bypass Picking

Sometimes you don't have to pick the lock at all in order to open it. You can sometimes "bypass" it. This is called *bypass picking*. It takes less skill than actual picking, but requires that the lock allows for it. It will only work on lighter security locks that have an exposed locking bolt in the rear of the keyway. Many desks, cabinets, and a few padlocks are like this. The concept is simple. Insert your bypass pick all the way into the lock and ignore the pins or wafers completely. Attempt to move the locking bolt manually by yourself. Whatever the plug's *tailpiece* will do, try doing the same thing to the bolt. You should be able to move it out of the shackle or slot, and it allows the lock to open. It is a simple concept, when you are lucky enough to have a lock on which it works.

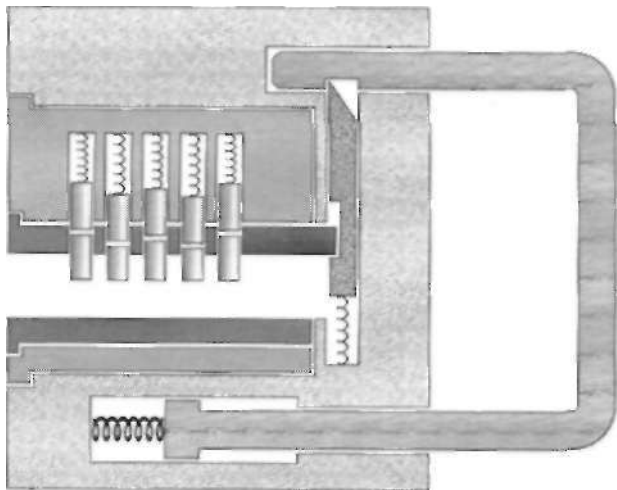

Example padlock

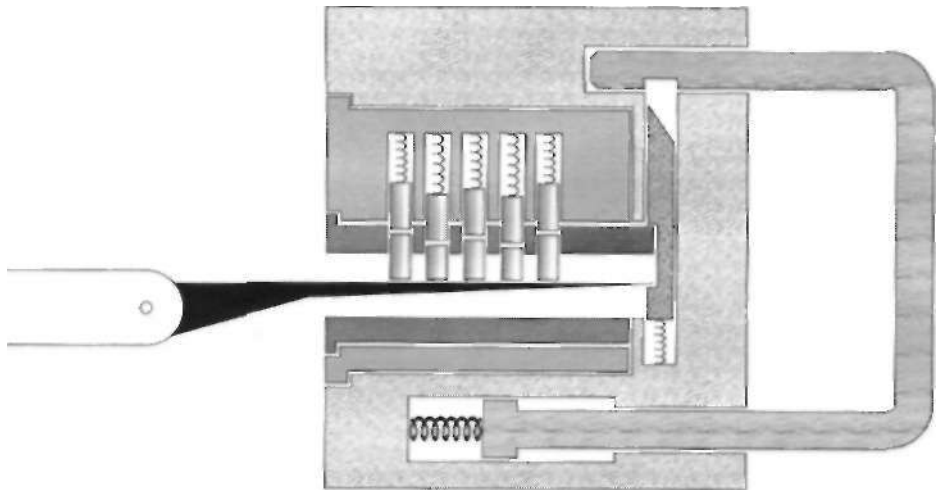

Example padlock - bypass picking

Shimming

Shimming is similar to bypassing, except that you are bypassing the locking bolt from "outside" the lock instead of from "inside" the lock. The idea is to stick some sort of object into the locking mechanism. The object should move the locking bolt, or whatever is holding the *shackle* inside the lock, out of the way. Since the mechanisms vary greatly, there is not any standard method for shimming a lock. Here are some examples, though.

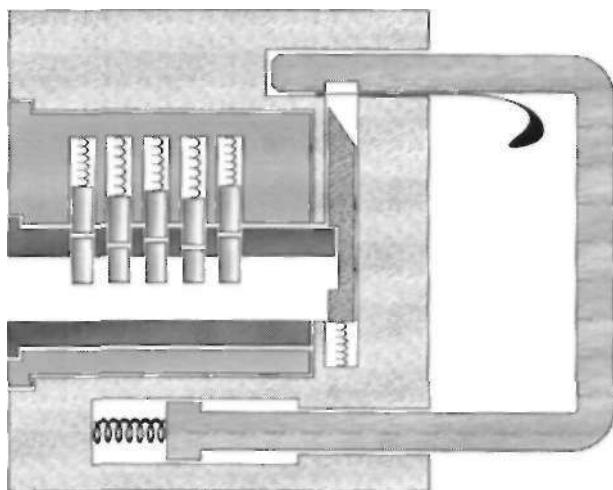

Example padlock - shimming

Shimming can be very effective on a wide variety of padlocks. Padlocks usually work by having a spring-loaded locking bolt fit into a notch in the shackle in order to hold it in the lock. Often the locking bolt will have an angled top, which allows the shackle to be locked without unlocking the lock. This means that, if you can fit a very thin strong object into the lock next to the shackle, you can sometimes slide the locking bolt out of the way and spring the shackle open. This requires that the lock's hole for the shackle be large enough to also allow for the shimming tool to fit inside. This method will also work for warded padlocks. The actual lock type is almost irrelevant.

Shimming is also very effective on common doorknobs. The *latch* is the portion of the locking bolt mechanism that sticks out of the door and holds it shut. One side is angled so that the door can be closed without turning the handle. The door can also be closed while the handle lock is locked. This is

because it is spring loaded. All one needs to do is to take a tool and stick it in the gap between the door jam and the door. You may have heard about credit cards being used for this, although better tools are manufactured specifically for this purpose. Now make contact with the bolt and work it back into the door and the door will open. If you can't, make contact with the angled side of the latch, you may still be able to use the tool to slowly work it into the door. Many sophisticated doorknob assemblies used in commercial applications are not susceptible to this. They have additional protrusions that stick out of the door. When the protrusions are pushed into the door as the door is closed, the locking bolt is then mechanically prevented from going back into the door without unlocking the lock.

Shimming usually works anytime you have an angled spring-loaded locking bolt. That's why deadbolts are generally more desirable. They cannot effectively be shimmed, since they are not spring loaded and cannot simply be pushed back into the door.

Other parts of the system may also be actuated, moved, provoked, or manipulated to open the lock. Remember, the lock itself can often be avoided entirely. Be creative and think about what you are trying to accomplish before you jump in and start picking. For example, many cars can simply be opened by sticking a tool down into the door through the opening for the side window and lifting a bar in the locking assembly. A "Slim Jim" is used for this purpose. A locksmith or other public service official should be very careful when performing this operation, as modern cars contain a plethora of sensitive electronics and wires within their doors. Always first consult a manual to determine that it is safe for the particular make and model of car.



Car door shimming tool designs

Vibration Picking

When done properly, *vibration picking* can be one of the fastest ways of opening a lock. This method is also beneficial because it does not require a great amount of skill. Vibration picking works on most pin tumblers, but is less successful with wafer locks and is not recommended. Law enforcement officers, or other professionals, who must open locks in emergencies where time is critical, often use this method. Often they also have other issues to worry about, and do not have the time or inclination to learn the art of lock picking. Vibration picking is useful, because they do not have to spend time practicing. Instead, they can just pick up the right tool and use it effectively.

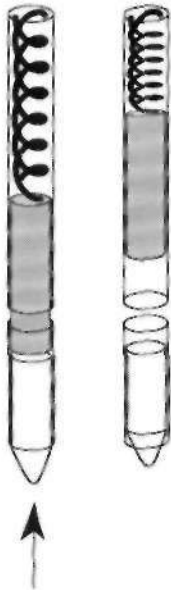

The concept is simple. The pins are violently vibrated up and down with the hope that at some point the shear line will be clear and the plug may rotate. The physics is similar to those desk toys that have one marble swing and hit a second. The momentum from the first marble is completely absorbed and passed to the second, which moves on with roughly the same speed, leaving the first marble in place. This is what the vibration pick attempts to do. It impacts the tips of the key pins with just enough force to knock them up and into the driver pins, thus knocking the driver pins up into the hull. The key pins themselves stay down, because they imparted all of their energy into the driver pins.

You really don't have to know all of this theory to effectively use a vibration pick. Just put it in the keyway, pull the trigger, and rotate your torque wrench. Simple.

You do, though, have to have the appropriate vibration pick. The most common is the "pick gun." This is a tool that you hold in one hand, and it usually has a lever that you squeeze with your fingers to provide the vibrating action. Remember, you still need to use a torque wrench with these devices. Place the pick gun all the way into the keyway, insert the torque wrench, apply a rotating pressure on the wrench and squeeze the trigger a few times. As the pick strikes the pins and knocks them upward, the torque

wrench catches the driver pins in the hull casing.

Modern electric versions that are battery powered are also available. It is widely believed, though, that electric ones are slightly less effective and more cumbersome. If you are feeling creative, or desperate, ad-hoc versions are also possible. These could be made from modified coat hangers, clothespins, or anything that has a springing or vibrating action. Use your imagination in making your new vibration pick tool, or just buy one off the shelf. For locks that are not susceptible to vibration picking, however, you are just out of luck and will have to resort to one of the manual methods described above.

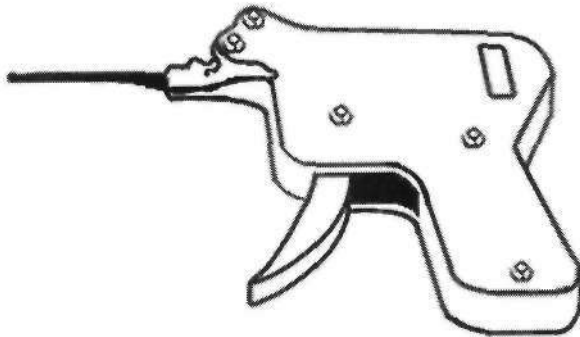

Pick Gun

Exercises

Understanding how a lock responds is very important. When you first attempt a lock, the pins will do their own thing and while the lock may open, you may not recognize exactly when the various pins set. Or, you may not be sure when you pushed the key pins up into the hull. In order for you to get to know what the pins are doing, here are a few exercises you can try:

First, find or buy a practice lock. These can be bought from almost any hardware store or locksmith. Also, be sure to get a pin tumbler. Make certain that it is one that is relatively easy to pick. Usually you can use price as a guideline for its difficulty. Locks designated for deadbolts make good choices for this exercise purpose. Feel free to pick up a more difficult lock for later on or for making comparisons.

Now, open the lock and remove the plug. Be careful when you do this, as the springs and pins will fly out. The key will only work the lock if the key pins are in the correct order. If you want to use the key, be sure to take note of their order. Of course, what do you really need the key for? At this point, reassemble the lock, but with only one pin. Picking this should be easy. Next, push up on the pin with a hook pick while applying a rotational torque with a torque wrench. When it reaches the breaking point, the plug will spin. Feel how the key pin is binding and the plug holds it in place. Also, feel how you can almost sense when the plug will turn a split-second before it actually does.

Take the lock apart again. Put it back together, only this time with two pins. While applying a small amount of torque, push up on first the front pin, then the back pin. Notice how one of them binds and the other one is springy. If they are both binding, then you know you are applying too much force. This is a very valuable lesson.

Now that you know how to determine which pin is binding, push up on that pin until you feel it "set." Become familiar with this feeling. Set the pin, clear it, and then set it again a few times. This is the response that you are trying to detect when you pick locks. After you set it, notice how the key pin

free falls down. Feel how the pin is now loose in its pin column and is neither binding in place nor is the spring pushing down on it. Now, set the pin and continue to push up. There will be significant resistance, and then the key pin will begin to enter the hull. When this occurs, the key pin will bind and the resistance of the pin will be as it was when the driver pin was binding. That is why it is so important, that you know what exactly it feels like when the pin sets. If you do not notice it, you might keep going and the key pin will bind and get stuck in the hull. You can tell when this has happened when you remove your pick and the key pin remains up in the lock and neither free falls down nor is pushed down by the spring. Experiment with this for a while and become familiar with it.

Set the first pin and make sure that the key pin falls. Move your pick to the second pin and notice how it is now binding. Compare this to how it was springy before. You should be able to push up on the second pin; and, as soon as you hit the breaking point, the plug will rotate. The last pin is always the most fun.

Repeat this process by progressively adding pins back into the lock one by one until you are comfortable with picking the lock with all pins. Feel free to intersperse this with the more difficult lock(s) that you obtained. Also, make sure to intersperse this exercise with frequent breaks. When something works well, stop and concentrate on what you did to make it work. Focus on that and try to repeat it again. Eventually, you will be quite comfortable with more types of locks.

To make things easier, you can get what is called a *plug follower*. This is a valuable tool for locksmiths. Instead of taking the lock apart in a bag or box to catch the flying springs, you simply unlock the lock and place the plug follower on the face of the plug and push. The plug follower is exactly the same diameter as the plug and will hold the driver pins and springs in the hull. The plug will just have the key pins inside, which you can move around to *re-key* the lock. When you are done re-keying, take the plug and push the plug follower out with it. By doing this, the driver pins and springs never leave the lock and never have a chance to get lost.

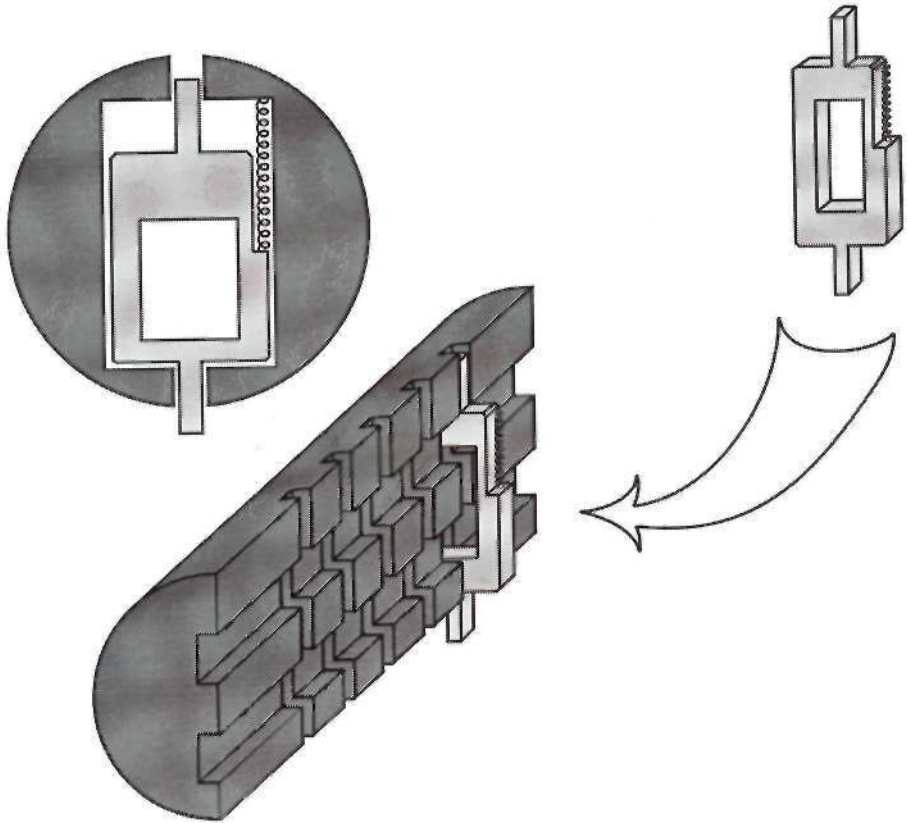



Wafer Locks

The *wafer lock tumbler*, or *disc tumbler*, is quite common in low-cost applications, because of their lower manufacturing cost. These can be found on desks, filing cabinets, car doors, windows, older vending machines, and fire security boxes, among other things. They are very similar to pin tumblers, except they use wafers instead of round pins. In fact, if you wish, you may ignore this chapter and solely use the techniques you have learned previously. It is generally agreed that a comparable wafer lock is easier to pick than the pin tumbler equivalent.

From the exterior, wafer locks appear similar to pin tumblers; and their keys look almost identical. The most distinctive feature used to distinguish them are the wafers. If you look inside the keyway, you will notice wide flat wafers instead of round pins. The internal workings of a wafer lock, however, are quite different.

They work simply by raising and lowering wafers, so that they do not protrude out of the rotating cylinder. If the wafer is raised too high, it extends from the top of the plug into a notch in the hull. Conversely, if the wafer is lowered too much, it sticks down into a corresponding notch on the other side of the hull. Once all of the wafers are aligned, it is unlocked; and the plug is free to rotate.

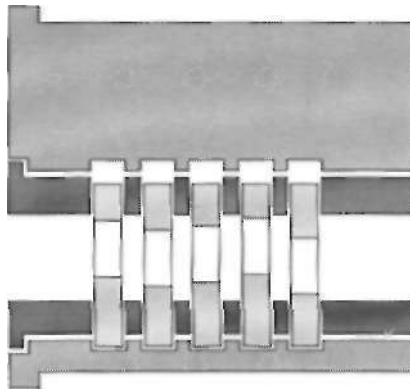

Side view of wafer lock

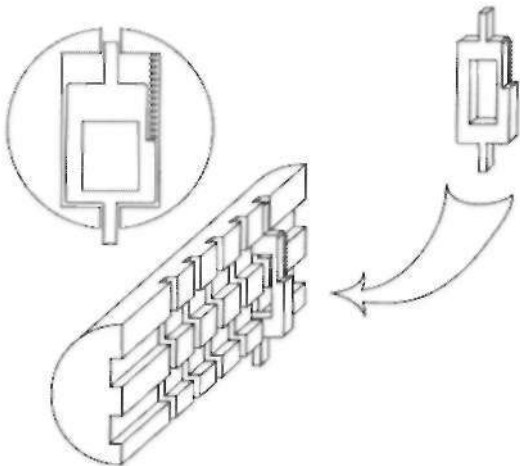

3/4 cutaway view of wafer in plug

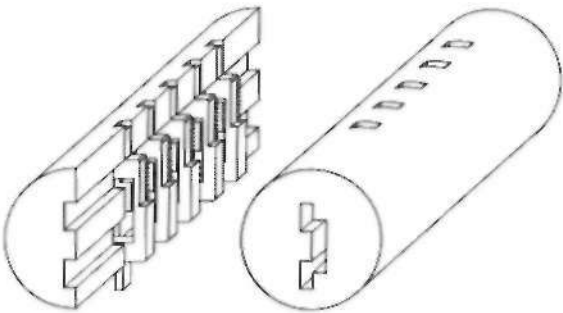

3/4 cutaway view of plug

In an attempt to increase their security locks, manufacturers devised the *double-sided wafer lock*, or *double-bitted disc tumbler*. Many automobile locks use double-sided wafers. They are easy to distinguish by their keys, which have ridges on both sides and may be inserted in either direction. The wafers have alternating springs and have to be pushed up, as well as down. Here is where your set of double sided picks will come in handy. You can push up on some wafers, then push down, without having to turn the pick upside down.

Side bar wafer locks further increase security by having a bar that will only fall into place once all of the wafers are aligned. Picking this type usually requires that some force be applied to the side bar to push it into the tumblers. This keeps the wafers in place once they are picked into position.

Remember, when picking wafer locks, that the same techniques as pin tumblers may be used. Due to their nature, some tools were developed specifically for wafer locks. One such tool is the *jiggler* or *tryout key*. A locksmith might have a large collection of such keys, which are essentially pieces of metal that vaguely resemble actual keys. They vary widely in shape with the idea that if one does not work, the next one might. The concept is simple—insert the jiggler key and try it out. Jiggle it around and move it up and down, while attempting to turn it with a slight bit of force. If it doesn't work, go on to the next. If that does not work, then try the next. Try several tryout keys. Your probability of success varies and depends on the type and quality of lock, the shapes of your keys, how it is jigged, your experience, and luck.



Tryout keys





4

**Final
Rants**

Final Rants

This book has covered the most common locks that you are likely to encounter. Most of the locks in use are either one of these types or subtle variations. However, they do come in a wide variety of shapes and sizes. If, during the course of your work, you are confronted with a wider variety of locks, or higher security cylinders, then you can consult later volumes of this series, which go into much greater detail about these locks. With just a little bit of practice, anyone can defeat most common locks, such as padlocks, locks on houses, desks, cabinets, etc... After trying these techniques, it is easy to lose faith in the common door lock. Familiarity will also help to insure peace of mind by obtaining appropriate security devices, as well as more knowledge of what assistance is necessary to obtain in a given situation.

Locksmithing is an ancient trade. Ever since locks have existed, society has needed people to maintain those locks. In the past, medieval guilds and other types of locksmith associations, unions, and organizations were more prevalent. They closely guarded their secrets in order to be able to exploit their knowledge by charging a lot for their services. Today, although this information is much more accessible in trade publications, locksmiths are still able to charge quite well for their services. The coming of the information age has led to an explosion in the amount of information available. If you do choose to read about this online, be very wary of your source. Although many such sources may be entertaining, many are also misleading and/or wrong.

One thing that has survived through the ages is a sense of ethics among the professional locksmithing community. It is best to maintain this tradition and a high personal integrity. Locksmithing is an occupation that requires a variety of skills. This book does not go into detail about many important concepts, such as how to install a deadbolt, carpentry, machining, electronics, etc... As a locksmith, you can also get involved with dealing with various kinds of security systems. What you choose to pursue is really up to you. Your motivation is your only limiting factor to your success.

Do not have an ego when approaching a lock or try to show off. Do not try to defeat the lock. Instead, try to work with the lock. Cooperate with it, and it will cooperate with you. Patience is a critical skill to master. When you lose patience, there is little hope of succeeding. Take your time, don't rush, and listen to what the lock is telling you. This may sound unnecessary, but you are dealing with small metal objects machined to tight tolerances moving over distances that are indiscernible to the naked eye. You have to be finely tuned with all of your senses in order to understand what the lock is saying. With time and practice you, too, can become a master locksmith.

Glossary

Actuator - In this context an actuator is a component that activates or deactivates a locking mechanism when operated.

Antipick latch - A secondary latch next to the primary spring latch. When depressed it prevents the main latch from being pushed in. This component is used to thwart shimming.

Bevel - An angled edge. Most spring-loaded latches have a beveled edge to allow them to close without unlocking the lock.

Binding - What occurs when *the hull and the plug crimp the pin, holding it in place.*

Bit - The end effector portion of the key that actually turns or actuates the locking bolt and/or makes contact with the tumblers.

Bitting - The configuration of the notches or cuts in the key that are made to match the lock.

Bitting depth - The height of a notch on the key.

Bitting position - The location of a notch on the key.

Blade - The portion of a key that contains the notches and bitting.

Blank - A key that has not yet been cut or shaped to fit a lock.

Bottom pin - see *Key pin*

Bow ~ The handle of the key. The portion of the key that is held with the fingers.

Break a pin ~ see *Set a pin*

Bypass picking - The method of "picking" a lock where the lock is bypassed and the locking bolt is actuated directly.

Case see *Casing*

Case screw The screw responsible for holding the lock's cover on.

Case ward - A portion of the case itself that acts as a ward. A key must be properly cut so as to avoid this obstruction.

Casing - The main structural portion of the lock. The plug rotates within the casing.

Chamber - The hole in the casing into which the plug is installed.

Changes - The number of keys a certain type of lock can differentiate between.

Clean opening - The act of skillfully opening a lock without damaging it or using force.

Core - see *Plug*

Cuts - see *Notches*

Cylinder - see *Plug*

Dead bolt - a bolt that is not beveled and is not spring-loaded. It may only be operated by locking or unlocking the lock directly.

Dead latch - see *Antipick latch*

Disc tumbler - see *Wafer tumbler*

Double-bitted disc tumbler - see *Double-sided wafer tumbler*

Double-custody lock - A lock that requires two different keys to be used simultaneously in order to open. Just one of the keys alone will not work.

Double-sided wafer tumbler- A wafer lock that has alternating springs that require some wafers to be pushed up while others need to be pushed down.

Driver pin - The upper pin in the pin cylinder that is pushed up into the hull when the key is inserted. The driver pin makes direct contact with the spring and "drives" the key pin below it downward.

Driver Spring - A spring at the top of the pin stack that pushes the pins or tumblers downward towards the keyway.

Floating pin - A pin that is able to move up and down freely.

Following tool - see *Plug follower*

Handle - The portion of a tool that may be used to hold onto.

Hook pick - A tool used to pick locks by manually manipulating each pin individually.

Hull - see *Casing*

Jiggler - see *Tryout key*

Key - A device design specifically to open one or more specific locks.

Key blank - see *Blank*

Key extractor- A tool used to extract broken key fragments or other small pieces from a lock's keyway.

Key pin - The lower pin in a pin cylinder that makes direct contact with the key. The key pins are cut at various heights to match the depths of the key's notches.

Keyhole - see *Keyway*

Keyway- The opening of the lock. The key is inserted into the keyway.

Latch - A bolt that extends out of the lock that enters the doorframe, strike plate, or other entity that secures the lock shut.

Lock - A device that attempts to prevent unauthorized access unless a pre-designated key, code, device, biometric, or other method of authentication is used.

Locking bolt - The bolt that is directly actuated by the rotating action of the cylinder, as the lock is locked/unlocked.

Lower pin - see *Key pin*

Neck - The long portion of the key between the *bow* and the *stem*.

Notches - Notches made in a key so that it will theoretically only unlock its designated lock(s).

Padlock - A portable lock with a shackle, loop, or other retaining component that may be attached to an object in order to secure it.

Pick - A tool of some fashion that may be used to open a lock without the designated key(s).

Pick gun - An automatic tool used for opening pin tumbler locks with minimal skill.

Pins - cylinder shaped pieces of metal that fit inside a lock and act as tumblers.

Pin tumbler - A lock design that utilizes pin stacks for their tumbler mechanism. The pins must be lifted to the proper height by the notches in a key such that they can separate at the shear line and allow the lock to open.

Plug - The plug or inner cylinder of a lock. The portion that rotates when the key is turned. Many locks can have their plug removed for re-keying.

Plug follower - A tool that is used to push out a plug. It fills the void left by the cylinder completely and retains the top driver pins and springs within the hull and outer casing.

Plug holder - Tool used to hold a plug in place while working on it.

Rake - A tool used to manipulate tumblers in order to unlock a lock without the designated key(s).

Re-key a lock - Rearranging or replacing the key pins with those of different heights such that a different arrangements of cuts are required for a key to work with the lock.

Set a pin - To cause the division between the top and bottom pins to be at the shear line. When a pin is set it will not prevent the plug from rotating.

Shackle - The metal loop of a padlock that attaches to whatever is being secured.

Shear line - The line of separation between the plug and the shell of the lock. When pins, discs, or other obstructions pass through this line the core is unable to rotate. When this line is free of obstructions the lock may be unlocked.

Shell - *see Casing*

Shimming - Unlocking a lock by directly moving the locking bolt or latch. This method of opening a lock avoids any manipulation of the tumblers or other locking mechanism.

Shoulder - The portion of the key that rests on the outside of the keyway when the key is fully inserted.

Side bar wafer lock - A wafer lock which incorporates a bar that will only fall into place once all of the wafer tumblers are aligned properly.

Skeleton key- A key for a warded lock that only has the parts needed to enter the lock and turn the bolt. There are no extra protrusions that could make contact with any wards and prevent it from turning. This is in effect a master key for all locks of that type.

Stem - The portion of the key or pick that is usually a long thin piece of metal that connects the handle with the tip.

Strike plate - A plate, usually metal, attached to a doorframe or other object that the lock's latch enters in order to secure shut.

Tailpiece - The actuator physically attached to the rear of the plug that moves the locking bolt.

Tang - *see Stem*

Tension Wrench - *see Torque wrench*

Tip - The end of the tool or key that is at the end of the tool and enters the keyway first. In the case of a pick or rake it is the part that makes direct contact with and manipulates the tumblers.

Top pin - see *Driver pin*

Torque wrench - A tool that is inserted into the keyway and used to apply a rotation force on the plug.

Torsion wrench - see *Torque wrench*

Turning tool - see *Torque wrench*

Tryoutkey- A key that when manipulated in a lock will open a significant subset of a particular type of lock.

Tumbler - An object that is moved a varying amount depending on the key used. It will only unlock when moved the appropriate amount in the appropriate direction.

Upper pin - see *Driver pin*

Vibration picking - A method of unlocking a lock whereby the pins are bounced up and down until the shear line is clear and the lock is free to open.

Wafer tumbler - A tumbler lock that uses disks instead of pins. There are many parallel discs inside the lock that each line up with a corresponding cut in a key. The discs move in relation to the height of notches cut in a key. Only notches of the correct height will move the tumblers properly and allow the plug to rotate.

Ward - An obstruction that prevents an incorrect key from entering, rotating, or moving within a lock.

Warded lock - A lock design that utilizes wards to differentiate between keys and only allow the correct key to operate the lock.