

Undergraduate Lecture Notes in Physics

Paul J. Nahin

Inside Interesting Integrals

 Springer

Undergraduate Lecture Notes in Physics

For further volumes:
<http://www.springer.com/series/8917>

Undergraduate Lecture Notes in Physics (ULNP) publishes authoritative texts covering topics throughout pure and applied physics. Each title in the series is suitable as a basis for undergraduate instruction, typically containing practice problems, worked examples, chapter summaries, and suggestions for further reading.

ULNP titles must provide at least one of the following:

- An exceptionally clear and concise treatment of a standard undergraduate subject.
- A solid undergraduate-level introduction to a graduate, advanced, or non-standard subject.
- A novel perspective or an unusual approach to teaching a subject.

ULNP especially encourages new, original, and idiosyncratic approaches to physics teaching at the undergraduate level.

The purpose of ULNP is to provide intriguing, absorbing books that will continue to be the reader's preferred reference throughout their academic career.

Series Editors

Neil Ashby

Professor Emeritus, University of Colorado, Boulder, CO, USA

William Brantley

Professor, Furman University, Greenville, SC, USA

Michael Fowler

Professor, University of Virginia, Charlottesville, VA, USA

Michael Inglis

Professor, SUNY Suffolk County Community College, Selden, NY, USA

Heinz Klose

Professor Emeritus, Humboldt University Berlin, Germany

Helmy Sherif

Professor, University of Alberta, Edmonton, AB, Canada

Paul J. Nahin

Inside Interesting Integrals

(with an introduction to contour integration)

A Collection of Sneaky Tricks, Sly Substitutions, and Numerous Other Stupendously Clever, Awesomely Wicked, and Devilishly Seductive Maneuvers for Computing Nearly 200 Perplexing Definite Integrals From Physics, Engineering, and Mathematics (Plus 60 Challenge Problems with Complete, Detailed Solutions)

 Springer

Paul J. Nahin
Electrical and Computer Engineering
University of New Hampshire
Durham, NH, USA

ISSN 2192-4791
ISBN 978-1-4939-1276-6
DOI 10.1007/978-1-4939-1277-3
Springer New York Heidelberg Dordrecht London

ISSN 2192-4805 (electronic)
ISBN 978-1-4939-1277-3 (eBook)

Library of Congress Control Number: 2014945223

© Springer Science+Business Media New York 2015

This work is subject to copyright. All rights are reserved by the Publisher, whether the whole or part of the material is concerned, specifically the rights of translation, reprinting, reuse of illustrations, recitation, broadcasting, reproduction on microfilms or in any other physical way, and transmission or information storage and retrieval, electronic adaptation, computer software, or by similar or dissimilar methodology now known or hereafter developed. Exempted from this legal reservation are brief excerpts in connection with reviews or scholarly analysis or material supplied specifically for the purpose of being entered and executed on a computer system, for exclusive use by the purchaser of the work. Duplication of this publication or parts thereof is permitted only under the provisions of the Copyright Law of the Publisher's location, in its current version, and permission for use must always be obtained from Springer. Permissions for use may be obtained through RightsLink at the Copyright Clearance Center. Violations are liable to prosecution under the respective Copyright Law.

The use of general descriptive names, registered names, trademarks, service marks, etc. in this publication does not imply, even in the absence of a specific statement, that such names are exempt from the relevant protective laws and regulations and therefore free for general use.

While the advice and information in this book are believed to be true and accurate at the date of publication, neither the authors nor the editors nor the publisher can accept any legal responsibility for any errors or omissions that may be made. The publisher makes no warranty, express or implied, with respect to the material contained herein.

Printed on acid-free paper

Springer is part of Springer Science+Business Media (www.springer.com)



Bernhard Riemann (1826–1866), the German mathematical genius whose integral is the subject of this book (AIP Emilio Segrè Visual Archives, T. J. J. See Collection)

This book is dedicated to all who, when they read the following line from John le Carré's 1989 Cold War spy novel *The Russia House*, immediately know they have encountered a most interesting character:

"Even when he didn't follow what he was looking at, he could relish a good page of mathematics all day long."

as well as to all who understand how frustrating is the lament in Anthony Zee's book *Quantum Field Theory in a Nutshell*:

"Ah, if we could only do the integral But we can't."

$$\int e^x = \{f(u)\}^n$$

$$\int \frac{d(\text{cabin})}{\text{cabin}} = \log\{\text{cabin}\} + C = \text{houseboat}$$

$$\left\{ \int_1^{\sqrt[3]{e}} z^2 dz \right\} \cos\left(\frac{3\pi}{9}\right) = \ln\{\sqrt[3]{e}\}$$

“The integral of z squared dz
From one to the cube root of three
All times the cosine
Of three pi o'er nine
Equals the natural log of the cube root of e”

— Three classic integral jokes beloved by that curious band
of people who, if given the choice between struggling
with a good math problem or doing just about anything
else, would think the decision to be obvious

In support of the theoretical calculations performed in this book, numerical ‘confirmations’ are provided by using several of the integration commands available in software packages developed by The MathWorks, Inc. of Natick, MA. Specifically, MATLAB[®] 8.1 (Release 2013a), and Symbolic Math Toolbox 5.10, with both packages running on a Windows 7 PC. This version of MATLAB[®] is now several releases old, but all the commands used in this book work with the newer versions, and are likely to continue to work for subsequent versions for several years more. MATLAB[®] is the registered trademark of The MathWorks, Inc. The MathWorks, Inc. does not warrant the accuracy of the text in this book. This book’s use or discussion of MATLAB[®] and of the Symbolic Math Toolbox does not constitute an endorsement or sponsorship by The MathWorks, Inc. of a particular pedagogical approach or particular use of the MATLAB[®] and the Symbolic Math Toolbox software.

Also by Paul J. Nahin

Oliver Heaviside (1988, 2002)
Time Machines (1993, 1999)
The Science of Radio (1996, 2001)
An Imaginary Tale (1998, 2007, 2010)
Duelling Idiots (2000, 2002)
When Least Is Best (2004, 2007)
Dr. Euler's Fabulous Formula (2006, 2011)
Chases and Escapes (2007, 2012)
Digital Dice (2008, 2013)
Mrs. Perkins's Electric Quilt (2009)
Time Travel (1997, 2011)
Number-Crunching (2011)
The Logician and the Engineer (2012)
Will You Be Alive Ten Years From Now? (2013)
Holy Sci-Fi! (2014)

Preface

Engineering is like dancing; you don't learn it in a darkened lecture hall watching slides: you learn it by getting out on the dance floor and having your toes stepped on.

—Professor Jack Alford (1920–2006), cofounder of the Engineering Clinic at Harvey Mudd College, who hired the author in 1971 as an assistant professor. The same can be said for doing definite integrals.

To really appreciate this book, one dedicated to the arcane art of calculating definite integrals, it is necessary (although perhaps it is *not* sufficient) that you be the sort of person who finds the following question fascinating, one right up there in a fierce battle with a hot cup of coffee and a sugar donut for first place on the list of sinful pleasures:

without actually calculating x , show that

if $x + \frac{1}{x} = 1$ it then follows that $x^7 + \frac{1}{x^7} = 1$.

Okay, I know what many (but, I hope, not *you*) are thinking at being confronted with a question like this: of what Earthly significance could such a problem possibly have? Well, *none* as far as I know, but its fascination (or not) for *you* provides (I think) excellent psychological insight into whether or not *you* should spend time and/or good money on this book. If the problem leaves someone confused, puzzled, or indifferent (maybe all three) then my advice to them would be to put this book down and to look instead for a good mystery novel, the latest Lincoln biography (there seems to be a new one every year—what could *possibly* be left unsaid?), or perhaps a vegetarian cookbook.

But, if your pen is already out and scrawled pages of calculations are beginning to pile-up on your desk, then by gosh you *are* just the sort of person for whom I wrote this book. (If, after valiant effort you are still stumped but nonetheless just *have* to see how to do it—or if your pen simply ran dry—an analysis is provided at the end of the book.) More specifically, I've written with three distinct types of readers in mind: (1) physics/engineering/math students in their undergraduate years; (2) professors looking for interesting lecture material; and (3) nonacademic professionals looking for a 'good technical read.'

There are two possible concerns associated with calculating definite integrals that we should address with no delay. First, do *real* mathematicians actually do that sort of thing? Isn't mere *computation* the dirty business (best done out of sight, in the shadows of back-alleys so as not to irreparably damage the young minds of impressionable youths) of grease-covered engineers with leaky pens in their shirts, or of geeky physicists in rumbled pants and chalk dust on their noses? Isn't it in the deep, clear ocean of analytical proofs and theorems where we find *real* mathematicians, swimming like powerful, sleek seals? As an engineer, myself, I find that attitude just a bit elitist, and so I am pleased to point to the pleasure in computation that many of the great mathematicians enjoyed, from Newton to the present day.

Let me give you two examples of that. First, the reputation of the greatest English mathematician of the first half of the twentieth century, G.H. Hardy (1877–1947), partially rests on his phenomenal skill at doing definite integrals. (Hardy appears in numerous places in this book.) And second, the hero of this book (Riemann) is best known today for (besides his integral) his formulation of the greatest unsolved problem in mathematics, about which I'll tell you lots more at the end of the book. But after his death, when his private notes on that very problem were studied, it was found that imbedded in all the deep theoretical stuff was a calculation of $\sqrt{2}$. To 38 decimal places!

The other concern I occasionally hear strikes me as just plain crazy; the complaint that there is no end to definite integrals. (This should, instead, be a cause for *joy*.) You can fiddle with integrands, and with upper and lower limits, in an uncountable infinity of ways,¹ goes the grumbling, so what's the point of calculating definite integrals since you can't possibly do them all? I hope writing this concern out in words is sufficient to make clear its ludicrous nature. We can never do all possible definite integrals, so why bother doing any? Well, what's next—you can't possibly add together all possible pairs of the real numbers, so why bother learning to add? Like I said—that's nuts!

What makes doing the specific integrals in this book of value aren't the specific answers we'll obtain, but rather the tricks (excuse me, the *methods*) we'll use in obtaining those answers; methods you may be able to use in evaluating the integrals you will encounter in the future in your own work. Many of the integrals I'll show you do have important uses in mathematical physics and engineering, but others are included just because they look, at first sight, to be so damn tough that it's a real kick to see how they simply crumble away when attacked with *the right trick*.

From the above you've probably gathered that I've written this book in a light-hearted manner (that's code for 'this is *not* a rigorous math textbook'). I am not going to be terribly concerned, for example, with proving the uniform convergence of *anything*, and if you don't know what that means don't worry about it because I'm not going to worry about it, either. It's not that issues of rigor aren't

¹ You'll see, in the next chapter, that with a suitable change of variable we can transform any integral into an integral from 0 to ∞ , or from 1 to ∞ , or from 0 to 1. So things aren't *quite* so bad as I've made them out.

important—*they are*—but not for us, here. When, after grinding through a long, convoluted sequence of manipulations to arrive at what we *think* is the value for some definite integral, I’ll then simply unleash a wonderful MATLAB numerical integration command (*quad*)—short for *quadrature*—and we’ll *calculate* the value. If our theoretical answer says it’s $\sqrt{\pi} = 1.772453\dots$ and *quad* says it’s -9.3 , we’ll of course suspect that *somewhere* in all our calculations we just maybe fell off a cliff! If, however, *quad* says it is 1.77246 , well then, that’s good enough for me and on we’ll go, happy with success and flushed with pleasure, to the next problem.

Having said that, I would be less than honest if I don’t admit, right now, that such happiness *could* be delusional. Consider, for example, the following counter-example to this book’s operational philosophy. Suppose you have used a computer software package to show the following:

$$\int_0^\infty \cos(x) \frac{\sin(4x)}{x} dx = 1.57079632679\dots,$$

$$\int_0^\infty \cos(x) \cos\left(\frac{x}{2}\right) \frac{\sin(4x)}{x} dx = 1.57079632679\dots,$$

$$\int_0^\infty \cos(x) \cos\left(\frac{x}{2}\right) \cos\left(\frac{x}{3}\right) \frac{\sin(4x)}{x} dx = 1.57079632679\dots,$$

and so on, all the way out to

$$\int_0^\infty \cos(x) \cos\left(\frac{x}{2}\right) \cos\left(\frac{x}{3}\right) \dots \cos\left(\frac{x}{30}\right) \frac{\sin(4x)}{x} dx = 1.57079632679\dots$$

One would have to be blind (as well as totally lacking in imagination) not to immediately suspect two things:

$$\text{the consistent value of } 1.57079\dots \text{ is actually } \frac{\pi}{2}, \tag{1}$$

and

$$\int_0^\infty \left\{ \prod_{k=1}^n \cos\left(\frac{x}{k}\right) \right\} \frac{\sin(4x)}{x} dx = \frac{\pi}{2} \text{ for all } n. \tag{2}$$

This is exciting! But then you run the very next case, with $n=31$, and the computer returns an answer of

$$\int_0^\infty \cos(x) \cos\left(\frac{x}{2}\right) \cos\left(\frac{x}{3}\right) \dots \cos\left(\frac{x}{30}\right) \cos\left(\frac{x}{31}\right) \frac{\sin(4x)}{x} dx = 1.57079632533\dots$$

In this book I would dismiss the deviation (notice those last three digits!) as round-off error—and *I would be wrong!* It's *not* round-off error and, despite the highly suggestive numerical computations, the supposed identity “for all n ” is simply *not true*. It's ‘almost’ true, but in math ‘almost’ doesn't cut-it.²

That's the sort of nightmarish thing that makes mathematicians feel obligated to clearly state any assumptions they make and, if they be really pure, to show that these assumptions are valid before going forward with an analysis. I will not be so constrained here and, despite the previous example of how badly things can go wrong, I'll assume just about anything that's convenient at the moment (short of something *really* absurd, like $1 + 1 = 3$), deferring the moment of truth to when we ‘check’ a theoretical result with MATLAB. A true mathematician would feel shame (perhaps even thinking that a state of moral degeneracy had been entered) if they should adopt such a cavalier attitude. I, on the other hand, will be immune to such soul-crushing doubts. Still, remain aware that we *will* be taking some risks.

So I *will* admit, again, that violation of one or more of the conditions that rigorous analyses have established *can* lead to disaster. Additional humorous examples of this disconcerting event can be found in a paper³ by a mathematician with a sense of humor. The paper opens with this provocative line: “Browsing through an integral table on a dull Sunday afternoon [don't you often do the very same thing?] some time ago, I came across four divergent trigonometric integrals. I wondered how those divergent integrals [with *incorrect* finite values] ended up in a respectable table.” A couple of sentences later the author writes “We have no intent to defame either the well-known mathematician who made the original error [the rightfully famous French genius Augustin-Louis Cauchy (1789–1857) that you'll get to know when we get to contour integration], or the editors of the otherwise fine tables in which the integrals appear. We all make mistakes and we're not out to point the finger at anyone . . .”

And if we *do* fall off a cliff, well, so what? Nobody need know. We'll just quietly gather-up our pages of faulty analysis, rip them into pieces, and toss the whole rotten mess into the fireplace. Our mathematical sins will be just between us and God (who is well known for being forgiving).

Avoiding a computer is not necessarily a help, however. Here's a specific example of what I mean by that. In a classic of its genre,⁴ Murray Spiegel (late professor of mathematics at Rensselaer Polytechnic Institute) asks readers to show that

²For an informative discussion of the fascinating mathematics behind these calculations, see Nick Lord, “An Amusing Sequence of Trigonometrical Integrals,” *The Mathematical Gazette*, July 2007, pp. 281–285.

³Erik Talvila, “Some Divergent Trigonometric Integrals,” *The American Mathematical Monthly*, May 2001, pp. 432–436.

⁴M. R. Spiegel, *Outline of Theory and Problems of Complex Variables with an Introduction to Conformal Mapping and Its Applications*, Schaum 1964, p. 198 (problem 91).

$$\int_0^{\infty} \frac{\ln(1+x)}{1+x^2} dx = \frac{\pi \ln(2)}{2}$$

which equals 1.088793 One can only wonder at how many students struggled (and for how long) to do this, as the given answer is incorrect. Later in this book, in (5.1.3), we'll do this integral correctly, but a use of *quad* (not available to Spiegel in 1964) quickly shows the numerical value is actually the *significantly* greater 1.4603 At the end of this Preface I'll show you two examples (including Spiegel's integral) of this helpful use of *quad*.

Our use of *quad* does prompt the question of *why*, if we can always calculate the value of any definite integral to as many decimal digits we wish, do we even care about finding exact expressions for these integrals? This is really a philosophical issue, and I think it gets to the mysterious interconnectedness of mathematics—how seemingly unrelated concepts can turn out to actually be intimately related. The expressions we'll find for many of the definite integrals evaluated in this book will involve such familiar numbers as $\ln(2)$ and π , and other numbers that are not so well known, like *Catalan's constant* (usually written as G) after the French mathematician Eugène Catalan (1814–1894). The common thread that stitches these and other numbers together is that all can be written as infinite series that can, in turn, be written as definite integrals:

$$\ln(2) = 1 - \frac{1}{2} + \frac{1}{3} - \frac{1}{4} + \frac{1}{5} - \dots = \int_0^1 \frac{2x}{1+x^2} dx = 0.693147 \dots$$

$$\frac{\pi}{4} = 1 - \frac{1}{3} + \frac{1}{5} - \frac{1}{7} + \frac{1}{9} - \dots = \int_0^1 \frac{1}{1+x^2} dx = 0.785398 \dots$$

$$G = \frac{1}{1^2} - \frac{1}{3^2} + \frac{1}{5^2} - \frac{1}{7^2} + \frac{1}{9^2} - \dots = \int_1^{\infty} \frac{\ln(x)}{1+x^2} dx = 0.9159655 \dots$$

And surely it is understanding at a far deeper level to know that the famous Fresnel integrals $\int_0^{\infty} \cos(x^2)dx$ and $\int_0^{\infty} \sin(x^2)dx$ are *exactly* equal to $\frac{1}{2}\sqrt{\frac{\pi}{2}}$, compared to knowing only that they are 'pretty near' 0.6267.

In 2004 a wonderful book, very much like this one in spirit, was published by two mathematicians, and so I hope my cavalier words will appear to be appalling ones only to the most rigid of hard-core purists. That book, *Irresistible Integrals* (Cambridge University Press) by the late George Boras, and Victor Moll at Tulane University, is not quite as willing as this one is to return to the devil-may-care, eighteenth century mathematics of Euler's day, but I strongly suspect the authors were often tempted. Their subtitle gave them away: *Symbolics, Analysis and*

Experiments [particularly notice this word!] in the *Evaluation of Integrals*. Being mathematicians, their technical will-power was stronger than is my puny electrical engineer's dedication to rigor, but every now and then even they could not totally suppress their sheer pleasure at doing definite integrals.

And then 3 years later, in another book coauthored by Moll, we find a statement of philosophy that exactly mirrors my own (and that of this book): "Given an interesting identity buried in a long and complicated paper on an unfamiliar subject, which would give you more confidence in its correctness: staring at the proof, or confirming computationally that it is correct to 10,000 decimal places?"⁵ That book and *Irresistible Integrals* are really fun math books to read.

Irresistible Integrals is different from this one, though, in that Boras and Moll wrote for a more mathematically sophisticated audience than I have, assuming a level of knowledge equivalent to that of a junior/senior college math major. They also use *Mathematica* much more than I use MATLAB. I, on the other hand, have assumed far less, just what a good student would know—with one BIG exception—after the first year of high school AP calculus, plus just a bit of exposure to the concept of a differential equation. That big exception is contour integration, which Boras and Moll avoided in their book because "not all [math majors] (we fear, few) study complex analysis."

Now *that*, I have to say, caught me by surprise. For a modern undergraduate math major not to have ever had a course in complex analysis seems to me to be shocking. As an electrical engineering major, *50 years ago*, I took complex analysis up through contour integration (from Stanford's math department) at the start of my junior year using R.V. Churchill's famous book *Complex Variables and Applications*. (I still have my beat-up, coffee-stained copy.) I think contour integration is just too beautiful and powerful to be left out of this book but, recognizing that my assumed reader may not have prior knowledge of complex *analysis*, all the integrals done in this book by contour integration are gathered together in their own chapter at the end of the book. Further, in that chapter I've included a 'crash mini-course' in the theoretical complex analysis required to understand the technique (assuming only that the reader has already encountered complex *numbers* and their manipulation).

Irresistible Integrals contains many beautiful results, but a significant fraction of them is presented mostly as 'sketches,' with the derivation details (often presenting substantial challenges) left up to the reader. In this book *every* result is *fully* derived. Indeed, there are results here that are not in the Boras and Moll book, such as the famous integral first worked out in 1697 by the Swiss mathematician John Bernoulli (1667–1748), a result that so fascinated him he called it his "series mirabili" ("marvelous series"):

⁵ *Experimental Mathematics in Action*, A. K. Peters 2007, pp. 4–5. Our calculations here with *quad* won't be to 10,000 decimal places, but the idea is the same.

$$\int_0^1 x^x dx = 1 - \frac{1}{2^2} + \frac{1}{3^3} - \frac{1}{4^4} + \frac{1}{5^5} - \dots = 0.78343\dots$$

or its variant

$$\int_0^1 x^{-x} dx = 1 + \frac{1}{2^2} + \frac{1}{3^3} + \frac{1}{4^4} + \frac{1}{5^5} + \dots = 1.29128\dots$$

Also derived here are the equally exotic integrals

$$\int_0^1 x^{x^2} dx = 1 - \frac{1}{3^2} + \frac{1}{5^3} - \frac{1}{7^4} + \frac{1}{9^5} - \dots = 0.89648\dots$$

and

$$\int_0^1 x^{\sqrt{x}} dx = 1 - \left(\frac{2}{3}\right)^2 + \left(\frac{2}{4}\right)^3 - \left(\frac{2}{5}\right)^4 + \left(\frac{2}{6}\right)^5 - \dots = 0.65858\dots$$

I don't believe either of these last two integrals has appeared in *any* book before now.

One famous integral that is also not in *Irresistible Integrals* is particularly interesting, in that it *seemingly* (I'll explain this in just a bit) owed its evaluation to a mathematician at Tulane University, Professor Moll's home institution. The then head of Tulane's math department, Professor Herbert Buchanan (1881–1974), opened a 1936 paper⁶ with the following words: “In the consideration of a research problem in quantum mechanics, Professor J.C. Morris of Princeton University recently encountered the integral

$$I = \int_0^{\infty} \frac{x^3}{e^x - 1} dx.$$

Since the integral does not yield to any ordinary methods of attack, Professor Morris asked the author to evaluate it [Joseph Chandler Morris (1902–1970) was a graduate of Tulane who did his PhD in physics at Princeton; later he was head of the physics department, and then a Vice-President, at Tulane].” Professor Buchanan then showed that the integral is equal to an infinite series that sums to 6.49 . . . , and just after arriving at that value he wrote “It had been found from other considerations [the details of which are not mentioned, but which I'm guessing were the results of either numerical calculations or even, perhaps, of *physics* experiments

⁶ H. E. Buchanan, “On a Certain Integral Arising in Quantum Mechanics,” *National Mathematics Magazine*, April 1936, pp. 247–248. I treated this integral, in a way different from Buchanan, in my book *Mrs. Perkins's Electric Quilt*, Princeton 2009, pp. 100–102, and in Chap. 5 we'll derive it in yet a different way, as a special case of (5.3.4).

done at Princeton by Morris] that the integral should have a value between 6.3 and 6.9. Thus the value above $[6.4939 \dots = \frac{\pi^2}{15}]$ furnishes a theoretical verification of experimental results.”

So here we have an important definite integral apparently ‘discovered’ by a physicist and solved by a mathematician. In fact, as you’ll learn in Chap. 5, Buchanan was *not* the first to do this integral; it had been evaluated by Riemann in 1859, long before 1936. Nonetheless, this is a nice illustration of the fruitful coexistence and positive interaction of experiment and theory, and it is perfectly aligned with the approach I took while writing this book.

There is one more way this book differs from *Irresistible Integrals*, that reflects my background as an engineer rather than as a professional mathematician. I have, all through the book, made an effort to bring into many of the discussions a variety of physical applications, from such diverse fields as radio theory and theoretical mechanics. In all such cases, however, math plays a central role. So, for example, when the topic of elliptic integrals comes up (at the end of Chap. 6), I do so in the context of a famous *physics* problem. The origin of that problem is due, however, not to a physicist but to a nineteenth century *mathematician*.

Let me close this Preface on the same note that opened it. Despite all the math in it, this book has been written in the spirit of ‘let’s have fun.’ That’s the same attitude Hardy had when, in 1926, he replied to a plea for help from a young undergraduate at Trinity College, Cambridge. That year, while he was still a teenager, H.S.M. Coxeter (1907–2003) had undertaken a study of various four-dimensional shapes. His investigations had *suggested* to him (“by a geometrical consideration and verified graphically”) several quite spectacular definite integrals, like⁷

$$\int_0^{\pi/2} \cos^{-1} \left\{ \frac{\cos(x)}{1 + 2 \cos(x)} \right\} dx = \frac{5\pi^2}{24}.$$

In a letter to the *Mathematical Gazette* he asked if any reader of the journal could show him how to *derive* such an integral (we’ll calculate the above so-called *Coxeter’s integral* later, in the longest derivation in this book). Coxeter went on to become one of the world’s great geometers and, as he wrote decades later in the Preface to his 1968 book *Twelve Geometric Essays*, “I can still recall the thrill of receiving [solutions from Hardy] during my second month as a freshman at Cambridge.” Accompanying Hardy’s solutions was a note scribbled in a margin

⁷ MATLAB’s *quad* says this integral is 2.0561677..., which agrees quite nicely with $\frac{5\pi^2}{24} = 2.0561675 \dots$. The code syntax is: `quad(@(x)acos(cos(x)/(1+2*cos(x))),0,pi/2)`.

For the integral I showed you earlier, from Spiegel’s book, the *quad* code is (I’ve used $1e6 = 10^6$ for the upper limit of infinity): `quad(@(x)log(1+x)/(1+x.^2),0,1e6)`. Most of the integrals in this book are one-dimensional but, for those times that we will encounter higher dimensional integrals there is *dblquad* and *triplequad*, and MATLAB’s companion, the Symbolic Math Toolbox and its command *int* (for ‘integrate’), can do them, too. The syntax for those cases will be explained when we first encounter multidimensional integrals.

declaring that “I tried very hard not to spend time on your integrals, but to me the challenge of a definite integral is irresistible.”⁸

If you share Hardy’s (and my) fascination for definite integrals, then this is a book for you. Still, despite my admiration for Hardy’s near magical talent for integrals, I don’t think he was *always* correct. I write that nearly blasphemous statement because, in addition to Boras and Moll, another bountiful source of integrals is *A Treatise on the Integral Calculus*, a massive two-volume work of nearly 1,900 pages by the English educator Joseph Edwards (1854–1931). Although now long out-of-print, both volumes are on the Web as Google scans and available for free download. In an April 1922 review in *Nature* that stops just short of being a sneer, Hardy made it quite clear that he did not like Edwards’ work (“Mr. Edwards’s book may serve to remind us that the early nineteenth century is not yet dead,” and “it cannot be treated as a serious contribution to analysis”). Finally admitting that there is *some* good in the book, even then Hardy couldn’t resist tossing a cream pie in Edwards’ face with his last sentence: “The book, in short, may be useful to a sufficiently sophisticated teacher, provided he is careful not to allow it to pass into his pupil’s hands.” Well, I disagree. I found Edwards’ *Treatise* to be a terrific read, a treasure chest absolutely *stuffed* with mathematical gems.

You’ll find some of them in this book. Also included are dozens of challenge problems, with complete, detailed solutions at the back of the book if you get stuck. Enjoy!

Durham, NH

Paul J. Nahin

⁸ And so we see where Boras and Moll got the title of their book. Several years ago, in my book *Dr. Euler’s Fabulous Formula* (Princeton 2006, 2011), I gave another example of Hardy’s fascination with definite integrals: see that book’s Section 5.7, “Hardy and Schuster, and their optical integral,” pp. 263–274. There I wrote “displaying an unevaluated definite integral to Hardy was very much like waving a red flag in front of a bull.” Later in this book I’ll show you a ‘first principles’ derivation of the optical integral (Hardy’s far more sophisticated derivation uses Fourier transforms).

Contents

1	Introduction	1
1.1	The Riemann Integral	1
1.2	An Example of Riemann Integration	5
1.3	The Lebesgue Integral	7
1.4	‘Interesting’ and ‘Inside’	10
1.5	Some Examples of Tricks	12
1.6	Singularities	17
1.7	Dalzell’s Integral	22
1.8	Where Integrals Come From	24
1.9	Last Words	39
1.10	Challenge Problems	40
2	‘Easy’ Integrals	43
2.1	Six ‘Easy’ Warm-Ups	43
2.2	A New Trick	48
2.3	Two Old Tricks, Plus a New One	55
2.4	Another Old Trick: Euler’s Log-Sine Integral	64
2.5	Challenge Problems	70
3	Feynman’s Favorite Trick	73
3.1	Leibniz’s Formula	73
3.2	An Amazing Integral	83
3.3	Frullani’s Integral	84
3.4	The Flip-Side of Feynman’s Trick	88
3.5	Combining Two Tricks	98
3.6	Uhler’s Integral and Symbolic Integration	102
3.7	The Probability Integral Revisited	105
3.8	Dini’s Integral	109
3.9	Feynman’s Favorite Trick Solves a Physics Equation	112
3.10	Challenge Problems	114

4	Gamma and Beta Function Integrals	117
4.1	Euler's Gamma Function	117
4.2	Wallis' Integral and the Beta Function	119
4.3	Double Integration Reversal	130
4.4	The Gamma Function Meets Physics	141
4.5	Challenge Problems	145
5	Using Power Series to Evaluate Integrals	149
5.1	Catalan's Constant	149
5.2	Power Series for the Log Function	153
5.3	Zeta Function Integrals	161
5.4	Euler's Constant and Related Integrals	167
5.5	Challenge Problems	183
6	Seven Not-So-Easy Integrals	187
6.1	Bernoulli's Integral	187
6.2	Ahmed's Integral	190
6.3	Coxeter's Integral	194
6.4	The Hardy-Schuster Optical Integral	201
6.5	The Watson/van Peype Triple Integrals	206
6.6	Elliptic Integrals in a Physical Problem	212
6.7	Challenge Problems	219
7	Using $\sqrt{-1}$ to Evaluate Integrals	225
7.1	Euler's Formula	225
7.2	The Fresnel Integrals	227
7.3	$\zeta(3)$ and More Log-Sine Integrals	231
7.4	$\zeta(2)$, At Last!	236
7.5	The Probability Integral <i>Again</i>	240
7.6	Beyond Dirichlet's Integral	241
7.7	Dirichlet Meets the Gamma Function	249
7.8	Fourier Transforms and Energy Integrals	252
7.9	'Weird' Integrals from Radio Engineering	257
7.10	Causality and Hilbert Transform Integrals	267
7.11	Challenge Problems	275
8	Contour Integration	279
8.1	Prelude	279
8.2	Line Integrals	280
8.3	Functions of a Complex Variable	282
8.4	The Cauchy-Riemann Equations and Analytic Functions	289
8.5	Green's Integral Theorem	292
8.6	Cauchy's First Integral Theorem	295
8.7	Cauchy's Second Integral Theorem	309
8.8	Singularities and the Residue Theorem	323
8.9	Integrals with Multi-valued Integrand	331
8.10	Challenge Problems	339

9	Epilogue	343
9.1	Riemann, Prime Numbers, and the Zeta Function	343
9.2	Deriving the Functional Equation for $\zeta(s)$	352
9.3	Challenge Questions	365
	Solutions to the Challenge Problems	369
	Index	409

Chapter 1

Introduction

1.1 The Riemann Integral

The immediate point of this opening section is to address the question of whether you will be able to understand the *technical commentary* in the book. To be blunt, do you know what an integral *is*? You can safely skip the next few paragraphs if this proves to be old hat, but perhaps it will be a useful over-view for some. It's far less rigorous than a pure mathematician would like, and my intent is simply to define terminology.

If $y = f(x)$ is some (any) 'sufficiently well-behaved' function (if you can draw it, then for us it is 'sufficiently well-behaved') then the *definite integral of $f(x)$* , as x varies from $x = a$ to $x = b \geq a$, is the area (a *definite* number, completely determined by a , b , and $f(x)$) bounded by the function $f(x)$ and the x -axis. It is, in fact, the shaded area shown in Fig. 1.1.1. That's why you'll often see the phrase 'area under the curve' in this and in other books on integrals. (We'll deal mostly with real-valued functions in this book, but there will be, towards the end, a fair amount of discussion dealing with complex-valued functions as well). In the figure I've shown $f(x)$ as crossing the x -axis at $x = c$; area *above* the x -axis (from $x = a$ to $x = c$) is *positive* area, while area *below* the x -axis (from $x = c$ to $x = b$) is *negative* area.

We write this so-called *Riemann integral*—after the genius German mathematician Bernhard Riemann (1826–1866)—in mathematical notation as $\int_a^b f(x) dx$, where the elongated s (that's what the integral sign *is*!) stands for *summation*. It is worth taking a look at how the Riemann integral is constructed, because *not all functions have a Riemann integral* (these are functions that are *not* 'well-behaved'). I'll show you such a function in Sect. 1.3. Riemann's ideas date from an 1854 paper.

Summation comes into play because the integral is actually the limiting value of an *infinite* number of terms in a sum. Here's how that happens. To calculate the area under a curve we imagine the integration interval on the x -axis, from a to b , is divided into n sub-intervals, with the i -th sub-interval having length Δx_i . That is, if the end-points of the sub-intervals are

Fig. 1.1.1 The Riemann definite integral $\int_a^b f(x) dx$

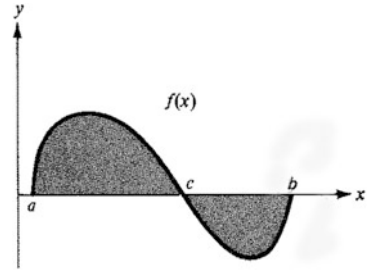

$$a = x_0 < x_1 < x_2 < \cdots < x_{i-1} < x_i < \cdots < x_{n-1} < x_n = b$$

then

$$\Delta x_i = x_i - x_{i-1}, 1 \leq i \leq n.$$

If we make the sub-intervals of equal length then

$$x_i = a + \frac{i}{n}(b - a)$$

which says

$$\Delta x_i = \Delta x = \frac{b - a}{n}.$$

We imagine that, for now, n is some finite (but ‘large’) integer which means that Δx is ‘small.’

Indeed, we imagine that Δx is sufficiently small that $f(x)$, from the beginning to the end of any given sub-interval, changes only slightly over the entire sub-interval. Let ζ_i be any value of x in the interval $x_{i-1} \leq \zeta_i \leq x_i$. Then, the area bounded by $f(x)$ over that sub-interval is just the area of a very thin, vertical rectangle of height $f(\zeta_i)$ and horizontal width Δx , that is, an area of $f(\zeta_i)\Delta x$. (The shaded vertical strip in Fig. 1.1.2.) If we add all these rectangular areas, from $x = a$ to $x = b$, we will get a very good approximation to the total area under the curve from $x = a$ to $x = b$, an approximation that gets better and better as we let $n \rightarrow \infty$ and so $\Delta x \rightarrow 0$ (the individual rectangular areas become thinner and thinner). That is, the value of the integral, I , is given by

$$I = \lim_{n \rightarrow \infty} \sum_{i=1}^n f(\zeta_i) \Delta x = \int_a^b f(x) dx$$

where the summation symbol has become the integral symbol and Δx has become the *differential* dx . We call $f(x)$ the *integrand* of the integral, with a and b the *lower* and *upper* integration limits, respectively.

Fig. 1.1.2 Approximating the 'area under the curve'

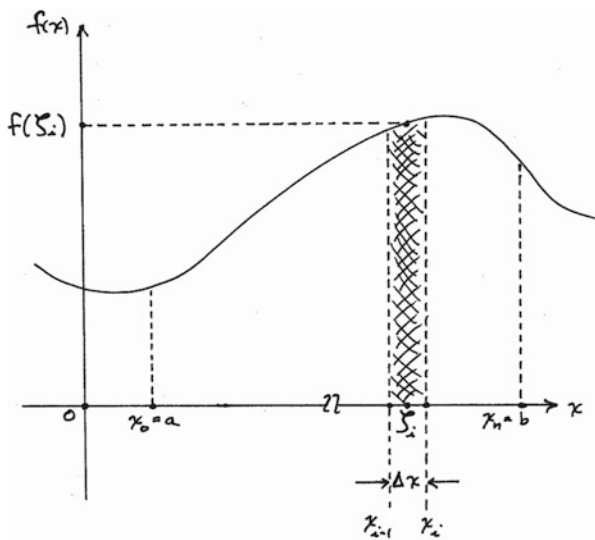

If a and b are both finite ($-\infty < a < b < \infty$), it is worth noting that we can always write the definite integral $\int_a^b f(x) dx$ as a definite integral $\int_0^1 g(t) dt$. That is, we can *normalize* the integration interval. Simply make the change of variable $t = \frac{x-a}{b-a}$. If a and b are not both finite, there is always still some change of variable that normalizes the integration interval. For example, suppose we have $\int_{-\infty}^{\infty} f(x) dx$. Write this as $\int_{-\infty}^0 f(x) dx + \int_0^{\infty} f(x) dx$ and make the change of variable $t = -x$ in the first integral. Notice, too, that the integral \int_0^{∞} can always be rewritten in the form \int_0^1 by writing $\int_0^{\infty} = \int_0^1 + \int_1^{\infty}$, and then changing variable in the last integral to $y = \frac{1}{x}$ which changes the limits to 0 and 1 on that integral, too. Now, having noted this, for the rest of this book I'll *not* bother with normalization.

We can write

$$I = \int_a^b f(x) dx = \int_a^b f(u) du$$

since the symbol we use to label the horizontal axis is *x only* because of tradition. Labeling it u makes no difference in the numerical value of I . We call the integration variable the *dummy* variable of integration. Suppose that we use u as the dummy variable, and replace the upper limit on the integral with the variable x and the lower limit with minus infinity. Now we no longer have a *definite* integral with a specific numerical value, but rather a *function* of x . That is,

$$F(x) = \int_{-\infty}^x f(u) du$$

and our original definite integral is given by

$$I = F(b) - F(a) = \int_a^b f(u) \, du.$$

What's the relationship between $F(x)$ and $f(x)$? Well, recall that from the definition of a derivative we have

$$\begin{aligned} \frac{dF}{dx} &= \lim_{\Delta x \rightarrow 0} \frac{F(x + \Delta x) - F(x)}{\Delta x} = \lim_{\Delta x \rightarrow 0} \frac{\int_{-\infty}^{x+\Delta x} f(u) \, du - \int_{-\infty}^x f(u) \, du}{\Delta x} \\ &= \lim_{\Delta x \rightarrow 0} \frac{\int_x^{x+\Delta x} f(u) \, du}{\Delta x} = \frac{f(x)\Delta x}{\Delta x} = f(x), \end{aligned}$$

where the last line follows because $f(x)$ is essentially a constant over an integration interval of length Δx . Integration and differentiation are each the inverse operation of the other. Since the derivative of any constant C is zero, we write the so-called *indefinite* integral (an integral with no upper and lower limits) as

$$F(x) + C = \int f(x) \, dx.$$

So, one way to do integrals is to simply find an $F(x)$ that, when differentiated, gives the integrand $f(x)$. This is called 'look it up in a table' and it is a *great* way to do integrals *when you have a table that has the entry you need*.

What do you do when there is no such entry available? Well, that is when matters become 'interesting'! You'll have to either get a more extensive table of $F(x) \leftrightarrow f(x)$ pairs, or work out $F(x)$ for yourself. Or, perhaps, you'll grudgingly have to accept the fact that maybe, for the particular $f(x)$ you have, there simply *is* no $F(x)$. Amazingly, though, it can happen in that last case that while there is no $F(x)$ there may still be a computable expression to the *definite* integral for specific values of the integration limits. For example, there is no $F(x)$ for $f(x) = e^{-x^2}$, and all we can write for the *indefinite* integral is the admission

$$\int e^{-x^2} \, dx = ?$$

and yet (as will be shown later in this book), we can still write the *definite* integral

$$\int_0^{\infty} e^{-x^2} \, dx = \frac{1}{2} \sqrt{\pi}.$$

This is about as close to a miracle as you'll get in mathematics.

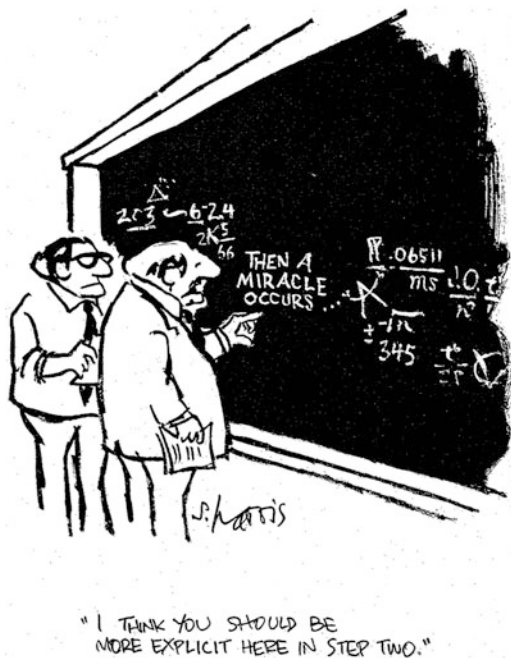

Drawing by arrangement with Sidney Harris, ScienceCartoonsPlus.com

1.2 An Example of Riemann Integration

Here's a pretty little calculation that nicely demonstrates the area interpretation of the Riemann integral. Consider the collection of all points (x, y) that, together, are the points in that region \mathbf{R} of the x, y -plane where $|x| + |y| < 1$, where $-1 < x < 1$. What's the area of \mathbf{R} ? Solving for y gives

$$|y| < 1 - |x|$$

which is a condensed version of the double inequality

$$-[1 - |x|] = y_2 < y < 1 - |x| = y_1.$$

Let's consider the cases of $x > 0$ and $x < 0$ separately.

Case 1: if $x > 0$ then $|x| = x$ and the double inequality becomes

$$-(1 - x) = y_2 < y < 1 - x = y_1$$

and the area for the $x > 0$ portion of \mathbf{R} is

$$\begin{aligned}\int_0^1 (y_1 - y_2) \, dx &= \int_0^1 \{(1 - x) + (1 - x)\} \, dx = \int_0^1 (2 - 2x) \, dx \\ &= (2x - x^2)\Big|_0^1 = 2 - 1 = 1.\end{aligned}$$

Case 2: if $x < 0$ then $|x| = -x$ and the double inequality becomes

$$-(1 + x) = y_2 < y < 1 + x = y_1$$

and the area for the $x < 0$ portion of \mathbf{R} is

$$\begin{aligned}\int_{-1}^0 (y_1 - y_2) \, dx &= \int_{-1}^0 \{(1 + x) + (1 + x)\} \, dx = \int_{-1}^0 (2 + 2x) \, dx \\ &= (2x + x^2)\Big|_{-1}^0 = 2 - 1 = 1.\end{aligned}$$

So, the total area of \mathbf{R} is 2.

Notice that we did the entire calculation without any concern about the shape of \mathbf{R} . So, what *does* \mathbf{R} look like? If we knew that, then maybe the area would be obvious (it will be!). For $x > 0$ we have

$$|y| < 1 - |x|$$

which says that one edge of \mathbf{R} is

$$y_a(x) = 1 - x, \quad x > 0$$

and another edge of \mathbf{R} is

$$y_b(x) = -(1 - x) = -1 + x, \quad x > 0.$$

For $x < 0$ we have

$$|x| + |y| < 1$$

or, as $|x| = -x$ for $x < 0$,

$$|y| < 1 + x.$$

Thus, a third edge of \mathbf{R} is

$$y_c(x) = 1 + x, \quad x < 0$$

and a fourth edge of \mathbf{R} is

Fig. 1.2.1 The shaded, rotated square is \mathbf{R}

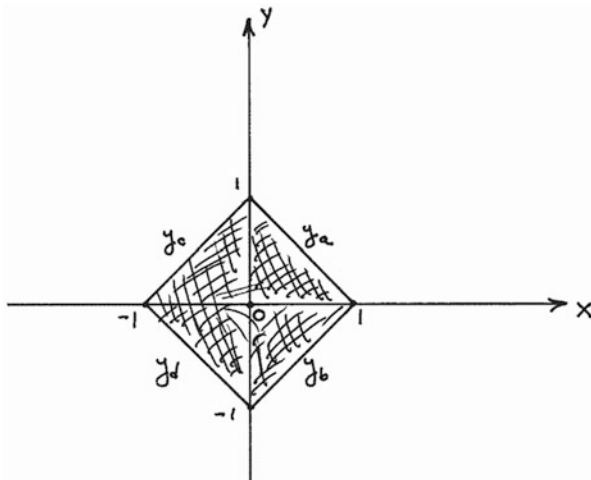

$$y_d(x) = -(1 + x) = -1 - x, \quad x < 0.$$

Figure 1.2.1 shows these four edges plotted, and we see that \mathbf{R} is a rotated (through 45°) square centered on the origin, with a side length of $\sqrt{2}$. That is, it has an area of 2, just as we calculated with the Riemann integral.

1.3 The Lebesgue Integral

Now, in the interest of honesty for the engineers reading this (and to avoid scornful denunciation by the mathematicians reading this!), I must take a time-out here and tell you that the Riemann integral (and its area interpretation) is not the end of the line when it comes to integration. In 1902 the French mathematician Henri Lebesgue (1875–1941) extended the Riemann integral to be able to handle integrand functions that, in no obvious way, bound an area. There *are* such functions; probably the most famous is the one cooked-up in 1829 by the German mathematician Lejeune Dirichlet (1805–1859):

$$\phi(x) = \begin{cases} 1 & \text{when } x \text{ is rational} \\ 0 & \text{when } x \text{ is irrational} \end{cases}$$

Try drawing a sketch of $\phi(x)$ —and I’ll bet you can’t! In any interval of finite length there are an infinity of rationals and irrationals, *each*, and Dirichlet’s function is a very busy one, jumping wildly back-and-forth an infinity of times between 0 and 1 like an over-caffeinated frog on a sugar-high. (That the rationals

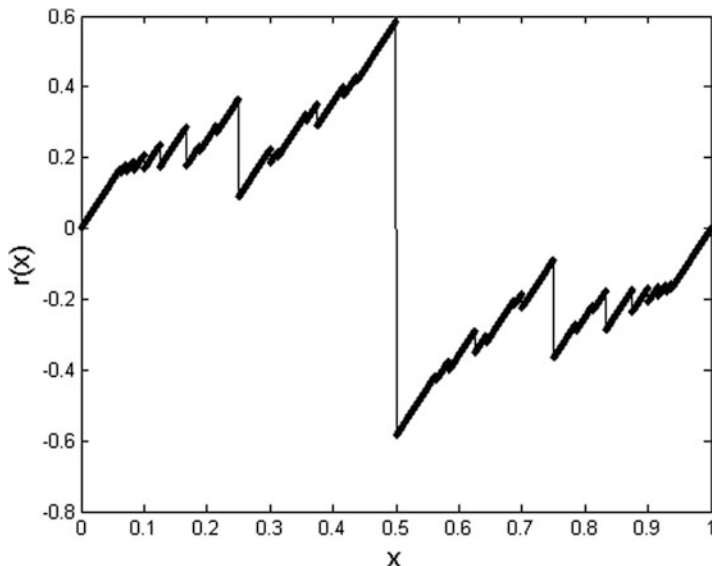

Fig. 1.3.1 Riemann's weird function

are a *countable* infinity and the irrationals are an *uncountable* infinity are two famous results in mathematics, both due to the Russian-born German mathematician Georg Cantor (1845–1918.) And if you can't even draw it, how can you talk of Dirichlet's function as 'bounding an area'? You can't, and Dirichlet's function is an example of a function that isn't integrable in the Riemann sense.

You might suspect that it is the infinite number of discontinuous jumps within a finite interval that makes $\phi(x)$ non-Riemann integrable, but in fact it possible to have a similarly wildly discontinuous function that remains Riemann integrable. Indeed, in 1854 Riemann himself created such a function. Define $[x]$ as the integer nearest to x . For example, $[9.8] = 10$ and $[-10.9] = -11$. If x is exactly between two integers, then $[x]$ is defined to be zero; $[3.5] = 0$. Riemann's infinitely discontinuous function is then

$$r(x) = \sum_{k=1}^{\infty} \frac{kx - [kx]}{k^2}.$$

In Fig. 1.3.1 I've plotted an *approximation* (using the first eight terms of the sum) to $r(x)$ over the interval 0–1. That figure will, I think, just *start* to give you a sense of just how crazy-wild $r(x)$ is; it has an infinite number of discontinuities in the interval 0–1, and yet Riemann showed that $r(x)$ is still integrable in the Riemann sense even while $\phi(x)$ is not.¹

¹For more on $r(x)$, see E. Hairer and G. Wanner, *Analysis by Its History*, Springer 1996, p. 232, and William Dunham, *The Calculus Gallery*, Princeton 2005, pp. 108–112.

But Dirichlet's function *is* integrable in the Lebesgue sense. Rather than sub-dividing the integration interval into sub-intervals as in the Riemann integral, the Lebesgue integral divides the integration interval into *sets of points*. Lebesgue's central intellectual contribution was the introduction of the concept of the *measure* of a set. For the Riemann sub-interval, its measure was simply its length. The Riemann integral is thus just a special case of the Lebesgue integral, as a sub-interval is just one *particular* way to define a set of points; but there are other ways, too. When the Riemann integral exists, so does the Lebesgue integral, but the converse is not true. When both integrals exist they are equal.

To see how this works, let's calculate the Lebesgue integral of $\phi(x)$ over the interval 0–1. In this interval, focus first on all the rational values of x that have the particular integer n in the denominator of the fraction $\frac{m}{n}$ (by definition, this is the form of a rational number). Given the n we've chosen, we see that m can vary from 0 to n , that is, there are $n + 1$ such rational values (points) along the x -axis from 0 to 1. Now, imagine each of these points embedded in an interval of length $\frac{\epsilon}{n^3}$, where ϵ is an arbitrarily small (but non-zero) positive number. That means we can imagine as tiny an interval as we wish, as long as it has a non-zero length. The total length of all the $n + 1$ intervals is then

$$(n + 1) \frac{\epsilon}{n^3} = \frac{\epsilon}{n^2} + \frac{\epsilon}{n^3}.$$

Remember, this is for a *particular* n .

Now, sum over all possible n , that is, let n run from 1 to infinity. There will, of course, be a lot of repetition: for example, $n = 2$ and $m = 1$, and $n = 26$ and $m = 13$, define the same point. So, the *total* length of all the intervals that cover *all* the rational numbers from 0 to 1 is *at most*

$$\epsilon \left\{ \sum_{n=1}^{\infty} \frac{1}{n^2} + \sum_{n=1}^{\infty} \frac{1}{n^3} \right\}.$$

As is well-known, both sums have a finite value (the first is, of course, Euler's famous result of $\frac{\pi^2}{6}$ which will be derived in Chap. 7, and the second sum is obviously even smaller). The point is that the total sum in the braces has some finite value S , and so the *total* length of all the intervals that cover *all* the rational numbers from 0 to 1 is at most ϵS , and we can make this as small as we wish by just picking ever smaller values for ϵ . Lebesgue says the *measure* of the set of all the rationals from 0 to 1 is zero and so, in the Lebesgue sense, we have

$$\int_0^1 \phi(x) dx = 0.$$

Now, with all that said, I'll simultaneously admit to the beauty of the Lebesgue integral as well as admit to the 'scandalous' fact that in this book I'm not going to

worry about it! In 1926 the President of the Mathematical Association (England) sternly stated “To be a serious mathematician and not to use the Lebesgue integral is to adopt the attitude of the old man in a country village who refuses to travel in a train.”² On the other hand, the American electrical engineer and computer scientist Richard Hamming (1915–1998) somewhat cavalierly rebutted that when he declared (in a 1997 address³ to *mathematicians!*)

... for more than 40 years I have claimed that if whether an airplane would fly or not depended on whether some function that arose in its design was Lebesgue but *not Riemann integrable*, then I would not fly in it. Would you? Does Nature recognize the difference? I doubt it! You may, of course, choose as you please in this matter, but I have noticed that year by year the Lebesgue integration, and indeed all of measure theory, seems to be playing a smaller and smaller role in other fields of mathematics, and *none at all in fields that merely use mathematics* [my emphasis].

I think Hamming has the stronger position, and all the integrals you’ll see from now on in this book are to be understood as Riemann integrals.

For mathematicians who might be tempted to dismiss Hamming’s words with ‘Well, what else would you expect from an *engineer!*,’ let me point out that the year before Hamming’s talk a mathematician had said essentially the same thing in a paper that Hamming had surely read. After admitting that the Lebesgue integral “has become the ‘official’ integral in mathematical research,” Robert Bartle (1927–2003) then stated “*the time has come to discard the Lebesgue integral as the primary integral* [Bartle’s emphasis].”⁴

1.4 ‘Interesting’ and ‘Inside’

So, what’s an interesting integral, and what does it mean to talk of being ‘inside’ it? I suppose the honest answer about the ‘interesting’ part is sort of along the lines of Supreme Court Associate Justice Potter Stewart’s famous 1964 comment on the question of “what is pornography?” He admitted it was hard to define “but I know it when I see it.” It’s exactly the same with an interesting integral!

In 1957, in the summer between my junior and senior years in high school, I bought a copy of the second edition of George B. Thomas’ famous textbook *Calculus and Analytic Geometry* for a summer school class at the local junior college. I still remember the thrill I felt when, flipping through the pages for the first

² Comment made after the presentation by E. C. Francis of his paper “Modern Theories of Integration,” *The Mathematical Gazette*, March 1926, pp. 72–77.

³ In Hamming’s paper “Mathematics On a Distant Planet,” *The American Mathematical Monthly*, August–September 1998, pp. 640–650.

⁴ See Bartle’s award-winning paper “Return to the Riemann Integral,” *The American Mathematical Monthly*, October 1996, pp. 625–632. He was professor of mathematics at the University of Illinois for many years, and then at Eastern Michigan University.

time, I happened across (on p. 369) the following (Thomas says it’s from the “lifting theory” of aerodynamics):

$$\int_{-1}^1 \sqrt{\frac{1+x}{1-x}} dx = \pi.$$

Why did I, a kid not yet seventeen who had only recently still been building model airplanes from balsa wood kits and leaky tubes of glue, find that ‘interesting’? I didn’t know then—and I’m not really sure I do even now—except that it just looks ‘mysterious and exotic.’

Now some may snicker at reading that, but I don’t care—by god, to me that aerodynamic integral *still* looks mysterious and exotic! It’s a line of writing as wonderful as anything you’ll find in Hemingway or Dostoevsky and, unlike with even the greatest fiction, it’s a line that nobody could just make-up. What, after all, does all that strange (to me, then) stuff on the left-hand-side of the equal sign have to do with π ? I of course knew even in those long-ago days that π was intimately connected to circles, but I didn’t see any circles on the left. Interesting!

This sort of emotional reaction isn’t limited to just amateur mathematicians; professionals can be swept-up by the same euphoria. In 1935, for example, at the end of his presidential address to the London Mathematical Society, the English mathematician G. N. Watson (1886–1965) mentioned this astonishing definite integral:

$$\int_0^\infty e^{-3\pi x^2} \frac{\sinh(\pi x)}{\sinh(3\pi x)} dx = \frac{1}{e^{2\pi/3}\sqrt{3}} \sum_{n=0}^\infty \frac{e^{-2n(n+1)\pi}}{(1+e^{-\pi})^2(1+e^{-3\pi})^2 \dots (1+e^{-(2n+1)\pi})^2}.$$

Of it he declared that it gave him “a thrill which is indistinguishable from the thrill which I feel when I enter the Sagrestia Nuova of the Capelle Medicee and see before me the austere beauty of the four statues representing Day, Night, Evening, and Dawn which Michelangelo has set over the tombs of Guiliano de’ Medici and Lorenzo de’ Medici.”

Wow.

Alright, now what does being ‘inside’ an integral mean? I’ll try to answer that by example. Suppose I tell you that

$$\int_0^1 \frac{\ln(1+x)}{1+x^2} dx = \frac{\pi}{8} \ln(2).$$

You’d probably just shrug your shoulders and say (or at least think it if too polite to actually say it) “Okay. Where did you get that from, a good table of integrals? Which one did you use? I’ll look it up, too.” And so you could, but could you *derive* the result? That’s what I mean by getting ‘inside’ an integral. It’s the art of starting with the integral on the left side of the equal sign and somehow getting to a computable expression on the right side. (We’ll do this integral later in the book—see (2.2.4).)

I use the word *art* with intent. There is no theory to doing definite integrals. Each new integral is a brand new challenge and each new challenge almost always demands a new trick or, at least, a new twist or two to a previous trick. That's right, a *trick*. Some people might recoil in horror at that, but a real analyst simply smiles with anticipation at the promise of a righteous struggle. And even if the integral wins for the moment, leaving the analyst exhausted and with a pounding headache, the analyst knows that there is always tomorrow in which to try again.

1.5 Some Examples of Tricks

Now, just so you know what I'm talking about when I use the word *trick*, here's the first example of a trick in this book (the rest of this book is, essentially, just one new trick after the next!). What goes on the right-hand side of

$$\int_{-1}^1 \frac{\cos(x)}{e^{(1/x)} + 1} dx = ?$$

This integral almost surely looks pretty scary to nearly everybody at first sight; trying to find an $F(x)$ that, when differentiated gives the integrand, certainly doesn't seem very promising. But in fact the *definite* integral *can* be done by a first-year calculus student *if that student sees the trick!* Play around with this for a while as I work my way towards the stunning revelation of the answer, and see if you can beat me to it.

Consider the more general integral

$$\int_{-1}^1 \frac{\cos(x)}{d(x) + 1} dx$$

where $d(x)$ is just about any function of x that you wish. (For the original integral, $d(x) = e^{(1/x)}$.) I'll impose a restriction on $d(x)$ in just a bit, but not right now. If we then write

$$g(x) = \frac{\cos(x)}{d(x) + 1}$$

then we arrive (of course!) at the integral

$$\int_{-1}^1 g(x) dx.$$

No matter what $g(x)$ is, we can always write it as the sum of an even function $g_e(x)$ and an odd function $g_o(x)$. That is,

$$g(x) = g_e(x) + g_o(x).$$

How do we know we can do this? Because we can actually write down what $g_e(x)$ and $g_o(x)$ are. By the definitions of even and odd we have

$$g(-x) = g_e(-x) + g_o(-x) = g_e(x) - g_o(x)$$

and so it is simple algebra to arrive at

$$g_e(x) = \frac{g(x) + g(-x)}{2}$$

and

$$g_o(x) = \frac{g(x) - g(-x)}{2}.$$

Now,

$$\int_{-1}^1 g(x) \, dx = \int_{-1}^1 g_e(x) \, dx + \int_{-1}^1 g_o(x) \, dx = \int_{-1}^1 g_e(x) \, dx$$

because by the ‘symmetry’ of an odd function around $x = 0$ we have (think ‘area under the curve’)

$$\int_{-1}^1 g_o(x) \, dx = 0.$$

From our original integral, we have

$$g(x) = \frac{\cos(x)}{d(x) + 1}$$

and so

$$g_e(x) = \frac{1}{2} \left[\frac{\cos(x)}{d(x) + 1} + \frac{\cos(-x)}{d(-x) + 1} \right]$$

or, because $\cos(-x) = \cos(x)$, that is, because the cosine is an even function,

$$g_e(x) = \frac{\cos(x)}{2} \left[\frac{1}{d(x) + 1} + \frac{1}{d(-x) + 1} \right] = \frac{\cos(x)}{2} \left[\frac{d(-x) + 1 + d(x) + 1}{d(x)d(-x) + d(x) + d(-x) + 1} \right]$$

or,

$$g_e(x) = \frac{\cos(x)}{2} \left[\frac{2 + d(-x) + d(x)}{d(x)d(-x) + d(x) + d(-x) + 1} \right].$$

Okay, suppose we now put a restriction on $d(x)$. Suppose $d(x)d(-x) = 1$. This is the case, you'll notice, for the $d(x)$ in our original integral ($= e^{(1/x)}$) because

$$d(x)d(-x) = e^{(1/x)}e^{(-1/x)} = e^0 = 1.$$

Well, then, you should now see that the numerator and the denominator of all that stuff in the brackets on the right-hand-side of the last expression for $g_e(x)$ are equal! That is, everything in the brackets reduces to 1 and so

$$g_e(x) = \frac{\cos(x)}{2}$$

and our scary integral has vanished like a balloon pricked with a pin:

$$\begin{aligned} \int_{-1}^1 \frac{\cos(x)}{e^{(1/x)} + 1} dx &= \int_{-1}^1 \frac{\cos(x)}{2} dx = \frac{1}{2} \int_{-1}^1 \cos(x) dx = \frac{1}{2} \{ \sin(x) \} \Big|_{-1}^1 \\ &= \frac{\sin(1) - \sin(-1)}{2} = \sin(1) = 0.8414709 \dots \quad ^5 \end{aligned}$$

Now *that's* a trick! MATLAB's *quad* agrees, computing a value of 0.8414623. The code syntax is: `quad(@cos(x)./(exp(1./x) + 1), -1, 1)`.

This was a fairly sophisticated trick, but sometimes even pretty low-level approaches can achieve 'tricky' successes. For example, what is the value of

$$\int_0^\infty \frac{\ln(x)}{1+x^2} dx = ?$$

Let's start with the obvious $\int_0^\infty = \int_0^1 + \int_1^\infty$. In the first integral on the right, make the change of variable $t = 1/x$ (and so $dx = -dt/t^2$). Then,

⁵ Writing $\sin(1)$ means, of course, the sine of 1 *radian* $= \frac{180^\circ}{\pi} = 57.3^\circ$ (not of 1 degree).

$$\begin{aligned}\int_0^1 \frac{\ln(x)}{1+x^2} dx &= \int_\infty^1 \frac{\ln(\frac{1}{t})}{1+\frac{1}{t^2}} \left(-\frac{1}{t^2} dt\right) = -\int_\infty^1 \frac{\ln(\frac{1}{t})}{t^2+1} dt = \int_1^\infty \frac{\ln(\frac{1}{t})}{t^2+1} dt \\ &= -\int_1^\infty \frac{\ln(t)}{t^2+1} dt.\end{aligned}$$

That is, recognizing that t and x are just dummy variables of integration, we have $\int_0^1 = -\int_1^\infty$. And so we immediately have our result (first derived by Euler):

(1.5.1)

$$\int_0^\infty \frac{\ln(x)}{1+x^2} dx = 0.$$

This is, in fact, a special case of the more general integral

$$\int_0^\infty \frac{\ln(x)}{b^2+x^2} dx.$$

See if you can calculate this integral (your answer should, of course, reduce to zero when $b = 1$); if you have trouble with it we'll evaluate this integral in the next chapter—in (2.1.3)—where you'll see that knowing the special case helps (a *lot!*) in doing the general case.

For a third example of a trick, let me show you one that illustrates just how clever the early students of the calculus could be in teasing-out the value of a definite integral. This trick dates back to 1719, when the Italian mathematician Giulio Fagnano (1682–1766) calculated $\int_0^\infty \frac{dx}{1+x^2}$. Today, of course, a first-year calculus freshman would recognize the *indefinite* integral to be $\tan^{-1}(x)$, and so the answer is $\tan^{-1}(\infty) - \tan^{-1}(0) = \frac{\pi}{2}$. But Fagnano's clever trick does not require knowledge of the indefinite integral,⁶ but only how to differentiate. Here's how Fagnano did it.

Imagine a circle with radius r , centered on the origin of the xy -plane. The arc-length L along the circumference of that circle that is subtended by a central angle of θ is $L = r\theta$. Now, suppose that $r = 1$. Then $L = \theta$ and so, with t as a dummy variable of integration,

⁶I am assuming that when you see $\int \frac{1}{a^2+x^2} dx$ you immediately recognize it as $\frac{1}{a} \tan^{-1}\left(\frac{x}{a}\right)$. This is one of the few 'fundamental' indefinite integrals I'm going to assume you've seen previously from a first course of calculus. Others are: $\int \frac{1}{x} dx = \ln(x)$, $\int e^x dx = e^x$, $\int x^n dx = \frac{x^{n+1}}{n+1}$ ($n \neq -1$), $\int \frac{dx}{\sqrt{a^2-x^2}} = \sin^{-1}(x)$, and $\int \ln(x) dx = x \ln(x) - x$.

$$L = \theta = \int_0^\theta dt.$$

Fagnano then played around with this very simple integrand (indeed, how could it possibly be any simpler!?) to make it *more* complicated! Specifically,

$$L = \int_0^\theta \frac{\frac{1}{\cos^2(t)}}{\frac{1}{\cos^2(t)}} dt = \int_0^\theta \frac{\frac{1}{\cos^2(t)}}{\frac{\cos^2(t) + \sin^2(t)}{\cos^2(t)}} dt = \int_0^\theta \frac{\frac{1}{\cos^2(t)}}{1 + \tan^2(t)} dt.$$

Next, change variable to $x = \tan(t)$, which says

$$dx = \frac{dt}{\cos^2(t)}.$$

Thus,

$$L = \int_0^{\tan(\theta)} \frac{dx}{1 + x^2}.$$

Suppose $\theta = \frac{\pi}{2}$. Then $\tan(\theta) = \tan\left(\frac{\pi}{2}\right) = \infty$, and of course L is one-fourth the circle's circumference and so equals $\frac{\pi}{2}$ because $\frac{\pi}{2}$ is one-fourth of 2π , the circumference of a unit radius circle. Thus, *instantly*,

$$\frac{\pi}{2} = \int_0^\infty \frac{dx}{1 + x^2}.$$

By the same reasoning, we *instantly* have

$$\frac{\pi}{4} = \int_0^1 \frac{dx}{1 + x^2},$$

and

$$\frac{\pi}{3} = \int_0^{\sqrt{3}} \frac{dx}{1 + x^2},$$

and

$$\frac{\pi}{6} = \int_0^{\sqrt{3}/3} \frac{dx}{1 + x^2}.$$

Pretty clever.

1.6 Singularities

Tricks are neat, and the discovery of each new one is like the thrill you get when digging through a box of raisins (think ‘routine’ integration methods, good for you, yeah, but still sorta boring) and every now and then coming across a chocolate-covered peanut (think ‘fantastic new trick’). But—one does have to be ever alert for pitfalls that, we hope, *quad* will be our last-ditch defense against. Here’s an example of what I’m getting at, in which that most common of operations—blindly plugging into a standard integration formula—can lead to disaster.

Suppose we have the integral $I = \int_{-1}^1 \frac{dx}{x^2}$. The integrand $f(x) = \left(\frac{1}{x}\right)^2$ is *never* negative because it’s the square of a real value (from -1 to 1). Thus, we know immediately, from the area interpretation of the Riemann integral, that $I > 0$. However, from differential calculus we also know that

$$\frac{d}{dx} \left(\frac{1}{x} \right) = -\frac{1}{x^2}$$

and so, upon integrating, we have

$$I = \left(-\frac{1}{x} \right) \Big|_{-1}^1 = \left(-\frac{1}{1} \right) - \left(-\frac{1}{-1} \right) = -1 - 1 = -2.$$

That’s right, *minus 2*, which is certainly *less* than zero. What’s going on with this?

The problem is that $f(x)$ blows-up at $x = 0$, right in the middle of the integration interval. The integral is called *improper*, and $x = 0$ is called a *singularity*. You have to be ever alert for singularities when you are doing integrals; always, *stay away* from singularities. Singularities are the black holes of integrals; don’t ‘fall into’ one (don’t integrate across a singularity). You’ll find, when we get to contour integration, this will be *very* important to keep in mind. Here’s how to do that for our integral. We’ll write I as follows, where ε is an arbitrarily small, *positive* quantity:

$$I = \int_{-1}^1 \frac{dx}{x^2} = \lim_{\varepsilon \rightarrow 0} \int_{-1}^{-\varepsilon} \frac{dx}{x^2} + \lim_{\varepsilon \rightarrow 0} \int_{\varepsilon}^1 \frac{dx}{x^2}.$$

Then,

$$\begin{aligned} I &= \lim_{\varepsilon \rightarrow 0} \left(-\frac{1}{x} \right) \Big|_{-1}^{-\varepsilon} + \lim_{\varepsilon \rightarrow 0} \left(-\frac{1}{x} \right) \Big|_{\varepsilon}^1 \\ &= \lim_{\varepsilon \rightarrow 0} \left[\left(-\frac{1}{-\varepsilon} \right) - \left(-\frac{1}{-1} \right) \right] + \lim_{\varepsilon \rightarrow 0} \left[\left(-\frac{1}{1} \right) - \left(-\frac{1}{\varepsilon} \right) \right] \\ &= \lim_{\varepsilon \rightarrow 0} \left(\frac{1}{\varepsilon} - 1 - 1 + \frac{1}{\varepsilon} \right) = \lim_{\varepsilon \rightarrow 0} \left(\frac{2}{\varepsilon} \right) - 2 = +\infty. \end{aligned}$$

The integral is (as we expected) positive—in fact, it’s *infinitely* positive! It certainly is *not* negative. Notice, too, that our first (incorrect) result of -2 is now understandable—it’s right there in the correct answer, *along with the infinite contribution from the singularity* that we originally missed.

Now, to see if you’ve *really* grasped the problem with the above integral, consider *this* integral, one made famous in mathematical physics by the Nobel prize-winning physicist Richard Feynman (1918–1988): if a and b are real-valued, arbitrary constants, then

(1.6.1)

$$\int_0^1 \frac{1}{[ax + b(1-x)]^2} dx = \frac{1}{ab} .$$

Do you see the issue here? If a and b have opposite algebraic signs then the right-hand side of the above formula is negative. But on the left-hand-side, the integrand is always something *squared*, no matter what a and b may be, and so the integrand is *never* negative. We appear to have a conflict. What’s going with this? Hint: ask yourself if the integrand has a singularity and, if so, where is it located?⁷ (See Challenge Problem 3 at the end of this chapter.)

Before leaving the subject of singularities, I should tell you that there are other infinity concerns besides the blowing-up of the integrand that can occur when doing integrals. What do we mean, for example, when we write $\int_{-\infty}^{\infty} f(x) dx$? The area interpretation of the Riemann integral can fail us in this case, even when $f(x)$ is a ‘nice’ function. For example, how much area is under the curve $f(x) = \sin(x)$, $-\infty < x < \infty$? Since $\sin(x)$ is an odd function it seems we should be able to argue that there is always a piece of negative area that cancels every piece of positive area, and so we’d like to write

$$\int_{-\infty}^{\infty} \sin(x) dx = 0.$$

But what then about the area under the curve $f(x) = \cos(x)$, $-\infty < x < \infty$? Now we have an even function (it’s just a shifted sine function!) but we can still apparently make the negative/positive area cancellation argument, and so is it true that

$$\int_{-\infty}^{\infty} \cos(x) dx = 2 \int_0^{\infty} \cos(x) dx = 0?$$

That is, is it true that

⁷This integral appeared in Feynman’s famous paper “Space-Time Approach to Quantum Electrodynamics,” *Physical Review*, September 15, 1949, pp. 769–789. Some historical discussion of the integral is in my book *Number–Crunching*, Princeton 2011, pp. xx–xxi.

$$\int_0^{\infty} \cos(x) dx = 0?$$

The answer is *no*, neither $\int_{-\infty}^{\infty} \sin(x) dx$ or $\int_{-\infty}^{\infty} \cos(x) dx$ exist. We can, however, write what mathematicians call the *Cauchy Principal Value* of the integral:

$$\int_{-\infty}^{\infty} f(x) dx = \lim_{R \rightarrow \infty} \int_{-R}^R f(x) dx,$$

an integral that is zero if $f(x)$ is odd. This approach, using a *symmetrical* limiting operation, means that the Cauchy Principal Value for $\int_{-\infty}^{\infty} \sin(x) dx$ *does* exist (it is zero), even though the integral does not.

If, however, we have an $f(x)$ integrand such that $\lim_{x \rightarrow \pm \infty} f(x) = 0$ ‘fast enough’—that means faster than $\frac{1}{x}$ (for example, $\frac{\sin(x)}{x}$)—then we don’t have these conceptual difficulties. But even this isn’t enough to fully capture all the subtle problems that can come with infinity. That’s because an integrand like $f(x) = \cos(x^2)$, which *doesn’t* go to zero as $x \rightarrow \pm \infty$, *does* have a definite integral over $-\infty < x < \infty$ (you’ll recall this integral—called a Fresnel integral—from the Preface). That’s because $\cos(x^2)$ oscillates faster and faster between ± 1 as x increases in both directions, and so the positive and negative areas above and below the x -axis *individually* go to zero faster and faster and so contribute less and less to the *total* area under the curve (an area which is finite).

Our little trick of ‘sneaking-up’ on a singularity can be quite powerful. Consider, for example, the interesting integral

$$\int_0^{\infty} \frac{dx}{x^3 - 1}.$$

When x is between 0 and 1 the integrand is negative, while when x is greater than 1 the integrand is positive. There is obviously a singularity at $x = 1$, with the integrand blowing-up to minus-infinity as x approaches 1 from values less than 1, and blowing-up to plus-infinity as x approaches 1 from values greater than 1. Is it possible, we might wonder, for these two infinite explosions (with opposite signs) to perhaps *cancel* each other? In fact they do, and to convince you of that I’ll use the ‘sneak’ trick to write our integral as

$$\int_0^{1-\varepsilon} \frac{dx}{x^3 - 1} + \int_{1+\varepsilon}^{\infty} \frac{dx}{x^3 - 1}$$

and then explore what happens as $\varepsilon \rightarrow 0$.

In the spirit of this book I’ll first use *quad* to *experimentally* study what happens as $\varepsilon \rightarrow 0$. In the following table I’ve listed the result of running the following MATLAB command for various, ever smaller, values of ε (stored in the vector $e(i)$):

```
quad(@(x)1./(x.^3-1),0,1-ei) + quad(@(x)1./(x.^3-1),1 + ei,1000)
```

ε	$\int_0^{1-\varepsilon} \frac{dx}{x^3-1} + \int_{1+\varepsilon}^{\infty} \frac{dx}{x^3-1}$
0.1	-0.53785
0.01	-0.59793
0.001	-0.60393
0.0001	-0.60453
0.00001	-0.60459
0.000001	-0.60459
0.0000001	-0.60459

So, from this numerical work it would appear that

$$\int_0^{\infty} \frac{dx}{x^3-1} = -0.60459.$$

Well, what could this curious number *be*? As it turns out we can answer this question, *exactly*, because it proves possible to actually find the *indefinite* integral! That's because we can write the integrand as the partial fraction expansion

$$\frac{1}{x^3-1} = \frac{1}{3(x-1)} - \frac{2x+1}{6(x^2+x+1)} - \frac{1}{2(x^2+x+1)}$$

or, completing the square in the denominator of the last term,

$$\frac{1}{x^3-1} = \frac{1}{3(x-1)} - \frac{2x+1}{6(x^2+x+1)} - \frac{1}{2\left[\left(x+\frac{1}{2}\right)^2 + \frac{3}{4}\right]}.$$

Each of the individual terms on the right is easily integrated, giving

$$\begin{aligned} \int \frac{dx}{x^3-1} &= \frac{1}{3} \ln(x-1) - \frac{1}{6} \ln(x^2+x+1) - \frac{1}{\sqrt{3}} \tan^{-1} \left(\frac{2x+1}{\sqrt{3}} \right) \\ &= \frac{1}{6} \{2\ln(x-1) - \ln(x^2+x+1)\} - \frac{1}{\sqrt{3}} \tan^{-1} \left(\frac{2x+1}{\sqrt{3}} \right) \\ &= \frac{1}{6} \ln \left\{ \frac{(x-1)^2}{x^2+x+1} \right\} - \frac{1}{\sqrt{3}} \tan^{-1} \left(\frac{2x+1}{\sqrt{3}} \right) \\ &= \frac{1}{6} \ln \left\{ \frac{x^2-2x+1}{x^2+x+1} \right\} - \frac{1}{\sqrt{3}} \tan^{-1} \left(\frac{2x+1}{\sqrt{3}} \right). \end{aligned}$$

The argument of the log function is well-behaved for all x in the integration interval *except* at $x=1$ where we get $\log(0)$, and so let's again use the sneak trick,

but this time *analytically*. That is, we'll integrate from 0 to $1 - \epsilon$ and add it to the integral from $1 + \epsilon$ to ∞ . Then we'll let $\epsilon \rightarrow 0$. So, noticing that the log function vanishes at both $x = 0$ and at $x = \infty$ (each give $\log(1)$), we have

$$\begin{aligned} \int_0^{\infty} \frac{dx}{x^3 - 1} &= \lim_{\epsilon \rightarrow 0} \left[\frac{1}{6} \ln \left\{ \frac{(1 - \epsilon)^2 - 2(1 - \epsilon) + 1}{(1 - \epsilon)^2 + (1 - \epsilon) + 1} \right\} - \frac{1}{\sqrt{3}} \tan^{-1} \left\{ \frac{2(1 - \epsilon) + 1}{\sqrt{3}} \right\} \right. \\ &\quad \left. + \frac{1}{\sqrt{3}} \tan^{-1} \left(\frac{1}{\sqrt{3}} \right) \right] + \lim_{\epsilon \rightarrow 0} \left[-\frac{1}{\sqrt{3}} \tan^{-1}(\infty) - \frac{1}{6} \ln \left\{ \frac{(1 + \epsilon)^2 - 2(1 + \epsilon) + 1}{(1 + \epsilon)^2 + (1 + \epsilon) + 1} \right\} \right. \\ &\quad \left. + \frac{1}{\sqrt{3}} \tan^{-1} \left\{ \frac{2(1 + \epsilon) + 1}{\sqrt{3}} \right\} \right]. \end{aligned}$$

The log terms expand as

$$\begin{aligned} &\frac{1}{6} \ln \left\{ \frac{1 - 2\epsilon + \epsilon^2 - 2 + 2\epsilon + 1}{1 - 2\epsilon + \epsilon^2 + 1 - \epsilon + 1} \right\} - \frac{1}{6} \ln \left\{ \frac{1 + 2\epsilon + \epsilon^2 - 2 - 2\epsilon + 1}{1 + 2\epsilon + \epsilon^2 + 1 + \epsilon + 1} \right\} \\ &= \frac{1}{6} \ln \left\{ \frac{\epsilon^2}{\epsilon^2 - 3\epsilon + 3} \right\} - \frac{1}{6} \ln \left\{ \frac{\epsilon^2}{\epsilon^2 + 3\epsilon + 3} \right\} = \frac{1}{6} \ln \left\{ \frac{\epsilon^2 + 3\epsilon + 3}{\epsilon^2 - 3\epsilon + 3} \right\}. \end{aligned}$$

As $\epsilon \rightarrow 0$ this last log term obviously vanishes. The \tan^{-1} terms expand as

$$\begin{aligned} &-\frac{1}{\sqrt{3}} \tan^{-1} \left\{ \frac{2 - 2\epsilon + 1}{\sqrt{3}} \right\} + \frac{1}{\sqrt{3}} \tan^{-1} \left(\frac{1}{\sqrt{3}} \right) - \frac{1}{\sqrt{3}} \tan^{-1}(\infty) \\ &+ \frac{1}{\sqrt{3}} \tan^{-1} \left\{ \frac{2 + 2\epsilon + 1}{\sqrt{3}} \right\} = -\frac{1}{\sqrt{3}} \tan^{-1} \left\{ \frac{3 - 2\epsilon}{\sqrt{3}} \right\} + \frac{1}{\sqrt{3}} \tan^{-1} \left(\frac{1}{\sqrt{3}} \right) \\ &-\frac{1}{\sqrt{3}} \left(\frac{\pi}{2} \right) + \frac{1}{\sqrt{3}} \tan^{-1} \left\{ \frac{3 + 2\epsilon}{\sqrt{3}} \right\} \end{aligned}$$

or, as $\epsilon \rightarrow 0$, this reduces to

$$\begin{aligned}
& -\frac{1}{\sqrt{3}} \tan^{-1} \left\{ \frac{3}{\sqrt{3}} \right\} + \frac{1}{\sqrt{3}} \tan^{-1} \left(\frac{1}{\sqrt{3}} \right) - \frac{1}{\sqrt{3}} \left(\frac{\pi}{2} \right) + \frac{1}{\sqrt{3}} \tan^{-1} \left\{ \frac{3}{\sqrt{3}} \right\} \\
&= \frac{1}{\sqrt{3}} \tan^{-1} \left(\frac{1}{\sqrt{3}} \right) - \frac{1}{\sqrt{3}} \left(\frac{\pi}{2} \right) = \frac{1}{\sqrt{3}} \left[\tan^{-1} \left(\frac{1}{\sqrt{3}} \right) - \frac{\pi}{2} \right] = \frac{1}{\sqrt{3}} \left[\frac{\pi}{6} - \frac{\pi}{2} \right] \\
&= -\frac{\pi}{3\sqrt{3}} = -\frac{\pi\sqrt{3}}{9}.
\end{aligned}$$

So, at last,

$$(1.6.2) \quad \int_0^{\infty} \frac{dx}{x^3 - 1} = -\frac{\pi\sqrt{3}}{9}$$

which is, indeed, the curious -0.60459 .

1.7 Dalzell's Integral

The rest of this book is simply a lot more tricks, some even more spectacular than the one I showed you in Sect. 1.5. But why, some may ask, should we study *tricks*? After all, with modern computer software even seemingly impossible integrals can be done far faster than a human can work. Please understand that I'm *not* talking about *numerical* integrators, like MATLAB's *quad* (although far less rapidly, mathematicians could do *that* sort of thing *centuries* ago!). I'm talking about *symbolic* integrators like, for example, the on-line (available for free) *Mathematica* symbolic integrator software that needs only a fraction of a second to evaluate the *indefinite* aerodynamic integral from earlier in this Introduction (Sect. 1.4):

$$\int \sqrt{\frac{1+x}{1-x}} dx = -\sqrt{1-x^2} + 2 \sin^{-1} \left(\sqrt{\frac{x+1}{2}} \right).$$

You can verify that this is indeed correct by simply differentiating the right-hand-side and observing the integrand on the left-hand-side appear. And when the lower and upper limits of -1 and $+1$, respectively, are plugged-in, we get π , just as Professor Thomas wrote in his book.

Now, I'd be the first to admit that there is a *lot* of merit to using automatic, computer integrators. If I had to do a tough integral as part of a job for which I was

getting paid, the *first* thing I would do is go to Wolfram (although, I should tell you, Wolfram *fails* on the indefinite $\int \frac{\cos(x)}{d(x)+1} dx$ that we solved for a *definite* case with our little even/odd trick—fails, almost surely, since there is no *indefinite* integral). That admission ignores the *fun* of doing definite integrals, however, the same sort of fun that so many people enjoy when they do Sudoku puzzles. Battling Sudoku puzzles *or* integrals is a combat of wits with an ‘adversary’ (the rules of math) that tolerates *zero* cheating. If you succeed at either, it ain’t luck—it’s skill.

Now, just to show you I’m serious when I say doing definite integrals can be fun, consider

$$I = \int_0^1 \frac{x^4(1-x)^4}{1+x^2} dx,$$

which first appeared (in 1944) on the pages of the *Journal of the London Mathematical Society*. What’s so ‘fun’ about this, you ask? Well, look at what we get when I is evaluated. Multiplying out the numerator, and then doing the long division of the result by the denominator, we get

$$I = \int_0^1 \left(x^6 - 4x^5 + 5x^4 - 4x^2 + 4 - \frac{4}{1+x^2} \right) dx,$$

integrations that are all easily done to give

$$\begin{aligned} I &= \int_0^1 \frac{x^4(1-x)^4}{1+x^2} dx = \left(\frac{x^7}{7} - \frac{2x^6}{3} + x^5 - \frac{4x^3}{3} + 4x - 4 \tan^{-1}(x) \right) \Big|_0^1 \\ &= \frac{1}{7} - \frac{2}{3} + 1 - \frac{4}{3} + 4 - \pi. \end{aligned}$$

That is,

$$(1.7.1) \quad \boxed{\int_0^1 \frac{x^4(1-x)^4}{1+x^2} dx = \frac{22}{7} - \pi.}$$

Since the integrand is never negative, we know that $I > 0$ and so we have the sudden (and, I think, totally unexpected) result that $\frac{22}{7} > \pi$. That is, the classic schoolboy approximation to π is an *overestimate*, a fact that is not so easy to otherwise establish.

Our calculations actually give us more information than just $\frac{22}{7} > \pi$; we can also get an idea of just how good an approximation $\frac{22}{7}$ is to π . That’s because if we replace the denominator of the integrand with 1 we’ll clearly get a bigger value for

the integral, while if we replace the denominator with 2 we'll get a smaller value for the integral. That is,

$$\int_0^1 \frac{x^4(1-x)^4}{2} dx < \int_0^1 \frac{x^4(1-x)^4}{1+x^2} dx = \frac{22}{7} - \pi < \int_0^1 x^4(1-x)^4 dx$$

or, multiplying out, integrating, and plugging-in the limits,

$$\frac{1}{2} \left(\frac{1}{5} - \frac{2}{3} + \frac{6}{7} - \frac{1}{2} + \frac{1}{9} \right) = \frac{1}{1,260} < \frac{22}{7} - \pi < \left(\frac{1}{5} - \frac{2}{3} + \frac{6}{7} - \frac{1}{2} + \frac{1}{9} \right) = \frac{1}{630}$$

or, multiplying through by -1 (which reverses the sense of the inequalities),

$$-\frac{1}{630} < \pi - \frac{22}{7} < -\frac{1}{1,260}$$

or, at last,

$$\frac{22}{7} - \frac{1}{630} < \pi < \frac{22}{7} - \frac{1}{1,260}.$$

To five decimal places, this says $3.14127 < \pi < 3.14206$, which nicely and fairly tightly bounds π ($=3.14159\dots$). Now who would deny that this sort of thing is *fun*?!

The author of the 1944 paper that first published this gem was D. P. Dalzell, a curious fellow who is mostly a ghost in the history of mathematics. All of the modern references to Dalzell's integral make no mention of the man, himself, even though he wrote a number of high quality mathematical papers and had an excellent reputation among mathematicians. Dalzell didn't help his cause by his habit of always using his initials. In fact, he was Donald Percy Dalzell (1898–1988), who graduated in 1921 from St. John's College, Cambridge, in mathematics and mechanical sciences. He received an MA degree in 1926, and his career was *not* as a mathematician but rather as a chartered engineer (a term used in England for a masters level professional engineer). He worked for a number of years for the Standard Telephones and Cables Company in London, and had two patents on electrical communication cables. The only known photograph of him is the one on the MacTutor math web-site (taken at the 1930 Edinburgh Mathematical Society Colloquium at St. Andrews).

1.8 Where Integrals Come From

Just about all of the discussions in this book are in the form of 'here's an integral, how can we evaluate it?' Mathematicians, of course, can simply 'make-up' integrals off the tops of their heads, but engineers and physicists generally encounter

integrals resulting from the analysis of a physical problem. I thought, therefore, that I should include examples of that sort of origin of integrals, too, in addition to the pure imagination of mathematicians. Still, with each of the first two examples in this section I have made an effort to keep the interest of mathematicians, too, by selecting *physical* problems, each giving birth to an integral, that are *mathematical* problems at heart; both of these examples come from probability. For a third example of where interesting integrals ‘come from,’ I’ve selected a problem that I first came across while reading *Irresistible Integrals*, a book I mentioned in the Preface. I think it nicely illustrates how mathematicians can need motivation, too (just like physicists), for some of the ‘weird’ integrals *they* conjure-up!

So, to start, here is what I call ‘The Circle in a Circle’ problem. Imagine a circle (let’s call it C_1) that has radius a . We then chose *at random*,⁸ and *independently*, three points from the interior of that circle. These three points, *if non-collinear*, uniquely determine another circle, C_2 . C_2 may or may not be totally contained within C_1 . What is the probability that C_2 lies totally inside C_1 ?⁹

To answer this, imagine that after picking the three points we’ve drawn C_2 as shown in Fig. 1.8.1. There I’ve shown C_2 as totally inside C_1 , but that’s just because I arbitrarily decided to do it that way instead of showing the alternative. Without any loss of generality, we can further imagine that the horizontal axis passes through the center of C_2 (as shown) because we can always rotate the figure to make that so. The center of C_2 is taken to be distance r from the center of C_1 , and the radius of C_2 is taken to be x .

Next, imagine a thin, circular band of width Δx is drawn that encloses the circumference of C_2 . The area of this band is, to a first approximation that gets better and better as $\Delta x \rightarrow 0$, given by $2\pi x \Delta x$. The probability a point selected at random from the interior of C_1 is from this band is, therefore, the ratio of the area of the band to the area of C_2 (see note 8 again):

$$\frac{2\pi x \Delta x}{\pi a^2} = \frac{2}{a^2} x \Delta x.$$

(I’ll comment further on this claim, in just a bit.) Since the *three* points that determine C_2 all fall inside the band (*by definition!*), and they are *independently* selected, then the probability of that event is

⁸ ‘At random’ has the following meaning. If we look at any tiny patch of area dA in the interior of C_1 , a patch of any shape, then the probability a point is selected from that area patch is dA divided by the area of C_1 . We say that each of the three points is selected *uniformly* from the interior of C_1 .

⁹ I think it almost intuitively obvious that the probability is *scale-invariant* (the same for any value of a), but just in case it isn’t obvious for you I’ll carry the radius of C_1 along explicitly. At the end of our analysis you’ll see that the scale-setting parameter a has disappeared, proving my claim.

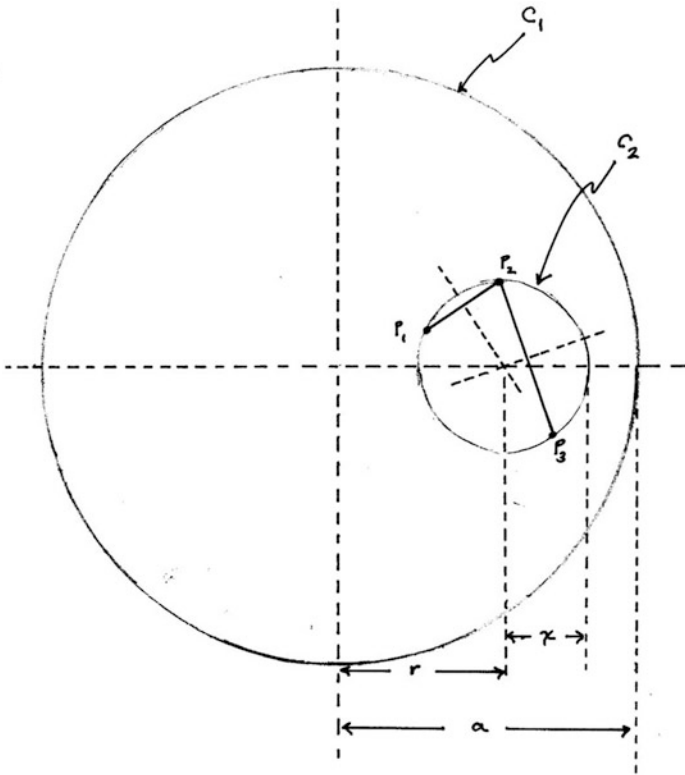

Fig. 1.8.1 A ‘Circle Inside A Circle’

$$\left\{ \frac{2}{a^2} x \Delta x \right\}^3 = \frac{8}{a^6} x^3 \{\Delta x\}^2 \Delta x = \frac{8}{a^6} x^3 \Delta A \Delta x$$

where $\Delta A = \{\Delta x\}^2$ is the differential area in rectangular coordinates. (I’ll elaborate on this claim, in just a bit.) I’ll write ΔA and Δx as dA and dx , respectively, from now on.

Obviously if $x = 0$ (that is, if C_2 is a degenerate circle that is actually a point) we see that C_2 is necessarily inside C_1 . In fact, as x increases from 0, it can get as large as $a - r$ before C_2 penetrates C_1 . So, the probability the C_2 circle, centered on a particular line (the horizontal axis), is totally within C_1 is

$$\frac{8}{a^6} \int_0^{a-r} x^3 dx = \frac{8}{a^6} \left\{ \frac{x^4}{4} \right\} \Big|_0^{a-r} = \frac{2}{a^6} (a - r)^4.$$

In general, of course, the center of C_2 could fall anywhere inside C_1 , with any value of r from 0 to a occurring, and so we need to integrate the above differential probability (*differential* because of the dA) over the entire interior of C_1 . This is most easily done by writing dA in polar coordinates, as $r dr d\theta$, and so the probability we are after is

$$\int_0^{2\pi} \int_0^a \frac{2}{a^6} (a-r)^4 r dr d\theta = \frac{2}{a^6} \int_0^{2\pi} \left\{ \int_0^a (a-r)^4 r dr \right\} d\theta = \frac{4\pi}{a^6} \int_0^a (a-r)^4 r dr,$$

since the θ -integral is obviously just 2π (there is no θ -dependency in the integrand).

The remaining r -integral is easily done by making the change of variable $u = a - r$ (and so $du = -dr$). So,

$$\begin{aligned} \int_0^a (a-r)^4 r dr &= \int_a^0 u^4 (a-u)(-du) = \int_0^a u^4 (a-u) du = a \int_0^a u^4 du - \int_0^a u^5 du \\ &= a \left\{ \frac{u^5}{5} \right\} \Big|_0^a - \left\{ \frac{u^6}{6} \right\} \Big|_0^a = \frac{a^6}{5} - \frac{a^6}{6} = \frac{a^6}{30}. \end{aligned}$$

Thus, the probability that C_2 lies totally inside C_1 is

$$\frac{4\pi}{a^6} \left(\frac{a^6}{30} \right) = \frac{4\pi}{30} = \frac{2\pi}{15} = 0.418879 \dots$$

Notice that the radius of C_1 , a , has cancelled away, which supports my earlier claim that the probability is scale-invariant.

Well, all this is fine as it stands, BUT—how do we *really know* that one of our admittedly casual manipulations along the way didn't have a hidden flaw in it?¹⁰ (Like the claim, for example, that $\{\Delta x\}^2$ is the differential area in rectangular coordinates, in which I've replaced the Δy in the usual $dA = \Delta x \Delta y$ with another Δx . Or, what about the claim a randomly selected point from the interior of C_1 is in the Δx band around C_2 , as that *assumes* C_2 is totally inside C_1 ?) The integral we evaluated was not a technically difficult one to do, but how do we know we arrived at the *correct* integral? This is a question, often confronting the engineering analyst, which might not be of great concern to a pure mathematician who is simply looking for an 'interesting integral.'

¹⁰The analysis I've just taken you through is the one given on pp. 817–818 of Edwards' book that I mentioned in the Preface. The result of $\frac{2\pi}{15}$ is the answer derived by Edwards.

When we ‘check’ integrals that are just given to us, we’ll use *quad* or *int*, but when we are faced with this new type of question we need to do something different. What we’ll do still uses a computer, but now we’ll *simulate* the physical process of drawing a circle C_2 using points chosen randomly from the interior of a given circle, C_1 . That is, our computer will ‘draw’ many such random C_2 circles and literally count the fraction of them that are totally inside C_1 . The computer code that accomplishes this will be developed by an analysis that is distinct, separate, and independent of the mathematical arguments used to arrive at the integral in our theoretical result. So, here’s how to create what physicists call a *Monte Carlo simulation* of the problem, a technique that in the pre-computer days of the 1920s Edwards could only have imagined in a science fiction fantasy.

Given three points that are not collinear, p_1, p_2 , and p_3 , where $p_1 = (x_1, y_1)$, $p_2 = (x_2, y_2)$, and $p_3 = (x_3, y_3)$, we form two chords: chord a as p_1p_2 and chord b as p_2p_3 , with centers as $(\frac{x_1+x_2}{2}, \frac{y_1+y_2}{2})$ and $(\frac{x_2+x_3}{2}, \frac{y_2+y_3}{2})$, respectively. The equations of these two chords are

$$y_a = m_a(x - x_1) + y_1$$

and

$$y_b = m_b(x - x_2) + y_2$$

where m_a and m_b are the slopes of chord a and chord b, respectively. In fact,

$$m_a = \frac{y_2 - y_1}{x_2 - x_1}$$

and

$$m_b = \frac{y_3 - y_2}{x_3 - x_2}.$$

The center of C_2 is the intersection point of the perpendicular bisectors of the two chords (dashed lines in Fig. 1.8.1). The slope of a line perpendicular to a line with slope m is the negative reciprocal of m , and so the equations of the perpendicular bisectors are

$$y_A = -\frac{1}{m_a} \left(x - \frac{x_1 + x_2}{2} \right) + \frac{y_1 + y_2}{2}$$

and

$$y_B = -\frac{1}{m_b} \left(x - \frac{x_2 + x_3}{2} \right) + \frac{y_2 + y_3}{2}.$$

The intersection point of the bisectors (the center of C_2) is such that $y_A = y_B$ and so, solving for the x -ordinate of the center, we have

$$x_c = \frac{m_a m_b (y_1 - y_3) + m_b (x_1 + x_2) - m_a (x_2 + x_3)}{2(m_b - m_a)}.$$

The value of y_c , the y -ordinate of the center, is found by substituting x_c into either of the y_A , y_B equations. Finally, the distance of the center of C_2 from the center of C_1 is $\sqrt{x_c^2 + y_c^2}$. The radius of C_2 is the distance between the center of C_2 and any one of the three points p_1, p_2, p_3 . As long as the sum of these two distances is no more than 1, C_2 is inside C_1 . Otherwise, C_2 penetrates C_1 .

The MATLAB code **circles.m** performs all of this grubby number-crunching, over and over, a total of one million times, keeping track of how many of those times C_2 is inside C_1 . Running **circles.m** numerous times produced estimates¹¹ for the probability C_2 is inside C_1 ranging over the interval 0.39992 to 0.400972. Comparing this interval with the theoretical result we computed earlier, 0.418879, leaves one (me, anyway) with a feeling of concern. A million samples is a lot of samples, and yet we have a disagreement between theory and ‘experiment’ of about 5%. That’s not an insignificant difference. In addition, you’ll notice that the code’s interval of estimates does not include the theoretical result while, in general, multiple Monte Carlo computer simulations will nearly always *bound* a theoretical result, sometimes overestimating and other times underestimating the theoretical value. It is difficult to look at the simulation results and not to come away with the feeling that the actual probability C_2 is inside C_1 is *exactly* 0.4. That is, $\frac{2}{5} = \frac{2}{15/3}$ rather than $\frac{2\pi}{15} = \frac{2}{15/\pi}$. But that’s simply speculation on my part.

Why the lack of better agreement between theory and experiment? I don’t know. *Perhaps* there is a subtle error in the theoretical analysis. Or *perhaps* I made an error in the code. But it doesn’t matter, for this book. My only point with this example is to show you how a theoretical analysis (involving an integral) and a computer can work together. *Something* is not quite right here, but I’m going to leave it to some enterprising reader to dig it out. If that reader is *you*, send your work to me and I’ll feature it in the second edition of this book!

¹¹ This *interval* of estimates is a result of the code’s use of a random number generator (with the *rand* command)—every time we run the code we get a new estimate that is (slightly) different from the estimates produced by previous runs.

circles.m

```

% Created by P.J.Nahin (9/12/2012) for Inside Interesting Integrals.
% This code performs simulations of the 'circle in a circle' problem
% one million times.
inside=0;
for loop1=1:1000000
    for loop2=1:3
        done=0;
        while done==0
            x=-1+2*rand;y=-1+2*rand;
            if x^2+y^2<=1;
                px(loop2)=x;py(loop2)=y;done=1;
            end
        end
    end
    ma=(py(2)-py(1))/(px(2)-px(1));
    mb=(py(3)-py(2))/(px(3)-px(2));
    xc=ma*mb*(py(1)-py(3))+mb*(px(1)+px(2))-ma*(px(2)+px(3));
    xc=xc/(2*(mb-ma));
    yc=(-1/ma)*(xc-((px(1)+px(2))/2));
    yc=yc+(py(1)+py(2))/2;
    center=sqrt(xc^2+yc^2);
    radius=sqrt((xc-px(1))^2+(yc-py(1))^2);
    if center+radius<=1
        inside=inside+1;
    end
end
inside/loop1

```

For a second example of where integrals come from, let's go back to June 1827, when the Scottish botanist Robert Brown (1773–1858) observed (through a one-lens microscope, that is, a magnifying glass, with a magnification in excess of 300) the chaotic motion of tiny grains of plant pollen suspended in water drops. This motion had earlier been noticed in passing by others, but Brown took the time to publish what he saw in a September 1828 paper in the *Philosophical Magazine*, and thereby initiated a search for what was going on. The German-born

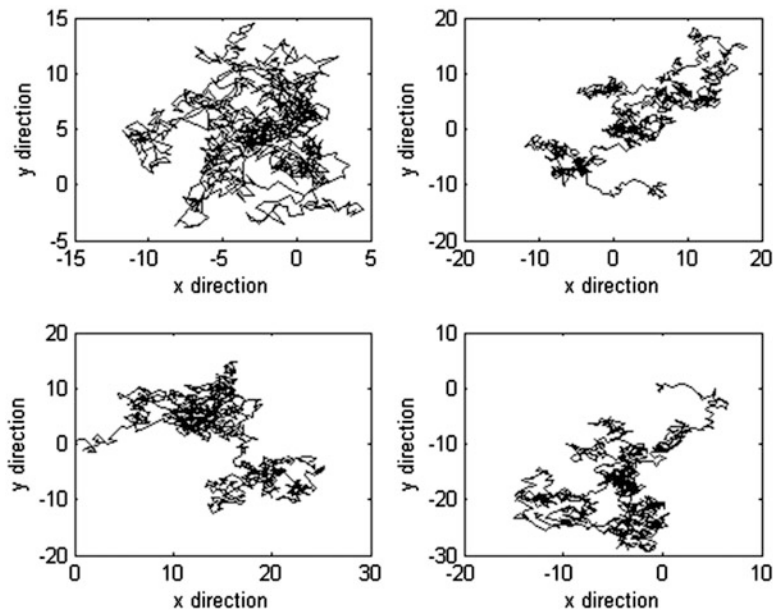

Fig. 1.8.2 Typical paths of two-dimensional Brownian motion (each 1,000 steps)

physicist Albert Einstein (1879–1955), in a series of papers published between 1905 and 1908, applied statistical mechanics to show that what is now called *Brownian motion* is the result of the random bombardment of the particles by the molecules of the suspension medium. Indeed, Brownian motion is viewed as strong macroscopic experimental evidence for the reality of molecules (and so of atoms, too).

Figure 1.8.2 shows four typical paths of particles executing Brownian motion in two dimensions,¹² and they *are* pretty erratic. In fact, in the early 1920s the American mathematician Norbert Wiener (1894–1964) made a deep analysis of the *mathematics* of Brownian motion (Einstein explained the *physics*), studying in particular what happens in the limit of a particle being *continuously* hit by molecules (that is, successive hits are separated by vanishingly small time intervals).

¹² Imagine that we have defined the maximum absolute value of a *step*, which will be our unit distance. Then, in one dimension (call it x) the particle moves, after each molecular hit, a distance randomly selected from the interval -1 to $+1$. In a second, perpendicular direction (call it y) the particle moves, after each molecular hit, a distance randomly selected from the interval -1 to $+1$. Figure 1.8.2 shows the combined result of these two *independent* motions for four particles, each for 1,000 hits (the four curves are MATLAB simulations).

In that limit, Brownian motion becomes what mathematicians somewhat forbiddingly call a *Wiener stochastic random process*. Each realization of such a process is called a ‘Wiener random walk,’ and they are continuous curves that are so kinky they *fail*, at almost every point, to have a derivative (that is, to have a direction)!

Now, suppose at time $t=0$ we put a particle at the origin of a plane and then watch it execute a one-dimensional Wiener walk on the x -axis. Where will it be at some later time $t > 0$? Certainly it will always be on the x -axis, but *where*? Since the walk is random, the best we can do is give the *probability* the particle will be somewhere, and this was one of the first things Einstein calculated in 1905. To be specific, let’s write $W(x, t)$ as the probability the particle will be somewhere in the interval $(x, x + \Delta x)$ at time t . (The W is, of course, in honor of Wiener.) Let’s assume this probability is, for very short intervals, *linear* in Δx (i.e., double the length the of the interval and so double the probability the particle is there), and so

$$W(x, t) = f(x, t)\Delta x$$

where $f(x, t)$ is called the *probability density function* of the Wiener walk (a *density* because we multiply it by the interval length Δx to get the probability).

Einstein showed, through ingenious physical arguments (which we can ignore here), that $f(x, t)$ is the solution to the second-order partial differential equation

$$\frac{\partial f}{\partial t} = D \frac{\partial^2 f}{\partial x^2}$$

where D is a constant. (D is determined by a number of physical constants, like the mass of the particle and the temperature, and Einstein derived a formula for D , but for us it is sufficient to just write D .) This differential equation is, in fact, a famous one in mathematical physics, called the *heat* or *diffusion* equation, and so D is called the *diffusion constant*. In the usual appearance of this equation, the function being solved for is the temperature in a solid as a function of location and time, but Einstein showed that the probability density function for the Wiener walk satisfies the very same equation. Amazing!

The solution for $f(x, t)$ is

$$f(x, t) = \frac{e^{-x^2/4Dt}}{2\sqrt{\pi Dt}},$$

which is easily verified by direct substitution, although it can be formally derived using nothing but simple combinatorial (that is, purely *mathematical*) arguments.¹³ Since the particle has to be *somewhere* (I do hope that is obvious!) it must be true

¹³ If you are curious about the details of such a derivation, you can find them in my book *Mrs. Perkins’s Electric Quilt*, Princeton University Press 2009, pp. 263–267.

that if we integrate the probability density over the *entire* x -axis we have to get a probability of 1. That is,

$$\int_{-\infty}^{\infty} f(x, t) dx = 1$$

for all $t \geq 0$.¹⁴

From elementary probability theory we know the average value of x , at any time t , is

$$\langle x \rangle = \int_{-\infty}^{\infty} x f(x, t) dx = 0.$$

This is *mathematically* so because $f(x, t)$ is even and so the integrand is an odd function of x , and it is *physically* so because a one-dimensional Wiener walk is equally likely to move in either direction at every instant in time. And yet, as Fig. 1.8.2 clearly illustrates, a *two*-dimensional Wiener walk does tend to slowly migrate away in absolute distance from the origin as t increases. A measure of this drift is the average *squared* value of x (because then the individual horizontal (and vertical) movements of the particle that have opposite signs don't tend to cancel each other). So, like Einstein, let's calculate

$$\langle x^2 \rangle = \int_{-\infty}^{\infty} x^2 f(x, t) dx = \frac{1}{2\sqrt{\pi Dt}} \int_{-\infty}^{\infty} x^2 e^{-x^2/4Dt} dx$$

or, since the integrand is an even function of x ,

$$\langle x^2 \rangle = \frac{1}{\sqrt{\pi Dt}} \int_0^{\infty} x^2 e^{-x^2/4Dt} dx.$$

Making the obvious change of variable $u = \frac{x^2}{4Dt}$, we have

$$\frac{du}{dx} = \frac{2x}{4Dt} = \frac{x}{2Dt}$$

and so

$$dx = \frac{2Dt}{x} du.$$

Or, since $x = 2\sqrt{Dt}\sqrt{u}$, we have

¹⁴ For a proof of this, see *Mrs. Perkins's*, pp. 282–283.

$$dx = \frac{2Dt}{2\sqrt{Dt}} \left(\frac{du}{\sqrt{u}} \right) = \sqrt{Dt} \frac{du}{\sqrt{u}}.$$

Thus,

$$\langle x^2 \rangle = \frac{1}{\sqrt{\pi Dt}} \int_0^\infty 4Dt u e^{-u\sqrt{Dt}} \frac{du}{\sqrt{u}} = Dt \frac{4}{\sqrt{\pi}} \int_0^\infty \sqrt{u} e^{-u} du.$$

At this point we actually have Einstein's basic result that $\langle x^2 \rangle$ varies *linearly* with t because, whatever the value of the integral, we know it is simply a *number*. For us *in this book*, however, the calculation of the integral (which has appeared in a natural way in a physical problem) is the challenge. In Chap. 4 we'll do this calculation—see (4.2.8)—and find that the integral's value is $\frac{1}{2}\sqrt{\pi}$. So (and just as Einstein wrote), $\langle x^2 \rangle = 2Dt$.

For my third example of where integrals come from, this time from pure mathematics, just imagine someone has just dropped *this* on your desk: show that

$$\int_1^\infty \frac{\{x\} - \frac{1}{2}}{x} dx = -1 + \ln(\sqrt{2\pi}) = -0.08106\dots,$$

where $\{x\}$ denotes the fractional part of x (for example, $\{5.619\} = 0.619$ and $\{7\} = 0$). Holy cow!, I can just hear most readers exclaim, how do you prove something like *that*? The authors of *Irresistible Integrals* outline a derivation (see their pp. 92–93) but skip over a *very* big step, with just a tiny hint at how to proceed. *At least* as interesting as the derivation, itself, is that the integral was not simply 'made-up out of the blue,' but is actually the result of a preliminary analysis.

Before getting into the derivation details, it is useful to get a 'physical feel' for the integral. In Fig. 1.8.3 the integrand is plotted over the interval $1 \leq x \leq 20$. You can see from that plot that the integrand starts off with a negative area over the interval $1 \leq x \leq 1.5$, which is then partially cancelled with positive area from $1.5 \leq x \leq 2$, followed by a negative area from $2 \leq x \leq 2.5$, which is then *almost* cancelled by positive area from $2.5 \leq x \leq 3$, and so on. These alternating area cancellations are never quite total, but as $x \rightarrow \infty$ the area cancellations do become ever closer to total, which physically explains why the integral exists (doesn't blow-up). Since the negative areas are always slightly bigger in magnitude than the positive ones, the final slightly negative value for the integral does make sense.

We can numerically check these observations with *quad*, over the integration interval in Fig. 1.8.3. Thus, $quad(@x)(x-floor(x)-0.5)./x,1,20) = -0.0769\dots$, where $floor(x)$ computes the largest integer less than x . That is, $floor(x)$ rounds x down and so $x - floor(x) = \{x\}$. This is in pretty good agreement with the *Irresistible Integrals* theoretical result.

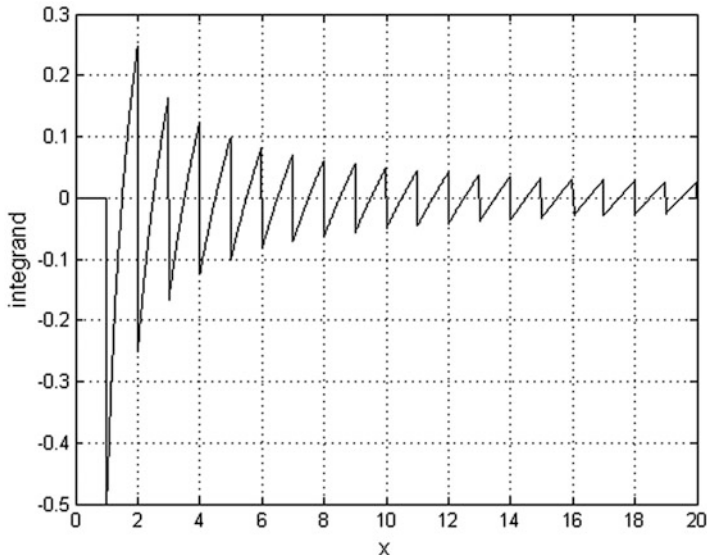

Fig. 1.8.3 The *Irresistible Integrals* integrand

We start with a famous result in mathematics, *Stirling’s asymptotic formula* for $n!$:

$$n! \sim \sqrt{2\pi} n^{n+\frac{1}{2}} e^{-n},$$

named after the Scottish mathematician James Stirling (1692–1770)—although it is known that the French mathematician Abraham de Moivre (1667–1754) knew an equivalent form at the same time (or even earlier)—who published it in 1730. Factorials get very large, very fast (my hand calculator first fails at 70!), and Stirling’s formula is quite useful in computing $n!$ for large n . It is called *asymptotic* because, while the *absolute* error in the right-hand side in evaluating the left-hand side blows-up as $n \rightarrow \infty$ the *relative* error goes to zero as $n \rightarrow \infty$ (that’s why \sim is used instead of $=$). That is,

$$\lim_{n \rightarrow \infty} \frac{n!}{\sqrt{2\pi} n^{n+\frac{1}{2}} e^{-n}} = 1$$

or, alternatively,

$$\lim_{n \rightarrow \infty} \frac{n!}{n^{n+\frac{1}{2}} e^{-n}} = \sqrt{2\pi}.$$

Tuck this away in your memory because we’ll use it at the end of our derivation of the above integral. So, here we go.

We start by writing

$$\ln\{n!\} = \ln\{n(n-1)(n-2)\dots(3)(2)(1)\} = \ln(n) + \ln(n-1) + \dots + \ln(2) + \ln(1)$$

or, since $\ln(1) = 0$,

$$\ln\{n!\} = \sum_{k=2}^n \ln(k).$$

Next, first notice that since

$$\int_1^k \frac{dx}{x} = \{\ln(x)\}_1^k = \ln(k)$$

then

$$\ln\{n!\} = \sum_{k=2}^n \int_1^k \frac{dx}{x},$$

and then further notice that

$$\int_1^k \frac{dx}{x} = \sum_{j=1}^{k-1} \int_j^{j+1} \frac{dx}{x}.$$

Thus,

$$\ln\{n!\} = \sum_{k=2}^n \left\{ \sum_{j=1}^{k-1} \int_j^{j+1} \frac{dx}{x} \right\}.$$

So far, so good. It is at this point, however, that the authors of *Irresistible Integrals* write that the next thing to do is “exchange the order of the two sums,” and then they *immediately* write

$$\ln\{n!\} = \int_1^n \frac{n - \lfloor x \rfloor}{x} dx$$

where the notation $\lfloor x \rfloor$ means the integer part of x (for example, $\lfloor 5.619 \rfloor = 5$). Clearly,

$$x = \lfloor x \rfloor + \{x\}.$$

This ‘exchange’ step may look mysterious to you (it did to me, at first!), but here’s how to see it. Write down the terms of the inner sum for each value of k as that index goes from 2 to n (the outer sum):

$$\begin{aligned}
 k = 2 & : \int_1^2 \\
 k = 3 & : \int_1^2 + \int_2^3 \\
 k = 4 & : \int_1^2 + \int_2^3 + \int_3^4 \\
 & \dots\dots\dots \\
 k = n & : \int_1^2 + \int_2^3 + \int_3^4 + \dots + \int_{n-1}^n .
 \end{aligned}$$

As written, the double summation adds all these integrals *horizontally*, across row by row. Exchanging the order of the sums simply means to add all the integrals *vertically*, down column by column. You get the same answer, either way! Thus,

$$\begin{aligned}
 \ln\{n!\} &= (n-1) \int_1^2 \frac{dx}{x} + (n-2) \int_2^3 \frac{dx}{x} + (n-3) \int_3^4 \frac{dx}{x} + \dots + \int_{n-1}^n \frac{dx}{x} \\
 &= \int_1^2 \frac{(n-1)}{x} dx + \int_2^3 \frac{(n-2)}{x} dx + \int_3^4 \frac{(n-3)}{x} dx + \dots + \int_{n-1}^n \frac{1}{x} dx.
 \end{aligned}$$

The general form of the terms in the last summation is, with $1 \leq j \leq n-1$,

$$\int_j^{j+1} \frac{(n-j)}{x} dx = \int_j^{j+1} \frac{n - [x]}{x} dx$$

because, for the integration interval $j \leq x < j+1$, we have *by definition* that $[x] = j$. Thus,

$$\ln\{n!\} = \int_1^n \frac{n - [x]}{x} dx$$

as claimed in *Irresistible Integrals*.

Now, since

$$[x] = x - \{x\}$$

then

$$n - [x] = n - [x - \{x\}] = n - x + \{x\}.$$

So,

$$\begin{aligned}
\ln\{n!\} &= \int_1^n \frac{n-x+\{x\}}{x} dx = \int_1^n \frac{n}{x} dx - \int_1^n dx + \int_1^n \frac{\{x\}}{x} dx \\
&= n \ln(n) - (n-1) + \int_1^n \frac{\{x\}}{x} dx = n \ln(n) - n + 1 + \frac{1}{2} \ln(n) + \int_1^n \frac{\{x\} - \frac{1}{2}}{x} dx \\
&= \left(n + \frac{1}{2}\right) \ln(n) - n + 1 + \int_1^n \frac{\{x\} - \frac{1}{2}}{x} dx \\
&= \ln\left(n^{n+\frac{1}{2}}\right) + \ln(e^{-n}) + 1 + \int_1^n \frac{\{x\} - \frac{1}{2}}{x} dx \\
&= \ln\left(n^{n+\frac{1}{2}} e^{-n}\right) + \ln\left(e^{1+\int_1^n \frac{\{x\}-\frac{1}{2}}{x} dx}\right) \\
&= \ln\left(n^{n+\frac{1}{2}} e^{-n} e^{1+\int_1^n \frac{\{x\}-\frac{1}{2}}{x} dx}\right).
\end{aligned}$$

So,

$$n! = n^{n+\frac{1}{2}} e^{-n} e^{1+\int_1^n \frac{\{x\} - \frac{1}{2}}{x} dx}$$

or,

$$e^{1+\int_1^n \frac{\{x\} - \frac{1}{2}}{x} dx} = \frac{n!}{n^{n+\frac{1}{2}} e^{-n}}$$

or, if we now let $n \rightarrow \infty$ and recall Stirling's formula, we have

$$e^{1+\int_1^\infty \frac{\{x\} - \frac{1}{2}}{x} dx} = \sqrt{2\pi}.$$

Thus,

$$1 + \int_1^\infty \frac{\{x\} - \frac{1}{2}}{x} dx = \ln(\sqrt{2\pi})$$

and so, just as *Irresistible Integrals* claimed,

(1.8.1)

$$\int_1^{\infty} \frac{x^{-\frac{1}{2}}}{x} dx = -1 + \ln(\sqrt{2\pi}).$$

To really be sure you've understood the derivation of (1.8.1), try your hand at the second challenge problem of Chap. 5 (when you get there).

1.9 Last Words

In a rightfully famous (and very funny) collection of autobiographical essays, physicist Richard Feynman writes¹⁵

I had learned to do integrals by various methods shown in a book that my high school teacher Mr. Bader had given me. . . . it was for a junior or senior course in college. It had Fourier series, Bessel functions, determinants, elliptic functions—all kinds of wonderful stuff that I didn't know anything about. That book also showed how to differentiate parameters under the integral sign—it's a certain operation. It turns out that's not taught very much in the universities; they don't emphasize it. But I caught on how to use that method, and I used that one damn tool again and again. So, because I was self-taught using that book, I had peculiar methods of doing integrals. The result was, when guys at MIT or Princeton had trouble doing a certain integral, it was because they couldn't do it with the standard methods they had learned in school. If it was contour integration, they would have found it; if it was a simple series expansion, they would have found it. Then I come along and try differentiating under the integral sign, and often it worked. So I got a great reputation for doing integrals, only because my box of tools was different from everybody else's, and they had tried all their tools on it before giving the problem to me.

Feynman was writing of his experiences in the late 1930s, long before Wolfram's on-line symbolic integrator was even just a science fiction fantasy, much less actually available. And so while he was clearly having fun doing integrals, there was also a real pay-off to his knowing a 'trick' that others didn't know. Later in the same book he writes¹⁶ of an encounter he had with another analyst who was stumped by an integral that had appeared in his work during the atom bomb project in the Second World War:

When one of the guys was explaining [his] problem, I said, 'Why don't you do it by differentiating under the integral sign?' In half an hour he had it solved, and they'd been working on it for three weeks. So, I did something, using my 'different box of tools.'

Later in this book I'll show you numerous examples of Feynman's favorite trick of 'differentiating under the integral sign' (which can be traced all the way back to

¹⁵ In the essay titled "A Different Box of Tools," in *Surely You're Joking, Mr. Feynman!*, W. W. Norton 1985, pp. 84–87.

¹⁶ In the essay "Los Alamos from Below" in *Surely You're Joking, Mr. Feynman!*, pp. 107–136.

Leibniz in the late seventeenth century), although it seems the final form of it that we use today is really a post-Leibniz development. We'll also use other tricks involving the more familiar operations of change of variable (as we did in the 'circle in a circle' integral in the previous section), power series, and integration-by-parts. And, as I promised in the Preface, we'll explore contour integration, too. In fact, why wait? Let's get started right now.

1.10 Challenge Problems

Before moving on to the next chapter, however, here are four challenge problems for your amusement.

(C1.1): Use the 'sneaking up on a singularity' trick to evaluate

$$\int_0^8 \frac{dx}{x-2}.$$

This is an improper integral because of the singularity in the integration interval at $x=2$, but it does have a value. Repeat for the integral

$$\int_0^3 \frac{dx}{(x-1)^{2/3}}$$

and show that, despite the singularity at $x=1$, this integral also has a value. Notice that unlike in the first integral, the integrand is always positive (there is no cancellation between negative and positive areas). Nevertheless, the integral still has a value.

(C1.2): Show that

$$\int_1^{\infty} \frac{dx}{\sqrt{x^3-1}}$$

exists because there is a finite upper-bound on its value. In particular, show that the integral¹⁷ is less than 4.

¹⁷ For a discussion of how this integral appears in a physics problem, see my book *Mrs. Perkins's Electric Quilt*, Princeton 2009, pp. 2–3 (and also p. 4, for how to attack the challenge question—but try on your own before looking there or at the solutions).

(C1.3): What is the answer to the Feynman integral puzzle in (1.6.1)? Start by deriving (1.6.1) and think about just how arbitrary the constants a and b really are.

(C1.4): For c any positive constant, start by confirming that the integral

$$\int_0^{\infty} \frac{e^{-cx}}{x} dx$$

is transformed by the change of variable $y = cx$ into the integral

$$\int_0^{\infty} \frac{e^{-y}}{y} dy.$$

Now if this is so then with a and b any two positive constants it would seem we could argue that

$$\begin{aligned} I &= \int_0^{\infty} \frac{e^{-ax} - e^{-bx}}{x} dx = \int_0^{\infty} \frac{e^{-ax}}{x} dx - \int_0^{\infty} \frac{e^{-bx}}{x} dx = \int_0^{\infty} \frac{e^{-y}}{y} dy - \int_0^{\infty} \frac{e^{-y}}{y} dy \\ &= 0. \end{aligned}$$

But, as we'll see in Chapter 3, in (3.3.3),

$$I = \int_0^{\infty} \frac{e^{-ax} - e^{-bx}}{x} dx = \ln\left(\frac{b}{a}\right)$$

which is zero only for the special case of $a = b$. So, there's the puzzle—what's wrong with the first argument that claims I is zero for any positive a and b ?

(C1.5): Here's one more example of an integral that appears in a real-world situation, and of how MATLAB makes short work of it. *Mercator's integral*, named after the inventor—Gerardus Mercator (1512–1594), born in what is today Belgium—of the famous *Mercator map* that renders the spherical surface of the Earth on a planar map, is $\int_{\theta_1}^{\theta_2} \frac{d\theta}{\cos(\theta)}$. It appears as a 'distortion' or 'warping' factor in the construction of a 'flat map' (θ_1 and θ_2 are the latitude extremes of the map). Mercator (who was a cartographer and not a mathematician) encountered this distortion in 1569, long before analytical integration techniques were developed, and he was forced to deal with it by other means (wouldn't he have loved MATLAB!). Today, of course, he would just use a table of integrals. What is the value of Mercator's integral if $\theta_1 = 0$ and $\theta_2 = \frac{\pi}{3}$ (60°)? MATLAB computes `quad(@(x)1./cos(x),0,pi/3) = 1.3169579...` (If you have a table of integrals handy, then you should find that the theoretical answer is $\ln(2 + \sqrt{3}) = 1.31695789\dots$)

Chapter 2

'Easy' Integrals

2.1 Six 'Easy' Warm-Ups

You should always be alert, when confronted by a definite integral, for the happy possibility that although the integral might look 'interesting' (that is, hard!) just *maybe* it will still yield to a direct, frontal attack. The first six integrals in this chapter are in that category. If a and b are positive constants, calculate:

$$(2.1.a) \quad \int_1^{\infty} \frac{1}{(x+a)\sqrt{x-1}} dx$$

and

$$(2.1.b) \quad \int_0^{\infty} \ln\left(1 + \frac{a^2}{x^2}\right) dx$$

and

$$(2.1.c) \quad \int_0^{\infty} \frac{\ln(x)}{x^2 + b^2} dx$$

and

$$(2.1.d) \quad \int_0^{\infty} \frac{1}{1 + e^{ax}} dx.$$

Finally, calculate

$$(2.1.e) \quad \int_{\sqrt{2}}^{\infty} \frac{1}{x + x\sqrt{2}} dx$$

and

$$(2.1.f) \quad \int_{-\infty}^{\infty} \frac{dx}{\cosh(x)}.$$

For (2.1.a) make the change of variable $x-1 = t^2$ and so

$$\frac{dx}{dt} = 2t$$

or

$$dx = 2t dt = 2\sqrt{x-1} dt.$$

Since

$$x = 1 + t^2$$

then we have

$$\int_1^{\infty} \frac{1}{(x+a)\sqrt{x-1}} dx = \int_0^{\infty} \frac{2\sqrt{x-1} dt}{(1+t^2+a)\sqrt{x-1}} = 2 \int_0^{\infty} \frac{dt}{(a+1)+t^2}.$$

We immediately recognize this last integral as being of the form

$$\int \frac{dt}{c^2 + t^2} = \frac{1}{c} \tan^{-1} \left(\frac{t}{c} \right)$$

and so

$$\begin{aligned} \int_1^{\infty} \frac{1}{(x+a)\sqrt{x-1}} dx &= 2 \left\{ \frac{1}{\sqrt{a+1}} \tan^{-1} \left(\frac{t}{\sqrt{a+1}} \right) \right\} \Big|_0^{\infty} \\ &= \frac{2}{\sqrt{a+1}} \tan^{-1}(\infty) = \frac{2}{\sqrt{a+1}} \left(\frac{\pi}{2} \right) \end{aligned}$$

which gives us

$$(2.1.1) \quad \int_1^\infty \frac{1}{(x+a)\sqrt{x-1}} dx = \frac{\pi}{\sqrt{a+1}}.$$

As a check, for $a = 99$ we have the value of the integral equal to $\frac{\pi}{10} = 0.31415\dots$, while *quad* says *quad*(@(x)1./((x+99).*sqrt(x-1)),1,1e5) = 0.30784... Notice that the upper limit of infinity has been replaced with the finite (but ‘large’) number 10^5 .

For (2.1.b) integration-by-parts will do the job. That is, we’ll use

$$\int_0^\infty u dv = (uv)|_0^\infty - \int_0^\infty v du,$$

where

$$u = \ln\left(1 + \frac{a^2}{x^2}\right)$$

and $dv = dx$. Then, $v = x$ and

$$du = \left(-\frac{2a^2}{x}\right)\left(\frac{1}{x^2 + a^2}\right) dx.$$

So,

$$\begin{aligned} \int_0^\infty \ln\left(1 + \frac{a^2}{x^2}\right) dx &= \left\{ x \ln\left(1 + \frac{a^2}{x^2}\right) \right\} \Big|_0^\infty - \int_0^\infty x \left(-\frac{2a^2}{x}\right) \left(\frac{1}{x^2 + a^2}\right) dx \\ &= 2a^2 \int_0^\infty \frac{dx}{x^2 + a^2} = 2a^2 \left\{ \frac{1}{a} \tan^{-1}\left(\frac{x}{a}\right) \right\} \Big|_0^\infty = 2a \tan^{-1}(\infty) \end{aligned}$$

and thus¹

¹In this derivation we’ve assumed $\lim_{x \rightarrow 0} x \ln\left(1 + \frac{a^2}{x^2}\right) = \lim_{x \rightarrow \infty} x \ln\left(1 + \frac{a^2}{x^2}\right) = 0$. To see that these two assumptions are correct, recall the power series expansion for the log function when $p \approx 0$: $\ln(1 + p) = p - \frac{1}{2}p^2 + \frac{1}{3}p^3 - \dots$. So, with $p = \frac{a^2}{x^2}$ (which $\rightarrow 0$ as $x \rightarrow \infty$), we have $x \ln\left(1 + \frac{a^2}{x^2}\right) = x \left[\frac{a^2}{x^2} - \frac{1}{2} \left(\frac{a^2}{x^2}\right)^2 + \frac{1}{3} \left(\frac{a^2}{x^2}\right)^3 - \dots \right] = \frac{a^2}{x} - \frac{1}{2} \frac{a^4}{x^3} + \dots$ which $\rightarrow 0$ as $x \rightarrow \infty$. On the other hand, as $x \rightarrow 0$ we have $x \ln\left(1 + \frac{a^2}{x^2}\right) \approx x \ln\left(\frac{a^2}{x^2}\right) = x \ln(a^2) - x \ln(x^2) = x \ln(a^2) - 2x \ln(x)$ and both of these terms go to zero as x goes to zero (the first term is obvious, and in the second term x vanishes faster than $\ln(x)$ blows-up).

$$(2.1.2) \quad \int_0^{\infty} \ln\left(1 + \frac{a^2}{x^2}\right) dx = \pi a .$$

As a check, for $a = 10$ we have the value of the integral equal to 31.415926... , while *quad* says *quad*(@(x)log(1+(100./x.^2)),0,1000) = 31.31593... .

For (2.1.c) let $x = \frac{1}{t}$ and so $dx = -\frac{1}{t^2} dt$. Our integral then becomes

$$\begin{aligned} I &= \int_0^{\infty} \frac{\ln(x)}{x^2 + b^2} dx = \int_{\infty}^0 \frac{\ln(\frac{1}{t})}{\frac{1}{t^2} + b^2} \left(-\frac{1}{t^2} dt\right) = -\int_{\infty}^0 \frac{\ln(\frac{1}{t})}{1 + b^2 t^2} dt \\ &= -\int_0^{\infty} \frac{\ln(t)}{1 + b^2 t^2} dt. \end{aligned}$$

Let $s = bt$ (and so $dt = \frac{1}{b} ds$). Then,

$$\begin{aligned} I &= -\int_0^{\infty} \frac{\ln(t)}{b^2 t^2 + 1} dt = -\int_0^{\infty} \frac{\ln(\frac{s}{b})}{s^2 + 1} \left(\frac{1}{b}\right) ds \\ &= \frac{1}{b} \left[-\int_0^{\infty} \frac{\ln(s)}{s^2 + 1} ds + \int_0^{\infty} \frac{\ln(b)}{s^2 + 1} ds \right] \end{aligned}$$

or, as the first integral in the brackets is zero—we showed this in (1.5.1)—then we have

$$I = \frac{\ln(b)}{b} \int_0^{\infty} \frac{1}{s^2 + 1} ds = \frac{\ln(b)}{b} \left\{ \tan^{-1}(s) \right\} \Big|_0^{\infty}$$

and thus

$$(2.1.3) \quad \int_0^{\infty} \frac{\ln(x)}{x^2 + b^2} dx = \frac{\pi}{2b} \ln(b) .$$

Notice that this reduces to zero (as it should) when $b = 1$. For $b = 2$ our formula says the integral is equal to $\frac{\pi}{4} \ln(2) = 0.544396...$ and MATLAB agrees: *quad*(@(x)log(x)./(4+x.^2),0,10000) = 0.543365... .

For (2.1.d) a simple substitution is all we need. Letting $u = e^{ax}$ (and so $\frac{du}{dx} = ae^{ax}$ and thus $dx = \frac{du}{ae^{ax}} = \frac{du}{a u}$) we have

$$\int_0^\infty \frac{1}{1 + e^{ax}} dx = \int_1^\infty \frac{1}{1 + u} \left(\frac{du}{au} \right) = \frac{1}{a} \int_1^\infty \frac{du}{u(1 + u)} = \frac{1}{a} \int_1^\infty \left\{ \frac{1}{u} - \frac{1}{1 + u} \right\} du$$

$$= \frac{1}{a} \{ \ln(u) - \ln(1 + u) \} \Big|_1^\infty = \frac{1}{a} \ln \left(\frac{u}{1 + u} \right) \Big|_1^\infty = -\frac{1}{a} \ln \left(\frac{1}{2} \right).$$

or,

(2.1.4) $\int_0^\infty \frac{1}{1 + e^{ax}} dx = \frac{\ln(2)}{a}.$

For $a = \pi$, for example, the integral's value is 0.220635 . . . , and in agreement we have $quad(@)(x)I./(1+exp(pi*x)),0,1000) = 0.220635 . . .$

For (2.1.e), consider the indefinite integral

$$\int \frac{dx}{x + x^m} = \int \frac{x^{-m}}{x^{1-m} + 1} dx.$$

Notice that

$$\frac{d}{dx} \ln(x^{1-m} + 1) = \frac{(1 - m)x^{1-m-1}}{x^{1-m} + 1} = \frac{(1 - m)x^{-m}}{x^{1-m} + 1}$$

and so

$$\int \frac{dx}{x + x^m} = \frac{1}{1 - m} \ln(x^{1-m} + 1) + C$$

where C is an arbitrary constant of integration. Thus, with $m = \sqrt{2}$, we have

$$\int_{\sqrt{2}}^\infty \frac{dx}{x + x^{\sqrt{2}}} = \frac{1}{1 - \sqrt{2}} \left\{ \ln \left(x^{1-\sqrt{2}} + 1 \right) \right\} \Big|_{\sqrt{2}}^\infty$$

or, because $1 - \sqrt{2} < 0$ and so $\lim_{x \rightarrow \infty} x^{1-\sqrt{2}} = 0$, a bit of elementary complex number arithmetic gives us our answer:

(2.1.5) $\int_{\sqrt{2}}^\infty \frac{dx}{x + x^{\sqrt{2}}} = (1 + \sqrt{2}) \ln \left\{ 1 + 2^{\frac{1}{2}(1-\sqrt{2})} \right\}.$

The expression on the right is 1.5063322 . . . , while $quad$ says the value of the integral is $quad(@)(x)I./(x+x.^{\sqrt{2}}),\sqrt{2},1e5) = 1.48592 . . .$

For (2.1.f) let $t = e^x$ and so $\frac{dt}{dx} = e^x$ or $dx = \frac{dt}{e^x} = \frac{dt}{t}$.

Then,

$$\begin{aligned} \int_{-\infty}^{\infty} \frac{dx}{\cosh(x)} &= \int_{-\infty}^{\infty} \frac{dx}{\frac{e^x + e^{-x}}{2}} = 2 \int_{-\infty}^{\infty} \frac{dx}{e^x + e^{-x}} = 2 \int_0^{\infty} \frac{1}{t + \frac{1}{t}} \frac{dt}{t} \\ &= 2 \int_0^{\infty} \frac{1}{t^2 + 1} dt = 2 \tan^{-1}(t) \Big|_0^{\infty} = 2 \left(\frac{\pi}{2} \right) \end{aligned}$$

and so

$$(2.1.6) \quad \boxed{\int_{-\infty}^{\infty} \frac{dx}{\cosh(x)} = \pi .}$$

MATLAB agrees, as `quad(@(x)1./cosh(x),-20,20) = 3.1415929...`

2.2 A New Trick

The next four examples illustrate an often powerful trick for calculating definite integrals, that of 'flipping' the integration variable's 'direction.' That is, if x goes from 0 to π , try changing to $y = \pi - x$. This may seem almost trivial, but it often works! With this idea in mind, let's calculate

$$(2.2.a) \quad \int_0^{\pi/2} \frac{\sqrt{\sin(x)}}{\sqrt{\sin(x)} + \sqrt{\cos(x)}} dx$$

and

$$(2.2.b) \quad \int_0^{\pi} \frac{x \sin(x)}{1 + \cos^2(x)} dx$$

and

$$(2.2.c) \quad \int_0^{\pi/2} \frac{\sin^2(x)}{\sin(x) + \cos(x)} dx$$

and

$$(2.2.d) \quad \int_0^1 \frac{\ln(x+1)}{x^2+1} dx.$$

For (2.2.a), make the substitution $x = \frac{\pi}{2} - y$. Then, $dx = -dy$ and

$$I = \int_{\pi/2}^0 \frac{\sqrt{\sin(\frac{\pi}{2} - y)}}{\sqrt{\sin(\frac{\pi}{2} - y) + \sqrt{\cos(\frac{\pi}{2} - y)}}} (-dy) = \int_0^{\pi/2} \frac{\sqrt{\cos(y)}}{\sqrt{\cos(y) + \sqrt{\sin(y)}}} dy.$$

Adding this expression to the original I (and changing the dummy variable of integration variable y back to x) gives

$$2I = \int_0^{\pi/2} \frac{\sqrt{\sin(x)} + \sqrt{\cos(x)}}{\sqrt{\sin(x)} + \sqrt{\cos(x)}} dx = \int_0^{\pi/2} dx = \frac{\pi}{2},$$

and so

$$(2.2.1) \quad \int_0^{\pi/2} \frac{\sqrt{\sin(x)}}{\sqrt{\sin(x)} + \sqrt{\cos(x)}} dx = \frac{\pi}{4}.$$

This says the integral is equal to 0.785398... , and *quad* agrees: *quad*(@(x)sqrt(sin(x))./(sqrt(sin(x))+sqrt(cos(x))),0,pi/2) = 0.785398... .

In (2.2.b) make the substitution $y = \pi - x$ (and so $dx = -dy$). Then,

$$\begin{aligned} I &= \int_{\pi}^0 \frac{(\pi - y) \sin(\pi - y)}{1 + \cos^2(\pi - y)} (-dy) \\ &= \int_0^{\pi} \frac{(\pi - y) \{ \sin(\pi) \cos(y) - \cos(\pi) \sin(y) \}}{1 + \{ \cos(\pi) \cos(y) + \sin(\pi) \sin(y) \}^2} dy \end{aligned}$$

or,

$$I = \int_0^{\pi} \frac{(\pi - y) \sin(y)}{1 + \cos^2(y)} dy = \pi \int_0^{\pi} \frac{\sin(y)}{1 + \cos^2(y)} dy - \int_0^{\pi} \frac{y \sin(y)}{1 + \cos^2(y)} dy.$$

That is,

$$I = \pi \int_0^{\pi} \frac{\sin(x)}{1 + \cos^2(x)} dx - I$$

or,

$$I = \frac{\pi}{2} \int_0^{\pi} \frac{\sin(x)}{1 + \cos^2(x)} dx.$$

Now, let $u = \cos(x)$ and so $\frac{du}{dx} = -\sin(x)$ (that is, $dx = -du/\sin(x)$). Thus,

$$\begin{aligned} I &= \frac{\pi}{2} \int_1^{-1} \frac{\sin(x)}{1+u^2} \left(-\frac{du}{\sin(x)} \right) = -\frac{\pi}{2} \int_1^{-1} \frac{du}{1+u^2} = \frac{\pi}{2} \int_{-1}^1 \frac{du}{1+u^2} = \frac{\pi}{2} \{ \tan^{-1}(u) \}_{-1}^1 \\ &= \frac{\pi}{2} [\tan^{-1}(1) - \tan^{-1}(-1)] = \frac{\pi}{2} \left[\frac{\pi}{4} + \frac{\pi}{4} \right] = \frac{\pi^2}{4}. \end{aligned}$$

So,

$$(2.2.2) \quad \boxed{\int_0^{\pi} \frac{x \sin(x)}{1 + \cos^2(x)} dx = \frac{\pi^2}{4}.}$$

This is equal to 2.4674 . . . , and *quad* agrees as *quad*(@(x)(x.*sin(x))./(1+(cos(x).^2)),0,pi) = 2.4674

For (2.2.c), make the substitution $x = \frac{\pi}{2} - y$. Then, $dx = -dy$ and

$$I = \int_{\pi/2}^0 \frac{\sin^2(\frac{\pi}{2} - y)}{\sin(\frac{\pi}{2} - y) + \cos(\frac{\pi}{2} - y)} (-dy).$$

Since

$$\sin\left(\frac{\pi}{2} - y\right) = \sin\left(\frac{\pi}{2}\right) \cos(y) - \cos\left(\frac{\pi}{2}\right) \sin(y) = \cos(y)$$

and

$$\cos\left(\frac{\pi}{2} - y\right) = \cos\left(\frac{\pi}{2}\right) \cos(y) + \sin\left(\frac{\pi}{2}\right) \sin(y) = \sin(y),$$

we have

$$I = \int_0^{\pi/2} \frac{\cos^2(y)}{\cos(y) + \sin(y)} dy$$

and so, changing the dummy variable of integration back to x ,

$$2I = \int_0^{\pi/2} \frac{\sin^2(x) + \cos^2(x)}{\cos(x) + \sin(x)} dx = \int_0^{\pi/2} \frac{1}{\cos(x) + \sin(x)} dx.$$

Now, change variable to

$$z = \tan\left(\frac{x}{2}\right).$$

Then we have

$$\frac{dz}{dx} = \frac{\frac{1}{2} \cos^2\left(\frac{x}{2}\right) + \frac{1}{2} \sin^2\left(\frac{x}{2}\right)}{\cos^2\left(\frac{x}{2}\right)} = \frac{\frac{1}{2}}{\cos^2\left(\frac{x}{2}\right)} = \frac{\frac{1}{2}}{\frac{1}{1 + \tan^2\left(\frac{x}{2}\right)}} = \frac{1}{2} \left[1 + \tan^2\left(\frac{x}{2}\right)\right]$$

or,

$$\frac{dz}{dx} = \frac{1 + z^2}{2}$$

and so

$$dx = \frac{2}{1 + z^2} dz.$$

From the double-angle formulas from trigonometry we can write

$$\sin(x) = 2 \sin\left(\frac{x}{2}\right) \cos\left(\frac{x}{2}\right) = 2 \frac{\sin\left(\frac{x}{2}\right)}{\cos\left(\frac{x}{2}\right)} \cos^2\left(\frac{x}{2}\right)$$

and so

$$\sin(x) = 2 \tan\left(\frac{x}{2}\right) \frac{1}{1 + \tan^2\left(\frac{x}{2}\right)} = \frac{2z}{1 + z^2},$$

as well as

$$\begin{aligned} \cos(x) &= \cos^2\left(\frac{x}{2}\right) - \sin^2\left(\frac{x}{2}\right) = \cos^2\left(\frac{x}{2}\right) \left[1 - \frac{\sin^2\left(\frac{x}{2}\right)}{\cos^2\left(\frac{x}{2}\right)}\right] \\ &= \frac{1}{1 + \tan^2\left(\frac{x}{2}\right)} \left[1 - \frac{\frac{\tan^2\left(\frac{x}{2}\right)}{1 + \tan^2\left(\frac{x}{2}\right)}}{\frac{1}{1 + \tan^2\left(\frac{x}{2}\right)}}\right] = \frac{1}{1 + \tan^2\left(\frac{x}{2}\right)} \left[1 - \tan^2\left(\frac{x}{2}\right)\right] = \frac{1 - z^2}{1 + z^2}. \end{aligned}$$

Thus,

$$\begin{aligned} 2I &= \int_0^1 \frac{1}{\frac{2z}{1+z^2} + \frac{1-z^2}{1+z^2}} \left(\frac{2}{1+z^2} \right) dz = 2 \int_0^1 \frac{dz}{1+2z-z^2} = 2 \int_0^1 \frac{dz}{2 - [z^2 - 2z + 1]} \\ &= 2 \int_0^1 \frac{dz}{2 - (z-1)^2}. \end{aligned}$$

Next, writing the integrand as a partial fraction expansion we have

$$\begin{aligned} 2I &= \frac{2}{2\sqrt{2}} \int_0^1 \left\{ \frac{1}{\sqrt{2} - (z-1)} + \frac{1}{\sqrt{2} + (z-1)} \right\} dz = \frac{2}{2\sqrt{2}} \int_0^1 \left\{ \frac{1}{1 + \sqrt{2} - z} + \frac{1}{-1 + \sqrt{2} + z} \right\} dz \\ &= \frac{2}{2\sqrt{2}} \left[\int_0^1 \frac{dz}{z + \sqrt{2} - 1} - \int_0^1 \frac{dz}{z - 1 - \sqrt{2}} \right]. \end{aligned}$$

Letting $u = z + \sqrt{2} - 1$ in the first integral in the brackets gives us

$$\int_0^1 \frac{dz}{z + \sqrt{2} - 1} = \int_{\sqrt{2}-1}^{\sqrt{2}} \frac{du}{u} = \ln(u) \Big|_{\sqrt{2}-1}^{\sqrt{2}} = \ln\left(\frac{\sqrt{2}}{\sqrt{2}-1}\right).$$

Letting $u = z - 1 - \sqrt{2}$ in the second integral in the brackets gives us

$$\int_0^1 \frac{dz}{z - 1 - \sqrt{2}} = \int_{-1-\sqrt{2}}^{-\sqrt{2}} \frac{du}{u} = \ln(u) \Big|_{-1-\sqrt{2}}^{-\sqrt{2}} = \ln\left(\frac{\sqrt{2}}{1 + \sqrt{2}}\right).$$

Thus,

$$\begin{aligned} 2I &= \frac{2}{2\sqrt{2}} \left[\ln\left(\frac{\sqrt{2}}{\sqrt{2}-1}\right) - \ln\left(\frac{\sqrt{2}}{1+\sqrt{2}}\right) \right] = \frac{2}{2\sqrt{2}} \ln\left(\frac{\sqrt{2}}{\sqrt{2}-1} \cdot \frac{1+\sqrt{2}}{\sqrt{2}}\right) \\ &= \frac{1}{\sqrt{2}} \ln\left(\frac{1+\sqrt{2}}{\sqrt{2}-1}\right) = \frac{1}{\sqrt{2}} \ln\left(\frac{1+\sqrt{2}}{\sqrt{2}-1} \cdot \frac{\sqrt{2}+1}{\sqrt{2}+1}\right) \\ &= \frac{1}{\sqrt{2}} \ln\left(\frac{\sqrt{2}+1+2+\sqrt{2}}{2-1}\right) = \frac{1}{\sqrt{2}} \ln(3+2\sqrt{2}) \end{aligned}$$

or,

$$(2.2.3) \quad \int_0^{\pi/2} \frac{\sin^2(x)}{\sin(x) + \cos(x)} dx = \frac{1}{2\sqrt{2}} \ln(3+2\sqrt{2}).$$

The value of the integral is 0.623225 . . . , and MATLAB agrees as `quad(@(x) sin(x).^2./(sin(x)+cos(x)),0,pi/2) = 0.623225 . . .`

In (2.2.d) let

$$x = \tan(\theta) = \frac{\sin(\theta)}{\cos(\theta)}$$

and so

$$\frac{dx}{d\theta} = \frac{\cos^2(\theta) + \sin^2(\theta)}{\cos^2(\theta)} = 1 + \tan^2(\theta)$$

and thus we have $dx = \{1 + \tan^2(\theta)\} d\theta$ and so our integral is

$$\begin{aligned} I &= \int_0^1 \frac{\ln(x+1)}{x^2+1} dx = \int_0^{\pi/4} \frac{\ln\{\tan(\theta)+1\}}{1+\tan^2(\theta)} \{1+\tan^2(\theta)\} d\theta \\ &= \int_0^{\pi/4} \ln\{\tan(\theta)+1\} d\theta. \end{aligned}$$

Now, make the change of variable that ‘flips’ the direction of integration, that is, $u = \frac{\pi}{4} - \theta$ (and so $du = -d\theta$). Then,

$$I = \int_{\pi/4}^0 \ln\left\{\tan\left(\frac{\pi}{4} - u\right) + 1\right\} (-du) = \int_0^{\pi/4} \ln\left\{\tan\left(\frac{\pi}{4} - u\right) + 1\right\} du$$

or, changing back to θ as the dummy variable of integration,

$$I = \int_0^{\pi/4} \ln\left\{\tan\left(\frac{\pi}{4} - \theta\right) + 1\right\} d\theta.$$

Next, recall the identity

$$\tan(\alpha - \beta) = \frac{\tan(\alpha) - \tan(\beta)}{1 + \tan(\alpha)\tan(\beta)}.$$

With $\alpha = \frac{\pi}{4}$ and $\beta = \theta$ we have

$$\tan\left(\frac{\pi}{4} - \theta\right) = \frac{\tan\left(\frac{\pi}{4}\right) - \tan(\theta)}{1 + \tan\left(\frac{\pi}{4}\right)\tan(\theta)} = \frac{1 - \tan(\theta)}{1 + \tan(\theta)}$$

and so

$$\begin{aligned} I &= \int_0^{\pi/4} \ln \left\{ \frac{1 - \tan(\theta)}{1 + \tan(\theta)} + 1 \right\} d\theta = \int_0^{\pi/4} \ln \left\{ \frac{2}{1 + \tan(\theta)} \right\} d\theta \\ &= \int_0^{\pi/4} \ln\{2\} d\theta - \int_0^{\pi/4} \ln\{1 + \tan(\theta)\} d\theta. \end{aligned}$$

But the last integral is I, and so

$$I = \frac{\pi}{4} \ln(2) - I$$

or, at last (and using x as the dummy variable of integration),

$$(2.2.4) \quad \int_0^1 \frac{\ln(x+1)}{x^2+1} dx = \int_0^{\pi/4} \ln\{1 + \tan(x)\} dx = \frac{\pi}{8} \ln(2).$$

This integral is often called *Serret's integral*, after the French mathematician Joseph Serret (1819–1885) who did it in 1844. Our result says the two above integrals are both equal to 0.27219826 ... and *quad* agrees, as *quad*(@(x)log(tan(x)+1),0,pi/4) = 0.27219826 ... and *quad*(@(x)log(x+1)/(x.^2+1),0,1) = 0.27219823...

If we make the change of variable $x = \frac{1}{a}$ we can generalize this result as follows. Since $dx = \frac{1}{a} dt$, then

$$\begin{aligned} \frac{\pi}{8} \ln(2) &= \int_0^1 \frac{\ln(x+1)}{x^2+1} dx = \int_0^a \frac{\ln\left(\frac{t}{a} + 1\right)}{\left(\frac{t}{a}\right)^2 + 1} \left(\frac{1}{a} dt\right) = a \int_0^a \frac{\ln(t+a) - \ln(a)}{t^2 + a^2} dt \\ &= a \left\{ \int_0^a \frac{\ln(t+a)}{t^2 + a^2} dt - \ln(a) \left[\frac{1}{a} \tan^{-1}\left(\frac{t}{a}\right) \right] \Big|_0^a \right\} \\ &= a \left\{ \int_0^a \frac{\ln(t+a)}{t^2 + a^2} dt - \frac{1}{a} \ln(a) [\tan^{-1}(1)] \right\} \\ &= a \left\{ \int_0^a \frac{\ln(t+a)}{t^2 + a^2} dt - \frac{\pi}{4a} \ln(a) \right\} = a \int_0^a \frac{\ln(t+a)}{t^2 + a^2} dt - \frac{\pi}{4} \ln(a). \end{aligned}$$

Thus,

$$\int_0^a \frac{\ln(t+a)}{t^2 + a^2} dt = \frac{\pi}{8a} \ln(2) + \frac{\pi}{4a} \ln(a) = \frac{\pi}{8a} \ln(2) + \frac{2\pi}{8a} \ln(a)$$

or, finally, changing the dummy variable of integration back to x ,

$$(2.2.5) \quad \int_0^a \frac{\ln(x+a)}{x^2+a^2} dx = \frac{\pi}{8a} \ln(2a^2).$$

2.3 Two Old Tricks, Plus a New One

The following integral, with *arbitrarily many and different* quadratic factors in the denominator of the integrand, may at first glance look impossibly difficult:

$\int_0^\infty \frac{dx}{(x^2+a_1^2)(x^2+a_2^2)(x^2+a_3^2)\dots(x^2+a_n^2)}$, with *all* of the $a_i \neq 0$ and *different*.

Not so, as I'll now show you. Let's start by writing the integrand in partial fraction form (look back at how we got (2.2.3)), as

$$\frac{1}{(x^2+a_1^2)(x^2+a_2^2)(x^2+a_3^2)\dots(x^2+a_n^2)} \\ = \frac{c_1}{x^2+a_1^2} + \frac{c_2}{x^2+a_2^2} + \frac{c_3}{x^2+a_3^2} + \dots + \frac{c_n}{x^2+a_n^2}$$

where the c 's are all constants.² Fix your attention on any one of the terms on the right, say the k -th one. Then, multiplying through by $x^2+a_k^2$, we have

$$\frac{x^2+a_k^2}{(x^2+a_1^2)(x^2+a_2^2)(x^2+a_3^2)\dots(x^2+a_k^2)\dots(x^2+a_n^2)} \\ = \frac{c_1(x^2+a_k^2)}{x^2+a_1^2} + \frac{c_2(x^2+a_k^2)}{x^2+a_2^2} + \dots + c_k + \dots + \frac{c_n(x^2+a_k^2)}{x^2+a_n^2}.$$

Thus, cancelling the $x^2+a_k^2$ factor in the numerator and denominator on the left in the above expression, and setting x to the particular value of $i a_k$ where $i = \sqrt{-1}$, we have³

² Writing the partial fraction expansion this way is where the assumption that all the a_i are different comes into play. If any of the a_i appears multiple times, then the correct partial fraction expansion of the integrand is *not* as I've written it.

³ There are two points to be clear on at this point. First, since we are working with an identity it must be true for all values of x , and I've just picked a particularly convenient one. Second, if the use of an imaginary x bothers you, just remember the philosophical spirit of this book—*anything* (well, *almost anything*) goes, and we'll check our result when we get to the end!

$$\frac{1}{(-a_k^2 + a_1^2)(-a_k^2 + a_2^2)(-a_k^2 + a_3^2) \dots (-a_k^2 + a_n^2)} = \frac{1}{\prod_{j=1, j \neq k}^n (a_j^2 - a_k^2)} = c_k$$

where only the c_k term survives on the right since all the other terms in the partial fraction expansion end-up with a zero in their numerator. So, our original partial fraction expansion is just

$$\frac{1}{(x^2 + a_1^2)(x^2 + a_2^2)(x^2 + a_3^2) \dots (x^2 + a_n^2)} = \sum_{k=1}^n \frac{c_k}{x^2 + a_k^2}$$

and thus

$$\begin{aligned} \int_0^\infty \frac{dx}{(x^2 + a_1^2)(x^2 + a_2^2)(x^2 + a_3^2) \dots (x^2 + a_n^2)} &= \sum_{k=1}^n c_k \int_0^\infty \frac{dx}{x^2 + a_k^2} \\ &= \sum_{k=1}^n c_k \frac{1}{a_k} \left[\tan^{-1} \left(\frac{x}{a_k} \right) \right]_0^\infty = \sum_{k=1}^n \frac{c_k}{a_k} \left(\frac{\pi}{2} \right) \end{aligned}$$

or, at last, with all the $a_i \neq 0$,

$$\int_0^\infty \frac{dx}{(x^2 + a_1^2)(x^2 + a_2^2)(x^2 + a_3^2) \dots (x^2 + a_n^2)} = \left(\frac{\pi}{2} \right) \sum_{k=1}^n \frac{c_k}{a_k},$$

where $c_k = \frac{1}{\prod_{j=1, j \neq k}^n (a_j^2 - a_k^2)}$ and $a_i \neq a_j$ if $j \neq i$.

(2.3.1)

For example, suppose $a_1^2 = 1$, $a_2^2 = 4$, and $a_3^2 = 9$. Then, $a_1 = 1$, $a_2 = 2$, and $a_3 = 3$. This gives the values of the c 's as

$$c_1 = \frac{1}{(4-1)(9-1)} = \frac{1}{24}, c_2 = \frac{1}{(1-4)(9-4)} = -\frac{1}{15}, c_3 = \frac{1}{(1-9)(4-9)} = \frac{1}{40}.$$

Then the value of the integral is

$$\left(\frac{\pi}{2} \right) \left[\frac{1}{24} - \frac{1}{15} + \frac{1}{40} \right] = \left(\frac{\pi}{2} \right) \left[\frac{1}{24} - \frac{1}{30} + \frac{1}{120} \right] = \left(\frac{\pi}{2} \right) \left[\frac{2}{120} \right] = \frac{\pi}{120} = 0.0261799 \dots$$

and *quad* agrees, as `quad(@(x)1./((x.^2+1).*(x.^2+4).*(x.^2+9)),0,100) = 0.02617989 ...`

Here's another example of the use of a partial fraction expansion to evaluate an integral. Here I'll do

$$\int_0^\infty \frac{dx}{x^4 + 2x^2 \cosh(2\alpha) + 1}$$

where α is an arbitrary constant. Writing the hyperbolic cosine in the denominator of the integrand out in exponential form, we have

$$\begin{aligned} x^4 + 2x^2 \cosh(2\alpha) + 1 &= x^4 + 2x^2 \left[\frac{e^{2\alpha} + e^{-2\alpha}}{2} \right] + 1 = x^4 + x^2 e^{2\alpha} + x^2 e^{-2\alpha} + 1 \\ &= (x^2 + e^{2\alpha})(x^2 + e^{-2\alpha}). \end{aligned}$$

So, we can write the integrand in the following partial fraction form (with A and B as constants):

$$\frac{1}{x^4 + 2x^2 \cosh(2\alpha) + 1} = \frac{A}{(x^2 + e^{2\alpha})} + \frac{B}{(x^2 + e^{-2\alpha})}.$$

That is,

$$(A + B)x^2 + Ae^{-2\alpha} + Be^{2\alpha} = 1$$

which, since there is no x^2 term on the right, immediately tells us that $A = -B$. Thus,

$$-Be^{-2\alpha} + Be^{2\alpha} = 1$$

and so the constant B is given by

$$B = \frac{1}{e^{2\alpha} - e^{-2\alpha}}.$$

Therefore,

$$\begin{aligned} \int_0^\infty \frac{dx}{x^4 + 2x^2 \cosh(2\alpha) + 1} &= \frac{1}{e^{2\alpha} - e^{-2\alpha}} \left[\int_0^\infty \frac{dx}{x^2 + e^{-2\alpha}} - \int_0^\infty \frac{dx}{x^2 + e^{2\alpha}} \right] \\ &= \frac{1}{e^{2\alpha} - e^{-2\alpha}} \left[\frac{1}{e^{-\alpha}} \tan^{-1} \left(\frac{x}{e^{-\alpha}} \right) - \frac{1}{e^\alpha} \tan^{-1} \left(\frac{x}{e^\alpha} \right) \right] \Bigg|_0^\infty \\ &= \frac{1}{e^{2\alpha} - e^{-2\alpha}} \left[e^\alpha \frac{\pi}{2} - e^{-\alpha} \frac{\pi}{2} \right] = \left(\frac{\pi}{2} \right) \frac{e^\alpha - e^{-\alpha}}{e^{2\alpha} - e^{-2\alpha}} \\ &= \left(\frac{\pi}{2} \right) \frac{e^\alpha - e^{-\alpha}}{(e^\alpha + e^{-\alpha})(e^\alpha - e^{-\alpha})} = \left(\frac{\pi}{2} \right) \frac{1}{(e^\alpha + e^{-\alpha})} \\ &= \left(\frac{\pi}{2} \right) \frac{\frac{1}{2}}{(e^\alpha + e^{-\alpha})} \\ &= \frac{\pi}{4(e^\alpha + e^{-\alpha})} \end{aligned}$$

or, finally,

$$(2.3.2) \quad \int_0^{\infty} \frac{dx}{x^4 + 2x^2 \cosh(2\alpha) + 1} = \frac{\pi}{4 \cosh(\alpha)}.$$

For $\alpha = 1$, for example, this integral equals 0.5089806 ... and *quad* agrees, as *quad*(@(x)I./(x.^4+2*cosh(2)*x.^2+1),0,1000) = 0.5089809 ...

Back in Chap. 1 (Sect. 1.5) I showed you how the 'evenness' or 'oddness' of an integrand (if one of those two properties is present) can be of great help in transforming a 'hard' integral into an 'easy' one. As a more sophisticated example of this than was the example in Chap. 1, let's calculate the value of

$$\int_0^{\infty} \frac{dx}{x^4 + 2x^2 \cos(2\alpha) + 1}$$

where, as before, α is an arbitrary constant. This may superficially look a lot like the integral we just finished but, as you'll soon see, there is a really big difference in how we'll do this new one.

We start by making the change of variable $y = \frac{1}{x}$ (and so $\frac{dy}{dx} = -\frac{1}{x^2}$ or $dx = -x^2 dy = -\frac{1}{y^2} dy$). Then,

$$\begin{aligned} I &= \int_0^{\infty} \frac{dx}{x^4 + 2x^2 \cos(2\alpha) + 1} \\ &= \int_{\infty}^0 -\frac{\frac{1}{y^2} dy}{\frac{1}{y^4} + 2\frac{1}{y^2} \cos(2\alpha) + 1} = \int_0^{\infty} \frac{y^2 dy}{y^4 + 2y^2 \cos(2\alpha) + 1}. \end{aligned}$$

If we then add our two versions of the integral (the left-most and the right-most integrals in the previous line, remembering that x and y are just dummy variables of integration) we have

$$2I = \int_0^{\infty} \frac{(1 + x^2) dx}{x^4 + 2x^2 \cos(2\alpha) + 1}$$

or,

$$I = \frac{1}{2} \int_0^{\infty} \frac{(1 + x^2) dx}{x^4 + 2x^2 \cos(2\alpha) + 1}.$$

And since the integrand is even, we can write

$$I = \frac{1}{4} \int_{-\infty}^{\infty} \frac{(1 + x^2) dx}{x^4 + 2x^2 \cos(2\alpha) + 1}.$$

Because $\cos(2\alpha) = 1 - 2\sin^2(\alpha)$ you can show by direct multiplication that

$$x^4 + 2x^2 \cos(2\alpha) + 1 = [x^2 - 2x \sin(\alpha) + 1][x^2 + 2x \sin(\alpha) + 1]$$

and so

$$I = \frac{1}{4} \int_{-\infty}^{\infty} \frac{(1 + x^2) dx}{[x^2 - 2x \sin(\alpha) + 1][x^2 + 2x \sin(\alpha) + 1]}.$$

Now, since the integrand is even, then if we include in the numerator of the integrand an *odd* function like $2x \sin(\alpha)$ we do not change the value of the integral, and so

$$I = \frac{1}{4} \int_{-\infty}^{\infty} \frac{[x^2 - 2x \sin(\alpha) + 1] dx}{[x^2 - 2x \sin(\alpha) + 1][x^2 + 2x \sin(\alpha) + 1]}$$

or

$$I = \frac{1}{4} \int_{-\infty}^{\infty} \frac{dx}{x^2 + 2x \sin(\alpha) + 1}.$$

Or, since $\sin^2(\alpha) + \cos^2(\alpha) = 1$ then

$$I = \frac{1}{4} \int_{-\infty}^{\infty} \frac{dx}{x^2 + 2x \sin(\alpha) + \sin^2(\alpha) + \cos^2(\alpha)} = \frac{1}{4} \int_{-\infty}^{\infty} \frac{dx}{[x + \sin(\alpha)]^2 + \cos^2(\alpha)}.$$

Let $u = x + \sin(\alpha)$ (and so $du = dx$), and then

$$\begin{aligned} I &= \frac{1}{4} \int_{-\infty}^{\infty} \frac{du}{u^2 + \cos^2(\alpha)} = \frac{1}{4} \left(\frac{1}{\cos(\alpha)} \right) \left[\tan^{-1} \left\{ \frac{u}{\cos(\alpha)} \right\} \right] \Bigg|_{-\infty}^{\infty} \\ &= \frac{1}{4 \cos(\alpha)} [\tan^{-1}\{\infty\} - \tan^{-1}\{-\infty\}] \end{aligned}$$

and so, at last,

$$(2.3.3) \quad \int_0^{\infty} \frac{dx}{x^4 + 2x^2 \cos(2\alpha) + 1} = \frac{\pi}{4 \cos(\alpha)}.$$

Special, interesting cases occur for some obvious values of α . Specifically, for $\alpha = \frac{\pi}{4}$ we have

$$(2.3.4) \quad \int_0^{\infty} \frac{dx}{x^4 + 1} = \int_0^{\infty} \frac{x^2 dx}{x^4 + 1} = \frac{\pi\sqrt{2}}{4}.$$

These two integrals are therefore equal to 1.11072 ... and MATLAB agrees, as $\text{quad}(@(\text{x})\text{I}./(\text{x}.\wedge 4+1),0,1000) = 1.11072 \dots$ and $\text{quad}(@(\text{x})(\text{x}.\wedge 2)./(\text{x}.\wedge 4+1),0,10000) = 1.11062 \dots$ For $\alpha = 30^\circ$ (that is, $\alpha = \frac{\pi}{6}$) we have

$$(2.3.5) \quad \int_0^\infty \frac{dx}{x^4 + x^2 + 1} = \frac{\pi}{2\sqrt{3}}.$$

This is equal to 0.906899 ..., and again MATLAB agrees as $\text{quad}(@(\text{x})\text{I}./(\text{x}.\wedge 4+x.\wedge 2+1),0,1000) = 0.9068993 \dots$ For $\alpha = 60^\circ$ (that is, $\alpha = \frac{\pi}{3}$) we have

$$(2.3.6) \quad \int_0^\infty \frac{dx}{x^4 - x^2 + 1} = \frac{\pi}{2}.$$

This is equal to 1.570796 ..., and indeed $\text{quad}(@(\text{x})\text{I}./(\text{x}.\wedge 4-x.\wedge 2+1),0,1000) = 1.570796 \dots$ And finally, for $\alpha = 0$ we have

$$(2.3.7) \quad \int_0^\infty \frac{dx}{x^4 + 2x^2 + 1} = \frac{\pi}{4}.$$

This is equal to 0.785398 ..., and $\text{quad}(@(\text{x})\text{I}./(\text{x}.\wedge 4+2*\text{x}.\wedge 2+1),0,1000) = 0.785398 \dots$

Here's a new trick, one using a difference equation to evaluate a class of definite integrals indexed on an integer-valued variable. Specifically,

$$I_n(\alpha) = \int_0^\pi \frac{\cos(n\theta) - \cos(n\alpha)}{\cos(\theta) - \cos(\alpha)} d\theta$$

where α is a constant and n is a non-negative integer ($n = 0, 1, 2, 3, \dots$). The first two integrals are easy to do by inspection: $I_0(\alpha) = 0$ and $I_1(\alpha) = \pi$. For $n > 1$, however, things get more difficult. What I'll do next is perfectly understandable as we go through the analysis step-by-step, but I have no idea what motivated the person who first did this. The mystery of mathematical genius!

If you recall the trigonometric identity

$$\cos\{(n+1)\theta\} + \cos\{(n-1)\theta\} = 2\cos(\theta)\cos(n\theta)$$

then perhaps you'd think of taking a look at the quantity $I_{n+1}(\alpha) + I_{n-1}(\alpha)$ to see if it is related in some 'nice' way to $I_n(\alpha)$. So, imagining that we have been so inspired, let's take a look at the quantity $Q = AI_{n+1}(\alpha) + BI_n(\alpha) + CI_{n-1}(\alpha)$, where A, B, and C are constants, to see what we get.

Thus,

$$Q = \int_0^\pi \frac{A[\cos\{(n+1)\theta\} - \cos\{(n+1)\alpha\}] + B[\cos(n\theta) - \cos(n\alpha)] + C[\cos\{(n-1)\theta\} - \cos\{(n-1)\alpha\}]}{\cos(\theta) - \cos(\alpha)} d\theta.$$

Suppose we now set $A = C = 1$ and $B = -2\cos(\alpha)$. Then,

$$Q = \int_0^\pi \frac{[\cos\{(n+1)\theta\} + \cos\{(n-1)\theta\}] - 2\cos(\alpha)\cos(n\theta)}{[\cos\{(n+1)\alpha\} + \cos\{(n-1)\alpha\}] - 2\cos(\alpha)\cos(n\alpha)} d\theta.$$

From our trig identity the second term in the numerator vanishes and the first term reduces to

$$\begin{aligned} Q &= \int_0^\pi \frac{2\cos(\theta)\cos(n\theta) - 2\cos(\alpha)\cos(n\theta)}{\cos(\theta) - \cos(\alpha)} d\theta = \int_0^\pi \frac{2\cos(n\theta)[\cos(\theta) - \cos(\alpha)]}{\cos(\theta) - \cos(\alpha)} d\theta \\ &= 2 \int_0^\pi \cos(n\theta) d\theta = 2 \left[\frac{\sin(n\theta)}{n} \right]_0^\pi = 0, n = 1, 2, \dots \end{aligned}$$

That is, we have the following second-order, linear difference equation:

$$I_{n+1}(\alpha) - 2\cos(\alpha)I_n(\alpha) + I_{n-1}(\alpha) = 0, n = 1, 2, 3, \dots,$$

with the conditions $I_0(\alpha) = 0$ and $I_1(\alpha) = \pi$.

It is well-known that such a so-called *recursive equation* has solutions of the form $I_n = Ce^{sn}$ where C and s are constants. So,

$$Ce^{s(n+1)} - 2\cos(\alpha)Ce^{sn} + Ce^{s(n-1)} = 0$$

or, cancelling the common factor of Ce^{sn} ,

$$e^s - 2\cos(\alpha) + e^{-s} = 0$$

or,

$$e^{2s} - 2\cos(\alpha)e^s + 1 = 0.$$

This is a quadratic in e^s , and so

$$\begin{aligned} e^s &= \frac{2\cos(\alpha) \pm \sqrt{4\cos^2(\alpha) - 4}}{2} = \frac{2\cos(\alpha) \pm 2i\sqrt{1 - \cos^2(\alpha)}}{2} \\ &= \cos(\alpha) \pm i\sin(\alpha), \end{aligned}$$

where $i = \sqrt{-1}$. Now, from Euler's fabulous formula we have $e^s = e^{\pm i\alpha}$ and thus $s = \pm i\alpha$. This means that the general solution for $I_n(\alpha)$ is

$$I_n(\alpha) = C_1 e^{i\alpha} + C_2 e^{-i\alpha}.$$

Since $I_0(\alpha) = 0$ then $C_1 + C_2 = 0$ or, $C_2 = -C_1$. Also, as $I_1(\alpha) = \pi$ we have

$$C_1 e^{i\alpha} - C_1 e^{-i\alpha} = \pi = C_1 i 2 \sin(\alpha)$$

which says that

$$C_1 = \frac{\pi}{i 2 \sin(\alpha)} \text{ and } C_2 = -\frac{\pi}{i 2 \sin(\alpha)}.$$

Thus,

$$I_n(\alpha) = \frac{\pi}{2 \sin(\alpha)} \left[\frac{e^{i n \alpha} - e^{-i n \alpha}}{i} \right] = \frac{\pi}{2 \sin(\alpha)} \left[\frac{i 2 \sin(n\alpha)}{i} \right]$$

or, at last, using x as the dummy variable of integration,

(2.3.8)

$$\int_0^\pi \frac{\cos(nx) - \cos(n\alpha)}{\cos(x) - \cos(\alpha)} dx = \pi \frac{\sin(n\alpha)}{\sin(\alpha)}.$$

For example, if $n = 6$ and $\alpha = \frac{\pi}{11}$ this result says our integral is equal to $\pi \frac{\sin(6\frac{\pi}{11})}{\sin(\frac{\pi}{11})}$ which is equal to 11.03747399... , and *quad* agrees because *quad*(@(x)(cos(6*x)-cos(6*pi/11))./(cos(x)-cos(pi/11)),0,pi) = 11.03747399... .

Here's a final, quick example of recursion used to solve an entire *class* of integrals:

$$I_n = \int_0^\infty x^{2n} e^{-x^2} dx, n = 0, 1, 2, 3, \dots$$

We start by observing that

$$\frac{d}{dx} (x^{2n-1} e^{-x^2}) = (2n-1)x^{2n-2} e^{-x^2} - 2x^{2n} e^{-x^2}, n \geq 1.$$

So, integrating both sides,

$$\int_0^\infty \frac{d}{dx} (x^{2n-1} e^{-x^2}) dx = (2n-1) \int_0^\infty x^{2n-2} e^{-x^2} dx - 2 \int_0^\infty x^{2n} e^{-x^2} dx.$$

The right-most integral is I_n , and the middle integral is I_{n-1} . So,

$$\int_0^{\infty} \frac{d}{dx} \left(x^{2n-1} e^{-x^2} \right) dx = (2n-1)I_{n-1} - 2I_n.$$

Now, notice that the remaining integral (on the left-hand-side) is simply the integral of a derivative *and so is very easy to do!* In fact,

$$\int_0^{\infty} \frac{d}{dx} \left(x^{2n-1} e^{-x^2} \right) dx = \left(x^{2n-1} e^{-x^2} \right) \Big|_0^{\infty} = 0$$

since $x^{2n-1} e^{-x^2} = 0$ at $x=0$ and as $x \rightarrow \infty$. So, we immediately have the recurrence

$$I_n = \frac{2n-1}{2} I_{n-1} = \frac{2n(2n-1)}{4n} I_{n-1}.$$

For the first few values n we have:

$$I_1 = \frac{2}{(4)(1)} I_0,$$

$$I_2 = \frac{(4)(3)}{(4)(2)} I_1 = \frac{(4)(3)(2)}{(4)(2)(4)(1)} I_0,$$

$$I_3 = \frac{(6)(5)}{(4)(3)} I_2 = \frac{(6)(5)(4)(3)(2)}{(4)(3)(4)(2)(4)(1)} I_0,$$

and by now you should see the pattern:

$$I_n = \frac{(2n)!}{4^n n!} I_0.$$

This is a nice result, but of course the next question is obvious: what is I_0 ? In fact,

$$I_0 = \int_0^{\infty} e^{-x^2} dx = \frac{1}{2} \sqrt{\pi},$$

which we have *not* shown (yet). In the next chapter, as result (3.1.4), I will show you (using a new trick) that

$$\int_{-\infty}^{\infty} e^{-x^2/2} dx = \sqrt{2\pi}.$$

If you make the change of variable $y = x\sqrt{2}$ (and remember that $\int_{-\infty}^{\infty} f(x) dx = 2 \int_0^{\infty} f(x) dx$ if $f(x)$ is even) then the value of I_0 immediately follows. Thus,

(2.3.9)

$$\int_0^{\infty} x^{2n} e^{-x^2} dx = \frac{(2n)!}{4^n n!} \left(\frac{1}{2}\right) \sqrt{\pi} .$$

If $n = 5$ this says the integral is equal to 26.171388... , while $\text{quad}(@)(x)(x.^10)$.
 $*\text{exp}(-(x.^2)),0,10) = 26.1713896 \dots$

2.4 Another Old Trick: Euler's Log-Sine Integral

In 1769 Euler computed (for $a = 1$) the value of (where $a \geq 0$)

$$I = \int_0^{\pi/2} \ln\{a \sin(x)\} dx,$$

which is equal to

$$\int_0^{\pi/2} \ln\{a \cos(x)\} dx.$$

The two integrals are equal because the integrands take-on the same values over the integration interval ($\sin(x)$ and $\cos(x)$ are mirror-images of each other over that interval). For many years it was commonly claimed in textbooks that these are quite difficult integrals to do, best tackled with the powerful techniques of contour integration. As you'll see with the following analysis, however, that is simply not the case.

So, to start we notice that

$$I = \frac{1}{2} \int_0^{\pi/2} [\ln\{a \sin(x)\} + \ln\{a \cos(x)\}] dx = \frac{1}{2} \int_0^{\pi/2} \ln\{a^2 \sin(x) \cos(x)\} dx.$$

Since $\sin(2x) = 2\sin(x)\cos(x)$, we have $\sin(x) \cos(x) = \frac{1}{2} \sin(2x)$ and therefore

$$\begin{aligned} I &= \frac{1}{2} \int_0^{\pi/2} \ln\left\{a \frac{1}{2} a \sin(2x)\right\} dx = \frac{1}{2} \int_0^{\pi/2} \left[\ln(a) + \ln\left(\frac{1}{2}\right) + \ln\{a \sin(2x)\} \right] dx \\ &= \frac{\pi}{4} \ln(a) - \frac{\pi}{4} \ln(2) + \frac{1}{2} \int_0^{\pi/2} \ln\{a \sin(2x)\} dx \end{aligned}$$

In the last integral, let $t = 2x$ (and so $dx = \frac{1}{2} dt$). Thus,

$$\frac{1}{2} \int_0^{\pi/2} \ln\{a \sin(2x)\} dx = \frac{1}{2} \int_0^{\pi} \ln\{a \sin(t)\} \frac{1}{2} dt = \frac{1}{2} I$$

where the last equality follows because (think of how $\sin(t)$ varies over the interval 0 to π)

$$\int_0^{\pi/2} \ln\{a \sin(t)\} dt = \frac{1}{2} \int_0^{\pi} \ln\{a \sin(t)\} dt.$$

So,

$$I = \frac{\pi}{4} \ln(a) - \frac{\pi}{4} \ln(2) + \frac{1}{2} I = \frac{\pi}{4} \ln\left(\frac{a}{2}\right) + \frac{1}{2} I$$

or,

$$\frac{1}{2} I = \frac{\pi}{4} \ln\left(\frac{a}{2}\right)$$

and so, at last, for $a \geq 0$,

$$(2.4.1) \quad \int_0^{\pi/2} \ln\{a \sin(x)\} dx = \int_0^{\pi/2} \ln\{a \cos(x)\} dx = \frac{\pi}{2} \ln\left(\frac{a}{2}\right).$$

Special cases of interest are $a = 1$ (Euler's integral) for which both integrals equal $-\frac{\pi}{2} \ln(2) = -1.088793 \dots$ and $a = 2$ for which both integrals are equal to zero. We can check both of these cases with *quad*; *quad*(@(x)log(sin(x)),0,pi/2) = -1.0888035 ... and *quad*(@(x)log(cos(x)),0,pi/2) = -1.0888043 ..., while *quad*(@(x)log(2*sin(x)),0,pi/2) = -1.0459 x 10⁻⁵ and *quad*(@(x)log(2*cos(x)),0,pi/2) = -1.1340 x 10⁻⁵. We'll see Euler's log-sine integral again, in Chap. 7.

With the result for $a = 1$, we can now calculate the interesting integral

$$\int_0^{\pi/2} \ln\left\{\frac{\sin(x)}{x}\right\} dx.$$

That's because this integral is

$$\begin{aligned}
 \int_0^{\pi/2} \ln\{\sin(x)\} dx - \int_0^{\frac{\pi}{2}} \ln\{x\} dx &= -\frac{\pi}{2} \ln(2) - [x \ln(x) - x] \Big|_0^{\pi/2} \\
 &= -\frac{\pi}{2} \ln(2) - \left[\frac{\pi}{2} \ln\left(\frac{\pi}{2}\right) - \frac{\pi}{2} \right] \\
 &= -\frac{\pi}{2} \ln(2) - \left[\frac{\pi}{2} \ln(\pi) - \frac{\pi}{2} \ln(2) - \frac{\pi}{2} \right] \\
 &= -\frac{\pi}{2} \ln(2) - \frac{\pi}{2} \ln(\pi) + \frac{\pi}{2} \ln(2) + \frac{\pi}{2} \\
 &= -\frac{\pi}{2} \ln(\pi) + \frac{\pi}{2}
 \end{aligned}$$

and so

$$(2.4.2) \quad \int_0^{\pi/2} \ln\left\{\frac{\sin(x)}{x}\right\} dx = \frac{\pi}{2} [1 - \ln(\pi)] .$$

Our result says this integral is equal to $-0.22734\dots$ and *quad* agrees, as *quad*(@(x)log(sin(x)/x),0,pi/2) = $-0.22734\dots$

With a simple change of variable in Euler's log-sine integral we can get yet another pretty result. Since $\sin^2(\theta) = 1 - \cos^2(\theta)$ then

$$\frac{\sin^2(\theta)}{\cos^2(\theta)} = \tan^2(\theta) = \frac{1}{\cos^2(\theta)} - 1$$

and so

$$\tan^2(\theta) + 1 = \frac{1}{\cos^2(\theta)}$$

which says

$$\ln\left\{\frac{1}{\cos^2(\theta)}\right\} = -\ln\{\cos^2(\theta)\} = -2\ln\{\cos(\theta)\} = \ln\{\tan^2(\theta) + 1\}.$$

That is,

$$\ln\{\cos(\theta)\} = -\frac{1}{2} \ln\{\tan^2(\theta) + 1\}.$$

So, in the integral

$$\int_0^{\pi/2} \ln\{\cos(x)\} dx$$

replace the dummy variable of integration x with θ and write

$$\int_0^{\pi/2} \ln\{\cos(\theta)\} d\theta = \int_0^{\pi/2} \left[-\frac{1}{2} \ln\{\tan^2(\theta) + 1\} \right] d\theta = -\frac{\pi}{2} \ln(2)$$

or,

$$\int_0^{\pi/2} \ln\{\tan^2(\theta) + 1\} d\theta = \pi \ln(2).$$

Now, change variable to $x = \tan(\theta)$. Then

$$\frac{dx}{d\theta} = \frac{1}{\cos^2(\theta)}$$

and thus

$$d\theta = \cos^2(\theta) dx = \frac{1}{\tan^2(\theta) + 1} dx = \frac{1}{x^2 + 1} dx.$$

So, since $x = 0$ when $\theta = 0$ and $x = \infty$ when $\theta = \frac{\pi}{2}$, we have

(2.4.3)

$$\int_0^{\infty} \frac{\ln(x^2 + 1)}{x^2 + 1} dx = \pi \ln(2) .$$

That is, this integral is equal to 2.177586 . . . , and *quad* agrees, as *quad*(@(x) log(x.^2+1)./(x.^2+1),0,1e6) = 2.1775581 . . . To end this discussion, here's a little calculation for *you* to play around with: writing $\int_0^{\infty} \frac{\ln(x^2 + 1)}{x^2 + 1} dx$ as $\int_0^1 + \int_1^{\infty}$, make the change of variable $u = \frac{1}{x}$ in the last integral and show that this leads to

(2.4.4)

$$\int_0^1 \frac{\ln\left(x + \frac{1}{x}\right)}{x^2 + 1} dx = \frac{\pi}{2} \ln(2) .$$

This is equal to 1.088793 . . . , and MATLAB agrees because *quad*(@(x) log(x+(1./x))./(x.^2+1),0,1) = 1.088799 . . .

The substitution $u = \frac{1}{x}$ is a trick well-worth keeping in mind. Here's another use of it to derive a result that almost surely would be much more difficult to get otherwise. Consider the integral

$$\int_0^{\infty} \frac{\ln(x^a + 1)}{x^2 - bx + 1} dx,$$

where $a \neq 0$ and b are constants. If we let $u = \frac{1}{x}$ (and so $dx = -\frac{1}{u^2} du$), we have

$$\begin{aligned} \int_0^{\infty} \frac{\ln(x^a + 1)}{x^2 - bx + 1} dx &= \int_{\infty}^0 \frac{\ln\left(\frac{1}{u^a} + 1\right)}{\frac{1}{u^2} - \frac{b}{u} + 1} \left(-\frac{1}{u^2} du\right) = \int_0^{\infty} \frac{\ln\left(\frac{1 + u^a}{u^a}\right)}{1 - bu + u^2} du \\ &= \int_0^{\infty} \frac{\ln(1 + u^a)}{1 - bu + u^2} du - a \int_0^{\infty} \frac{\ln(u)}{1 - bu + u^2} du. \end{aligned}$$

That is,

$$\int_0^{\infty} \frac{\ln(x^a + 1)}{x^2 - bx + 1} dx = \int_0^{\infty} \frac{\ln(1 + x^a)}{1 - bx + x^2} dx - a \int_0^{\infty} \frac{\ln(x)}{1 - bx + x^2} dx$$

and so we immediately have

(2.4.5)

$$\int_0^{\infty} \frac{\ln(x)}{1 - bx + x^2} dx = 0.$$

Notice that the case of $b = 0$ in (2.4.5) reduces this result to (1.5.1),

$$\int_0^{\infty} \frac{\ln(x)}{1 + x^2} dx = 0,$$

what we also get when we set $b = 1$ in (2.1.3). The value of b can't be just *anything*, however, and you'll be asked more on this point in the challenge problem section.

To end the chapter, let me remind you of a simple technique that you encountered way back in high school algebra—'completing the square.' This is a 'trick' that is well-worth keeping in mind when faced with an integral with a quadratic polynomial in the denominator of the integrand (but see also Challenge Problem 2 for its use in a *cubic* denominator, and look back at the final integration of Sect. 1.6, too). As another example, let's calculate

$$\int_0^1 \frac{1 - x}{1 + x + x^2} dx.$$

We'll start by rewriting the denominator of the integrand by completing the square:

$$x^2 + x + 1 = x^2 + x + \frac{1}{4} + \left(1 - \frac{1}{4}\right) = \left(x + \frac{1}{2}\right)^2 + \frac{3}{4}.$$

Thus,

$$\int_0^1 \frac{1-x}{1+x+x^2} dx = \int_0^1 \frac{dx}{\left(x + \frac{1}{2}\right)^2 + \frac{3}{4}} - \int_0^1 \frac{x}{\left(x + \frac{1}{2}\right)^2 + \frac{3}{4}} dx.$$

Now, change variable to

$$u = x + \frac{1}{2}$$

(and so $dx = du$). Then, our integral becomes

$$\int_{\frac{1}{2}}^{\frac{3}{2}} \frac{du}{u^2 + \frac{3}{4}} - \int_{\frac{1}{2}}^{\frac{3}{2}} \frac{u - \frac{1}{2}}{u^2 + \frac{3}{4}} du = \frac{3}{2} \int_{\frac{1}{2}}^{\frac{3}{2}} \frac{du}{u^2 + \frac{3}{4}} - \int_{\frac{1}{2}}^{\frac{3}{2}} \frac{u}{u^2 + \frac{3}{4}} du.$$

The first integral on the right is

$$\begin{aligned} \int_{\frac{1}{2}}^{\frac{3}{2}} \frac{du}{u^2 + \left(\frac{\sqrt{3}}{2}\right)^2} &= \frac{2}{\sqrt{3}} \tan^{-1} \left(\frac{u}{\sqrt{3}/2} \right) \Big|_{1/2}^{3/2} \\ &= \frac{2}{\sqrt{3}} \tan^{-1} \left(\frac{2u}{\sqrt{3}} \right) \Big|_{1/2}^{3/2} = \frac{2}{\sqrt{3}} \left[\tan^{-1} \left(\frac{3}{\sqrt{3}} \right) - \tan^{-1} \left(\frac{1}{\sqrt{3}} \right) \right] \\ &= \frac{2}{\sqrt{3}} \left[\tan^{-1}(\sqrt{3}) - \tan^{-1} \left(\frac{1}{\sqrt{3}} \right) \right] = \frac{2}{\sqrt{3}} \left[\frac{\pi}{3} - \frac{\pi}{6} \right] = \frac{\pi}{3\sqrt{3}}. \end{aligned}$$

So,

$$\int_0^1 \frac{1-x}{1+x+x^2} dx = \frac{\pi}{2\sqrt{3}} - \int_{\frac{1}{2}}^{\frac{3}{2}} \frac{u}{u^2 + \frac{3}{4}} du.$$

In the integral on the right, change variable to

$$t = u^2 + \frac{3}{4}.$$

Then, $dt = 2u \, du$ and

$$\int_{\frac{1}{2}}^{\frac{3}{2}} \frac{u}{u^2 + \frac{3}{4}} \, du = \int_1^3 \frac{u}{t} \frac{dt}{2u} = \frac{1}{2} \int_1^3 \frac{dt}{t} = \frac{1}{2} \ln(t) \Big|_1^3 = \frac{1}{2} \ln(3).$$

So,

$$\int_0^1 \frac{1-x}{1+x+x^2} \, dx = \frac{\pi}{2\sqrt{3}} - \frac{1}{2} \ln(3)$$

or,

(2.4.6)

$$\int_0^1 \frac{1-x}{1+x+x^2} \, dx = \frac{1}{2} \left[\frac{\pi}{\sqrt{3}} - \ln(3) \right]$$

which equals 0.35759 . . . , and MATLAB agrees because `quad(@(x)(1-x)/(1+x+x.^2),0,1) = 0.357593 . . .`

2.5 Challenge Problems

That was all pretty straightforward, but here are some problems that *will*, I think, give your brain a really good workout. And yet, like nearly everything else in this book, *if you see the trick* they will unfold for you like a butterfly at rest.

(C2.1): According to Edwards' *A Treatise on the Integral Calculus* (see the end of the Preface), the following question appeared on an 1886 exam at the University of Cambridge: show that

$$\int_0^4 \frac{\ln(x)}{\sqrt{4x-x^2}} \, dx = 0.$$

Edwards included no solution and, given that it took me about 5 h spread over 3 days to do it (in my quiet office, under no pressure), my awe for the expected math level of some of the undergraduate students at nineteenth century Cambridge is unbounded. See if you can do it faster than I did (and if not, my solution is at the end of the book). A quick numerical check by MATLAB should convince you that the given answer is correct:

$$\text{quad}(@(x)\log(x)/\text{sqrt}(4*x-x.^2),0,4) = 0.0000066.$$

(C2.2): Calculate the value of $\int_0^1 \frac{dx}{x^3+1}$. Hint: first confirm the validity of the partial

fraction expansion $\frac{1}{x^3+1} = \frac{1}{3} \left[\frac{1}{x+1} - \frac{x-2}{x^2-x+1} \right]$ and so $\int_0^1 \frac{dx}{x^3+1} = \frac{1}{3} \int_0^1 \frac{dx}{x+1} - \frac{1}{3} \int_0^1 \frac{x-2}{x^2-x+1} \, dx$. The first integral on the right will yield to an obvious change

of variable, and the second integral on the right will yield to another change of variable, one just as obvious if you first complete the square in the denominator of the integrand. Your theoretical answer should have the numerical value 0.8356488. . .

(C2.3): Here's a pretty little recursive problem for you to work through. Suppose you know the value of

$$\int_0^\infty \frac{dx}{x^4 + 1}.$$

This integral is not particularly difficult to do—we did it in (2.3.4)—with a value of $\frac{\pi}{2\sqrt{2}}$. The point here is that with this knowledge you then also immediately know the values of

$$\int_0^\infty \frac{dx}{(x^4 + 1)^m}$$

for all integer $m > 1$ (and not just for $m = 1$). Show this is so by deriving the recursion

$$\int_0^\infty \frac{dx}{(x^4 + 1)^{m+1}} = \frac{4m - 1}{4m} \int_0^\infty \frac{dx}{(x^4 + 1)^m}.$$

For example,

$$\int_0^\infty \frac{dx}{(x^4 + 1)^3} = \frac{(4)(2) - 1}{(4)(2)} \int_0^\infty \frac{dx}{(x^4 + 1)^2} = \frac{7}{8} \int_0^\infty \frac{dx}{(x^4 + 1)^2}$$

and

$$\int_0^\infty \frac{dx}{(x^4 + 1)^2} = \frac{(4)(1) - 1}{(4)(1)} \int_0^\infty \frac{dx}{x^4 + 1} = \frac{3}{4} \int_0^\infty \frac{dx}{x^4 + 1}.$$

Thus,

$$\int_0^\infty \frac{dx}{(x^4 + 1)^3} = \left(\frac{7}{8}\right) \left(\frac{3}{4}\right) \int_0^\infty \frac{dx}{x^4 + 1} = \left(\frac{21}{32}\right) \frac{\pi}{2\sqrt{2}} = \frac{21\pi}{64\sqrt{2}} = 0.72891 \dots$$

MATLAB agrees, as `quad(@(x)1./((x.^4+1).^3),0,1000) = 0.72891 . . .`

Hint: Start with $\int_0^\infty \frac{dx}{(x^4 + 1)^m}$ and integrate by parts.

(C2.4): For what values of b does the integral in (2.4.5) make sense? Hint: think about where any singularities in the integrand are located.

(C2.5): Show that $\int_0^\infty \frac{\ln(1+x)}{x\sqrt{x}} dx = 2\pi$. Hint: integrate by parts.

Chapter 3

Feynman's Favorite Trick

3.1 Leibniz's Formula

The starting point for Feynman's trick of 'differentiating under the integral sign,' mentioned at the end of Chap. 1, is Leibniz's formula. If we have the integral

$$I(\alpha) = \int_{a(\alpha)}^{b(\alpha)} f(x, \alpha) \, dx$$

where α is the so-called *parameter* of the integral (*not* the dummy variable of integration which is, of course, x), then we wish to calculate the derivative of I with respect to α . We do that in just the way you'd expect, from the very definition of the derivative:

$$\frac{dI}{d\alpha} = \lim_{\Delta\alpha \rightarrow 0} \frac{I(\alpha + \Delta\alpha) - I(\alpha)}{\Delta\alpha}.$$

Now, since the integration limits depend (in general) on α , then a $\Delta\alpha$ will cause a Δa and a Δb and so we have to write

$$\begin{aligned} I(\alpha + \Delta\alpha) - I(\alpha) &= \int_{a+\Delta a}^{b+\Delta b} f(x, \alpha + \Delta\alpha) \, dx - \int_a^b f(x, \alpha) \, dx \\ &= \left(\int_{a+\Delta a}^a + \int_a^b + \int_b^{b+\Delta b} \right) f(x, \alpha + \Delta\alpha) \, dx - \int_a^b f(x, \alpha) \, dx \\ &= \int_a^b \{f(x, \alpha + \Delta\alpha) - f(x, \alpha)\} \, dx + \int_b^{b+\Delta b} f(x, \alpha + \Delta\alpha) \, dx \\ &\quad - \int_a^{a+\Delta a} f(x, \alpha + \Delta\alpha) \, dx. \end{aligned}$$

As $\Delta\alpha \rightarrow 0$ we have $\Delta a \rightarrow 0$ and $\Delta b \rightarrow 0$, too, and so

$$\begin{aligned} & \lim_{\Delta\alpha \rightarrow 0} \{I(\alpha + \Delta\alpha) - I(\alpha)\} \\ &= \lim_{\Delta\alpha \rightarrow 0} \int_a^b \{f(x, \alpha + \Delta\alpha) - f(x, \alpha)\} dx + f(b, \alpha)\Delta b - f(a, \alpha)\Delta a \end{aligned}$$

where the last two terms follow because as $\Delta a \rightarrow 0$ and $\Delta b \rightarrow 0$ the value of x over the entire integration interval remains practically unchanged at $x = a$ or at $x = b$, respectively. Thus,

$$\begin{aligned} \frac{dI}{d\alpha} &= \lim_{\Delta\alpha \rightarrow 0} \frac{I(\alpha + \Delta\alpha) - I(\alpha)}{\Delta\alpha} = \lim_{\Delta\alpha \rightarrow 0} \frac{1}{\Delta\alpha} \int_a^b \{f(x, \alpha + \Delta\alpha) - f(x, \alpha)\} dx \\ &+ \lim_{\Delta\alpha \rightarrow 0} f(b, \alpha) \frac{\Delta b}{\Delta\alpha} - \lim_{\Delta\alpha \rightarrow 0} f(a, \alpha) \frac{\Delta a}{\Delta\alpha} \end{aligned}$$

or, taking the $\frac{1}{\Delta\alpha}$ inside the integral (the Riemann integral itself is defined as a limit, so what we are doing is reversing the order of two limiting operations, something a pure mathematician would want to justify but, as usual in this book, we won't worry about it!),

$$(3.1.1) \quad \frac{dI}{d\alpha} = \int_a^b \frac{\partial f}{\partial \alpha} dx + f(b, \alpha) \frac{db}{d\alpha} - f(a, \alpha) \frac{da}{d\alpha} .$$

This is the full-blown Leibniz formula for how to differentiate an integral, including the case where the integrand *and the limits* are functions of the parameter α . If the limits are not functions of the parameter (such as when the limits are constants) then the last two terms vanish and we simply (partially) differentiate the integrand under the integral sign with respect to the parameter α (*not* x).

Here's a quick example of the power of Leibniz's formula. We've used, numerous times, the elementary result

$$\int_0^\infty \frac{1}{x^2 + a^2} dx = \left\{ \frac{1}{a} \tan^{-1} \left(\frac{x}{a} \right) \right\} \Big|_0^\infty = \frac{\pi}{2a} .$$

Treating a as a parameter, differentiation then immediately gives us the new result that

$$\int_0^\infty \frac{-2a}{(x^2 + a^2)^2} dx = -\frac{2\pi}{4a^2}$$

or,

$$(3.1.2) \quad \int_0^\infty \frac{1}{(x^2 + a^2)^2} dx = \frac{\pi}{4a^3} .$$

One could, of course, not stop here but continue to differentiate this new result again (and then again and again), each time producing a new result. For example, another differentiation gives

$$(3.1.3) \quad \int_0^\infty \frac{1}{(x^2 + a^2)^3} dx = \frac{3\pi}{16a^5} .$$

For $a=1$ this is $0.58904\dots$ and $\text{quad}(@)(x)1./(x.^2 + 1).^3,0,100) = 0.58904\dots$

A more sophisticated example of the formula's use is the evaluation of

$$\int_{-\infty}^\infty e^{-\frac{x^2}{2}} dx .$$

This is the famous *probability integral*,¹ so-called because it appears in the theory of random quantities described by Gaussian (bell-shaped) probability density functions (about which you need know *nothing* for this book). Because this integral has an even integrand, we can instead study

$$\int_0^\infty e^{-\frac{x^2}{2}} dx$$

and then simply double the result.

To introduce a parameter (t) with which we can differentiate with respect to, let's define the function

$$g(t) = \left\{ \int_0^t e^{-\frac{x^2}{2}} dx \right\}^2 ,$$

and so what we are after is

¹ The probability integral is most commonly evaluated in textbooks with the trick of converting it to a double integral in polar coordinates (see, for example, my books *An Imaginary Tale: the story of $\sqrt{-1}$* , Princeton 2012, pp. 177–178, and *Mrs. Perkins's Electric Quilt*, Princeton 2009, pp. 282–283), and the use of Leibniz's formula that I'm going to show you here is uncommon. It is such an important integral that at the end of this chapter we will return to it with some additional analyses.

$$\int_{-\infty}^{\infty} e^{-\frac{x^2}{2}} dx = 2\sqrt{g(\infty)}.$$

Note, *carefully*, that the parameter t and the dummy variable of integration x , are *independent* quantities.

Differentiating $g(t)$ using Leibniz's formula (notice that the upper limit on the integral is a function of the parameter t , but the integrand and the lower limit are not), we get

$$\frac{dg}{dt} = 2 \int_0^t e^{-\frac{x^2}{2}} dx \left\{ e^{-\frac{t^2}{2}} \right\} = 2 \int_0^t e^{-\frac{(t^2+x^2)}{2}} dx.$$

Next, change variable to $y = \frac{x}{t}$ (so that as x varies from 0 to t , y will vary from 0 to 1). That is, $x = yt$ and so $dx = t dy$ and we have

$$\frac{dg}{dt} = \int_0^1 2te^{-\frac{(t^2+y^2)t^2}{2}} dy = \int_0^1 2te^{-\frac{(1+y^2)t^2}{2}} dy.$$

Now, notice that the integrand can be written as a (partial) derivative as follows:

$$2te^{-\frac{(1+y^2)t^2}{2}} = \frac{\partial}{\partial t} \left\{ -\frac{2e^{-\frac{(1+y^2)t^2}{2}}}{1+y^2} \right\}.$$

That is,²

$$\frac{dg}{dt} = \int_0^1 \frac{\partial}{\partial t} \left\{ -\frac{2e^{-\frac{(1+y^2)t^2}{2}}}{1+y^2} \right\} dy = -2 \frac{d}{dt} \int_0^1 \frac{e^{-\frac{(1+y^2)t^2}{2}}}{1+y^2} dy.$$

And so, integrating,

$$g(t) = -2 \int_0^1 \frac{e^{-\frac{(1+y^2)t^2}{2}}}{1+y^2} dy + C$$

where C is the constant of integration. We can find C as follows. Let $t=0$. Then

²The reason we write a *partial* derivative inside the integral and a total derivative outside the integral is that the integrand is a function of two variables (t and y) while the integral itself is a function only of t (we've 'integrated out' the y dependency).

$$g(0) = \left\{ \int_0^0 e^{-\frac{x^2}{2}} dx \right\}^2 = 0$$

and, as $t \rightarrow 0$,

$$\int_0^1 \frac{e^{-\frac{(1+y^2)t^2}{2}}}{1+y^2} dy \rightarrow \int_0^1 \frac{1}{1+y^2} dy = \tan^{-1}(y)|_0^1 = \frac{\pi}{4}.$$

Thus, $0 = -2\left(\frac{\pi}{4}\right) + C$ and so $C = \frac{\pi}{2}$ and therefore

$$g(t) = \frac{\pi}{2} - 2 \int_0^1 \frac{e^{-\frac{(1+y^2)t^2}{2}}}{1+y^2} dy.$$

Now, let $t \rightarrow \infty$. The integrand clearly vanishes over the entire interval of integration and we have $g(\infty) = \frac{\pi}{2}$. That is,

$$(3.1.4) \quad \int_{-\infty}^{\infty} e^{-\frac{x^2}{2}} dx = 2 \sqrt{\frac{\pi}{2}} = \sqrt{2\pi} .$$

$\sqrt{2\pi} = 2.506628 \dots$, and *quad* agrees: `quad(@(x)exp(-(x.^2)/2),-1000,1000) = 2.506628 ...`

We can use differentiation under the integral sign, again, to generalize this result in the evaluation of

$$I(t) = \int_0^{\infty} \cos(tx)e^{-\frac{x^2}{2}} dx.$$

From our last result, we know that $I(0) = \sqrt{\frac{\pi}{2}}$. Then, differentiating with respect to t ,

$$\frac{dI(t)}{dt} = \int_0^{\infty} -x \sin(tx)e^{-\frac{x^2}{2}} dx.$$

We can do this integral by-parts; let $u = \sin(tx)$ and $dv = -xe^{-\frac{x^2}{2}} dx$. Then, $du = t \cos(tx)dx$ and $v = e^{-\frac{x^2}{2}}$. Thus,

$$\frac{dI(t)}{dt} = \left\{ \sin(tx)e^{-\frac{x^2}{2}} \right\} \Big|_0^\infty - \int_0^\infty t \cos(tx)e^{-\frac{x^2}{2}} dx.$$

The first term on the right vanishes at both the upper and lower limits, and so we have the elementary first-order differential equation

$$\frac{dI(t)}{dt} = -t \int_0^\infty \cos(tx)e^{-\frac{x^2}{2}} dx = -t I(t).$$

Rewriting, this is

$$\frac{dI(t)}{I(t)} = -t dt$$

and this is easily integrated to give

$$\ln\{I(t)\} = -\frac{t^2}{2} + C$$

where, as usual, C is a constant of integration. Since $I(0) = \sqrt{\frac{\pi}{2}}$, we have $C = \ln\left(\sqrt{\frac{\pi}{2}}\right)$ and so

$$\ln\{I(t)\} - \ln\left(\sqrt{\frac{\pi}{2}}\right) = \ln\left(I(t)\sqrt{\frac{2}{\pi}}\right) = -\frac{t^2}{2}$$

or, at last,

$$(3.1.5) \quad \int_0^\infty \cos(tx)e^{-\frac{x^2}{2}} dx = \sqrt{\frac{\pi}{2}} e^{-\frac{t^2}{2}}.$$

For $t = 1$, for example, our result says the integral is equal to $\sqrt{\frac{\pi}{2}} = 0.760173 \dots$ and `quad(@(x)cos(x).*exp(-(x.^2)/2),0,1000) = 0.760171 \dots`

From this last result, if we return to the original limits of $-\infty$ to ∞ we can write

$$\int_{-\infty}^\infty e^{-\frac{x^2}{2}} \cos(tx) dx = 2\sqrt{\frac{\pi}{2}} e^{-\frac{t^2}{2}} = \sqrt{2\pi} e^{-\frac{t^2}{2}}.$$

Then, if we write

$$\int_{-\infty}^{\infty} e^{-\frac{x^2}{2}} \cos(s + tx) \, dx = \int_{-\infty}^{\infty} e^{-\frac{x^2}{2}} \cos(s) \cos(tx) \, dx - \int_{-\infty}^{\infty} e^{-\frac{x^2}{2}} \sin(s) \sin(tx) \, dx$$

where I've used the trig identity for the cosine of a sum, we have

$$\int_{-\infty}^{\infty} e^{-\frac{x^2}{2}} \cos(s + tx) \, dx = \cos(s) \int_{-\infty}^{\infty} e^{-\frac{x^2}{2}} \cos(tx) \, dx - \sin(s) \int_{-\infty}^{\infty} e^{-\frac{x^2}{2}} \sin(tx) \, dx.$$

But since the last integral on the right is zero because its integrand is odd, we have

$$\int_{-\infty}^{\infty} e^{-\frac{x^2}{2}} \cos(s + tx) \, dx = \cos(s) \int_{-\infty}^{\infty} e^{-\frac{x^2}{2}} \cos(tx) \, dx$$

and so, finally (using our result (3.1.5))

$$\int_{-\infty}^{\infty} e^{-\frac{x^2}{2}} \cos(s + tx) \, dx = \sqrt{2\pi} e^{-\frac{t^2}{2}} \cos(s).$$

(3.1.6)

For $t=s=1$ this is $0.82144\dots$ and `quad(@(x)exp(-(x.^2)/2).*cos(1 + x),-10,10)=0.82144...`

The trick of evaluating an integral by finding a differential equation for which the integral is the solution can be used to determine the value of

$$I(a) = \int_0^{\infty} \frac{\cos(ax)}{x^2 + b^2} \, dx$$

where a and b are each positive (a is the parameter and b is a constant). If we integrate by parts, writing

$$u = \frac{1}{x^2 + b^2}, \, dv = \cos(ax) \, dx$$

then

$$du = -\frac{2x}{(x^2 + b^2)^2} \, dx, \, v = \frac{\sin(ax)}{a}$$

and so

$$I(a) = \left\{ \frac{\sin(ax)}{a(x^2 + b^2)^2} \right\} \Big|_0^\infty + \frac{2}{a} \int_0^\infty \frac{x \sin(ax)}{(x^2 + b^2)^2} dx$$

or, as the first term on the right vanishes at both the upper and the lower limit, we have

$$I(a) = \frac{2}{a} \int_0^\infty \frac{x \sin(ax)}{(x^2 + b^2)^2} dx$$

and so it perhaps looks as though we are making things worse! As you'll soon see, we are not.

From our last result we multiply through by a and arrive at

$$aI(a) = 2 \int_0^\infty \frac{x \sin(ax)}{(x^2 + b^2)^2} dx$$

and then differentiate with respect to a to get

$$a \frac{dI(a)}{da} + I(a) = 2 \int_0^\infty \frac{x^2 \cos(ax)}{(x^2 + b^2)^2} dx.$$

The integrand can be re-written in a partial fraction expansion:

$$\frac{x^2 \cos(ax)}{(x^2 + b^2)^2} = \frac{\cos(ax)}{x^2 + b^2} - \frac{b^2 \cos(ax)}{(x^2 + b^2)^2}.$$

Thus,

$$2 \int_0^\infty \frac{x^2 \cos(ax)}{(x^2 + b^2)^2} dx = 2 \int_0^\infty \frac{\cos(ax)}{x^2 + b^2} dx - 2b^2 \int_0^\infty \frac{\cos(ax)}{(x^2 + b^2)^2} dx$$

and, since the first integral on right is $I(a)$, we have

$$a \frac{dI(a)}{da} + I(a) = 2I(a) - 2b^2 \int_0^\infty \frac{\cos(ax)}{(x^2 + b^2)^2} dx$$

or,

$$a \frac{dI(a)}{da} - I(a) = -2b^2 \int_0^\infty \frac{\cos(ax)}{(x^2 + b^2)^2} dx.$$

Differentiating this with respect to a , we get

$$a \frac{d^2 I(a)}{da^2} + \frac{dI(a)}{da} - \frac{dI(a)}{da} = 2b^2 \int_0^\infty \frac{x \sin(ax)}{(x^2 + b^2)^2} dx$$

or,

$$a \frac{d^2 I(a)}{da^2} = 2b^2 \int_0^\infty \frac{x \sin(ax)}{(x^2 + b^2)^2} dx.$$

If you look back at the start of the last paragraph, you'll see that we found the integral on the right to be

$$\int_0^\infty \frac{x \sin(ax)}{(x^2 + b^2)^2} dx = \frac{a}{2} I(a),$$

and so

$$a \frac{d^2 I(a)}{da^2} = 2b^2 \frac{a}{2} I(a)$$

or, rearranging, we have the following *second-order*, linear differential equation for $I(a)$:

$$\frac{d^2 I(a)}{da^2} - b^2 I(a) = 0.$$

Such equations are well-known to have exponential solutions— $I(a) = C e^{ka}$, where C and k are constants—and substitution into the differential equation gives

$$Ck^2 e^{ka} - b^2 C e^{ka} = 0$$

and so $k^2 - b^2 = 0$ or $k = \pm b$. Thus, the general solution to the differential equation is the sum of these two particular solutions:

$$I(a) = C_1 e^{ab} + C_2 e^{-ab}.$$

We need two conditions on $I(a)$ to determine the constants C_1 and C_2 , and we can get them from our two different expressions for $I(a)$: the original

$$I(a) = \int_0^\infty \frac{\cos(ax)}{x^2 + b^2} dx$$

and the expression we got by integrating by parts

$$I(a) = \frac{2}{a} \int_0^\infty \frac{x \sin(ax)}{(x^2 + b^2)^2} dx.$$

From the first we see that

$$I(0) = \int_0^\infty \frac{1}{x^2 + b^2} dx = \frac{1}{b} \left\{ \tan^{-1}\left(\frac{x}{b}\right) \right\} \Big|_0^\infty = \frac{\pi}{2b},$$

and from the second we see that $\lim_{a \rightarrow \infty} I(a) = 0$.

Thus,

$$I(0) = \frac{\pi}{2b} = C_1 + C_2$$

and

$$I(\infty) = 0$$

which says that $C_1 = 0$. Thus, $C_2 = \frac{\pi}{2b}$ and we have this beautiful result:

$$(3.1.7) \quad \int_0^\infty \frac{\cos(ax)}{x^2 + b^2} dx = \frac{\pi}{2b} e^{-ab},$$

discovered in 1810 by Laplace. If $b = 1$ and $a = \pi$ then the integral is equal to $\frac{\pi}{2}e^{-\pi} = 0.06788 \dots$, and $\text{quad}(@)(x)\cos(\pi*x)/(x.^2 + 1),0,1e10) = 0.06529 \dots$ Before moving on to new tricks, let me observe that with a simple change of variable we can often get some spectacular results from previously derived ones. For example, since (as we showed earlier in (3.1.4))

$$\int_{-\infty}^\infty e^{-\frac{x^2}{2}} dx = \sqrt{2\pi}$$

it follows (with $u = x\sqrt{2}$) that

$$\int_0^\infty e^{-u^2} du = \frac{1}{2}\sqrt{\pi}.$$

Then, letting $t = e^{-x^2}$, we have $x = \sqrt{-\ln(t)}$ (and so $dx = -\frac{dt}{2xe^{-x^2}} = \frac{dt}{-2xt}$) and thus

$$\int_0^\infty e^{-x^2} dx = \int_1^0 t \frac{dt}{-2xt} = \frac{1}{2} \int_0^1 \frac{dt}{\sqrt{-\ln(t)}} = \frac{1}{2} \sqrt{\pi}$$

which says

(3.1.8)

$$\int_0^1 \frac{dx}{\sqrt{-\ln(x)}} = \sqrt{\pi}$$

which is 1.77245 . . . , and agreeing is $quad(@)(x)1./sqrt(-log(x)),0,1) = 1.77245 . . .$

3.2 An Amazing Integral

We start with the function $g(y)$, defined as

$$g(y) = \int_0^\infty e^{-xy} \frac{\sin(ax)}{x} dx, \quad y > 0,$$

where a is some constant (more about a , soon). Differentiating with respect to the parameter y (notice, carefully, that x is the dummy variable of integration),

$$\frac{dg}{dy} = \int_0^\infty \frac{\partial}{\partial y} \left\{ e^{-xy} \frac{\sin(ax)}{x} \right\} dx = \int_0^\infty -xe^{-xy} \frac{\sin(ax)}{x} dx$$

or,

$$\frac{dg}{dy} = - \int_0^\infty e^{-xy} \sin(ax) dx.$$

If this integral is then integrated-by-parts *twice*, it is easy to show that

$$\frac{dg}{dy} = - \frac{a}{a^2 + y^2}$$

which is easily integrated to give

$$g(y) = C - \tan^{-1}\left(\frac{y}{a}\right)$$

where C is an arbitrary constant of integration. We can calculate C by noticing, in the original integral definition of $g(y)$, that $g(\infty) = 0$ because the e^{-xy} factor in the

integrand goes to zero *everywhere* as $y \rightarrow \infty$ (because, over the entire interval of integration, $x \geq 0$).

Thus,

$$0 = C - \tan^{-1}(\pm\infty),$$

where we use the + sign if $a > 0$ and the – sign if $a < 0$. So, $C = \pm \frac{\pi}{2}$ and we have

$$g(y) = \pm \frac{\pi}{2} - \tan^{-1}\left(\frac{y}{a}\right).$$

The special case of $y=0$ (and so $\tan^{-1}\left(\frac{y}{a}\right) = 0$) gives us the following wonderful result, called *Dirichlet’s discontinuous* integral (after the German mathematician Gustav Dirichlet (1805–1859)):

$$(3.2.1) \quad \int_0^\infty \frac{\sin(ax)}{x} dx = \begin{cases} \frac{\pi}{2} & \text{if } a > 0 \\ 0 & \text{if } a = 0 \\ -\frac{\pi}{2} & \text{if } a < 0. \end{cases}$$

The value of the integral at $a = 0$ is zero, as the numerator of the integrand is then zero over the entire interval of integration, with the exception of the *single point* $x = 0$ where the integrand has value a . Euler derived the $a = 1$ special case sometime between 1776 and his death in 1783. The plot in Fig. 3.2.1, generated by using *quad* to evaluate the integral for 1,000 values of a over the interval $-0.5 < a < 0.5$, hints at the correctness of our calculations, with the all-important sudden jump as a goes from negative to positive dramatically illustrated (the wiggles are due to the *Gibbs phenomenon*, which is inherent in any attempt to represent a discontinuous function as a finite sum of sinusoids and, after all, integrating with *quad* is such a sum—see any book on Fourier series).

3.3 Frullani’s Integral

As yet another example of differentiating under the integral sign, let’s calculate

$$I(a, b) = \int_0^\infty \frac{\tan^{-1}(ax) - \tan^{-1}(bx)}{x} dx.$$

Notice that $I(a, a) = 0$. Differentiating with respect to a (using a *partial* derivative as I is a function of the *two* parameters a and b):

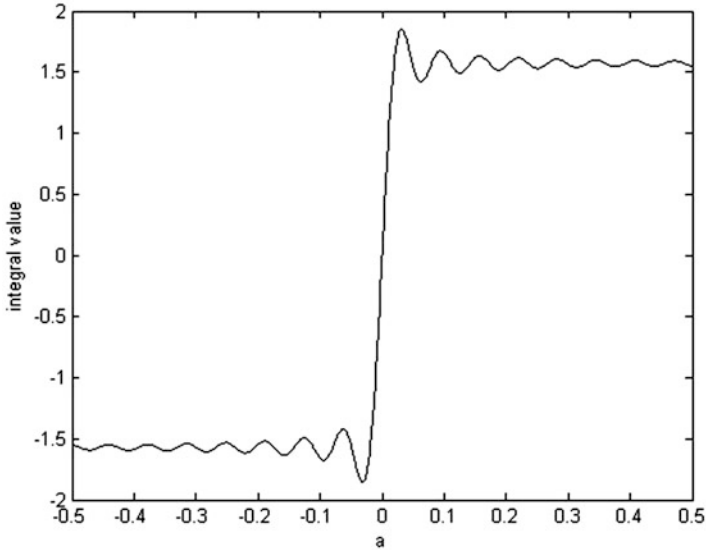

Fig. 3.2.1 Dirichlet's discontinuous integral

$$\begin{aligned} \frac{\partial I}{\partial a} &= \int_0^\infty \left(\frac{1}{x}\right) \frac{\partial}{\partial a} \tan^{-1}(ax) \, dx = \int_0^\infty \left(\frac{1}{x}\right) \left\{ \frac{x}{1+a^2x^2} \right\} dx \\ &= \int_0^\infty \frac{1}{1+a^2x^2} \, dx = \frac{1}{a} \left\{ \tan^{-1}\left(\frac{x}{a}\right) \right\} \Big|_0^\infty = \frac{1}{a} \tan^{-1}(\infty) = \frac{\pi}{2a}. \end{aligned}$$

So, integrating with respect to a,

$$I(a, b) = \frac{\pi}{2} \ln(a) + C(b),$$

where C(b) is an arbitrary function (of b) of integration. Writing C(b) in the alternative form of $\frac{\pi}{2} \ln(C(b))$ —a more convenient constant!—we have

$$I(a, b) = \frac{\pi}{2} \ln(a) + \frac{\pi}{2} \ln(C(b)) = \frac{\pi}{2} \ln(aC(b)).$$

Since $I(a, a) = 0$, we have $aC(a) = 1$ or, $C(a) = \frac{1}{a}$. So, $C(b) = \frac{1}{b}$ and thus

$$\int_0^\infty \frac{\tan^{-1}(ax) - \tan^{-1}(bx)}{x} \, dx = \frac{\pi}{2} \ln\left(\frac{a}{b}\right).$$

(3.3.1)

If $a = \pi$ and $b = 1$, for example, then

$$\int_0^{\infty} \frac{\tan^{-1}(\pi x) - \tan^{-1}(x)}{x} dx = \frac{\pi \ln(\pi)}{2} = 1.798137 \dots$$

and, in agreement, $\text{quad}(@)(x)(\text{atan}(\pi*x)-\text{atan}(x))./x,0,1000) = 1.797461 \dots$

This result is a special case of what is called *Frullani's integral*, after the Italian mathematician Giuliano Frullani (1795–1834), who first wrote of it in an 1821 letter to a friend. We'll use Frullani's integral later in the book, and so it is worth doing a general derivation, which is usually *not* given in textbooks. Here's one way to do it, where we assume we have a function $f(x)$ such that both $f(0)$ and $f(\infty)$ exist. Our derivation starts with the definition of U as (where a is some positive constant)

$$U = \int_0^{h/a} \frac{f(ax) - f(0)}{x} dx$$

where h is some positive constant (for *now* h is a finite constant, but in just a bit we are going to let $h \rightarrow \infty$). Replacing a with b , we could just as well write

$$U = \int_0^{h/b} \frac{f(bx) - f(0)}{x} dx.$$

(To see that these two expressions for U are indeed equal, remember that a is an *arbitrary* constant and so it doesn't matter if we write a or if we write b .) So,

$$\int_0^{h/a} \frac{f(ax)}{x} dx = U + f(0) \int_0^{h/a} \frac{dx}{x}$$

and

$$\int_0^{h/b} \frac{f(bx)}{x} dx = U + f(0) \int_0^{h/b} \frac{dx}{x}.$$

Subtracting the last equation from the preceding one,

$$\begin{aligned} \int_0^{h/a} \frac{f(ax)}{x} dx - \int_0^{h/b} \frac{f(bx)}{x} dx &= f(0) \left[\int_0^{h/a} \frac{dx}{x} - \int_0^{h/b} \frac{dx}{x} \right] = f(0) \int_{h/b}^{h/a} \frac{dx}{x} \\ &= f(0) \{ \ln(x) \}_{h/b}^{h/a} = f(0) \ln \left(\frac{h/a}{h/b} \right) = f(0) \ln \left(\frac{b}{a} \right). \end{aligned}$$

Then, subtracting and adding $\int_{h/b}^{h/a} \frac{f(bx)}{x} dx$ to the initial left-hand-side of this last equation, we have

$$\int_0^{h/a} \frac{f(ax)}{x} dx - \int_0^{h/b} \frac{f(bx)}{x} dx - \int_{h/b}^{h/a} \frac{f(bx)}{x} dx + \int_{h/b}^{h/a} \frac{f(bx)}{x} dx = f(0) \ln\left(\frac{b}{a}\right)$$

or, combining the second and third terms on the left,

$$\int_0^{h/a} \frac{f(ax)}{x} dx - \int_0^{h/b} \frac{f(bx)}{x} dx + \int_{h/b}^{h/a} \frac{f(bx)}{x} dx = f(0) \ln\left(\frac{b}{a}\right)$$

or,

$$\int_0^{h/a} \frac{f(ax) - f(bx)}{x} dx + \int_{h/b}^{h/a} \frac{f(bx)}{x} dx = f(0) \ln\left(\frac{b}{a}\right).$$

Now, imagine that $h \rightarrow \infty$. Then the upper limit on the left-most integral $\rightarrow \infty$, and *both* limits on the second integral $\rightarrow \infty$. That means $f(bx) \rightarrow f(\infty)$ over the entire interval of integration in the second integral and so

$$\begin{aligned} \lim_{h \rightarrow \infty} \int_{h/b}^{h/a} \frac{f(bx)}{x} dx &= \lim_{h \rightarrow \infty} f(\infty) \int_{h/b}^{h/a} \frac{dx}{x} = f(\infty) \lim_{h \rightarrow \infty} \ln\left(\frac{b}{a}\right) \\ &= f(\infty) \ln\left(\frac{b}{a}\right). \end{aligned}$$

This all means that our last equation becomes, as $h \rightarrow \infty$,

$$\int_0^{\infty} \frac{f(ax) - f(bx)}{x} dx + f(\infty) \ln\left(\frac{b}{a}\right) = f(0) \ln\left(\frac{b}{a}\right)$$

or, writing $\ln\left(\frac{b}{a}\right) = -\ln\left(\frac{a}{b}\right)$, we have our result (Frullani's integral):

$$(3.3.2) \quad \int_0^{\infty} \frac{f(ax) - f(bx)}{x} dx = \{f(\infty) - f(0)\} \ln\left(\frac{a}{b}\right).$$

This result assumes, as I said before, that $f(x)$ is such that *both* $f(\infty)$ and $f(0)$ exist. This is the case in the first example of $f(x) = \tan^{-1}(x)$, and $f(x) = e^{-x}$ works, too, as then $f(0) = 1$ and $f(\infty) = 0$ and so

$$\int_0^{\infty} \frac{e^{-ax} - e^{-bx}}{x} dx = -\ln\left(\frac{a}{b}\right) = \ln\left(\frac{b}{a}\right), \quad a, b > 0.$$

(3.3.3)

But not every $f(x)$ meets this requirement.

For example, can we calculate

$$I(a, b) = \int_0^\infty \frac{\cos(ax) - \cos(bx)}{x} dx$$

using Frullani's integral? No, because here we have $f(x) = \cos(x)$ and so while $f(0) = 1$ exists, $f(\infty)$ does not (the cosine function oscillates endlessly between -1 and $+1$ and has no limiting value). What we *can* do, however, is calculate

$$I(t) = \int_0^\infty e^{-tx} \left\{ \frac{\cos(ax) - \cos(bx)}{x} \right\} dx$$

and see what happens as $t \rightarrow 0$. I'll defer doing this calculation until the next section, where I'll first show you yet another neat trick for doing integrals and then we'll use it to do $I(t)$. Interestingly, it turns out to be sort of the 'inverse' of Feynman's trick of differentiating under the integral sign.

3.4 The Flip-Side of Feynman's Trick

I'll demonstrate this new trick by using it to calculate the value of

$$I(a, b) = \int_0^\infty \frac{\cos(ax) - \cos(bx)}{x^2} dx.$$

We can write the integrand of this integral as an integral, itself, because

$$\frac{\cos(ax) - \cos(bx)}{x^2} = - \int_b^a \frac{\sin(xy)}{x} dy.$$

This works because the integral, when evaluated (remember, the integration is with respect to y and so the x can be treated as a constant), is

$$- \int_b^a \frac{\sin(xy)}{x} dy = - \frac{1}{x} \int_b^a \sin(xy) dy = \frac{1}{x} \left\{ \frac{\cos(xy)}{x} \right\} \Big|_b^a = \frac{\cos(ax) - \cos(bx)}{x^2}.$$

So,

$$I(a, b) = - \int_0^\infty \left\{ \int_b^a \frac{\sin(xy)}{x} dy \right\} dx.$$

This may look like a (huge!) step backward, as we now have a *double* integral to do. One thing you can do with double integrals that you can't do with single

integrals, however, is *reverse the order* of integration. Of course we might run into objections that we haven’t proven we are justified in doing that but, remember the philosophical approach we are taking: *we will just go ahead and do anything we please and not worry about it*, and only when we are done will we ‘check’ our formal answer with *quad*. So, reversing,

$$I(a, b) = - \int_b^a \left\{ \int_0^\infty \frac{\sin(xy)}{x} dx \right\} dy.$$

Now, recall our earlier result, the discontinuous integral of Dirichlet in (3.2.1):

$$\int_0^\infty \frac{\sin(cx)}{x} dx = \begin{cases} \frac{\pi}{2} & \text{if } c > 0 \\ 0 & \text{if } c = 0 \\ -\frac{\pi}{2} & \text{if } c < 0. \end{cases}$$

In the inner integral of our double integral, y (taken as positive) plays the role of c and so

$$I(a, b) = - \int_b^a \frac{\pi}{2} dy$$

and so, *just like that*, we have our answer:

$$(3.4.1) \quad \int_0^\infty \frac{\cos(ax) - \cos(bx)}{x^2} dx = \frac{\pi}{2} (b - a).$$

If $a = 0$ and $b = 1$, for example, then

$$\int_0^\infty \frac{1 - \cos(x)}{x^2} dx = \frac{\pi}{2} = 1.57079 \dots$$

and *quad* agrees: *quad*(@(x)(1-cos(x))./x.^2,0,1000) = 1.57073 ... ‘More’ dramatically, if $a = \sqrt{2}$ and $b = \sqrt{3}$ then our result says the integral is equal to $\frac{\pi}{2} (\sqrt{3} - \sqrt{2}) = 0.499257 \dots$, and again *quad* agrees as *quad*(@(x)(cos(sqrt(2)*x)-cos(sqrt(3)*x))./x.^2,0,1000) = 0.498855 ...

Flipping Feynman’s differentiating trick on its head and integrating an integral is a useful new trick, applicable in many interesting ways. For example, recall from earlier the result

$$\int_0^\infty e^{-x^2} dx = \frac{1}{2} \sqrt{\pi}.$$

Change variable to $x = t\sqrt{a}$ (and so $dx = \sqrt{a} dt$) and thus

$$\int_0^\infty e^{-a t^2} \sqrt{a} dt = \frac{1}{2} \sqrt{\pi}$$

or,

$$\int_0^\infty e^{-a t^2} dt = \frac{\sqrt{\pi}}{2\sqrt{a}}.$$

Now integrate both sides of this with respect to a , from p to q :

$$\begin{aligned} \int_p^q \left\{ \int_0^\infty e^{-a t^2} dt \right\} da &= \int_p^q \frac{\sqrt{\pi}}{2\sqrt{a}} da \\ &= \frac{1}{2} \sqrt{\pi} \int_p^q \frac{da}{\sqrt{a}} = \frac{1}{2} \sqrt{\pi} \{2\sqrt{a}\} \Big|_p^q = \sqrt{\pi}(\sqrt{q} - \sqrt{p}). \end{aligned}$$

Reversing the order of integration in the double integral,

$$\int_0^\infty \left\{ \int_p^q e^{-a t^2} da \right\} dt = \int_0^\infty \left\{ -\frac{e^{-a t^2}}{t^2} \right\} \Big|_p^q dt = \int_0^\infty \frac{e^{-p t^2} - e^{-q t^2}}{t^2} dt$$

or, finally,

$$(3.4.2) \quad \int_0^\infty \frac{e^{-p t^2} - e^{-q t^2}}{t^2} dt = \sqrt{\pi} (\sqrt{q} - \sqrt{p}).$$

With $p = 1$ and $q = 2$ the integral is equal to $\sqrt{\pi} (\sqrt{2} - 1) = 0.73417 \dots$, and `quad(@(x)(exp(-(x.^2))-exp(-2*(x.^2)))./x.^2,0,20) = 0.73416 \dots`

As another example of the technique, suppose you were faced with evaluating

$$\int_0^1 \frac{x^a - 1}{\ln(x)} dx, \quad a \geq 0.$$

We can do this by first observing that the integrand can be written as an integral as follows:

$$\int_0^a x^y \, dy = \int_0^a e^{\ln(x^y)} \, dy = \int_0^a e^{y \ln(x)} \, dy = \left\{ \frac{e^{y \ln(x)}}{\ln(x)} \right\} \Big|_0^a = \frac{e^{a \ln(x)} - 1}{\ln(x)} = \frac{x^a - 1}{\ln(x)}.$$

So,

$$\int_0^1 \frac{x^a - 1}{\ln(x)} \, dx = \int_0^1 \left\{ \int_0^a x^y \, dy \right\} \, dx$$

or, upon reversing the order of integration,

$$\int_0^1 \frac{x^a - 1}{\ln(x)} \, dx = \int_0^a \left\{ \int_0^1 x^y \, dx \right\} \, dy = \int_0^a \left\{ \frac{x^{y+1}}{y+1} \right\} \Big|_0^1 \, dy = \int_0^a \frac{1}{y+1} \, dy.$$

Making the obvious change of variable $u = y + 1$, we have

$$\int_0^1 \frac{x^a - 1}{\ln(x)} \, dx = \ln(u) \Big|_1^{a+1}$$

or, at last, we arrive at the very pretty

$$(3.4.3) \quad \int_0^1 \frac{x^a - 1}{\ln(x)} \, dx = \ln(a + 1), \quad a \geq 0.$$

For example, $\int_0^1 \frac{x - 1}{\ln(x)} \, dx = \ln(2) = 0.693147 \dots$ and

$$\int_0^1 \frac{x^2 - 1}{\ln(x)} \, dx = \ln(3) = 1.098612 \dots$$

In agreement, $quad(@(x)(x-1)/log(x),0,1) = 0.693139 \dots$ and $quad(@(x)(x.^2-1)/log(x),0,1) = 1.098604 \dots$

From this result we can write

$$\int_0^1 \frac{x^a - x^b}{\ln(x)} \, dx = \int_0^1 \frac{x^a - 1}{\ln(x)} \, dx - \int_0^1 \frac{x^b - 1}{\ln(x)} \, dx = \ln(a + 1) - \ln(b + 1)$$

and so

$$(3.4.4) \quad \int_0^1 \frac{x^a - x^b}{\ln(x)} dx = \ln\left(\frac{a+1}{b+1}\right).$$

Now that we've seen how integrating under the integral sign works, let's return to the integral I didn't do at the end of the previous section,

$$I(t) = \int_0^\infty e^{-tx} \left\{ \frac{\cos(ax) - \cos(bx)}{x} \right\} dx.$$

Notice that we can write the portion of the integrand that is in the braces as an integral:

$$\frac{\cos(ax) - \cos(bx)}{x} = \int_a^b \sin(xs) ds.$$

Thus,

$$I(t) = \int_0^\infty e^{-tx} \left\{ \int_a^b \sin(xs) ds \right\} dx$$

or, upon reversing the order of integration (note, *carefully*, that since we are going to the x -integration first we have to bring the exponential factor into the inner integral, too) we have

$$I(t) = \int_a^b \left\{ \int_0^\infty e^{-tx} \sin(xs) dx \right\} ds.$$

From standard integration tables we find

$$\int e^{-tx} \sin(xs) dx = \frac{e^{-tx} \{s \sin(xs) - x \cos(xs)\}}{t^2 + s^2}.$$

and so

$$I(t) = \int_a^b \left[\frac{e^{-tx} \{s \sin(xs) - x \cos(xs)\}}{t^2 + s^2} \right] \Big|_0^\infty ds = \int_a^b \frac{s}{t^2 + s^2} ds.$$

Making the change of variable $u = t^2 + s^2$ (and so $ds = \frac{du}{2s}$), gives

$$I(t) = \int_{t^2+a^2}^{t^2+b^2} \frac{s}{u} \left(\frac{du}{2s} \right) = \frac{1}{2} \int_{t^2+a^2}^{t^2+b^2} \frac{du}{u} = \frac{1}{2} \ln\left(\frac{t^2+b^2}{t^2+a^2}\right)$$

or, at last

$$(3.4.5) \quad I(t) = \int_0^\infty e^{-tx} \left\{ \frac{\cos(ax) - \cos(bx)}{x} \right\} dx = \ln \sqrt{\frac{t^2 + b^2}{t^2 + a^2}}.$$

And so, as $t \rightarrow 0$, we find

$$(3.4.6) \quad \int_0^\infty \frac{\cos(ax) - \cos(bx)}{x} dx = \ln \left(\frac{b}{a} \right).$$

If $b = 2$ and $a = 1$ the integral equals $\ln(2) = 0.693147 \dots$ and agreeing is *quad* $(@ (x)(\cos(x) - \cos(2 * x)) ./ x, 0, 1000) = 0.6935 \dots$ Notice that if either a or b is zero the integral blows-up. That is,

$$\int_0^\infty \frac{1 - \cos(x)}{x} dx$$

does not exist.

A twist on the use of integral differentiation is illustrated with the problem of calculating integrals like

$$\int_0^1 \{\ln(x)\}^2 dx$$

or

$$\int_0^1 \sqrt{x} \{\ln(x)\}^2 dx.$$

A trick that does the job is to introduce a parameter (I'll call it a) that we can differentiate with respect to and then, if we set that parameter equal to a specific value, reduces the integral to one of the above. For example, consider

$$I(a) = \int_0^1 x^a \{\ln(x)\}^2 dx,$$

which reduces to the above first integral if $a = 0$ and to the second integral if $a = \frac{1}{2}$.

So, differentiating,

$$\begin{aligned} \frac{dI}{da} &= \frac{d}{da} \int_0^1 e^{\ln(x)^a} \{\ln(x)\}^2 dx = \frac{d}{da} \int_0^1 e^{a \ln(x)} \{\ln(x)\}^2 dx \\ &= \int_0^1 e^{a \ln(x)} \ln(x) \{\ln(x)\}^2 dx = \int_0^1 x^a \{\ln(x)\}^3 dx. \end{aligned}$$

Now this may look as though we've just made things worse—and we have! *But*—it also should give you a hint on how to turn the situation around to going our way. Look at what happened: differentiating $I(a)$ gave us the same integral back except that the power of $\ln(x)$ *increased* by 1. This should nudge you into seeing that our original integral can be thought of as coming from differentiating $\int_0^1 x^a \ln(x) dx$, with that integral in turn coming from differentiating $\int_0^1 x^a dx$, an integral that is *easy* to do.

That is,

$$\int_0^1 x^a \ln(x) dx = \frac{d}{da} \int_0^1 x^a dx = \frac{d}{da} \left[\left. \frac{x^{a+1}}{a+1} \right|_0^1 \right] = \frac{d}{da} \left(\frac{1}{a+1} \right) = -\frac{1}{(a+1)^2}.$$

Thus,

$$\int_0^1 x^a \{\ln(x)\}^2 dx = \frac{d}{da} \int_0^1 x^a \ln(x) dx = \frac{d}{da} \left\{ -\frac{1}{(a+1)^2} \right\} = \frac{2(a+1)}{(a+1)^4}$$

or,

$$(3.4.7) \quad \int_0^1 x^a \{\ln(x)\}^2 dx = \frac{2}{(a+1)^3}.$$

So, for $a=0$ we have

$$\int_0^1 \{\ln(x)\}^2 dx = 2$$

and, in agreement, $quad(@x)log(x).^2,0,I) = 2.000009 \dots$. And for $a = \frac{1}{2}$ we have the integral equal to $\frac{2}{(\frac{3}{2})^3} = \frac{16}{27} = 0.5925925 \dots$; in agreement, $quad(@x)sqrt(x).log(x).^2,0,I) = 0.592585 \dots$

As the final examples of this section, let's see how to do the integrals

$$I(a) = \int_0^\pi \ln\{a + b \cos(x)\} dx$$

where $a > b \geq 0$, and

$$I(b) = \int_0^\pi \frac{\ln\{1 + b \cos(x)\}}{\cos(x)} dx$$

where $0 \leq b < 1$. The analysis will be a two-step process, with the first step being the evaluation of the derivative with respect to a of $I(a)$, that is, the integral

$$\frac{dI}{da} = \int_0^\pi \frac{1}{a + b \cos(x)} dx$$

where $a > b \geq 0$. For this integral, change variable to $z = \tan\left(\frac{x}{2}\right)$. Then, as shown back in Chap. 2 (in the analysis leading up to (2.2.3)), we established that

$$\cos(x) = \frac{1 - z^2}{1 + z^2}$$

and

$$dx = \frac{2}{1 + z^2} dz,$$

and so

$$\begin{aligned} \int_0^\pi \frac{1}{a + b \cos(x)} dx &= \int_0^\infty \frac{1}{a + b \frac{1 - z^2}{1 + z^2}} \left(\frac{2}{1 + z^2} \right) dz = 2 \int_0^\infty \frac{dz}{a(1 + z^2) + b(1 - z^2)} \\ &= 2 \int_0^\infty \frac{dz}{(a + b) + z^2(a - b)} = \frac{2}{a - b} \int_0^\infty \frac{dz}{\frac{a + b}{a - b} + z^2} \\ &= \left(\frac{2}{a - b} \right) \frac{1}{\sqrt{\frac{a + b}{a - b}}} \tan^{-1} \left(\frac{z}{\sqrt{\frac{a + b}{a - b}}} \right) \Big|_0^\infty \\ &= \frac{2}{\sqrt{a^2 - b^2}} \tan^{-1} \left(z \sqrt{\frac{a - b}{a + b}} \right) \Big|_0^\infty. \end{aligned}$$

Thus,³

$$(3.4.8) \quad \int_0^\pi \frac{1}{a + b \cos(x)} dx = \frac{\pi}{\sqrt{a^2 - b^2}}, \quad a > b.$$

Now, for the evaluation of our two integrals, starting with I(a). Differentiating with respect to a, we have from (3.4.8) that

$$\frac{dI}{da} = \int_0^\pi \frac{1}{a + b \cos(x)} dx = \frac{\pi}{\sqrt{a^2 - b^2}}.$$

So, integrating indefinitely with respect to a,

$$I(a) = \int \frac{\pi}{\sqrt{a^2 - b^2}} da$$

or, from standard integration tables,

$$I(a) = \pi \ln \left\{ a + \sqrt{a^2 - b^2} \right\} + C$$

where C is the constant of integration. We find C as follows: when $b = 0$ in the integral we have

$$I(a) = \int_0^\pi \ln(a) da = \pi \ln(a),$$

and so setting this equal to our integration result (with $b = 0$) we have

³The integral in (3.4.8) occurs in a paper by R. M. Dimeo, “Fourier Transform Solution to the Semi-Infinite Resistance Ladder,” *American Journal of Physics*, July 2000, pp. 669–670, where it is done by contour integration. Our derivation here shows contour integration is actually not necessary. Professor Dimeo states that contour integration is “well within the abilities of the undergraduate physics major,” in agreement with the philosophical position I take in the Preface. Notice that we can use (3.4.8) to derive all sorts of new integrals by differentiation. For example, suppose $b = -1$, and so we have $\int_0^\pi \frac{1}{a - \cos(x)} dx = \frac{\pi}{\sqrt{a^2 - 1}}$. Then, differentiating both sides with respect to a, we get $\int_0^\pi \frac{1}{[a - \cos(x)]^2} dx = \frac{\pi a}{(a^2 - 1)^{3/2}}$. If, for example, $a = 5$, this new integral is equal to $\frac{5\pi}{24^{3/2}} = \frac{5\pi}{48\sqrt{6}} = 0.1335989\dots$. To check, we see that $quad(@)(x)I./((5-\cos(x)).^2),0,\pi) = 0.1335989\dots$

$$\pi \ln\{2a\} + C = \pi \ln(a)$$

which tells us that $C = -\pi \ln(2)$. Thus,

$$I(a) = \pi \ln\left\{a + \sqrt{a^2 - b^2}\right\} - \pi \ln(2)$$

or

$$\int_0^\pi \ln\{a + b \cos(x)\} dx = \pi \ln\left\{\frac{a + \sqrt{a^2 - b^2}}{2}\right\}, a > b .$$

(3.4.9)

If $a=2$ and $b=1$, for example, our integral is equal to $\pi \ln\left\{\frac{2+\sqrt{3}}{2}\right\} = 1.959759\dots$, and checking: $quad(@x)\log(2 + \cos(x),0,\pi) = 1.959759\dots$

Finally, turning to the $I(b)$ integral, differentiation with respect to b gives

$$\frac{dI}{db} = \int_0^\pi \frac{\frac{\cos(x)}{1+b\cos(x)}}{\cos(x)} dx = \int_0^\pi \frac{1}{1+b\cos(x)} dx.$$

But from (3.4.8) we have (with $a = 1$)

$$\frac{dI}{db} = \frac{\pi}{\sqrt{1-b^2}}.$$

So, integrating indefinitely with respect to b , we have

$$I(b) = \pi \sin^{-1}(b) + C$$

where C is the constant of integration. Since $I(0) = 0$ by inspection of the original integral, we finally have our answer:

(3.4.10)
$$\int_0^\pi \frac{\ln\{1 + b \cos(x)\}}{\cos(x)} dx = \pi \sin^{-1}(b) .$$

If, for example, $b = \frac{1}{3}$, this integral has a value of $\pi \sin^{-1}\left(\frac{1}{3}\right) = 1.067629\dots$ and checking, we see that $quad(@x)\log(1 + (\cos(x)/3))/\cos(x),0,\pi) = 1.06761\dots$

3.5 Combining Two Tricks

In this section we'll combine the differentiation of an integral with the recursion trick that we used back in Chap. 2 (Sect. 2.3) to solve a whole class of integrals. Here we'll tackle

$$I_n = \int_0^{\pi/2} \frac{1}{\{a \cos^2(x) + b \sin^2(x)\}^n} dx, n = 1, 2, 3, \dots$$

where we'll take both a and b as parameters we can differentiate with respect to. If you calculate $\frac{\partial I_n}{\partial a}$ and $\frac{\partial I_n}{\partial b}$ you should be able to see, by inspection, that

$$\frac{\partial I_n}{\partial a} = -n \int_0^{\pi/2} \frac{\cos^2(x)}{\{a \cos^2(x) + b \sin^2(x)\}^{n+1}} dx$$

and

$$\frac{\partial I_n}{\partial b} = -n \int_0^{\pi/2} \frac{\sin^2(x)}{\{a \cos^2(x) + b \sin^2(x)\}^{n+1}} dx.$$

From these two results we then immediately have

$$\frac{\partial I_n}{\partial a} + \frac{\partial I_n}{\partial b} = -n \int_0^{\frac{\pi}{2}} \frac{1}{\{a \cos^2(x) + b \sin^2(x)\}^{n+1}} dx = -n I_{n+1}.$$

Or, if we replace n with n - 1, we have the recursion

$$I_n = -\frac{1}{n-1} \left[\frac{\partial I_{n-1}}{\partial a} + \frac{\partial I_{n-1}}{\partial b} \right].$$

From the boxed recursion we see that the first value of n we can use with it is $n = 2$,⁴ and even then only if we already know I_1 . Then, once we have I_2 we can use it to find I_3 , and so on. But first, we need to find

⁴ For $n = 1$, the recursion gives I_1 in terms of I_0 , where $I_0 = \int_0^{\pi/2} dx = \frac{\pi}{2}$ with no dependency on either a or b. That is, $\frac{\partial I_0}{\partial a} = \frac{\partial I_0}{\partial b} = 0$ and the recursion becomes the useless, *indeterminate* $I_1 = \frac{0}{0} I_0$.

$$I_1 = \int_0^{\pi/2} \frac{1}{a \cos^2(x) + b \sin^2(x)} dx = \int_0^{\pi/2} \frac{\frac{1}{\cos^2(x)}}{a + b \tan^2(x)} dx.$$

Changing variable to $y = \tan(x)$, we have $\frac{dy}{dx} = \frac{1}{\cos^2(x)}$ or, $dx = \cos^2(x) dy$. Thus,

$$\begin{aligned} I_1 &= \int_0^{\infty} \frac{\frac{1}{\cos^2(x)}}{a + b y^2} \cos^2(x) dy = \frac{1}{b} \int_0^{\infty} \frac{1}{\frac{a}{b} + y^2} dy = \frac{1}{b} \left\{ \sqrt{\frac{b}{a}} \tan^{-1} \left(\frac{y}{\sqrt{\frac{a}{b}}} \right) \right\} \Big|_0^{\infty} \\ &= \frac{1}{\sqrt{ab}} \tan^{-1}(\infty) \end{aligned}$$

or,

$$(3.5.1) \quad \boxed{I_1 = \int_0^{\pi/2} \frac{1}{a \cos^2(x) + b \sin^2(x)} dx = \frac{\pi}{2\sqrt{ab}} .}$$

To find I_2 , we first calculate

$$\frac{\partial I_1}{\partial a} = \frac{-2\pi\sqrt{b}\frac{1}{2}a^{-\frac{1}{2}}}{4ab} = -\left(\frac{\pi}{4}\right) \frac{\sqrt{b}}{ab}$$

and

$$\frac{\partial I_1}{\partial b} = \frac{-2\pi\sqrt{a}\frac{1}{2}b^{-\frac{1}{2}}}{4ab} = -\left(\frac{\pi}{4}\right) \frac{\sqrt{a}}{ab}.$$

Thus, using the boxed (unshaded) recursion with $n = 2$,

$$I_2 = \frac{\pi}{4ab} \left[\sqrt{\frac{b}{a}} + \sqrt{\frac{a}{b}} \right] = \left(\frac{\pi}{4ab} \right) \frac{b+a}{ab}$$

or,

$$(3.5.2) \quad \boxed{I_2 = \int_0^{\pi/2} \frac{1}{\{a \cos^2(x) + b \sin^2(x)\}^2} dx = \left(\frac{\pi}{4\sqrt{ab}} \right) \left(\frac{1}{a} + \frac{1}{b} \right) .}$$

We can repeat this process endlessly (although the algebra rapidly gets ever grubbier!), and I'll let you fill-in the details to show that the recursion (with $n = 3$) gives

$$I_3 = \int_0^{\pi/2} \frac{1}{\{a \cos^2(x) + b \sin^2(x)\}^3} dx = \left(\frac{\pi}{16\sqrt{ab}} \right) \left(\frac{3}{a^2} + \frac{3}{b^2} + \frac{2}{ab} \right).$$

(3.5.3)

To check this (as well as the results we got earlier, since a mistake earlier would show-up here, too), if $a = 1$ and $b = 2$ then $I_3 = \frac{4.75\pi}{16\sqrt{2}} = 0.65949 \dots$ Using MATLAB directly on the integral, `quad(@(x)1./((cos(x).^2 + 2*sin(x).^2).^3),0,pi/2) = 0.65949 \dots`

As a final example of recursion, consider a generalized version of the integral that appeared in the first section of this chapter, in (3.1.2) and (3.1.3):

$$I_n(y) = \int_0^y \frac{dx}{(x^2 + a^2)^n}.$$

Earlier, we had the special case of $y = \infty$. We can use recursion, combined with integration by parts, to evaluate this more general integral. In the integration by parts formula let

$$u = \frac{1}{(x^2 + a^2)^n}$$

and $dv = 1$. Then obviously $v = x$ and you can quickly confirm that

$$du = -n \frac{2x}{(x^2 + a^2)^{n+1}} dx.$$

Thus,

$$I_n(y) = \left\{ \frac{x}{(x^2 + a^2)^n} \right\} \Big|_0^y + n \int_0^y \frac{2x^2 dx}{(x^2 + a^2)^{n+1}}$$

or, as $2x^2 = 2(x^2 + a^2) - 2a^2$, we have

$$I_n(y) = \frac{y}{(y^2 + a^2)^n} + n \left[\int_0^y \frac{2(x^2 + a^2) dx}{(x^2 + a^2)^{n+1}} - 2a^2 \int_0^y \frac{dx}{(x^2 + a^2)^{n+1}} \right]$$

or,

$$I_n(y) = \frac{y}{(y^2 + a^2)^n} + 2nI_n(y) - 2na^2I_{n+1}(y)$$

and so, finally, we arrive at the recursion

$$I_{n+1}(y) = \frac{y}{2na^2(y^2 + a^2)^n} + \frac{2n-1}{2na^2} I_n(y) .$$

(3.5.4)

We start the recursion in (3.5.4) with

$$I_1(y) = \int_0^y \frac{dx}{x^2 + a^2} = \frac{1}{a} \tan^{-1}\left(\frac{x}{a}\right) \Big|_0^y = \frac{1}{a} \tan^{-1}\left(\frac{y}{a}\right),$$

and so for the case of $y = \infty$ we have $I_1(y) = \frac{\pi}{2a}$. Then, as

$$I_{n+1}(\infty) = \frac{2n-1}{2na^2} I_n(\infty),$$

we have

$$I_2(\infty) = \frac{1}{2a^2} I_1(\infty) = \frac{\pi}{4a^3}$$

and

$$I_3(\infty) = \frac{3}{4a^2} I_2(\infty) = \frac{3\pi}{16a^5}$$

which are exactly what we calculated in (3.1.2) and (3.1.3), respectively. And a new result that we didn't have before is

$$I_4(\infty) = \int_0^\infty \frac{dx}{(x^2 + a^2)^4} = \frac{5}{6a^2} I_3(\infty) = \frac{15\pi}{96a^7}.$$

As a check, if $a = 1$ the value of $I_4(\infty)$ is 0.490873... , and `quad(@(x)1./((x.^2 + 1).^4),0,100) = 0.490874...`

3.6 Uhler's Integral and Symbolic Integration

This chapter celebrates Feynman's association with 'differentiation under the integral sign,' but of course the technique greatly pre-dates him. As his own words at the end of Chap. 1 make clear, he learned the method from a well-known textbook (the 1926 *Advanced Calculus* by MIT math professor Frederick Woods (1864–1950)), and the method was popular among mathematicians and physicists long before Feynman entered the picture. For example, in the October 1914 issue of *The American Mathematical Monthly* a little challenge problem appeared, posed by a Yale physics professor named Horace Scudder Uhler⁵ (1872–1956). There he asked readers how they would evaluate the double integral

$$I = \int_0^a (a^2 - x^2) x \, dx \int_{a-x}^{a+x} \frac{e^{-cy}}{y} \, dy,$$

which had occurred while “in the process of solving a certain physical problem.” The values of a and c are positive.

Uhler actually already knew how to do it—he even included the final answer when he made his challenge—but he was curious about how *others* might approach this double integral. A solution from a reader was published in the December issue, and finally Uhler showed (in the January 1915 issue, more than 3 years before Feynman was born) how *he* had done it, by differentiation with respect to the parameter c . Here's what he wrote: “Differentiate I with respect to the parameter c , then

$$\frac{dI}{dc} = \int_0^a (a^2 - x^2) x \, dx \int_{a-x}^{a+x} e^{-cy} \, dy,$$

which can be evaluated at once [I think this “at once” is just a bit misleading as, even using standard integration tables, I found the routine algebra pretty grubby] and gives

$$\frac{dI}{dc} = \frac{2a^2}{c^3} - \frac{6a}{c^4} + \frac{6}{c^5} - \left(\frac{6a}{c^4} + \frac{6}{c^5} + \frac{2a^2}{c^3} \right) e^{-2ac}.$$

We can now integrate both sides of this equation [for a condition to determine the constant of integration, notice that $I(\infty) = 0$ because the integrand of the inner y -integral goes to zero as $c \rightarrow \infty$], thus [and then Uhler gives the answer]

⁵ Uhler was a pioneer in heroic numerical calculation, made all the more impressive in that he worked in the pre-electronic computer days. His major tool was a good set of log tables. I describe his 1921 calculation of, to well over 100 decimal digits, the value of $(\sqrt{-1})^{\sqrt{-1}} = e^{-\frac{\pi}{2}}$ in my book *An Imaginary Tale: the story of $\sqrt{-1}$* , Princeton 2010, pp. 235–237.

$$I = \frac{1}{c^2} \left[a^2 - \frac{3a}{c} + \frac{1}{c} \left(a + \frac{3}{2c} \right) (1 - e^{-2ac}) \right].''$$

We can make a partial check of this as follows. For the case of $a = 1$ and $c = 1$, for example, Uhler's formula becomes

$$I = \left[1 - 3 + \left(1 + \frac{3}{2} \right) (1 - e^{-2}) \right] = -2 + \frac{5}{2} (1 - e^{-2}) = 0.16166179 \dots$$

MATLAB (if accompanied by Symbolic Math Toolbox) can numerically evaluate (with double precision) Uhler's double integral *directly* as follows for these particular values of a and c , where the symbols x and y are first declared to be symbolic quantities:

```
syms x y
double(int(int((1-x^2)*x*exp(-y)/y,y,I-x,I+x),x,0,I))
```

The computer result is in *outstanding* agreement with Uhler's formula: 0.16166179 The reason why Uhler's formula and MATLAB's integration are in such good agreement is that the nested *int* (for 'integrate') commands actually perform *symbolic* integrations, resulting in the *exact* answer of $-5/2 * exp(-2) + 1/2$. The final command of *double* converts that exact symbolic answer into double precision numerical form.

The syntax for the use of nested *int* commands to symbolically evaluate multiple integrals should now be obvious but, *just to be sure*, here's a teaser. You may recall that at the end of the Preface I mentioned something called the 'Hardy-Schuster optical integral.' We'll treat this integral analytically later in the book where, a little ways into the analysis, we'll get it into the form of a *triple* definite integral:

$$\int_0^\infty \left\{ \int_x^\infty \left\{ \int_x^\infty \cos(t^2 - u^2) dt \right\} du \right\} dx.$$

Our analysis will show that this perhaps intimidating expression is equal to $\frac{1}{2} \sqrt{\frac{\pi}{2}} = 0.62665706 \dots$. To have Symbolic Math Toolbox evaluate it, however, all that is required are the following two lines (where *inf* is the symbolic representation for infinity):

```
syms x t u
int(int(int(cos(t^2-u^2),t,x,inf),u,x,inf),x,0,inf)
```

When MATLAB returns the answer, it begins by telling you that no explicit integral could be found, but then it prints out a rather long and cryptic expression that it calls *ans* (for 'answer'). If you then convert *ans* to numeric form by typing *double(ans)* you get (BIG drum roll): 0.62665706

Isn't that neat?

So far I have used *quad* to check one dimensional integrations, and now *int* to check multi-dimensional integrations. But of course *int* can easily do one-dimensional integrals, too, *if* Symbolic Math Toolbox is installed on your

computer along with MATLAB (*quad* is part of MATLAB and so it is always available). To see *int* used on a one-dimensional integral, recall our result (2.1.4):

$$\int_0^{\infty} \frac{dx}{1 + e^{ax}} = \frac{\ln(2)}{a}.$$

Differentiating with respect to the parameter a , we get

$$\int_0^{\infty} \frac{xe^{ax}}{(1 + e^{ax})^2} dx = \frac{\ln(2)}{a^2}.$$

Now, change variable to $t = e^{ax}$ and so $x = \frac{1}{a} \ln(t)$. This means $dx = \frac{dt}{at}$ and thus

$$\int_1^{\infty} \frac{\frac{1}{a} \ln(t)t}{(1 + t)^2} \left(\frac{dt}{at} \right) = \frac{\ln(2)}{a^2}$$

or, after cancelling the a 's and t 's and changing the dummy variable of integration back to x ,

(3.6.1)

$$\int_1^{\infty} \frac{\ln(x)}{(1 + x)^2} dx = \ln(2).$$

Invoking the Symbolic Math Toolbox, we can check this result by writing

`syms x`

`int(log(x)/((1 + x)^2),x,1,inf)`

which returns the exact *symbolic* result of:

$$ans = \log(2).$$

Or, for another one-dimensional example, recall the aerodynamic integral from the Introduction,

$$\int_{-1}^1 \sqrt{\frac{1+x}{1-x}} dx = \pi.$$

The Symbolic Math Toolbox agrees, as

`syms x`

`int(sqrt((1 + x)/(1-x)),x,-1,1)`

produces the exact *symbolic* result of:

$$ans = pi$$

while `quad(@(x)sqrt((1 + x)/(1-x)),-1,1) = 3.14159789 . . .` (the actual numerical value of π is, of course, 3.14159265 . . .).

As one more example of the Symbolic Math Toolbox, recall the second challenge problem from Chap. 1, where you were asked to show that

$$\int_1^{\infty} \frac{dx}{\sqrt{x^3 - 1}} < 4.$$

With the Symbolic Math Toolbox we can get a far more precise value for this integral:

```
syms x
double(int(1/sqrt(x^3-1),1,inf)) = 2.42865...
```

3.7 The Probability Integral Revisited

In footnote 1 of this chapter I promised you some more discussion of the probability integral

$$\int_{-\infty}^{\infty} e^{-\frac{x^2}{2}} dx.$$

To start, I'll derive it again but in a different way (but still using differentiation under the integral sign). Let

$$I = \int_0^{\infty} e^{-x^2} dx$$

and further define $f(x) = \left(\int_0^x e^{-t^2} dt \right)^2$ and $g(x) = \int_0^1 \frac{e^{-x^2(1+t^2)}}{1+t^2} dt$.

Then,

$$\frac{df}{dx} = 2 \left\{ \int_0^x e^{-t^2} dt \right\} e^{-x^2} = 2e^{-x^2} \int_0^x e^{-t^2} dt$$

and

$$\begin{aligned} \frac{dg}{dx} &= \int_0^1 \frac{-2x(1+t^2)e^{-x^2(1+t^2)}}{1+t^2} dt = -2 \int_0^1 x e^{-x^2(1+t^2)} dt \\ &= -2x \int_0^1 e^{-x^2} e^{-x^2 t^2} dt = -2x e^{-x^2} \int_0^1 e^{-x^2 t^2} dt. \end{aligned}$$

Let $u = tx$ (which means $du = x dt$) and so $dt = \frac{du}{x}$. Thus,

$$\frac{dg}{dx} = -2x e^{-x^2} \int_0^x e^{-u^2} \frac{du}{x} = -2e^{-x^2} \int_0^x e^{-u^2} du = -\frac{df}{dx}.$$

So,

$$\frac{df}{dx} + \frac{dg}{dx} = 0$$

or, with C a constant, we have $f(x) + g(x) = C$.

In particular $f(0) + g(0) = C$, but since $f(0) = 0$ and since

$$g(0) = \int_0^1 \frac{1}{1+t^2} dt = \tan^{-1}(t) \Big|_0^1 = \frac{\pi}{4}$$

we have $C = \frac{\pi}{4}$. That is, $f(x) + g(x) = \frac{\pi}{4}$.

But that means $f(\infty) + g(\infty) = \frac{\pi}{4}$ and since $f(\infty) = I^2$ and $g(\infty) = 0$ (because the integrand of the $g(x)$ integral $\rightarrow 0$ as $x \rightarrow \infty$) then

$$I^2 = \frac{\pi}{4}.$$

That is,

$$I = \int_0^{\infty} e^{-x^2} dx = \frac{1}{2} \sqrt{\pi}$$

or, doubling the interval of integration,

$$\int_{-\infty}^{\infty} e^{-x^2} dx = \sqrt{\pi}.$$

Now, let $x = \frac{u}{\sqrt{2}}$ (and so $dx = \frac{du}{\sqrt{2}}$). Then,

$$\int_{-\infty}^{\infty} e^{-x^2} dx = \int_{-\infty}^{\infty} e^{-\frac{u^2}{2}} \frac{du}{\sqrt{2}} = \sqrt{\pi}$$

or, as we derived in (3.1.4), with the dummy variable of integration changed back to x ,

$$\int_{-\infty}^{\infty} e^{-\frac{x^2}{2}} dx = \sqrt{2\pi}.$$

Now, to complete this chapter's discussion of the probability integral, let's derive yet another generalization of it, one first done by the French mathematician Pierre-Simon Laplace (1749–1827) 200 years ago. What we'll calculate is the integral

$$I = \int_0^{\infty} e^{-ax^2 - \frac{b}{x^2}} dx,$$

and in particular we see that $2I$ reduces to the probability integral for $a = \frac{1}{2}$ and $b = 0$.

To start, let $t = x\sqrt{a}$. Then, $dx = \frac{dt}{\sqrt{a}}$ and so

$$I = \int_0^{\infty} e^{-t^2 - \frac{ab}{t^2}} \frac{dt}{\sqrt{a}} = \frac{1}{\sqrt{a}} \int_0^{\infty} e^{-t^2 - \frac{ab}{t^2}} dt = \frac{1}{\sqrt{a}} I_2$$

where

$$I_2 = \int_0^{\infty} e^{-t^2 - \frac{ab}{t^2}} dt.$$

Next, define

$$y = \frac{\sqrt{ab}}{t}.$$

Then

$$\frac{dy}{dt} = -\frac{\sqrt{ab}}{t^2} = -\frac{\sqrt{ab}}{\frac{ab}{y^2}} = -\frac{y^2}{\sqrt{ab}}$$

or,

$$dt = -\sqrt{ab} \frac{dy}{y^2}.$$

So, as $ab = y^2 t^2$ we have

$$I_2 = \int_{\infty}^0 e^{-\frac{ab}{y^2} - y^2} \left(-\sqrt{ab} \frac{dy}{y^2} \right) = \sqrt{ab} \int_0^{\infty} \frac{e^{-y^2 - \frac{ab}{y^2}}}{y^2} dy.$$

Thus,

$$2I_2 = \int_0^{\infty} e^{-t^2 - \frac{ab}{t^2}} dt + \sqrt{ab} \int_0^{\infty} \frac{e^{-t^2 - \frac{ab}{t^2}}}{t^2} dt$$

or,

$$2I_2 = \int_0^\infty e^{-(t^2 + \frac{ab}{t^2})} \left\{ 1 + \frac{\sqrt{ab}}{t^2} \right\} dt.$$

Now, change variable again, this time to

$$s = t - \frac{\sqrt{ab}}{t}.$$

So,

$$\frac{ds}{dt} = 1 + \frac{\sqrt{ab}}{t^2}$$

or,

$$dt = \frac{ds}{1 + \frac{\sqrt{ab}}{t^2}}.$$

Then, since $s^2 = t^2 - 2\sqrt{ab} + \frac{ab}{t^2}$ we have (notice that $s = -\infty$ when $t = 0$)

$$2I_2 = \int_{-\infty}^\infty e^{-s^2 - 2\sqrt{ab}} \left\{ 1 + \frac{\sqrt{ab}}{t^2} \right\} \frac{ds}{1 + \frac{\sqrt{ab}}{t^2}}$$

or,

$$I_2 = \frac{1}{2} \int_{-\infty}^\infty e^{-s^2 - 2\sqrt{ab}} ds = \frac{e^{-2\sqrt{ab}}}{2} \int_{-\infty}^\infty e^{-s^2} ds$$

and so

$$I_2 = e^{-2\sqrt{ab}} \int_0^\infty e^{-s^2} ds.$$

Now, since $I = \frac{1}{\sqrt{a}} I_2$ then

$$I = \int_0^\infty e^{-ax^2 - \frac{b}{x^2}} dx = \frac{1}{\sqrt{a}} e^{-2\sqrt{ab}} \int_0^\infty e^{-s^2} ds,$$

and since

$$\int_0^\infty e^{-s^2} ds = \frac{\sqrt{\pi}}{2}$$

we then have the beautiful

$$\int_0^\infty e^{-ax^2 - \frac{b}{x^2}} dx = \frac{1}{2} \sqrt{\frac{\pi}{a}} e^{-2\sqrt{ab}} .$$

(3.7.1)

To numerically check this result, for $a = b = 1$ the integral is equal to $\frac{\sqrt{\pi}}{2e^2} = 0.11993777\dots$ and in agreement we have `quad(@(x)exp(-(x.^2) + 1./(x.^2)),0,10) = 0.119939\dots`

3.8 Dini's Integral

To wrap this chapter up, let's work our way through a logarithmic integral with important applications in mathematical physics and engineering, one first evaluated in 1878 by the Italian mathematician Ulisse Dini (1845–1918). It is

$$I(\alpha) = \int_0^\pi \ln\{1 - 2\alpha \cos(x) + \alpha^2\} dx$$

where the parameter α is *any* real number. Notice that since $\cos(x)$ runs through all its values from -1 to $+1$ as x varies from 0 to π , we see that the sign of α is immaterial, that is, $I(\alpha) = I(|\alpha|)$. So, from now on I'll discuss just the two cases of $0 \leq \alpha < 1$ and $\alpha > 1$.

Differentiating, we have

$$\begin{aligned} \frac{dI}{d\alpha} &= \int_0^\pi \frac{-2 \cos(x) + 2\alpha}{1 - 2\alpha \cos(x) + \alpha^2} dx = \frac{1}{\alpha} \int_0^\pi \left\{ 1 - \frac{1 - \alpha^2}{1 - 2\alpha \cos(x) + \alpha^2} \right\} dx \\ &= \frac{\pi}{\alpha} - \frac{1}{\alpha} \int_0^\pi \frac{1 - \alpha^2}{1 - 2\alpha \cos(x) + \alpha^2} dx. \end{aligned}$$

Next, make the change of variable $z = \tan\left(\frac{x}{2}\right)$ which means, as we showed back in Chap. 2 (see the analysis leading up to (2.2.3)), that

$$\cos(x) = \frac{1 - z^2}{1 + z^2}$$

and

$$dx = \frac{2}{1+z^2} dz.$$

Thus,

$$\begin{aligned} \frac{dI}{d\alpha} &= \frac{\pi}{\alpha} - \frac{1}{\alpha} \int_0^\infty \frac{1-\alpha^2}{1-2\alpha\frac{1-z^2}{1+z^2} + \alpha^2} \left(\frac{2}{1+z^2} dz \right) \\ &= \frac{\pi}{\alpha} - \frac{2(1-\alpha^2)}{\alpha} \int_0^\infty \frac{dz}{1+z^2-2\alpha(1-z^2) + \alpha^2(1+z^2)} \end{aligned}$$

which becomes, with just a little algebra,

$$\frac{dI}{d\alpha} = \frac{\pi}{\alpha} - \left(\frac{2}{\alpha} \right) \left(\frac{1-\alpha}{1+\alpha} \right) \int_0^\infty \frac{dz}{\left(\frac{1-\alpha}{1+\alpha} \right)^2 + z^2}.$$

This integrates as follows:

$$\begin{aligned} \frac{dI}{d\alpha} &= \frac{\pi}{\alpha} - \frac{2}{\alpha} \left(\frac{1-\alpha}{1+\alpha} \right) \frac{1}{\frac{1-\alpha}{1+\alpha}} \left\{ \tan^{-1} \left(\frac{z}{\frac{1-\alpha}{1+\alpha}} \right) \right\} \Big|_0^\infty \\ &= \frac{1}{\alpha} \left[\pi - 2 \tan^{-1} \left(\frac{1+\alpha}{1-\alpha} z \right) \Big|_0^\infty \right]. \end{aligned}$$

If $\alpha > 1$, then $1+\alpha > 0$ and $1-\alpha < 0$ which means $\frac{1+\alpha}{1-\alpha} < 0$ and therefore $\tan^{-1} \left(\frac{1+\alpha}{1-\alpha} z \right) \Big|_0^\infty = -\frac{\pi}{2}$ and so

$$\frac{dI}{d\alpha} = \frac{1}{\alpha} \left[\pi - 2 \left(-\frac{\pi}{2} \right) \right] = \frac{2\pi}{\alpha}, \alpha > 1.$$

If $0 \leq \alpha < 1$, however, then $1+\alpha > 0$ and $1-\alpha > 0$ and so $\frac{1+\alpha}{1-\alpha} > 0$ and therefore $\tan^{-1} \left(\frac{1+\alpha}{1-\alpha} z \right) \Big|_0^\infty = +\frac{\pi}{2}$ and so

$$\frac{dI}{d\alpha} = \frac{1}{\alpha} \left[\pi - 2 \left(\frac{\pi}{2} \right) \right] = 0, 0 \leq \alpha < 1.$$

Now, since

$$I(0) = \int_0^\pi \ln(1) d\alpha = 0,$$

then

$$\frac{dI}{d\alpha} = 0, 0 \leq \alpha < 1$$

integrates *by inspection* to

$$I(\alpha) = 0, 0 \leq \alpha < 1.$$

To integrate $\frac{dI}{d\alpha} = \frac{2\pi}{\alpha}$ for $\alpha > 1$ we need to get a specific value of $I(\alpha)$ for some $\alpha > 1$ in order to evaluate the constant of integration. Alas, there is no obvious value of α that leads to a 'nice' integral to evaluate (like we had for $I(0)$)! Fortunately there is a clever trick that will get us around this difficulty. What we'll do is first pick a value (call it β) such that $0 \leq \beta < 1$, which means

$$I(\beta) = \int_0^\pi \ln\{1 - 2\beta \cos(x) + \beta^2\} dx = 0$$

by our previous argument. Then, we'll pick the specific α value we're going to use to be $\alpha = \frac{1}{\beta}$ which will, of course, mean that $\alpha > 1$. That is,

$$\begin{aligned} I(\beta) = 0 &= I\left(\frac{1}{\alpha}\right) = \int_0^\pi \ln\left\{1 - 2\frac{1}{\alpha} \cos(x) + \frac{1}{\alpha^2}\right\} dx \\ &= \int_0^\pi \ln\left\{\frac{\alpha^2 - 2\alpha \cos(x) + 1}{\alpha^2}\right\} dx \\ &= \int_0^\pi \ln\{\alpha^2 - 2\alpha \cos(x) + 1\} dx - \int_0^\pi \ln\{\alpha^2\} dx \\ &= \int_0^\pi \ln\{\alpha^2 - 2\alpha \cos(x) + 1\} dx - \int_0^\pi 2\ln\{\alpha\} dx \end{aligned}$$

which, recall, equals zero (look back to where this line of math starts: $I(\beta) = 0 = I(\frac{1}{\alpha})$). That is, when $\alpha > 1$ we have

$$\int_0^\pi \ln\{\alpha^2 - 2\alpha \cos(x) + 1\} dx = \int_0^\pi 2\ln\{\alpha\} dx = 2\ln\{\alpha\} \int_0^\pi dx = 2\pi \ln\{\alpha\}$$

and we see, in fact, that this is indeed in agreement with $\frac{dI}{d\alpha} = \frac{2\pi}{\alpha}$ for $\alpha > 1$.

So,

$$I(\alpha) = \begin{cases} 0, & 0 \leq \alpha < 1 \\ 2\pi \ln\{\alpha\}, & \alpha > 1 \end{cases}$$

as well as $I(\alpha) = I(|\alpha|)$. The easiest way to write all this compactly is

$$\int_0^\pi \ln\{1 - 2\alpha \cos(x) + \alpha^2\} dx = \begin{cases} 0, & \alpha^2 < 1 \\ \pi \ln\{\alpha^2\}, & \alpha^2 > 1 \end{cases}.$$

(3.8.1)

To check, for $\alpha = \frac{1}{2}$ for example, we have $quad(@(x)\log((5/4)-\cos(x)),0,\pi) = 1.127 \times 10^{-7}$ (pretty close to zero), and for $\alpha = 2$ we have $quad(@(x)\log(5-4*\cos(x)),0,\pi) = 4.3551722\dots$ while $\pi \ln(2^2) = 2\pi \ln(2) = 4.3551721\dots$

3.9 Feynman's Favorite Trick Solves a Physics Equation

In a physics paper published⁶ several years ago, a classic problem in mechanics was given an interesting new treatment. The details of that analysis are not important here, just that once all the dust had settled after the *physics* had been done, the author arrived at the following equation to be solved:

$$(3.9.1) \quad V^2(\phi) = V^2(0) + 2\{\cos(\phi) - \mu\sin(\phi)\} - 2\mu \int_0^\phi V^2(x) dx.$$

In (3.9.1) μ is a non-negative constant, and $V^2(0)$ is also a constant (it is, of course, the value of $V^2(\phi)$ when $\phi = 0$). The goal is to solve (3.9.1) for $V^2(\phi)$ as a function of ϕ , μ , and $V^2(0)$.

Once he had arrived at (3.9.1) the author wrote “[This] is a Volterra [after the Italian mathematician Vito Volterra (1860–1940)] integral equation of the second kind, for which the solution is straightforward.” He didn’t provide any solution details; after referring readers to a brief appendix, where he cited the general formula for the solution to such an equation (in general, integral equations can be difficult because the unknown quantity to be found appears both inside *and* outside an integral), he simply wrote down the answer. Using this formula allowed “the solution [to be] found straightforwardly, albeit laboriously.” Now, in fact he was perfectly correct in declaring the solution to be “straightforward,” but there really isn’t anything that has to be “laborious” about solving (3.9.1). That is, there doesn’t *if* you know how to differentiate an integral.

So, differentiating (3.9.1) with respect to ϕ using (3.1.1), we have

⁶ Waldemar Klobus, “Motion On a Vertical Loop with Friction,” *American Journal of Physics*, September 2011, pp. 913–918.

$$\frac{dV^2(\phi)}{d\phi} = 2\{-\sin(\phi) - \mu\cos(\phi)\} - 2\mu V^2(\phi)$$

or, rearranging, we have the following first-order differential equation for $V^2(\phi)$:

$$(3.9.2) \quad \frac{dV^2(\phi)}{d\phi} + 2\mu V^2(\phi) = -2\{\sin(\phi) + \mu\cos(\phi)\}.$$

Next, we multiply through (3.9.2) by $e^{2\mu\phi}$ to get

$$\frac{dV^2(\phi)}{d\phi} e^{2\mu\phi} + 2\mu V^2(\phi) e^{2\mu\phi} = -2\{\sin(\phi) + \mu\cos(\phi)\} e^{2\mu\phi}.$$

This is useful because the left-hand-side is now expressible as a derivative, as follows:

$$(3.9.3) \quad \frac{d}{d\phi} \{V^2(\phi) e^{2\mu\phi}\} = -2\{\sin(\phi) + \mu\cos(\phi)\} e^{2\mu\phi}.$$

This last step is, in fact, an application of a technique routinely taught in a first course in differential equations, called an *integrating factor* (the $e^{2\mu\phi}$ is the factor).

And that is our next step, to *integrate* (3.9.3) from 0 to ϕ :

$$\int_0^\phi \frac{d}{dx} \{V^2(x) e^{2\mu x}\} dx = -2 \int_0^\phi \{\sin(x) + \mu\cos(x)\} e^{2\mu x} dx.$$

The left-hand-side is

$$\begin{aligned} \int_0^\phi \frac{d}{dx} \{V^2(x) e^{2\mu x}\} dx &= \int_0^\phi d\{V^2(x) e^{2\mu x}\} = \{V^2(x) e^{2\mu x}\} \Big|_0^\phi \\ &= V^2(\phi) e^{2\mu\phi} - V^2(0), \end{aligned}$$

and so

$$V^2(\phi) e^{2\mu\phi} = V^2(0) - 2 \int_0^\phi \{\sin(x) + \mu\cos(x)\} e^{2\mu x} dx$$

or,

$$(3.9.4) \quad V^2(\phi) = e^{-2\mu\phi} V^2(0) - 2e^{-2\mu\phi} \int_0^\phi \{\sin(x) + \mu\cos(x)\} e^{2\mu x} dx.$$

Both of the integrals on the right-hand-side of (3.9.4) are easy to do (either by-parts, or just look them up in a table of integrals) and, if you work through the details (which I'll leave to you), you'll arrive at

$$(3.9.5) \quad V^2(\phi) = e^{-2\mu\phi} \left[V^2(0) + \frac{2(2\mu^2 - 1)}{1 + 4\mu^2} \right] \\ - \frac{2}{1 + 4\mu^2} [3\mu \sin(\phi) + (2\mu^2 - 1) \cos(\phi)]$$

which is, indeed, the solution given by the author of the physics paper, and so we have yet another success story for 'Feynman's favorite trick.'

3.10 Challenge Problems

(C3.1): Treat a as a parameter and calculate

$$\int_0^{\infty} \frac{\ln(1 + a^2x^2)}{b^2 + x^2} dx,$$

where a and b are positive. If you look back at (2.4.3) you'll see that this is a generalization of that integral, for the special case of $a = b = 1$. That is, your answer for the above integral should reduce to $\pi \ln(2)$ if $a = b = 1$.

(C3.2): Calculate the Cauchy Principle Value of

$$\int_{-\infty}^{\infty} \frac{\cos(ax)}{b^2 - x^2} dx, a > 0, b > 0.$$

Hint: make a partial fraction expansion, follow that with the appropriate change of variable (it should be obvious), and then finally recall Dirichlet's integral.

(C3.3): In (3.1.7) we found that

$$\int_0^{\infty} \frac{\cos(ax)}{x^2 + b^2} dx = \frac{\pi}{2b} e^{-ab}.$$

Combine that result with your result from the previous challenge problem to calculate

$$\int_{-\infty}^{\infty} \frac{\cos(ax)}{b^4 - x^4} dx.$$

(C3.4): Show that the Cauchy Principle Value of

$$\int_0^{\infty} \frac{x \sin(ax)}{x^2 - b^2} dx = \frac{\pi}{2} \cos(ab).$$

Again, don't forget Dirichlet's integral.

(C3.5): Since we are using Dirichlet's integral so much, here's another look at it. Suppose a and b are both real numbers, with $b > 0$ but a can have either sign. Show that:

$$\int_0^{\infty} \cos(ax) \frac{\sin(bx)}{x} dx = \begin{cases} \frac{\pi}{2}, & |a| < b \\ 0, & |a| > b \\ \frac{\pi}{4}, & |a| = b \end{cases} .$$

(C3.6): I've mentioned the "lifting theory" integral several times in the book, and told you its value is π . MATLAB agrees with that and, indeed, I showed you the *indefinite* integration result in Chap. 1 (Sect. 1.7) that you could confirm by differentiation. See if you can *directly* derive the specific case

$\int_{-1}^1 \sqrt{\frac{1+x}{1-x}} dx = \pi$. Hint: try the change of variable $x = \cos(2u)$, and remember the double-angle identities.

(C3.7): Here's a classic puzzler involving double integrals for you to think about (since we touched on double integrals in Sect. 3.6). A standard trick to try on double integrals, as I discussed in Sect. 3.4, is to *reverse* the order of integration, with the idea being the order of integration shouldn't matter but maybe one order is easier to do than the other. That is, the assumption is

$$\int_a^b \left\{ \int_c^d f(x, y) dx \right\} dy = \int_c^d \left\{ \int_a^b f(x, y) dy \right\} dx.$$

'Usually' this is okay *if* $f(x,y)$ is what mathematicians call 'well-behaved.' *But it's not always true.* If, for example, $a = c = 0$ and $b = d = 1$, and $f(x, y) = \frac{x-y}{(x+y)^3}$, then the equality fails. Each of the two double integrals does indeed exist, but they are not equal. Show that this is so by direct calculation of each double integral. Any idea on *why* they aren't equal?

(C3.8): Show that

$$\int_{-\infty}^{\infty} x e^{-x^2-x} dx = -\frac{1}{2} \sqrt{\pi \sqrt{e}}$$

and that

$$\int_{-\infty}^{\infty} x^2 e^{-x^2-x} dx = \frac{3}{4} \sqrt{\pi\sqrt{e}}.$$

Hint: Consider $I(a, b) = \int_{-\infty}^{\infty} e^{-ax^2+bx} dx$, complete the square in the exponent, make the obvious change of variable, and recall (3.7.1). Then, differentiate $I(a, b)$ with respect to a and with respect to b , and in each case set $a = 1$ and $b = -1$.

(C3.9): Given that $\int_0^{\infty} \frac{\sin(mx)}{x(x^2+a^2)} dx = \frac{\pi}{2} \left(\frac{1-e^{-am}}{a^2} \right)$ for $a > 0, m > 0$ —later, in Chap. 8 (in Challenge Problem 8.2), you'll be asked to derive this result using contour integration—differentiate with respect to the parameter a and thereby evaluate $\int_0^{\infty} \frac{\sin(mx)}{x(x^2+a^2)^2} dx$. Hint: If $m=a=1$ then your result should reduce to $\frac{\pi}{2} \left(1 - \frac{3}{2e} \right) = 0.70400\dots$, and MATLAB agrees: `quad(@(x)sin(x))/(x.*(x.^2 + 1)).^2),0,1000) = 0.70400\dots`

(C3.10): Despite Feynman's enthusiasm for the technique of differentiating integrals, he certainly did use other techniques as well; his famous 1949 paper (see note 7 in Chap. 1), for example, is full of contour integrations. And yet, even there, he returned to his favorite trick. Recall his integral $\frac{1}{ab} = \int_0^1 \frac{dx}{[ax + b(1-x)]}$. In a note at the end of the 1949 paper Feynman observed how additional identities could be easily derived from this integral, such as $\frac{1}{2a^2b} = \int_0^1 \frac{x dx}{[ax + b(1-x)]^3}$. Differentiate his original integral with respect to a , and so confirm this second integral. (While a good exercise—and you *should* do this—it is so easy I've not bothered to include a solution at the end of the book.)

(C3.11): As I said in the text, integral equations can be very tough to solve. Here's another one that is just a bit more challenging than is (3.9.1) but, still, it *can* be solved using only math at the level of this book. Specifically, for $p(0) = 1$ solve $p(x)\phi(x) = \int_x^{\infty} p(u)du$ for $p(x)$ as a function of the given function $\phi(x)$, and thus show that

$\ln\{p(x)\} = \ln\{\phi(0)\} - \ln\{\phi(x)\} - \int_0^x \frac{du}{\phi(u)}$. This problem occurs in my probability book *Will You Be Alive Ten Years From Now?* Princeton 2014, and you can find the solution there on pp. 170–172.

Chapter 4

Gamma and Beta Function Integrals

4.1 Euler's Gamma Function

In two letters written as 1729 turned into 1730, the great Euler created what is today called the *gamma function*, $\Gamma(n)$, defined today in textbooks by the integral

$$(4.1.1) \quad \Gamma(n) = \int_0^{\infty} e^{-x} x^{n-1} dx, \quad n > 0.$$

This definition is the modern one (equivalent to Euler's), dating from 1809, and due to the French mathematician Adrien-Marie Legendre (1752–1833). For $n = 1$ it is an easy integration to see that

$$\Gamma(1) = \int_0^{\infty} e^{-x} dx = \{-e^{-x}\} \Big|_0^{\infty} = 1.$$

Then, using integration by parts on

$$\Gamma(n + 1) = \int_0^{\infty} e^{-x} x^n dx,$$

where we define $u = x^n$ and $dv = e^{-x} dx$ (and so $du = nx^{n-1}dx$ and $v = -e^{-x}$), we get

$$\Gamma(n + 1) = \{-x^n e^{-x}\} \Big|_0^{\infty} + \int_0^{\infty} e^{-x} nx^{n-1} dx = n \int_0^{\infty} e^{-x} x^{n-1} dx.$$

That is, we have the so-called *functional equation* for the gamma function:

$$(4.1.2) \quad \Gamma(n + 1) = n\Gamma(n).$$

So, in particular, for n a positive integer,

$$\begin{aligned} \Gamma(2) &= 1 \bullet \Gamma(1) = 1 \bullet 1 = 1, \\ \Gamma(3) &= 2 \bullet \Gamma(2) = 2 \bullet 1 = 2, \\ \Gamma(4) &= 3 \bullet \Gamma(3) = 3 \bullet 2 = 6, \\ \Gamma(5) &= 4 \bullet \Gamma(4) = 4 \bullet 6 = 24, \end{aligned}$$

and so on. In general, you can see that for positive integer values of n

$$\Gamma(n + 1) = n!$$

or, equivalently,

$$(4.1.3) \quad \Gamma(n) = (n - 1)!, \quad n \geq 1.$$

The gamma function is intimately related to the factorial function (and this connection was, in fact, the original motivation for Euler's interest in $\Gamma(n)$).

The importance of the functional equation (4.1.2) is that it allows the extension of the gamma function to *all* of the real numbers, not just to the positive integers. For example, if we put $n = -\frac{1}{2}$ into (4.1.2) we get $\Gamma(\frac{1}{2}) = -\frac{1}{2}\Gamma(-\frac{1}{2})$ and so $\Gamma(-\frac{1}{2}) = -2\Gamma(\frac{1}{2})$. We'll calculate $\Gamma(\frac{1}{2})$ to be $\sqrt{\pi}$ later in this chapter, and thus $\Gamma(-\frac{1}{2}) = -2\sqrt{\pi}$. We can use this same technique to extend the values of $\Gamma(n)$ for positive values of n (as calculated from the integral in (4.1.1)) to all the negative numbers. The gamma function can be extended to handle complex arguments, as well. When we get to Chap. 8 I'll show you how Riemann did the same sort of thing for the *zeta function* (to be defined in the next chapter). Riemann's functional equation for the zeta function extends (or *continues*) the zeta function's definition from all complex numbers with a real part greater than 1, to the *entire* complex plane. That, in turn, has resulted in the greatest unsolved problem in mathematics today. Exciting stuff! But that's for later.

Equation (4.1.3) is particularly interesting because it shows that, contrary to the initial reaction of most students when first encountering the factorial function, $0! \neq 0$. Rather, setting $n = 1$ in (4.1.3) gives

$$\Gamma(1) = (1 - 1)! = 0! = 1.$$

The gamma function occurs in many applications, ranging from pure mathematics to esoteric physics to quite practical engineering problems. As with other such useful functions (like the trigonometric functions), the values of $\Gamma(n)$ have been extensively computed and tabulated. MATLAB even has a special command for it named (you shouldn't be surprised) *gamma*.

As an example of its appearance in mathematics, let's evaluate

$$\int_0^{\infty} e^{-x^3} dx.$$

Making the change of variable $y = x^3$ (which means $x = y^{\frac{1}{3}}$), and so

$$dx = \frac{dy}{3x^2} = \frac{dy}{3y^{\frac{2}{3}}}.$$

Thus,

$$\int_0^{\infty} e^{-x^3} dx = \int_0^{\infty} e^{-y} \frac{dy}{3y^{\frac{2}{3}}} = \frac{1}{3} \int_0^{\infty} e^{-y} y^{-\frac{2}{3}} dy.$$

This looks just like (4.1.1) with $n - 1 = -\frac{2}{3}$, and so $n = \frac{1}{3}$ and we have

$$\int_0^{\infty} e^{-x^3} dx = \frac{1}{3} \Gamma\left(\frac{1}{3}\right).$$

Or, using (4.1.2),

$$\frac{1}{3} \Gamma\left(\frac{1}{3}\right) = \Gamma\left(\frac{4}{3}\right)$$

and so

$$(4.1.4) \quad \int_0^{\infty} e^{-x^3} dx = \Gamma\left(\frac{4}{3}\right).$$

Using MATLAB's gamma function, $\text{gamma}(4/3) = 0.8929795\dots$ and *quad* agrees; $\text{quad}(@(\text{x})\text{exp}(-\text{x}.\wedge 3),0,10) = 0.8929799\dots$

4.2 Wallis' Integral and the Beta Function

Sometime around 1650 the English mathematician John Wallis studied the integral

$$I(n) = \int_0^1 (x - x^2)^n dx$$

which he could directly evaluate for small integer values of n . For example,

$$I(0) = \int_0^1 dx = 1,$$

$$I(1) = \int_0^1 (x - x^2) dx = \left\{ \frac{1}{2}x^2 - \frac{1}{3}x^3 \right\} \Big|_0^1 = \frac{1}{2} - \frac{1}{3} = \frac{1}{6},$$

$$\begin{aligned} I(2) &= \int_0^1 (x - x^2)^2 dx = \int_0^1 (x^2 - 2x^3 + x^4) dx = \left\{ \frac{1}{3}x^3 - \frac{1}{2}x^4 + \frac{1}{5}x^5 \right\} \Big|_0^1 \\ &= \frac{1}{3} - \frac{1}{2} + \frac{1}{5} = \frac{10}{30} - \frac{15}{30} + \frac{6}{30} = \frac{1}{30}, \end{aligned}$$

and so on. From this short list of numbers, Wallis somehow then guessed (!) the general result for $I(n)$. Can you? In this section we'll derive $I(n)$, but see if you can duplicate Wallis' feat before we finish the formal derivation.

We start by defining the *beta function*:

$$(4.2.1) \quad B(m, n) = \int_0^1 x^{m-1} (1-x)^{n-1} dx, \quad m > 0, n > 0.$$

The beta function is intimately related to the gamma function, as I'll now show you. Changing variable in (4.1.1) to $x = y^2$ (and so $dx = 2y dy$) we have

$$\Gamma(n) = \int_0^\infty e^{-y^2} y^{2n-2} 2y dy = 2 \int_0^\infty e^{-y^2} y^{2n-1} dy.$$

We get another true equation if we replace n with m , and the dummy integration variable y with the dummy integration variable x , and so

$$(4.2.2) \quad \Gamma(m) = 2 \int_0^\infty e^{-x^2} x^{2m-1} dx.$$

Thus,

$$\begin{aligned} \Gamma(m)\Gamma(n) &= 4 \int_0^\infty e^{-x^2} x^{2m-1} dx \int_0^\infty e^{-y^2} y^{2n-1} dy \\ &= 4 \int_0^\infty \int_0^\infty e^{-(x^2+y^2)} x^{2m-1} y^{2n-1} dx dy. \end{aligned}$$

This double integral looks pretty awful, but the trick that brings it to its knees is to switch from Cartesian coordinates to polar coordinates. That is, we'll write $r^2 = x^2 + y^2$ where $x = r \cos(\theta)$ and $y = r \sin(\theta)$, and the differential area $dx dy$ transforms to $r dr d\theta$. When we integrate the double integral over the region $0 \leq x, y < \infty$ we are integrating over the entire first quadrant of the plane, which is equivalent to integrating over the region $0 \leq r < \infty$ and $0 \leq \theta \leq \frac{\pi}{2}$. So,

$$\Gamma(m)\Gamma(n) = 4 \int_0^{\frac{\pi}{2}} \int_0^{\infty} e^{-r^2} \{r \cos(\theta)\}^{2m-1} \{r \sin(\theta)\}^{2n-1} r \, dr \, d\theta$$

or,

$$(4.2.3) \quad \Gamma(m)\Gamma(n) = \left[2 \int_0^{\infty} e^{-r^2} r^{2(m+n)-1} \, dr \right] \left[2 \int_0^{\frac{\pi}{2}} \cos^{2m-1}(\theta) \sin^{2n-1}(\theta) \, d\theta \right].$$

Let's now examine, in turn, each of the integrals in square brackets on the right in (4.2.3). First, if you compare

$$2 \int_0^{\infty} e^{-r^2} r^{2(m+n)-1} \, dr$$

to (4.2.2), you see that they are the same if we associate $x \leftrightarrow r$ and $m \leftrightarrow (m+n)$. Making those replacements, the first square-bracket term in (4.2.3) becomes

$$2 \int_0^{\infty} e^{-r^2} r^{2(m+n)-1} \, dr = \Gamma(m+n).$$

Thus,

$$(4.2.4) \quad \Gamma(m)\Gamma(n) = \Gamma(m+n) \left[2 \int_0^{\frac{\pi}{2}} \cos^{2m-1}(\theta) \sin^{2n-1}(\theta) \, d\theta \right].$$

Next, returning to (4.2.1), the definition of the beta function, make the change of variable $x = \cos^2(\theta)$ (and so $dx = -2 \sin(\theta) \cos(\theta) \, d\theta$), which says that $1-x = \sin^2(\theta)$. So,

$$B(m, n) = \int_0^1 x^{m-1} (1-x)^{n-1} \, dx = -2 \int_{\frac{\pi}{2}}^0 \cos^{2m-2}(\theta) \sin^{2n-2}(\theta) \sin(\theta) \cos(\theta) \, d\theta$$

or

$$B(m, n) = 2 \int_0^{\frac{\pi}{2}} \cos^{2m-1}(\theta) \sin^{2n-1}(\theta) \, d\theta$$

which is the integral in the square brackets of (4.2.4). Therefore,

$$\Gamma(m)\Gamma(n) = \Gamma(m+n)B(m, n)$$

or, rewriting, we have a very important result, one that ties the gamma and beta functions together:

$$(4.2.5) \quad B(m, n) = \frac{\Gamma(m)\Gamma(n)}{\Gamma(m+n)}.$$

Now we can write down the answer to Wallis' integral almost immediately. Just observe that

$$I(k) = \int_0^1 (x - x^2)^k dx = \int_0^1 x^k (1 - x)^k dx = B(k+1, k+1) = \frac{\Gamma(k+1)\Gamma(k+1)}{\Gamma(2k+2)}$$

or, using (4.1.3),

$$I(k) = \frac{k!k!}{(2k+1)!} = \frac{(k!)^2}{(2k+1)!}.$$

So,

$$(4.2.6) \quad I(n) = \int_0^1 (x - x^2)^n dx = \frac{(n!)^2}{(2n+1)!}.$$

If you look back at the start of this section, at the first few values for $I(n)$ that we (Wallis) calculated by direct integration, you'll see that (4.2.6) gives those same results. For 'large' values of n , however, direct evaluation of the integral becomes pretty grubby, while the right-hand side of (4.2.6) is easy to do. For example, if $n = 7$ we have

$$\int_0^1 (x - x^2)^7 dx = \frac{(7!)^2}{15!} = 1.94 \dots \times 10^{-5}$$

and MATLAB agrees, as `quad(@(x)(x-x.^2).^7,0,1) = 1.93 ... x10-5`.

One quite useful result comes directly from (4.2.6), for the case of $n = \frac{1}{2}$. This is, of course, a *non-integer* value, while we have so far (at least implicitly) taken n to be a positive integer. In keeping with the spirit of this book, however, let's just blissfully ignore that point and see where it takes us. For $n = \frac{1}{2}$, (4.2.6) becomes the claim

$$\int_0^1 \sqrt{x - x^2} dx = \frac{(\frac{1}{2}!)^2}{2!} = \frac{1}{2} \left(\frac{1}{2}!\right)^2.$$

Alternatively, we can *directly* evaluate the integral on the left using the area interpretation of the Riemann integral, as follows. The integral is the area under the curve (and above the x -axis) described by $y(x) = \sqrt{x - x^2}$ from $x = 0$ to $x = 1$.

That curve is probably more easily recognized if we write it as $y^2 = x - x^2$ or, $x^2 - x + y^2 = 0$ or, by completing the square, as

$$\left(x - \frac{1}{2}\right)^2 + y^2 = \left(\frac{1}{2}\right)^2.$$

That is, the curve is simply the circle with radius $\frac{1}{2}$ centered on the x-axis at $x = \frac{1}{2}$. The area associated with our integral is, then, the area of the *upper-half* of the circle, which is $\frac{\pi}{8}$. So,

$$\frac{1}{2} \left(\frac{1}{2}!\right)^2 = \frac{\pi}{8}$$

or,

$$(4.2.7) \quad \left(\frac{1}{2}\right)! = \frac{1}{2} \sqrt{\pi}.$$

Does (4.2.7) 'make sense'? Yes, and here's one check of it. Recall (4.1.3),

$$\Gamma(n) = (n - 1)!$$

that, for $n = \frac{3}{2}$ gives $(\frac{1}{2})!$ and so, putting $n = \frac{3}{2}$ in (4.1.1) and using (4.2.7), we arrive at

$$(4.2.8) \quad \int_0^\infty e^{-x} \sqrt{x} \, dx = \frac{1}{2} \sqrt{\pi} .$$

This is 0.886226 ... and MATLAB agrees, as `quad(@(x)exp(-x).*sqrt(x),0,100) = 0.8862228...`

We can use (4.2.8) to establish yet another interesting integral, that of

$$\int_0^1 \sqrt{-\ln(x)} \, dx.$$

Make the change of variable $y = -\ln(x)$. Then,

$$e^y = e^{-\ln(x)} = e^{\ln(x^{-1})} = e^{\ln(\frac{1}{x})} = \frac{1}{x},$$

and since

$$\frac{dy}{dx} = -\frac{1}{x} = -e^y,$$

we have

$$dx = -\frac{dy}{e^y}.$$

Thus,

$$\int_0^1 \sqrt{-\ln(x)} \, dx = \int_{-\infty}^0 \sqrt{y} \left(-\frac{dy}{e^y}\right) = \int_0^{\infty} \sqrt{y} e^{-y} \, dy.$$

But this last integral is (4.2.8) and so

$$(4.2.9) \quad \boxed{\int_0^1 \sqrt{-\ln(x)} \, dx = \frac{1}{2} \sqrt{\pi} .}$$

MATLAB agrees, as `quad(@(x)sqrt(-log(x)),0,1) = 0.88623...` (It's interesting to compare (4.2.9) with (3.1.8).)

With our work in this chapter, we can even talk of *negative* factorials; suppose, for example, $n = \frac{1}{2}$ in (4.1.3), which gives

$$\Gamma\left(\frac{1}{2}\right) = \left(-\frac{1}{2}\right)!.$$

From (4.1.1), setting $n = \frac{1}{2}$ we have

$$\Gamma\left(\frac{1}{2}\right) = \int_0^{\infty} \frac{e^{-x}}{\sqrt{x}} \, dx,$$

an integral we can find using (3.7.1). There, if we set $a = 1$ and $b = 0$ we have

$$\int_0^{\infty} e^{-x^2} \, dx = \frac{1}{2} \sqrt{\pi}.$$

If we now change variable to $s = x^2$ then $\frac{ds}{dx} = 2x = 2\sqrt{s}$ and so $dx = \frac{ds}{2\sqrt{s}}$. That gives us

$$\int_0^{\infty} e^{-x^2} \, dx = \int_0^{\infty} e^{-s} \frac{ds}{2\sqrt{s}} = \frac{1}{2} \sqrt{\pi}$$

or, replacing the dummy variable of integration s back to x ,

$$(4.2.10) \quad \int_0^\infty \frac{e^{-x}}{\sqrt{x}} dx = \sqrt{\pi} .$$

This is 1.77245..., and *quad* agrees: *quad*(@(x)exp(-x)/sqrt(x),0,10) = 1.772448....

Thus,

$$(4.2.11) \quad \Gamma\left(\frac{1}{2}\right) = \left(-\frac{1}{2}\right)! = \sqrt{\pi}.$$

Another way to see (4.2.11) is to use (4.2.4). There, with $m = n = \frac{1}{2}$, we have

$$\Gamma\left(\frac{1}{2}\right)\Gamma\left(\frac{1}{2}\right) = \Gamma(1) \left[2 \int_0^{\frac{\pi}{2}} d\theta\right] = \Gamma(1) \left[2 \left(\frac{\pi}{2}\right)\right] = \Gamma(1)\pi$$

or, as $\Gamma(1) = 1$,

$$\Gamma^2\left(\frac{1}{2}\right) = \pi$$

and so, again,

$$\Gamma\left(\frac{1}{2}\right) = \sqrt{\pi}.$$

Together, the gamma and beta functions let us do some downright nasty-looking integrals. For example, even though the integrand itself is pretty simple looking, the integral

$$\int_0^{\frac{\pi}{2}} \sqrt{\sin(x)} dx$$

seems to be invulnerable to attack by any of the tricks we've developed up to now—but look at what happens when we make the change of variable $u = \sin^2(x)$. Then

$$dx = \frac{du}{2 \sin(x) \cos(x)}$$

and, as

$$\sin(x) = u^{\frac{1}{2}}$$

and

$$\cos(x) = \sqrt{1 - \sin^2(x)} = (1 - u)^{\frac{1}{2}},$$

we have

$$\int_0^{\frac{\pi}{2}} \sqrt{\sin(x)} \, dx = \int_0^1 \frac{u^{\frac{1}{4}}}{2u^{\frac{1}{2}}(1-u)^{\frac{1}{2}}} \, du = \frac{1}{2} \int_0^1 u^{-\frac{1}{4}}(1-u)^{-\frac{1}{2}} \, du = \frac{1}{2} B\left(\frac{3}{4}, \frac{1}{2}\right).$$

From (4.2.5) this becomes (the integral on the far-right follows because, over the integration interval, the sine and cosine take-on the same values),

$$\int_0^{\frac{\pi}{2}} \sqrt{\sin(x)} \, dx = \frac{\Gamma(\frac{3}{4})\Gamma(\frac{1}{2})}{2\Gamma(\frac{5}{4})} = \int_0^{\frac{\pi}{2}} \sqrt{\cos(x)} \, dx .$$

(4.2.12)

MATLAB's gamma function says this is equal to $\text{gamma}(3/4)*\text{gamma}(1/2)/(2*\text{gamma}(5/4)) = 1.19814\dots$, and *quad* agrees as $\text{quad}(@(\text{x})\text{sqrt}(\text{sin}(\text{x})),0,\text{pi}/2) = 1.19813\dots$

The same substitution works for

$$\int_0^{\frac{\pi}{2}} \frac{dx}{\sqrt{\sin(x) \cos(x)}},$$

which transforms into

$$\frac{1}{2} \int_0^1 \frac{du}{\left\{u^{\frac{1}{2}}(1-u)^{\frac{1}{2}}\right\}^{\frac{3}{2}}} = \frac{1}{2} \int_0^1 u^{-\frac{3}{4}}(1-u)^{-\frac{3}{4}} du = \frac{1}{2} B\left(\frac{1}{4}, \frac{1}{4}\right) = \frac{\Gamma^2(\frac{1}{4})}{2\Gamma(\frac{1}{2})}$$

or, using (4.2.11),

$$\int_0^{\frac{\pi}{2}} \frac{dx}{\sqrt{\sin(x)\cos(x)}} = \frac{\Gamma^2(\frac{1}{4})}{2\sqrt{\pi}} .$$

(4.2.13)

MATLAB's gamma function says this is equal to $(\text{gamma}(1/4)^2)/(\text{sqrt}(\text{pi})) = 3.708149\dots$ and *quad* agrees: $\text{quad}(@(\text{x})1./\text{sqrt}(\text{sin}(\text{x})*\text{cos}(\text{x})),0,\text{pi}/2) = 3.708170\dots$

As another example, we can use (4.2.13) and the double-angle formula from trigonometry to write

$$\int_0^{\frac{\pi}{2}} \frac{dx}{\sqrt{\sin(x)\cos(x)}} = \int_0^{\frac{\pi}{2}} \frac{dx}{\sqrt{\frac{1}{2}\sin(2x)}} = \frac{\Gamma^2(\frac{1}{4})}{2\sqrt{\pi}}.$$

Make the change of variable $u = 2x$ and so $dx = \frac{1}{2}du$ and thus

$$\int_0^{\pi} \frac{du}{2\sqrt{\frac{1}{2}\sin(u)}} = \frac{\sqrt{2}}{2}(2) \int_0^{\frac{\pi}{2}} \frac{du}{\sqrt{\sin(u)}} = \frac{\Gamma^2(\frac{1}{4})}{2\sqrt{\pi}}$$

or,

$$\int_0^{\frac{\pi}{2}} \frac{dx}{\sqrt{\sin(x)}} = \left(\frac{1}{\sqrt{2}}\right) \frac{\Gamma^2(\frac{1}{4})}{2\sqrt{\pi}}.$$

Or, finally (the integral on the far-right follows because, over the integration interval, the sine and cosine take-on the same values),

$$(4.2.14) \quad \int_0^{\frac{\pi}{2}} \frac{dx}{\sqrt{\sin(x)}} = \frac{\Gamma^2(\frac{1}{4})}{2\sqrt{2\pi}} = \int_0^{\frac{\pi}{2}} \frac{dx}{\sqrt{\cos(x)}}.$$

MATLAB's gamma function says this is equal to $(\text{gamma}(1/4)^2)/(2*\text{sqrt}(2*\text{pi})) = 2.62205\dots$, and *quad* agrees: $\text{quad}(@(\text{x})1./\text{sqrt}(\text{sin}(\text{x})),0,\text{pi}/2) = 2.62207\dots$

Finally, in the definition (4.2.1) of the beta function make the change of variable

$$x = \frac{y}{1+y}$$

and so

$$1 - x = 1 - \frac{y}{1+y} = \frac{1}{1+y}$$

and

$$-\frac{dx}{dy} = -\frac{1}{(1+y)^2}$$

and so

$$dx = \frac{dy}{(1+y)^2}.$$

Thus,

$$B(m, n) = \int_0^\infty \left(\frac{y}{1+y}\right)^{m-1} \left(\frac{1}{1+y}\right)^{n-1} \frac{dy}{(1+y)^2} = \int_0^\infty \frac{y^{m-1}}{(1+y)^{m+n}} dy.$$

Then, setting $n = 1 - m$, we have

$$\int_0^\infty \frac{y^{m-1}}{1+y} dy = B(m, 1-m) = \Gamma(m)\Gamma(1-m)$$

(4.2.15)

where the second equality follows by (4.2.5) because $\Gamma(1) = 1$. Later, in Chap. 8 (in (8.7.9), we'll show (using contour integration) that

$$\int_0^\infty \frac{y^{m-1}}{1+y} dy = \frac{\pi}{\sin(m\pi)}$$

and so

$$(4.2.16) \quad \Gamma(m)\Gamma(1-m) = \frac{\pi}{\sin(m\pi)}$$

which is the famous *reflection formula* for the gamma function, discovered by Euler in 1771.

The reflection formula will be of great use to us when we get to Chap. 9 (the Epilogue). There I'll show you Riemann's crowning achievement, his derivation of the functional equation for the zeta function (the zeta function will be introduced in the next chapter) in which (4.2.16) will play a central role. There is one additional result we'll need there, as well, one that we can derive right now with the aid of the beta function. We start with (4.2.5),

$$B(m, n) = \frac{\Gamma(m)\Gamma(n)}{\Gamma(m+n)} = \frac{(m-1)!(n-1)!}{(m+n-1)!},$$

from which it follows that

$$B(m+1, n+1) = \frac{m!n!}{(m+n+1)!}.$$

So, writing $m = n = z$, we have

$$B(z + 1, z + 1) = \frac{z!z!}{(2z + 1)!}.$$

From the definition of the beta function in (4.2.1),

$$B(z + 1, z + 1) = \int_0^1 x^z(1 - x)^z dx$$

and so

$$\frac{z!z!}{(2z + 1)!} = \int_0^1 x^z(1 - x)^z dx.$$

Next, make the change of variable $x = \frac{1+s}{2}$ (and so $1 - x = \frac{1-s}{2}$) to get

$$\frac{z!z!}{(2z + 1)!} = \int_{-1}^1 \left(\frac{1+s}{2}\right)^z \left(\frac{1-s}{2}\right)^z \frac{1}{2} ds = 2^{-2z-1} \int_{-1}^1 (1 - s^2)^z ds$$

or, since the integrand is even,

$$\frac{z!z!}{(2z + 1)!} = 2^{-2z} \int_0^1 (1 - s^2)^z ds.$$

Make a second change of variable now, to $u = s^2$ and (so $ds = \frac{du}{2\sqrt{u}}$), to arrive at

$$\frac{z!z!}{(2z + 1)!} = 2^{-2z} \int_0^1 (1 - u)^z \frac{du}{2\sqrt{u}} = 2^{-2z-1} \int_0^1 (1 - u)^z u^{-\frac{1}{2}} du.$$

The last integral is, from (4.2.1),

$$B\left(\frac{1}{2}, z + 1\right) = \frac{\Gamma(\frac{1}{2})\Gamma(z + 1)}{\Gamma(z + \frac{3}{2})} = \frac{(-\frac{1}{2})!z!}{(z + \frac{1}{2})!}$$

and so, recalling from (4.2.11) that $(-\frac{1}{2})! = \sqrt{\pi}$, we have

$$\frac{z!z!}{(2z + 1)!} = 2^{-2z-1} \frac{z!\sqrt{\pi}}{(z + \frac{1}{2})!}.$$

Cancelling a $z!$ on each side, and then cross-multiplying, gives us

$$(4.2.17) \quad z! \left(z + \frac{1}{2}\right)! = 2^{-2z-1} \sqrt{\pi} (2z + 1)!$$

and since

$$\left(z + \frac{1}{2}\right)! = \left(z + \frac{1}{2}\right) \left(z - \frac{1}{2}\right)! = \left(\frac{2z+1}{2}\right) \left(z - \frac{1}{2}\right)!$$

and also

$$(2z + 1)! = (2z + 1)(2z)!,$$

then we can alternatively write

$$(4.2.18) \quad z! \left(z - \frac{1}{2}\right)! = 2^{-2z} \sqrt{\pi} (2z)!$$

(4.2.17) and (4.2.18) are variations on what mathematicians commonly call the *Legendre duplication formula*. We'll use (4.2.18), in particular, in Chap. 9.

4.3 Double Integration Reversal

In Chap. 3 (Sect. 3.4) I discussed how reversing the order of integration in a double integral can be a useful technique to have tucked away in your bag of tricks. In this section I'll show you some more examples of that trick in which the gamma function will appear. Our starting point is the double integral

$$\int_0^\infty \int_0^\infty \sin(bx) y^{p-1} e^{-xy} dx dy.$$

If we argue that the value of this integral is independent of the order of integration, then we can write

$$(4.3.1) \quad \int_0^\infty \sin(bx) \left\{ \int_0^\infty y^{p-1} e^{-xy} dy \right\} dx = \int_0^\infty y^{p-1} \left\{ \int_0^\infty \sin(bx) e^{-xy} dx \right\} dy.$$

Concentrate your attention for now on the right-hand-side of (4.3.1). We have, for the inner x -integral,

$$\int_0^{\infty} \sin(bx)e^{-xy} dx = \frac{b}{b^2 + y^2},$$

a result you can get either by integrating-by-parts, or find worked-out using yet another trick that I'll show you in Chap. 7, in the result (7.1.2). For now, however, you can just accept it. Then, the right-hand-side of (4.3.1) is calculated as

$$\int_0^{\infty} y^{p-1} \frac{b}{b^2 + y^2} dy = b \int_0^{\infty} \frac{y^{p-1}}{b^2 \left(1 + \frac{y^2}{b^2}\right)} dy = \frac{1}{b} \int_0^{\infty} \frac{y^{p-1}}{1 + \left(\frac{y}{b}\right)^2} dy.$$

Now, make the change of variable

$$t = \frac{y}{b},$$

and so $dy = b dt$, which means the right-hand-side of (4.3.1) is

$$\frac{1}{b} \int_0^{\infty} \frac{(tb)^{p-1}}{1 + t^2} b dt = b^{p-1} \int_0^{\infty} \frac{t^{p-1}}{1 + t^2} dt.$$

As I'll show you in Chap. 8, when we get to contour integration, we'll find in (8.7.8) that

$$\int_0^{\infty} \frac{x^m}{1 + x^n} dx = \frac{\frac{\pi}{n}}{\sin \left\{ (m+1) \frac{\pi}{n} \right\}}.$$

So, if we let $n = 2$ and $m = p - 1$ we have

$$\int_0^{\infty} \frac{t^{p-1}}{1 + t^2} dt = \frac{\frac{\pi}{2}}{\sin \left\{ \frac{p\pi}{2} \right\}}.$$

Thus, the right-hand-side of (4.3.1) is

$$\frac{b^{p-1} \pi}{2 \sin \left\{ \frac{p\pi}{2} \right\}}.$$

Next, shift your attention to the left-hand-side of (4.3.1). For the inner, y -integral, make the change of variable $u = xy$ (where, of course, at this point we treat x as a constant). Then, $du = x dy$ and so

$$\int_0^{\infty} y^{p-1} e^{-xy} dy = \int_0^{\infty} \left(\frac{u}{x}\right)^{p-1} e^{-u} \frac{du}{x} = \frac{1}{x^p} \int_0^{\infty} u^{p-1} e^{-u} du.$$

The last integral is just the definition of $\Gamma(p)$ in (4.1.1), and so

$$\int_0^{\infty} y^{p-1} e^{-xy} dy = \frac{1}{x^p} \Gamma(p).$$

Thus, we immediately see that the left-hand-side of (4.3.1) is

$$\Gamma(p) \int_0^{\infty} \frac{\sin(bx)}{x^p} dx.$$

Equating our two results for each side of (4.3.1), we have (for $0 < p < 2$),

$$(4.3.2) \quad \int_0^{\infty} \frac{\sin(bx)}{x^p} dx = \frac{b^{p-1} \pi}{2\Gamma(p) \sin\left\{\frac{p\pi}{2}\right\}}.$$

This result reproduces Dirichlet's integral if $b = 1$ and $p = 1$ (that's *good*, of course!), but the real value of (4.3.2) comes from its use in doing an integral that, until now, would have stopped us cold:

$$\int_0^{\infty} \frac{\sin(x^q)}{x^q} dx = ?$$

For example, if $q = 3$, what is

$$\int_0^{\infty} \frac{\sin(x^3)}{x^3} dx = ?$$

Note, carefully, that this is *not*

$$\int_0^{\infty} \left\{ \frac{\sin(x)}{x} \right\}^3 dx$$

which we'll do later in Chap. 7, in (7.6.2).

We start with the obvious step of changing variable to $u = x^q$. Then

$$\frac{du}{dx} = qx^{q-1} = q \frac{x^q}{x} = \frac{qu}{u^{1/q}}$$

and so

$$dx = \frac{u^{1/q}}{qu} du.$$

Thus,

$$\int_0^\infty \frac{\sin(x^q)}{x^q} dx = \int_0^\infty \frac{\sin(u)}{u} \left(\frac{u^{1/q}}{qu} du \right) = \frac{1}{q} \int_0^\infty \frac{\sin(u)}{u^{2-1/q}} du.$$

The last integral is of the form (4.3.2), with $b = 1$ and $p = 2 - \frac{1}{q}$, and so

$$\int_0^\infty \frac{\sin(x^q)}{x^q} dx = \frac{\pi}{2q\Gamma\left(2 - \frac{1}{q}\right) \sin\left\{\left(2 - \frac{1}{q}\right)\frac{\pi}{2}\right\}}.$$

Since

$$\begin{aligned} \sin\left\{\left(2 - \frac{1}{q}\right)\frac{\pi}{2}\right\} &= \sin\left(\pi - \frac{\pi}{2q}\right) = \sin(\pi) \cos\left(\frac{\pi}{2q}\right) - \cos(\pi) \sin\left(\frac{\pi}{2q}\right) \\ &= \sin\left(\frac{\pi}{2q}\right) \end{aligned}$$

we have

$$(4.3.3) \quad \int_0^\infty \frac{\sin(x^q)}{x^q} dx = \frac{\pi}{2q\Gamma\left(2 - \frac{1}{q}\right) \sin\left(\frac{\pi}{2q}\right)}.$$

The result in (4.3.3) is formally an answer to our question, but we can simplify it a bit. The following is a summary of the properties of the gamma function where, because of the functional equation (4.1.2), z is now *any* real number and not just a positive integer.

- (a) $\Gamma(z) = (z - 1)!$;
- (b) $\Gamma(z + 1) = z!$;
- (c) $(z - 1)! = \frac{z!}{z}$ (alternatively, $z! = z(z - 1)!$);
- (d) $\Gamma(z)\Gamma(1 - z) = \frac{\pi}{\sin(\pi z)}$.

From (b) we can write $\Gamma\left(2 - \frac{1}{q}\right) = \left(1 - \frac{1}{q}\right)!$ and then, from (c),

$$\left(1 - \frac{1}{q}\right)! = \left(1 - \frac{1}{q}\right) \left(-\frac{1}{q}\right)!$$

So, (4.3.3) becomes

$$\int_0^\infty \frac{\sin(x^q)}{x^q} dx = \frac{\pi}{2q\left(1 - \frac{1}{q}\right) \left(-\frac{1}{q}\right)! \sin\left\{\frac{\pi}{2q}\right\}}$$

or,

$$(4.3.4) \quad \int_0^{\infty} \frac{\sin(x^q)}{x^q} dx = \frac{\pi}{2(q-1) \left(-\frac{1}{q}\right)! \sin\left\{\frac{\pi}{2q}\right\}}.$$

Next, from (a), (b), and (d) we have

$$\Gamma(z)\Gamma(1-z) = \frac{\pi}{\sin(\pi z)} = (z-1)!(-z)! = \frac{z(z-1)!(-z)!}{z} = \frac{z!(-z)!}{z}$$

and so

$$(-z)! = \frac{\pi z}{z! \sin(\pi z)}.$$

Writing $\frac{1}{q}$ for z , this becomes

$$(4.3.5) \quad \left(-\frac{1}{q}\right)! = \frac{\pi^{\frac{1}{q}}}{\left(\frac{1}{q}\right)! \sin\left(\frac{\pi}{q}\right)}.$$

Substituting (4.3.5) into (4.3.4), we get

$$\begin{aligned} \int_0^{\infty} \frac{\sin(x^q)}{x^q} dx &= \frac{\pi}{2(q-1) \frac{\pi^{\frac{1}{q}}}{\left(\frac{1}{q}\right)! \sin\left(\frac{\pi}{q}\right)} \sin\left\{\frac{\pi}{2q}\right\}} = \frac{\left(\frac{1}{q}\right)! \sin\left(\frac{\pi}{q}\right)}{2(q-1) \left(\frac{1}{q}\right) \sin\left(\frac{\pi}{2q}\right)} \\ &= \frac{\left(\frac{1}{q}\right)! 2 \sin\left(\frac{\pi}{2q}\right) \cos\left(\frac{\pi}{2q}\right)}{2(q-1) \left(\frac{1}{q}\right) \sin\left(\frac{\pi}{2q}\right)} \end{aligned}$$

or,

$$(4.3.6) \quad \int_0^{\infty} \frac{\sin(x^q)}{x^q} dx = \frac{\left(\frac{1}{q}\right)!}{\frac{1}{q}} \left(\frac{1}{q-1}\right) \cos\left(\frac{\pi}{2q}\right).$$

From (c), which says $z! = z(z-1)!$, we can write

$$\frac{\left(\frac{1}{q}\right)!}{\frac{1}{q}} = \frac{\frac{1}{q} \left(\frac{1}{q}-1\right)!}{\frac{1}{q}} = \left(\frac{1}{q}-1\right)! = \Gamma\left(\frac{1}{q}\right)$$

where the last equality follows from (a). Using this in (4.3.6), we at last have our answer:

$$(4.3.7) \quad \int_0^\infty \frac{\sin(x^q)}{x^q} dx = \frac{\Gamma\left(\frac{1}{q}\right)}{q-1} \cos\left(\frac{\pi}{2q}\right), \quad q > 1.$$

If $q = 3$, for example, (4.3.7) says

$$\int_0^\infty \frac{\sin(x^3)}{x^3} dx = \frac{\Gamma\left(\frac{1}{3}\right)}{2} \cos\left(\frac{\pi}{6}\right) = \frac{\Gamma\left(\frac{1}{3}\right)}{2} \left(\frac{\sqrt{3}}{2}\right) = \frac{\sqrt{3}}{4} \Gamma\left(\frac{1}{3}\right)$$

and MATLAB agrees: `sqrt(3)*gamma(1/3)/4 = 1.16001...` and `quad(@(x) sin(x.^3)./x.^3,0,10000) = 1.15928...`

The trick of double integration reversal is so useful, let's use it again to evaluate

$$\int_0^\infty \frac{\cos(bx)}{x^p} dx,$$

which is an obvious variation on (4.3.2). We start with

$$\int_0^\infty \int_0^\infty \cos(bx) y^{p-1} e^{-xy} dx dy$$

and then, as before, assume that the value of the double integral is independent of the order of integration. That is,

$$(4.3.8) \quad \int_0^\infty \cos(bx) \left\{ \int_0^\infty y^{p-1} e^{-xy} dy \right\} dx = \int_0^\infty y^{p-1} \left\{ \int_0^\infty \cos(bx) e^{-xy} dx \right\} dy.$$

Concentrate your attention for now on the right-hand side of (4.3.8). We have, for the inner, x-integral (from integration-by-parts)

$$\int_0^\infty \cos(bx) e^{-xy} dx = \frac{y}{b^2 + y^2}.$$

Thus, the right-hand side of (4.3.8) is

$$\int_0^\infty y^{p-1} \frac{y}{b^2 + y^2} dy = \int_0^\infty \frac{y^p}{b^2 \left(1 + \frac{y^2}{b^2}\right)} dy = \frac{1}{b^2} \int_0^\infty \frac{y^p}{1 + \frac{y^2}{b^2}} dy.$$

Now, make the change-of-variable

$$t = \frac{y}{b}$$

and so $dy = b dt$, which means that the right-hand side of (4.3.8) is

$$\frac{1}{b^2} \int_0^\infty \frac{(tb)^p}{1+t^2} b dt = b^{p-1} \int_0^\infty \frac{t^p}{1+t^2} dt.$$

Again, as before, we next use a result to be established later as (8.7.8):

$$\int_0^\infty \frac{x^m}{1+x^n} dx = \frac{\frac{\pi}{n}}{\sin \left\{ (m+1) \frac{\pi}{n} \right\}}.$$

So, if we let $n=2$ and $m=p$, we have

$$\int_0^\infty \frac{t^p}{1+t^2} dt = \frac{\frac{\pi}{2}}{\sin \left\{ \frac{(p+1)\pi}{2} \right\}} = \frac{\frac{\pi}{2}}{\cos \left\{ \frac{p\pi}{2} \right\}}.$$

Thus, the right-hand side of (4.3.8) is

$$\frac{b^{p-1}\pi}{2 \cos \left\{ \frac{p\pi}{2} \right\}}.$$

Next, shift your attention to the left-hand side of (4.3.8). For the inner, y -integral, you'll recall that we've already worked it out to be

$$\int_0^\infty y^{p-1} e^{-xy} dy = \frac{1}{x^p} \Gamma(p).$$

So, the left-hand side of (4.3.8) is

$$\Gamma(p) \int_0^\infty \frac{\cos(bx)}{x^p} dx.$$

Equating our two results for each side of (4.3.8), we have

$$(4.3.9) \quad \int_0^\infty \frac{\cos(bx)}{x^p} dx = \frac{b^{p-1}\pi}{2\Gamma(p)\cos\left\{\frac{p\pi}{2}\right\}}, \quad 0 < p < 1.$$

There is still a *lot* more we can do with these results. For example, if we write (4.3.2) with u rather than x as the dummy variable of integration, then

$$\int_0^{\infty} \frac{\sin(bu)}{u^p} du = \frac{b^{p-1} \pi}{2\Gamma(p) \sin\left\{\frac{p\pi}{2}\right\}},$$

and if we then let $p = 1 - \frac{1}{k}$ this becomes

$$\int_0^{\infty} \frac{\sin(bu)}{u^{1-\frac{1}{k}}} du = \frac{b^{-\frac{1}{k}} \pi}{2\Gamma\left(1 - \frac{1}{k}\right) \sin\left\{\frac{(1-\frac{1}{k})\pi}{2}\right\}}$$

or,

$$\int_0^{\infty} u^{\frac{1}{k}} \frac{\sin(bu)}{u} du = \frac{\pi}{2b^{\frac{1}{k}} \Gamma\left(1 - \frac{1}{k}\right) \sin\left\{\frac{\pi}{2} - \frac{\pi}{2k}\right\}}.$$

Now, let $u = x^k$ and so

$$\frac{du}{dx} = k x^{k-1}$$

and so

$$du = k \frac{x^k}{x} = k \frac{u}{u^{\frac{1}{k}}} dx.$$

Thus,

$$\int_0^{\infty} u^{\frac{1}{k}} \frac{\sin(bu)}{u} du = \int_0^{\infty} u^{\frac{1}{k}} \frac{\sin(bx^k)}{u} k \frac{u}{u^{\frac{1}{k}}} dx = k \int_0^{\infty} \sin(bx^k) dx$$

and so

$$\int_0^{\infty} \sin(bx^k) dx = \frac{\pi}{2kb^{\frac{1}{k}} \Gamma\left(1 - \frac{1}{k}\right) \sin\left\{\frac{\pi}{2} - \frac{\pi}{2k}\right\}}.$$

From the reflection formula (4.2.16) for the gamma function

$$\Gamma\left(\frac{1}{k}\right) \Gamma\left(1 - \frac{1}{k}\right) = \frac{\pi}{\sin\left\{\frac{\pi}{k}\right\}}$$

and so

$$\Gamma\left(1 - \frac{1}{k}\right) = \frac{\pi}{\Gamma\left(\frac{1}{k}\right) \sin\left\{\frac{\pi}{k}\right\}}$$

or,

$$\int_0^{\infty} \sin(bx^k) dx = \frac{\Gamma\left(\frac{1}{k}\right) \sin\left\{\frac{\pi}{k}\right\}}{2kb^{\frac{1}{k}} \sin\left\{\frac{\pi}{2} - \frac{\pi}{2k}\right\}} = \frac{2\Gamma\left(\frac{1}{k}\right) \sin\left\{\frac{\pi}{2k}\right\} \cos\left\{\frac{\pi}{2k}\right\}}{2kb^{\frac{1}{k}} \sin\left\{\frac{\pi}{2} - \frac{\pi}{2k}\right\}}.$$

Thus, as

$$\sin\left\{\frac{\pi}{2} - \frac{\pi}{2k}\right\} = \sin\left\{\frac{\pi}{2}\right\} \cos\left\{\frac{\pi}{2k}\right\} - \cos\left\{\frac{\pi}{2}\right\} \sin\left\{\frac{\pi}{2k}\right\} = \cos\left\{\frac{\pi}{2k}\right\},$$

we arrive at

$$(4.3.10) \quad \int_0^{\infty} \sin(bx^k) dx = \frac{\Gamma\left(\frac{1}{k}\right) \sin\left\{\frac{\pi}{2k}\right\}}{kb^{\frac{1}{k}}}, \quad b > 0, \quad k > 1.$$

For example, if $b = 1$ and $k = 3$ then (4.3.10) says that

$$\int_0^{\infty} \sin(x^3) dx = \frac{\Gamma\left(\frac{1}{3}\right) \sin\left\{\frac{\pi}{6}\right\}}{3} = \frac{\frac{1}{2}\Gamma\left(\frac{1}{3}\right)}{3} = \frac{1}{6}\Gamma\left(\frac{1}{3}\right) = 0.446489\dots$$

If, in (4.3.9), we use u rather than x as the dummy variable of integration, then

$$\int_0^{\infty} \frac{\cos(bu)}{u^p} du = \frac{b^{p-1} \pi}{2\Gamma(p) \cos\left\{\frac{p\pi}{2}\right\}}.$$

As before, let $p = 1 - \frac{1}{k}$ (and then $u = x^k$) and so (skipping a few steps)

$$k \int_0^{\infty} \cos(bx^k) dx = \frac{b^{-\frac{1}{k}} \pi}{2\Gamma\left(1 - \frac{1}{k}\right) \cos\left\{\frac{\pi}{2} - \frac{\pi}{2k}\right\}}$$

and thus

$$\int_0^{\infty} \cos(bx^k) dx = \frac{\pi}{2kb^{\frac{1}{k}} \Gamma\left(1 - \frac{1}{k}\right) \cos\left\{\frac{\pi}{2} - \frac{\pi}{2k}\right\}}.$$

Since

$$\cos \left\{ \frac{\pi}{2} - \frac{\pi}{2k} \right\} = \cos \left\{ \frac{\pi}{2} \right\} \cos \left\{ \frac{\pi}{2k} \right\} + \sin \left\{ \frac{\pi}{2} \right\} \sin \left\{ \frac{\pi}{2k} \right\} = \sin \left\{ \frac{\pi}{2k} \right\},$$

and, since as before

$$\Gamma \left(1 - \frac{1}{k} \right) = \frac{\pi}{\Gamma \left(\frac{1}{k} \right) \sin \left\{ \frac{\pi}{k} \right\}} = \frac{\pi}{2\Gamma \left(\frac{1}{k} \right) \sin \left\{ \frac{\pi}{2k} \right\} \cos \left\{ \frac{\pi}{2k} \right\}},$$

we have

$$\int_0^\infty \cos(bx^k) dx = \frac{\Gamma \left(\frac{1}{k} \right) \cos \left\{ \frac{\pi}{2k} \right\}}{kb^{\frac{1}{k}}}, \quad b > 0, \quad k > 1.$$

(4.3.11)

If $b = 1$ and $k = 3$ then (4.3.11) says that

$$\int_0^\infty \cos(x^3) dx = \frac{\Gamma \left(\frac{1}{3} \right) \cos \left\{ \frac{\pi}{6} \right\}}{3} = \frac{\frac{\sqrt{3}}{2} \Gamma \left(\frac{1}{3} \right)}{3} = \frac{1}{2\sqrt{3}} \Gamma \left(\frac{1}{3} \right) = 0.77334 \dots$$

Notice that $\int_0^\infty \cos(x^3) dx \neq \int_0^\infty \sin(x^3) dx$.

Finally, here's one more example of the reversal of double integration order trick. Recall our earlier starting point in deriving (4.3.9):

$$\int_0^\infty \cos(bx) e^{-xy} dx = \frac{y}{b^2 + y^2}.$$

If we integrate both sides *with respect to y* from 0 to $c \geq 0$ we have

$$\int_0^c \left\{ \int_0^\infty \cos(bx) e^{-xy} dx \right\} dy = \int_0^c \frac{y}{b^2 + y^2} dy$$

or, reversing the order of integration on the left,

$$(4.3.12) \quad \int_0^\infty \cos(bx) \left\{ \int_0^c e^{-xy} dy \right\} dx = \int_0^c \frac{y}{b^2 + y^2} dy.$$

Clearly,

$$\int_0^c e^{-xy} dy = \left(-\frac{e^{-xy}}{x} \right) \Big|_0^c = \frac{1 - e^{-cx}}{x}.$$

Now, on the right-hand side of (4.3.12) let $u = b^2 + y^2$, and so

$$\frac{du}{dy} = 2y$$

or,

$$dy = \frac{du}{2y}.$$

Thus,

$$\int_0^c \frac{y}{b^2 + y^2} dy = \int_{b^2}^{b^2+c^2} \frac{y}{u} \left(\frac{du}{2y} \right) = \frac{1}{2} \int_{b^2}^{b^2+c^2} \frac{du}{u} = \frac{1}{2} \ln(u) \Big|_{b^2}^{b^2+c^2} = \frac{1}{2} \ln \left(\frac{b^2 + c^2}{b^2} \right).$$

So, (4.3.12) becomes

$$\int_0^\infty \frac{1 - e^{-cx}}{x} \cos(bx) dx = \frac{1}{2} \ln \left(\frac{b^2 + c^2}{b^2} \right).$$

(4.3.13)

This is obviously correct for $c = 0$ (giving zero on both sides of (4.3.13)). If $b = c = 1$, then (4.3.13) says that

$$\int_0^\infty \frac{1 - e^{-x}}{x} \cos(x) dx = \frac{1}{2} \ln(2) = 0.3465 \dots$$

and MATLAB 'agrees' as `quad(@(x)(1-exp(-x)).*cos(x),x,0,500) = 0.3456...`

If we write (4.3.13) twice, first with $c = r$ and $b = p$, we have

$$\int_0^\infty \frac{1 - e^{-rx}}{x} \cos(px) dx = \frac{1}{2} \ln \left(\frac{p^2 + r^2}{p^2} \right),$$

and then again with $c = s$ and $b = q$, we have

$$\int_0^\infty \frac{1 - e^{-sx}}{x} \cos(qx) dx = \frac{1}{2} \ln \left(\frac{q^2 + s^2}{q^2} \right).$$

Thus,

$$\int_0^\infty \frac{1 - e^{-sx}}{x} \cos(qx) dx - \int_0^\infty \frac{1 - e^{-rx}}{x} \cos(px) dx = \frac{1}{2} \ln \left(\frac{q^2 + s^2}{q^2} \right) - \frac{1}{2} \ln \left(\frac{p^2 + r^2}{p^2} \right)$$

or,

$$\begin{aligned} & \int_0^\infty \frac{\cos(qx) - \cos(px)}{x} dx + \int_0^\infty \frac{e^{-rx} \cos(px) - e^{-sx} \cos(qx)}{x} dx \\ &= \frac{1}{2} \ln \left(\frac{\frac{q^2 + s^2}{q^2}}{\frac{p^2 + r^2}{p^2}} \right) = \frac{1}{2} \ln \left(\frac{q^2 + s^2}{p^2 + r^2} \cdot \frac{p^2}{q^2} \right) = \frac{1}{2} \ln \left(\frac{q^2 + s^2}{p^2 + r^2} \right) + \frac{1}{2} \ln \left(\frac{p^2}{q^2} \right) \\ &= \frac{1}{2} \ln \left(\frac{q^2 + s^2}{p^2 + r^2} \right) + \ln \left(\frac{p}{q} \right). \end{aligned}$$

But since the first integral on the left in the last equation is $\ln\left(\frac{p}{q}\right)$ by (3.4.6), we have the result

$$\int_0^\infty \frac{e^{-rx} \cos(px) - e^{-sx} \cos(qx)}{x} dx = \frac{1}{2} \ln \left(\frac{q^2 + s^2}{p^2 + r^2} \right)$$

(4.3.14)

For example, if $r = q = 0$ and $p = s = 1$, then (4.3.14) reduces to

$$\int_0^\infty \frac{\cos(x) - e^{-x}}{x} dx = 0,$$

a result which we'll derive again in Chap. 8, in (8.6.4), in an entirely different way using contour integration.

4.4 The Gamma Function Meets Physics

Back in Chap. 1 (Sect. 1.8) I showed you some examples of integrals occurring in *physical* problems and, as we are now approximately half-way through the book, I think the time is right for another such illustration. In the following analysis you'll see how gamma functions appear in a problem involving the motion of a point mass under the influence of an inverse power force field (*not* necessarily restricted to the inverse-square law of gravity). Specifically, imagine a point mass m held *at rest* at $y = a$, in a force field of magnitude $\frac{k}{y^{p+1}}$ directed straight down the y -axis towards the origin, where k and p are both positive constants. (An inverse-square gravitational force field is the special case of $p = 1$, but our analysis will hold for *any* $p > 0$.)

For the case of $p = 0$, see Challenge Problem 7.) Our problem is simple to state: The mass is allowed to move at time $t = 0$ and so, of course, it begins accelerating down the y -axis towards the origin. At what time $t = T$ does the mass arrive at the origin?

From Mr. Newton we have the observation ‘force equals mass times acceleration’ or, in math,¹

$$F = m \frac{d^2y}{dt^2}.$$

Now, if we denote the speed of the mass by v then

$$v = \frac{dy}{dt}$$

and so

$$\frac{dv}{dt} = \frac{d^2y}{dt^2}$$

which says (invoking the amazingly useful chain-rule from calculus) that

$$F = m \frac{dv}{dt} = m \left(\frac{dv}{dy} \right) \left(\frac{dy}{dt} \right) = mv \frac{dv}{dy}.$$

So,

$$(4.4.1) \quad -\frac{k}{y^{p+1}} = mv \frac{dv}{dy},$$

where we use the minus sign because the force field is operating in the negative direction, down the y -axis towards the origin. This differential equation is easily integrated, as the variables are separable:

$$-\frac{k dy}{m y^{p+1}} = v dv.$$

¹ Newton didn’t actually say this (what is known as the second law of motion), but rather the much more profound ‘force is the rate of change of momentum.’ If the mass doesn’t change with time (as is the case in our problem here) then the above is okay, but if you want to study rocket physics (the mass of a rocket decreases as it burns fuel and ejects the combustion products) then you have to use what Newton really said.

Now, integrating indefinitely,

$$\frac{1}{2}v^2 = -\frac{k}{m} \int \frac{dy}{y^{p+1}} = -\frac{k}{m} \int y^{-p-1} dy = \left(-\frac{k}{m}\right) \left(\frac{y^{-p}}{-p}\right) + C = \frac{k}{mpy^p} + C$$

or,

$$v^2 = \frac{2k}{mpy^p} + 2C$$

where C is the arbitrary constant of integration. Using the initial condition $v=0$ when $y=a$, we see that

$$C = -\frac{k}{mpa^p}.$$

So,

$$v^2 = \frac{2k}{mpy^p} - \frac{2k}{mpa^p} = \frac{2k}{mp} \left(\frac{1}{y^p} - \frac{1}{a^p}\right).$$

Thus,

$$\left(\frac{dy}{dt}\right)^2 = \frac{2k}{mp} \left(\frac{1}{y^p} - \frac{1}{a^p}\right)$$

or, solving² for the differential dt ,

$$dt = \pm \sqrt{\frac{mp}{2k}} \left(\frac{dy}{\sqrt{\frac{1}{y^p} - \frac{1}{a^p}}}\right) = \pm \sqrt{\frac{mp}{2k}} \frac{dy}{\sqrt{\frac{a^p - y^p}{a^p y^p}}} = \pm \sqrt{\frac{mp}{2k}} \frac{a^{p/2}}{\sqrt{\left(\frac{a}{y}\right)^p - 1}} dy.$$

Integrating t from 0 to T on the left (which means we integrate y from a to 0 on the right),

$$\int_0^T dt = T = \pm a^{p/2} \sqrt{\frac{mp}{2k}} \int_a^0 \frac{dy}{\sqrt{\left(\frac{a}{y}\right)^p - 1}}.$$

² Notice that sign of dt is written with the ambiguous \pm . I'm doing that because it's not clear at this point (at least it isn't to me!) which of the two possibilities coming from the square-root operation is the one to use. *Physically*, though, we know $T > 0$, and we'll eventually use that condition to make our decision.

Changing variable to $u = \frac{y}{a}$ (and so $dy = a du$), this becomes

$$T = \pm a^{p/2} \sqrt{\frac{mp}{2k}} \int_1^0 \frac{a}{\sqrt{\frac{1}{u^p} - 1}} du = \pm a^{(\frac{p}{2})+1} \sqrt{\frac{mp}{2k}} \int_1^0 \frac{u^{p/2}}{\sqrt{1 - u^p}} du$$

or, using the minus sign to make $T > 0$ (see the last footnote),

$$T = a^{(\frac{p}{2})+1} \sqrt{\frac{mp}{2k}} \int_0^1 \frac{u^{p/2}}{\sqrt{1 - u^p}} du.$$

Now, let

$$x = u^p$$

and so

$$\frac{dx}{du} = pu^{p-1} = \frac{pu^p}{u} = \frac{px}{x^{\frac{1}{p}}}$$

or,

$$du = \frac{x^{\frac{1}{p}}}{px} dx.$$

Thus,

$$\begin{aligned} T &= a^{(\frac{p}{2})+1} \sqrt{\frac{mp}{2k}} \int_0^1 \frac{x^{\frac{1}{2}}}{\sqrt{1-x}} \left(\frac{x^{\frac{1}{p}}}{px} \right) dx = a^{(\frac{p}{2})+1} \sqrt{\frac{mp}{2k}} \left(\frac{1}{p} \right) \int_0^1 \frac{x^{\frac{1}{p} - \frac{1}{2}}}{\sqrt{1-x}} dx \\ &= a^{(\frac{p}{2})+1} \sqrt{\frac{m}{2kp}} \int_0^1 x^{\frac{1}{p} - \frac{1}{2}} (1-x)^{-\frac{1}{2}} dx. \end{aligned}$$

This last integral has the form of the beta function integral in (4.2.1), with

$$m - 1 = \frac{1}{p} - \frac{1}{2}$$

and

$$n - 1 = -\frac{1}{2}.$$

That is,

$$m = \frac{1}{p} + \frac{1}{2}$$

and

$$n = \frac{1}{2}.$$

So,

$$T = a^{(\frac{p}{2})+1} \sqrt{\frac{m}{2kp}} B\left(\frac{1}{p} + \frac{1}{2}, \frac{1}{2}\right)$$

and since, from (4.2.5),

$$B\left(\frac{1}{p} + \frac{1}{2}, \frac{1}{2}\right) = \frac{\Gamma\left(\frac{1}{p} + \frac{1}{2}\right)\Gamma\left(\frac{1}{2}\right)}{\Gamma\left(\frac{1}{p} + 1\right)} = \frac{\Gamma\left(\frac{1}{p} + \frac{1}{2}\right)\sqrt{\pi}}{\Gamma\left(\frac{1}{p} + 1\right)}$$

we at last have our answer:

$$(4.4.2) \quad T = a^{(\frac{p}{2})+1} \sqrt{\frac{m\pi}{2kp}} \left\{ \frac{\Gamma\left(\frac{1}{p} + \frac{1}{2}\right)}{\Gamma\left(\frac{1}{p} + 1\right)} \right\}, \quad p > 0.$$

A final observation: the mass arrives at the origin with infinite speed because the force field becomes arbitrarily large as the mass approaches $y = 0$. That means there is some point on the positive y -axis where the speed of the mass exceeds that of light which, it has been known since Einstein's special theory of relativity, is impossible. This is a nice freshman math/physics textbook analysis in *classical* physics, but it is not relativistically correct.

4.5 Challenge Problems

(C4.1): Find

$$I(n) = \int_0^1 (1 - \sqrt{x})^n dx$$

and, in particular, use your general result to show that

$$I(9) = \int_0^1 (1 - \sqrt{x})^9 dx = \frac{1}{55}.$$

(C4.2): Prove that

$$\int_0^1 x^m \ln^n(x) dx = (-1)^n \frac{n!}{(m+1)^{n+1}}.$$

We'll use this result later, in Chap. 6, to do some really impressive, historically important integrals.

(C4.3): Show that the integral of $x^a y^b$ over the triangular region defined by the x and y axes, and the line $x + y = 1$, is $\frac{a!b!}{(a+b+2)!}$, where a and b are both non-negative constants.

(C4.4): Use (4.3.2) to evaluate $\int_0^\infty \frac{\sin(x)}{\sqrt{x}} dx$ and (4.3.9) to evaluate $\int_0^\infty \frac{\cos(x)}{\sqrt{x}} dx$.

These are famous integrals, which we'll later re-derive in an entirely different way in (7.5.2). Also, use (4.3.10) and (4.3.11) to evaluate $\int_0^\infty \sin(x^2) dx$ and $\int_0^\infty \cos(x^2) dx$. These are also famous integrals, and we'll re-derive them later in an entirely different way in (7.2.1) and (7.2.2). (Notice that while we showed $\int_0^\infty \cos(x^3) dx \neq \int_0^\infty \sin(x^3) dx$, $\int_0^\infty \cos(x^2) dx$ *does* equal $\int_0^\infty \sin(x^2) dx$.)

(C4.5): Use the double-integration reversal trick we used to derive (4.3.13) to evaluate (for $b > 0$, $c > 0$) $\int_0^\infty \frac{\sin(bx)}{x} e^{-cx} dx$. Hint: start with the integral we used to begin the derivation of (4.3.2), $\int_0^\infty \sin(bx) e^{-xy} dx = \frac{b}{b^2 + y^2}$, and then integrate both sides with respect to y from c to infinity. Notice that the result is a generalization of Dirichlet's integral in (3.2.1), to which it reduces as we let $c \rightarrow 0$.

(C4.6): Evaluate the integral $\int_0^\infty \frac{x^a}{(1+x^b)^c} dx$ in terms of gamma functions, where a , b , and c are constants such that $a > -1$, $b > 0$, and $bc > a+1$, and use your formula to calculate the value of $\int_0^\infty \frac{x\sqrt{x}}{(1+x)^3} dx$. Hint: make the change-of-variable $y = x^b$ and then recall the zero-to-infinity integral form of the beta function that we derived just before (4.2.15): $B(m, n) = \int_0^\infty \frac{y^{m-1}}{(1+y)^{m+n}} dy$.

(C4.7): Notice that T in (4.4.2) is undefined for the $p = 0$ case (the case of an inverse *first* power force field). See if you can find T for the $p = 0$ case. Hint: Set $p = 0$ in

(4.4.1) and *then* integrate. You'll find (3.1.8) to be quite useful in evaluating the integral you'll encounter.

(C4.8): How does the gamma function behave at the negative integers? Hint: use the reflection formula in (4.2.16).

(C4.9): Show that $\int_0^\infty \frac{\sin(x^2)}{\sqrt{x}} dx = \frac{\pi}{4\Gamma(\frac{3}{4})\sin(\frac{3\pi}{8})}$ and that $\int_0^\infty \frac{\cos(x^2)}{\sqrt{x}} dx = \frac{\pi}{4\Gamma(\frac{3}{4})\cos(\frac{3\pi}{8})}$. To 'check' these results, the evaluations of the expressions on the right-hand-sides of the equality signs are $\pi/(4*\text{gamma}(3/4)*\sin(3*\pi/8)) = 0.69373\dots$ and $\pi/(4*\text{gamma}(3/4)*\cos(3*\pi/8)) = 1.67481\dots$, respectively, while the integrals themselves evaluate as (using Symbolic Toolbox, after defining x as a symbolic variable) $\text{double}(\text{int}(\sin(x^2)/\text{sqrt}(x),0,\text{inf})) = 0.69373\dots$ and $\text{double}(\text{int}(\cos(x^2)/\text{sqrt}(x),0,\text{inf})) = 1.67481\dots$.

Hint: In (4.3.2) and in (4.3.9) set $b = 1$ and make the substitution $x = y^2$.

Chapter 5

Using Power Series to Evaluate Integrals

5.1 Catalan's Constant

To start this chapter, here's a very simple illustration of the power series technique for the calculation of integrals, in this case giving us what is called *Catalan's constant* (mentioned in the Preface) and written as $G = 0.9159655 \dots$. The power series expansion of $\tan^{-1}(x)$, for $|x| < 1$, is our starting point, and it can be found as follows. The key idea is to write

$$\int_0^x \frac{dy}{1+y^2} = \tan^{-1}(y)|_0^x = \tan^{-1}(x).$$

Then, by long division of the integrand, we have

$$\begin{aligned} \tan^{-1}(x) &= \int_0^x (1 - y^2 + y^4 - y^6 + y^8 - \dots) dy \\ &= \left(y - \frac{y^3}{3} + \frac{y^5}{5} - \frac{y^7}{7} + \frac{y^9}{9} - \dots \right) \Big|_0^x = x - \frac{x^3}{3} + \frac{x^5}{5} - \frac{x^7}{7} + \dots \end{aligned}$$

and so

$$\frac{\tan^{-1}(x)}{x} = 1 - \frac{x^2}{3} + \frac{x^4}{5} - \frac{x^6}{7} + \dots$$

and therefore, integrating term-by-term, we have

$$\int_0^1 \frac{\tan^{-1}(x)}{x} dx = \left[x - \frac{x^3}{3^2} + \frac{x^5}{5^2} - \frac{x^7}{7^2} + \dots \right] \Big|_0^1 = \frac{1}{1^2} - \frac{1}{3^2} + \frac{1}{5^2} - \frac{1}{7^2} + \dots$$

That is,

$$(5.1.1) \quad \boxed{\int_0^1 \frac{\tan^{-1}(x)}{x} dx = G.}$$

We check our calculation with $quad(@x)atan(x)./x,0,1) = 0.9159656\dots$

We can use power series to show that an entirely different integral is also equal to G. Specifically, let's take a look at the following integral (mentioned in the Preface):

$$\int_1^\infty \frac{\ln(x)}{x^2 + 1} dx.$$

We can write the 'bottom-half' of the integrand as

$$\frac{1}{x^2 + 1} = \frac{1}{x^2(1 + \frac{1}{x^2})} = \frac{1}{x^2} \left[1 - \frac{1}{x^2} + \frac{1}{x^4} - \frac{1}{x^6} + \dots \right]$$

where the endless factor in the brackets follows from long division. Thus,

$$\int_1^\infty \frac{\ln(x)}{x^2 + 1} dx = \int_1^\infty \left\{ \frac{\ln(x)}{x^2} - \frac{\ln(x)}{x^4} + \frac{\ln(x)}{x^6} - \dots \right\} dx.$$

We see that all the integrals on the right are of the general form

$$\int_1^\infty \frac{\ln(x)}{x^k} dx, \quad k \text{ an even integer } \geq 2,$$

an integral that is easily done by parts. Letting $u = \ln(x)$ —and so $\frac{du}{dx} = \frac{1}{x}$ which says $du = \frac{dx}{x}$ —and letting $dv = \frac{1}{x^k} dx$ and so $v = \frac{x^{-k+1}}{-k+1} = -\frac{1}{k-1} \left(\frac{1}{x^{k-1}} \right)$, we then have

$$\begin{aligned} \int_1^\infty \frac{\ln(x)}{x^k} dx &= - \left\{ \frac{\ln(x)}{k-1} \left(\frac{1}{x^{k-1}} \right) \right\} \Big|_1^\infty + \frac{1}{k-1} \int_1^\infty \left(\frac{1}{x^{k-1}} \right) \frac{dx}{x} = \frac{1}{k-1} \int_1^\infty \frac{dx}{x^k} \\ &= \frac{1}{k-1} \left\{ \frac{x^{-k+1}}{-k+1} \right\} \Big|_1^\infty = - \left\{ \frac{1}{(k-1)^2 x^{k-1}} \right\} \Big|_1^\infty = \frac{1}{(k-1)^2}. \end{aligned}$$

So,

$$\int_1^\infty \frac{\ln(x)}{x^2 + 1} dx = \frac{1}{(2-1)^2} - \frac{1}{(4-1)^2} + \frac{1}{(6-1)^2} - \dots = \frac{1}{1^2} - \frac{1}{3^2} + \frac{1}{5^2} - \dots$$

or,

(5.1.2)
$$\int_1^\infty \frac{\ln(x)}{x^2 + 1} dx = G.$$

And so it is, as $quad(@x)log(x)/(x.^2+1),1,1e6) = 0.91595196\dots$
 We can combine this result with an earlier one to now calculate

$$\int_0^\infty \frac{\ln(x + 1)}{x^2 + 1} dx,$$

which we can write as

$$\int_0^1 \frac{\ln(x + 1)}{x^2 + 1} dx + \int_1^\infty \frac{\ln(x + 1)}{x^2 + 1} dx.$$

We've already done the first integral on the right, in our result (2.2.4) that found it equal to $\frac{\pi}{8} \ln(2)$, and so we have

$$\begin{aligned} \int_0^\infty \frac{\ln(x + 1)}{x^2 + 1} dx &= \frac{\pi}{8} \ln(2) + \int_1^\infty \frac{\ln(x + 1)}{x^2 + 1} dx = \frac{\pi}{8} \ln(2) + \int_1^\infty \frac{\ln\left\{x\left(1 + \frac{1}{x}\right)\right\}}{x^2 + 1} dx \\ &= \frac{\pi}{8} \ln(2) + \int_1^\infty \frac{\ln(x)}{x^2 + 1} dx + \int_1^\infty \frac{\ln\left(1 + \frac{1}{x}\right)}{x^2 + 1} dx. \end{aligned}$$

The first integral on the right is (5.1.2) and so

$$\int_0^\infty \frac{\ln(x + 1)}{x^2 + 1} dx = \frac{\pi}{8} \ln(2) + G + \int_1^\infty \frac{\ln\left(1 + \frac{1}{x}\right)}{x^2 + 1} dx,$$

and in the remaining integral on right make the change of variable $u = \frac{1}{x}$ (and so $\frac{du}{dx} = -\frac{1}{x^2}$ or, $dx = -x^2 du = -\frac{du}{u^2}$). Thus,

$$\int_1^{\infty} \frac{\ln(1 + \frac{1}{x})}{x^2 + 1} dx = \int_1^0 \frac{\ln(1 + u)}{\frac{1}{u^2} + 1} \left(-\frac{du}{u^2}\right) = \int_0^1 \frac{\ln(1 + u)}{u^2 + 1} du,$$

but this is just (2.2.4) again! So,

$$\int_0^{\infty} \frac{\ln(x + 1)}{x^2 + 1} dx = \frac{\pi}{8} \ln(2) + G + \frac{\pi}{8} \ln(2)$$

or, finally,

(5.1.3)

$$\int_0^{\infty} \frac{\ln(x + 1)}{x^2 + 1} dx = \frac{\pi}{4} \ln(2) + G.$$

This is equal to 1.46036 ... while $\text{quad}(@x)\log(x+1)/(x.^2+1),0,1e6) = 1.46034839\dots$

Returning to the main theme of this chapter, as our last example of the use of power series in this section, consider now the integral

$$I = \int_0^{\pi} \frac{\theta \sin(\theta)}{a + b \cos^2(\theta)} d\theta$$

where $a > b > 0$. Then, expanding the integrand as a power series,

$$\begin{aligned} I &= \frac{1}{a} \int_0^{\pi} \theta \sin(\theta) \left\{ 1 - \left(\frac{b}{a}\right) \cos^2(\theta) + \left(\frac{b}{a}\right)^2 \cos^4(\theta) - \left(\frac{b}{a}\right)^3 \cos^6(\theta) + \dots \right\} d\theta \\ &= \frac{1}{a} \left[\int_0^{\pi} \theta \sin(\theta) d\theta - \left(\frac{b}{a}\right) \int_0^{\pi} \theta \sin(\theta) \cos^2(\theta) d\theta + \left(\frac{b}{a}\right)^2 \int_0^{\pi} \theta \sin(\theta) \cos^4(\theta) d\theta - \dots \right]. \end{aligned}$$

Looking at the general form of the integrals on the right, we see that for $n = 0, 1, 2, \dots$ we have

$$\int_0^{\pi} \theta \sin(\theta) \cos^{2n}(\theta) d\theta.$$

This is easily integrated by parts to give (use $u = \theta$ and $dv = \sin(\theta) \cos^{2n}(\theta) d\theta$)

$$\begin{aligned} \int_0^{\pi} \theta \sin(\theta) \cos^{2n}(\theta) d\theta &= \left\{ -\frac{\theta \cos^{2n+1}(\theta)}{2n+1} \right\} \Big|_0^{\pi} \\ &\quad + \frac{1}{2n+1} \int_0^{\pi} \cos^{2n+1}(\theta) d\theta = \frac{\pi}{2n+1} \end{aligned}$$

because it is clear from symmetry (notice that $2n + 1$ is *odd* for all n) that

$$\int_0^\pi \cos^{2n+1}(\theta) d\theta = 0.$$

So,

$$\begin{aligned} I &= \frac{\pi}{a} \left[1 - \frac{1}{3} \left(\frac{b}{a}\right) + \frac{1}{5} \left(\frac{b}{a}\right)^2 - \frac{1}{7} \left(\frac{b}{a}\right)^3 + \dots \right] \\ &= \frac{\pi \sqrt{a}}{a \sqrt{b}} \left[\frac{\sqrt{b}}{\sqrt{a}} - \frac{1}{3} \left(\frac{b\sqrt{b}}{a\sqrt{a}}\right) + \frac{1}{5} \left(\frac{b^2\sqrt{b}}{a^2\sqrt{a}}\right) - \frac{1}{7} \left(\frac{b^3\sqrt{b}}{a^3\sqrt{a}}\right) + \dots \right] \\ &= \frac{\pi}{\sqrt{ab}} \left[\left(\frac{b}{a}\right)^{1/2} - \frac{1}{3} \left(\frac{b}{a}\right)^{3/2} + \frac{1}{5} \left(\frac{b}{a}\right)^{5/2} - \frac{1}{7} \left(\frac{b}{a}\right)^{7/2} + \dots \right] \end{aligned}$$

or, if you recall the power series expansion for $\tan^{-1}(x)$ from the start of this section and set $x = \left(\frac{b}{a}\right)^{1/2}$, we see that

$$\int_0^\pi \frac{\theta \sin(\theta)}{a + b \cos^2(\theta)} d\theta = \frac{\pi}{\sqrt{ab}} \tan^{-1} \left(\sqrt{\frac{b}{a}} \right), \quad a > b$$

(5.1.4)

For example, if $a = 1$ and $b = 3$ then

$$\int_0^\pi \frac{x \sin(x)}{a + b \cos^2(x)} dx = \frac{\pi}{\sqrt{3}} \tan^{-1}(\sqrt{3}) = 1.899406\dots$$

while `quad(@(x)x.*sin(x)./(1 + 3*cos(x).^2),0,pi) = 1.8994058...`

5.2 Power Series for the Log Function

Using essentially the same approach that we just used to study Catalan’s constant, we can evaluate

$$\int_0^1 \frac{\ln(1+x)}{x} dx.$$

We first get a power series expansion for $\ln(x+1)$, for $|x| < 1$, by writing

$$\begin{aligned}\int_0^x \frac{dy}{1+y} &= \ln(1+y)\Big|_0^x = \ln(1+x) = \int_0^x (1-y+y^2-y^3+\cdots)dy \\ &= \left(y - \frac{y^2}{2} + \frac{y^3}{3} - \frac{y^4}{4} + \cdots\right)\Big|_0^x\end{aligned}$$

or,

$$\ln(1+x) = x - \frac{x^2}{2} + \frac{x^3}{3} - \frac{x^4}{4} + \cdots, \quad |x| < 1.$$

(You may recall that I previously cited this series (without derivation) in a footnote in Chap. 2.)

Thus,

$$\begin{aligned}\int_0^1 \frac{\ln(1+x)}{x} dx &= \int_0^1 \left(1 - \frac{x}{2} + \frac{x^2}{3} - \frac{x^3}{4} + \cdots\right) dx \\ &= \left(x - \frac{x^2}{2^2} + \frac{x^3}{3^2} - \frac{x^4}{4^2} + \cdots\right)\Big|_0^1 = 1 - \frac{1}{2^2} + \frac{1}{3^2} - \frac{1}{4^2} + \cdots.\end{aligned}$$

In 1734 Euler showed that¹

$$\sum_{k=1}^{\infty} \frac{1}{k^2} = 1 + \frac{1}{2^2} + \frac{1}{3^2} + \frac{1}{4^2} + \cdots = \frac{\pi^2}{6},$$

which is the sum of the reciprocals squared of *all* the positive integers. If we write just the sum of the reciprocals squared of all the *even* positive integers we have

$$\sum_{k=1}^{\infty} \frac{1}{(2k)^2} = \frac{1}{4} \sum_{k=1}^{\infty} \frac{1}{k^2} = \frac{\pi^2}{24}.$$

¹I mentioned this sum earlier, in the Introduction (Sect. 1.3). Later in this book, in Chap. 7, I'll show you a beautiful way—using integrals, of course!—to derive this famous and very important result. What I'll show you then is *not* the way Euler did it, but it has the distinct virtue of being perfectly correct while Euler's original approach (while that of a genius—for details, see my book *An Imaginary Tale*, Princeton 2010, pp. 148–9) is open to some serious mathematical concerns.

So, the sum of the reciprocals squared of all the *odd* positive integers must be

$$\frac{\pi^2}{6} - \frac{\pi^2}{24} = \frac{\pi^2}{8}.$$

If you look at the result we got for our integral, you'll see it is the sum of the reciprocals squared of all the odd integers *minus* the sum of the reciprocals squared of all the even integers (that is, $\frac{\pi^2}{8} - \frac{\pi^2}{24} = \frac{\pi^2}{12}$) and so

(5.2.1)
$$\int_0^1 \frac{\ln(1+x)}{x} dx = \frac{\pi^2}{12}.$$

This is equal to 0.822467..., and *quad* agrees: *quad*(@(x)log(1+x).)x,0,1) = 0.822467... It is a trivial modification to show (I'll let *you* do this!—see also Challenge Problem 7) that

(5.2.2)
$$\int_0^1 \frac{\ln(1-x)}{x} dx = -\frac{\pi^2}{6}.$$

This is -1.644934..., and *quad* again agrees: *quad*(@(x)log(1+x).)x,0,1) = -1.64494....

Okay, what can be done with *this* integral:

$$\int_0^1 \frac{1}{x} \ln \left\{ \left(\frac{1+x}{1-x} \right)^2 \right\} dx = ?$$

You, of course, suspect that the answer is: *use power series!* To start, write

$$\int_0^1 \frac{1}{x} \ln \left\{ \left(\frac{1+x}{1-x} \right)^2 \right\} dx = 2 \int_0^1 \frac{1}{x} \{ \ln(1+x) - \ln(1-x) \} dx.$$

Earlier we wrote out the power series expansion for $\ln(1+x)$, and so we can immediately get the expansion for $\ln(1-x)$ by simply replacing x with $-x$. Our integral becomes

$$\begin{aligned} & 2 \int_0^1 \frac{1}{x} \left\{ \left(x - \frac{x^2}{2} + \frac{x^3}{3} - \frac{x^4}{4} + \dots \right) - \left(-x - \frac{x^2}{2} - \frac{x^3}{3} - \frac{x^4}{4} - \dots \right) \right\} dx \\ &= 2 \int_0^1 \frac{1}{x} \left(2x + 2\frac{1}{3}x^3 + 2\frac{1}{5}x^5 + \dots \right) dx = 4 \int_0^1 \left(1 + \frac{1}{3}x^2 + \frac{1}{5}x^4 + \dots \right) dx \\ &= 4 \left(x + \frac{1}{9}x^3 + \frac{1}{25}x^5 + \dots \right) \Big|_0^1 = 4 \left(\frac{1}{1^2} + \frac{1}{3^2} + \frac{1}{5^2} + \dots \right) = 4 \left(\frac{\pi^2}{8} \right) \end{aligned}$$

or, finally,

$$(5.2.3) \quad \int_0^1 \frac{1}{x} \ln \left\{ \left(\frac{1+x}{1-x} \right)^2 \right\} dx = \frac{\pi^2}{2} .$$

This is equal to 4.934802 . . . , and *quad* agrees: *quad*((@)(x)log(((1+x)/(1-x)).^2)./x,0,1) = 4.934815

We can mix trig and log functions using the power series idea to evaluate an integral as nasty-looking as

$$\int_0^{\pi/2} \cot(x) \ln\{\sec(x)\} dx.$$

Let $t = \cos(x)$. Then $\frac{dt}{dx} = -\sin(x)$ or, $dx = -\frac{dt}{\sin(x)}$. So,

$$\begin{aligned} \int_0^{\pi/2} \cot(x) \ln\{\sec(x)\} dx &= \int_0^{\pi/2} \frac{1}{\tan(x)} \ln\left\{\frac{1}{\cos(x)}\right\} dx \\ &= -\int_1^0 \frac{\cos(x)}{\sin(x)} \ln\{\cos(x)\} \left\{-\frac{dt}{\sin(x)}\right\} \\ &= -\int_0^1 \frac{\cos(x)}{\sin^2(x)} \ln\{\cos(x)\} dt = -\int_0^1 \frac{t}{1-t^2} \ln(t) dt. \end{aligned}$$

Over the entire interval of integration we can write

$$\frac{t}{1-t^2} = t\{1 + t^2 + t^4 + t^6 + \dots\}$$

which is easily verified by cross-multiplying. That is,

$$\frac{t}{1-t^2} = t + t^3 + t^5 + t^7 + \dots = \sum_{n=0}^{\infty} t^{2n+1}.$$

Thus, our integral is

$$-\int_0^1 \left\{ \sum_{n=0}^{\infty} t^{2n+1} \right\} \ln(t) dt$$

or, assuming that we can reverse the order of integration and summation,² we have

$$\int_0^{\pi/2} \cot(x) \ln\{\sec(x)\} dx = -\sum_{n=0}^{\infty} \left\{ \int_0^1 t^{2n+1} \ln(t) dt \right\}.$$

We can do this last integral by parts: let $u = \ln(t)$ and $dv = t^{2n+1} dt$. Thus $\frac{du}{dt} = \frac{1}{t}$ or, $du = \frac{1}{t} dt$ and $v = \frac{t^{2n+2}}{2n+2}$. So,

$$\begin{aligned} \int_0^1 t^{2n+1} \ln(t) dt &= \left\{ \frac{t^{2n+2}}{2n+2} \ln(t) \right\} \Big|_0^1 - \int_0^1 \frac{t^{2n+2}}{2n+2} \left(\frac{1}{t} \right) dt = -\frac{1}{2n+2} \int_0^1 t^{2n+1} dt \\ &= -\frac{1}{2n+2} \left\{ \frac{t^{2n+2}}{2n+2} \right\} \Big|_0^1 = -\frac{1}{(2n+2)^2}. \end{aligned}$$

So,

$$\begin{aligned} \int_0^{\pi/2} \cot(x) \ln\{\sec(x)\} dx &= \sum_{n=0}^{\infty} \frac{1}{(2n+2)^2} = \frac{1}{4} \sum_{n=0}^{\infty} \frac{1}{(n+1)^2} \\ &= \frac{1}{4} \sum_{k=1}^{\infty} \frac{1}{k^2} = \frac{1}{4} \left(\frac{\pi^2}{6} \right) \end{aligned}$$

or,

$$(5.2.4) \quad \int_0^{\pi/2} \cot(x) \ln\{\sec(x)\} dx = \frac{\pi^2}{24} .$$

This is 0.4112335 . . . , and *quad* agrees: *quad*(@(x)cot(x).*log(sec(x)),0,pi/2) = 0.411230 . . .

For one more example of a power series integration involving log functions, let's see what we can do with

$$\int_0^1 \ln(1+x) \ln(1-x) dx.$$

If you look at this for just a bit then you should be able to convince yourself that, by symmetry of the integrand around $x = 0$, we can write

²This reversal is an example of a step where a mathematician would feel obligated to first show uniform convergence before continuing. I, on the other hand, with a complete lack of shame, will just plow ahead and *do* the reversal and then, once I have the 'answer,' will ask *quad* what it 'thinks.'

$$\int_0^1 \ln(1+x)\ln(1-x)dx = \frac{1}{2} \int_{-1}^1 \ln(1+x)\ln(1-x)dx.$$

(Or, if you prefer, make the change of variable $u = -x$ and observe that the integral becomes $\int_{-1}^0 \ln(1-u)\ln(1+u)du$. *The integrand is unchanged.* So, $\int_0^1 = \int_{-1}^0$ and thus $\int_{-1}^0 + \int_0^1 = \int_{-1}^1 = 2 \int_0^1$, as claimed.) Now, make the change of variable $y = \frac{x+1}{2}$ (and so $dx = 2dy$). Since $x = 2y - 1$ then $1+x = 2y$ and $1-x = 1 - (2y - 1) = 2-2y$, all of which says

$$\begin{aligned} \int_0^1 \ln(1+x)\ln(1-x)dx &= \frac{1}{2} \int_0^1 \ln(2y)\ln(2-2y)2dy = \int_0^1 \ln(2y)\ln\{2(1-y)\}dy \\ &= \int_0^1 [\ln(2) + \ln(y)][\ln(2) + \ln(1-y)]dy \\ &= \int_0^1 [\{\ln(2)\}^2 + \ln(2)\{\ln(y) + \ln(1-y)\} + \ln(y)\ln(1-y)]dy \\ &= \{\ln(2)\}^2 + \ln(2) \left\{ \int_0^1 \ln(y)dy + \int_0^1 \ln(1-y)dy \right\} + \int_0^1 \ln(y)\ln(1-y)dy. \end{aligned}$$

Since

$$\int_0^1 \ln(y)dy = \int_0^1 \ln(1-y)dy,$$

either ‘by inspection’ or by making the change of variable $u = 1 - y$ in one of the integrals, we have (changing the dummy variable of integration back to x)

$$\int_0^1 \ln(1+x)\ln(1-x)dx = \{\ln(2)\}^2 + 2\ln(2) \int_0^1 \ln(x)dx + \int_0^1 \ln(x)\ln(1-x)dx.$$

Since

$$\int_0^1 \ln(x)dx = \{x\ln(x) - x\} \Big|_0^1 = -1,$$

we have

$$\int_0^1 \ln(1+x)\ln(1-x)dx = \{\ln(2)\}^2 - 2\ln(2) + \int_0^1 \ln(x)\ln(1-x)dx$$

and so all we have left to do is the integral on the right. To do

$$\int_0^1 \ln(x)\ln(1-x)dx$$

we'll use the power series expansion of $\ln(1-x)$. As shown earlier,

$$\ln(1-x) = -x - \frac{x^2}{2} - \frac{x^3}{3} - \frac{x^4}{4} - \dots, |x| < 1,$$

and so we have

$$\int_0^1 \ln(x)\ln(1-x)dx = -\sum_{k=1}^{\infty} \frac{1}{k} \int_0^1 x^k \ln(x)dx.$$

If you look back at our analysis that resulted in (5.2.4), you'll see that we've already done the integral on the right. There we showed that

$$\int_0^1 t^{2n+1} \ln(t)dt = -\frac{1}{(2n+2)^2}$$

and so we immediately have (replacing $2n+1$ with k) the result

$$\int_0^1 x^k \ln(x)dx = -\frac{1}{(k+1)^2}.$$

Thus,

$$\begin{aligned} \int_0^1 \ln(x)\ln(1-x)dx &= \sum_{k=1}^{\infty} \frac{1}{k(k+1)^2} = \sum_{k=1}^{\infty} \left\{ \frac{1}{k(k+1)} - \frac{1}{(k+1)^2} \right\} \\ &= \sum_{k=1}^{\infty} \left[\left\{ \left(\frac{1}{k} \right) - \left(\frac{1}{k+1} \right) \right\} - \frac{1}{(k+1)^2} \right] \\ &= \left(1 + \frac{1}{2} + \frac{1}{3} + \frac{1}{4} + \dots \right) - \left(\frac{1}{2} + \frac{1}{3} + \frac{1}{4} + \dots \right) - \sum_{k=1}^{\infty} \frac{1}{(k+1)^2} \\ &= 1 - \left(\frac{1}{2^2} + \frac{1}{3^2} + \frac{1}{4^2} + \dots \right) = 1 - \left(\frac{\pi^2}{6} - 1 \right) = 2 - \frac{\pi^2}{6}. \end{aligned}$$

So, finally,

$$\int_0^1 \ln(1+x)\ln(1-x)dx = \{\ln(2)\}^2 - 2\ln(2) + 2 - \frac{\pi^2}{6}.$$

(5.2.5)

This is equal to $-0.550775\dots$, and in agreement is $quad(@(x)log(1+x).*log(1-x),0,1) = -0.55078\dots$

I'll end this section with the calculation of

$$\int_0^1 \frac{\{\ln(x)\}^2}{1+x^2} dx,$$

an integral that will find an important use later in the book. The trick here is to make the change of variable $x = e^{-y}$, which is equivalent to $y = -\ln(x)$. Thus, $dy = -\frac{1}{x} dx$ and so $dx = -x dy = -e^{-y} dy$. So,

$$\begin{aligned} \int_0^1 \frac{\{\ln(x)\}^2}{1+x^2} dx &= \int_{\infty}^0 \frac{y^2}{1+e^{-2y}} \{-e^{-y} dy\} = \int_0^{\infty} y^2 (1 - e^{-2y} + e^{-4y} - e^{-6y} + \dots) e^{-y} dy \\ &= \int_0^{\infty} y^2 (e^{-y} - e^{-3y} + e^{-5y} - e^{-7y} + \dots) dy. \end{aligned}$$

From standard integration tables (or integration by parts)

$$\int_0^{\infty} y^2 e^{ay} dy = \frac{e^{ay}}{a} \left(y^2 - \frac{2y}{a} + \frac{2}{a^2} \right) \Big|_0^{\infty} = -\frac{2}{a^3} > 0$$

because $a < 0$ in every term in our above infinite series integrand. Thus,

$$\int_0^1 \frac{\{\ln(x)\}^2}{1+x^2} dx = 2 \left[\frac{1}{1^3} - \frac{1}{3^3} + \frac{1}{5^3} - \frac{1}{7^3} + \dots \right],$$

but it is known³ that the alternating series is equal to $\frac{\pi^3}{32}$. So,

(5.2.6)

$$\int_0^1 \frac{\{\ln(x)\}^2}{1+x^2} dx = \frac{\pi^3}{16}.$$

This value is $1.9378922\dots$ and, using *quad* to check: $quad(@(x)log(x).^2./(1+x.^2),0,1) = 1.9379\dots$

There are two additional comments we can make about this integral. First,

$$\int_0^{\infty} \frac{\{\ln(x)\}^2}{1+x^2} dx = 2 \int_0^1 \frac{\{\ln(x)\}^2}{1+x^2} dx = \frac{\pi^3}{8}.$$

³ See my *Dr. Euler's Fabulous Formula*, Princeton 2011, p. 149 for the derivation of this result using Fourier series.

I'll let you fill-in the details (simply notice that $\int_0^\infty = \int_0^1 + \int_1^\infty$ and then make the change of variable $y = \frac{1}{x}$ in the \int_1^∞ integral). And second, look at what we get when we consider the *seemingly* unrelated integral

$$\int_0^{\pi/2} [\ln\{\tan(\theta)\}]^2 d\theta$$

if we make the change of variable $x = \tan(\theta)$. Because

$$\frac{dx}{d\theta} = \frac{\cos^2(\theta) + \sin^2(\theta)}{\cos^2(\theta)} = 1 + \tan^2(\theta)$$

we have

$$d\theta = \frac{1}{1 + \tan^2(\theta)} dx = \frac{1}{1 + x^2} dx$$

and so

$$\int_0^{\pi/2} [\ln\{\tan(\theta)\}]^2 d\theta = \int_0^\infty \frac{\{\ln(x)\}^2}{1 + x^2} dx.$$

Thus,

(5.2.7)

$$\int_0^{\pi/2} [\ln\{\tan(\theta)\}]^2 d\theta = \frac{\pi^3}{8} .$$

This is 3.8757845... , and *quad* confirms it: *quad*(@(x)log(tan(x)).^2,0,pi/2) = 3.8758... . We'll use this result in Chap. 7, when we finally calculate Euler's sum of the reciprocal integers squared.

5.3 Zeta Function Integrals

In the previous section I mentioned Euler's discovery of

$$\sum_{k=1}^\infty \frac{1}{k^2} = \frac{\pi^2}{6} .$$

This is actually a special case of what is called the *Riemann zeta function*:

$$\zeta(s) = \sum_{k=1}^\infty \frac{1}{k^s},$$

where s is a complex number with a real part greater than 1 to insure that the sum converges.⁴ Euler's sum is for $s=2$ but, in fact, his method for finding $\zeta(2)$ —spoken as *zeta-two*—works for *all* positive, *even* integer values of s ; $\zeta(4) = \frac{\pi^4}{90}$, $\zeta(6) = \frac{\pi^6}{945}$, $\zeta(8) = \frac{\pi^8}{9,450}$, and $\zeta(10) = \frac{1,280\pi^{10}}{119,750,400}$. In general, $\zeta(s) = \frac{m}{n}\pi^s$, where m and n are integers, *if* s is an even positive integer. Euler's method fails for all positive *odd* integer values of s , however, and nobody has succeeded in the nearly 300 years since Euler's discovery of $\zeta(2)$ in finding a formula that gives $\zeta(s)$ for even a single *odd* value of s .

Mathematicians can, of course, calculate the *numerical* value of $\zeta(s)$, for any s , as accurately as desired. For example, $\zeta(3) = 1.20205\dots$, and the values of those dots are now known out to *at least* a hundred *billion* (!) decimal places. But it is a *formula* that mathematicians want, and the discovery of one for $\zeta(3)$ would be an event of supernova-magnitude in the world of mathematics.

Ironically, it is easy to write $\zeta(s)$, for *any* integer value of s , even or odd, as a double integral. To see this, write the power series expansion of $\frac{x^a y^a}{1-xy}$, where a is (for now) a constant:

$$\frac{x^a y^a}{1-xy} = x^a y^a \left\{ 1 + xy + (xy)^2 + (xy)^3 + (xy)^4 + (xy)^5 + \dots \right\}, |xy| < 1.$$

Then, using this as the integrand of a double integral, we have

$$\begin{aligned} \int_0^1 \int_0^1 \frac{x^a y^a}{1-xy} dx dy &= \int_0^1 x^a \left\{ \int_0^1 \left\{ y^a + xy^{a+1} + x^2 y^{a+2} + x^3 y^{a+3} + \dots \right\} dy \right\} dx \\ &= \int_0^1 x^a \left\{ \frac{y^{a+1}}{a+1} + x \frac{y^{a+2}}{a+2} + x^2 \frac{y^{a+3}}{a+3} + x^3 \frac{y^{a+4}}{a+4} + \dots \right\} \Big|_0^1 dx \\ &= \int_0^1 \left\{ \frac{x^a}{a+1} + \frac{x^{a+1}}{a+2} + \frac{x^{a+2}}{a+3} + \frac{x^{a+3}}{a+4} + \dots \right\} dx \\ &= \left\{ \frac{x^{a+1}}{(a+1)^2} + \frac{x^{a+2}}{(a+2)^2} + \frac{x^{a+3}}{(a+3)^2} + \frac{x^{a+4}}{(a+4)^2} + \dots \right\} \Big|_0^1 \\ &= \frac{1}{(a+1)^2} + \frac{1}{(a+2)^2} + \frac{1}{(a+3)^2} + \dots \end{aligned}$$

and so

⁴For $s=1$, $\zeta(1)$ is just the harmonic series, which has been known for *centuries* before Euler's day to diverge.

$$(5.3.1) \quad \int_0^1 \int_0^1 \frac{x^a y^a}{1 - xy} \, dx \, dy = \sum_{n=1}^{\infty} \frac{1}{(n + a)^2} .$$

Now, if we set $a = 0$ then (5.3.1) obviously reduces to

$$\int_0^1 \int_0^1 \frac{1}{1 - xy} \, dx \, dy = \sum_{n=1}^{\infty} \frac{1}{n^2} = \zeta(2),$$

but we can actually do *much* more with (5.3.1) than just $\zeta(2)$. Here's how. Remembering Feynman's favorite trick of differentiating under the integral sign, let's differentiate (5.3.1) with respect to a (which started off as a constant but which we'll now treat as a parameter). Then, on the right-hand side we get

$$-2 \sum_{n=1}^{\infty} \frac{1}{(n + a)^3} .$$

On the left-hand side we first write

$$x^a y^a = (xy)^a = e^{\ln\{(xy)^a\}} = e^{a \ln(xy)}$$

and so differentiation of the integral gives

$$\frac{d}{da} \int_0^1 \int_0^1 \frac{x^a y^a}{1 - xy} \, dx \, dy = \int_0^1 \int_0^1 \frac{\ln(xy) e^{a \ln(xy)}}{1 - xy} \, dx \, dy .$$

Thus,

$$\int_0^1 \int_0^1 \frac{\ln(xy) e^{a \ln(xy)}}{1 - xy} \, dx \, dy = -2 \sum_{n=1}^{\infty} \frac{1}{(n + a)^3} .$$

Now, differentiate again, and get

$$\int_0^1 \int_0^1 \frac{\{\ln(xy)\}^2 e^{a \ln(xy)}}{1 - xy} \, dx \, dy = (-2)(-3) \sum_{n=1}^{\infty} \frac{1}{(n + a)^4} .$$

Indeed, if we differentiate over and over you should be able to see the pattern:

$$\int_0^1 \int_0^1 \frac{\{\ln(xy)\}^{s-2} e^{a \ln(xy)}}{1 - xy} \, dx \, dy = (-2)(-3) \dots (-\{s - 1\}) \sum_{n=1}^{\infty} \frac{1}{(n + a)^s} .$$

So, returning $e^{a \ln(xy)}$ back to $(xy)^a$ we have, for $s \geq 2$,

$$\int_0^1 \int_0^1 \frac{(xy)^a \{\ln(xy)\}^{s-2}}{1-xy} dx dy = (-1)^s (s-1)! \sum_{n=1}^{\infty} \frac{1}{(n+a)^s} .$$

(5.3.2)

Or, for the particularly interesting case of $a = 0$,

$$\zeta(s) = \frac{(-1)^s}{(s-1)!} \int_0^1 \int_0^1 \frac{\{\ln(xy)\}^{s-2}}{1-xy} dx dy .$$

(5.3.3)

For $s=5$, for example, it is easy to calculate $\zeta(5)$ directly from the sum-definition of the zeta function to get 1.0369277... , while the right-hand-side of (5.3.3) is found with the following MATLAB Symbolic Toolbox code (*factor* = $-\frac{1}{24}$ is $\frac{(-1)^5}{(4)!}$) to be 1.0369277... .

```
syms x y
factor = -1/24;
int(int(log(x*y)^3/(1-x*y),x,0,1),y,0,1)*factor
```

To end this section, I'll now show you a beautiful result that connects the gamma function from Chap. 4 with the zeta function. You'll recall from (4.1.1) that

$$\Gamma(s) = \int_0^{\infty} e^{-x} x^{s-1} dx .$$

So, starting with the integral

$$\int_0^{\infty} e^{-kx} x^{s-1} dx, k > 0,$$

make the change of variable $u = kx$ which gives

$$\int_0^{\infty} e^{-kx} x^{s-1} dx = \int_0^{\infty} e^{-u} \left(\frac{u}{k}\right)^{s-1} \frac{du}{k} = \frac{1}{k^s} \int_0^{\infty} e^{-u} u^{s-1} du = \frac{\Gamma(s)}{k^s} .$$

Then, summing over both sides, we have

$$\sum_{k=1}^{\infty} \int_0^{\infty} e^{-kx} x^{s-1} dx = \sum_{k=1}^{\infty} \frac{\Gamma(s)}{k^s} = \Gamma(s) \sum_{k=1}^{\infty} \frac{1}{k^s} = \Gamma(s) \zeta(s) .$$

Next, assuming that we can interchange the order of summation and integration, we have

$$\Gamma(s)\zeta(s) = \int_0^\infty x^{s-1} \sum_{k=1}^\infty e^{-kx} dx.$$

The summation in the integrand is a geometric series, easily calculated to be

$$\sum_{k=1}^\infty e^{-kx} = \frac{1}{e^x - 1},$$

and so we immediately have the amazing

(5.3.4)
$$\int_0^\infty \frac{x^{s-1}}{e^x - 1} dx = \Gamma(s)\zeta(s)$$

that was discovered in 1859 by non-other than Riemann, himself, the hero of this book. For $s = 4$, for example, (5.3.4) says that—recalling Euler’s result $\zeta(4) = \frac{\pi^4}{90}$ —

$$\int_0^\infty \frac{x^3}{e^x - 1} dx = \Gamma(4)\zeta(4) = (3!) \left(\frac{\pi^4}{90}\right) = \frac{\pi^4}{15}$$

and you’ll recall both this integral and its value from the Preface (see note 6 there). This theoretical value is 6.493939... and MATLAB agrees, as `quad(@(x)(x.^3)./(exp(x)-1),0,100) = 6.493939...`

With a little preliminary work we can use the same approach to do an interesting variant of (5.3.4), namely

$$\int_0^\infty \frac{x^{s-1}}{e^x + 1} dx.$$

To set things up, define the two functions

$$u_s = \frac{1}{1^s} + \frac{1}{3^s} + \frac{1}{5^s} + \frac{1}{7^s} + \dots$$

and

$$v_s = \frac{1}{1^s} - \frac{1}{2^s} + \frac{1}{3^s} - \frac{1}{4^s} + \dots$$

and so

$$\zeta(s) = u_s + \frac{1}{2^s} + \frac{1}{4^s} + \frac{1}{6^s} + \dots = u_s + \frac{1}{2^s} \left[\frac{1}{1^s} + \frac{1}{2^s} + \frac{1}{3^s} + \dots \right] = u_s + \frac{1}{2^s} \zeta(s).$$

Thus,

$$(5.3.5) \quad u_s = \zeta(s) \left[1 - \frac{1}{2^s} \right].$$

Also,

$$\begin{aligned} v_s &= \left[\frac{1}{1^s} + \frac{1}{3^s} + \frac{1}{5^s} + \cdots \right] - \left[\frac{1}{2^s} + \frac{1}{4^s} + \cdots \right] \\ &= u_s - \frac{1}{2^s} \left[\frac{1}{1^s} + \frac{1}{2^s} + \frac{1}{3^s} + \cdots \right] = u_s - \frac{1}{2^s} \zeta(s). \end{aligned}$$

So, using (5.3.5),

$$v_s = \zeta(s) \left[1 - \frac{1}{2^s} \right] - \frac{1}{2^s} \zeta(s) = \zeta(s) \left[1 - \frac{2}{2^s} \right].$$

Thus,

$$(5.3.6) \quad v_s = \zeta(s) [1 - 2^{1-s}].$$

But, noticing that

$$v_s = \sum_{k=1}^{\infty} \frac{(-1)^{k-1}}{k^s},$$

we have

$$(5.3.7) \quad \sum_{k=1}^{\infty} \frac{(-1)^{k-1}}{k^s} = \zeta(s) [1 - 2^{1-s}].$$

Now we can do our integral! We start with

$$\int_0^{\infty} (-1)^{k-1} e^{-kx} x^{s-1} dx,$$

again make the change of variable $u = kx$, and then repeat what we did for (5.3.4). Everything will go through as before, except that you'll get one sum that will yield to (5.3.7), and another that will be $\sum_{k=1}^{\infty} (-1)^{k-1} e^{-kx}$ instead of $\sum_{k=1}^{\infty} e^{-kx}$. That will still give a geometric series, one still easy to do, with a sum of

$$\frac{e^{-x}}{1 + e^{-x}} = \frac{1}{e^x + 1}.$$

The end-result is

$$\int_0^\infty \frac{x^{s-1}}{e^x + 1} dx = [1 - 2^{1-s}] \Gamma(s) \zeta(s), s > 1.$$

(5.3.8)

For $s = 4$, for example, this says

$$\int_0^\infty \frac{x^3}{e^x + 1} dx = [1 - 2^{-3}] \Gamma(4) \zeta(4) = \left(\frac{7}{8}\right) \frac{\pi^4}{15} = 5.68219\dots$$

and MATLAB agrees, as `quad(@(x)(x.^3)/(exp(x)+1),0,100) = 5.68219...`

By the way, notice that for $s = 1$ (5.3.8) gives an *indeterminate* value for the integral;

$$\int_0^\infty \frac{1}{e^x + 1} dx = [1 - 2^{1-1}] \Gamma(1) \zeta(1) = (0)(1)(\infty) = ?$$

because $\zeta(1)$ is the divergent harmonic series. This, despite the fact that the integral clearly exists since the integrand is always finite and goes to zero *very quickly* as x goes to infinity. This indeterminacy is, of course, precisely why the restriction $s > 1$ is there. So, what *is* the value of the integral for $s = 1$? We've already answered this, back in our result (2.1.4), where we showed that

$$\int_0^\infty \frac{1}{e^{ax} + 1} dx = \frac{\ln(2)}{a}.$$

For $s = 1$ in (5.3.8) we set $a = 1$ in (2.1.4) and our integral is equal to $\ln(2)$.

5.4 Euler's Constant and Related Integrals

Since the 13th century it has been known that the harmonic series diverges. That is,

$$\lim_{n \rightarrow \infty} \sum_{k=1}^n \frac{1}{k} = \lim_{n \rightarrow \infty} H(n) = \infty.$$

The divergence is quite slow, growing only as the logarithm of n , and so it seems quite reasonable to suspect that the *difference* between $H(n)$ and $\log(n) = \ln(n)$ might *not* diverge. In fact, this difference, in the limit, is famous in mathematics

as *Euler's constant* (or simply as *gamma*, written as γ).⁵ That is, $\gamma = \lim_{n \rightarrow \infty} \gamma(n)$ where

$$\gamma(n) = \sum_{k=1}^n \frac{1}{k} - \ln(n).$$

It is not, I think, at all obvious that this expression does approach a limit as $n \rightarrow \infty$ but, using the area interpretation of the Riemann integral, it is easy to establish both that the limit exists and that it is somewhere in the interval 0 to 1. Here's how to do that.

Since

$$\gamma(n) = 1 + \frac{1}{2} + \frac{1}{3} + \cdots + \frac{1}{n} - \ln(n)$$

then

$$\begin{aligned} \gamma(n+1) - \gamma(n) &= \left\{ 1 + \frac{1}{2} + \frac{1}{3} + \cdots + \frac{1}{n} + \frac{1}{n+1} - \ln(n+1) \right\} \\ &\quad - \left\{ 1 + \frac{1}{2} + \frac{1}{3} + \cdots + \frac{1}{n} - \ln(n) \right\} \\ &= \frac{1}{n+1} + \ln(n) - \ln(n+1) = \frac{1}{n+1} + \ln\left(\frac{n}{n+1}\right) \end{aligned}$$

or,

$$\gamma(n+1) - \gamma(n) = \frac{1}{n+1} + \ln\left(1 - \frac{1}{n+1}\right).$$

Clearly, $\ln\left(1 - \frac{1}{n+1}\right) < 0$ as it is the logarithm of a number less than 1. But we can actually say much more than just that.

Recalling the power series for $\ln(1+x)$ that we established at the beginning of Sect. 5.2, setting $x = -\frac{1}{n+1}$ gives us

⁵ A technically sophisticated yet quite readable treatment of 'all about γ ,' at the level of this book, is Julian Havil's *Gamma*, Princeton University Press 2003. The constant is also sometimes called the *Euler-Mascheroni constant*, to give some recognition to the Italian mathematician Lorenzo Mascheroni (1750-1800) who, in 1790, calculated γ to 32 decimal places (but, alas, not without error). As I write, γ has been machine-calculated to literally *billions* of decimal places, with the first few digits being 0.5772156649 Unlike π or e which are known to be irrational (transcendental, in fact), the rationality (or not) of γ is unknown. There isn't a mathematician on the planet who doesn't believe γ is irrational, but there is no known *proof* of that belief.

$$\ln\left(1 - \frac{1}{n+1}\right) = -\frac{1}{n+1} - \frac{1}{2(n+1)^2} - \frac{1}{3(n+1)^3} - \dots$$

This says that $\ln\left(1 - \frac{1}{n+1}\right)$ is *more negative* than $-\frac{1}{n+1}$ and so

$$\gamma(n+1) - \gamma(n) < 0.$$

That is, $\gamma(n)$ steadily *decreases* as n *increases* and, in fact, since $\gamma(1) = 1 - \ln(1) = 1$, we have established that $\gamma(n)$ steadily decreases from 1 as n increases.

Next, observe that

$$\int_1^n \frac{dt}{t} = \ln(t)|_1^n = \ln(n) = \int_1^2 \frac{dt}{t} + \int_2^3 \frac{dt}{t} + \dots + \int_{n-1}^n \frac{dt}{t}.$$

Now,

$$\int_j^{j+1} \frac{dt}{t} < \frac{1}{j}$$

because $\frac{1}{t}$ steadily decreases over the integration interval and, taking the integrand as a constant equal to its *greatest* value in that interval, *overestimates* the integral. Thus,

$$\ln(n) < 1 + \frac{1}{2} + \frac{1}{3} + \dots + \frac{1}{n-1}$$

and so

$$0 < 1 + \frac{1}{2} + \frac{1}{3} + \dots + \frac{1}{n-1} - \ln(n).$$

Adding $\frac{1}{n}$ to both sides of this inequality,

$$\frac{1}{n} < 1 + \frac{1}{2} + \frac{1}{3} + \dots + \frac{1}{n-1} + \frac{1}{n} - \ln(n) = \gamma(n)$$

which, combined with our first result, says

$$0 < \frac{1}{n} < \gamma(n) \leq 1.$$

So, what we have shown is that $\gamma(n)$ is (for all $n \geq 1$) in the interval 0 to 1 and that, as n increases, $\gamma(n)$ steadily decreases from 1 *without ever reaching* 0. Thus, $\gamma(n)$ must approach a limiting value as $n \rightarrow \infty$. But what *is* that limiting value?

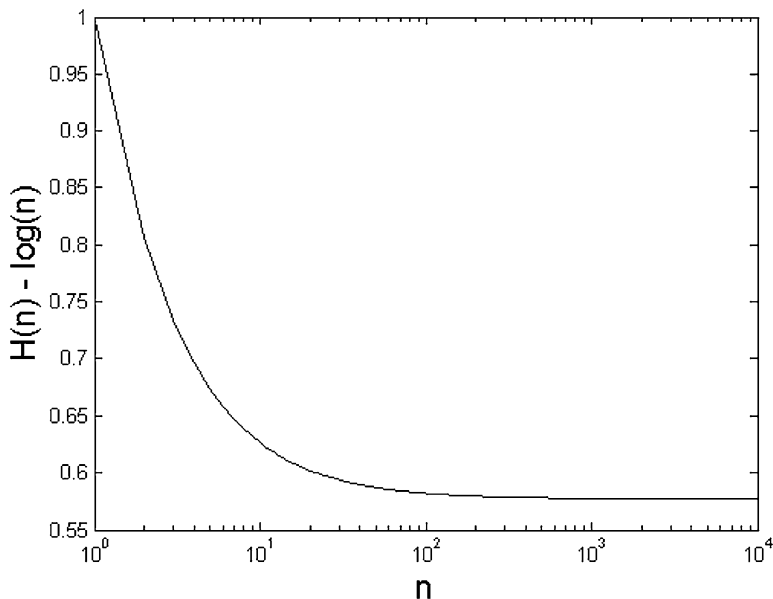

Fig. 5.4.1 Euler's constant as a limit

Figure 5.4.1 shows a semi-log plot of $\gamma(n) = H(n) - \ln(n)$ as n varies over the interval $1 \leq n \leq 10,000$, and γ does appear to both exist (with an approximate value of 0.57) and to be approached fairly quickly. Such a plot is, of course, not a *proof* that γ exists (we've already established that), but it is fully in the spirit of this book. By adding γ to our catalog of constants, joining such workhorses as e , π , $\ln(2)$, and G , we can now 'do' some new, very interesting integrals.

I'll start by showing you how to write $H(n)$ as an integral, and then we'll manipulate this integral into a form that will express γ as an integral, too. In the integral

$$\int_0^1 \frac{1 - (1-x)^n}{x} dx$$

change variable to $u = 1 - x$ (and so $dx = -du$) to get

$$\begin{aligned}
\int_0^1 \frac{1 - (1-x)^n}{x} dx &= \int_1^0 \frac{1 - u^n}{1-u} (-du) = \int_0^1 \frac{(1-u)(1+u+u^2+u^3+\cdots+u^{n-1})}{1-u} du \\
&= \int_0^1 \{1+u+u^2+u^3+\cdots+u^{n-1}\} du \\
&= \left\{ u + \frac{1}{2} u^2 + \frac{1}{3} u^3 + \frac{1}{4} u^4 + \cdots + \frac{1}{n} u^n \right\} \Big|_0^1 \\
&= 1 + \frac{1}{2} + \frac{1}{3} + \frac{1}{4} + \cdots + \frac{1}{n} = H(n).
\end{aligned}$$

Next, change variable in our original integral (an integral we now know is $H(n)$) to $u = nx$ (and so $dx = \frac{1}{n} du$) and write

$$\begin{aligned}
H(n) &= \int_0^n \frac{1 - \left(1 - \frac{u}{n}\right)^n}{\frac{u}{n}} \left(\frac{1}{n} du\right) = \int_0^n \frac{1 - \left(1 - \frac{u}{n}\right)^n}{u} du \\
&= \int_0^1 \frac{1 - \left(1 - \frac{u}{n}\right)^n}{u} du + \int_1^n \frac{1 - \left(1 - \frac{u}{n}\right)^n}{u} du \\
&= \int_0^1 \frac{1 - \left(1 - \frac{u}{n}\right)^n}{u} du + \int_1^n \frac{du}{u} - \int_1^n \frac{\left(1 - \frac{u}{n}\right)^n}{u} du \\
&= \int_0^1 \frac{1 - \left(1 - \frac{u}{n}\right)^n}{u} du + \ln(n) - \int_1^n \frac{\left(1 - \frac{u}{n}\right)^n}{u} du.
\end{aligned}$$

We thus have

$$\gamma(n) = H(n) - \ln(n) = \int_0^1 \frac{1 - \left(1 - \frac{u}{n}\right)^n}{u} du - \int_1^n \frac{\left(1 - \frac{u}{n}\right)^n}{u} du.$$

Letting $n \rightarrow \infty$, and recalling the definition of e^u as

$$e^u = \lim_{n \rightarrow \infty} \left(1 + \frac{u}{n}\right)^n,$$

we arrive at

(5.4.1)

$$\gamma = \lim_{n \rightarrow \infty} \gamma(n) = \int_0^1 \frac{1 - e^{-u}}{u} du - \int_1^\infty \frac{e^{-u}}{u} du .$$

The curious expression in (5.4.1) for γ is *extremely* important—which is why I've put it in a box—and I'll show you some applications of it in the calculations that follow. Checking it with *quad*, *quad*(@(x)(1-exp(-x))./x,0,1)-*quad*(@(x)exp(-x)./x,1,10) = 0.577219. . . .

To start, consider the integral

$$\int_0^{\infty} e^{-x} \ln(x) dx$$

which we can write as

$$(5.4.2) \quad \int_0^{\infty} e^{-x} \ln(x) dx = \int_0^1 e^{-x} \ln(x) dx + \int_1^{\infty} e^{-x} \ln(x) dx.$$

Alert! Pay *careful* attention at our next step, where we'll observe that

$$e^{-x} = -\frac{d}{dx}(e^{-x} - 1).$$

This is of course true, but *why* (you are surely wondering) are we bothering to write the simple expression on the left in the more complicated form on the right? The answer is that we are going to do the first integral on the right in (5.4.2) by parts and, without this trick in notation, things will not go well (when we get done, you should try to do it all over again without this notational trick).

So, continuing, we have for the first integral on the right

$$-\int_0^1 \frac{d}{dx}(e^{-x} - 1) \ln(x) dx$$

which becomes, with

$$u = \ln(x)$$

and

$$dv = \frac{d}{dx}(e^{-x} - 1) dx$$

(and so $du = \frac{1}{x} dx$ and $v = e^{-x} - 1$),

$$\begin{aligned} \int_0^1 e^{-x} \ln(x) dx &= -\int_0^1 \frac{d}{dx}(e^{-x} - 1) \ln(x) dx \\ &= -\left(\{\ln(x)[e^{-x} - 1]\}_0^1 - \int_0^1 \frac{e^{-x} - 1}{x} dx \right) = -\int_0^1 \frac{1 - e^{-x}}{x} dx. \end{aligned}$$

For the second integral on the right in (5.4.2) we also integrate by parts, now with $u = \ln(x)$ and $dv = e^{-x}$, and so

$$\int_1^\infty e^{-x} \ln(x) dx = \{-e^{-x} \ln(x)\} \Big|_1^\infty + \int_1^\infty e^{-x} \frac{1}{x} dx = \int_1^\infty e^{-x} \frac{1}{x} dx.$$

So,

$$\int_0^\infty e^{-x} \ln(x) dx = - \int_0^1 \frac{1 - e^{-x}}{x} dx + \int_1^\infty e^{-x} \frac{1}{x} dx.$$

By (5.4.1) the right-hand-side is $-\gamma$ (remember, I *told* you (5.4.1) would be important!) and so we see that

(5.4.3) $\int_0^\infty e^{-x} \ln(x) dx = -\gamma.$

Checking this with MATLAB, `quad(@(x)exp(-x).*log(x),0,10) = -0.57733...`

Sometimes, particularly when reading an advanced math book, you'll run across a comment that says (5.4.3) can be established by differentiating the integral definition of the gamma function $\Gamma(z)$ and then setting $z = 1$. If you write

$$x^{z-1} = e^{\ln(x^{z-1})} = e^{(z-1)\ln(x)} = e^{z\ln(x)} e^{-\ln(x)}$$

it isn't difficult to differentiate

$$\Gamma(z) = \int_0^\infty e^{-x} x^{z-1} dx$$

to get

$$\frac{d\Gamma(z)}{dz} = \Gamma'(z) = \int_0^\infty e^{-x} \ln(x) x^{z-1} dx$$

and so

$$\Gamma'(1) = \int_0^\infty e^{-x} \ln(x) dx.$$

But what tells us that $\Gamma'(1) = -\gamma$?????

The authors of such books are assuming their readers are familiar with what mathematicians call the *digamma function*, which is⁶

$$\frac{\Gamma'(z)}{\Gamma(z)} = -\frac{1}{z} - \gamma + \sum_{r=1}^{\infty} \left(\frac{1}{r} - \frac{1}{r+z} \right).$$

Setting $z = 1$ gives (because $\Gamma(1) = 0! = 1$)

$$\begin{aligned} \Gamma'(1) &= -1 - \gamma + \sum_{r=1}^{\infty} \left(\frac{1}{r} - \frac{1}{r+1} \right) \\ &= -1 - \gamma + \left\{ \left(1 - \frac{1}{2} \right) + \left(\frac{1}{2} - \frac{1}{3} \right) + \cdots \right\} \end{aligned}$$

or,

$$\Gamma'(1) = -\gamma$$

as claimed and we get (5.4.3).

Okay, let's next consider the interesting integral

$$\int_0^1 \ln\{-\ln(x)\} \, dx.$$

Make the obvious change of variable $u = -\ln(x)$ and fill-in the routine integration by parts details to arrive at

$$\int_0^1 \ln\{-\ln(x)\} \, dx = \int_0^{\infty} e^{-u} \ln(u) \, du$$

which is (5.4.3). Thus,

(5.4.4)

$$\int_0^1 \ln\{-\ln(x)\} \, dx = -\gamma.$$

⁶I won't pursue the derivation of $\frac{\Gamma'(z)}{\Gamma(z)}$, but if you're interested you can find a nice presentation in Havil's book (see note 5, pp. 55–58). We'll use the digamma function in the final calculation of this chapter, the derivation of (5.4.11). See also Challenge Problem 5.10.

Checking with MATLAB, $quad(@(x)log(-log(x)),0,1) = -0.57721\dots$

Another dramatic illustration of the power of (5.4.1) comes from the early 20th century mathematician Ramanujan (who will be discussed in more length in Chap. 9), who evaluated the exponentially-stuffed integral

$$I = \int_0^\infty \{e^{-\alpha e^x} + e^{-\alpha e^{-x}} - 1\} dx$$

for α any positive constant. Observing that the integrand is an even function, he started by doubling the integration interval and writing

$$2I = \int_{-\infty}^\infty \{e^{-\alpha e^x} + e^{-\alpha e^{-x}} - 1\} dx$$

and then changing variable to $u = e^x$ (and so $dx = \frac{du}{u}$). Thus,

$$2I = \int_0^\infty \frac{e^{-\alpha u} + e^{-\frac{\alpha}{u}} - 1}{u} du.$$

Next, he broke this integral into a sum of two integrals:

$$2I = \int_0^{\frac{1}{\alpha}} \frac{e^{-\alpha u} + e^{-\frac{\alpha}{u}} - 1}{u} du + \int_{\frac{1}{\alpha}}^\infty \frac{e^{-\alpha u} + e^{-\frac{\alpha}{u}} - 1}{u} du.$$

He then broke *each* of these two integrals into two more:

$$\begin{aligned} 2I &= \int_0^{\frac{1}{\alpha}} \frac{e^{-\alpha u} - 1}{u} du + \int_0^{\frac{1}{\alpha}} e^{-\frac{\alpha}{u}} du + \int_{\frac{1}{\alpha}}^\infty \frac{e^{-\alpha u}}{u} du + \int_{\frac{1}{\alpha}}^\infty \frac{e^{-\frac{\alpha}{u}} - 1}{u} du \\ &= \left\{ -\int_0^{\frac{1}{\alpha}} \frac{1 - e^{-\alpha u}}{u} du + \int_{\frac{1}{\alpha}}^\infty \frac{e^{-\alpha u}}{u} du \right\} + \left\{ \int_{\frac{1}{\alpha}}^\infty e^{-\frac{\alpha}{u}} du - \int_{\frac{1}{\alpha}}^\infty \frac{1 - e^{-\frac{\alpha}{u}}}{u} du \right\}. \end{aligned}$$

Now, for the two integrals in the first pair of curly brackets make the change of variable $x = \alpha u$ (and so $du = \frac{1}{\alpha} dx$), and for the two integrals in the second pair of curly brackets make the change of variable $x = \frac{\alpha}{u}$ (and so $du = -\frac{\alpha}{x^2} dx$). Then,

$$\begin{aligned}
2I &= -\int_0^1 \frac{1-e^{-x}}{\frac{x}{\alpha}} \left(\frac{1}{\alpha} dx\right) + \int_1^\infty \frac{e^{-x}}{\frac{x}{\alpha}} \left(\frac{1}{\alpha} dx\right) + \int_\infty^{\alpha^2} \frac{e^{-x}}{\frac{\alpha}{x}} \left(-\frac{\alpha}{x^2} dx\right) \\
&\quad - \int_{\alpha^2}^0 \frac{1-e^{-x}}{\frac{\alpha}{x}} \left(-\frac{\alpha}{x^2} dx\right) = -\int_0^1 \frac{1-e^{-x}}{x} dx + \int_1^\infty \frac{e^{-x}}{x} dx \\
&\quad + \int_{\alpha^2}^\infty \frac{e^{-x}}{x} dx - \int_0^{\alpha^2} \frac{1-e^{-x}}{x} dx.
\end{aligned}$$

Since the first two integrals on the right are $-\gamma$ by (5.4.1), then

$$2I = -\gamma + \int_{\alpha^2}^\infty \frac{e^{-x}}{x} dx - \int_0^{\alpha^2} \frac{dx}{x} + \int_0^{\alpha^2} \frac{e^{-x}}{x} dx$$

or, combining the first and last integrals on the right,

$$2I = -\gamma + \int_0^\infty \frac{e^{-x}}{x} dx - \int_0^{\alpha^2} \frac{dx}{x}.$$

Continuing,

$$2I = -\gamma + \left\{ \int_0^1 \frac{e^{-x}}{x} dx + \int_1^\infty \frac{e^{-x}}{x} dx \right\} - \left\{ \int_0^1 \frac{dx}{x} - \int_{\alpha^2}^1 \frac{dx}{x} \right\}$$

or, combining the first and third integrals on the right,

$$\begin{aligned}
2I &= -\gamma + \left\{ \int_1^\infty \frac{e^{-x}}{x} dx + \int_0^1 \frac{e^{-x} - 1}{x} dx \right\} + \int_{\alpha^2}^1 \frac{dx}{x} \\
&= -\gamma + \left\{ \int_1^\infty \frac{e^{-x}}{x} dx - \int_0^1 \frac{1-e^{-x}}{x} dx \right\} + \ln(x) \Big|_{\alpha^2}^1.
\end{aligned}$$

The two integrals in the final pair of curly brackets are, again by (5.4.1), $-\gamma$, and so

$$2I = -2\gamma - \ln(\alpha^2) = -2\gamma - 2\ln(\alpha).$$

Thus, finally, we have Ramanujan's integral

$$(5.4.5) \quad \int_{-\infty}^{\infty} \{e^{-\alpha e^x} + e^{-\alpha e^{-x}} - 1\} dx = -\gamma - \ln(\alpha).$$

To check this, for $\alpha = 1$ the integral is $-\gamma$, while for $\alpha = 2$ the integral is $-\gamma - \ln(2) = -1.270362\dots$, and MATLAB agrees as `quad(@(x)(exp(-exp(x))+exp(-exp(-x))-1),0,100) = -0.577216\dots` and `quad(@(x)(exp(-2*exp(x))+exp(-2*exp(-x))-1),0,100) = -1.270357\dots`

As yet another example of (5.4.1), consider the following mysterious-looking integral:

$$\int_0^{\infty} \frac{e^{-x^a} - e^{-x^b}}{x} dx$$

where a and b are both positive constants. This integral ‘looks like’ a Frullani integral (see Chap. 3 again), but it is not. It is *much* deeper. Without our equally mysterious (5.4.1) I think it would be impossible to make any headway with this integral. Here’s how to do it.

$$\int_0^{\infty} \frac{e^{-x^a} - e^{-x^b}}{x} dx = \int_0^{\infty} \frac{e^{-x^a} - e^{-(x^a)^{\frac{b}{a}}}}{x} dx = \int_0^{\infty} \frac{e^{-x^a} - e^{-(x^a)^p}}{x} dx, p = \frac{b}{a}.$$

Let

$$u = x^a$$

and so

$$dx = \frac{du}{ax^{a-1}}.$$

Thus,

$$\begin{aligned} \int_0^{\infty} \frac{e^{-x^a} - e^{-x^b}}{x} dx &= \int_0^{\infty} \frac{e^{-u} - e^{-u^p}}{x} \left(\frac{du}{ax^{a-1}} \right) = \frac{1}{a} \int_0^{\infty} \frac{e^{-u} - e^{-u^p}}{u} du \\ &= \frac{1}{a} \left[\int_0^{\infty} \frac{e^{-u} - 1}{u} du - \int_0^{\infty} \frac{e^{-u^p} - 1}{u} du \right] \\ &= \frac{1}{a} \left[\int_0^1 \frac{e^{-u} - 1}{u} du + \int_1^{\infty} \frac{e^{-u} - 1}{u} du - \int_0^1 \frac{e^{-u^p} - 1}{u} du - \int_1^{\infty} \frac{e^{-u^p} - 1}{u} du \right] \\ &= \frac{1}{a} \left[\left\{ -\int_0^1 \frac{1 - e^{-u}}{u} du + \int_1^{\infty} \frac{e^{-u}}{u} du \right\} - \left\{ \int_0^1 \frac{e^{-u^p} - 1}{u} du + \int_1^{\infty} \frac{e^{-u^p}}{u} du \right\} \right] \\ &= \frac{1}{a} \left[-\gamma - \left\{ \int_0^1 \frac{e^{-u^p} - 1}{u} du + \int_1^{\infty} \frac{e^{-u^p}}{u} du \right\} \right], \end{aligned}$$

where once again (5.4.1) comes into play.

Next, in the two integrals on the right in the previous line, make the change of variable

$$y = u^p$$

and so

$$du = \frac{dy}{pu^{p-1}}.$$

Thus,

$$\left\{ \int_0^1 \frac{e^{-u^p} - 1}{u} du + \int_1^\infty \frac{e^{-u^p}}{u} du \right\} = \frac{1}{p} \left\{ \int_0^1 \frac{e^{-y} - 1}{y} dy + \int_1^\infty \frac{e^{-y}}{y} dy \right\}$$

and we have (where (5.4.1) is used yet again)

$$\begin{aligned} \int_0^\infty \frac{e^{-x^a} - e^{-x^b}}{x} dx &= \frac{1}{a} \left[-\gamma - \frac{1}{p} \left\{ \int_0^1 \frac{e^{-u} - 1}{u} du + \int_1^\infty \frac{e^{-u}}{u} du \right\} \right] \\ &= \frac{1}{a} \left[-\gamma - \frac{1}{p} \left\{ -\int_0^1 \frac{1 - e^{-u}}{u} du + \int_1^\infty \frac{e^{-u}}{u} du \right\} \right] \\ &= \frac{1}{a} \left[-\gamma - \frac{1}{p} \{-\gamma\} \right] = \gamma \left[-\frac{1}{a} + \frac{1}{ap} \right] = \gamma \left[\frac{1}{b} - \frac{1}{a} \right] \end{aligned}$$

or, at last,

$$(5.4.6) \quad \int_0^\infty \frac{e^{-x^a} - e^{-x^b}}{x} dx = \gamma \frac{a-b}{ab}.$$

To check this, suppose $a = 2$ and $b = 1$. Then (5.4.6) says

$$\int_0^\infty \frac{e^{-x^2} - e^{-x}}{x} dx = \frac{1}{2}\gamma$$

or, equivalently,

$$2 \int_0^\infty \frac{e^{-x^2} - e^{-x}}{x} dx = \gamma.$$

And, in fact, MATLAB agrees, as `2*quad(@(x)(exp(-(x.^2))-exp(-x))./x,0,100) = 0.5772153....`

Our result in (5.4.1) is so useful that I think it helpful to see it developed in an alternative, quite different way. We start with a result from earlier in the book, (3.3.3), where we showed that

$$\ln\left(\frac{b}{a}\right) = \int_0^{\infty} \frac{e^{-ax} - e^{-bx}}{x} dx.$$

In particular, if we set $a = 1$ and $b = t$, we have

$$(5.4.7) \quad \ln(t) = \int_0^{\infty} \frac{e^{-x} - e^{-tx}}{x} dx.$$

Next, for n any positive integer, we have

$$\int_0^{\infty} e^{-nx} dx = \left(-\frac{1}{n} e^{-nx}\right) \Big|_0^{\infty} = \frac{1}{n}.$$

So, summing over all n from 1 to N , we have

$$\sum_{n=1}^N \frac{1}{n} = \sum_{n=1}^N \int_0^{\infty} e^{-nx} dx = \int_0^{\infty} \left\{ \sum_{n=1}^N e^{-nx} \right\} dx.$$

The sum is a geometric series, easily evaluated to give

$$\sum_{n=1}^N e^{-nx} = \frac{e^{-x} - e^{-(N+1)x}}{1 - e^{-x}}.$$

Thus,

$$(5.4.8) \quad \sum_{n=1}^N \frac{1}{n} = \int_0^{\infty} \frac{e^{-x} - e^{-(N+1)x}}{1 - e^{-x}} dx.$$

Now, recall the definition of γ from the beginning of this section:

$$\gamma = \lim_{N \rightarrow \infty} \left\{ \sum_{n=1}^N \frac{1}{n} - \ln(N) \right\}.$$

Putting (5.4.7) and (5.4.8) into the expression on the right, we have

$$\gamma = \lim_{N \rightarrow \infty} \int_0^{\infty} \left[\left\{ \frac{e^{-x} - e^{-(N+1)x}}{1 - e^{-x}} \right\} - \left\{ \frac{e^{-x} - e^{-Nx}}{x} \right\} \right] dx$$

and so

$$\begin{aligned}\gamma &= \int_0^{\infty} \frac{e^{-x}}{1-e^{-x}} dx - \int_0^{\infty} \frac{e^{-x}}{x} dx \\ &= \int_0^{\infty} \frac{e^{-x}}{1-e^{-x}} dx - \left\{ \int_0^1 \frac{e^{-x}}{x} dx + \int_1^{\infty} \frac{e^{-x}}{x} dx \right\}.\end{aligned}$$

In the first integral on the right, let $s = 1 - e^{-x}$. Then, $\frac{ds}{dx} = e^{-x}$ and so $dx = \frac{ds}{e^{-x}}$. Thus,

$$\begin{aligned}\gamma &= \int_0^1 \frac{e^{-x}}{s} \left(\frac{ds}{e^{-x}} \right) - \int_0^1 \frac{e^{-x}}{x} dx - \int_1^{\infty} \frac{e^{-x}}{x} dx \\ &= \int_0^1 \frac{1}{s} ds - \int_0^1 \frac{e^{-x}}{x} dx - \int_1^{\infty} \frac{e^{-x}}{x} dx\end{aligned}$$

or,

$$\gamma = \int_0^1 \frac{1 - e^{-x}}{x} dx - \int_1^{\infty} \frac{e^{-x}}{x} dx$$

which is just (5.4.1).

Equation (5.4.1) isn't the only tool we have for working with γ , and to illustrate that let's do the exotic integral

$$\int_0^{\infty} e^{-x^2} \ln(x) dx$$

as the final calculation for this chapter. This will be a calculation that will require us to recall Feynman's favorite trick from Chap. 3 of differentiating an integral, as well as the power series for the log function that we used earlier in this chapter. The answer will feature a (perhaps) surprising appearance of γ . We start with a class of integrals indexed on the parameter m :

$$(5.4.9) \quad I(m) = \int_0^{\infty} x^m e^{-x^2} dx.$$

Differentiating with respect to m ,

$$\frac{dI}{dm} = \frac{d}{dm} \int_0^{\infty} e^{\ln(x^m)} e^{-x^2} dx = \frac{d}{dm} \int_0^{\infty} e^{m \ln(x)} e^{-x^2} dx = \int_0^{\infty} \ln(x) e^{m \ln(x)} e^{-x^2} dx$$

and so

$$\frac{dI}{dm} = \int_0^{\infty} x^m \ln(x) e^{-x^2} dx.$$

This tells us that the integral we are after is the $m=0$ case, that is,

$$(5.4.10) \quad \int_0^{\infty} e^{-x^2} \ln(x) dx = \left. \frac{dI}{dm} \right|_{m=0}.$$

Next, returning to (5.4.9), make the change of variable $t=x^2$ (and so $dx = \frac{dt}{2\sqrt{t}}$). Then,

$$I(m) = \int_0^{\infty} t^{\frac{m}{2}} e^{-t} \frac{dt}{2\sqrt{t}} = \frac{1}{2} \int_0^{\infty} e^{-t} t^{\frac{m}{2}-\frac{1}{2}} dt.$$

Recalling (4.1.1), this last integral is the gamma function $\Gamma(n)$ for the case of $n-1 = \frac{m}{2} - \frac{1}{2}$ (for $n = \frac{m+1}{2}$). Thus,

$$I(m) = \frac{1}{2} \Gamma\left(\frac{m+1}{2}\right)$$

and so, from (5.4.10),

$$(5.4.11) \quad \int_0^{\infty} e^{-x^2} \ln(x) dx = \left. \frac{1}{2} \left\{ \frac{d}{dm} \Gamma\left(\frac{m+1}{2}\right) \right\} \right|_{m=0}.$$

To do the differentiation of the gamma function, recall the digamma function from earlier in this section, where we have

$$\Gamma'(z) = \frac{d\Gamma(z)}{dz} = \Gamma(z) \left[-\frac{1}{z} - \gamma + \sum_{r=1}^{\infty} \left(\frac{1}{r} - \frac{1}{r+z} \right) \right].$$

So, with $z = \frac{m+1}{2}$, we have

$$\begin{aligned} \frac{d\Gamma\left(\frac{m+1}{2}\right)}{d\left(\frac{m+1}{2}\right)} &= \frac{d\Gamma\left(\frac{m+1}{2}\right)}{\frac{1}{2} dm} = 2 \frac{d\Gamma\left(\frac{m+1}{2}\right)}{dm} \\ &= \Gamma\left(\frac{m+1}{2}\right) \left[-\frac{1}{\frac{m+1}{2}} - \gamma + \sum_{r=1}^{\infty} \left(\frac{1}{r} - \frac{1}{r + \frac{m+1}{2}} \right) \right]. \end{aligned}$$

That is, for the case of $m=0$,

$$\left\{ \frac{d}{dm} \Gamma\left(\frac{m+1}{2}\right) \right\} \Big|_{m=0} = \frac{1}{2} \Gamma\left(\frac{1}{2}\right) \left[-2 - \gamma + \sum_{r=1}^{\infty} \left(\frac{1}{r} - \frac{1}{r + \frac{1}{2}} \right) \right]$$

$$= \frac{1}{2} \sqrt{\pi} \left[-2 - \gamma + \sum_{r=1}^{\infty} \left(\frac{2}{2r} - \frac{2}{2r + 1} \right) \right]$$

and so, putting this into (5.4.11), we have

$$(5.4.12) \quad \int_0^{\infty} e^{-x^2} \ln(x) dx = \frac{1}{4} \sqrt{\pi} \left[-2 - \gamma + 2 \sum_{r=1}^{\infty} \left(\frac{1}{2r} - \frac{1}{2r + 1} \right) \right].$$

Now, concentrate on the summation

$$\sum_{r=1}^{\infty} \left(\frac{1}{2r} - \frac{1}{2r + 1} \right) = \left(\frac{1}{2} - \frac{1}{3} \right) + \left(\frac{1}{4} - \frac{1}{5} \right) + \left(\frac{1}{6} - \frac{1}{7} \right) + \dots$$

Then, recalling the power series for $\ln(1+x)$ that we derived at the start of Sect. 5.2, we see that

$$\ln(2) = 1 - \frac{1}{2} + \frac{1}{3} - \frac{1}{4} + \frac{1}{5} - \dots$$

and so

$$\frac{1}{2} - \frac{1}{3} + \frac{1}{4} - \frac{1}{5} + \frac{1}{6} - \frac{1}{7} + \dots = 1 - \ln(2),$$

which means

$$\sum_{r=1}^{\infty} \left(\frac{1}{2r} - \frac{1}{2r + 1} \right) = 1 - \ln(2).$$

Putting this into (5.4.12) we have

$$\int_0^{\infty} e^{-x^2} \ln(x) dx = \frac{1}{4} \sqrt{\pi} [-2 - \gamma + 2\{1 - \ln(2)\}]$$

or, at last, we have the beautiful

$$(5.4.13) \quad \int_0^{\infty} e^{-x^2} \ln(x) dx = -\frac{1}{4} \sqrt{\pi} [\gamma + 2\ln(2)].$$

This is equal to $-0.8700577\dots$ and MATLAB agrees as `quad(@(x)exp(-(x.^2)).*log(x),0,10) = -0.87006\dots`

5.5 Challenge Problems

(C5.1): Consider the class of definite integrals defined by

$$I(m, n) = \int_0^1 \frac{1 - x^m}{1 - x^n} dx,$$

where m and n are positive integers. $I(m, n)$ exists for all such m and n since the integrand is everywhere finite over the interval of integration.⁷ Make a power series expansion of the integrand and then integrate term-by-term to arrive at an infinite sum that can be easily evaluated with a simple computer program (no use of MATLAB's `quad` or any other similar high-powered software allowed!). If you have access to a computer, write a code to evaluate $I(m, n)$ for given values of m and n . You can check your code by seeing if it gives the correct answers for those cases easy to do by hand (obviously, $I(n, n) = 1$ for all n). For example,

$$I(2, 1) = \int_0^1 \frac{1 - x^2}{1 - x} dx = \int_0^1 (1 + x) dx = \left(x + \frac{1}{2}x^2 \right) \Big|_0^1 = 1.5$$

and

$$I(1, 2) = \int_0^1 \frac{1 - x}{1 - x^2} dx = \int_0^1 \frac{1}{1 + x} dx = \int_1^2 \frac{du}{u} = \ln(2) = 0.6931.$$

Then, use your code to compute, *with at least the first six decimal digits correct*, the values of $I(5, 7)$ and $I(7, 5)$.

(C5.2): Show that

$$\int_1^{\infty} \frac{\{x\}}{x^2} dx = 1 - \gamma$$

where $\{x\}$ is the fractional part of x . To give you confidence that this is correct, MATLAB calculates `quad(@(x)(x-floor(x))./x.^2,1,100) = 0.41861\dots`, while

⁷ At the upper limit the integrand does become the indeterminate $\frac{0}{0}$, but we can use L'Hospital's rule to compute the perfectly respectable $\lim_{x \rightarrow 1} \frac{1 - x^m}{1 - x^n} = \lim_{x \rightarrow 1} \frac{-m x^{m-1}}{-n x^{n-1}} = \frac{m}{n}$.

$1 - \gamma = 0.42278\dots$. Hint: you might find it helpful to look back at Chap. 1 and review the derivation of (1.8.1).

(C5.3): If you *really* understand the trick involved in doing integrals with fractional-part integrands then you should now be able to show that the great nemesis of the great Euler, $\zeta(3)$, can be written as the quite interesting integral

$$\zeta(3) = \frac{3}{2} - 3 \int_1^{\infty} \frac{\{x\}}{x^4} dx .$$

To give you confidence that this is correct, recall that the value of $\zeta(3)$ is 1.20205..., while MATLAB calculates `1.5-3*quad(@(x)(x-floor(x))./x.^4,1,100)` = 1.202018....

(C5.4): It can be shown (using the contour integration technique we'll discuss in Chap. 8) that $\int_0^{\infty} \frac{dx}{(x+a)\{\ln^2(x) + \pi^2\}} = \frac{1}{1-a} + \frac{1}{\ln(a)}$, $a > 0$. Each term on the right blows-up when $a = 1$, and so it isn't immediately apparent what the value of the integral is when $a = 1$. The integrand, itself, doesn't do anything 'weird' at $a = 1$ however, and MATLAB encounters no problem at $a = 1$: `quad(@(x)1./((x+1).*(log(x).^2+pi^2)),0,1e17)` = 0.474... Using the power series expansion for $\ln(1+x)$ for $-1 < x < 1$, show the actual value of the integral at $a = 1$ is $\frac{1}{2}$. (Notice that $\frac{1}{1-a}$ and $\frac{1}{\ln(a)}$ individually blow-up in *opposite* directions as $a \rightarrow 1$, either from below or from above, and so it is *a priori* plausible that their sum could be finite.)

(C5.5): For the case of $s = 2$, (5.3.7) says that

$$\begin{aligned} \zeta(2) &= \frac{1}{1-2^{-1}} \sum_{k=1}^{\infty} \frac{(-1)^{k-1}}{k^2} = \frac{1}{1-\frac{1}{2}} \left[\frac{1}{1^2} - \frac{1}{2^2} + \frac{1}{3^2} - \frac{1}{4^2} + \dots \right] \\ &= 2 \left[\frac{1}{1^2} - \frac{1}{2^2} + \frac{1}{3^2} - \frac{1}{4^2} + \dots \right]. \end{aligned}$$

But by Euler's original definition we know that

$$\zeta(2) = \frac{1}{1^2} + \frac{1}{2^2} + \frac{1}{3^2} + \frac{1}{4^2} + \dots$$

Thus, it must be true that

$$2 \left[\frac{1}{1^2} - \frac{1}{2^2} + \frac{1}{3^2} - \frac{1}{4^2} + \dots \right] = \frac{1}{1^2} + \frac{1}{2^2} + \frac{1}{3^2} + \frac{1}{4^2} + \dots$$

Starting with the expression on the left, show that it is, *indeed*, equal to the expression on the right.

(C5.6): Show that

$$\int_0^1 \frac{\ln^2(1-x)}{x} dx = 2\zeta(3).$$

Hint: try the change of variable $1-x = e^{-t}$, and then remember (5.3.4).

(C5.7): Show that $\int_0^1 \frac{\{-\ln(x)\}^p}{1-x} dx = \Gamma(p+1)\zeta(p+1)$, $p > 0$. Notice that the case of $p=1$ says $\zeta(2) = \int_0^1 \frac{-\ln(x)}{1-x} dx = \frac{\pi^2}{6} = 1.644934\dots$ and MATLAB agrees: `quad(@(x)-log(x)/(1-x),0,1) = 1.64494\dots` Hint: Make the appropriate change of variable in (5.3.4). Notice, too, that if you make the change of variable $u = 1-x$ then the result for $p=1$ gives another derivation of (5.2.2). You should confirm this.

(C5.8): Right after deriving (5.3.1) we showed that $\int_0^1 \int_0^1 \frac{1}{1-xy} dx dy = \zeta(2)$.

Show that this is the $n=2$ special case of a more general integration over an n -dimensional unit hypercube. That is, show that

$$\int_0^1 \int_0^1 \dots \int_0^1 \frac{1}{1-x_1x_2\dots x_n} dx_1 dx_2 \dots dx_n = \zeta(n).$$

(C5.9): Show that $\int_0^\infty \ln\left(\frac{e^x + 1}{e^x - 1}\right) dx = \frac{\pi^2}{4}$.

(C5.10): Show that $\int_0^\infty e^{-x}\ln^2(x)dx = \gamma^2 + \frac{\pi^2}{6}$. MATLAB agrees with this, as $\gamma^2 + \frac{\pi^2}{6}$ equals 1.978111\dots, and `quad(@(x)exp(-x).*(log(x).^2),0,100) = 1.97812\dots` Hint: Start with $I(m) = \int_0^\infty x^m e^{-x} dx$ and then think about how to express $I(m)$ as the *second* derivative of a gamma function. To do the differentiations involved, you'll need to apply a *double* dose of the digamma function.

(C5.11): Starting with (5.4.1), show that $\gamma = \int_0^1 \frac{1 - e^{-x} - e^{-\frac{1}{x}}}{x} dx$. This is a particularly useful expression for γ because, over the entire *finite* interval of integration, the integrand is *finite*. MATLAB computes the integral as `quad(@(x)(1-exp(-x)-exp(-1./x))./x,0,1) = 0.577215\dots`

Chapter 6

Seven Not-So-Easy Integrals

6.1 Bernoulli's Integral

As I mentioned in the Preface, in 1697 John Bernoulli evaluated the exotic-looking integral

$$\int_0^1 x^x dx.$$

How can this be done? And what about other similar integrals, ones that Bernoulli's integral might inspire, like

$$\int_0^1 x^{-x} dx$$

and

$$\int_0^1 x^{x^2} dx$$

and

$$\int_0^1 x^{\sqrt{x}} dx$$

and . . . well, you get the picture! In this opening section I'll show you a unified way to do all of these calculations.

We start with the identity

$$x^{cx^a} = e^{\ln(x^{cx^a})} = e^{cx^a \ln(x)}$$

where a and c are constants. Then, since the power series expansion of the exponential is

$$e^y = 1 + y + \frac{y^2}{2!} + \frac{y^3}{3!} + \dots$$

then, with $y = cx^a \ln(x)$, we have

$$x^{cx^a} = 1 + cx^a \ln(x) + \frac{1}{2!} c^2 x^{2a} \ln^2(x) + \frac{1}{3!} c^3 x^{3a} \ln^3(x) + \dots$$

and so

$$\begin{aligned} \int_0^1 x^{cx^a} dx &= \int_0^1 dx + c \int_0^1 x^a \ln(x) dx + \frac{c^2}{2!} \int_0^1 x^{2a} \ln^2(x) dx \\ (6.1.1) \quad &+ \frac{c^3}{3!} \int_0^1 x^{3a} \ln^3(x) dx + \dots \end{aligned}$$

You can do all of the integrals in (6.1.1) if you did the challenge problem I gave you at the end of Chap. 4: the derivation of

$$\int_0^1 x^m \ln^n(x) dx = (-1)^n \frac{n!}{(m+1)^{n+1}}.$$

If you didn't do this (or got stuck) now is a good time to take a look at the Challenge Problem solutions at the end of the book. All of the integrals in (6.1.1) are of this form, with different values for m and n .¹

Using this general result on each of the integrals on the right-hand side of (6.1.1), we arrive at

$$\int_0^1 x^{cx^a} dx = 1 - \frac{c}{(a+1)^2} + \frac{c^2}{2!} \left\{ \frac{2!}{(2a+1)^3} \right\} - \frac{c^3}{3!} \left\{ \frac{3!}{(3a+1)^4} \right\} + \frac{c^4}{4!} \left\{ \frac{4!}{(4a+1)^5} \right\} - \dots$$

or,

$$(6.1.2) \quad \int_0^1 x^{cx^a} dx = 1 - \frac{c}{(a+1)^2} + \frac{c^2}{(2a+1)^3} - \frac{c^3}{(3a+1)^4} + \frac{c^4}{(4a+1)^5} - \dots$$

¹This is *not* the way Bernoulli did his original evaluation, but rather is the modern way. The evaluation of $\int_0^1 x^m \ln^n(x) dx$ that I give in the solutions uses the gamma function, which was still in the future in Bernoulli's day. Bernoulli used repeated integration by parts, which in fact is perfectly fine. The lack of a specialized tool doesn't stop a genius!

So, with $a = c = 1$ we have Bernoulli's integral:

$$(6.1.3) \quad \int_0^1 x^x dx = 1 - \frac{1}{2^2} + \frac{1}{3^3} - \frac{1}{4^4} + \frac{1}{5^5} - \dots$$

It is easy to write a little program to sum the right-hand side; using the first ten terms, we get 0.78343... , and in agreement is $quad(@(x)x.^x,0,1) = 0.78343\dots$

If $c = -1$ and $a = 1$ then (6.1.2) becomes

$$(6.1.4) \quad \int_0^1 x^{-x} dx = 1 + \frac{1}{2^2} + \frac{1}{3^3} + \frac{1}{4^4} + \frac{1}{5^5} + \dots$$

Summing the first ten terms on the right gives 1.29128... , and in agreement is $quad(@(x)x.^(-x),0,1) = 1.29128\dots$. By the way, since (6.1.4) can be written as

$$\int_0^1 \frac{1}{x^x} dx = \sum_{k=1}^{\infty} \frac{1}{k^k}$$

it is sometimes called the *sophomore's dream* because, while the similar forms on each side of the equality 'look too good to be true,' it is a true statement.

If $c = 1$ and $a = 2$ then (6.1.2) becomes

$$(6.1.5) \quad \int_0^1 x^{x^2} dx = 1 - \frac{1}{3^2} + \frac{1}{5^3} - \frac{1}{7^4} + \frac{1}{9^5} - \dots$$

Summing the first six terms on the right gives 0.896488... and MATLAB agrees as $quad(@(x)x.^(x.^2),0,1) = 0.896487\dots$

If $c = 1$ and $a = \frac{1}{2}$ then (6.1.2) becomes

$$\int_0^1 x^{\sqrt{x}} dx = 1 - \frac{1}{\left(\frac{3}{2}\right)^2} + \frac{1}{\left(\frac{4}{2}\right)^3} - \frac{1}{\left(\frac{5}{2}\right)^4} + \frac{1}{\left(\frac{6}{2}\right)^5} - \dots$$

or,

$$\int_0^1 x^{\sqrt{x}} dx = 1 - \left(\frac{2}{3}\right)^2 + \left(\frac{2}{4}\right)^3 - \left(\frac{2}{5}\right)^4 + \left(\frac{2}{6}\right)^5 - \dots$$

(6.1.6)

Summing the first ten terms on the right gives 0.658582... and MATLAB agrees as $quad(@(x)x.^sqrt(x),0,1) = 0.658586\dots$

6.2 Ahmed's Integral

In this section we'll do Ahmed's integral, named after the Indian mathematical physicist Zafar Ahmed who proposed it in 2002. Interesting in its own right, we'll also use it in the next section to do the derivation of Coxeter's integral that I mentioned in the Preface. Ahmed's integral is,

$$(6.2.1) \quad \int_0^1 \frac{\tan^{-1}(\sqrt{2+x^2})}{(1+x^2)\sqrt{2+x^2}} dx,$$

and it can be done using Feynman's favorite trick of differentiating under the integral sign. That is, we'll start with a 'u-parameterized' version of (6.2.1),

$$(6.2.2) \quad I(u) = \int_0^1 \frac{\tan^{-1}(u\sqrt{2+x^2})}{(1+x^2)\sqrt{2+x^2}} dx,$$

and then differentiate it with respect to u. $I(1)$ is Ahmed's integral.

Notice that if $u \rightarrow \infty$ then the argument of the inverse tangent also $\rightarrow \infty$ for all $x > 0$ and so, since $\tan^{-1}(\infty) = \frac{\pi}{2}$, we have

$$(6.2.3) \quad I(\infty) = \frac{\pi}{2} \int_0^1 \frac{dx}{(1+x^2)\sqrt{2+x^2}}.$$

The integral in (6.2.3) is easy to do once you recall the standard differentiation formula

$$\frac{d}{dx} \tan^{-1}\{f(x)\} = \frac{1}{1+f^2(x)} \left(\frac{df}{dx} \right).$$

If we use this formula to calculate

$$\frac{d}{dx} \tan^{-1} \left\{ \frac{x}{\sqrt{2+x^2}} \right\},$$

then *you* should confirm that

$$\frac{d}{dx} \tan^{-1} \left\{ \frac{x}{\sqrt{2+x^2}} \right\} = \frac{1}{(1+x^2)\sqrt{2+x^2}}$$

which is the integrand of (6.2.3). That is,

$$\begin{aligned} I(\infty) &= \frac{\pi}{2} \int_0^1 \frac{d}{dx} \tan^{-1} \left\{ \frac{x}{\sqrt{2+x^2}} \right\} dx = \frac{\pi}{2} \left[\tan^{-1} \left\{ \frac{x}{\sqrt{2+x^2}} \right\} \right] \Big|_0^1 \\ &= \frac{\pi}{2} \left[\tan^{-1} \left\{ \frac{1}{\sqrt{3}} \right\} - \tan^{-1} \{0\} \right] = \left(\frac{\pi}{2} \right) \left(\frac{\pi}{6} \right) \end{aligned}$$

or,

$$I(\infty) = \frac{\pi^2}{12}.$$

Now, differentiate (6.2.2) with respect to u , again using

$$\frac{d}{dx} \tan^{-1} \{f(u)\} = \frac{1}{1+f^2(u)} \left(\frac{df}{du} \right),$$

with $f(u) = u\sqrt{2+x^2}$. Then, with just a bit of algebra,

$$\frac{dI}{du} = \int_0^1 \frac{dx}{(1+x^2)(1+2u^2+u^2x^2)}.$$

With a partial fraction expansion this becomes

$$\frac{dI}{du} = \int_0^1 \frac{1}{(1+u^2)} \left[\frac{1}{1+x^2} - \frac{u^2}{1+2u^2+u^2x^2} \right] dx$$

or,

$$\frac{dI}{du} = \frac{1}{(1+u^2)} \left[\int_0^1 \frac{dx}{1+x^2} - \int_0^1 \frac{dx}{\frac{1+2u^2}{u^2} + x^2} \right].$$

These last two integrals are each of the form

$$\int \frac{dx}{a^2+x^2} = \frac{1}{a} \tan^{-1} \left(\frac{x}{a} \right)$$

and so, doing the integrals, we have

$$\frac{dI}{du} = \frac{1}{(1+u^2)} \left[\tan^{-1}(x) - \frac{u}{\sqrt{1+2u^2}} \tan^{-1} \left(\frac{xu}{\sqrt{1+2u^2}} \right) \right] \Big|_0^1$$

or,

$$(6.2.4) \quad \frac{dI}{du} = \frac{1}{(1+u^2)} \left[\frac{\pi}{4} - \frac{u}{\sqrt{1+2u^2}} \tan^{-1} \left(\frac{u}{\sqrt{1+2u^2}} \right) \right].$$

Next, integrate both sides of (6.2.4) from 1 to ∞ with respect to u . On the left we get

$$\int_1^{\infty} \frac{dI}{du} du = \int_1^{\infty} dI = I(\infty) - I(1),$$

and on the right we get

$$\frac{\pi}{4} \int_1^{\infty} \frac{du}{1+u^2} - \int_1^{\infty} \frac{u}{(1+u^2)\sqrt{1+2u^2}} \tan^{-1}\left(\frac{u}{\sqrt{1+2u^2}}\right) du.$$

The first integral is easy:

$$\frac{\pi}{4} \int_1^{\infty} \frac{du}{1+u^2} = \frac{\pi}{4} [\tan^{-1}(\infty) - \tan^{-1}(1)] = \frac{\pi}{4} \left[\frac{\pi}{2} - \frac{\pi}{4} \right] = \frac{\pi^2}{16}.$$

Thus,

$$(6.2.5) \quad I(\infty) - I(1) = \frac{\pi^2}{16} - \int_1^{\infty} \frac{u}{(1+u^2)\sqrt{1+2u^2}} \tan^{-1}\left(\frac{u}{\sqrt{1+2u^2}}\right) du.$$

That final integral looks pretty awful—but looks are deceiving. The integral yields with not even a whimper if we make the change of variable $t = \frac{1}{u}$ (and so $du = -\frac{1}{t^2} dt$) as follows:

$$\begin{aligned} & \int_1^{\infty} \frac{u}{(1+u^2)\sqrt{1+2u^2}} \tan^{-1}\left(\frac{u}{\sqrt{1+2u^2}}\right) du \\ &= \int_1^0 \frac{\frac{1}{t}}{\left(1+\frac{1}{t^2}\right)\sqrt{1+\frac{2}{t^2}}} \tan^{-1}\left(\frac{\frac{1}{t}}{\sqrt{1+\frac{2}{t^2}}}\right) \left(-\frac{1}{t^2} dt\right) \\ &= \int_0^1 \frac{\frac{1}{t}}{(t^2+1)\frac{\sqrt{t^2+2}}{t}} \tan^{-1}\left(\frac{\frac{1}{t}}{\frac{\sqrt{t^2+2}}{t}}\right) dt \\ &= \int_0^1 \frac{1}{(t^2+1)\sqrt{t^2+2}} \tan^{-1}\left(\frac{1}{\sqrt{t^2+2}}\right) dt. \end{aligned}$$

Now, recall the identity

$$\tan^{-1}(s) + \tan^{-1}\left(\frac{1}{s}\right) = \frac{\pi}{2}$$

which becomes instantly obvious if you draw a right triangle with perpendicular sides of lengths 1 and s and remember that the two acute angles add to $\frac{\pi}{2}$. This says

$$\tan^{-1}\left(\frac{1}{\sqrt{t^2+2}}\right) = \frac{\pi}{2} - \tan^{-1}\left(\sqrt{t^2+2}\right)$$

and so we can write

$$\begin{aligned} & \int_0^1 \frac{1}{(t^2+1)\sqrt{t^2+2}} \tan^{-1}\left(\frac{1}{\sqrt{t^2+2}}\right) dt \\ &= \frac{\pi}{2} \int_0^1 \frac{dt}{(t^2+1)\sqrt{t^2+2}} - \int_0^1 \frac{\tan^{-1}(\sqrt{t^2+2})}{(t^2+1)\sqrt{t^2+2}} dt. \end{aligned}$$

That is, (6.2.5) becomes

$$I(\infty) - I(1) = \frac{\pi^2}{16} - \frac{\pi}{2} \int_0^1 \frac{dt}{(t^2+1)\sqrt{t^2+2}} + \int_0^1 \frac{\tan^{-1}(\sqrt{t^2+2})}{(t^2+1)\sqrt{t^2+2}} dt,$$

and you should now see that *two* wonderful things have happened. First, if you look back at (6.2.3) you'll see that the first integral on the right is $I(\infty)$. Second, the right-most integral, from (6.2.1), is just $I(1)$, that is, *Ahmed's integral!* So,

$$I(\infty) - I(1) = \frac{\pi^2}{16} - I(\infty) + I(1)$$

and so

$$2I(\infty) - \frac{\pi^2}{16} = 2I(1)$$

or, at last,

$$I(1) = I(\infty) - \frac{\pi^2}{32} = \frac{\pi^2}{12} - \frac{\pi^2}{32}$$

and we have our answer:

$$(6.2.6) \quad \int_0^1 \frac{\tan^{-1}(\sqrt{2+x^2})}{(1+x^2)\sqrt{2+x^2}} dx = \frac{5\pi^2}{96}$$

This is equal to 0.51404189 . . . , and MATLAB agrees, as `quad(@(x)atan(sqrt(2+x.^2))./(1+x.^2).*sqrt(2+x.^2)),0,1) = 0.51404188 . . .`

6.3 Coxeter's Integral

In this section we'll do the integral that the young H. S. M. Coxeter pleaded for help with in the Preface, a plea which the great Hardy answered. I don't know the details of what Hardy sent to Coxeter, and so here I'll show you an analysis that makes use of (6.2.6). The integral we are going to evaluate is

$$(6.3.1) \quad I = \int_0^{\pi/2} \cos^{-1} \left\{ \frac{\cos(x)}{1+2\cos(x)} \right\} dx,$$

and it will be a pretty long haul; prepare yourself for the longest derivation in this book. I've tried to make every step crystal clear but still, in the immortal words of Bette Davis in her 1950 film *All About Eve*, "Fasten your seatbelts, it's going to be a bumpy night."

To start our analysis, we'll cast (6.3.1) into a different form. The double-angle formula from trigonometry for the cosine says that, for any θ ,

$$(6.3.2) \quad \cos(2\theta) = 2\cos^2(\theta) - 1.$$

If we write $u = \cos(\theta)$ —and so $\theta = \cos^{-1}(u)$ —then (6.3.2) says that

$$\cos(2\theta) = 2u^2 - 1,$$

from which it immediately follows that

$$\cos^{-1}(2u^2 - 1) = \cos^{-1}\{\cos(2\theta)\} = 2\theta = 2\cos^{-1}(u).$$

So, since u is simply an arbitrary variable (as is θ) we can write

$$(6.3.3) \quad \cos^{-1}(2\theta^2 - 1) = 2\cos^{-1}(\theta).$$

Next, writing $\alpha = 2\theta^2 - 1$ (which means $\theta = \sqrt{\frac{1+\alpha}{2}}$), we have from (6.3.3) that

$$\cos^{-1}(\alpha) = 2 \cos^{-1}\left(\sqrt{\frac{1+\alpha}{2}}\right).$$

Looking back at (6.3.1), let's write

$$\alpha = \frac{\cos(x)}{1 + 2 \cos(x)}$$

and so we have

$$\cos^{-1}\left(\frac{\cos(x)}{1 + 2 \cos(x)}\right) = 2 \cos^{-1}\left(\sqrt{\frac{1 + \frac{\cos(x)}{1 + 2 \cos(x)}}{2}}\right) = 2 \cos^{-1}\left(\sqrt{\frac{1 + 3 \cos(x)}{2 + 4 \cos(x)}}\right). \tag{6.3.4}$$

Now, if you apply the Pythagorean theorem to a right triangle with an acute angle whose cosine is $\sqrt{\frac{1+3\cos(x)}{2+4\cos(x)}}$, you'll see that the tangent of that same angle is $\sqrt{\frac{1+\cos(x)}{1+3\cos(x)}}$. That is,

$$\cos^{-1}\left(\frac{\cos(x)}{1 + 2 \cos(x)}\right) = 2 \tan^{-1}\left\{\sqrt{\frac{1 + \cos(x)}{1 + 3 \cos(x)}}\right\}$$

and so Coxeter's integral I in (6.3.1) becomes

$$I = 2 \int_0^{\pi/2} \tan^{-1}\left\{\sqrt{\frac{1 + \cos(x)}{1 + 3 \cos(x)}}\right\} dx. \tag{6.3.5}$$

Make the change of variable $x = 2y$ (and so $dx = 2dy$) which converts (6.3.5) to

$$I = 4 \int_0^{\pi/4} \tan^{-1}\left\{\sqrt{\frac{1 + \cos(2y)}{1 + 3 \cos(2y)}}\right\} dy.$$

Using (6.3.2) again, and then applying a bit of algebraic simplification, we have

$$\sqrt{\frac{1 + \cos(2y)}{1 + 3 \cos(2y)}} = \frac{\cos(y)}{\sqrt{2 - 3 \sin^2(y)}}$$

and so

$$(6.3.6) \quad I = 4 \int_0^{\pi/4} \tan^{-1} \left\{ \frac{\cos(y)}{\sqrt{2-3\sin^2(y)}} \right\} dy.$$

Now, put (6.3.6) aside for the moment and notice the following (which may appear to be out of left-field, but be patient and you'll see its relevance soon):

$$\int_0^1 \frac{1}{1 + \left[\frac{\cos^2(y)}{2-3\sin^2(y)} \right] t^2} dt$$

is of the form

$$\int_0^1 \frac{1}{1+b^2t^2} dt = \frac{1}{b^2} \int_0^1 \frac{1}{\frac{1}{b^2} + t^2} dt = \frac{1}{b^2} \{ b \tan^{-1}(bt) \} \Big|_0^1 = \frac{1}{b} \tan^{-1}(b), \quad b = \frac{\cos(y)}{\sqrt{2-3\sin^2(y)}}.$$

Thus,

$$\int_0^1 \frac{1}{1 + \left[\frac{\cos^2(y)}{2-3\sin^2(y)} \right] t^2} dt = \frac{\sqrt{2-3\sin^2(y)}}{\cos(y)} \tan^{-1} \left\{ \frac{\cos(y)}{\sqrt{2-3\sin^2(y)}} \right\}.$$

That is, the integrand of (6.3.6) is given by

$$\tan^{-1} \left\{ \frac{\cos(y)}{\sqrt{2-3\sin^2(y)}} \right\} = \frac{\cos(y)}{\sqrt{2-3\sin^2(y)}} \int_0^1 \frac{1}{1 + \left[\frac{\cos^2(y)}{2-3\sin^2(y)} \right] t^2} dt$$

and so (6.3.6) is, itself, the *double* integral

$$(6.3.7) \quad I = 4 \int_0^{\pi/4} \frac{\cos(y)}{\sqrt{2-3\sin^2(y)}} \left\{ \int_0^1 \frac{1}{1 + \left[\frac{\cos^2(y)}{2-3\sin^2(y)} \right] t^2} dt \right\} dy.$$

Wow! This may look like we've made things (a lot) worse. Well, hang in there because they're going to appear to get *even worse* before they get better—but they *will* get (a lot) better, although not for a while.

Continuing, we have

$$\begin{aligned}
 I &= \int_0^{\pi/4} \int_0^1 \frac{4 \cos(y) \{2 - 3 \sin^2(y)\}}{\sqrt{2 - 3 \sin^2(y)} \{2 - 3 \sin^2(y) + t^2 \cos^2(y)\}} dt dy \\
 &= \int_0^{\pi/4} \int_0^1 \frac{4 \cos(y) \sqrt{2 - 3 \sin^2(y)}}{2 - 3 \sin^2(y) + t^2 - t^2 \sin^2(y)} dt dy
 \end{aligned}$$

or,

$$(6.3.8) \quad I = \int_0^{\pi/4} \int_0^1 \frac{4 \cos(y) \sqrt{2 - 3 \sin^2(y)}}{(t^2 + 2) - (t^2 + 3) \sin^2(y)} dt dy.$$

Next, make the change of variable $\sin(y) = \sqrt{\frac{2}{3}} \sin(w)$ in (6.3.8), and so $dy = \sqrt{\frac{2}{3}} \frac{\cos(w)}{\cos(y)} dw$. We have $w = 0$ when $y = 0$, and when $y = \frac{\pi}{4}$ we have $\sin(\frac{\pi}{4}) = \frac{1}{\sqrt{2}}$ and so $\sin(w) = \left(\sqrt{\frac{3}{2}}\right) \left(\frac{1}{\sqrt{2}}\right) = \frac{\sqrt{3}}{2}$ which says $w = \frac{\pi}{3}$. So

$$\begin{aligned}
 I &= \int_0^{\pi/3} \int_0^1 \frac{4 \cos(y) \sqrt{2 - 3 \frac{2}{3} \sin^2(w)}}{(t^2 + 2) - (t^2 + 3) \frac{2}{3} \sin^2(w)} dt \frac{\cos(w)}{\cos(y)} dw \sqrt{\frac{2}{3}} \\
 &= \int_0^{\pi/3} \int_0^1 \frac{4 \sqrt{2 - 2[1 - \cos^2(w)]}}{(t^2 + 2) - (t^2 + 3) \frac{2}{3} [1 - \cos^2(w)]} dt \cos(w) dw \sqrt{\frac{2}{3}} \\
 &= \int_0^{\pi/3} \int_0^1 \frac{4 \sqrt{2} \cos(w) \sqrt{2} \cos(w)}{(t^2 + 2) - (t^2 + 3) \frac{2}{3} [1 - \cos^2(w)]} dt \frac{1}{\sqrt{3}} dw
 \end{aligned}$$

and, after some straightforward algebra which I'm going to let you fill-in, we arrive at

$$(6.3.9) \quad I = \int_0^{\pi/3} \int_0^1 \frac{8 \sqrt{3} \cos^2(w)}{t^2 + (2t^2 + 6) \cos^2(w)} dt dw.$$

Our next step is another change of variable, to $s = \tan(w)$. Thus, as $\tan(w) = \frac{\sin(w)}{\cos(w)}$, we have

$$\frac{ds}{dw} = \frac{\cos^2(w) + \sin^2(w)}{\cos^2(w)} = \frac{1}{\cos^2(w)},$$

and so $dw = \cos^2(w) ds$. Since

$$1 + s^2 = 1 + \tan^2(w) = 1 + \frac{\sin^2(w)}{\cos^2(w)} = \frac{1}{\cos^2(w)}$$

we have

$$\frac{1}{1 + s^2} = \cos^2(w)$$

and so

$$dw = \frac{ds}{1 + s^2}.$$

Therefore, since $s = 0$ when $w = 0$, and $s = \sqrt{3}$ when $w = \frac{\pi}{3}$, we have

$$\begin{aligned} I &= \int_0^{\sqrt{3}} \int_0^1 \frac{8\sqrt{3} \frac{1}{1+s^2}}{t^2 + (2t^2 + 6) \frac{1}{1+s^2}} dt \frac{ds}{1+s^2} \\ &= \int_0^{\sqrt{3}} \int_0^1 \frac{8\sqrt{3}}{t^2(1+s^2)^2 + (2t^2 + 6)(1+s^2)} dt ds \end{aligned}$$

or, after again some more straightforward algebra which you can do, we arrive at

$$(6.3.10) \quad I = \int_0^{\sqrt{3}} \int_0^1 \frac{8\sqrt{3}}{(1+s^2)(t^2s^2 + 3t^2 + 6)} dt ds.$$

Krusty the Clown on the Simpson's TV cartoon-comedy show is fond of yelling, when frustrated, "Will it ever end?," and the answer here is, 'Not yet.' So, bravely plowing-on, let's now make a partial fraction expansion of the integrand in (6.3.10). That is, if we write

$$\frac{1}{(1+s^2)(t^2s^2 + 3t^2 + 6)} = \frac{A}{1+s^2} + \frac{B}{t^2s^2 + 3t^2 + 6}$$

it is then easy to confirm that

$$A = \frac{1}{2t^2 + 6}, B = -\frac{t^2}{2t^2 + 6}$$

and so

$$I = \int_0^{\sqrt{3}} \int_0^1 8\sqrt{3} \left[\frac{1}{1+s^2} - \frac{t^2}{t^2s^2 + 3t^2 + 6} \right] dt ds$$

which with just a little algebra (and a reversal of the order of integration) can be written as

$$(6.3.11) \quad I = \int_0^1 \frac{4\sqrt{3}}{t^2+3} \left\{ \int_0^{\sqrt{3}} \frac{ds}{1+s^2} - \int_0^{\sqrt{3}} \frac{ds}{s^2+3+\frac{6}{t^2}} \right\} dt.$$

The first inner integral on the right is easy:

$$\left\{ \tan^{-1}(s) \right\} \Big|_0^{\sqrt{3}} = \tan^{-1}(\sqrt{3}) = \frac{\pi}{3}.$$

The second inner integral is almost as easy, as it is equal to

$$\begin{aligned} \int_0^{\sqrt{3}} \frac{ds}{s^2 + \left[\sqrt{3 + \frac{6}{t^2}} \right]^2} &= \frac{1}{\sqrt{3 + \frac{6}{t^2}}} \left\{ \tan^{-1} \left(\frac{s}{\sqrt{3 + \frac{6}{t^2}}} \right) \right\} \Big|_0^{\sqrt{3}} \\ &= \frac{t}{\sqrt{3}\sqrt{t^2+2}} \tan^{-1} \left(\frac{st}{\sqrt{3}\sqrt{t^2+2}} \right) \Big|_0^{\sqrt{3}} \\ &= \frac{t}{\sqrt{3}\sqrt{t^2+2}} \tan^{-1} \left(\frac{t}{\sqrt{t^2+2}} \right). \end{aligned}$$

Thus,

$$\begin{aligned} I &= \int_0^1 \frac{4\sqrt{3}}{t^2+3} \left\{ \frac{\pi}{3} - \frac{t}{\sqrt{3}\sqrt{t^2+2}} \tan^{-1} \left(\frac{t}{\sqrt{t^2+2}} \right) \right\} dt \\ &= \frac{4\sqrt{3}\pi}{3} \int_0^1 \frac{dt}{t^2 + (\sqrt{3})^2} - 4 \int_0^1 \left\{ \frac{t}{(t^2+3)\sqrt{t^2+2}} \tan^{-1} \left(\frac{t}{\sqrt{t^2+2}} \right) \right\} dt \\ &= \frac{4\sqrt{3}\pi}{3} \left\{ \frac{1}{\sqrt{3}} \tan^{-1} \left(\frac{t}{\sqrt{3}} \right) \right\} \Big|_0^1 - 4 \int_0^1 \left\{ \frac{t}{(t^2+3)\sqrt{t^2+2}} \tan^{-1} \left(\frac{t}{\sqrt{t^2+2}} \right) \right\} dt, \end{aligned}$$

or, as

$$\frac{4\sqrt{3}\pi}{3} \left\{ \frac{1}{\sqrt{3}} \tan^{-1} \left(\frac{t}{\sqrt{3}} \right) \right\} \Big|_0^1 = \frac{4\pi}{3} \tan^{-1} \left(\frac{1}{\sqrt{3}} \right) = \frac{4\pi}{3} \left(\frac{\pi}{6} \right) = \frac{2\pi^2}{9},$$

we have

$$(6.3.12) \quad I = \frac{2\pi^2}{9} - 4 \int_0^1 \left\{ \frac{t}{(t^2+3)\sqrt{t^2+2}} \tan^{-1} \left(\frac{t}{\sqrt{t^2+2}} \right) \right\} dt.$$

We are now in the homestretch, as we can do the integral in (6.3.12) by parts. To see this, let

$$u = \tan^{-1}\left(\frac{t}{\sqrt{t^2+2}}\right)$$

and

$$dv = \frac{t}{(t^2+3)\sqrt{t^2+2}} dt.$$

Then, remembering how to differentiate the inverse tangent from the opening discussion of this section, we have

$$\frac{du}{dt} = \frac{1}{(t^2+1)\sqrt{t^2+2}}.$$

And you can verify that

$$v = \tan^{-1}\left(\sqrt{t^2+2}\right)$$

by simply differentiating this v and observing that we get the above dv back. So, plugging all this into the integration by parts formula, we have

$$\begin{aligned} I &= \frac{2\pi^2}{9} - 4 \left[\left\{ \tan^{-1}\left(\frac{t}{\sqrt{t^2+2}}\right) \tan^{-1}\left(\sqrt{t^2+2}\right) \right\} \Big|_0^1 - \int_0^1 \frac{\tan^{-1}(\sqrt{t^2+2})}{(t^2+1)\sqrt{t^2+2}} dt \right] \\ &= \frac{2\pi^2}{9} - 4 \left[\tan^{-1}\left(\frac{1}{\sqrt{3}}\right) \tan^{-1}(\sqrt{3}) - \int_0^1 \frac{\tan^{-1}(\sqrt{t^2+2})}{(t^2+1)\sqrt{t^2+2}} dt \right] \\ &= \frac{2\pi^2}{9} - 4 \left[\left(\frac{\pi}{6}\right) \left(\frac{\pi}{3}\right) - \int_0^1 \frac{\tan^{-1}(\sqrt{t^2+2})}{(t^2+1)\sqrt{t^2+2}} dt \right] \\ &= \frac{2\pi^2}{9} - \frac{2\pi^2}{9} + 4 \int_0^1 \frac{\tan^{-1}(\sqrt{t^2+2})}{(t^2+1)\sqrt{t^2+2}} dt \end{aligned}$$

and so,

$$I = 4 \int_0^1 \frac{\tan^{-1}(\sqrt{t^2+2})}{(t^2+1)\sqrt{t^2+2}} dt.$$

Now, look back at (6.2.6), our result for Ahmed's integral. *It is precisely the above integral.* Coxeter's integral is four times Ahmed's integral and so, *at last* (!),

$$(6.3.13) \quad \int_0^{\pi/2} \cos^{-1} \left\{ \frac{\cos(x)}{1 + 2\cos(x)} \right\} dx = \frac{5\pi^2}{24} .$$

Wow! What a derivation! But is it correct? MATLAB says it is, as our theoretical answer of 2.05616758... matches `quad(@(x)acos(cos(x)/(1+2*cos(x))),0,pi/2) = 2.0561677...`

6.4 The Hardy-Schuster Optical Integral

In 1925 the German-born English physicist Arthur Schuster (1851–1934) published a paper on the theory of light. In that paper he encountered the intriguing integral

$$(6.4.1) \quad J = \int_0^{\infty} \{C^2(x) + S^2(x)\} dx,$$

where $C(x)$ and $S(x)$ are themselves integrals (called *Fresnel integrals*, and we'll see them again in the next chapter for the special case of $x = 0$):

$$C(x) = \int_x^{\infty} \cos(t^2) dt, \quad S(x) = \int_x^{\infty} \sin(t^2) dt.$$

In fact, since we'll eventually need to know one of these two specific values— $S(0)$ —to find J , here is its value now (we'll *derive* it in the next chapter as result (7.2.2)):

$$(6.4.2) \quad S(0) = \int_0^{\infty} \sin(t^2) dt = \frac{1}{2} \sqrt{\frac{\pi}{2}}.$$

Schuster was unable to evaluate J , but did write that the *physics* of the problem he was studying would be satisfied *if* J had a certain value. Alas, he couldn't show that J had that value and that is where he left matters.

Schuster's paper soon came to the attention of the great Hardy, who then (are you surprised and if so, why?) quickly computed J (confirming Schuster's conjecture) using *two* different approaches. One of them used sophisticated Fourier transform theory,² but in this section I'll show you an alternative 'freshman calculus' derivation that freely uses the physical interpretation of the Riemann integral. It is based on an idea that Hardy himself sketched in his other approach.

²For a detailed discussion of Schuster's integral and Hardy's transform solution, see my book *Dr. Euler's Fabulous Formula*, Princeton 2006, pp. 263–274.

From the definitions of $C(x)$ and $S(x)$ we can write

$$C^2(x) = \int_x^\infty \cos(t^2) dt \int_x^\infty \cos(u^2) du = \int_x^\infty \int_x^\infty \cos(t^2) \cos(u^2) dt du$$

and

$$S^2(x) = \int_x^\infty \sin(t^2) dt \int_x^\infty \sin(u^2) du = \int_x^\infty \int_x^\infty \sin(t^2) \sin(u^2) dt du.$$

Thus,

$$C^2(x) + S^2(x) = \int_x^\infty \int_x^\infty \{ \cos(t^2) \cos(u^2) + \sin(t^2) \sin(u^2) \} dt du.$$

From trigonometry we have the identity

$$\cos(a - b) = \cos(a) \cos(b) + \sin(a) \sin(b)$$

and so it immediately follows that

$$C^2(x) + S^2(x) = \int_x^\infty \int_x^\infty \cos(t^2 - u^2) dt du.$$

From (6.4.1) we then have

$$(6.4.3) \quad J = \int_0^\infty \left\{ \int_x^\infty \int_x^\infty \cos(t^2 - u^2) dt du \right\} dx.$$

(At this point you should take a look back at Sect. 3.6, where I showed you how to use MATLAB's Symbolic Math Toolbox to numerically evaluate this triple integral.)

Let's now agree to write $f(t, u) = \cos(t^2 - u^2)$, and so (6.4.3) becomes

$$(6.4.4) \quad J = \int_0^\infty \left\{ \int_x^\infty \int_x^\infty f(t, u) dt du \right\} dx.$$

We can express in words what (6.4.4) says as follows: The outermost integral (x) says 'starting with $x = 0$, evaluate $\{ \int_0^\infty \int_0^\infty f(t, u) dt du \} \Delta x$. Then, increment x by Δx to $x = \Delta x$ and evaluate $\{ \int_{\Delta x}^\infty \int_{\Delta x}^\infty f(t, u) dt du \} \Delta x$. Then increment x by Δx to $x = 2\Delta x$ and evaluate $\{ \int_{2\Delta x}^\infty \int_{2\Delta x}^\infty f(t, u) dt du \} \Delta x$. And so on. Then add all of these evaluations.'

We can reformulate this *mathematical* interpretation of (6.4.4) as a *physical* one by assigning the three variables x , t , and u to the axes of a three-dimensional Cartesian coordinate system, as shown in Fig. 6.4.1, where the x and u axes are in

Fig. 6.4.1 A coordinate system

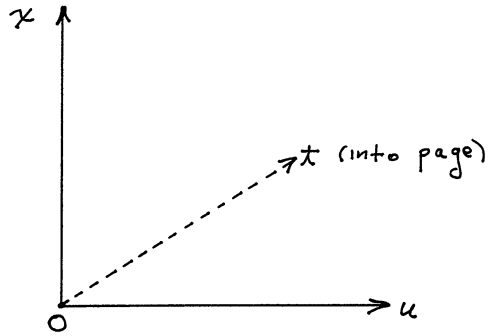
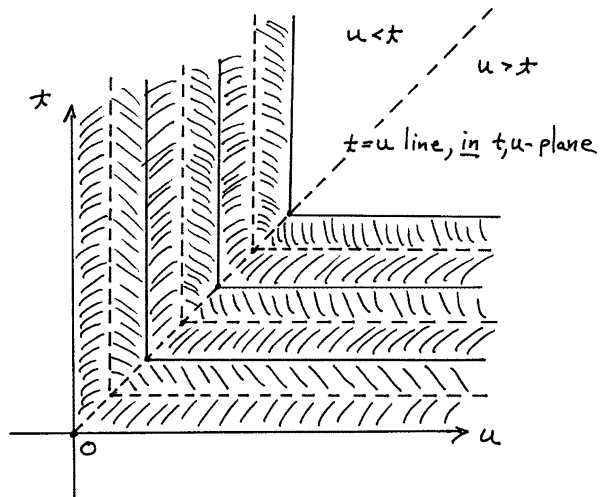

Fig. 6.4.2 A wedding cake volume



the plane of the page and the t -axis is perpendicular to the page (the positive t -axis is *into* the page).

Each of the individual integrals in our sum is simply the integral of $f(t,u)$ over the volume of an infinite ‘slab’ of thickness Δx , where the ‘bottom’ slab’s corner³ starts at the origin ($t=0, u=0$). The corners of the subsequent slabs lying above the bottom slab are gradually slid *up* (along the x -axis) and *away from* the origin along the line $t = u$. So, if you imagine yourself in space, hovering over the t,u -plane and looking down along the x -axis, Fig. 6.4.2 is what you’d see. That is, the volume we are integrating $f(t, u)$ over looks like a *layered wedding cake*! The steps formed by the layers have height and depth Δx . (For a carpenter building a staircase, these would be the values of the *riser* and the *tread* of the steps, respectively.) That is,

³ Since the volume we are integrating over is infinite in extent in both the t and u directions, the corner at the origin is the *only* corner of the bottom slab.

Fig. 6.4.3 The foot of the wedding cake at the origin

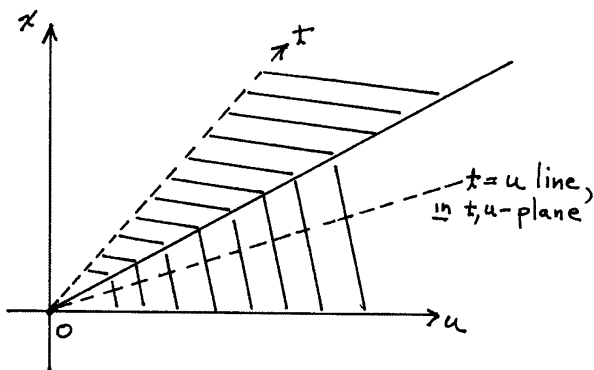

$$(6.4.5) \quad J = \int_{\text{cake}} f(t, u) \, dV$$

where dV is the differential volume of the wedding cake.

In a side view of the cake (now with $\Delta x \rightarrow 0$), the corner of the cake at the origin looks like the foot of a pyramid, as shown in Fig. 6.4.3.

There is another way, different from (6.4.4), to write the integral of $f(t, u)$ over the wedding cake volume. To start to set this new form up, notice that if we cut the cake with a plane perpendicular to the t, u -plane (the base of the cake) with the plane passing through the line $t = u$, then we cut the cake into two equal parts. In one half we have $u < t$ (I'll call this the *upper half*) and in the other half we have $u > t$ (I'll call this the *lower half*), as shown in Fig. 6.4.2.

We first pick a tiny rectangular 'footprint' $dtdu$ in the t, u -plane, at (t, u) . Then, we move upward (increasing x direction) until we hit the surface of the cake. For a given u and t (the location of the 'footprint') this occurs at height $x = \min(t, u)$. If the footprint is in the lower half then $\min(t, u) = t$, and if the footprint is in the upper half then $\min(t, u) = u$. In either case, the differential volume of this vertical plug through the wedding cake is given by

$$(6.4.6) \quad dV = \left\{ \int_0^{\min(t, u)} dx \right\} dtdu = \begin{cases} u \, dtdu, & u < t \text{ (upper half)} \\ t \, dtdu, & u > t \text{ (lower half)} \end{cases}$$

For $u > t$ (lower half) we have u varying from 0 to ∞ and t varying from 0 to u . So, for the case of $u > t$ the integral in (6.4.5) is

$$J_{\text{lower}} = \int_0^\infty \left\{ \int_0^u t f(t, u) dt \right\} du.$$

For $u < t$ (upper half) we have t varying from 0 to ∞ and u varying from 0 to t . So, for the case of $u < t$ the integral in (6.4.5) is

$$J_{\text{upper}} = \int_0^\infty \left\{ \int_0^t u f(t, u) du \right\} dt.$$

Thus,

$$\begin{aligned} J &= J_{\text{lower}} + J_{\text{upper}} = \int_0^\infty \left\{ \int_0^u t f(t, u) dt \right\} du + \int_0^\infty \left\{ \int_0^t u f(t, u) du \right\} dt \\ &= \int_0^\infty \left\{ \int_0^u t \cos(t^2 - u^2) dt \right\} du + \int_0^\infty \left\{ \int_0^t u \cos(t^2 - u^2) du \right\} dt. \end{aligned}$$

These last two integrals are obviously equal since, if we swap the two dummy variables t and u in either integral, we get the other integral. So,

$$J = 2 \int_0^\infty \left\{ \int_0^t u \cos(t^2 - u^2) du \right\} dt.$$

The inner integral can be integrated by inspection:

$$\int_0^t u \cos(t^2 - u^2) du = \left\{ -\frac{1}{2} \sin(t^2 - u^2) \right\} \Big|_0^t = \frac{1}{2} \sin(t^2),$$

and so

$$J = 2 \int_0^\infty \frac{1}{2} \sin(t^2) dt = \int_0^\infty \sin(t^2) dt$$

which is just $S(0)$. That is,

$$(6.4.7) \quad \int_0^\infty \left\{ \int_x^\infty \int_x^\infty \cos(t^2 - u^2) dt du \right\} dx = \frac{1}{2} \sqrt{\frac{\pi}{2}} .$$

This is 0.626657... and, as shown in Sect. 3.6, that's what the Symbolic Math Toolbox calculates as well.

6.5 The Watson/van Peype Triple Integrals

In 1939 the English mathematician George N. Watson (1886–1965) published an elegant paper⁴ in which he showed how to evaluate the following three integrals:

$$I_1 = \frac{1}{\pi^3} \int_0^\pi \int_0^\pi \int_0^\pi \frac{du \, dv \, dw}{1 - \cos(u) \cos(v) \cos(w)},$$

$$I_2 = \frac{1}{\pi^3} \int_0^\pi \int_0^\pi \int_0^\pi \frac{du \, dv \, dw}{3 - \cos(v) \cos(w) - \cos(w) \cos(u) - \cos(u) \cos(v)},$$

$$I_3 = \frac{1}{\pi^3} \int_0^\pi \int_0^\pi \int_0^\pi \frac{du \, dv \, dw}{3 - \cos(u) - \cos(v) - \cos(w)}.$$

These three integrals were not pulled out of thin air, but rather all had appeared in a paper⁵ published the previous year by W. F. van Peype, a student of the famous Dutch physicist H. A. Kramers (1894–1952). Van Peype was able to evaluate I_1 , but not I_2 or I_3 . Kramers was apparently sufficiently fascinated by these integrals that he sent them to the British physicist Ralph Fowler (1889–1944) who, apparently also stumped, passed them on into the hands of—who else?—G. H. Hardy, famous slayer of definite integrals.

At this point, matters become interesting beyond just mathematics. As Watson wrote in the opening of his paper, “The problem then became common knowledge first in Cambridge [Hardy’s lair] and subsequently in Oxford, when it made the journey to Birmingham [Watson was on the faculty at the University of Birmingham] without difficulty.” Perhaps I am reading too much into that, but I suspect this was one of those rare cases where Hardy *failed* to evaluate a definite integral, and Watson was only too happy to (not so subtly) allude to that as he started to present his solutions. Birmingham was small potatoes compared to Cambridge, and I think just a bit of friendly ‘in your face’ was involved here.

Watson’s analyses of I_1 , I_2 , and I_3 are quite clever. Watson wrote that I_1 and I_2 “are easily expressible in terms of gamma functions whose arguments are simple fractions,” but he was not able to do that for I_3 . I_3 , he suspected, *required* the use of

⁴G. N. Watson, “Three Triple Integrals,” *Quarterly Journal of Mathematics*, 1939, pp. 266–276.

⁵W. F. van Peype, “Zur Theorie der Magnetischen Anisotropie Kubischer Kristalle Beim Absoluten Nullpunkt,” *Physica*, June 1938, pp. 465–482. That is, van Peype was studying magnetic behavior in certain cubic crystalline lattice structures at very low temperatures (*low* means near absolute zero). The Watson/van Peype integrals turn-up not only in the physics of frozen magnetic crystals, but also in the pure mathematics of random walks. You can find a complete discussion of both the history and the mathematics of the integrals in I. J. Zucker, “70+ Years of the Watson Integrals,” *Journal of Statistical Physics*, November 2011, pp. 591–612.

elliptic integrals,⁶ mathematical creatures I'll say a little bit more about in the next section. In this belief, Watson was wrong. In fact,

$$I_1 = \frac{\Gamma^4\left(\frac{1}{4}\right)}{4\pi^3} = 1.393203929 \dots,$$

$$I_2 = \frac{3\Gamma^6\left(\frac{1}{3}\right)}{2^{14/3}\pi^4} = 0.448220394 \dots,$$

$$I_3 = \frac{\Gamma\left(\frac{1}{24}\right)\Gamma\left(\frac{5}{24}\right)\Gamma\left(\frac{7}{24}\right)\Gamma\left(\frac{11}{24}\right)}{16\sqrt{6}\pi^3} = 0.505462019 \dots$$

To give you the ‘flavor’ of what Watson did, I'll take you through the derivation for I_1 . Before starting, however, notice that all three integrals are volume integrals over a three-dimensional cube with edge-length π , normalized to the volume of that cube. I'll ignore the normalizing π^3 until we get to the end of the analysis.

We start with the change of variables

$$x = \tan\left(\frac{1}{2}u\right), \quad y = \tan\left(\frac{1}{2}v\right), \quad z = \tan\left(\frac{1}{2}w\right)$$

which convert the 0 to π integrations in u , v , and w in I_1 into 0 to ∞ integrations in x , y , and z , respectively. Now, since

$$u = 2 \tan^{-1}(x)$$

then

$$\frac{du}{dx} = \frac{2}{1+x^2}$$

⁶ Integrals with the integrands $\frac{1}{\sqrt{1-k^2\sin^2(\theta)}}$ and $\sqrt{1-k^2\sin^2(\theta)}$ are *elliptic integrals* of the first and second kind, respectively (there is a third form, too). Such integrals occur in many important physical problems, such as the theory of the non-linear pendulum. As another example, the Italian mathematical physicist Galileo Galilei (1564–1642) studied the so-called “minimum descent time” problem, which involves an elliptic integral of the first kind, and its evaluation puzzled mathematicians for over a century. Eventually the French mathematician Adrien Marie Legendre (1752–1833) showed that the reason for the difficulty was that such integrals are *entirely new functions*, different from all other known functions. You can find more about Galileo’s problem, and the elliptic integral it encounters, in my book *When Least is Best*, Princeton 2007, pp. 200–210 and 347–351. A nice discussion of the non-linear pendulum, and the numerical evaluation of its elliptic integral, is in the paper by T. F. Zheng *et al.*, “Teaching the Nonlinear Pendulum,” *The Physics Teacher*, April 1994, pp. 248–251.

or,

$$du = \frac{2}{1+x^2} dx.$$

Similarly,

$$dv = \frac{2}{1+y^2} dy$$

and

$$dw = \frac{2}{1+z^2} dz.$$

Also, from the half-angle formula for the tangent, we have

$$\tan\left(\frac{1}{2}u\right) = \sqrt{\frac{1 - \cos(u)}{1 + \cos(u)}} = x$$

and so, solving for $\cos(u)$,

$$\cos(u) = \frac{1-x^2}{1+x^2}.$$

Similarly,

$$\cos(v) = \frac{1-y^2}{1+y^2}$$

and

$$\cos(w) = \frac{1-z^2}{1+z^2}.$$

Putting these results for the differentials, and the cosines, into the I_1 integral (remember, we are temporarily ignoring the normalizing π^3), we have

$$\int_0^\pi \int_0^\pi \int_0^\pi \frac{du dv dw}{1 - \cos(u)\cos(v)\cos(w)} = 8 \int_0^\infty \int_0^\infty \int_0^\infty \frac{\left(\frac{dx}{1+x^2}\right)\left(\frac{dy}{1+y^2}\right)\left(\frac{dz}{1+z^2}\right)}{1 - \left(\frac{1-x^2}{1+x^2}\right)\left(\frac{1-y^2}{1+y^2}\right)\left(\frac{1-z^2}{1+z^2}\right)}$$

$$= 8 \int_0^\infty \int_0^\infty \int_0^\infty \frac{dx dy dz}{(1+x^2)(1+y^2)(1+z^2) - (1-x^2)(1-y^2)(1-z^2)}$$

which, after a bit of multiplying and combining of terms in the denominator, reduces to

$$4 \int_0^\infty \int_0^\infty \int_0^\infty \frac{dx dy dz}{x^2 + y^2 + z^2 + x^2 y^2 z^2}$$

Notice, carefully, that this is a volume integral over the entire positive octant ($x \geq 0, y \geq 0, z \geq 0$) in three-dimensional space.

Next, change variables again as follows:

$$x = r\sin(\theta) \cos(\phi), \quad y = r\sin(\theta) \sin(\phi), \quad z = r\cos(\theta)$$

which is, physically, simply a shift to spherical coordinates from the rectangular coordinates in our last integral.⁷ To continue to be physically integrating over the entire positive octant in three-dimensional space, we see that our triple integral, with differentials $dr, d\theta,$ and $d\phi,$ must be over the intervals 0 to $\infty, 0$ to $\frac{\pi}{2},$ and 0 to $\frac{\pi}{2},$ respectively. The differential volume element in rectangular coordinates ($dx dy dz$) becomes the differential volume element $r^2 \sin(\theta)d\phi d\theta dr$ in spherical coordinates. Thus, in this new coordinate system the I_1 integral becomes

$$4 \int_0^{\pi/2} \int_0^{\pi/2} \int_0^\infty \frac{r^2 \sin(\theta)d\phi d\theta dr}{r^2 \sin^2(\theta) \cos^2(\phi) + r^2 \sin^2(\theta) \sin^2(\phi) + r^2 \cos^2(\theta) + r^6 \sin^2(\theta) \cos^2(\phi) \sin^2(\theta) \sin^2(\phi) \cos^2(\theta)}$$

$$= 4 \int_0^{\pi/2} \int_0^{\pi/2} \int_0^\infty \frac{\sin(\theta)d\phi d\theta dr}{1 + r^4 \sin^4(\theta) \cos^2(\theta) \sin^2(\phi) \cos^2(\phi)}$$

⁷ In this notation, the angle ϕ is measured from the positive x -axis and θ is measured from the positive z -axis. Some authors reverse this convention, but of course if one maintains consistency from start to finish everything comes out the same. The symbols are, after all, just squiggles of ink.

or, with the order of integration explicitly displayed,

$$= 4 \int_0^{\pi/2} \left\{ \int_0^{\pi/2} \left\{ \int_0^{\infty} \frac{\sin(\theta)}{1 + r^4 \sin^4(\theta) \cos^2(\theta) \sin^2(\phi) \cos^2(\phi)} dr \right\} d\theta \right\} d\phi.$$

Now, define the variable

$$\psi = 2\phi.$$

Then, the double-angle formula for the sine says

$$\sin(\phi) \cos(\phi) = \frac{1}{2} \sin(2\phi)$$

and so

$$\sin^2(\phi) \cos^2(\phi) = \frac{1}{4} \sin^2(2\phi) = \frac{1}{4} \sin^2(\psi).$$

Since

$$d\phi = \frac{1}{2} d\psi$$

our integral then becomes

$$2 \int_0^{\pi} \left\{ \int_0^{\pi/2} \left\{ \int_0^{\infty} \frac{\sin(\theta)}{1 + \frac{1}{4} r^4 \sin^4(\theta) \cos^2(\theta) \sin^2(\psi)} dr \right\} d\theta \right\} d\psi.$$

At this point things may superficially appear to be bordering on the desperate but, as the old saying goes, ‘appearances can be deceptive’; we are actually almost done. First, the outer-most integration (with respect to ψ) is symmetrical in ψ around $\psi = \frac{\pi}{2}$. That is, as Watson says in his paper,

$$“\frac{1}{2} \int_0^{\pi} (\dots) d\psi = \int_0^{\pi/2} (\dots) d\psi, ”$$

which is, of course, the result of ψ appearing in the integrand only as $\sin^2(\psi)$. Thus, our integral becomes

$$4 \int_0^{\pi/2} \left\{ \int_0^{\pi/2} \left\{ \int_0^{\infty} \frac{\sin(\theta)}{1 + \frac{1}{4} r^4 \sin^4(\theta) \cos^2(\theta) \sin^2(\psi)} dr \right\} d\theta \right\} d\psi.$$

Second, Watson uses the fact that the inner-most (that is, the *first*) integration (with respect to r) is performed for θ and ψ held fixed. That is, in the change of variable

$$t = r \sin(\theta) \sqrt{\frac{1}{2} \cos(\theta) \sin(\psi)}$$

t is actually a function *only* of just r , and not of r , *and* θ , *and* ψ . So, making that change we have

$$dr = \frac{dt}{\sin(\theta) \sqrt{\frac{1}{2} \cos(\theta) \sin(\psi)}}$$

and

$$t^4 = \frac{1}{4} r^4 \sin^4(\theta) \cos^2(\theta) \sin^2(\psi),$$

which converts our integral to

$$\begin{aligned} & 4 \int_0^{\pi/2} \left\{ \int_0^{\pi/2} \left\{ \int_0^{\infty} \frac{\sin(\theta)}{\sin(\theta) \sqrt{\frac{1}{2} \cos(\theta) \sin(\psi)} (1+t^4)} dt \right\} d\theta \right\} d\psi \\ &= 4\sqrt{2} \int_0^{\pi/2} \left\{ \int_0^{\pi/2} \left\{ \int_0^{\infty} \frac{1}{\sqrt{\cos(\theta)} \sqrt{\sin(\psi)} (1+t^4)} dt \right\} d\theta \right\} d\psi, \end{aligned}$$

a scary-looking object that—suddenly and with unspeakable joy to the analyst⁸—separates into the product of three *one*-dimension integrals, each of which we’ve already done! That is, we have

$$\int_0^\pi \int_0^\pi \int_0^\pi \frac{du dv dw}{1 - \cos(u) \cos(v) \cos(w)} = 4\sqrt{2} \int_0^\infty \frac{dt}{(1+t^4)} \int_0^{\pi/2} \frac{d\theta}{\sqrt{\cos(\theta)}} \int_0^{\pi/2} \frac{d\psi}{\sqrt{\sin(\psi)}}$$

⁸ I can only imagine what Watson’s words to his cat must have been when he reached this point in his work. Perhaps, maybe, they were something like this: “By Jove, Lord Fluffy, I’ve done it! Cracked the damn thing wide-open, just like when that egg-head Humpty-Dumpty fell off his bloody wall!”

The first (t) integral is, from (2.3.4), equal to $\frac{\pi\sqrt{2}}{4}$, while the θ and ψ integrals are, from (4.2.14), each equal to $\frac{\Gamma^2(\frac{1}{4})}{2\sqrt{2\pi}}$. Thus, remembering the π^3 normalizing factor, we have

$$I_1 = \frac{1}{\pi^3} 4\sqrt{2} \left(\frac{\pi\sqrt{2}}{4} \right) \left(\frac{\Gamma^2(\frac{1}{4})}{2\sqrt{2\pi}} \right) \left(\frac{\Gamma^2(\frac{1}{4})}{2\sqrt{2\pi}} \right)$$

and so

$$\frac{1}{\pi^3} \int_0^\pi \int_0^\pi \int_0^\pi \frac{du dv dw}{1 - \cos(u)\cos(v)\cos(w)} = \frac{\Gamma^4(\frac{1}{4})}{4\pi^3} .$$

(6.5.1)

This answer is given in van Peype's paper, *without* derivation.

If we attempt (as we did earlier with the Hardy-Schuster optical integral) to check (6.5.1) with MATLAB's Symbolic Toolbox, by writing

```
syms u v w
int(int(int(1/(1-cos(u)*cos(v)*cos(w)),w,0,pi),v,0,pi),u,0,pi)/(pi^3)
```

then we encounter—failure! MATLAB simply goes into an endless loop. But all is not lost, as we can use MATLAB's numerical quadrature command *triplequad*. It does for triple integrals what *quad* does for one-dimensional integrals (there is *dblquad*, too, for double integrals, which works the same way as *triplequad*). For our problem, here, the syntax is:

```
integrnd = @(u,v,w) 1./(1-cos(u).*cos(v).*cos(w));
triplequad(integrnd, 0.001, pi, 0.001, pi, 0.001, pi)/(pi^3)
```

which produces the answer: 1.3879... , in fairly good agreement with the theoretical result I gave you earlier for I_1 . (Notice that the integration limits start at just a little greater than zero, since when $u = v = w = 0$ the integrand blows-up.)

6.6 Elliptic Integrals in a Physical Problem

To finish this chapter, I'll elaborate just a bit on the topic of elliptic integrals, which were mentioned in passing in the previous section (see note 6 again). Specifically,

$$(6.6.1) \quad F(k, \phi) = \int_0^\phi \frac{d\phi'}{\sqrt{1 - k^2 \sin^2(\phi')}} .$$

Fig. 6.6.1 The falling rope

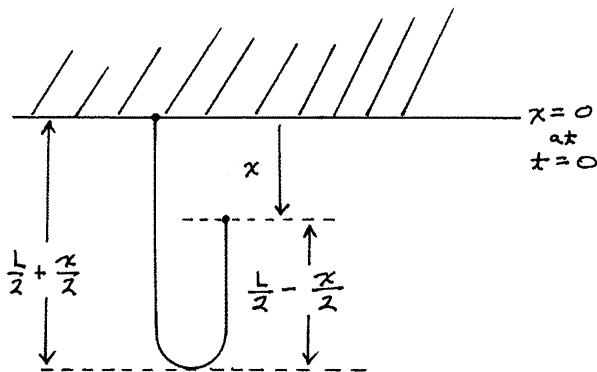

and

$$(6.6.2) \quad E(k, \phi) = \int_0^\phi \sqrt{1 - k^2 \sin^2(\phi')} \, d\phi'$$

are the elliptic integrals of the first and second kind, respectively, where $0 \leq k \leq 1$ (the constant k is called the *modulus*). When $\phi < \frac{\pi}{2}$ the integrals are called *incomplete*, while when $\phi = \frac{\pi}{2}$ the integrals are called *complete*. Except for the two special cases of $k = 0$ and $k = 1$, $F(k, \phi)$ and $E(k, \phi)$ are *not* expressible in terms of any of the elementary functions we typically use (trigonometric, exponential, algebraic, and so on).

You might think it would require a complicated physical situation for either F or E to make an appearance, but that's not so. What I'll show you now is a *seemingly* simple physical problem that will nonetheless involve elliptic integrals (both E and F , in fact). Making the problem even more interesting is that it has appeared in textbooks for well over a century, but until 1989 was routinely analyzed incorrectly.⁹

Figure 6.6.1 shows a perfectly flexible, inextensible (that is, there is no stretching as in a bungee cord) rope with a constant mass density of μ per unit length. The rope has length L , with one end (the left end) permanently attached to a ceiling. The other end is temporarily held at the ceiling, too, until at time $t = 0$ that end is released. The released portion of the rope then, of course, begins to fall (the figure shows the situation after the falling end has descended a distance of x) until, at time $t = T$, the rope is hanging straight down. Our question is simple: what is T ?

The one assumption we'll make in answering this question is that the falling rope conserves energy, which means there are no energy dissipation mechanisms in play (such as internal frictional heating losses in the rope caused by flexing at the bottom of the bend). At all times the sum of the rope's potential and kinetic energies will be

⁹ See M. G. Calkin and R. H. March, "The Dynamics of a Falling Chain. I," *American Journal of Physics*, February 1989, pp. 154–157.

a constant. When we get done with our analysis we'll find that the result for T has a *very* surprising aspect to it.

The center of mass of the left-hand-side of the rope is $\frac{1}{2}\left(\frac{L+x}{2}\right) = \frac{L+x}{4}$ below the ceiling, while the center of mass of the right-hand-side of the rope is $x + \frac{1}{2}\left(\frac{L-x}{2}\right) = \frac{L+3x}{4}$ below the ceiling. So, taking the zero of potential energy (P.E.) at the ceiling, the P.E. of the rope when the released end of the rope has descended by x is given by (where g is the acceleration of gravity)

$$\text{P.E.} = -\left[\mu\left(\frac{L+x}{2}\right)\right]g\frac{L+x}{4} - \left[\mu\left(\frac{L-x}{2}\right)\right]g\frac{L+3x}{4}$$

which reduces (after just a little easy algebra) to

$$(6.6.3) \quad \text{P.E.} = -\frac{1}{4}\mu g[L^2 + 2xL - x^2].$$

The kinetic energy (K.E.) of the rope is the K.E. of the descending right-hand-side of the rope, which is the only portion of the rope that is moving. Since the K.E. of a mass $m = \mu\left(\frac{L-x}{2}\right)$ moving at speed $v = \frac{dx}{dt}$ is $\frac{1}{2}mv^2$, we have the K.E. of the rope as

$$(6.6.4) \quad \text{K.E.} = \frac{1}{4}\mu(L-x)\left(\frac{dx}{dt}\right)^2.$$

From (6.6.3), the *initial* (when $x=0$) P.E. is $-\frac{1}{4}\mu gL^2$. Also, since the rope starts its fall from rest, the *initial* K.E. is zero. Thus, the total initial energy of the rope is $-\frac{1}{4}\mu gL^2$ and by conservation of energy this is the total energy of the rope for all $t \geq 0$. So,

$$\frac{1}{4}\mu(L-x)\left(\frac{dx}{dt}\right)^2 - \frac{1}{4}\mu g[L^2 + 2xL - x^2] = -\frac{1}{4}\mu gL^2$$

which reduces to

$$(6.6.5) \quad \frac{1}{4}(L-x)\left(\frac{dx}{dt}\right)^2 = \frac{1}{4}g(2L-x)x.$$

Notice that μ has canceled away, and so our analysis holds for *any* rope with *arbitrary* (constant) mass density.

Solving (6.6.5) for the differential dt , we have

$$dt = \sqrt{\frac{L-x}{g(2L-x)x}}$$

or,

$$(6.6.6) \quad \sqrt{g} \, dt = \sqrt{\frac{L-x}{(2L-x)x}}.$$

If we integrate both sides of (6.6.6), where time runs from 0 to t and the descent distance of the falling end of the rope varies from 0 to x , we have (I've changed the dummy variables of integration from t to t' and from x to x' so that we can keep t and x as our final variables) then

$$(6.6.7) \quad \int_0^t \sqrt{g} \, dt' = \int_0^x \sqrt{\frac{L-x'}{(2L-x')x'}} dx' = t \sqrt{g}.$$

Now, x varies from 0 (at $t=0$) to L (at $t=T$). So, if we define the variable ϕ as

$$\sin(\phi) = \sqrt{\frac{x}{L}}$$

then ϕ varies from 0 to $\frac{\pi}{2}$. Since $x = L \sin^2(\phi)$, let's now change variable in (6.6.7) to $x' = L \sin^2(\phi')$ and so

$$\frac{dx'}{d\phi'} = 2L \sin(\phi') \cos(\phi')$$

or,

$$dx' = 2L \sin(\phi') \cos(\phi') d\phi'.$$

Also, with just a bit of easy algebra you should be able to show that

$$\sqrt{\frac{L-x'}{(2L-x')x'}} = \frac{\cos(\phi')}{\sqrt{L} \sin(\phi') \sqrt{1 + \cos^2(\phi')}}.$$

Thus, (6.6.7) becomes

$$t \sqrt{g} = \int_0^{\phi} \frac{\cos(\phi')}{\sqrt{L} \sin(\phi') \sqrt{1 + \cos^2(\phi')}} 2L \sin(\phi') \cos(\phi') d\phi'$$

or, with a bit of cancelling and rearranging,

$$\frac{t}{\sqrt{\frac{2L}{g}}} = \sqrt{2} \int_0^\phi \frac{\cos^2(\phi')}{\sqrt{1 + \cos^2(\phi')}} d\phi'$$

and so, finally, since $t = T$ when $\phi = \frac{\pi}{2}$,

$$(6.6.8) \quad \frac{T}{\sqrt{\frac{2L}{g}}} = \sqrt{2} \int_0^{\frac{\pi}{2}} \frac{\cos^2(\phi')}{\sqrt{1 + \cos^2(\phi')}} d\phi'.$$

‘Why the curious form of the left-hand-side of (6.6.8)?’, you are no doubt wondering. To see the why of it, suppose you drop a point mass at time $t = 0$, starting from $x = 0$. How long does it take for that point mass to fall distance L ? From freshman physics we know the mass will fall distance $\frac{1}{2}gt^2$ in time t and so $\frac{1}{2}gt^2 = L$ or, $t = \sqrt{\frac{2L}{g}}$, which is the curious denominator on the left in (6.6.8).

Thus, if $T > \sqrt{\frac{2L}{g}}$, that is, if the rope fall takes longer than the free-fall time of the point mass, then the right-hand-side of (6.6.8) will be greater than 1, but if the rope falls *faster* than does the point mass then the right-hand-side of (6.6.8) will be *less* than 1. Finally, if the rope falls *with* the acceleration of gravity (as does the point mass) then the right-hand-side of (6.6.8) will be exactly 1. So, which is it?

This is an easy question for MATLAB to answer for us, and in fact the rope falls *faster* (!) than does the point mass because `sqrt(2)*quad(@(x)(cos(x).^2)./sqrt((1+cos(x).^2)),0,pi/2) = 0.847213...`. This is not an insignificant deviation from 1 (that is, it isn’t round-off error), and the rope falls more than 15 % faster than does the point mass. Are you surprised? If not, why not? After all, as I mentioned the point mass falls with the acceleration of gravity and so, for the rope to beat the point mass, it must fall ‘faster than gravity!’ How can that be?¹⁰

¹⁰The reason is that the falling part of the rope does so under the influence of not just gravity alone, but also from the non-zero tension in it that joins with gravity in pulling the rope down. To pursue this point here would take us too far away from the theme of the book but, if interested, it’s all worked out in the paper cited in note 9. The ‘faster than gravity’ prediction was experimentally confirmed, indirectly, in note 9 via tension measurements made during actual falls. In 1997 direct photographic evidence was published, and today you can find YouTube videos on the Web clearly showing ‘faster than gravity’ falls.

At this point an engineer or physicist would probably (after shaking their head in amused surprise) start searching for the physical reason behind this curious result. A mathematician,¹¹ however, would more likely first wonder just what nice mathematical expression is that curious number 0.847213... equal to? The answer is, as you might expect from the title of this section, *elliptic integrals*. Here's why.

Starting with just the integral on the right-hand-side of the equation just before (6.6.8)—we'll put the $\sqrt{2}$ factor in at the end—we have

$$\begin{aligned} \int_0^\phi \frac{\cos^2(\phi')}{\sqrt{1 + \cos^2(\phi')}} d\phi' &= \int_0^\phi \frac{1 - \sin^2(\phi')}{\sqrt{2 - \sin^2(\phi')}} d\phi' = \int_0^\phi \frac{1}{\sqrt{2 - \sin^2(\phi')}} d\phi' \\ &\quad - \int_0^\phi \frac{\sin^2(\phi')}{\sqrt{2 - \sin^2(\phi')}} d\phi' = \frac{1}{\sqrt{2}} \int_0^\phi \frac{1}{\sqrt{1 - \frac{1}{2} \sin^2(\phi')}} d\phi' \\ &\quad - \frac{1}{\sqrt{2}} \int_0^\phi \frac{\sin^2(\phi')}{\sqrt{1 - \frac{1}{2} \sin^2(\phi')}} d\phi' \end{aligned}$$

and so, recalling (6.6.1),

$$\int_0^\phi \frac{\cos^2(\phi')}{\sqrt{1 + \cos^2(\phi')}} d\phi' = \frac{1}{\sqrt{2}} F\left(\frac{1}{\sqrt{2}}, \phi\right) - \frac{1}{\sqrt{2}} \int_0^\phi \frac{\sin^2(\phi')}{\sqrt{1 - \frac{1}{2} \sin^2(\phi')}} d\phi'. \quad (6.6.9)$$

Now, concentrate on the integral on the right-hand-side of (6.6.9).

¹¹ Mathematicians are just as interested in this problem, and in related problems, as are physicists. Indeed, the study of falling ropes and chains was initiated by the British *mathematician* Arthur Cayley (1821–1895): see his note “On a Class of Dynamical Problems,” *Proceedings of the Royal Society of London* 1857, pp. 506–511, that opens with the words “There are a class of dynamical problems which, so far as I am aware, have not been considered in a general manner.” That’s certainly not the case today, with Cayley’s problem in particular still causing debate over when energy is (and isn’t) conserved: see Chun Wa Wong and Kosuke Yasui, “Falling Chains,” *American Journal of Physics*, June 2006, pp. 490–496. Take a look, too, at Challenge Problem 6.4.

$$\begin{aligned}
\int_0^\phi \frac{\sin^2(\phi')}{\sqrt{1 - \frac{1}{2} \sin^2(\phi')}} d\phi' &= \int_0^\phi \frac{1 - \frac{1}{2} \sin^2(\phi')}{\sqrt{1 - \frac{1}{2} \sin^2(\phi')}} d\phi' + \int_0^\phi \frac{-1 + \frac{3}{2} \sin^2(\phi')}{\sqrt{1 - \frac{1}{2} \sin^2(\phi')}} d\phi' \\
&= \int_0^\phi \sqrt{1 - \frac{1}{2} \sin^2(\phi')} d\phi' - \int_0^\phi \frac{d\phi'}{\sqrt{1 - \frac{1}{2} \sin^2(\phi')}} \\
&\quad + \frac{3}{2} \int_0^\phi \frac{\sin^2(\phi')}{\sqrt{1 - \frac{1}{2} \sin^2(\phi')}} d\phi'.
\end{aligned}$$

Thus, using (6.6.2), and (6.6.1) again, we have

$$\int_0^\phi \frac{\sin^2(\phi')}{\sqrt{1 - \frac{1}{2} \sin^2(\phi')}} d\phi' = E\left(\frac{1}{\sqrt{2}}, \phi\right) - F\left(\frac{1}{\sqrt{2}}, \phi\right) + \frac{3}{2} \int_0^\phi \frac{\sin^2(\phi')}{\sqrt{1 - \frac{1}{2} \sin^2(\phi')}} d\phi'$$

or,

$$\frac{1}{2} \int_0^\phi \frac{\sin^2(\phi')}{\sqrt{1 - \frac{1}{2} \sin^2(\phi')}} d\phi' = F\left(\frac{1}{\sqrt{2}}, \phi\right) - E\left(\frac{1}{\sqrt{2}}, \phi\right).$$

That is, we have the interesting identity

$$(6.6.10) \quad \int_0^\phi \frac{\sin^2(\phi')}{\sqrt{1 - \frac{1}{2} \sin^2(\phi')}} d\phi' = 2F\left(\frac{1}{\sqrt{2}}, \phi\right) - 2E\left(\frac{1}{\sqrt{2}}, \phi\right), 0 \leq \phi' \leq \frac{\pi}{2}.$$

Using (6.6.10) in (6.6.9), we have

$$\begin{aligned}
\int_0^\phi \frac{\cos^2(\phi')}{\sqrt{1 + \cos^2(\phi')}} d\phi' &= \frac{1}{\sqrt{2}} F\left(\frac{1}{\sqrt{2}}, \phi\right) \\
&\quad - \frac{1}{\sqrt{2}} \left[2F\left(\frac{1}{\sqrt{2}}, \phi\right) - 2E\left(\frac{1}{\sqrt{2}}, \phi\right) \right] \\
&= \left(\frac{1}{\sqrt{2}} - \sqrt{2} \right) F\left(\frac{1}{\sqrt{2}}, \phi\right) + \sqrt{2} E\left(\frac{1}{\sqrt{2}}, \phi\right)
\end{aligned}$$

and so we have a second interesting identity

$$\int_0^\phi \frac{\cos^2(\phi')}{\sqrt{1 + \cos^2(\phi')}} d\phi' = \sqrt{2}E\left(\frac{1}{\sqrt{2}}, \phi\right) - \frac{1}{\sqrt{2}}F\left(\frac{1}{\sqrt{2}}, \phi\right), 0 \leq \phi \leq \frac{\pi}{2}. \quad (6.6.11)$$

Putting this result into (6.6.8), and including the $\sqrt{2}$ factor in front of the integral, we arrive at (for $\phi = \frac{\pi}{2}$),

$$\frac{T}{\sqrt{\frac{2L}{g}}} = 2E\left(\frac{1}{\sqrt{2}}, \frac{\pi}{2}\right) - F\left(\frac{1}{\sqrt{2}}, \frac{\pi}{2}\right). \quad (6.6.12)$$

Does (6.6.12) explain MATLAB's result of 0.847213...? Yes, because a quick look in math tables for the values of the complete elliptic integrals of the first and second kind tells us that

$$F\left(\frac{1}{\sqrt{2}}, \frac{\pi}{2}\right) = 1.8540746 \dots$$

and

$$E\left(\frac{1}{\sqrt{2}}, \frac{\pi}{2}\right) = 1.3506438 \dots$$

The right-hand-side of (6.6.12) is thus numerically equal to

$$2(1.3506438 \dots) - (1.8540746 \dots) = 0.847213 \dots$$

and so (6.6.12) and MATLAB are in *excellent* agreement.

6.7 Challenge Problems

To end this chapter on tough integrals, it seems appropriate to challenge you with some tough integrals.

(C6.1): Look back at Sect. 6.3, where we evaluated what I called Coxeter's integral. But that wasn't the *only* Coxeter integral. Coxeter was actually (as you'll recall from the Preface) stumped by a number of integrals, all of which Hardy solved. So, here's another one of Coxeter's original integrals for you to try your hand at:

$$\int_0^{\pi/2} \cos^{-1} \left\{ \frac{1}{1 + 2 \cos(x)} \right\} dx.$$

When this is given to MATLAB we get `quad(@(x)acos(1./(1+2*cos(x))),0,pi/2) = 1.64493...` which ought to suggest to you (after reading Sect. 5.3) that the exact value is Euler’s $\zeta(2) = \frac{\pi^2}{6}$. Your challenge here is to prove that this is indeed so. Hint: this actually isn’t all *that* tough—at least it shouldn’t be after reading Sect. 6.3—and the integral will yield using the same approach we used in the text.

(C6.2): When we get to Chap. 8 on contour integration we’ll do the integral $\int_0^\infty \frac{x^m}{x^n + 1} dx$, where (to insure the integral exists) m and n are non-negative integers such that $n - m \geq 2$. For the special case of $m = 1$ —see (8.7.8)—the result is $\int_0^\infty \frac{x}{x^n + 1} dx = \frac{\pi/n}{\sin(\frac{2\pi}{n})}$, $n \geq 3$. If we evaluate the right-hand-side for the first few values of permissible n , we get

n	Value of integral
3	1.2091995
4	0.7853981
5	0.6606532
6	0.6045997
7	0.5740354

Now, consider the integral $\int_0^\infty \frac{dx}{x^{n-1} + x^{n-2} + \dots + x + 1}$, $n \geq 3$. If we use MATLAB’s `quad` to numerically evaluate this integral for the same values of n we get

n	Value of integral
3	1.2091992
4	0.7853988
5	0.6606537
6	0.6046002
7	0.5740356

These numerical results strongly suggest that the two integrals might be equal. You *could* study this question directly, by ‘simply’ evaluating the second integral (but that might not be so ‘simple’!). Another possibility is to first write the difference of the two integrands $f(x) = \frac{x}{x^n + 1} - \frac{1}{x^{n-1} + x^{n-2} + \dots + x + 1}$, and then (somehow) show that $\int_0^\infty f(x) dx = 0$. See if you can do this.

(C6.3): Here’s a problem reminiscent of the ‘sophomore’s dream’ of (6.1.4). There is a value of c with $0 < c < 1$ such that $\int_0^1 c^x dx = \sum_{k=1}^\infty c^k$. Calculate the value of c accurate to *at least* 13 decimal places and, for that value, what is the common value

of the integral and the sum? Hint: to start, observe that since c is between 0 and 1 there must be some $\lambda > 0$ such that $c = e^{-\lambda}$. ($\lambda = 0$ gives $c = 1$, and $\lambda = \infty$ gives $c = 0$.) This notational trick makes both the integral and the sum easy to evaluate. Then, equate your expressions for the integral and the sum to get a transcendental equation for λ , an equation that can be solved numerically using any number of well-known algorithms (my suggestion: see any book on numerical analysis and look for a discussion of the *binary chop* algorithm) to give c to the required accuracy.

(C6.4): I mentioned ‘Cayley’s Problem’ in the text, but didn’t provide any details. It is the problem of computing how a uniform mass density (μ) linked-chain, initially heaped-up near the edge of a table, falls from the table as it slides without friction over the edge. If x is the length of the chain hanging over the edge at time t , then the problem is to find the differential equation of motion (involving x and t) and then to solve (that is, integrate) it for x as a function of t . In his 1943 book *Mechanics*, the German physicist Arnold Sommerfeld (1868–1951) stated without derivation that the equation of motion is (where g is the acceleration of gravity) $\frac{d}{dt}(x\dot{x}) = x\ddot{x} + \dot{x}^2 = gx$. In this dot notation (due to Newton) $\dot{x} = \frac{dx}{dt}$ and $\ddot{x} = \frac{d^2x}{dt^2}$. In Leibnitz’s more suggestive differential notation, Sommerfeld’s equation of motion is $\frac{d}{dt}(x \frac{dx}{dt}) = x \frac{d^2x}{dt^2} + (\frac{dx}{dt})^2 = gx$, and of it he said “its integration is somewhat difficult.” A very clever derivation of Sommerfeld’s equation can be found in the paper by David Keiffer, “The Falling Chain and Energy Loss,” *American Journal of Physics*, March 2001, pp. 385–386. Keiffer made no reference to Sommerfeld, but rather based his derivation on a direct analysis of how a chain slides off a table, link-by-link. Keiffer gave an interesting twist to problem by converting it to determining the speed of the falling chain as a function not of time, but rather as a function of the length of chain that has already slid off the table (that is, of x). Calling the speed $v(x)$, his equation of motion is $\frac{d(v^2)}{dx} = -\frac{2}{x}v^2 + 2g$.

- Show that Keiffer’s equation and Sommerfeld’s equation are one-in-the-same;
- Noticing that Keiffer’s equation is a first-order differential equation in v^2 , use the same approach we used in Chap. 3 (Sect. 3.9) to integrate Keiffer’s equation to find v^2 . Hint: consider using x^2 as the integrating factor;
- Show that the chain falls with the constant acceleration $\frac{1}{3}g$ (this was Cayley’s central result);
- Use your result from (b) to calculate T , the time for a chain of length L to completely slide off the table.

Now, in the interest of honesty, I have to tell you that while all your calculations in response to the above questions represent good, solid *math*, there has been much debate in recent years on whether or not it is good *physics*! The Cayley, Sommerfeld, Keiffer analyses involve a failure of energy conservation when a chain slides off a table. This is actually quite easy to show. The chain’s initial P.E. and K.E. are both zero (the table top is our zero reference level for P.E., and the chain is initially at rest), and so the initial total energy is

zero. When the chain has just finished sliding completely off the table, its speed is $\sqrt{\frac{2gL}{3}}$, a result you should have already come across in your earlier analyses. So, its K.E. is $\frac{1}{2}(\mu L)\frac{2gL}{3} = \mu\frac{L^2g}{3}$. The chain's center of mass is at $\frac{1}{2}$ below the table top, and so its P.E. is $-\mu Lg\frac{1}{2} = -\mu\frac{L^2g}{2}$. Thus, at the completion of the fall its total energy is $\mu\frac{L^2g}{3} - \mu\frac{L^2g}{2} < 0$. Thus, energy was lost during the fall. (This is a puzzle in its own right, since the slide was said to be frictionless. So, *how* is energy dissipated? This was, in fact, the question that stimulated Keiffer to write his paper in the first place.) In recent years, other physicists have claimed that Cayley's falling chain *does* conserve energy. So, for your last question here,

- (e) Assuming conservation of energy, show that the chain falls with the constant acceleration of $\frac{1}{2}g$ (not Cayley's $\frac{1}{3}g$).

(C6.5): This problem involves a very different appearance of integrals in yet another physics problem. (See James M. Supplee and Frank W. Schmidt, "Brachistochrone in a Central Force Field," *American Journal of Physics*, May 1991, pp. 402 and 467.) Imagine a tiny bead of mass m with a wire threaded through a hole in it, allowing the bead to slide *without friction* along the wire. The wire lies entirely in a horizontal plane, with one end (in terms of the polar coordinates r and θ) at $(R, \frac{\pi}{3})$ and the other end on the horizontal axis at $(R, 0)$. The only force acting on the bead is the inverse-square gravitational force due to a point mass M located at the origin. That is, the bead slides on the wire because it experiences the attractive radial force $F = G\frac{Mm}{r^2}$, where G is the universal gravitational constant. The bead has initial speed $\sqrt{2\frac{GM}{R}}$. What shape function $r(\theta)$ should the wire have to minimize the travel time of the bead as it slides from $(R, 0)$ to $(R, \frac{\pi}{3})$? To answer this question, fill-in the details of the following steps.

- (a) Show that the initial potential energy (P.E.) of the bead is $-\frac{GMm}{R}$, and that the initial kinetic energy (K.E.) of the bead is $\frac{GMm}{R}$, and so the total initial energy is zero. Hint: the initial P.E. is the energy required to transport the mass m in from infinity along the positive horizontal axis to $r = R$, which is given by $\int_{\infty}^R F dr$. This energy is *negative* because gravity is *attractive*;
- (b) If T is the total time for the bead to travel from one end to the other, then T

$$= \int dt = \int \frac{ds}{v}$$
 where v is the instantaneous speed of the bead and ds is the differential path length along the wire. In polar coordinates $(ds)^2 = (dr)^2 + (rd\theta)^2$ and thus $ds = d\theta\sqrt{\left(\frac{dr}{d\theta}\right)^2 + r^2}$. Invoking conservation of energy (K.E. + P.E. = 0, *always*, because there is no friction), show that

$$T = \frac{1}{\sqrt{2GM}} \int_0^{\pi/3} \sqrt{r\left(\frac{dr}{d\theta}\right)^2 + r^3} d\theta;$$

- (c) To minimize T is a problem beyond ordinary freshman differential calculus, where we try to find the value of a variable that gives the extrema of some function. Our problem here is to find a *function* that minimizes the integral for T . This is a problem in what is called the *calculus of variations*, and a fundamental result from that subject is the *Euler-Lagrange equation*: if we write the integrand of the T -integral as $K = \sqrt{rr'^2 + r^3}$, where $r' = \frac{dr}{d\theta}$, then $\frac{\partial K}{\partial r} - \frac{d}{d\theta} \left(\frac{\partial K}{\partial r'} \right) = 0$. This result is derived in any book on the calculus of variations (or see my book *When Least Is Best*, Princeton 2004, 2007, pp. 233–238). Euler knew it by 1736, but the derivation I give in *WLIB* is the now standard one developed by the French-Italian mathematical physicist Joseph Louis Lagrange (1736–1813), in a letter the then *teenage* (!) Lagrange wrote to Euler in 1755. Use the Euler-Lagrange equation to show that the required $r(\theta)$ satisfies the differential equation $5r'^2 + 3r^2 = 2r'r''$, where $r'' = \frac{d^2r}{d\theta^2}$;
- (d) Change variable to $u = \frac{r'}{r}$, and show that the differential equation in (c) becomes $u^2 + 1 = \frac{2}{3}u'$, where $u' = \frac{du}{d\theta}$. Hint: Start by writing the differential equation in (c) as

$$3r'^2 + 3r^2 = 2r'r'' - 2r'^2;$$

- (e) The differential equation in (d) is $\frac{3}{2}d\theta = \frac{du}{1+u^2}$ which you should be able to easily integrate indefinitely to show that $u = \tan\left(\frac{3}{2}\theta + C_1\right)$, where C_1 is an arbitrary constant;
- (f) The result in (e) says $\frac{1}{r} \frac{dr}{d\theta} = \tan\left(\frac{3}{2}\theta + C_1\right)$, which you should be able to integrate indefinitely to show that $r = C_2 \cos^{-2/3}\left(\frac{3}{2}\theta + C_1\right)$;
- (g) Use the coordinates of the ends of the wire to evaluate the constants C_1 and C_2 , thus arriving at $r(\theta) = \frac{R}{\sqrt[3]{2} \cos^{2/3}\left(\frac{3}{2}\theta - \frac{\pi}{4}\right)}$, a curve called a *brachistochrone*, from the Greek *brachistos* (shortest) and *chronos* (time). Note, carefully, that it is *not* the shortest *length* curve, which of course would be a straight line segment.

Chapter 7

Using $\sqrt{-1}$ to Evaluate Integrals

7.1 Euler’s Formula

The use of $i = \sqrt{-1}$ to compute integrals is nicely illustrated with a quick example. Let’s use i to do

$$\int_1^\infty \frac{dx}{x(x^2 + 1)}.$$

Making a partial fraction expansion of the integrand, we can write

$$\begin{aligned} \int_1^\infty \frac{dx}{x(x^2 + 1)} &= \int_1^\infty \left\{ \frac{1}{x} - \frac{1}{2(x - i)} - \frac{1}{2(x + i)} \right\} dx \\ &= \left\{ \ln(x) - \frac{1}{2}\ln(x - i) - \frac{1}{2}\ln(x + i) \right\} \Big|_1^\infty \\ &= \left\{ \ln(x) + \ln\left(\frac{1}{\sqrt{x - i}}\right) + \ln\left(\frac{1}{\sqrt{x + i}}\right) \right\} \Big|_1^\infty \\ &= \ln\left\{ \frac{x}{\sqrt{(x - i)(x + i)}} \right\} \Big|_1^\infty = \ln\left\{ \frac{x}{\sqrt{x^2 + 1}} \right\} \Big|_1^\infty = \ln(1) - \ln\left(\frac{1}{\sqrt{2}}\right) \\ &= \ln(\sqrt{2}) = \frac{1}{2}\ln(2) = 0.34657\dots \end{aligned}$$

Checking with *quad*, $quad(@(x)1./(x.*(x.^2 + 1)),1,1000) = 0.34657\dots$

This is nice, yes, but the utility of complex-valued quantities in doing definite integrals will *really* become clear when we get to the next chapter, on contour integration. The value of the complex can be immediately appreciated at a ‘lower’

level, however, without having to wait for contour integrals, and all we'll really need to get started is Euler's famous identity:

$$(7.1.1) \quad e^{ibx} = \cos(bx) + i \sin(bx),$$

where b is any real quantity. I'll take (7.1.1) as known to you, but if you want to explore it further, both mathematically and historically, you can find more in two of my earlier books.¹

A very straightforward and yet still quite interesting demonstration of Euler's identity can be found in the problem of calculating

$$\int_0^{\infty} \sin(bx)e^{-xy} dx.$$

This is usually done by-parts in freshman calculus, but using $\sqrt{-1}$ is easier. Since

$$e^{-ibx} = \cos(bx) - i \sin(bx)$$

it then follows that

$$\sin(bx) = \frac{e^{ibx} - e^{-ibx}}{2i}.$$

Thus,

$$e^{-xy} \sin(bx) = \frac{e^{-x(y-ib)} - e^{-x(y+ib)}}{2i}$$

and so

$$\begin{aligned} \int_0^{\infty} e^{-xy} \sin(bx) dx &= \frac{1}{2i} \int_0^{\infty} \left\{ e^{-x(y-ib)} - e^{-x(y+ib)} \right\} dx \\ &= \frac{1}{2i} \left\{ \frac{e^{-x(y-ib)}}{-(y-ib)} - \frac{e^{-x(y+ib)}}{-(y+ib)} \right\} \Big|_0^{\infty} = \frac{1}{2i} \left\{ \frac{1}{y-ib} - \frac{1}{y+ib} \right\} \\ &= \frac{1}{2i} \left\{ \frac{y+ib - y+ib}{y^2 + b^2} \right\} = \frac{2ib}{2i(y^2 + b^2)} \end{aligned}$$

¹ *An Imaginary Tale: the story of $\sqrt{-1}$* , and *Dr. Euler's Fabulous Formula: cures many mathematical ills*, both published by Princeton University Press (both in multiple editions).

and so

$$(7.1.2) \quad \int_0^\infty \sin(bx)e^{-xy} dx = \frac{b}{y^2 + b^2}.$$

7.2 The Fresnel Integrals

Well, that last calculation was certainly interesting but, to *really* demonstrate to you the power of Euler's identity, I'll now show you how to use it to derive two famous definite integrals named after the French scientist Augustin Jean Fresnel (1788–1827). There is just a bit of irony in the fact that, despite the name, it was actually *Euler* who first found the values (in 1781) of—before Fresnel was even born!—the ‘Fresnel’ integrals,

$$\int_0^\infty \cos(x^2) dx \quad \text{and} \quad \int_0^\infty \sin(x^2) dx,$$

using a different approach from what I'm going to show you.² (We used the value of the second integral in Sect. 6.4, in the discussion of the Hardy-Schuster optical integral.)

We start with

$$G(x) = \left\{ \int_0^x e^{it^2} dt \right\}^2 + i \int_0^1 \frac{e^{ix^2(t^2+1)}}{t^2+1} dt.$$

(I'll explain where this rather curious $G(x)$ comes from in just a moment.)

Notice, in passing, that

$$G(0) = 0 + i \int_0^1 \frac{dt}{t^2+1} = i \tan^{-1}(1) = i \frac{\pi}{4},$$

which will be important for us to know a few steps from now. Differentiating $G(x)$ with respect to x ,

$$\begin{aligned} \frac{dG}{dx} &= 2 \left\{ \int_0^x e^{it^2} dt \right\} e^{ix^2} + i \int_0^1 \frac{i2x(t^2+1)e^{ix^2(t^2+1)}}{t^2+1} dt \\ &= 2e^{ix^2} \int_0^x e^{it^2} dt - 2x \int_0^1 e^{ix^2 t^2} e^{ix^2} dt = 2e^{ix^2} \int_0^x e^{it^2} dt - 2xe^{ix^2} \int_0^1 e^{ix^2 t^2} dt. \end{aligned}$$

²Euler used the gamma function (another of his creations that you'll recall from Chap. 4) in his 1781 analysis, and you can see how *he* did the Fresnel integrals in *An Imaginary Tale*, pp. 175–180. As you'd expect from Euler, it's breathtakingly clever.

In the last integral change variable to $u = tx$ (and so $du = x dt$ or, $dt = du/x$). Then,

$$\frac{dG}{dx} = 2e^{ix^2} \int_0^x e^{it^2} dt - 2xe^{ix^2} \int_0^x e^{iu^2} \frac{du}{x} = 2e^{ix^2} \left[\int_0^x e^{it^2} dt - \int_0^x e^{iu^2} du \right] = 0.$$

That is, $G(x)$ has zero rate of change with respect to x , for *all* x . $G(x)$ is therefore a *constant* and, since $G(0) = i\frac{\pi}{4}$, *that's* the constant. This result explains the origin of the remarkably 'strange' $G(x)$; it was specially created to have the property of a zero-everywhere derivative!

Now, as $x \rightarrow \infty$, we have

$$\lim_{x \rightarrow \infty} \int_0^1 \frac{e^{ix^2(t^2+1)}}{t^2+1} dt = 0,$$

a claim that I'll justify at the end of this section (but see if you can do it for yourself before I get to the end of the section). For now, just accept it. Then,

$$G(\infty) = \left\{ \int_0^\infty e^{it^2} dt \right\}^2 = \left\{ \int_0^\infty \cos(t^2) dt + i \int_0^\infty \sin(t^2) dt \right\}^2.$$

Let's write this as

$$G(\infty) = (A + iB)^2$$

where A and B are the Fresnel integrals:

$$A = \int_0^\infty \cos(t^2) dt \quad \text{and} \quad B = \int_0^\infty \sin(t^2) dt.$$

Then, since $G(\infty) = i\frac{\pi}{4}$ (remember, $G(x)$ doesn't change as x changes and so $G(\infty) = G(0)$) we have

$$(A + iB)^2 = i\frac{\pi}{4} = A^2 + i2AB - B^2$$

and so, equating real and imaginary parts on both sides of the last equality, we have $A^2 - B^2 = 0$ (which means $A = B$) and $2AB = \frac{\pi}{4}$. So, $2A^2 = \frac{\pi}{4}$ and, suddenly, *we are done*: $A = \sqrt{\frac{\pi}{8}} = \frac{1}{2}\sqrt{\frac{\pi}{2}} = 0.6266\dots$ and (because $A = B$) we have the Fresnel integrals:

$$(7.2.1) \quad \int_0^\infty \cos(x^2) dx = \frac{1}{2} \sqrt{\frac{\pi}{2}}$$

and

$$(7.2.2) \quad \int_0^\infty \sin(x^2) dx = \frac{1}{2} \sqrt{\frac{\pi}{2}}$$

Checking, $quad(@(x)\sin(x.^2),0,30) = 0.6255\dots$ and $quad(@(x)\cos(x.^2),0,35) = 0.6235\dots$, both suggestively close to $\frac{1}{2}\sqrt{\frac{\pi}{2}}$. And since

$$\int_0^\infty e^{ix^2} dx = \int_0^\infty \cos(x^2) dx + i \int_0^\infty \sin(x^2) dx$$

we have the interesting integral

$$(7.2.3) \quad \int_0^\infty e^{ix^2} dx = \frac{1}{2} \sqrt{\frac{\pi}{2}} (1 + i)$$

To finish this discussion, I really should justify my earlier claim that

$$\lim_{x \rightarrow \infty} \int_0^1 \frac{e^{ix^2(t^2+1)}}{t^2+1} dt = 0.$$

To show this, use Euler's identity to write

$$\int_0^1 \frac{e^{ix^2(t^2+1)}}{t^2+1} dt = \int_0^1 \frac{\cos\{x^2(t^2+1)\}}{t^2+1} dt + i \int_0^1 \frac{\sin\{x^2(t^2+1)\}}{t^2+1} dt.$$

Since

$$\cos\{x^2(t^2+1)\} = \cos(x^2t^2 + x^2) = \cos(x^2t^2)\cos(x^2) - \sin(x^2t^2)\sin(x^2)$$

and

$$\sin\{x^2(t^2+1)\} = \sin(x^2t^2 + x^2) = \sin(x^2t^2)\cos(x^2) + \cos(x^2t^2)\sin(x^2),$$

and because as $x \rightarrow \infty$ the factors $\cos(x^2)$ and $\sin(x^2)$ remain confined to ± 1 , our claim will be established if we can show that

$$\lim_{x \rightarrow \infty} \int_0^1 \frac{\sin \{x^2 t^2\}}{t^2 + 1} dt = \lim_{x \rightarrow \infty} \int_0^1 \frac{\cos \{x^2 t^2\}}{t^2 + 1} dt = 0.$$

Consider the first integral, and make the change of variable $u = t^2$. Then $\frac{du}{dt} = 2t$ and so $dt = \frac{1}{2t} du$ or, as $t = \sqrt{u}$, we have $dt = \frac{1}{2\sqrt{u}} du$. So,

$$\begin{aligned} \int_0^1 \frac{\sin \{x^2 t^2\}}{t^2 + 1} dt &= \int_0^1 \frac{\sin \{x^2 u\}}{u + 1} \left(\frac{1}{2\sqrt{u}} \right) du = \frac{1}{2} \int_0^1 \frac{\sin \{x^2 u\}}{(u + 1)\sqrt{u}} du \\ &< \int_0^1 \frac{\sin \{x^2 u\}}{\sqrt{u}} du, \end{aligned}$$

where the inequality follows both from dropping the $\frac{1}{2}$ factor and replacing the denominator in the integrand with a smaller quantity. Notice that the integrand of the right-most integral is an amplitude-damped sinusoid, with each new half-cycle bounding ever-less area (with alternating signs). The areas of the half-cycles form the terms of a monotonically decreasing *alternating* series, and the total area of the half-cycles is the value of the integral.

Now, recall a beautiful result from numerical analysis that says any partial sum of such a series, with more than one term, is less than the *first* term.³ Since the zeros of $\sin\{x^2 u\}$ occur at $x^2 u = n\pi$, then the first two zeros in the integration interval (the start and end of the first half-cycle) are at $u = 0$ and $u = \frac{\pi}{x^2}$, respectively, and so replacing $\sin\{x^2 u\}$ with its greatest value of 1, we have the even stronger inequality

$$\int_0^1 \frac{\sin \{x^2 t^2\}}{t^2 + 1} dt < \int_0^{\pi/x^2} \frac{1}{\sqrt{u}} du = 2(\sqrt{u}) \Big|_0^{\pi/x^2} = \frac{2\sqrt{\pi}}{x}$$

and so, since any partial sum of our alternating series is clearly never negative, we have

$$\lim_{x \rightarrow \infty} \int_0^1 \frac{\sin \{x^2 t^2\}}{t^2 + 1} dt = \lim_{x \rightarrow \infty} \frac{2\sqrt{\pi}}{x} = 0.$$

A trivial modification in the above argument shows that

$$\lim_{x \rightarrow \infty} \int_0^1 \frac{\cos \{x^2 t^2\}}{t^2 + 1} dt = 0$$

as well.

³ You can find the proof of this (which requires only elementary algebra) in just about any freshman calculus textbook. Look in the index under the ‘conditional convergence of alternating series,’ or something along those lines. In my old copy of Thomas’ *Calculus and Analytic Geometry*, for example, that I mentioned back in the Introduction (Chap. 1, Sect. 1.4), it’s on pp. 614–615.

7.3 $\zeta(3)$ and More Log-Sine Integrals

You'll recall, from Chap. 5 (Sect. 5.3), Euler's fascination with the zeta function $\zeta(s) = \sum_{k=1}^{\infty} \frac{1}{k^s}$. He found explicit formulas for $\zeta(s)$ for any positive *even* integer value of s but he couldn't do the same for the odd values of s , even though he devoted enormous time and energy to the search. In 1772 he came as close as he ever would when he stated

$$\int_0^{\pi/2} x \ln\{\sin(x)\} dx = \frac{7}{16} \zeta(3) - \frac{\pi^2}{8} \ln(2).$$

The key to understanding how such an incredible result could be discovered, as you might expect from the earlier sections of this chapter, is Euler's identity. Here's how it goes.

Define the function $S(y)$ as

$$S(y) = 1 + e^{iy} + e^{i2y} + e^{i3y} + \dots + e^{imy}$$

where m is some finite integer. This looks like a geometric series and so, using the standard trick for summing such series, multiply through by the common factor e^{iy} that connects any two adjacent terms. Then,

$$e^{iy}S(y) = e^{iy} + e^{i2y} + e^{i3y} + \dots + e^{imy} + e^{i(m+1)y}$$

and so

$$e^{iy}S(y) - S(y) = e^{i(m+1)y} - 1.$$

Solving for $S(y)$,

$$\begin{aligned} S(y) &= \frac{e^{i(m+1)y} - 1}{e^{iy} - 1} = \frac{e^{i(m+1)y} - 1}{e^{i\frac{y}{2}}(e^{i\frac{y}{2}} - e^{-i\frac{y}{2}})} = \frac{e^{i(m+\frac{1}{2})y} - e^{-i\frac{y}{2}}}{i2 \sin(\frac{y}{2})} \\ &= \frac{\cos\{(m+\frac{1}{2})y\} + i \sin\{(m+\frac{1}{2})y\} - \cos(\frac{y}{2}) + i \sin(\frac{y}{2})}{i2 \sin(\frac{y}{2})} \end{aligned}$$

Now, looking back at the original definition of $S(y)$, we see that it can also be written as

$$S(y) = 1 + \sum_{n=1}^m \cos(ny) + i \sum_{n=1}^m \sin(ny).$$

So, equating the imaginary parts of our two alternative expressions for $S(y)$, we have

$$-\frac{\cos\left\{\left(m + \frac{1}{2}\right)y\right\}}{2 \sin\left(\frac{y}{2}\right)} + \frac{\cos\left(\frac{y}{2}\right)}{2 \sin\left(\frac{y}{2}\right)} = \sum_{n=1}^m \sin(ny).$$

At this point it is convenient to change variable to $y = 2t$, and so

$$-\frac{\cos\{(2m+1)t\}}{\sin(t)} + \cot(t) = 2 \sum_{n=1}^m \sin(2nt).$$

Then, integrate this expression, term-by-term, from $t = x$ to $t = \frac{\pi}{2}$, getting

$$-\int_x^{\frac{\pi}{2}} \frac{\cos\{(2m+1)t\}}{\sin(t)} dt + \int_x^{\frac{\pi}{2}} \cot(t) dt = 2 \sum_{n=1}^m \int_x^{\frac{\pi}{2}} \sin(2nt) dt.$$

The integral on the right of the equality sign is easy to do:

$$\begin{aligned} \int_x^{\frac{\pi}{2}} \sin(2nt) dt &= \left\{ -\frac{\cos(2nt)}{2n} \right\}_x^{\frac{\pi}{2}} = \frac{-\cos(n\pi) + \cos(2nx)}{2n} \\ &= \frac{\cos(2nx) - (-1)^n}{2n}. \end{aligned}$$

The last integral on the left of the equality sign is just as easy:

$$\int_x^{\frac{\pi}{2}} \cot(t) dt = [\ln\{\sin(t)\}]_x^{\frac{\pi}{2}} = \ln\left\{\sin\left(\frac{\pi}{2}\right)\right\} - \ln\{\sin(x)\} = -\ln\{\sin(x)\}.$$

Thus,

$$\boxed{-\int_x^{\frac{\pi}{2}} \frac{\cos\{(2m+1)t\}}{\sin(t)} dt - \ln\{\sin(x)\} = \sum_{n=1}^m \frac{\cos(2nx)}{n} - \sum_{n=1}^m \frac{(-1)^n}{n} .}$$

You'll recall that at the start of Sect. 5.2 we had the power series

$$\ln(1+x) = x - \frac{x^2}{2} + \frac{x^3}{3} - \frac{x^4}{4} + \dots$$

and so, with $x = 1$, this says

$$\ln(2) = -\sum_{n=1}^m \frac{(-1)^n}{n}.$$

So, if we let $m \rightarrow \infty$ in the above boxed equation we have

$$-\lim_{m \rightarrow \infty} \int_x^{\frac{\pi}{2}} \frac{\cos \{(2m + 1)t\}}{\sin(t)} dt - \ln\{\sin(x)\} = \sum_{n=1}^{\infty} \frac{\cos(2nx)}{n} + \ln(2).$$

Since the limit of the integral at the far left is zero,⁴ we arrive at

$$\ln\{\sin(x)\} = -\sum_{n=1}^{\infty} \frac{\cos(2nx)}{n} - \ln(2).$$

The next step (one not particularly obvious!) is to first multiply through by x and then integrate from 0 to $\frac{\pi}{2}$. That is, to write

$$\begin{aligned} \int_0^{\frac{\pi}{2}} x \ln\{\sin(x)\} dx &= -\sum_{n=1}^{\infty} \frac{1}{n} \int_0^{\frac{\pi}{2}} x \cos(2nx) dx - \ln(2) \int_0^{\frac{\pi}{2}} x dx \\ &= -\sum_{n=1}^{\infty} \frac{1}{n} \int_0^{\frac{\pi}{2}} x \cos(2nx) dx - \frac{\pi^2}{8} \ln(2). \end{aligned}$$

To do the integral on the right, use integration by parts, with $u = x$ and $dv = \cos(2nx)dx$. By this time in the book you should find this to be old hat, and so I'll let *you* fill-in the details to show that

$$\int_0^{\frac{\pi}{2}} x \cos(2nx) dx = \begin{cases} -\frac{1}{2n^2}, & \text{if } n \text{ is odd} \\ 0, & \text{if } n \text{ is even.} \end{cases}$$

Thus,

$$\int_0^{\frac{\pi}{2}} x \ln\{\sin(x)\} dx = \frac{1}{2} \left\{ \sum_{n=1, n \text{ odd}}^{\infty} \frac{1}{n^3} \right\} - \frac{\pi^2}{8} \ln(2).$$

We are now almost done. All that's left to do is to note that

$$\begin{aligned} \sum_{n=1, n \text{ even}}^{\infty} \frac{1}{n^3} &= \frac{1}{2^3} + \frac{1}{4^3} + \frac{1}{6^3} + \dots = \frac{1}{(2 \cdot 1)^3} + \frac{1}{(2 \cdot 2)^3} + \frac{1}{(2 \cdot 3)^3} + \dots \\ &= \frac{1}{8} \left(\frac{1}{1^3} + \frac{1}{2^3} + \frac{1}{3^3} + \dots \right) = \frac{1}{8} \sum_{n=1}^{\infty} \frac{1}{n^3} = \frac{1}{8} \zeta(3). \end{aligned}$$

⁴This assertion follows from the almost intuitively obvious *Riemann-Lebesgue lemma*, which says that if $f(t)$ is *absolutely integrable* over the interval a to b , then $\lim_{m \rightarrow \infty} \int_a^b f(t) \cos(mt) dt = 0$. In our case, $f(t) = \frac{1}{\sin(t)}$ which is absolutely integrable over $0 < x \leq t \leq \frac{\pi}{2}$ since over that interval $|\ln\{f(t)\}| < \infty$. You can find a proof of the lemma (it's not difficult) in Georgi P. Tolstov's book *Fourier Series* (translated from the Russian by Richard A. Silverman), Dover 1976, pp. 70–71.

And so, since

$$\sum_{n=1, n \text{ odd}}^{\infty} \frac{1}{n^3} + \sum_{n=1, n \text{ even}}^{\infty} \frac{1}{n^3} = \zeta(3)$$

we have

$$\sum_{n=1, n \text{ odd}}^{\infty} \frac{1}{n^3} = \zeta(3) - \sum_{n=1, n \text{ even}}^{\infty} \frac{1}{n^3} = \zeta(3) - \frac{1}{8}\zeta(3) = \frac{7}{8}\zeta(3).$$

Thus, just as Euler declared,

(7.3.1)

$$\int_0^{\pi/2} x \ln\{\sin(x)\} dx = \frac{7}{16}\zeta(3) - \frac{\pi^2}{8}\ln(2).$$

The right-hand-side of (7.3.1) is $(\frac{7}{16})(1.20205\dots) - \frac{\pi^2}{8}\ln(2) = -0.32923\dots$, while the integral on the left is equal to $\text{quad}(@x)x.*\log(\sin(x)),0,\pi/2) = -0.32923\dots$

As I mentioned in Chap. 2 (Sect. 2.4), years ago it was often claimed in textbooks that Euler's log-sine integral was best left to the massive power of contour integration. Yet, as you've seen in this book, classical techniques do quite well. I'll now show you that even if we 'up-the-anty,' to log-sine integrals with a *squared* integrand, we can still do a lot. Specifically, let

$$I_1 = \int_0^{\pi/2} \ln^2\{a \sin(\theta)\} d\theta = \int_0^{\pi/2} \ln^2\{a \cos(\theta)\} d\theta$$

and

$$I_2 = \int_0^{\pi/2} \ln\{a \sin(\theta)\} \ln\{a \cos(\theta)\} d\theta$$

where a is a positive constant. These integrals were *not* evaluated by Euler, but rather are due to the now nearly forgotten English mathematician Joseph Wolstenholme (1829–1891). Here's how to do them.

$$\begin{aligned} & \int_0^{\pi/2} [\ln\{a \sin(\theta)\} + \ln\{a \cos(\theta)\}]^2 d\theta \\ &= \int_0^{\pi/2} \ln^2\{a^2 \sin(\theta) \cos(\theta)\} d\theta \\ &= \int_0^{\pi/2} \ln^2\{a \sin(\theta)\} d\theta + \int_0^{\pi/2} \ln^2\{a \cos(\theta)\} d\theta \\ &+ 2 \int_0^{\pi/2} \ln\{a \sin(\theta)\} \ln\{a \cos(\theta)\} d\theta = 2I_1 + 2I_2. \end{aligned}$$

But since

$$\int_0^{\pi/2} \ln^2 \left\{ a^2 \sin(\theta) \cos(\theta) \right\} d\theta = \int_0^{\pi/2} \ln^2 \left\{ a^2 \frac{\sin(2\theta)}{2} \right\} d\theta$$

then

$$\begin{aligned} 2I_1 + 2I_2 &= \int_0^{\pi/2} \ln^2 \left\{ a^2 \frac{\sin(2\theta)}{2} \right\} d\theta = \int_0^{\pi/2} \left[\ln\{a \sin(2\theta)\} - \ln\left\{\frac{2}{a}\right\} \right]^2 d\theta \\ &= \int_0^{\pi/2} \ln^2\{a \sin(2\theta)\} d\theta - 2\ln\left\{\frac{2}{a}\right\} \int_0^{\pi/2} \ln\{a \sin(2\theta)\} d\theta + \ln^2\left\{\frac{2}{a}\right\} \int_0^{\pi/2} d\theta. \end{aligned}$$

Write $\phi = 2\theta$. So, as $d\theta = \frac{1}{2}d\phi$, we have

$$\int_0^{\pi/2} \ln^2\{a \sin(2\theta)\} d\theta = \frac{1}{2} \int_0^{\pi} \ln^2\{a \sin(\phi)\} d\phi = \int_0^{\pi/2} \ln^2\{a \sin(\phi)\} d\phi = I_1$$

and, by (2.4.1),

$$\int_0^{\pi/2} \ln\{a \sin(2\theta)\} d\theta = \frac{1}{2} \int_0^{\pi} \ln\{a \sin(\phi)\} d\phi = \int_0^{\pi/2} \ln\{a \sin(\phi)\} d\phi = \frac{\pi}{2} \ln\left(\frac{a}{2}\right).$$

Thus,

$$2I_1 + 2I_2 = I_1 - 2\ln\left\{\frac{2}{a}\right\} \frac{\pi}{2} \ln\left(\frac{a}{2}\right) + \frac{\pi}{2} \ln^2\left\{\frac{2}{a}\right\}$$

or,

$$I_1 + 2I_2 = -2\ln\left\{\frac{2}{a}\right\} \frac{\pi}{2} \ln\left(\frac{a}{2}\right) + \frac{\pi}{2} \ln^2\left\{\frac{2}{a}\right\}.$$

Also,

$$\begin{aligned} &\int_0^{\pi/2} [\ln\{a \sin(\theta)\} - \ln\{a \cos(\theta)\}]^2 d\theta \\ &= \int_0^{\pi/2} \ln^2\{a \sin(\theta)\} d\theta + \int_0^{\pi/2} \ln^2\{a \cos(\theta)\} d\theta - 2 \int_0^{\pi/2} \ln\{a \sin(\theta)\} \ln\{a \cos(\theta)\} d\theta \\ &= 2I_1 - 2I_2 = \int_0^{\pi/2} \ln^2\left\{\frac{a \sin(\theta)}{a \cos(\theta)}\right\} d\theta = \int_0^{\pi/2} \ln^2\{\tan(\theta)\} d\theta = \frac{\pi^3}{8} \end{aligned}$$

by (5.2.7). So, we have the simultaneous pair of equations

$$I_1 + 2I_2 = -2\ln\left\{\frac{2}{a}\right\} \frac{\pi}{2} \ln\left(\frac{a}{2}\right) + \frac{\pi}{2} \ln^2\left\{\frac{2}{a}\right\}$$

$$I_1 - I_2 = \frac{\pi^3}{16}$$

which are easily solved to give

$$(7.3.2) \quad \int_0^{\pi/2} \ln^2\{a \sin(\theta)\}d\theta = \int_0^{\pi/2} \ln^2\{a \cos(\theta)\}d\theta$$

$$= \frac{\pi^3}{24} + \frac{\pi}{6} \left[\ln^2\left\{\frac{2}{a}\right\} - 2\ln\left\{\frac{2}{a}\right\} \ln\left(\frac{a}{2}\right) \right].$$

and

$$(7.3.3) \quad \int_0^{\pi/2} \ln\{a \sin(\theta)\} \ln\{a \cos(\theta)\}d\theta = \frac{\pi}{6} \left[\ln^2\left\{\frac{2}{a}\right\} - 2\ln\left\{\frac{2}{a}\right\} \ln\left(\frac{a}{2}\right) \right] - \frac{\pi^3}{48}.$$

For example, if $a=2$ this is equal to $-\frac{\pi^3}{48} = -0.645964\dots$ and MATLAB agrees, as

`quad(@(x)log(2*sin(x)).*log(2*cos(x)),0,pi/2) = -0.645979\dots`, while for $a=1$ (7.3.3) reduces to $\frac{\pi}{2} \ln^2\{2\} - \frac{\pi^3}{48} = 0.108729\dots$ and `quad(@(x)log(sin(x)).*log(cos(x)),0,pi/2) = 0.10873\dots`.

7.4 $\zeta(2)$, At Last!

A much more impressive demonstration of the use of Euler's identity is the derivation I have long promised you—the value of $\zeta(2)$, first calculated by Euler. We've already used this result ($\frac{\pi^2}{6}$) numerous times, but now I'll derive it in a way you almost surely have not seen before.

Recall again the power series expansion from Chap. 5 (Sect. 5.2) for $\ln(1+z)$:

$$\ln(1+z) = z - \frac{z^2}{2} + \frac{z^3}{3} - \frac{z^4}{4} + \dots$$

where now I'm taking z as a complex-valued quantity, and not simply a real quantity as I did in Chap. 5 where I wrote x instead of z .⁵ If we write $z = e^{i\theta}$ where a and θ are real, then

⁵How do we know we can do this? This is a non-trivial question, and a mathematician would rightfully want to vigorously pursue it. But remember our philosophical approach—we'll just make the assumption that all is okay, see where it takes us, and then *check* the answers we eventually calculate with *quad*.

$$\ln(1 + ae^{i\theta}) = ae^{i\theta} - \frac{a^2 e^{i2\theta}}{2} + \frac{a^3 e^{i3\theta}}{3} - \frac{a^4 e^{i4\theta}}{4} + \dots$$

or, expanding each term with Euler's identity and collecting real and imaginary parts together,

$$\begin{aligned} \ln(1 + ae^{i\theta}) &= a \cos(\theta) - \frac{1}{2}a^2 \cos(2\theta) + \frac{1}{3}a^3 \cos(3\theta) - \frac{1}{4}a^4 \cos(4\theta) + \dots \\ &+ i \left\{ a \sin(\theta) - \frac{1}{2}a^2 \sin(2\theta) + \frac{1}{3}a^3 \sin(3\theta) - \dots \right\}. \end{aligned}$$

Now, $1 + ae^{i\theta} = 1 + a \cos(\theta) + i a \sin(\theta)$ is a complex quantity with magnitude and angle in the complex plane (with respect to the positive real axis)⁶ and so we can write it as

$$\begin{aligned} 1 + ae^{i\theta} &= \sqrt{\{1 + a \cos(\theta)\}^2 + a^2 \sin^2(\theta)} e^{i\phi} \\ &= \sqrt{1 + 2a \cos(\theta) + a^2 \cos^2(\theta) + a^2 \sin^2(\theta)} e^{i\phi} \\ &= \sqrt{1 + 2a \cos(\theta) + a^2} e^{i\phi}. \end{aligned}$$

Thus,

$$\ln(1 + ae^{i\theta}) = \ln\left\{\sqrt{1 + 2a \cos(\theta) + a^2}\right\} + i\phi$$

or, equating real parts,

$$\frac{1}{2} \ln\{1 + 2a \cos(\theta) + a^2\} = a \cos(\theta) - \frac{1}{2}a^2 \cos(2\theta) + \frac{1}{3}a^3 \cos(3\theta) - \frac{1}{4}a^4 \cos(4\theta) + \dots$$

or,

$$\ln\{1 + 2a \cos(\theta) + a^2\} = 2 \left[a \cos(\theta) - \frac{1}{2}a^2 \cos(2\theta) + \frac{1}{3}a^3 \cos(3\theta) - \frac{1}{4}a^4 \cos(4\theta) + \dots \right].$$

⁶ The angle is given by $\phi = \tan^{-1} \left\{ \frac{a \sin(\theta)}{1 + a \cos(\theta)} \right\}$, but we'll never actually need to know this.

So, if we write $a = -x$ we have

$$\ln\{1 - 2x \cos(\theta) + x^2\} = -2 \left[x \cos(\theta) + \frac{1}{2}x^2 \cos(2\theta) + \frac{1}{3}x^3 \cos(3\theta) + \dots \right]$$

and so

$$\begin{aligned} \ln^2\{1 - 2x \cos(\theta) + x^2\} &= 4 \left[x \cos(\theta) + \frac{1}{2}x^2 \cos(2\theta) + \frac{1}{3}x^3 \cos(3\theta) + \dots \right]^2 \\ &= 4 \left[x^2 \cos^2(\theta) + \frac{x^4}{2^2} \cos^2(2\theta) + \frac{x^6}{3^2} \cos^2(3\theta) + \dots \right] \end{aligned}$$

plus

all the cross-product terms of the form $\cos(m\theta)\cos(n\theta)$, $m \neq n$.

Integrals of these cross-product terms are easy to do, since

$$\int_0^\pi \cos(m\theta) \cos(n\theta) d\theta = \frac{1}{2} \int_0^\pi [\cos\{(m-n)\theta\} + \cos\{(m+n)\theta\}] d\theta.$$

These integrals are easy to do because the integral of a cosine with a non-zero argument (remember, $m \neq n$) gives a sine and so, between the given limits, every one of the cross-product integrals is zero. So,

$$\begin{aligned} \int_0^\pi \ln^2\{1 - 2x \cos(\theta) + x^2\} d\theta \\ = 4 \left[x^2 \int_0^\pi \cos^2(\theta) d\theta + \frac{x^4}{2^2} \int_0^\pi \cos^2(2\theta) d\theta + \frac{x^6}{3^2} \int_0^\pi \cos^2(3\theta) d\theta + \dots \right] \end{aligned}$$

From integral tables we have

$$\int_0^\pi \cos^2(k\theta) d\theta = \left[\frac{\theta}{2} + \frac{\sin(2k\theta)}{4k} \right] \Big|_0^\pi = \frac{\pi}{2}$$

and so

$$\int_0^\pi \ln^2\{1 - 2x \cos(\theta) + x^2\} d\theta = 4 \left(\frac{\pi}{2} \right) \left[x^2 + \frac{x^4}{2^2} + \frac{x^6}{3^2} + \dots \right]$$

or,

$$\frac{1}{2\pi} \int_0^\pi \ln^2 \{ 1 - 2x \cos(\theta) + x^2 \} d\theta = \frac{x^2}{1^2} + \frac{x^4}{2^2} + \frac{x^6}{3^2} + \dots$$

Since $\cos(\theta)$ varies from $+1$ to -1 over the interval of integration, we can change the sign in the integrand without changing the value of the integral to give

$$\frac{1}{2\pi} \int_0^\pi \ln^2 \{ 1 + 2x \cos(\theta) + x^2 \} d\theta = \frac{x^2}{1^2} + \frac{x^4}{2^2} + \frac{x^6}{3^2} + \dots$$

Thus, setting $x = 1$, we have

$$\begin{aligned} \frac{1}{2\pi} \int_0^\pi \ln^2 \{ 2 + 2 \cos(\theta) \} d\theta &= \frac{1}{1^2} + \frac{1}{2^2} + \frac{1}{3^2} + \dots = \zeta(2) \\ &= \frac{1}{2\pi} \int_0^\pi \ln^2 \{ 2 [1 + \cos(\theta)] \} d\theta. \end{aligned}$$

We are getting close!

If we can do the integral on the right, we'll have Euler's famous result. So, continuing, the double-angle formula from trigonometry says $\cos(2\alpha) = 2 \cos^2(\alpha) - 1$ and so

$$\begin{aligned} \zeta(2) &= \frac{1}{2\pi} \int_0^\pi \ln^2 \left\{ 2 \left[2 \cos^2 \left(\frac{\theta}{2} \right) \right] \right\} d\theta = \frac{1}{2\pi} \int_0^\pi \ln^2 \left\{ \left[2 \cos \left(\frac{\theta}{2} \right) \right]^2 \right\} d\theta \\ &= \frac{1}{2\pi} \int_0^\pi 4 \ln^2 \left\{ 2 \cos \left(\frac{\theta}{2} \right) \right\} d\theta = \frac{2}{\pi} \int_0^\pi \ln^2 \left\{ 2 \cos \left(\frac{\theta}{2} \right) \right\} d\theta. \end{aligned}$$

Now, let $\alpha = \frac{\theta}{2}$ and so $d\theta = 2 d\alpha$. Then,

$$\zeta(2) = \frac{2}{\pi} \int_0^{\pi/2} \ln^2 \{ 2 \cos(\alpha) \} 2 d\alpha = \frac{4}{\pi} \int_0^{\pi/2} \ln^2 \{ 2 \cos(\alpha) \} d\alpha.$$

From (7.3.2), with $a = 2$, we see that

$$\int_0^{\pi/2} \ln^2 \{ 2 \cos(\alpha) \} d\alpha = \frac{\pi^3}{24}$$

and so

$$\zeta(2) = \left(\frac{4}{\pi} \right) \left(\frac{\pi^3}{24} \right) = \frac{\pi^2}{6},$$

just as Euler showed (in a completely different way).

7.5 The Probability Integral Again

Earlier in the book I've shown you how some of our tricks can be combined to really bring terrific force to attacking particularly difficult integrals. Here I'll do it again, but now we additionally have Euler's identity to join in the mix. First, let me remind you of (3.7.1) where, if we set $a = 1$ and $b = 0$ we have

$$(7.5.1) \quad \int_0^{\infty} e^{-x^2} dx = \frac{1}{2}\sqrt{\pi}.$$

Now, make the change of variable $x = u\sqrt{z}$, where z is a positive quantity. Then $dx = \sqrt{z} du$ and so

$$\int_0^{\infty} e^{-x^2} dx = \int_0^{\infty} e^{-u^2z} \sqrt{z} du = \frac{1}{2}\sqrt{\pi}$$

or

$$\frac{1}{\sqrt{z}} = \frac{2}{\sqrt{\pi}} \int_0^{\infty} e^{-u^2z} du.$$

The next step is the central trick: multiply both sides by e^{iz} , integrate with respect to z from a to b (where $b > a > 0$), and then reverse the order of integration in the resulting double integral on the right. When we do that we arrive at

$$\int_a^b \frac{e^{iz}}{\sqrt{z}} dz = \int_a^b e^{iz} \left\{ \frac{2}{\sqrt{\pi}} \int_0^{\infty} e^{-u^2z} du \right\} dz = \frac{2}{\sqrt{\pi}} \int_0^{\infty} \left\{ \int_a^b e^{z(i-u^2)} dz \right\} du.$$

The inner integral is easy to do:

$$\int_a^b e^{z(i-u^2)} dz = \left\{ \frac{e^{z(i-u^2)}}{i-u^2} \right\} \Big|_a^b = \frac{e^{b(i-u^2)} - e^{a(i-u^2)}}{i-u^2}.$$

Next, imagine that we let $b \rightarrow \infty$ and $a \rightarrow 0$. Then the first exponential on the right $\rightarrow 0$ and the second exponential on the right $\rightarrow 1$. That is,⁷

$$\int_0^{\infty} e^{z(i-u^2)} dz = \frac{-1}{i-u^2}$$

and so (remembering that $i^2 = -1$) we have

⁷Mathematicians will want to check that the limiting operations $b \rightarrow \infty$, $a \rightarrow 0$, and that the reversal of the order of integration in the double integral, are valid, but again remember our guiding philosophy in this book: just *do it*, and check with *quad* at the end.

$$\begin{aligned} \int_0^\infty \frac{e^{iz}}{\sqrt{z}} dz &= -\frac{2}{\sqrt{\pi}} \int_0^\infty \frac{1}{i - u^2} du = -\frac{2}{\sqrt{\pi}} \int_0^\infty \frac{-i - u^2}{(i - u^2)(-i - u^2)} du \\ &= \frac{2}{\sqrt{\pi}} \int_0^\infty \frac{i + u^2}{1 + u^4} du. \end{aligned}$$

Or, if we use Euler’s identity on the z-integral and equate real and imaginary parts, we arrive at the following pair of equations:

$$\int_0^\infty \frac{\cos(z)}{\sqrt{z}} dz = \frac{2}{\sqrt{\pi}} \int_0^\infty \frac{u^2}{1 + u^4} du$$

and

$$\int_0^\infty \frac{\sin(z)}{\sqrt{z}} dz = \frac{2}{\sqrt{\pi}} \int_0^\infty \frac{1}{1 + u^4} du.$$

We showed earlier, in (2.3.4), that the two u-integrals are each equal to $\frac{\pi\sqrt{2}}{4}$, and so we immediately have the beautiful results (where I’ve changed back to x as the dummy variable of integration)

(7.5.2)

$$\int_0^\infty \frac{\cos(x)}{\sqrt{x}} dx = \int_0^\infty \frac{\sin(x)}{\sqrt{x}} dx = \sqrt{\frac{\pi}{2}} .$$

That is, both integrals are numerically equal to 1.253314... , and we check that conclusion with *quad*(@(x)cos(x).sqrt(x),0,1000) = 1.279... and *quad*(@(x)sin(x).sqrt(x),0,1000) = 1.235... . These numerical estimates by *quad* aren’t as good as have been many of the previous checks we’ve done, and that’s because the integrands are really not that small even at x = 1000 (\sqrt{x} is not a fast-growing denominator, and the numerators don’t decrease but rather simply oscillate endlessly between ± 1). I’ll say more on this issue in Chap. 8.

7.6 Beyond Dirichlet’s Integral

Looking back at Dirichlet’s integral that we derived in (3.2.1),

$$\int_0^\infty \frac{\sin(ax)}{x} dx = \frac{\pi}{2}, \quad a > 0,$$

it might occur to you to ask what is

$$\int_0^{\infty} \left\{ \frac{\sin(x)}{x} \right\}^2 dx$$

equal to? This is easy to answer if you recall (3.4.1):

$$\int_0^{\infty} \frac{\cos(ax) - \cos(bx)}{x^2} dx = \frac{\pi}{2}(b - a).$$

With $a = 0$ and $b = 2$ we have

$$\int_0^{\infty} \frac{1 - \cos(2x)}{x^2} dx = \pi,$$

and since $1 - \cos(2x) = 2 \sin^2(x)$, we immediately have our answer:

(7.6.1)

$$\int_0^{\infty} \left\{ \frac{\sin(x)}{x} \right\}^2 dx = \frac{\pi}{2}.$$

This is 1.57079 . . . , and MATLAB agrees: `quad(@(x)(sin(x)./x).^2,0,1000) = 1.57056 . . .`

Okay, that wasn't very difficult, and so the next obvious question is to ask what

$$\int_0^{\infty} \left\{ \frac{\sin(x)}{x} \right\}^3 dx$$

is equal to? This is just a *bit* more difficult to answer, but certainly not impossibly so. Integrating by parts does the job. Let $u = \sin^3(x)$ and $dv = \frac{dx}{x^3}$ and so $\frac{du}{dx} = 3 \sin^2(x) \cos(x)$ and $v = -\frac{1}{2x^2}$. Thus,

$$\begin{aligned} \int_0^{\infty} \left\{ \frac{\sin(x)}{x} \right\}^3 dx &= \left\{ -\frac{\sin^3(x)}{2x^2} \right\} \Big|_0^{\infty} + \frac{3}{2} \int_0^{\infty} \frac{\sin^2(x) \cos(x)}{x^2} dx \\ &= \frac{3}{2} \int_0^{\infty} \frac{\sin^2(x) \cos(x)}{x^2} dx. \end{aligned}$$

Then, integrate by parts again, with $u = \sin^2(x)\cos(x)$ and $dv = \frac{dx}{x^2}$. Then $v = -\frac{1}{x}$ and $\frac{du}{dx} = 2 \sin(x) \cos^2(x) - \sin^3(x) = 2 \sin(x)[1 - \sin^2(x)] - \sin^3(x) = 2 \sin(x) - 3 \sin^3(x)$. Thus,

$$\int_0^\infty \left\{ \frac{\sin(x)}{x} \right\}^3 dx = \frac{3}{2} \left[\left\{ -\frac{\sin^2(x) \cos(x)}{x} \right\} \Big|_0^\infty + \int_0^\infty \frac{2 \sin(x) - 3 \sin^3(x)}{x} dx \right]$$

$$= 3 \int_0^\infty \frac{\sin(x)}{x} dx - \frac{9}{2} \int_0^\infty \frac{\sin^3(x)}{x} dx = 3 \left(\frac{\pi}{2} \right) - \frac{9}{2} \int_0^\infty \frac{\sin^3(x)}{x} dx.$$

Since

$$\int_0^\infty \frac{\sin^3(x)}{x} dx = \int_0^\infty \frac{\frac{3}{4} \sin(x) - \frac{1}{4} \sin(3x)}{x} dx = \frac{3}{4} \int_0^\infty \frac{\sin(x)}{x} dx - \frac{1}{4} \int_0^\infty \frac{\sin(3x)}{x} dx$$

$$= \frac{3}{4} \left(\frac{\pi}{2} \right) - \frac{1}{4} \left(\frac{\pi}{2} \right) = \frac{\pi}{4},$$

then

$$\int_0^\infty \left\{ \frac{\sin(x)}{x} \right\}^3 dx = 3 \left(\frac{\pi}{2} \right) - \frac{9}{2} \left(\frac{\pi}{4} \right) = \frac{12\pi}{8} - \frac{9\pi}{8}$$

or,

(7.6.2)

$$\int_0^\infty \left\{ \frac{\sin(x)}{x} \right\}^3 dx = \frac{3\pi}{8}.$$

This is equal to 1.1780972... , and a MATLAB check agrees: `quad(@(x)(sin(x)./x).^3,0,1000) = 1.178086...`

To keep going in this way—what is $\int_0^\infty \left\{ \frac{\sin(x)}{x} \right\}^4 dx$, for example?—will soon prove to be onerous. Try it! With a more systematic approach, however, we can derive additional intriguing results with (hardly) any pain. We start with Euler's identity, and write

$$z = e^{ix} = \cos(x) + i \sin(x), \quad i = \sqrt{-1}.$$

Then, for any integer $m \geq 0$,

$$z^m = e^{imx} = \cos(mx) + i \sin(mx)$$

and

$$\frac{1}{z^m} = z^{-m} = e^{-imx} = \cos(mx) - i \sin(mx)$$

and so

$$z^m - \frac{1}{z^m} = i 2 \sin(mx).$$

In particular, for $m = 1$

$$z - \frac{1}{z} = i 2 \sin(x).$$

So,

$$\{i 2 \sin(x)\}^{2n-1} = \left\{z - \frac{1}{z}\right\}^{2n-1}$$

or, expanding with the binomial theorem (where you'll recall the notation

$$\binom{a}{b} = \frac{a!}{(a-b)!b!},$$

$$\begin{aligned} \{i 2 \sin(x)\}^{2n-1} &= \sum_{r=0}^{2n-1} \binom{2n-1}{r} z^{2n-1-r} \left(-\frac{1}{z}\right)^r \\ &= \sum_{r=0}^{2n-1} (-1)^r \binom{2n-1}{r} z^{(2n-1)-2r}. \end{aligned}$$

When the summation index r runs from $r=0$ to $r=2n-1$, it runs through $2n$ values. Half of those values are $r=0$ to $r=n-1$ (for which the exponent on z is greater than zero), and the other half ($r=n$ to $r=2n-1$) give the same exponents but with negative signs. So, we can write

$$\{i 2 \sin(x)\}^{2n-1} = \sum_{r=0}^{n-1} (-1)^r \binom{2n-1}{r} \left[z^{(2n-1)-2r} - \frac{1}{z^{(2n-1)-2r}} \right].$$

But

$$z^{(2n-1)-2r} - \frac{1}{z^{(2n-1)-2r}} = i 2 \sin\{(2n-2r-1)x\}$$

and so

$$\begin{aligned} \{i 2 \sin(x)\}^{2n-1} &= \sum_{r=0}^{n-1} (-1)^r \binom{2n-1}{r} i 2 \sin\{(2n-2r-1)x\}. \\ &= i^{2n-1} 2^{2n-1} \sin^{2n-1}(x). \end{aligned}$$

Now $i^{2n-1} = i(-1)^{n-1}$ and so⁸

$$i(-1)^{n-1} 2^{2n-1} \sin^{2n-1}(x) = \sum_{r=0}^{n-1} (-1)^r \binom{2n-1}{r} 2i \sin \{(2n-2r-1)x\}$$

or,

(7.6.3) $\sin^{2n-1}(x) = \frac{(-1)^{n-1}}{2^{2n-1}} \sum_{r=0}^{n-1} (-1)^r \binom{2n-1}{r} 2 \sin \{(2n-2r-1)x\}.$

Dividing both sides of (7.6.3) by x , and integrating from 0 to ∞ , we have

$$\int_0^\infty \frac{\sin^{2n-1}(x)}{x} dx = \frac{(-1)^{n-1}}{2^{2n-1}} \sum_{r=0}^{n-1} (-1)^r \binom{2n-1}{r} 2 \int_0^\infty \frac{\sin \{(2n-2r-1)x\}}{x} dx.$$

In the integral on the right change variable to $y = (2n-2r-1)x$ and so

$$\int_0^\infty \frac{\sin \{(2n-2r-1)x\}}{x} dx = \int_0^\infty \frac{\sin(y)}{\frac{y}{2n-2r-1}} \left(\frac{dy}{2n-2r-1} \right) = \int_0^\infty \frac{\sin(y)}{y} dy = \frac{\pi}{2}.$$

Thus,

$$\int_0^\infty \frac{\sin^{2n-1}(x)}{x} dx = \frac{(-1)^{n-1}}{2^{2n-1}} \pi \sum_{r=0}^{n-1} (-1)^r \binom{2n-1}{r}.$$

We can simplify this by recalling the following combinatorial identity which you can confirm by expanding both sides:

$$\binom{s}{k} = \binom{s-1}{k-1} + \binom{s-1}{k}.$$

Here's how this result helps us. Consider the alternating sum

⁸ To see this, write $i^{2n-1} = ii^{2n-2} = i \frac{i^{2n}}{i} = i \frac{(i^2)^n}{(-1)} = i \frac{(-1)^n}{(-1)} = i(-1)^{n-1}$.

$$\sum_{k=0}^m (-1)^k \binom{s}{k} = \binom{s}{0} - \binom{s}{1} + \binom{s}{2} - \binom{s}{3} + \dots + (-1)^m \binom{s}{m}.$$

The first term on the right is 1, and then expanding each of the remaining terms with our combinatorial identity, we have

$$\begin{aligned} \sum_{k=0}^m (-1)^k \binom{s}{k} &= 1 - \left[\binom{s-1}{0} + \binom{s-1}{1} \right] + \left[\binom{s-1}{1} + \binom{s-1}{2} \right] \\ &\quad - \left[\binom{s-1}{2} + \binom{s-1}{3} \right] + \dots \\ &\quad + (-1)^m \left[\binom{s-1}{m-1} + \binom{s-1}{m} \right]. \end{aligned}$$

Since $\binom{s-1}{0} = 1$, and since the last term in any square bracket cancels the first term in the next square bracket, we see that only the last term in the final square bracket survives. That is,

$$\sum_{k=0}^m (-1)^k \binom{s}{k} = (-1)^m \binom{s-1}{m}.$$

Thus, with $m = n - 1$, $k = r$, and $s = 2n - 1$, we have

$$\int_0^\infty \frac{\sin^{2n-1}(x)}{x} dx = \frac{(-1)^{n-1}}{2^{2n-1}} \pi (-1)^{n-1} \binom{2n-2}{n-1}$$

or, as $(-1)^{n-1}(-1)^{n-1} = (-1)^{2n-2} = 1$, we have the pretty result

$$(7.6.4) \quad \int_0^\infty \frac{\sin^{2n-1}(x)}{x} dx = \frac{\pi}{2^{2n-1}} \binom{2n-2}{n-1}.$$

For $n = 5$, for example, this says

$$\int_0^\infty \frac{\sin^9(x)}{x} dx = \frac{35\pi}{256} = 0.42951\dots$$

and a MATLAB check agrees, as `quad(@(x)(sin(x).^9)./x,0,1000) = 0.4292...`

Now, looking back at (7.6.3) and multiplying through by $\cos(x)$,

$$\sin^{2n-1}(x) \cos(x) = \frac{(-1)^{n-1}}{2^{2n-1}} \sum_{r=0}^{n-1} (-1)^r \binom{2n-1}{r} 2 \sin\{(2n-2r-1)x\} \cos(x)$$

and remembering that $\sin(\alpha) \cos(\beta) = \frac{1}{2}[\sin(\alpha + \beta) + \sin(\alpha - \beta)]$, we have

$$\sin^{2n-1}(x) \cos(x) = \frac{(-1)^{n-1}}{2^{2n-1}} \sum_{r=0}^{n-1} (-1)^r \binom{2n-1}{r} [\sin\{2(n-r)x\} \\ + \sin\{2(n-r-1)x\}].$$

$$\text{Thus, } \int_0^\infty \frac{\sin^{2n-1}(x) \cos(x)}{x} dx = \frac{(-1)^{n-1}}{2^{2n-1}} \sum_{r=0}^{n-1} (-1)^r \binom{2n-1}{r} \left[\int_0^\infty \frac{\sin\{2(n-r)x\}}{x} dx + \int_0^\infty \frac{\sin\{2(n-r-1)x\}}{x} dx \right].$$

For every value of r from 0 to $n-1$ the first integral on the right is $\frac{\pi}{2}$, from Dirichlet's integral. For every value of r from 0 to $n-1$ *except* for $r=n-1$ (where the argument of the sine function is zero) the second integral on the right is also $\frac{\pi}{2}$. For $r=n-1$ the second integral is zero. So, if we 'pretend' the $r=n-1$ case for the second integral also gives $\frac{\pi}{2}$ we can write the following (where the last term corrects for the 'pretend'!):

$$\int_0^\infty \frac{\sin^{2n-1}(x) \cos(x)}{x} dx = \left[\frac{(-1)^{n-1}}{2^{2n-1}} \pi \sum_{r=0}^{n-1} (-1)^r \binom{2n-1}{r} \right] \\ - \frac{\pi}{2^{2n}} \binom{2n-1}{n-1}.$$

Now, just as before,

$$\sum_{r=0}^{n-1} (-1)^r \binom{2n-1}{r} = (-1)^{n-1} \binom{2n-2}{n-1}$$

and so

$$\int_0^\infty \frac{\sin^{2n-1}(x) \cos(x)}{x} dx = \frac{(-1)^{n-1}}{2^{2n-1}} \pi (-1)^{n-1} \binom{2n-2}{n-1} - \frac{\pi}{2^{2n}} \binom{2n-1}{n-1} \\ = \frac{\pi}{2^{2n-1}} \binom{2n-2}{n-1} - \frac{\pi}{2^{2n}} \binom{2n-1}{n-1} = \frac{\pi}{2^{2n}} \left[2 \binom{2n-2}{n-1} - \binom{2n-1}{n-1} \right].$$

Or, since

$$2 \binom{2n-2}{n-1} - \binom{2n-1}{n-1} = \frac{1}{n} \binom{2n-2}{n-1}$$

as you can easily verify by expanding the binomial coefficients, we have

$$(7.6.5) \quad \int_0^{\infty} \frac{\sin^{2n-1}(x)\cos(x)}{x} dx = \frac{\pi}{2^{2n}} \binom{2n-2}{n-1}.$$

For $n=2$, for example,

$$\int_0^{\infty} \frac{\sin^3(x)\cos(x)}{x} dx = \frac{\pi}{2^4} \binom{2}{1} = \frac{\pi}{16} = 0.196382\dots$$

and a MATLAB check says `quad(@(x)(sin(x).^3).*cos(x)./x,0,1000) = 0.196382...`

To finish this section, notice that

$$\int_0^{\infty} \frac{\sin^{2n}(x)}{x^2} dx$$

can be integrated by parts as follows. Let $u = \sin^{2n}(x)$ and $dv = \frac{dx}{x^2}$. Then $v = -\frac{1}{x}$ and $\frac{du}{dx} = 2n\sin^{2n-1}(x)\cos(x)$ and we have

$$\begin{aligned} \int_0^{\infty} \frac{\sin^{2n}(x)}{x^2} dx &= \left\{ -\frac{\sin^{2n}(x)}{x} \right\} \Big|_0^{\infty} + \int_0^{\infty} \frac{2n\sin^{2n-1}(x)\cos(x)}{x} dx \\ &= 2n \int_0^{\infty} \frac{\sin^{2n-1}(x)\cos(x)}{x} dx \end{aligned}$$

and so, looking at (7.6.5), we see that

$$\int_0^{\infty} \frac{\sin^{2n}(x)}{x^2} dx = 2n \frac{\pi}{2^{2n}} \binom{2n-2}{n-1} = \frac{\pi}{2^{2n-1}} \binom{2n-2}{n-1}.$$

Thus, looking back at (7.6.4) we have the interesting result that

$$(7.6.6) \quad \int_0^{\infty} \frac{\sin^{2n}(x)}{x^2} dx = \int_0^{\infty} \frac{\sin^{2n-1}(x)}{x} dx = \frac{\pi}{2^{2n-1}} \binom{2n-2}{n-1}.$$

For example, if $n=19$ (7.6.6) says

$$\int_0^{\infty} \frac{\sin^{38}(x)}{x^2} dx = \int_0^{\infty} \frac{\sin^{37}(x)}{x} dx = \frac{\pi}{2^{37}} \binom{36}{18} = 0.20744\dots$$

and MATLAB agrees, as `quad(@(x)(sin(x).^38)./x.^2,0,1000) = 0.20628...` and `quad(@(x)(sin(x).^37)./x,0,1000) = 0.208078...`

7.7 Dirichlet Meets the Gamma Function

In this penultimate section of the chapter we'll continue with the sequence of calculations we started in the previous section, that of determining

$$\int_0^{\infty} \left\{ \frac{\sin(x)}{x} \right\}^n dx,$$

integrals we've already done for the $n = 1, 2,$ and 3 cases. To do the $n \geq 4$ cases becomes challenging—*unless we see a new trick*. That's what I'll show you now.

We start (you'll see *why*, soon) with the integral

$$\int_0^{\infty} u^{q-1} e^{-xu} du.$$

If we change variable to $y = xu$, then differentiating with respect to y (treating x as a positive 'constant') gives

$$du = \frac{1}{x} dy.$$

Thus,

$$\int_0^{\infty} u^{q-1} e^{-xu} du = \int_0^{\infty} \left(\frac{y}{x}\right)^{q-1} e^{-y} \frac{1}{x} dy = \int_0^{\infty} \frac{y^{q-1}}{x^q} e^{-y} dy = \frac{1}{x^q} \int_0^{\infty} y^{q-1} e^{-y} dy.$$

This last integral should look familiar—it is the gamma function, defined in (4.1.1), equal to $\Gamma(q) = (q-1)!$. Thus,

$$\frac{1}{x^q} = \frac{1}{(q-1)!} \int_0^{\infty} u^{q-1} e^{-xu} du$$

and so

$$\int_0^{\infty} \frac{\sin^p(x)}{x^q} dx = \frac{1}{(q-1)!} \int_0^{\infty} \sin^p(x) \left\{ \int_0^{\infty} u^{q-1} e^{-xu} du \right\} dx$$

or, reversing the order of integration (this should remind you of the sort of thing we did back in Sect. 4.3),

$$\int_0^{\infty} \frac{\sin^p(x)}{x^q} dx = \frac{1}{(q-1)!} \int_0^{\infty} u^{q-1} \left\{ \int_0^{\infty} e^{-xu} \sin^p(x) dx \right\} du.$$

The inner, x -integral is easily done with integration by parts, *twice*. I'll let you fill-in the details, with the result being

$$\int_0^{\infty} e^{-xu} \sin^p(x) dx = \frac{p(p-1)}{p^2 + u^2} \int_0^{\infty} e^{-xu} \sin^{p-2}(x) dx.$$

Suppose p is even (≥ 2). Then we can repeat the integration by parts, over and over, each time reducing the power of the sine function in the integrand by 2, until we reduce that power down to zero, giving a final integral of

$$\int_0^{\infty} e^{-xu} dx = \left\{ \frac{e^{-xu}}{-u} \right\} \Big|_0^{\infty} = \frac{1}{u}.$$

And so

$$\int_0^{\infty} e^{-xu} \sin^p(x) dx = \frac{p!}{[p^2 + u^2][(p-2)^2 + u^2] \dots [2^2 + u^2]} \left(\frac{1}{u} \right), p \text{ even.}$$

Similarly for p odd, except that we stop integrating when we get the power of the sine function down to the first power:

$$\int_0^{\infty} e^{-xu} \sin^p(x) dx = \frac{p!}{[p^2 + u^2][(p-2)^2 + u^2] \dots [1^2 + u^2]}, p \text{ odd.}$$

So, we have our central results:

$$(7.7.1) \quad \int_0^{\infty} \frac{\sin^p(x)}{x^q} dx = \frac{p!}{(q-1)!} \int_0^{\infty} \frac{u^{q-2}}{[u^2 + 2^2][u^2 + 4^2] \dots [u^2 + p^2]} du, p \text{ even}$$

and

$$(7.7.2) \quad \int_0^{\infty} \frac{\sin^p(x)}{x^q} dx = \frac{p!}{(q-1)!} \int_0^{\infty} \frac{u^{q-1}}{[u^2 + 1^2][u^2 + 3^2] \dots [u^2 + p^2]} du, p \text{ odd.}$$

For the question of what is

$$\int_0^{\infty} \left\{ \frac{\sin(x)}{x} \right\}^4 dx = ?,$$

the question we asked (but didn't answer) just after (7.6.2), we have $p = q = 4$ (and so p even) and (7.7.1) tells us that

$$\int_0^\infty \left\{ \frac{\sin(x)}{x} \right\}^4 dx = \frac{4!}{3!} \int_0^\infty \frac{u^2}{[u^2 + 2^2][u^2 + 4^2]} du = 4 \int_0^\infty \frac{u^2}{[u^2 + 4][u^2 + 16]} du.$$

Making a partial fraction expansion, we have

$$\begin{aligned} \int_0^\infty \left\{ \frac{\sin(x)}{x} \right\}^4 dx &= 4 \left[\int_0^\infty \frac{-\frac{1}{3}}{u^2 + 4} du + \int_0^\infty \frac{\frac{4}{3}}{u^2 + 16} du \right] \\ &= -\frac{4}{3} \left\{ \frac{1}{2} \tan^{-1} \left(\frac{u}{2} \right) \right\} \Big|_0^\infty + \frac{16}{3} \left\{ \frac{1}{4} \tan^{-1} \left(\frac{u}{4} \right) \right\} \Big|_0^\infty \\ &= -\frac{2}{3} \tan^{-1}(\infty) + \frac{4}{3} \tan^{-1}(\infty) \\ &= \frac{2}{3} \tan^{-1}(\infty) = \left(\frac{2}{3} \right) \left(\frac{\pi}{2} \right) \end{aligned}$$

or, at last,

$$(7.7.3) \quad \int_0^\infty \left\{ \frac{\sin(x)}{x} \right\}^4 dx = \frac{\pi}{3}.$$

This is 1.047197... and MATLAB agrees, as `quad(@(x)(sin(x)/x).^4,0,1000) = 1.0472...`

You might think from all of these calculations that our integrals will always turn out to be some rational number times π . That, however, is not true. For example, suppose $p = 3$ and $q = 2$. Then we get a result of an entirely different nature. Using (7.7.2) because p is odd,

$$\begin{aligned} \int_0^\infty \frac{\sin^3(x)}{x^2} dx &= \frac{3!}{1!} \int_0^\infty \frac{u}{[u^2 + 1^2][u^2 + 3^2]} du = 6 \left[\int_0^\infty \frac{\frac{1}{8}u}{u^2 + 1^2} du - \int_0^\infty \frac{\frac{1}{8}u}{u^2 + 3^2} du \right] \\ &= \frac{6}{8} \left[\frac{1}{2} \ln(u^2 + 1^2) - \frac{1}{2} \ln(u^2 + 3^2) \right] \Big|_0^\infty = \frac{3}{8} \ln \left(\frac{u^2 + 1^2}{u^2 + 3^2} \right) \Big|_0^\infty = -\frac{3}{8} \ln \left(\frac{1}{3^2} \right) \\ &= \frac{3}{8} \ln(3^2) \end{aligned}$$

or, finally,

$$(7.7.4) \quad \int_0^{\infty} \frac{\sin^3(x)}{x^2} dx = \frac{3\ln(3)}{4}.$$

This is equal to 0.8239592... , and a MATLAB check agrees, as `quad(@(x)(sin(x).^3)./x.^2),0,1000)=0.82387...`

7.8 Fourier Transforms and Energy Integrals

In this section we'll come full circle back to the opening section and its use of Euler's identity. Here I'll show you a new trick that illustrates how some *physical* considerations well-known to electrical engineers and physicists will allow us to derive some very interesting integrals.

In the study of electronic information processing circuitry, the transmission of pulse-like signals in time is at the heart of the operation of such circuits. So, let's start with the simplest such time signal, a single pulse that is finite in both amplitude and duration. For example, let

$$(7.8.1) \quad f(t) = \begin{cases} 1, & a < t < b \\ 0, & \text{otherwise} \end{cases}$$

where a and b are both positive constants. (For electronics engineers, the particular time $t=0$ is simply short-hand for some especially interesting event, like 'when we turned the power on to the circuits' or 'when we started to pay attention to the output signal.')

The signal $f(t)$ might, for example, be a voltage pulse of unit amplitude and duration $b - a$ (where, of course, $b > a$). If this voltage pulse is the voltage drop across a resistor, for example, then the *instantaneous power* of $f(t)$ is proportional to $f^2(t)$, which is a direct consequence of Ohm's law for resistors, a law familiar to all high school physics students.⁹ Since *energy* is the time integral of power, then the energy of this $f(t)$, written as W_f , is (since $f^2(t) = 1$)

$$(7.8.2) \quad W_f = \int_{-\infty}^{\infty} f^2(t) dt = \int_a^b dt = b - a.$$

All of these comments are admittedly 'engineering' in origin but, in fact, given (7.8.1) even a pure mathematician would, if asked for the energy of $f(t)$ in (7.8.1), also immediately write (7.8.2). The physical terminology of *power* and *energy* has been adopted by mathematicians. Now, further pondering on the issue of the energy of a time signal leads to the concept of the so-called *energy spectrum* of that signal. A time signal can be thought of as the totality of many (perhaps infinitely many)

⁹ I mention this only for completeness. If Ohm's law is of no interest to you, that's okay.

sinusoidal components of different amplitudes and frequencies (usually written as $\omega = 2\pi\nu$, where ν is in cycles per second or hertz, and ω is in radians per second). The energy spectrum of $f(t)$ is a description of how the total energy W_f is distributed across the frequency components of $f(t)$. To get an idea of where we are going with this, suppose we had the energy spectrum of $f(t)$, which I'll write as $S_f(\omega)$, in-hand. If we integrate $S_f(\omega)$ over all ω we should arrive the total energy of $f(t)$, that is, W_f . That means, using (7.8.2),

$$(7.8.3) \quad W_f = \int_{-\infty}^{\infty} f^2(t)dt = \int_{-\infty}^{\infty} S_f(\omega)d\omega = b - a$$

and it's this equality of two integrals that can give us some quite 'interesting integrals.' So, that's our immediate problem: how do we calculate the energy spectrum for a given time signal? The answer is the Fourier transform.

One of the beautiful results from what is called *Fourier theory* (after the French mathematician Joseph Fourier (1768–1830)) is the so-called *Fourier transform*. If we call $G(\omega)$ the Fourier transform of an arbitrary time signal $g(t)$, then

$$(7.8.4) \quad G(\omega) = \int_{-\infty}^{\infty} g(t)e^{-i\omega t}dt.$$

We can recover $g(t)$ from $G(\omega)$ by doing another integral, called the *inverse transform*:

$$(7.8.5) \quad g(t) = \frac{1}{2\pi} \int_{-\infty}^{\infty} G(\omega)e^{i\omega t}d\omega.$$

Together, $g(t)$ from $G(\omega)$ form what we called a *Fourier transform pair*,¹⁰ usually written as

$$g(t) \leftrightarrow G(\omega).$$

In general, $G(\omega)$ will be complex, with real and imaginary parts $R(\omega)$ and $X(\omega)$, respectively. That is, $G(\omega) = R(\omega) + i X(\omega)$. If $g(t)$ is a real-valued function of time (as of course are all the signals in any electronic circuitry that can actually be constructed) then $G(\omega)$ will have some special properties. In particular, $R(\omega)$ will be even and $X(\omega)$ will be odd: $R(-\omega) = R(\omega)$ and $X(-\omega) = -X(\omega)$. If, in addition to being real, $g(t)$ has certain symmetry properties, then $G(\omega)$ will have additional

¹⁰ Where these defining integrals in a Fourier pair come from is explained in any good book on Fourier series and/or transforms. Or, for an 'engineer's treatment' in the same spirit as this book, see *Dr. Euler* (note 1), pp. 200–204.

corresponding special properties. If, for example, $g(t)$ is even (as is $\cos(\omega t)$) then $G(\omega)$ will be real, and if $g(t)$ is odd (as is $\sin(\omega t)$) then $G(\omega)$ will be imaginary: $X(\omega) = 0$ and $R(\omega) = 0$, respectively. All of these statements are easily established by simply writing-out the Fourier transform integral using Euler's identity and examining the integrands of the $R(\omega)$ and $X(\omega)$ integrals (these claims are so easy to verify, in fact, that they aren't at the level of being Challenge Problems, but you should be sure *you* can establish them).

What makes (7.8.4) and (7.8.5) so incredibly useful to us in this book is what is called *Rayleigh's theorem*, after the English mathematical physicist John William Strutt (1842–1919), who won the 1904 Nobel Prize in physics and is better known today as Lord Rayleigh. It tells us how to calculate the energy spectrum of $g(t)$ (and so, of course, of $f(t)$, which is simply a particular $g(t)$). Rayleigh's theorem is quite easy to derive, which makes a curious puzzle in the history of mathematics for why it didn't appear in print until the relatively recent date of 1889.

We start by writing

$$W_g = \int_{-\infty}^{\infty} g^2(t) dt = \int_{-\infty}^{\infty} g(t)g(t) dt$$

and then replace one of the $g(t)$ factors in the second integral with its inverse transform form from (7.8.5). So,

$$W_g = \int_{-\infty}^{\infty} g(t)g(t) dt = \int_{-\infty}^{\infty} g(t) \left\{ \frac{1}{2\pi} \int_{-\infty}^{\infty} G(\omega) e^{i\omega t} d\omega \right\} dt.$$

Reversing the order of integration,

$$W_g = \int_{-\infty}^{\infty} \frac{1}{2\pi} G(\omega) \left\{ \int_{-\infty}^{\infty} g(t) e^{i\omega t} dt \right\} d\omega.$$

Since $g(t)$ is a real-valued function of time—what would a *complex*-valued voltage pulse look like on an oscilloscope screen!?!—then the inner t -integral on the right is the *conjugate* of $G(\omega)$ because that integral looks just like (7.8.4) except it has $+i$ in the exponential instead of $-i$. That is,

$$\int_{-\infty}^{\infty} g(t) e^{i\omega t} dt = G^*(\omega)$$

and so

$$W_g = \int_{-\infty}^{\infty} \frac{1}{2\pi} G(\omega) G^*(\omega) d\omega = \int_{-\infty}^{\infty} \frac{|G(\omega)|^2}{2\pi} d\omega.$$

Or, if we now specifically let $g(t) = f(t)$, then Rayleigh's energy theorem is

$$W_f = \int_{-\infty}^{\infty} \frac{|F(\omega)|^2}{2\pi} d\omega = \int_{-\infty}^{\infty} f^2(t) dt, \quad F(\omega) = R(\omega) + iX(\omega),$$

and so the energy spectrum of the $f(t)$ in (7.8.1) is, by (7.8.3)

$$S_f(\omega) = \frac{|F(\omega)|^2}{2\pi}, \quad -\infty < \omega < \infty.$$

For all real $f(t)$, $|F(\omega)|^2 = R^2(\omega) + X^2(\omega)$ will be an even function because both $R^2(\omega)$ and $X^2(\omega)$ are even.

The Fourier transform of $f(t)$ in (7.8.1) is

$$F(\omega) = \int_{-\infty}^{\infty} f(t)e^{-i\omega t} dt = \int_a^b e^{-i\omega t} dt = \left\{ \frac{e^{-i\omega t}}{-i\omega} \right\} \Big|_a^b = \frac{e^{-i\omega b} - e^{-i\omega a}}{-i\omega} = \frac{e^{-i\omega a} - e^{-i\omega b}}{i\omega}$$

and so the energy spectrum of $f(t)$ is

$$(7.8.6) \quad S_f(\omega) = \frac{|e^{-i\omega a} - e^{-i\omega b}|^2}{2\pi\omega^2}.$$

Inserting (7.8.6) into (7.8.3), we get

$$(7.8.7) \quad \frac{1}{2\pi} \int_{-\infty}^{\infty} \frac{|e^{-i\omega a} - e^{-i\omega b}|^2}{\omega^2} d\omega = b - a.$$

Now, *temporarily* forget all the physics I've mentioned, that is, put aside for now all that business about time functions and energy distributed over frequency, and just treat (7.8.7) as a pure mathematical statement. To be absolutely sure we are now thinking 'purely mathematical,' let's change the dummy variable of integration from ω to x , to write

$$(7.8.8) \quad \frac{1}{2\pi} \int_{-\infty}^{\infty} \frac{|e^{-ixa} - e^{-ixb}|^2}{x^2} dx = b - a, \quad b > a.$$

Concentrate for the moment on the numerator of the integrand in (7.8.8): using Euler's identity we have

$$\begin{aligned}
 |e^{-ixa} - e^{-ixb}|^2 &= |\{\cos(ax) - i\sin(ax)\} - \{\cos(bx) - i\sin(bx)\}|^2 \\
 &= |\{\cos(ax) - \cos(bx)\} - i\{\sin(ax) - \sin(bx)\}|^2 \\
 &= \{\cos(ax) - \cos(bx)\}^2 + \{\sin(ax) - \sin(bx)\}^2
 \end{aligned}$$

which, if you multiply-out and combine terms, becomes

$$= 2[1 - \{\cos(ax)\cos(bx) + \sin(ax)\sin(bx)\}].$$

Putting this into (7.8.8), we arrive at

$$\frac{1}{\pi} \int_{-\infty}^{\infty} \frac{1 - \{\cos(ax)\cos(bx) + \sin(ax)\sin(bx)\}}{x^2} dx = b - a, \quad b > a,$$

or, in very slightly rearranged form (you'll see why, soon),

$$(7.8.9) \quad \int_{-\infty}^{\infty} \frac{1 - \cos(ax)\cos(bx)}{x^2} dx - \int_{-\infty}^{\infty} \frac{\sin(ax)\sin(bx)}{x^2} dx = \pi(b - a), \quad b > a.$$

Next, look back at (3.4.1), which we can use to write the integral (as the special case of the parameters there found by setting a to zero and b to one)

$$\int_0^{\infty} \frac{1 - \cos(u)}{u^2} du = \frac{\pi}{2}$$

or, as the integrand is even,

$$(7.8.10) \quad \int_{-\infty}^{\infty} \frac{1 - \cos(u)}{u^2} du = \pi.$$

We now change variable in (7.8.10) to $u = (a + b)x$, and so

$$\int_{-\infty}^{\infty} \frac{1 - \cos(ax + bx)}{(a + b)^2 x^2} (a + b) dx = \pi$$

or, using the trigonometric identity for $\cos(ax + bx)$,

$$\int_{-\infty}^{\infty} \frac{1 - [\cos(ax)\cos(bx) - \sin(ax)\sin(bx)]}{x^2} dx = (a + b)\pi$$

and so, in very slightly rearranged form,

$$(7.8.11) \quad \int_{-\infty}^{\infty} \frac{1 - \cos(ax) \cos(bx)}{x^2} dx + \int_{-\infty}^{\infty} \frac{\sin(ax) \sin(bx)}{x^2} dx = \pi(a + b).$$

Finally, subtract (7.8.9) from (7.8.11), to get

$$2 \int_{-\infty}^{\infty} \frac{\sin(ax) \sin(bx)}{x^2} dx = \pi(a + b) - \pi(b - a) = 2\pi a, b > a$$

or, at last,

$$\int_{-\infty}^{\infty} \frac{\sin(ax) \sin(bx)}{x^2} dx = \pi a, b > a.$$

Of course, by the symmetry of the integrand we could equally-well write

$$\int_{-\infty}^{\infty} \frac{\sin(ax) \sin(bx)}{x^2} dx = \pi b, a > b.$$

Both of these statements can be written as one, as

$$(7.8.12) \quad \int_{-\infty}^{\infty} \frac{\sin(ax) \sin(bx)}{x^2} dx = \pi \min(a, b).$$

As a special case, if $a = b$ then (7.8.12) reduces to

$$\int_{-\infty}^{\infty} \frac{\sin^2(ax)}{x^2} dx = \pi a$$

which is just (7.6.1) with $a = 1$ (see also Challenge Problem 7.5).

7.9 'Weird' Integrals from Radio Engineering

In this section I'll show you some quite interesting (almost bizarre) integrals that arise in the theory of radio (although I'll limit the discussion to pure mathematics, and not a single transistor, capacitor, or antenna will make an appearance). Let's start by recalling Dirichlet's integral from (3.2.1):

$$(7.9.1) \quad \int_0^\infty \frac{\sin(t\omega)}{\omega} d\omega = \begin{cases} \frac{\pi}{2}, & t > 0 \\ \square & \\ -\frac{\pi}{2}, & t < 0 \end{cases}$$

where I've replace the parameters a and x in (3.2.1) with the parameters t and ω , respectively. Since the integrand in (7.9.1) is even, we can double the integral by integrating from $-\infty$ to ∞ . Thus,

$$(7.9.2) \quad \int_{-\infty}^\infty \frac{\sin(t\omega)}{\omega} d\omega = \begin{cases} \pi, & t > 0 \\ \square & \\ -\pi, & t < 0 \end{cases}.$$

In radio engineering analyses it is found that a time signal that is -1 for negative time and $+1$ for positive time is highly useful (you'll see why, soon). It is given the special name *signum*—written $\text{sgn}(t)$ —for its property of being the *sign* function (not to be confused with the sine function!). So, (7.9.2) can be written as

$$\int_{-\infty}^\infty \frac{\sin(t\omega)}{\omega} d\omega = \pi \text{sgn}(t).$$

Notice that using Euler's identity we can write

$$\int_{-\infty}^\infty \frac{e^{i\omega t}}{\omega} d\omega = \int_{-\infty}^\infty \frac{\cos(\omega t)}{\omega} d\omega + i \int_{-\infty}^\infty \frac{\sin(\omega t)}{\omega} d\omega$$

and, as the first integral on the right vanishes since its integrand is odd, we have

$$(7.9.3) \quad \boxed{\int_{-\infty}^\infty \frac{e^{i\omega t}}{\omega} d\omega = i\pi \text{sgn}(t).}$$

Another time signal that radio engineers find useful, one closely related to $\text{sgn}(t)$, is the so-called unit step, equal to zero for negative time and to $+1$ for positive time. Written as $u(t)$, we can connect $u(t)$ to $\text{sgn}(t)$ by writing

$$(7.9.4) \quad u(t) = \frac{1 + \text{sgn}(t)}{2}.$$

The unit step is a constant for all t *except* at $t=0$ where it *instantly* jumps from 0 to 1 as t passes from being negative to being positive. This jump occurs in zero time, and so the 'derivative' of $u(t)$ is infinite at $t=0$ and zero for all $t \neq 0$. For a long time mathematicians did not consider the derivative of $u(t)$ to be a respectable function, but nonetheless the English physicist Paul Dirac (1902–1984) showed that

working with such a thing—called an *impulse function* and written as $\delta(t)$ —could indeed be quite useful.¹¹ Dirac formally wrote

$$\delta(t) = \frac{d}{dt}u(t)$$

and so, formally differentiating (7.9.4), we have

$$\delta(t) = \frac{d}{dt} \left(\frac{1 + \operatorname{sgn}(t)}{2} \right) = \frac{1}{2} \frac{d}{dt} \{ \operatorname{sgn}(t) \}.$$

Now, if (as usual in this book) we boldly assume we can differentiate under the integral sign in (7.9.3), then

$$\frac{d}{dt} \int_{-\infty}^{\infty} \frac{e^{i\omega t}}{\omega} d\omega = \frac{d}{dt} \{ i\pi \operatorname{sgn}(t) \} = i\pi \frac{d}{dt} \{ \operatorname{sgn}(t) \} = \int_{-\infty}^{\infty} \frac{i\omega e^{i\omega t}}{\omega} d\omega = i \int_{-\infty}^{\infty} e^{i\omega t} d\omega.$$

That is,

$$(7.9.5) \quad \int_{-\infty}^{\infty} e^{i\omega t} d\omega = \pi \frac{d}{dt} \{ \operatorname{sgn}(t) \}.$$

From our differentiation of (7.9.4) we have

$$\frac{d}{dt}u(t) = \delta(t) = \frac{1}{2} \frac{d}{dt} \{ \operatorname{sgn}(t) \}$$

and so

$$\frac{d}{dt} \{ \operatorname{sgn}(t) \} = 2\delta(t).$$

Putting this into (7.9.5), we have

¹¹ Although Dirac won the 1933 Nobel Prize in *physics*, he was the Lucasian Professor of *mathematics* at Cambridge University. His physical insight into such a bizarre thing as an infinite derivative was powered (by his own admission) with his undergraduate training in *electrical engineering*: he graduated with first-class honors in EE from the University of Bristol in 1921. Dirac was clearly ‘a man for all seasons’! The mathematics of impulses has been placed on a firm theoretical foundation since Dirac’s intuitive use of them in quantum mechanics. The central figure in that great achievement is generally considered to be the French mathematician Laurent Schwartz (1915–2002), with the publication of his two books *Theory of Distributions* (1950, 1951). For that work, Schwartz received the 1950 Fields Medal, often called the ‘Nobel Prize of mathematics.’

(7.9.6)

$$\int_{-\infty}^{\infty} e^{i\omega t} d\omega = 2\pi\delta(t).$$

The statement in (7.9.6) is an astonishing one because the integral just doesn't exist if we attempt to actually evaluate it, since $e^{i\omega t}$ doesn't even approach a limit as $|\omega| \rightarrow \infty$. The real and imaginary parts of $e^{i\omega t}$ both simply oscillate for all t other than zero as ω varies. The only way we can make any sense of (7.9.6) is, as Dirac did, by interpreting the integral on the left as a collection of printed squiggles that denote the same *concept* as do the printed squiggles on the right (for which we at least have a physical feel). Any time we encounter the integral squiggles we'll just replace them with the squiggles ' $2\pi\delta(t)$.' As you'll soon see, impulses can occur with arguments more complicated than just ' t ,' and the general rule is that an impulse goes to infinity when its argument vanishes. So, for example, $\delta(t - t_0)$ is zero for all $t \neq t_0$ and infinity at $t = t_0$.

With (7.9.3) and (7.9.6) we can now find the Fourier transforms of $\text{sgn}(t)$, $\delta(t)$, and $u(t)$. For $\text{sgn}(t)$, I claim its transform is $\frac{2}{i\omega}$. To see this, put $\frac{2}{i\omega}$ into the inverse transform integral of (7.8.5) to get

$$\frac{1}{2\pi} \int_{-\infty}^{\infty} \frac{2}{i\omega} e^{i\omega t} d\omega = \frac{1}{\pi i} \int_{-\infty}^{\infty} \frac{e^{i\omega t}}{\omega} d\omega$$

and then recall (7.9.3) which says the integral on the right is $i\pi \text{sgn}(t)$. That is,

$$\frac{1}{\pi i} \int_{-\infty}^{\infty} \frac{e^{i\omega t}}{\omega} d\omega = \frac{1}{\pi i} i\pi \text{sgn}(t) = \text{sgn}(t).$$

So, we have the transform pair

$$(7.9.7) \quad \text{sgn}(t) \leftrightarrow \frac{2}{i\omega}.$$

The energy spectrum of $\text{sgn}(t)$ is

$$S_f(\omega) = \frac{|\frac{2}{i\omega}|^2}{2\pi} = \frac{2}{\pi\omega^2}, \quad -\infty < \omega < \infty$$

and so, if we integrate this spectrum over all ω , we get infinity. That is, $\text{sgn}(t)$ is an infinite energy signal (something obvious from the get-go, of course, for a signal whose magnitude is 1 for all time), a clear clue that it is impossible to actually generate it!

Next, I claim the Fourier transform of $\delta(t)$ is 1, and again you can see this by putting 1 into the inverse transform integral of (7.8.5) to get

$$\frac{1}{2\pi} \int_{-\infty}^{\infty} 1 e^{i\omega t} d\omega = \frac{1}{2\pi} \int_{-\infty}^{\infty} e^{i\omega t} d\omega$$

and then recall (7.9.6) which says the integral on the right is $2\pi\delta(t)$. So, we have the transform pair

$$(7.9.8) \quad \delta(t) \leftrightarrow 1.$$

The energy spectrum of $\delta(t)$ is uniform over all ω or, as radio engineers sometimes put it, $\delta(t)$ has a *flat* spectrum.¹² From Rayleigh’s theorem we see that $\delta(t)$, like $\text{sgn}(t)$, is an infinite energy signal and so is impossible to actually generate. Unlike $\text{sgn}(t)$, this infinity is *not* obvious from the time behavior of the impulse (which property dominates, the infinite value at one instant of time, or the fact that it is just one instant of time?). It’s the energy spectrum that gives us the answer.

Now, what is the transform of the unit step, $u(t)$? From (7.9.4) we can write the transform of $u(t)$ as the sum of the transforms of $\frac{1}{2}$ and $\frac{1}{2}\text{sgn}(t)$. That is, using (7.9.7), we have

$$(7.9.9) \quad u(t) \leftrightarrow \int_{-\infty}^{\infty} \frac{1}{2} e^{-i\omega t} dt + \frac{1}{i\omega}.$$

‘All’ we have to do is figure-out what the integral on the right in (7.9.9) is—and to do that, let me show you a neat little trick in notation. Look back at (7.9.6). Since it is an equality it *remains* an equality if we perform exactly the same operations on both sides. So, on the left replace every ω with t , and every t with ω , and on the right do the same. Then,

$$(7.9.10) \quad \int_{-\infty}^{\infty} e^{it\omega} dt = 2\pi\delta(\omega)$$

where $\delta(\omega)$ is an impulse in the ω -domain. Just as $\delta(t)$ is zero for all $t \neq 0$ and infinite at $t = 0$, $\delta(\omega)$ is zero for all $\omega \neq 0$ and infinite at $\omega = 0$. That is, all the infinite energy of a signal that is a *constant* for all time should have no energy at any

¹²In an analogy with white light, in which all optical frequencies (colors) are uniformly present, such an energy distribution is also often said to be a *white* spectrum. To continue with this terminology, signals with energy spectrums that are not flat (not white) are said to have a *pink* (or *colored*) spectrum. Who says radio engineers aren’t romantic souls?!

non-zero frequency, because otherwise the signal wouldn't be *constant* but rather would have a time-varying component.

Next, change variable in (7.9.10) to $u = -t$ ($dt = -du$). Then,

$$\int_{-\infty}^{\infty} e^{it\omega} dt = \int_{\infty}^{-\infty} e^{i(-u)\omega} (-du) = \int_{-\infty}^{\infty} e^{-i\omega u} du.$$

That is,

$$2\pi\delta(\omega) = \int_{-\infty}^{\infty} e^{-i\omega u} du$$

or, if we change the dummy variable of integration from u back to t ,

$$(7.9.11) \quad \int_{-\infty}^{\infty} e^{-i\omega t} dt = 2\pi\delta(\omega).$$

Notice, from (7.9.10) and (7.9.11), that we've shown

$$\int_{-\infty}^{\infty} e^{it\omega} dt = 2\pi\delta(\omega) = \int_{-\infty}^{\infty} e^{-i\omega t} dt.$$

That is, $\delta(-\omega) = \delta(\omega)$ and so the impulse function, mathematically, is *even*. In any case, the integral on the right in (7.9.9), the Fourier transform of $\frac{1}{2}$, is $\pi\delta(\omega)$, and so we now have the pair

$$(7.9.12) \quad u(t) \leftrightarrow \pi\delta(\omega) + \frac{1}{i\omega}$$

and so of course, like $\text{sgn}(t)$ and $\delta(t)$, $u(t)$ is an infinite energy signal.

We can expand on the physical meaning of $\delta(\omega)$ by computing the Fourier transform of the pure sinusoidal signal $\cos(\omega_0 t)$, $-\infty < t < \infty$. By definition, the transform is

$$\begin{aligned} \int_{-\infty}^{\infty} \cos(\omega_0 t) e^{-i\omega t} dt &= \int_{-\infty}^{\infty} \frac{e^{i\omega_0 t} + e^{-i\omega_0 t}}{2} e^{-i\omega t} dt \\ &= \frac{1}{2} \int_{-\infty}^{\infty} e^{-i(\omega - \omega_0)t} dt + \frac{1}{2} \int_{-\infty}^{\infty} e^{-i(\omega + \omega_0)t} dt. \end{aligned}$$

Recalling (7.9.11) we see that the first integral on the right is $2\pi\delta(\omega - \omega_0)$ and the second integral on the right is $2\pi\delta(\omega + \omega_0)$. So, we have the pair

$$(7.9.13) \quad \cos(\omega_0 t) \leftrightarrow \pi\delta(\omega - \omega_0) + \pi\delta(\omega + \omega_0).$$

Since an impulse ‘occurs’ where its argument is zero, we see that all the (infinite) energy of the pure sinusoidal time signal $\cos(\omega_0 t)$ is equally concentrated at the *two* frequencies¹³ $\omega = \pm \omega_0$.

There is one final property of the impulse function that is important to state. Returning to Dirac’s formal definition of the impulse as derivative of the step, that is to

$$\delta(t) = \frac{d}{dt} \{u(t)\},$$

then if we formally integrate this we get

$$\int_{-\infty}^t \delta(y) dy = \int_{-\infty}^t \frac{d}{dy} \{u(y)\} dy = \int_{-\infty}^t d\{u(y)\} = u(y)|_{-\infty}^t = u(t) - u(-\infty)$$

or, because $u(-\infty) = 0$,

$$\int_{-\infty}^t \delta(y) dy = u(t) = \begin{cases} 1, & t > 0 \\ \square, & t = 0 \\ 0, & t < 0 \end{cases}.$$

That is, even though the impulse has zero duration, it is nonetheless ‘so infinite’ that it bounds unit area! This is impossible to justify in the framework of nineteenth century mathematics, which is why mathematicians for so long dismissed the impulse as being utter nonsense (electrical engineers and physicists, however, didn’t have much of a problem with it because the impulse solved many of their ‘real-life’ problems)—until the work of Laurent Schwartz.

One intuitive way to ‘understand’ this result (a view common among physicists and radio engineers), is to think of the impulse as a very narrow pulse of height $\frac{1}{\epsilon}$ for $-\frac{\epsilon}{2} < t < \frac{\epsilon}{2}$ (where $\epsilon \approx 0$), and with zero height for all other t . (Notice that this makes the impulse *even*, as we concluded it must be after deriving (7.9.11).) For *all* ϵ this pulse always bounds unit area, even as we let $\epsilon \rightarrow 0$. So, suppose $\phi(t)$ is any function that is continuous at $t = 0$. Then, during the interval $-\frac{\epsilon}{2} < t < \frac{\epsilon}{2}$, $\phi(t)$ can’t change by much and so is essentially *constant* over that entire interval (an approximation that gets ever better as we let $\epsilon \rightarrow 0$) with value $\phi(0)$, and so we can write

¹³ There are *two* frequencies in the transform because of the two exponentials in the transform integral, each of which represents a rotating vector in the complex plane. One rotates counter-clockwise at frequency $+\omega_0$ (making an instantaneous angle with the real axis of $\omega_0 t$) and the other rotates clockwise at frequency $-\omega_0$ (making an instantaneous angle with the real axis of $-\omega_0 t$). The imaginary components of these two vectors always cancel, while the real components add along the real axis to produce the real-valued signal $\cos(\omega_0 t)$.

$$\int_{-\infty}^{\infty} \delta(t)\phi(t)dt = \int_{-\frac{\epsilon}{2}}^{\frac{\epsilon}{2}} \frac{1}{\epsilon}\phi(0)dt = \phi(0) \int_{-\frac{\epsilon}{2}}^{\frac{\epsilon}{2}} \frac{1}{\epsilon}dt = \phi(0)\frac{1}{\epsilon}\epsilon = \phi(0).$$

More generally, if $\phi(t)$ is continuous at $t = a$ then

$$(7.9.14) \quad \int_{-\infty}^{\infty} \delta(t - a)\phi(t) dt = \phi(a).$$

The integral of (7.9.14) is often called the *sampling property* of the impulse.

Now, to finish this section I'll take you through three simple theoretical results in Fourier transform theory. We'll find all three highly useful in the next section. To start, we can use the same notational trick we used to get (7.9.10) to derive what is called the *duality theorem*. Suppose we have the transform pair $g(t) \leftrightarrow G(\omega)$. Then, from the inverse transform integral (7.8.5), we have

$$g(t) = \frac{1}{2\pi} \int_{-\infty}^{\infty} G(\omega)e^{i\omega t}d\omega$$

or, replacing t with $-t$ on both sides of the equality (which leaves the equality as an equality), we have

$$g(-t) = \frac{1}{2\pi} \int_{-\infty}^{\infty} G(\omega)e^{-i\omega t}d\omega.$$

Then, using our symbol-swapping trick again (so it's a *method!*)—replace t with ω , and ω with t —we get

$$g(-\omega) = \frac{1}{2\pi} \int_{-\infty}^{\infty} G(t)e^{-it\omega}d\omega$$

or,

$$2\pi g(-\omega) = \int_{-\infty}^{\infty} G(t)e^{-it\omega}d\omega.$$

That is,

$$(7.9.15) \quad \begin{array}{l} \text{if } g(t) \leftrightarrow G(\omega) \\ \text{then } G(t) \leftrightarrow 2\pi g(-\omega) \end{array}.$$

Our second result, called the *time/frequency scaling theorem*, starts with the given transform pair $f(t) \leftrightarrow F(\omega)$. We then ask: what is the transform of $f(at)$, where a is a positive constant? The answer is of course

$$\int_{-\infty}^{\infty} f(at)e^{-i\omega t} dt$$

which, if we change variable to $u = at$ ($dt = \frac{du}{a}$), becomes

$$\int_{-\infty}^{\infty} f(u)e^{-i\omega \frac{u}{a}} \frac{du}{a} = \frac{1}{a} \int_{-\infty}^{\infty} f(u)e^{-i(\frac{\omega}{a})u} du = \frac{1}{a} F\left(\frac{\omega}{a}\right).$$

That is,

if $f(t) \leftrightarrow F(\omega)$
then $f(at) \leftrightarrow \frac{1}{a} F\left(\frac{\omega}{a}\right)$.

(7.9.16)

And finally, given the two time functions $g(t)$ and $m(t)$, with Fourier transforms $G(\omega)$ and $F(\omega)$, respectively, what is the Fourier transform of $m(t)g(t)$? By definition, the transform is

$$\int_{-\infty}^{\infty} m(t)g(t)e^{-i\omega t} dt = \int_{-\infty}^{\infty} m(t) \left\{ \frac{1}{2\pi} \int_{-\infty}^{\infty} G(u)e^{iut} du \right\} e^{-i\omega t} dt$$

where $g(t)$ has been written in the form of an inverse Fourier transform integral (I’ve used u as the dummy variable of integration in the inner integral, rather than ω , to avoid confusion with the outer ω). Continuing, if we reverse the order of integration we have the transform of $m(t)g(t)$ as

$$\int_{-\infty}^{\infty} \frac{1}{2\pi} G(u) \left\{ \int_{-\infty}^{\infty} m(t)e^{iut} e^{-i\omega t} dt \right\} du = \frac{1}{2\pi} \int_{-\infty}^{\infty} G(u) \left\{ \int_{-\infty}^{\infty} m(t) e^{-i(\omega-u)t} dt \right\} du$$

or, as the inner integral is just $M(\omega - u)$, we have the Fourier transform pair

$m(t)g(t) \leftrightarrow \frac{1}{2\pi} \int_{-\infty}^{\infty} G(u)M(\omega - u) du.$

(7.9.17)

The integral on the right in (7.9.17) occurs so often in mathematical physics that it has its own name: the *convolution integral*, written in short hand as $G(\omega) * M(\omega)$.¹⁴

¹⁴Note, *carefully*: the $*$ symbol denotes *complex conjugation* when used as a superscript as was done in Sect. 7.8 when discussing the energy spectrum, and *convolution* when used in-line. Equation (7.9.16) is called the *frequency convolution integral*, to distinguish it from its twin, the *time convolution integral*, which says $m(t) * g(t) \leftrightarrow G(\omega)M(\omega)$. We won’t use that pair in what follows, but you should now be able to derive it for yourself. Try it!

Since it is arbitrary which time function we call $m(t)$ and which we call $g(t)$, then in fact convolution is commutative and so $m(t)g(t) \leftrightarrow \frac{1}{2\pi}G(\omega) * M(\omega) = \frac{1}{2\pi}M(\omega) * G(\omega)$.

We'll use (7.9.17) in the next section as a purely mathematical result but, to finish this section, you may find it interesting to know that it is the reason radio works. Here's why. Imagine Alice and Bob are each talking into a microphone at radio stations A and B, respectively. Since the sounds produced by both are generated via the same physical process (vibrating human vocal chords), the energies of the two voice signals will be concentrated at essentially the same frequencies, typically a few tens of hertz up to a few thousand hertz. That is, the frequency interval occupied by the electrical signals produced on the wires emerging from Alice's microphone is the same as the frequency interval occupied by the electrical signals produced on the wires emerging from Bob's microphone. This common interval of frequencies determines what is called the *baseband spectrum*, centered on $\omega = 0$.

To apply the baseband electrical signal from a microphone directly to an antenna will *not* result in the efficient radiation of energy into space, as Maxwell's equations for the electromagnetic field tell us that for the efficient coupling of the antenna to space to occur the physical size of the antenna must be comparable to the wavelength of the radiation (if you're not an electrical engineer or a physicist, just take my word for this). At the baseband frequency of 1 kHz, for example, a wavelength of electromagnetic radiation is *one million feet*, which is pretty long. To get a reasonably sized antenna, we need to reduce the wavelength, that is, to *increase* the frequency.

What is done in commercial broadcast AM (amplitude modulated) radio to accomplish that is to shift the baseband spectrum of the microphone signal up somewhere between about 500 kHz to 1,500 kHz, the so-called AM radio band. (Each radio station receives a license from the Federal Communications Commission—the FCC—that gives it permission to do the upward frequency shift by a value that no other station in the same geographical area may use.) At 1,000 kHz, for example, the wavelength is a thousand times shorter that it is at 1 kHz—that is, 1,000 feet. If a station's antenna is constructed to be a quarter-wavelength, for example, then it will have an antenna 250 feet high, which is just about what you'll see when next drive by your local AM radio station's transmitter site.

So, suppose that at station A Alice's baseband signal is up-shifted by 900 kHz, while at station B Bob's baseband signal is up-shifted by 1,100 kHz. A radio receiver then selects which signal to listen to by using a tunable filter centered on either 900 kHz or 1,100 kHz (in AM radio, the bandwidth of such a filter is 10 kHz, and knowing how to design such a filter is part of the skill-set of radio engineers). Note that radio uses a frequency up-shift for *two* reasons: (1) to move baseband energy up to so-called 'radio frequency' to achieve efficient radiation of energy and (2) to *separate* the baseband energies of multiple radio stations by using a *different* up-shift frequency at each station. At a receiver we need a final frequency down-shift to place the energy of the selected station signal back at the baseband frequencies to which our ears respond.

To accomplish these frequency shifts, both up and down, is as simple as doing a multiplication.¹⁵ Here's how (7.9.17) works for the transmitter up-shift. Let $M(\omega)$ be the Fourier transform of either Alice's or Bob's baseband microphone signal. Then, remembering (7.9.13), the transform for $\cos(\omega_0 t)$, (7.9.17) tells us that the transform of $m(t)\cos(\omega_0 t)$ is

$$\begin{aligned} M(\omega) * [\pi\delta(\omega - \omega_0) + \pi\delta(\omega + \omega_0)] &= \frac{1}{2\pi} \int_{-\infty}^{\infty} [\pi\delta(u - \omega_0) + \pi\delta(u + \omega_0)] M(\omega - u) du \\ &= \frac{1}{2} \int_{-\infty}^{\infty} \delta(u - \omega_0) M(\omega - u) du + \frac{1}{2} \int_{-\infty}^{\infty} \delta(u + \omega_0) M(\omega - u) du \end{aligned}$$

and so, remembering (7.9.14), the sampling property of the impulse, the transform of $m(t)\cos(\omega_0 t)$ is $\frac{1}{2}M(\omega - \omega_0) + \frac{1}{2}M(\omega + \omega_0)$. That is, while the energy spectrum of $m(t)$ is centered on $\omega = 0$, the energy spectrum of $m(t)\cos(\omega_0 t)$ is centered on $\omega = \pm \omega_0$. The energy spectrum of the original baseband signal $m(t)$ now rides piggy-back on $\cos(\omega_0 t)$ (picturesquely called the *carrier wave* by radio engineers), and is efficiently radiated into space by a physically 'short' antenna. When used in radio, (7.9.17) is called the *heterodyne theorem*.¹⁶

7.10 Causality and Hilbert Transform Integrals

You'll recall that in Sect. 7.8 I made the following statements about the general transform pair $g(t) \leftrightarrow G(\omega)$: In general, $G(\omega)$ will be complex, with real and imaginary parts $R(\omega)$ and $X(\omega)$, respectively. That is, $G(\omega) = R(\omega) + i X(\omega)$. If $g(t)$ is a real-valued function of time (as of course are all the signals in any electronic circuitry that can actually be constructed) then $G(\omega)$ will have some special properties. In particular, $R(\omega)$ will be even and $X(\omega)$ will be odd: $R(-\omega) = R(\omega)$ and $X(-\omega) = -X(\omega)$. If, in addition to being real, $g(t)$ has certain symmetry properties, then $G(\omega)$ will have additional corresponding special properties. If, for example, $g(t)$ is even (as is $\cos(\omega t)$) then $G(\omega)$ will be real, and if $g(t)$ is odd (as is $\sin(\omega t)$) then $G(\omega)$ will be imaginary: $X(\omega) = 0$ and $R(\omega) = 0$, respectively.

¹⁵ To be honest, multiplying at radio frequencies is *not* easy. To learn how radio engineers accomplish multiplication *without* actually multiplying, see *Dr. Euler*, pp. 295–297, 302–305, or my book *The Science of Radio*, Springer 2001, pp. 233–249.

¹⁶ The *mathematics* of all this was of course known long before AM radio was invented, but the name of the theorem is due to the American electrical engineer Reginald Fessenden (1866–1932), who patented the multiplication idea in 1901 for use in a radio circuit. The word 'heterodyne' comes from the Greek *heteros* (for external) and *dynamic* (for force). Fessenden thought of the $\cos(\omega_0 t)$ signal as the 'external force' being generated by the radio receiver circuitry itself for the final frequency down-shift of the received signal to baseband (indeed, radio engineers call that part of an AM radio receiver the *local oscillator* circuit).

If we now impose even further restrictions on $g(t)$ then, as you'd expect, there will be even further restrictions on $R(\omega)$ and $X(\omega)$. One restriction that is fundamental to the real world is *causality*. To understand what that means, suppose we have what electronics engineers call a 'black box,' with an input and an output. (The term 'black box' means we don't know the details of the circuitry inside the box and, indeed, we don't care.) All we know is that if we apply an input signal starting at time $t = 0$ then, whatever the output signal is, *it had better be zero for $t < 0$* . That is, there should be no output before we apply the input. Otherwise we have what is called an *anticipatory* output, which is a polite name for a time machine! So, there's our question: If $g(t)$ is the output signal, a signal real-valued and zero for all $t < 0$, what more can we say about its Fourier transform $G(\omega) = R(\omega) + i X(\omega)$?

To start our analysis, let's write $g(t)$ as the sum of even and odd functions of time, that is, as

$$(7.10.1) \quad g(t) = g_e(t) + g_o(t)$$

where, by definition,

$$g_e(-t) = g_e(t), g_o(-t) = -g_o(t).$$

That we can actually write $g(t)$ in this way is most directly shown by simply demonstrating what $g_e(t)$ and $g_o(t)$ are (we did this back in Chap. 1, but here it is again). From (7.10.1) we can write

$$(7.10.2) \quad g(-t) = g_e(-t) + g_o(-t) = g_e(t) - g_o(t)$$

and so, adding (7.10.1) to (7.10.2) we get

$$(7.10.3) \quad g_e(t) = \frac{1}{2}[g(t) + g(-t)],$$

and subtracting (7.10.2) from (7.10.1) we get

$$(7.10.4) \quad g_o(t) = \frac{1}{2}[g(t) - g(-t)].$$

So, (7.10.1) is always possible to write.

Since $g(t)$ is to be causal (and so by definition $g(t) = 0$ for $t < 0$), we have from (7.10.3) and (7.10.4) that

$$\begin{aligned} g_e(t) &= \frac{1}{2}g(t) && \square \\ & && \square \text{ if } t > 0 \\ g_o(t) &= \frac{1}{2}g(t) && \square \end{aligned}$$

and

$$\begin{aligned}
 g_e(t) &= \frac{1}{2}g(-t) && \square \\
 &&& \square \quad \text{if } t < 0. \\
 g_o(t) &= -\frac{1}{2}g(-t) && \square
 \end{aligned}$$

That is,

$$\begin{aligned}
 g_e(t) &= g_o(t), & t > 0 \\
 g_e(t) &= -g_o(t), & t < 0
 \end{aligned}$$

and so

$$(7.10.5) \quad g_e(t) = g_o(t)\text{sgn}(t).$$

In a similar way, we can also write

$$(7.10.6) \quad g_o(t) = g_e(t)\text{sgn}(t).$$

Now, because of (7.10.1) we can write

$$G(\omega) = G_e(\omega) + G_o(\omega)$$

and since $g_e(t)$ is even we know that $G_e(\omega)$ is purely real, while since $g_o(t)$ is odd we know that $G_o(\omega)$ is purely imaginary. Thus,

$$(7.10.7) \quad G_e(\omega) = R(\omega)$$

and

$$(7.10.8) \quad G_o(\omega) = i X(\omega).$$

Now, recall the transform pair from (7.9.7):

$$\text{sgn}(t) \leftrightarrow \frac{2}{i\omega}.$$

From (7.10.5), and the frequency convolution theorem of (7.9.17), we have

$$G_e(\omega) = \frac{1}{2\pi}G_o(\omega) * \frac{2}{i\omega}$$

and so, using (7.10.7) and (7.10.8),

$$(7.10.9) \quad R(\omega) = \frac{1}{2\pi} i X(\omega) * \frac{2}{i\omega} = \frac{1}{\pi} X(\omega) * \frac{1}{\omega}.$$

Also, from (7.10.6) and the frequency convolution theorem we have

$$G_o(\omega) = \frac{1}{2\pi} G_e(\omega) * \frac{2}{i\omega}$$

and so, using (7.10.7) and (7.10.8),

$$i X(\omega) = \frac{1}{2\pi} R(\omega) * \frac{2}{i\omega}$$

or,

$$(7.10.10) \quad X(\omega) = -\frac{1}{\pi} R(\omega) * \frac{1}{\omega}.$$

Writing (7.10.9) and (7.10.10) as integrals, we arrive at

$$(7.10.11) \quad \boxed{\begin{aligned} R(\omega) &= \frac{1}{\pi} \int_{-\infty}^{\infty} \frac{X(u)}{\omega - u} du \\ X(\omega) &= -\frac{1}{\pi} \int_{-\infty}^{\infty} \frac{R(u)}{\omega - u} du \end{aligned}}$$

These two equations show that $R(\omega)$ and $X(\omega)$ each determine the other for a causal signal. The integrals that connect $R(\omega)$ and $X(\omega)$ are called *Hilbert transforms*,¹⁷ a name introduced by our old friend throughout this book, G. H. Hardy. Hardy published the transform for the first time *in English* in 1909 but, when he later learned that the German mathematician David Hilbert (1862–1943) had known of these formulas since 1904, Hardy began to call them Hilbert transforms. But Hilbert had not been the first, either, as they had appeared decades earlier in the 1873 doctoral dissertation of the Russian mathematician Yulian-Karl Vasilievich Sokhotsky (1842–1927).

¹⁷ They are also sometimes called the *Kramers-Kronig relations*, after the Dutch physicist Hendrik Kramers (we encountered him back in Sect. 6.5, when discussing the Watson/van Peype triple integrals), and the American physicist Ralph Kronig (1904–1995), who encountered (7.10.11) when studying the spectra of x-rays scattered by the atomic lattice structures of crystals. See Challenge Problem 7.9 for an alternative way to write (7.10.11).

Notice that the Hilbert transform does *not* change domain, as does the Fourier transform. That is, in (7.9.11) the Hilbert transform is in the same domain (ω) on both sides of the equations. One can also take the Hilbert transform of a time function $x(t)$, getting a new time time function¹⁸ written as $\overline{x(t)}$:

$$(7.10.12) \quad \overline{x(t)} = \frac{1}{\pi} \int_{-\infty}^{\infty} \frac{x(u)}{t-u} du.$$

For example, if $x(t)$ is any constant time function (call it k) then its Hilbert transform is zero. To show this, I'll use our old 'sneak' trick to handle the integrand singularity at $u = t$. That is,

$$\overline{x(t)} = \frac{1}{\pi} \int_{-\infty}^{\infty} \frac{k}{t-u} du = \frac{k}{\pi} \lim_{\epsilon \rightarrow 0, T \rightarrow \infty} \left[\int_{-T}^{t-\epsilon} \frac{du}{t-u} + \int_{t+\epsilon}^T \frac{du}{t-u} \right].$$

Changing variable in both integrals on the right to $s = t - u$ ($ds = -du$), then

$$\begin{aligned} \overline{x(t)} &= \frac{k}{\pi} \lim_{\epsilon \rightarrow 0, T \rightarrow \infty} \left[\int_{t+T}^{\epsilon} \left(-\frac{ds}{s} \right) + \int_{-\epsilon}^{t-T} \left(-\frac{ds}{s} \right) \right] \\ &= \frac{k}{\pi} \lim_{\epsilon \rightarrow 0, T \rightarrow \infty} \left[\int_{\epsilon}^{t+T} \frac{ds}{s} + \int_{t-T}^{-\epsilon} \frac{ds}{s} \right] = \frac{k}{\pi} \lim_{\epsilon \rightarrow 0, T \rightarrow \infty} \left[\ln(s) \Big|_{\epsilon}^{t+T} + \ln(s) \Big|_{t-T}^{-\epsilon} \right] \\ &= \frac{k}{\pi} \lim_{\epsilon \rightarrow 0, T \rightarrow \infty} [\ln(t+T) - \ln(\epsilon) + \ln(-\epsilon) - \ln(t-T)] \\ &= \frac{k}{\pi} \lim_{\epsilon \rightarrow 0, T \rightarrow \infty} \left[\ln \left(\frac{t+T}{\epsilon} \right) + \ln \left(\frac{-\epsilon}{t-T} \right) \right] \\ &= \frac{k}{\pi} \lim_{\epsilon \rightarrow 0, T \rightarrow \infty} \left[\ln \left\{ \left(\frac{t+T}{\epsilon} \right) \left(\frac{\epsilon}{T-t} \right) \right\} \right] \end{aligned}$$

and so, noticing that the ϵ 's cancel,

¹⁸Combining a time signal $x(t)$ with its Hilbert transform to form the complex signal $z(t) = x(t) + i \overline{x(t)}$, you get what the Hungarian-born electrical engineer Dennis Gabor (1900–1979)—he won the 1971 Nobel Prize in physics—called the *analytic signal*, of great interest to engineers who study single-sideband (SSB) radio. To see how the analytic signal occurs in SSB radio theory, see *Dr. Euler*, pp. 309–323.

$$\overline{x(t)} = \frac{k}{\pi} \lim_{T \rightarrow \infty} \left[\ln \left\{ \left(\frac{T+t}{T-t} \right) \right\} \right] = \frac{k}{\pi} \ln(1) = 0.$$

This gives us the interesting

(7.10.13)

$$\int_{-\infty}^{\infty} \frac{du}{t-u} = 0.$$

To finish this section, let me now take you through the analysis of a particular causal time signal, which will end with the discovery of yet another interesting integral. To start, recall the Fourier transform of the $f(t)$ in (7.8.1):

$$F(\omega) = \frac{e^{-i\omega a} - e^{-i\omega b}}{i\omega}$$

for

$$f(t) = \begin{cases} 1, & a < t < b \\ 0, & \text{otherwise} \end{cases}.$$

Suppose we set $a = -\frac{1}{2}$ and $b = \frac{1}{2}$. We then have a signal that is important enough in radio engineering to have its own name (it is called the *gate* function), and its own symbol, $\pi(t)$. That is,

$$(7.10.14) \quad \pi(t) = \begin{cases} 1, & -\frac{1}{2} < t < \frac{1}{2} \\ 0, & \text{otherwise} \end{cases}.$$

The Fourier transform of $\pi(t)$ is

$$(7.10.15) \quad \Pi(\omega) = \frac{e^{i\omega\frac{1}{2}} - e^{-i\omega\frac{1}{2}}}{i\omega} = \frac{i2 \sin\left(\frac{\omega}{2}\right)}{i\omega} = \frac{\sin\left(\frac{\omega}{2}\right)}{\left(\frac{\omega}{2}\right)}, \quad -\infty < \omega < \infty.$$

From the duality theorem of (7.9.15) we have, from (7.10.14) and (7.10.15), the pair¹⁹

¹⁹Note, carefully, the dual use of the symbol “ π ”—once for the number, and again for the name of the gate function. There will never be any confusion, however, because the gate function will always appear with an argument while π *alone* is the number.

$$\Pi(t) \leftrightarrow 2\pi \pi(-\omega)$$

and so

$$(7.10.16) \quad \frac{\sin(\frac{t}{2})}{(\frac{t}{2})} \leftrightarrow 2\pi \pi(-\omega) = 2\pi \pi(\omega)$$

because $\pi(\omega)$ is an even function. Next, applying the time/frequency scaling theorem of (7.9.16) with $a = 2$, (7.10.16) says

$$\frac{\sin(t)}{t} \leftrightarrow \pi \pi\left(\frac{\omega}{2}\right).$$

Since the gate function is 1 over the interval for which its argument is in the interval $-\frac{1}{2}$ to $\frac{1}{2}$ (this interval is $-\frac{1}{2} < \frac{\omega}{2} < \frac{1}{2}$, or $-1 < \omega < 1$), we have

$$(7.10.17) \quad \frac{\sin(t)}{t} \leftrightarrow \begin{cases} \pi, & -1 < \omega < 1 \\ \square & \\ 0, & \text{otherwise} \end{cases}.$$

Now, the time signal in (7.10.17) is not a causal signal since it exists for all t , but we can use it to make a causal signal (zero for $t < 0$) by multiplying it by the step function. That is,

$$g(t) = \frac{\sin(t)}{t} u(t)$$

is a causal time function. As we showed at the beginning of this section, we can always write any causal time function as the sum of an even function and an odd function, where the even function is $\frac{1}{2}g(t)$, which for our problem here is $\frac{\sin(t)}{2t}$. You'll also recall that we showed the real part of $G(\omega)$ is due entirely to this even time function. So,

$$\frac{\sin(t)}{2t} \leftrightarrow R(\omega).$$

Looking back at (7.10.17), we see that

$$(7.10.18) \quad \frac{\sin(t)}{2t} = \frac{1}{2} \left\{ \frac{\sin(t)}{t} \right\} \leftrightarrow R(\omega) = \begin{cases} \frac{\pi}{2}, & -1 < \omega < 1 \\ \square & \\ 0, & \text{otherwise} \end{cases}.$$

So, from (7.10.11) we can find $X(\omega)$, the imaginary part of $G(\omega)$, as

$$X(\omega) = -\frac{1}{\pi} \int_{-\infty}^{\infty} \frac{R(u)}{\omega - u} du = -\frac{1}{2} \int_{-1}^1 \frac{du}{\omega - u}.$$

Doing this integral isn't quite as straightforward as it might initially appear. That's because there is a singularity at $u = \omega$. If $|\omega| > 1$ this singularity is not in the interval of integration and we can proceed in the obvious way. Change variable to $s = \omega - u$ and so $ds = -du$. Then,

$$X(\omega) = -\frac{1}{2} \int_{\omega+1}^{\omega-1} \left(\frac{-ds}{s} \right) = \frac{1}{2} \int_{\omega+1}^{\omega-1} \left(\frac{ds}{s} \right) = \frac{1}{2} \ln(s) \Big|_{\omega+1}^{\omega-1} = \frac{1}{2} \ln \left(\frac{\omega - 1}{\omega + 1} \right), \quad |\omega| > 1.$$

For $|\omega| > 1$ the argument of the log function is positive and all is okay. For the case of $|\omega| < 1$, however, the argument is negative and the log function gives an imaginary result, which is *not* okay. The reason for this difficulty is that the singularity is in the interval of integration when $|\omega| < 1$.

The fix is to use our sneak trick. In the limit as $\varepsilon \rightarrow 0$ we write

$$\begin{aligned} X(\omega) &= -\frac{1}{2} \left[\int_{-1}^{\omega-\varepsilon} \frac{du}{\omega - u} + \int_{\omega+\varepsilon}^1 \frac{du}{\omega - u} \right] = -\frac{1}{2} \left[\int_{\omega+1}^{\varepsilon} \left(\frac{-ds}{s} \right) + \int_{-\varepsilon}^{\omega-1} \left(\frac{-ds}{s} \right) \right] \\ &= \frac{1}{2} \left[\ln(s) \Big|_{\omega+1}^{\varepsilon} + \ln(s) \Big|_{-\varepsilon}^{\omega-1} \right] = \frac{1}{2} \left[\ln \left(\frac{\varepsilon}{\omega + 1} \right) + \ln \left(\frac{\omega - 1}{-\varepsilon} \right) \right] \\ &= \frac{1}{2} \left[\ln \left(\frac{\varepsilon}{\omega + 1} \right) + \ln \left(\frac{1 - \omega}{\varepsilon} \right) \right] \end{aligned}$$

or, as the ε 's cancel even before we let $\varepsilon \rightarrow 0$,

$$X(\omega) = \frac{1}{2} \ln \left(\frac{1 - \omega}{1 + \omega} \right), \quad |\omega| < 1.$$

We can handle both cases, $|\omega| > 1$ and $|\omega| < 1$, simultaneously, by writing

$$(7.10.19) \quad X(\omega) = \frac{1}{2} \ln \left(\left| \frac{1 - \omega}{1 + \omega} \right| \right), \quad -\infty < \omega < \infty.$$

Now, from Rayleigh's energy theorem and (7.10.7) we can write

$$\int_{-\infty}^{\infty} g_e^2(t) dt = \frac{1}{2\pi} \int_{-\infty}^{\infty} R^2(\omega) d\omega,$$

and from Rayleigh's energy theorem and (7.10.8) we can write

$$\int_{-\infty}^{\infty} g_0^2(t) dt = \frac{1}{2\pi} \int_{-\infty}^{\infty} X^2(\omega) d\omega.$$

From (7.10.5) or (7.10.6) we see that the time integrals are clearly equal, and so then must be the frequency integrals. That is, for a causal signal,

$$\int_{-\infty}^{\infty} R^2(\omega) d\omega = \int_{-\infty}^{\infty} X^2(\omega) d\omega.$$

Since (7.10.18) says

$$\int_{-\infty}^{\infty} R^2(\omega) d\omega = \int_{-1}^1 \frac{\pi^2}{4} d\omega = \frac{\pi^2}{2},$$

then using (7.10.19) in the $X(\omega)$ integral we have

$$\int_{-\infty}^{\infty} \frac{1}{4} \ln^2 \left(\left| \frac{1-\omega}{1+\omega} \right| \right) d\omega = \frac{\pi^2}{2}$$

or, since $\int_0^{\infty} = \frac{1}{2} \int_{-\infty}^{\infty}$, we have the pretty result

(7.10.20)

$$\int_0^{\infty} \ln^2 \left(\left| \frac{1-x}{1+x} \right| \right) dx = \pi^2.$$

This is 9.8696... , and MATLAB agrees as `quad(@(x)log(abs((x-1)/(x+1))), 2,0,10000) = 9.8692...`

7.11 Challenge Problems

(C7.1): What are the values of

$$\int_0^{\infty} \left\{ \frac{\sin(x)}{x} \right\}^n dx$$

for $n = 5, 6,$ and 7 ?

(C7.2): Use Euler's identity to show that if

$$F(x) = \int_x^\infty \int_x^\infty \sin(t^2 - u^2) dt du$$

then $F(x)$ is *identically zero* (that is, $F(x) = 0$ for all x). Hint: Look back at Sect. 6.4, to the discussion there of the Hardy-Schuster optical integral, where we used the trig formula for $\cos(a - b)$ to establish that if $C(x)$ and $S(x)$ are the Fresnel cosine and sine integrals, respectively, then $C^2(x) + S^2(x) = \int_x^\infty \int_x^\infty \cos(t^2 - u^2) dt du$. Start now with $\int_x^\infty e^{it^2} dt = C(x) + iS(x)$ and see where that takes you. (At some point, think about taking a conjugate.) This is (I think) not an obvious result, and just to help give you confidence that it's correct, the following table shows what MATLAB's Symbolic Math Toolbox numerically calculated for the value of $F(x)$ for various arbitrarily selected values of x , using the code

```
syms t u
int(int(sin(t^2-u^2),t,x,inf),u,x,inf)
```

The numerical value of x was substituted into the second line *before* each execution.

x	F(x)
-7	$-1x 10^{-33} - i3.03x10^{-34}$
-2	0
0	0
1	$-1.6x 10^{-34}$
5	$-9x 10^{-36}$
29	$-2x 10^{-37}$

(C7.3): In a recent physics paper²⁰ integrals of the form

$$\int_{-\infty}^{\infty} \frac{dx}{\sqrt{1 - ix^3}}$$

occur. The authors state, without proof, that this integral exists. Show this claim is, in fact, true. Hint: use the theorem from calculus that says

$$\left| \int_{-\infty}^{\infty} f(x) dx \right| \leq \int_{-\infty}^{\infty} |f(x)| dx$$

which, using the area interpretation of the Riemann integral, should be obvious to you for the case where $f(x)$ is real. Using contour integrals in the complex plane (see Chap. 8), this theorem can be extended to the case where $f(x)$ is complex.

²⁰ Carl Bender, et al., "Observation of PT phase transitions in a simple mechanical system," *American Journal of Physics*, March 2013, pp. 173–179.

(C7.4): Recall the integral we worked-out in the first chapter (Sect. 1.8), $\int_1^\infty \frac{\{x\} - \frac{1}{2}}{x} dx = -1 + \ln(\sqrt{2\pi})$, as well as the integrals of the second and third challenge problems of Chap. 5: $\int_1^\infty \frac{\{x\}}{x^2} dx = 1 - \gamma$ where $\{x\}$ is the fractional part of x and γ is Euler's constant, and $\zeta(3) = \sum_{k=1}^\infty \frac{1}{k^3} = \frac{3}{2} - 3 \int_1^\infty \frac{\{x\}}{x^4} dx$. See if you can apply the same trick we used there to show that

$$\int_1^\infty \frac{\{x\}}{x^3} dx = 1 - \frac{\pi^2}{12},$$

now that we've formally calculated $\zeta(2) = \frac{\pi^2}{6}$ (in Sect. 7.4). MATLAB may help give you confidence this is correct, as $1 - \frac{\pi^2}{12} = 0.177532\dots$ while `quad(@(x)(x-floor(x))./x.^3,1,100) = 0.177279\dots`

(C7.5): Derive a more general form of (7.6.1) by differentiating

$$I(a) = \int_0^\infty \frac{\sin^2(ax)}{x^2} dx$$

with respect to a . That is, show that $I(a) = \frac{\pi}{2}|a|$, and so (7.6.1) is the special case of $a = 1$.

(C7.6): Look back to Sect. 4.3, to the results in (4.3.10) and (4.3.11), and show how the Fresnel integrals immediately follow from them.

(C7.7): Apply Rayleigh's theorem to the time signal
$$e^{-at}, 0 \leq t \leq m$$
 □

$$0, \text{ otherwise}$$

where a and m are both positive constants. Hint: you should find that you have re-derived (3.1.7) in a way far different from the method used in Chap. 3.

(C7.8): Calculate the Fourier transforms of the following time signals:

- (a) $\frac{1}{t^2+1}$;
- (b) $\frac{t}{t^2+1}$;
- (c) $\frac{1}{2}\delta(t) + i\frac{1}{2\pi t}$;
- (d) $E_i(t) = \begin{cases} \int_t^\infty \frac{e^{-u}}{u} du, & t \geq 0 \\ 0, & t < 0 \end{cases}$.

Hint: For (a) you may find (3.1.7) helpful, for (b) don't forget Feynman's favorite trick (of differentiating integrals), and for (c) keep (7.9.3) and (7.9.14) in mind. (The Fourier transform of the complex time signal in (c) is at the heart of SSB radio.) And finally, for (d), make the change of variable $x = \frac{u}{t}$, write the Fourier transform integral (which will of course be a double integral), and then reverse the

order of integration. (The perhaps mysterious-looking $E_i(t)$ is the *exponential-integral function*, and it occurs in many advanced applications of engineering and physics. For an example of this, in a study of long free-falls through a variable density atmosphere with a square-law drag force, see my book *Mrs. Perkins's Electric Quilt and other intriguing stories of mathematical physics*, Princeton University Press 2009, pp. 70–78.)

(C7.9): Looking at the first Hilbert transform integral in (7.10.11), we see that we can write $\pi R(\omega) = \int_{-\infty}^{\infty} \frac{X(u)}{\omega - u} du = \int_{-\infty}^0 \frac{X(u)}{\omega - u} du + \int_0^{\infty} \frac{X(u)}{\omega - u} du$. If $x(t)$ is real then $R(-\omega) = R(\omega)$ and $X(-\omega) = -X(\omega)$, and so if we make the change of variable $s = -u$ in the first integral on the right we have $\pi R(\omega) = \int_{\infty}^0 \frac{X(-s)}{\omega + s} (-ds) + \int_0^{\infty} \frac{X(u)}{\omega - u} du = -\int_0^{\infty} \frac{X(s)}{\omega + s} ds + \int_0^{\infty} \frac{X(u)}{\omega - u} du = \int_0^{\infty} X(u) \left[\frac{1}{\omega - u} - \frac{1}{\omega + u} \right] du = \int_0^{\infty} X(u) \frac{2u}{\omega^2 - u^2} du$. That is, an alternative form for the first Hilbert transform integral in (7.10.11) is $R(\omega) = \frac{2}{\pi} \int_0^{\infty} \frac{uX(u)}{\omega^2 - u^2} du$. Use this same approach to find an alternative form for the second Hilbert transform integral in (7.10.11), one that gives $X(\omega)$ as an integral of $R(\omega)$ for the case of $x(t)$ real.

(C7.10): Suppose $x(t)$, $y(t)$, and $h(t)$ are time signals such that the following three conditions hold:

- (a) $x(t)$ has finite energy:
- (b) $y(t) = x(t) * h(t) = \int_{-\infty}^{\infty} x(u)h(t - u)du$;
- (c) $\int_{-\infty}^{\infty} |h(t)|dt < \infty$.

Show that $y(t)$ has finite energy. Hint: Use Fourier transforms, Rayleigh's energy theorem, and a look back at the hint for (C7.3) may also help.

(C7.11): Calculate the Hilbert transforms of $\cos(\omega_0 t)$ and $\sin(\omega_0 t)$. Hint: Use Euler's identity in the defining integral (7.10.12) for the Hilbert transform of a time signal, and you may also find that recalling (7.9.3) is helpful.

Chapter 8

Contour Integration

8.1 Prelude

In this, the penultimate chapter of the book, I'll give you a really fast, stripped-down, 'crash-course' presentation of the very beginnings of complex function theory, and the application of that theory to one of the gems of mathematics: *contour integration* and its use in doing definite integrals. As we start this chapter I'll assume only that you are familiar with complex *numbers* and their manipulation. I've really already done that, of course, in Chap. 7, and so I think I am on safe ground here with that assumption. The first several sections will lay the theoretical groundwork and then, quite suddenly, you'll see how they all come together to give us the beautiful and powerful technique of contour integration. None of these preliminary sections is very difficult, but each is absolutely essential for understanding. Don't skip them!

In keeping with the spirit of this book, the presentation leans heavily on intuitive, plausible arguments and, while I don't think I do anything wildly outrageous, there will admittedly be occasions where professional mathematicians might feel tiny stabs of pain. (Mathematicians are a pretty tough bunch, though, and they will survive!) This may be the appropriate place to quote the mathematician John Stalker (of Trinity College, Dublin), who once wrote "In mathematics, as in life, virtue is not always rewarded, *nor vice always punished* [my emphasis]."¹ As always, I'll feel vindicated when, after doing a series of manipulations, MATLAB's numerical calculations agree with whatever theoretical result we've just derived.

¹ In his book *Complex Analysis: Fundamentals of the Classical Theory of Functions*, Birkhäuser 1998, p. 120.

8.2 Line Integrals

Imagine two points, A and B, in the two-dimensional x,y plane. Further, imagine that A and B are the two end-points of the curve C in the plane, as shown in Fig. 8.2.1. A is the *starting* end-point and B is the *terminating* end-point. Now, suppose that we divide C into n parts (or arcs), with the k -th arc having length Δs_k (where k runs from 1 to n). Each of these arcs has a projection on the x -axis, where we'll write Δx_k as the x -axis projection of Δs_k . In the same way, we'll write Δy_k as the y -axis projection of Δs_k . Again, see Fig. 8.2.1. Finally, we'll assume, as $n \rightarrow \infty$, that $\Delta s_k \rightarrow 0$, that $\Delta x_k \rightarrow 0$, and that $\Delta y_k \rightarrow 0$, for each and every k (that is, the points along C that divide C into n arcs are distributed, loosely speaking, 'uniformly' along C).

Continuing, suppose that we have some function $h(x, y)$ that is defined at every point along C. If we form the two sums $\sum_{k=1}^n h(x_k, y_k) \Delta x_k$ and $\sum_{k=1}^n h(x_k, y_k) \Delta y_k$ where (x_k, y_k) is an arbitrary point in the arc Δs_k , then we'll write the limiting values of these sums as²

$$(8.2.1) \quad \lim_{n \rightarrow \infty} \sum_{k=1}^n h(x_k, y_k) \Delta x_k = \int_C h(x, y) dx = I_x$$

and

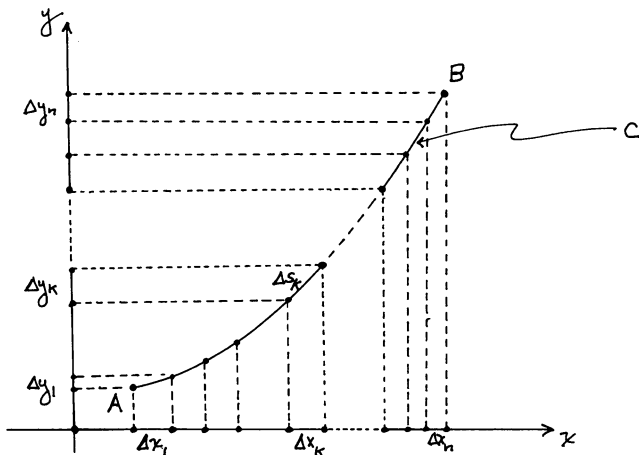
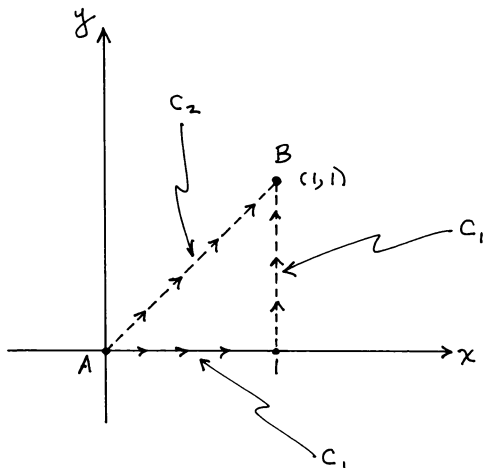

Fig. 8.2.1 A curve in the plane, and its projections on the x and y axes

² In keeping with the casual approach I'm taking in this book, I'll just *assume* that these two limits exist and then we'll see where that assumption takes us. Eventually we'll arrive at a new way to do definite integrals (contour integration) and *then* we'll check our assumption by seeing if our theoretical calculations agree with MATLAB's direct numerical evaluations.

Fig. 8.2.2 Two different line integral paths



$$(8.2.2) \quad \lim_{n \rightarrow \infty} \sum_{k=1}^n h(x_k, y_k) \Delta y_k = \int_C h(x, y) dy = I_y.$$

The C 's at the bottom of the integral signs in (8.2.1) and (8.2.2) are there to indicate that we are integrating *from A to B along C*. We'll call the two limits in (8.2.1) and (8.2.2) *line integrals* (sometimes the term *path integral* is used, commonly by physicists). If $A = B$ (that is, if C is a *closed loop*³) then the result is called a *contour integral*. When we encounter contour integrals it is understood that C never crosses itself (such a C is said to be *simple*). Further, it is understood that a contour integral is done in the counter-clockwise sense; to reverse the direction of integration will reverse the algebraic sign of the integral.

The value of a line integral depends, in general, on the coordinates of A and B , the function $h(x, y)$, and on the specific path C that connects A and B . For example, suppose that $A = (0, 0)$, $B = (1, 1)$, and that $h(x, y) = xy$. To start, let's suppose that $C = C_1$ is the broken path shown in Fig. 8.2.2. The first part is along the x -axis from $x = 0$ to $x = 1$, and then the second part is straight-up from $x = 1$ ($y = 0$) to $x = 1$ ($y = 1$). So, for this path we have $y = 0$ along the x -axis (and so $h(x, y) = 0$), and $x = 1$ on the vertical portion of C_1 (and so $h(x, y) = y$). Thus, our two line integrals on this path are

³ There are, of course, *two* distinct ways we can have $A = B$. The trivial way is if C simply has zero length, which immediately says $I_x = I_y = 0$. The non-trivial way is if C goes from A out into the plane, wanders around for a while, and then returns to A (which we re-label as B). It is this second way that gives us a closed loop.

$$I_x = \int_{C_1} h(x, y) dx = \int_0^1 0 dx + \int_1^1 y dx = 0 + 0 = 0$$

and

$$I_y = \int_{C_1} h(x, y) dy = \int_0^0 0 dy + \int_0^1 y dy = \left(\frac{1}{2}y^2\right)\Big|_0^1 = \frac{1}{2}.$$

Along the path C_2 , on the other hand, we have $y = x$ from A to B, and so $h(x, y) = x^2$ (or, equivalently, y^2). So, on *this* path the line integrals are

$$I_x = \int_{C_2} h(x, y) dx = \int_0^1 x^2 dx = \left(\frac{1}{3}x^3\right)\Big|_0^1 = \frac{1}{3}$$

and

$$I_y = \int_{C_2} h(x, y) dy = \int_0^1 y^2 dy = \left(\frac{1}{3}y^3\right)\Big|_0^1 = \frac{1}{3}.$$

Clearly, the values of the I_x, I_y line integrals are path-dependent and, for a given path, the I_x, I_y line integrals may or may not be equal. We can combine the I_x and I_y line integrals to write *the* line integral along C as $I_C = I_x + iI_y$, and so $I_{C_1} = i\frac{1}{2}$ while $I_{C_2} = \frac{1}{3} + i\frac{1}{3}$.

Looking back at the previous section, notice that in Fig. 8.2.2 we could write the unbroken line segment AB as $z = x + iy$ or, as $y = x$, $z = x + ix = x(1 + i)$ and so $dz = (1 + i) dx$. Then, as $h(x, y) = h(x, x) = x^2$, we have

$$I_{C_2} = \int_0^1 x^2(1 + i) dx = (1 + i)\left(\frac{1}{3}x^3\right)\Big|_0^1 = \frac{1}{3} + i\frac{1}{3}.$$

which is just as we calculated before.

For now, we'll put aside these considerations and turn to expanding this book's discussion from functions of a real variable to functions of a complex variable. Soon, however, you'll see how this expanded view of functions will 'circle back'—how appropriate!—to closed contour line integrals, and what we've done in this section will prove to be *most* useful.

8.3 Functions of a Complex Variable

I will write the complex variable z as

$$(8.3.1) \quad z = x + iy$$

where x and y are each real with each varying over the doubly-infinite interval $-\infty$ to $+\infty$, and $i = \sqrt{-1}$. Geometrically, we'll interpret z as a point in an infinite, two-dimensional plane (called the *complex plane*) with x measured along a horizontal axis and y measured along a vertical axis. And we'll write a complex function of the complex variable z as

$$(8.3.2) \quad f(z) = f(x + iy) = u(x, y) + iv(x, y)$$

where u and v are each real-valued functions of the two real-valued variables x and y . For example, if

$$f(z) = z^2 = (x + iy)^2 = x^2 - y^2 + i2xy$$

then, in this case, $u = x^2 - y^2$ and $v = 2xy$. In x, y notation, we are said to be working in rectangular (or *Cartesian*) coordinates.

It is often convenient to work in polar coordinates, which means we write the complex variable z as

$$(8.3.3) \quad z = re^{i\theta}$$

where r and θ are each real: r is the radial distance from the origin of the coordinate system of the complex plane to the point z (and so $0 \leq r < \infty$), and θ is the angle of the *radius vector* (of length r) measured counter-clockwise from the positive horizontal x -axis to the radius vector (and so we *generally* take $0 \leq \theta < 2\pi$). Note, carefully, however, that θ is not *uniquely* determined, as we can add (or subtract) any multiple of 2π from θ and still be talking about the same point in the complex plane.

From Euler's fabulous formula (look back at Chap. 7) we have from (8.3.3) that

$$(8.3.4) \quad z = r\{\cos(\theta) + i\sin(\theta)\}.$$

For example, if $f(z) = z^2$ then

$$f(z) = (re^{i\theta})^2 = r^2\{\cos(\theta) + i\sin(\theta)\}^2$$

or, expanding both sides of the last equality,

$$r^2e^{i2\theta} = r^2\{\cos(2\theta) + i\sin(2\theta)\} = r^2\{\cos^2(\theta) - \sin^2(\theta) + i2\cos(\theta)\sin(\theta)\}.$$

Since the real and imaginary parts of the expressions in the last equality must be separately equal, we conclude that $\cos(2\theta) = \cos^2(\theta) - \sin^2(\theta)$ as well as $\sin(2\theta) = 2\cos(\theta)\sin(\theta)$. These two formulas are the well-known *double-angle* formulas from

trigonometry, and so already we have a nice illustration of the powerful ability of complex functions to do useful work for us.⁴

I'll end this section with two more spectacular demonstrations of that power. First, the calculation of

$$\int_0^{2\pi} e^{\cos(\theta)} d\theta,$$

an integral I am absolutely sure you have never seen done by the 'routine' integration techniques of freshman calculus. We'll do it here (using the polar form of z) with a contour integration in the complex plane. With $z = e^{i\theta}$, which puts z on the unit circle ($r = 1$) centered on the origin, we can write

$$\cos(\theta) = \frac{1}{2} \left(z + \frac{1}{z} \right)$$

because $\frac{1}{z} = e^{-i\theta}$ and Euler's formula says this is $\cos(\theta) - i \sin(\theta)$. Now, consider the complex function

$$f(z) = \frac{e^{\frac{1}{2}(z+\frac{1}{z})}}{z}$$

which we'll integrate counter-clockwise *once* around the unit circle. That is, we'll compute

$$\oint_C \frac{e^{\frac{1}{2}(z+\frac{1}{z})}}{z} dz$$

where C is the circle $z = e^{i\theta}$. (The circle on the integral sign is there simply to emphasize that we are working with a *closed* line integral.)

The reason for the z in the denominator of the integrand is because $dz = i e^{i\theta} d\theta$ and we need an $e^{i\theta}$ in the denominator to cancel the $e^{i\theta}$ in dz . So,

$$(8.3.5) \quad \oint_C \frac{e^{\frac{1}{2}(z+\frac{1}{z})}}{z} dz = \int_0^{2\pi} \frac{e^{\cos(\theta)}}{e^{i\theta}} i e^{i\theta} d\theta = i \int_0^{2\pi} e^{\cos(\theta)} d\theta.$$

That is, the contour integral at the left in (8.3.5) is the integral we are after multiplied by i . To directly calculate the contour integral, we start by expanding the exponential in the left-most integral in a power series. That is,

⁴ If, instead, we had started with $f(z) = z^3 = (re^{i\theta})^3 = r^3 e^{i3\theta} = r^3 \{\cos(\theta) + i \sin(\theta)\}^3$, then we could have just as easily have derived the *triple-angle* formulas that are not so easy to get by other means (just take a look at any high school trigonometry text).

$$\oint_C \frac{e^{\frac{1}{2}(z+\frac{1}{z})}}{z} dz = \oint_C \frac{1}{z} \sum_{n=0}^{\infty} \frac{\left\{\frac{1}{2}\left(z+\frac{1}{z}\right)\right\}^n}{n!} dz = \oint_C \frac{1}{z} \sum_{n=0}^{\infty} \frac{1}{2^n n!} \left(z+\frac{1}{z}\right)^n dz.$$

Using the binomial theorem to write

$$\left(z+\frac{1}{z}\right)^n = \sum_{k=0}^n \binom{n}{k} z^k \left(\frac{1}{z}\right)^{n-k} = \sum_{k=0}^n \binom{n}{k} z^k \frac{1}{z^{n-k}} = \sum_{k=0}^n \binom{n}{k} \frac{z^{2k}}{z^n},$$

we have

$$\begin{aligned} \oint_C \frac{e^{\frac{1}{2}\left(z+\frac{1}{z}\right)}}{z} dz &= \oint_C \frac{1}{z} \sum_{n=0}^{\infty} \frac{1}{2^n n!} \left\{ \sum_{k=0}^n \binom{n}{k} \frac{z^{2k}}{z^n} \right\} dz \\ &= \oint_C \sum_{n=0}^{\infty} \frac{1}{2^n n!} \left\{ \sum_{k=0}^n \binom{n}{k} z^{2k-n-1} \right\} dz \\ &= \sum_{n=0}^{\infty} \frac{1}{2^n n!} \left\{ \sum_{k=0}^n \binom{n}{k} \oint_C z^{2k-n-1} \right\} dz. \end{aligned}$$

Now, concentrate on that last integral, where we'll replace z with $e^{i\theta}$ and dz with $ie^{i\theta}d\theta$:

$$\oint_C z^{2k-n-1} dz = \int_0^{2\pi} (e^{i\theta})^{2k-n-1} ie^{i\theta} d\theta = i \int_0^{2\pi} e^{i(2k-n)\theta} d\theta = \begin{cases} 2\pi i & \text{if } 2k-n=0 \\ 0 & \text{if } 2k-n \neq 0 \end{cases}.$$

This is remarkable! Every one of these integrals on the right vanishes as n and k run through their values *except* for those cases where $k = \frac{n}{2}$. This has a profound implication, as then k can be an integer (which of course it is) only if n is *even*. For all odd values of n the integrals vanish, and in the cases of n even they vanish, too, if $k \neq \frac{n}{2}$. We can include all the integrals that don't vanish with the simple trick of writing $n = 2m$, where $m = 0, 1, 2, 3, \dots$, and so we have

$$\begin{aligned} \oint_C \frac{e^{\frac{1}{2}\left(z+\frac{1}{z}\right)}}{z} dz &= \sum_{m=0}^{\infty} \frac{1}{2^{2m}(2m!)} \binom{2m}{m} 2\pi i = 2\pi i \sum_{m=0}^{\infty} \frac{1}{2^{2m}(2m!)} \frac{(2m!)}{m!m!} \\ &= 2\pi i \sum_{m=0}^{\infty} \frac{1}{2^{2m}(m!)^2}. \end{aligned}$$

From (8.3.5) we can now write

$$2\pi i \sum_{m=0}^{\infty} \frac{1}{2^{2m}(m!)^2} = i \int_0^{2\pi} e^{\cos(\theta)} d\theta$$

or, cancelling the i 's, we have our answer:

$$(8.3.6) \quad \int_0^{2\pi} e^{\cos(\theta)} d\theta = 2\pi \sum_{m=0}^{\infty} \frac{1}{2^{2m}(m!)^2}.$$

The terms in the series on the right decrease very rapidly and so the series quickly converges. Using just the first four terms the sum is $2\pi\left(1 + \frac{1}{4} + \frac{1}{64} + \frac{1}{2,304}\right) = 7.95488$ and MATLAB agrees, as `quad(@(x)exp(cos(x)),0,2*pi) = 7.95492...`

For the final demonstration in this section (this one from physics) of the amazing utility of complex functions, imagine a point mass m moving in a plane along the path given by (8.3.3),

$$(8.3.7) \quad z(t) = r(t)e^{i\theta(t)}$$

where now z , r and θ are specifically indicated to be functions of time (t). (The meaning of each of these variables is as given at the beginning of this section.) The motion of m is due entirely to a force acting along the line connecting the mass to the source of the force: the classic example of this situation is the Earth (the ‘point’ mass) moving under the influence of the gravitational field of the Sun (which we’ll take as being at the origin of the x - y coordinate system). The *attractive* force on the Earth is, of course, always directed *radially inward* towards the Sun.

If we write the magnitude of the force on m as $f(r, \theta)$, Newton’s famous second law of motion (‘force is mass times acceleration’) says

$$(8.3.8) \quad f(r, \theta)e^{i\theta} = m \frac{d^2z}{dt^2}.$$

From (8.3.7) we have

$$\frac{dz}{dt} = \frac{dr}{dt}e^{i\theta} + ir \frac{d\theta}{dt}e^{i\theta}$$

and so

$$\frac{d^2z}{dt^2} = \frac{d^2r}{dt^2}e^{i\theta} + \frac{dr}{dt}i \frac{d\theta}{dt}e^{i\theta} + i \left[\frac{dr}{dt} \frac{d\theta}{dt}e^{i\theta} + r \frac{d^2\theta}{dt^2}e^{i\theta} + r \frac{d\theta}{dt}i \frac{d\theta}{dt}e^{i\theta} \right]$$

or,

$$(8.3.9) \quad \frac{d^2z}{dt^2} = \left[\frac{d^2r}{dt^2} - r \left(\frac{d\theta}{dt} \right)^2 \right] e^{i\theta} + i \left[2 \frac{dr}{dt} \frac{d\theta}{dt} + r \frac{d^2\theta}{dt^2} \right] e^{i\theta}.$$

Using (8.3.9) in (8.3.8) and cancelling all the $e^{i\theta}$ (which are *never* zero), we arrive at

$$f(r, \theta) = m \left[\frac{d^2 r}{dt^2} - r \left(\frac{d\theta}{dt} \right)^2 \right] + i m \left[2 \frac{dr}{dt} \frac{d\theta}{dt} + r \frac{d^2 \theta}{dt^2} \right].$$

Equating real and imaginary parts of this last expression gives us the famous differential equations of motion in a radial force field:

$$(8.3.10) \quad f(r, \theta) = m \left[\frac{d^2 r}{dt^2} - r \left(\frac{d\theta}{dt} \right)^2 \right]$$

and

$$(8.3.11) \quad 2 \frac{dr}{dt} \frac{d\theta}{dt} + r \frac{d^2 \theta}{dt^2} = 0.$$

Interestingly, the result in (8.3.11) was implicitly known long *before* Newton. Mathematics alone tells us that

$$\frac{d}{dt} \left\{ r^2 \frac{d\theta}{dt} \right\} = 2r \left(\frac{dr}{dt} \right) \frac{d\theta}{dt} + r^2 \frac{d^2 \theta}{dt^2} = r \left[2 \left(\frac{dr}{dt} \right) \frac{d\theta}{dt} + r \frac{d^2 \theta}{dt^2} \right]$$

and, since the expression in the square brackets is zero by (8.3.11), we have

$$\frac{d}{dt} \left\{ r^2 \frac{d\theta}{dt} \right\} = 0.$$

Thus, integration gives us

$$(8.3.12) \quad r^2 \frac{d\theta}{dt} = C$$

where C is a constant. This result has a historically important physical interpretation in the theory of planetary motion.

Look at Fig. 8.3.1, which shows a planet's location at times t and $t + \Delta t$, with the Sun at the origin of our coordinate system. We assume Δt is so small that the angular change $\Delta\theta$ in the radius vector's angle is also very small, and that the length of the radius vector remains essentially unchanged. Then, the area between the two dashed lines is essentially that of an isosceles triangle with area ΔA given by

$$\Delta A = \frac{1}{2} \text{ base times height} \approx \frac{1}{2} (r\Delta\theta)r = \frac{1}{2} r^2 \Delta\theta.$$

Dividing through by Δt gives

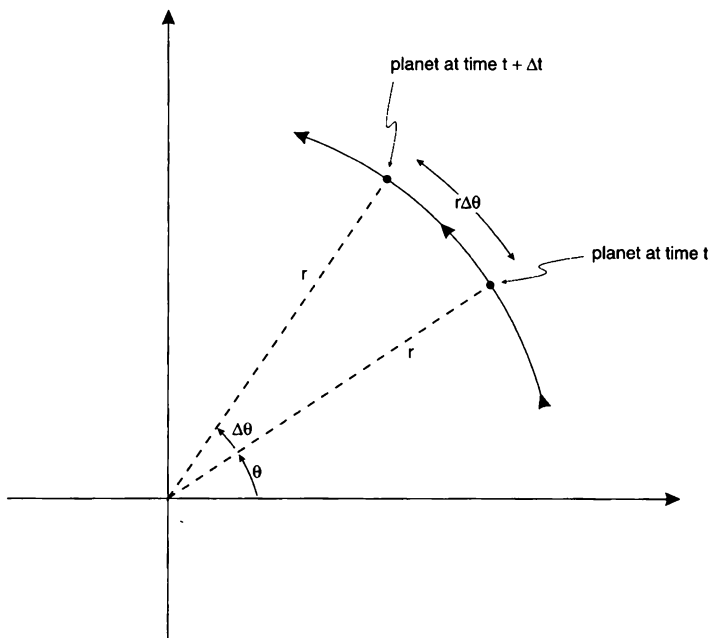

Fig. 8.3.1 Interpreting $r^2 \frac{d\theta}{dt}$

$$\frac{\Delta A}{\Delta t} \approx \frac{1}{2} r^2 \frac{\Delta \theta}{\Delta t},$$

an expression that becomes exact as $\Delta t \rightarrow 0$. That is, replacing the delta quantities with differential ones, we have

$$\frac{dA}{dt} = \frac{1}{2} r^2 \frac{d\theta}{dt}$$

or, from (8.3.12),

$$r^2 \frac{d\theta}{dt} = 2 \frac{dA}{dt} = C.$$

This last expression is the mathematical form of the statement (given in 1609) by the German astronomer Johann Kepler (1671-1630) of his famous *area law*: the line joining the Sun to a planet sweeps over equal areas in equal time intervals. Kepler deduced this (the second of three general laws he discovered) not by physics or complex function theory, but rather from years of tedious observational data.

8.4 The Cauchy-Riemann Equations and Analytic Functions

Complex function theory really starts with the study of what it means to talk of the *derivative* of $f(z)$. In real function theory, the derivative of $g(x)$ at $x = x_0$ is defined as

$$\frac{dg}{dx} \Big|_{x=x_0} = \lim_{\Delta x \rightarrow 0} \frac{g(x_0 + \Delta x) - g(x_0)}{\Delta x} = g'(x_0).$$

We do almost the same thing with a complex function. Indeed, the formal definition for the derivative of a complex $f(z)$ at $z = z_0$ is

$$\frac{df}{dz} \Big|_{z=z_0} = \lim_{\Delta z \rightarrow 0} \frac{f(z_0 + \Delta z) - f(z_0)}{\Delta z} = f'(z_0).$$

The vanishing of $\Delta z = \Delta x + i\Delta y$ is, however, not quite as straightforward as it is in the case of a real variable. In that simpler case, where we let $\Delta x \rightarrow 0$ to calculate $g'(x_0)$, Δx only has to vanish along the *one*-dimensional real axis. That is, Δx can shrink to zero in just two ways: either from the left of x_0 or from the right of x_0 . But in the complex case we must take into account that, since z_0 is a point in the complex, *two*-dimensional *plane*, then Δz can shrink to zero in an *infinity* of different ways (from the left of z_0 , from the right of z_0 , from below z_0 , from above z_0 or, indeed, from *any* direction of the compass). So, just how *does* $\Delta z \rightarrow 0$?

Mathematicians consider the most condition-free definition possible for the derivative to be the best definition, and so their answer to our question is: we want $f'(z_0)$ to be the same *independent* of how $\Delta z \rightarrow 0$. To have this be the case, as you might suspect, comes with a price. If $f = u + iv$ then the price for a derivative at $z = z_0$ that doesn't depend on the precise nature of how $\Delta z \rightarrow 0$ is that u and v cannot be just *any* functions of x and y , but rather must satisfy certain conditions. If these conditions are satisfied at $z = z_0$ and at all points in a *region* (*domain* or *neighborhood* are terms that are also used) surrounding z_0 , then we say that $f(z)$ is an *analytic function* in that region (not to be confused with the analytic signal from radio theory that we encountered in the previous chapter).

The conditions for $f(z)$ to be analytic are called the *Cauchy-Riemann* (C-R) *equations*, which are actually pretty easy to state: at $z = z_0$ it must be true that

$$(8.4.1) \quad \frac{\partial u}{\partial x} = \frac{\partial v}{\partial y}$$

and

$$(8.4.2) \quad \frac{\partial u}{\partial y} = -\frac{\partial v}{\partial x}.$$

For example, suppose that $f(z) = z$. That is, $f(x, y) = x + iy = u(x, y) + i v(x, y)$ which means that $u(x, y) = x$ and that $v(x, y) = y$. Then,

$$\frac{\partial u}{\partial x} = 1, \frac{\partial u}{\partial y} = 0, \frac{\partial v}{\partial x} = 0, \frac{\partial v}{\partial y} = 1$$

and we see that the C-R equations are satisfied. Indeed, since the C-R equations are independent of z (of z_0) then $f(z) = z$ is analytic over the entire *finite* complex plane.⁵ As a counter-example, of a $f(z)$ that is *nowhere* analytic, consider $f(z) = \bar{z} = x - iy$, where \bar{z} is the *conjugate* of z . Then,

$$\frac{\partial u}{\partial x} = 1, \frac{\partial u}{\partial y} = 0, \frac{\partial v}{\partial x} = 0, \frac{\partial v}{\partial y} = -1$$

and so (8.4.1) is *never* satisfied.

Under not particularly harsh requirements the C-R equations are *necessary and sufficient* conditions for $f(z)$ to be analytic, and I'll refer you to any good text devoted to complex function theory for a proof of this.⁶ To show that the C-R equations are *necessary* is not at all difficult, however. Since $\Delta z = \Delta x + i\Delta y$ then to have $\Delta z \rightarrow 0$ requires that both $\Delta x \rightarrow 0$ and $\Delta y \rightarrow 0$. That is, to speak of the derivative of $f(z)$ at $z = z_0$ means to calculate

$$f'(z_0) = \lim_{\Delta x \rightarrow 0, \Delta y \rightarrow 0} \frac{f(x_0 + \Delta x, y_0 + \Delta y) - f(x_0, y_0)}{\Delta x + i\Delta y}.$$

Now, out of the infinity of ways that both Δx and Δy can vanish, let's consider just two. First, assume that $\Delta y = 0$ and so $\Delta z = \Delta x$. That is, z approaches z_0 parallel to the x -axis. Second, assume that $\Delta x = 0$ and so $\Delta z = i\Delta y$. That is, z approaches z_0 parallel to the y -axis. If $f'(z_0)$ is to be unique, independent of the details of how $\Delta z \rightarrow 0$, then these two particular cases must give the same result. In the first case we have

$$f'(z_0) = \lim_{\Delta z = \Delta x \rightarrow 0} \frac{f(x_0 + \Delta x, y_0) - f(x_0, y_0)}{\Delta x}$$

⁵ The word *finite* is important: $f(z) = z$ blows-up as $|z| \rightarrow \infty$ and so $f(z)$ is *not* said to be analytic at infinity. In fact, there is a theorem in complex function theory that says the only functions that are analytic over the entire complex plane, even at infinity, are constants. In those cases all four partial derivatives in the C-R equations are identically zero.

⁶ See, for example, Joseph Bak and Donald J. Newman, *Complex Analysis* (3rd edition), Springer 2010, pp. 35-40. While the C-R equations *alone* are not sufficient for analyticity, if the partial derivatives in them are *continuous* then we do have sufficiency.

$$\begin{aligned}
&= \lim_{\Delta x \rightarrow 0} \frac{\{u(x_0 + \Delta x, y_0) + i v(x_0 + \Delta x, y_0)\} - \{u(x_0, y_0) + i v(x_0, y_0)\}}{\Delta x} \\
&= \lim_{\Delta x \rightarrow 0} \frac{\{u(x_0 + \Delta x, y_0) - u(x_0, y_0)\} + i \{v(x_0 + \Delta x, y_0) - v(x_0, y_0)\}}{\Delta x} \\
&= \frac{\partial u}{\partial x} + i \frac{\partial v}{\partial x}.
\end{aligned}$$

And in the second case we have

$$\begin{aligned}
f'(z_0) &= \lim_{\Delta z = i\Delta y \rightarrow 0} \frac{f(x_0, y_0 + \Delta y) - f(x_0, y_0)}{i\Delta y} \\
&= \lim_{\Delta y \rightarrow 0} \frac{\{u(x_0, y_0 + \Delta y) + i v(x_0, y_0 + \Delta y)\} - \{u(x_0, y_0) + i v(x_0, y_0)\}}{i\Delta y} \\
&= \lim_{\Delta y \rightarrow 0} \frac{\{u(x_0, y_0 + \Delta y) - u(x_0, y_0)\} + i \{v(x_0, y_0 + \Delta y) - v(x_0, y_0)\}}{i\Delta y} \\
&= \frac{1}{i} \frac{\partial u}{\partial y} + \frac{\partial v}{\partial y} = \frac{\partial v}{\partial y} - i \frac{\partial u}{\partial y}.
\end{aligned}$$

Equating the real and the imaginary parts of these two expressions for $f'(z_0)$ gives the C-R equations in (8.4.1) and (8.4.2).

Analytic functions are clearly a rather special subset of all possible complex functions, but certain broad classes are included. They are:

- (1) Every polynomial of z is analytic;
- (2) Every sum and product of two analytic functions is analytic;
- (3) Every quotient of two analytic functions is analytic *except* at those values where the denominator function is zero;
- (4) An analytic function of an analytic function is analytic.

So, from (1) $f(z) = z^2$ and $f(z) = e^z$ are both analytic, because in the first case $f(z)$ is a polynomial and in the second case because the exponential can be expanded in a power series. From (2) $f(z) = z^2 e^z$ is analytic, and from (3) $f(z) = e^z / (z^2 + 1)$ is analytic *except* at $z = \pm i$ which are called the *singularities* of $f(z)$ because, at those values of z , $f(z)$ blows-up.⁷ And finally, from (4) $f(z) = e^{e^z}$ is analytic.

⁷If the function $f(z)$ is analytic everywhere in some region except for a finite number of singularities, mathematicians say $f(z)$ is *meromorphic* in that region and I tell you this simply so you won't be paralyzed by fear if you should ever come across that term.

8.5 Green's Integral Theorem

In this section we'll continue our earlier discussion of line integrals to derive what is called *Green's theorem*.⁸ We begin by imagining a closed path (*contour*) C that encloses a region R of the complex plane, as shown in Fig. 8.5.1. We further imagine that there are two real functions of the real variables x and y , $P(x, y)$ and $Q(x, y)$, defined at every point along C and in the region R (the *interior* of C). Then, Green's theorem says that

$$(8.5.1) \quad \oint_C \{P(x, y) dx + Q(x, y) dy\} = \iint_R \left\{ \frac{\partial Q}{\partial x} - \frac{\partial P}{\partial y} \right\} dx dy.$$

The circle on the line integral in the left-hand side of (8.5.1) is there to emphasize that C is a *closed, non-self-intersecting* path (a simple curve traversed in the CCW sense, as mentioned in Sect. 8.2). R is called a *simply connected region*, which means every closed curve in R encloses only points in R . If a region is not simply connected then it is said to be *multiply-connected*: an example is a simply connected region that has a hole cut in it. The points 'in the hole' are considered to be in the *exterior* of C .

Green's theorem relates a contour integral along C to an *area* integral over the interior of C . For the contour of Fig. 8.5.1 it's pretty obvious where the interior of C is, but in just a bit we'll encounter contours whose interiors won't be so obvious. Here's a simple, low-level way to always locate the interior of a C : as you walk along C in the CCW sense, imagine you drag both hands along the ground. Your *left* hand will be in the *interior*, while your right hand will be in the *exterior* of C .

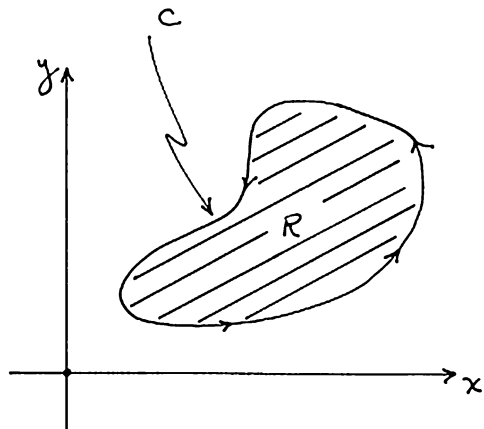
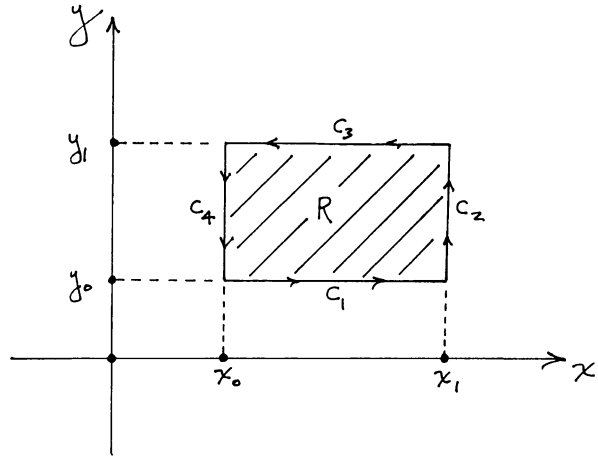

Fig. 8.5.1 A contour C and its interior R

⁸For the interesting history of this theorem, named after the English mathematician George Green (1793-1841), see my *An Imaginary Tale*, Princeton 2010, pp. 204-205.

Fig. 8.5.2 When R is a rectangle



To prove Green's theorem isn't difficult, or at least it isn't if we make some highly simplifying assumptions. These assumptions are actually not required, but to remove them complicates the proof. To start, our first assumption is that R is a rectangular patch oriented parallel to the x and y axes, as shown in Fig. 8.5.2. (I've drawn the patch totally in the first quadrant, but that's just the way I drew it—in all that follows that is irrelevant.) The boundary edge of R is $C = C_1 + C_2 + C_3 + C_4$, which simply means that C is made of four sides. When we are done with this special R, I'll make some admittedly hand-waving (but plausible, too, I hope) arguments to try to convince you that far more complicated shapes for R are okay, too.

Starting with the $\iint_R -\frac{\partial P}{\partial y} dx dy$ term on the right-hand side of Green's theorem, we have

$$\begin{aligned} \iint_R -\frac{\partial P}{\partial y} dx dy &= -\int_{x_0}^{x_1} \left\{ \int_{y_0}^{y_1} \frac{\partial P}{\partial y} dy \right\} dx \\ &= -\int_{x_0}^{x_1} \{P(x, y_1) - P(x, y_0)\} dx = \int_{x_0}^{x_1} P(x, y_0) dx + \int_{x_1}^{x_0} P(x, y_1) dx \\ &= \int_{C_1} P(x, y) dx + \int_{C_3} P(x, y) dx. \end{aligned}$$

Notice, carefully, that in the last two integrals I have dropped the subscripts on y_0 and y_1 , subscripts that *were* included in the earlier integrals. I can do that because the subscripts were originally there to distinguish between integrating along the lower edge (y_0) or along the upper edge (y_1) of R, and that job is now done in the last two integrals by writing C_1 (the lower edge) and C_3 (the upper edge) beneath

the appropriate integral sign. Notice, too, that writing $\int_{y_0}^{y_1} \frac{\partial P}{\partial y} dy = P(x, y_1) - P(x, y_0)$ makes the assumption that there is no discontinuity in $\frac{\partial P}{\partial y}$, that is, the partial derivative is *continuous*.

Similar integrals with respect to x can be written for the other two edges (C_2 and C_4) as well and, since those are *vertical* edges, we know that everywhere along them $dx = 0$. That is,

$$\int_{C_2} P(x, y) dx = \int_{x_1}^{x_1} P(x, y) dx = 0$$

and

$$\int_{C_4} P(x, y) dx = \int_{x_0}^{x_0} P(x, y) dx = 0.$$

Since those integrals vanish we can formally add them to our C_1 and C_3 integrals without changing anything. So,

$$\begin{aligned} \iint_R -\frac{\partial P}{\partial y} dx dy &= \int_{C_1} P(x, y) dx + \int_{C_2} P(x, y) dx + \int_{C_3} P(x, y) dx + \int_{C_4} P(x, y) dx \\ &= \oint_C P(x, y) dx. \end{aligned}$$

If you repeat all the above for the $\iint_R \frac{\partial Q}{\partial x} dx dy$ term in Green's theorem, and observe $dy = 0$ along the horizontal edges C_1 and C_3 , you should easily see that

$$\iint_R \frac{\partial Q}{\partial x} dx dy = \oint_C Q(x, y) dy,$$

and that completes the proof of Green's theorem *for our nicely oriented rectangle* in Fig. 8.5.2. In fact, however, this proof extends rather easily to other much more complicated shapes for R .

In Fig. 8.5.3, for example, you see how a semicircular disk can be constructed from many very thin rectangles—the thinner they each are the more of them there are, yes, but that's okay; make them all each as thin as the finest onion-skin paper, if you like—the thinner they are the better they approximate the half-disk. If the boundary edge of the half-disk is denoted by C , and if the *complete* (all four edges) boundaries of the individual rectangles are denoted by C_1, C_2, C_3, \dots , then

Fig. 8.5.3 Making a half-disk out of many thin rectangles

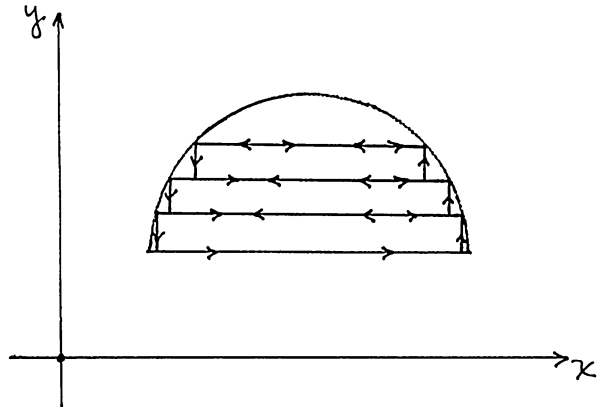

$$\oint_C \{P dx + Q dy\} = \int_{C_1} \{P dx + Q dy\} + \int_{C_2} \{P dx + Q dy\} + \int_{C_3} \{P dx + Q dy\} + \dots$$

because those edges of the individual rectangular boundaries that are parallel to the x-axis are traversed *twice*, once in each sense (CW and CCW), and so their contributions to the various line integrals on the right-hand-side of the above equation cancel. The only exception to this cancellation is the very bottom horizontal edge of the half-disk.

In addition, the integrations along the individual *vertical* edges of the thin rectangles avoid cancellation and, if the rectangles are *very* thin then the union of the vertical edges *is* the circular portion of the half-disk boundary. So, after integrating around all the rectangles, we are left with nothing more than integrating along the bottom of the half-disk and the circular portion. You can see that, using this same basic idea, we can build very complicated shapes out of appropriately arranged rectangles and, since Green's theorem works for each rectangle, then it works for all of them together and so Green's theorem works for their composite (and perhaps quite complicated) region R.

8.6 Cauchy's First Integral Theorem⁹

Well, it's taken a bit to get to this point, but it will soon be clear it was worth the effort. Our basic result is easy to state: if $f(z)$ is analytic everywhere on and inside C then

⁹By convention, the theorem in this section is named after Cauchy who published it in 1814, but in a letter dated December 1811, written by the great Carl Friedrich Gauss (1777-1855) to his fellow German mathematician Friedrich Wilhelm Bessel (1784-1846), he states (without proof) the theorem we will prove here. In mathematics, alas for Gauss (as if he really needed more to add to his resumé), credit goes to the first to *publish*.

$$(8.6.1) \quad \oint_C f(z) dz = 0.$$

To show this, recall (8.3.1) and (8.3.2). That is, with $f(z) = u(x, y) + i v(x, y)$ and writing $dz = dx + i dy$, we have

$$\oint_C f(z) dz = \oint_C (u + i v)(dx + i dy) = \oint_C (u dx + i u dy + i v dx - v dy)$$

or,

$$(8.6.2) \quad \oint_C f(z) dz = \oint_C (u dx - v dy) + i \oint_C (v dx + u dy).$$

Now, because of Green's theorem, the two contour integrals on the right are *each* equal to zero. To see this, consider the first integral on the right-hand side of (8.6.2), and look back at (8.5.1). You see that we have $P(x, y) = u(x, y)$ and $Q(x, y) = -v(x, y)$, and so the partial derivatives on the right-hand side of (8.5.1) are

$$\frac{\partial Q}{\partial x} = -\frac{\partial v}{\partial x}, \quad \frac{\partial P}{\partial y} = \frac{\partial u}{\partial y}.$$

The C-R equation of (8.4.2), which holds here because we are assuming $f(z)$ is analytic, says the integrand of the double integral in Green's theorem is

$$\frac{\partial Q}{\partial x} - \frac{\partial P}{\partial y} = -\frac{\partial v}{\partial x} - \frac{\partial u}{\partial y} = -\frac{\partial v}{\partial x} - \left(-\frac{\partial v}{\partial x}\right) = 0.$$

For the second integral on the right-hand side of (8.6.2) we have $P(x, y) = v(x, y)$ and $Q(x, y) = u(x, y)$. So now

$$\frac{\partial Q}{\partial x} = \frac{\partial u}{\partial x}, \quad \frac{\partial P}{\partial y} = \frac{\partial v}{\partial y}$$

and the C-R equation of (8.4.1) says the integrand of the double integral in Green's theorem is

$$\frac{\partial Q}{\partial x} - \frac{\partial P}{\partial y} = \frac{\partial u}{\partial x} - \frac{\partial v}{\partial y} = \frac{\partial v}{\partial y} - \frac{\partial v}{\partial y} = 0$$

because, again, $f(z)$ is analytic. So, (8.6.1) is proven.

There is no denying that (8.6.1) looks pretty benign. But it has tremendous power. For example, consider the case of

Fig. 8.6.1 A contour that avoids a singularity at the origin

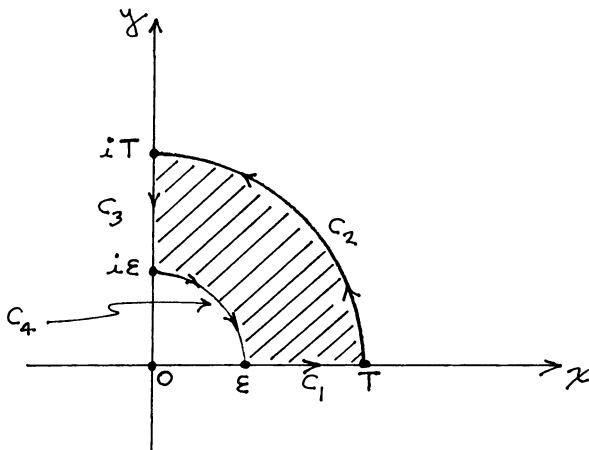

$$f(z) = \frac{e^{iz}}{z},$$

which is analytic everywhere *except* at $z = 0$ because there $f(z)$ blows-up. So, if we integrate $f(z)$ around *any* C that avoids putting $z = 0$ in its interior, we know from (8.6.1) that we'll get zero for the integral. With that in mind, consider the contour C shown in Fig. 8.6.1, where $\epsilon > 0$ and T is finite, and the two arcs are circular. In the notation of Fig. 8.6.1, we have

$$(8.6.3) \quad \oint_C f(z)dz = \int_{C_1} f(z)dz + \int_{C_2} f(z)dz + \int_{C_3} f(z)dz + \int_{C_4} f(z)dz = 0.$$

For each of the four segments of C , we can write: on C_1 : $z = x, dz = dx$; on C_2 : $z = Te^{i\theta}, dz = iTe^{i\theta}d\theta, 0 < \theta < \frac{\pi}{2}$; on C_3 : $z = iy, dz = i dy$; on C_4 : $z = \epsilon e^{i\theta}, dz = i\epsilon e^{i\theta}d\theta, \frac{\pi}{2} > \theta > 0$;

Thus, (8.6.3) becomes

$$\int_{\epsilon}^T \frac{e^{ix}}{x} dx + \int_0^{\frac{\pi}{2}} \frac{e^{iT e^{i\theta}}}{T e^{i\theta}} iT e^{i\theta} d\theta + \int_T^{\epsilon} \frac{e^{i(iy)}}{iy} i dy + \int_{\frac{\pi}{2}}^0 \frac{e^{i\epsilon e^{i\theta}}}{\epsilon e^{i\theta}} i\epsilon e^{i\theta} d\theta = 0.$$

Then, doing all the obvious cancellations and reversing the direction of integration on the third and fourth integrals (and, of course, their algebraic signs, too), we arrive at

$$\int_{\epsilon}^T \frac{e^{ix}}{x} dx + i \left\{ \int_0^{\frac{\pi}{2}} \left(e^{iT e^{i\theta}} - e^{i\epsilon e^{i\theta}} \right) d\theta \right\} - \int_{\epsilon}^T \frac{e^{-y}}{y} dy = 0.$$

If, in the last integral, we change the dummy variable of integration from y to x , we then have

$$(8.6.3) \quad \int_{\varepsilon}^T \frac{e^{ix} - e^{-x}}{x} dx + i \left\{ \int_0^{\frac{\pi}{2}} (e^{iT e^{i\theta}} - e^{i\varepsilon e^{i\theta}}) d\theta \right\} = 0.$$

Now, focus on the second integral and expand its integrand with Euler's formula:

$$\begin{aligned} e^{iT e^{i\theta}} - e^{i\varepsilon e^{i\theta}} &= e^{iT\{\cos(\theta) + i\sin(\theta)\}} - e^{i\varepsilon\{\cos(\theta) + i\sin(\theta)\}} \\ &= e^{-T\sin(\theta)} e^{iT\cos(\theta)} - e^{-\varepsilon\sin(\theta)} e^{i\varepsilon\cos(\theta)}. \end{aligned}$$

If we let $T \rightarrow \infty$ and $\varepsilon \rightarrow 0$ then the first term on the right goes to zero because $\lim_{T \rightarrow \infty} e^{-T\sin(\theta)} = 0$ for all $0 < \theta < \frac{\pi}{2}$, while the second term goes to 1 because $\lim_{\varepsilon \rightarrow 0} e^{-\varepsilon\sin(\theta)} = \lim_{\varepsilon \rightarrow 0} e^{i\varepsilon\cos(\theta)} = e^0 = 1$ for all $0 < \theta < \frac{\pi}{2}$.

Thus, (8.6.3) becomes, as $T \rightarrow \infty$ and $\varepsilon \rightarrow 0$,

$$\int_0^{\infty} \frac{e^{ix} - e^{-x}}{x} dx + i \left\{ \int_0^{\frac{\pi}{2}} (-1) d\theta \right\} = 0$$

or, using Euler's formula again,

$$\int_0^{\infty} \frac{\cos(x) + i \sin(x) - e^{-x}}{x} dx - i \frac{\pi}{2} = 0$$

or,

$$\int_0^{\infty} \frac{\cos(x) - e^{-x}}{x} dx + i \int_0^{\infty} \frac{\sin(x)}{x} dx = i \frac{\pi}{2}.$$

Equating imaginary parts, we have

$$\int_0^{\infty} \frac{\sin(x)}{x} dx = \frac{\pi}{2}$$

which we've already derived in (3.2.1)—and it's certainly nice to see that our contour integration agrees—while equating real parts gives

$$(8.6.4) \quad \int_0^{\infty} \frac{\cos(x) - e^{-x}}{x} dx = 0.$$

MATLAB agrees, too, as `quad(@(x)(cos(x)-exp(-x))./x,0,1000) = 0.000826...` which, while not exactly zero, is pretty small. You'll recall this integral as a special case of (4.3.14), derived using 'normal' techniques.

Fig. 8.6.2 Avoiding singularities with circular indents

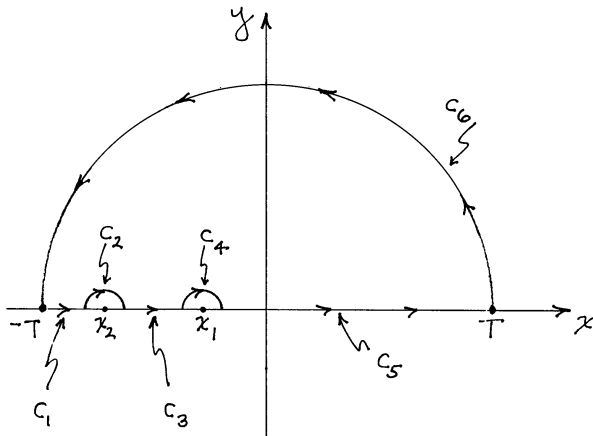

You can see that the ability of contour integration in the *complex plane* to do improper *real* integrals, integrals like \int_0^∞ and $\int_{-\infty}^\infty$, depends on the proper choice of the contour C . At the start, C encloses a finite region of the plane, with part of C lying on the real axis. Then, as we let C expand so that the real axis portion expands to $-\infty$ to ∞ , or to 0 to ∞ , the other portions of C result in integrations that are, in some sense, ‘easy to do.’

The calculation of (8.6.4) was a pretty impressive example of this process, but here’s another application of Cauchy’s first integral theorem that, I think, tops it. Suppose a , b , and c are *any* real numbers ($a \neq 0$) such that $b^2 \geq 4ac$. What is the value of the integral

$$\int_{-\infty}^\infty \frac{dx}{ax^2 + bx + c} = ?$$

I think you’ll be surprised by the answer. Here’s how to calculate it, starting with the contour integral

$$\oint_C f(z)dz = \oint_C \frac{dz}{az^2 + bz + c}$$

where we notice that the integrand has two singularities that are both on the real axis, as shown in Fig. 8.6.2. That’s because of the given $b^2 \geq 4ac$ condition, which says the denominator vanishes at the two *real* values (remember the quadratic formula!) of $x_2 = -\frac{b}{2a} - \frac{1}{2a}\sqrt{b^2 - 4ac}$ and $x_1 = -\frac{b}{2a} + \frac{1}{2a}\sqrt{b^2 - 4ac}$.

The equality $b^2 = 4ac$ is the case where the two real roots have merged to form a *double* root.

In Fig. 8.6.2 I’ve shown the singularities as being on the negative real axis, but they could both be on the positive real axis—just where they are depends on the signs of a and b . All that actually matters, however, is that the singularities are *both*

on the *real axis*. This means, when we select C , that we must arrange for its real axis portion to *avoid* those singularities as you'll remember the big deal I made on that very point in Chap. 1 with the discussion there of the 'sneaking up on a singularity' trick. With contour integration we don't so much 'sneak up' on a singularity as 'swing around and avoid' it, which we do with the C_2 and C_4 portions of C shown in Fig. 8.6.2 (and take a look back at Fig. 8.6.1, too, with its C_4 avoiding a singularity at $z = 0$). Those circular swings (called *indents*) are such as to keep the singularities in the *exterior* of C . Each indent has radius ε , which we'll eventually shrink to zero by taking the limit $\varepsilon \rightarrow 0$.

So, here's what we have, with $C = C_1 + C_2 + C_3 + C_4 + C_5 + C_6$. on C_1, C_3, C_5 : $z = x, dz = dx$; on C_2 : $z = x_2 + \varepsilon e^{i\theta}, dz = i\varepsilon e^{i\theta} d\theta, \pi > \theta > 0$; on C_4 : $z = x_1 + \varepsilon e^{i\theta}, dz = i\varepsilon e^{i\theta} d\theta, \pi > \theta > 0$; on C_6 : $z = T e^{i\theta}, dz = iT e^{i\theta} d\theta, 0 < \theta < \pi$.

Cauchy's first integral theorem says

$$\oint_C f(z) dz = \left\{ \int_{C_1} f(z) dz + \int_{C_3} f(z) dz + \int_{C_5} f(z) dz \right\} + \left\{ \int_{C_2} f(z) dz + \int_{C_4} f(z) dz + \int_{C_6} f(z) dz \right\} = 0.$$

When we eventually let $\varepsilon \rightarrow 0$ and $T \rightarrow \infty$, the first three line integrals will combine to give us the real integral we are after. The value of that integral will therefore be given by

$$-\left\{ \int_{C_2} f(z) dz + \int_{C_4} f(z) dz + \int_{C_6} f(z) dz \right\}.$$

So, let's now calculate each of these three line integrals.

For C_2 ,

$$\begin{aligned} \int_{C_2} f(z) dz &= \int_{\pi}^0 \frac{i\varepsilon e^{i\theta} d\theta}{a(x_2 + \varepsilon e^{i\theta})^2 + b(x_2 + \varepsilon e^{i\theta}) + c} \\ &= \int_{\pi}^0 \frac{i\varepsilon e^{i\theta} d\theta}{a(x_2^2 + 2x_2\varepsilon e^{i\theta} + \varepsilon^2 e^{i2\theta}) + b(x_2 + \varepsilon e^{i\theta}) + c} \\ &= \int_{\pi}^0 \frac{i\varepsilon e^{i\theta} d\theta}{(ax_2^2 + bx_2 + c) + (2ax_2\varepsilon e^{i\theta} + a\varepsilon^2 e^{i2\theta} + b\varepsilon e^{i\theta})}. \end{aligned}$$

Since $(ax_2^2 + bx_2 + c) = 0$ because x_2 is a zero of the denominator (*by definition*), and as $\varepsilon^2 \rightarrow 0$ faster than $\varepsilon \rightarrow 0$, then for very small ε we have

$$\lim_{\varepsilon \rightarrow 0} \int_{C_2} f(z) dz = \lim_{\varepsilon \rightarrow 0} \int_{\pi}^0 \frac{i\varepsilon e^{i\theta} d\theta}{(2ax_2 + b)\varepsilon e^{i\theta}} = -i \int_0^{\pi} \frac{d\theta}{(2ax_2 + b)} = -\pi i \frac{1}{2ax_2 + b}.$$

In the same way,

$$\lim_{\epsilon \rightarrow 0} \int_{C_4} f(z) dz = -\pi i \frac{1}{2ax_1 + b}.$$

And finally,

$$\int_{C_6} f(z) dz = \int_0^\pi \frac{iT e^{i\theta} d\theta}{aT^2 e^{i2\theta} + bT e^{i\theta} + c}$$

and, since the integrand vanishes like $\frac{1}{T}$ as $T \rightarrow \infty$, then

$$\lim_{T \rightarrow \infty} \int_{C_6} f(z) dz = 0.$$

Thus,

$$\int_{-\infty}^\infty \frac{dx}{ax^2 + bx + c} = \pi i \left[\frac{1}{2ax_2 + b} + \frac{1}{2ax_1 + b} \right].$$

Since

$$2ax_2 + b = 2a \left[-\frac{b}{2a} - \frac{1}{2a} \sqrt{b^2 - 4ac} \right] + b = -\sqrt{b^2 - 4ac}$$

and

$$2ax_1 + b = 2a \left[-\frac{b}{2a} + \frac{1}{2a} \sqrt{b^2 - 4ac} \right] + b = \sqrt{b^2 - 4ac}$$

we see that the two singularities cancel each other and so we have the interesting result

(8.6.5) $\int_{-\infty}^\infty \frac{dx}{ax^2 + bx + c} = 0, \quad a \neq 0, b^2 \geq 4ac$

for all possible values of a, b , and c . This, I think, is not at all obvious! (In Challenge Problem 8.5 you are asked to do an integral that generalizes this result.)

An immediate question that surely comes to mind now is, what happens if $b^2 < 4ac$? If that's the case the singularities of $f(z)$ are no longer on the real axis, but instead have non-zero imaginary parts. We'll come back to this question in the next section, where we'll find that the integral in (8.6.5) is no longer zero under this new condition.

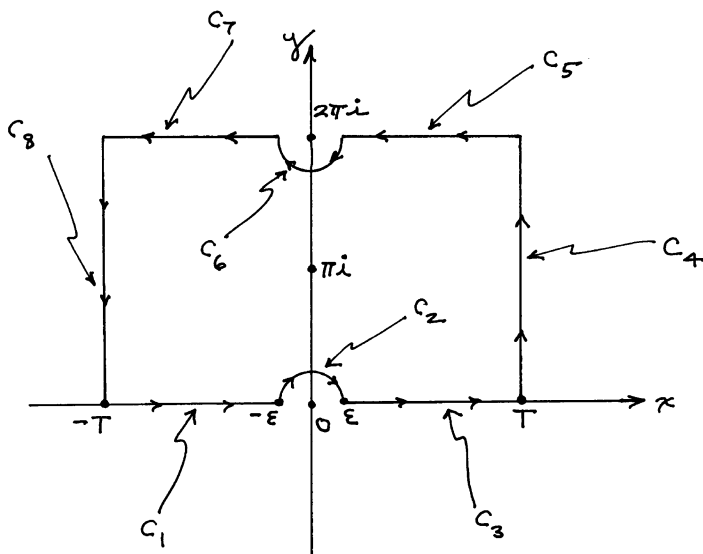

Fig. 8.6.3 A curious contour

Contour indents around singularities are such a useful device that their application warrants another example. So, what I'll do next is use indents to derive a result that would be extremely difficult to get by other means: the value of

$$\int_{-\infty}^{\infty} \frac{e^{ax}}{1 - e^x} dx, 0 < a < 1.$$

To evaluate this integral, we'll study the contour integral

$$(8.6.6) \quad \oint_C \frac{e^{az}}{1 - e^z} dz,$$

using the curious contour C shown in Fig. 8.6.3.

The reasons for choosing this particular C (looking a bit like a block of cheese that mice have been nibbling on) probably require some explanation. The real-axis portions (C_1 and C_3) are perhaps obvious, as eventually we'll let $T \rightarrow \infty$, and these parts of C (where $z = x$) will give us the integral we are after. That is, the sum of the C_1 and C_3 integrals is

$$\int_{-T}^{-\epsilon} \frac{e^{ax}}{1 - e^x} dx + \int_{\epsilon}^T \frac{e^{ax}}{1 - e^x} dx.$$

The semi-circular indent (C_2) with radius ϵ (which we'll eventually let $\rightarrow 0$) around the origin is also probably obvious because $z = 0$ is a singularity of the

integrand, and so you can see I'm trying to set things up to use Cauchy's first integral theorem (which requires that C enclose *no* singularities). It's the other portions of C , the two vertical sides (C_4 and C_8), and the two sides parallel to the real axis (C_5 and C_7), that are probably the ones puzzling you right now.

Since I am trying to avoid enclosing *any* singularities, you can understand why I am not using our previous approach of including a semi-circular arc from T on the positive real axis back to $-T$ on the negative real axis, an arc that then expands to infinity as $T \rightarrow \infty$. That won't work here because the integrand has an *infinity* of singularities on the imaginary axis, spaced up and down at intervals of $2\pi i$ (because Euler's identity tells us that $1 - e^z = 0$ has the solutions $z = 2\pi ik$ for k any integer). A semi-circular arc would end-up enclosing an infinite number of singularities!

There is another issue, too. The $k=0$ singularity is the one we've already avoided on the real-axis, but why (you might ask) are we intentionally running right towards the singularity for $k = 1$ (at $2\pi i$ on the imaginary axis)? Isn't the C in Fig. 8.6.3 just asking for trouble? Sure, we end-up avoiding that singularity with another semi-circular indent, but why not just run the top segment of C *below* the $k = 1$ singularity and so completely and automatically miss the singularity that way? Well, trust me— there *is* a reason, soon to be revealed.

Since we have arranged for there to be no singularities inside C we have, by Cauchy's first integral theorem,

$$\sum_{k=1}^8 \int_{C_k} \frac{e^{az}}{1 - e^z} dz = 0$$

or, since on C_1 and C_3 we have $z = x$,

$$(8.6.7) \quad \int_{-T}^{-\varepsilon} \frac{e^{ax}}{1 - e^x} dx + \int_{\varepsilon}^T \frac{e^{ax}}{1 - e^x} dx = - \int_{C_2} - \int_{C_4} - \int_{C_5} - \int_{C_6} - \int_{C_7} - \int_{C_8}.$$

Soon, of course, we'll be letting $T \rightarrow \infty$ and $\varepsilon \rightarrow 0$ in these integrals. Let's now start looking at the ones on the right in more detail, starting with C_4 .

On C_4 we have $z = T + iy$ where $0 \leq y \leq 2\pi$. The integrand of the C_4 integral is therefore

$$\frac{e^{az}}{1 - e^z} = \frac{e^{a(T+iy)}}{1 - e^{(T+iy)}} = \frac{e^{aT} e^{iay}}{1 - e^T e^{iy}}.$$

As $T \rightarrow \infty$ we see that the magnitude of the numerator blows-up like e^{aT} ($|e^{iay}| = 1$), while the magnitude of the denominator blows-up like e^T . So, the magnitude of the integrand behaves like $e^{(a-1)T}$ as $T \rightarrow \infty$ which means, since $0 < a < 1$, that the integrand goes to zero and so we conclude that the C_4 integral vanishes as $T \rightarrow \infty$. In the same way, on C_8 we have $z = -T + iy$ with $2\pi > y > 0$. The integrand of the C_8 integral is

$$\frac{e^{az}}{1 - e^z} = \frac{e^{a(-T+iy)}}{1 - e^{(-T+iy)}} = \frac{e^{-aT}e^{iay}}{1 - e^{-T}e^{iy}}$$

and so as $T \rightarrow \infty$ we see that the magnitude of the numerator goes to zero as e^{-aT} (because a is positive) while the magnitude of the denominator goes to 1. That is, the integrand behaves like e^{-aT} and so the C_8 integral also vanishes as $T \rightarrow \infty$.

Next, let's look at the C_5 and C_7 integrals. Be alert!—*this* is where you'll see why running C right towards the imaginary axis singularity at $2\pi i$ is a good idea, even though we are going to avoid it 'at the very last moment' (so to speak) with the C_6 semi-circular indent. On the C_5 and C_7 integrals we have $z = x + 2\pi i$ and so $dz = dx$ (just like on the C_1 and C_3 integrals). Writing-out the C_5 and C_7 integrals in detail, we have

$$\int_T^\varepsilon \frac{e^{a(x+2\pi i)}}{1 - e^{x+2\pi i}} dx + \int_{-\varepsilon}^{-T} \frac{e^{a(x+2\pi i)}}{1 - e^{x+2\pi i}} dx = \int_T^\varepsilon \frac{e^{ax}e^{2\pi ai}}{1 - e^x e^{2\pi i}} dx + \int_{-\varepsilon}^{-T} \frac{e^{ax}e^{2\pi ai}}{1 - e^x e^{2\pi i}} dx$$

or, because $e^{2\pi i} = 1$ (this is the crucial observation!) we have the sum of C_5 and C_7 integrals as

$$-e^{2\pi ai} \left[\int_\varepsilon^T \frac{e^{ax}}{1 - e^x} dx + \int_{-T}^{-\varepsilon} \frac{e^{ax}}{1 - e^x} dx \right].$$

Notice that, to within the constant factor $-e^{2\pi ai}$, this is the sum of the C_1 and C_3 integrals. We have this simplifying result *only* because we ran the top segment of C directly towards the $2\pi i$ singularity. All this means we can now write (8.6.7) as (because, don't forget, the C_4 and C_8 integrals vanish as $T \rightarrow \infty$):

$$(8.6.8) \quad (1 - e^{2\pi ai}) \left[\int_\varepsilon^T \frac{e^{ax}}{1 - e^x} dx + \int_{-T}^{-\varepsilon} \frac{e^{ax}}{1 - e^x} dx \right] = - \int_{C_2} - \int_{C_6}.$$

On C_2 we have $z = \varepsilon e^{i\theta}$ for $\pi \geq \theta \geq 0$ and so $dz = i\varepsilon e^{i\theta} d\theta$. Thus,

$$\int_{C_2} = \int_\pi^0 \frac{e^{a\varepsilon e^{i\theta}}}{1 - e^{\varepsilon e^{i\theta}}} i\varepsilon e^{i\theta} d\theta.$$

Recalling the power series expansion of the exponential and keeping only the first-order terms in ε (because all the higher-order terms go to zero even faster than does ε), we have

$$1 - e^{\varepsilon e^{i\theta}} \approx 1 - [1 + \varepsilon e^{i\theta}] = -\varepsilon e^{i\theta}.$$

In the same way,

$$e^{a\epsilon e^{i\theta}} \approx 1 + a\epsilon e^{i\theta}$$

and so

$$\lim_{\epsilon \rightarrow 0} \int_{C_2} = \lim_{\epsilon \rightarrow 0} \int_{\pi}^0 \frac{1 + a\epsilon e^{i\theta}}{-\epsilon e^{i\theta}} i\epsilon e^{i\theta} d\theta = i \int_0^{\pi} d\theta = \pi i.$$

On C_6 we have $z = 2\pi i + \epsilon e^{i\theta}$ for $0 \geq \theta \geq -\pi$ and so $dz = i\epsilon e^{i\theta} d\theta$. Thus,

$$\int_{C_6} = \int_0^{-\pi} \frac{e^{a(2\pi i + \epsilon e^{i\theta})}}{1 - e^{2\pi i + \epsilon e^{i\theta}}} i\epsilon e^{i\theta} d\theta = \int_0^{-\pi} \frac{e^{a2\pi i} e^{a\epsilon e^{i\theta}}}{1 - e^{\epsilon e^{i\theta}}} i\epsilon e^{i\theta} d\theta$$

or, as we let $\epsilon \rightarrow 0$,

$$\int_{C_6} = i e^{a2\pi i} \int_0^{-\pi} \frac{e^{a\epsilon e^{i\theta}}}{-\epsilon e^{i\theta}} \epsilon e^{i\theta} d\theta = -i e^{a2\pi i} \int_0^{-\pi} d\theta = i\pi e^{a2\pi i}.$$

Plugging these two results for the C_2 and C_6 integrals into (8.6.8) we get

$$\begin{aligned} \int_{-\infty}^{\infty} \frac{e^{ax}}{1 - e^x} dx &= -\frac{\pi i + i\pi e^{a2\pi i}}{1 - e^{2\pi ai}} = \pi i \frac{1 + e^{a2\pi i}}{e^{2\pi ai} - 1} = \pi i \frac{e^{a\pi i} [e^{-a\pi i} + e^{a\pi i}]}{e^{a\pi i} [e^{a\pi i} - e^{-a\pi i}]} \\ &= \pi i \frac{2 \cos(a\pi)}{2i \sin(a\pi)} \end{aligned}$$

or

$$\int_{-\infty}^{\infty} \frac{e^{ax}}{1 - e^x} dx = \frac{\pi}{\tan(a\pi)}, \quad 0 < a < 1.$$

(8.6.9)

Be sure to carefully note that the value of the integral in (8.6.9) comes *entirely* from the vanishingly small semi-circular paths around the two singularities. Singularities, and integration paths of ‘zero’ length around them, matter! If $a = \frac{1}{4}$ the integral is equal to π and MATLAB agrees because (using our old trick of ‘sneaking up’ on the singularity at $x = 0$),

```
quad(@(x)exp(x/4)./(1-exp(x)),-1000,-.0001) + quad(@(x)exp(x/4)./(1-exp(x)),.0001,1000) = 3.14154...
```

Before leaving this section I should tell you that not every use of Cauchy's first integral theorem is the calculation of the closed-form value of an integral. Another quite different and very nifty application is the transformation of an integral that is difficult to accurately calculate *numerically* into another equivalent integral that is much easier to calculate *numerically*. Two examples of this are

$$I(a) = \int_0^{\infty} \frac{\cos(x)}{x+a} dx = \lim_{T \rightarrow \infty} \int_0^T \frac{\cos(x)}{x+a} dx$$

and

$$J(a) = \int_0^{\infty} \frac{\sin(x)}{x+a} dx = \lim_{T \rightarrow \infty} \int_0^T \frac{\sin(x)}{x+a} dx.$$

where a is a positive constant. These two integrals have no closed-form values, and each has to be numerically evaluated for each new value of a .

To do that, *accurately*, using the usual numerical integration techniques is not easy, for the same reasons I gave in the last chapter when we derived (7.5.2). That is, the integrands of both $I(a)$ and $J(a)$ are really not that small even for ‘large’ T , as the denominators increase slowly and the numerators don’t really decrease at all but simply *oscillate* endlessly between ± 1 . To numerically calculate $I(a)$, for example, by writing `quad(@(x)cos(x)/(x+a),0,T)` with the numerical values of a and T inserted doesn’t work well. For example, if $a = 1$ then for the four cases of $T = 5, 10, 50,$ and 100 we get

T	I(1)
5	0.18366...
10	0.30130...
50	0.33786...
100	0.33828...

The calculated values of $I(1)$ are not stable out to more than a couple of decimal places, even for $T = 100$. A similar table for $J(1)$ is

T	J(1)
5	0.59977...
10	0.70087...
50	0.60264...
100	0.61296...

These values for $J(1)$ are even more unstable than are those for $I(1)$.

What I’ll do now is show you how the first integral theorem can be used to get really excellent numerical accuracy, even with a ‘small’ value of T . What we’ll do is consider the contour integral

$$\oint_C \frac{e^{iz}}{z+a} dz$$

where $C = C_1 + C_2 + C_3$ is the first quadrant circular contour shown in Fig. 8.6.4. The integrand has a lone singularity on the negative real axis at $z = -a < 0$, which lies *outside* of C . Thus, we immediately know from the first theorem that, for this C ,

Fig. 8.6.4 A contour that excludes a singularity

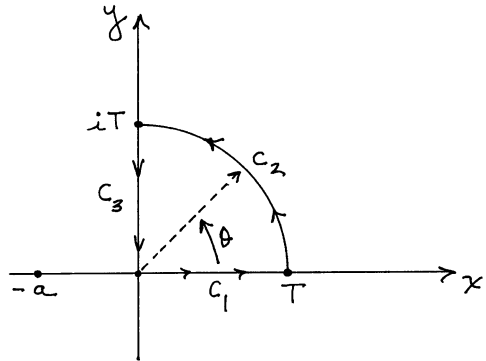

$$(8.6.10) \quad \oint_C \frac{e^{iz}}{z+a} dz = 0.$$

Now, for the three distinct sections of C, we have: on C_1 : $z = x$ and so $dz = dx$, $0 \leq x \leq T$; on C_2 : $z = Te^{i\theta}$, $dz = iTe^{i\theta}d\theta$, $0 < \theta < \frac{\pi}{2}$; on C_3 : $z = iy$, $dz = i dy$, $T \geq y \geq 0$.

So, starting at the origin and going around C in the counterclockwise sense, (8.6.10) becomes

$$\int_0^T \frac{e^{ix}}{x+a} dx + \int_0^{\frac{\pi}{2}} \frac{e^{iT e^{i\theta}}}{T e^{i\theta} + a} iT e^{i\theta} d\theta + \int_T^0 \frac{e^{i(iy)}}{iy+a} i dy = 0$$

or,

$$\int_0^T \frac{e^{ix}}{x+a} dx - \int_0^T \frac{ie^{-y}}{iy+a} dy = -i \int_0^{\frac{\pi}{2}} e^{iT e^{i\theta}} e^{i\theta} \frac{T}{T e^{i\theta} + a} d\theta.$$

Our next step is to look at what happens when we let $T \rightarrow \infty$. Using Euler's formula, we have

$$e^{iT e^{i\theta}} = e^{iT\{\cos(\theta) + i \sin(\theta)\}} = e^{-T \sin(\theta)} e^{iT \cos(\theta)}$$

and so

$$\begin{aligned} e^{iT e^{i\theta}} e^{i\theta} \frac{T}{T e^{i\theta} + a} &= e^{-T \sin(\theta)} e^{iT \cos(\theta)} e^{i\theta} \frac{T(T e^{-i\theta} + a)}{(T e^{i\theta} + a)(T e^{-i\theta} + a)} \\ &= e^{-T \sin(\theta)} e^{iT \cos(\theta)} \frac{T^2 + a T e^{i\theta}}{T^2 + a T(e^{i\theta} + e^{-i\theta}) + a^2} \end{aligned}$$

and so

$$\begin{aligned} \lim_{T \rightarrow \infty} \left| e^{iT e^{i\theta}} e^{i\theta} \frac{T}{T e^{i\theta} + a} \right| &= \lim_{T \rightarrow \infty} |e^{-T \sin(\theta)}| |e^{iT \cos(\theta)}| \left| \frac{T^2 + a T e^{i\theta}}{T^2 + a T (e^{i\theta} + e^{-i\theta}) + a^2} \right| \\ &= \lim_{T \rightarrow \infty} |e^{-T \sin(\theta)}| = 0. \end{aligned} \quad {}^{10}$$

Thus, as $T \rightarrow \infty$ we arrive at

$$\int_0^\infty \frac{e^{ix}}{x+a} dx - \int_0^\infty \frac{ie^{-y}}{iy+a} dy = 0.$$

That is,

$$\int_0^\infty \frac{\cos(x) + i \sin(x)}{x+a} dx = \int_0^\infty \frac{ie^{-y}(-iy+a)}{(iy+a)(-iy+a)} dy = \int_0^\infty \frac{ye^{-y} + i ae^{-y}}{y^2 + a^2} dy$$

or, equating real and imaginary parts, and changing the dummy variable of integration from y to x ,

$$I(a) = \int_0^\infty \frac{\cos(x)}{x+a} dx = \int_0^\infty \frac{xe^{-x}}{x^2 + a^2} dx$$

and

$$J(a) = \int_0^\infty \frac{\sin(x)}{x+a} dx = a \int_0^\infty \frac{e^{-x}}{x^2 + a^2} dx.$$

The new integrals on the right for $I(a)$ and $J(a)$ have integrands that decrease rapidly as x increases from zero.

Calculating $I(1)$ and $J(1)$ again, using these alternative integrals, we have the following new tables:

T	I(1)
5	0.342260...
10	0.343373...
50	0.343378...
100	0.343378...
T	J(1)
5	0.621256...
10	0.621449...
50	0.621450...
100	0.621450...

¹⁰ Because $|e^{iT \cos(\theta)}|$ simply oscillates forever between 0 and 1, and $\lim_{T \rightarrow \infty} \left| \frac{T^2 + a T e^{i\theta}}{T^2 + a T (e^{i\theta} + e^{-i\theta}) + a^2} \right| = 1$.

You can see from these tables the *vastly* improved numerical performance of our calculations, and we can now say *with confidence* that

$$(8.6.11) \quad \int_0^\infty \frac{\cos(x)}{x+1} dx = 0.34337 \dots$$

$$\int_0^\infty \frac{\sin(x)}{x+1} dx = 0.62145 \dots$$

8.7 Cauchy's Second Integral Theorem

When we try to apply Cauchy's first integral theorem we may find it is not possible to construct a useful contour C such that a portion of it lies along the real axis and yet does not have a singularity in its interior. The integral of (8.6.5) for the case of $b^2 < 4ac$ will prove to be an example of that situation, and I'll show you some other examples in this section, as well. The presence of singularities inside C means that Cauchy's first integral theorem no longer applies. 'Getting around' (pun intended!) this complication leads us to Cauchy's second integral theorem: if $f(z)$ is analytic everywhere on and inside C then, if z_0 is inside C ,

$$(8.7.1) \quad \oint_C \frac{f(z)}{z - z_0} dz = 2\pi i f(z_0).$$

By successively differentiating with respect to z_0 under the integral sign, it can be shown that *all* the derivatives of an analytic $f(z)$ exist (we'll use this observation in the next section):

$$f^{(n)}(z_0) = \frac{n!}{2\pi i} \oint_C \frac{f(z)}{(z - z_0)^{n+1}} dz,$$

where z_0 is any point inside C and $f^{(n)}$ denotes the n -th derivative of f .

While $f(z)$ itself has no singularities (because it's analytic) inside C , the integrand of (8.7.1) *does* have a *first-order singularity*¹¹ at $z = z_0$. Now, before I prove (8.7.1) let me show you a pretty application of it, so you'll believe it will be well-worth your time and effort to understand the proof. What we'll do is evaluate the contour integral

¹¹ The singularity in (8.7.1) is called first-order because it appears to the first power. By extension, $\frac{f(z)}{(z-z_0)^2}$ has a *second-order* singularity, and so on. I'll say much more about high-order singularities in the next section.

Fig. 8.7.1 A contour enclosing a single, first-order singularity

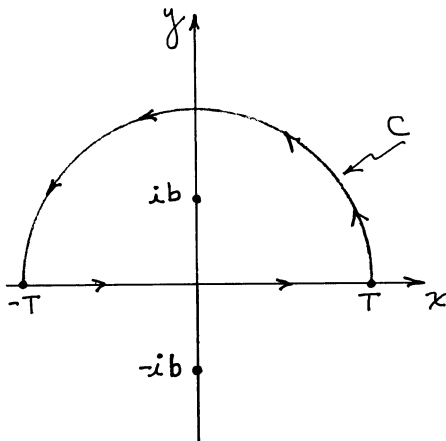

$$\oint_C \frac{e^{iaz}}{b^2 + z^2} dz$$

where C is the contour shown in Fig. 8.7.1, and a and b are each a positive constant. When we are nearly done, we'll let $T \rightarrow \infty$ and you'll see we will have derived a famous result (one we've already done, in fact, in (3.1.7)), with the difference being that using Cauchy's second integral theorem will be the *easier* of the two derivations! Along the real axis part of C we have $z = x$, and along the semicircular arc we have $z = Te^{i\theta}$, where $\theta = 0$ at $x = T$ and $\theta = \pi$ at $x = -T$. So,

$$\oint_C \frac{e^{iaz}}{b^2 + z^2} dz = \int_{-T}^T \frac{e^{iax}}{b^2 + x^2} dx + \int_0^\pi \frac{e^{ia(Te^{i\theta})}}{b^2 + z^2} i Te^{i\theta} d\theta.$$

The integrand of the contour integral can be written in a partial fraction expansion as

$$\frac{e^{iaz}}{b^2 + z^2} = \frac{e^{iaz}}{(z + ib)(z - ib)} = \frac{e^{iaz}}{i2b} \left[\frac{1}{z - ib} - \frac{1}{z + ib} \right],$$

and so we have

$$\frac{1}{i2b} \left[\oint_C \frac{e^{iaz}}{z - ib} dz - \oint_C \frac{e^{iaz}}{z + ib} dz \right] = \int_{-T}^T \frac{e^{iax}}{b^2 + x^2} dx + \int_0^\pi \frac{e^{ia(Te^{i\theta})}}{b^2 + T^2 e^{i2\theta}} i Te^{i\theta} d\theta.$$

Since the integrand of the second contour integral on the left-hand side is analytic everywhere inside of C—that integrand does have a singularity, yes, but it's at $z = -ib$ which is *outside* of C, as shown in Fig. 8.7.1—then we know from Cauchy's first integral theorem that the second contour integral on the left-hand side

is zero. And once $T > b$ (remember, eventually we are going to let $T \rightarrow \infty$) then the singularity for the remaining contour integral on the left is *inside* C , at $z = ib$. Thus,

$$\frac{1}{i2b} \oint_C \frac{e^{iaz}}{z - ib} dz = \int_{-T}^T \frac{e^{iax}}{b^2 + x^2} dx + \int_0^\pi \frac{e^{ia(Te^{i\theta})}}{b^2 + T^2 e^{i2\theta}} iTe^{i\theta} d\theta.$$

The integrand of the contour integral on the left looks exactly like $f(z)/(z - z_0)$, with $f(z) = e^{iaz}$ and $z_0 = ib$. Cauchy's second integral theorem tells us that, if $T > b$, the contour integral is equal to $2\pi i f(z_0)$, and so the left-hand side of the last equation is equal to

$$\frac{1}{i2b} 2\pi i e^{ia(ib)} = \frac{\pi}{b} e^{-ab}.$$

That is,

$$\int_{-T}^T \frac{e^{iax}}{b^2 + x^2} dx + \int_0^\pi \frac{e^{ia(Te^{i\theta})}}{b^2 + T^2 e^{i2\theta}} iTe^{i\theta} d\theta = \frac{\pi}{b} e^{-ab}, T > b.$$

Now, if we at last let $T \rightarrow \infty$ then, making the same sort of argument that we did concerning the line integral along the circular arc in the previous section, we see that the second integral on the left vanishes like $\frac{1}{T}$. And so, using Euler's formula, we have

$$\int_{-\infty}^\infty \frac{e^{iax}}{b^2 + x^2} dx = \frac{\pi}{b} e^{-ab} = \int_{-\infty}^\infty \frac{\cos(ax)}{b^2 + x^2} dx + i \int_{-\infty}^\infty \frac{\sin(ax)}{b^2 + x^2} dx.$$

Equating imaginary parts we arrive at

$$\int_{-\infty}^\infty \frac{\sin(ax)}{b^2 + x^2} dx = 0$$

which is surely no surprise since the integrand is an odd function of x . Equating real parts gives us the far more interesting

$$\int_{-\infty}^\infty \frac{\cos(ax)}{b^2 + x^2} dx = \frac{\pi}{b} e^{-ab}.$$

I haven't put this result in a box, however, as we've already derived it using 'routine' methods—see (3.1.7). We also did it, using the concept of the energy spectrum of a time signal, in Challenge Problem 7.7 (you *did* do that problem, right?). As I've said before, it's good to see contour integration in agreement with previous analysis.

Fig. 8.7.2 A simple curve C (enclosing point z_0) connected to an inner circle C^* via the cross-cut ab

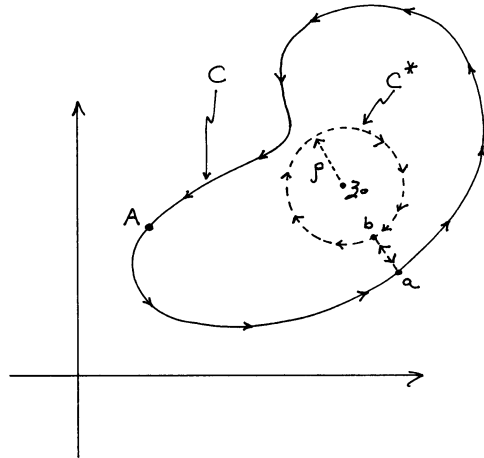

Okay, here's how to see what's behind Cauchy's second integral theorem. The proof is beautifully elegant. In Fig. 8.7.2 I have drawn the contour C and, in its interior, marked the point z_0 . In addition, centered on z_0 I've drawn a circle C^* with a radius ρ that is sufficiently small that C^* lies completely in the interior of C . Now, imagine that, starting on C at some arbitrary point (call it A), we begin to travel along C in the positive (CCW) sense until we reach point a , whereupon we then travel inward to point b on C^* . Once at point b we travel CW (that is, in the *negative* sense) along C^* until we return to point b . We then travel back out to C along the same path we traveled inward on until we return to point a . We then continue on along C in the CCW sense until we return to our starting point A .

Here's the first of two *crucially important* observations on what we've just done. *The complete path we've followed has always kept the annular region between C and C^* to our left.* That is, this path is the edge of a region which does *not* contain the point z_0 . So, in that annular region from which $z = z_0$ has been excluded by construction, $f(z)/(z - z_0)$ is analytic everywhere. Thus, by Cauchy's first integral theorem, since $z = z_0$ is *outside* C we have

$$(8.7.2) \quad \oint_{C, ab, -C^*, ba} \frac{f(z)}{z - z_0} dz = 0.$$

The reason for writing $-C^*$ in the path description of the contour integral is that we went around C^* in the *negative* sense.

Here's the second of our two *crucially important* observations. The two trips along the ab -connection between C and C^* (mathematicians call this two-way connection a *cross-cut*) are in opposite directions and so *cancel each other*. That means we can write (8.7.2) as

$$(8.7.3) \quad \oint_{C, -C^*} \frac{f(z)}{z - z_0} dz = 0 = \oint_C \frac{f(z)}{z - z_0} dz - \oint_{C^*} \frac{f(z)}{z - z_0} dz.$$

The reason for the minus sign in front of the C^* contour integral at the far-right of (8.7.3) is, again, because we went around C^* in the negative sense. The two far-right integrals in (8.7.3) are in the positive sense, however, and so the minus sign has been moved from the $-C^*$ path descriptor at the bottom of the integral sign to the front of the integral, itself.

Now, while C is an arbitrary simple curve enclosing z_0 , C^* is a *circle* with radius ρ centered on z_0 . So, on C^* we can write $z = z_0 + \rho e^{i\theta}$ (which means $dz = i\rho e^{i\theta} d\theta$) and, therefore, as θ varies from 0 to 2π on our one complete trip around C^* , (8.7.3) becomes

$$\oint_C \frac{f(z)}{z - z_0} dz = \oint_{C^*} \frac{f(z)}{z - z_0} dz = \int_0^{2\pi} \frac{f(z_0 + \rho e^{i\theta})}{\rho e^{i\theta}} i\rho e^{i\theta} d\theta = i \int_0^{2\pi} f(z_0 + \rho e^{i\theta}) d\theta.$$

If the integral on the far left is to have a value then, whatever it is must be *independent* of ρ . After all, the integral at the far left has no ρ in it! So, the integral on the far right must be independent of ρ , too, even though it *does* have ρ in it. That means we must be able to use any value of ρ we wish. So, let's use a value for ρ that is convenient.

In particular, let's use a very small value, indeed one so small as to make the difference between $f(z)$ and $f(z_0)$, for all z on C^* , as small as we like. We can do this because $f(z)$ is assumed to be analytic, and so has a derivative everywhere inside C (including at $z = z_0$), and so is certainly continuous there. Thus, as $\rho \rightarrow 0$ we can argue $f(z) \rightarrow f(z_0)$ all along C^* and thus

$$\oint_C \frac{f(z)}{z - z_0} dz = i \int_0^{2\pi} f(z_0) d\theta.$$

Finally, pulling the *constant* $f(z_0)$ out of the integral, we have

$$\oint_C \frac{f(z)}{z - z_0} dz = i f(z_0) \int_0^{2\pi} d\theta = 2\pi i f(z_0),$$

which is (8.7.1) and our proof of Cauchy's second integral theorem is done.

We can now do the integral in (8.6.5) for the case of $b^2 < 4ac$. That is, we'll now study the contour integral

$$\oint_C \frac{dz}{az^2 + bz + c}, \quad a \neq 0, b^2 < 4ac.$$

The integrand of this integral has two singularities, neither of which is on the real axis. Since $b^2 < 4ac$ these singularities are complex, and are given by

Fig. 8.7.3 A contour enclosing one of two singularities

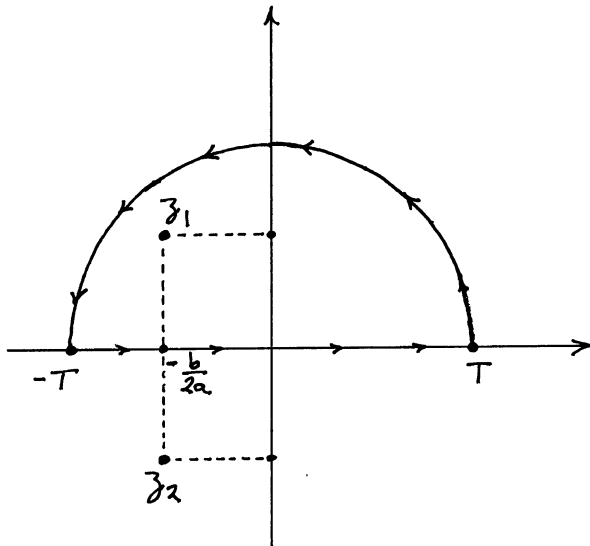

$$z_2 = -\frac{b}{2a} - i\frac{1}{2a}\sqrt{4ac - b^2}$$

and

$$z_1 = -\frac{b}{2a} + i\frac{1}{2a}\sqrt{4ac - b^2}.$$

In Fig. 8.7.3 I've shown these singular points having negative real parts, but they could be positive, depending on the signs of a and b . It really doesn't matter, however: all that matters is that with the contour C drawn in the figure only one of the singular points is inside C (arbitrarily selected to be z_1) while the other singularity (z_2) is in the exterior of C .

Now, write the integrand as a partial fraction expansion:

$$\frac{1}{az^2 + bz + c} = \frac{1}{a} \left[\frac{A}{z - z_1} + \frac{B}{z - z_2} \right] = \frac{1}{a} \left[\frac{-i\frac{a}{\sqrt{4ac - b^2}}}{z - z_1} + \frac{i\frac{a}{\sqrt{4ac - b^2}}}{z - z_2} \right].$$

Thus,

$$\oint_C \frac{dz}{az^2 + bz + c} = \frac{1}{a} \oint_C \frac{-i\frac{a}{\sqrt{4ac - b^2}}}{z - z_1} dz + \frac{1}{a} \oint_C \frac{i\frac{a}{\sqrt{4ac - b^2}}}{z - z_2} dz.$$

The second integral on the right is zero by Cauchy's first integral theorem (the singularity z_2 is not enclosed by C) and so

$$\oint_C \frac{dz}{az^2 + bz + c} = -i \frac{1}{\sqrt{4ac - b^2}} \oint_C \frac{dz}{z - z_1}$$

From Cauchy's second integral theorem that we just proved (with $f(z) = 1$) we have

$$\oint_C \frac{dz}{z - z_1} = 2\pi i$$

and so

$$\oint_C \frac{dz}{az^2 + bz + c} = \frac{2\pi}{\sqrt{4ac - b^2}}$$

But, the line integral around C is

$$\int_{-T}^T \frac{dx}{ax^2 + bx + c} + \int_0^\pi \frac{iTe^{i\theta}}{a(Te^{i\theta})^2 + b(Te^{i\theta}) + c} d\theta$$

and the θ -integral clearly vanishes like $\frac{1}{T}$ as $T \rightarrow \infty$. Thus,

(8.7.4)
$$\int_{-\infty}^{\infty} \frac{dx}{ax^2 + bx + c} = \frac{2\pi}{\sqrt{4ac - b^2}}, \quad a \neq 0, b^2 < 4ac .$$

For example, if $a = 5, b = 7,$ and $c = 3$ (notice that $b^2 = 49 < 4ac = 4(5)(3) = 60$) then (8.7.4) says our integral is equal to $\frac{2\pi}{\sqrt{11}} = 1.89445 \dots$ and MATLAB agrees, as `quad(@(x)1./(5*x.^2 + 7*x + 3),-1e5,1e5) = 1.894449...`

For a dramatic illustration of the first and second theorems, I'll now use them to calculate an entire class of integrals:

$$\int_0^\infty \frac{x^m}{x^n + 1} dx,$$

where m and n are any non-negative integers such that (to insure the integral exists) $n - m \geq 2$. What we'll do is study the contour integral

(8.7.5)
$$\oint_C \frac{z^m}{z^n + 1} dz$$

with an appropriately chosen C . The integrand in (8.7.5) has n first-order singularities, at the n n -th roots of -1 . These singular points are uniformly spaced around the unit circle in the complex plane. Since Euler's formula tells us that

$$-1 = e^{i(1+2k)\pi}$$

for k any integer, then these singular points are located at

$$z_k = (-1)^{\frac{1}{n}} = e^{i\left(\frac{1+2k}{n}\right)\pi}, \quad k = 0, 1, 2, \dots, n-1.$$

For other values of k , of course, these same n points simply repeat. Now, let's concentrate our attention on just one of these singular points, the one for $k=0$. We'll pick C to enclose *just that one* singularity, at $z = z_0 = e^{i\frac{\pi}{n}}$, as shown in Fig. 8.7.4. The central angle of the wedge is $\frac{2\pi}{n}$ and the singularity is at half that angle, $\frac{\pi}{n}$.

As we go around C to do the integral in (8.7.5), the descriptions of the contour's three portions are: on C_1 : $z = x$, $dz = dx$, $0 \leq x \leq T$; on C_2 : $z = Te^{i\theta}$, $dz = iTe^{i\theta}d\theta$, $0 \leq \theta \leq \frac{2\pi}{n}$; on C_3 : $z = re^{i\frac{2\pi}{n}}$, $dz = e^{i\frac{2\pi}{n}}dr$, $T \geq r \geq 0$;

So,

$$\begin{aligned} \oint_C \frac{z^m}{z^n + 1} dz &= \int_0^T \frac{x^m}{x^n + 1} dx + \int_0^{\frac{2\pi}{n}} \frac{(Te^{i\theta})^m}{(Te^{i\theta})^n + 1} iTe^{i\theta} d\theta + \int_T^0 \frac{r^m e^{i\frac{m}{n}2\pi}}{r^n e^{i2\pi} + 1} e^{i\frac{2\pi}{n}} dr \\ &= \int_0^T \frac{x^m}{x^n + 1} dx - \int_0^T \frac{r^m e^{i(m+1)\frac{2\pi}{n}}}{r^n + 1} dr + \int_0^{\frac{2\pi}{n}} \frac{T^{m+1} e^{im\theta}}{T^n e^{in\theta} + 1} i e^{i\theta} d\theta. \end{aligned}$$

Now, clearly, as $T \rightarrow \infty$ the θ -integral goes to zero because $m+1 < n$. Also,

$$\int_0^T \frac{r^m e^{i(m+1)\frac{2\pi}{n}}}{r^n + 1} dr = e^{i(m+1)\frac{2\pi}{n}} \int_0^T \frac{r^m}{r^n + 1} dr = e^{i(m+1)\frac{2\pi}{n}} \int_0^T \frac{x^m}{x^n + 1} dx.$$

So, as $T \rightarrow \infty$

$$\oint_C \frac{z^m}{z^n + 1} dz = \int_0^\infty \frac{x^m}{x^n + 1} dx \left[1 - e^{i(m+1)\frac{2\pi}{n}} \right].$$

Or, as

$$\left[1 - e^{i(m+1)\frac{2\pi}{n}} \right] = e^{i(m+1)\frac{\pi}{n}} \left[e^{-i(m+1)\frac{\pi}{n}} - e^{i(m+1)\frac{\pi}{n}} \right] = -2i \sin \left\{ (m+1) \frac{\pi}{n} \right\} e^{i(m+1)\frac{\pi}{n}},$$

we have

$$(8.7.6) \quad \oint_C \frac{z^m}{z^n + 1} dz = -2i \sin \left\{ (m+1) \frac{\pi}{n} \right\} e^{i(m+1)\frac{\pi}{n}} \int_0^\infty \frac{x^m}{x^n + 1} dx.$$

Since

Fig. 8.7.4 A pie-shaped contour enclosing one of n singularities

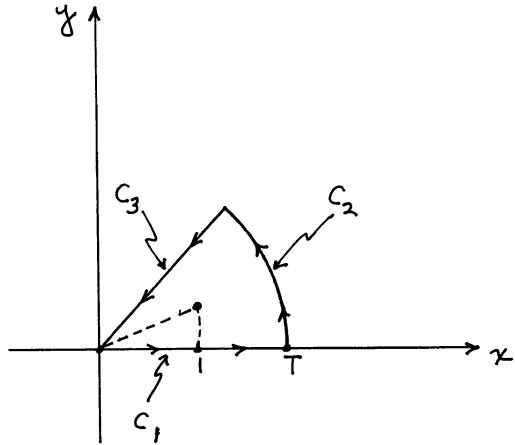

$$z^n + 1 = \prod_{k=0}^{n-1} (z - z_k)$$

we can write the integrand of the contour integral in (8.7.5) as a partial fraction expansion:

$$\frac{z^m}{z^n + 1} = \frac{N_0}{z - z_0} + \frac{N_1}{z - z_1} + \frac{N_2}{z - z_2} + \frac{N_3}{z - z_3} + \dots + \frac{N_{n-1}}{z - z_{n-1}}$$

where the N 's are constants. Integrating this expansion term-by-term, we get

$$\oint_C \frac{z^m}{z^n + 1} dz = N_0 \oint_C \frac{dz}{z - z_0}$$

since Cauchy's first integral theorem says all the other integrals are zero because, by construction, C does not enclose the singularities z_1, z_2, \dots, z_{n-1} . The only singularity C encloses is z_0 . Cauchy's second integral theorem in (8.7.1), with $f(z) = 1$, says that the integral on the right is $2\pi i$, and so (8.7.6) becomes

$$(8.7.7) \quad -2i \sin \left\{ (m + 1) \frac{\pi}{n} \right\} e^{i(m+1)\frac{\pi}{n}} \int_0^{\infty} \frac{x^m}{x^n + 1} dx = 2\pi i N_0.$$

Our next (and final) step is to calculate N_0 . To do that, multiply through the partial fraction expansion of the integrand in (8.7.5) by $z - z_0$ to get

$$\frac{(z - z_0)z^m}{z^n + 1} = N_0 + \frac{(z - z_0)N_1}{z - z_1} + \frac{(z - z_0)N_2}{z - z_2} + \frac{(z - z_0)N_3}{z - z_3} + \dots$$

and then let $z \rightarrow z_0$. This causes all the terms on the right after the first to vanish, and so

$$N_0 = \lim_{z \rightarrow z_0} \frac{(z - z_0)z^m}{z^n + 1} = \lim_{z \rightarrow z_0} \frac{z^{m+1} - z_0z^m}{z^n + 1} = \frac{0}{0}.$$

So, to resolve this indeterminacy, we'll use L'Hôpital's rule:

$$N_0 = \lim_{z \rightarrow z_0} \frac{(m + 1)z^m - mz_0z^{m-1}}{nz^{n-1}} = \lim_{z \rightarrow z_0} \frac{mz^m + z^m - mz_0z^{m-1}}{nz^{n-1}} = \frac{z_0^{m-n+1}}{n}$$

or, with $z_0 = e^{i\frac{\pi}{n}}$,

$$N_0 = \frac{e^{i\frac{\pi}{n}(m-n+1)}}{n} = \frac{e^{i\frac{m\pi}{n} - i\pi + i\frac{\pi}{n}}}{n} = \frac{e^{-i\pi} e^{i(\frac{m+1}{n})\pi}}{n} = -\frac{e^{i(\frac{m+1}{n})\pi}}{n}.$$

Inserting this result into (8.7.7),

$$\int_0^\infty \frac{x^m}{x^n + 1} dx = \frac{2\pi i \left\{ -\frac{e^{i(\frac{m+1}{n})\pi}}{n} \right\}}{-2i \sin \left\{ (m + 1) \frac{\pi}{n} \right\} e^{i(m+1)\frac{\pi}{n}}},$$

and so we have the beautiful result

$$\int_0^\infty \frac{x^m}{x^n + 1} dx = \frac{\frac{\pi}{n}}{\sin \left\{ (m + 1) \frac{\pi}{n} \right\}}, n - m \geq 2 .$$

(8.7.8)

For a specific example, you can confirm that $m = 0$ and $n = 4$ reproduces our result in (2.3.4). As a new result, if $m = 0$ and $n = 3$ then (8.7.8) says that

$$\int_0^\infty \frac{dx}{x^3 + 1} = \frac{\frac{\pi}{3}}{\sin \left\{ \frac{\pi}{3} \right\}} = \frac{\frac{\pi}{3}}{\frac{\sqrt{3}}{2}} = \frac{2\pi}{3\sqrt{3}} = 1.209199 \dots \text{ and MATLAB agrees:}$$

$$\text{quad}(@ (x) 1 ./ (x.^3 + 1), 0, 1000) = 1.209199 \dots$$

The result of (8.7.8) can be put into at least three alternative forms that commonly appear in the math literature. First, define $t = x^n$ and so

$$\frac{dt}{dx} = nx^{n-1}$$

which means

$$dx = \frac{dt}{nx^{n-1}} = \frac{dt}{n(t)^{\frac{n-1}{n}}}.$$

Thus, (8.7.8) becomes

$$\int_0^\infty \frac{(t)^{\frac{m}{n}}}{t+1} \left(\frac{dt}{n(t)^{\frac{n-1}{n}}} \right) = \frac{\frac{\pi}{n}}{\sin \left\{ (m+1) \frac{\pi}{n} \right\}} = \frac{1}{n} \int_0^\infty \frac{(t)^{\frac{m}{n} - \frac{n-1}{n}}}{t+1} dt$$

or,

$$\int_0^\infty \frac{(t)^{\frac{m-n+1}{n}}}{t+1} dt = \frac{\pi}{\sin \left\{ (m+1) \frac{\pi}{n} \right\}} = \int_0^\infty \frac{(t)^{\frac{m+1}{n}-1}}{t+1} dt.$$

Now, define

$$a = \frac{m+1}{n},$$

which says¹²

(8.7.9) $\int_0^\infty \frac{x^{a-1}}{x+1} dx = \frac{\pi}{\sin(a\pi)}, 0 < a < 1.$

For example, if $a = \frac{1}{2}$ then

$$\int_0^\infty \frac{dx}{\sqrt{x}(x+1)} = \frac{\pi}{\sin\left(\frac{\pi}{2}\right)} = \pi$$

and MATLAB agrees as `quad(@x)1./(sqrt(x).*(x+1)),0,1e10) = 3.141546...`

Another way to reformulate (8.7.8) is to start with (8.7.9) and define $t = \ln(x)$, and so

¹² The limits on a are because, first, since $n - m \geq 2$ it follows that $m + 1 \leq n - 1$ and so $a < 1$. Also, for $x \ll 1$ the integrand in (8.7.9) behaves as x^{a-1} which integrates to $\frac{x^a}{a}$ and this blows-up at the lower limit of integration if $a < 0$. So, $0 < a$.

$$\frac{dt}{dx} = \frac{1}{x} = \frac{1}{e^t}.$$

Thus, (8.7.9) becomes (because $x=0$ means $t = -\infty$)

$$\int_{-\infty}^{\infty} \frac{e^{t(a-1)}}{1+e^t} e^t dt = \int_{-\infty}^{\infty} \frac{e^{at}}{1+e^t} dt.$$

That is,

$$(8.7.10) \quad \int_{-\infty}^{\infty} \frac{e^{ax}}{1+e^x} dx = \frac{\pi}{\sin(a\pi)}, \quad 0 < a < 1.$$

For example, if $a = \frac{1}{3}$ the integral equals $\frac{\pi}{\sin(\pi/3)} = \frac{\pi}{\sqrt{3}/2} = \frac{2\pi}{\sqrt{3}} = 3.62759\dots$ and MATLAB agrees as `quad(@(x)exp(x/3)/(1+exp(x)),-100,100) = 3.62760\dots`. It's interesting to compare (8.7.10) with (8.6.9).

And finally, in (8.7.9) make the change of variable

$$u = \frac{1}{x}$$

and so

$$dx = -\frac{du}{u^2}.$$

Then,

$$\int_0^{\infty} \frac{x^{a-1}}{x+1} dx = \int_{\infty}^0 \frac{\left(\frac{1}{u}\right)^{a-1}}{\left(\frac{1}{u}+1\right)} \left(-\frac{du}{u^2}\right) = \int_0^{\infty} \frac{du}{\left(\frac{1+u}{u}\right)(u^{a-1})u^2} = \int_0^{\infty} \frac{du}{\left(\frac{1+u}{u}\right)(u^a)u^2},$$

and so

$$(8.7.11) \quad \int_0^{\infty} \frac{dx}{(1+x)x^a} = \frac{\pi}{\sin(a\pi)}, \quad 0 < a < 1.$$

I'll end this section with an example of the use of Cauchy's second integral theorem in a problem where multiple singularities of first-order appear. For the arbitrary positive constant a , we'll calculate the value of

$$\int_0^{2\pi} \frac{d\theta}{a + \sin^2(\theta)}.$$

We can handle the multiple singularities by simply using the cross-cut idea from earlier in this section. That is, as we travel around a contour C , just move inward along a cross-cut to the first singularity and then travel around it on a tiny circle with radius ρ and then back out along the cross-cut to C . Then, after traveling a bit more on C do the same thing with a new cross-cut to the second singularity. And so on, for all the rest of the singularities. ('Tiny' means pick ρ small enough that none of the singularity circles intersect, and that all are always inside C .) For each singularity we'll pick-up a value of $2\pi i f(z_0)$, where the integrand of the contour integral we are studying is $\frac{f(z)}{(z-z_0)}$.

So, what contour integral *will* we be studying? On the unit circle C we have

$$(8.7.12) \quad z = e^{i\theta} = \cos(\theta) + i \sin(\theta), \frac{1}{z} = e^{-i\theta} = \cos(\theta) - i \sin(\theta)$$

and so

$$dz = ie^{i\theta} d\theta = iz d\theta$$

as well as

$$\sin(\theta) = z - \frac{1}{z} = \frac{z^2 - 1}{2zi}.$$

Thus,

$$\sin^2(\theta) = -\frac{(z^2 - 1)^2}{4z^2}$$

and so the contour integral we'll study is

$$(8.7.13) \quad \oint_C \frac{\frac{dz}{iz}}{a - \frac{(z^2-1)^2}{4z^2}} = 4i \oint_C \frac{z dz}{z^4 - z^2(2 + 4a) + 1}.$$

The integrand clearly has four first-order singularities, all located on the real axis at:

$$z = \pm\sqrt{u}, u = (1 + 2a) + 2\sqrt{a(a + 1)}$$

and

$$z = \pm\sqrt{u}, u = (1 + 2a) - 2\sqrt{a(a+1)}.$$

By inspection it is seen that for the first pair of singularities $|z| > 1$ and so both lie *outside* C , while for the second pair $|z| < 1$ and so both lie *inside* C . Specifically, let's write z_1 and z_2 as the *inside* singularities where

$$z_1 = \sqrt{(1 + 2a) - 2\sqrt{a(a+1)}}$$

and

$$z_2 = -\sqrt{(1 + 2a) - 2\sqrt{a(a+1)}} = -z_1,$$

while z_3 and z_4 are the *outside* singularities where

$$z_3 = \sqrt{(1 + 2a) + 2\sqrt{a(a+1)}}$$

and

$$z_4 = -\sqrt{(1 + 2a) + 2\sqrt{a(a+1)}} = -z_3.$$

The integrand of the contour integral on the right in (8.7.13) is

$$\begin{aligned} \frac{z}{(z - z_1)(z - z_2)(z - z_3)(z - z_4)} &= \frac{z}{(z - z_1)(z - z_2)(z - z_3)(z + z_3)} \\ &= \frac{z}{(z - z_1)(z - z_2)(z^2 - z_3^2)}. \end{aligned}$$

So, from Cauchy's second integral theorem, the contour integral is equal to

$$2\pi i \left[\frac{z}{(z - z_2)(z^2 - z_3^2)} \Big|_{z=z_1} + \frac{z}{(z - z_1)(z^2 - z_3^2)} \Big|_{z=z_2} \right].$$

I'll let you verify the algebra (which really isn't awful, *if you're careful*) which shows that each of the two terms in the square brackets is $-\frac{1}{8\sqrt{a(a+1)}}$. Thus,

$$\oint_C \frac{z dz}{z^4 - z^2(2 + 4a) + 1} = -\frac{\pi i}{2\sqrt{a(a+1)}}$$

and so, from (8.7.13), we multiply by $4i$ to get

$$(8.7.14) \quad \int_0^{2\pi} \frac{d\theta}{a + \sin^2(\theta)} = \frac{2\pi}{\sqrt{a(a+1)}}, \quad a > 0.$$

If $a = 3$ this is 1.81379936... , and MATLAB agrees because `quad(@(x)1./(3+(sin(x).^2)),0,2*pi) = 1.81379936...`

8.8 Singularities and the Residue Theorem

In this section we'll derive the wonderful *residue theorem*, which will reduce what appear to be astoundingly difficult definite integrals to ones being simply of 'routine' status. We start with a $f(z)$ that is analytic everywhere in some region \mathbf{R} in the complex plane *except* at the point $z = z_0$ which is a singularity of order $m \geq 1$. That is,

$$(8.8.1) \quad f(z) = \frac{g(z)}{(z - z_0)^m}$$

where $g(z)$ is analytic throughout \mathbf{R} . Because $g(z)$ is analytic we know it is 'well-behaved,' which is math-lingo for 'all the derivatives of $g(z)$ exist.' (Take a look back at (8.7.1) and the comment that follows it.) That means $g(z)$ has a Taylor series expansion about $z = z_0$ and so we can write

$$(8.8.2) \quad g(z) = c_0 + c_1(z - z_0) + c_2(z - z_0)^2 + c_3(z - z_0)^3 + \dots$$

Putting (8.8.2) into (8.8.1) gives

$$f(z) = \frac{c_0}{(z - z_0)^m} + \frac{c_1}{(z - z_0)^{m-1}} + \frac{c_2}{(z - z_0)^{m-2}} + \dots + c_m + c_{m+1}(z - z_0) + c_{m+1}(z - z_0)^2 + \dots$$

or, as it is usually written,

$$(8.8.3) \quad f(z) = \sum_{n=0}^{\infty} a_n(z - z_0)^n + \sum_{n=1}^{\infty} \frac{b_n}{(z - z_0)^n}$$

where in the second sum all the $b_n = 0$ for $n > m$.

The series expansion in (8.8.3) of $f(z)$, an expansion about a singular point that involves both positive *and* negative powers of $(z - z_0)$, is called the *Laurent series* of $f(z)$, named after the French mathematician Pierre Alphonse Laurent (1813-1854) who developed it in 1843. (In books dealing with complex analysis in far more detail than I am doing here, it is shown that the Laurent series expansion is

unique.) We can find formulas for the a_n and b_n coefficients in (8.8.3) as follows. Begin by observing that if k is any integer (negative, zero, or positive), then if C is a circle of radius ρ centered on z_0 (which means that on C we have $z = z_0 + \rho e^{i\theta}$), then

$$\begin{aligned} \oint_C (z - z_0)^k dz &= \int_0^{2\pi} \rho^k e^{ik\theta} i\rho e^{i\theta} d\theta = i\rho^{k+1} \int_0^{2\pi} e^{i(k+1)\theta} d\theta \\ &= i\rho^{k+1} \left\{ \frac{e^{i(k+1)\theta}}{i(k+1)} \right\}_0^{2\pi} = \frac{\rho^{k+1}}{k+1} \left\{ e^{i(k+1)\theta} \right\}_0^{2\pi}. \end{aligned}$$

As long as $k \neq -1$ this last expression is 0. If, on the other hand, $k = -1$ our expression becomes the indeterminate $\frac{0}{0}$. To get around that, for $k = -1$ simply back-up a couple of steps and write

$$\oint_C (z - z_0)^{-1} dz = \int_0^{2\pi} \frac{1}{\rho e^{i\theta}} i\rho e^{i\theta} d\theta = i \int_0^{2\pi} d\theta = 2\pi i.$$

That is, for k any integer,

$$(8.8.4) \quad \oint_C (z - z_0)^k dz = \begin{cases} 0, & k \neq -1 \\ 2\pi i, & k = -1. \end{cases}$$

So, to find a particular a -coefficient (say, a_j), simply divide through (8.8.3) by $(z - z_0)^{j+1}$ and integrate term-by-term. All of the integrals will vanish because of (8.8.4) with a single exception:

$$\oint_C \frac{f(z)}{(z - z_0)^{j+1}} dz = \oint_C \frac{a_j}{z - z_0} dz = 2\pi i a_j.$$

That is,

$$(8.8.5) \quad a_j = \frac{1}{2\pi i} \oint_C \frac{f(z)}{(z - z_0)^{j+1}} dz, \quad j = 0, 1, 2, 3, \dots$$

And to find a particular b -coefficient (say, b_j), simply multiply by $(z - z_0)^{j-1}$ through (8.8.3) and integrate term-by-term. All of the integrals will vanish because of (8.8.4) with a single exception:

$$\oint_C f(z)(z - z_0)^{j-1} dz = \oint_C b_j(z - z_0)^{-1} dz = \oint_C \frac{b_j}{z - z_0} dz = 2\pi i b_j.$$

That is,

$$(8.8.6) \quad b_j = \frac{1}{2\pi i} \oint_C \frac{f(z)}{(z - z_0)^{-j+1}} dz, \quad j = 1, 2, 3, \dots$$

One of the true miracles of contour integration is that, of the potentially infinite number of coefficients given by the formulas (8.8.5) and (8.8.6), only *one* will be of interest to us. That chosen one is b_1 and here's why. If we set $j = 1$ in (8.8.6) then¹³

$$(8.8.7) \quad \oint_C f(z) dz = 2\pi i b_1,$$

which is almost precisely (to within a factor of $2\pi i$) the ultimate quest of our calculations, the determination of

$$\oint_C f(z) dz.$$

But of course we don't do the integral to find b_1 (if we could directly do the integral, who cares about b_1 ?!), but rather we *reverse the process* and calculate b_1 by *some means other than integration* and then use that result in (8.8.7) to find the integral. The value of b_1 is called the *residue* of $f(z)$ at the singularity $z = z_0$.

What does 'some means other than integration' mean? As it turns out, it is not at all difficult to get our hands on b_1 . Let's suppose (as we did at the start of this section) that $f(z)$ has a singularity of order m . That is, writing-out (8.8.3) in just a bit more detail,

$$f(z) = \dots + a_1(z - z_0) + a_0 + \frac{b_1}{z - z_0} + \frac{b_2}{(z - z_0)^2} + \dots + \frac{b_m}{(z - z_0)^m}.$$

So, multiplying through by $(z - z_0)^m$ gives

$$(z - z_0)^m f(z) = \dots + a_1(z - z_0)^{m+1} + a_0(z - z_0)^m + b_1(z - z_0)^{m-1} + b_2(z - z_0)^{m-2} + \dots + b_m.$$

Next, differentiate with respect to z a total of $m - 1$ times. That has three effects: (1) all the a -coefficient terms will retain a factor of $(z - z_0)$ to at least the first power; (2) the b_1 term will be multiplied by $(m - 1)!$, but will have no factor involving $(z - z_0)$; and (3) all the other b -coefficient terms will be differentiated to zero. Thus, if we then let $z \rightarrow z_0$ the a -coefficient terms will vanish and we'll be left with nothing but $(m - 1)! b_1$. Therefore,

¹³ The contour C in (8.8.7) has been a *circle* of radius ρ up to this point, but in fact by using the cross-cut idea of Figure 8.7.2 we can think of C as being *any* contour enclosing z_0 such that $f(z)$ is everywhere analytic on and within C (except at z_0 , of course).

$$(8.8.8) \quad \boxed{b_1 = \frac{1}{(m-1)!} \lim_{z \rightarrow z_0} \frac{d^{m-1}}{dz^{m-1}} \{(z - z_0)^m f(z)\}}$$

where z_0 is a m -order singularity of $f(z)$. This is so important a result that I've put (8.8.8) in a box.

For a first-order singularity ($m = 1$) the formula in (8.8.8) reduces, with the interpretation of $\frac{d^{m-1}}{dz^{m-1}} = 1$ if $m = 1$, to

$$b_1 = \lim_{z \rightarrow z_0} (z - z_0) f(z).$$

Alternatively, write

$$f(z) = \frac{g(z)}{h(z)}$$

where, as before, $g(z)$ is analytic at the singularity $z = z_0$ (which is then, of course, a first-order *zero* of $h(z)$). That is,

$$h(z_0) = 0.$$

Then,

$$\lim_{z \rightarrow z_0} (z - z_0) f(z) = \lim_{z \rightarrow z_0} (z - z_0) \frac{g(z)}{h(z)} = \lim_{z \rightarrow z_0} \frac{g(z)}{\frac{h(z) - h(z_0)}{z - z_0}}$$

where the denominator on the far-right follows because $h(z) = h(z) - h(z_0)$ because $h(z_0) = 0$. So,

$$\lim_{z \rightarrow z_0} (z - z_0) f(z) = \frac{g(z_0)}{\left. \frac{d}{dz} h(z) \right|_{z=z_0}}.$$

That is, the residue for a *first-order* singularity at $z = z_0$ in the integrand $f(z) = \frac{g(z)}{h(z)}$ can be computed as

$$(8.8.9) \quad \boxed{b_1 = \frac{g(z_0)}{h'(z_0)}}.$$

I'll show you an example of the use of (8.8.9) in the next section of this chapter.

Sometimes you can use other ‘tricks’ to get the residue of a singularity. Here’s one that directly uses the Laurent series without requiring *any* differentiation at all. Let’s calculate

$$\int_0^{2\pi} \cos^k(\theta) d\theta$$

for k an *even* positive integer. (The integral is, of course, zero for k an odd integer because the cosine is symmetrical about the θ -axis over the interval 0 to 2π and so bounds zero area.) Using (8.7.12) again, on the unit circle C we have

$$\cos(\theta) = \frac{z^2 + 1}{2z}$$

and $dz = iz d\theta$. So, let’s study the contour integral

$$(8.8.10) \quad \oint_C \left(\frac{z^2 + 1}{2z}\right)^k \frac{dz}{iz} = \frac{1}{i2^k} \oint_C \frac{(z^2 + 1)^k}{z^{k+1}} dz.$$

Here we have a singularity at $z = 0$ of order $m = k + 1$. That can be a *lot* of differentiations, using (8.8.8), if k is a large number!

A better way to get the residue of this high-order singularity is to use the binomial theorem to expand the integrand as

$$\frac{(z^2 + 1)^k}{z^{k+1}} = \frac{1}{z^{k+1}} \sum_{j=0}^k \binom{k}{j} (z^2)^j (1)^{k-j} = \sum_{j=0}^k \binom{k}{j} z^{2j-k-1}$$

which is a series expansion in negative and positive powers of z around the singular point at zero. It must be, that is, the Laurent expansion of the integrand (remember, such expansions are unique) from which we can literally read off the residue (the coefficient of the z^{-1} term). Setting $2j - k - 1 = -1$, we find that $j = \frac{k}{2}$ and so the residue is

$$\binom{k}{\frac{k}{2}} = \frac{k!}{\left(\frac{k}{2}\right)! \left(\frac{k}{2}\right)!} = \frac{k!}{\left[\left(\frac{k}{2}\right)!\right]^2}.$$

Thus,

$$\oint_C \frac{(z^2 + 1)^k}{z^{k+1}} dz = 2\pi i \frac{k!}{\left[\left(\frac{k}{2}\right)!\right]^2}$$

and so, from (8.8.10),

$$(8.8.11) \quad \int_0^{2\pi} \cos^k(\theta) d\theta = \frac{2\pi}{2^k} \frac{k!}{\left[\left(\frac{k}{2}\right)!\right]^2}, \quad k \text{ even.}$$

For example, if $k = 18$ the integral is equal to 1.16534603 and MATLAB agrees because

$$\text{quad}(@(\theta)\cos(\theta).^18,0,2*\pi) = 1.165347\dots$$

Next, let's do an example using (8.8.8). In (3.4.8) we derived the result (where a and b are each a positive constant, with $a > b$)

$$\int_0^{\pi} \frac{1}{a + b\cos(\theta)} d\theta = \frac{\pi}{\sqrt{a^2 - b^2}},$$

which is equivalent to

$$\int_0^{2\pi} \frac{1}{a + b\cos(\theta)} d\theta = \frac{2\pi}{\sqrt{a^2 - b^2}}$$

because $\cos(\theta)$ from π to 2π simply runs through the same values it does from 0 to π . Now, suppose we set $a = 1$ and write $b = k < 1$. Then (3.4.8) says

$$\int_0^{2\pi} \frac{1}{1 + k\cos(\theta)} d\theta = \frac{2\pi}{\sqrt{1 - k^2}}, \quad k < 1.$$

This result might prompt one to 'up the ante' and ask for the value of

$$\int_0^{2\pi} \frac{1}{\{1 + k\cos(\theta)\}^2} d\theta = ?$$

If we take C to be the unit circle centered on the origin, then on C we have as in the previous section that $z = e^{i\theta}$ and so, from Euler's identity, we can write

$$\cos(\theta) = \frac{1}{2} \left(z + \frac{1}{z} \right) = \frac{z^2 + 1}{2z}.$$

So, on C we have

$$\frac{1}{1 + k\cos(\theta)} = \frac{1}{1 + k\left(\frac{z^2+1}{2z}\right)} = \frac{2z}{2z + kz^2 + k}$$

and therefore

$$\frac{1}{\{1 + k\cos(\theta)\}^2} = \left(\frac{4}{k^2}\right) \frac{z^2}{\left(z^2 + \frac{2}{k}z + 1\right)^2}.$$

Also, as before,

$$dz = ie^{i\theta}d\theta = iz d\theta$$

and so

$$d\theta = \frac{dz}{iz}.$$

All this suggests that we consider the contour integral

$$\oint_C \left(\frac{4}{k^2}\right) \frac{z^2}{\left(z^2 + \frac{2}{k}z + 1\right)^2} \frac{dz}{iz} = \frac{1}{i} \left(\frac{4}{k^2}\right) \oint_C \frac{z}{\left(z^2 + \frac{2}{k}z + 1\right)^2} dz.$$

We see that the integrand has two singularities, and that each is *second-order*. That is, $m = 2$ and the singularities are at

$$z = \frac{1}{2} \left(-\frac{2}{k} \pm \sqrt{\frac{4}{k^2} - 4} \right) = \frac{-1 \pm \sqrt{1 - k^2}}{k}.$$

Since $k < 1$ the singularity at

$$z = z_{01} = \frac{-1 - \sqrt{1 - k^2}}{k}$$

is *outside* C , while the singularity at

$$z = z_{02} = \frac{-1 + \sqrt{1 - k^2}}{k}$$

is *inside* C . That is, z_{02} is the only singularity for which we need to compute the residue as given by (8.8.8).

So, with $m = 2$, that residue is

$$b_1 = \frac{1}{1!} \lim_{z \rightarrow z_{02}} \frac{d}{dz} \left\{ (z - z_{02})^2 \frac{z}{\left(z^2 + \frac{2}{k}z + 1\right)^2} \right\}.$$

Since

$$\begin{aligned} (z - z_{02})^2 \frac{z}{\left(z^2 + \frac{2}{k}z + 1\right)^2} &= (z - z_{02})^2 \frac{z}{(z - z_{01})^2(z - z_{02})^2} = \frac{z}{(z - z_{01})^2} \\ &= \frac{z}{\left(z + \frac{1 + \sqrt{1 - k^2}}{k}\right)^2}, \end{aligned}$$

we have

$$\frac{d}{dz} \left\{ (z - z_{02})^2 \frac{z}{\left(z^2 + \frac{2}{k}z + 1\right)^2} \right\} = \frac{d}{dz} \left\{ \frac{z}{\left(z + \frac{1 + \sqrt{1 - k^2}}{k}\right)^2} \right\}$$

which, after just a bit of algebra that I'll let you confirm, reduces to

$$\frac{-z + \frac{1 + \sqrt{1 - k^2}}{k}}{\left(z + \frac{1 + \sqrt{1 - k^2}}{k}\right)^3}.$$

Then, finally, we let $z \rightarrow z_{02} = \frac{-1 + \sqrt{1 - k^2}}{k}$ and so

$$b_1 = \frac{\frac{1 - \sqrt{1 - k^2}}{k} + \frac{1 + \sqrt{1 - k^2}}{k}}{\left(\frac{-1 + \sqrt{1 - k^2}}{k} + \frac{1 + \sqrt{1 - k^2}}{k}\right)^3} = \frac{\frac{2}{k}}{\frac{8(1 - k^2)^{3/2}}{k^3}} = \frac{k^2}{4(1 - k^2)^{3/2}}.$$

Thus,

$$\oint_C \frac{z}{\left(z^2 + \frac{2}{k}z + 1\right)^2} dz = 2\pi i \frac{k^2}{4(1 - k^2)^{3/2}} = \frac{\pi i k^2}{2(1 - k^2)^{3/2}}$$

and so

$$\int_0^{2\pi} \frac{1}{\{1 + k\cos(\theta)\}^2} d\theta = \frac{1}{i} \left(\frac{4}{k^2}\right) \frac{\pi i k^2}{2(1 - k^2)^{3/2}}.$$

That is,

$$(8.8.12) \quad \int_0^{2\pi} \frac{1}{\{1 + k\cos(\theta)\}^2} d\theta = \frac{2\pi}{(1 - k^2)^{3/2}} .$$

For example, if $k = \frac{1}{2}$ then our result is 9.67359... , and MATLAB agrees because

```
quad(@(x)1./(1+0.5*cos(x)).^2,0,2*pi) = 9.67359...
```

To finish this section, I'll now formally state what we've been doing all through it: if $f(z)$ is analytic on and inside contour C with the exception of N singularities, and if R_j is the residue of the j -th singularity, then

$$(8.8.13) \quad \oint_C f(z) dz = 2\pi i \sum_{j=1}^N R_j .$$

This is the famous *residue theorem*. For each singularity we'll pick-up a contribution to the integral of $2\pi i$ times the residue of that singularity, with the residue calculated according to (8.8.8), or (8.8.9) if $m = 1$, using the value of m that goes with each singularity. That's it! In the next (and final) section of this chapter I'll show you an example of (8.8.13) applied to an integral that has one additional complication we haven't yet encountered.

8.9 Integrals with Multi-valued Integrands

All of the wonderful power of contour integration comes from the theorems that tell us what happens when we travel once around a *closed* path in the complex plane. The theorems apply *only* for paths that are *closed*. I emphasize this point—particularly the word *closed*—because there is a subtle way in which closure can fail, so subtle in fact that it is all too easy to miss. Recognizing the problem, and then understanding the way to get around it, leads to the important concepts of *branch cuts* and *branch points* in the complex plane.

There are numerous examples that one could give of how false closed paths can occur, but the classic one involves integrands containing the logarithmic function. Writing the complex variable as we did in (8.3.3) as $z = re^{i\theta}$, we have $\log(z) = \ln(z) = \ln(re^{i\theta})$

$= \ln(r) + i\theta, 0 \leq \theta < 2\pi$. Notice, *carefully*, the \leq sign to the left of θ but that it is the strict $<$ sign on the right. As was pointed out in Sect. 8.3, θ is not uniquely determined, as we can add (or subtract) any multiple of 2π from θ and still seemingly be talking about the same physical point in the complex plane. That is, we should really write $\log(z) = \ln(r) + i(\theta \pm 2\pi n), 0 \leq \theta < 2\pi, n = 0, 1, 2, \dots$. The logarithmic function is said to be *multi-valued* as we loop endlessly around the origin. The mathematical problem we run into with this more complete formulation

of the logarithmic function is that it is *not continuous* on any path that crosses the positive real axis! Here's why.

Consider a point $z = z_0$ on the positive real axis. At that point, $r = x_0$ and $\theta = 0$. But the imaginary part of $\log(z)$ is not a continuous function of z at x_0 because its value, in all tiny neighborhoods 'just below' the positive real axis at x_0 , is arbitrarily near 2π , not 0. The crucial implication of this failure of continuity is that the *derivative* of $\log(z)$ fails to exist as we cross the positive real axis, which means analyticity fails there, too. And that means all our wonderful integral theorems are out the window!

What is happening, geometrically, as we travel around what *seems* to be a closed circular path (starting at x_0 and then winding around the origin) is that we do *not* return to the starting point x_0 . Rather, we cross the positive real axis we enter a new *branch* of the log function. An everyday example of this occurs when you travel along a spiral path in a multi-level garage looking for a parking space and move from one level (branch) to the next level (another branch) of the garage.¹⁴ Your spiral path 'looks closed' to an observer on the roof looking downward (just like you looking down on your math paper as you draw what *seems* to be a closed contour in a flat complex plane), but your parking garage trajectory is *not* closed. And neither is that apparently 'closed' contour. There is no problem for your car with this, of course, but it seems to be a fatal problem for our integral theorems.

Or, perhaps not. Remember the old saying: "If your head hurts because you're banging it on the wall, then stop banging your head on the wall!" We have the same situation here: "If crossing the positive real axis blows-up the integral theorems, well then, *don't cross the positive real axis.*" What we need to do here, when constructing a contour involving the logarithmic function, is to simply avoid crossing the positive real axis. What we do is label the positive real axis, from the origin out to plus-infinity, as a so-called *branch cut* (the end-points of the cut, $x = 0$ and $x = +\infty$, are called *branch points*), and then avoid crossing that line. Any contour that we draw satisfying this restriction is absolutely guaranteed to be closed (that is, to always remain on a single branch) and thus our integral theorems remain valid.

Another commonly encountered multi-valued function that presents the same problem is the fractional power $z^p = r^p e^{ip\theta}$, where $-1 < p < 1$ and, as before, we take $0 \leq \theta < 2\pi$. Suppose, for example, we have the function \sqrt{z} and so $p = \frac{1}{2}$. Any point *on* the positive real axis has $\theta = 0$, but in a tiny neighborhood 'just below' the positive real axis the angle of z is arbitrarily near to 2π and so the angle of \sqrt{z} is $\frac{2\pi}{2} = \pi$. That is, *on* the positive real axis the function value at a point is \sqrt{r} while an

¹⁴ Each of these branches exists for each new interval of θ of width 2π , with each branch lying on what is called a *Riemann surface*. The logarithmic function has an infinite number of branches, and so an infinite number of Riemann surfaces. The surface for $0 \leq \theta < 2\pi$ is what we observe as the usual complex plane (the entry level of our parking garage). The concept of the Riemann surface is a very deep one, and my comments here are meant only to give you an 'elementary geometric feel' for it.

arbitrarily tiny downward shift of the point into the fourth quadrant gives a function value of $\sqrt{r}e^{i\pi} = -\sqrt{r}$. The function value is not continuous across the positive real axis. The solution for handling z^p is, again, to define the positive real axis as a branch cut and to avoid using a contour C that crosses that cut.

The fact that I've taken $0 \leq \theta < 2\pi$ is the reason the branch cut is along the *positive* real axis. If, instead, I'd taken $-\pi < \theta \leq \pi$ we would have run into the failure of continuity problem as we crossed the *negative* real axis, and in that case we would simply make the negative real axis the branch cut and avoid any C crossing it. In both cases $z = 0$ would be the branch point. Indeed, in the examples I've discussed here we could pick any direction we wish, starting at $z = 0$, draw a straight from there out to infinity, and call *that* our branch cut.

Let's see how this all works. For the final calculation of this chapter, using these ideas, I'll evaluate

$$(8.9.1) \quad \int_0^\infty \frac{\ln(x)}{(x+a)^2 + b^2} dx, \quad a \geq 0, b > 0,$$

where a and b are constants. We've already done two special cases of (8.9.1). In (1.5.1), for $a = 0$ and $b = 1$, we found that

$$\int_0^\infty \frac{\ln(x)}{x^2 + 1} dx = 0,$$

and in (2.1.3) we generalized this just a bit to the case of arbitrary b :

$$\int_0^\infty \frac{\ln(x)}{x^2 + b^2} dx = \frac{\pi}{2b} \ln(b), \quad b > 0.$$

In (8.9.1) we'll now allow a , too, to have any non-negative value. The contour C we'll use is shown in Fig. 8.9.1, which you'll notice avoids crossing the branch cut (the positive real axis), as well as circling around the branch point at the origin. This insures that C lies entirely on a single branch of the logarithmic function, and so C is truly closed.

The contour C consists of four parts, where ρ and R are the radii of the small (C_4) and large (C_2) circular portions, respectively, and ε is a small *positive* angle: on C_1 : $z = re^{i\varepsilon}$, $dz = e^{i\varepsilon} dr$, $\rho < r < R$; on C_2 : $z = Re^{i\theta}$, $dz = iRe^{i\theta} d\theta$, $\varepsilon < \theta < 2\pi - \varepsilon$; on C_3 : $z = re^{i(2\pi - \varepsilon)}$, $dz = e^{i(2\pi - \varepsilon)} dr$, $R > r > \rho$; on C_4 : $z = \rho e^{i\theta}$, $dz = i\rho e^{i\theta} d\theta$, $2\pi - \varepsilon > \theta > \varepsilon$.

We will, eventually, let $\rho \rightarrow 0$, $R \rightarrow \infty$, and $\varepsilon \rightarrow 0$.

Notice, carefully, that for C_3 I have avoided continuing the expressions for z and dz beyond their $e^{i(2\pi - \varepsilon)}$ factors. That is, I did not give-in to the temptation to write $e^{i(2\pi - \varepsilon)} = e^{i2\pi} e^{-i\varepsilon} = e^{-i\varepsilon}$ (replacing $e^{i2\pi}$ with 1, from Euler's identity). That would be in error because then we would be working with the negative angle $-\varepsilon$, which would put us on a new branch of the logarithmic function (to use the parking garage

Fig. 8.9.1 A closed contour that avoids crossing a branch cut

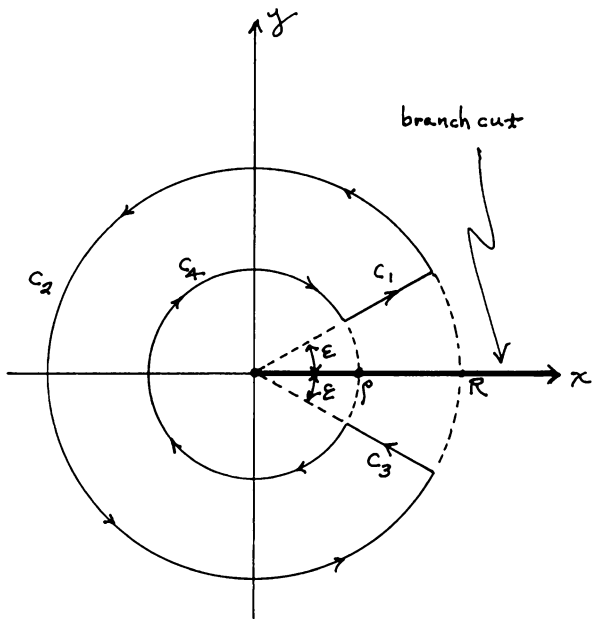

metaphor, on the level *below* the entry level). To work with e^{-ie} would result in C not being a closed contour, and that would doom our analysis to failure.

Our integrand will be

$$(8.9.2) \quad f(z) = \frac{\{\ln(z)\}^2}{(z + a)^2 + b^2},$$

and you are almost surely wondering why the numerator is $\ln(z)$ *squared*? Why not just $\ln(z)$? The quick answer is that the C_1 and C_3 integrals are in opposite directions as $\epsilon \rightarrow 0$, and so would cancel each other if we just use $\ln(z)$. This isn't 'wrong,' but it won't give us the integral we are after. Using $\ln^2(z)$ avoids the cancellation, and I'll point that out when our analysis gets to where the cancellation would otherwise occur.

The integrand has three singularities: one at $z = 0$ where the numerator blows-up, and two at $z = -a \pm ib$ where the denominator vanishes. Only the last two are inside C as ρ and ϵ each go to zero, and as R goes to infinity, and each is first-order. From the residue theorem, (8.8.13), we have

$$\oint_C f(z) dz = 2\pi i \sum_{j=1}^2 R_j$$

where R_1 is the residue of the singularity at $z = -a + ib$ and R_2 is the residue of the singularity at $z = -a - ib$. As we showed in (8.8.9), the residue of a first-order singularity at $z = z_0$ in the integrand function

$$f(z) = \frac{g(z)}{h(z)}$$

is given by

$$\frac{g(z_0)}{h'(z_0)}.$$

For our problem,

$$g(z) = \{\ln(z)\}^2$$

and

$$h(z) = (z + a)^2 + b^2.$$

Since

$$h'(z_0) = \frac{d}{dz}h(z)|_{z=z_0} = 2(z + a)|_{z=z_0}$$

then, as

$$2(-a + ib + a) = i2b$$

and

$$2(-a - ib + a) = -i2b,$$

we have

$$R_1 = \frac{\{\ln(-a + ib)\}^2}{i2b}$$

and

$$R_2 = \frac{\{\ln(-a - ib)\}^2}{-i2b}.$$

Since a and b are both non-negative, the $-a + ib$ singularity is in the second quadrant, and the $-a - ib$ singularity is in the third quadrant. In polar form, then, the second quadrant singularity is at

$$-a + ib = \sqrt{a^2 + b^2} e^{i\{\pi - \tan^{-1}(\frac{b}{a})\}}$$

and the third quadrant singularity is at

$$-a - ib = \sqrt{a^2 + b^2} e^{i\{\pi + \tan^{-1}(\frac{b}{a})\}}.$$

Therefore,

$$R_1 = \frac{\left\{ \ln \left(\sqrt{a^2 + b^2} e^{i\{\pi - \tan^{-1}(\frac{b}{a})\}} \right) \right\}^2}{i2b} = \frac{\left[\ln \left(\sqrt{a^2 + b^2} \right) + i\{\pi - \tan^{-1}(\frac{b}{a})\} \right]^2}{i2b}$$

and

$$R_2 = \frac{\left\{ \ln \left(\sqrt{a^2 + b^2} e^{i\{\pi + \tan^{-1}(\frac{b}{a})\}} \right) \right\}^2}{-i2b} = \frac{\left[\ln \left(\sqrt{a^2 + b^2} \right) + i\{\pi + \tan^{-1}(\frac{b}{a})\} \right]^2}{-i2b}.$$

Thus, $2\pi i$ times the sum of the residues is

$$\begin{aligned} 2\pi i(R_1 + R_2) &= 2\pi i \left(\frac{\left[\ln \left(\sqrt{a^2 + b^2} \right) + i\{\pi - \tan^{-1}(\frac{b}{a})\} \right]^2}{i2b} - \frac{\left[\ln \left(\sqrt{a^2 + b^2} \right) + i\{\pi + \tan^{-1}(\frac{b}{a})\} \right]^2}{i2b} \right) \\ &= \frac{2\pi i}{i2b} \left(\left[\ln \left(\sqrt{a^2 + b^2} \right) + i\left\{ \pi - \tan^{-1} \left(\frac{b}{a} \right) \right\} \right]^2 - \left[\ln \left(\sqrt{a^2 + b^2} \right) + i\left\{ \pi + \tan^{-1} \left(\frac{b}{a} \right) \right\} \right]^2 \right) \\ &= \frac{\pi}{b} \left(\begin{aligned} &2\ln \left(\sqrt{a^2 + b^2} \right) i \left\{ \pi - \tan^{-1} \left(\frac{b}{a} \right) \right\} - \left\{ \pi - \tan^{-1} \left(\frac{b}{a} \right) \right\}^2 \\ &- 2\ln \left(\sqrt{a^2 + b^2} \right) i \left\{ \pi + \tan^{-1} \left(\frac{b}{a} \right) \right\} + \left\{ \pi + \tan^{-1} \left(\frac{b}{a} \right) \right\}^2 \end{aligned} \right) \\ &= \frac{\pi}{b} \left(\begin{aligned} &-4i\ln \left(\sqrt{a^2 + b^2} \right) \tan^{-1} \left(\frac{b}{a} \right) - \left\{ \pi^2 - 2\pi \tan^{-1} \left(\frac{b}{a} \right) + \left[\tan^{-1} \left(\frac{b}{a} \right) \right]^2 \right\} \\ &+ \left\{ \pi^2 + 2\pi \tan^{-1} \left(\frac{b}{a} \right) + \left[\tan^{-1} \left(\frac{b}{a} \right) \right]^2 \right\} \end{aligned} \right) \\ &= \frac{\pi}{b} \left(4\pi \tan^{-1} \left(\frac{b}{a} \right) - 4i\ln \left(\sqrt{a^2 + b^2} \right) \tan^{-1} \left(\frac{b}{a} \right) \right) = \frac{4\pi}{b} \tan^{-1} \left(\frac{b}{a} \right) \left[\pi - i\ln \left(\sqrt{a^2 + b^2} \right) \right]. \end{aligned}$$

So, for the $f(z)$ in (8.9.2) and the C in Fig. 8.9.1, we have

$$\begin{aligned}
 \oint_C f(z) dz &= \frac{4\pi}{b} \tan^{-1}\left(\frac{b}{a}\right) \left[\pi - i\ln\left(\sqrt{a^2 + b^2}\right) \right] \\
 (8.9.3) \qquad &= \int_{C_1} + \int_{C_2} + \int_{C_3} + \int_{C_4}.
 \end{aligned}$$

Based on our earlier experiences, we expect our final result is going to come from the C_1 and C_3 integrals because, as we let ρ , ϵ , and R go to their limiting values (of 0, 0, and ∞ , respectively), we expect the C_2 and C_4 integrals will each vanish. To see that this is, indeed, the case, let's do the C_2 and C_4 integrals first. For the C_2 integral we have

$$\int_{C_2} = \int_{\epsilon}^{2\pi-\epsilon} \left[\frac{\{\ln(\text{Re}^{i\theta})\}^2}{(\text{Re}^{i\theta} + a)^2 + b^2} \right] [i\text{Re}^{i\theta}] d\theta.$$

Now, as $R \rightarrow \infty$ consider the expression in the left-most square-brackets in the integrand. The numerator blows-up like $\ln^2(R)$ for any given θ in the integration interval, while the denominator blows-up like R^2 . That is, the left-most square-brackets behave like $\frac{\ln^2(R)}{R^2}$. The expression in the right-most square-brackets blows-up like R . Thus, the integrand behaves like

$$\frac{\ln^2(R)}{R^2} R = \frac{\ln^2(R)}{R}$$

and so the C_2 integral behaves like

$$2\pi \frac{\ln^2(R)}{R}$$

as $R \rightarrow \infty$. Now

$$\lim_{R \rightarrow \infty} 2\pi \frac{\ln^2(R)}{R} = \frac{\infty}{\infty}$$

which is, of course, indeterminate, and so let's use L'Hospital's rule:

$$\begin{aligned}
 \lim_{R \rightarrow \infty} 2\pi \frac{\ln^2(R)}{R} &= \lim_{R \rightarrow \infty} 2\pi \frac{\frac{d}{dR} \ln^2(R)}{\frac{d}{dR} R} \\
 &= 2\pi \lim_{R \rightarrow \infty} 2\ln(R) \frac{1}{R} = 4\pi \lim_{R \rightarrow \infty} \frac{\ln(R)}{R} = 0.
 \end{aligned}$$

So, our expectation of the vanishing of the C_2 integral is justified. Turning next to the C_4 integral, we have

$$\int_{C_4} = \int_{2\pi-\varepsilon}^{\varepsilon} \left[\frac{\{\ln(\rho e^{i\theta})\}^2}{(\rho e^{i\theta} + a)^2 + b^2} \right] [i\rho e^{i\theta}] d\theta.$$

As $\rho \rightarrow 0$ the expression in the left-most square-brackets in the integrand behaves like $\frac{\ln^2(\rho)}{a^2+b^2}$ while the expression in the right-most square-brackets behaves like ρ . So, the C_4 integral behaves like

$$2\pi \frac{\ln^2(\rho)}{a^2 + b^2} \rho$$

as $\rho \rightarrow 0$. Now,

$$\lim_{\rho \rightarrow 0} 2\pi \frac{\ln^2(\rho)}{a^2 + b^2} \rho = \frac{2\pi}{a^2 + b^2} \lim_{\rho \rightarrow 0} \rho \ln^2(\rho).$$

Define $u = \frac{1}{\rho}$. Then, as $\rho \rightarrow 0$ we have $u \rightarrow \infty$ and so

$$\lim_{\rho \rightarrow 0} \rho \ln^2(\rho) = \lim_{u \rightarrow \infty} \frac{1}{u} \ln^2\left(\frac{1}{u}\right) = \lim_{u \rightarrow \infty} \frac{\ln^2(u)}{u},$$

which we've just shown (in the C_2 integral analysis) goes to zero. So, our expectation of the vanishing of the C_4 integral is also justified.

Turning our attention at last to the C_1 and C_3 integrals, we have

$$\begin{aligned} \int_{C_1} + \int_{C_3} &= \int_{\rho}^R \frac{\{\ln(re^{i\varepsilon})\}^2}{(re^{i\varepsilon} + a)^2 + b^2} e^{i\varepsilon} dr + \int_R^{\rho} \frac{\{\ln(re^{i(2\pi-\varepsilon)})\}^2}{(re^{i(2\pi-\varepsilon)} + a)^2 + b^2} e^{i(2\pi-\varepsilon)} dr \\ &= \int_{\rho}^R \frac{\{\ln(r) + i\varepsilon\}^2}{(re^{i\varepsilon} + a)^2 + b^2} e^{i\varepsilon} dr - \int_{\rho}^R \frac{\{\ln(r) + i(2\pi - \varepsilon)\}^2}{(re^{i(2\pi-\varepsilon)} + a)^2 + b^2} e^{i(2\pi-\varepsilon)} dr \end{aligned}$$

or, as $\rho \rightarrow 0$, $R \rightarrow \infty$, and $\varepsilon \rightarrow 0$,

$$\begin{aligned} \int_{C_1} + \int_{C_3} &= \int_0^{\infty} \frac{\ln^2(r)}{(r+a)^2 + b^2} dr - \int_0^{\infty} \frac{\{\ln(r) + i2\pi\}^2}{(re^{i2\pi} + a)^2 + b^2} e^{i2\pi} dr \\ &= \int_0^{\infty} \frac{\ln^2(r) - \{\ln(r) + i2\pi\}^2}{(r+a)^2 + b^2} dr = \int_0^{\infty} \frac{-i4\pi\ln(r) + 4\pi^2}{(r+a)^2 + b^2} dr. \end{aligned}$$

(Notice, carefully, how the $\ln^2(r)$ terms cancel in these last calculations, leaving just $\ln(r)$ in the final expression.) Inserting these results into (8.9.3), we have

$$4\pi^2 \int_0^\infty \frac{dr}{(r+a)^2 + b^2} - i4\pi \int_0^\infty \frac{\ln(r)}{(r+a)^2 + b^2} dr$$

$$= \frac{4\pi^2}{b} \tan^{-1}\left(\frac{b}{a}\right) - i \frac{4\pi}{b} \tan^{-1}\left(\frac{b}{a}\right) \ln(\sqrt{a^2 + b^2}).$$

Equating real parts, we get

$$\int_0^\infty \frac{dx}{(x+a)^2 + b^2} = \frac{1}{b} \tan^{-1}\left(\frac{b}{a}\right)$$

which shouldn't really be a surprise. Equating imaginary parts is what gives us our prize:

$$(8.9.4) \quad \int_0^\infty \frac{\ln(x)}{(x+a)^2 + b^2} dx = \frac{1}{b} \tan^{-1}\left(\frac{b}{a}\right) \ln(\sqrt{a^2 + b^2}).$$

This reduces to our earlier results for particular values of a and b. To see (8.9.4) in action, if both a and b equal 1 (for example) then

$$\int_0^\infty \frac{\ln(x)}{(x+1)^2 + 1} dx = \frac{\pi}{4} \ln(\sqrt{2}) = 0.272198 \dots$$

and MATLAB agrees, as `quad(@(x)log(x)./(x+1).^2 + 1),0,1e5) = 0.27206...`

8.10 Challenge Problems

(C8.1): Suppose $f(z)$ is analytic everywhere in some region \mathbf{R} in the complex plane, with an m -th order zero at $z = z_0$. That is, $f(z) = g(z)(z - z_0)^m$, where $g(z)$ is analytic everywhere in \mathbf{R} . Let C be any simple, closed CCW contour in \mathbf{R} that encircles z_0 . Explain why

$$\frac{1}{2\pi i} \oint_C \frac{f'(z)}{f(z)} dz = m.$$

(C8.2): Back in Challenge Problem C3.9 I asked you to accept that $\int_0^\infty \frac{\sin(mx)}{x(x^2 + a^2)} dx = \frac{\pi}{2} \left(\frac{1 - e^{-am}}{a^2}\right)$ for $a > 0, m > 0$. Here you are to derive this result using contour integration. Hint: Notice that since the integrand is even, $\int_0^\infty = \frac{1}{2} \int_{-\infty}^\infty$. Use $f(z) = \frac{e^{imz}}{z(z^2 + a^2)}$, notice where the singularities are (this should suggest to you the appropriate contour to integrate around) and then, at some point, think about taking an imaginary part.

(C8.3): Derive the following integration formulas:

- (a) $\int_0^{2\pi} \frac{d\theta}{1 - 2a \cos(\theta) + a^2} = \frac{2\pi}{1-a^2}, 0 < a < 1;$
- (b) $\int_{-\infty}^{\infty} \frac{\cos(x)}{(x+a)^2 + b^2} dx = \frac{\pi}{b} e^{-b} \cos(a)$ and $\int_{-\infty}^{\infty} \frac{\sin(x)}{(x+a)^2 + b^2} dx = -\frac{\pi}{b} e^{-b} \sin(a),$
 $a > 0, b > 0;$
- (c) $\int_{-\infty}^{\infty} \frac{\cos(x)}{(x^2 + a^2)(x^2 + b^2)} dx = \frac{\pi}{a^2 - b^2} \left(\frac{e^{-b}}{b} - \frac{e^{-a}}{a} \right), a > b > 0;$
- (d) $\int_{-\infty}^{\infty} \frac{\cos(ax)}{(x^2 + b^2)^2} dx = \frac{\pi}{4b^3} (1 + ab)e^{-ab}, a > 0, b > 0.$

In (a), use the approach of Sect. 8.3 to convert the integral into a contour integration around the unit circle. In (b), (c), and (d), use the contour in Fig. 8.7.1.

(C8.4): Using the contour in Fig. 8.9.1, show that $\int_0^{\infty} \frac{x^k}{(x^2 + 1)^2} dx = \frac{\pi(1-k)}{4 \cos(\frac{k\pi}{2})}, -1 < k < 3.$ Before doing any calculations, explain the limits on k . Hint: Use $f(z) = \frac{z^k}{(z^2+1)^2}$, notice that the singularities at $z = \pm i$ are both *second-order*, and write $z^k = e^{\ln(z^k)} = e^{k \ln(z)}$.

(C8.5): Show that $\int_{-\infty}^{\infty} \frac{\cos(mx)}{ax^2 + bc + c} dx = -2\pi \frac{\cos(\frac{mb}{2a}) \sin\left(\frac{m\sqrt{b^2-4ac}}{2a}\right)}{\sqrt{b^2-4ac}}$ when $b^2 \geq 4ac$. Notice that this result contains (8.6.5) as the special case of $m = 0$.

(C8.6): Show that $\int_0^{\infty} \frac{x^p}{(x+1)(x+2)} dx = (2^p - 1) \frac{\pi}{\sin(p\pi)}, -1 < p < 1.$ For $p = \frac{1}{2}$ this is $(\sqrt{2} - 1)\pi = 1.30129\dots$, and MATLAB agrees as `quad(@(x)sqrt(x))/(x+1).* (x+2),0,1e7) = 1.300\dots` Use the contour in Fig. 8.9.1.

(C8.7): In his excellent 1935 book *An Introduction to the Theory of Functions of a Complex Variable*, Edward Copson (1901-1980), who was professor of mathematics at the University of St. Andrews in Scotland, wrote “A definite integral which can be evaluated by Cauchy’s method of residues can always be evaluated by other means, though generally not so simply.” Here’s an example of what Copson meant, an integral attributed to the great Cauchy himself. It is easily done with contour integration, but would (I think) otherwise be pretty darn tough: show that $\int_0^{\infty} \frac{e^{\cos(x)} \sin\{\sin(x)\}}{x} dx = \frac{\pi}{2}(e - 1).$ MATLAB agrees with Cauchy, as this is $2.69907\dots$ and `quad(@(x)exp(cos(x)).*sin(sin(x))./x,0,1000) = 2.6978\dots`. Hint: Look back at how we derived (8.6.4)—in particular the contour in Fig. 8.6.1—and try to construct the proper $f(z)$ to integrate on that contour.

(C8.8): Here's an example of an integral that Copson himself assigned as an end-of-chapter problem to be done by contour integration and residues, but which is actually *easier* to do by freshman calculus: show that $\int_{-\infty}^{\infty} \frac{x^2}{(x^2 + a^2)^3} dx = \frac{\pi}{8a^3}$, $a > 0$. The two singularities in the integrand are each third-order and, while not a really terribly difficult computation (you should do it), here's a simpler and more general approach. You are to fill-in the missing details.

(a) Start with $\int_{-\infty}^{\infty} \frac{x^2}{(x^2 + a^2)(x^2 + b^2)} dx$, with $a \neq b$, make a partial fraction expansion, and do the resulting two easy integrals; (b) let $b \rightarrow a$ and so arrive at the value for $\int_{-\infty}^{\infty} \frac{x^2}{(x^2 + a^2)^2} dx$; (c) finally, use Feynman's favorite trick of differentiating an integral to get Copson's answer. Notice that you can now continue to differentiate *endlessly* to calculate $\int_{-\infty}^{\infty} \frac{x^2}{(x^2 + a^2)^n} dx$ for any $n > 3$ you wish.

Chapter 9

Epilogue

9.1 Riemann, Prime Numbers, and the Zeta Function

Starting with the frontispiece photo, this entire book, devoted to doing Riemannian definite integrals, has been a continuing ode to the genius of Bernhard Riemann. He died far too young, of tuberculosis, at age 39. And yet, though he was just reaching the full power of his intellect when he left this world, you can appreciate from the numerous times his name has appeared here how massively productive he was. He left us with many brilliant results, but he also left the world of mathematics its greatest *unsolved* problem, too, a problem that has often been described as the Holy Grail of mathematics. It's a problem *so* difficult, and *so* mysterious, that many mathematicians have seriously entertained the possibility that it *can't* be solved. And it is replete with interesting integrals!

This is the famous (at least in the world of mathematics) *Riemann Hypothesis* (RH), a conjecture which has so far soundly defeated, since Riemann formulated it in 1859, all the efforts of the greatest mathematical minds in the world (including his) to either prove or disprove it. Forty years after its conjecture, and with no solution in sight, the great German mathematician David Hilbert (we discussed his transform back in Chap. 7) decided to add some incentive. In 1900, at the Second International Congress of Mathematicians in Paris, he gave a famous talk titled "Mathematical Problems." During that talk he discussed a number of problems that he felt represented potentially fruitful directions for future research. The problems included, for example, the transcendental nature (or not) of $2^{\sqrt{2}}$, Fermat's Last Theorem (FLT), and the RH, in *decreasing* order of difficulty (in Hilbert's estimation).

All of Hilbert's problems became famous overnight, and to solve one brought instant celebrity among fellow mathematicians. Hilbert's own estimate of the difficulty of his problems was slightly askew, however, as the $2^{\sqrt{2}}$ issue was settled by 1930 (it *is* transcendental!), and FLT was laid to rest by the mid-1990s. The RH, however, the presumed 'easiest' of the three, has proven itself to be the toughest.

Hilbert eventually came to appreciate this. A well-known story in mathematical lore says he once remarked that, if he awoke after sleeping for 500 years, the first question he would ask is ‘Has the Riemann hypothesis been proven?’ The answer is currently still *no* and so, a century after Hilbert’s famous talk in Paris, the Clay Mathematics Institute in Cambridge, MA proposed in 2000 seven so-called “Millennium Prize Problems,” with each to be worth a one million dollar award to its solver. The RH is one of those elite problems and, as I write in 2014, the one million dollars for its solution remains unclaimed.

The RH is important for more than just being famous for being unsolved; there are numerous theorems in mathematics, all of which mathematicians believe to be correct, that are based on the assumed truth of the RH. If the RH is someday shown to be false, the existing proofs of all those theorems collapse and they will have to be revisited and new proofs (hopefully) found. To deeply discuss the RH is far beyond the level of this book, but since it involves complex numbers and functions, bears Riemann’s name, abounds in integrals, and is *unsolved*, it nonetheless seems a fitting topic with which to end this book.

Our story begins, as do so many of the fascinating tales in mathematics, with an amazing result from Euler. In 1748 he showed that if s is real and greater than 1, and if we write the zeta function (see Sect. 5.3 again)

$$(9.1.1) \quad \zeta(s) = \sum_{n=1}^{\infty} \frac{1}{n^s} = 1 + \frac{1}{2^s} + \frac{1}{3^s} + \cdots,$$

then

$$(9.1.2) \quad \zeta(s) = \frac{1}{\prod_{j=1}^{\infty} \left\{ 1 - \frac{1}{p_j^s} \right\}},$$

where p_j is the j th prime ($p_1 = 2$, $p_2 = 3$, $p_3 = 5$, $p_4 = 7$, and so on). That is, Euler showed that there is an intimate, *surprising* connection between $\zeta(s)$, a continuous function of s , and the primes which as integers are the very signature of discontinuity.¹

Riemann was led to the zeta function because of Euler’s connection of it to the primes (he called it his “point of departure”), with the thought that studying $\zeta(s)$ would aid in his quest for a formula for $\pi(x)$, defined to be the number of primes not greater than x . $\pi(x)$ is a measure of how the primes are distributed among the integers. It should be obvious that $\pi(\frac{1}{2}) = 0$, that $\pi(2) = 1$, and that $\pi(6) = 3$, but perhaps it is not quite so obvious that $\pi(10^{18}) = 24,739,954,287,740,860$.

¹To derive (9.1.2) is not difficult, just ‘devilishly’ clever; you can find a proof in any good book on number theory. Or see my book, *An Imaginary Tale: The Story of $\sqrt{-1}$* , Princeton 2010, pp. 150–152.

When Riemann started his studies of the distribution of the primes, one known approximation to $\pi(x)$ is the so-called *logarithmic integral*, written as

$$(9.1.3) \quad \text{li}(x) = \int_2^x \frac{du}{\ln(u)},$$

which is actually a pretty good approximation.² For example,

$$\begin{aligned} \frac{\pi(1,000)}{\text{li}(1,000)} &= \frac{168}{178} = 0.94\dots, \\ \frac{\pi(100,000)}{\text{li}(100,000)} &= \frac{9,592}{9,630} = 0.99\dots, \\ \frac{\pi(100,000,000)}{\text{li}(100,000,000)} &= \frac{5,761,455}{5,762,209} = 0.999\dots, \\ \frac{\pi(1,000,000,000)}{\text{li}(1,000,000,000)} &= \frac{50,847,478}{50,849,235} = 0.9999\dots \end{aligned}$$

In an 1849 letter the great German mathematician C. F. Gauss, who signed-off on Riemann’s 1851 doctoral dissertation with a glowing endorsement, claimed to have known of this behavior of $\text{li}(x)$ since 1791 or 1792, when he was just 14. With what is known of Gauss’ genius, there is no doubt that is true!

Numerical calculations like those above immediately suggest the conjecture

$$\lim_{x \rightarrow \infty} \frac{\pi(x)}{\text{li}(x)} = 1,$$

which is a statement of what mathematicians call the *prime number theorem*. Although highly suggestive, such numerical calculations of course *prove* nothing, and in fact it wasn’t until 1896 that mathematical proofs of the prime number theorem were simultaneously and independently discovered by Charles-Joseph de la Vallée-Poussin (1866–1962) in Belgium and Jacques Hadamard (1865–1963) in France. Each man used very advanced techniques from complex function theory, applied to the zeta function. It was a similar quest (using the zeta function as well) that Riemann was on in 1859, years before either Vallée-Poussin or Hadamard had been born.

Riemann’s fascination with the distribution of the primes is easy to understand. The primes have numerous properties which, while easy to state, are almost paradoxical.

² A slight variation is the modern $\text{li}(x) = \int_2^x \frac{du}{\ln(u)} + 1.045\dots$ which, for $x = 1,000$ (for example), MATLAB computes `quad(@(x)1./log(x),2,1000) + 1.045 = 177.6`.

For example, it has been known since Euclid that the primes are infinite in number and yet, if one looks at a list of consecutive primes from 2 on up to very high values, it is evident that they become, *on average*, ever less frequent. I emphasize the ‘on average’ because, every now and then, one does encounter *consecutive* odd integers (every prime but 2 is, of course, odd) that are both primes. Such a pair forms a *twin prime*. It is not known if the twin primes are infinite in number. Mathematicians believe they are, but can’t *prove* it.

If one forms the sum of the reciprocals of all the positive integers then we have the harmonic series which, of course, diverges. That is, $\zeta(1) = \infty$. If you then go through and eliminate all terms in that sum except for the reciprocals of the primes, the sum *still* diverges, a result that almost always surprises when first seen demonstrated. (This also proves, in a way different from Euclid’s proof, that the primes are infinite in number.) In 1919 the Norwegian mathematician Viggo Brun (1885–1975) showed that if one further eliminates from the sum all terms but the reciprocals of the twin primes, *then* the sum is finite. Indeed, the sum isn’t very large at all. The value, called *Brun’s constant*, is

$$\left(\frac{1}{3} + \frac{1}{5}\right) + \left(\frac{1}{5} + \frac{1}{7}\right) + \left(\frac{1}{11} + \frac{1}{13}\right) + \left(\frac{1}{17} + \frac{1}{19}\right) + \dots \approx 1.90216\dots$$

The finite value of Brun’s constant does *not* preclude the twin primes from being infinite in number, however, and so that question remains open.

Here’s another example of the curious nature of the distribution of the primes: for any $a > 1$ there is always at least one prime between a and $2a$. And yet, for any $a > 1$ there is also always a stretch of at least $a - 1$ consecutive integers that is *free* of primes! This is true, no matter how large a may be. The first statement is due to the French mathematician Joseph Bertrand (1822–1900), whose conjecture of it in 1845 was proven (it’s *not* an ‘easy’ proof) by the Russian mathematician P. L. Chebyshev (1821–1894) in 1850. For the second statement, simply notice that every number in the consecutive sequence $a! + 2, a! + 3, a! + 4, \dots, a! + a$ is divisible and so none are prime.

In 1837 a really remarkable result was established by Dirichlet (the same Dirichlet we first met in Chap. 1): if a and b are relatively prime positive integers (that means their greatest common factor is 1) then the arithmetic progression $a, a + b, a + 2b, a + 3b, \dots$ contains an infinite number of primes. This easy-to-state theorem immediately gives us the not very obvious conclusion that there are infinitely many primes ending with 999 (as do 1,999, 100,999, and 1,000,999). That’s because *all* the numbers in the progression (not *all* of which are prime) formed from $a = 999$ and $b = 1,000$ (which have only the factor 1 in common) end in 999.

With examples like these in mind, it should now be easy to understand what the mathematician Pál Erdős (1913–1996) meant when he famously (at least in the world of mathematics) declared “It will be another million years, at least, before we

understand the primes.” With properties like the ones above, how could *any* mathematician, including Riemann, *not* be fascinated by the primes?³

To start his work, Riemann immediately tackled a technical issue concerning the very definition of $\zeta(s)$ as given in (9.1.1), namely, the sum converges only if $s > 1$. More generally, if we extend the s in Euler’s definition of the zeta function from being real to being complex (that is, $s = \sigma + i t$) then $\zeta(s)$ as given in (9.1.1) makes sense only if $\sigma > 1$. Riemann, however, wanted to be able to treat $\zeta(s)$ as defined *everywhere* in the complex plane or, as he put it, he wanted a formula for $\zeta(s)$ “which remains valid for all s .” Such a formula would give the same values for $\zeta(s)$ as does (9.1.1) when $\sigma > 1$, but would also give sensible values for $\zeta(s)$ even when $\sigma < 1$. Riemann was fabulously successful in discovering how to do that.

He did it by discovering what is called the *functional equation* of the zeta function and, just to anticipate things a bit, here it is (we’ll derive it in the next section):

$$(9.1.4) \quad \zeta(s) = 2(2\pi)^{s-1} \sin\left(\frac{\pi s}{2}\right) \Gamma(1-s) \zeta(1-s).$$

Riemann’s functional equation is considered to be one of the gems of mathematics. Here’s how it works. What we have is

$$\zeta(s) = F(s)\zeta(1-s), \quad F(s) = 2(2\pi)^{s-1} \sin\left(\frac{\pi s}{2}\right) \Gamma(1-s).$$

$F(s)$ is a well-defined function for all σ . So, if we have an s with $\sigma > 1$ we’ll use (9.1.1) to compute $\zeta(s)$, but if $\sigma < 0$ we’ll use (9.1.4) (along with (9.1.1) to compute $\zeta(1-s)$ because the real part of $1-s$ is > 1 if $\sigma < 0$).

There is, of course, the remaining question of computing $\zeta(s)$ for the case of $0 < \sigma < 1$, where s is in the so-called *critical strip* (a vertical band with width 1 extending from $-i\infty$ to $+i\infty$). The functional equation doesn’t help us now, because if s is in the critical strip then so is $1-s$. This is actually a problem we’ve already solved, however, as you can see by looking back at (5.3.7), where we showed

$$\sum_{k=1}^{\infty} \frac{(-1)^{k-1}}{k^s} = [1 - 2^{1-s}] \zeta(s).$$

So, for example, right in the middle of the critical strip, on the real axis, we have $s = \frac{1}{2}$ and so

³The English mathematician A. E. Ingham (1900–1967) opens his book *The Distribution of the Primes* (Cambridge University Press 1932) with the comment “A problem *at the very threshold of mathematics* [my emphasis] is the question of the distribution of the primes among the integers.”

$$\sum_{k=1}^{\infty} \frac{(-1)^{k-1}}{k^{1/2}} = \left[1 - 2^{1-(\frac{1}{2})}\right] \zeta\left(\frac{1}{2}\right) = \left[\frac{1}{\sqrt{1}} - \frac{1}{\sqrt{2}} + \frac{1}{\sqrt{3}} - \frac{1}{\sqrt{4}} - \dots\right].$$

Thus,

$$\zeta\left(\frac{1}{2}\right) = \frac{1}{1 - \sqrt{2}} \left[1 - \frac{1}{\sqrt{2}} + \frac{1}{\sqrt{3}} - \frac{1}{\sqrt{4}} - \dots\right].$$

If we keep the first one million terms—a well-known theorem in freshman calculus tells us that the partial sums of an alternating series (with monotonically decreasing terms) converge, and the maximum error we make is less than the first term we neglect and so our error *for the sum* should be less than 10^{-3} —we get

$$\zeta\left(\frac{1}{2}\right) \approx -1.459147\dots$$

The actual value is known to be

$$\zeta\left(\frac{1}{2}\right) = -1.460354\dots$$

This is obviously *not* a very efficient way (a *million* terms!?) to calculate $\zeta\left(\frac{1}{2}\right)$, but the point here is that (5.3.7) is correct.

For Euler's case of s purely real, the plots in Fig. 9.1.1 show the general behavior of $\zeta(s)$. For $s > 1$, $\zeta(s)$ smoothly decreases from $+\infty$ towards 1 as s increases from 1, while for $s < 0$ $\zeta(s)$ oscillates, eventually heading off to $-\infty$ as s approaches 1 from below. Figure 9.1.1 indicates that $\zeta(0) = -0.5$, and in the next section I'll show you how to *prove* that $\zeta(0) = -\frac{1}{2}$ using the functional equation. Notice, too, that Fig. 9.1.1 hints at $\zeta(s) = 0$ for s a *negative*, even integer, another conclusion supported by the functional equation.

To make that last observation crystal-clear, let's write $s = -2n$, where $n = 0, 1, 2, 3, \dots$. Then, (9.1.4) becomes

$$\zeta(-2n) = -2^{-2n} \pi^{-(2n+1)} \Gamma(1+2n) \sin(n\pi) \zeta(1+2n) = 0$$

because all of the factors on the right of the first equality are finite, for all n , including $\sin(n\pi)$ which is, of course, zero for all integer n . We must exclude the case of $n = 0$, however, because then $\zeta(1+2n) = \zeta(1) = \infty$, and this infinity is sufficient to overwhelm the zero of $\sin(0)$. We know this because, as stated above, and as will be shown in the next section, $\zeta(0) \neq 0$ but rather $\zeta(0) = -\frac{1}{2}$. When a value of s gives $\zeta(s) = 0$ then we call that value of s a *zero of the zeta function*. Thus, all the even, negative integers are zeros of $\zeta(s)$, and because they are so easy to 'compute' they are called the *trivial zeros* of $\zeta(s)$. There are other zeros

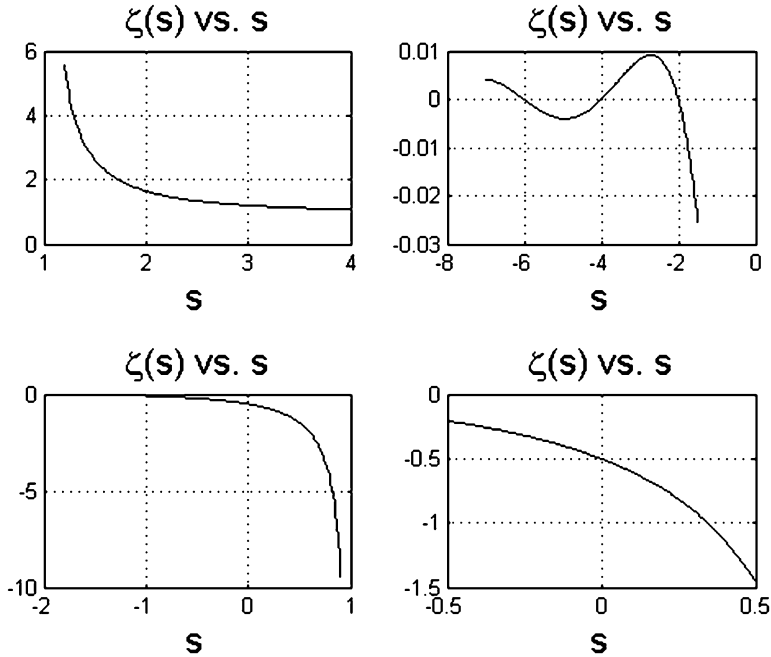

Fig. 9.1.1 The zeta function for real s

of $\zeta(s)$, however, which are not so easy to compute,⁴ and where they are in the complex plane is what the RH is all about.

Here is what Riemann correctly believed about the non-trivial zeros (even if he couldn't prove all the following in 1859):

1. they are infinite in number;
2. all are complex (of the form $\sigma + i t$, $t \neq 0$);
3. all are in the critical strip ($0 < \sigma < 1$);
4. they occur in pairs, symmetrically displaced around the vertical $\sigma = \frac{1}{2}$ line (called the *critical line*), that is, if $\frac{1}{2} - \varepsilon + i t$ is a zero, then so is $\frac{1}{2} + \varepsilon + i t$ for some ε in the interval $0 \leq \varepsilon < \frac{1}{2}$;
5. they are symmetrical about the real axis ($t = 0$), that is, if $\sigma + i t$ is a zero then so is $\sigma - i t$ (the zeros appear as conjugate pairs).

⁴The methods used to compute the non-trivial zeros are far from 'obvious' and beyond the level of this book. If you are interested in looking further into how such computations are done, I can recommend the following four books: (1) H. M. Edwards, *Riemann's Zeta Function*, Academic Press 1974; (2) E. C. Titchmarsh, *The Theory of the Riemann Zeta-Function* (2nd edition, revised by D. R. Heath-Brown), Oxford Science Publications 1986; (3) Aleksandar Ivić, *The Riemann Zeta-Function*, John Wiley & Sons 1985; and (4) *The Riemann Hypothesis* (Peter Borwein et al., editors), Springer 2008.

The RH is now easy to state: $\varepsilon = 0$. That is, *all* of the complex zeros are *on* the critical line and so have real part $\frac{1}{2}$. More precisely, Riemann conjectured “it is *very probable* [my emphasis] that all the [complex zeros are on the critical line].” Since 1859, all who have tried to prove the RH have failed, including Riemann, who wrote “Certainly one would wish [for a proof]; I have meanwhile temporarily put aside the search for [a proof] after some fleeting futile attempts, as it appears unnecessary for [finding a formula for $\pi(x)$].”

There *have* been some impressive partial results since 1859. In 1914 it was shown by the Dane Harald Bohr (1887–1951) and the German Edmund Landau (1877–1938) that all but an infinitesimal proportion of the complex zeros are arbitrarily close to the critical line (that is, they are in the ‘arbitrarily thin’ vertical strip $\frac{1}{2} - \varepsilon < \sigma < \frac{1}{2} + \varepsilon$ for any $\varepsilon > 0$). That same year Hardy proved that an infinity of complex zeros are *on* the critical line (this does *not* prove that *all* of the complex zeros are on the critical line). In 1942 it was shown by the Norwegian Atle Selberg (1917–2007) that an (unspecified) fraction of the zeros are on the critical line. In 1974 Selberg’s fraction was shown to be greater than $\frac{1}{3}$ by the American Norman Levinson (1912–1975), and then in 1989 the American J. B. Conrey showed the fraction is greater than $\frac{2}{5}$.

There is also what appears, *at first glance*, to be quite substantial computational support for the truth of the RH. Ever since Riemann himself computed the locations of the first three complex zeros,⁵ the last few decades have seen that accomplishment

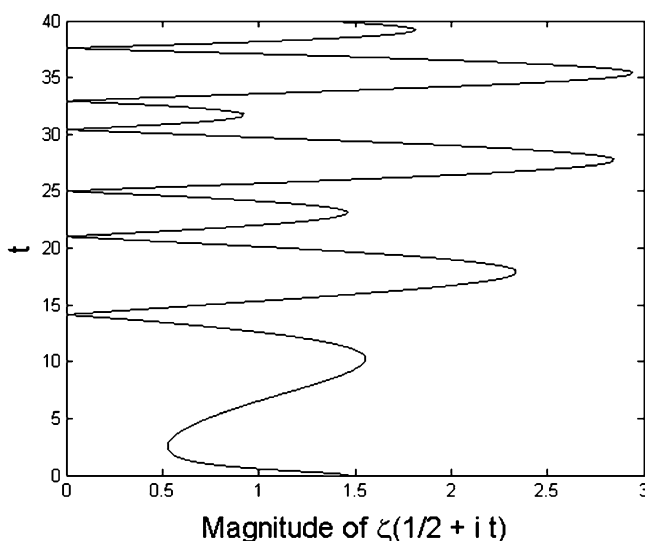

Fig. 9.1.2 The first six non-trivial zeros of $\zeta(\frac{1}{2} + it)$

⁵ Because of the symmetry properties of the complex zero locations, one only has to consider the case of $t > 0$. The value of t for a zero is called the *height* of the zero, and the zeros are ordered by increasing t (the first six zeros are shown in Fig. 9.1.2, where a zero occurs each place $|\xi(\frac{1}{2} + it)|$)

vastly surpassed. In 2004, the first 10^{13} (yes, ten *trillion!*) zeros were shown to all be on the critical line. Since even a single zero off the critical line is all that is needed to disprove the RH, this looks pretty impressive—but mathematicians are, frankly, *not* impressed. As Ivić wrote in his book (see note 4), “No doubt the numerical data will continue to accrue, but number theory is unfortunately one of the branches of mathematics where numerical evidence does not count for much.”

There are, in fact, lots of historical examples in mathematics where initial, massive computational ‘evidence’ has prompted conjectures which later proved to be false. A particularly famous example involves $\pi(x)$ and $\text{li}(x)$. For all values of x for which $\pi(x)$ and $\text{li}(x)$ are known, $\pi(x) < \text{li}(x)$. Further, the difference between the two increases as x increases and, for ‘large’ x the difference is significant; for $x = 10^{18}$, for example, $d(x) = \text{li}(x) - \pi(x) \approx 22,000,000$. Based on this impressive numerical ‘evidence’ it was commonly believed for a long time that $d(x) > 0$ for all x . Gauss believed this (as did Riemann) all his life. *But it’s not true.*

In 1912, Hardy’s friend and collaborator J. E. Littlewood (1885–1977) proved that there is some x for which $d(x) < 0$. Two years later he extended his proof to show that as x continues to increase the sign of $d(x)$ flips back-and-forth endlessly. The value of x at which the first change in sign of $d(x)$ occurs is not known, only that it is *very* big. In 1933 the South African Stanley Skewes (1899–1988) derived a stupendously huge upper-bound on the value of that first x : $e^{e^{79}} \approx 10^{10^{34}}$. This has become famous (at least in the world of mathematics) as the *first Skewes number*. In his derivation Skewes assumed the truth of the RH, but in 1955 he dropped that assumption to calculate a new upper-bound for the first x at which $d(x)$ changes sign: this is the *second Skewes number* equal to $10^{10^{1,000}}$ and it is, of course, *much* larger than the first one. In 2000 the upper-bound was dropped to ‘just’ 1.39×10^{316} . All of these numbers are far beyond anything that can be numerically studied on a computer, and the number of complex zeros that have been found on the critical line is minuscule in comparison. It is entirely possible that the first complex zero off the critical line (thus disproving the RH) may not occur until a vastly greater height is reached than has been examined so far.

Some mathematicians have been markedly less than enthusiastic about the RH. Littlewood, in particular, was quite blunt, writing “I believe [the RH] to be false. There is no evidence for it . . . One should not believe things for which there is no evidence . . . I have discussed the matter with several people who know the problem in relation to electronic calculation; they are all agreed that the chance of finding a zero off the line in a lifetime’s calculation is millions to one against it. It looks then as if we may never know.”⁶ A slightly more muted (but perhaps not by much) position is that of the American mathematician H. M. Edwards (born 1936), who wrote in his classic book on the zeta function (see note 4) “Riemann based his hypothesis on no insights . . . which are not available to us today . . . and

touches the vertical t-axis). The heights of the first six zeros are 14.134725, 21.022040, 25.010856, 30.424878, 32.935057, and 37.586176. In addition to the first 10^{13} zeros, billions more zeros at heights as large as 10^{24} have also all been confirmed to be on the critical line.

⁶From Littlewood’s essay “The Riemann Hypothesis,” in *The Scientist Speculates: An Anthology of Partly-Baked Ideas* (I. J. Good, editor), Basic Books 1962.

that, on the contrary, had he known some of the facts which have since been discovered, he might well have been led to reconsider ... unless some basic cause is operating which has eluded mathematicians for 110 years [155 years now, as I write in 2014], occasional [complex zeros] off the [critical] line are altogether possible ... Riemann's insight was stupendous, but it was not supernatural, and what seemed 'probable' to him in 1859 might seem less so today."

9.2 Deriving the Functional Equation for $\zeta(s)$

The derivation of the functional equation for $\zeta(s)$ that appears in Riemann's famous 1859 paper involves a contour integral in which a branch cut is involved. We've already been through an example of that, however, and so here I'll show you a different derivation (one also due to Riemann) that makes great use of results we've already derived in the book.

We start with the integral

$$\int_0^{\infty} x^{m-1} e^{-ax} dx, \quad m \geq 1, \quad a > 0,$$

and make the change of variable $u = ax$ (and so $dx = \frac{du}{a}$). Thus,

$$\int_0^{\infty} x^{m-1} e^{-ax} dx = \int_0^{\infty} \left(\frac{u}{a}\right)^{m-1} e^{-u} \frac{du}{a} = \frac{1}{a^m} \int_0^{\infty} u^{m-1} e^{-u} du.$$

The right-most integral is, from (4.1.1), $\Gamma(m)$, and so

$$(9.2.1) \quad \int_0^{\infty} x^{m-1} e^{-ax} dx = \frac{\Gamma(m)}{a^m}.$$

Now, if we let

$$m - 1 = \frac{1}{2}s - 1 \quad \left(m = \frac{1}{2}s\right)$$

and

$$a = n^2\pi,$$

then (9.2.1) becomes

$$(9.2.2) \quad \int_0^{\infty} x^{\frac{1}{2}s-1} e^{-n^2\pi x} dx = \frac{\Gamma(\frac{1}{2}s)}{(n^2\pi)^{\frac{1}{2}s}} = \frac{\Gamma(\frac{1}{2}s)}{\pi^{\frac{1}{2}s} n^s}.$$

Then, summing (9.2.2) over all positive integer n , we have

$$\sum_{n=1}^{\infty} \int_0^{\infty} x^{\frac{1}{2}s-1} e^{-n^2\pi x} dx = \sum_{n=1}^{\infty} \frac{\Gamma(\frac{1}{2}s)}{\pi^{\frac{1}{2}} n^s}$$

or, reversing the order of summation and integration on the left,

$$(9.2.3) \quad \int_0^{\infty} x^{\frac{1}{2}s-1} \sum_{n=1}^{\infty} e^{-n^2\pi x} dx = \pi^{-\frac{1}{2}s} \Gamma\left(\frac{1}{2}s\right) \sum_{n=1}^{\infty} \frac{1}{n^s} = \pi^{-\frac{1}{2}s} \Gamma\left(\frac{1}{2}s\right) \zeta(s).$$

At this point Riemann defined the function

$$(9.2.4) \quad \psi(x) = \sum_{n=1}^{\infty} e^{-n^2\pi x},$$

and then used the identity⁷

$$(9.2.5) \quad \sum_{n=-\infty}^{\infty} e^{-n^2\pi x} = \frac{1}{\sqrt{x}} \sum_{n=-\infty}^{\infty} e^{-n^2\pi/x}.$$

The left-hand side of (9.2.5) is (because $n^2 > 0$ for n negative *or* positive)

$$\begin{aligned} \sum_{n=-\infty}^{-1} e^{-n^2\pi x} + 1 + \sum_{n=1}^{\infty} e^{-n^2\pi x} &= \sum_{n=1}^{\infty} e^{-n^2\pi x} + 1 + \sum_{n=1}^{\infty} e^{-n^2\pi x} \\ &= 2\psi(x) + 1 \end{aligned}$$

The right-hand side of (9.2.5) is (for the same reason)

$$\frac{1}{\sqrt{x}} \sum_{n=-\infty}^{\infty} e^{-n^2\pi/x} = \frac{1}{\sqrt{x}} \left\{ 2\psi\left(\frac{1}{x}\right) + 1 \right\}.$$

Thus,

$$2\psi(x) + 1 = \frac{1}{\sqrt{x}} \left\{ 2\psi\left(\frac{1}{x}\right) + 1 \right\}$$

⁷In my book *Dr. Euler's Fabulous Formula*, Princeton 2011, pp. 246–253, you'll find a derivation of the identity $\sum_{k=-\infty}^{\infty} e^{-\alpha k^2} = \sqrt{\frac{\pi}{\alpha}} \sum_{n=-\infty}^{\infty} e^{-\pi^2 n^2/\alpha}$. If you write $\alpha = \pi x$ then (9.2.5) immediately results. The derivation in *Dr. Euler* combines Fourier theory with what mathematicians call *Poisson summation*, all of which might sound impressively exotic. In fact, it is all at the level of nothing more than the end of freshman calculus. If you can read this book then you can easily follow the derivation of (9.2.5) in *Dr. Euler*.

or, solving for $\psi(x)$,

$$(9.2.6) \quad \psi(x) = \frac{1}{\sqrt{x}}\psi\left(\frac{1}{x}\right) + \frac{1}{2\sqrt{x}} - \frac{1}{2} = \sum_{n=1}^{\infty} e^{-n^2\pi x}.$$

Now, putting (9.2.4) into (9.2.3) gives us

$$\pi^{-\frac{1}{2}}s\Gamma\left(\frac{1}{2}s\right)\zeta(s) = \int_0^{\infty} x^{\frac{1}{2}s-1}\psi(x)dx$$

or, breaking the integral into two parts,

$$(9.2.7) \quad \pi^{-\frac{1}{2}}s\Gamma\left(\frac{1}{2}s\right)\zeta(s) = \int_0^1 x^{\frac{1}{2}s-1}\psi(x)dx + \int_1^{\infty} x^{\frac{1}{2}s-1}\psi(x)dx.$$

Using (9.2.6) in the first integral on the right of (9.2.7), we have

$$\begin{aligned} \pi^{-\frac{1}{2}}s\Gamma\left(\frac{1}{2}s\right)\zeta(s) &= \int_0^1 x^{\frac{1}{2}s-1} \left\{ \frac{1}{\sqrt{x}}\psi\left(\frac{1}{x}\right) + \frac{1}{2\sqrt{x}} - \frac{1}{2} \right\} dx \\ &\quad + \int_1^{\infty} x^{\frac{1}{2}s-1} \psi(x) dx = \int_0^1 x^{\frac{1}{2}s-1} \left\{ \frac{1}{2\sqrt{x}} - \frac{1}{2} \right\} dx \\ &\quad + \int_0^1 x^{\frac{1}{2}s-\frac{3}{2}} \psi\left(\frac{1}{x}\right) dx + \int_1^{\infty} x^{\frac{1}{2}s-1} \psi(x) dx. \end{aligned}$$

The first integral on the right is easy to do (for $s > 1$):

$$\begin{aligned} \int_0^1 x^{\frac{1}{2}s-1} \left\{ \frac{1}{2\sqrt{x}} - \frac{1}{2} \right\} dx &= \frac{1}{2} \int_0^1 x^{\frac{1}{2}s-\frac{3}{2}} dx - \frac{1}{2} \int_0^1 x^{\frac{1}{2}s-1} dx \\ &= \frac{1}{2} \left(\frac{x^{\frac{1}{2}s-\frac{1}{2}}}{\frac{1}{2}s-\frac{1}{2}} \right) \Big|_0^1 - \frac{1}{2} \left(\frac{x^{\frac{1}{2}s}}{\frac{1}{2}s} \right) \Big|_0^1 \\ &= \frac{1}{2} \left(\frac{1}{\frac{1}{2}s-\frac{1}{2}} \right) - \frac{1}{2} \left(\frac{1}{\frac{1}{2}s} \right) = \frac{1}{s-1} - \frac{1}{s} = \frac{1}{s(s-1)}. \end{aligned}$$

Thus,

$$(9.2.8) \quad \pi^{-\frac{1}{2}s} \Gamma\left(\frac{1}{2}s\right) \zeta(s) = \frac{1}{s(s-1)} + \int_0^1 x^{\frac{1}{2}s-\frac{3}{2}} \psi\left(\frac{1}{x}\right) dx + \int_1^\infty x^{\frac{1}{2}s-1} \psi(x) dx.$$

Next, in the first integral on the right in (9.2.8) make the change of variable $u = \frac{1}{x}$ (and so $dx = -\frac{du}{u^2}$). Then,

$$\begin{aligned} \int_0^1 x^{\frac{1}{2}s-\frac{3}{2}} \psi\left(\frac{1}{x}\right) dx &= \int_\infty^1 \left(\frac{1}{u}\right)^{\frac{1}{2}s-\frac{3}{2}} \psi(u) \left\{-\frac{du}{u^2}\right\} = \int_1^\infty \frac{1}{u^{\frac{1}{2}s+\frac{1}{2}}} \psi(u) du \\ &= \int_1^\infty x^{-\frac{1}{2}s-\frac{1}{2}} \psi(x) dx \end{aligned}$$

and therefore (9.2.8) becomes

$$(9.2.9) \quad \pi^{-\frac{1}{2}s} \Gamma\left(\frac{1}{2}s\right) \zeta(s) = \frac{1}{s(s-1)} + \int_1^\infty \left\{x^{-\frac{1}{2}s-\frac{1}{2}} + x^{\frac{1}{2}s-1}\right\} \psi(x) dx.$$

Well!—you might exclaim at this point, as you look at the integral in (9.2.9)—*what do we do now?* You might even feel like repeating the words that Oliver Hardy often directed towards Stan Laurel, after the two old-time movie comedians had stumbled into one of their idiotic jams: “Look at what a fine mess you’ve gotten us into *this* time!”

In fact, however, we are not in a mess, and all we need do is notice, as did Riemann, that the right-hand side of (9.2.9) is *unchanged* if we replace every occurrence of s with $1-s$. Try it and see. But that means we can do the same thing on the left-hand side of (9.2.9) because, after all, (9.2.9) is an equality. That is, it must be true that

$$(9.2.10) \quad \pi^{-\frac{1}{2}s} \Gamma\left(\frac{1}{2}s\right) \zeta(s) = \pi^{-\frac{1}{2}(1-s)} \Gamma\left(\frac{1-s}{2}\right) \zeta(1-s).$$

We are now almost done, with just a few more ‘routine’ steps to go to get the form of the functional equation for $\zeta(s)$ that I gave you in (9.1.4).

Solving (9.2.10) for $\zeta(s)$, we have

$$(9.2.11) \quad \zeta(s) = \pi^{s-\frac{1}{2}} \frac{\Gamma\left(\frac{1-s}{2}\right)}{\Gamma\left(\frac{1}{2}s\right)} \zeta(1-s).$$

Now, recall (4.2.18), one of the forms of Legendre’s duplication formula:

$$z! \left(z - \frac{1}{2}\right)! = 2^{-2z} \pi^{\frac{1}{2}} (2z)!$$

or, expressed in gamma notation,

$$(9.2.12) \quad \Gamma(z+1)\Gamma\left(z+\frac{1}{2}\right) = 2^{-2z}\pi^{\frac{1}{2}}\Gamma(2z+1).$$

If we write $2z+1 = 1-s$ then $z = -\frac{s}{2}$ and (9.2.12) becomes

$$\Gamma\left(-\frac{s}{2}+1\right)\Gamma\left(-\frac{s}{2}+\frac{1}{2}\right) = 2^s\pi^{\frac{1}{2}}\Gamma(1-s) = \Gamma\left(1-\frac{s}{2}\right)\Gamma\left(\frac{1-s}{2}\right)$$

or,

$$(9.2.13) \quad \Gamma\left(\frac{1-s}{2}\right) = \frac{2^s\pi^{\frac{1}{2}}\Gamma(1-s)}{\Gamma\left(1-\frac{s}{2}\right)}.$$

From (4.2.16), the reflection formula for the gamma function,

$$\Gamma(m)\Gamma(1-m) = \frac{\pi}{\sin(m\pi)}$$

or, with $m = \frac{s}{2}$,

$$\Gamma\left(\frac{s}{2}\right)\Gamma\left(1-\frac{s}{2}\right) = \frac{\pi}{\sin\left(\frac{\pi s}{2}\right)}$$

and this says

$$(9.2.14) \quad \Gamma\left(1-\frac{s}{2}\right) = \frac{\pi}{\Gamma\left(\frac{s}{2}\right)\sin\left(\frac{\pi s}{2}\right)}.$$

So, putting (9.2.14) into (9.2.13),

$$\Gamma\left(\frac{1-s}{2}\right) = \frac{2^s\pi^{\frac{1}{2}}\Gamma(1-s)}{\frac{\pi}{\Gamma\left(\frac{s}{2}\right)\sin\left(\frac{\pi s}{2}\right)}} = 2^s\pi^{-\frac{1}{2}}\Gamma\left(\frac{s}{2}\right)\sin\left(\frac{\pi s}{2}\right)\Gamma(1-s)$$

or,

$$(9.2.15) \quad \frac{\Gamma\left(\frac{1-s}{2}\right)}{\Gamma\left(\frac{s}{2}\right)} = 2^s\pi^{-\frac{1}{2}}\sin\left(\frac{\pi s}{2}\right)\Gamma(1-s).$$

Inserting (9.2.15) into (9.2.11), we arrive at

$$\zeta(s) = \pi^{s-\frac{1}{2}} 2^s \pi^{-\frac{1}{2}} \sin\left(\frac{\pi s}{2}\right) \Gamma(1-s)(1-s)$$

or, at last,

(9.2.16) $\zeta(s) = 2(2\pi)^{s-1} \sin\left(\frac{\pi s}{2}\right) \Gamma(1-s) \zeta(1-s),$

the functional equation I gave you earlier in (9.1.14).

As a simple ‘test’ of (9.2.16), suppose $s = \frac{1}{2}$. Then,

$$\zeta\left(\frac{1}{2}\right) = 2(2\pi)^{-\frac{1}{2}} \sin\left(\frac{\pi}{4}\right) \Gamma\left(\frac{1}{2}\right) \zeta\left(\frac{1}{2}\right)$$

which says, once we cancel the $\zeta\left(\frac{1}{2}\right)$ on each side,⁸ that

$$1 = \frac{2}{\sqrt{2\pi}} \sin\left(\frac{\pi}{4}\right) \Gamma\left(\frac{1}{2}\right).$$

Is this correct? Yes, because the right-hand side is

$$\left(\sqrt{\frac{2}{\pi}}\right) \left(\frac{1}{\sqrt{2}}\right) (\sqrt{\pi}) = 1.$$

So, (9.2.16) is consistent for $s = \frac{1}{2}$.

As an example of how (9.2.16) works, let’s use it to calculate $\zeta(-1)$. Thus, with $s = -1$,

$$\zeta(-1) = 2(2\pi)^{-2} \sin\left(-\frac{\pi}{2}\right) \Gamma(2) \zeta(2).$$

Since $\Gamma(2) = 1$, $\sin\left(-\frac{\pi}{2}\right) = -1$, and $\zeta(2) = \frac{\pi^2}{6}$, then

$$\zeta(-1) = \frac{2}{4\pi^2} (-1) \frac{\pi^2}{6} = -\frac{1}{12}.$$

This result is the basis for an interesting story in the history of mathematics co-starring, once again, G. H. Hardy.

In late January 1913 Hardy received the first of several mysterious letters from India. Written by the then unknown, self-taught mathematician Srinivasa Ramanujan (1887–1920), who was employed as a lowly clerk in Madras, the letters

⁸ We know we can do this because, as shown in the previous section, $\xi\left(\frac{1}{2}\right) = -1.4\dots \neq 0$.

were pleas for the world-famous Hardy to look at some of his results. Many of those results were perplexing, but none more than this one:

$$1 + 2 + 3 + 4 + \dots = -\frac{1}{12}.$$

Most professional mathematicians would have simply chucked that into the trash, and dismissed the clerk as a pathetic lunatic. It was Hardy’s genius that he didn’t do that, but instead soon made sense of Ramanujan’s sum. What the clerk meant (but expressed badly) is understood by writing the sum as

$$1 + 2 + 3 + 4 + \dots = \frac{1}{1} + \frac{1}{2} + \frac{1}{3} + \frac{1}{4} + \dots = \frac{1}{1^{-1}} + \frac{1}{2^{-1}} + \frac{1}{3^{-1}} + \frac{1}{4^{-1}} + \dots$$

which is *formally* $\zeta(-1)$. Where Ramanujan’s $-\frac{1}{12}$ came from I don’t know but, indeed, as we’ve just shown using (9.2.16), $\zeta(-1) = -\frac{1}{12}$. Ramanujan had discovered a special case of the extended zeta function before he had ever heard of Riemann!

After Ramanujan’s death, Hardy remarked (in his 1921 obituary notice that appeared in the *Proceedings of The London Mathematical Society*, as well as in the *Proceedings of the Royal Society*) that his friend’s mathematical knowledge had some remarkable gaps: “[He] had found for himself the functional equation of the Zeta-function,” but “he had never heard of . . . Cauchy’s theorem,” “had indeed but the vaguest idea of what a function of a complex variable was,” and that “it was impossible to allow him to go through life supposing that all the zeros of the Zeta-function were real.” Hardy later said, with perhaps little exaggeration, that Ramanujan was his greatest discovery.⁹

As a more substantial application of (9.2.16), I’ll use it next to calculate the value of $\zeta(0)$, the penultimate calculation in this book. If we do something as crude as just shove $s = 0$ into (9.2.16) we quickly see that we get nowhere:

$$\zeta(0) = 2(2\pi)^{-1} \sin(0)\Gamma(1)\zeta(1) = \text{????}$$

because the zero of $\sin(0)$ and the infinity of $\zeta(1)$ are at war with each other. Which one wins? To find out, we’ll have to be a lot more subtle in our calculations. Strange as it may seem to you, we’ll get our answer by studying the case of $s = 1$ (not $s = 0$), which I’ll simply ask you to take on faith as we start.

Looking back at (9.2.9), we have

$$\zeta(s) = \frac{1}{\pi^{-\frac{1}{2}}s\Gamma(\frac{1}{2}s)s(s-1)} + \frac{1}{\pi^{-\frac{1}{2}}s\Gamma(\frac{1}{2}s)} \int_1^\infty \left\{ x^{-\frac{1}{2}s-\frac{1}{2}} + x^{\frac{1}{2}s-1} \right\} \psi(x) dx.$$

⁹ You can read more about Ramanujan’s amazing life in the biography by Robert Kanigel, *The Man Who Knew Infinity: A Life of the Genius Ramanujan*, Charles Scribner’s Sons 1991.

If we let $s \rightarrow 1$ then we see that the right-hand side does indeed blow-up (as it should, because $\zeta(1) = \infty$), strictly because of the first term on the right, *alone*, since the integral term is obviously convergent.¹⁰ In fact, since $\lim_{s \rightarrow 1} \pi^{-\frac{1}{2}} s \Gamma(\frac{1}{2} s) = \frac{\Gamma(\frac{1}{2})}{\sqrt{\pi}} = \frac{\sqrt{\pi}}{\sqrt{\pi}} = 1$, then $\zeta(s)$ blows-up like $\frac{1}{s-1}$ as $s \rightarrow 1$. *Remember this point—it will prove to be the key to our solution.*

Now, from (9.2.16) we have

$$\zeta(1 - s) = \frac{\zeta(s)}{2(2\pi)^{s-1} \sin(\frac{\pi s}{2}) \Gamma(1 - s)}.$$

From the reflection formula for the gamma function we have

$$\Gamma(s)\Gamma(1 - s) = \frac{\pi}{\sin(\pi s)}$$

and so

$$\Gamma(1 - s) = \frac{\pi}{\Gamma(s) \sin(\pi s)}$$

which says

$$\zeta(1 - s) = \frac{\zeta(s)}{2(2\pi)^{s-1} \sin(\frac{\pi s}{2}) \frac{\pi}{\Gamma(s) \sin(\pi s)}} = \frac{\Gamma(s) \sin(\pi s) \zeta(s)}{2\pi(2\pi)^{s-1} \sin(\frac{\pi s}{2})}.$$

Since $\sin(\pi s) = 2 \cos(\frac{\pi s}{2}) \sin(\frac{\pi s}{2})$, we arrive at

$$\zeta(1 - s) = \frac{\Gamma(s) \cos(\frac{\pi s}{2}) \zeta(s)}{\pi(2\pi)^{s-1}},$$

(9.2.17)

an alternative form of the functional equation for the zeta function. This is the form we'll use to let $s \rightarrow 1$, thus giving $\zeta(0)$ on the left.

¹⁰I use the word *obviously* because, over the entire interval of integration, the integrand is finite and goes to zero *very* fast as $x \rightarrow \infty$. Indeed, the integrand vanishes even faster than *exponentially* as $x \rightarrow \infty$, which you can show by using (9.2.4) to write $\psi(x) = \sum_{n=1}^{\infty} e^{-n^2 \pi x} = e^{-\pi x} + e^{-4\pi x} + e^{-9\pi x} + \dots < e^{-\pi x} + e^{-2\pi x} + e^{-3\pi x} + \dots$, a geometric series easily summed to give $\psi(x) < \frac{1}{e^{\pi x - 1}}$, $x > 0$, which behaves like $e^{-\pi x}$ for x ‘large.’ With $s = 1$ the integrand behaves (for x ‘large’) like $\frac{\psi(x)}{x^{3/2+x/2}} \approx \frac{e^{-\pi x}}{x\sqrt{x}}$ for x ‘large.’

So, from (9.2.17) we have

$$\begin{aligned}\lim_{s \rightarrow 1} \zeta(1-s) &= \zeta(0) = \lim_{s \rightarrow 1} \frac{\Gamma(s) \cos\left(\frac{\pi s}{2}\right) \zeta(s)}{\pi(2\pi)^{s-1}} = \frac{\Gamma(1)}{\pi} \lim_{s \rightarrow 1} \cos\left(\frac{\pi s}{2}\right) \zeta(s) \\ &= \frac{1}{\pi} \lim_{s \rightarrow 1} \cos\left(\frac{\pi s}{2}\right) \zeta(s)\end{aligned}$$

or,

$$(9.2.18) \quad \zeta(0) = \frac{1}{\pi} \lim_{s \rightarrow 1} \frac{\cos\left(\frac{\pi s}{2}\right)}{s-1}$$

where I've used our earlier conclusion (that I told you to remember, remember?): $\zeta(s)$ behaves like $\frac{1}{s-1}$ as $s \rightarrow 1$. The limit in (9.2.18) gives the indeterminate result $\frac{0}{0}$, and so we use L'Hospital's rule to compute

$$\zeta(0) = \frac{1}{\pi} \lim_{s \rightarrow 1} \frac{\frac{d}{ds} \left\{ \cos\left(\frac{\pi s}{2}\right) \right\}}{\frac{d}{ds} \{s-1\}} = \frac{1}{\pi} \lim_{s \rightarrow 1} \frac{-\frac{\pi}{2} \sin\left(\frac{\pi s}{2}\right)}{1}$$

or, at last, we have our answer:

$$\zeta(0) = -\frac{1}{2}.$$

To finish our calculation of particular values of $\zeta(s)$, let me now show you a beautiful way to calculate $\zeta(2)$ —which we've already done back in Chap. 7—that also gives us all the other values of $\zeta(2n)$ for $n > 1$ at the same time. What makes this calculation doubly interesting is that *all* of the analysis is at the level of just freshman calculus. We start by finding the power series expansion for $\tan(x)$ around $x \approx 0$, that is, the so-called *Taylor series*.

Why we start with this is, of course, not at all obvious, but go along with me for a bit and you'll see how it will all make sense in the end. So, what we'll do is write

$$\tan(x) = \sum_{k=0}^{\infty} c_k x^k = c_0 + c_1 x + c_2 x^2 + c_3 x^3 + \dots$$

and then find the c 's. This is a standard part of freshman calculus, and I'm going to assume that most readers have seen it before and can skip ahead. If it's been a while for you, however, here's a quick run-through. If you insert $x = 0$ into the series you immediately get $\tan(0) = 0 = c_0$. To find c_1 , first differentiate the series with respect to x and *then* set $x = 0$. That is,

$$\frac{d}{dx} \{ \tan(x) \} = \frac{d}{dx} \left\{ \frac{\sin(x)}{\cos(x)} \right\} = \frac{1}{\cos^2(x)} = c_1 + 2c_2 x + 3c_3 x^2 + \dots$$

and so, setting $x = 0$,

$$\frac{1}{\cos^2(0)} = 1 = c_1.$$

To find c_2 , differentiate again and then set $x = 0$ (you should find that $c_2 = 0$), and so on for all the other c 's. If you are careful with your arithmetic, you should get

$$\tan(x) = x + \frac{1}{3}x^3 + \frac{2}{15}x^5 + \frac{17}{315}x^7 + \frac{62}{2,835}x^9 + \frac{1,382}{155,925}x^{11} + \dots,$$

and where you stop calculating terms is a function only of your endurance!

Next, we'll use this result to get the power series for $\cot(x)$, by writing

$$\begin{aligned} \cot(x) &= \frac{1}{\tan(x)} = \frac{1}{x + \frac{1}{3}x^3 + \frac{2}{15}x^5 + \frac{17}{315}x^7 + \frac{62}{2,835}x^9 + \frac{1,382}{155,925}x^{11} + \dots} \\ &= \frac{1}{x} \left\{ \frac{1}{1 + \frac{1}{3}x^2 + \frac{2}{15}x^4 + \frac{17}{315}x^6 + \dots} \right\}. \end{aligned}$$

Then, if you carefully perform the long-division indicated by the fraction inside the curly brackets, you should get

$$\cot(x) = \frac{1}{x} \left\{ 1 - \frac{1}{3}x^2 - \frac{1}{45}x^4 - \frac{2}{945}x^6 - \dots \right\}$$

or,

$$(9.2.18) \quad \cot(x) = \frac{1}{x} - \frac{1}{3}x - \frac{1}{45}x^3 - \frac{2}{945}x^5 - \dots.$$

Okay, put (9.2.18) aside for now.

Next, consider this amazing identity: for α any real, *non-integer* value,

$$(9.2.19) \quad \cos(\alpha t) = \frac{\sin(\alpha\pi)}{\pi} \left[\frac{1}{\alpha} + 2\alpha \sum_{n=1}^{\infty} \frac{(-1)^n}{\alpha^2 - n^2} \cos(nt) \right].$$

This looks pretty spectacular, but in fact (9.2.19) is quickly derived via a simple, routine Fourier series expansion of the periodic function that is the repetition of a single period given by $\cos(\alpha t)$, $-\pi < t < \pi$, extended infinitely far in both directions

along the t-axis.¹¹ (You can now see why α cannot be an integer—if it was, then the $n = \alpha$ term in the sum would blow-up.)

If we set $t = \pi$ in (9.2.19) we get

$$\cos(\alpha\pi) = \frac{\sin(\alpha\pi)}{\pi} \left[\frac{1}{\alpha} + 2\alpha \sum_{n=1}^{\infty} \frac{(-1)^n}{\alpha^2 - n^2} \cos(n\pi) \right]$$

or, since $\cos(n\pi) = (-1)^n$ and since $(-1)^n(-1)^n = \{(-1)^2\}^n = 1$, then

$$\frac{\cos(\alpha\pi)}{\sin(\alpha\pi)} = \cot(\alpha\pi) = \frac{1}{\pi} \left[\frac{1}{\alpha} + 2\alpha \sum_{n=1}^{\infty} \frac{1}{\alpha^2 - n^2} \right].$$

Thus,

$$\cot(\alpha\pi) = \frac{1}{\alpha\pi} + \frac{\alpha\pi}{\pi^2} \sum_{n=1}^{\infty} \frac{2}{\alpha^2 - n^2} = \frac{1}{\alpha\pi} + \sum_{n=1}^{\infty} \frac{2(\alpha\pi)}{(\alpha\pi)^2 - n^2\pi^2}.$$

If we define $x = \alpha\pi$ then we get another series for $\cot(x)$:

$$(9.2.20) \quad \cot(x) = \frac{1}{x} + \sum_{n=1}^{\infty} \frac{2x}{x^2 - n^2\pi^2}.$$

From (9.2.20) it follows that

$$\begin{aligned} 1 - x \cot(x) &= - \sum_{n=1}^{\infty} \frac{2x^2}{x^2 - n^2\pi^2} = \sum_{n=1}^{\infty} \frac{2x^2}{n^2\pi^2 - x^2} \\ &= \frac{2x^2}{\pi^2} \sum_{n=1}^{\infty} \frac{1}{n^2} \left\{ \frac{1}{1 - \frac{x^2}{n^2\pi^2}} \right\} \\ &= \frac{2x^2}{\pi^2} \sum_{n=1}^{\infty} \frac{1}{n^2} \left\{ 1 + \frac{x^2}{n^2\pi^2} + \frac{x^4}{n^4\pi^4} + \frac{x^6}{n^6\pi^6} + \dots \right\} \end{aligned}$$

or,

$$(9.2.21) \quad 1 - x \cot(x) = \frac{2x^2}{\pi^2} \sum_{n=1}^{\infty} \frac{1}{n^2} + \frac{2x^4}{\pi^4} \sum_{n=1}^{\infty} \frac{1}{n^4} + \frac{2x^6}{\pi^6} \sum_{n=1}^{\infty} \frac{1}{n^6} + \dots$$

¹¹ All the details in the derivation of (9.2.19) can be found on pp. 154–155 of *Dr. Euler*.

And from (9.2.18) it follows that

$$(9.2.22) \quad 1 - x \cot(x) = \frac{1}{3}x^2 + \frac{1}{45}x^4 + \frac{2}{945}x^6 + \dots$$

Equating (9.2.21) and (9.2.22), and then equating the coefficients of equal powers of x , we have

$$\begin{aligned} \frac{2}{\pi^2} \sum_{n=1}^{\infty} \frac{1}{n^2} &= \frac{1}{3}, \\ \frac{2}{\pi^4} \sum_{n=1}^{\infty} \frac{1}{n^4} &= \frac{1}{45}, \\ \frac{2}{\pi^6} \sum_{n=1}^{\infty} \frac{1}{n^6} &= \frac{2}{945}, \end{aligned}$$

and so on. That is,

$$\begin{aligned} \zeta(2) &= \frac{1}{3} \left(\frac{\pi^2}{2} \right) = \frac{\pi^2}{6}, \\ \zeta(4) &= \frac{1}{45} \left(\frac{\pi^4}{2} \right) = \frac{\pi^4}{90}, \\ \zeta(6) &= \frac{2}{945} \left(\frac{\pi^6}{2} \right) = \frac{\pi^6}{945}, \end{aligned}$$

and so on. This isn't the way Euler found $\zeta(2n)$ but, believe me, he would have loved this approach!

One of the open questions about the zeta function concerns the values of $\zeta(2n + 1)$, $n \geq 1$. Not one of these values, not even just the very first one for $\zeta(3)$, is known other than through the direct numerical evaluation of its defining infinite series. There are certainly no known formulas involving powers of π , as there are for $\zeta(2n)$. Why there is this sharp distinction between even and odd arguments of the zeta function is one of the deep mysteries of mathematics, one that has puzzled the world's greatest mathematicians from Euler to the present day.

Now, some final comments. All that I've told you here about the zeta function and the RH is but a *very tiny* fraction of what is known. And yet, the RH remains today a vast, dark mystery, with its resolution hidden somewhere in a seemingly very long (perhaps endless), twisting tunnel with not even a glimmer of light visible ahead to hint that there is an end to it. Riemann is rightfully famous for many things in mathematical physics,¹² but it is no small irony that the most famous of all is his

¹²When Riemann submitted his doctoral dissertation (*Foundations for a General Theory of Functions of a Complex Variable*) to Gauss, the great man pronounced it to be "penetrating,"

creation of a puzzle that has (so far) resisted all attempts by the world's greatest mathematicians to solve. All that mighty effort has not been in vain, however.

One of Isaac Newton's contemporaries was Roger Cotes (1682–1716), who was a professor at Cambridge by age 26, and editor of the second edition of Newton's masterpiece *Principia*, a work that revolutionized physics. His death from a violent fever one month before his 34th birthday—even younger than were Riemann and Clifford at their deaths—cut short what was a truly promising scientific life. It was reported that, after Cotes' death, Newton himself said of him "If he had lived we might have known something." No one ever said that of Riemann, however, because the world had learned a *lot* from him even before he departed this life.

This book starts with a story involving G. H. Hardy, and for symmetry alone let me conclude with yet one more. Hardy was fascinated by the RH all his working life, and never missed a chance to puzzle over it. One famous story, that amusingly reflects just how deep was the hook the RH had in him, relates how, after concluding a visit with a mathematician friend in Copenhagen, Denmark, Hardy was about to return to England. His journey was to be by boat, over a wild and stormy North Sea. Hoping to avoid potential catastrophe, Hardy quickly, just before boarding, wrote and mailed a postcard to his friend declaring "I have a proof of the Riemann hypothesis!" He was confident, Hardy said later, after reaching England safely, that God would not let him die with the false glory of being remembered for doing what he really had not achieved. Hardy, it should be noted, was a devout atheist in all other aspects of his life.

By some incredible coincidence, I write these final words of this book on the British cruise ship *Queen Elizabeth*, while returning from holiday in Norway. The QE is home-based in Southampton, England, and my journey there has taken me through the North Sea and right past Copenhagen. So, here I sit, a 100 years after Hardy with my feet propped-up on the railing of my stateroom balcony, writing of his little joke perhaps right where he had sailed a century before. Somehow, I think Hardy's ghost is not at all surprised as it peers over my shoulder that the mystery of the RH is still unresolved and, as far as anyone can see into the future, it may well *still* be a mystery a 100 years from now.

"creative," "beautiful," and to be a work that "far exceeds" the standards for such works. To actually be able to teach, however, Riemann had to give a trial lecture to an audience of senior professors (including Gauss), and Gauss asked that it be on the foundations of geometry. That Riemann did in June 1854 and—in the words of Caltech mathematician Eric Temple Bell in his famous book *Men of Mathematics*—it "revolutionized differential geometry and prepared the way for the geometrized physics of [today]." What Bell was referring to is Einstein's later description of gravity as a manifestation of curved spacetime, an idea Riemann might have come to himself had he lived. After Riemann's death the British mathematician William Kingdon Clifford (1845–1879) translated Riemann's lecture into English and was perhaps the only man then alive who truly appreciated what Riemann had done. Clifford, himself, came within a whisker of the spirit of Einstein's theory of gravity in a brief, enigmatic note written in 1876 ("On the Space Theory of Matter"), three years before Einstein's birth. Sadly, Clifford too died young of the same disease that had killed Riemann.

For mathematicians, however, this is as great a lure as an ancient, magical artifact hidden in a vast warehouse would be to Indiana Jones, and so the hunt goes gloriously on!

9.3 Challenge Questions

Since this chapter deals with the unresolved issue of the RH, I've decided to be more philosophical than analytical with the challenge problems. So, rather than *problems*, here are three *questions* for you to ponder.

(C9.1): As in the text, let p_n denote the n th prime: $p_1 = 2$, $p_2 = 3$, and so on. Suppose we define q_n to be the first prime greater than $p_1 p_2 \dots p_n + 1$, and then calculate $q_n - (p_1 p_2 \dots p_n)$. If we do this for the first seven values of n we get the following table:

n	$p_1 p_2 \dots p_n$	$p_1 p_2 \dots p_n + 1$	q_n	$q_n - (p_1 p_2 \dots p_n)$
1	2	3	5	3
2	6	7	11	5
3	30	31	37	7
4	210	211	223	13
5	2,310	2,311	2,333	23
6	30,030	30,031	30,047	17
7	510,510	510,511	510,529	19

Looking at the right-most column of the table, does a conjecture *strongly* suggest itself to you? Can you *prove* your conjecture? It's questions like this about the primes, so easy to cook-up and oh-so-hard to prove, that fascinated Riemann in 1859 and continue to fascinate today. For example, the twin prime conjecture that I mentioned in Sect. 9.1 has been the basis for recent (2013) excitement in the world of mathematics, with the proof that there is an infinity of prime pairs separated by gaps of no more than 600. A long way from the original conjecture with a gap of 2, yes, but still . . .

(C9.2): While numerical computations generally don't prove theorems (although they might well *disprove* a conjecture by finding a counterexample), they can be quite useful in *suggesting* a possibility worthy of further examination. For example, since Fig. 9.1.1 indicates that, for $\epsilon > 0$, $\lim_{\epsilon \rightarrow 0} \zeta(1 - \epsilon) = -\infty$ and $\lim_{\epsilon \rightarrow 0} \zeta(1 + \epsilon) = +\infty$, then it is at least conceivable that $\lim_{\epsilon \rightarrow 0} \{\zeta(1 - \epsilon) + \zeta(1 + \epsilon)\}$ could be finite. In fact, it is easy to use MATLAB to compute the following table:

ϵ	$\{\zeta(1 - \epsilon) + \zeta(1 + \epsilon)\}/2$
0.1	0.577167222774279
0.01	0.577215180384336
0.001	0.577215660056368
0.0001	0.577215664853611

From these calculations it *appears* that $\lim_{\varepsilon \rightarrow 0} \{\zeta(1 - \varepsilon) + \zeta(1 + \varepsilon)\}/2 = 0.57721566\dots$. Does this suggest to you that the limit is a well-known constant? Can you *prove* your conjecture?

(C9.3): Two undergraduate math majors, Sally and Sam, are discussing the RH in general and, in particular, the view held by some mathematicians that the reason nobody has solved the question, even after 150 years of intense trying, is simply because it's unsolvable. Sally says while that may well be true, it's also true that nobody will ever be able to *prove* the RH is unsolvable. When Sam asks why not, Sally replies "If the RH could be shown to be unsolvable, that would mean nobody could ever find a complex zero off the critical line, even by accident, no matter how long they looked. Not even if they could check zeros at the rate of $10^{10^{10}}$ each nanosecond, no matter how high up that exponential stack of tens you went. That's because if you did find such a zero then you would have proven the RH to be false. That's a contradiction with the initial premise that there exists a proof that the problem is unsolvable. But *that* would mean there *is* no zero off the critical line, and *that* would mean the RH had been solved by showing it is true. That's a contradiction, too. The only way out of this quagmire is to conclude that *no such proof exists.*"

Sam thinks that over and, finally, replies with "Well, I'm not so sure about all that. There are infinitely many complex zeros, and so no matter how many of them you could check each nanosecond, it would still take infinite time to check them all. So, you'd *never* be done, and a contradiction doesn't occur *until* you are done."

What do you think of each of these arguments?

As you ponder the words of Sam and Sally, we come to THE END and your author rides off into the mathematical sunset like the 'Arizona ranger with the big gun on his hip' in that old but still great western ballad by the late Marty Robbins. This book has given you a lot of ammo for *your* big integral gun, however, so as I say good-bye I'll simply wish you success (when you next match wits with a new 'outlaw integral') as follows (because I grew-up in 1950s Southern California, just 100 miles north of the Mexican border):

Adios, mi amigo, vaya con Dios.

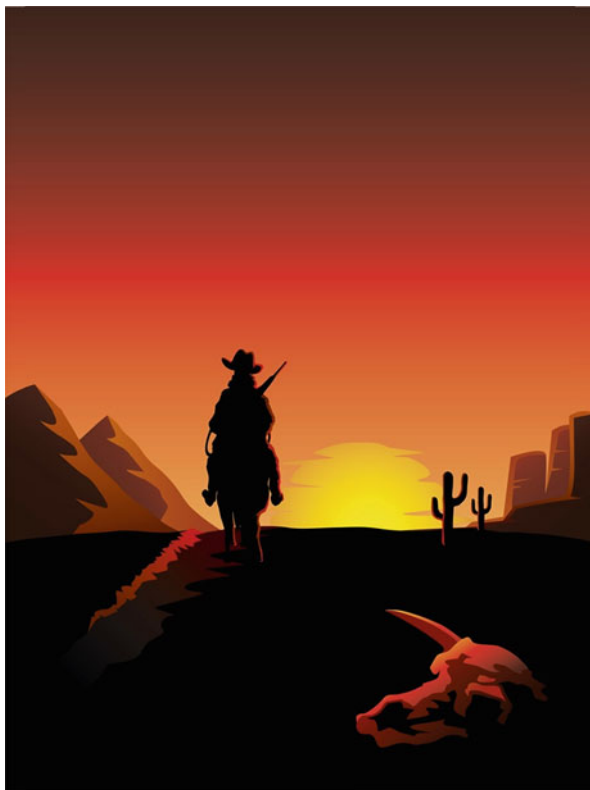

Reproduced by permission of Toon Vectors (Austin, Texas)

Solutions to the Challenge Problems

Preface

Since $x + \frac{1}{x} = 1$, then multiplying through by x gives $x^2 + 1 = x$ or, rearranging, $x^2 = x - 1$. Multiplying through by x again, $x^3 = x^2 - x$ or, substituting our expression for x^2 , $x^3 = x - 1 - x = -1$. Squaring this gives $x^6 = 1$, and then multiplying through by x we have $x^7 = x$. So, substituting x^7 for x in the original $x + \frac{1}{x} = 1$ we have $x^7 + \frac{1}{x^7} = 1$ and we are done.

Chapter 1

(C1.1): Change variable to $u = x - 2$ (and so $du = dx$) which says

$$\begin{aligned} \int_0^8 \frac{dx}{x-2} &= \int_{-2}^6 \frac{du}{u} = \lim_{\epsilon \rightarrow 0} \left[\int_{-2}^{-\epsilon} \frac{du}{u} + \int_{\epsilon}^6 \frac{du}{u} \right] = \lim_{\epsilon \rightarrow 0} \left[\ln(u) \Big|_{-2}^{-\epsilon} + \ln(u) \Big|_{\epsilon}^6 \right] \\ &= \lim_{\epsilon \rightarrow 0} \left[\ln(-\epsilon) - \ln(-2) + \ln(6) - \ln(\epsilon) \right] = \lim_{\epsilon \rightarrow 0} \left[\ln\left(\frac{-\epsilon}{-2}\right) + \ln\left(\frac{6}{\epsilon}\right) \right] \\ &= \lim_{\epsilon \rightarrow 0} \left[\ln\left\{ \left(\frac{\epsilon}{2}\right) \left(\frac{6}{\epsilon}\right) \right\} \right] = \ln(3). \end{aligned}$$

That is,

$$\int_0^8 \frac{dx}{x-2} = \ln(3).$$

$\int_0^3 \frac{dx}{(x-1)^{2/3}} = \lim_{\varepsilon \rightarrow 0} \int_0^{1-\varepsilon} \frac{dx}{(x-1)^{2/3}} + \lim_{\varepsilon \rightarrow 0} \int_{1+\varepsilon}^3 \frac{dx}{(x-1)^{2/3}}$. In both integrals

on the right, change variable to $u = x - 1$ and so $du = dx$. Then $\int_0^3 \frac{dx}{(x-1)^{2/3}} =$

$$\lim_{\varepsilon \rightarrow 0} \left\{ \int_{-1}^{-\varepsilon} \frac{du}{u^{2/3}} + \int_{\varepsilon}^2 \frac{du}{u^{2/3}} \right\} = \lim_{\varepsilon \rightarrow 0} \left\{ (3u^{1/3}) \Big|_{-1}^{-\varepsilon} + (3u^{1/3}) \Big|_{\varepsilon}^2 \right\} = 3 \lim_{\varepsilon \rightarrow 0} \left\{ (-\varepsilon)^{1/3} - (-1)^{1/3} + (2)^{1/3} - (\varepsilon)^{1/3} \right\} = 3 \{1 + 2^{1/3}\}.$$

(C1.2): Write $\int_1^{\infty} \frac{dx}{\sqrt{x^3-1}} = \int_1^{\infty} \frac{dx}{\sqrt{x-1}\sqrt{x^2+x+1}} < \int_1^{\infty} \frac{dx}{\sqrt{x-1}\sqrt{x^2}} = \int_1^{\infty} \frac{dx}{x\sqrt{x-1}}$, where the inequality follows because in the integral just before the

one at the far-right I've replaced a denominator factor in the integrand with a quantity that is *smaller*. Now, change variable to $u = x - 1$ in the last integral. So,

$\int_1^{\infty} \frac{dx}{\sqrt{x^3-1}} < \int_0^{\infty} \frac{du}{(u+1)\sqrt{u}} = \int_0^{\infty} \frac{du}{u^{3/2} + u^{1/2}}$ or, writing the last integral as the

sum of two integrals, we have $\int_1^{\infty} \frac{dx}{\sqrt{x^3-1}} < \int_0^1 \frac{du}{u^{3/2} + u^{1/2}} + \int_1^{\infty} \frac{du}{u^{3/2} + u^{1/2}}$.

We make the inequality even stronger by replacing the denominators of the integrands on the right-hand-side with smaller quantities, and so $\int_1^{\infty} \frac{dx}{\sqrt{x^3-1}} <$

$$\int_0^1 \frac{du}{u^{1/2}} + \int_1^{\infty} \frac{du}{u^{3/2}} = (2u^{1/2}) \Big|_0^1 - (2u^{-1/2}) \Big|_1^{\infty} = 2 + 2 = 4.$$

(C1.3): In Feynman's integral $\int_0^1 \frac{dx}{[ax + b(1-x)]^2}$ change variable to $u = ax + b$

$(1-x)$ and so $dx = \frac{du}{a-b}$ and the integral becomes $\int_b^a \frac{1}{u^2} \left(\frac{du}{a-b} \right) =$

$$\frac{1}{a-b} \left\{ -\frac{1}{u} \right\} \Big|_b^a = \frac{1}{a-b} \left\{ \frac{1}{b} - \frac{1}{a} \right\} = \frac{a-b}{(a-b)ab} = \frac{1}{ab},$$
 just as Feynman claimed.

This all makes sense as long as the integrand doesn't blow-up somewhere inside the integration interval (that is, as long as there is no x such that $ax + b(1-x) = 0$ in the interval $0 \leq x \leq 1$). Now, the quantity $ax + b(1-x)$ *does* equal zero

when $x = \frac{b}{b-a}$ and so we therefore require either $\frac{b}{b-a} < 0$ (call this Condition 1) or that $\frac{b}{b-a} > 1$ (call this Condition 2). For Condition 1 we can write, with k some positive number, $\frac{b}{b-a} = -k$. Or, $b = -bk + ak$ and so, multiplying through by a , $ab = -abk + a^2k$. Solving for ab , we have $ab = \frac{a^2k}{1+k}$. Since k is positive (and, obviously, so is a^2) we then conclude that $ab > 0$. For Condition 2 we can write, with k some number greater than 1, $\frac{b}{b-a} = k$. Or, $b = bk - ak$ and so, multiplying through by a , we have $ab = abk - a^2k$. Solving for ab , we have $ab = \frac{a^2k}{k-1}$. Since $k > 1$ we conclude that $ab > 0$. That is, for both conditions (conditions that insure the integrand doesn't blow-up somewhere inside the integration interval) we conclude that $ab > 0$. That is, a and b must have the same algebraic sign and that eliminates the puzzle of Feynman's integral.

(C1.4): Transforming $\int_0^\infty \frac{e^{-cx}}{x} dx$ into $\int_0^\infty \frac{e^{-y}}{y} dy$ with the change of variable $y = cx$ (assuming $c > 0$) is straightforward. With $x = \frac{y}{c}$ we have $dx = \frac{1}{c} dy$ and so $\int_0^\infty \frac{e^{-cx}}{x} dx = \int_0^\infty \frac{e^{-\frac{y}{c}}}{\frac{y}{c}} (\frac{1}{c} dy) = \int_0^\infty \frac{e^{-y}}{y} dy$. This is *formally* okay, but it is really just an exercise in symbol-pushing. That's because the key to understanding the puzzle is to realize that the integral $\int_0^\infty \frac{e^{-y}}{y} dy$ *doesn't exist!* Here's how to see that. For any given finite value of the upper limit greater than zero (call it δ), the value of $\int_0^\delta \frac{e^{-y}}{y} dy = \infty$. That's because for $0 \leq y \leq \delta$ we have $e^{-y} \geq e^{-\delta}$ and so $\int_0^\delta \frac{e^{-y}}{y} dy \geq \int_0^\delta \frac{e^{-\delta}}{y} dy = e^{-\delta} \{\ln(y)\}_0^\delta = \infty$. Thus, when we write $\int_0^\infty \frac{e^{-ax} - e^{-bx}}{x} dx = \int_0^\infty \frac{e^{-ax}}{x} dx - \int_0^\infty \frac{e^{-bx}}{x} dx = \int_0^\infty \frac{e^{-y}}{y} dy - \int_0^\infty \frac{e^{-y}}{y} dy$ what we are actually doing is subtracting an *infinite* quantity from another *infinite* quantity and the result is undefined. A deeper analysis is required to determine the result and that, as stated in the challenge statement, is done in Chap. 3. The problem of subtracting one infinity from another was given an interesting treatment in the short science fiction story "The Brink of Infinity" by Stanley Wienbaum (1902–1935), which appeared posthumously in the December 1936 issue of *Thrilling Wonder Stories* magazine (it's reprinted in the Wienbaum collection *A Martian Odyssey and Other Science Fiction Tales*, Hyperion Press 1974). A man is terribly injured when an experiment goes wrong, and he blames the mathematician who did the preliminary analysis incorrectly. In revenge on mathematicians in general, he lures one to his home. Holding him at gun point, he tells him he'll be shot unless he answers the following question correctly: the gunman is thinking of a mathematical

expression and the mathematician must figure out what that expression is by asking no more than ten questions. One of the mathematician's questions is "What is the expression equal to?" and the answer is "anything." And that is just what the end of the story reveals to the reader—the gunman is thinking of " $\infty - \infty$."

Chapter 2

(C2.1): $\ln \int_0^4 \frac{\ln(x)}{\sqrt{4x-x^2}} dx$ change variable to $y = \frac{x}{4}$. Then $x=4y$ and so $dx=4 dy$.

The integral then becomes $\int_0^1 \frac{\ln(4y)}{\sqrt{16y-16y^2}} 4 dy = \int_0^1 \frac{\ln(4) + \ln(y)}{\sqrt{y-y^2}} dy =$

$\ln(4) \int_0^1 \frac{dy}{\sqrt{y}\sqrt{1-y}} + \int_0^1 \frac{\ln(y)}{\sqrt{y}\sqrt{1-y}} dy$. In both of these last two integrals make the

change of variable to $y = \sin^2(\theta)$, which means that when $y=0$ we have $\theta=0$,

and when $y=1$ we have $\theta = \frac{\pi}{2}$. Also, $\frac{dy}{d\theta} = 2 \sin(\theta) \cos(\theta)$ and so $\int_0^1 \frac{dy}{\sqrt{y}\sqrt{1-y}} =$

$\int_0^{\pi/2} \frac{2 \sin(\theta) \cos(\theta)}{\sqrt{\sin^2(\theta)}\sqrt{1-\sin^2(\theta)}} d\theta = 2 \int_0^{\pi/2} \frac{\sin(\theta) \cos(\theta)}{\sin(\theta) \cos(\theta)} d\theta = 2 \int_0^{\pi/2} d\theta = \pi$, and

$\int_0^1 \frac{\ln(y)}{\sqrt{y}\sqrt{1-y}} dy = \int_0^{\pi/2} \frac{\ln\{\sin^2(\theta)\}}{\sin(\theta) \cos(\theta)} 2 \sin(\theta) \cos(\theta) d\theta = 4 \int_0^{\pi/2} \ln\{\sin(\theta)\} d\theta = 4$

$\left[-\frac{\pi}{2} \ln(2)\right] = -2\pi \ln(2)$ where I've used the Euler log-sine integral we derived in (2.4.1). So, what we have is

$$\begin{aligned} \int_0^4 \frac{\ln(x)}{\sqrt{4x-x^2}} dx &= \ln(4) \int_0^1 \frac{dy}{\sqrt{y}\sqrt{1-y}} + \int_0^1 \frac{\ln(y)}{\sqrt{y}\sqrt{1-y}} dy = \ln(4)\pi - 2\pi \ln(2) \\ &= \ln(2^2)\pi - 2\pi \ln(2) = 2\ln(2)\pi - 2\pi \ln(2) = 0 \end{aligned}$$

and we are done.

(C2.2): We start with $\int_0^1 \frac{dx}{x^3+1} = \frac{1}{3} \int_0^1 \frac{dx}{x+1} - \frac{1}{3} \int_0^1 \frac{x-2}{x^2-x+1} dx$. In the first

integral on the right let $u=x+1$ ($dx=du$). Then, $\frac{1}{3} \int_0^1 \frac{dx}{x+1} =$

$\frac{1}{3} \int_1^2 \frac{du}{u} = \frac{1}{3} \{\ln(u)\}_1^2 = \frac{1}{3} \ln(2)$. In the second integral write (following the hint)

$\frac{1}{3} \int_0^1 \frac{x-2}{x^2-x+1} dx = \frac{1}{3} \int_0^1 \frac{x-2}{x^2-x+\frac{1}{4}+\frac{3}{4}} dx = \frac{1}{3} \int_0^1 \frac{x-2}{\left(x-\frac{1}{2}\right)^2 + \left(\frac{\sqrt{3}}{2}\right)^2} dx$. Next, let $u = x - \frac{1}{2}$

(and so $dx=du$) and we get $\frac{1}{3} \int_0^1 \frac{x-2}{x^2-x+1} dx = \frac{1}{3} \int_{-1/2}^{1/2} \frac{u-\frac{3}{2}}{u^2 + \left(\frac{\sqrt{3}}{2}\right)^2} du =$

$\frac{1}{3} \int_{-1/2}^{1/2} \frac{u}{u^2 + \left(\frac{\sqrt{3}}{2}\right)^2} du - \frac{1}{2} \int_{-1/2}^{1/2} \frac{du}{u^2 + \left(\frac{\sqrt{3}}{2}\right)^2}$. The first integral on the right is zero as

the integrand is odd and the limits are symmetrical around zero, and so

$$\frac{1}{3} \int_0^1 \frac{x-2}{x^2-x+1} dx = -\frac{1}{2} \int_{-\frac{1}{2}}^{\frac{1}{2}} \frac{du}{u^2 + \left(\frac{\sqrt{3}}{2}\right)^2} = -\frac{1}{2} \left\{ \frac{2}{\sqrt{3}} \tan^{-1} \left(\frac{2u}{\sqrt{3}} \right) \right\}_{-\frac{1}{2}}^{\frac{1}{2}} = -\frac{1}{\sqrt{3}} \left\{ \tan^{-1} \left(\frac{1}{\sqrt{3}} \right) - \tan^{-1} \left(-\frac{1}{\sqrt{3}} \right) \right\} = -\frac{1}{\sqrt{3}} \left\{ 2 \tan^{-1} \left(\frac{1}{\sqrt{3}} \right) \right\} = -\frac{2}{\sqrt{3}} \left(\frac{\pi}{6} \right) = -\frac{\pi}{3\sqrt{3}}.$$

So,

$$\int_0^1 \frac{dx}{x^3+1} = \frac{1}{3} \ln(2) + \frac{\pi}{3\sqrt{3}}$$

or,

$$\int_0^1 \frac{dx}{x^3+1} = \frac{1}{3} \left\{ \ln(2) + \frac{\pi}{\sqrt{3}} \right\} .$$

This equals 0.8356488... and MATLAB agrees, as `quad(@(x)1./(x.^3+1), 0,1) = 0.8356488...`

(C2.3): Define the integral $I(m-1) = \int_0^\infty \frac{dx}{(x^4+1)^m}$ which we'll then integrate by parts. That is, in the standard notation of $\int u dv = uv - \int v du$ let $dv = dx$ and $u = \frac{1}{(x^4+1)^m}$. Then, $v = x$ and $\frac{du}{dx} = -4m \frac{x^3}{(x^4+1)^{m+1}}$ and so $\int_0^\infty \frac{dx}{(x^4+1)^m} = \frac{x}{(x^4+1)^m} \Big|_0^\infty + 4m \int_0^\infty \frac{x^4}{(x^4+1)^{m+1}} dx = 4m \int_0^\infty \frac{x^4}{(x^4+1)^{m+1}} dx$. Now, write

$$\begin{aligned} \int_0^\infty \frac{x^4}{(x^4+1)^{m+1}} dx &= \int_0^\infty \frac{x^4+1}{(x^4+1)^{m+1}} dx - \int_0^\infty \frac{1}{(x^4+1)^{m+1}} dx \\ &= \int_0^\infty \frac{1}{(x^4+1)^m} dx - \int_0^\infty \frac{1}{(x^4+1)^{m+1}} dx. \end{aligned}$$

So,

$$\int_0^{\infty} \frac{dx}{(x^4 + 1)^m} = 4m \left[\int_0^{\infty} \frac{1}{(x^4 + 1)^m} dx - \int_0^{\infty} \frac{1}{(x^4 + 1)^{m+1}} dx \right] \text{ or, rearranging,}$$

$$4m \int_0^{\infty} \frac{dx}{(x^4 + 1)^{m+1}} = 4m \int_0^{\infty} \frac{dx}{(x^4 + 1)^m} - \int_0^{\infty} \frac{dx}{(x^4 + 1)^m}$$

$$= (4m - 1) \int_0^{\infty} \frac{dx}{(x^4 + 1)^m}.$$

Thus,

$$\int_0^{\infty} \frac{dx}{(x^4 + 1)^{m+1}} = \frac{4m - 1}{4m} \int_0^{\infty} \frac{dx}{(x^4 + 1)^m} \text{ and we are done.}$$

(C2.4): The denominator of the integrand is zero at the values given by $x = \frac{b \pm \sqrt{b^2 - 4}}{2}$. If $-2 < b < 2$ then both of these values are complex and so not on the real axis, which means that the denominator never vanishes in the interval of integration. And if $b \leq -2$ then both values of $x < 0$, which again means that the denominator never vanishes in the interval of integration. So, the integral in (2.4.5) exists only if $b < 2$. MATLAB agrees, as experimenting with *quad* shows that random choices for b that are less than 2 always give values for the integral that are either zero or pretty darn close to zero, while any $b \geq 2$ results in MATLAB responding with 'NaN' (not a number), MATLAB's way of saying the integral doesn't exist.

(C2.5): In $\int_0^{\infty} \frac{\ln(1+x)}{x\sqrt{x}} dx$ let $u = \ln(1+x)$ and $dv = \frac{dx}{x^{3/2}}$. Then, $du = \frac{dx}{1+x}$ and $v = -\frac{2}{\sqrt{x}}$, and so $\int_0^{\infty} \frac{\ln(1+x)}{x\sqrt{x}} dx = -2 \frac{\ln(1+x)}{\sqrt{x}} \Big|_0^{\infty} + 2 \int_0^{\infty} \frac{1}{\sqrt{x}} \frac{dx}{1+x} = 2 \int_0^{\infty} \frac{dx}{(1+x)\sqrt{x}}$. Next, change variable to $t = \sqrt{x}$ and so $x = t^2$ and $dx = 2t dt$. Thus, $\int_0^{\infty} \frac{\ln(1+x)}{x\sqrt{x}} dx = 2 \int_0^{\infty} \frac{2t dt}{(1+t^2)t} = 4 \int_0^{\infty} \frac{dt}{(1+t^2)} = 4 \tan^{-1}(t) \Big|_0^{\infty} = 4 \left(\frac{\pi}{2}\right) = 2\pi$.

Chapter 3

(C3.1): Start with $I(a) = \int_0^\infty \frac{\ln(1 + a^2x^2)}{b^2 + x^2} dx$ and differentiate with respect to a to get $\frac{dI}{da} = \int_0^\infty \frac{2ax^2}{(1 + a^2x^2)(b^2 + x^2)} dx = \int_0^\infty \left\{ \frac{A}{1 + a^2x^2} + \frac{B}{b^2 + x^2} \right\} dx$ and so $Ab^2 + Ax^2 + B + Ba^2x^2 = x^2(A + Ba^2) + Ab^2 + B = 2ax^2$. Thus, $A + Ba^2 = 2a$ and $Ab^2 + B = 0$. Solving for A and B , we have $A = \frac{2a}{1 - a^2b^2}$ and $B = -\frac{2ab^2}{1 - a^2b^2}$. So,

$$\begin{aligned} \frac{dI}{da} &= \frac{2a}{1 - a^2b^2} \int_0^\infty \frac{dx}{1 + a^2x^2} - \frac{2ab^2}{1 - a^2b^2} \int_0^\infty \frac{dx}{b^2 + x^2} \\ &= \frac{2/a}{1 - a^2b^2} \int_0^\infty \frac{dx}{\frac{1}{a^2} + x^2} - \frac{2ab^2}{1 - a^2b^2} \int_0^\infty \frac{dx}{b^2 + x^2} \\ &= \frac{\frac{2}{a}}{1 - a^2b^2} (a) \tan^{-1}(xa) \Big|_0^\infty - \frac{2ab^2}{1 - a^2b^2} \left(\frac{1}{b}\right) \tan^{-1}\left(\frac{x}{b}\right) \Big|_0^\infty \\ &= \frac{\pi}{2} \left[\frac{2}{1 - a^2b^2} - \frac{2ab}{1 - a^2b^2} \right] = \frac{\pi}{2} 2 \left[\frac{1 - ab}{1 - a^2b^2} \right] = \pi \frac{1}{1 + ab}. \end{aligned}$$

So, $\frac{dI}{da} = \pi \frac{1}{1 + ab}$ and thus $I = \int \pi \frac{1}{1 + ab} da$. Let $u = 1 + ab$ and so $\frac{du}{da} = b$ and therefore $da = \frac{1}{b} du$. Thus, $I = \pi \int \frac{\frac{1}{b} du}{u} = \frac{\pi}{b} \ln(u) + C$ where C is a constant of integration. We know from the very definition of $I(a)$ that $I(0) = 0$, which says $C = 0$. So, at last,

$$\int_0^\infty \frac{\ln(1 + a^2x^2)}{b^2 + x^2} dx = \pi \frac{\ln(1 + ab)}{b} .$$

(C3.2): Write $\int_{-\infty}^\infty \frac{\cos(ax)}{b^2 - x^2} dx = \int_{-\infty}^\infty \cos(ax) \left\{ \frac{1}{(b-x)(b+x)} \right\} dx = \frac{1}{2b} \int_{-\infty}^\infty \cos(ax) \left\{ \frac{1}{(b+x)} + \frac{1}{(b-x)} \right\} dx = \frac{1}{2b} \left[\int_{-\infty}^\infty \frac{\cos(ax)}{(b+x)} dx + \int_{-\infty}^\infty \frac{\cos(ax)}{(b-x)} dx \right]$. In the first integral let $u = b + x$ (and so $du = dx$), and in the second integral let $u = b - x$ (and so $du = -dx$). Then, $\int_{-\infty}^\infty \frac{\cos(ax)}{b^2 - x^2} dx = \frac{1}{2b} \left[\int_{-\infty}^\infty \frac{\cos(au - ab)}{u} du + \int_{-\infty}^\infty \frac{\cos(ab - au)}{u} (-du) \right] = \frac{1}{2b} \left[\int_{-\infty}^\infty \frac{\cos(au - ab)}{u} du + \int_{-\infty}^\infty \frac{\cos(ab - au)}{u} du \right]$ or, as

$\cos(-\theta) = \cos(\theta)$, we have $\int_{-\infty}^{\infty} \frac{\cos(ax)}{b^2 - x^2} dx = \frac{1}{b} \int_{-\infty}^{\infty} \frac{\cos(au - ab)}{u} du$. Now, since $\cos(x - y) = \cos(x)\cos(y) + \sin(x)\sin(y)$, then $\int_{-\infty}^{\infty} \frac{\cos(ax)}{b^2 - x^2} dx = \frac{1}{b} \int_{-\infty}^{\infty} \frac{\cos(au)\cos(ab)}{u} du + \frac{1}{b} \int_{-\infty}^{\infty} \frac{\sin(au)\sin(ab)}{u} du = \frac{\cos(ab)}{b} \int_{-\infty}^{\infty} \frac{\cos(au)}{u} du + \frac{\sin(ab)}{b} \int_{-\infty}^{\infty} \frac{\sin(au)}{u} du$. The first integral has a Cauchy Principal Value of zero as $\frac{\cos(au)}{u}$ is an odd function. For $a > 0$ the second integral is π from Dirichlet's integral. So,

$$\int_{-\infty}^{\infty} \frac{\cos(ax)}{b^2 - x^2} dx = \pi \frac{\sin(ab)}{b} .$$

(C3.3): Since $\int_0^{\infty} \frac{\cos(ax)}{b^2 + x^2} dx = \frac{\pi}{2b} e^{-ab}$ then as the integrand is an even function we can write $\int_{-\infty}^{\infty} \frac{\cos(ax)}{b^2 + x^2} dx = \frac{\pi}{b} e^{-ab}$. Thus, $\int_{-\infty}^{\infty} \frac{\cos(ax)}{b^2 + x^2} dx + \int_{-\infty}^{\infty} \frac{\cos(ax)}{b^2 - x^2} dx = \frac{\pi}{b} e^{-ab} + \pi \frac{\sin(ab)}{b} = \int_{-\infty}^{\infty} \cos(ax) \left\{ \frac{1}{b^2 + x^2} + \frac{1}{b^2 - x^2} \right\} dx = 2b^2 \int_{-\infty}^{\infty} \frac{\cos(ax)}{b^4 - x^4} dx$ and so we immediately have our result:

$$\int_{-\infty}^{\infty} \frac{\cos(ax)}{b^4 - x^4} dx = \frac{\pi \{e^{-ab} + \sin(ab)\}}{2b^3} .$$

(C3.4): Notice that since the integrand is an even function we can write

$$\begin{aligned} \int_0^{\infty} \frac{x \sin(ax)}{x^2 - b^2} dx &= \frac{1}{2} \int_{-\infty}^{\infty} x \sin(ax) \left\{ \frac{1}{(x-b)(x+b)} \right\} dx \\ &= -\frac{1}{2} \int_{-\infty}^{\infty} x \sin(ax) \left\{ \frac{1}{(b-x)(b+x)} \right\} dx \\ &= -\frac{1}{4b} \int_{-\infty}^{\infty} x \sin(ax) \left\{ \frac{1}{b+x} + \frac{1}{b-x} \right\} dx \\ &= -\frac{1}{4b} \left[\int_{-\infty}^{\infty} \frac{x \sin(ax)}{b+x} dx + \int_{-\infty}^{\infty} \frac{x \sin(ax)}{b-x} dx \right] \end{aligned}$$

In the first integral change variable to $u = b + x$ and in the second integral to $u = b - x$. Then,

$$\begin{aligned} \int_0^\infty \frac{x \sin(ax)}{x^2 - b^2} dx &= -\frac{1}{4b} \left[\int_{-\infty}^\infty \frac{(u - b) \sin(au - ab)}{u} du + \int_{-\infty}^\infty \frac{(b - u) \sin(ab - au)}{u} (-du) \right] \\ &= -\frac{1}{4b} \left[\int_{-\infty}^\infty \frac{(u - b) \sin(au - ab)}{u} du + \int_{-\infty}^\infty \frac{(u - b) \sin(au - ab)}{u} du \right] \\ &= -\frac{1}{4b} \int_{-\infty}^\infty \frac{2(u - b) \sin(au - ab)}{u} du \\ &= -\frac{1}{2b} \left[\int_{-\infty}^\infty \sin(au - ab) du - b \int_{-\infty}^\infty \frac{\sin(au - ab)}{u} du \right]. \end{aligned}$$

In the first integral change variable to $s = au - ab$. Then, $\int_{-\infty}^\infty \sin(au - ab) du = \frac{1}{a} \int_{-\infty}^\infty \sin(s) ds$ which has a Cauchy Principal Value of zero. Thus, $\int_0^\infty \frac{x \sin(ax)}{x^2 - b^2} dx = \frac{1}{2} \int_{-\infty}^\infty \frac{\sin(au - ab)}{u} du$ or, as $\sin(\alpha - \beta) = \sin(\alpha)\cos(\beta) - \cos(\alpha)\sin(\beta)$, $\int_0^\infty \frac{x \sin(ax)}{x^2 - b^2} dx = \frac{1}{2} \int_{-\infty}^\infty \frac{\sin(au)\cos(ab) - \cos(au)\sin(ab)}{u} du = \frac{1}{2} \left[\cos(ab) \int_{-\infty}^\infty \frac{\sin(au)}{u} du - \sin(ab) \int_{-\infty}^\infty \frac{\cos(au)}{u} du \right]$.

The first integral is, from Dirichlet's integral, π , and the second integral is zero because the integrand is an odd function. Thus,

$$\int_0^\infty \frac{x \sin(ax)}{x^2 - b^2} dx = \frac{\pi}{2} \cos(ab).$$

(C3.5): Start by recalling the trigonometric identity $\cos(ax)\sin(bx) = \frac{1}{2}[\sin\{(b - a)x\} + \sin\{(b + a)x\}]$. Since the cosine is an even function we have $\cos(ax) = \cos(|a|x)$ and so $\cos(ax)\sin(bx) = \frac{1}{2}[\sin\{(b - |a|)x\} + \sin\{(b + |a|)x\}]$ and so $\int_0^\infty \cos(ax) \frac{\sin(bx)}{x} dx = \frac{1}{2} \int_0^\infty \frac{\sin\{(b - |a|)x\}}{x} dx + \frac{1}{2} \int_0^\infty \frac{\sin\{(b + |a|)x\}}{x} dx$. From (3.2.1) we have

$$\begin{aligned} &\frac{\pi}{2}, \quad c > 0 \\ \int_0^\infty \frac{\sin(cx)}{x} dx &= 0, \quad c = 0 \\ &-\frac{\pi}{2}, \quad c < 0 \end{aligned}$$

and so,

(1) if $|a| < b$ then $b - |a| > 0$ and $b + |a| > 0$ and so

$$\int_0^{\infty} \cos(ax) \frac{\sin(bx)}{x} dx = \frac{1}{2} \left(\frac{\pi}{2} \right) + \frac{1}{2} \left(\frac{\pi}{2} \right) = \frac{\pi}{2};$$

(2) if $|a| > b$ then $b - |a| < 0$ and $b + |a| > 0$ and so

$$\int_0^{\infty} \cos(ax) \frac{\sin(bx)}{x} dx = \frac{1}{2} \left(-\frac{\pi}{2} \right) + \frac{1}{2} \left(\frac{\pi}{2} \right) = 0;$$

(3) if $|a| = b$ then $b - |a| = 0$ and $b + |a| > 0$ and so

$$\int_0^{\infty} \cos(ax) \frac{\sin(bx)}{x} dx = \frac{1}{2}(0) + \frac{1}{2} \left(\frac{\pi}{2} \right) = \frac{\pi}{4}.$$

(C3.6): We start by following the hint and let $x = \cos(2u)$. Then $\frac{du}{dx} = -2 \sin(2u)$ and so (remembering the double-angle identity) $dx = -2 \sin(2u) du = -4 \sin(u) \cos(u) du$. Thus,

$$\int_{-1}^1 \sqrt{\frac{1+x}{1-x}} dx = \int_{\pi/2}^0 \sqrt{\frac{1+\cos(2u)}{1-\cos(2u)}} \{-4 \sin(u) \cos(u) du\} = 4 \int_0^{\pi/2} \sin(u) \cos(u) \sqrt{\frac{1+\cos(2u)}{1-\cos(2u)}} du.$$

Next, remembering the identities $1 + \cos(2u) = 2 \cos^2(u)$ and $1 - \cos(2u) = 2 \sin^2(u)$, we have $\int_{-1}^1 \sqrt{\frac{1+x}{1-x}} dx = 4 \int_0^{\pi/2} \sin(u) \cos(u) \sqrt{\frac{2 \cos^2(u)}{2 \sin^2(u)}} du = 4 \int_0^{\pi/2} \cos^2(u) du = 4 \int_0^{\pi/2} \left\{ \frac{1}{2} + \frac{1}{2} \cos(2u) \right\} du = 4 \left\{ \frac{1}{2} u + \frac{1}{4} \sin(2u) \right\} \Big|_0^{\pi/2} = 4 \left\{ \frac{\pi}{4} \right\}$ and so $\int_{-1}^1 \sqrt{\frac{1+x}{1-x}} dx = \pi$.

(C3.7): In $\int_0^1 \left\{ \int_0^1 \frac{x-y}{(x+y)^3} dx \right\} dy$ let $t = x+y$ in the inner integral. Then $dx = dt$

and $\int_0^1 \frac{x-y}{(x+y)^3} dx = \int_y^{1+y} \frac{t-2y}{t^3} dt = \int_y^{1+y} \frac{dt}{t^2} - 2y \int_y^{1+y} \frac{dt}{t^3} = \left(-\frac{1}{t} \right) \Big|_y^{1+y} - 2y \left(-\frac{1}{2t^2} \right) \Big|_y^{1+y} = \left(\frac{1}{y} - \frac{1}{1+y} \right) + y \left[\frac{1}{(1+y)^2} - \frac{1}{y^2} \right]$ or, after a little simple algebra,

this reduces to $-\frac{1}{(1+y)^2}$. So, $\int_0^1 \left\{ \int_0^1 \frac{x-y}{(x+y)^3} dx \right\} dy = -\int_0^1 \frac{dy}{(1+y)^2}$. Let $t = 1+y$,

and this integral becomes $-\int_1^2 \frac{dt}{t^2} = -\left(-\frac{1}{t}\right) \Big|_1^2 = -\left(-\frac{1}{2} + 1\right) = -\frac{1}{2}$. That is,

$\int_0^1 \left\{ \int_0^1 \frac{x-y}{(x+y)^3} dx \right\} dy = -\frac{1}{2}$. If you repeat this business for $\int_0^1 \left\{ \int_0^1 \frac{x-y}{(x+y)^3} dy \right\} dx$ you'll get $+\frac{1}{2}$. The lack of equality is caused by the integrand

blowing-up as we approach the lower left corner ($x=y=0$) of the region of integration. Don't forget the lesson of Chap. 1—*beware of exploding integrands!*

(C3.8): We know from (3.7.1) that (with $b=0$) $\int_{-\infty}^{\infty} e^{-ax^2} dx = \sqrt{\frac{\pi}{a}}$. Now, following the hint, consider $\int_{-\infty}^{\infty} e^{-ax^2+bx} dx = \int_{-\infty}^{\infty} e^{-(ax^2-bx)} dx = \int_{-\infty}^{\infty} e^{-a(x^2-\frac{b}{a}x)} dx = \int_{-\infty}^{\infty} e^{-a(x^2-\frac{b}{a}x+\frac{b^2}{4a^2}-\frac{b^2}{4a^2})} dx = \int_{-\infty}^{\infty} e^{\frac{b^2}{4a}} e^{-a(x-\frac{b}{2a})^2} dx = e^{\frac{b^2}{4a}} \int_{-\infty}^{\infty} e^{-a(x-\frac{b}{2a})^2} dx$. Next, change variable to $y = x - \frac{b}{2a}$. Then, $e^{\frac{b^2}{4a}} \int_{-\infty}^{\infty} e^{-a(x-\frac{b}{2a})^2} dx = e^{\frac{b^2}{4a}} \int_{-\infty}^{\infty} e^{-ay^2} dy = e^{\frac{b^2}{4a}} \sqrt{\frac{\pi}{a}}$ and so

$I(a, b) = \int_{-\infty}^{\infty} e^{-ax^2+bx} dx = e^{\frac{b^2}{4a}} \sqrt{\frac{\pi}{a}}$. Differentiating with respect to b gives us $\frac{\partial I}{\partial b} = \int_{-\infty}^{\infty} xe^{-ax^2+bx} dx = \frac{2b}{4a} e^{\frac{b^2}{4a}} \sqrt{\frac{\pi}{a}} = \frac{b}{2a} e^{\frac{b^2}{4a}} \sqrt{\frac{\pi}{a}}$. Setting $a=1$ and $b=-1$ says

$\int_{-\infty}^{\infty} xe^{-x^2-x} dx = -\frac{1}{2}\sqrt{\pi}e^{\frac{1}{4}} = -\frac{1}{2}\sqrt{\pi\sqrt{e}} = -1.137937\dots$ MATLAB agrees, as `quad(@(x)x.*exp(-x.^2-x),-10,10) = -1.137938\dots` If we differentiate $I(a, b)$ with respect

to a , we get $\frac{\partial I}{\partial a} = \int_{-\infty}^{\infty} -x^2 e^{-ax^2+bx} dx = \sqrt{\frac{\pi}{a}} \left[-\frac{4b^2}{16a^2} e^{\frac{b^2}{4a}} \right] + e^{\frac{b^2}{4a}} \left[\frac{-\frac{1}{2}a^{-1/2}\sqrt{\pi}}{a} \right] = -\sqrt{\frac{\pi}{a}} \frac{b^2}{4a^2} e^{\frac{b^2}{4a}} - \frac{\sqrt{\pi}}{2a^{3/2}} e^{\frac{b^2}{4a}}$. So, with $a=1$ and $b=-1$ we have

$\int_{-\infty}^{\infty} x^2 e^{-x^2-x} dx = \sqrt{\pi} \frac{1}{4} e^{\frac{1}{4}} + \frac{\sqrt{\pi}}{2} e^{\frac{1}{4}} = \frac{3}{4}\sqrt{\pi\sqrt{e}} = 1.7069068\dots$ MATLAB agrees, as `quad(@(x)x.^2.*exp(-x.^2-x),-10,10) = 1.706907\dots`

(C3.9): Following the hint, differentiation gives $\int_0^{\infty} \frac{\sin(mx)}{x}$

$\left\{ \frac{-2a}{(x^2+a^2)^2} \right\} dx = \frac{\pi}{2} \left\{ \frac{a^2(me^{-am}) - (1 - e^{-am})2a}{a^4} \right\}$. So, $\int_0^{\infty} \frac{\sin(mx)}{x(x^2+a^2)^2} dx = \frac{\pi}{2} \left\{ \frac{a^2(me^{-am}) - (1 - e^{-am})2a}{-2a^5} \right\}$ which, after a bit of simple algebra becomes

$$\int_0^{\infty} \frac{\sin(mx)}{x(x^2+a^2)^2} dx = \frac{\pi}{2a^4} \left[1 - \frac{2+ma}{2} e^{-am} \right].$$

Chapter 4

(C4.1): Change variable to $u = \sqrt{x} = x^{\frac{1}{2}}$ and so $\frac{du}{dx} = \frac{1}{2\sqrt{x}}$ which means that $dx = 2\sqrt{x} = 2u \, du$. Thus,
$$I(n) = \int_0^1 (1 - \sqrt{x})^n dx = \int_0^1 (1 - u)^n 2u \, du = 2 \int_0^1 u(1 - u)^n du = 2B(2, n + 1) = 2 \frac{\Gamma(2)\Gamma(n + 1)}{\Gamma(n + 3)} = 2 \frac{1!n!}{(n + 2)!}$$
 or, finally,

$$I(n) = \int_0^1 (1 - \sqrt{x})^n dx = \frac{2}{(n+1)(n+2)}.$$

In particular, $I(9) = \frac{2}{(10)(11)} = \frac{1}{55}$.

(C4.2): Make the change of variable $u = -\ln(x)$. Since $\ln(x) = -u$ then $x = e^{-u}$ and so $dx = -e^{-u} du$. So, $\int_0^1 x^m \ln^n(x) \, dx = \int_\infty^0 e^{-um} (-u)^n (-e^{-u} du) = (-1)^n \int_0^\infty u^n e^{-(m+1)u} \, du$. Change variable again, now to $t = (m+1)u$ and so $du = \frac{dt}{m+1}$. Thus,
$$\int_0^1 x^m \ln^n(x) \, dx = (-1)^n \int_0^\infty \left(\frac{t}{m+1}\right)^n e^{-t} \frac{dt}{m+1} = \frac{(-1)^n}{(m+1)^{n+1}} \int_0^\infty t^n e^{-t} \, dt.$$
 From (4.1.1) we have $\Gamma(q) = \int_0^\infty t^{q-1} e^{-t} \, dt$ and so our integral is the $q-1 = n$ case, that is, $q = n+1$ and so
$$\int_0^1 x^m \ln^n(x) \, dx = \frac{(-1)^n}{(m+1)^{n+1}} \Gamma(n+1).$$
 But by (4.1.3), $\Gamma(n+1) = n!$ and so

$$\int_0^1 x^m \ln^n(x) \, dx = \frac{(-1)^n n!}{(m+1)^{n+1}}.$$

(C4.3): Write the double integral over the triangular region R as
$$\iint_R x^a y^b \, dx \, dy = \int_0^1 x^a \left\{ \int_0^{1-x} y^b \, dy \right\} dx = \int_0^1 x^a \left\{ \left(\frac{y^{b+1}}{b+1}\right) \Big|_0^{1-x} \right\} dx = \frac{1}{b+1} \int_0^1 x^a (1-x)^{b+1} \, dx.$$
 From the defining integral for the beta function, $B(m, n) = \int_0^1 x^{m-1} (1-x)^{n-1} dx$, we have $m-1 = a$ and $n-1 = b+1$. Thus, $m = 1+a$ and $n = b+2$. So,
$$\iint_R x^a y^b \, dx \, dy = \frac{B(1+a, b+2)}{b+1} = \frac{\Gamma(1+a)\Gamma(b+2)}{(b+1)\Gamma(a+b+3)} = \frac{a!(b+1)!}{(b+1)(a+b+2)!} = \frac{a!b!}{(a+b+2)!}.$$

(C4.4): Simply set $b=1$ and $p=\frac{1}{2}$ in (4.3.2) to get $\int_0^\infty \frac{\sin(x)}{\sqrt{x}} dx = \frac{\pi}{2\Gamma(\frac{1}{2})\sin(\frac{\pi}{4})} = \frac{\pi}{2\sqrt{\pi}\frac{1}{\sqrt{2}}} = \sqrt{\frac{\pi}{2}}$. Do the same in (4.3.9) to get $\int_0^\infty \frac{\cos(x)}{\sqrt{x}} dx = \frac{\pi}{2\Gamma(\frac{1}{2})\cos(\frac{\pi}{4})} = \frac{\pi}{2\sqrt{\pi}\frac{1}{\sqrt{2}}} = \sqrt{\frac{\pi}{2}}$.

(C4.5): $\int_c^\infty \left\{ \int_0^\infty e^{-xy} \sin(bx) dx \right\} dy = \int_c^\infty \frac{b}{b^2+y^2} dy$ and so, with the integration order reversed on the left, $\int_0^\infty \sin(bx) \left\{ \int_c^\infty e^{-xy} dy \right\} dx = b \int_c^\infty \frac{dy}{b^2+y^2} = b \left[\frac{1}{b} \tan^{-1}\left(\frac{y}{b}\right) \right]_c^\infty$ or, $\int_0^\infty \sin(bx) \left\{ -\frac{e^{-xy}}{x} \right\}_c^\infty dx = \tan^{-1}(\infty) - \tan^{-1}\left(\frac{c}{b}\right) = \frac{\pi}{2} - \tan^{-1}\left(\frac{c}{b}\right)$. But, since $\tan^{-1}\left(\frac{c}{b}\right) = \frac{\pi}{2} - \tan^{-1}\left(\frac{b}{c}\right)$ —if you don't see this, draw the obvious right triangle—we have

$$\int_0^\infty \sin(bx) \frac{e^{-cx}}{x} dx = \tan^{-1}\left(\frac{b}{c}\right),$$

a generalization of Dirichlet's integral, (3.2.1), to which it reduces as $c \rightarrow 0$. If $b=c=1$ we have $\int_0^\infty \frac{\sin(x)}{x} e^{-x} dx = \tan^{-1}(1) = \frac{\pi}{4} = 0.78536\dots$ MATLAB agrees, as `quad(@(x)(sin(x))./x).*exp(-x),0,20) = 0.78539\dots`

(C4.6): Following the hint, make the substitution $x^b = y$ in $\int_0^\infty \frac{x^a}{(1+x^b)^c} dx$. Then, $\frac{dy}{dx} = bx^{b-1} = b\frac{x^b}{x} = b\frac{y}{y^{1/b}} = by^{1-\frac{1}{b}}$ or, $dx = \frac{dy}{by^{1-\frac{1}{b}}}$. So, $\int_0^\infty \frac{x^a}{(1+x^b)^c} dx = \int_0^\infty \frac{y^{a/b}}{(1+y)^c by^{1-\frac{1}{b}}} dy = \frac{1}{b} \int_0^\infty \frac{y^{\frac{a}{b}+\frac{1}{b}-1}}{(1+y)^c} dy = \frac{1}{b} \int_0^\infty \frac{y^{\frac{1+a}{b}-1}}{(1+y)^c} dy$. This is in the form of the beta function $B(m,n) = \int_0^\infty \frac{y^{m-1}}{(1+y)^{m+n}} dy$ where $m = \frac{1+a}{b}$ and $m+n=c$ ($n=c-m=c-\frac{1+a}{b}$). Thus, $\int_0^\infty \frac{x^a}{(1+x^b)^c} dx = \frac{1}{b} B\left(\frac{1+a}{b}, c-\frac{1+a}{b}\right) = \frac{\Gamma(\frac{1+a}{b})\Gamma(c-\frac{1+a}{b})}{b\Gamma(c)}$. For example, if $a=3$, $b=2$, and $c=4$, then $\int_0^\infty \frac{x^3}{(1+x^2)^4} dx = \frac{\Gamma(\frac{1+3}{2})\Gamma(4-\frac{1+3}{2})}{2\Gamma(4)} = \frac{\Gamma(2)\Gamma(2)}{2\Gamma(4)} = \frac{1!1!}{2(3!)} = \frac{1}{12} = 0.0833333\dots$ MATLAB agrees, as `quad(@(x)(x.^3)./(1+x.^2).^4),0,100) = 0.083334\dots`

(C4.7): Writing (4.4.2) for an inverse first power force law, $-\frac{k}{y} = mv \frac{dv}{dy}$, which separates into $-k \frac{dy}{y} = mv dv$ and this integrates indefinitely to $-k \ln(y) + \ln(C) = \frac{1}{2}mv^2$ where C is an arbitrary (positive) constant. Since $v=0$ at $y=a$ we have $-k \ln(a) + \ln(C) = 0$ and so $\ln(C) = k \ln(a)$. Thus, $-k \ln(y) + k \ln(a) = \frac{1}{2}mv^2 = \frac{1}{2} m \left(\frac{dy}{dt}\right)^2 = k \ln\left(\frac{a}{y}\right)$. That is, $\left(\frac{dy}{dt}\right)^2 = \frac{2k}{m} \ln\left(\frac{a}{y}\right)$. Solving for dt , $dt = \pm \sqrt{\frac{m}{2k}} \frac{dy}{\sqrt{\ln\left(\frac{a}{y}\right)}}$ and so $\int_0^T dt = T = \pm \sqrt{\frac{m}{2k}} \int_a^0 \frac{dy}{\sqrt{\ln\left(\frac{a}{y}\right)}}$. Let $u = \frac{y}{a}$ and so $dy = a du$. Then, $T = \pm \sqrt{\frac{m}{2k}} \int_1^0 \frac{a du}{\sqrt{\ln\left(\frac{1}{u}\right)}} = \pm a \sqrt{\frac{m}{2k}} \int_1^0 \frac{du}{\sqrt{-\ln(u)}}$ or, using the minus sign to give $T > 0$, $T = a \sqrt{\frac{m}{2k}} \int_0^1 \frac{du}{\sqrt{-\ln(u)}}$. From (3.1.8) the integral is $\sqrt{\pi}$ and so $T = a \sqrt{\frac{m\pi}{2k}}$.

(C4.8): The reflection formula for the gamma function says $\Gamma(1-m) = \frac{\pi}{\Gamma(m) \sin(m\pi)}$. For $m > 1$ we have $1-m < 0$, and so on the left of the reflection formula we have the gamma function with a negative argument. On the right, both $\Gamma(m)$ and π are positive quantities, while $\sin(m\pi)$ goes through zero for every integer value of m . So, as m increases from 2, $1-m$ decreases from -1 . As each new negative integer is encountered the gamma function blows-up, *in both directions*, as the sign of $\sin(m\pi)$ goes positive and negative as it passes periodically through zero as m increases.

Chapter 5

(C5.1): The integrand is $\frac{1-x^m}{1-x^n} = (1-x^m)(1+x^n+x^{2n}+x^{3n}+\dots)$ and so $I(m, n) = \int_0^1 (1-x^m) \left\{ \sum_{k=0}^{\infty} x^{kn} \right\} dx = \sum_{k=0}^{\infty} \int_0^1 \{x^{kn} - x^{kn+m}\} dx = \sum_{k=0}^{\infty} \left\{ \frac{x^{kn+1}}{kn+1} - \frac{x^{kn+m+1}}{kn+m+1} \right\} \Big|_0^1 = \sum_{k=0}^{\infty} \left\{ \frac{1}{kn+1} - \frac{1}{kn+m+1} \right\} = \sum_{k=0}^{\infty} \frac{kn+m+1-kn-1}{(kn+1)(kn+m+1)} = m \sum_{k=0}^{\infty} \frac{1}{(kn+1)(kn+m+1)}$.

For given values of m and n this last summation is easy to code as an accumulating sum inside a loop, which is a near-trivial coding situation for any modern language. The MATLAB code named **cp5.m** does the case of $m = 9, n = 11$:

cp5.m

```
m=9;n=11;s=0;k=0;
while 1>0
    f1=k*n+1;f2=f1+m;k=k+1;
    s=s+1/(f1*f2);m*s
end
```

Since 1 is *always* greater than 0, **cp5.m** is stuck in an endless *while* loop, and I just let the code run while I watched the successive values of the summation stream upward on my computer screen until I didn't see the sixth decimal digit change anymore (and then I let the code run for 15 or 20 s more). I finally stopped the code with a Control-C. This is less than elegant, sure, but totally in keeping with the pretty casual philosophical approach I've taken all through this book. The results: $I(9, 11) = 0.972662$ and $I(11, 9) = 1.030656$.

(C5.2): Start by writing $\int_1^k \frac{dx}{x^2} = \left(-\frac{1}{x}\right)\Big|_1^k = 1 - \frac{1}{k}$. Since $\int_1^k \frac{dx}{x^2} = \sum_{j=1}^{k-1} \int_j^{j+1} \frac{dx}{x^2}$ we can write $\sum_{k=1}^n \int_1^k \frac{dx}{x^2} = \sum_{k=1}^n \sum_{j=1}^{k-1} \int_j^{j+1} \frac{dx}{x^2} = \sum_{k=1}^n \left(1 - \frac{1}{k}\right) = n - \sum_{k=1}^n \frac{1}{k}$. Next, you'll recall from the opening of Sect. 5.4 that $\gamma(n) = \sum_{k=1}^n \frac{1}{k} - \ln(n)$ where Euler's constant $\gamma = \lim_{n \rightarrow \infty} \gamma(n)$, and so $\sum_{k=1}^n \frac{1}{k} = \gamma(n) + \ln(n)$ which says $\sum_{k=1}^n \sum_{j=1}^{k-1} \int_j^{j+1} \frac{dx}{x^2} = n - \gamma(n) - \ln(n)$. Writing out the double summation, term-by-term, we have

$$\begin{aligned}
 k = 1: & \text{nothing} \\
 k = 2: & \int_1^2 \frac{dx}{x^2} \\
 k = 3: & \int_1^2 \frac{dx}{x^2} + \int_2^3 \frac{dx}{x^2} \\
 k = 4: & \int_1^2 \frac{dx}{x^2} + \int_2^3 \frac{dx}{x^2} + \int_3^4 \frac{dx}{x^2} \\
 \dots & \\
 k = n: & \int_1^2 \frac{dx}{x^2} + \int_2^3 \frac{dx}{x^2} + \int_3^4 \frac{dx}{x^2} + \dots + \int_{n-1}^n \frac{dx}{x^2}.
 \end{aligned}$$

Adding these terms *vertically* to recover the double-sum we have

$$\begin{aligned} & (n-1) \int_1^2 \frac{dx}{x^2} + (n-2) \int_2^3 \frac{dx}{x^2} + (n-3) \int_3^4 \frac{dx}{x^2} + \cdots + (1) \int_{n-1}^n \frac{dx}{x^2} \\ &= \int_1^2 \frac{(n-1) dx}{x^2} + \int_2^3 \frac{(n-2) dx}{x^2} + \int_3^4 \frac{(n-3) dx}{x^2} + \int_{n-1}^n \frac{dx}{x^2} = n - \gamma(n) - \ln(n) \end{aligned}$$

The general form of the integrals is $\int_j^{j+1} \frac{(n-j)}{x^2} dx$. Since the interval of integration is $j \leq x \leq j+1$ we have, *by definition*, $[x] = j$. So, $n - \gamma(n) - \ln(n) = \int_1^n \frac{n - [x]}{x^2} dx$. Or, as $\{x\} = x - [x]$ and so $[x] = x - \{x\}$, then $n - [x] = n - [x - \{x\}] = n - x + \{x\}$. Thus,

$$\begin{aligned} n - \gamma(n) - \ln(n) &= \int_1^n \frac{n - x + \{x\}}{x^2} dx = n \int_1^n \frac{dx}{x^2} - \int_1^n \frac{dx}{x} + \int_1^n \frac{\{x\}}{x^2} dx \\ &= n \left(-\frac{1}{x} \right) \Big|_1^n - [\ln(x)] \Big|_1^n + \int_1^n \frac{\{x\}}{x^2} dx = n \left(1 - \frac{1}{n} \right) - \ln(n) + \int_1^n \frac{\{x\}}{x^2} dx \\ &= n - 1 - \ln(n) + \int_1^n \frac{\{x\}}{x^2} dx \end{aligned}$$

or, $\int_1^n \frac{\{x\}}{x^2} dx = 1 - \gamma(n)$. Finally, letting $n \rightarrow \infty$, we have

$$\int_1^\infty \frac{\{x\}}{x^2} dx = 1 - \gamma.$$

(C5.3): For the $\zeta(3)$ calculation, things go in much the same way. Starting with

$$\begin{aligned} \int_1^k \frac{dx}{x^4} &= \sum_{j=1}^k \int_j^{j+1} \frac{dx}{x^4} = \left(-\frac{1}{3x^3} \right) \Big|_1^k = \frac{1}{3} \left(1 - \frac{1}{k^3} \right), \text{ we have } \sum_{k=1}^n \int_1^k \frac{dx}{x^4} = \\ & \sum_{k=1}^n \frac{1}{3} \left(1 - \frac{1}{k^3} \right) = \frac{1}{3}n - \frac{1}{3} \zeta_n(3), \text{ where } \lim_{n \rightarrow \infty} \zeta_n(3) = \zeta(3). \text{ Writing out the} \\ & \text{double summation, term-by-term just as we did in (C5.2), and then doing the} \\ & \text{'adding vertically' trick, you should now be able to show that } \frac{1}{3}n - \frac{1}{3} \zeta_n(3) = \\ & \int_1^n \frac{n-x+\{x\}}{x^4} dx = n \int_1^n \frac{dx}{x^4} - \int_1^n \frac{dx}{x^3} + \int_1^n \frac{\{x\}}{x^4} dx = n \left(-\frac{1}{3x^3} \right) \Big|_1^n - \left(-\frac{1}{2x^2} \right) \Big|_1^n + \\ & \int_1^n \frac{\{x\}}{x^4} dx = n \left(\frac{1}{3} - \frac{1}{3n^3} \right) - \left(\frac{1}{2} - \frac{1}{2n^2} \right) + \int_1^n \frac{\{x\}}{x^4} dx = \frac{1}{3}n - \frac{1}{3n^2} - \frac{1}{2} + \frac{1}{2n^2} + \end{aligned}$$

$$\int_1^n \frac{\{x\}}{x^4} dx = \frac{1}{3}n - \frac{1}{3}\zeta_n(3). \text{ So, } \int_1^n \frac{\{x\}}{x^4} dx = \frac{1}{2} + \frac{1}{3n^2} - \frac{1}{2n^2} - \frac{1}{3}\zeta_n(3) \text{ or, as } n \rightarrow \infty,$$

$$\int_1^n \frac{\{x\}}{x^4} dx = \frac{1}{2} - \frac{1}{3}\zeta(3). \text{ Thus, } \zeta(3) = \frac{3}{2} - 3 \int_1^\infty \frac{\{x\}}{x^4} dx.$$

(C5.4): Let $a = 1 + x$, with $x \approx 0$. Then, $\frac{1}{1-a} + \frac{1}{\ln(a)} = \frac{1}{-x} + \frac{1}{\ln(1+x)}$ or, using the power-series expansion for $\ln(1+x)$ given at the beginning of Sect. 5.2, for $-1 < x < 1$, we have

$$\begin{aligned} \frac{1}{1-a} + \frac{1}{\ln(a)} &= \lim_{x \rightarrow 0} \left\{ -\frac{1}{x} + \frac{1}{x - \frac{x^2}{2} + \frac{x^3}{3} - \frac{x^4}{4} + \dots} \right\} \\ &= \lim_{x \rightarrow 0} \left\{ -\frac{1}{x} + \frac{1}{x \left(1 - \frac{x}{2} + \frac{x^2}{3} - \frac{x^3}{4} + \dots \right)} \right\} \\ &= \lim_{x \rightarrow 0} \left\{ \frac{1}{x} \left[-1 + \frac{1}{1 - \frac{x}{2} + \frac{x^2}{3} - \frac{x^3}{4} + \dots} \right] \right\} \\ &= \lim_{x \rightarrow 0} \left\{ \frac{1}{x} \left[-1 + 1 + \frac{x}{2} \right] \right\} = \frac{1}{2}. \end{aligned}$$

(C5.5): We start with $2 \left[\frac{1}{1^2} - \frac{1}{2^2} + \frac{1}{3^2} - \frac{1}{4^2} + \dots \right] = 2 \left[\left\{ \frac{1}{1^2} + \frac{1}{3^2} + \frac{1}{5^2} + \dots \right\} - \left\{ \frac{1}{2^2} + \frac{1}{4^2} + \frac{1}{6^2} + \dots \right\} \right]$. The two sums in the curly brackets are the sum of the odd terms of $\zeta(2)$, and of the even terms of $\zeta(2)$, respectively. Now, consider the sum of the even terms: $\frac{1}{2^2} + \frac{1}{4^2} + \frac{1}{6^2} + \dots = \frac{1}{(2 \cdot 1)^2} + \frac{1}{(2 \cdot 2)^2} + \frac{1}{(2 \cdot 3)^2} + \dots = \frac{1}{4} \left[\frac{1}{1^2} + \frac{1}{2^2} + \frac{1}{3^2} + \frac{1}{4^2} + \dots \right] = \frac{1}{4}\zeta(2)$. This means the sum of the odd terms is $\frac{3}{4}\zeta(2)$. So, our initial expression is $2 \left[\frac{3}{4}\zeta(2) - \frac{1}{4}\zeta(2) \right] = \zeta(2)$, as was to be shown.

(C5.6): In $\int_0^1 \frac{\ln^2(1-x)}{x} dx$, follow the hint and change variable to $1-x = e^{-t}$. Thus, $-\frac{dx}{dt} = -e^{-t}$ or, $dx = e^{-t} dt$. Now, when $x=0$ we have $t=0$, and when $x=1$ then $t = \infty$. So, $\int_0^1 \frac{\ln^2(1-x)}{x} dx = \int_0^\infty \frac{\ln^2(e^{-t})}{1-e^{-t}} e^{-t} dt = \int_0^\infty \frac{t^2}{1-e^{-t}} e^{-t} dt = \int_0^\infty \frac{t^2}{e^t - 1} dt$. From (5.3.4) we see that this is $\Gamma(s)\zeta(s)$ for $s=3$. That is, $\int_0^1 \frac{\ln^2(1-x)}{x} dx = \Gamma(3)\zeta(3) = 2!\zeta(3) = 2\zeta(3)$.

(C5.7): In (5.3.4) write $p = s - 1$, and so we have $\int_0^\infty \frac{x^p}{e^x - 1} dx = \Gamma(p + 1)\zeta(p + 1)$.

Continuing, $\int_0^\infty \frac{x^p}{e^x - 1} dx = \int_0^\infty \frac{x^p}{e^x(1 - e^{-x})} dx$. Let $u = e^{-x}$ and so $e^x = \frac{1}{u}$.

Also, $\ln(u) = -x$ or, $x = -\ln(u)$. Finally, $\frac{du}{dx} = -e^{-x} = -u$, and so $dx = -\frac{du}{u}$.

So, $\int_0^\infty \frac{x^p}{e^x(1 - e^{-x})} dx = \int_1^0 \frac{\{-\ln(u)\}^p}{\frac{1}{u}(1 - u)} \left(-\frac{du}{u}\right) = \int_0^1 \frac{\{-\ln(u)\}^p}{1 - u} du$. Thus, $\int_0^1 \frac{\{-\ln(x)\}^p}{1 - x} dx = \Gamma(p + 1)\zeta(p + 1)$.

(C5.8): Since $\frac{1}{1-p} = 1 + p + p^2 + \dots = \sum_{k=0}^\infty p^k$, then $\frac{1}{1-x_1x_2x_3\dots x_n} =$

$\sum_{k=0}^\infty (x_1x_2x_3\dots x_n)^k$ and so $\int_0^1 \int_0^1 \dots \int_0^1 \frac{1}{1-x_1x_2x_3\dots x_n} dx_1 dx_2 dx_3 \dots dx_n =$

$\int_0^1 \int_0^1 \dots \int_0^1 \sum_{k=0}^\infty (x_1x_2x_3\dots x_n)^k dx_1 dx_2 dx_3 \dots dx_n = \sum_{k=0}^\infty \int_0^1 \int_0^1 \dots \int_0^1 x_1^k x_2^k \dots x_n^k$

$dx_1 dx_2 \dots dx_n$. Now, $\int_0^1 \int_0^1 \dots \int_0^1 x_1^k x_2^k \dots x_n^k dx_1 dx_2 \dots dx_n = \int_0^1 x_1^k dx_1$

$\int_0^1 x_2^k dx_2 \dots \int_0^1 x_n^k dx_n = \left(\frac{x_1^{k+1}}{k+1}\right)\Big|_0^1 \left(\frac{x_2^{k+1}}{k+1}\right)\Big|_0^1 \dots \left(\frac{x_n^{k+1}}{k+1}\right)\Big|_0^1 = \frac{1}{(k+1)^n}$. So,

$\int_0^1 \int_0^1 \dots \int_0^1 \frac{1}{1-x_1x_2x_3\dots x_n} dx_1 dx_2 dx_3 \dots dx_n = \sum_{k=0}^\infty \frac{1}{(k+1)^n} = \frac{1}{1^n} + \frac{1}{2^n} + \frac{1}{3^n} + \frac{1}{4^n} + \dots = \zeta(n)$.

(C5.9): In $\int_0^\infty \ln\left(\frac{1+e^{-x}}{1-e^{-x}}\right) dx$, let $u = e^{-x}$ and so $\frac{du}{dx} = -u$ which means

$dx = -\frac{du}{u}$. Thus,

$$\begin{aligned} \int_0^\infty \ln\left(\frac{1+e^{-x}}{1-e^{-x}}\right) dx &= \int_1^0 \ln\left(\frac{1+u}{1-u}\right) \left(-\frac{du}{u}\right) = \int_0^1 \frac{1}{u} \ln\left(\frac{1+u}{1-u}\right) du \\ &= \int_0^1 \frac{1}{u} \{\ln(1+u) - \ln(1-u)\} du \\ &= \int_0^1 \frac{1}{u} \left\{ \left(u - \frac{u^2}{2} + \frac{u^3}{3} - \frac{u^4}{4} + \dots\right) - \left(-u - \frac{u^2}{2} - \frac{u^3}{3} - \frac{u^4}{4} - \dots\right) \right\} du \\ &= \int_0^1 \frac{1}{u} \left(2u + 2\frac{u^3}{3} + 2\frac{u^5}{5} + \dots\right) du = 2 \int_0^1 \left(1 + \frac{u^2}{3} + \frac{u^4}{5} + \dots\right) du \\ &= 2 \left(1 + \frac{u^3}{9} + \frac{u^5}{25} + \dots\right) \Big|_0^1 = 2 \left(\frac{1}{1^2} + \frac{1}{3^2} + \frac{1}{5^2} + \dots\right) = 2 \left(\frac{\pi^2}{8}\right) = \frac{\pi^2}{4} \end{aligned}$$

(C5.10): Following the hint, write $I(m) = \int_0^\infty x^m e^{-x} dx = \int_0^\infty e^{m \ln(x)} e^{-x} dx$. Then, $\frac{dI}{dm} = \int_0^\infty \ln(x) e^{m \ln(x)} e^{-x} dx$, and so $\frac{d^2 I}{dm^2} = \int_0^\infty \ln^2(x) e^{m \ln(x)} e^{-x} dx$. Thus, $\int_0^\infty e^{-x} \ln^2(x) dx = \frac{d^2 I}{dm^2} \Big|_{m=0}$. Notice that $I(m)$ is the gamma function $\Gamma(n)$ for $n - 1 = m$, that is, $n = m + 1$. So, $I(m) = \Gamma(m + 1)$ and $\int_0^\infty e^{-x} \ln^2(x) dx = \left\{ \frac{d^2}{dm^2} \Gamma(m + 1) \right\} \Big|_{m=0}$. Now, the digamma function says $\frac{d\Gamma(z)}{dz} = \Gamma(z) \left[-\frac{1}{z} - \gamma + \sum_{r=1}^\infty \left(\frac{1}{r} - \frac{1}{r+z} \right) \right]$ and so, for $z = m + 1$, $\frac{d\Gamma(m+1)}{d(m+1)} = \frac{d\Gamma(m+1)}{dm} = \Gamma(m + 1) \left[-\frac{1}{m+1} - \gamma + \sum_{r=1}^\infty \left(\frac{1}{r} - \frac{1}{r+m+1} \right) \right]$. Differentiating again, $\frac{d^2 \Gamma(m+1)}{dm^2} = \frac{d\Gamma(m+1)}{dm} \left[-\frac{1}{m+1} - \gamma + \sum_{r=1}^\infty \left(\frac{1}{r} - \frac{1}{r+m+1} \right) \right] + \Gamma(m+1) \left[\frac{1}{(m+1)^2} + \sum_{r=1}^\infty \frac{1}{(r+m+1)^2} \right]$. So, since $\Gamma(1) = 1$,

$$\begin{aligned} \frac{d\Gamma(m+1)}{dm} \Big|_{m=0} &= \Gamma(1) \left[-1 - \gamma + \sum_{r=1}^\infty \left(\frac{1}{r} - \frac{1}{r+1} \right) \right] \\ &= -1 - \gamma + \left(1 - \frac{1}{2} \right) + \left(\frac{1}{2} - \frac{1}{3} \right) + \dots \\ &= -1 - \gamma + 1 = -\gamma \text{ and } \frac{d^2 \Gamma(m+1)}{dm^2} \Big|_{m=0} \\ &= -\gamma \left[-1 - \gamma + \sum_{r=1}^\infty \left(\frac{1}{r} - \frac{1}{r+1} \right) \right] + \Gamma(1) \left[1 + \sum_{r=1}^\infty \frac{1}{(r+1)^2} \right] \\ &= \gamma + \gamma^2 - \gamma \left[\left(1 - \frac{1}{2} \right) + \left(\frac{1}{2} - \frac{1}{3} \right) + \dots \right] \\ &\quad + 1 + \frac{1}{2^2} + \frac{1}{3^2} + \dots = \gamma + \gamma^2 - \gamma + 1 + \frac{1}{2^2} + \frac{1}{3^2} + \dots \\ &= \gamma^2 + \zeta(2) = \gamma^2 + \frac{\pi^2}{6} = \int_0^\infty e^{-x} \ln^2(x) dx. \end{aligned}$$

(C5.11): From (5.4.1), $\gamma = \int_0^1 \frac{1 - e^{-u}}{u} du - \int_1^\infty \frac{e^{-u}}{u} du$. In the second integral, let $t = \frac{1}{u}$ and so $du = -\frac{1}{t^2} dt$. Then, $\int_1^\infty \frac{e^{-u}}{u} du = \int_1^0 \frac{e^{-\frac{1}{t}}}{\frac{1}{t}} \left(-\frac{1}{t^2} dt \right) = \int_0^1 \frac{e^{-\frac{1}{t}}}{t} dt$. So, $\gamma = \int_0^1 \frac{1 - e^{-u}}{u} du - \int_0^1 \frac{e^{-\frac{1}{t}}}{t} dt$ or, as was to be shown, $\gamma = \int_0^1 \frac{1 - e^{-u} - e^{-\frac{1}{u}}}{u} du$.

Chapter 6

(C6.1): Follow the same path described in Sect. 6.3.

(C6.2): Following the hint, consider $f(x) = \frac{x}{x^n + 1} - \frac{1}{x^{n-1} + x^{n-2} + \dots + x + 1}$. By direct multiplication, you can confirm that $x^n - 1 = (x - 1)(x^{n-1} + x^{n-2} + \dots + x + 1)$, and so $f(x) = \frac{x}{x^n + 1} - \frac{1}{\frac{x^n - 1}{x - 1}} = \frac{x}{x^n + 1} - \frac{x - 1}{x^n - 1} = \left[\frac{x}{x^n + 1} - \frac{x}{x^n - 1} \right] + \frac{1}{x^n - 1} = -\frac{2x}{x^{2n} - 1} + \frac{1}{x^n - 1}$. Next, pick a value for a such that $0 \leq a \leq 1$. Then

$$\int_0^a f(x) dx = \int_0^a \frac{dx}{x^n - 1} - \int_0^a \frac{2x}{x^{2n} - 1} dx.$$

In the second integral on the right in the box let $y = x^2$ and so $\frac{dy}{dx} = 2x$ or, $dx = \frac{dy}{2x}$ and so $\int_0^a \frac{2x}{x^{2n} - 1} dx = \int_0^{a^2} \frac{2x}{y^n - 1} \frac{dy}{2x} = \int_0^{a^2} \frac{dy}{y^n - 1}$. Thus, $\int_0^a f(x) dx = \int_0^a \frac{dx}{x^n - 1} - \int_0^{a^2} \frac{dy}{y^n - 1}$ or, as $a^2 < a$ (since $a < 1$), we can write

$$\int_0^a f(x) dx = \int_{a^2}^a \frac{dx}{x^n - 1}.$$

Next, return to the first box and replace the integration limits with b to infinity, where $b > 1$. That is, $\int_b^\infty f(x) dx = \int_b^\infty \frac{dx}{x^n - 1} - \int_b^\infty \frac{2x}{x^{2n} - 1} dx$. In the second integral on the right let $y = x^2$ (just as before) and so $\int_b^\infty f(x) dx = \int_b^\infty \frac{dx}{x^n - 1} - \int_{b^2}^\infty \frac{dy}{y^n - 1} = \int_b^{b^2} \frac{dx}{x^n - 1}$ because $b^2 > b$ (because $b > 1$). Now, in the integral on the right, let $y = \frac{1}{x}$ and so $\frac{dy}{dx} = -\frac{1}{x^2} = -y^2$ or, $dx = -\frac{dy}{y^2}$. So, $\int_b^{b^2} \frac{dx}{x^n - 1} = \int_{1/b}^{1/b^2} \frac{-\frac{dy}{y^2}}{\frac{1}{y^n} - 1} = -\int_{1/b^2}^{1/b} \frac{y^{n-2}}{1 - y^n} dy = \int_{1/b^2}^{1/b} \frac{y^{n-2}}{1 - y^n} dy$ and we have

$$\int_b^\infty f(x) dx = \int_{1/b^2}^{1/b} \frac{y^{n-2}}{1 - y^n} dy.$$

Thus, adding the two results in the second and third boxes, we get

$$\int_0^a f(x) dx + \int_b^\infty f(x) dx = \int_{a^2}^a \frac{dx}{x^n - 1} + \int_{1/b^2}^{1/b} \frac{y^{n-2}}{1 - y^n} dy$$

or, $\int_0^a f(x) dx + \int_b^\infty f(x) dx = \int_{a^2}^a \frac{dx}{x^n - 1} - \int_{\frac{1}{b^2}}^{\frac{1}{b}} \frac{x^{n-2}}{x^n - 1} dx$. Let $b = \frac{1}{a}$ (since $a < 1$

then $b > 1$, just as we supposed), and so $\int_0^a f(x) dx + \int_{\frac{1}{a}}^\infty f(x) dx = \int_{a^2}^a \frac{dx}{x^n - 1} -$

$$\int_{a^2}^a \frac{x^{n-2}}{x^n - 1} dx = \int_{a^2}^a \frac{1 - x^{n-2}}{x^n - 1} dx \text{ or, } \int_0^a f(x) dx + \int_{\frac{1}{a}}^\infty f(x) dx = - \int_{a^2}^a \frac{1 - x^{n-2}}{1 - x^n} dx.$$

Our last step is to now let $a \rightarrow 1$. Notice that the integrand in the integral on the right is a continuous function that always has a finite value, even when $x = 1$, because of

L'Hospital's rule: $\lim_{x \rightarrow 1} \frac{1 - x^{n-2}}{1 - x^n} = \lim_{x \rightarrow 1} \frac{-(n-2)x^{n-3}}{-nx^{n-1}} = \frac{n-2}{n}$. Thus, the integral

always exists. So, as $a \rightarrow 1$, we have $\int_0^1 f(x) dx + \int_1^\infty f(x) dx = - \int_1^1 \frac{1 - x^{n-2}}{1 - x^n} dx = 0 = \int_0^\infty f(x) dx$ and we are done.

(C6.3): Following the hint, write $\int_0^1 c^x dx = \int_0^1 (e^{-\lambda})^x dx = \int_0^1 e^{-\lambda x} dx =$

$\left(\frac{e^{-\lambda x}}{-\lambda}\right)\Big|_0^1 = \frac{e^{-\lambda} - 1}{-\lambda} = \frac{1 - e^{-\lambda}}{\lambda}$. Also, $\sum_{k=1}^\infty c^k = \sum_{k=1}^\infty e^{-\lambda k}$ which is, of course, simply a geometric series easily summed using the standard trick (which I'm assuming you know—if you need a reminder, look in any high school algebra text) to give $\frac{e^{-\lambda}}{1 - e^{-\lambda}}$.

So, $\frac{1 - e^{-\lambda}}{\lambda} = \frac{e^{-\lambda}}{1 - e^{-\lambda}}$ which, with just a bit of elementary algebra becomes $e^{2\lambda} - (2 + \lambda)e^\lambda + 1 = f(\lambda) = 0$. Note, *carefully*, that while $f(0) = 0$, it is *not* true that $\lambda = 0$ is a solution to the problem. That's because then $c = e^{-\lambda} = 1$ and this c obviously fails to satisfy $\int_0^1 c^x dx = \sum_{k=1}^\infty c^k$. Now, observe that $f(1) = e^2 - 3e + 1 = 0.23 > 0$ and that $f(\frac{1}{2}) = e - 2.5\sqrt{e} + 1 = -0.4 < 0$. So, $f(\lambda) = 0$ for some λ in the interval $\frac{1}{2} < \lambda < 1$. We can get better and better (that is, narrower and narrower) intervals in which this λ lies using the simple, easy-to-program 'binary chop' method. That is, we start by defining two variables, *lower* and *upper*, and set them to the initial bounds on λ of 0.5 and 1, respectively. We then set the variable *lambda* to the value $\frac{1}{2}(\text{lower} + \text{upper})$. If $f(\text{lambda}) > 0$ then set *upper* = *lambda*, and if $f(\text{lambda}) < 0$ then set *lower* = *lambda*. Each time we do this cycle of operations we reduce the interval in which the solution λ lies by one-half (if, at some point, $f(\text{lambda}) = 0$ then, of course, we are immediately done). So, running through 100 such cycles (done in a flash on a modern computer) we reduce the initial interval, of width $\frac{1}{2}$, by a factor of 2^{100} , and so both *lower* and *upper* will have converged toward each other to squeeze *lambda* closer to the solution λ by many more than the 13 decimal digits requested. The result (see the following code **cp6.m**) is $\lambda = 0.9308211936517\dots$ and so $c = e^{-\lambda} = 0.3942298383683\dots$. The common value of the integral and the sum is 0.65079\dots

cp6.m

```

lower=0.5;upper=1;
for loop=1:100
    lambda=(lower+upper)/2;
    term=exp(lambda);
    f=term^2-(2+lambda)*term+1;
    if f<0
        lower=lambda;
    else
        upper=lambda;
    end
end
c=exp(-lambda)

```

(C6.4): (a) Taking advantage of the suggestive nature of Leibniz's differential notation that I hinted at in the problem statement, write the *differentiation operator* $\frac{d}{dt} = \frac{dx}{dt} \frac{d}{dx} = \dot{x} \frac{d}{dx}$. Thus, $\frac{d}{dx} (\dot{x}^2) = 2\dot{x} \frac{d\dot{x}}{dx} = 2\left[\dot{x} \frac{d}{dx}\right]\dot{x}$. So, replacing the operator $\dot{x} \frac{d}{dx}$ in the curly brackets with the equivalent operator $\frac{d}{dt}$, we have $\frac{d}{dx} (\dot{x}^2) = 2 \frac{d\dot{x}}{dt} = 2\ddot{x}$. Thus, $\frac{x}{2} \frac{d}{dx} (\dot{x}^2) = \frac{x}{2} 2\ddot{x} = x\ddot{x}$ and so, starting with Sommerfeld's equation $x\ddot{x} + \dot{x}^2 = gx$, we can rewrite it as $\frac{x}{2} \frac{d}{dx} (\dot{x}^2) + \dot{x}^2 = gx$ or, $\frac{d}{dx} (\dot{x}^2) + \frac{2}{x} \dot{x}^2 = g$ or, as $\dot{x}^2 = v^2$, we arrive at $\frac{d}{dx} (v^2) = -\frac{2}{x} v^2 + 2g$, which is Keiffer's equation.

(b) Following the hint, multiply through Keiffer's equation by x^2 to get $x^2 \frac{d}{dx} (v^2) + 2xv^2 = 2gx^2$. Then, $\frac{d}{dx} (x^2 v^2) = 2gx^2$ or, integrating, $\int_0^x \frac{d}{dx} (x^2 v^2) dx' = \int_0^x 2gx' dx'$ and so $\int_0^x d(x^2 v^2) = 2g \frac{1}{3} x^3 = x^2 v^2$. Thus, $v^2 = \frac{2}{3} gx = \left(\frac{dx}{dt}\right)^2$ and so $\frac{dx}{dt} = \sqrt{\frac{2}{3}g} \sqrt{x}$.

(c) From (b), $\frac{d^2 x}{dt^2} = \sqrt{\frac{2}{3}g} \left(\frac{1}{2\sqrt{x}}\right) \frac{dx}{dt} = \sqrt{\frac{2}{3}g} \left(\frac{1}{2\sqrt{x}}\right) \sqrt{\frac{2}{3}g} \sqrt{x} = \frac{2}{3}g \frac{1}{2} = \frac{1}{3}g$.

(d) From (b), $\frac{dx}{\sqrt{x}} = \sqrt{\frac{2}{3}g} dt$ and so $\int_0^L \frac{dx}{\sqrt{x}} = \int_0^T dt \sqrt{\frac{2}{3}g} = T \sqrt{\frac{2}{3}g} = (2x^{1/2}) \Big|_0^L = 2\sqrt{L}$. Thus, $T = 2\sqrt{L} \sqrt{\frac{3}{2g}} = \sqrt{\frac{6L}{g}}$.

(e) When a length x of the chain (with mass μx) has slid over the edge, it is moving at speed $v = \frac{dx}{dt}$ and so its K.E. is $\frac{1}{2}\mu x \left(\frac{dx}{dt}\right)^2$. The center of mass is $\frac{1}{2}x$ below the table top and so the P.E. is $-\mu x g \frac{1}{2}x = -\frac{1}{2}\mu g x^2$. Assuming conservation of energy says K.E. + P.E. = 0, and so $\frac{1}{2}\mu x \left(\frac{dx}{dt}\right)^2 - \frac{1}{2}\mu g x^2 = 0$ or, $\left(\frac{dx}{dt}\right)^2 = \frac{gx^2}{x} = gx$. Thus, $\frac{dx}{dt} = \sqrt{g} \sqrt{x}$ and the acceleration of the chain is $\frac{d^2 x}{dt^2} = \sqrt{g} \left(\frac{1}{2\sqrt{x}}\right) \frac{dx}{dt} = \sqrt{g} \left(\frac{1}{2\sqrt{x}}\right) \sqrt{g} \sqrt{x} = \frac{1}{2}g$.

Chapter 7

(C7.1): For the $n = 5$ case we have p odd and so use (7.7.2) to write (with $p = q = 5$)

$\int_0^\infty \left\{ \frac{\sin(x)}{x} \right\}^5 dx = \frac{5!}{4!} \int_0^\infty \frac{u^4}{(u^2 + 1^2)(u^2 + 3^2)(u^2 + 5^2)} du = 5 \left[\int_0^\infty \frac{A}{u^2 + 1^2} du + \int_0^\infty \frac{B}{u^2 + 3^2} du + \int_0^\infty \frac{C}{u^2 + 5^2} du \right]$. So, we have $A[u^2 + 9][u^2 + 25] + B[u^2 + 1][u^2 + 25] + C[u^2 + 1][u^2 + 9] = u^4$. Multiplying out, we arrive at $A[u^4 + 34u^2 + 225] + B[u^4 + 26u^2 + 25] + C[u^4 + 10u^2 + 9] = u^4$. Then, equating coefficients of equal powers of u on each side of the equality gives us three simultaneous algebraic equations for A , B , and C :

$$\begin{aligned} A + B + C &= 1, \\ 34A + 26B + 10C &= 0, \\ 225A + 25B + 9C &= 0. \end{aligned}$$

This system is easily solved, as follows, using determinants (*Cramer's rule*, which you can find in any good book on algebra). First, the system determinant is

$$D = \begin{vmatrix} 1 & 1 & 1 \\ 34 & 26 & 10 \\ 225 & 25 & 9 \end{vmatrix} \text{ which expands as } D = \begin{vmatrix} 26 & 10 \\ 25 & 9 \end{vmatrix} - \begin{vmatrix} 34 & 10 \\ 225 & 9 \end{vmatrix} + \begin{vmatrix} 34 & 26 \\ 225 & 25 \end{vmatrix}$$

$$= (234 - 250) - (306 - 2,250) + (850 - 5,850) = -16 + 1,944 - 5,000 = -3,072.$$

Thus, the values of A , B , and C are:

$$A = \frac{\begin{vmatrix} 1 & 1 & 1 \\ 0 & 26 & 10 \\ 0 & 25 & 9 \end{vmatrix}}{D} = \frac{\begin{vmatrix} 26 & 10 \\ 25 & 9 \end{vmatrix}}{-3,072} = \frac{-16}{-3,072} = \frac{16}{3,072}, \quad B = \frac{\begin{vmatrix} 1 & 1 & 1 \\ 34 & 0 & 10 \\ 225 & 0 & 9 \end{vmatrix}}{D} =$$

$$-\frac{\begin{vmatrix} 34 & 10 \\ 225 & 9 \end{vmatrix}}{-3,072} = \frac{1,944}{-3,072} = -\frac{1,944}{3,072}, \text{ and so } C = 1 - A - B = 1 - \frac{16}{3,072} + \frac{1,944}{3,072}$$

$$= \frac{3,072 - 16 + 1,944}{3,072} = \frac{5,000}{3,072}. \text{ So,}$$

$$\begin{aligned} \int_0^\infty \left\{ \frac{\sin(x)}{x} \right\}^5 dx &= 5 \left[\frac{16}{3,072} \left(\frac{1}{1} \right) \tan^{-1}(\infty) - \frac{1,944}{3,072} \left(\frac{1}{3} \right) \tan^{-1}(\infty) + \frac{5,000}{3,072} \left(\frac{1}{5} \right) \tan^{-1}(\infty) \right] \\ &= \frac{\pi}{2} \left[\frac{80}{3,072} - \frac{9,720}{3,072} \left(\frac{1}{3} \right) + \frac{25,000}{3,072} \left(\frac{1}{5} \right) \right] = \frac{\pi}{2} \left[\frac{80 - 3,240 + 5,000}{3,072} \right] \\ &= \frac{\pi}{2} \left[\frac{1,840}{3,072} \right] = \frac{920}{3,072} \pi \end{aligned}$$

or, at last,

$$\int_0^\infty \left\{ \frac{\sin(x)}{x} \right\}^5 dx = \frac{115}{384} \pi .$$

For the $n=6$ case we have p even and so use (7.7.1) to write (with $p=q=6$)

$$\int_0^\infty \left\{ \frac{\sin(x)}{x} \right\}^6 dx = \frac{6!}{5!} \int_0^\infty \frac{u^4}{(u^2+2^2)(u^2+4^2)(u^2+6^2)} du = 6 \left[\int_0^\infty \frac{A}{u^2+4} du + \int_0^\infty \frac{B}{u^2+16} du + \int_0^\infty \frac{C}{u^2+36} du \right] \text{ and so}$$

$$A[u^2+16][u^2+36] + B[u^2+4][u^2+36] + C[u^2+4][u^2+16] = u^4 \text{ and therefore}$$

$$A[u^4+52u^2+576] + B[u^4+40u^2+144] + C[u^4+20u^2+64] = u^4 \text{ and so}$$

$$A + B + C = 1,$$

$$52A + 40B + 20C = 0,$$

$$576A + 144B + 64C = 0.$$

The system determinant is $D = \begin{vmatrix} 1 & 1 & 1 \\ 52 & 40 & 20 \\ 576 & 144 & 64 \end{vmatrix} = -7,680$, and so

$$A = \frac{\begin{vmatrix} 1 & 1 & 1 \\ 0 & 40 & 20 \\ 0 & 144 & 64 \end{vmatrix}}{D} = \frac{320}{7,680}, C = \frac{\begin{vmatrix} 1 & 1 & 1 \\ 52 & 40 & 0 \\ 576 & 144 & 0 \end{vmatrix}}{D} = \frac{15,552}{7,680}, \text{ and then } B = 1 - A$$

$-C = -\frac{8,192}{7,680}$. Thus, $\int_0^\infty \left\{ \frac{\sin(x)}{x} \right\}^6 dx = 6 \left[\frac{320}{7,680} \left(\frac{1}{2} \right) \tan^{-1}(\infty) - \frac{8,192}{7,680} \left(\frac{1}{4} \right) \tan^{-1}(\infty) + \frac{15,552}{7,680} \left(\frac{1}{6} \right) \tan^{-1}(\infty) \right]$ and so, after just a bit of trivial (but tedious) arithmetic,

$$\int_0^\infty \left\{ \frac{\sin(x)}{x} \right\}^6 dx = \frac{11}{40} \pi .$$

For the $n=7$ case we are back to p odd and so back to (7.7.2) with $p=q=7$, which says

$$\int_0^\infty \left\{ \frac{\sin(x)}{x} \right\}^7 dx = \frac{7!}{6!} \int_0^\infty \frac{u^6}{(u^2+1^2)(u^2+3^2)(u^2+5^2)(u^2+7^2)} du = 7 \left[\int_0^\infty \frac{A}{u^2+1^2} du + \int_0^\infty \frac{B}{u^2+3^2} du + \int_0^\infty \frac{C}{u^2+5^2} du + \int_0^\infty \frac{D}{u^2+7^2} du \right]$$

and so now you see we are going to be working with 4×4 determinants which is starting to be *really* tedious and so I'll let you grind through the routine arithmetic to arrive at

$$\int_0^\infty \left\{ \frac{\sin(x)}{x} \right\}^7 dx = \frac{5,887}{23,040} \pi .$$

This is equal to 0.8027151... , and MATLAB agrees as `quad(@(x)sin(x)./x).^7,0,100) = 0.802710...`

(C7.2): To start, write $\int_x^\infty e^{it^2} dt = \int_x^\infty \cos(t^2) dt + i \int_x^\infty \sin(t^2) dt = C(x) + iS(x)$.

Then, $\int_x^\infty e^{-it^2} dt = \int_x^\infty \cos(t^2) dt - i \int_x^\infty \sin(t^2) dt = C(x) - iS(x) = \int_x^\infty e^{-iu^2} du$.

(Remember, t and u are *dummy* variables.) So, $\{C(x) + iS(x)\}\{C(x) - iS(x)\} = \int_x^\infty e^{it^2} \int_x^\infty e^{-iu^2} du$ and so $C^2(x) + S^2(x) = \int_x^\infty \int_x^\infty e^{i(t^2-u^2)} dt du = \int_x^\infty \int_x^\infty \cos(t^2 - u^2) dt du + i \int_x^\infty \int_x^\infty \sin(t^2 - u^2) dt du$. Since $C^2(x) + S^2(x)$ is *purely real* then its imaginary part must vanish, that is, $\int_x^\infty \int_x^\infty \sin(t^2 - u^2) dt du = 0$ for any x and we are done.

(C7.3): To start, write $1 - ix^3 = \sqrt{1 + x^6} e^{i\theta}$ where θ puts this complex vector in the fourth quadrant if $x > 0$ and in the first quadrant if $x < 0$. Since $|e^{i\theta}| = 1$ for any θ then the specific value of θ doesn't actually matter when we calculate the absolute value of $1 - ix^3$ as $\sqrt{1 + x^6}$. Thus, $\left| \frac{1}{1-ix^3} \right| = \frac{1}{|1-ix^3|} = \frac{1}{\sqrt{1+x^6}} = \frac{1}{(1+x^6)^{1/2}}$ and so

$$\left| \frac{1}{\sqrt{1-ix^3}} \right| = \frac{1}{(1+x^6)^{1/4}}. \quad \text{Thus,} \quad \int_{-\infty}^\infty \frac{dx}{\sqrt{1-ix^3}} \leq \int_{-\infty}^\infty \frac{dx}{(1+x^6)^{1/4}} = 2 \int_0^\infty \frac{dx}{(1+x^6)^{1/4}}$$

because the integrand in the middle integral is even. Now,

$$\int_0^\infty \frac{dx}{(1+x^6)^{1/4}} = \int_0^1 \frac{dx}{(1+x^6)^{1/4}} + \int_1^\infty \frac{dx}{(1+x^6)^{1/4}}. \quad \text{Since} \quad \int_0^1 \frac{dx}{(1+x^6)^{1/4}} = M, \quad \text{where } M$$

is some *finite* number because the integrand is finite over the entire interval of integration, and noticing that $1 + x^6 > x^6$ we can write

$$\int_0^\infty \frac{dx}{(1+x^6)^{1/4}} \leq M + \int_1^\infty \frac{dx}{x^{3/2}}. \quad \text{And since} \quad \int_1^\infty \frac{dx}{x^{3/2}} = (-2x^{-1/2}) \Big|_1^\infty = 2, \quad \text{then}$$

$$\int_{-\infty}^\infty \frac{dx}{\sqrt{1-ix^3}} \leq M + 2 \quad \text{and so} \quad \int_{-\infty}^\infty \frac{dx}{\sqrt{1-ix^3}} \text{ exists.}$$

(C7.4): Start with $\int_1^k \frac{dx}{x^3} = \sum_{j=1}^{k-1} \int_j^{j+1} \frac{dx}{x^3} = \left(-\frac{1}{2x^2}\right)\Big|_1^k = \frac{1}{2}\left(1 - \frac{1}{k^2}\right)$. Then,

$$\sum_{k=1}^n \int_1^k \frac{dx}{x^3} = \sum_{k=1}^n \sum_{j=1}^{k-1} \int_j^{j+1} \frac{dx}{x^3} = \sum_{k=1}^n \frac{1}{2}\left(1 - \frac{1}{k^2}\right) = \frac{1}{2}(1 - S(n))$$

where $S(n) = \sum_{k=1}^n \frac{1}{k^2}$. (Remember, $\lim_{n \rightarrow \infty} S(n) = \frac{\pi^2}{6}$.) Writing out the double summation, term-by-term just as we did in (C5.2), and then doing the ‘adding vertically’ trick, you should now be able to show that $\frac{n}{2} - \frac{1}{2}S(n) =$

$$\int_1^n \frac{n-x+\{x\}}{x^3} dx = \frac{n}{2} - \frac{1}{2n} - 1 + \frac{1}{n} + \int_1^n \frac{\{x\}}{x^3} dx. \text{ That is,}$$

$\int_1^n \frac{\{x\}}{x^3} dx = 1 - \frac{1}{2}S(n) - \frac{1}{n}$ and so, letting $n \rightarrow \infty$ we have $\int_1^\infty \frac{\{x\}}{x^3} dx = 1 - \frac{1}{2}S(\infty)$ or, at last,

$$\int_1^\infty \frac{\{x\}}{x^3} dx = 1 - \frac{\pi^2}{12}.$$

(C7.5): Starting with $I(a) = \int_0^\infty \frac{\sin^2(ax)}{x^2} dx$, differentiate with respect to the parameter a . Then, $\frac{dI}{da} = \int_0^\infty \frac{2x \sin(ax) \cos(ax)}{x^2} dx = \int_0^\infty \frac{2 \sin(ax) \cos(ax)}{x} dx$.

Recalling the identity $\sin(ax) \cos(ax) = \frac{1}{2} \sin(2ax)$, we have

$$\frac{dI}{da} = \int_0^\infty \frac{\sin(2ax)}{x} dx = \pm \frac{\pi}{2} \text{ from (3.2.1), where the sign on the right depends on}$$

the sign of a (+ if $a > 0$ and - if $a < 0$). Then doing the *indefinite* integral, $\int dI =$

$\pm \int \frac{\pi}{2} da + C$ or, $I(a) = \pm \frac{\pi}{2} a + C$ where C is an arbitrary constant. Since $I(0) = 0$ we know that $C = 0$ and so

$$I(a) = \int_0^\infty \frac{\sin^2(ax)}{x^2} dx = \frac{\pi}{2} |a|.$$

(C7.6): If you set $b = 1$ and $k = 2$ in (4.3.10) and (4.3.11) then the Fresnel integrals follow immediately.

(C7.7): Following the hint, the Fourier transform of $f(t)$ is (I’ll let you fill-in the easy integration details) $F(\omega) = \frac{1 - e^{-m\alpha} \cos(m\omega) + ie^{-m\alpha} \sin(m\omega)}{a + i\omega}$ and so $|F(\omega)|^2 =$

$$\frac{1 + e^{-2m\alpha} - 2e^{-m\alpha} \cos(m\omega)}{\omega^2 + a^2}. \text{ The time integral for the energy of } f(t) \text{ is } \int_{-\infty}^\infty f^2(t) dt =$$

$\int_0^m e^{-2at} dt = \frac{1-e^{-2ma}}{2a}$ while the frequency integral for the energy is $\int_{-\infty}^{\infty} \frac{|F(\omega)|^2}{2\pi} d\omega = \frac{1}{2\pi} \int_{-\infty}^{\infty} \frac{1 + e^{-2ma} - 2e^{-ma} \cos(m\omega)}{\omega^2 + a^2} d\omega$. Equating these two integrals, and then doing some easy algebra (where I've also changed the dummy variable of integration from ω to x), gives $\int_{-\infty}^{\infty} \frac{\cos(mx)}{x^2 + a^2} dx = \frac{\pi}{a} e^{-ma}$. You'll recognize this as (3.1.7), where in that result I wrote b in place of m , and the integration interval (of an even integrand) is 0 to ∞ rather than $-\infty$ to ∞ (thus accounting for the 2 on the right in (3.1.7)).

(C7.8): (a) $\int_{-\infty}^{\infty} \frac{1}{t^2 + 1} e^{-i\omega t} dt = \int_{-\infty}^{\infty} \frac{\cos(\omega t)}{t^2 + 1} dt - i \int_{-\infty}^{\infty} \frac{\sin(\omega t)}{t^2 + 1} dt$. The last integral is zero because the integrand is odd. Now, $\int_{-\infty}^{\infty} \frac{1}{t^2 + 1} e^{-i\omega t} dt = 2 \int_0^{\infty} \frac{\cos(\omega t)}{t^2 + 1} dt$ and the last integral is, with $b = 1$ and $a = \omega$ in (3.1.7), equal to $\frac{\pi}{2} e^{-\omega}$. So, for $\omega > 0$ the transform is $\pi e^{-\omega}$. Since the time signal is even, we have a purely real transform and we know that is even. So, for $\omega < 0$ the transform is πe^{ω} . Thus, for all ω , $\frac{1}{t^2+1} \leftrightarrow \pi e^{-|\omega|}$.

(b) Since the Fourier transform of $f(t)$ is $F(\omega) = \int_{-\infty}^{\infty} f(t) e^{-i\omega t} dt$, then $\frac{dF}{d\omega} = \int_{-\infty}^{\infty} -itf(t) e^{-i\omega t} dt$. Thus, $\int_{-\infty}^{\infty} tf(t) e^{-i\omega t} dt = -\frac{1}{i} \frac{dF}{d\omega} = i \frac{dF}{d\omega}$. So, if $f(t) \leftrightarrow F(\omega)$ then $tf(t) \leftrightarrow i \frac{dF}{d\omega}$. Now, as shown in (a), for $\omega > 0$ the transform of $\frac{1}{t^2+1}$ is $\pi e^{-\omega}$, and so the transform of $\frac{t}{t^2+1}$ is $i \frac{d}{d\omega} (\pi e^{-\omega}) = -i\pi e^{-\omega}$. Since the time function is odd we have a purely imaginary transform which we know is odd. That is, for $\omega < 0$ the transform must be $i\pi e^{\omega}$. So, for all ω we write $\frac{t}{t^2+1} \leftrightarrow -i\pi e^{-|\omega|} \text{sgn}(\omega)$.

(c) $\int_{-\infty}^{\infty} \left\{ \frac{1}{2} \delta(t) + i \frac{1}{2\pi t} \right\} e^{-i\omega t} dt = \frac{1}{2} \int_{-\infty}^{\infty} \delta(t) e^{-i\omega t} dt + \frac{i}{2\pi} \int_{-\infty}^{\infty} \frac{e^{-i\omega t}}{t} dt$. From (7.9.14) the first integral on the right is 1 . And from (7.9.3) we have $\int_{-\infty}^{\infty} \frac{e^{-i\omega t}}{t} dt = i\pi \text{sgn}(-\omega)$. So, the transform is $\frac{1}{2} + \frac{i}{2\pi} [i\pi \text{sgn}(-\omega)] = \frac{1}{2} - \frac{1}{2} \text{sgn}(-\omega)$. Since $\text{sgn}(x) = +1$ if $x > 0$ and -1 if $x < 0$, then the transform is $\frac{1}{2} - \frac{1}{2}(-1) = \frac{1}{2} + \frac{1}{2} = 1$ if $\omega > 0$ and $\frac{1}{2} - \frac{1}{2}(+1) = \frac{1}{2} - \frac{1}{2} = 0$ if $\omega < 0$. But this is just $u(\omega)$, the step function in the ω -domain. So,

$$\frac{1}{2} \delta(t) + i \frac{1}{2\pi t} \leftrightarrow u(\omega).$$

(d) Following the hint, let $x = \frac{u}{t}$ and so $xt = u$ and $du = t dx$. Thus, $E_i(t) = \int_t^{\infty} \frac{e^{-u}}{u} du = \int_1^{\infty} \frac{e^{-xt}}{xt} t dx = \int_1^{\infty} \frac{e^{-xt}}{x} dx$, $t \geq 0$ and zero otherwise. So, the Fourier transform is

$$\begin{aligned}
\int_0^{\infty} \left\{ \int_1^{\infty} \frac{e^{-xt}}{x} dx \right\} e^{-i\omega t} dt &= \int_1^{\infty} \frac{1}{x} \left\{ \int_0^{\infty} e^{-(x+i\omega)t} dt \right\} dx = \int_1^{\infty} \frac{1}{x} \left\{ \frac{e^{-(x+i\omega)t}}{-(x+i\omega)} \right\} \Big|_0^{\infty} dx \\
&= \int_1^{\infty} \frac{1}{x(x+i\omega)} dx = \frac{1}{i\omega} \int_1^{\infty} \left(\frac{1}{x} - \frac{1}{x+i\omega} \right) dx \\
&= \frac{1}{i\omega} [\ln(x) - \ln(x+i\omega)] \Big|_1^{\infty} \\
&= \frac{1}{i\omega} \ln \left(\frac{x}{x+i\omega} \right) \Big|_1^{\infty} = -\frac{1}{i\omega} \ln \left(\frac{1}{1+i\omega} \right) = \frac{\ln(1+i\omega)}{i\omega}
\end{aligned}$$

That is, $\int_1^{\infty} \frac{e^{-u}}{u} du \leftrightarrow \frac{\ln(1+i\omega)}{i\omega}$.

(C7.9): The second Hilbert transform integral in (7.10.11) is $\pi X(\omega) = -\int_{-\infty}^{\infty} \frac{R(u)}{\omega - u} du = -\int_{-\infty}^0 \frac{R(u)}{\omega - u} du - \int_0^{\infty} \frac{R(u)}{\omega - u} du$. If, in the first integral on the right of the equals sign, we make the change of variable $s = -u$, we have $\pi X(\omega) = -\int_0^{\infty} \frac{R(-s)}{\omega + s} (-ds) - \int_0^{\infty} \frac{R(u)}{\omega - u} du = (\text{when } x(t) \text{ is real}) - \int_0^{\infty} \frac{R(s)}{\omega + s} ds - \int_0^{\infty} \frac{R(u)}{\omega - u} du = -\int_0^{\infty} R(u) \left[\frac{1}{\omega - u} + \frac{1}{\omega + u} \right] du = -\int_0^{\infty} R(u) \frac{2\omega}{\omega^2 - u^2} du$ and so, *when $x(t)$ is real*, $X(\omega) = -\frac{2\omega}{\pi} \int_0^{\infty} \frac{R(u)}{\omega^2 - u^2} du$.

(C7.10): By Rayleigh's theorem the energy of $x(t)$ is $\frac{1}{2\pi} \int_{-\infty}^{\infty} |X(\omega)|^2 d\omega$ and, since the energy is given as finite, we have (A) $\int_{-\infty}^{\infty} |X(\omega)|^2 d\omega < \infty$. Also, since $y(t) = x(t) * h(t)$ we have $Y(\omega) = X(\omega)H(\omega)$. (See note 14 again in Chap. 7.) Thus, $|Y(\omega)| = |X(\omega)H(\omega)| = |X(\omega)||H(\omega)|$ and so $|Y(\omega)|^2 = |X(\omega)|^2|H(\omega)|^2$. From this we conclude (B), $\frac{1}{2\pi} \int_{-\infty}^{\infty} |Y(\omega)|^2 d\omega = \frac{1}{2\pi} \int_{-\infty}^{\infty} |X(\omega)|^2 |H(\omega)|^2 d\omega$. Finally, $H(\omega) = \int_{-\infty}^{\infty} h(t)e^{-i\omega t} dt$ and so $|H(\omega)| = \left| \int_{-\infty}^{\infty} h(t)e^{-i\omega t} dt \right| \leq \int_{-\infty}^{\infty} |h(t)e^{-i\omega t}| dt$. (See the hint in Challenge Problem C7.3.) Continuing, $|H(\omega)| \leq \int_{-\infty}^{\infty} |h(t)| |e^{-i\omega t}| dt = \int_{-\infty}^{\infty} |h(t)| dt$ because $|e^{-i\omega t}| = 1$. This last integral is given to us as finite, and so $|H(\omega)| < \infty$, that is $|H(\omega)|^2 < \infty$. This means $|H(\omega)|^2$ has a maximum value, which we'll call M . Putting that into (B) we have $\frac{1}{2\pi} \int_{-\infty}^{\infty} |Y(\omega)|^2 d\omega \leq \frac{1}{2\pi} \int_{-\infty}^{\infty} |X(\omega)|^2 M d\omega = \frac{M}{2\pi} \int_{-\infty}^{\infty} |X(\omega)|^2 d\omega$. From (A) we know that this last integral is finite, and so $\frac{1}{2\pi} \int_{-\infty}^{\infty} |Y(\omega)|^2 d\omega < \infty$. But this integral is the energy of $y(t)$, and so the energy of $y(t)$ is finite.

(C7.11): For $\omega_0 > 0$, $\bar{x}(t) = \frac{1}{\pi} \int_{-\infty}^{\infty} \frac{\cos(\omega_0 t)}{t-u} du = \frac{1}{2\pi} \int_{-\infty}^{\infty} \frac{e^{i\omega_0 t} + e^{-i\omega_0 t}}{t-u} du$.

Let $s = t - u$, $du = -ds$. Then $\bar{x}(t) = \frac{1}{2\pi} \int_{-\infty}^{\infty} \frac{e^{i\omega_0(t-s)}}{s} (ds) + \frac{1}{2\pi} \int_{-\infty}^{\infty} \frac{e^{-i\omega_0(t-s)}}{s} (ds) = \frac{e^{i\omega_0 t}}{2\pi} \int_{-\infty}^{\infty} \frac{e^{-i\omega_0 s}}{s} ds + \frac{e^{-i\omega_0 t}}{2\pi} \int_{-\infty}^{\infty} \frac{e^{i\omega_0 s}}{s} ds$. From (7.9.3) we have $\int_{-\infty}^{\infty} \frac{e^{i\omega s}}{\omega} d\omega = i\pi \operatorname{sgn}(t)$, and so $\int_{-\infty}^{\infty} \frac{e^{i\omega_0 s}}{s} ds = i\pi \operatorname{sgn}(\omega_0) = i\pi$ because $\omega_0 > 0$ and $\operatorname{sgn}(\text{positive argument}) = +1$. Also, $\int_{-\infty}^{\infty} \frac{e^{-i\omega_0 s}}{s} ds = i\pi \operatorname{sgn}(-\omega_0) = -i\pi$ because $\omega_0 > 0$ and $\operatorname{sgn}(\text{negative argument}) = -1$. So, $\bar{x}(t) = \frac{1}{2\pi} [-i\pi e^{i\omega_0 t} + i\pi e^{-i\omega_0 t}] = \frac{-i\pi}{2\pi} [e^{i\omega_0 t} - e^{-i\omega_0 t}] = \frac{-i\pi}{2\pi} 2i \sin(\omega_0 t) = \sin(\omega_0 t)$, the Hilbert transform of $\cos(\omega_0 t)$. If you re-do all this for the Hilbert transform of $\sin(\omega_0 t)$, you should find that it is $-\cos(\omega_0 t)$.

Chapter 8

(C8.1): Since $f(z) = g(z)(z - z_0)^m$ then $\oint_C \frac{f'(z)}{f(z)} dz = \oint_C \frac{g'(z)m(z - z_0)^{m-1} + g'(z)(z - z_0)^m}{g(z)(z - z_0)^m} dz = \oint_C \frac{m}{z - z_0} dz + \oint_C \frac{g'(z)}{g(z)} dz = m \oint_C \frac{dz}{z - z_0} + \oint_C \frac{g'(z)}{g(z)} dz$. Now, the first integral is $2\pi i$ by (8.7.1), and the second integral is zero by (8.6.1) because $g(z)$ is analytic which means $g'(z)$ is analytic and so $\frac{g'(z)}{g(z)}$ is analytic with no zeros inside C (by the given statement of the problem). Thus, $\oint_C \frac{f'(z)}{f(z)} dz = 2\pi i m$ and we are done.

(C8.2): Since we are going to work with $f(z) = \frac{e^{imz}}{z(z^2 + a^2)}$ we see that we have three first-order singularities to consider: $z = 0$, $z = -ia$, and $z = ia$. This suggests the contour C shown in Fig. C8, where eventually we'll let $\epsilon \rightarrow 0$ and $R \rightarrow \infty$. The first two singularities will always be outside of C , while the third one will, as $R \rightarrow \infty$, be inside C (remember, $a > 0$).

Now, $\oint_C f(z) dz = \int_{C_1} + \int_{C_2} + \int_{C_3} + \int_{C_4}$. On C_1 and C_3 we have $z = x$ and $dz = dx$. Thus, $\int_{C_1} + \int_{C_3} = \int_{-R}^{-\epsilon} \frac{e^{imx}}{x(x^2 + a^2)} dx + \int_{\epsilon}^R \frac{e^{imx}}{x(x^2 + a^2)} dx$ or, as $\epsilon \rightarrow 0$ and $R \rightarrow \infty$, $\int_{C_1} + \int_{C_3} = \int_{-\infty}^{\infty} \frac{e^{imx}}{x(x^2 + a^2)} dx$. On C_2 we have $z = \epsilon e^{i\theta}$, $-\pi < \theta < 0$, $dz = i\epsilon e^{i\theta} d\theta$.

Fig. C8 The contour for Challenge Problem C8.2

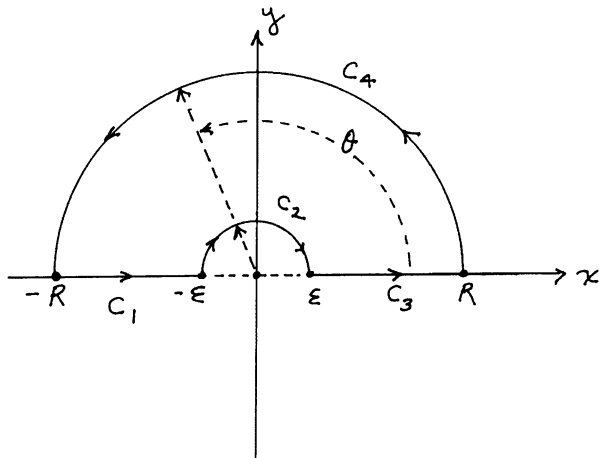

Thus, $\int_{C_2} = \int_{\pi}^0 \frac{e^{i\pi\epsilon e^{i\theta}}}{\epsilon e^{i\theta}(\epsilon^2 e^{i2\theta} + a^2)} i\epsilon e^{i\theta} d\theta$ or, as $\epsilon \rightarrow 0$, $\int_{C_2} = -i \int_0^{\pi} \frac{d\theta}{a^2} = -i \frac{\pi}{a^2}$.

On C_4 we have $z = R e^{i\theta}$, $0 < \theta < \pi$, and $dz = i R e^{i\theta} d\theta$. Thus,

$\int_{C_4} = \int_0^{\pi} \frac{e^{im R e^{i\theta}}}{R e^{i\theta} (R^2 e^{i2\theta} + a^2)} i R e^{i\theta} d\theta = i \int_0^{\pi} \frac{e^{im R e^{i\theta}}}{R^2 e^{i2\theta} + a^2} d\theta$. The absolute value of the integrand behaves, as $R \rightarrow \infty$, like $\frac{1}{R^2}$ because the absolute value of the numerator is 1 for all R and θ . Thus, as $R \rightarrow \infty$ the integral behaves as $\frac{\pi}{R^2}$ which goes to zero as $R \rightarrow \infty$.

Thus, $\oint_C = \int_{-\infty}^{\infty} \frac{e^{imx}}{x(x^2 + a^2)} dx - i \frac{\pi}{a^2}$. But we know that $\oint_C = 2\pi i$ (residue of singularity at $z = ia$). That residue is $\lim_{z \rightarrow ia} (z - ia)$

$$\frac{e^{imz}}{z(z-ia)(z+ia)} = \frac{e^{imia}}{ia(2ia)} = -\frac{e^{-ma}}{2a^2}. \text{ So, } \int_{-\infty}^{\infty} \frac{e^{imx}}{x(x^2 + a^2)} dx - i \frac{\pi}{a^2} = 2\pi i \left(-\frac{e^{-ma}}{2a^2}\right) = -i \frac{\pi e^{-ma}}{a^2}.$$

And thus, $\int_{-\infty}^{\infty} \frac{e^{imx}}{x(x^2 + a^2)} dx = i \frac{\pi}{a^2} - i \frac{\pi e^{-ma}}{a^2} = i \frac{\pi}{a^2} (1 - e^{-ma})$. Using Euler's

identity on the numerator of the integrand, $\int_{-\infty}^{\infty} \frac{\cos(mx)}{x(x^2 + a^2)} dx +$

$i \int_{-\infty}^{\infty} \frac{\sin(mx)}{x(x^2 + a^2)} dx = i \frac{\pi}{a^2} (1 - e^{-ma})$. Equating real parts of this last equation we

get $\int_{-\infty}^{\infty} \frac{\cos(mx)}{x(x^2 + a^2)} dx = 0$, which is no surprise since the integrand is odd. More

interesting is the result from equating imaginary parts:

$$\int_{-\infty}^{\infty} \frac{\sin(mx)}{x(x^2 + a^2)} dx = \frac{\pi}{a^2} (1 - e^{-ma}) \text{ or, since } \int_0^{\infty} = \frac{1}{2} \int_{-\infty}^{\infty}, \text{ we have}$$

$$\int_0^\infty \frac{\sin(mx)}{x(x^2 + a^2)} dx = \frac{\pi}{2} \left(\frac{1 - e^{-ma}}{a^2} \right),$$

which earlier we simply assumed.

(C8.3): (a) Writing $z = e^{i\theta}$ (and so $d\theta = \frac{dz}{iz}$) on the unit circle C , we have $\cos(\theta) = \frac{z+z^{-1}}{2}$. Now, consider $\oint_C f(z)dz$ with $f(z) = \frac{1}{1-2az+\frac{z^{-1}}{a^2}}$. Then

$$\int_0^{2\pi} \frac{d\theta}{1 - 2a \cos(\theta) + a^2} = \oint_C \frac{dz}{1 - 2a \frac{z+z^{-1}}{2} + a^2} \left(\frac{dz}{iz} \right) = \frac{i}{a} \oint_C \frac{dz}{z^2 - \frac{a^2+1}{a}z + 1}.$$

There are two first-order singularities at $z = \frac{a^2+1 \pm \sqrt{(a^2+1)^2 - 4}}{2}$ which, after a bit of algebra, reduces to $z = a$ and $z = \frac{1}{a}$. Since $0 < a < 1$, the first is inside C and the second is outside C .

So, $\oint_C \frac{dz}{z^2 - \frac{a^2+1}{a}z + 1} = 2\pi i$ (residue at $z = a$). From (8.8.9) that residue

is $\frac{1}{\frac{d}{dz}(z^2 - \frac{a^2+1}{a}z + 1)} \Big|_{z=a} = \frac{1}{(2z - \frac{a^2+1}{a})} \Big|_{z=a} = \frac{1}{(2a - \frac{a^2+1}{a})} = \frac{a}{a^2-1}$. So, $\int_0^{2\pi} \frac{d\theta}{1-2a \cos(\theta)+a^2} =$

$$\frac{i}{a} 2\pi i \frac{a}{a^2-1} = \frac{2\pi}{1-a^2}, 0 < a < 1. \text{ If } a = \frac{1}{2}, \text{ for example, we have } \int_0^{2\pi} \frac{d\theta}{\frac{3}{4} - \cos(\theta)} = \frac{2\pi}{1-\frac{1}{4}} = \frac{8\pi}{3} = 8.37758\dots \text{ and MATLAB agrees because } \text{quad}(@(\theta)1./(1.25-\cos(\theta)),0,2*\pi) = 8.37758\dots$$

(b) Let $f(z) = \frac{e^{iz}}{(z+a)^2 + b^2}$, that is consider the contour integral $\oint_C \frac{e^{iz}}{(z+a)^2 + b^2} dz$ where C is shown in Fig. 8.7.1. The integrand has two singularities (are each first-order), at $z = -a \pm ib$. Since a and b are both positive, only the $z = -a + ib$ singularity is inside C . Thus, $\oint_C \frac{e^{iz}}{(z+a)^2 + b^2} dz = 2\pi i$ (residue at $z = -a + ib$).

On the real axis $z = x$, $dz = dx$, and on the semi-circular arc $z = Te^{i\theta}$, $dz = iTe^{i\theta}d\theta$, $0 < \theta < \pi$. So, on the semi-circular arc we have the integral

$$\int_0^\pi \frac{e^{iT e^{i\theta}}}{(Te^{i\theta} + a)^2 + b^2} iT e^{i\theta} d\theta.$$

The absolute value of the numerator is T for all θ and, as $T \rightarrow \infty$, the absolute value of the denominator behaves like $\frac{1}{T^2}$.

So, the integral behaves as $\pi \frac{T}{T^2} = \frac{\pi}{T} \rightarrow 0$ as $T \rightarrow \infty$. Thus, $\oint_C \frac{e^{iz}}{(z+a)^2 + b^2} dz =$

$$\lim_{T \rightarrow \infty} \int_{-T}^T \frac{e^{ix}}{(x+a)^2 + b^2} dx = 2\pi i \text{ (residue at } z = -a + ib) = \int_{-\infty}^\infty \frac{e^{ix}}{(x+a)^2 + b^2} dx.$$

Now, the residue at $z = -a + ib$ is given by $\lim_{z \rightarrow -a+ib} [z - (-a + ib)]$

$\frac{e^{iz}}{[z-(a+ib)][z-(-a-ib)]} = \frac{e^{i(-a+ib)}}{-a+ib+a+ib} = \frac{e^{-ia} e^{-b}}{i2b} = \frac{e^{-b} \cos(a) - i e^{-b} \sin(a)}{i2b}$ and so $\int_{-\infty}^{\infty} \frac{e^{ix}}{(x+a)^2 + b^2} dx = 2\pi i \left[\frac{e^{-b} \cos(a) - i e^{-b} \sin(a)}{i2b} \right]$. Expanding the numerator of the integral with Euler's identity and equating real parts, we get $\int_{-\infty}^{\infty} \frac{\cos(x)}{(x+a)^2 + b^2} dx = \frac{\pi}{b} e^{-b} \cos(a)$, while equating imaginary parts gives $\int_{-\infty}^{\infty} \frac{\sin(x)}{(x+a)^2 + b^2} dx = -\frac{\pi}{b} e^{-b} \sin(a)$. If $a = 1$ and $b = 1$, for example these two integrals are equal to $0.6244\dots$ and $-0.97251\dots$, respectively, and MATLAB agrees since `quad(@(x)cos(x),/(x+1).^2+1,-1000,1000) = 0.6245\dots` and `quad(@(x)sin(x),/(x+1).^2+1,-1000,1000) = -0.9697\dots`

(c) Let $f(z) = \frac{e^{iz}}{(z^2+a^2)(z^2+b^2)}$, that is consider the contour integral

$\oint_C \frac{e^{iz}}{(z^2+a^2)(z^2+b^2)} dz$ where C is shown in Fig. 8.7.1. The integrand has four first-order singularities at $z = \pm ia$ and at $z = \pm ib$, but since a and b are positive only $z = +ia$ and $z = +ib$ are inside C . So, $\oint_C \frac{e^{iz}}{(z^2+a^2)(z^2+b^2)} dz = 2\pi i$ (residue at $z = +ia$ plus residue at $z = +ib$). Those residues are: at $z = +ia$, $\lim_{z \rightarrow ia} (z - ia)$

$$\frac{e^{iz}}{(z-ia)(z+ia)(z-ib)(z+ib)} = \frac{e^{i(ia)}}{i2a(ia-ib)(ia+ib)} = \frac{e^{-a}}{-i2a(a-b)(a+b)} = i \frac{e^{-a}}{2a(a^2-b^2)},$$

and at $z = +ib$, $\lim_{z \rightarrow ib} (z - ib) \frac{e^{iz}}{(z-ia)(z+ia)(z-ib)(z+ib)} = \frac{e^{i(ib)}}{(ib-ia)(ib+ia)i2b} = \frac{e^{-b}}{-i2b(b-a)(b+a)} = i \frac{e^{-b}}{2b(b^2-a^2)}$.

On the semi-circular arc $z = Te^{i\theta}$, $dz = iTe^{i\theta}d\theta$, $0 < \theta < \pi$, and so that integral is

$$\int_0^\pi \frac{e^{iT e^{i\theta}}}{(T^2 e^{i2\theta} + a^2)(T^2 e^{i2\theta} + b^2)} iTe^{i\theta}d\theta$$

which, as $T \rightarrow \infty$, behaves like $\pi \frac{T}{T^3} \rightarrow 0$. So, all that we

have left is the portion of C that lies along the real axis, which says that

$$\begin{aligned} \int_{-\infty}^{\infty} \frac{e^{ix}}{(x^2+a^2)(x^2+b^2)} dx &= 2\pi i \left[i \frac{e^{-a}}{2a(a^2-b^2)} + i \frac{e^{-b}}{2b(b^2-a^2)} \right] \\ &= -2\pi \left[\frac{e^{-a}}{2a(a^2-b^2)} + \frac{e^{-b}}{2b(b^2-a^2)} \right] \\ &= \pi \left[\frac{e^{-b}}{b(a^2-b^2)} - \frac{e^{-a}}{a(a^2-b^2)} \right] \\ &= \int_{-\infty}^{\infty} \frac{\cos(x)}{(x^2+a^2)(x^2+b^2)} dx \\ &\quad + i \int_{-\infty}^{\infty} \frac{\sin(x)}{(x^2+a^2)(x^2+b^2)} dx. \end{aligned}$$

Equating real parts gives us our answer: $\int_{-\infty}^{\infty} \frac{\cos(x)}{(x^2 + a^2)(x^2 + b^2)} dx = \frac{\pi}{(a^2 - b^2)} \left[\frac{e^{-b} - e^{-a}}{b} - \frac{e^{-a}}{a} \right]$. If $a = 2$ and $b = 1$ this reduces to $\frac{\pi(2e-1)}{6e^2} = 0.31438\dots$, and MATLAB agrees: `quad(@(x)cos(x)./(x.^2+1).*(x.^2+4)),-1000,1000) = 0.31436...`

(d) Let $f(z) = \frac{e^{iaz}}{(z^2 + b^2)^2}$, that is consider the contour integral $\oint_C \frac{e^{iaz}}{(z^2 + b^2)^2} dz$ where C is shown in Fig. 8.7.1. The integrand has two *second-order* singularities at $z = \pm ib$ and, since b is positive, only $z = +ib$ is inside C . So, $\oint_C \frac{e^{iaz}}{(z^2 + b^2)^2} dz = 2\pi i$ (residue at $z = ib$). We calculate that residue as follows, from (8.8.8), using $m = 2$: $\lim_{z \rightarrow ib} \frac{d}{dz} \left\{ (z - ib)^2 \frac{e^{iaz}}{(z^2 + b^2)^2} \right\} = \frac{d}{dz} \left\{ \frac{e^{iaz}}{(z+ib)^2} \right\} \Big|_{z=ib} = \frac{(z+ib)^2 iae^{iaz} - e^{iaz} 2(z+ib)}{(z+ib)^4} \Big|_{z=ib}$ which reduces (after just a bit of algebra) to $-i \frac{1+ab}{4b^3} e^{-ab}$. Thus, $\oint_C \frac{e^{iaz}}{(z^2 + b^2)^2} dz = 2\pi i \left(-i \frac{1+ab}{4b^3} e^{-ab} \right) = \frac{\pi}{2b^3} (1 + ab)e^{-ab}$. On the semi-circular arc $z = Te^{i\theta}$, $dz = iTe^{i\theta} d\theta$, $0 < \theta < \pi$, and so the integrand is $\frac{e^{iaTe^{i\theta}}}{(T^2 e^{i2\theta} + b^2)^2} Te^{i\theta}$, with an absolute value that behaves as $\frac{T}{T^4} = \frac{1}{T^3}$ as $T \rightarrow \infty$. The integral therefore behaves as $\frac{\pi}{T^3}$ which vanishes as $T \rightarrow \infty$. Thus, since on the real axis $z = x$ we have in the limit of $T \rightarrow \infty$ that $\int_{-\infty}^{\infty} \frac{e^{iax}}{(x^2 + b^2)^2} dx = \frac{\pi}{2b^3} (1 + ab)e^{-ab}$. Equating real parts (after using Euler's identity in the numerator of the integrand) gives us the result: $\int_{-\infty}^{\infty} \frac{\cos(ax)}{(x^2 + b^2)^2} dx = \frac{\pi}{2b^3} (1 + ab)e^{-ab}$ or, since $\int_0^{\infty} = \frac{1}{2} \int_{-\infty}^{\infty}$ because the integrand is even, we have our result: $\int_0^{\infty} \frac{\cos(ax)}{(x^2 + b^2)^2} dx = \frac{\pi}{4b^3} (1 + ab)e^{-ab}$. If $a = b = 1$ this equals $\frac{\pi}{2e} = 0.57786\dots$ and MATLAB agrees: `quad(@(x)cos(x)./(x.^2+1).^2),0,1000) = 0.57786...`

(C8.4): In the integral $\int_0^{\infty} \frac{x^k}{(x^2 + 1)^2} dx$, the integrand, for large x , behaves like $\frac{x^k}{x^4} = \frac{1}{x^{4-k}}$. For the integral not to blow-up as $x \rightarrow \infty$ we must have the exponent $4 - k > 1$ or $3 > k$ or, $k < 3$. For small x the integrand behaves like $x^k = \frac{1}{x^{-k}}$. For the integral not to blow-up as $x \rightarrow 0$ we must have the exponent $-k < 1$ or $k > -1$ or, $-1 < k$. Thus, $-1 < k < 3$. Now, following the hint, let's consider the integral $\oint_C f(z) dz$ where C is the contour in Fig. 8.9.1 and $f(z) = \frac{e^{k \ln(z)}}{(z^2 + 1)^2}$. This integrand has two second-order singularities, at $z = \pm i$, and both will be inside C as we let $R \rightarrow \infty$ and both ϵ and $\rho \rightarrow 0$. On C_2 , $z = Re^{i\theta}$ and $dz = iRe^{i\theta} d\theta$ and we see that the absolute value of the integrand behaves as $\frac{1}{R^3}$ as $R \rightarrow \infty$. That is, the integral on C_2

will vanish as $R \rightarrow \infty$. On C_4 , $z = \rho e^{i\theta}$ and $dz = i\rho e^{i\theta} d\theta$ and we see that the absolute value of the integrand behaves as ρ as $\rho \rightarrow 0$. That is, the integral on C_4 will vanish as $\rho \rightarrow 0$. So, all we have left to calculate is $\int_{C_1} + \int_{C_3}$. On C_1 , $z = re^{i\varepsilon}$ and $dz = e^{i\varepsilon} dr$,

and on C_3 , $z = re^{i(2\pi - \varepsilon)}$ and $dz = e^{i(2\pi - \varepsilon)} dr$. So, $\int_{C_1} + \int_{C_3} = \int_{\rho}^R \frac{e^{k \ln(re^{i\varepsilon})}}{(r^2 e^{i2\varepsilon} + 1)^2} e^{i\varepsilon} dr$
 $+ \int_R^{\rho} \frac{e^{k \ln\{re^{i(2\pi - \varepsilon)}\}}}{(r^2 e^{i2(2\pi - \varepsilon)} + 1)^2} e^{i(2\pi - \varepsilon)} dr$ or, as we let $\varepsilon \rightarrow 0$, $\int_{C_1} + \int_{C_3} = \int_{\rho}^R \frac{e^{k \ln(r)}}{(r^2 + 1)^2} dr$
 $+ \int_R^{\rho} \frac{e^{k\{\ln(r) + i2\pi\}}}{(r^2 + 1)^2} dr$. If we now let $\rho \rightarrow 0$ and $R \rightarrow \infty$, we have

$$\begin{aligned} \int_{C_1} + \int_{C_3} &= \int_0^{\infty} \frac{e^{\ln(r^k)}}{(r^2 + 1)^2} dr - \int_0^{\infty} \frac{e^{\ln(r^k) + i2\pi k}}{(r^2 + 1)^2} dr = \int_0^{\infty} \frac{r^k - r^k e^{i2\pi k}}{(r^2 + 1)^2} dr \\ &= \int_0^{\infty} \frac{r^k [1 - e^{i2\pi k}]}{(r^2 + 1)^2} dr = \int_0^{\infty} \frac{r^k e^{i\pi k} [e^{-i\pi k} - e^{i\pi k}]}{(r^2 + 1)^2} dr \\ &= \int_0^{\infty} \frac{r^k e^{i\pi k} [-2i \sin(\pi k)]}{(r^2 + 1)^2} dr \end{aligned}$$

Now, $\oint_C f(z) dz = \int_0^{\infty} \frac{r^k e^{i\pi k} [-2i \sin(\pi k)]}{(r^2 + 1)^2} dr = 2\pi i(\text{residue at } z = -i \text{ plus residue at } z = +i)$. Since $f(z) = \frac{z^k}{(z+i)^2(z-i)^2}$, and since for a second-order singularity at $z = z_0$ we have from (8.8.8) that the residue is $\lim_{z \rightarrow z_0} \frac{d}{dz} \left\{ (z - z_0)^2 f(z) \right\}$, then for $z_0 = -i$, the residue is R_1 where $R_1 = \lim_{z \rightarrow -i} \frac{d}{dz} \left\{ (z + i)^2 \frac{z^k}{(z+i)^2(z-i)^2} \right\} = \lim_{z \rightarrow -i} \frac{d}{dz} \left\{ \frac{z^k}{(z-i)^2} \right\} = \lim_{z \rightarrow -i} \frac{(z-i)^2 k z^{k-1} - z^k 2(z-i)}{(z-i)^4} = \frac{(-2i)^2 k (-i)^{k-1} - (-i)^k 2(-2i)}{(-2i)^4} = \frac{-4k(-i)^{k-1} + (-i)^k 4i}{16}$ or, $R_1 = \frac{-k(-i)^{k-1} + i(-i)^k}{4}$. If you repeat this for the other residue, R_2 , you'll find that

$$\begin{aligned} R_2 &= \lim_{z \rightarrow i} \frac{d}{dz} \left\{ (z - i)^2 \frac{z^k}{(z + i)^2(z - i)^2} \right\} = \lim_{z \rightarrow i} \frac{d}{dz} \left\{ \frac{z^k}{(z + i)^2} \right\} \\ &= \frac{-k(i)^{k-1} - i(i)^k}{4}. \end{aligned}$$

So,

$$\begin{aligned} R_1 + R_2 &= -\frac{k}{4} [(-i)^{k-1} + (i)^{k-1}] + \frac{i}{4} [(-i)^k - (i)^k] \\ &= -\frac{k}{4} \left[\frac{(-i)^k}{-i} + \frac{(i)^k}{i} \right] + \frac{i}{4} [(-i)^k - (i)^k] \\ &= \frac{k}{4i} [(-i)^k - (i)^k] + \frac{i}{4} [(-i)^k - (i)^k] = \left[-i\frac{k}{4} + \frac{i}{4} \right] [(-i)^k - (i)^k] \\ &= \frac{i}{4} (1 - k) [(-i)^k - (i)^k]. \end{aligned}$$

Thus, $2\pi i(R_1 + R_2) = -\frac{\pi}{2}(1 - k) [(-i)^k - (i)^k]$ and so

$$\int_0^\infty \frac{r^k e^{i\pi k} [-2i \sin(\pi k)]}{(r^2 + 1)^2} dr = -\frac{\pi}{2} (1 - k) [(-i)^k - (i)^k]$$

or,

$$\int_0^\infty \frac{r^k}{(r^2 + 1)^2} dr = \frac{\pi(1-k)[(-i)^k - (i)^k]}{4i \sin(\pi k) e^{i\pi k}}. \text{ Since } -i = e^{i\frac{3\pi}{2}} \text{ and } i = e^{i\frac{\pi}{2}}, \text{ we have}$$

$$\begin{aligned} (-i)^k - (i)^k &= e^{ik\frac{3\pi}{2}} - e^{ik\frac{\pi}{2}} = e^{i\pi k} \left\{ e^{i(k\frac{3\pi}{2} - \pi k)} - e^{i(k\frac{\pi}{2} - \pi k)} \right\} = e^{i\pi k} \left\{ e^{i(\frac{k\pi}{2})} - e^{-i(\frac{k\pi}{2})} \right\} \\ &= e^{i\pi k} 2i \sin\left(\frac{k\pi}{2}\right) \end{aligned}$$

Thus, $\int_0^\infty \frac{r^k}{(r^2 + 1)^2} dr = \frac{\pi(1-k)e^{i\pi k} 2i \sin(\frac{k\pi}{2})}{4i \sin(\pi k) e^{i\pi k}} = \frac{\pi(1-k)}{2} \left\{ \frac{\sin(\frac{k\pi}{2})}{\sin(\pi k)} \right\}$. Or, since $\sin(\pi k) = 2 \sin(\frac{k\pi}{2}) \cos(\frac{k\pi}{2})$, and changing the dummy variable of integration from r to x , we arrive at $\int_0^\infty \frac{x^k}{(x^2 + 1)^2} dx = \frac{\pi(1-k)}{4 \cos(\frac{k\pi}{2})}$, $-1 < k < 3$. MATLAB agrees, as if $k = \frac{1}{2}$ then $\int_0^\infty \frac{\sqrt{x}}{(x^2 + 1)^2} dx = \frac{\pi}{8 \cos(\frac{\pi}{4})} = \frac{\pi}{8\sqrt{2}} = \frac{\pi\sqrt{2}}{8} = 0.55536\dots$, and `quad(@(x)sqrt(x))./(x.^2 + 1).^2,0,1000) = 0.55535\dots`, while if $k = \frac{1}{3}$ then

$$\int_0^\infty \frac{x^{1/3}}{(x^2 + 1)^2} dx = \frac{\pi\frac{2}{3}}{4 \cos(\frac{\pi}{6})} = \frac{\pi}{6\sqrt{3}} = \frac{\pi}{3\sqrt{3}} = 0.60459\dots,$$

and `quad(@(x)(x^(1/3))./(x.^2 + 1).^2,0,1000) = 0.60459\dots`

(C8.5): Consider $\oint_C f(z)dz$, where $f(z) = \frac{e^{imz}}{az^2+bz+c}$ where $m \geq 0$, $b^2 \geq 4ac$, and C is the contour in Fig. 8.6.2. As in the derivation of (8.6.5), there are two singularities on the real axis, at x_1 and x_2 , as shown in Fig. 8.6.2. The values of x_1 and x_2 are as given in the text. The analysis here goes through just as in the text, taking into account the change in $f(z)$. That is, the three integrals along C_1 , C_3 , and C_5 will combine (as we let $\varepsilon \rightarrow 0$ and $T \rightarrow \infty$) to give us the integral we are after, and its

value will be $-\left\{ \int_{C_2} f(z)dz + \int_{C_4} f(z)dz + \int_{C_6} f(z)dz \right\}$. So, let's calculate each of these three line integrals. For C_2 ,

$$\begin{aligned} \int_{C_2} f(z)dz &= \int_{\pi}^0 \frac{e^{im(x_2+\varepsilon e^{i\theta})} i\varepsilon e^{i\theta}}{a(x_2 + \varepsilon e^{i\theta})^2 + b(x_2 + \varepsilon e^{i\theta}) + c} d\theta \\ &= \int_{\pi}^0 \frac{e^{imx_2} e^{im\varepsilon e^{i\theta}} i\varepsilon e^{i\theta}}{a(x_2^2 + 2x_2\varepsilon e^{i\theta} + \varepsilon^2 e^{i2\theta}) + b(x_2 + \varepsilon e^{i\theta}) + c} d\theta \\ &= \int_{\pi}^0 \frac{e^{imx_2} e^{im\varepsilon e^{i\theta}} i\varepsilon e^{i\theta}}{(ax_2^2 + bx_2 + c) + (2ax_2\varepsilon e^{i\theta} + a\varepsilon^2 e^{i2\theta} + b\varepsilon e^{i\theta})} d\theta. \end{aligned}$$

Since $ax_2^2 + bx_2 + c = 0$ because x_2 is a zero of the denominator, and as $\varepsilon^2 \rightarrow 0$ faster than $\varepsilon \rightarrow 0$, then for 'small' ε we have $\lim_{\varepsilon \rightarrow 0} \int_{C_2} f(z)dz =$

$$\lim_{\varepsilon \rightarrow 0} \int_{\pi}^0 \frac{e^{imx_2} i\varepsilon e^{i\theta}}{2ax_2\varepsilon e^{i\theta} + b\varepsilon e^{i\theta}} d\theta = i \int_{\pi}^0 \frac{e^{imx_2}}{2ax_2 + b} d\theta = -\pi i \frac{e^{imx_2}}{2ax_2 + b}.$$

In the same way,

$$\lim_{\varepsilon \rightarrow 0} \int_{C_4} f(z)dz = -\pi i \frac{e^{imx_1}}{2ax_1 + b}.$$

Also, as before, $\lim_{\varepsilon \rightarrow 0} \int_{C_6} f(z)dz = 0$. Thus,

$$\int_{-\infty}^{\infty} \frac{\cos(mx) + i \sin(mx)}{ax^2 + bx + c} dx = \pi i \left[\frac{e^{imx_1}}{2ax_1 + b} + \frac{e^{imx_2}}{2ax_2 + b} \right].$$

Now,

$$2ax_1 + b = \sqrt{b^2 - 4ac} \quad \text{and} \quad 2ax_2 + b = -\sqrt{b^2 - 4ac} \quad \text{and so}$$

$$\begin{aligned} \int_{-\infty}^{\infty} \frac{\cos(mx) + i \sin(mx)}{ax^2 + bx + c} dx &= \pi i \left[\frac{e^{imx_1}}{\sqrt{b^2 - 4ac}} - \frac{e^{imx_2}}{\sqrt{b^2 - 4ac}} \right] = i \frac{\pi}{\sqrt{b^2 - 4ac}} (e^{imx_1} - e^{imx_2}) \\ &= i \frac{\pi}{\sqrt{b^2 - 4ac}} [\cos(mx_1) + i \sin(mx_1) - \cos(mx_2) - i \sin(mx_2)] \end{aligned}$$

or, equating real

parts on each side of the equality, $\int_{-\infty}^{\infty} \frac{\cos(mx)}{ax^2 + bx + c} dx =$

$$\frac{\pi}{\sqrt{b^2 - 4ac}} [\sin(mx_2) - \sin(mx_1)].$$

Using the trigonometric identity

$$\sin(A) - \sin(B) = 2 \cos\left(\frac{A+B}{2}\right) \sin\left(\frac{A-B}{2}\right),$$

we have

$$\begin{aligned} \int_{-\infty}^{\infty} \frac{\cos(mx)}{ax^2 + bx + c} dx &= \frac{\pi}{\sqrt{b^2 - 4ac}} \left[2 \cos\left(\frac{mx_2 + mx_1}{2}\right) \sin\left(\frac{mx_2 - mx_1}{2}\right) \right] \\ &= \frac{2\pi}{\sqrt{b^2 - 4ac}} \left[\cos\left(-\frac{mb}{2a}\right) \sin\left(\frac{m}{2} \left\{ -\frac{1}{a} \sqrt{b^2 - 4ac} \right\} \right) \right] \\ &= -\frac{2\pi}{\sqrt{b^2 - 4ac}} \left[\cos\left(\frac{mb}{2a}\right) \sin\left(\frac{m\sqrt{b^2 - 4ac}}{2a}\right) \right]. \end{aligned}$$

(C8.6): Following the hint and using Fig. 8.9.1, there are two first-order singularities inside C (as we let $\varepsilon \rightarrow 0$, $\rho \rightarrow 0$, and $R \rightarrow \infty$), one at $z = -1 = e^{i\pi}$ and one at $z = -2 = 2e^{i\pi}$. The residue of a first-order singularity at $z = z_0$ in the integrand function $f(z) = \frac{g(z)}{h(z)}$ is $\frac{g(z_0)}{h'(z_0)}$. For $f(z) = \frac{z^p}{(z+1)(z+2)}$ we have $g(z) = z^p$ and $h(z) = (z+1)$

$(z+2)$ and so $h'(z) = (z+1) + (z+2) = 2z+3$. Thus, the residue at -1 is $\frac{(e^{i\pi})^p}{2(-1)+3} = \frac{e^{ip\pi}}{-2+3} = e^{ip\pi}$, and the residue at -2 is $\frac{(2e^{i\pi})^p}{2(-2)+3} = \frac{2^p e^{ip\pi}}{-4+3} = -2^p e^{ip\pi}$. Thus,

$2\pi i$ times the sum of the residues is $2\pi i(e^{ip\pi} - 2^p e^{ip\pi}) = 2\pi i e^{ip\pi}(1 - 2^p)$. So, $\int_{C_1} + \int_{C_2} + \int_{C_3} + \int_{C_4} = 2\pi i e^{ip\pi}(1 - 2^p)$. Now, $\int_{C_1} = \int_{\rho}^R \frac{(re^{i\varepsilon})^p}{(re^{i\varepsilon} + 1)(re^{i\varepsilon} + 2)} e^{i\varepsilon} dr$ and

$\int_{C_3} = \int_R^{\rho} \frac{(re^{i(2\pi-\varepsilon)})^p}{(re^{i(2\pi-\varepsilon)} + 1)(re^{i(2\pi-\varepsilon)} + 2)} e^{i(2\pi-\varepsilon)} dr$ and so, as $\varepsilon \rightarrow 0$, $\rho \rightarrow 0$, and $R \rightarrow \infty$,

$\int_{C_1} + \int_{C_3} = \int_0^{\infty} \frac{r^p}{(r+1)(r+2)} dr - \int_0^{\infty} \frac{r^p e^{i2p\pi}}{(r+1)(r+2)} dr = \int_0^{\infty} \frac{r^p(1 - e^{i2p\pi})}{(r+1)(r+2)} dr$. Next,

$\int_{C_2} = \int_{\varepsilon}^{2\pi-\varepsilon} \frac{(Re^{i\theta})^p}{(Re^{i\theta} + 1)(Re^{i\theta} + 2)} iRe^{i\theta} d\theta$. Since as $R \rightarrow \infty$ the numerator of the integrand blows-up like R^{p+1} for any θ in the integration interval, while the denominator blows-up like R^2 , then the integrand behaves like $\frac{R^{p+1}}{R^2} = R^{p-1} = \frac{1}{R^{1-p}}$.

The C_2 integral thus behaves like $\frac{2\pi}{R^{1-p}}$. For $p < 1$, $\int_{C_2} \rightarrow 0$ as $R \rightarrow \infty$. Also,

$\int_{C_4} = \int_{2\pi-\varepsilon}^{\varepsilon} \frac{(\rho e^{i\theta})^p}{(\rho e^{i\theta} + 1)(\rho e^{i\theta} + 2)} i\rho e^{i\theta} d\theta$. Now, as $\rho \rightarrow 0$ the numerator behaves like ρ^{p+1} while the denominator behaves like 2. So, the integral behaves like $\pi \rho^{p+1}$

which clearly $\rightarrow 0$ as $\rho \rightarrow 0$ as long as $p > -1$. So, we have $\int_{C_2} + \int_{C_4} = 0$ which

means $\int_{C_1} + \int_{C_3} = \int_0^{\infty} \frac{r^p(1 - e^{i2p\pi})}{(r+1)(r+2)} dr = 2\pi i e^{ip\pi}(1 - 2^p)$ or,

$$\begin{aligned} \int_0^{\infty} \frac{x^p}{(x+1)(x+2)} dx &= 2\pi i \frac{e^{ip\pi}(1 - 2^p)}{1 - e^{i2p\pi}} = 2\pi i \frac{e^{ip\pi}(1 - 2^p)}{e^{ip\pi}(e^{-ip\pi} - e^{ip\pi})} \\ &= 2\pi i \frac{(1 - 2^p)}{-2i \sin(p\pi)} = \pi \frac{(2^p - 1)}{\sin(p\pi)}, \quad -1 < p < 1. \end{aligned}$$

(C8.7): Following the hint, we'll use the contour in Fig. 8.6.1 to compute $\oint_C \frac{e^{iz}}{z} dz$

$= \int_{C_1} + \int_{C_2} + \int_{C_3} + \int_{C_4} = 0$ because C keeps the lone singularity of the integrand

(at the origin) in its exterior. So, $\int_{\varepsilon}^T \frac{e^{ix}}{x} dx + \int_0^{\frac{\pi}{2}} \frac{e^{e^{iTe^{i\theta}}}}{Te^{i\theta}} iT e^{i\theta} d\theta + \int_T^{\varepsilon} \frac{e^{e^{i(iy)}}}{iy} i dy +$

$\int_{\frac{\pi}{2}}^0 \frac{e^{e^{i\varepsilon e^{i\theta}}}}{\varepsilon e^{i\theta}} i\varepsilon e^{i\theta} d\theta = 0.$ That is,

$\int_{\varepsilon}^T \frac{e^{ix}}{x} dx + i \int_0^{\frac{\pi}{2}} e^{e^{iTe^{i\theta}}} d\theta - \int_{\varepsilon}^T \frac{e^{e^{-y}}}{y} dy - i \int_0^{\frac{\pi}{2}} e^{e^{i\varepsilon e^{i\theta}}} d\theta = 0.$ In the last integral, as we

let $\varepsilon \rightarrow 0$, $e^{e^{i\varepsilon e^{i\theta}}} \rightarrow e$ and so the integral is $\frac{\pi}{2}e$. In the second integral, $e^{e^{iTe^{i\theta}}} =$

$e^{e^{T[\cos(\theta) + i \sin(\theta)]}} = e^{e^{T\cos(\theta) - T\sin(\theta)}} = e^{\left\{ \frac{e^{iT\cos(\theta)}}{e^{T\sin(\theta)}} \right\}}$ and so as $T \rightarrow \infty$ the integrand goes to $e^0 = 1$ and so the integral is $\frac{\pi}{2}$. Thus, as $\varepsilon \rightarrow 0$ and $T \rightarrow \infty$,

$\int_0^{\infty} \frac{e^{ix}}{x} dx + i \frac{\pi}{2} - \int_0^{\infty} \frac{e^{e^{-y}}}{y} dy - i \frac{\pi}{2} e = 0.$ So,

$$\int_0^{\infty} \frac{e^{\cos(x) + i \sin(x)}}{x} dx - \int_0^{\infty} \frac{e^{e^{-y}}}{y} dy = i \frac{\pi}{2} e - i \frac{\pi}{2} = i \frac{\pi}{2} (e - 1)$$

or,

$$\int_0^{\infty} \frac{e^{\cos(x)} e^{i \sin(x)}}{x} dx - \int_0^{\infty} \frac{e^{e^{-y}}}{y} dy = i \frac{\pi}{2} (e - 1)$$

or,

$$\int_0^{\infty} \frac{e^{\cos(x)} [\cos \{ \sin(x) \} + i \sin \{ \sin(x) \}]}{x} dx - \int_0^{\infty} \frac{e^{e^{-y}}}{y} dy = i \frac{\pi}{2} (e - 1) \quad \text{or,}$$

equating imaginary parts, we have Cauchy's result: $\int_0^{\infty} \frac{e^{\cos(x)} \sin \{ \sin(x) \}}{x} dx = \frac{\pi}{2} (e - 1).$

(C8.8): Following the hint, write $\int_{-\infty}^{\infty} \frac{x^2}{(x^2 + a^2)(x^2 + b^2)} dx = \int_{-\infty}^{\infty} \frac{A}{x^2 + a^2} dx$

$+ \int_{-\infty}^{\infty} \frac{B}{x^2 + b^2} dx$ and so $\int_{-\infty}^{\infty} \frac{x^2}{(x^2 + a^2)(x^2 + b^2)} dx = \int_{-\infty}^{\infty} \frac{Ax^2 + Ab^2 + Bx^2 + Ba^2}{(x^2 + a^2)(x^2 + b^2)} dx.$ This

means that $A + B = 1$ and $Ab^2 + Ba^2 = 0.$ These two equations are easily solved to

give $A = \frac{a^2}{a^2 - b^2}, B = -\frac{b^2}{a^2 - b^2}.$ So, $\int_{-\infty}^{\infty} \frac{x^2}{(x^2 + a^2)(x^2 + b^2)} dx = \frac{a^2}{a^2 - b^2} \int_{-\infty}^{\infty} \frac{1}{x^2 + a^2} dx$

$- \frac{b^2}{a^2 - b^2} \int_{-\infty}^{\infty} \frac{1}{x^2 + b^2} dx = \frac{a^2}{a^2 - b^2} \left\{ \frac{1}{a} \tan^{-1} \left(\frac{x}{a} \right) \right\} \Big|_{-\infty}^{\infty} - \frac{b^2}{a^2 - b^2} \left\{ \frac{1}{b} \tan^{-1} \left(\frac{x}{b} \right) \right\} \Big|_{-\infty}^{\infty} = \frac{a}{a^2 - b^2} \pi -$

$\frac{b}{a^2-b^2}\pi = \frac{\pi}{a+b}$. Now, let $b \rightarrow a$. Then, $\int_{-\infty}^{\infty} \frac{x^2}{(x^2+a^2)^2} dx = \frac{\pi}{2a}$. Finally, differentiating with respect to a , $\int_{-\infty}^{\infty} \frac{-2x^2(x^2+a^2)2a}{(x^2+a^2)^4} dx = -\frac{2\pi}{4a^2} = -\frac{\pi}{2a^2}$. Thus, $\int_{-\infty}^{\infty} \frac{x^2}{(x^2+a^2)^3} dx = \frac{\pi}{8a^3}$. For $a=1$ this is $0.392699\dots$, and $\text{quad}((x(x.^2)/(x.^2+1).^3),-100,100) = 0.392699\dots$

Index

A

Aerodynamic integral, 11, 22, 104, 115
Ahmad, Zafar, 190–194
Alford, Jack, xi
Analytic function, 289–291, 295–296,
309–310, 312–313, 323, 325–326,
331–332, 339
Analytic signal, 271, 289
Average value, 33

B

Bartle, Robert, 10
Bell, Eric Temple, 364
Bernoulli, John, xvi, 187–189
Bertrand, Joseph, 346
Bessel, Friedrich Wilhelm, 295
Binary chop algorithm, 221
Binomial coefficient, 244–248
Binomial theorem, 244, 285, 327
Bohr, Harald, 350
Boras, George, xv–xvi, xix
Brachistochrone, 223
Branch
 cut, 331–333, 352
 point, 331–332
Brownian motion, 31–32
Brown, Robert, 30
Brun, Viggo, 346
Buchanan, Herbert, xvii–xviii

C

Cantor, George, 8
Catalan, Eugène, xv

Catalan's constant, xv, 149–152
Cauchy, Augustine-Louise, xiv, 295, 340
Cauchy Principal Value, 19, 114–115
Cauchy–Riemann equations, 289–291, 296
Cauchy's integral theorems
 first, 295–310, 312, 314, 317
 second, 309–322
Causality, 268–270, 275
Cayley, Arthur, 217, 221–222
Chain rule, 142
Chebyshev, P. L., 346
Clifford, William Kingdon, 364
Conditional convergence, 230
Conjugate (complex), 254, 265, 276, 290
Conrey, J.B., 350
Convolution, 265–267, 269–270
Copson, Edward, 340–341
Cotes, Roger, 364
Coxeter, H.S.M., xviii, 194, 219
Critical line, 349, 366
Critical strip, 347, 349
Cross-cut, 312, 321, 325

D

Dalzell, Donald Percy, 24
Davis, Bette, 194
dblquad (MATLAB command), xviii, 212
de Moivre, Abraham, 35
Diffusion constant, 32
Dini, Ulisse, 109
Dirac, Paul, 258–260, 263
Dirichlet, Lejeune, 7, 84
Double-angle formulas (trigonometry), 51,
115, 127, 194, 210, 239, 283

Duality theorem, 264, 272

Dummy variable, (of integration), 3, 15, 49–50,
53–54, 58, 62, 73, 76, 83, 106

E

Edwards, H.M., 349, 351

Edwards, Joseph, xix, 27–28, 70

Einstein, Albert, 31–34, 145

Equation

difference, 60–61

functional, 118, 133

integral, 112, 116

Erdős, Pál, 346

Euclid, 346

Euler, Leonhard, xv, 9, 15, 62, 64, 84, 117–118,
128, 154, 161–162, 165, 184, 220, 223,
227, 231, 236, 241, 344, 348, 363

Euler's constant, 168, 170, 277

Euler's identity, 226–227, 229, 231,
236–237, 240, 243, 252, 254–256,
258, 276, 278, 283–284, 298, 303,
307, 311, 315–316, 328, 333

F

Fagnano, Giulio, 15–16

Fessenden, Reginald, 267

Feynman, Richard, 18, 39–41, 73, 89, 102, 116,
163, 180, 190, 277, 341

floor (MATLAB command), 14, 34,
183–184, 277

Fourier, Joseph, 253

Fowler, Ralph, 206

Fresnel, Augustin Jean, 227

Frullani, Giuliano, 15–16, 86

Function

beta, 120–122, 144

complex, 282–283

digamma, 174, 181, 185

Dirichlet, 7–9

even, 13, 18, 33, 58–59, 75, 129, 175,
253, 269

factorial, 118

gamma, 117–118, 181, 185, 206, 227, 249

gate, 272–273

impulse, 259–264

odd, 13, 18–19, 33, 58, 79, 253, 269, 311

probability density, 32–33, 75

Riemann's, 1–8

signum, 258, 260

unit step, 258–259, 261–263

G

Gabor, Dennis, 271

Galilei, Galileo, 207

gamma

function, 117–118, 147, 188, 206

number, 168

gamma (MATLAB command), 118–119,
126–127, 135, 147

Gauss, Carl Friedrich, 295, 345, 351, 363–364

Gibbs phenomenon, 84

Green, George, 292

Green's integral theorem, 292–296

H

Hadamard, Jacques, 345

Hamming, Richard, 10

Hardy, G.H., xii, xviii–xix, 201, 206, 219, 270

Hardy, Oliver, 355

Heterodyne theorem, 267

Hilbert, David, 270, 343–344

Hilbert transform, 267–272

I

Indent, 300, 302, 304

Indiana Jones, 365

Ingham, A.E., 347

int (MATLAB command), xviii, 28, 103–105

Integral

Ahmed's, 190–194, 200, 276

area interpretation, 1–10, 122–123, 168

convolution, 265–266

Coxeter's, xviii, 194–201, 219–220

Dalzell's, 23–24

derivative of, 73–74

Dini's, 109–112

Dirichlet's, 84–85, 89, 114–115, 132, 136,
241, 247, 257

elliptic, 207, 212–219

equations, 112, 116

Fresnel's, xv, 19, 201, 227–229, 276

Frullani's, 84–88, 177

Hardy–Schuster optical, 103, 201–205,
212, 227, 276

improper, 17, 40, 299

Lebesgue's, 7–10

lifting theory, 11, 115

line, 280–282, 295, 300, 311, 315

logarithmic, 345

log-sine, 64–66, 234–236

probability, 75–79, 105–109

Ramanujan's, 175–177
 Riemann's, 1–7, 17–18
 Serret's, 54
 Integrating factor, 113, 221
 Integration by-parts, 45, 77, 79, 81, 83, 100,
 114, 117, 131, 135, 150, 152, 157, 160,
 172–174, 188, 200, 226, 233, 242,
 248–250
Irresistible Integrals, xv–xvii, 25, 34–37, 39
 Ivić Aleksandar, 351

K

Keiffer, David, 221
 Kepler, Johann, 288
 Kramers, H.A., 206
 Kronig, Ralph, 270
 Krusty the Clown, 198

L

Lagrange, Joseph Louise, 223
 Landau, Edmund, 350
 Laplace, Pierre-Simon, 82, 106
 Laurel, Stan, 355
 Laurent, Pierre Alphonse, 323
 Laurent series, 323–327
 Lebesgue, Henri, 7
 Legendre, Adrien-Marie, 117, 207
 Legendre duplication formula, 130, 355
 Leibniz, Gottfried, 40, 221
 Levinson, Norman, 350
 L' Hospital's rule, 183, 318, 337, 360
 Littlewood, J.E., 351
 Lord Rayleigh, 254

M

Mascheroni, Lorenzo, 168
Mathematica, 22
 MATLAB, xiii–xiv, xvi, xviii 19, 31, 365.
See also specific commands (*dblquad*,
floor, *int*, *quad*, *rand*, *syms*, *triplequad*)
 Mercator, Gerardus, 41
 Moll, Victor, xv–xvii, xix.
 Monte Carlo simulation, 28–30
 Morris, Joseph Chandler, xvii–xviii
 Multiply connected, 292. *See also* simply
 connected

N

Newton, Isaac, xii, 142, 221, 286–287, 364

O

Ohm's law, 252

P

Partial fraction expansion, 20, 52, 55–57, 70,
 80, 114, 191, 198, 225, 251, 310, 314,
 317, 341
 Poisson summation, 353
 Polar coordinates, 27, 75, 120, 222, 283
 Pole. *See* Singularity
 Prime
 numbers, 344–347, 365
 number theorem, 345

Q

quad (MATLAB command), xiii, xviii

R

Radius vector, 283
 Ramanujan, Srinivasa, 175, 357–358
rand (MATLAB command), 29
 Rayleigh's energy theorem, 254–255,
 274–275, 277–278
 Recursion, 61–63, 71, 100–101
 Reflection formula (gamma function), 128,
 137, 356, 359
 Residue, 325–327, 329, 334–336
 Residue theorem, 323–331, 334
 Riemann, Bernhard, 1, 8, 118, 128, 165,
 343–345, 347, 349–353, 363–365
 Riemann hypothesis, 343–344, 350–352,
 363–366
 Riemann–Lebesgue lemma, 233
 Riemann surface, 332

S

Sampling property, 264, 267
 Schuster, Arthur, 201
 Schwartz, Laurent, 259, 263
 Selberg, Atle, 350
 Series. *See also* Taylor series
 geometric, 165–166, 179, 231, 359
 harmonic, 162, 167, 346
 infinite, xv
 “merabili,” xvi
 power, 149–182, 284–285, 304
 Series expansions
 e^x , 188, 284–285, 304
 $\ln(2)$, 182, xv

- Series expansions (*cont.*)
 $\log(1+x)$, 19, 154–155, 168–169, 182, 184,
 231, 236
 $\tan^{-1}(x)$, 149, 153
 Serret, Joseph, 54
 Simple curve, 281, 313, 339
 Simply connected, 292
 Singularity, 17–19, 40, 271, 274, 291,
 297–298, 301–306, 313–314
 first order, 309, 315–316, 320–323,
 326, 334
 high order, 309, 323, 325–327, 329, 341
 Skewes, Stanley, 351
 Sokhotsky, Vasilievich, 270
 Sommerfeld, Arnold, 221
 Sophomore's dream, 189, 220
 Spectrum
 baseband, 266
 energy, 252–255, 265, 267, 311
 Spherical coordinates, 209
 Spiegel, Murray, xiv–xv, xviii
 Stalker, John, 279
 Stirling, James, 35
 Stirling's asymptotic formula, 35, 38
 Strutt, John William. *See* Lord Rayleigh
 Symbolic Math Toolbox (MATLAB), xviii,
 103–105, 147, 164, 202, 205, 212, 276
syms (MATLAB command), 103–105, 164,
 212, 276
- T**
 Taylor series, 323, 360
 Thomas, George B., 10–11, 22, 230
- Time/frequency scaling theorem, 264, 273
 Transform
 Fourier, xix, 201, 253–255, 260–262, 265,
 267, 277–278
 Hilbert, 267–272, 278
triplequad (MATLAB command), xviii, 212
- U**
 Uhler, Horace Scudder, 102–103
 Uniform convergence, xii, 157
- V**
 Vallée-Poussin, Charles-Joseph de la, 345
 van Peype, W. F., 206, 270
 Volterra, Vito, 112
- W**
 Wallis, John, 119–120, 122
 Watson, G.N., 11, 206–212, 270
 Wiener, Norbert, 31
 Wiener random walk, 32–33
 Wolstenholme, Joseph, 234
 Woods, Frederick, 102
- Z**
 Zeta function, 118, 128, 161–167, 231, 344,
 363–365
 functional equation, 347–348, 352–359
 zero, 348, 350–351, 366