

# ADVANCED TECHNIQUES

OF CLANDESTINE PSYCHEDELIC &  
AMPHETAMINE MANUFACTURE



By **UNCLE FESTER**

Intro By **JIM HOGSHIRE**

**Advanced Techniques  
Of  
Clandestine  
Psychedelic & Amphetamine  
Manufacture**



**Advanced Techniques  
Of  
Clandestine  
Psychedelic & Amphetamine  
Manufacture**

*by Uncle Fester*

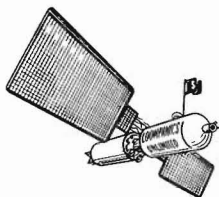

**Loompanics Unlimited  
Port Townsend, Washington**

*This book is sold for informational purposes only. Neither the author nor the publisher will be held accountable for the use or misuse of the information contained in this book.*

## **Advanced Techniques Of Clandestine Psychedelic & Amphetamine Manufacture**

© 1998 by Uncle Fester

All rights reserved. No part of this book may be reproduced or stored in any form whatsoever without the prior written consent of the publisher. Reviews may quote brief passages without the written consent of the publisher as long as proper credit is given.

### **Published by:**

Loompanics Unlimited

PO Box 1197

Port Townsend, WA 98368

Loompanics Unlimited is a division of Loompanics Enterprises, Inc.

1-360-385-2230

E-mail: [loompanx@olympus.net](mailto:loompanx@olympus.net)

Web site: [www.loompanics.com](http://www.loompanics.com)

Cover art and illustrations by Jim B.

**ISBN 1-55950-174-X**

**Library of Congress Card Catalog 98-65684**



# Contents

<b>Introduction</b> .....	i
<b>Preface</b> .....	v
<b>Chapter One</b>	
Scams And Schemes For Obtaining Chemicals.....	1
<b>Chapter Two</b>	
The Fester Formula.....	11
<b>Chapter Three</b>	
A Convenient Tabletop MDA Synthesis.....	29
<b>Chapter Four</b>	
Rubbers As Cell Dividers.....	43
<b>Chapter Five</b>	
Preparation Of Palladium Chloride.....	45
<b>Chapter Six</b>	
A New Low Profile Phenylacetone Synthesis .....	49
<b>Chapter Seven</b>	
Phenylacetic Acid From Ethylbenzene.....	55
<b>Chapter Eight</b>	
Another Low Profile Phenylacetone Factory .....	65

<b>Chapter Nine</b>	
A High Yield Phenylacetone Recipe .....	79
<b>Chapter Ten</b>	
Electric Phenylacetone .....	85
<b>Chapter Eleven</b>	
Obtaining Lithium Metal From Lithium Batteries .....	93
<b>Chapter Twelve</b>	
An Electric Variation On The Birch Reduction.....	97
<b>Chapter Thirteen</b>	
The Poor Man's Hydrogenation Device .....	103
<b>Chapter Fourteen</b>	
"I Want Some Methylamine!" .....	107
<b>Chapter Fifteen</b>	
Apartment Dweller's Crank or X: A Convenient Tabletop Method .....	115
<b>Chapter Sixteen</b>	
More Bromosafrole.....	127
<b>Chapter Seventeen</b>	
A Convenient Method For Making Ammonia Saturated Alcohol .....	131
<b>Chapter Eighteen</b>	
"War Stories From The Pen" .....	135



*Introduction*  
by Jim Hogshire

i

**Introduction**  
by Jim Hogshire

It is my pleasure to present you one of the finest treatises since the publication of Avicenna's *Canon of Medicine*. In the nearly one thousand years since then, the world has given us Galileo, Marie Curie, Enrico Fermi, Werner von Braun and of course... Uncle Fester.

In *Advanced Techniques of Clandestine Psychedelic & Amphetamine Manufacture*, Fester introduces and details his breakthrough findings in what amounts to the application of yet another branch of science to speed synthesis: electrochemistry. At the heart of these new syntheses the philosopher's stone of crank cookery: "The Fester Formula" — an invention that is to amphetamines what breadmaking machines are to a freshly baked loaf of bread. What is normally a time-consuming, laborious and somewhat messy operation is reduced to a sort of "meth in a box." Don't be surprised to see some version of it hawked on late night infomercials.

*"Just add cold pills, press the start button and in one hour and 45 minutes you can enjoy your own home-made meth — like the old man used to make!"*

# Advanced Techniques of Clandestine Psychedelic & Amphetamine Manufacture

ii

## The Fester Formula

For years, “electric” drug synthesis has been maddeningly elusive, crackpot, and “impossible” theory. That theory has become reality. Meth-cooking will never be the same.

Electrolytic methamphetamine manufacture neatly skirts the need for specialized glassware, exotic or restricted chemicals... or even a hell of a lot of education. This method erases all danger of fire, explosion... and it doesn't even smell bad! The Fester Formula is essentially undetectable. But the real jackpot is the fine product it makes, makes quickly and at very high yields and is free of nasty contaminants so common in today's typical bathtub crank.

All of the ingredients for the Fester Formula are readily available, the essential reagent is now electricity — electricity in such small amounts a manufacturing unit could be assembled and powered by a few “D” sized batteries.

Even if everything were to “go wrong,” nothing happens. This would-be chemist can even keep his cold pills if he likes.

## What Fester hath wrought

Fester's little foray into the world of electrochemical drug synthesis has done more than just up the ante in the cops & cooks “game.” It changes all the rules. As Fester put it shortly after he'd perfected his method, “They're finished! Through! Everybody will be doing it!”

Narcotics police (excuse me, *narcoswine*) around the country — nay, the world — have met their match this time. The information in this book should change their lives just as much as it should change the lives of anyone else interested in the tons of “illegal” methamphetamine produced each year.

Fester's four previous editions of *Secrets of Methamphetamine Manufacture* have taught easily thousands of people



*Introduction*  
*by Jim Hogshire*

iii

how to make their own methamphetamine. An Uncle Fester "groupie," with no chemistry training at all, can proudly say she used Fester's earlier book to make enough speed to pay off the mortgage on her trailer. And that was back when Fester's methods, (though written with the novice in mind), still required dedication at the very least.

Paying the mortgage just got even easier. This book will no doubt change the face of clandestine drug manufacture forever.

In an ever-rotating schedule, meth has replaced crack as "worst possible drug" thus giving it the power to transform straight-A Eagle scouts into ax murderers. Narc agencies and "lawmakers" used meth as the reason citizens deserved less freedom. To fight their drug war, narcs cut off access to more chemicals, more glassware, all the while making still more innocuous things "crimes" and running a program of mass incarceration unprecedented in world history. Since 1996 it has been a felony just to have a three-necked boiling flask.

Fester responded by giving instructions on homemade equipment made from kitchen equipment or simple welding. When decent ephedrine pills became so adulterated with unknown "binders," Fester devoted his free moments devising an effective way to "desplooge" them.

Each time the cops threw up a chemical road block, Fester considered it his duty to surmount it. All too soon, the effort needed to overcome the obstacles caused the quality of crank to suffer noticeably. Sadly, at this very same time, many good meth cooks were imprisoned, driven into the greedy hands of those few with enough coin to capitalize such operations, or else they went overseas like everything else. In the 1990s, America came to depend on Mexican laboratories for its crank needs, putting millions at the mercy of foreigners. Foreigners who didn't necessarily share the cultural val-

## Advanced Techniques of Clandestine Psychedelic & Amphetamine Manufacture

iv

ues of the motorcycle gangs who distributed the product for them. The situation was getting tense.

**Enter Uncle Fester**, champion of the working stiff, everyday genius of the loading dock and clandestine chemist extraordinaire.

Hardly had the Fourth Edition of *Secrets of Methamphetamine Manufacture* come off the presses in 1996, than America's most beloved clandestine chemist had turned up with so many revisions for the book it was no longer possible to expand the previous edition. Besides, this stuff was way more than just updated material. His typed-up sheaf of papers (Fester still hasn't gotten a computer) promised to be a watershed in the history of clandestine chemistry. Loompanics decided to publish it as a second volume — the one you hold in your hands.

As you read this book, please keep in mind it is the product of a man who — by the establishment's lights — is worthy of nothing better than slaving his whole life away in a factory. His status as felon has made him “unfit” for jury duty, for voting, for firearms ownership and (as one DEA agent calls him) the “felon from Hell.” Cops around the country bristle at the sound of his name, and none fail to consider ownership of his book to be incriminating evidence for damn near anything.

But what they hate is a real American. All of Fester's books have embodied true Yankee ingenuity, that “can do” ethos and fearless search of knowledge that is nearly extinct in Slave State, USA. Put in on your shelf next to the works of Benjamin Franklin and Thomas Jefferson.

Enjoy this book in good health and Purity of Essence.

Jim Hogshire  
June 1998



## Preface

Welcome to *Advanced Techniques of Clandestine Psychedelic & Amphetamine Manufacture*. Don't be intimidated by the title. Neither the publisher nor I could think up a better title. These advanced techniques aren't more difficult than the standard methods presented in my previous books. In fact, in most cases, they are simpler. Through the application of American technology, formerly difficult problems have been solved, and life made simpler and better. That's what this book is about, an end to counterpunching in response to the latest governmental excesses. It's about seizing the initiative to bring crank and trips to the starved masses.

Foremost amongst this display of American technology is the greatest achievement of my career as a chemist — The Fester Formula. The most low profile and convenient method ever invented to make stash quantities of crank. All one needs are some OTC pills, acetic acid, sulfuric acid, a piece of palladium metal, a DC transformer and a rubber to make a few grams of speed. Can't get chemical glassware? No problem! American technology triumphs. Best of all, meth made by this method doesn't give one the body and soul racking hangovers

## Advanced Techniques of Clandestine Psychedelic & Amphetamine Manufacture

vi

so characteristic of production by some other methods. A similarly simple method is also given for making MDA.

On the opposite end of the production spectrum, methods are presented suitable for industrial chemicals easily available in drums, pails and bags to come together through production pathways not yet covered by government reporting requirements. Nor are these industrial chemicals ever likely to be subject to such reporting due to the huge volumes of them routinely bought and sold every day.

As an added bonus, Mr. X is back again. He writes from the federal pen to give us case by case analyses of fellow cookers with whom he is doing time. He shows where they made the mistakes that ended their cooking careers, and illustrates standard police investigative techniques in tracking down clandestine chemists. Mr. X also discusses proper etiquette and procedures when doing business with industrial chemical suppliers. On a related topic, there's also a "Scams and Schemes For Obtaining Chemicals" chapter.

But that's not enough! Clandestine cookers from points unknown have shared their chemical secrets. To follow in their lead, my own experience in relevant chemical techniques and clandestine equipment construction is liberally sprinkled throughout. This is another installment in the "Journal of Clandestine Cookers!"

Come, share in my triumph! You'll be quite pleased, I'm sure.

*Fester*

## **Chapter One**

# **Scams And Schemes For Obtaining Chemicals**

With the passage of time in this continuing sick display called the “drug war,” it has now begun to dawn upon our overlords that just restricting access to a certain defined list of chemicals has very little beneficial effect if one’s aim is to prevent the clandestine manufacture of drugs. The many and varied synthetic routes leading to the desired substance weave a web too thoroughly intertwined with innocent chemical commerce. This finger in the dike approach inevitably leads to new leaks springing up right next to the one “plugged.” Exposing the ridiculous nature of this authoritarian thinking has been a constant theme in my books.

Apparently, the learning disabled folks who consider themselves fit to be our masters are now catching on to this. Over the past couple of years, efforts have apparently ceased to add more and more chemicals to the so called “controlled list.” This really breaks my heart, because it was a life long goal of mine to get every chemical under the sun put on that list. I guess now I’ll just have to move onto other goals.

The new approach embraced by the narco swine elite is two pronged. Prong number one is to increase further the penalty for cooking and distributing various goodies, espe-

## Advanced Techniques of Clandestine Psychedelic & Amphetamine Manufacture

cially my favorite — methamphetamine. This approach is doomed to failure. The penalties are already insane, even as clandestine meth cooking has entered into a “golden era.” Apparently their threats leave the cooker undeterred. A federal government six trillion dollars in debt can't afford to keep locking people up. When they have to choose between paying Social Security, and running the gulag, what will be the choice? Default on the Social Security, and those old geezers will have those traitors doing a dance on the end of a rope. Default on making their interest payments to their bond holders, then their fate will be nowhere nearly as kind. Debt will force the abandonment of all mass imprisonment schemes.

The second prong in the new strategy is to persuade chemical companies to stop doing business with new customers — at least not until they send a sales crew out to check them out. So that's how it is now. The major chemical companies are now just branches of the police, sending out investigators before they do business. This is no great loss, as they always were a stinking bunch of snitches anyway. Better not to do business with them, rather than be a victim of their snitching.

One's goal when doing clandestine synthesis should be to use industrial chemicals, hardware store chemicals, and household chemicals to the maximum extent possible. This recurring theme in my previous books shifts into high gear in this volume. The electrochemical methods detailed here, to a large extent, eliminate the need for chemical purchases. The active agent of transformation in an electric synthesis is a piece of metal, charged with DC current. This piece of metal can be used over and over, and electricity flows from everyone's wall sockets.

*Chapter One*  
*Scams And Schemes For Obtaining Chemicals*

Still, in most synthetic routes, the need for some chemical supply can't be done away with. For simple, multipurpose chemicals that any moderately stocked experimenter should have, such as the mineral acids and common salts, a lot of smaller outlets still survive. Even mail-order chemical supply firms can be trusted with such orders. In the case of the mail-order firms, just check over their catalog of offered chemicals. So long as they don't offer anything on the so called "List I" (see *Secrets of Methamphetamine Manufacture* or *Practical LSD Manufacture* for the List I chemicals, or 21 CFR 1300 onward) they can probably be trusted for the order of simple chemicals. These mail-order chemical firms advertise in the classified section of various magazines.

For somewhat more complex chemicals, such as sodium borohydride, several good choices exist. There is, of course, the smaller local distributor of chemicals. Most of these businesses won't deal with individuals, so just call yourself a company name. A very good reason for wanting borohydride is to remove heavy metal contaminants from water. Say, for example, that you do some electroplating, and that the water in which you rinse your parts is loaded with metals such as nickel, and so is no longer any good. The metal is complexed with, let's say ammonia, and so doesn't sludge out by adding hydroxide. You want borohydride to precipitate the metal in the metallic form before you sewer the water. Wrapping yourself in the cloak of protecting the environment is a uniformly good move.

To further our scenario with borohydride, this is a good example of an industrial chemical which can be picked up pretty easily from manufacturers of industrial products. Sodium borohydride is the reducing component of many electroless nickel plating baths which produce a nickel-boron

## Advanced Techniques of Clandestine Psychedelic & Amphetamine Manufacture

alloy plate. These plating baths generally come in a three component package. Component one is a water solution of nickel chloride or sulfate, component two is the complexor and stabilizer, and component three is a water solution of the reducer — either sodium borohydride or dimethylamino-borane. One quart samples of these three components are easy to get by calling the manufacturers of electroless nickel products. Your name is XYZ Plating and Finishing, and the numbers of the manufacturers can be found by looking in the magazines, *Plating and Surfacing Finishing*, *Products Finishing*, and *Metal Finishing*. Make sure they send the product that contains sodium borohydride, as aminoboranes are less powerful reducers. When the product comes, the blue-green colored nickel solution component can be saved if one also wishes to plate the Raney nickel cathodes described in this book. The complexor can be sewerred. The reducing component can either be used as is in water solution, once the concentration of borohydride has been determined, or the water can be evaporated away under a vacuum to leave a residue of crystalline borohydride. Boiling without a vacuum will rapidly destroy the borohydride.

Another source of chemical supply, the waste exchanges, has been covered in detail in both *Secrets of Methamphetamine Manufacture* and *Practical LSD Manufacture*. Some further amplification on the points presented is called for here. One need not restrict oneself to listings offering laboratory chemicals. The great majority of the listings are for industrial materials, and a lot of them contain chemicals of interest for the clandestine cooker. For example, a listing offering used chrome plating solution is a great source of  $\text{Cr}^{+6}$  in the form of chromic acid,  $\text{HCrO}_4$ . The typical chrome plating bath contains two pounds per gallon of chromic acid, along with a small amount of sulfuric acid, less still fluoride,

*Chapter One*  
*Scams And Schemes For Obtaining Chemicals*

and some dissolved iron, copper, etc. Such a listing would be perfect for someone wanting  $\text{Cr}^{+6}$  to use to make cat, and it could even be used in the phenylacetic acid from ethylbenzene recipe given in this book. In that case, one would just add sodium hydroxide to the chrome plating bath to form a water solution of dichromate, and sludge out the tramp metals as hydroxides. After decanting or filtering off the metal sludge, the dichromate solution is ready to go. A solution pH of 8-9 would be most preferable in this case to form the dichromate and metal hydroxide sludge.

Similarly, waste solvents are often listed on the exchanges. Things you never thought you would see, like THF, acetonitrile and DMF. They are generally contaminated with water, maybe some ammonia or alcohol. The listings will describe the contaminants. They are all easily removed to give pure solvent. The general procedure would be to distill fractionally, dry with suitable dehydrating agent, then distill again. See *Vogel's Textbook of Practical Organic Chemistry* for detailed directions for each solvent. The big point here is that the industrial material listings often have chemicals of interest.

A more aggressive version of the same theme has the person seeking chemicals playing the role of lion rather than vulture. Pretty much every lab and industrial site has old, excess or no longer used chemicals. This is certainly the case where I work. They just take up space in the lab or workplace, and the people in charge would gladly be rid of them if they didn't have to go through the hassles involved in declaring them hazardous waste, and getting them hauled away by a hazardous waste disposal crew.

One can play into this common concern, and be a real help to the people working at the lab or industrial site by offering to take them off their hands. The key here is to avoid declar-



## **Advanced Techniques of Clandestine Psychedelic & Amphetamine Manufacture**

6

ing these surplus items waste. Rather they are surplus commodities, destined for resale to others who will put them to use. They'll be put to use all right, but we'll leave out the resale part. A letter similar to the following should open up many doors for you in your own area.

### **S&M & B&D CHEMICAL SALVAGE "One With The Earth"**

Dear Sirs:

In these environmentally conscious times, the haphazard disposal of one's surplus, old, or no longer useful chemicals is strictly forbidden. Still, the problem remains of what to do with those chemical items which have been taking up shelf space for too long, and creating a nuisance, if not actual danger.

We at S&M & B&D offer an alternative to disposal through hazardous waste haulers. We know that most chemical items have value, and aren't waste just because they are no longer involved in production, or were part of a project now finished, or because their use is no longer necessary. Our alternative is salvage and resale to others who will put orphans gathering dust on the shelf to productive use.

This environmentally superior option to waste disposal should be part of your waste minimization plan. We make it easy for you. There is no charge for our resale service, as we make our money when we resell this valuable but out of place commodity.

Our sales rep will contact you in the near future to inquire which surplus items you may have. If we can find a buyer for the item, it will be our pleasure to handle the transaction, and present you with certification of resale salvage.

Sincerely,

Joe Blow  
S&M & B&D Chemical Salvage

*Chapter One*  
*Scams And Schemes For Obtaining Chemicals*

One should send this letter to schools and universities addressed to their Science or Chemistry departments. Industries in the area should be profiled by a look through the state *Manufacturers Register* available at the library. Pick out the concerns likely to have a lab, or likely to use chemicals of interest in their production. Address it to technical director or environmental officer. Testing labs should also be sent letters, addressed to the lab director.

Naturally, you will only want chemicals of use to you, so most places will be dead ends, even if they are interested in doing business. One is best advised to show up in a suit and tie when doing business, and not have a buzz going. The certificate of resale salvage you give them in exchange can be something you designed and ran off on a copy machine. The term has no actual meaning, it's just to make them feel good.

Some chemicals keep better than others on the shelf. For those subject to decomposing with age, distilling the chemical, or recrystallizing it prior to use would be called for. Nitroethane is an example of a chemical which goes bad with age.

Another approach to obtaining chemicals is the old straightforward method of simply going into a business which uses some of the chemicals of interest. One then sets up accounts with various chemical companies, orders enough chemicals to last a lifetime, then shop is closed and cooking can begin elsewhere. The use of false identity is highly recommended with this plan. One should also never order List I chemicals by this approach, as scrutiny during the accumulation phase of the project would be as unwelcome as later on. Having to do without List I chemicals is no big deal, as has been repeatedly demonstrated in my previous books.

## Advanced Techniques of Clandestine Psychedelic & Amphetamine Manufacture

An example of such a front business would be perfumery. Ethyl and methyl phenylacetate are widely used in perfume formations. These two chemicals are on no reporting lists as of mid 1997, yet they are the ethyl and methyl esters, respectively, of phenylacetic acid. Saponification to phenylacetic acid is a very simple procedure. To order these chemicals, one would be best advised to read through perfume trade publications such as *Soap, Perfumes, and Cosmetics* and look for ads from suppliers of chemicals to perfumers. Many useful solvents would also be available through this source. I would suggest a reading of books such as *Perfume and Flavor Chemicals* by Arctander, and *The Perfume Handbook* by Groom, to familiarize oneself with the field before placing orders. It's never good to sound stupid on the phone when doing business.

The next alternative supply route may sound a bit bold, but it's also quite powerful. That alternative is to take a trip south of the border to that wonderland of corruption and squalor called Mexico. This home to our modern day counterparts of the Vandals, Huns and Visigoths is a place where anything can be had for a price. That includes chemicals of all types. Thanks to NAFTA, you may even be able to get them to deliver with just a phone call. Money talks loud and clear down there, and the chemical trade hasn't been so burdened with regulation and paranoia as it has in the U.S. Rule number one when doing business down there is to place no orders for List I chemicals. Importing them without authorization is a federal felony. We have no need for stinking List I chemicals anyway. Rule number two is to be aware that more than a few finks are in business down there, set up by the DEA. They shovel chemicals to DEA or CIA approved cookers, and work to set up the competition. The placement of radio beepers on jugs or drums of chemicals is trick favorito numero uno. Should

*Chapter One*  
*Scams And Schemes For Obtaining Chemicals*

such a beeper be found, don't panic. Just toss it onto the back of some pickup truck at a stop sign, and let them follow the pickup.

Once again, the cardinal rule that supply and cooking be two distinct phases of the operation must be followed. If one should get stopped and searched at the border, all that one has is some innocent chemicals. They're cheaper down there, that's your story, and you're sticking to it. So long as one doesn't have chemicals in combination to show a synthetic intent, or a lab location traceable to the border crosser, all should be well. The vast majority of border crossers don't get stopped and searched anyway. The hordes of invaders from south of the border find it to be quite porous.

Compared to the trip south of the border, the next plan is pretty tame, but almost as effective. It's a plan best called "the inside job." I'll make the assumption that most readers out there are capable of turning out good product using these advanced techniques in this book are chemists, or at least in a technical profession. In this position, one of course has access to lots of chemicals, some useful, and some not. In one's position as chemist in a production or testing situation, the opportunity is always there to take home a bit of the raw materials. A couple of gallons from a 55 gallon drum will never be missed, and besides, you owe it to that chemical to give it a much more exciting life than the dull industrial existence into which it was born.

For a chemist in an industrial setting, tweaking the various processes to make use of materials of interest rather than useless ones is no great challenge. All it takes is research and imagination, along with a little drive. The only thing one must avoid is, once again, not to bother with the List I chemicals. They are way more bother than they are worth. The last time I read the federal regulations, they were expecting all List I

## **Advanced Techniques of Clandestine Psychedelic & Amphetamine Manufacture**

chemicals to be locked down at any facility, under surveillance, and weighed regularly. They also expect anyone with access to List I chemicals to undergo a background check. The best advice I can give you is to forget about them, they're not worth whatever convenience in synthesis they might provide.

Finally, the last option for obtaining chemicals is the old fashioned, tried and true, five finger discount method. This differs from "the inside job" in that burglary, rather than shoplifting, is involved. Correspondingly, this is a much higher risk proposition. It is only advisable if one has inside information on the target regarding possible security on the site, and placement of the desired items. Information on the latter is openly available to all members of the community via the publicly filed "Emergency Planning and Community Right To Know" reports filed by businesses each year. A floor plan and location of chemicals is listed in the report. Call your county government for where the reports are kept. Say you're some environmentalist type or something similar. That will get you the floor plan and locations. Security measures aren't discussed in these reports, so be warned. Also be warned that the exact location of chemicals is only given for those contained within the plant above the reporting threshold. This is generally over a thousand pounds, but less for Extremely Hazardous chemicals. In any case, the floor plan is informative.

## **Chapter Two**

# **The Fester Formula**

The pressing need for someone to find and make public a simple, convenient, effective and clandestinely low profile method for producing stash amounts of meth has long been a matter of concern for me. A suitable method would have to pass several hurdles. To be suitable for the casual consumer-producer, the method would have to be operable without access to chemical glassware. This hurdle is higher than it would seem at first glance because it requires that the product produced from the process must be pure enough to use as is without distilling or other complicated manipulations. The method would have to be free of odiferous emanations which would alert meddlesome neighbors to unusual goings on. It's even better if the process is sufficiently odor free that it can be done in some room without disapproving wives or yakking children noticing. Yes, it would be really great if one could run a batch in a dorm room without anyone noticing. Finally, the chemicals used would have to be so common that anyone would have easy access to them, either at work or school, or even so common and possessing so many mundane uses that they can be safely ordered from any of the various mail-order "hobbyist" chemical suppliers without bringing any attention to the or-

## Advanced Techniques of Clandestine Psychedelic & Amphetamine Manufacture

derer. These hurdles have all been cleared in what is probably the greatest achievement of my career as a chemist — The Fester Formula.

Some background information will be of benefit to those who would wish to understand where the inspiration for this procedure came from. For some time now, it has been evident that the field of electro-organic synthesis is where clandestine chemistry should be moving. When doing an electric synthesis, a piece of metal and DC current are the reagents. The logistics of supplying oneself to do an electric synthesis are consequently quite simple. The only reason why this fertile field has not long ago been harvested by clandestine cooks is lack of education. One can easily go through four years of college chemistry, and even grad school, without ever being required to do an electric synthesis. Its techniques are, for some reason, not taught unless one chooses to go into the specialized field of electro-organic chemistry. The discoveries made by those working in this field are generally ignored by chemists in other fields, as they are quite comfortable using conventional chemical reagents to do their molecular manipulations. Even so, the electro-organic people are generally quite satisfied with the results they get, and their marginalization miffs them, to say the least.

It's my intent to plant a crop on this fertile ground, that you may reap the harvest. The strategy which has produced the most advances in clandestine chemistry is to take a general synthetic method, and apply it in a previously unknown manner. That's where the lithium metal in ammonia reduction of ephedrine or pseudoephedrine to meth or phenyl-propanolamine to Dexedrine recipe came from. Ditto for hydroiodic acid and red phosphorus put to the same purpose. Also, the Method X LSD synthesis using propionic anhydride is an extension of a previously known procedure.



*Chapter Two*  
*The Fester Formula*

13

A search of the chemical literature for electric methods of reducing benzyl alcohols, the class of chemicals to which ephedrine, etc., belong, to alkanes, which is the transformation needed to turn it into meth or Dexedrine, comes up with a few interesting papers. See first of all *Journal of the Electrochemical Society*, April 1959, pages 325-27, by Wawzonek and *Journal of Organic Chemistry*, Volume 35, pages 1604-05 (1970), by Erickson. In these two papers, benzyl alcohols such as mandelonitrile and mandelic acid were reduced. They first converted the alcohol to an ester, and were able to reduce the former alcohol grouping to the alkane in a divided cell using mercury as the cathode. They found that it was absolutely necessary that a quaternary ammonium compound such as tetraethylammonium bromide, or tetramethylammonium iodide, or tetrabutyl ammonium iodide be present in the reaction mixture as electrolyte for the reduction to occur. Having other salts in the solution as current carrier didn't work. I considered tweaking this procedure, trying the waterbed water conditioner ingredient alkyl dimethyl benzylammonium chloride, to see if this quaternary ammonium salt would also work in the process. After some consideration, I decided against it because of the mercury cathode. My feeling is that mercury metal and less than highly skilled dope cooks don't mix. This procedure may very well work, so if someone feels they are practiced enough to handle and keep mercury, feel free to give it a go.

Another interesting article is to be found in *Tetrahedron Letters*, No. 25, pages 2157-60 (1979). In this paper, a wide variety of alcohols were reduced to the alkane with uniformly good results. Here too, they didn't directly reduce the alcohol. First they converted the alcohol to the methane sulfonic acid ester. Then they did the electric reduction in a divided cell using dry dimethylformamide as the solvent, and the quaternary ammonium compound tetraethyl ammonium p-toluene-sulfonate as the electrolyte. The electrolyte allows current to

## Advanced Techniques of Clandestine Psychedelic & Amphetamine Manufacture

pass through the solution, as pure dimethyl formamide isn't a conductor. This is a good method, but isn't clandestine suitable. Dry dimethylformamide and the exotic quaternary ammonium compound aren't run of the mill chemicals. I also think this method would give off powerful odors if the methane sulfonic acid were to be reduced to methyl mercaptan. People would think you are raising skunks.

A much better line of pursuit is to be found in *Transactions of the Faraday Society*, Volume 60, pages 913-18 (1964) and Volume 55, pages 1400-20 (1959), *Journal of Electroanalytical Chemistry*, Volume 114, pages 273-81 (1980) and *Electrochimica Acta*, Vol. 21, pp. 449-50 (1976). In these articles, they found that if a metal which is a hydrogenation catalyst, such as palladium and platinum, is used as a cathode, i.e., it is connected to the negative terminal of a DC transformer, then the hydrogen generated at the surface of the catalytic cathode can be used to do convenient tabletop catalytic hydrogenations. This principle is also put to use in the next chapter where a Raney nickel cathode is the key to a convenient tabletop MDA synthesis. The unanimous finding is that the freshly generated atomic hydrogen at the catalytic cathode is a surprisingly powerful and effective means of doing a catalytic hydrogenation. The authors cited above wasted their time hydrogenating things such as ethylene. We can think of better things to hydrogenate electrically than that.

A series of related methods are known for converting ephedrine, pseudoephedrine or phenylpropanolamine (PPA) to meth or dexedrine respectively using catalytic hydrogenation. These are all good methods, but they haven't been able to approach the method using hydroiodic acid and red phosphorus in popularity among clandestine cooks. For complete coverage and comparison of these methods see Chapter Fifteen in *Secrets of Methamphetamine Manufacture*, Fourth Edition.

*Chapter Two*  
*The Fester Formula*

15

The explanation of why the HI and red P method has remained preeminent is probably twofold. All of the hydrogenation methods use palladium black as the catalyst. Even though this substance isn't on reporting lists to the feds, its only common source is from those dens of snitches at mainstream suppliers. Palladium black is easily made from palladium chloride. See *Secrets of Methamphetamine Manufacture*, Fourth Edition, Chapter Fifteen for details, or go to the *Organic Syntheses* collective volumes for the procedures. Even so, it would appear that getting palladium chloride from those snitches isn't much smarter. Note that it was disclosed in the Fourth Edition of the meth book that  $\text{PdCl}_2$  is also sold by companies supplying precious metal salts to electroplaters of these metals. All of this speculation is now just academic anyway, because in this book a most simple and effective procedure is given for making your own  $\text{PdCl}_2$  from an ingot of palladium, some hydrochloric acid, a couple of rubbers, and a source of DC current. I've tried this procedure, and the results are quite satisfying. Take it from your Uncle, no home should be without an ingot of palladium. Head on down to your local precious metals and coins dealer. Spend the \$240 or more for one ounce of palladium. It'll be the best buy of your life.

The second reason why the HI and red P method has remained most popular is no doubt the lack of cheap, reliable and easily available hydrogenation equipment. See "The Poor Man's Hydrogenation Device," Chapter Thirteen in this book. An aluminum fire extinguisher is easily converted into a really good hydrogenation device that allows for magnetic stirring of the contents. Of course, the aluminum won't stand up to the sulfuric, acetic, hydrochloric, or perchloric acids used in these hydrogenation procedures, so the inside of the extinguisher should be coated with Teflon or Teflon loaded paint such as Xylan 1006. See *Vestbusters* for details on ordering and applying these useful materials.

## Advanced Techniques of Clandestine Psychedelic & Amphetamine Manufacture

But I digress. So which of the catalytic hydrogenation methods could be converted to an electrocatalytic process? Going to Chapter Fifteen of my meth book, the first procedure given uses dry HCl in acetic acid and palladium black to reduce ephedrine, or whatever, to the amphetamine. This procedure wasn't even considered by me for further research. The next procedure given requires that one first take the ephedrine hydrochloride, or whatever, that one has isolated from OTC pills, and add it to sulfuric acid to form the sulfuric acid ester. Electrocatalytic hydrogenation of this sulfuric acid ester in water solution proved to be a failure, giving back what I assume to be unreduced ester. Perhaps in alcohol solution it may work, so serious experimenters take note.

The next method given uses a mixture of sulfuric acid in acetic acid and palladium black to yield the amphetamine. Electrocatalytic hydrogenation of this mixture results in just a small raising of the octane numbers of the ephedrine fed into the process. The solution is just too strong to allow for a good rate of generation of hydrogen on the palladium cathode.

What does work is now given. First one starts with the OTC pills containing the ephedrine, pseudoephedrine or PPA, and extracts out the active ingredient using water as described in Chapter Fifteen of my meth book. Note that pills have become even more loaded with fillers since the publication of that book, so even more water is required to get complete extraction of the active ingredient from the pills. Then after adding a dash of HCl to the water extract and boiling it down to concentrate it, the water extract is made strongly alkaline with lye, the ephedrine extracted with a couple portions of toluene, and the toluene extract bubbled with dry HCl to give about 2 grams of crystalline ephedrine hydrochloride from each 100 lot of 25 mg ephedrine pills extracted. See the meth book Chapter Fifteen for a more complete discussion of this extraction and isolation procedure. Note that some brands of pills require a preliminary

*Chapter Two*  
*The Fester Formula*

17

soaking with toluene to degum and desplooge them prior to water extraction. Without doing the desplooge, these certain brands of pills will give a milkshake like emulsion upon being made strongly alkaline and extracted with toluene.

Now one gram of ephedrine, pseudoephedrine or PPA hydrochloride is put into a large test tube, along with 5-7 ml of glacial acetic acid. The bottom of the test tube is placed into a pot of hot water, and when the ephedrine hydrochloride, or whatever, is about all dissolved, a few drops of concentrated sulfuric acid are added. Mix it all in, and loosely stopper the end of the test tube with a cork to prevent steam from entering. Heat the hot water bath to just about boiling, and use this hot water bath to heat the test tube and its contents for a few hours. This forms the acetic acid ester of the ephedrine, pseudoephedrine or PPA, used in the reaction.

The solution should appear clear and water-like, and completely homogenous. After heating, the reaction mixture can be kept stoppered as is with no harm for at least a few days, but it's best to use it immediately after it's cooked and cooled.

This reaction to form the acetic acid ester is a typical ester forming reaction, and the usual rules apply. Water must be kept out of the reaction mixture, as its presence greatly reduces the yield. As a consequence, only crystalline ephedrine, pseudoephedrine or PPA hydrochloride can be fed into the process. A concentrated water extract won't do. An excess of acetic acid pushes the equilibrium toward making more ester. As a result, 7 or more ml of acetic acid is preferable to 5 ml. Only glacial acetic acid can be used, as diluted acetic acid is full of water. It would be best to reflux the ester forming mixture, but the simple procedure given here, heating to about the boiling point of water with precaution to keep steam from getting into the test tube, works good enough to give satisfying results.

Next mix up a solution of 5 ml of concentrated sulfuric acid in 100 ml of water. Take a 250 ml beaker, place it on a mag-

## Advanced Techniques of Clandestine Psychedelic & Amphetamine Manufacture

netic stirrer. Clip a well scrubbed Kling-Tite Naturalamb rubber in one side of the beaker, and put a piece of lead about  $\frac{1}{2}$ -inch in diameter, and a few inches long, inside the rubber. On the opposite side of the beaker, stand up a one ounce ingot of palladium. Using alligator clips, make contact with the ingot, and with the piece of lead. Next pour most of the dilute sulfuric acid solution into the beaker. Save enough that some can be poured into the rubber so that the solution levels are about equal inside the rubber and the beaker at large. The ingot of palladium should be almost completely immersed. The alligator clip should be up out of the solution and there should be enough space left to add the ester reaction mixture from the test tube to the beaker without causing the solution level to reach the alligator clip. See the drawing below.

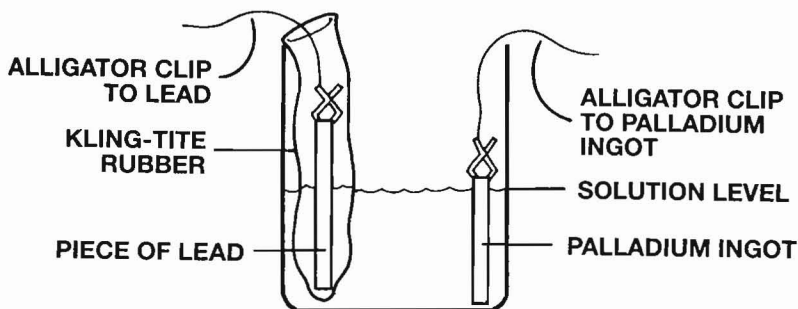

The choice of a 250 ml beaker here is based solely upon having room inside the beaker to put a standard size magnetic stir bar along with the two electrodes and rubber. A 100 ml beaker would no doubt be superior, as the one ounce palladium ingot would be considerably larger in relation to the catholyte

*Chapter Two*  
*The Fester Formula*

19

volume in a 100 ml beaker. The ester of ephedrine, pseudoephedrine or PPA would also be considerably more concentrated in a 100 ml beaker, allowing for more efficient electric reduction. In a 250 ml beaker, the ester reaction mixture will be diluted over 10 times by the catholyte whereas in a 100 ml beaker, the dilution will be more like five times. A perfectly usable magnetic stir bar can be made by cutting a section of bar magnet and coating it with a few coats of tough paint. In this way, a suitable size stir bar for the smaller beaker can easily be made.

A glass beaker isn't the only reaction vessel which can be used. The only requirements are that it be non-conductive so that the cell doesn't short out, and it must also be inert to the dilute acetic and sulfuric acid used in the process. A measuring cup with a pour lip would be a quite good substitute, and a drink tumbler would also be serviceable.

The lead anode shown in the drawing can be replaced with other materials as well. The only function of the anode is to pump current into the solution. It doesn't take part in the reaction in any other way. Suitable replacements for lead would be graphite rod obtained at the welding supply shop or dissected out of a dry cell battery. One could also use platinum metal. Unsuitable choices for anode materials include iron and steel, copper and brass, and aluminum. All of these metals will dissolve in dilute sulfuric acid when made anodic. The exact size or shape of the anode isn't particularly important. So long as it has dimensions about that shown in the drawing, it will work fine. As stated earlier, its only function is to pump current into the solution.

The rubber serves two purposes. It first of all keeps the ephedrine, pseudoephedrine or PPA from coming into contact with the anode. These substances will oxidize at the anode, resulting in cleavage producing benzaldehyde, methylamine or acetaldehyde. This makes one wonder whether the process



## Advanced Techniques of Clandestine Psychedelic & Amphetamine Manufacture

could be run backwards with electric reduction. Methamphetamine will oxidize at the anode to form a tar which clings to the anode surface. See *Chem. Pharm. Bull.*, volume 25, pp. 1619-22 (1980) for more on this subject. The rubber also serves to keep the oxygen which is generated at the anode surface from leaking into the solution by the cathode. This would interfere with the hydrogenation taking place there.

The surface of the palladium ingot should be lightly sanded prior to use. This increases its surface area a little, and exposes fresh clean metal. The piece of lead should be scrubbed free of grease and dirt. The wire lead to the palladium ingot can be clipped to the side of the beaker with a clothes pin or paper clip, to prevent the ingot from falling over during the course of the reaction. A DC current meter (amp meter) should be put in line on the wiring. A perfectly good one can be had at Radio Shack for about \$50. Note that the model I have was made in China, and the instructions for how to wire it in to measure current were wrong. You'll figure it out, I'm sure.

First the wires are hooked up so that the palladium ingot is connected to the positive pole of the DC transformer, and the piece of lead to the negative. The typical one ounce ingot will have a face with an area of about 6 square centimeters immersed in the solution, and about one square centimeter up out of the solution. Only count the area on the side facing the lead piece. The back side doesn't count because current can't reach it. With this typical size ingot apply about 2 amps for one or two minutes. Oxygen will bubble freely from the ingot, and hydrogen from the piece of lead. Blackening will be noted on the edges of the ingot, where the current is most intense, and a lighter discoloration on the flat face of the ingot. This pre-treatment is called "anodizing." It has been found that anodizing increases the ability of the palladium ingot to absorb hydrogen when the wiring is turned around, and the ingot is made the cathode.

Chapter Two  
The Fester Formula

21

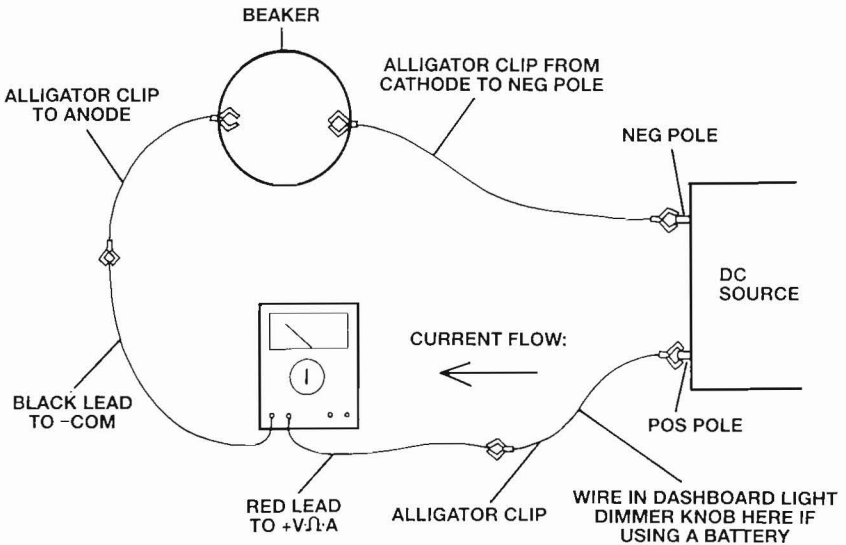

Next, redo the wiring so that the palladium ingot is attached to the negative pole of the DC transformer, and the piece of lead to the positive. Turn back on the juice, and for this typical size ingot, run between one and two amps of current for about 20 minutes. At first, the amount of hydrogen generated at the palladium ingot will appear small, because it absorbs the hydrogen so well. After about 5 minutes of current passage, the whole surface of the ingot will freely bubble off hydrogen.

An alternative to the use of sulfuric acid electrolyte is to use 2% HCl solution. In this case, the ingot is first hooked up as anode, and a current of one or two amps is applied for a minute or two. The surface layer of the ingot will dissolve as a reddish brown solution of palladium chloride. Then the palladium ingot is made the cathode and about 50 milliamps per square cm of face applied for about 10 to 20 minutes. Most of the dissolved  $\text{PdCl}_2$  will electroplate onto the surface of the ingot. The surface treatment is called "palladized palladium." Now "anodize"

## Advanced Techniques of Clandestine Psychedelic & Amphetamine Manufacture

in dilute sulfuric acid solution as in the previous example. Next, return the ingot to the 2% HCl solution and charge up the ingot with hydrogen for about 20 minutes as in the previous example. The electrocatalytic hydrogenation of the acetic acid ester of ephedrine, or whatever, is then done in this solution, just like in the example which follows. A lead anode can't be used in this variation, as it would dissolve. Other than being more complicated, this variation is probably superior to using dilute sulfuric acid, as this acid tends to poison the catalytic property of the palladium surface over time.

After the 20 minute charging with hydrogen, begin magnetic stirring of the solution, then pour in the ester reaction mixture from the large test tube. Adjust the current flow to between 35-50 milliamps per square centimeter of the ingot face. If one has 6 square centimeters of the ingot facing the lead anode actually immersed in the solution, a current of between 200-300 milliamps is called for.

This will result in some gassing off of hydrogen from the edges of the ingot, but over the rest of the surface of the ingot the hydrogen formed will react before it bubbles off. The lead anode will form a brown layer of lead oxide, and not dissolve at all in the sulfuric acid solution. Some surface particles will be kicked off the lead when it's first charging, but they don't make it through the rubber. The lead anode can be replaced with a piece of platinum if one desires, but lead is a lot cheaper.

Keep an eye on the current meter, and make sure that the current flow stays in the 200-300 milliamp (.2-.3 amp) range for the size ingot given in this example. Allowing too much current to flow will cause the ingot surface to be covered by hydrogen bubbles, and the solution won't be able to come into free contact with the metal surface. Turning the current down too low may result in no hydrogen being formed at the palladium surface.

*Chapter Two*  
*The Fester Formula*

The best and most convenient DC electric power source is a rectifier such as those commonly used by electroplaters to do lab scale electroplating testing and experimentation. Such rectifiers cost about \$500-600 from suppliers of electroplating equipment. Using such a device, the current flow is easily controlled by turning up or down the voltage output of the rectifier. The higher the voltage output, the more current is passed through the solution.  $E=IR$ .

The next best current source is a 12 volt car battery with its voltage output modulated by hooking into the wiring to the beaker a dashboard light control knob. This dashboard light control will cost a few bucks at the auto parts store, and will function in this electric cell just as on the dashboard. Turn the knob up, as you would to brighten the dashboard light, and the voltage is increased and more current will pass through the solution.

A toy train transformer may also work, but beware of a thing called "AC ripple" found with such cheap power sources. This is where AC current is superimposed upon the DC current. Generally it will produce a "picket fence" output visible on an oscilloscope. So long as the spikes all run in the desired direction, I think that it will work OK. If, on the other hand, the AC ripple causes the palladium ingot to oscillate between anodic and cathodic, you're in for trouble.

When about 3000 coulombs have passed through the solution, the process can be considered to be complete for a one gram batch. A coulomb is one amp-second, so let's use the 300 milliamp current flow to calculate reaction time. 3000 amp-seconds divided by .3 amp = 10,000 seconds, or 2 hours 45 minutes.

Three thousand coulombs per gram of feed material has been found to give good yields of a fine product, but by no means assume this number to be the optimal. It may well be that greater yields would be obtained by passing more current. It

## Advanced Techniques of Clandestine Psychedelic & Amphetamine Manufacture

may also be that pseudoephedrine and PPA differ from ephedrine in their ease of electrocatalytic hydrogenation, and again require the passage of more current. I don't think that any harm can be done by passing too much current, within reasonable limits, so by all means experiment with the amount of current passed.

During the course of the reduction, the color of the reaction mixture slowly changes from its initially clear color to slightly tinted with yellow. It's not known if this color change is due to some of the Kling-Tite rubber soaking out to form a tea, or if it is the result of the reaction. In any case, this is a remarkably clean reaction.

When the desired amount of current has passed, the work-up and isolation of the product is very simple. The Kling-Tite rubber is removed from the beaker. After pulling out the lead or platinum anode, the rubber is flushed down the toilet. The anode can be reused over and over. Then the palladium cathode is removed, and rinsed off. It too can be reused an innumerable number of times. The process of "anodizing" the palladium will have to be repeated prior to each run. Some fresh metal may have to be exposed on occasion by light sanding of the metal surface. An ingot of palladium should last for a lifetime.

The reaction mixture should be poured into a sep funnel, and approximately 20% solution of NaOH (lye) in water should be added with shaking until the mixture is strongly (13+) alkaline to pH paper. Then extract with one or two portions of toluene. Fifty to one hundred ml of toluene is more than enough to extract one gram of product. The toluene extracts are next bubbled with dry HCl to get the crystalline hydrochloride product. After filtering and rinsing them off with some fresh toluene, they are spread out to dry. The most pleasantly surprising finding is that crank produced by this method doesn't give one the body and soul wrenching hangovers so typical of the product made by the HI and red phosphorus method. This

*Chapter Two*  
*The Fester Formula*

25

process is a highly desirable way to keep one's own party rocking and rolling.

If one should wish to produce more than a gram or so at a time, a larger palladium catalytic cathode should be used. Linking together more ingots of palladium would get pretty expensive, so a more economical alternative will be detailed. That alternative is electroplating some copper or brass screen with a thick coating of palladium.

The simplest way to get this section of screen electroplated with palladium is to go to the yellow pages, look under electroplaters, and find one who electroplates palladium. Ask for a plate build-up of several thousandths of an inch thickness, so that enough palladium is deposited to last for a while.

This palladium plated screen would then be used exactly like an ingot of palladium. First it must be "anodized," then charged up with hydrogen in exactly the same way. The sole difference is that the greater surface area of the screen facing the rubber ensconced anode requires a correspondingly greater amount of current be passed. Then during the course of the reduction, again 50 milliamps per square centimeter of surface area facing the anode is used. The total of 3000 or so coulombs per gram of feed material doesn't change by increasing the size of the catalytic cathode.

An alternative to sending a section of screen out to be plated is to plate it yourself. One starts with an ingot of palladium, and anodically dissolves a portion of it to form a  $\text{PdCl}_2$  solution. Follow the directions for doing this in the  $\text{PdCl}_2$  chapter in this book. The procedure given here using a Kling-Tite rubber as a shield for the negative pole of the circuit works very well in my experience. The concentration of  $\text{PdCl}_2$  in solution is found by weighing the palladium anode as it dissolves. The amount dissolved times 1.7 is the amount of  $\text{PdCl}_2$  in solution.

## Advanced Techniques of Clandestine Psychedelic & Amphetamine Manufacture

A bath for electroplating palladium can be made up as follows:

palladium chloride	30-50 g/liter
ammonium chloride	30 g/liter
hydrochloric acid	adjust pH to .1-.5

With this plating bath made up, the section of copper or brass screen can be plated. First scrub off all dirt and grease with hot dishwater. Make sure there is no lacquer on the screen. Then rinse well, and immerse the screen in 5% HCl for about 30 seconds. The copper will take on a more intense red color as the surface oxides are removed in the acid. Rinse thoroughly, and if it is going to take more than a few seconds to get the screen into the plating bath, leave it immersed in rinse water.

Now the plating bath is put into a beaker, and an ingot of palladium (the remnants of  $\text{PdCl}_2$  production will serve well) is partially immersed into the plating bath. I say partially, because the alligator clip connection shouldn't come into contact with the plating bath. The palladium ingot is attached to the positive pole of a DC transformer. Now take the section of screen, and attach it to the negative pole of the DC transformer. Make sure it stays wet from the rinse during this manipulation, so that the surface doesn't go passive, causing bad adhesion of the electroplate.

Turn on the DC transformer, and apply a few volts. Then immerse the section of screen. Make sure that the screen doesn't contact the Pd ingot, as this would cause a short. Once immersed in the plating solution, adjust the current flow to .03 amp per square inch of screen facing the palladium anode. Begin stirring the solution once the screen is in the solution. Plate the section of screen at the specified current rate for about an hour. When done, remove it and rinse it off. It's ready to use. The plating bath will keep forever in a tightly stoppered

*Chapter Two*  
*The Fester Formula*

27

dark bottle. It can be reused to plate new catalytic cathodes whenever desired.

Note: It is no doubt a good idea to flame the surface of the palladium ingot or electroplate for about 15 seconds with a propane torch after each batch is done and the ingot well rinsed. This flame treatment will burn organics out of the metal surface that may cause the surface to lose catalytic activity. It will also destroy evidence traces on the ingot. Regular flame treatments should greatly extend the useful life of the metal surface, and delay the need for sanding the surface.

### **Definitions**

**Anode:** the electrode in an electrochemical cell which is attached to the positive pole of a DC transformer or rectifier.

Oxidations occur here.

**Cathode:** the electrode in an electrochemical cell which is attached to the negative pole of a DC transformer or rectifier.

Reductions occur here.

**Divided Cell:** a method of constructing an electrochemical cell wherein the solution in contact with the anode is kept separate from the solution in contact with the cathode. A cell divider is used to keep the two solutions separate. It must pass current, and be unaffected by the solutions used. Rubbers are the cell dividers most often used in this book.

**Electrolyte:** a material added to the solutions in an electric cell which allows the solutions to carry current. Pure water or other solvents just aren't conductors. Dilute acids or bases make good electrolytes in water, as do salts.

**Anolyte:** the solution in a divided cell which fills that portion of a divided cell in contact with the anode.

**Catholyte:** the solution in a divided cell which fills that portion of a divided cell in contact with the cathode. The anolyte and



## **Advanced Techniques of Clandestine Psychedelic & Amphetamine Manufacture**

28

catholyte are often pretty much identical with the exception of the substrate or precursor being acted upon.

## **Chapter Three**

# **A Convenient Tabletop MDA Synthesis**

There has long been a need for some simple and efficient method of making MDA and other amphetamines from their phenylacetones. The long accepted best method is catalytic hydrogenation of the phenylacetone with either ammonia, or better still, ammonium acetate, which serves as both ammonia source and condensing agent to encourage the formation and stability of the Schiff's base.

The problem with this procedure is that it uses Raney nickel as the catalyst for the hydrogenation. Not only is this catalyst pretty much exclusively available from those snitch filled scientific supply houses, it further is cursed by being quite similar to iron filings in its attraction to magnets. This magnetic property means that this catalyst is unsuitable for use in simple makeshift hydrogenation equipment such as "The Poor Man's Hydrogenation Device" found in this book.

An alternative to catalytic hydrogenation using Raney nickel is given in Dr. Shulgin's book *PIHKAL*. In that book several examples are given of reducing a mixture of the phenylacetone and ammonium acetate in methanol solution with sodium cyanoborohydride. See the MDA recipe in that book for a typical procedure and result.

## Advanced Techniques of Clandestine Psychedelic & Amphetamine Manufacture

The shortcomings of this alternative procedure are immediately obvious. Ignoring problems of supply of this borohydride, the method just plain doesn't work very well. Yields are well below 50%, with a reaction time of several days required. The cyanoborohydride just reacts too slowly, and the Schiff's base formed in the solution goes on to form polymers and other undesirable materials before this borohydride gets around to doing the reduction.

In this chapter, your uncle will suggest a new alternative. That alternative is similar to the method used in the preceding chapter, an electrocatalytic hydrogenation using a Raney nickel cathode. The hardest part of doing this method is the melting of a Raney alloy in a crucible using a propane torch. From there it's all downhill, needing only a beaker for a reaction vessel and a source of DC current.

Several papers have been published on the use of Raney nickel cathodes. See especially *Tetrahedron Letters*, Volume 25, pages 5347-50 (1984). Also see *Chemistry Letters*, pages 1089-92 (1982) and *Bulletin of the Chemistry Society of Japan*, Volume 56, pages 719-23 (1983). The finding in all these papers is that the hydrogen electrically generated at the surface of the Raney nickel cathode is exceptionally active, and gives results similar to that obtained using a bomb at high pressure. To quote one of the papers, it is a "powerful, versatile and inexpensive hydrogenation method."

Choosing an appropriate solution in which to conduct an electrocatalytic hydrogenation is the key to success. In this case, the solution must almost quantitatively tie up the phenylacetone as the Schiff's base, as the phenylacetone is also reducible. The solution must also conduct current easily. Most important of all, the solution must break down at the cathode to give large volumes of hydrogen gas without having to turn up the voltage to excessive levels. The hydrogenation solution revealed in US Patent 3,187,047

*Chapter Three*  
*A Convenient Tabletop MDA Synthesis*

31

meets all these requirements. This solution also just so happens to be the preferred hydrogenation solution for substituted phenylacetones. The solution proportions are:

- 3 kilos of substituted phenylacetone
- 1.2 kilos of ammonium acetate
- 180 ml of acetic acid
- 9.5 liters of methanol
- 300 ml of water
- 500 gr of Raney nickel

This solution is also given in the Second Edition of *Practical LSD Manufacture*. If you have the first printing of that book, note that there is a typo. It lists the amount of methanol in the solution as one liter. 9.5 liters is the correct amount. Of course, the reaction size can be scaled down, so long as the relative proportions are maintained.

The construction and operation of this cell for electrocatalytic hydrogenation is remarkably similar to the cell used in the previous chapter for the Fester formula. A typical cell design is shown below:

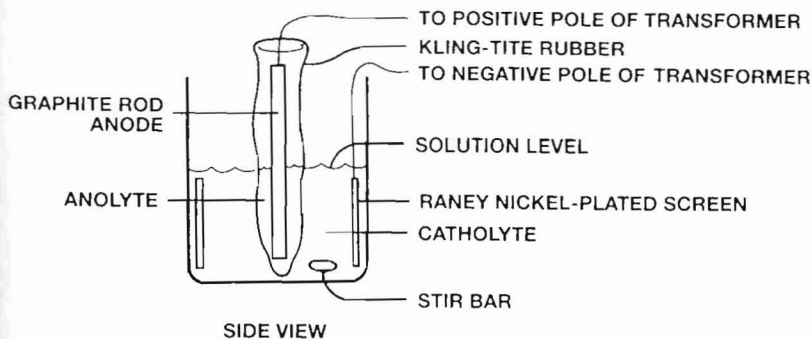

## Advanced Techniques of Clandestine Psychedelic & Amphetamine Manufacture

32

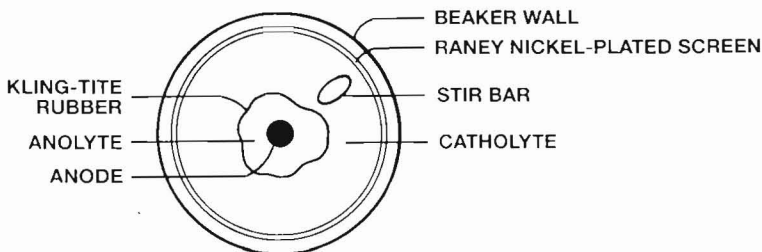

TOP VIEW

To construct the cell, one starts with a section of brass or copper screen cut so that its height will be short enough that all of the screen will be submerged by the hydrogenation mixture, and long enough that the screen will line the inside surface of the beaker used in the electrocatalytic hydrogenation. The screen must be entirely submerged because Raney nickel will ignite if it dries out. The hydrogenation mixture is flammable, so this is a bad combination. One can always add more methanol to the mixture if you are a little short on batch size.

The anode is most preferably a rod of graphite about  $\frac{1}{2}$  inch diameter obtained from the welding supply shop nearest you. Platinized mesh would also work, but it costs plenty. The anode should be in a central position relative to the Raney nickel cathode. The placement of the anode is important. If it is offset from center, the current density on the Raney nickel cathode will be greater where the anode is closer, and less where it is more distant.

To make a Raney nickel plated screen, one starts with that section of brass or copper screen described above. Don't use aluminum screen, as this metal is difficult to plate. Ditto for stainless steel screen. You have to be a plater who knows this artform to use these screens. Copper and brass are easy,

*Chapter Three*  
*A Convenient Tabletop MDA Synthesis*

quite suitable for beginners to electroplating. The screen should be new and clean to begin with, but first scrub the section of screen with hot water using dish soap. Rinse it off thoroughly with hot water, then sit the screen on paper toweling to keep it clean. Have clean hands to avoid smearing grease on the screen.

Next thread a copper wire through the screen near its top edge, and twist it down tightly to assure good electrical contact. Then immerse the copper or brass screen in 5% hydrochloric acid solution for about 30 seconds or so. This removes oxides from the surface of the copper or brass, and leaves the surface active and ready to accept an adherent electroplate. Rinse the screen in clean water. You will note that the screen is now more reddish colored.

Immediately after the water rinse, and while the copper or brass screen is still quite wet with the rinse water, immerse the screen into a plating solution containing the following ingredients in water solution:  $\text{NiSO}_4 \cdot 6\text{H}_2\text{O}$  (120 g/liter);  $\text{NH}_4\text{Cl}$  (15g/liter);  $\text{H}_3\text{BO}_3$  (15g/liter). The nickel sulfate can be replaced with nickel chloride if this chemical is more handy. The boric acid additive is quite important and shouldn't be left out.

Most importantly of all, add about 10 grams of unleached Raney nickel alloy (50% nickel, 50% aluminum) for each 100 ml of plating solution. The Raney nickel alloy should be 200-325 mesh. This particle size corresponds to a fine grit. My experience with melting Raney nickel alloy and grinding off a fine grit is given later in this chapter. Begin stirring to keep the particles suspended in solution.

The best container for doing this electroplating is a beaker about the same size as the anticipated batch reduction container. It could even be the same beaker. Put the section of screen along the inside wall of the beaker, just as shown in the figure given earlier in this chapter for the reduction cell.

## Advanced Techniques of Clandestine Psychedelic & Amphetamine Manufacture

Run the copper wire to the negative pole of a DC transformer. In the center of the beaker put a piece of nickel, iron or graphite rod as the anode. Attach it to the positive pole of a DC transformer. Apply a current of .07-.1 amp per square centimeter of the screen surface facing the anode. Don't count the surface area on the back side. Plate with stirring for about 15 minutes. No rubber needs to be used in this electroplating operation. If a nickel anode is used, the nickel will dissolve at a rate that matches the rate that it plates out at the screen. This will assure that the plating solution can be used many times without problems. Iron anodes will contaminate the solution and ultimately the plate with iron, but that shouldn't be harmful at least in the short run. The only purpose served by the nickel plate is to be sort of a metallic glue to paste particles of Raney nickel alloy to the screen.

The plating solution and the necessary wiring, including amp meter, should be set up and ready to go prior to beginning the acid dip of the copper or brass screen. Undue delay in beginning the electroplating of the screen after the acid dip and rinse can result in the surface of the copper or brass screen becoming passive and unable to accept a strongly bonded electroplate. This will result in flaking and peeling of the plate. After the 15 minutes of electroplating, the screen should be entirely coated with a dull gray colored nickel plate liberally studded with particles of Raney nickel alloy. They should be obvious to see, and take up about 20% of the surface area of the screen.

At the end of the electroplating process, turn off the current, remove the screen from the plating bath, and give it a water rinse. After air drying the screen, it can be kept indefinitely in a dry place.

The phenylacetones used in this procedure are best made from essential oils containing the desired carbon skeleton as

*Chapter Three*  
*A Convenient Tabletop MDA Synthesis*

35

a major ingredient. For a thorough discussion of this topic, see the Second Edition of *Practical LSD Manufacture*. As an example, calamus oil will generally contain a large percentage of asarone or B-asarone. This substance has the carbon skeleton of TMA-2. On the side chain, it has a double bond in the propenyl position. The phenylacetone can be made by the general procedure given in *PIHKAL* using formic acid and 30% peroxide to form the glycol, and then when the glycol is heated with dilute sulfuric acid, the phenylacetone is formed. A better procedure is given in *Practical LSD Manufacture*. In an undivided electric cell with a central graphite anode surrounded at a distance of 1 cm with stainless steel cathode, the epoxide is formed. Rearrangement of the epoxide gives the phenylacetone. Also see *Journal of Organic Chemistry*, Vol 46, pp. 3312-3315 (.1981), and *Journal of Organic Chemistry*, Vol. 49, pp. 1830-1832 (1984).

When the essential oil contains the desired carbon skeleton with the double bond in the allyl position, as for instance safrole in sassafras oil, then the best way to make the phenylacetone is by the so called "Wacker Oxidation."

Enough background, this chapter is about how to use a Raney nickel cathode! The section of screen which has been plated with a composite of nickel and Raney alloy is immersed in 300 ml of distilled water. Then add 50 grams of sodium hydroxide pellets, and stir them into solution. An exothermic reaction occurs with a lot of fizzing off of hydrogen as the aluminum dissolves out of the Raney alloy. When the fizzing slows down, heat the mixture to 60° C for 30 minutes with occasional stirring of the solution. Then let the mixture cool to room temperature.

When the mixture has cooled down, pour out the sodium hydroxide solution, and begin a thorough rinsing of the



## Advanced Techniques of Clandestine Psychedelic & Amphetamine Manufacture

screen with water. Hydroxide clings to surfaces, so at least four swirling rinses of the screen will be required.

Immediately after the rinse, place the Raney cathode screen into the electric cell diagrammed earlier in this chapter. For illustration, consider a batch using 30 ml of methylenedioxyphenylacetone made from safrole. A 250 ml beaker would be about the right size container in which to do this batch. A screen about 3 cm high, and 20 cm long would nicely line the lower inside wall of the beaker. A stock solution containing 12 grams of ammonium acetate, 1.8 ml of acetic acid, and 3 ml water in 100 ml of methanol is made up, and the majority of it is added to the beaker. Enough is poured into the rubber to equalize the liquid depth inside the beaker and the rubber. One must get this solution into the beaker before the screen dries out, because dried Raney nickel will start fires. The screen must be completely submerged by the solution.

Next, connect the screen to the negative pole of a DC transformer. The anode should be connected to the positive pole of the transformer, and an amp meter should be put in line on the wiring. The wiring which serves the anode is the correct place to place the amp meter. Begin a flow of about 5 amps through the cell. This is a current density of about 50 milliamps per square centimeter of the screen face. A gentle evolution of hydrogen will be noted from the screen. Continue passing current at this rate for about  $\frac{1}{2}$  hour to charge the Raney nickel with hydrogen fully.

Now add the phenylacetone to the beaker, and begin stirring. Turn down the current flow in the cell to between 1 and 1.5 amps. This corresponds to 10-15 milliamps per square centimeter of the screen face. About 3 faradays per mole of phenylacetone should pass through the cell. The methylenedioxyphenylacetone has a molecular weight of 174 and a density of about 1, so 30 ml is about .17 mole. A

*Chapter Three*  
*A Convenient Tabletop MDA Synthesis*

37

faraday is 96,500 coulombs or amp seconds, so 3 faradays times .17 mole equals about  $\frac{1}{2}$  faraday, or about 50,000 coulombs. At a current of one amp, this takes  $13\frac{3}{4}$  hours.

When the required amount of current has passed, turn off the transformer or rectifier, and remove the rubber and its anode from the beaker. Then lift the Raney nickel cathode from solution, and rinse it with alcohol. Store it under alcohol. It should be good for reuse within the next couple of months.

Then pour the reaction mixture into a vacuum flask or similar vacuum container, and evaporate away most of the alcohol under a vacuum. Warm water and shaking the contents speed the evaporation. Pour the residue after the evaporation into a sep funnel, and add 20% sodium hydroxide solution in portions, with shaking between adds of hydroxide. Cool the mixture in water if it gets too hot. Continue adding hydroxide until a product layer forms on top of the water layer. Check the pH of the water layer. It should be 13+ to pH paper. If not, add more hydroxide with strong shaking between adds.

Next extract out the product with about 100 ml of toluene. Separate the toluene-product layer. It should be no darker than yellow. It should also reek of ammonia. Remove the ammonia by some vacuum evaporation in a vacuum flask. It will be obvious to the nose when it is gone. Then dilute with more toluene until a total solution volume of about 250 ml is reached. Next bubble the solution with dry HCl to produce crystals of the substituted amphetamine hydrochloride product. They are filtered out using a vacuum assist with a Buchner funnel as the toluene solution of the product thickens during the course of the HCl bubbling. The filtered crystals are rinsed with fresh toluene, and spread out to dry. This process is discussed in detail in Chapter Five of *Secrets*

## Advanced Techniques of Clandestine Psychedelic & Amphetamine Manufacture

38

*of Methamphetamine Manufacture.* The total yield of crystals of MDA hydrochloride should be around an ounce.

There is a possibility that an oil layer may form and settle to the bottom of the beaker during the HCl bubbling. This is most likely due to the presence of a lot of unreacted phenylacetone in the toluene extract. This would be caused by poorly prepared Raney nickel, or a plated screen that didn't have many particles of the Raney alloy imbedded in it. If this happens, shake the oily toluene with an equal volume of 10% HCl solution for about 5 minutes. The product will go into the water solution, while the phenylacetone will remain in the toluene. Keep the toluene layer for recovery of the phenylacetone. Make the water layer strongly basic (pH13+) with sodium hydroxide solution, and extract with toluene.

The toluene layer should be separated, and bubbled with dry HCl gas to get clean crystals of MDA hydrochloride.

### Melting Raney Nickel Alloy

To melt an approximately 20 gram batch of Raney nickel alloy, one should start with a crucible at least 20-25 ml in size. The high alumina crucible made by Coors is preferable to regular porcelain crucibles, because the high alumina crucible has a maximum rated temperature limit of 1750° C, versus 1300° C for the porcelain crucible.

Suspend this crucible on a ringstand. If one has a ceramic triangular shaped crucible holder, this is the preferred tool for the job. Lacking this item, one can take stainless steel rod about 1/8 inch diameter and bend it around some pipe of the same diameter as the crucible. This stainless steel rod will make a good crucible holder, so long as it rides well up the sides of the crucible where the heat isn't so intense. Two of

*Chapter Three*  
*A Convenient Tabletop MDA Synthesis*

39

these stainless steel holding rods placed at right angles on the crucible will give good stability.

Next dress up in your welding outfit. This includes a clear face shield, a little beany to cover the top of your head, leather jacket and leather gloves. Whether your genitals deserve protection is up to you. A fan should also be set up to carry metal fumes downwind. I didn't notice much fuming in my experiments.

Then take 10 grams of aluminum foil, and fold it over on top of itself repeatedly to get a compact bundle. Pack it down tightly, then cut it in half. This will be about all you will be able to stuff into a 20 ml crucible for starters. Place an oxy-acetylene torch under the crucible, and light its fire. Don't turn up the gas flow rate to a level suitable for metal cutting, just have a nice blue flame under the crucible and heat its bottom. A simple propane torch would also be hot enough to melt this alloy, as an air-propane flame has a temperature of 1900° C, compared to 2300° C for air-acetylene, and still higher for oxy-acetylene. Too aggressive heating with an oxy-acetylene torch will burn through the crucible. A hotter burning alternative to propane (MAPP) may also be too hot.

The aluminum will soon start to melt, making room for the rest of the aluminum foil in the crucible. Aluminum melts at 660° C, quickly forming a puddle of liquid aluminum in the bottom of the crucible. When the aluminum has mostly all melted, add 10 grams of nickel metal cut up into approximately split pea size. Large wire cutters will serve to cut up pieces of nickel metal. Make sure the nickel pieces are clean before putting them into the pot. There are several sources of pure nickel metal. I'm told that old nickels actually were made of nickel. Lyndon Johnson debased the coinage in the mid-60s, and now they may be nickel plated junk. Pure nickel can be obtained by going to an electroplater who plates nickel, and asking to buy a few of his nickel

## Advanced Techniques of Clandestine Psychedelic & Amphetamine Manufacture

40

anodes. They come in pieces about the size and appearance of chicken turds, and are of quite high purity. Tell him you pound them into jewelry or some such story, and you should have no problem talking him out of a few of them. One could also ask for a nickel Hull Cell anode. This is a rectangular piece of nickel about 2½ inches square and about 1/8 inch thick, and will sell for under \$10.

Pure nickel metal melts at 1555° C, but the melting temperature will be lower than this in the pot with molten aluminum by an effect similar to the lowered melting temperature of ice in alcohol. The melting of nickel into molten aluminum to form an alloy is also a quite exothermic process, so if using an oxy-acetylene torch, take care with the heating.

Once the pieces of nickel have been in the pot for a minute or so, some stirring is called for. If one has a nickel Hull Cell anode, cutting a thin strip off the side of the anode makes a good stirrer. Hold it with a pliers, and stir the molten metal around for a few seconds, then remove the stir stick from the pot and let the stick cool off. Repeat the stirring every minute or so until the pieces have all melted, then continue for at least a few minutes longer to assure a homogenous alloy. A rod of stainless steel can also be used as a stir stick, but it's nowhere near as good as a nickel metal stick. Be careful the steel doesn't start to melt on the first stir. The remelting of the alloy which clings to the end of the stick will help to prevent contamination on succeeding stirs.

When a homogenous alloy has been achieved, stop the heating, cover up the crucible and let it cool. If the inside surface of the crucible isn't too pitted, the chunk of alloy will fall out when tipped over and tapped on a book cover. A pitted crucible may have to be broken to remove the alloy. Try cooling in a freezer to contract the alloy before resorting to a hammer.

*Chapter Three*  
*A Convenient Tabletop MDA Synthesis*

41

The homemade Raney alloy will be grey colored, and a lot of it will be pulverizable using the hammer. So beat on the chunk of alloy, gently, being sure not to let fragments escape. The residue which isn't pulverizable with a hammer should be placed on a piece of paper, held in place with a vise grip or pliers and filed on with a fine toothed file to reduce this remnant to a fine grit. The powdered alloy and the filed grits should be placed in a clean glass jar or baggie until used.

# Advanced Techniques of Clandestine Psychedelic & Amphetamine Manufacture

## EFFECTS OF SOME VARIABLES UPON THE AMOUNT OF RANEY NICKEL ELECTROPLATED UPON THE CATHODE.

TABLE I. Effect of Raney Powder Concentration in the Electrolyte on the Volume Percent in the Deposit and Cathode Efficiency during plating of the screen.

Concentration in solution g/L	Volume in Deposit, %	Cathode Efficiency, %
0.5	8.25	98.9
1.0	9.98	96.9
1.5	10.9	93.9
2.0	14.5	90.8
2.6	17.7	88.7
3.5	24.0	88.0

3 A/dm<sup>2</sup>, 30° C. 3.5 pH, 0-2 pm powder.

TABLE II. Effect of Cathode Current Density on the Volume Percent and Cathode Efficiency

Current Density A/dm <sup>2</sup>	Volume in Deposit, %	Cathode Efficiency, %
2.0	20.8	87.5
3.0	17.7	86.7
4.0	16.6	85.3

Particle concentration 2.6 gl

Table III. Effect of Solution Temperature on the Volume Percent and Cathode Efficiency

Temperature, ° C	Volume in Deposit, %	Cathode Efficiency, %
30	17.7	88.7
45	12.8	92.1
60	8.29	94.8

TABLE IV. Effect of Solution pH on the Volume Percent and Cathode Efficiency

pH	Volume in Deposit, %	Cathode Efficiency, %
2.5	19.4	85.5
3.5	17.7	88.7
4.2	15.0	90.2

## **Chapter Four**

# **Rubbers As Cell Dividers**

Most of the electric synthetic methods presented in this book require the use of a cell divider to separate the cathode and its surrounding catholyte from the anode and its associated anolyte. In the scientific literature, the most commonly used cell dividers are made of porcelain or fritted glass. These materials have a high electric resistance, are fragile, not disposable, and not very commonly available.

For these reasons, our friend the condom has been used as the cell divider. It has none of the problems cited above, and is so cheap and easily available that it can just be flushed down the toilet when the reaction is finished.

Not all rubbers are created equal, however. My experience has been that the most suitable rubber for use in the Fester Formula and for electric production of palladium chloride from an ingot is the Kling-Tite Naturalamb condom made from lambs' guts. It stands up to the dilute acids used in the processes quite well, and has a quite low electric resistance. No more than a volt or two is wasted to push current through this membrane, yet it serves very well to keep anolyte separate from catholyte. Apparently, it is also pretty resistant to the diffusion of anions such as chloride. I could detect no erosion of the lead anode in the Fester Formula process.



## Advanced Techniques Of Clandestine Psychedelic & Amphetamine Manufacture

Other rubbers can be used similarly, but they have associated difficulties. The biggest problem with latex rubbers is that when they are new, they have a pretty substantial electric resistance. Applying over 20 volts to a brand new rubber will still not cause it to pass current. I can't tell you how many volts are required to break the insulation on a new rubber, because 20 volts is all I can get out of my DC transformer. As rubbers made of latex age, however, their resistance lowers markedly. My house is just full of old rubbers, and I have found that Trojan Extra Sensitive condoms a year or two past their expiration date will pass current when about 5 volts is applied to them. These old rubbers work admirably to separate the anolyte from catholyte, and are also quite resistant to diffusion. Their ability to stand up to acids and bases is also quite good. If one has an old package of rubbers around the house, take one out, scrub it up, and see how well it passes current. There may very well be solutions in which the use of an old rubber is preferable to using a new Kling-Tite.

## **Chapter Five**

# **Preparation Of Palladium Chloride**

One of the most useful substances a serious cooker can have is palladium chloride. From making palladium black catalysts for hydrogenation, to the so called "wacker oxidation" wherein  $\text{PdCl}_2$  catalyses the transformations of allylbenzenes such as safrole from sassafras oil to phenylacetones, to your own palladium plating bath to plate "catalytic cathodes," palladium chloride plays a central role.

The last time I checked,  $\text{PdCl}_2$  was still pretty easily available from outlets which supply precious-metal salts to electroplaters, but this situation is likely to change in the near future. As a consequence, a simple procedure for making one's own supply of this substance in a very low-profile manner is of obvious value.

To make palladium chloride, one starts with a glass bread loaf baking dish or similar glass container. One also needs a thoroughly cleaned condom made of rubber or sheep guts. The extra thin, sensitive brands are best as they have less resistance to passage of electricity.

The next thing one needs is an ingot of palladium. These can be obtained from one's local dealer in precious metals. (You're hedging against an outbreak of inflation or monetary

## Advanced Techniques Of Clandestine Psychedelic & Amphetamine Manufacture

collapse!) One troy ounce will cost upwards of \$240, and make a couple of ounces of  $\text{PdCl}_2$ . If small ingots are available, they may be the way to go.

Take the ingot, and either hammer on a corner or squeeze a corner in a vise to make an elongated lip on which to make electrical contact. This will allow contact to be made to the ingot without immersing the copper jaws from the battery charger in the hydrochloric acid solution, thereby contaminating it with copper. Palladium is, in general, fairly malleable, but if it has been cold-worked, its strength increases greatly. If you have trouble hammering or squeezing out a lip for contact, try heating the ingot to redness on a stove burner.

The next step is to paint the exposed copper on the red or positive lead from one's battery charger. Leave the teeth on the lead unpainted so that they can still make electrical contact. The paint prevents acid mist, which will come up from the solution, from dissolving copper into it.

Now pour hydrochloric acid into the baking dish or beaker until it's about half full. The exact strength of the hydrochloric acid isn't critical, but lab-strength (35%) HCl cut in half with water is a reasonable choice.

Place the palladium ingot into the HCl solution. The lip made for electrical contact should be up out of the solution so that copper from the charger's jaws doesn't get into the solution. Attach the red or positive charger lead to the palladium ingot.

On the opposite end of the dish, two condoms, preferably Trojan Extra Sensitive brand, are rolled one on top of the other to form a double thickness rubber barrier. The inner condom is filled with the same hydrochloric acid solution so that the liquid depth inside the condom about equals that in the dish. Some of the acid is also poured into the space be-

*Chapter Five*  
*Preparation Of Palladium Chloride*

47

tween the two condoms so that current can flow. Insert the black or negative lead of the charger inside the condom, immersed in its supply of acid. See the illustration below. In my experiments with this process, I found that the double layering of the condoms was absolutely necessary, as a single condom was just too permeable to the hydrogen formed at the negative pole. If this hydrogen should get into the solution, it could sludge out the palladium chloride.

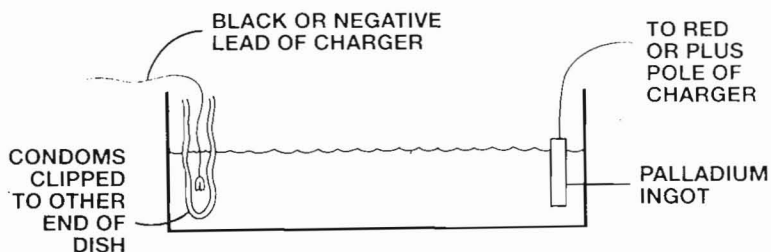

Begin magnetic stirring in the dish, and turn on the charger. First try the 6 volt setting, and check the current meter to see if any current is being passed. In all probability, no current will flow at 6 volts. Trojan Extra Thins don't pass current until 12 volts is applied, and thicker condoms will require even higher voltage to break the insulation. Adjust the voltage so that a slow current flows. For an ingot about an inch long and half inch wide, no more than an amp or two should flow. Smaller pieces of palladium should have a proportionally smaller amount of current applied. This must be DC current, not AC! A transformer may have to be put in line to adjust the current to the proper range. The black lead inside the condom will, of course, fizz crazily, producing hydrogen, but one wants to avoid production of oxygen or chlorine at the palladium anode. The sole anode reaction should be the dissolution of the palladium metal to make a solution of  $\text{PdCl}_2$ .

## Advanced Techniques Of Clandestine Psychedelic & Amphetamine Manufacture

Failure to pass current is most likely due to insufficient voltage being applied to break the insulation of the condoms, but one should also check to make sure that a good contact is being made on the palladium ingot. This ingot must be well cleaned and grease-free prior to immersion in the acid.

At a current of one amp, 54 hours are required to dissolve 106 grams of palladium. One ounce will dissolve in a little over 14 hours. Some sludge may form from flaking off the palladium anode, but so long as the hydrogen made at the cathode doesn't get into the solution, sludge formation will be minimal.

When the palladium ingot has mostly dissolved, turn off the current. Pull the condoms out of the solution, and also remove the remnant of the palladium ingot. Weigh this remnant, then filter the hydrochloric acid solution containing the  $\text{PdCl}_2$ . The filtered out sludge should also be weighed when it's dry.

The combined weight of the remains of the ingot and the recovered metal sludge can be used to figure how much  $\text{PdCl}_2$  is in the solution. The amount of palladium metal dissolved times 1.7 equals the weight of  $\text{PdCl}_2$  in solution.

Next, the excess acid should be removed from the solution. This is done by boiling the solution. Distilled water should be added to the beaker while it is boiling to make up for that which boils away, maintaining the original solution level. When the steam coming off the beaker no longer gets a strongly acid reaction from pH paper, the process can be considered completed. The volume of the solution should be measured, and the amount of  $\text{PdCl}_2$  per ml calculated. Then the solution should be bottled up, tightly stoppered, and stored in a cool dark place like the refrigerator. The water solution of  $\text{PdCl}_2$  can then be used as a source of  $\text{PdCl}_2$  and water.

## Chapter Six

# A New Low Profile Phenylacetone Synthesis

I'm always in the mood for a new phenylacetone recipe, especially when it uses cheap, commonly available ingredients. I'm sure you are too. That's why when a correspondent named Chris sent me this procedure, I got a smile on my face and said, "This has to be published."

This method is based upon the procedure given in *Organic Syntheses*, Collective Volume 5, pp. 567-71. The name of the recipe is ethyl indole-2-carboxylate. As given, it's an interesting indole synthesis, and that's all. However, when one substitutes toluene for the nitrotoluene in the recipe, and ethyl acetate for the diethyl oxalate in the recipe, one gets phenylacetone rather than ethyl nitrophenylpyruvate in the first stage of the reaction scheme.

This procedure is similar to the phenylacetone recipe using benzyl cyanide as the starting material found in *Secrets of Methamphetamine Manufacture*, and also in *Organic Syntheses*. The key difference here which allows toluene to be used rather than that List I chemical benzyl cyanide is potassium metal. In contrast to sodium metal, potassium is active enough to cause a linkage with toluene directly. There's no need for a leaving group like cyanide to be

## Advanced Techniques Of Clandestine Psychedelic & Amphetamine Manufacture

50

attached to the toluene when potassium metal is used. The reaction sequence is illustrated below:

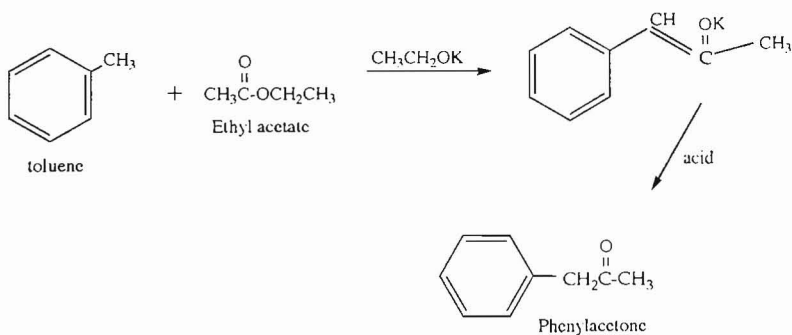

To do the reaction, a 5000 ml three-necked round bottom flask is fitted with a dropping funnel, a motor driven stirrer with seal, and a reflux condenser protected with a calcium chloride drying tube. Put 300 ml of anhydrous ether in the flask, along with 39.1 grams of freshly cut potassium metal. Potassium metal is some nasty stuff, at least as active as sodium metal. Care must be taken to protect oneself. Gloves and eye protection are mandatory. The chunk of potassium metal should be immersed in xylene (found in the paint section of the hardware store) contained in a mortar. A beaker is just too fragile to use as a container when cutting up this chunk of potassium metal. A Tupperware container would probably also work. Check its plastic for resistance to xylene prior to use. Then while the chunk of metal remains immersed under the xylene, scrape off the discolored outer skin of the potassium metal to reveal the shiny metallic luster of good potassium. A clean, sharp steel blade is OK for cutting potassium. Toss the scraped off skin into another container holding some xylene, so the metal remains immersed.

*Chapter Six*  
*A New Low Profile Phenylacetone Synthesis*

51

When the skin has been removed, cut up the potassium into pea-sized pieces. Then quickly remove a piece with a tweezer, blot it really quick with some filter paper, and drop it into a beaker on a scale which contains enough xylene to keep the piece covered with liquid. Note the weight before and after adding the piece of potassium. The weight gain is the amount that chunk weighs. Toss that chunk into the reaction flask. Continue weighing and adding chunks until 39.1 grams have been added.

The remaining block of potassium metal should be kept under its protective liquid. The scrapings and residue of potassium on the knife are very dangerous, and likely to start a fire if not immediately decomposed. The little flakes floating on top of the xylene are especially dangerous. Move the beaker containing the scrapings well away from the ether into a well ventilated area. Have a cover ready for the beaker to extinguish any fire which may well start. With a medicine dropper, add 91% isopropyl alcohol (t-butyl alcohol is much better) one drop at a time to the xylene and potassium scrapings. No other flammables or source of flame should be nearby. Continue adding alcohol until all of the metal has dissolved. Then flush it down the toilet. Repeat this procedure with the mortar or Tupperware container used to cut the potassium metal.

Never touch potassium metal! All manipulations and transfers of this metal should be done using a tweezer or similar tool!

When all 39.1 grams of potassium are in the flask, and the residues are decomposed and flushed, and the block of potassium metal is returned to its container, the reaction can be done. Flush the flask with nitrogen to prevent the danger of fires, then with stirring add a mixture of 250 ml of absolute ethanol and 200 ml of anhydrous ether from the dropping funnel just fast enough to maintain mild boiling.



## Advanced Techniques Of Clandestine Psychedelic & Amphetamine Manufacture

52

When all of the potassium metal has dissolved, the slow flow of nitrogen to the flask that was maintained after the initial flushing can be stopped. It takes about 1½ to 2 hours to dissolve the potassium with stirring. Up to 3 hours without stirring.

The solution is then allowed to cool to room temperature, and then 2500 ml of anhydrous ether is added, followed by 98 ml of ethyl acetate. After stirring this mixture for ten minutes, add 106 ml of toluene, and stir for an additional ten minutes.

Now transfer this solution into a 5000 ml Ehrlenmeyer flask, stopper it and let it sit in a cool place for at least 24 hours. A lumpy, crystalline mass of the potassium salt of the enol of phenylacetone should separate out. Collect these crystals by filtration. Crystals clinging to the sides of the Ehrlenmeyer flask can be loosened and scraped out with a glass rod. After the crystals have air dried a bit, they should be added to 200 ml of glacial acetic acid. After some swirling, a yellow, opaque solution of phenylacetone should form. Next, slowly, with stirring or shaking, pour this solution into 1000 ml of water containing 130 grams of sodium hydroxide (lye). This neutralizes the acetic acid to form sodium acetate. The phenylacetone should float on top. Extract the solution with two 100 ml portions of toluene. The combined toluene extracts, which contain the phenylacetone, should be washed by shaking with about 500 ml of 5% NaOH solution, then the top layer, which contains the phenylacetone dissolved in toluene, should be transferred to a distilling flask.

Fractional distillation is commenced, just as described in *Secrets of Methamphetamine Manufacture*, Chapter Three. First some toluene-water azeotrope distills at 85° C. It has a milky appearance. Then pure toluene distills at 110° C. When most of the toluene has distilled out, heating is

*Chapter Six*  
*A New Low Profile Phenylacetone Synthesis*

53

stopped, and a vacuum is applied from an aspirator, cautiously at first to keep the distilling pot from boiling over. Then full vacuum is applied, and heating begun again. A good aspirator will distill phenylacetone at about 120-130° C. If the water isn't very cold where you live, the temperature will be correspondingly higher. The yield should be in the neighborhood of 100 ml, and the product should be clear to maybe slightly pale yellow. It should have that characteristic strange, chemical, fruity smell of phenylacetone.

For those familiar with phenylacetone, just recognizing its smell, and noting its boiling point is sufficient to confirm its identity. For those not so blessed by experience, one can positively ID the product as a methyl ketone by seeing if it forms a solid bisulfite addition compound. Take about 5 ml of the distillate, put it in a test tube along with at least an equal volume of water saturated with sodium bisulfite or metabisulfite. Shake for a couple of hours. If the product is phenylacetone, a solid, crystalline product will form.

For the clandestine cooker, the recipe as given presents one big problem, and a couple minor ones. The big problem is the large amount of solvent it uses, and the fact that this solvent is anhydrous ether. Anhydrous ether purchased in large amounts is an item of suspicion, and its characteristic smell carries well downwind. Performing this procedure in a populated area would be ill advised.

A possible way around this problem would be to substitute the very common and easily available industrial solvent hexane for the ether. It only costs a couple of dollars per gallon when purchased in drums, and its smell is nowhere near so pronounced as ether. The recycling of this solvent is pretty simple as well, in contrast to ether, which tends to form explosive peroxides. To recycle hexane, one needs only wash it with some water, then redistill it. Hexane forms an

## Advanced Techniques Of Clandestine Psychedelic & Amphetamine Manufacture

54

azeotrope with water that distills at 61° C versus 69° C for the pure hexane, so any entrained water will be removed in the distillation leaving dry hexane to distill in the main fraction. Naphtha may also work.

A much less troublesome problem is the need for absolute alcohol in this procedure. One can obtain this as is from chemical suppliers, or if one desires to be very low profile, absolute ethyl alcohol can be made pretty easily from 190 proof vodka.

For example, one can mix equal quantities of 95% ethyl alcohol and benzene, then distill out the benzene as its water azeotrope which distills at 69° C. The residual water in the alcohol can be removed by adding a little sodium metal, then distilling the pure alcohol. As a general rule, one is better advised to try to get pure absolute alcohol. Another potential problem may arise in obtaining potassium metal. It's not on any lists of guilt-implying chemicals, but one might feel uncomfortable ordering it. If so, it can be made pretty easily by use of an electric cell. The same procedure used in *Secrets of Methamphetamine Manufacture* to make sodium metal from sodium hydroxide can be used to make potassium metal from potassium hydroxide. A similar procedure can be found in US Patent 2,480,655. The metal is very nasty reactive stuff, so buying it ready made is greatly preferable.

## **Chapter Seven**

# **Phenylacetic Acid From Ethylbenzene**

The most convenient precursor to phenylacetic acid among unlisted industrial chemicals is its ester, ethyl phenylacetate. A simple hydrolysis of the ester yields this very desirable but tightly controlled precursor to phenylacetone. Consequently, if one wishes to pursue this synthetic pathway, tapping into the perfumers' supply line is the most logical course of action. However, in the future the esters of phenylacetic acid may also come under regulation. Should this come to pass, a simple and high yielding procedure using common industrial materials is a valuable backup. The chromate oxidation of the industrial solvent ethylbenzene to phenylacetic acid fills this role nicely.

The logistics of supply for this alternative route to phenylacetic acid are pretty simple and easy. To set up a factory of meth production yielding around 200 pounds of pure meth prior to cutting, one just needs a 55 gallon drum of ethylbenzene and several hundred pounds of sodium dichromate or several hundred gallons of used chrome plating bath picked up through a waste exchange. For example, a drum of ethylbenzene weighing about 400 pounds will yield a similar weight of phenylacetic acid, up to about 450 pounds or so if all goes well and the chemical god

## Advanced Techniques Of Clandestine Psychedelic & Amphetamine Manufacture

56

smiles upon your efforts. There are quite a variety of methods for converting phenylacetic acid to phenylacetone given in my book *Secrets of Methamphetamine Manufacture*, and I have personal experience with several of them. For a large scale operation such as one starting with a drum of ethylbenzene, the best method is the tube furnace utilizing thorium oxide catalyst. The procedure is found in the meth book, or *Organic Syntheses*, Collective Volume 1,2, or 3. Look for methyl benzyl ketone in the table of contents. The aerogel modification of the catalyst bed would be most appropriate for such a large scale production, as it allows a greater rate of feed. The glacial acetic acid used to make phenylacetone with the tube furnace is very easily available in drums, and a yield of around 50% is very realizable, yielding a little over 200 pounds of phenylacetone from a drum of ethylbenzene.

To convert the phenylacetone to meth, one is going to need about 100 pounds of methylamine. Methylamine is a hot List I commodity, but is very easily made on a large scale by the method given in my meth book, or by the alternate methods given in this work. Reducing the methylamine and phenylacetone mixture to give meth is best done on this scale using platinum catalyst and the poor man's hydrogenation device described in this book. The yield is nearly quantitative if the catalyst is kept in good working order.

In this manner, a factory could be set up in some industrial site with four work stations — one to convert ethylbenzene to phenylacetic acid, another to make phenylacetone from the phenylacetic acid, another to produce the methylamine, and a final site that turns out meth. Two hundred pounds of meth, cut in half to give 400 pounds, and sold at \$5000 a pound works out to 2 million dollars for an investment of a few thousand.

*Chapter Seven*  
*Phenylacetic Acid From Ethylbenzene*

57

This reaction is pretty simple and cheap to do, but requires a little bit of preliminary engineering and construction. The engineering and construction consists of getting some sturdy steel pipe, welding two or three agitator vanes on the inside of the pipe, and pulling the agitation gearing out of an old washing machine and reinstalling it onto the pipe. It's no great challenge.

This reaction was originally reported in *Journal of Organic Chemistry*, Volume 27, pp. 27-28 (1962). It was found that when ethylbenzene was heated with sodium dichromate in water solution at a temperature of 275° C inside an autoclave, a 90% yield of phenylacetic acid resulted.

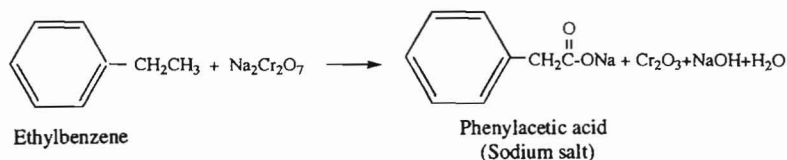

Ethylbenzene is churned out in huge quantities by the chemical industry, as it finds use as a feedstock for making styrene and also as a solvent for plastic resins. Any attempt to try to keep track of its commercial flow would be futile. Drums of it are easily available once you give yourself a corporate name.

Similarly, sodium dichromate is heavily used by industry. Its largest and most common use is probably to passivate stainless steel. This process essentially consists of immersing a piece of stainless steel into a vat containing a mixture of nitric acid and sodium dichromate.

The passivated stainless steel is more corrosion resistant than untreated steel. Calling yourself some kind of metal

## Advanced Techniques Of Clandestine Psychedelic & Amphetamine Manufacture

58

finishing or polishing operation and getting a shed or something to work in will make ordering a thousand pounds of sodium dichromate pretty easy.

An alternative source of dichromate is a used chrome plating bath picked up on one of the waste exchanges. See *Practical LSD Manufacture* or *Secrets of Methamphetamine Manufacture* for information on waste exchanges. The typical used chrome plating bath will contain 32 ounces per gallon of chromic acid. The exact concentration will come with the analytical sheet. This is a 2 molar chromic acid solution. At this concentration, the great majority of the chromic acid is in the form of the dichromate. To get a sodium dichromate solution, add a 20% solution of sodium hydroxide to the chrome plating bath, slowly and with stirring, until the pH reaches 8 or 9. Then add water until the volume of the solution is double that of the starting chrome plating bath. This results in a .5 molar solution of sodium dichromate. The tramp metals in the bath, such as iron, copper or nickel, will settle out as a hydroxide sludge. Decant off this sludge, and filter to get a clean .5 molar dichromate solution.

The following example is given for a .25 molar size batch, but the procedure could easily be scaled up to at least one molar and beyond by giving allowance for the longer period of time such a larger batch would require to heat up to the proper reaction temperature.

First one starts with a section of heavy pipe, of a volume of about 1500 ml. It should have fine threads on each end. Obtain heavy pipe caps with matching threads for both ends. Most pipe will come with a heavy coating of zinc galvanizing on it. This must be removed by immersing the pipe and caps in 5% hydrochloric acid solution until the rapid fizzing caused by the dissolving of the zinc slows to a

*Chapter Seven*  
*Phenylacetic Acid From Ethylbenzene*

59

crawl. Then thoroughly rinse the pipe and caps in clean water, and dry them to prevent rust.

Then agitator vanes should be welded onto the interior of the pipe. There should be three or more vanes, depending upon the diameter of the pipe. For example, a one gallon size pipe section for a one mole batch scale should have four vanes to get good agitation. They should run the entire length of the pipe section, and extend about halfway in from the wall of the pipe to its center point, as shown in the example below (which, of course, features only three vanes):

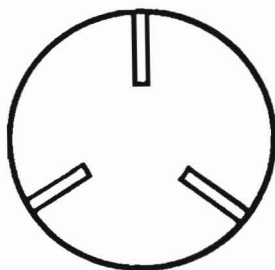

**TOP VIEW**

The agitator vanes, of course, should be made of steel, and be clean and free of paint.

Once the vanes are welded in, the bottom cap can be screwed on the pipe, tightened down with a pipe wrench, and preferably welded into place.

Now the cap assembly is constructed. It consists of a shaft welded onto the top of the upper pipe cap. The shaft runs to the washing machine agitator gearing, preferably with a bearing about halfway up the shaft to prevent wobbling as the agitation is going. See the figure on page 60:



## Advanced Techniques Of Clandestine Psychedelic & Amphetamine Manufacture

60

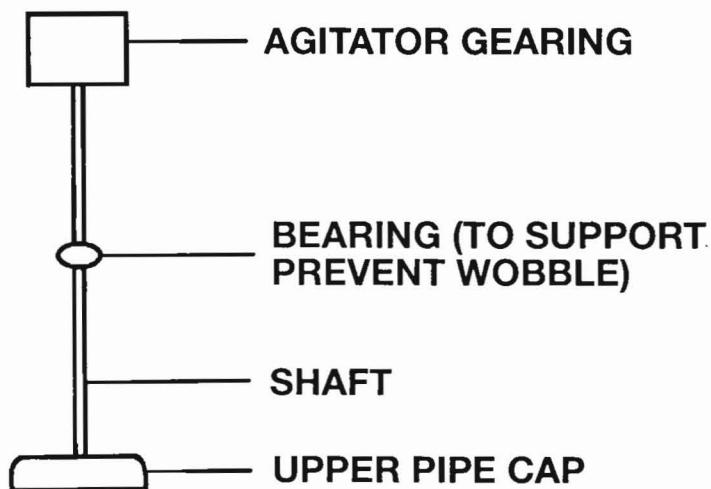

To do the reaction, put 1000 ml of water into the pipe, along with 74 grams of sodium dichromate. Alternatively, put 600 ml of water in the pipe along with 400 ml of the .5 molar dichromate solution made from the used chrome plating bath. Next add 30 ml of ethylbenzene. Then screw the pipe into the upper pipe cap, and tighten it with a pipe wrench.

The reaction mixture must be rapidly heated to 275° C. The best way I can think of to do this is to use solder as a high temperature heating bath. Spools of solder can be easily picked up at the hardware store and tossed into a heavy iron pot for melting. Solder melts at about 220° C, and so makes a suitable heating bath for this reaction. The solder bath should be heated to about 300° C, then the pipe reaction vessel should be immersed in it to a depth about equal to the depth of the liquid inside the pipe, and agitation should then

*Chapter Seven*  
*Phenylacetic Acid From Ethylbenzene*

61

be commenced on the pipe reaction vessel. The solder bath should be of a volume at least equal to the reaction pipe so that it holds a fair sized heat reservoir. The temperature of the solder bath will quickly fall when the pipe is immersed, but it shouldn't be allowed to fall below 275° C.

It will take about 15-20 minutes for a batch of this size to warm up to the reaction temperature of 275° C. A larger batch will take longer to warm up. The geometry of the pipe will also effect the length of time required for the reaction mixture to warm up. A longer, narrower length of pipe presents more surface area, and so warms up faster than a shorter, fatter one.

Once the reaction temperature is reached, continue heating at 275° C with good effective agitation for one hour. The back and forth agitation action must be vigorous enough to force the ethylbenzene, which floats on top of the water and chromate solution, into contact with the chromate. Once it reacts and forms the sodium salt of phenylacetic acid, it freely dissolves in the water. If at the end of this process one should find an organic layer still floating on top of the water, then the agitation was too slow, or not enough time was allowed for the mixture to reach reaction temperature prior to counting off the one hour reaction time.

During the course of the reaction, there will be a steam pressure inside the pipe amounting to hundreds of pounds per square inch. For this reason, the top must be cranked down good and tight, and the pipe must be of heavy construction. As a precaution, don't hover around the batch while it cooks. Also wear a face shield, leather jacket, apron and gloves. Be watchful of globs of solder spinning off the outside of the pipe.

When the one hour reaction heating period is over, the agitation should be stopped, and the kettle of molten solder lowered from the reaction pipe and wheeled away. Next,

## Advanced Techniques Of Clandestine Psychedelic & Amphetamine Manufacture

62

cool down the reaction pipe by immersing it in a tub of water. When it has cooled down, the tub of water may be removed, and the pipe reaction vessel opened with a pipe wrench.

The green colored contents should be poured into a beaker, and then filtered to remove the chrome oxide sludge. Rinse the sludge to get any product off it. If time permits, it might be easier just to let the sludge settle to the bottom of the beaker, decant off the liquid for filtering, resuspend the sludge with a little water, and then filter this remnant.

Now to the filtered reaction mixture, add 6N sulfuric acid (this is concentrated sulfuric acid diluted in half with water) slowly with stirring until the pH of the reaction mixture gets down to two or even one. This causes the sodium salt of phenylacetic acid which was produced in the reaction to convert to phenylacetic acid. Phenylacetic acid will dissolve in hot water, but crystallizes out of cold water.

Using a funnel to prevent spillage, transfer the now acidified reaction mixture to a large separatory funnel. Then extract two times with 100 ml portions of toluene. This solvent can be found at the hardware store in the paint section. They may call it toluol.

The extracts should be transferred to a distilling flask, and the glassware rigged for fractional distillation. The first portion of toluene distilling will azeotropically dry the phenylacetic acid. It will distill with a milky appearance. Then the main body of the toluene will distill with a clear color. When most of it has distilled, remove the residual toluene in the product by applying a vacuum.

When the toluene has been distilled out, stop the vacuum and the heating, and while the phenylacetic acid is still molten in the flask, pour it out into a sturdy glass baking dish, or something similar. There it can set up into a hard, white mass that you can chip at when needed. The yield from

*Chapter Seven*  
*Phenylacetic Acid From Ethylbenzene*

63

this size run will be 25-30 grams. A one gallon size batch will yield over 100 grams.

Now that the basic process has been explained, some further discussion from one learned in this art is called for. The first point to consider has to do with the distillation just done. If one is using home constructed stainless steel distilling vessels as described in the Fourth Edition of *Secrets of Methamphetamine Manufacture*, one would be well advised to devote one set just to this process, and use it for no other procedures. The bottom of the distilling flask could be rounded, and a stopcock with valve welded into the lowest point of the bottom. Then the molten product could just be drained into the baking dish at the end of the distillation. This will keep the mess making with the very smelly phenylacetic acid to a minimum.

The second point has to do with just that, the reeky smell of phenylacetic acid. It smells like you have a whole troop of screaming tom cats pissing away at the walls. The sodium salt of phenylacetic acid doesn't stink, but the free acid sure does. The narco swine are well aware of what that cat piss smell means, so lay down newspapers where some may spill or drip. Then burn the papers! Once on a surface phenylacetic acid will continue to stink forever, almost, and is very difficult to wash away. One washing procedure that does work is to dissolve some lye in rubbing alcohol, and using gloves, of course, sponge the surface that is contaminated. This will produce the non-stinky sodium salt, which also dissolves well in water and so can be scrubbed away.

On the topic of water, if this process is scaled up to where hundreds of pounds of sodium dichromate are being used, some attention to pollution should be paid. The filtered out chrome sludge should not just be dumped into a sewer. Most all places served by sewers in the civilized world have monitoring of the incoming sewer water. These monitoring

## **Advanced Techniques Of Clandestine Psychedelic & Amphetamine Manufacture**

64

stations are located on the sewer mains, and if they pick up loads of chrome coming at them, they are going to look for the source. The trivalent chrome produced by this reaction isn't really bad like hexavalent chrome is, but you can still get yourself unwanted attention by dumping chrome into the sewers. A few pounds nobody will notice. A few hundred is another matter. For a large scale operation, my advice is to drum up the sludge. When the cooking is completed, spend the thousand or so dollars to have it carted away by a hazardous waste firm.

## **Chapter Eight**

### **Another Low Profile**

### **Phenylacetone Factory**

In the previous section, a low chemical feed profile phenylacetone factory using ethylbenzene to produce phenylacetic acid was detailed. That procedure is quite practical and workable, but not without its problems. Prominent among the problems attendant to that method are the persistent stink of phenylacetic acid, and the dangers inherent to the use of a high temperature pressure vessel to make the phenylacetic acid.

In this section, an equally low profile chemical feed method for producing large amounts of phenylacetone will be covered. It doesn't suffer from the two major difficulties cited for the ethylbenzene process, but it has three areas of concern unique to it. It uses chlorine gas in the process, requiring that the factory be set up in a lightly populated area such as a countryside garage with very good ventilation.

The procedure itself is very nasty and unpleasant to be around. My experience with this process dates to 1979 or 1980, and I can personally attest to the hell which will be experienced without adequate ventilation, and care in handling the materials. Chloroacetone, which is first made from acetone and chlorine, then fed into a Friedel-Crafts reaction with benzene to make phenylacetone, is a most

## Advanced Techniques Of Clandestine Psychedelic & Amphetamine Manufacture

66

potent tear gas agent. Even at room temperature, the fumes coming off this material from an opened bottle are enough to clear an unventilated room quickly.

Another problem with this procedure is the seemingly unavoidable low yield of product one gets. The literature states a yield in the low 30s of phenylacetone based upon the amount of chloroacetone used. My experience is that this is probably a little bit on the high side, and that 25-30% is more realistic. The original authors of the procedure tried using a greater dilution with benzene to raise the yield, and had no success. A correspondent wrote once claiming that he had found a way to vary the procedure to get a 50% yield, but he gave no details. This correspondent is known for making inflated claims, besides being a snitch who would sell his mother down the river to save his hide, so judge this claim with caution.

See *Journal of the American Chemical Society*, Volume 62, page 1622 (1940), for the original disclosure of this procedure. Chloroacetone reacts with benzene using anhydrous aluminum chloride catalyst to produce phenylacetone, along with a bunch of tarry by-products.

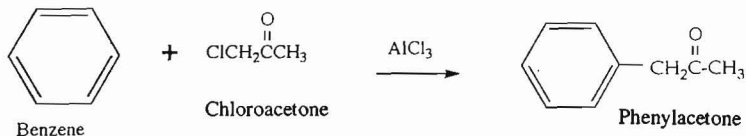

Into a 5000 ml three necked flask equipped with a reflux condenser protected with drying tube in one neck, a mechanical stirrer in another, and a dropping funnel in the third neck, put 410 grams of anhydrous aluminum chloride, and 1000 ml of benzene. Benzene is a fairly common industrial solvent whose use isn't as widespread as it used to

*Chapter Eight*  
*Another Low Profile Phenylacetone Factory*

67

be before the discovery of its purported carcinogenic properties. Five gallon pails and 55 gallon drums are fairly easily obtained at dealers of industrial chemicals. Look in the yellow pages for dealers, and read over the "War Stories From The Pen" chapter for ordering etiquette. Anhydrous aluminum chloride isn't so commonly used as the hydrated form, but it too should be pretty easy to get at industrial chemical outlets. Avoid dealing with scientific supply houses, and other hotbeds of chemical sales reporting. If they sell List I chemicals, stay away. 5000 ml three necked flasks don't exactly grow on trees these days, but a stainless steel replica coated on the inside of both the flask and condenser with Teflon will give good service. See *Vestbusters* for Teflon and Teflon-based paint ordering and application procedures.

Then with stirring, heat the benzene to a mild reflux boil. Using a coated steel pot, this would be difficult to see. In that case heat the pot in an oil bath maintained at 90° C, and when the neck of the pot leading to the reflux condenser gets hot, the pot is boiling. When the mixture is hot, dropwise add 140 ml of chloroacetone through the dropping or addition funnel. This addition should take between ½ hour to a full hour. When the addition is complete, continue boiling the mixture for an additional 5 hours. The mixture turns an ugly, very dark black shade, and HCl escapes through the top of the reflux condenser while the mixture cooks.

When the 5 hour boil is complete, cool down the mixture. Then slowly add water to the mixture with stirring. A lot of HCl is given off when the water is added, especially at first. Add about one liter of water. By the end of this water addition, evolution of HCl should have ceased, although the mixture will continue to smell like hydrochloric acid. Next add a mixture of 200 ml of water and 200 ml of concentrated hydrochloric acid (30-35% strength) with continued stirring.



## Advanced Techniques Of Clandestine Psychedelic & Amphetamine Manufacture

68

This assures that the aluminum salts end up in the water layer.

Next, pour the mixture into a large separatory funnel, and separate off the black benzene layer. The product is in there somewhere. Then take the water layer and extract it four times with 250 ml portions of benzene. Add these extracts to the black benzene layer. Finally, filter the benzene-product mixture.

Now return the filtered benzene product mixture to a 5000 ml distilling flask. Rig this flask for fractional distillation. The fractionating column doesn't have to be anything elaborate, as just a little bit of fractionating power will do. Heat the mixture and distill off the benzene. The first portion will be the benzene-water azeotrope boiling at about 70° C. It will have a milky appearance, and can be reused as the extractant in the previous paragraph. When all the water has been removed the distillate will be clear colored, and the benzene will boil at about 80° C. This benzene can be reused in the production reaction.

When almost all of the benzene has been distilled off (the rate at which it distills over falls greatly), transfer the residue in the distilling flask to a 1000 ml distilling flask or, if possible, a 500 ml distilling flask. Rig this flask for fractional vacuum distillation, and apply a vacuum. The residual benzene quickly comes off. Then apply heat, and vacuum distill the residue. About 90 ml of liquid distills below 123° C at a vacuum of 20 torr. The distillation temperature will of course vary with vacuum strength, so the general rule is to collect the first 90-100 ml of product that distills once the benzene is gone. This is the crude product.

The residue left in the distilling flask will quickly set up into a mass that's next to impossible to remove if it isn't poured out immediately at the end of the distillation. Do so at the earliest possible opportunity once the crude product is

*Chapter Eight*  
*Another Low Profile Phenylacetone Factory*

69

secured. The thin film left clinging to the distilling flask can be removed with solvent, but if the whole mass of tar is allowed to set up, it's next to impossible to remove with solvents.

The crude product should be purified by means of the bisulfite addition product. Phenylacetone will react with sodium bisulfite to form a solid derivative. To make the derivative, take the roughly 100 ml of crude phenylacetone, and put it in any convenient container. Next add 300 ml of a saturated solution of sodium bisulfite or sodium metabisulfite in water. Roughly 30 grams of bisulfite will dissolve in 100 ml of water. Shake or stir violently for a few hours. A thick mass of crystals should form in the mixture. Filter these out, and rinse them with a little solvent such as benzene or toluene. These crystals are the bisulfite addition product of phenylacetone.

To regenerate phenylacetone from this addition product, put them in a flask along with about 800 ml of a saturated solution of sodium bicarbonate in water. About 80 grams of bicarb will dissolve in 800 ml of water. Heat the mixture to boil under a reflux for a few hours. This should completely decompose the addition product to give back phenylacetone. It can be recovered by adding about 100 ml of toluene or benzene to the flask, shaking to extract phenylacetone, then separating the product layer that floats on top of the water with a sep funnel. After the benzene or toluene is boiled away, the residue is phenylacetone. The yield should be around 70 ml.

If there is any evidence that the bisulfite addition product is less than completely decomposed, the phenylacetone should be recovered from the bicarbonate solution by means of steam distillation. The exact technique of doing a steam distillation is covered in any Organic Lab text, and will always be done as part of Organic Lab coursework, so the

## **Advanced Techniques Of Clandestine Psychedelic & Amphetamine Manufacture**

70

details won't be covered here. Just a few tips. A pressure cooker is a good source of steam. Just run a line from the steam vent at the top into the flask. It will take a few liters of water to steam distill about 70 ml of phenylacetone. The phenylacetone is then recovered from the steam distillate by extracting with some toluene or benzene, and the solvent boiled away to give a residue of phenylacetone. It should be transparent with a clear to light yellow color, and have that characteristic chemical kind of fruity smell of phenylacetone. There should be no trace of the chloroacetone.

### **Preparation of Chloroacetone**

While chloroacetone isn't on any federal reporting lists as of mid-1997, it has no industrial usefulness that I know of. That means that the only likely source of it ready made is from scientific supply houses. Let your Uncle be your guide here, and stay away from these sources. One is much better served cooking your own chloroacetone from acetone and chlorine than putting your name on their snitch list. The people who run these supply houses aren't so stupid that they have no idea of the uses to which chloroacetone can be put. Any bottle obtained from them would have to be redistilled before use anyway because the stuff gets black and tarry in storage. If you are going to have to go through that, you might as well make the stuff.

The materials from which chloroacetone is made are very easily available, cheap, and in large quantities. A meth lab project which would make the operator rich beyond the dreams of avarice is easily realized by this production route. The same can be said of the route using ethylbenzene. The choice is one based upon taste, one's choice of persistent stink or a tear gas assault.

*Chapter Eight*  
*Another Low Profile Phenylacetone Factory*

71

Acetone can be picked up at any hardware store, in the paint department. It comes in one gallon pails for under \$10 each. If production is going to be scaled up to the point where a lot of these pails are going to be consumed, spread out the purchases to a bunch of hardware stores. I recall seeing a "Most Wanted" type show where a hardware store owner called the cops because the same person kept coming back for all these pails of acetone. Hardware store acetone will contain a percent or two of water which must be removed prior to use, but this is easy to do. The hardware store is still the place to get acetone.

Chlorine is an industrial gas with a variety of legitimate uses. The chemical truck which pulls up to the plant where I work is often carrying cylinders of chlorine. They go to places which use them for water purification, making pool chemicals or to destroy cyanide in waste water from electroplating operations. Fashion your company name accordingly when ordering this material.

Similarly, the sodium bisulfite or metabisulfite used to purify the phenylacetone is an easily available commodity. In smaller packages of a pound or so, one need go no farther than the local brew supply shop. Home brewers use the chemical to disinfect their brewing vessels. Vintners add it to their wine to prevent spoilage. The plant where I work consumes tons of the stuff in the waste water treatment process. We use it to reduce hexavalent chrome to trivalent, which can then be sludged out of the water by adding hydroxide. For this purpose, it comes in 50 pound bags. Obtaining it from an industrial supplier of chemicals is no problem. Once again, see the "War Stories From The Pen" chapter for ordering and pick up etiquette.

The process for making chloroacetone is simple enough, giving a high purity product so long as the acetone and chlorine are free of water. Some simple engineering is

## Advanced Techniques Of Clandestine Psychedelic & Amphetamine Manufacture

72

required to assemble the reaction apparatus. The best place to put this apparatus is in a countryside garage, in the central section of said garage. One should work upwind from the apparatus, and have a fan to assist the natural direction of air flow.

See US Patents 2,235,562 and 2,243,484 for more information on this process and alternative construction designs for the reaction apparatus. The assembly shown below is the simplest design I could think of using standard parts.

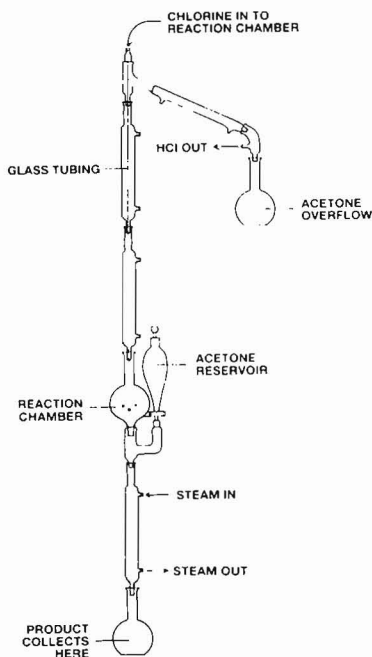

The reaction apparatus is constructed with standard chemical glassware, preferably 24/40 size. At the bottom is a flask where the chloroacetone produced collects. Fitted above it is a condenser, which is heated by passing a flow of

*Chapter Eight*  
*Another Low Profile Phenylacetone Factory*

73

steam through the water jacket. As was mentioned earlier, a pressure cooker is a good source of steam. It's best to put a few pieces of broken glass inside this condenser so that drops of acetone can't just fall into the product flask. Above the heated condenser, one puts a claisen adapter. On one branch of the adapter, put a dropping funnel or addition funnel. Acetone is put in this funnel, and dripped into the reaction apparatus while doing the reaction.

On the other branch of the adapter, put a kugelrohr bulb. This is the reaction chamber. Above that is placed two condensers. Cold water is run through them to condense acetone vapors. Above that, a stillhead is put into place. Through the top of the stillhead run a narrow piece of glass tubing down to the center of the reaction chamber. The glass tubing carries chlorine gas into the reaction chamber. It should be of narrow diameter so that the condenser will not easily flood out with acetone unable to flow downward to the reaction chamber. Finally, a standard distillation receiver assembly is attached to the stillhead to catch any acetone vapors which make it out the top of the condensers, and also to provide an outlet for the HCl gas produced in this reaction.

Chlorine reacts with acetone vapors to produce three possible products:

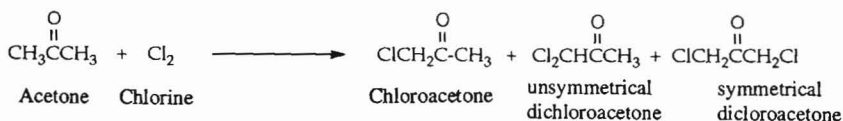

A molecule of HCl is also produced for each chlorine atom that adds to the acetone.

It is pretty easy to assure that the vast majority of the product is the desired chloroacetone. The byproduct sym-

## Advanced Techniques Of Clandestine Psychedelic & Amphetamine Manufacture

74

metrical dichloroacetone is produced when too much chlorine is introduced into the reaction chamber. One can keep the reactants in balance simply by watching the color of the vapors in the reaction chamber. A faint shade of green is desirable. If the color gets darker green, the rate of input of chlorine gas should be decreased, or the rate of input of acetone increased.

The byproduct unsymmetrical dichloroacetone is produced when water is present in either the acetone or chlorine. This byproduct is very troublesome because it boils at the same temperature as chloroacetone. As a result, removing it from the product by distilling is impossible. One must therefore assure that both the acetone and chlorine are free from traces of moisture.

The most suitable method of removing the traces of water from the acetone is to use Epsom salts as a drying agent. As they come from the store, the Epsom salts ( $\text{MgSO}_4 \cdot 7\text{H}_2\text{O}$ ) contain a lot of adsorbed moisture. To use them as a drying agent, this water must be baked off. Get a glass baking dish, and put a layer of Epsom salts about  $\frac{1}{4}$  inch thick into the dish. Bake it in an electric oven at 400-450° F for an hour or two to drive off the water. Then turn off the heat to the oven. When it cools down to where you can just handle the dish with oven mitts, pour the baked Epsom salts into a glass jar, and crank the lid back on the jar. This will keep the baked Epsom salts from reabsorbing water from the air. To dry hardware store acetone, put about 100 grams of these baked Epsom salts into a gallon pail of acetone. Close up the cover on the acetone pail, and periodically shake it around, or tip it onto its various sides. Let the Epsom salts work for about a day, then let them settle. The acetone should be directly poured from the pail to the acetone reservoir with help from a funnel when the reaction is done. It's best to have filter paper in the funnel to catch any suspended Epsom salts.

*Chapter Eight*  
*Another Low Profile Phenylacetone Factory*

75

The chlorine gas feed for the reaction should similarly be dried. This is done by passing the gas into a wash bottle containing some concentrated sulfuric acid as shown below. This not only assures that the chlorine is free of moisture, it also is an easy visual way to gauge and adjust the rate of flow of chlorine into the reaction.

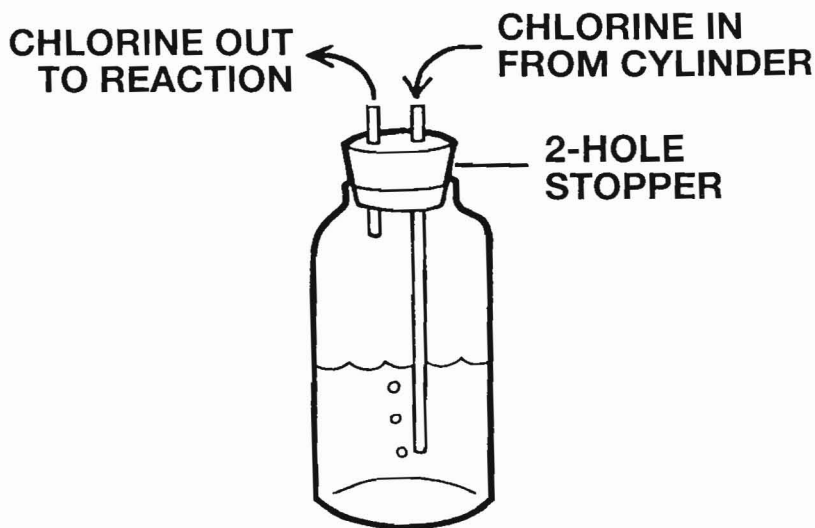

Glass tubing is used in the wash bottle. Plastic tubing can be used as the gas line from the cylinder and out to the reaction.

To make chloroacetone, first begin passing steam through the lower condenser, marked steam in and steam out in the diagram. Then start the flow of cold water through the other three condensers. Next add a little bit of acetone, like about 5-10 ml, into the apparatus through the acetone reservoir. It will vaporize as it flows down the claisen adapter into the heated condenser. The vapors will condense in the upper cold condensers, flow back down, and cycle like that.



## Advanced Techniques Of Clandestine Psychedelic & Amphetamine Manufacture

76

Next, begin a slow flow of chlorine from the cylinder. It will take a little bit of time for the chlorine to fill up the wash bottle, and then make its way into the reaction chamber. When it makes its way into the reaction vessel, a color change from clear to slight greenish tint will be noticed. Chloroacetone will form, and the liquid will flow down the steam heated condenser into the flask that collects the product. Chloroacetone boils at 118° C, and so will not boil on its way down into the product flask.

Once the chlorine makes its way to the reaction apparatus, a drip flow of acetone from its reservoir should begin. The rate of addition of acetone should be such that the cold water condensers don't flood out or send acetone up over the top to the acetone overflow flask. The rate at which chlorine is added should be adjusted so that a faint greenish color is maintained in the reaction chamber and surrounding reaction areas in the apparatus. A darker green color indicates that too much chlorine is being added relative to the acetone available to react with it.

The darker green color shows the formation of dichloroacetone, which should be avoided. In this way, the rate of addition of acetone and chlorine are balanced to produce high yields of a good product.

When enough product has collected to last about a week or so, the process is stopped by first turning off the chlorine, then stopping the drop of acetone. Stockpiling production more than a week or so ahead is bad as the product doesn't keep well. Storage in a freezer helps.

The product should be poured into a sep funnel, and washed with saturated solutions of bicarb in water. The washing should continue until the fizzing stops, and the bicarb solution remains alkaline. Beware of the pressure building up in the sep funnel, spraying mists of product in your face. Wear eye protection, and stay upwind. Rubber

*Chapter Eight*  
*Another Low Profile Phenylacetone Factory*

77

gloves are required as well. The water layers from the bicarb solution washes can be thrown away. The product layer should be poured into a beaker, then it is dried by adding flakes of calcium chloride with stirring. Calcium chloride can be found at the store in 50 pound bags. It's used to melt ice. Once the bag is opened, it will soak up water from the air, and melt. Calcium chloride used for this purpose should first be baked in the oven at about 450° F, just like Epsom salts, then stored in a sealed container until use. Slowly add the calcium chloride with stirring until a water phase separates from the product.

Using a sep funnel, separate off the water phase. Now the product is ready for distillation. A fractionating column should be used, like the glass packed claisen adapter shown in the Fourth Edition of *Secrets of Methamphetamine Manufacture*. Pure chloroacetone boils at 118° C at normal pressure. Some vacuum is preferred for distilling this substance, such as the vacuum delivered from a cheap aspirator. Too strong a vacuum will lower the boiling point too much and make the substance difficult to capture. A vacuum of 50 torr will result in a boiling point of about 60° C. No stronger vacuum should be used, in my opinion. The product should be kept in a stoppered glass container, and stored in the cold until used. Too long a period of storage will result in the product turning black.



## **Chapter Nine**

### **A High Yield**

# **Phenylacetone Recipe**

At the time of this writing, the acid chloride of phenylacetic acid, phenylacetyl chloride, is not included in the list of reportable chemical transactions. No doubt, this oversight will soon be corrected so that the world can be saved. Nevertheless, the acid chloride of phenylacetic acid is a very good precursor for the manufacture of phenylacetone. If one is in a position where the other chemicals required to do this reaction are easily available, then this is one of the best procedures for making phenylacetone.

Let's start with the making of the acid chloride of phenylacetic acid, phenylacetyl chloride. Directions are found in the *Journal of the American Chemical Society*, Volume 70, pp. 4241-45 (1948). In a 500 ml round bottom flask, place 136 grams of phenylacetic acid, and 110 ml of thionyl chloride. The last time I checked, thionyl chloride was on the California list of controlled chemicals. Other states may also require reporting of its sales, so check first. It's far better if this material is just laying around on some shelf for the taking.

Now attach a reflux condenser to the flask, and boil at reflux. HCl and SO<sub>2</sub> will be given off, so a plastic tube attached to the top of the condenser leading to fume disposal is required at first. Then as the reaction nears completion, the

## Advanced Techniques Of Clandestine Psychedelic & Amphetamine Manufacture

80

fume production slows and then stops. One can determine when it has stopped either by sniffing at the top of the reflux condenser, or preferably by moistening some pH paper and holding it at the top of the condenser. When it doesn't give a quick and strong acid reaction, then the process has reached completion.

Next rig for fractional distillation. The unreacted thionyl chloride can be distilled off at a boiling point of 76° C, then a vacuum is applied to get a 95% yield of phenylacetyl chloride which boils at 95° C under a vacuum of 12 torr, 105° C at 24 torr, and correspondingly higher temperatures at less powerful vacuums.

The procedure for making phenylacetone in about 70% yield from phenylacetyl chloride can be found in the *Journal of the American Chemical Society*, Volume 68, p. 1386 (1946). The following reaction is done:

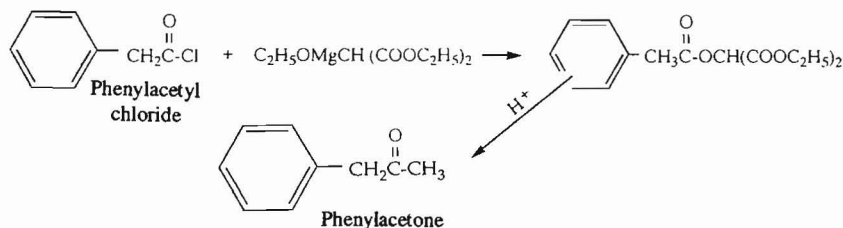

The procedure for turning phenylacetyl chloride into phenylacetone is fairly simple, but it requires that one use magnesium turnings, which are on the California list of restricted chemicals. Also, anhydrous ether is needed as the solvent. The smell of ether carries well downwind, and ether poses a fire hazard as sparks can easily set the fumes aflame. Additionally, anhydrous ether isn't a particularly low profile substance to obtain. This method is only recommended to those who have easy access to the chemicals. The low profile phenylacetone prep from phenylacetic acid is the use of a tube furnace packed with thorium oxide catalyst.

*Chapter Nine*  
*A High Yield*  
*Phenylacetone Recepte*

81

To do the reaction, a 2000 ml round bottom flask which has been baked to remove traces of water is loaded with 26.75 grams of similarly baked magnesium turnings. Then add 25 ml of absolute alcohol and 2.5 ml of carbon tetrachloride. Start magnetic stirring, and the reaction starts almost immediately. Allow the reaction to go a few minutes, then add 375 ml of anhydrous ether slowly. Heat the mixture with steam, and add a solution of 176 grams of diethyl malonate in 100 ml absolute alcohol and 125 ml anhydrous ether at such a rate that a rapid reflux is maintained. Apply steam heat if needed to keep the reflux going during the addition. Then reflux for 3 hours or until the magnesium dissolves.

To the clear solution that results when the magnesium has dissolved, add with vigorous stirring 132 ml of phenylacetyl chloride dissolved in an equal volume of anhydrous ether. Reflux for  $\frac{1}{2}$  hour, then cool the solution.

The cooled solution is next poured into a large sep funnel, and 500 ml of a 10% by volume solution of sulfuric acid in water is added. The mixture is shaken for a few minutes, then allowed to stand. The water layer in the bottom of the sep funnel is next drained out of the sep funnel. Check the water to make sure it is still acid. If not, shake the ether layer in the sep funnel with an additional 150 ml of sulfuric acid solution, drain it off and check it for acidity.

Now pour the ether solution into a large filtering flask, or other container to which a vacuum can be applied. Extract the sulfuric acid solution with a couple hundred ml of ether, and add this ether extract to the vacuum evaporation container. Apply a vacuum to evaporate off the ether.

To the residue left in the evaporation container when the ether is gone, add a mixture of 300 ml of glacial acetic acid, 38 ml of sulfuric acid and 200 ml of water. Reflux for five hours. Phenylacetone has now been formed.

## Advanced Techniques Of Clandestine Psychedelic & Amphetamine Manufacture

82

Chill the mixture in an ice bath, and add a solution of a pound of lye dissolved in five pints of water. Shake the mixture strongly for about five minutes, then let it cool down some more in the ice bath.

Next add about 300 ml of toluene, and shake the mixture for a couple minutes. Separate off the toluene layer floating on the top. It contains the phenylacetone. Pour it into a distilling flask. Rig for fractional distillation, and distill first at atmospheric pressure. The toluene-water azeotrope will distill first at 85° C, followed by pure toluene at 110° C. When almost all of the toluene has distilled out, apply a vacuum to remove the rest of the toluene, and then distill the phenylacetone. A good aspirator will distill phenylacetone at about 110° C to 120° C. The exact boiling point will depend upon how strong the applied vacuum is. The yield is about 100 ml of phenylacetone.

A few years after the previously mentioned paper was printed, a guy named Bowman reported on an improved recipe. See *Journal of the Chemistry Society of London*, pp. 322-25 (1950). In this improved procedure, he replaced the anhydrous ether with benzene. Just this is a big improvement. He further went on to improve the procedure by distilling off the unreacted excess alcohol from the first stage of the procedure as the benzene-alcohol azeotrope which distills at 68° C, prior to going on to adding the acid chloride. This eliminates a side reaction of the acid chloride with the alcohol. He also went on to tinker with the acid hydrolysis step to make the conversion to the ketone more complete. While he didn't use phenacetyl chloride in his experiments, he used many other acid chlorides with uniformly excellent results. By using this improved procedure, the yield can be expected to increase from the low 70% range up into the eighties or nineties. Serious experimenters would be well advised to try his improved

*Chapter Nine*  
*A High Yield*  
*Phenylacetone Recipe*

83

method when making phenylacetone by this route. Try using toluene instead of benzene. All the other problems with this route concerning availability of needed chemicals such as the acid chloride and the magnesium turnings remain, however.





## **Chapter Ten**

# **Electric Phenylacetone**

In *Chemistry Letters*, pp. 1021-24 (1977), a fairly simple method is given for the direct conversion of benzyl chloride to phenylacetone. The standard methods for converting benzyl chloride to phenylacetone are first to react with cyanide to get benzyl cyanide, and then benzyl cyanide is either converted to phenylacetic acid, which is then used to make phenylacetone, or the benzyl cyanide is condensed with sodium metal and ethyl acetate in anhydrous alcohol to give an intermediate which yields phenylacetone when heated with sulfuric acid.

The method revealed in the *Chemistry Letters* article is a direct conversion of benzyl chloride to phenylacetone, in a yield similar to the standard procedures outlined above. This method uses acetyl chloride as the chemical which links up with benzyl chloride to form phenylacetone. This chemical is under no types of regulation or control as of this writing, in contrast to benzyl chloride which is on a less stringent federal reporting list. This reporting list requires that chemical transactions involving more than 1 kilo of benzyl chloride be kept on record by the vendor for a couple of years, and supplied to the feds on request. Benzyl chloride is

## Advanced Techniques Of Clandestine Psychedelic & Amphetamine Manufacture

86

a very good material to bring across the border from Mexico, as imports of less than 4 kilos need not be reported.

This method uses a lot of acetonitrile as solvent, and uses tetraethylammonium p-toluenesulfonate as the electrolyte. The acetonitrile can no doubt be easily recycled back into the process, but the large dilution holds down the amount of product which can be obtained from a given size reaction apparatus. The electrolyte isn't exactly your common garden variety chemical that any experimenter would want to have. Further, both of the reactants, benzyl chloride and acetyl chloride are foul materials that are best suited to be tear gasses, and not things that you would want to play around with in some unventilated basement. Weigh all these factors in judging the desirability of this process.

Graphite electrodes are needed to do this reaction. Rod shaped graphite electrodes can be obtained from welding supply shops in diameters up to about 1/2 inch. Better still would be flat sheets of graphite, as they present more surface for a given length, and it's also easier to keep the current density constant over the active surface of the electrode. More surface means more current can be passed, allowing for quicker reactions. Keeping the current density within a prescribed range of values makes for a cleaner product. Flat sheets of graphite can be obtained from plating supply companies.

To do a .2 mole sized batch, which will yield about 9 ml of phenylacetone, one starts with a 2000 ml beaker and a porcelain or other ceramic cup. Remove all the glazing off both the inner and outer surface of the cup with sandpaper or sandblasting. Without removing the glaze, the cup can't pass current. The cup serves the purpose of preventing contact of the reaction solution with the anode. For the cell to be able to pass current, the porcelain or other ceramic should be no more than 3 or 4 mm thick. If it is thicker than this, then an

Chapter Ten  
Electric Phenylacetone

87

impractical amount of voltage would have to be applied. Also, a pretty fair amount of heat is generated by the resistance of the ceramic. In effect it is a heater for the solution. Too much resistance would translate into more heat than could be carried away by a water bath on the outside of the beaker.

Assemble the reaction cell as shown below:

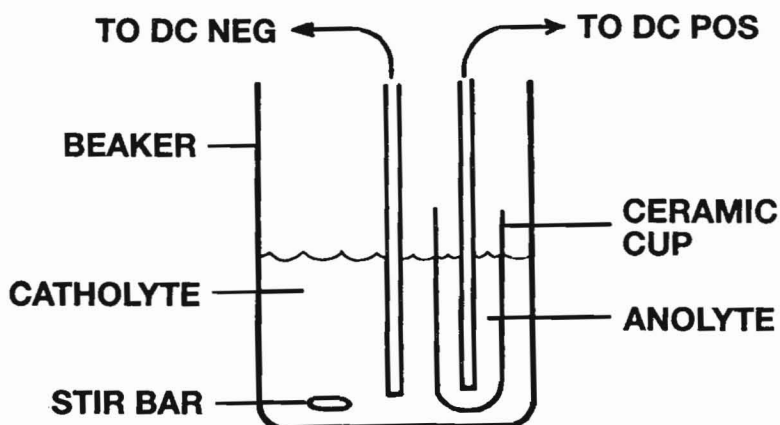

Basically what is done is the ceramic cup is placed inside the beaker, then a graphite anode is placed inside the cup, and a similar size graphite cathode is positioned outside the cup, close to but not touching its outer wall. Electrical contact to both the anode and cathode must be secure to prevent sparking. Since acetonitrile is quite flammable, sparks due to bad contacts would be disastrous! A convenient way to make contact with graphite is to turn a brass screw into the graphite, and then wrap and clamp down copper wire around the screw. I picture the anode and cathode extending above the top of the beaker, but this isn't necessary. The tops just need be above solution level.

## Advanced Techniques Of Clandestine Psychedelic & Amphetamine Manufacture

88

Next put about 640 ml of acetonitrile (anhydrous) in the beaker, and dissolve 15 grams of tetraethylammonium p-toluenesulfonate in the acetonitrile. This is the catholyte. Then add acetonitrile to the ceramic cup until its level is about equal to the catholyte. Record how much acetonitrile was put into the cup, then add tetraethylammonium p-toluenesulfonate to the cup so that its concentration is equal to the catholyte. This is the anolyte. Stir it around to mix it in.

Now to the catholyte in the beaker add 25 ml of benzyl chloride, and 50 ml of acetyl chloride. Begin a rapid stir of the catholyte, and begin to apply voltage to the two electrodes. About 90 to 120 volts DC will be required to break through the ceramic cup, so a DC arc welder is the most convenient power source. The graphite cathode inside the beaker is connected to the negative pole of the welder, and the anode in the cup is connected to the positive pole of the welder. An amp meter must be put in line on the wiring, and it must be sensitive and accurate. One can be had at Radio Shack for about \$50.

As the voltage is increased, at first there will be no reading of current flow on the amp meter. Finally, once the insulative effect of the ceramic is overcome, some current will begin to flow. How much more to turn up the voltage output is the next topic which must be addressed. The *Chemistry Letters* article uses a standard calomel electrode to give an absolute measurement of how negatively charged the cathode is. They run the reaction at -2.1 to -2.4 volts. To simplify, let's convert this to current density, which can be read right off the amp meter. It's reasonable to conjecture that the cathode in the cell described in the article had an area of about 2 square cm, given their batch size.

From the time it took them to pass the required amount of current, their current density on the cathode was about .1

Chapter Ten  
Electric Phenylacetone

89

amp per square cm. If a graph is made when doing a reaction of current flow through the cell versus applied voltage, one should get something that looks like this:

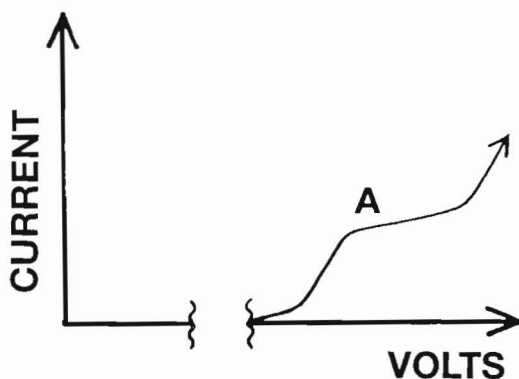

Once the electricity manages to break through the ceramic cup, the current flow should gradually increase with voltage, until the voltage is increased enough for the reaction to occur. Then a steep rise in current called the reduction wave is seen. After the wave, the current again gradually increases with voltage until the next possible reaction, such as reduction of the solvent, occurs. Then another wave is seen. One wants to set the voltage at the crest of the first wave, labeled A in the graph. This will probably be about 5 volts beyond the point where current first begins to flow. The current density on the cathode will probably be about .1 amp per square cm. In calculating the surface area of the cathode, only measure the side facing the ceramic cup, as the back side is shielded from current flow. As current flows, the following reaction occurs:

## Advanced Techniques Of Clandestine Psychedelic & Amphetamine Manufacture

90

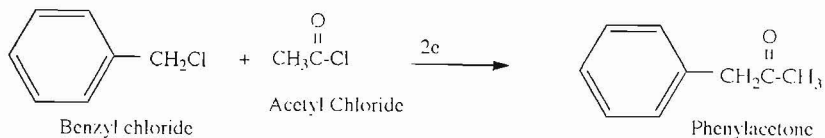

Two electrons are needed for the reaction, but four are used in the procedure given in *Chemistry Letters* because of inefficiency in the process. If one's cathode measures 10 square cm, allowing a current of one amp, then a .2 molar batch requires 77,200 amp-seconds, or 21.4 hours at a current of one amp. A 20 square cm cathode carrying 2 amps would require 10.7 hours for a .2 molar batch.

The heat produced must be carried away by keeping the reaction beaker surrounded with cold water. The reaction mixture shouldn't be allowed to rise above room temperature. A big batch might even require that cooling coils be immersed in the reaction mixture in addition to cooling the outside of the beaker.

When the required amount of current has passed, the ceramic cup is removed, and the anolyte is poured into a container to be saved for future use. To get the product, the article recommends pouring the catholyte solution into about an equal volume of saturated salt solution in water. This brine solution was next extracted with three large portions of ether, and after evaporating the ether, the product was distilled.

A more practical isolation procedure would seem to be to distill off the acetonitrile. Using a cheap vacuum pump, such as an aquarium pump, should lower the boiling point of the acetonitrile from about 80° C to around 50° C. With ice water in the condenser, it should be easy to condense all the acetonitrile at that boiling temperature, and thereby save it

*Chapter Ten*  
*Electric Phenylacetone*

91

for reuse. When most of the acetonitrile has distilled off, then following the procedure of pouring the residue into saturated brine, extracting and distilling the product would seem to be much more efficient. The yield should be about 9 ml of phenylacetone, which is comparable to the amount of phenylacetone which would be obtained from 25 ml of benzyl chloride by using the standard procedures.





## **Chapter Eleven**

# **Obtaining Lithium Metal From Lithium Batteries**

The so-called “birch reduction” whereby reduction is done by the action of solvated electrons produced by dissolving lithium, sodium or potassium metal in ammonia or amines is a very excellent and convenient method of producing meth or amphetamine from ephedrine, pseudoephedrine or phenylpropanolamine respectively. The biggest obstacle to putting this method to use, other than the need to get pills containing these ingredients and extract them, is that lithium metal isn’t generally thought of as a common household item available with a few minutes of very minor labor.

This common perception is dead wrong, as every trip to the store brings us past a veritable motherlode of lithium metal in the battery section. Over the past few years, the 3 volt lithium battery has become more and more dominant in the battery market. As a result, anyone’s supply of lithium metal is no further away than the store down the street, with no hassles, suspicion or worry for the purchaser.

The typical lithium battery is exemplified by the Duracell DL 2430 Long Life Lithium selling for about \$2.25 each in mid-1997. Its construction is shown on the next page:

## Advanced Techniques Of Clandestine Psychedelic & Amphetamine Manufacture

94

LITHIUM METAL  
INSIDE BATTERY

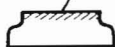

SIDE VIEW

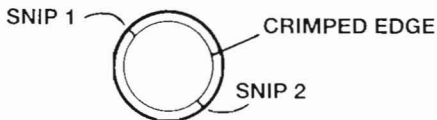

TOP VIEW

The construction is most simply described as two shallow cylindrical pots crimped together. The smaller pot contains a little less than one-half of a gram of lithium metal, while the larger one contains a black moist substance. A sheet of filter paper separates the two materials.

To get out the lithium, set the battery on a tabletop, with the smaller diameter pot facing up as shown in the above drawings. With a small fine screwdriver, quickly jam down into the crimped edge that joins the two pots, and separate them from each other. Work quickly, as each time you jam down in, you are shorting the battery when one metal pot makes electrical contact with the other.

When you have separated the crimping, take a wire cutter and snip through the metal of the larger diameter pot along one edge as shown in the diagram. Then go to the opposite side of the battery, and make another snip. Now the larger diameter pot can be easily peeled off from the smaller diameter pot that contains the lithium metal. Toss out any of the black gunk inside the smaller pot, then with a tweezers or similar tool, peel back the filter paper covering the lithium metal. Pluck out the strip of lithium metal. Then place the strip into the liquid ammonia. The lithium metal dissolves to form the solvated electrons.

See *Secrets of Methamphetamine Manufacture*, Fourth Edition, for directions to do this reaction. It is Method 1 under direct reductions of ephedrine, pseudophedrine or PPA

*Chapter Eleven*  
*Obtaining Lithium Metal*  
*From Lithium Batteries*

95

to meth or amphetamine. Here is some further commentary on this procedure that was not given there. Know that in the Fourth Edition of *Secrets of Methamphetamine Manufacture*, I gave directions using the absolute minimum amount of liquid ammonia. Feel free to double or triple the amount of liquid ammonia from that given in the recipe.

Point number two is an observation I have made during experiments with these batteries. It appears that there is something mixed with the lithium metal in these batteries that makes the solvated electron solution unstable on standing. I don't believe that I had any water in the mixture, so perhaps there are traces of iron or other transition metals in the lithium. As a result, it is advisable to reverse the order of addition from that given in the book when using battery lithium. That is, the ephedrine, PPA, or whatever, should first be added to the liquid ammonia along with cosolvent, then the lithium batteries are added one at a time. The amount of time it takes to tear apart each lithium battery is just about the right spacing between each addition. This is how most dissolving metal reductions are done anyway. Continue adding batteries until the blue color produced by the dissolving lithium persists a little bit rather than just quickly being sucked up by the solution.

The third point is the need to be sure that the toluene or mineral spirits extract of the free base of ephedrine, or whatever, from the pills (see *Secrets of Methamphetamine Manufacture* for pill extraction directions) is free of any water. Water would quickly quench the solvated electrons. To be sure that it is free of water, take the toluene or mineral spirits extract, and put it in a distilling flask. Distill off some of the solvent through a fractionating column. If water is present, it will be removed azeotropically. If the distillate has a milky appearance, that is water in the azeotrope. Note the temperature of distillation. For toluene, the water azeotrope

## **Advanced Techniques Of Clandestine Psychedelic & Amphetamine Manufacture**

96

distills at 85° C. Continue distilling until the liquid distilling looks clear rather than milky. Then the ephedrine-solvent mixture in the distilling pot will be dry and ready for use once it has cooled down.

## **Chapter Twelve**

# **An Electric Variation On The Birch Reduction**

In the previous chapter, a simple procedure for obtaining lithium metal by dissecting lithium batteries was covered. In this chapter, an alternate course of action will be detailed. This course of action is the production of lithium or sodium metal inside the liquid ammonia and pill extract mixture. This metal then dissolves as it is formed to effect the reduction of ephedrine, pseudoephedrine, or phenylpropanolamine to the amphetamine.

Like all methods that depend upon a pill extract source, this procedure isn't suitable for scaling up to large quantity production. Large sales of pills are reported to the heat, so lacking an inside source of diverted pills or pure ephedrine, this method is good for stash and circle of friends level production.

This process isn't exactly what one would call stealthy as far as one's close neighbors go either. It uses liquid ammonia in the procedure, and this ammonia must be allowed to evaporate off at the end of the reaction to isolate your product. It will also evaporate freely during the course of the reaction unless dry ice cooling is applied to the liquid ammonia.

## Advanced Techniques Of Clandestine Psychedelic & Amphetamine Manufacture

98

In nearly every respect, the Fester Formula is a far superior choice to effect this desired conversion.

In the interests of a more complete education, however, this alternative should be at least explained. Reduced to a nutshell, what happens in this alternative process can be summarized as follows: two platinum electrodes are immersed in liquid ammonia containing pill extract and either lithium chloride or sodium chloride. When electric current is applied, lithium or sodium metal electroplates at the negative electrode. It dissolves as it forms, and the dissolving lithium or sodium metal reduces the pill extract to the desired amphetamine.

A series of good reviews and articles can be found on this electric generation and reaction of so called "light metals." See first of all *Topics in Current Chemistry*, pp. 149-219 (1987), by Leskov. Then see *Journal of Organic Chemistry*, Volume 34, pages 3970-74 (1969), and Volume 35, pp. 261-62 (1970). Also see *Journal of the American Chemical Society*, Volume 85, pages 2858-59 (1963), and Volume 86, pages 5272-76 (1964). All of these articles are by Benkeser.

To do this reaction one starts with a three-necked flask, as shown on the next page. One then cuts sections of platinized mesh an inch or so long, and just narrow enough to fit down the necks of the flask with a little bit of bending. Platinum or platinized electrodes have been mentioned elsewhere in this book. A listing of suppliers can be obtained from the *Metal Finishing Guidebook*. Just tell the electrode maker that you electroplate gold jewelry, and any other anode in your gold plating bath just makes a mess of the bath — a very expensive proposition.

When the platinized electrodes have been cut to size, loop some copper wire into each one of the electrodes, and twist it down tightly to make good electrical contact. Then paint over

*Chapter Twelve*  
*An Electric Variation On*  
*The Birch Reduction*

99

the exposed copper metal with some Xylan Teflon paint. See *Vestbusters* for ordering and application information. Put the two electrodes down the outer necks of the three-necked flask as shown below:

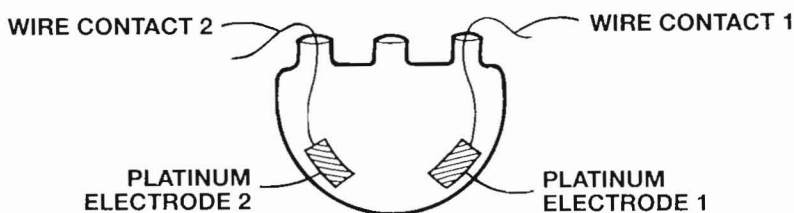

The three-necked flask doesn't have to be made of glass. They are becoming difficult to obtain these days. A stainless steel replica can be fabricated, then coated on the inside with Xylan Teflon paint. This will prevent short circuits, as the paint is an insulator.

Corks are then put into the outer necks of the flask to help keep the fumes of ammonia from leaking out these necks, and to hold the wires leading to the electrodes in place. They can't come into contact with each other, as this would cause a short.

Next, 1000 25 mg ephedrine pills are ground up, desplooged if necessary with solvent, then extracted with enough water to dissolve the active ingredient. See *Secrets of Methamphetamine Manufacture*, Chapter Fifteen for more details. To the filtered water extract, add a dash of HCl solution, then boil down the water extract to a volume of 100-200 ml. Make this water extract strongly alkaline (13+ pH to pH paper) with sodium hydroxide solution, then extract out the ephedrine free base with several portions of mineral spirits or naphtha. These solvents aren't as efficient at extracting the free base as is toluene, so make certain of



## Advanced Techniques Of Clandestine Psychedelic & Amphetamine Manufacture

100

complete extraction. A well done extraction of 1000 pills should yield about .1 mole of free base in the naphtha solvent.

Now into a 2000 ml three-necked flask, put 900 ml of liquid ammonia. This should be enough to submerge the platinized electrode completely. Then add 30-40 grams of lithium chloride or sodium chloride. No doubt the lithium salt is hugely preferable, as it would be more soluble in the liquid ammonia. Finally, add the mineral spirits or naphtha extract containing the ephedrine free base. This solution should be clear, not cloudy. Cloudiness would indicate entrained water. If the water won't settle out of the extract, then dry with some baked Epsom salts, or distill the solution a little bit to dry it.

With the ingredients in the pot, it's time to pass DC current through the solution. It takes a lot of voltage to pass current through liquid ammonia, about 90 volts. The most convenient source of this much voltage is a DC arc welder. Connect the copper wire leading to one of the platinized electrodes to the negative pole of the welder, and connect the other platinized electrode to the positive pole. An amp meter should also be wired in on the line leading to the positive electrode, just as in the drawing given with the Fester Formula. Turn up the voltage until the amp meter shows that 200 milliamps per square cm of electrode is being passed. If one, for example, has electrodes measuring 2 by 5 cm, for a face area of 10 square cm, then a total of two amps would be drawn. Continue passing current until two faradays per mole have passed. For a .1 mole size batch, this is about 20,000 coulombs. At two amps, this requires 10,000 seconds, or two hours and 45 minutes.

When the required amount of current has passed, turn off the DC power source and allow the ammonia to evaporate. When all the ammonia has evaporated off, add water, cau-

*Chapter Twelve*  
*An Electric Variation On*  
*The Birch Reduction*

101

tiously at first with swirling. Add enough to dissolve all the lithium chloride or sodium chloride. Extract out the product with a couple portions of toluene, and bubble these extracts with dry HCl to get the crystalline hydrochloride product. Spread the crystals out to dry on a plate. If lithium chloride was used it can be recovered for reuse by evaporating off the water in which it is dissolved. Yields by this method should be good to excellent, but for convenience and stealth, it can't compare to the Fester Formula.

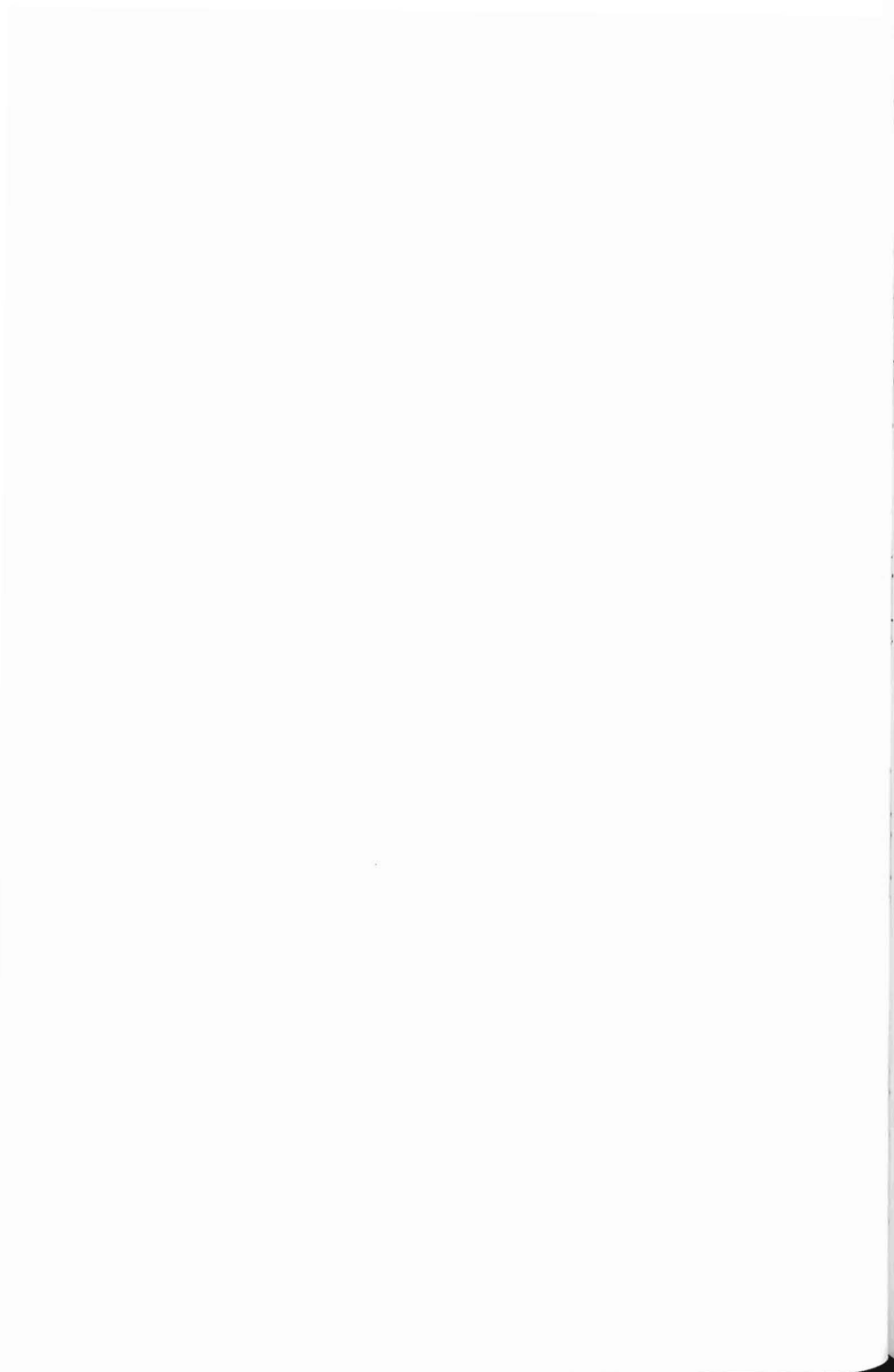

## **Chapter Thirteen**

### **The Poor Man's**

# **Hydrogenation Device**

In many cases, catalytic hydrogenation is the quickest, cheapest, most low profile and highest yielding method for a clandestine chemist to use to produce a desired substance. For example, to make MDMA or meth from their corresponding phenylacetones, by far the quickest, cleanest, and best method is the reductive amination using platinum catalyst. Further, many of the best and quickest methods for converting ephedrine, pseudoephedrine or phenylpropanolamine center upon using catalytic hydrogenation and a palladium catalyst to yield meth or amphetamine. The details of all these processes, along with plentiful references back to the original scientific literature can be found in the Fourth Edition of *Secrets of Methamphetamine Manufacture*.

In that book, I suggested the use of a champagne bottle as a hydrogenation vessel. This construction design has several advantages. The bottle is built to withstand the pressures of hydrogenation done at up to 40-50 psi, the glass is quite inert to the action of corrosive chemicals, and the glass allows the passage through it of magnetic force, which allows magnetic stirring of the contents. This greatly simplifies the hydrogenation process, as no shaker device has to be constructed.

## Advanced Techniques of Clandestine Psychedelic & Amphetamine Manufacture

104

There are serious drawbacks to this design choice, however. First and foremost among these shortfalls is that processes which involve heating the contents of the hydrogenation vessel can't be done in a champagne bottle, as the glass isn't meant to take heat and will fracture. Under a pressure of 30 pounds or so, this is a dangerous situation. Coating the outside of the bottle with fiberglass resin, as suggested in the meth book, helps to minimize this danger, but the danger is still not eliminated.

A further deficiency of the champagne bottle design is that it is difficult to attach gas line fittings to the bottle. There just isn't an obvious place on the spout of the bottle where the gas line can be attached and tightened down with a pipe clamp to prevent leakage. Since the bottle is made of glass, there is a limit to how tight such connections can be made.

A couple of years ago, a correspondent who calls himself the Iceworm wrote with his solution, which he calls the "Poor Man's Hydrogenation Device." I find his design to be superior, and worthy of passing on to you. It allows for heating the reaction contents, easy and secure attachment of gas lines, and magnetic stirring. This design comes with my highest recommendations.

The sole shortfall of this design is its vulnerability to caustic chemicals like hydrogen chloride, sulfuric acid and sodium hydroxide. This vulnerability can be overcome by coating the inside of the reaction bottle with Teflon-based paint such as Xylan. See *Vestbusters* for details on how to order and apply this very useful material.

The Poor Man's Hydrogenation Device is a fire extinguisher, the bottle of which is made of aluminum. It is very important that aluminum be used rather than steel, as this allows magnetic stirring. The tech sheet on the extinguisher should state the material of construction, but if one is just shopping, a magnet will reveal what it is made of.

*Chapter Thirteen*  
*The Poor Man's*  
*Hydrogenation Device*

105

Steel will, of course, attract the magnet, while aluminum will have no action. The 5 pound capacity extinguisher is the best choice. This will easily hold the pint or so reaction size which is about the maximum that can be vigorously stirred magnetically.

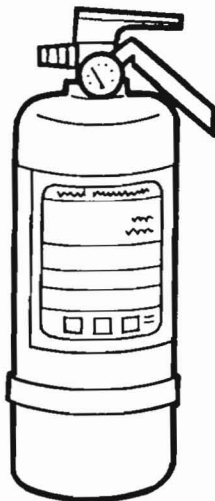

To turn this extinguisher into a hydrogenation device, one first discharges its contents. Screw off the top, and clean everything out completely. Next toss a magnetic stirring bar into the bottle, and watch to make sure that it spins properly. Failure to spin well could indicate that the bottle is made of a non-magnetic stainless steel. If caustic chemicals are going to be used in the device, it should then be coated on the inside with Teflon-based paint, and bake cured. A couple of preliminary coats with the low temp bake cure cycle, followed by a final coat with the high temp bake cycle would be the best metal protection. Follow the warnings in *Vestbusters* about excessive coat thickness to avoid bubbling and cracks.

Following coating, the extinguisher is ready to live its new life as a hydrogenation bomb. Pour the mixture to be

## Advanced Techniques of Clandestine Psychedelic & Amphetamine Manufacture

106

hydrogenated into the bottle, along with catalyst and magnetic stir bar. Screw the cap back on and it's ready to go! The discharge nozzle allows for easy attachment to a vacuum source to suck the air out of the device, and similar easy attachment to the hydrogen tank for pressurization. Be mindful that you have to pull on the hand lever to open the valve to both suck the air out, and add hydrogen. The extinguisher even comes with its own pressure valve to monitor internal pressure. This makes keeping track of the progress of the hydrogenation very simple. Sources of leaks are eliminated. A pressure of up to a couple hundred pounds is possible with this device. This is way more than one will need using platinum or palladium catalysts. Periodic checks between batches on the integrity of the Teflon coating inside the bottle are highly recommended when exposing the bottle to caustic chemicals. Ammonia, amines and phenylacetones won't bother aluminum, but more aggressive chemicals will. A dentist's mirror, and small flashlight are desirable tools for these checks.

To heat this hydrogenation vessel, just sit it in an oil bath in a beaker, and heat it on your hot plate-stirrer. It's all very simple with this device. The only area in which it lacks is that the use of Raney nickel is still not so simple. Since this catalyst is magnetic, magnetic stirring is impossible. A way around this is revealed in this book. See the chapter on the Raney nickel cathode (Chapter Three) for a simple, table-top method of using Raney nickel to great effect in making MDA and the other psychedelic amphetamines from their phenylacetones.

## Chapter Fourteen

# "I Want Some Methylamine!"

To make MDMA, one absolutely has to have methylamine. Similarly, to make meth from phenylacetone, methylamine is a required chemical. As a result, methylamine has been a hot item with the narco swine since well back in the late seventies. Methylamine now sits on the notorious List I, and is a definite "do not purchase or do business with people who sell it" item.

Through the various editions of *Secrets of Methamphetamine Manufacture*, a procedure taken from *Organic Syntheses* for making your own methylamine has been given. This procedure is quite practical, and gives reasonably good results. Now other processes will be given that offer advantages of their own, along with their own process specific disadvantages. Pick and choose for the method best suited for your situation.

### Method One — The Pipe Bomb

This method is taken from US Patent 2,085,785. It offers good yields of methylamine in a shorter reaction time than that required using the procedure from *Organic Syntheses*.



## Advanced Techniques Of Clandestine Psychedelic & Amphetamine Manufacture

108

Also, the chemical glassware "kit" isn't needed to make methylamine by this method. A heavy steel pipe reaction vessel and a heater will make the methylamine. Then a good aspirator for vacuum, and a vacuum evaporation chamber are required to recover the crystals of methylamine hydrochloride.

The method has the further advantage of replacing the formaldehyde used in the *Organic Syntheses* process with methanol. Both of these chemicals are easily available from suppliers of industrial chemicals in both 5 gallon pails and 55 gallon drums, not to mention in smaller amounts from hobbyist mail-order chemical outlets. The difference comes in that methanol (wood alcohol) is even more widely used than formaldehyde. You may even be able to find it on the local hardware store shelf, or get them to order you a pail of it. You just can't pass up hardware store chemicals when they are available. HEET is fairly pure methanol.

Both of these methods use ammonium chloride as the other ingredient to make methylamine. This material is easily available from industrial chemical suppliers in 50 pound bags, and in smaller amounts from "hobbyist" chemical outlets. A common use for larger quantities is to slow the melting of snow on ski slopes or sled runs. Craft a company name accordingly.

To produce methylamine hydrochloride by this method, one starts with a section of heavy steel pipe of about 2 quart volume. It must be threaded on both ends, and matching screw-on end caps obtained. Steel pipe is generally heavily galvanized with zinc. This must be removed by immersing the pipe and end caps in 5% HCl solution until the initially vigorous fizzing slows to a crawl. Then rinse the pipe thoroughly in clean water to remove residual acid.

*Chapter Fourteen*  
*"I Want Some Methylamine!"*

109

Now screw the cap on the bottom of the pipe, and tighten it down with a pipe wrench. It's best to then weld this cap into place.

Next put 400 ml of methyl alcohol (methanol) into the pipe, along with 535 grams of ammonium chloride, 400 ml of water, and 2.5 grams of ferric chloride. This common chemical often comes as a 40% solution in water for industrial waste water treatment purposes. About 5 ml of this solution would be plenty for the purpose. Mix the ingredients thoroughly, then screw on the top cap. Tighten it down with a pipe wrench as well.

The reaction mixture must be heated at 290° C to 300° C for about two hours. To reach this temperature, the same procedure as given in Chapter Seven should be used. A pot filled with solder should be heated until it melts at about 400° F (205° C). The pipe should then be put in the pot, and the temperature of the pot raised to the desired temperature. Maintain this temperature for a couple of hours. A pressure of hundreds of pounds per square inch will develop inside the pipe, so don't hover around it while it cooks.

When the cooking period is over, turn off the heat and remove the pipe from the pot before the solder solidifies. When it is cool, the cap can be removed, and the contents poured into a large filtering flask. The main reaction product is methylamine hydrochloride, along with some unreacted ammonium chloride and methanol, and some dimethylamine hydrochloride byproduct. The ferric chloride catalyst will color the mixture reddish brown.

To get pure methylamine hydrochloride, the mixture should be evaporated under a vacuum. Just stopper the top of the large filtering flask, and apply aspirator vacuum and heat. As the amount of crystals formed during the evaporation gets copious, they should be filtered out and kept in a glass jar with lid. The mother liquor should then be returned to the

## Advanced Techniques Of Clandestine Psychedelic & Amphetamine Manufacture

110

filtering flask for more evaporation. This process should be continued until the volume of the mother liquor reaches between 100-200 ml.

Next recrystallize the collected crude crystals of methylamine hydrochloride. This process will remove ammonium chloride, ferric chloride and dimethylamine hydrochloride from them. Clean out the large filtering flask, then put all the collected crystals in it. Add about a quart of 190 proof vodka to the flask, and heat the contents using a boiling hot water bath. Swirl the contents of the flask around as it gets hot. When it is hot, allow the crystals to settle, then decant off the vodka solution into another flask, and filter the vodka out of the settled crystals. Combine the vodka from the decanting and filtering, and cool it down in the freezer. Return the crystals to the filtering flask.

When the vodka gets cold, crystals of pure methylamine will form. Filter them out, and store them in a glass jar with a lid. Return the vodka to the filtering flask to repeat the heating/decanting/filtering/cooling and crystal collecting process. After a few runs through this process, all of the methylamine hydrochloride will be leached out of the ammonium chloride which remains undissolved in the vodka. The ferric chloride will remain dissolved in the vodka, and should stay completely out of the product crystals. Ditto for the dimethylamine, which shouldn't form in enough quantity to reach saturation in the vodka. The yield should be over a pound of methylamine hydrochloride crystals.

It's a good idea to check for the presence of dimethylamine hydrochloride in the product. This is done by taking a sample of the product and placing it in a beaker. Add enough chloroform that a slush is formed. Stir it around for a few minutes, then filter. Allow the chloroform to evaporate away. If crystals form from the chloroform, this is dimethylamine

*Chapter Fourteen*  
*"I Want Some Methylamine!"*

111

hydrochloride. If there is a significant amount, the entire product should be rinsed with chloroform.

If a person has difficulty getting ferric chloride, it can be easily made. Take iron or steel filings, and put them in a beaker. Add 15% HCl, about 20 ml per gram of iron, and heat. The iron will dissolve as ferric chloride. One gram of iron will make 3 grams of ferric chloride. If there is any trace of blue or green color in the resultant solution, pass a stream of air through the solution for about ½ hour to oxidize all the iron to the +3 state. The correct solution color is yellow or brownish yellow. Then boil off most all the acid, until the steam no longer gives an acid reaction with pH paper. Some additional water may have to be added to get all the acid out during the boil down. Don't evaporate the liquid completely away, as overheated ferric chloride will decompose.

### **Method Two — From Methyl Iodide**

This method gives satisfying yields of very pure methylamine hydrochloride, but it requires that one have methyl iodide in addition to hexamethylenetetramine. The latter is easily made from formaldehyde and ammonium hydroxide. See *Home Workshop Explosives* in the RDX chapter for the recipe. An additional problem with this recipe is that about a week of reaction time is needed. That aside, it's very easily done and is recommended if the required materials are at hand.

To make methylamine hydrochloride by this method, dissolve 140 grams of hexamethylenetetramine in 1500 ml of 190 proof vodka. It will be necessary to heat the vodka in a hot water bath to get the hexamethylenetetramine to dissolve. As a result, one should choose a reaction vessel which isn't

## Advanced Techniques Of Clandestine Psychedelic & Amphetamine Manufacture

112

going to be infiltrated with the steam. A 2000 ml volumetric flask, or one gallon glass jug are good choices.

When the hexamine has dissolved, add 142 grams (63 ml) of methyl iodide. Stir this substance in well, then stopper the reaction flask and set it aside for about a week. During the course of this week, a crystalline precipitate will form. This crystalline precipitate should be completely finished forming at the end of one week standing.

Now a magnetic stir bar is placed in the reaction vessel and, with stirring, a stream of dry HCl gas is passed into the reaction solution. See *Secrets of Methamphetamine Manufacture*, Chapter Five for details of putting together your own dry HCl generator using salt and sulfuric acid. As the HCl passes into the reaction solution, the crystalline precipitate which had formed will dissolve, and new crystals of ammonium chloride will form. Continue passing dry HCl into the solution until the solution is saturated with HCl. This can be determined by drawing out a sample, and putting it in a beaker. If it wafts off white fume clouds of HCl, and smells very strongly of HCl, then it is saturated.

The mixture is next filtered to remove the ammonium chloride. The vodka filtrate contains about 50 grams of methylamine hydrochloride. It is recovered by boiling off almost all of the vodka under a vacuum. The resulting crystals of methylamine hydrochloride are then mixed with about 2 times their weight of 50% sodium hydroxide solution. (Caution! Mix slowly with ice bath cooling and lots of stirring to avoid losing product.) The resulting free base solution can be used as a source of methylamine by heating the mixture and piping the methylamine gas into a reaction solution. See Chapter Four of *Secrets of Methamphetamine Manufacture* for a typical glassware set up to do this. Alcohol chilled with an ice-salt bath will catch the stream of methylamine produced by this procedure. This alcohol solution of methyl-

*Chapter Fourteen*  
*"I Want Some Methylamine!"*

113

amine free base can then be used in reductive hydrogenation methods of producing MDMA or meth.

In other procedures, the methylamine hydrochloride can be used directly as is. For example, when using aluminum foil amalgamated with mercuric chloride as the reducer, one just adds the methylamine hydrochloride to the alcohol solution. Then about twice its weight of 50% sodium hydroxide solution is mixed in to give free base plus some salt and a little excess sodium hydroxide. The presence of both salt and some excess sodium hydroxide in the reaction mixture is helpful to the process.

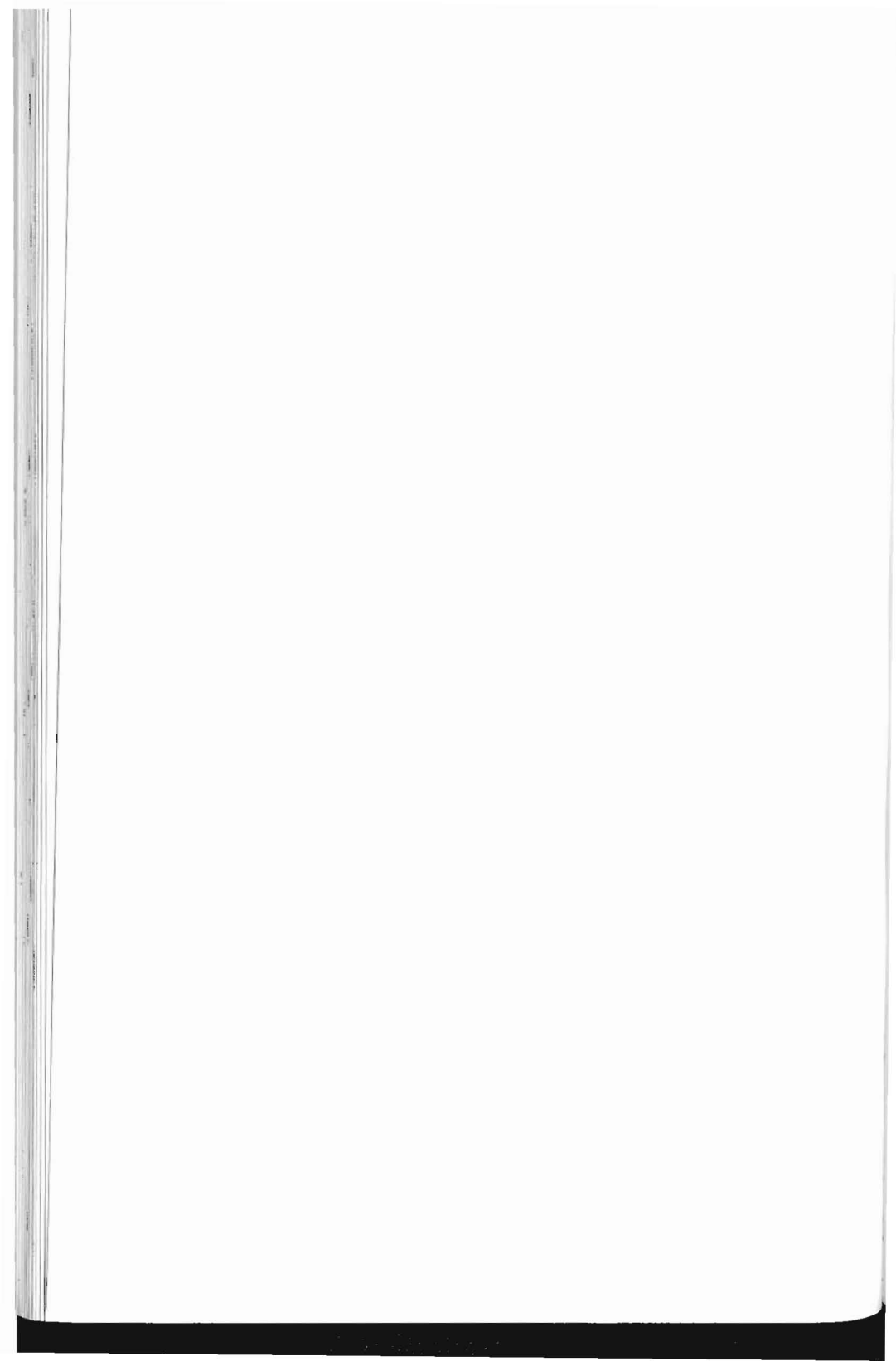

## **Chapter Fifteen**

# **Apartment Dweller's Crank Or X: A Convenient Tabletop Method**

**WARNING!** *The procedure as given in the scientific literature uses mercury metal as the cathode in this electric reduction procedure. If you've never done an organic synthesis, this is a bad one to start to learn with! The process is quite safe when done correctly, but be warned!*

The best procedure to use in the reductive alkylation of phenylacetone or methylenedioxyphenylacetone with methylamine to yield meth or MDMA respectively is catalytic reduction using platinum catalyst. The "poor man's hydrogenation device" described in this book is ideally suited to use in this reaction as it allows easy magnetic stirring of the reaction contents, easy attachment of a gas line from the hydrogen tank, has its own pressure gauge to monitor the course of the hydrogenation, and great strength under pressure.

For many of us, however, this apparatus is just too conspicuous. Meddling do-gooder neighbors, kids, wives, girlfriends and roommates just might wonder why you have a cylinder of hydrogen in the kitchen. They also might not believe excuses along the lines of "I like to play around with welding."



# Advanced Techniques Of Clandestine Psychedelic & Amphetamine Manufacture

116

For those of us who need a really inconspicuous reaction device that produces little or no waste to dispose of, electric reduction of the phenylacetone-methylamine mixture is made to order. The original research upon which this chapter is based can be found in *Synthesis*, pages 1005-7 (1987). In this paper, the authors did reductive alkylations with a wide variety of aldehydes and ketones, including the substituted phenylacetone which yields fenfluramine. They got a 90% yield of fenfluramine, and all the other reductions they did had similar excellent results. You can be sure that this procedure will work just as well with phenylacetone and methylenedioxyphenylacetone, or any other phenylacetone that one wishes to convert to a methylamphetamine.

The theory behind this procedure is simple enough. When methylamine is mixed with a phenylacetone, it will react to produce a Schiff's base. This is a reversible and equilibrium reaction. Formation of the Schiff's base is favored by using an excess of the methylamine, and hindered by the presence of water since water is produced when the methylamine combines with the phenylacetone. The Schiff's base can be selectively reduced, because it reduces at a lower applied voltage than the phenylacetone. By controlling the applied voltage, only the Schiff's base gets reduced, allowing complete conversion of the phenylacetone to the methylamphetamine.

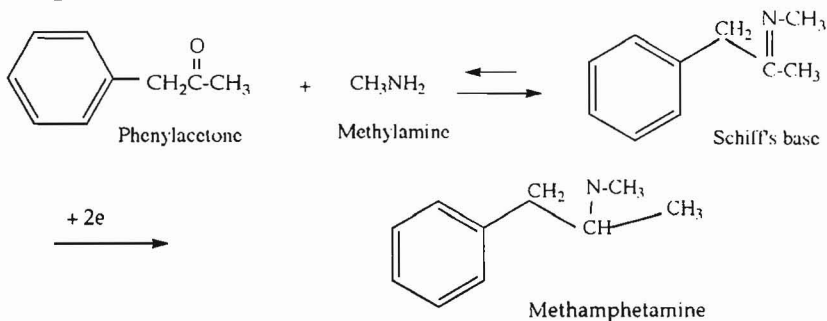

*Chapter Fifteen*  
*Apartment Dweller's Crank Or X:*  
*A Convenient Tabletop Method*

117

The researchers in the scientific paper cited earlier used a divided cell of the type illustrated in *Reductions in Organic Chemistry* by Hudlicky, page 25. If you have such a device, this will work fine. It's the aim of this book to substitute household items whenever possible, so I'll pass along what my investigations have shown on this matter. My investigation has shown that a regular beaker or other glass container can be used to do this reaction.

A 2000 ml beaker is placed on a tabletop, and enough liquid mercury metal is poured into the beaker to cover the bottom of the beaker to a depth of a few millimeters. Then into the beaker put 500 ml of 190 proof vodka. In my area, Ambur 190 Vodka produced by Ambur Distilled Products of Chicago is the only brand available. Talk to your friendly local liquor store about getting you some if none is on the shelf. Next add 130 ml of 40% methylamine in water and 250 ml of 3N hydrochloric acid (made by mixing one part 35% lab hydrochloric acid and 3 parts water). After stirring, the pH of the solution should be between 10 and 11. This is the desired range.

I know what you're saying here. "40% methylamine in water? Hah! I have to cook my own methylamine, and all the good methods give methylamine hydrochloride." Well, in that case, add to the vodka 100 grams of methylamine hydrochloride, 100 ml of strong ammonia solution (28%  $\text{NH}_3$ , 56%  $\text{NH}_4\text{OH}$ ) and 300-350 ml of water. This too should yield a solution with a pH of between 10-11. It's not acceptable to use sodium hydroxide to partially neutralize the methylamine hydrochloride because sodium in the solution would form sodium amalgam once the current is turned on, and this chemical reductant wouldn't have the selectivity of the electrical reduction. Finally add 13½ ml of phenylacetone or 18 ml of methylenedioxyphenylacetone, or .1 mole of any other substituted phenylacetone.

## Advanced Techniques Of Clandestine Psychedelic & Amphetamine Manufacture

118

Next run an insulated copper wire down the side of the beaker, and immerse the couple of millimeters of bare copper wire exposed from the insulation under the surface of the mercury. No bare copper wire should extend above the surface of the mercury. Run this wire lead to the negative or black pole of a DC transformer.

Next obtain a section of stainless steel rod about a foot long and at least ½-inch diameter. If it has sharp edges, sand them down. This is your anode. The guys who wrote the original paper used platinum, and if you have some laying around, that's fine. My experiments show a stainless steel rod will work with no problems. Make electric contact to the top of the stainless rod, and go with it to the plus or red pole of the DC transformer. An amp meter must be put in line on the wiring, and a voltage meter is a good idea, too.

Scrub up a Trojan Very Sensitive condom using detergent, and rinse it clean. Put that condom over the end of the stainless steel rod, immerse it in the solution until it's about ¾-inch short of reaching the mercury pool, then clamp it into place. The clamp should be insulated and it's best if it also holds up the condom. Then, using a pipette, squirt an anolyte solution made up from 100 ml 190 proof vodka, 20 ml strong ammonia solution, 10 ml of concentrated hydrochloric acid, and 50 ml water. Check the pH of this solution, it should be around 10 or so. Add this mixture inside the condom until the liquid level inside the condom equals the liquid level in the beaker. The set-up should look like the illustration on page 119:

*Chapter Fifteen*  
*Apartment Dweller's Crank Or X:*  
*A Convenient Tabletop Method*

119

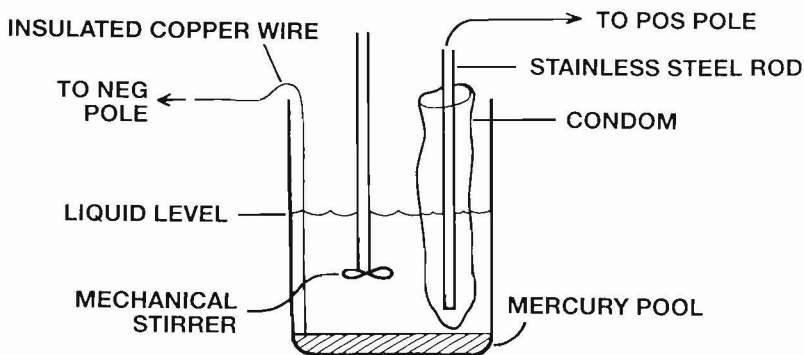

My experiments have shown that the Trojan Very Sensitive condom will stand up for hours to a solution made up of about half 190 proof vodka, one quarter water, and the other quarter made up of strong ammonia, half neutralized with hydrochloric acid. I passed current through this solution for hours with no damage to the condom. It took about 4 volts to break the insulation in this solution. Some of the stainless steel anode dissolved to form iron sludge and a yellow color to the anolyte from the chrome dissolving out of the stainless, but none of this made it through the condom into the catholyte. It is possible that methylamine may be more aggressive, but I kind of doubt it. If so, switch to one of those new polyurethane rubbers. I'm pretty sure that the 10-11 pH buffering takes most of the rubber dissolving punch out of the mixture.

To begin to do the reduction, first check the temperature of the catholyte solution. 10° C is the preferred temperature. Some heat will be produced when the methylamine combines with the phenylacetone, and some further heat will be produced during the passage of the current through the solu-

## Advanced Techniques Of Clandestine Psychedelic & Amphetamine Manufacture

120

tion. A cool water bath will maintain the desired temperature range.

The next thing the authors specify is to purge the catholyte with nitrogen, and presumably keep the solution blanketed with nitrogen during the course of the reduction. I don't know if this is really necessary. I've seen lots of examples of reductions done at a mercury cathode without using a nitrogen atmosphere. It may be that dissolved oxygen in the catholyte will get reduced to peroxide, and this side reaction will confuse the amperage flow calculation which determines how long to run the reduction. There is no harm in keeping the current on longer than needed. The drop in current flow at the completion of the reduction signals its end, and so long as the voltage isn't turned up, there is no danger of reducing the benzene ring. It's my opinion that the nitrogen can be skipped. If experimenters out there find out otherwise, nitrogen is easy to get at the welding shop. Some cellophane over the top of the beaker will keep it in. The condom holding the anolyte will produce a lot of oxygen, but it can be rigged like a smoke stack to vent outside the beaker. It's my belief that so long as the stirrer doesn't go so fast as to whip air into the solution, the little bit of oxygen dissolved in it to start with will be no problem. Stir slow enough that a whirlpool isn't formed to pull air into the mix.

Now start slow stirring, fast enough to keep the solution churning, but slow enough that no whirlpool forms. Then turn on the current source, and gradually increase the voltage. At about 3 or 4 volts, the insulative effect of the rubber will break, and current will start to flow. How much more to increase the voltage is the next topic to consider.

If one has a standard calomel electrode, then the mercury cathode pool is set -1.75 volts relative to the standard electrode. If you don't have such an electrode, graphing current flow versus applied voltage will make it clear where to set

*Chapter Fifteen*  
*Apartment Dweller's Crank Or X:*  
*A Convenient Tabletop Method*  
121

the voltage. A graph of current versus voltage should look like this in this system:

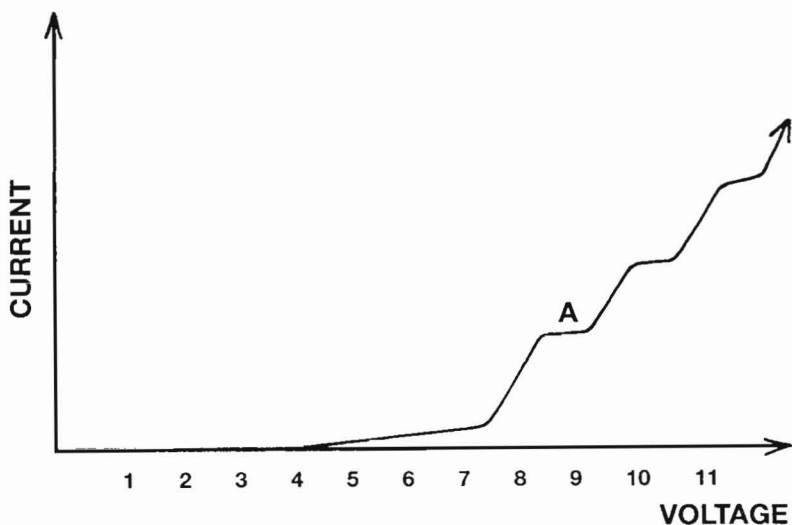

The first sharp increase in current with voltage is the reduction wave for the Schiff's base. With increasing voltage, waves are also seen for the reduction of the phenylacetone that's still floating around free in the solution, and for the reduction of the ammonium ion, the benzene ring, and so on. One should set the voltage at the crest of the first wave and leave it there. With a beaker of typical dimensions (i.e., neither an unusually tall and skinny beaker nor a short fat one) the current flow at the crest of the first wave on this size batch will be around  $\frac{1}{2}$  amp. The current reading will depend upon how much mercury surface is exposed to react, and the speed of stirring.

The current flow will remain pretty much steady for the first few hours, then start to drop as the concentration of Schiff's base left to be reduced falls. Continue the electrolysis until 19,600 amp-seconds have passed through the solution. At a constant current of  $\frac{1}{2}$  amp, that will take

## Advanced Techniques Of Clandestine Psychedelic & Amphetamine Manufacture

122

10.8 hours. With the drop off of current that occurs later on in this reduction, a total reduction time of over 12 hours is to be expected. The process is over when the current consumption drops to 20-30 milliamps.

To obtain the product, pour the catholyte into a large filtering flask or other container in which a vacuum can be applied to the liquid. The anolyte inside the condom can be thrown away, as can the condom. One run per rubber is plenty. Pour the mercury back into its bottle, and pour some water on top of it. This prevents mercury from evaporating into the air and contaminating its surroundings.

Next add 2N hydrochloric acid to the catholyte slowly with stirring until the pH of the catholyte reaches 1. Now apply a vacuum to the liquid, and boil out the alcohol. When the alcohol has evaporated away, pour the remaining liquid into a large sep funnel, and chill it down with ice. When it is cold, add a 20% by weight solution of lye dissolved in water, slowly, with shaking and then cooling between addition of portions of the lye solution. One wants to keep the solution cold so that all the unused methylamine can be recovered, and the heat of neutralization will send up plumes of methylamine if the solution isn't kept cold.

Continue adding lye until the pH of the solution gets up to around 14. pH paper is best for making this measurement. As the solution gets basic, the product will come out of solution as an oil which floats on top of the water. It should be light yellow colored. Since it floats on top, the best way to track the pH is to dribble a little water out of the bottom of the sep funnel and measure the pH of this, rather than sticking pH paper down through the oil layer. When the required pH has been reached, shake the sep funnel really hard for a few minutes to ensure that all the product salt has been free based. Allow the sep funnel to sit for a few minutes to let the oil float to the top, then check the pH again. If it's still OK,

*Chapter Fifteen*  
*Apartment Dweller's Crank Or X:*  
*A Convenient Tabletop Method*  
123

add about 50 ml of toluene, and shake to extract the product. Separate off and save the toluene solution. Extract again with another 50 ml portion of toluene. Combine the two toluene extracts. They should only have a very light tint. If they are dark colored, then distilling the product will be required. The guys who wrote the paper got a pure product without distilling.

Next sniff the toluene extract. It probably smells like methylamine and ammonia. To recover the methylamine, and to remove it from the product solution, get two bottles and rig up the bubbler shown below:

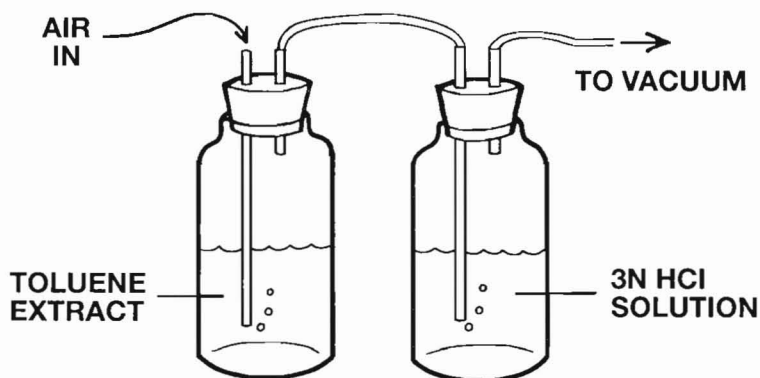

Put two-hole rubber stoppers in each bottle, and glass tubing as shown. By applying a vacuum at one end of the bubbler train, air gets pulled through the toluene extract contaminated with methylamine and ammonia. The air flushes it out, and it gets caught in the hydrochloric acid solution, forming the hydrochloride for reuse. Pull air through until you can't smell much of any methylamine or ammonia when you pull out the stopper from the toluene extract bottle.



## Advanced Techniques Of Clandestine Psychedelic & Amphetamine Manufacture

124

The product can now be obtained as the hydrochloride salt by pouring the extract into a beaker and bubbling dry HCl gas through the solution. The crystals are recovered by filtration, rinsing with fresh toluene, and air drying. This procedure is covered in detail in Chapter Five of *Secrets of Methamphetamine Manufacture*.

The biggest problem with this procedure is that it uses an inordinately large amount of methylamine, a 15 fold excess relative to the phenylacetone. Luckily, it is easy to recover the unreacted methylamine. If 40% methylamine was used, just pour the 3N HCl solution that was used to catch the methylamine in the solvent into the extracted reaction mixture. All the unused methylamine is now in one pot. Check its pH. If it isn't around 14 anymore, add more sodium hydroxide. Now the methylamine can be recovered as the hydrochloride by heating the solution to boil the methylamine out, and piping it into clean hydrochloric acid where it forms methylamine hydrochloride. Use the apparatus shown below:

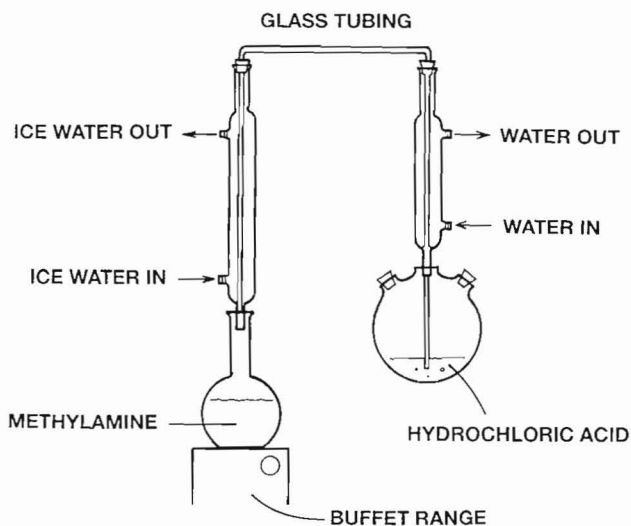

*Chapter Fifteen*  
*Apartment Dweller's Crank Or X:*  
*A Convenient Tabletop Method*  
125

This is done exactly the same way as boiling out methylamine and piping it into formic acid as described in Chapter Four of *Secrets of Methamphetamine Manufacture*. Cooling the hydrochloric acid solution with ice is a good idea, as a large amount of heat will be produced in the process. About 200 ml of concentrated hydrochloric acid in the receiving side is plenty to catch all the methylamine.

When all the methylamine is boiled into the hydrochloric acid, pour the captured methylamine hydrochloride solution into a large filtering flask or other vacuum container, and evaporate away the water and excess hydrochloric acid under a vacuum to get crystals of methylamine hydrochloride to use in the next batch.

If methylamine hydrochloride was used in the batch, and ammonia was used to raise the pH of the reaction solution to the 10-11 range, then a separation of the ammonia from the methylamine must be done prior to recycling. This is done by the hot vodka separation method used in the methylamine chapter. The extracted reaction mixture is made acid to about pH 1 with hydrochloric acid. The water is evaporated away under a vacuum to leave a crystalline mass of methylamine hydrochloride and ammonium chloride. This mass is extracted with hot 190 proof vodka as in the methylamine chapter. The filtered vodka extract is cooled in the freezer to give crystals of pure methylamine hydrochloride. These are filtered out, and the vodka returned to the crystalline mass for more heating, cooling, and filtering cycles until all the methylamine hydrochloride has been removed, leaving the ammonium chloride crystals, which don't dissolve in vodka.

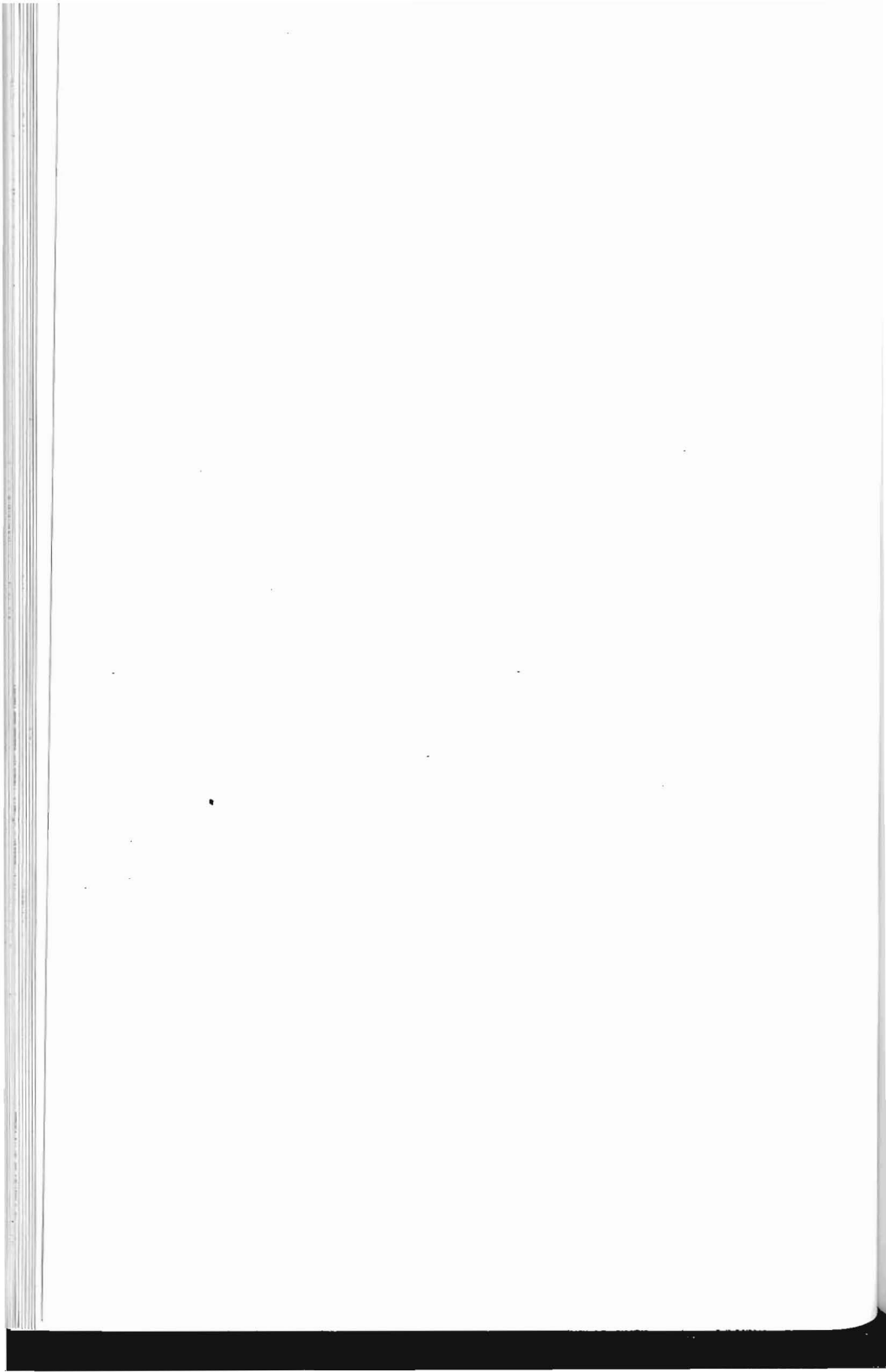

## Chapter Sixteen

### More Bromosafrole

In my books *Secrets of Methamphetamine Manufacture* and *Practical LSD Manufacture*, I detail an original recipe of mine for making bromosafrole, a useful precursor to MDA and MDMA, from sassafras oil and 48% HBr. From reading my e-mail, I see that some people are having problems recreating my original research. Sorry that I didn't immediately answer the e-mail. The narco swine now populate cyber space, and just carrying on a conversation with them will land you in the slam as part of their "conspiracy." Funny how conspiracies are ridiculed unless they want to charge you as being part of one. Then conspiracies are everyday matter of fact things. I read a story in *Hustler* about a guy doing 33 years for sharing twisted sexual fantasies with these on-line slugs, freedom of speech in the land of the free, huh?

Problems in doing this process stem from a small detail that I thought was of no consequence. I state in the directions that the sassafras oil and glacial acetic acid and 48% HBr are placed in an "appropriate size flask." Experience has shown that not just any flask will do.

The proper flask for doing the reaction in is an Ehrlenmeyer flask of a size chosen so that it will be nearly full when filled with the reactants. Into the Ehrlenmeyer flask put

## Advanced Techniques Of Clandestine Psychedelic & Amphetamine Manufacture

128

one volume of sassafras oil, one volume of glacial acetic acid, and two volumes of 48% HBr. Begin strong stirring, and pass a stream of dry HCl through the solution. The stream of HCl bubbles should be introduced at the bottom of the flask near the stirrer so that they are sucked into the vortex. The inward sloping walls of the Ehrlenmeyer flask act to slow the ascent of the bubbles, and provide a long column height of liquid for the bubbles to pass through. A plug of glass wool stuffed into the neck of the flask extending a few cm down into the solution will get even more play out of the HCl bubbles.

The drying of 48% HBr with dry HCl is a surface phenomenon on the HCl bubbles. Dry HCl will quickly absorb two molecules of water at least from the HBr solution. Some will also go into solution to raise the ionic strength of the solution. The time of contact of the bubbles with the reaction solution has been shown to be very important. If one's magnetic stirrer isn't strong enough to suck in and whip around the HCl bubbles, switch to a mechanical stirrer. Breaking up the bubbles greatly increases their surface area.

The amount of dry HCl produced from dripping about 100 ml of sulfuric acid onto a bed of salt moistened with hydrochloric acid is about enough to do a batch containing 50 ml of sassafras oil. The smell change of a sample, from candy shop sassafras oil to phenylacetone-like, is the indicator of enough HCl. Also take care that the ice bath keeps the reaction cooled to below 10° C.

### Method Two

An obvious fan who calls himself Pugsly has posted this method for making bromosafrole on the Internet, and it has been getting rave reviews from people trying it. It's very

*Chapter Sixteen*  
*More Bromosafrole*

129

simple to do, uses simple chemicals, and gets practically 100% yields. The practical up shot of this recipe is that the so-called pipe bomb method of making MDA and MDMA is now by far the clandestine choice. See *Practical LSD Manufacture* or *Secrets of Methamphetamine Manufacture* for details on doing the pipe bomb method. See also the chapter in this book for a convenient method of making ammonia saturated alcohol solution. The best alcohol to use in the pipe bomb method is isopropyl alcohol, of at least 91% strength, obtained at the drug store. Even better is ISO-HEET gas line de-icer, which is like 99% isopropyl alcohol. To get good results in the pipe bomb method, water should be kept out of the solution to the extent possible.

Now to details of the so-called DMSO method of making bromosafrole which Pugsly has posted. The scale given is just for example, it can be scaled up to any size desired. To 100 ml of ice cold DMSO (dimethylsulfoxide) add 7.8 ml of concentrated sulfuric acid. Mix this in well, then add 30 grams of sodium bromide, or 35 grams of potassium bromide. Both work, so use whichever is most easily obtained. Mix this solution up thoroughly. The solution will gradually turn orange colored, and crystals of sodium sulfate will form. Don't bother to filter them out, just let the process go. If the DMSO, sulfuric acid and NaBr were free of water, then the HBr formed will also be anhydrous. This is important to getting good results.

Next add 5 ml of sassafras oil, and stir it in well. Then allow the solution to warm up to room temperature. Over the course of a day or two the solution will progress through green color to purple and finally ending in a burgundy color, just as in the case of dehydrating 48% HBr with HCl gas. After a couple of days, dilute the solution with about 1000 ml of water. The bromosafrole product settles to the bottom. If you cool down the mixture, the bromosafrole becomes

## Advanced Techniques Of Clandestine Psychedelic & Amphetamine Manufacture

130

pretty sticky, so that the water and DMSO solution can just be poured off from the settled bromosafrole.

Now that's an easy recipe! Nothing stinky to give one's self away. The DMSO one could even find at a health food store or other places catering to alternative medicine. In any case it is a quite common industrial solvent. The sulfuric acid one can get from mail order chemical suppliers, as can the NaBr or KBr. Hobby shops and the local chemical "experimenters" shop can also be trusted to get these innocuous chemicals. This method is unstoppable! As to the ammonia needed to make the MDA from the bromosafrole, this too is safely ordered from the same outlets. If one doesn't want to do that, I'm told that Ace Hardware stocks a "Janitors Industrial Strength Ammonia" which is 28%  $\text{NH}_3$  or 56%  $\text{NH}_4\text{OH}$ . This can be used to make ammonia in alcohol solution by the simple method given in this book in the chapter of that title. If MDMA or "X" is desired, just use methylamine instead. See the procedures for making methylamine in this book, and in *Secrets of Methamphetamine Manufacture*. The free base of methylamine must be used, not methylamine hydrochloride. Methylamine can also be boiled out of solution and piped into alcohol to make the methylamine/alcohol solution by the procedures given in the *Secrets of Methamphetamine Manufacture*, and in this book.

For the best results, the bromosafrole made by this method should then be dissolved in some toluene, washed with bicarb solution, then distilled under a vacuum in the usual manner for bromosafrole. See *Secrets of Methamphetamine Manufacture* or *Practical LSD Manufacture*.

## Chapter Seventeen A Convenient Method For Making Ammonia Saturated Alcohol

One of the better methods of making MDA, MDMA, or other psychedelic amphetamines from commonly available essential oils is to react the allylbenzene found in the essential oil with hydrobromic acid to give the bromo derivative, and then heat the bromo derivative inside a steel pipe with an alcohol solution saturated with ammonia or methylamine to produce the amphetamine. To illustrate for MDA:

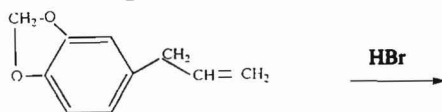

**Safrole**  
(80-90% of sassafras oil)

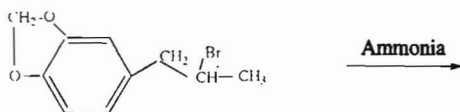

**Bromosafrole**

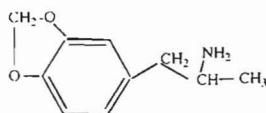

**MDA**



## Advanced Techniques Of Clandestine Psychedelic & Amphetamine Manufacture

132

See the Fourth Edition of *Secrets of Methamphetamine Manufacture* for a complete discussion of the ins and outs of doing this reaction sequence. Of particular value in that book is my own procedure for using the more commonly available 48% strength HBr to produce bromosafrole. Previously published procedures used exotic reagents like 70% HBr or HBr gas.

One of the more bothersome aspects of using this reaction sequence to make MDA is the downwind smell and labor involved in making alcohol saturated with ammonia. One can't simply take the 28% strength ammonium hydroxide so easily available and pour it into alcohol to get ammonia in alcohol. The 72% of water that this ammonium hydroxide contains interferes with the reaction, producing unwanted byproducts. To get good results, the amount of water in the mixture must be kept down.

In my previous books, I suggested two methods for getting reasonably dry ammonia solutions in alcohol. Method number one, which is still the best, is to get a cylinder of ammonia at the welding supply shop (for refrigeration uses). The cylinder of anhydrous ammonia can then be held upside down, and liquid ammonia run into the alcohol by cracking open the valve.

Suggested method number two, which I personally know to work well, is to pour some of the 28%  $\text{NH}_3$  or 56%  $\text{NH}_4\text{OH}$  into a round bottom flask, attach a reflux condenser to the flask and run cold water through it.

Then the ammonium hydroxide is heated to boil out the ammonia, and the vapors of ammonia which pour out the top of the condenser are piped into some alcohol. The alcohol must be cooled and rapidly stirred to catch most of the ammonia piped into it. Still, a lot escapes to create a stench

*Chapter Seventeen*  
*A Convenient Method For Making*  
*Ammonia Saturated Alcohol*

133

which may cause unwelcome attention. Also a couple hours of labor are required to make a few hundred mls of ammonia saturated alcohol.

A correspondent has written with his improved method for making alcohol saturated with ammonia. Virtually no labor is involved, and grocery store equipment is used. I haven't personally tried it, but it looks really good, and should produce an alcohol product that has very little added water.

My correspondent starts with a one gallon pickle jar or other similar glass container with a wide top. After dumping out the pickles and cleaning everything up, the jar is placed on a flat surface, and a one pint mayonnaise jar or similar container is placed inside the jar. It is filled with strong ammonia solution (28%  $\text{NH}_3$ , 56%  $\text{NH}_4\text{OH}$ ). Then in the space around the smaller jar inside the jug, put about a pint of alcohol. Then close the lid on the pickle jar.

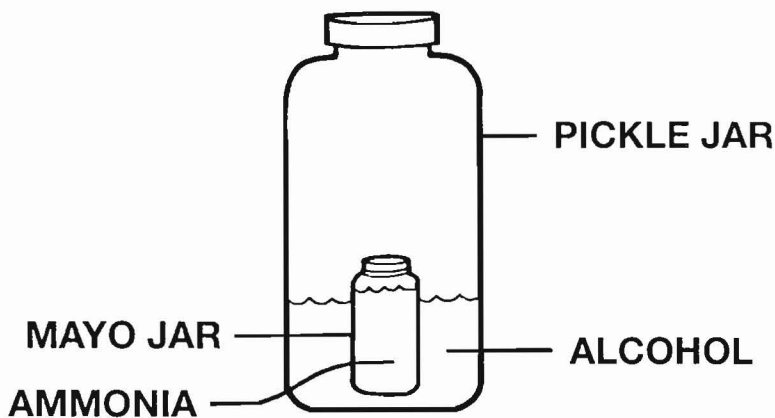

In a day or two, the ammonia vapors work their way into the alcohol to the point where the two solutions reach equal concentrations, about 15%, which is about the saturation

## **Advanced Techniques Of Clandestine Psychedelic & Amphetamine Manufacture**

134

point for alcohol. Then the mayo jar and its ammonia is removed, and the saturated alcohol is poured into a champagne bottle with a plastic stopper. It can be kept there until it is used.

*Chapter Eighteen*  
*“War Stories From The Pen”*

135

**Chapter Eighteen**  
**“War Stories From The Pen”**

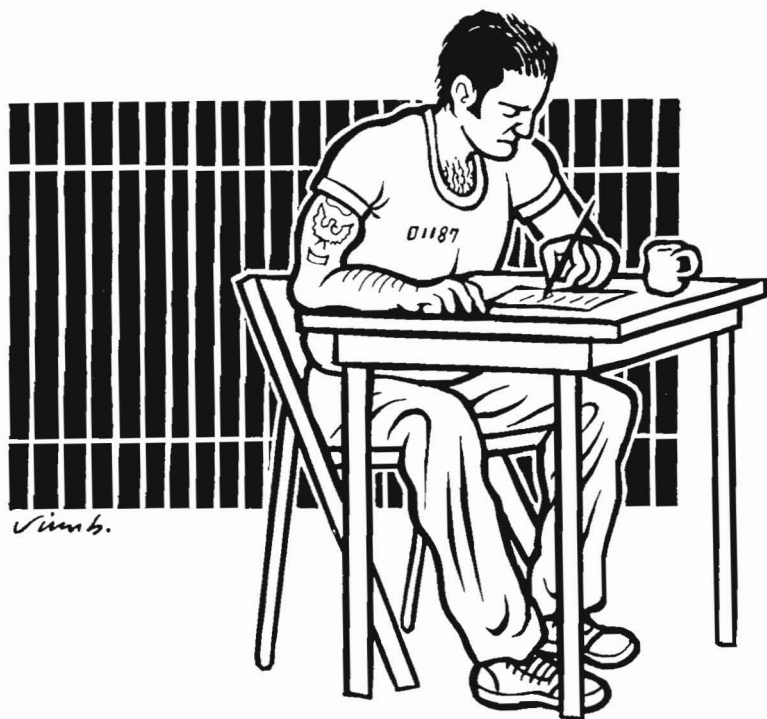

## Advanced Techniques Of Clandestine Psychedelic & Amphetamine Manufacture

136

June 14, 1997

Dear Fester,

Greetings once again. I trust you're doing well and taking advantage of this spring weather. I thoroughly enjoyed your correspondence and admire your ability to tackle yet another book. But I hope you're not thinking of abandoning a future edition of *Secrets of Methamphetamine Manufacture* that I just happen to be looking forward to. You know, questions are always popping up in my head when I read about this subject. But your Fourth edition answered each of these, and what was left to my imagination was sufficiently alluded to, to allow me to quickly locate the answers.

You were so generous in sharing your knowledge that I might comment that the second aspect of successful manufactures (that being enjoying it too without apprehension), may have been under emphasized a bit, although I realize the central focus of your book is on how the labs produce their product. And I commend you on your ventures to inform us readers how the chemist avoids detection as much as you did. But I can't help wondering if your readers don't need a fuller picture of this subject. After all, cooking the cake in a kitchen full of heat is only half the story, isn't it? As interesting as the subject is, I understand that few master the art of secrecy to survive these temperatures. And, believe me, in today's world, secrecy is definitely an art.

If I may, I'd like to share a couple of friends' stories along these lines, and suggest some information that your readers may find valuable. Although some of this information may not be news to some of your readers, it may be very informative to the others.

In 1991 Fred and his buddies manned their vehicles for a trip to Louisiana. They had heard somewhere that phenyl-acetic acid was freely and legally sold there. Fred's buddy

*Chapter Eighteen*  
*"War Stories From The Pen"*

137

had called to ensure the items they wanted were in stock. He had told the chemical supply representative he needed ten pounds of sodium acetate, twenty pounds of phenylacetic acid and fifteen thousand milliliters of acetic anhydride. The man advised that this was no problem, and advised the items would be available when he was ready to pick them up. The plan was that Fred and his buddies would wait at a nearby supermarket parking lot while one went on to retrieve the chemicals. There was no sense in everyone being subjected to the ordeal. They all (I'm a Texan) pitched in their money and waited just as planned once they were within a few blocks of the chemical supply company. And the selected pick-up man soon returned to open his trunk, and demonstrate he'd got the stuff, and everything was all right. Well, least wise it seemed that way until the DEA showed up and placed them all under arrest.

What is quite evident here is that a ratio of four parts phenylacetic acid, three parts acetic anhydride and two parts sodium acetate combine to make phenylactone, a controlled substance that is useless, except to make methamphetamine or amphetamine. Furthermore, in 1991, if there was one hot chemical on the fed's chemical watch list, it was phenylacetic acid. Fred is now working on the latter part of a ten year sentence without possibility of parole in the federal penitentiary. He is an intelligent man, but he lacked experience and appropriate advise. His story illustrates the importance of caution when dealing with chemicals associated with amphetamine manufactures.

Russell had always been known to me as "Peewee." I was one of his best friends, and he, one of mine. During 1986 to 1989 he lived in a big nice house on a large plot of lake front property, carried thousand of dollars around in his pockets, and was living the high life. He and a knowledgeable buddy had successfully manufactured and sold many pounds of

## Advanced Techniques Of Clandestine Psychedelic & Amphetamine Manufacture

138

methamphetamine during these years. Peewee told me he owed this success to the fact that only he and his partner knew exactly how he had come across the speed. In 1992 Peewee discovered he was dying of a rare hereditary disease. He located his partner with the intention of leaving his small children some money. About this time, a young lady friend mentioned an advertisement she had noticed while in Seattle, Washington. The company offered chemicals in bulk at sale price. Peewee called the phone number and arranged to purchase a fifty-five gallon drum of acetone. Peewee told me that he and his partner didn't get far before the DEA was all over them.

Although acetone is not on the precursor watch list, it is classified as an essential chemical on the fed's List II chemical watch list. But it's also widely used as a paint solvent. K-Mart stocks it in one gallon pails for this purpose. Peewee was questioned on why he would drive from Texas to Seattle to purchase this chemical while he had a former record for methamphetamine possession. He was jailed without bond, given these circumstances. He related to me that his attorney had told him that the prosecutor probably couldn't convince a jury that this drum of paint thinner was intended for manufacturing drugs. And the prosecution had offered a one year sentence to support this conclusion. If only Peewee would plead guilty, that is. Months passed in the county jail while he awaited his trial. Peewee told me he just decided he'd take the year and get it over with, under the circumstances.

Like Fred, who had ordered a forbidden chemical without extensive planning, Peewee had failed to inquire at some of the surrounding businesses to see how long this company had been in operation. And then, too, the company wasn't recommended by any reasonably reliable source. So Peewee became a small fish caught in a common sting operation set

*Chapter Eighteen*  
*"War Stories From The Pen"*

139

up by DEA. (Under most conditions his purchase would not have been questioned.) Unfortunately, Peewee left us just three months after his release.

As you are aware, the watch list (as it is sometimes referred to) is a federal law that lists two sets of chemicals, one called precursor or List I chemicals, and the other called essential or List II chemicals. If a person simply purchases a chemical outside those listed in the list of chemicals, a grand jury indictment cannot be issued, unless there is more evidence of the purchaser's intent to use it for illegal manufacturing. This would be true even if the person has drug distribution, possession, or even one conviction for manufacturing on his record. And no one is ever required to give his intention for possessing or purchasing any chemical (including chemicals listed), that is, except to a jury in a losing trial. On the other hand, to obtain a conviction in a trial for purchasing or possessing a listed chemical with illegal intent to manufacture, the government must overcome the burden that there is some legitimate use of the chemical for the person who purchased it, or that the illegitimacy of its use was unknown.

Similarly, to obtain a conviction under the law for what the government calls "attempted manufacturing" (as opposed to listed chemical purchases or possession), the prosecution must establish that no legitimate use existed when the chemical was purchased, and that a substantial step was taken towards attempting a manufacture. Since possessing or purchasing most any chemical with the intent to manufacture is considered a substantial step under current federal law, it seems pretty obvious to me that the government's listed chemical laws mean little in the prosecution of clandestine manufactures in all but rare circumstances.

The law does, however, serve as an instruction to those companies dealing in listed chemicals, that they are principal components of, and used in, manufacturing illegal drugs.



## Advanced Techniques Of Clandestine Psychedelic & Amphetamine Manufacture

140

Title 21 USC §830(b)(1) and 21 CFR §1310.05 direct the vendors of these chemicals to make verbal contact with the DEA division covering its area, quote, "at the earliest practical opportunity after the [company] becomes aware... (and before the transaction concludes, if possible) of... any transaction involving an extraordinary quantity of listed chemical, an uncommon method of payment or delivery, or any other circumstance that the [company] believes may indicate," unquote, the listed chemical will be used unlawfully to manufacture a drug. This section in the law is followed by an assurance that all information disclosed will remain confidential and the Justice Department may furnish additional information to the company dealing in List I chemicals on these circumstances.

The listed chemical laws require these companies to verify business entities (i.e., checking the phone book, credit bureau, Chamber of Commerce, etc.), or a new representative's status with the firm, if he orders a listed chemical. On the other hand, all customers (including individual and cash customers), who purchase quantitatively or cumulatively per month amounts equaling or more than the following:

### List I Chemicals:

2 lbs.	Phenylacetic acid
Any amount of	Ephedrine (400 tablets in tablet form)
2 lbs.	Pseudoephedrine
5 lbs.	Phenylpropanolamine
2 lbs.	Methylamine
1 liter	Hydroiodic acid (Hydrogen Iodine)
2 lbs.	Benzylcyanide
2 lbs.	Ethylephedrine

*Chapter Eighteen*  
*"War Stories From The Pen"*

141

2 lbs.	Methylephedrine
2 lbs.	Methylpseudoephedrine
Any amount of	Racephedrine
5 lbs.	Norpseudoephedrine
1 gram	Propionic Anhydride
Any amount of	Benzaldehyde*
Any amount of	Nitroethane*

\* (Fester's Note: Last I heard the threshold was a few kilos for these.)

**List II Chemicals:**

250 gallons	Acetic Anhydride
110 lbs.	Potassium Permanganate
50 gallons	Methyl Ethyl Ketone (M.E.K.) (Non-domestic sales, quantitative only)
2 lbs.	Benzyl chloride
50 gallons	Ethyl ether
50 gallons	Acetone (Non-domestic sales, quantitative only)
50 gallons	Toluene (Non-domestic sales, quantitative only)

must provide a drivers license and one other form of identification, a signature, business or other address and phone number. New chemicals can be added to these lists on a monthly basis, if they so desire. The listed chemicals that could be used in a speed cook, as of the spring of 1997, are as listed above. Not included here are other listed chemicals pertinent to other illegal drug manufactures. Similarly, each state may have its own set of listed chemicals, which may include the same or different chemicals. These usually can

## Advanced Techniques Of Clandestine Psychedelic & Amphetamine Manufacture

142

be located in the states' penal code law book available at your university law library, and at some public libraries. The federal and most state laws on listed chemicals do not apply to listed chemicals classified and marketed in products under the federal Food, Drug and Cosmetic Act (Title 21 USC §301 et. seq.), except where ephedrine and pseudoephedrine are sold as the sole active ingredient in the product. A possible exception to this may be if the product is formulated in such a way that extraction of the listed chemical would be deterred, subject to approval by the Attorney General.

It appears that companies which do not deal in List I chemicals are more relaxed, because the listed chemical laws (specifically Title 21 USC §822, §823(h) and 21 CFR 1310.03) require companies dealing in a List I chemical to register with the Attorney General for a license, which subjects them to D.E.A. inspection at any time (21 USC §822(f), §880, and 21 CFR §1310.04), more particularly, inspection of their required record keeping. See *infra*. Furthermore, such a company can only be issued a registration license upon meeting what the government refers to as "maintenance... of effective controls against diversion" of the listed chemicals for illegal use. (21 USC §823(h)(1). The company must also maintain a record of any transaction involving any previously mentioned "threshold quantities" of List I chemicals, the purchaser's name, address, phone number, the name and quantity of the chemical, and method of transfer (i.e., truck, delivery truck, customer pick-up, etc.).

Listed chemicals are not all taboo from purchase by the clandestine chemist, particularly, List II chemicals. They are legitimately purchased and used every day. Some attract intense curiosity, while others are so commonly used that no company could be accused of recklessly maintaining ineffective controls against diversion into clandestine manufacturers' hands, so long as the purchases are fashioned within

*Chapter Eighteen*  
*"War Stories From The Pen"*

143

the mainstream of usual business. The former would include phenylacetic acid (although small quantities are used in floral scents and perfumes), the synthetic ephedrine and phenylpropanolamine (predominately used in commercial production of medications), while the later would include toluene (a fast enamel reducer), acetone (a general paint thinner), ethyl ether (a janitorial special cleaner and organic solvent), nitroethane (a solvent for vinyl chloride thermoplastic used for protective coatings on metal, wood and numerous other materials), and to a certain extent benzyl chloride (an organic solvent in perfumes, disinfectants, etc., when mixed 1 pound per 10 gallon of ethyl alcohol). Note that the uses for the chemicals I've given here are by no means exhausted. Most technical grade benzaldehyde is not controlled, as it is exempted under the Food, Drug and Cosmetic Act as a food ingredient.

In addition to the federal and state listed chemicals, there are chemicals that are not listed, but which can attract just as much attention when purchased. These are chemicals that by their very chemical nature (structure) are so closely related to amphetamine, methamphetamine, or other illegal drugs that any person moderately educated in chemistry could easily recognize a non-corporate purchase as highly unusual. Most chemical supply personnel are moderately educated in chemistry. Just a few examples of these would be:

Chloroephedrine

Bromoephedrine

Phenylacetaldehyde

2-Chloro-1-Phenyl-Propane

Chloroacetone

1-Phenyl-2-Hydroxy-Propane

## Advanced Techniques Of Clandestine Psychedelic & Amphetamine Manufacture

144

I'm sure you have some more you wouldn't feel comfortable purchasing.

Chemical suppliers are most comfortable with company checks, and loading delivery service or rented trucks and vans. A truck bearing home fumigation advertisements or other such business emblems works fine, too. In so far as, "unextraordinary quantities" are concerned, and the amount requested usually fits the purpose for which the product will be used. Very often the quantities offered for sale reflect the chemical's common use. For instance, chromic acid used to oxidize ephedrine to methcathinone is sold in 110-lb. drums (approx. \$210.00) for chrome plating, or in hundred gram plastic bottles, which are used commonly for chemical synthesis. Liquid ammonia, used as a solvent in ephedrine reduction to methamphetamine, may be sold in large tanks for farm fertilization, but it's sold used in small cylinders as a refrigeration medium in gas-flame refrigerators. A picture taken of oneself that just happened to catch components of a faulty refrigerator being converted over to gas flame operation would be very convincing to a jury on the issue of one's intent in purchasing cylinders of liquid ammonia. So would a library receipt that shows one had checked out a book on the subject.

You might ask how the government ever gets a conviction, if proving a multi-purpose chemical was intended for clandestine manufacture is the benchmark for the prosecutor to prove a man guilty. Well, what they are experts at is getting that small added extra piece of evidence that tips the scales to convince the jury.

Allen was a successful manufacturer of amphetamine for years. So much so, it had won him a new country home, new trucks and cars, and other fine things of life. Phenylacetic acid had not been placed on the listed chemical list, and associated as it is today, with speed cooks. One day he had se-

*Chapter Eighteen*  
*"War Stories From The Pen"*

145

cured a supply of acetic anhydride, sodium acetate, and mercuric chloride and was almost ready to cook a few pounds. In 1989 the name ethyl ether, and its aroma, was probably more associated with amphetamine manufactures than phenylacetic acid. Ethyl ether and phenylacetic acid were ingredients in Allen's formula. After work an employee recommended Allen call an individual in Dallas, Texas, who would gladly pick up a 110-pound barrel of phenylacetic acid, and twenty five gallons of ether, and deliver it where he wanted it. After thinking the matter over, Allen advised his employee to have the chemicals delivered to an associate he had in Dallas.

The next morning, the person recommended by Allen's employee went to D.F.W. Chemical Supply and picked up a drum of phenylacetic. They didn't have any ether in stock, and told him he might check back the following day. He then delivered the phenylacetic to Allen's man, J.D. (as he was called), who instructed him to put it in the back of his pickup parked in his drive.

The following morning this person returned to D.F.W. Chemical Supply to check if the company had the ether he needed. He entered the business, but they didn't have it, and he left to check elsewhere. But on this day, Department of Public Safety Narcotic Service agents were watching the business. They watched our man go in and come out. They then followed him to B-J Chemical Company, where he purchased five five-gallon cans of ether, and then drove to where J.D. worked to notify him he had the other chemicals. While he was in J.D.'s place of employment, narcotic agents walked through the parking lot to observe the green ether cans in the back of the pickup. Agents then followed the truck to J.D.'s house, where it was unloaded in the back of J.D.'s truck (where the barrel of phenylacetic acid was located from the previous day). Allen had paid well for these chemicals: one pound of high grade amphetamine, plus the

## Advanced Techniques Of Clandestine Psychedelic & Amphetamine Manufacture

146

cost of the chemicals. The unnamed person then went his way after leaving J.D.'s. Surveillance was then focused on J.D.'s white and red pickup truck located in his driveway. In the agents' application for the search warrant that was later issued, agents said they had observed a blue container, the type commonly used to house 110 pounds of phenylacetic acid. Later that evening, J.D. arrived home and put three empty five-gallon paint buckets and some trash bags in the back of his truck. Narcotics agents had established a four car drive-by surveillance. J.D. then drove the truck (with chemicals) out of town to an old barn. Agents said the acid drum was clearly visible while in transit. At the barn, J.D. sifted the phenylacetic acid, looking for a small tracking device, and poured the ether in five-gallon gas cans. The company containers were discarded to destroy any tracking devices that might have been in them. J.D. then returned home for the night. But agents had noticed the chemicals were not in the back of the truck anymore. J.D. had put the acid in five-gallon paint buckets. The narcotics agents suspected J.D. had switched containers, a common practice to elude tracking devices, they thought. The agents then decided to call in a patrol car to do a license check on the truck. The patrolman advised the agents that the truck was carrying several gas cans and three five-gallon paint buckets, which appeared to be full. J.D. continued to his house, unaware of the trick just pulled on him. Agents then began to suspect J.D. was manufacturing at his house. He had removed the chemical containers to the attached garage of his home. Plans were in full swing to secure a search warrant, by way of carphone, when J.D. emerged from his garage to load the chemicals in the back of a another truck belonging to an individual who had just arrived at the residence.

J.D. and the other gentleman then left with the chemicals to the highway, which would take them to Allen's country

*Chapter Eighteen*  
*"War Stories From The Pen"*

147

home in Oklahoma. At this time the narcotics rats were hot on J.D.'s tail. A six rat surveillance was established for the highway journey, and a helicopter was called to join in. On the ground one unmarked followed along for awhile, then a second undercover (following the first) would move up in his place. Once Allen's house was under surveillance, they observed Allen and his associate twice going to a mini-storage building and loading boxes that resembled the kind that might hold condensers and glassware. The rest of Allen's story is fairly obvious. He had thought that since he hadn't been connected to the chemical purchases and someone else had handled it, he wouldn't catch any heat. Allen was arrested under a search warrant with an operational lab in his garage.

At this time Allen was in his fifties. He is now doing 20 years in federal prison, another victim of the governments' drug war.

I told you Allen's story to emphasize these narco rat creatures are not without habit. It's not unlike a fishing expedition to them. When they become aware of a fishing hole, they'll fish from the bush. And when the fish nibbles on the bait, they don't mind it at all. But when they think the cork has reached its destination, they sink the hook, because they have learned that the fish are eating the bait at this time. Successful manufacturers know that companies selling List I chemicals are fishing holes for the DEA from time to time. Most successful manufacturers only purchase one ingredient at a time (that is, one ingredient a government chemist could tie to the manufacture). And purchases are spread out among different chemical supply companies. Of great importance is that the chemical be put in what I call a "cooling-off period." The manufacturer's home (and any related areas that DEA may associate or suspect in the event of an investigation) are cleared free of all incriminating evidence. This includes the



## Advanced Techniques Of Clandestine Psychedelic & Amphetamine Manufacture

148

cooling-off area where the chemical will be delivered to and stored for more than ten days.

Although DEA will not seize evidence it turns up indicating legitimate use of the chemical, the chemist's planting of such evidence would be very valuable in case of standing trial. Recall the casual picture of the chemist and the liquid ammonia refrigerator components that happened to be in the picture. Another example would be to have a project started in which the chemical purchased plays a part. Witnesses from before the purchase of the chemical sent to describe this project while a suspect is awaiting a release hearing are very valuable. This is just a matter of staying one step ahead in a game (excuse me, this isn't a game) where the price of mistakes is high. A successful manufacturer will remove any identification of the place where the chemical was purchased from the packaging or bottle to keep his source secret. Otherwise, detectives will check this company's business records and phone records, which will result in a higher sentence and evidence the government needs to convict. The chemical and its packaging may be thoroughly checked for a small tracking device a few days after the chemical is placed in the cooling-off area. Taking packages and containers to a secluded public dumpster within a few hours of purchase is considered a common tactic to avoid detection by DEA, and it will be presented to a jury that way. It also helps the DEA to convince a judge to issue a search warrant. During the cooling-off period, agents have been known to place a tracking device in a stored chemical or its packaging, where there was none before. They may also place a triggering device in an entry or elsewhere to signal the chemical's movement. The manufacturer checks for these before removing the chemical from its cooling-off period.

In Allen's story, ether was associated with clandestine manufactures, but the status of a chemical to a given manu-

*Chapter Eighteen*  
*"War Stories From The Pen"*

149

facture is no reason to disregard precautionary measures. The cards played following any type of chemical purchase make or break a manufacturer. A good example is the purchase of lye just after a chemical associated to clandestine manufactures has been purchased or received in the mail. Companies which deal in mail-order ephedrine tablets are sometimes monitored by DEA (usually for unusual orders of ephedrine tablets or large quantities). The prosecution will put any number of its army of DEA agents involved in the surveillance, or search warrant execution, on the stand, one by one, who will each testify, "lye Drano is an essential component in the manufacture process." Then any witness to the Drano purchase will take the stand to testify that the defendant purchased lye Drano. A very convincing piece of evidence.

Another common habit of these shit-eating dogs was mentioned in Allen's story. They will enter a parking lot or public area, and casually look in the truck or car to see if the chemical has or hasn't been dropped off at a previous stop made during the surveillance. Not mentioned in Allen's story is the agent's common tactic of entering a public business or store to observe the actions of the person followed.

A little subterfuge may be employed to confuse those conducting surveillances. Had Allen's man sent a truck out with the chemical containers full of sand, agents probably would have dropped surveillance on a second vehicle leaving a few hours later to tend to life's usual business. One individual I know even went so far (and rightly so) as to purchase three drums of phenylacetic acid shortly after its placement in the listed chemical laws, and removed all the acid, except ten pounds in each drum. He then set the drums on fire in a small shed where he silk-screened rose-printed T-shirts and scented them with perfume made from the phenylacetic (you could wash the shirt and the scent wouldn't wash away). When the fire department and DEA arrived, they all said,

## Advanced Techniques Of Clandestine Psychedelic & Amphetamine Manufacture

150

"Yah, it's all burned-up, 'cause here is the residue." Thirty pounds, a valuable quantity, but a small price to pay, considering the stakes.

For those who have never been witness to the DEA's execution of a search warrant, it's a little more shocking than on television, especially for women or children. The victims of such raids are usually casually watching TV, cooking supper, or tending to other family activities, when suddenly the front door is thrust open. An army of men dressed in masks, body armor, and army fatigues rush in with guns leveled at the occupants. They shout for everyone to hit the floor. Those still standing a few terrifying seconds later are quickly smashed to the floor, face down. Handcuffs are then put on the arms of the adults behind their back, and they are yanked to their feet. Those that appear the weakest are immediately separated from the others, hustled to a separate room where they are advised to cooperate, and left to think about it awhile. A few minutes later agents begin intense interrogation. Agents will advise the person he or she has a right to have an attorney present before or during any questioning, but because most people haven't been told that these rights mean something more than just a phrase that's repeated when someone is arrested, they simply ignore this protection. Once a person has asked to speak with an attorney, these rats, by law, shouldn't ask any further questions concerning their investigation (unless the person in custody voluntarily raises a subject). And if they do continue with their questions, the answers can usually be suppressed during any trial, along with any other resulting evidence. Other agents will then split up in the residence and the property to search for items that must be listed on the search warrant. They may pour dog food out on the floor, overturn beds, rip children's toys apart, chuck books out of their bookcase, and so on. Those who realize that evidence may have been dis-

*Chapter Eighteen*  
*"War Stories From The Pen"*

151

covered will begin to worry that they may be taken to jail. Indeed, one of the chief concerns of these rats may become their realization that they could find neither an operating lab, nor evidence that the chemical purchased was intended for manufacturing amphetamine. The agents will become focused more on the information in the minds of those before them, since they are well aware that their mission is about to end without something more than a simple chemical purchase. It may well mean a monetary civil lawsuit in federal court for illegal search and seizure against the agents. A simple complaint form is available by writing the clerk of court at your nearest federal courthouse, or by contacting an attorney. I'm going to skip the subjects of undercover drug buys, and information discovered by local police while nosing through stopped vehicles, and discuss the penalties for manufacturing and distribution of meth and amphetamine, if you'll bear with me.

Many will be surprised to know that it's the amount of drugs involved in the entire crime that determines the sentence, in all but simple possession convictions. In 1984, Reagan declared war on drugs. Since then, nationwide propaganda has fueled the war on to what it is today. The government did away with parole in its prisons, and all sentences after November 1, 1987, are without possibility of parole. Eighty-five percent of the prison term is now required (with good time included) before a release is possible. In 1986-1987 the federal government began relieving the states of the burden of prosecuting drug-related cases. Eighty percent of all prisoners currently in federal prison are in on drug charges. As of today, the feds handle the vast majority of manufacturing and distribution prosecutions nationwide. Also, in 1987 the government devised a law book known as the *Federal Sentencing Guideline Manual*. It controls the length of each sentence for each federal

## Advanced Techniques Of Clandestine Psychedelic & Amphetamine Manufacture

152

crime. Sentences for all drug offenses (except simple possession) are determined by a chart located at the back of the book. Even more surprising is that it's not the amount of drugs seized making the determination, but the amount that the prosecutor can establish, by the lightest of light standards, to have been involved at any time before and leading up to the arrest. This means any old junkie off the streets testifying to the amount manufactured or sold will do. If the manufacturer's source of chemicals is discovered, then they will be estimated to produce a quantity of drugs (usually the most that can be squeezed out thereof), by the court. Chemical supply companies' or other sources' records of sales will surface as evidence of the amount of drugs involved during the life of the crime. Even the quantity of drugs that could have been produced from an empty chemical container will be used. And the possibilities go on. A simplified version of the chart the judge uses to calculate the sentence is provided on the next page. Note also that a person's past criminal history also plays a role in the ultimate sentence.

If one has one prior conviction (state or federal) for distribution or manufacturing (as opposed to simple possession), the five and ten year sentences in brackets are doubled. These are called mandatory minimums. See Title 21 USC §841. If the person has two prior convictions for distribution or manufacturing, the sentence will automatically be life imprisonment without chance of parole.

Recall that intent to use a chemical purchased or possessed for manufacturing purposes is considered an attempted manufacture under current federal law. Under the penalties of this chart, an attempted manufacture carries the same sentence as if the manufacture had been completed. Also, distribution of a manufactured drug carries the same sentence. In other words, if you intended to do it, you attempted to do it. And if you attempted to do it, you did it! And if you

## Chapter Eighteen "War Stories From The Pen"

153

manufactured it, man, you might as well have sold it, too, because the sentence is going to be the same. This is how our wonderful government is now operating.

### CRIMINAL HISTORY (RECORD)

DRUG QUANTITY	No Criminal History	1 Misdemeanor OR 1 Felony	2 Misdemeanor OR 1 Misdemeanor & 1 Felony
Methamphetamine 5 grams to 9.9 grams	1yr 4mo-1yr 9mo	1yr 6mo-2yrs	1yr 9mo-2yr 3mo
Amphetamine 5 grams to 3/4 oz	1yr -1yr 4mo	1yr 2mo-1yr 6mo	1yr 4mo-1yr 9mo
Methamphetamine 10 gms to 3/4 oz	[5 years]	[5 years]	[5 years]
Amphetamine 3/4 oz to 2 1/4 oz	1yr 4mo-2yr 3mo	1yr 6mo-2yr 6mo	1yr 9mo-2yr 9mo
Methamphetamine 3/4 oz to 2 1/4 oz	[5 years]	[5 years]	[5 years]
Amphetamine 2 1/4 to 3 oz	2yr 3mo-2yr 3mo	2yr 6mo-2yr 6mo	2yr 9mo-2yr 9mo
Methamphetamine 2 1/4 to 3 oz	[10 years]	[10 years]	[10 years]
Amphetamine 3 oz to 7/8 lb	2yr 3mo-4yr 3mo	2yr 6mo-4yr 9mo	2yr 9mo-5yr 3mo
Methamphetamine 3 oz to 7/8 lb	[10 years]	[10 years]	[10 years]
Amphetamine 7/8 lb to 2 lbs	4yr 3mo-6yr 6mo	4yr 9mo-7yr 3mo	5yr 3mo-8yr 1mo
Methamphetamine 7/8 lb to 2 lbs	[10 years]	10yr-11yr 3mo	10yr-11yr 9mo
Amphetamine 2 lb to 20 lbs	6yr 6mo-15yr 6mo	7yr 3mo-17yr 6mo	8yr 1mo-19yr 7mo
Methamphetamine 2 lb to 20 lbs	10yr-14yr 3mo	11yr 3mo-16yr 6mo	11yr 9mo-18yr 8mo
Amphetamine 20 lb to 50 lb or more	15yr 6mo-19yr 7mo	17yr-21yr 10mo	19yr 7mo-24yr
Methamphetamine 20 lb to 50 lb or more	14yr 8mo-24yr 5mo	16yr-27yr 3mo	18yr 8mo-30yrs

1 Felony & 2 Misdemeanor OR 2 Felony	2 Felony & 1 Misdemeanor OR 3 Felony & 1 Misdemeanor	3 Felony & 2 Misdemeanor OR 4 Felony OR MORE
2yr 3mo-2yr 9mo	2yr 9mo-3yrs	3yr 1mo-3yr 10mo
1yr 9mo-2yr 3mo [5 years]	2yr 3mo-2yr 9mo [5 years]	2yr 6mo-3yr 1mo [5 years]
2yr 3mo-3yr 5mo [5 years]	2yr 9mo-4yr 3mo [5 years]	3yr 1mo-4yr 9mo [5 years]
3years 5mo [10 years]	4years 3mo [10 years]	4years 9mo [10 years]
3yr 5mo-6yr 6mo [10 years]	4yr 3mo-8years [10yrs 11yr 6mo]	4yr 9mo-8yr 3mo [10yr -12yr 6mo]
6yr 6mo-9yr 7mo [10yr- 13years]	8 yr-11yr 5mo [1Cyr -14yr 8mo]	8yr 3mo-12yr 6mo [10yr-16yr 6mo]
9yr 7mo-21yr 10mo [13yrs-21yr 10mo]	11yr 5mo-24yr 5mo [14yr 8mo-24yr 5mo]	12yr 6mo-27yr 3mo [16yr 6mo-27yr 3mo]
21yr 10mo-27yrs [21yr 10mo-34yrs]	24yr-30yrs [24yr-30yrs]	27yr 3mo-33yr 9mo [27yr 3mo-Life]

## Advanced Techniques Of Clandestine Psychedelic & Amphetamine Manufacture

154

Let's talk about the government's number one weapon fighting the drug war, turning those who enjoy amphetamine against each other. Looking at the sentencing chart, it doesn't take a genius to realize that a person manufacturing usually will produce more than 2 to 20 pounds of product. And the government knows this. So most manufacturers and distributors of amphetamine and meth are looking at more than 10 years, and in many cases, more than 15 or 20 years. At the same time these penalties were enacted in 1987 a little known provision designated as §5K1.1 in the *Federal Sentencing Manual* was included. It allows for a person sitting in jail, who has little chance of winning a trial, and looking at a minimum of 10, 20, or 30 years in prison, to receive a drastic reduction in sentence, or no sentence at all, if she or he will provide what the government calls "substantial assistance" (I call it simply ratting others off and testifying against them in trial). This dirty plan works so well for the government, that one drug arrest often results in a domino effect spanning twenty to eighty convictions, before it dies out with one or more people with morals too strong to rat.

Because a person may be convicted on circumstantial evidence amounting to guilt beyond reasoning otherwise, and that wonderful maggot known as the prosecutor has a nasty habit of calling numerous lying government agents, the government's conviction rate is extremely high.

Along with these convictions the government seizes millions from its victims' assets. The family home, the family car, and anything of value are confiscated and auctioned off to fill the pockets of those living off the governments' drug war propaganda. The only requisite needed to confiscate the property of those not even involved in the crime is that the property is associated in some way to the drug crime, and a slight indication that the owner was aware of some aspect of the illegal activity. Or a slight indication the property was

*Chapter Eighteen*  
*"War Stories From The Pen"*

155

derived from the profits of the crime. By the way, unexplained money and assets are often used to convince the jury of the defendants' guilt.

The family is usually gutted when the man of the household falls in the government's hands due to the rat who gave him up. The resulting years behind bars usually leave his wife and children on welfare without a home. The marriage and privilege of watching the children grow up is also dissolved in most instances. Of those who are ratted-out in their 40's or 50's, many never survive the sentence to walk the streets free again, because the government doesn't consider age as a factor for those in its vise. But the rat, who enjoys the same drug and can manage to sell-out one or more of his fellow generation, will walk the streets a free man, even as the victims are being sentenced to another world he may never know.

There is a solution to this infection that plagues the clandestine chemist, if he would only exercise it. That is to not draw anyone else in, nor let anyone learn of his manufactures, nor furnish anyone with any cumulative quantities that could be worth the government's time and expense to prosecute. (Under federal law, possessing or sharing amphetamines or meth carries a light sentence, not more than five years. The state, however, will be a different story, and is more likely to handle such a case.) And if the chemist decides he wants to sell some of his product he could deal only with one or two distributors in such a way that his chances of being ratted out are slim to none.

"Total secrecy" is no easy task in our society. Most of us live in a social setting, where we work, play, and tend to our affairs with people who know us and our habits. They can easily read a puzzle unfolding before them, even in well separated sections, many times. People are inherently curious about each other. And they are especially curious of anything



## Advanced Techniques Of Clandestine Psychedelic & Amphetamine Manufacture

156

you might like to keep hidden from them. I've had plenty of occasion to witness busy-bodies take extreme action to discover what they can't find out by being straightforward.

A secret is no longer a secret if the tongue slips once, or if the wrong eye catches a few curious movements to piece a puzzle together. The chemist should wipe the subject from his conversation. His actions are done with patience in mind at every level of preparation. And, as a rule of thumb, the chemist never dismisses a possibility in the back of his mind that could place him in jeopardy.

Every person who boasts his secret greatly increases his chances of conviction if he gets busted manufacturing or selling more than 3 ounces of it. And every person present or involved in a chemist's manufacture or sale of its goods who is investigated and questioned with slight evidence to obtain a grand jury indictment against them, greatly increases the chemist's chances of conviction. (Sadly, this includes most immediate family members). And slight evidence is easy to come by these days. And if these facts don't convince the clandestine chemist to maintain total secrecy and patience, then spending the next 20 or 30 years of his life in a can at the federal penitentiary, surely will.

Loved ones, for example, the wife or family members, who learn about the chemist's intentions and are used in any way to make the crime go forward, or who are present during a raid, may be inflicted with the same penalties. Also, those closest to the chemist are usually the first ones questioned or interrogated, especially if circumstances disclose that they must have an answer to a question needed to break the chemist in court. So why get the family or anyone else involved?

One may ask, well, what sale transactions have little to no chance of apprehension? As of yet I've found no 100% proven method. But I do believe that the chances of arrest

*Chapter Eighteen*  
*"War Stories From The Pen"*

157

can be reduced. And here again, the best counter tactic is to place the receipt of the payment in a "cooling-off period." Several payments can be placed (for instance in a rented lockers) where they will remain for thirty days or more. During this period, the settling should be such that each payment can be quickly and discretely transferred to another spot, where it will remain for the remainder of the period. The selected spot should be where surveillance must work 24 hours.

This transaction will require a great deal of genius. Certain other things are required also. A well trusted individual from out of town, or better yet, out of state, is required, preferably, a female. The clandestine supplier must give up his enjoyment of amphetamine and other drugs. He should do this well in advance of the following transactions. He and his said lady companion will do one or two casual get-togethers with a person empowered to distribute the quantities in stock. The lady friend can then get to know this person, and out of the presence of the supplier (if possible), comment that she has been told that he is able to turn some amphetamine.

She asks the dealer if he would be willing to accept deliveries in the future by picking up the drug and dropping the money at a select place. If he agrees, very specific instructions are given. She then steps out of any danger of becoming the government's victim, and returns to her home to forget the ordeal. Letter communication will direct the distributor, or in exceptional circumstances, another person paid to give specific instruction via payphone. Such instruction need not disclose what the instruction is directly about. Voice scramblers are available at local spy shops for under \$200, but the use of it would have to be explained to the distributor, which may lead to the puzzle being put together.

## **Advanced Techniques Of Clandestine Psychedelic & Amphetamine Manufacture**

158

The identity of the lady friend will, of course, never be disclosed, nor her true address. It is unlikely she will ever be located for questioning should the distributor fall. And so long as the missing linkage between the clandestine supplier and the distributor is maintained, he side steps the government's number one weapon. There must be a connection made to show that the clandestine supplier was aware of the future drug transactions that took place between his lady friend and the distributor before a conviction can be obtained or sentence issued.

There are many possible variations of the scenario just described. For instance, the trusted individual from out of town may be a cool relative. The place where the get-togethers occur, and the manner in which they are brought about, can vary. In any event the supplier must be disconnected from the transactions.

Following is another possibility, in which the supplier can be directly involved in the transactions, and collect his hard-earned payment within a few hours of the money drop-off. It may be used in whole or in combination with the previous method.

The clandestine supplier spends a period under an assumed name. This may include relocating, paying cash for the rent, electric, and water. Local police will instruct an out-of-towner to change his tags, so care is taken in transit. The top three methamphetamine cities in the U.S. (listed in order) are San Diego, California, Phoenix, Arizona, and Seattle, Washington, if my memory serves me right. But another part of his hometown may work just as well. He then begins to locate and meet new people. He may then make a few purchases of amphetamine until he becomes acquainted enough to meet people with ounce, quarter pound, or greater sales capacity. This is a crucial period for the clandestine supplier, because small sales are more likely to bust him than bigger

*Chapter Eighteen*  
*"War Stories From The Pen"*

159

ones. He then selects one or two people and allows them to sell an ounce or so. The clandestine supplier may then work out future arrangements for a "trend towards larger quantities." This arrangement may, or may not, be on the pretense that the clandestine supplier is moving away, and he will be notifying his distributor when other shipments come in. These will be taped under a sink (with deep well molding underneath) in a well used public restroom near his area, in a gas station, for example. Or, it might be made on the pretense that the clandestine supplier just doesn't want to take any chances on his dealers catching any unnecessary heat. If he wants to deal, he will agree. Deliveries are then made by directing the distributor to the location. But yet, he will be directed to different locations near his residence, via payphone, or typed letters, fingerprint-free.

The clandestine supplier will be tipped off that his selected person has been jailed, if a payment has not been received, or a delivery picked up. (Many times an arrested distributor doesn't volunteer to be an informant right away. He may be jailed and have to discuss the matter with his attorney.) Also the clandestine supplier will be alerted if his selected man attempts to draw him in, in person.

Payments from the distributor are received with tripping devices (motion sensors), fiber optic video camera, tracking devices, surveillance, undercover agent, and witnesses in mind. The distributor is phoned and told to deposit loose, large bills in a clear Ziplock baggie, and travel to a selected night club, where he will be called on the payphone at a selected time. The clandestine supplier will then direct the distributor to place the money in the water tank of a select toilet, at the selected night club. (The distributor may be advised in advance, and the call to the club dispensed with. After the first or second delivery, this would be fine.) A different night club is used for most transactions.

## **Advanced Techniques Of Clandestine Psychedelic & Amphetamine Manufacture**

160

The purpose of the floating money is to avoid any tripping devices. It also allows for the money to be clearly viewed before it is fully removed from the tank. External tripping devices on the lid should be easily detectable by careful inspection, internal devices, by observing anything unusual. Explosive inks are hard to employ on the inside of the tank, but covering the finger tips, lifting the back of the lid first, and using the lid as shield can foil this device. Tripping devices attached to the zip-baggie can be detected, by flushing the toilet and lifting the bag slightly for inspection. Sharp bathroom noises can muffle the quick replacement of the tank's top. The money is then hidden from plain view, and quickly delivered to another hidden spot in the same restroom, i.e., in another toilet tank, in the trash can, under the sink, etc. If all goes well, the money can be inspected for tracking devices and retrieved later.

The restroom selected should not have smoke detection, air vents, easily removable mirrors, nor a false ceiling, for fear of video surveillance, although, the chances of a judge issuing a video surveillance search warrant in a public bathroom, where citizens are exposed, are low. Several law suits for invasion of privacy can arise over such a warrant. A restroom with private stalls is preferred. The night club selected should be fairly big, dark, and busy at the time of the drop-off.

The distributor will be told to deliver the money and leave before a selected time, and asked where he can be reached by phone to confirm that the delivery has been made. At this point, the idea will be to retrieve the money before possible agents have time to install any surveillance equipment, yet not so soon as to fall right in the hands of eager undercover agents who may be lurking about. The clandestine supplier can dress with the mainstream. He should change his appearance as much as possible from the appearance the distributor

*Chapter Eighteen*  
*"War Stories From The Pen"*

161

saw. For instance, wear a cowboy or baseball hat and glasses, grow or shave facial hair, etc. If the night club is well selected, it will provide an atmosphere where identification will be difficult. At closing time the club occupants will flood out in all directions. This is a good time for the supplier to leave with his payment.

The use of another person to pick the money up is an alternative with its advantages and disadvantages. The disadvantages are: he may rip the money off; he will want a piece of the action; he must also know the clandestine supplier by his assumed name. And he may cut a deal and turn rat if apprehended. The advantages are: the best he can do (if apprehended) is give the same description of the clandestine supplier as the distributor did; the clandestine supplier has an opportunity to observe whether the pick-up man is being watched; the clandestine supplier has the opportunity to observe or detect whether his man has been arrested; the pick-up man has not collected the heat the distributor may have during his distribution of the amphetamines, so he is not likely to be fingered by anyone once the period of transactions are completed, and he goes his way; the pick-up man stands a reasonable chance he may not be indicted or convicted in trial, because he could have just found the money like any other citizen when the toilet wouldn't stop running water and flush. He should be warned that telling the truth will likely result in charges and conviction. (Note: these slight advantages are probably not available to the clandestine supplier because of the distributor's likely identification of him).

The danger of being ripped-off may be reduced by running a test pick-up. To do this, a couple of twenties and some blank paper (fake money) are tightly wrapped in waxed paper, and tightly taped when placed in the Ziplock bag. It should be recognizable as a large sum of money, yet the

## Advanced Techniques Of Clandestine Psychedelic & Amphetamine Manufacture

162

blank paper undetectable. If it has been tampered with, the supplier will know this is the wrong man for the job.

Another problem in hiring someone to make the pick-up is finding an individual who is willing to take such a job. In somewhat similar instances, I've employed sincerity and placed my cards on the table. But, as I've said, removing the individuals who might assist the government's contrivances should raise the clandestine supplier's chances of avoiding apprehension greatly. And, therefore, in only rare instances should the clandestine supplier give up his secret, and never, if possible. The statute of limitations on drug offenses is five years from the date the offense ended.

Although false identification is not required for this operation, I have moved in several states under a totally different name, and lived there as another person from six months to several years without anyone ever knowing who I really was.

I also had the pleasure of meeting many individuals who loved to party with amphetamine and other drugs. Each city has its cool people, and each area of the city has its individual set of party folks. They can judge whether the clandestine supplier is legitimate or a rat during the period he is being accepted, just as the clandestine supplier can judge and learn about them.

Another alternative to picking up the money, with its drawbacks, is just to drop in at the dude's residence unannounced. Surveillance will only work for agents camped out at the residence, or in a rented apartment across the way. If calls are placed before the door is answered, it will take the local police at least some time to get there. However, the supplier may be recorded, videotaped, or his license tag recorded if he hasn't magnetized an old plate from the wrecking yard on it during the brief transaction. The advantage of this method is eye-to-eye contact.

*Chapter Eighteen*  
*"War Stories From The Pen"*

163

Most successful clandestine manufacturers who decide to sell their product begin in small quantities. A quarter pound, half pound, or so for the first few months. Then one and two pound quantities are requested. A few months into the business, ten and twenty pounds quantities may start going. (So many times, the problem is that after a few thousand dollars, greed begins to collect these clandestine manufacturers in prison. A successful supplier must have a definite stopping point, especially since the stakes have now grown to a life term.) The network below them needs a turn over time. More times than not, the danger with this operation is that the clandestine supplier has pound quantities branching out in every direction. And when one pound runs into undercover or turns up in a traffic search by state troopers while en route, then everyone higher in the operation usually falls with the runner who turns rat to save his own skin. Racketeering is usually among the charges.

Another good reason to go totally solo is founded in the government's number two weapon, "Conspiracy." The United States employed this weapon when it unveiled the rest of its arsenal in 1984. Here is what it looks like. Title 21 USC §846. "Any person who attempts or conspires to commit any offense... is punishable by imprisonment... which may not exceed the maximum punishment prescribed for the offense, the commission of which was the object of the attempt or conspiracy." And here is how it works. Any person who conspires with one other person (other than a government informant or undercover agent) to commit an illegal act will be penalized as if he or she had completed the act. This applies to manufacturing, distribution, and most any other federal offenses. A conspiracy is usually defined as the meeting of two minds in an agreement to violate the law, and may or may not include some slightly significant act to reach the goal of the crime agreed upon. In other words, if the gov-



## **Advanced Techniques Of Clandestine Psychedelic & Amphetamine Manufacture**

164

ernment convinces a jury that two people talked about manufacturing or selling amphetamine, and one of them (including the one who originally come up with the idea) does something in furtherance of this idea (even without the other's knowledge), then both are guilty of the crime of conspiracy. Usually the agreement is easily established by one or more simple actions towards the illegal result, and a rat testifies for the reduced sentence that the agreement existed between him and the other person. Or the government will turn selected members of a multi-person conspiracy into rats and their testimony alone will convince the jury of the others' agreement and involvement in the manufacture or distribution. You can see how the government's number one weapon and number two weapon work very well together. Usually the rat can easily point to evidence within his knowledge of the others' actions, allowing the jury to conclude they were involved in the conspiracy in some way, shape, or fashion.

After talking with numerous manufacturers who have been arrested, I conclude that there are three major reasons that account for most of these apprehensions: one, DEA sting operations; two, being ratted out by their fall partners or others; and three, conflicts between the manufacturer and some other individual. The latter has been known to trap the manufacturer in many ways. Very often there's a beautiful woman involved. One man doing eighteen years currently was entrapped when a persuasive young lady decided to work with DEA to get her boyfriend (and probably herself) out of trouble with the feds. DEA furnished her all the necessary chemicals and most of the equipment, and she furnished it to our man now doing the eighteen years. Another man's only mistake was letting such a woman know his business. He successfully netted over a million dollars in a single year. His young lady friend got involved with another manufacturer and she did enough talking to bust our million-

*Chapter Eighteen*  
*"War Stories From The Pen"*

165

aire down to just a few dollars when this other manufacturer's loose operation fell to pieces on a simple slip. These stories I know because I assist these unfortunate fellows with their legal difficulties.

I think the secrets of methamphetamine manufacture is a deep subject with a lot to be learned. This includes finding out the possible consequences; taking a realistic look at what can be gained or enjoyed from it; considering the odds of success and failure; and all things considered, honestly asking myself if I am willing to take these chances.

I hope you find this letter helpful to your readers, Uncle Fester. Certainly I could not cover all there is to cover on this subject in this one letter. And I had many more important and interesting stories of those who enjoy this trade. But I'm afraid I can't get to them now, because, as you can see, this letter has gotten a little long. Until next time. Enjoy life, and keep up the good work when you have time.

Your fan and friend,

Mr. X

## Advanced Techniques Of Clandestine Psychedelic & Amphetamine Manufacture

166

Fester,

Hello again. How are you doing? It was good to hear from you. I hope you found my previous letter interesting. And if I may, "the rest of the story."

James had been manufacturing when phenylacetic acid was easy to come by. Ephedrine reduction was and is the hottest thing going. James joined in with the red phosphorous/iodine crystal method. When he began his spree he used Anthony to obtain the store-bought ephedrine tablets. The deal was, Anthony would get the ephedrine tablets, and James would give him a cut of the product. Later on, as you might expect, Anthony realized he could be manufacturing on his own. He soon went his own way, and did so.

A few months later James felt the hard repercussions of disclosing his secret. Anthony had been busted and the DEA was offering a deal if he would give up a clandestine manufacturer or two. Anthony furnished the information that allowed the agents to know where James kept his lab, and for the issuance of the search warrant that would be executed. Anthony just couldn't face the consequences of his own actions. Busted with him was his partner, Michael, whom James had formerly sold meth to, and who also testified to this effect against James at his trial.

It is here that I emphasize the types of persons who boast their secrets to another. The chemist does well to notice the persons doing the ratting are people who are prone to be arrested: those who do drugs heavy, sell drugs, and make them, and to a lesser degree, those who are apt to be in some sort of conflictive relationship. Therefore, if anyone must know about the meth cook's business, he is better off with a cool individual, but one who isn't involved in ongoing high-risk activities.

*Chapter Eighteen*  
*"War Stories From The Pen"*

167

Back to James' story. Agents raided his residence. They seized, and laid before a jury, just about every conceivable category of evidence possible in a bust for manufacturing illicit drugs. There were:

1. Eyewitnesses (Anthony and Michael)
2. The end product (meth oil)
3. Unexplainable quantities of precursor chemical
4. Various chemist's glassware (with chemical residue)
5. Miscellaneous, but essential chemicals for the manufacture
6. The recipe
7. Evidence of drug distribution (mini plastic Zip-lock baggies)

Because there was at least one other person involved, James was convicted of conspiracy to manufacture. Anthony furnished ephedrine tablets, and that's all that was necessary to find guilt. Had James not conspired with another, his charge would have been attempted manufacture. Since successful clandestine manufacturers do not need to involve a second person, I will not dwell on conspiracies.

Focusing on attempted manufactures, the listed categories of evidence above are fatal to the clandestine manufacturer when found in combination. But, with the exception of unexplainable quantities of precursor chemicals, indications within the lab equipment that shows signs of manufacture of illicit drugs, and meth itself, each of these categories leaves room for the juror to have some reasonable doubt as to its exact purpose, provided only one of them is discovered. For example, DEA executes a search warrant and all they find is clean glassware and other scientific equipment. Or, all they

## Advanced Techniques Of Clandestine Psychedelic & Amphetamine Manufacture

168

find is a recipe and a witness who says he saw the chemist manufacture. Or, all they find is minor miscellaneous chemicals essential to meth manufacture (i.e., red phosphorus, acetone, and toluene) and evidence of drug distribution (such as those very incriminating mini Zip-lock baggies). Thus, the less likely DEA are to find all the pieces of the puzzle, the more chances the clandestine manufacturer has of walking on a possible prosecution. This is done by splitting the pieces up in different locations.

The meth cook may wish to put all his eggs in one basket. It has the advantage of reducing the number of places the DEA can locate the evidence. It's also convenient. Just pull it all out and put it back. Let's call it the "all or nothing deal." But, as in Allen's story, it has the disadvantage that the meth cook may be under surveillance and the DEA has observed him going to his "all or nothing" hiding spot.

Which method of storing the evidence the chemist chooses depends upon the availability of hiding spots. The best place for items associated with household use is where they normally belong, provided they're not in unusual quantities. Acetone and toluene go where the paint and varnish are stored. Coleman fuel (said to be 100% benzene) goes with the camping and fishing equipment. The only place for Red Devil Lye is the sink (a very incriminating piece of evidence elsewhere). Muriatic acid is used to clean and etch concrete, but unless there is a swimming pool around it's very incriminating and not really a common household item.

Because the nature of the hiding place is often more damaging than the items hidden there, the best place I've found to hide things is where the item doesn't appear unusual being there. Lab glassware and all equipment must pass forensic detection of its use. A four by five-foot storage building room containing numerous other stored items is a good place for these. Non-precursor chemicals, such as iodine crystals,

*Chapter Eighteen*  
*"War Stories From The Pen"*

169

red phosphorous, muriatic acid, etc. are best stored in various areas of a different location. (But too many, or too much at one locale is not good). Some can go in a box of pesticides. Others in another box along with cleaning supplies on the other side of the room.

Except for a brief period when the chemicals are being consumed in the cook, the precursors are stored on other properties than the other evidence. After it has gone through the cooling off period, and a decision is made not to store it there, the precursor can be ditched somewhere for later use. The reason being that if DEA come looking, they usually have at least some other evidence that the chemist has manufactured. And one more piece of evidence along side the precursor is usually pretty good circumstances for a conviction for attempted manufacture.

From the point where chemicals are purchased for the first cook, the chemist gets rid of or trashes all the distribution paraphernalia. Evidence of distribution is very damaging when a dude is standing trial for manufacturing drugs. Keeping these items at a friend's may be okay. Books and other recipes can be boxed with other books and stored at a relative's house. They are also very incriminating at a trial.

The chemist's most guarded secret should be where he buys his chemicals and stores his lab. With a word (the name of the chemical company), a clandestine manufacturer can be convicted and escorted to prison. DEA will contact the company for their business and phone records. And they will look at the total chemicals ordered. Just like the former partners' observation of the lab's location, once the location for the chemicals purchased is given to a person or persons, years of the chemist's life are riding with those persons' ability to not fall prey to DEA, and to keep the secret. Only an imbecile would use a credit card to buy chemicals.

## **Advanced Techniques Of Clandestine Psychedelic & Amphetamine Manufacture**

170

Precursor chemicals and lab equipment usually mean a conviction. A recipe and miscellaneous chemicals essential to the manufacture usually result in a conviction. Precursor chemicals and eyewitness testimony (especially two or more), usually result in a conviction. And the combinations go on.

James not only did not take the precaution of separately storing various pieces of the lab at different locations, but also made the mistake of storing it at the most likely place the DEA would first look. Since the precursors involved were two boxes of 250 bottles of ephedrine tablets, each containing 250 thirty-milligram tablets, he is now doing well over ten years in federal prison.

The date was February 12, 1995. The place was near Phoenix, Arizona. Jose was being pulled over for speeding. When he rolled his window down, the trooper smelled an "overpowering" cherry fragrance. She asked for his drivers license, insurance, and vehicle registration. He did not have insurance and the title he offered for the registration was not under his name. Jose explained that a friend had asked him to drive the car from Los Angeles to Phoenix, that he knew his friend had borrowed the car from a lady and drove it to Los Angeles on a business trip, but got tied up, and asked Jose to drive the car back to Phoenix.

The trooper checked to see if the car had been stolen. It had not. She advised Jose that she was just going to issue him a warning for speeding, which she did. But as they walked back towards Jose's car, the trooper asked if he had any drugs, weapons, large sums of money, or anything else she might find in the car to be contraband. Jose answered no to each of the questions. The trooper then said, "Well, you don't have any problem with me taking a look around inside the vehicle then, do you?" Jose said no. The trooper then retrieved a consent to search form which Jose signed. When

*Chapter Eighteen*  
*"War Stories From The Pen"*

171

the trooper searched the interior of the car she found nothing. But when she opened the trunk she discovered 27 pounds of methamphetamine hidden in the quarter panel where the jack is usually stored.

I told you Jose's story because I find myself running across these stories quite often. As the saying goes, "You could learn a lot from a dummy." When a person *knows* he has got drugs in the car, he should never give the cop permission to search the vehicle. (The same applies to a house, a mail package, a piece of luggage, and so on.) If Jose had not given her permission to search, then either the cop wouldn't have looked (no permission was given), or if she looked, the evidence would have been suppressed. And without evidence there is no case. The Constitution says that people have the right to privacy in their personal effects. And the Supreme Court has long held that the way to prevent infractions is to punish the officers by suppressing the fruits (the objects and all evidence connected) of their searches that violate this right to privacy. But those who give consent to be searched have no rights.

To protect themselves, officers do have the right to search for weapons within the reach of the people in a vehicle. And they do have the right to "inventory" everything in the vehicle's interior and trunk if the driver is being arrested and thus the car impounded. They have no excuse to look under the hood of a person's car. Therefore, if under the hood is where they look, the evidence can be suppressed. Everyone carrying drugs should be told this.

July 28, 1995. Cedar Rapids, Iowa. DEA receives enough information from "Tips for Cash" to obtain a phone tap warrant on the suspect. Days later they record enough information to make an arrest. The suspect was dealing methamphetamine. She was apprehended at her home and handcuffed. But instead of taking her to jail, DEA took her to



## Advanced Techniques Of Clandestine Psychedelic & Amphetamine Manufacture

172

their headquarters, where she soon gave up Carmella. A search warrant was obtained and executed. Agents found nothing and focused on Carmella. They had enough to arrest. But they did not have enough to make the grand jury stick an indictment on her. They handcuffed her hands behind her back, then sat her down and told her about the informant and the information she would give at trial. They gave her the option of cooperating or going to jail. Then they started asking questions and receiving answers. Carmella told DEA she got her meth from her associate, Martha.

Agents told Carmella that if she was willing to help them she could stay at home and charges probably wouldn't be brought against her. They asked her when the next deal was supposed to go down. Just then the phone rang. It was Martha. Agents quickly instructed Carmella to offer \$16,000 for a pound of meth. Martha thought it was a little peculiar that she would pay an extra \$4,000 more than the usual price. Carmella explained that was the price she would pay if Martha could get it that day. Martha agreed, and suggested the usual place for exchanging the money. Carmella agreed and sat the phone down.

Agents then asked how the deal was supposed to be made. Carmella told agents that Martha would collect the money and she (Carmella) would return home to wait for a call giving her directions where she could pick up the pound. She told the agents that it was at one of three different places. An agent asked if she knew who Martha's connection was. Carmella said all she knew was his name was Cirilo.

Posing as the buyer of the deal, one agent accompanied Carmella to the location where the payment was to be collected. He was wired. Other undercover agents watched as Martha arrived and got in the car with Carmella and her undercover buyer. Martha accepted the money, got out of the car, and was arrested.

*Chapter Eighteen*  
*"War Stories From The Pen"*

173

Martha was advised of the magnitude of the offense of distributing one pound of meth and of the previous quantities Carmella agreed to testify to. Furthermore, she was correctly advised that the only way around it was to prove she was innocent or give up her sources. They advised her they knew his name was Cirilo. Martha said it wasn't Cirilo, but a dude named Jose. Agents then asked, "Who was Cirilo then?" She told the agents Cirilo was his name, but he wasn't involved. A few minutes later at DEA headquarters, agents interrogating Carmella got a call. DEA had arrested Cirilo driving near one of the drop sights. And there was a pound of meth in a pipe in a culvert next to the remote gravel road where the drop was supposed to be made.

Cirilo and Martha had the right general idea. But as you see, it contained flaws. Flaws that cost Cirilo and Martha a lot of years. Just because Martha called Carmella out of the blue doesn't mean she couldn't be convicted of use of a telephone to commit a crime. Those who turn informant because they are busted can accept and make calls while DEA assist in recording the conversation, whereas, the DEA agents themselves must get a phone tap warrant, which requires proof of illegal activity at that number.

The collecting of the money in person and the delivery to several known locations were the worst flaws. Martha could have used Cirilo to call Carmella. And Martha could have long ago prearranged for Carmella to put the money under the seat of her car and drive it to a nearby public location, where both the key and the money are locked in the car. Shortly afterward, Martha could have called some friends explaining that her car was ripped off, even reported it at the police station. Then she could have "discovered" the car, later on finding the money. If she was arrested discovering the car, she could then call her witnesses, and testify herself that she found the car on the way to the store with a friend.

## Advanced Techniques Of Clandestine Psychedelic & Amphetamine Manufacture

174

As to the delivery, Cirilo should have picked a new location each time, and had the meth in place before he made the call. And finally, Martha should have been dealing with better people.

Well, because I promised myself I would not keep you as long as the last letter, I will turn to some tips I've gained from the stories yet to tell. Then I'll leave you with a few brief tips on what the clandestine chemist should do if he unfortunately finds himself facing charges for manufacturing.

First, I'd like to discuss a method I used to avoid detection, one that has worked well for me.

One must consider the trail of evidence very seriously, preferably, as it develops. It lets the chemist know how far to push one or more aspects of his activities. It keeps track so nothing is overlooked. And it's an accurate measurement of just how secret the chemist really is. I call it my "Hot List," and here is how it works.

Shortly after I began cooking meth I started a record of all the people and things that could possibly alert DEA or the cops to who I was and what I was up to, except I wrote it in code, a code that only I could understand. As I went along gathering various chemicals and equipment needed I privately wrote down every person who strongly sensed I was up to making drugs, and why I thought they did. It got to where I just hated adding another name, and I became more secretive. I entered each amount of chemical I purchased for each place it was purchased, and kept totals. I also made entries concerning any suspicion I had about the place where I did the manufacturing. I even made notes about the things that could happen beyond what I was aware of. And most importantly, when each place, thing, or aspect of my operation was approaching a risky point, I entered that aspect, place, or thing under the heading "Hot," and left it alone.

*Chapter Eighteen*  
*"War Stories From The Pen"*

175

Playing it safe cost time and progress. But I knew going past the approach to risky would cost a lot more. Actually taking the extra step taught me plenty, and, on more than one occasion, prevented the past from slipping up on me. It would have been nice to share the experience and the knowledge with someone else I liked at the time. And it would have been nice to have someone there to help out. But I knew telling someone would lead to the details of the crime, something that very well could get me a conspiracy charge at some point down the line. When I had a problem, that was when I most needed someone to talk to. But I found the answers myself at the local college chemistry library.

Another angle I recently discovered is that undercover agents do not sell or give drugs away without arresting the recipient right away. Of course, this doesn't apply to informants. But in all the hundreds of cases I've read about, I've never once seen an undercover agent sell the suspect drugs and not arrest him. Then I read where it's against federal law for them to do this. I wonder if asking for a few buds of weed before really getting down to the serious dope dealing isn't such a bad idea. Hey, it wouldn't look good at a person's trial (for drug dealing) if the agent was dealing himself.

I know a few arrested, and I've run across quite a few cases, where the meth manufacturer is approached by an individual who postulates he is able to get all or part of the lab and chemicals, mostly the important chemicals. And a day or so later the DEA arrests them. It's done with those who are busted and whom the DEA back with the necessary chemicals. Or it is done with undercover agents who have infiltrated the circle some way. It is an old trick that is still jailing quite a few meth cooks. Most of them are very smart at what they do. The successful meth cooks refuse such offers from people not really known well. And even the ones known well

## **Advanced Techniques Of Clandestine Psychedelic & Amphetamine Manufacture**

176

should be looked upon with a very sharp eye before accepting such an offer.

A word or two about the ex-drug offenders is in order. Once DEA know they have a cook or distributor identified, you can count on the DEA notifying the local police to jump at any chance to get this dude back in prison, particularly through a busted associate who is willing to go in and set up a controlled dope deal. DEA will go to great lengths to see this fellow back in prison.

The home telephone. It's convenient, but it will bust a meth cook and increase his sentence all in one blow. The first thing DEA do when they get a suspected manufacturer is to get a copy of his phone statements, to check out where the calls have been going to. If chemical companies have been called, and the chemist is busted, or suspected, they will check their business records to prove the chemical buys. The companies' phone statements will show if other calls have been made from that locale and, thus, if anyone else is involved. Therefore calling collect doesn't work either. The way to get around this is to call from a pay phone (preferably not from a small town where home is located) or have a pretty damn good excuse for the calls made. The home phone bill also explains events that occur at or about the same time as the call is made.

Firearms in the same house as drugs call for an automatic increase of two to four years imprisonment. Should the firearm be shown to have been employed in a drug transaction (i.e., the presence of a gun near or with the drugs or in the same car involved in a drug transaction) the increase is five to ten years more imprisonment.

Revisiting my sentencing chart, you will notice that for quantities less than two pounds there is a significant difference in the sentences for methamphetamine and amphetamine. For those with a fairly extensive criminal history the

*Chapter Eighteen*  
*"War Stories From The Pen"*

177

big difference lies below 7/8th of a pound. Those who are not cooking quantities above these amounts should seriously consider leaving the meth alone and switching strictly to amphetamine. The amphetamine is almost as good as the meth, and it sells just as well. Be reminded that it is the total quantities involved during the entire life of the crime that determines the length of the sentence to be served. And the slight evidence needed to prove these past quantities is very often available to prosecution after an arrest, depending on which branch of the manufacture or distribution network is busted. Those with one or more prior convictions for distributing or manufacturing any drug are flirting with a life sentence by messing around with more than three ounces of methamphetamine.

Many times amphetamine cooks are arrested before any drug has been made. In that case, proving the seized chemicals (i.e., phenylacetone or other chemicals it takes to make it) were not intended for methamphetamine manufacture is difficult to do at sentencing phases of the trial. In some states, or more precisely, some circuits, the sentencing judges will stick the methamphetamine on him, when amphetamine was the object of the manufacture. But, in other states, the burden of proving it was meth is on the prosecution. In any event, the presence of meth production evidence (i.e., methylamine, ephedrine, meth recipes, etc.) creates a particularly good situation for an unnecessary higher sentence.

The clandestine chemist should not be saving any liquids with detectable amounts of amphetamine or methamphetamine in it (i.e., waste water, unrefined mixtures, uncrystallized solutions, etc.). The reason is that many courts will weigh the entire mixture against the chemist and sentence him as one who was captured with the same weight in fairly pure amphetamine.

## Advanced Techniques Of Clandestine Psychedelic & Amphetamine Manufacture

178

If the clandestine manufacturer is going to go for the big quantities that could get him a sentence longer than he is likely to live, he will consider a very well planned one time cooking spree, and get it over with. I can think of nothing worse than a cook who repeatedly takes the same risks over and over again. To limit the possible sentence, he will split the product up in smaller quantities and hide each one of them at different location.

Let's talk about the misfortune of facing federal charges for manufacturing. In federal court the accused must show a reasonable doubt. The government's burden is satisfied shortly after the trial begins by the evidence seized and the jury being focused solely on the incriminating nature of it. I may not be an attorney, but there are some basic principles that are obvious to a defense for illicit drug manufacturing.

The key factor is the defendant's practical use or excuse for the evidence at hand. This should be the primary focus of the defense's presentation and rebuttal of the evidence.<sup>1</sup> Of course, this is best achieved by having the use or excuse at the time the incriminating evidence is obtained or recognized. But it must be practical. An important part of the defense will come from the defendant's own experts on the government's evidence,<sup>2</sup> who will testify to the variety of practical uses of the object discovered by the DEA.

In the case of overwhelming evidence, but short of direct evidence, a defense that the DEA planted the evidence allegedly discovered while acting on the informant's tip may be the correct approach, especially if the evidence could have been easily obtained once the DEA discovered there was little or no evidence to seize when they arrived. It is not be-

---

<sup>1</sup> Don't let a defense attorney sell you anything different.

<sup>2</sup> Don't let a defense attorney sell you on using the government's testifying expert in the same field, i.e., don't rely on his cross examination of this liar to carry the day. He will continue his lies.

*Chapter Eighteen*  
*"War Stories From The Pen"*

179

yond these devils to go to Wal-Mart and pick some evidence up and throw it in with other household items to make a case. And since they often lie a lot on the witness stand, asking for a recess to obtain an expert or other proof adds support.

One might ask why James went to trial with all that overwhelming evidence against him. Why didn't he plead guilty in exchange for a reduced sentence? The answer is because the most the feds will reduce a sentence for pleading guilty is about two years. It's a law. The federal court system is totally different from state court systems. If a plea agreement is offered by the defense attorney and signed, at the plea hearing the judge will accept the plea of guilty and 99% of the time refuse to follow the government's recommendation to reduce the sentence from its guideline. And there is no withdrawal of the plea of guilty. Many times he will postpone his determination to the later date of sentencing, but the result is the same: no reduced sentence other than the two years allowed by law.

Often, never telling the defense attorney the details of guilt is better. The reason is that they fear and can be subject to penalties for presenting a false defense. Many attorneys underneath have little sympathy for a clandestine manufacturer. And they go out on a limb for very few. Thus, defenses may be lost with the truth. The question should be, "What can you come up with to discredit the government's evidence?"

In all my experience with the criminal justice system I have very rarely known anyone to get a spectacularly lower sentence than is normally given for the quantity of drugs involved when large sums of money have been paid to an attorney. This is because the sentences are set by laws that the judge and the prosecutor must follow. Most who blow thousands of dollars on lawyers in non-borderline cases are throwing their money away.



## **Advanced Techniques Of Clandestine Psychedelic & Amphetamine Manufacture**

180

Public defenders are paid fairly well, eight to twelve thousand for a trial case, but although they can do more, many times do not. Experts may be dispensed with in order to justify their charges to the court for services. One might consider hiring an outside attorney to check the public defender's proposed line of defense, experts, etc., just before trial. They also have a nasty habit of convincing the chemist to plead guilty before the appropriate motions to suppress evidence, because of illegal search and seizure, have been presented and heard. Many also play a very instrumental role in getting the accused to rat others out for a reduced sentence. But not all of these attorneys are bad. It's how they are focused on the trial that counts.

Well, we've covered a lot of ground, Fester. Until next time.

Your friend,

Mr. X

*Chapter Eighteen*  
*"War Stories From The Pen"*

181

Dear Uncle Fester,

The Comprehensive Methamphetamine Control Act of 1996 has mandated that the maximum sale of ephedrine, pseudoephedrine or phenylpropanolamine be 24 grams of base. This means that 1000 of the 25-milligram ephedrine pills is the maximum single purchase. For the other substances, calculate on your own. It gets better from there. The law also states that all sales records from mail-order pill suppliers be submitted on a regular basis to the heat. They have a "suspicious transactions response team" to follow up on these sales reports. I'll bet people are dropping like flies as a result. The law also directs the Attorney General to look into putting iodine and red phosphorus on the chemical diversion list. As of 1997, in April, they haven't made their way onto the list.

One point to be taken from this is that methods using ephedrine, etc., are strictly for making stash amounts, unless you have access to larger amounts of the materials by over the counter sales, or a pipeline to the inside. Another point is that the red P and iodine process is now the focus of maximum heat. Don't buy those materials! A cop comes right with them! I hear you have a "Fester Formula" to make the world safe for stash cookers. Good. That HI/red P method caused more hangovers than the buzz was worth. God, I miss phenylacetone! You say the "Fester Formula" doesn't cause these hangovers. I think I'll wire up some batteries in my jail cell.

Your friend,

Mr. X



## You Will Also Want To Read:

- **85376 SECRETS OF METHAMPHETAMINE MANUFACTURE, 6th Edition, Including Recipes for MDA, Ecstasy, and Other Psychedelic Amphetamines, by Uncle Fester.** A revised edition of one of our best-selling "cookbooks." The result of a decade of practical experience, this is a step-by-step, how-to-do-it book on the manufacture of methamphetamine and psychedelic amphetamines. This book is not meant to encourage anyone to break the law, but it does point out the ultimate futility of government prohibitions of "controlled substances" by showing just how easily they can be manufactured. *Sold for informational purposes only. 2002, 8½ x 11, 200 pp, illustrated, soft cover. \$30.00.*
  
- **85241 PRACTICAL LSD MANUFACTURE, Revised and Expanded, 2nd Edition, by Uncle Fester.** This book contains the most detailed, comprehensive and concise descriptions ever compiled of several innovative procedures for extracting the hallucinogenic substance 2,4-5-trimethoxyamphetamine (TMA-2) from the common widely available calamus plant! Includes tips on solvent management, cautionary notes and more. *Sold for informational purposes only. 1997, 5½ x 8½, 160 pp, illustrated, soft cover. \$20.00.*
  
- **85102 RECREATIONAL DRUGS, by Professor Buzz.** The single finest book ever written on the manufacture of recreational drugs. Profusely illustrated, it covers the equipment, techniques and reagents used in the clandestine manufacture of illegal drugs. Procedures for crystallization, chromatography, distillation and reductions are given for the following types of drugs: Amphetamines; Hallucinogens; THC; Analgesics; Hypnotics, Sedatives and Tranquilizers. Also includes detailed instructions for buying and making precursors. *Sold for informational purposes only. 1989, 8½ x 11, 166 pp, illustrated, soft cover. \$21.95.*

- **85024 PSYCHEDELIC CHEMISTRY**, by *Michael Valentine Smith*. The most complete book ever written on how to manufacture psychedelic drugs! Intended only for those who have a thorough knowledge of advanced lab techniques in organic chemistry. Extracting THC from marijuana. Making LSD. Synthesizing cocaine. Mescaline, harmaline, muscimole and more. *Sold for informational purposes only.* **1981, 5½ x 8½, 200 pp, illustrated, soft cover. \$19.95.**
- **85063 THE CONSTRUCTION AND OPERATION OF CLANDESTINE DRUG LABORATORIES, Second Edition**, by *Jack B. Nimble*. This revised and updated book describes in step-by-step detail how to set-up and run a clandestine drug lab *without getting caught*. Jack B. Nimble reveals how to select a location, discusses safety precautions — including how and when to shut down — and advice on covering your tracks. *Sold for informational purposes only.* **1994, 5½ x 8½, 130 pp, illustrated, soft cover. \$17.95.**
- **85186 OPIUM FOR THE MASSES: A Practical Guide to Growing Poppies and Making Opium**, by *Jim Hogshire*. Everything you want to know about the beloved poppy and its amazing properties, including: What does the opium high feel like?; The stunning similarities between opium and your body's natural endorphins; Morphine and its derivatives; How to grow opium poppies; Sources for fertile poppy seeds; And much more! Also includes rare photographs and detailed illustrations. **1994, 5½ x 8½, 112 pp, illustrated, soft cover. \$14.95.**
- **85182 PSYCHEDELIC SHAMANISM, The Cultivation, Preparation and Shamanic Use of Psychotropic Plants**, by *Jim DeKorne*. From the author of *The Hydroponic Hot House* comes the boldest exploration of psychedelic plants since Terence McKenna's *Food of the Gods*. DeKorne guides the reader through the history and lore of psychotropic plants. Plants and combinations covered include: Belladonna Alkaloids; D-Lysergic Acid Amide; Mescaline; Ayahuasca; and more. **1994, 8½ x 11, 163 pp, illustrated, indexed, soft cover. \$19.95.**

- **85212 THE POLITICS OF CONSCIOUSNESS**, by **Steve Kubby with a Foreword by Terence McKenna**. The War on Drugs is really a war on freedom of thought. Our fundamental right to pursuit of happiness includes the innate right to explore inner space without government interference. Author Steve Kubby explains how the authorities have short-circuited democracy through illegal, unconstitutional sanctions on the use of psychoactive plants and substances... and voices a fiercely patriotic rallying cry for a campaign of liberation that will enable us to recapture our freedom to think as we choose. This is a compelling, brutally honest book that is unlike anything ever published before. **1995, 8½ x 11, 160 pp, illustrated, soft cover. \$18.95.**
  
- **85346 HERBS OF THE NORTHERN SHAMAN, A Guide to Mind-Altering Plants of the Northern Hemisphere**, by **Steve Andrews**. This book describes in clear, understandable terms the plants and fungi, their active constituents, the dosages, and their effects on the human mind and body. Whether you are an explorer of alternative realities or a botany buff and consummate student this book is for you. **2000, 8½ x 11, 116 pp, illustrated, indexed, soft cover. \$14.95.**
  
- **94317 SEX, DRUGS, & THE TWINKIE MURDERS**, by **Paul Krassner**. The "Zen Bastard" rides again! In this brand-new collection of satirical pieces, Paul Krassner, America's sharpest and funniest social commentator lets fly at everything from sex and drugs to the Twinkie murders. More than 40 pieces are included, all of them demonstrating why Paul Krassner ought to be declared a National Resource. **2000, 5½ x 8½, 368 pp, soft cover. \$19.95.**
  
- **88888 Loompanics Unlimited 2001 Main Catalog, THE BEST BOOK CATALOG IN THE WORLD**. Over 800 titles listed. See our catalog ad at the end of this book. **\$5.00.**

- **85203 STONED FREE, How To Get High Without Drugs, by Patrick Wells and Douglas Rushkoff.** Now you can say "NO!" to drugs.. and get high anyway! This book enumerates many drugless consciousness altering techniques, both timeless and recent in origin, that anyone can make use of. Meditation, breathing techniques, high-tech highs, sleep and dream manipulation, and numerous other methods are examined in detail. Avoid incarceration, save money, and skip the wear and tear on your body, while getting higher than a kite. **1995, 5½ x 8½, 157 pp, illustrated, soft cover. \$14.95.**
  
- **85276 INVISIBLE MARIJUANA AND PSYCHEDELIC MUSHROOM GARDENS, by Robert Bunch.** This book is unlike other "grow" books, in that the emphasis is on how to keep your garden hidden. This book reveals the "High in the Sky" system, which the author has found foolproof. Included are methods on how to conceal outdoor marijuana gardens and helicopters and other snoops; how to grow psychedelic mushrooms without getting caught; how to cheaply obtain all the equipment you will need to start growing both marijuana and mushrooms; eye-popping color insert of buds and shrooms grown using the methods detailed in this book; and much more. The author says, "People are going to grow and smoke dope, that is all there is to it. I am just providing an easier way to grown, that also has the benefit of being risk-free." *Sold for informational purposes only.* **1998, 8½ x 11, 152 pp, illustrated, soft cover. \$17.95.**
  
- **10065 HOW TO HIDE THINGS IN PUBLIC PLACES, by Dennis Fiery.** Did you ever want to hide something from prying eyes, yet were afraid to do so in your home? Now you can secrete your valuables away from home, by following the eye-opening instructions contained in this book, which identifies many of the public cubbyholes and niches that can be safely employed for this purpose. Absolutely the finest book ever written on the techniques involved in hiding your possessions in public hiding spots. **1996, 5½ x 8½, 220 pp, illustrated, soft cover. \$15.00.**

Please send me the books I have marked below.

- 85376, **Secrets of Methamphetamine Manufacture, \$30.00**
- 85241, **Practical LSD Manufacture, \$20.00**
- 85102, **Recreational Drugs, \$21.95**
- 85024, **Psychedelic Chemistry, \$19.95**
- 85063, **Construction and Operation of Clandestine Drug Laboratories, \$17.95**
- 85184, **Opium for The Masses, \$14.95**
- 85182, **Psychedelic Shamanism, \$19.95**
- 85203, **Stoned Free, \$14.95**
- 85276, **Invisible Marijuana Gardens, \$17.95**
- 10066, **How to Hide Things in Public Places, \$15.00**
- 85212, **The Politics of Consciousness, \$18.95**
- 85346, **Herbs of The Northern Shaman, \$14.95**
- 94317, **Sex, Drugs, & The Twinkie Murders, \$19.95**
- 88888, **Loompanics Unlimited Main Catalog, \$5.00, (FREE if you order any of the above titles.)**

---

**Loompanics Unlimited**  
**PO Box 1197**  
**Port Townsend, WA 98368**

**AT02**

I have enclosed \$ \_\_\_\_\_ which includes \$5.95 for shipping and handling of the first \$25 ordered. I have added \$1 for each additional \$25 ordered. Washington residents include 8.2% sales tax.

Name \_\_\_\_\_

Address \_\_\_\_\_

City/State/Zip \_\_\_\_\_

We accept Visa, Discover, and MasterCard.

To place a credit card order call **toll-free 1-800-380-2230**,  
24 hours a day, 7 days a week.

Check out our Web site: **www.loompanics.com**



# The Best Book Catalog In The World!!

We offer hard-to-find books on the world's most unusual subjects. Here are a few of the topics covered IN DEPTH in our exciting new catalog:

*Hiding/Concealment of physical objects! A complete section of the best books ever written on hiding things.*

*Fake ID/Alternate Identities! The most comprehensive selection of books on this little-known subject ever offered for sale! You have to see it to believe it!*

*Investigative/Undercover methods and techniques! Professional secrets known only to a few, now revealed to you to use! Actual police manuals on shadowing and surveillance!*

*And much, much, more, including Locks and Lock Picking, Self-Defense, Intelligence Increase, Life Extension, Money-Making Opportunities, Human Oddities, Exotic Weapons, Sex, Drugs, Anarchism, and more!*

Our book catalog is over 250 pages, 8½ x 11, packed with more than 800 of the most controversial and unusual books ever printed! You can order every book listed! Periodic supplements keep you posted on the LATEST titles available!!! Our catalog is \$5.00, including shipping and handling.

*Our book catalog is truly THE BEST BOOK CATALOG IN THE WORLD! Order yours today. You will be very pleased, we know.*

**LOOMPANICS UNLIMITED  
PO BOX 1197  
PORT TOWNSEND, WA 98368**

Name \_\_\_\_\_

Address \_\_\_\_\_

City/State/Zip \_\_\_\_\_

We accept Visa, Discover, and MasterCard. For credit card orders *only*, call 1-800-380-2230, 24 hours a day, 7 days a week.

Check out our Web site: [www.loompanics.com](http://www.loompanics.com)

## ***Advanced Techniques of Clandestine Psychedelic & Amphetamine Manufacture***

Uncle Fester, America's best-selling countercultural-chemist author, has done it again! Now, you can add to the knowledge contained in his other works, such as *Practical LSD Manufacture* and *Secrets of Methamphetamine Manufacture*. Some highlights of this edition of ***Advanced Techniques of Clandestine Psychedelic & Amphetamine Manufacture*** you're holding in your hands include:

- The Fester Formula — The perfect stash-sized speed recipe!
- A Convenient Tabletop MDA Recipe — This astounding process uses no exotic chemicals and is so stealthy that it can be done in a dorm room!
- Scams & Schemes for Obtaining Chemicals — From a few grams to a few tons! Cover your ass à la Uncle Fester!
- Many New Phenylacetone Recipes — This awesome amphetamine precursor is now poised to make its comeback via the use of very mundane chemicals!
- Great Low-Profile Operator
- Letters from Mr. X — Writing from within a federal penitentiary, Mr. X relates the stories of the outlaw meth-makers he's doing time with!

***Advanced Techniques of Clandestine Psychedelic & Amphetamine Manufacture*** has nearly 190 pages of vital data and explanatory illustrations that Uncle Fester has crafted together in order to further his ongoing campaign to keep his readers well ahead of the fascist War-on-Drugs repression which is sweeping across the land! Complete with an Introduction by Jim Hogshire (author of *Opium for the Masses*), this is the most incredible chemistry guidebook ever written! *Sold for informational purposes only!*

**\$27.95**

